

Please do not upload this copyright pdf document to any other website. Breach of copyright may result in a criminal conviction.

This Acrobat document was generated by me, Colin Hinson, from a document held by me. I requested permission to publish this from Texas Instruments (twice) but received no reply. It is presented here (for free) and this pdf version of the document is my copyright in much the same way as a photograph would be. If you believe the document to be under other copyright, please contact me.

The document should have been downloaded from my website <https://blunham.com/Radar>, or any mirror site named on that site. If you downloaded it from elsewhere, please let me know (particularly if you were charged for it). You can contact me via my Genuki email page: <https://www.genuki.org.uk/big/eng/YKS/various?recipient=colin>

You may not copy the file for onward transmission of the data nor attempt to make monetary gain by the use of these files. If you want someone else to have a copy of the file, point them at the website. (<https://blunham.com/Radar>). Please do not point them at the file itself as it may move or the site may be updated.

It should be noted that most of the pages are identifiable as having been processed by me.

I put a lot of time into producing these files which is why you are met with this page when you open the file.

In order to generate this file, I need to scan the pages, split the double pages and remove any edge marks such as punch holes, clean up the pages, set the relevant pages to be all the same size and alignment. I then run Omnipage (OCR) to generate the searchable text and then generate the pdf file.

Hopefully after all that, I end up with a presentable file. If you find missing pages, pages in the wrong order, anything else wrong with the file or simply want to make a comment, please drop me a line (see above).

It is my hope that you find the file of use to you personally – I know that I would have liked to have found some of these files years ago – they would have saved me a lot of time !

Colin Hinson

In the village of Blunham, Bedfordshire.



Microsoft* Multiplan*

Electronic Worksheet

SOLID STATE CARTRIDGE AND DISKETTE

A personal productivity tool that helps you design “spreadsheets” for row-column calculations—expense statements, planning forms, data analysis, budgets, financial reports, and more.

This cartridge is designed to be used with the TI-99/4A Home Computer only. Requires the TI Memory Expansion unit and the TI Disk Memory System (TI Disk Drive Controller and Disk Memory Drive)—sold separately.

*Microsoft and Multiplan are trademarks of the Microsoft Corporation.

Microsoft* Multiplan*

Electronic Worksheet

User's Guide

* Microsoft and Multiplan are trademarks of the Microsoft Corporation.

VisiCalc is a trademark of VisiCorp, Inc.

Copyright © 1983 Texas Instruments Incorporated.

Cartridge program contents copyright © 1981, 1982 Microsoft Corporation.

Diskette program contents copyright © 1982 Microsoft Corporation and Texas Instruments Incorporated.

See important warranty information at the back of this book.

Preface

Microsoft* Multiplan* Electronic Worksheet is a personal productivity tool that will help you analyze data. As an aid for both business and personal needs, Multiplan is one of the most powerful modeling and planning tools ever invented. With Multiplan, you can do the capital budgeting for a small company; you can make major sales force decisions or analyze product planning; you can plan your personal investments and put together a budget for your family . . . and much more.

Multiplan is easy to learn, and its versatility is enhanced by the skill of its user. As you become more familiar with Multiplan, and better able to exercise its powers, you'll be surprised at how quickly and efficiently you'll accomplish various tasks.

The two parts of this manual are designed as a tutorial and a reference guide to Multiplan. Part 1 is tutorial; it gives you an overview of the features of the system. Part 2 is a detailed reference guide to all Multiplan features. Parts 1 and 2 complement one another—together they will teach you the concepts as well as the uses of Multiplan.

Welcome! We hope you enjoy working with your powerful new assistant: Multiplan.

* Microsoft and Multiplan are trademarks of the Microsoft Corporation.

Contents

Introduction	9
Operating Information	11
Part 1 Using Multiplan	15
1 Fundamentals	17
The Screen	17
The Direction Keys	18
Moving the Cell Pointer	18
The Status Line	18
Scrolling the Worksheet	19
The Goto (G) Command	19
Command Selection from Menus	21
Multiplan Proposed Responses	22
Filling in the Command Line: The TAB Key	22
Carrying Out a Command: The ENTER Key	22
Cancelling a Command: The CANCEL Key	23
Assistance with a Command: The HELP Key	23
The Quit (Q) Command	24
Summary	25
2 Building a Worksheet	27
The Worksheet Number Grid	28
Entering Text: The Alpha (A) Command	29
Correcting Typing Errors: The BACKSPACE Key	30
Entering Data with the Direction Keys	30
Column Width	32
The Format Width Command	32
Entering Numbers	33
The Format Default Cells Command	34
Alignment	35
Formats	35
Saving Work: The Transfer Save Command	37
The Quit (Q) Command	38
Summary	38

3	Entering Formulas	39
	Loading a File: The Transfer Load Command	40
	The Insert Command	40
	Entering Additional Text	42
	Entering Additional Numbers	43
	Aligning Cell Contents	44
	Ranges: The Colon	45
	The Blank Command	46
	Formulas	46
	Building a Formula	47
	Reviewing or Changing a Formula	49
	The Status Line: Cell Contents	49
	Drawing Lines	50
	The Transfer Save Command (Review)	51
	Summary	51
4	Naming Cells and Copying	53
	The Transfer Load Command (Review)	54
	Titles	54
	Format: Align Center	55
	The Copy Right Command	57
	Formulas (Review)	59
	Naming Cells	60
	Building a Formula Using Names	62
	The Goto Name Command	64
	Calculating Functions: SUM	65
	Number Signs (#)	68
	Error Values	69
	Relative References and Absolute References	70
	Copying a Formula: The Copy From Command	73
	Summary	74
5	Windows, Copying Formulas, and Options	75
	Fixing Titles: The Window Split Title Command	76
	Opening a Window: The Window Split Command	77
	Linking Windows: The Window Link Command	78
	Bordering Windows: The Window Border Command	78
	Building a Formula to Show Increasing Sales	79
	Copying a Formula to the Right: The Copy Right Command (Review)	79
	What if...?	80
	Protecting the Worksheet: The Lock Formulas Command	80
	The NEXT UNLOCKED CELL Key	80
	Unlocking Cells	81
	The Options Command	81
	Summary	82

6	Printing a Worksheet	83
	The Print Command	84
	The Print Subcommands	84
	Print Margins	84
	Print Options	84
	Print Printer	85
	Print File	86
	Summary	86
7	Using Multiple Worksheets	87
	Relating Worksheets to Each Other	88
	The Transfer Clear Command	89
	Building a Supporting Sheet	90
	Naming Related Worksheets	92
	The eXternal Copy Command	93
	Revising a Supporting Sheet	95
	Dissolving Connections between Worksheets	96
	The eXternal List Command	97
	Additional Commands	97
	Summary	98
	Learning More about Multiplan	98
	Part 2 Reference to Multiplan	99
8	Elements of Multiplan	101
	The Multiplan Worksheet	102
	Entering Commands	103
	Selecting a Command	104
	Selecting Responses for the Command Fields	104
	Proposed Responses	105
	Editing	105
	Formulas	106
	Numbers	107
	Text	108
	References to Cells	108
	Absolute References	109
	Relative References	109
	Names	111
	Intersection Operator	112
	Range Operator	113
	Union Operator	114
	Logical Values	116
	Error Values	116
	Files	117
	Problems with File Access	118
	Problems When Reading	118
	Problems When Writing	118
	External Relationships	118
	Transforming the Worksheet	120

9	Command Directory	121
	Alpha	123
	Blank	124
	Copy	125
	Copy Down	125
	Copy From	126
	Copy Right	127
	Delete	128
	Delete Column	128
	Delete Row	129
	Edit	130
	Format	131
	Format Cells	132
	Format Default	134
	Format Default Cells	135
	Format Default Width	135
	Format Options	136
	Format Width	136
	Goto	137
	Goto Name	137
	Goto Row-col	138
	Goto Window	138
	Help	139
	Insert	140
	Insert Column	140
	Insert Row	141
	Lock	141
	Lock Cells	142
	Lock Formulas	142
	Move	143
	Move Column	144
	Move Row	144
	Name	145
	Options	146
	Print	146
	Print File	147
	Print Margins	147
	Print Options	148
	Print Printer	149
	Quit	149
	Sort	150
	Transfer	151
	Transfer Clear	152
	Transfer Delete	152
	Transfer Load	153
	Transfer Options	154
	Transfer Rename	155
	Transfer Save	155
	Value	156
	Window	157
	Window Border	157
	Window Close	158
	Window Link	158
	Window Split	159
	Window Split Horizontal	159
	Window Split Titles	160
	Window Split Vertical	161
	eXternal	161
	eXternal Copy	162
	eXternal List	163
	eXternal Use	164

1 0 Function Directory	165
ABS	166
AND	167
ATAN	167
AVERAGE	168
COLUMN	168
COS	168
COUNT	169
DOLLAR	169
EXP	170
FALSE	170
FIXED	171
IF	171
INDEX	172
INT	172
ISERROR	173
ISNA	173
LEN	173
LN	174
LOG10	174
LOOKUP	175
MAX	176
MID	176
MIN	177
MOD	177
NA	177
NOT	178
NPV	178
OR	179
PI	179
REPT	179
ROUND	180
ROW	180
SIGN	181
SIN	181
SQRT	181
STDEV	182
SUM	182
TAN	182
TRUE	183
VALUE	183

1 1 Message Directory	185
------------------------------------	-----

Appendices	191
-------------------------	-----

1 Helpful Hints	193
2 Glossary	195
3 Notes for the Visi Calc™ User	199
4 The SYLK (SYmbolic LinK) File Format	205
5 Solving Extended Problems with the Iteration Option	209
6 Multiplan Reference Summary	225

Index	235
--------------------	-----

Three-Month Limited Warranty	240
---	-----

Introduction

Multiplan is an electronic worksheet—a large grid of entries, each of which can be words, numbers, or formulas. You can set up the Multiplan worksheet with titles and numbers. But more than that, Multiplan can replace your pen and paper and your calculator because Multiplan can perform the calculations for you.

Multiplan frees you from the limitations of more traditional methods of calculation. Because Multiplan remembers the relationships between entries on the worksheet, it can automatically perform calculations—and this is where the real power comes from. You get a chance to ask “What if?” to test out plans and to forecast. For example, if one number changes, what is the effect on the worksheet?

What if:

- ... costs rise by 10% for one item and 6.5% for another?
- ... production increases?
- ... sales of one item skyrocket?
- ... home utility bills soar?

Alter a critical number and watch the figures change across your worksheet; observe the effects over time of a small change here or an improvement there. You can run sensitivity analyses, do budget and resource planning, and schedule more efficiently.

Multiplan overcomes the limitations of paper worksheets. It offers you a worksheet 255 rows long and 63 columns wide for words, numbers, and formulas. Multiplan also allows you to connect several worksheets so that you can build up a chain of sheets that provide information to each other. You can, as necessary, instantly move, insert, or erase data, widen or shrink columns. You can also insert or delete space, thus eliminating the costly and tiresome work of typing or hand printing the worksheet over and over.

Multiplan communicates with you as directly and naturally as possible, providing many aids to help you accomplish your objectives. As you learn to manipulate data to obtain the answers you need, you will agree that Multiplan is a vast improvement over “hand calculating” methods.

HOW TO PROCEED

An interactive program like Multiplan can be learned only by use. This manual is designed to be read and used as you use Multiplan. It's important that you try, test, and experiment as you learn. You'll be surprised at how quickly it all falls together. Nothing you type can damage the computer or Multiplan, so don't hesitate to experiment.

Part 1, "Using Multiplan," introduces Multiplan in a tutorial manner, in simple steps with many practical examples. You'll learn by using Multiplan to make a financial analysis of a model firm—Spencer Ceramics. The tutorial demonstrates the main Multiplan features as they are commonly used.

Begin by working through Part 1. Chapter 1, "Fundamentals," and Chapter 2, "Building a Worksheet," help you become familiar with the keyboard and screen display and introduce you to the Multiplan typing aids. "Entering Formulas" and "Naming Cells and Copying," Chapters 3 and 4, lead you further into the use of Multiplan. When you complete these chapters, you'll have used some of the most important Multiplan commands and features.

Chapter 5, "Windows, Copying Formulas, and Options," introduces the finer points of the Multiplan screen display. After completing it, you'll be ready to print some samples of your work. Chapter 6, "Printing a Worksheet," tells you how. The final chapter in the tutorial, Chapter 7, "Using Multiple Worksheets," takes you beyond working with a single sheet. You learn how to organize data on multiple sheets and to draw data from them for use on another sheet.

Part 2, "Reference to Multiplan," begins with Chapter 8, "Elements of Multiplan," which explains the Multiplan worksheet in depth: how to enter commands, how to edit, what formulas are, how file access works, and what happens when the worksheet undergoes changes that move data.

Detailed descriptions of all Multiplan commands are presented in Chapter 9, "Command Directory." All mathematical and statistical functions are described in Chapter 10, "Function Directory." All messages that Multiplan can display are covered in Chapter 11, "Message Directory."

At the end of Part 2, you'll find appendices that contain additional helpful information. Appendix 1, entitled "Helpful Hints," is the most important. These hints suggest ways to make your Multiplan sessions more efficient and effective; if you follow the hints, you'll save time and space.

Begin applying Multiplan to simple tasks, making frequent use of Part 2. As you gain experience, use Multiplan for more complex tasks, such as organizing multiple worksheets. You'll soon find that you have a firm grip on a powerful tool.

Operating Information

There are a few things you should know about your computer system before proceeding with Multiplan. These points include what items are needed to support Multiplan, how to get from "computer off" to "Multiplan running," and how Multiplan works with various input/output devices.

HARDWARE AND SUPPLIES NEEDED FOR MULTIPLAN

You should plan on having the following available when you put your Multiplan to work.

Included with Multiplan: Microsoft Multiplan User's Guide
Multiplan Cartridge
Multiplan Program Diskette
Quick Reference Card
Strip Overlay for the Keyboard

Sold separately:

- TI-99/4A Home Computer*
- Two or more storage diskettes
- One, two, or three disk drives (two recommended)
- TI Disk Drive Controller
- TI Memory Expansion
- Peripheral Expansion System (If you have card-type peripherals)
- TI RS232 Interface (optional)
- Compatible printer* such as the TI-99/4 Impact Printer (optional)

*Multiplan is not designed for the TI-99/4 Home Computer or for the TI Solid State Printer.

BEFORE USING MULTIPLAN

The Multiplan Electronic Worksheet requires the use of both the Solid State Cartridge and the program diskette. Since Multiplan cannot be operated without the program diskette, we strongly suggest that you make at least one backup copy of the program diskette and use the backup copy when operating Multiplan. Store the original program diskette in a safe place to prevent accidental damage. Any backup copies of the program diskette are intended for your personal use and not for resale. Refer to your TI Disk Memory System manual for instructions on backing up diskettes. (Note: Select single disk drive operation when backing up diskettes if you are using only one disk drive.)

Data diskettes need to be initialized (as described in the TI Disk Memory System manual) before they can be used for storing files.

Before you use Multiplan, a TI Memory Expansion and TI Disk Memory System (and, optionally, a TI RS232 Interface and a compatible printer) must be properly attached to the computer and turned on. (See the appropriate owner's manuals for instructions on the set-up of each peripheral.)

GETTING STARTED

Note: An automatic reset feature is built into the computer. When a cartridge is inserted into the console, the computer returns to the master title screen. All data or program material that has been entered but not saved on diskette will be erased.

Be sure the cartridge is free of static electricity before inserting it into the computer.

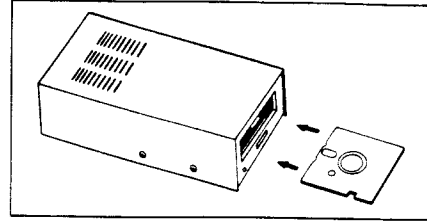
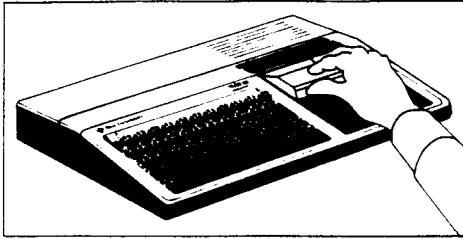

1. First turn on the peripherals; then turn on the monitor and the console. Wait for the master title screen to appear. Slide the cartridge into the slot on the console. The disk drive(s) will turn for a few seconds.
2. Press any key to make the master selection list appear. Then press **2** to select Multiplan. You can now choose any of 12 color schemes by advancing through them with the **SPACE BAR**. The screen colors being used at the time the program diskette is loaded will be in effect for the session. You can also adjust the appearance of the screen with the monitor's controls.
3. Insert your backup copy of the program diskette into Disk Drive 1 and press **ENTER**. The disk is read and Multiplan is loaded into your computer. Numbers appear along the left and top edges of the screen and the word "COMMAND:" followed by a list of choices near the bottom of the screen. Multiplan is ready for you to start developing a worksheet. Or you can use the Transfer Load command to load an existing worksheet for printing or revision.

While using Multiplan, you should be aware of the system's conventions. Preliminary topics include filenames, the use of disk drives, and printer capabilities.

FILENAMES

Files are stored on diskettes. Because there may be many files on each diskette, files are identified by filenames. This makes it easy for you to find specific information.

Filenames may be up to eight characters long. Filenames should begin with a letter, followed by any of these characters: A—Z, 0—9, (underline), or **-** (hyphen).

To further distinguish among files that may be named similarly, a period and up to three additional letters may be appended to a filename as an extension of the name. The most common use for filename extensions is in categorizing the file (types of data or related worksheets) at a glance.

Each diskette has a filename directory to help you and the computer keep track of which files are on the diskette. To view the directory, use the direction keys with the Transfer Load command (explained in Chapter 9).

USE OF DISK DRIVES

There are two types of diskettes needed for Multiplan: one that contains information dedicated to Multiplan (included with Multiplan), and one for storing your worksheets (sold separately). Multiplan can operate with a single disk drive, but two are recommended.

Several of Multiplan's functions rely on the Multiplan program diskette being immediately accessible. If the program diskette is not in the drive when it is needed, Multiplan tells you "Press Y to retry access to MP"—meaning that it could not find the file it needs. You would need to install the program disk before continuing. With two drives, you can leave the program diskette in one drive and use the other drive for saving and loading files. Many commands do not involve the diskette, but on those that do, it is best to have the Multiplan diskette instantly accessible.

IMPORTANT NOTE: When using a single disk drive, leave the program diskette in the drive for all commands except the following:

- Print File
- Transfer Load
- Transfer Save
- Transfer Delete
- Transfer Rename
- eXternal Copy

For these commands, you need to place your data storage diskette in the disk drive.

Initially, Multiplan is set up to use Drive 1 when looking for a data file. Drive 1 is also the first one checked for the Multiplan diskette. If you have more than one drive, your system operates more efficiently with Multiplan set to use Drive 2 or 3 for data files. Set Multiplan for Drive 2 operation as follows.

Select the Transfer Options command. Press **T**, then the letter **O**.

Advance to the setup field. Press **TAB (CTRL A)**.

Designate the data file drive as **DSK2**. Type **DSK2** (this field can be **DSK1**, **DSK2**, or **DSK3**). Press **ENTER**.

Note: Commands, subcommands, and command fields are explained in Chapter 1 (before you need to access data files). You do not need to set Multiplan to use Drive 2 or 3 until after Chapter 1.

PRINTER

Multiplan is designed for simple use with a printer. The various print options let you make the necessary settings to fit the size of the form you are using. Given these specifications, Multiplan sends the worksheet to the printer in page-size sections. You can use the TI RS232 Interface unit and a serially addressed printer such as the TI-99/4 Impact Printer or the parallel port on the RS232 Interface Card with a parallel-addressed printer. If your system has an RS232 card communicating with a 300 baud printer, you do not need to type in a specification since the default setting is RS232.BA = 300. If your printer is set at 1200 baud, specify 1200 baud printing as follows.

Select the Print Options command. Press **P**, then the letter **O**.

Advance to the setup field. Press **TAB (CTRL A)**.

Specify the port and baud rate. Type **RS232.BA = 1200**. (The baud rate must agree with the setting of your printer. The parallel port is specified by PIO and does not involve a baud rate.) Press **ENTER**.

Other possible baud rates and software options can be found in the Printer and the RS232 Interface manuals.

COMBINING MULTIPLAN WITH TEXT INFORMATION USING TI-WRITER

Using the Print File command to save a worksheet produces a file which is compatible with the TI-WRITER Word Processor Package. TI-WRITER can merge a text file with a worksheet file. When this merged file is printed, the result is a report containing text with tabular information where you placed it.

There are several ways of combining text and tables. You can merge the text file and the worksheet file to create a third file, leaving the original two intact. Instead of creating a third file from two, you can alter the text file by inserting the worksheet file. For each different worksheet, you will need a separate file to insert into the text file. You can also alter the worksheet file by inserting the text file.

Refer to the TI-WRITER Word Processor manual for details on merging files.

Part 1: Using Multiplan

Chapter 1: Fundamentals

The Screen
The Direction Keys
Moving the Cell Pointer
The Status Line
Scrolling the Worksheet
The Goto (G) Command
Command Selection from Menus
Multiplan Proposed Responses
Filling in the Command Line: The TAB Key
Carrying Out a Command: The **ENTER** Key
Canceling a Command: The **CANCEL** Key
Assistance with a Command: The **HELP** Key
The Quit (Q) Command
Summary

THE SCREEN

To work with Multiplan, you need the Multiplan diskette. Refer to the "Operating Information" section at the beginning of this manual for specific information about "Getting Started."

When Multiplan is loaded and ready, the basic Multiplan screen appears.

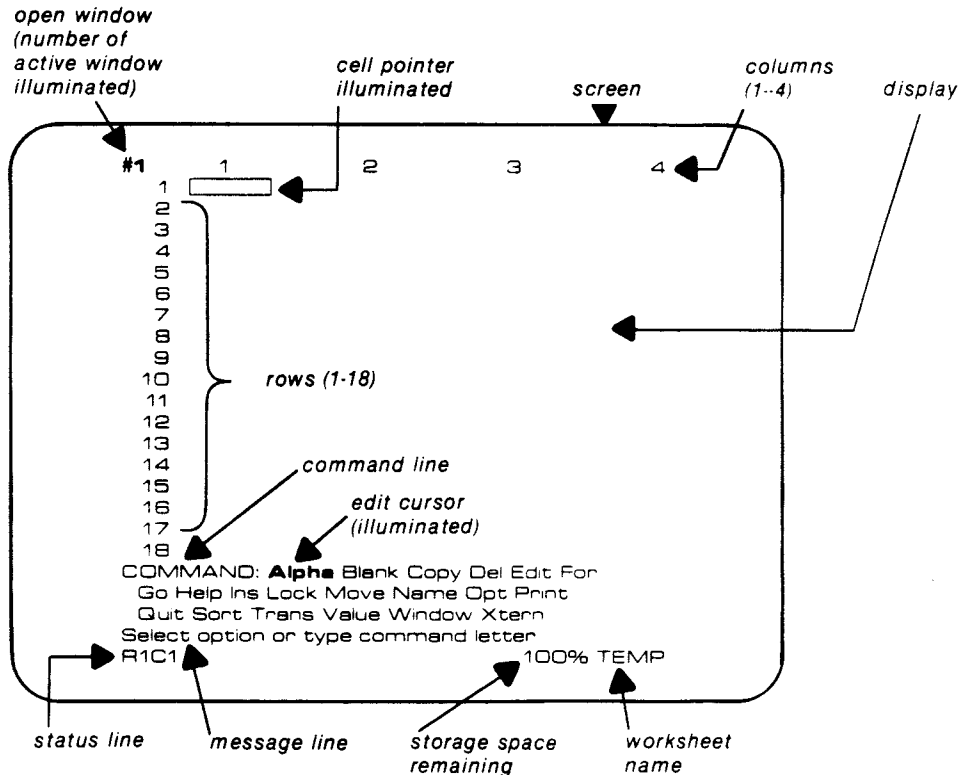

What you now see is the basic Multiplan screen. Notice the row and column numbers, command line, message line, and status line, as well as three highlighted areas for window number, cell pointer, and command menu.

Your screen displays only a small portion of the actual worksheet available to you. You can imagine the screen as a window which can be moved to view any portion of the worksheet.

With Multiplan, it is possible to simultaneously display information on separate areas of the worksheet by splitting the viewing window. You will learn how to do that in Chapter 5.

Columns are numbered across the top. The illustrated screen now shows you 4 of the 63 worksheet columns.

Rows are numbered down the left side of the display. The illustrated screen now shows you 18 of the 255 worksheet rows.

Imagine lines running vertically between the column numbers and horizontally between the row numbers to form boxes on the worksheet. Each box is called a "cell." Cells hold the values of the worksheet.

The cell that is available for immediate use, the active cell, is illuminated by the cell pointer. The cell pointer is currently in the upper left corner of the display; in row 1, column 1. A cell is identified by its location; the row number is always given first. Cell "row 1, column 1" (R1C1) is the active cell now.

THE DIRECTION KEYS

Find the direction keys: UP (FCTN E), DOWN (FCTN X), LEFT (FCTN S), and RIGHT (FCTN D). These keys are used to move the cell pointer around the worksheet (and for other functions you will learn about later).

MOVING THE CELL POINTER

Press the RIGHT direction key once. Now look at the cell pointer. You moved it one cell to the right, to column 2. The pointer is now in row 1, column 2 (R1C2). That cell is now the active cell.

Try the other direction keys. Watch how the cell pointer moves.

Try to move the cell pointer to row 4, column 4 (R4C4). You can press the direction keys in any order you want.

THE STATUS LINE

The bottom line of the screen is called the status line. It tells you the location of the active cell and what it contains. Right now the status line should read R4C4, which is a location. If any other location is shown, use the direction keys to move the cell pointer to row 4, column 4. The space next to R4C4 in the status line shows the contents of the cell; right now the cell is blank, so the space is empty.

Look at the percentage at the right of the status line. It tells you how much working memory is left.

100% means that all of working memory is available for your use. Check this percent as you continue your work. The number shows how much room is left to continue your work. You may try things on your own in addition to the techniques presented by this book or you may make a typing or formula error that uses memory space. Do not be alarmed if the percentages of space remaining shown in this book do not agree exactly with the percentages on the screen.

You can name worksheets for ready reference. The status line will also tell you the name of the worksheet currently in use. Until you give your sheet a name of your own, Multiplan calls it TEMP (for temporary).

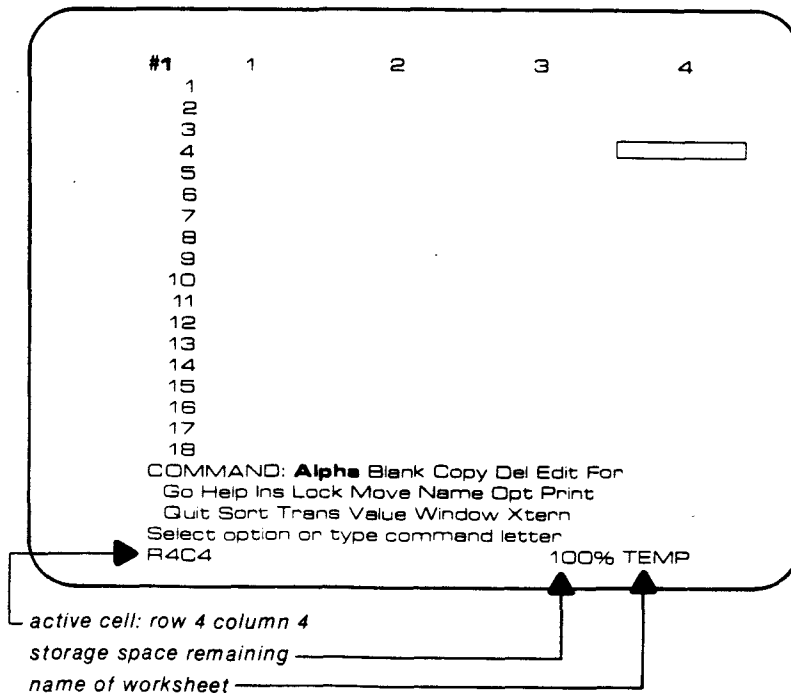

SCROLLING THE WORKSHEET

The illustrated screen shows you only 4 columns. What if you want to see column 15? Press the RIGHT direction key until the cell pointer reaches the right edge of the display. As you continue to press the RIGHT direction key, the pointer remains still, but the columns move to the left. This is called scrolling. Press the RIGHT direction key until column 15 is reached. Columns 1 through 11 are no longer visible on the left. You are now in row 4, column 15 (R4C15).

Now press the DOWN direction key until the cell pointer reaches row 33. You are now in row 33, column 15 (R33C15).

Notice that during all of these movements, the cell pointer always stays on the screen. When the cell pointer reaches the edge of the display, the row numbers or the column numbers scroll across the screen. Visualize this as sliding the window around the worksheet.

You could return to the upper left corner of the worksheet (R1C1) by pressing the UP and LEFT direction keys until the cell pointer arrives there. But, there is another, faster way to move the cell pointer to R1C1.

Press the HOME key (CTRL 1). The cell pointer returns in one movement to the upper left corner (R1C1).

THE GOTO (G) COMMAND

There is a way that is faster than using the direction keys to reach a cell on a different part of the worksheet. Press the G key. At the bottom of the screen on the command line (above the status line and message line), you should see the command:

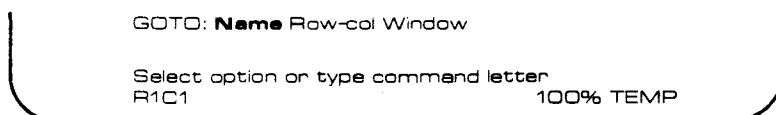

You can see that the Goto command now offers you a choice of subcommands: Name (highlighted—the proposed response), Row-col(umn), or Window. (Names will be discussed in Chapter 4; Windows in Chapter 5.) For now, we'll consider the Row-col subcommand.

Look at the illuminated box on the command line. It shows which command is selected on a menu.

If you now press R, you will see:

```
GOTO row: 1      column: 1

Enter a number
R1C1                                100% TEMP
```

Multiplan displays numbers in the command line in this example; one number next to “row” and one number next to “column.” The words *row* and *column* are the names of command “fields,” which are areas you fill in to specify how you want a command carried out. Entries in these command fields are called “responses.” When you first select a command, the command fields are occupied by responses which are proposed by Multiplan. These responses are called “proposed responses” and result from various aspects of the worksheet including previous responses in command fields. In this case, the proposed responses in the command fields are based on the current position of the cell pointer.

Look at the message line below the command line. It reads, “Enter a number.” The highlight (called the edit cursor) is in the first field (“row”). Respond with the last row on the worksheet, row 255: type 255.

The command line should now look like this:

```
GOTO row: 255  column: 1

Enter a number
R1C1                                100% TEMP
```

The edit cursor is now after the 255. Press TAB (CTRL A) to move the cursor to the second field in the command line.

With the edit cursor in the second field (“column”), pick the last column on the worksheet, column 63: type 63. The command line looks like this:

```
GOTO row: 255      column: 63 

Enter a number
R1C1                                100% TEMP
```

You have now selected the cell (by its row and column numbers) to which you want the cell pointer to go. But Multiplan does not carry out the command until you tell it to do so. Press ENTER. Your screen should look like this:

```
#1      63
251
252
253
254
255 
```



```
COMMAND: Alpha Blank Copy Del Edit For
         Go Help Ins Lock Move Name Opt Print
         Quit Sort Trans Value Window Xtern
Select option or type command letter
R255C63                                100% TEMP
```

Notice that Multiplan has returned to the command line—it is ready for another command.

What if you change your mind? You can use the Goto command again to move quickly to any part of the worksheet.

Suppose you decide you want row 155 instead of row 255. Press **G**, then **R**. When the edit cursor is in the first field for row number, simply type **155**. If you want to change the last field for column number, use the **TAB** key (**CTRL A**) to move the edit cursor to that field and type in the new number; for example, **3**. Notice that as you type the **3**, the **63** is discarded.

Press **ENTER** to carry out the command. The cell pointer is now on row 155, column 3.

COMMAND SELECTION FROM MENUS

All Multiplan commands are selected as the Goto command was. From the main menu, the initial letter of the command selects the command. A menu offering you different versions of the command then appears. This secondary menu shows the “subcommands” of the command. The initial letter of a subcommand selects the subcommand.

Note: If you press a key that does not work as a command (an invalid command), such as the letter **J**, the command line will not change, but you will see the message “Illegal option.”

```
COMMAND: Alpha Blank Copy Del Edit For
          Go Help Ins Lock Move Name Opt Print
          Quit Sort Trans Value Window Xterm
Illegal option
R155C3                                100% TEMP
```

If you have pressed other keys while you were moving the cell pointer, or if you pressed the wrong command letter, press the **CANCEL** key (**CTRL C**) to clear the command line.

The term “menu” is appropriate because it refers to a list of available choices. Whenever a menu is shown, Multiplan expects you to select one of the options from the menu. The message line will tell you to “Select an option.” It is most convenient to select an option by typing the first letter of the option you want.

There's another way to select commands and other options. Press the **SPACE BAR** and watch the command line. The highlight moves left to right, stopping at each command name. Press the **SPACE BAR** until Goto is highlighted. Now press **ENTER**. The command line should look the same as it did when you typed **G** earlier.

Similarly, you can press **SPACE BAR** to move between “Name,” “Row-col,” and “Window.” When the highlight rests on “Row-col,” press **ENTER** and you'll see the “row” and “column” fields, as before.

BACKSPACE (FCTN 9) can be used to back up (move right to left) through a menu.

To save you time, Multiplan presents the subcommands in the order they are most frequently needed. If several subcommands are needed equally as often, they are presented in alphabetical order.

You continue to select subcommands until the command line no longer presents a menu of subcommands. After the final subcommand is selected, the command line becomes a list of specifications, each followed by a colon. Next to each specification is a “field” for entering information about a command. Command fields tell Multiplan how to perform the command.

MULTIPLAN PROPOSED RESPONSES

When the command line shows fields (for the Goto Row-col command, the fields are "row" and "column"), each field shows a proposed response. There are two types of command fields: a field in which information is to be entered (entry field) or a field in which you select from a menu (menu field).

A proposed response in an entry field can be shown as:

- a blank field
- a typed-in response.

A proposed response in a menu field can be shown as:

- highlight (when the edit cursor is in that field)
- parentheses (when the edit cursor is in another field).

Proposed responses often reflect the current settings, positions, and name of the worksheet that you are working with. If you agree with the proposed response, just press **ENTER** to carry out the command or press **TAB (CTRL A)** to move to the next command field. If you do not want the proposed response, you can change the command field by typing the response you want.

When you are selecting a command or subcommand, the first choice shown is highlighted. This is also called a proposed response. If you agree with the proposed response, press **ENTER**. Or, press **SPACE BAR** or **BACKSPACE (FCTN 9)** to move to another choice. The command line will change to display your choice.

FILLING IN THE COMMAND LINE: THE TAB KEY

The command line is divided into as many fields as there are choices to be made. The edit cursor shows you which field is active (available for immediate use).

The edit cursor is moved from field to field by the **TAB** key and returns to the first field after the last field has been reached.

In commands with more than two fields, the **TAB** key moves the cursor like this:

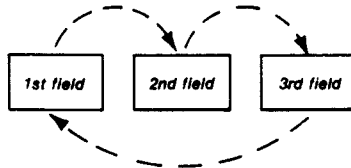

Look at the message line below the command line. Multiplan tells what kind of response you should make in each field. As you move from field to field, the message may change. For the Goto Row-col command the message doesn't change because both fields require the same type of response. However, the message will change for other commands, as we'll see later.

CARRYING OUT A COMMAND: THE ENTER KEY

Multiplan does not carry out a command until you tell it to do so. Pressing the **ENTER** key carries out commands.

Also, as shown earlier, the **ENTER** key is used after you use **SPACE BAR** or **BACKSPACE** to move the highlight to a command or subcommand name.

You may press **ENTER** whenever the responses in all the command fields are correct; you are not required to move the edit cursor first.

When a command has been carried out, the command line reappears and waits for a new command from you.

CANCELLING A COMMAND: THE CANCEL KEY

At any time before you press **ENTER** to carry out a command, you may press the **CANCEL** key (**CTRL C**) to cancel the command. When you press the **CANCEL** key, the main command menu reappears and the worksheet looks as it did before you began the command.

ASSISTANCE WITH A COMMAND: THE HELP KEY

Multiplan includes a special **HELP** key to assist you. The help information is always available to you.

Let's use the Goto command to illustrate how the **HELP** key works.

Select the Goto command by using **SPACE BAR** (do not press **ENTER**). When the highlight rests on Go, press **HELP (FCTN I)**; this key is labeled ? on its front surface. The Multiplan worksheet will be replaced by the help information for the Goto command.

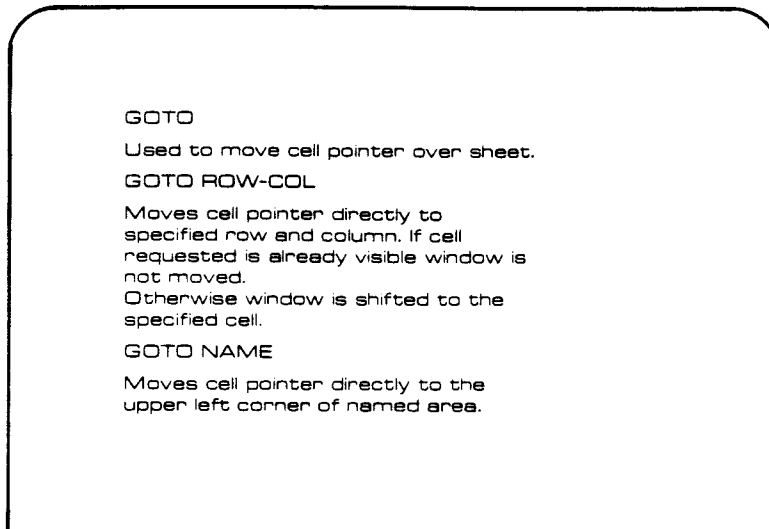

As you can see, the information given for "GOTO ROW-COL" describes what happened when you used the Goto Row-col command.

Notice also that there is a new menu in the command line.

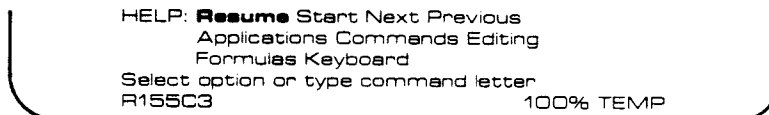

These subcommands are used to view various parts of the help information.

For right now, press **C** (for Commands). The Goto information is replaced by the beginning of the **COMMAND OVERVIEW**, which describes how to select commands.

Now, press **N** (for Next). The rest of the **COMMAND OVERVIEW** is shown. You will often need to use the **N** subcommand because the information for many topics is longer than one screen.

Now, press **R** (for Resume). The Multiplan worksheet display resumes exactly as you left it; no changes were made. As you can see, the Goto command is still highlighted.

If you try out the **HELP** key, you'll begin to see how it adapts the information to your situation. Let's take **Goto** again.

Select **Goto** (if you use **SPACE BAR** to do this, press **ENTER**). With the "Name" subcommand highlighted, press the **HELP** key (**FCTN I**).

Now the screen shows only part of the **Goto** information, with **GOTO NAME** at the top.

Press **R** (for Resume). Move the highlight to **Row-col** and press **HELP**. Now **GOTO ROW-COL** is at the top.

Whenever you request help information with the **HELP** key, the information describing the command or subcommand you have selected is listed at the top of the screen.

You can also get help using the **Help** command. This command is only available in the main command menu—press **CANCEL (CTRL C)**. When the main command menu is on display, press **H**. Multiplan replaces the worksheet display with the beginning of the **Help** information.

Now, you can use the **Help** subcommands in the menu to move through the help information.

Whenever you need quick assistance from now on you know you can get help by pressing the **HELP** key or by using the **Help** command.

One final bit of help: the key assignments for Multiplan functions can be found within Multiplan in addition to the listings in this manual. Select the **Help** command and then press **K** (for Keyboard). The beginning of the list of keys appears. Use "Next" (press **N**) to view the rest of the list. When you are ready to continue, press **R** (for resume).

THE QUIT (Q) COMMAND

In your next Multiplan lesson, you will learn how to place information on the worksheet. For now, however, there is nothing on the worksheet to save before quitting. Select the **Quit** command by pressing **Q**.

The command line asks you to confirm your decision to erase the screen by typing **Y** for Yes. Press **Y**.

After you've learned to place information on the worksheet, you'll learn how to save your work before you use the **Quit** command.

The main title screen now appears.

SUMMARY

In this session you learned:

- What the different parts of the screen look like, and what they mean.
- Where the the direction keys are located on the keyboard, and what they do.
- How to move the cell pointer using the direction keys and HOME key.
- Where the status line is located, and what it tells you.
- How to scroll the worksheet by using the direction keys.
- How to get to another cell quickly by using the Goto (G) command.
- How a command is put together from a main command, subcommands, and command fields.
- How Multiplan helps you by presenting proposed responses.
- How to move the edit cursor between fields by using the TAB key.
- How to carry out a command by using the ENTER key.
- How to request help by using the HELP key and the Help (H) command.
- How to leave Multiplan by using the Quit (Q) command.

Chapter 2:

Building a Worksheet

The Worksheet Number Grid
Entering Text: The Alpha (A) Command
Correcting Typing Errors: The BACKSPACE Key
Entering Data with the Direction Keys
Column Width
The Format Width Command
Entering Numbers
The Format Default Cells Command
Alignment
Formats
Saving Work: The Transfer Save Command
The Quit (Q) Command
Summary

In Chapter 1, you learned how to start Multiplan and how the rows and columns are used to identify the cells of the worksheet.

You also learned how to move the cell pointer to different parts of the worksheet by using the direction keys and how to move the pointer quickly by using the Goto command.

In this session you will begin to build a worksheet. You will learn how to change cell entries and correct mistakes as you go along. You will also begin work on a financial analysis for a model company—Spencer Ceramics.

A large industrial firm is considering buying Spencer Ceramics and has requested a projected income statement; the firm has asked you for a summary of the operating budget, showing projected sales, costs, and gross profits. If Spencer Ceramics looks like a good investment on the basis of this information, the firm will send in its own accountants to do a more detailed survey.

THE WORKSHEET NUMBER GRID

Start Multiplan according to the instructions given in the "Operating Information" section of this manual. In a moment, you will see the row and column numbers and the command, message, and status lines appear on the screen.

The row and column numbers are merely guides for entering data. The information on the command, message, and status lines is there only to help you enter the data on the worksheet and will not appear on the final printed form.

To plan what needs to be done in your analysis of Spencer Ceramics, let's sketch a brief outline with pencil and paper, showing how the table will be set up.

<i>Spencer Ceramics</i>														
<i>Projected Income Statement</i>														
<i>Period: one year - 12</i>														
	<i>Jan</i>	<i>Feb</i>	<i>Mar</i>	<i>Apr</i>	<i>May</i>	<i>Jun</i>	<i>Jul</i>	<i>Aug</i>	<i>Sept</i>	<i>Oct</i>	<i>Nov</i>	<i>Dec</i>	<i>Ann</i>	<i>Sum</i>
<i>Sales</i>														
<i>Cost</i>														
<i>Profit</i>														

With Multiplan, it is easy to expand the worksheet later to add more items, to insert rows or columns of space, or to delete unwanted items. It is also easy to change a figure, such as January sales, because Multiplan will recalculate the entire table automatically.

ENTERING TEXT: THE ALPHA (A) COMMAND

To prepare the worksheet for Spencer Ceramics, begin by entering the headings for the rows and columns. You can add a title to the sheet later.

Text and numbers are entered in different ways. Since Multiplan is designed to deal primarily with numbers and formulas, it automatically recognizes numbers as soon as they are typed. However, when you want to enter text or a title, you must specifically tell Multiplan that you want to enter text, and not a formula, into the cell. You do this by using the Alpha (A) command.

Before you begin, look at the cell pointer on your screen. It should be in row 1, column 1 (R1C1). If it is not there, use the direction keys or the HOME key (CTRL 1) to place it there.

Since later you will need some room at the top of your table for the names of the months, move the cell pointer down two rows. The pointer is now in row 3, column 1 (R3C1).

Now press A. You will see:

```
ALPHA: 
Enter text (no double quotes)
R3C1                                     100% TEMP
```

The command line indicates selection of the Alpha command, and the message line informs you that the next step is to enter text. Begin by entering Sales in column 1.

Type **Sales**.

Now you see:

```
ALPHA: Sales 
Enter text (no double quotes)
R3C1                                     100% TEMP
```

CORRECTING TYPING ERRORS: THE BACKSPACE KEY

The edit cursor is located immediately after the text you have typed. Before you press **ENTER** to enter the text in the cell, try editing the word *Sales* by using the **BACKSPACE** key. Press **BACKSPACE (FCTN 9)** three times. You will see that the edit cursor deletes the character to its left as it moves.

This time type the word incorrectly. Finish typing *Sakes*. Notice that the new characters appear just to the left of the edit cursor. When you've finished typing, you have:

ALPHA: Sakes

Enter text (no double quotes)
R3C1 100% TEMP

Now use **BACKSPACE** again and correct the text to *Sales* once again, so that the screen looks like:

ALPHA: Sales

Enter text (no double quotes)
R3C1 100% TEMP

ENTERING DATA WITH THE DIRECTION KEYS

Now that the correct word (*Sales*) is typed, you can enter it into the cell in two ways:

1. You can first press **ENTER**, and *Sales* appears in the cell R3C1. Try it to see. You still need to press a direction key to move the pointer to the next cell. This entry method is fine for entering one cell's data, but the entry of several cells calls for a more efficient method.
2. A faster way to enter text is to press the **DOWN** direction key (instead of **ENTER**), which moves the pointer to the next cell in which you want to work. *Sales* will be entered automatically. Try it. Press **A** (for Alpha); *Sales* now appears next to ALPHA: in the command line. Now press the **DOWN** direction key. *Sales* appears in cell R4C1, and the cell pointer moves down to R4C1. (You may, of course, use any direction key; your choice will depend on the cell you want to use next.) Notice the command line; it shows:

ALPHA/VALUE:

Enter text or value
R4C1 99% TEMP

The next key you press selects either the Alpha command or the Value command, just as if you pressed **A** or **V**.

If you type any digit (**0-9**) or press one of the characters = (equals), + (plus), - (minus), . (period), ((left parenthesis), or " (quotation mark), you select the Value command. All other keys select the Alpha command.

This feature will save you many keystrokes as you continue to work with Multiplan, especially when entering a sequence of text and values in successive cells.

To enter *Cost*, move the cell pointer down to row 5 in column 1 (R5C1).

Multiplan is waiting for your next instruction. If the next character typed is a letter, Multiplan knows you are entering text. If the next character typed is a number, Multiplan knows you are entering a value. Begin to type *Cost*. When you type the first letter, the command line changes from ALPHA/VALUE: to ALPHA:, and the message line changes from "Enter text or value" to "Enter text."



Finish typing *Cost*.

To enter *Cost* in row 5, column 1 (R5C1), press the DOWN direction key. To allow for additional lines of cost information, press the DOWN direction key until you reach row 8.

Now enter *Gross Profits* in cell R8C1 (your current position) using **ENTER** rather than the DOWN direction key.

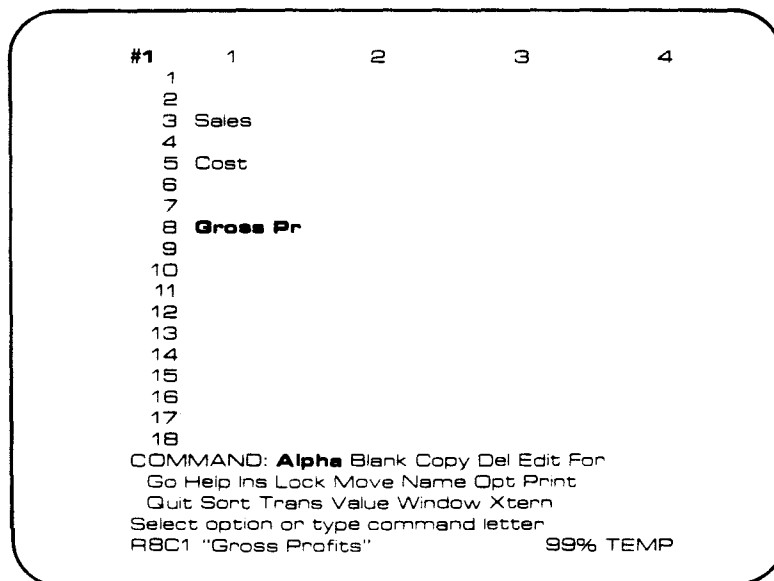

COLUMN WIDTH

Look at row 8, column 1. You can see that the column is not wide enough to accommodate all the characters in *Gross Profits*. Multiplan has not lost any of the information you have entered. It displays as much of it as it can in the space it has. If you give the column more space, it will display the remainder of the characters.

When you started Multiplan, the column width was set at 8 characters. Column width is easily changed using the Format Width command.

THE FORMAT WIDTH COMMAND

Press **F**. On the command line you will see:

```
FORMAT: Cells Default Options Width
Select option or type command letter
R8C1 "Gross Profits"          99% TEMP
```

At this point, you need to set the Format Width. Press **W**. You will see:

```
FORMAT WIDTH in chars or d(default): d
column: 1 through: 1
Enter a number or d for default
R8C1 "Gross Profits"          99% TEMP
```

In the first field, Multiplan shows "d" (for default) as the proposed response. Since 8 characters (the current column width) is not wide enough to show your heading completely, choose the width you will need. *Gross Profits* has 13 characters (12 letters and 1 space). Select 15 characters of width to give yourself enough room. Type **15**. Now you see:

```
FORMAT WIDTH in chars or d(default): 15 
column: 1 through: 1
Enter a number or d for default
R8C1 "Gross Profits"          99% TEMP
```

Multiplan lets you select the columns you want to widen. The proposed response is to widen column 1 through column 1. As you only want to widen column 1 at this time, accept the proposed responses; simply press **ENTER** (you don't need to tab or change any responses).

Gross Profits may now be seen fully in column 1 because that column has been widened.

Note: Before you go on, widen the remaining columns to 10 characters to allow for the length of numbers you will be using. Set the Format Default Width to 10 characters as follows:

press **F**
press **D**
press **W**
type **10**
press **ENTER**.

Your sheet is now ready for the first numbers.

ENTERING NUMBERS

The sales figures for Spencer Ceramics show that the average amount of monthly sales last year was \$20,000.

Move the cell pointer to row 3, column 2 (R3C2) opposite *Sales*. Type **20000**. (Use the numbers at the top of the keyboard.)

VALUE: 20000

Enter a formula
R3C2

99% TEMP

Note: Multiplan handles commas in a special way (using the Format Options command), so you do not use commas (20,000) or spaces (20 000) when entering numbers. Also, you do not have to tell Multiplan that you want to enter a number, as you do for text (to enter text, you use the Alpha command). As soon as you type a digit from 0 to 9, Multiplan treats it as if you had selected the Value command.

Do not type the \$ now. Fill in all the figures first. You'll learn how to show them with the dollar sign later.

Press the DOWN direction key.

Notice that the ALPHA/VALUE: command line appears again, just as it did when you pressed the DOWN direction key after entering the titles.

Spencer Ceramics' costs were \$15,000 per month. Enter 15000 in row 5, column 2, like this:

1. Move the pointer to the desired cell (row 5, column 2).
2. Type **15000**.
3. Press **ENTER** to enter the number in the cell.

Now your screen should look like this:

#1	1	2
1		
2		
3	Sales	20000
4		
5	Cost	15000
6		
7		
8	Gross Profits	
9		
10		
11		
12		
13		
14		
15		
16		
17		
18		

COMMAND: Alpha Blank Copy Del Edit For
Go Help Ins Lock Move Name Opt Print
Quit Sort Trans Value Window Xtern
Select option or type command letter
R5C2 15000 99% TEMP

Since all the figures you are working with on this project have to do with finances, you may decide that it would be better to have all the numbers displayed as dollars. It's easy to make the change.

THE FORMAT DEFAULT CELLS COMMAND

Multiplan offers a wide selection of formats in which cell entries may be displayed. The command used for this purpose is Format.

Press F. You will see:

```
FORMAT: Cells Default Options Width
Select option or type command letter
R5C2 15000 99% TEMP
```

This time you want to change the format of all cells, so choose Default.

The command line shows:

```
FORMAT DEFAULT: Cells Width
Select option or type command letter
R5C2 15000 99% TEMP
```

Now select the proposed response "Cells" by pressing **ENTER** (or **C**). The command line now shows:

```
FORMAT DEFAULT CELLS align: C Gen L R
code: Cont Exp Fix(Gen)Int $ * %
# of decimals: 0
Select option
R5C2 15000 99% TEMP
```

In the first field you will choose the alignment setting.

ALIGNMENT

Alignment means where text and numbers are placed in a cell: flush with the left edge, flush with the right edge, centered, or a mix of right and left (called General).

The "alignment" field offers you these choices:

Settings	Examples	Effect
Center	Sales \$1000.25 \$50.25	text and numbers centered
General	Sales \$1000.25 \$50.25	text flush left numbers flush right
Left	Sales \$1000.25 \$50.25	text and numbers flush left
Right	Sales \$1000.25 \$50.25	text and numbers flush right

Any alignment choice that sets the numbers to the right would be acceptable because you want the decimal points to be in line with each other. Therefore, you could choose Gen or Right with the same effect on the numbers. However, because this command can affect all cells, including column 1, all of your text would be moved to the right, too. Since the proposed response (Gen) is acceptable, this field can be left "as is."

FORMATS

You have several choices for the second field, the format of the display. At this point, you know you want the format code for dollars. Some of the other choices are quite specialized. The following chart gives a brief summary of these formats; they are thoroughly explained in the "Command Directory" in Part 2.

Settings	Meanings	Examples
Cont	Continuous	Spencer Ce ramics
Exp	Scientific	1.4301E - 23 4.67E5
Fix	Fixed Point	4.513
Gen	General	text and numbers shown in standard format
Int	Integer	3.1416 shown as 3
\$	Dollars	\$20000.00 (\$150.00)
*	Bar Graph	3 shown as ***
%	Percent	.0513 shown as 5.13%
—	(Do not change format)	

Now press TAB (CTRL A) to move to the second field where you'll choose the format of the display.

```

FORMAT DEFAULT CELLS align: C(Gen)L R
code: Cont Exp Fix Gen Int $ * %
# of decimals: 0
Select option
R5C2 15000                                99% TEMP
    
```

Choose the dollar format instead of the proposed response by typing a dollar sign (\$).

```

FORMAT DEFAULT Cells align: C(Gen)L R
code: Cont Exp Fix Gen Int $ * %
# of decimals: 0
Select option
R5C2 15000                                99% TEMP
    
```

Selecting the dollar format automatically gives you two decimal places, so you do not need to specify a number in the last field.

As soon as you have made certain that all your choices are correct, press ENTER to carry out your choices.

```

#1      1      2
1
2
3 Sales      $20000.00
4
5 Cost      $15000.00
6
7
8 Gross Profits
9
10
11
12
13
14
15
16
17
18
COMMAND: Alpha Blank Copy Del Edit For
Go Help Ins Lock Move Name Opt Print
Quit Sort Trans Value Window Xtern
Select option or type command letter
R5C2 15000                                99% TEMP
    
```

You have made three choices in the Format command:

1. You selected Format Default Cells to choose settings for all cells.
2. You selected the proposed alignment of the contents of the cells.
3. You selected the display format for dollars (\$), which automatically gave you two decimal places.

Note: You can change the way numbers are displayed any time you like without changing their values. For example, you could show the same value as 3, 3E0, \$3.00, or 300%, or even “****”, depending on the format setting you select. See “Format” in Chapter 9, “Command Directory,” in Part 2.

You have learned about formatting in this session, and you will learn more in the next chapter. You will also use a more detailed breakdown of costs to make a more comprehensive forecast for Spencer Ceramics.

SAVING WORK: THE TRANSFER SAVE COMMAND

Unless you save your worksheet, you will have to start over the next time you use Multiplan. To save your worksheet, use the Transfer Save command.

Note: Be sure that a data storage diskette is installed before you save a worksheet. If you are using one disk drive, it is necessary to remove the Multiplan program diskette and install a storage diskette. When the transfer is complete, reinstall the Multiplan program diskette. If you are using two drives, specify the data file drive as described in the "Operating Information" section of this manual.

Press **T**. The command line now shows:

```
TRANSFER: Load Save
           Clear Delete Options Rename

Select option or type command letter:
R5C2 15000                               99% TEMP
```

To save your work, choose "Save" by pressing **S**.

```
TRANSFER SAVE filename: TEMP

Enter a filename
R5C2 15000                               99% TEMP
```

Give your worksheet a meaningful filename, so that it will be easy to remember when you load the sheet in the next session.

Type **SPENCER**.

```
TRANSFER SAVE filename: SPENCER 

Enter a filename
R5C2 15000                               99% TEMP
```

You have replaced the name **TEMP**, which Multiplan had given the sheet in the absence of another name. From now on, you must ask for this file by its exact name when you want to load it, or Multiplan will not be able to find it.

Press **ENTER** to complete the command. Notice that the sheet name on the status line has changed to reflect the new sheet name.

```
COMMAND: Alpha Blank Copy Del Edit For
          Go Help Ins Lock Move Name Opt Print
          Quit Sort Trans Value Window Xtern
Select option or type command letter
R5C2 15000                               99% SPENCER
```

THE QUIT (Q) COMMAND

To leave Multiplan, press **Q** (for Quit), as you did at the end of the last session.

Be sure you have saved your work with the Transfer Save command before you press **Y**.

Press **Y**. The main title screen will appear.

When you begin the next session, you will use the Transfer Load command to pick up where you left off.

SUMMARY

In this session you learned:

How to use the Alpha (**A**) command to enter text.

How to use **BACKSPACE** to correct typing errors by deleting characters.

How to enter data using the direction keys.

How to change the width of columns using the Format Width command.

How to enter numbers in cells.

How to change cells to the dollar format, using the Format Default Cells command.

What alignment settings are available.

What format settings are available.

How to save your work using the Transfer Save command.

Chapter 3: Entering Formulas

Loading a File: The Transfer Load Command
The Insert Command
Entering Additional Text
Entering Additional Numbers
Aligning Cell Contents
Ranges: The Colon
The Blank Command
Formulas
Building a Formula
Reviewing or Changing a Formula
The Status Line: Cell Contents
Drawing Lines
The Transfer Save Command (Review)
Summary

In the last session you learned to put text (using the Alpha command) and numbers into cells by pointing to them with the cell pointer, typing the information in the command line, and then entering it into the cell by pressing either **ENTER** or one of the direction keys.

You also learned to use the Format command to display numbers in dollar format.

At the end of the session you saved your worksheet in a file that you named *SPENCER*.

In this session you will get more practice with entering words and numbers and in formatting cells. Most importantly, you will learn to enter formulas.

LOADING A FILE: THE TRANSFER LOAD COMMAND

When you start your Multiplan program, the row and column numbers appear on the screen, but not the information you typed in earlier. You have to load the file before that information will appear. Check that your data diskette is in the correct drive. Press T (for Transfer). The command line will show:

```
TRANSFER: Load Save
           Clear Delete Options Rename

Select option or type command letter
R1C1                                     100% TEMP
```

The proposed response for TRANSFER is "Load." Since you want to load your file into Multiplan, press ENTER (or press L). The command line will show:

```
TRANSFER LOAD File: 

Enter a filename (arrow for directory)
R1C1                                     100% TEMP
```

Type the name of the file you wish to load, **SPENCER**. You should see:

```
TRANSFER LOAD File: SPENCER 

Enter a filename (arrow for directory)
R1C1                                     100% TEMP
```

Then press ENTER.

Notice that the cell pointer is at cell R5C2, just as it was when you saved this worksheet at the end of the last chapter. You are now ready to modify your worksheet.

THE INSERT COMMAND

Look at the following breakdown of Spencer Ceramics' monthly costs:

Material	=	\$ 4,000.00
Labor	=	\$ 7,000.00
Overhead	=	\$ 4,000.00
Total Costs	=	\$15,000.00

Your worksheet must be expanded to make room for this new information. You will need space for *Material*, *Labor*, and *Overhead*, as well as *Total Costs*. It would be logical to place this information between the *Cost* and the *Gross Profits* titles. To prepare for inserting this new information, move the cell pointer to R6C2.

To insert either empty rows or empty columns, use the Insert command. Press I.

```
INSERT: Row Column

Select option or type command letter
R6C2                                     99% SPENCER
```

The proposed response, "Row," is what you want. (You need to add some extra rows of space.) Press **ENTER** to select "Row."

```

INSERT ROW # of rows: 1
                before row: 6
                between columns: 1 and: 63
Enter a number
R6C2                                99% SPENCER
    
```

Notice that the proposed responses are based on the position of the cell pointer. Because the cell pointer is at row 6, Multiplan proposes the insertion of 1 row of space before row 6, extending from column 1 through 63—in other words, across the whole worksheet.

The new figures will require at least 5 rows (4 for figures and 1 for the total costs). Allow yourself enough room by adding 7 rows. Press 7.

```

INSERT ROW # of rows: 7 
                before row: 6
                between columns: 1 and: 63
Enter a number
R6C2                                99% SPENCER
    
```

Look at the second field. In the "before row" field, you tell Multiplan where to insert the new space by filling in which row the space should go in front of. You need the space between row 5 and row 8. You may put the new rows in front of row 6, 7, or 8. Since the proposed response of row 6 is all right, we don't need to change it.

Multiplan also proposes that you insert the new rows of space across all of the columns by saying, "between columns 1 and 63." Since you want the space to extend across your worksheet, you also do not need to type any numbers in either the third or fourth fields. Just press **ENTER** to carry out the command as it stands.

Now you see:

#1	1	2
1		
2		
3	Sales	\$20000.00
4		
5	Cost	\$15000.00
6		<input type="text"/>
7		
8		
9		
10		
11		
12		
13		
14		
15	Gross Profits	
16		
17		
18		

COMMAND: Alpha Blank Copy Del Edit For
 Go Help Ins Lock Move Name Opt Print
 Quit Sort Trans Value Window Xtern
 Select option or type command letter
 R6C2 99% SPENCER

ENTERING ADDITIONAL TEXT

You will be able to add the new information in the space you have created. Under *Cost* (row 5), you will type the subcategories of *Material* in row 6, *Labor* in row 7, and *Overhead* in row 8. Leave a row of space between *Overhead* and *Total Costs* for a line, and type *Total Costs* in row 10. The procedure is the same as given in Chapter 2 and is summarized here:

Move the cell pointer to row 6, column 1 (using either the direction keys or the Goto command). Use the Alpha command.

Press **A** (or **ENTER**).

Type **Material**. If you make a mistake in entering text, **BACKSPACE (FCTN 9)** and type over the mistake.

Press the **DOWN** direction key to enter *Material* and to advance the cell pointer to row 7. Your screen now looks like this:

#1	1	2
1		
2		
3	Sales	\$20000.00
4		
5	Cost	\$15000.00
6	Material	
7		
8		
9		
10		
11		
12		
13		
14		
15	Gross Profits	
16		
17		
18		

ALPHA/VALUE:

Enter text or value
R7C1

99% SPENCER

As in Chapter 2, the **ALPHA/VALUE:** command reappears after pressing a direction key, and the next character you type selects either the Alpha or the Value command.

Enter **Labor** in row 7 and **Overhead** in row 8 by simply typing the title and then pressing the **DOWN** direction key.

Leave row 9 empty for now, and move the cell pointer to row 10. Enter **Total Costs**, as you entered *Labor* and *Overhead*. Your screen should now look like this:

#1	1	2
1		
2		
3	Sales	\$20000.00
4		
5	Cost	\$15000.00
6	Material	
7	Labor	
8	Overhead	
9		
10	Total Costs	
11	<input type="text"/>	
12		
13		
14		
15	Gross Profits	
16		
17		
18		

ALPHA/VALUE:

Enter text or value
R11C1

98% SPENCER

ENTERING ADDITIONAL NUMBERS

Now you are ready to enter the numbers.

Move the cell pointer to row 6, column 2. Notice that the ALPHA/VALUE: command remains on the command line.

Type **4000**.

Press the DOWN direction key.

Type **7000**, and press the DOWN direction key.

For the last number (by *Overhead*), type **4000**, and press **ENTER**. You will see:

#1	1	2
1		
2		
3	Sales	\$20000.00
4		
5	Cost	\$ 15000.00
6	Material	\$ 4000.00
7	Labor	\$ 7000.00
8	Overhead	\$ 4000.00
9		
10	Total Costs	
11		
12		
13		
14		
15	Gross Profits	
16		
17		
18		

COMMAND: **Alpha** Blank Copy Del Edit For
Go Help Ins Lock Move Name Opt Print
Quit Sort Trans Value Window Xterm
Select option or type command letter
RBC2 4000

98% SPENCER

ALIGNING CELL CONTENTS

To make it clear that the four entries under *Cost* (*Material*, *Labor*, *Overhead*, and *Total Costs*) are subcategories, you align them to the right side of column 1. First position the cell pointer on the first cell to be aligned (row 6, column 1).

To align cells, use the Format command. Press **F**.

```

FORMAT: Cells Default Options Width
Select option or type command letter
R6C1 "Material"                98% SPENCER
    
```

From the command line choices, choose "Cells" (by pressing **C** or **ENTER**). The command line now shows:

```

FORMAT cells: R6C1 align: (D)C G L R -
cd:(Def)Cont Exp Fix Gen Int $ * % -
# of decimals: 0
Enter reference to cell(s)
R6C1 "Material"                98% SPENCER
    
```

The first field ("cells") shows the "active" cell (where the cell pointer is located, R6C1). Since we want to align this single cell to the right to see how it looks, leave the proposed response as is.

TAB (**CTRL A**) to the next field ("alignment"). To select an alignment here, use the same method you used for the Format Default Cells command in Chapter 2. Press **R** (for Right). The command line shows:

```

FORMAT cells: R6C1 align: (D)C G L R -
cd:(Def) Cont Exp Fix Gen Int $ * % -
# of decimals: 0
Enter reference to cell(s)
R6C1 "Material"                98% SPENCER
    
```

The proposed response in the "format code" field is suitable and the "# of decimals" doesn't concern us now, so press **ENTER**. You will see:

#1	1	2
1		
2		
3	Sales	\$20000.00
4		
5	Cost	\$15000.00
6	Material	\$ 4000.00
7	Labor	\$ 7000.00
8	Overhead	\$ 4000.00
9		
10	Total Costs	
11		
12		
13		
14		
15	Gross Profits	
16		
17		
18		

```

COMMAND: Alpha Blenk Copy Del Edit For
Go Help Ins Lock Move Name Opt Print
Quit Sort Trans Value Window Xtern
Select option or type command letter
R6C1 "Material"                98% SPENCER
    
```

You also want to align rows 7 through 10 in column 1 to the right. You can align these four cells at once by using the symbol for "range," as explained in the next section.

RANGES: THE COLON

With Multiplan, you can perform tasks on more than one cell at a time by typing two cell locations separated by a colon. Let's try this with *Labor*, *Overhead*, and *Total Cost* in column 1.

1. Move the cell pointer to *Labor* (R7C1).
2. Press **F** (for Format).
3. Press **C** (for Cells). You can now see R7C1 in the "cells" field:

```

FORMAT cells: R7C1 align:(D)CGLR -
cd:(Def)Cont Exp Fix Gen Int $ * % -
# of decimals: 0
Enter reference to cell(s)
R7C1 "Labor" 98% SPENCER
    
```

4. Press the colon (:). Notice that the response in the field is not deleted. When the colon (:) is pressed, Multiplan knows to leave the beginning value of the range as the proposed response.
5. Now let Multiplan do the work for you. Press the DOWN direction key until the cell pointer is in row 10 (R10C1). Notice the response in the "cells" field. It shows the range of cells you want to change.

```

FORMAT cells: R7C1:R10C1 align:(D)
)CGLR - cd:(Def)Cont Exp Fix Gen I
nt $ * % - # of decimals: 0
Select option
R10C1 "Total Costs" 98% SPENCER
    
```

6. **TAB (CTRL A)** to the second field, alignment. In the second field, you again want to change the proposed response from "D" (Default aligns words to the left) to "R" (Right alignment).
7. Press **R**.
8. As before, the proposed responses in the other two fields are suitable, so press **ENTER**.

Your screen should now show you the new alignment for rows 6 through 10 in column 1:

```

#1      1      2
 1
 2
 3 Sales      $20000.00
 4
 5 Cost      $15000.00
 6           Material $ 4000.00
 7           Labor    $ 7000.00
 8           Overhead $ 4000.00
 9
10           Total Costs
11
12
13
14
15 Gross Profits
16
17
18
COMMAND: Alpha Blank Copy Del Edit For
Go Help Ins Lock Move Name Opt Print
Quit Sort Trans Value Window Xtern
Select option or type command letter
R7C1 "Labor" 98% SPENCER
    
```

In Chapter 4, we will discuss "ranges" and other kinds of references to cells more extensively.

THE BLANK COMMAND

Now you are ready to enter values for *Total Costs* in row 10.

When you do so, you have two rows showing total costs. You started with *Cost* in row 5, and now you have another row for *Total Costs*. To correct this duplication, you will want to blank out the number \$15000.00 in row 5, column 2. The worksheet will be clearer if the heading *Cost* is left as a major category heading in column 1, but you want the number to appear next to *Total Costs*.

Use the Blank command to blank out the \$15000.00. First move the cell pointer to row 5, column 2.

Press **B** (for Blank). The command line shows:

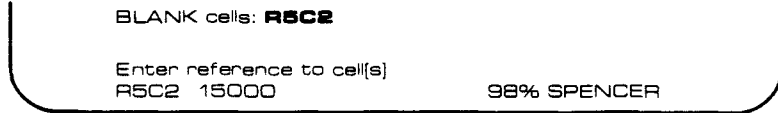

Look at the cell number highlighted by the edit cursor. It shows you that the cell pointer is in row 5, column 2. All you have to do is press **ENTER** to erase the contents of that cell. Watch R5C2 as you press **ENTER**. The active cell is now blank.

You can also use this command to blank out a group of cells. You can first press **B** (for Blank), and then specify a range, as you did earlier for the Format Cells command. But we don't need to do this now.

FORMULAS

Now you are ready to enter a formula for calculating the total costs. The total costs in row 10 will be figured by adding the three rows above it. Move the cell pointer down next to *Total Costs*, (row 10, column 2).

8. Press **ENTER**. You will see \$15000.00 now appear next to *Total Costs*. Look at the status line to see the formula Multiplan used to calculate the total. (Although Multiplan shows only those characters in the formula which will fit on the status line, the entire formula still exists.)

#1	1	2
1		
2		
3	Sales	\$20000.00
4	.	
5	Cost	
6	Material	\$ 4000.00
7	Labor	\$ 7000.00
8	Overhead	\$ 4000.00
9		
10	Total Costs	\$15000.00
11		
12		
13		
14		
15	Gross Profits	
16		
17		
18		

COMMAND: **Alpha** Blank Copy Del Edit For
 Go Help Ins Lock Move Name Opt Print
 Quit Sort Trans Value Window Xtern
 Select option or type command letter
 R10C2 R[-4]C + R[-3]C + R[-2]C 98% SPENCER

Note: The dollar format you selected in Chapter 2 with the Format Default Cells command automatically gives you two decimal places. Because of this default setting, any numbers you enter will appear in dollars unless you specifically change them with the Format Cells command.

The formula you see on the status line is the way Multiplan states what you said as you built the formula. Multiplan states:

$$\begin{array}{ccccccc} \overbrace{1} & \overbrace{2} & \overbrace{3} & \overbrace{4} & \overbrace{5} & \overbrace{6} & \overbrace{7} \\ R10C2 & = & R[-4]C & + & R[-3]C & + & R[-2]C \end{array}$$

1. "The active cell ...
2. contains ...
3. the cell 4 rows up from here (or 'this row minus 4') in this column ...
4. plus ...
5. the cell 3 rows up from here ...
6. plus ...
7. the cell 2 rows up from here."

Note: When a formula in Multiplan does not give a row or column number, it means "this" row or "this" column.

REVIEWING OR CHANGING A FORMULA

At some time later, you may forget exactly how you calculated the figure in a particular cell. You can see the contents of a cell by moving the cell pointer to it and looking at the status line.

If you wish to change the formula, place the cell pointer on that cell and use the Edit command (press **E**) to bring the formula onto the command line. Then use the CHARACTER FORWARD (**CTRL 4**) and CHARACTER BACK (**FCTN 4**) keys with the BACKSPACE (**FCTN 9**) key to make the changes you want. (You can also use the DELETE key (**FCTN 0**). CHARACTER FORWARD moves the edit cursor one character to the right; CHARACTER BACK moves the edit cursor one character to the left; DELETE erases the character that is highlighted rather than the character to its left, as BACKSPACE does.)

These four keys are part of the editing keys that Multiplan provides you. With the editing keys you can move the highlight around the command line, insert new text, and delete or replace old text. All the editing keys are explained in Part 2, Chapter 8, in the "Editing" section.

THE STATUS LINE: CELL CONTENTS

If a formula is too long to be shown in full on the status line, use Edit to place the formula in the command line so that you can review all of it.

The status line shows what is actually contained in the active cell. While the active cell may display the number \$15000.00, the status line will tell us what formula governs that cell. The value displayed for the cell may change, but the formula will remain constant. If, for example, the cost of materials were \$6000.00 instead of \$4000.00, the figure displayed in the *Total Costs* cell would change to \$17000.00. Yet, the status line would still show the same formula.

Try it. Move the cell pointer to R6C2 (\$4000.00). Type **6000**. Press **ENTER** and watch the new value appear.

#1	1	2
1		
2		
3	Sales	\$20000.00
4		
5	Cost	
6	Material	\$ 6000.00
7	Labor	\$ 7000.00
8	Overhead	\$ 4000.00
9		
10	Total Costs	\$17000.00
11		
12		
13		
14		
15	Gross Profits	
16		
17		
18		

COMMAND: Alpha Blank Copy Del Edit For
Go Help Ins Lock Move Name Opt Print
Quit Sort Trans Value Window Xtern
Select option or type command letter
R6C2 6000 98% SPENCER

Total Costs now shows \$17000.00. Now, change the cost of materials back to \$4000.00 and watch *Total Costs* change back to \$15000.00.

DRAWING LINES

To make the worksheet easier to read, draw a line in row 9, column 2, using dashes to separate the subcategories from *Total Costs*. Follow the same procedure you used earlier to enter text:

1. Move the cell pointer to row 9.
2. Press **A** (for Alpha).

Note: If you missed this step and tried to enter the dash without the Alpha command, the command line would show **VALUE** and be ready for a negative number or a formula. If you did do this, press the **CANCEL** key (**CTRL C**), and start this step over again.

3. Type the dash 9 times to fill the spaces in the cell:

```
ALPHA: ----- 
Enter text (no double quotes)
R9C2                               98% SPENCER
```

4. Press **ENTER**. You now see:

#1	1	2
1		
2		
3	Sales	\$20000.00
4		
5	Cost	
6	Material	\$ 4000.00
7	Labor	\$ 7000.00
8	Overhead	\$ 4000.00
9		-----
10	Total Costs	\$15000.00
11		
12		
13		
14		
15	Gross Profits	
16		
17		
18		

COMMAND: **Alpha** Blank Copy Del Edit For
Go Help Ins Lock Move Name Opt Print
Quit Sort Trans Value Window Xtern
Select option or type command letter
R9C2 "-----" 98% SPENCER

You will learn later how to extend this line across the entire worksheet, or across as many columns as you wish. Later, you will also get more practice in entering formulas using the cell pointer.

THE TRANSFER SAVE COMMAND (REVIEW)

Save your work by using the Transfer Save command as you did before:

Check that your data diskette is in the correct drive. Press T. Choose save by pressing S.

The proposed response is the last filename used, *SPENCER*. Since that is what you want, press **ENTER**. Multiplan now asks you if you want the worksheet on the screen to replace the one in the file.

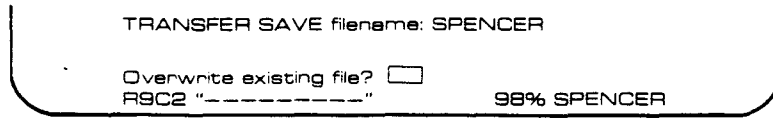

Since you do want your new work saved, press **Y** (for Yes). The command line will now return to:

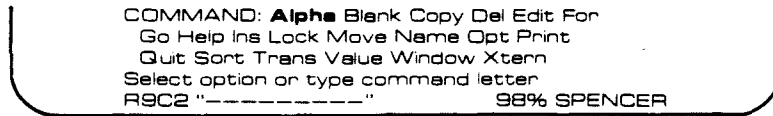

Any time you select a command that can affect a worksheet as a whole, Multiplan will ask you to confirm the action by pressing **Y**. This is true of worksheets on the screen and worksheets in a disk file. These actions include, for example, saving a file under a name previously used, or quitting a Multiplan session.

Your worksheet has been saved. Leave Multiplan for this session by typing **Q** (Quit) and **Y** (Yes) to confirm.

SUMMARY

In this session you learned:

- How to load your file.
- How to create more space by inserting empty rows using the Insert command (**I**).
- How to enter additional text using the Alpha command with the direction keys.
- How to enter additional numbers.
- How to align the contents of specific cells.
- How to specify a group of cells using the range symbol (colon).
- How to erase the contents of specific cells using the Blank (**B**) command.
- How to build formulas using the cell pointer and how to read the formula on the status line.
- How to use the cell pointer and the status line to review a formula.
- How to use the cell pointer and the Edit command (**E**) to change a formula.
- How to draw a line using the dash (**—**).
- How to save your new work with the Transfer Save command (writing over old work).

Chapter 4:

Naming Cells and Copying

The Transfer Load Command (Review)
Titles
Format: Align Center
The Copy Right Command
Formulas (Review)
Naming Cells
Building a Formula Using Names
The Goto Name Command
Calculating Functions: SUM
Number Signs (#)
Error Values
Relative References and Absolute References
Copying a Formula: The Copy From Command
Summary

In the last session, you entered cost figures into the worksheet. You then built a formula for *Total Costs* using the cell pointer.

In this session you will practice building more formulas. You will also learn how to copy cells and how to name them.

Press the RIGHT direction key to move the cell pointer to the next cell, row 1, column 3. Remember that moving the cell pointer automatically enters the word and places you in the ALPHA/VALUE: command each time you press a direction key to enter data. There is no need to press ENTER or Alpha each time.

Follow the same procedure until you have listed all twelve months. You will automatically scroll the screen as you move the cell pointer. Press ENTER after the last month to enter the final title and to return to the main command menu.

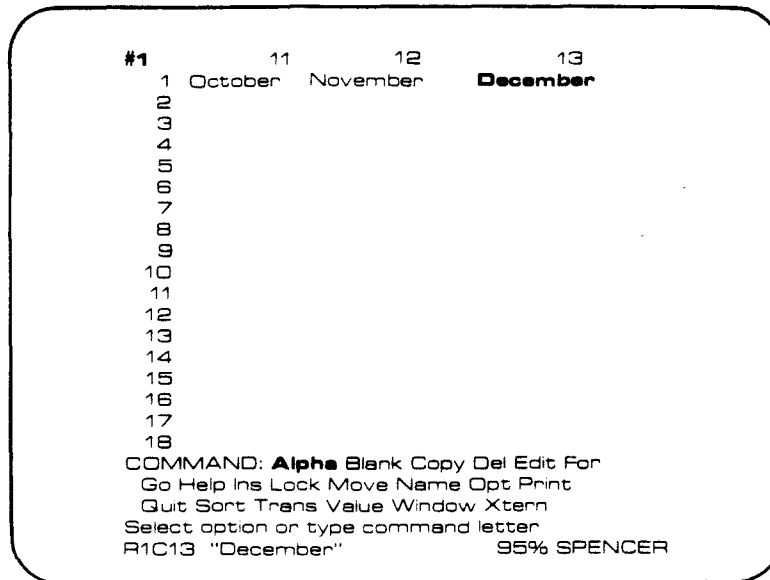

FORMAT: ALIGN CENTER

Because they are text, the names of the months are aligned to the left in the Multiplan "General" format (the format in which your worksheet began). The worksheet would look nicer and would be easier to follow if the names of the months were centered over the columns. Use the Format Cells command with the "Center" alignment to accomplish this.

Move the pointer back to January (row 1, column 2).

Press F.

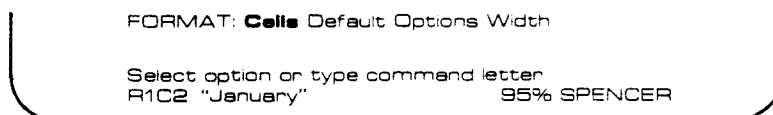

Press C or ENTER (for Cells).

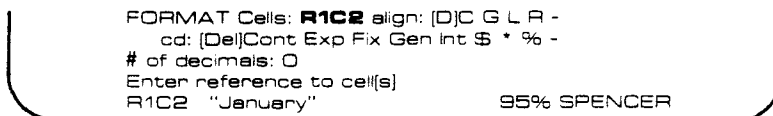

You want to format all twelve months, so you could follow the same procedure you used earlier to format a range of cells (the subheadings for *Cost*). But, it is much faster and more efficient to format the whole row at once.

Press the CHARACTER FORWARD key (CTRL 4) to move the edit cursor to the end of the proposed response in the first field (R1C2).

Earlier, instead of pressing the RIGHT direction key a number of times to give the range, we typed : (colon) and another cell reference. This time we want to format a whole row. You could type the column numbers yourself (1:63), but there's a more efficient way. Simply delete the C2 from the cell reference, using BACKSPACE (FCTN 9). The R1 remains.

```
FORMAT Cells: R1  align:(D)C G L R -
cd:(Del)Cont Exp Fix Gen Int $ * % -
# of decimals: 0
Enter reference to cell(s)
R1C2 "January" 95% SPENCER
```

This leaves the response as R1, which tells Multiplan to format the whole row. (Similarly, C1 would mean format all of column 1.)

Press TAB (CTRL A) to move to the second field. Type C to choose "Center."

Press ENTER now, because the proposed response in the "format code" field is correct and the "# of decimals" field does not apply.

The names of the months are now aligned in the center over the columns of numbers and are easier to read.

THE COPY RIGHT COMMAND

The figures you entered for Spencer Ceramics were for only one month. You will also want to show the rest of the year. Start by copying the figures you have for January into the remaining months of the year (the next 11 columns). You can later change some figures for costs or sales to see the effects of the changes on Spencer Ceramics' profits.

To copy the number for *Sales* (\$20000.00) into the next eleven cells, move the cell pointer to \$20000.00 (row 3, column 2). Press **C** (for Copy). Your command line shows:

```

COPY: Right Down From
Select option or type command letter
R3C2 20000 95% SPENCER
    
```

Choose the **Right** subcommand to copy from one cell (for January) into the cells to its right. Press **R**. The command line shows:

```

COPY RIGHT number of cells: 
starting at: R3C2
Enter a number
R3C2 20000 95% SPENCER
    
```

Where the edit cursor is located, type **11**, for the number of times you want the value in R3C2 copied.

```

COPY RIGHT number of cells: 11 
starting at: R3C2
Enter a number
R3C2 20000 95% SPENCER
    
```

Multiplan has proposed the cell you want to copy (the location of the cell pointer) as the starting point. You have already specified how many copies of that cell you want.

Press **ENTER**. Press **PAGE RIGHT (CTRL D)** to look at the next months. The number \$20000.00 is copied for each month.

```

#1      3      4      5
1 February March April
2
3 $20000.00 $20000.00 $20000.00
4
    
```

The screen is too small to display the whole year at one time, but you can see the rest of the year by using the direction keys to scroll the sheet beneath the pointer. Scroll until both columns 13 and 14 are visible. The sales figures stop at column 13 (the last of the twelve months of the year).

```

#1      12      13      14
1 November December
2
3 $20000.00 $20000.00
4
5
6
7
8
9
10
11
12
13
14
15
16
17
18
COMMAND: Alpha Blank Copy Del Edit For
Go Help Ins Lock Move Name Opt Print
Quit Sort Trans Value Window Xtern
Select option or type command letter
R3C13 20000 95% SPENCER
    
```

Now, fill in the cost figures, using the Copy command. Instead of copying one row at a time (as you did when you copied the \$20000.00 for Sales), use the Copy Right command to copy a group of cells.

First, move the cell pointer to the upper left corner of the area you want to copy. You want to copy the information from rows 6 through 10 in column 2, to the same rows in columns 3 through 13 to fill in the rest of the months. Move the cell pointer to row 6 in column 2.

#1	1	2
1		January
2		
3	Sales	\$20000.00
4		
5	Cost	
6	Material	\$ 4000.00
7	Labor	\$ 7000.00
8	Overhead	\$ 4000.00
9		-----
10	Total Costs	\$15000.00
11		
12		
13		
14		
15	Gross Profits	
16		
17		
18		

COMMAND: **Alpha** Blank Copy Del Edit For
 Go Help Ins Lock Move Name Opt Print
 Quit Sort Trans Value Window Xterm
 Select option or type command letter
 R6C2 4000 95% SPENCER

Press C (for Copy).

Then press R (for Right). Notice that the "number of cells" field shows 11—the same number you typed the last time you used the Copy Right command. Multiplan will always propose the number you used for the last Copy Right command.

COPY RIGHT number of cells: 11	
starting at: R6C2	
Enter a number	
R6C2 4000	95% SPENCER

Once again you want to copy 11 times just as you did with *Sales*.

```

COPY RIGHT number of cells: 11
                        starting at: R6C2

Enter reference to cells(s)
R10C2 R[-4]C + R[-3]C + R[-
95% SPENCER
  
```

Press TAB (CTRL A) to move to the "starting at" field.

Note: If you were copying only one row, the proposed response would be right. But you want to copy 5 rows of column 2 to the right, so you need to enter a range.

Press : (colon).

Then press the DOWN direction key until the cell pointer is on \$15000.00 (next to *Total Costs*). Notice how easily the range has been built.

```

COPY RIGHT number of cells: 11
                        starting at: R6C2: R10C2 

Enter reference to cells(s)
R10C2 R[-4]C + R[-3]C + R[-
95% SPENCER
  
```

Press ENTER and then PAGE RIGHT. Notice the values in other months. The value for *Total Costs* involves copying a formula; Multiplan has to calculate the value after it finishes copying the formulas. You should now see:

#1	3	4	5
	February	March	April
1			
2			
3	\$20000.00	\$20000.00	\$20000.00
4			
5			
6	\$4000.00	\$4000.00	\$4000.00
7	\$7000.00	\$7000.00	\$7000.00
8	\$4000.00	\$4000.00	\$4000.00
9			
10	\$15000.00	\$15000.00	\$15000.00
11			
12			
13			
14			
15			
16			
17			
18			

COMMAND: Alpha Blank Copy Del Edit For
 Go Help Ins Lock Move Name Opt Print
 Quit Sort Trans Value Window Xtern
 Select option or type command letter
 R6C3 4000 92% SPENCER

FORMULAS (REVIEW)

A formula will do calculations for you, and it allows you to change numbers and have Multiplan recalculate the result. So you want to build formulas wherever you can.

In Chapter 3, you built a formula to calculate *Total Costs*. Now, you want to build a formula to calculate *Gross Profits*. *Gross Profits* equals *Sales* minus *Total Costs*. A formula that uses these names is easily recognizable and as easy to build as the formulas you have built already. Before you can build such a formula, you must define names for some cells.

NAMING CELLS

Multiplan has a way to name cells or groups of cells so that you can refer to them easily. You can, for example, name a whole row, such as row 3; you can name it *Sales*, meaning the whole line of numbers showing sales.

Note: When you name a cell or group of cells, make the name continuous; do not use spaces or hyphens. (For more information, see the discussion of the Name command in Chapter 9.)

To build a formula for *Gross Profits*, you must first name the groups of cells that contain sales and total cost figures. Then these names can be used to build your formula.

Start by naming row 3 *Sales*.

Move the cell pointer to R3C1 (row 3, column 1).

Press **N** (for Name).

```
NAME: define name: Sales
           to refer to: R3C1

Enter name
R3C1 "Sales"                                92% SPENCER
```

In the first field, Multiplan proposes *Sales* as the name to be defined. This is helpful for quickly turning titles on a worksheet into names. Titles are text that you place in a cell. Names are references to areas on the worksheet. A name may be the same as a title, as it is here. But the cell that shows the title is not necessarily the area to which the name refers.

Press **TAB (CTRL A)** to move to the next field.

Notice that when you tab to the "to refer to" field, the message changes to "Enter reference to cell(s)." Multiplan is asking you to specify which cells this name refers to.

```
NAME: define name: Sales
           to refer to: R3C1

Enter reference to cell(s)
R3C1 "Sales"                                92% SPENCER
```

You want *Sales* to refer to the cells in row 3, columns 2 through 13.

Press the **RIGHT** direction key once; the response in the "to refer to" field is now R3C2.

Press **:** (colon).

Then press the **RIGHT** direction key to move the cell pointer to column 13 (December). You should see:

```
NAME: define name: Sales
           to refer to: R3C2:R3C13 

Enter reference to cell(s)
R3C13 20000                                92% SPENCER
```

Press **ENTER**.

You could have typed **13** after the colon instead of using the cell pointer. This method is faster if you know which cells compose the group you are naming.

Now Name the group of cells that defines *Total Costs*.

Move the cell pointer to *Total Costs* (R10C1).

Press **N** (for Name). You should see:

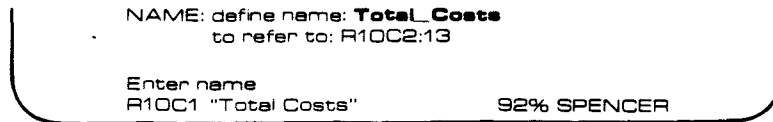

Notice *Total_Costs* in the "define name:" field and R10C2:13 in the "to refer to:" field. The column range C2:13 is the same as for *Sales* and the row R10 has changed to reflect the current position. You need only press **ENTER** to define *Total_Costs*.

Note: Multiplan changes any spaces in titles to underlines and deletes any illegal characters when titles are defined as names. The titles themselves are unaffected.

The same procedure would work for *Material*, *Labor*, and *Overhead*, if you wanted to define these or any other names as well (it's not necessary for the Spencer Ceramics example):

1. Move the cell pointer to the title.
2. Press **N** (for Name).
3. Press **ENTER**.

By proposing responses, Multiplan makes it easy to define names quickly for groups of cells that have similar shapes. In other cases, the proposed responses may not be suitable. You should always check the definition proposed for a name before you press **ENTER**.

The names do not appear on the screen. Nevertheless, the name can be used later in a formula or any other way that cell references can be used. It can also be used to refer to data on this worksheet from other worksheets. You'll learn more about this later.

If you forget which cells a name refers to, you can use the Name command to find out. Press **N**, then use the **RIGHT** direction key to "step forward through" the list of names. Each time you press the **RIGHT** direction key, another name appears, and the group of cells it refers to appears in the second field. If you forget which name you used, follow the same procedure until the name you are searching for appears. (Press **CANCEL (CTRL C)** to return to the regular command line.)

BUILDING A FORMULA USING NAMES

Consider that *Gross Profits* is *Sales* minus *Total Costs*.

$$\text{Gross Profits} = \text{Sales} - \text{Total Costs}$$

Now build the formula.

1. Move the cell pointer to row 15, column 2, next to *Gross Profits*.

#1	1	2
1		January
2		
3	Sales	\$20000.00
4		
5	Cost	
6		Material \$ 4000.00
7		Labor \$ 7000.00
8		Overhead \$ 4000.00
9		-----
10	Total Costs	\$15000.00
11		
12		
13		
14		
15	Gross Profits	<input type="text"/>
16		
17		
18		

COMMAND: **Alpha** Blank Copy Del Edit For
Go Help Ins Lock Move Name Opt Print
Quit Sort Trans Value Window Xtern
Select option or type command letter
R15C2 92% SPENCER

2. Press =.

VALUE:

Enter a formula
R15C2 92% SPENCER

3. Type **Sales**.

VALUE: Sales

Enter a formula
R15C2 92% SPENCER

4. Press - (minus).

```
VALUE: Sales -   
Enter a formula  
R15C2                               92% SPENCER
```

5. Type Total_Costs (names must be typed exactly as defined; be sure to include the underline character between Total and Costs).

```
VALUE: Sales - Total_Costs   
Enter a formula  
R15C2                               92% SPENCER
```

Press ENTER and your formula is complete.

```
#1          1          2  
1          1          January  
2  
3 Sales          $20000.00  
4  
5 Cost  
6          Material $ 4000.00  
7          Labor   $ 7000.00  
8          Overhead $ 4000.00  
9          -----  
10         Total Costs $15000.00  
11  
12  
13  
14  
15 Gross Profits          $ 5000.00  
16  
17  
18  
COMMAND: Alpha Blank Copy Del Edit For  
Go Help Ins Lock Move Name Opt Print  
Quit Sort Trans Value Window Xterm  
Select option or type command letter  
R15C2 Sales-Total_Costs          91% SPENCER
```

Look at the cell for *Gross Profits* (row 15, column 2). When you pressed **ENTER**, Multiplan calculated your formula and placed the results in the cell. *Gross Profits* now shows \$5000.00, and the status line displays the *Gross Profits* formula (*Sales* – *Total_Costs*).

Now copy this formula to the right 11 times (type **C, R, 11, ENTER**). Multiplan copies this formula for the remaining months.

Remember that *Sales* is defined as a 12 cell area (January through December). And so is *Total_Costs*. The \$5000.00 is, of course, the correct result for each month for the data you have entered so far. Later, however, if you change either a sales figure or a cost figure for one month, the *Gross Profits* figure changes in that column only.

Even though you specify part or all of a row, as you did here by using the names *Sales* and *Total_Costs*, Multiplan calculates in only one column at a time when it needs only one value for the result. Multiplan works the same way if you specify all or part of a column; it calculates in only one row at a time when it needs only one value for the result. This topic is discussed thoroughly in the “Formulas” section of Chapter 8.

THE GOTO NAME COMMAND

Named cells are easy to locate by using the Goto command.

Press **G** (for Goto).

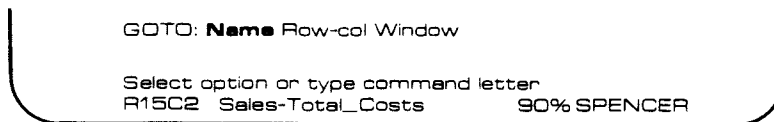

GOTO: **Name** Row-col Window
Select option or type command letter
R15C2 Sales-Total_Costs 90% SPENCER

Choose Name by pressing **N** or **ENTER**.

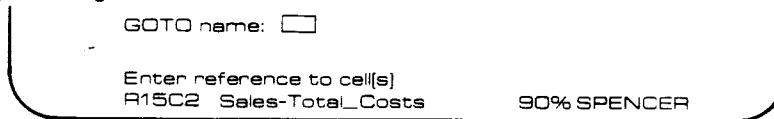

GOTO name:
Enter reference to cell(s)
R15C2 Sales-Total_Costs 90% SPENCER

Type **Sales**.

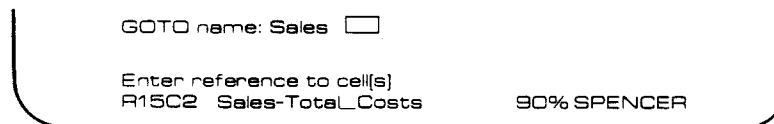

GOTO name: Sales
Enter reference to cell(s)
R15C2 Sales-Total_Costs 90% SPENCER

Note: Just as with the Name command, you can use the direction keys to “step through” the list of names. When the name you want appears, press **ENTER**.

Press **ENTER**. Your cell pointer has moved to the first cell in the *Sales* area.

The cell pointer always goes to the first cell in the named area. The pointer moves to the leftmost cell if the area is a row, to the uppermost cell if it's a column, and to the upper leftmost cell if it's a block of cells.

When you name a cell, the name will stay the same no matter what is in the cell. For example, you named a group of cells, *Sales*, and you can change the contents whenever you want. The cell will still be called *Sales*, and you can get to it by typing **G** (for Goto), **N** (for Name), *Sales* (the name of the cell) and pressing **ENTER**.

Note: The only way you can remove a name is to define it as blank. For example, to remove the name *Sales*, press **N**, then the **RIGHT** direction key until *Sales* appears, and then **TAB** (**CTRL A**). Now, simply press the **DELETE** key (**FCTN 0**) to erase the row and column numbers to which *Sales* refers.

You should press the **CANCEL** key (**CTRL C**) now because you don't want to remove *Sales* as a defined name. If you do remove the name *Sales*, you'll need to redefine *Sales* as referring to R3C2:13 before continuing.

CALCULATING FUNCTIONS: SUM

It looks as if Spencer Ceramics has made a lot of money. Wouldn't you like to see how much? Let's add another column heading in column 14, row 1, for the sums. Use the Goto command to move the cell pointer to R1C14.

Press **G** (for Goto).

Press **R** (for Row).

Type **1**, press **TAB (CTRL A)**, type **14**.

Press **ENTER**.

Enter the title **Sum** in column 14.

Press **A** (for Alpha).

Type **Sum**.

Press **ENTER**.

Now your screen should show:

#1	14	15	16
1	Sum		
2			
3			
4			
5			
6			
7			
8			
9			
10			
11			
12			
13			
14			
15			
16			
17			
18			

COMMAND: **Alpha** Blank Copy Del Edit For
Go Help Ins Lock Move Name Opt Print
Quit Sort Trans Value Window Xtern
Select option or type command letter
R1C14 "SUM" 90% SPENCER

The word *Sum* is centered over column 14 because you used the Format Cells command earlier to “center” the whole row.

To calculate the sales total for Spencer Ceramics for the twelve months, use the Multiplan function SUM. Begin by moving the cell pointer to the cell where the result will appear—row 3, column 14.

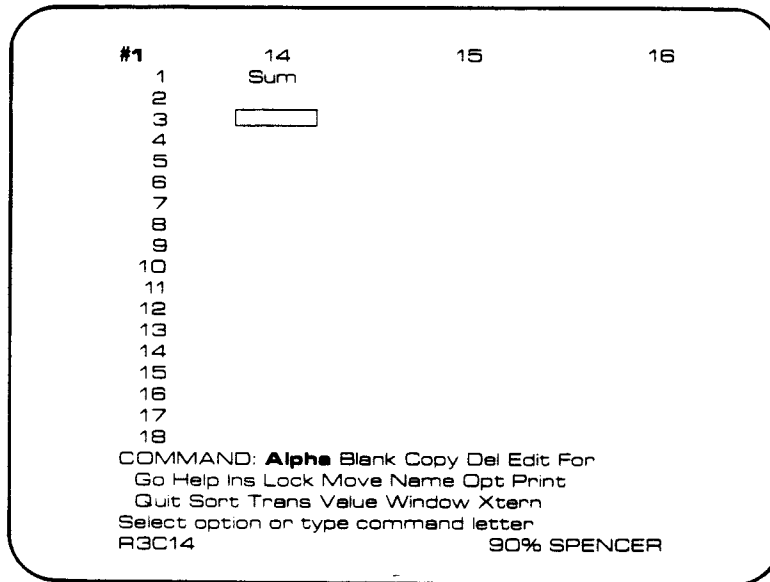

Press =. The command line will show:



Type **SUM(Sales)**.

Note: When using any of the Multiplan functions, type the function name followed immediately by an opening parenthesis, (. Do not leave any space between the function name and the opening parenthesis.

Press **ENTER**. You will see:

```
#1      14      15      16
1      Sum
2
3      #####
4
5
6
7
8
9
10
11
12
13
14
15
16
17
18
COMMAND: Alpha Blank Copy Del Edit For
Go Help Ins Lock Move Name Opt Print
Quit Sort Trans Value Window Xtern
Select option or type command letter
R3C14 SUM(Sales)          90% SPENCER
```

NUMBER SIGNS (#)

When numbers are too large to be shown in the current formatted column width, they are displayed as number signs (###) until the column is widened enough to accommodate the number.

Column 14 has not been widened so it is not wide enough to accommodate the sum-of-sales figure in the dollar format (remember: your whole sheet is formatted in dollars) because the dollar format adds a dollar sign, a decimal point, and two places after the decimal point. Look at the status line. It shows that cell R3C14 contains SUM(Sales). You will have to widen the column to display the dollar value as numbers instead of as number signs. Use the Format Width command to widen column 14.

Press **F**.

Press **W**.

Type **15**, as you did when you widened column 1.

Press **ENTER**. You will see:

```
#1      14      15
1      Sum
2
3      $24000.00
4
5
6
7
8
9
10
11
12
13
14
15
16
17
18

COMMAND: Alpha Blank Copy Del Edit For
Go Help Ins Lock Move Name Opt Print
Quit Sort Trans Value Window Xtern
Select option or type command letter
R3C14 SUM(Sales)          90% SPENCER
```

ERROR VALUES

If you enter a formula that Multiplan cannot calculate to a number or text, Multiplan uses one of the special error values as the result. Error values start with a number sign (#). For example, look at the value in cell R3C14, which is the sum of sales. (If the cell pointer is not there already, move it to R3C14.) The formula is SUM(Sales).

Let's "undefine" *Sales*. Press **N**. Press the **RIGHT** direction key until *Sales* appears in the "define name" field. Press **TAB** (**CTRL A**). Now press the **DELETE** key (**FCTN 0**). The reference for *Sales* disappears. Press **ENTER** and the name *Sales* no longer exists.

Notice at the same time what happens in cell R3C14. The value changes from \$240000.00 to **#NAME?**.

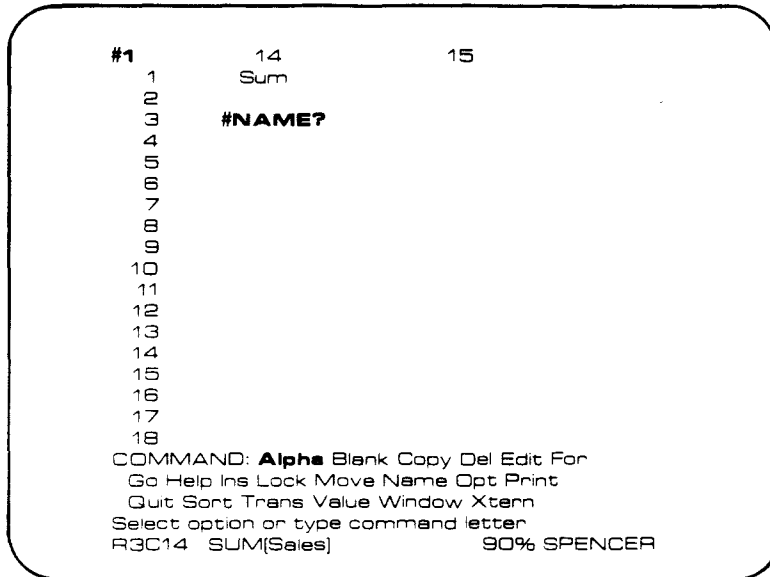

This means that Multiplan encountered a name not currently defined.

Now, redefine *Sales* to refer to R3C2:13. Press **N**. The "define name:" field is blank, but the "to refer to:" field shows R3C2:13.

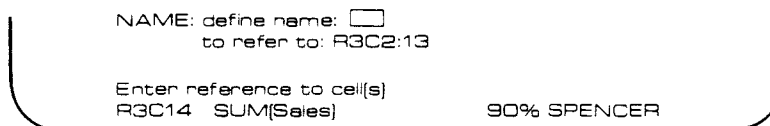

Type **Sales**, then press **ENTER**. The value \$240000.00 reappears in cell R3C14.

Remember, when you defined *Total Costs*, the "to refer to" field had a proposed response that fit. Because *Sales* will refer to a group of cells with the same row-column arrangement as the group of cells of the last name defined (*Total Costs*), the proposed response is correct for redefining *Sales*, as long as the cell pointer is in the correct row before starting the Name command.

The other error values you might see as you build a worksheet are: **#DIV/0!**, **#N/A**, **#NULL!**, **#NUM!**, **#REF!**, and **#VALUE!**. All of the error values are described fully under "Error Values" in the "Formulas" section of Chapter 8.

RELATIVE REFERENCES AND ABSOLUTE REFERENCES

So far we've been using three different ways to refer to cells. Sometimes, we referred to a cell as R3C14 or a group of cells as R3C2:13. Sometimes, we referred to a group of cells by name, as when we built the formula SUM(Sales) or Sales — Total_Costs. Sometimes, we referred to a cell by R[-4]C, as when we built the formula for *Total Costs*.

When you refer to cells by R3C14, R3C2:13, or similar references to specific row numbers and specific column numbers, you are using absolute references. When you refer to a cell by R[-4]C and similar references to the current row plus or minus a number of rows, you are using relative references (which can also be used for columns).

The major difference between absolute and relative references appears when copying formulas. When you copied the formula for *Total Costs* across all 12 months, the correct value appeared in each column. You wouldn't see any difference between a formula with absolute references and one with relative references in this case because the values for *Material*, *Labor*, and *Overhead* are the same in each column. But if one or more values were changed in one column, the value of *Total Costs* in that one column would differ.

On the other hand, if the formula contained absolute references, all copies of *Total Costs* would depend on the values in column 2 rather than on the values in each column.

If you had specified the exact row and column number for *Material*, *Labor*, and *Overhead* by making an absolute reference to their position, such as R6C2 + R7C2 + R8C2, you would have had to change each of the references for the *Total Costs* formula in each column for the formula to remain correct.

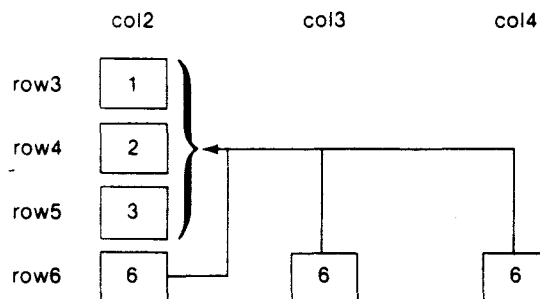

Absolute Formula in row6: R3C2 + R4C2 + R5C2

If the 2 in col2 becomes a 3, then all 6's in row6 become 7's; if any value in row3, row4, or row5 of col3 or col4 changes, there is no effect in row6.

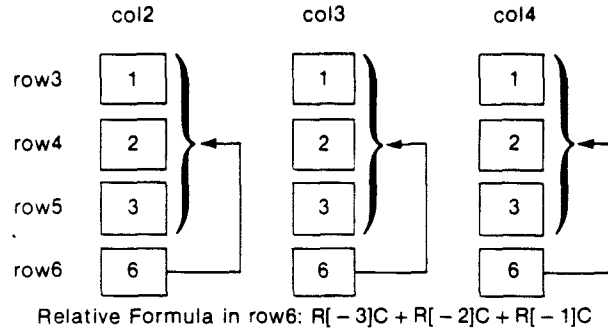

If one of the 2's in row4 becomes a 3, then the value in row6 only for that column becomes a 7. $1 + 2 + 3 = 6$ changes to $1 + 3 + 3 = 7$.

For reasons of flexibility, you used a formula with relative references, built by using the cell pointer, to calculate *Total Costs*. Similarly, using a formula with relative references to calculate the sum of *Sales* allows you to copy a flexible formula for calculating the sums of *Total Costs* and *Gross Profits*.

First, you need to edit the formula in row 3, column 14 (R3C14). Right now it contains the formula SUM(Sales). Because names are defined by absolute references, *Sales* is handled the same as an absolute reference. You need to change *Sales* to relative references.

Move the cell pointer to R3C14.

Press E (for Edit). The formula in the active cell is now displayed on the command line:

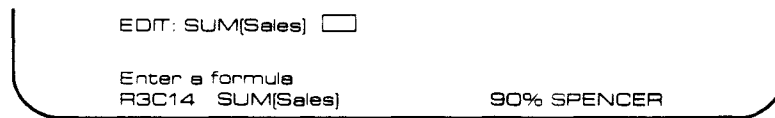

Now sum the same cells by their absolute references. Press BACKSPACE (FCTN 9) to erase the characters "*Sales*", leaving SUM(. You should see:

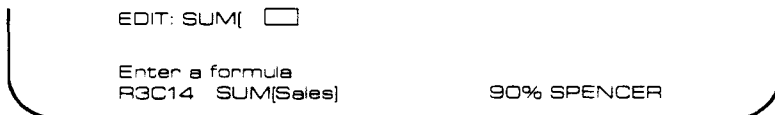

Press the LEFT direction key until the cell pointer reaches R3C2. Multiplan adds the new reference to the previous formula.

```

EDIT: SUM[RC[-12]] 
Enter a formula
R3C2 20000                                90% SPENCER
  
```

The cell pointer position determines the relative reference into your formula. Press : (colon).

```

EDIT: SUM[RC[-12]:] 
Enter a formula
R3C14 SUM[Sales]                            90% SPENCER
  
```

Then press the LEFT direction key once (to R3C13), and Multiplan lists the final value of the range.

```

EDIT: SUM[RC[-12]:RC[-1]] 
Enter a formula
R3C13 20000                                90% SPENCER
  
```

Press) (the right parenthesis) to complete the function.

```

EDIT: SUM[RC[-12]:RC[-1]] 
Enter a formula
R3C14 SUM[Sales]                            90% SPENCER
  
```

Press ENTER. The total of row 3 appears under Sum:

```

#1      14      15
 1      Sum
 2
 3      $24000.00
 4
 5
 6
 7
 8
 9
10
11
12
13
14
15
16
17
18
COMMAND: Alpha Blank Copy Del Edit For
Go Help Ins Lock Move Name Opt Print
Quit Sort Trans Value Window Xterm
Select option or type command letter
R3C14 Sum[RC[-12]:RC[-1]]          90% SPENCER
  
```

Now, you can easily use this same formula to calculate the sums for *Total Costs* and *Gross Profits* by copying the formula into cells R10C14 and R15C14 using the Copy From command.

COPYING A FORMULA: THE COPY FROM COMMAND

Press C (for Copy), then F (for From).

```
COPY FROM cells: R3C14
to cells: R3C14

Enter reference to cell(s)
R3C14 SUM(RC[-12]:RC[-1] 90% SPENCER
```

Multiplan proposes that you copy from the active cell, which is what you want to do. Press TAB (CTRL A). The proposed response in the "to cells" field is not correct. Press the DOWN direction key until the cell pointer reaches row 10.

```
COPY FROM: cells R3C14
to cells: R10C14 

Enter reference to cell(s)
R10C14 90% SPENCER
```

R10C14 is one of the cells to receive a copy of the formula. The other is in row 15. Because the cells are not next to each other, you can't use a range as you've done before with the colon. You need, instead, to make a list of cells. To make a list, use the comma.

Press , (comma).

```
COPY FROM cells: R3C14
to cells: R10C14, 

Enter reference to cell(s)
R3C14 SUM(RC[-12]:RC[-1] 90% SPENCER
```

Now press the DOWN direction key until the cell pointer reaches row 15.

```
COPY FROM cells: R3C14
to cells: R10C14,R15C14 

Enter reference to cell(s)
R15C14 90% SPENCER
```

Press ENTER, and watch the values appear in rows 10 and 15 of column 14:

#1	14	15
1	Sum	
2		
3	\$24000.00	
4		
5		
6		
7		
8		
9		
10	\$18000.00	
11		
12		
13		
14		
15	\$60000.00	
16		
17		
18		

COMMAND: Alpha Blank Copy Del Edit For
Go Help Ins Lock Move Name Opt Print
Quit Sort Trans Value Window Xtern
Select option or type command letter
R3C14 SUM(RC[-12]:RC[-1] 90% SPENCER

It's time to take a break. In the next session, you will see how Spencer Ceramics' profits change as costs and sales change.

To make it easier when you return, move the cell pointer back to the beginning of the worksheet. Multiplan always loads a worksheet exactly as it was when you saved it.

Use Goto Row command to move the cell pointer to row 3, column 2.

Save your work with the Transfer Save command. To review:

Check that your data diskette is in the correct drive.

Press **T** (Transfer).

Press **S** (Save).

Press **ENTER**.

You will see the question:

Overwrite existing file?

Type **Y** (to update, or overwrite, the old file with the information you have added).

Your work has now been saved and will be available for you when you return. Press **Q** (for Quit), and **Y** (to confirm).

SUMMARY

In this session you learned:

How to load your worksheet with the Transfer Load command (review).

How to place titles on your worksheet.

How to center titles in columns (Format Cells command).

How to copy one cell to the right.

How to copy a group of cells to the right.

How to build formulas (review).

How to name cells and groups of cells.

How to build a formula using names.

How to go to the beginning of a named area using the Goto Name command.

How to calculate the sum of a named area.

How Multiplan indicates that a number is too large to be displayed within the present width of a column by displaying number signs (#).

How Multiplan displays error values for formulas that it cannot calculate.

How relative references and absolute references differ.

How to copy a formula using the Copy From command.

Chapter 5: Windows, Copying Formulas, and Options

Fixing Titles: The Window Split Title Command
Opening a Window: The Window Split Command
Linking Windows: The Window Link Command
Bordering Windows: The Window Border Command
Building a Formula to Show Increasing Sales
Copying a Formula to the Right: The Copy Right Command (Review)
What If...?
Protecting the Worksheet: The Lock Formulas Command
The NEXT UNLOCKED CELL Key
Unlocking Cells
The Options Command
Summary

In the last session you reviewed the procedure for building formulas, and you learned how to copy cells into other cells on the worksheet. You also learned how to name cells, how to use the Goto command to move the pointer to the named area, and how to do a calculation using a name and a function.

In this session you will learn how to view several portions of the worksheet at once by "opening windows," as well as how to manipulate these windows quickly and easily.

Load the Multiplan diskette. Check that the data diskette is in the correct drive. Then Transfer Load *SPENCER*. The screen should look just as it did when you left it last time. Remember to reinstall the program diskette if you are using only one disk drive.

FIXING TITLES: THE WINDOW SPLIT TITLE COMMAND

It is possible to keep the headings for *Sales*, *Cost*, etc., in view while you look at the last half of the year. It can be difficult to tell what numbers you are looking at when you get past January if you can't see the headings.

You can "fix" the titles in place, so that they will remain visible as you scroll the columns by using the Window Split command.

Press **W** (for Window).

```
WINDOW: Split Border Close Link
Select option or type command letter
R3C2 20000                               89% SPENCER
```

There are several subcommands to choose from. You want to split off the titles from the figures, so choose Split by pressing **S** or **ENTER**.

Of three subcommands you see, pick Titles because you want to place the titles (or headings) in place in column 1.

Press **T**.

```
WINDOW SPLIT TITLES: # of rows: 2
# of columns: 1
Enter a number
R3C2 20000                               89% SPENCER
```

In the first field, type a zero (0) because you only want to split the the window vertically, by columns.

```
WINDOW SPLIT TITLES: # of rows: 0 
# of columns: 1
Enter a number
R3C2 20000                               89% SPENCER
```

In the second field ("# of columns"), Multiplan asks how many columns you would like to split. You want one column for the titles. As "1" is the proposed response, just press **ENTER**.

Note: You cannot ask Multiplan to split more columns or rows than you can see on the screen. If you do, the "Window will not fit" message will appear.

Now, when you scroll to December, you will still be able to see the headings for *Sales*, *Costs*, and *Gross Profits*, the column you have just fixed in place. Try pressing the RIGHT direction key until July comes into view. The titles are still fixed at the left of the screen. Now press the LEFT direction key to get back to January.

OPENING A WINDOW: THE WINDOW SPLIT COMMAND

You have actually opened a second window by splitting the one you were working on. Save your work at this stage (check that your data diskette is in the correct drive) by using the Transfer Save command (press **Y**, for Yes, to overwrite the existing file). Remember to reinstall the program diskette if you are using only one disk drive.

Note: It is important that you save the worksheet as it now stands since the changes you make experimenting with the worksheet do not need to be saved. After you practice opening and closing windows, you will reload the *SPENCER* worksheet, which will replace the active worksheet with the *SPENCER* worksheet as it now stands.

Now experiment with opening and closing windows by using the Window Split command.

Position the cell pointer on the row you want (for horizontal splits) or on the column you want (for vertical splits) before you start the Window command. For now, move the cell pointer to R11C2.

Now press **W** as you did before.

Now press **S**.

You have not yet tried either the horizontal or vertical subcommands. The Horizontal choice allows you to split a window across the screen at the row number you specify. The Vertical choice will let you split a window up and down at the column you choose.

Press **H** (for Horizontal).

The first field ("at row:") determines the row at which to split the window. Multiplan proposes row 11, which is what we'll do for now. It is convenient to locate the cell pointer in the appropriate cell before starting a command so that the proposed response is correct.

The second field shows linking status: "linked: Yes(No)". When windows are linked, they scroll together. That means that as you move the cell pointer at the edge of one of the linked windows, the contents of both windows move across the screen at the same time.

For now, press **ENTER**. The screen should look like:

#1	1	#2	2
1			January
2			
3	Sales		\$20000.00
4			
5	Cost		
6		Material	\$ 4000.00
7		Labor	\$ 7000.00
8		Overhead	\$ 4000.00
9			-----
10	Total Costs		\$15000.00
11		#3	2
12		11	<input type="text"/>
13		12	
14		13	
15	Gross Profits	14	
16		15	\$ 5000.00
17		16	
18		17	

COMMAND: **Alpha** Blank Copy Del Edit For
Go Help Ins Lock Move Name Opt Print
Quit Sort Trans Value Window Xtern
Select option or type command letter
R11C2 89% SPENCER

Notice the column numbers at the top of window #3. Scroll across to column 14, then scroll back to column 2. Window #2 is unaffected. When windows are not linked, you can scroll them separately to view different parts of the worksheet simultaneously. If you had specified "Yes" when splitting, windows #2 and #3 would scroll together.

LINKING WINDOWS: THE WINDOW LINK COMMAND

Once windows are split, you can change their link status with the Window Link command. Press **W** (for Window); then press **L** (for Link).

```
WINDOW LINK window number 3
                with window number: 2
                linked: Yes(No)
Enter a number
R11C2                                89% SPENCER
```

Multiplan proposes linking window #3 (the proposed active window) with window #2 (the window from which the active window was split). Press **TAB** (**CTRL A**) twice to advance to the third field.

Press **Y** or **SPACE BAR** to select "Yes."

Press **ENTER** and they are linked. Scroll to column 14. The information in both windows scrolls. Scroll back to column 1; the information again moves together across the screen.

BORDERING WINDOWS: THE WINDOW BORDER COMMAND

If a window is bordered, it has a line drawn around it that sets it off from the surrounding worksheet. The sheet you now have is not bordered.

Try the Window Border command to see what a bordered window looks like. Press **W**, then **B**.

Multiplan proposes the active window #3, but you could give any open window number.

Simply press **ENTER** to place a border around window #3.

The display should look like:

```

#1          1          #2          2
1
2          January
3 Sales          $20000.00
4
5 Cost
6          Material $ 4000.00
7          Labor    $ 7000.00
8          Overhead $ 4000.00
9
10         Total Costs $15000.00
11
12
13
14
15 Gross Profits
16
17
18
#3          2
11          [ ]
12
13
14
15          $ 5000.00

COMMAND: Alpha Blank Copy Del Edit For
Go Help Ins Lock Move Name Opt Print
Quit Sort Trans Value Window Xtern
Select option or type command letter
R11C2                                89% SPENCER
```

If you split a bordered window, both resulting windows have borders.

Try opening (press **W**, then **S**) and closing (press **W**, then **C**) windows until you become familiar with the command. Use the **NEXT WINDOW** key (**CTRL W**) to move the pointer from window to window until it is in the window you wish to split.

When you are finished, reload your worksheet (Transfer Load *SPENCER*) from your data diskette. Any changes you have made since you last saved the *SPENCER* worksheet will be eliminated.

BUILDING A FORMULA TO SHOW INCREASING SALES

Your information on Spencer Ceramics indicates that sales have been increasing by about 1% a month. To see the effect of a 1% monthly increase in sales, first move the pointer to row 3, column 3, under February, which is the first month that will show an increase.

Press **=**. The command "Value" appears.

Using January sales as a base for the remaining months, type in a formula that will calculate each month's sales as a 1% increase over the preceding month's sales. Move the cell pointer back to row 3, column 2, under January.

To show February's sales as a 1% increase over January's, you need to multiply January's sales by 101% (that is, February sales are 101% of January's).

Press ***** (the asterisk is the sign for multiplication).



Now type **101%** (use the digit 1, not the lowercase letter l).

Press **ENTER**. You should see the new cell value for February showing a 1% increase over the previous month, January.

A screenshot of a spreadsheet showing a table with columns labeled #1, 1, #2, and 3. Row 1 contains the numbers 1, 1, 3, and 3. Row 2 contains the numbers 2, 1, February, and February. Row 3 contains the numbers 3, Sales, and \$20200.00.

#1	1	#2	3
1	1	3	3
2	1	February	February
3	Sales		\$20200.00

COPYING A FORMULA TO THE RIGHT: THE COPY RIGHT COMMAND (REVIEW)

Because January acts as the "base" month for the 1% increase, the cell for January Sales does not contain a formula. You will therefore be copying the formula for February Sales into the remaining 10 months of the year. To copy this formula to the right, be sure the cell pointer is on R3C3 (under February), and press **C**.

Press **R** or **ENTER**.

In the first field ("number of cells"), type **10**.

In the second field ("starting at"), you see that R3C3 (the active cell) is the proposed response. That is where you want to start because the other 10 cells are to be copies of this cell.

As you press **ENTER**, watch the results.

Move the cell pointer to row 3, column 14, to see the sales figures resulting from a 1% monthly increase. The formula was copied to the remainder of the year, and the cells that depended on sales figures (*Gross Profits* and *sum of Sales*, for example) have been updated to include the new information.

Before you go on, save your work (Transfer, Save, and Y to overwrite) on your data storage diskette.

WHAT IF...?

The *SPENCER* worksheet is based on the assumption that the company will have \$20,000.00 in sales in the "base" month (January). The rest of the sales figures are calculated from a formula that assumes a sales increase of 1% per month. All the cost figures are the same for each month.

What if the actual "base" figures (figures you typed in rather than figures calculated from formulas) are different from the estimates you typed in? You would want to change the "base" figures, but you would want to protect your formulas (especially those for calculating *Total Costs* and *Gross Profits*) from alteration. How do you protect your formulas from accidental alteration? How do you quickly find which cells contain the "base" figures?

Multiplan has a Lock command to protect formulas and text and a NEXT UNLOCKED CELL key to move quickly from one base figure to the next.

PROTECTING THE WORKSHEET: THE LOCK FORMULAS COMMAND

Press L (for Lock), then F (for Formulas). The command line changes to:

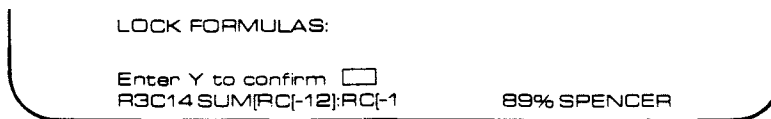

The message line shows the message "Enter Y to confirm." Enter Y if you want to lock all cells with formulas or text. Press any other key to cancel the command.

Press Y. The command menu returns.

THE NEXT UNLOCKED CELL KEY

To see the effect of the Lock Formulas command, press the HOME key (CTRL 1) to go to R1C1. Now press the NEXT UNLOCKED CELL key (CTRL 3).

The cell pointer moves to R3C2, which is the first cell from the beginning of the worksheet that contains typed in numbers rather than text or a formula. Notice that blank cells are also ignored.

Type 18000, then press ENTER. Again, press the NEXT UNLOCKED CELL key (CTRL 3).

The value in R3C2 (January Sales) changed, and Multiplan recalculated the figures in the *Sales* and *Gross Profits* rows. The cell pointer is now at R6C2, the next unlocked cell. If you want, you can alter the value in this cell, and then watch the changes on the profit picture. Already you can see that gross profits dropped from \$5000 to \$3000 in January, with similar reductions in the following months.

You might want to press the NEXT UNLOCKED CELL key several more times to see which cells remain unlocked.

UNLOCKING CELLS

To unlock cells again, press **L** (for Lock), and then **C** (for Cells). In the "cells" field, specify the entire active area of the worksheet, as follows:

Press the **HOME** key (**CTRL 1**) to place the cell pointer at the upper left corner of the worksheet.

Press **:** (colon) to create a range.

Press the **LOWER RIGHT** key (**CTRL Z**) to place the cell pointer at the most lower right cell that contains data or has been formatted.

Press **ENTER**.

All cells should now be unlocked. Press the **NEXT UNLOCKED CELL** key (**CTRL 3**) several times; the cell pointer should move from one cell to the next, just as if you were pressing the **RIGHT** direction key, except that blank cells are still skipped.

THE OPTIONS COMMAND

As you have seen, if you change the contents of a cell, such as January Sales, Multiplan recalculates all of the cells that depend upon that cell.

Use the **Goto** command to move your pointer to row 3, column 2. Change January sales by typing **30000**. Press **ENTER** and watch the remaining sales and profits figures change.

Likewise, if you change the formula in row 3, column 3 (under February), to reflect a 2% increase (*102%), Multiplan will automatically recalculate the worksheet.

If your worksheet contains many formulas, each change may require several moments to complete the recalculation. To speed up entering a number of changes, you can turn off the automatic recalculation option by using the **Options** command. Press **O**.

Select "No" by pressing **N**.

Press **ENTER**.

Now change the number for January sales to **10000** and press **ENTER**. You will see that only the cell for January sales changed.

During the time the option to recalculate is turned off, you can do calculations by pressing the **RECALC** key (**FCTN 8**). Press the **RECALC** key and watch the screen. The worksheet has been recalculated. *Gross Profits* (row 15) now shows losses in parentheses.

Use the **Options** command to change back to automatic recalculation. Press **O, Y, ENTER**). It's time to end this session now. Remember, your work has already been saved by the earlier **Transfer Save** command. Press **Q, Y** and the master title screen appears.

SUMMARY

In this session you learned:

How to fix row and column titles to let you view the headings while you scroll the worksheet (Window Split Titles).

How to open a new window (Window Split).

How to link windows so that they scroll together, either by rows or by columns or both (Window Link).

How to draw a border around a window (Window Border).

How to enter a formula to show an increasing sales percentage.

How to copy a formula into other cells to the right (Copy Right review).

How to lock cells that contain formulas or text so you can perform "what if" experiments.

How to use the NEXT UNLOCKED CELL key to find cells that contain typed-in numbers.

How to unlock locked cells.

How to use the Options command to suspend the Multiplan automatic recalculation feature.

Chapter 6: Printing A Worksheet

The Print Command
The Print Subcommands
 Print Margins
 Print Options
 Print Printer
 Print File
Summary

You have now become familiar with the basic command structure of Multiplan, and how to use the keyboard and commands to build a worksheet that responds quickly and accurately to changes.

In this session you will learn to use the Multiplan Print command to print a copy of the summary operating budget you developed to show Spencer Ceramics' projected sales and profits. (You can print your work on paper or save it in a disk file.)

THE PRINT COMMAND

Before you print the worksheet, be sure the printer is connected properly, turned on, and ready to print. The printer manual provides information on making the printer operational.

Start up Multiplan and load the *SPENCER* file. Next, use the Print command. Press **P**.

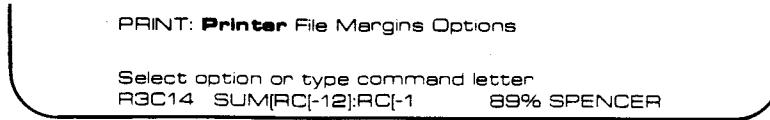

You can select any of the four options. Do not select Printer until Margins and Options are correctly set.

THE PRINT SUBCOMMANDS

The Print command includes four subcommands which are summarized here. For more complete descriptions of these subcommands, refer to Chapter 9, "Command Directory," in Part 2.

Print Margins

This subcommand lets you set the margins for printing a worksheet. You do not have to set the margins if the default settings are appropriate.

The default settings are:

left	5 characters
top	6 lines
print width	70 characters
print length	54 lines
page length	66 lines

Multiplan prints as many columns across the page as will fit within these margins. Any columns left over will be printed on a second page, with row and column numbers continued.

This method of printing permits you to cut and attach the printed pages to form a worksheet with the same dimensions you set up on the screen.

Print Options

This subcommand lets you choose whether to print all or part of the worksheet, and whether to print formulas instead of values.

You may print:

- Only the parts of the worksheet you specify. For example, you could specify just the column showing the sums for sales, costs, and gross profits (column 14).
- The formulas in the cells instead of the values. For example, with the formulas option turned on, Multiplan would print *Sales – Total – Costs* (the formula for *Gross Profits*) instead of \$5000.00.
- The worksheet with row and column numbers included.

Print Printer

Multiplan's proposed response for the Print command is "Printer." Press **P** or **ENTER** to send your worksheet to your printer in page-sized sections according to the Margin settings. Should you need to stop the printout before printing is complete, the **PRINT CANCEL** key (**FTN 4**) provides this function.

The printed pages should resemble the next three illustrations:

	January	February	March	April	May
Sales	\$20000.00	\$20200.00	\$20402.00	\$20606.02	\$20812.08
Cost					
Material	\$4000.00	\$4000.00	\$4000.00	\$4000.00	\$4000.00
Labor	\$7000.00	\$7000.00	\$7000.00	\$7000.00	\$7000.00
Overhead	\$4000.00	\$4000.00	\$4000.00	\$4000.00	\$4000.00
-----	-----	-----	-----	-----	-----
Total Costs	\$15000.00	\$15000.00	\$15000.00	\$15000.00	\$15000.00
Gross Profits	\$5000.00	\$5200.00	\$5402.00	\$5606.02	\$5812.08

	June	July	August	September	October	November	December
	\$21020.20	\$21230.40	\$21442.71	\$21657.13	\$21873.71	\$22092.44	\$22313.37
	\$4000.00	\$4000.00	\$4000.00	\$4000.00	\$4000.00	\$4000.00	\$4000.00
	\$7000.00	\$7000.00	\$7000.00	\$7000.00	\$7000.00	\$7000.00	\$7000.00
	\$4000.00	\$4000.00	\$4000.00	\$4000.00	\$4000.00	\$4000.00	\$4000.00
	-----	-----	-----	-----	-----	-----	-----
	\$15000.00	\$15000.00	\$15000.00	\$15000.00	\$15000.00	\$15000.00	\$15000.00
	\$6020.20	\$6230.40	\$6442.71	\$6657.13	\$6873.71	\$7092.44	\$7313.37

Sum

\$253650.06

\$180000.00

\$73650.06

Depending on your printer, Options, or Margin settings, the printout may vary from the illustrations shown here.

Print File

This subcommand lets you store a printable version of a worksheet on diskette.

This printable "file" version of the worksheet has several uses. You can print the worksheet from a BASIC program at any time, just as if you were printing any normal file. If your system does not have a printer, you can take the diskette to another TI-99/4A computer system for printing the worksheet. The worksheet can be edited with a word processing program such as TI WRITER and included in reports prepared by the word processing program.

SUMMARY

In this session you learned:

- How to set Print Margins and Print Options.

- How to begin printing.

- What Print File is used for.

Chapter 7: Using Multiple Worksheets

Relating Worksheets to Each Other
The Transfer Clear Command
Building a Supporting Sheet
Naming Related Worksheets
The eXternal Copy Command
Revising a Supporting Sheet
Dissolving Connections between Worksheets
The eXternal List Command
Additional Commands
Summary
Learning More about Multiplan

In this session you will learn to use information from other worksheets in entries and formulas on your active sheet.

The worksheet you have been compiling for Spencer Ceramics is a summary worksheet showing sales, costs, and gross profits. It is based on information for one month, which was then projected into the remaining months of the year to show potential profits. Review the data you already have. Transfer Load the *SPENCER* worksheet from your data diskette.

On this summary sheet, the costs of many types of items are added together to calculate the cost of materials and overhead for each month. You are now ready to use more detailed information about the company.

Look at the following breakdown of Spencer Ceramics' material and overhead costs for January.

Material		Overhead	
Clay	\$1500	Utilities	\$1100
Glaze	1500	Rent	2500
Brushes	500	Telephone	200
Sponges	200	Water	<u>200</u>
Plaster	<u>300</u>	Total	\$4000
Total	\$4000		

In the course of business, Spencer Ceramics would keep a record of each type of item that makes up *Material* and *Overhead* shown on the summary sheet. Your report on Spencer Ceramics would be more complete if you added these details. You can do this by setting up a worksheet for costs, which will supply totals for rows 6 and 8 of the summary sheet (we are assuming for the present that labor costs will remain the same).

RELATING WORKSHEETS TO EACH OTHER

With Multiplan, you can set up separate worksheets, which can draw information, as needed, from one another. The information on Spencer Ceramics could be set up to relate like this:

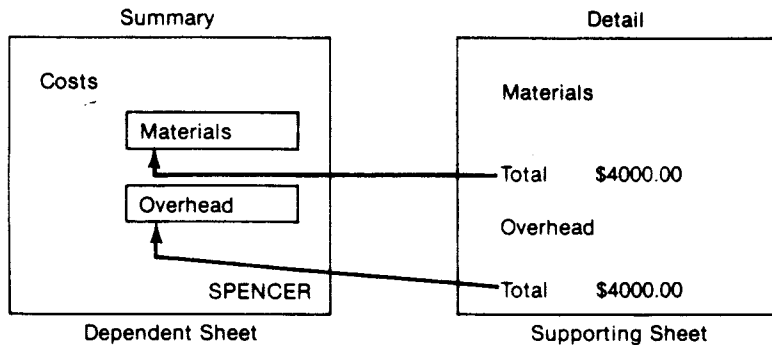

Sheets that provide data for another sheet are called supporting sheets: they support the calculations of the other sheet by providing data to it. Sheets that use data from other sheets are called dependent sheets: they depend on the data of other sheets for their calculations.

Once a supporting worksheet has been set up, named cells on the supporting sheet may be copied to the dependent sheet.

If, for example, a cost figure changes on the supporting sheet, related numbers on the summary (dependent) worksheet will change as well, the next time the summary sheet is loaded.

THE TRANSFER CLEAR COMMAND

Use the Transfer Clear command to clear the screen so that you can build a new worksheet.

Note: The Transfer Clear command clears the sheet of all numbers, text, name definitions, and other information. It prepares a completely new sheet. The information on the screen is destroyed and can only be recovered if it has been saved. Therefore, if you have entered any new information you want saved since you loaded the sheet, be sure to save it before using Transfer Clear.

Press **T, C, Y**. Your screen will look just as it does when you first start up Multiplan.

BUILDING A SUPPORTING SHEET

It is not necessary to construct an elaborate supporting sheet to illustrate how Multiplan draws from other worksheets.

For this sheet, you need to set the default column width to 10. Press **F, D, W, 10, ENTER**. Also set the default cell format to \$. Press **F, D, C, TAB (CTRL A)** to code, **SPACE BAR** to \$, **ENTER**.

Before you continue with the new figures, a summary of the process of connecting worksheets will give you an idea of what's to come.

First, you build a supporting sheet to calculate the values you want to use in your work on the summary (dependent) worksheet.

Second, Name the groups of cells that contain the values you want to use.

Third, Transfer Save the supporting sheet.

Fourth, Transfer Load the dependent sheet.

Fifth, eXternal Copy the named cells from the supporting sheet.

Build the supporting sheet, using the following sample worksheet as a guide. On your supporting worksheet, enter only the data that is circled:

#1	1	2	3
1		January	February
2	Material		
3		Clay \$1500.00	
4		Glaze \$1500.00	
5		Brushes \$500.00	
6		Sponges \$200.00	
7		Plaster \$300.00	
8	Total	\$4000.00	
9			
10	Overhead		
11		Utilities \$1100.00	
12		Rent \$2500.00	
13		Telephone \$200.00	
14		Water \$200.00	
15	Total	\$4000.00	
16			
17			
18			

COMMAND: Alpha Blank Copy Del Edit For
Go Help Ins Lock Move Name Opt Print
Quit Sort Trans Value Window Xtern
Select option or type command letter
R15C2 4000 94% TEMP

Because you will use only the total costs of materials and overhead on the summary sheet, you need to set up only the totals of those two main categories, using row 8 for *Total Material Costs* and row 15 for *Total Overhead Costs*.

On the *SPENCER* worksheet, we projected a 1% increase in sales each month. We know that costs will increase as sales increase. Include these increases in your worksheet. Starting with February, enter a formula increasing total costs in each category by 0.8% ($RC[-1]*100.8\%$). Copy these formulas to the right 10 cells.

To enter the formula in both cells, go to R8C3 and press = LEFT, * 100.8%, ENTER, G, R, 16, TAB, 3, ENTER, C, F, R8C3, and ENTER.

To copy these formulas to the right ten times, press C, R, 10, TAB, R8, 15C3, and ENTER.

#1	1	2	3
1		January	February
2	Material		
3			
4			
5			
6			
7			
8	Total	\$40000.00	\$4032.00
9			
10	Overhead		
11			
12			
13			
14			
15	Total	\$4000.00	\$4032.00
16			
17			
18			

COMMAND: **Alpha** Blank Copy Del Edit For
 Go Help Ins Lock Move Name Opt Print
 Quit Sort Trans Value Window Xterm
 Select option or type command letter
 R15C3 RC[-1]*100.8% 94% TEMP

You need to name two groups of cells before you connect this worksheet with the *SPENCER* summary worksheet. The connections between worksheets are made through defined names. You will recall that you already defined names on the *SPENCER* worksheet: *Sales*, *Material*, *Labor*, and *Overhead*.

Use the same process here to define names on the supporting sheet for the two groups of cells that you will copy to the *SPENCER* worksheet.

For now, define *Materialcosts* to refer to R8C2:13.

Move the cell pointer to R8C2.

Press N.

Type **Materialcosts**.

Press TAB (CTRL A).

Press : (colon).

Type 13.

Press ENTER.

And, define *Overheadcosts* to refer to R15C2:13.

Move the cell pointer to R15C2.

Press **N**.

Type **Overheadcosts**.

Press **ENTER**.

Now, you will want to save this worksheet with a name that indicates a relationship between the supporting (detail) sheet and the dependent (summary) sheet. The next section describes one way to name related worksheets.

NAMING RELATED WORKSHEETS

Each supporting worksheet must be given a name and saved in a file. That filename is used with the *eXternal* command to make the data accessible to dependent sheets. Multiplan is able to find any worksheet on the diskette being used, but giving the sheets related names makes it easier to keep track of them and use them quickly and accurately.

You named the first worksheet *SPENCER*. Using a form of that name for related worksheets (which are also files once they have been saved) will help you to recognize later which sheets belong together. It is helpful to capitalize the names of the sheets to distinguish them from cell names, but it is not essential. If necessary, refer to the discussion of filenames in the "Operating Information" section at the beginning of this manual.

To name a supporting sheet, you could follow this procedure:

1. Use the general filename first (or some abbreviation of it).

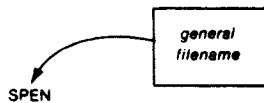

2. Next, append an additional name or abbreviation to create the supporting filename (a name that quickly identifies the worksheet to you as a supporting worksheet of the main worksheet).

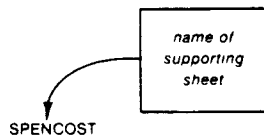

On your data diskette, Transfer Save **SPENCOST** for the next section.

THE EXTERNAL COPY COMMAND

Transfer Load *SPENCER*.

Move the cell pointer to R6C2.

The eXternal command is selected by pressing X (for “eXternal”). Press X.

```
EXTERNAL: Copy List Use
Select option or type command letter
R6C2 4000                               89% SPENCER
```

Press C or ENTER to select “Copy.” The command line should look like:

```
EXTERNAL COPY from sheet: 
name:                               to: R6C2
linked: (Yes)No
Enter filename
R6C2 4000                               89% SPENCER
```

In the first field (“from sheet”), type the name of the supporting sheet from which you want to copy information. Type *SPENCOST*.

```
EXTERNAL COPY from sheet: SPENCOST 
name:                               to: R6C2
linked:(Yes)No
Enter filename
R6C2 4000                               89% SPENCER
```

TAB (CTRL A) to the second field (“name”). Type the name of the group of cells you want to copy to the active cell. Type *Materialcosts*.

```
EXTERNAL COPY from sheet: SPENCOST
name:Materialcosts  to: R6C2
linked:(Yes)No
Enter name on external sheet
R6C2 4000                               89% SPENCER
```

Notice that the third field (“to”) proposes the active cell as the beginning of the area to receive the copied information. This is the correct response because you positioned the cell pointer before starting to use the eXternal command.

The proposed response in the “linked” field is “Yes.” This means that a permanent connection will be set between *SPENCER* and *SPENCOST*. You want a permanent connection between worksheets whenever you will put the current figures on one worksheet but want the summary to be on another, as you have been doing with *SPENCOST* (current figures) and *SPENCER* (summary).

Leave the “Yes” response as is; press ENTER.

Something’s wrong! In the message line you see: “Cannot copy into non-blank cell.”

The eXternal Copy command, unlike the regular Copy commands, only copies into blank cells to protect the information on the active sheet from inadvertent elimination. So, you must first blank out the cells in row 6.

Press B (for Blank). Press : (colon). Press the RIGHT direction key until the cell pointer reaches column 13. Press ENTER. The cells in row 6, columns 2 through 13, should be blank.

Now, use the eXternal Copy command again, as previously described.

1. Press **X**.
2. Press **C**.
3. Type **SPENCOST**.
4. Press **TAB (CTRL A)**.
5. Type **Materialcosts**.
6. Press **ENTER**.

Press **PAGE RIGHT (CTRL D)** to see the changes brought about by *SPENCOST*. Press **PAGE LEFT (CTRL S)** to return to column 2.

The message line shows the name of the supporting sheet and the defined name of the cells copied.

```
COMMAND: Alpha Blank Copy Del Edit For
Go Help Ins Lock Move Name Opt Print
Quit Sort Trans Value Window Xtern
Select option or type command letter
R6C2 [SPENCOST Materia 88% SPENCER
```

Now, Name the area. Press **N**.

Note: Names longer than the line will hold continue on the next line.

```
NAME: define name: SPENCOST.Materialco
sts to refer to: R6C2:13
Enter name
R6C2 [SPENCOST Materia 88% SPENCER
```

Multiplan proposes to define the name *SPENCOST.Materialcosts* to refer to R6C2:13, the area that received the values. To define the name, simply press **ENTER**.

When the Name command is used immediately after an eXternal Copy command, Multiplan proposes the response in the "name" field of the eXternal Copy command as the name to be defined. This makes it easy to define names for the cells that receive values from another worksheet. Simply press **N**, then **ENTER** as soon as you finish each eXternal Copy command. This is the only time the name on the supporting sheet is proposed as a name on the active sheet.

Now, let's copy information from *SPENCOST* for Overhead costs. Move the cell pointer to R8C2.

Remember: you must first blank out the cells that will receive the values from another sheet. Press **B**, then **:** (colon). Type **13**. Press **ENTER**.

Now, press **X** (for eXternal), then **C** (for Copy).

Notice that Multiplan proposes the name of the last worksheet named, *SPENCOST*, so all you have to do now is **TAB** to the "name" field. Press **TAB (CTRL A)**.

Type **Overheadcosts**.

As before, the responses in the "to" and "linked" fields are correct.

Press **ENTER**. Press **PAGE RIGHT (CTRL D)** to see the changes brought about by *SPENCOST*.

Once again take advantage of the proposed responses for the Name command just after an eXternal Copy command. Press N.

```

NAME: define name: SPENCOST.Overheadoo
sta to refer to: R8C2:13

Enter name
R8C2 [SPENCOST Overhea 86% SPENCER
  
```

Press ENTER.

The relation between *SPENCER* and *SPENCOST* is not permanent until you save the active sheet (*SPENCER*). Multiplan will record the dependency—established with the eXternal Copy command—in both saved sheets. After you have saved *SPENCER*, *SPENCER* will always depend on *SPENCOST*, and *SPENCOST* will always support *SPENCER*. If you don't save *SPENCER* before you start work on another sheet or before you Quit Multiplan, you will have to redo the eXternal Copy commands when you next load *SPENCER*. Save the *SPENCER* worksheet now.

REVISING A SUPPORTING SHEET

Now, you might like to experiment with the *SPENCOST* supporting sheet to see how revisions on it affect the *SPENCER* summary sheet.

Transfer Load *SPENCOST*.

Move the cell pointer to R15C2.

Type 5000.

Press ENTER; the values for the total of overhead should change.

#1	1	2	3
1		January	February
2	Material		
3			
4			
5			
6			
7			
8	Total	\$4000.00	\$4032.00
9			
10	Overhead		
11			
12			
13			
14			
15	Total	\$5000.00	\$5040.00
16			
17			
18			

COMMAND: **Alpha** Blank Copy Del Edit For
 Go Help Ins Lock Move Name Opt Print
 Quit Sort Trans Value Window Xtern
 Select option or type command letter
 R15C2 5000 93% SPENCOS

Now Transfer Save *SPENCOST*, pressing Y to confirm overwriting the old file.

Transfer Load **SPENCER**. When the *SPENCER* worksheet is displayed, you'll see that *Overhead* shows \$5000.00 for January and the appropriate amounts for the other months.

If, when you used the eXternal Copy command, you had responded "No" in the "linked" field, the *SPENCER* worksheet would not have been affected by the revisions to *SPENCOST*. You will want to select "No" in the "linked" field whenever the data you copy will never change or, if it does change, you don't need the change reflected on the "dependent" worksheet.

For example, suppose you want to set up the *SPENCOST* worksheet with all the month titles across the top, not just January and February as it is now. *SPENCER* already has all the months entered. Instead of typing each month title again, simply use the eXternal Copy command without linking (select "No" in the "linked" field). The steps would be: Transfer Load *SPENCOST* and Blank January and February (R1C2:3).

Press **X** then **C**. Type **SPENCER**. Press **TAB (CTRL A)**. Type **R1C2:13** (the range of cells that contain the titles you want). Press **TAB** twice (we're assuming the cell pointer is at the first destination cell). Press **N** and then **ENTER**.

The month titles will appear across the top of the sheet.

If you do this example, Transfer Save *SPENCOST*; then Transfer Load *SPENCER*.

DISSOLVING CONNECTIONS BETWEEN WORKSHEETS

At some time you may want to dissolve the connections between worksheets. This process is very similar to building the connections. Let's delete the connection with *Materialcosts*. First, position the cell pointer at R6C2.

Select the eXternal Copy command; press **X**, then **C**. The "from sheet" field should show the name of the worksheet last copied in this case, **SPENCOST**.

```
EXTERNAL COPY from sheet: SPENCOST
name:                               to: R6C2
linked:(Yes)No
Enter filename
R6C2 (SPENCOST Materia      86% SPENCER
```

Press **TAB (CTRL A)** to move to the "name" field.

Type the name of the group of cells you want to delete. In this case we are deleting the connection with *Materialcosts*. Type **Materialcosts**.

```
EXTERNAL COPY from sheet: SPENCOST
name:Materialcosts  to: R6C2
linked:(Yes)No
Enter name on external sheet
R6C2 (SPENCOST Materia      86% SPENCER
```

Press **TAB (CTRL A)** to move to the "to" field. The entire proposed response is highlighted.

```
EXTERNAL COPY from sheet: SPENCOST
name: Materialcosts to: R6C2:13
linked:(Yes)No
Enter reference to cell(s)
R6C2 (SPENCOST Materia      86% SPENCER
```

Press the **DELETE** key (**FCTN 0**); the response disappears.

```
EXTERNAL COPY from sheet: SPENCOST
name: Materialcosts to: 
linked:(Yes)No
Enter reference to cell(s)
R6C2 SPENCOST Materia      86% SPENCER
```

Now, press **ENTER**, and the values disappear from row 6.

The name you defined after using the eXternal Copy command to copy *Materialcosts* is still a defined name on the active worksheet. If you want to delete the definition for the sake of tidiness, use the Name command now. Press **N**.

Multiplan proposes *SPENCOST.Materialcosts* as the name to be defined. Notice that the “to refer to” field is blank. All you have to do to delete the definition of *SPENCOST.Materialcosts* as a name is press **ENTER**.

THE EXTERNAL LIST COMMAND

You may review the connections between worksheets by using the eXternal List command. Press **X** and then **L**, and the table disappears while the list is displayed.

The eXternal List command displays what Multiplan knows about the relationship between the various sheets. The list of “sheets supporting” shows the names used in the present sheet that call for values from other, saved sheets. The list of “sheets depending on” shows the names of other, saved sheets that call for a value or values from the active sheet.

Notice that *SPENCOST* supports *SPENCER*, but not vice versa because the copy of the month titles was not a permanent link.

Press any key to redraw the active sheet (to see table again) on the screen.

Once you have entered all of the detail information in new worksheets, named the cells you will need, and saved the sheets, you will be able to use the eXternal Copy command to copy information from as many of these related sheets as you need to supply information to the active (dependent) sheet.

The example of Spencer Ceramics is completed.

ADDITIONAL COMMANDS

There are commands which were not used at all for the *SPENCER* worksheet.

- Delete
- Move
- Sort

The Delete command is similar to the Blank command, but it does more. Blank does not affect the position of cells on the sheet, but Delete completely removes cells. The other cells shift to close the gap left by the removal of cells due to Delete.

The Move command applies the relocation of cell contents. If you wish to move a row of numbers—or even one cell—to a different location, the move command removes it from its old location and slips it into its new location. The cells between the former location and the new placement shift to close the gap left by the removal of cells.

Delete and Move are best learned by experimentation with Multiplan.

Sort places a range of rows in alphabetical and numeric order. The order may be ascending or descending, and it may be based on any column of the rows involved. Suppose you had a list of telephone numbers for various associates. You could sort them by first name, last name, number, or address just by choosing the appropriate column to sort by (as long as each person’s information is entered in an organized cell grouping, such as first name in column 1, last name in column 2, etc.).

SUMMARY

In this session you learned:

- How worksheets interrelate.
- How worksheets provide data to and/or take data from other worksheets.
- How to clear the screen, using the Transfer Clear command.
- How to build supporting sheets.
- How to define names on supporting sheets.
- How to name related worksheets for easy identification.
- How to use the eXternal Copy command.
- How to revise supporting sheets.
- How to dissolve connections between worksheets.
- How to review the relationships between sheets, using the eXternal List command.
- Some additional commands.

LEARNING MORE ABOUT MULTIPLAN

There are other tasks and other problems to be solved that require additional commands and functions. Multiplan provides them.

Multiplan is described completely in Part 2, "Reference to Multiplan." In Part 2, you'll find descriptions of additional options and uses for familiar commands like:

- Copy
- Format
- Goto
- Lock
- Options
- Print
- Transfer
- eXternal

Multiplan provides mathematical, financial, and statistical functions for calculations and problem solving. So far you've only seen SUM.

In addition, in Part 2 you'll find descriptions of additional editing keys that make building a worksheet easier. And you'll find an alphabetical list of all the messages Multiplan can display on the message line. An appendix of "Helpful Hints" suggests ways to save time and space while using Multiplan.

Now that you've learned how to use Multiplan in Part 1, you can use Part 2 to explore the full potential of Microsoft Multiplan.

Part 2:

Reference to Multiplan

Chapter 8: Elements of Multiplan

- The Microsoft Multiplan Worksheet
- Entering Commands
 - Selecting a Command
 - Selecting Responses for the Command Fields
 - Proposed Responses
- Editing
- Formulas
 - Numbers
 - Text
 - References to Cells
 - Absolute References
 - Relative References
 - Names
 - Intersection Operator
 - Range Operator
 - Union Operator
- Logical Values
- Error Values
- Files
 - File Handling
 - Problems with File Access
 - Problems When Reading
 - Problems When Writing
 - External Relationships
- Transforming the Worksheet

This chapter is divided into six sections that describe Multiplan structure, features, and operation. The commands, functions, and messages are covered only generally in this chapter. There is a separate chapter on commands, on functions, and on messages to describe each in detail.

THE MULTIPLAN WORKSHEET

The worksheet is a rectangular arrangement of intersecting rows and columns. The sheet may be up to 63 columns wide and 255 rows long. An area one column wide by one row high is called a cell.

Each cell possesses both a value that may be displayed on the Multiplan screen and a formula for computing that value. This formula may be as simple as the number 19.95, or it may be more complex, containing functions and references to other cells—for example, “previous cell times growth rate.”

The potential dependence of the value of one cell on the values in other cells is the key idea behind the worksheet. When cells have been connected by references among them, a change in one cell (for example, changing 19.95 to 18.50) causes Multiplan to calculate the effect of the change on all other cells. This process is called “recalculating the worksheet.” Recalculation may be automatic after every change, or it may be turned off (see Options command, Chapter 9). If automatic recalculation is turned off, recalculation takes place only when you press the **RECALC** key (**FCTN 8**).

The order of calculating the cells is automatically chosen by Multiplan so that the calculation of a cell precedes the calculation of other cells that depend on it. If such an order is impossible, the “Circular references unresolved” error message is displayed.

The Multiplan screen is a movable “window” through which to view part of the worksheet. When Multiplan starts, only one window is open. You may open up to eight windows to the worksheet. Each window opened is given a consecutive window number. For the following discussion, assume that only one window is open, just as when you start a Multiplan session.

Across the top of the window are column numbers. Down the left edge of the window are row numbers. The row and column numbers tell you what area of the worksheet you are viewing.

One cell within the window is highlighted. The highlight is called the cell pointer, and it points to the “active cell.” Many operations do something with the active cell.

Across the bottom of the screen are five lines of text. The top three lines are called the command line. The actions you want Multiplan to perform are selected from these commands. The command line is discussed more in the “Entering Commands” section. The commands are described in Chapter 12, “Command Directory.”

Just below the command line is the message line. The message line shows either an error message or a prompt message. An error message indicates what the problem is. A prompt message indicates in general terms your next step in entering a command. The prompt message changes as you work your way through a command. See the “Entering Commands” section for more information about command entry and the “Message Directory” for explanations of message line messages.

The bottom line on the screen is called the status line. Here, Multiplan displays the position of the cell pointer, the current contents of the active cell, the percent of free memory, and the name of the active sheet.

The position (row number and column number) of the active cell is shown first on the status line. The formula used for calculating the value of the active cell is shown next to the coordinates. When the contents of the active cell are text or numbers, the status line shows the text in double quotes or the number itself.

The cell pointer can be moved around by using the direction keys.

UP moves the cell pointer towards the top of the window.

DOWN moves the cell pointer towards the bottom of the window.

LEFT moves the cell pointer towards the left edge of the window.

RIGHT moves the cell pointer towards the right edge of the window.

When the cell pointer reaches the edge of the window, the window begins to move across the worksheet one cell at a time. This is called scrolling. Attempting to scroll past the edge of the worksheet leaves the cell pointer at the edge of the worksheet and causes the console to beep.

The page keys scroll across the worksheet a whole windowful at a time in the direction selected.

The HOME key may be used to go to row 1 column 1 quickly. The LOWER RIGHT key may be used to go to the last row and last column of the active area of the worksheet. The active area is the smallest rectangle that encompasses the cell in the upper left corner of the worksheet (row 1 column 1, referred to as R1C1) and the last cell to the right and down that has been given contents or formatting. When Multiplan starts, HOME and LOWER RIGHT are both at R1C1.

ENTERING COMMANDS

You direct Multiplan to perform the tasks you want done by entering commands. The commands are described individually in Chapter 9, "Command Directory." This section describes the methods of command entry.

You select a command when the main command menu is on the screen. The main command menu shows the choice of commands:

```
COMMAND: Alpha Blank Copy Del Edit For
          Go Help Ins Lock Move Name Opt Print
          Quit Sort Trans Value Window Xtern
```

When this menu is on the display, Multiplan is waiting for you to select a command. When Multiplan is computing, the main command menu is not visible, and no message appears on the message line. When the main command menu reappears, Multiplan is ready for more commands.

Some of the main commands have subcommands. In these cases, when the main command has been chosen, the main command menu is replaced with a subcommand menu.

Remember: the message line shows a prompt message that indicates your next step in entering the command. See Chapter 11, "Message Directory," for descriptions of these messages.

To enter a command:

1. Select an active cell (move the cell pointer to the appropriate cell), if required by the command to be selected.
2. Select a command.
3. Select responses for the command fields. The responses are used to specify where to Goto, what to Format, where and how to split windows, and so forth.
4. Press **ENTER** to carry out the command. Or press **CANCEL (CTRL C)** during the first three steps to cancel the command.

Selecting the active cell is described in the section entitled "The Multiplan Worksheet." Steps 2 and 3 are described below.

Selecting a Command

When you are prompted to select an option from a menu, select in one of two ways:

1. Type the first letter of the option you want.

or

2. Use **SPACE BAR** and **BACKSPACE** to move the highlight to the appropriate command word. **SPACE BAR** moves the highlight to the right, **BACKSPACE** to the left. Press **ENTER**.

When you have selected a command, Multiplan displays the main command name followed by either a subcommand menu or one or more command fields. Typically, a new subcommand menu will follow selection of a main command. Select a subcommand as you would a main command.

The command line shows the command and subcommands you have already selected in capital letters. For example:

```
WINDOW: Split Border Close Link
```

If "Split" is selected, the command line changes to:

```
WINDOW SPLIT: Horiz Vertical Titles
```

Continue selecting subcommands until the command fields are displayed. The names of command fields are shown in lower-case letters followed by a colon. For example:

```
WINDOW SPLIT HORIZONTAL at row: 7  
Linked: Yes[No]
```

This command line has two fields: the "at row:" field and the "linked:" field. Note that the "linked:" field contains a small menu.

Selecting Responses for the Command Fields

The next step is to enter responses for the command field or fields. There may already be responses in the fields. These are responses proposed by Multiplan. If a proposed response suits your purpose, you need not enter a response in that field. In fact, if the proposed responses in all the fields are suitable, you can just press **ENTER** to carry out the command.

Entering responses proceeds field by field starting at the first one. A highlight indicates the "active" field (the field in which a response is being entered). Other fields will not contain a highlight. In this manual, highlighted responses are indicated by bold type.

To move the highlight from field to field, press the **TAB** key (**CTRL A**). Pressing the **TAB** key when the highlight is in the last field returns it to the first field.

The message line gives you messages prompting entries in the command fields. Whenever the message line starts with "Enter...", the field must be filled in. To "fill in" the field, either accept the proposed response or simply type the characters. For example:

```
TRANSFER LOAD file: INCOME
```

```
Enter filename [arrow for directory]
```

where *INCOME* was typed. In this case, there is only one field, and the **TAB** key is not needed. Simply press **ENTER** to carry out the command.

In certain fields, the direction keys may be used to view and select from a list of possible responses. The message line will indicate when the direction keys may be used. The **RIGHT DIRECTION** key will propose the next response on the list; the **LEFT**, the previous response. The **UP DIRECTION** key will propose the first response on the list; the **DOWN**, the last response.

When the message line shows "Select option," the field contains a menu of options. Select the option you want by either of the two methods used for selecting commands: either type the initial letter or use **SPACE BAR** and **BACKSPACE** to move the highlight to your choice. Note that when a command field with a menu is not active, the current option is shown enclosed in parentheses, as in the "linked" field in the example above.

Proposed Responses

The proposed response depends on the specific command; thus proposed responses are described with the commands in Chapter 9, "Command Directory." However, proposed responses follow a few general principles:

1. When a command field contains a menu, the "proposed" response is the current setting. For example, the Options command initially appears as:

OPTIONS recal: **Yes** No mute: Yes[No]

with the highlight on Yes showing the current setting in the "recalc" field and the parentheses showing the current setting in the "mute" field. Thus, the same menu may be used to inspect as well as select options in command fields.

2. In other fields, the proposed response will be the one entered the last time the command was used. This simplifies entering a series of related commands.
3. Other fields reflect the position or contents of the active cell. For this reason, positioning the cell pointer before selecting a command may be helpful.

All proposed responses may be edited by using Multiplan editing keys, described in the "Editing" section which follows.

EDITING

Microsoft Multiplan provides editing keys to edit responses in command fields. Multiplan editing can be used any time you are entering responses in command fields. To edit the contents of cells, move the cell pointer to the cell, use the Alpha command for cells with text or the Edit command for cells with formulas, and edit the proposed responses in the command line.

Either just after a command is selected or just after pressing the TAB key, the whole field containing a proposed response is highlighted.

To replace the proposed response, simply type the replacement. Multiplan automatically deletes the proposed response as you type the new one.

To delete the proposed response and leave the field empty, press **DELETE**. All text that is highlighted is deleted.

To append to the proposed response: For cell references (when the message line shows "Enter reference to cell or group of cells"), type a colon (:) or other operator. For other responses, press either the CHARACTER FORWARD key or the WORD FORWARD key, and then type the additional text.

Once the proposed response is altered, one character or word in the field is highlighted. This highlight is the edit cursor. The edit cursor may be moved to designate where or what to edit.

Use CHARACTER BACK, CHARACTER FORWARD, WORD BACK, and WORD FORWARD keys to move the edit cursor.

The CHARACTER BACK and CHARACTER FORWARD keys move the edit cursor left or right one character.

The WORD BACK and WORD FORWARD keys move the edit cursor left or right highlighting words or the space or punctuation between words. In formulas, the values and the operators are highlighted alternately.

To *insert* new text, type the text. It will be inserted in front of the edit cursor.

To *delete* text, use BACKSPACE to delete characters on the left side of the cursor. Use DELETE to delete what is highlighted by the cursor.

To *replace* text, delete the old text and type the new.

The following formula-editing keys simplify the typing of formulas. These keys all insert text in front of the edit cursor.

1. As you begin to enter a formula or just after you enter an operator, the direction keys (as well as the HOME and LOWER RIGHT keys) can be used to enter a relative cell reference of the form:

$R[\pm n]C[\pm m]$

in the field by pointing to the cell you want (see the "Formulas" section for an explanation of cell references, relative references, absolute references, and Names). As you move the cell pointer, the reference changes accordingly. The cell pointer returns to its original position as soon as any key other than a direction key is pressed.

2. The direction keys can be used to enter absolute references of the form:

$RnCm$

in fields that accept a cell reference (when the message line shows "Enter reference to cell(s)").

3. Relative references created with the direction keys (as described under item 1 above) may be changed to absolute references by pressing the REFERENCE key (CTRL 7) immediately after the direction keys.
4. Names may be entered by pressing the REFERENCE key first, then using the direction keys to step through the list of defined names.
5. Finally, a formula may be replaced with its resulting value by pressing the RECALC key (FCTN 8) after the formula is entered.

FORMULAS

Formulas are "recipes" for calculating values. When these values are displayed on the computer screen or printed on a printer, they compose the results of a Multiplan worksheet.

Multiplan works with different types of values, which are appropriate in different circumstances:

Value	Use
numbers	used for financial, statistical, scientific, and other calculations.
text	characters treated as words, including numbers in special displays, such as \$10.00 or 6/14/81. Text is always shown in double quotes ("text") in the status line.
references to cells	used to express dependency of a value in one cell on values in other cells on the worksheet. Groups of cells can be specified by "intersection," "range," and "union" operators.
logical values (<i>true</i> and <i>false</i>)	used in making conditional, "either-or" decisions.
error values	used as substitutes for values that cannot be calculated because of a mistake in a formula. For example, the "result" of division by 0 is an error value.

New cell values may be calculated by combining other values with the operators, described below under the topics "Numbers," "Text," and "References to Cells" or by using functions, such as MIN or MAX, described in Chapter 10.

The following sections describe each type of cell value.

Numbers

Numbers may be written as integers (123), as decimal fractions (123.45), or in scientific notation. In the latter case, an integer or decimal fraction (mantissa) is followed by the letter *E* and a positive or negative integer exponent. This notation multiplies the mantissa of the number by 10 raised to the given power. For example:

12.1E2 means 1,210 (12.1×10^2)
(note: + sign may be omitted)

1E - 5 means .00001 (1×10^{-5})

1.5E + 6 means 1,500,000 (1.5×10^6)

Percentages may be written as numbers followed by % (same as division by 100):

15% means .15 (15/100)

Numbers are calculated to a precision of 13 digits. In scientific notation, the exponent of ten can range from -63 to +62. This means that Multiplan's smallest positive nonzero number is:

$.1 \times 10^{-63}$

and its largest number is:

$9.999999999999 \times 10^{+62}$

Mathematical operators are the following:

Operator	Meaning
^	exponentiation. Calculated by the rule: $a^b = \exp(\ln(a) * b)$.
*	multiplication.
/	division.
%	percent. Written after the value and has the same meaning as /100.
+	arithmetic addition.
-	subtraction. May also be used in front of a value to denote "negative."

Operator precedence is: - (negative value) is evaluated first, then %, then ^, followed by * and /, then + and - (subtraction), and finally the logical operators described under "Logical Values" below. Parentheses may be used to alter the order in which Multiplan performs the calculation when more than one operator appears in a formula.

Chapter 10 describes Multiplan functions for performing mathematical, statistical, and financial calculations.

Text

A text value may contain up to 255 characters. Text is enclosed in quotation marks ("Text"). Text may not include a quotation mark as a character. For example,

"salary =" is 8 characters of text
"1.0" is also text, not a number

Two text values may be concatenated (linked) using the & operator. The result is a text value that consists of the left text immediately followed by the right. For example:

"\$" & "1.00" concatenate to form "\$1.00"

Chapter 10 describes functions that operate on or return text values. For example:

LEN(T) returns the number of characters in a text value.
MID(T,s,c) returns a specified part of a text value.

Functions are also provided for converting numbers into text and vice versa. For example:

FIXED(1,2) returns the text "1.00"
VALUE("0.1") returns the number .1

All the functions are described in detail in Chapter 10.

References to Cells

References to cells describe the location of one or more cells on the worksheet. References are the means of access to the values in cells.

A cell reference consists of a row reference and a column reference, in that order. (You can give cell references by entering the column reference followed by the row reference, but Multiplan stores the reference in row-column order.)

A cell reference indicates the place where a specific row and a specific column intersect.

For example, R4C3 is a reference to the cell at row 4, column 3. Assuming that this cell contains the value 5, the result of the formula R4C3 + 1 is 6.

		column				
		1	2	3	4	5
row	1					
	2					
	3					
	4			•		
	5					

R4C3 + 1 = 6

Cell Reference Gives Access to a Value

References may be written three ways:

- as an absolute reference
- as a relative reference
- as a name reference.

Absolute References

An absolute reference consists of the letters "R" and "C" and the actual row number and column number (as illustrated above).

The forms are:

Form	Meaning
Rn	row number n (1 – 255)
Cn	column number n (1 – 63)
Rn:m	all rows from n through m
Cn:m	all columns from n through m

Placing an R form and a C form together denotes the rectangle formed by the intersection of the rows and columns:

Form	Meaning
RnCm	single cell at row n, column m
Rn:mCp:q	a rectangle of cells

Relative References

A relative reference describes the location of another cell in terms of the location of the current cell. ("Current" means the cell that contains the cell reference.) A relative reference gives a direction by "+" for right or down or "-" for left or up and a number indicating how many rows or columns away from the current cell.

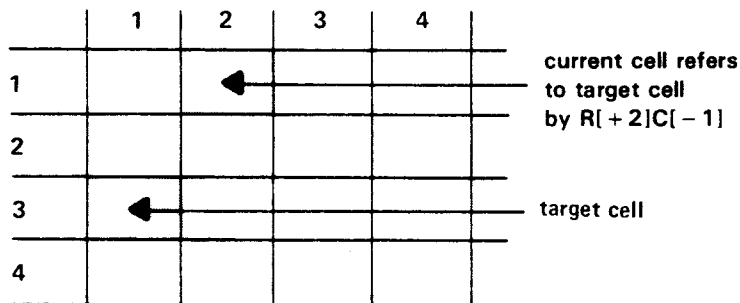

Relative Cell Reference

The "target" cell is 2 rows down from the current cell (+2) and 1 column left of the current cell (-1).

The forms of relative references are:

Form	Meaning
R	current row
C	current column
R[+ n]	the row that is n rows below R (the + may be omitted)
C[+ n]	the column that is n columns to the right of C (the + may be omitted)
R[- n]	the row that is n rows above R
C[- n]	the column that is n columns to the left of C

As for absolute references placing a relative R form and C form together denotes the rectangle formed by the intersection of the rows and columns.
For example:

Form	Meaning
RC[- 1]	the single cell just to the left of the current cell

The difference between absolute and relative references becomes apparent only when a reference is copied (see Copy command, Chapter 9). Absolute references always refer to exactly the same cell or cells in all of the copies. The cells referred to by relative references, however, are different for each copy:

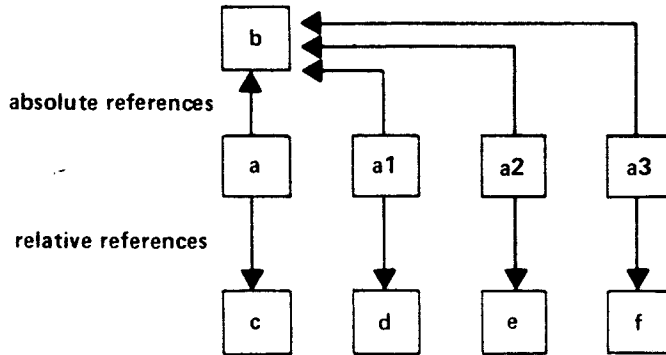

Comparison of Absolute and Relative References

If a reference in cell *a* is absolute and refers to cell *b*, the copied references in cells *a1*, *a2*, and *a3* will all refer to cell *b*.

If a reference in cell *a* is relative and refers to cell *c* as 3 rows down [+ 3], cell *a1* will refer to cell *d* (not cell *c*), cell *a2* will refer to cell *e*, and cell *a3* will refer to cell *f*.

Names

Names are words used to identify a cell or group of cells. A Name may be defined as an absolute reference with the Name command (see Chapter 9). The spelling rules for names are:

- Names must start with a letter,
- followed by letters, digits, periods, and underline () characters,
- up to 31 characters maximum.

Words that are the same as absolute or relative references (for instance, R1C1 or R) must not be used for names.

Once defined, a Name may be used as you would use any absolute reference. For example, you might define the name *Sales* to refer to R3C2:8.

The name of the reference suggests that the calculation involves sales figures. The absolute form, R3C2:8, is not mnemonically suggestive of sales figures. However, to the Multiplan program, the meanings are identical.

The name in the example above may be illustrated as:

	1	2	3	4	5	6	7	8
1								
2								
3	<i>Sales</i>							
4								
5								

Names as Cell References

Three operators may be used to combine references: intersection, range, and union.

Intersection Operator (Space)

The intersection operator is used to combine two references to refer to all the cells that belong to both references.

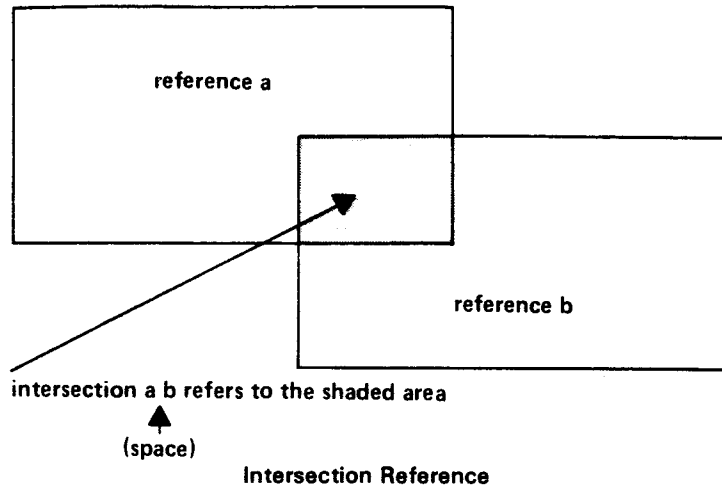

As a specific example,

R C3
↑
(space)

refers to the cell where the current row and column 3 intersect.

	C3	
R	R C3	

Relative - Absolute Intersection Reference

When reference forms are combined (that is, an absolute with a relative, an absolute with a name, a relative with a name, or a name with a name), the intersection operator must separate them to indicate access to the value or values where the two references intersect.

For example: RC3 is not permitted, write R C3 instead.

If the two references do not intersect, Multiplan returns a #NULL! error value.

Range Operator (Colon) (:)

The range operator is used to combine two references so that the values in a group of contiguous cells may be used.

The area of a range is the smallest rectangle that includes both references.

Typically, in a reference written as a:b, the *a* reference is in the upper left corner, and the *b* reference is in the lower right. For example:

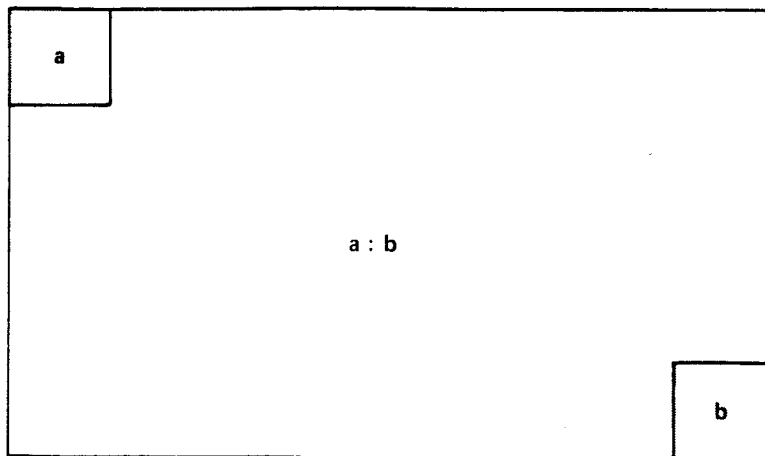

Range Reference

The range operator may be used to combine any of the reference forms (absolute, relative, or name) in any order.

Union Operator (Comma),)

The union operator is used to combine references to include all cells that belong to either reference. For example:

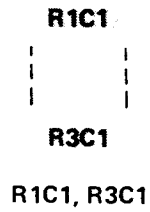

Each reference in a union may be any form (absolute, relative, or name), an intersection, or a range.

A union usually refers to cells that are not contiguous. Where a union describes contiguous cells, it describes a rectangle in the same way as a range reference. For example:

R1C1, R1C2 equals R1C1:2

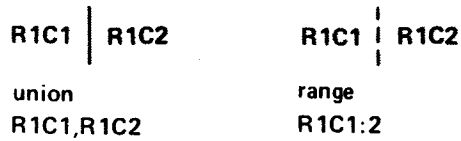

but R1C1, R3C1 does not equal R1:3C1.

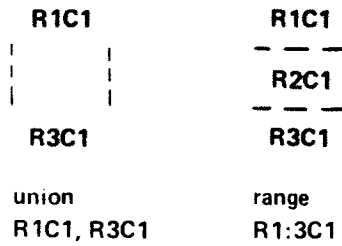

The range reference in the second example includes cells not specified by the union reference.

References may be used in formulas that require the value of a single cell. When the reference describes a single cell and a single value is required (for example, R1C1 + 1), the resulting value is the value of the cell described plus the value 1. (Note that this value may be a number, text, logical, or error value, depending on the value in the cell referred to.)

When the reference describes a group of cells but a single value is required, Multiplan chooses the value to be used from the cell where the current row or column intersects the group of cells. In particular, for groups that are parts of rows, Multiplan chooses the value in the current column. Similarly, from parts of columns, the value in the current row is chosen. The following figure illustrates a use for this feature. Using a group of cells that is not either a row or a column (or a part of one of these) does not yield useful results.

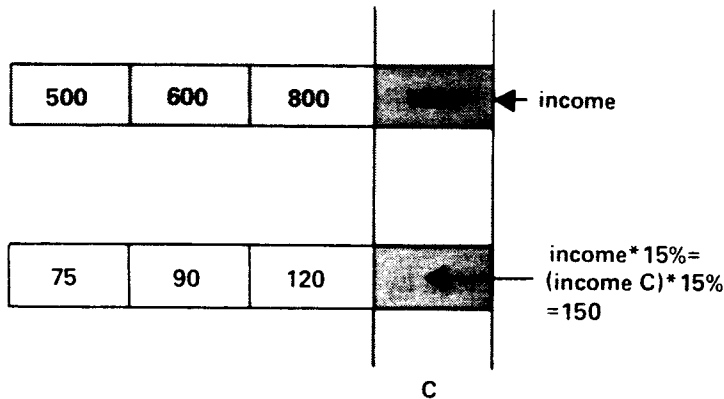

Single Value from a Reference to a Group of Cells

Chapter 10 contains descriptions of the functions that can process a collection of values. For instance, SUM(...) can be used to add all the values in a named area, in a list of cells, or in a range of cells. Any type of reference may be given as an argument (input) to such a function. The value of all the cells that are described, whether one or many, will be processed.

Note: The argument of a function—the expression given to the function for it to operate on—will appear as “...” in the next few pages.

Logical Values

The logical values true and false are returned by the comparison operators that compare two numbers:

Operator	Meaning
<	less than
< =	less than or equal
=	equal
> =	greater than or equal
>	greater than
< >	not equal

The functions AND(...), OR(...), NOT(...), TRUE(...), and FALSE(...) also perform logical operations.

The purpose of logical values is to make “either-or” decisions using the IF(...) function. All of these functions are explained in Chapter 10.

Note that text values cannot be compared except by the Sort command.

Error Values

When a Multiplan function, operation, or reference is used incorrectly, an error value results. There are different error values for different error conditions, as described below. Error values “propagate,” meaning that operations or functions resulting in error values in one cell will cause the same error values in all the cells that refer to the first cell. This also means that when an error value appears in a cell, the propagation has to be unraveled step-by-step until the source of the error is found.

For example, we notice that cell R1C1 displays the #NAME? (undefined name) error value. The formula in R1C1 is a + 1. We check the definition of a using the Name command. We find that the name a is defined to refer to R1C2. That cell is the next step in the search. When we look in cell R1C2, we may find the source of error, but we may also find references to other quantities which will have to be inspected. We may have to look at more than one cell to find the source of an error.

The error values and their causes are:

Value	Cause
#DIV/0!	result of an attempt to divide by 0.
#NAME?	result of an undefined label reference.
#N/A	result when the value is not available. Also, #NA is a special value that may be created using the NA() function and which will be propagated by arithmetic.
#NULL!	result of specifying an intersection of disjoint areas, e.g., R1 R2 (use union instead: R1,R2).
#NUM!	result of overflow (number is too large or too small) or of an illegal use of an arithmetic function, e.g., SQRT(-1).
#REF!	result of a relative reference reaching outside the sheet or of a reference to a deleted area.
#VALUE!	result of using text where a number is needed or vice versa, or of using references when a value is needed.

FILES

This section describes how Multiplan uses files, when it reads and writes files and how links between files are handled.

This information helps you to more effectively plan your use of Multiplan files.

File Handling

Files are permanent repositories of information kept on diskettes. Files are identified by filenames which are kept in a directory. Multiplan uses files mainly to store worksheets. (For more information on diskettes, see the section entitled "Operating Information.")

Multiplan can read and write files. For both operations, Multiplan requires access to the file.

However, the machine may have more than one disk drive and different files may reside on different diskettes. Therefore, it is important to make sure that the proper diskette is mounted in the proper drive.

See also the section entitled "Operating Information" and the Transfer Options command in Chapter 9 for details on reading and writing files.

Operations with multiple diskettes may require some advance planning. Should the planning fail, however, Multiplan will simply display the message:

Enter Y to retry access to *filename*

When you see this message, it may be necessary to replace the diskette, if it does not contain the file.

The following lists describe when Multiplan reads files, when it writes files, and what problems Multiplan may have with reading and writing files. This information may help you anticipate file access by Multiplan.

Multiplan reads files:

1. When a sheet is loaded (Transfer Load command) in any mode (Normal, Symbolic, Other).
2. When a sheet is loaded that has supporting sheets. The supporting sheets are read one by one.
3. When the eXternal Copy command is executed. The source sheet is read.
4. When the eXternal Use command is executed. The affected copies are redone, and the source sheets are read. (See the eXternal Use command in Chapter 9.)
5. When commands are executed or Help is requested. The Multiplan system diskette is read for parts of the Multiplan program.

Multiplan writes the file to the diskette:

1. When a sheet is saved (Transfer Save command) in any mode.
2. When a sheet is renamed or deleted. The file directory is read or written. The file directory shares the diskette with the worksheet files.
3. When the Print File command is executed.
4. When sheet-linking relationships change. A Transfer Save or Transfer Rename command, in addition to normal duties, gains access to all supporting sheets to issue or to revoke receipts.

Problems with File Access

If problems with file access persist, check for possible causes from the following lists.

Problems When Reading

1. The information may not be on the diskette. Use the Transfer Load command and the direction keys to display the directory of files on the diskette.
2. The information is not reliably readable or is unreadable. You should maintain backup copies of important files.
3. The information is not in the expected format. Check the "mode" setting of the Transfer Options command. The eXternal Copy command requires that sheets be saved in Normal mode.
4. The information is not up to date. This may happen if incorrect procedures are used for updating a collection of externally linked sheets. See the section, "External Relationships," for details.

Problems When Writing

1. The diskette may become filled. Diskettes can store only a limited amount of information. As more files are stored on them, they may fill up. The *Disk Memory System Manual* contains a program for determining the amount of space used on a diskette.
2. Previous information stored in a file may be valuable. Multiplan will ask you:
Overwrite existing file?
Pause and decide if this is what you want.
3. The diskette may be write-protected by a piece of adhesive foil covering a notch on the edge of the diskette. Consider the reason for write-protection before removing the foil.
4. Errors during writing, such as an interruption, may leave incorrect information on the diskette. Make sure that write operations are completed without interruption.

External Relationships

The information in this section applies to the eXternal group of commands. Refer to the discussion of these commands in Chapter 9 for additional information.

External relationships between worksheets may be illustrated as follows:

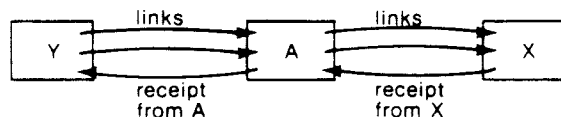

Active Sheet

Sheets
depending
on Y

A

Sheets
supporting A

Y

Sheets
supporting X

A

Sheets
depending
on A

X

External Relationships between Worksheets

The set of external links can be reviewed by stepping through the supporting sheet names and the source and target areas in the eXternal Copy command.

Changing data on a supporting sheet has no immediate effect on its dependent sheets. When a dependent sheet is loaded, the current information is read from its supporting sheet. Thus, when changes are made to sheet Y, nothing changes on sheet A until sheet A is loaded. When sheet A is loaded, then sheet Y is read, and its data is copied to sheet A.

Similarly, when sheet A is changed (including changes from sheet Y), sheet X does not change until it is loaded. When sheet X is loaded, then sheet A is read, and its data is copied to sheet X. Note that for the information read from A to X to be current with the information on Y, A must have been loaded *and saved* at least once before X was loaded. Information is copied only one link at a time.

In a more complex set of worksheets, the relationships between the worksheets may be unraveled using the eXternal List command on each sheet and creating a dependency diagram similar to the one above.

Consistency of all data can be assured by starting with a set of sheets that are not supported by any sheets. Load and save a second set of sheets that depend on the set of unsupported sheets, and then load and save sheets that depend on the second set of sheets, and so on until all sheets have been loaded and saved.

This process is illustrated in the following diagram:

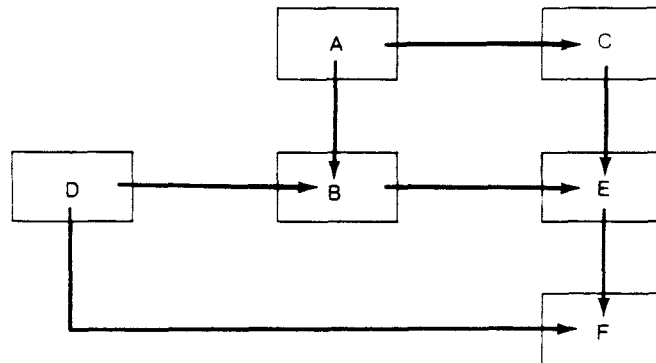

Dependency Diagram

Sheets A and D are not supported by any other sheets. If the information on them is current, then:

load and save sheets C and B,

load and save sheet E, and finally,

load and save sheet F.

When preparing the dependency diagram, remember that the list of “depending sheets” on each sheet is not necessarily complete. For example, the listing of sheets depending on A is contingent upon a “receipt” being issued when the link was established by B.

A “receipt” is an entry in the supporting file that says sheet B receives data from this sheet. When you give the eXternal List command, Multiplan looks at the receipts to build the list of “Sheets depending on.” The “receipt” must have been written correctly onto A just after B was saved. If, for any reason, Multiplan cannot enter the receipt onto sheet A, the “depending” list on A is not current. Even so, the data from the supporting sheets can be copied as specified by the eXternal Copy command.

The list of “supporting” sheets will always be correct.

TRANSFORMING THE WORKSHEET

The information in this section applies to the Delete, Insert, Move, and Sort commands. Refer to the discussions of these commands in Chapter 9 for additional information.

When rows or columns are inserted, deleted, moved, or sorted, sections of the worksheet may be displaced. For example:

1. One column is inserted before column 2. This moves the part of the worksheet that is to the right of column 2 one column farther to the right.
2. Row 2 is moved to before row 10. Besides moving the contents of row 2 to row 9, the former rows 3-9 are displaced one row toward the top of the sheet.

Because these commands may change the location of cells, Multiplan also automatically adjusts any references to the cells—whether they occur in formulas or in the definition of names. However, the adjustments to some references after the worksheet has been transformed may cause problems. The problems fall into the following general categories:

1. References to cells which have been deleted from the sheet are replaced by #REF! error values. All formulas that contained the references must be edited. These formulas are found by inspecting the cells that display the #REF! error value.
2. If the reference is to a group of cells that when transformed could change the rectangular group into a more complex shape (for example, if a corner cell is deleted from a rectangular area), the name definition is not changed.
3. If cells are inserted adjacent to a group of cells, references to the group are not updated to include the new cells. If an enlargement of the group is desired, the insertion must be made in the interior of the group rather than at the boundary. If necessary, the new cells may be inserted at an unambiguous place (e.g., in the interior of the group), with the cell contents copied as required.
4. Related problems may occur when rows or columns containing a group’s boundary are moved. Such moves will “slide” the boundary line defining the group. If this is not desired, the move can still be accomplished by an insert, copy, delete sequence.
5. If a formula is copied into a number of cells using the Copy Down, Copy Right, or Copy From commands, the relative references in all of the formulas are adjusted equally. The model formula for the adjustment is the first one encountered on the sheet. This means, for example, if the formula

$RC[-1]*1.05$

is copied from R1C2 to R1C14, and if column 5 is deleted, all formulas will be adjusted according to R1C2; no change in this case. However, if column 1 is deleted, the reference in R1C2 will become #REF! (see rule 1 above), and the other formulas will follow accordingly. To fix undesirable results, edit the model formula and recopy it.

Note that the Sort command may move many rows and, therefore, may cause any of these problems.

Chapter 9: Command Directory

Alpha	Name
Blank	Options
Copy	Print
Copy Down	Print File
Copy From	Print Margins
Copy Right	Print Options
Delete	Print Printer
Delete Column	Quit
Delete Row	Sort
Edit	Transfer
Format	Transfer Clear
Format Cells	Transfer Delete
Format Default	Transfer Load
Format Default Cells	Transfer Options
Format Default Width	Transfer Rename
Format Options	Transfer Save
Format Width	Value
Goto	Window
Goto Name	Window Border
Goto Row-col	Window Close
Goto Window	Window Link
Help	Window Split
Insert	Window Split Horizontal
Insert Column	Window Split Titles
Insert Row	Window Split Vertical
Lock	eXternal
Lock Cells	eXternal Copy
Lock Formulas	eXternal List
Move	eXternal Use
Move Column	
Move Row	

actory explains each Multiplan command.

of each command description, the complete menu for the command or
hown with proposed responses. In most cases, the proposed response is
osition and contents of the active cell. For consistency of reference, a
s used for proposed responses, as follows:

s the active cell

s the row number of the active cell

s the column number of the active cell

s the active window

s a description of proposed response; for example, (contents of RC)

ponses, usually numbers, are shown as they appear when the command is

ided are intended to give you a sample of the uses for the command. A short
ction to be performed precedes a command format with proposed responses
reate the example yourself, use any of the methods for entering responses
l line looks like the examples illustrated.

xecuted (carried out) by pressing the **ENTER** key.

commands are listed under the heading *See A/so*. Commands that offer
escribed only generally under the main command heading. Refer to the
ptions for the details of performing a particular action.

ALPHA

ALPHA: [contents of RC]

Enter text [no double quotes]

Description

Places text in the active cell. If the active cell already contains text, that text is the proposed response to the Alpha prompt.

The proposed response may be edited, but if you simply begin typing, the proposed response is replaced entirely.

The Alpha command is executed by pressing the **ENTER** key or any action key that moves the cell pointer, such as the direction keys.

The contents of a cell that contains text are displayed in quotation marks in the status line. Multiplan supplies these quotes automatically.

Alpha may not be used to blank a cell. Use the **Blank** command for this.

The Alpha command is highlighted in the command menu when Multiplan is idle. This means that:

- Alpha can be selected by pressing **ENTER**.
- If **ENTER** is pressed inadvertently, you may find yourself in the Alpha command.

Entering text or values in successive cells is made easier because of the following feature:

If either the Alpha or Value command is executed by an action key that moves the cell pointer, the cell pointer is moved accordingly, and Multiplan displays on the command line:

ALPHA/VALUE:

Enter text or value

The first character typed selects the standard Alpha or Value command. The command line changes to either ALPHA: or VALUE:.

The Value command is selected if you press one of the digits 0-9 or one of the characters = (equals), + (plus), - (minus), . (period), ((open parenthesis), or " (quotation mark). The characters selecting the Value command have the same effect as when selecting from the main command menu. This effect is described under the Value command in this chapter. All other characters select the Alpha command.

This process can be repeated for entering text, numbers, and formulas in successive cells until the **ENTER** or **CANCEL** key is pressed.

Example

To enter the text "*Net Profit*" into the active cell:

ALPHA: Net Profit

To enter the text *Spencer*, the text *Sales*, and the number *1000* in adjacent cells, press **A** (for Alpha), type **Spencer**, press the **RIGHT** direction key, type **Sales**, press the **RIGHT** direction key, type **1000**, and press **ENTER**.

See Also

Format Cells Continuous to permit the display of cell contents to cross a cell boundary.

Format Width to accommodate text within a column.

Name to create names for cells.

Value to enter numbers and formulas.

BLANK

BLANK cells: RC

Enter reference to cell[s]

Description

Replaces contents of specified cells with blanks. The proposed response permits quick blanking of the active cell.

The format of the cell is not changed. The cell is still available for storing values.

Names are not affected. If a cell was named before the Blank command was used, that name will still apply.

When a formula refers to a blank cell, its number value is taken as zero, or its text value is a blank.

Examples

To blank the cell in row 3 column 2:

BLANK cells: R3C2

To blank all cells in the area named *Sales*:

BLANK cells: Sales

To blank an irregular area:

BLANK cells: R1:6C1,R7:8

See Also

Delete to remove cells from the sheet entirely.

Transfer Clear to clear the entire sheet.

COPY

COPY: Right Down From

Select option or type command letter

Description

Presents a choice of ways to copy some cells into other cells. Both the contents and the formats of the source cells are copied. Source cells are not altered.

Copy Right copies one cell or a column of cells into cells to its right.

Copy Down copies one cell or a row of cells into cells below it.

Copy From is the general form and can be used for all copying on the active worksheet. Copy Right and Copy Down are included because they make a common copying task easier.

The subcommands are explained individually on the following pages.

See Also

Insert to add new cells between existing ones.

Move to move cells to other locations.

eXternal Copy to copy cells from an inactive worksheet.

COPY DOWN

COPY DOWN number of cells: 1
starting at: RC

Enter a number

Description

Copies the specified cell the number of times specified in the "number of cells:" field into the cells below it.

The proposed response for the "number of cells:" field is the number used in the last Copy Down or Copy Right command. The total number of identical cells will be the number specified plus one (for the original).

The command can also copy down a row of cells by specifying a row or part of a row in the "starting at:" field.

Examples

To copy the value and format of R1C1 into the 10 cells below it:

COPY DOWN number of cells: 10
starting at: R1C1

To copy the first five cells in row 1 into the next four rows below:

COPY DOWN number of cells: 4
starting at: R1C1:5

COPY FROM

COPY FROM cells: RC
to cells: RC

Enter reference to cell[s]

Description

Copies the contents of a cell or group of cells to another location on the sheet. Copy From is used, for example, when the source cells and the destination cells are not in the same row or column.

When there is only one source cell, the cell contents are copied into each destination cell.

When the source is a group of cells, the entire group is copied. When only one destination cell is given, but the source is a group of cells, the destination cell marks the upper left corner of the destination area.

In general, either the source or the destination should consist of a single cell.

In special circumstances, copying vectors can be accomplished. (A vector is a line of two or more cells, either in a row or in a column.) Copying from a row to a row or from a column to a column is allowed if the source and the destination are the same size. If copying is done from a row vector to a column vector, or from a column to a row, the resulting copy is a rectangle in which the source vector is copied, starting at each cell of the target vector.

The following diagrams illustrate the results of copying vectors, as described above:

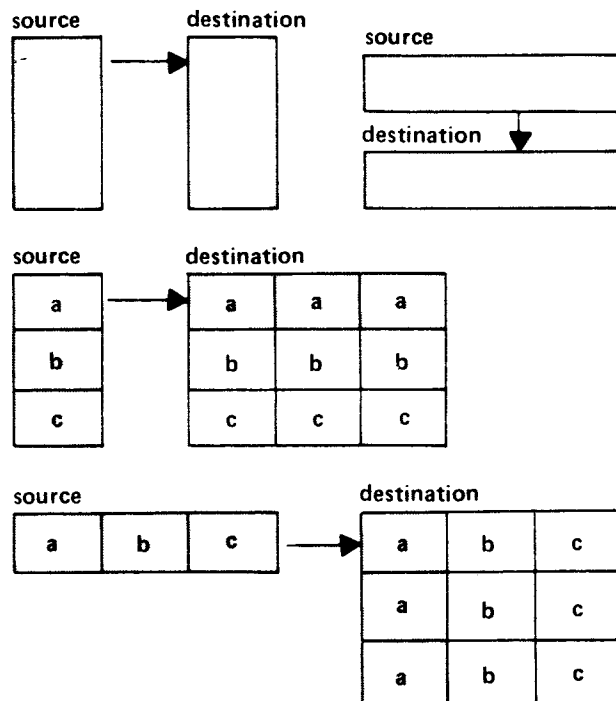

If other forms of copies are attempted, the system cancels the copy command and displays the "Illegal parameter" message.

Examples

To copy the contents of cell R1C1 into cell R5C3:

```
COPY FROM cells: R1C1
to cells: R5C3
```

To copy the contents of cell R1C1 into all cells in column 8:

```
COPY FROM cells: R1C1
to cells: C8
```

To copy a square patch of cells in the upper left corner of the worksheet into a square patch beginning at R8C1:

```
COPY FROM cells: R1:4C1:4
to cells: R8C1
```

The upper left cell of the new patch is R8C1. After the copying, R8C1 is a copy of R1C1; R8C2 is a copy of R1C2, and so on, to R11C4, which is a copy of R4C4.

Likewise, the same copy can be made by also specifying a destination area that matches the source area:

```
COPY FROM cells: R1:4C1:4
to cells: R8:11C1:4
```

To copy the first four cells in column three into column six:

```
COPY FROM cells: R1:4C3
to cells: R1C6 [upper left of area]
```

```
COPY FROM cells: R1:4C3
to cells: R1:4C6 [matching area]
```

To copy the first four cells in column six three times:

```
COPY FROM cells: R1:4C6
to cells: R1C6:8
```

The source cells are part of a column, and the destination area is part of a row. The source column is copied down, beginning at each cell of the destination.

COPY RIGHT

```
COPY RIGHT number of cells: 1
starting at: RC
```

Enter a number

Description

Copies the specified cell the specified number of times into the cells to the right of the specified cell.

The proposed response for the "number of cells" field is the number used in the last Copy Down or Copy Right command. The total number of identical cells will be the number specified plus one (for the original).

The command can also Copy Right a column of cells by specifying a column or part of a column in the "starting at" field.

Examples

To copy the contents of the active cell R1C1 into the 8 cells to the right of it:

COPY RIGHT number of cells: 8
starting at: R1C1

To copy the contents of the 5 cells in column 1 (R1:5C1) into column 2, giving two side-by-side columns with the same contents:

COPY RIGHT number of cells: 1
starting at: R1:5C1

DELETE

DELETE: Row Column

Select option or type command letter

Description

Presents choices for deleting cells from the worksheet and closing up the space.

Delete Row deletes a row or rows and moves the rest up.

Delete Column deletes a column or columns and moves the rest to the left.

Multiplan adjusts all references affected by any deletion. See "Transforming the Worksheet" in Chapter 8 for the description of how the Delete command affects references.

The subcommands are explained individually on the following pages.

See Also

Blank to make cells empty.

DELETE COLUMN

DELETE COLUMN # of columns: 1
starting at: C
between rows: 1 and: 255

Enter a number

Description

Deletes all or part of a column or columns. The proposed response for the starting column is the column of the active cell. This command is most commonly used to delete complete columns by accepting the proposed responses of rows 1 and 255.

Columns to the right of the deleted columns move left, and new columns of blank cells are added at the right edge of the sheet.

Parts of columns can be deleted. The deletion takes place between the specified rows; other rows are not affected.

Examples

To delete the entire column 4:

```
DELETE COLUMN # of columns: 1
  starting at: 4
  between rows: 1    and: 255
```

To delete a rectangular area in columns 3 and 4, between rows 3 and 8:

```
DELETE COLUMN # of columns: 2
  starting at: 3
  between rows: 3    and: 8
```

The portion of the worksheet in rows 3 through 8 which was to the right of column 4 will move two columns to the left.

DELETE ROW

```
DELETE ROW # of rows: 1
  starting at: R
  between columns: 1    and: 63
```

Enter a number

Description

Deletes all or part of a row or rows. This command is most commonly used to delete complete rows by accepting the proposed responses of columns 1 and 63.

Rows below those deleted move up, and new rows of blank cells are added at the bottom of the sheet.

The proposed response for the starting row is the row of the active cell.

Parts of rows can be deleted. The deletion takes place between the specified columns; other columns are not affected.

Examples

To delete the active row (R1):

```
DELETE ROW # of rows: 1
  starting at: 1
  between columns: 1    and: 63
```

To delete a rectangular area in rows 6 and 7 between columns 1 and 8:

```
DELETE ROW # of rows: 2
  starting at: 6
  between columns: 1    and: 8
```

The portion of the worksheet in columns 1 through 8 which was below row 7 moves up two rows.

EDIT

EDIT: [contents of RC]

Enter a formula

Description

Used to edit a formula or value in the active cell. If you edit text with the Edit command, remember to enclose the text in double quotes.

The current contents are shown in the command line. The edit cursor is placed at the end of the current contents.

After you have edited the cell's contents, press **ENTER** or a key that moves the cell pointer, such as a direction key, to put the contents into the cell. If you use a direction key to place the contents in the cell, Multiplan changes to the ALPHA/VALUE: command rather than returning to the main command menu. Refer to the description under the Alpha command.

To cancel your changes and return to the main command menu, press **CANCEL (CTRL C)** before pressing **ENTER** or a direction key.

If the cell contains a formula, Multiplan checks the formula for errors when **ENTER** is pressed. If the formula contains an error, the erroneous part is highlighted, and the Multiplan Edit command remains active.

See the "Editing" section in Chapter 8 for the description of the editing keys.

See Also

Alpha for entering or editing text.

FORMAT

FORMAT: Cells Default Options Width

Select option or type command letter

Description

Presents a choice of various display adjustments.

Format Cells alters the alignment and format of a cell or group of cells.

Format Default sets the default alignment, format, and width for all cells.

Format Options controls the display of formulas and of commas in numbers.

Format Width sets the width of a column or columns.

The display of cell contents is controlled by the settings in the “alignment” and “format” fields of the Format Cells command.

The setting in the “alignment” field controls the placement of the contents within the available spaces of the cell—whether the empty space is placed to the right, to the left, or on both sides of the contents.

The setting in the “format” field, together with the response in the “# of decimals” field, controls how the value is displayed: as a dollar amount, a percentage, a decimal value, and so on.

In both the “alignment” and “format” fields, there is a “Default” setting. The “Default” setting is defined by the Format Default Cells command. The settings selected in the “alignment” and “format” fields of the Format Default Cells command define the display of all cells with the “Default” setting.

All cells have the “Default” setting initially. (When Multiplan is first started, the display is controlled by “General” alignment and “General” format.) If you insert new rows or columns, the inserted cells receive the default setting.

The format given to the default settings can be changed at any time by using the Format Default command. This allows you to easily change the format of all cells that use the default setting (typically, the majority of the cells use the default).

We recommend that you define the default as the most common format you will be using in order to minimize the number of format alterations necessary. It is more efficient to set the format for most of the cells with one command and alter the exceptions than it is to individually format most of the cells and not take advantage of the default capabilities.

The subcommands are explained individually on the following pages.

See Also

Print Margins to set the format of a printed copy of the sheet.

FORMAT CELLS

FORMAT cells: RC align:[D]C G L R -
cd: [Def] Cont Exp Fix Gen Int \$ * % -
of decimals:

Enter reference to cell[s]

Description

Alters the alignment and format codes of one or more cells.

The proposed responses are the format codes of the active cell. This command may be used to review the settings for the active cell.

The settings of the active cell may be given to a group of cells by changing the response in the "cells" field.

If you are changing the alignment code of a group of cells but not the format code, you must select the hyphen response in the "format code" field to keep the format codes as they are. Otherwise, all cells in the group will receive the format code of the menu setting.

Similarly, if you want to change the format code but not the alignment code of a group of cells, select the hyphen response in the "alignment field."

The alignment codes are:

- D Default Align this cell by the default alignment.
- C Center Center the cell display in the column.
- G General Align text left, numbers right.
- L Left Left-justify the cell display in the column.
- R Right Right-justify the cell display in the column.
- Hyphen Leave all alignment codes as they are. Used when changing the format code of a group of cells, but not the alignment codes.

Text is displayed only for the width of the cell unless the Continuous format code is selected.

The format codes are:

Def	Default	Display this cell with the default format.
Cont	Continuous	Text longer than the column width is displayed at its full width, crossing into the column on the right if necessary (the cell to the right must be blank and must have the Continuous format also). Numbers are displayed as a decimal notation times a power of ten; for instance, 2.1E6 for 2100000. The number of decimal places used code.
Exp	Scientific	Numbers are displayed as a decimal notation times a power of ten for instance, 2.1E6 for 2100000. The number of decimal places used is set in the "# of decimals:" field of the Format Cells command.
Fix	Fixed point	Numbers are displayed rounded to a fixed number of digits of decimal fraction. The number of decimal places is set in the "# of decimals" field of the Format Cells command.
Gen	General	Numbers are displayed as precisely as possible in the available width of the cell, with scientific notation used automatically, as needed.
Int	Integer	Numbers with a decimal fraction are rounded to integers.
\$	Dollar	Money amounts are displayed with a leading dollar sign and two decimal places. Negative numbers are shown in parentheses.
*	Bar graph	<p>When the cell contains a number, it is rounded to an integer and that many asterisks are displayed. For example, all values between 2.5 and 3.5 are displayed as three asterisks.</p> <p>Use the Bar graph format code to build a bar graph. Negative numbers are shown in parentheses. Only as many asterisks as the width of the cell allows are shown. To see all asterisks, use the Format Width command to widen the cell.</p> <p>See also the REPT function for creating bar graphs composed of other characters.</p>
%	Percent	Numbers are displayed as a percentage. The number of decimals is set in the "# of decimals:" field of the Format Cells command. For example, the value .1 will be displayed as 10% if the # of decimals is zero; or as 10.0% if the # of decimals is 1.
-	No Changes	Leave all format codes as they are. Used when changing the alignment code of a group of cells but not the format codes.

The "# of decimals" field is used only for the Fix, Exp, and % format codes. If you enter a response to this prompt for the other format codes, your response is ignored. If you are not specifying one of these three format codes, you can simply press **ENTER** after specifying the format code.

Examples

To align the contents of the active cell R5C15 in the center of the available spaces:

```
FORMAT cells: R5C15    align: D(C)G L R -  
cd:[Def]Cont Exp Fix Gen Int $ * % -  
# of decimals: 0
```

To display cells in column 2, rows 3 through 6, as money values preceded by a dollar sign and displayed with two decimal places:

```
FORMAT cells: R3:6C2    align:[D]C G  
L R - cd: Def Cont Exp Fix Gen Int  
[$]* % - # of decimals: 0
```

Notice that the alignment of all cells in this group is now "Default." If any of the cells had an alignment setting other than "Default" and if you want to preserve the special alignment, select the hyphen response instead of the "Def" response in the "align" field.

To display the values in rows 1 through 12 of column 10 as percentages with four decimal places:

```
FORMAT cells: R1:12C10  align: D C G  
L R[-] cd: Def Cont Exp Fix Gen Int $  
*[%] - # of decimals: 4
```

Any alignment already specified for any of the cells in this group is retained.

See Also

Format Default to set the default format.

Format Width to set the width of specific columns.

FORMAT DEFAULT

FORMAT DEFAULT: Cells Width

Description

Presents a choice of two kinds of defaults to be changed.

Format Default Cells sets default alignment and format codes.

Format Default Width sets the default width of all columns.

See Also

Format Cells to alter the format and alignment codes of specific cells.

Format Width to alter column widths of specific columns.

FORMAT DEFAULT CELLS

FORMAT DEFAULT CELLS align: C Gen L R
code: Cont Exp Fix Gen Int \$ * %
of decimals: 0

Description

Sets the alignment and format for all cells that have the default setting. The initial default alignment and format code is General.

The alignment and format codes are listed and described under the Format Cells command.

Example

To set the default format code to money amounts (\$):

```
FORMAT DEFAULT CELLS align: C[Gen]L R  
code: Cont Exp Fix Gen Int[$]* %  
# of decimals: 0
```

FORMAT DEFAULT WIDTH

FORMAT DEFAULT width in chars: 8

Enter a number

Description

Sets the width of all columns that have the "default" width setting. See Format Width for an explanation of default width.

The initial default width is 8 characters.

Example

To set the default width to 12:

```
FORMAT DEFAULT width in chars: 12
```

See Also

Format Width to alter the width of some columns.

FORMAT OPTIONS

FORMAT OPTIONS commas: Yes No
formulas: Yes No

Select option

Description

The proposed responses are the current settings of the options.

For cells that have "Fix," "Int," "\$," or "%" format settings, the comma option groups a number into thousands and separates the groups with commas. For example, a number such as 12345678 under the comma option would be displayed as 12,345,678.

The formulas option permits you to see what generates the value in every cell. A cell normally displays the value of a formula placed in it. Selecting "Yes" for the formulas option causes cells that contain formulas to display their formulas instead of their values. The width of all columns is doubled. Cells that contain text display their contents in double quotes.

When the "formulas" option is off (No), check the formula in a cell by using the Edit command or by moving the cell pointer to the cell, the formula will appear in the status line.

Example

To display formulas in the cells that contain them:

```
FORMAT OPTIONS commas: Yes [No]
                formulas: [Yes] No
```

FORMAT WIDTH

FORMAT WIDTH in chars or d[efault]: d
column: C through: C

Enter a number or d for default

Description

Alters the width of one or more columns to the number of characters specified.

The proposed response for the "in chars or d(efault)" field is always d. "d" is a special "default" setting, similar to the default setting for format and alignment codes. When the width setting is "d", the column width is controlled by the Format Default Width command.

All columns have the default setting initially. The width of all columns with the default setting can be changed easily, using the Format Default Width command. You can set the most convenient width as the default with the Format Default Width command, and you can alter specific columns to other widths with the Format Width command.

If a cell contains text which is wider than the column, Multiplan cuts off the display at the right edge of the column. Use this command to widen the column or use the "Continuous" cell format.

If a cell contains a number that cannot be displayed in the column width, Multiplan displays a series of number signs (#) instead. This can be fixed by widening the column or, sometimes, by using a different format code.

Examples

To change the width of column 1:

```
FORMAT WIDTH in chars or d(efault): 12
      column: 1 through: 1
```

To change the width of columns 4 through 8 to 20 characters:

```
FORMAT WIDTH in chars or d(efault): 20
      column: 4 through: 8
```

See Also

Format Cells to set Continuous format code.

Format Default Width to set the default column width.

GOTO

GOTO: Name Row-col Window

Description

Presents a choice of ways to move the cell pointer to a new position.

Goto Name makes the first cell of a named area the active cell.

Goto Row-col makes the specified cell the active cell.

If a requested cell is already visible through the active window, only the cell pointer is moved.

If the requested cell is not visible through the active window, the active window is shifted so that the named area appears in the specified window.

Goto Window makes the specified cell the active cell and places it at the upper left corner of the specified window.

The subcommands are explained individually on the following pages.

GOTO NAME

GOTO name:

Enter reference to cell[s]

Description

Places the cell pointer on the upper left corner cell of the named area, making that cell the active cell.

Use the direction keys to step through the list of names.

Example

To move the cell pointer to the upper left corner of the area named *SumCosts*:

```
GOTO name: SumCosts
```

GOTO ROW-COL

GOTO row: R column: C

Enter a number

Description

Places the cell pointer on the specified cell, making that cell the active cell.

Examples

To move to row 25 in the active column (column 1):

GOTO row: 25 column: 1

The proposed response in the "column" field was not changed.

If rows 1 thorough 20 are visible through the window when you enter this command, the window will be shifted so that cell R25C1 is visible in the upper left quarter of the active window.

To make row 37, column 9 (R37C9) visible:

GOTO row: 37 column: 9

GOTO WINDOW

GOTO WINDOW window number: W
row: R column: C

Enter a number

Description

Places the specified cell in the upper left corner of the window specified.

If you use this command with the proposed responses (which are the active window and active cell), Multiplan redraws the active window, placing the active cell in the upper left corner.

Examples

To set the active cell as the upper leftmost cell of window number 3:

GOTO WINDOW window number: 3
row: 5 column: 15

To set cell R100C45 as the upper leftmost cell of window number 5:

GOTO WINDOW window number: 5
row: 100 column: 45

See Also

Window Split to open windows.

HELP

HELP: Resume Start Next Previous
Applications Commands Editing
Formulas Keyboard

Select option or type command letter

Description

Provides helpful information about Multiplan.

Help information is read from a diskette file. Information in the Help file is requested two ways: either (1) by selecting Help from the main command menu, or (2) by pressing the HELP action key, except when using the Alpha command (this places a question mark as a response to Alpha). When you request Help, the worksheet is replaced by text from the Help file, and the Help command menu appears.

The worksheet display resumes when you either select the "Resume" subcommand (press R or ENTER), or press CANCEL (CTRL C). "Resume" returns to the exact place where Help was requested. CANCEL returns to the main command menu.

The information displayed depends on when Help is requested. For example:

If you use **SPACE BAR** or **BACKSPACE** to highlight a command word in a menu, a description of that command is shown when you request Help.

If the edit cursor is in a command field, a description of that field is shown.

If the message line shows an error message, either a description of the previous command or a description of the error is shown.

Once in the Help command, you can request Help information by selecting one of the following options on the Help menu:

Option	Result
Resume	return to the menu where you requested Help.
Start (or HOME)	show the beginning of the Help file.
Next (or PAGE DOWN)	show the next screenful of Help information. Typically, not all the relevant information is shown, and Next (press the letter N) should be used.
Previous	show the previous screenful of Help (or PAGE UP) information.
Applications	show a list of common problems paired with the names of the commands that offer solutions.
Commands	show descriptions of the commands, beginning with Alpha.
Editing	show the description of Multiplan editing.
Formulas	show a list of all functions and the rules about formulas.
Keyboard	show the keytop labels corresponding to Multiplan action keys.

INSERT

INSERT: Row Column

Select option or type command letter

Description

Presents a choice of ways to insert new cells into the worksheet.

Insert Row inserts new rows, moving the rest down.

Insert Column inserts new columns, moving the rest to the right.

Multiplan adjusts all references affected by the insertion. See "Transforming the Worksheet" in Chapter 8 for the description of how the Insert command affects references.

The Insert command will not be carried out if the insertion would push data off the edge of the sheet. If, for example, you have data in column 63, an attempt to insert even one column will receive the message "Illegal parameter." Similarly, if you have data in column 50 and attempt to insert 14 columns, you will receive the "Illegal parameter" message.

The subcommands are explained individually on the following pages.

See Also

Move to move rows or columns on the sheet.

Delete to remove rows or columns.

INSERT COLUMN

```
INSERT COLUMN # of columns: 1
      before column: C
      between rows: 1      and: 255
```

Enter a number

Description

Inserts all or part of a column or columns of blank cells. This command is most commonly used to insert blank columns by accepting the proposed responses of rows 1 and 255.

Parts of columns can be inserted. Insertion takes place between the specified rows; other rows are not affected.

Cells to the right of the inserted ones move right.

Examples

To add a column just left of the active one (column 3):

```
INSERT COLUMN # of columns: 1
      before column: 3
      between rows: 1      and: 255
```

To insert a rectangular area in columns 5 and 6 between rows 3 and 8, causing parts of rows 3-8 to move right:

```
INSERT COLUMN # of columns: 2
      before column: 5
      between rows: 3      and: 8
```

INSERT ROW

```
INSERT ROW # of rows: 1
      before row: R
      between columns: 1   and: 63
```

Enter a number

Description

Inserts all or part of a row or rows of blank cells. This command is most commonly used to insert complete rows above the active row by accepting the proposed responses of the active cell and columns 1 and 63.

The command can be used to insert parts of rows. Insertion takes place between the specified columns; other columns are not affected.

Cells below the ones added move down.

Examples

To insert a new row above row 7:

```
INSERT ROW # of rows: 1
      before row: 7
      between columns: 1   and: 63
```

To insert a rectangular area in rows 4 and 5 between columns 1 and 8, causing the lower parts of columns 1-8 to move down:

```
INSERT ROW # of rows: 2
      before row: 4
      between columns: 1   and: 8
```

LOCK

LOCK: Cells Formulas

Description

Provides two ways to lock cells to protect them from accidental change.

Lock Cells locks and unlocks selected cells.

Lock Formulas locks all cells that contain text or formulas.

The values of locked cells cannot be changed by the commands Alpha, Blank, Copy, Edit, Value, or eXternal.

Locked cells are affected by the commands Delete, Format Cells, Insert, Move, and Sort.

When some cells are locked, the NEXT UNLOCKED CELL key positions the cell pointer on the next unlocked cell that is not blank. Using the Lock command and this action key, you can quickly locate variable quantities on a complex worksheet and perform "what if" experiments.

The subcommands are explained individually on the following pages.

LOCK CELLS

LOCK cells: RC
status: Locked [Unlocked]

Enter reference to cell(s)

Description

Displays and changes the protection status of cells.

The proposed responses show the status of the active cell. Lock or unlock selected cells by selecting the appropriate response in the "status" field.

Cells locked by eXternal Copy may not be unlocked with this command.

Examples

To lock an unlocked active cell (R1C1):

LOCK cells: R1C1
status:[Locked] Unlocked

To unlock all cells on a worksheet:

LOCK cells: R1:R255
status: Locked [Unlocked]

LOCK FORMULAS

LOCK FORMULAS:

Enter Y to confirm

Description

Entering Y locks all cells that contain text or formulas. Cells that contain numbers are not affected by the Lock Formulas command.

The Lock Formulas command protects all values generated by formulas. Numbers and any entries made after locking are the exception, and you must decide which unlocked cells you want to lock.

See Also

Lock Cells to lock cells with numbers and to unlock cells.

MOVE

MOVE: Row Column

Select option or type command letter

Description

Presents a choice of ways to move cells from one place to another on the sheet.

Move Row moves whole rows.

Move Column moves whole columns.

More complex moves can be made by inserting blank cells at the destination, copying the source cells into the destination cells, and then deleting the source cells.

The destination of a move is identified by the row or column that will follow the moved cells. That row may or may not be displaced, depending on the direction of the move.

For example:

Move 1 to before 5

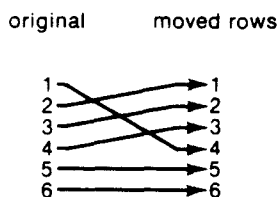

Move 5 to before 2

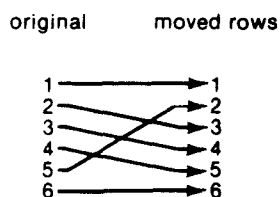

Moving cells causes the worksheet arrangement and all references to be adjusted. See "Transforming the Worksheet" in Chapter 8 for the description of how the Move command affects the worksheet.

The subcommands are explained individually on the following pages.

See Also

Copy to duplicate cells.

Delete to delete rows or columns.

Insert to add rows or columns.

MOVE COLUMN

MOVE COLUMN from column: C
to left of column: C
of columns: 1

Enter a number

Description

Moves a group of columns to a new position on the worksheet.

Example

You can visualize the moved column as leaving a gap at its old position and wedging into its new position. The columns between these positions are displaced towards the gap at the old position. Moving the active column (column 9) to the left edge of the sheet moves all columns between the active column and the leftmost column right one column:

MOVE COLUMN from column: 9
to left of column: 1
of columns: 1

MOVE ROW

MOVE ROW from row: R
to before row: R
of rows: 1

Enter a number

Description

Moves a row or group of rows to a new position on the worksheet.

Example

Move the active row (row 5) to the top of the sheet moves all rows between the active row and the top row down one row to accommodate the moved row:

MOVE ROW from row: 5
to before row: 1
of rows: 1

NAME

NAME: define name:
to refer to:

Enter name

Description

Assigns a name to a cell or area of cells. The name may then be used to refer to that cell or area in a command or formula.

The proposed response for the “define name” field is either a blank or text. If the active cell contains text, Multiplan proposes that text, with any illegal characters removed, as the name to be defined. This makes it easy to convert a row or column title into a name.

If cell R5C1 contains the text *Costs* as a title, then the Name command can be used to define the name *Costs* as R5C2:15. Text used as titles and names are very different and should not be confused. However, it will be easier to read your formulas if the names in them correspond to the visible titles on your worksheet.

If you want the name to be something besides the proposed response, simply type the new response.

The proposed response for the “to refer to:” field is either the active cell or, if the last name defined was a vector (portion of a row or column), the same vector shifts to the active row or column. This feature makes defining parallel groups a simple task.

If the name you enter is already defined, after you press TAB the proposed response in the “to refer to:” field will show the current definition.

Names must begin with a letter. The rest of the characters of a name may be any combination of letters, numbers, the period (.), or the underscore (_). (These rules are the same ones used in the BASIC programming language.) Proposed responses are automatically made to conform to these rules. Illegal characters are ignored, and underscores are substituted for blanks embedded in text strings.

Names may be up to 31 characters long.

Names may not be a combination of characters that could be confused with a reference. See the descriptions of references in the “Formulas” section of Chapter 8.

To see the names that have been defined, select the Name command. Use the direction keys to display each defined name and its definition in the command fields.

To change the definition of a name after viewing it, use the edit keys to alter the response in the “to refer to” field and press **ENTER**.

Names are deleted by making them refer to no area. Enter the name in the “define name” field, delete the response in the “to refer to” field, and press **ENTER**.

Example

To define row 10, columns 3 through 15 as Sales:

```
NAME: define name: Sales  
to refer to: R10C3:15
```

See Also

eXternal Copy for names associated with external links.

OPTIONS

OPTIONS recalc: Yes No mute: Yes No
 iteration: Yes No
 completion test at:

Select option

Description

The proposed responses show the current settings.

The "recalc" option controls when Multiplan performs formula calculations. If the "recalc" option is set to "Yes," Multiplan recalculates all formulas whenever a cell is changed. If the "recalc" option is set to "No," recalculation is done only when the RECALC (FCTN 8) key is pressed or during Transfer Save.

The length of time Multiplan takes to recalculate a sheet depends on how many cells are in use, and on the complexity of the formulas in them. When you want to make several entries on a busy worksheet, set the "recalc" option to "No" for quicker response. Set "recalc" to "Yes" again when you want to see the effect of each change.

The "mute" option controls the Multiplan error tone. The initial setting is "No," which means the tone sounds when an error is made. Select "Yes" when you want to eliminate the error tone.

After you press the **ENTER** key, Multiplan will display in the message line its version number and the total bytes of storage (corresponding to 100% Free) that are available to Multiplan.

PRINT

PRINT: Printer File Margins Options

Description

Presents a choice of four actions related to printing the active worksheet.

Print Printer begins printing.

Print File stores printable output in a disk file.

Print Margins sets the margins for the printed output.

Print Options specifies the part of the worksheet to be printed and controls part of the printed format and printer setup.

The subcommands are explained individually on the following pages.

PRINT FILE

PRINT on file:

Description

Stores printed output in a disk file rather than sending it to the printer. Such files have several uses. The file might be printed at a later time. You might use a text editor to alter the file before printing it, or you could include the file as an illustration in another text file.

If a file of the same name exists, Multiplan will display the message "Overwrite existing file?". Press Y to start printing. Pressing any other key cancels the Print File command.

Example

To write a print formatted version of a file to the name *BUDGET*:

```
PRINT on file: BUDGET
```

PRINT MARGINS

```
PRINT MARGINS: left: 5   top: 6  
print width: 70   print length: 54  
page length: 66
```

Description

Alters the margins and page length for printed output. The left margin and the print width are given as a number of characters. The top margin, print length, and page length are given as a number of lines.

The "print width:" field sets the maximum number of characters to be printed on each line. The "print length:" field sets the maximum number of lines of print on each page. The "page length:" field sets the length of the paper so that a form feed advances the paper the correct number of lines to begin printing on the next page.

The proposed responses are those created by the last Print Margins command. Margins are saved with the sheet.

When the Print Margins command is complete, the Print command is displayed again.

Example

A sheet of letter-size paper is 8-1/2" x 11". Assuming the printer prints 10 characters per inch across a page and 6 lines per inch down a page, the page length is 66 lines and the page width is 85 characters. To fill these dimensions, you might want a top margin of 3 and a print length of 60 for a bottom margin of 3 ($66 = 3 + 60 + 3$). A print width of 65 characters leaves 20 characters total for the right and left margins. To center lines on the page, you need a left margin of 10 ($85 = 10 + 65 + 10$).

```
PRINT MARGINS: left: 10   top: 3  
print width: 65   print length: 60  
page length: 66
```

PRINT OPTIONS

PRINT OPTIONS: area:

setup:

formulas: Yes No r-c nums: Yes No

Description

Sets four optional features before printing:

- printing only part of the sheet,
- printing formulas rather than their values,
- suppressing row and column numbers from the printed page,
- and some setup of printer hardware.

If you want to print only part of the worksheet, specify a reference to a rectangular group of cells in the "area:" field.

Depending on your hardware configuration, the "setup:" field may be used to set up the printer hardware (see the section entitled "Operating Information").

If you choose to print "formulas," the listing will display the actual formulas that appear in each cell, rather than the calculated values of the formulas, as it normally would. This feature is useful when you want a record of the logic behind a worksheet. Column widths are doubled when "formulas" is set to "Yes."

If you select Yes for the "row-column numbers" field, row and column numbers will be printed.

Example

To print only an area named "Factors," which holds discount percentages:

```
PRINT OPTIONS: area: Factors
```

```
setup:
```

```
formulas: Yes[No]    r-c nums: Yes[No]
```

PRINT PRINTER

PRINT on printer:

Description

Starts printing the sheet under the conditions set up by the Print Margins and Print Options commands.

The time it takes to print depends on the size of the sheet and the speed of the printer.

Empty columns at the right of, and empty rows at the bottom of the sheet are not printed. Multiplan prints as many columns across the page as will fit in the print margins. If there are rows left over, it prints a second page, repeating the same columns. When all the rows have been displayed, Multiplan starts the next set of columns on a new page. Thus, if the area to be printed is wider than the paper, you can assemble the complete width by cutting and pasting later.

If you wish to cancel printing, press PRINT CANCEL (FCTN 4). It may be necessary to hold down this key a few seconds.

During printing, PRINT CANCEL is the only key that is functional and it is only effective while "PRINT on printer:" is displayed on the command line. If the main command line appears at the bottom of the screen while the printer is still printing, the PRINT CANCEL key will not work, and the only way to stop printing is to disable the printer. (Depending on your printer, you may be able to switch it off-line or completely off.)

If printing is canceled by the PRINT CANCEL key or if a printer error occurs during printing, Multiplan will display the "Printer error" message.

See Also

Print File to direct output to a disk file.

Print Margins to set the dimensions of a page.

Print Options to print part of a sheet, to print formulas, or to print row and column numbers.

QUIT

QUIT:

Enter Y to confirm

Description

Ends the Multiplan session. The active sheet is not automatically saved. If you wish to save the worksheet, use the Transfer Save command before using the Quit command.

After you select the Quit command, Multiplan displays the message "Enter Y to confirm." If you press Y, the computer returns to the master title screen, and all worksheet information not saved on diskette is lost. Pressing any other key cancels the command.

See Also

Transfer Save to save the active sheet.

SORT

SORT by column: C
between rows: 1 and: 255
order: [>]<

Description

Reorders the rows on the worksheet within the specified column so that the values will be sorted.

The proposed response for the column field is the active column. The proposed response for the rows is the whole column. The proposed sorting order is ascending order, from least to greatest.

The column to be sorted may contain numbers, text, or other values. Sorting collects the different types into the following groups:

- 1st – Numbers
- 2nd – Text
- 3rd – Logical and error values
- 4th – Blank cells

Numbers and text are further sorted into either ascending (>) or descending (<) order. Text is arranged according to the ASCII standard character sequence, which is, from “least” to “greatest”:

SPACE ! # \$ % & ' () * + , - . / 0-9 : ; < = > ? @ A-Z [\] ^ _ ` a-z { | } ~

Within each type, equal values are left in the order Multiplan encounters them.

The worksheet can be sorted on multiple columns. To do this, sort the least significant column first. Then, sort the other columns one at a time, from the least significant to the most significant. The example below illustrates this method.

Note that the Sort command causes Multiplan to adjust references to sorted rows. This is described in the “Transforming the Worksheet” section of Chapter 8.

To generate a sorted report without the effects of the adjusted formulas, turn off the automatic recalculation. Multiplan then displays the values calculated before the sort was performed. You can print this sorted sheet, but do not save it.

Note also that numbers intermixed with text in a cell or dates represented as text are sorted by the rules of standard alphabetization. For example, “A10” is sorted as *less than* “A9” since 1 (the first character in 10) is less than 9.

Example

To sort a list of checks into categories (in column 1) by amount (in column 2) with the largest amount at the top of each category, first sort all checks by amount in descending order:

```
Sort by column: 2
  between rows: 1    and: 255
  order: >[<]
```

The checks are listed from largest to smallest, but with the categories unsorted. To sort the categories alphabetically:

```
Sort by column: 1
  between rows: 1 and: 255
  order:[>]<
```

The checks are now sorted into categories. The checks within each category are arranged from largest to smallest. Because Multiplan leaves equal items in the order it finds them in the column it is sorting, any previous sorting in other columns is retained.

TRANSFER

```
TRANSFER: Load Save
          Clear Delete Options Rename
```

Description

Offers a choice of six subcommands which affect an entire sheet.

Transfer Load loads a saved sheet, replacing the active sheet.

Transfer Save saves the active sheet in a diskette file.

Transfer Clear clears the active sheet, deleting all its contents.

Transfer Delete deletes a file on the diskette.

Transfer Options specifies which disk drive to use, or which file format.

Transfer Rename saves the active sheet under a new name and updates external links.

The subcommands are explained individually on the following pages.

TRANSFER CLEAR

TRANSFER CLEAR:

Enter Y to confirm

Description

Clears the active sheet after you type Y to confirm the command. Typing any other key cancels the command.

Using the Transfer Clear command is almost the same as starting up Multiplan; that is, all cells are deleted; all columns are set to the default width; the default alignment and format are set to General; all names and all links to external sheets are cleared; and the sheet name is set to TEMP. The only settings preserved are those set with the Options, Format Options, Transfer Options, and Print Options commands.

If a copy of the active sheet has previously been saved with Transfer Save, that copy is not affected.

See Also

Blank to replace the contents of specified cells with blanks.

Delete to delete specified cells.

Transfer Save to save the active sheet as a disk file.

TRANSFER DELETE

TRANSFER DELETE filename:

Enter a filename, [arrow for directory]

Description

Deletes a saved worksheet from a diskette.

Pressing one of the direction keys causes Multiplan to display a directory of files on the diskette. To use the direction keys, see the directory display explanation under the Transfer Load command. Press the **ENTER** key to select the filename that is highlighted.

When you press the **ENTER** key, Multiplan displays the message "Enter Y to confirm." Press Y to delete the file. Pressing any other key cancels the Transfer Delete command.

Use Transfer Delete to clear your diskette of unwanted files.

TRANSFER LOAD

TRANSFER LOAD file:

Description

Loads a sheet from a diskette file. The diskette file's name must be spelled and punctuated exactly as it was when the sheet was saved with the Transfer Save command.

Pressing any one of the direction keys causes Multiplan to display a directory of files on the diskette. The direction keys may be used whether the "filename" field is empty or has a filename filled in.

When the "filename" field is empty, the whole directory is displayed.

When you enter a filename in the "filename" field and then press a direction key, Multiplan uses the filename you enter as a pattern and displays only those filenames on the default diskette that match the pattern.

Once the directory is on the screen, use the direction keys to move the highlight among the filenames. As you do, the highlighted filename also appears as a proposed response in the "filename" field in the command line. Press the **ENTER** key to load the highlighted file.

Multiplan can display up to 18 filenames on one screen. To scroll to additional filenames:

1. Select the Transfer Load command and press one of the direction keys to display the first 18 filenames.
2. Type any filename that appears near the bottom of the display, then again press one of the direction keys. The filename you typed will be the first filename at the top of the next screen of filenames.

While the directory is visible, pressing any other key besides a direction key causes the worksheet previously on the screen to reappear. This other key has the same effect as it does while editing responses in command fields that need to be filled in, as described in the "Editing" section of Chapter 8.

When a "Normal" mode Multiplan worksheet diskette file is loaded, it replaces the sheet on display and becomes the active sheet.

As a special feature, the Transfer Load command can also load worksheets from files written by other systems in an acceptable interchange format (described under Transfer Options and Appendix 4, "The SYLK (SYmbolic LinK) File Format"). Data read from one of these files will be merged with the active worksheet, rather than replacing it. To avoid this merging, first use the Transfer Clear command.

Example

To load a sheet saved in a file named *INCOME*:

```
TRANSFER LOAD file: INCOME
```

See Also

Transfer Save to save the active sheet as a diskette file.

TRANSFER OPTIONS

TRANSFER OPTIONS

mode: Normal Symbolic Other

setup:

Description

The "mode" field specifies the file format for all subsequent Transfer Load and Transfer Save commands.

The format choices are:

- Normal Multiplan binary format. External references require that the referenced worksheet be saved in Normal format. This format is also the most efficient use of diskette space and requires the least transfer time.
- Symbolic The format for data interchange with other programs. This format is described in Appendix 4, "The SYLK (SYmbolic LinK) File Format."
- Other VisicalcTM file format. Multiplan can load files in this format. The loaded file is merged with the active sheet. See Transfer Load and Appendix 3. Worksheets cannot be saved in Other mode. If you try to do so, Multiplan displays an "Illegal parameter" error message.

The "setup" field changes the default disk drive from the drive currently being used to the drive specified for all subsequent Transfer commands.

The proposed responses show the current settings.

Example

Multiplan was started on DSK1. To simplify use of a data diskette in DSK2:

TRANSFER OPTIONS

mode:[Normal]Symbolic Other

setup: DSK 2

Multiplan will look for data files in DSK2 for the rest of the work session or until the setting is changed.

TRANSFER RENAME

TRANSFER RENAME filename: [name of active sheet]

Description

Saves the active sheet in Normal mode under a new name and adjusts external links to supporting and dependent sheets. Deletes the file with the previous sheet name. (See the "Files" section of Chapter 8 for a description of external links.)

If the sheet was previously saved in a mode other than Normal mode, using the Transfer Rename command results in the error message "Illegal option."

Example

To rename the active sheet *JUNE82*:

TRANSFER RENAME filename: JUNE82

See Also

Transfer Load to load a saved sheet.

Transfer Save to save the active sheet as a disk file.

TRANSFER SAVE

TRANSFER SAVE filename: [name of active sheet]

Enter a filename

Description

Saves the active sheet as a diskette file, which can later be loaded with Transfer Load. The proposed name for the diskette file is the name last given with Transfer Save or Transfer Rename, or the name last loaded with Transfer Load, or *TEMP* if the sheet is clear or was not previously named.

If the filename is a duplicate of one that exists on the diskette already, the message "Overwrite existing file?" appears when you press **ENTER**. Press **Y** to replace the file on diskette with the worksheet on the screen. Pressing any other key cancels the Transfer Save command.

If you want to rename the sheet, we recommend using the Transfer Rename command if you have any external links to supporting sheets. Transfer Save will not update the "receipts" on the supporting sheets if you rename the active sheet using the Transfer Save command. Refer to "Files" in Chapter 8 for a discussion of external links and "receipts."

You can save your Multiplan files in either Normal or Symbolic mode.

Examples

To save the active sheet under the proposed name, simply press **ENTER**.

To save the active worksheet under the name *PRACTICE*:

TRANSFER SAVE filename: PRACTICE

See Also

Print File to put the displayed form of the sheet in a disk file.

Transfer Load to load a sheet saved previously.

Transfer Options to set the mode.

Transfer Rename to save the worksheet under a new name and to update "receipts."

VALUE

VALUE:

Enter a formula

Description

Used to enter a formula or a number into the active cell.

Besides selecting Value from the command menu by highlighting Value and pressing **ENTER** or by typing **V**, the Value command can be selected by:

1. typing any digit, 0-9
2. typing one of the characters =, +, -, ., ", and (. Except for the equal sign (=), these characters are also entered as the first character of the formula.

Within formulas the direction keys enter relative references into the formula. See the "Editing" section of Chapter 8 for more information about editing responses to a command.

Terminate the Value command by:

1. pressing **ENTER**

OR

2. pressing a key that moves the cell pointer, such as a direction key, at the end of a number or complete formula. The formula or number is stored in the active cell, and the cell pointer is moved as directed. Multiplan then displays in the command line:

ALPHA/VALUE:

and awaits the entry of text or another value. This feature is described in detail under the Alpha command.

Text may be entered if it is enclosed in quotes.

Example

The simple method of entering a list of numbers, using a direction key:

```
31 RIGHT 28 RIGHT 31 RIGHT 30 RIGHT 31 ENTER
```

is a series of Value commands.

Note that dates of the form 1/27/82 can be interpreted as formulas. Be sure to enter dates as text, using the Alpha command, or enclose them in double quotes.

See Also

Alpha for entering text and titles or a sequence of text and values.

Edit for editing formulas.

WINDOW

WINDOW: Split Border Close Link

Select option or type command letter

Description

Presents a choice of window operations.

Window Split opens a new window by splitting the active window horizontally or vertically, or opens a window used for titles.

Window Border adds or removes a border around a window.

Window Close closes a window by removing it from the screen.

Window Link links two windows so that their contents scroll together.

The NEXT WINDOW key moves the cell pointer from one window to another.

The subcommands are explained individually on the following pages.

WINDOW BORDER

WINDOW change border in window number: W

Enter a number

Description

Changes the border of the specified window. If the window presently has a border, it is removed. If it lacks a border, one is added.

A border takes up one screen position on each side of the window, reducing the area for the display of data by two screen lines and two screen columns.

WINDOW CLOSE

WINDOW CLOSE window number: W

Enter a number

Description

Removes the specified window from the screen. The active window is the proposed response.

The size of the remaining windows is increased to occupy the screen area used by the closed window. Windows are renumbered. Cells contents are not affected by closing a window.

If there is only one window open, the Window Close command is ignored.

See Also

Window Split to open windows.

WINDOW LINK

WINDOW LINK window number: W
with window number: W
linked: Yes No

Description

Reviews and revises the links between two windows. The links may have been established under the Window Split command, or they may not exist yet, in which case you may establish links between windows split from a common window so that the two windows scroll together.

The proposed responses specify the active window and either a window split from the active window or the window from which the active window was split. If no window splitting has occurred, both proposed window responses will be the active window.

You may enter any two window numbers as responses. However, only those pairs that share the split relationship can be linked. Attempts to link other pairs receive the message "Cannot link those windows" in the message line.

When windows are linked, the contents of the two windows scroll together. If the window split was horizontal, the synchronized scrolling is horizontal. If the window split was vertical, the synchronized scrolling is vertical.

When two previously unlinked windows are linked, one set of row or column numbers disappears from the screen. If the pairs are related by a horizontal split, the column numbers disappear. Columns are identified by the numbers in the window above.

If the pairs are related by a vertical split, the row numbers disappear. Rows are identified by the numbers in the window to the left.

This command is also used to unlink windows, but you cannot unlink windows that are split by the Window Split Titles command.

Example

Window #4 was split from window #1. To link them so that they scroll together:

```
WINDOW LINK window number: 4
with window number: 1
linked:[Yes]No
```

See Also

Window Split for a description of window links.

WINDOW SPLIT

WINDOW SPLIT: Horiz Vertical Title

Description

Presents a choice of three ways to open a window by splitting the active window.

Window Split Horizontal splits the active window across the screen, giving two windows, one above the other.

Window Split Vertical splits the active window between columns.

Window Split Titles splits the screen both vertically and horizontally to display titles in separate windows.

Up to eight windows may be opened using the Window Split commands.

The Window Split commands retain window borders, giving both windows a border if the original window has one.

See Also

Window Close to close a window.

Window Link to link and unlink existing windows.

WINDOW SPLIT HORIZONTAL

```
WINDOW SPLIT HORIZONTAL at row: R
linked: Yes No
```

Description

The active window is split horizontally. The region used by the given row and the rows below it becomes the new window. The area above the given row remains part of the original window.

The new window is given the next unused window number and becomes the active window.

The original window and the new window may be linked. If you select "Yes" in the "linked" field, whenever you scroll one of the windows horizontally, both windows scroll together. Notice also that the column numbers of the lower window do not appear on the screen. Rather, the column numbers of the window above are used to identify columns in the linked window.

Examples

To split the active window at the active row, just press **ENTER**.

To split the active window at the display line presently showing row 34, and to link the windows:

```
WINDOW SPLIT HORIZONTAL at row: 34
    linked:[Yes]No
```

See Also

Window Link to review or revise links between windows.

WINDOW SPLIT TITLES

```
WINDOW SPLIT TITLES: # of rows:
    # of columns:
```

Description

The active window is split to form two or four windows. The windows formed are linked so that they scroll together. Windows linked by this command cannot be unlinked.

The specified number of rows becomes a window at the top of the display space occupied by the original window, unless the number is 0.

The specified number of columns becomes a window at the left of the display space occupied by the original window, unless the number is 0.

The remaining display space becomes the active window. It is linked for horizontal movement with the window above it and for vertical movement with the window to its left, if any.

The proposed responses split the window so that the active cell becomes the upper left corner cell of the active window.

Example

Suppose that column 1 contains descriptive titles for the rows of the worksheet and that columns 2-25 contain data matching those titles. You would like to scroll the data columns horizontally while holding the titles fixed on the screen. If you scroll vertically, both titles and data should move so that the titles will remain aligned with the matching data. Move the cell pointer to R1C2, then the proposed response will be:

```
WINDOW SPLIT TITLES: # of rows: 0
    # of columns: 1
```

See Also

Window Border to draw a border around any of the windows.

WINDOW SPLIT VERTICAL

WINDOW SPLIT VERTICAL at column: C
linked: Yes No

Description

The active window is split vertically. The display space used for the given column and the columns to its right is used for the new window. The space used for columns to the left of the active column remains part of the original window.

The new window is given the next unused window number and becomes the active window.

The original window and the new window may be linked. If you select "Yes" in the "linked" field, whenever you scroll one of the windows vertically, both windows scroll together.

Examples

To split the window at the active column, just press **ENTER**.

To split the window at the column presently displaying column 3:

```
WINDOW SPLIT VERTICAL at column: 3  
linked:[Yes]No
```

See Also

Window Link to review or revise links between windows.

eXTERNAL

EXTERNAL: Copy List Use

Description

Presents a choice of actions relating to the use of data on inactive (external) sheets.

eXternal Copy copies data from an inactive worksheet to the active worksheet. This command can also establish an external link, a permanent relationship that automatically causes data to be copied from a source, or supporting sheet, to the active, or dependent, sheet every time the latter is loaded into Multiplan.

eXternal List displays the lists of supporting and dependent worksheets.

eXternal Use assigns a substitute name for a specified sheet.

See the "Files" section in Chapter 8 for more information on external links and file accesses.

The subcommands are explained individually on the following pages.

EXTERNAL COPY

EXTERNAL COPY from sheet:

name: to: RC
linked:[Yes]No

Description

Copies values from a group of cells on an external worksheet to the active sheet. The source sheet is defined in the "from sheet" field of the command. The proposed response for the "from sheet" field is the most recent new supporting sheet.

The cells to be copied from the source sheet are described in the "name:" field. This field may contain a name which is defined on the source sheet to refer to a group of cells, or it may be an absolute reference to a single rectangle on that sheet (e.g., R2C1:12; see also the discussion of absolute references in the "Formulas" section of Chapter 8).

The "to:" field is used to specify the destination of the copy on the active sheet. The proposed response is the active cell. If a single cell is specified in this field, the source group will be copied starting at that cell. If a group of cells is specified in the "to:" field, the shape of the group must correspond to the shape of the source group, cell by cell. Otherwise, an error message is displayed, and the copy does not take place.

The integrity of the active sheet is further protected by checking that all destination cells are blank. An attempt to copy into a nonblank cell also causes an error message, and copying is canceled.

The eXternal Copy command does not copy formulas, but only the values derived from formulas. This is different from the "Copy" group of commands because those commands copy formulas as well as values. For example, if a cell containing the formula $100 * rate$ is copied from an external sheet, the destination cell may receive the constant value 20 (assuming $rate = .20$).

This value alone does not show the dependence of the result on changes to the *rate* cell on an external sheet. The external link facility is provided to permanently express the relationship between the value on the "dependent" sheet and the source of the value (the formula on the "supporting" sheet).

External links are controlled by the options in the "link" field of the eXternal Copy command. If "No" link is selected, the command has no other effect than copying the values as described above. Information on possible dependencies is not recorded at all. If the source data is not expected to change, this option would be the most convenient.

Selecting "Yes" in the "link" field establishes an external link between the source data and the destination. The source sheet supports the active, or dependent, sheet. Of course, the same sheet may be in supporting and dependent roles in different external links.

After an external link is established, every time the dependent sheet is loaded (using the Transfer Load command), all the data described in the external links is automatically copied from the source sheets to the specified destinations. Any change in the source data is reflected on the dependent sheet.

The "formulas" associated with the destination cells—as seen on the status line or using the "formulas" Format Option—also show the data in the cells as dependent on a link, in the form:

[*sheetname sourcename*]

Destination cells are protected from changes just as if they were locked. They can be "unlocked" only by removing or redefining the external link in which the cells participate.

To remove a link, specify the source sheet, source name, empty destination, and "Yes" for linking in the eXternal Copy command.

To redefine a link so that it has a different destination on the active sheet, redefine the link with a new destination on the active sheet. Because a source area on an inactive sheet may be copied only once by each active sheet, the new destination replaces the former one in the link.

Both the removing and redefining of links, as well as the review of the existing links, is simplified by the use of the direction keys to step through the source (supporting) sheet names or the names of source cells in a given sheet. The "to:" field is filled in by Multiplan to show the destination of the external link, as currently defined.

The Name command, when used immediately after an eXternal Copy, proposes to define the name

sheetname.sourcename

to refer to the destination of the copy. When defined (by pressing **ENTER**), this name can be used in other formulas on the active sheet to refer to the copied data.

The automatic copying process from supporting sheets requires that the files that contain the sheets be available to Multiplan. This topic is discussed in the "Files" section in Chapter 8.

Before copying the data in each link, the definition of the name for the source cells is checked. If the shape (size) of the named area has been changed, an error message is displayed, and the copy does not take place. Otherwise, the cells are copied to the destination cells, even if the destination cells are not blank but contain the results of the previous external copy.

Example

To copy the value of the area named *Sales* from the worksheet named *INCOME* to the area starting at cell R5C5 on the active worksheet, and to set a permanent link:

```
EXTERNAL COPY from sheet: INCOME
  name: Sales    to :R5C5
  linked:[Yes]No
```

Assuming that the area named *Sales* is 12 cells wide, the destination for the copy will be R5C5:16. The Name command will propose:

```
NAME define name: INCOME.Sales to refer to R5C5:16
```

EXTERNAL LIST

EXTERNAL LIST:

Description

Produces a display of the names of worksheets supporting the active sheet and those dependent on the active sheet. The "supporting" and "dependent" relationships are explained in detail under eXternal Copy and in the "Files" section in Chapter 8.

The list of supporting sheets includes the "alias" names defined by eXternal Use.

Example

```
Sheets supporting Department:
  Year81           instead of Year
  Labor
```

```
Sheets depending on Department:
  Consolidated
```

EXTERNAL USE

EXTERNAL USE filename:
instead of:

Enter filename

Description

Allows the interchangeability of supporting sheets, as long as the supporting sheets are arranged identically. No changes are needed on the dependent sheet or its links when changing to a different supporting sheet.

External use sets a substitute name (alias) for a supporting file. The name in the "filename" field is the desired file and the name in the "instead of" field is the name appearing in the "sheet" field of the external copy command.

The name in the "instead of" field need not be the name of an actual file. All references to the name in the "instead of" field are redirected to the name in the "filename" field. External copies from the supporting file, if any, are redone.

The proposed response in the "instead of" field is the previous response, if any; otherwise, the field is blank.

Example

Assume that an active sheet has links to the supporting file *JAN_UTIL*. To view the figures that result from using the data on *FEB_UTIL* instead (which must be identical in format to *JAN_UTIL*):

```
EXTERNAL USE filename: FEB_UTIL  
instead of: JAN_UTIL
```

This saves removing the links from *JAN_UTIL* and then redefining links to *FEB_UTIL*. Also, you can return to *JAN_UTIL* easily by specifying *JAN_UTIL* in both fields of this command.

As an alternative, you could use a "logical name" when referring to supporting sheets. (A "logical name" is not the name of an actual file, but a name used only for setting up external links). Under this method, a substitution must be made through the eXternal Use command before setting up links between sheets:

```
EXTERNAL USE filename: JAN_UTIL  
instead of: UTILITY
```

Then, the name *UTILITY*, which is not a file but a "logical name" used for defining links, may be used to set up the links in the eXternal Copy command and as a response in the "instead of" field in the eXternal Use command in future substitutions. For example, when you want to utility costs for February:

```
EXTERNAL USE filename: FEB_UTIL  
instead of: UTILITY
```

and all links will now be changed to refer to *FEB_UTIL*.

This method permits you to refer to whatever file you choose in the eXternal Use command without having to remember which file is the pattern for the substitutions.

Chapter 10: Function Directory

ABS
AND
ATAN
AVERAGE
COLUMN
COS
COUNT
DOLLAR
EXP
FALSE
FIXED
IF
INDEX
INT
ISERROR
ISNA
LEN
LN
LOG10
LOOKUP
MAX
MID
MIN
MOD
NA
NOT
NPV
OR
PI
REPT
ROUND
ROW
SIGN
SIN
SQRT
STDEV
SUM
TAN
TRUE
VALUE

This chapter describes the functions that can be used in Multiplan formulas. Each entry describes the operation of a function and any special requirements for its argument.

To enter a formula, use any of the methods described under the Value command in Chapter 9. The functions are entered as part of a formula.

The argument to a function, enclosed in parentheses, follows the function name. No space is permitted between the function name and the open parenthesis.

Entries within the parentheses describe the argument to the function. The following abbreviations are used in argument descriptions:

N represents a number or a formula that yields a number. Wherever *N* is shown, only one entry is allowed. When more than one is allowed, *List* is shown. Where an argument needs to be a radian angle, *theta* is shown.

T represents text or a formula that yields text.

Logical represents a logical value, which must be a reference to a single cell, a formula expressing a relation (=, <, >, <=, >=, <>), or a function that returns a logical value. Otherwise, a #VALUE! error value is returned.

List represents a list of items, separated by commas. An "item" may be either a value that represents itself or a reference to a group of cells that represent the collection of values in those cells. An example is the list

1,B

where the name *B* is defined as of R1C2:3. With the value 2 in R1C2 and the value 3 in R1C3, the list represents the collection of values 1,2,3. Lists may be up to five items long, but they may represent any number of values through references.

See the "Formulas" section in Chapter 8 to review the descriptions of numbers, formulas, and text.

Related functions are listed under the heading "See Also."

ABS(N)

Description

Returns the absolute value of the argument *N*.

Examples

"Difference:"&DOLLAR(ABS(first – second))

ABS(AVERAGE(R1C1:10) – R1C1)

yields how far the first item is from the average.

See Also

SIGN for the sign of a number; ABS is equivalent to number*SIGN(number).

MAX for the maximum of two or more values.

MIN for the minimum of two or more values.

AND(List)

Description

Returns the logical value true if all of the specified argument values are true. Otherwise, it returns false.

Requirements

The argument entries must be logical values. If not, the #VALUE! error value is returned.

Example

`IF(AND(SUM(Homework)>82,Final>50),credit,"not qualified")`

If either condition of the AND argument is not met, the conclusion "not qualified" is made. If all the AND argument conditions are true, the value for credit is returned.

See Also

OR and *NOT* to operate on logical values.

IF to test a logical value.

ATAN(N)

Description

Calculates the Arctangent (inverse Tangent) function of the argument, yielding an angle in radians in the range ($-\pi/2$ to $+\pi/2$).

ATAN can be used to calculate Arcsine and Arccosine (see Appendix 3, Table 1).

Example

`ATAN(2.5)`

See Also

TAN for the Tangent function.

AVERAGE(List)

Description

Calculates the average of the specified argument values. Yields the same result as entering the formula $SUM(list)/COUNT(list)$.

Examples

$AVERAGE(Balance)$

$AVERAGE(1,5,6.5,5)$

See Also

STDEV for the standard deviation of the number values.

SUM for the sum of number values.

COUNT for a count of number values.

COLUMN()

Description

Returns the number of the column in which the formula containing this function appears.

Example

$1981 + COLUMN() - 4$

can produce the sequence of years 1981, 1982,..., starting in column 4. (Place this formula in column 4, then Copy Right from column 4 as many cells as the number of years you want in the series.)

COS(theta)

Description

Calculates the Cosine of the argument, an angle in radians.

Example

$COS(PI()/3)$

See Also

SIN and *TAN* for the other trigonometric functions.

COUNT(List)

Description

Returns the count of number values represented by the List. Cells are counted only if they contain number values.

Example

DOLLAR(COUNT(checks)*0.15 + 1.00)& "is service charge"

See Also

AVERAGE for the average value.

SUM for the sum of the number values.

DOLLAR(N)

Description

Converts the argument to text showing a dollar amount, just like the "\$" format code under the Format Cells command in Chapter 9.

The argument is rounded to two decimal places. If the argument is less than 1, a zero appears in the units position. A dollar sign is added before the leftmost digit. If the argument is less than zero, the result is enclosed in parentheses (the standard way of showing a negative balance in bookkeeping).

Examples

DOLLAR(2.715) produces \$2.72

DOLLAR(.15) produces \$0.15

DOLLAR(0) produces \$0.00

DOLLAR(- 1) produces (\$1.00)

See Also

FIXED to format a number without the dollar sign.

VALUE to change text back to a number.

EXP(N)

Description

Calculates e (2.7182818..., the base of the natural logarithm) to the power of the argument. This is the inverse function of LN.

Powers of other bases are calculated using the exponentiation operator (^).

Examples

“ ‘e’ is”&FIXED(EXP(1),14)

“SINH =”&FIXED((EXP(PI()) – EXP(– PI()))/2,8)

See Also

LN for the natural logarithm of a number.

FALSE()

Description

Returns the logical value false.

Example

If you put a complicated conditional statement into a cell, you can use FALSE() to create a known condition to test the statement before applying it to a real situation.

See Also

AND, *OR*, and *NOT* to operate on logical values.

IF to test a logical value.

FIXED(N,Digits)

Description

Converts the specified value to text showing a fixed-decimal number with the number of decimal digits specified, just like the "Fix" format code under the Format Cells command in Chapter 9.

If the value is negative, a minus sign is placed before the leftmost digit. If digits is negative, the value to the left of the decimal point is rounded.

Requirements

Digits must be an integer between 0 and 30.

Example

`FIXED((first/second)*100,2)&"percent"`

See Also

DOLLAR to format money amounts.

VALUE to convert text back to a number.

ROUND to return the number value of rounding.

IF(Logical,Then Value,Else Value)

Description

If the Logical is true, it returns the Then value. Otherwise, it returns the Else value. These values may be numeric, text, or logical values.

Example

`IF(grade>80,"excellent",grade)`

See Also

AND, *OR*, and *NOT* to operate on logical values.

ISNA and *ISERROR* to check for error values.

INDEX(Area,Subscripts)

Description

Returns the value of a cell selected by Subscripts from the rectangular area.

One or two subscripts may be given. With one subscript, the area must be part of one row or one column. Subscript value 1 selects the first cell in the row or column, value 2 the second cell, and so on.

If two subscripts (separated by commas) are given, the area may be rectangular. The subscripts select the row and column in the area, starting at 1 in each case.

If any index exceeds the limits of the area, the #N/A (not available) error value is returned.

Examples

To repeat the first column in the first row, copy the formula

```
INDEX(C1,COLUMN())
```

throughout the first row.

If the area Score is a table giving adjusted composite scores for raw scores on two components in a test, then:

```
INDEX(Score,Raw1 C,Raw2 C)
```

will give the appropriate composite score, based on the two raw scores.

INT(N)

Description

Returns the largest integer less than or equal to N.

Examples

```
"fraction = "&FIXED(number - INT(number),4)
```

INT(6) is 6

INT(8.9) is 8

INT(-123.999) is -124

See Also

ROUND to round a number to a certain decimal place.

ISERROR(Value)

Description

Returns the logical value true if the argument is any of the error values (#N/A, #VALUE!, #REF!, #DIV/0!, #NUM!, #NAME?, #NULL!). Otherwise, it returns false.

Example

`IF(ISERROR(ratio),"check your numbers","")`

See Also

IF to test a logical value.

ISNA(Value)

Description

Returns the logical value true if the argument is #N/A (not available). Otherwise, it returns false.

Example

`IF(ISNA(balance),"0",balance)`

See Also

NA to produce #N/A value.

IF to test a logical value.

ISERROR to test for all error values.

LEN(T)

Description

Returns the number of characters in the text value.

Example

`MID(T,LEN(T),1)` is the last character of the text *T*.

See Also

MID to return specified characters from a text value.

LN(N)

Description

Calculates the natural logarithm of the argument.

Requirements

N must be positive. A #NUM! error value is returned if *N* is less than or equal to zero.

Example

```
“log2 = ”&FIXED(LN(value)/LN(2),8)
```

See Also

ABS to ensure that the argument is positive.

EXP for the inverse of LN.

LOG10 for logarithms to the base 10.

LOG10(N)

Description

Calculates the base 10 logarithm of the argument.

Requirements

N must be positive. A #NUM! error value is returned if *N* is negative.

Example

```
“Order of Magnitude: ”&FIXED(LOG10(value),0)
```

See Also

ABS to ensure that the argument is positive.

LN for logarithms to the base e and other bases.

LOOKUP(N,Table)

Description

Searches for *N* in the first row or column of Table. Returns the contents of a cell from the last row or column of Table. Table is a group of cells on the worksheet.

The dimensions of Table determine the direction of the search.

If Table is square, or higher than it is wide, Multiplan searches in the first column of Table until it finds the cell that has the largest value that is less than or equal to *N*. The value in the last cell in that row of Table is returned as the result of the function. If the values in all cells in the first column are less than *N*, the last row of Table is used. If the values in all cells in the first column are greater than *N*, a #N/A value is returned.

If Table is wider than it is high (has more columns than it has rows), then Multiplan searches for *N* in the first row of Table. The value in the last cell in that column of Table is returned as the result of the function. If the values in all cells in the first row are less than *N*, the last column of Table is used. If the values in all cells in the first row are greater than *N*, a #N/A value is returned.

Requirements

Table should be a cell reference to a rectangular area in the active worksheet. The result returned may be either a number value, a text value, or a logical value.

LOOKUP expects that you entered the values in the first row or column in ascending order. If values are not in ascending order, LOOKUP may return either the #VALUE! or #N/A error value.

Note: Multiplan 1.04 (this version) does not permit the use of logical values in the table.

Example

Assume that column 1 (C1) lists base salaries, column 2 (C2) lists minimum tax, and column 3 (C3) lists marginal tax rates as percents:

C1	C2	C3
0	0	0%
2300	0	14%
3400	154	16%
4400	314	18%
6500	692	19%
8500	1072	21%
...

Also assume that a name, *Salary*, has been defined and that it contains a value, *N*.

The tax on a salary in one of the brackets in Table can be expressed as:

$$\text{LOOKUP}(\text{Salary}, \text{C1:C2}) + (\text{Salary} - \text{LOOKUP}(\text{Salary}, \text{C1})) \\ * \text{LOOKUP}(\text{Salary}, \text{C1:C3})$$

Notice that in the first lookup, we find the tax on the "base" amount (using C1 to find a value in C2). In the second lookup, we find the actual base amount (using C1 to find a value in itself; in fact, Table can be one column wide or one row high). And in the third lookup, we find the marginal tax rate for the amount of the salary that exceeds the base amount (using C1 to find a value in C3).

MAX(List)

Description

Returns the largest number value from List. Returns zero if List represents no number values.

Example

```
“Best of”&FIXED(COUNT(scores),0)&  
“is”&FIXED(MAX(scores),2)
```

See Also

MIN for the minimum of two or more values.

MID(T,Start,Count)

Description

Returns specified characters from *T*.

Start specifies the position of the first character of *T* to be taken, counted from the left end of *T*. The first character is position 1.

Count specifies the number of characters to be taken.

If Count is zero, or if start is greater than the length of the result of *T*, no characters are returned.

If Count is negative, a #VALUE! error value is returned.

Requirements

Start and Count must be *N* values. If either Start or Count has a fraction, the fractional part is truncated before the integer part is used.

Example

```
MID(“FFFFFFDCBAA”,INT(grade/10),1)
```

See Also

LEN for the length of the text value.

MIN(List)

Description

Returns the smallest number value from List.

Example

“Lowest of”&FIXED(COUNT(times),0)&
“is”&FIXED(MIN(times),0)

See Also

MAX for the maximum of two or more values.

MOD(Dividend,Divisor)

Description

Returns the remainder of Dividend divided by Divisor. The result has the same sign as Divisor.

Requirements

Both parts of the argument must be an *N* value. If the Divisor is zero, a #DIV/0! error value is returned.

Examples

MOD(3,2) = 1
MOD(-3,2) = 1
MOD(-3,-2) = -1
MOD(3,-2) = -1

In general: $MOD(x,y) = x - INT(x/y)*y$

NA()

Description

Returns the #N/A (not available) special value. This value may be used to mark data points that are yet to be defined.

Example

By assigning NA() to the interest rate, all values on the worksheet that depend on the interest rate will change to #N/A.

NOT(Logical)

Description

Returns the opposite of the logical value argument (false if the argument is true; true if the argument is false).

Example

```
IF(OR(credit > limit, NOT(AND(conditions))),  
  "not qualified", "")
```

where "conditions" is a group of cells and each cell contains one necessary condition of credit worthiness.

See Also

AND and *OR* to operate on logical values.

IF to test a logical value.

NPV(Rate,List)

Description

Net Present Value (NPV) calculates the amount of money required now to produce a specified cash flow in the future, given some interest rate.

The formula used is:

$$\sum_{i=1}^n \frac{\text{list}_i}{(1+\text{rate})^i}$$

Requirements

Rate is an interest rate, expressed as a decimal fraction (0.11 is a rate of 11%). It must be an *N* value.

The first value represented by List is income required at the end of the first period; the second value is the income required at the end of the next period, and so on.

Example

You are given the opportunity to lease a parking lot for five years for an \$80,000 one-time payment. The lot currently generates \$15,000 net operating income annually. Based on research and profit studies you have done, you expect the income to increase 30% annually.

Place \$15,000 in cell R1C1. Place $R[-1]C*1.3$ in cell R2C1, and copy it right to the next three cells. Name the area Flow. Now, you can figure the net present value of the cash flow.

If your opportunity rate is 15%, then $\text{NPV}(15\%, \text{Flow})$ gives you the present value of \$84,598.24. Since this is greater than the cost of the lease, you conclude that it is a worthwhile investment.

OR(List)

Description

Returns the logical value true if any value in List is true. Otherwise, it returns false.

Requirements

The argument entries must be logical values. If not, the #VALUE! error value is returned.

Example

IF(OR(grade>80,final > = 150),"good work","")

See Also

AND and *NOT* to operate on logical values.

IF to test a logical value.

PI()

Description

Returns the value 3.141592653588, an approximation of the mathematical constant π .

Example

SIN(PI()/4)

REPT(T,Count)

Description

Returns a text value consisting of Count repetitions of *T*. If Count is zero or negative, #VALUE! is returned. Otherwise, the length of the result will be the length of *T* multiplied by Count.

This function may be used to create bar graphs, or repeating patterns (such as printer's rules) to separate areas of the worksheet.

Requirements

T is usually a single character, but it may be any number of characters.

Count must be an *N* value, which will be truncated to an integer.

Example

REPT(" + ",Score/3)

ROUND(N,Digits)

Description

Returns a value, rounded to the number of decimal places specified by Digits.

Digits specifies the rounding as follows:

If Digits is greater than zero, then the result will be rounded to that many decimal places. For example, `ROUND(3.1416,3)` produces 3.142.

If Digits is zero, the result is rounded to an integer.

If Digits is negative, rounding is carried into the integer. For example, `ROUND(21, - 1)` produces 20 (the 10s position rounded) while `ROUND(991, - 2)` produces 1000 (the 100s position rounded).

Requirements

Digits must be an *N* value.

Example

`Balance + ROUND(Balance*Interest/12,2)`

See Also

INT to return the integer part of a number.

ROW()

Description

Returns the number of the row in which the formula containing this function appears.

Example

Copying the expression `ROW()*10` throughout the first column creates the sequence of numbers:

10
20
30
...

See Also

COLUMN for the current column number.

SIGN(N)

Description

Returns a number representing the algebraic sign of the argument.

If the sign of the argument is positive, the function returns 1.

If the argument value is zero, the function returns 0.

If the sign of the argument is negative, the function returns -1.

Example

To display the magnitude of a number in bar chart form and its sign:

```
REPT(MID(' - + ',SIGN(N) + 2,1),ABS(N))
```

See Also

ABS to return the absolute value of a number.

SIN(theta)

Description

Calculates the sine of the argument, an angle in radians.

Example

```
SIN(PI()/4)
```

See Also

COS and *TAN* for the other trigonometric functions.

SQRT(N)

Description

Returns the square root of the argument.

Requirements

N must be positive. If *N* is negative, a #NUM! error value is returned.

Example

```
SQRT(x*x + y*y)
```

STDEV(List)

Description

Calculates the sample standard deviation of the number values represented by List according to the formula:

$$s = \sqrt{\frac{\sum x^2 - \frac{(\sum x)^2}{n}}{n-1}}$$

Example

STDEV(grades)

See Also

AVERAGE for the average value.

SUM(List)

Description

Returns the sum of number values represented by List.

Example

(1 + rate)*SUM(deposits,January)

See Also

MAX for the maximum of two or more values.

MIN for the minimum of two or more values.

AVERAGE for the average value.

COUNT for the count of the number values.

TAN(theta)

Description

Calculates the tangent of the argument, an angle in radians.

Example

TAN(PI()/4)

See Also

COS and *SIN* for the other trigonometric functions.

ATAN for the inverse tangent function.

TRUE()

Description

Returns the logical value true.

Example

If you put a complicated conditional statement into a cell, you can use TRUE() to create a known condition to test the statement before applying it to a real situation.

See Also

AND, *OR*, and *NOT* to operate on logical values.

FALSE

IF to test a logical value.

VALUE(T)

Description

Returns the number represented as text in the argument. The argument must be the text form of a number, similar to those produced by the formatting code used by Multiplan. It may contain a leading dollar sign or a leading minus sign. It may be written in scientific notation.

For example, all the following text forms yield the value 10: 10, \$10.00, 1E1. The following text forms yield negative 10: -10, -1E1.

Requirements

If the contents of *T* do not describe a number—if they include letters, for instance, or two decimal points—a #VALUE! error value is returned. You can avoid this problem by first isolating numbers mixed with nonnumeric characters, as the example below shows.

Example

Suppose that the cell named "date" contains the text "6/14/83." Then,

```
VALUE(MID(date,3,2))
```

returns the number 14.

Chapter 11: Message Directory

The following directory lists in alphabetical order all the possible messages that Multiplan may display, along with descriptions of possible causes and what actions you may take in response to them.

Cannot copy into non-blank cell

Cause. The destination area of an eXternal Copy contains a nonblank cell.

Action. Review the response to the eXternal Copy command. Make sure that the destination area you specify is not used for any other purpose. If appropriate, blank the cells that are not blank.

Cannot link those windows

Cause. An attempt was made to link two windows that were not split from each other. Also occurs on unlinking, especially unlinking a Title split.

Action. Refer to the Window Link command in Chapter 9.

Cannot read file

Cause. Confirms a negative response to the "Enter Y to retry access to filename" message. May also appear after the directory display is requested, but an unknown file was named.

Action. No special action is necessary. See the "Files" section in Chapter 8 for more information.

Cannot write file

Cause. The file last named is available but cannot be written to diskette either because (1) the diskette is full, or (2) the diskette is write-protected.

Action. First, save your work on a different diskette. Check the available space and write protection of the diskette that caused the error message. See the "Files" section in Chapter 8 and the section at the beginning of this volume entitled "Operating Information" for more information.

Cell locked by External Copy

Cause. Either an attempt was made to unlock a cell that is the destination of a linked eXternal Copy, or an attempt was made to copy from an area of the worksheet that is the destination of a linked eXternal Copy.

Action. Such cells must not be changed, for any change would be erased the next time the sheets are loaded and the external copies executed. To regain access to the cell, exclude it from copying. Redefine the eXternal Copy command accordingly.

Calls to recalculate: number

Cause. You entered a new value into the worksheet while Multiplan was in automatic recalculation mode, or you pressed the RECALC key (FCTN 8) after entering a new value while Multiplan was not in automatic recalculation mode. This message appears only if there are more than two dozen cells to be recalculated.

Action. Simply watch the number count down to zero. The number tells you where Multiplan is in the recalculation. When the number reaches zero, you can continue your Multiplan session.

Circular references unresolved

Cause. Cells refer to each other in a chain so that the last refers back to the first. (The simplest case is a cell containing a reference to itself—RC—but the chain may be many steps long.) Multiplan has calculated all the cells of the chain once and found itself starting over. It stops calculating, leaving the cells in the circular chain in an undefined state.

Action. Alter the logic of the sheet so that there is no circularity. Use the same methods described in the “Formulas” section of Chapter 8 for finding the source of error values.

Command is too long

Cause. The command, formula, or text on the command line is too long to be displayed there.

Action. The command, formula, or text must be shortened.

Confirm change: sheet name

Cause. The name of an area, the source of a linked eXternal Copy, has been changed on the supporting sheet. Copying will not take place. The system will wait for a character to be typed.

Action. Type any character. The rest of the specified files, if any, will be loaded. Review the eXternal Copy command in view of the change on the supporting sheet. Redefine the eXternal Copy command as appropriate.

Disk error

Cause. While attempting to read or write a file, Multiplan was told of a serious error by the operating system.

Action. See the “Files” section in Chapter 8 for possible problems with reading or writing files.

Disk full

Cause. There is no more room on the diskette.

Action. Use a different diskette. As an alternative, use the Transfer Delete command to look at the file directory on the diskette, and delete unneeded files.

Enter a filename

Cause. The active field of the command takes the name of a file to be written.

Action. Enter a filename, or press CANCEL to cancel the command.

Enter a filename (arrow for directory)

Cause. The active field of the command takes a filename existing on a disk.

Action. If you know the name of the file desired, enter it. If you want to examine the names of all saved sheets, use the direction keys as described under the Transfer Load command. Or press CANCEL to cancel the command.

Enter a formula

Cause. Multiplan awaits a formula. The direction keys can be used to put a cell reference into the formula.

Action. Enter a formula, a number, or text (enclosed in quotes), or press CANCEL to cancel the command.

Enter a number

Cause. The active field of the command takes a single number: a row or column number, or a quantity, such as margin spacing.

Action. Enter a number or press CANCEL to cancel the command. Note that it is possible to enter a formula, though it must result in a small integer.

Enter a number or d for default

Cause. In the Format Width command, the width of a column can be set to a specific width in characters, or to the width set by the Format Default Width command.

Action. Enter a number from 3 to 32 or the letter **d**, or press CANCEL to cancel the command.

Enter name

Cause. The active field of the command takes a name. See the Name command in Chapter 9 for the rules governing names.

Action. Enter a name, or press CANCEL to cancel the command.

Enter reference to cell or group of cells

Cause. The active field of the command takes a reference of any kind, including a range, intersection, or a list (a union) of references.

Action. Enter a reference to a cell (or cells), or press CANCEL to cancel the command. The direction keys may be used to enter references to particular cells.

Enter sheet name

Cause. In eXternal Use command, this message prompts for the sheet name for which a substitution will be made.

Action. Supply the sheet name, or press CANCEL to cancel the command.

Enter text (no double quotes)

Cause. The active field of the command takes text. Double quotes (") are not permitted because they are used to delimit text in formulas.

Action. Enter text, or press CANCEL to cancel the command.

Enter text or value

Cause. You press a cursor movement key (such as a direction key) following either the Alpha command, Value command, or Edit command.

Action. If you want to enter additional data, simply type what you want entered. Multiplan automatically selects the appropriate command (Alpha or Value). If you want to return to the main command menu, press CANCEL. If you press **ENTER** instead of a cursor movement key following any of these three commands, Multiplan returns to the main command menu as soon as the command is carried out.

Enter Y to confirm

Cause. You have asked Multiplan to make a major change in the active sheet. Please carefully consider whether this action is correct.

Action. If it is safe for the command to proceed, type a Y. If it is not safe, press any other character, and Multiplan returns to the main command menu without changing the worksheet.

Enter Y to retry access to filename

Cause. The file named is not accessible to Multiplan.

Action. Enter N if the file is not appropriate. Make sure that the correct diskette is mounted in the correct drive. Change the "default drive" if necessary. See the "Files" section in Chapter 8 and the section at the beginning of this manual entitled "Operating Information" for more information. Then try Y again. If you still get this message, N cancels the command and returns the main command menu and worksheet display. If Multiplan is asking for the system diskette, entering N terminates the session immediately.

Error in formula

Cause. See the rules for formulas in the "Formulas" section in Chapter 8. The highlighted area begins at the point an error was noted.

Action. Check all punctuation, especially parentheses, quotes, and brackets. Check the spelling of function names. Check for a mismatch of data types, as in concatenating text to a number.

Field has too many words

Cause. The formula or text being edited has more numbers or words than Multiplan can handle for purposes of moving from word to word with the WORD BACK and WORD FORWARD keys.

Action. None needed; the formula or text is valid and may be used. However, the WORD BACK and WORD FORWARD keys cannot be used while editing it.

File format error: line number

Cause. File being read is in the incorrect format. The file read stopped at the line number displayed.

Action. Check the mode setting of the Transfer Options command. Be sure that the mode setting is the same as the format of the file being read.

File is not a saved worksheet

Cause. The file you are trying to load or link to was not saved with the Transfer Save command.

Action. Check the spelling of the filename. Make sure the "mode" of the transfer is correct if you are trying to load other than Normal format files.

Help file not available

Cause. The diskette file containing the on-line reference information cannot be found.

Action. See the "Files" section in Chapter 8.

Illegal option

Cause. While a menu is displayed, you have typed a character that does not appear as a starting letter of any of the menu options.

Action. Check the menu for the option that you wish to select, and type the first letter of the menu item, or press CANCEL to cancel the command.

Illegal parameter

Cause. One field of the command last entered had a numeric response that was illegal. For instance, if the "number of cells" field of Copy Down was given the response 299, this message would appear when **ENTER** was pressed. There are only 255 rows, so 299 copies could never be made.

Action. Reenter the command correctly.

Illegal width of column

Cause. The column width you requested was out of range.

Action. Reenter the command correctly. Make sure you specify the width as a number between 3 and 32 inclusive.

Insufficient memory

Cause. Multiplan has run out of storage space; it has no space left for new cell contents.

Action. Save the sheet at once. Then consider ways to simplify it. Blank cells take little space, so blank any unwanted cells. If you have large areas of blanks between areas in use, make the sheet more compact. The Delete commands remove cells from your sheet. Beyond that, you may have to break the application into dependent and supporting sheets to fit in all the information.

Locked cells may not be changed

Cause. An attempt was made to modify the value of a locked cell. Note that the lock may have been set by eXternal Copy.

Action. If you need to change the cell, unlock it first, using the Lock Cells command.

Name not defined: sheet name

Cause. An eXternal Copy was attempted from a named area that is not defined on the source sheet.

Action. Check the source sheet for the correct name. Redefine the external link if necessary.

Name too long

Cause. Names may not exceed 31 characters. The name you have entered exceeds this.

Action. Use a shorter name.

Overwrite existing file?

Cause. The diskette file Multiplan is about to create—either a saved worksheet or a file of printer lines from the Print File command—has the same name as an existing file. If Multiplan continues, it will replace the existing file with the new one.

Action. Think carefully! If you agree that the existing file is of no importance, reply **Y** to let the command proceed. If the file might be important, reply **N** and reenter the command, giving a different, unique filename.

Press any key to redraw screen

Cause. The eXternal List command has put an information display on the screen in place of the usual display.

Action. When you finish reviewing the information display, press any key to return to the normal display.

Printer error

Cause. The printer is not responding to a Multiplan request.

Action. Check to see that the printer is connected properly and ready to print.

Reading line number

Cause. You commanded Multiplan to read a symbolic file.

Action. None. The line number increases as Multiplan reads through the file. When the file has been read completely, you can continue your Multiplan session.

Select option

Cause. Multiplan is waiting for your choice among a short list of options.

Action. Selection in this case is similar to command selection. Move the edit cursor to the desired option using the **SPACE BAR** or **BACKSPACE** key (as necessary). Or type the initial letter of the option.

Select option or type command letter

Cause. Multiplan awaits your choice from a list of options.

Action. Select one of the items shown by moving the edit cursor to it with the **SPACE BAR** or **BACKSPACE** key and then pressing **ENTER**. Or just type the initial letter of the item you want.

Shapes of areas do not match

Cause. The destination area of an eXternal Copy command does not have the same "shape" (or size) as the source area.

Action. Specify a single cell as the upper left corner of the destination to suppress the shape check. However, the mismatch suggests a review of the names on the supporting sheet and on the active sheet.

Too many depending sheets

Cause. Multiplan can keep track of eight dependent sheets at most. The message signals that there are more than eight dependent sheets.

Action. No action is necessary, but you cannot rely on the accuracy of the eXternal List command. See also the discussion of eXternal Relationships in the "Files" section in Chapter 8.

Too many windows

Cause. There is a limit of eight windows, and the Window Split command has been used in an attempt to open a ninth.

Action. Review the existing windows; use the Window Close command to delete some of them.

Window will not fit

Cause. The window you are trying to Border or Split is too small.

Action. Close an adjacent window to get more room on the screen, or rethink your screen layout.

Appendices

- 1 Helpful Hints
- 2 Glossary
- 3 Notes for the VisiCalc™ User
- 4 The SYLK (Symbolic Link) File Format
- 5 Solving Extended Problems with the Iteration Option
- 6 Multiplan Reference Summary

Appendix 1: Helpful Hints

This appendix offers hints for saving space in memory and on your diskettes, for saving time during your Multiplan sessions, and for making Multiplan easier to use.

1. Use the eXternal commands to split sheets at logical places. The method of splitting up your work should follow the natural breaks in your tasks. By splitting up your task into smaller tasks, you can keep your worksheets smaller and faster to work with.
2. Keep the worksheet compact. Keep the amount of blank space within the worksheet to a minimum. Also, avoid extending the worksheet size unnecessarily.

Placing any number outside the general work area, even formatting a cell unintentionally, can use more memory and diskette storage than necessary.

If you suspect that too much memory is being used (check the % Free indicator at the bottom of the screen), try deleting all columns to the right and all rows below your work area on the sheet. This ensures the minimum size for your worksheet.

3. Place common subexpressions in an intermediate cell, then refer to that cell when the subexpression is needed in a formula in another cell. This saves retyping and recomputing the same information. For example, if SUM(Sales) appears in several formulas:

MIN(1000,SUM(Sales))

SUM(Sales)*commission%

AVERAGE(Sales) (This example has SUM hidden. An equivalent is
SUM(Sales)/COUNT(Sales).)

it is more efficient to compute SUM(Sales) once in a cell and then refer to that cell from the formulas. Having the intermediate result visible also helps with tracing problems in the setup of the formulas.

4. Define names for the common areas on your worksheet. By defining names, you speed up references to a group of cells. For example, *Sales* is easier and faster to type than R2C3:15 and *Hotspots* is easier than R3C4,R5C6,R5C8. Use the REFERENCE key (CTRL 7) to enter names directly from the name table.
5. Use the Copy commands for filling in cells with identical values, especially formulas, but also numbers and text. Copying is simpler, less error prone, and more space efficient than manually entering repeated values into cells individually.
6. To quickly copy the format of a group of cells into another part of the worksheet, first copy the group of cells as they are. Then, blank the cells in the new area.
7. Use primitive forms of references wherever possible. For example, it is more efficient to use R2C2 than R2 C2 or R1:2C1 than R1C1:R2C1.
8. Turn off automatic recalculation, and use the RECALC key (FCTN 8). This way you can enter new values and edit current values without waiting for each recalculation. Recalculation also occurs when you change text.
9. Use "Continuous" cell format code sparingly—formatting whole rows with "Continuous" format or specifying "Continuous" as the default setting is inefficient.
10. Format entire rows or columns at one time, except for "Continuous" format. Formatting entire rows or columns does not extend your worksheet.
11. Avoid functions or operations over unnecessarily large ranges. For example, instead of SUM(R2), specify only the range of columns that contain values, for instance SUM(R2C1:5). Try to restructure the function or operation so that large ranges are not necessary.

12. Avoid extensive use of forward references, because they are slower to recalculate. For example, a reference to cell R10C10 from cell R5C5 is slower than a reference to R5C5 from R10C10.
13. Use the page direction, HOME, and LOWER RIGHT keys to scroll rapidly across and down the worksheet.
14. Perform similar operations together. Try to define all names at once. Copy all cells at once. By performing similar operations together, you can make maximum use of the proposed responses, which saves considerable time.
15. Simply press the **ENTER** key to select the Alpha command whenever the main command menu is displayed.
16. Position the cell pointer before selecting a command. This also makes it easier to use proposed responses.
17. Use the Normal mode for saving and loading files whenever possible (see Transfer Options command). If you load a file that is in Symbolic or Other mode, save it in Normal mode when you are finished with it. Files in Normal mode load much faster than files in the other modes.

Appendix 2: Glossary

Absolute reference: A reference to a cell that uses specific row and column numbers — for instance, R17C12. Alternative to a relative reference, such as R[+ 1] C[- 2].

Action keys: Keys that cause Multiplan to carry out an action at once. The action keys include the CANCEL key, NEXT WINDOW key, and ENTER key. See also Direction keys, Edit keys.

Active: Something in use right now and immediately accessible, such as the active window, active cell, or active field of a command.

Active cell: The cell indicated by the cell pointer. The contents of the active cell can be seen on the status line and may be edited with the Edit command.

Active window: The window containing the active cell, marked on the screen by a highlighted window number.

Alignment: The rule for the horizontal positioning of the display of a cell's value. Values may be left justified, right justified, or centered.

CANCEL key: Action key that causes Multiplan to abandon the current command and return to the command menu.

Cell: One position on the worksheet, a place where data or a formula may be stored. A cell has a location and may be referred to by one or more names. The contents of a cell determine its value; the cell's format determines how its value is displayed.

Cell pointer: A highlighted pointer that selects one cell from all the cells in the worksheet. That cell becomes the active cell. The cell pointer can be moved from cell to cell with the direction keys or directly to a specified cell with the Goto command.

Character: A symbol that can be displayed on the screen, including letters, digits, punctuation, and special characters like \$, +, and %.

Column: A vertical line of cells down the worksheet. There are 63 columns, designated by the numbers 1 through 63.

Command: An instruction to Multiplan to do something. A command may have one or more fields in which to specify how the command should be carried out.

Command line: The screen lines just under the worksheet area, beginning with the word COMMAND: and showing the main command menu.

Contents (of a cell): That which has been put into a cell. If nothing has been put in, the cell is empty and its contents are blank. Otherwise, the cell contains either data (text or a number) or a formula. If a cell contains a formula, the cell's value, which is the result of the formula, is usually displayed.

Cursor: See Edit cursor.

Dependent sheet: A sheet that uses values from another sheet. The dependent sheet depends on information calculated on another sheet (saved as a diskette file) to which it is linked by the eXternal Copy command. See also: Link.

Direction keys: Keys that move the cell pointer. The UP, DOWN, LEFT, and RIGHT keys move the pointer one cell at a time. The HOME key moves it to the cell in the upper left corner of the active window.

Directory: The table of file names kept on each diskette by the operating system. The directory lists each file on the diskette.

Edit: Altering a response in a field of a command. The edit keys are used to move the edit cursor over the response, and the character keys are used to replace or insert characters.

Edit cursor: The highlighted part of a command on the command line, which may be as small as one character or as large as an entire field. The edit cursor is moved with edit keys. It shows where alterations can be made to the command.

Edit keys: Keys that move the edit cursor within the command line. Includes, for example, the WORD FORWARD, WORD BACK, CHARACTER FORWARD, and CHARACTER BACK keys.

Field: A portion of a command in which you type a response to instruct Multiplan in some detail of the command's work. When Multiplan first shows a field, it contains a proposed response; you can replace or edit that response if it isn't what you want.

File: A named unit of data stored on disk or diskette. When a worksheet is saved it is written into a file. Not all files are saved worksheets, but those that are can be loaded or linked to other worksheets.

Filename: The name used to refer to a worksheet when it is saved, loaded, or linked to another sheet.

Format: How a cell's value is displayed. The format controls numeric punctuation and the alignment of the displayed value. A format can be specified for a cell or cells with the Format Cells command; cells without a specific format are displayed according to a default format set with the Format Default command.

Formula: A recipe for how a value is to be calculated. Whenever the contents of a cell are changed, Multiplan recalculates all the formulas on the worksheet (unless automatic recalculation is turned off).

Function: A built-in mathematical or statistical operation that Multiplan can perform on one or more values; e.g., SUM or AVERAGE.

Group of cells: A collection of one or more cells on the worksheet that may be named, e.g., Sales.

Highlight: An area on the display that appears emphasized. Highlights are used to indicate the edit cursor, active cell, active window number, and current menu item.

Link: In Multiplan, the use of data from an inactive sheet in calculations on the active sheet. The inactive sheet is called the supporting sheet. The data to be copied must have been marked with the Name command or must be specified by an absolute reference. Then data from the supporting sheet may be used in formulas on the active sheet. Link is also used to express connection between windows for synchronized scrolling.

Load: To make a saved sheet active again. The sheet to be loaded must have been saved. The Transfer Load command is used to copy the saved sheet from its file to working storage, where it becomes the active sheet.

Lock: Protection of cells that contain formulas or text from inadvertent alteration.

Menu: A list of alternatives. A choice from a menu is selected in one of two ways: by moving through the list with the **SPACE BAR** (a highlight will move along the menu to indicate the current selection) and selecting the highlighted choice with the **ENTER** key, or by typing the initial letter of the desired item.

Message: A notice displayed by Multiplan on the message line to explain a problem or to suggest what kind of input the system is waiting for.

Message line: The next to the last line on the display.

Name (of a cell or group of cells): A tag associated with a group of cells by the Name command. The name can be used to refer to the cell or cells in formulas.

NEXT UNLOCKED CELL key: Key that moves the cell pointer to the next cell that is not blank and is not locked. Used to find cells that contain numbers (rather than a formula or text) so you can perform “what if” experiments.

Proposed response: Response supplied by Multiplan. It is usually based on the most recent responses by the user or on the current status of Multiplan.

Range: The smallest rectangle of cells containing two references. A range is designated by the colon (:). The range R3:R8 defines the rectangular area containing all of rows 3 and 8, namely rows 3, 4, 5, 6, 7, and 8. See also: Reference.

Reference: The designation of a cell or an area of cells. The simplest reference is to a single cell: R9C2. A reference may be relative to the cell containing the reference, as in R[-1]C. A reference may be to a single cell, as the prior two, or to an area of cells: R6 refers to all of row 6.

A reference may be composed of intersections of references, ranges of references, or unions of references. A reference may be a name defined to refer to one or more cells. See also: Range and Name.

Relative reference: A reference to a cell relative to the cell containing the reference, as R[-1]C meaning “the row above, in this column.” Alternative to an absolute reference, in which the actual column and row numbers are stated.

Response: What the user types in a command field. May be a row or column number, a count, a name, or the contents to be put in a cell. When Multiplan displays a command on the command line, it usually supplies a proposed response in every field of the command; the user may replace the proposed response, edit it, or leave it as proposed.

Row: A horizontal line of cells across the worksheet. There are 255 possible rows, designated by the numbers 1 through 255.

Save: The operation of making a permanent copy of the active worksheet in a file.

Scroll: To move one or more windows across the worksheet one row or column at a time. Scrolling is done with the direction keys. For example, if the RIGHT DIRECTION key is pressed until the cell pointer reaches the right edge of the screen and then pressed again, Multiplan scrolls the worksheet display one column to the left.

Status line: Bottom line of the screen, where Multiplan presents status information such as the location of the active cell and its contents.

Supporting sheet: A sheet providing values to another sheet. The sheet supports the other sheet (the dependent sheet) with data that has been designated with the eXternal Copy command. Data on the supporting sheet must have been named with the Name command. See also: Link.

Text: A string of characters that may be used for titles in the worksheet. Multiplan formulas can perform operations on text also.

Value: The information content of a cell—its numeric value, if it contains a number, its text, if it contains text, or, if it contains a formula, the result of calculating that formula.

Window: A rectangular portion of the display area within which Multiplan displays a part of the worksheet. As many as eight windows may be open at once; they are opened or closed with the Window command. Each window has a window number from 1 through 8 shown in its upper left corner. The window number of the active window is highlighted, and that window contains the active cell, highlighted by the cell pointer.

Worksheet: A grid of cells displayed by Multiplan to store formulas and values.

Appendix 3: Notes for the VisiCalc* User

If you have used VisiCalc previously, you are probably curious about how that product differs from Multiplan. This appendix compares the operations and features of the two. Described first are the operations the two programs have in common, roughly in the order they are presented on the VisiCalc reference card. The features unique to Multiplan are described second.

The Multiplan Screen

Multiplan divides the screen into a display area, command lines, a message line, and a status line. Parts of the worksheet are shown in the display area. Unlike VisiCalc, which allows you to create just two windows, Multiplan allows you to create as many as eight windows within the display area. You have control over the size and placement of each window. You can have windows with or without borders, and you can freeze title columns and rows. All these functions are controlled by the Window commands (see Chapter 9).

The message line displays Multiplan comments on the progress of any command. The status line at the bottom of the screen displays the coordinates of the active cell, its actual contents, and the percent of storage that remains.

Moving the Cell Pointer

The four direction keys move the cell pointer around the active window. The HOME key sends the cell pointer to the upper left corner of the worksheet. The LOWER RIGHT key sends the cell pointer to the lower right corner of the data area. You may also move the cell pointer to a specific cell with the Goto command, which lets you move to a particular row and column or to a particular cell by name (see "Names" below). The NEXT WINDOW key moves the cell pointer to the next window in sequence.

Correcting Errors, Cancelling Commands

In Multiplan, the CANCEL key cancels any command you have begun. The BACKSPACE key erases the last character typed. There are several other editing keys used to correct typing errors (see Chapter 8).

Entering Titles and Text

In Multiplan, a cell may contain a title or simple text made of characters documenting a row or column on the worksheet. To enter text, choose the Alpha command, type the title, and press ENTER or any direction key.

Unlike VisiCalc, Multiplan can use text in formulas. To include text as part of a formula, enter it in double quotes. You can use the titles on your worksheet in formulas (as references to parts of the worksheet) if the titles are also defined with the Name command.

* VisiCalc is a trademark of VisiCorp, Inc.

Entering Numbers

A cell may contain a number. To enter one, just start typing it. Put the finished number in the active cell by pressing **ENTER** or any direction key. Numbers may be in decimal form or in scientific notation.

Entering Formulas

A formula is composed of text, numbers, cell references, operators (+ - * /), and function names (SUM, MIN, etc.). Unlike VisiCalc, but like most programming languages, Multiplan evaluates formulas according to the precedence of operators: exponentiation (^) first, then multiplication (*) and division (/), then addition (+) and subtraction (-), and finally text concatenation (&). You may use parentheses to change the order of calculation.

Values can be compared using the operators less than (<), greater than (>), less than or equal (<=), greater than or equal (>=), equal (=), and not equal (<>).

The & (concatenate) and % (percent) operators are unique to Multiplan.

To enter a formula, first type = or +, then the formula. Within a formula, you may enter a reference to another cell by pointing to that cell with the direction keys. All the editing keys are available to you while entering a formula; the WORD FORWARD and WORD BACK keys are especially helpful.

References

Note that Rows and Columns are both numbered, the Row indication given first. Thus, the VisiCalc reference B3 can be written in Multiplan as R3C2.

In a formula, you may refer to the value of a cell or a group of cells in any of several ways. You may give an absolute reference to a row and column (R3C5) or to a range along a row or column (R3:6C9, R5, C1:8). You may give a reference relative to the cell holding the formula (R[-1]C for "this column, one row up"). Most importantly, you can give a name to any cell or group of cells. For instance, the name *Sales* might refer to R9C2:9 (row 9, columns 2 through 9). The formula SUM(Sales) produces the sum of all numbers in those cells.

References of any of those three kinds may be combined by intersection or union to make other references (see Chapter 8 for details and examples).

Multiplan Names

In Multiplan, the Name command allows you to define a name as a reference to a single cell, or to a group of cells. Once you've done so, you may use that name as an argument of a function or, in many cases, as a response in a command. A name must start with a letter, and it may contain letters, numbers, periods (.), and underline () characters, up to 31 characters maximum.

This naming ability can make a big difference in the clarity of your sheets. Consider this formula (as VisiCalc presents it):

$B1 * B2 * (1 - B3)$

Notice the improvement if you write it using names:

$Quantity * Price * (1 - Discount)$

The Name command also allows you to review your name definitions using the direction keys.

Functions

Multiplan supports all of the functions familiar to you from VisiCalc and others unique to Multiplan. Table 1 compares the Multiplan functions with their VisiCalc counterparts. See Chapter 10 for details on each Multiplan function. Note that Multiplan function names do not begin with “@”.

Multiplan also provides several unique functions. See Table 2.

Table 1: Multiplan Functions and Their VisiCalc Counterparts

Multiplan	VisiCalc
ABS(N)	@ABS(N)
use $\text{PI}()/2 - \text{ATAN}(N/\text{SQRT}(1 - N*N))$	@ACOS(N)
AND(list)	@AND(list)
use $\text{ATAN}(N/\text{SQRT}(1 - N*N))$	@ASIN(N)
ATAN(N)	@ATAN(N)
AVERAGE(list)	@AVERAGE(list)
INDEX(area,subscripts)	@CHOOSE
COS(N)	@COS(N)
COUNT(list)	@COUNT(list)
use undefined name	@ERROR
EXP(N)	@EXP(N)
FALSE()	@FALSE
IF(l,v1,v2)	@IF(l,v1,v2)
INT(N)	@INT(N)
ISERROR(N)	@ISERROR(N)
ISNA(N)	@ISNA(N)
LN(N)	@LN(N)
LOG10(N)	@LOG10(N)
LOOKUP(N, area)	@LOOKUP(N,range)
MAX(list)	@MAX(list)
MIN(list)	@MIN(list)
NA()	@NA
NOT(l)	@NOT(l)
NPV(dr, list)	@NPV(dr,range)
OR(list)	@OR(list)
PI()	@PI
SIN(N)	@SIN(N)
SQRT(N)	@SQRT(N)
SUM(list)	@SUM(list)
TAN(N)	@TAN(N)
TRUE()	@TRUE

Table 2: Functions Unique to Multiplan

Function	Description
COLUMN()	Current column number
DOLLAR(<i>N</i>)	Text form of <i>N</i> formatted as dollar amount; negative <i>N</i> shown in parentheses
FIXED(<i>N</i> , <i>d</i>)	Text form of <i>N</i> formatted with <i>d</i> decimal places
LEN(<i>T</i>)	Length of text <i>T</i> in characters
MID(<i>T</i> , <i>s</i> , <i>c</i>)	The <i>c</i> characters of text value <i>T</i> starting at <i>s</i>
MOD(<i>N</i> ₁ , <i>N</i> ₂)	Remainder of <i>N</i> ₁ / <i>N</i> ₂
REPT(<i>T</i> , <i>N</i>)	Text made of <i>N</i> repetitions text <i>T</i>
ROUND(<i>N</i> , <i>d</i>)	Value of <i>N</i> rounded to <i>d</i> decimal places
ROW()	Current row number
SIGN(<i>N</i>)	- 1, 0, or + 1 depending on <i>N</i>
STDEV(List)	Standard deviation
VALUE(<i>T</i>)	Number value of text <i>T</i>

Commands

Multiplan commands are chosen from the menu by highlighting a command word or by typing the first letter of a menu item. Table 3 shows the Multiplan commands and their VisiCalc counterparts (for complete details on the Multiplan commands, see Chapter 9). Remember as you scan Table 3 that you type only the capitalized letters when choosing a Multiplan command.

If a command has more than one argument “field”, they are separated by TAB instead of **ENTER**, as in VisiCalc. In Multiplan, **ENTER** executes the command.

It’s worth noting that the Multiplan Insert, Delete, and Move commands can operate on more than one row or column at a time. You can Insert several blank rows, or Delete several rows. Move allows you to move any rectangular area; you aren’t restricted to moving entire rows or columns. Multiplan adjusts all references (absolute or relative) and name definitions to account for the changes.

The Multiplan Format command can set the format of one cell or of a group of cells.

Multiplan automatically recalculates cells until all have reached the correct values (or until Multiplan finds an endless chain of references) so the VisiCalc “/GO” (order of calculation) command isn’t needed. You don’t have to be concerned with the order of calculation in Multiplan or worry about forward references.

Multiplan provides several unique commands that VisiCalc does not have. See Table 4.

Table 3: Multiplan Commands and Their VisiCalc Counterparts

Multiplan	VisiCalc
Blank	/B
Transfer Clear	/C
Delete Columns, Delete Rows	/D
Edit, Alpha	/E
Format Cells	/F
Format Width	/GC
Format Default	/GF
not needed; see text	/GO
Option	/GR
Insert Columns, Insert Rows	/I
Move Columns, Move Rows	/M
Print	/P
Copy	/R
Transfer Load	/SL
Quit	/SQ
Transfer Save	/SS
Window Split Titles	/T
Option	/V
Window Open, Window Split, etc.	/W
Window Link	/WS, /WU
Goto Row-col	>
NEXT WINDOW key	;
RECALC key	!
use references	#
see Table 2, REPT function	/-

Note: You type only the capitalized letters of the Multiplan command names.

Table 4: Commands Unique to Multiplan

Format Options
 Help
 Lock
 Name
 Sort
 Window
 eXternal

Printing

Multiplan has a full set of printing operations, initiated by the Print command. You may print all or any rectangular area of the worksheet; an area can be specified by name or specific references. Multiplan can send the printed representation of the worksheet to a file on disk. You may then use that file with operating system commands and other programs: you could, for instance, incorporate a worksheet listing into another document. Multiplan also gives you the option to print the formulas in cells instead of their resulting values.

Copying Cells

Multiplan's Copy command performs the operations that, in VisiCalc, are done with "/R". Copy Down and Copy Right provide especially easy ways to duplicate one cell down a column or across a row. The general Copy From operation will duplicate a single cell into an area of any shape, or duplicate an area of any shape in another area of the same shape. Multiplan doesn't ask whether references should be adjusted or not; if you build your formulas with relative references and names, they will be position-independent.

Worksheet Transfers

The Transfer command handles operations on the whole worksheet.

The DIF* format is not directly supported by Multiplan. However, DIF* files can be readily converted into the Multiplan SYLK format described in Appendix 4.

By the proper choice of Transfer Options (see Transfer Options command in Chapter 9), Multiplan can load saved VisiCalc files directly. Simply select the Transfer Options command and set the "mode" to Other. Then use the Transfer Load command as you would for any Multiplan file. Just as in VisiCalc, the loaded sheet will be merged with the active sheet. This feature automatically compensates for the following differences:

- arithmetic operator precedence
- names of functions and the order of arguments
- format of cell references (all cell references are converted to relative reference).

Linking Sheets

The Multiplan eXternal Copy command may be used to copy data from a named area in a saved worksheet to the active sheet. The data sharing relationship between the sheets may be made permanent, in which case Multiplan will automatically copy the data from the "supporting" sheet every time the "dependent" sheet is loaded. You can find the details of this important Multiplan feature in Chapter 9.

Sorting

The Multiplan Sort command (described in Chapter 9) may be used to sort the worksheet on any column or columns containing numbers or text, in ascending or descending order.

Lock

The Multiplan Lock command can be used to lock individual cells or to lock all cells that contain formulas or text. This command makes it safe to test "What if...?" situations without disrupting or destroying your valuable worksheet structure.

* DIF is a trademark of VisiCorp, Inc.

Appendix 4: The SYLK (Symbolic Link) File Format

Note: Symbolic link allows manipulation of Multiplan file contents. Most applications of Multiplan will never require knowledge of Symbolic link. You should only use the file manipulations made possible by Symbolic link if you have an advanced understanding of the detailed structure of ASCII files.

The purpose of the SYLK (SYmbolic LinK) format is to exchange information between Multiplan and application programs. The format is designed with extensibility, ease of generation, ease of parsing, and storage efficiency in mind. The worksheet can be completely represented by SYLK files. This means that a program can generate a Multiplan worksheet, such as a program to build a cash-flow forecasting worksheet from a general ledger chart of accounts. It is useful to subdivide the definition of SYLK into the following "layers":

1. SYLK record and field formats: this layer provides for the identification of the files, a degree of data compression, and an easy way for a program to separate information that is important for its purpose from information that the program is not interested in handling.
2. The "C" or cell or data point record. This is probably the record type of the most universal interest.
3. Other Multiplan-specific records and fields. This collection of formats affords complete control or complete overview for a communicating program of the state of a Multiplan session, including the worksheet, windows, options, etc.

The first layer is defined as follows. The contents of a SYLK file—encoded in ASCII—are divided into records by either CR or LF characters. Empty records are ignored. Non-empty records are further subdivided into an RTD (record-type descriptor), optionally followed by a list of fields. Each field in the list is preceded by an FTD (field-type descriptor). The contents of the fields is determined by the RTD and the FTD, as described below:

RTDs consist of up to two letters. They determine the meaning of the record according to the standards described below.

FTDs consist of a semicolon and a single letter that determines the meaning of the field. The meanings of FTDs (;U, ;V, ;W, ;X, ;Y, and ;Z) will be the same for all records. The meanings of other FTD's will depend on the record type.

The field contents can be arbitrary, except for the following: CRs or LFs may not be included, and semicolons must be doubled.

A degree of data compression is achieved by the following rule: for certain fields, the last field value will be automatically substituted if the field contents are empty. Such fields are said to be differentially encoded and will be marked by (diff) in their description.

The FTDs ;X and ;Y determine x and y coordinates in a worksheet or other two-dimensional space containing data points. Coordinates of the first cell are 1,1. ;X and ;Y are differentially encoded, and they may be altogether omitted from records if the last defined value is to be used.

In general, programs that process SYLK files cannot be expected to handle all RTDs, all FTDs, or even the full range of field contents for two reasons. First, their interest may be limited to some aspect of the available data. Second, SYLK may very well be expanded after the release of the program in question. This means that programs must be prepared to ignore records and fields that they do not understand. Data with coordinates that lie outside of the space that the program can process should be also ignored.

The following data records and fields are currently defined.

Record type: C

These records describe a data point that exists in a two-dimensional space with coordinates ;X and ;Y. The Multiplan concept of cell is one example of a data point. Besides its coordinates, data points may also possess a number or text value, an expression, a protection state (locked or unlocked), and several Multiplan-specific properties. Formatting properties for data points may be specified in a separate record type (F, see below).

Fields are:

- ;X,;Y (diff) cell coordinates.
- ;K Value of the data point. Numerical values are given in decimal or exponential form (see Multiplan "Gen" format code). Text values are enclosed in double quotes. The logical values TRUE and FALSE are given this way. Error values are preceded by # and appear as in Multiplan.
- ;P Protection state. If ;P appears, the data is locked; otherwise, it is not locked.
- ;E An expression that computes the value of the data point. The field contents appear exactly as a Multiplan formula.
- ;R,;C (diff) Used by ;S
- ;S Expression for the data point is given at another coordinate. X is given by ;C (column), y is given by ;R (row). The field contents are decimal coordinates. Note that ;E must not appear together with ;S. Moreover, the data point at (;R,;C) must be marked with either ;D or ;G. In the latter case, the value of the data point is taken to be the (constant) expression.
- ;D ;E expression is shared by some other data point.
- ;G ;K value is shared by some other data point. ;E must not appear.

Record type: B

Defines the bounds of the two-dimensional space of data points. This record should appear at the beginning of a SYLK file.

Record type: E

Defines the end of the SYLK file.

Record type: F

Describes the Multiplan formatting properties of individual cells or of the whole worksheet. (See also the descriptions of the Format group of commands in Chapter 9.)

Fields are:

- `;X;;Y` (diff) Cell coordinates.
- `;Fc1nc2` (diff) Cell formatting properties are defined by the contents where c1 is a one-character formatting code (D, C, E, F, G, \$, or *), n is the "# of digits" argument, and c2 is a one-character alignment code (D, C, G, L, or R).
- `;R;;C` ;F properties are to be applied to a whole row or whole column of the Multiplan worksheet. Contents are decimal row or column numbers, respectively.
- `;Dc1nc2n3` "Default" format properties are defined as in ;F (except that the "D" codes may not be used). n3 is the "default" width of columns (see also the Format Default Width command, Chapter 9).
- `;K;;E` Appear if the the commas and formulas Format Options are set, respectively.
- `;Wn1n2n3` Defines the widths of a group of columns in the worksheet where n1 is the first column (x), n2 is the last column in the group, and n3 is the width of the columns in the group expressed as number of characters (cf. Format Width command). Columns that are not mentioned in any format record will have the "default" width setting.

Record type: ID

The first record in the SYLK file must be an ID record. This convention helps with the identification of the file as a SYLK file.

Field is:

- `;Pname` The name of the program that produced the file (for example, MP).

Record type: NN

This record defines a Multiplan name as a union of rectangular areas expressed with absolute references (see also the Name command, Chapter 9).

Fields are:

- `;Nname` The name to be defined.
- `;Ee` Expression describing the area. Its general form is:
 $Rn11:n12Cn13:n14,Rn21:n22Cn23:n24,\dots$
 Ranges over single values may be written without the ":" operator. Ranges R1:255 or C1:63 (but not both) may be omitted.

Record type: NE

The record describes a link to an inactive sheet. See also the eXternal group of commands in Chapter 9.

Fields are:

- ;F Filename (or logical filename) for source sheet.
- ;S Description of the source area, typically a name of a group of cells.
- ;E Expression defining target area, as in NN.

Record type: NU

Describes an external filename substitution. See eXternal Use command, Chapter 9.

Fields are:

- ;L Filename (or logical filename)
- ;F Filename to be used instead of ;L

Record type: W

The window structure of a Multiplan screen is described in part by the states of the windows and in part by the operations that create the windows. To discover the correct description for a particular window arrangement, the best approach is to use Multiplan to set up the windows and then to inspect SYLK output from Multiplan.

Fields are:

- ;N Window number, as shown by Multiplan.
- ;Ay x Coordinates of the cell shown in the upper left corner of window ;N
- ;B Window ;N is bordered if (and only if) ;B appears.
- ;STcy cx or
;SHIcy or
;SVIcx Split window ;N to create new window. The window number of the new window will be one greater than the largest number previously in use. The letters T, H, or V define Title, Horizontal, or Vertical splits, respectively. The symbol I stands for the letter L if the windows are to be linked for scrolling, otherwise it is omitted. The number of character positions in the new window is cx, and the number of screen lines in the new window is cy.

Order of records

There are only a few restrictions on the order of records in SYLK files.

1. ID must be the first record.
2. B should be used (although not required) for Multiplan input.
3. For Multiplan C records: ;D or ;G must appear before another C record that refers to it (with ;S, ;R, ;C).
4. Name definition should precede name use for efficiency, although this is not required.
5. Window splits and window properties must be in strict logical order.
6. NU records must precede NE records.
7. E must be the last record.

Appendix: 5 Solving Extended Problems with the Iteration Option

The Microsoft Multiplan electronic worksheet includes an option that extends the number of solvable problems.

Consider this example. Spencer Ceramics must pay a bonus that is equal to 10% of the profits. The bonus is calculated and then subtracted from the profits to yield the net profit.

Set up this simple calculation in Multiplan as follows (the "Suggested Steps" column is just one way to enter data on the worksheet):

Note: Setting up this simple example may seem rather long, but it provides the basis for a subsequent discussion of extended problems.

Entries	Suggested Steps
Move cell pointer to R1C1	Press the HOME key (CTRL 1)
Enter <i>Gross P</i> in R1C1	Press A, type Gross P , press DOWN
Enter <i>Bonus</i> in R2C1	Type Bonus , press DOWN
Enter <i>Net P</i> in R3C1	Type Net P , press ENTER
Name R3C2 as <i>Net_P</i>	Press N, TAB (CTRL A), RIGHT, ENTER
Name R2C2 as <i>Bonus</i>	Press UP, N, TAB, RIGHT, ENTER
Name R1C2 as <i>Gross_P</i>	Press UP, N, TAB, RIGHT, ENTER
Enter <i>1000</i> in R1C2	Press RIGHT, type 1000 , press DOWN
Enter <i>Gross_P*10%</i> in R2C2	Type =Gross_P*10% , press DOWN
Enter <i>Gross_P-Bonus</i>	Type =Gross_P-Bonus , press ENTER
Format column 2 to \$	Press F, C, type C2 Press TAB, TAB, \$, ENTER

At this point, your screen looks like:

Gross P	\$1000.00
Bonus	\$100.00
Net P	\$900.00

This bonus is calculated on the gross profits, but the contract calls for the bonus to be calculated on the net profit instead of the gross. You may try to change the worksheet:

Enter <i>Net_P*10%</i> in R2C2	Press UP, V Type Net P*10% Press ENTER
--------------------------------	---

Multiplan displays the error message:

Circular references unresolved

The error message indicates a more complicated calculation that requires a different approach. The bonus calculation depends on the net profit. The net profit, in turn, depends on the size of the bonus, which must be subtracted from gross profit to get net profit, a seemingly endless circle. To solve the problem on paper, we would set up an equation and use algebra to find the bonus from the gross profit. Once the equation is set up, the bonus can be calculated manually or using any calculator.

Instead of spending time setting up complex algebraic formulas, you can let Multiplan automatically solve this extended problem without algebra, as follows:

Press **O** (for Options)

Make sure "Yes" is selected in the "recalc" field

Press **TAB (CTRL A)** twice to move to the "iteration" field

Press **Y** (for "Yes")

Press **ENTER**

The numbers on the screen change in rapid succession until they become \$90.91 for Bonus and \$909.09 for Net P. These are the solutions. If you change the gross profit to 1100, Multiplan quickly recalculates the new bonus as \$100 and the net profit as \$1000. The "Circular references unresolved" error message does not reappear.

What happened? Multiplan used iteration to calculate the solution. To iterate means to repeat a calculation using the results of the previous calculation instead of an unknown quantity. Of course, previous results do not solve the problem exactly, but each iteration produces results that fit better. In the Spencer Ceramics example, the solution was produced as follows.

Just before the first iteration, we had the initial values:

Bonus \$90.00

Net P \$900.00

The calculations then progressed as follows:

90			
900	$900 \cdot .1 = 90$		
	$1000 - 90 = 910$	$910 \cdot .1 = 91$	
		$1000 - 91 = 909$	$909 \cdot .1 = 90.9$
			$1000 - 90.9 = 909.1$

...and so on.

When iteration causes values to become more precise, the process is called convergence. Not all models converge. Some models converge only partially. Convergence may also depend on the initial values as well as on the model. Unless you specify otherwise, Multiplan stops iterating when the maximum change in all cell values on the worksheet is less than 0.001. This limit assures that the results are precise at least to the penny or percent without jeopardizing the chances for normal termination.

If, for some reason, a model fails to converge within the limit, pressing the **CANCEL** key interrupts the recalculation at the end of the iteration that is in progress (see the description of the Options command below).

In the next section, you'll find descriptions of the Multiplan command and functions for controlling iteration. Iteration involves the Options command and the **ITERCNT** and **DELTA** functions.

Following that, you'll find examples of some useful iterative worksheets; one for an Income Statement and Balance Sheet, one for calculating the Internal Rate of Return (IRR), and one for finding roots of equations using the binary search technique.

Finally, you'll find a summary of hints for creating iterative models.

For more information on the mathematical theories of iterative methods, consult any handbook on Numerical Analysis.

The Iteration Option and Supporting Functions

Multiplan enters an iteration phase at the end of any normal worksheet recalculation if the following conditions exist:

1. The worksheet contains at least one circular chain of references.
2. The "iteration" field of the Options command is set "Yes."
3. The completion test (see below) is not TRUE at the end of the first recalculation.

The Options command and two functions (DELTA and ITERCNT) support the iteration option.

OPTIONS

OPTIONS recalc: Yes No mute: Yes No
 iteration: Yes No
 completion test at:

Select option

Description

See the Options command in Chapter 9 for details of the "recalc" and "mute" fields.

Select "Yes" in the "iteration" field if Multiplan displays the "Circular references unresolved" error message and if you want to calculate values from formulas that form a circle of references. Once you have entered a circular reference, select "No" in the "recalc" field while making new entries to the worksheet. This saves time and confusion when entering or changing values. Also, selecting "No" in the "recalc" field instead of the "iteration" field prevents Multiplan from displaying the "Circular references unresolved" error message.

In the "completion test at" field, enter an absolute or name reference to the cell that contains either a completion test or a convergence test. Storing the test formula in a cell lets you store and display a complex test as a part of the worksheet. If you leave this field blank, Multiplan applies the formula

$\text{DELTA}() < 0.001$

as the convergence test (see the DELTA function below for details).

If you want to specify your own completion or convergence test, the formula in the cell must return a logical value (TRUE or FALSE). See the DELTA and ITERCNT functions for details about completion and convergence tests.

Stepping through an iteration model one iteration at a time permits debugging and illustrating an iterative solution. To set this up, enter as a response in the "completion test at" field an absolute or name reference of a cell that contains the TRUE() function. This means that Multiplan calculates the model only once. By repeatedly pressing the RECALC key, a step-wise solution is produced.

Pressing the CANCEL key stops iteration. Only the CANCEL key has an effect during iteration because all other keys would be entries and are therefore ignored. Multiplan checks for the CANCEL key at the beginning of each iteration. Thus, if you press the CANCEL key during an iteration, then Multiplan completes that iteration, checks the completion or convergence test, and finally (if the completion or convergence test is not TRUE) Multiplan stops iteration and displays the "Circular references unresolved" error message. (If the completion or convergence test is TRUE, Multiplan ends iteration as if you had not pressed the CANCEL key.)

The responses in the Options command "iteration" and "completion test at" fields are saved with the worksheet in Normal mode (see Transfer Options command in Chapter 9). Thus, when you load a worksheet that contains an iterating model, the fields of the Options command receive the responses saved with the worksheet. If you later start another sheet, you may want to reset "iteration" to "No" and delete the response in the "completion test at" field.

Example

To cause Multiplan to recalculate the worksheet using iteration and to place a completion or convergence test in R20C5 which you have named "Done":

```
OPTIONS recalc:[Yes]No      mute: Yes[No]
        iteration:[Yes]No  completion test at: Done
```

See "Creating Iteration Models" for actual models that include iteration.

DELTA()

Description

Returns the maximum absolute value of the changes in values from one iteration to the next. Multiplan counts only the values in the cells that are read between two successive DELTA functions. (Each time Multiplan encounters a DELTA function, it resets the internal DELTA value to 0.) By entering more than one DELTA function, you can isolate the maximum change in a particular part of the worksheet. The DELTA function returns the #N/A error value when $ITERCNT() = 1$ or when $ISNA(ITERCNT())$ appears on the worksheet (that is, during the first calculation of a circular model), because no previous values exist from which to calculate changes.

You can apply the result of the DELTA function in a convergence test. First, enter a formula that contains the DELTA function somewhere on the worksheet. Enter the absolute or a name reference to the cell that contains the formula in the "completion test at" field of the Options command. If you leave the "completion test at" field blank, Multiplan calculates convergence results to a precision of 0.001. You can enter the DELTA function in a convergence test formula to calculate the results of an iteration to any desired precision. For example:

```
DELTA()<0.000001
```

returns TRUE when convergence results are less than 0.000001.

You can also set up the worksheet model so that the DELTA function returns only local values. To create a DELTA() that only applies to the differences of a part of the worksheet, bracket the cells with cells that contain the DELTA function. Each DELTA() resets the DELTA value to 0. To avoid problems with order of evaluation, enter the first DELTA function in the cell immediately above the block of cells for which you want a local DELTA value. Then, enter the test DELTA formula in the cell immediately below the block of cells to return a local DELTA value.

The following sketches illustrate these guidelines:

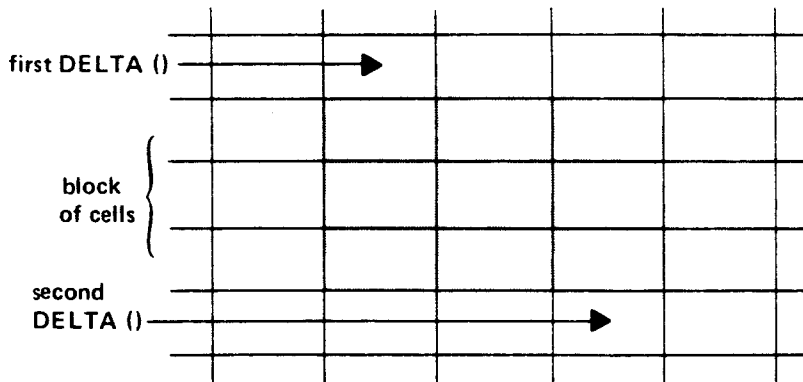

Multiplan recalculates the block of cells column by column. This model provides local values of DELTA only if these columns contain no other circular references. The next sketch illustrates a better model design:

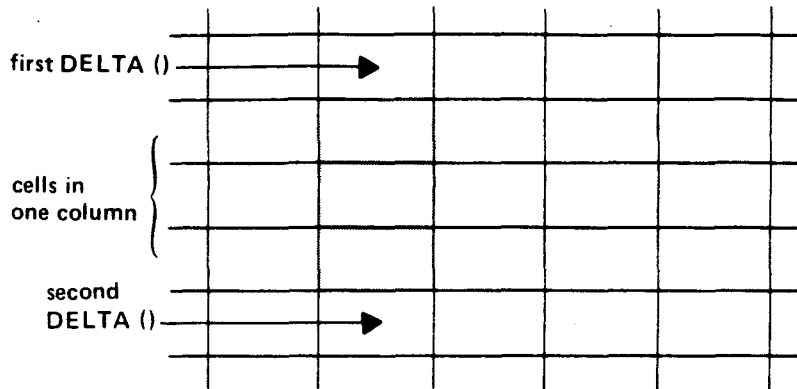

Note that subsequent evaluations of the second DELTA function include changes to the cell with the first DELTA function. The simple formula DELTA() is usually not sufficient; instead, enter a formula such as:

```
IF(TRUE(),"",DELTA())
```

which clears the maximum DELTA value while appearing blank on the screen.

Note that if you enter the DELTA function as a completion test and the ITERCNT function by itself in a model (see the ITERCNT function), you may create divergence. The DELTA function also reads the cell that contains the ITERCNT function. Because ITERCNT changes by 1 during each iteration, DELTA will always return at least 1 unless you set up the worksheet model to return local values of DELTA or you eliminate the ITERCNT formula. Note that the formula ITERCNT()>20 returns TRUE or FALSE after each iteration and therefore would not affect convergence.

Example

Take the simple example of Spencer Ceramics given at the beginning of this appendix, but now calculate the results to the nearest dollar instead of to the nearest penny:

1. Enter DELTA() $<$ 1 in R4C2.

This gives a TRUE value when the difference between the previous and the current result is less than one dollar.

2. Select the Options command and enter R4C2 in the "completion test at" field.
3. Now, enter 1000 in R1C2, the gross profit cell.

The results that Multiplan returns are not the same as before, but they are now within one dollar of accuracy; that is, Bonus is now \$90.90 instead of \$90.91. (Refer to the series of calculations that iteration produced in the Spencer Ceramics example.)

See "Creating Iteration Models" for actual models that include the DELTA function.

ITERCNT()

Description

Returns the current iteration count, starting with 1 for the first iteration. During the first recalculation after each change to the worksheet, ITERCNT returns the #N/A error value.

The ITERCNT function is especially helpful for providing initial values for iterative models, for creating a table of iteration results, and for providing a completion test.

Initial Values

Many worksheet models require an explicit initial value. Yet, during subsequent iterations, the model requires a formula. To arrange this, substitute a conditional formula (with the IF function) in place of the formula that requires an initial value.

For example, as in the Spencer Ceramics example, to start with an initial value of Initial__Net__Profit, then switch to the formula Gross__Profit-Bonus, and enter the formula:

```
IF(ISNA(ITERCNT()),Initial__Net__Profit,Gross__Profit-Bonus)
```

IF selects Initial__Net__Profit when the condition is TRUE; that is, when ITERCNT() returns the #N/A error value (which it does during the first recalculation after each change to the worksheet), the ISNA() function returns TRUE. After that, ITERCNT returns a number, causing ISNA to return FALSE; then, IF selects the formula Gross__Profit-Bonus.

Table of Iteration Results

You can create a table of partial results from an iteration by copying the formula:

```
IF(ITERCNT() = ROW() - 9,Net__Profit,RC)
```

into successive rows starting at row 10. Note that each row receives the value of Net__Profit during a particular iteration and stays unchanged (RC) for all other iterations, before and after.

Completion Test

Enter a formula that includes ITERCNT to limit the number of iterations. For example, enter the formula:

```
ITERCNT() > 20
```

Enter the absolute or name reference to the cell that contains this formula in the "completion test at" field of the Options command. Multiplan calculates 20 iterations and then stops.

Note that if you enter the DELTA function as a completion test and the ITERCNT function by itself in a model, you may create divergence. The DELTA function also reads the cell that contains the ITERCNT function. Because ITERCNT changes by 1 during each iteration, DELTA will always return at least 1 unless you set up the worksheet model to return local values of DELTA (see the DELTA function) or you eliminate the ITERCNT formula. Note that the formula ITERCNT() > 20 returns TRUE or FALSE after each iteration and does not affect convergence.

Creating Iteration Models

Iteration is a powerful problem-solving tool. To illustrate this power, we provide three examples that include iteration. Before you begin to study the examples, you should be aware of the order of evaluation Multiplan follows during iteration.

Unlike Multiplan worksheet models without iteration, models with iteration must take into account the order of evaluation of each cell. During iteration, the current value of cells referred to in the formulas affects the iteration. Fortunately for the worksheet builder, the order of evaluation of circular references is strictly defined when ITERCNT() >= 1. Multiplan always calculates the circular references one column at a time, top to bottom, starting with the first cell of the first column.

A general guideline that helps avoid problems is to place all the circular references in a single column. Care must also be taken that the ordering is correct for iterative methods, such as Newton's method (see example 2) and binary search (see example 3).

For solving simultaneous equations, order is less critical because Multiplan assumes that each iteration converges on the solution. However, in some situations the order of evaluation determines whether the solution converges or diverges. If the original order produces divergence, rearranging the order may bring about convergence.

Example 1: Financial Gap Model

Integrated Income Statement and Balance Sheet

We based the discussion of this example on the following model. If you want to recreate the model, the formulas, text, and data appear following the discussion.

	1	2	3	4	5	6
1	sales	\$100.00	\$300.00	\$800.00		
2	costs	\$50.00	\$420.00	\$620.00		
3	profit	\$50.00	(\$120.00)	\$180.00		
4	int income		\$3.89	\$23.21		
5	int expense		\$0.00	\$0.00		
6	net profit	\$50.00	(\$116.11)	\$203.21	delta	0.000415
7	beg ret earns	\$75.00	\$125.00	\$8.89	itercnt	13
8	end ret earns	\$125.00	\$8.89	\$212.10		
9	cash	\$10.00	\$10.00	\$10.00		
10	funds surplus	\$155.00	\$38.89	\$232.10	done	TRUE
11	total asset	\$10.00	\$48.89	\$242.10	max i	50
12					max d	0.001
13	liabilities	\$40.00	\$40.00	\$30.00		
14	funds deficit	\$0.00	\$0.00	\$0.00		
15	tot liab	\$40.00	\$40.00	\$30.00		
16	tot liab + re	\$165.00	\$48.89	\$242.10		
17	difference	\$0.00	\$0.00	\$0.00		
18	funds		\$38.89	\$232.10		

This model shows a common business application of iteration. Throughout, this model contains examples of one result depending on the result of another calculation in circles. That is the situation that iteration handles.

Entries and calculations on a balance sheet must satisfy the condition:

$$\text{total assets} = \text{total liabilities} + \text{retained earnings}$$

To achieve this balance, you vary the funds surplus and the funds deficit. This is an iterative process because varying the funds alters the interest, which affects the profits, which changes the retained earnings. This circle of calculation throws the sheet back out of balance.

Funds surplus and funds deficit are really the same thing. One of these values will always equal 0. The actual value is in the "funds" line (R18). If this value is positive, you have funds surplus. If this value is negative, you have funds deficit.

Notice the formulas (see next page) for funds surplus and funds deficit. For funds surplus, the formula `MAX(0,funds)` returns the value of funds only if funds is positive; otherwise, it returns 0. For funds deficit, the formula `-MIN(0,funds)` returns the absolute value of funds when funds is negative.

Notice also the formula `IF(TRUE(),"",DELTA())` in R8C6. This formula keeps the `ITERCNT()` function in R7C6 from interfering with the `DELTA()` function in R6C6.

The completion test is in R10C6. It checks both the `DELTA` value and the `ITERCNT` value. When one of the two returns `TRUE` (that is, either a maximum `DELTA` of 0.001 or an `ITERCNT` of 50), iteration stops.

Columns 3 and 4 show two new time periods. Column 3 shows a large increase in capital outlay and an increase in sales that is not large enough to offset it. Thus, the profit line (R3) shows a loss. In column 4, however, sales have grown enough to offset the capital outlay. The profit line (R3) shows a profit. This is a typical situation in which the effect of a capital outlay on sales is delayed. You can apply these same formulas to analyze how much increase in sales you need to offset a particular capital outlay.

This model can also help you analyze how much money you must borrow at any specific interest rate to receive as much usable funds as you need.

See the listing of the formulas behind the model on the next page.

Formulas for Integrated Income and Balance Sheet Model

To show the formulas without breaking them across several lines, the worksheet appears in two parts, in a manner similar to the Multiplan method of printing. Columns 1 and 2 appear first, then columns 3 and 4, and then columns 5 and 6. Note that the row numbers are the same for each part; that is, enter the six columns side-by-side.

1	2	3	4
1 "sales"	100	300	800
2 "costs"	$0.5 * R[-1]C$	$300 + (0.4 * R[-1]C)$	$300 + (0.4 * R[-1]C)$
3 "profit"	$R[-2]C - R[-1]C$	$R[-2]C - R[-1]C$	$R[-2]C - R[-1]C$
4 "int income"		$0.1 * R[+6]C$	$0.1 * R[+6]C$
5 "int expense"		$0.1 * R[+9]C$	$0.1 * R[+9]C$
6 "net profit"	$R[-3]C + R[-2]C - R[-1]C$	$R[-3]C + R[-2]C - R[-1]C$	$R[-3]C + R[-2]C - R[-1]C$
7 "beg ret earns"	75	$R[+1]C[-1]$	$R[+1]C[-1]$
8 "end ret earns"	$R[-2]C + R[-1]C$	$R[-2]C + R[-1]C$	$R[-2]C + R[-1]C$
9 "cash"	10	10	10
10 "funds surplus"	155	$MAX(0, R[+8]C)$	$MAX(0, R[+8]C)$
11 "total assets"	$R[-2]C + R[-1]C$	$R[-2]C + R[-1]C$	$R[-2]C + R[-1]C$
12		12	
13 "liabilities"	40	40	30
14 "funds deficit"	0	$- MIN(0, R[+4]C)$	$- MIN(0, R[+4]C)$
15 "tot liab"	$R[-2]C + R[-1]C$	$R[-2]C + R[-1]C$	$R[-2]C + R[-1]C$
16 "tot liab + re"	$R[-1]C + R[-8]C$	$R[-1]C + R[-8]C$	$R[-1]C + R[-8]C$
17 "difference"	$R[-6]C - R[-1]C$	$R[-6]C - R[-1]C$	$R[-6]C - R[-1]C$
18 "funds"		$IF(ISNA(ITERCNT()), 0, RC - diff)$	$IF(ISNA(ITERCNT()), 0, RC - diff)$

	5	6
1		
2		
3		
4		
5		
6	"delta"	DELTA()
7	"itercnt"	ITERCNT()
8		IF(TRUE(),"",DELTA())
9		
10	"done"	OR(R[-4]C < R[+2]C, R[-3]C > R[+1]C
11	"max i"	50
12	"max d"	0.001
13		
14		
15		
16		
17		
18		

Example 2: IRR Model

Internal Rate of Return Calculation

In Multiplan, the Internal Rate of Return (IRR) of a group of cash flows is the Rate for which

$$NPV(\text{Rate}, \text{Cash_Flow}) = 0$$

The name Cash__Flow refers to the part of the worksheet that contains the cash flows. There may be many solutions to the IRR equation. The one found by this method will typically be the one closest to the initial root.

The following set of formulas automatically searches for the correct Rate. You can include these formulas in any worksheet under the following conditions:

1. Each of these formulas should be in a single row.
2. If other parts of the model include iteration and if the completion test refers to the IRR convergence, also include the method for returning vocal values of DELTA (see the DELTA function).

Formulas for IRR Model

	1	2	3	4
1				"Cash Flow"
2	"IRR"	IF(ISNA(ITERCNT()), R[+ 4]C, IF(ABS(RC) > R[+ 8]C, - (R[+ 4]C + ITERCNT()/100), IF(R[+ 2]C = 0, RC + SIGN(R[+ 1]C*0.000001, RC - R[+ 1]C/R[+ 2]C)))		"-----"
3	"NPV"	NPV(IRR,Cash__Flow)		- 1000
4	"NPV'"	IF(IRR = 0, (R[- 1]C - NPV(0.0001, Cash__Flow))/0.001, (NPV(IRR*1.01,Cash__Flow) - R[- 1]C)/IRR*0.01))		300
5				400
6	"EST. IRR"	0.01		300
7				- 200
8	"STATUS"	DELTA() < 0.01		1000
9				- 1000
10	"LIMIT"	500		2000
11				"-----"

For this model, the following names are defined:

IRR = R2C2
 Cash__Flow = R3:10C4

The labels represent:

IRR is the Internal Rate of Return.

NPV is the Net Present Value.

NPV' is the first derivative of NPV (used for Newton's method).

EST. IRR is the initial IRR entered by you. An IRR close to 0, such as 1%, usually gives the first positive IRR, which is the one you seek.

STATUS indicates when the calculation is done.

LIMIT is the largest positive IRR to try before trying negative roots.

These formulas yield the following results:

	1	2	3	4
1				Cash Flow
2	IRR	27%		-----
3	NPV	0.0		- 1000
4	NPV'	- 2226.3		300
5				400
6	EST. IRR	1%		300
7				- 200
8	STATUS	TRUE		1000
9				- 1000
10	LIMIT	50000%		2000
11				-----

The following paragraphs explain briefly the mathematical basis of IRR calculation.

Solving the equation

$$NPV(IRR, \text{Cash_Flow}) = 0$$

for IRR employs the numerical method known as Newton's method. (This method was first published by Sir Isaac Newton in Principia (1686) as a solution for a cubic polynomial.) Newton's method solves for an initial estimate that is close to a root of the equation then extrapolates along the tangent of this root to find its intersection with the x-axis as the next root to try. Iteration continues until either successive x values converge or the value of the function converges on 0.

The tangent of a given equation $f(x)$ is the first derivative $f'(x)$. Therefore, Newton's method for successive approximations is:

$$x_{(n+1)} = x_n - (f(x_n)/f'(x_n))$$

Applying this equation to the solution of the IRR equation produces:

$$IRR_{(n+1)} = IRR_n - (NPV(IRR_n, \text{Cash_Flow})/NPV'(IRR_n, \text{Cash_Flow}))$$

Now, $f'(x)$ becomes:

$$f'(x) = \lim_{\Delta x \rightarrow 0} \frac{(f(x + \Delta x)) - f(x)}{\Delta x}$$

In our case, with a Δx of 0.01 of x , the equation becomes:

$$NPV'(IRR_n, \text{Cash_Flow}) = \frac{(NPV(IRR_n + (IRR_n * 0.01), \text{Cash_Flow}) - NPV(IRR_n))}{(IRR_n * 0.01)}$$

This general method solves effectively many equations that have more than one root, although you must realize that this method may converge to a root different from the expected root or may even diverge if the starting value is not close enough to the root. In the case of IRR, the first root found that is greater than zero is normally the correct answer.

Example 3

Binary Search Model

Binary Search to Find Roots of Equations

The IRR formulas in the last section readily adapt to finding the roots of arbitrary equations using the binary search technique.

Assume that you have a polynomial

$$x^3 + 4x^2 + 5$$

Further suppose that you want to solve for a value of x that yields a result of 30. The following model solves for one root of the polynomial using the binary search technique.

	1	2	3	4	5	6
1	"f(x)"	"c_low"	"c_high"	"x"	"low"	"high"
2	$x^3 + 4x^2 + 5$	IF(ISNA (ITERCNT()), low,IF(fx > res, RC,x))	If(ISNA (ITERCNT()), high,IF(fx < res, RC,x))	(c_low + c_high)/2	0	100
3						
4						
5	"result"					
6	30					

For this model, the following names are defined:

c_low	=	R2C2	(current low value)
c_high	=	R2C3	(current high value)
x	=	R2C4	
low	=	R2C5	(low value entered by you)
high	=	R2C6	(high value entered by you)
fx	=	R2C1	
res	=	R6C1	(your desired result; you enter)

The calculation proceeds as follows:

1. In cell R2C2, Multiplan evaluates the IF function. During the first iteration, the ITERCNT function returns the #N/A error value, making the ISNA function return TRUE. Thus, IF selects the value of "low," which in this model is 0.
2. For all other iterations, ITERCNT returns an integer, making ISNA return FALSE. Thus, IF selects the "Else" value, which is another conditional formula.
3. The second IF formula in R2C2 compares the result of using the value of "x," (calculated in R2C4) in the polynomial $f(x)$ in R2C1 with the desired result, 30, in R6C1. If the value of $f(x)$ is more than 30, IF selects the current value of the cell (for the second iteration, 0). If the value of $f(x)$ is less than 30, IF selects the value of "x" calculated in R2C4.
4. The same steps apply to the conditional formula in R2C3, except this formula selects the "high" value during the first iteration. During subsequent iterations, IF selects the current value of the cell if $f(x)$ is less than 30 or the value of "x" in R2C4 if $f(x)$ is more than 30.

Once Multiplan begins iteration, the calculations proceed rapidly, and it is difficult to see the numbers clearly before they change. The following list of values for each cell describes, in part, what happens as Multiplan iterates towards a result:

	1	2	3	4	5	6
1						
2		0	100	50	0	100
3		0	50	25	0	100
4		0	25	12.5	0	100
5		0	12.5	6.25	0	100
6		0	6.25	3.125	0	100
7		0	3.125	1.5625	0	100
8		1.5625	3.125	2.34375	0	100
...						
16	29.999762	2.0352602	2.035284	2.0352721	0	100

At this point, iteration stops because the maximum change in any value is less than 0.001, the internal DELTA value of Multiplan. The root Multiplan calculated is 2.0352721. (The changing values for $f(x)$ in column one are left to you to find.)

For more precision, enter a DELTA formula in a cell that sets a limit smaller than 0.001. Or, enter an ITERCNT formula that sets a limit higher than 16. Then, enter either an absolute reference to that cell or the name of the cell in the "completion test at" field of the Options command.

Summary of Hints for Creating Iteration Models

1. Order of Evaluation

Unlike Multiplan worksheet models without iteration, the order of evaluation of each cell is important during iteration because the current value of cells referred to in the formulas affects the iteration. Fortunately for the worksheet builder, the order of evaluation of circular references is strictly defined when `ITERCNT() >= 1`. Multiplan always calculates the circular references one column at a time, top to bottom, starting with the first cell of the first column.

A general guideline that helps avoid problems is to place all the circular references in a single column. Care must also be taken that the ordering is correct for iterative methods such as Newton's method (see example 2) and binary search (see example 3).

For solving simultaneous equations, order is less critical because Multiplan assumes that each iteration converges on the solution. However, in some situations the order of evaluation determines whether the solution converges or diverges. If the original order produces divergence, rearranging the order may bring about convergence.

2. Providing for Initial Values

As discussed in the `ITERCNT` function, you may enter a conditional formula to provide an initial value for formulas on the worksheet. For example, because `ITERCNT()` returns `#N/A` for the first time it is called, a simple `IF` statement such as:

```
IF(ISNA(ITERCNT()),initial_value,formula)
```

provides `initial_value` for the first calculation, then the formula in subsequent iterations.

3. Obtaining Local Values of DELTA

To obtain a `DELTA()` that only applies to the differences of a part of the worksheet, bracket the cells with cells that contain the `DELTA` function. Each `DELTA()` resets the `DELTA` value to 0. To avoid problems with order of evaluation, enter the first `DELTA` function in the cell immediately above the block of cells for which you want a local `DELTA` value. Then, enter the test `DELTA` formula in the cell immediately below the block of cells to return a local `DELTA` value. See `DELTA` function for further details. Note that subsequent evaluations of the second `DELTA` function include changes to the cell with the first `DELTA` function. The simple formula

`DELTA()` is usually not sufficient; instead, enter a formula such as:

```
IF(TRUE(),"",DELTA())
```

which clears the maximum `DELTA` value while appearing blank on the screen.

4. `ITERCNT()` and `DELTA()` Interaction

If you enter both the `DELTA` function with a specific limit and the `ITERCNT` function as a formula by itself in a model, you may create divergence. The `DELTA` function also reads the cell that contains the `ITERCNT` function. Because `ITERCNT` changes by 1 during each iteration, `DELTA` will always return at least 1 unless you set up the worksheet model to return local values of `DELTA` or you eliminate the `ITERCNT` formula. Note that the formula `ITERCNT() > 20` returns `TRUE` or `FALSE` after each iteration and therefore would not affect convergence.

5. Single Stepping Iteration Models

Stepping through an iteration model one iteration at a time permits debugging and illustrating an iterative solution. To set this up, enter as a response in the "completion test at" field an absolute or name reference of a cell that contains the `TRUE()` function. This means that Multiplan calculates the model only once. And, repeatedly pressing the `RECALC` key produces a step-wise solution.

6. General Information

To save time and avoid confusion, turn off iteration and/or automatic recalculate when building models.

The responses in the Options command "iteration" and "completion test at" fields are saved with the worksheet in Normal mode (see Transfer Options command in Chapter 9). Thus, when you load a worksheet that contains an iterating model, the fields of the Options command receive the responses saved with the worksheet. If you later start another sheet, you may want to reset "iteration" to "No" and delete the response in the "completion test at" field.

Pressing the CANCEL key stops iteration. Only the CANCEL key has an affect during iteration because all other keys would be entries and are therefore ignored.

Multiplan checks for the CANCEL key at the beginning of each iteration. Thus, if you press the CANCEL key during an iteration, Multiplan completes that iteration, checks the completion or convergence test, and finally (if the completion or convergence test is not TRUE) Multiplan stops iteration and displays the "Circular references unresolved" error message. (If the completion or convergence test is TRUE, Multiplan ends iteration as if you had not pressed the CANCEL key.)

Appendix 6: Multiplan Reference Summary

Multiplan has two "cursors": the cell pointer and the edit cursor. Certain keys are reserved for moving the cell pointer while others move only the edit cursor.

Moving the Cell Pointer, Scrolling

FCTN E (up)	(Direction Keys) Move cell pointer in direction
FCTN X (down)	indicated. Continue moving cell pointer to scroll
FCTN S (left)	contents of window.
FCTN D (right)	
CTRL E (up)	(Page Scroll) Scroll to show the next window-
CTRL X (down)	sized section of the worksheet in the indicated
CTRL S (left)	direction.
CTRL D (right)	
CTRL W or CTRL 6	(NEXT WINDOW) Moves cell pointer to next window.
CTRL 3 or CTRL F	(NEXT UNLOCKED CELL) Moves cell pointer to next unlocked, nonblank cell.
CTRL 1 or CTRL Q	(HOME) Moves cell pointer to R1C1.
CTRL Z or FCTN 1	(LOWER RIGHT) Moves cell pointer to lower right corner of the active portion of the worksheet.

Action Keys

SPACE BAR	(SPACE) Selects next item on menu.
FCTN 9 or CTRL H	(BACKSPACE) Selects previous item on menu.
CTRL A , CTRL 2 , or CTRL I	(TAB) Selects the entire contents of a field and Moves to the next field of a command line.
CTRL C or CTRL =	(CANCEL) Cancels present operation and returns to the main command menu.
FCTN 4	(PRINT CANCEL) Cancels a printout and returns to the main command menu, if printing is in progress. May require holding the key for a short time.
ENTER or CTRL M	(ENTER) Starts a command selected from a menu or carries out a completed command.
FCTN I or FCTN 7	(HELP) Requests information about the selected command or command in progress.
FCTN 8	(RECALC) Recalculates entire worksheet. If typed in a formula, the formula will be replaced by its result.
-, +, 0, 1, ...9	Invoke the Value command.

Editing Keys

Editing keys may be used any time command parameters are filled in. Text may be inserted in front of the selection just by typing it.

Exceptions:

1. After a TAB, the proposed response will be replaced by what is typed.
2. In reference fields, the characters typed are appended to the proposed response when appropriate.

FCTN 9 or CTRL H	(BACKSPACE) Deletes character to the left of the selection.
FCTN 0 or CTRL Y	(DELETE) Deletes selected characters. Replacement text may be typed in.
CTRL 4 or CTRL L	(CHARACTER FORWARD) Selects character to the right of the current selection.
FCTN 4 or CTRL K	(CHARACTER BACK) Selects character to the left of the current selection.
CTRL 5 or CTRL P	(WORD FORWARD) Selects word to the right of the current selection.
FCTN 5 or CTRL O	(WORD BACK) Selects word to the left of the current selection.
CTRL 7	(REFERENCE) Changes relative references to absolute.
Direction Keys	May be used to insert a reference that is relative to the current active cell; step through a set of legal values for a command parameter; insert a name in a formula when preceded by RECALC.

Commands

ALPHA: ____ Allows entry (and editing) of text in cells.

BLANK cells: ____ Erases contents of specified cell(s).

COPY: Right Down From .

COPY RIGHT number of cells: ____ starting at: ____
Copies the contents of the starting cell(s) to the right the specified number of times.

COPY DOWN number of cells: ____ starting at: ____
Copies the contents of the starting cell(s) down the specified number of times.

COPY FROM number of cells: ____ to cells: ____
Copies the contents of the starting cell(s) downward the specified number of times.

DELETE: Row Column

DELETE ROW # of rows: ____ starting at: ____
between columns: ____ and: ____
Deletes row(s) between specified columns.

DELETE COLUMN # of columns:
between columns: ____ and: ____
Deletes column(s) between specified rows.

EDIT: ____ Puts contents of active cell on command line for editing (text is shown within double quotes). Editing value is reassigned to cell when ENTER is pressed.

FORMAT: Cells Default Options Width

FORMAT cells: ____ align: D C G L R -
cd: Def Cont Exp Fix Gen Int \$ * % -
of decimals:
Sets the formatting properties of the specified cell(s). The "# of decimals" field affects Exp, Fix, and %. Numbers will be rounded to the displayed decimals.

Alignment

D	(Default) Aligns as specified in the Format Default command.
C	Centers cell display within column.
G	(General) Aligns text left, number right (initial default).
L	Aligns cell display to the left.
R	Aligns cell display to right.
-	Does not change alignment.

Format Code

Def	(Default) Formats as specified in the Format Default command.
Cont	Continues long text across column boundaries as long as adjoining cells are empty and also formatted "Cont."
Exp	(Exponential) Displays numbers as decimal times the power of 10.
Fix	(Fixed) Displays number of decimal places specified in "# of decimals" field.
Gen	(General) Displays numbers in most appropriate form considering the size of the cell and of the number (initial default).
Int	(Integer) Displays number as integer.
\$	Displays numbers with leading dollar sign and 2 decimal places. Encloses negative numbers in parentheses.
*	(Bar graph) Displays as many asterisks as the value of the number.
%	(Percent) Displays the number times 100 followed by the percent sign.

FORMAT DEFAULT: Cells Width

FORMAT DEFAULT CELLS alignment: C Gen L R

code: Cont Exp Fix Gen Int \$ * % # of decimals: ____

Sets actual format and alignment for "Def" cells. Codes are as above.

FORMAT OPTIONS commas: Yes No formulas: Yes No

Commas: displays all numbers (except Exp and Gen) with commas separating every third digit.

Formulas: displays formulas instead of the value of the formulas.

GOTO: Name Row-col Window

GOTO name: ____ Moves cell pointer directly to upper left corner of named area.

GOTO row: ____ column: ____
Moves cell pointer to specified cell.

GOTO window number: ____ row: ____ column: ____
Moves cell pointer and cell to the upper left corner of the specified window.

HELP: Resume Start Next Previous Applications Commands Editing Formulas Keyboard

- HELP Resume Returns to the worksheet state where Help was requested.
- HELP Start Begins Help tutorial.
- HELP Next Moves to next screenful in the Help text.
- HELP Previous Moves to the previous screenful in the Help text.
- HELP Applications Lists a number of common problems together with the commands that address them.
- HELP Commands Describes command selection and lists all commands.
- HELP Editing Describes editing.
- HELP Formulas Lists all functions and formula composition rules.
- HELP Keyboard Describes the keyboard.

INSERT: Row column

INSERT ROW # of rows: ____ before row: ____
between columns: ____ and: ____
Inserts new row(s) between specified columns.

INSERT COLUMN # of columns: ____ before column: ____
between rows: ____ and: ____
Inserts new column(s) between specified rows.

LOCK: Cells Formulas

LOCK cells: ____ status: Locked Unlocked
Locks (or unlocks) the specified cell(s). Locked cells cannot be altered.

LOCK FORMULAS: Locks all cells that contain formulas or text. Cells containing constant numbers are left unaltered.

MOVE: Row Column

MOVE ROW from row: ____ to before row: ____ # of rows: ____
Moves whole rows from one place to another in the sheet.

MOVE COLUMN from column: ____ to left of column: ____
of columns ____
Moves whole columns from one place to another in the sheet.

NAME: define name: ____ to refer to: ____
Names a cell or a group of cells.

OPTIONS recalc: Yes No mute: Yes No
iterations: Yes No
completion test at:
Recalc: controls automatic recalculation of the worksheet whenever the contents of a cell is changed.
Mute: silences audible alarm.
Iteration: sets Multiplan to perform iterative calculations.
Completion test at: identifies the cell that contains either a completion test or a convergence test.

PRINT: Printer File Margins Options

PRINT on printer: Starts printing on the printer.

PRINT on file: Starts printing with output directed to a file instead of a printer.

PRINT MARGINS: left: ____ top: ____ print width: ____
print length: ____ page length: ____

Sets page dimensions for printed output.

Left: left margin (in number of characters).

Top: top margin (in number of lines).

Print width: width of printable area on the page (in characters).

Print length: height of printable area on the page (in lines).

Page length: height of page (in lines).

PRINT OPTIONS: area: ____ setup: ____
formulas: Yes No row-col: Yes No

Area: specifies the part of the worksheet to be printed.

Setup: may be used to select features of the printer.

The other options allow the formulas to be printed, rather than the values of the formulas, or the worksheet, with the row and column numbers.

QUIT: Ends Multiplan session when confirmed.

SORT by column: ____ between rows: ____ and: ____
order: > <

Sorts the specified range of rows so that value in the specified "key" column will be in an ascending (>) or descending (<) order. Numeric as well as text values may be sorted.

TRANSFER: Load Save Clear Delete Options Rename

TRANSFER LOAD filename: ____

Loads a worksheet from a disk file. Direction keys will display file directory and allow the selection of the file by pointing.

TRANSFER SAVE filename: ____

Saves the worksheet after confirmation.

TRANSFER CLEAR: Clears entire worksheet after confirmation.

TRANSFER DELETE filename: ____

Deletes the named file.

TRANSFER OPTIONS mode: Normal Symbolic Other setup: ____

Modifies the context of the following transfer operation. The mode selects the file format. The setup argument defines the directory or disk drive where the files are.

TRANSFER RENAME filename: ____

Renames the active worksheet to the specified name.

VALUE: ____

Enters a value or formula in the active cell. May also be invoked by typing = or the digits 0, 1,...9, or +, -, ., ", or (.

WINDOW: Split Border Close Link

WINDOW SPLIT: Horizontal Vertical Titles

WINDOW SPLIT HORIZONTAL at row: ____ linked: Yes No

Splits active window across the screen at the specified row. The two windows may be linked for synchronized scrolling.

WINDOW SPLIT VERTICAL at column: ____ linked: Yes No

Splits active window vertically at the specified column.

WINDOW SPLIT TITLES: # of rows: ____ # of columns: ____

Splits off a vertical window containing the specified number of columns, and a horizontal window containing the specified number of rows. Scrolling is linked appropriately.

WINDOW change border in window number: ____

Borders a window or removes the border from a window.

WINDOW CLOSE window number: ____

Removes window from screen.

WINDOW LINK window number: ____ with window number: ____

linked: Yes No

Sets or breaks link for synchronized scrolling between windows.

eXTERNAL: Copy List Use

eXTERNAL COPY from sheet: ____ name: ____

to: ____ Linked: Yes No

Copies data from a named group of cells on an external sheet to the active sheet. Optionally, a permanent link may be established between the active sheet and the source of the data.

eXTERNAL LIST: Displays the list of external sheets supporting and depending on the active sheet.

eXTERNAL USE filename: ____ instead of: ____

Sets a substitute name for a supporting sheet.

Formulas

Formulas may be composed of constants, references to cells, and functions.

Numeric Constants

May be written in standard notation (e.g., 3.1416) or scientific notation (e.g., 1.5E6).

Text Strings

Must be enclosed in double quotes (e.g., "\$"), when in formulas.

Absolute References

Rn or Cn Specifies row number n (1 to 255) or column number n (1 to 63).

Rn:m or Cn:m Range of rows or columns.

Relative References

- R or C The active row or column.
- R[+ n] or C[+ n] Row n above the active row or the column n to the right of the active column. The + sign may be omitted.
- R[- n] or C[- n] Row n above the active row or the column n to the left of the active column.

A pair of R and C forms may be juxtaposed to denote the intersection of the references; e.g., RnCm is an absolute reference to a single cell, RC[- 1] is the cell to the left of the active cell.

Names

Must start with a letter; may contain letters, digits, periods, and underscores. Names may be defined to refer to any cell or group of cells.

Operations on Groups of Cells

- :
- Specifies a range: the smallest rectangle that includes both operands (e.g., R1:R5 means rows 1 through 5).
- ,
- Specifies a union (e.g., R7C1,R8C2 means the cell in row 7, column 1 and the cell in row 8, column 2).
- (space)
- Specifies an intersection: the cell(s) that belong to both operands (e.g., R10C4 is the single cell where row 10 intersects with column 4).

Example

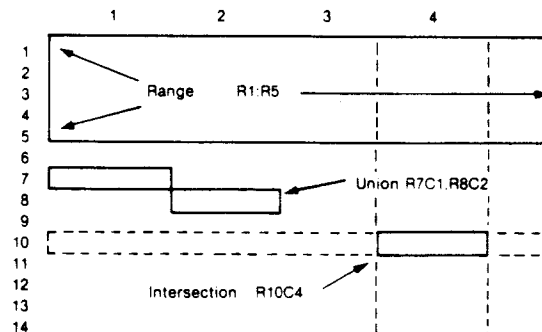

Functions

Operations on Numeric and Text Values

- + Add
- Subtract
- / Divide
- * Multiply
- ^ Exponentiation
- % Percent, same as /100
- & String concatenation

Functions of Groups of Cells

AND(List)	True if (and only if) all values are true; otherwise returns false.
AVERAGE(List)	The average of the values (=SUM/COUNT).
COUNT(List)	Number of values given as arguments or by reference.
MAX(List)	Largest of the values.
MIN(List)	Smallest of the values.
NPV(Rate, List)	Net present value of the cash flow represented by the values on the list.
OR(List)	True if (and only if) any of the values are true; otherwise returns false.
STDEV(List)	The standard deviation of the values.
SUM(List)	The sum of the values.

Mathematical, Logical, and Text Functions

ABS(N)	Absolute value of N.
ATAN(N)	Arctangent of N in radians.
COS(N)	Cosine of the angle N given in radians.
COLUMN()	Current column number.
DOLLAR(N)	The text string showing the value N in \$ format.
EXP(N)	e to the power N.
FALSE()	The logical value False.
FIXED(N,m)	The text containing N in Fix format with m decimals. m = 0 is the same as Int format.
IF(Logical, Then Value, Else Value)	Returns the Then Value if Logical expression is true; the Else Value if false.
INDEX(Area, Subscripts)	Returns the value from cell in Area indicated by Subscripts.
INT(N)	The integer portion of N truncated toward 0.
ISERROR(Value)	Returns True if (and only if) Value is an error value.
ISNA(Value)	Returns True if (and only if) Value is an #N/A value.
LEN(T)	The length of the text T in characters.
LN(N)	The base e logarithm of N.
LOG10(N)	The base 10 logarithm of N.
LOOKUP(Value,Table)	If Table (a rectangular group of cells) is higher than wide, Multiplan searches for the first row in the first column that contains a number less than or equal to Value. The result is the value in the last column of the same row. For a table wider than high, rows and columns are interchanged.

Table of Columns

	500	x	x	5	
value between--	1000	x	x	7	-- number returned
1000 and 1499	1500	x	x	9	
	2000	x	x	13	
	2500	x	x	17	
	3000	x	x	22	
	3500	x	x	27	
	4000	x	x	33	
	4500	x	x	38	

MID(T,s,c)	The c number of character starting at s of the text T.
MOD(Divisor,Dividend)	The remainder of the integer division of Dividend/Divisor.
NA()	Returns the #N/A (not available) value.
NOT(Logical)	Returns the opposite of the Logical value.
PI()	The value of pi (3.14159...).
REPT(T,n)	The text T repeated n times.
ROUND(N,m)	N rounded to m decimal places.
ROW()	The current row number.
SIGN(N)	Returns -1 if N < 0, 0 if N = 0, otherwise 1.
SIN(N)	The sine of the angle N specified in radians.
SQRT(N)	The square root of N.
TAN(N)	The tangent of the angle N.
TRUE()	The logical value True.
VALUE(T)	The text T must contain the text representation of a numeric constant. The value of that constant is returned.

Error Values

#N/A	Data not available.
#NAME?	Name not defined.
#NUM!	Overflow or illegal arithmetic.
#DIV/O	Division by 0.
#REF!	Reference to nonexistent cell.
#NULL!	Intersection of disjoint areas.
#VALUE!	Wrong type of value used.

INDEX

% (percent operator).....91, 107
& (concatenation operator).....108
^ (exponentiation operator).....107
* (multiplication operator).....91, 107
+ (addition operator).....47, 107
, (union operator).....91, 114
- (subtraction operator).....107
/ (division operator).....107
: (range operator).....45, 113
< (less than).....116
< = (less than or equal).....116
< > (not equal).....116
= (equal).....116
> (greater than).....116
> = (greater than or equal).....116

ABS.....166
Absolute references.....70, 109
Addition operator (+).....47, 107
Alignment.....35, 44
Alignment (center).....55
Alpha command.....29, 123
AND.....167
Assistance with a command.....23
ATAN.....167
AVERAGE.....168

BACKSPACE key.....30
Blank command.....46, 124
Building a formula.....47, 79
Building a formula using
 names.....62
Building a supporting sheet.....90

Calculating functions.....65
CANCEL key.....23
Cancelling a command.....23
Carrying out a command.....22
Cell contents.....49
Cell references.....70, 108
Cells.....18
Center alignment.....55
Changing a formula.....49
Character Back key.....49, 105
Character Forward key.....49, 105
Colon (:) (range operator).....45, 113
COLUMN.....168
Column width.....32
Comma (,) (union operator).....91, 114
Command selection from
 menus.....21

Commands.....121
 Alpha.....29, 123
 Alpha/Value.....30, 123
 Blank.....46, 124
 Copy.....125
 Copy Down.....125
 Copy From.....73, 126
 Copy Right.....57, 127
 Delete.....97, 128
 Delete Column.....128
 Delete Row.....129
 Edit.....130
 eXternal.....161
 eXternal Copy.....93, 162
 eXternal List.....97, 163
 eXternal Use.....164
 Format.....55, 131
 Format Cells.....132
 Format Default.....134
 Format Default Cells.....34, 135
 Format Default Width.....135
 Format Options.....136
 Format Width.....32, 136
 Goto.....19, 137
 Goto Name.....64, 137
 Goto Row-col.....20, 138
 Goto Window.....138
 Help.....23, 139
 Insert.....40, 140
 Insert Column.....140
 Insert Row.....141
 Lock.....141
 Lock Cells.....142
 Lock Formulas.....142
 Move.....143
 Move Column.....144
 Move Row.....144
 Name.....60, 145
 Options.....81, 146
 Print.....84, 146
 Print File.....86, 147
 Print Margins.....84, 147
 Print Options.....84, 148
 Print Printer.....85, 149
 Quit.....24, 38, 149
 Sort.....97, 150
 Transfer.....151
 Transfer Clear.....89, 152
 Transfer Delete.....152
 Transfer Load.....40, 54, 153
 Transfer Options.....154
 Transfer Rename.....155
 Transfer Save.....37, 51, 155
 Value.....47, 156

Commands (<i>continued</i>)		Format Default.....	134
Window.....	157	Format Default Cells command.	34, 135
Window Border.....	78, 157	Format Default Width command...	135
Window Close.....	158	Format Options command.....	136
Window Link.....	78, 158	Format Width command.....	32, 136
Window Split.....	159	Formats.....	35
Window Split Horizontal.....	159	Formula for increasing sales.....	91
Window Split Titles.....	76, 160	Formula using names.....	62
Window Split Vertical.....	161	Formulas.....	46, 106
Concatenation operation (&).....	108	Changing.....	49
Copy.....	125	Reviewing.....	49
Copy Down command.....	125	Functions.....	165
Copy From command.....	73, 126	ABS.....	166
Copy Right command.....	57, 127	AND.....	167
Correcting typing errors.....	30	ATAN.....	167
COS.....	168	AVERAGE.....	168
COUNT.....	169	COLUMN.....	168
		COS.....	168
Delete.....	97, 128	COUNT.....	169
Delete Column command.....	128	DOLLAR.....	169
Delete Row command.....	129	EXP.....	170
Direction keys.....	18	FALSE.....	170
Dissolving connections between		FIXED.....	171
worksheets.....	96	IF.....	171
Division operator (/).....	107	INDEX.....	172
DOLLAR.....	169	INT.....	172
Drawing lines.....	50	ISERROR.....	173
		ISNA.....	173
Edit.....	130	LEN.....	173
Edit cursor.....	30, 105	LN.....	174
Editing.....	105	LOG10.....	174
ENTER key.....	22	LOOKUP.....	175
Entering data.....	30	MAX.....	176
Entering numbers.....	33, 43	MID.....	176
Entering text.....	29, 42	MIN.....	177
Equal (=).....	116	MOD.....	177
Error Values.....	69, 106, 115	NA.....	177
EXP.....	170	NOT.....	178
Exponentiation (^).....	107	NPV.....	178
eXternal.....	161	OR.....	179
eXternal Copy command.....	93, 162	PI.....	179
eXternal List command.....	97, 163	REPT.....	179
External relationships.....	118	ROUND.....	180
eXternal Use command.....	164	ROW.....	180
		SIGN.....	181
FALSE.....	116, 170	SIN.....	181
File access, problems with.....	118	SQRT.....	181
File access, problems with.....	118	STDEV.....	182
File handling.....	117	SUM.....	67, 182
File mode.....	154	TAN.....	182
Normal mode.....	154	TRUE.....	183
Other mode.....	154	VALUE.....	183
Symbolic mode.....	154		
Filling in the command line.....	22	Goto command.....	19, 137
FIXED.....	171	Goto Name command.....	64, 137
Format.....	55, 131	Goto Row-col command.....	20, 138
Format Cells command.....	132	Goto Window command.....	138
		Greater than (>).....	116
		Greater than or equal(>=).....	116

Help command	23, 139
IF	171
Increasing formula	91
INDEX	172
Insert	40, 140
Insert Column command	140
Insert Row command	141
INT	172
Intersection operator	112
ISERROR	173
ISNA	173
LEN	173
Less than (<)	116
Less than or equal (<=)	116
Lines	50
LN	174
Loading a file	40
Lock	141
Lock Cells command	142
Lock Formulas command	142
LOG10	174
Logical values	116
LOOKUP	175
MAX	176
MID	176
MIN	177
MOD	177
Mode of file	154
Normal mode	154
Other mode	154
Symbolic mode	154
Move	143
Move Column command	144
Move Row command	144
Moving the cell pointer	18
Multiplication operator (*)	91, 107
NA	177
Name command	60, 145
Names	111
Names as cell references	64
Naming cells	60
Naming related worksheets	92
NEXT UNLOCKED CELL key	80
Normal mode	154
NOT	178
Not equal (<>)	116
NPV	178
Number signs (#)	68
Numbers	107

Operators

Addition (+)	47, 107
Concatenation (&)	108
Division (/)	107
Equal (=)	116
Exponentiation (^)	107
Greater than (>)	116
Greater than or equal(>=)	116
Intersection (space)	112
Less than (<)	116
Less than or equal (<=)	116
Multiplication (*)	91, 107
Not equal (<>)	116
Percent (%)	91, 107
Range (:)	45, 113
Subtraction (-)	107
Union (comma ,)	91, 114
Options command	81, 146
OR	179
Other mode	154
Percent operator (%)	91, 107
PI	179
Print	84, 146
Print File command	86, 147
Print Margins command	84, 147
Print Options command	84, 148
Print Printer command	85, 149
Print subcommands	84
Problems with file access	118
Proposed responses	22, 105
Protecting the worksheet	80
Quit command	24, 38, 149
Range operator (:)	113
Ranges: the colon	45
References	70, 108
References to cells	108
Relating worksheets	88
Relative references	70, 109
REPT	179
Reviewing a formula	49
Revising a supporting sheet	95
ROUND	180
ROW	180

Saving space.....	193
Saving time.....	193
Saving work.....	193
Screen.....	17
Scrolling the worksheet.....	19
SIGN.....	181
SIN.....	181
Sort command.....	97, 150
SPACE BAR	21
Space (intersection operator).....	112
SQRT.....	181
Status line.....	49
STDEV.....	182
Subtraction operator (-).....	107
SUM.....	182
Symbolic mode.....	154
TAB key.....	22
TAN.....	182
Text.....	108
The Status line.....	18
Titles.....	54
Transfer.....	151
Transfer Clear command.....	89, 152
Transfer Delete command.....	152
Transfer Load command.....	40, 54, 153
Transfer Options command.....	154
Transfer Rename command.....	155
Transfer Save command.....	37, 51, 155
Transforming the worksheet.....	120
TRUE.....	116, 183
Typing errors.....	30
Union operator (,).....	91, 114
Unlocking cells.....	81
VALUE.....	183
Value command.....	47, 156
Width.....	32
Window.....	157
Window Border command.....	78, 157
Window Close command.....	158
Window Link command.....	78, 158
Window Split.....	77, 159
Window Split Horizontal.....	159
Window Split Titles.....	76, 160
Window Split Vertical.....	161
Word Back key.....	105
Word Forward key.....	105
Worksheet number grid.....	28