

**Please do not upload this copyright pdf document to any other website. Breach of copyright may result in a criminal conviction.**

This Acrobat document was generated by me, Colin Hinson, from a document held by the Henlow Signals Museum, believed to be out of copyright. It is presented here (for free) and this pdf version of the document is my copyright in much the same way as a photograph would be. If you believe the document to be under other copyright, please contact me.

The document should have been downloaded from my website <https://blunham.com/Radar>, or any mirror site named on that site. If you downloaded it from elsewhere, please let me know (particularly if you were charged for it). You can contact me via my Genuki email page: <https://www.genuki.org.uk/big/eng/YKS/various?recipient=colin>

**You may not copy the file for onward transmission of the data nor attempt to make monetary gain by the use of these files. If you want someone else to have a copy of the file, point them at the website. (<https://blunham.com/Radar>). Please do not point them at the file itself as it may move or the site may be updated.**

It should be noted that most of the pages are identifiable as having been processed by me.

---

I put a lot of time into producing these files which is why you are met with this page when you open the file.

In order to generate this file, I need to scan the pages, split the double pages and remove any edge marks such as punch holes, clean up the pages, set the relevant pages to be all the same size and alignment. I then run Omnipage (OCR) to generate the searchable text and then generate the pdf file.

Hopefully after all that, I end up with a presentable file. If you find missing pages, pages in the wrong order, anything else wrong with the file or simply want to make a comment, please drop me a line (see above).

It is my hope that you find the file of use to you personally – I know that I would have liked to have found some of these files years ago – they would have saved me a lot of time !

Colin Hinson

In the village of Blunham, Bedfordshire.

# No. 85 TELEPRINTER PRINTING REPERFORATOR

MODEL 85R Receiving only (without Keyboard)

MODEL 85/M with 3-row Motorised Keyboard

MODEL 85/N3 with 3-row Shift-Lock Pattern Keyboard

MODEL 85/N4 with 4-row Shift-Lock Keyboard

MODEL 85/T4 with 4-row Storage (Commercial Typewriter Keyboard)

## *Creed & Company Limited*

TELEGRAPH HOUSE  
CROYDON

*Telegraphic Address :*  
CREDO, TELEX, CROYDON

*Telephone :*  
MUNICIPAL 2424

*Telex :* 28836



## INTRODUCTION AND ORDERING INSTRUCTIONS

**T**HIS part list has been compiled to assist our customers in identifying and ordering spare parts for all models of the No. 85 Teleprinter Printing Reperforator.

As several units of this machine are identical, or are similar, to the corresponding units of the No. 7 Teleprinter, the information has not been repeated in this list, but reference to the appropriate Part Lists in which it can be found is clearly given.

Those parts of the receiving portion of the No. 85 Reperforator which are also used on the No. 7 Teleprinter will be found in Part List No. 1078.

See Part List No. 3750 for Cam Unit Type 3 (Overlap Pattern)

See Technical Information Supplement No. 7 for the friction damping Typehead and Clutch (No. 47 pattern).

For Keyboard Units, see :—

Part List No. 1078M	—	Type 'M' Keyboard Unit
Part List No. 1047K	—	Types N3 and N4 Keyboard Unit
Part List No. CTK/1078	—	Type T4 Commercial Typewriter Keyboard

When referring to the list, it should be noted that the suffix letters "C.P." indicate "a complete part" which is an assembly of two or more smaller parts. The term "unit" is applied in general to each distinct section of the mechanism which is mounted on its own sub-base, and may be easily removed as a whole from the machine.

**Note :** When a part is being ordered, the following information should be given :—

1. Part Name.
  2. Part Number.
  3. Model of Machine
  4. Machine Serial Number
- } as shown on nameplate.

### Sets of Recommended Spares.

Telegraph communication services frequently impose the difficulty that isolated machines or groups of machines are disposed at widely separated and often remotely located stations, and the holding of an adequate range of spares at locations convenient to the maintenance personnel, even if many items are only occasionally used, is a wise precaution to safeguard against interruption of the service.

If sets of recommended parts are ordered when purchasing new machines, then, at the end of the first year of operation, customers should be in a position to judge from their own experience their future spares requirements and to re-order the requisite quantities of those parts which have been used, before a safe minimum stock figure is reached.

A list of recommended spares for the Teleprinter Printing Reperforator No. 85 can be supplied on application.

## INTRODUCTION ET INSTRUCTIONS POUR COMMANDES

**C**E catalogue a été établi pour permettre à nos clients d'identifier et de commander les différentes pièces de rechange de tous les modèles du téléimprimeur reperforateur-imprimeur No. 85.

Plusieurs ensembles de cet appareil étant identiques ou similaires aux ensembles correspondants du téléimprimeur No. 7, référence est faite aux listes de pièces détachées dans lesquelles se trouvent les renseignements les concernant.

Les pièces de la partie réceptrice du reperforateur No. 85 utilisées également sur le téléimprimeur No.7 se trouvent dans la Liste de Pièces Détachées No. 1078.

Voir "Information Technique No. 7" pour l'amortisseur à friction de la roue des types et de l'embrayage (modèle No. 47).

Pour les ensembles de clavier voir :

Liste de Pièces Détachées No. 1078M	— Ensemble de clavier, modèle "M"
„ No. 1047K	— „ modèle "N3" & "N4"
„ No. CTK/1078	— Clavier commercial, modèle "T4"

En ce qui concerne ce catalogue il faut noter que les lettres "C.P." suivant la désignation d'une pièce indiquent un ensemble de deux ou plusieurs pièces plus petites. L'expression "unit" signifie une section bien définie de l'appareil montée séparément et pouvant facilement en être retirée.

### REMARQUE

Pour commander une pièce de rechange, prière de donner les renseignements suivants :

- 1 - La désignation de la pièce de rechange
  - 2 - Le numéro correspondant
  - 3 - Le modèle de la machine
  - 4 - Le numéro de série
- } comme indiqué sur la plaquette de la machine

### JEUX DE PIÈCES RECOMMANDÉES

Les services télégraphiques utilisent fréquemment des machines isolées ou des groupes de machines situées à de grandes distances et, bien souvent, à des endroits difficilement accessibles. De ce fait et pour éviter de longues interruptions de service il est prudent de constituer des réserves de pièces détachées à la disposition du personnel d'entretien, même si une grande partie des pièces approvisionnées ne doit être que rarement utilisée.

Après une année d'utilisation il sera bon de compléter la réserve primitive et de commander les pièces dont le besoin s'est fait le plus sentir.

La liste des pièces recommandées pour le téléimprimeur reperforateur-imprimeur No. 85 peut être fournie sur demande.

---

## EINFÜHRUNG UND BESTELLANWEISUNG

**D**IESE Bestandteilliste wurde zur Unterstützung unserer Kunden bei der Bestellung von Reserveteilen für alle Modelle der Fernschreib-Empfangslochertype Nr. 85 herausgegeben.

Da verschiedene Einheiten dieser Maschine gleich oder ähnlich den entsprechenden Einheiten der Fernschreibertype Nr. 7 sind, wurden die diesbezüglichen Anweisungen nicht wiederholt, sondern es wird nur angegeben, an welcher Stelle der Teilliste für die Type Nr. 7 nähere Details zu finden sind.

Angaben über die Empfängerteile des Lochstreifenschreibers Nr. 85, die im Fernschreiber Nr. 7 ebenfalls in Verwendung sind, können der Teilliste Nr. 1078 entnommen werden.

Weiters ist der technische Informationsbrief Nr. 7 bezüglich der Reibungsdämpfung des Typenkopfes und der Kupplung (Type Nr. 47) zu beachten.

Auf Tastatureinheiten wird in folgenden Listen Bezug genommen :

Teilliste Nr. 1078 M	— Type "M" Tastatur
Teilliste Nr. 1047K	— Type "N3" Tastatur
Teilliste Nr. CTK/1078	— Type "T4" normale Schreibmaschinentastatur

Unter Bezugnahme auf diese Liste wird darauf hingewiesen, dass die Buchstaben C.P. einen kompletten Teil bezeichnen, der aus zwei oder mehreren Einzelteilen besteht. Der Ausdruck "Einheit" (Unit) wird

allgemein für jeden deutlich getrennten Abschnitt der Maschine verwendet, der auf einer eigenen Grundplatte montiert ist und leicht als Ganzes von der Maschine abmontiert werden kann.

Anmerkung: Bei Bestellung von Einzelteilen sollen folgende Angaben gemacht werden:

- 1) Name des Einzelteiles
  - 2) Nummer des Einzelteiles
  - 3) Modellnummer der Maschine
  - 4) Seriennummer der Maschine
- } auf der Nummernplatte angegeben.

### **Komplette Sätze der von uns zur Anschaffung empfohlenen Reserveteile**

Im Fernschreibverkehr treten oft dadurch Schwierigkeiten auf, dass einzelne Maschinen oder Gruppen von Maschinen sehr weit voneinander entfernt und oft in recht abseits gelegenen Orten in Verwendung stehen, sodass die Lagerhaltung einer entsprechenden Menge von Reserveteilen an, für das Bedienungspersonal, leicht zu erreichenden Orten eine ratsame Vorsichtsmassnahme gegen längere Unterbrechungen im Betrieb der Fernschreiber darstellt, auch wenn viele der Einzelteile nur gelegentlich benötigt werden.

Wenn gleichzeitig mit dem Ankauf neuer Maschinen komplette Sätze der von uns empfohlenen Reserveteile bestellt werden, dann kann der Kunde nach einem Betriebsjahr aus eigener Erfahrung seinen weiteren voraussichtlichen Bedarf an Reserveteilen angeben und die benötigten Mengen nachbestellen, bis ein sicheres Minimal-Reservelager vorhanden ist.

Ein Liste der zur Anschaffung empfohlenen Reserveteile für den Lochstreifenschreiber Nr. 85 kann auf Wunsch zugeschickt werden.

---

## **INSTRUCCIONES SOBRE LA FORMA DE HACER LOS PEDIDOS**

**E**STA lista de piezas ha sido preparada para que sirva de ayuda a nuestros clientes en la identificación y en la manera de efectuar los pedidos de piezas de reserva para todos los Modelos de Reperforador Impresor Teletipográfico No. 85.

Puesto que varias unidades de esta máquina son idénticas o semejantes a las unidades correspondientes del Teletipógrafo No. 7, no se ha repetido la información de las mismas en esta Lista, pero se hace referencia de una manera clara a las Listas de Piezas apropiadas, en las cuales se pueden encontrar las unidades que interese.

Aquellas piezas de la parte receptora del Reperforador No. 85, que se usan también en el Teletipógrafo No. 7, se hallarán en la Lista de Piezas No. 1078.

Véase la Información Técnica No. 7 para el Cabezal de tipos y Embrague amortiguador de fricción (patrón No. 47).

Para los Unidades de Teclado, véase:

- |                              |   |
|------------------------------|---|
| Lista de Piezas No. 1078M    | — Unidad de Teclado tipo "M".               |
| Lista de Piezas No. 1047K    | — Unidad de Teclado tipo "N3" y "N4".       |
| Lista de Piezas No. CTK/1078 | — Teclado de escribir comercial, tipo "T4". |

Al referirse a la Lista hay que tener en cuenta que las letras sufixas "C.P." indican una "pieza o parte completa," que es un conjunto de dos o más piezas más pequeñas. El término "unidad" se aplica en general a cada sección distinta del mecanismo, que se halla montada sobre su sub-base propia y puede ser retirada fácilmente de la máquina, formando un conjunto.

**Nota:** Cuando haya de pedirse una pieza, deben facilitarse los siguientes datos sobre la misma:

- 1 - Nombre de la pieza
- 2 - Número de la pieza
- 3 - Modelo de la máquina
- 4 - Número de serie de la máquina.

Los datos 3 y 4 figuran en la placa de características de la máquina.

### **Juegos de piezas de reserva recomendadas**

Los servicios de comunicaciones telegráficas precisan frecuentemente disponer máquinas aisladas o grupos de máquinas alejados unos de otros, y a menudo en estaciones situadas muy distantes, y la posesión de un adecuado margen de piezas de reserva en lugares convenientes para el personal de conservación, es una medida prudente para asegurar el servicio contra una interrupción o avería.

Si al adquirir máquinas nuevas se piden juegos de piezas de reserva recomendadas, entonces, al final del primer año de funcionamiento, los clientes estarán en condiciones de juzgar por su propia experiencia las necesidades futuras de reservas y pedir de nuevo las cantidades precisas de aquellas piezas que ha sido necesario reemplazar, antes de llegar a tener el stock mínimo de seguridad.

Se puede suministrar a quien lo solicite, una lista de piezas de reserva recomendadas para el Reperforador Impresor Teletipográfico No. 85.

## CONTENTS

	<i>Page</i>
INTRODUCTION AND ORDERING INSTRUCTIONS	
INTRODUCTION ET INSTRUCTIONS POUR COMMANDES .. .. .	1
EINFUHRUNG UND BESTELLANWEISUNG .. .. .	1
INSTRUCCIONES SOBRE LA FORMA DE HACER LOS PEDIDOS .. .. .	2
TELEPRINTER PRINTING REPERFORATOR MODEL 85R .. .. .	5
TELEPRINTER PRINTING REPERFORATOR MODELS 85/M, 85/N3, 85/N4 AND 85/T4	5
REPERFORATOR SUB. ASSEMBLY S.2865A (GROUP 3).. .. .	6
COMBINATION HEAD UNIT S.2867 (GROUP 2) .. .. .	9
CONTROL LEVER UNIT S.2868 (GROUP 2) .. .. .	11
PERFORATOR UNIT S.2870 .. .. .	13
PERFORATOR UNIT CASTING AND SETTING LEVER ASSEMBLY .. .. .	13
PUNCHING CAM ASSEMBLY 2870/158 .. .. .	15
PUNCH BLOCK ASSEMBLY 2870/152A .. .. .	17
TAPE ROLL HOLDER UNIT S.2869A (GROUP 1) .. .. .	19
ACCESSORIES .. .. .	20
TOOLS .. .. .	21
NUMERICAL INDEX .. .. .	22

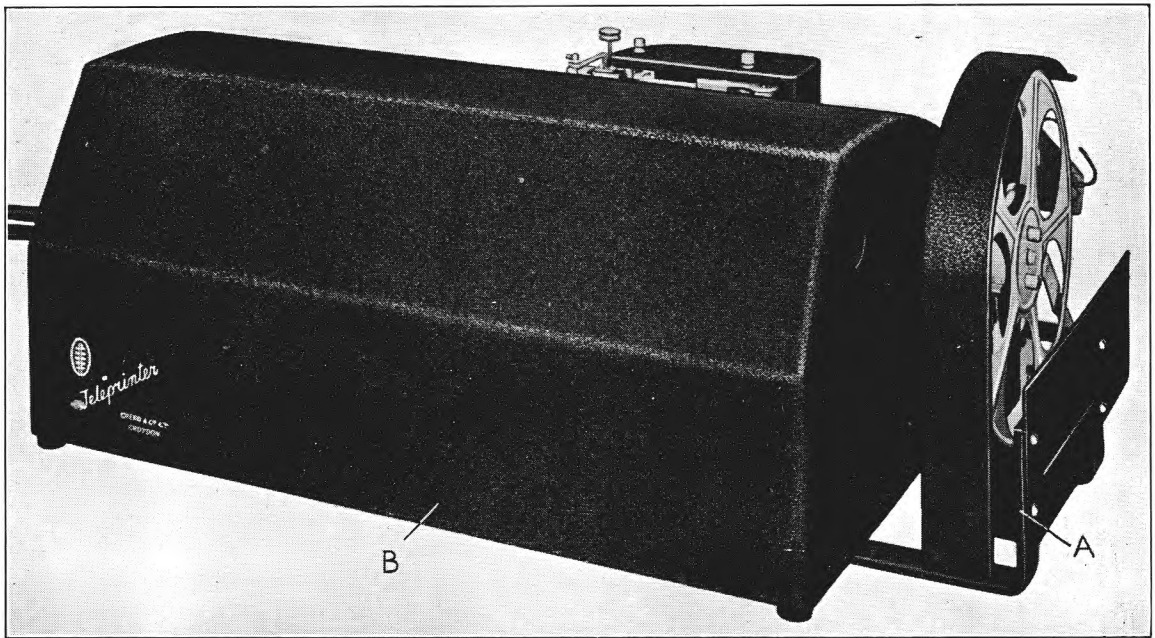

FIG. 1. MODEL 85R TELEPRINTER PRINTING REPERFORATOR (*Front View*)

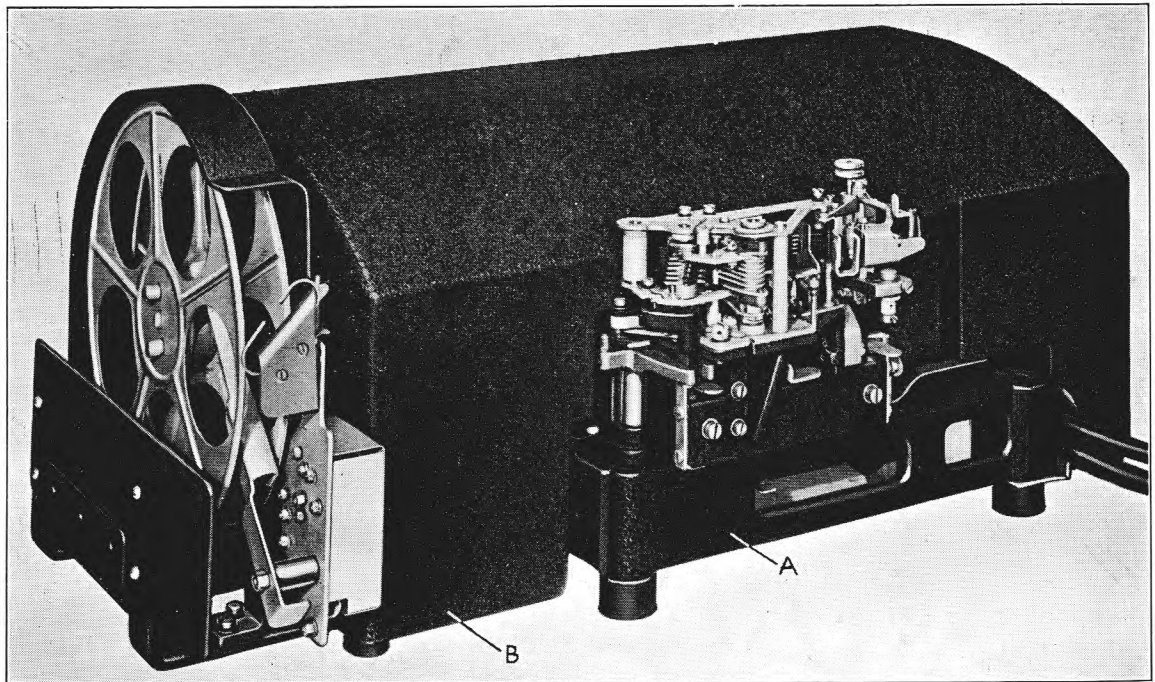

FIG. 2. MODEL 85R TELEPRINTER PRINTING REPERFORATOR  
(*Rear view, with Perforator Unit cover removed*)

## TELEPRINTER PRINTING REPERFORATOR, MODEL 85R

(See FIGS. 1 and 2)

<i>Index Letter</i>	<i>Part No.</i>	<i>Part Name</i>	
A	S.2865A Gr. 3 1841/16	REPERFORATOR SUB. ASSEMBLY. Keyboard Dummy Front.	See page 6.
B	PS.4583-1 S.2927A	Std. $\frac{5}{16}$ " B.S.F. screw (2 per set) for securing keyboard dummy front. Dust cover unit.	

## TELEPRINTER PRINTING REPERFORATOR

**MODELS 85/M, 85/N3, 85/N4 and 85/T4**

(See FIGS. 1 and 2)

<i>Index Letter</i>	<i>Part No.</i>	<i>Part Name</i>	
A	S.2865A Gr. 3	REPERFORATOR SUB. ASSEMBLY.	See page 6.
	S.1822B	KEYBOARD UNIT (Type "M")	See Part List 1078M, Sect. 4.
	S.2087	or KEYBOARD UNIT (Type "N3" or "N4").	See Part List 1047K.
	S.1945	or KEYBOARD UNIT (Type T4).	See Part List CTK/1078.
	PS.4583-1	Std. $\frac{5}{16}$ " B.S.F. Screw (2 per set) for securing Keyboard Unit.	
	S.2940A Gr. 1	DUST COVER UNIT (for machines without End-of-Line Indicator)	}
	S.2940A Gr. 2	or DUST COVER UNIT (for machines with End-of-Line Indicator)	
	S.2941 Gr. 1	or DUST COVER UNIT (for machines without End-of-Line Indicator)	}
	S.2941 Gr. 2	or DUST COVER UNIT (for machines with End-of-Line Indicator)	

**Kindly state Model of Machine and Serial Number when ordering spare parts.**



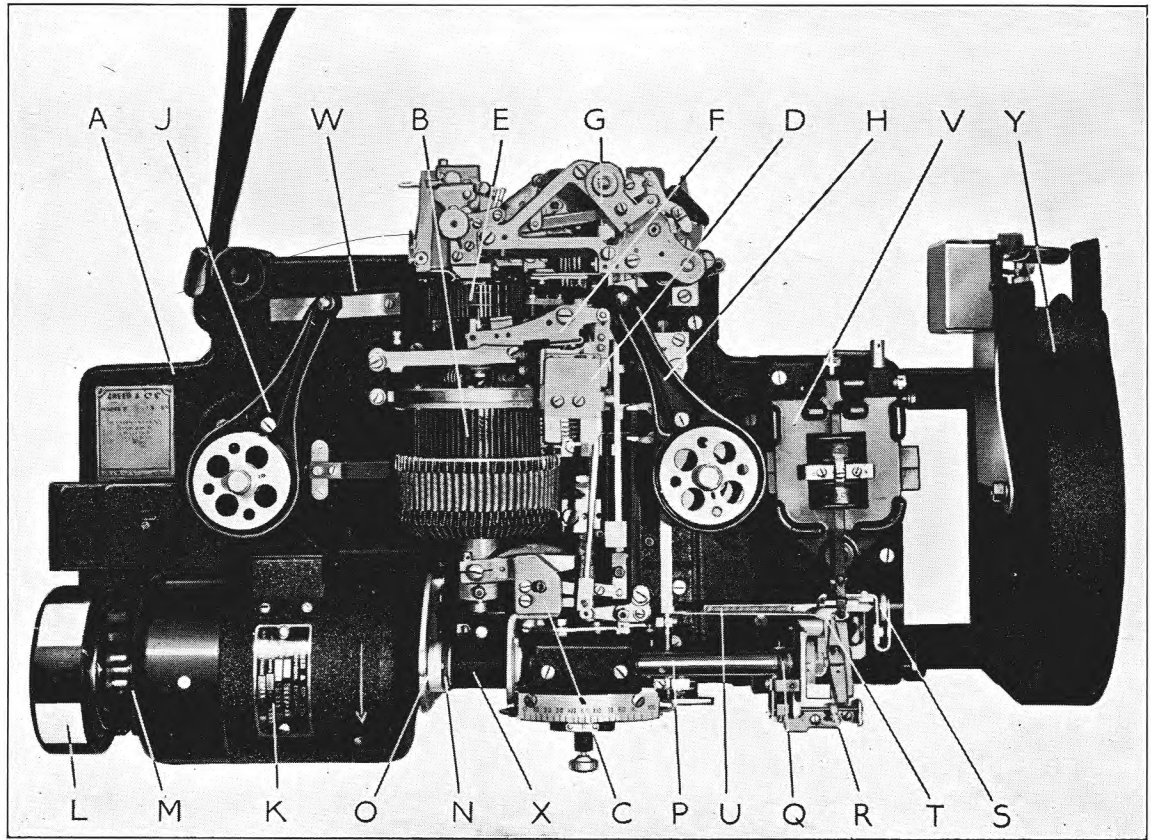

FIG. 3. REPERFORATOR SUB. ASSEMBLY

### REPERFORATOR SUB. ASSEMBLY S.2865A GROUP 3

(See FIG. 3)

Index Letter	Part No.	Part Name	
A	2865/2	MAIN BASE UNIT (see Addendum No. 4 to Part List 1078, 9th Edition, but with the following items deleted.) Item K 1836/5A Carriage latch plate. PP.7559 Shouldered pin. P.W.5115 Special washer. Item L 1836/195 Abutment C.P. PW.5071 Special washer. PS.1074-1 Std. 0BA screw. PW.2002 Std. 0BA Spring washer.	
B	S.2867 Gr. 2 PS.1390-1 PP.1157	COMBINATION HEAD UNIT Std. 2BA screw (2 per set) for securing item B. Parallel pin (for positioning item B). Customers must be prepared to fit this item.	See page 9.
C	S.2866B Gr.1 S.3750 PS.1390-1	CAM UNIT, Type 2 (Orientation Pattern) see Part List 1078. or CAM UNIT, Type 3 (Overlap Pattern) see Part List 3750. Std. 2BA screw (3 per set) for securing item C.	
D	S.2868 Gr. 2 PS.1354-1	CONTROL LEVER UNIT. Std. 2BA screw (2 per set) for securing item D.	See page 11.
E	S.2936 2945/3	TYPEHEAD UNIT. See T.I.S. No. 7. Shim (fitted between Typehead Support Bracket and Control Lever Unit Casting) not visible.	
F	S.1834 PS.5289 PW.2037 PW.1013-1	TYPEHAMMER UNIT. See Part List 1078. Special screw Std. 6BA spring washer Std. 6BA washer	} for retaining item F.

Kindly state Model of Machine and Serial Number when ordering Spare Parts.

## TELEPRINTER SUB. ASSEMBLY S.2865A, GROUP 3 (contd.)

Index Letter	Part No.	Part Name	
G	S.2870 Gr. 4	PERFORATOR UNIT	} See page 13.
	S.2870 Gr. 5	PERFORATOR UNIT	
	PS.1374-1	Std. 2BA screw	} 2 of each per set for securing item G.
	PW.2013	Std. 2BA spring washer	
	PW.1005-1	Std. 2BA washer	
H	S.2871	RIBBON FEED BRACKET (R.H.) C.P.	} Similar to 1828/1A and 1828/2A Ribbon Feed Bracket (see Part List 1078) but with 1828/36 Ribbon Guide C.P. replaced by 2871/4 Ribbon Guide C.P.
J	S.2872	RIBBON FEED BRACKET (L.H.) C.P.	
K	PS.1354-1	Std. 2BA screw (4 per set) for securing items H and J.	} Included in Motor Unit.
	Ref.26	Motor unit (Universal for any same D.C. or A.C. voltage)—state voltage and frequency.	
	1858/26A	Motor cover (plastic)	
	1858/12	Motor terminal block	
	PS.1777-1	Std. 4BA screw (2 per set)	
	BO.2874	Ballrace (for motor) 2 per set	
L	S.1910	SPARE MOTOR BRUSHES. See Part List 1078, page 46.	
M	1824/39A	GOVERNOR UNIT (SERIES). See Part List 1078, page 42.	
		MOTOR SUPPORT PLATE C.P. (Motor Support Plate 1824/5 shown following item with the exception that 1825/4 Typehead Gear is now replaced by Motor Support Plate C.P. 1824/40A).	
	PS.1162-1	Std. 1BA screw (2 per set) for securing item M.	
N	1841/11	Coupling disc. (S.R.B.F.).	
O	1841/7C	Driving disc (secured to end of motor spindle).	
	PS.1765-1	Std. 4BA screw (2 per set) for securing driving disc.	
P	1825/99	MAINSHAFT C.P. comprises the same items as 1825/71 (See Part List 1078 page 22) with the exception that 1825/4 Typehead Gear is replaced by GR.4039 Typehead Gear.	
Q	1825/63	Starter driving worm C.P.	} for retaining mainshaft in end bearing.
	PW.1025-1	Std. 0BA washer	
	PN.5046	Special nut	
	PS.1162-1	Std. 1BA screw	
	PW.2009	Std. 1BA spring washer	} for securing mainshaft bearing.
R	S.1825D	STARTER SWITCH CONTROL UNIT. See Part List 1078, page 23.	
	PS.1374-1	Std. 2BA screw (2 per set) for securing item R.	
	1841/14A	Switch cover.	
	PS.2069-1	Std. 6BA screw (3 per set) for securing switch cover.	
S	S.1814	RELAY BIASING UNIT.	} Not used with Electromagnet Unit S.2848A.
	PS.1332-1	Std. 2BA screw (for securing item S).	
T	1841/46A	Electromagnet link C.P.	
	23955A	Locking ring (for retaining item T).	
U	PG.7102	Tension spring (for biasing electromagnet). Not used with Electromagnet Unit S.2848A.	
V	S.2848A	OPERATING ELECTROMAGNET UNIT. See Part List 1078, page 40.	
	PS.1456-1	Std. 2BA screw (2 per set) for securing item V.	
W	1841/20	Ink ribbon (black).	} for securing item V.
	1841/19	or Ink ribbon (purple).	
	1841/21	Ribbon spool.	
X	1841/13	Typehead drive cover.	
	PS.1663-1	Std. 4BA screw (for securing item X).	
Y	S.2869A Gr. 1	TAPE ROLL HOLDER UNIT. See page 19.	
	2869/48	Packing piece.	} for Item Y.
	2869/46	Packing piece ( $\frac{1}{16}$ " thick)	
	2869/57	or Packing piece ( $\frac{1}{32}$ " thick)	
	2869/58	or Packing piece ( $\frac{3}{64}$ " thick)	
	PS.1739-1	Std. 4BA screw	} 2 of each per set
	PW.2025	Std. 4BA spring washer	
	PW.1009-1	Std. 4BA washer	
	PS.2168-1	Std. 6BA screw	
	PW.2038	Std. 6BA spring washer	
	PW.1013-1	Std. 6BA washer	} for securing item Y.

**Kindly state Model of Machine and Serial Number when ordering Spare Parts.**

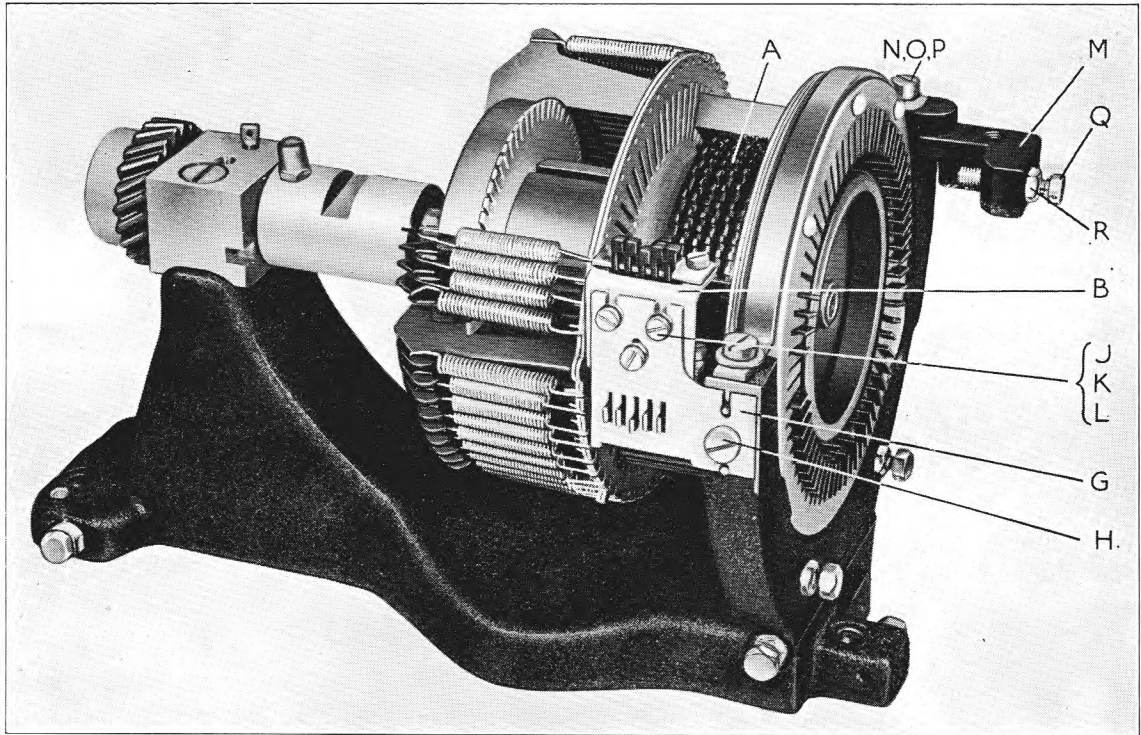

FIG. 4. COMBINATION HEAD UNIT

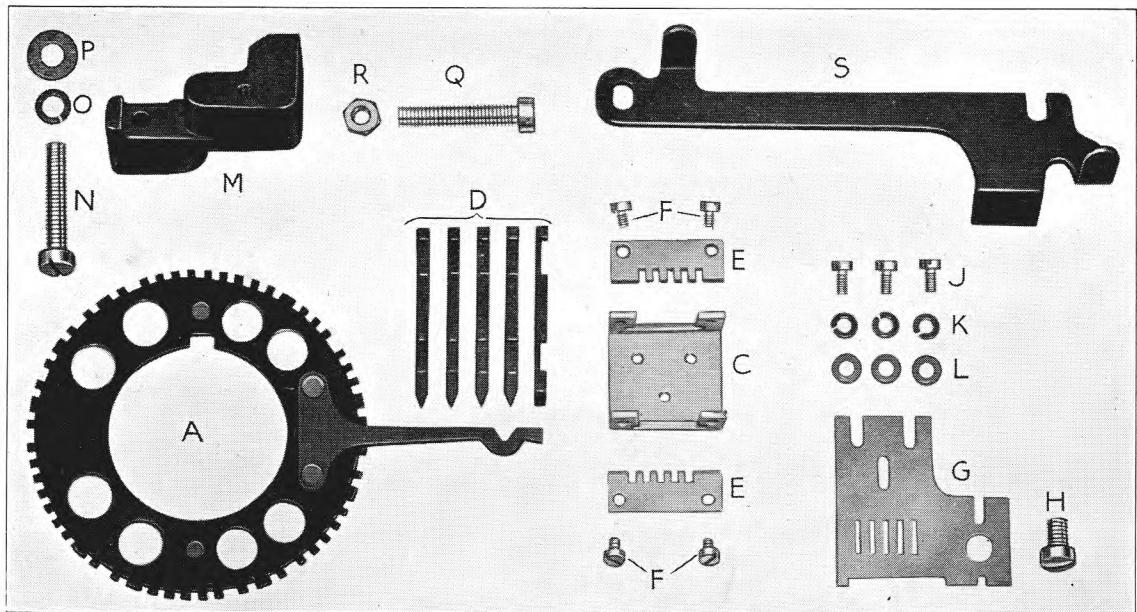

FIG. 5. SELECTOR PUSH RODS AND BRACKET

## COMBINATION HEAD UNIT S.2867, GROUP 2

(See FIGS. 4 and 5)

NOTE : Only the parts peculiar to the No. 85 Printing Reperforator Combination Head Unit are listed. Please refer to Part List No. 1078 (9th Edition), for parts common to both No. 7 Teleprinter and No. 85 Reperforator. Refer to Technical Information Supplement No. 7, for parts affected by the introduction of the new Typehead Clutch and for the new Typehead Unit S.2936.

Index Letter	Part No.	Part Name
A	2867/4	Receiving comb C.P. (5 per set). Marking on each comb should be given when ordering.
B	2867/10	Transfer push rod C.P., comprises :
C	2867/6	Transfer push rod bracket.
D	2867/8	Transfer push rod (5 per set).
E	2867/7	Transfer push rod guide (2 per set).
F	PS.2430-1	Std. 8BA screw (4 per set) for securing item E.
G	2867/3	Comb stop. (for machines fitted with Orientation Pattern Cam Unit).
	or 2867/21	Comb stop (for machines fitted with Overlap Cam Unit).
H	PS.1682-1	Std. 4BA screw (for securing item G).
J	PS.2445-1	Std. 8BA screw
K	PW.2050	Std. 8BA spring washer
L	PW.1017-1	Std. 8BA washer
M	1841/57A	Overthrow stop support L.H.
N	PS.1771-1	Std. 4BA screw
O	PW.2025	Std. 4BA spring washer
P	PW.1033-1	Std. 4BA washer
Q	PS.1777-1	Std. 4BA screw
R	PN.1509-1	Std. 4BA lock-nut
S	2868/29A	Overthrow stop
	PS.1687-1	Std. 4BA screw
	PW.2025	Std. 4BA spring washer
	PW.1009-1	Std. 4BA washer
	1826/136	W.R.U. Control Bellcrank (Stamped with letter W) replaces item QA on page 27 of Part List 1078.
	2867/14	W.R.U. Lever
	PG.7182	Tension spring (for W.R.U. lever)
	PW.5029	Special washer (6 per set)
	PW.5040	Special washer
	CS.1061	Set collar and screw

} 3 of each per set  
for securing item B to item G.

} for securing item M.

} for adjusting item S.

} 2 of each per set  
for securing item S

} not part of the  
Combination head  
Unit.

} For W.R.U.  
Signal  
Suppression  
Mechanism

**Kindly state Model of Machine and Serial Number when ordering Spare Parts.**

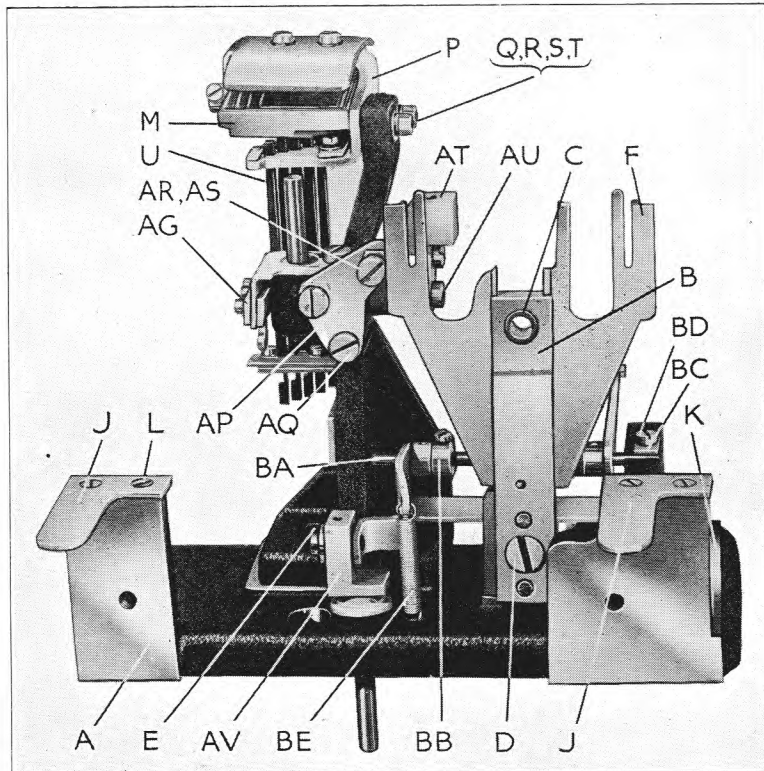

FIG. 6. CONTROL LEVER UNIT

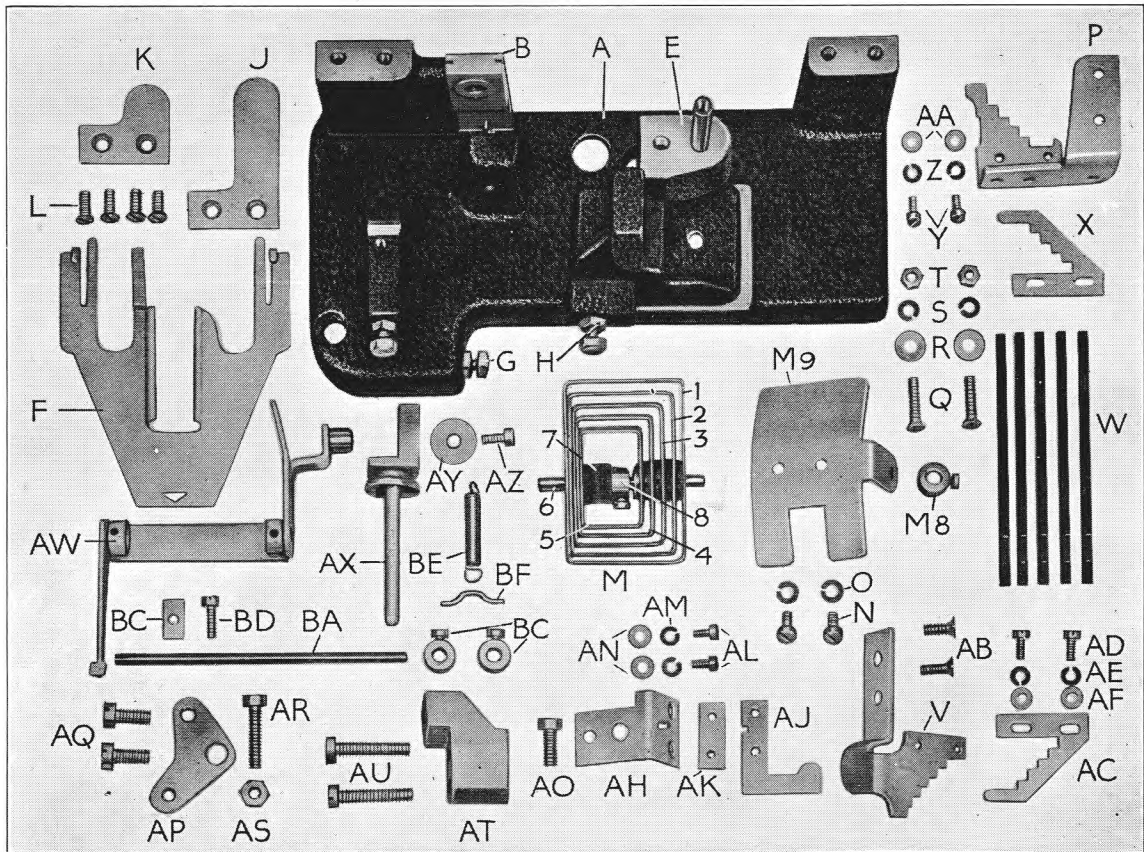

FIG. 7. CONTROL LEVER UNIT COMPONENTS



## CONTROL LEVER UNIT S.2868 Group 2

(See FIGS. 6 and 7)

Index Letter	Part No.	Part Name
<b>CASTING, TYPEHEAD SUPPORT BRACKET AND JUMPER.</b>		
A	2868 /47	★Control lever unit casting C.P.
B	2946 /1	★Typehead support bracket C.P., includes :
C	PB.4073	Oil-impregnated bush (customers must be prepared to machine the face of this bush when fitting).
D	PS.1354-1	Std. 2BA screw (for securing item B).
E	2868 /28A	★Typehammer support casting C.P.
F	PS.1342-1	Std. 2BA screw (for securing item E).
	1838 /41B	Ink ribbon jumper.
<b>ABUTMENTS</b>		
G	PS.5032	Special screw
H	PN.1509-1	Std. 4BA locknut
J	2868 /20	Locating plate (2 per set).
K	2868 /19A	Abutment plate.
L	PS.2079-1	Std. 6BA screw (6 per set) for securing items J and K.
<b>TRANSFER FRAMES</b>		
M	2869 /39	Transfer rocker assembly, comprises :
M1	2868 /7	Transfer frame (No. 1) C.P.
M2	2868 /9	Transfer frame (No. 2) C.P.
M3	2868 /11	Transfer frame (No. 3) C.P.
M4	2868 /13	Transfer frame (No. 4) C.P.
M5	2868 /15	Transfer frame (No. 5) C.P.
M6	PP.1144	Parallel pin.
M7	PW.5455	Lubricating washer (2 per set).
M8	CS.1021	Set collar and screw (2 per set).
M9	2868 /35	Guard plate.
N	PS.2045-1	Std. 6BA screw
O	PW.2037	Std. 6BA spring washer
		} 2 of each per set for securing item M.
<b>TRANSFER PUSH RODS AND GUIDE BRACKETS</b>		
P	2868 /34	Upper guide bracket.
Q	PS.2127-1	Std. 6BA screw
R	PW.1013-1	Std. 6BA washer
S	PW.2038	Std. 6BA spring washer
T	PN.1013-1	Std. 6BA nut
U	2868 /41	Transfer push rods and bracket C.P., comprises :
V	2868 /6	Lower guide bracket.
W	2868 /26	Transfer push rod (5 per set).
X	2868 /5	Transfer push rod guide.
Y	PS.2445-1	Std. 8BA screw
Z	PW.2050	Std. 8BA spring washer
AA	PW.1017-1	Std. 8BA washer
		} 2 of each per set.
AB	PS.2079-1	Std. 6BA screw (for securing item U).
AC	2868 /5	Transfer push rod guide.
AD	PS.2445-1	Std. 8BA screw.
AE	PW.2050	Std. 8BA spring washer.
AF	PW.1017-1	Std. 8BA washer.
<b>TRIP PLATE</b>		
AG	2868 ,40	Trip plate C.P., comprising :
AH	2868 ,24	Trip bracket C.P.
AJ	2868 ,27	Trip plate.
AK	2868 ,4	Clamp plate.
AL	PS.2457-1	Std. 8BA screw
AM	PW.2050	Std. 8BA spring washer
AN	PW.1017-1	Std. 8BA washer
		} 2 of each per set.
AO	PS.1694-1	Std. 4BA screw (for securing item AG).
<b>OVERTHROW STOP PARTS</b>		
AP	2868 30	Overthrow stop abutment plate.
AQ	PS.1694-1	Std. 4BA screw (2 per set).
AR	PS.1729-1	Std. 4BA screw
AS	PN.1509-1	Std. 4BA locknut
		} Abutment.
AT	2868 /31	Overthrow stop support casting.
AU	PS.1761-1	Std. 4BA screw (2 per set) for securing item AT.
<b>BELL LEVER AND SWITCH ROD C.P.</b>		
AV	2868 /38	Bell lever and switch rod C.P., comprises :
AW	2868 ,21	Bell lever C.P.
AX	1838 /73A	Switch operating rod C.P.
AY	PS.2061-1	Std. 6BA screw.
AZ	PW.5276	Special washer.
BA	PP.6529	Parallel pin.
BB	CS.1021	Set collar and screw.
BC	1838 /26	Retaining plate.
BD	PS.2077-1	Std. 6BA screw.
BE	PG.7120	Tension spring.
BF	2868 /23	Spring anchor (underneath base, not visible) for item BE.
★Customers ordering these items must be prepared to dowell them in position.		

**Kindly state Model of Machine and Serial Number when ordering Spare Parts.**

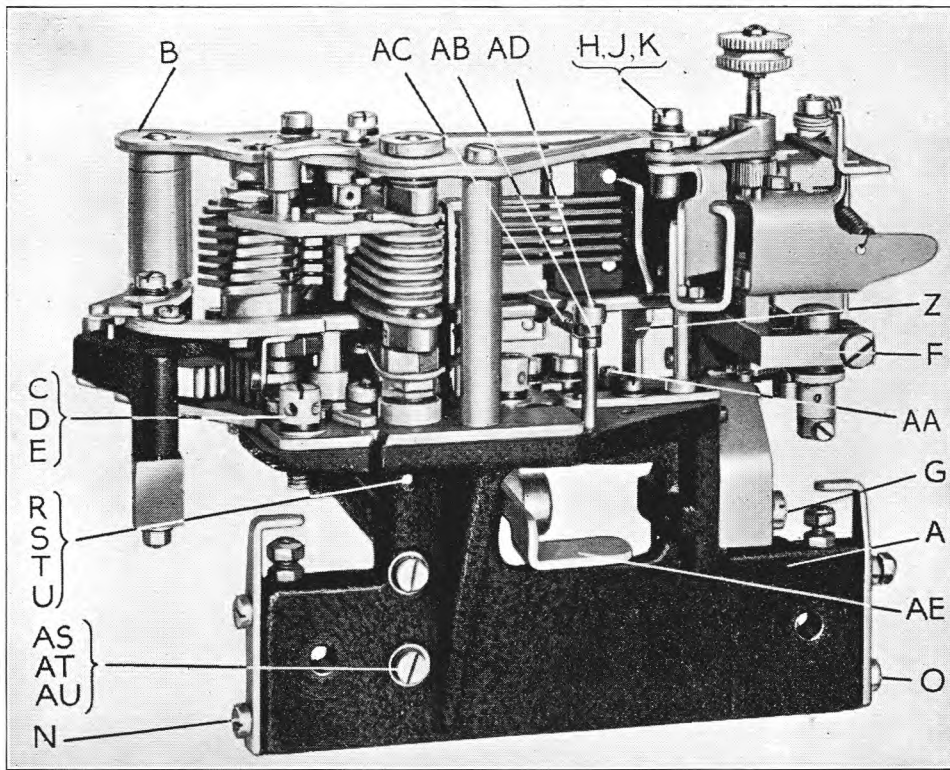

FIG. 8. PERFORATOR UNIT

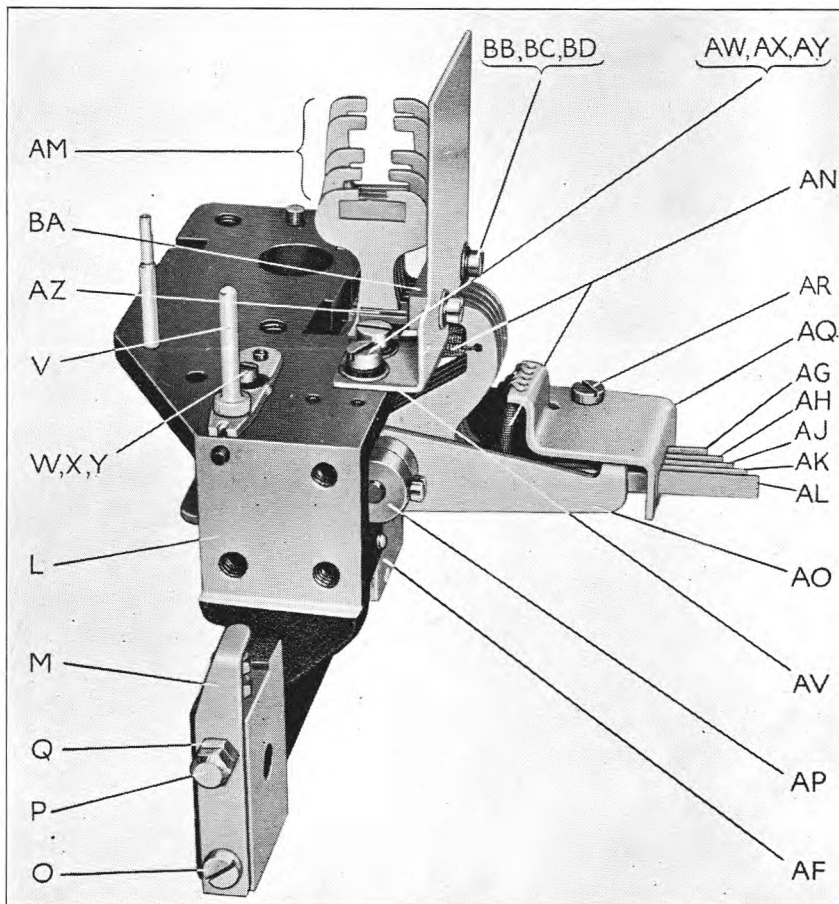

FIG. 9. PERFORATOR UNIT CASTING AND SETTING LEVERS (*End View*)

# PERFORATOR UNIT S.2870

{ Group 4 for Centre Feed.  
Group 5 for Advanced Feed.

(See FIGS. 8, 9, 10, 11, 12 and 13)

Index Letter	Part No.	Part Name	
A		PERFORATOR UNIT CASTING AND SETTING LEVERS ASSEMBLY	
		<i>See below.</i>	
B	2870 /158	Gr. 1 PUNCHING CAM ASSEMBLY (Centre Feed)	} See page 15.
	2870 /158	or Gr. 2 PUNCHING CAM ASSEMBLY (Advanced Feed)	
C	PS.1340-1	Std. 2BA screw	} 2 of each per set for securing item B.
D	PW.2013	Std. 2BA spring washer	
E	PW.1005-1	Std. 2BA washer	
F	2870 /152A	Gr. 1 PUNCH BLOCK ASSEMBLY (Centre Feed)	} See page 17.
	2870 /152A	or Gr. 2 PUNCH BLOCK ASSEMBLY (Advanced Feed)	
G	PS.1374-1	Std. 2BA screw (3 per set) for securing item F.	} retains item B to item F.
H	PS.1729-1	Std. 4BA screw	
J	PW.2027	Std. 4BA spring washer	
K	PW.1009-1	Std. 4BA washer	

## PERFORATOR UNIT CASTING AND SETTING LEVER ASSEMBLY

(See FIGS. 8 and 9)

### CASTING ASSEMBLY AND ABUTMENTS

L	2870 /174	Perforator casting C.P., comprises :	
M	2870 /1	Perforator casting sub. C.P.	
N	2870 /4	Abutment guide (2 per set).	
O	PS.1676-1	Std. 4BA screw (2 per set)	} used with 1 of items P and Q for securing item M.
P	PS.1659-1	Std. 4BA screw	
Q	PS.5032	Abutment screw (2 per set).	
R	PN.1509-1	Std. 4BA lock-nut (3 per set).	
S	2319 /143	Abutment.	
T	PS.2077-1	Std. 6BA screw	} for securing item R.
U	PW.2037	Std. 6BA spring washer	
V	PW.1013-1	Std. 6BA washer	
W	2870 /97	Tape pawl guide C.P. (or 2870 /278 Pawl Guide Block and 2870 /279 Tape Pawl Guide)*	
X	PS.2061-1	Std. 6BA screw	} for securing item V.
Y	PW.2037	Std. 6BA spring washer	
Z	PW.1013-1	Std. 6BA washer	
AA	2870 /96	Tape pawl rack (or 2870 /277 Tape Pawl Rack)*.	
AB	PS.2462-1	Std. 8BA screw (2 per set) for securing item Z (or PS.2541-1 Std. 8BA Screw)*.	
AC	PB.2059	Spring anchor bush.	
AD	PG.7208	Tension spring (for item T, see figs. 10 and 11) or PG.7041 Tension Spring.*	
	CS.1011	Set collar and screw (for retaining item AB).	

### SETTING LEVER ASSEMBLY

AE	2870 /177	Setting levers C.P., comprises :	
AF	2870 /124	Setting lever bracket C.P. (or 2870 /274 Setting Lever Bracket)*.	
AG	PB.1971	Spacing collar (not visible, between AF and AG).	
AH	2870 /131	Setting bellcrank No. 1 (shortest).	
AJ	2870 /130	Setting bellcrank No. 2.	
AK	2870 /129	Setting bellcrank No. 3.	
AL	2870 /128	Setting bellcrank No. 4.	
AM	2870 /127	Setting bellcrank No. 5 (longest).	
AN	2870 /179	Setting arms C.P. (5 arms wired together as a set).	
AO	PG.7069	Tension spring (10 per set) for items AG-AM.	
AP	2870 /142	Bellcrank depression lever C.P.	
AQ	CS.1066	Set collar and screw (retains item AO).	
AR	2870 /126	Setting bellcrank rack.	
AS	PS.1676-1	Std. 4BA screw (2 per set) for securing item AQ.	
AT	PS.1729-1	Std. 4BA screw	} 2 of each per set for securing item AE.
AU	PW.2027	Std. 4BA spring washer	
	PW.1009-1	Std. 4BA washer	

### GUARD PLATE AND SETTING ARM RACK

AV	2870 /146A	Guard plate.	
AW	PS.1694-1	Std. 4BA screw	} for securing item AV.
AX	PW.2027	Std. 4BA spring washer	
AY	PW.1009-1	Std. 4BA washer	
AZ	2870 /145A	Setting arm rack.	
BA	2870 /147	Clamp plate	
BB	PS.2077-1	Std. 6BA screw	} 2 of each per set for retaining item AZ to item AV.
BC	PW.2037	Std. 6BA spring washer	
BD	PW.1013-1	Std. 6BA washer	

### PERFORATOR UNIT COVER

	2870 /148	Cover C.P. (not shown).
	PS.6224	Special screw (2 per set) for securing cover C.P.

\* Replacing Parts when W.R.U. Signal Suppression Mechanism is fitted.

### NEW PARTS REQUIRED FOR W.R.U. SUPPRESSION

	2870 /269	Pawl throwout lever "A".
	2870 /273	Pawl throwout lever "B".
	2870 /276	Pawl extractor.
	PG.7359	Tension spring.
	PS.2088-1	Std. 6BA Cap hd. screw.
	PW.2038	Std. 6BA Spring washer.
	PW.1013-1	Std. 6BA Washer.



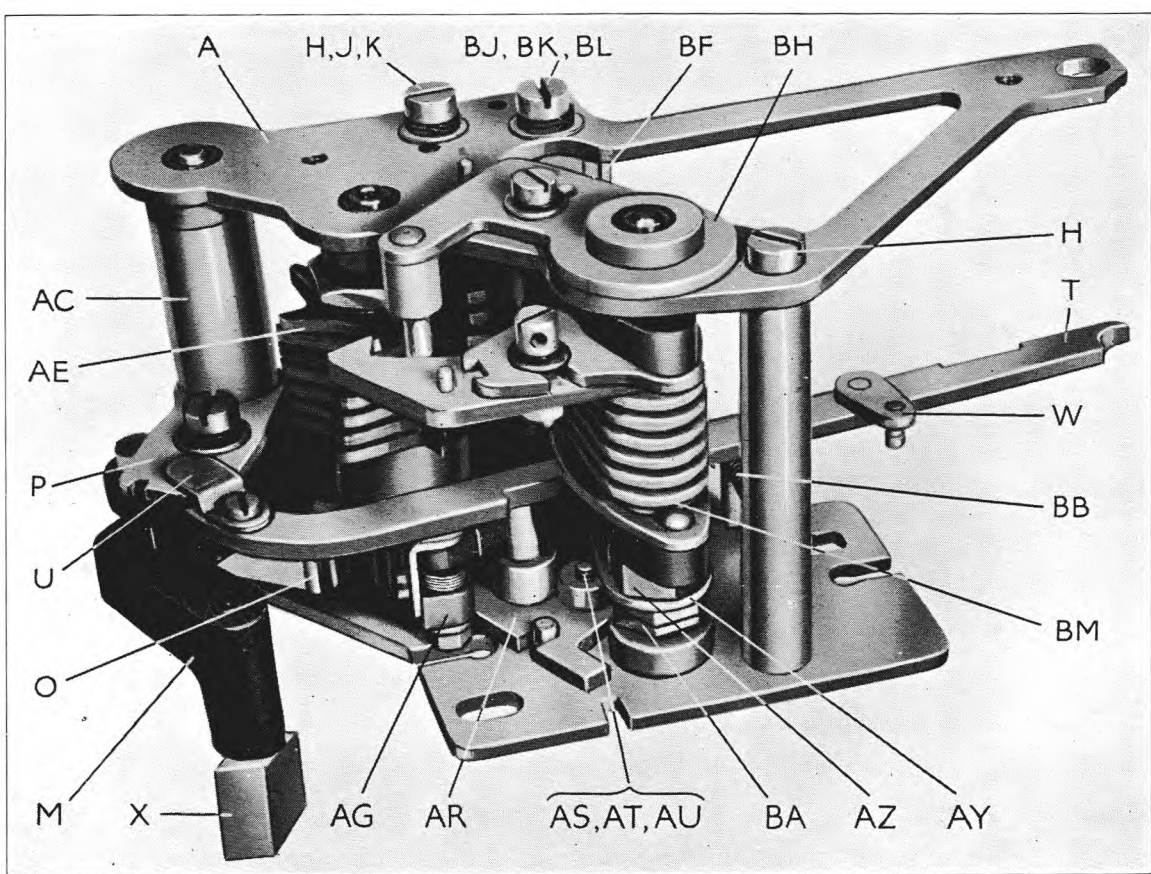

FIG. 10. PUNCHING CAM ASSEMBLY

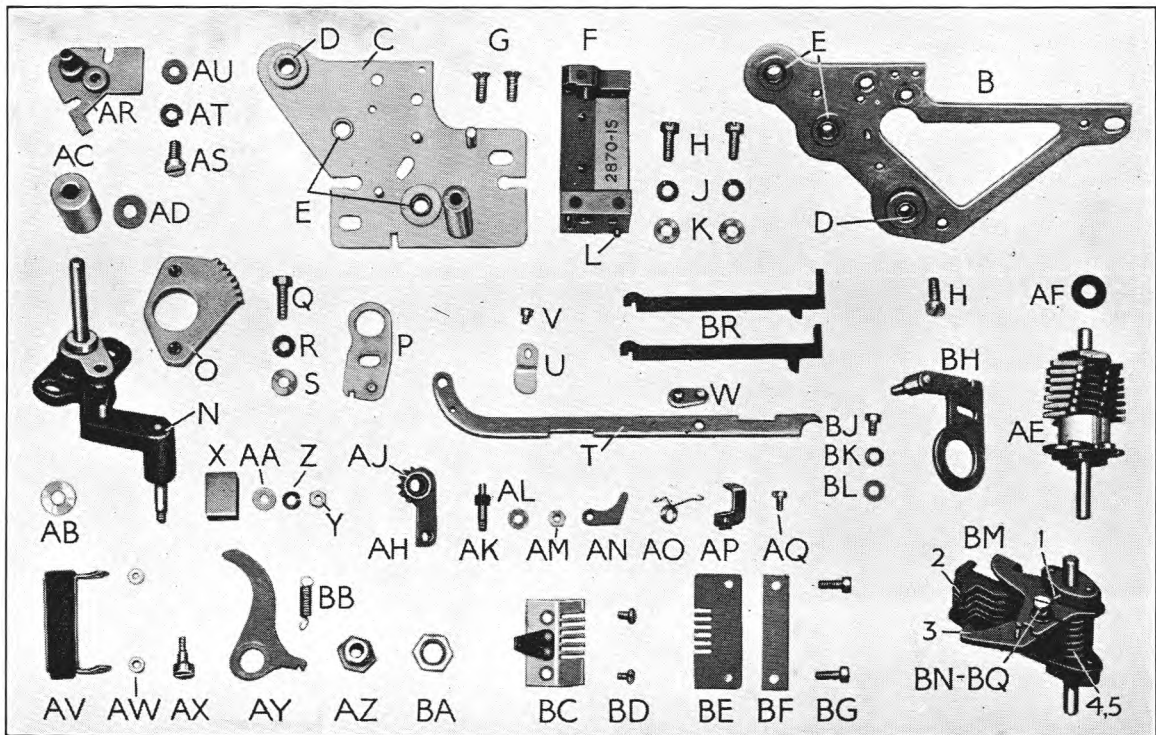

FIG. 11. PUNCHING CAM ASSEMBLY COMPONENTS

NEW PARTS (not shown) FOR MICROMETER ADJUSTMENT OF PUNCHING DEPTH

2870 /257	Adjustment block C.P.
PS.5379	Special screw.
2870 /259	Pillar block.
PS.5380	Special screw.
PG.7358	Tension spring.
PS.5722	Special screw.

# PUNCHING CAM ASSEMBLY 2870/158

Group 1 for Centre Feed only.  
Group 2 for Advanced Feed only.

(See FIGS. 10 and 11)

Index Letter	Part No.	Part Name
<b>PUNCHING CAM FRAME ASSEMBLY</b>		
A	2870/173	Punching cam frame C.P., comprises :
B	2870/160	Top plate C.P.
C	2870/159	Bottom plate C.P. } each includes :
D	FCT.85	Oil impregnated bush (flanged).
E	CT.100	Oil impregnated bush (parallel) 2 per set.
F	2870/14	Rack pillar C.P.
G	PS.1696-1	Std. 4BA screw (2 per set)
H	PS.1694-1	Std. 4BA screw (3 per set)
J	PW.2027	Std. 4BA spring washer
K	PW.1009-1	Std. 4BA washer
L	PP.1094	Parallel pin (dowel pin) 4 per set
<b>CAM FEED LEVER</b>		
M	2870/172	Cam feed lever C.P., comprises :
N	2870/31	Feed lever sub. C.P.
O	2870/34	Cam driving sector.
P	2870/35	Feed adjusting lever C.P.
Q	PS.1708-1	Std. 4BA screw
R	PW.2027	Std. 4BA spring washer
S	PW.1009-1	Std. 4BA washer
T	2870/105	Tape feed pawl (or 2870/275 tape feed pawl when W.R.U. signal suppression mechanism is fitted).
U	2870/106	Keep plate.
V	PS.2430-1	Std. 8BA screw (for securing item U).
W	2870/116	Anchor plate C.P.
X	2870/33	Trunnion block.
Y	PN.1013-1	Std. 6BA nut
Z	PW.2037	Std. 6BA spring washer
AA	PW.1013-1	Std. 6BA washer
AB	PW.1030-15	Std. 2BA washer (2 per set as required) fitted in recess of item M.
AC	RL.1096	Tape guide roller
AD	PW.5199	Shim (5 per set) fitted between items AC and A for adjusting height of item AC.
<b>CAM SHAFT AND FEED PINION</b>		
AE	2870/38	Cam shaft C.P.
AF	PW.5199	Shim (5 per set) for item AE.
AG	2870/50	Cam feed pinion C.P. comprises :
AH	2870/255	Feed pinion C.P., includes :
AJ	CT.100	Oil impregnated bush (parallel).
AK	PP.9075	Special pin (feed pawl pin).
AL	PW.2037	Std. 6BA spring washer.
AM	PN.1031-1	Std. 6BA nut.
AN	2870/102	Feed pawl.
AO	PG.3107	Torsion spring (for item AN).
AP	2870/103	Keep plate.
AQ	PS.2457-1	Std. 8BA screw.
<b>FEED PAWL STOP</b>		
AR	2870/99	Pawl stop C.P.
AS	PS.1687-1	Std. 4BA screw
AT	PW.2027	Std. 4BA spring washer
AU	PW.1009-1	Std. 4BA washer
<b>CAM LUBRICATION PAD</b>		
AV	2870/20	Oil pad C.P.
AW	PB.1972	Collar (2 per set).
AX	PS.6419	Pip-end screw (pivot for item AV).
<b>CAM RETENTION LEVER</b>		
AY	2870/60A	Retention lever.
AZ	2870/180	Eccentric bush.
BA	2870/181	Nut.
BB	PG.7176	Tension spring (for item AY).
<b>CAM LEVER AND PUNCH BAR RACKS</b>		
BC	2870/17	Cam lever rack.
	PG.3138	Torsion spring (not shown) replaces flat spring on item BC.
BD	PS.2047-1	Std. 6BA screw (2 per set) for securing item BC.
BE	2870/24	Punch bar rack.
BF	2870/30	Abutment plate.
BG	PS.2077-1	Std. 6BA screw (2 per set) for securing items BE and BF.
<b>RESETTING LEVER STOP</b>		
BH	2870/121	Stop pin plate C.P.
BJ	PS.2045-1	Std. 6BA screw
BK	PW.2037	Std. 6BA spring washer
BL	PW.1013-1	Std. 6BA washer
<b>PUNCHING AND RESETTING LEVERS</b>		
BM	2870/52	Punching and resetting levers assembly includes :
BM1	23926A	Taper pin (2 per set) for fixing position of levers on shaft.
BM2	2870/54	Punching lever C.P. (6 per set).
BM3	2870/56	Resetting lever C.P.
BM4	PW.5475	Special washer (2 per set)
BM5	PW.5484	Shim (5 per set)
BN	PS.2104-1	Std. 6BA screw
BO	PW.2037	Std. 6BA spring washer
BP	PW.1013-1	Std. 6BA washer
BQ	PN.1513-1	Std. 6BA lock-nut
<b>PUNCHING BARS</b>		
BR	2870/161	Set of punching bars (for centre feed only)
	2870/245	or Set of punching bars (for advanced feed only)

Kindly state Model of Machine and Serial Number when ordering Spare Parts.

Index Letters AJ  
and AH should, in  
each case, be Z.

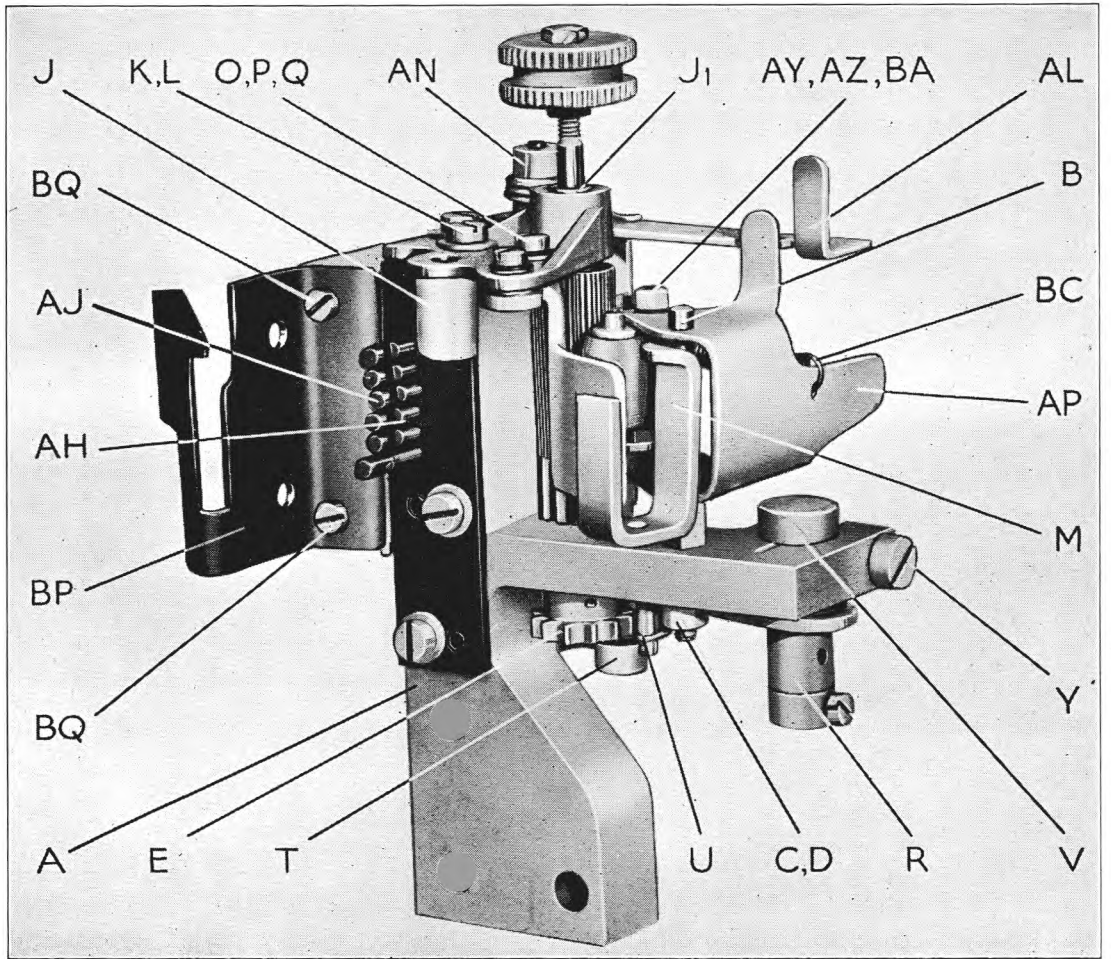

FIG. 12. PUNCH BLOCK ASSEMBLY

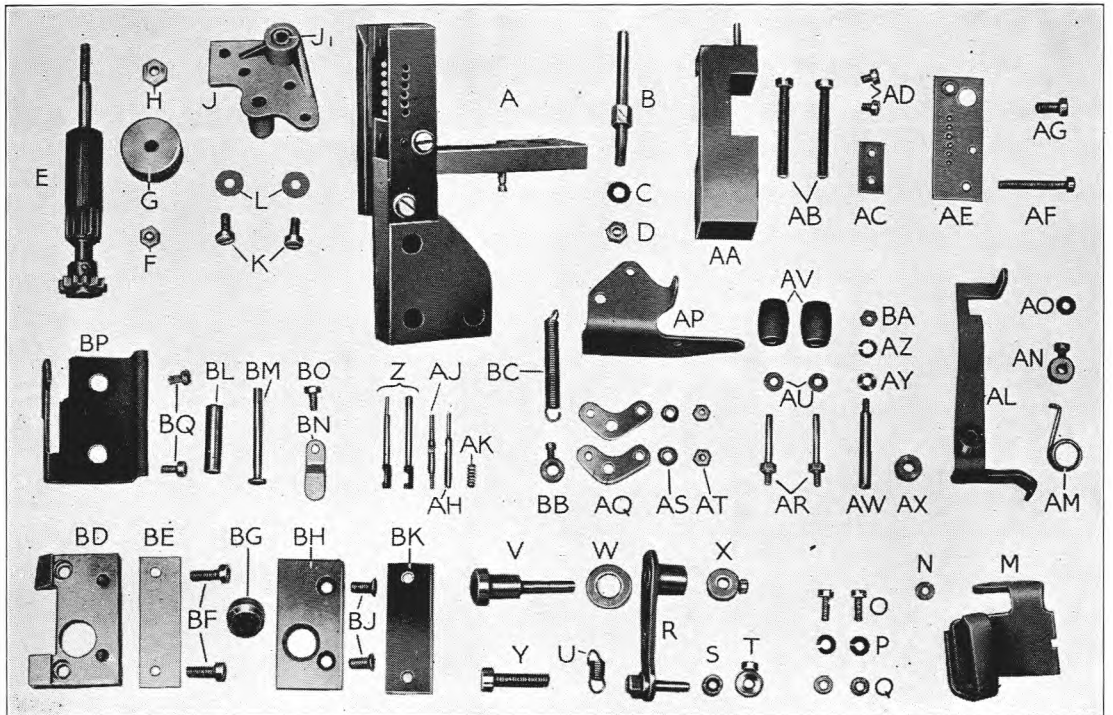

FIG. 13. PUNCH BLOCK ASSEMBLY COMPONENTS

**PUNCH BLOCK ASSEMBLY 2870/152A** { **Group 1 for Centre Feed.**  
**Group 2 for Advanced Feed.**  
 (See FIGS. 12 and 13)

Index Letter	Part No.	Part Name	
<b>PUNCH MOUNTING</b>			
A	2870/171B	Punch mounting C.P. (for centre feed only)	} each include :
	2870/178B	or Punch mounting C.P. (for advanced feed only)	
	CT.100	Oil impregnated bush (parallel) not visible, for item E.	
B	2870/7	Pressure arm pivot.	
C	PW.2037	Std. 6BA spring washer	} for securing item B.
D	PN.1013-1	Std. 6BA nut	
<b>FEED SPINDLE AND KNOB</b>			
E	2870/154	Feed spindle C.P.	
F	PN.1513-1	Std. 6BA lock-nut.	
G	KN.1025	Feed knob.	
H	PN.5056	Special nut.	
J	2870/155	Feed spindle bearing plate C.P., includes :	
J <sub>1</sub>	CT.102	Oil impregnated bush (parallel).	
K	PS.2061-1	Std. 6BA screw	} 2 of each per set for securing item J to item A.
L	PW.1013-1	Std. 6BA washer	
<b>TAPE KNIFE</b>			
M	2870/291	Tape knife C.P.	
N	PW.1017-1	Std. 8BA washer (6 per set) for adjusting height of item M.	
O	PS.2462-1	Std. 8BA screw	} 2 of each per set for securing item M.
P	PW.2050	Std. 8BA spring washer	
Q	PW.1017-1	Std. 8BA washer	
<b>JOCKEY ROLLER AND PIVOT</b>			
R	2870/175	Jockey roller C.P., includes :	
S	RL.1094	Roller.	
T	CS.1105	Set collar and screw (retains item S).	
U	PG.7314	Tension spring (for item R).	
V	2870/168	Jockey roller pivot.	
W	PW.5464	Spacing washer.	
X	CS.1021	Set collar and screw (retains item R).	
Y	PS.1729-1	Std. 4BA screw (for clamping item V).	
<b>PUNCHES</b>			
Z	2870/157	Set of punches (comprises 5 code punches and 1 feed hole punch).	
<b>PAPER LAYER MOUNTING</b>			
AA	2870/237	Paper laying mounting block C.P. (for centre feed only).	} after fitting with their springs item AK, these layers should be flush with the die-plate.
	2870/243	or Paper laying mounting block C.P. (for advanced feed only).	
AB	PS.2253-1	Std. 6BA screw (2 per set) secures item AA (replaced by 2870/304 threaded stud, 2 per set, not shown).	
AC	2870/238	Stop plate.	
AD	PS.2430-1	Std. 8BA screw (2 per set) for securing item AC.	
AE	2870/236	Layer guide plate (for centre feed only).	} for securing item AE.
	2870/244	or Layer guide plate (for advance feed only).	
AF	PS.2590-1	Std. 8BA screw	
AG	PS.2061-1	Std. 6BA screw	
<b>PAPER LAYERS AND SPRINGS</b>			
AH	2870/200	Paper layer (code hole) 5 per set	} after fitting with their springs item AK, these layers should be flush with the die-plate.
AJ	2870/201	Paper layer (feed hole)	
AK	PG.5073	Compression spring (6 per set).	
<b>PRESSURE ARM LATCH</b>			
AL	2870/70A	Pressure arm latch C.P.	
AM	PG.3117	Torsion spring (for item AL).	
AN	CS.1102	Set collar and screw (retains items AM and AL).	
AO	PW.1017-1	Std. 8BA washer (4 per set) for adjusting height of item AL.	
<b>TAPE PRESSURE ROLLER.</b>			
	2870/240	Twin pressure roller C.P. comprises :	
AP	2870/239	Twin pressure roller frame.	
AQ	2870/241	Twin roller bearing plate (2 per set).	
AR	PP.8763	Roller pivot pin (2 per set).	
AS	PW.2050	Std. 8BA spring washer	} 2 of each per set for securing item AQ.
AT	PN.1017-1	Std. 8BA nut	
AU	PW.1017-1	Std. 8BA washer (2 per set) bearing washer for item AV.	
AV	RL.1134	Roller (synthetic fabric) 2 per set.	
AW	PP.7799A	Pressure roller pivot.	
AX	PB.4072	Collar.	
AY	PW.1017-1	Std. 8BA washer (for adjusting height of Twin Pressure Roller C.P. 2870/240)	
AZ	PW.2050	Std. 8BA spring washer	} for securing the Twin pressure roller C.P.
BA	PN.1017-1	Std. 8BA nut	
BB	CS.1016	Set collar and screw (retains item AP).	
BC	PG.7355	Tension spring (for item AP).	
<b>PLATEN BLOCK AND PLATEN</b>			
BD	2870/107	Platen block.	
BE	2870/108	Shim (6 per set).	
BF	PS.2077-1	Std. 6BA screw (2 per set).	
BG	2870/156	Platen C.P.	} for retaining item BG.
BH	2870/111	Platen retaining plate	
BJ	PS.2063-1	Std. 6BA screw (2 per set)	
BK	2870/170	Platen holder location plate.	
<b>TAPE GUIDE ROLLER</b>			
BL	RL.1095	Tape guide roller.	
BM	PP.6722	Roller pivot pin.	
BN	2870/114	Keep plate.	
BO	PS.2445-1	Std. 8BA screw (for securing item BN).	
BP	2870/115A	Paper guide plate.	
BQ	PS.2445-1	Std. 8BA screw (2 per set) secures item BP.	

**Kindly state Model of Machine and Serial Number when ordering Spare Parts.**



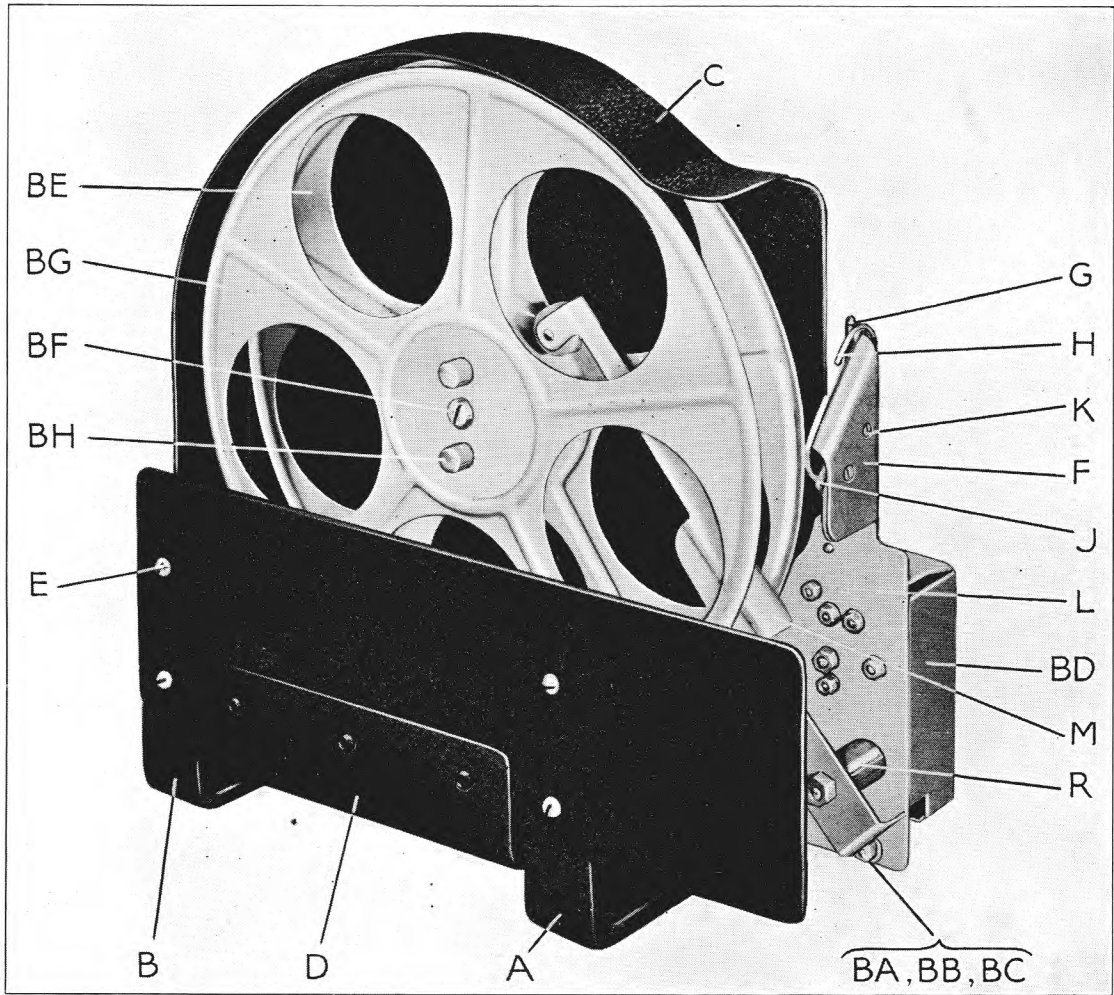

FIG. 14. TAPE ROLL HOLDER UNIT

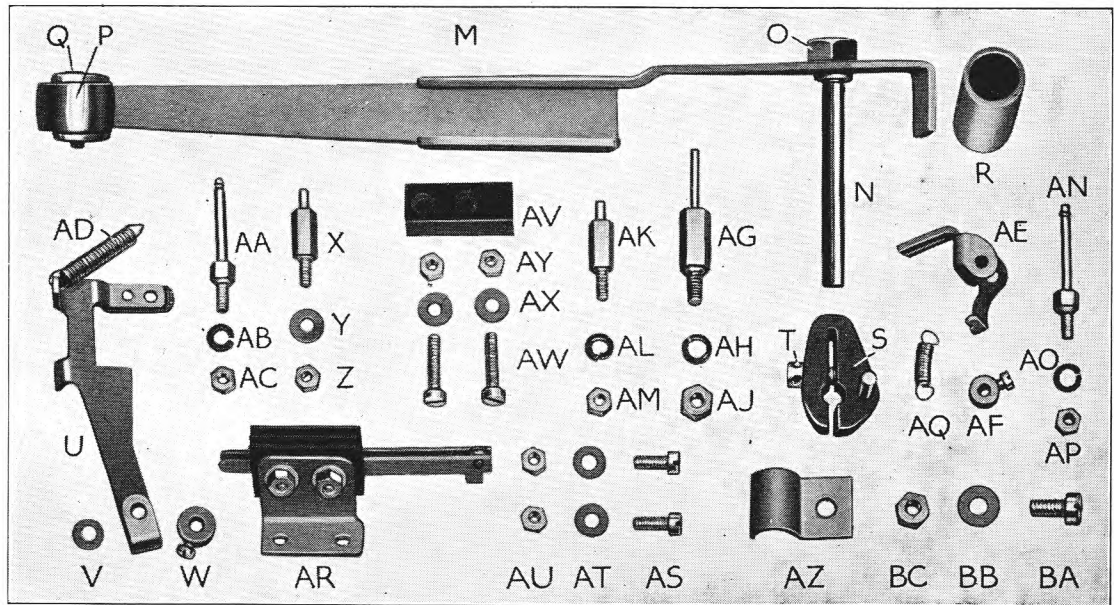

FIG. 15. TAPE EXHAUST ALARM COMPONENTS

# TAPE ROLL HOLDER UNIT S.2869A, GROUP 1

(See FIGS. 14 and 15)

Index Letter	Part No.	Part Name
<b>MAIN FRAME AND GUARD</b>		
A	2869/55	Tape guard bracket (R.H.).
B	2869/51	Tape guard bracket (L.H.).
	2869/49	Tape wheel bracket ( <i>not visible</i> ).
	PS.1708-1	Std. 4BA screw
	PW.2025	Std. 4BA spring washer
	PW.1009-1	Std. 4BA washer
	2869/50	Retaining clip ( <i>not visible</i> ).
	PS.1737-1	Std. 4BA screw
	PW.2025	Std. 4BA spring washer
	PW.1009-1	Std. 4BA washer
	2869/63	Cover guide C.P.
C	2869/56A	Tape wheel guard.
	PS.1676-1	Std. 4BA screw
	PW.2025	Std. 4BA spring washer
	PW.1009-1	Std. 4BA washer
D	2869/54A	Tape guard plate C.P.
E	PS.1680-1	Std. 4BA screw (4 per set) secures item D.
<b>TAPE GUIDE</b>		
F	2869/42A	Tape guide C.P. comprises :
G	2869/17A	Tape guide plate C.P.
	2869/68	Tape guide.
H	2869/19	Tape retainer.
J	2869/20	Clamp plate
K	PS.2063-1	Std. 6BA screw (2 per set)
	PS.2077-1	Std. 6BA screw
	PW.1013-1	Std. 6BA washer
	PN.1013-1	Std. 6BA nut
<b>TAPE EXHAUST ALARM MECHANISM</b>		
L	2869/1	Mounting plate C.P.
	PS.1678-1	Std. 4BA screw (3 per set), for securing item L.
M	2869/44	Follower arm C.P., includes :
N	PP.5534	Follower arm pivot.
O	PN.1005-1	Std. 2BA nut.
P	2869/23	Tape roller.
Q	PP.1158	Parallel pin ( <i>pivot for item P</i> ).
R	PB.2061	Sleeve.
S	2869/22	Pivot block C.P.
T	PS.2136-1	Std. 6BA screw.
U	2869/14	Contact lever C.P.
V	PW.5021	Special washer.
W	CS.1021	Set collar and screw ( <i>retains item U</i> ).
X	PP.5536	Stop pin ( <i>for item U</i> ).
Y	PW.1013-1	Std. 6BA washer.
Z	PN.1013-1	Std. 6BA nut.
AA	PP.5537	Anchor pin ( <i>for item AD</i> ).
AB	PW.2038	Std. 6BA spring washer.
AC	PN.1013-1	Std. 6BA nut.
AD	PG.7209	Tension spring ( <i>for item U</i> ).
AE	2869/12	Latch.
AF	CS.1011	Set collar and screw.
AG	PP.5535	Pivot pin.
AH	PW.2025	Std. 4BA spring washer.
AJ	PN.1009-1	Std. 4BA nut.
AK	PP.5536	Stop pin ( <i>for item AE</i> ).
AL	PW.2038	Std. 6BA spring washer.
AM	PN.1013-1	Std. 6BA nut.
AN	PP.5537	Anchor pin ( <i>for item AQ</i> ).
AO	PW.2038	Std. 6BA spring washer.
AP	PN.1013-1	Std. 6BA nut.
AQ	PG.7054	Tension spring ( <i>for item AE</i> ).

**Kindly state Model of Machine and Serial Number when ordering Spare Parts.**

## TAPE ROLL HOLDER UNIT S.2869A Group 1 (contd.)

<i>Index Letter</i>	<i>Part No.</i>	<i>Part Name</i>
<b>TAPE EXHAUST ALARM CONTACTS.</b>		
AR	2869/38	Contact spring-set C.P.
AS	PS.2077-1	Std. 6BA screw.
AT	PW.1013-1	Std. 6BA washer
AU	PN.1013-1	Std. 6BA nut
AV	2869/33	Buffer block.
AW	PS.2125-1	Std. 6BA screw
AX	PW.1013-1	Std. 6BA washer
AY	PN.1013-1	Std. 6BA nut
AZ	PK.2062	Cable cleat.
BA	PS.1687-1	Std. 4BA screw
BB	PW.1009-1	Std. 4BA washer
BC	PN.1009-1	Std. 4BA nut
BD	2869/37	Tape failure alarm cover.
	PS.2045-1	Std. 6BA screw
	PW.1013-1	Std. 6BA washer

} 2 of each per set  
for securing item AR.

} 2 of each per set  
for securing item AV.

} for securing item AZ.

} 2 of each per set for securing item BD.

### TAPE WHEEL (FRONT AND REAR).

BE	2869/45	Tape rear wheel C.P., includes :
	2869/67	Tape boss.
	PS.1676-1	Std. 4BA screw (4 per set) for securing tape boss.
	2869/43	Spring collar (not visible).
	PP.5546	Tape wheel pivot.
	PW.2002	Std. 0BA spring washer.
	PN.1001-1	Std. 0BA nut.
BF	PS.7006	Special screw (retains item BE).
BG	2869/39	Tape front wheel C.P., includes :
	2869/8	Retention clip C.P.
	PG.5059	Compression spring (2 per set).
BH	KN.1026	Knurled screw
	PW.1013-1	Std. 6BA washer
	PN.1013-1	Std. 6BA nut.

} 2 of each per set.

## ACCESSORIES

Accessory Lists No. 27 for Model 85R, No. 28 for Models 85/M, 85/N3, 85/N4 and No. 29 for Model 85/T4, comprising the following Accessories, are supplied if required and are no longer included in the price of a complete machine.

<i>Accessory List</i>			<i>Part Name</i>
No. 27	No. 28	No. 29	<i>Part No.</i>
-	1	1	TA.1095 .. ¼-Pint Can Lubricant No. 1 ( <i>Thin Oil</i> ).
1	1	1	TA.1096 .. ¼-Pint Can Lubricant No. 2 ( <i>Medium Oil</i> ).
1	1	1	TA.1097 .. ½-Oz. Tube Lubricant No. 4 ( <i>Grease</i> ).
1	1	1	TA.1098 .. ½-Oz. Tube Lubricant No. 5 ( <i>Grease</i> ).
1	1	1	8184 .. Paper Tape, 1 coil, 8" diameter × 1/16" wide, code word "ABAST".
1	1	1	.. Unpacking and Installation Instructions (U1/7A/2).
1	1	1	.. Instruction Booklet No. 85 (3rd Issue).
1	1	1	.. Instruction Booklet No. 78 (11th Edition).
-	-	1	.. Instruction Booklet No. CTK/78 (5th Edition).
-	1	-	.. Instruction Booklet No. 47K
-	1	-	.. Part List No. 1047K (2nd edition). } for 85/N3, N4 and NT4 only
1	1	1	.. Part List No. 1078 (9th Edition—with corrections).
1	1	1	.. Part List No. 1085 (1st Edition—reprint with corrections).
-	-	1	.. Part List No. CTK/1078 (2nd Edition).
-	1	1	.. Copy of Keyboard Chart
1	1	1	.. Copy of Typehead Chart } to which machine is prepared.
1	1	1	.. Technical Information Supplement No. 7.
1	1	1	.. Part List No. 3750 (for machines fitted with S.3750 Overlap Pattern Cam Unit only).

**Kindly state Model of Machine and Serial Number when ordering Spare Parts.**

## TOOLS

Tool Kits, No. 27 for Model 85R, No. 28 for Models 85/M, 85/N3, 85/N4 and No. 29 for Model 85/T4, comprising the following Tools, are supplied, if required, and are no longer included in the price of a complete machine. When a number of Reperforators are employed at one location, one Tool Kit per machine is not normally necessary, but a smaller number of Kits than the number of Reperforators, sufficient for the personnel who will maintain them. The quantity of Kits should be specified when ordering the machines.

<i>Tool Kit</i>	<i>Tool Kit</i>	<i>Tool Kit</i>	<i>Part No.</i>	<i>Part Name</i>
<i>No. 27</i>	<i>No. 28</i>	<i>No. 29</i>		
1	1	1	TA.1008	.. Spring Hook.
1	1	1	TA.1039	.. Spanner, 0BA-1BA.
1	1	1	TA.1038	.. Spanner, 2BA-3BA.
2	2	2	TA.1022	.. Spanner 4BA-6BA.
1	1	1	TA.1036	.. Spanner, 8BA-10BA.
1	1	1	TA.1048	.. Spanner "A" ( <i>for Camshaft and Answer-Back Unit</i> ).
-	1	1	TA.1047	.. Spanner "B" ( <i>for Clutch Body and Answer-Back Unit</i> ).
-	1	1	TA.1051	.. Spanner "C" ( <i>for Answer-Back Unit</i> ).
1	1	1	TA.1052	.. Spanner 0.615 across flats ( <i>for Cam Shaft and Answer-Back Unit</i> ).
2	2	2	TA.1115	.. Spanner, $\frac{1}{2}$ inch Whit. ( <i>for Receiver Cam Shaft lock-nuts</i> ).
1	1	1	TA.1127	.. Pin Spanner C.P.
1	1	1	TA.1011	.. Tommy Pin ( <i>medium</i> ).
1	1	1	TA.1019	.. Tommy Pin ( <i>large</i> ).
-	1	1	TA.1020	.. Tommy Pin ( <i>small</i> ).
-	1	1	TA.1118	.. { 1 Special Clamp ( <i>used when dismantling Typehead Clutch</i> ). 1 Special Plate ( <i>for supporting Typehead when tapping out the Taper Pin</i> ).
1	1	1	TA.1015	.. Grease Gun.
1	1	1	TA.1023	.. Pair of Special Pliers ( <i>for removing Locking Rings</i> ).
1	1	1	TA.1110	.. Governor Adjusting Clamp.
1	1	1	TA.1123A	.. Double ended pin guage.
1	1	1	TA.1117	.. Fork Stroboscope ( <i>speed 125 v.p.s. for 50 Bauds</i> ).
1	1	1	TA.1112	.. Lapping Block C.P.
-	1	1	TA.1030	.. Burnisher C.P.
-	-	1	TA.1049	.. Packing Strip .
1	1	1	TA.1053	.. Screwdriver $3\frac{1}{2}'' \times \frac{1}{16}''$ .
1	1	1	8549	.. Screwdriver $5'' \times \frac{1}{8}''$ .
1	1	1	8550	.. Screwdriver $5'' \times \frac{1}{4}''$ .
1	2	2	8620	.. Oil Can ( <i>Watch pattern</i> ).
1	1	1	8199	.. Pair of Tweezers.

**Kindly state Model of Machine and Serial Number when ordering Spare Parts.**



# NUMERICAL INDEX

Part No.	Part Name	Page	Index Letters		Part No.	Part Name	Page	Index Letters
S.1814	Relay biasing unit .. ..	7	S		S.2868 Gr. 2	Control lever unit .. ..	11	—
					/1	Control lever unit casting ..	11	A
S.1822B	Keyboard unit (Type "M")				/4	Clamp plate .. ..	11	AK
	7½ unit .. ..	5	A		/5	Transfer push rod guide ..	11	X
1824/39A	Motor support plate C.P. ..	7	M		/6	Lower guide bracket .. ..	11	AC
/40A	Motor support plate C.P. ..	7	M		/7	Transfer frame (No. 1) C.P. ..	11	V
S.1825D	Starter switch control unit ..	7	R		/9	Transfer frame (No. 2) C.P. ..	11	M1
/63	Starter driving worm C.P. ..	7	Q		/11	Transfer frame (No. 3) C.P. ..	11	M2
/99	Mainshaft C.P. .. ..	7	P		/13	Transfer frame (No. 4) C.P. ..	11	M3
1826/136	W.R.U. control bellcrank ..	9	S		/15	Transfer frame (No. 5) C.P. ..	11	M4
S.1834	Typehammer unit .. ..	6	F		/19A	Abutment plate .. ..	11	M5
1838/26	Retaining plate .. ..	11	BC		/20	Locating plate .. ..	11	K
/41B	Ribbon jumper .. ..	11	F		/21	Bell lever C.P. .. ..	11	J
/73A	Switch operating rod C.P. ..	11	AX		/23	Spring anchor .. ..	11	AW
1841/7C	Driving disc .. ..	7	O		/24	Trip bracket C.P. .. ..	11	BF
/11	Fibre coupling disc .. ..	7	N		/26	Transfer push rod .. ..	11	AH
/13	Typehead drive cover .. ..	7	X		/27	Trip plate .. ..	11	W
/14A	Switch cover .. ..	7	R		/28A	Typehammer support casting		AJ
/16	Keyboard dummy front .. ..	5	A			C.P. .. ..	11	E
/19	Ink ribbon (purple) .. ..	7	W		/29A	Overthrow stop .. ..	9	S
/20	Ink ribbon (black) .. ..	7	W		/30	Overthrow stop abutment		AP
/21	Ribbon spool .. ..	7	W			plate .. ..	11	
/46A	Electromagnet link C.P. ..	7	T		/31	Overthrow stop support		AT
/57A	Overthrow stop support L.H.	9	M			casting .. ..	11	P
1858/12	Motor terminal block .. ..	7	K		/34	Upper guide bracket .. ..	11	M9
/26A	Motor cover .. ..	7	K		/35	Guard plate .. ..	11	AV
S.1910	Governor unit (series) .. ..	7	L		/38	Bell lever and switch rod C.P.	11	M
S.1945	Keyboard unit (type "T") .. ..	5	A		/39	Transfer rocker assembly ..	11	AG
S.2087	Keyboard unit (type "N3" or				/40	Trip plate C.P. .. ..	11	U
	"N4") .. ..	5	A		/41	Transfer push rods and		A
2319/143	Abutment .. ..	13	R			bracket C.P. .. ..	11	
S.2848A	Operating electromagnet unit	7	V		/47	Control lever unit casting C.P.	11	
S.2865A Gr. 3	Reperforator sub assembly ..	6	—		S.2869A Gr. 1	Tape roll holder unit .. ..	19	—
/2	Main base unit .. ..	6	A		/1	Mounting plate C.P. .. ..	19	L
S.2866B Gr. 1	Cam Unit (Type 2) .. ..	6	C		/8	Retention clip C.P. .. ..	20	BG
S.2867 Gr. 2	Combination head unit .. ..	9	—		/12	Latch .. ..	19	AE
/3	Comb stop .. ..	9	G		/14	Contact lever C.P. .. ..	19	U
/4	Receiving comb C.P. .. ..	9	A		/17A	Tape guide plate C.P. .. ..	19	G
/6	Transfer push bracket .. ..	9	C		/19	Tape retainer .. ..	19	H
/7	Transfer push rod guide .. ..	9	E		/20	Clamp plate .. ..	19	J
/8	Transfer push rod .. ..	9	D		/22	Pivot block C.P. .. ..	19	S
/10	Transfer push rod C.P. .. ..	9	B		/23	Tape roller .. ..	19	P
/14	W.R.U. lever .. ..	9	S		/33	Buffer block .. ..	20	AV
/21	Comb stop .. ..	9	F		/37	Tape failure alarm cover ..	20	BD
					/38	Contact spring-set C.P. ..	20	AR
					/39	Tape front wheel C.P. ..	20	BG
					/42A	Tape guide C.P. .. ..	19	F
					/43	Spring collar .. ..	20	BE
					/44	Follower arm C.P. .. ..	19	M
					/45	Tape rear wheel C.P. .. ..	20	BE
					/46	Packing piece (¼" thick) ..	7	Y
					/48	Packing piece .. ..	7	Y
					/49	Tape wheel bracket .. ..	19	B
					/50	Retaining clip .. ..	19	B
					/51	Tape guard bracket L.H. ..	19	B
					/54A	Tape guard plate C.P. .. ..	19	D
					/55	Tape guard bracket R.H. ..	19	A
					/56A	Tape wheel guard .. ..	19	C
					/57	Packing piece (⅜" thick) ..	7	Y
					/58	Packing piece (⅜" thick) ..	7	Y
					/63	Cover guide C.P. .. ..	19	B
					/67	Tape boss .. ..	20	BE
					/68	Tape guide .. ..	19	G
					S.2870	Perforator unit .. ..	13	—
					/1	Perforator casting sub C.P. ..	13	L
					/4	Abutment guide .. ..	13	M
					/7	Pressure arm pivot .. ..	17	B
					/14	Rack pillar C.P. .. ..	15	F
					/17	Cam lever rack .. ..	15	BC
					/20	Oil pad C.P. .. ..	15	AV

Part No.	Part Name	Page	Index Letters
/24	Punch bar rack .. ..	15	BE
/30	Abutment plate .. ..	15	BF
/31	Feed lever sub. C.P. ..	15	N
/33	Trunnion block .. ..	15	X
/34	Cam driving sector .. ..	15	O
/35	Feed adjusting lever C.P. ..	15	P
/38	Camshaft C.P. .. ..	15	AE
/50	Cam feed pinion C.P. ..	15	AG
/52	Punching and resetting levers assembly .. ..	15	BM
/54	Punching lever C.P. .. ..	15	BM2
/56	Resetting lever C.P. .. ..	15	BM3
/60A	Retention lever .. ..	15	AY
/70A	Pressure arm latch C.P. ..	17	AL
/87A	Tape knife C.P. .. ..	17	M
/96	Tape pawl rack .. ..	13	Z
/97	Tape pawl guide C.P. ..	13	V
/99	Pawl stop C.P. .. ..	15	AR
/102	Feed pawl .. ..	15	AN
/103	Keep plate .. ..	15	AP
/105	Tape feed pawl .. ..	15	T
/106	Keep plate .. ..	15	U
/107	Platen block .. ..	17	BD
/108	Shim .. ..	17	BE
/111	Platen retaining plate ..	17	BH
/114	Keep plate .. ..	17	BN
/115A	Paper guide plate .. ..	17	BP
/116	Anchor plate C.P. .. ..	15	W
/121	Stop pin plate C.P. .. ..	15	BH
/124	Setting lever bracket C.P. ..	13	AF
/126	Setting bellcrank rack ..	13	AQ
/127	Setting bellcrank (No. 5) ..	13	AL
/128	Setting bellcrank (No. 4) ..	13	AK
/129	Setting bellcrank (No. 3) ..	13	AJ
/130	Setting bellcrank (No. 2) ..	13	AH
/131	Setting bellcrank (No. 1) ..	13	AG
/142	Bellcrank depression lever C.P. .. ..	13	AO
/145A	Setting arm rack .. ..	13	AZ
/146A	Guard plate .. ..	13	AV
/147	Clamp plate .. ..	13	BA
/148	Cover C.P. .. ..	13	BD
/152A	Punch block assembly .. ..	17	—
/154	Feed spindle C.P. .. ..	17	E
/155	Feed spindle bearing plate C.P. .. ..	17	J
/156	Platen C.P. .. ..	17	BG
/157	Set of punches .. ..	17	Z
/158	Punching cam assembly ..	15	—
/159	Bottom plate C.P. .. ..	15	C
/160	Top plate C.P. .. ..	15	B
/161	Set of punching bars .. ..	15	BR
/168	Jockey roller pivot .. ..	17	V
/170	Platen holder location plate ..	17	BK
/171B	Punch mounting C.P. .. ..	17	A
/172	Cam feed lever C.P. .. ..	15	M
/173	Punching cam frame C.P. ..	15	A
/174	Perforator casting C.P. ..	13	K
/175	Jockey roller C.P. .. ..	17	R
/177	Setting levers C.P. .. ..	13	AE
/178B	Punch mounting C.P. .. ..	17	A
/179	Setting arms C.P. .. ..	13	AM
/180	Eccentric bush .. ..	15	AZ
/181	Nut .. ..	15	BA
/200	Paper layer .. ..	17	AH
/201	Paper layer (feed hole) ..	17	AJ
/236	Layer guide plate .. ..	17	AE
/237	Paper laying mounting block C.P. .. ..	17	AA
/238	Stop plate .. ..	17	AC
/239	Twin pressure roller frame ..	17	AP
/240	Twin pressure roller C.P. ..	17	AO
/241	Twin roller bearing plate ..	17	AQ
/243	Paper laying mounting block C.P. .. ..	17	AA
/244	Layer guide plate .. ..	17	AE
/245	Set of punching bars .. ..	15	BR
/255	Feed pinion C.P. .. ..	15	AH

Part No.	Part Name	Page	Index Letters
/257	Adjustment Block C.P. ..	14	—
/259	Pillar block .. ..	14	—
/269	Pawl throwout lever "A" ..	13	—
/273	Pawl throwout lever "B" ..	13	—
/274	Setting lever bracket .. ..	13	AF
/275	Tape feed pawl .. ..	15	T
/276	Pawl extractor .. ..	13	—
/277	Tape pawl rack .. ..	13	Z
/278	Pawl guide block .. ..	13	V
/279	Tape pawl guide .. ..	13	V
/291	Tape knife C.P. .. ..	17	M
/304	Threaded stud .. ..	17	AB
S.2871	Ribbon feed bracket (R.H.) C.P. .. ..	7	H
/4	Ribbon guide C.P. .. ..	7	J
S.2872	Ribbon feed bracket (L.H.) C.P. .. ..	7	J
S.2927A	Dust cover unit .. ..	5	B
S.2936	Typehead unit .. ..	6	E
S.2940A Gr. 1	Dust cover unit .. ..	5	A
S.2940A Gr. 2	Dust cover unit .. ..	5	A
S.2941 Gr. 1	Dust cover unit .. ..	5	A
S.2941 Gr. 2	Dust cover unit .. ..	5	A
2945/3	Shim .. ..	6	E
2946/1	Typehead support bracket C.P. .. ..	11	B
23926A	Taper pin .. ..	15	BM1
23955A	Locking ring ( $\frac{3}{32}$ " bore) ..	7	T
CT.100	Oil impregnated bush (parallel) ..	15	E
CT.102	Oil impregnated bush (parallel) ..	17	AJ
FCT.85	Oil impregnated bush (flanged) ..	15	A
Ref. 26	Motor unit .. ..	7	J1
			D
			K
<b>BO NUMBERS</b>			
BO2874	Ballrace .. ..	7	K
<b>CS. NUMBERS (SET COLLARS AND SCREWS).</b>			
CS.1011	$\frac{3}{32}$ " set collar and screw ..	13	AD
CS.1016	$\frac{1}{8}$ " set collar and screw ..	17	AF
CS.1021	$\frac{1}{8}$ " set collar and screw ..	11	BB
		11	M8
		17	BB
		19	X
CS.1061	$\frac{3}{32}$ " set collar and screw ..	9	W
CS.1066	$\frac{3}{16}$ " set collar and screw ..	13	S
CS.1102	$\frac{3}{32}$ " set collar and screw ..	17	AP
CS.1105	$\frac{3}{32}$ " set collar and screw ..	17	AN
			T
<b>GR NUMBERS (GEARS).</b>			
GR.4039	Helical gear .. ..	7	P
<b>KN. NUMBERS (KNOBS).</b>			
KN.1025	Feed knob .. ..	17	G
KN.1026	Knurled screw .. ..	20	BH
<b>PB. NUMBERS (BUSHES).</b>			
PB.1971	Spacing collar $\frac{3}{16}$ " I.D. $\times \frac{1}{8}$ " ..	13	AF
PB.1972	Collar $\frac{3}{32}$ " I.D. $\times \frac{5}{64}$ " ..	15	AW
PB.2059	Spring anchor bush $\frac{3}{32}$ " I.D. $\times \frac{3}{16}$ " .. ..	13	AB

Part No.	Part Name	Page	Index Letters
<b>PB. NUMBERS (SPRINGS) continued.</b>			
PB.2061	Sleeve $\frac{3}{8}$ " I.D. $\times \frac{5}{16}$ " ..	19	R
PB.4072	Collar $\frac{1}{2}$ " I.D. $\times \frac{9}{16}$ " ..	17	AX
PB.4073	Oil impregnated bush $\frac{3}{16}$ " I.D. $\times \frac{13}{16}$ " ..	11	C
<b>PG. NUMBERS (SPRINGS).</b>			
PG.3107	Torsion spring .. ..	15	AO
PG.3117	Torsion spring .. ..	17	AM
PG.3138	Torsion spring .. ..	15	BC
PG.5059	Compression spring .. ..	20	BG
PG.5073	Compression spring .. ..	17	AK
PG.7041	Tension spring .. ..	13	AC
PG.7054	Tension spring .. ..	19	AQ
PG.7069	Tension spring .. ..	13	AN
PG.7102	Tension spring .. ..	7	U
PG.7120	Tension spring .. ..	11	BE
PG.7176	Tension spring .. ..	15	BB
PG.7182	Tension spring .. ..	9	S
PG.7208	Tension spring .. ..	13	AC
PG.7209	Tension spring .. ..	19	AD
PG.7314	Tension spring .. ..	17	U
PG.7355	Tension spring .. ..	17	BC
PG.7358	Tension spring .. ..	13	—
PG.7359	Tension spring .. ..	13	—
<b>PK NUMBERS (CLIPS).</b>			
PK.2062	Cable cleat .. ..	20	AZ
<b>PN NUMBERS (NUTS).</b>			
PN.1001-1	Std. 0BA hex. M.S. ..	20	BE
PN.1005-1	Std. 2BA hex. M.S. ..	19	O
PN.1009-1	Std. 4BA hex. M.S. ..	19	AJ
		20	BC
		11	T
		15	Y
		15	AM
		17	D
		19	K
PN.1013-1	Std. 6BA hex. M.S. ..	19	Z
		19	AC
		19	AM
		19	AP
		20	AU
		20	AY
		20	BH
PN.1017-1	Std. 8BA hex. M.S. ..	17	AT
		17	BA
		9	R
PN.1509-1	Std. 4BA hex. lock M.S. ..	11	H
		11	AS
		13	Q
		15	BQ
PN.1513-1	Std. 6BA hex. lock M.S. ..	17	F
PN.5046	Std. 0BA M.S. ..	7	Q
PN.5056	Special 6BA hex. $\frac{3}{32}$ " dia. hole M.S. ..	17	H
<b>PP. NUMBERS (PINS).</b>			
PP.1094	Parallel pin $\frac{3}{32}$ " dia. $\times \frac{1}{16}$ " ..	15	L
PP.1144	Parallel pin $\frac{1}{8}$ " dia. $\times 1\frac{1}{8}$ " ..	11	M6
PP.1157	Parallel pin $\frac{3}{32}$ " dia. $\times \frac{1}{8}$ " ..	6	B
PP.1158	Parallel pin $\frac{5}{32}$ " dia. $\times \frac{1}{16}$ " ..	19	Q
PP.5534	Flanged pin $\frac{3}{16}$ " dia. $\times 1\frac{5}{16}$ " ..	19	N
PP.5535	Threaded pin $\frac{3}{32}$ " dia. $\times 1\frac{9}{32}$ " ..	19	AG
PP.5536	Threaded pin $\frac{3}{32}$ " dia. $\times \frac{13}{16}$ " ..	19	X
		19	AK
PP.5537	Spring anchor pin .. ..	19	AA
		19	AN
PP.5546	Flanged bearing pin $\frac{5}{16}$ " dia. $\times 1\frac{13}{16}$ " ..	20	BE
PP.6529	Parallel pin $\frac{1}{8}$ " dia. $\times 2\frac{13}{16}$ " ..	11	BA
PP.6722	Flanged pin $\frac{3}{32}$ " dia. $\times 1$ " ..	17	BM
PP.7799A	Parallel pin $\frac{1}{8}$ " dia. $\times \frac{1}{16}$ " ..	17	AW
PP.8763	Flanged pin $\frac{3}{32}$ " $\times \frac{1}{2}$ " ..	17	AR
PP.9075	Flanged threaded pin $\frac{1}{8}$ " dia. $\times \frac{9}{16}$ " ..	15	AK

Part No.	Part Name	Page	Index Letters
<b>PS. NUMBERS (SCREWS).</b>			
PS.1162-1	Std. 1BA $\times \frac{1}{2}$ " Ch. Hd. M.S. {	7	M
		7	Q
PS.1332-1	Std. 2BA $\times \frac{1}{2}$ " Ch. Hd. M.S.	7	S
PS.1340-1	Std. 2BA $\times \frac{1}{2}$ " Cap. Hd. M.S.	13	C
PS.1342-1	Std. 2BA $\times \frac{9}{16}$ " Ch. Hd. M.S.	11	E
		6	D
PS.1354-1	Std. 2BA $\times \frac{5}{8}$ " Ch. Hd. M.S. {	7	J
		11	D
		7	G
PS.1374-1	Std. 2BA $\times \frac{3}{4}$ " Ch. Hd. M.S. {	7	R
		13	G
		6	B
PS.1390-1	Std. 2BA $\times \frac{7}{8}$ " Ch. Hd. M.S. {	6	C
		7	V
PS.1456-1	Std. 2BA $\times 1\frac{1}{8}$ " Ch. Hd. M.S.	7	O
PS.1659-1	Std. 4BA $\times \frac{3}{16}$ " Ch. Hd. M.S.	13	X
PS.1663-1	Std. 4BA $\times \frac{3}{16}$ " Fil. Hd. M.S.	7	N
		13	AR
PS.1676-1	Std. 4BA $\times \frac{1}{4}$ " Ch. Hd. M.S. {	13	C
		19	BE
		20	L
PS.1678-1	Std. 4BA $\times \frac{1}{4}$ " C/sk. Hd. M.S.	19	E
PS.1680-1	Std. 4BA $\times \frac{1}{4}$ " Rd. Hd. M.S.	19	H
PS.1682-1	Std. 4BA $\times \frac{1}{4}$ " Fil. Hd. M.S.	9	S
		9	AS
PS.1687-1	Std. 4BA $\times \frac{5}{16}$ " Ch. Hd. M.S. {	15	BA
		20	
		11	AO
PS.1694-1	Std. 4BA $\times \frac{3}{8}$ " Ch. Hd. M.S. {	11	AQ
		13	AW
		15	H
PS.1696-1	Std. 4BA $\times \frac{3}{8}$ " C/sk. Hd. M.S.	15	G
PS.1708-1	Std. 4BA $\times \frac{7}{16}$ " Ch. Hd. M.S. {	15	Q
		19	B
		11	AR
PS.1729-1	Std. 4BA $\times \frac{9}{16}$ " Ch. Hd. M.S. {	13	H
		13	AS
		17	Y
PS.1737-1	Std. 4BA $\times \frac{3}{8}$ " Hex. Hd. M.S.	19	B
PS.1739-1	Std. 4BA $\times \frac{3}{8}$ " Hex. Hd. M.S.	7	Y
PS.1761-1	Std. 4BA $\times \frac{3}{4}$ " Ch. Hd. M.S.	11	AU
PS.1765-1	Std. 4BA $\times \frac{3}{4}$ " rd. Hd. M.S.	7	O
PS.1771-1	Std. 4BA $\times \frac{13}{16}$ " Ch. Hd. M.S.	9	N
		7	K
PS.1777-1	Std. 4BA $\times \frac{7}{8}$ " Ch. Hd. M.S. {	9	Q
PS.2045-1	Std. 6BA $\times \frac{3}{16}$ " Ch. Hd. M.S. {	11	N
		15	BJ
		20	BD
PS.2047-1	Std. 6BA $\times \frac{3}{16}$ " C/sk. Hd. M.S. ..	15	BD
		15	AY
PS.2061-1	Std. 6BA $\times \frac{1}{4}$ " Ch. Hd. M.S. {	11	W
		13	K
		17	AG
		17	
PS.2063-1	Std. 6BA $\times \frac{1}{4}$ " C/sk. Hd. M.S. {	17	BJ
		19	K
PS.2069-1	Std. 6BA $\times \frac{1}{4}$ " Inst. Hd. M.S.	7	R
		11	BD
		13	S
		13	BB
PS.2077-1	Std. 6BA $\times \frac{5}{16}$ " Ch. Hd. M.S. {	15	BG
		17	BF
		19	K
		20	AS
PS.2079-1	Std. 6BA $\times \frac{5}{16}$ " C/sk. Hd. M.S. {	11	L
		11	AB
PS.2104-1	Std. 6BA $\times \frac{3}{8}$ " Cap. Hd. M.S.	15	BN
PS.2125-1	Std. 6BA $\times \frac{1}{2}$ " Ch. Hd. M.S.	20	AW
PS.2127-1	Std. 6BA $\times \frac{1}{2}$ " C/sk. Hd. M.S.	11	Q
PS.2136-1	Std. 6BA $\times \frac{3}{8}$ " Cap. Hd. M.S.	19	T
PS.2168-1	Std. 6BA $\times \frac{3}{8}$ " Hex. Hd. M.S.	7	Y
PS.2253-1	Std. 6BA $\times 1$ " Ch. Hd. M.S.	17	AB

Part No.	Part Name	Page	Index Letters
<b>P.S. NUMBERS (SCREWS) continued.</b>			
PS.2430-1	Std. 8BA × $\frac{1}{8}$ " Ch. Hd. M.S.	9 15 17	F V AD
PS.2445-1	Std. 8BA × $\frac{3}{16}$ " Ch. Hd. M.S.	9 11 17 17	J Y AD BO
PS.2457-1	Std. 8BA × $\frac{7}{32}$ " Ch. Hd. M.S.	11 15 13	AL AQ AA
PS.2462-1	Std. 8BA × $\frac{1}{4}$ " Ch. Hd. M.S.	17	O
PS.2590-1	Std. 8BA × $\frac{3}{4}$ " Ch. Hd. M.S.	17	AF
PS.4583-1	Std. $\frac{1}{16}$ " 22 T.P.I. B.S.F. × $\frac{3}{4}$ " Ch. Hd. M.S.	5	A
PS.5032	Special 4BA × $\frac{1}{2}$ " shouldered Hd. M.S.	11 13	G P
PS.5289	Special 6BA × $\frac{1}{4}$ " Fil. Hd. M.S.	6	F
PS.5379	Special screw 6BA × $\frac{7}{16}$ " Ch. Hd. M.S.	14	—
PS5380	Special screw 6BA × $\frac{1}{8}$ " Ch. Hd. M.S.	14	—
PS.5722	Special cap Hd. screw M.S.	14	—
PS.6224	Special 6BA knurled Hd. screw	13	BD
PS.6419	Pip-end screw	15	AX
PS.7006	Special 6BA × $\frac{1}{4}$ " M.S.	20	BF
<b>P.W. NUMBERS (WASHERS).</b>			
PW.1005-1	Std. 2BA M.S.	7 13 7 9 13 13 13	G E Y S K AU AY
PW.1009-1	Std. 4BA M.S.	15 15 15 19 19 20 6 7 11 13 13 15	K S AU B C BB F Y R U Y BD AA
PW.1013-1	Std. 6BA M.S.	15 15 17 19 19 20 20 20 20	BL BP L K Y AT AX BD BH
PW.1017-1	Std. 8BA M.S.	9 11 11 11 17 17 17 17	L AA AF AN N Q AO AU AY

Part No.	Part Name	Page	Index Letters
<b>P.W. NUMBERS (WASHERS) continued.</b>			
PW.1025-1	Std. 0BA M.S.	7	Q
PW.1030-15	Std. 2BA Br. . . . .	15	AB
PW.1033-1	Std. 4BA M.S.	9	P
PW.2002	Std. 0BA S.C. spring washer	20	BE
PW.2009	Std. 1BA S.C. spring washer	7	Q
PW.2013	Std. 2BA S.C. spring washer	7 13	G D
PW.2025	Std. 4BA S.C. spring washer	7 9 9 19 19	Y O S B C AH
PW.2027	Std. 4BA D.C. spring washer	13 13 13 15 15 15	J AT AX J R AT
PW.2037	Std. 6BA S.C. spring washer	6 11 13 13 13 15 15 15 15 17	F O T X BC Z AL BK BO C
PW.2038	Std. 6BA S.C. spring washer	7 11 19 19 19	Y S AB AL AO
PW.2050	Std. 8BA S.C. spring washer	9 11 11 11 11 17 17 17	K Z AE AM P AS AZ
PW.5021	Special washer $\frac{1}{8}$ " I.D. M.S.	19	V
PW.5029	Special washer $\frac{1}{32}$ " thick M.S.	9	S
PW.5040	Special washer .015" thick M.S.	9	S
PW.5199	Special washer $\frac{3}{16}$ " I.D. spring steel	15 15	AD AF
PW.5276	Special washer .113 I.D. M.S.	11	AZ
PW.5455	Lubricating washer $\frac{1}{8}$ " I.D. Felt	11	M7
PW.5464	Spacing washing $\frac{1}{4}$ " I.D. M.S.	17	W
PW.5475	Special washer .113 I.D. M.S.	15	BM4
PW.5484	Shim $\frac{3}{16}$ " I.D. spring steel	15	BM5
<b>RL. NUMBERS (ROLLERS).</b>			
RL.1094	Roller . . . . .	17	S
RL.1095	Roller . . . . .	17	BL
RL.1096	Roller . . . . .	15	AC
RL.1134	Roller . . . . .	17	AV

**AMENDMENTS TO ADDENDUM 1 TO PART LIST 1085**

**(1st ed. with corrections)**

**MODEL 86 TELEPRINTER PRINTING REPERFORATOR**

This Technical Information Supplement amends the Text of the above Part List to conform with Printing Reperforators now being supplied.

*ITEMS TO BE INSERTED*

<i>Page</i>	<i>Following Index Letter</i>	<i>Part No.</i>	<i>Part Name</i>
3	M	2870/218	Cover C.P. ( <i>Not shown</i> )
4	G	2870/327	Set of Punches ( <i>comprising set of 5 Code hole punches 2870/91 and 1 feed hole punch 2870/198</i> ).
6	Q	PW5403	Shim

**AMENDMENTS TO PART LIST NO. 1085**  
(1st edition with corrections)  
**MODEL 85 TELEPRINTER PRINTING REPERFORATOR**

This Technical Information Supplement amends the text of the above Part List to conform with Printing Reperforators now being supplied.

	<i>ALTER ITEM</i>			<i>TO READ</i>	
<i>Page</i>	<i>Index Letter</i>	<i>Part No.</i>	<i>Part Name</i>	<i>Part No.</i>	<i>Part Name</i>
11	M	2869/39	Transfer Rocker Assembly	2868/39	Transfer Rocker Assembly
11	AG	2868/40	Trip Plate C.P.	2868/40 Gr. 1	Trip Plate C.P.
13	AE	2870/177	Setting Levers C.P.	2870/177A	Setting Levers C.P.
13	AF	2870/124	Setting Lever Bracket C.P.	2870/124A	Setting Lever Bracket C.P.
13	-	2870/274	Setting Lever Bracket	2870/274A	Setting Lever Bracket
13	AF	PB1971	Spacing Collar	PW5031	Shim
20	BG	2869/8	Retention Clip C.P.	2869/6	Retention Clip
20	BG	PG5059	Compression Spring	PG5059A	Compression Spring

*ITEMS TO BE INSERTED*

## INSERT

<i>Page</i>	<i>Following Index Letter</i>	<i>Part No.</i>	<i>Part Name</i>
11	AG	2868/40Gr. 2	Trip Plate C.P. (For machines fitted with Overlap Cam Unit)
11	AJ	2868/48	Trip Plate (For machines fitted with Overlap Cam Unit)

ADDENDUM No.1  
To PART LIST NO. 1085  
(1st Edition reprint with corrections)

# MODEL 86 TELEPRINTER PRINTING REPERFORATOR

(Variant of Model 85 Reperforator producing  
 $\frac{7}{8}$ " wide fully punched and printed tape.)

Printed July 1956

*Creed & Company Limited*

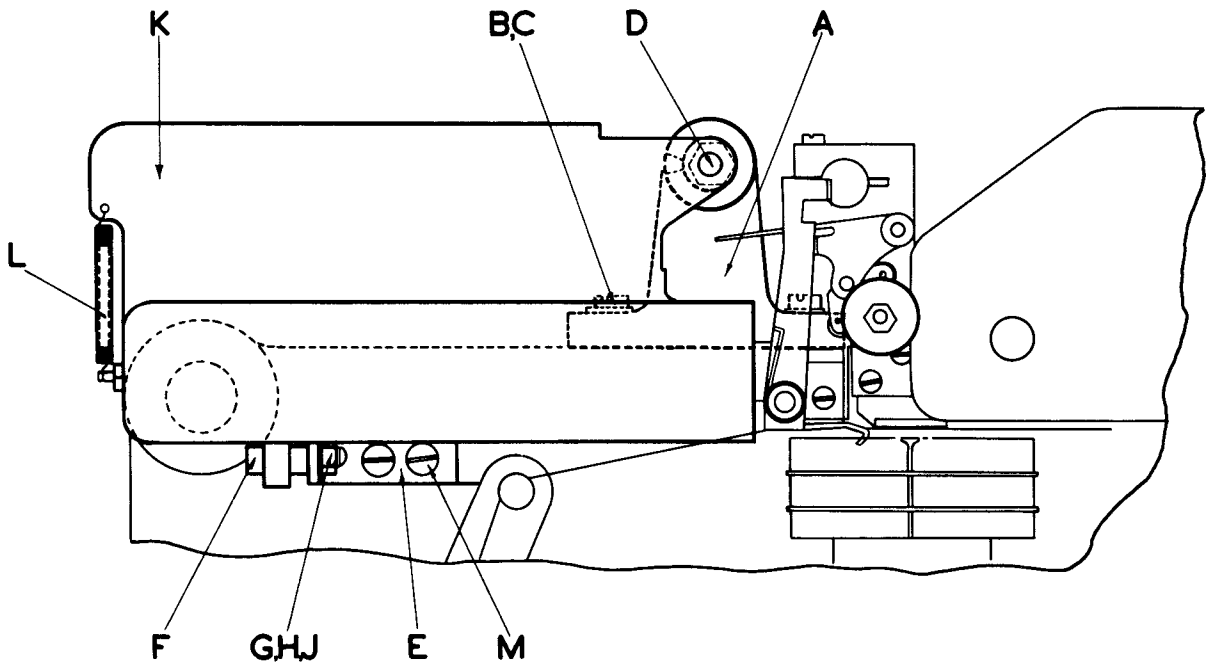

Fig. 1 CUTTINGS BOX ASSEMBLY

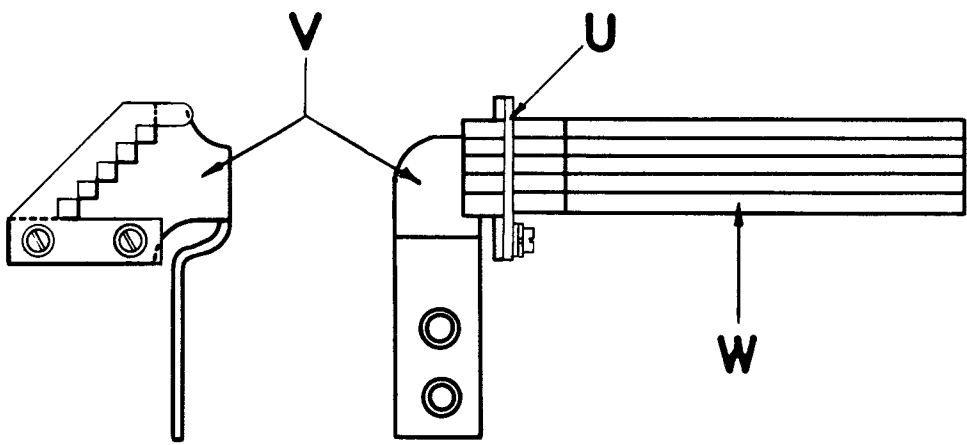

Fig. 2 TRANSFER PUSH ROD AND BRACKET C.P.



## MODEL 86 PRINTING REPERFORATOR SUB ASSEMBLY S3764 GRP. 3 AND 6

<i>Index Letter</i>	<i>Part No.</i>	<i>Part Name</i>	
D	S.2868 Gr.4	Control Lever Unit	<i>See Page 2</i>
G	S.2870 Gr.6	Perforator Unit	<i>See pages 3, 4 and 6</i>
Y	S.2869A Gr.2	Tape Roll Holder Unit	<i>See page 8</i>

### *CUTTINGS BOX (See Fig 1)*

*The following items have no equivalent on the Model 85 Printing Reperforator as this produces "chadless" tape:-*

A	2870/223	Swivel pin bracket	
B	PS.1717-1	Std. 4BA Screw	} (3 of each per set) for securing Swivel pin bracket.
C	PW.1009-1	Std. 4BA Washer	
D	PP.5549	Swivel pin (pivot for Cuttings box C.P.)	
	PW.1005-1	Std. 2BA Washer	} for securing Swivel pin.
	PW.2013	Std. 2BS Spring Washer	
	PN.1005-1	Std. 2BA Nut	
	2870/221	Locating block C.P. comprises:-	(locates Cuttings box C.P.)
E	2870/220	Locating bracket	
F	PP.5548	Locating pin	
G	PW.1009-1	Std. 4BA Washer (2 per set)	} for securing Locating Pin to Locating Bracket.
H	PW.2025	Std. 4BA Spring washer	
J	PN.1009-1	Std. 4BA Nut	
K	2870/260	Cuttings Box C.P. includes:-	
L	PG.7053	Tension spring	
M	PS.1676-1	Std. 4BA Nut (2 per set) for securing item E.	

FOR ALL OTHER ITEMS SEE PART LIST No. 1085 (pages 6 and 7)

## CONTROL LEVER UNIT S.2868 GRP.4

*(See Fig. 2)*

<i>Index Letter</i>	<i>Part No.</i>	<i>Part Name</i>
U	2868/41 Gr.2	Transfer push rod and bracket C.P. includes:-
V	2868/44	Lower guide bracket
W	2870/203	Transfer push rod (5 per set).

FOR ALL OTHER ITEMS SEE PART LIST No. 1085 (Page 11).

## PERFORATOR UNIT S.2870 GRP.6

<i>Index Letter</i>	<i>Part No.</i>	<i>Part Name</i>	
<i>PERFORATOR UNIT CASTING (See Fig. 3)</i>			
	2870/174 Gr.2	Perforator Unit casting C.P.:-	} <i>Replacing corresponding items L and M on page 13 of Part List No. 1085.</i>
		<i>Comprises the same items as used on the Model 85 Reperforator, but with items:-</i>	
L	2870/1 Gr.2	Perforator Unit frame C.P.	
M	2870/195	Abutment Guide (2 per set)	

FOR ALL OTHER ITEMS SEE PART LIST No. 1085 (Page 13)

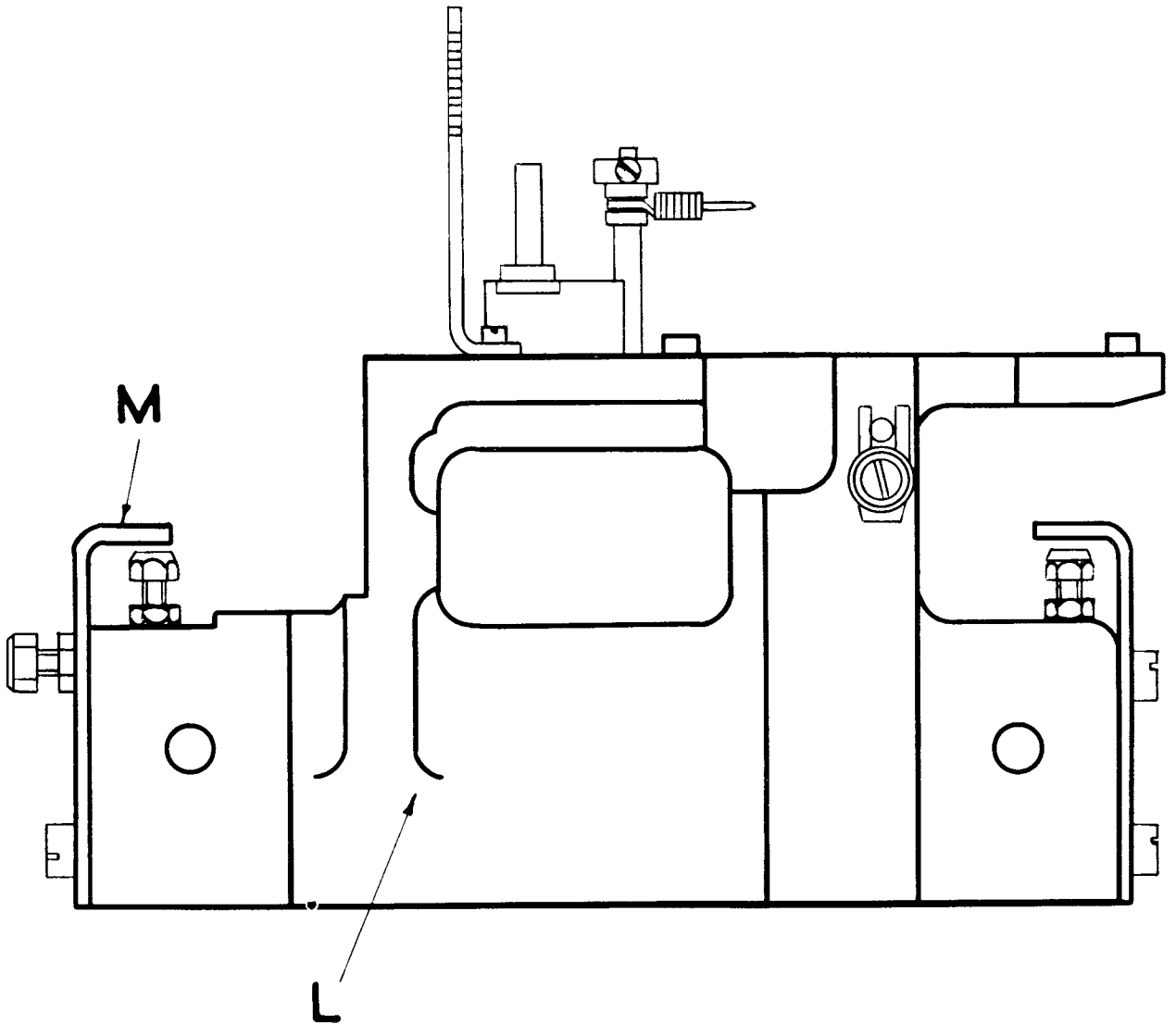

Fig. 3 PERFORATOR UNIT CASTING C.P.

## PERFORATOR UNIT S2870 GRP.6 (CONTD.)

Index Letter	Part No.	Part Name
--------------	----------	-----------

**PUNCHING CAM ASSEMBLY (See Fig. 4.)**

	2870/158 Gr.3	Punching cam assembly. <i>Comprises:- the same items as used on the Model 85 Reperforator but with items:-</i>	
M	2870/172 Gr.2	Cam feed lever C.P.	} Replacing corresponding items M and AC on page 15 of Part List No. 1085.
AC	RL.1122	Roller	

FOR ALL OTHER ITEMS SEE PART LIST No. 1085 (Page 15)

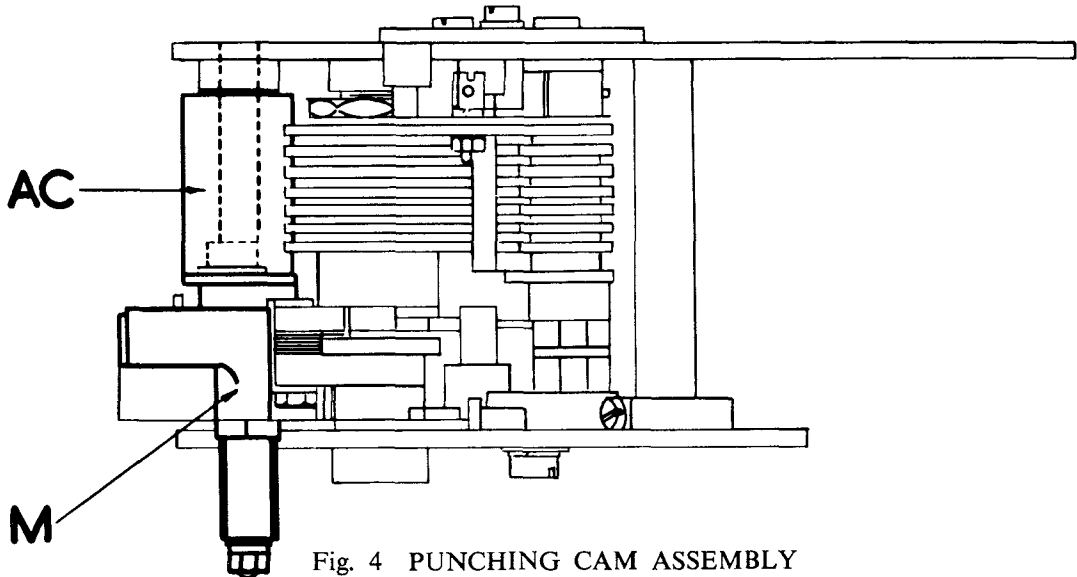

Fig. 4 PUNCHING CAM ASSEMBLY

### PUNCH BLOCK ASSEMBLY 2870/226

(See Fig. 5)

Index Letter	Part No.	Part Name
--------------	----------	-----------

**PUNCH MOUNTING**

	2870/310	Punch mounting C.P. <i>includes:-</i>	
A	2870/212A	Punch mounting sub C.P. <i>includes:-</i>	
	2870/5 Gr.2	Punch mounting C.P.	
B	2870/253A	Die and front guide plate C.P.	
C	2870/250	Shim (between Die and front guide plate C.P. and Punch Mounting C.P.)	
D	2870/305	Screwed stud	} (2 of each per set) for securing Die and front guide plate C.P. and Shim.
	PW.2037	Std. 6BA spring washer	
E	2870/300	Feed spindle C.P.	
	PW.5484	Special washer (4 per set) for adjusting height of Feed Spindle C.P.	
F	2870/303	Special sprocket C.P.	
G	2870/155	Feed bearing plate C.P. <i>includes:-</i>	
	CT.102	Oil impregnated bush	
	PS.2061-1	Std. 6BA screw	} (2 of each per set) for securing Feed bearing bracket C.P.
	PW.1013-1	Std. 6BA washer	
	2870/91	Set of punches (code hole) 5 per set. <i>Not visible.</i>	
	2870/198	Punch (feed hole). <i>Not visible.</i>	
H	2870/197	Chute mounting block	
	PS.2477-1	Std. 8BA screw	} (2 of each per set) } for securing Chute Mounting Block.
	PW.2037	Std. 6BA spring washer	
	PN.1013-1	Std. 6BA nut	

**PLATEN BLOCK AND PLATEN**

	2870/205	Platen holder locating plate	} (not visible)
	2870/199	Shim (6 per set)	
J	2870/211	Platen block	
	PS.2077-1	Std. 6BA screw (2 per set) for securing Platen block	
	2870/156	Platen C.P. ( <i>not visible</i> ).	
K	2870/194	Platen retaining plate	
	PS.2063-1	Std. 6BA screw (2 per set)	

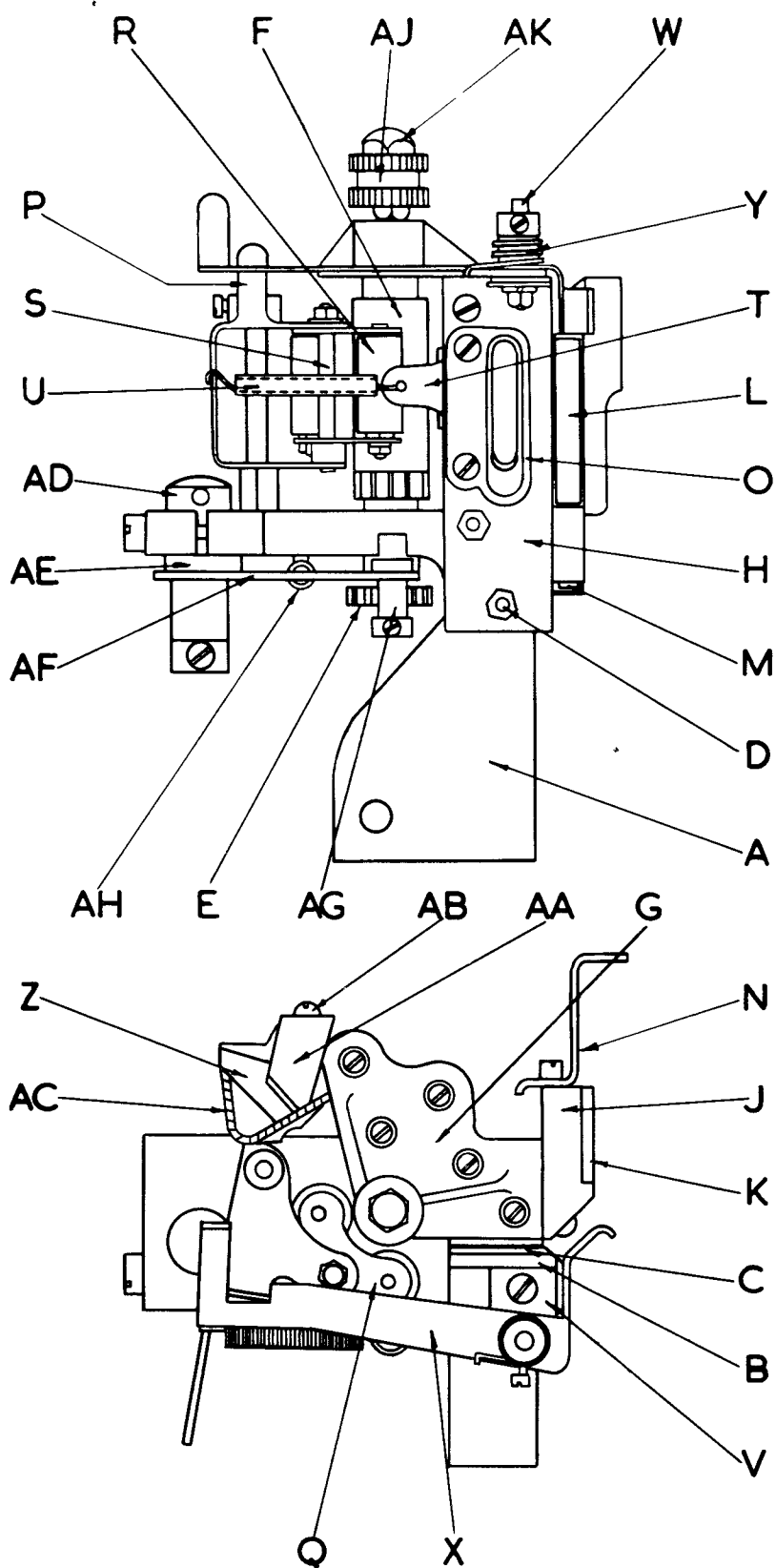

Fig. 5 PUNCH BLOCK ASSEMBLY

## PUNCH BLOCK ASSEMBLY 2870/226 (CONTD.)

<i>Index Letter</i>	<i>Part No.</i>	<i>Part Name</i>
<b>TAPE GUIDE ROLLER</b>		
L	RL.1125	Tape guide roller
M	PP.7836	Roller pivot pin
	2870/114	Keep plate
	PS.2445-1	Std. 8BA screw (for securing keep plate)
N	2870/207	Punch side support
	PS.2445-1	Std. 8BA screw (2 per set) for securing item N
<b>CUTTINGS CHUTE</b>		
O	2870/219	Cuttings chute
	PS.7018	Special screw (2 per set) for securing item O
<b>TAPE PRESSURE ROLLER</b>		
	2870/315	Twin pressure roller C.P. comprises:-
P	2870/314	Twin pressure roller frame
Q	2870/241	Twin roller bearing plate (2 per set)
	PP.8899	Roller pivot pin (2 per set)
	PN.1017-1	Std. 8BA Nut
	PW.2050	Std. 8BA Spring washer
	PW.1017-1	Std. 8BA Washer (2 per set) bearing for rollers
R	RL.1163	Roller (2 per set)
	PB.4072	Collar
S	PP.7799A	Pressure roller pivot
	PW.1017-1	Std. 8BA Washer
	PW.2050	Std. 8BA Spring washer
	PN.1017-1	Std. 8BA Nut
	CS.1016	Set collar and screw (for retaining item Twin pressure roller C.P.)
T	2870/225	Spring bracket
	PS.2447-1	Std. 8BA screw (2 per set) for securing Spring bracket.
U	PG.7436	Tension spring
<b>PRESSURE ARM LATCH</b>		
V	2870/214	Latch mounting plate
	PS.2045-1	Std. 6BA screw
W	2870/215	Latch pivot
	PW.2050	Std. 8BA spring washer
	PN.1017-1	Std. 8BA nut
	PW.1017-1	Std. 8BA washer (4 per set) for adjusting height of item X.
X	2870/70A	Pressure arm latch C.P.
Y	PG.3117	Torsion spring
	CS.1103	Set collar and screw (for retaining item X)
<b>TAPE TEAR OFF</b>		
	2870/291	Tape tear-off C.P. comprises:-
Z	2870/292	Tape guide block
AA	2870/294	Tape guide
AB	PS.5383	Special screw (2 per set) for securing Tape guide
AC	2870/293A	Tape tear-off
	PS.5383	Special screw (2 per set) for securing Tape tear-off
	2870/295	Tape platform (secured to the underside of item Z)
	PS.2029-1	Std. 6BA screw (for securing Tape platform)
	2870/297	Distance piece (not visible)
	PS.2095-1	Std. 6BA screw (for securing Distance piece)
	PB4258	Collar (2 per set) between item G and Distance piece.
	PS.2526-1	Std. 8BA screw
	PW.1017-1	Std. 8BA washer
	PW.2050	Std. 8BA spring washer
		(2 of each per set) for securing Tape tear-off C.P.
<b>JOCKEY ROLLER AND PIVOT</b>		
AD	2870/302	Jockey roller pivot
	PS.1729	Std. 4BA screw (for clamping item AD)
AE	PW.5464	Spacing washer
AF	2870/175	Jockey roller C.P. includes:-
AG	RL.1094	Roller
	CS.1105	Set collar and screw
AH	PG.7314	Tension spring
	CS.1021	Set collar and screw (for retaining item AF)
<b>FEED KNOB</b>		
	PN.1513-1	Std. 6BA Locknut
AJ	KN.1025	Feed Knob
AK	PN.5056	Special nut (for securing item AJ)

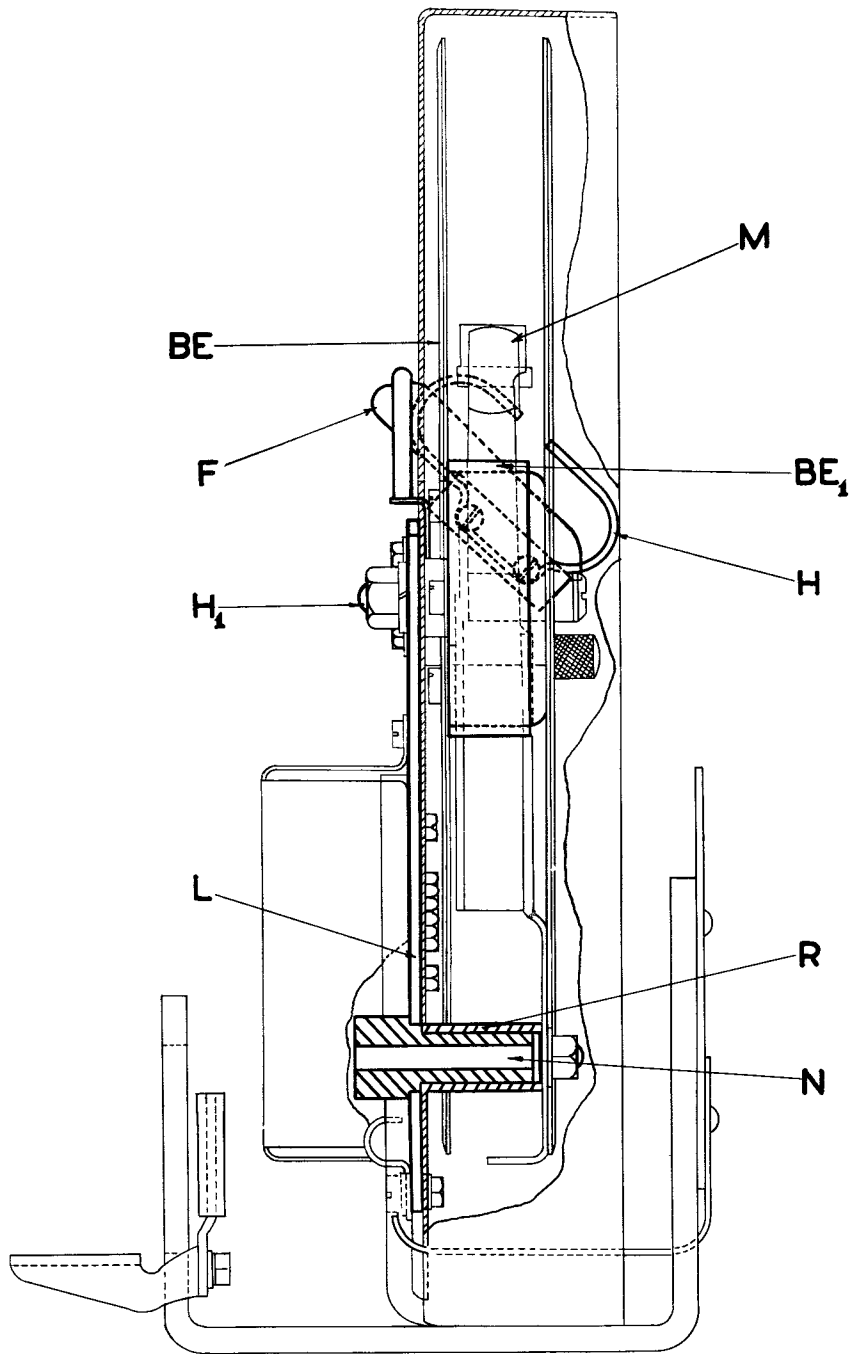

Fig. 6 TAPE ROLL HOLDER UNIT

## TAPE ROLL HOLDER UNIT S2869A, GRP.2

(See Fig. 6)

<i>Index Letter</i>	<i>Part No.</i>	<i>Part Name</i>
F	2869/42A Gr.2	Tape guide C.P. <i>includes:-</i>
H	2869/216	Tape retainer
H <sub>1</sub>	PP.5551	Threaded pin
L	2869/1 Gr.2	Mounting plate C.P.
M	2869/44 Gr.2	Follower arm C.P. <i>includes:-</i>
N	PP.5550	Threaded pin
R	RL.1124	Sleeve
BE	2869/45 Gr.2	Tape rear wheel C.P. <i>includes:-</i>
BE <sub>1</sub>	2869/59	Tape boss
	2869/100	Spring collar ( <i>Replaces 2869/43 used on No. 85</i> )

FOR ALL OTHER ITEMS SEE PART LIST No. 1085 (Pages 19 and 20)

# NUMERICAL INDEX

Part No.	Part Name	Page	Index Letters	Part No.	Part Name	Page	Index Letters
S2868	Control lever unit Gr.4	2	—	<b>KN. NUMBERS (KNOBS)</b>			
/41	Transfer push rod and bracket C.P. Gr.2	2	U	KN.1025	Feed Knob	6	AJ
/44	Lower guide bracket	2	V	<b>PB. NUMBERS (COLLARS)</b>			
S2869A	Tape roller and guard C.P. Gr.2	8	—	PB.4072	Collar	6	R
/1	Tape reel mounting plate C.P. Gr.2	8	L	PB.4258	Collar	6	AC
/7A	Tape reel back plate	8	B	<b>PG. NUMBERS (SPRINGS)</b>			
/42A	Tape retainer C.P. Gr.2	8	F	PG.3117	Torsion spring	6	Y
/44	Tape follower arm C.P. Gr.2	8	M	PG.7053	Tension spring	2	L
/45	Tape Rear Wheel C.P.	8	BE	PG.7314	Tension spring	6	AH
/59	Tape Boss	8	BE <sub>1</sub>	PG.7436	Tension spring	6	U
/100	Spring collar	8	BE <sub>1</sub>	<b>PN. NUMBERS (NUTS)</b>			
/216	Tape retainer	8	H	PN.1005-1	Std. 2BA Hex. nut	2	D
S2870	Reperforator unit	3	—	PN.1009-1	Std. 4BA Hex. nut	2	J
/1	Perforator unit frame Gr.2	3	L	PN.1013-1	Std. 6BA Hex nut	4	H
/5	Punch mounting C.P. Gr.2	4	A	PN.1017-1	Std. 8BA Hex. nut	6	Q
/70A	Pressure Arm latch C.P.	6	X			6	S
/91	Set of punches	4	G			6	W
/114	Keep plate	6	M	PN.1513-1	Std. 6BA Hex. lock nut	6	AH
/155	Feed bearing plate C.P.	4	G	PN.5056	Special nut	6	AK
/156	Platen C.P.	4	J	<b>PP. NUMBERS (PINS)</b>			
/158	Punching cam assembly Gr.3	4	—	PP.5548	Locating pin	2	F
/172	Cam feed lever Gr.2	4	M	PP.5549	Swivel pin	2	D
/174	Perforator unit casting C.P. Gr.2	3	—	PP.5550	Threaded pin	8	N
/175	Jockey roller C.P.	6	AF	PP.5551	Threaded pin	8	H <sub>1</sub>
/194	Platen retaining plate	4	K	PP.7799A	Pressure roller pivot	6	S
/195	Abutment guide	3	M	PP.7836	Roller Pivot Pin	6	M
/197	Chute mounting block	4	H	PP.8899	Roller Pivot Pin	6	Q
/198	Punch (feed hole)	4	G	<b>PS. NUMBERS (SCREWS)</b>			
/199	Shim	4	H	PS.1676-1	Std. 4BA × 1/4" ch. hd. M.S.	2	M
/203	Transfer push rod (No.2)	2	W			8	C
/205	Platen holder locating plate	4	H	PS.1717-1	Std. 4BA × 1/2" ch. hd. M.S.	2	B
/207	Punch side support	6	N	PS.1729-1	Std. 4BA × 9/16" ch. hd. M.S.	6	AD
/211	Platen block	4	J	PS.2029-1	Std. 6BA × 1/8" ch. hd. M.S.	6	AC
/212A	Punch mounting sub C.P.	4	A	PS.2045-1	Std. 6BA × 3/16" ch. hd. M.S.	6	V
/214	Latch mounting plate	6	V	PS.2061-1	Std. 6BA × 1/4" ch. hd. M.S.	4	G
/215	Latch pivot	6	W	PS.2063-1	Std. 6BA × 1/4" c/sk. hd. M.S.	4	K
/219	Cuttings chute	6	O	PS.2077-1	Std. 6BA × 5/16" ch. hd. M.S.	4	J
/220	Locating bracket	2	E	PS.2095-1	Std. 6BA × 3/8" c/sk. hd. M.S.	6	AC
/221	Locating block C.P.	2	D	PS.2445-1	Std. 6BA × 3/16" ch. hd. M.S.	6	M
/223	Swivel pin bracket	2	A			6	N
/225	Spring bracket	6	T	PS.2477-1	Std. 8BA × 3/16" c/sk. hd. M.S.	4	H
/241	Twin roller bearing plate	6	Q			6	T
/250	Shim	4	C	PS.2526-1	Std. 8BA × 1/2" ch. hd. M.S.	6	AC
/253A	Die and front guide plate C.P.	4	B	PS.5383-1	Special 6BA × 3/16" rd. hd. M.S.	6	AB
/260	Cuttings box C.P.	2	K			6	AC
/291	Tape tear-off C.P.	6	Y	PS.7018-1	Special 8BA × 3/4" ch. hd. M.S.	6	O
/292	Tape guide block	6	Z	<b>PW. NUMBERS (WASHERS)</b>			
/293A	Tape tear-off	6	AC	PW.1005-1	Std. 2BA M.S.	2	D
/294	Tape guide	6	AA	PW.1009-1	Std. 4BA M.S.	2	C
/295	Tape platform	6	AC	PW.1013-1	Std. 6BA M.S.	4	G
/297	Distance piece	6	AC			6	Q
/300	Feed spindle C.P.	4	E	PW.1017-1	Std. 8BA M.S.	6	S
/302	Jockey roller pivot	6	AD			6	W
/303	Special sprocket C.P.	4	F			6	AC
/305	Screwed stud	4	D	PW.2013	Std. 2BA spring washer	2	D
/310	Punch mounting C.P.	4	—	PW.2025	Std. 4BA spring washer	2	H
/314	Twin pressure roller frame	6	P				
/315	Twin pressure roller C.P.	6	O				
CT.102	Oil impregnated bush	4	G				
<b>CS. NUMBERS (SET COLLARS AND SCREWS)</b>							
CS.1016	1/8" set collar and screw	6	S				
CS.1021	1/8" set collar and screw	6	AH				
CS.1103	3/32" set collar and screw	6	Y				
CS.1105	3/32" set collar and screw	6	AG				



<i>Part No.</i>	<i>Part Name</i>	<i>Page</i>	<i>Index Letters</i>	<i>Part No.</i>	<i>Part Name</i>	<i>Page</i>	<i>Index Letters</i>
<b>PW. NUMBERS (WASHERS) contd.</b>				<b>RL. NUMBERS (ROLLERS)</b>			
PW.2037	Std. 6BA spring washer . .	{ 4	D	RL.1094	Roller . . . .	6	AG
		{ 4	H	RL.1122	Roller . . . .	4	AC
		{ 6	Q	RL.1124	Sleeve . . . .	8	R
PW.2050	Std. 8BA spring washer . .	{ 6	S	RL.1125	Tape guide roller . .	6	L
		{ 6	W	RL.1163	Roller . . . .	6	R
PW.5464	Spacing washer . . . .	6	AC				
PW.5484	Shim (.005" thick) . .	4	AE				
			E				