

Please do not upload this copyright pdf document to any other website. Breach of copyright may result in a criminal conviction.

This Acrobat document was generated by me, Colin Hinson, from a document held by the Henlow Signals Museum, believed to be out of copyright. It is presented here (for free) and this pdf version of the document is my copyright in much the same way as a photograph would be. If you believe the document to be under other copyright, please contact me.

The document should have been downloaded from my website <https://blunham.com/Radar>, or any mirror site named on that site. If you downloaded it from elsewhere, please let me know (particularly if you were charged for it). You can contact me via my Genuki email page: <https://www.genuki.org.uk/big/eng/YKS/various?recipient=colin>

You may not copy the file for onward transmission of the data nor attempt to make monetary gain by the use of these files. If you want someone else to have a copy of the file, point them at the website. (<https://blunham.com/Radar>). Please do not point them at the file itself as it may move or the site may be updated.

It should be noted that most of the pages are identifiable as having been processed by me.

I put a lot of time into producing these files which is why you are met with this page when you open the file.

In order to generate this file, I need to scan the pages, split the double pages and remove any edge marks such as punch holes, clean up the pages, set the relevant pages to be all the same size and alignment. I then run Omnipage (OCR) to generate the searchable text and then generate the pdf file.

Hopefully after all that, I end up with a presentable file. If you find missing pages, pages in the wrong order, anything else wrong with the file or simply want to make a comment, please drop me a line (see above).

It is my hope that you find the file of use to you personally – I know that I would have liked to have found some of these files years ago – they would have saved me a lot of time !

Colin Hinson

In the village of Blunham, Bedfordshire.

GERMAN & ITALIAN AIRCRAFT



HOW TO SPOT THEM

THE ONLY COMPLETE ILLUSTRATED RECORD

5th Thousand



1/-
NET

A UNIQUE COLLECTION OF PHOTOGRAPHS
SILHOUETTES & ILLUSTRATIONS, WITH
EXPLANATORY NOTES DEPICTING ALL TYPES
OF GERMAN AND ITALIAN AIRCRAFT

*GERMAN AND ITALIAN
AIRCRAFT*

★

HOW TO SPOT THEM

★

164

*DRAWINGS AND PHOTOGRAPHS
WITH DESCRIPTIONS*

55th Thousand

*HUTCHINSON & CO. (Publishers) LTD.
LONDON AND MELBOURNE*

FOREWORD

It is dangerous to dogmatize when discussing the military aircraft of any nation, so the popular question, "What are enemy aircraft like?" cannot be answered in a word. In some respects they are very good and in others surprisingly bad. For example, the German Heinkel He 113 fighter is very fast, but it is not thought that its manoeuvrability represents an advance over the Messerschmitt Me 109. Its armament, too, is lighter than that of our Hurricane and Spitfire, which have been in service for a very much longer period. Again, considered as a piece of aeronautical engineering, the Heinkel He 111K bomber is a splendid machine, but its armament bears no comparison with that of the equivalent R.A.F. machines.

Similarly, it is dangerous to generalize on the recognition of aircraft. It cannot be said that German machines are long and slim and Italians short and fat, though it will be gathered from a study of this book that development may proceed along characteristic lines. This is exemplified by the partiality of the Italians for three-engined bombers and biplane fighters.

The recognition of aircraft is a subject which demands enthusiasm and infinite care, and it is only by constant study of reliable pictures and data that accuracy can be achieved. The student must learn how wings vary in taper, how fuselages differ in outline, and how some tails have one fin and rudder and others two, or even three. Trivial as these points may seem to the uninitiated, they may, in certain circumstances, make all the difference between life and death to the observer on the ground or to the crew of an aircraft. On a number of occasions wrong identification has led to disastrous results, not, be it said, in this country alone.

It is the purpose of this book to provide something more than the usual recognition data. A great deal of information is given, which, it is hoped, will stimulate interest in the characteristics and duties of the various machines and so facilitate ready recognition.

LIST OF ILLUSTRATIONS

GERMAN AIRCRAFT

Arado Ar 95	64-66	Heinkel He 115	62-63
Blohm and Voss Ha 140	21	Heinkel He 118	25
Bucker Jungmeister	31	Heinkels over Shetlands	48-49
Dornier Do 17	40-42	Henschel Hs 123	22-24
Dornier Do 18K	60, 61	Henschel Hs 126	28-30
Dornier Do 22	67	Junkers Ju 52	10-12
Dornier Do 24	58, 59	Junkers Ju 86	8, 9
Dornier Do 215	44-47	Junkers Ju 86 K	56, 57
Fieseler Storch	13	Junkers Ju 87	32-35
Focke-Wulf Condor	6, 7	Junkers Ju 88	54, 55
Glider	68	Junkers Ju 89	26, 27
Heinkel He 59	43	Junkers Ju 90	4, 5
Heinkel He 60	17	Messerschmitt Me 109	18-20
Heinkel He 111 K	50-53	Messerschmitt Me 110	36-38
Heinkel He 113	14-16	Messerschmitt Jaguar	39

ITALIAN AIRCRAFT

A.U.T. 18	94	Fiat C.R. 42	84
Breda 65	79	Fiat G. 50	74
Breda 88	91	Macchi C. 200	80, 81
Cant Z 501	87	Magni Vale	78
Cant Z 506 B	86	Meridionali Ro 37 bis	85
Caproni Ca 134	90	Meridionali Ro 41	95
Caproni Ca 135 bis	82, 83	Meridionali Ro 43	88, 89
Caproni(Bergameschi)A.P.1	70, 71	Meridionali Ro 44	75
Fiat B.R. 20	76, 77	Piaggio P 50 II	96
Fiat C.R. 32	92-93	Savoia-Marchetti S.M. 79	72, 73

A number of illustrations in this book are reproduced from drawings specially made for *Flight*, the recognized weekly authority on aviation.

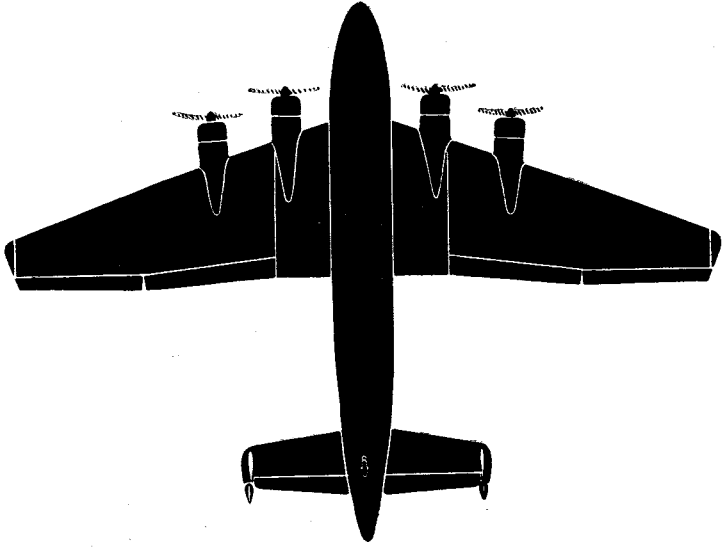
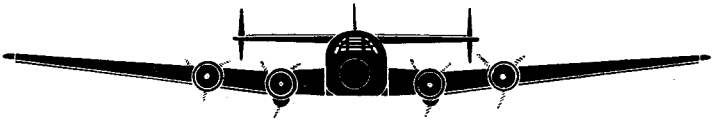

JUNKERS Ju 90

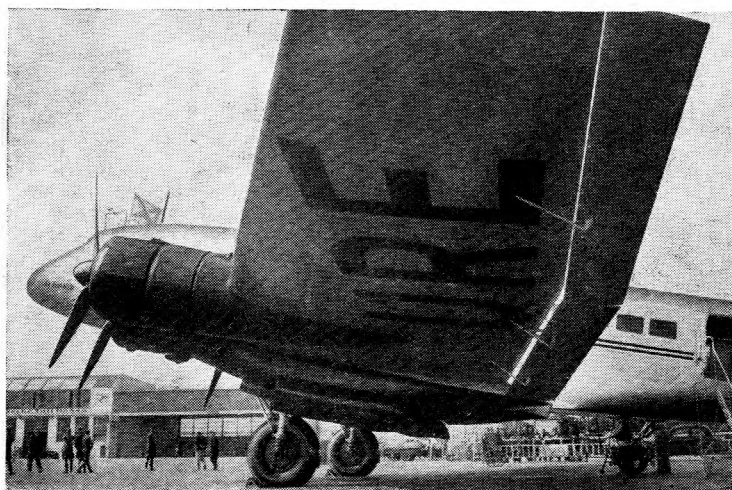
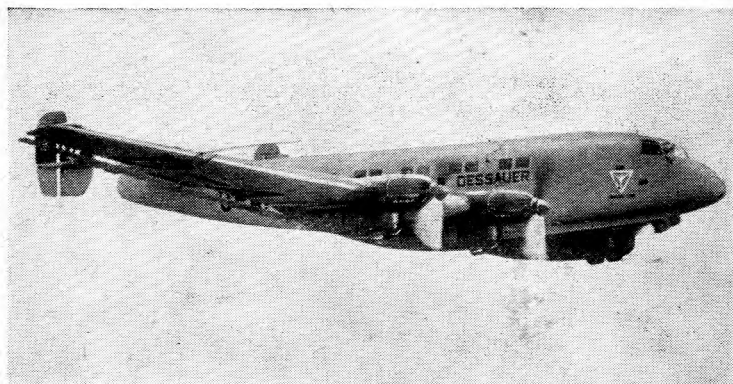

JUNKERS Ju 90

The Ju 90 was designed as a forty-passenger commercial machine but is readily adaptable for use as a military transport or for the dropping of parachute troops. There is a marked sweep-back on the low cantilever wing, which carries four engines in line abreast, and the usual Junkers "double-wing" is incorporated. The tail unit is of very large dimensions and has twin fins and rudders. Fitted with four BMW 132 H engines the machine attains a top speed of 217 m.p.h. The span is 114 ft. 10 in. and the gross weight over 50,000 lb.

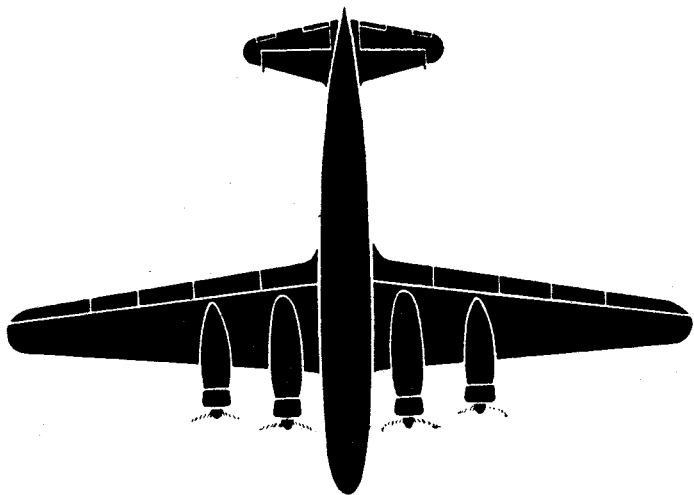
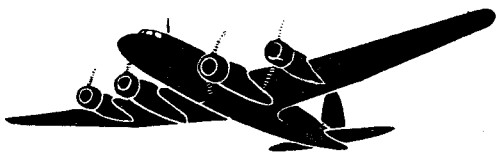

FOCKE-WULF CONDOR

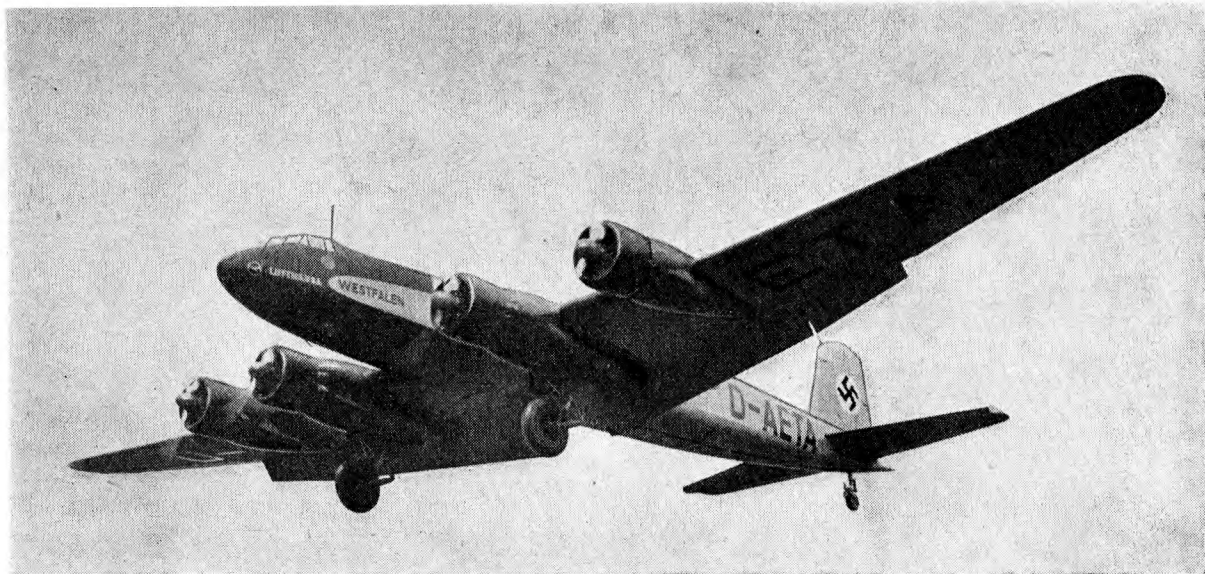

FOCKE-WULF CONDOR

Alternatively known as the Fw 200, the Condor is a large four-engine low-wing monoplane (span 108 ft. 3 in.) of graceful appearance and high performance. Basically a civil machine, it would make a useful military transport having a top speed of over 230 m.p.h. when fitted with BMW 132 G engines. It is said that the Focke-Wulf concern have plans for a bomber of similar characteristics. The all-up weight of the civil machine is over 32,000 lb. and the normal range about 770 miles.

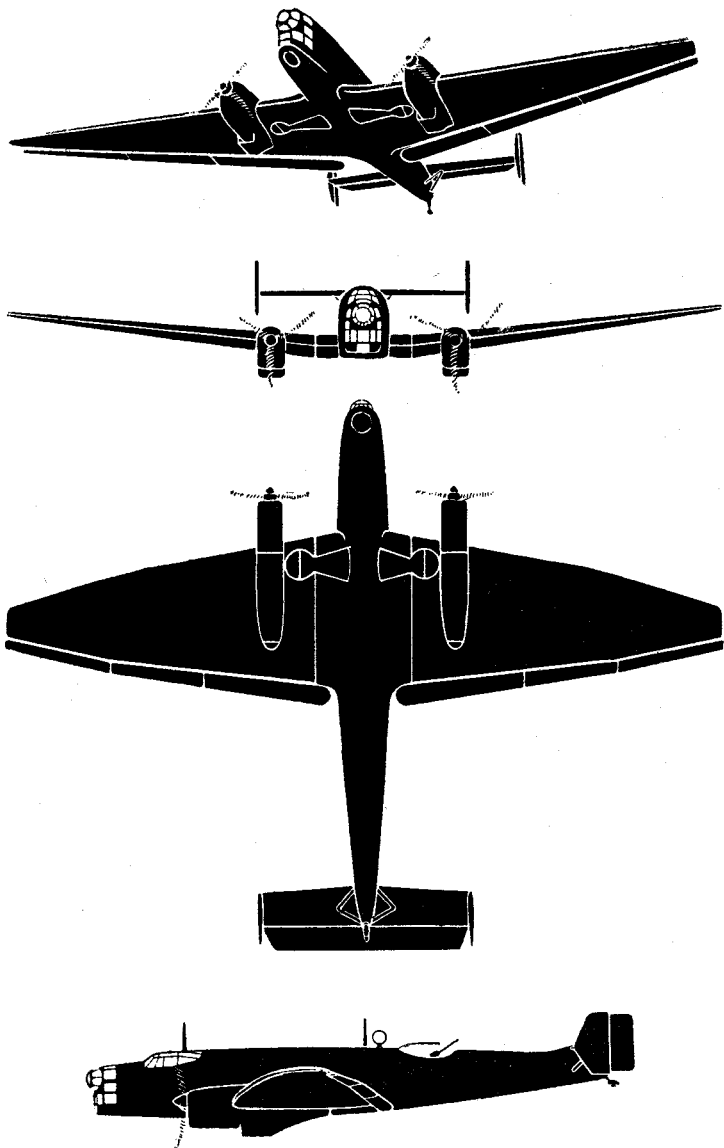

JUNKERS Ju 86

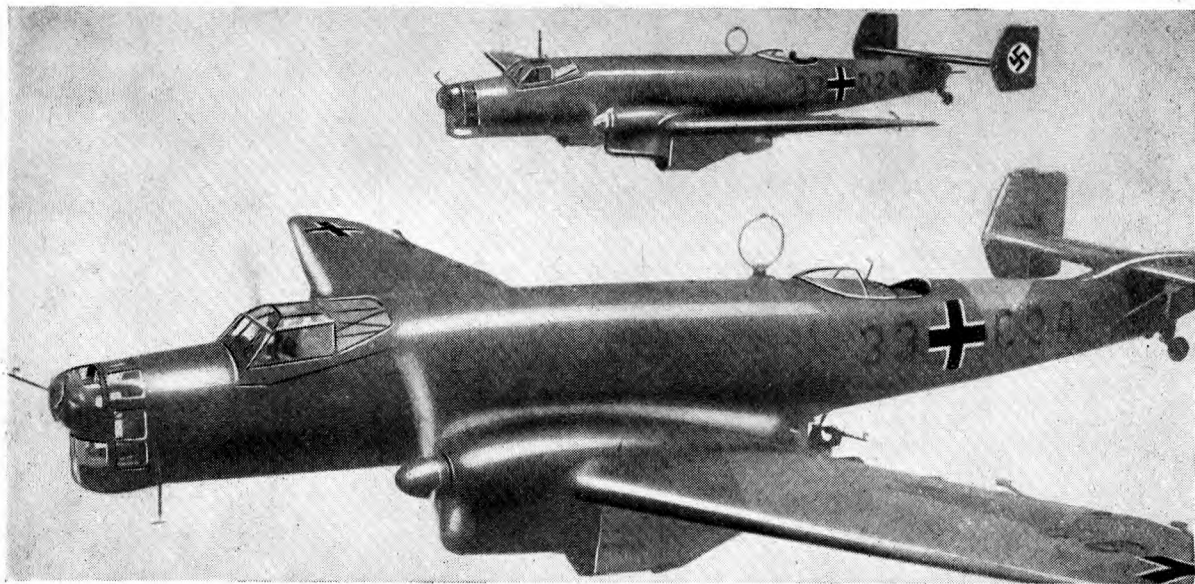

JUNKERS Ju 86

This machine is a low-wing monoplane fitted with two Jumo Diesel engines. The wing span is 73 ft. and a length of 57 ft. Two square-cut rudders; sharply tapered wings; square-cut wing tips and tail plain and a retractable undercarriage. It has accommodation for approximately twelve troops and is quite a fast machine for a troop carrier, its speed being 200 miles m.p.h. The curious shape of the trailing edge renders it very prominent and easily identified by observers on the ground.

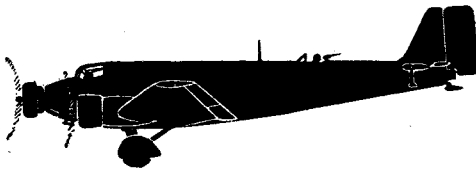
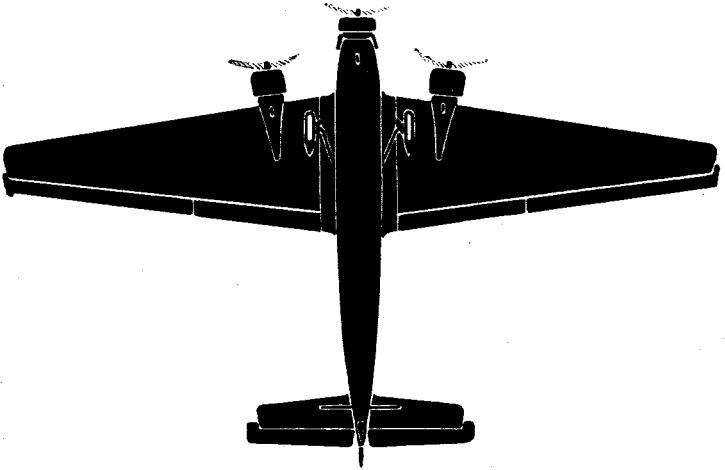
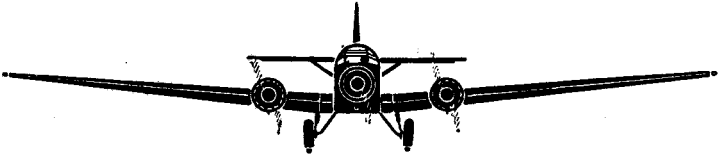
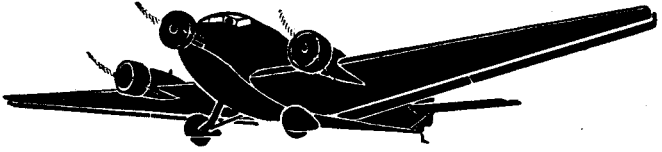

JUNKERS Ju 52

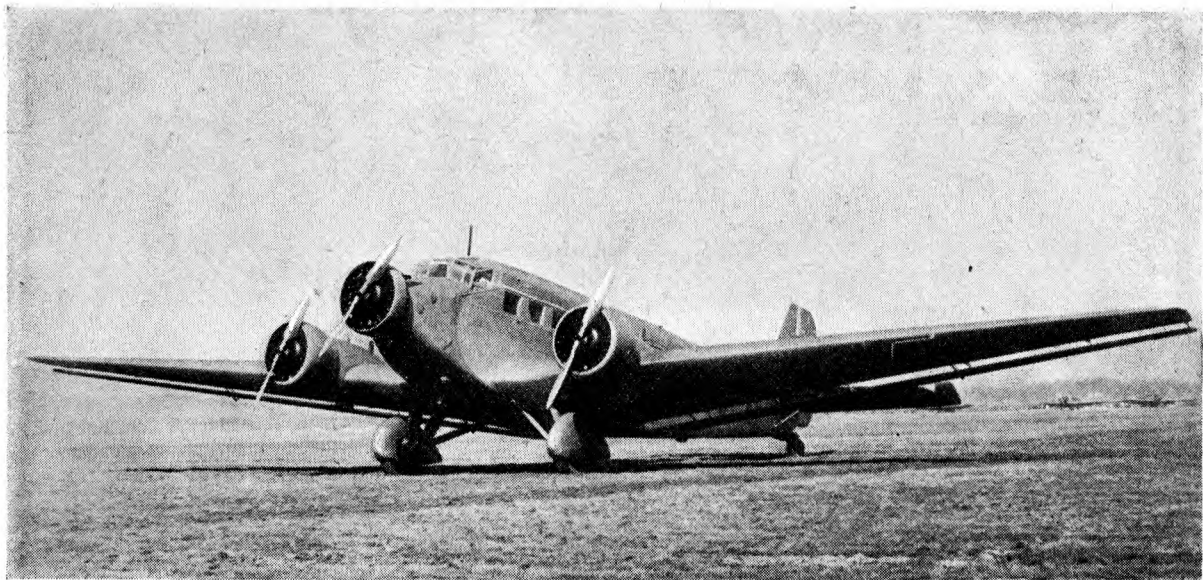

JUNKERS Ju 52

In the Spanish war this three-engined low-wing monoplane was used as a bomber but nowadays it is considered mainly as a transport for military stores and personnel (especially parachute troops). The machine is not outstandingly fast (in no case does the speed exceed 189 m.p.h.) but is very sturdy and can be operated from small aerodromes. Passenger accommodation varies from fourteen to seventeen seats. Almost any type of radial engine up to 760 h.p. can be fitted. Frequently the machine is operated on floats.

It can be provided with two machine-gun positions.

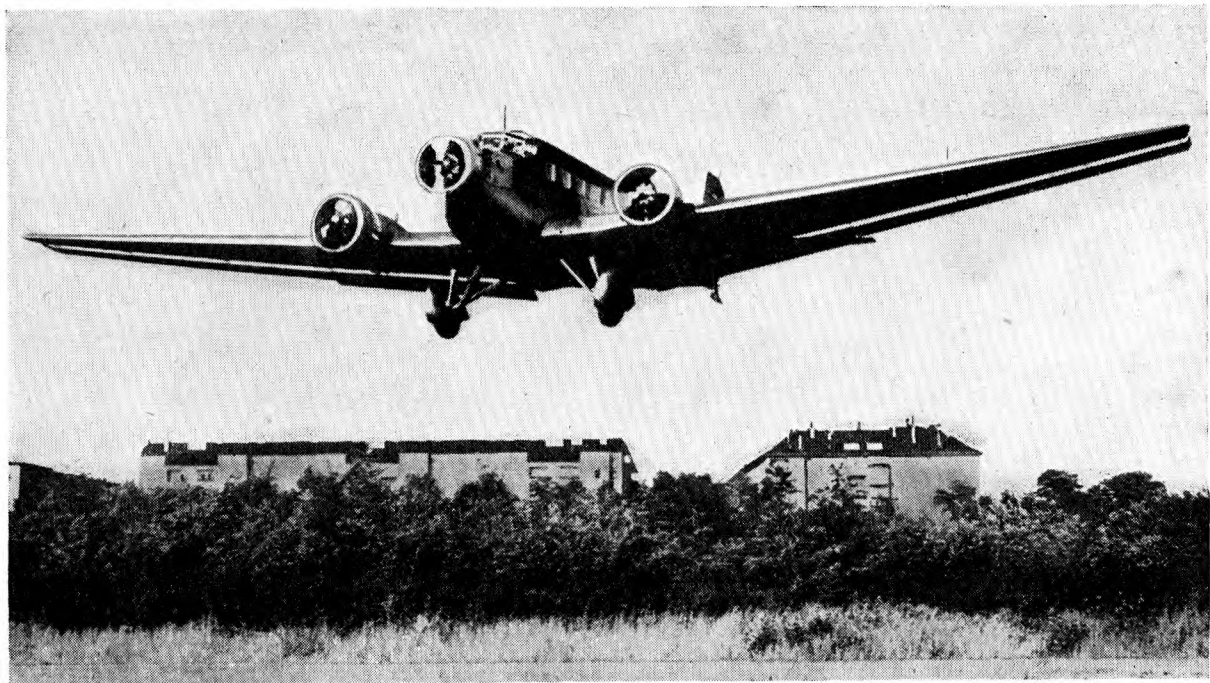

JUNKERS Ju 52

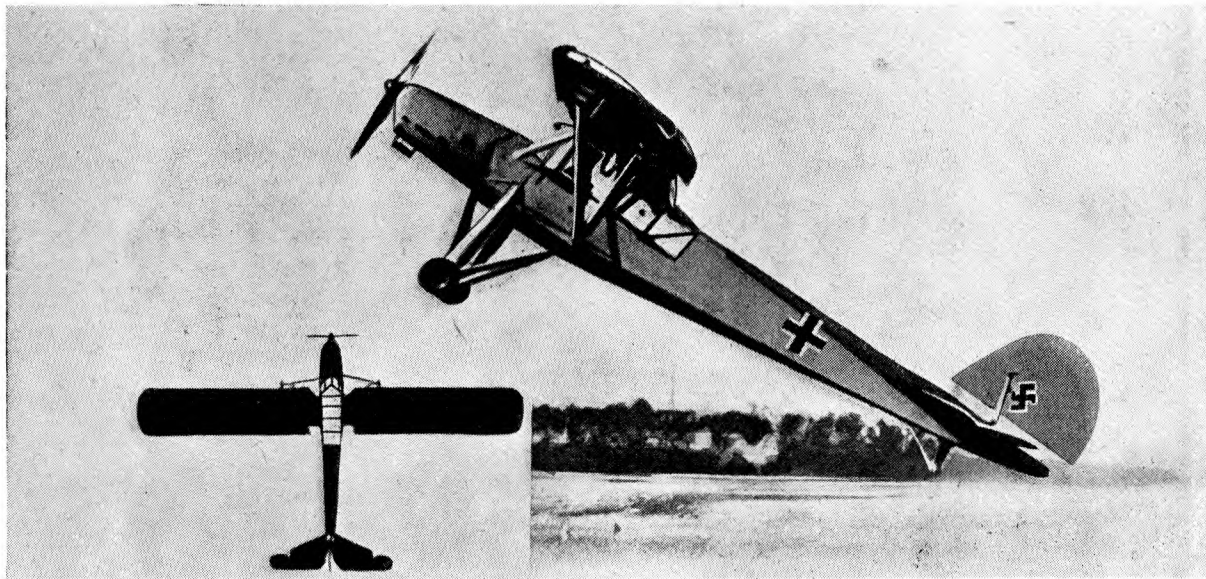

FIESELER STORCH

A feature of the German occupation of Paris was the landing of German staff officers in a Fieseler Storch army co-operation machine. The Storch (Fi 156) is a bizarre-looking high-wing, strut-braced monoplane with a wide, fixed undercarriage and a 240 h.p. Argus engine. Designed to fly at very low speeds and with slots and flaps in action it can continue under full control at little more than 30 m.p.h. The cabin is designed to allow a wide field of vision for the observer. The landing run in a wind of about 8 m.p.h. is only about 19 vds.

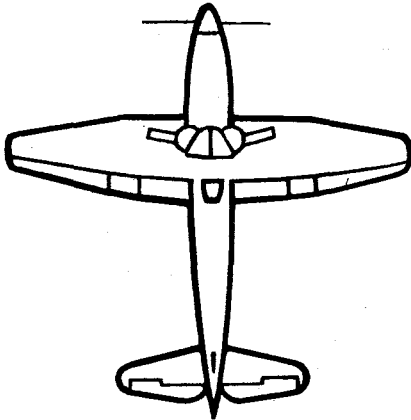
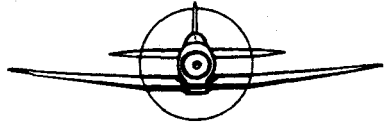
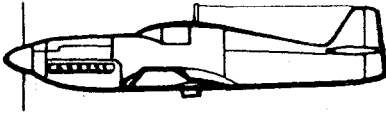
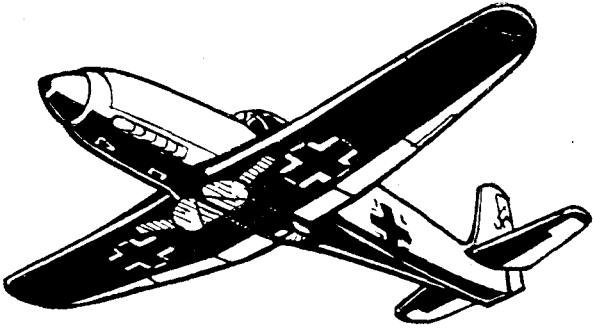

HEINKEL He 113

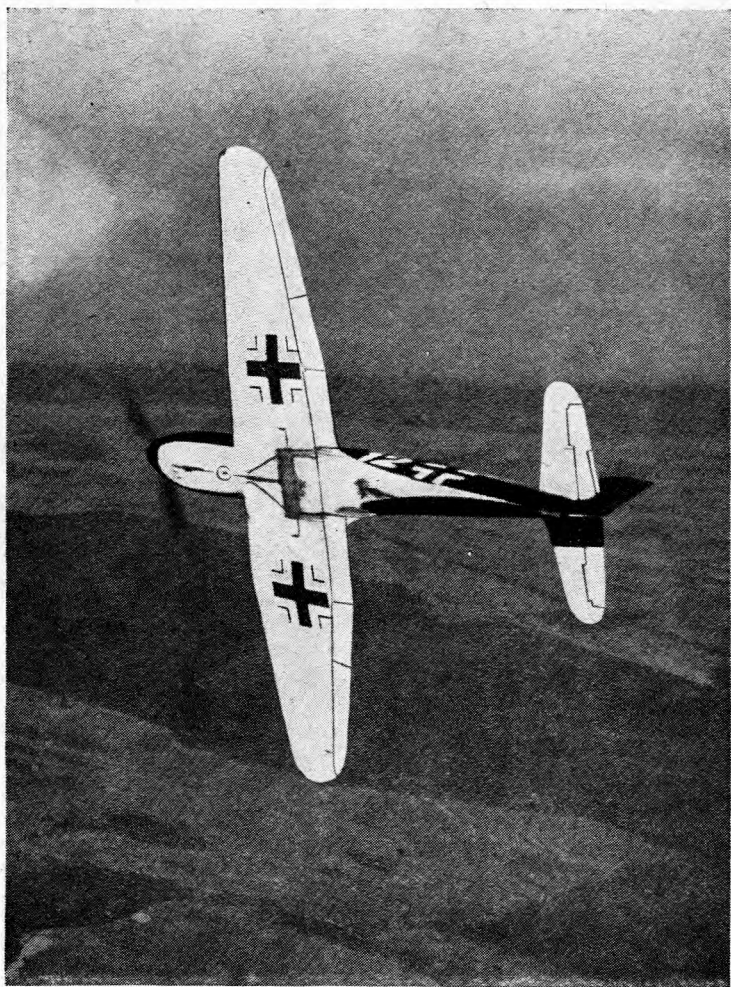

HEINKEL He 113

Newest of Germany's single-engined single-seater fighters, the He 113 has been in service only a few months but does not seem to have demonstrated any very outstanding characteristics. It is undoubtedly fast, being of small dimensions (the span is less than 31 ft.) and having a Daimler-Benz DB 601 engine giving something like 1,500 h.p. In appearance the machine resembles the earlier He 112 having an "inverted gull" wing. The armament is believed to comprise one shell-gun firing through the airscrew hub and two heavy machine-guns in the wing roots.

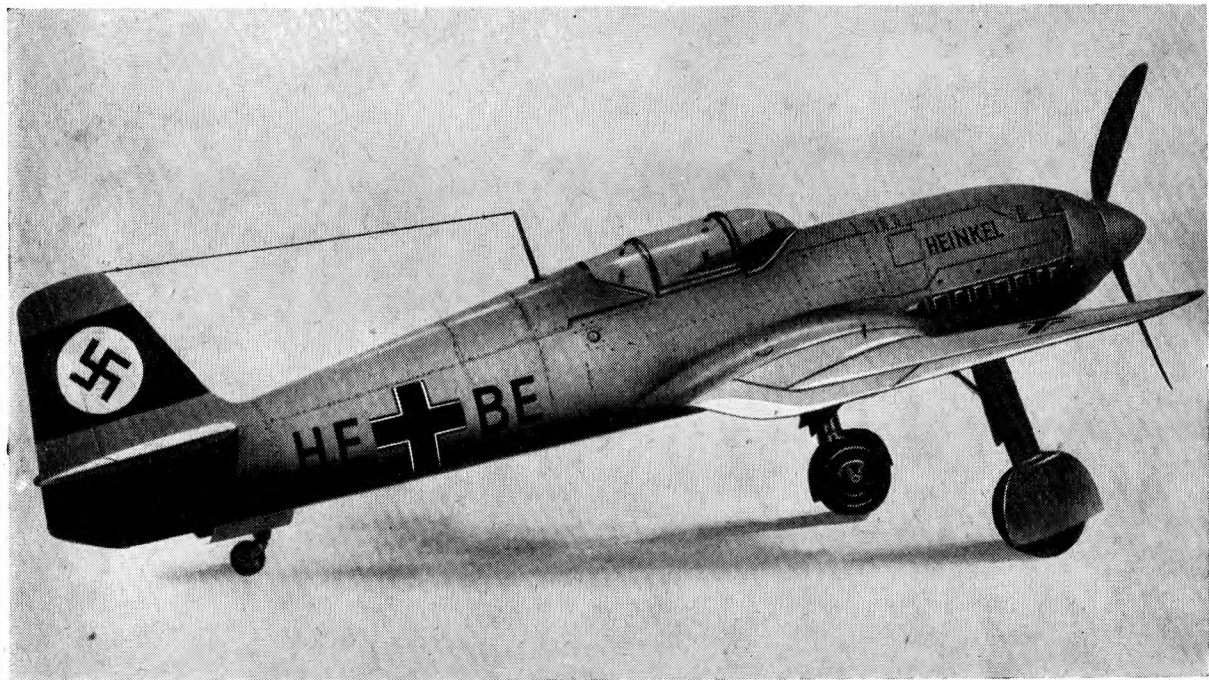

HEINKEL He 113



HEINKEL He 60

A single-engined twin-float biplane, the He 60 played a bigger part in the Spanish war. The machine was at one time used as a catapult aircraft from German warships, but was replaced by the Heinkel He 114 and Arado 96 types. The He 60 is a two-seater and carries two machine-guns in addition to a light bomb load. Being fitted with a BMW VI liquid-cooled unsupercharged engine and having a great deal of external strutting the machine is by no means fast. The all-up weight is about 7,500 lb.

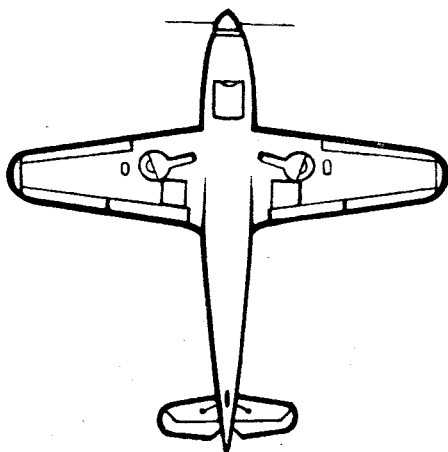
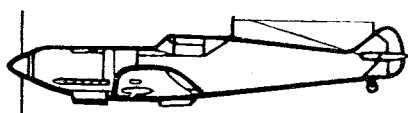
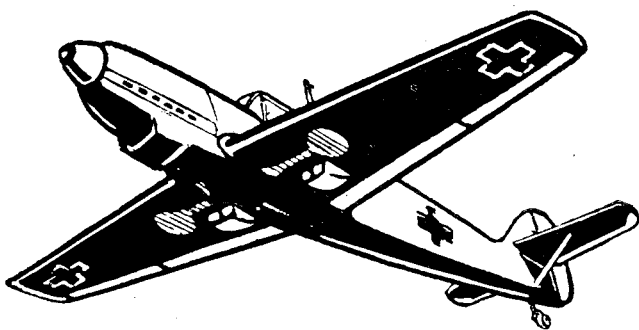

MESSERSCHMITT Me 109

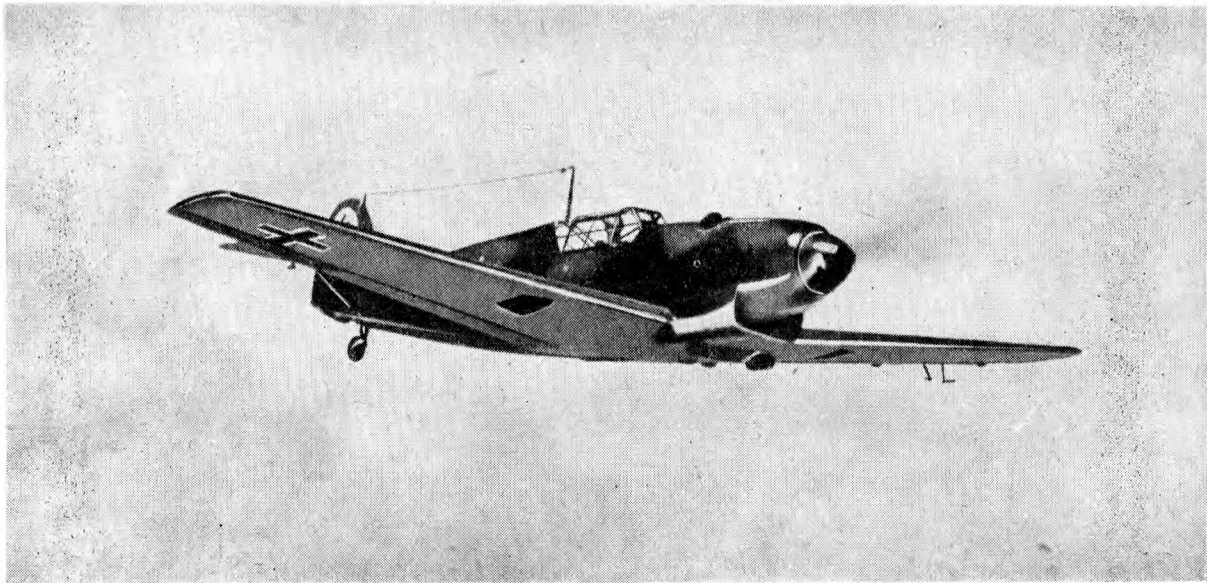

MESSERSCHMITT Me 109

The normal type of single-seater fighter used by German squadrons, the Me 109 is now usually fitted with a Daimler-Benz DB 601 engine of about 1,150 h.p. Compared with our Hurricane and Spitfire the machine cannot be considered to be outstandingly "clean" aerodynamically though a top speed of over 350 m.p.h. is claimed. The most common armament is four machine-guns, two in the fuselage and two in the wings, though shell-firing armament is sometimes specified. Manœuvrability is definitely inferior to that of our Hurricane and Spitfire.

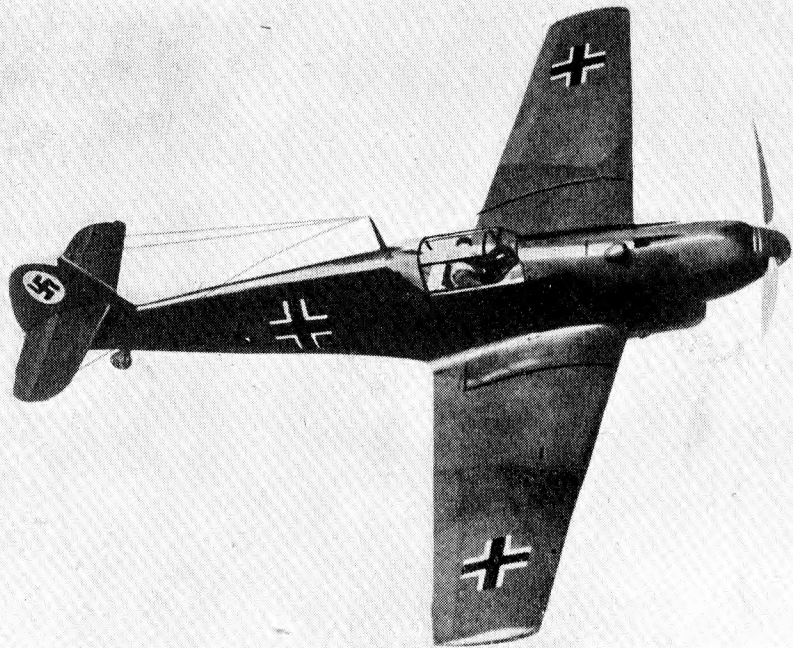

MESSERSCHMITT Me 109

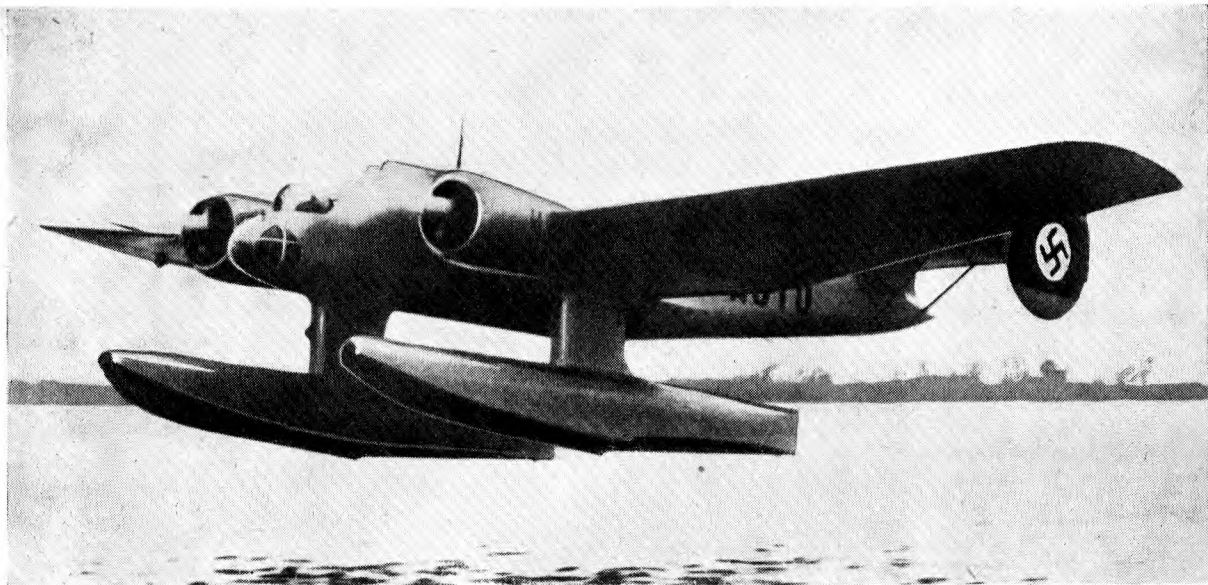

BLOHM AND VOSS Ha 140

Observers should have little difficulty in recognizing this mid-wing, twin-engined, twin-float seaplane. It is a product of Blohm and Voss of Hamburg, and is designed to function as a reconnaissance machine, bomber, torpedo-carrier or mine-layer. Two BMW 132 radial engines are fitted and beneath and behind these are the massive pillar-like supports for the floats. The tail unit has twin fins and rudders and the wing has a marked sweep-back on the leading edge. Three machine-guns form the defensive armament. A top speed of about 200 m.p.h. is claimed.

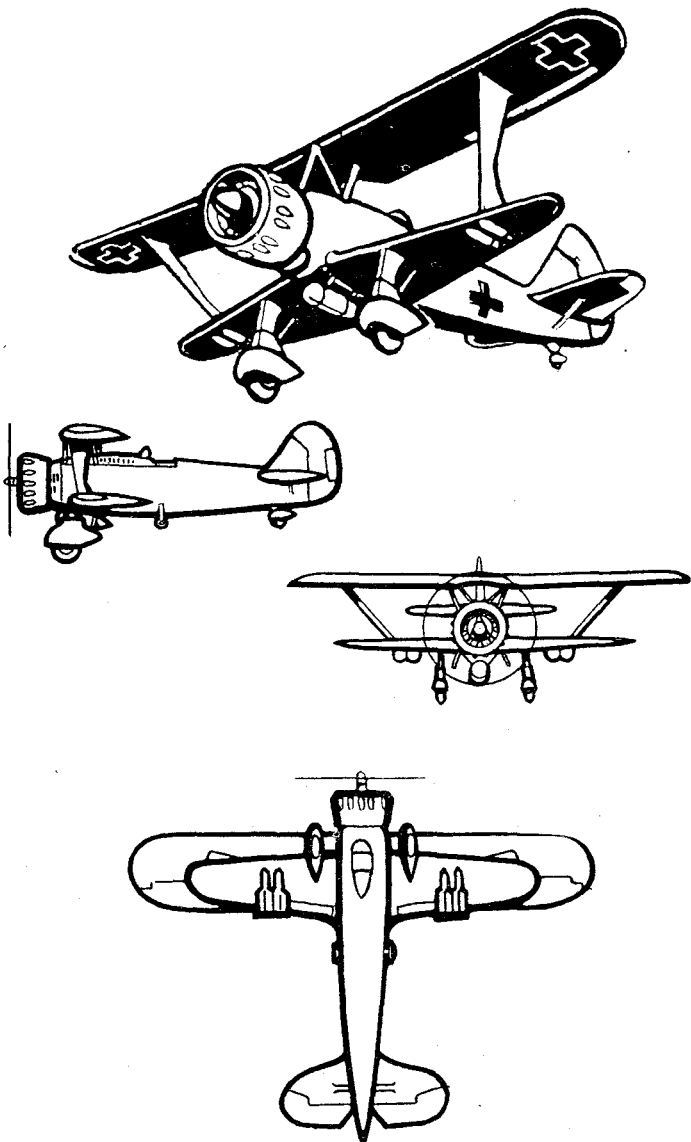

HENSCHEL Hs 123

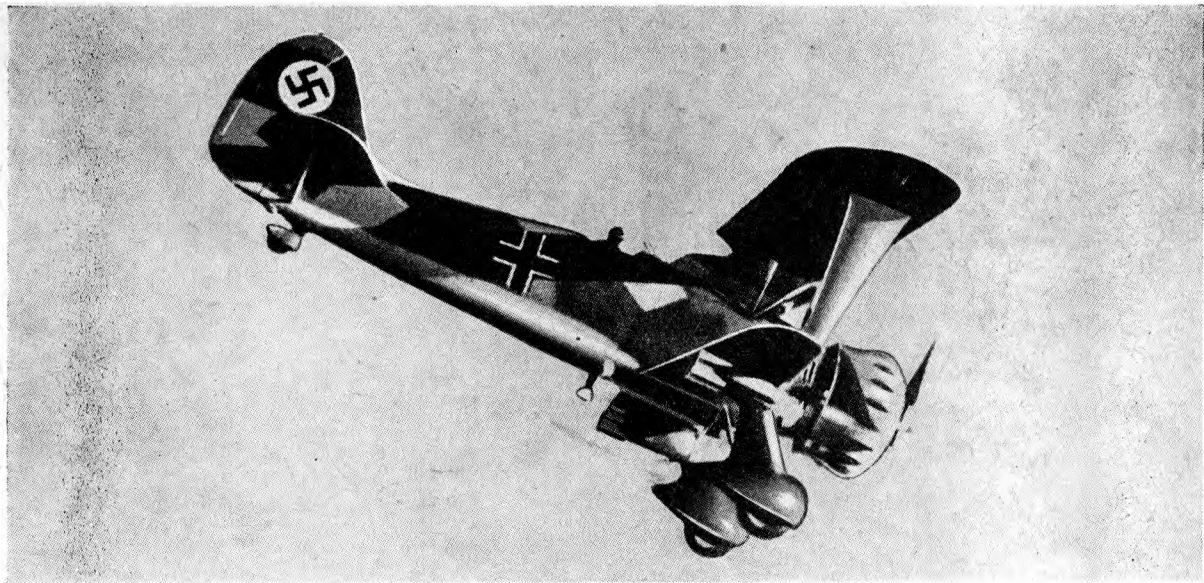

HENSCHEL Hs 123

An easily recognized radial engined, single-seater dive-bomber and ground-attack aircraft, the Hs 123 is now obsolete. The machine is of sturdy construction but carries only a light bomb load (four bombs of 100 lb. each). The streamlined object sometimes carried beneath the fuselage is a fuel tank. Two machine-guns are fitted to fire through the airscrew arc. With a BMW engine of 660 h.p. the top speed is about 220 m.p.h.

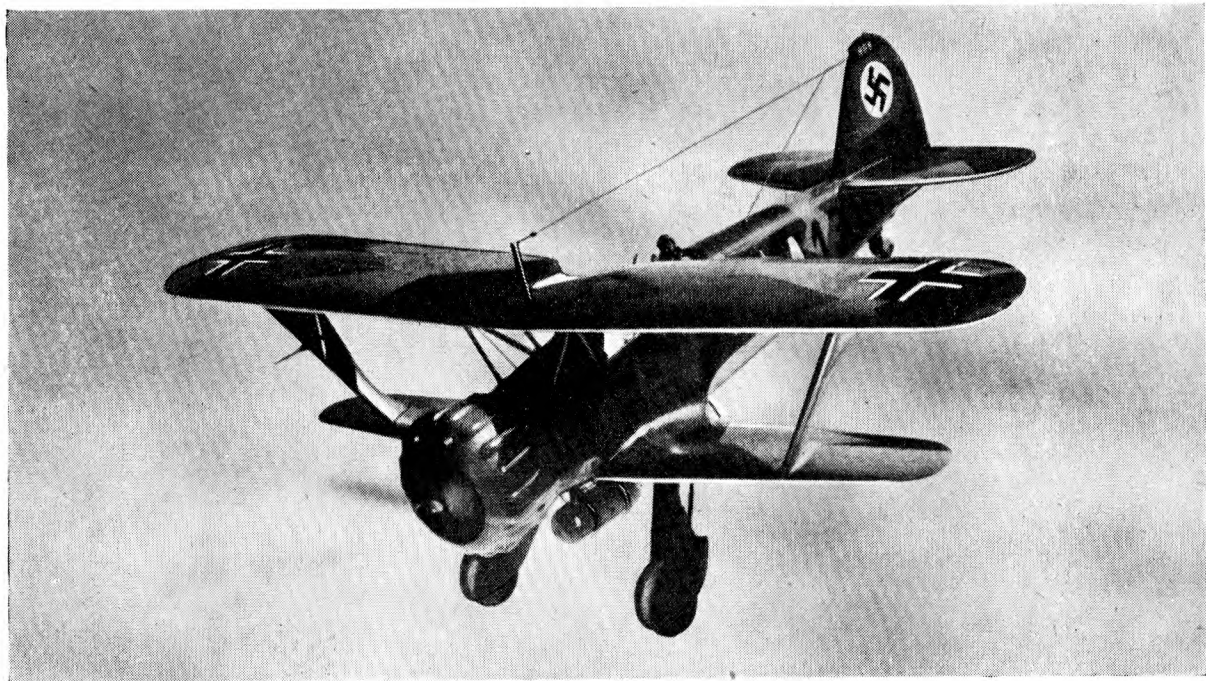

HENSCHEL Hs 123

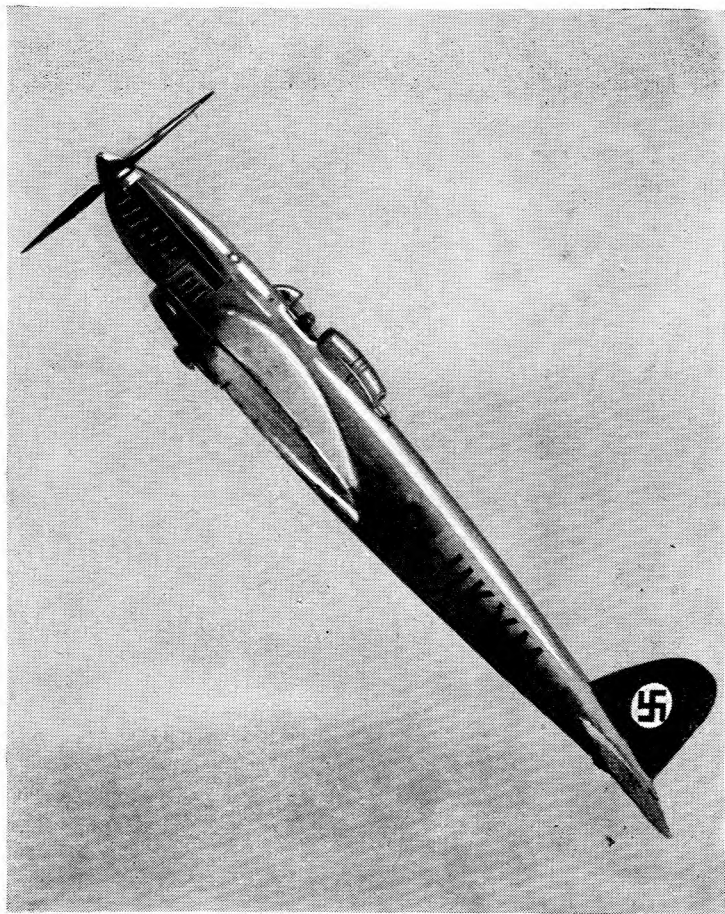

HEINKEL He 118

A high-performance two-seater monoplane designed to function as a dive-bomber or ground attack machine. In appearance it resembles the famous He 70 single-engined transport, having the characteristic up-swept wing roots. A Daimler-Benz DB 600 inverted vee-twelve engine is fitted and gives a top speed of about 250 m.p.h. Four machine-guns can be fixed in the wings and there is provision for a free gun in the rear cockpit. Diving attacks can be made with a single 1,100 lb. bomb, or low-flying attacks, on troop concentrations, etc., with a number of small bombs.

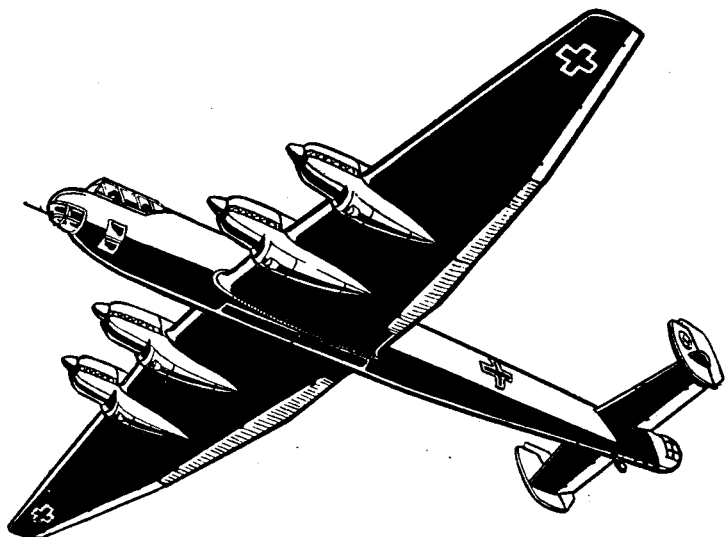

JUNKERS Ju 89

The Junkers Ju 89 is a military version of the Ju 90 and is fitted with four 880 h.p. Junkers Jumo 211 twelve-cylinder inverted vee liquid-cooled engines. The exact performance of this military type is not known but it is credited with a maximum speed of round about 250 m.p.h. The span is 115 ft. ; the length 86 ft. and the maximum gross load for take-off 50,800 lb. It is probable that this type is used rather more as a troop transport machine and for the dropping of parachute troops, than as a bomber.

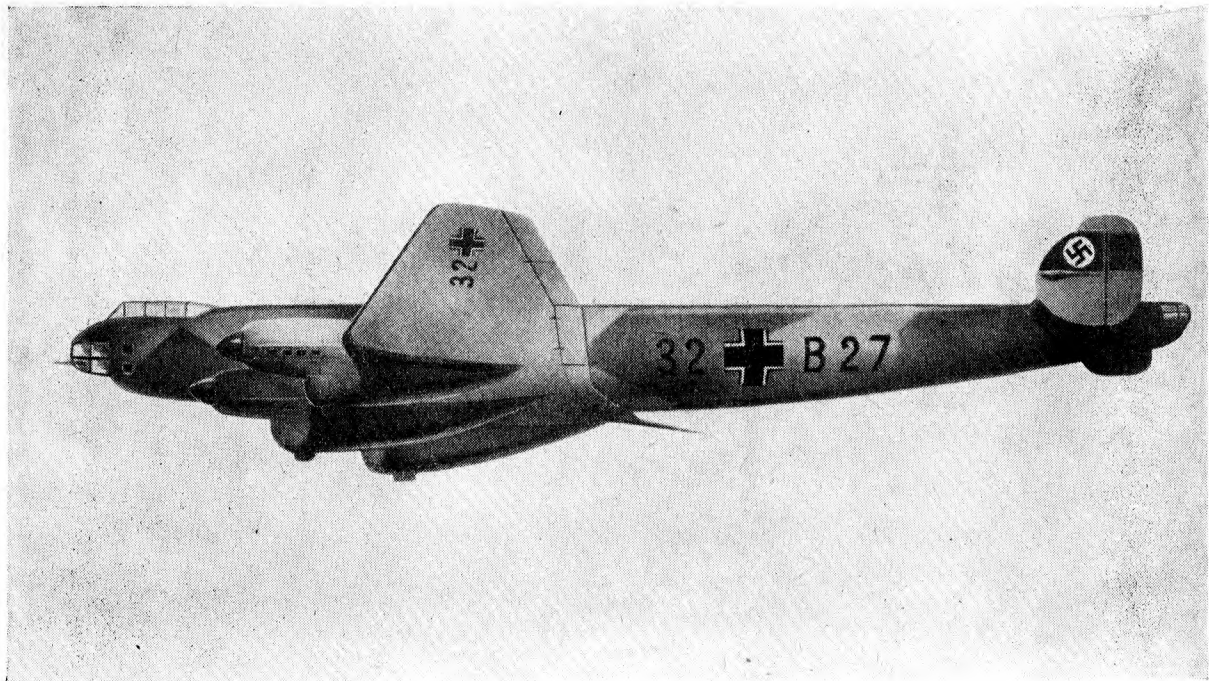

JUNKERS Ju 89

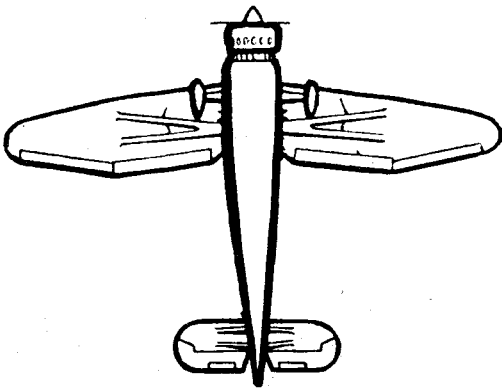
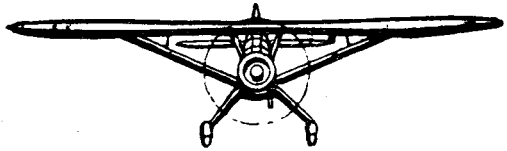
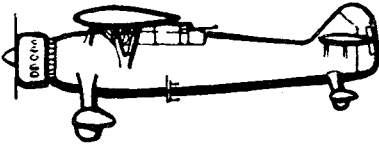
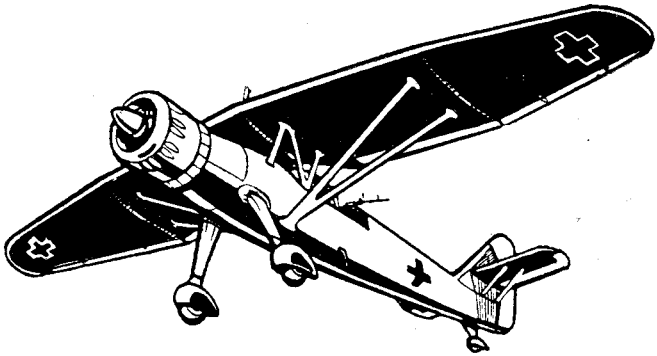

HENSCHEL Hs 126

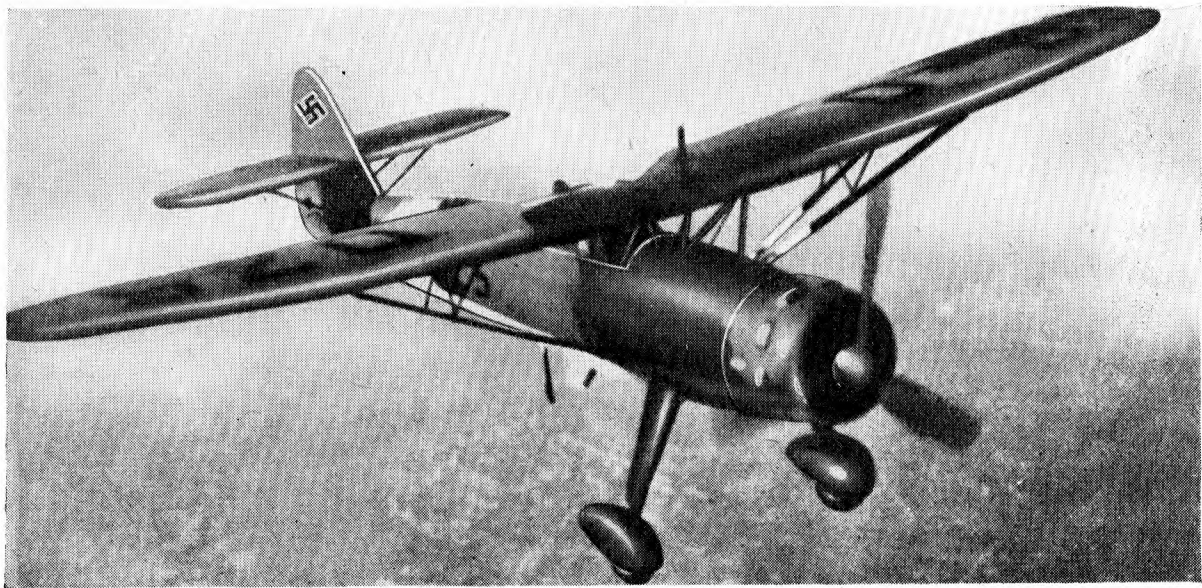

HENSCHEL Hs 126

The counterpart of our Westland Lysander army co-operation machine, the Hs 126 is a single-engined parasol monoplane with a fixed undercarriage. Although the type has not been extensively employed a number were shot down by the B.E.F. and Allied fighters. As the top speed is only 230 m.p.h. and the armament two machine-guns, the Hs 126 stands little chance if intercepted. A system of flaps enables the machine to fly very slowly when taking photographs or spotting for the artillery. The engine is a BMW 132 radial.

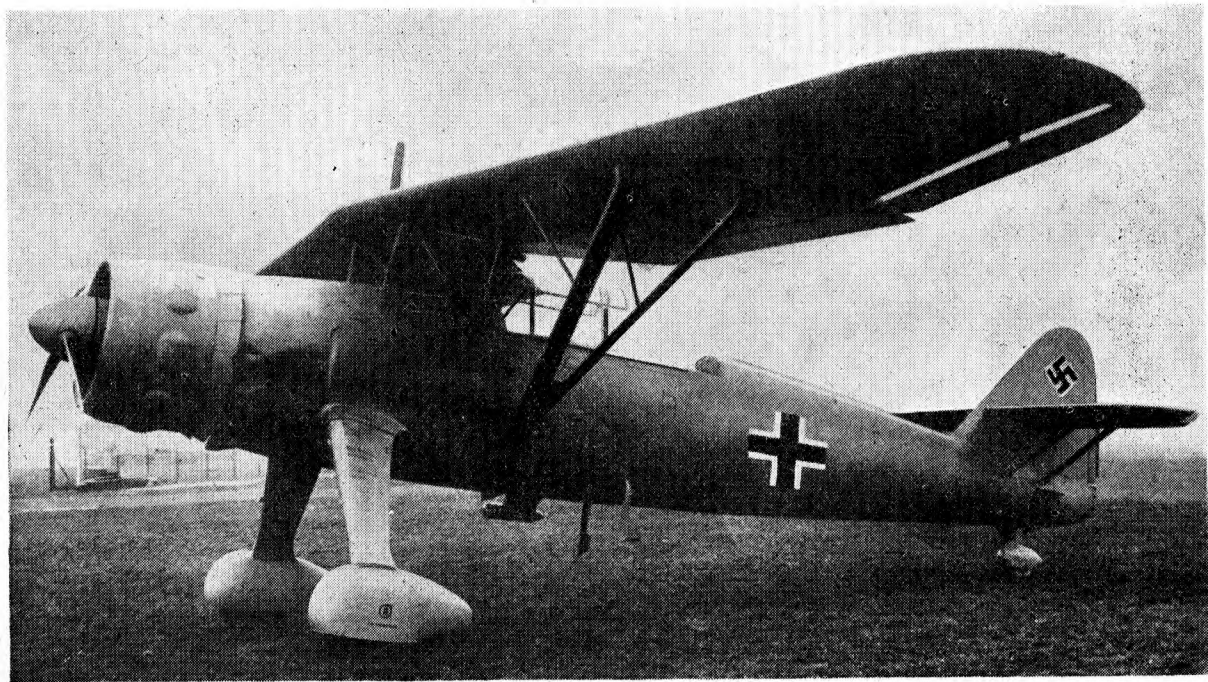

HENSCHEL Hs 126



BUCKER JUNGMEISTER

The Bucker concern is famed for its training aircraft and the single-seater Jungmeister is one of its most popular products. It is possible that this machine is the most manoeuvrable in the world, the primary design being planned to that end. Fitted with a Siemens radial engine of 160 h.p. the top speed is 134 m.p.h. Factors making for the high degree of manoeuvrability attained are the well-designed controls, the short span (21 ft. 7½ in.) and the low wing loading.

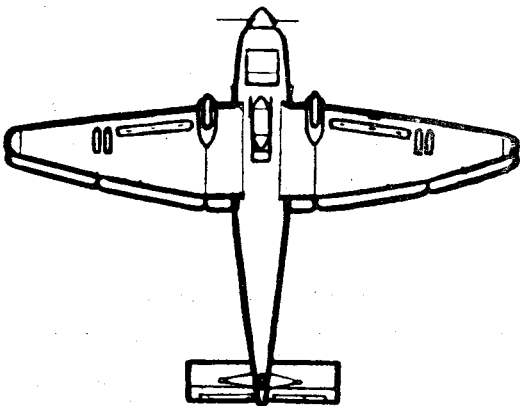
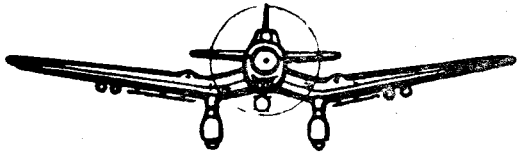
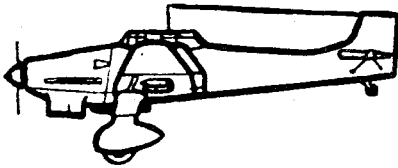
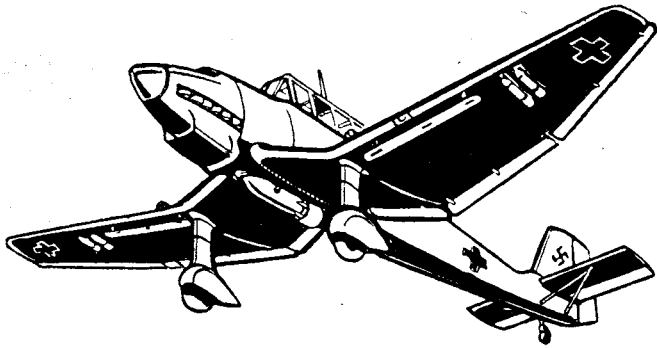

JUNKERS Ju 87

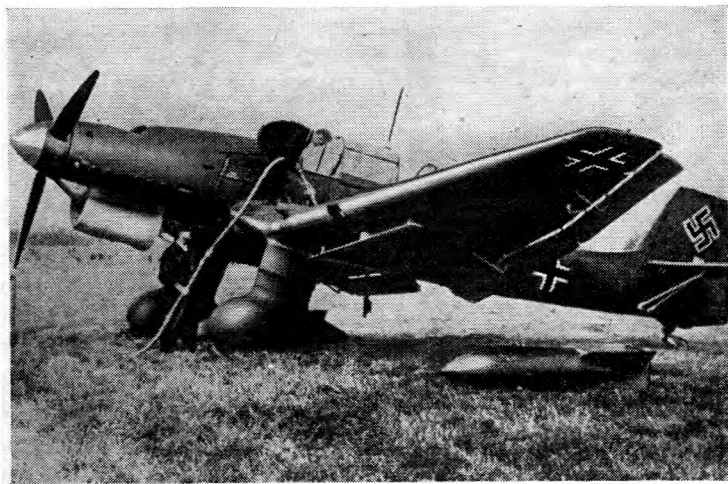
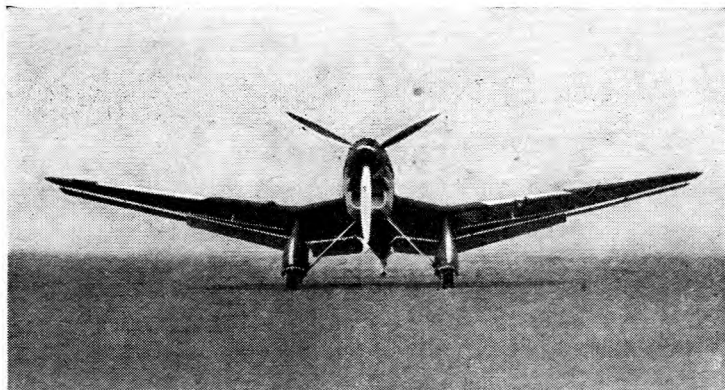

JUNKERS Ju 87

The "Stuka" (dive bomber) is a single-engined monoplane with a peculiar "cranked" wing and a fixed "spatted" undercarriage. Pilot and gunner are housed beneath a transparent enclosure. The standard engine is the Junkers Jumo 211 of over 1,000 h.p. A single large bomb of 1,100 lb. can be carried beneath the fuselage in conjunction with a special "ejector" arrangement which ensures its clearing the airscrew during a diving release. Smaller bombs can be carried beneath the wing, which incorporates diving brakes. The armament is two machine-guns and the top speed 240 m.p.h.

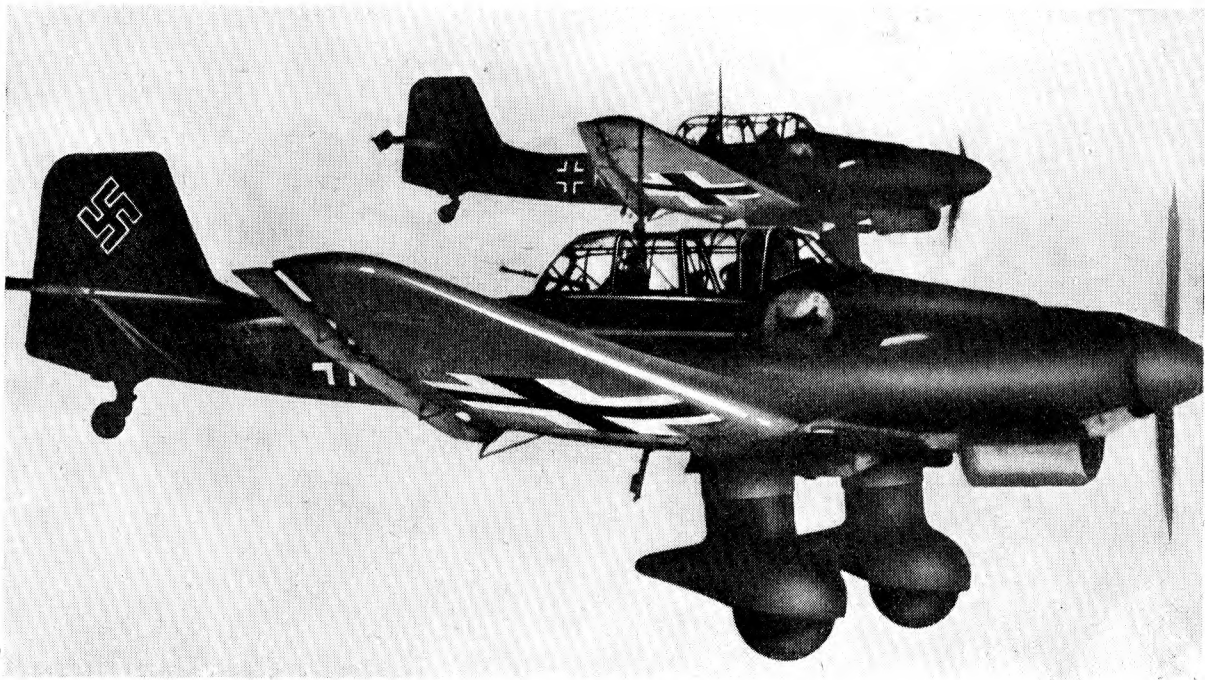

JUNKERS Ju 87

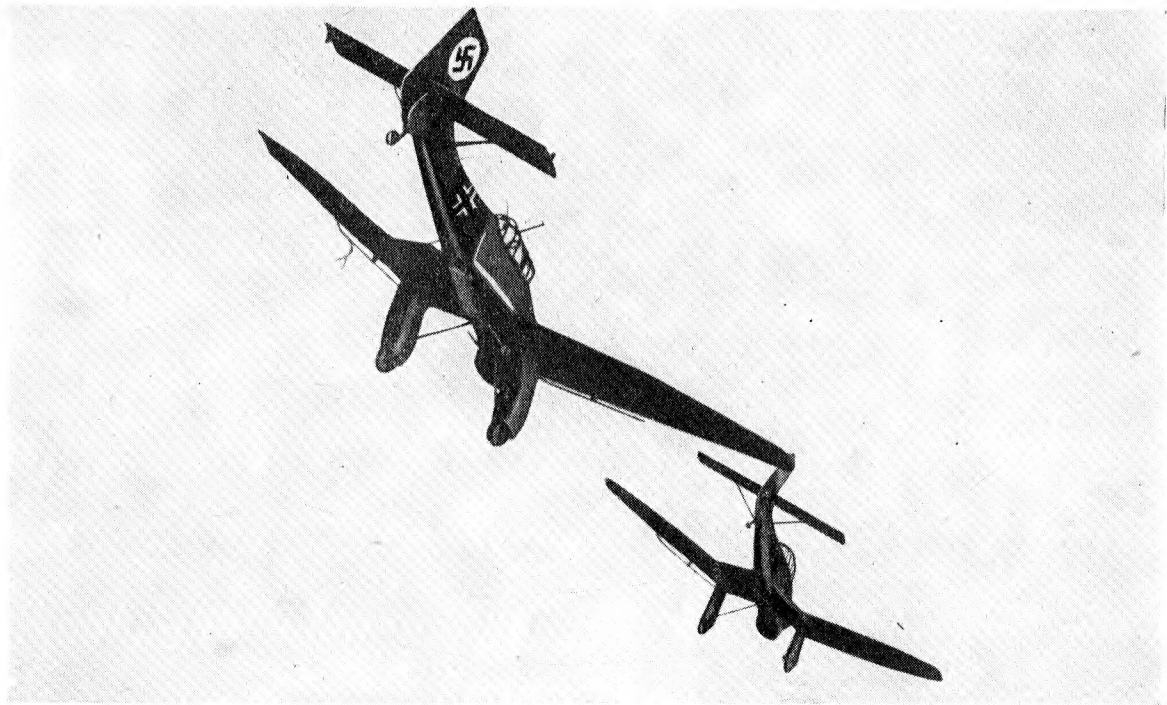

JUNKERS Ju 87

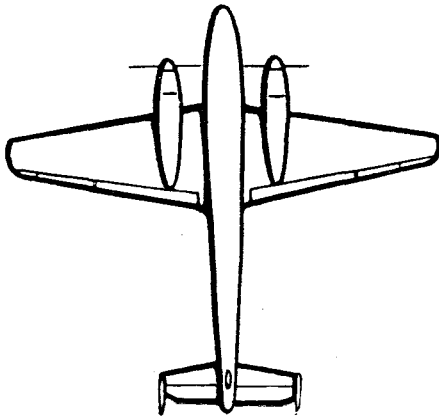
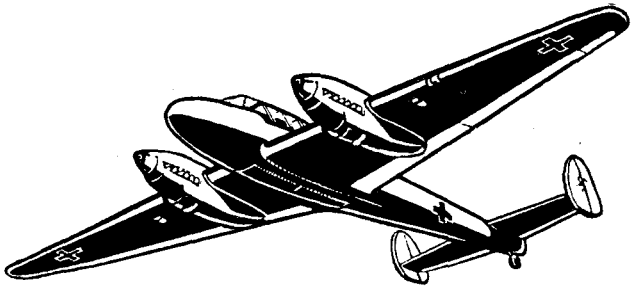

MESSERSCHMITT Me 110

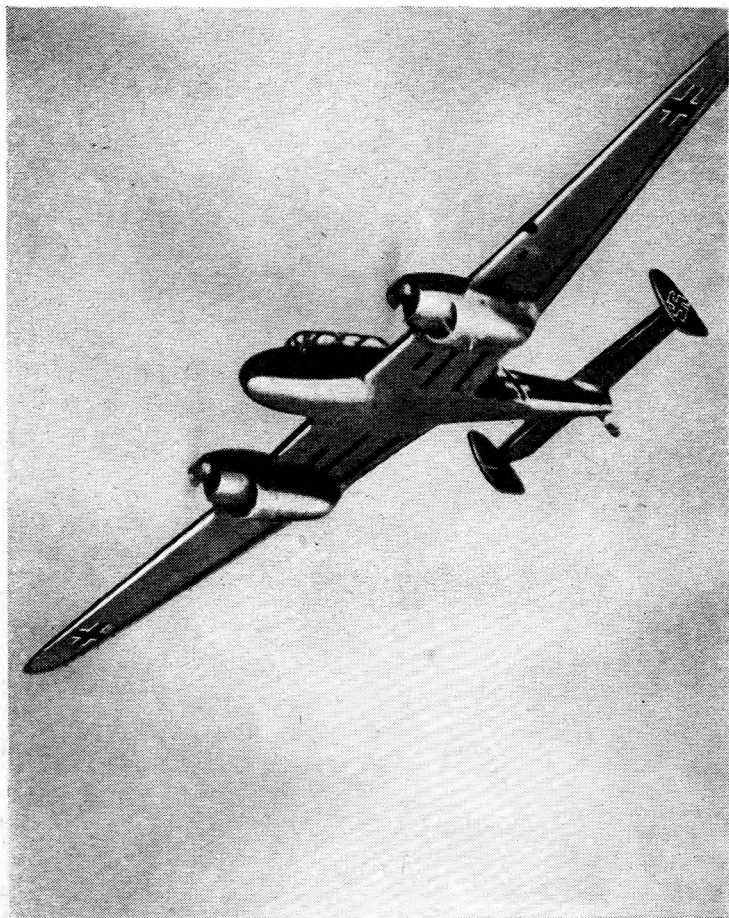

MESSERSCHMITT Me 110

The twin-engined two-seater fighter Me 110 has fared badly against British fighters. The pilot and gunner sit in tandem under a long transparent enclosure which distinguishes the machine from other twin-engined German types. Daimler-Benz DB 601 engines are usually fitted; the armament load being two shell-firing guns and five machine-guns. As the free armament is manually trained it is difficult to fire with accuracy at any appreciable angle from the line of flight. A bomber on similar lines—the Jaguar—has a redesigned fuselage incorporating a transparent nose.

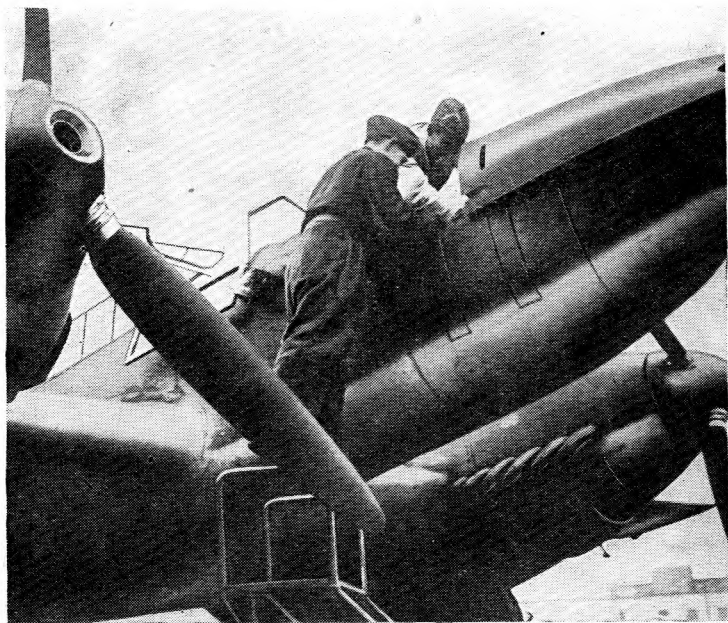
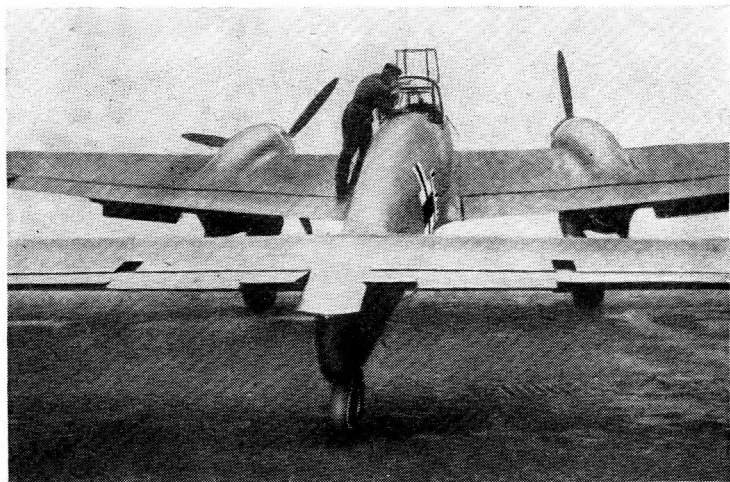

MESSERSCHMITT Me 110

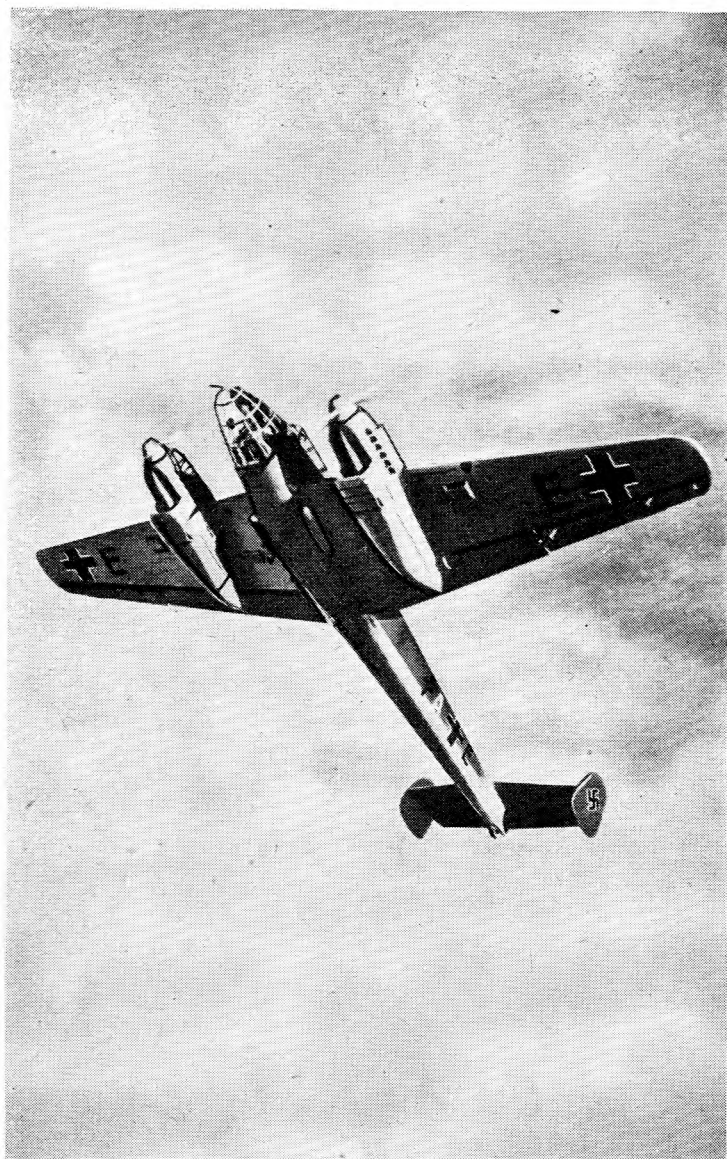

Me 110 JAGUAR (Bomber)

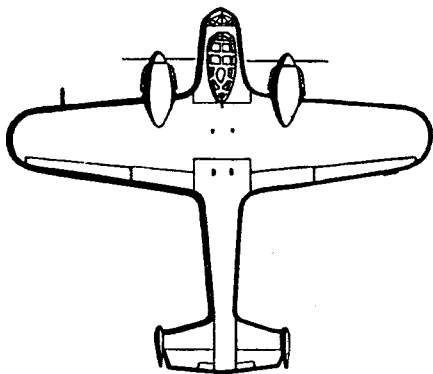
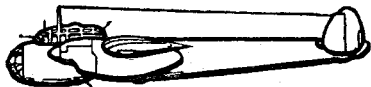
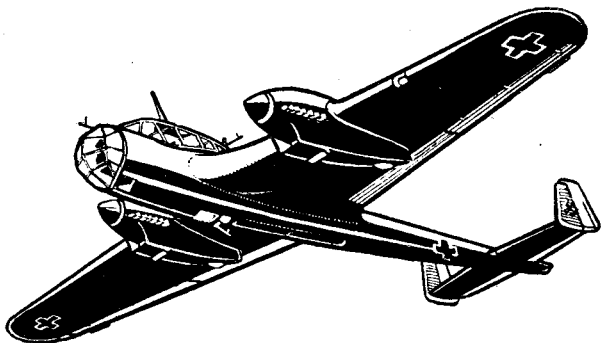

DORNIER Do 17

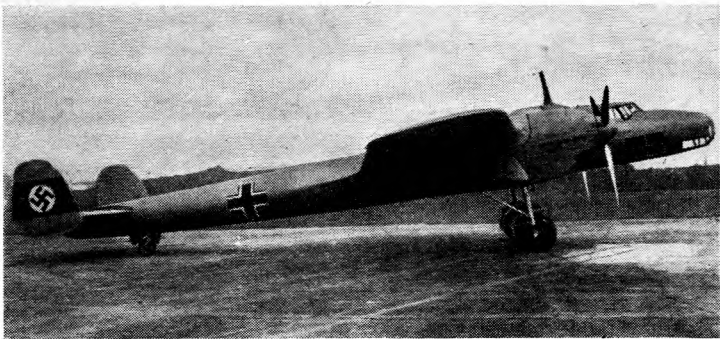
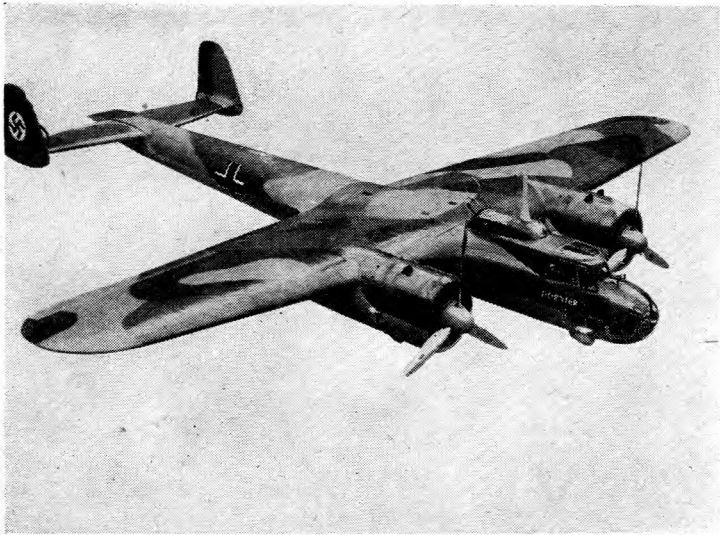

DORNIER Do 17

Although called the "Flying Pencil", the slim fuselage of the Do 17 is only apparent in side elevation. From beneath it looks quite wide, as the sides of the fuselage slope out where they merge with the wing. It is of high-wing layout, the standard type having a rounded transparent nose. Most Do 17's in service have BMW or Bramo radial engines though the Daimler-Benz liquid-cooled type is an alternative. Top speed is 280 m.p.h., and the armament three machine-guns. A battery of cameras can replace the bomb load.



DORNIER Do 17



HEINKEL He 59

Of ungainly appearance and low performance the twin-engined twin-float He 59 seaplane was employed in the Spanish war and has more recently been operated over the North Sea from German and Scandinavian bases. Aerodynamic refinement has been sacrificed to seaworthiness, ease of maintenance and the comfort of the crew. Two BMW VI engines with nose type radiators are fitted and drive four-bladed wooden airscrews. There are unprotected manually-operated gun mountings in the bows, on top of the fuselage aft of the wings and beneath the fuselage.

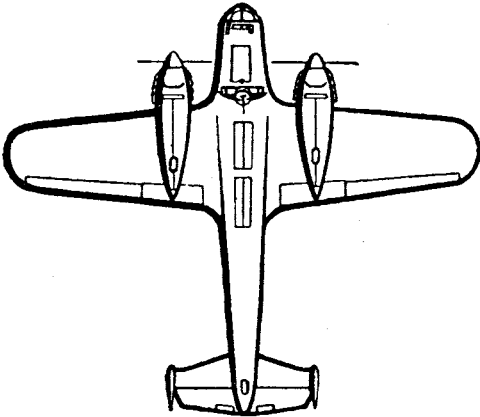
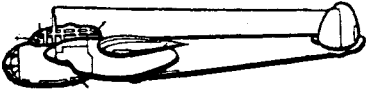
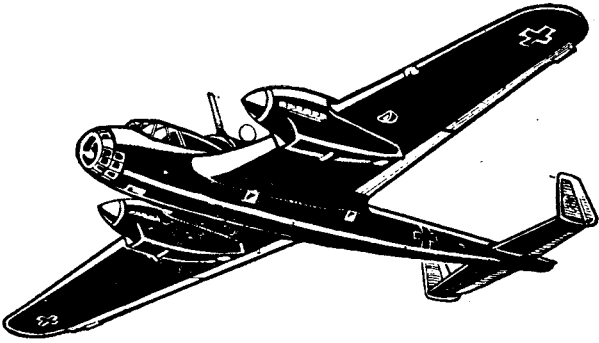

DORNIER Do 215

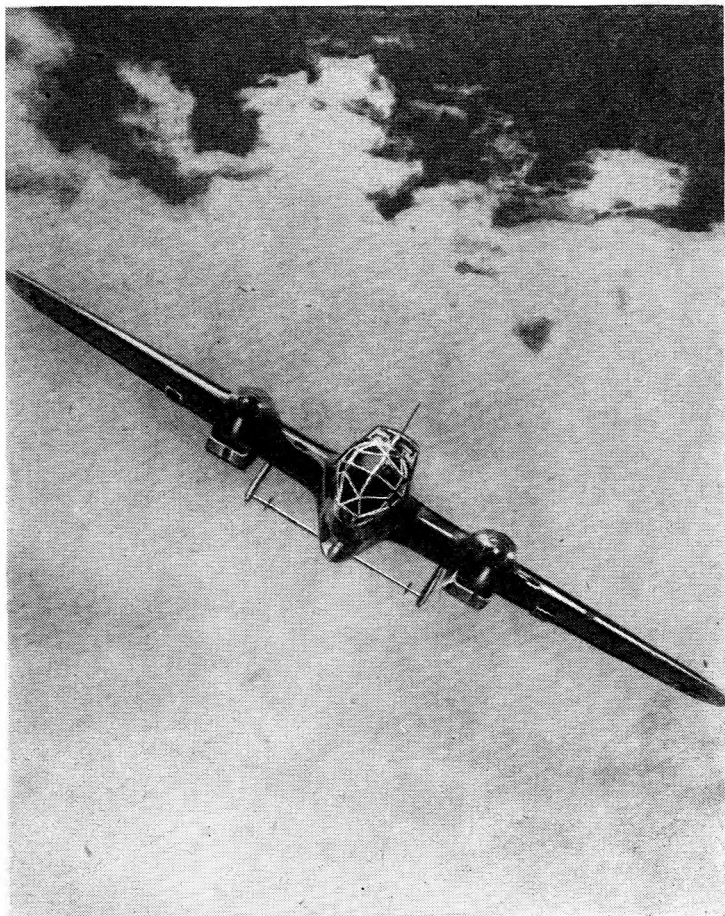

DORNIER Do 215

The Do 215 is a modified Do 17, most of the redesigning being in the nose portion, which is deeper than in the Do 17 and more angular in appearance. One machine-gun operated by the second pilot fires over the nose, a second is at the rear of the cockpit enclosure and a third beneath the fuselage. Although radial engines are often used, Daimler-Benz DB 601 liquid-cooled, inverted vee-twelves, with a top speed of over 300 m.p.h., are also fitted. With "reconnaissance" load the range is about 1,500 miles.

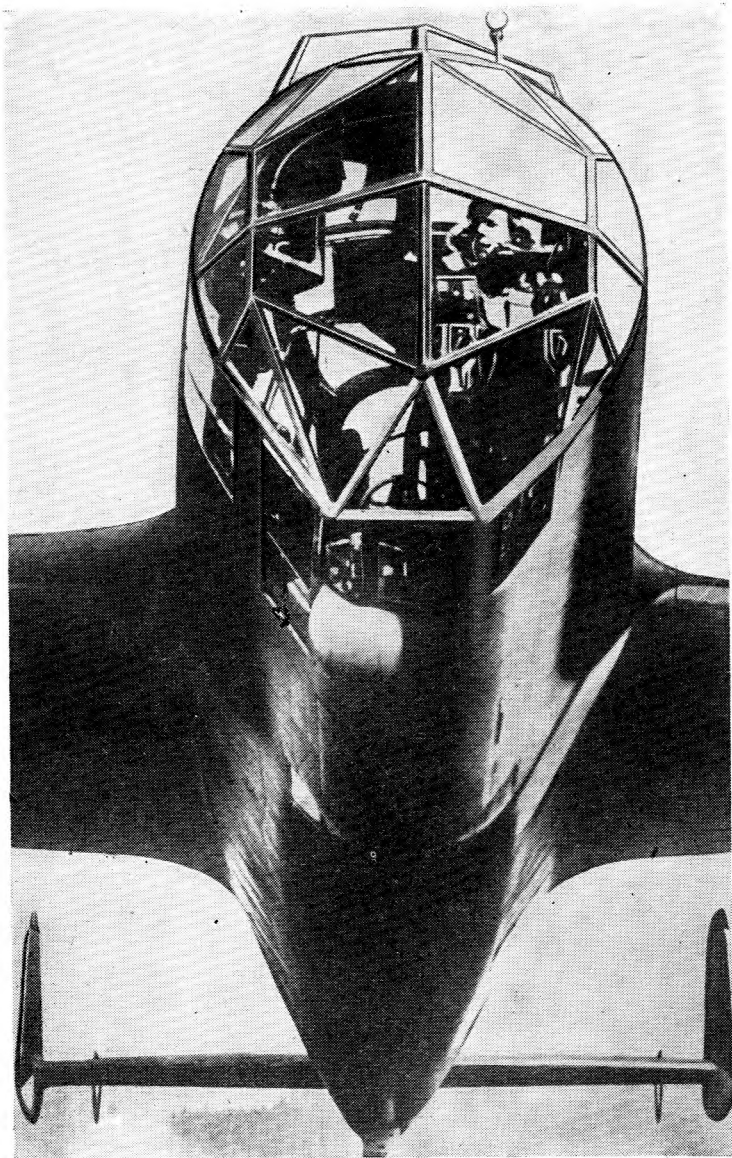

DORNIER Do 215

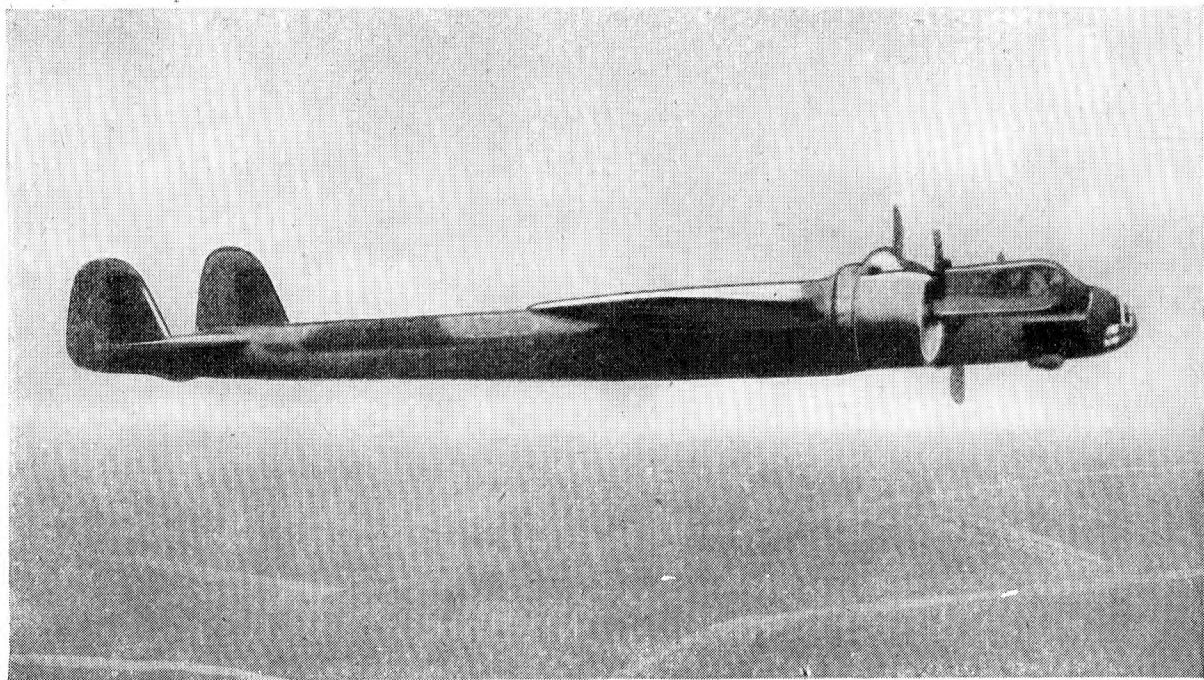

DORNIER Do 215

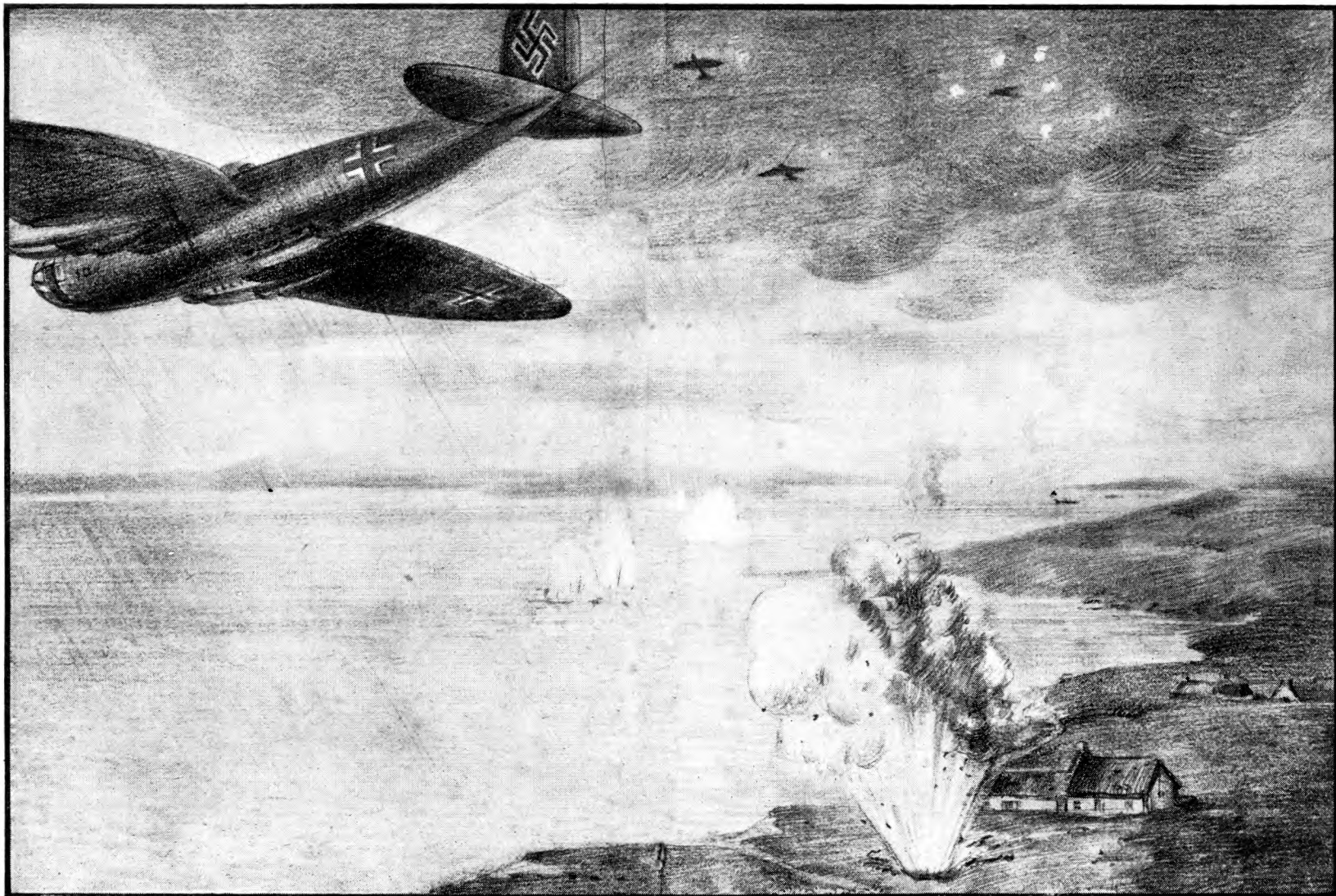

Reproduced by special permission of

HUTCHINSON'S PICTORIAL HISTORY OF THE WAR

NAZI BOMBERS RAIDING THE SHETLANDS

An artist's reconstruction of the German air raid on the Shetland Islands on 13th November, 1939, when the first bombs to fall on British soil were dropped. Although during the raid on the Firth of Forth on 16th October bombs fell into the water, these were the first bombs actually to fall on land.

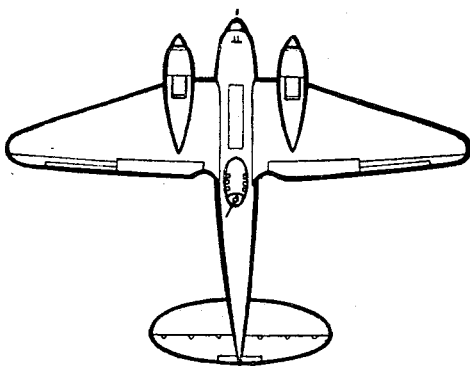
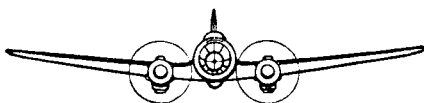
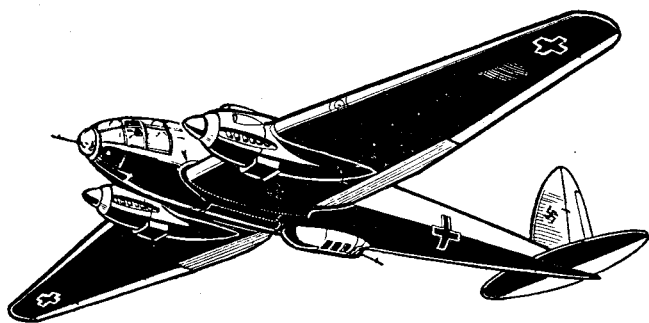

HEINKEL He 111 K

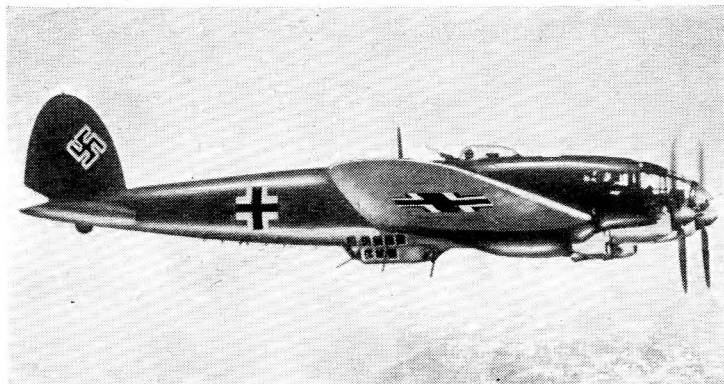

HEINKEL He 111K

The version of the He 111K now in general use differs from earlier types in that the wings are straight-edged and the nose is deeper and more streamlined. Upper and lower gun positions have also been modified though the armament is still three machine-guns. Most of the machines have Junkers Jumo 211 engines though some have Daimler-Benz DB 601s. Installation differences are not noticeable from a distance. A top speed of over 270 m.p.h. is claimed, which is very good for a machine carrying up to 4,000 lb. of bombs.

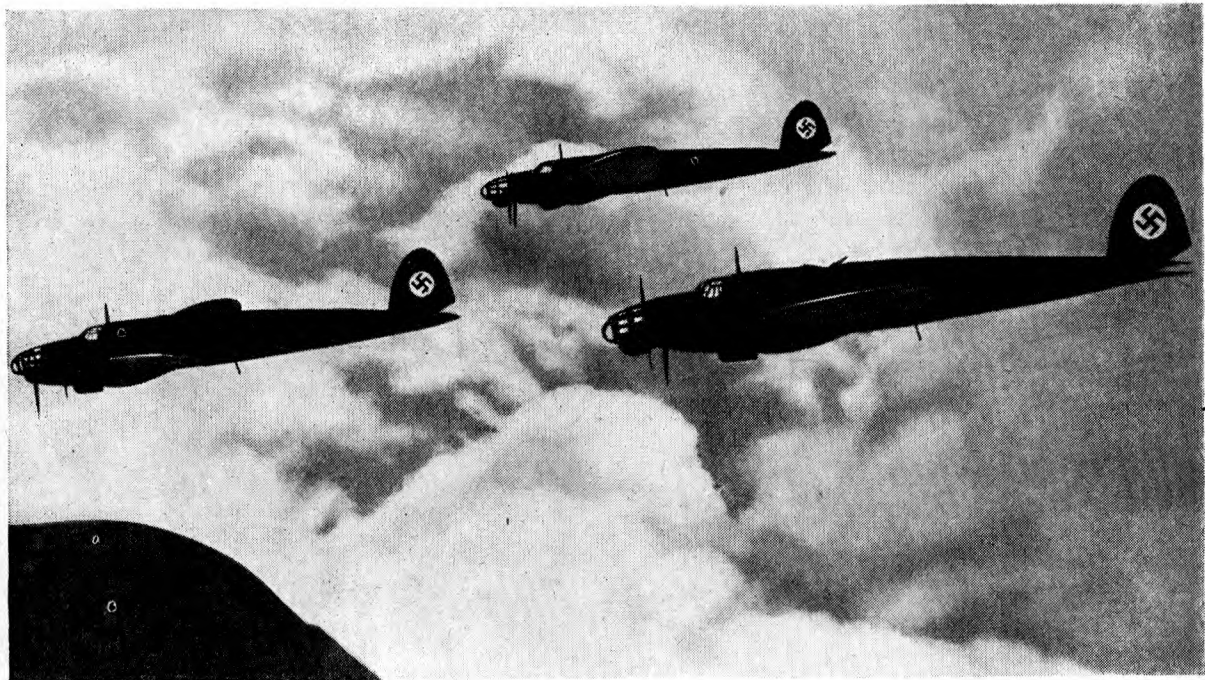

HEINKEL He 111K

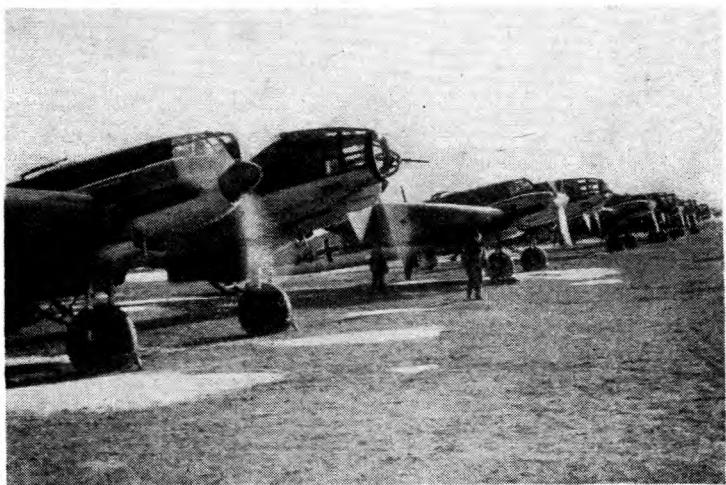
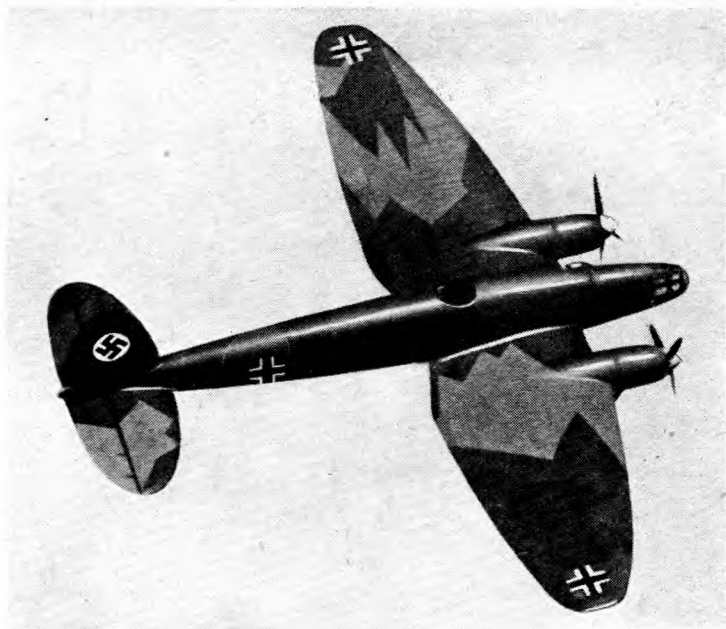

HEINKEL He 111 K

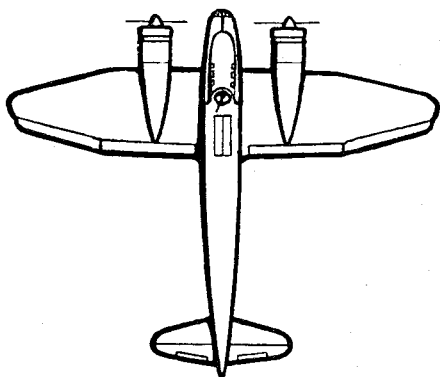
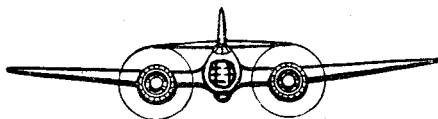
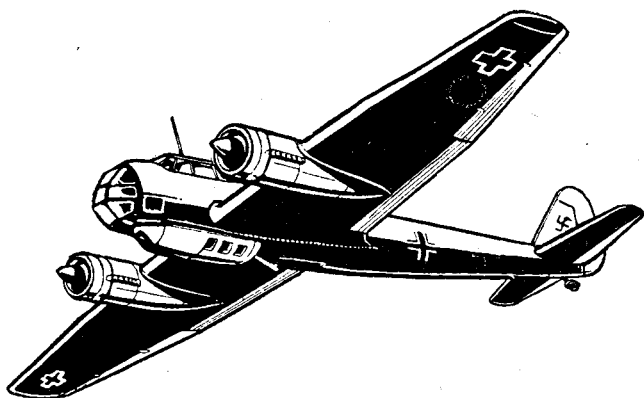

JUNKERS Ju 88

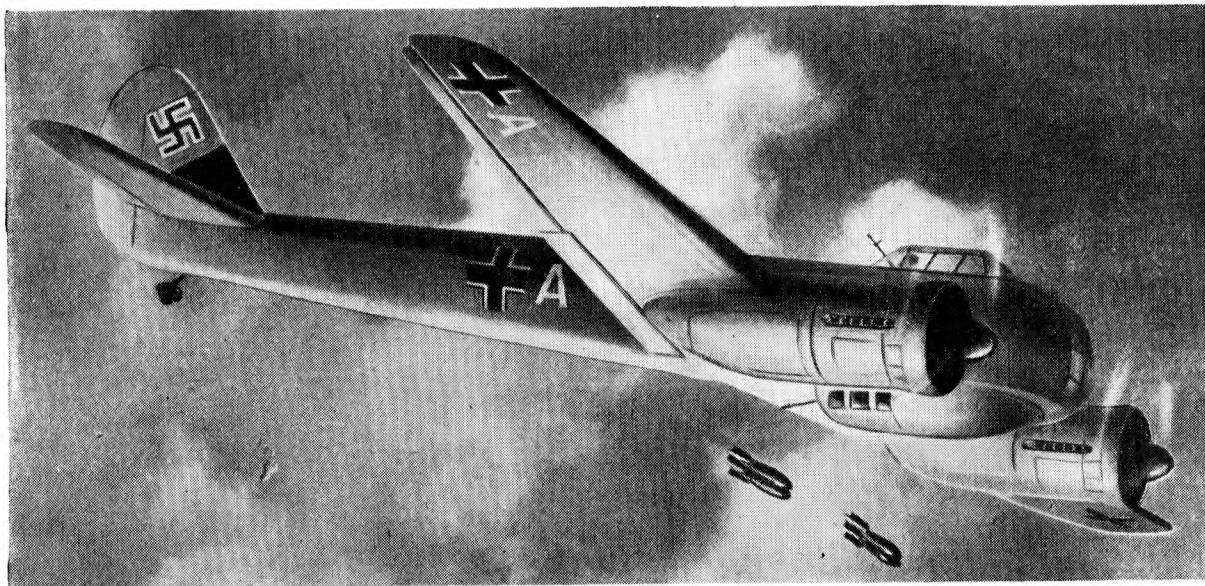

JUNKERS Ju 88

Originally the Ju 88 was shrouded in mystery, but so many have been shot down by our eight-gun fighters, that little mystery remains. A feature of interest are the "venetian blind" diving brakes which can be lowered from the wings to retard speed in a bombing dive. The radiators for the Junkers Jumo 211 engines are also unusual, being of circular form and located in the noses of the engine nacelles. The forward part of the fuselage is like that of the Do 215. Bombs are carried beneath the centre section of the wing.

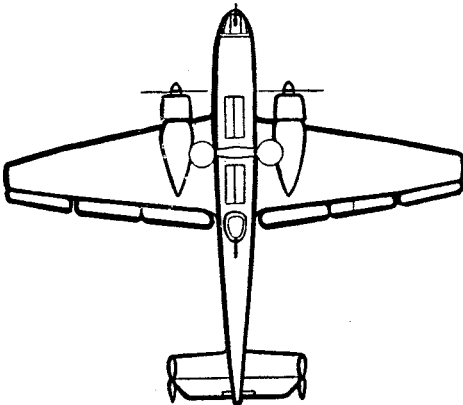
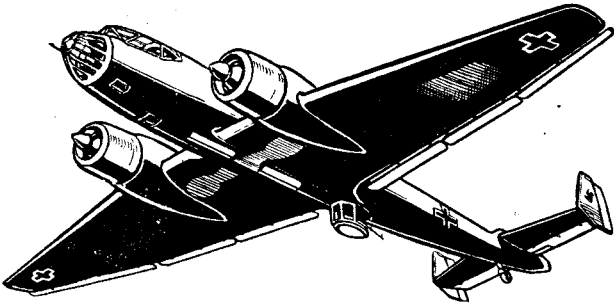

JUNKERS Ju 86 K

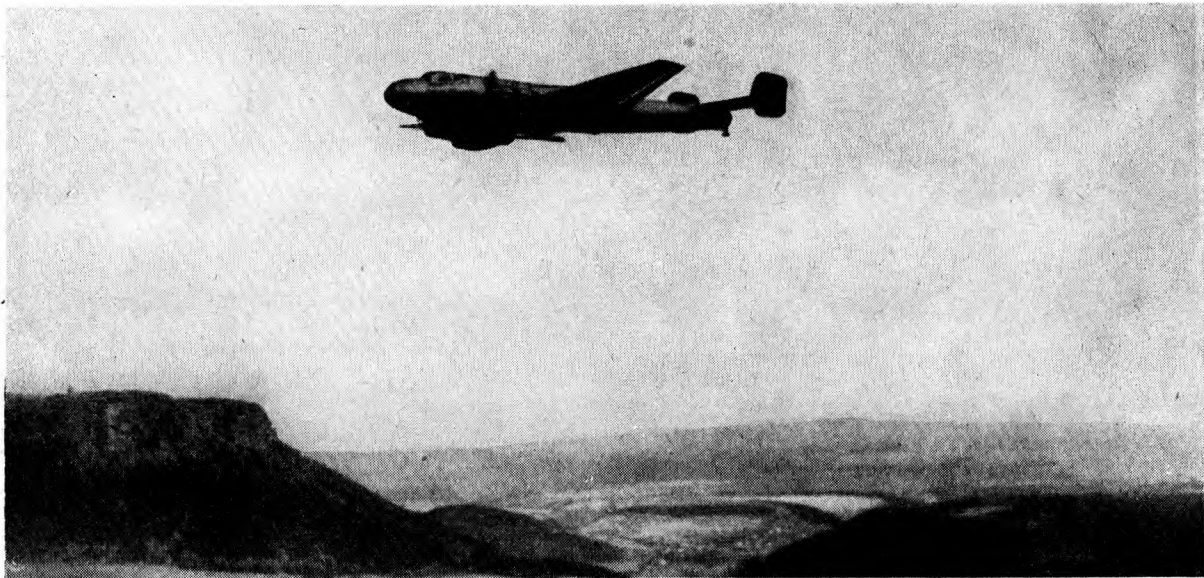

JUNKERS Ju 86 K

Although obsolete as first-line equipment, the Ju 86 K is still flown. Developed from the Ju 86 transport, it is a low-wing monoplane, the wing being of characteristic Junkers shape. Earlier models had Junkers Jumo Diesel engines but performance was improved when BMW radial petrol engines were installed. There is one machine-gun in the nose, a second on top of the fuselage behind the wing, and a third in a "dustbin" below the fuselage. Bombs are stowed vertically in the fuselage. Top speed is 224 m.p.h., and range about 1,500 miles.

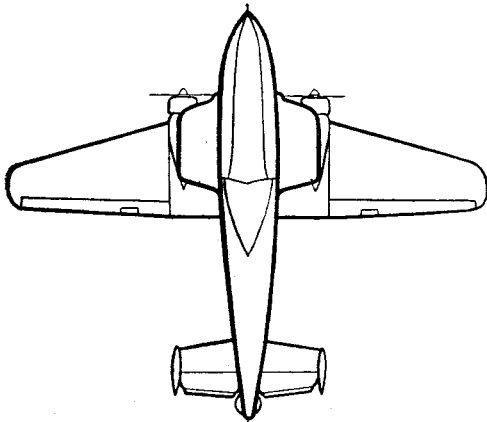
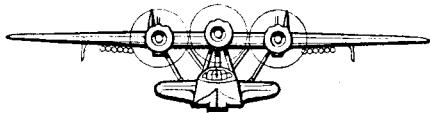
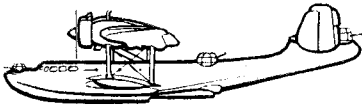
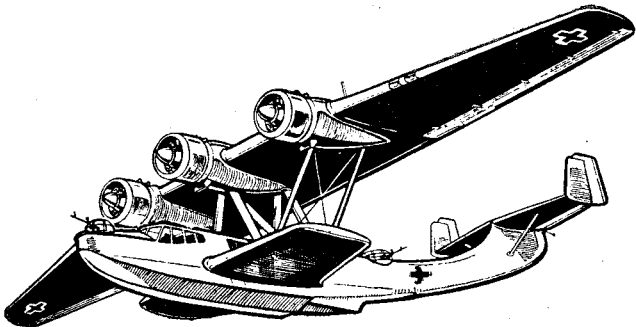

DORNIER Do 24

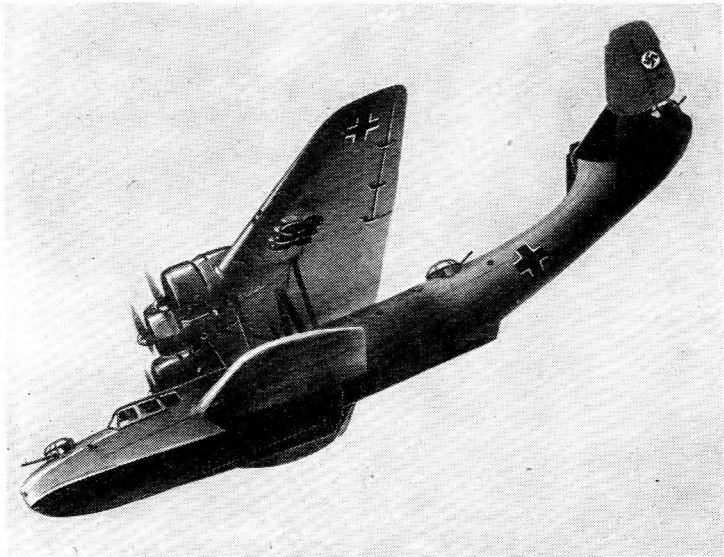
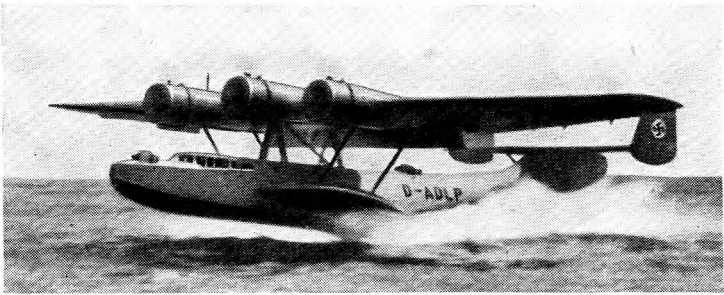

DORNIER Do 24

In certain respects the Do 24 resembles a scaled-up Do 18 K. Noticeable points of difference, however, are the installation in "line abreast" of three radial engines and the use of twin fins and rudders. Machine-guns (bows, amidships and stern) are carried in turrets and bombs can be slung below the wing. The hull is broad in the beam and comparatively shallow, the upper portion being of semi-circular formation except at the forward end. The span of the machine is 88 ft. 7 in. and the top speed in the neighbourhood of 200 m.p.h.

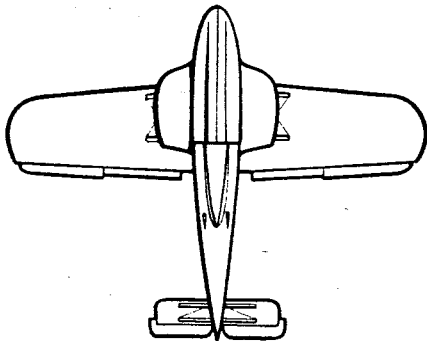
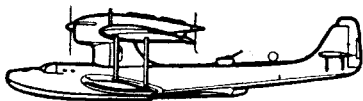
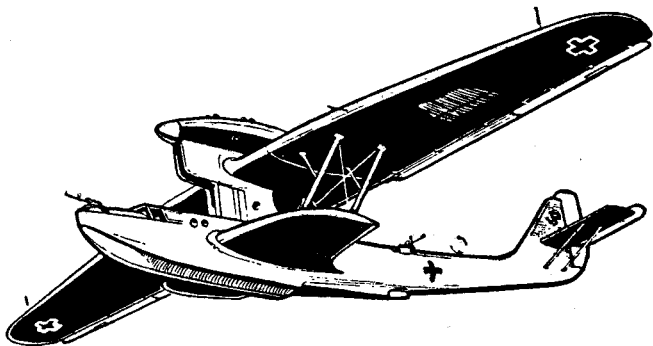

DORNIER Do 18 K

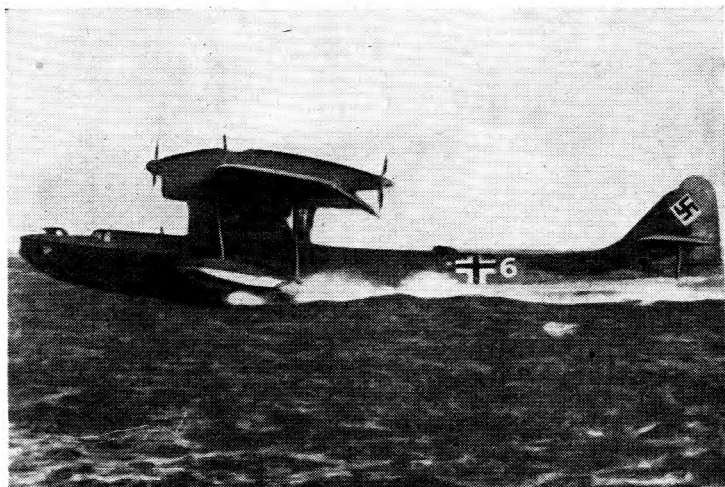
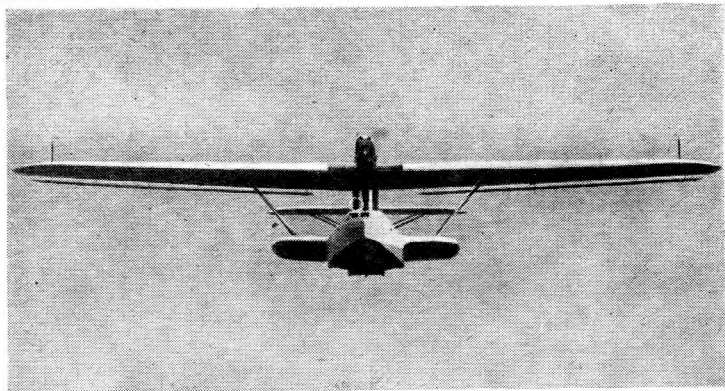

DORNIER Do 18 K

Perhaps the most interesting technical feature of this reconnaissance flying boat, which has suffered badly at the hands of the R.A.F., is the installation, in tandem, of two Junkers Jumo Diesel engines. Another feature is the use of sponsons, or "seawings" instead of the more usual wing-tip floats. To increase the range the machine is sometimes catapulted. It is not, however, of high performance and the top speed is little more than 250 m.p.h. The type has functioned as a mine-layer but is very poorly armed having only two or three machine-guns.

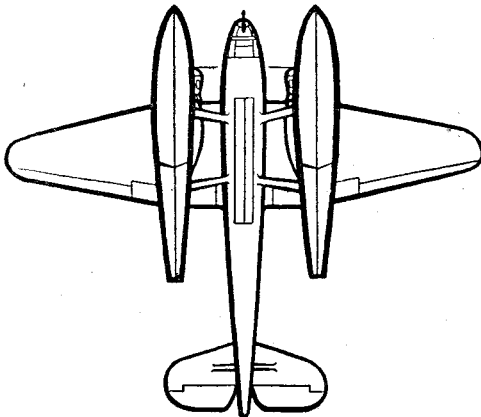
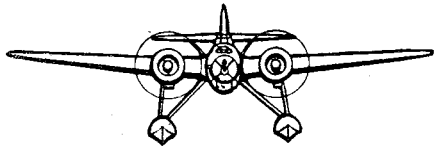
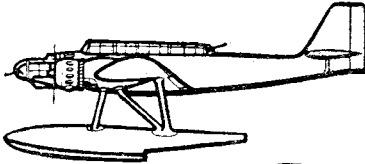
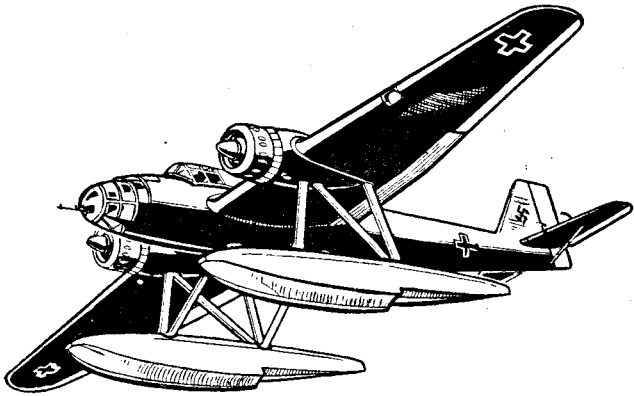

HEINKEL He 115

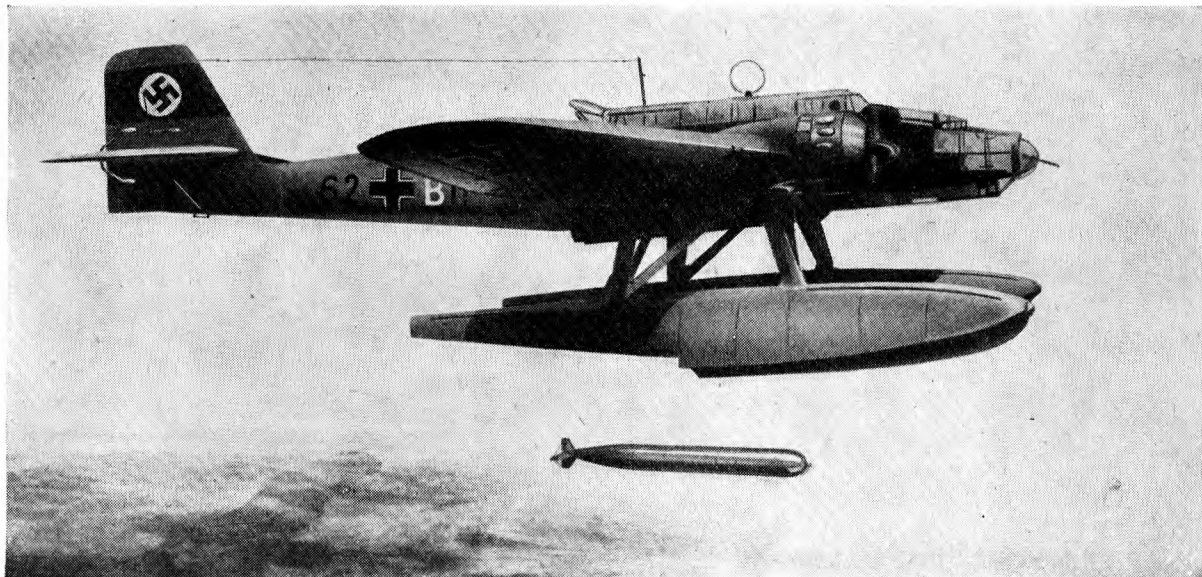

HEINKEL He 115

Several examples of this large twin-engined, twin-float seaplane have been shot down. The He 115 can function as a bomber, reconnaissance machine, torpedo-carrier or mine-layer. Top speed is about 220 m.p.h. when fitted with BMW 132 radial engines. Defensive armament is three machine-guns but the machine is by no means formidable in combat, one having been brought down by a low-powered Avro Anson reconnaissance machine. The machine is not merely a float-plane version of the He 111K but was specially designed as a seaplane.

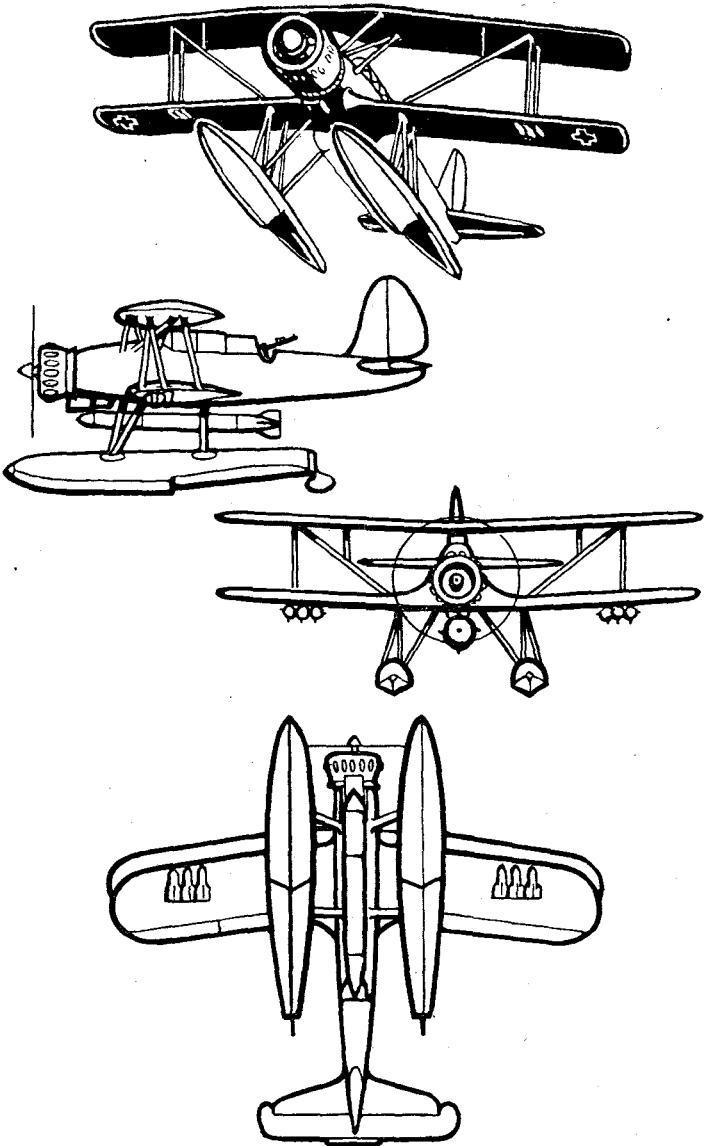

ARADO Ar 95

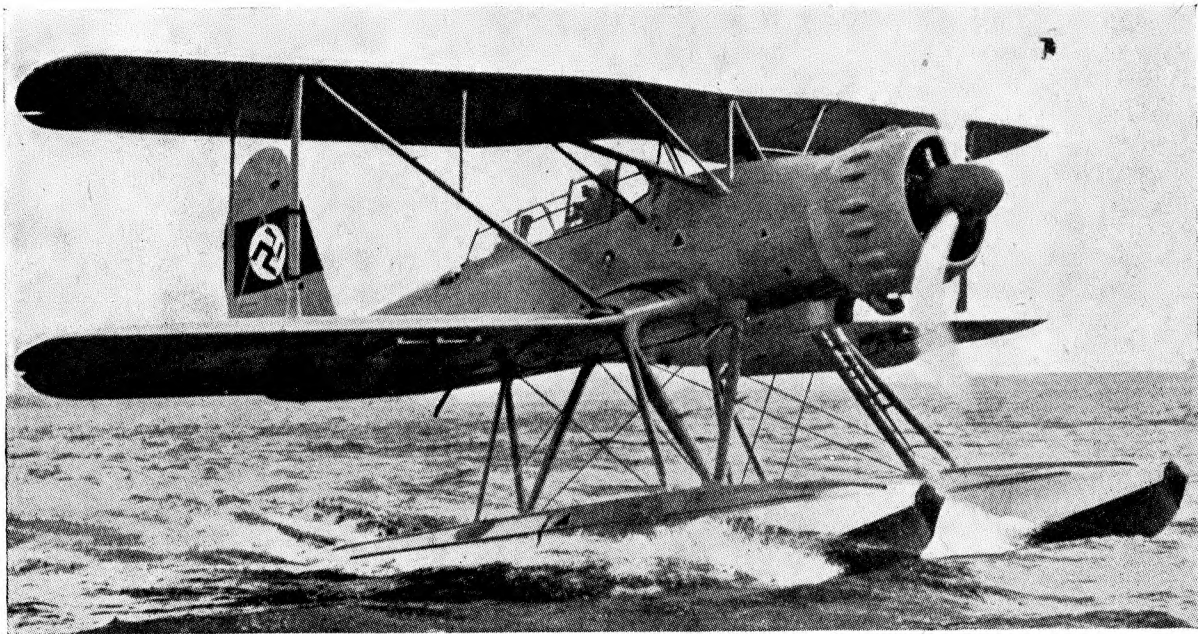

ARADO Ar 95

A veritable maid-of-all-work the Ar 95 biplane can be operated on wheels, floats or skis and can be used for reconnaissance, bombing, smoke-screen laying, target-towing, or torpedo-dropping. As an alternative to a bomb load of 600 lb. the machine can carry a torpedo of 1,760 lb. beneath the fuselage. Or, if need be, a single bomb of 1,100 lb. Fitted with floats and powered with a BMW 132 engine the top speed is 187 m.p.h., the substitution of the land undercarriage adding about 15 m.p.h.

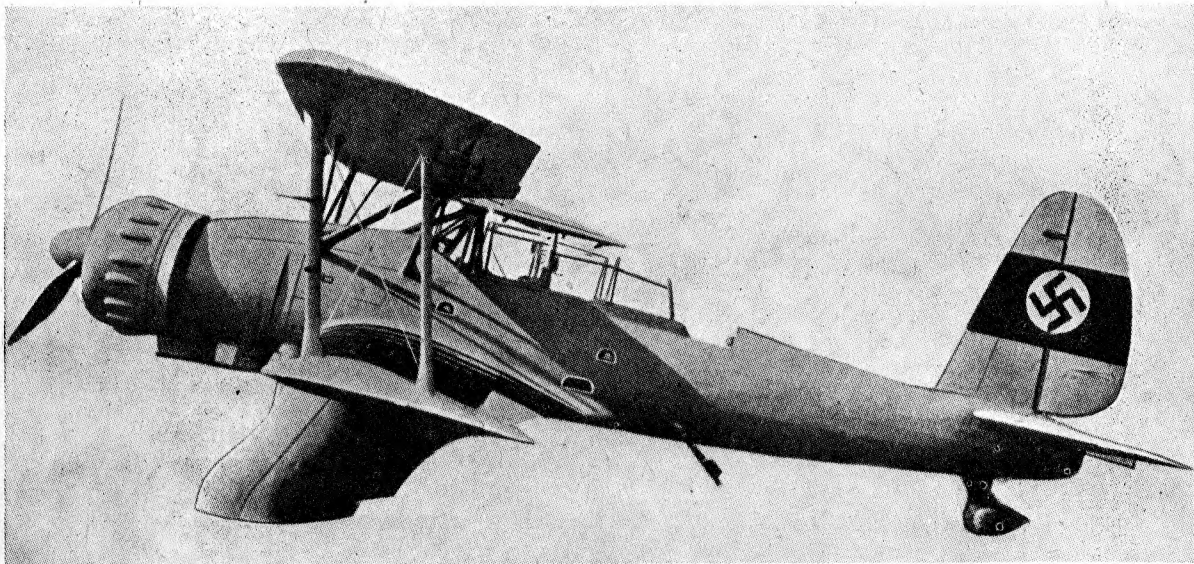

ARADO Ar 95 LAND PLANE

A veritable maid-of-all-work the Ar 95 biplane can be operated on wheels, floats or skis and can be used for reconnaissance, bombing, smoke-screen laying, target-towing, or torpedo-dropping. As an alternative to a bomb load of 600 lb. the machine can carry a torpedo of 1,760 lb. beneath the fuselage, or, if need be, a single bomb of 1,100 lb. Fitted with floats and powered with a BMW 132 engine the top speed is 187 m.p.h. This machine is similar to the one described on page 65 except that it is fitted with a land undercarriage.

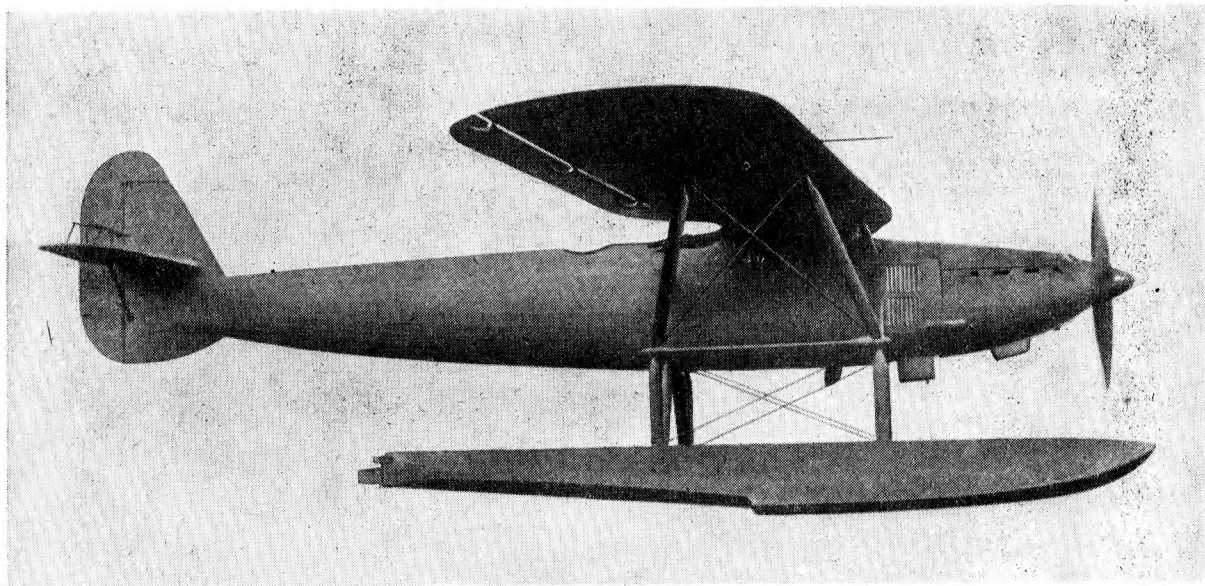

DORNIER Do 22

Although statements have frequently appeared to the contrary, the Do 22 is not a standard type in the German Air Force. It has, however, been supplied to other countries. The machine is arranged as a parasol monoplane and is normally operated on floats though a land undercarriage has been developed. There are three cockpits in tandem and equipment can be installed to suit the machine for operation as a reconnaissance aircraft, bomber or torpedo-carrier. The version supplied to the Yugoslav Government has a Hispano-Suiza engine which gives a top speed of over 210 m.p.h.

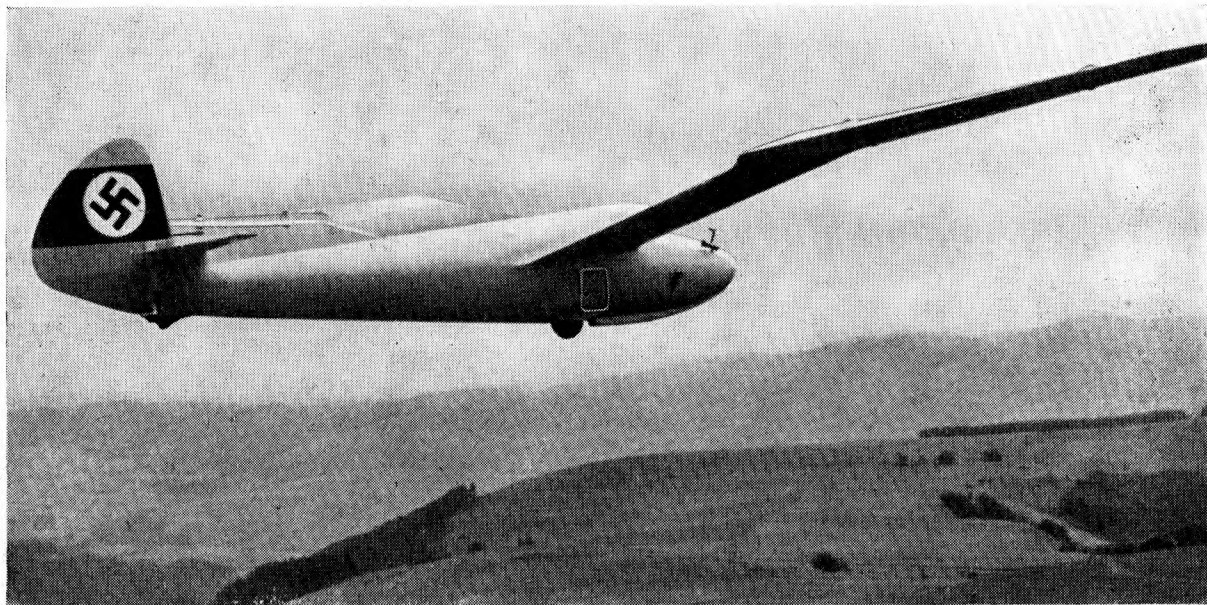

MODERN GERMAN GLIDER

The use of several gliders towed by high-powered aircraft and each holding six to eight fully-equipped soldiers ready for action is a possibility which our Defence Forces may have to meet. The silent approach would compensate the disadvantages of the vulnerability of the glider to attack from the air or from the ground. Detection at night would be most difficult.

ITALIAN
AIRCRAFT

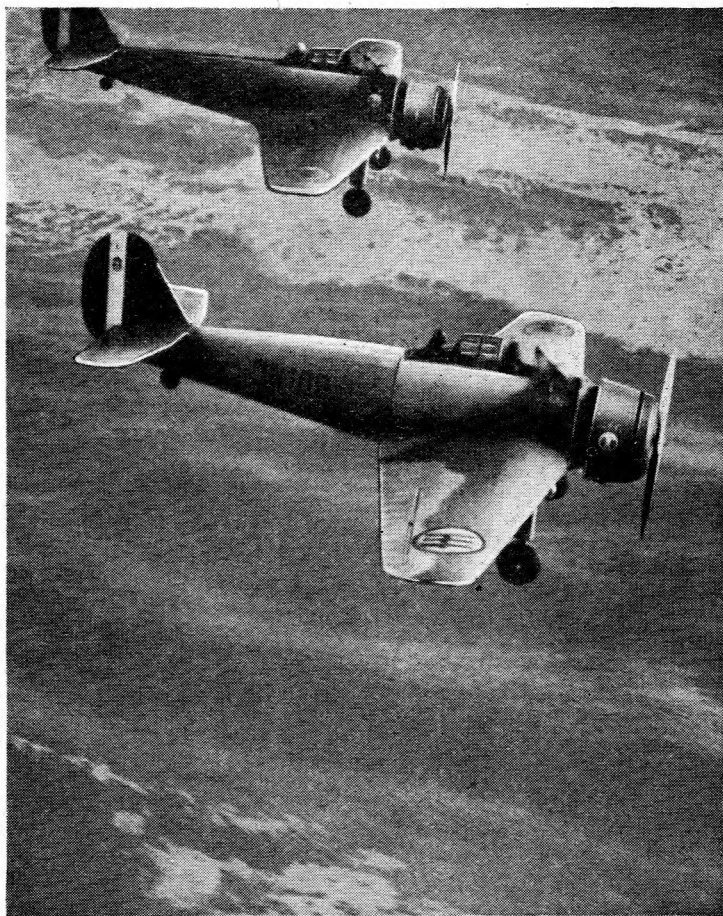

CAPRONI (Bergameschi) A.P.1

This low-wing monoplane originally made its appearance as a single-seater for fighting or ground attack. As adopted by the Italian Air Force, however, it is a two-seater and is used for ground attack. The first undercarriage fitted was of the "trousered" type but production machines had a different design. The normal armament comprises two fixed machine-guns and one free gun plus a number of small bombs suitable for attacking troop concentrations, etc. An Alfa-Romeo 125 radial engine is fitted and gives a top speed of about

210 m.p.h.

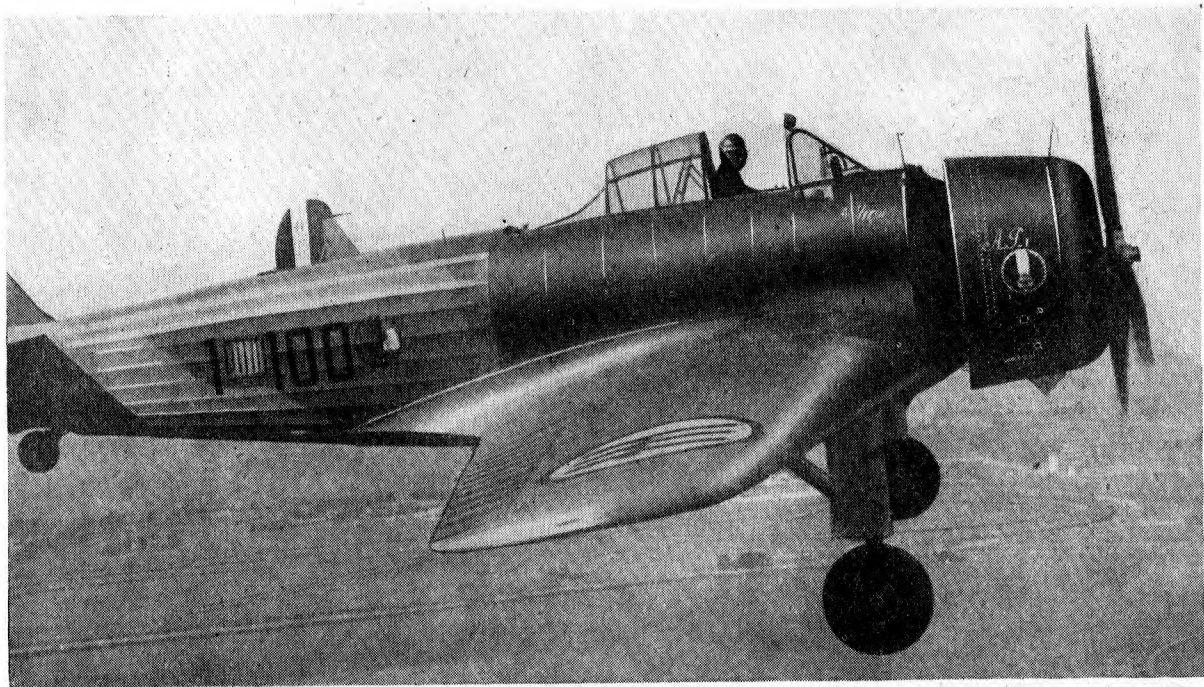

CAPRONI (Bergameschi) A.P.1

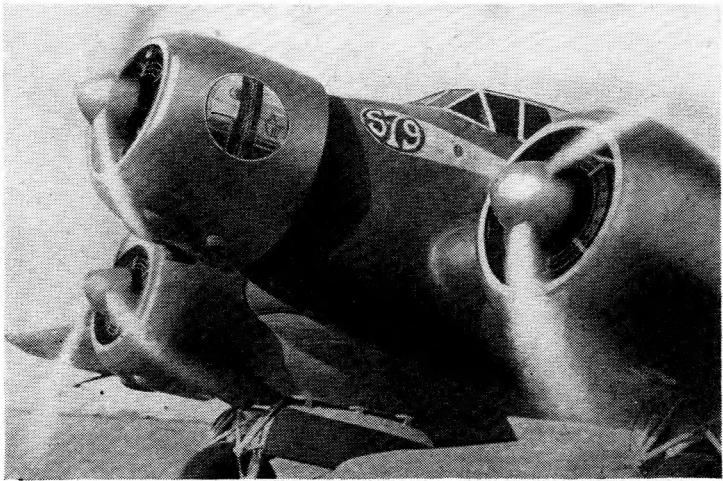
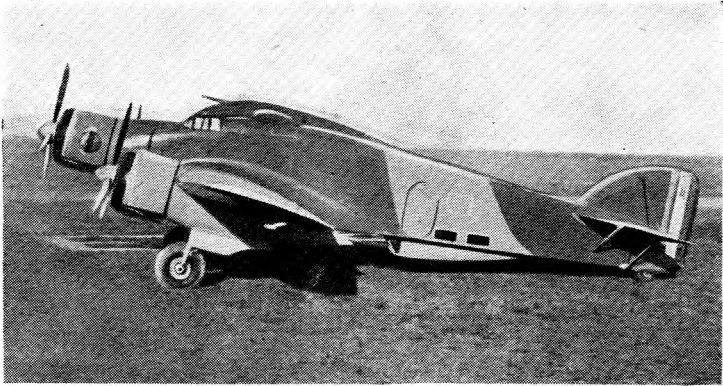

SAVOIA-MARCHETTI S.M. 79

Probably the best-known of all the Italian bombers, this machine has been built to a formula which is typically Italian, it is a low-wing monoplane with three radial engines. The power units normally installed are of Alfa-Romeo manufacture, built under licence from the Bristol Company. Advantage is also taken of Handley Page leading-edge slots to permit the use of a high-wing loading and so assist towards the attainment of a top speed of 270 m.p.h. Its armament comprises three 12·7 mm. guns.

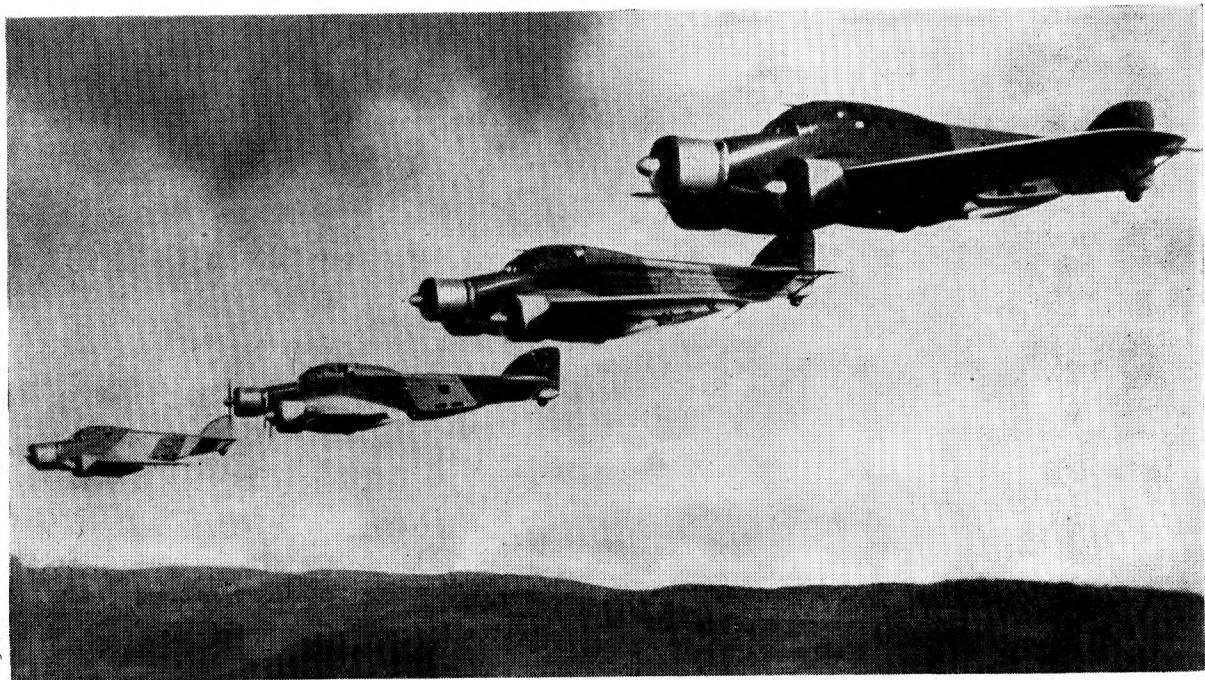

SAVOIA-MARCHETTI S.M. 79

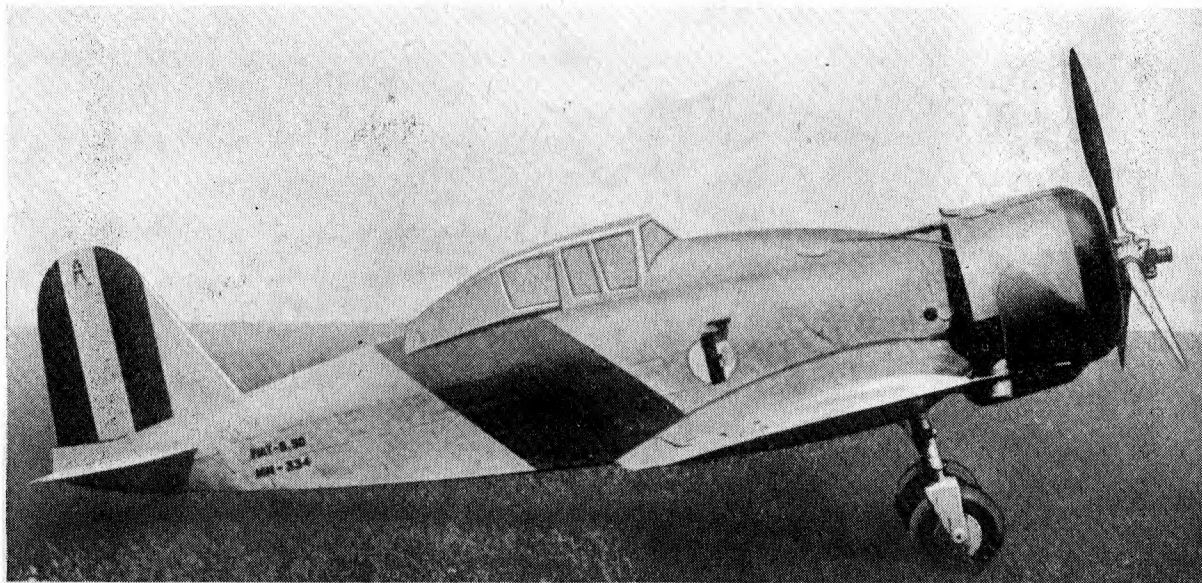

FIAT G. 50

A low-wing single-seater fighter of less refined design than the Macchi C. 200, the Fiat G. 50 has a top speed of only about 300 m.p.h. An easily recognized feature is the centre section of the wing which has a much sharper taper than the outboard panels. The placing of the pilot's enclosure to permit good vision results in a somewhat humped appearance. Two heavy machine-guns fire over the engine cowling and through the airscrew arc and provision has been made for two small-bore guns to be fitted in the wings.

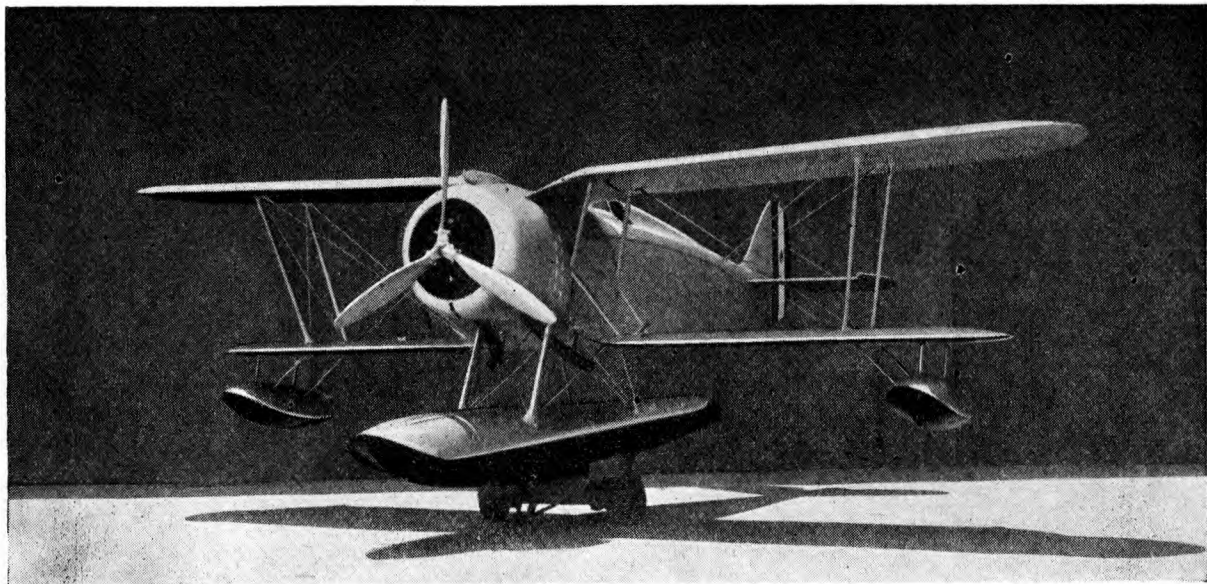

MERIDIONALI Ro 44

Used by the Italian Navy as a single-seater fighter this machine is similar to the Ro 43, which is a two-seater naval reconnaissance machine. Like the Americans, the Italians favour the single-float arrangement for shipboard aircraft though this, of course, necessitates the fitting of wing-tip floats in addition. Another feature of the Ro 44 is the "gulling" of the inner sections of the top wings. Two heavy machine-guns are carried and the top speed, attained with a Piaggio radial engine, is less than 200 m.p.h.

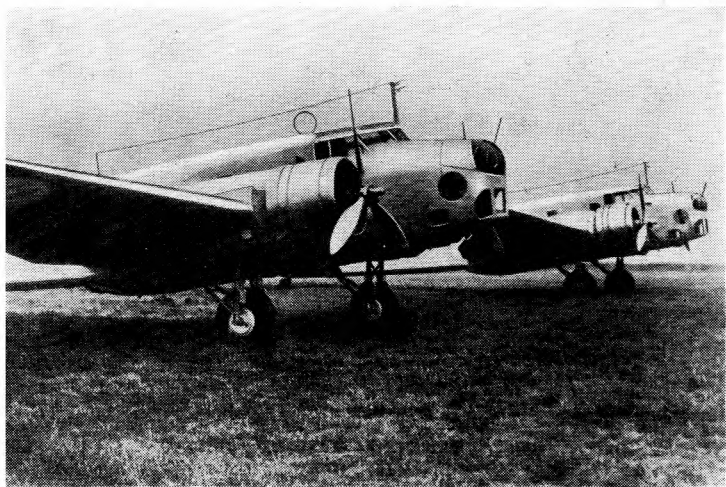
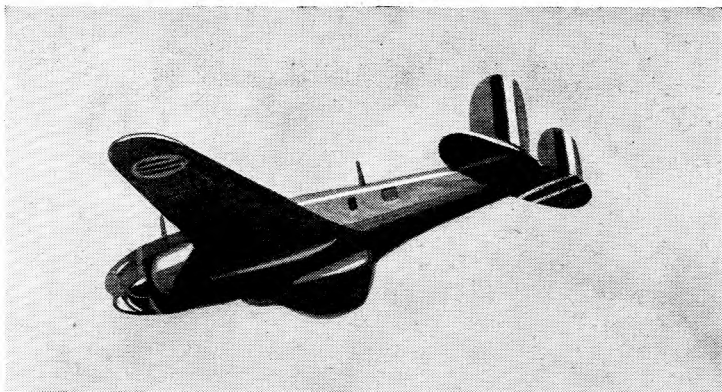

FIAT B.R. 20

Like the Savoia-Marchetti S.M. 79 and S.M. 81 machines, this big Fiat bomber was tried out in Spain. It is a low-wing monoplane powered with two Fiat radial engines of 1,000 h.p. each. In the nose is a heavy machine-gun in a power-driven Breda turret; a second gun of this type is installed on a mounting for firing below the fuselage; and a third is placed in a turret on top of the fuselage. If the claimed top speed of 270 m.p.h. is correct this must be considered creditable for a machine of 23,100 lb. all-up weight.

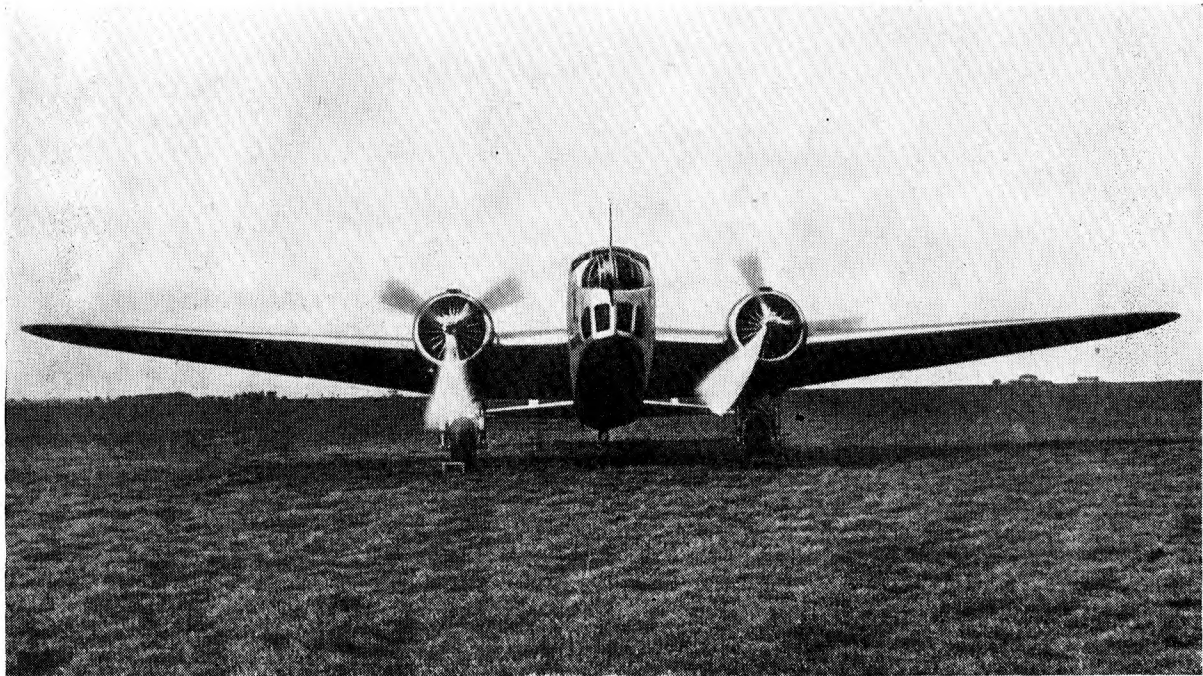

FIAT B.R. 20

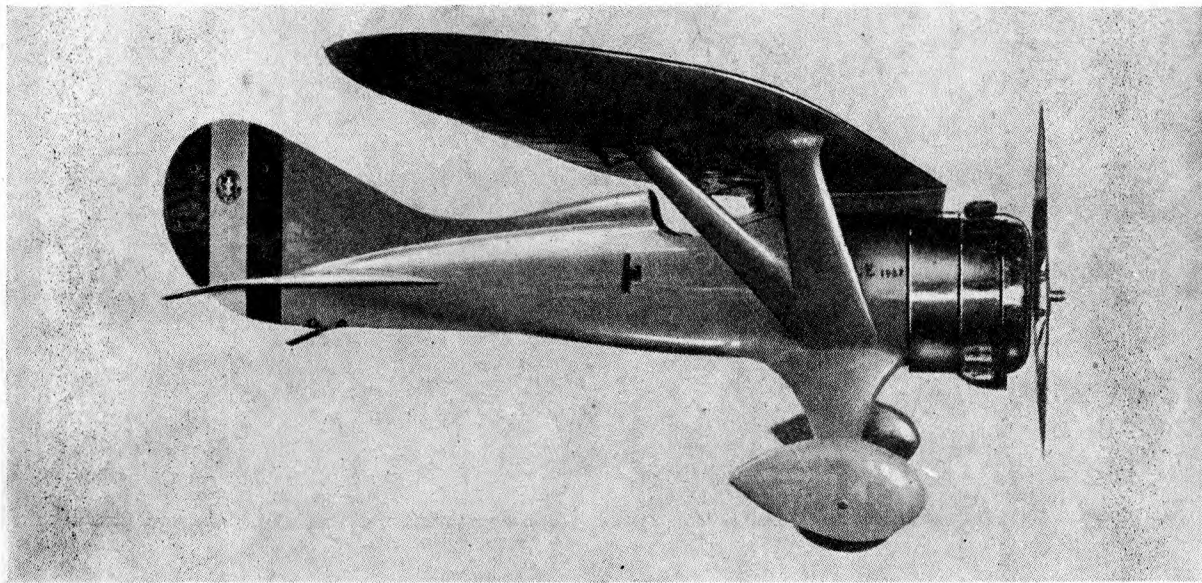

MAGNI VALE

A small high-wing monoplane intended for training, the Vale is of intriguing appearance. It is a single-seater and has quite a high performance considering that the Farina engine fitted is of only 130 h.p. The top speed is over 150 m.p.h. and the machine will climb to nearly 23,000 ft. An interesting technical feature is that the engine mount may be swung to either side to provide access to the rear of the engine. A patent form of engine cowling is used and long streamlined spats are fitted over the wheels.

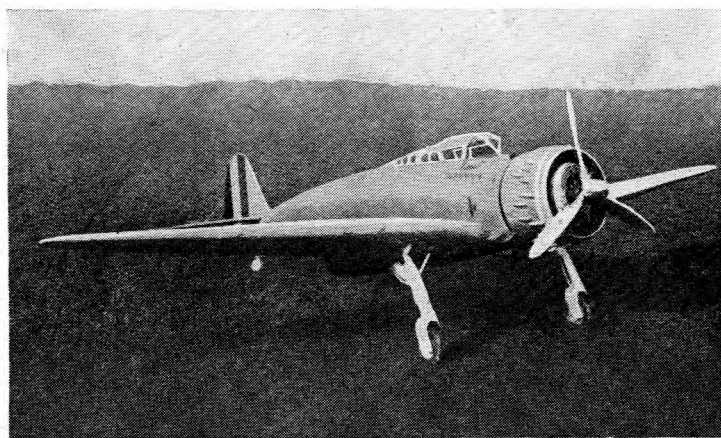
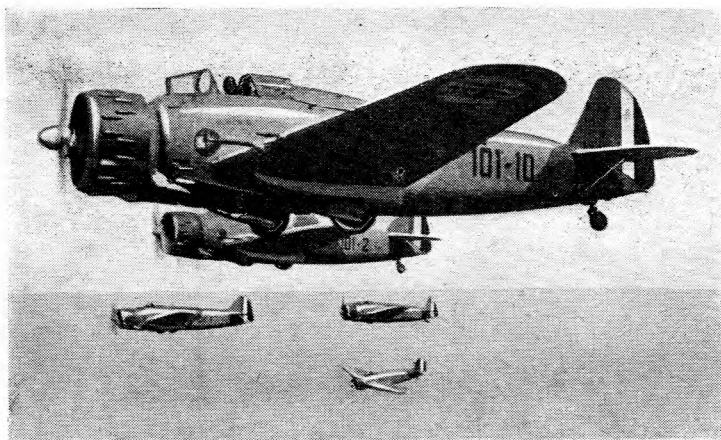

BREDA 65

Designed to be used as a single or as a two-seater, this low-wing monoplane is normally employed as an "assault" (ground attack) aircraft, which means that it carries light bombs and light and heavy machine-guns for attacking troops, convoys and similar targets. The pilot is seated well forward and has a good view. Protruding from the leading edge of the wing are two 12.7 mm. guns and two 7.7 mm. weapons. It will be noted that the wheels are not entirely retracted in flight. With a Fiat radial engine of 1,000 h.p. a top speed of about 250 m.p.h. is attained.

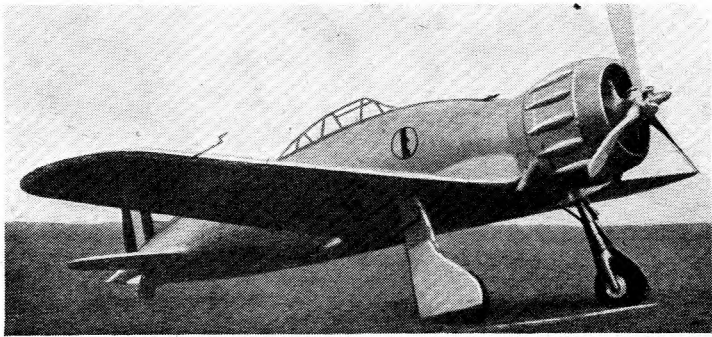
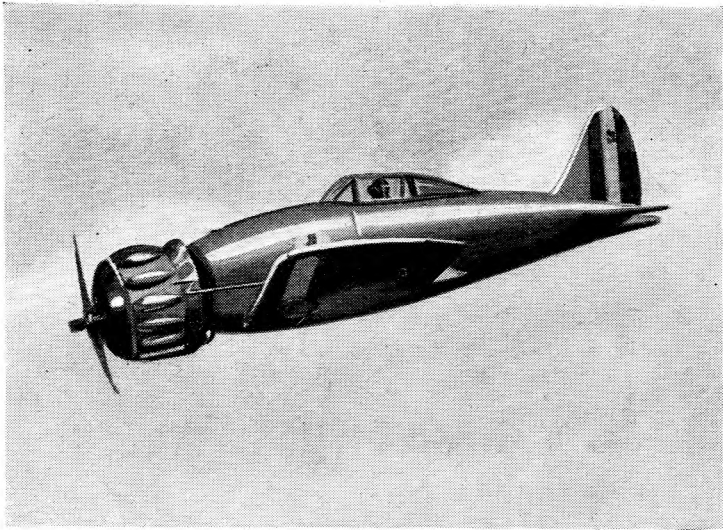

MACCHI C.200

Although it is the fastest of all the single-seater fighters in service with the Italian Air Force, the C.200 has a top speed of only 313 m.p.h. This is explained by the fact that it is fitted with a Fiat radial engine of only 840 h.p. The machine is very strong (over 500 m.p.h. was obtained in a dive) and, like all other Italian fighters, very manoeuvrable. It has two heavy machine-guns (12·7 mm.) firing through the airscrew arc. The rate of climb is good (19,680 ft. in 6·5 min.) and an absolute ceiling of 32,000 ft. is claimed.

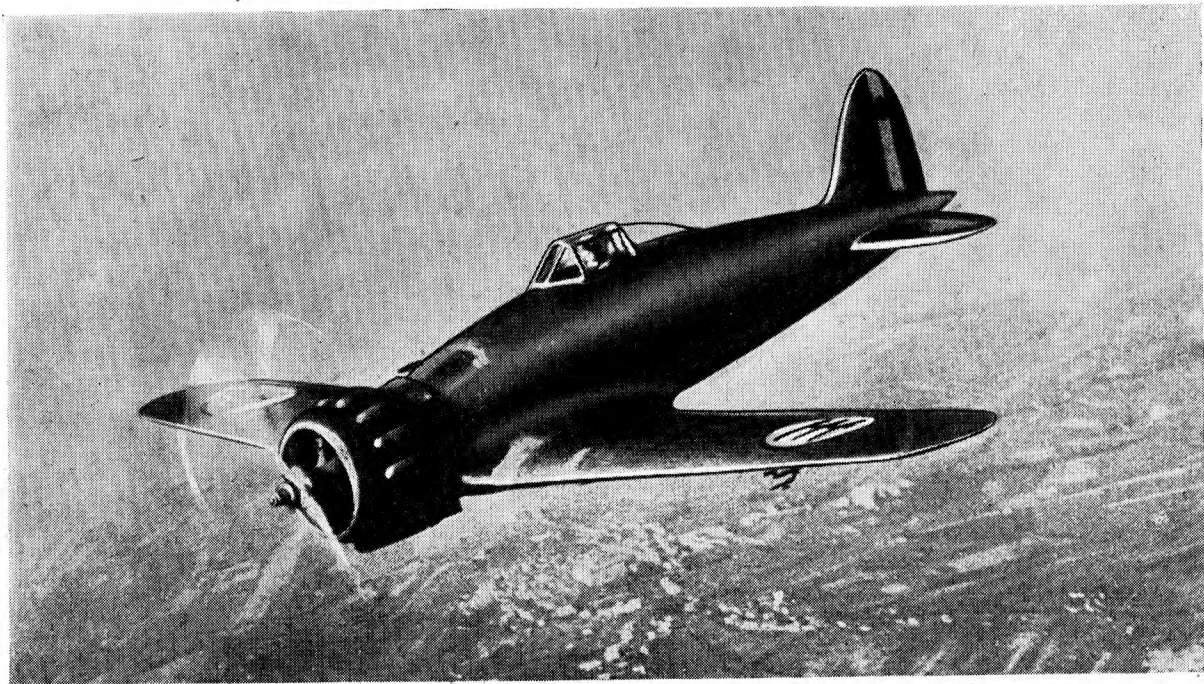

MACCHI C. 200

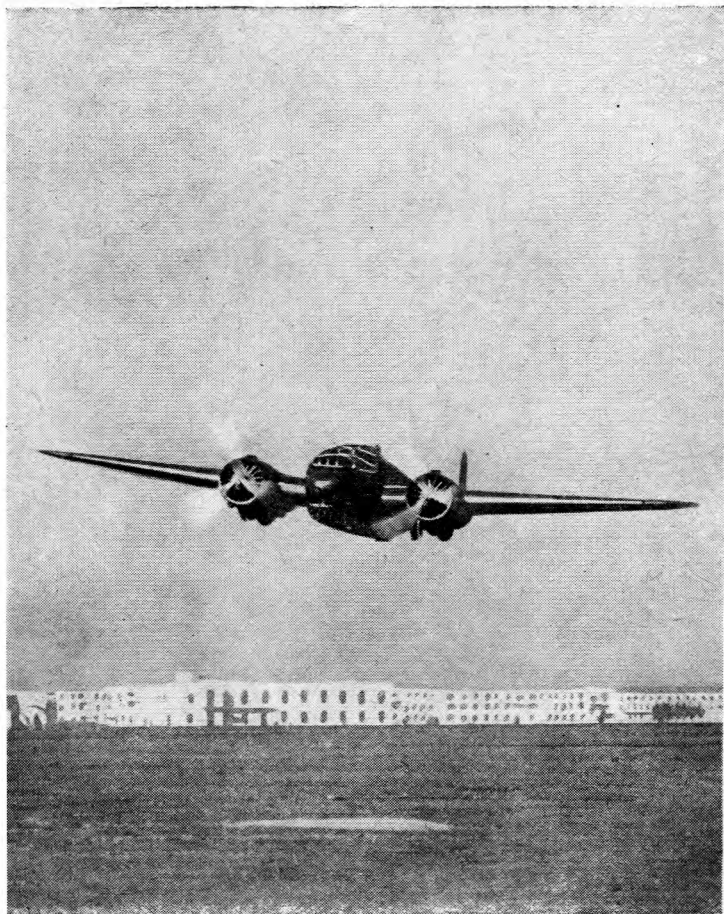

CAPRONI Ca 135 bis

Differing from the earlier Ca 135 in that it has air-cooled instead of water-cooled engines, this Caproni bomber—a mid-wing machine with twin tails—embodies an interesting type of gun turret. This is of the semi-retractable type and is situated aft of the pilot's cockpit. There are two guns which fire in opposite directions as the turret can be rotated only through 180 degrees. In addition to these guns there is a third in the nose and a fourth on a retractable mounting in the bottom of the fuselage. A top speed of 273 m.p.h. is claimed with Piaggio engines.

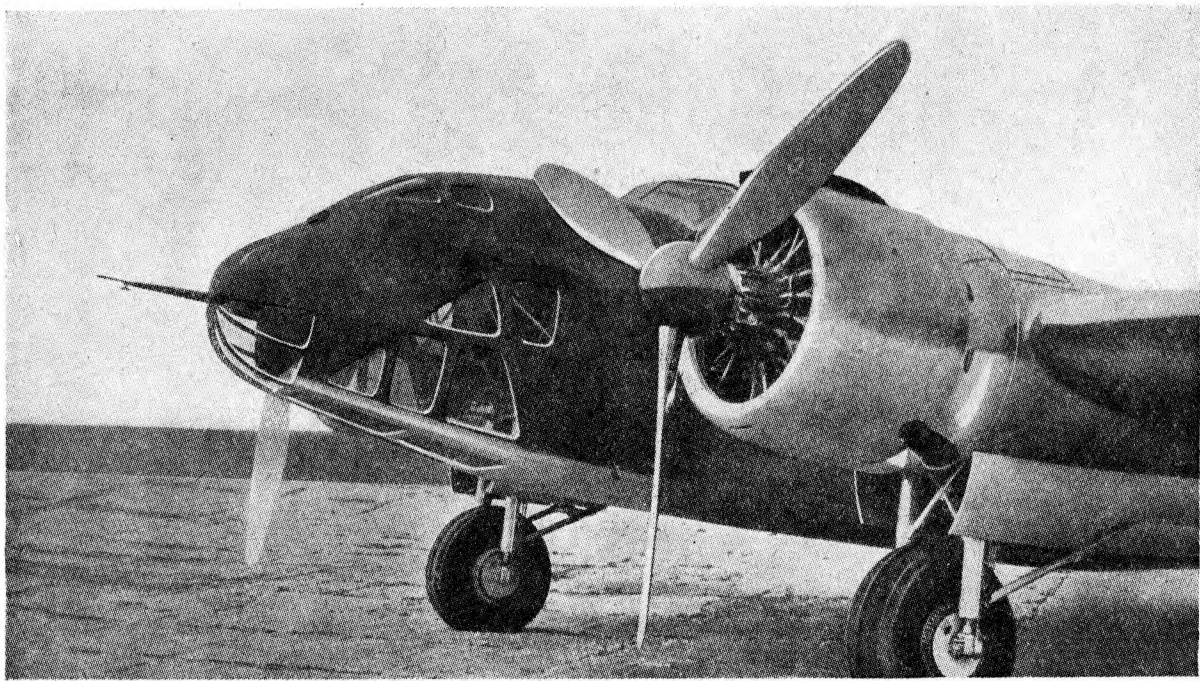

CAPRONI Ca 135 bis

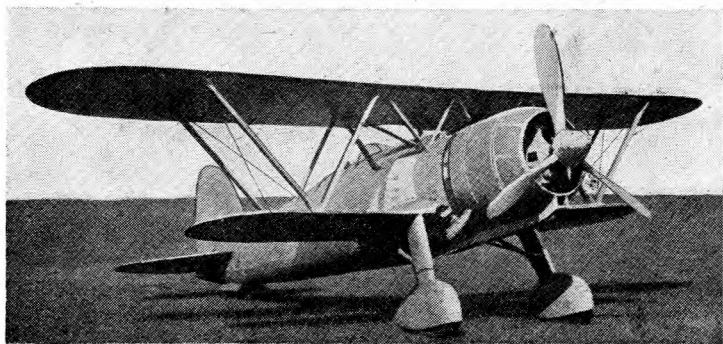
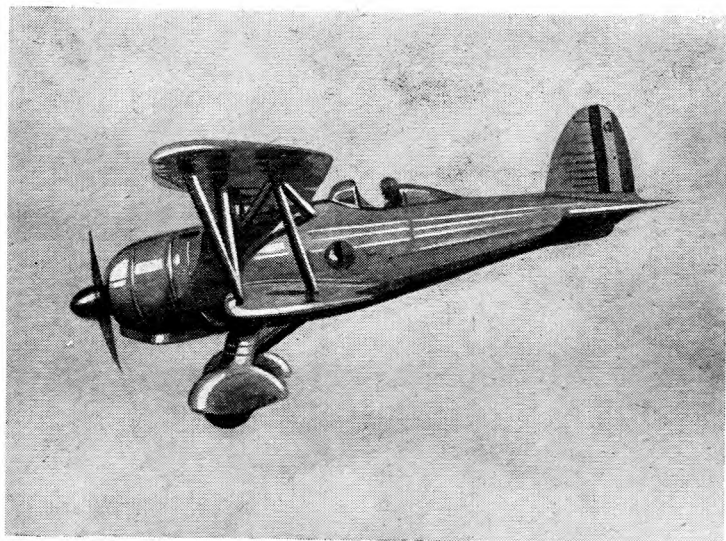

FIAT C.R. 42

The counterpart of our own Gloster Gladiator the C.R. 42 is a development of the C.R. 32 though there are very considerable differences. A top speed of 270 m.p.h. has been attained, the biggest factor contributing to this performance being the supercharged Fiat radial engine of 840 h.p. The armament is the same as for the C.R. 32 but the undercarriage fuselage and tail have been redesigned. An interesting point is that the machine is practically unique among modern fighters in that it has no enclosure over the pilot's cockpit.



MERIDIONALI Ro 37 bis

A single-engine army co-operation biplane, the Ro 37 bis was used in Abyssinia and Spain for light bombing work. It is a sturdy-looking aircraft with a nine-cylinder Piaggio radial engine which gives it a top speed of about 200 m.p.h. The pilot has two fixed synchronized guns of 7.7 mm. calibre and the observer has a gun of similar type. There are large windows in the side of the fuselage which facilitate the observer's task and a transparent enclosure is fitted over the cockpits.

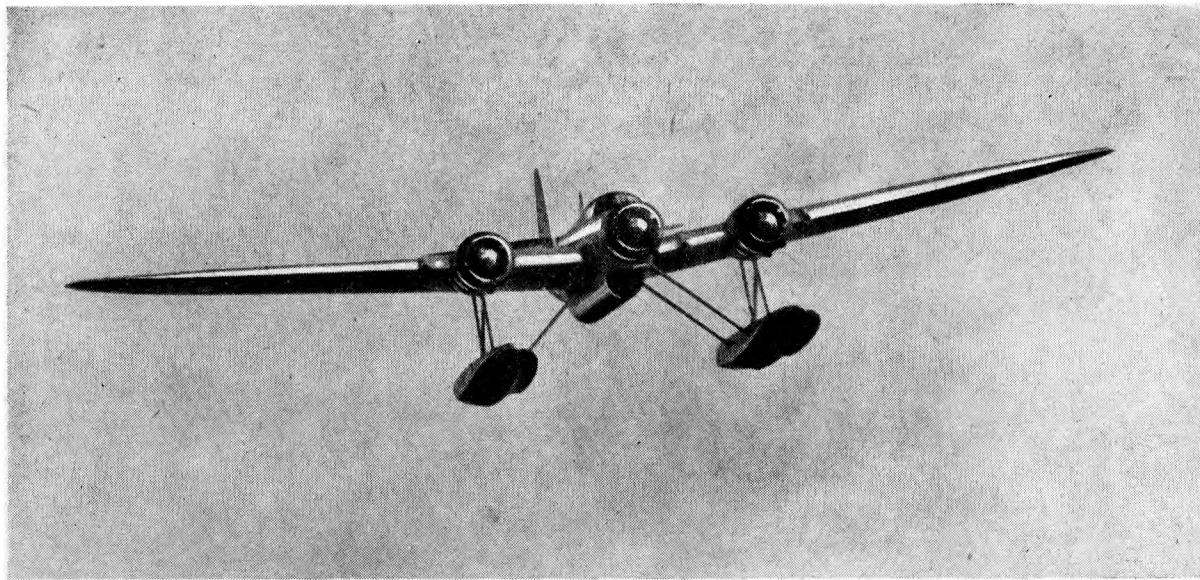

CANT Z. 506 B

This large coastal defence machine is a three-engined twin-float seaplane designed for bombing, reconnaissance or torpedo-dropping. Like many other Italian machines it is built entirely of wood (with the exception of the floats) and is armed with heavy machine-guns. Of these one is installed in a power-driven turret on top of the fuselage and a second is arranged to fire below. Despite the size and weight of the machine (span 86 ft. 11 in.) it is claimed to have a top speed of over 230 m.p.h.

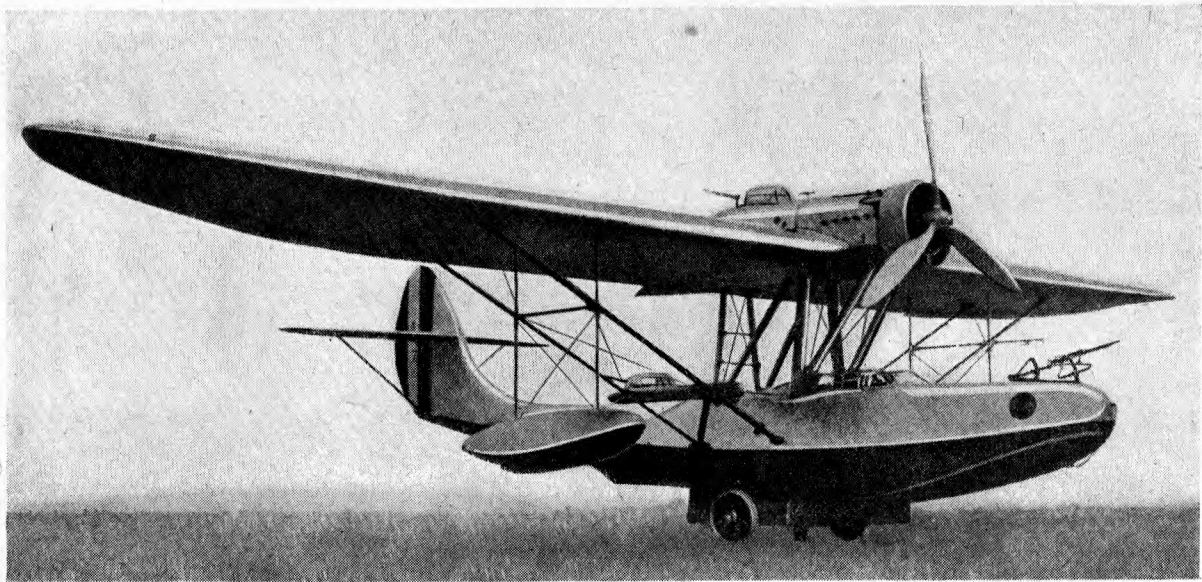

CANT Z. 501

Although at first sight this bomber-reconnaissance flying boat may resemble the German Dornier Do 18, examination will show that there are actually many differences. The 74-ft. wing is carried high above the hull on a system of struts. Just forward of the leading edge is mounted a single Isotta Fraschini water-cooled engine of 900 h.p. Behind this, in the nacelle, is a gunner's position commanding a wide field. Other guns are carried in the bow and amidships. A top speed of 170 m.p.h. is claimed and the range at a cruising speed of 149 m.p.h. is 1,490 miles.

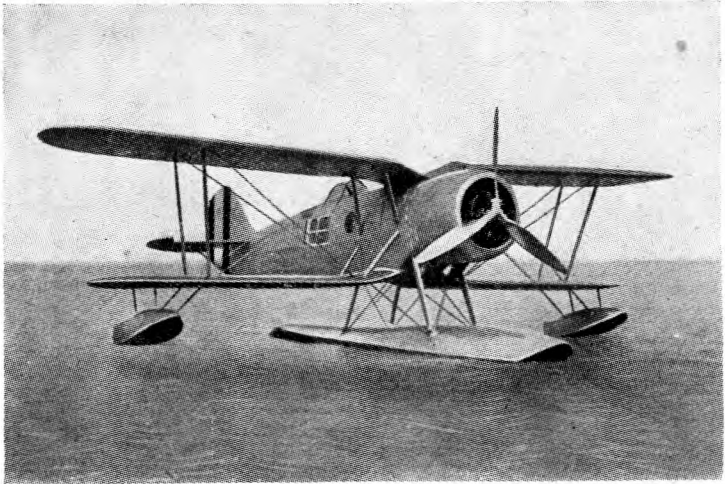
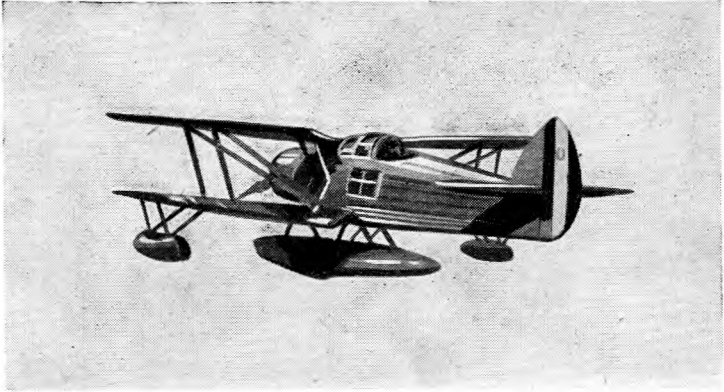

MERIDIONALI Ro 43

The Ro 43 is used by the Italian Navy and was designed expressly for catapult launching. It has folding wings and a single-float undercarriage. The cockpits are in tandem and have dual control, and full reconnaissance equipment is carried. Fitted with a Piaggio PX R 9-cylinder air-cooled engine, the machine is claimed to have a speed of 187 m.p.h. One 7.7 mm. gun is arranged to fire through the airscrew and a similar gun is carried on a free mounting in the rear cockpit.

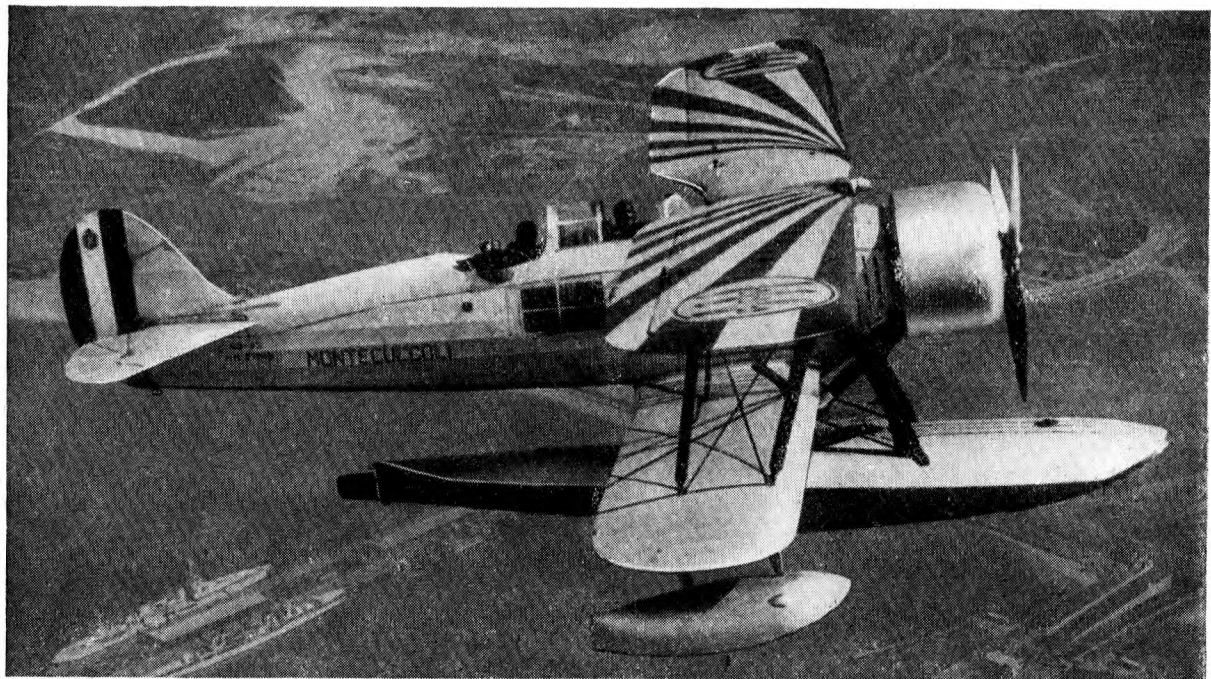

MERIDIONALI Ro 43

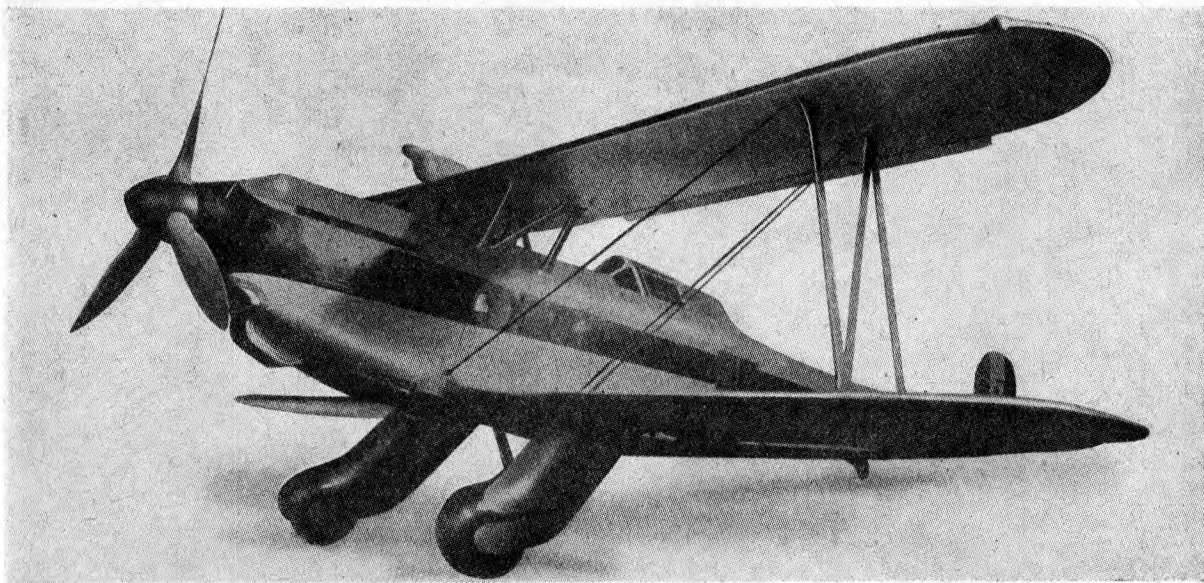

CAPRONI Ca 134

Almost unique among modern aircraft in that it has a biplane tail the Ca 134 is not thought to have been put into production for the Italian Air Force. It has heavily staggered biplane wings and a well-faired undercarriage. The engine is a 900 h.p. water-cooled Isotta Fraschini, which according to the manufacturer's data gives a top speed of over 240 m.p.h. The pilot has one or two fixed guns and there is a single gun in the rear cockpit. Provision can be made for light fragmentation bombs.

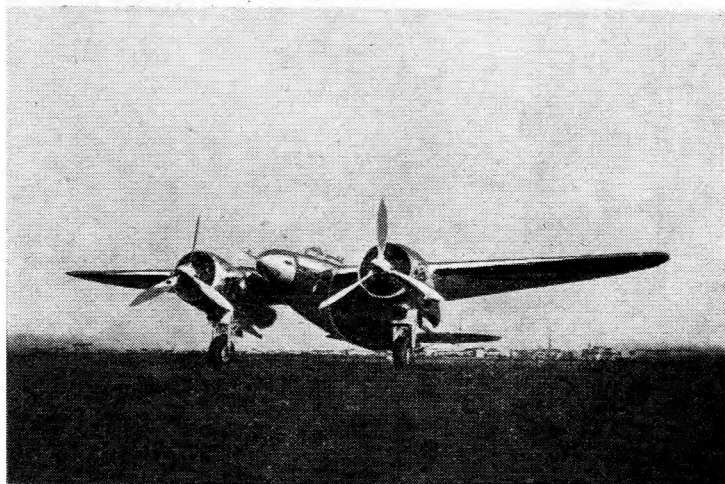
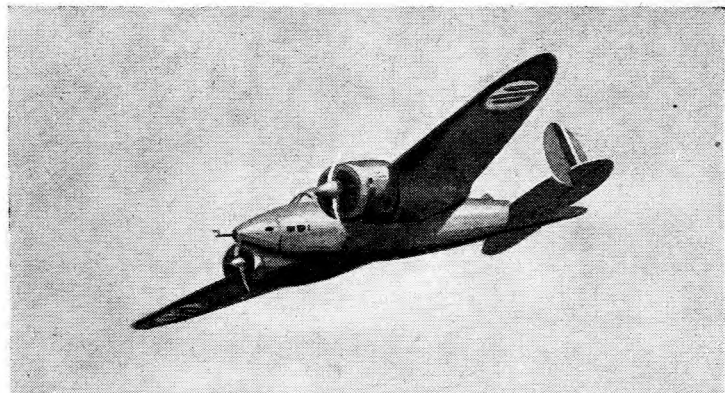

BREDA 88

Although in the "multi-purpose" category, which means that it can be used for fighting, ground attack, light bombing or reconnaissance, the Breda 88 is actually faster than the specialized single-seater single-engined fighters currently used in the Italian Air Force. The machine is arranged as a "shoulder-wing" monoplane and is normally fitted with two of the big Piaggio 18-cylinder radials of 1,000 h.p. each. In addition to a battery of fixed guns in the nose, one or two free guns can be mounted to fire to the rear. It is said that the top speed is about 320 m.p.h. and the ceiling 27,850 ft.

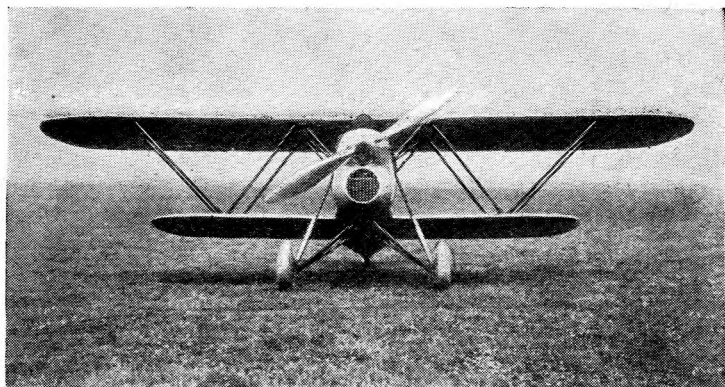

FIAT C.R. 32

During the Spanish war this Fiat fighter biplane achieved considerable success. Although manoeuvrable and strong its top speed is about 235 m.p.h. which is explained partly by the considerable strutting and partly by the fact that the Fiat water-cooled engine fitted is unsupercharged. Two heavy machine-guns are mounted in the top cowling and some machines of the type have been fitted with two small-bore guns in the lower wings. Like the radial-engined C.R. 42 the machine is easily recognized by the "Warren girder" interplane bracing.

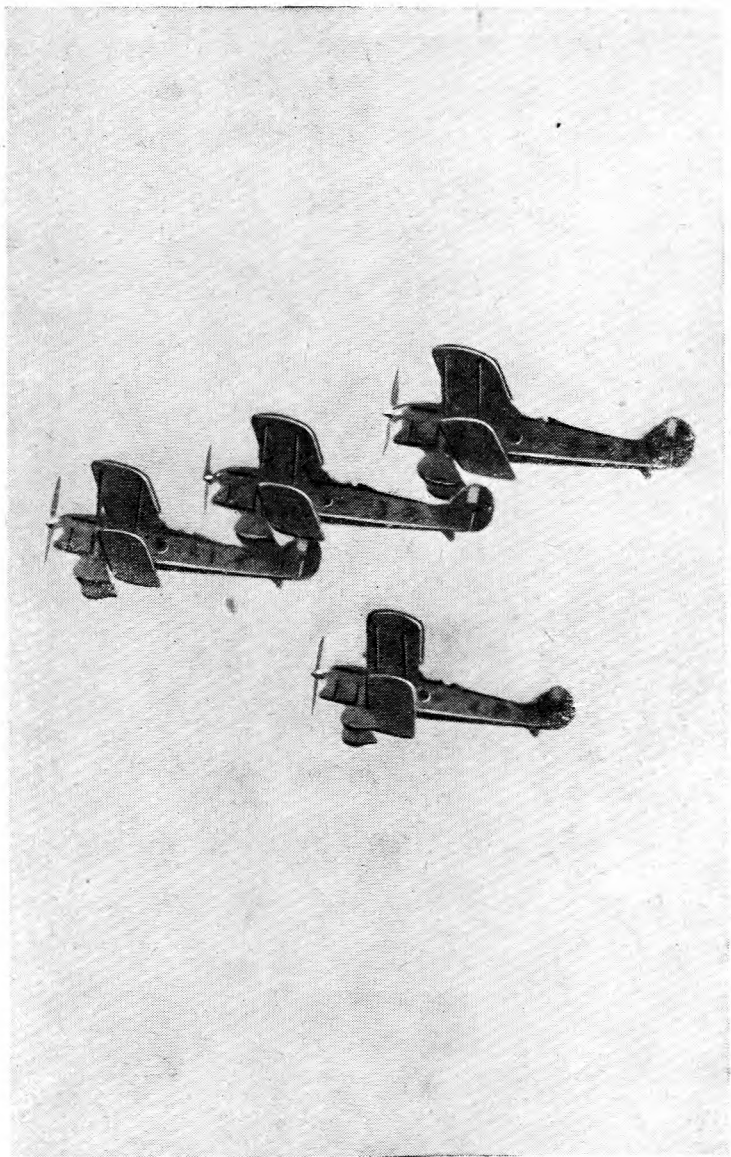

FIAT C.R. 32

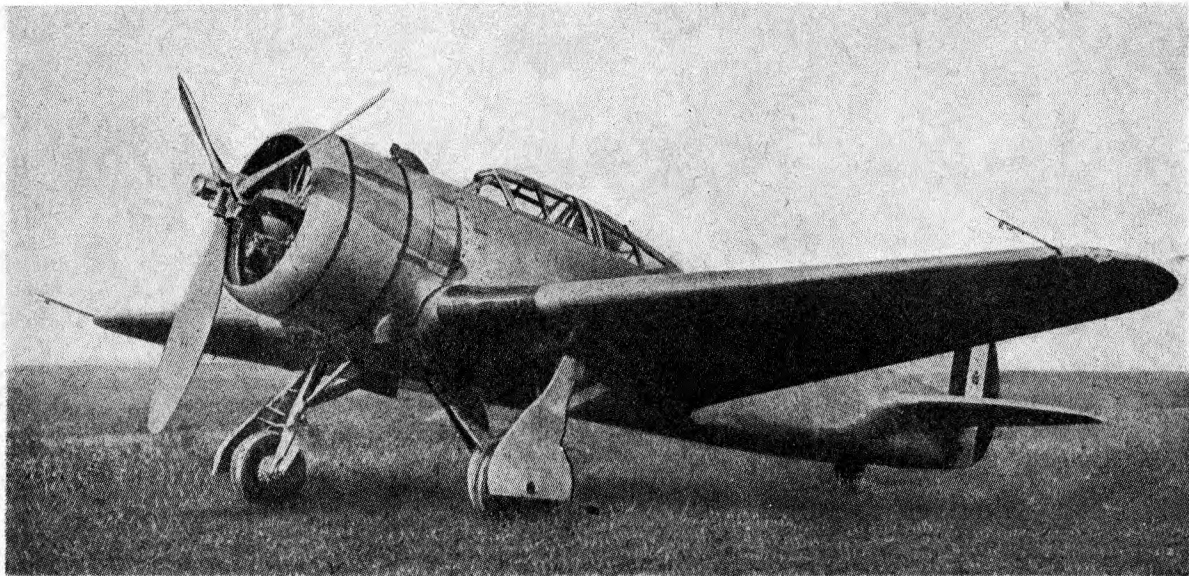

A.U.T. 18

A single-seater fighter of comparatively recent design the A.U.T. 18, makes use of the Fiat 18-cylinder 1,000 h.p. radial engine. The machine is a low-wing monoplane with heavily tapered wings. A further point which aids recognition is that the tail has very sweeping lines. As on the majority of Italian fighters two 12.7 mm. machine-guns are fitted and great pains have been taken to ensure that the pilot's view is as unrestricted as possible. No performance figures are available but it is known that the span is a little more than 37½ feet.

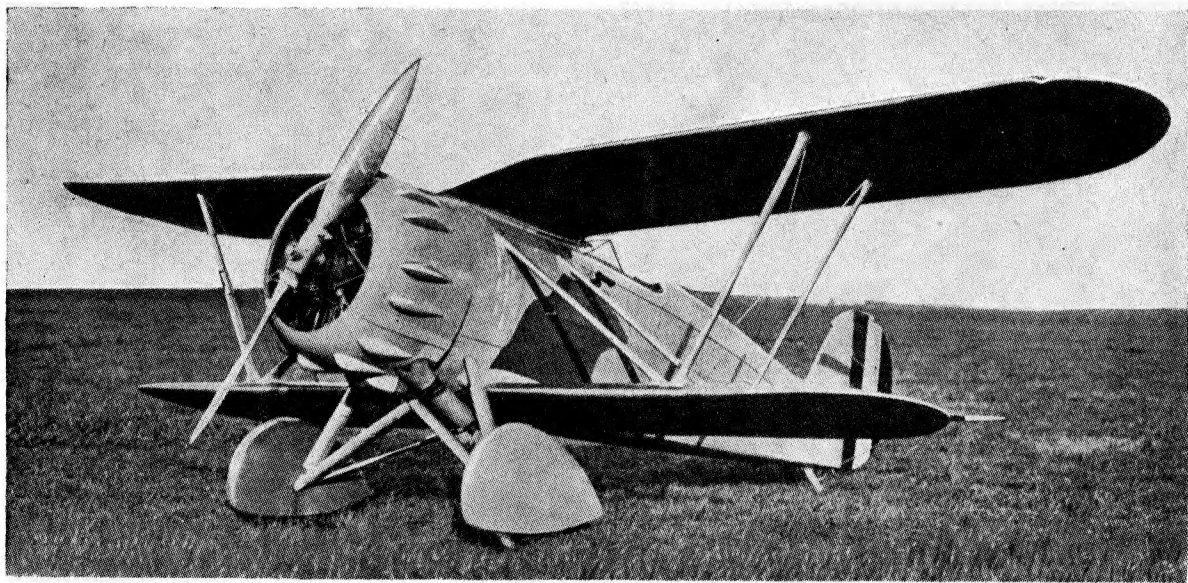

MERIDIONALI Ro 41

This highly manoeuvrable biplane was first produced as a light single-seater fighter but nowadays is regarded more as an advanced trainer. A two-seater version was produced for the Italian Government. As on the "Ro" types used by the Italian Navy, the inner sections of the top wings are "gulled" into the fuselage. Although the Piaggio radial engine fitted delivers only 390 h.p. it is supercharged to give power at about 14,700 ft. The top speed is actually 211 m.p.h. at 16,400 ft. Two fixed synchronized rifle-bore guns form the armament.

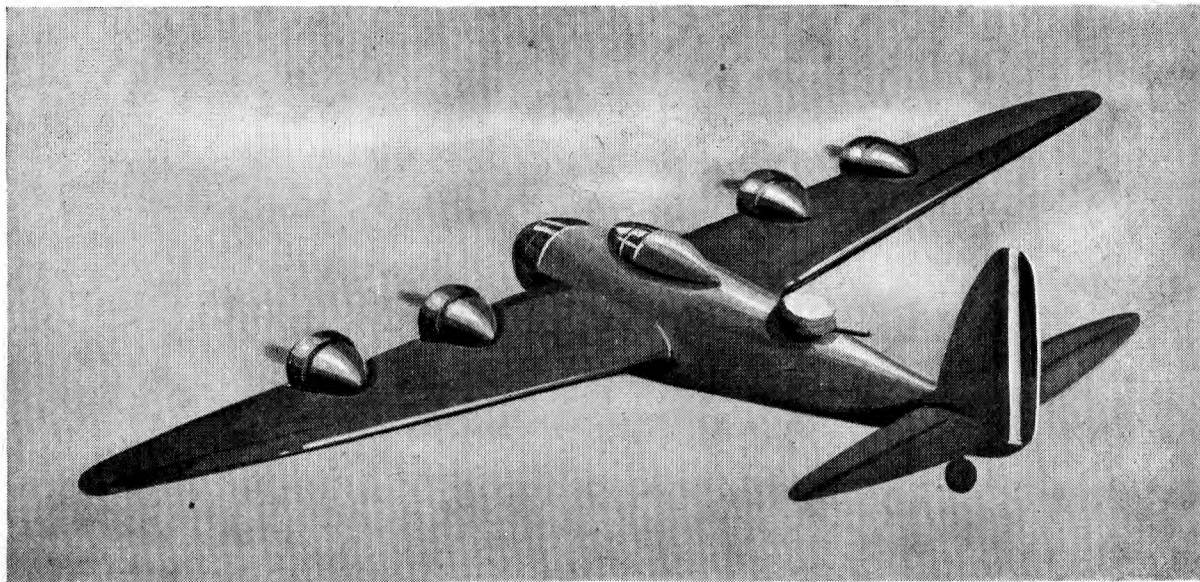

PIAGGIO P. 50 II

A large four-engined bomber, the P. 50 II corresponds to the American "Flying Fortress". It is a mid-wing type of comparatively short span so that the outboard engines appear to be near the wing-tips. The undercarriage retracts into the inboard nacelles and there is a single fin and rudder. Unlike the Piaggio P 23 R three-engined monoplane, the P. 50 II does not have the unusual double flaps on the wings. According to one report there are two large-bore machine-guns in each wing which are sighted from a special turret in the fuselage.

*10 minutes' P-E-A-C-E
-so mine's a Minor!*



DE RESZKE MINORS are 'peace-time' cigarettes in a double sense. For they are still made from pre-war stocks of fine tobaccos, carefully selected and stored in large quantities to ensure that the De Reszke standard of quality is maintained. That is one reason why Minors are out and out 'the best value on the market'