

**Please do not upload this copyright pdf document to any other website. Breach of copyright may result in a criminal conviction.**

This pdf document was generated by me Colin Hinson from a Crown copyright document held at R.A.F. Henlow Signals Museum. It is presented here (for free) under the Open Government Licence (O.G.L.) and this pdf version of the document is my copyright (along with the Crown Copyright) in much the same way as a photograph would be.

The document should have been downloaded from my website <https://blunham.com/Radar>, or any mirror site named on that site. If you downloaded it from elsewhere, please let me know (particularly if you were charged for it). You can contact me via my Genuki email page: <https://www.genuki.org.uk/big/eng/YKS/various?recipient=colin>

**You may not copy the file for onward transmission of the data nor attempt to make monetary gain by the use of these files. If you want someone else to have a copy of the file, point them at the website. (<https://blunham.com/Radar>). Please do not point them at the file itself as it may move or the site may be updated.**

It should be noted that most of the pages are identifiable as having been processed by me.

---

I put a lot of time into producing these files which is why you are met with this page when you open the file.

In order to generate this file, I need to scan the pages, split the double pages and remove any edge marks such as punch holes, clean up the pages, set the relevant pages to be all the same size and alignment. I then run Omnipage (OCR) to generate the searchable text and then generate the pdf file.

Hopefully after all that, I end up with a presentable file. If you find missing pages, pages in the wrong order, anything else wrong with the file or simply want to make a comment, please drop me a line (see above).

It is my hope that you find the file of use to you personally – I know that I would have liked to have found some of these files years ago – they would have saved me a lot of time !

Colin Hinson

In the village of Blunham, Bedfordshire.

AIR PUBLICATION  
**2557 A**  
VOLUME I

SECOND EDITION  
(Formerly S D 0208)

# GEE MK. II. AIRBORNE EQUIPMENT

(ARI. 5083)

Prepared by direction of the  
Minister of Supply



Promulgated by order of the  
Air Council

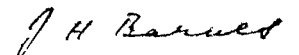

**AIR MINISTRY**

*Issued in reprint June, 1948  
Previously reprinted March, 1946 and May, 1947*



# GEE MK. II. AIRBORNE EQUIPMENT

## LIST OF CONTENTS

	<i>Para.</i>	
Leading particulars .. .. .	1	RF unit type 25 .. .. .
Introduction .. .. .	2	RF unit type 26 .. .. .
General description .. .. .	7	RF unit type 27 .. .. .
Receiver .. .. .	10	IF unit .. .. .
Indicator unit type 62 .. .. .	17	Operation of the anti-jamming system .. .. .
Control panel type 3 .. .. .	22	Power supply unit .. .. .
Aerials and loading units .. .. .	24	Indicator unit type 62 .. .. .
Aerials aircraft type 201 and 329 .. .. .	25	Crystal oscillator and divider unit .. .. .
Loading units type 2 and 51 .. .. .	28	Main time base .. .. .
Electric detonator .. .. .	32	Strobe time base .. .. .
Instructions for installing .. .. .	33	Expanded strobe time base .. .. .
Circuit description .. .. .		Flyback blackout .. .. .
Receiver R.1355 .. .. .	88	Y plate reverser valve V3 .. .. .
RF unit type 24 .. .. .	89	Power supply .. .. .

## LIST OF ILLUSTRATIONS

	<i>Fig.</i>	
Block schematic diagram of Gee Mark II installation .. .. .	1	Operation of back bias—IF stages .. .. .
ARI5083, typical interconnection diagram .. .. .	2	Receiver power unit, circuit .. .. .
Receiver type R.1355, block schematic diagram .. .. .	3	R.1355, right-hand side of chassis .. .. .
Indicator unit type 62, block schematic diagram .. .. .	4	R.1355, top left-hand side of chassis .. .. .
Gee Mark II time base .. .. .	5	R.1355, underside of chassis .. .. .
Screen indications .. .. .	6	Indicator unit type 62, circuit .. .. .
Loading unit type 2, circuit .. .. .	7	Waveforms (1) .. .. .
Loading unit type 51, circuit .. .. .	8	Waveforms (2) .. .. .
Exploded view illustrating attachment of loading unit to aerial .. .. .	9	Indicator unit type 62, right-hand side of chassis .. .. .
Detonator firing circuit .. .. .	10	Indicator unit type 62, top left-hand side of chassis .. .. .
RF unit type 24, circuit .. .. .	11	Indicator unit type 62, underside of chassis .. .. .
Positions of trimmers on RF units type 24 and 25 .. .. .	12	Indicator unit type 62, presets on top of chassis .. .. .
RF unit type 25, circuit .. .. .	13	Diagram to illustrate partial DC restoration of CRT .. .. .
RF units types 24 and 25, side views .. .. .	14	Interconnection—Kit type 30 .. .. .
RF units 24 and 25, underside view .. .. .	15	Power unit type 285, circuit .. .. .
RF unit type 26, circuit .. .. .	16	"A" strobe locking waveforms .. .. .
RF unit types, 26 and 27 .. .. .	17	Indicator unit type 62A, circuit .. .. .
RF unit, type 27—calibration curve .. .. .	18A	Indicator unit type 62A, Top of chassis .. .. .
RF unit, type 26—calibration curve .. .. .	18B	Indicator unit type 62A, R.H. side of chassis .. .. .
RF unit type 27, circuit .. .. .	19	Indicator unit type 62A, L.H. side of chassis .. .. .
R.1355, IF amplifier circuit .. .. .	20	Indicator unit type 62A, underside of chassis .. .. .

## LIST OF APPENDICES

Appendix I —List of Principal Components.  
 Appendix II —Apparatus Kit Type 30.  
 Appendix III—Indicator Unit Type 62A.

Appendix IV —List of Principal Components.  
 Appendix V —Servicing Instructions.

## LEADING PARTICULARS

### 1. Receiver R.1355

Stores Ref.	.....	10D/13032
Dimensions	.....	18 in. × 9 in. × 8 in.
Weight	.....	35 lb. approx.
Type of circuit	.....	Superheterodyne
RF frequency coverage	.....	20 to 30 Mc/s and 40 to 85 Mc/s
IF frequency	.....	7.5 Mc/s.
Second channel rejection	.....	Greater than 100 times

### Indicator unit type 62

Stores Ref.	.....	10Q/13000
Dimensions	.....	9 in. × 12 in. × 18 in.
Weight	.....	36 lbs. approx.

### Control panel type 3

Stores Ref.	.....	5U/1269
Dimensions	.....	12 in. × 12 in. × 12 in.
Weight	.....	20 lb. approx.

## INTRODUCTION

2. The present chapter deals exclusively with Gee Mark II. airborne equipment, ARI.5083. The general principles of Gee are covered in A.P.1093D and it is assumed here for the most part that the reader is familiar with these principles.

3. ARI.5083 is an airborne radar navigational device and its use enables an aircraft navigator to obtain a "fix" of high accuracy under all weather conditions and at any instant. The equipment functions in conjunction with ground stations which radiate pulses. One of these transmitters, known as the "A" station, is the master transmitter, and the other transmitters, known as the "B", "C", and "D" slave stations respectively, are synchronized with (but not necessarily in phase with) the "A" transmitter.

4. The ARI.5083 equipment is capable of measuring the time interval between the reception of the "A" and "B", "A" and "C", or "A" and "D" pulses, and hence is capable of indicating the position of the aircraft with respect to the ground stations. Specially prepared maps are provided to enable the navigator to interpret the display on the Gee Mark II. indicator.

5. The "B" and "C" stations are synchronized to alternate "A" pulses, and hence the pulse recurrence frequency of these slave stations (namely 250) is half that of the "A" station (namely 500). With the "A" station, the "B" and "C" stations are normally sufficient to provide the navigator with enough information to obtain a fix. In certain areas, however, (see A.P.1093D) because of the acute intersection of the "B" and "C" lattice curves, good accuracy of fix is not obtainable. For this reason, a third slave transmitter, the "D" station, is provided and is used by the aircraft navigator over the areas which would otherwise give a low accuracy Gee fix. To distinguish the "D" pulse from the "B" and "C" pulses, it comprises a double pulse, and as its pulse recurrence frequency is only 500/3 c/s, it appears as a ghost double pulse on both the "B" and "C" traces.

6. The equipment comprises essentially a superheterodyne receiver and an indicator. The receiver picks up the signals from the ground stations, the resulting output being fed to the Y plates of the cathode ray tube in the indicator. The CRT display is provided with a calibrated time base so that the required time intervals can be measured.

## GENERAL DESCRIPTION

7. ARI. 5083 comprises the following units:—

- (i) Receiver R.1355 (Stores Ref. 10D/13032)
- (ii) Indicator unit, type 62 (Stores Ref. 10Q/13000)
- (iii) Control panel type 3 (Stores Ref. 5U/1269)
- (iv) Aerials —
  - (a) Aerial, aircraft, type 201 (Stores Ref. 10B/1520) which consists of rod, aerial, type 87 (Stores Ref. 10B/13180) and loading unit type 2 (Stores Ref. 10B/13239)
  - or (b) Aerial aircraft type 329 (Stores Ref. 10B/16026) which consists of rod, aerial, type 257 (Stores Ref. 10B/1979) and loading unit type 51 (Stores Ref. 10B/16025)
- (v) Connector set (type dependent on aircraft)
- (vi) Electric detonator (Stores Ref. 12D/455)
- (vii) Miscellaneous cables, lamps, switches and fuses.

8. In addition the following test gear is required to instal the equipment in the aircraft and check its functioning :—

- (i) Petrol-electric A.C., test set (Stores Ref. 42Y/1) or Petrol-electric AC, test set (Stores Ref. 42Y/2)
- (ii) Engine-driven, dual purpose, AC/DC generator type RC. (Stores Ref. 5U/1273) or other suitable generator
- (iii) Insulation resistance tester type A (Stores Ref. 5G/1621)
- (iv) Test meter type F—i.e. Avometer model 7 (Stores Ref. 10S/1) or test meter type D (Stores Ref. 10S/10610)
- (v) Valve tester type 4 (Stores Ref. 10S/13001)
- (vi) Oscilloscope type 1 (Stores Ref. 10S/103)
- (vii) Suitable test set or signal generator, e.g. Signal generator type 160A or 210.

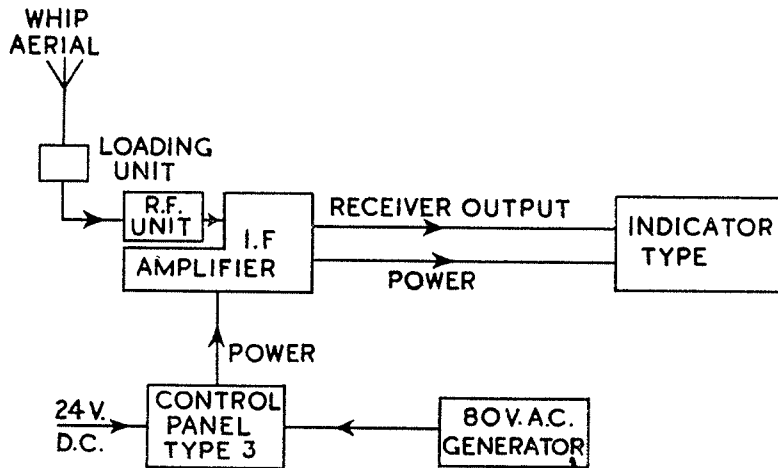

Fig. 1.—Block schematic diagram of Gee Mark II installation.

9. A block schematic diagram of the installation is illustrated in fig. 1, and an interconnection diagram is shown in fig. 2. The positions of the units in the aircraft is dependent on the type of aircraft.

### Receiver R.1355.

10. The function of the receiver, which uses a superheterodyne circuit, is to amplify the pulses received from the ground stations. The amplified signals are fed to the Y plates of the CRT in the indicator.

11. The receiver consists of three parts : a detachable RF unit ; an IF and video frequency amplifier ; and a power unit which also supplies power to the indicator. The RF unit containing the RF amplifier, local oscillator, and a mixer valve, is enclosed in a screened box. A Jones plug is provided at the rear of the RF unit, and the unit itself is secured to the receiver by four screws at the front ; thus it may readily be removed and a different one covering a different frequency band plugged in.

12. Four types of RF units are provided. The frequency band which each covers is as follows :—

<i>RF unit Type</i>	.. ..	24	25	26	27
<i>Band covered Mc/s</i>	..	20—30	40—50	50—65	65—85

13. With RF units types 24 and 25, any one of five preset spot frequencies in the band may be selected by a switch. The RF units types 26 and 27 may be continuously tuned over the radio frequency ranges by a tuning dial. The following table gives the spot frequencies to which the switch positions on RF units types 24 and 25 are normally tuned on leaving the factory :—

<i>Switch position</i>	<i>RF Unit, Type 24</i> Mc/s	<i>RF Unit, Type 25</i> Mc/s
1	22.0	43.0
2	22.9	44.9
3	25.3	46.79
4	27.3	48.75
5	29.7	50.5

14. The remainder of the receiver accommodates a five-stage IF amplifier, second detector, video amplifier, and cathode follower output stage on one chassis ; and on a second chassis, a power unit which supplies power to the receiver itself and to the indicator unit.

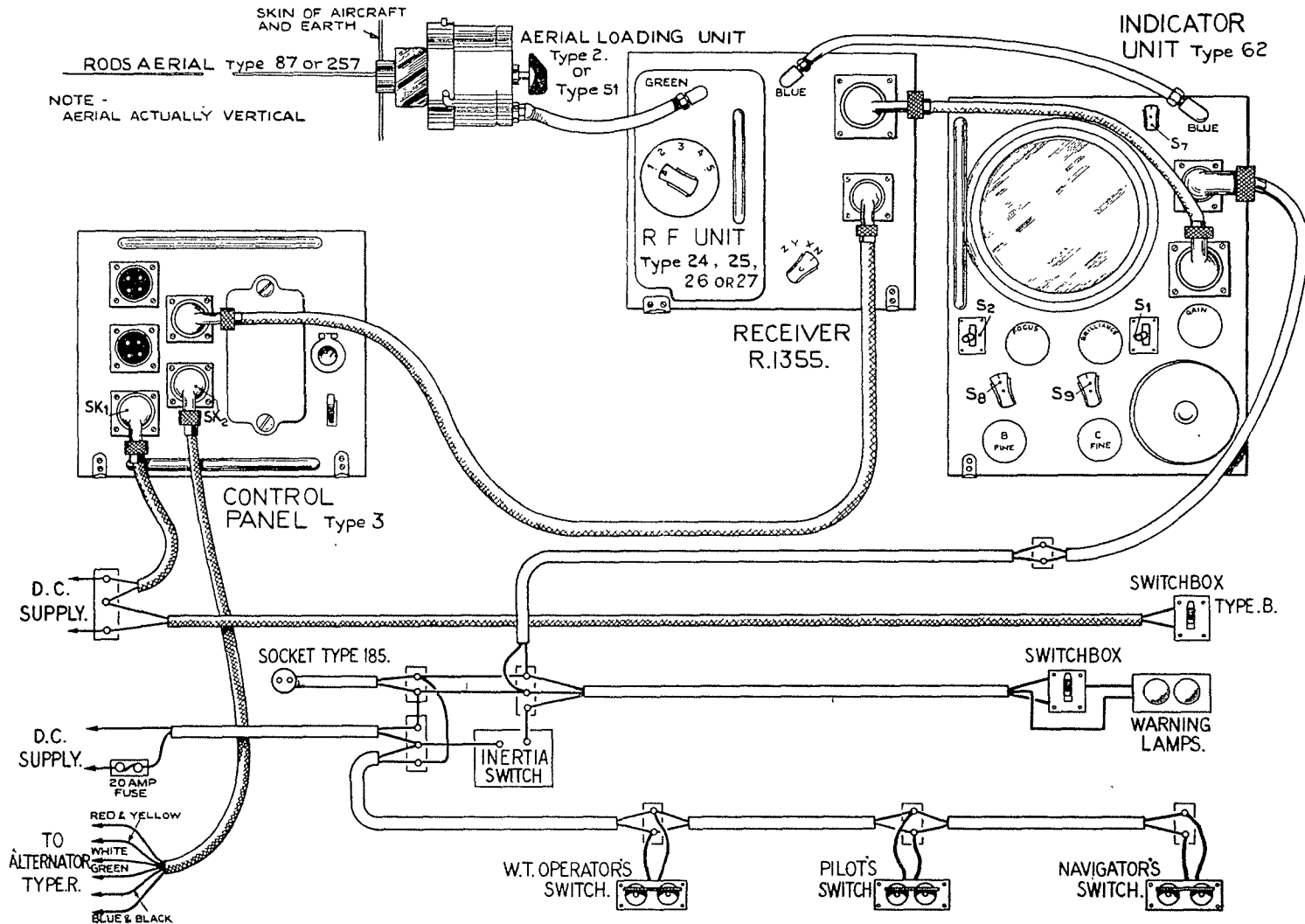

Fig. 2.—ARI.5083, typical interconnection diagram.

15. The following controls, sockets, and plugs are provided on the front panel of the receiver :—

- (i) *Pye plug coloured green.*—This is the aerial input plug and is located on the RF unit.
- (ii) *Pye plug coloured blue.*—This is the receiver output plug, and is connected externally with an input plug on the indicator unit.
- (iii) *Tuning control.*—This is located on the RF unit. On RF units types 24 and 25 it consists of a 5-position selector switch, and on RF units types 26 and 27 a tuning dial with an illuminated scale is provided ; a small knob at the bottom left-hand corner of the front panel of RF units types 26 and 27 is used for trimming.
- (iv) *Anti-jamming switch.*—This is a 4-position selector switch, each position marked “N”, “X”, “Y”, or “Z” :
  - (a) N is the normal position of the switch and is used when no jamming is experienced.
  - (b) X position is selected when railing type jamming is met.
  - (c) Y position is used if the jamming has a low frequency sinewave modulation superimposed on the railings.
  - (d) Z position is used for CW jamming and LF AMCW jamming.
- (v) *4-pin W plug.*—This plug is connected externally to the aircraft alternator, and pins 1 and 2 provide the 80 v. 1500 c/s (nominal) AC supply to the power unit in the receiver. Pins 3 and 4 are not used.
- (vi) *6-pin W plug.*—This plug is connected externally to the indicator unit and, except for pin 3, provides power for this unit from the power unit in the receiver. Pin 3 provides variable bias to the receiver from the receiver gain control on the indicator.

16. Further information on the receiver and a circuit description are provided in para. 88 to 126. Fig. 3 shows a block schematic diagram, figs. 11, 13, 16, 19, 20 and 22 circuit diagrams, and figs. 14, 15, 17, 23, 24 and 25 annotated pictorial views of the interior of the receiver. The operation of the anti-jamming circuit is illustrated in fig. 21.

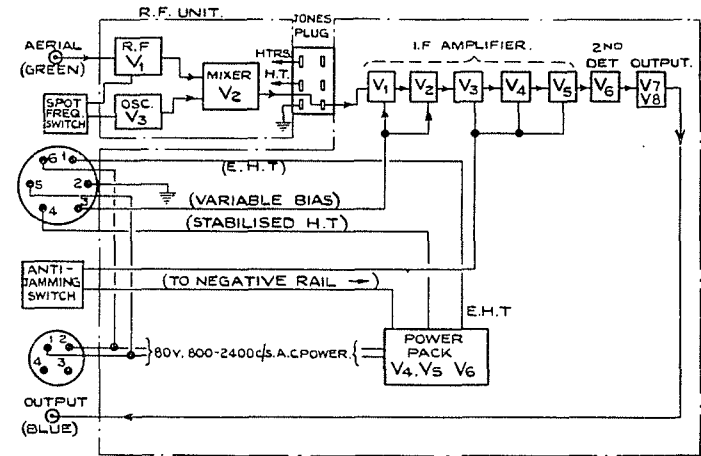

Fig. 3.—Receiver type R.1355, block schematic diagram.

### Indicator unit, type 62

17. The prime function of the indicator unit is to display the pulses received from the receiver on a cathode ray tube in a manner most suitable for interpretation by the navigator. Three time base circuits are incorporated in the indicator and each may be used ; the main time base, which is comparatively slow ; the strobe time base, which is fast and may be selected to cover any part of the main time base ; and the expanded strobe time base which is still faster than the strobe time base.

18. Two traces are shown on the CRT in the main time base position. The reason for this may be explained as follows. The pulse recurrence frequency of the “A” master station is 500 c/s and that of the “B” and “C” stations 250 c/s. The frequency of the complete time base is 250 c/s, so that the CRT displays two “A” pulses, one “B” pulse, and one “C” pulse. To obtain a time base of greater length it is in effect, expanded to twice the width of the tube and then “divided” at its mid point, see fig. 5. Thus one “A” pulse and the “B” pulse appear on one half, and the other “A” pulse and the “C” pulse appear on the other half. This effect of “dividing” is obtained by causing the time base to sweep the tube twice as fast (i.e. 500 c/s) and by applying simultaneously a 250 c/s square wave to the Y plates so displacing alternate sweeps.



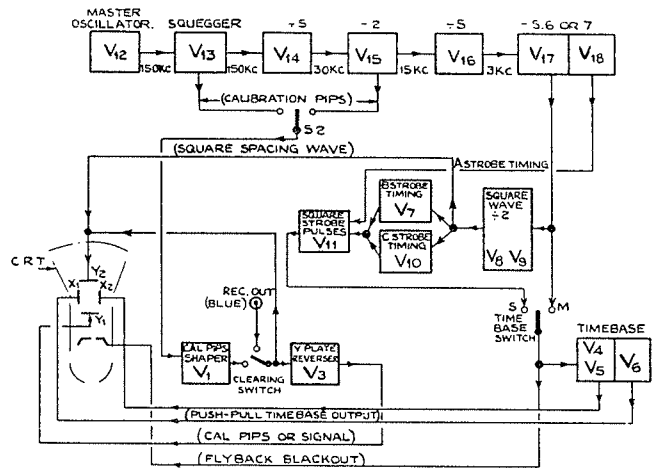

Fig. 4.—Indicator unit type 62, block schematic diagram.

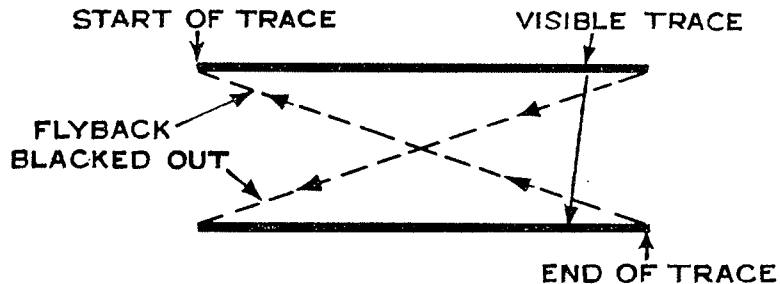

Fig. 5.—Gee Mark II time base.

19. A crystal-controlled oscillator and its associated divider circuit is housed in the indicator unit. The frequency of the oscillator may be controlled within fine limits and it has a two-fold function: it provides a stabilized source of frequency whereby the frequency of the time base may be synchronized accurately with the ground station; and it generates *calibration pips* which may be fed to the Y plates of the CRT at will to facilitate the use of the apparatus.

20. The following controls, sockets, and plugs are provided on the front panel of the indicator unit.

- (i) *Recurrence frequency switch*.—This switch controls the division ratio (divide-by-6 or divide-by-7) of the last stage in the dividers. This switch is normally in the divide-by-6 position, and moving it to the divide-by-7 position changes the time base rate of sweep in the ratio of 7 to 6.
- (ii) *Pye plug coloured blue*.—This is the receiver output plug by which the output from the receiver is applied to the Y plates of the CRT.
- (iii) *2-pin W plug*.—This is the detonator plug, and connects the self-destructor in the indicator with the external electrical circuit.
- (iv) *6-pin W plug*.—This supplies power to the indicator unit, and on pin 3, the connection whereby the receiver gain is controlled at the indicator.
- (v) *Gain control*.—This knob enables the gain of the receiver to be varied.
- (vi) *Clearing switch*.—With this 2-position switch either calibration pips generated by the dividers or the output of the receiver may be applied to the Y plates of the CRT.
- (vii) *Time base switch*.—This 3-position switch enables either the main time base, strobe time base, or expanded strobe time base to be selected.
- (viii) *Focus control* for adjusting the focus of the trace on the CRT.
- (ix) *Brilliance control* for adjusting the brilliance of the trace on the CRT.
- (x) *“B” strobe coarse control* and *“B” strobe fine control* which together enable the position of the “B” strobe time base to be moved along the “B” main time base
- (xi) *“C” strobe coarse control* and *“C” strobe fine control* which together enable the position of the “C” strobe time base to be moved along the “C” main time base.
- (xii) *Fine frequency oscillator control*.—This enables the frequency of the master oscillator to be controlled within fine limits.

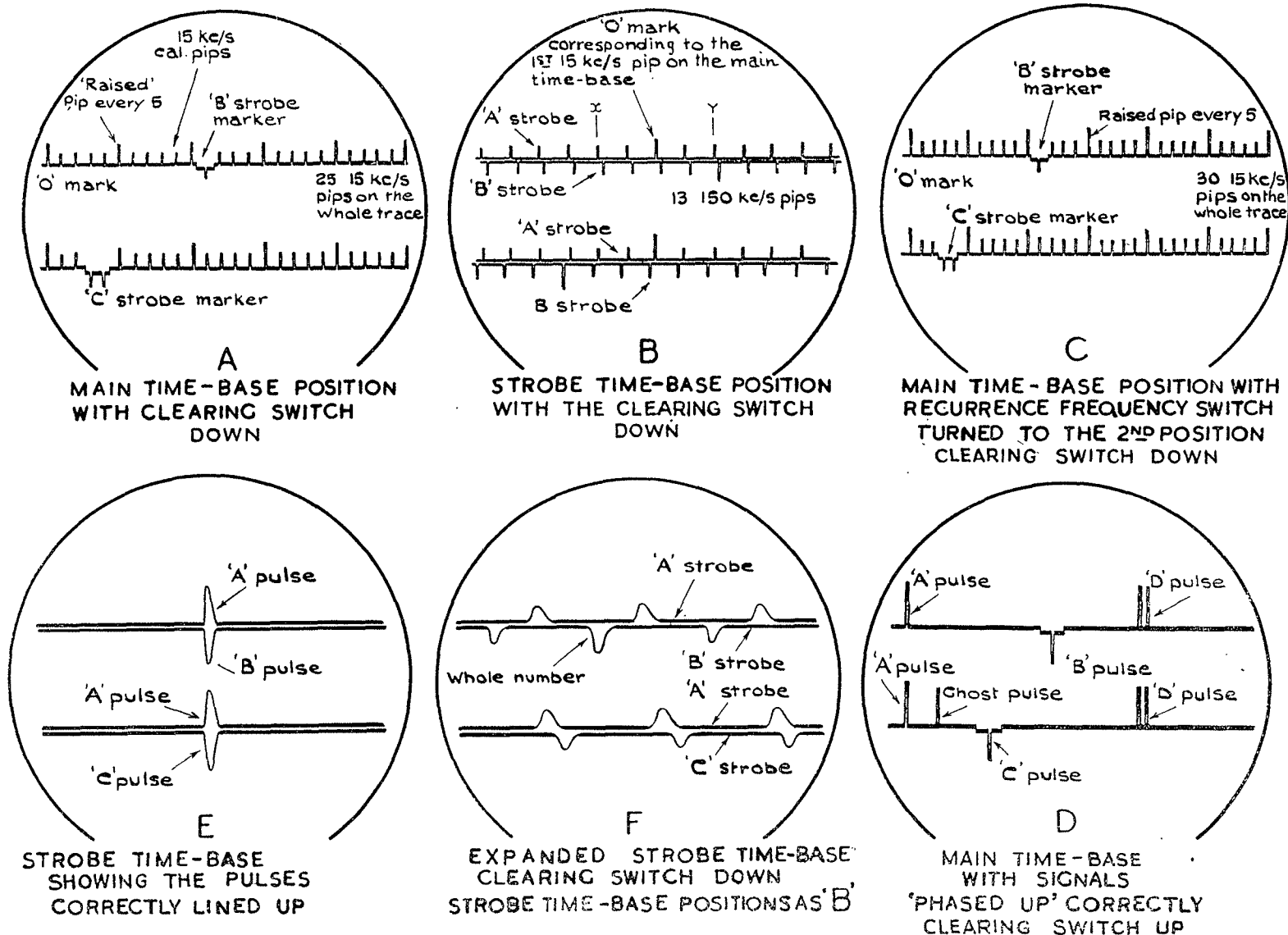

Fig. 6.—Screen indications.

21. Further information of the indicator and the circuit description are provided in paras. 127 to 166. Fig. 4 shows a block schematic diagram, fig. 26 a circuit diagram, and figs. 29, 30 and 31 annotated pictorial views of the interior of the indicator. Specimen oscillograms are given in figs. 27 and 28.

### Control panel type 3

22. Control panel type 3 is the one most commonly employed, but on aircraft fitted also with other radar equipment another control panel may be used.

23. The control panel type 3 is described in full in A.P.1095, Vol. I, Sect. V, Chap. 24, or in A.P.1186D, Vol. I, Sec. 1, Chap. 1, to which reference should be made for complete information. Briefly, the function of the control panel is to stabilize the output of the 80 volts, AC generator which supplies AC to the equipment. It incorporates a carbon pile regulator which is connected in the field circuit of the alternator, and a suppressor whose function is to prevent the slot ripple in the field from being fed out of the control panel.

### Aerials and loading units

24. Provision is made on the aircraft for the fitting of a quarter-wave whip aerial 5 feet long which is used with a loading unit type 2. In the future this aerial and loading unit will be replaced by a whip 3 feet  $7\frac{3}{4}$  in. long which will be used with loading unit type 51.

25. *Aerials aircraft types 201 and 329.* Aerial aircraft type 201 comprises a 5 foot whip aerial (namely, rod aerial type 87) with a base insulator and a spring mounting to accommodate loading unit type 2. It is designed to cover the 40 to 51 Mc/s band and the four spot frequencies in the band 22 to 30 Mc/s. As a temporary measure it is also being used to cover the band 51 to 85 Mc/s. Earthing lugs are provided on the insulator base for bonding to the aircraft structure.

26. Aerial aircraft type 329 comprises a 3 ft.  $7\frac{3}{4}$  in. whip aerial (namely, rod aerial type 257) with a base and spring mounting to accommodate the loading unit type 51. It covers all the Gee frequencies in the band 20 to 85 Mc/s.

27. Electrical connections between the aerial and the loading unit is made by an adaptor plug type 587, and the feeder from the receiver is coupled to the loading unit by means of a Pye plug and socket.

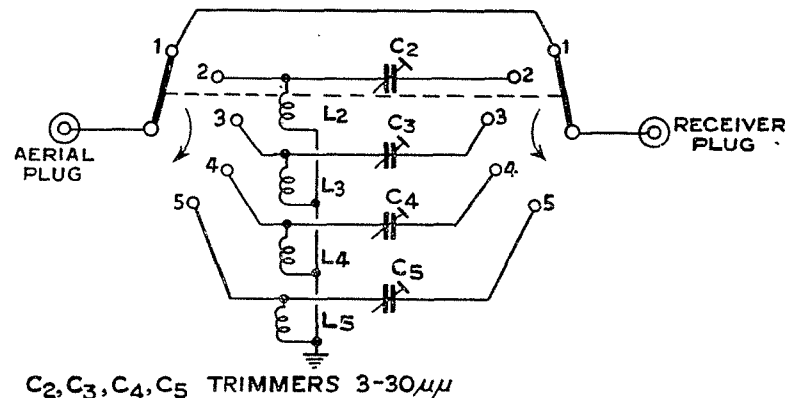

Fig. 7.—Loading unit type 2, circuit.

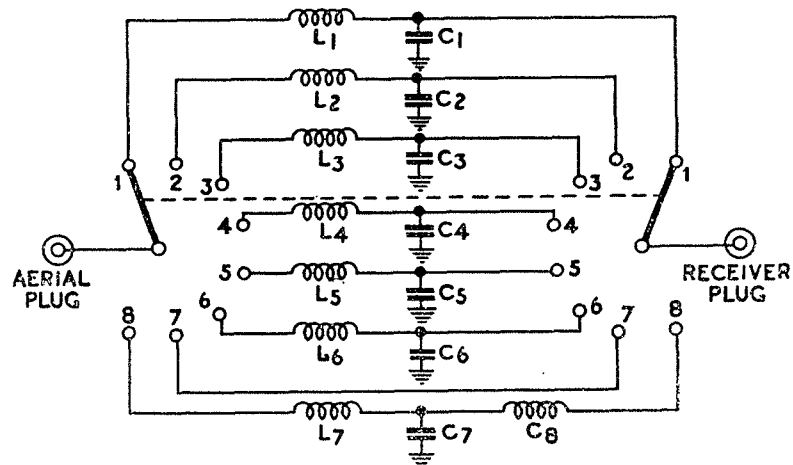

Fig. 8.—Loading unit type 51, circuit.

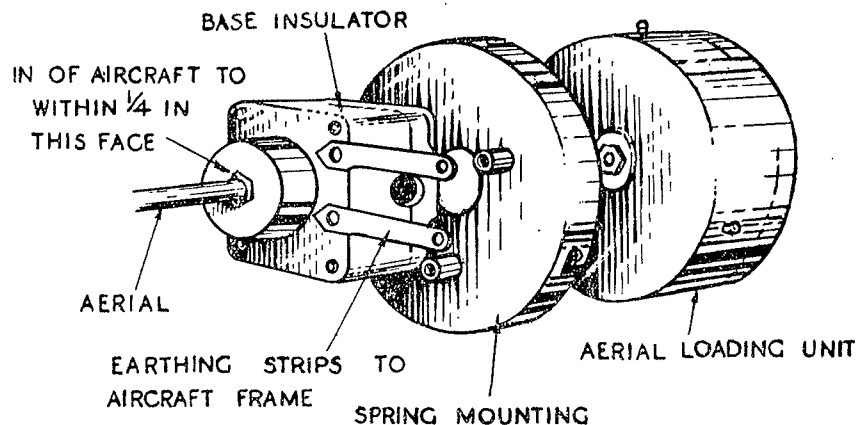

Fig. 9.—Exploded view illustrating attachment of loading unit to aerial.

28. Loading units types 2 and 51, fig. 7 and 8. The loading units types 2 and 51 are mechanically, but not necessarily electrically interchangeable. Each is provided with bayonet slot fixings and fit into the mounting type 369 which is in turn secured to the base insulator holding the whip aerial (see fig 9).

29. Loading unit type 2 is fitted with a five position Yaxley switch in which the switch positions are numbered 1 to 5 respectively. The first position gives a direct connection through from the aerial to the to the feeder line, and is to be used over the band 40 to 51 Mc/s. The series inductance of the lead inside the loading unit in this switch position gives a sufficiently accurate impedance match over this range of frequencies. The remaining switch positions, numbered 2, 3, 4 and 5, correspond to the four spot frequencies in the band 22 to 30 Mc/s. Each is provided with a separate matching section to give an impedance match at the spot frequencies required. The trimmer condensers used in the loading units are sealed, and under no circumstance are these seals to be broken.

30. Loading unit type 51 is for use on the Gee frequencies on the band 20 to 85 Mc/s. Externally it is similar to loading unit type 2, but differs in its internal mechanical and electrical design, allowing for a total of eight separate switch positions.

31. The frequency coverage obtainable at each switch position of the loading units is given in the following table.

Loading Unit type no.	Length of aerial	Switch position	Frequency coverage
2	5 ft.	1	40 to 51 Mc/s band
		2	22.9 Mc/s spot frequency
		3	25.3 Mc/s spot frequency
		4	27.3 Mc/s spot frequency
		5	29.7 Mc/s spot frequency
51	3 ft. 7 $\frac{3}{4}$ in.	1	22.1 to 23.6 Mc/s.
		2	23.6 to 25.7 Mc/s.
		3	25.7 to 28.0 Mc/s.
		4	28.0 to 30.8 Mc/s.
		5	42.0 to 47.5 Mc/s.
		6	47.5 to 54.5 Mc/s.
		7	54.5 to 73 Mc/s.
		8	53 to 85 Mc/s.

### Electric detonator

32. A self-destruction device comprising an electrically detonated charge is mounted in the indicator unit and is detonated by either an inertia switch (which is automatic in operation) or manual switches by the the pilot and the navigator. The circuit is illustrated in fig. 10.

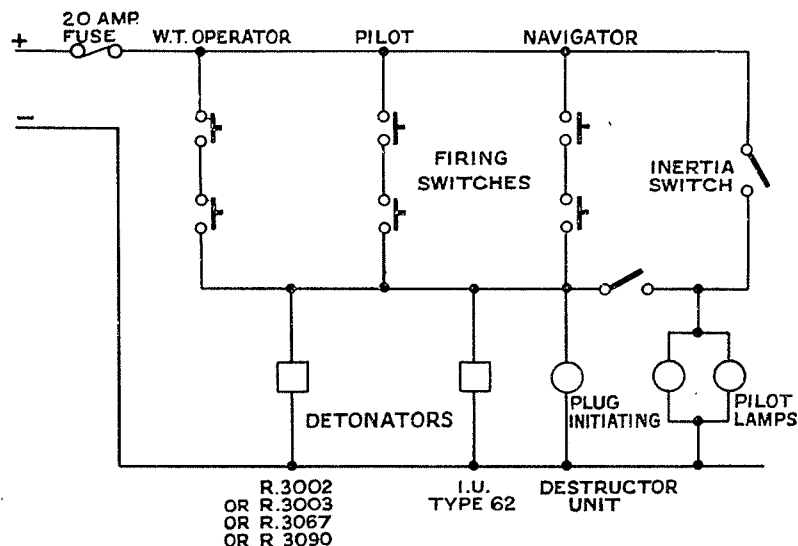

Fig. 10.—Detonator firing circuit.

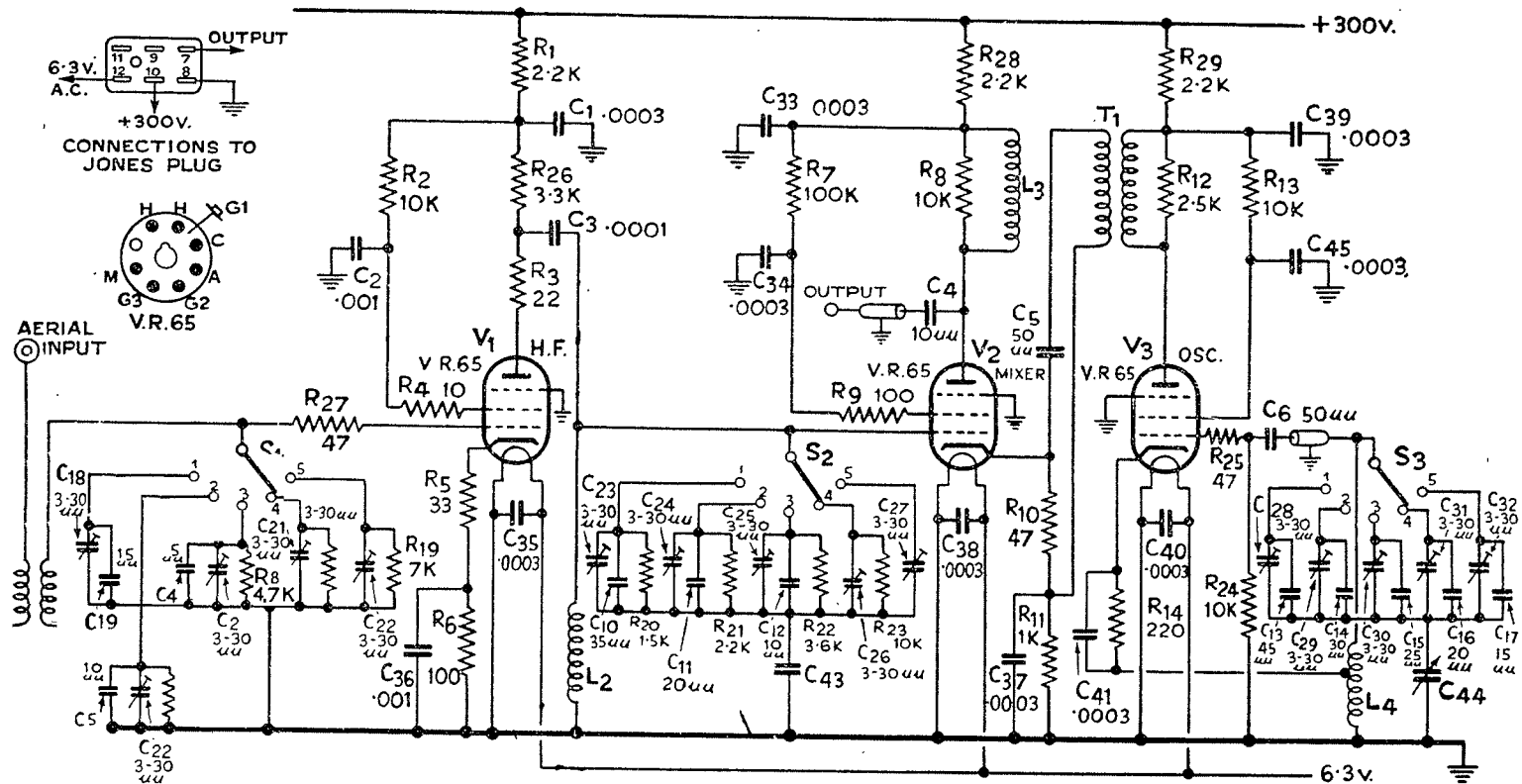

Fig. 11.—RF unit type 24, circuit.

## INSTRUCTIONS FOR INSTALLING

33. An interconnection diagram is given in fig. 2, and this, together with the colour coding of the plugs and sockets (see para 15 and 20) should provide sufficient information to enable the equipment to be correctly installed.

34 to 87. These paragraphs have been superseded by Appendix V.

## CIRCUIT DESCRIPTION

### RECEIVER R.1355

88. The circuit diagrams of the RF units are shown in fig. 11, 13, 16 and 19, of the power unit in fig. 22, and of the IF amplifier in fig. 20. The four RF units are described first; the band width of each unit is  $\pm 0.5$  Mc/s at 2 to 3 dB down.

89. *RF unit type 24.* RF unit type 24 covers the frequency band 20 to 30 Mc/s, tuning to any one of five spot frequencies in this band.

90. It has one stage of RF amplification, namely that employing VI (see fig. 11). The grid inductance L1 of VI is tuned by means of the trimmers C18 to C22, any one of which can be selected by the bank S1 of the spot frequency selector switch. The aerial feeder is matched in by means of the transformer of which L1 is the secondary winding.

91. The output of the RF stage is fed through C3 to the first grid of the mixer valve V2. The grid circuit of V2 is tuned in a similar manner to the grid circuit of VI, L2 being the tuning inductance. The appropriate trimmers are selected by the bank S2 of the selector switch.

92. The oscillator valve V3 has its frequency controlled by the inductance L4 and the condensers C28 to C32, the appropriate condenser being selected by the third bank S3 of the spot frequency selector switch. The oscillator uses a Hartley circuit (the cathode of the valve is tapped on to the tuning inductance), and it is electron-coupled, that is, the cathode, grid, and screen grid of the valve form the oscillator, the anode being used only to provide an output to the mixer; the frequency of the oscillator is always above the signal frequency. Electron coupling is used because it provides good frequency stability.

93. The output from the oscillator to the mixer is fed through the transformer T1, which has a pass band greater than 10 Mc/s, into the cathode circuit of the mixer valve V2 across the resistor R10. The oscillator voltage developed across the latter is about 1v. RMS.

94. The coupling between the mixer and IF amplifier is through the inductance L3 and the capacitance C4 to the grid circuit of the first IF stage in the IF amplifier. L3 is fitted with an adjustable dust iron core and the circuit is resonated to 7.7 Mc/s, as is the grid of the first IF valve. The mixer anode circuit and the first IF grid circuit form, together with the concentric tube coupling the units, a band pass filter. This coupling is common to all RF units.

95. *RF unit type 25.* RF unit type 25 is generally similar to RF unit type 24, and has a spot frequency selector switch. The frequency coverage is 40 to 50 Mc/s. The circuit differs only in detail from that of RF unit type 24 and the differences become apparent on comparing fig. 13 with fig. 11.

96. The oscillator in this case uses a Colpitts circuit, and it is again electron-coupled to the mixer. The damping resistors associated with the switched tuning condensers in the RF unit type 24 are not necessary in this unit, because, at these higher frequencies, the input resistance of the valves provides all the damping required.

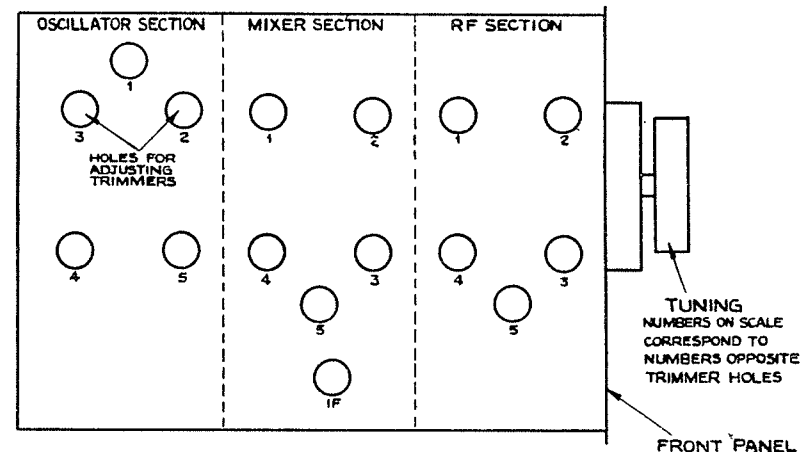

Fig. 12.—Positions of trimmers on RF units type 24 and 25.

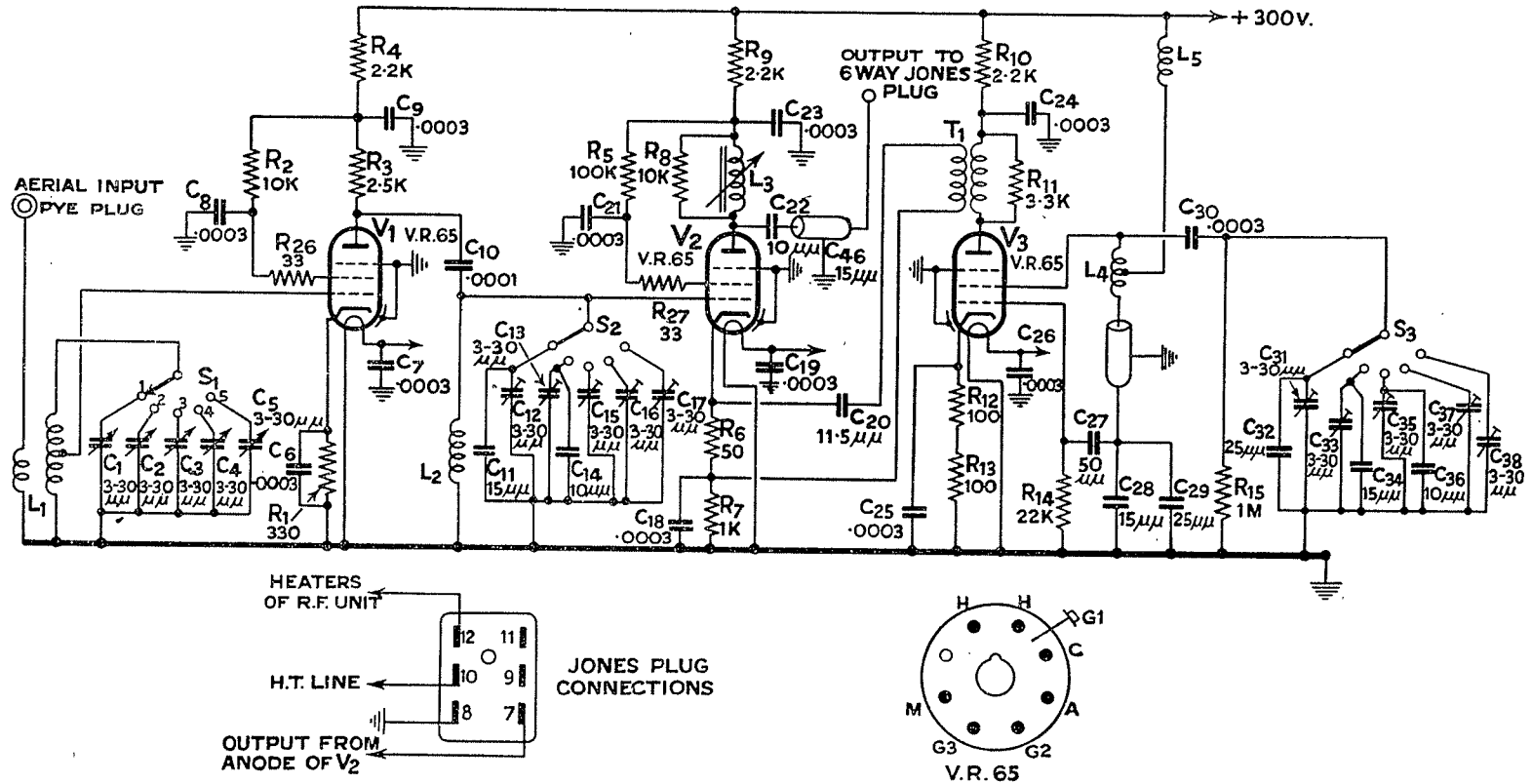
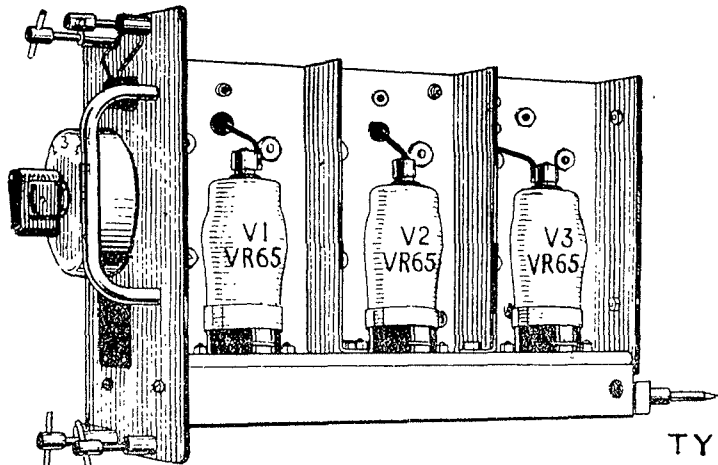
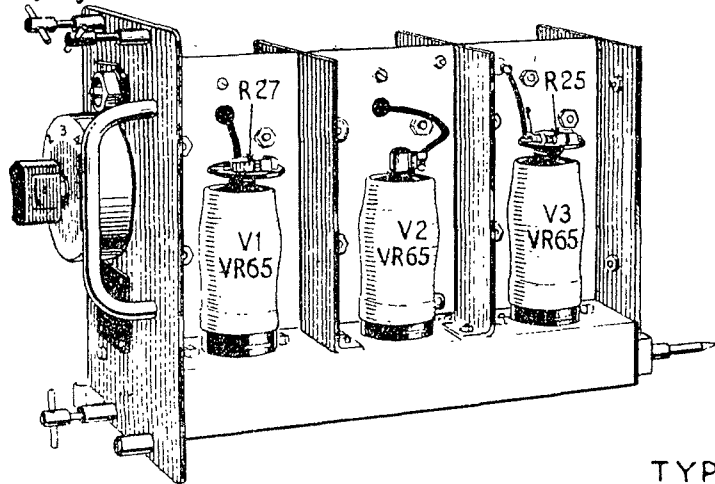
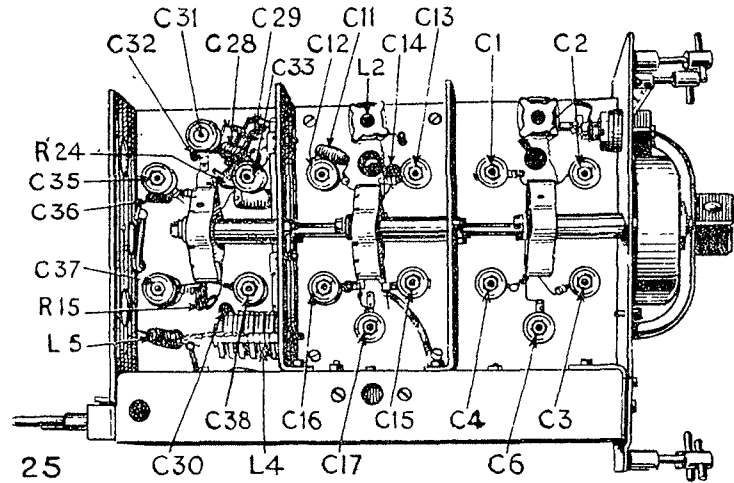

Fig. 13.—RF unit type 25, circuit.



TYPE 25



TYPE 24

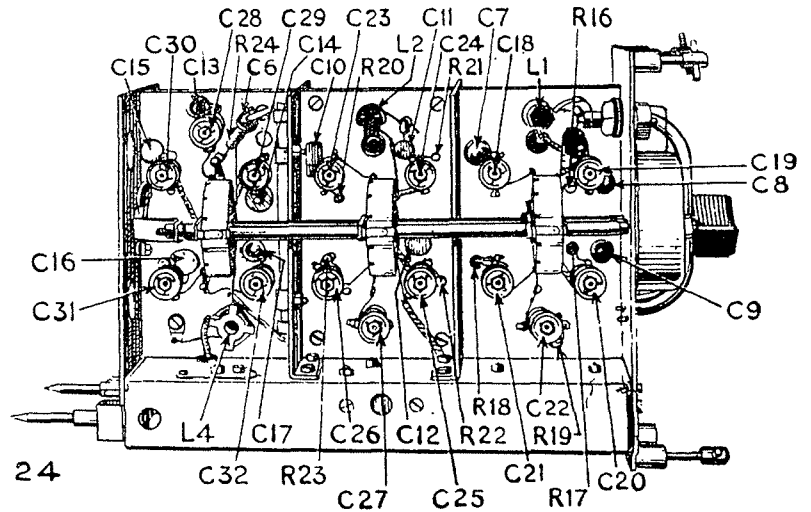
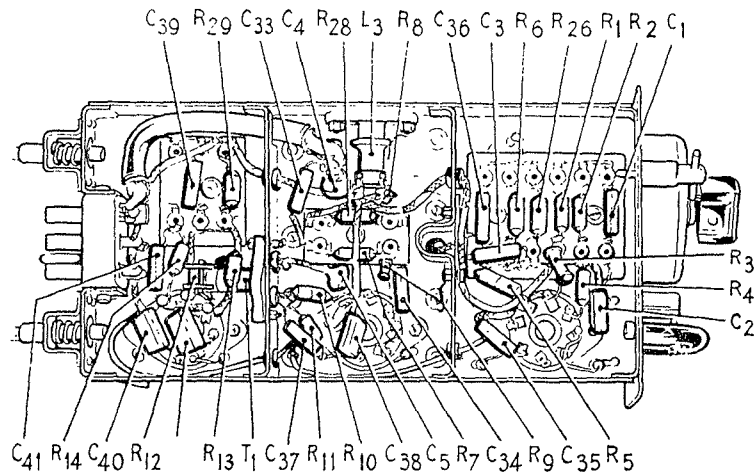
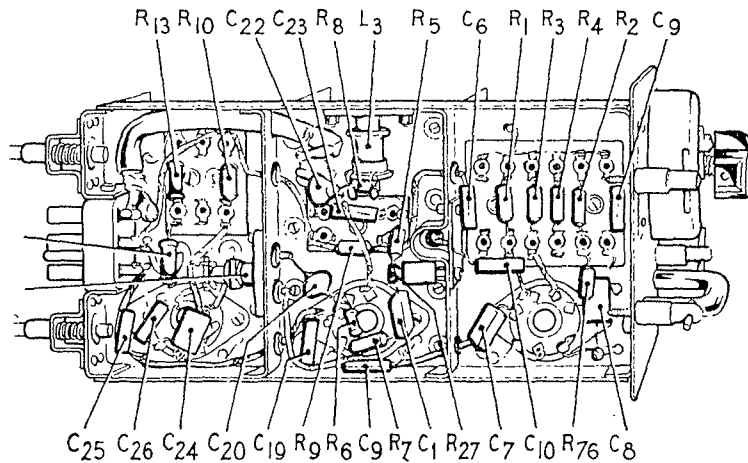

Fig. 14.—RF units types 24 and 25, side views.





TYPE 24



TYPE 25

Fig. 15.—RF units types 24 and 25, underside view.

97. *RF unit type 26.* RF unit type 26 covers the frequency band 50 to 65 Mc/s; it differs from the two previously described RF units mainly in the fact that continuous tuning is provided over the band (see fig. 16). The unit contains three valves; an RF amplifying valve (VR 136), a mixer valve (VR 136) and an oscillator valve (VR 137). The VR 136 is a pentode and the VR 137 a triode, and they are used because the VR 65 is unsuitable for use at these higher frequencies.

98. There are three tuned circuits; the RF grid, the mixer grid, and the oscillator. At these frequencies the valve input resistance is so low that it provides the whole of the damping required on its associated tuned circuit to maintain the necessary band width; but the input resistance of the valve varies rapidly with frequency (as  $1/f^2$ ), and if the variable tuning condenser were connected in parallel with the tuning inductance in the usual way, the combined effect of the change of capacity over the tuning range would cause the band width of the unit to change by about four to one over the band.

99. A variable condenser is therefore connected in series with the tuning inductance, and the two then act as a variable inductance which tunes with the fixed stray capacities. It can be shown that the bandwidth of such a circuit, damped by a valve input resistance, is practically independent of frequency. All three tuned circuits are of this form.

100. The three tuned circuits are ganged. The oscillator tuned circuit frequency must remain a constant amount (7.5 Mc/s) above the frequency of the other two tuned circuits as the condenser is rotated; this is accomplished by suitably proportioning the inductances and capacities. It is essential that the wiring and components of the tuned circuits be not altered in any way, as even small changes would upset the ganging of the circuits.

101. The coupling circuit between the aerial input and the first tuned circuit is designed to match the constant feeder impedance to the varying valve input resistance, and to increase the attenuation of any signals at IF frequency coming from the aerial.

102. The oscillator uses a Colpitts circuit so that no tap is required on the coil. The resonant circuit can therefore be made of the same form as the signal frequency tuned circuits, thus simplifying tracking problems. The oscillator output is fed to the mixer grid through a  $2\mu\mu\text{F}$  condenser and a pipe. The oscillator voltage developed on the mixer grid is about 2v. RMS.

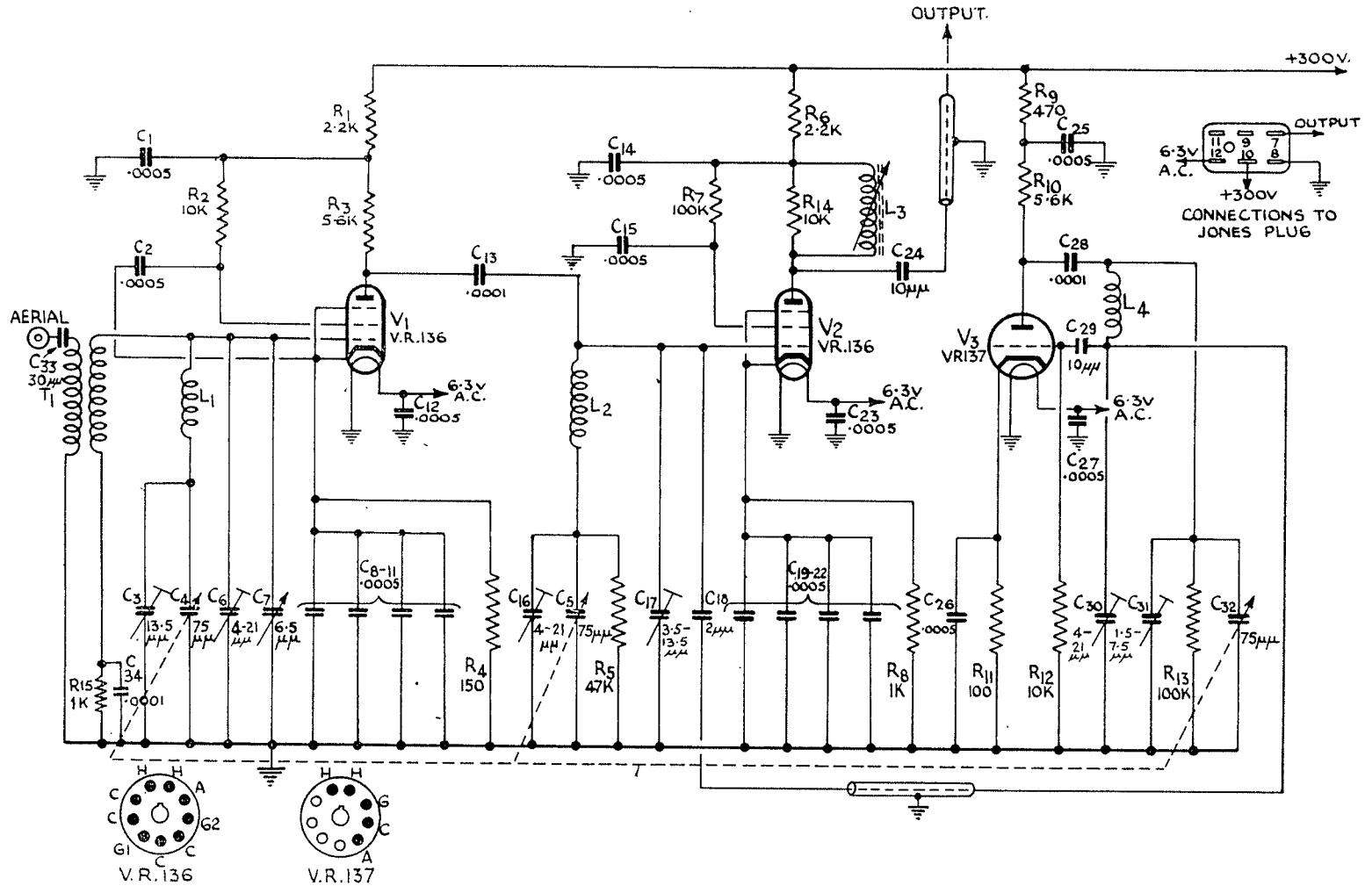

Fig. 16.—RF unit type 26, circuit.

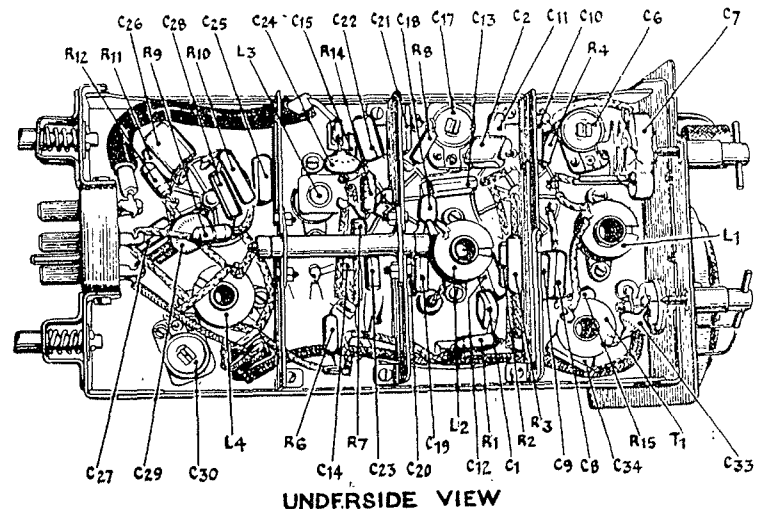
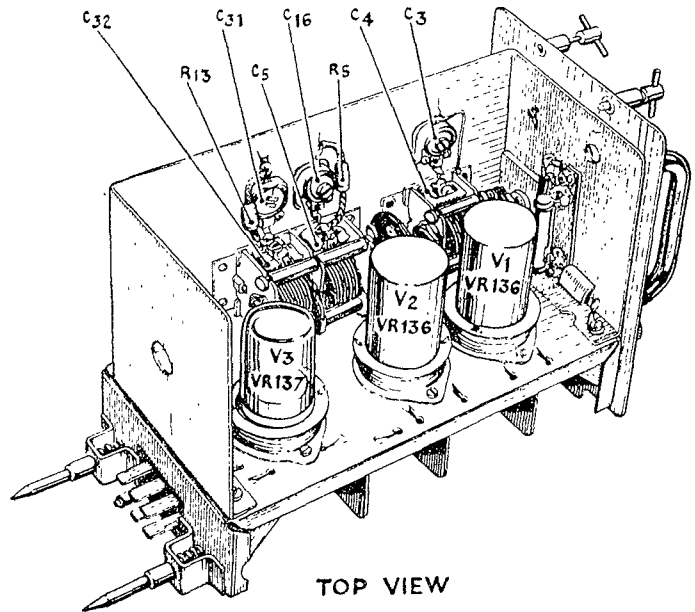

Fig. 17.—RF unit types 26 and 27.

103. The mixer anode circuit is identical with that of the RF units types 24 and 25. That is, it forms with the IF amplifier input circuit and the connecting pipe a band pass filter.

104. RF unit type 27. RF unit type 27 covers the frequency band 65 to 80 Mc/s continuously, and it differs from the RF unit type 26 only in the frequency coverage obtained (see fig. 19).

**IF unit**

105. There are five stages of IF amplification, valves V1 to V5, these being RF pentodes of the VR65 type. The diode V6 is a VR92 and it serves as the second detector. The valve V7 is a video amplifier, and V8 is a cathode follower feeding the output of the receiver to the indicator unit.

106. The grid circuit of V1 consisting of the variable inductance L1 and the coupling capacity C1 forms part of the band pass coupling between the mixer stage and the IF amplifier, and resonates at 7.7 Mc/s. All the other IF tuned circuits L2, L3, L4, L5 and L6 are peaked at 7.5 Mc/s and the overall curve of the whole amplifier peaks at 7.5 Mc/s, the band width being  $\pm 0.6$  Mc/s for 6 dB down measured from the first IF amplifier grid.

107. The first two valves V1 and V2 are provided with variable bias through the resistance R2, R4, R5, R10, R57 and the variable gain potentiometer which is situated in the indicator unit. The stages V3, V4 and V5 are fitted with special "back bias" circuit to enable the signal to be read through jamming. The operation of the circuit is described in para. 110 to 118.

108. The 4-position anti-jamming switch is provided to enable certain circuit elements to be altered to cope with different forms of jamming signals. When the switch is in position I the condensers C15, C23 and C32 are shorted out and the circuit functions as an ordinary straight amplifier. In this position cathode bias to V3, V4 and V5 is provided by means of the resistors R17, R27 and R35. An extra dropping resistor R42 is introduced into the screen circuit of V3, V4 and V5. This serves to adjust the gain of each stage to a suitable value and also to prevent the anode voltages dropping to too low a value. This can occur if too much anode current is allowed to flow, as the resistors R22, R30 and R39 are all of high value. The resistor R5 is also introduced in this position in series with the gain control potentiometer, and serves to reduce the maximum gain available, which would otherwise be too great.

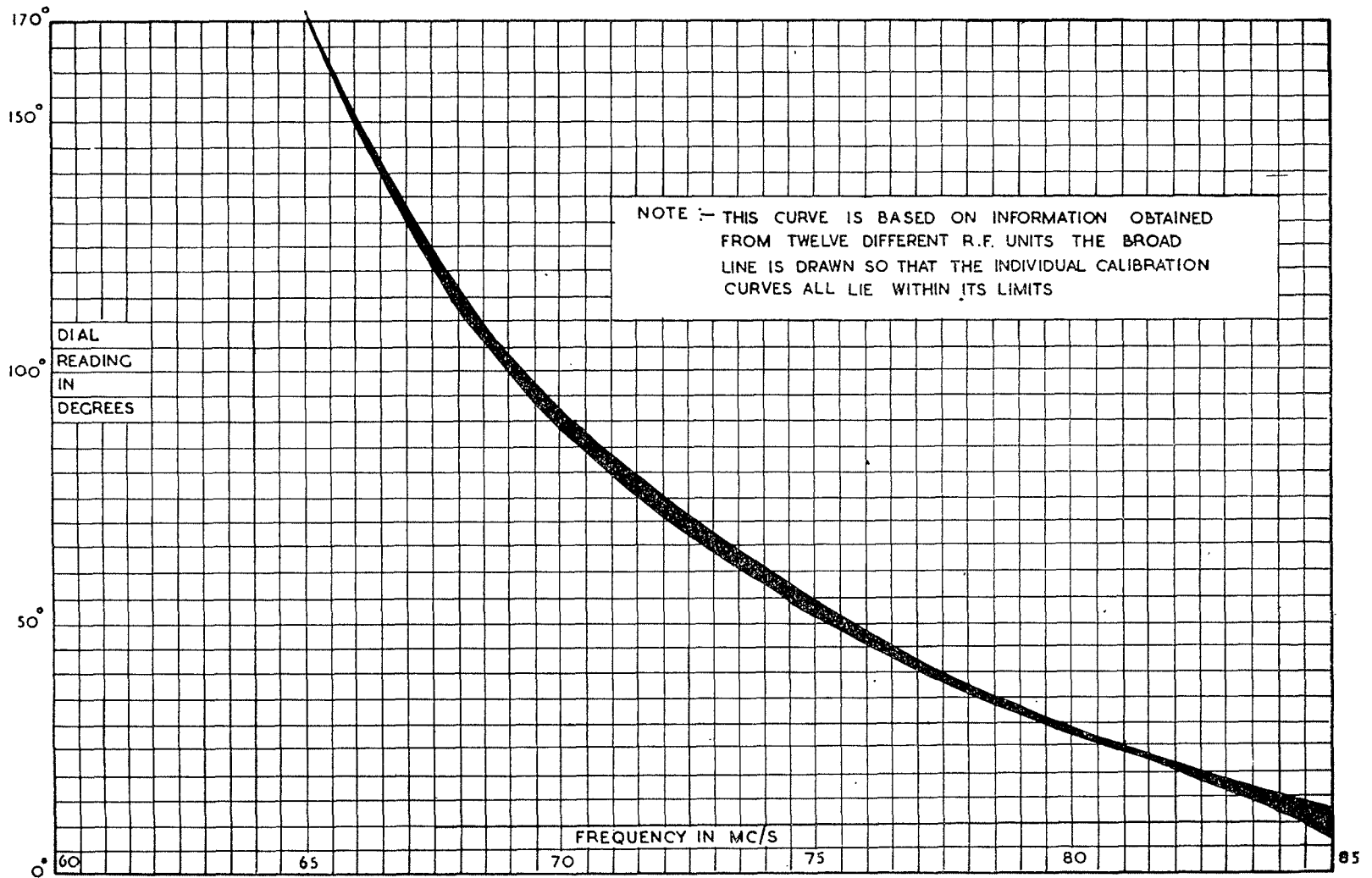

Fig. 18A.—RF unit, type 27—calibration curve.

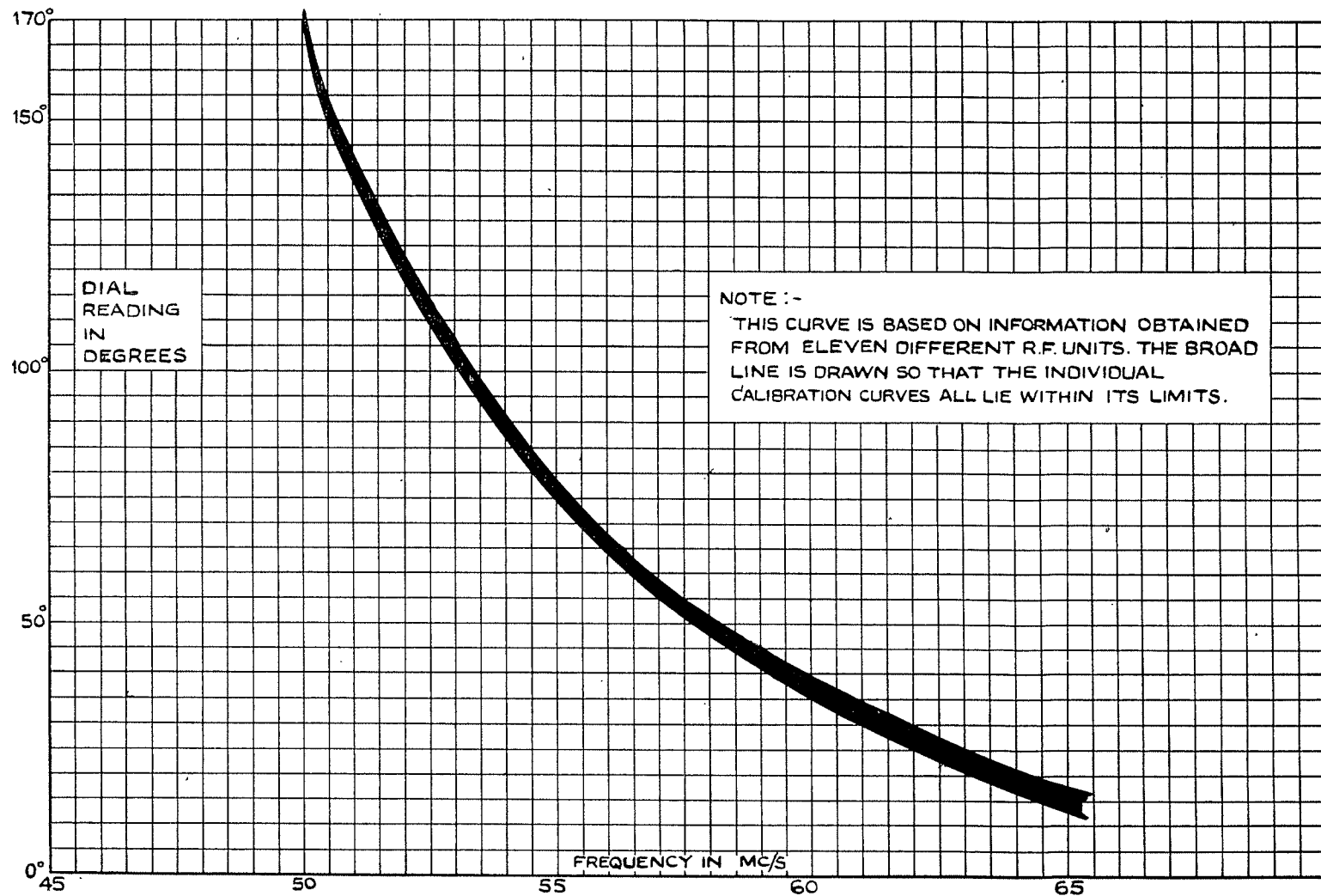

Fig. 18B.—RF unit, type 26—calibration curve.

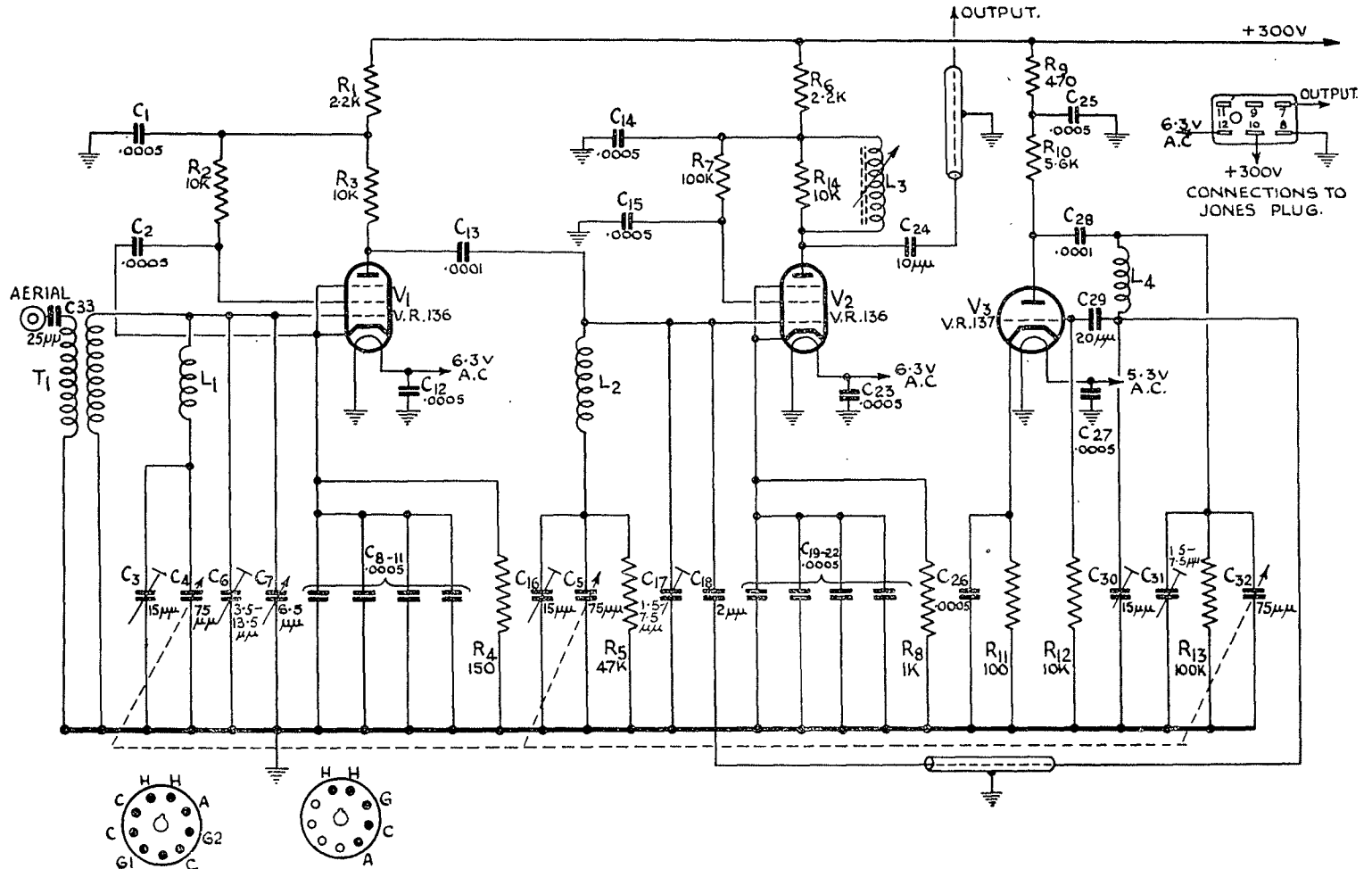

Fig. 19.—RF unit type 27, circuit.

C1	C5	C2 C3 C4	C9	C7	C11 C10 C12 C14 C8 C54 C13 C15	C16	C17	C19	C24	C25 C29	C26 C28 C30 C31	C33	R35 R34	C38 C40 C39	C42	C41 C43	C45	C46	C47 C49 C50 C51 C52 C48	C55 C53	
R1	R2 R58 R5	R7 R8 R9 R4	R6	R59 R57	R13 R11 R12	R10	R14 R18 R19	R15 R16 R17	R22 R23	R24 R19	R25 R28 R26 R27	R30 R29	R31	R32 R36	R33 R37 R34 R35	R39 R38	R40 R41	R42 R44 R45	R49 R47 R46	R50 R51 R48	R61 R60 R54 R56 R55 R62

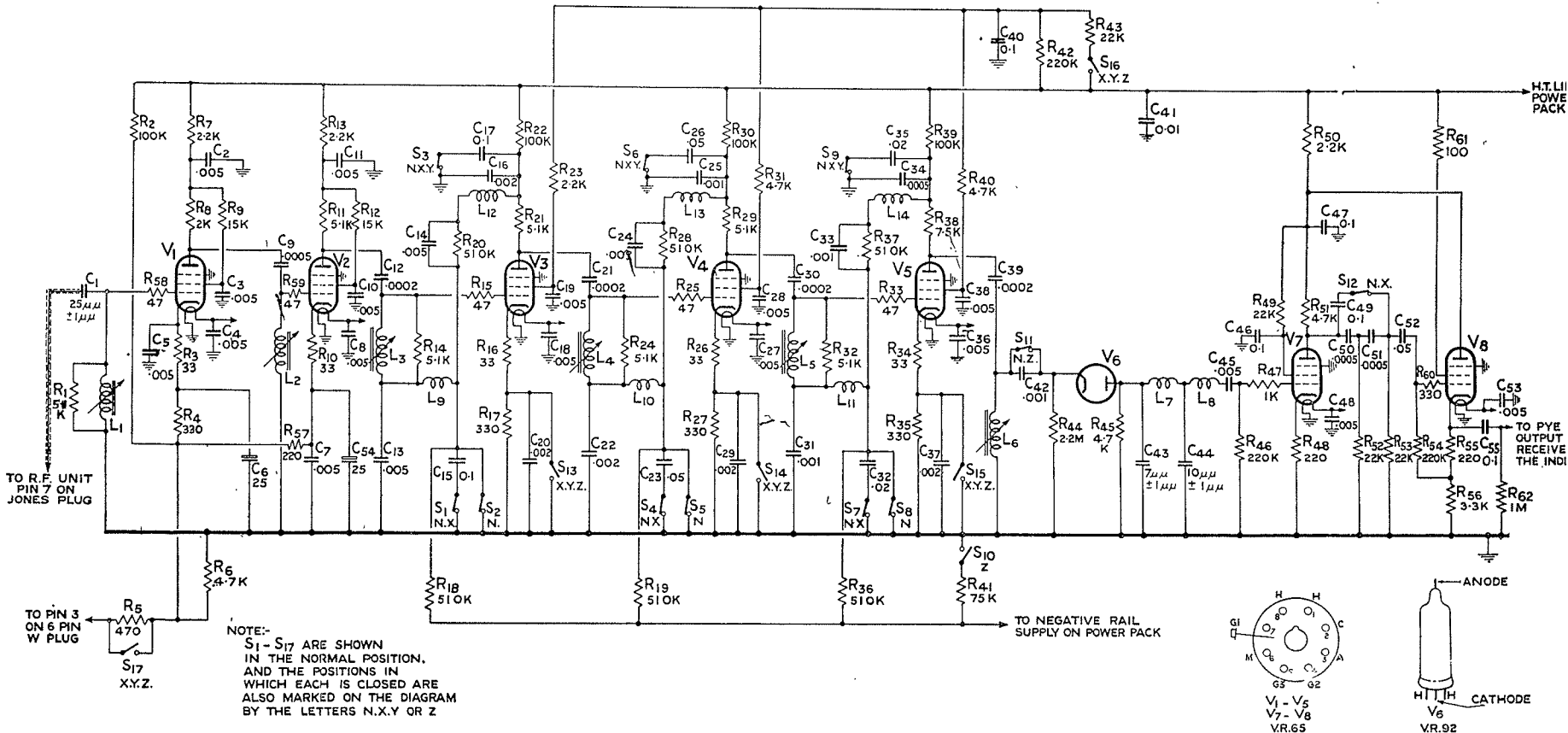

Fig. 20.—R.1355, IF amplifier circuit.

109. The filter condenser C42 is shorted out in the straight position as is also the filter C50, R52 C51, R53 between the signal frequency amplifier and the cathode follower. The output from the receiver is connected to a Pye plug B, which is fed to the indicator unit.

### Operation of the anti-jamming system

110. Consider the circuit diagram of fig. 20. The anode circuit has a resistance R22 in series with a normal load R21. R22 is about 100,000 ohms and R21 about 5,000 ohms. The junction of R21 and R22 is joined to the bottom end of the grid coil through the 0.5 megohm resistance R20. The lower end of the grid coil is connected through another 0.5 megohm resistor R18 to a negative HT rail of approximately 150 to 230 v. The chokes L9 and L12 act as IF suppressors.

111. The junction of R21 and R22 is by-passed to earth by the condenser C16 and the lower end of the grid coil is by-passed to earth by the condenser C13. Additional condensers, C17 and C15, can be switched across these two to increase the time constants; condensers connected across the resistor R20 complete a condenser potentiometer between the grid and anode circuits of V3. The circuits for the valves V4 and V5 are almost identical with that for V3 except that values of some of the condensers in the potentiometer chain are different.

112. An additional resistor R41 is connected across the negative rail supply with the selector switch in position Z. The supply has a poor regulation and the switching in of this resistor drops the voltage from the normal 230 v. to 150 v.

113. Consider the operation of the stage V3 with the anti-jamming switch in position Z, which is the position suitable for dealing with CW jamming or low frequency modulated CW. The main HT line is 350 v. positive with respect to earth, whilst the negative rail is at a potential of 130 v. below earth. The potential at the junction of the resistors R21 and R22 will depend upon the drop in potential across R22, since this is a very much larger resistance than R21. This drop in potential will be determined by the anode current taken by the valve V3.

114. The anode current taken by V3 with the anti-jamming switch in position Z is adjusted to be 2.3 mA, and this will cause the junction of the resistors R22 and R21 to be at a potential 120 v. positive with respect to earth. The resistances R20 and R18 are equal in value so that the grid of V3 will take up a potential mid-way between 120 v. positive and 130 v. negative, i.e. 5 v. negative with respect to earth.

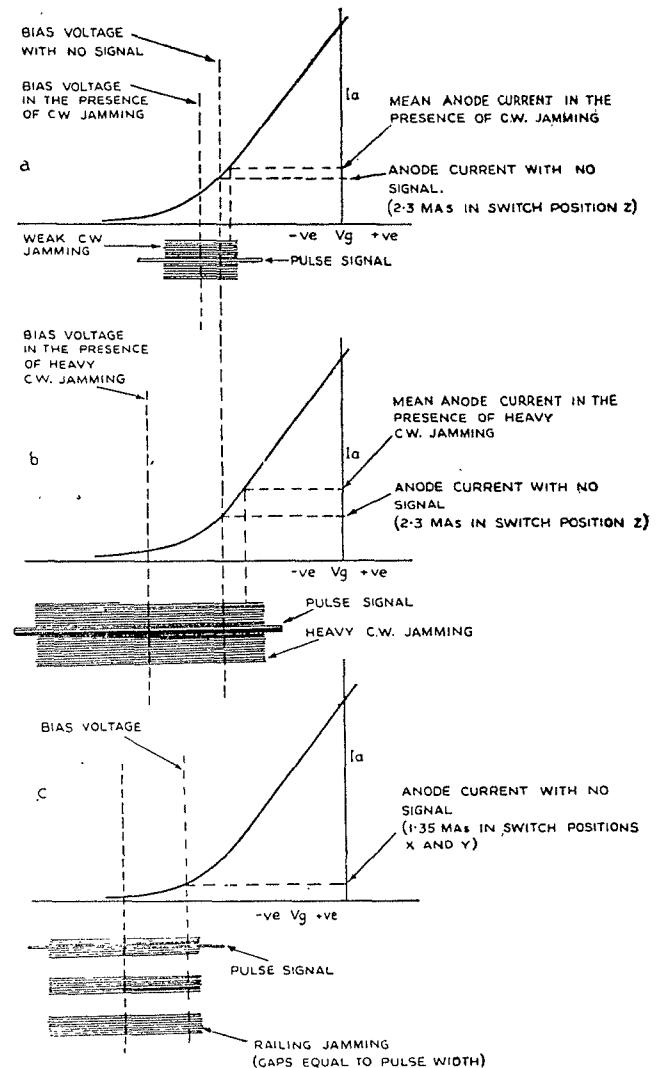

Fig. 21.—Operation of back bias—IF stages.



115. The anode current grid voltage curves of fig. 21 help to explain the operation of the stage. Consider the curve of fig. 21 (a) where a small CW jamming signal is applied to the grid V3 together with the required pulse signal. The CW signal will tend to drive the grid more positive and make the valve take more anode current. An increase of mean anode current will cause a greater drop in potential across R22 so that the grid will take up a potential more negative with respect to earth. The feedback arrangement thus tries to keep the mean anode current of the valve constant.

116. Fig. 21(b) illustrates the case of the very large CW jamming signal. The bias potential on the grid of the valve is shifted so much negative in the presence of the jamming that the required pulse signal is still able to pass through the valve on top of the jamming signal as shown. The decoupling condenser C16 and C13 in the anode and grid circuits of V3 are sufficiently large to prevent any change in the bias conditions for the duration of the pulse.

117. If the jamming signal is CW modulated by a low frequency sine wave a waveform similar to the modulation envelope will appear across the anode decoupling condenser C16 since this has a small capacity and will present a fairly high impedance to modulation frequency up to about 4 Kc/s. This valve is fed back to the grid circuit through the the condenser potentiometer C42 and C13, causing a reduction in the modulation percentage of the jamming signal which gets through the V3 stage. Further reduction in the percentage modulation occurs in the stages V4 and V5, and additional high pass filter consisting of the condensers and resistances C50, C51, R52, R53 is included between the video frequency amplifier V7 and the cathode follower V8 to remove the last traces of ripple.

118. The improvement obtained with this amplifier as compared with a straight receiver in the presence of either pure CW or pure very low frequency modulated CW is of the order of 1000 : 1.

119. The operation of the scheme for a "railing" type of jamming is somewhat different, and the diagram of fig. 21(c) helps to explain the action. In the case illustrated the jamming signal consists of square pulses of somewhat greater width than the required pulse signal, separated by gaps of equal width. The anti-jamming switch will be in position X for this type of jamming. This means that the potential of the negative rail will be approximately 230 v. and the anode current obtained by the valves V3, V4 and V5 will be about 1.35 mA with no

signal coming through. Extra condensers (C17 and C15 in the circuit of V3) are switched in on all three back-biased stages making the time constants long in the anode and grid circuits.

120. During the period of the "railing" pulse the bias applied to the grid of the valve will not change appreciably owing to the large condensers C17 and C15 in the grid and anode circuits. If the required signal pulse happens to occur at the same time as the "railing" pulse it will be received satisfactorily on top of the "railing" pulse as shown. During the gap in jamming no signals will be received but this is not very important unless the jamming is locked to some multiple of the recurrence frequency of the signal and a "gap" happens to occur at the same point as the signal. Normally the recurrence frequency of the jamming will be drifting with respect to the recurrence frequency of the signal so that signals will be received whenever a jamming pulse coincides with the signal.

121. The small amount of the modulation envelope of the jamming signal which comes through the IF amplifier is filtered out from the pulse by C42 and R44. R44 is a very high resistance so that a charge accumulated by C42 when V6 takes current can only decrease slowly and thus the voltage across C42 becomes equal to the peak voltage of the "railing" jamming. The diode will thus pass very little of the "railing" but will let through the signal which is riding unimpaired on top of the "railing".

122. Position Y on the anti-jamming switch is similar to position X except that the condensers in the grid circuit of the three back-biased stages are reduced in value, allowing some negative feedback between grid and anode circuits. This position is helpful if some low frequency sine wave modulation is superimposed on the "railing" jamming. The negative feedback in the back-biased stages (V3, V4 and V5) helps to reduce the percentage in this modulation as in the case of CW modulated at low frequency (see para. 121).

123. The back-bias arrangements will also operate if the jamming signal has a sine wave modulation instead of square pulses, but the improvement obtained is not so good, as owing to the waveform of the jamming there is less time available at the peaks during which a pulse can be received. The improvement over a straight amplifier is of the order of 20 : 1 with pure HF modulated CW jamming, and of the order of 200 : 1 with pure "railing" jamming.

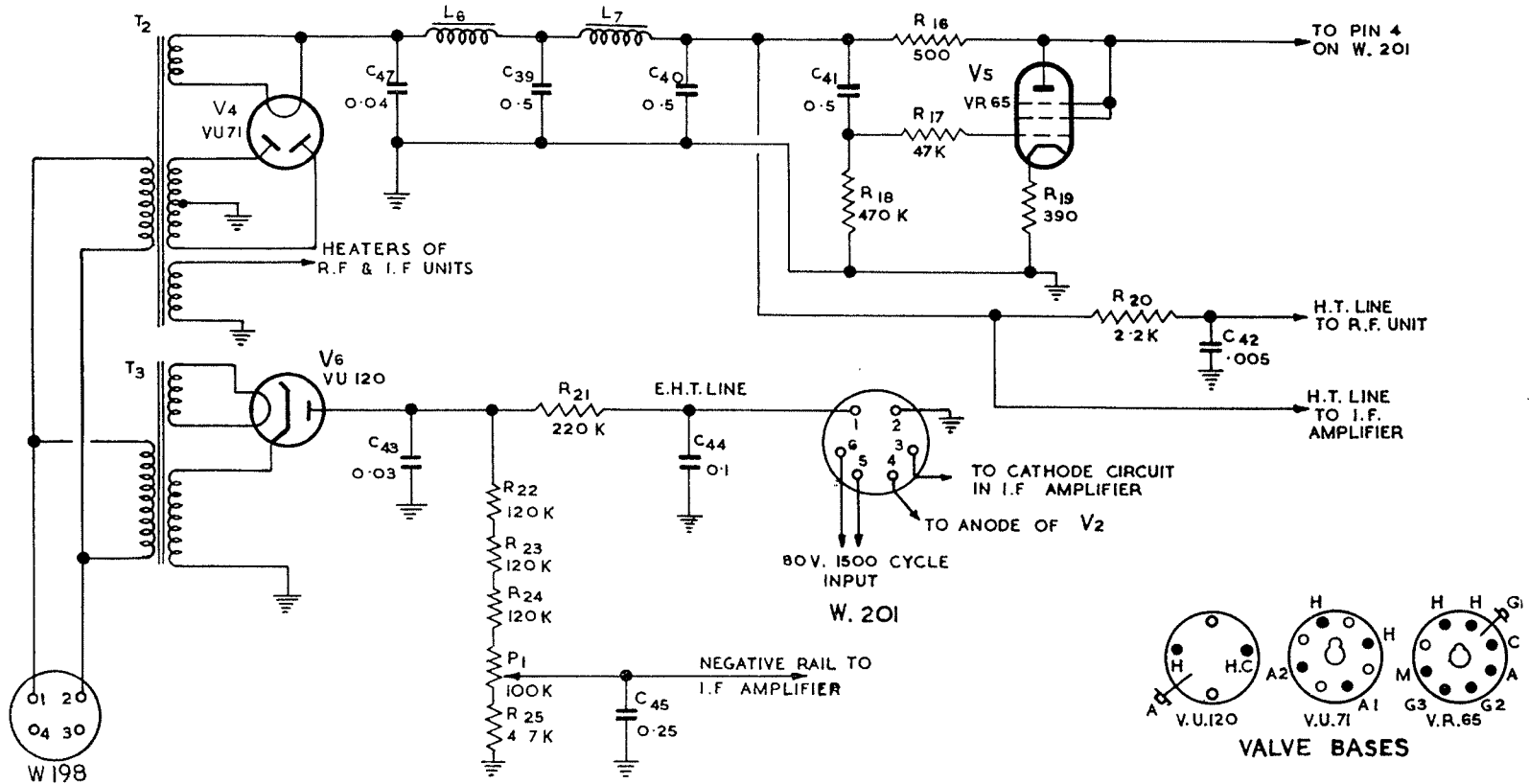

Fig. 22.—Receiver power unit, circuit.

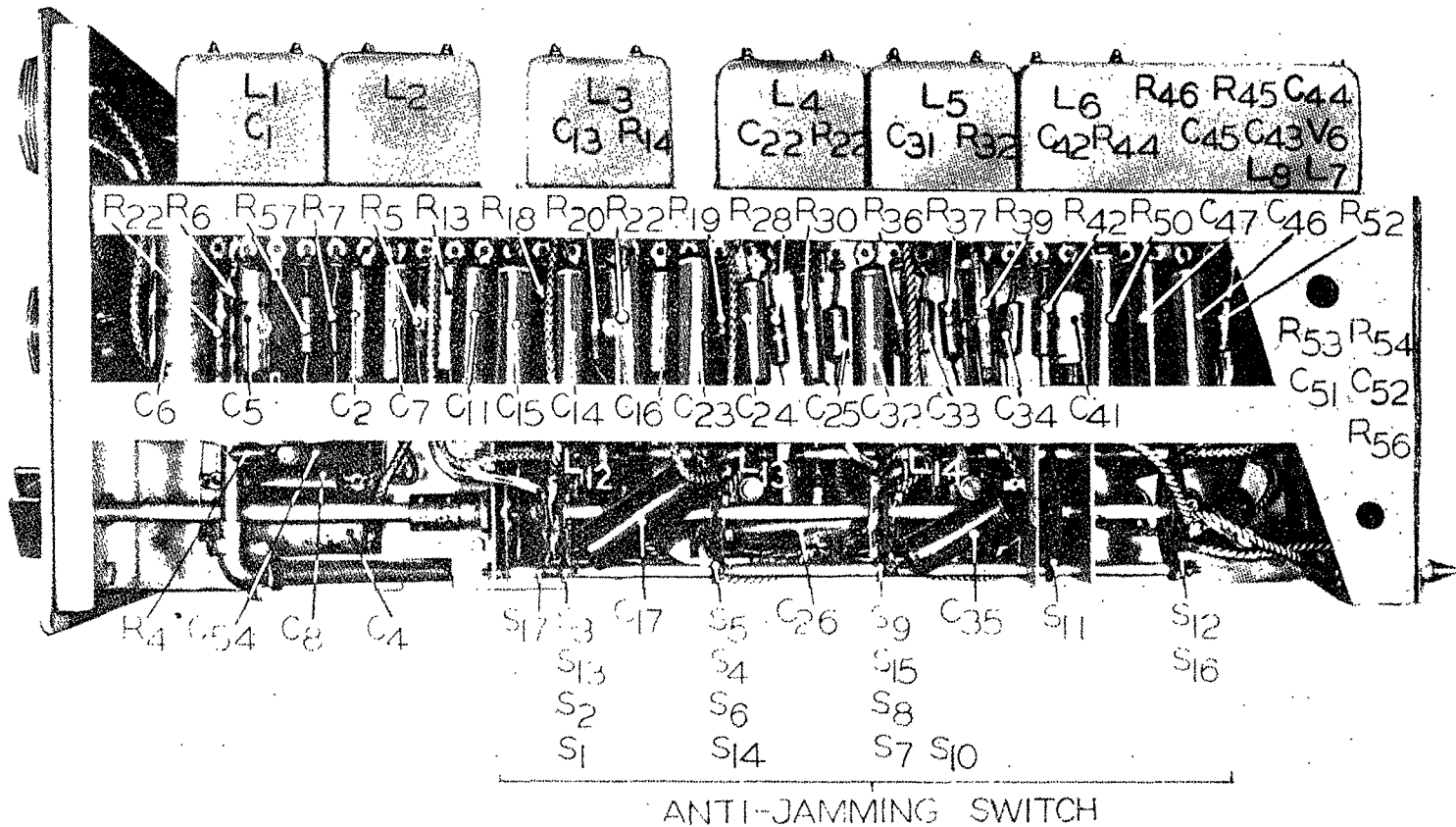

Fig. 23.—R.1355, right-hand side of chassis.

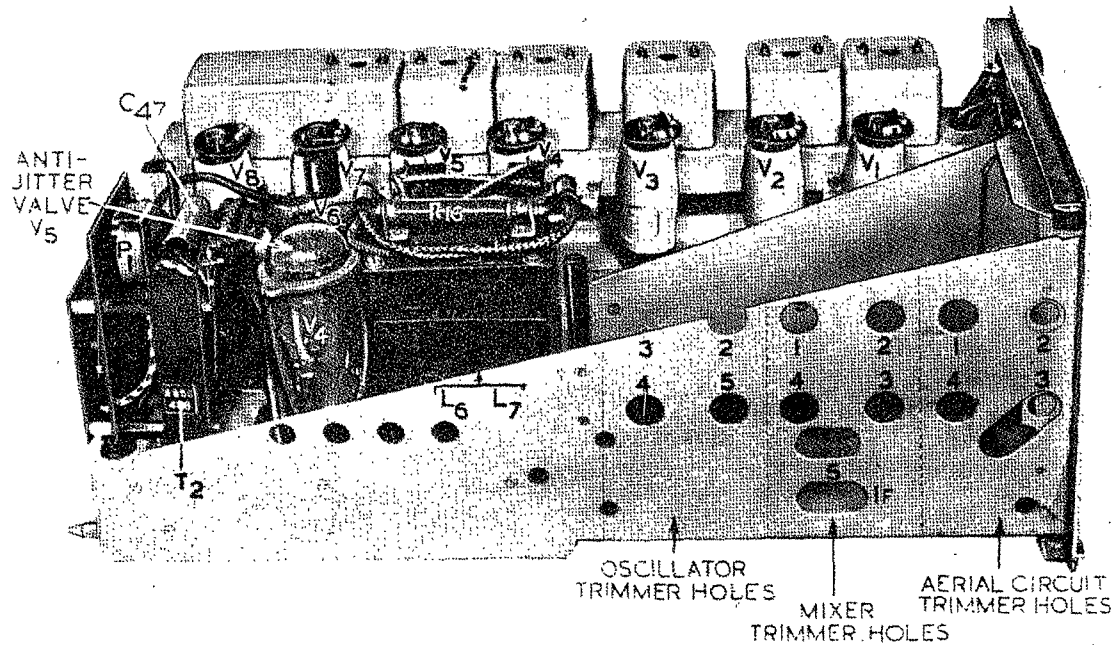

Fig. 24.—R.1355, top left-hand side of chassis.

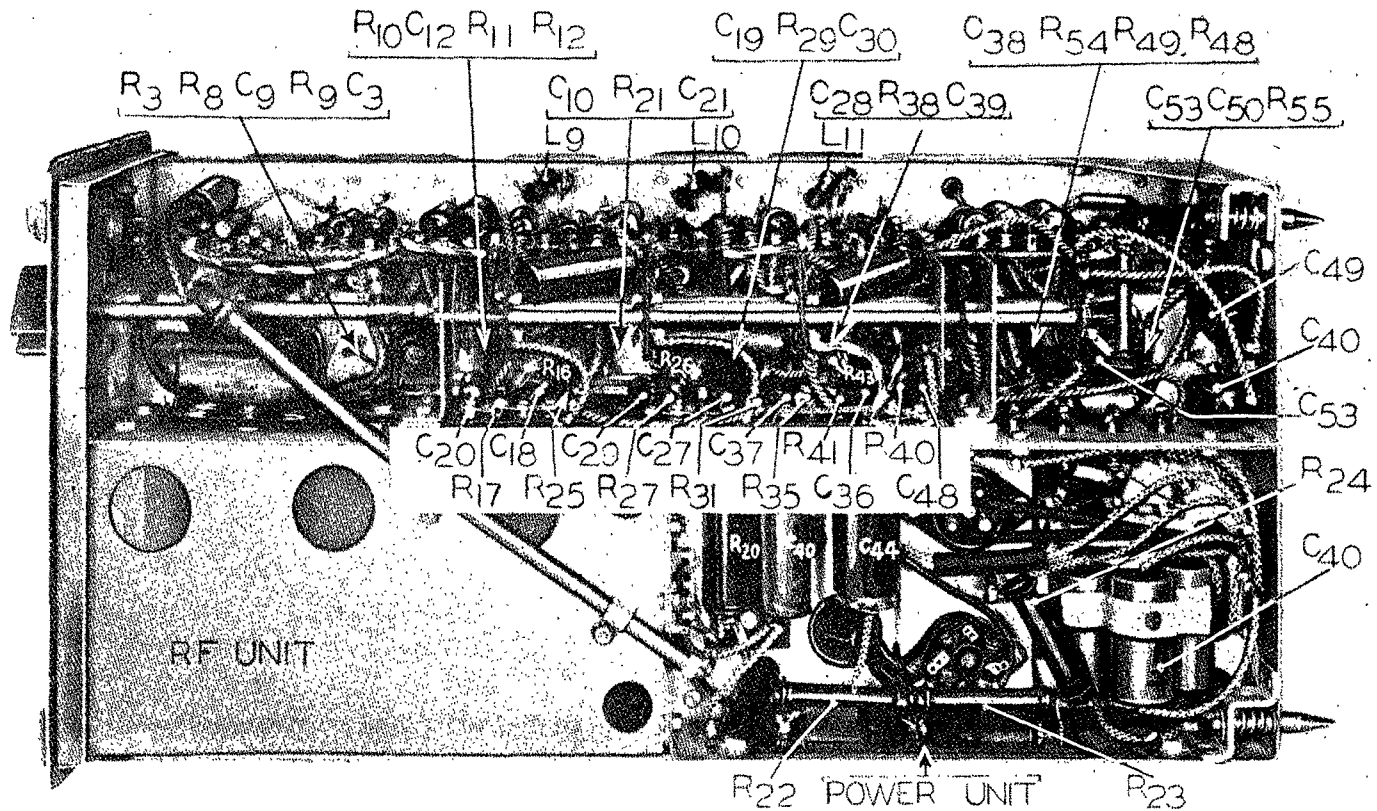

Fig. 25.—R.1355, underside of chassis.

124. *Power supply unit.* The HT supply for the equipment is obtained from the transformer T2 and the valve V4 operating as a normal full-wave rectifier. Smoothing is carried out by means of the chokes L6 and L7, and the condensers C39 and C40. The valve V5 acts as a stabiliser against very low frequency jitter which is generally present with the normal type of engine driven generator. Some of this ripple is fed on to the grid of V5 and the gain is adjusted so that the ripple developed across the anode resistor R16 exactly balances the ripple coming through direct from the power unit.

125. Stabilised HT supply from the anode V5 is fed to the indicator unit through a large 6-pin W plug. Unstabilised HT supply is fed to the receiver unit and the portion of this going to the RI unit is taken through a dropping resistor R20 and decoupling condenser C42 to reduce the voltage.

126. The EHT supply for the CRT and the negative rail supply are obtained from the transformer T3 and half-wave rectifier V6. The EHT supply is smoothed by means of the resistor R21 and the condenser C44. The negative rail supply is obtained from the potential divider consisting of the resistors R22, R23, R24, P1 and R25. The potentiometer P1 enables the voltage to be accurately adjusted. The heater supply for the receiver is obtained from a winding of the transformer T2.

#### INDICATOR UNIT TYPE 62

127. The circuit diagram of the indicator unit type 62 is illustrated in fig. 26. In the description that follows it is assumed that the reader is familiar with such circuits as the squegger and the multivibrator. Information on these circuits may be obtained, if required, by reference to A.P.1093A.

128. *Crystal oscillator and divider unit.* The pentode V12 is the crystal oscillator stage and is a VR65. The crystal has a fundamental frequency of 75 Kc/s and is connected in the grid circuit. The  $50\mu\mu\text{F}$  variable condenser C42 is connected across the crystal to give fine control of the frequency. The inductance L1 and condenser C43 form an impedance screen circuit to maintain the oscillation. The transformer T1 in the anode circuit has its primary and secondary tuned to 150 Kc/s, the second harmonic of the crystal frequency, and they are critically coupled in order to eliminate any trace of 75 Kc/s in the

output. The output across the secondary winding of T1 is a sine wave having an amplitude of at least 100V. peak to peak, and it is applied to the grid circuit of the valve V13 through a small condenser C50.

129. The valve V13 acts as a "squegger" type of oscillator through the transformer T2 which has two tightly coupled windings connected to the grid and anode circuits of the valve as shown. The recurrence frequency of the "squegger" is locked by means of the 150 Kc/s sine wave applied to the grid of the valve V13 so that the output will consist of a series of sharp pulses having a recurrence frequency of 150 Kc/s. These are fed to the next stage in the divider V14 through a winding on transformer T3 which is connected in series with the anode circuit winding of the transformer T2.

130. V14. is another "squegger" oscillator having a similar arrangement to V13. The grid leak R69 has its top end joined to the slider of the potentiometer P11 which forms part of a chain of resistors R70, P11 and R68 from the HT line to earth. The potential to which the grid leak is returned is therefore adjustable by means of the potentiometer P11, and this serves to adjust the division ratio of the stage.

131. The mode of operation of the dividers can best be understood by reference to fig 27, which shows the waveforms obtained at various points in the divider circuit. (The waveforms are drawn as they would appear on an oscilloscope ; during normal operation they are far sharper.) Consider the valve V14 ; when the valve has completed one cycle of operation the grid condenser is charged very negative thus cutting off the valve and preventing further oscillation. The grid condenser will now commence to discharge through the grid leak R69. The synchronising pulses will appear positive on the grid condenser as shown on fig. 25. Eventually one of the synchronising pulses will drive the grid sufficiently near zero bias to enable the valve to oscillate.

132. The first half cycle of oscillation will drive the grid more positive, but the potential across the grid condenser cannot rise much above earth potential as grid current will flow. The second half cycle of oscillation will drive the grid negative again and cut off the valve ; the whole cycle is then repeated again. The setting of the potentiometer P11 controls the rate of discharge of the condenser and thus can be used to set the division ratio. Normally this stage is arranged to divide by five.



133. The resistance R71 in the cathode circuit of V14 provides synchronising pulses for the following stage V15. The grid condenser for this stage, C54, is connected to earth in series with this resistance so that positive synchronising pulses will be injected into the grid circuit. The valve V15 functions in exactly the same manner as V14 and the waveforms obtained are shown in fig. 27. This stage only divides by two so that no preset control is provided.

134. The next stage V16 has a similar circuit, synchronising pulses being fed in through a third winding on the transformer T5 which is connected in series with the anode circuit winding of the transformer T4. The potentiometer P12 is the preset control for the division ratio, and this stage is adjusted to divide by five.

135. The last stage of division is a multivibrator consisting of the valves V17 and V18. The time constant in the grid circuit of V17 (C61, R85) is much longer than the time constant in the grid circuit of V18 (C62, R86), so that the waveform from the multivibrator is unsymmetrical. Negative synchronising pulses (see fig. 27) are derived from a small resistor R80 and fed to the grid of V18 through a small condenser C59. The pulses are amplified by V18 and applied as positive pulses to the grid of V17. The control of the time constants at the two grids is carried out by the potentiometers P13 and P14. P13 controls the width of the narrow positive pulse which appears at the anode of V18. The width of this pulse determines the flyback time of the time base, and its trailing edge is used to initiate the "A" strobe time base. The potentiometer P14 controls the recurrence frequency of the multivibrator and is the control for setting up the division ratio.

136. The multivibrator stage V17 and V18 normally divides by six, but can be made to divide by 7 by switching in the resistance R89 in series with the normal grid leak R85. This switching is accomplished by the recurrence frequency switch mounted on the front panel of the instrument. Two outputs are taken from the divider to the time base, namely from the anodes of V17 and V18, and the waveforms obtained are shown in fig. 27 (g) to fig. 28 (g).

137. The purpose of the third winding on the transformers T2 and T4 may now be explained. Across the third winding on T2, 150 Kc/s calibration pips are produced which it is desired to feed on to the Y plate of the CRT to act as calibration markers. It is also desired to

raise the amplitude of every 10th 150 Kc/s pip to indicate the whole number and to assist in counting. This is accomplished as follows:—

138. One end of the third winding on T2 is joined to the cathode of V15, the 15 Kc/s stage, and a small resistor R74 is connected between cathode and earth. A wide positive pulse is produced across this resistor and the resultant waveform between the free end of the winding on T2 and earth is as shown in fig. 27 (j), every 10th 150 Kc/s pip being raised above the others. The third winding on T4 behaves in the same manner, every 5th 15 Kc/s pulse being raised up by means of a pulse across the cathode resistor of V16 (R78); the waveform is as shown in fig. 27 (k). These two waveforms are cleaned up in a manner described later (see para. 158), and applied to the Y plate of the CRT as calibration markers.

139. *Main time base.* The operation can best be understood by referring to fig. 28 which gives the waveforms at various points in the circuit. The valves V5 and V6 in the circuit are used to produce the time base sweep. In the main time base position output from the anode V17 in the divider is fed to the suppressor grid of V5 through the condensers C58 and C10. DC restoration is provided at the suppressor grid by means of one half of the double diode V4.

140. The valve V5 has a condenser C9 connected between the anode and control grid, and C63 is connected in parallel with C9 by the switch S10. The grid leak R18 is connected to the slider of the potentiometer P2 which forms part of a chain of resistances P1, R16 and P2 between the HT line and earth. During the short negative pulse (see fig. 28 (j)), input to suppressor grid) the anode current will be cut off so that the condensers C9 and C63 will charge up to the potential of the HT line through the resistances R20 and the grid to cathode impedance of V5.

141. At the end of the short negative pulse the suppressor grid is brought up to zero bias again and the anode potential commences to fall. For the first few volts the fall of potential is very rapid as the grid has been at zero bias and is now carried down with the anode to a normal bias. The anode voltage will then fall steadily in a linear fashion as the condensers C9 and C63 are discharged by current through R18 in such a manner that the grid voltage is kept to the grid voltage—anode current characteristic of V5. The next negative pulse causes the condenser C9 and C63 to charge up again to HT potential when the whole cycle is repeated.



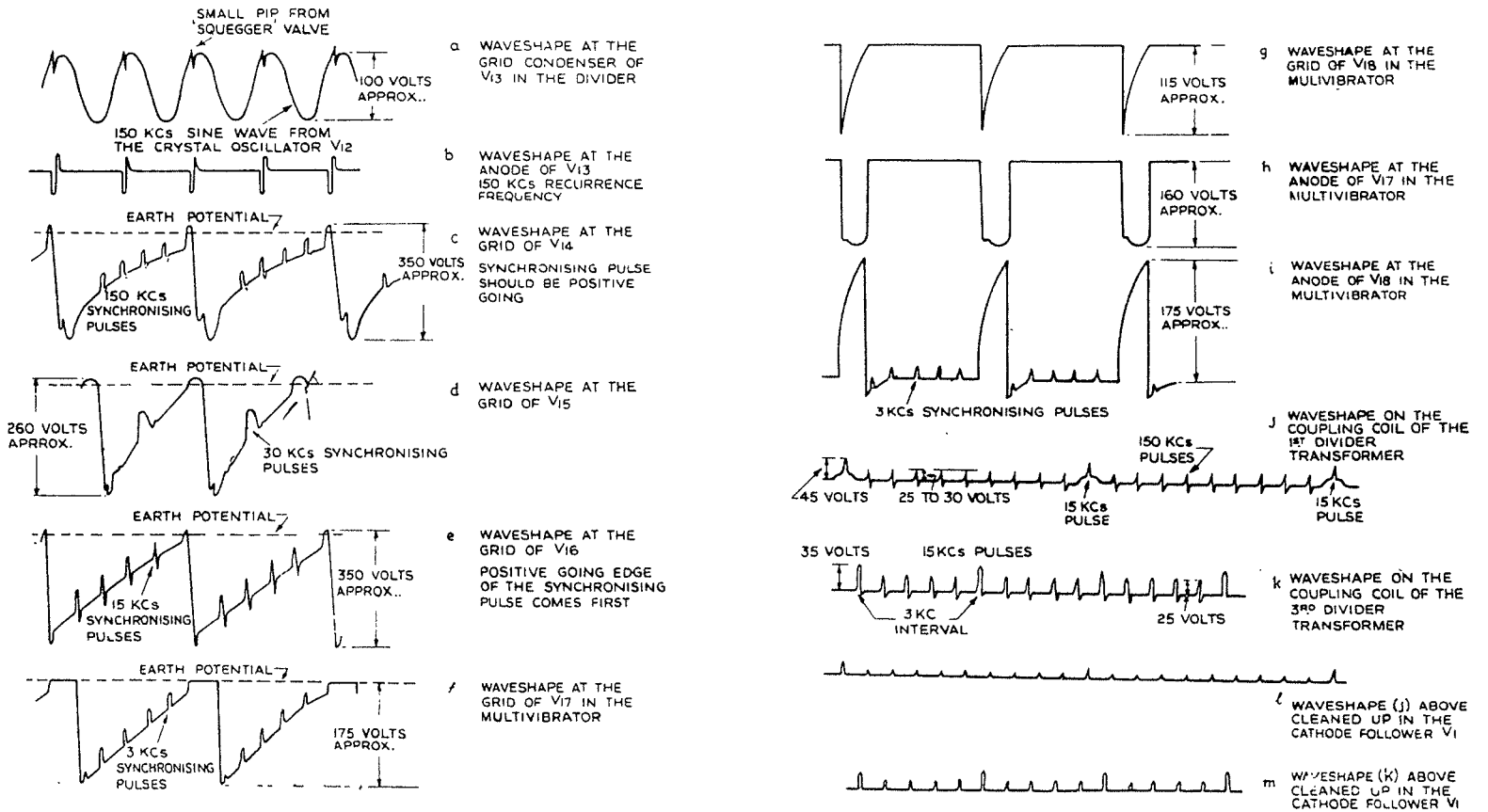

Fig.27.—Waveforms [1].

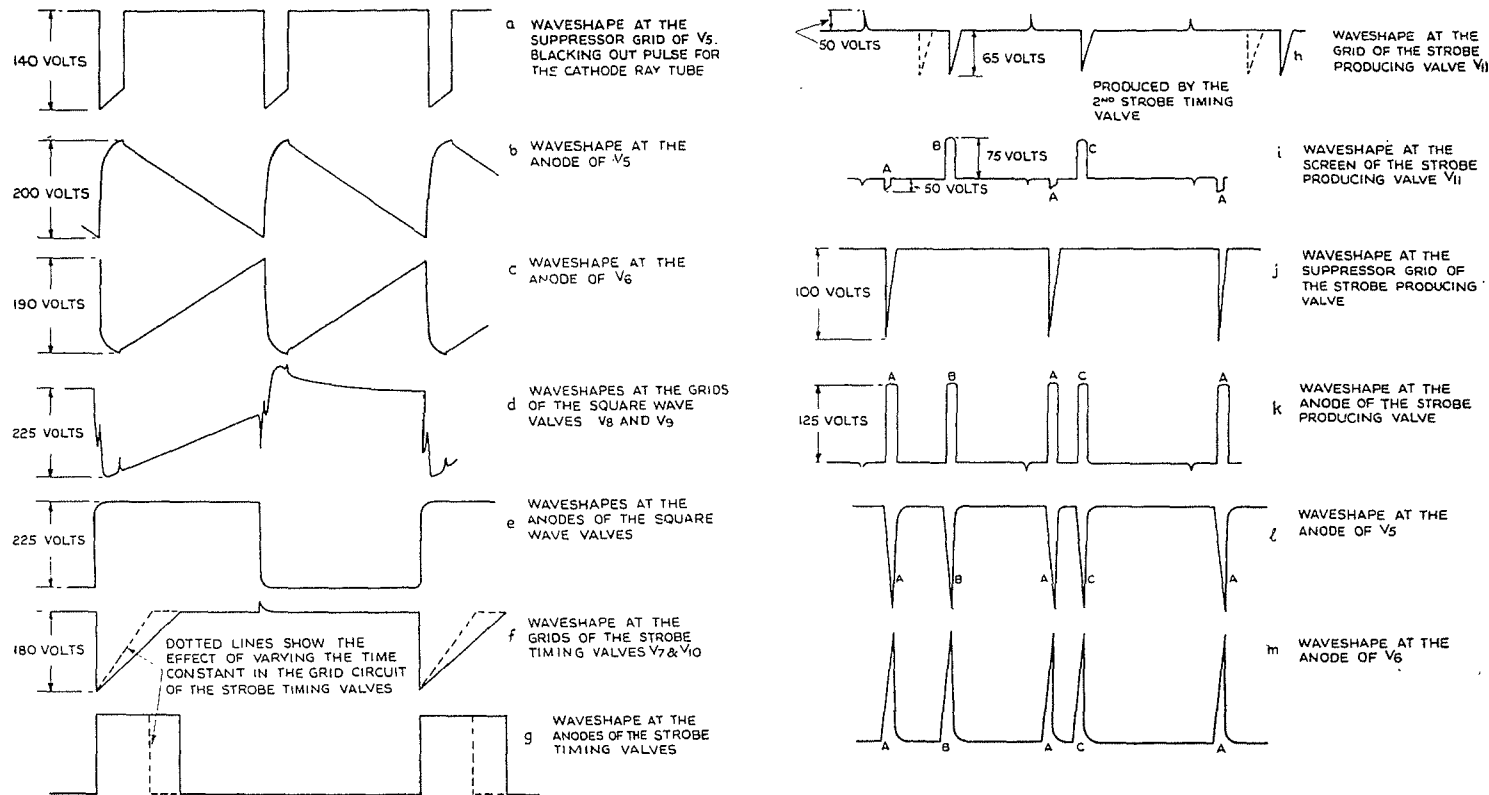

Fig. 28.—Waveforms [2].

142. Amplitude control of the sweep is carried out by means of the potentiometer P2. Push-pull deflection is obtained by using the valve V6. The grid of this valve is fed with output from the anode of V5 through the resistance condenser network shown in the circuit, R23 and R24 being high resistances of equal value. The X plates of the CRT are DC coupled to the anodes of V5 and V6, the shift being obtained by altering the bias of V6 by means of the potentiometer P3, thus altering the mean potential at the anode. The resistance R22 is connected between the anode of V5 and earth to lower the mean anode potential of this valve, so that the mean anode potential of V6 may be either raised or lowered with respect to that of V5.

143. The spacing between the traces is produced by applying square waveforms to one of the Y plates of the CRT. The square wave is produced by a multivibrator consisting of the valves V8 and V9. The circuit is arranged so that the multivibrator action takes place between the grids and screens of the two valves; the anodes have load resistances R39 and R47 from which the outputs are taken. The multivibrator is synchronised from the waveform at the anode of V17 which is differentiated by the condensers C24 and C25 and the resistors R43 and R44, and applied to both grids of the multivibrator. The spacing waveform is taken off the anode V8 through R38 and P8 and applied directly to the Y2 plate; C23 is a blocking condenser to keep off the HT voltage. The preset potentiometer P8 controls the amplitude of the spacing waveform applied to the Y plate.

144. *Strobe time base.* The two "A" strobe time bases (see fig. 28) are initiated from the trailing edge of the positive pulse produced at the anode of V18. The "B" and "C" strobe time bases are initiated from a timing edge produced at the anodes of V7 and V10.

145. Consider the operation of the valve V7. The grid is connected through the condensers C16 and C22 to the anode of V8 and so receives a square wave input. The grid leak R36 has its top end connected to the junction of R53 and R54, two resistances between the HT line and earth. The grid of V7 is thus returned to a point positive with respect to earth. During the positive-going portion of the square wave the grid V7 will remain at zero bias and the anode tension will be low. When the square wave goes negative V7 will be cut off but the grid potential will gradually leak back towards zero potential at a rate depending on the time constant (C16 to C22 and R36). Eventually the valve will conduct again, and the grid will remain at zero potential until the next negative going square wave comes along. The anode waveform will be a square pulse as shown in fig. 28 (g), the width of

which is controlled by varying the value of the capacity in the grid circuit.

146. The strobe time base is initiated off the back edge of this pulse, and can be set to any position between one negative-going and the following positive-going edge of the square wave; it will therefore be possible to move the strobe along one trace of the time base. Coarse control of the strobe timing is carried out by means of the fixed capacities C16 to C20 which are switched in circuit by means of S8. Fine control is carried out by the variable condenser C22. Both these controls are brought out to the front panel of the indicator unit.

147. The valve V10 works in exactly the same manner as V7, except that its grid is fed from the opposite valve in the square wave generator V9. The strobe timing edge produced at the anode of V10 will therefore occur on the opposite trace to that produced at the anode of V7. Coarse control of the strobe position is carried out by means of the condensers C30 to C34 which are switched in circuit by S9; C36 is the fine control. Both controls are brought out to the front panel of the indicator unit.

148. It is now necessary to convert the timing edges produced at the anodes of V18, V7 and V2 into square pulses of sufficient width to produce the strobe time base. This is accomplished by the valve V11.

149. The outputs from the anodes of V7 and V10 are fed to the grid of V11 through the small condensers C38 and C39. The grid leak R56 has its free end joined to the slider of the potentiometer P10 which is part of a chain of resistors between the HT line and earth, consisting of P9, P10 and R55. The grid leak is thus returned to a point which is positive with respect to earth.

150. The output from the anode of V18 is connected to the suppressor grid of V11 through a small condenser C41 and stopper resistance R62. The purpose of this latter resistance is to filter out the small 3 Kc/s synchronising pulses which will appear at the anode of V18. The leak to the suppressor grid R58 is joined to the slider of the potentiometer P9 which forms part of the chain previously mentioned between the HT line and earth. The suppressor grid leak is thus returned to a point positive with respect to earth, but the suppressor grid itself is held at earth potential by means of one half of the double diode V4. The negative input signal through C41 must therefore exceed the dropping potential across R62 before it will have any effect on the suppressor grid. Since the 3 Kc/s synchronising pulses have a much smaller amplitude than the wanted input pulses it is possible to filter them out by means of this circuit.

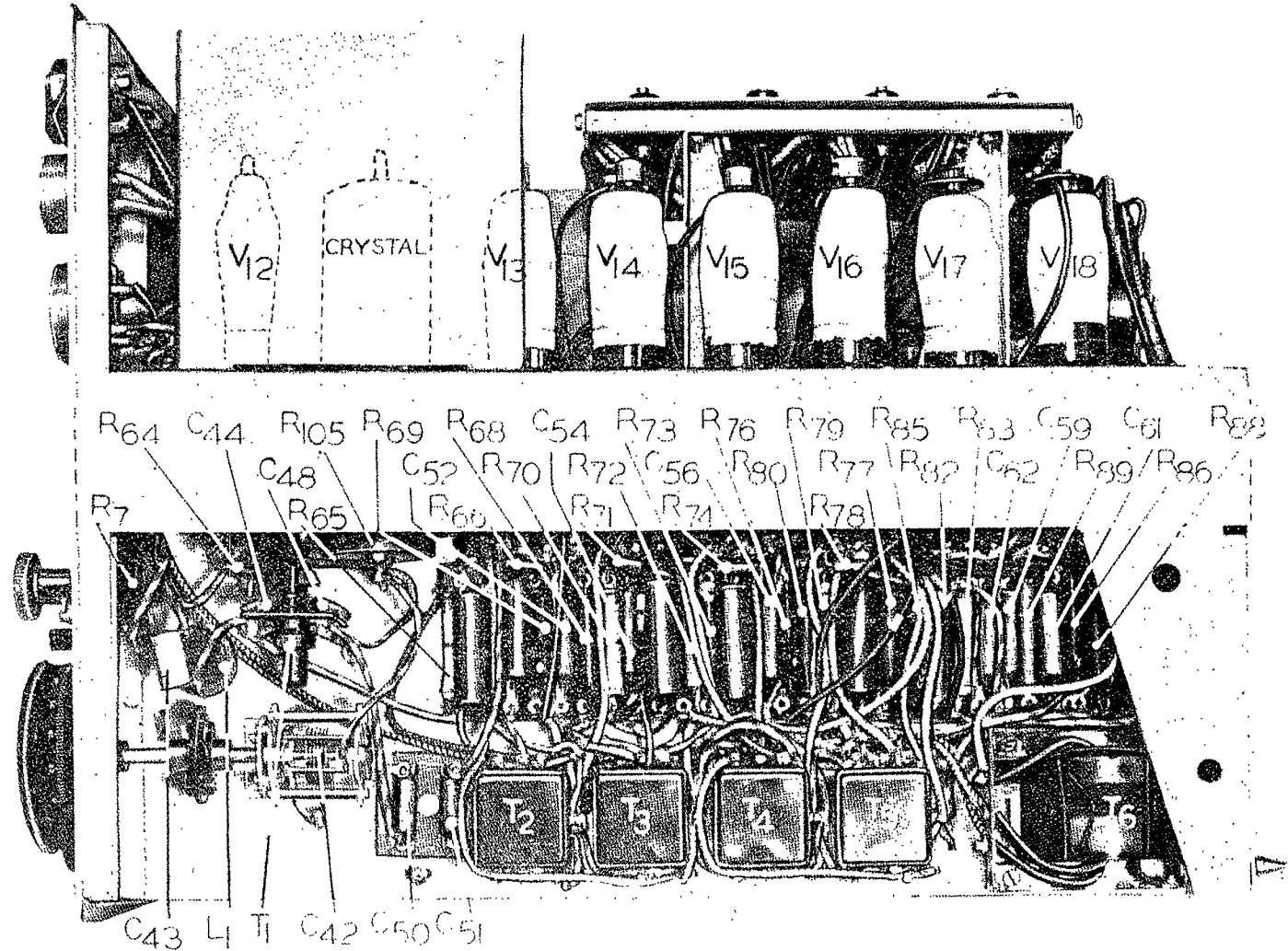

Fig. 29.—Indicator unit type 62, right-hand side of chassis.

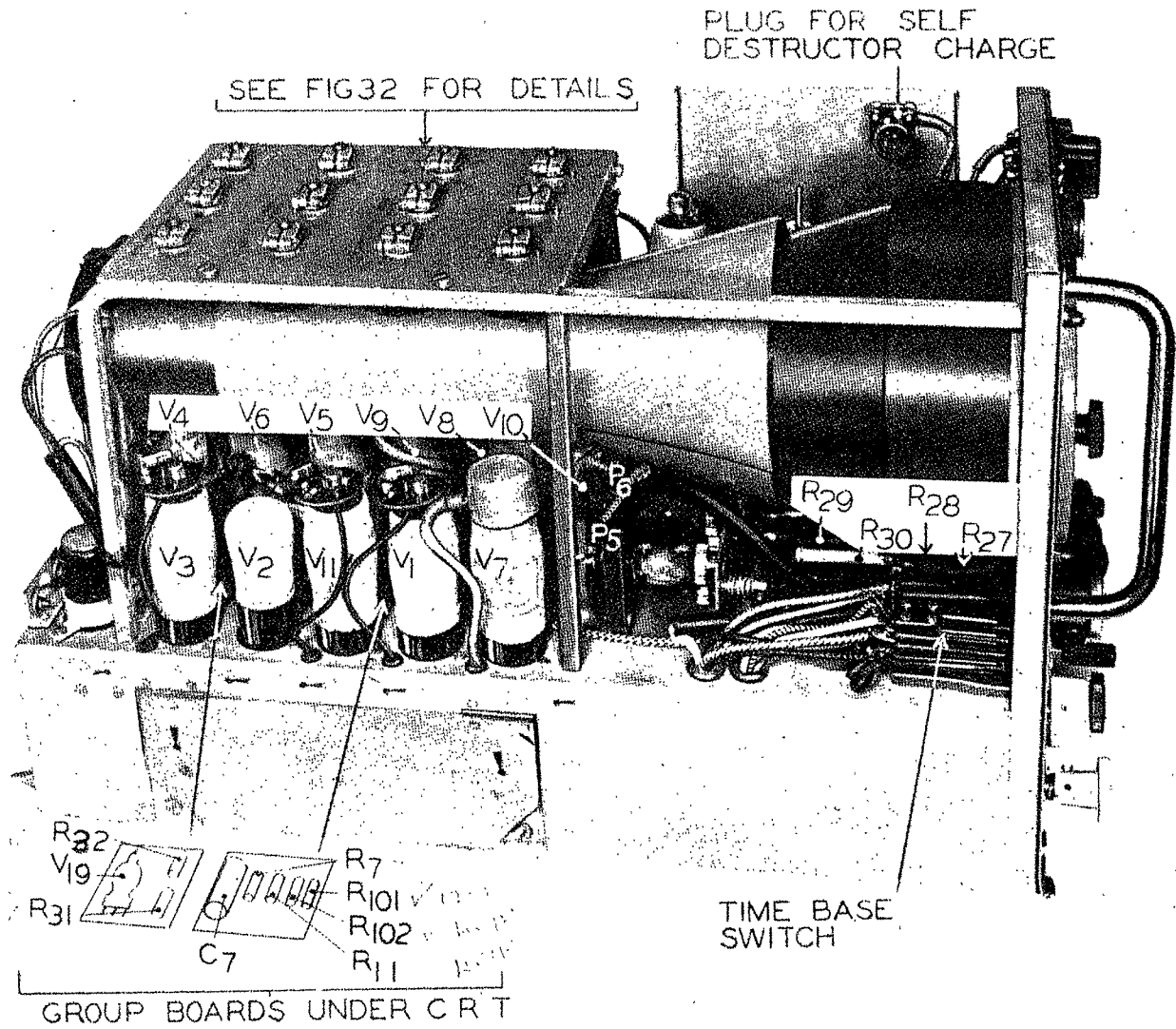

Fig. 30.—Indicator unit type 62, top left-hand side of chassis.

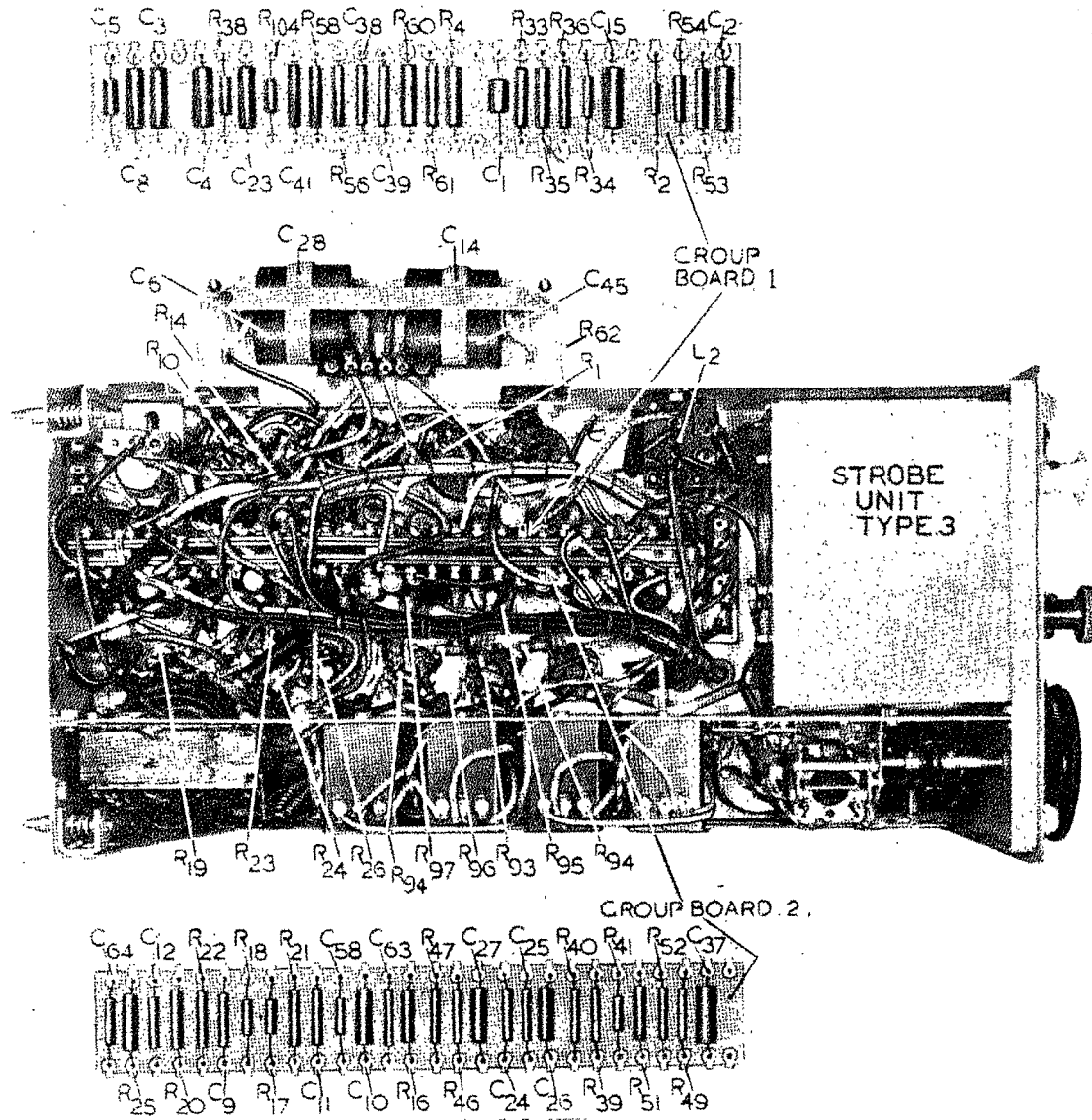

Fig. 31.—Indicator unit type 62, underside of chassis.

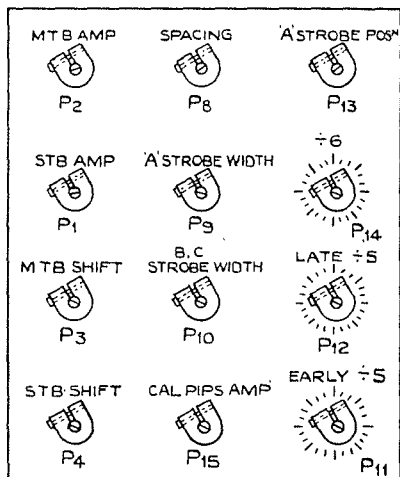

Fig. 32.—Indicator unit type 62, presets on top of chassis.

151. The pulses from the anodes of V7 and V10 are differentiated by means of the small condensers C38 and C9 and the grid leak R56. The positive-going pulse will be nearly eliminated due to grid current but the negative-going pulse will cut off the valve. The charge on C38 (or C39) will then leak up towards zero and eventually the valve will conduct again. A square pulse will thus be produced across the anode and screen resistors of V11 (R60 and R61). The width of this pulse will be controlled by the capacity of C38 or C39, the value of the grid leak R56 and the potential to which the grid leak is returned. This latter is controlled by means of the preset potentiometer P10 which therefore serves to control the width of the square pulse produced at the anode and the screen.

152. The same action takes place at the suppressor grid of the valve through the condenser C41 and the grid leak R58, except that the suppressor grid will have little or no control on screen on the valve (actually a small negative-going pulse is produced). The potentiometer P9 controls the width of the pulse at the suppressor grid.

153. Thus positive-going-square pulses of the correct width for producing the strobe time base and corresponding to the "B" and "C" strobe positions will be produced at the screen of V11, and positive-going pulses corresponding to the "A". "B" and "C" strobe positions will be produced at the anode of V11. The output from the screen of V11 is fed to a special Y plate amplifier valve, the operation of which is described later (see para. 161). The output from the anode is fed through the switch S5 (one of the contacts on the time base change-over switch) to the suppressor grid of V5. The suppressor grid is normally cut off by means of the automatic bias provided by C10 and R19.

154. When the positive pulse arrives the valve V5 will conduct so that the anode potential will fall as described for the main time base. The rate of fall will be much faster than in the main time base position as the grid leak R18 is now connected to the potentiometer P1 which is at a much higher positive potential with respect to earth than the potentiometer P2. P1 controls the amplitude of the strobe time base. At the end of the positive pulse on the suppressor grid of V5 the valve is cut off so that the condenser C9 charges up to the HT potential again through the resistance R20. The valve V6 functions as for the main time base excepting that the potentiometer P4 now controls the bias of V6 and this controls the shift.

155. *The expanded strobe time base.* The expanded strobe time base is obtained by operating the bank S10 on the time base switch. This reduces the time base condenser from C63+C9 to C9, and speeds up the time base. The anode potential of V5 thus falls very quickly when a strobe time base pulse appears at the suppressor grid until it reaches about 50 volts above earth when it stays constant until the pulse on the suppressor grid disappears.

156. *Flyback blackout.* Blackout pulses for the cathode ray tube modulator are taken from the suppressor grid of V5 through the condenser C13. On the strobe time base position, positive pulses are applied to the modulator to brighten up the tube during the trace, whilst on the main time base the negative pulse on the suppressor grid blacks out the tube during flyback. The diode V19 DC restores at the grid of the cathode ray tube. The DC restoring action is made slightly inefficient by means of the resistance R32 in series with the diode; this tends to equalise the brightness between the main and strobe time bases.

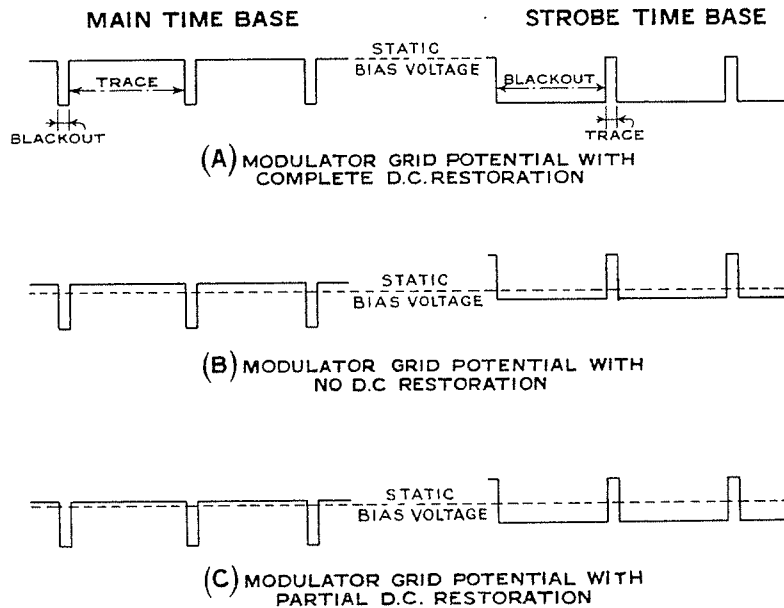

Fig. 33.—Diagram to illustrate partial DC restoration of CRT grid.

157. The action of the diode V19 and V32 may be explained as follows. If V19 were omitted from the circuit (i.e. no DC restoration were attempted) the mean potential of the modulator grid of the cathode ray tube would be zero or, in other words, during the time when no pulses were being received from the suppressor of V5 the potential of the modulator would be positive by an amount dependent on the magnitude and width of the negative-going pulse. That is, the trace brightness would depend on the magnitude and width of the blackout pulse.

158. Now in the strobe time base position, the blackout pulse to the cathode ray tube is of much longer duration than in the main time base position (see fig. 33). Therefore, with V19 omitted, the positive modulator potential during the trace would be much higher for the strobe time base than for the main time base; so much higher in fact that the strobe time base would appear brighter than the main time base in spite of its increased speed of scan.

159. Suppose now that complete DC restoration were attempted, that is, V19 were connected in circuit but R32 were short circuited. In this case, because of the unidirectional conductivity of the diode the modulator grid could not rise above earth potential and hence the potential during scanning would always be zero. It would follow therefore that the higher speed strobe time base would be less bright than the main time base.

160. It will be clear from a consideration of para. 157 to 159, that a solution of the problem of maintaining the main time base at the same brightness as the strobe base lies in partially DC restoring the modulator grid of the cathode ray tube; this is done by V19 in conjunction with R32. During the forward scan, when V19 is conducting, the potential drop across R32 ensures that the modulator grid is at a potential above cut-off, but not by the full amount that would obtain if V19 were not present. The value of R32 is chosen so that during the forward scan the modulator grid potential on the strobe time base is just sufficiently higher than on the main time base to compensate for the higher speed of scan of the strobe time base.

161. *Y plate reverser valve V3.* Input to the grid of the valve V3 comes either from the receiver output or from the calibration marker valve V1 according to the position of the clearing switch S1. The Y1 plate of the CRT is connected to the anode of V3 through the condenser C5. The output from the receiver, which is positive-going, is DC restored by the lower half of the double diode V2. The suppressor grid of V3 is fed with positive-going pulses from the screen of V11 corresponding to the "B" and "C" strobe time bases (see fig. 27) through the condenser C8 and the resistance R14. The suppressor is also connected to the anode of the diode V21 to prevent it being driven positive. The lower end of R14 is connected to a point on the chain of resistances across the negative supply voltage to the CRT, which is at a potential of  $-80$  v. with respect to earth.

162. The anode current of V3 is normally cut off by this bias, at the suppressor grid, and the valve will only pass anode current for a short period corresponding to the "B" and "C" strobe pulses. The anode of V3 is connected back to the input circuit condenser C3 through the resistances R5 and R6, C4 being a blocking condenser. The second half of the double diode V2 is connected between the junction of R5 and R6 and the grid of V3, and prevents the grid from being driven positive.



163. In the normal position with the anode current to V3 cut off, the signals will pass to the Y plate through R5 and R6. The signal reaching the Y plate will be reduced to about two-thirds of its original value. When V3 is in operation the signal is phase reversed by the valve, and owing to negative feedback through R5 and R6, the resistance values of which are in the ratio of 2 : 3, the gain is only about two-thirds, i.e. the signal on the anode is equal in size but opposite in sign to the signal when the valve is cut off.

164. The step on the main time base to mark the position of the strobos is produced because a small steady anode current flows in V3 when the valve is brought on by the suppressor grid during the "B" and "C" strobos. This current develops across R9 a negative pulse equal to the width of the strobe which is fed to the Y plate.

165. *Power supply.* The transformer T6 provides the heater supply for all the valves in the time base and divider circuits, the CRT, and the DC restoring diode V19. Its primary winding is fed from the 80 v. AC supply which comes into the indicator unit through pin 5 and 6 on the large 6-pin W plug mounted on the front panel. The HT supply is fed to the indicator through pin 4 of this same W plug. Pin 3 feeds the receiver gain control potentiometer P7 mounted on the front panel of the unit. Pin 1 of the W plug provides the EHT for the CRT, namely —1600 v.

166. The choke L2 with the condenser C45 prevents any ripple getting along the HT line to the indicator from the receiver in the presence of certain types of jamming.

## APPENDIX I

### LIST OF PRINCIPAL COMPONENTS

This list is issued for information only. When ordering spares for this equipment, reference should be made to Volume III of this publication.

<i>Annotation in figure</i>	<i>Stores Ref.</i>	<i>Description</i>	<i>Annotation in figure</i>	<i>Stores Ref.</i>	<i>Description</i>
<i>Fig. 11</i>	10D/13032	<b>Receiver R.1355</b>	R10	10C/114	6800 ohms $\pm 10\%$ , $\frac{1}{2}$ watt
L1	10D/1015	<i>RF unit type 24</i>	R14, R20	10C/11671	10K $\pm 10\%$ , $\frac{1}{4}$ watt
L2	10D/1191	Aerial coil	R25, R28	10C/6079	10K $\pm 20\%$ , $\frac{1}{2}$ watt
L4	10D/1192	Mixer Grid coil		10C/12110	Resistance unit Type 235 comprising :—
L3	10D/1193	Oscillator coil	R13	10C/1847	2200 ohms $\pm 20\%$ , $\frac{1}{2}$ watt
T1	10D/1088	Mixer anode coil	R15	10C/6840	100K $\pm 20\%$ , $\frac{1}{2}$ watt
	10D/1194	Oscillator coupling coil		10C/12111	Resistance-condenser unit Type 239 comprising :—
C8	10C/2108	5 $\mu$ F $\pm 5\%$ , 500v. D.C.	C2	10C/2076	0.0003 $\mu$ F $\pm 15\%$ , 300 v. D.C.
C16, C6, C22	10C/3303	10 $\mu$ F $\pm 5\%$ , 500v. D.C.	C11	10C/3100	0.001 $\mu$ F—25% + unlimited, 350v. D.C.
C20, C40	10C/10948	20 $\mu$ F $\pm 5\%$ , 500v. D.C.	C12	10C/53	100 ohms $\pm 10\%$ , $\frac{1}{2}$ watt
C38	10C/5168	25 $\mu$ F $\pm 5\%$ , 500v. D.C.	R1	10C/1847	2200 ohms $\pm 20\%$ , $\frac{1}{2}$ watt
C4, C42	10C/10607	15 $\mu$ F $\pm 5\%$ , 500v. D.C.	R2	10C/310	3000 ohms $\pm 10\%$ , $\frac{1}{2}$ watt
C36	10C/3434	30 $\mu$ F $\pm 5\%$ , 500v. D.C.	R3	10C/6079	10K $\pm 20\%$ , $\frac{1}{2}$ watt
C34	10C/12113	35 $\mu$ F $\pm 5\%$ , 500v. D.C.			Resistance-condenser unit Type 240 comprising :—
C18	10C/12114	40 $\mu$ F $\pm 5\%$ , 350v. D.C.	C28	10C/2076	0.0003 $\mu$ F $\pm 15\%$ , 350v. D.C.
C32, C27	10C/3025	50 $\mu$ F $\pm 15\%$ , 500v. D.C.	R23	10C/1847	2200 ohms $\pm 20\%$ , $\frac{1}{2}$ watt
C13	10C/96	0.0001 $\mu$ F $\pm 15\%$ , 350v. D.C.	S1, S2, S3	10F/1630	3-bank selector switch
C12, 14, 15, 25, 26, 29, 30, 31	10C/2076	0.0003 $\mu$ F $\pm 15\%$ , 350v. D.C.	V1, V2, V3	10E/11446	Screened pentode valve, VR.65
C1	10C/3100	0.001 $\mu$ F—25% + unlimited, 350v. D.C.	<i>Fig. 12</i>	10D/1016	<i>RF unit type 25</i>
C3, 5, 7, 9, 10, 33, 35, 37, 39, 41, 17, 19, 21, 23, 24	10C/4917	3 to 30 $\mu$ F air, variable concentric	L5	10C/11594	HF choke 100 turns, 40 S.W.G.
Aerial input	10H/528	Single pole coaxial plug Type 229	L1	10D/1084	Aerial coil
	10H/1523	6-pole "Jones" plug Type 360	L2	10D/1085	Mixer Grid coil
		Resistances :—	L4	10D/1086	Oscillator coil
R5	10C/8821	10 ohms $\pm 20\%$ , $\frac{1}{4}$ watt	T1	10D/1087	Oscillator coupling coil
R4	10C/9466	22 ohms $\pm 20\%$ , 1/10 watt	L3	10D/1088	Mixer anode coil
R11	10C/9467	27 ohms $\pm 10\%$ , 1/10 watt	C14, 22	10C/3303	Condensers :—
R21, R26	10C/8391	47 ohms $\pm 10\%$ , 1/10 watt	C36	10C/4478	10 $\mu$ F $\pm 5\%$ , 500v. D.C.
R6	10C/8297	47 ohms $\pm 20\%$ , 1/10 watt	C20	10C/11569	10 $\mu$ F $\pm 1\mu$ F, 350 v. D.C.
R16	10C/8684	100 ohms $\pm 20\%$ , 1/10 watt	C28	10C/10607	11.5 $\mu$ F $\pm \frac{1}{2}\mu$ F, 500v. D.C.
R27	10C/1653	220 ohms $\pm 10\%$ , $\frac{1}{2}$ watt	C11, 32, 34	10C/11558	15 $\mu$ F $\pm 5\%$ , 500v. D.C.
R22	10C/11678	1000 ohms $\pm 10\%$ , $\frac{1}{2}$ watt	C29	10C/12074	15 $\mu$ F $\pm 10\%$ 350v. D.C.
R17	10C/1082	1500 ohms $\pm 10\%$ , $\frac{1}{4}$ watt	C27	10C/10568	25 $\mu$ F $\pm 5\%$ 350v. D.C.
R18	10C/691	2200 ohms $\pm 10\%$ , $\frac{1}{4}$ watt	C10	10C/96	50 $\mu$ F $\pm 1\mu$ F, 500v. D.C.
R24	10C/10862	2400 ohms $\pm 10\%$ , $\frac{1}{4}$ watt	C7, 8, 18, 19, 21, 24, 25, 26, 30		100 $\mu$ F $\pm 15\%$ 350v. D.C.
R19	10C/10864	3600 ohms $\pm 10\%$ , $\frac{1}{4}$ watt	C1, 2, 3, 4, 5, 12, 13, 15, 16, 17, 31, 33, 35, 37, 38	10C/2076	300 $\mu$ F $\pm 15\%$ , 350v. D.C.
R7	10C/8760	3900 ohms $\pm 10\%$ , $\frac{1}{4}$ watt		10C/4917	3 to 30 $\mu$ F air, variable, concentric
R8	10C/948	4700 ohms $\pm 10\%$ , $\frac{1}{4}$ watt		10H/528	S.P. coaxial plug type 229
R9	10C/10865	6200 ohms $\pm 10\%$ , $\frac{1}{4}$ watt		10H/1523	6 pole "Jones" plug type 360

<i>Annotation in figure</i>	<i>Store Ref.</i>	<i>Description</i>	<i>Annotation in figure</i>	<i>Stores Ref.</i>	<i>Description</i>
Fig. 12		RF unit type 25—continued		10H/528	S.P. Coaxial plug type 229
R26, 27	10C/8619	Resistances :—		10H/1523	6-pole "Jones" plug type 360
		33 ohms $\pm 20\%$ 1/10 watt	R16	10C/1105	Resistances :—
	10C/6926	33 ohms $\pm 20\%$ $\frac{1}{2}$ watt			56 ohms $\pm 10\%$ 1 watt
R6	10C/8391	47 ohms $\pm 10\%$ 1/10 watt	R11	10C/11665	100 ohms $\pm 10\%$ $\frac{1}{2}$ watt
	10C/540	47 ohms $\pm 10\%$ $\frac{1}{2}$ watt	R4	10C/1931	150 ohms $\pm 20\%$ $\frac{1}{2}$ watt
R12	10C/1954	100 ohms $\pm 20\%$ $\frac{1}{2}$ watt	k9	10C/690	470 ohms $\pm 10\%$ $\frac{1}{2}$ watt
R7	10C/1867	1000 ohms $\pm 20\%$ $\frac{1}{2}$ watt	R15	10C/11667	1000 ohms $\pm 10\%$ $\frac{1}{2}$ watt
R11	10C/8915	3300 ohms $\pm 10\%$ 1/10 watt	R8	10C/1867	1000 ohms $\pm 20\%$ $\frac{1}{2}$ watt
R8	10C/1839	10K $\pm 10\%$ 1/10 watt	R1, 6	10C/1869	2200 ohms $\pm 20\%$ $\frac{1}{2}$ watt
R14	10C/1879	22K $\pm \frac{1}{2}$ watt	R3, 10	10C/1744	5600 ohms $\pm 10\%$ $\frac{1}{2}$ watt
R5	10C/6840	100K $\pm 20\%$ $\frac{1}{2}$ watt	R12	10C/11671	10K $\pm 10\%$ $\frac{1}{2}$ watt
R15	10C/6322	1 megohm $\pm 20\%$ $\frac{1}{2}$ watt	R14	10C/1839	10K $\pm 10\%$ 1/10 watt
	10C/11591	Resistance unit type 218 comprising :—	R2	10C/1955	10K $\pm 20\%$ $\frac{1}{2}$ watt
R13	10C/1954	100 ohms $\pm 20\%$ $\frac{1}{2}$ watt	R5	10C/546	47K $\pm 10\%$ $\frac{1}{2}$ watt
R10	10C/1847	2200 ohms $\pm 20\%$ $\frac{1}{2}$ watt	R7, 13	10C/993	10K $\pm 20\%$ $\frac{1}{2}$ watt
	10C/11599	R.C. unit type 206 comprising :—	V1, 2	10E/386	Screened pentode valve VR136
	10C/2076	300 $\mu$ F	V3	10E/394	Triode VR137
C6, 9	10C/2076	300 $\mu$ F			
R1	10C/6082	330 ohms $\pm 20\%$ $\frac{1}{2}$ watt			
R4	10C/1847	2200 ohms $\pm 20\%$ $\frac{1}{2}$ watt	Fig. 17	10D/1054	RF. unit type 27
R3	10C/906	2400 ohms $\pm 5\%$ $\frac{1}{2}$ watt	T1	10D/1792	Aerial coil
	10C/6182	2500 ohms $\pm 5\%$ $\frac{1}{2}$ watt	L1	10D/1793	Grid coil
R2	10C/6079	10K $\pm 20\%$ $\frac{1}{2}$ watt	L2	10D/1794	Mixer grid coil
	10C/11600	R.C. unit type 207 comprising :—	L4	10D/1795	Oscillator coil
	10C/2076	300 $\mu$ F	L3	10D/1088	Mixer Anode coil
C23	10C/1847	2200 ohms $\pm 20\%$ $\frac{1}{2}$ watt			Condensers :—
R9	10E/1630	3-bank selector switch	C18	10C/3671	2 $\mu$ F $\pm 20\%$ 500v D.C.
S1, S2, S3	10E/1630	3-bank selector switch	C24	10C/16	10 $\mu$ F $\pm 10\%$ 500v D.C.
V1, 2, 3	10E/11446	Screened pentode valve VR.65	C29	10C/3200	20 $\mu$ F $\pm 10\%$ 500v D.C.
			C33	10C/2403	25 $\mu$ F $\pm 10\%$ 500v D.C.
Fig. 15	10D/1017	RF unit type 26	C13, 28	10C/96	0.0001 $\mu$ F $\pm 15\%$ 350v D.C.
T1	10D/1782	Aerial coil	C1, 2, 8, 9, 10, 11, 12, 14, 15,		
L1, 2	10D/1783	Grid coil	19, 20, 21, 22, 23, 25, 26,		
L4	10D/1784	Oscillator coil	27, 34	10C/94	0.0005 $\mu$ F $\pm 15\%$ 350v D.C.
L3	10D/1088	Mixer anode coil	C17, 31	10C/11744	1.5 $\mu$ F to 7.5 $\mu$ F trimmer
C18	10C/3671	Condensers :—	C3, 6, 16, 30	10C/3908	4 $\mu$ F to 21 $\mu$ F trimmer
		2 $\mu$ F $\pm 20\%$ 500 v. D.C.	C7	10C/13600	2.5 $\mu$ F to 6.5 $\mu$ F, air variable
C24, 29	10C/16	10 $\mu$ F $\pm 10\%$ 500v D.C.	C4, 5	10C/13601	7 $\mu$ F to 75 $\mu$ F 2 gang air variable
C33	10C/2920	30 $\mu$ F $\pm 10\%$ v D.C.	C32	10C/13602	7 $\mu$ F to 75 $\mu$ F single gang air variable
C13, 28, 34	10C/96	0.0001 $\mu$ F $\pm 15\%$ 350v D.C.		5L/359	2v 0.2 w dial lamp
C2, 8, 9, 10, 11, 12, 14,				10H/428	S.P. Coaxial plug type 229
15, 19, 20, 21, 22, 23, 25,				10H/1523	6-Pole "Jones" plug type 360
26, 27, 35	10C/94	0.0005 $\mu$ F $\pm 15\%$ 350v D.C.	R15	10C/1105	Resistances :—
C31	10C/11744	1.5 $\mu$ F to 7.5 $\mu$ F trimmer			56 ohms $\pm 10\%$ 1 watt
C17	10C/13599	3.5 $\mu$ F to 13.5 $\mu$ F trimmer	R11	10C/11665	100 ohms $\pm 10\%$ $\frac{1}{2}$ watt
C3, 6, 16,	10C/3908	4 $\mu$ F to 21 $\mu$ F trimmer	R4	10C/1931	150 ohms $\pm 20\%$ $\frac{1}{2}$ watt
C7	10C/13600	2.5 $\mu$ F to 6.5 $\mu$ F air variable	R9	10C/9507	470 ohms $\pm 20\%$ $\frac{1}{2}$ watt
C4, 5	10C/13601	7 $\mu$ F to 75 $\mu$ F 2 gang air variable	R8	10C/1867	1,000 ohms $\pm 20\%$ $\frac{1}{2}$ watt
C32	10C/13602	7 $\mu$ F to 75 $\mu$ F single gang, air variable	R1, 6	10C/1869	2,200 ohms $\pm 20\%$ $\frac{1}{2}$ watt
		2v 0.2 w dial lamp	R10	10C/1744	5,600 ohms $\pm 10\%$ $\frac{1}{2}$ watt
			R14	10C/1839	10,000 ohms $\pm 10\%$ 1/10 watt

Annotation in figure	Stores Ref.	Description	Annotation in figure	Stores Ref.	Description
R12	10C/11671	10,000 ohms $\pm 10\%$ $\frac{1}{4}$ watt	C45	10C/11602	R-C unit type 208 comprising :—
R2	10C/1955	10,000 ohms $\pm 20\%$ $\frac{1}{4}$ watt	R46	10C/11122	0.005 $\mu$ F $\pm 25\%$ , 1,000v D.C.
R3	10C/813	10,000 ohms $\pm 10\%$ 1 watt	R3, 10, 16, 26, 34	10C/589	270K $\pm 10\%$ $\frac{1}{2}$ watt
R5	10C/546	47,000 ohms $\pm 10\%$ $\frac{1}{2}$ watt	R15, 25, 33		Resistances :—
R7	10C/993	100,000 ohms $\pm 20\%$ $\frac{1}{4}$ watt	R58, 59	10C/8619	33 ohms $\pm 20\%$ 1/10 watt
V1	10E/386	Screened pentode valve VR136	R48	10C/8391	47 ohms $\pm 10\%$ 1/10 watt
V3	10E/394	Triode valve VR.137	R55	10C/7754	47 ohms $\pm 20\%$ $\frac{1}{2}$ watt
Fig. 20	10D/179	Amplifying unit type 192 (not available as an assembled spare)	R48	10C/1634	200 ohms $\pm 5\%$ $\frac{1}{4}$ watt
L9, 10, 11	10C/11592	IF grid H.F. choke	R60	10C/6080	220 ohms $\pm 20\%$ $\frac{1}{2}$ watt
C12, 21, 30, 39	10C/4268	Condensers :—	R61	10C/1863	330 ohms $\pm 20\%$ $\frac{1}{4}$ watt
C9, 50	10C/94	200 $\mu$ F $\pm 15\%$ 350v D.C.	R47	10C/1858	100 ohms $\pm 20\%$ $\frac{1}{4}$ watt
C42	10C/3100	500 $\mu$ F $\pm 350$ v D.C.	R8	10C/6083	1,000 ohms $\pm 20\%$ $\frac{1}{2}$ watt
C3, 10, 19, 28, 38, 53	10C/11122	0.001 $\mu$ F $\pm 25\%$ + unlimited, 350v D.C.	R8	10C/1001	2,000 ohms $\pm 5\%$ $\frac{1}{2}$ watt
C4, 8	10C/11573	0.005 $\mu$ F $\pm 25\%$ , 1,000v D.C.	R51	10C/7842	4,700 ohms $\pm 10\%$ 1 watt
C6	10C/2205	25 $\mu$ F 25v D.C.	R11, 21, 29	10C/877	5,110 ohms $\pm 5\%$ $\frac{1}{4}$ watt
C40, C49	10C/11574	Condenser unit type 94 comprising :—	R38	10C/832	7,500 ohms $\pm 5\%$ $\frac{1}{2}$ watt
L1	10D/1076	0.1 $\mu$ F $\pm 15\%$ 450v D.C.	R9, 12	10C/8424	15K $\pm 20\%$ $\frac{1}{2}$ watt
C1	10C/5168	IF input unit type 11 comprising :—	R49	10C/6838	22K $\pm 20\%$ $\frac{1}{2}$ watt
R1	10C/7215	IF coil	R62	10C/1889	1 megohm $\pm 20\%$ $\frac{1}{2}$ watt
L2	10D/1078	25 $\mu$ $\pm 5\%$ 500v D.C. condenser	L12, 13, 14	10C/11606	R-C unit type 209 comprising :—
C13	10C/2627	5,100 ohms $\pm 5\%$ 1/10 watt resistance	C34, 51	10C/11617	H.F. chokes
R14	10D/1073	2nd IF unit type 12 comprising :—	C25, 33	10C/94	500 $\mu$ F $\pm 15\%$ 350v D.C.
L4	10D/1078	IF coil	C16, C24	10C/3100	0.001 $\mu$ F $\pm 25\%$ + unlimited 350v D.C.
C22	10C/12884	IF coil	C2, 5, 7, 11	10C/12884	0.002 $\mu$ F $\pm 15\%$ , 450 v D.C.
R24	10C/7125	0.005 $\mu$ F $\pm 15\%$ 450v D.C. condenser	C14	10C/1122	0.005 $\mu$ F $\pm 25\%$ , 1,000v D.C.
L5	10D/1074	5,100 ohms $\pm 5\%$ 1/10 watt	C41	10C/1135	0.005 $\mu$ F $\pm 10\%$ , 1,000v D.C.
C31	10C/3100	0.001 $\mu$ F $\pm 25\%$ + limited, 350v D.C. condenser	C32	10C/1123	0.01 $\mu$ F $\pm 25\%$ , 1,000v D.C.
R32	10C/7215	5,100 ohms $\pm 5\%$ 1/10 watt resistance	C52	10C/5704	0.02 $\mu$ F $\pm 15\%$ , 450v D.C.
L7, 8	10D/1075	3rd IF unit type 13 comprising :—	C23	10C/11125	0.05 $\mu$ F $\pm 20\%$ , 500v D.C.
L6	10D/1078	IF coil	C46, 47	10C/2630	0.05 $\mu$ F $\pm 15\%$ , 450v D.C.
C43	10C/13275	IF coil	C15	10C/11127	0.1 $\mu$ F $\pm 20\%$ , 500v D.C.
C44	10C/3303	7 $\mu$ F $\pm 10\%$ , 500v D.C. condenser	C55	10C/2167	0.1 $\mu$ F $\pm 15\%$ , 450v D.C.
R45	10C/753	10 $\mu$ F $\pm 5\%$ 500v D.C. condenser	C54	10C/11126	0.1 $\mu$ F $\pm 20\%$ , 350v D.C.
R44	10C/8819	4,700 ohms $\pm 10\%$ $\frac{1}{2}$ watt resistance	R4, 57	10C/2205	25 $\mu$ F, 25v D.C.
		1.8 megohm $\pm 10\%$ $\frac{1}{2}$ watt resistance	R5	10C/6080	220 ohms $\pm 20\%$ , $\frac{1}{2}$ watt
			R7, 13	10C/875	470 ohms $\pm 10\%$ , $\frac{1}{2}$ watt
			R50	10C/6416	1,800 ohms $\pm 10\%$
			R56	10C/8756	2,200 ohms $\pm 20\%$ 2 watt
			R6	10C/7736	3,300 ohms $\pm 20\%$ $\frac{1}{2}$ watt
			R52, 53	10C/753	4,700 ohms $\pm 10\%$
			R22, 30, 39	10C/1482	27K $\pm 10\%$ , $\frac{1}{2}$ watt
			R2	10C/6396	100K $\pm 5\%$ , 1 watt
			R42	10C/7465	100K $\pm 20\%$ , 1 watt
			R54	10C/927	200K $\pm 10\%$ , $\frac{1}{2}$ watt
			R18, 19, 20, 28, 36, 37	10C/589	270K $\pm 10\%$ , $\frac{1}{2}$ watt
				10C/8305	510K $\pm 5\%$ , $\frac{1}{2}$ watt (These six 51K resistors are matched to within 1% of each other by selection)
			Ac.1740	10C/11608	R-C unit type 210 comprising :—
			C27, 36, 48	10C/12884	0.002 $\mu$ F $\pm 15\%$ , 450v D.C.
			R27, 35	10C/11122	0.005 $\mu$ F $\pm 25\%$ , 1,000v D.C.
				10C/1619	300 ohms $\pm 5\%$ , $\frac{1}{2}$ watt

Annotation in figure	Stores Ref.	Description	Annotation in figure	Stores Ref.	Description
Fig. 20		<i>Amplifying unit type 192 continued</i>			
R31, 40	10C/753	4,700 ohms $\pm 10\%$ , $\frac{1}{2}$ watt		10H/394	6 pole H.T. plug W.201
R41	10C/1481	75K $\pm 5\%$ , $\frac{1}{2}$ watt		10H/397	2 pole plug W.204
	10C/12005	R-C unit type 211 comprising :—		10H/528	S.P. coaxial plug type 209
	10C/12884	0.002 $\mu$ F $\pm 15\%$ , 450v D.C.	P6	10C/11585	Resistance unit type 214 comprising :—
C18	10C/11122	0.005 $\mu$ F $\pm 25\%$ , 1,000v D.C.	P5	10C/6076	100K potentiometer 2W
R17	10C/1619	300 ohms $\pm 5\%$ , $\frac{1}{2}$ watt		10C/7935	1/2 megohm potentiometer 2W
R23	10C/6416	1,800 ohms $\pm 10\%$ , $\frac{1}{2}$ watt		10C/11586	Resistance unit type 215 (potentiometer panel) comprising :—
	10F/1256	Switch unit type 120 comprising :—	R55	10C/8424	15K $\pm 20\%$ , $\frac{1}{2}$ watt
C35	10C/5704	0.02 $\mu$ F $\pm 15\%$ , 450v D.C.	P3, 4	10C/8924	1,000 ohms potentiometer 3W wire linear
C26	10C/2630	0.05 $\mu$ F $\pm 20\%$ , 500v D.C.			
C17	10C/2167	0.1 $\mu$ F $\pm 20\%$ , 400v D.C.	P2	10C/8925	5,000 ohms potentiometer 3W wire linear
R43	10C/7411	22K $\pm 20\%$ , 1 watt			
V1, 2, 3, 4, 5, 7, 8	10E/11446	Screened pentodes VR65	P15	10C/8926	10K potentiometer 3W wire linear
V6	10E/105	Diode VR.92	P1, 9, 10, 11, 12, 13, 14	10C/8927	25K potentiometer 3W wire linear
			P8	10C/8928	50K potentiometer 2W carbon linear
			S6, 7	10F/13189	Selector switch type 854 rotary
			V20	10E/222	CRT.VCR.97
Fig. 22	10K/968	<i>Power unit type 305</i> (not available as an assembled spare)			
L6	10C/11609	L.F. choke 2H, at 200mA D.C.			
		Condensers :—	Fig. 26	10A/14715	<i>Dividing unit type 13</i>
C42	10C/11122	0.005 $\mu$ F $\pm 25\%$ , 1,000v D.C.	L1	10D/1082	Oscillator coil
C43	10C/13057	0.03 $\mu$ F $\pm 20\%$ , 2,500v D.C.	T1	10D/1083	Oscillator output coil including :—
C44	10C/11557	0.1 $\mu$ F $\pm 15\%$ , 2,500v D.C.	C44, 48	10C/11564	500 $\mu$ F $\pm 2\%$ , 350v D.C.
	10C/11128	0.25 $\mu$ F $\pm 20\%$ , 350v D.C.			Condensers :—
C39, 40, 41	10C/4909	0.5 $\mu$ F $\pm 15\%$ , 450v D.C.	C43	10C/5056	35 $\mu$ F $\pm 2\%$ , 350v D.C.
R19	10C/1650	Resistances :—	C42	10C/4870	50 $\mu$ F, variable, airspaced
		390 ohms $\pm 10\%$ , $\frac{1}{2}$ watt		10C/11571	Condenser unit type 92 comprising :—
R20	10C/8930	2,200 ohms $\pm 10\%$ , 2 watt	C51	10C/11560	30 $\mu$ F $\pm 5\%$ , 350v D.C.
R17	10C/6081	47K ohms $\pm 20\%$ , $\frac{1}{2}$ watt		10C/1006	100 $\mu$ F $\pm 5\%$ , 350v D.C.
R22, 23, 24	10C/7673	120 $\pm 10\%$ , 2 watt	C50	10XC/2	Crystal unit type 10XC/2
R18	10C/6320	470K $\pm 20\%$ , $\frac{1}{2}$ watt			Resistances :—
		6 pole "Jones" socket type 303	R74	10C/6475	200 ohms $\pm 5\%$ , $\frac{1}{2}$ watt
	10K/976	Transformer unit type 66 comprising :—	R78	10C/6082	330 ohms $\pm 20\%$ , $\frac{1}{2}$ watt
C47	10C/11124	0.2 $\mu$ F $\pm 20\%$ , 740v D.C.	R84, 87	10C/6851	470 ohms $\pm 10\%$ , $\frac{1}{2}$ watt
R25	10C/539	47K $\pm 10\%$ , $\frac{1}{2}$ watt	R71	10C/8377	820 ohms $\pm 10\%$ , $\frac{1}{2}$ watt
R21	10C/927	220K $\pm 10\%$ , $\frac{1}{2}$ watt	R63	10C/6083	1,000 ohms $\pm 20\%$ , $\frac{1}{2}$ watt
P1	10C/8931	100K 2 watt potentiometer	R64	10C/6416	1,800 ohms $\pm 10\%$ , $\frac{1}{2}$ watt
T3	10K/978	Transformer type 1028	R91	10C/6079	10,000 ohms $\pm 20\%$ , $\frac{1}{2}$ watt
T2	10K/979	Transformer unit type 67	R92	10C/9255	8,200 ohms $\pm 5\%$ , $\frac{1}{2}$ watt
		Output 1 : 6.3v $\pm 5\%$ at 7.5A	R93	10C/6086	33K $\pm 20\%$ , $\frac{1}{2}$ watt
		Output 2 : 5v $\pm 5\%$ at 3A	R66	10C/15076	51K stability $\pm 5\%$ , $\frac{1}{2}$ watt high
		Output 3 : 540—0—450 $\pm 5\%$ at 15A	R105	10C/8819	1.8 meg. $\pm 10\%$ , $\frac{1}{2}$ watt
		including :—	P7	10C/8929	5,000 ohms potentiometer 3W wire linear
		500 ohms $\pm 10\%$ , 10 watt			
R16	10C/10642	Screened pentode VR.65		10C/11596	R-C unit type 203 comprising :—
V5	10E/11446	FW rectifier VU71	C52	10C/11565	500 $\mu$ F $\pm 5\%$ , 350v D.C.
V4	10E/11529	HW rectifier VU120	C54, 56, 62	10C/3961	0.001 $\mu$ F $\pm 5\%$ , 350v D.C.
V6	10E/121		C61	10C/3957	0.002 $\mu$ F $\pm 5\%$ , 350v D.C.
			C47	10C/11122	0.005 $\mu$ F $\pm 25\%$ , 1,000v D.C.
Fig. 26	10Q/13000	<i>Indicator unit type 62</i>	O53, 55, 57, 60	10C/11127	0.1 $\mu$ F $\pm 20\%$ , 500v D.C.
	5X/750	2 pole plug type M	R80	10C/1312	120 ohms $\pm 10\%$ , $\frac{1}{2}$ watt

Annotation in figure	Stores Ref.	Description	Annotation in figure	Stores Ref.	Description
Fig. 26		Power unit type 13 continued	R26	10C/577	470K $\pm$ 10%, $\frac{1}{2}$ watt
R81	10C/753	4,700 ohms $\pm$ 10%, $\frac{1}{2}$ watt	R14, 19	10C/6322	1 Meg. $\pm$ 20%, $\frac{1}{2}$ watt
R65, 70	10C/7842	4,700 ohms $\pm$ 10%, 1 watt		10C/11589	Resistance unit type 216 including :—
R77	10C/15077	5,100 ohms $\pm$ 5%, 1 watt high	R30	10C/752	180K $\pm$ $\frac{1}{2}$ watt
R68	10C/15087	10K $\pm$ 10%, 1 watt high stability	R27, 28, 29	10C/8550	470,000 ohms $\pm$ 10%, 1 watt
R73, 79	10C/1803	18K $\pm$ 10%, 1 watt		10C/11590	Resistance unit type 217, including :—
R82	10C/8630	27K $\pm$ 10%, 1 watt	R5	10C/1001	2,000 ohms $\pm$ 5%, $\frac{1}{2}$ watt
R88	10C/8782	27K $\pm$ 10%, 2 watt	R6	10C/830	3,000 ohms $\pm$ 5%, $\frac{1}{2}$ watt
R83	10C/1812	47K $\pm$ 10%, 1 watt	R9, 12	10C/6079	10K $\pm$ 20%, $\frac{1}{2}$ watt
R69	10C/10939	75K $\pm$ 5%, 1 watt High stability		10C/11597	R-C unit type 204 including :—
R72	10C/10940	150K $\pm$ 5%, 1 watt High stability	C9, 38, 39	10C/2006	100 $\mu$ F $\pm$ 5%, 350v D.C.
R89	10C/15078	160K $\pm$ 5%, 1 watt High stability	C41	10C/11563	300 $\mu$ F $\pm$ 5%, v D.C.
R76	10C/10559	390K $\pm$ 5%, 1 watt High stability	C63	10C/11263	400 $\mu$ F $\pm$ 5%, 350v D.C.
R86	10C/10942	510K $\pm$ 5%, 1 watt High stability	C11, 24, 25	10C/11565	500 $\mu$ F $\pm$ 5%, 350v D.C.
R85	10C/10943	820K $\pm$ 5%, 1 watt High stability	C58	10C/3961	0.001 $\mu$ F $\pm$ 5%, 350v D.C.
T2	10K/971	L.F. transformer type 1023, three windings	C1	10C/11121	0.002 $\mu$ F $\pm$ 25%, 1,000v D.C.
T3	10K/972	L.F. transformer type 1023, three windings	C5, 12, 26, 27, 64	10C/11123	0.01 $\mu$ F $\pm$ 25%, 1,000v D.C.
T4	10K/973	L.F. transformer, three windings	C8, 10	10C/11125	0.05 $\mu$ F $\pm$ 20%, 500v D.C.
T5	10K/974	L.F. transformer, three windings		10C/2630	0.05 $\mu$ F $\pm$ 15%, 450v D.C.
T6	10K/975	Mains transformer	C2, 3	10C/11126	0.1 $\mu$ F $\pm$ 20%, 350v D.C.
V12, 17, 18	10E/11446	Screened pentode VR65	C4, 15, 23	10C/11128	0.25 $\pm$ 20%, 350v D.C.
V13, 14, 15, 16	10E/CV118	Screened pentode CV118	R2	10C/6083	1,000 ohms $\pm$ 20%, $\frac{1}{2}$ watt
Fig. 26	10A/14715	Strobe unit type 3	R34, 41	10C/6416	1,800 ohms $\pm$ 10%, $\frac{1}{2}$ watt
C21, C35	10C/5970	Condensers :—	R60	10C/6845	10K $\pm$ 20%, 2 watt
C16, 17, 18, 19, 20, 30, 31			R40, 46	10C/8630	27K $\pm$ 10%, 1 watt
32, 33, 34	10C/11125	250 $\mu$ F $\pm$ 2%, 350v D.C.	R20, 21, 25	10C/8782	27K $\pm$ 10%, 2 watt
		0.05 $\mu$ F $\pm$ 20%, 500v D.C.	R54	10C/15079	33K $\pm$ 5%, $\frac{1}{2}$ watt
C22, 36	10C/11568	13.541 $\mu$ F Air, variable, metal	R61	10C/7692	39K $\pm$ 10%, 1 watt
R48	10C/989	Resistances :—	R39, 47	10C/1812	47K $\pm$ 10%, 1 watt
R36, R39	10C/10942	470 $\pm$ 10%, $\frac{1}{2}$ watt	R16, 35, 51,	10C/6559	47K $\pm$ 10%, 2 watt
		410K $\pm$ 5%, 1 watt high stability	R38	10C/6840	100K $\pm$ 20%, $\frac{1}{2}$ watt
Fig. 26	10D/1558	Time base unit type 26	R33, 52	10C/7465	10K $\pm$ 20%, 1 watt
L2	10C/11610	L.F. choke 2H at 130m/A D.C.	R4	10C/7312	100K $\pm$ 20%, 2 watt
C13	10C/11555	Condensers :—	R17	10C/6910	39K $\pm$ 10%, $\frac{1}{2}$ watt
		0.03 $\mu$ F $\pm$ 15%, 2500v D.C.	R53	10C/10940	150K $\pm$ 5%, 1 watt, high stability
C6, 14, 28, 45	10C/4909	0.5 $\mu$ F $\pm$ 15%, 450v D.C.	R22	10C/7464	150K $\pm$ 20%, 1 watt
	10Q/26	Diode unit A.B.1774, including	R18	10C/15074	200K $\pm$ 5%, $\frac{1}{2}$ watt high stability
R32	10C/6416	1,800 ohms $\pm$ 10%, $\frac{1}{2}$ watt	R106	10C/875	470 ohms $\pm$ 10%, $\frac{1}{2}$ watt
R31	10C/6322	1 meg. $\pm$ 20%, $\frac{1}{2}$ watt	R56	10C/10942	510K $\pm$ 5%, 1 watt
R8, 94, 95, 96, 97, 98, 99, 100		Resistances :—	R58	10C/15075	560K $\pm$ 5%, 1 watt
		330 ohms $\pm$ 20%, $\frac{1}{2}$ watt	R104	10C/8923	6.8 megohm $\pm$ 20% $\frac{1}{2}$ watt
		470 ohms $\pm$ 10%, 1/10 watt	C7	10C/11126	R-C unit type 205 including :—
		51K $\pm$ 5%, $\frac{1}{2}$ watt	R11, 102	10C/753	0.1 $\mu$ $\pm$ 21%, 350v D.C.
R37, 50	10C/6851	100K $\pm$ 20%, 1/10 watt	R7	10C/6838	4,700 ohms $\pm$ 10%, $\frac{1}{2}$ watt
R62	10C/7304	240K $\pm$ 5%, 1/10 watt	R101	10C/749	22K $\pm$ 20%, $\frac{1}{2}$ watt
R1, 13	10C/8197	270K $\pm$ 10%, $\frac{1}{2}$ watt	S1	10F/8142	120K $\pm$ 10%, $\frac{1}{2}$ watt
R23, 24	10C/8921		S2, 3, 4, 5, 10	10F/559	Switch type 77
R43, 44	10C/589		V2, 4	10E/11400	Switches type 484
			V1, 3, 5, 6, 7, 8, 9, 10, 11	10E/11446	Diode VR 54
			V19, 20	10E/105	Pentode VR 65
					Small diode VR92

# APPENDIX II APPARATUS KIT, TYPE 30

(Stores Ref. No. 10A/14525)

NOTE:~ Cable grips Ref. 10 H/1774  
to be fitted on all Pye Plugs

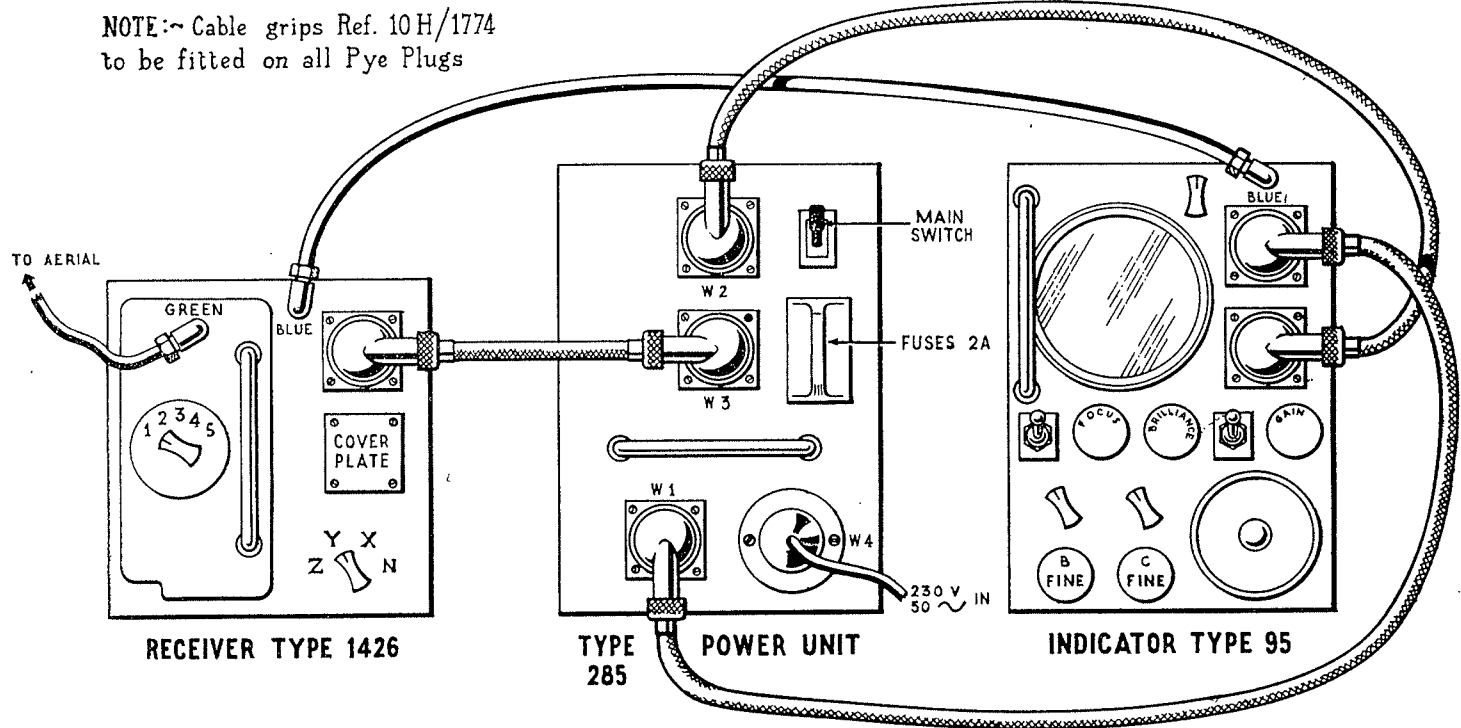

Fig. 34.—Interconnection—Kit type 30.

1. This equipment is a modified form of the A.R.I.5083 and is designed to operate from normal 230 volt, 50-cycle mains. The kit is made up as follows:—

- Indicator unit, type 95 (type 62 modified)
- Receiver, type R.1426 (type R.1355 modified)
- Power unit, type 285

2. The power unit is enclosed in an additional box with the same dimensions as the indicator unit.

3. Apart from the differences listed below, the design and operation of the equipment is as for the ARI.5083.

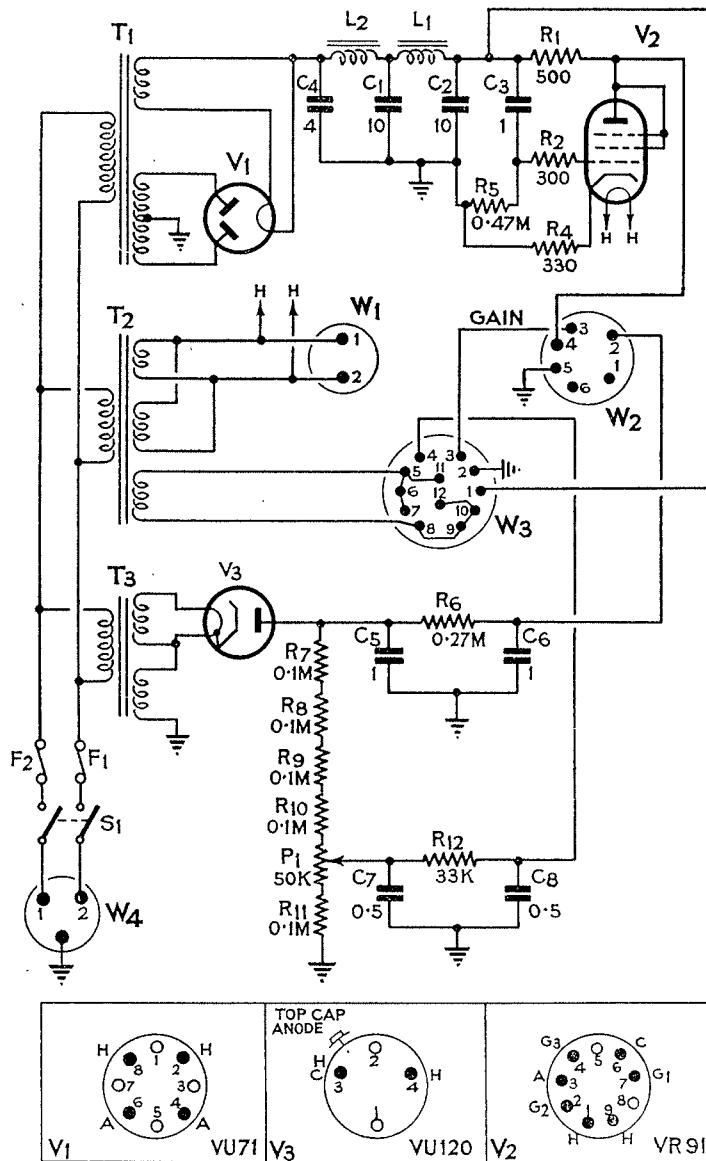

Fig. 35.—Power unit type 285, circuit.

### Circuit difference from A.R.I.5083

4. *Indicator, type 95.*—The following circuit changes to indicator, type 62 (fig. 26 in this publication) have been made.

- (i) V5. Anode stopper added. 330 ohms,  $\frac{1}{4}$  watt, R.108.
- (ii) V6. Anode stopper added. 330 ohms,  $\frac{1}{4}$  watt, R.107
- (iii) V18. Cathode resistor added 470 ohms,  $\frac{1}{2}$  watt, R.106
- (iv) L2. is replaced by a 50-cycle choke.
- (v) T6. Heater transformer is changed.

5. It should be noted that the primary winding of the new transformer is fed with 6.3 volts from the large 2-pin W plug. The heater volts for most of the indicator valves also come from this W plug, while the secondary windings of the transformer only supply the C.R.T. and the diode (V19) heaters.

6. *Receiver.* The I.F. amplifier is unchanged apart from the W-plug connections which are dealt with under power supply.

7. The R.F. unit is unmodified and is interchangeable with R.F. units from any R.1355.

8. *Power supply.* The power supply unit normally mounted in the receiver R.1355 is deleted with the exception of the 2.2 K. ohms resistor and 0.005 mf. condenser which form the additional decoupling in the H.T. supply to the R.F. unit.

9. This unit is replaced by a third box, power unit type 285, containing a 50-cycle power pack. The circuit (fig. 35) is of the power unit, and the W plug connections apply to the plugs on the power unit and the corresponding plugs on the other units. Plugs W1 and W2 both feed the indicator while W3 feeds the receiver.

10. The general layout of the units and their connections is shown in fig. 34.



## APPENDIX III

### INDICATOR UNIT TYPE 62A (STORES REF. 10Q/37)

#### INTRODUCTION

1. Indicator unit type 62A is a VR91 version of indicator unit type 62 and it is electrically and mechanically interchangeable with indicator unit type 62. Externally, the controls are the same, but internally there are some differences necessitated mainly by the need to accommodate the VR91 valves. Indicator unit type 62A employs VR91 valves in place of the VR65 and CV118 valves used in the type 62 indicator, except for V7, V8, V9 and V10, which in the type 62A indicator are CV118 valves instead of VR65's.

2. The present appendix describes the differences between the Indicator unit type 62A and the Indicator unit type 62. Apart from these changes the two indicators are identical. The circuit diagram of the indicator unit type 62A is given in fig. 37, some waveforms are illustrated in fig. 36, and views of the chassis are shown in fig. 38, 39, 40 and 41.

#### MECHANICAL CHANGES

3. Mechanically, the indicator unit type 62A is an improvement on the indicator unit type 62. The potentiometer tray illustrated in fig. 32 has now been divided into two panels which are mounted vertically on each side of the CRT. This reduces heating of the unit and renders the components more accessible.

4. The use of L.H. type Morganite potentiometers, which are considerably smaller than the normal type of potentiometer, has enabled the focus and brilliance controls to be taken straight through to the front panel without gearing.

5. The detonators have been removed and the crystal is now moved to the front of the divider chassis, V12 occupying the original crystal position; i.e. the crystal and V12 exchange positions. V21, a VR92 diode, has been moved from under the chassis to a position alongside V19, the DC restoration diode, and V22, which is the diode used to clean up the spacing waveform.

#### CIRCUIT CHANGES

6. Electrically, indicator unit type 62A conforms to the specification laid down for indicator unit type 62. Waveforms obtained from a

typical indicator unit type 62A are found to be within 10% of those obtained from a standard indicator unit type 62. The lower input capacity of the VR91 (8pF as against 14 pF for a VR65) improves the average overall swing of the crystal oscillator by 45 per cent or 150 parts per million.

1. The division ranges obtained on the divider potentiometer, together with the time-base amplitude and shift controls, are similar to those on the indicator unit type 62. In order to give coverage on the strobe period controls, the value of R55 has been reduced from 25,000 ohms to 15,000 ohms.

**Note.**—*Some later Indicator units type 62 are also provided with an R55 of 15,000 ohms.*

8. The heater current consumption is approximately half that of the type 62 indicator and the heater transformer is half the size of the original heater transformer. In addition the smaller 1.3 mH choke is adequate to prevent serious ripple passing back from the indicator to the receiver.

9. As has already been explained CV118 type valves were chosen for V7, V8, V9 and V10 because VR91 valves proved to be too microphonic, and thus gave strobe instability in these positions. To further improve strobe stability the anode loads of V8 and V9 (i.e. R39 and R47 respectively) were increased in value to 150,000 ohms each thereby improving the "bottoming" of these anodes, and the grid leaks of V7 and V10 (i.e. R36 and R49) were increased to 1.2 megohms each (temperature stabilized) and taken up to a higher potential by interchanging the values of R53 and R54. In order to avoid an unduly large ratio of screen to anode current, the screen resistors have been increased to 120,000 ohms.

10. The resistance chain between the anode of V8 and earth, from which is tapped the spacing waveform, has been modified; the values of the resistors have been changed. In addition, V22, which is a VR92 diode, is introduced to cut off the top of the square wave (which has been distorted by increasing the values of R39 and R47) and so give a clean spacing waveform.

11. "A" strobe locking. A function known as "A" strobe locking is introduced; in which the cathode of V17 is tied back to the cathode of V15 thus obtaining a 15 Kc/s locking pulse which stabilises the "A" strobe position and corrects "A" squint; i.e. horizontal misalignment of "A" strobes in certain positions of the "B" and "C" strobes.

12. To do this the time-constant in the grid circuit of V18 is increased by making the value of C62 0.0025 instead of 0.001  $\mu$ F. This delays the rise of the grid of V18 until the synchronising pulse arrives from the screen of V17 by amplification of the positive 15 kc/s pulses on the cathode (see fig. 36E). These are equivalent to negative pulses on the grid, which is waiting at cathode potential, and thus the 15 Kc/s synchronising pulses shut the valve V18 off, and the multivibrator takes place. The locked positive-going edge of the waveform at the anode of V17 brings on V18 (see fig. 36F) so fixing the negative-going edge at the anode of V18. It is from this negative-going edge that the "A" strobe is originated.

13. The "A" strobe potentiometer (P13) is now replaced by a fixed resistor R111, and P13 becomes the screen load of V17, with its sliding contact connected to the HT side of C62. This modification serves to prevent any variation in size of the 3 Kc/s calibration pips applied to the grid of V17, due to the variation of grid current through R87 when P13 is varied. The introduction of R106 tends to make the size of these pips independent of the slope of V18.

14. It will be seen that using this method of locking the "A" strobe means that there will be no microphonic or drift considerations affecting the "A" strobe; i.e. microphonic valves can be tolerated in the V17 and V18 positions.

15. As the "A" strobe is locked to a 15 Kc/s calibration pip, the "A" strobe zero will be displaced towards the right-hand side of the trace on the strobe time-base. This is quite satisfactory as there will be no "A" strobe drift to cause "A" zero to move off the trace.

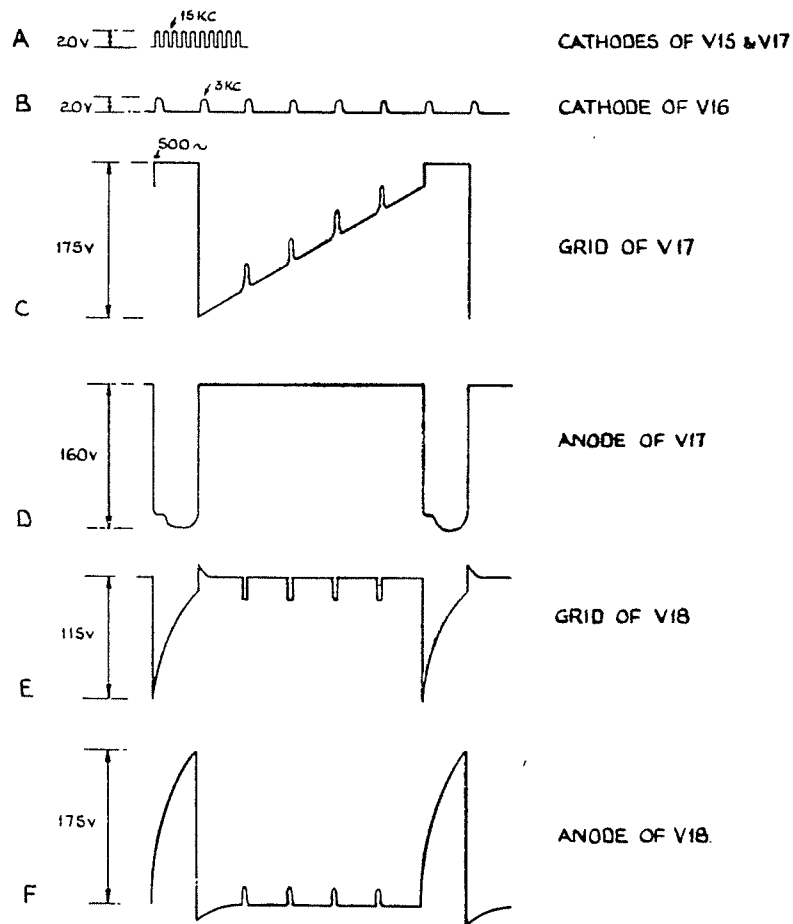

Fig. 36.—"A" strobe locking waveforms.

APPENDIX IV.  
LIST OF PRINCIPAL COMPONENTS OF  
INDICATOR UNIT TYPE 62A

This list is issued for information only. When ordering spares for this equipment,  
refer to Volume III. of this publication.

Annotation in figure	Stores Ref.	Description	Annotation in figure	Stores Ref.	Description
Fig. 37	10D/2287	Dividing unit type 19 (Not available as a separate spare) consisting of	R88	10W/1806	22,000 ohms $\pm 10\%$ , 2 watt
L2	10C/14653	H.F. choke type 682, 1.1 henries at 120 MA, 5v, 50 c/s D.C. resistance	R82, 111	10W/8630	27,000 ohms $\pm 10\%$ , 1 watt
		130 ohms	R66	10W/1799	33,000 ohms $\pm 10\%$ , $\frac{1}{4}$ watt
L1	10D/1082	Oscillator coil 1370 turns of 42 SWG	R93	10W/1998	33,000 ohms $\pm 20\%$ , $\frac{1}{4}$ watt
T1	10D/2421	Oscillator output coils with iron dust cores : 325 turns of 40 SWG and 315 turns of 40 SWG	R69	10W/10939	75,000 ohms $\pm 5\%$ , 1 watt, High Stability
			R72	10W/10940	150,000 ohms $\pm 5\%$ , 1 watt " "
			R89	10W/15078	160,000 ohms $\pm 5\%$ , 1 watt " "
			R76	10W/10559	390,000 ohms $\pm 5\%$ , 1 watt " "
			R86	10W/10942	510,000 ohms $\pm 5\%$ , 1 watt " "
			R85	10W/10943	820,000 ohms $\pm 5\%$ , 1 watt " "
			R105	10W/549	1.8 megohms $\pm 10\%$ , $\frac{1}{4}$ watt " "
C44, C48	10C/5144	500 $\mu$ F $\pm 2\%$ , 350v D.C. wkg. Sil. mica	P11, 12, 13, 14	10W/8927	25,000 ohms, 3 watt
C50	10C/2006	100 $\mu$ F $\pm 5\%$ , 350v D.C. wkg. Sil. mica	P7	10W/8929	5,000 ohms, 3 watt
C43	10C/5056	35 $\mu$ F $\pm 2\%$ , 350v D.C. wkg. Sil. mica			Transformers :—
C51	10C/14609	47 $\mu$ F $\pm$ , 350v D.C. wkg. Sil. mica	T2	10K/971	L.F. 3 windings
C52, C59	10C/14834	470 $\mu$ F $\pm 5\%$ , 350v D.C. wkg. Sil. mica	T3	10K/972	L.F. 3 windings
C54, C56	10C/3961	0.001 $\mu$ F $\pm 5\%$ , 350v D.C. wkg. Sil. mica	T4	10K/973	L.F. 3 windings
C61	10C/3957	0.002 $\mu$ F $\pm 5\%$ , 350v D.C. wkg. Sil. mica	T5	10K/974	L.F. 3 windings
C62	10C/12095	0.0025 $\mu$ F $\pm 5\%$ , 350v D.C. wkg. Sil. mica	T6	10K/1722	3 heater windings
C47	10C/11122	0.005 $\mu$ F $\pm 25\%$ , 1,000v D.C. wkg. paper		10A/14715	Strobe unit, Type 3
C46, 53, 55, 57, 60	10C/11127	0.1 $\mu$ F $\pm 20\%$ , 500v D.C. wkg. paper			Condensers :—
C45	10C/11131	0.5 $\mu$ F $\pm 20\%$ , 500v D.C. wkg. paper	C21, C35	10C/5970	250 $\mu$ F $\pm 2\%$ , 250v D.C. wkg. Sil. mica
C42	10C/4870	50 $\mu$ F air spaced variable	C16, 17, 18, 19,	10C/5144	500 $\mu$ F $\pm 20\%$ , 350v D.C. wkg. Sil. mica.
	10XC/2	Crystal unit type 10XC/2	C20, 30, 31, 32, 33, 34		
		Resistors :—	C29	10C/2630	0.05 $\mu$ F $\pm 15\%$ , 450v D.C. wkg.
R80	10W/8284	120 ohms $\pm 10\%$ , $\frac{1}{4}$ watt	C22, 36	10C/11568	13-541 $\mu$ F. Air variable metal frame
R74	10W/1634	200 ohms $\pm 5\%$ , $\frac{1}{4}$ watt	R48	10W/989	Resistances Type 989, 470,000 ohms $\pm 10\%$ $\frac{1}{4}$ watt
R78	10W/1863	330 ohms $\pm 20\%$ , $\frac{1}{4}$ watt	S8, 9	10F/1257	Switches type 1007, 1 pole, 5 positions
R84, 87	10W/9507	470 ohms $\pm 20\%$ , $\frac{1}{4}$ watt			Remaining components on chassis
R106	10W/875	470 ohms $\pm 10\%$ , $\frac{1}{4}$ watt			Condensers :—
R71	10W/10340	910 ohms $\pm 5\%$ , $\frac{1}{4}$ watt	C9, 38, 39	10C/2006	100 $\mu$ F $\pm 5\%$ , 350v D.C. wkg. Sil. Mica
R63	10W/1867	1,000 ohms $\pm 20\%$ , $\frac{1}{4}$ watt	C41	10C/5477	350 $\mu$ F $\pm 2\%$ , 350v D.C. wkg. Sil. Mica
R64	10W/6911	1,800 ohms $\pm 10\%$ , $\frac{1}{4}$ watt	C63	10C/14877	390 $\mu$ F $\pm 5\%$ , 350v, D.C. wkg. Sil. Mica
R114	10W/1869	2,200 ohms $\pm 20\%$ , $\frac{1}{4}$ watt	C11	10C/14770	470 $\mu$ F $\pm 10\%$ , 350v D.C. wkg. Sil. Mica
R65, 70	10W/8160	4,700 ohms $\pm 20\%$ , 1 watt	C24, 25	10C/14834	470 $\mu$ F $\pm 5\%$ , 350v D.C. wkg. Sil. Mica
R81	10W/1850	4,700 ohms $\pm 20\%$ , $\frac{1}{4}$ watt	C58	10C/3961	1,000 $\mu$ F $\pm 5\%$ , 350v D.C. wkg. Sil. Mica
R77	10W/15077	5,100 ohms $\pm 5\%$ , 1 watt, High Stability	C1	10C/11121	0.002 $\mu$ F $\pm 25\%$ , 1,000v D.C. wkg. paper
R91	10W/1955	10,000 ohms $\pm 20\%$ , $\frac{1}{4}$ watt	C66	10C/11124	0.02 $\mu$ F $\pm 20\%$ , 750v D.C. wkg. paper
R83	10W/6079	10,000 ohms $\pm 20\%$ , $\frac{1}{4}$ watt	C5, 26, 27, 64	10C/11123	0.01 $\mu$ F $\pm 25\%$ , 1,000v D.C. wkg. paper
R68	10W/15087	10,000 ohms $\pm 10\%$ , 1 watt, High Stability	C12	10C/14582	0.01 $\mu$ F $\pm 20\%$ , 350v. D.C. wkg. Sil. Mica
R73, 79	10W/1803	18,000 ohms $\pm 10\%$ , 1 watt			

<i>Annotation in figures</i>	<i>Stores Ref.</i>	<i>Description</i>	<i>Annotation in figures</i>	<i>Stores Ref.</i>	<i>Description</i>
C13	10C/12497	0.03 $\mu$ F $\pm$ 20%, 2500v D.C. wkg. paper	R40, 46	10W/8299	120,000 ohms $\pm$ 10%, 1 watt
C8, 10	10C/11125	0.05 $\mu$ F $\pm$ 20%, 500v D.C. wkg. paper	R113	10W/7373	150,000 ohms $\pm$ 20%, $\frac{1}{4}$ watt
C2, 3, 7	10C/11126	0.1 $\mu$ F $\pm$ 20%, 350v D.C. wkg. paper	R39, 47	10W/624	150,000 ohms $\pm$ 10%, 1 watt
C4, 15, 23, 37, 65	10C/11128	0.25 $\mu$ F $\pm$ 20%, 350v D.C. wkg. paper	R22	10W/7464	150,000 ohms $\pm$ 20%, 1 watt
C6, 14, 28	10C/11131	0.5 $\mu$ F $\pm$ 20%, 500v D.C. wkg. paper	R54	10W/10940	150,000 ohms $\pm$ 5%, 1 watt, High Stability
	10H/394	Plug W201 6 pole, H.T. mounting	R30	10W/752	180,000 ohms $\pm$ 10%, $\frac{1}{2}$ watt
	10H/528	Plug type 229, single Pole, coaxial	R18	10W/15074	200,000 ohms $\pm$ 5%, $\frac{1}{4}$ watt, High Stability
		Resistors :—	R43, 44.	10W/548	270,000 ohms $\pm$ 10%, $\frac{1}{4}$ watt
R5	10W/1869	2,200 ohms $\pm$ 20%, $\frac{1}{4}$ watt insulated	R38	10W/8828	330,000 ohms $\pm$ 20%, $\frac{1}{4}$ watt
R6	10W/1870	3,300 ohms $\pm$ 20%, $\frac{1}{4}$ watt insulated	R107, 108	10W/760	330,000 ohms $\pm$ 10%, $\frac{1}{2}$ watt
R23, 24	10W/548	270,000 ohms $\pm$ 10%, $\frac{1}{4}$ watt insulated	R109, 110	10W/9612	390,000 ohms $\pm$ 10%, $\frac{1}{2}$ watt
R8, 94, 95, 96, 97, 98			R26	10W/1884	470,000 ohms $\pm$ 20%, $\frac{1}{4}$ watt
99, 100	10W/1863	330 ohms $\pm$ 20%, $\frac{1}{4}$ watt	R56	10W/10942	510,000 ohms $\pm$ 5%, 1 watt, High Stability
R115, 116	10W/6082	330 ohms $\pm$ 20%, $\frac{1}{2}$ watt	R58	10W/15075	560,000 ohms $\pm$ 5%, 1 watt, High Stability
R37, 50	10W/9507	470 ohms $\pm$ 20%, $\frac{1}{4}$ watt	R14, 19, 31, 112	10W/1889	1 megohm $\pm$ 20%, $\frac{1}{4}$ watt
R2	10W/1867	1,000 ohms $\pm$ 20%, $\frac{1}{4}$ watt	R36, 49	10W/16031	1.2 megohm $\pm$ 5%, $\frac{1}{4}$ watt, High Stability
R34, 41	10W/6416	1,800 ohms $\pm$ 10%, $\frac{1}{2}$ watt	R104	10W/10354	6.8 megohm $\pm$ 20%, $\frac{1}{4}$ watt
R32	10W/1869	2,200 ohms $\pm$ 20%, $\frac{1}{4}$ watt	P3, 4	10W/8924	1,000 ohms potentiometer, 3 watt
R11, 102	10W/948	4,700 ohms $\pm$ 10%, $\frac{1}{4}$ watt	P2	10W/8925	5,000 ohms potentiometer, 3 watt
R60	10W/6845	10,000 ohms $\pm$ 20%, 2 watt	P15	10W/8926	10,000 ohms potentiometer, 3 watt
R9, 12	10W/1955	10,000 ohms $\pm$ 20%, $\frac{1}{4}$ watt	P1, 9, 10	10W/8927	25,000 ohms potentiometer, 3 watt
R55	10W/8424	15,000 ohms $\pm$ 20%, $\frac{1}{4}$ watt	P6	10W/10714	100,000 ohms $\pm$ 20%, $\frac{1}{4}$ watt
R7, 10	10W/1879	22,000 ohms $\pm$ 20%, $\frac{1}{4}$ watt	P8	10W/16245	200,000 ohms $\pm$ 20%, 1.5 watt
R20, 21, 25	10W/8782	27,000 ohms $\pm$ 10%, 2 watt	P5	10W/8023	500,000 ohms $\pm$ 20%
R53	10W/15079	33,000 ohms $\pm$ 5%, $\frac{1}{2}$ watt, High Stability	S1	10F/8142	Switches Type 77
R17	10W/6910	39,000 ohms $\pm$ 10%, $\frac{1}{4}$ watt	S2, 3, 4, 5, 10	10F/559	Switches, Type 484
R61	10W/7692	39,000 ohms $\pm$ 10%, 1 watt	S6, 7	10F/13189	Switches, Type 854
R16	10W/9669	47,000 ohms $\pm$ 20%, 2 watt			Valves :—
R35, 51	10W/6559	47,000 ohms $\pm$ 10%, 2 watt	V7, 8, 9, 10	10E/CV118	S.Pentode, Brit. Octal. 6.3 v.
R62	10W/8780	68,000 ohms $\pm$ 20%, $\frac{1}{4}$ watt	V1, 3, 5, 6, 11, 12, 13, 14,		
R1, 13, 42, 45, 57	10W/993	100,000 ohms $\pm$ 20%, $\frac{1}{4}$ watt	15, 16, 17, 18	10E/92	VR.91, S.Pentode, Special 9, 6.3 v.
R33, 52	10W/7465	100,000 ohms $\pm$ 20%, 1 watt	V2, 4	10E/11400	VR.54, D.Diode, Int. Octal, 6.3 v.
R4	10W/7312	100,000 ohms $\pm$ 20%, 2 watt	V19, 21, 22	10E/105	VR.92 Small diode, 3 pin, 6.3 v.
R101	10W/885	120,000 ohms $\pm$ 10%, $\frac{1}{4}$ watt			

## APPENDIX V

# SERVICING INSTRUCTIONS FOR A.R.I. 5083

### DAILY INSPECTION

#### Introduction

1. The daily or pre-flight inspection is carried out by one mechanic. The test gear required comprises only the P.E. test set. In many cases other equipments will be carried in the same aircraft which will necessitate the use of two P.E. sets, and the services of more than one mechanic.

#### Inspection schedule.

2. (i) Connect up the P.E. set and switch on as required for the particular equipments in use. Allow a minimum of 1 minute for the equipment to warm up.

(ii) Check the AC supply from the voltage control panel for stability, with and without the load. The reading should be  $80V \pm 1v$ .

(iii) Check that the indicator bulb in the voltage control panel is servicable and that a spare fuse is contained in the fuse box stowage.

3. Set the time base (T.B.) switch to the down position (Main time base), the clearing switch to "calibration pips" and check that the pulse recurrence frequency (p.r.f.) switch is in the normal or divide by 6 (anti-clockwise) position. The normal picture showing 25 calibration divisions with every 5th pip raised should appear on the tube face. Check that focus and brilliance controls function.

4. Set the T.B. switch to the central position (Strobe time base). The picture should appear normal with 12 to 14 pips on each of the strobe time bases. On the "B" and "C" strobes it should be possible to see two "raised" pips simultaneously by moving the "B" and "C" fine strobe controls. There should be 10 small pips between each pair of "raised" pips counting in one but not both of these "raised" pips. On the "A" strobes a "raised" pip should appear at about the centre of the scan.

5. Reset the T.B. switch to main time base. Check that the Zero mark is a "raised" pip. Operate the coarse strobe controls. For each step on the switch the strobe marker should jump about  $6\frac{1}{2}$  to 7 small divisions of the main time base (M.T.B.). Check that the markers will move from one end of the scan to the other end and that the fine strobe controls operate smoothly. The total rotation of each fine strobe control should cover about  $7\frac{1}{2}$  small divisions of the M.T.B.

6. Turn the p.r.f. switch to its clockwise position. There should now be 30 small divisions on the M.T.B. and the trace length should remain the same to within about  $\frac{1}{8}$  inch. Reset the p.r.f. switch to normal.

7. Operate the T.B. switch to the expanded strobe time base (S.T.B.) position and check that the are about three divisions along the time base and that the time bases are steady.

8. With the clearing switch in the "up" position signals should be received, although it is possible that only one pulse may be visible and that may be drifting along the trace. Check that the receiver pulse (or pulses) may be stopped or caused to drift slowly in either direction by means of the frequency control.

9. Check that the gain control operates to increase signal amplitude when turning clockwise and to bring up "noise" on the tube in the extreme position.

10. On the receiver, if an R.F. type 24 or 25 is being used, check that the "spot" frequency selector switch is in the required position, and the loading unit switch is set to correspond.

11. If an R.F. unit type 26 or 27 is fitted, check that the tuning control is set to the required reading and that the loading unit switch is set to correspond.

12. The anti-jamming selector should be set to position N.

13. After disconnection of the P.E. set see that all aircraft cables are replaced on the V.C.P.

14. Check that all cables are in good condition and are connected firmly.

15. Inspect aerial for any sign of damage.

#### Record keeping

16. Fill in any records that may be required, e.g. serial numbers of changed units.

## PERIODIC INSPECTION

### Introduction

17. The periodic inspection is a more thorough inspection which will be carried out at regular intervals. These intervals should correspond if possible with the "minor" aircraft inspection. If, however, a unit is found to be faulty and requires repairing it will be necessary to treat it as though it were undergoing its periodic inspection, notwithstanding the fact that the latter may not be due for some considerable time. "Minor" inspections normally are carried out about once every 30 flying hours in Fighter Command and about once every 70 hours in Bomber and Coastal Commands, although this period depends on the type of aircraft.

### Inspection schedule

18. Remove both indicator and receiver from the aircraft for subsequent bench testing and replace them with units which have been thoroughly bench tested.

19. Check that the new units have had all authorised modifications done, by reference to the labels on the units.

20. (i) Carry out a full installation procedure as laid down in paras. 57 to 61.

(ii) Check that the AC output of the voltage control panel on an aircraft engine test, with the Gee load, is 80 v.  $\pm$  2 v.

(iii) On every alternate Periodic Inspection, remove the voltage control panel from the aircraft and set up on the Bench.

## BENCH TESTING

### Introduction

21. A test set, type 210 will be required for R.F. adjustment and other items of test gear may be required in the event of faults developing.

22. Inspect both units thoroughly for broken valves or valves not properly inserted in sockets, for broken wiring and loose connections and for burned or charred parts.

23. Make sure that all authorised modifications have been made on both units, as indicated on the modification labels.

24. See that units are thoroughly clean.

25. Connect up the bench set in accordance with fig. 2, omitting the aerial until ready to test the receiver. Remove the indicator dust cover, switch on and check that the supply voltage is  $80V \pm 1V$ , if not, adjust the V.C.P.

### Indicator unit, type 62 or type 62A

26. Set the Time Base switch to "S.T.B.", the clearing switch to "calibration pips" and the p.r.f. switch to "normal". The picture should appear as in fig. 6B, i.e. there should be ten, 150 Kc/s pips between every pair of raised pips counting in one but not both of them.

27. Check the setting of P11 (first divide-by-5 stage). Loosen the locking control of P11 and rotate in one direction until a point is reached where the divider goes out of adjustment and the picture will either jitter or the number of pips will alter from 10 to either 8 or 12. Note the scale setting of P11. Rotate the control in the opposite direction until the divider again commences to jitter or divide by 12 or 8. Note the new scale setting and reset P11 to a position on the scale midway between the settings noted. Relock the control.

28. Set the Time Base switch to "M.T.B." Set P12 (second divide-by-5 stage) in a similar manner to that given in para. 27 above. The number of minor calibration pips should alter from 4 to 5 or 6 (counting one but not both raised pips) depending on the setting of P12. Relock control after adjustment.

29. Set P14 (third divider stage, divide by 6) in a similar manner to that given in paras 27 and 28 above. For the correct setting there will be twenty-five 15 Kc/s pips on each of the main time base traces as shown in fig. 6A. For the setting on either side of this position there will be 20 or 30 pips.

30. Adjust P13 ("A" strobe position control) until a raised pip (zero mark) occurs just at the beginning of the M.T.B. Switch to S.T.B. when the raised pip on the "A" strobe time base should now occur about midway along the trace. If this is not so re-adjust P13 and relock.

31. Re-check the setting of P14 after performing the above, and, after setting correctly, switch the p.r.f. switch to the clockwise position, (i.e. divide by 7), when the M.T.B. should show thirty, 15 Kc/s calibration pips instead of 25. Relock P14 and set the p.r.f. switch back to normal.

32. The following adjustments (para. 33 to 40) should only be carried out if necessary :—

33. Adjust P15 so that :—

(i) The minor calibration pips on S.T.B. are greater than one-eighth inch.

(ii) The minor calibration pips on M.T.B. are greater than one-sixteenth inch.

(iii) Base line between calibration marks shall be clear and free from distortion and all calibration marks clear on both M.T.B. and S.T.B.

34. Adjust P2 so that the Main Time Base amplitude is  $4'' \pm \frac{1}{8}$  inch.

35. Adjust P1 so that the Strobe Time Base amplitude is  $4'' \pm \frac{1}{8}$  inch.

36. Adjust P3 so that the Main Time Bases are central on the tube face.

37. Adjust P4 so that the Strobe Time Bases are centred on the tube face.

38. Adjust P8 so that the spacing between Main Time Base traces is  $1\frac{1}{8}'' \pm \frac{1}{8}''$

39. Adjust P9 to give eleven to fourteen 150 Kc/s pips on "A" strobe traces of S.T.B.

40. Adjust P10 so that the mean length of the "B" and "C" strobe traces is equal to that of the "A" strobe. The difference in length between the "B" and "C" strobes shall not exceed one minor division. For this test the "B" and "C" strobe markers should be approximately halfway along the M.T.B. The spacing between "A" and "B" strobe traces and between "A" and "C" strobe traces should not exceed  $\frac{3}{32}$  inch.

41. On both M.T.B. and S.T.B. the "B" and "C" strobes must be inverted with respect to the "A" strobes and their amplitude shall be the same as that of the "A" strobes within  $\pm 20\%$ . The strobe time bases should not overlap into each other when viewed with receiver noise at full gain.

42. On M.T.B., check that the strobe markers will move from one end of the trace to the other. For each step on the switch the strobe marker should jump about  $6\frac{1}{2}$  to 7 small divisions. The total rotation of each fine strobe control should cover about  $7\frac{1}{2}$  small divisions.

#### Receiver type R.1355 and loading unit, type 2 or 51

43. *General.* Throughout the following tests the anti-jamming switch must be kept in the N (normal) position.

44. Connect a vertical "whip" aerial (type 87 or 257 rod aerial) together with the corresponding loading unit (type 2 or 51 respectively) as used on the aircraft: the length of feeder cable should be similar to that used in the aircraft. The "whip" aerial should be mounted on an earthed plate or wire mesh of at least 4 ft. diameter, the thin end of the whip being well away from surrounding objects.

45. Set up a test set, type 210. Reference should be made to A.P.2563J for details of this set and the method of R.F. alignment.

46. *Loading units, types 2 and 51.* (See figs. 7 and 8). These two units are mechanically interchangeable. Type 2 is fitted with a 5-position Yaxley switch. Type 51 is fitted with an 8-position Yaxley switch and is designed to cover the whole Gee band from 20 to 85 Mc/s.

47. The frequency coverage obtainable at each switch position of the loading units is given below :—

Loading unit, type No.	Length of aerial	Switch position	Frequency coverage
2	5 ft.	1	40 to 51 Mc/s band
		2	22.9 Mc/s spot frequency
		3	25.3 " " "
		4	27.3 " " "
		5	29.7 " " "
51	3 ft. $7\frac{3}{4}$ ins	1	22.1 to 23.6 Mc/s band
		2	23.6 " 25.7 " "
		3	25.7 " 28.0 " "
		4	28.0 " 30.8 " "
		5	42.0 " 47.5 " "
		6	47.5 " 54.5 " "
		7	54.5 " 73 " "
		8	73 " 85 " "

48. *R.F. unit, type 24.* Align the unit to the following "spot" frequencies :—

<i>Switch position of R.F. unit</i>	<i>Frequency Mc/s</i>	<i>Tolerance Mc/s</i>
1	22.0	±0.1
2	22.9	"
3	25.3	"
4	27.3	"
5	29.7	"

The frequency selector switch on the aerial loading unit must also be set to the frequency being checked. The appropriate trimmers in the three R.F. compartments and in the aerial loading unit are adjusted to give maximum signals. The location of these trimmers on the R.F. unit is shown in fig. 12.

49. If the signals tend to saturate the receiver the gain should be turned down so that the exact tuning point can be found. It may be found necessary to break the sealing compound locking the trimmers in position in order to adjust them. After adjustment they should not be resealed as this has been found unnecessary. It will be found necessary to remove the R.F. unit from the I.F. chassis in order to break the sealing.

50. After alignment of the R.F. stages a check should be made to ensure that any ground stations normally received can be picked up with their usual strength.

51. *R.F. unit, type 25.* Align the unit to the following "spot" frequencies :—

<i>Switch position of R.F. unit</i>	<i>Frequency Mc/s</i>	<i>Tolerance Mc/s</i>
1	43.0	±0.1
2	44.9	"
3	46.8	"
4	48.75	"
5	50.5	"

The instructions detailed and remarks made relating to R.F. unit, type 24 above similarly apply to this unit.

52. *R.F. units, types 26 and 27.* Set the test frequency of test set, type 210 to the value at which tuning is to be checked and leave it at this value.

53. Rotate the tuning dial of the R.F. unit about the position corresponding to this frequency until the pulses are received at maximum.

54. Check that the dial reading is approximately correct : fig. 18B gives dial readings against operational frequencies for type 26 and fig. 18A those for type 27.

55. Adjust the trimmer knob at the bottom left-hand corner of the corner of the R.F. Unit front panel for optimum pulse shape and size. This is best carried out with the pulse on the strobe time base. Check that the trimmer is not tuning at one of its extreme positions, as indicated by the marks on the knob and panel.

56. *Power unit and I.F. amplifier circuit.* The negative rail voltage to the anti-jamming circuits should be adjusted as follows :—

- (i) Set the gain knob on indicator unit to zero.
- (ii) Place anti-jamming switch in position X or Y.
- (iii) Adjust P1 in the power unit until the average of the voltages across R22, R30 and R39 in the anode circuits of V3, V4 and V5, respectively, is 135V.

The operation of the circuit is such that there is automatic compensation for the voltmeter current provided this does not exceed 1 mA. For preference use an Avominor, high resistance, or a test meter, type D on the 750V. range.

- (iv) Lock P1 in position. Re-check the voltages to make sure that the potentiometer has not been turned during locking.

## INITIAL INSTALLATION AND ADJUSTMENT IN AN AIRCRAFT

57. The installation diagram is given in fig. 2. Before installation an equipment would normally be set up fully on the bench unless it was known that this had already been done at the source of origin of the equipment.



58. *Fixtures in the aircraft.* Before commencing the units in the aircraft, carry out the following :—

- (i) Check all Pye leads to ensure that the grub screws are tight.
- (ii) Inspect the aerial system for security.
- (iii) Ensure that the whip aerial is free from rust. Clean with an oily rag if necessary but do not use emery cloth or similar abrasive material. After cleaning treat the aerial rod with lanolin or vaseline.
- (iv) Remove the loading unit and using the insulation tester, type A, check that the resistance between the aerial and the air frame is greater than 10 megohms.

59. *Connction of equipment.* The equipment should be connected in accordance with fig. 2, taking care to see that all cables are connected correctly and firmly. In particular, ensure that retaining clips for Pye plugs are correctly fitted and in place.

#### Initial adjustment

60. Connect up a P.E. set and check that the regulated voltage is stable by testing on no load and on the Gee load, and that the value is  $80V \pm 1V$ . If necessary, change the V.C.P.

61. (i) Carry out a careful and full D.I. as indicated in paras 1 to 16.
- (ii) Check that the AC output of the voltage control panel, on an aircraft engine test, with the Gee load, is  $80V \pm 2V$ .

#### FAULTS

62. The following is a brief list of common faults known to develop in the Gee equipment, together with the probable cause of the faults :—

No.	Symptoms	Probable Causes .....
1	No display on C.R.T.	(i) Damage to rectifier V4. (ii) Input condenser (C47) of smoothing filter on main H.T. short circuit.
2	No signals	(i) A.J. chokes in last three I.F. stages open circuit. These are L12, L13, L14 in the anode circuits and L9, L10, L11 connected down to the negative rail: often broken off in maintenance. (ii) If the first ones are broken anode current ceases: if second are broken valves saturate. (iii) The Jones plug on the R.F. unit buckles by careless replacement of R.F. unit in I.F. chassis giving bad contact. Some supplies to R.F. unit missing. (iv) Pye sockets open-circuited.
3	No signals in X, Y and Z positions of A.J. switch	Incorrect setting of negative rail supply.

No.	Symptoms	Probable Causes
4	No signals. Smoke from Receiver, R.1355.	Screen decoupling condensers (C8 and C21—0.0003 mfd) in R.F. unit become short-circuited. R2, R5 and R20 (in power unit) may char and smoke due to over-loading.
5	Unstable strobos.	Indicator, type 62. Faulty valves V7, V10, or V11. Dirty contacts of time-base switch. Dirt in vanes of strobe position condensers C22, C36.
6	Signals drifting very quickly across time-base.	(i) Crystal bumped excessively and knocked out of mounting. No synchronism to T.B. No output from V12 but V13 continues to work at about 150 Kc/s so that T.B. continues.  (ii) Slug tuning 150 Kc/s circuit of V12 badly adjusted. Low or no output from V12 and no synchronism to T.B.  (iii) Drifting of pulses may in general be due to wrong setting-up of the divider stages.
7	Time-base longer than usual—greater apparent sensitivity of tube.	E.H.T. rectifier V6 in receiver down in emission or C43 leaky to lower E.H.T.
8	No display on C.R.T. or display not central.	Wires knocked off C.R.T. base.

## SUPPLEMENTARY DATA

### Voltage data

63. All voltages shown are on the assumption that the input voltage is set at 80V R.M.S.

64. Receiver, type R.1355. Voltages to earth are given in the following table.

Part of circuit	Valve	Anode volts	Pin No.	Screen volts	Pin No.	Cathode bias volts	Pin No.	Remarks	
R.F. unit type 24	V1	250	3	240	4	2.5	2	H.T. line to unit=300V.	
	V2	280	3	160	4	3.0	2		
	V3	270	3	290	4	2.6	2		
R.F. unit, type 25	V1	260	3	255	4	2.8	2	H.T. line to unit=300V.	
	V2	295	3	190	4	2.9	2		
	V3	280	3	300	4	2.8	2		
R.F. unit type 26	V1	210	2	240	3	1.6	4.5	H.T. line to unit=300V.	
	V2	290	2	200	3	4.5	4.5		
	V3	210	4	—	—	1.4	3		
R.F. unit, type 27	V1	180	2 <sup>6</sup>	250	3	2.6	4.5	do.	
	V2	295	2	195	3	3.9	4.5		
	V3	240	4	—	—	1.7	3		
I.F. unit	V1	340	3	310—320	4	5—8	2	Screen and cathode potentials depend on the gain control setting.	
	V2	340	3	320—330	4	5—8	2		
	V3	—	—	45	4	0.8	2		A.J. switch in position N.
	V3	—	—	335	4	—	—		A.J. switch in positions X, Y.
	V3	—	—	310	4	—	—		A.J. switch in position Z.
	V4	—	—	45	4	0.7	2		A.J. switch in position N.
I.F. unit	V4	—	—	335	4	—	—	A.J. switch in positions X, Y.	
	V4	—	—	310	4	—	—	A.J. switch in position Z.	
	V5	—	—	45	4	0.75	2	A.J. switch in position N.	
	V5	—	—	335	4	—	—	A.J. switch in positions X, Y.	
	V5	—	—	310	4	—	—	A.J. switch in position Z.	
	V7	200	3	170	4	3	2		
	V8	350	3	—	—	27	2		

In the above table the voltages given are approximate only and may vary by as much as 25% from one receiver to another.

**ote**

- (i) The H.T. line volts to the R. F. unit should be  $300\text{ V} \pm 10\%$  measured from junction of R20 and C42 to earth.
- (ii) The H.T. line volts to the I.F. units should be  $350\text{V} \pm 10\%$  measured from junction of L7 and C40 to earth.
- (iii) The heater voltages in I.F. and R.F. units should be  $6.3\text{V AC} \pm 10\%$  for all valves.
- (iv) Measure the negative rail volts between the junction of C40 with L7 and earth.
  - (a) With the A.J. switch in positions N, X, and Y this voltage should be capable of variation over the range 200 to 260 volts.
  - (b) Set the above voltages to 230 volts, then set the A.J. switch to position Z. The voltage should fall to 130 volts.

65. *Power pack voltages.* The voltages in the power pack are as follows :—

- (i) H.T. line to indicator  $300\text{V} \pm 10\%$  (Measured at the anode of the anti-jitter valve V5—Pin 3).
- (ii) H.T. line to the I.F. amplifier  $350 \pm 10\%$ . (*See para. 64*).
- (iii) H.T. line to the R.F. unit  $300\text{V} \pm 10\%$ . (*See para. 64*).

- (iv) E.H.T. line to the indicator  $1650\text{V} \pm 10\%$ . (Measured with the electrostatic voltmeter at pin 1 of the 6-way W plug).
- (v) The heater voltages are as follows V4 (VU71)— $5\text{V} \pm 0.1\text{V}$  ; V5 (VR65)— $6.3\text{V} \pm 0.2\text{V}$  ; V6 (VR120) — $2.0\text{V} \pm 0.1\text{V}$ .

**Current data**

66. *Receiver, type R.1355.* The I.F. unit anode currents are given in the following table.

Valve	A.J switch in position X or Y.	A.J. switch in position
V3	$1.35\text{ mA} \pm 5\%$	$2.30\text{ mA} \pm 5\%$
V4	"	"
V5	"	"

Measure the anode currents of V3, V4 and V5 by measuring the voltage drop across the corresponding 100K resistors, R22, R30 and R39 in the anode circuits of these valves. Use a high resistance voltmeter of not less than 200,000 ohms if available.

**Waveforms**

67. Typical waveforms giving approximate amplitude are shown in figs. 27 and 28, while fig. 6 shows the various pictures seen on the tube face.



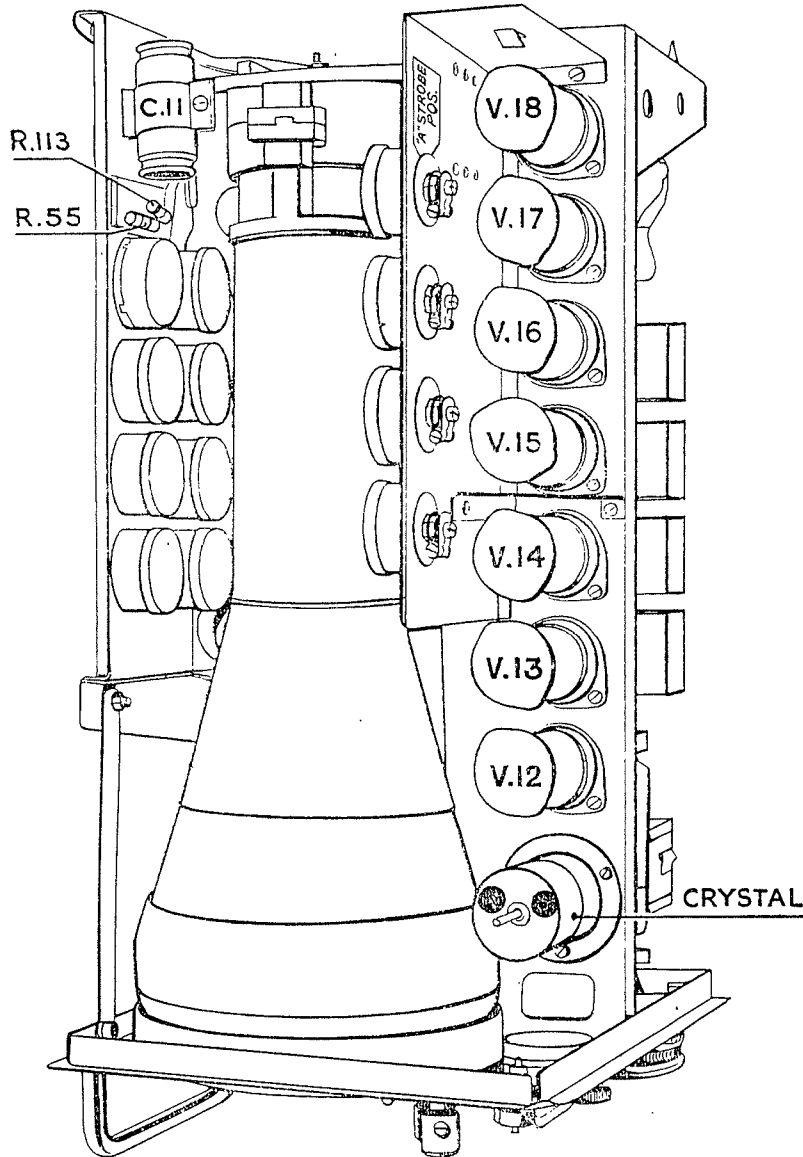
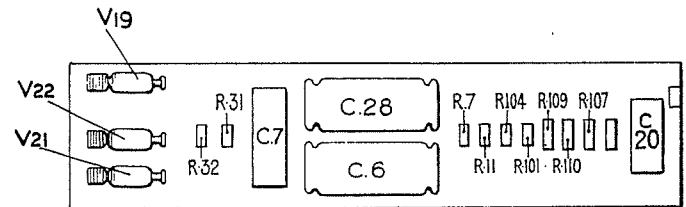
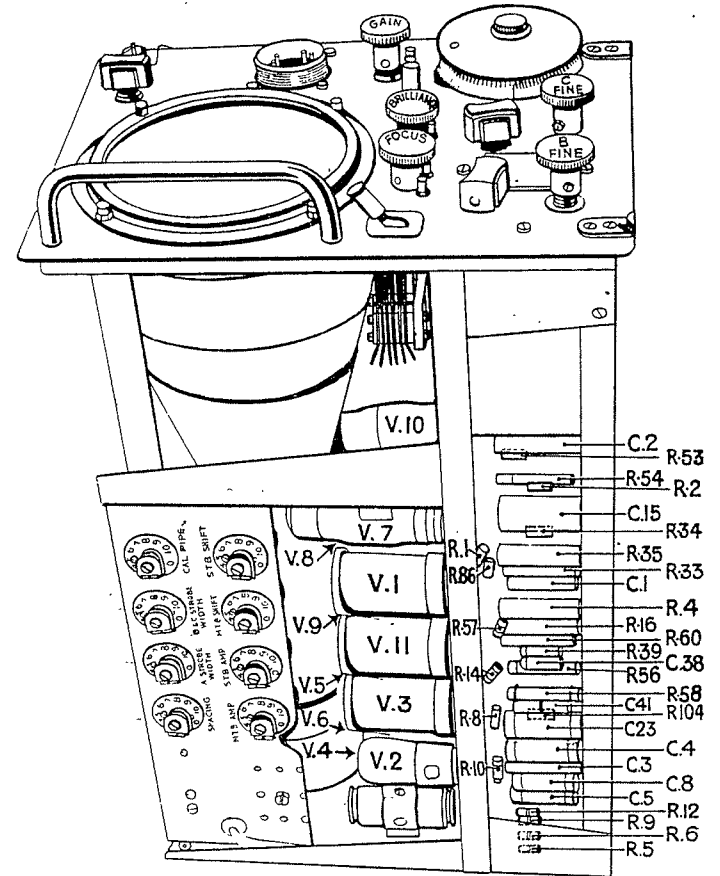

Fig. 38.—Indicator unit type 62A, top of chassis.



GROUP BOARD UNDER C.R.T

Fig. 39.—Indicator unit type 62A, R.H. side of chassis.

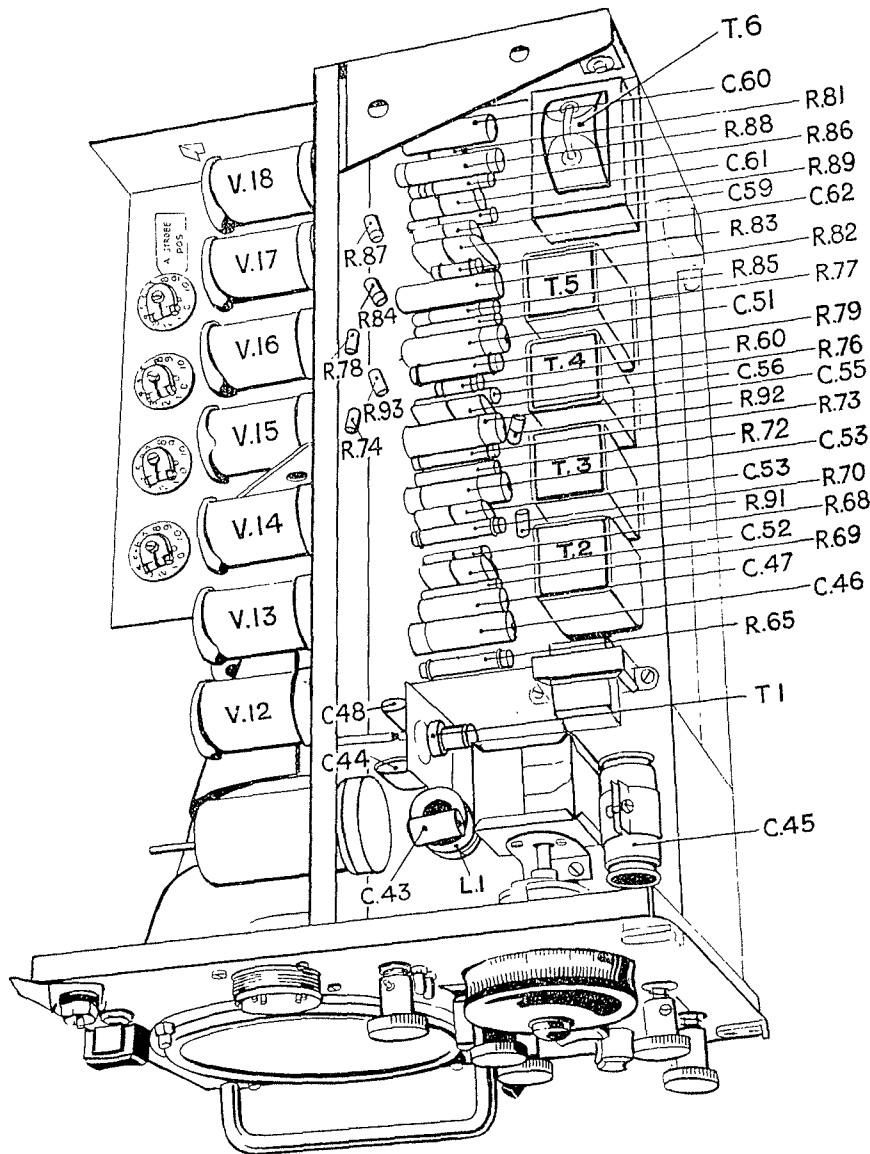

Fig. 40.—Indicator unit type 62A, L.H. side of chassis.

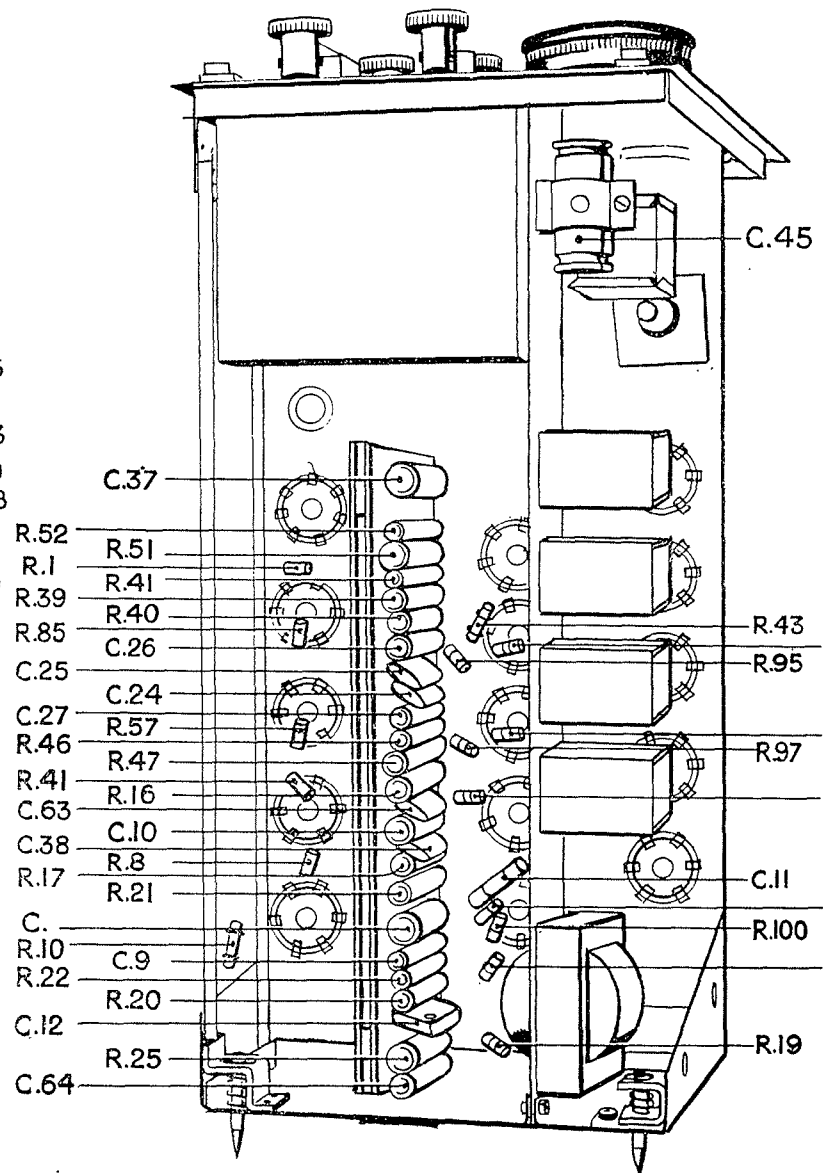

Fig. 41.—Indicator unit type 62A, underside of chassis.