

Please do not upload this copyright pdf document to any other website. Breach of copyright may result in a criminal conviction.

This pdf document was generated by me Colin Hinson from a Crown copyright document held at R.A.F. Henlow Signals Museum. It is presented here (for free) under the Open Government Licence (O.G.L.) and this pdf version of the document is my copyright (along with the Crown Copyright) in much the same way as a photograph would be.

The document should have been downloaded from my website <https://blunham.com/Radar>, or any mirror site named on that site. If you downloaded it from elsewhere, please let me know (particularly if you were charged for it). You can contact me via my Genuki email page: <https://www.genuki.org.uk/big/eng/YKS/various?recipient=colin>

You may not copy the file for onward transmission of the data nor attempt to make monetary gain by the use of these files. If you want someone else to have a copy of the file, point them at the website. (<https://blunham.com/Radar>). Please do not point them at the file itself as it may move or the site may be updated.

It should be noted that most of the pages are identifiable as having been processed by me.

I put a lot of time into producing these files which is why you are met with this page when you open the file.

In order to generate this file, I need to scan the pages, split the double pages and remove any edge marks such as punch holes, clean up the pages, set the relevant pages to be all the same size and alignment. I then run Omnipage (OCR) to generate the searchable text and then generate the pdf file.

Hopefully after all that, I end up with a presentable file. If you find missing pages, pages in the wrong order, anything else wrong with the file or simply want to make a comment, please drop me a line (see above).

It is my hope that you find the file of use to you personally – I know that I would have liked to have found some of these files years ago – they would have saved me a lot of time !

Colin Hinson

In the village of Blunham, Bedfordshire.

AP 116L-0131-1

**TANDBERG TAPE RECORDER
SERIES 15**

GENERAL AND TECHNICAL INFORMATION

BY COMMAND OF THE DEFENCE COUNCIL

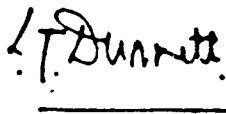
A handwritten signature in black ink, appearing to read 'J. T. Dunne', is written above a solid horizontal line.

Ministry of Defence

**FOR USE IN THE
ROYAL AIR FORCE**

Prepared by the Procurement Executive, Ministry of Defence

Preface

This service manual covers the standard models of Series 14 and 15, and the special versions 15 SL, 15 GT and 15 F. Modifications introduced since production started in December 1967 is dealt with in separate chapter.

Oslo, February 1970.

TANDBERGS RADIOFABRIKK A/S

Errata

1. Clutch spring

In illustrations as well as in text and parts lists the clutch spring for take-up turntable has wrong part number. The correct number is 214701.

2. Error in schematic for Model 15 SL, board No. 15001

Terminal 29 is connected to ground and not to the junction of R201/R203 as indicated in schematic.

3. FREE HEAD

In the schematic, the FREE HEAD socket is connected to terminal F on board 15101. In units having this connection some trouble can occur when using the Tape Slide Synchronizer and when playing stereo tape via auxiliary power amplifier connected to FREE HEAD output. The FREE HEAD socket should be connected to terminal D on board 15101.

Contents

| | | | | | |
|--------|--|----|--------|---|----|
| 1.0 | Technical Specifications | 2 | 5.10 | Heads and Track Selector | 25 |
| 1.1 | Standard Model | 2 | 5.10.1 | Position DUO | 25 |
| 1.2 | SL Model | 3 | 5.10.2 | Position NORMAL | 26 |
| 1.3 | GT Model | 3 | 5.10.3 | Position EXTRA | 26 |
| | | | 5.11 | Function Selector | 26 |
| 2.0 | Operating Controls | 4 | 6.0 | Alignment of Tape Path and Electric Circuits | 27 |
| 3.0 | Connections | 5 | 6.1 | Tape Guide Posts | 27 |
| 4.0 | Mechanical Description and Adjustment Procedures | 6 | 6.2 | Record/Playback Head | 27 |
| 4.1 | The Operating Lever | 6 | 6.2.1 | Initial Lateral Adjustment | 27 |
| 4.1.1 | Eccentric Segment (990203) | 7 | 6.2.2 | Height Adjustment | 27 |
| 4.1.2 | Pressure Wheel Arm (990202) | 7 | 6.2.3 | Azimuth Adjustment | 27 |
| 4.1.3 | Operating Arm (248186) | 7 | 6.2.4 | Final Lateral Adjustment | 27 |
| 4.2 | Turntables | 9 | 6.3 | Erase Head | 28 |
| 4.2.1 | Supply Turntable for Series 14 (990226) | 9 | 6.3.1 | Height Adjustment | 28 |
| 4.2.2 | Supply Turntable for Series 15 (990226) | 10 | 6.3.2 | Azimuth Adjustment | 28 |
| 4.2.3 | Tape Tensioner | 10 | 6.3.3 | Lateral Adjustment | 28 |
| 4.2.4 | Take-Up Turntable (990227) for Series 14 | 11 | 6.4 | Track Control | 28 |
| 4.2.5 | Adjustment of Turntables | 12 | 6.4.1 | Visual Track Control, 2-Track Model | 28 |
| 4.3 | Clutches | 13 | 6.4.2 | Track Control with Test Tape, 4-Track Model | 28 |
| 4.3.1 | Neutral | 13 | 6.4.3 | Height Adjustment of Record/Playback Head by Track Measurement on 4-Track Model | 28 |
| 4.3.2 | Normal Forward Drive | 14 | 6.5 | Bias Current | 28 |
| 4.3.3 | Fast Forward Winding | 14 | 6.5.1 | Oscillator Frequency, 2-Track Model | 28 |
| 4.3.4 | Fast Reverse Winding | 15 | 6.5.2 | Oscillator Frequency, 4-Track Model | 28 |
| 4.3.5 | Free | 16 | 6.6 | Record Current and Record Level Indicator | 28 |
| 4.4 | Motor Pulley (254040) for Series 14 | 16 | 6.7 | Verification of Frequency Curves | 28 |
| 4.5 | Motor Pulley (243940) for Series 15 | 16 | 6.8 | Distortion Check | 29 |
| 4.6 | Drive Belt (213997) | 17 | 6.9 | Output Amplifier | 29 |
| 4.7 | Transfer Wheel (990233) | 17 | 6.9.1 | Output Symmetry | 29 |
| 4.8 | Lifting Arm (990201) Series 14 | 17 | 6.9.2 | Quiescent Current | 29 |
| 4.9 | Lifting Arm (990201) Series 15 | 17 | 7.0 | Special Versions | 29 |
| 4.10 | Flywheel (990312) with Capstan | 18 | 7.1 | Model 15 SL | 29 |
| 4.11 | Speed Selector, Series 14 | 19 | 7.1.1 | Playback Amplifier | 29 |
| 4.12 | Speed Selector, Series 15 | 19 | 7.1.2 | Mechanical Interlock | 29 |
| 4.13 | Instantaneous Start/Stop Mechanism | 20 | 7.2 | Model 15 GT — Group Trainer | 30 |
| 4.14 | Pressure Pad Spring (Original Version) | 20 | 7.2.1 | Input Amplifier | 30 |
| 4.15 | Pressure Pad Spring (Modified Version) | 20 | 7.2.2 | Output Amplifier | 30 |
| 4.16 | End Stop Mechanism | 22 | 7.2.3 | Programme Amplifier | 30 |
| 4.16.1 | Neutral | 22 | 7.2.4 | Adjustment of Signal Levels | 30 |
| 4.16.2 | Normal Forward Drive | 22 | 7.3 | Model 15 F | 30 |
| 4.16.3 | End Stop or Tape Break | 22 | 7.3.1 | Mechanical Operation | 30 |
| 4.16.4 | Free | 22 | 7.3.2 | Electrical Operation | 31 |
| 4.16.5 | Tape Feeler Tension | 22 | 8.0 | Modifications | 30 |
| 5.0 | Electric Circuits | 24 | 8.1 | Circuit Modification for Low Noise Tape | 32 |
| 5.1 | Line Amplifier | 24 | 8.2 | Modification of F-Model from Serial No. 2510 020 | 32 |
| 5.2 | Microphone Amplifier | 24 | 8.2.1 | Microswitch for Oscillator Voltage | 32 |
| 5.3 | Buffer Amplifier | 24 | 8.2.2 | New Microswitch | 33 |
| 5.4 | Equalizing Amplifier | 24 | 8.2.3 | Rewiring | 33 |
| 5.4.1 | Equalizing Network for Recording | 24 | 8.3 | Modification from 2-Track to Full-Track Model | 33 |
| 5.4.2 | Equalizing Network in Playback Mode | 25 | 8.4 | Modifications 50 to 60 Hz or Vice Versa | 33 |
| 5.5 | Playback Booster | 25 | 9.0 | Parts Lists | 34 |
| 5.6 | Indicator Amplifier | 25 | | | |
| 5.7 | Oscillator | 25 | | | |
| 5.8 | Output Amplifier | 25 | | | |
| 5.9 | Power Supply and Voltage Regulator | 25 | | | |

1.0 Technical Specifications

1.1 STANDARD MODEL 100/1178578

| | |
|----------------------------|---|
| Power requirements: | 240/230/115 V, 50 Hz, or 240/230/115 V, 60 Hz. See circuit diagram concerning wiring of motor and transformer for operation on various voltages. |
| Power consumption: | 50 W. |
| Motor: | 2-pole, asynchronous shadow-pole. |
| Tape speeds: | 7½, 3¾ and 1⅞ ips for series 15. Series 14 has the two lowest speeds only. |
| Speed tolerance: | ± 1.5 %. |
| Winding times: | 1⅔ minutes for 1200 ft reels, 2½ minutes for 1800 ft reels. |
| Tape: | Machines below serial number 2 619 561 for Series 14 and 2 515 502 for Series 15 are adjusted for standard tape. Later units are adjusted for recording on Low Noise tape. |
| Reel size: | 7" maximum. |
| Number of tracks: | 2 or 4. |
| Heads: | 1 erase head, 1 combined record/playback head. |
| Bias: | Conventional. |
| Erase- and Bias frequency: | 85.5 kHz ± 2 kHz. Distortion less than 0.5 %. |
| Indicator: | Moving coil meter for peak indication of record level. Illuminated in record mode. |
| Counter: | Indicates revolutions of take up turntable. Push-button reset. |
| Speaker: | Internal speaker 4" x 7". |
| Output power: | Maximum 10 W from output amplifier. Can be utilized only in external 4 ohm speaker. Maximum power supplied to internal speaker: 5 W. |
| Inputs: | MIC: For dynamic microphone with impedance less than 600 ohm. Sensitivity 0.1 mV. Maximum signal 10 mV. RADIO: For recording from radio. Impedance 100 kohm. Sensitivity 10 mV. Maximum signal 1 V. DIN socket and phono socket in parallel. P.U.: For record player with crystal or ceramic pick up. Impedance 1 Mohm. Sensitivity 100 mV. Maximum signal 10 V. DIN socket and phono socket in parallel. |
| Outputs: | PRE-AMP.: For playback through external amplifier. Minimum load impedance 20 kohm. Output voltage 0.9 V. DIN socket. FREE HD: For connection of Tandberg Tape Slide Synchronizer Model 2 or 3. Minimum load impedance 20 kohm. Phono socket. EXT SPKR: Maximum output power 10 W obtained for 4 ohm load (including internal speaker). DIN- socket and phone jack in parallel. |
| Transistors: | 20. |

| | | |
|------------------------------------|--------------------------|---------------|
| Bass control: | ± 10 dB at 60 Hz. | |
| Treble control: | ± 10 dB at 8 000 Hz. | |
| Frequency curves: | DIN 45511 | ± 2 dB |
| 7 ¹ / ₂ ips: | 40–18 000 Hz. | 40–16 000 Hz. |
| 3 ³ / ₄ ips: | 40–10 000 Hz. | 50– 9 000 Hz. |
| 1 ⁷ / ₈ ips: | 40– 5 000 Hz. | 60– 4 500 Hz. |
| WOW, maximum: | DIN 45511 | R.M.S. |
| 7 ¹ / ₂ ips: | 0.1 % | 0.07 % |
| 3 ³ / ₄ ips: | 0.2 % | 0.14 % |
| 1 ⁷ / ₈ ips: | 0.4 % | 0.28 % |

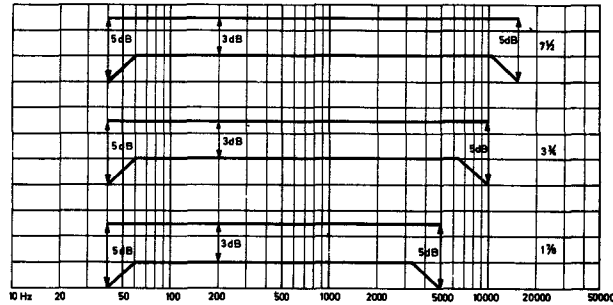

Fig. 1.1 DIN-specified frequency range with tolerances.

| Signal/Tape noise at highest speed: | 4-track | 2-track |
|-------------------------------------|------------|------------|
| DIN 45511 (weighted) | 48 (50) dB | 50 (52) dB |
| DIN 45511 (unweighted) | 47 (48) dB | 47 (48) dB |
| IEC, A-curve | 56 (57) dB | 58 (59) dB |
| IEC, unweighted R.M.S. | 51 (52) dB | 51 (52) dB |

Numbers in brackets apply for Series 15 only.

Distortion: From record amplifier at 0 dB level: 0.5 %.
 From playback amplifier at 0.9 V output: 0.2 %.
 From tape at 0 dB level: 3–5 %.

Dimensions: Width 15¹/₈" (39 cm). Depth 11³/₄" (30 cm). Height 6³/₄" (17 cm).

Weight: 19 lbs (8.7 kg).

1.2 SL-model

100 / 6260400

As standard model except for the following:

Transistors: 25.

Outputs: FREE HD output is connected to output of extra playback amplifier.
 Impedance approx 100 ohm. Output level maximum 1 V.

1.3 GT-model

As standard model except for the following:

Power Consumption: 60 W.

Transistors: 77.

Outputs: Headphones: Impedance 100 ohm. 1 mV into microphone input gives 0.8 V across 200 ohm load. Maximum output voltage 2 V across 200 ohm.

Dimensions: Height 8¹/₂" (21.5 cm).

Weight: 23 lbs (10.5 kg).

2.0 Operating Controls

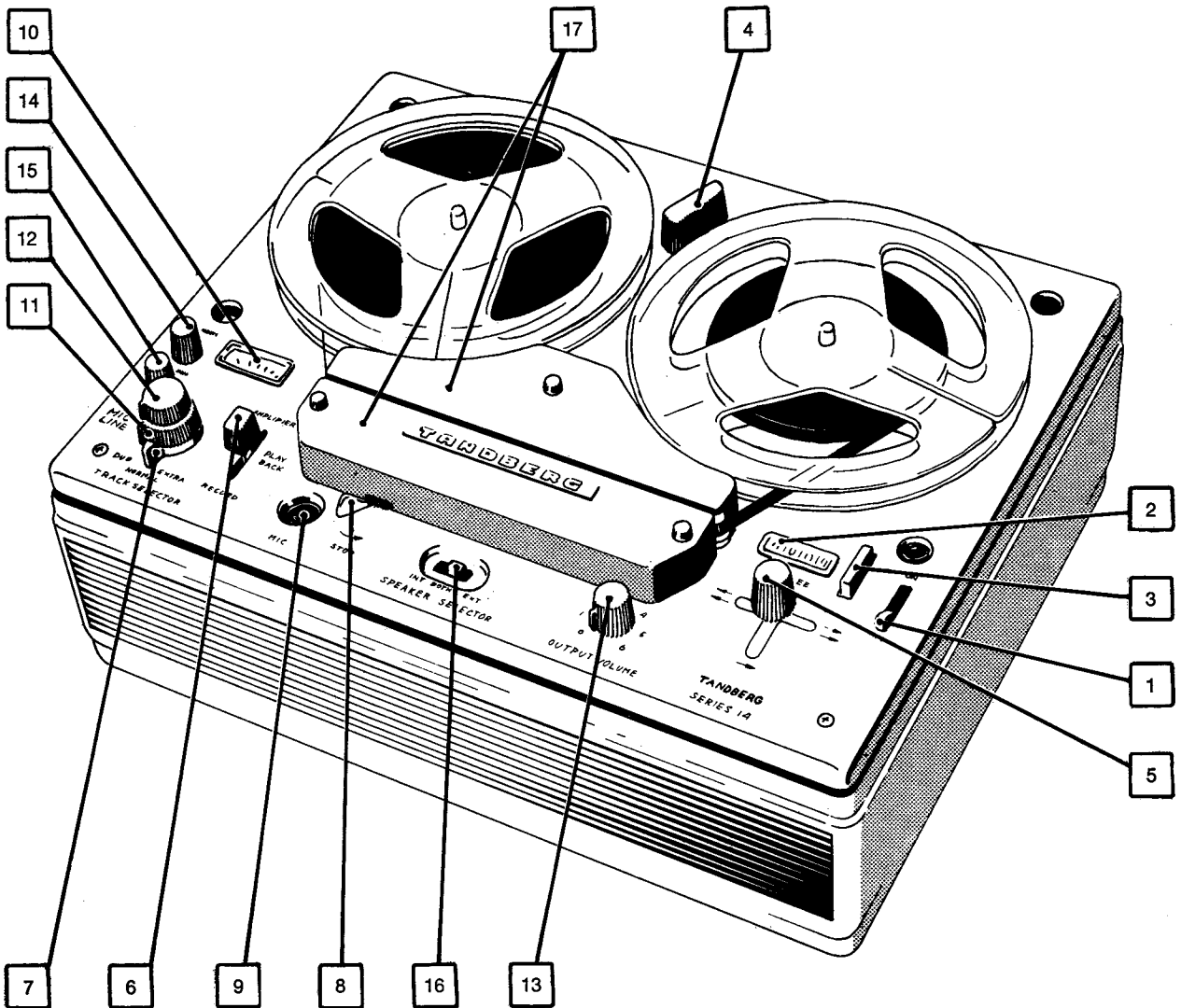

Fig. 2.1.

1. Power on/off switch.
2. 4-digit counter, indicating revolutions of take-up turntable.
3. Counter reset button.
4. Tape speed selector.
5. Operating lever for selection of tape motion modes forward and reverse winding, forward drive, free and neutral.
6. Function selector for selection of amplifier modes RECORD, PLAYB or AMPLIFIER.
7. Track selector with three positions:

NORMAL: Record/playback upper track. Lower track to FREE HD.

EXT: Record/playback lower track. Upper track to FREE HD.

DUO: Mixing of upper and lower tracks in playback.

8. Start/stop lever. For instantaneous start or stop in normal forward drive.
9. Microphone socket.
10. Record level meter.
11. Record level control for line input.
12. Record level control for microphone input.
13. Output level control.
14. Treble control.
15. Bass control.
16. Speaker selector with three positions:
 - INT: Internal speaker only.
 - EXT: External speaker only.
 - BOTH: Internal and external speakers.
17. Dust covers that can be removed for cleaning of heads and tape path.

3.0 Connections

3.1 ALL MODELS

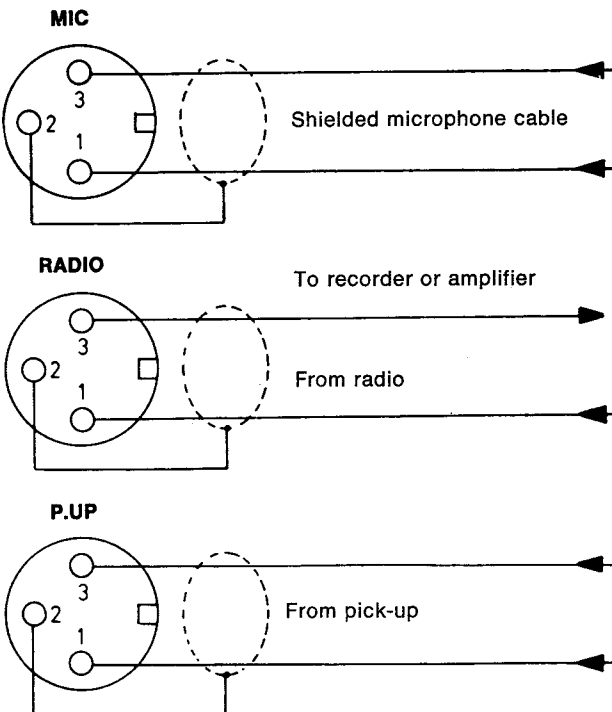

Fig. 3.1.

3.2 MODEL 15SL

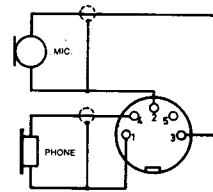

Fig. 3.2.

3.3 MODELS 15GT, MASTER AND 1-10

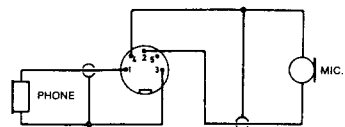

Fig. 3.3.

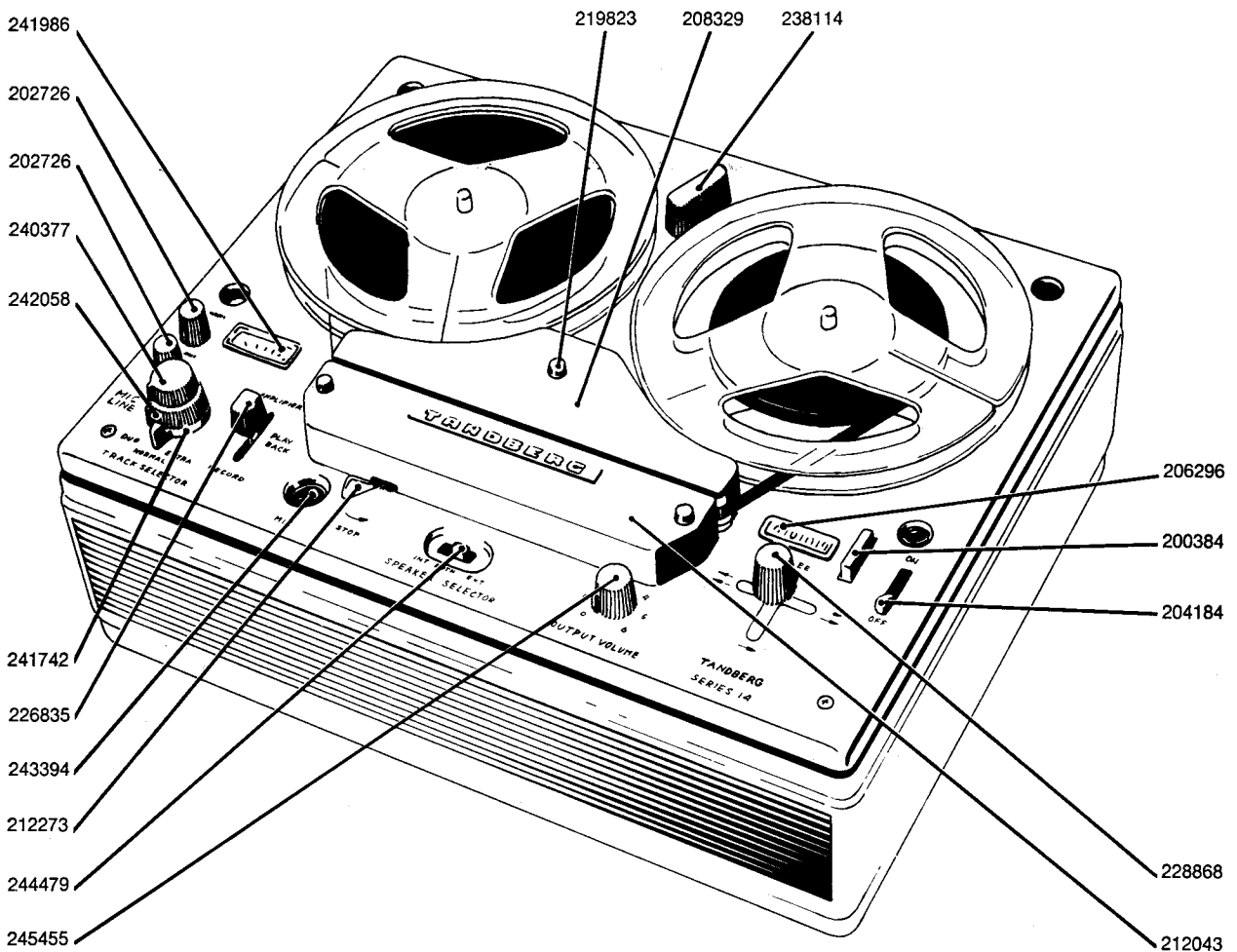

Fig. 4.1 Front top view of the recorder.

4.0 Mechanical Description and Adjustment Procedures

The purpose of the tape transport mechanism is to accomplish the tape motion for the following modes of operation:

1. Normal forward drive.
2. Fast forward winding.
3. Fast reverse winding.

These modes can be selected by the tape motion lever.

4.1 THE OPERATING LEVER

The operating lever is situated in front of the counter, and is attached to the lower mounting plate (**990216 D**). The lever can be set to the following five positions:

1. Neutral.
2. Normal forward drive.
3. Fast forward winding.
4. Fast reverse winding.
5. Free.

Parts associated with the tape motion lever:

The eccentric segment **990203**, which operates the pressure wheel arm, **990202**, and the lifting arm **990201**. The operating arm **248186** operates clutch levers **990229** and **990228**, underneath the friction disc **209658**.

4.1.1 The Eccentric segment (990203).

The eccentric segment is situated underneath upper mounting plate 990220, and is linked with the operating lever shaft 990225. The eccentric segment moves the pressure wheel arm 990202 with pressure wheel 990234 against the capstan when the operating lever is set to position Normal Forward Drive.

The lifting arm 990201 is linked with the eccentric segment 990203 and lifts the transfer wheel 990233 from the motor pulley 254040 when the operating lever is set to one of the following positions:

Fast forward winding, fast reverse winding, neutral or free.

The transfer wheel is engaged with the motor pulley in normal forward drive. See fig. 4.1.

Adjustments:

Set the operating lever in neutral position, and adjust the resting position of the pressure roller assembly by bending bracket A. See fig. 4.2.

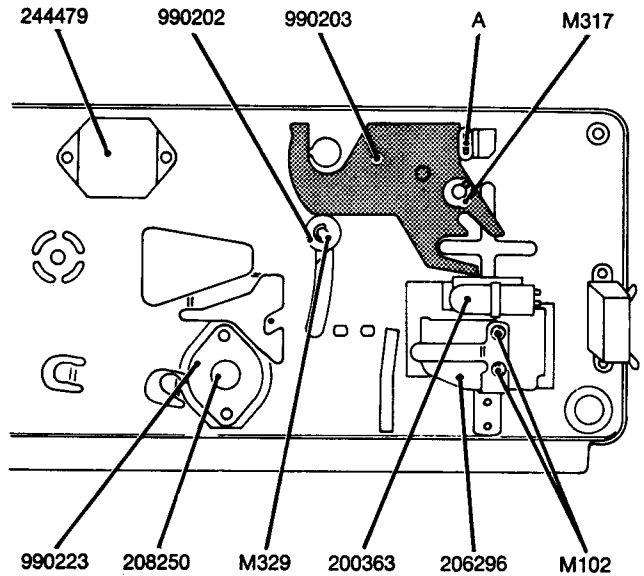

Fig. 4.2 Bottom view of upper mounting plate.

4.1.2 Pressure Wheel Arm (990202).

The pressure roller assembly is moved against the capstan by the eccentric segment 990203 when the operating lever 990225 is set to position normal forward drive. The pressure wheel 990234 is suspended under balanced spring tension as shown in fig. 4.3.

Adjustments:

The balanced spring tension is adjusted to obtain that the pressure from the pressure wheel against the capstan and the tape is evenly distributed across the width of the tape in normal forward drive.

Start tape recorder in normal forward drive. Twist the latch 215563 clockwise or counterclockwise after first having loosened the screw M120, until the tape moves smoothly over the pressure wheel. No air bubbles must be formed between the tape and the pressure ring on the pressure wheel.

4.1.3 The Operating Arm (248186)

The operating arm is attached to the lower mounting plate 990216 D, and operates clutch levers 990229 and 990228 underneath the friction discs 209658. See fig. 4.5. The operating arm is linked with the operating lever 990225.

Figures 4.9 and 4.6 show the take-up turntable assembly 990227 and supply turntable assembly 990226 with friction discs 209658 and clutch levers 990229 and 990228.

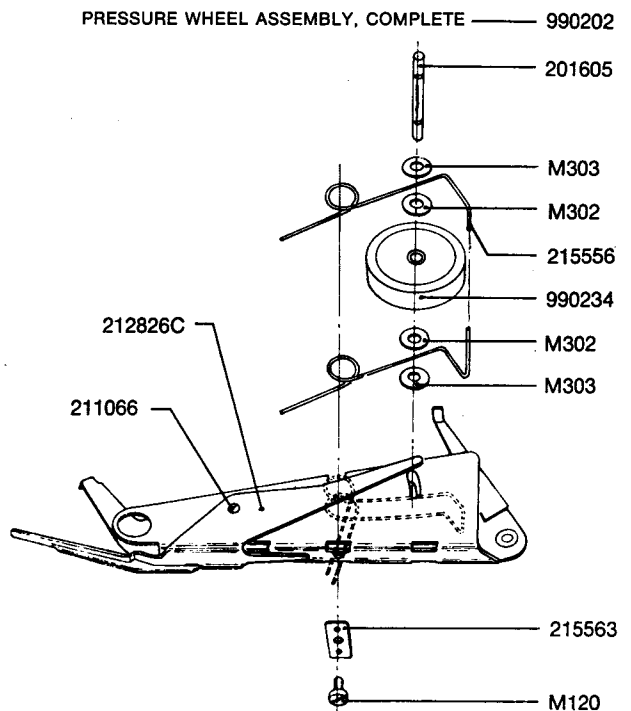

Fig. 4.3 Pressure wheel arm, exploded view.

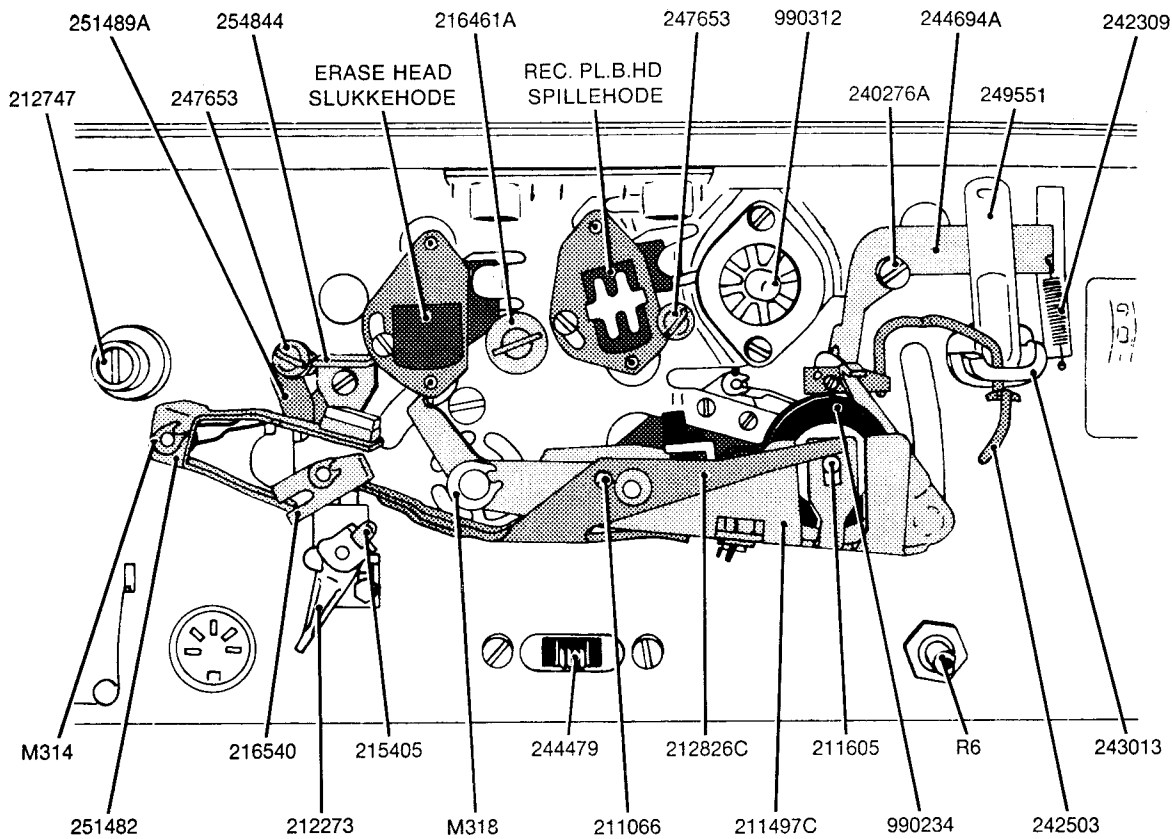

Fig. 4.4 Tape path.

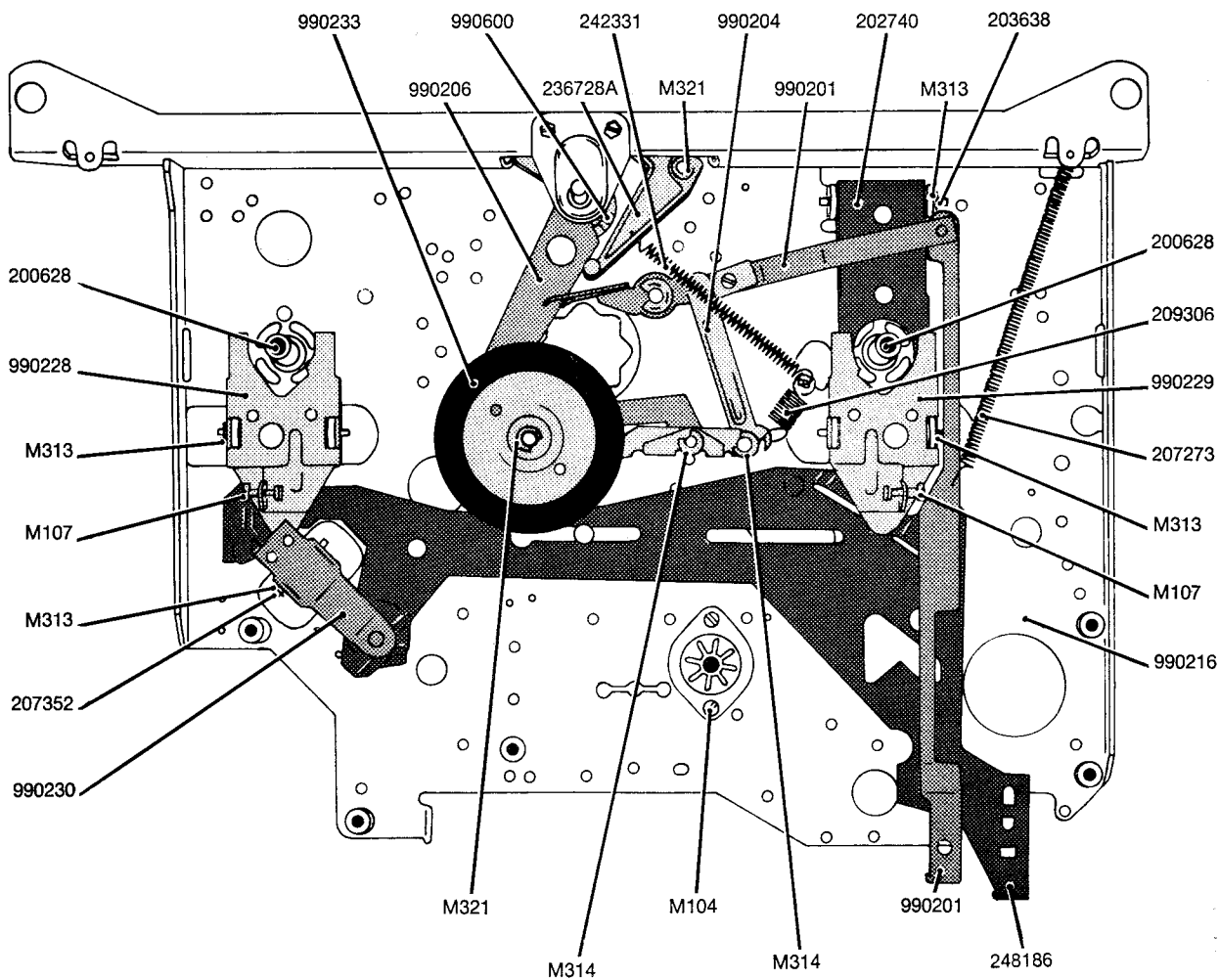

Fig. 4.5 Lower mounting plate with mechanical parts.

4.2 TURNTABLES

Figures 4.6 and 4.9 show supply- and take-up turntable assemblies with friction discs **209658** and clutch levers **990229** and **990228**.

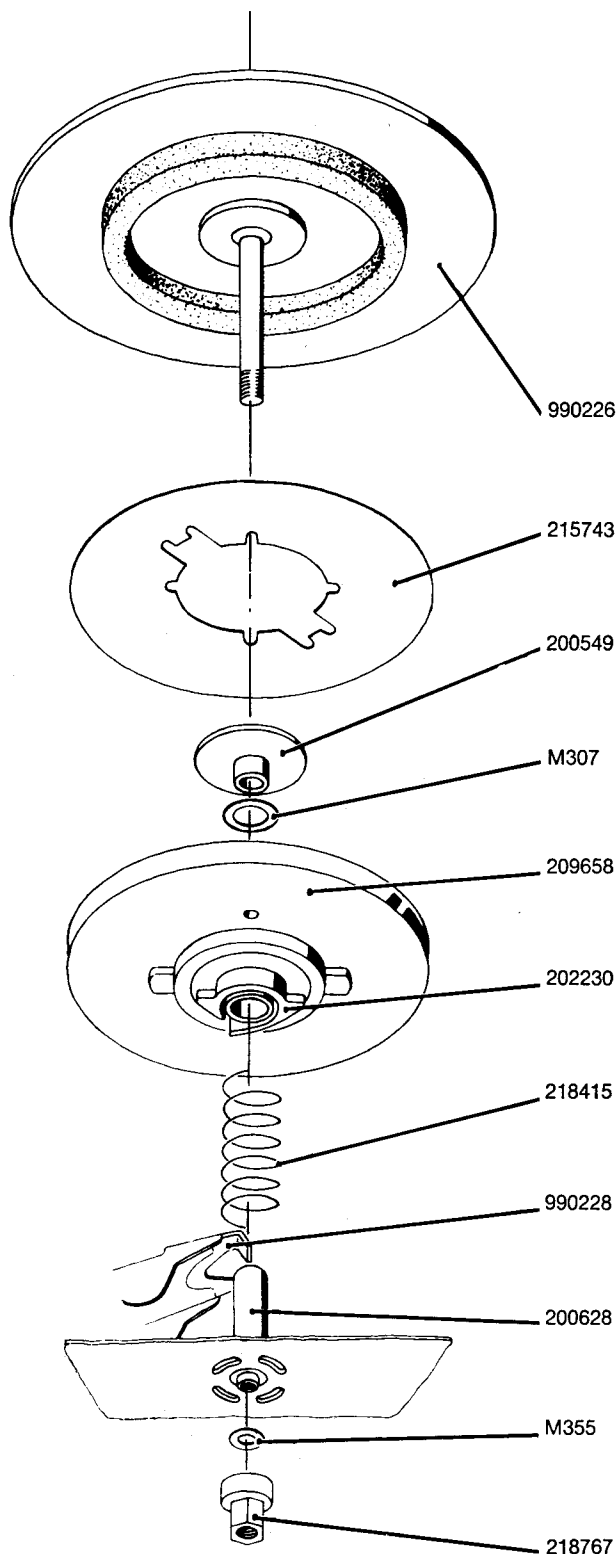

Fig. 4.6 Supply turntable assembly, Series 14.

4.2.1 Supply Turntable (990226) for series 14

See fig. 4.6. The supply turntable and the friction coupling are assembled as follows:

Place the helical spring **218415** and the friction disc **209658** over the bearing housing **200628** with one end of the spring resting in the cylindrical groove of the housing **202230**. The tongue on the bushing should point at the front of the recorder. Push the friction disc down, ensuring that the lugs on the bushing pass between the fingers of the clutch lever **990228**. Then turn the bushing 90 degrees clockwise until the tongue fits into the notch on the lever shown in fig. 4.7.

The bushing is now locked in this position. Put on the mylar sheet **215743**. Press the flange **200549** down through upper part of the housing and move the turntable shaft through the housing. Set the operating lever **990225** in position fast forward winding. The friction disc is thereby pressed down by the clutch lever and the turntable rests on the flange. Put the teflon washer **M355** on the turntable shaft, and screw on the delrin bushing **218767**. The turntable should now move freely, and the axial slack of the turntable shaft should be approx. 0.1 mm (4 mil).

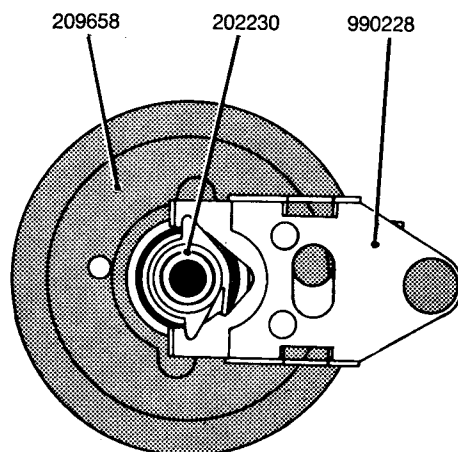

Fig. 4.7 Friction disc with clutch lever.

4.2.2 Supply Turntable (990226) for series 15

See fig. 4.8.

Proceed as in 4.2.1 until the mylar sheet has been put on the top of the friction disc. While pressing the flange **219816** down into the upper end of the bearing housing, insert the two springs **217510** into the circular recesses in the friction disc. Then place the tape tight disc on top with its smaller guide pins extending into the springs. Put the turntable shaft through the bearing housing. Set the operating lever **990225** in position fast forward winding.

The friction wheel is pressed down by the lever and the turntable rests on the tape tight disc **219198**. Put the teflon washer **M355** down on the turntable shaft before the hexagonal delrin bushing **218767** is screwed on. The turntable should now move freely, and the axial slack of the turntable shaft should be approx. 0.1 mm (4 mil).

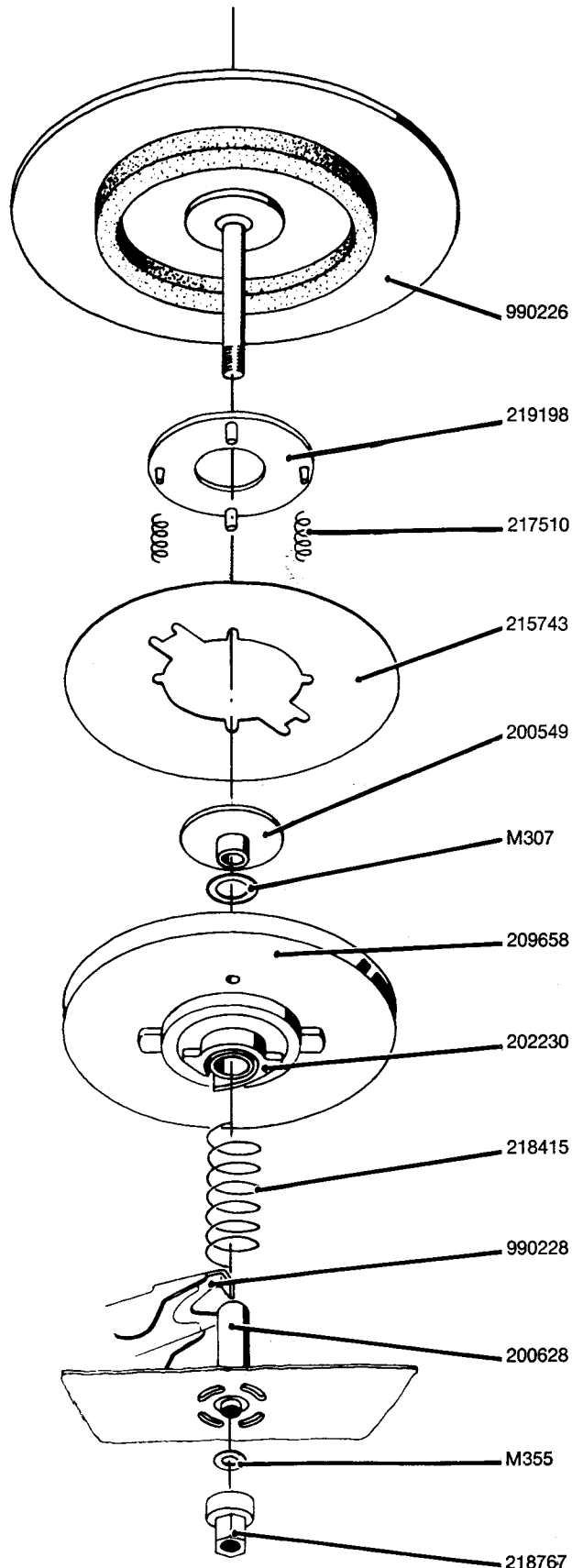

4.2.3 Tape Tensioner

When the instantaneous start/stop lever is operated in normal forward drive with a full 7" reel on the supply turntable, there might be a tendency to forming of tape loops between the supply reel and the head covers. In order to avoid this, a slight breaking torque is applied on the supply turntable.

Adjustment:

Adjustment is accomplished by stretching or cutting the two springs **217510** until the breaking torque is sufficient to prevent forming of loops during normal forward drive and when the tape is stopped with the instantaneous start/stop lever. Use a full 7" reel on the supply turntable.

Fig. 4.8 Supply turntable assembly, Series 15.

4.2.4 Take-Up Turntable (990227) for series 14/15

See fig. 4.9. The take-up turntable assembly is put together as follows:

Place the helical spring **218415** and the friction disc **209658** over the bearing housing **200628** with one end of the spring resting in the cylindrical groove of the bushing **202230**. The tongue on the bushing should point at the rear of the tape recorder. Push the friction disc

205698 down, with the delrin studs on the bushing passing through the notch in the upper clutch lever **990229**. Press the lower clutch lever **202740** against lower mounting plate **990216** by means of a screwdriver. The spacing between upper and lower levers will now be approx. 6 mm ($1/2''$). Turn the bushing 90° counterclockwise until the two delrin studs are locked by the two claws on lower clutch lever.

Put on the mylar washer **215743**, press the flange **200549** down into the upper end of the housing and insert the turntable shaft through the housing. Move the operating lever **990225** to position fast reverse winding, whereby the friction disc is pressed down by upper clutch lever causing the turntable to rest on the flange. Put the teflon washer **M355** on the turntable shaft and fasten the counter pulley **211339**. The turntable should now more freely with an axial slack of approx. 0.1 mm (4 mil).

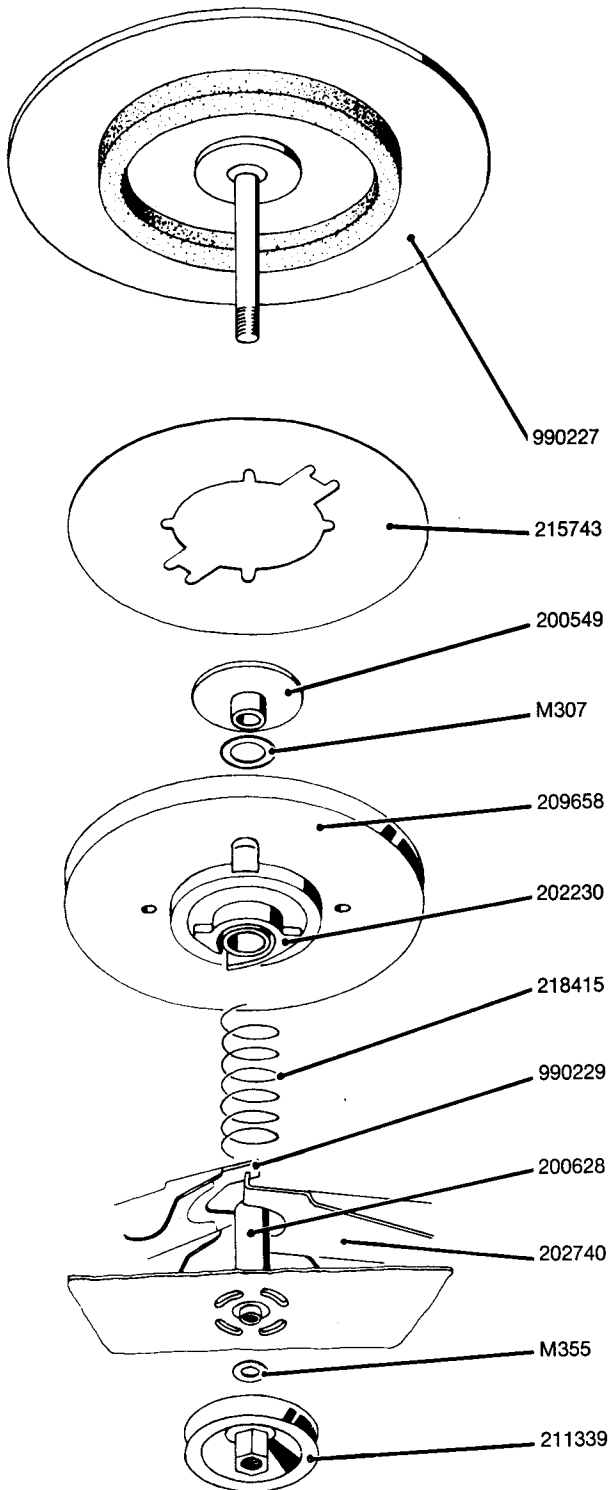

Fig. 4.9 Take-up turntable assembly, Series 14/15.

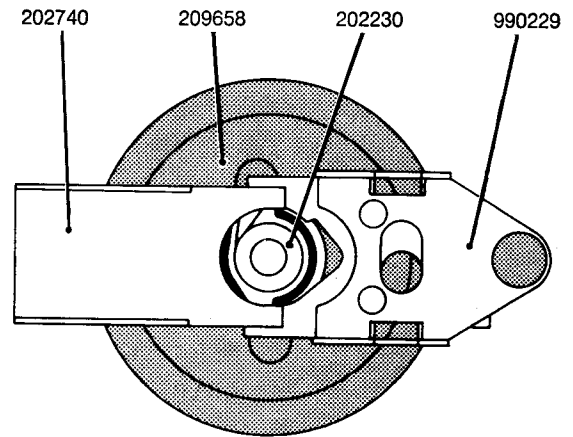

Fig. 4.10 Take-up friction disc with clutch levers.

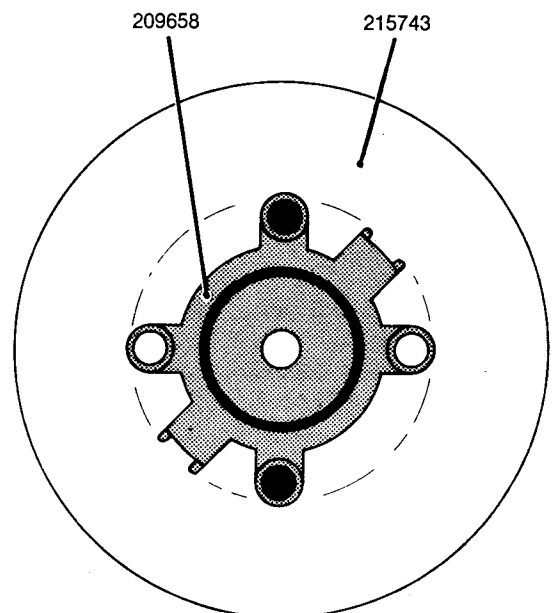

Fig. 4.11 Friction disc with mylar sheet.

4.2.5 Adjustment of Turntables

Use special tools no 1, 2 and 3. See fig. at rear of the manual.

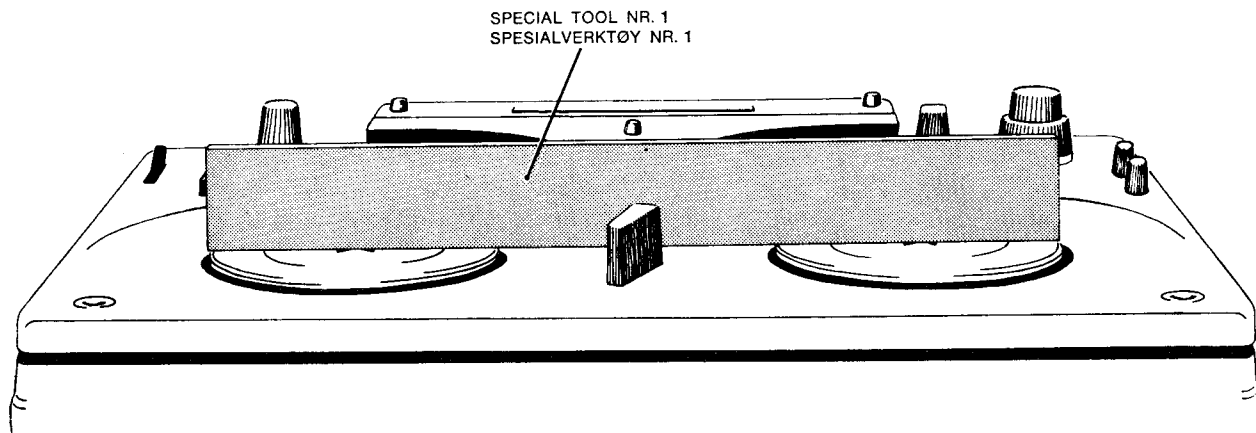

Fig. 4.12 Checking of horizontal position.

Horizontal adjustment:

See fig. 4.12. Check the horizontal position of the turntable with reference to a line parallel to the front of the tape recorder by means of special tool no 1 placed on both turntables. There should be no spacing between the tool and the ribs on the turntables.

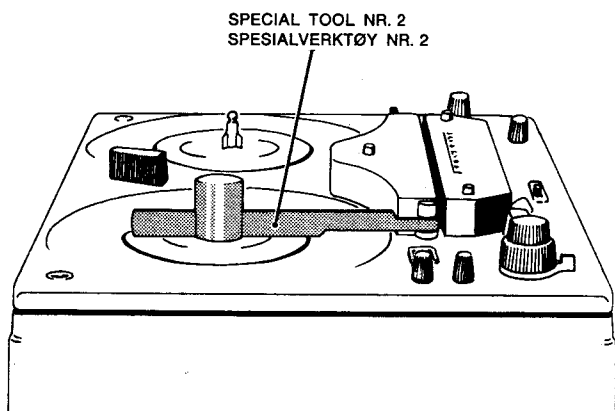

Fig. 4.13 Checking of horizontal position.

Check the horizontal position of the turntables along a line perpendicular to the front of the tape recorder by placing special tool no. 2 on supply turntable and take-up turntable respectively as shown in fig. 4.13. The end of the tool should pass freely through the slot in the tape guide post when the operating lever is in position neutral.

Adjustment of the turntable bearing is in both cases performed with special tool no 3 which is put down on the center pin of the turntable. In order not to risk any bending of the turntable shaft, grip the tool just above the turntable. See fig. 4.14.

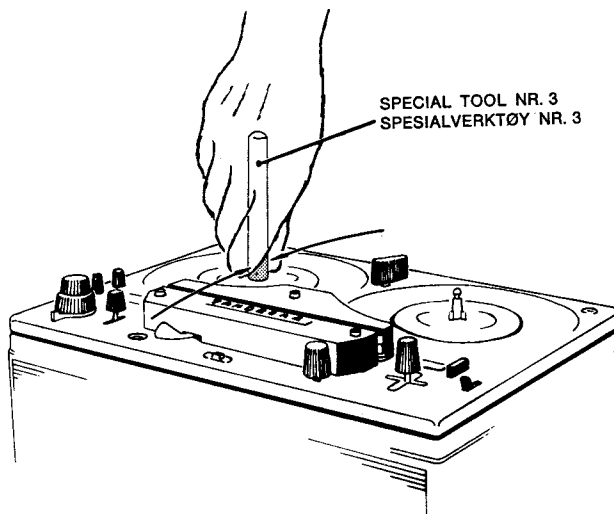

Fig. 4.14 Adjustment of horizontal position.

Height adjustment:

When the horizontal adjustment has been performed, the vertical position of the turntable is checked with 7" reels on both turntables, and the tape correctly inserted in the tape path. Check that the tape runs freely between the flanges of the reels in all positions of the operating lever. The turntables can be raised or lowered by adding or removing turbax washers type **M307** between the flange **200549** and housing **200628**, see fig. 4.29. Recheck the horizontal position of both turntables.

4.3 CLUTCHES

The motor torque is transferred to the turntables by means of the friction discs and the felt ring which is glued on to the bottom side of the turntables. The amount of friction is determined by the clutches which are operated by the operating arm **248186**. The operating arm is linked with the operating lever **990225**.

4.3.1 Neutral

See fig. 4.15.

The motor current is switched off by the switch **202151** and both friction discs **209658** are stationary.

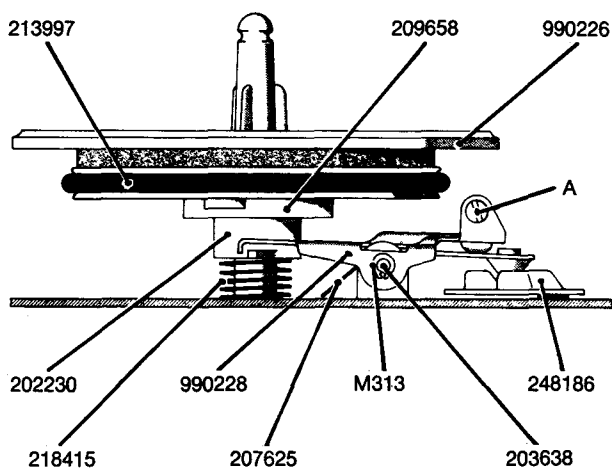

Fig. 4.15.

Supply turntable 990226

In position neutral, the friction between the turntable and the friction disc **209658** is at maximum. The friction disc is pressed against the felt ring underneath the turntable by the spring **218415**. The operating arm **248186** is in a position that allows the delrin knob on the lever **990228** to rest in the lower position. The delrin studs on the bushing **202230** are disengaged from the clutch lever.

Adjustment:

Adjust screw **A** until the spacing between the lever and delrin studs on the bushing is 0.5–1 mm (20–40 mil). Check the lever position in all operating modes and seal screw **A**.

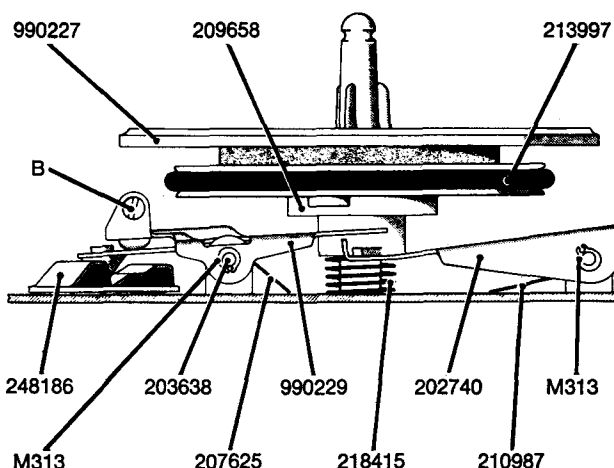

Fig. 4.16.

Take-up turntable (990227), fig. 4.16

When the operating lever is in position neutral, maximum friction exists between the friction discs **209658** and the take-up turntable. The friction disc is pressed against the felt ring underneath the turntable by the spring **218415**, and by the spring loaded lower clutch lever **202740** which exerts pressure against the delrin bushing **202230** from underneath. The operating arm **248186** is in a position so as to leave the delrin knob on the upper clutch lever **990229** in the lower position.

Adjustment:

Adjust screw **B** until the spacing between upper and lower clutch levers is approx. 0.5 mm (20 mil). Check the lever position in all operating modes and seal screw **B**.

4.3.2 Normal Forward Drive

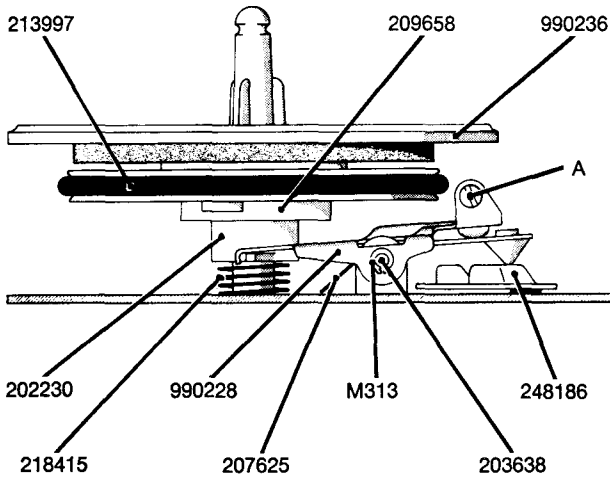

Fig. 4.17.

Supply turntable. Fig. 4.17.

The supply turntable is free in normal forward drive mode. The delrin knob on the clutch lever **990228** is held in upper position by the operating lever **248186**. The delrin bushing **202230** and the friction disc **209658** are pressed down.

Adjustment:

Adjust screw **A** until the spacing between the friction disc and the felt ring underneath the turntable is between 0.5 and 1 mm (20–40 mil). Check clutch lever positions in all operating modes, and seal screw **A**.

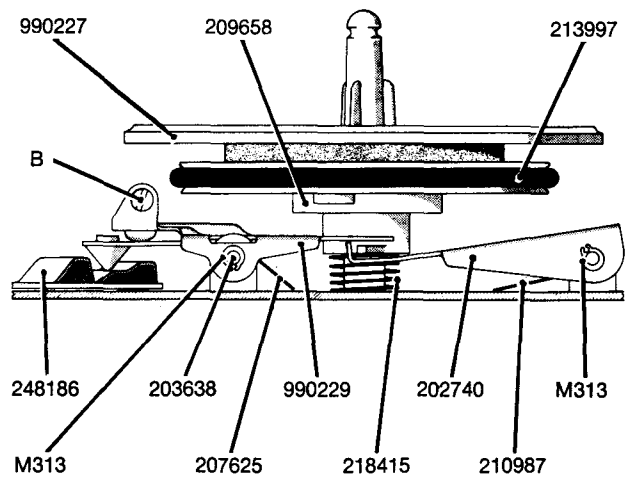

Fig. 4.18.

Take-up turntable. Fig. 4.18.

In normal forward drive the take-up turntable has a winding torque which is just sufficient to wind the tape in record or playback mode. The operating arm holds the delrin knob on the lever in an intermediate position. The upper clutch lever **990229** will press down the lower clutch lever **202740** thereby releasing the pressure of the friction disc against the turntable. The friction disc is pressed against the turntable felt ring by the spring **218415**.

Adjustments:

By means of screw **B**, bring the studs of bushing **202230** to a position half-way between upper and lower clutch levers. The winding torque should amount to 120–200 g cm (1.7–2.8 oz. in). Check the position of the levers in all operating models and seal screw **B**.

4.3.3 Fast Forward Winding

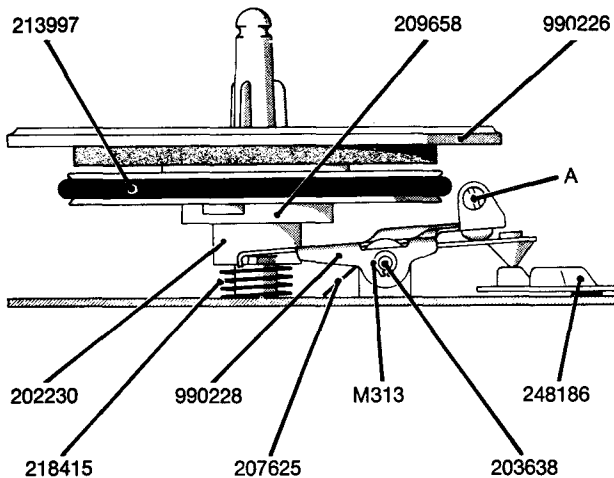

Fig. 4.19.

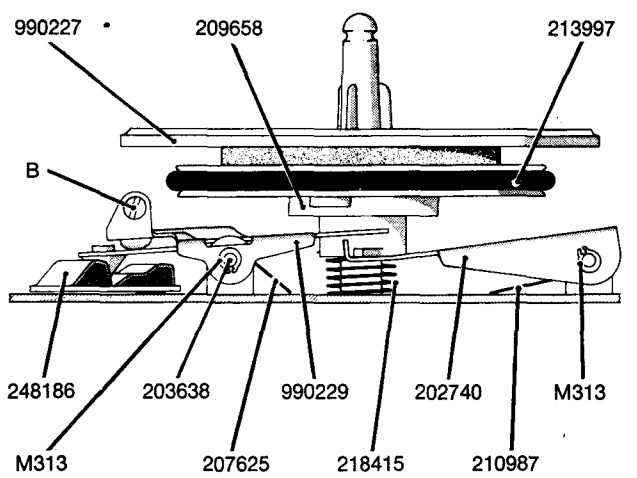

Fig. 4.20.

Supply turntable

This turntable is free in fast forward winding. The delrin knob on the clutch lever **990228** is held in its uppermost position by the operating arm **248186**, and depresses bushing **202230** and friction disc **209658**.

Adjustment:

By means of screw **A**, adjust the clearance between the friction disc and the felt ring on the turntable to 0.5–1 mm (20–40 mil). Check the position of the clutch lever in all operating modes, and seal screw **A**.

Take up turntable. Fig. 4.20.

This turntable has maximum torque in fast forward winding. The operating arm is in a position that allows the delrin knob on the upper clutch lever **990229** to rest in its bottom position. Upper and lower clutch levers are disengaged. The friction disc is pressed against the felt ring underneath the turntable by spring **218415** and the spring loaded lower clutch lever is pressed against the delrin bushing.

Adjustment:

By means of screw **B** adjust the clearance between upper and lower levers to approx. 0.5 mm (20 mil). The winding torque should amount to minimum 520 g cm (7.2 oz. in). Check the position of the clutch levers for all positions of the operating lever, and seal screw **B**.

4.3.4 Fast Reverse Winding

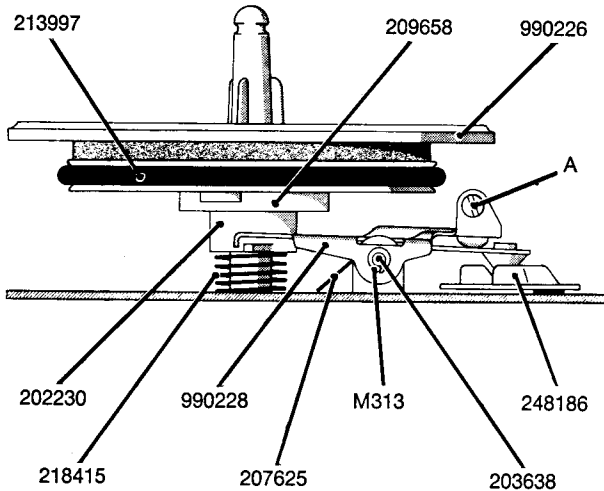

Fig. 4.21.

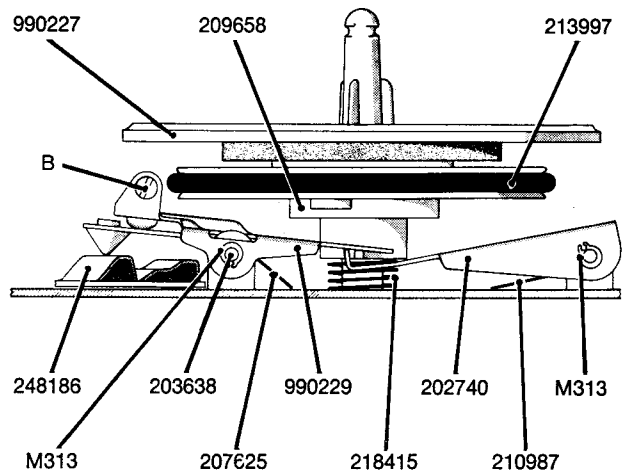

Fig. 4.22.

Supply turntable. Fig. 4.21.

This turntable has maximum torque in fast reverse winding. The operating arm is in a position that allows the delrin knob on the clutch lever to rest in its lower position. The studs on the bushing **202230** are disengaged from the clutch lever and the friction disc is pressed against the felt ring underneath the turntable by the spring **218415**.

Adjustment:

By means of screw **A**, adjust the clearance between the studs on the delrin bushing and the clutch lever to 0.5–1 mm (20–40 mil). The winding torque should be minimum 600 g cm (8.3 oz. in). Check the position of the clutch levers for all positions of the operating lever and seal screw **A**.

Take-up turntable. Fig. 4.22.

The take-up turntable is free in fast reverse winding. The delrin knob on upper clutch lever **990229** depresses lower clutch lever **202740**, and the bushing with the friction disc.

Adjustment:

By means of screw **B** adjust the clearance between the friction disc and the felt ring underneath the turntable to 0.5–1 mm (20–40 mil). Check the position of the clutch levers for all positions of the operating lever and seal screw **B**.

4.3.5 Free

The motor is switched off by the switch **202151** and both friction discs are stationary.

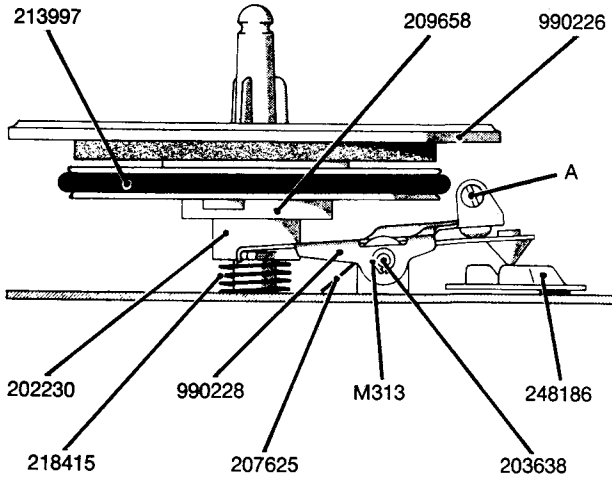

Fig. 4.23.

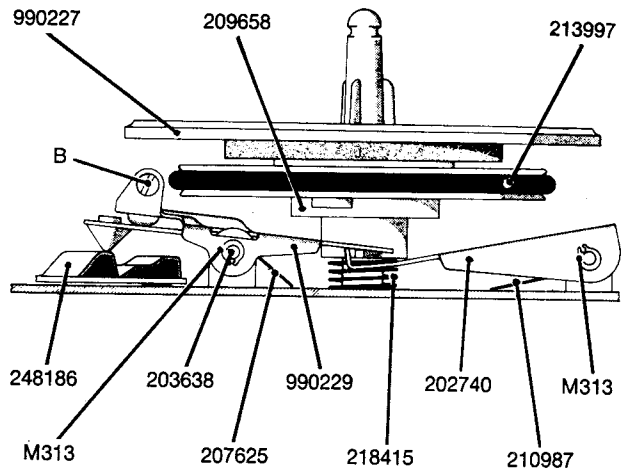

Fig. 4.24.

Supply turntable. Fig. 4.23.

The supply turntable is free. For adjustment, see chapter 4.3.3.

Take-up turntable. Fig. 4.24.

The take-up turntable is free. For adjustment see chapter 4.3.4.

4.4 MOTOR PULLEY (254040) SERIES 14

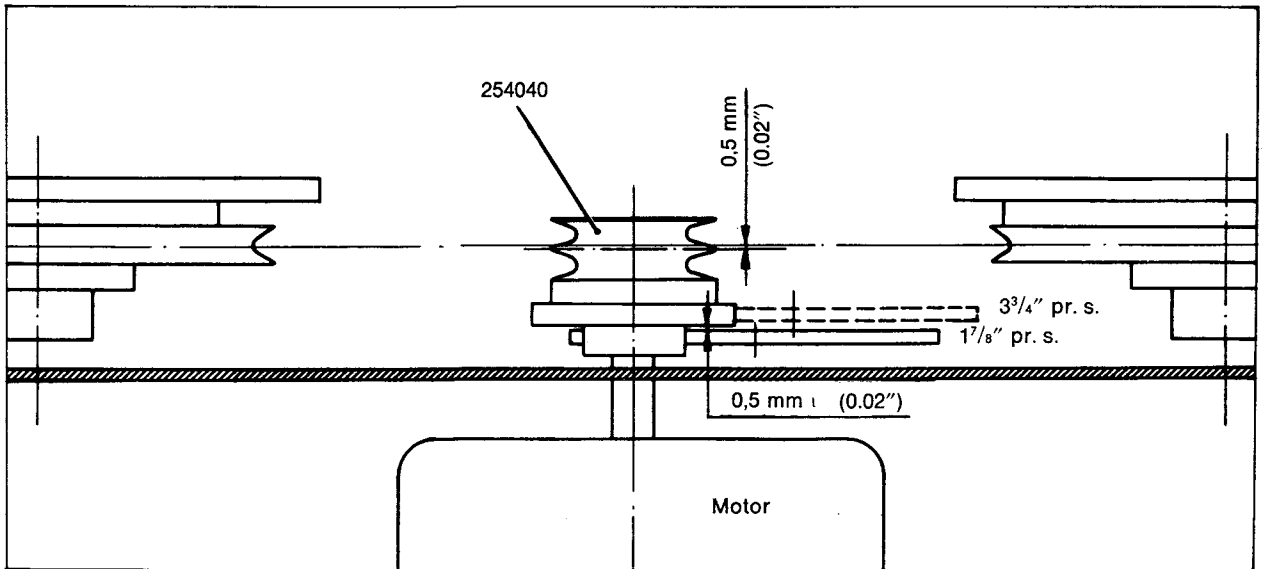

Fig. 4.25 Rear view of drive mechanism.

The models 14-4 and 14-2 have two speeds: $1\frac{7}{8}$ ips and $3\frac{3}{4}$ ips as determined by the diameter of the selected motor pulley track. Fig. 4.25 is a rear view of the drive mechanism with the transfer wheel **990233** engaged with the motor pulley track for $1\frac{7}{8}$ ips.

4.5 MOTOR PULLEY (243940C) Series 15

The models 15-4 and 15-2 have three tape speeds: $1\frac{7}{8}$ ips, $3\frac{3}{4}$ ips and $7\frac{1}{2}$ ips, as determined by the diameter of the selected motor pulley track.

Adjustment:

The vertical position of the motor pulley can be adjusted when the operating lever is in position neutral (center position). The dividing rib on the motor pulley should lie 0.5 mm (20 mil) below an imaginary line drawn between the bottom of the belt grooves on the friction discs.

4.6 DRIVE BELT (213997)

The drive belt is crossed, so as to run in the upper track at the front side of the motor pulley and in the lower track at the rear side. The belt crossing should lie between supply turntable and motor pulley.

4.7 TRANSFER WHEEL (990233)

The transfer wheel is attached to the mounting arm **990206** and serves as the speed transfer medium between motor pulley and flywheel. The spring **209306** provides the required pressure against these two wheels. See fig. 4.26.

Adjustment:

Set speed selector to position $1\frac{7}{8}$ ips. Loosen screws **M116**, and adjust speed selector bracket **209816** for a clearance of 1 mm (40 mil) between the mounting arm and lower mounting plate. Ensure that the mounting arm is parallel with lower mounting plate. The clearance between the transfer wheel and the $3\frac{3}{4}$ ips track on the motor pulley should be approx. 0.5 mm (20 mil). If necessary, adjust vertical position of the transfer wheel by adding or removing turbax washers in upper or lower flywheel bearing respectively. Set the speed selector to $3\frac{3}{4}$ ips. The full width of the transfer wheel should engage with motor pulley and flywheel.

4.8 LIFTING ARM (990201), SERIES 14

The lifting arm (consisting of parallel arm and adjustment arm) is located on lower mounting plate and is linked with the eccentric segment **990203**. See fig. 4.26. The lifting arm disengages the transfer wheel **990233** from the motor pulley when the operating lever is set to position fast forward winding, reverse winding, free or neutral. The transfer wheel should engage with the motor pulley in normal forward drive mode only.

Adjustment:

For each one of the tape speeds the transfer wheel should leave the motor pulley as soon as the operating lever is moved from normal forward drive position to neutral position and reach maximum clear-

ance before the motor is switched off by the micro-switch **202151**. The minimum clearance in position neutral should be 3 mm ($1/8$ "). If necessary, adjust by bending the lifting arm fingers x and y for the relevant speeds. Set the speed selector for $1\frac{7}{8}$ ips and the operating lever to neutral position. Loosen screw **C** and adjust parallel arm **990204** for 0.5 mm (20 mil) clearance between transfer wheel and flywheel. Set the speed selector for $3\frac{3}{4}$ ips and check that the clearance is the same. Readjust if necessary, tighten and seal screw **C**.

If the lifting arm **990202** in Series 14 has been replaced, see chapter 4.9.

4.9 LIFTING ARM (990201), SERIES 15

Adjustment:

Produced as in 4.8, and adjust also for $7\frac{1}{2}$ ips. After adjustment recheck clearance also for $7\frac{1}{2}$ ips.

The lifting arm **990201** in Series 14 has two fingers, x and y, whereas the one in Series 15 has three, x, y and z. For convenience, the double-split arm only is stocked as service part, because it can be used for replacement in Series 14 and 15.

4.10 FLYWHEEL (990312) WITH CAPSTAN

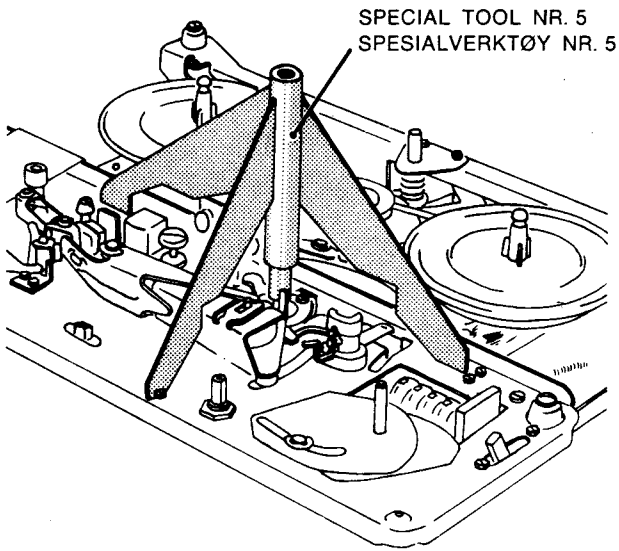

Fig. 4.28 Alignment of capstan.

The flywheel and the capstan comprises one integral part with the flywheel shaft serving as capstan. The unit is mounted in selflubricating bearings **208250**, see fig. 4.27.

Adjustment:

For vertical adjustment of the capstan use special tool no 5 as shown in fig. 4.28. Loosen the two screws **M125** in washer **990222** in the upper flywheel bearing. Push the tool cautiously down on to the capstan until all three legs rest against upper mounting plate. Then tighten screws **M125**, and remove the tool. Wipe off any impurities on the capstan by means of a clean piece of cloth.

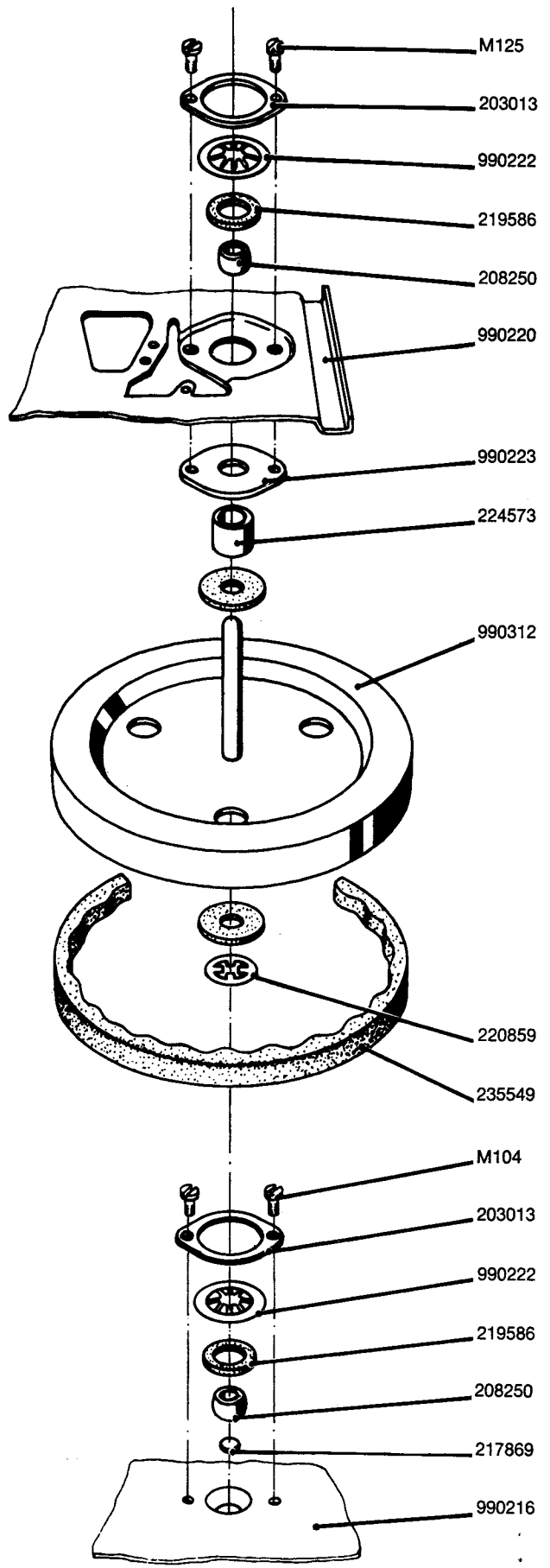

Fig. 4.27 Exploded view of flywheel with bearings.

4.11 SPEED SELECTOR, SERIES 14

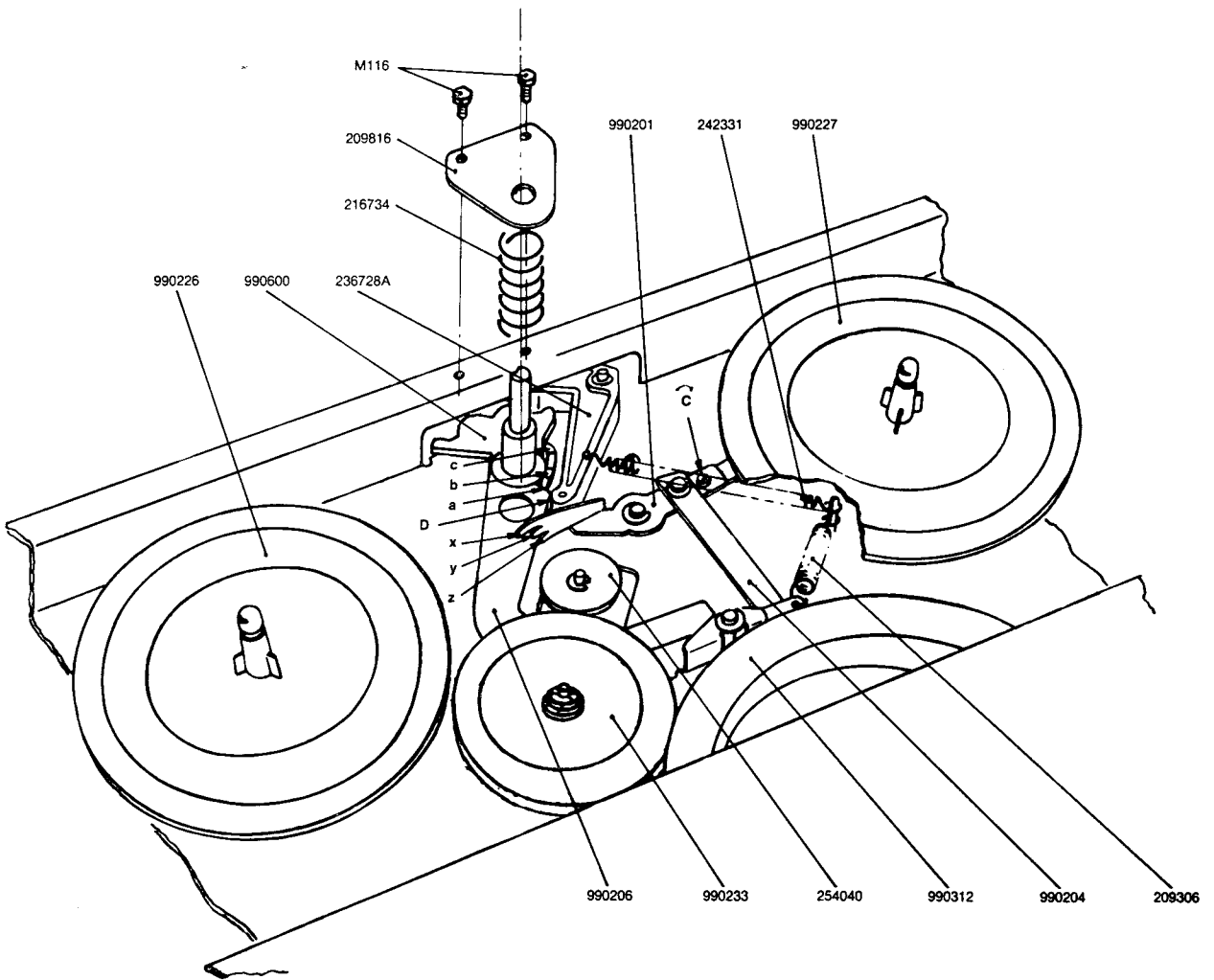

Fig. 4.26 Speed selector mechanism.

Fig. 4.26 shows the design and operation of the speed selector. The transfer wheel is shown in engagement with the $1\frac{7}{8}$ ips track on the motor pulley **254040**.

The mounting arm **990206** is engaged with the lowest step on the cam disc **990600**, and arm **236728A** rests against the curved edge of the cam disc. When the speed selector is moved towards the $3\frac{3}{4}$ ips position, the arm presses against the mounting arm at point **D** and moves the arm and the transfer wheel approx. 1 cm ($3/8$ ") horizontally to the left. The vertical movement of the mounting arm occurs simultaneously and is controlled by the slope between steps a and b on the cam disc. The transfer wheel moves horizontally towards the $3\frac{3}{4}$ ips track on the motor pulley. When the movement is completed, the cam disc arm returns to normal position. No adjustments are provided for the speed selector mechanism.

4.12 SPEED SELECTOR, SERIES 15

The description of the speed selector in chapter 4.11 applies also for series 15, except that the additional speed, $7\frac{1}{2}$ ips, implies that motor pulley and cam disc have different part numbers, see fig. 4.26.

4.13 INSTANTANEOUS START/STOP MECHANISM (990232)

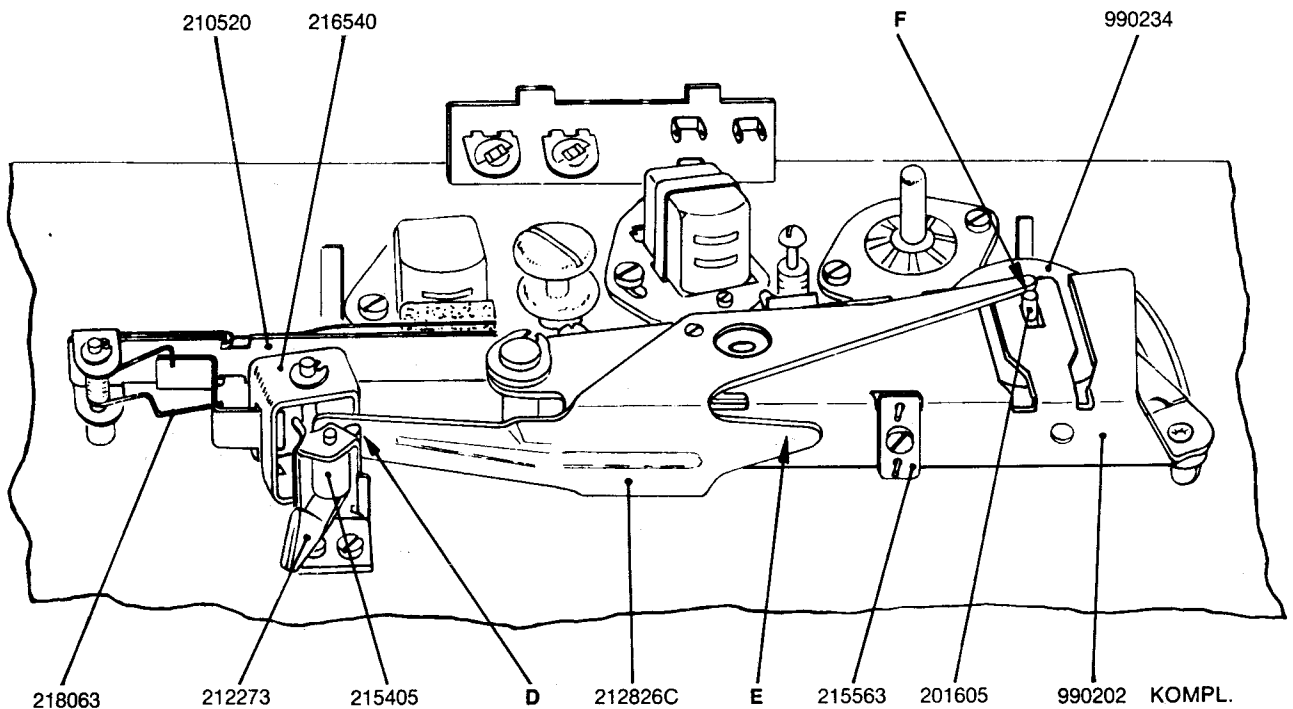

Fig. 4.29 Instantaneous start/stop mechanism with pressure wheel arm assembly.

See fig. 4.29. When the start/stop lever **212273** is moved towards the stop position, the delrin part **215405** is pressed against the pressure wheel lever **212826 C** at point **D**. The lever moves the pressure wheel away from the capstan, and the tape stops.

Adjustment:

Set the operating lever to normal forward drive position and the start/stop lever to stop position. Adjust the pressure wheel lever by bending the flat part **E** to obtain a clearance of 0.5 mm (20 mil) between capstan and pressure wheel. Check that the clearance between pressure wheel lever and linkage **216540** is approx. 0.2 mm (8 mil). Start the tape by moving the start/stop lever to the left. Adjust the clearance at point **F** between pressure wheel lever and pressure wheel shaft to approx. 1 mm (40 mil) by bending the tongue **E**. Finally check that the clearance between the pressure wheel lever and the delrin part **215405** is approx. 0.5 mm (20 mil).

4.14 PRESSURE PAD SPRING (Original Version)

The spring **990210** with the pressure pad is attached to the pressure pad arm **210520** in front of the erase head. The purpose of the pressure pad is to enhance contact between erase head and tape, and to ensure correct friction in the tape path. The spring is linked with the pressure wheel lever **212826 C** via linkage **216540**. The pressure pad is pressed against the erase head when the operating lever is set to position normal forward drive.

Adjustment:

Set operating lever to normal forward drive position. Adjust by bending the spring to obtain a pad pressure of 75–100 g (2.7–3.5 oz) against the erase head. Fig. 4.29.

4.15 PRESSURE PAD SPRING (Modified Version)

From serial no 2 619 561 for series 14 and from serial no 2 515 502 for series 15, the pressure pad arrangement is modified. The bracket **253163** holding the pressure pad is attached to the pressure arm **251482**. The pressure pad is pressed against the tape rest **254844**, and ensures constant tape tension in normal forward drive mode. When the operating lever is in one of the other positions, the pressure pad is kept at a distance from the tape. See fig. 4.30.

Adjustment:

Set the operating lever to neutral position. The clearance between the pressure pad and the tape rest should be approx. 6.5 mm (1/4") as shown in fig. 4.31. If necessary, adjust by bending arm **210520** as shown in fig. 4.32.

Set the operating lever to normal forward drive position. The pressure against the tape rest should be 80 g (2.8 oz) $\pm 10\%$, see fig. 4.33. If necessary, adjust by bending spring **218063** as shown in fig. 4.32.

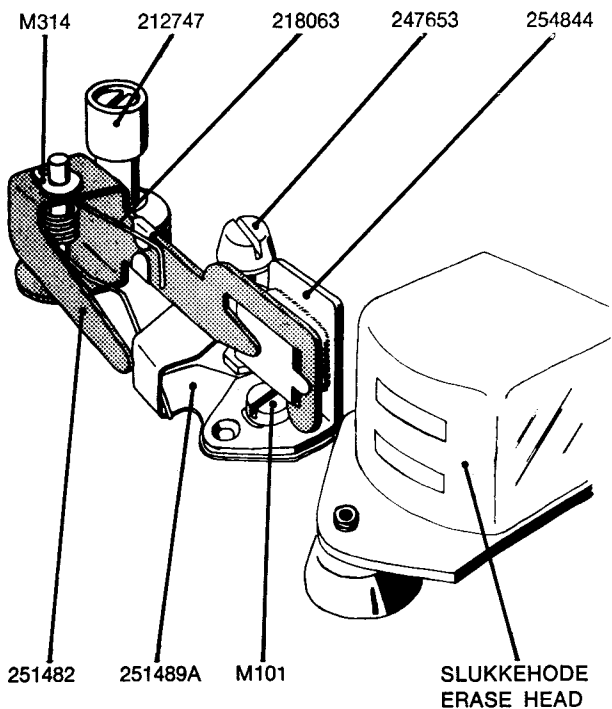

Fig. 4.30.

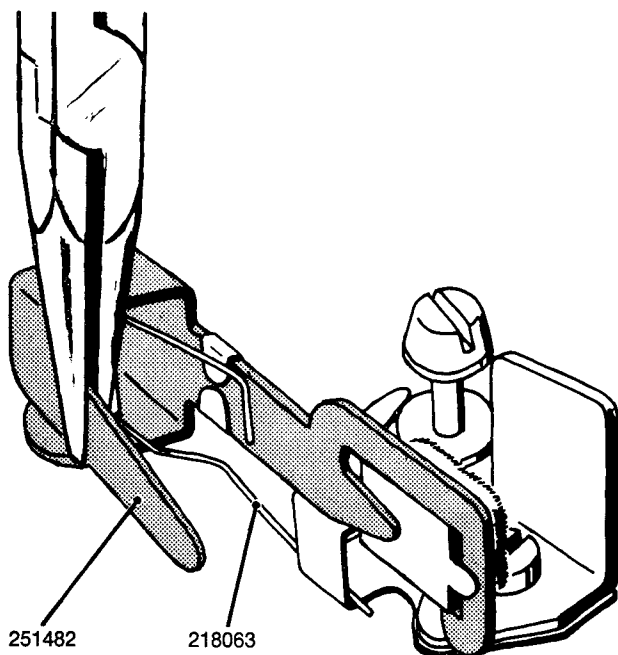

Fig. 4.32.

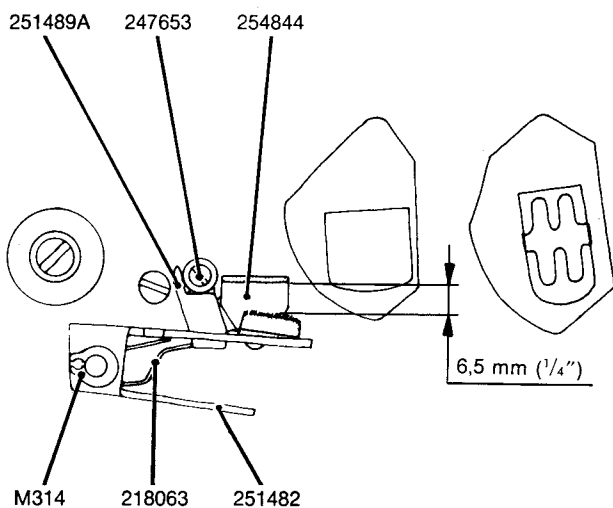

Fig. 4.31.

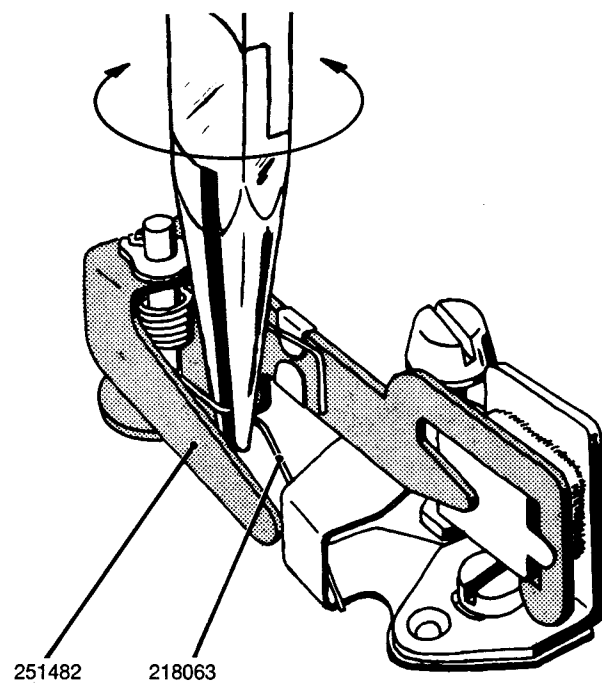

Fig. 4.34.

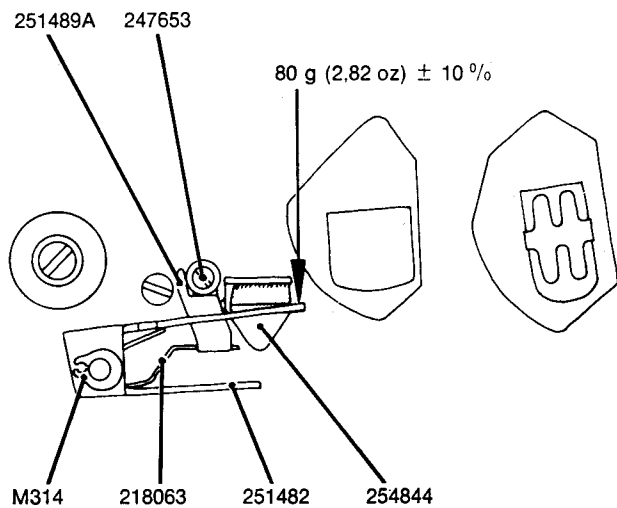

Fig. 4.33.

Note: The pressure pad should be brushed clean at regular intervals to avoid incorrect friction being caused by dust and other particles. The pad must not be dampened in any way, as this will alter the surface structure and properties of the pad.

4.16 END STOP MECHANISM

The purpose of the automatic end stop mechanism is to switch off the motor at the end of the tape, or in case of tape break. The end stop feeler **242503** is located on upper mounting plate and extends through the cross-shaped hole in right hand guide post **243013**. The feeler operates microswitch **202151** via lever **244342A**, and rests with a light spring tension against the tape when the operating lever is in normal forward drive, and winding positions.

4.16.1 Neutral

Figure 4.35 shows the position of the relevant parts when the operating lever is in neutral (stop). Arm **244694A** has a flap extending through the upper mounting plate, and is held in an intermediate position by the operating lever. The arm attacks the tape feeler at point **A** and keeps the feeler clear of the guide post. Arm **244694A** exerts pressure on lever **244342A**, and the microswitch is depressed to its off position.

4.16.2 Normal Forward Drive

Fig. 4.36 shows the situation when the operating lever is set to normal forward drive, forward or reverse winding, with a tape properly inserted in the tape path. Arm **244694A** is now moved by the operating lever in the direction of the arrow, and the pressure against the tape feeler at point **A** ceases. Simultaneously the pressure at point **B** ceases, because the arm **244694A**, which rests in a groove of the lever **244342A**, is released. The microswitch returns to the closed position and the motor starts. The tape feeler rests gently against the tape, due to the tension of the spring **243990**.

4.16.3 End Stop or Tape Break

Fig. 4.37 shows the situation when the tape has run out, or in case of tape break.

The spring **243990** pulls the delrin part of the feeler fully in and the feeler activates the microswitch so as to switch off the motor.

4.16.4 Free

Fig. 4.38 shows the position of the relevant parts when the operating lever is in position FREE. The arm **244694A** is moved in a direction away from the normal forward drive position. The tape feeler is locked in open position at point **D**, and the tape can be inserted. The lever **244342A** is locked in position **E**, holding the microswitch depressed (motor switched off).

4.16.5 Tape Feeler Tension

The feeler tension against the tape should be between 8 and 10 gr. (0.28–0.35 oz) in drive and winding modes. Adjustment of the tension is accomplished by tightening or slackening the spring **243990**.

Adjustment of Tape Feeler Movement

For the adjustment of the tape feeler movement refer to fig. 4.39. Set the operating lever in normal forward drive position, or forward or reverse winding. The mains switch is set to ON. No tape should be inserted. The tape feeler will therefore rest in the position where the motor is switched off.

Push the feeler slowly in direction of the tape path. When the contact surface (polished) of the feeler is 0.5–1.0 mm (20–40 mil) from the contact surface of the guide post, the microswitch should close and start the motor. If not, loosen screw **F**, and move the microswitch slowly until the motor starts when the tape feeler is in the position specified above. Then tighten the screw. When the tape feeler is released, the microswitch should open, and stop the motor when the spacing between tape feeler and the arm **244694A** is maximum 1.5 mm (60 mil). See fig. 4.37.

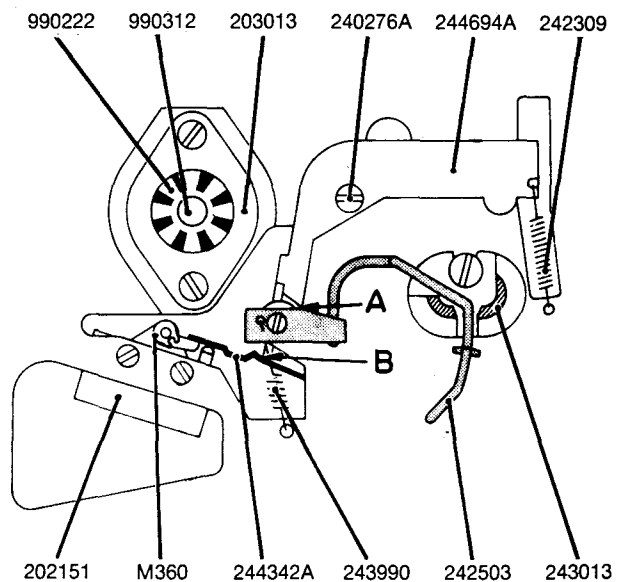

Fig. 4.35 Neutral.

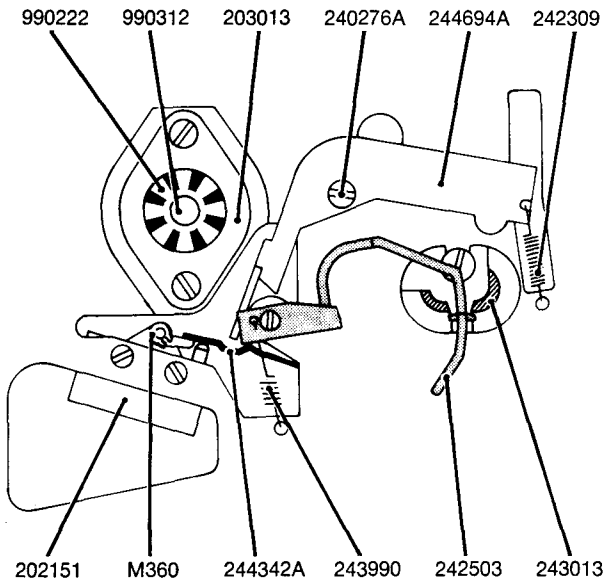

Fig. 4.36 Normal forward drive, winding.

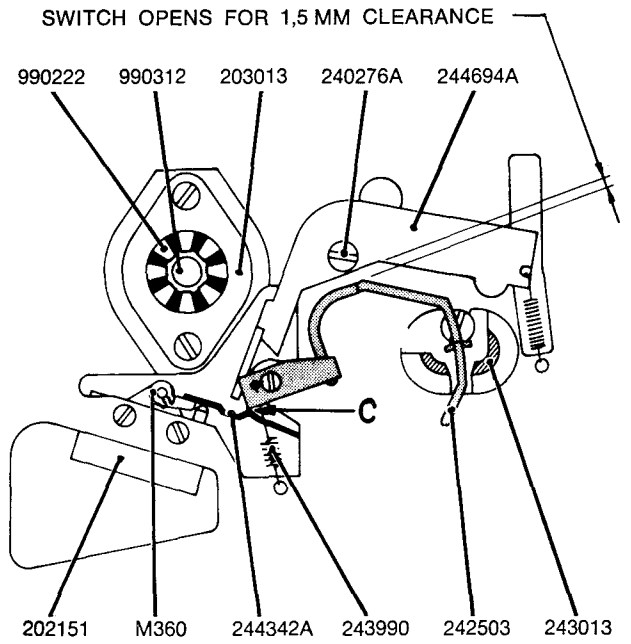

Fig. 4.37 End stop or tape break.

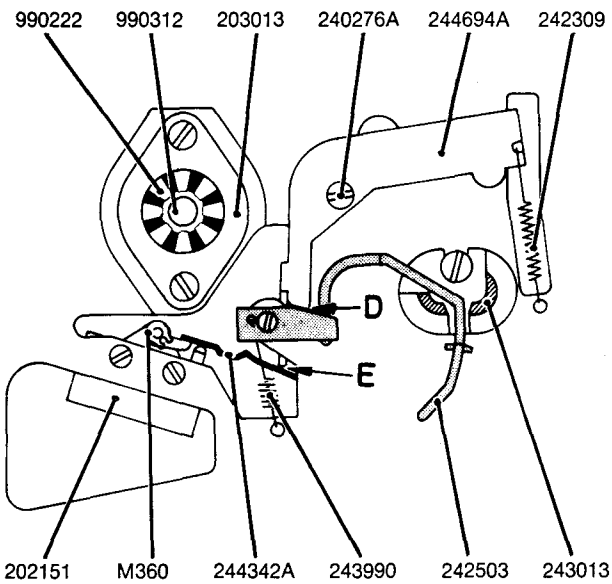

Fig. 4.38 Free.

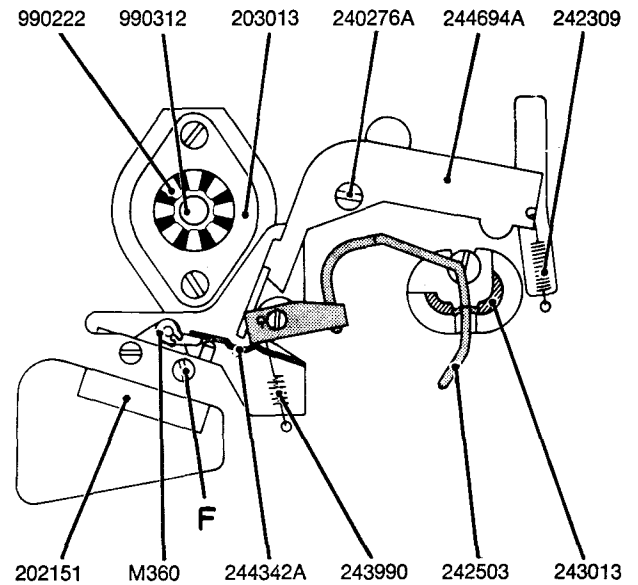

Fig. 4.39 Adjustment.

5.0 Electric Circuits

5.1 LINE AMPLIFIER

The line amplifier comprises transistor Q101 with associated components, and is identified as LINE AMPLIFIER on the circuit diagram. The amplifier has a flat frequency response extending from 30–20 000 Hz, and has a voltage amplification of 4.5 times. The capacitor C102 serves as decoupling for high frequency signals. The output is connected to the top of LINE LEVEL potentiometer R2 via C104.

5.2 MICROPHONE AMPLIFIER

The microphone amplifier comprises transistors Q102 and Q103 and is identified in the main circuit diagram, as MICROPHONE AMPLIFIER. The frequency response is flat from 30–20 000 Hz, and the amplification is 150 times. Negative feedback from the collector of Q103 to the emitter of Q102 is applied through the components C109, R113 and R111. The feedback is stabilizing and frequency independent. Capacitor C106 serves as a decoupling for high frequency signals. The signal from Q103 is fed to the MIC LEVEL potentiometer R5 via C112.

5.3 BUFFER AMPLIFIER

The amplifier comprises transistor Q208 with associated components and is identified on the main circuit diagram, as BUFFER AMPLIFIER. The signals from MIC LEVEL and LINE LEVEL potentiometers are mixed and fed to transistor Q208 via C126. The buffer amplifier has a flat frequency response and an amplification of 5.5 times.

5.4 EQUALIZING AMPLIFIER

The equalizing amplifier consists of transistors Q201 Q202 and Q203 with associated components. A frequency depending network connected from emitter of Q203 to emitter of Q201 establishes the appropriate frequency response for recording and playback.

5.4.1 Equalizing Network for Recording

A simplified diagram for the equalizing network in record mode is shown in fig. 5.1. The emitter feedback

reduces the amplification approximately 30 dB in the intermediate frequency range. The frequency response in this frequency range is determined by capacitor C207, while C208 and R213 determine the response in the lower part of the frequency range. The series resonance circuit L201, C204, R208, R209 and C211 are the frequency determining components in the upper frequency range. The equalizing switch is linked with the speed selector, and correct equalizing for the various speeds is automatically established when the speed is changed. The components mentioned above refer to the tape speed 7¹/₂ ips. The speed correction for 3³/₄ ips is obtained by means of C205. At 1⁷/₈ ips, correct equalizing is obtained by means of C206. The resulting record equalizing curve is shown in fig. 5.2a. See chapter 8.1 on modifications for Low Noise tape.

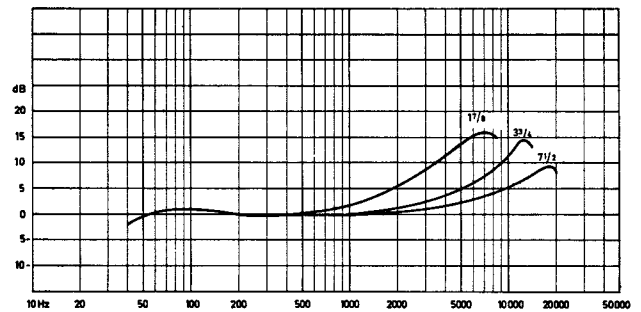

Fig. 5.2 a Record equalizing curves.

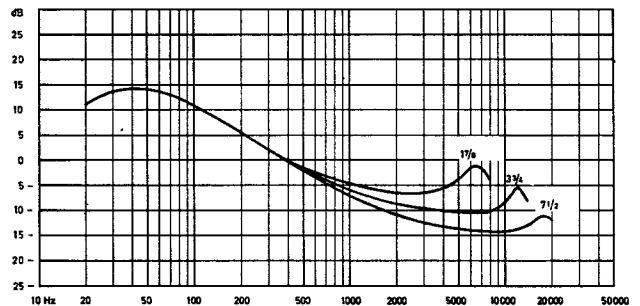

Fig. 5.2 b Playback equalizing curves.

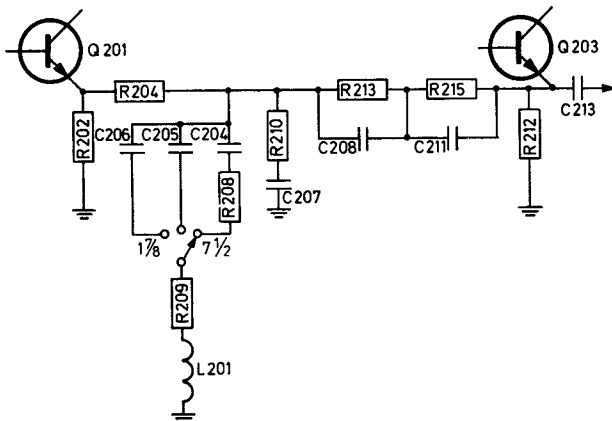

Fig. 5.1 Record equalizing network.

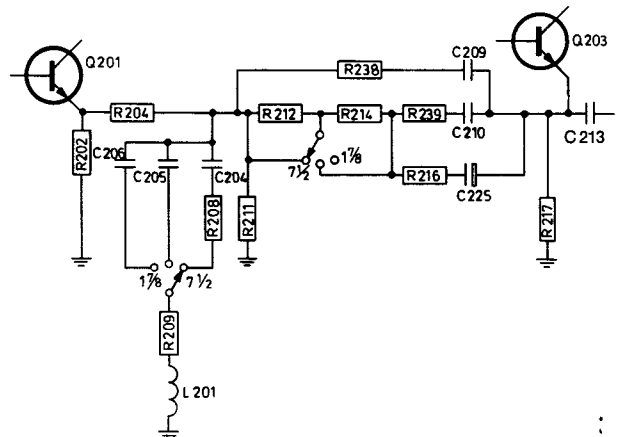

Fig. 5.3 Playback equalizing network.

5.4.2 Equalizing Network in Playback Mode.

A simplified circuit diagram for the equalizing amplifier in playback mode is shown in fig. 5.3. The negative feedback circuit from emitter of Q203 to emitter of Q201 gives the playback frequency curves shown in fig. 5.2b. The capacitor C210 determines the playback curve in the range 70–300 Hz. The series resonance circuit L201, C204, R208, R209 determines the frequency response in the upper frequency range. The components mentioned above refer to 7½ ips. See chapter 8.1 on modifications for Low Noise tape. The equalizer switch is linked with the speed selector, and correct equalizing at the various speeds is obtained automatically when the speed is changed. At 3¾ ips, a speed correction is obtained by means of resistors R239 and R212 and capacitor C205. At 1⅞ ips, speed correction is obtained by R239, R212, R214, C206 and C210. The output signal is fed via C213 to PLAYBACK BOOSTER.

5.5 PLAYBACK BOOSTER

The playback booster is a part of the preamplifier and consists of transistor Q204 with associated components, which gives a flat frequency response from 30–20 000 Hz. The amplification is 6 times, giving a signal level of 750 mV at the PREAMP output during playback of a tape recorded at normal level.

5.6 INDICATOR AMPLIFIER

The indicator amplifier comprises transistor Q205 with associated components. Signal is applied to the base of the transistor from the emitter of Q203, via C216 and the adjustment potentiometer R225. The indicator is connected in series with the emitter resistor for the transistor. The transistor is biased so as to conduct during positive halfcycles of the signal only. Capacitor C218 will charge rapidly while Q205 conducts. If the input level decreases, the transistor will cut off, and C218 will discharge through R228 at a relatively slow rate.

5.7 OSCILLATOR

Transistors Q206 and Q207 form a push-pull oscillator identified in the main circuit diagram, as ERASE OSCILLATOR, which generates erase and bias voltage at a frequency of 85.5 kHz. The frequency is mainly determined by the erase head and the inductance of T201 in parallel with the adjustment capacitor C221. The purpose of C229 is to protect the transistors Q206 and Q207, when shorting the bias head for measurement of record current.

5.8 OUTPUT AMPLIFIER

The output amplifier is identified in the main circuit diagram as 10 WATT POWER AMPLIFIER and comprises transistors Q104 through Q109 with associated components. The signal is applied via potentiometer VOLUME and is amplified in Q104 and Q105. The balance point for Q105 can be set by means of R127. The quiescent current in the phase-shifter transistors Q106 and Q107 is set by means of R129.

5.9 POWER SUPPLY AND VOLTAGE REGULATOR

The mains voltage is applied to the primary of the mains transformer via the ON/OFF switch. The DC-voltage is fed from the fullwave rectifier to the voltage regulator comprising transistors Q110 through Q112 with the zener diode D101 as voltage reference. The motor is connected on the primary side of the transformer via a microswitch which is operated by means of the tape motion lever when tape is inserted in the tape path. The combination R10, C3 reduces noise from the microswitch.

5.10 HEADS AND TRACK SELECTOR

The four track models of series 14 and 15 have a track selector that enables recording and playback on upper or lower track while the vacant head half is connected directly to the output FREE HEAD.

On two track models, recording and playback always take place on upper track while FREE HEAD is connected to lower head half. The connection is indicated within dotted lines in the lower left corner of the main circuit diagram. Simplified diagrams of the head connection for the three positions of the track selector are given below.

5.10.1 Position DUO

This position can not be used in record mode. In playback, the two head halves are connected in series as shown in fig. 5.4. Prerecorded stereo tape can then be played back in mono. Furthermore, the position DUO enables playback of commentary from one track and background music from the other track.

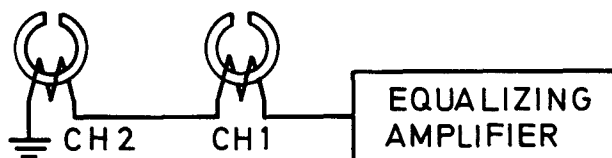

Fig. 5.4 Playback DUO.

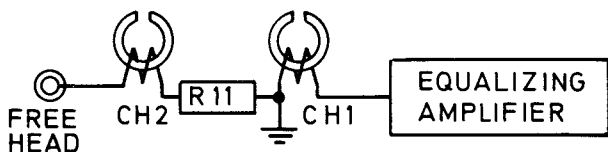

Fig. 5.5 Playback NORMAL.

5.10.2 Position NORMAL

Fig. 5.5 shows the head connection for playback. Track one is reproduced through the equalizing amplifier, whereas signals from track two are fed directly to the FREE HEAD output. In record mode, track one is connected to the equalizing amplifier whereas track two is connected to FREE HEAD output. See fig. 5.6.

5.10.3 Position EXTRA

As shown in fig. 5.7 and 5.8 the heads are interchanged for recording/playback via equalizing amplifier on track two, while track one is connected to FREE HEAD output.

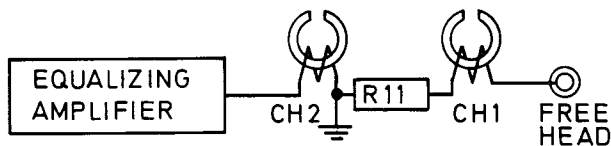

Fig. 5.7 Playback EXTRA.

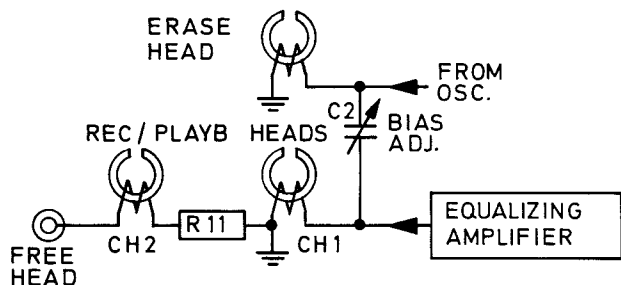

Fig. 5.6 Recording NORMAL.

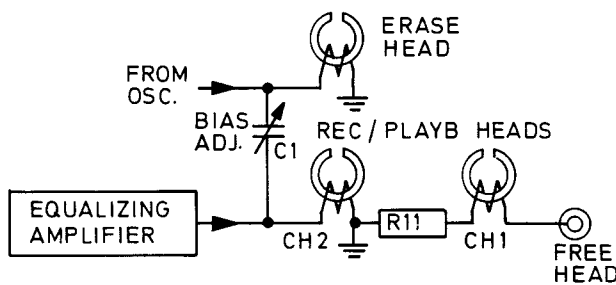

Fig. 5.8 Recording EXTRA.

5.11 FUNCTION SELECTOR

The function selector has the following positions:

AMP: Signals from MIC/LINE potentiometer are fed via BUFFER AMPLIFIER direct to OUTPUT VOLUME potentiometer.

PLAYBACK: Signals are fed from the relevant head-half (see 5.10. 1–3) to the input of the equalizing amplifier. The equalizing network is connected in playback configuration.

RECORD: Signals from MIC/LINE potentiometer are fed via BUFFER AMPLIFIER through equalizing amplifier and further through R218 to the relevant recording head, (see 5.10. 1–3). The equalizing network is connected in record configuration. Operating voltage is supplied to the oscillator.

6.0 Alignment of Tape Path and Electric Circuits

Note that any use of magnetised tools in the vicinity of heads and tape path must be succeeded by careful demagnetization.

6.1 Tape Guide Posts

With tape properly inserted and tightened, move the operating lever slowly towards normal forward drive position. The tape should not touch the flanges of adjustment screws 4 and 5 (see fig. 6.1). If it does, adjust the screws. Should the tape still touch one of the flanges, the reason may be incorrect alignment of capstan and pressure roller.

6.2 Record/Playback Head

6.2.1 Initial Lateral Adjustment

Check by visual inspection that the tape appears to touch the head in the middle of the curved surface, i.e. angles **a** and **b** should be equal.

6.2.2 Height Adjustment

Adjust the height of the head by means of the two height adjustment screws (1 and 2) in such a way that the tape and the upper track on the head coincide along the upper edge. Use both screws in order to maintain the vertical position of the headfront. Fig. 6.2.

6.2.3 Azimuth Adjustment

4-track:

Play back a tape with a 10 000–15 000 Hz signal recorded at constant amplitude. (Tandberg Test Tape no 2). Set the track selector to position NORMAL and then to EXTRA. Adjust azimuth screw 3 to obtain highest possible voltage at PREAMP output in both positions of the track selector.

2-track:

The 2-track model has no track selector. Otherwise proceed as for 4-track model.

6.2.4 Final Lateral Adjustment

Brake the supply (left) reel lightly. This should not cause more than 0.5 dB increase of the voltage measured at the output. If this tolerance is exceeded, turn the record/playback head to one side or the other until an increase of the tape tension (imposed by braking of the supply turntable) does not cause the output voltage to increase by more than 0.5 dB. Avoid turning the record/playback head too much to the right, as this may cause poor recording quality. Tape tension affecting output voltage may also be caused by the head front being obliquely positioned with respect to the capstan, low pressure wheel tension, or tape tracking over to one side of the guide posts.

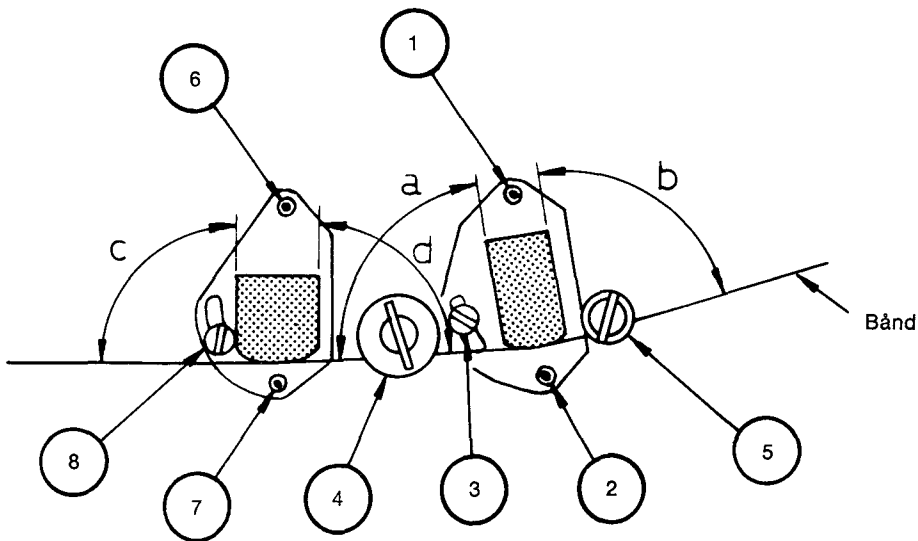
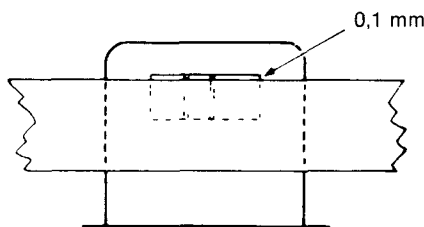
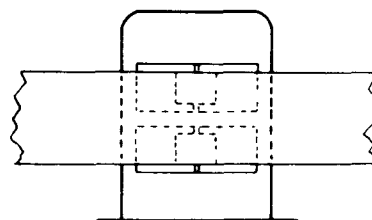

Fig. 6.1.



Slukkehode
Erase Head

Fig. 6.2 Erase head 2-track model.



Spillehode
Rec. PL.B HD

Fig. 6.3 Record/playb. head 2-track model.

6.3 Erase Head

6.3.1 Height Adjustment

2-track:

The height is adjusted with screws 6 and 7. Approximately 0.1 mm (4 mil) of the head gap should be visible above the upper edge of the tape. Headfront and tape must be parallel. Fig. 6.2 shows the correct position of the tape with respect to the head.

4-track:

As for 2-track model, except that approximately 0.2 mm (8 mil) of the erase head gap should be visible above the tape.

6.3.2 Azimuth Adjustment

Adjust screw 8 to bring the head baseplate into parallel alignment with upper mounting plate.

6.3.3 Lateral Adjustment

Check that the tape touches the head in the middle of the curved surface. In other words angles **c** and **d** should be equal.

6.4 Track Control

6.4.1 Visual Control with Test Tape, 2-Track Model

Check that the tape runs as shown in figs. 6.2 and 6.3.

6.4.2 Track Control with Test Tape, 4-Track Model

Play back a Tandberg Test Tape no. 1 (1000 Hz full track at constant level, with a 30 dB reduction of track 3). Set OUTPUT VOLUME to maximum and the track selector to EXTRA (playback track 3). Adjust the height of the record/playback head with screws 1 and 2 until minimum voltage is measured at the PREAMP output.

Check the azimuth position according to paragraph 6.2.3.

6.4.3 Height Adjustment of Record/Playback Head by Track Measurement on 4-Track Model

On a new or erased tape record a 1 000 Hz signal well above normal level, first with the track selector in position NORMAL (track 1), then in position EXTRA (track 3). Turn the tape around and record in the opposite direction for both positions of the track selector (track 4 and 2). Cut off a piece of the tape and dip it in Magna-See solution or sprinkle iron oxide powder on the tape. The recorded tracks will then appear as four dark stripes approx 1 mm (40 mil) wide, with narrower spacings in a lighter shade. The spacings should have equal width, and the two outer dark stripes should flush with the tape edge. If the tracks are not correctly distributed across the width of the tape, the height of the record/playback head should be readjusted with screws 1 and 2. Use both screws to maintain the headfront in parallel alignment with the capstan. Recheck azimuth position. The use of special tools is recommended.

6.5 Bias Current

6.5.1 Oscillator Frequency, 2-Track Model

Connect a 100 ohm resistor in series with the record/playback head and ground. Set the function selector to RECORD and the operating lever to normal forward drive. Connect a frequency meter across the resistor and adjust C221 for a frequency reading of 85.5 kHz.

Bias Current

Adjust C2 for a voltage reading of 85 mV across the 100 ohm resistor (corresponds to 850 uA bias current).

6.5.2 Oscillator Frequency, 4-Track Model

Set the track selector to NORMAL. Set the function selector to RECORD, and the operating lever to normal forward drive. Measure the frequency across a 100 ohm resistor connected in series between upper half of the record/playback head and ground. Adjust C221 for a frequency reading of 85.5 kHz. Then set the track selector to EXTRA and connect the frequency meter across a 100 ohm resistor in the lower half of the record/playback head. The frequency reading should be $85.5 \text{ kHz} \pm 2.5 \text{ kHz}$. If the frequency falls outside one of these limits, adjust C221 to obtain an equal departure from the nominal frequency in both positions of the track selector.

Bias Current

Measure the voltage across the 100 ohm resistor with the track selector in position NORMAL and EXTRA. Adjust to 65 mV with C2 and C1 respectively (corresponds to 650 μ A bias current).

6.6 Record Current and Record Level Indicator

Connect a voltmeter across a 100 ohm resistor inserted in series between the record/playback head and ground. In 4-track models, the track selector should be set to NORMAL and a 100 ohm resistor connected in series with upper half of the record/playback head. Short-circuit terminals 26 and 27 on board 15001 (or short circuit erase head).

Feed a 400 Hz signal into the pick-up input and set the recorder for recording. Adjust LINE for the following voltmeter readings:

2-track: 18 mV (180 μ A)

4-track: 12 mV (120 μ A).

Finally set R225 for 0 dB reading on the record level indicator.

6.7 Verification of Frequency Curves

The overall frequency curves should lie within the tolerance ranges specified in DIN 45511. (Fig. 6.4). See paragraph 8.1 for recorders with serial no. above 2 619 561 for series 14 and 2 515 502 for series 15 which are adjusted for Low Noise tape.

Set the machine for recording. Connect an audio generator to the pick-up input and adjust the frequency to 400 Hz. Set input level LINE knob for 0 dB reading on the indicator. Reduce the generator output voltage by 30 dB and record at several frequencies within the specified range, ensuring that the signal level is same at all frequencies.

Rewind and play back from the PREAMP output the 400 Hz signal which is to be taken as a 0 dB reference. Then check that the signal levels at the other frequencies lie within the tolerance range.

If the signal amplitudes in the treble range are too high or too low, increase or decrease the bias. See 6.5.1.

6.8 Distortion Check

Using a new tape, record a 400 Hz signal at 0 dB reading on the record level meter.

Check that the distortion is 3–5%. If there is too much distortion, reduce the record current. See paragraph 6.6.1. If the distortion is less than 3%, the record current can be increased.

6.9 Output Amplifier

Connect an audio generator set at 1000 Hz to the PICK UP socket and an oscilloscope and a VTVM in parallel with a 4 ohm 15 W resistor to EXT SPKR output. Set VOLUME to maximum, function selector to AMP and speaker selector to EXT. Turn bass- and treble controls to their centre position.

6.9.1 Output Symmetry

Increase the input signal level until clipping of the waveform can be observed on the oscilloscope. Adjust R127 (Balance Adj.) for equal clipping of positive and negative peaks. Reduce the input signal below the clipping level. The output voltage should then be 6.3 V (10 W in 4 ohm).

6.9.2 Quiescent Current

Connect a mA-meter in series with R133 in the output amplifier and set VOLUME to minimum. Adjust R129 (Current Adj.) for a meter reading of 30 mA. Alternatively adjust for a voltage drop of 16 mV across R133.

7.0 Special Versions

7.1 Model 15 SL

Model 15 SL differ from the standard Version by an extra playback amplifier that enables simultaneous playback of the two tracks.

In order to prevent accidental erasure of master programme on upper track, when the track selector is in STUDENT position (recording on lower, playback from upper track), the track selector is locked when the function selector is in PLAYBACK. The interlock is released by momentarily setting the function switch to AMPLIFIER.

7.1.1 Playback Amplifier

The amplifier is assembled on a separate board and comprises transistors Q301–Q305 with associated components. Playback equalization is obtained with frequency dependent feedback from Q303 to Q301. Playback volume is adjustable with R12.

The amplifier is via the track selector supplied with signals from the head half that is not used for recording (free head). Signals from the output of power amplifier and additional amplifier are mixed in resistors R322 and R323 and fed to pin 4 in the DIN-socket MIC.

7.1.2 Mechanical Interlock

Fig. 7.1 shows the track selector disc **237209** when locked in position STUDENT.

The function selector arm **245894** is in position PLAYBACK, and the locking arm is engaged with track selector disc by means of spring **238890**.

Fig. 7.2 shows the situation when the locking arm has been released. When the function selector is set to AMPLIFIER the locking arm is pushed away and the catch on the locking arm is disengaged from the track selector disc. The track selector is now free to be set to any position.

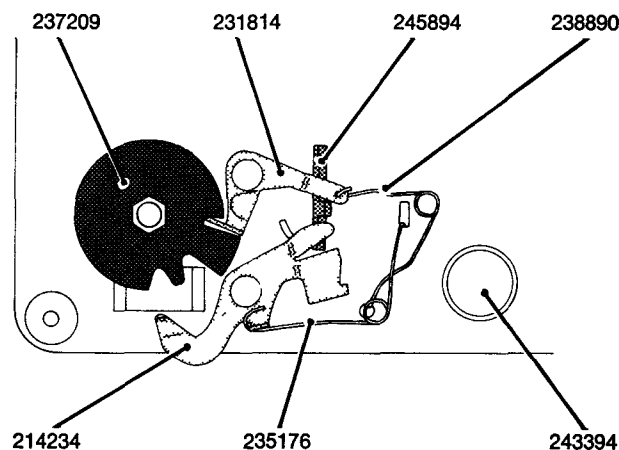

Fig. 7.1.

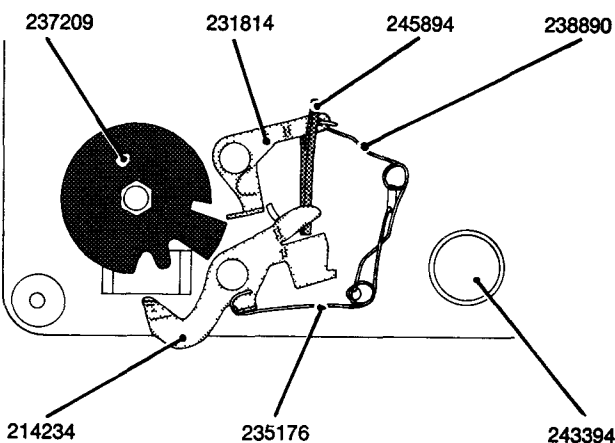

Fig. 7.2.

7.2 Model 15 GT – Group Trainer

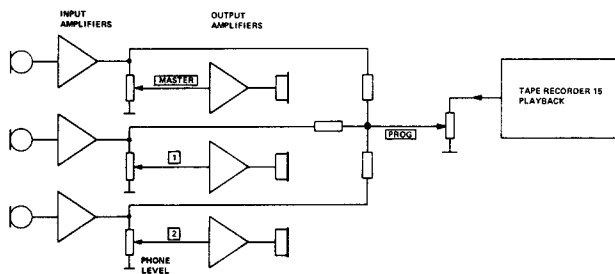

Fig. 7.3 NORMAL

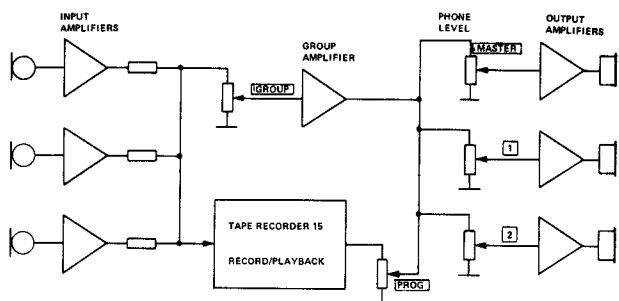

Fig. 7.4 GROUP

Model 15 GT is mechanically identical to the standard version. The height of the cabinet has, however, been increased to accommodate the extra electronics that enables distribution of programme to a group of 11 participants, or recording of a group conference. These two functions are named NORMAL and GROUP respectively, and can be selected with switch on the front panel. Block diagrams for the two functions are shown in figs. 7.3 and 7.4. Three of the eleven amplifiers are shown. The additional electronics comprises 11 input amplifiers with preset gain, and 12 output amplifiers with variable gain. Output amplifier no 1 is used as group amplifier. A separate programme amplifier is also incorporated.

7.2.1 Input Amplifier

Each input amplifier comprises transistors Q201 through Q203 with associated components. See diagram at the rear of the manual. Signal from the headset microphone is fed to the corresponding DIN-socket pin 2. After amplification in Q201 and Q202, the microphone signal is tapped off and fed through the mixing resistor R209 to GROUP/NORMAL selector. In GROUP mode the same signal is also fed to terminal 1 on amplifier board no. 15001 in the tape recorder. Transistor Q203 provides further amplification of the signal before it is fed to the output amplifier for the headset.

7.2.2 Output Amplifier

Each output amplifier comprises transistors Q301 and Q302 with associated components. Output ampli-

fier no. 1 is used as a group amplifier and is supplied with signals from all remaining output amplifiers when the GROUP/NORMAL switch is in GROUP position. The output signal from the group amplifier is distributed via another section of the same switch to the remaining output amplifiers (2–12) via the programme amplifier.

Input signal to each output amplifier is supplied from the corresponding input amplifier via potentiometer R301. The signal is mixed with signal from the programme amplifier at the top of R304.

The output signal from each output amplifier (2–12) is fed to the corresponding headphone.

7.2.3 Programme Amplifier

The programme amplifier is built around Q220. The input signal is supplied from the PREAMP output of the tape recorder only when the GROUP/NORMAL switch is in NORMAL position. In position GROUP, this signal is mixed with signal from the group amplifier. The programme amplifier output is connected to R305 in all output amplifiers 2–12.

7.2.4 Adjustment of Signal Levels

Adjust R301 to obtain 0.8 V across headphone for 1 mV input and with R304 in output amplifier (Adj. Stud. Phones), turned to maximum.

Adjust R304 in group amplifier to obtain 0.8 V across headphone during playback for a tape containing a 400 Hz signal recorded at normal level, and with the same setting for Adj. Stud. Phones as above.

Adjust R301 (Adj. Group Level) to obtain 0.8 V across headphones 3 through 12, with 1 mV into microphone input 2, and with GROUP/NORMAL selector in position GROUP.

7.3 Model 15 F

This model differs from the standard model by the remote control facilities for start, stop and rewind. The remote control unit is a foot pedal connected to the recorder with a 3-pin plug.

The pedal has three positions. In unoperated position the tape recorder is in STOP. Normal forward drive is accomplished by depressing the front part of the pedal. Depressing the rear part puts the recorder into rewind mode. When the remote control unit is to be used, the operating lever must be in normal forward drive position.

7.3.1 Mechanical Operation

The mechanical functions in connection with the remote control equipment are operated by solenoids controlled by microswitches and the pedal switches.

Start/Stop Solenoid

The start/stop solenoid controls an eccentric mechanism operating the pressure wheel assembly. When current is passed through the start/stop solenoid, the

pressure wheel lever disengages the pressure wheel from the capstan. To allow remote control of rewinding, the F models are not equipped with a tape brake. When there is no current through the start/stop solenoid, the pressure of the start/stop lever against the pressure wheel lever is released, and the tension of the pressure wheel spring will force the pressure wheel against the capstan, providing normal forward motion. The start/stop solenoid also controls a microswitch for connection/disconnection of operating voltage to terminal 19 on board no. 15001. Wiring of this switch has been modified from serial no. 2 510 020. (See paragraph 8.2.1).

The Brake Solenoid

The brake solenoid controls a brake located underneath the right hand turntable.

When current passes through the brake solenoid, the brake is pressed against the turntable, preventing rotation.

When the current to the brake solenoid is switched off, the brake is released and normal winding takes place.

The Rewind Solenoid

The rewind solenoid controls both the clutch mechanism and the pressure pad arm. When current is passed through the rewind solenoid, the pressure pad is disengaged from the erase head, and the clutches are set for fast rewind.

The rewind solenoid also controls the microswitches II and III, which in turn control the start/stop solenoid and brake solenoid respectively.

7.3.2 Electrical Operation

The following explanation of the main operating modes is referred to schematic.

When the current is switched on and the tape motion lever set to position → microswitch I is activated to provide current to the remote control mechanism.

Stop (Pedal unoperated)

Current passes through the start/stop solenoid, the brake solenoid and to earth. The start/stop solenoid keeps the pressure wheel disengaged from the capstan, and the brake solenoid forces the brake pad against the right hand turntable. Forward motion is thereby stopped. The start/stop solenoid also activates a switch that disconnects the supply voltage from terminal 19 on board on 15 001 causing the oscillator to stop.

Note: From serial no. 2 510 020 the wiring of the microswitch has been altered. (See paragraph 8.2.1). Simultaneously a new switch is connected in series with wire from potentiometer VOLUME to the input of the output amplifier (see paragraph 8.2.2).

Rewind (rear part of pedal depressed)

Capacitor C504 (4 μ F) is charged in the stop position. Current now passes through the rewind solenoid and to earth through microswitch II. The resulting power shock (approx. 0.6 A) is absorbed by the discharge of C501 (80 μ F). C501 is charged when the tape recorder is switched on. It then acts as a reserve for the rewind power shock. When the rewind solenoid is actuated, microswitches II and III operate. During the transition time for switch II, current through the rewind solenoid is maintained by C503 (8 μ F) being charged. C504 (4 μ F) supplies current to the start/stop solenoid and the brake solenoid during switch-over so that the pressure wheel is kept disengaged from the capstan, and the brake pad is pressed against the right hand turntable. The tape motion is then stopped. When switches II and III are switched over, the current passes through the rewind solenoid, the start/stop solenoid and switch III (the brake solenoid is short-circuited) and to ground. The rewind solenoid and start/stop solenoid are connected in series, thereby limiting the current to a magnitude within the capability of the rectifier and which is sufficient to hold the solenoid activated. The clutch assemblies are thereby set for fast rewind, and supply voltage for the oscillator is disconnected. (See paragraph 8.2.1). Unwanted erasure of the tape in RECORD position is thereby avoided and noise is eliminated in the PLAYBACK position (the tape touches the heads during rewinding).

To stop rewinding, the pedal is released. The current passes through the start/stop solenoid and the brake solenoid. For quick retardation C502, (40 μ F) is discharged through the brake solenoid. (C502 is charged during rewind).

Start (front part of pedal depressed)

The current to all solenoids is switched off. The pressure wheel spring forces the pressure wheel against the capstan, the brake pad is released from the right hand turntable, and normal forward tape motion starts. As no current passes through the start/stop solenoid, the supply voltage to board no 15 001 is switched on, (see paragraph 8.2.1 on modification from serial no 2 510 020).

The diode BY 112 prevents C502 (40 μ F) from being charged in the stop position. C502 would otherwise discharge through the brake solenoid in the start position, and this would result in the brake pad being held against the take-up turntable for a period of time after the capstan had started the tape motion. This would result in loop formation. Capacitors C501, C502, C503 and C504 are all located in the same can.

8.0 Modifications

8.1 Circuit Modification for Low Noise Tape

All units with serial no higher than 2 619 561 for Model 14 and 2 515 502 for Model 15 are adjusted for recording on Low Noise tape. This implies the following modifications:

- R208 to be altered from 56 ohm to 82 ohm
- R209 » » » » 39 ohm to 15 ohm
- R212 » » » » 5.6 kohm to 3.3 kohm
- R214 » » » » 3.3 kohm to 1.5 kohm
- R218 » » » » 22 kohm to 15 kohm
- R239 » » » » 100 kohm to 1.5 kohm

A 27 ohm resistor is connected in series with C205. The type of record/playback head has been altered as follows:

- 2-track models: from 39 H to 81 H
- 4-track models: from 40 H to 82 H.

The equalizing coil is adjusted at 13.5 kHz, when operating in 3³/₄ ips. Equalizing curves for recording and playback are shown in figures 8.1 and 8.2. Tolerance range according to DIN 45511 is shown in fig. 8.3.

Frequency Range, ± 2 dB:

- 7¹/₂ ips: 40–18 000 Hz
- 3³/₄ ips: 50–12 000 Hz
- 1⁷/₈ ips: 60– 6 500 Hz

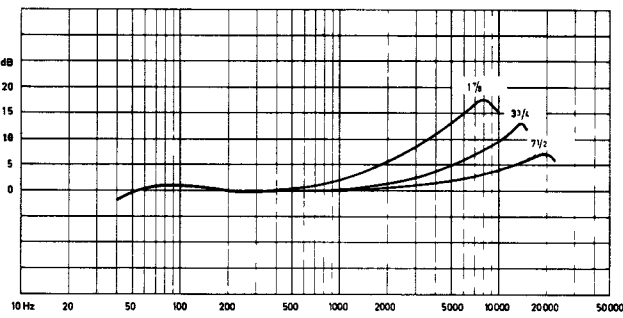

Fig 8.1.

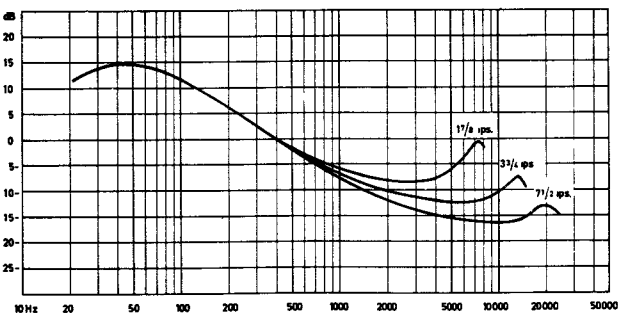

Fig 8.2.

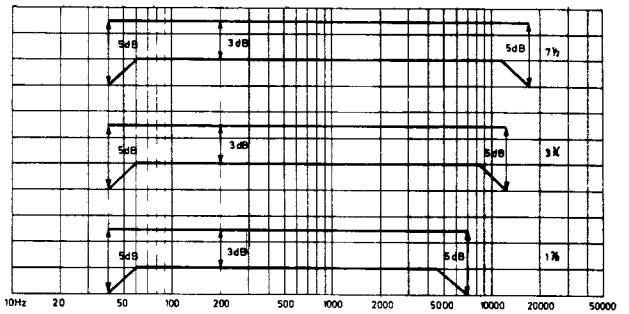

Fig. 8.3 DIN-curves for frequency range.

Signal/Tape noise at highest speed:

| | 4-track | 2-track |
|------------------------|------------|------------|
| DIN 45511 (weighted) | 50 (52) dB | 52 (54) dB |
| DIN 45511 (unweighted) | 49 (50) dB | 49 (50) dB |
| IEC, A-curve | 58 (59) dB | 60 (61) dB |
| IEC, unweighted R.M.S. | 53 (54) dB | 53 (54) dB |

8.2 Modification of F-Model from Serial No 2 510 020

8.2.1 Microswitch for Oscillator Voltage

Microswitch for disconnection of operating voltage in stop and rewind modes has been rewired in such a way that only operating voltage for the bias oscillator is switched off. All amplifiers are therefore operative at any time, and the record level can be set when the tape recorder is in stop mode. Furthermore, the bias voltage recovers much faster after stop. See diagram at the rear of manual.

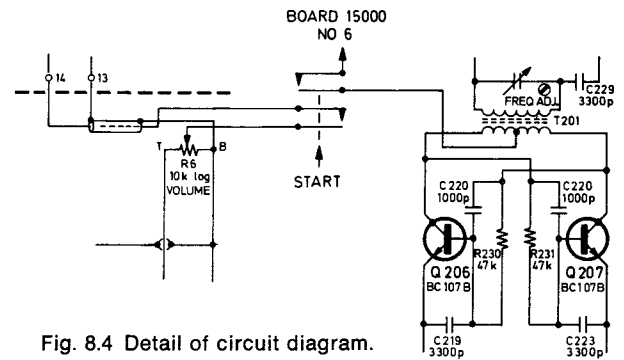

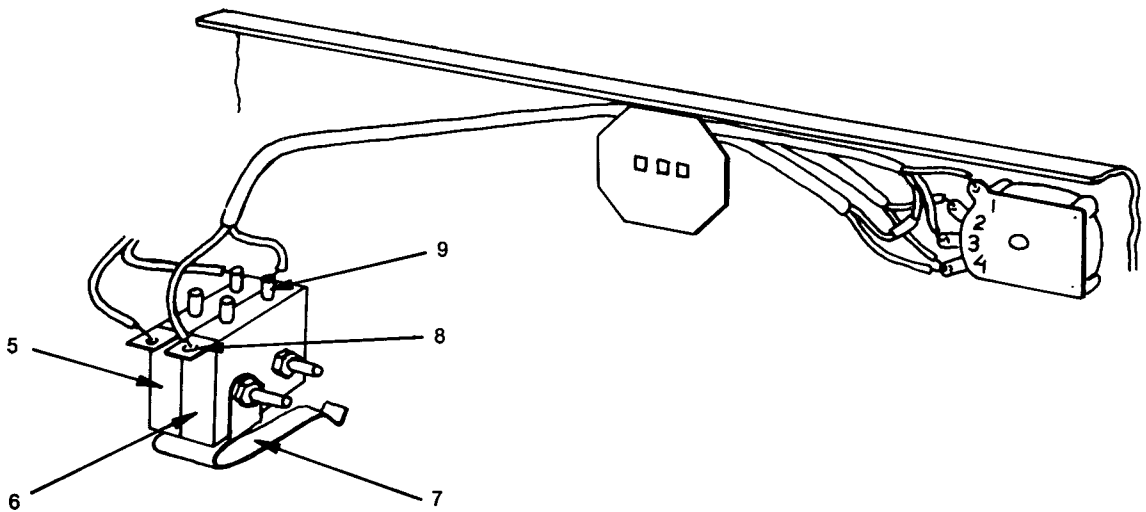

Fig. 8.6 Introduction of extra microswitch.

8.2.2 New Microswitch

An extra microswitch operated by the start/stop solenoid is connected in series with the potentiometer VOLUME, thereby effectively muting the output amplifier in stop and rewind modes. See diagram.

8.2.3 Rewiring

- Mount an extra microswitch (6) on the same bracket as the switch used for operating voltage (5).
- Remove the wire to terminal 19 on preamplifier board 15001 from the switch and connect it permanently to terminal 6 on the voltage stabilizer (board 15 000).
- Connect a new wire from the now vacant terminal on the switch to the preamplifier board as shown in fig. 8.5, and cut the foil as shown in the same figure.
- Connect a shielded wire from the microswitch (6) and the potentiometer VOLUME as shown in fig. 8.6. Solder the shield to terminal 1 on the potentiometer.
- Disconnect the existing wire from terminal 3 on the potentiometer and connect the same wire to the lead from terminal 8 on the microswitch. Connect the other wire from the microswitch to terminal 3 on the potentiometer.

8.3 Modifications from 2-Track to Full-Track Model

Replace record/playback head 39 H by 72 H and erase head 69 H by 73 H.

To obtain correct record current ($360 \mu\text{A}$) reduce R218 from 22 kohm to 10 kohm.

A 220 pF styroflex capacitor should be connected in parallel with C221 to obtain correct oscillator frequency. The bias is adjusted as follows:

Connect a 100 ohm resistor in series with the lower half of the record/playback head. Adjust C2 for 220 mV across the resistor.

If adjustment range is not sufficient, connect a capacitor (approx. 25 pF) in parallel with C2.

8.4 Modifications 50 to 60 Hz or Vice Versa

The motors used in tape recorders series 14 and 15 are only recommended for use on nominal line frequency. On modification for a different line frequency, the motor must be replaced. As usual the motor pulley must be replaced by one dimensioned for the relevant frequency.

| | Part no. | Draw. no. | Type | |
|-------|--------------------|-----------|----------------------------------|---------|
| 50 Hz | Motor | 241009 | 110/220 V SP24.32-2-950 Papst | |
| | Motor pulley TB 14 | 254040 | | 14006 |
| | Motor pulley TB 15 | 243940 C | | 15033-3 |
| 60 Hz | Motor | 254973 | 110/220 V SP24.32-2-830 Papst | |
| | Motor pulley TB 14 | 250326 | | 14007 |
| | Motor pulley TB 15 | 248351 | | 15083-3 |

9.0 Parts Lists

standard model 14—15

Resistors

| Ref.no. | Description | | | Remarks |
|---------|-------------|---------------|------|---------|
| R1K | 1 Mohm | 1/4 W | 5 % | |
| R3 | 10 kohm | 1/3 W | 10 % | |
| R4 | 10 kohm | 1/3 W | 10 % | |
| R9 | 3,9 ohm | 5 W wirewound | 10 % | |
| R12 | 47 kohm | 1/4 W | 5 % | |
| R102 | 1 Mohm | 1/3 W | 5 % | |
| R103 | 100 kohm | 1/2 W | 5 % | |
| R105 | 10 kohm | 1/3 W | 5 % | |
| R106 | 1 kohm | 1/2 W | 5 % | |
| R107 | 1 kohm | 1/2 W | 5 % | |
| R108 | 220 kohm | 1/2 W | 5 % | |
| R109 | 100 kohm | 1/2 W | 5 % | |
| R110 | 39 kohm | 1/3 W | 5 % | |
| R111 | 56 ohm | 1/2 W | 5 % | |
| R112 | 27 kohm | 1/2 W | 5 % | |
| R113 | 22 kohm | 1/2 W | 5 % | |
| R114 | 1 Mohm | 1/3 W | 5 % | |
| R115 | 100 kohm | 1/2 W | 5 % | |
| R116 | 4,7 kohm | 1/3 W | 5 % | |
| R117 | 470 ohm | 1/2 W | 5 % | |
| R118 | 1 kohm | 1/2 W | 5 % | |
| R119 | 1 kohm | 1/3 W | 10 % | |
| R120 | 330 kohm | 1/3 W | 10 % | |
| R121 | 12 kohm | 1/3 W | 10 % | |
| R122 | 330 ohm | 1/3 W | 5 % | |
| R123 | 3,3 kohm | 1/3 W | 10 % | |
| R124 | 68 ohm | 1/3 W | 10 % | |
| R125 | 22 kohm | 1/3 W | 10 % | |
| R126 | 1 kohm | 1/3 W | 10 % | |
| R128 | 2,2 kohm | 1/3 W | 10 % | |
| R130 | 130 ohm | NTC | 20 % | |
| R131 | 56 ohm | 1/3 W | 10 % | |
| R132 | 56 ohm | 1/3 W | 10 % | |
| R133 | 0,47 ohm | 1 W wirewound | 10 % | |
| R134 | 0,47 ohm | 1 W wirewound | 10 % | |
| R135 | 220 ohm | 1/3 W | 10 % | |
| R136 | 33 ohm | 1/2 W | 5 % | |
| R137 | 330 ohm | 1/3 W | 5 % | |
| R138 | 1 kohm | 1/3 W | 10 % | |
| R139 | 100 ohm | 1/3 W | 10 % | |
| R140 | 510 ohm | 1/3 W | 10 % | |
| R141 | 1 kohm | 1/3 W | 10 % | |
| R142 | 1,8 kohm | 1 W | 10 % | |
| R143 | 680 ohm | 1 W | 10 % | |
| R144 | 130 ohm | NTC | 20 % | |
| R145 | 39 kohm | 1/3 W | 5 % | |
| R201 | 68 kohm | 1/3 W | 5 % | |
| R202 | 680 ohm | 1/3 W | 5 % | |
| R203 | 10 kohm | 1/3 W | 5 % | |
| R204 | 100 kohm | 1/3 W | 5 % | |
| R205 | 220 kohm | 1/2 W | 5 % | |
| R206 | 10 kohm | 1/2 W | 5 % | |
| R207 | 510 ohm | 1/3 W | 5 % | |
| R208* | 56 ohm | 1/3 W | 10 % | |
| R209* | 39 ohm | 1/3 W | 10 % | |
| R210 | 120 ohm | 1/3 W | 10 % | |
| R211 | 120 ohm | 1/3 W | 10 % | |
| R212* | 5,6 kohm | 1/3 W | 5 % | |

* Component with new value above serial no. 2 619 561 for series 14 and 2 515 502 for series 15.

| Ref.no. | Description | | | Remarks |
|---------|-------------|-------|------|---|
| R213 | 47 kohm | 1/3 W | 10 % | 10 kohm in full track models |
| R214* | 3,3 kohm | 1/3 W | 5 % | |
| R216 | 150 kohm | 1/3 W | 5 % | |
| R217 | 1 kohm | 1/2 W | 5 % | |
| R218* | 22 kohm | 1/4 W | 5 % | |
| R219 | 68 kohm | 1/3 W | 5 % | |
| R220 | 1 Mohm | 1/3 W | 5 % | |
| R221 | 100 kohm | 1/3 W | 5 % | |
| R222 | 330 ohm | 1/3 W | 5 % | |
| R223 | 4,7 kohm | 1/3 W | 10 % | |
| R224 | 390 ohm | 1/3 W | 10 % | |
| R226 | 1 Mohm | 1/3 W | 10 % | |
| R227 | 8,2 kohm | 1/3 W | 10 % | |
| R228 | 8,2 kohm | 1/3 W | 10 % | |
| R229 | 120 ohm | 1/3 W | 10 % | |
| R230 | 47 kohm | 1/3 W | 10 % | |
| R231 | 47 kohm | 1/3 W | 10 % | |
| R232 | 120 ohm | 1/3 W | 10 % | |
| R233 | 510 ohm | 1/3 W | 5 % | |
| R234 | 1 Mohm | 1/3 W | 5 % | |
| R235 | 68 kohm | 1/3 W | 5 % | |
| R236 | 680 ohm | 1/3 W | 5 % | |
| R237 | 10 kohm | 1/3 W | 5 % | |
| R238 | 2,2 kohm | 1/3 W | 10 % | |
| R239 | 100 ohm | 1/3 W | 5 % | from serial no. 261961 for TB 14, serial no. 2515502 for TB 15 |
| R240 | 27 ohm | 1/2 W | 10 % | |

* Component with new value above serial no. 2 619 561 for series 14 and 2 515 502 for series 15.

Capacitors

| Ref.no. | Description | | Type | Remarks |
|---------|-------------|------------|--------------|---------|
| C1 | 10—60 pF | | | |
| C101 | 2,2 µF | 100 V | Electrolytic | |
| C102 | 180 pF | 500 V 10 % | Cer. 2 | |
| C104 | 2,2 µF | 100 V | Electrolytic | |
| C105 | 22 µF | 20 V | Electrolytic | |
| C106 | 180 µF | 500 V 10 % | Cer. 2 | |
| C107 | 2,2 µF | 100 V | Electrolytic | |
| C108 | 100 µF | 6 V | Electrolytic | |
| C109 | 2,2 µF | 100 V | Electrolytic | |
| C111 | 80 µF | 25 V | Electrolytic | |
| C112 | 2,2 µF | 100 V | Electrolytic | |
| C113 | 0,22 µF | 160 V 10 % | Polyester | |
| C114 | 2,2 µF | 100 V | Electrolytic | |
| C115 | 80 µF | 25 V | Electrolytic | |
| C116 | 470 pF | 500 V 10 % | Cer. 2 | |
| C117 | 1000 µF | 25 V | Electrolytic | |
| C118 | 0,022 µF | 400 V 10 % | Met. paper | |
| C119 | 0,47 µF | 160 V 10 % | Polyester | |
| C120 | 330 µF | 3 V | Electrolytic | |
| C121 | 0,33 µF | 160 V 10 % | Polyester | |
| C122 | 2,2 µF | 100 V | Electrolytic | |
| C123 | 1000 µF | 35/40 V | Electrolytic | |
| C124 | 0,01 µF | 160 V 10 % | Polyester | |
| C125 | 1000 µF | 55/60 V | Electrolytic | |
| C201 | 2,2 µF | 100 V | Electrolytic | |

| Ref.no. | Description | Type | Remarks |
|---------|---------------------|--------------|---------|
| C202 | 80 µF 25 V | Electrolytic | |
| C203 | 68 pF 500 V 10 % | Cer. 2 | |
| C204 | 0,022 µF 160 V 5 % | Polyester | |
| C205 | 0,047 µF 160 V 5 % | Polyester | |
| C206 | 0,15 µF 160 V 5 % | Polyester | |
| C207 | 0,022 µF 400 V 10 % | Met. paper | |
| C208 | 0,1 µF 200 V 10 % | Met. paper | |
| C209 | 2200 pF 63 V 2,5 % | Styroflex | |
| C210 | 0,022 µF 160 V 5 % | Polyester | |
| C211 | 470 pF 500 V 10 % | Cer. 2 | |
| C212 | 470 pF 500 V 10 % | Cer. 2 | |
| C213 | 2,2 µF 100 V | Electrolytic | |
| C214 | 80 µF 25 V | Electrolytic | |
| C215 | 0,1 µF 200 V 10 % | Met. paper | |
| C216 | 2,2 µF 100 V | Electrolytic | |
| C217 | 2,2 µF 100 V | Electrolytic | |
| C218 | 10 µF 50 V | Electrolytic | |
| C219 | 3300 pF 63 V 5 % | Styroflex | |
| C220 | 1000 pF 63 V 5 % | Styroflex | |
| C221 | 150—750 pF | | |
| C222 | 1000 pF 63 V 5 % | Styroflex | |
| C223 | 3300 pF 63 V 5 % | Styroflex | |
| C224 | 22 µF 20 V | Electrolytic | |
| C226 | 2,2 µF 100 V | Electrolytic | |
| C227 | 2,2 µF 100 V | Electrolytic | |
| C228 | 1000 pF 63 V 5 % | Styroflex | |
| C229 | 0,01 µF 400 V 20 % | Met. paper | |
| C230 | 180 pF 500 V 10 % | Cer. 2 | |
| C232 | 180 pF 500 V 10 % | Cer. 2 | |

Transistors

| | |
|------|--------------------|
| Q101 | BC 149B, low noise |
| Q102 | BC 149B, low noise |
| Q103 | BC 149B, low noise |
| Q104 | BC 147B |
| Q105 | BC 147B |
| Q106 | AC 127 |
| Q107 | AC 152 |
| Q108 | AD 150 |
| Q109 | AD 150 |
| Q110 | BC 147B |
| Q111 | BC 107B |
| Q112 | AUY 21 |
| Q201 | BC 149B, low noise |
| Q202 | BC 149B, low noise |
| Q203 | BC 107B |
| Q204 | BC 147A |
| Q205 | BC 147B |

| | |
|------|--------------------|
| Q206 | BC 107B |
| Q207 | BC 107B |
| Q208 | BC 149B, low noise |

Potentiometers

| | | | |
|------|----------|------|-----------|
| R127 | 470 kohm | lin. | Pot.meter |
| R129 | 1 kohm | lin. | Pot.meter |
| R225 | 47 kohm | lin. | Pot.meter |
| R7 | spec. | | Pot.meter |
| R8 | spec. | | Pot.meter |

Miscellaneous Components

| | |
|-------------|---------------------------|
| Diode D101 | ZF 24, Zener |
| Loudspeaker | HT 111 — 3 ohm |
| Indicator | GM-251/R8200 A-BS |
| Pilot lamps | 24 V, 1.2 Watt |
| Rectifier | B 36 C 1200/650 AEG 10747 |
| Fuse | 1.6 A |

Heads

| | | Below ser.no. 2619561, Series 14 Below ser.no. 2515502, Series 15 | | | Above ser.no. 2619561, Series 14 Above ser.no. 2515502, Series 15 | | |
|----------------------|----------|--|---------|------------|--|---------|------------|
| | | 4-track | 2-track | full-track | 4-track | 2-track | full-track |
| Erase head | Type no. | 44 H | 69 H | 73 H | 41 H | 69 H | 73 H |
| | Art. no. | 552 | 633 | A 14 | 552 | 633 | A 14 |
| Record/playback head | Type no. | 40 H | 39 H | 72 H | 82 H | 81 H | 72 H |
| | Art. no. | 551 | 550 | A 13 | C 15 | C 14 | A 13 |

The article numbers unambiguously define head type and application and can be used alone for ordering of replacement heads.

Model 15 GT

Resistors

| Ref.no. | Description | | | Remarks |
|---------|-------------|-------|------|---------|
| R201 | 330 ohm | 1/2 W | 5 % | |
| R202 | 150 kohm | 1/2 W | 5 % | |
| R203 | 100 kohm | 1/2 W | 5 % | |
| R204 | 510 ohm | 1/2 W | 5 % | |
| R205 | 6,8 kohm | 1/2 W | 5 % | |
| R206 | 39 kohm | 1/2 W | 5 % | |
| R207 | 6,8 kohm | 1/2 W | 5 % | |
| R208 | 47 ohm | 1/2 W | 5 % | |
| R209 | 15 kohm | 1/4 W | 5 % | |
| R220 | 10 kohm | 1/3 W | 10 % | |
| R221 | 10 kohm | 1/3 W | 5 % | |
| R222 | 1 kohm | 1/3 W | 10 % | |
| R223 | 47 ohm | 1/3 W | 10 % | |
| R302 | 2,2 kohm | 1/2 W | 5 % | |
| R303 | 1,8 kohm | 1/2 W | 5 % | |
| R305 | 10 kohm | 1/2 W | 5 % | |
| R306 | 27 kohm | 1/2 W | 5 % | |
| R307 | 560 kohm | 1/2 W | 5 % | |
| R308 | 180 ohm | 1/3 W | 10 % | |
| R309 | 6,8 kohm | 1/2 W | 5 % | |
| R310 | 10 kohm | 1/2 W | 5 % | |
| R311 | 56 kohm | 1/2 W | 5 % | |
| R312 | 1 kohm | 1 W | 10 % | |
| R313 | 22 ohm | 1/2 W | 5 % | |

Capacitors

| Ref.no. | Description | | Type |
|---------|-------------|------------|--------------|
| C201 | 2 µF | 15 V | Electrolytic |
| C202 | 180 pF | 500 V 10 % | Cer. 2 |
| C203 | 470 pF | 500 V 10 % | Cer. 2 |
| C204 | 25 µF | 25 V | Electrolytic |
| C205 | 2 µF | 15 V | Electrolytic |
| C206 | 2 µF | 15 V | Electrolytic |
| C220 | 2 µF | 100 V | Electrolytic |
| C221 | 2 µF | 100 V | Electrolytic |
| C222 | 25 µF | 25 V | Electrolytic |
| C301 | 2 µF | 15 V | Electrolytic |
| C302 | 2 µF | 15 V | Electrolytic |
| C304 | 330 pF | 500 V | Electrolytic |
| C304 | 25 µF | 25 V | Electrolytic |
| C305 | 25 µF | 25 V | Electrolytic |
| C303 | 330 pF | 500 V 20 % | Cer. 2 |

Transistors

| Ref.no. | Type | Remarks |
|---------|---------|---------|
| Q201 | BC 149B | |
| Q202 | BC 148B | |
| Q203 | BC 147B | |
| Q220 | BC 115 | |
| Q301 | BC 148B | |
| Q302 | BC 115 | |

Potentiometers

| Ref.no. | Description | Type |
|---------|-----------------|-----------|
| R301 | 10 ohm adjustm. | Pot.meter |
| R304 | 10 ohm lin. | Pot.meter |

Model 15 SL

Resistors

| Ref.no. | Description | | | Remarks |
|---------|-------------|-------|------|---------|
| R301 | 68 kohm | 1/2 W | 5 % | |
| R302 | 680 ohm | 1/2 W | 5 % | |
| R303 | 10 kohm | 1/2 W | 5 % | |
| R304 | 10 kohm | 1/2 W | 5 % | |
| R305 | 220 kohm | 1/2 W | 5 % | |
| R306 | 100 ohm | 1/3 W | 5 % | |
| R307 | 560 ohm | 1/3 W | 5 % | |
| R308 | 560 ohm | 1/3 W | 5 % | |
| R309 | 120 kohm | 1/2 W | 5 % | |
| R310 | 2,2 kohm | 1/2 W | 5 % | |
| R311 | 3,3 kohm | 1/2 W | 5 % | |
| R311 | 5,6 kohm | 1/2 W | 5 % | |
| R312 | 120 kohm | 1/4 W | 5 % | |
| R312 | 120 ohm | 1/2 W | 5 % | |
| R313 | 1 kohm | 1/2 W | 5 % | |
| R313 | 10 kohm | 1/2 W | 5 % | |
| R314 | 1 kohm | 1/2 W | 5 % | |
| R315 | 510 kohm | 1/2 W | 5 % | |
| R316 | 27 kohm | 1/2 W | 5 % | |
| R317 | 6,8 kohm | 1/2 W | 5 % | |
| R318 | 180 ohm | 1/3 W | 10 % | |
| R319 | 10 kohm | 1/2 W | 5 % | |
| R320 | 39 kohm | 1/2 W | 5 % | |
| R321 | 1 kohm | 1 W | 10 % | |
| R322 | 220 kohm | 1/2 W | 5 % | |
| R323 | 100 ohm | 1/3 W | 10 % | |
| R324 | 100 ohm | 1/3 W | 10 % | |
| R325 | 100 ohm | 1/2 W | 10 % | |
| R326 | 68 ohm | 1/2 W | 10 % | |

Capacitors

| Ref.no. | Description | | | Type |
|---------|-------------|-------|-------|--------------|
| C301 | 2,2 µF | 100 V | | Electrolytic |
| C302 | 25 µF | 25 V | | Electrolytic |
| C303 | 68 pF | 500 V | 10 % | Cer. 2 |
| C304 | 560 pF | 500 V | 10 % | Cer. 2 |
| C305 | 25 µF | 25 V | | Electrolytic |
| C306 | 25 µF | 25 V | | Electrolytic |
| C307 | 220 pF | 63 V | 2,5 % | Styroflex |
| C308 | 0,022 µF | 160 V | 5 % | Polyester |
| C309 | 2,2 µF | 100 V | | Electrolytic |
| C310 | 560 pF | 500 V | 10 % | Cer. 2 |
| C311 | 2,2 µF | 100 V | | Electrolytic |
| C312 | 2,2 µF | 100 V | | Electrolytic |
| C313 | 2,2 µF | 100 V | | Electrolytic |
| C314 | 1000 pF | 500 V | 20 % | Cer. 2 |
| C315 | 25 µF | 25 V | | Electrolytic |
| C316 | 100 µF | 40 V | | Electrolytic |

Model 15 F

Resistors

| Ref.no. | Description | | | Remarks |
|---------|-------------|-------|------|---------|
| R501 | 20 kohm | 1/4 W | 5 % | |
| R502 | 51 ohm | 1/2 W | 10 % | |
| R503 | 51 ohm | 1/2 W | 10 % | |
| R504 | 51 ohm | 1/2 W | 10 % | |
| R505 | 51 ohm | 1/2 W | 10 % | |

Capacitors

| | Description | Type | Remarks |
|------|----------------------------|--------------|--|
| C501 | 80 μ F/350 V | Electrolytic | C501–504 are encapsulated in the same can. |
| C502 | 40 μ F/350 V | | |
| C503 | 8 μ F/350 V | | |
| C504 | 4 μ F/350 V | | |
| C505 | 0,1 μ F/400 V, 10–20 % | Oil paper | |
| C506 | 0,1 μ F/400 V, 10–20 % | Oil paper | |
| C507 | 0,1 μ F/400 V, 10–20 % | Oil paper | |
| C508 | 0,1 μ F/400 V, 10–20 % | Oil paper | |
| C509 | 0,1 μ F/400 V, 10–20 % | Oil paper | |

Miscellaneous

| | |
|---------|------------------------------------|
| D500 | Diode BY 127 Rectifier B250/C75 |
| 990237 | Brake solenoid assembly |
| 990238 | Start/stop solenoid assembly |
| 990239 | Winding solenoid assembly |
| | Socket B3/US MC Murdo |
| 206814 | Brake solenoid, coil only |
| 203100A | Start/stop solenoid, coil only |
| 219637 | Winding solenoid, coil only |
| | Fuse 0.35 A |

Transistors

| Ref.no. | Type |
|---------|---------|
| Q301 | BC 149B |
| Q302 | BC 149B |
| Q303 | BC 107B |
| Q304 | BC 148B |
| Q305 | BC 115 |

Mechanical Parts

| Ref.no. | Part name | Fig. ref. | Remarks |
|---------|--|---|---------|
| 200363 | Pilot lamp, 24 V, counter, indicator | 4.2 | |
| 200384 | Insulator sheet | 4.1 | |
| 200549 | Flange, take-up turntable housing | 4.6, 4.8, 4.9 | |
| 200628 | Housing | 4.5, 4.6, 4.8, 4.9 | |
| 201605 | Shaft, pressure wheel | 4.3, 4.29 | |
| 201878 | Spring, equaliz. selector | | |
| 201957 | Shaft, pressure pad arm | | |
| 202008 | Cable, mains 115 V, w/plug | | |
| 202102 | Phono connector, FREE head | | |
| 202151 | Microswitch RX1 | 4.35, 4.36, 4.37, 4.38, 4.39 | |
| 202230 | Bushing, friction disc | 4.6, 4.7, 4.8, 4.9, 4.10, 4.15, 4.17, 4.19 | |
| 202309 | Shaft, eccentric segment | | |
| 202726 | Button, bass, treble | 4.1 | |
| 202740 | Lever, additional friction | 4.5, 4.9, 4.10, 4.16, 4.18, 4.20, 4.22, 4.24 | |
| 203013 | Thrust washer, flywheel bearing | 4.27, 4.35, 4.36, 4.37, 4.38 | |
| 203250 | Cable, mains 220 V, w/plug | | |
| 203365 | Shield, pilotlamp counter | | |
| 203559 | Spring brake lever | | |
| 203638 | Shaft clutch lever | 4.5, 4.15, 4.16, 4.17, 4.18, 4.19, 4.20, 4.21, 4.22, 4.23 | |
| 203990 | Spacer, lower mounting plate | | |
| 204184 | Mains switch | 4.1 | |
| 204918 | Clamp, driver transistors | | |
| 205671 | Stud, parallel arm and cover plate | | |
| 206017 | Rubber washer, mounting | | |
| 206023 | Shaft, roller, pressure wheel lever | | |
| 206296 | Window, revolution counter | 4.1, 4.2 | |
| 207273 | Spring, linkage arm | 4.5 | |
| 207352 | Shaft, brake lever supply turntable | 4.5 | |
| 207625 | Spring, lever friction wheel | 4.15, 4.16, 4.17, 4.18, 4.19, 4.20, 4.21, 4.22, 4.23, 4.24 | |
| 207977 | Roller, pressure wheel bracket | | |
| 208329 | Bearing, flywheel, self-lubricating | 4.2, 4.27 | |
| 208250 | Cover, heads | 4.1 | |
| 208444 | Felt washer for knob | | |
| 208724 | Clamp, mains cable | | |
| 209112 | Bracket, operating lever | | |
| 209306 | Spring, transfer wheel holder | 4.5, 4.26 | |
| 209385 | Stud, transfer wheel holder | | |
| 209658 | Friction disc | 4.6, 4.7, 4.8, 4.9, 4.10, 4.11, 4.15, 4.16, 4.17, 4.18 | |
| 209816 | Speed selector bracket | 4.26 | |
| 210283 | Rubber belt, revolution counter | | |
| 210520 | Pressure pad arm | 4.29 | |
| 210987 | Spring, clutch lever take-up friction disc | 4.16, 4.18, 4.20, 4.22, 4.24 | |
| 211066 | Shaft, pressure wheel lever | 4.3, 4.4 | |
| 211339 | Pulley, revolution counter | 4.9 | |
| 211418 | Shaft, clutch lever | | |
| 211612 | Lower rubber mounting, rear | | |
| 212043 | Rear trim cover | 4.1 | |
| 212273 | Lever, start/stop | 4.1, 4.4, 4.29 | |
| 212395 | Bushing, adjustable tape guide | | |
| 212461 | Securing pin | | |
| 212747 | Tape guide left | 4.4, 4.30 | |
| 212826C | Lever, pressure wheel | 4.3, 4.4, 4.29 | |
| 213020 | Spring, interlock arm | | |
| 213997 | Rubber drive belt | 4.15, 4.16, 4.17, 4.18, 4.19, 4.20, 4.21, 4.22 | |

| Ref.no. | Part name | Fig. ref. | Remarks |
|---------|--|---|---------|
| 214155 | Clip for operating lever | | |
| 214234 | Interlock arm, track selector | | |
| 214349 | Spring, adjustable tape guide | | |
| 214701 | Spring, friction disc | | |
| 214859A | Trip bar | | |
| 214925 | Socket, pilot lamp | | |
| 215053 | Pulley for revolution counter | | |
| 215326A | Upper rubber mounting, rear | | |
| 215405 | Momentary stop, delrin part | 4.4, 4.29 | |
| 215556 | Spring for pressure wheel bracket | 4.3 | |
| 215563 | Latch, spring, pressure wheel | 4.3, 4.29 | |
| 215640 | Lever, pressure pad | | |
| 215678 | Bearing, turntable self-lubricating | | |
| 215743 | Mylar sheet for take-up friction disc | 4.6, 4.8, 4.9, 4.11 | |
| 216109 | Rivet, linkage arm | | |
| 216211 | Rivet, foot, cabinet | | |
| 216267A | Interlock arm, function selector | | |
| 216461 | Adjustable tape guide | | |
| 216540 | Linkage pressure pad arm | 4.4, 4.29 | |
| 216734 | Spring, speed selector | 4.26 | |
| 217086 | Delrin button for clutch levers | | |
| 217510 | Spring for tape tight disc | 4.8 | |
| 217869 | Thrust washer | 4.27 | |
| 218063 | Spring, pressure pad arm | 4.30, 4.31, 4.32, 4.33, 4.34 | |
| 218415 | Spring, left friction disc | 4.6, 4.8, 4.9, 4.15, 4.16, 4.17, 4.18, 4.19 | |
| 218494 | Rivet, parallel arm and trip bar | | |
| 218767 | Delrin nut | 4.6, 4.8 | |
| 218925 | Bracket for revolution counter | | |
| 219198 | Tape tight disc | 4.8 | |
| 219221 | Clamp, wires from speaker switch | | |
| 219234 | Shaft, pressure wheel bracket | | |
| 219277 | Retainer, flywheel bearing | | |
| 219586 | Felt ring for flywheel bearing | 4.27 | |
| 219816 | Flange for supply turntable housing | | |
| 219823 | Screw, covers | 4.1 | |
| 219889 | Securing pin 10 mm | | |
| 220155 | Stud, lifting arm and interlock arm | | |
| 220384 | Revolution counter | | |
| 220859 | Spring lock, flywheel | 4.27 | |
| 223488 | Socket, component board, 5 pin | | |
| 224573 | Bushing, flywheel | 4.27 | |
| 224601 | Core, coil L201 | | |
| 226835 | Knob, function selector | 4.1 | |
| 227776 | Washer, grounding screw | | |
| 228286 | Mounting, plastic styroflex capacitors | | |
| 228868 | Knob, operating lever | 4.1 | |
| 230629 | Roller, cam disc arm | | |
| 233365 | Socket, comp. board, 3 pin | | |
| 233495 | Washer, track selector | | |
| 233911 | Adjustable tape guide, right | | |
| 234960 | Washer, speed selector knob | | |
| 235176 | Spring, interlock arm, track selector | | |
| 235549 | Felt, flywheel | 4.27 | |
| 236159 | Bracket, motor | | |
| 236728A | Cam disc arm | 4.5, 4.26 | |
| 237209 | Index disc, track selector, delrin | | |
| 238114 | Knob, speed selector | 4.1 | |
| 239738 | Shaft, cam disc arm | | |
| 240276 | Stud, end stop | | |
| 240377 | Knob, volume control, upper | 4.1 | |
| 240578 | Shaft equalization switch | | |
| 240930 | Shaft, switch lever | | |

| Ref.no. | Part name | Fig. ref. | Remarks |
|---------|---|---|---------|
| 241009 | Motor, 110/220 V | | |
| 241081 | Ring, pot.meter | | |
| 241318 | Bracket, switch | | |
| 241498 | Bracket amplifier board | | |
| 241555A | Spring, function selector lever return | | |
| 241742 | Handle, track selector | 4.1 | |
| 241749 | Arm, equaliz. switch | | |
| 241877 | Ext. speaker output jack | | |
| 241986 | Record level indicator | 4.1 | |
| 242058 | Knob, pot.meter, lower | 4.1 | |
| 242244 | Socket P. UP/RADIO | | |
| 242309 | Spring, end stop | 4.4, 4.35, 4.36, 4.38, 4.39 | |
| 242331 | Spring, cam disc arm | 4.5, 4.26 | |
| 242439 | Bracket, switch lever | | |
| 242503 | Arm, end stop feeler | 4.4, 4.35, 4.36, 4.37, 4.38, 4.39 | |
| 242554 | Shield, lamp, indicator | | |
| 242834 | Index spring, function selector | | |
| 243013 | Tape guide, right | 4.4, 4.35, 4.36, 4.37, 4.38, 4.39 | |
| 243351 | Bracket, component board, heatsink | | |
| 243394 | Socket, microphone input | 4.1 | |
| 243538 | Retainer spring, function selector | | |
| 243925 | Retaining ring, connectors | | |
| 243940 | Motor pulley, Series 15, 50 Hz | | |
| 243990 | Spring, end stop, feeler arm | 4.35, 4.36, 4.37, 4.38, 4.39 | |
| 244120 | Plastic tip, arm, equalization switch | | |
| 244235 | Bracket, chassis | | |
| 244292A | Spring, function selector lever, recording position | | |
| 244342 | Lever, end stop | | |
| 244479 | Switch, loudspeaker | | |
| 244515 | Cabinet, teak | 4.1, 4.2, 4.4 | |
| 244630 | Switch, equalization | | |
| 244694 | Arm, end stop transfer | | |
| 244752 | Track selector | | |
| 245354 | Supressor, motor switch (C3 R10) | | |
| 245455 | Knob, playback volume | 4.1 | |
| 245864 | Top cover | | |
| 245894 | Arm, function selector | | |
| 246231 | Plate, retainer, function selector | | |
| 246440 | Bracket, component board | | |
| 246533 | Board, switch stator, function selector | | |
| 246712 | Screw, end stop 2 x 5 mm M174 | | |
| 247395 | Clamp, wire, preamp board | | |
| 247611 | Function selector | | |
| 248027 | Insulation, microswitch | | |
| 248186 | Operating arm | 4.5, 4.15, 4.16, 4.17, 4.18, 4.19, 4.20, 4.21 | |
| 248199 | Connector, ext. speaker | | |
| 248242A | Spring, equalization switch | | |
| 248351B | Motor pulley, Series 15, 60 Hz | | |
| 248617 | Set of knobs | | |
| 248752 | Tape brake block | | |
| 248847 | Shield, phono connectors | | |
| 248874 | Terminal strip w/phono connectors | | |
| 249068 | Shielding can, motor | | |
| 249485 | Insulation plate terminal strip | | |
| 249622 | Bracket, switching board | | |
| 249759 | Top cover | | |
| 249852 | Label, 230/115 V motor | | |
| 249966 | Spring, tape brake | | |
| 250326 | Motor pulley, Series 14, 60 Hz | | |
| 251482 | Pressure arm | 4.4, 4.30, 4.31, 4.32, 4.33, 4.34 | |
| 251489A | Spring, tape rest | 4.4, 4.30, 4.31, 4.33 | |

| Ref.no. | Part name | Fig. ref. | Remarks |
|---------|--|---|---------|
| 252746 | Transformer no. 722, F-model | | |
| 253163 | Bracket, plush pad | | |
| 254040 | Motor pulley, Series 14, 50 Hz | | |
| 254779 | Transformer 115/220 V no. 720 | | |
| 254844 | Tape Rest | 4.25, 4.26 | |
| 254973 | Motor 110/220 V, 60 Hz | | |
| 990201 | Transfer wheel lifting arm, complete | 4.4, 4.30, 4.31, 4.33 | |
| 990202 | Bracket, pressure wheel complete | | |
| 990203 | Eccentric segment | 4.5, 4.26 | |
| 990204 | Parallel arm, complete | 4.2, 4.3, 4.29 | |
| 990205 | Operating lever, function selector | 4.2 | |
| 990206 | Mounting arm, transfer wheel | 4.5, 4.26 | |
| 990207 | Bracket for front trim cover, left | | |
| 990208 | Bracket for front trim cover, right | 4.5, 4.26 | |
| 990209 | Thrust spring with delrin knob | | |
| 990210 | Spring with plush pressure knob | | |
| 990211 | Lever for pressure wheel | | |
| 990212 | Slide w/contact springs, function selector | | |
| 990213 | Transfer wheel holder | | |
| 990214 | Cover plate 1 | | |
| 990215 | Cover plate 2 | | |
| 990216 | Lower mounting plate, complete | | |
| 990217 | Bracket w/shaft, momentary stop | 4.27 | |
| 990218 | Amplifier board assembly | | |
| 990219 | Preamplifier board assembly | | |
| 990220 | Upper mounting plate | | |
| 990221 | Terminal strip, heads | 4.27 | |
| 990222 | Spring washer, upper flywheel bearings | | |
| 990223 | Retainer, flywheel bearing, threaded | 4.27, 4.35, 4.36, 4.37, 4.38, 4.39 | |
| 990224 | Cam disc w/shaft, Series 15 | 4.2, 4.27 | |
| 990225 | Operating lever shaft with delrin ball | | |
| 990226 | Supply turntable | 4.6, 4.8, 4.15, 4.17, 4.19, 4.21, 4.23, 4.26 | |
| 990227 | Take-up turntable | 4.9, 4.16, 4.18, 4.20, 4.22, 4.24 | |
| 990228 | Clutch lever, supply friction disc. | 4.5, 4.6, 4.7, 4.8, 4.15, 4.17, 4.19, 4.21, 4.23 | |
| 990229 | Clutch lever, take-up friction disc | 4.5, 4.9, 4.10, 4.16, 4.18, 4.20, 4.22, 4.24 | |
| 990230 | Brake lever take-up friction disc, complete | 4.5 | |
| 990231 | Bracket for rear trim cover | | |
| 990232 | Momentary stop kit | | |
| 990233 | Transfer wheel | 4.5, 4.26 | |
| 990234 | Pressure wheel | 4.3, 4.4, 4.29 | |
| 990235 | Flywheel | | |
| 990236 | Bracket w/shaft and stop | | |
| 990312 | Friction disc, left and right | 4.4, 4.27, 4.26, 4.35, 4.36, 4.37 4.5, 4.26 | |
| 990600 | Cam disc w/shaft, Series 14 | 4.5 | |

Screws, Washers and Lockwashers

| | | | | | |
|------|----------------------------------|------|----------------------------------|------|----------------------------------|
| M101 | Screw 3 x 4 mm cyl. head | M125 | Screw 3 x 6 mm, 1.5 mm head | M318 | Lockwasher 6 mm |
| M102 | Screw 3 x 4.5 mm cyl. head | M130 | Screw 3 x 8 mm countersink head | M321 | Lockwasher 4 x 0.6 mm |
| M104 | Screw 3 x 6 mm cyl. head | M132 | Screw Unbrako 1/4" x 3.5 mm | M325 | Washer 16 x 4.2 x 1.65 mm |
| M107 | Screw 3 x 8 mm cyl. head | M301 | Turbax washer 7.5 x 4.2 x 0.2 mm | M329 | Lockwasher 2.3 mm |
| M112 | Screw 4 x 6 mm cyl. head | M302 | Turbax washer 7.5 x 4.2 x 0.3 mm | M331 | Bakelite washer 18 x 10 x 0.5 mm |
| M113 | Screw 4 x 8 mm cyl. head | M303 | Turbax washer 7.5 x 4.2 x 0.5 mm | M333 | Spring washer 1/8" |
| M114 | Screw 4 x 10 mm cyl. head | M307 | Turbax washer 11 x 6.5 x 0.5 mm | M348 | Teflon washer 6.5 x 4.2 x 0.2 mm |
| M116 | Screw 1/4" No. 4, self-threading | M313 | Lockwasher 2.5 mm | M349 | Lockwasher 4 mm |
| M120 | Screw 2.6 x 4 mm cyl. head | M314 | Lockwasher 3 mm | M355 | Teflon washer 6.5 x 4.2 x 0.5 mm |
| M121 | Screw 2.3 x 12 mm cyl. head | M315 | Lockwasher 3.5 mm | M360 | Lockring 2.5 mm |
| M122 | Screw 4 x 22 mm mcyl. head | M317 | Lockwasher 5 mm | M403 | Rivet 3.5 mm |

LUBRICATING

The motor:

The motor should be lubricated after approx. every 3000 hours of use.

The upper and the lower bearing should be lubricated with Lubricating oil, synthetic 9150-99-664-3825 (Teresso 32) or 9150-99-664-3826 (Teresso 46).

The self-lubricating bearings:

The turntables, the flywheel, and the speed transfer wheel are mounted in self-lubricating bearings and should usually not be lubricated. If, however, it should be necessary to lubricate the bearings for any reason use Lubricating oil, synthetic 9150-99-664-3825 (Teresso 32) or 9150-99-664-3826 (Teresso 46).

Note: Utmost care must be taken while lubricating, use only one fraction of a drop of oil for each bearing. Excessive oil might seriously affect the friction drive.

AL1

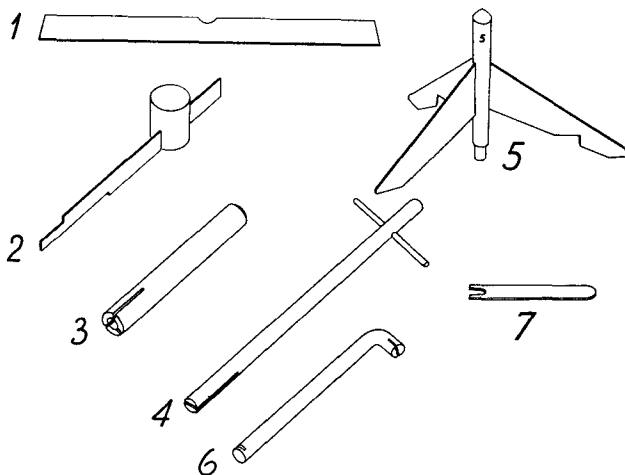
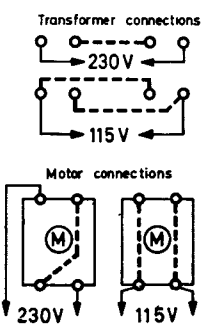
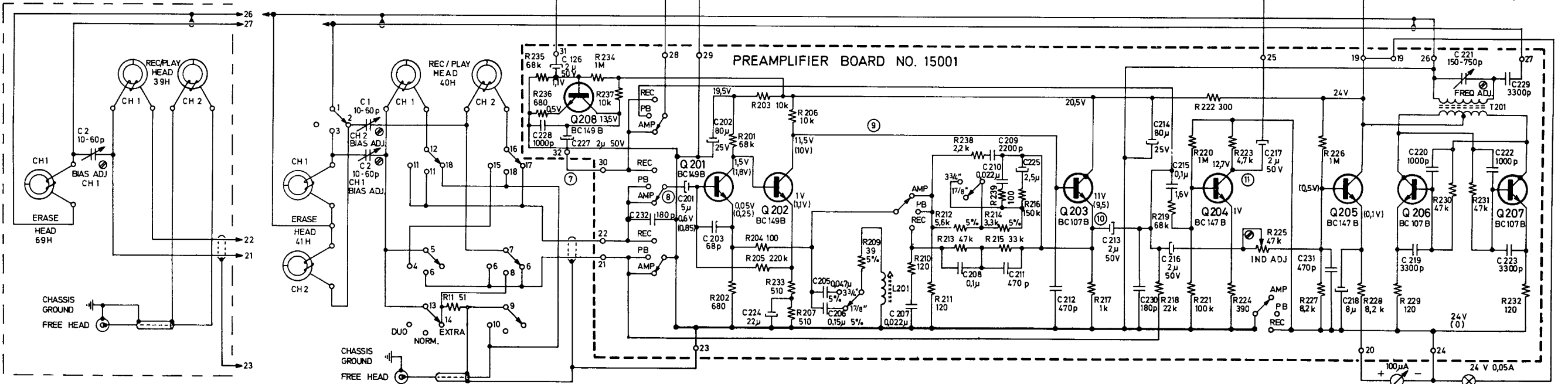
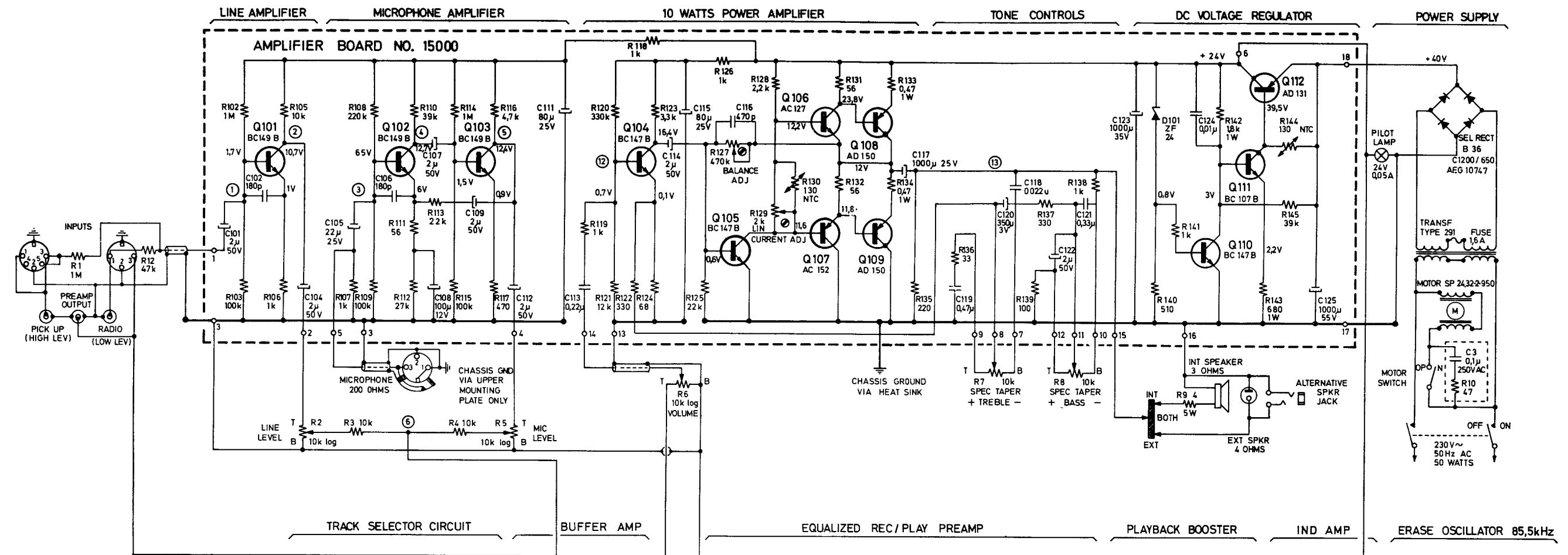

Fig. 9.1. The special tools.



NOTES.
 O23 = connection point
 Resistors indicated in ohms unless otherwise specified
 k = 1000 ohms M = 1000000 ohms

All DC-voltages measured without signal.
 Voltages given in paranthesis refer to record position

SENSITIVITY 400 Hz

| RECORD | PLAYBACK | | AMPLIFIER | |
|--------|----------|---------|-----------|--------|
| | LINE | MIC | LINE | MIC |
| 1 | 5mV | | 5mV | |
| 2 | 22mV | | 22mV | |
| 3 | | 0,1 mV | | 0,1 mV |
| 4 | | 5mV | | 5mV |
| 5 | | 22mV | | 22mV |
| 6 | 10 mV | | 10 mV | |
| 7 | 55 mV | | 55 mV | |
| 8 | 55 mV | 0,25 mV | | |
| 9 | 2,5 V | 55 mV | | |
| 10 | 2,5 V | 55 mV | | |
| 11 | | 300 mV | | |
| 12 | 55 mV | 55 mV | 55 mV | |
| 13 | 6,3V | 6,3V | 6,3V | |

Schematic series 14, 2-track and 4-track models.

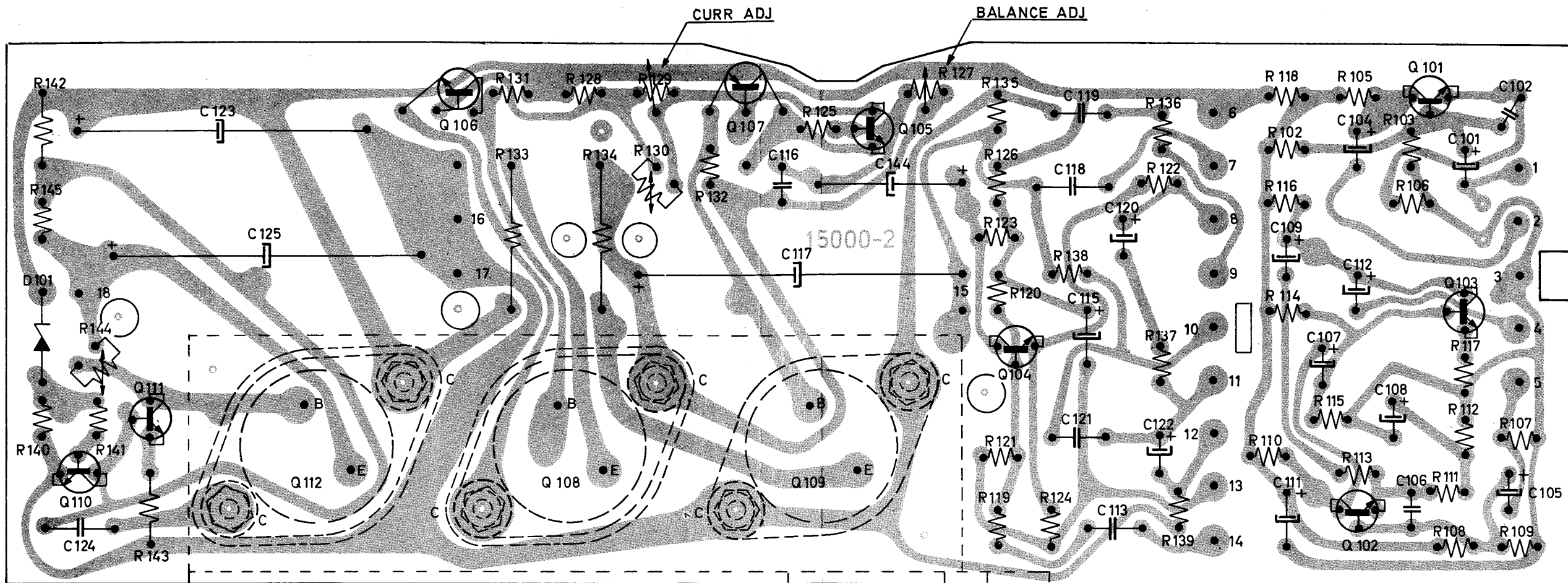

Board for line amplifier, microphone amplifier and voltage regulator, all models. Seen from print side.

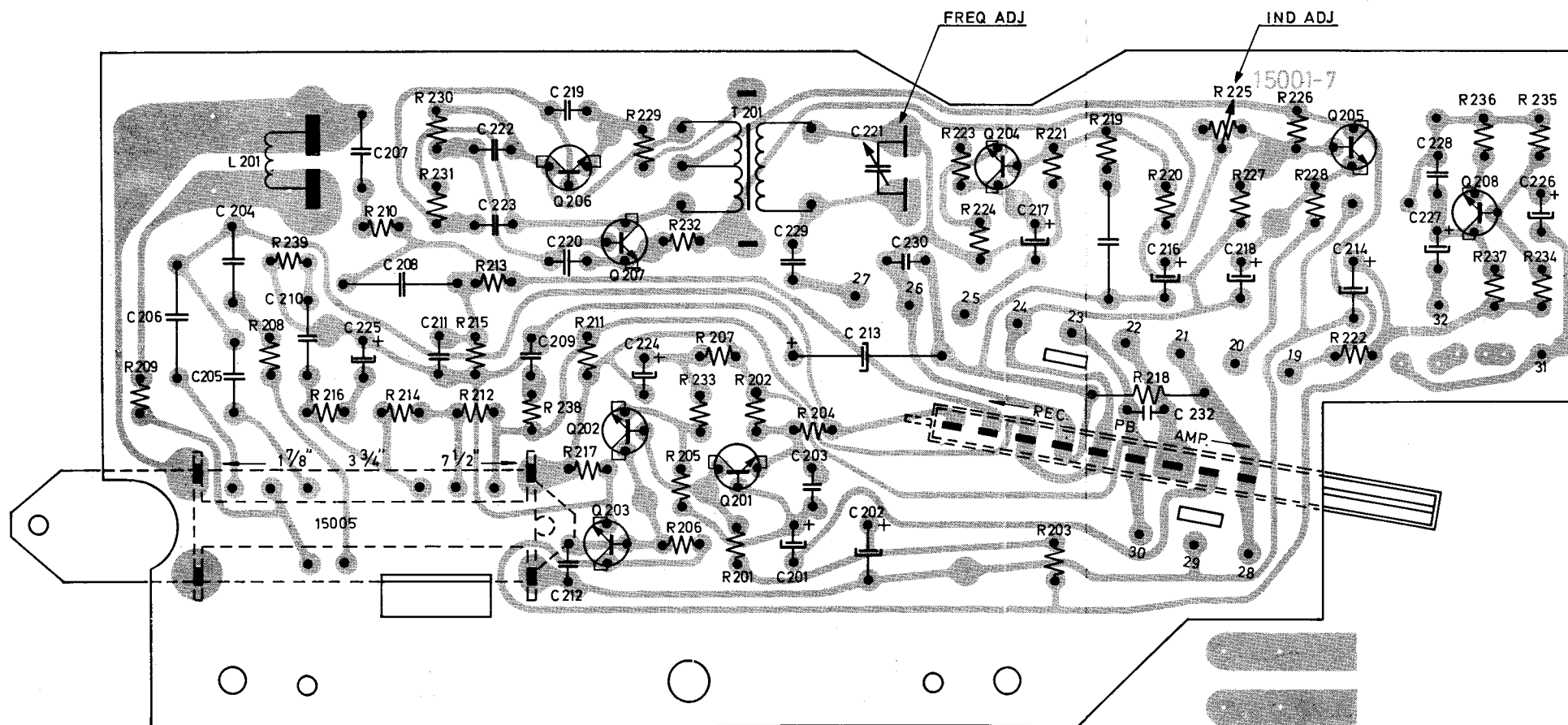

Board for record/playback amplifier, indicator amplifier and oscillator, all models. Seen from print side.

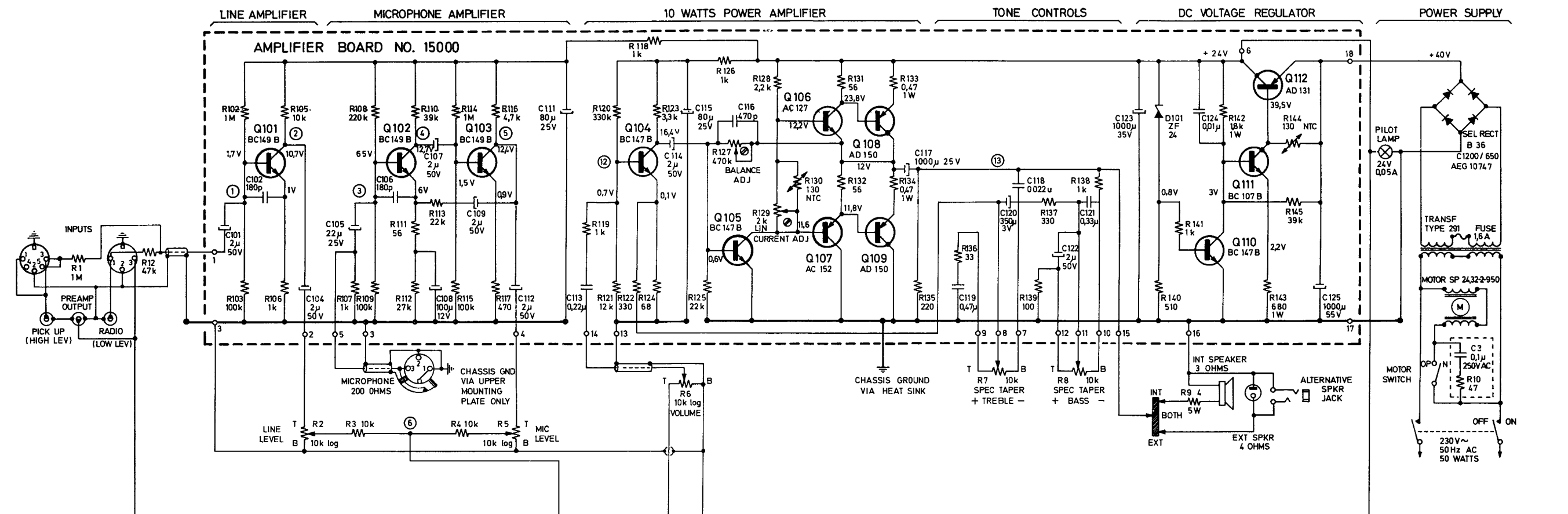

TRACK SELECTOR CIRCUIT BUFFER AMP EQUALIZED REC/PLAY PREAMP PLAYBACK BOOSTER IND. AMP ERASE OSCILLATOR 85,5kHz

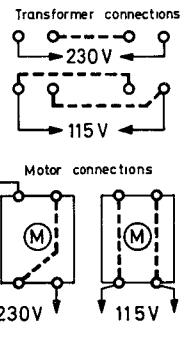
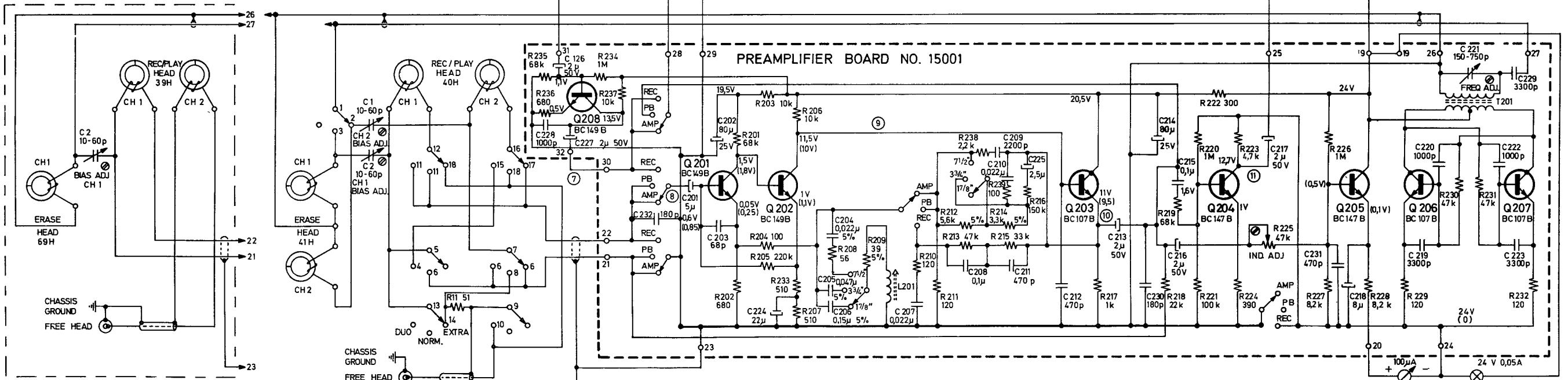

NOTES.
 O 23 = connection point
 Resistors indicated in ohms unless otherwise specified
 k = 1000 ohms M = 1000000 ohms
 All DC-voltages measured without signal
 Voltages given in paranthesis refer to record position

SENSITIVITY 400 Hz

| | RECORD | PLAYBACK | AMPLIFIER |
|----|--------|----------|-----------|
| | LINE | MIC | LINE |
| 1 | 5mV | | 5mV |
| 2 | 22mV | | 22mV |
| 3 | | 0,15mV | 0,15mV |
| 4 | | 5mV | 5mV |
| 5 | | 22mV | 22mV |
| 6 | 10mV | | 10mV |
| 7 | 55mV | | 55mV |
| 8 | 55mV | 0,25mV | 55mV |
| 9 | 2,5V | 55mV | |
| 10 | 2,5V | 55mV | |
| 11 | | 300mV | |
| 12 | 55mV | 55mV | 55mV |
| 13 | 6,3V | 6,3V | 6,3mV |

Schematic series 15, 2-track and 4-track models.

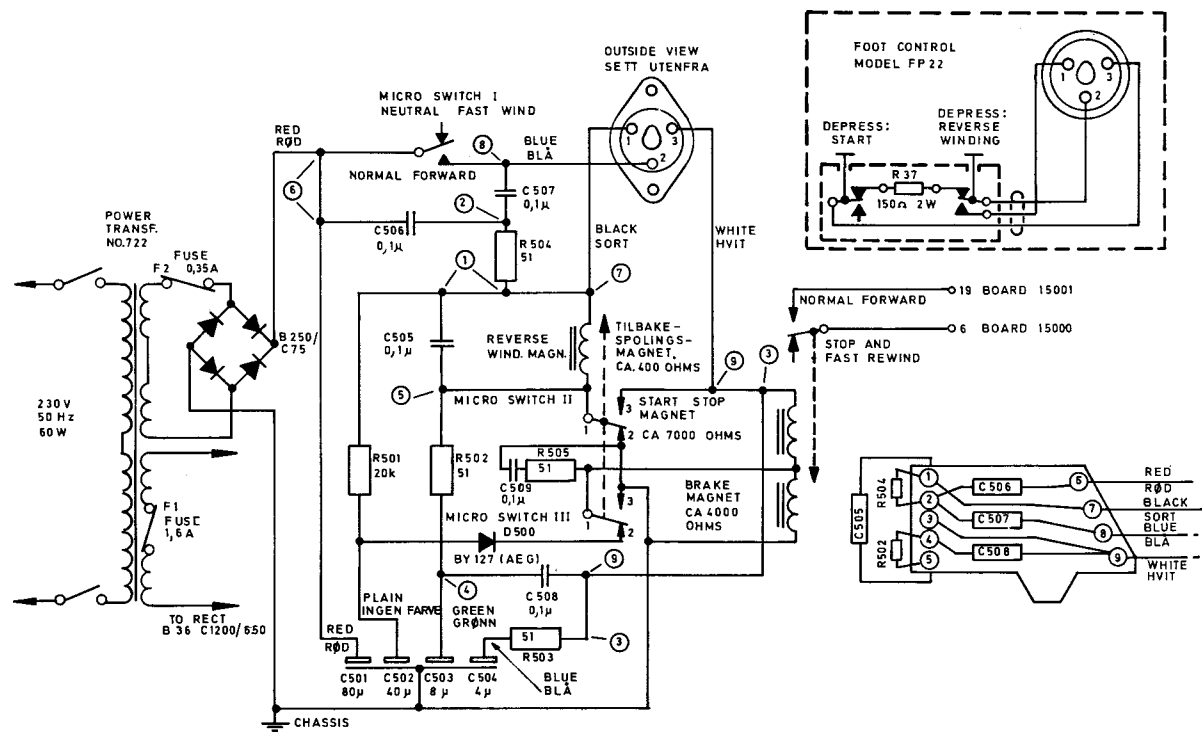

Schematic for remote control unit, model 15F. Below series no. 2 510 020.

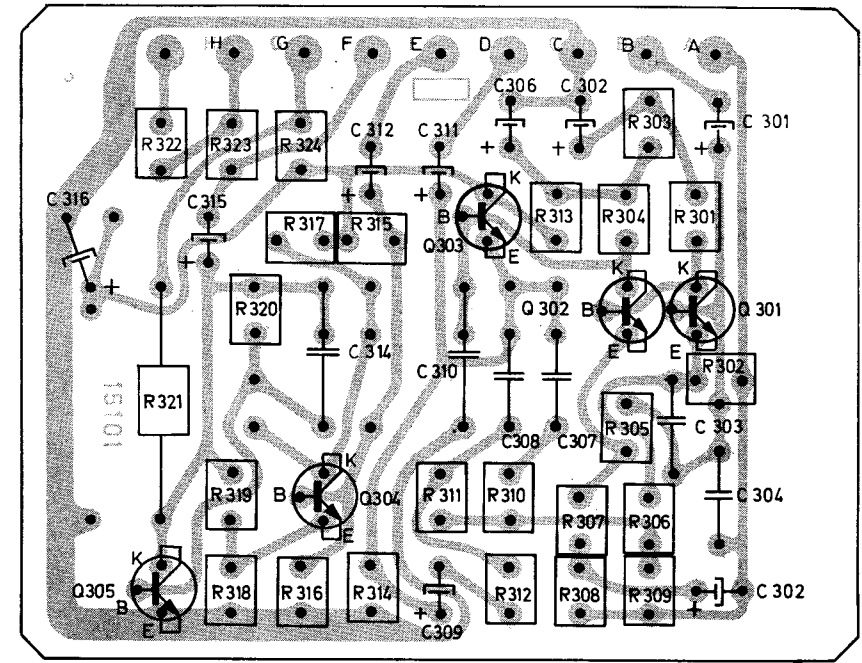

Board for extra playback amplifier, model 15SL. Seen from print side.

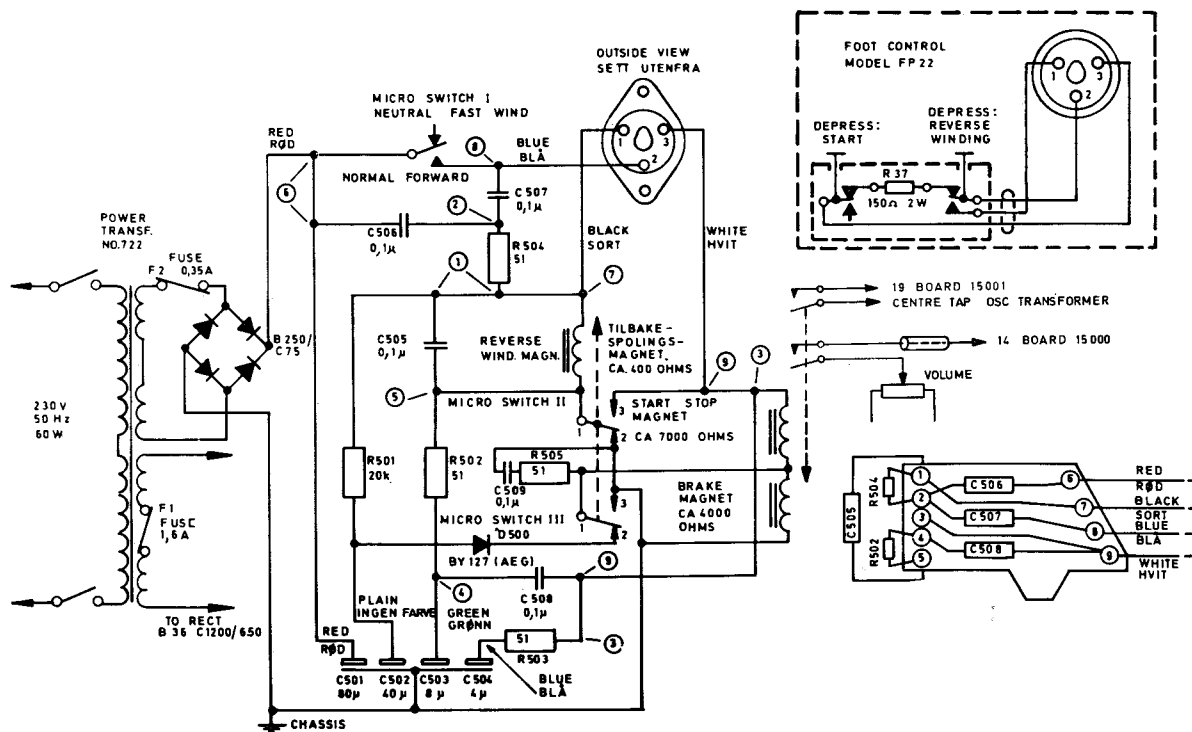

Schematic for remote control unit model 15F. Above serial no. 2 510 020.

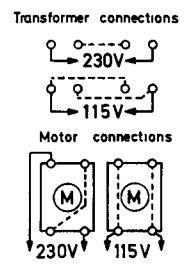
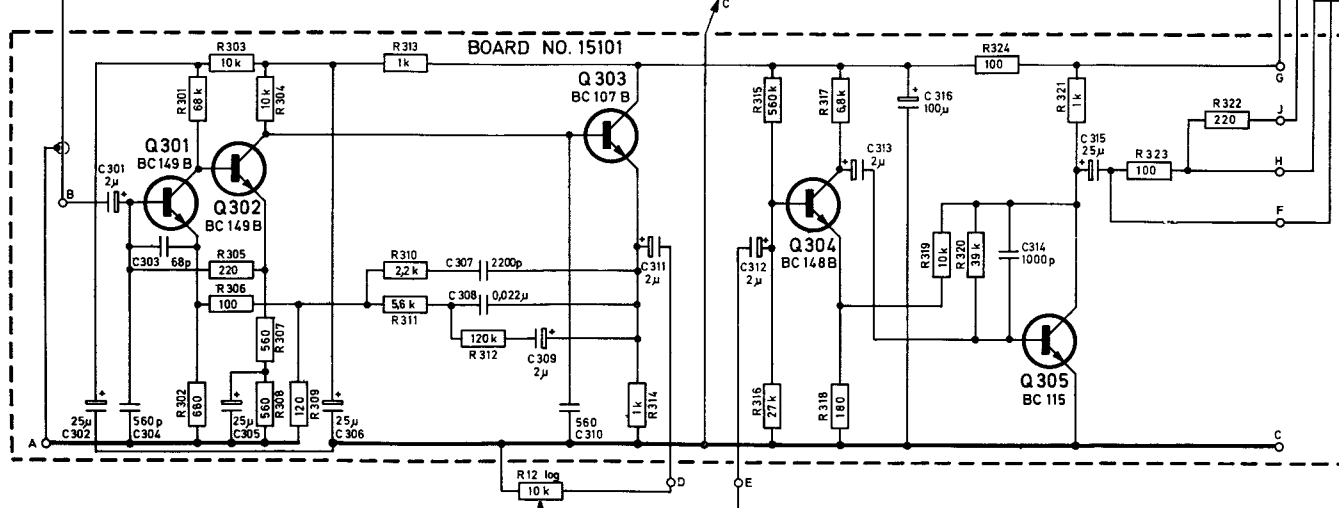
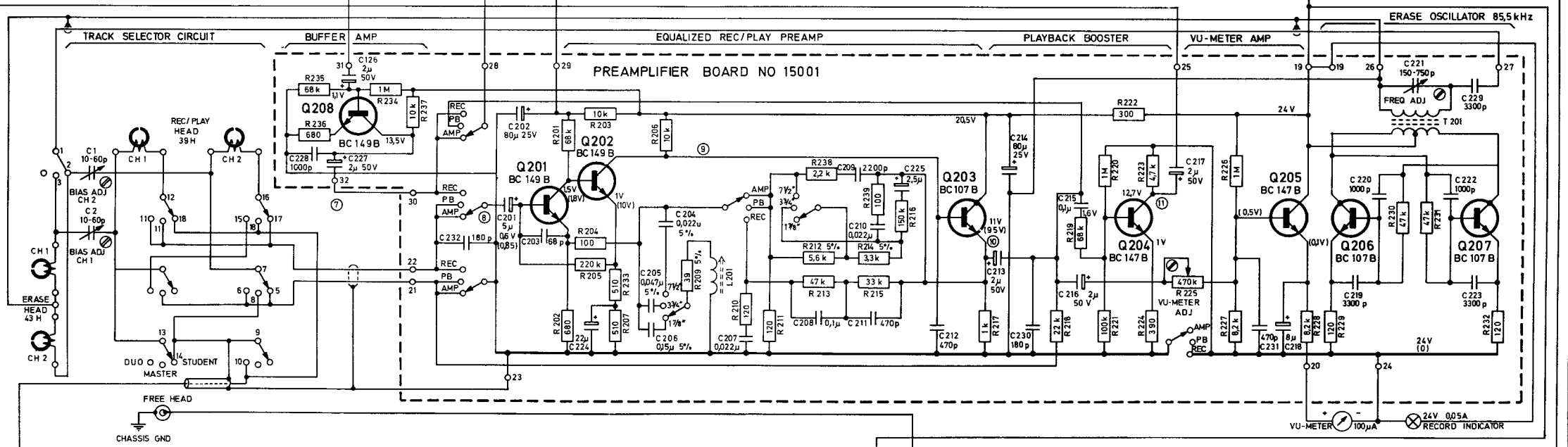
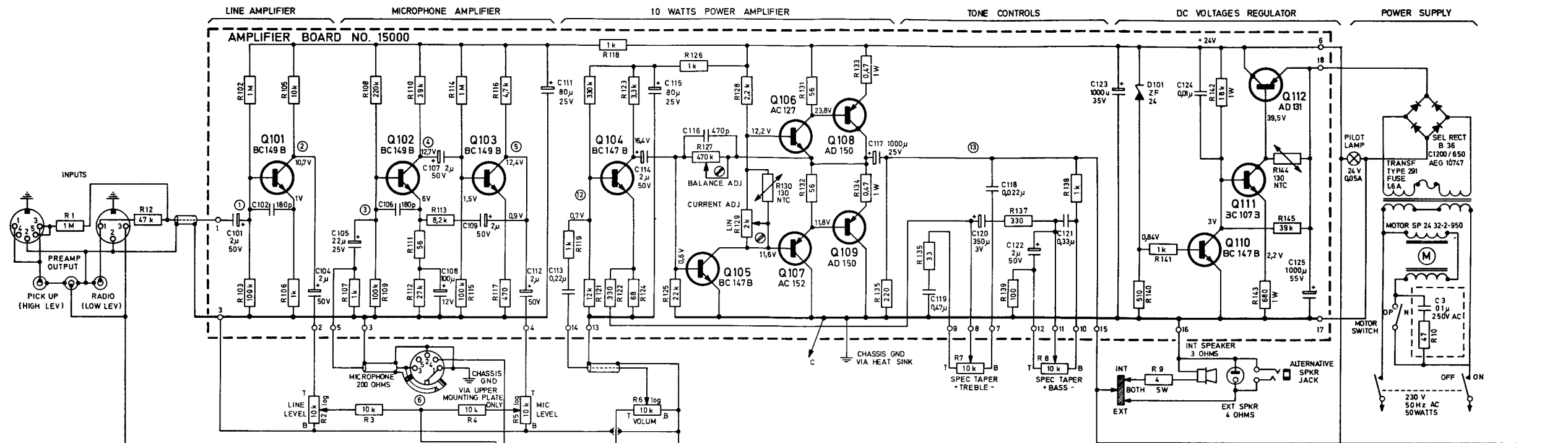

SENSITIVITY 400 Hz

| | RECORD | PLAYBACK | AMPLIFIER |
|----|----------|----------|-----------|
| | LINE MIC | | LINE MIC |
| 1 | 5 mV | | 5 mV |
| 2 | 22 mV | | 22 mV |
| 3 | 0.15 mV | | 0.15 mV |
| 4 | 5 mV | | 5 mV |
| 5 | 22 mV | | 22 mV |
| 6 | 10 mV | | 10 mV |
| 7 | 55 mV | | 55 mV |
| 8 | 55 mV | 0.25 mV | 55 mV |
| 9 | 2.5 V | 55 mV | |
| 10 | 2.5 V | 55 mV | |
| 11 | | 300 mV | |
| 12 | 55 mV | 55 mV | 55 mV |
| 13 | 6.3 V | 6.3 V | 6.3 V |

NOTES
 O23 = connection point
 Resistors indicated in ohms unless specified.
 k = 1000 ohms M = 1000 000 ohms
 All DC - voltages measured without signal
 Voltages given in paranthesis refer to record position

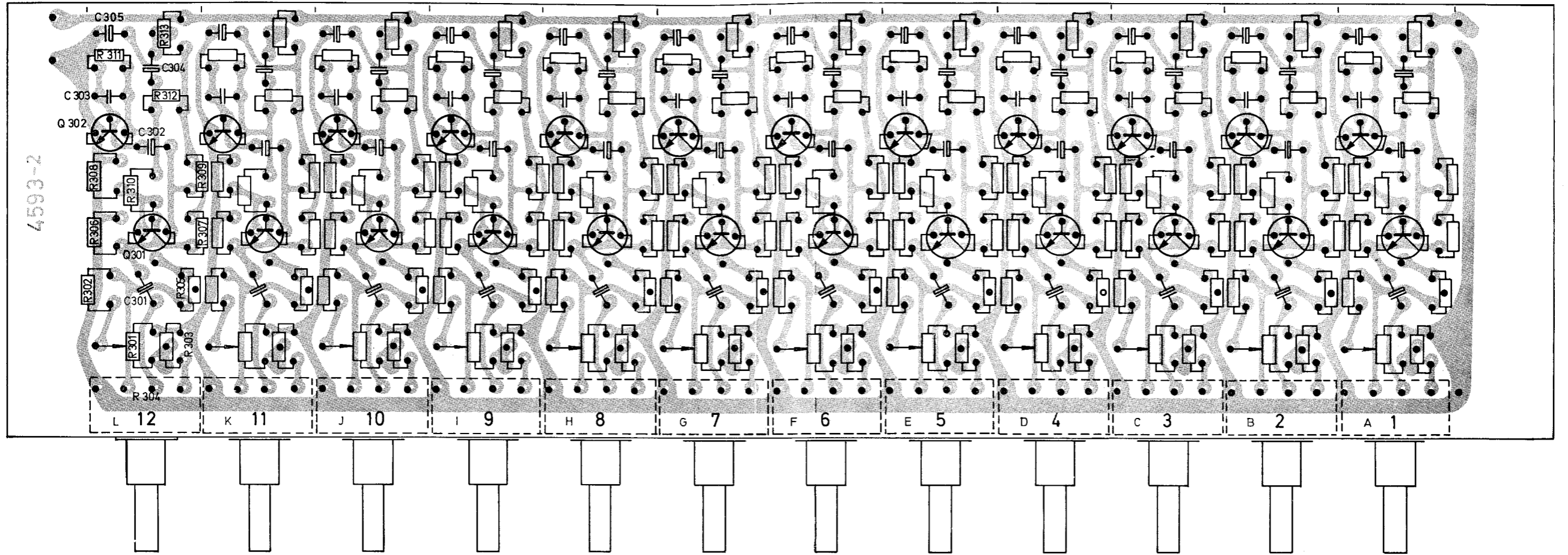

Board for output amplifiers, Model 15GT. Seen from print side.

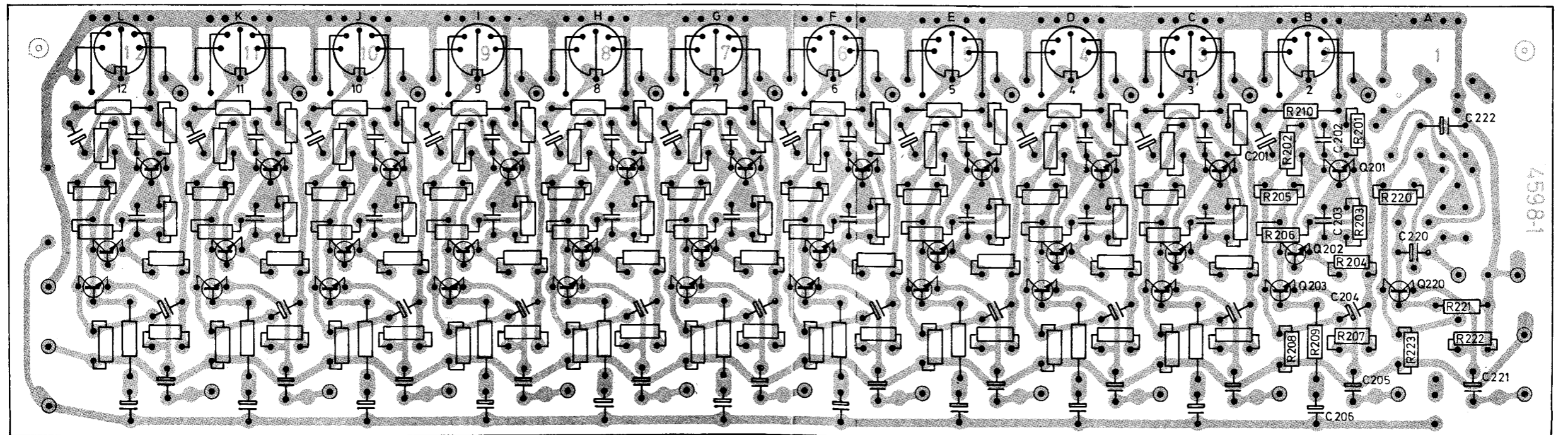

Board for input amplifiers, Model 15GT. Seen from print side.

NOTE:
 Output amplifier no. 1
 is the Group amplifier.
 Input amplifier no. 1.
 is the program amplifier.

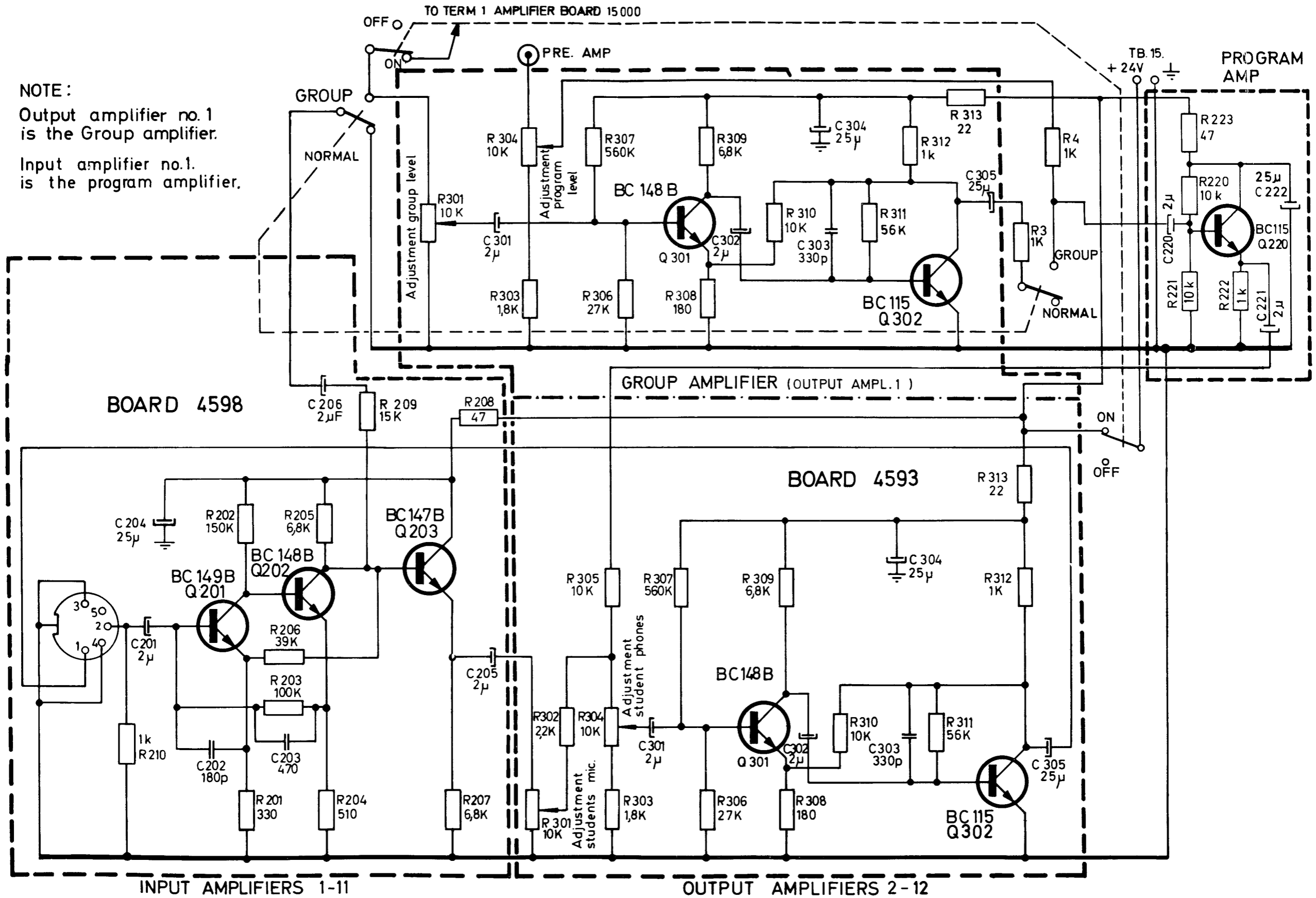

Schematic for additional amplifiers, Model 15GT.