

# THE POST OFFICE ELECTRICAL ENGINEERS' JOURNAL

**VOL. 33**

**OCTOBER, 1940**

**PART 3**

## CONTENTS

	PAGE
BALDOCK FREQUENCY CONTROL STATION—C. F. Booth A.M.I.E.E., and G. Gregory .. .. .	105
INSULATING GAPS AS A REMEDY TO ELECTROLYTIC ACTION—C. E. C. Skuse .. .. .	115
A SIMPLIFIED COMPANDOR EQUIPMENT FOR TRUNK CIRCUITS—J. Lawton, M.Sc., and D. J. Marks, B.Sc.(Eng.)	120
MODERN MATERIALS IN TELECOMMUNICATIONS—W. G. Radley, Ph.D.(Eng.), M.I.E.E., C. E. Richards, F.I.C., E. A. Speight, Ph.D., D.I.C., A.R.C.S., and E. V. Walker, B.Sc., A.R.S.M. Part II—Some Organic Structures and their Properties .. .. .	127
STORM DAMAGE TO THE MAIN AERIAL SYSTEM AT RUGBY RADIO STATION .. .. .	134
THE 3,000-TYPE LATCHING RELAY—J. H. Broadhurst ..	136
MAILBAG CONVEYOR IN THE FOREIGN POSTAL SORTING OFFICE, LONDON—J. Piggott, B.Sc. (Eng.).. .. .	138
BOOK REVIEW .. .. .	133
NOTES AND COMMENTS .. .. .	142
REGIONAL NOTES .. .. .	144
STAFF CHANGES .. .. .	147

Price 1/- net

**THE INSTITUTION OF POST OFFICE ELECTRICAL ENGINEERS**



# G.E.C.

## MEASURING INSTRUMENTS

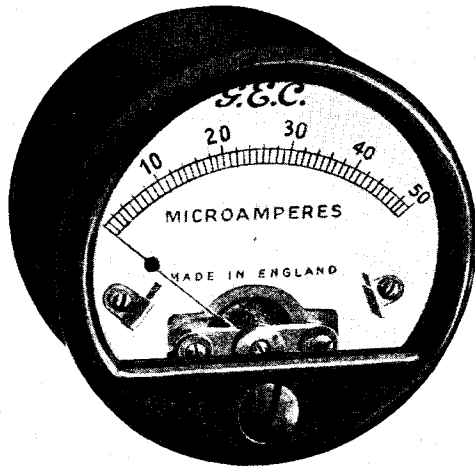

Good instruments can be designed and produced consistently only as the result of great experience in experiment and research extending over many years.

Salford Electrical Instruments Ltd. have been making first-quality instruments for half a century, and their products are used in Power Houses, Test Rooms and Laboratories all over the world.

Instruments in sizes from 2" upwards are available for almost every electrical measurement. The 2½" flush or projecting types are specially suited for radio purposes, and may be supplied as:—Milliammeters, Microammeters, Ammeters, and Voltmeters, D.C. and A.C.

Portable types are also made in most of these ranges. For H.F. measurements a range of Valve Voltmeters is available.

### SALFORD ELECTRICAL INSTRUMENTS LTD.

Telephones : BLAckfriars 8888 (3 lines).

Telegrams and Cables : "SPARKLESS, MANCHESTER."

PROPRIETORS : THE GENERAL ELECTRIC CO., LTD., OF ENGLAND

# EDISWAN

## TELEPHONE LINE PROTECTOR PANELS

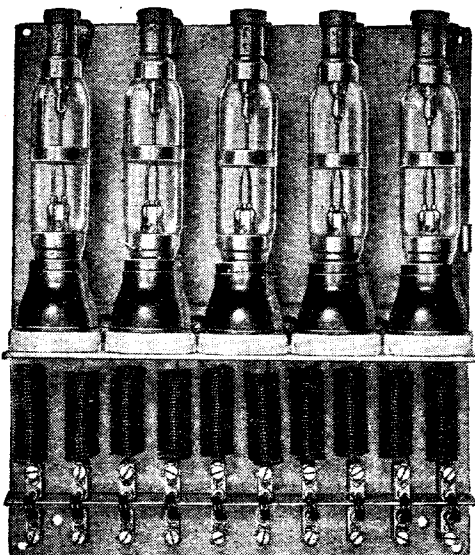

5-circuit panel for overhead lines incorporating choke coils, spark gaps, etc.

EDISWAN-SHOTTER-GREETHAM PATENT

(British Patent No. 353924)

**for the protection of telephone systems against surges induced by faults on neighbouring power lines**

Of the difficulties attendant upon the employment of overhead systems one of the most serious is to ensure uninterrupted working of the telephone system, by providing adequate protection against induced surges caused by switching or line faults in adjacent power lines or by lightning.

The Ediswan Patent Protectors provide the solution. They are inert at the normal working pressure of the telephone line, they keep the voltage on the line down to a pre-determined figure by providing a path of low resistance to earth whereby the surge is cleared and they again become inert immediately the surge is cleared.

They ensure simultaneous discharge of both lines and are capable of clearing heavy discharges without detriment to the system or the protector.

**Ediswan Telephone Line Protectors have now been in use by Supply Companies for many years.**

THE EDISON SWAN ELECTRIC CO. LTD.,  155 CHARING CROSS ROAD, LONDON, W.C.2

# ANACOS

REGD.

## WIRES

in

### BRONZE AND CADMIUM-COPPER

AS SUPPLIED TO H.M. POST OFFICE  
FOR TELEPHONE LINES

SEND US PARTICULARS OF YOUR JOB  
AND OUR TECHNICAL ENGINEERS WILL  
PROVIDE YOU WITH THE DATA YOU NEED

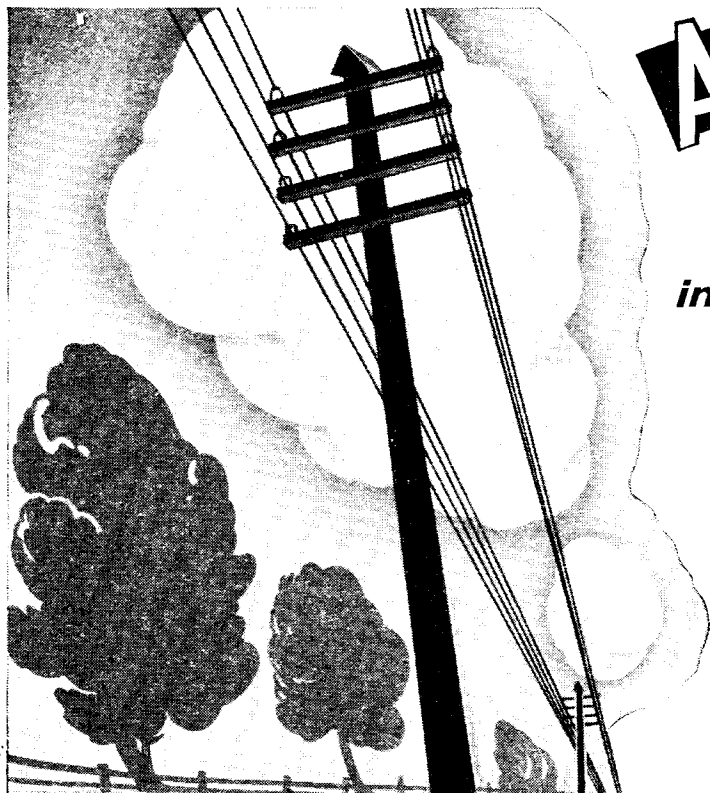

TELEPHONE  
BLACKFRIARS  
8701 (8 lines)

**FREDERICK SMITH & COMPANY**  
(INCORPORATED IN THE LONDON ELECTRIC WIRE COMPANY AND SMITHS, LIMITED)  
ANACONDA WORKS, SALFORD, 3, LANCS.

TELEGRAMS  
"ANACONDA"  
MANCHESTER

## Differential Moving Coil MILLIAMMETERS

For Telegraph Circuits

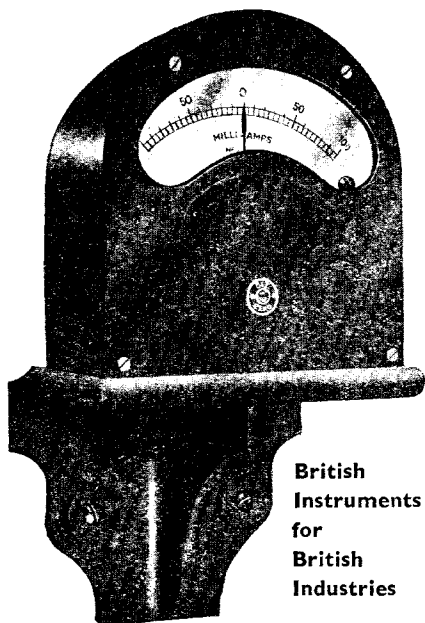

T. 1098. WALL MOUNTING TYPE.

British  
Instruments  
for  
British  
Industries

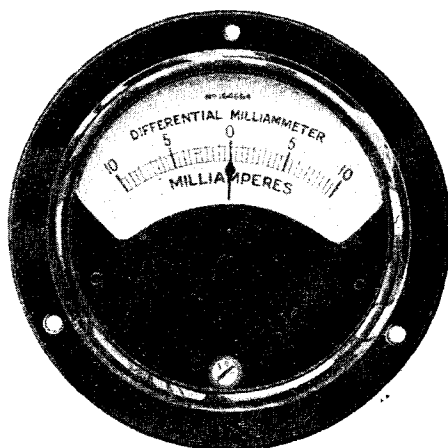

T. 1089. PANEL MOUNTING TYPE.

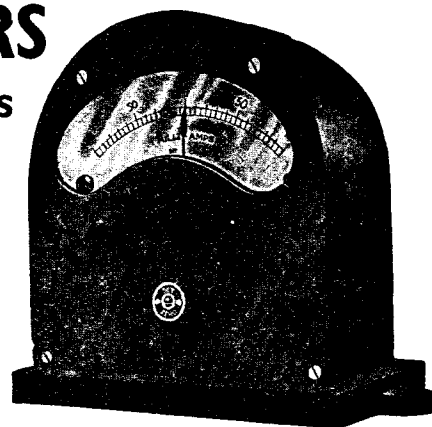

T. 1097. TABLE MOUNTING TYPE.

**TABLE, WALL AND PANEL  
MOUNTING TYPES**

INVALUABLE as line Milliammeters  
on Differential Duplex, Sub-Audio  
Frequency and many other Telegraph Systems, also for testing  
purposes in connection with Land Lines and Radio Communication.

Particulars will be sent on request.

**ELLIOTT BROTHERS (London) LTD., Century Works, Lewisham, S.E.13**

in association with

**SIEMENS BROTHERS & COMPANY, LIMITED, Woolwich, London, S.E.18**

Telephone :  
Tideway 3232

Telephone :  
Woolwich 2020.

# SIMPLIFIED SERVICING MAINTENANCE & FAULT FINDING



BRITISH MADE

**D**ESIGNED by technicians who have made a special study of the service and maintenance engineers' problems, the Model 7 Universal AvoMeter is acknowledged throughout the world as the one indispensable combination testing instrument. A single meter, yet at the touch of two simple switches it provides for any one of the 46 ranges of measurements for testing and tracing all electrical faults.

Entirely self-contained, the Model 7 Universal AvoMeter is essentially portable and, above all, simple to use. It is dead-beat in action, has a 5-inch hand-calibrated scale with anti-parallax mirror, and conforms to B.S. 1st Grade accuracy requirements. It is fully protected by an automatic cut-out against damage through overload.

#### Also available :

Model 7 Resistance range Extension Unit (for measurements down to 1/100th. ohm.)

40-range Universal Avo Meter

● Write for fully descriptive pamphlet.

Sole Proprietors and Manufacturers

The Automatic Coil Winder & Electrical Equipment Co., Ltd.,  
Winder House, Douglas Street, London, S.W.1. Telephone : Victoria 3404/7

**46 Ranges**  
of  
Direct  
Readings

VOLTAGE			
A.C.		D.C.	
Range.	Value per division	Range.	Value per division
0- 5 Volts	50 mV.	0- 150 mV (1 mA range)	0.5 mV.
0- 10 "	100 "	0- 100 mV (2 mA range)	1 "
0- 50 "	500 "	0- 500 mV	5 "
0- 100 "	1 Volt	0- 1 Volt	10 "
0- 200 "	2 "	0- 5 "	50 "
0- 400 "	4 "	0- 10 "	100 "
0- 500 "	5 "	0- 50 "	500 "
0-1,000 "	10 "	0- 100 "	1 Volt
		0- 200 "	2 "
		0- 400 "	4 "
		0- 500 "	5 "
		0-1,000 "	10 "
CURRENT			
A.C.		D.C.	
Range.	Value per division	Range.	Value per division
0- 5 mA	50 $\mu$ A	0- 1 mA	10 $\mu$ A
0- 10 "	100 "	0- 2 "	20 "
0- 50 "	500 "	0- 5 "	50 "
0-100 "	1 mA	0- 10 "	100 "
0-500 "	5 "	0- 50 "	500 "
0- 1 Amp.	10 "	0-100 "	1 mA
0- 5 "	50 "	0-500 "	5 "
0- 10 "	100 "	0- 1 Amp.	10 "
		0- 5 "	50 "
		0- 10 "	100 "
RESISTANCE			
Range.	First indication.		
0-10,000 ohms	0.5 ohms	} using internal 1½-volt cell.	
0-100,000 "	5 "	} using internal 9-volt battery.	
0- 1 megohm	50 "	} using external source of	
0-10 "	500 "	} A.C. or D.C. voltage.	
0-40 "	2,000 "		
CAPACITY		POWER	
0 to 20 mFd.		in 4,000 $\Omega$	DECIBELS
First indication		internal resistance	reference level
0.01 mFd.		0 to 4 watts	50 mW
		First indication	-10 Db. to
		1 mW	+15 Db.

The 46-RANGE UNIVERSAL

# AVOMETER

Regd Trade Mark

Electrical Measuring Instrument

Model 7



# SIEMENS

## ELECTRICAL PRODUCTS

*Manufacturers of*

TELEPHONE CABLES

Aerial, Underground, Submarine

LOADING COILS

ELECTRIC WIRES & CABLES

of all types

CABLE JOINT BOXES

OVERHEAD LINE MATERIAL

MARINE APPARATUS

WIRELESS EQUIPMENT FOR SHIPS

PUBLIC TELEPHONE EXCHANGES

PRIVATE TELEPHONE SYSTEMS

ELECTRIC TOTALISATORS

CELLS & BATTERIES

Dry, Fluid and Inert

MEASURING & RECORDING  
INSTRUMENTS

ELECTRICITY METERS

ELECTRIC LAMPS

Contractors for the  
laying and  
maintenance of  
Submarine  
and  
Land Cables  
for  
Telegraphy,  
Telephony  
and  
Power Transmission.



Contractors for the  
erection and  
maintenance of  
Marine Wireless  
Installations,  
Public and  
Private Telephone  
Exchanges,  
and  
Carrier Equipment  
for  
Telephone Lines.

**SIEMENS BROTHERS & CO. LIMITED**

WOOLWICH, LONDON, S.E.18

Telephone : WOOLWICH 2020.



***'Go far—too far you cannot. Still the farther  
the more experience finds you'***

*John Fletcher*

Since it was formed, the Alton Company has gone both far and fast—far in the development of its products, fast in the growth of its business and the accumulation of experience. But it is far from satisfied with present success. It has no intention of looking back on its tracks — except to refer to the valuable lessons of

its experience. The Company sets no limit to its ambition to go on improving its products and developing its business; and it will continue the policy it has invariably followed of making batteries of the first quality and carrying out replating of the highest standard at the lowest rates that show a reasonable profit.

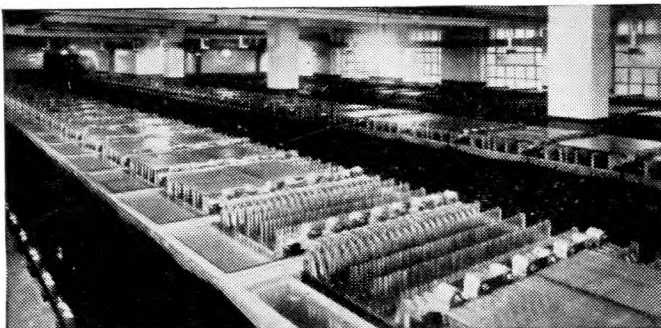

*Illustration shows an installation of Alton Batteries of merit at an important London Telephone Exchange.*

# ALTON

*Batteries of Merit*

**THE ALTON BATTERY COMPANY LTD,**

*(Incorporating Fuller Accumulator Co. (1926) Ltd.),*

**ALTON, HANTS.**

Telephone Alton 2267 and 2268

Telegrams 'Battery, Alton'



# YOU WANT HELP

## I HAVE HELPED THOUSANDS OF OTHERS

... and when I say thousands, I do not exaggerate, as I can produce well over 10,000 unsolicited testimonials from grateful students who, through our Postal Training, have achieved their life's ambition.

During the last war many people learned how to write short stories, etc. To-day a number of them are world-famed authors.

By becoming efficient in your vocation you can give the best service to your country and to yourself. The more you increase your earning power the better it is for the country and for yourself personally.

War or no war, earning power always brings its possessor to the front. It is no use waiting for better times. The ideal opportunity never arrives. We have to make the best of existing conditions. Therefore, delay is useless; it is worse, it is harmful.



If it is your desire to make progress and establish yourself in a good career, write to us for free particulars on any subject which interests you, or if your career is undecided, write and tell us of your likes and dislikes, and we will give you practical advice as to the possibilities of a vocation and how to succeed in it. You will be under no obligation whatever. It is our pleasure to help. We never take students for courses unless we feel satisfied they are suitable. Do not forget that success is not the prerogative of the brilliant. Our experience of over thirty years proves that *the will to succeed* achieves more than outstanding brilliancy.

*J. W. Bennett*

**LET ME BE YOUR FATHER**

## DO ANY OF THESE SUBJECTS INTEREST YOU?

Accountancy Examinations  
Advertising and Sales Management  
Agriculture  
A.M.I. Fire E. Examinations  
Applied Mechanics  
Army Certificates  
Auctioneers and Estate Agents  
Aviation Engineering  
Aviation Wireless  
Banking  
Blue Prints  
Boilers  
Book-keeping, Accountancy and Modern Business Methods  
B.Sc. (Eng.)  
Building, Architecture and Clerk of Works  
Builders' Quantities  
Cambridge Senior School Certificate  
Civil Engineering  
Civil Service  
All Commercial Subjects  
Commercial Art  
Concrete and Structural Engineering

Draughtsmanship. All branches  
Engineering. All branches, subjects and Examinations  
General Education  
G.P.O. Engineering Dept.  
Heating and Ventilating  
Industrial Chemistry  
Institute of Housing  
Insurance  
Journalism  
Mathematics  
Matriculation  
Metallurgy  
Mining. All subjects  
Mining. Electrical Engineering  
Motor Engineering  
Motor Trade  
Municipal and County Engineers  
Naval Architecture  
Novel Writing  
Pattern Making  
Play Writing  
Police, Special Course  
Preceptors, College of

Press Tool Work  
Pumps and Pumping Machinery  
Radio Communication  
Radio Service Engineering  
Road Making and Maintenance  
Salesmanship, I.S.M.A.  
Sanitation  
School Attendance Officer  
Secretarial Exams.  
Sheet Metal Work  
Shipbuilding  
Shorthand (Pitman's)  
Short Story Writing  
Speaking in Public  
Structural Engineering  
Surveying  
Teachers of Handicrafts  
Telephony and Telegraphy  
Television  
Transport Inst. Exams.  
Weights and Measures Inspector  
Welding  
Wireless Telegraphy and Telephony  
Works Managers



If you do not see your own requirements above, write to us on any subject. Full particulars free.

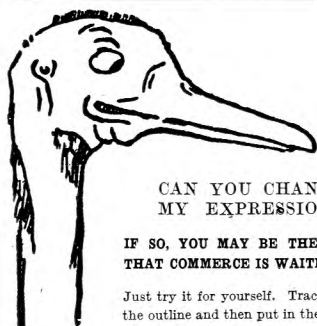

CAN YOU CHANGE MY EXPRESSION?

IF SO, YOU MAY BE THE ARTIST THAT COMMERCE IS WAITING FOR.

Just try it for yourself. Trace or draw the outline and then put in the features.

There are hundreds of openings in connection with Humorous Papers, Advertisement Drawing, Posters, Calendars, Catalogues, Textile Designs, Book Illustrations, etc.

60 per cent. of Commercial Art Work is done by "Free Lance Artists" who do their work at home and sell it to the highest bidder. Many Commercial Artists draw "retaining fees" from various sources, others prefer to work full-time employment or partnership arrangement. We teach you not only how to draw what is wanted, but how to make buyers want what you draw. Many of our students who originally took up Commercial Art as a hobby have since turned it into a full-time paying profession with studio and staff of assistant artists; there is no limit to the possibilities. Let us send full particulars for a FREE TRIAL and details of our course for your inspection. You will be under no obligation whatever.

*Jim Duval* ART DEPT. 24

Every Department is a Complete College :  
Every Student is a Class to Himself

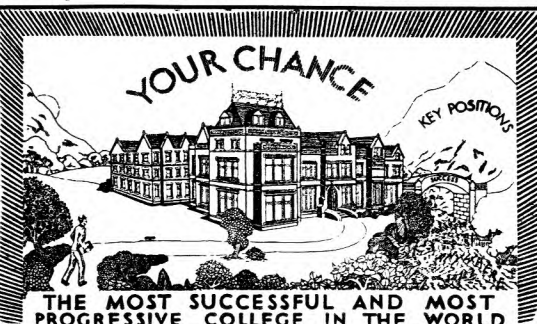

IF YOU ATTEND TO THIS NOW, IT MAY MAKE A WONDERFUL DIFFERENCE TO YOUR FUTURE  
**COUPON—CUT THIS OUT**

To Dept. 24, THE BENNETT COLLEGE LTD., SHEFFIELD

Please send me (free of charge) Particulars of.....

Your private advice about.....  
(Cross out line which does not apply)

PLEASE WRITE IN BLOCK LETTERS

Name.....  
Address.....

STUDY AT HOME IN  
YOUR SPARE TIME

## JOURNALISM

Short Story, Novel and Play Writing

There is money and pleasure in Journalism and in Story Writing. No apprenticeship, no pupillage, no examinations, no outfit necessary. Writing for newspapers, novels or pictures is not a gift; it is a science that can be acquired by diligent application and proper guidance. It is the most fascinating way of making part-time profitable. Trained ability only is required, we do the training by post. Let us tell you about it.

DEPARTMENT OF LITERATURE 24

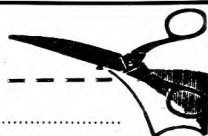

NOTE ADDRESS : DEPT. 24, THE BENNETT COLLEGE LTD., SHEFFIELD



# SELENIUM RECTIFIERS IN SERVICE No. 8

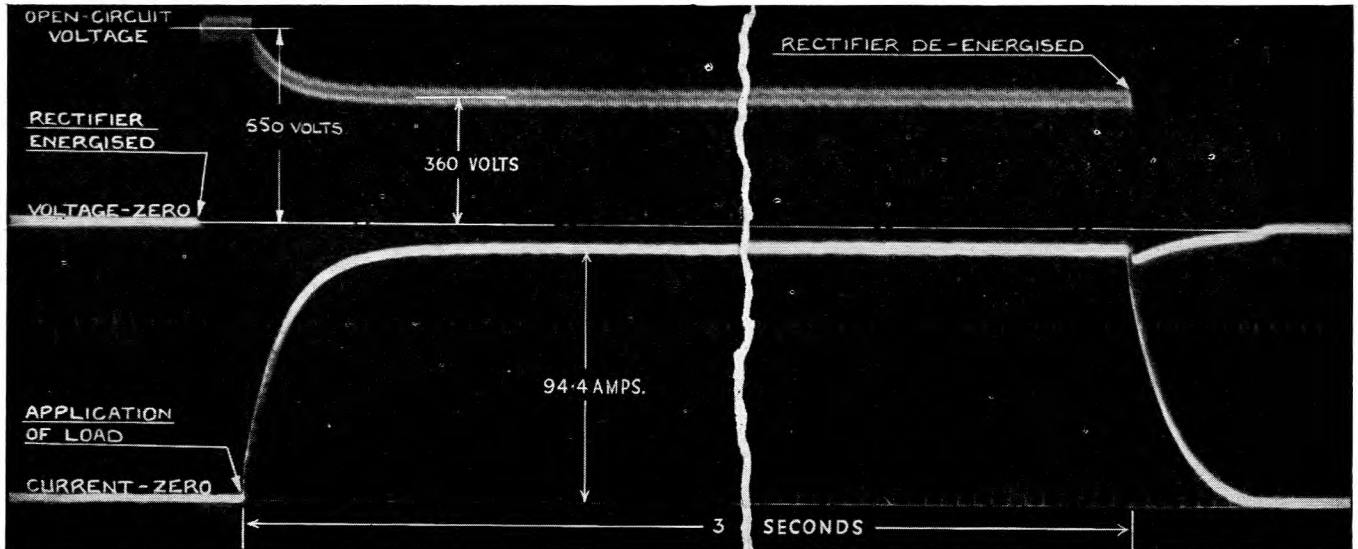

## OPERATION OF LARGE CIRCUIT-BREAKERS

**A**N application of the *Standard* Selenium Rectifier which is of great practical importance is the operation of circuit-breaker closing mechanism from A.C. supplies. As is well known, A.C. solenoids are unsatisfactory in comparison with D.C. solenoids for closing circuit-breakers and the use of an A.C. operating motor does not, in general, give the rapid closing action required by modern switchgear practice.

The most satisfactory apparatus for converting the A.C. supply to a direct current for this purpose is the *Standard* Selenium switch-closing Rectifier. The electrical characteristics of a Selenium Rectifier suitable for circuit-breaker operation are illustrated by the oscillogram above which shows the voltage across and the current obtained on an inductive load which, in this instance, consisted of a coil such as is used for solenoid operating mechanisms.

This oscillogram was taken during tests made to determine the suitability of the *Standard* Selenium Rectifier for circuit-breaker closing duty.

Bulletin No. S.R. 154 gladly supplied upon request.

*Standard Telephones and Cables Limited*

NEW SOUTHGATE, LONDON, N. 11

Telephone : ENTERprise 1234



# THE POST OFFICE ELECTRICAL ENGINEERS' JOURNAL

Vol. XXXIII

October, 1940

Part III

## Baldock Frequency Control Station

C. F. BOOTH, A.M.I.E.E., and  
G. GREGORY

U.D.C. 621.396.7 : 621.317.361.029.6

The article describes the frequency measuring station maintained by the Post Office for the purpose of monitoring radio transmitter frequencies and tracing the causes of interference to radio communication services, duties for which the Post Office is responsible under international agreement so far as British transmitters are concerned. The control station is located on a site selected for its good reception conditions and is equipped with the necessary apparatus to enable the frequency of intercepted signals to be measured by comparison with standard frequencies.

### *Introduction.*

THE rapid development in the art of radio communication which followed advances in thermionic valve technique after the last war, together with the application of short waves to transmission over world-wide ranges and the advent of broadcasting resulted in a large demand for exclusive frequencies by countries eager to take advantage of the unique facilities which broadcasting and long distance short-wave radio communication offered. During the period immediately following the realisation of the properties of short waves, about the year 1924, thousands of frequency allocations were registered at the Berne International Frequency Bureau, and that portion of the frequency spectrum known to be suitable for communication over distances exceeding 100 kilometres, i.e., 15 to 30,000 kc/s, was rapidly acquired for radio transmitters located in various parts of the world. To furnish a maximum number of radio communication channels in this frequency spectrum, regulations were framed by International Radio Conventions limiting the frequency band occupied by each transmitter to the minimum necessary for the conveyance of intelligence by the system employed, and stipulating the frequency stability of the emitted carrier wave. Whereas a band width of  $\pm 3$  kc/s is sufficient for the modulation of a commercial telephony carrier wave, frequency instability of the carrier amounting to  $\pm 0.1$  per cent. increases the effective band width at a carrier frequency of 15,000 kc/s to  $\pm 15$  kc/s. Frequency stability of a high order is clearly of paramount importance, and the frequency tolerances of radio transmitters have been successively reduced by international conventions so that tolerances as exacting as  $\pm 0.01$  and  $\pm 0.005$  per cent. are now stipulated for certain transmitters. Thus, the permissible frequency deviation for a transmitter working on a frequency of 15,000 kc/s and conforming to a tolerance of  $\pm 0.01$  per cent. is  $\pm 1,500$  c/s. A carrier frequency stability of this order can be achieved and maintained only by employing some form of stable frequency generator, such as a piezo-electric crystal oscillator, as the transmitter carrier

wave source, and by regularly monitoring the frequency of the emitted wave. Most transmitters have been equipped with crystal or other frequency control devices during the past decade, and a remarkable all-round improvement in the frequency stability of radio transmissions has resulted. Despite this improvement, however, the congested state of the frequency spectrum, due to the large number of radio stations now in operation and the narrow tolerances imposed, necessitates regular surveillance of the transmitter carrier frequencies to ensure that they do not deviate beyond the stipulated limits. This duty devolves on the Administration or authority responsible for the control of radio communication and is most conveniently performed at a central station equipped with interception receivers and precision frequency measuring apparatus. The Post Office, as the department responsible for the control of radio communication in this country, has maintained a central frequency measuring station for some ten years and for a still longer period has maintained primary frequency standards at Dollis Hill.

### *History.*

The importance of accurate frequency measurement, and frequency stability was fully appreciated by delegates at the International Radiotelegraph Convention of Washington, 1927. Article 3 of the regulations agreed upon at that convention states:—

“The Administrations must take the measures necessary to assure themselves that the frequency meters used for the adjustment of the sending apparatus are calibrated as accurately as possible by comparison with their national standard instruments.”

“In cases of international dispute comparisons are made by an absolute method of measuring frequencies.”

Article 4 states:—

“The waves emitted by a station must be maintained at the authorised frequency as exactly as the state of technical development permits,

and their radiation must also be as free as practicable from all emissions which are not essential to the type of communication effected."

About the time these regulations were framed the Post Office already had in operation at Dollis Hill a primary frequency standard, and associated apparatus was available for frequency measurement purposes. It was realised, however, that routine frequency measurement and interference investigation work could not be adequately performed at Dollis Hill, and in 1929 it was decided to transfer the work to a station specially designed for the purpose. A semi-permanent station was therefore constructed at Colney Heath, St. Albans, and apparatus of a type generally similar to that in use at Dollis Hill was fitted. This apparatus being utilised for routine measurements was not required to be capable of measuring to the same high degree of accuracy. The equipment consisted of a sub-standard 1,000 c/s tuning fork controlling a 1,000 c/s multivibrator from which harmonics were derived and selected for the measurement, by comparison, of intercepted signals in the range 15 to 24,000 kc/s. Simultaneously new frequency standards of increased precision were installed at Dollis Hill and facilities were provided for performing regular comparisons of the Colney Heath sub-standard frequency with the Dollis Hill primary standard. The Colney Heath station was brought into operation in 1930, and was in continuous day and night service until October 1938. Similar measuring stations were equipped in various European countries and in the U.S.A. by their respective administrations, or by radio companies. By their combined activities in the investigation and removal of interference to radio communication services throughout the world these stations contributed to the marked improvement which modern technique has conferred on such services.

The initial overall measurement accuracy of the Colney Heath station was some  $\pm 20$  parts in  $10^6$  improved later to some  $\pm 12$  parts in  $10^6$ . This accuracy, although adequate for the measurement of most transmitters during the period 1930 to 1935, fell short of the requirements imposed when quartz crystal controlled transmitters of high frequency stability outnumbered all other types after 1935. Early in 1937 it was decided to design and construct new frequency measuring equipment and to transfer the station from Colney Heath to Baldock. A precise crystal frequency standard, together with associated apparatus, was therefore designed and constructed at Dollis Hill, but was ultimately used for another purpose. It was replaced by a commercially produced frequency standard with additional apparatus produced at Dollis Hill and the new station (Fig. 1) was ready for operation in October, 1938.

#### *Functions of a Frequency Control Station.*

The duties of a frequency control station may be summarised as follows:—

- (i) To make routine frequency measurements of all radio stations under the control of the Administration in the range 15 to 30,000 kc/s. (Frequencies higher than 30,000 kc/s cannot be regularly intercepted at a central station.)
- (ii) To investigate and assist in the removal of interference to, or by, radio stations, including amateur stations under the Administration's control.
- (iii) To measure the frequencies of incoming overseas radio telephony and telegraphy services.
- (iv) To measure, on request, the frequency of stations located in various parts of the world.
- (v) To carry out observations in connection with the selection of suitable frequencies for new communication channels.
- (vi) To survey the activities of the Administration's amateur transmitters, and to perform special interception work as required.

The procedure adopted at the Baldock Control Station in dealing with interference is based on that employed for many years on the Anglo-Continental telegraphy services in soliciting the co-operation of distant terminals, and consists in communicating with offenders by service messages transmitted over the appropriate routes. The service messages, which are couched in discreet, courteous terms, quote the measured frequencies of the stations concerned, describe the nature of the interference and seek assistance in removing the cause. If the offending transmitter is located in a country possessing a frequency control station, the message is addressed to that station, which then verifies the complaint and communicates with the transmitter. Despite the informal nature of

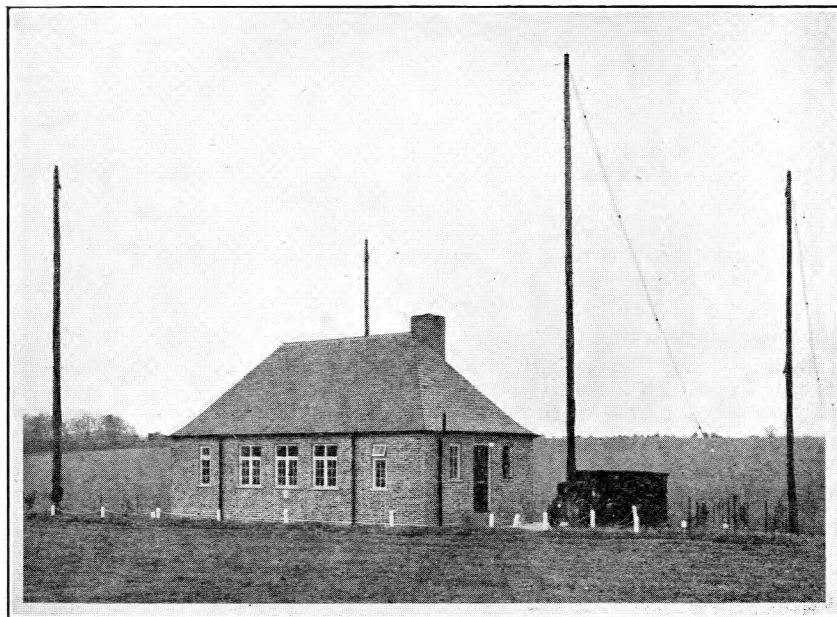

FIG. 1.—AERIAL SYSTEM.



# THE INSTITUTION OF POST OFFICE ELECTRICAL ENGINEERS

## PRINTED PAPERS

The following papers contributed to the proceedings of the Institution have been printed by authority of the Council and may be obtained, if still in print, from

**"THE LIBRARIAN, The Institution of Post Office Electrical Engineers, G.P.O. (ALDER HOUSE), LONDON, E.C.1."**

The prices do *not* include postage, and in every case, Members, Associate Members and Associates have the privilege of purchasing copies at two-thirds the stated price.

No. 121	"X-RAYS, AND THE STRUCTURE OF SOME ENGINEERING MATERIALS."—W. G. RADLEY, B.Sc. 1929 .. .. .	9d.
No. 122	"THE MEASUREMENT OF RELAY TIMES."—R. W. PALMER, A.M.I.E.E. 1929.. .. .	9d.
No. 123	"MODERN ELECTRICAL ILLUMINATION."—J. J. EDWARDS, B.Sc.(Eng.) ,A.C.G.I., D.I.C. 1928 .. .. .	9d.
No. 124	"THE MEASUREMENT OF SOUND AND ITS APPLICATION TO TELEPHONY."—A. J. ALDRIDGE, A.C.G.I., A.M.I.E.E. 1929 .. .. .	9d.
No. 125	"THE DEVELOPMENT OF AUTOMATIC ROUTINERS IN THE BRITISH POST OFFICE."—A. SPEIGHT, A.M.I.E.E. 1929 .. .. .	9d.
No. 134	"SOUND AND HEARING."—Capt. N. F. CAVE-BROWNE-CAVE, B.Sc., A.M.I.E.E. 1930.. .. .	1s.
No. 136	"SOME DEVELOPMENTS IN TELEGRAPH TECHNIQUE AS APPLIED TO RADIO CIRCUITS."—H. FAULKNER, B.Sc., A.M.I.E.E., and G. T. EVANS. 1931. .. .. .	1s.
No. 139	"DISTRICT ACCOUNTING."—T. FEWSTER. 1931 .. .. .	9d.
No. 140	"SOME NON-METALLIC SUBSTANCES AND THEIR CHARACTERISTICS."—Capt. N. F. CAVE-BROWNE-CAVE, B.Sc., A.M.I.E.E. 1931 .. .. .	9d.
No. 142	"PRIVATE BRANCH EXCHANGE INSTALLATIONS."—R. T. A. DENNISON. 1932 .. .. .	1s. 3d.
No. 146	"LAYING ARMoured CABLE BY MEANS OF A MOLE-DRAINER."—L. G. SEMPLE, B.Sc.(Eng.), and R. O. BOCKOCK, B.Sc.(Eng.). 1932 .. .. .	9d.
No. 147	"DESIGN AND CONSTRUCTION OF ELECTRIC WAVE FILTERS."—R. J. HALSEY, B.Sc., etc. 1932. .. .. .	1s. 3d.
No. 148	"STORES SPECIFICATIONS AND ACCEPTANCE TESTING."—Capt. J. LEGG, B.Sc., A.M.I.E.E. 1933 .. .. .	9d.
No. 149	"RECENT DEVELOPMENTS IN UNDERGROUND CONSTRUCTION, LAYING AND LOADING ARMoured CABLES."—J. E. Z. BRYDEN, B.Sc.(Eng.), A.M.I.E.E., and T. HARGREAVES, A.M.I.E.E. 1933 .. .. .	1s.
No. 150	"TELEPRINTERS."—E. S. RITTER, M.I.E.E. 1933 .. .. .	1s.
No. 151	"RECENT REPEATER STATION INSTALLATIONS."—Major F. E. A. MANNING, M.C., B.Sc.(Eng.), M.I.E.E., A.M.I.Mech.E. 1933 .. .. .	1s.
No. 152	"SOME NOTES ON EXCHANGE EQUIPMENT FACTORY COSTING AND THE ECONOMICS OF PRODUCTION."—S. J. HUSBAND, Assoc.I.E.E. 1933 .. .. .	1s. 3d.
No. 153	"MODERN DEVELOPMENTS IN TELEPHONE TRANSMISSION OVER LINES."—J. STRATTON, A.C.G.F.C., and W. G. LUXTON. 1933 .. .. .	1s. 3d.
No. 154	"THE TELEGRAPH POLE."—W. H. BRENT, B.Sc., A.M.I.E.E. 1933 .. .. .	1s.
No. 156	"MODERN TENDENCIES IN THE SUPPLY OF POWER TO TELEPHONE EXCHANGES."—H. C. JONES, B.Sc.(Eng.). 1935 .. .. .	9d.
No. 158	"ULTRA SHORT WAVE RADIO TELEPHONE CIRCUITS."—D. A. THORN, B.Sc.(Eng.), A.M.I.E.E., and H. T. MITCHELL, A.M.I.E.E. 1935 .. .. .	1s.
No. 159	"MODERN ELECTRIC PASSENGER LIFTS."—R. S. PHILLIPS, A.M.I.E.E. 1935 .. .. .	9d.
No. 161	"MODERN TELEPHONE REPEATER STATION POWER PLANT."—F. W. G. DYB. 1936	6d.
No. 162	"VOICE FREQUENCY SIGNALLING ON TRUNK CIRCUITS."—T. H. FLOWERS, B.Sc., A.M.I.E.E., and B. M. HADFIELD, B.Sc., A.M.I.E.E. 1937 .. .. .	1s.
No. 163	"AUTOMATIC EXCHANGE DESIGN."—H. E. FRANCIS. 1936 .. .. .	1s. 3d.
No. 164	"THE LONDON-BIRMINGHAM COAXIAL CABLE SYSTEM."—A. H. MUMFORD, B.Sc.(Eng.), A.M.I.E.E. 1937 .. .. .	1s. 3d.
No. 165	"PROPERTIES AND TESTING OF DI-ELECTRIC MATERIALS."—J. F. DOUST and W. J. SULSTON, M.Sc., A.Inst.P. 1938 .. .. .	1s.
No. 166	"CHEMISTRY AND COMMUNICATIONS."—D. W. GLOVER, M.Sc., A.I.C. 1937 .. .. .	6d.
No. 167	"TWELVE-CIRCUIT CARRIER TELEPHONE SYSTEMS."—G. J. S. LITTLE, B.Sc., A.M.I.E.E. 1938 .. .. .	6d.
No. 168	"THE DEVELOPMENT OF MAGNETIC MATERIALS."—C. E. MORGAN, A.M.I.E.E. 1938.. .. .	6d.
No. 169	"CROSSTALK."—H. C. S. HAYES, A.M.I.E.E., R. A. SEYMOUR and P. R. BRAY, M.Sc.(Eng.), Grad.I.E.E. 1938 .. .. .	1s. 3d.
No. 170	"SUBSCRIBERS' CABLE DISTRIBUTION—RECENT DEVELOPMENTS."—L. MEEK, A.M.I.E.E. 1939 .. .. .	6d.
No. 171	"MULTI-CIRCUIT CARRIER TELEPHONY."—E. M. RICHARDS, A.C.G.I., B.Sc. (Eng.), M.I.E.E., and F. J. D. TAYLOR, B.Sc. (Eng.). 1938 .. .. .	1s. 6d.

this procedure and the absence of any form of pressure it has proved satisfactory in practice due to the spirit of friendly collaboration which developed between the various frequency control stations and transmitters in a common endeavour to avoid mutual interference. As a result, the number of interference cases which require Administrative action, i.e., semi-diplomatic negotiations between the countries in which the stations concerned are located is only a very small percentage of the total.

The most common forms of interference are caused by a transmitter being outside its tolerance limits; excessive bandwidth of heavily modulated telegraphy transmitters, e.g., facsimile transmissions, harmonic radiation and key clicks from C.W. telegraphy transmitters. Interference due to key clicks and excessive bandwidth is often a function of the relative field strengths of the wanted and interfering signals, and can be avoided only by changing the transmission path or the frequency. Harmonic interference is usually experienced if there is appreciable harmonic radiation and when seasonal conditions favour the propagation of harmonics. Such interference can be removed either by reducing the harmonic content of the transmitter, or by slight adjustments to its fundamental frequency, to pitch the harmonic clear of the wanted signal. As an instance of the success achieved by the adopted procedure, it may be mentioned that the second harmonic of a Continental telegraphy transmitter persistently ruined the reception of a B.B.C. Empire transmission in various parts of the world. Owing to the high frequency of the harmonic and the skip distance effect, the interference could not be detected at the frequency control station associated with the interfering transmitter and was heard only intermittently at the British control station. Nevertheless, the complaint was verified and as a result of direct co-operation between the British frequency control station and the offending transmitter, the interference was completely suppressed.

#### Outline of the Principle of Frequency Measurement

The principle of radio frequency measurement is the comparison of the unknown frequency with known harmonics of a standard frequency, the measurement being made by the well-known interpolation process. The accuracy of measurement is dependent on the accuracy of the interpolation and of the standard frequency. For precise measurements the essential requirements are:—

- (i) The generation of a standard frequency of high stability.
- (ii) A precise method of measuring the standard frequency.
- (iii) A knowledge of the short period stability of the standard frequency, i.e., of the momentary frequency fluctuations about its mean value.
- (iv) The derivation from the standard frequency of a series of harmonic frequencies which can be used as reference points throughout the desired frequency range.
- (v) Interception of signals to be measured and their comparison with harmonic frequencies.

The system is illustrated in Fig. 2. Given the harmonic reference frequencies the interpolation is performed

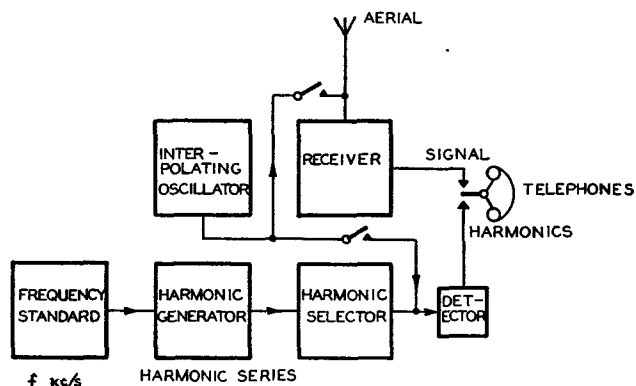

FIG. 2.—SYSTEM USED FOR FREQUENCY MEASUREMENTS OF INTERCEPTED RADIO SIGNALS.

with a receiver and a stable frequency interpolating oscillator. The oscillator has an interpolating scale of high discrimination and the oscillator frequency is usually designed to be a linear function of the scale readings. The oscillator is synchronised first with the signal to be measured, and then in turn with known harmonic frequencies respectively above and below the signal frequency. From the interpolating scale readings for the three settings the signal frequency can be calculated. Thus, if  $F_1$  and  $F_2$  are the two known harmonic frequencies respectively above and below the signal frequency,  $S_1$  and  $S_2$  the interpolating scale readings for  $F_1$  and  $F_2$ , and  $S_3$  is the interpolating scale reading for the signal, then  $F_3$ , the signal frequency is given by

$$F_2 + \frac{(S_3 - S_2)}{(S_1 - S_2)} (F_1 - F_2)$$

#### Specification of the Equipment and Measurement Accuracy for Baldock F.C.S.

The specification of the equipment necessary to obtain the accuracy essential for the measurement work to be performed at the station was stringent. Apart from associated precision apparatus the specification called for the generation of a standard frequency with a long period stability (period of weeks) within at least  $\pm 1$  part in  $10^6$  and with a short period stability (period of hours) of  $\pm 1$  part in  $10^7$ . The production of a standard frequency possessing these stabilities is most easily achieved with a quartz crystal oscillator. The chief factors which affect the stability of such an oscillator are changes in the crystal and its mounting system, in the components of the drive circuit, in the load, and in the supply voltages. The frequency variations due to these causes can be made very small by the design of the crystal mounting system, by maintaining the crystal at a constant temperature and pressure, by the use of high grade components in the maintaining circuit, by the provision of a buffer stage between the crystal oscillator and the output and by employing regulated voltage supplies. These features except pressure control were stipulated in the equipment to be installed.



The harmonic reference frequencies derived from the crystal were required to cover the frequency range 0.1 to 30,000 kc/s and to be available at close frequency intervals. The standard frequency was to be determinable in terms of mean solar time, and of the Post Office primary standard at Dollis Hill. Two independent measuring positions were to be fitted, ranges 500 to 30,000 kc/s and 14.5 to 600 kc/s respectively, the two positions to be capable of simultaneous operation. The receivers were required to be sensitive, selective, and to be fitted with rapid and accurate tuning devices to cover the widest practicable frequency ranges. The interpolating oscillators were stipulated to have a high inherent stability, and to be fitted with interpolating scales of high discrimination with linear frequency laws. A choice of several aerials for the receivers was desirable to enable the most suitable aerial to be used for a particular frequency or measurement method. Finally, the batteries for supplying power to the equipment were required to be float charged, to be voltage regulated to within at least  $\pm 2$  per cent., and to be of sufficient capacity to maintain supplies during A.C. mains interruptions up to 24 hours. The overall measurement accuracy of the complete equipment provisionally specified was:—

Approximate Range kc/s	Overall Accuracy Parts in $10^6$
1,000 to 30,000	$\pm 5$
100 to 1,000	$\pm 10$
15 to 100	$\pm 50$

#### General.

It was originally intended to equip the Baldock Station with one of the high-grade quartz crystal frequency standards developed in the Radio Laboratories at Dollis Hill. A standard could not, however, be released. It was therefore decided to substitute it, for a time, by a commercially produced frequency standard, and to design the complete installation around the commercial unit. The standard selected was a Marconi-Ekco Type 482-C instrument. In addition to generating a standard frequency the instrument provides a comprehensive series of harmonic frequencies, and includes two interpolating oscillators, a crystal controlled clock and a listening post. It is, therefore, an assembly of apparatus for the measurement of unknown frequencies suitably presented to it. For compliance with the specification of the Baldock Station, however, a considerable

amount of additional radio and audio frequency apparatus was necessary. The normal frequency comparison range of the 482-C instrument, 150- to 30,000 kc/s, is governed by the ranges of its two interpolating oscillators. To extend the range to cover the important long wave band 150 to 14.5 kc/s

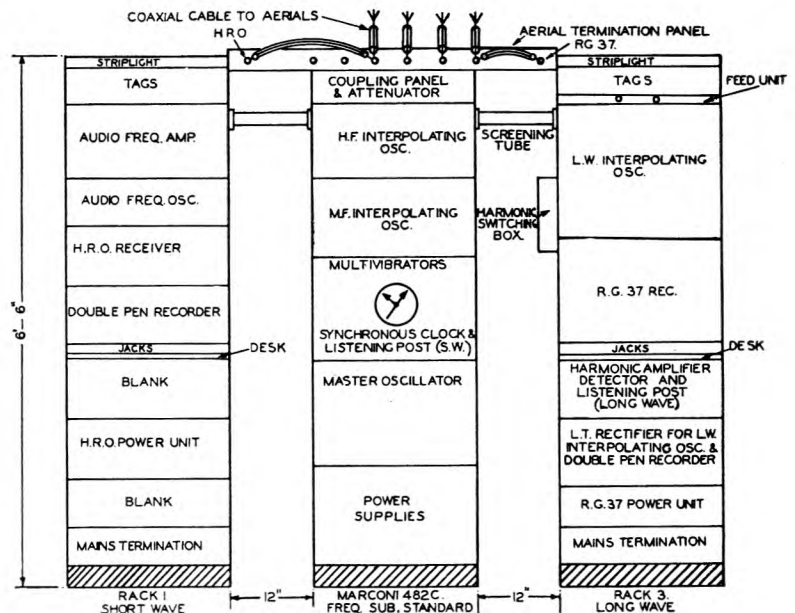

FIG. 3.—RACK AND PANEL LAYOUT.

an additional interpolating oscillator was necessary. In the measuring process the interpolating oscillator outputs are employed to heterodyne the received signals, an operation involving the use of coupling and attenuator units, selective receivers and supplementary apparatus to enable precise measurements to be made in the frequency range not catered for by the 482-C instrument. Furthermore, the determination of the standard frequency in terms of mean solar time cannot accurately be made without the aid of a chronograph. With the exception of the two commercial receivers and the chronograph the additional apparatus was designed and constructed by the Post Office.

#### Description of the Equipment.

The complete equipment is shown in Fig. 3. With the apparatus shown, the standard frequency can be determined in terms of mean solar time and of the P.O. primary standard. Simultaneous frequency measurements can be made at the short wave position, 150 to 400 and 500 to 30,000 kc/s, and at the long wave position 14.5 to 600 kc/s. Alternatively, the long wave position can be used for interception work in the range 14.5 to 31,000 kc/s.

#### Marconi-Ekco Type 482-C Instrument.

The type 482-C instrument is designed to operate from float-charged 200 V H.T. and 2 V L.T. batteries, the potentials of which are maintained sensibly constant by manual regulation of controls located on its power supply panel. In addition to improved smoothing and voltage regulation the use of float-charged batteries renders the apparatus immune from normal mains interruptions. The associated multivibrators are critical to supply variations exceeding  $\pm 2.5$  per cent., and for this reason it was found desirable to protect the batteries from wide temperature changes. The L.T. battery is fitted near the apparatus racks to reduce voltage drop in the cabling and the H.T. battery which is housed in an exposed battery hut is maintained at about 18 deg. C with a thermostatically controlled heater. These precautions enable the supplies to be regulated within  $\pm 1.0$  per cent.

Fig. 4 shows a block schematic of the various units and their functions. The master oscillator includes a 250 kc/s quartz crystal of low temperature—frequency coefficient, temperature but not pressure controlled, in an oven maintained at 66 deg. C by a bridge type thermostat. The drive circuit employs a double triode valve and somewhat resembles a multivibrator circuit in which one of the anode-grid coupling condensers is replaced by the crystal, the coupling being ineffective except at the series resonant frequency of the crystal. Provision is made for adjusting the oscillation frequency, coarsely by the crystal air gaps, and finely with a variable capacitor, the respective total frequency changes being  $\pm 50$  and  $\pm 7$  parts in  $10^6$ . The coarse adjustment is provided for initial lining-up purposes and the fine adjustment to compensate for ageing of components and change of the drive valve. The oscillator is protected from output load variations by

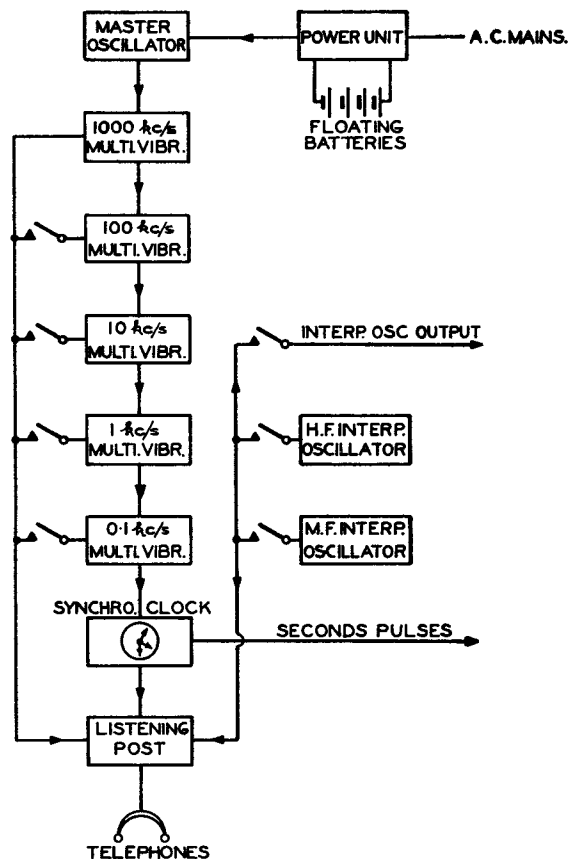

FIG. 4.—BLOCK SCHEMATIC DIAGRAM OF MARCONI-EKCO TYPE 482-C FREQUENCY MEASURING EQUIPMENT.

a buffer stage, the anode circuit of which is tuned to the crystal fourth harmonic, 1,000 kc/s.

An output of the buffer is taken to the multivibrator unit and caused to control a 1,000 kc/s multivibrator which forms part of a frequency dividing chain consisting of five multivibrators synchronised with each other at decade intervals from 1,000 to 0.1 kc/s. The multivibrator series provides a spectrum of harmonic frequencies extending from 100 c/s to at least 30,000 kc/s. Outputs from each multivibrator are available, and by switches can be connected to the listening post detector valve. The switches enable the output from any multivibrator to be selected, or combined, according to the frequency range and harmonic intervals desired. Thus, with an interpolating oscillator output also connected to the detector valve, the oscillator frequency can be synchronised with multivibrator harmonics, i.e., with standard frequencies throughout the frequency range.

Two interpolating oscillators are incorporated in the 482-C instrument, the effective combined frequency range being 150 to 30,000 kc/s. Each oscillator is calibrated directly in kc/s and is provided with continuously variable coarse and fine tuning controls, the latter being employed for the interpolation. The interpolation accuracy is better than  $\pm 10/10^6$  over the complete range.

The listening post is a simple detector-amplifier with switching facilities to enable an operator to listen to the audio output of an associated receiver

or to beats between the interpolating oscillator and a multivibrator harmonic or between the oscillator and a signal to be measured.

To enable the crystal oscillator to be compared with mean solar time a synchronous 50 c/s clock is driven by an amplified output of the 0.1 kc/s multivibrator. The clock is fitted with contacts for the transmission of D.C. pulses to a double pen recorder by which its rate is compared with time signals. In addition to the units described the 482-C rack was extended at Dollis Hill to accommodate the interpolating oscillator coupling and attenuator panel and the aerial termination panel shown mounted above the interpolating oscillators. These panels were designed to afford facilities for various coupling, attenuating and switching functions required in the measurement of signals.

In further references to the master oscillator of the 482-C instrument the term sub-standard will be used to differentiate between it and the Dollis Hill standard of frequency.

#### Associated Apparatus.

**Rack 1** (Short wave position). This rack contains an audio frequency amplifier used to relay tone from the 1,000 c/s multivibrator to Dollis Hill for frequency comparisons with the standard, an audio frequency oscillator, a H.R.O. receiver, a double pen recorder and power supply units. The A.F. oscillator is employed to increase the interpolation accuracy as explained later. It is of the beat frequency type, has a range of from 200 to 8,000 c/s and is very stable in frequency. The double pen recorder is a Marconi type UG 7 instrument, comprising a synchronous motor which draws tape at uniform speed beneath two pens. The electromagnet which operates one pen is connected to the sub-standard crystal clock and is impulsed at second intervals, the impulses being recorded on the tape 10 cms. apart. The electromagnet associated with the other pen is connected in the anode circuit of a rectifier valve, and is impulsed by the audio output of a receiver. The receiver output may be a received time signal such as is emitted by Rugby Radio, Nauen, etc., or the low frequency beat between a signal to be measured and a harmonic produced in the multivibrator series. The instrument can thus be used for comparing the crystal clock time with standard time signals and for measuring beat frequencies against crystal clock seconds. The methods employed are discussed later.

**Rack 3** (Long wave position). Rack 3 contains an interpolating oscillator, range 14.5 to 600 kc/s, Marconi-Ekco receiver, harmonic switching unit, harmonic amplifier, listening post and power units. The interpolating oscillator is directly calibrated in frequency. Coarse and fine tuning controls are provided, the latter which has a linear frequency law being used for the interpolation. The oscillatory circuits comprising ten switched ranges, are contained in a thermostatically controlled oven. The power

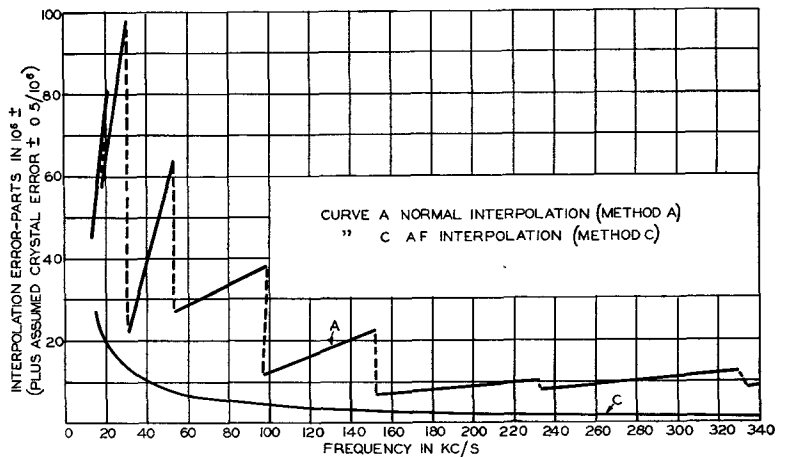

FIG. 5.—L.W. AND A.F. OSCILLATORS—INTERPOLATION ERROR (PLUS ASSUMED CRYSTAL ERROR OF  $\pm 0.5/10^6$ ).

supplies are obtained from voltage regulated float charged batteries. The interpolation accuracy for seven ranges of the oscillator is shown in Fig. 5. The maximum possible error varies from  $\pm 98$  parts in  $10^6$  at 28 kc/s to  $\pm 1$  part in  $10^6$  at 600 kc/s. Curve C shows the increased accuracy obtainable when the A.F. oscillator is employed to measure the audio beat between a signal and the interpolating oscillator as described later.

The harmonic switching and attenuator unit is provided to enable outputs of the 482-C instrument 10, 1 and 0.1 kc/s multivibrators to be selected and made available at the long wave measuring position. The selected multivibrator outputs are then fed to a harmonic amplifier, the output of which is taken to the detector valve of the long wave listening post together with an output of the long wave interpolating oscillator. The harmonic switching unit is also used to enable an operator to:—

- (i) Listen to the interpolating oscillator synchronised with a multivibrator harmonic.
- (ii) Listen to a received signal heterodyned with the interpolating oscillator output.
- (iii) Listen to the receiver signal.

Suitable attenuating facilities are available for each of the above functions.

Illumination for the racks is by shaded, adjustable striplights.

#### Receiving System.

##### Aerials and Earth System.

Due to the necessity for omni-directional reception over the entire commercial frequency range 14.5 to 30,000 kc/s, and to the installation of sensitive receivers, a simple arrangement of three short wave and one long wave aerials was provided and erected on four 45 ft. poles. The aerials are fitted with static discharge devices at the receiving room windows, and are led to the apparatus rack on coaxial cables. Here they are connected to the aerial termination panel above Rack 2 for selection as required. The earth system consists of copper wires radiating from the receiving room, buried in low-lying damp ground.



### H.R.O. Receiver.

This receiver is of American origin and is widely used in this country on account of its compact construction, good design and performance. The range of the receiver 50 to 30,000 kc/s (except the I.F. band 400 to 500 kc/s) is covered with nine sets of coils designed to slide into the receiver body. Single dial tuning is employed with reduction gearing and an open scale. Ease of operation, together with rapid tuning facilities, and the provision of a crystal filter, A.G.C. and I.F. beat oscillator render the receiver a very suitable instrument for use with frequency measuring equipment. Its chief drawback is the I.F. gap mentioned.

### Marconi—Ekco RG 37 Receiver.

The range of this receiver is from 14.5 to 31,000 kc/s in nine switched stages. Single dial tuning is employed. By suitable coupling the receiver frequency is indicated directly in kc/s, and a more precise setting is given by a counting dial which registers a set of figures corresponding to the tuning for a particular frequency or station. Three intermediate frequencies are used, the required I.F. being automatically selected as the range switch is rotated. The sensitivity of the receiver over the greater part of its range is such that a C.W. signal of a  $2 \mu\text{V}/\text{meter}$  produces an output of 1 mW.

### METHODS OF MEASUREMENT

#### Determination of the Sub-standard Frequency.

##### (a) In Terms of Mean Solar Time.

The synchronous clock is driven by the 100 c/s multivibrator, and as the multivibrators are rigidly locked to each other and are controlled by the crystal oscillator, the clock rate is a function of the mean crystal frequency. The clock is designed to keep precise mean solar time when the mean crystal frequency is precisely 250 kc/s. If the mean crystal frequency differs from 250 kc/s, then the rate of the clock, expressed as a fraction of its nominal value, is equal to the actual frequency of the sub-standard oscillator expressed as a fraction of its nominal value, 250 kc/s. The clock time is compared with standard time signals emitted by Rugby Radio daily by measuring on a double pen recorder tape the displacement of the crystal clock seconds from consecutive time signals separated by 24 hour intervals. The linear displacement of the clock reference second on the tape is measured to within  $\pm 0.02 \text{ cm.}$ , i.e.,  $\pm 0.002$  seconds for each of six signals (0955, 0956, etc., to 1000 G.M.T.), and the average of the results is used to compute the mean crystal frequency in the manner shown by the example of Fig. 6. The reference second preceding the time signals is identified, either from the clock second-hand position when the time signals are heard in the receiver telephones, or from the minute impulses which the clock also transmits to the recorder.

The accuracy of the determination is dependent on a number of factors, the chief of which is usually the error of the time signal itself. Including a time signal error of up to  $\pm 10$  milliseconds on a 24-hour interval,

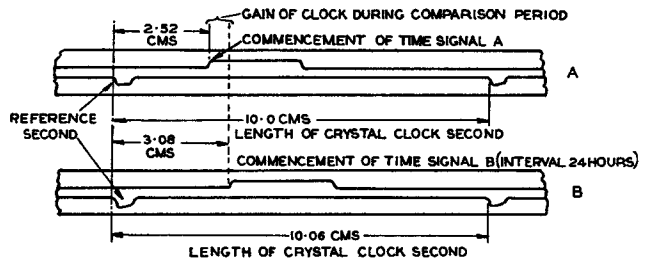

Tape	Length of Second in cm.	Lead of Clock in cm.	Lead of Clock in Seconds.	Difference in Seconds.	Interval in Hours.	Rate Parts in $10^6$
						Diff. in Secs. $\times 277.8$
A	10.00	2.52	0.252	—	—	—
B	10.06	3.08	0.306	0.054	24	$\frac{0.054 \times 277.8}{24} = +0.6$

Specimen Tapes and Calculations.

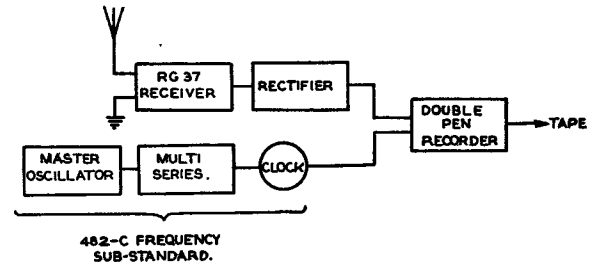

FIG. 6.—METHOD OF DETERMINING FREQUENCY IN TERMS OF MEAN SOLAR TIME.

the accuracy of the determination is within about  $\pm 2$  parts in  $10^7$ .

##### (b) In Terms of the Dollis Hill Standard.

Regular checks of the sub-standard frequency are made by comparison with the standard maintained in the radio laboratories at Dollis Hill. Fig. 7 shows a block schematic of the system employed. An output from the Baldock 1 kc/s multivibrator is amplified and transmitted over an order wire to Dollis Hill where it is filtered and caused to control a 1 kc/s multivibrator. A harmonic of the multivibrator, 100 kc/s is then selected, filtered in a crystal filter, and heterodyned with a corresponding frequency output of the standard, derived in a similar manner. The resultant rectified beats are caused to mark

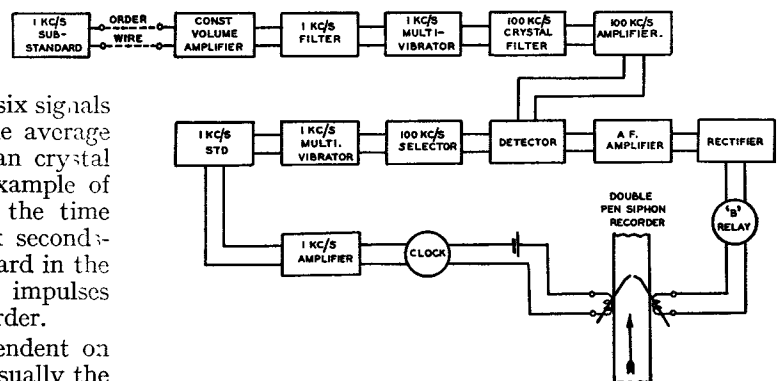

FIG. 7—APPARATUS FOR THE MEASUREMENT OF 1,000 c/s TONE AT RADIO FREQUENCY

the tape of a double pen siphon recorder which is also marked at second intervals by impulses from the standard driven phonic clock. The beat frequency is determined from the tape record to within  $\pm 0.01$  c/s, and the sense of the beats is found by substituting the standard frequency with a source of different known frequency. The comparison accuracy at 100 kc/s is within  $\pm 5$  parts in  $10^8$ . The comparison is completed in two or three minutes; thus the measurement obtained may be termed the "instantaneous" value of the sub-standard frequency as distinct from the mean value over a 24-hour period given by the Baldock determinations in terms of mean solar time. The Dollis Hill and Baldock values usually agree to within less than  $\pm 5$  parts in  $10^7$ , and the checks therefore, provide evidence that the day-to-day stability of the sub-standard is of this order.

#### MEASUREMENT OF RECEIVED SIGNALS

*Method A. Normal Interpolation (Range 14.5 to 30,000 kc/s).*

In this method, which is employed when extreme accuracy is not essential, the signal is tuned in the receiver and heterodyned with an output of the interpolating oscillator as shown schematically in Fig. 8. The oscillator is synchronised with the signal

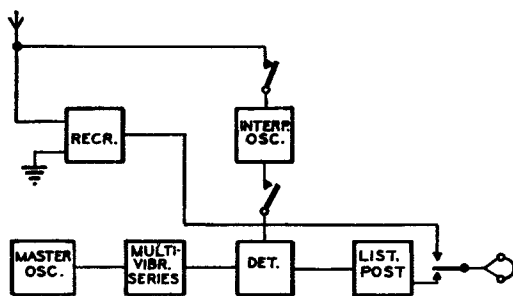

FIG. 8.—METHOD A. NORMAL INTERPOLATION.

frequency, and with adjacent harmonics respectively above and below the signal frequency as previously described. For example, assume that the frequency of a signal to be measured is known from the receiver calibration to be in the region of 5,000 kc/s. The appropriate tuning scale of the H.F. interpolating oscillator is aligned with a multivibrator harmonic, in this example the fifth of the 1,000 kc/s multivibrator, so that the scale pointer checks with the calibration (5,000 kc/s) when the oscillator frequency is exactly synchronised with the harmonic frequency. The oscillator output is connected to the receiver aerial and the oscillator fine control varied to heterodyne the signal. At precise synchronism of the oscillator and signal frequencies the interpolating scale pointer reading is noted and the oscillator is then synchronised with adjacent multivibrator harmonics. (For this purpose the 100 and 10 kc/s multivibrators are switched to the listening post detector.) From the oscillator scale the adjacent harmonic frequencies are given as (say) 5,030 and 5,040 kc/s. The scale readings for the harmonics and

signal are recorded and the calculation with representative figures is :—

$$\begin{aligned} \text{Interpolating scale reading for } 5,030 \text{ kc/s} &= 137 \\ \text{Interpolating scale reading for } 5,040 \text{ kc/s} &= 352 \\ \text{Interpolating scale reading for signal} &= 204 \\ \text{Signal frequency} &= 5,030 \text{ kc/s} + \frac{(204 - 137)}{(352 - 137)} \times 10 \\ &= 5,033.1 \text{ kc/s.} \end{aligned}$$

The determination of precise synchronism between the oscillator and signal and between the oscillator and reference harmonics is achieved by injecting a 1,000 c/s tone (obtained from the 1 kc/s multivibrator) into the listening post telephones. The oscillator frequency is then adjusted to be 1,000 c/s above the signal and harmonic frequencies. The resulting beat tone, 1,000 c/s, can then be synchronised exactly with the injected tone. The accuracy of measurement is dependent on the error of the crystal from its nominal frequency, the accuracy of discrimination and linearity of the interpolating scale and the drift of the interpolating oscillator during the synchronising processes. The maximum overall measurement error is  $\pm 10/10^6$  in the range 150 to 30,000 kc/s and  $\pm 100/10^6$  for the range 14.5 to 150 kc/s.

*Method B. Inter-Modulation (Range 1,000 to 30,000 kc/s).*

In this method it is essential that the signal frequency be known approximately as is the case in nearly all routine measurements. If unknown, the approximate frequency may quickly be found by Method A, using direct visual interpolation from the interpolating oscillator scale.

The principle of measurement (Fig. 9) is one in which the frequency of a harmonic from the 1,000 kc/s multivibrator,  $1,000n$  kc/s, is modulated by an output from the interpolating oscillator,  $f_0$ , the frequency of the oscillator being adjusted so that the sum or difference frequency,  $1,000n + f_0$  or  $1,000n - f_0$ , is coincident with the signal frequency  $f_s$ . Then, from a knowledge of  $f_0$ , of the harmonic order  $n$  and, according to whether the sum or difference frequency is employed,  $f_s$  is determined. The value of  $f_0$  is determined in the normal manner by direct measurement and pre-knowledge of the approximate value of  $f_s$  indicates both the harmonic order and the sign of  $f_0$ .

The advantage of this method is that the actual interpolation frequency is reduced from  $f_s$  to  $f_0$ ,  $f_0$  being arranged to lie within the range 150 to 1,000 kc/s. As the maximum possible value of the interpolation inaccuracy in cycles/second decreases from  $\pm 150$  c/s at a frequency of 15,000 kc/s to  $\pm 10$  c/s at a frequency of 1,000 kc/s, the overall measurement accuracy is increased approximately 150/10 times by performing the interpolation at 1,000 kc/s rather than on 15,000 kc/s. The maximum interpolation error in the range 150 — 1,000 kc/s is less than  $\pm 10$  c/s, so that the overall error in the range in which the system can be usefully employed, 1,000 — 30,000 kc/s, is the sum of the error in the sub-standard, normally  $\pm 5/10^7$ , and the interpolation error  $< 10$  c/s. The maximum error of measurement

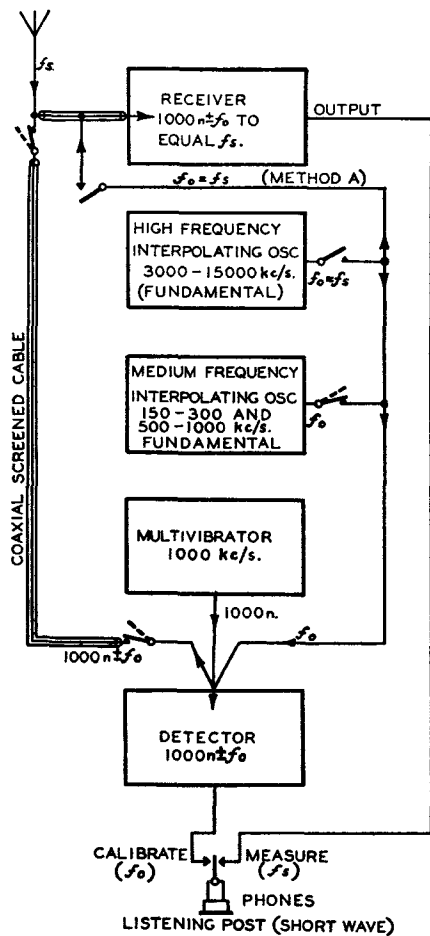

FIG. 9.—BLOCK SCHEMATIC SHOWING METHOD B.

for frequencies in the range 1,000 to 30,000 kc/s is illustrated by the curve in Fig. 10.

Method B is used for most routine short-wave measurements.

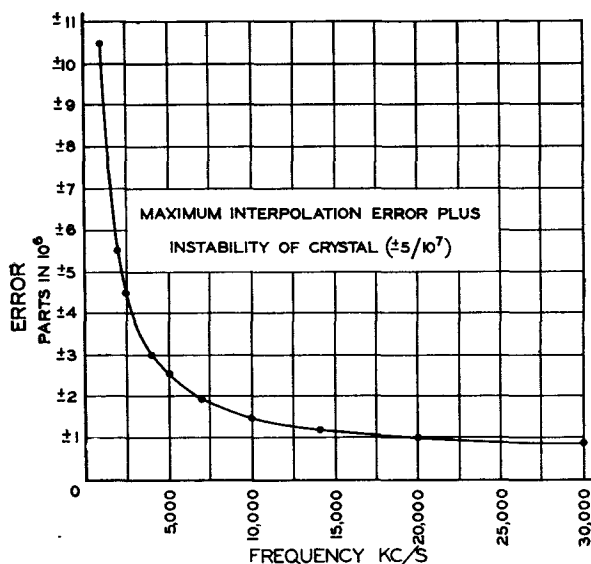

FIG. 10.—MAXIMUM MEASUREMENT INACCURACY, METHOD B.

*Method C. Audio-frequency Interpolation (Range 14.5 to 1,000 kc/s).*

This method is used in conjunction with Method A to increase the measurement accuracy on long and medium waves. The method is used chiefly in the range 14.5 to 600 kc/s at the long-wave measuring position. The audio frequency oscillator is employed to measure the value of the beat frequency between a signal to be measured and the interpolating oscillator with which the signal is heterodyned, see Fig. 11.

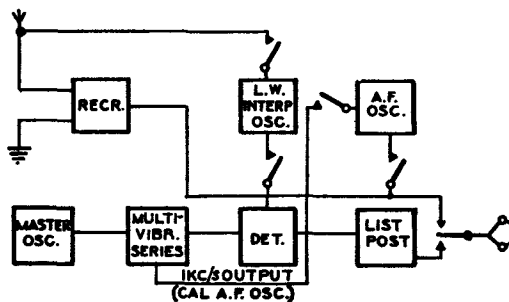

FIG. 11.—METHOD C. A.F. INTERPOLATION.

The A.F. oscillator is first calibrated with an output from the 1,000 c/s multivibrator. The interpolating oscillator is then synchronised with a multivibrator harmonic separated in frequency from the signal to be measured by an audio frequency. The frequency of the beat tone produced between the interpolating oscillator and the signal is then measured with the A.F. oscillator, and is given directly by the A.F. oscillator calibration. The sense of the beat tone is readily determined by altering the frequency of the interpolating oscillator in a known direction and observing the resultant change in the beat frequency. The measurement accuracy depends almost entirely on the stability of the A.F. and interpolating oscillators during the comparison period. The stability of the long-wave interpolating oscillator is such that the frequency drift during a measurement occupying one minute is less than  $\pm 0.3$  c/s at 80 kc/s. The frequency drift of the A.F. oscillator during the same period is  $\pm 0.1$  c/s. The total error due to oscillator drift is thus within  $\pm 5$  parts in  $10^6$  at a frequency of 80 kc/s. In this way the accuracy of measurement is increased as shown in Fig. 5, where curve A represents the measurement accuracy with method A and curve C the accuracy attained with method C. Method C is very useful for measurements of the band width of wobbled telephony carriers and avoids the necessity for making two measurements of the carrier frequencies F1 and F2, corresponding to minimum and maximum wobbler capacitor positions at the transmitter.

*Method D. Direct beating of a signal with a harmonic and recording the beats against crystal clock seconds.*

Due to recording limitations this method can only be used for signals the frequencies of which are within about  $\pm 30$  c/s of a multivibrator harmonic. The signal is heterodyned directly by an output from the multivibrator series connected to the aerial. The resultant slow beats, less than 30 c/s, are rectified



and applied to one pen of the double pen recorder, the other pen of which is actuated by seconds impulses from the crystal-controlled clock. The beats are recorded on the recorder tape against crystal clock seconds and may be measured to an accuracy of 0.1 c/s. A block schematic of the method is given in Fig. 12. In order to make the slow beats audible,

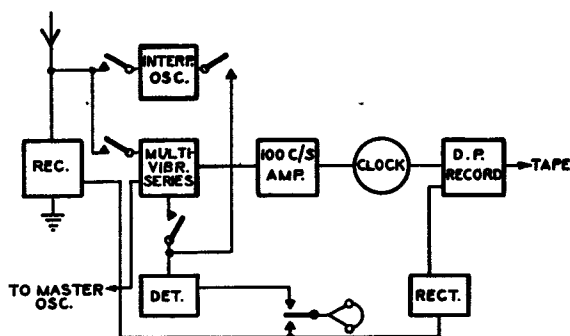

FIG. 12.—METHOD D. DIRECT BEATING.

the double-beat system is employed, in which an interpolating oscillator output is caused to produce a convenient arbitrary beat tone with the signal. Under these conditions the interpolating oscillator frequency has no influence on the beat frequency between the signal and the harmonic. The sense of the beats is determined by momentarily altering the harmonic frequency with the crystal pre-set fine control capacitor, and noting the change in beat frequency between signal and harmonic as the harmonic frequency is moved with respect to the signal. The overall measurement accuracy is determined by the error of the crystal and amounts to some  $\pm 5$  parts in  $10^7$ .

#### PERFORMANCE OF THE SUB-STANDARD

The performance of the crystal oscillator shortly after its installation at Baldock was somewhat erratic. Random frequency variations of some  $\pm 3$  parts in  $10^6$  occasionally occurred, the cause of which was traced to the crystal mounting system. The suspension was corrected and the crystal gaps were adjusted. As a result, the subsequent performance of the crystal has been very satisfactory. Throughout a period of six months ending June, 1940, the maximum crystal frequency variations as determined at Baldock from time signals were of the order of  $\pm 5$  parts in  $10^7$  about a mean value some 1 or 2 parts in  $10^7$  below the specified frequency. Fig. 13 shows the daily mean crystal frequency according to the Baldock determinations for the period December 1st,

1939, to February 7th, 1940. The figure also shows periodical checks of the "instantaneous" or short period value as measured at Dollis Hill by comparison with the standard, together with two corrections for time signal errors. The graphs are typical results and indicate that for considerable periods the error of the crystal does not exceed about  $\pm 3$  parts in  $10^7$  and that the "instantaneous" value as given by the Dollis Hill measurements is normally in agreement with the Baldock mean value to within less than  $\pm 3$  parts in  $10^7$ . Apparent frequency deviations of a relatively large order are often due to imprecision of the time signals. Corrections for time signal errors are issued by the Royal Observatory but are not available for immediate application.

#### OVERALL MEASUREMENT ACCURACY

From the foregoing it is seen that the sub-standard frequency can safely be assumed to be within some  $\pm 5$  parts in  $10^7$  of its specified frequency at all times. Periodical checks of the Baldock F.C.S. overall measurement accuracy have been made by two methods. Firstly, a list of radio stations was selected and their carrier frequencies were measured simultaneously at Baldock and at Dollis Hill. The Baldock measurements were made in terms of the sub-standard and the Dollis Hill measurements in terms of the standard. Despite the fact that this test was made shortly after the opening of Baldock F.C.S., when the staff were relatively unfamiliar with the new equipment, and the difficulty experienced in exactly synchronising the measurement times, the agreement between the Baldock and Dollis Hill figures was good. The maximum difference was 4.5 parts in  $10^6$  and the average difference less than  $\pm 2$  parts in  $10^6$ . The second check is regularly carried out in peace time and consists in measuring the standard frequency transmissions radiated quarterly from the N.P.L. transmitter G5HW on 1,780 kc/s. The measurements are made at Baldock by heterodyning the standard transmission with a harmonic, 1,780 kc/s derived from the sub-standard, and by measuring the resultant rectified beats against crystal clock seconds. The Dollis Hill results are similarly obtained except that a harmonic of the standard is used. The transmission occupies nearly an hour and measurements are made every ten seconds throughout the transmission. The frequency of the transmission as determined at Baldock and at Dollis Hill usually agrees within a few parts in  $10^7$ . With these checks, and the regular measurements of the crystal frequency in terms of the Dollis Hill standard, the overall measurement accuracy of the Baldock station is established and maintained at a high order.

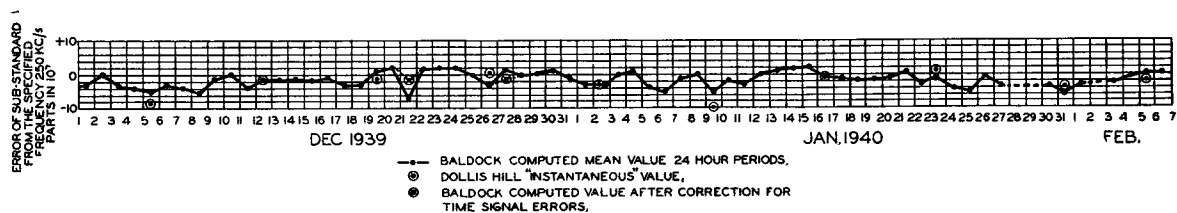

FIG. 13.—COMPARISON OF BALDOCK FREQUENCY SUB-STANDARD, WITH THE DOLLIS HILL STANDARD, DEC. 1ST, 1939, TO FEB. 7TH, 1940.

# Insulating Gaps as a Remedy to Electrolytic Action

C. E. C. SKUSE

U.D.C. 620.193.7 : 621.315.221

The author illustrates how insulating gaps in the sheaths of lead-covered cables may be used to eliminate damage due to electrolytic action from stray currents.

## Introduction.

THE corrosion of lead-covered cables due to electrolytic action may be divided under the following headings:—

1. *Natural current electrolysis*, i.e., electrolytic action by currents of small magnitude self-propagated between points of varying potential within the cable system, arising from natural causes.
2. *Stray current electrolysis* due to the passage of stray currents to and from the cable system, the main sources of such stray currents being
  - (a) Leakage from D.C. traction systems using uninsulated rail returns.
  - (b) Electro-chemical action between the soil and metallic conduits.

Corrosion under the first heading is not usually very rapid, due to the small magnitude of the current, and insulating gaps are not normally considered as a remedy to such corrosion—although should repeated failures occur in such an area, insulating gaps fitted at carefully selected points should minimise the sheath current flow, if not completely eliminating it.

Under the second heading corrosion by stray currents is by far the most dangerous, current values in excess of 2 amperes being frequently recorded in the sheaths of cables adjacent to D.C. uninsulated rail return traction systems and of several hundred milliamperes in the sheaths of cables in earthenware conduit having their sheaths in physical contact with cables in isolated sections of metallic conduit. The British Post Office is, as a result of a large scale experiment, endeavouring to protect underground cable systems from electrolytic corrosion by breaking the electrical continuity of the cable sheaths at suitable points.

Where insulating gaps have been fitted in cable sheaths at the time the cable was laid, no case of electrolytic corrosion has been brought to notice. This method of protection has a considerable advantage over all but one of the other known methods inasmuch as it can be applied to existing cables in situ.

It is mainly the purpose of this article to illustrate the methods adopted and the results achieved by the use of insulating gaps in localities where corrosion has occurred.

## Insulating Gaps and the Method of Fitting.

An insulating gap consists essentially of a break in the continuity of the lead sheathing of a cable achieved by cutting a ring of lead approximately  $\frac{1}{2}$  in. in width from the cable sheath.

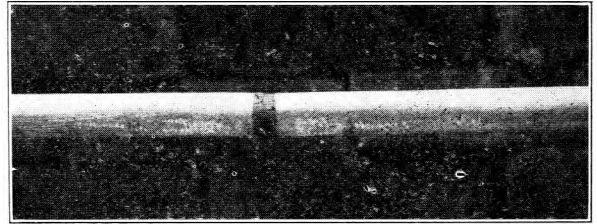

FIG. 1.—GAP FILLED WITH RUBBER TAPE.

The mechanical components of an insulating gap are a split rubber sleeve and a bolted metal coupling to fit over the sleeve, in order completely to seal the rubber on to the cable and obtain a completely rigid finish.

The gap in the sheath is filled by wrapping, under tension, adhesive rubber tape to the level of the sheathing (Fig. 1). The cleaned and roughened



FIG. 2.—CABLE TAPED FOR 10 IN.

sheathing is then wrapped for approximately 10 in. with an even lapped layer or layers of rubber tape again applied under tension and in one length per layer (Fig. 2). The last point is important in that a joint in the wrapping would not allow the rubber sleeve to seat evenly. Over this is placed the split rubber sleeve (Fig. 3) which should, as previously

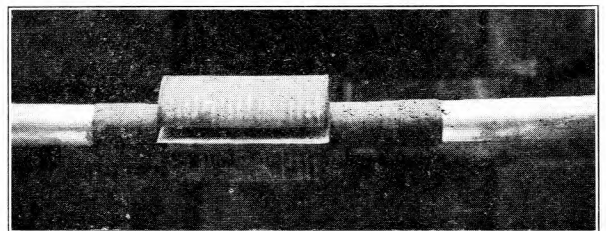

FIG. 3.—ADDITION OF SPLIT RUBBER SLEEVE.

mentioned, seat evenly, with a  $\frac{1}{4}$  in. gap between the cut faces. The metal coupling painted on the inside fits over the rubber sleeve, and the fixing bolts should be tightened consecutively round the coupling until the flanges of each half reach the spacing washers. An air pressure test is applied to prove that the gap is airtight and the whole fitment is then





the cable sheath and temporary earth electrode was no doubt accounted for by increase of contact resistance with earth of the isolated cable resulting from the fitting of the insulating gaps. Sheath current was recorded at one point only, and then values were of small magnitude, comparable with values of current found at points in cable systems remote from traction systems and unlikely to result in serious electrolytic corrosion. The maximum value recorded will be seen to be 40 mA, the cable being 5 mV positive to earth at this point.

It is also interesting to note that no cable failure has occurred in this area due to electrolytic corrosion since the insulating gaps were installed (i.e., approximately 1½ years).

A further example of an insulating gap scheme is depicted in Figs. 7 and 8. Fig. 7 is a plan of the site

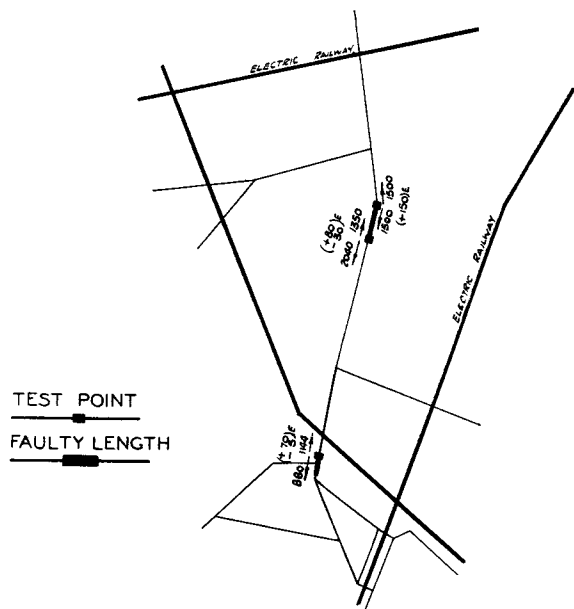

FIG. 7.—FURTHER EXAMPLE OF STRAY CURRENTS BEFORE FITTING INSULATING GAPS.

of a failure subsequent to which investigations were carried out and the test results recorded. Tests conducted immediately after the failure gave the following results :

*Test 1. North end of faulty length.*

- Sheath current flowing North, 1,500 mA maximum reading.
- Sheath current flowing South, 1,500 mA maximum reading.
- Potential difference cable to earth positive, 150 mV maximum reading.

*Test 2. South end of faulty length.*

- Sheath current flowing North 1,350 mA
- Sheath current flowing South 2,040 mA.
- P.D. cable to earth positive 80 mV.
- P.D. cable to earth negative 30 mV.

In this case complete isolation of the cable system, within which the failure occurred from the traction system bounding it, was proposed.

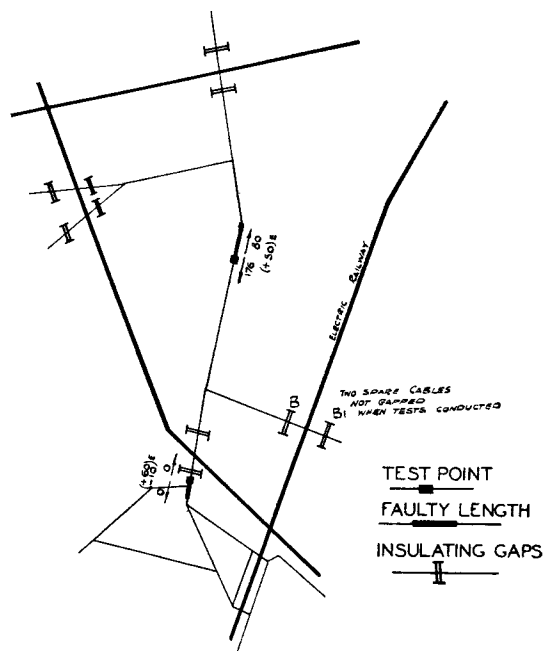

FIG. 8.—RESULTS OF FITTING INSULATING GAPS.

To achieve this, gaps were fitted on all cables on each side of points where the traction system crossed or came into close proximity. Fig. 8 indicates the points selected for the fitting of gaps and the test results subsequent to the fitting have been included in this diagram. It will be seen that the maximum

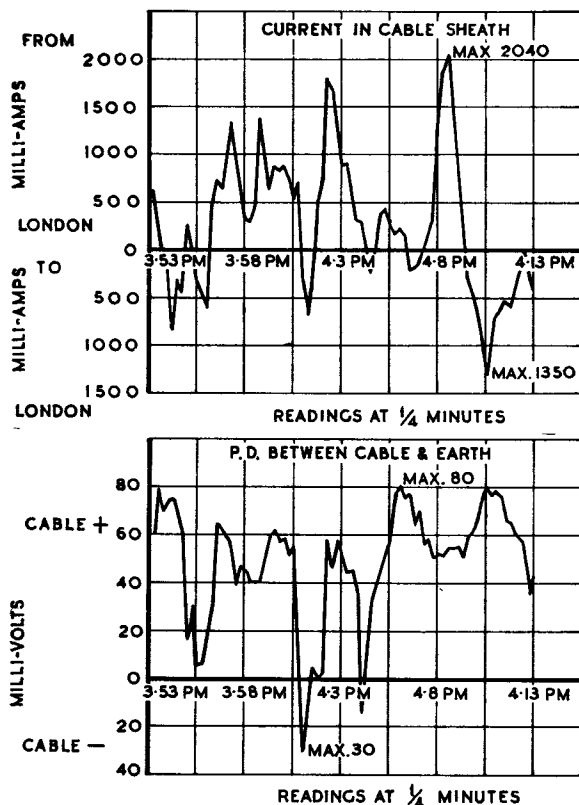

FIG. 9.—ELECTRICAL TESTS AT SOUTH END OF FAULTY LENGTH BEFORE FITTING GAPS.

values recorded were considerably reduced as a result of the work carried out. The maximum recorded readings were :—

*Test Point, South end of faulty length.*

Sheath current to London 80 mA  
 Sheath current from London 176 mA  
 P.D. cable to earth positive 50 mV

The sheath current flowing at this time was due, no doubt, to the fact that, at the points marked B and B1 in Fig. 8, two cables had not been gapped when the tests were conducted, rendering the fitted gaps only partially effective. When these gaps have been completed, elimination of the sheath current is anticipated.

Figs. 9 and 10 are the graphical records of the tests conducted at the south end of the faulty length, the former prior to application of remedial measures and the latter after the gapping work was complete.

The results recorded in Fig. 9 are typical of the effect of traction leakage, as are, to a lesser degree, those shown in Fig. 10, thereby confirming the assumption that some current was still finding a path via the cable sheaths at the crossing adjacent to points B and B1. This illustrates the need for

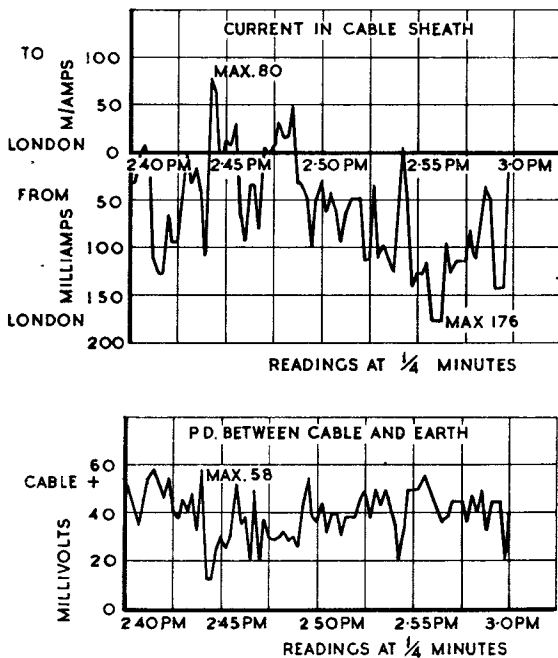

FIG. 10.—ELECTRICAL TESTS AT SOUTH END OF FAULTY LENGTH AFTER FITTING GAPS.

careful supervision and examination of cable and plant records to ensure that no cable or route is overlooked when the positions for fitting insulating gaps are determined, and that it is essential that all cable routes within the area to be isolated be considered in order that no gaps at any one point are rendered ineffective by other cables in circuitous routes. The most efficacious method to ensure this is to work from line plant records, in the initial stages of preparation of an insulating gap scheme.

Fig. 11 indicates a typical example of the conditions likely to be encountered. Insulating gaps suggested at points A and B to isolate the cable route from the traction system would be rendered ineffective when cables terminated at points R and S and X and Y were linked by cable in the proposed new routes. It is, therefore, essential that all information should be collected of proposed alterations to existing cable routes before planning an insulating gap scheme. In this case it would be necessary eventually to fit additional gaps at points C and D, or, alternatively, fit gaps at B1 and A in the first instance and subsequently at C only.

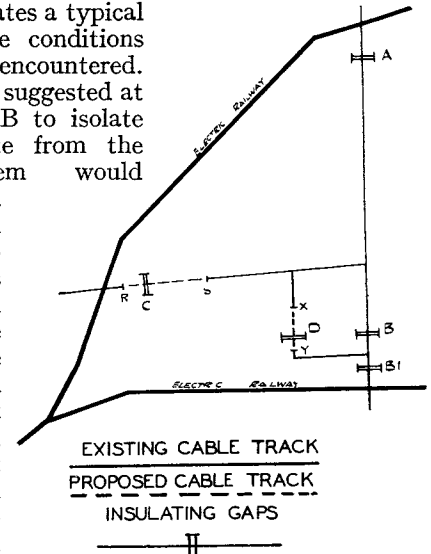

FIG. 11.—TYPICAL EXAMPLE OF CHANGED CONDITIONS.

Further to this, it is essential that care be taken in a manhole within which insulating gaps are to be fitted, that no low resistance path is overlooked which will short-circuit the fitted gaps. Cases have occurred where gaps have been short-circuited via several other cable sheaths in contact, the nature of the short-circuit not being apparent upon first sight.

When the nature of the plant in the locality permits, tests may be conducted with temporary gaps at the selected points prior to permanent fitment. The result of such an investigation is given in Figs. 12 and 13.

Fig. 12 shows in straight line form the cable routes with the points at which failures have occurred. Test results shown, indicate that at the site of each failure, the cable route is positive to earth with sheath current unidirectional, whereas at the point marked

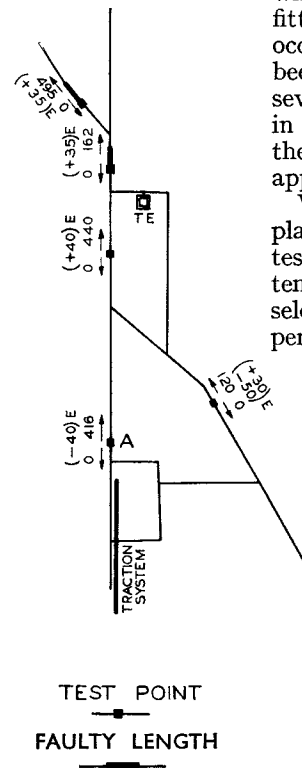

FIG. 12.—RESULTS OF ELECTRICAL TESTS BEFORE FITTING TEMPORARY INSULATING GAPS.

A adjacent to the traction system, the cable route is entirely negative to earth.

It was decided to conduct repeat tests at two points to ascertain the effect of gapping the sheaths of all cables at the jointing point where these were found to be negative to earth, i.e., at point A, Fig. 12.

Fig. 13 shows the results of these further tests, indicating that gaps at the selected temporary position had a beneficial effect, although not resulting in complete elimination of the stray current. Subsequently cable records were studied, and one additional point, marked B in Fig. 13, was selected for permanent insulating gaps, in order to isolate effectively the sheaths of the cables in the area under consideration from those in proximity to the traction system.

It will be seen by reference to Fig. 13 that the cable route from A to C via B

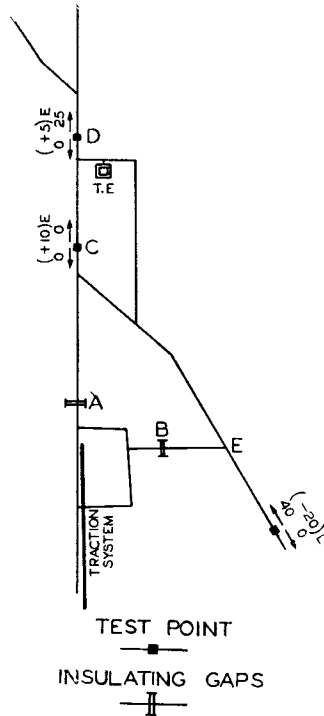

FIG. 13.—RESULT OF FITTING A TEMPORARY GAP AT A.

and E had the effect of short-circuiting the insulating gaps at A and was partially responsible for the current recorded at D. It will be noted that this route to be gapped linked the cables adjacent to the traction system to those passing via the exchange to the section of duct in which damage had occurred, and was also responsible for a portion of the current found to flow at the point of damage.

In order that the efficiency of the fitted gaps remains unimpaired, it is necessary that new works and rearrangements of cables within the manhole housing the gaps are carried out with care, and working parties should be impressed with the necessity of placing branching cables in such positions that existing insulating gaps will not be short-circuited, and that attention should be drawn to the need for fitment of insulating gaps on new cables, if not provided for under the estimate.

Insulating gap sites should be recorded on plant records in the estimate stage in order that when new works are under consideration, the provision of insulating gaps, where necessary, will not be overlooked.

In conclusion, the need for the efficient maintenance of insulating gaps as such cannot be too strongly emphasised. The inadvertent short-circuiting of one insulating gap may result in the recurrence of cable failures due to electrolytic corrosion.

A large number of gaps have been fitted in the London Region, and work is in hand providing for the protection of other danger areas; thus it is hoped to reduce the number of failures due to electrolytic action in this Region.

TELEGRAPH AND TELEPHONE PLANT IN THE UNITED KINGDOM  
TELEPHONES AND WIRE MILEAGES. THE PROPERTY OF, AND MAINTAINED BY, THE POST OFFICE IN EACH REGION AS AT 30TH JUNE, 1940.

OVERHEAD WIRE MILEAGES			REGION	UNDERGROUND WIRE MILEAGES		
Trunks and Telegraphs	Junctions	Subscribers *		Trunks and Telegraphs†	Junctions‡	Subscribers§
14,543	39,821	280,658	Home Counties ..	880,641	196,018	1,074,986
10,704	33,470	202,918	South Western ..	410,886	75,897	562,276
11,192	24,079	164,364	Midland ..	588,492	221,099	716,661
9,690	23,260	114,063	W. and Border Counties	336,986	56,074	223,956
13,349	21,631	143,364	North Eastern ..	524,041	165,468	807,816
2,866	8,015	101,286	North Western ..	469,144	259,957	1,042,568
8,744	7,170	24,472	Northern Ireland ..	41,928	13,656	99,318
24,196	32,504	151,496	Scottish ..	446,443	147,650	609,067
826	1,465	65,704	London ..	537,598	1,354,644	3,420,464
96,110	191,415	1,248,325	Totals	4,236,159	2,490,463	8,557,112
97,922	192,475	1,239,872	Totals as at 31st March, 1940	41,495,77	2,382,371	8,479,024

\* Includes all spare wires. † All wires (including spares) in MU cables. ‡ All wires (including spares) in wholly Junction cables. § All wires (including spares) in Subscribers' and mixed Junction and Subscribers' cables.



# A Simplified Compressor Equipment for Trunk Circuits

U.D.C. 621.395.648.2

J. LAWTON, M.Sc. and  
D. J. MARKS, B.Sc.(Eng.).

The principle of operation of the volume range compressor-expander was recently described in this Journal. The present article describes the design considerations and construction of a new experimental compressor equipment intended primarily for use on trunk lines. Important features are its simplicity of operation and compactness of layout.

## Introduction.

IN a recent article<sup>1</sup> the use of compressors on trunk circuits to reduce the effective level of line noise and crosstalk was discussed in some detail, and the principle of operation of the device was explained. It is now proposed to describe an experimental compressor of simple design primarily intended for use on trunk circuits.

The operation of the device may be briefly outlined as follows:—It consists of two units, a volume range compressor at the sending end of the line and a volume range expander (or restorer) at the receiving end. It may be recalled that circuit noise is reduced by a compressor only if it originates in the part of the system between the compressor and expander units. Both the units of the compressor consist essentially of loss devices which are automatically controlled by the signal level, each loss device being followed by a linear amplifier. As the signal level decreases, the loss introduced into the transmission path by the compressor also decreases, but that introduced by the expander increases. If the compressor and expander units are accurately matched, then at all times, the sum of the losses in the two units will be constant, from which it will be seen that the overall loss of such a system is independent of signal level.

The reason for the improvement in the apparent noise and crosstalk level may be explained as follows:—Consider a circuit where the received noise level is relatively high. When there is no compressor in circuit the lower level speech elements will be swamped by the noise, and only the loudest speech sounds will have an adequate signal to noise ratio. Now suppose that a compressor is connected into circuit. Since at the sending end, the loss in the compressor decreases as the signal level falls, the effective gain of its associated amplifier is increased for low level signals. Consequently, the absolute level of the weaker speech sounds is raised before they are transmitted to line, whereas that of the disturbing noise remains unchanged, since the latter enters the system after the compressor unit. At the receiving end of the line, the expander automatically inserts a loss equal to the effective additional gain introduced by the compressor. This restores the signal element to its original level, but at the same time reduces the level of the accompanying noise by the amount of the loss inserted. The reduction in received noise level so obtained varies from a large amount in the silent intervals, to zero at a particular (high) signal level, at which the loss in the expander unit is zero. At this level, also, which has been referred to as the "reference" level, the loss in the compressor unit equals the gain of its associated amplifier.

<sup>1</sup>*P.O.E.E. J.*, Vol. 32, p. 32.

The manner in which the loss devices in the compressor and expander units are controlled by the signal level is most conveniently defined by a graph showing the level of the output power from the unit concerned, plotted against the corresponding steady power level applied to the input. It is necessary to do this for one of the units only, since when this is done the performance of the other is also fully established if the system is to be linear in its overall response. The graphs so obtained for the two units are referred to as the compression and expansion characteristics respectively.

It is very desirable that these characteristics (when the levels are plotted in logarithmic units) should be straight lines over the working range of levels. This permits the characteristics to be easily defined and also ensures that the overall response of the system remains linear even if the net loss in the circuit between the compressor and expander units should drift from its correct value. With a curved compression characteristic, the overall response will be linear only when the loss in the circuit between the two units is correct. If drift should occur it will be seen that a given range of signal levels will then operate the expander over a different part of its characteristic from that which is complementary to the operative part of the compressor characteristic.

When the compression characteristic is a straight line, its slope, i.e., the ratio of an incremental change of output level to the corresponding change of input level is referred to as the compression factor. The analogous term for the expander is obviously the expansion factor, and for a linear system the product of the two is unity. In the present design a compression factor of  $\frac{1}{2}$  has been used. This value has been found suitable, judged both from the reduction in noise level which it provides, and from the readiness with which it can be obtained in practice.

It will be seen therefore that the design of a compressor provides two main problems, firstly, to ensure that the compressor and expander characteristics are complementary, so that the system will be linear overall, and secondly to obtain from the compressor the desired compression characteristic over a sufficiently wide range of levels. The first problem is of particular importance when the equipment is intended for use on trunk circuits. These, for practical reasons, are lined up at one particular level of testing tone (1 mW) which is fairly high compared with the speech level of the average subscriber. If, therefore, the overall loss changes with signal level, then either the transmission efficiency for weak subscribers is impaired or else near singing distortion or actual instability may occur.

*Method of Ensuring Overall Linearity.*

All companders depend for their action on some form of non-linear circuit element. This may be a gain device such as a valve of the "variable mu" type, or it may be a non-linear impedance element arranged to introduce a loss into the transmission path. In both devices a control voltage or current, having a definite relationship to the signal level, determines the amount of this gain or loss. Examples of non-linear impedance elements which have been successfully employed both in this country and abroad are the triode valve in which the anode-cathode impedance is governed by the grid potential, the dry plate (copper oxide) rectifier, and discs of a material known as Thyrite. The impedance of the rectifier or Thyrite disc arrangements is determined by a super-imposed control current much greater than the signal current flowing in the impedance. In all the above methods a push-pull (or bridge) arrangement of the impedance elements is employed to reduce the level of intermodulation products in the output signal. Another method makes use of the resistance-temperature characteristic of a metal filament lamp which functions as the non-linear impedance element.

In the design described in this article metal rectifiers have been used. By operating the rectifier elements under suitable conditions it is possible to obtain the desired compression characteristic. By entirely empirical means it would perhaps be possible to obtain the complementary expansion characteristic. It is clearly much more satisfactory, however, if the fundamental circuit design of the compressor and expander units is such that the two characteristics are inherently complementary if substantially identical non-linear impedance networks are used in both units. This has been achieved in the following manner.<sup>2</sup>

The equivalent circuit of the compressor unit may be represented in its simplest form as shown in Fig. 1(a). The network incorporating the non-linear impedance is represented by "x," the E.M.F. "E<sub>1</sub>" of the ideal generator is proportional to the

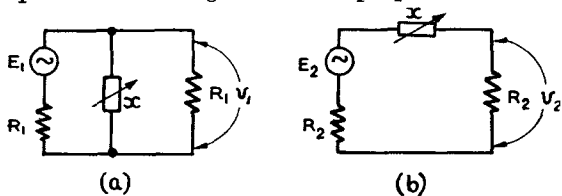

FIG. 1 (a) & (b)

instantaneous input signal voltage and R<sub>1</sub> is the characteristic impedance of the associated circuit; v<sub>1</sub> is the output voltage applied to the grid of the associated output amplifier.

The insertion loss caused by the impedance x is given by the well-known expression:—

$$L_1 = 20 \log \left\{ 1 + \frac{R_1}{2x} \right\} \dots\dots\dots(1)$$

If, under all circumstances, R<sub>1</sub> is very large compared with 2x, then equation (1) reduces to:—

$$L_1 = 20 \log \left\{ \frac{R_1}{2x} \right\} \dots\dots\dots(2)$$

This simplification necessitates, however, that under all circumstances the insertion loss must be high, and a considerable gain is required from the associated amplifier.

Considering now, the expander, its equivalent circuit is shown in Fig. 1(b), in which the various symbols with the suffix 2 are the counterparts of those shown in Fig. 1(a). Here, however, the non-linear impedance network "x" is in series with the transmission path, and the insertion loss is expressed by:—

$$L_2 = 20 \log \left\{ 1 + \frac{x}{2R_2} \right\} \dots\dots\dots(3)$$

If the ratio x/2R<sub>2</sub> is very great compared with unity, then here also the same reduction may be made:—

$$L_2 = 20 \log \left\{ \frac{x}{2R_2} \right\} \dots\dots\dots(4)$$

If the two units are worked in cascade at either end of a linear transmission system, then E<sub>2</sub> will be proportional to v<sub>1</sub> and the sum of the losses introduced by the compressor and expander units is then obtainable from equations (2) and (4):—

$$L_1 + L_2 = 20 \log \left\{ \frac{R_1}{4R_2} \right\} \dots\dots\dots(5)$$

It will be seen that this expression is independent of x, and since both R<sub>1</sub> and R<sub>2</sub> are linear resistances, the sum of L<sub>1</sub> and L<sub>2</sub> is independent of signal level. As already stated above, this is the required condition for linear overall operation of the compander.

It will be obvious that it may not always be possible, or economical, to provide the very high and very low circuit impedances which are seen to be necessary in the compressor and expander units respectively. If the equations (2) and (4) do not represent the actual working conditions with a fair degree of accuracy, then equation (5) will not hold, and the equipment will introduce non-linearity.

Linear operation, however, can always be ensured even when the compressor and expander circuit impedances deviate considerably from the ideal values of infinity and zero respectively. This is done

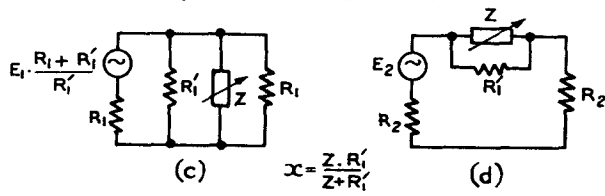

FIG. 1 (c) & (d)

in the following manner. Consider firstly the compressor unit and suppose that R<sub>1</sub> is reduced to R'<sub>1</sub>, a sufficiently low value to invalidate the assumption by which equation (1) was simplified to the form of equation (2). This condition can be represented as shown in Fig. 1(c), since a "generator" of internal impedance R'<sub>1</sub> may be represented by one of relatively very high internal impedance R<sub>1</sub> shunted by a resistance R'<sub>1</sub>, and with an increased internal E.M.F. as shown in the diagram. Suppose also that a second resistor of value R'<sub>1</sub> is shunted across the non-linear impedance network in the expander unit. If the symbol x now represents the resultant impedance of R'<sub>1</sub> and the non-linear impedance network z in

<sup>2</sup>R. J. Halsey—Prov. Pat. No. 2466/39.

parallel, then the circuits (c) and (d) become identical to circuits (a) and (b) respectively. It follows therefore that the circuits (c) and (d) when operating in cascade will have a linear overall response, since equation (5) now applies equally well to circuits (c) and (d) as to circuits (a) and (b), for which it was originally derived.

In a similar manner, if the circuit impedance of the expander unit is  $R'_2$  instead of the comparatively negligible value  $R_2$  previously assumed, the compressor circuit can be modified to compensate for this. Figs. 1(e) and 1(f) show how this is done. The

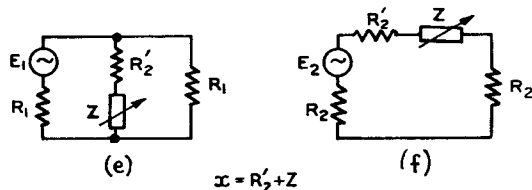

FIG. 1 (e) & (f)

resistance  $R'_2$  is considered to be part of the non-linear impedance network so that  $x = R'_2 + Z$ . It is therefore necessary to insert a resistance  $R'_2$  in series with the non-linear impedance network of the compressor. The circuits of Figs. 1(e) and 1(f) are then identical in form to those of Figs. 1(a) and 1(b) respectively, and a linear overall response will be obtained when they are operated in cascade.

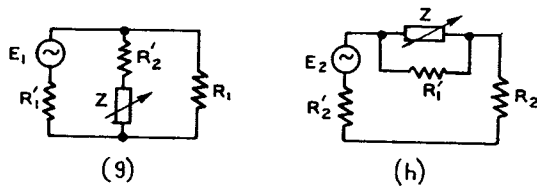

FIG. 1 (g) & (h)

It will be apparent that both the above corrections can be applied simultaneously as shown in Figs. 1(g) and 1(h). Full correction is obtained with the impedance values shown in the diagram, only if  $R'_2$  is negligible compared with  $R'_1$ . If this condition is not fulfilled, full correction can still be obtained, but the resistances in series with or in parallel with "Z" in the compressor and expander units

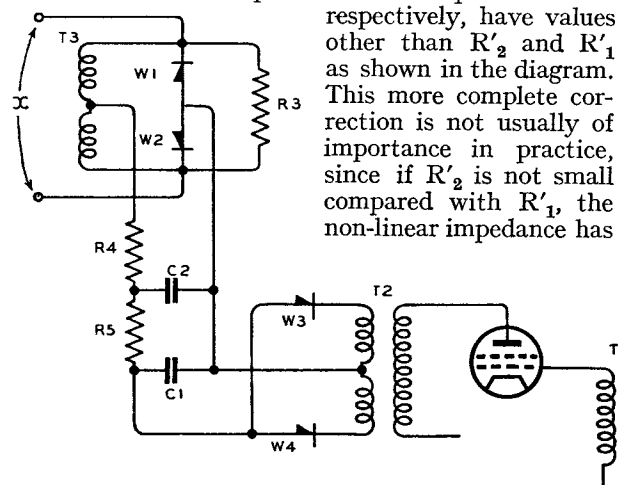

FIG. 2.—SCHEMATIC OF THE CONTROL CIRCUIT.

only a restricted control of the insertion loss and the range of levels over which effective compressions can be obtained is correspondingly limited.

### The Design of the Non-linear Impedance Networks.

Once the shape of the required compression characteristic has been decided, equation (2) determines the relationship which the impedance "x" must bear to the level of the applied signal. The experimental design, described in this article, has a straight line compression characteristic with a compression factor of 0.5. This means that for 1 db. reduction in the level of the output signal from the compressor, the loss in the transmission path must be reduced by 1 db., so that the corresponding change of input level will be 2 db. Since the loss (in decibels) is therefore directly proportional to the output level (also in decibels), it follows from equation (2) that the value of x (in ohms) must be inversely proportional to the amplitude of the output signal (in volts). This condition can be fulfilled by the circuit shown schematically in Fig. 2, which shows the essential features of the control amplifier, the control current rectifier, and the non-linear impedance network, of which the impedance has been referred to above as "x."

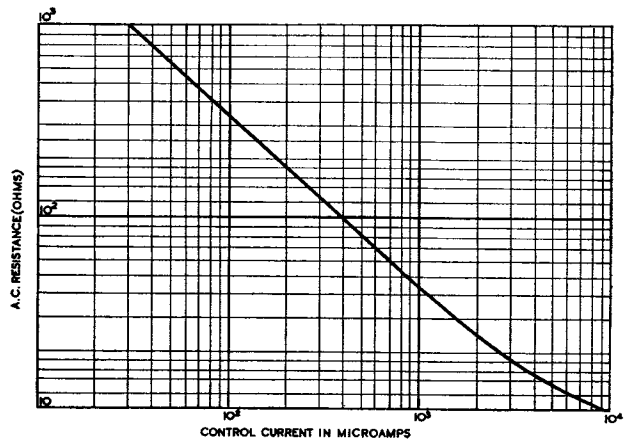

FIG. 3.—IMPEDANCE CHARACTERISTIC OF TYPICAL COPPER OXIDE RECTIFIER

The non-linear impedance consists of the two copper oxide rectifier assemblies  $W_1$  and  $W_2$ , which are connected in push-pull, and are polarised by the uni-directional output current of the control amplifier, the transformer winding  $T_3$  completing the return path. Fig. 3 shows the A.C. impedance or polarising current-density characteristic of a typical copper oxide rectifier. It will be seen that over a considerable range the characteristic is a straight line indicating the exponential relationships of the impedance and current density. This may be represented by

$$R_x = K.(I_a)^{-n} \dots \dots \dots (6)$$

The value of n is approximately 0.9. If therefore the current output from the control amplifier were exactly proportional to the amplitude of its input signal, the impedance of the rectifier network would

be inversely proportional to the 0.9th power of the amplitude of the compressor output signal, instead of the first power, as is required. The response of the control amplifier, however, is actually non-linear due to the presence of the rectifiers  $W_3$  and  $W_4$ , and also due to the change of D.C. resistance with current, of the rectifiers  $W_1$  and  $W_2$ . The effects of this non-linearity can be controlled by the series resistors  $R_4$  and  $R_5$ , and the shunt resistor  $R_3$ . By correctly proportioning the values of these resistors, the impedance "x" can be made substantially inversely proportional to the signal voltage at the input to the control amplifier for a 35 to 1 change of signal amplitude. It should be observed that in practice  $R_3$  is partly made up of the circuit impedance of the compressor path across which the impedance "x" is bridged, in order to provide the required impedance compensation discussed above.

The detailed design of the compressor and expander circuits is based upon a knowledge of the following factors:

- (1) The highest power level which is to be handled.
- (2) The maximum ratio, of R.M.S. signal current to polarising current, below which the rectifier impedance is to be independent of the signal current.
- (3) The maximum polarising current density for which the impedance of the rectifiers (x) can be maintained inversely proportional to the signal amplitude at the control amplifier input.
- (4) The minimum permissible compressor circuit impedance ( $R_1$ ) which is decided by the value of  $R_3$  (Fig. 2).

The above conditions applied to the equivalent circuits of the compressor and expander, enable the values of all circuit components to be calculated in the normal way. It is perhaps of interest to note, however, that the effect of the above conditions is to

make the power handling capacity of the compressor and expander circuits directly proportional, both to the cross-sectional area of the rectifier elements and to the number of discs in series per rectifier.

#### Description of Compressor Unit.

The circuit diagram of an experimental compressor unit designed on the above principles is shown in Fig. 4. It is designed to operate in a circuit of 600 ohms impedance, in common with other audio-frequency repeater equipment. The input transformer  $T_1$  has a high step-up ratio to give the required high circuit impedance across which to bridge the control rectifiers  $W_1$  and  $W_2$ . The highest value reached by the impedance of  $W_1$  and  $W_2$  is small compared with the circuit impedance on the secondary side of  $T_1$ . The impedance of these rectifiers seen from the primary side of  $T_1$  is therefore practically negligible compared with the required input impedance, which is thus almost wholly determined by the resistor  $R_6$ . The resistor  $R_7$ , in parallel with the impedance looking back into the secondary winding of transformer  $T_1$ , together make up the resistance represented by  $R_3$  in Fig. 2.  $R_7$ , however, is much the smaller of the two components, so that changes in the impedance of the circuit to which the compressor is connected have but a small effect on the resultant impedance.

The compressor network is followed by the grid transformer  $T_2$  which steps up the voltage applied to the grid of the valve  $V_1$ . This valve is a fairly high slope pentode of the "voltage amplifier" type (V.T.106) and is choke fed via  $L_1$ . On account of the high internal impedance of  $V_1$ , the primary side of the output transformer  $T_3$  is closed by the resistor  $R_{11}$  to obtain the desired output impedance.

The gain of the valve  $V_1$  is arranged to be such that when the highest value of control current (1.75 mA) for which the compression characteristic remains

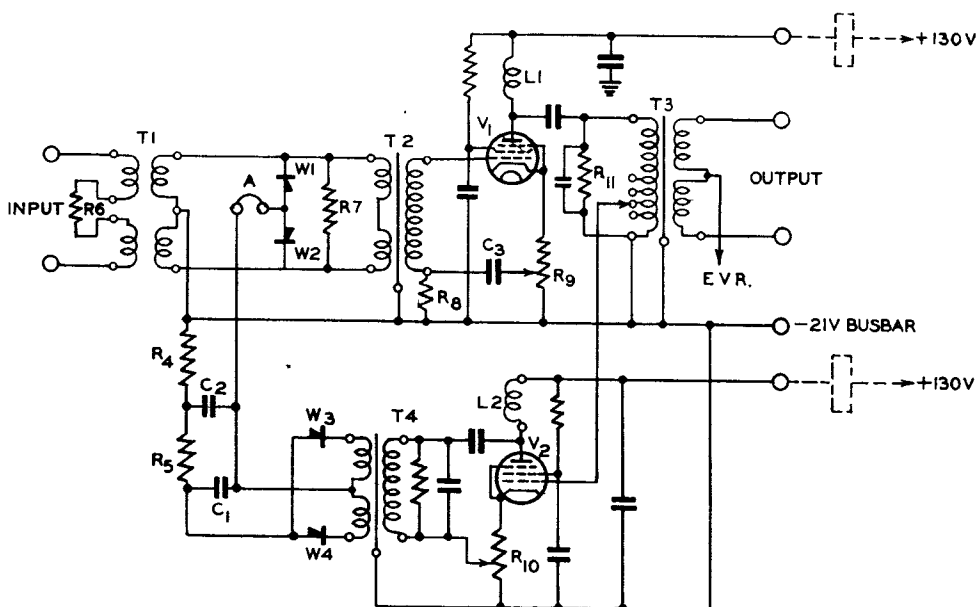

FIG. 4.—CIRCUIT OF THE EXPERIMENTAL COMPRESSOR UNIT.



linear, is flowing in the rectifiers  $W_1$  and  $W_2$ , the loss in the transmission path from input to output of the unit is zero. The potentiometer  $R_9$  provides a control of gain in this circuit of  $\pm 3$  db. by altering the negative feedback due to the auto bias resistor. This accommodates differences between individual valves.

The input signal to the control amplifier is obtained by taps on the primary winding of the transformer  $T_3$ , the voltage so obtained being applied directly to the grid of the valve  $V_2$ . This valve is of the same type as  $V_1$ , namely a V.T.106, the output of which is rectified by the elements  $W_3$  and  $W_4$ , thus providing the unidirectional control current.

It is clearly essential that the control current must be a function of the signal envelope and not of the instantaneous signal voltage. This is ensured by the resistance-capacitance filter  $C_1, R_5, C_2, R_4$ , which has a high attenuation to currents of signal frequency. Such a filter obviously imposes a time lag on the changes in the loss in the transmission path which are produced by the corresponding changes in signal level. The lower limit to the length of this time lag is set by the amount of distortion permissible at the lowest signal frequency. The upper limit is set by the quickness of perception of the human ear, which fortunately is very tolerant in this respect, and the length of the operating delay is not very critical. The lengths of operating delays which have been employed are approximately 10 mS. for increases in signal level, and 20 mS. for decreases in signal level. These values have been found in practice to be quite suitable for trunk line use.

In order that the compressor unit may be used at points in the transmission circuit at different relative levels, the gain of the control amplifier is made variable by 5 db. taps on the primary winding of transformer  $T_3$ , and by the potentiometer  $R_{10}$ , which gives an additional control of  $\pm 3$  db. by

varying the negative feedback introduced by the autobias resistor. The compressor unit is suitable for operation at relative level points between  $-10$  db. and  $+5$  db.

The device has been designed to have zero gain when a power of 1 mW is applied to the 2-wire terminal of the transmission circuit, and as stated above, the device should have zero gain when the value of the control current is 1.75 mA. When the compressor unit is to be set up, the following procedure is necessary: The U-link "A" is removed and a suitable D.C. milliammeter connected in circuit. An 800 c/s tone is then applied to the input, at a level referred to 1 mW corresponding to the relative level of the point of insertion in the transmission circuit. To make the gain zero and at the same time to adjust the control current to 1.75 mA, the following course must be adopted, since owing to the retro-active form of the circuit these two adjustments are inter-dependent.

The potentiometer  $R_9$  is set near the middle of its range of adjustment and by the taps on the transformer  $T_3$  and the potentiometer  $R_{10}$ , the control current is set to 1.75 mA. It will then be found that the overall loss of the device is not zero. Half the actual loss (or gain) is then taken up on the gain control  $R_9$  and the remainder on the other gain control  $R_{10}$ . It will be found that the deviation of the control current from 1.75 mA caused by the adjustment of  $R_9$  will have been neutralised by the subsequent re-adjustment of  $R_{10}$ .

#### DESCRIPTION OF EXPANDER UNIT

Fig. 5 shows the circuit diagram of the experimental expander unit. In respect of the speech amplifier and control amplifier-rectifier portions of the circuit, the expander is identical with the compressor, with the one exception that, whereas the input signal for the control amplifier is derived from the com-

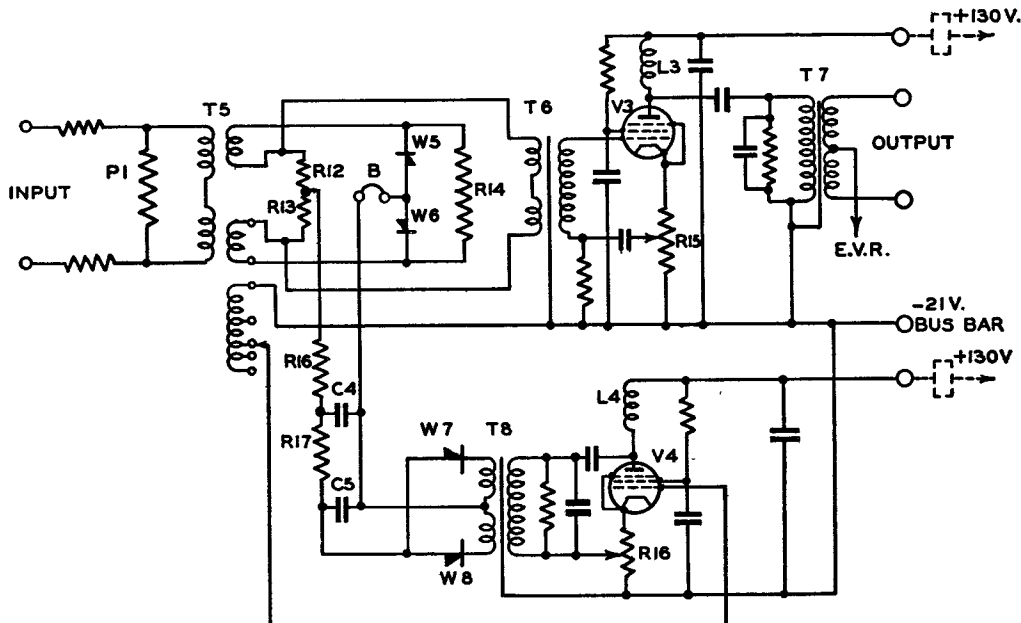

FIG. 5.—CIRCUIT OF THE EXPERIMENTAL EXPANDER UNIT.

pressor output circuit, in the expander it is derived from the input circuit. This arrangement is adopted in order that the two control circuits shall be separated only by a linear circuit thus enabling the non-linear impedance networks in both the compressor and expander units to be controlled by the signal level in an identical manner.

In Fig. 5 the transformer  $T_5$  has a high step down ratio and this, together with the asymmetrical pad  $P_1$  provides the required low circuit impedance when looking back into the secondary winding of the transformer  $T_5$ . The resistors  $R_{12}$  and  $R_{13}$  together correspond with the resistor  $R_2$  of Fig. 1, the series circuit being completed by the non-linear impedance network  $W_5$ ,  $W_6$  and  $R_{14}$ , together corresponding to "x" in Fig. 1(b). It will be seen that this network is identical with that in the compressor circuit, except that  $R_{14}$  is equal to the resistance of  $R_7$  in parallel with its associated circuit impedance in Fig. 4, thus providing the impedance compensation shown in Figs. 1(c) and 1(d). Compensation for the series resistance of the expander circuit in the manner of Figs. 1(e) and 1(f) was not found to be necessary.

The output signal voltage from the expander network, which is developed across the resistors  $R_{12}$  and  $R_{13}$ , is stepped up by the transformer  $T_6$  before it is applied to the amplifier valve  $V_3$ . Both of the valves used in the expander are of the same type as in the compressor.

The input signal to the control amplifier is derived from the tertiary winding on the transformer  $T_5$ . This winding is tapped at 5 db. intervals, so that, as in the compressor unit, the expander can be operated at points in the transmission circuit of different relative levels. The range covered is zero to + 10 db. relative to a zero level point in the transmission circuit.

The setting-up procedure for the expander is similar to that already described for the compressor. The transmission path gain adjustment  $R_{15}$ , and the control amplifier gain adjustment  $R_{16}$  are, however, independent in their operation, and can therefore be adjusted individually.

#### PANEL LAYOUT

Fig. 6 shows a laboratory model of a complete compandor. The 8 $\frac{3}{4}$  in. by 19 in. panel carries one

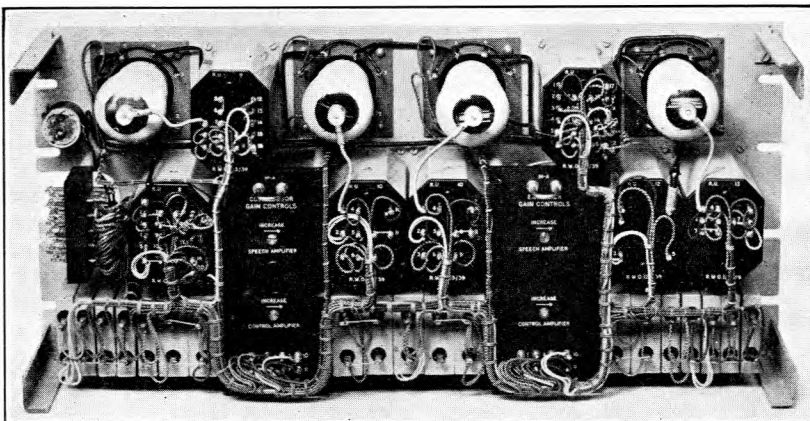

FIG. 6.—LABORATORY MODEL OF ONE COMPANDOR.

compressor unit and one expander unit. Although there are certain applications envisaged where pairs of compressors or pairs of expanders on the one panel will be required, the arrangement shown is a convenient one for the majority of uses.

In the design of this unit, use has been made of a transformer assembly which enables two transformers, or a transformer and a choke to be mounted, together with auxiliary components, in a single pot. The base area of this pot is identical with that of the standard Post Office transformer pot used for the  $\frac{1}{2}$  in. core bobbins, and the fixing centres also are the same. By this means a considerable saving in space has been obtained, and full use has been made of the available depth beneath the 4 $\frac{3}{4}$  in. cover, standardised for repeater equipment.

The left-hand half of the panel is occupied by the compressor and the right-hand half by the expander. The rectifiers, together with the gain control potentiometers, are mounted under the ebonite sub-panels, which are readily removable to permit of inspection of these components.

The four valves are run in series, and a padding resistor included on the panel enables it to be run directly from the 21 V "A" battery supply. The current required is 1 A. To obtain the required power handling capacity from the valves, the A and B batteries are used in series giving 150 V H.T., by connecting the "earth" line of the amplifier valve circuits to the - 21 V busbar as shown in Figs. 4 and 5. The total H.T. consumption is approximately 25 mA.

#### Performance.

It has been found possible to obtain a straight line compression characteristic within close limits for a range of input levels of some 60 db. The following table is typical of the characteristics which have been obtained in the laboratory. The input and output levels are both relative to the power at which the gain of the device has been adjusted to zero, i.e., the reference level.

TABLE I.

Input level—db.	0	-10	-20	-30	-40	-50	-60
Output level—db.	0	-5.3	-10.4	-15.3	-20.0	-24.9	-30.4

To obtain characteristics of the same degree of linearity between the levels of - 40 and - 60 db., as that given in Table I, the rectifiers used must be selected. The basis of selection, however, is not at all severe and should not give rise to any production difficulties.

The overall linearity of a compressor and an expander unit in cascade is shown in the following table. The levels are measured relative to the same datum as those given in Table I.

It would therefore appear that no difficulty should be encountered under production conditions in

keeping the overall non-linearity within  $\pm 0.5$  db., at least, over a range of levels of 50 db.

TABLE II

Input level to compressor unit, db.	0	-10	-20	-30	-40	-50	-60
Input level to expander unit, db.	0	-10	-20	-30	-40.1	-50	-59.6

In respect of the frequency response of the equipment, the performance obtained is satisfactory for all trunk circuit requirements. The overall loss of the compressor and expander in cascade is within  $\pm 0.5$  db. of the 800 c/s value for all frequencies between 300 and 2,600 c/s.

The transient performance obtained is indicated by the oscillograms of Fig. 7, which were taken with the two units in cascade. The upper oscillogram shows the action of the compandor when the signal level is suddenly changed by approximately 10 db. The trace "A" is the input signal to the compressor unit and "B" is the corresponding output signal which was then applied to the input of the expander. Trace "C" shows the output signal from the expander. The amount of transient distortion in the operating period is shown by trace "C" to be negligible.

The lower oscillogram of Fig. 7 shows the distortion produced when an impulse of tone is suddenly applied to the compandor in the quiescent state. The trace "C" again shows the output signal from the expander section. A slight amount of wavefront distortion is noticeable although otherwise the restoration of the waveform effected by the

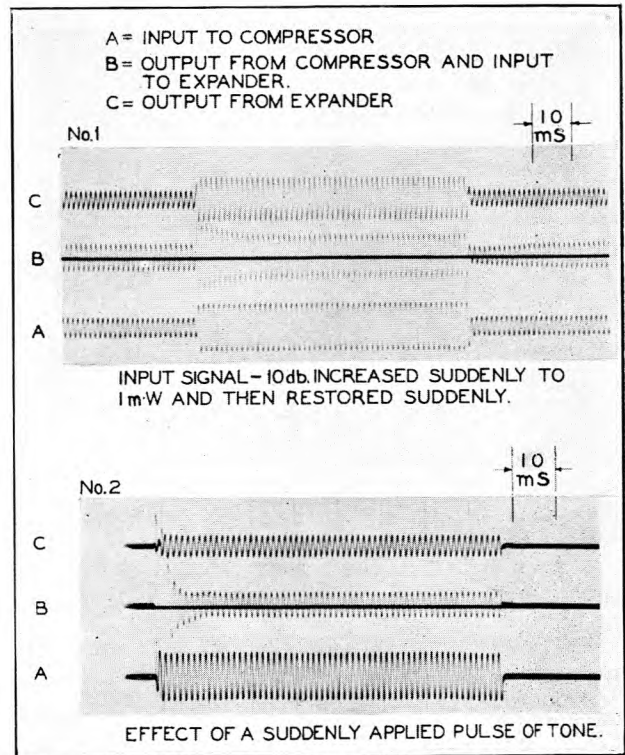

FIG. 7.—OSCILLOGRAMS OF COMPRESSOR AND EXPANDER IN CASCADE.  $f = 800$  c/s.

expander is satisfactory. The wavefront distortion is due to overloading of the transmission path between the compressor and expander during the first 1 or 2 mS of the impulse.

## The Evolution of the Standard Diagram Corner Stamp

The earliest form of diagram used in the Engineering Department consisted merely of a circuit, a title and a diagram number, with these arranged in a variety of ways. Gradually the need for some form of departmental identification, coupled with a desire for a uniform layout of the tracing, led to the first attempt to devise a simple arrangement of number box. This was usually stamped in the top right-hand corner of the tracing, and from this method the name "corner stamp" originated and has ever since been associated with the specially ruled-off portion for the insertion of all particulars relevant to a diagram. Later, when the stamp became enlarged and improved, it was stencilled on the tracing from a master

POST OFFICE ENGINEERING DEPT.			
ENGINEER-IN-CHIEF'S OFFICE			
DGM.			
SUPERSEDE			
SPECIFICATION DIAGRAM NOTES			
<input type="checkbox"/> SLOW OPERATE	<input type="checkbox"/> SLOW RELEASE		
APPROVED IN		BRANCH	
AMENDMENT	ENG'R	DATE	SUFFIX

stencil, but the present-day method is to supply tracing blanks with printed corner stamps.

With the gradual increase in the Department's requirements the corner stamp was enlarged from time to time to include such entries as supersession notes, specification numbers, diagram notes and the originating Branch. The symbols for the slow-operate and slow-release relays were also added on circuit diagram as a result of the reversal of these conventions in accordance with the international agreement on symbols.

Then came a comprehensive agreement between all the hitherto conflicting interests by which the sizes of tracings were finally laid down and standardised, and this paved the way for the latest stamp which has been designed to meet the requirements of all users of diagrams. It has been standardised for all circuit diagrams except loose leaf and those on demy quarto or double demy quarto, and is supplied with or without the relay symbols.

Drawing Office references and initials are not provided for in the stamp but are accorded a small box in the 1 in. margin of the blank; this has allowed space for a greater number of approval signatures which is necessary for diagrams approved by more than one section of a Branch.—C. D. L.

# Modern Materials in Telecommunications

U.D.C. 539 679.5.678

W. G. RADLEY, Ph.D.(Eng.), M.I.E.E.

C. E. RICHARDS, F.I.C.

E. A. SPEIGHT, Ph.D., D.I.C., A.R.C.S.

E. V. WALKER, B.Sc., A.R.S.M.

## Part II.—Some Organic Structures and their Properties

This article deals with some of the organic materials which are used in making telecommunication apparatus and may in the future be even more extensively used. Following a brief introduction to structural organic chemistry, the building up of large molecules is discussed and the relationship between the structure and fundamental properties of some of these substances is described.

### Introduction.

At first sight it might appear that the structures of the compounds of carbon, generally called organic compounds because they were at one time believed to be associated entirely with living matter, are a great deal more complicated than those of metals and alloys. It is true that organic materials are built up of molecules each containing, it may be, a score, or perhaps many more, atoms, and that each molecule appears of itself to be an elaborate and complex structure. Within each molecule, however, the atoms are held together by chemical bonds of which chemists have a very definite picture as a result of much study of the compounds of carbon. The organic chemist, therefore, starts his process of constructing materials with preformed units which, being complete molecules, are considerably larger than the atomic "bricks" available to the metallurgist.

In pure metals all the atoms are alike; even in alloys the number of different kinds of atom present is usually small, and it is possible to produce series of alloys having a continuously varying range of compositions, many of which do not correspond to the formation of chemical compounds.

So far, scientists have not succeeded in probing the secrets of the bonds holding metallic atoms together as deeply as they have those in organic compounds. In consequence the rules to which the atomic engineer can look for guidance on the synthesis of new metallic materials are, at present, much less clearly defined. For this reason the structure of organic substances may, with advantage, be studied first.

### The Fundamental Structure of the Carbon Compounds.

Carbon compounds are often a source of mystery to non-chemists. This may largely be due to the chemist's shorthand way of writing the structures of these substances, frequently without even indicating what elements are present. When the conventions followed are understood these structural formulæ give a clue to all the important general properties of a compound.

The basis of the structure of organic compounds is that the carbon atom has four symmetrically placed points at which other atoms or groups may be attached. In all stable organic compounds all these points are connected to other groups and none of them is left spare. The bonds connecting atoms or groups together are called *valencies*, and so carbon is termed a *tetravalent* element.

The simplest organic compound known is methane; its analysis has shown that its composition is  $\text{CH}_4$ .

This analysis gives no clue to the way in which the hydrogen atoms are attached to the carbon. Since carbon is tetravalent and hydrogen monovalent the structure of methane must be something like this

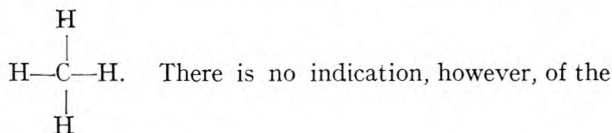

direction or equality of the bonds; it would, therefore, seem that four compounds  $\text{CH}_3\text{Cl}$  might be possible:

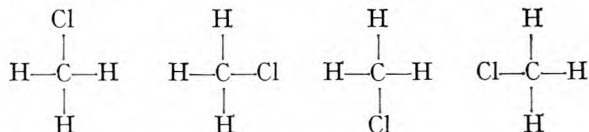

Actually only one compound of this composition exists, so it must be inferred that all the four valencies of the carbon atom have exactly equal values. The only pictorial way in which this can be represented is to regard the carbon atom as being situated at the centre of an imaginary regular tetrahedron, and having its valencies acting towards the corners.

Considering the three simple carbon compounds, methane,  $\text{CH}_4$ , ethane,  $\text{C}_2\text{H}_6$ , and ethylene,  $\text{C}_2\text{H}_4$ , and representing carbon in the usual way their structures are:

Methane: Composition  $\text{CH}_4$

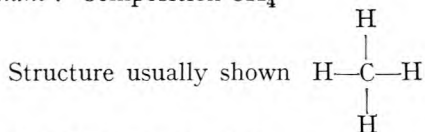

Actual space structure

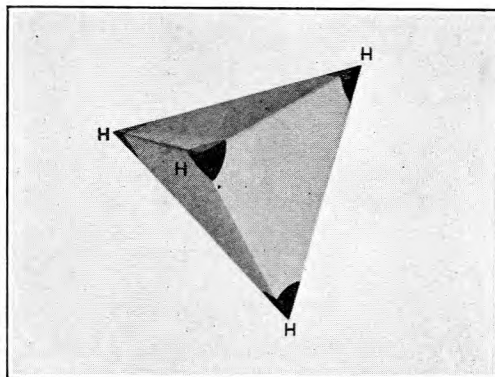



Ethane: Composition  $C_2H_6$

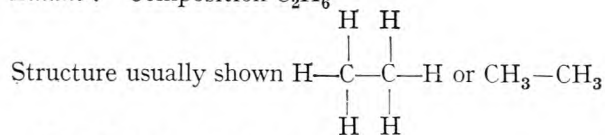

Actual space structure

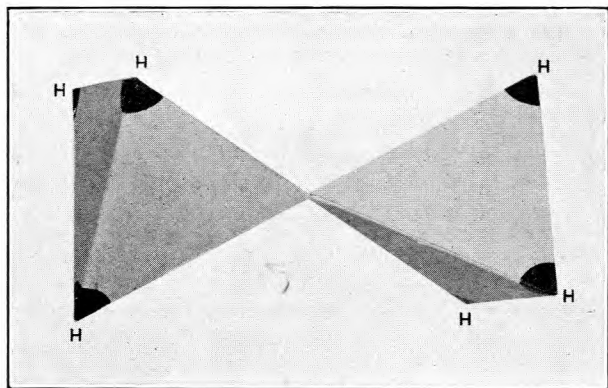

In the ethane structure it will be seen that there is only one point connection between the two  $\text{CH}_3$  units, which are, therefore, free to rotate with respect to one another. This is the only kind of linkage between carbon atoms in hydrocarbons of this type which are called *saturated*, but there is another class of compound called *unsaturated* in which there are two or three points of attachment between adjacent carbon atoms. This is typified by:

Ethylene: Composition  $C_2H_4$

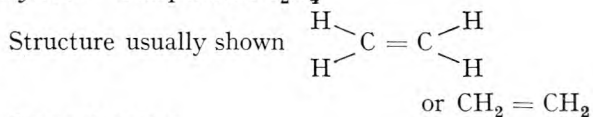

Space structure

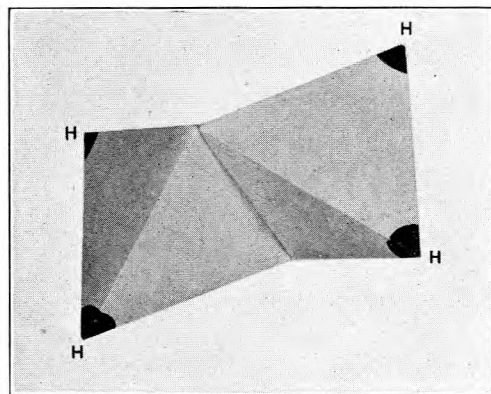

Here the units are joined at two places and consequently rotation of one of the  $\text{CH}_2$  units with respect to the other is not possible. This has been proved chemically, and confirmed by examination of the physical properties of ethylene and some of its derivatives.

Similarly acetylene  $\text{CH} \equiv \text{CH}$ , briefly indicated with a triple bond, has a three-point connection between the carbon atoms:

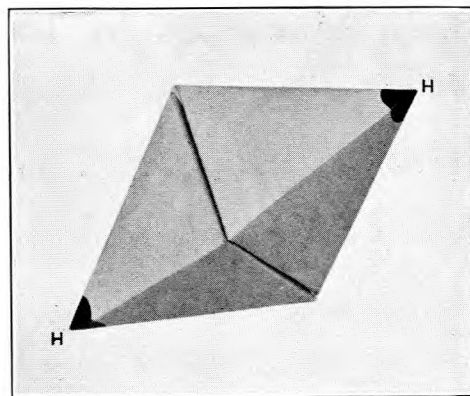

In writing down the structural formulae of carbon compounds the short way, two slightly different methods are found in the literature; in one the bonds between carbon atoms are shown as short dashes and in the other they are dots. For example propylene,  $C_3H_6$ , may be shown:

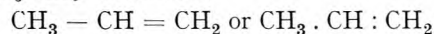

Both these mean the same, but since dots are often used to indicate electrons, the former method will be adopted in these articles.

A noteworthy feature of organic compounds is the fact that very frequently groups of atoms forming part of a molecule persist unchanged throughout a long series of chemical changes or, alternatively, may be transferred bodily from one compound to another. In one sense such a group appears to behave like a single large atom, and is called a "radical." This fact leads to a considerable simplification of structural formulae. The group of atoms  $\text{CH}_3$  — is one of many examples. This is the methyl group or methyl radical and is conveniently abbreviated to Me.

From the structures given above it might be inferred that compounds such as ethylene,  $\text{CH}_2 = \text{CH}_2$ , which contain a double bond would be more stable than those such as ethane,  $\text{CH}_3 - \text{CH}_3$ , which have only single bonds. This is definitely not so—a fact which is easily realised if we consider the positions of the atoms and bonds in space.

In the saturated hydrocarbons both theory and the results of X-ray diffraction show that the bond between any two carbon atoms lies along the straight line joining the centres of these atoms. Thus, although the formula of the hydrocarbon propane is usually written:

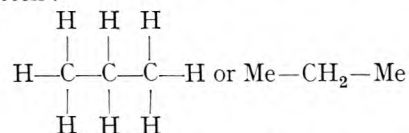

the tetrahedral theory of the carbon atom implies that the two bonds joining the two methyl groups to the central carbon atom are not collinear, but are actually inclined at an angle of  $109^\circ 28'$  (the so-called "tetrahedral angle") to one another.

In ethylene, on the other hand, these conditions cannot be satisfied, as two bonds starting from one carbon atom have to terminate at the same second carbon atom. Either the bonds must be bent or

the angle between them cannot be  $109^{\circ} 28'$ , or, most probably, both these effects are present. It follows that the linkage between the carbon atoms is in a state of strain—a fact which is easily substantiated by experiment and gives rise to the known lower order of stability of unsaturated compounds.

Carrying the argument a stage further, substances which contain triple bonds are usually very unstable. Acetylene, for example, under suitable conditions will decompose spontaneously with explosive violence in the absence even of air or oxygen.

It should not be thought, however, that weakness of the kind caused by double or triple bonds is necessarily a disadvantage. On the contrary, doubly or trebly linked carbon atoms are centres of high chemical activity which, as will be seen later, have been very fully exploited by chemists. In fact, practically all the new organic materials used by the engineer owe their existence to processes which utilise the peculiar reactivity of the double bond. To choose a simple example, the substance ethylene dibromide:  $\text{CH}_2\text{Br}-\text{CH}_2\text{Br}$  (used in the preparation of "ethyl fluid" anti-detonant for petrol) could be made by replacing two of the hydrogen atoms of ethane by two bromine atoms. This reaction is, however, so slow and difficult to carry out that it would be commercially impossible. Ethylene, however, reacts practically instantaneously with bromine at ordinary temperatures by simple addition at the double bond:<sup>1</sup>

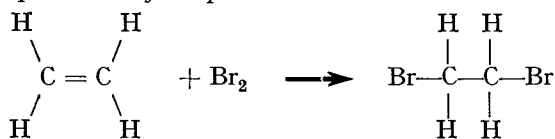

There are two general types of organic compounds, the aliphatic and the aromatic. Aliphatic compounds are so called because of their relationship with the fats and the name is applied to all compounds which may be regarded as derivatives of methane,  $\text{CH}_4$ . Such materials as octane,  $\text{C}_8\text{H}_{18}$ , stearic acid,  $\text{C}_{17}\text{H}_{35}\text{COOH}$ , and ethyl alcohol,  $\text{C}_2\text{H}_5\text{OH}$ , are representatives of this group, all of which have essentially open chain structures, e.g., octane:

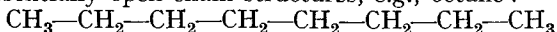

Aromatic compounds, on the other hand, have a closed chain or ring structure similar to that of benzene. Benzene itself has the composition  $\text{C}_6\text{H}_6$  and the structure:

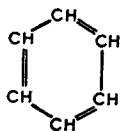

which is for convenience reduced to:

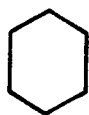

Another typical aromatic compound, naphthalene,  $\text{C}_{10}\text{H}_8$ , is:

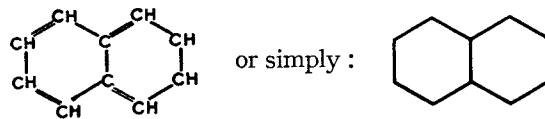

Many compounds, of course, combine both aromatic and aliphatic elements, for example, styrene,  $\text{C}_8\text{H}_8$ , is written:

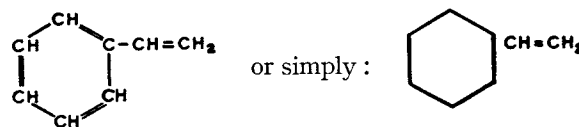

### Large Molecules.

The manufacture of most of the new synthetic insulating materials depends mainly on the ability of scientists to synthesise large molecules. Large molecules are, in themselves, no new things; for several years the layman has been able to talk and think intelligently about proteins, which he gets in his roast beef, and starch, which is the essential component of roast potatoes and Yorkshire pudding. Protein and starch are representatives of the class of large molecules. Even the synthesis of large molecules has a classic flavour; organic chemists have ever been plagued by reactions which, for some reason, have taken the wrong turning, and instead of producing nicely crystalline or coloured compounds have left the unfortunate with a flask full of glutinous substance, called, for the want of a better word, tar.

Until 30 or 40 years ago it was usual to throw away these tarry messes and to start again, hoping to avoid the error which led to their formation. Baekeland's work, published in 1909, immediately reversed this process, and chemists all over the world have been eagerly seeking reactions which will produce resinous bodies. The fact that these bodies are frequently of unknown constitution is considered no drawback if they have technically valuable properties. A great deal of work has, however, been done to elucidate the constitutions of these substances and, as a result, chemists are now able largely to design these products to have properties "made to measure."

In building up large molecules two processes are now generally considered the most useful; these are polymerisation and condensation. Polymerisation often takes place alone, but condensation is often accompanied by polymerisation. These two processes have given us the large majority of plastic materials used in telephone equipment, a distinguishing feature of these materials being their construction from large molecules. A third process, esterification, is used to modify the properties of certain large molecules, but has little effect on their size.

*Polymerisation* consists of linking up a number of similar small molecules (called the monomer) to give a large one (the polymer), which has the same percentage composition as the small one but different

<sup>1</sup>Although from the two dimensional formula it might seem that more than one compound  $\text{CH}_2\text{Br}-\text{CH}_2\text{Br}$  could exist, study of the solid model shows that this cannot be so.

physical and chemical properties. Thus, if we consider ethylene,  $C_2H_4$ , the monomer is a gas whose molecules are distributed at random. If this is suitably treated we obtain poly-ethylene :

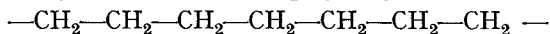

The length of this chain may be 1,000 ethylene units, and the product may be an oil or a waxy solid (depending on the chain length), differing physically and chemically from the original substance.

*Condensation* is a process which consists of the linking together of two or more molecules accompanied by the elimination of some substance, usually water.

*Esterification* may be regarded as a particular type of condensation. It involves the combination of an alcohol and an acid, and is accompanied by elimination of water.

#### *Polymerisation Synthetics.*

All those at present in commercial use may be considered as derivatives of ethylene. Their properties are, however, largely modified by the non-ethylenic residue in the molecule. For convenience these may be regarded as falling into three classes:

1. Polymers of rubber-like texture which are saturated compounds, therefore chemically inert.
2. Polymers of rubber-like texture which are unsaturated compounds, chemically active.
3. Polymers which are hard in the pure state.

#### *Chemically Inert, Rubber-like Polymers.*

Two commercial materials exist which are essentially paraffinoid in structure, e.g., they are hydrocarbons of the general type  $CH_3(CH_2)_nCH_3$ . These are poly-ethylene ("Polythene") and poly-isobutylene (Oppanol, Vistanex). Both of these are of more than usual interest to the telecommunications engineer, as it seems possible that they may provide him with a submarine cable dielectric, having electrical properties superior to those of materials such as paragutta which are compounded from natural products.

Ethylene, as already mentioned, polymerises to a straight chain of  $CH_2$  groups, maybe 2,000 units long.

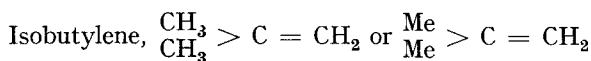

polymerises to a similar long chain. The resulting polymer has the structure :

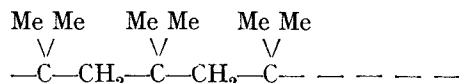

union between molecules having taken place in the usual way at the double bonds.

Polythene and Oppanol have the following general properties :

- (a) They are chemically very stable.
- (b) The molecule length may be reduced by mechanical means.
- (c) They are permanently thermoplastic.

#### *Chemically Active, Rubber-like Polymers.*

The truly rubber-like materials are generally based on monomers which, unlike ethylene and isobutylene, have not one, but two double bonds in the molecule. Rubber itself appears to be a polymer of isoprene

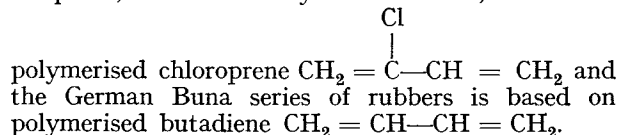
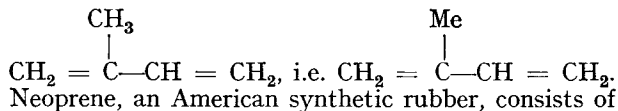

Neoprene may be used instead of rubber when resistance to oil, oxidation or sunshine is required ; it has also the advantage of being non-inflammable. Its resistance to ozone makes it suitable for high tension ignition cable, but its electrical properties are poor compared with ordinary rubbers.

Few of the Buna series of rubbers are well known outside Germany. They resist ageing better than natural rubber, and some of them are exceedingly oil resistant. In Germany they have been used for almost all purposes to which rubber is put, particularly for soft rubbers. Buna tyre rubber (Buna S) is claimed to last about 25 per cent. longer than natural tyre rubber.

The structure of Buna will not be discussed here, not because it is lacking in interest but because the various grades consist of cross-linked polymers of butadiene with other materials such as styrene.

In the polymerisation of isoprene and chloroprene only one double bond in the unit needs to react so as to give a long chain polymer ; the other one actually moves one step along the chain during this process, so we have the reaction :

#### *Isoprene :*

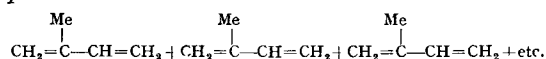

#### *Rubber :*

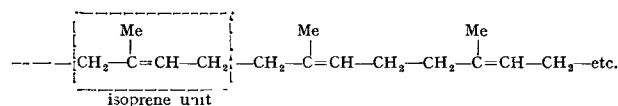

The similarity between this chain and the Oppanol chain is clear, as is its difference ; at intervals in the chain there still exists a chemically active double bond.

Rubber and Neoprene have the following general properties :

- (a) They are chemically active.
- (b) The molecule length may be reduced by mechanical work.
- (c) They are permanently thermoplastic.

The properties of the rubber-like substances can be changed by acting on the double bond. The action of sulphur in vulcanising rubber is not completely understood. It is known to add itself on at

the double bond, and is believed to cause a certain amount of cross linkage between molecules. Whether this cross linkage takes place through the sulphur atom or is merely assisted by the sulphur in vulcanisation is not clear, but the final structure of vulcanised rubber may be:

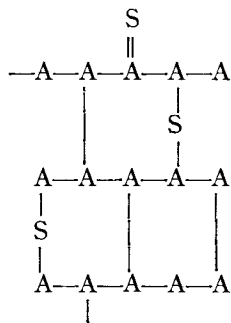

where A represents the basic isoprene unit.

Neoprene is also capable of vulcanisation but here cross-linkage can also occur spontaneously. These vulcanised products differ in one fundamental property from those substances previously described; they are no longer thermoplastic. The cross-linking which has occurred has stiffened the molecule so that although still elastic, it has a definite shape, and when deformed it tends to return to that shape. Sulphur is not the only element which can be added to rubber at the double bond. Oxygen, chlorine, hydrochloric acid, etc., will all combine.

#### Styrol, Vinyl and Acrylic Acid Resins.

Commercial examples of these are Trolitul, Mipolam and Vinylite and Diakon (or Perspex). Trolitul, Vinylite and Diakon are extensively used for decorative mouldings, Diakon being used for the familiar coloured telephones. Perspex which is a sheet form of Diakon, is used for aeroplane windshields and for several optical purposes. Mipolam has been largely used as an extruded insulation for electric wires. All these substances can be attractively coloured.

When it was realised that the presence of the so called vinyl structure (i.e., the  $-C=CH_2$  group at the end of a carbon chain) in a substance was a good indication of a tendency to polymerise, all materials containing this structure were examined to see whether they would give valuable products. Many commercial substances are now available having these structures. The three most important ones known in this country are polystyrene, polyvinyl chloride and poly-methyl methacrylate.

#### Polystyrene (Trolitul, Distrene).

Styrene



polymerises in the

usual way, giving a long chain product which can be depicted:

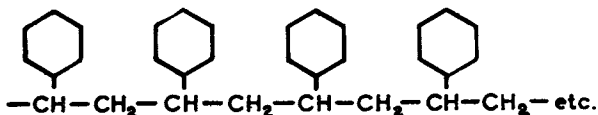

#### Polyvinyl Chloride (Mipolam, Vinylite).

Vinyl chloride  $Cl-CH=CH_2$  also polymerises to a chain structure:

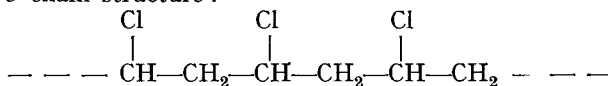

#### Poly-methyl Methacrylate (Diakon, Perspex).

Methyl methacrylate,  $COO-Me$  has the characteristic vinyl grouping and polymerises in the usual way. Writing X for  $COO-Me$  we have a polymer of the structure:

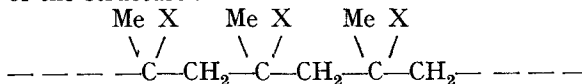

Again the long straight chain.

The general properties of this group are:

- Chemically they are inert.
- The molecule length may be reduced by mechanical work.
- They are permanently thermoplastic.

#### Cellulose Products.

Cellulose plastics include celluloid—probably the most versatile of all plastics—cellulose lacquers, as used on motor bodies, high-class artificial silk, and many decorative mouldings. Cellulose acetate has a high resistance to mechanical shock, which has led to its being adopted for cradles and plungers for hand micro-telephones.

Cellulose is one of nature's syntheses of long-chain products. Logically, therefore, it should be considered before man-made materials. From some points of view, however, it is much more complicated than the synthetic plastics, an understanding of the structure of which may assist in visualising the cellulose structure. Again, although many of the cellulose derivatives have physical properties similar to those of the synthetic long-chain polymers, it is probable that nature actually builds up cellulose not by polymerisation but by a condensation process from a large number of molecules of glucose. The latter, then, is the fundamental unit of cellulose and has the formula:

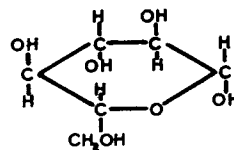

Writing this unit



the cellulose chain becomes:

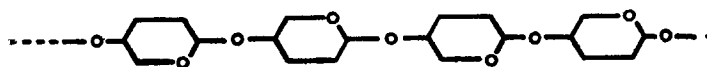

Cellulose itself is, of course, not a plastic in the ordinary way, it is a cellular fibrous structure. When converted into acetate or nitrate, however, it becomes similar in properties to many of the other thermoplastics.



### General Properties of Long-chain Polymers.

Long-chain polymers are in general elastic bodies. Their strength and elasticity are largely dependent upon chain length which approaches ordinary measuring units. It may seem strange that long straight chains of units should be elastic, but in reality these "straight" chains are zig-zags, or helices. That this must be so will be realised from the tetrahedral representation of the carbon atom, in which adjacent single carbon bonds lie at the angle of  $109^{\circ} 28'$ . It has already been stated that the properties of these thermoplastic substances can be altered by milling or other mechanical work. The usual example of this is rubber, which, during preparation for vulcanising, is passed several times between hot rolls, a process which tends to break down the chain length, and also allows some oxidation to take place at the double bonds.

With the synthetic plastics modification of mechanical properties is more usually brought about by incorporating a quantity of 'plasticiser' in the material. A plasticiser is a non-volatile softening agent which can be incorporated with the hard resin. Some plasticisers work by causing gelatinous swelling of the resin (like water on glue), and others are definite solvents. The classical example of a plasticiser is the use of camphor in celluloid. This was patented by Parkes in 1864, and for its purpose has never been surpassed.

By incorporating plasticisers the mechanical properties of thermoplastic resins may be so modified that no table of properties could cover all the possibilities. A particularly interesting example is that of polyvinyl chloride; the pure material is hard and brittle, but, suitably plasticised, the substance can be stretched or twisted into grotesque shapes, and, when the stress is released, will quite slowly revert to its original shape.

### Condensation Synthetics.

Only two types of these resins are widely used in this country, though many others are known, several of which are used abroad. Of these resins, the phenol-formaldehyde type, popularly known as bakelite, represents a large proportion of the world output of plastics.

"Bakelite" type plastics are the Jacks of all trades in the moulding world. Such things as door handles, car instrument boards, instrument cases, ash trays, radio sets and telephones are examples of their uses. Laminated sheet with paper filling is a well-known insulator, and with a fabric filling is used for gear wheels, etc. Urea plastics are used for the more delicately tinted articles—radio sets in pastel shades, cosmetic boxes, and other decorative mouldings—which cannot be made from phenolic plastics as these are naturally dark coloured and grow darker with age and exposure to light.

The final structures of these thermo-setting plastics (so called because once they have been moulded their shape is permanent and they cannot be softened by heating) are not yet fully understood. In the earlier stages of the reaction long-chain molecules are formed which are thermoplastic, but in the last stages of the manufacture of a thermo-setting resin these linear

polymers and condensation products join up to give cross-linked structures built up more or less in the following way :

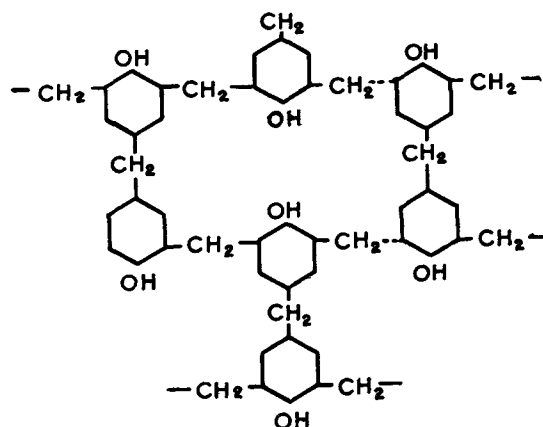

This structure has been assigned to the phenol-formaldehyde resins; urea-formaldehyde resins, such as "Beetle," are believed to have a similar type of structure.

Resins of this type are hard and infusible; they cannot readily be made softer by the use of plasticisers. It is, therefore, necessary to accept this hardness and to modify them within limits by incorporating different kinds of fillers. It is usual for a commercial moulded phenol plastic to contain about 50 per cent. by weight of wood flour or other cellulose filler, but other fillers such as slate powder are used for special purposes.

### General Summary.

Plastics, synthetic and natural, fall into three large groups, all of which are capable of much subdivision.

1. Chemically saturated bodies built upon a skeleton chain of carbon atoms of the following type :

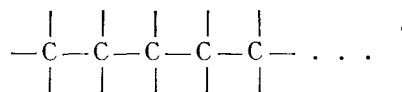

These are inert, permanently thermoplastic, can be modified by incorporating plasticisers and have individual properties determined by the nature of each unit.

2. Chemically unsaturated bodies based on the general structures :

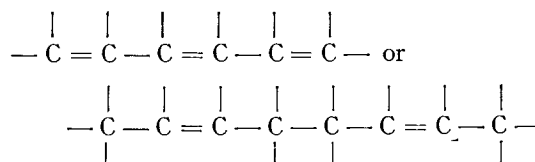

These are active chemically, permanently thermoplastic, and can be modified by incorporating plasticisers. By suitable chemical treatment additions can take place at some or all of the double bonds, converting them into materials of group 3.

3. Cross linked structures such as :

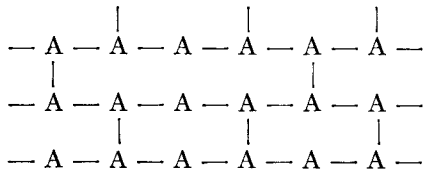

in which A may represent a complex unit.

These substances are not thermoplastic ; once they have been formed into their shapes they cannot be heated and reformed into other shapes.

*The Mechanical Strength of Plastics.*

It is now known that the mechanical strength of most materials is much lower than theoretical calculations would indicate. This fact has received considerable attention during the past few years and some hypotheses have been put forward to account for it.

The phenol-formaldehyde thermo-setting resins have been the subject of special treatment. de Boer<sup>2</sup> shows that in a resin of this type, if the whole mass were completely polymerised throughout, and all the possible carbon-carbon linkages formed, the strength should be about 4,000 kg./mm<sup>2</sup>. If, instead of the whole block being one unit, it consists of a number of irregular smaller blocks held together by the ordinary forces of physical cohesion in materials, then the value should be about 35 kg./mm<sup>2</sup>. The actually measured strength was only 7.8 kg./mm<sup>2</sup>. It is suggested that some of the linkages shown in the structure for thermo-setting resins have not actually been made, owing to the units being too far apart in space. This is easier to understand when it is realised

<sup>2</sup>Trans. Farad. Soc. 1936, 32, 10.

## Book Review

"Cathode Ray Oscillographs." J. H. Reyner, B.Sc., A.C.G.I., D.I.C., A.M.I.E.E., M.Inst.R.E. 177 pp. 128 ill. Pitman. 8s. 6d.

This book is intended to provide a guide to practical applications of cathode ray oscillographs which are becoming more and more an essential part of many types of measuring and indicating apparatus. With ordinary measuring methods, employing meters as the indicating devices, a laborious set of measurements is generally required to obtain the same information as is shown nearly instantaneously on the cathode ray screen. The present book does not attempt to enumerate all the uses to which this type of oscillograph has been put, but by discussing the practical difficulties associated with their use, and the more important classes of application, it should act as a valuable guide to their use in any new application.

The design of cathode ray tubes is only treated in brief outline, as the book is intended to be a text on cathode ray oscillographs and not on cathode ray tubes. There is a useful chapter on the various distortions of the oscillograph record brought about by defects in the tube, its power supply or time base.

In view of the wide industrial application of cathode ray oscillographs, the simple treatment of the subject is to be recommended, but it is doubtful whether it should be necessary to explain the meaning of root mean square values in a book of this type. In addition, accuracy of statement should never be sacrificed for simplicity. For example, on p.52, it is stated that the

that although these structures are, for simplicity, shown in one plane, they actually are solid three dimensional frameworks, and that, although two reacting groups may appear properly lined up when drawn on paper they may actually be far apart in space. Thus, drawing the units of the resin as  $\square$  its structure might be like the following in which the dotted lines represent bonds which do not lie in the same plane as the rest of the molecule.

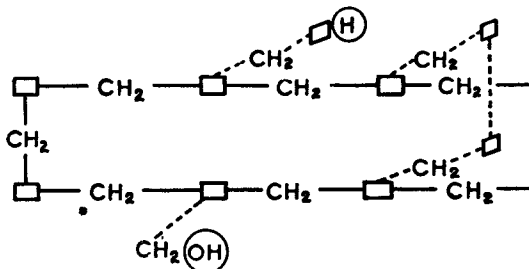

In this structure the  $\text{H}$  and  $\text{OH}$  might be expected to react to give another bridge in the structure, but owing to their spatial arrangement they cannot reach to do so. In this way, a resin, instead of being a solid mass, may contain a lot of fissures at which linkage has not occurred, and these will form weak spots in the fabric at which mechanical rupture will start. This theory is known as the "Lockerstellen" (loose points) theory. It may be remarked that some well-oriented cellulose derivatives actually develop the order of tensile strength required by theoretical considerations.

maximum phase angle in any "single circuit" is 90 deg., but exactly what is meant by such a circuit is not made clear. The "phase of the current" is referred to on p. 160, but it is not made clear that this phase is measured relative to the phase of the voltage applied to the circuit.

Deflection amplifiers form one of the most important accessories of cathode ray oscillographs in view of the large deflection voltages required, particularly with hard tubes, and the author has appreciated this by including a useful chapter on the design of simple amplifiers. In view of the wide differences in frequency range required from such amplifiers, the differences between the design of an amplifier to cover audio frequencies and one to cover a frequency range of 1 Mc/s, or more, might have been made clearer by comparison between two typical circuits covering these ranges.

The remaining chapters are devoted to the principal uses of cathode ray oscillographs, including waveform examination, production of frequency response, and valve characteristic curves, frequency comparison, examination of modulation envelopes, and other special applications.

The book is copiously illustrated with diagrams and photographs, and the many practical tips included indicate that the author has had a close personal acquaintance with cathode ray oscillographs as laboratory tools. The book can be recommended to all who have occasion to use these oscillographs, and it should stimulate their use in new applications. R.F.J.J.

# Storm Damage to the Main Aerial System at Rugby Radio Station

U.D.C. 621.396.67 621.315.1.056.5

## General.

A RECENT article described how the main aerial system at the Rugby Radio Station<sup>1</sup> was replaced after having been in continuous use for about fourteen years. There was, therefore, every hope of getting another long period of use before any major maintenance again became necessary but the severe ice storm in January, 1940, destroyed that hope in the first year. The main aerial system was extensively damaged, the photographs accompanying this note giving some idea of the magnitude.

The difficulties of the maintenance engineers in ascertaining the extent of the damage can well be imagined remembering that a heavy mist followed the ice formation. In fact, it was two or three days before the mist cleared sufficiently to allow anything of the aerial system more than 100 ft. above the ground to be seen, and the helpless feeling of the maintenance staff patiently waiting for the mist to clear to see the tangles which they were sure had occurred at heights up to 800 ft., before they could

breakage of the insulators had resulted in the halyard end and insulator attachment whipping back over the masthead and carrying with it the cathead guard.

Fig. 2 shows a span of the main aerial which has fallen across the main mast stays. The aerial spreader in the foreground has had four of its arms torn from their sockets as a result of the aerial wire fouling the mast stays.

A main insulator assembly, one of the insulators being broken at its outer cap, can be seen in Fig. 3. The assembly is supported by the main halyard, the aerial tail rope is twisted round the insulators, and the aerial up-lead and one main span hang from the bottom of the insulators.

In Fig. 4 a span of the main aerial has fallen on an overhead line, due to breakage of the main insulators. The outer insulator caps and aerial attachment appear in the foreground. The heavy ice formation on the part of the aerial still suspended near the main mast is apparent.

Fig. 5 is a close-up view of the suspended portion

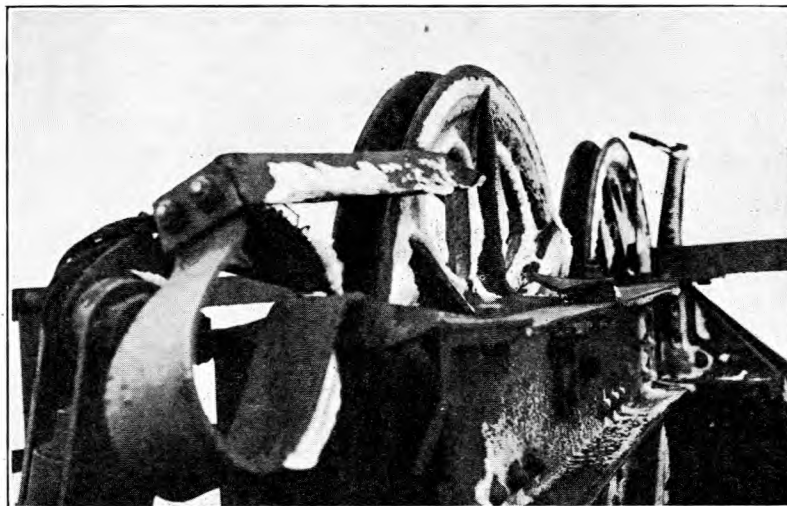

FIG. 1.—CATHEAD AT THE TOP OF A MAST.

start any unravelling at all, can well be imagined. Moreover, any work in the open was made extremely hazardous by the pieces of ice which kept falling from aloft, and it need not be a very large piece of ice, if of the right shape, to be exceedingly dangerous after falling some hundreds of feet. One log sent in noted that the local military had found it necessary to beat an orderly retreat from the immediate vicinity of the aerial system.

## Notes on the Illustrations.

A view from the rear of the cathead at the top of the mast is given in Fig. 1 showing conditions after

of the aerial shown in Fig. 4, illustrating the extent of the ice formation. The wires on which the ice has formed are 7/14 bronze ( $\frac{1}{4}$  in. diameter).

## Conclusion.

Ice formation of this order is unique in the experience of the present members of the British Post Office and they trust that it will remain so; but if not sadder men, they hope at least they are a little wiser as a result. Finally, a tribute must be paid to all the maintenance staff concerned for their devotion to duty, display of resource and anxiety to restore the aerial in the shortest possible time.

A. H. M.

<sup>1</sup>P.O.E.E.J. Vol. 32, p. 22.

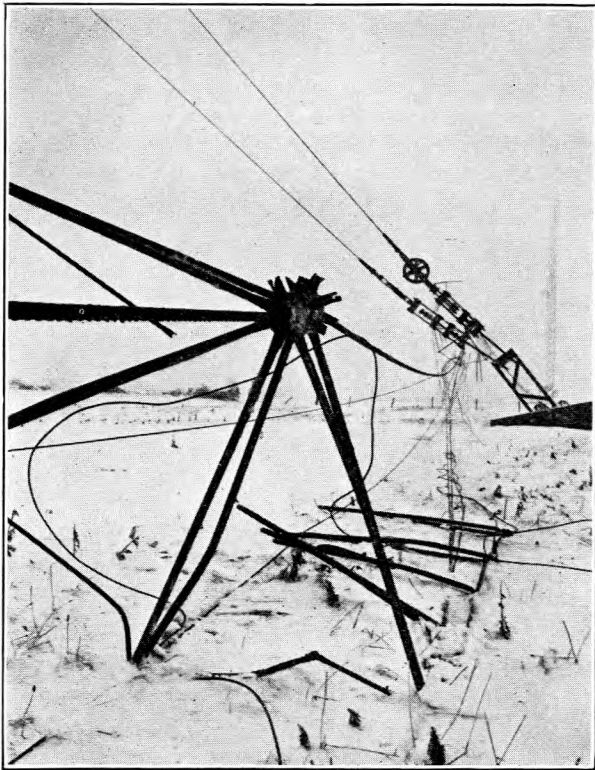

FIG. 2.—BROKEN SPAN OF MAIN AERIAL.



FIG. 4.—GENERAL VIEW OF FALLEN AERIAL.

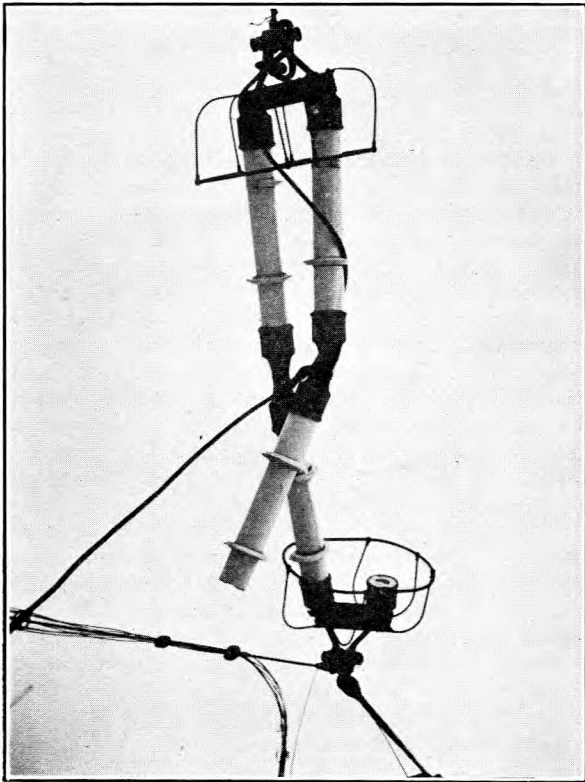

FIG. 3.—BROKEN MAIN INSULATOR ASSEMBLY.

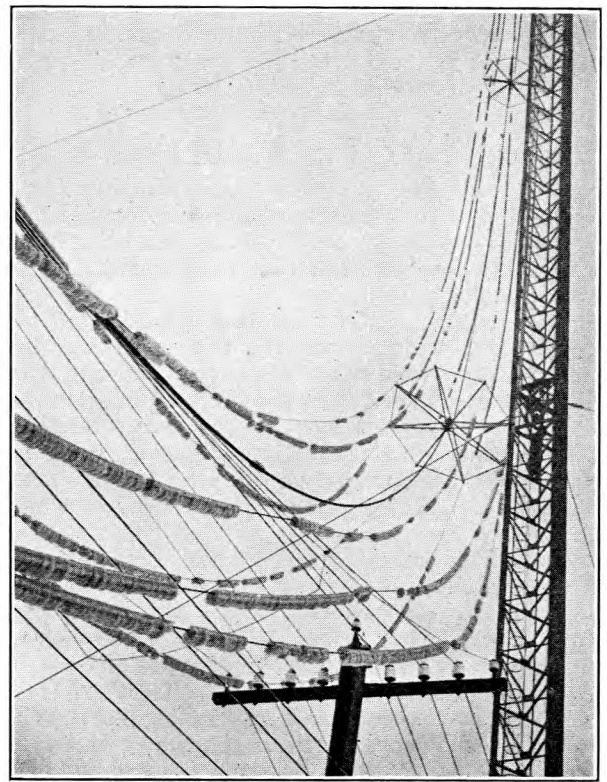

FIG. 5.—CLOSE-UP VIEW OF SUSPENDED AERIAL.



# The 3,000-Type Latching Relay

J. H. BROADHURST

U.D.C. 621.395.641

A new addition to the family of 3000-type relays is the latching relay described in this article. It consists essentially of two ordinary relays, the contacts of the first of which are held operated mechanically until released by the operation of the second unit.

## Introduction.

THE provision of certain facilities, such as night service, transfer service, etc., has necessitated the use of relays which are continuously operated for long periods with the result that there is a considerable current drain on the exchange batteries. This is obviously a serious disadvantage, and to overcome the difficulty it was decided to develop a latching relay of the 3,000-type which would provide the following facilities:—

- (a) The contacts to remain operated after the operating current had been disconnected.
- (b) The contacts to restore to normal on the subsequent application of current to a releasing coil.
- (c) As far as practicable, the number and type of contact units to be equivalent to those of an ordinary 3,000-type relay.

For such an item to be an economical proposition, it was necessary to limit its mounting space to that occupied by two standard 3,000-type relays and to use as far as possible 3,000-type piece parts in its construction.

A latching relay which satisfies these requirements has now been developed by Messrs. Standard Telephones & Cables, Ltd., in conjunction with the Post Office.

## Description.

The latching relay, which is illustrated in Fig. 1, consists of two relays mounted side by side on a common base plate, the relay on the left being known as the latching unit and that on the right as the release unit.

The latching unit carries two normal 3,000-type spring sets which, once the relay coil has been energised, are held operated by the armature which is mechanically locked in the operated position until released by an extension on the armature of the release unit. The release unit may also carry two spring sets, although only one is shown on the model illustrated. These spring sets are not, of course, latched.

The latching mechanism consists of a small phosphor bronze latch L pivoted on a brass fixing post P screwed into the yoke of the latching unit just in front of the buffer block. A spring S fitted on the fixing post holds the latch against the side of the case-hardened steel extension plate EP which is screwed to the armature of the latching unit. When this unit is operated, the latch rotates through a small arc into position behind the extension plate and prevents the armature from returning to normal

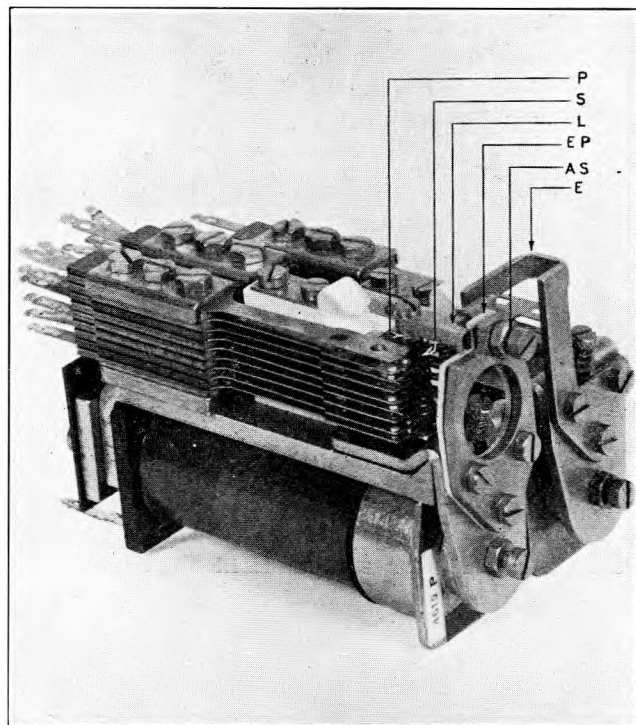

FIG. 1.—3,000-TYPE LATCHING RELAY.

when the current through the coil is disconnected. The movement of the latch is restricted by the armature extension E of the release unit which is so adjusted that, when operated, it moves the latch back to its original position and releases the armature of the latching unit.

Although the adjusting screw AS permits close adjustment of the extension plate, a certain amount of "back lash" on the armature of the latching unit is unavoidable when the current through the coil is disconnected. To ensure, therefore, that standard contact lift and contact clearances are obtained when the armature is in the locked position, an additional 5 mils is added to the armature travel, which would otherwise be the same as that for a similar spring set on a standard 3,000-type relay.

For certain applications the latching unit may be required to operate and lock and at the same time break its own operate circuit. This means that the armature must have sufficient momentum to complete its travel and lock after the current through the relay coil has been disconnected. This momentum can be provided electrically by the use of a 1 in. front-end slug and a non-inductive shunt across the winding, the relay being operated via its own "Y" break action contact unit. The latching unit shown in Fig. 1 is of this type.

It will be seen that apart from the locking and releasing mechanism, both units are similar to the standard 3,000-type relay, having standard relay coils, spring sets and buffer blocks which can be varied to suit particular applications. Further, the latching relay may be fitted on either strip or jacked-in mountings, two models being available, differing only in the size of the common back plate.

AH2 closes when the pointer indicates a discharge of 4 per cent. or more of the full dial reading.

Relays MSO and MSR are the latching and release units respectively of a 3,000-type latching relay.

When the main battery has discharged 4 per cent., AH2 closes and operates relay AHR.

AHR1 operates relay MSO which latches.

MSO1 disconnects AHR which, in turn, disconnects MSO. The latter, however, remains held by the latch.

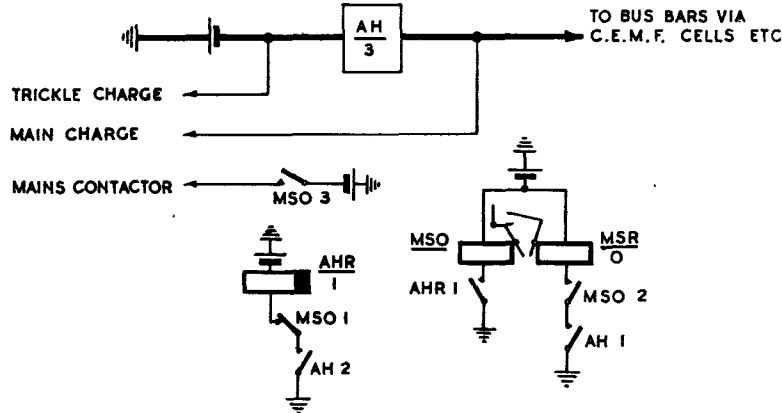

FIG. 2.—TYPICAL CIRCUIT APPLICATION.

#### Typical Application.

In addition to those uses already mentioned, other applications for the latching relay are being considered, one of which is illustrated in Fig. 2. This shows a portion of the control circuit for an exchange automatic power plant, and, together with the following brief circuit description, will illustrate the circumstances under which the latching relay can be used with advantage.

The main battery is connected to the exchange busbars via an ampere hour meter AH, which is actuated in reverse directions by charge and discharge currents. AH is fitted with three contacts, two of which are shown in the diagram. These operate as follows:—

AH1 closes when the pointer indicates zero, i.e., when the battery is fully charged.

MSO2 prepares a circuit for the operation of MSR. MSO3 operates the mains contactor, and charging commences and continues until the ampere hour meter indicates zero, when AH1 closes and operates MSR which releases MSO.

MSO1 prepares the circuit for the re-operation of AHR. MSO2 disconnects MSR.

MSO3 releases the contactor and charging ceases.

It will be seen that, apart from its initial operating current, the latching unit puts no load on the exchange battery although its contacts may remain operated for a considerable period, especially when the exchange load is heavy.

It should be pointed out that only the essential circuit details have been shown. Other contacts and functions of relay MSO have been omitted for the sake of simplicity.

# Mailbag Conveyor in the Foreign Postal Sorting Office, London

U.D.C. 621.867

J. PIGGOTT, B.Sc.(Eng.).

A floor-level conveyor for mail bags is described, a novel feature of which is a weighing machine which weighs the bags while travelling on the conveyor and records the total weight of the bags carried.

## Introduction.

As part of a scheme for mechanising the postal sorting office, London, in which outward foreign mails are handled, the first conveyor has recently been completed. The conveyor, which is 233 ft. long and 30 in. wide, serves all the important outward sorting frames for newspapers and packets on the south side of the office (all destinations outside Europe) and carries the sealed and labelled bags to a spiral chute which discharges on to the mail van platform. The full scheme will incorporate an identical conveyor serving the north side of the office (European Section).

In view of the desirability of keeping reliable statistics of the amount of mail carried, a weighing machine has been installed as an integral part of the conveyor. This weighing machine

- (1) gives visual indication of the weight of each individual bag ;
- (2) automatically records the total weight of mail passing over the system in any given time ; and
- (3) records the number of bags despatched.

The average number of bags carried in a normal week is approximately 10,000, although present conditions have substantially reduced this figure. At the Christmas period nearly 20,000 bags are despatched from this part of the office each week. Foreign mailbags, being made up to the maximum weight allowable, are nearly always heavier than Inland mailbags (maximum weight Inland = 50 lbs.—rarely attained in practice, maximum weight Foreign = 66 lbs.), and it was, therefore, decided to install the conveyor to run at floor level to eliminate unnecessary lifting. It is believed that this installation is the first in which a cotton conveyor band runs flush with the floor.

The full mailbags, after having been labelled, tied and sealed, are stacked at the end of the sorting frames until the time when a despatch is to be made. The checking officer, usually known in the sorting office as the "Ticking Out Clerk," keeps a record of the numbers of bags despatched to each destination, and the mail porters call out the destination of each bag as it is loaded on to the conveyor. The mailbags are placed approximately one foot apart and pass down the sorting office and over the weighing machine. As each bag runs on to the weighing machine the weight is shown on the scale by a beam of light, and the integrator or totalisator adds the weight on to the existing total, the result being recorded on a dial. The bags are then discharged into a spiral chute and the contacts on a flap in the floor of the chute

operate an electro-magnetic counter. It has been found necessary to fit a damping device to this flap to prevent each mailbag giving several impulses.

The contractors for this work were Messrs. Lamson Engineering Co., Ltd., with Messrs. Adequate Weighers, Ltd., as sub-contractors for the weighing machine.

## The Conveyor.

The general layout of the conveyor is shown in Fig. 1.

The conveyor is driven by a 10 h.p., 750 r.p.m., 3 phase, slip ring induction motor, which is coupled

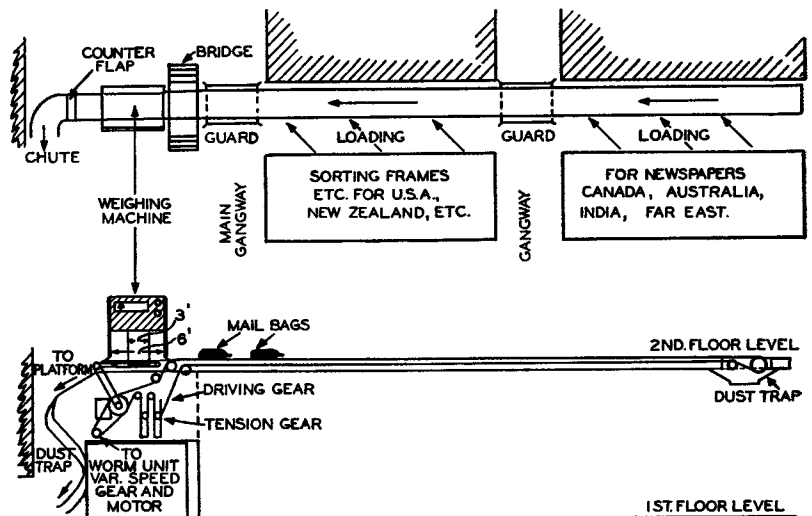

FIG. 1.—LAYOUT OF THE CONVEYOR.

to a variable speed "Crofts" gear, and the output shaft of this gear drives the main driving drum through a fixed reduction worm gear unit and bushed roller chain. The variable speed gear is operated by a remote controlled fractional horse power motor fitted with a magnetic brake, which controls the position of two cone pulleys by means of levers. The speed of the conveyor is thus continuously variable between 15 and 100 ft. per minute. When the mail despatches are light, and no immediate haste is necessary, the conveyor is set to run at 15 to 30 ft. per minute, in which range of speeds it is quite safe to walk across the band. When the last of a batch of bags is to be despatched, it is usually found necessary to speed up the transit of these bags out of the office, and the conveyor is then set to run at 80 to 100 ft. per minute, at which speeds it is necessary to lower guards across the two gangways to prevent accidents. A small bridge has been fitted at the main gangway for use at these times.

The speed control push buttons are located conveniently in the sorting office for the controlling officers, and an indicator (a voltmeter supplied from a small

generator, driven from the output of the variable speed gear) gives the conveyor speed in feet per minute. The guards come down automatically as soon as the dangerous speed is reached, and return to the position shown in Fig. 2 when the band

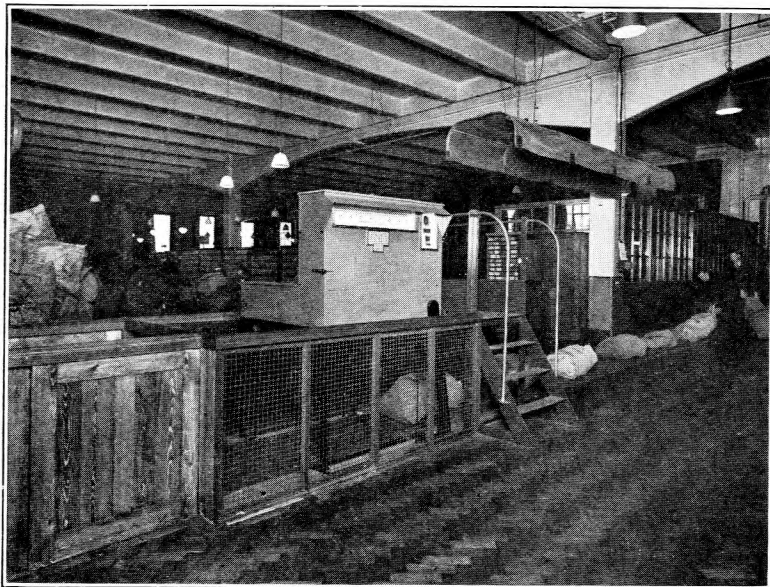

FIG. 2.—WEIGHING MACHINE (GUARD IN "UP" POSITION).

is returned to the safe speed range. The speeds at which the guards operate can be varied over the whole range by altering the angular position of contacts on a cam controller which makes the circuits for the guard motors. The controller is driven from the variable speed gear operating motor.

The construction of the conveyor bed is shown in Fig. 3. Owing to the construction of the building only the wood block floor could be removed, leaving the ferro-concrete intact, but this fortunately proved sufficient by using a cotton band instead of the wooden slat type of band normally used for floor level conveyors. The band is of solid woven cotton, approximately  $\frac{1}{4}$  in. thick, not treated in any way, and, it is estimated, should give satisfactory service under arduous conditions for several years. The weaving of this type of belting is performed in one operation in a loom, there being four main layers of horizontal warp and weft bound together during weaving by many additional vertical warp threads. After weaving the belting is tensioned to the limit to take out all initial stretch. The strength of these bands is remarkable, and heavy mail trolleys, barrows, &c., may be wheeled across

while the conveyor is stationary, or moving up to about 30 ft. per minute, without fear of damage.

The joints in the band have been made by splicing the four layers of horizontal threads and staggering the joints in each layer over a length of 9 in. All faces were treated with latex solution and rubber solution, and the joint hand-sewn throughout. No increase in thickness results from this construction.

To keep the belt free from dust and dirt a dust-trap is fitted near the driving drum. Experience has shown that the small amount of dust finding its way on to the band in no way affects the working of the conveyor.

The tensioning gear, which is placed after the driving drum, consists principally of a roller free to move vertically between two guides. This roller is loaded with 1,000 lbs. weight, giving a constant tension for a given load irrespective of belt stretch. Another similar roller, the movement of which is controlled by a hand wheel operating through bevel gears, allows the "long term" stretch of the band to be taken up, but after the first six months of working it is seldom necessary to make any adjustment except perhaps in very humid weather.

Daily attention is given to cleaning but beyond oiling at necessary intervals no further maintenance is required.

*The Weighing Machine* (Fig. 4).

The main conveyor band has a tension which varies between 1,000 and 2,000 lbs. according to the load. The value actually varies along the length of the conveyor between these two extremes. This tension is too high and too variant to enable this band to be used direct for weighing, and it was, therefore, necessary to discharge the bags from the main band on to a short terminal weighing band. This band is made of balata plies, and the joint is made by cutting the plies apart and butt jointing each layer separately, the joints being arranged diagonally and staggered in the different layers so as to maintain the weight per foot run constant. The adjoining faces are covered with rubber solution and the whole joint vulcanised. The tension in this band is fixed and is just sufficient to maintain the drive when the maximum load is passing. This short length of balata belting is, for all practical purposes, unaffected by weather conditions. A correction is made in the

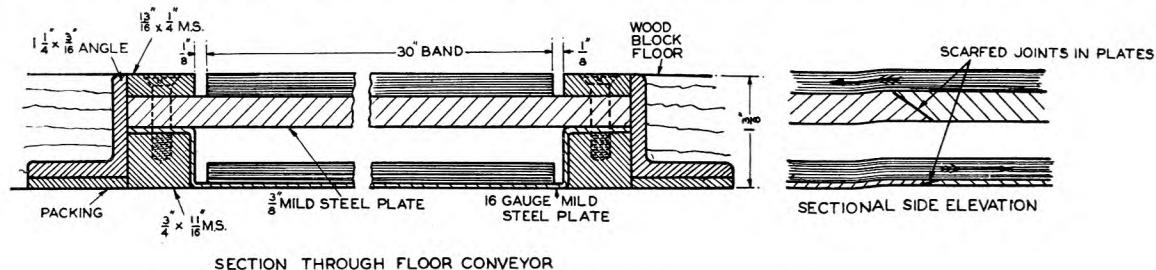

FIG. 3.—CONSTRUCTION OF THE CONVEYOR BED.



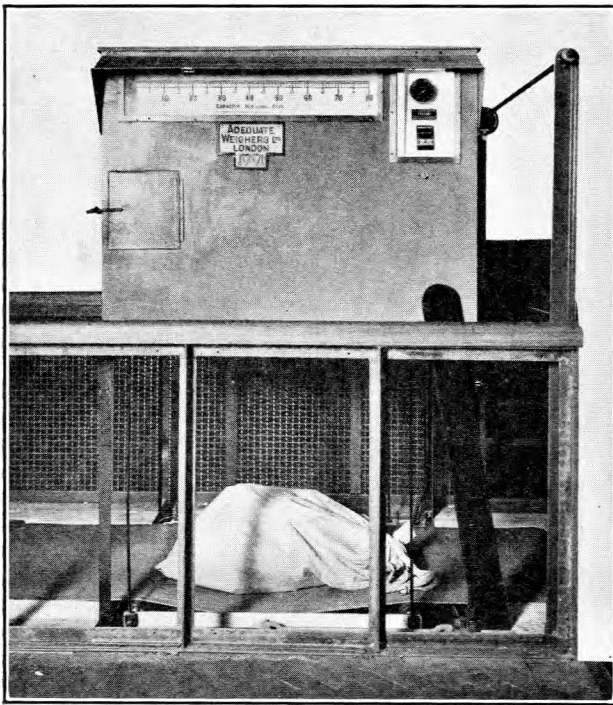

FIG. 4.—WEIGHING MACHINE—FRONT VIEW.

calibration of the weighing machine to neutralise the weight of this band and the slight effect of the tension in it. Fig. 5 shows the arrangement of this weighing band.

The first 6 ft. of the weighband is known as the "weighing length" and loads outside this length cannot affect the weigher. The load is transmitted to the weighing mechanism by four rods at the corners of the centre 3 ft. of the weighing length. It would appear, therefore, that the minimum spacing between loads to give accurate results on the visual indicator would be 1 ft. 6 in. It has been found in practice, however, that a spacing of approximately 1 ft. between mailbags does not affect the readings.

The limit of weight on the machine is 80 lb., and whatever the spacing of the loads the integrator,

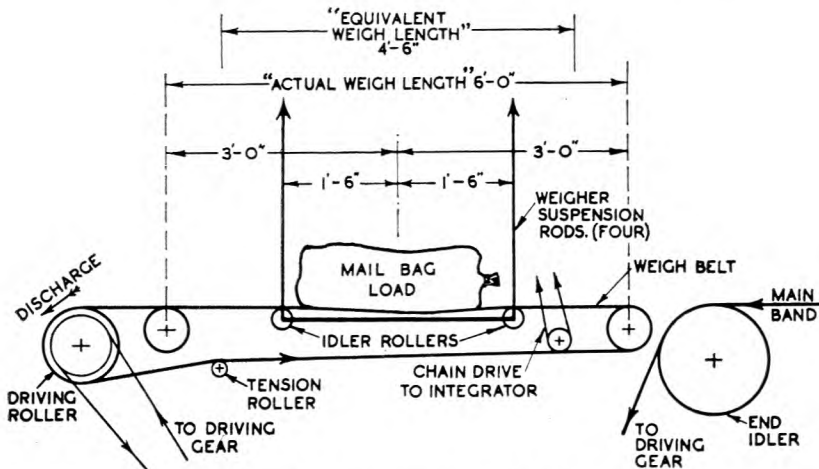

FIG. 5.—ARRANGEMENT OF WEIGHING BAND.

which is described below, will give accurate results so long as the above limit is not exceeded. It will be seen, therefore, that this type of weighing machine is suitable for "continuously weighing" any product such as grain, coal, small machine parts, etc., on a moving conveyor even at high speed.

The mechanism of the visual indicator is a straightforward weigher system working against a helical spring. The pointer on the scale at the front of the machine is actually a spot of light, and the reading is given accurately to within  $\frac{1}{2}$  lb., the true weight being the maximum weight recorded.

The most interesting part of the weigher is the integrator or totaliser, which automatically records the total weight of all mail passing over the weigh band. Fig. 6 shows a plan view of the integrator, a diagrammatic view of which is given in Fig. 7. The accuracy of this mechanism is remarkable, and during tests the error has been found to be less than  $\frac{1}{6}$  per cent. The operation is as follows:—

Coupled to the ordinary weigher levers are two long parallel tubular rods A (Fig. 6 and Fig. 8). These are strutted for rigidity. As the weigher moves from zero to 80 lb. these rods move in an arc. Two ball bearings guide the large steel ball B along the track made by the two shafts P and T, the adjacent surfaces of which are parallel and the axes lie in the same horizontal plane. The linkage A is such that the ball is held throughout its stroke between the two ball bearings, the arc of travel being small compared with the length of the rods A. Shaft P is driven through chain gears and spur wheels from the weighband, and therefore, for any definite setting of the main conveyor speed regulator, the speed of rotation of shaft P is constant. The shaft is the same diameter throughout its length. Shaft T, on the other hand, is tapered, the larger diameter being nearer the gear box. It receives its drive from the ball B. Hence, the ball B acts as an intermediate gear wheel between the two shafts P and T, which rotate in the same direction. Ball B moves normally between two extreme positions marked zero and 80 lb. (Fig. 8), the first being the position assumed when the conveyor is empty, and the second when an 80-lb. load is on the centre of the weighing length. The diameter of the tapered shaft T at the zero point is the same as that of the cylindrical shaft P, so that when the ball is at this point the speed of the two shafts is the same.

To prevent slipping between the ball and the shafts P and T a strong magnetic field is employed. Both the ball and shafts are of hardened stainless steel, and the spacing is such that the ball can almost pass through the gap. This gives a wedge action drive and the magnetic field provides an additional cohesive force. The field is obtained from permanent magnets having a 35 per cent. cobalt content, which set up a uniform field along the stroke of



the ball. The top of the centre pole can be seen in Fig. 6. The two outside poles of opposite polarity to the centre are under the shafts. (Fig. 7.)

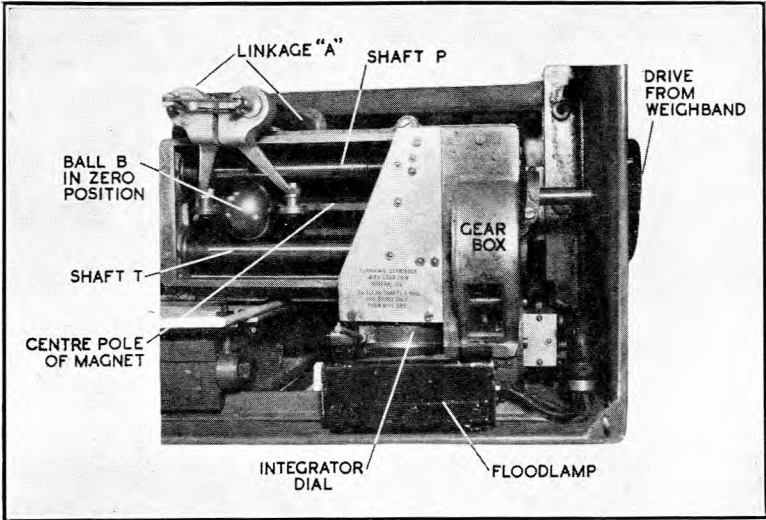

FIG. 6.—PLAN VIEW OF INTEGRATOR.

When any weight passes over the weighing mechanism the ball is traversed along the shafts, and the speed of shaft T decreases due to it being tapered. The change in speed of shaft T is proportional to the weight on the machine, and this is utilised in a differential gear box to operate the integrator counter dial. It is the actual difference in the number of revolutions made by shafts P and T during the transit time of any load across the weighbelt that is recorded.

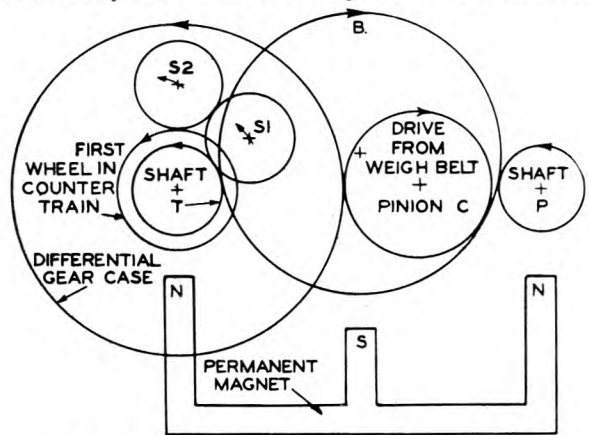

FIG. 7.—DIAGRAMMATIC VIEW OF INTEGRATOR.

The housing of the differential gear (Fig. 7) is driven in the same direction of rotation as shafts P and T by the pinion C, but at a slower speed. Inside and fixed to the casing are two short shafts S1 and S2, each mounting two gears fixed together but free to rotate on the shafts. These two shafts receive an eccentric rotation in space from the gear casing. The two gear wheels on shaft S1 are meshed, one with a gear wheel fixed to the end of shaft T, and the other with one on shaft S2. The output gear wheel from shaft S2 meshes with a train of wheels driving the counter needle.

It will be seen that if shaft T is at first regarded as fixed and the differential casing is revolving, the output wheel on shaft S2 will cause the first wheel in the train to the integrator needle to rotate in an anti-clockwise direction. Shaft T is, however, actually rotating anti-clockwise, and through the gears on shafts S1 and S2 the rotation of the first wheel in the needle train is, therefore, affected in opposite sense. The ratio of the gears is such that when the tapered shaft T is revolving at the same speed as shaft P (which has a fixed ratio to the differential gear case) the first wheel in the needle train is stationary and no motion is, therefore, transmitted to the counter. Should the above conditions be upset, as when the ratio between the cylindrical and tapered shafts is altered by the position of the ball, the first wheel in the needle train rotates at a speed proportional to the above change in ratio and the weight which caused this change is, thereby, recorded.

*Conclusion.*

The installation of a cotton band conveyor running at floor level has shown that this material is satisfactory for such arduous service. It has not reduced the effective floor space of the sorting office or interfered seriously with gangways. Unnecessary trucking and handling of mails inside the office has been considerably reduced and by the addition of the automatic weighing machine a further step has been taken towards obtaining a continuous and mechanical record of the traffic in the postal service.

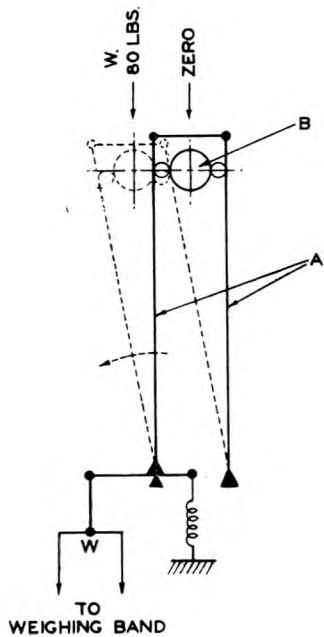

FIG. 8.—WEIGHING MECHANISM.

# Notes and Comments

## Roll of Honour

The Board of Editors deeply regrets to have to record the deaths of the following members of the Engineering Department while serving with the Armed Forces.

Aberdeen Telephone Area..	Scott, A. ..	Unestablished Skilled Workman	Private, The Black Watch
Belfast Telephone Area ..	Devine, E. D. ..	Unestablished Skilled Workman	Lance Corporal, Royal Ulster Rifles
Birmingham Telephone Area	Hitchmough, A..	Unestablished Skilled Workman	Able Seaman, Royal Navy
Canterbury Telephone Area	Parker, R. F. ..	Unestablished Skilled Workman	Able Seaman, Royal Navy
Chester Telephone Area ..	Jones, A. T. ..	Skilled Workman, Class II	Signalman, Royal Corps of Signals
Edinburgh Telephone Area	Bentley, G. F. ..	Unestablished Skilled Workman	Signalman, Royal Corps of Signals
Edinburgh Telephone Area	McDonald, W. ..	Unestablished Skilled Workman, Class I	Signalman, Royal Corps of Signals
Glasgow Telephone Area ..	Henderson, G. M.	Unestablished Skilled Workman	Acting Sergeant, Highland Light Infantry
Liverpool Telephone Area..	Morris, A. E. ..	Labourer .. ..	Leading Stoker, Royal Navy
London Telecommunications Region	Bignell, W. P. ..	Labourer .. ..	Private, Duke of Cornwall's Light Infantry
London Telecommunications Region	Bryan, D. ..	Unestablished Skilled Workman	Private, Loyal Regiment
London Telecommunications Region	Cross, S. C. ..	Labourer .. ..	Trooper, Dragoon Guards
London Telecommunications Region	Goodwill, H. F. ..	Unestablished Skilled Workman	Signalman, Royal Corps of Signals
London Telecommunications Region	Hills, A. A. ..	Unestablished Skilled Workman	Able Seaman, Royal Navy
London Telecommunications Region	Humphreys, S. A.	Labourer .. ..	Corporal, Royal Norfolk Regiment
London Telecommunications Region	Semple, J. G. ..	Labourer .. ..	Private, Kings Own Scottish Borderers
London Telecom. Region	Tocock, J. C. ..	Labourer .. ..	Lance Corporal, Middlesex Regiment
Middlesbrough Telephone Area	Millar, A. ..	Unestablished Skilled Workman	Lance Corporal, Royal Armoured Corps
Newcastle Telephone Area	Hunter, T. ..	Labourer .. ..	Fusilier, Royal Northumberland Fus.
Nottingham Telephone Area	Jones, C. J. E. ..	Unestablished Skilled Workman	Trooper, Royal Hussars
Peterborough Telephone Area	Pearson, S. J. F.	Labourer .. ..	Leading Stoker, Royal Navy
Plymouth Telephone Area	Callicott, P. ..	Skilled Workman, Class II	Corporal, Royal Air Force
Reading Telephone Area ..	Butler, L. R. ..	Unestablished Skilled Workman	Sergeant, Royal Air Force
Scotland West Telephone Area	Howison, R. M..	Unestablished Skilled Workman	Pioneer, Gordon Highlanders
Sheffield Telephone Area ..	Hamilton, E. ..	Unestablished Skilled Workman	Trooper, Royal Lancers

The Board of Editors has learnt with great pleasure that the following members of the Engineering Department at present serving with the Armed Forces have been honoured for the services they have rendered to their country. The Board offers its congratulations on the signal honour they have earned.

Engineer-in-Chief's Office ..	Wilkinson, E. H.	Chief Inspector ..	Lieutenant, Royal Corps of Signals	Military Cross
London Telecommunications Region	Kelly, F... ..	Skilled Workman, Class II	Warrant Officer, Class I, Royal Corps of Signals	Mentioned in Despatches
London Telecommunications Region	Syrett, C. E. ..	Unestablished Skilled Workman	Chief Petty Officer, Royal Navy	Distinguished Service Medal
Scottish Region .. ..	Wood, E. W. ..	Regional Motor Transport Officer	Major, Royal Engineers	Mentioned in Despatches

## Malayan Posts & Telegraphs Department

It is gratifying to note from the annual report for 1939 that the Malayan Posts and Telegraphs Department is maintaining steady progress. On the telecommunications side, telephone installations increased by 8·7 per cent., 65 of the 117 exchanges being of the automatic type. A start has been made with the introduction of no-delay trunk working, and a third 3-circuit and another single-circuit carrier system were installed to augment the trunk network. In addition a direct radio link with North America was introduced, although this had to be suspended on the outbreak of war.

### Obituary

The past few weeks have seen the passing of two grand old men of science, Sir Oliver Lodge and Sir J. J. Thomson. Sir Oliver Lodge, who was 89 when he died, started work at 14 and studied in his spare time. At 23 he began an academic career, filling

posts successively at London, Liverpool and Birmingham Universities. These enabled him to devote a large part of his energies to original investigation. He will be remembered chiefly for his work on the relation between matter and the ether, and for his inventions and discoveries in the field of wireless communication.

Sir J. J. Thomson, like Sir Oliver Lodge, lived to a good age; he was 83. He will always be associated with Cambridge University and the Cavendish Laboratories, where his principal researches were carried out, including his revolutionary discovery of the electron. This was followed by his hypothesis on the mechanics of the electric field, in which he combined the wave motion and corpuscular theories.

Both men were honoured with a knighthood, and by many universities and scientific societies both in this country and abroad, for their substantial contributions to the advancement of electrical science.

## The Institution of Post Office Electrical Engineers

### LIST OF HON. LOCAL SECRETARIES OF CENTRES

#### LONDON.

Centre Secretary, Mr. C. A. R. Burdick, London Telecommunications Region (E.B.), Waterloo Bridge House, Waterloo Bridge Road, S.E.1.

L.T.R. Secretary, Mr. J. E. Martin, London Telecommunications Region (E.B.), Waterloo Bridge House, Waterloo Bridge Road, S.E.1.

E.-in-C.O. Secretary, Mr. W. H. Fox, Engineer-in-Chief's Office (Tp.1 Branch), Alder House, Aldersgate Street, E.C.1.

S.E. Secretary, Mr. E. W. Atkins, Post Office Engineering Department, 34 Sydenham Road, Croydon, Surrey.

#### HARROGATE.

Secretary, Mr. E. W. Norfolk, Engineer-in-Chief's Office (Tp. Branch), Prince of Wales Hotel, Harrogate.

Eastern Centre, Mr. W. E. T. Andrews, Home Counties Region (E.B.), 100 Hills Road, Cambridge.

N. Midland (Nottingham Centre), Mr. A. E. Twycross, Telephone Manager's Office, 37 Stoney Street, Nottingham.

N. Midland (Birmingham Centre), Mr. R. J. Clark, Development Group, Telephone House, Newhall Street, Birmingham, 3.

N. Eastern, Mr. T. E. Walker, Regional Director's Office, Room 502, 5th Floor, 36 Park Row, Leeds, 1.

Northern, Mr. E. Jeffery, Engineering Branch, Newcastle.

Scot. East, Mr. T. Lawrie, Scottish Region (Eng. Branch), G.P.O., Edinburgh.

Scot. West, Mr. J. Paton, Telephone Manager's Office, H.P.O., Glasgow, C.2.

N. Western (Preston Centre), Mr. G. A. G. Evans, Telephone Manager's Office, 63 Westcliff, Preston Lancs.

N. Western (Manchester Centre), Mr. F. Leach, Regional Director's Office (E.B.), Bridgewater House, Whitworth Street, Manchester, 1.

N. Wales, Mr. S. T. Stevens, Chief Regional Engineer's Office, Welsh and Border Counties Region, The Mount, Shrewsbury.

S. Wales, Mr. F. J. B. Clarke, T.M.O. (Eng. Branch), Dominion House, Cardiff.

S. Midland, Mr. W. Bell, H.C.R. (E.B.), 90 Eastern Avenue, Reading, Berks.

S. Western, Mr. R. G. Alexander, T.M.O., Room 15A, St. Stephens Chambers, Baldwin Street, Bristol.

N. Ireland, Mr. C. E. Worthington, E.B. Telephone House, 1 Cromac Street, Belfast.

### ESSAY COMPETITION, 1940

The Council have offered five prizes of two guineas each for the five most meritorious essays submitted by members of the Engineering Department of the Post Office below the ranks of Inspector and Draughtsmen Class II, and, in addition, to award a limited number of Certificates of Merit. Particulars may be obtained from the local secretaries.

### CITY AND GUILDS OF LONDON INSTITUTE EXAMINATIONS

The following candidates received the prizes awarded by the I.P.O.E.E. upon the results of the recent examinations of the Institute:—

#### *Transmission and Lines—Grade II:*

1st Prize of £3.—Mr. Arthur Douglas Board  
P.O. Engineering Dept., Bideford.

2nd Prize of £2.—Mr. Kerwin William Bourne,  
P.O. Engineering Dept., London.

#### *Technical Electricity—Grade II:*

1st Prize of £2.—Mr. Alan Don Airth, P.O.  
Engineering Dept., Newcastle.

2nd Prize of £1.—Mr. Thomas Richard Boxall,  
P.O. Engineering Dept., Poole.

# Regional Notes

## London Region

### TREE ROOT ACCUMULATION IN MANHOLE

The photo shows the growth of tree roots which have accumulated in a manhole in Stanmore New Road and which apparently have come from an Italian Poplar in an adjacent garden. The manhole, an R.F.I., contains one C.I. pipe and one S.A.D. and is a loading point.

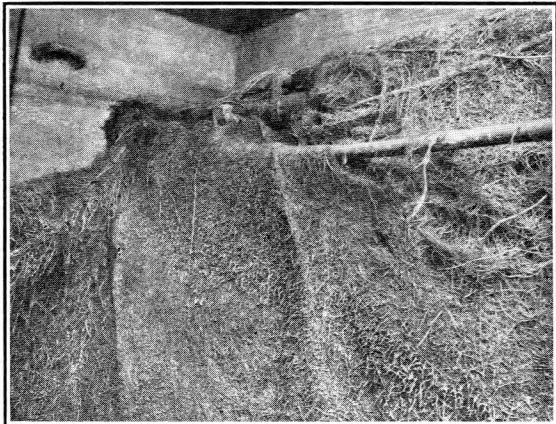

It is situated in a country area and has missed the periodical inspection for some years. The growth was found when an inspection was made early this year. The roots have worked their way through the S.A.D. and into the manhole and have, it is thought, taken about five years to reach the present position.

### CLERKENWELL AUTOMATIC EXCHANGE

This exchange was brought into service at 1.30 p.m. on Saturday, June 1st, when about 4,600 subscribers were transferred from Clerkenwell manual exchange. A total of about 2,550 junctions are provided for the new automatic exchange. The auto-manual board consists of 32 positions of the sleeve control type, half of which are Toll Control and the remainder Assistance. The ultimate capacity of the automatic equipment which is of the 2,000 selector type is 10,000 lines. The equipment was manufactured and installed by Messrs. Ericssons Ltd. The method of cut-over was via tees in the external cables.

The new power plant consists of three motor generator sets, one rated at 200 A and two at 500 A output and two 3,000 Ah batteries arranged to operate on the divided battery float scheme. A mains rectifier trickle charger is provided to condition the idle battery.

It is worthy of note that Clerkenwell was the last manual exchange in the City Area of the L.T.R. and this area can now, it is thought, claim to be the first "all automatic" telephone area in the country.

### DARTFORD NON-DIRECTOR AUTOMATIC EXCHANGE

This exchange, installed by Messrs. Siemens Bros., Ltd., has an initial capacity of 2,100 lines, and ultimate capacity of 3,000 lines. At 1.30 p.m. on July 17th, 1940, 1,424 subscribers were transferred from the manual exchange to the new equipment, and 265 junction circuits were connected to serve the new exchange.

The automatic equipment is of the standard line finder type. The sleeve control manual board of thirteen positions is situated in the same building. The power

plant is of the parallel battery float type. The two batteries, each of 1,100 Ah capacity, were installed by the Hart Accumulator Co., and are charged automatically by two 50 A mercury arc rectifiers of the glass bulb type.

### MECHANICAL JOINTS FOR THROUGH CABLES

In an article entitled "Gas Leakages, Precautionary Measures," which appeared in the JOURNAL for July, 1935, Mr. P. J. Ridd referred to the satisfactory trials of mechanical joints for auxiliary joints, and indicated that laboratory experiments were being conducted with a mechanical joint for use on through cables.

The auxiliary joint is now familiar to all engaged on external work, but the straight through mechanical joint is just emerging from a series of field trials which have proved generally satisfactory. It is thought that some details of the joint on which these trials have been conducted may be of interest to readers.

Four sizes of joint were fitted on current work in the London Region, accommodating four ranges of cable diameters, namely .45 in.-.55 in., .55 in.-.75 in., .75 in.-1.2 in., 1.2 in.-1.5 in. The figure shows the smallest joint, assembled.

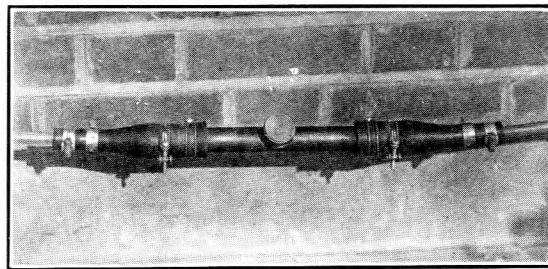

The joint consists essentially of a brass tube carrying a pressure testing nozzle and two shaped, tough rubber muffs. Suitable hose clips, arranged as shown, clamp the rubber muffs to the sleeve, and to the cable sheath.

In fitting, the clips were opened out and loosely positioned on the muffs and the muffs and tube were threaded on to the cable ends before the lead was stripped. The jointed wires were wrapped in the usual way, the cable ends lightly dressed and any scores or cuts in the sheath smoothed out with a blunt tool. The mechanical joint was assembled centrally over the joint. It was observed that in each case complete tightening of the clips resulted in a pressure-tight joint on the first attempt.

The joints have been in service for periods varying between 6-12 months, and, up to the time of writing, a failure has not been reported. At the expiry of six months, two joints were pressure tested and found to be sound. They were then opened; the muffs were in good condition and the joints were opened without difficulty, but serious rusting was found on all clips and screws.

It is generally appreciated that some form of joint which will dispense with the use of naked lights for plumbing is desirable, and the type of joint under review offers this advantage and overcomes several inherent weaknesses in the plumbed joint.

In difficult situations where the pot and ladle method cannot be employed exclusively for plumbing, the mechanical joint avoids the need for a blowlamp with its attendant risk of explosions. Moreover, the application of heat in plumbing tends to impair the quality of the lead of the cable sheath producing a porosity which increases its liability to mechanical failure. The



mechanical joint can be fitted easily and opened frequently without damage to the joint, and the flexibility provided by the rubber muffs should reduce considerably the liability of breakdown which, on plumbed cables, may be due to vibration fatigue or to porous wipes or sheath.

The trial has given rise to several criticisms of the design of mechanical joints, and suggested modifications to overcome the shortcomings :

- (1) Since the watertightness of the joints depends in a large measure upon the efficiency of the clips, it is essential that they be made of a non-corrosive material.
- (2) Difficulty is experienced in installing the joints in the smaller sizes of joint box owing to their length. Since the overall length available to accommodate the cable joint is considerably greater than necessary, a reduction in the length could be effected by shortening the tube, the sole purpose of which is to provide a firm base upon which the larger clips can be tightened. With the Engineer-in-Chief's concurrence this modification has been carried out successfully in several cases.
- (3) It is felt that while the weights of the larger joints are in conformity with the thickness of the sheath and the weights of the cable to which they are fitted, in the smaller sizes the joints are relatively much heavier and there is risk of fracture of the lead sheath occurring. The proposed reduction in the length of the brass tube would, of course, help to meet this criticism, but a further weight reduction could be effected by shortening the brass tube to a minimum and increasing the length of the corresponding portion of the rubber muffs. It might also be possible to use a tube of lighter gauge.

For all sizes of joint, as an alternative to the brass tube, consideration is being given to a proposal to extend the rubber muffs to lap one over the other ; the inner muff being stiffened with reinforced moulding to support the pressure of the clip.

H. G. K.

### South-Western Region

#### ERECTION OF INTERRUPTION CABLE IN UNUSUAL CIRCUMSTANCES

As a result of a fault occurring in a length of submarine cable, it became necessary, recently, to run an interruption cable across a railway bridge of considerable height and length.

The most important of the 104 circuits affected were diverted into other cables, but the measure of relief by this means was very limited. When it became obvious that considerable delay would be experienced in effecting

repairs, it was decided to run an interruption cable across the river via the railway bridge.

The submarine cable terminated in junction boxes at both ends, and at these points the height of the bridge was 120 ft. and distance across 550 yards, the total length of the bridge being approximately 1,000 yards. The interruption cable was laid across the bridge between points immediately above the junction boxes. For this purpose cable 104/20 P.C.Q.T. lead sheathed was used.

It was found most helpful to drag the cable on the wood sleepers outside the rails. This gave an excellent bearing surface, and although the staff available was rather limited the cable was drawn out in two lengths. It might be mentioned that the bridge carried a single track and traffic was very heavy ; in fact the longest period for which work was able to proceed without interruption was  $\frac{1}{4}$  hour. All breaks in the cable were arranged to be adjacent to recesses in the bridge so that the cable ends could be turned in and the joiner was able to work without interruption. Aerial cable was erected between the bridge and the junction boxes, 104/20 P.C.Q.T. lead-sheathed cable being used, the weight of this cable for each side being 4 cwt. The cable had to be supported and kept clear of the bridge to prevent abrasion. A pole was erected as close as possible to each junction box and steel suspension wires were erected from the bridge to the top of each pole. The method of erecting the cable was the same for both sides of the river. The cable was wound with hessian tape and tied by Marline ties to a second steel wire. The end of this wire was then taken to the top of the pole and attached to the suspension wire by aerial cable hooks as shown. A block and tackle was fixed to the bridge and the cable and wire were pulled up, the cable hooks sliding on the suspension wire, additional hooks being fitted at intervals of 6 ft.

When the cable was finally in position the steel wire to which it had been tied was fixed to the bridge and to the top of the pole. The result was to give adequate support to the cable with very little sag, and at the same time kept the cable clear of the bridge. In addition, most of the work was done off the bridge with consequent freedom from interruption. The aerial hooks slid quite easily along the suspension wire and no difficulty was experienced in hauling the cable into position. Erection of the poles close to the junction boxes reduced all underground work to a minimum.

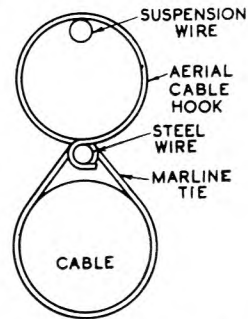

#### AIR RAID DAMAGE TO UNDERGROUND PLANT

During a recent air raid on a " South Western " town a bomb fell on the track of a 122 pr./20 M.U. cable. The results will be of interest to many, and may even afford a measure of comfort to those whose duty it is to maintain such plant during the present emergency.

The bomb dropped in the grass verge slightly to one side of the cable track forming a crater 31 ft. in diameter. The road is artificially elevated in the section concerned and has a concrete foundation and kerb. It would appear that the duct and cable, together with the edge of the roadway, lifted with the force of the explosion and that a block of concrete then fell on the cable, forcing it into the crater to a depth of 10 ft. below the surface of the road. The duct was demolished but the cable in the crater was undamaged except for a few cracks in the sheathing.



The cable happened to have A.C.D.'s fitted, and in the manhole on one side of the fault the anti-creepage device held firmly, but owing to the pull of the core and subsequent rebound the cable appears to have moved 6 in. from its normal position in the direction away from the explosion, leaving the sheath in a severely crimped condition. On the other side of the fault the cable was free to move in the direction of the crater and from the subsequent position of the anti-creepage device it was possible to ascertain the extent of movement. At the manhole nearest to the point of damage the cable had been drawn 2 ft. 3 in. towards the crater and 6 in. and 3 in. respectively at the subsequent manholes.

There were only three faulty pairs in the 122 pair cable, the faults being all at the A.C.D. where the sheath was crimped. The remainder of the cable pairs carried circuits without interruption.

## North-Western Region

### MULTI-WAY THRUST BORING

One of the problems associated with thrust boring is the alignment of the separate bores when more than one way is required, and the following description of a 2-way bore successfully carried out under a level crossing at Warrington, where the subsoil was not suited to normal practice may be of interest.

It was required to lay a 2-way pipe line under the crossing, and to avoid the difficulties attendant to the excavating and laying it was decided to lay two 3½-in. steel pipes by means of the Mangnall-Irving Hydraulic Thrust Boring Machine, using the tri-head supplied by the makers. It is claimed that two or three 3½-in. steel pipes could be coupled to the tri-head by 4-in. or 5-in. enlarging heads, and pulled in direct behind it. By this method the fins of the tri-head have to cut virgin ground alongside the pilot bore, and the two enlarging heads force their way through the subsoil with the pipes behind; but this operation is dependent upon the nature of the subsoil and is not successful in sandy soils.

The length of the required bore was 15 yds. After consultation with the Borough Surveyor and the District Engineer to the Railway, it was decided that it was safe to bore in a certain line at a depth of 4 ft. The crossing was very congested, the obstructions including numerous E.H.T., L.T., gas and water mains, two Post Office duct tracks, the sewer, the operating mechanism for the level-crossing gates, and a railway cable laid direct in the ground. Pilot holes were made at each side of the railway, and a single line of driving rods was first driven through in the normal manner. When the pilot rod appeared at the receiving pit it was removed and the tri-head attached in its place. Two 5-in. enlarging

heads, each with a single length of 3½-in. steel pipe, were attached to the tri-head and the pulling back of the rods attempted. The subsoil taken out of the pilot holes, and presumably that under the crossing, was of a sandy nature, and the resistance to the boring was such that, after the enlarging heads had travelled six or nine inches from the receiving pit, the indicated pressure of the oil in the machine had risen to such a value that it was decided to abandon the attempt. The enlarging heads were pushed back into the pit and uncoupled from the tri-head. In their place ordinary boring rods were attached, and these were pulled through to the operating pit, giving two parallel bores approximately 1 ft. apart. The tri-head was then uncoupled and the machine moved a few inches to line up with one of the rods just pulled in. This line of rods was now connected to a 3½-in. steel pipe by the 5-in. enlarging head, which was pulled through in the normal manner. The machine was then moved to line up with the second set of rods and the operation repeated successfully. In this way two 3½-in. steel pipes were successfully laid parallel 1 ft. apart under a very busy railway level crossing, without interfering with the road or rail traffic. The work took four men two days to complete.

The general construction of the tri-head is shown in the sketch.

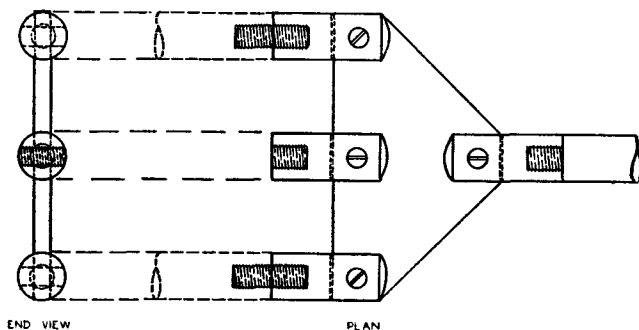

It is thought that, where two or three ways have to be laid under roads or level crossings, where thrust boring is obviously advantageous and practicable, the tri-head could be successfully and economically used. The employment of this item may—as it did in this instance—involve the use of more boring rods, couplings and enlarging heads than normally supplied with the machine, but the provision of these items is considered economical, having regard to the results obtained. The extra items for this work were loaned by the Hydraulic Engineering Company of Chester, who were most helpful in the supply of the items and in the practical advice offered.

# Staff Changes

## Promotions

Name	Region	Date	Name	Region	Date
<i>From Exec. Eng. to Acting A.S.E.</i>			<i>From Insp. to Acting Chief Insp.—continued</i>		
Husband, S. J.	E.-in-C.O.	31.7.40	Douglas, A. S.	W. & B.C. Reg.	28.7.40
Epps, H. F.	L.T. Reg.	16.7.40	Ford, F. V.	S.W. Reg.	7.7.40
<i>From Asst. Engr. to Acting Exec. Engr.</i>			Streeter, A. R.	St. Albans R/Stn. to Ginlialirk R/Stn.	16.7.40
Coates, G. H.	E.-in-C.O.	21.9.40	Pierson, J. H.	N. Ireland Reg.	14.5.40
Gill, C. J.	Mid. Reg. to N.E. Reg.	30.6.40	Anderson, F.	E.-in-C.O.	9.4.40
Dickson, E.	W. & B.C. Reg.	7.8.40	Kelly, T. S.	H.C. Reg.	28.7.40
Skinner, E. J.	L.T. Reg.	17.8.40	German, A. G.	E.-in-C.O.	9.4.40
Worthy, L. F.	L.T. Reg.	1.9.40	Kirkham, W. D.	E.-in-C.O.	17.7.39
Franklin, G.	E.-in-C.O.	10.7.40	Green, E. S.	Test Section, London	8.1.40
Blair, D. C.	E.-in-C.O. to Scot. Reg.	1.1.41	<i>From S.W.I. to Acting Insp.</i>		
Young, J. E.	E.-in-C.O.	10.7.40	Gates, G. F. W.	L.T. Reg.	24.6.40
<i>From C.I. with allowance to Acting A.E.</i>			Menage, E. A.	L.T. Reg.	24.6.40
Smith, B. J.	S.W. Reg.	7.7.40	Ives, F. M.	L.T. Reg.	24.6.40
<i>From Chief Insp. to Acting Asst. Engr.</i>			Green, W. J.	L.T. Reg.	24.6.40
Burnett, H. J.	L.T. Reg.	4.7.40	Greniston, W. T.	L.T. Reg.	24.6.40
Iles, S. B.	N.W. Reg.	8.8.40	Rapson, H. F.	L.T. Reg.	24.6.40
Naylor, S. E.	H.C. Reg. to E.-in-C.O.	11.8.40	Davis, J. H.	L.T. Reg.	24.6.40
Brock, W. P.	H.C. Reg. to L.T.R.	1.9.40	Adams, K.	L.T. Reg.	24.6.40
Whittingham, L.	W. & B.C. Reg. to Mid. Reg.	28.7.40	Robinson, R. A.	Baldock R/Stn. to St. Albans R./Stn.	27.7.40
Miles, A.	H.C. Reg. to E.-in-C.O.	11.8.40	<i>A.M.T.O. to Acting R.M.T.O.</i>		
Rhodes, W.	E.-in-C.O.	31.5.40	Daft, W. E.	London to W. & B.C. Reg.	29.6.40
Stewart, T.	E.-in-C.O.	31.5.40	Ball, F. T.	B'ham to Mid. Reg.	29.6.40
Sharpe, G. E.	Mid. Reg.	18.7.40	Palser, F. D.	London to S.W. Reg.	29.6.40
Hasnip, A. G.	Mid. Reg.	21.7.40	<i>M.T.O. Class III to Acting M.T.O. Class II</i>		
Thompson, A. J.	H.C. Reg.	10.7.40	Chapman, E.	E.-in-C.O.	29.6.40
Lloyd, H. H.	Mid. Reg. to E.-in-C.O.	10.7.40	<i>Tech. Asst. to Acting Asst. R.M.T.O.</i>		
Sherriff, L.	E.-in-C.O.	10.7.40	Coventon, A. E.	London to H.C. Reg.	29.6.40
<i>From C.I. to C.I. with allowance</i>			Dring, G. S.	Exeter to Mid. Reg.	30.6.40
Hubbard, W. J.	L.T. Reg.	19.2.40	<i>Tech. Asst. to Acting M.T.O. Class III</i>		
Ralph, H. P.	L.T. Reg.	12.7.40	Gibson, J.	N.W. Reg. to E.-in-C.O.	30.6.40
Blott, T. G.	S.W. Reg.	28.7.40	E. T. Hunt	Leeds to E.-in-C.O.	7.6.40
<i>From Insp. to Acting Chief Insp.</i>			J. Lakey	E.-in-C.O.	7.6.40
Smallwood, W. K.	Portishead R/Stn. to E.-in-C.O.	23.4.40	<i>C.O. to Acting Asst. R.M.T.O.</i>		
Dean, W. J.	Mid. Reg.	1.8.40	Border, W. A.	Nottingham to Mid. Reg.	29.6.40
Shaw, J.	S.W. Reg.	2.7.40	<i>Mech.-in-Charge Gde. I to Acting Tech. Asst.</i>		
Webster, C. J.	H.C. Reg.	15.6.39	Sewell, W. A. H.	Peckham to H.C. Reg.	30.6.40
Leaper, L. L.	Baldock R/Stn. to St. Albans R/Stn.	1.7.40	Mathewson, F. J.	Glasgow to Leeds	2.7.40
Ade, A. F.	Mid. Reg.	10.7.40	Wiles, E. J.	Cambridge to W. & B.C. Reg.	30.6.40
Benham, F. W.	L.T. Reg.	4.6.40	Jenkins, A. A.	London to N.W. Reg.	18.8.40
Holloway, A.	Mid. Reg.	20.7.40	<i>D'man Class II to Acting Tech. Asst.</i>		
Davis, S.	L.T. Reg.	27.5.40	Collings, E. R.	E.-in-C.O.	1.9.40
Donovan, J. G.	L.T. Reg.	1.7.40			
Sherwin, E.	N.W. Reg. to L.T. Reg.	28.7.40			
Lester, T.	N.W. Reg.	23.6.40			

## Transfers

Name	Region	Date	Name	Region	Date
<i>Asst. Engr.</i>			<i>Prob. Insp.</i>		
Winterborn, E. E. L.	N.E. Reg. to Mid. Reg.	23.6.40	Cook, S. V.	E.-in-C.O. to N.W. Reg.	9.6.40
Atherton, W. S.	E.-in-C.O. to L.T.R.	12.6.40	Hetherington, T.	N.W. Reg. to E.-in-C.O.	9.6.40
Dickson, E.	E.-in-C.O. to W. & B.C. Reg.	14.7.40	<i>Acting R.M.T.O.</i>		
Gosney, G.	E.-in-C.O. to L.T.R.	28.7.40	Griffiths, W. R.	E.-in-C.O. to H.C. Reg.	29.6.40
<i>Prob. Asst. Engr.</i>			<i>M.T.O. III</i>		
Martin, B. R.	N.E. Reg. to E.-in-C.O.	5.6.40	Chapman, E.	Ldn. to E.-in-C.O.	21.5.40
<i>Chief Insp.</i>			<i>A.R.M.T.O.</i>		
Iles, S. B.	Scot. Reg. to N.W. Reg.	1.8.40	Huxley, R. T.	E.-in-C.O. to Ldn.	21.5.40
Kidd, C.	E.-in-C.O. to Rugby R/Stn.	7.7.40			
<i>Insp.</i>					
Stenning, F. A.	E.-in-C.O. to H.C. Reg.	1.7.40			

### Reversion

Name	Region	Date	Name	Region	Date
<i>Acting C.R.E. to Reg. Engr.</i>					
Davis, H. G. . . .	Scot. Reg. . . .	.. ..			22.7.40

### Retirements

Name	Region	Date	Name	Region	Date
<i>Deputy C.R.E.</i>					
Edgerton, T. H. . .	L.T. Reg. . . .	.. ..			30.6.40
<i>Exec. Engr.</i>					
Armitage, D. . . .	Mid. Reg. . . .	.. ..			8.7.40
Prescott, J. . . .	L.T. Reg. . . .	.. ..			31.8.40
<i>Asst. Engr.</i>					
Boulton, J. D. . .	L.T. Reg. . . .	.. ..			26.6.40
Parker, N. W. . . .	E.-in-C.O. . . .	.. ..			30.4.40
Leithhead, W. . . .	Scot. Reg. . . .	.. ..			31.5.40
<i>Chief Insp.</i>					
Reed, H. L. . . .	N.E. Reg. . . .	.. ..			22.6.40
Horridge, J. A. . .	Test Sect., London	.. ..			30.6.40
Mitchell, A. J. . .	S.W. Reg. . . .	.. ..			30.6.40
Stoney, J. J. . . .	W. & B.C. Reg. . .	.. ..			30.6.40
<i>Chief Insp.—continued</i>					
Barnard, A. G. E. . .	H.C. Reg. . . .	.. ..			31.7.40
Mills, E. G. . . .	Mid. Reg. . . .	.. ..			31.7.40
Edwards, J. R. . . .	N.E. Reg. . . .	.. ..			12.6.40
Tate, G. . . .	N.E. Reg. . . .	.. ..			30.6.40
Willett, G. E. . . .	L.T. Reg. . . .	.. ..			30.6.40
Johnson, J. . . .	L.T. Reg. . . .	.. ..			11.7.40
Willmot, A. J. . . .	E.-in-C.O. . . .	.. ..			26.6.40
<i>Insp.</i>					
Willmott, C. T. . .	Test Section, Birmingham	.. ..			30.6.40
Gatward, H. A. . .	Test Section, London	.. ..			30.6.40
Little, E. A. . . .	H.C. Reg. . . .	.. ..			25.6.40
<i>Commander H.M.T.S. "Alert"</i>					
Hutchons, E. R. . .					25.7.40

### Resignation

Name	Region	Date	Name	Region	Date
<i>Insp.</i>					
Seymour, H. G. B. . .	L.T. Reg. . . .	.. ..			22.6.40

### Deaths

Name	Region	Date	Name	Region	Date
<i>Asst. Engr.</i>					
Curling, T. N. . . .	L.T. Reg. . . .	.. ..			16.8.40
<i>Chief Insp.</i>					
Morrow, J. G. M. . .	North Ire. Reg. . .	.. ..			5.6.40
<i>Insp.</i>					
Stride, H. S. . . .	E.-in-C.O. . . .	.. ..			31.7.40

### BOARD OF EDITORS

- A. J. GILL, B.Sc., M.I.E.E., M.I.R.E., Chairman.  
 F. E. NANCARROW, A.R.C.Sc., M.I.E.E.  
 P. B. FROST, B.Sc., M.I.E.E.  
 A. H. MUMFORD, B.Sc.(ENG.), A.M.I.E.E.  
 C. W. BROWN, A.M.I.E.E.  
 R. E. JONES, M.Sc., A.M.I.E.E.  
 H. LEIGH, B.Sc.(ENG.), A.M.I.E.E., Acting Managing Editor.  
 G. E. STYLES, A.M.I.E.E., Acting Assistant Editor.

#### Copyright

The entire contents of this JOURNAL are covered by general copyright, and special permission is necessary for reprinting long extracts, but Editors are welcome to use not more than one-third of any article, provided credit is given at the beginning or end thus: "From the *Post Office Electrical Engineers' Journal*."

The Board of Editors is not responsible for the statements made or the opinions expressed in any of the articles in this JOURNAL, unless such statement is made specifically by the Board.

#### Communications

All Communications should be addressed to the Managing Editor, *P.O.E.E. Journal*, Engineer-in-Chief's Office, Alder House, Aldersgate Street, London, E.C.1. Telephone: HEADquarters 1234. Remittances should be made payable to "The *P.O.E.E. Journal*" and should be crossed " & Co."

#### Binding Cases

Cases for binding are available, and may be obtained from the Local Agents for 1s. 9d. Subscribers can have their copies of Volumes bound, at a cost of 3s., by sending the complete set of parts to the Local Agents or to the *P.O.E.E. Journal*, Engineer-in-Chief's Office, Alder House, Aldersgate Street, London, E.C.1. Orders for binding for Vols. 1-19 should indicate whether the original binding case with black lettering, or the later pattern with gold, is required. Cases with gold lettering are the only type stocked from Vol. 20 onwards.

#### Back Numbers

The price of the JOURNAL, which is published quarterly, is 1s. (1s. 3d. post free) per copy, or 5s. per annum post free. Back numbers can be supplied, subject to availability of stocks, at 1s. each (1s. 3d. post free). Orders for back numbers may be sent to the Local Agents or to the Publishers.

#### Advertisements

All communications relating to space reservations should be addressed to the Advertisement Editor, *P.O.E.E. Journal*, Alder House, Aldersgate Street, London, E.C.1. Communications regarding advertisement copy, proofs, etc., should be addressed to the Publishers, Messrs. Birch & Whittington (Prop. Dorling & Co. [Epsom], Ltd.), 49 Upper High Street, Epsom, Surrey.

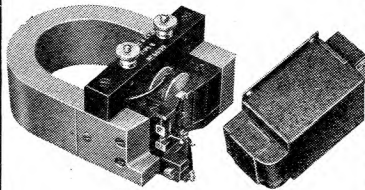
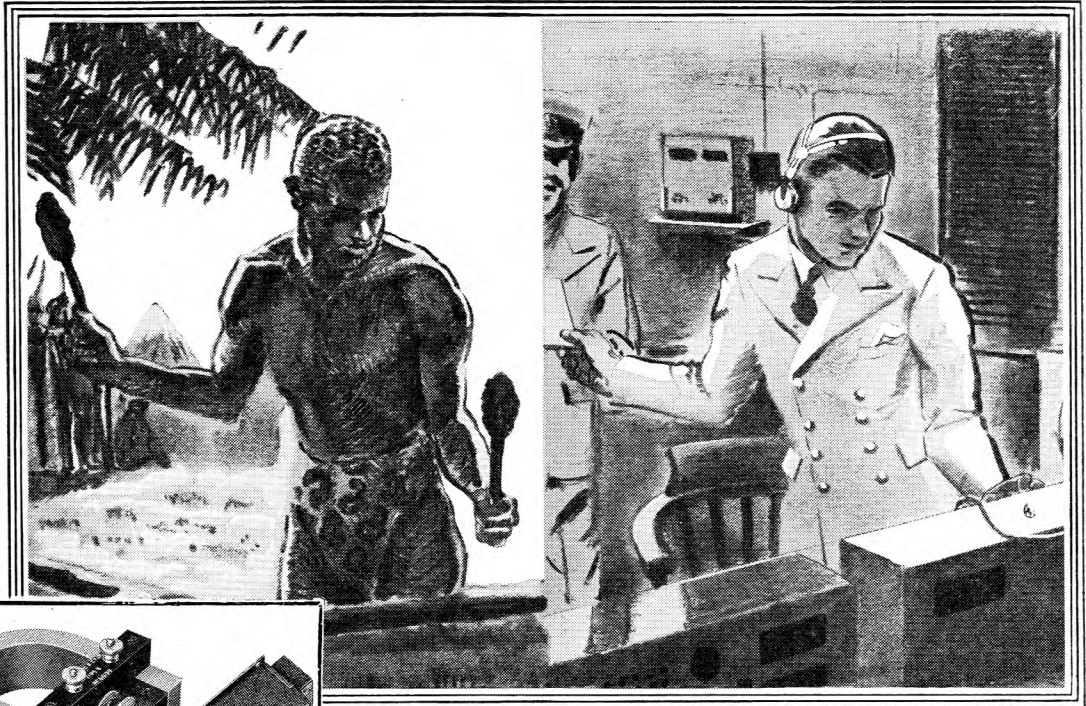

#### OSCILLOGRAPHS

Although the Type 5 Oscillograph is usually associated with Echo Sounding Equipment and Picture Telegraphy, it also provides a simple and robust instrument for the demonstration of alternating current phenomena. The standard instrument has an undamped resonant frequency between 600 and 800 c.p.s. but is damped until it is sensibly aperiodic. Instruments may be supplied having resonant frequencies up to 3000 c.p.s.

MUIRHEAD AND COMPANY  
LIMITED  
ELMERS END, KENT  
TELEPHONE: BECKENHAM 0041-0042.

# MUIRHEAD

## *To-morrow is another day*

It is not so very long ago that telegraphy became a practical fact. It is not much longer since transport the world over was by foot, horse or the power of the wind at sea. Still more recently the whole field of communication has been extended by the use of radio.

In all of these great and recent developments, that within a short hundred years have so reduced the world in size, Muirheads have taken a part, and not infrequently an important part. To-day in Telegraphy and Telephony, in Marine Radio and Depth Sounding, in Road and Railway Signalling, in Aircraft and in Picture Transmission, Muirhead instruments are playing their part.

And to-morrow? Many of the devices and instruments that will still further advance the science of communication are already taking shape in the Muirhead Laboratory.

FOR OVER 60 YEARS DESIGNERS & MAKERS OF PRECISION INSTRUMENTS



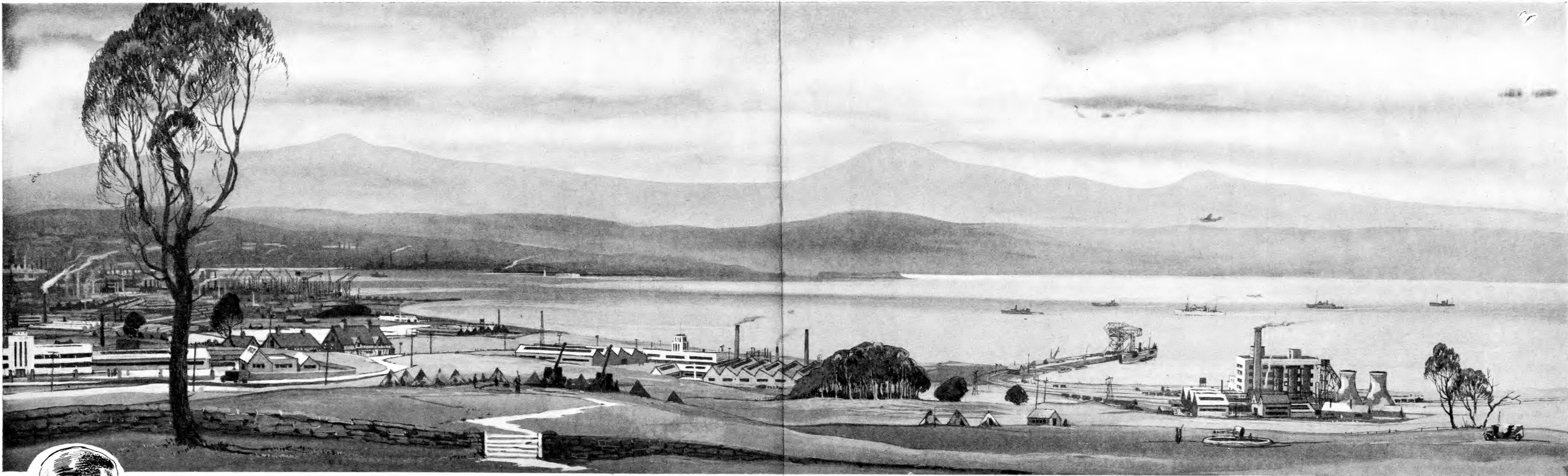

# TELEPHONY

## ... VITAL TO THE VICTORY DRIVE

Communications are a factor of paramount importance and they affect every aspect of the Nation's War Effort. Military, industrial, commercial and civil requirements are being met, and in this hour of National need the advantages of telephone service are being appreciated as they have rarely been before. The provision and operation of adequate telephone service by the Post Office has been no light task and its maintenance may prove increasingly difficult in days to come, but it is certain that the effort will be made to accomplish the task as efficiently in the future as it has been in the past.

Automatic Telephone & Electric Co. Ltd., as manufacturers of Strowger Automatic Telephone Equipment for the Post Office are proud to feel that they are associated with the success of this enterprise.



**STROWGER AUTOMATIC TELEPHONE EQUIPMENT**

**AUTOMATIC TELEPHONE & ELECTRIC CO. LTD.**

NORFOLK HOUSE, NORFOLK ST., STRAND, W.C.2.

Phone, Temple Bar 9262 • Grams, 'Autelco, Estrand, London'

STROWGER WORKS, LIVERPOOL, 7

Phone, Stoneycroft 4830 • Grams, 'Strowger, Liverpool'





# Austinlite

## AUTOMATIC STANDBY PLANT

Recently completed AUSTIN-LITE STANDBY PLANTS range in size from a 200 k.w. Automatic Plant for a large Municipal Power Station to a 2½ k.w. Plant for an A.R.P. Shelter.

Whatever the size and purpose of the plant the same stringent test conditions are applied.

### AUSTINLITE LTD.

*Proprietors :*  
CHANCE BROTHERS & CO. LIMITED  
LIGHTHOUSE WORKS, SMETHWICK

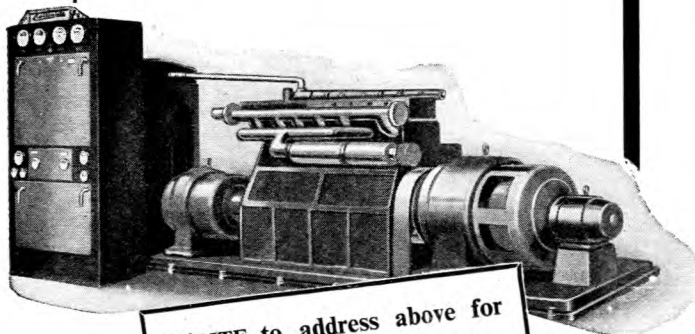

WRITE to address above for full details and specifications covering your requirements.

# Ferranti

## CLIP-ON AMMETER

Just turn the switch to change the range.



**THE CLIP-ON AMMETER** has become established as an indispensable instrument for the rapid measurement of currents in busbars, fuses and cables.

You simply take the instrument in one hand, clip round the conductor and observe the reading!

Don't worry if the conductor is bare—the core is completely insulated and the frame is of moulded bakelite.

COMPREHENSIVE RANGES AVAILABLE:		
0 - 100 - 500	0 - 7.5 - 75	0 - 20 - 100
0 - 100 - 1000		
0 - 200 - 1000	0 - 10 - 50	0 - 25 - 150
0 - 300 - 1500	0 - 15 - 75	0 - 50 - 250

Write for List IN. 11.

**FERRANTI LTD., HOLLINWOOD, LANCS.**  
London Office, BUSH HOUSE, ALDWYCH, W.C.2



*For the remotest spots...*

We are supplying more and more Rural Automatic Exchanges and so bringing the telephone to many small communities otherwise secluded from the outer world. In spite of heavy national demands we are giving our friends abroad our usual services and attention.

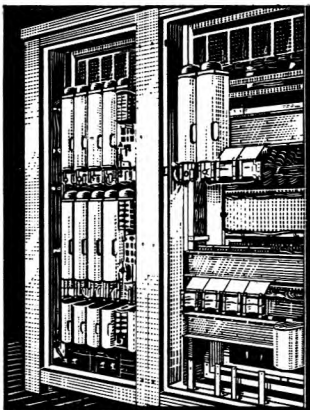

↙ Illustrated above is the Bamawm R.A.X. Building, Victoria, Australia. On the left are typical exchange units with a capacity ranging from 50/200 lines.

**G.E.C.**

REGD TRADE MARK

**THE GENERAL ELECTRIC CO., LTD., OF ENGLAND**  
**TELEPHONE WORKS COVENTRY ENGLAND**  
 COVENTRY 4111 (10 LINES) ★ ★ SPRINGJACK COVENTRY  
 HEAD OFFICE: MAGNET HOUSE, KINGSWAY, LONDON, W.C.2.

---



---

# CAPCO

---



---

REGISTERED TRADE MARK

# Quartz Cutting Machine

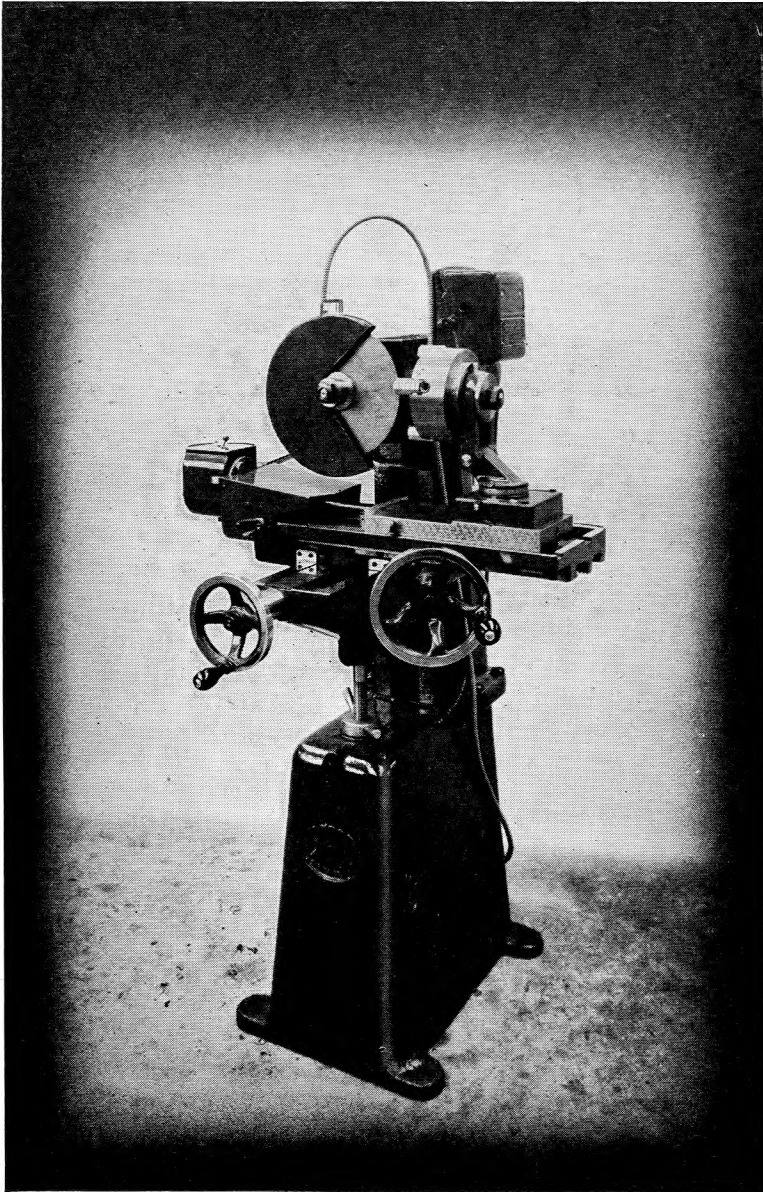

Illustration shows latest Model of the Quartz Cutting Machine developed and designed in collaboration with engineers of the Radio Branch of the Post Office.

Similar machines have been supplied to the Post Office and to the leading Telephone and Radio Manufacturers.

Standard and heavy duty cutting machines with high rates of cutting to accuracies of .001 in.

Fixtures to hold any shape of crystal can be supplied.

Heavy Duty Machine can now be supplied with nine rates automatic feed through specially designed gear box, sensitive instantaneous stop through specially designed clutch.

Acknowledged to be the finest machines of their kind for this class of work.

*Manufacturers :*

# CAPLIN

## ENGINEERING CO. LTD.

Precision Engineers

BEACONSFIELD RD., WILLESDEN  
LONDON, N.W.10

Telephone :  
WILlesden 0692.

Cables :  
Caplinko, London.

ESTABLISHED 1918

Sole Agents : CAPCO (SALES) LTD.

---



---



---

*Designers and Manufacturers of Capco Sound-on-Film recorders and equipment. Capco built recorders are in use at Elstree, Pathe News and British Talking Pictures, etc. Patentees and Manufacturers of Capco Enamelled Wire cleaning machines.*



THE SULLIVAN-GRIFFITHS  
SUBSTANDARD DYNATRON

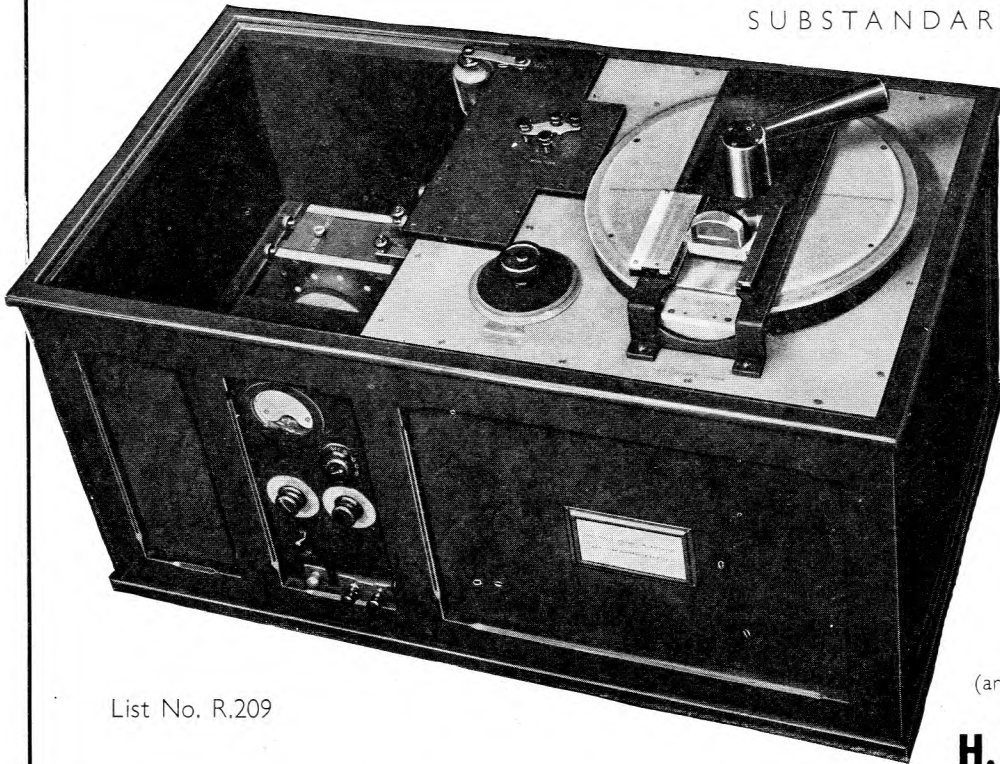

List No. R.209

## WAVEMETER

HAS A

**DIRECT  
READING  
FREQUENCY  
SCALE**

WITH AN ACCURACY OF

**0.01 %**

FROM

**30 kc/s**

TO

**15000 kc/s**

(and by harmonics up to 45000 kc/s)

**H. W. SULLIVAN LTD**

LONDON, S.E.15

Telephones : NEW CROSS 3225 (P.BX)

*"Sullivan" guarantees accuracy*

For New Telephone Developments—Technical, Plant, Commercial, Traffic, as well as late news affecting use of telephones—**READ**

## TELEPHONY!

The weekly journal of the telephone industry.

In these changing times the best investment a telephone man can make is to invest in himself. Competent men—the men who are well informed about their particular work and the business as well—are the ones who win promotion.

"TELEPHONY" covers every department of the telephone industry. It is informative, factual, inspirational; it publishes the latest developments, tells the approved telephone practices and current telephone news.

## READ TELEPHONY!

Subscription price, \$5.00 per year; 52 issues. Published since 1901.

Address : Odhams Press, Ltd., Technical Book Dept., 85 Long Acre, London, W.C.2 (Telephone : Temple Bar 2468) for a sample copy of TELEPHONY, or write direct to :

**TELEPHONY PUBLISHING CORPN.**  
608 S. Dearborn Street, Chicago, Ill., U.S.A.

# TUNGSTONE BATTERIES

Are being regularly used by

**G.P.O. Stores & Engineering Depts.**

**Empire Post & Telegraph Depts.**

**Admiralty**

**War Office**

**Air Ministry**

- Open or Enclosed types in Glass Containers.
- Large Capacities in Lead Lined Wood Boxes.
- **TUNGSTONE** High-pressure Die-cast Plates conform to British Standard Specification.
- **British Empire Lead exclusively used.**

**TUNGSTONE PRODUCTS LTD.**  
SALISBURY SQUARE LONDON, E.C.4

# The New Star of the Telephone World



**T**HE new Ericsson Automatic Telephone No. 1002 shown here has a casework of black moulded bakelite in a modern, distinctive and pleasing design. It incorporates a form of cradle or micro-telephone rest which is not readily damaged should the instrument get violently knocked or fall to the ground.

The whole of the interior apparatus which is mounted on a frame can be removed as a unit, the base plate which incorporates a useful sliding tray fitment being first removed. Dimensions, 6 by  $9\frac{1}{2}$  by  $8\frac{1}{2}$  inches ; weight, 6 lbs.

**NOW AVAILABLE TO P.O. SUBSCRIBERS**

*Full particulars from makers :*

**ERICSSON TELEPHONES LTD.**

HEAD OFFICE : 22 LINCOLN'S INN FIELDS, LONDON, W.C.2.

Works : Beeston, Notts.

(Telephone : HOLborn 6936)

CREATED BY

**Ericsson**

TELEPHONES LTD.



## INDEX TO ADVERTISERS

Alton Battery Co., Ltd., The .. .. .	viii	Hall Telephone Accessories (1928), Ltd. .. .. .	xxi
Austinlite, Ltd. .. .. .	xiv	International Correspondence Schools, Ltd. .. .. .	xxi
Automatic Coil Winder & Electrical Equipment Co., Ltd. .. .. .	iii	Institution of Post Office Electrical Engineers, The .. .. .	xxii
Automatic Telephone & Electric Co., Ltd. .. .. .	xii & xiii	Muirhead & Co., Ltd. .. .. .	xi
Bennett College .. .. .	ix	Pirelli-General Cable Works, Ltd. .. .. .	xxiv
Caplin Engineering Co., Ltd. .. .. .	xvi	Siemens Brothers & Co., Ltd. .. .. .	vi & vii
Creed & Co., Ltd. .. .. .	xxi	Smith, Frederick, & Co. .. .. .	xxiii
Edison Swan Electric Co., Ltd., The .. .. .	ii	Standard Telephones & Cables, Ltd. .. .. .	x
Elliott Bros. (London), Ltd. .. .. .	xxiii	Sullivan, H. W., Ltd. .. .. .	xvii
Ericsson Telephones, Ltd. .. .. .	xviii & xix	Telephony Publishing Corporation .. .. .	xiv
Exide .. .. .	iv	Tungstone Products, Ltd. .. .. .	xvii
Ferranti, Ltd. .. .. .	xiv	Turner, Ernest .. .. .	xvii
General Electric Co., Ltd., The .. .. .	ii & xv	Westinghouse Brake & Signal Co., Ltd. .. .. .	v

# TURNER DIFFERENTIAL MILLIAMMETERS G.P.O. No. 17 & No. 18

Meet the most  
exacting demands  
for balancing currents  
in multiplex telegraph circuits.

A quality  
product of outstanding  
merit

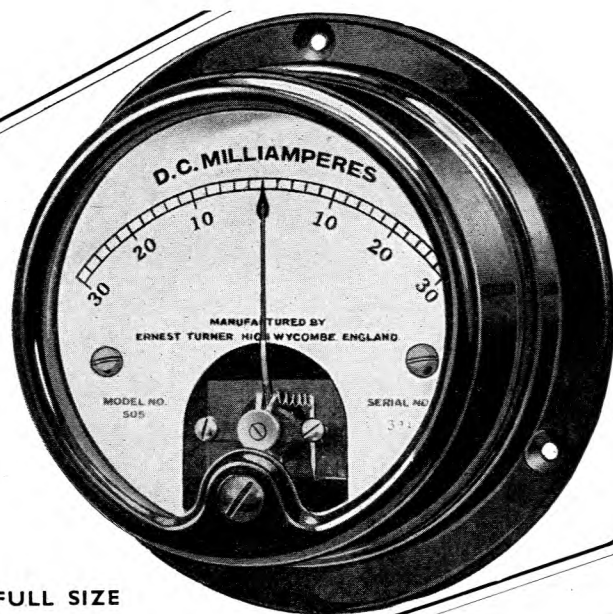

FULL SIZE

Also manufacturers of G.P.O. Detector No. 4, and a comprehensive line of instruments for precision electrical measurements.

**ERNEST TURNER ELECTRICAL INSTRUMENTS, Ltd.**

**CHILTERN WORKS,  
49-73 TOTTERIDGE AVENUE,  
HIGH WYCOMBE,  
BUCKS, ENGLAND**

Telephone: High Wycombe 1301, 1302.  
Telegrams: Gorgeous, High Wycombe.

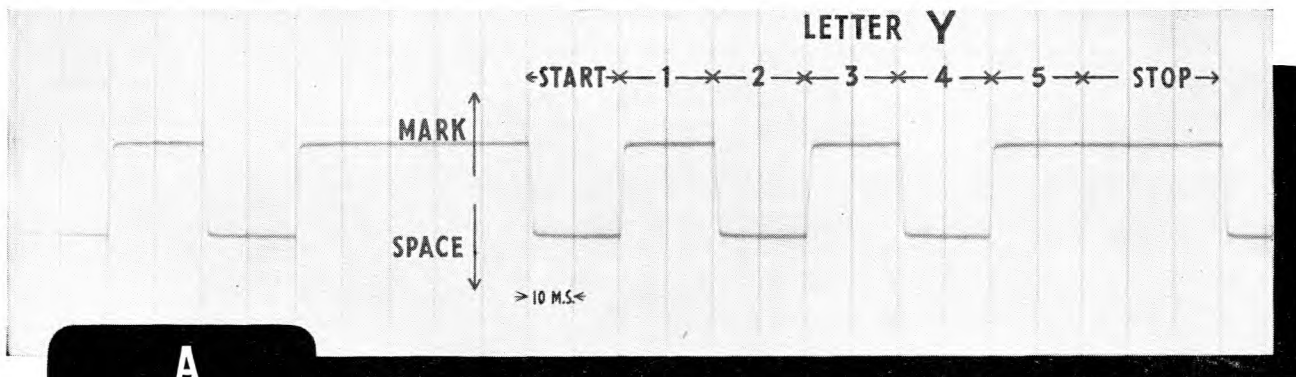

**A  
NOTEWORTHY  
ADVANCE IN**

# TELEGRAPH TRANSMISSION

**I**n the Creed Laboratory efforts are constantly directed towards effecting further progress in Printing Telegraph Communication. A new Teleprinter Transmitter designated Transmitting Unit S.2184, is a recent Creed development of considerable importance. Some of its outstanding features are:—

The provision of high quality Transmission with greatly reduced maintenance.

The Transmission performance is attained without critical adjustment and remains constant over extended periods without readjustment.

Accurate timing, complete freedom from contact rebound and the almost imperceptible transit time will be noted from the above reproduced oscillogram of actual Transmission.

Transmitting Unit S.2184 is now standardized on all Model 7 Creed Teleprinters, and is interchangeable with the previously fitted Transmitting Unit S.1842.

**CREED & CO. LTD., TELEGRAPH HOUSE, CROYDON.** Telephone: CROYDON 2121 (6 lines)

## Hall Telephone Accessories (1928) Limited

Suppliers to the British Post Office, Air Ministry, Admiralty, War Office and Foreign Government Departments.

Manufacturers of prepayment telephone multi-coin collectors, gas leak indicators, precision instruments, automatic stamp selling and ticket selling machines, automatic slot machines and fire alarm apparatus.

Registered  
Office & Works: **70, DUDDEN HILL LANE,  
WILLESDEN,**

Tel. WILLESDEN 5141/2/3. **LONDON, N.W. 10**  
Also GUEST WORKS, DOWLAIS, STH. WALES



## Spare-Time Training by Post in all Electrical Subjects

*The International Correspondence Schools, largest and most successful institution of its kind in the world, offers thoroughly sound Courses of Instruction to cover the following subjects:*

Electrical Engineering	Electric Illumination and Heating
Electrical Designing	Hydro-Electric
Electric Lighting	Oil-Power Electric
Electric Power	Power-House Attendants
Electric Traction	Steam Electric
Electrical Transmission and Distribution	Telegraph Engineering
	Telephone Engineering

*Also the following Examinations:*

Associate Membership, I.E.E.  
City and Guilds Elec. Eng. Practice, Elec. Installation and Telecommunications  
P.M.G. Certificate for Wireless Operators  
Provisional Certificate in Radio Telephony and Telegraphy

**WRITE FOR OUR SPECIAL FREE BOOKLET**

and mention the subject in which you are especially interested.  
..... You may use this coupon .....

**INTERNATIONAL CORRESPONDENCE SCHOOLS**  
LTD.

Dept. 108, International Buildings, Kingsway, London, W.C.2  
Please send your Booklet "Electrical Engineering" (72 pages)

I am specially interested in.....

Name .....

Age.....

Address .....





# MAINTAINING EFFICIENCY



THE HIGH STANDARD OF EFFICIENCY OF  
PIRELLI-GENERAL TELEPHONE CABLES IS  
MAINTAINED BY THE CONTINUOUS  
RESEARCH WORK OF AN EXPERIENCED  
TECHNICAL STAFF.

TELEPHONE  
SOUTHAMPTON  
2141 (3 LINES)

**PIRELLI-GENERAL**  
CABLE WORKS, Ltd., SOUTHAMPTON.

TELEGRAMS,  
"PIGEKAYBEL,  
SOUTHAMPTON."