

THE POST OFFICE ELECTRICAL ENGINEERS' JOURNAL

VOL. 35

JULY, 1942

PART 2

CONTENTS

	PAGE
BURIED CABLES—W. H. Brent, B.Sc., A.M.I.E.E., and A. H. Brown	41
THE MEASUREMENT OF THE LOSS COEFFICIENTS OF MAGNETIC DUST CORE MATERIALS—V. G. Welsby, B.Sc.(Eng.)	46
THE APPLICATION OF WELDING TO REPAIR WORK—C. W. Brett, M.Inst.W. (Barimar, Ltd.)	50
DELAYED CALL FORMULÆ WHEN CALLS ARE SERVED IN RANDOM ORDER—S. D. Mellor, B.Eng., A.M.I.E.E.	53
NEW LAMP SIGNALLING P.M.B.X. SWITCHBOARD—J. J. Roche and N. D. Smith	57
FREQUENCY DIVISION WITHOUT FREE OSCILLATION—D. J. Tucker, B.Sc.(Eng.), A.M.I.E.E., and H. J. Marchant, B.Sc., A.K.C.	62
A CARRIER-FREQUENCY HETERODYNE OSCILLATOR—K. W. Bourne	65
NOTES AND COMMENTS	68
REGIONAL NOTES	70
STAFF CHANGES	71

Price 1/- net

THE INSTITUTION OF POST OFFICE ELECTRICAL ENGINEERS

ALTON

Batteries

of

Merit

**THE
ALTON BATTERY Co. LTD.**

ALTON · HANTS

★
ALTON & FULLER

BATTERIES

Telephone: ALTON 2267 & 2268

Telegrams: "BATTERY, ALTON"

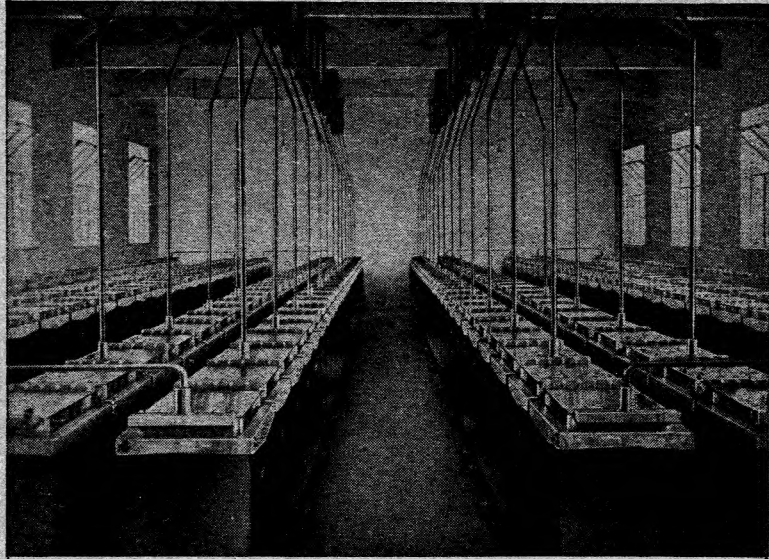

*ALTON Battery of 264 DLWII Type Cells at a
Corporation Electricity Works*

ACTION . . .

"Can do" is easily carried about.

Walter Scott.

In matters relating to stationary batteries for all purposes, the Alton organization by virtue of its experience and competence is able to carry out all conceivable normal requirements. This applies, too, to replating—whether the original battery be of Alton or other manufacture. There are, in short, few stationary battery problems for which the Alton organization cannot provide a solution. If action is possible, then Alton "can do."

THE POST OFFICE ELECTRICAL ENGINEERS' JOURNAL

Vol. XXXV

July, 1942

Part 2

Buried Cables

U.D.C. 621.315.23

W. H. BRENT, B.Sc., A.M.I.E.E., and
A. H. BROWN.

This article describes experience which has been gained in the use of mechanical aids for burying cables and indicates the extent of the economy in manual labour which may be effected thereby.

Introduction

A FEATURE of war-time construction work is the provision of circuits in outlying places. Many miles of small cables, principally 20-pair P.C.T. 20-lb. type, have been and are being laid in all parts of the United Kingdom, and the experience gained in the Midland Region in this class of work may, therefore, be of interest. With the shortage of labour and the need for speeding up the provision of these circuits, it is not surprising that standard methods of underground construction have had to be relaxed and new standards for cable laying in open country adopted. These now permit lead-covered cables with or without hessian tape and compound protection, according to the character of the soil, to be laid direct in the ground at a minimum depth of 9 ins., with extra depth and mechanical protection at road crossings. Future development (the main advantage of the use of duct work) can be provided for by selecting routes where there is room for a second cable to be laid with a reasonable clearance, say about 4 ft., from the first. A considerable programme of work of this character was in view, and the opportunity thus presented itself for new methods to be adopted to complete the works to schedule.

Available methods employing mechanical equipment for the saving of labour are: (1) the ordinary deep furrow agricultural plough, (2) the Killefer plough and ripper, (3) the Allen-Parsons bucket excavator, (4) the modified moledrainer, and (5) the modified ripper plough. All these have been tried with varying results.

The Agricultural Plough

The deep digging agricultural plough capable of digging to a depth of 16 ins. and turning a furrow from 14 to 18 ins. wide was first tried out as an aid to laying wood troughing. The results were satisfactory in that the work of excavation was reduced, but it was considered that too much manual labour was still required for the completion of the trench and the subsequent filling in, and that further experiment was warranted.

The Killefer Plough

In several localities the Killefer plough has been used. This is a large double share plough of very strong construction requiring a caterpillar type

tractor of 110 h.p. (D8 type) to pull it. A trench is cut to a depth which, under favourable conditions, may reach 2 ft. 6 ins. and of a tapering width 3 ft. 6 ins. at the top and 8 ins. at the bottom. The excavated soil is thrown up on either side, but this tends to fall back so that only a net depth of 1 ft. 6 ins. may be left, and several passes are usually made before a satisfactory trench results. Most obstacles are removed by this plough, and any type of soil can be dealt with, but if difficulties are anticipated the ripper (or rooter) tool, consisting of a plain steel bar ($3\frac{1}{4}$ ins. \times 8 ins.) with a steel shoe at the foot, is first dragged through the soil. The overall width of trench with the accompanying mounds of soil is 10 to 14 ft., and choice of route has to be made with this in mind. The soil can be subsequently pushed back into the trench by an angledozer fitting on the front of the tractor.

In locality "A" this equipment was used. An appreciable amount of manual labour was expended to "bottom-up" a somewhat rough trench and to provide an initial filling layer of about 6 ins. of fine soil, so that the cable was not damaged during the mechanised filling operations subsequently carried out by the angledozer. The actual effective time spent on laying 3,980 yds. of cable was 520 man-hours (excluding the tractor operator's time), half of which was expended in levelling the bottom of the trench and the remainder in laying the cable and covering it with a layer of soil. The average rate for comparative purposes was thus 230 man-hours per mile.

The Allen-Parsons Excavator

The Allen-Parsons excavator, having an endless chain of buckets, is well known and is mentioned because trenches opened by this means have been used for buried cables. A good straight-sided trench 12 ins. wide and 2 ft. deep can be excavated in most soils and is suitable with little extra work for laying ducts. A number of such duct laying works have been carried out and a considerable amount of excavating (but not refilling) labour saved. Experience shows that level ground is necessary, both to ensure a vertically-sided trench and to avoid the risk of the machine falling over. It has, therefore, often been necessary to provide a track of timber on the lower side of sloping ground. Clayey soils tend to clog the buckets and retard progress considerably. The machine requires a space approxi-

mately 7 ft. in width for operation and, in common with other mechanical appliances, freedom from the obstruction of other services, so that the field of use for this equipment is limited. As, however, the overhanging seat for the driver can be used on either side of the machine and arranged to overhang the road, it is possible for the machine to work on about 4 ft. width of verge. An account of work done by this type of machine is to be found in the October, 1941, issue of this JOURNAL.¹

The Moledrainer Plough

Some previous experience of laying cables direct in the ground, using a moledrainer, was obtained in 1932,² and that experience has been the basis of the more recent work of September and October, 1941. In the earlier works the cable was drawn in directly behind the mole, the leading end being attached to it, and severe stresses were at times imposed on the cable. Following descriptions of recent American and Canadian practices in this field and recent development work in the Cambridge Area in which the cable is fed into the ground through a pipe fixed to the rear of the mole blade, great improvement has resulted. The tensile stress induced in the cable is almost negligible, being only that due to friction in passing through the pipe, and, in consequence, full drum lengths of cable can be laid without joints, whereas with the older method the length of pull had to be strictly limited and the cable protected by a mechanical fuse to restrict the stress which could be induced on the cable. Further, with the cable feed-tube method, not only can the moledrainer be coupled to the rear of a caterpillar type tractor through a mechanical fuse, thus giving greater speed of working, but a straight course is no longer essential, so permitting greater freedom in the choice of route. Finally, tractor-winchs necessary for the older method but not for the new are in limited supply, and the transport of a few special machines over long distances is avoided, suitable caterpillar tractors being hired locally as required.

A Ransome C86 type moledrainer having a 2½-in. mole attached to a blade, which is adjustable to a depth of 18 ins. in the ground, was obtained and arrangements made to modify it for cabling work. The modification is illustrated in Fig. 1, and it will be seen that a 1½-in. diameter pipe extending from an extension piece behind the mole to a position above the top of the chassis is attached to the plough. The pipe is rigidly clamped to the chassis by a bracket and is held between two mild steel plates secured to the blade of the plough by countersunk rivets. It is welded to the extension piece at the bottom and terminates in a cup at the top to facilitate entrance of the cable. The Ransome implement digs itself in; has a self-lift mechanism and a simple device for grading the depth of the mole, and these facilities have been used with advantage in practice.

After consultation with agricultural experts as to the appropriate type of tractor, a Caterpillar D6 tractor (45-60 h.p.), with operator, was hired in the

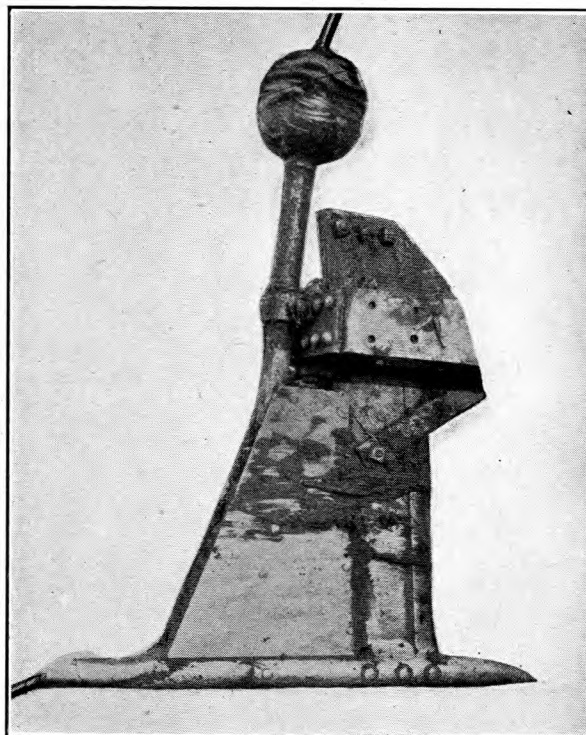

FIG. 1.—MOLEDRAINER MODIFIED FOR CABLING WORK.

vicinity and operations were commenced with a working party consisting of a foreman and five men equipped with a 2-ton Albion stores-carrying vehicle, with driver, from which to pay out the cable. Subsequent experience has confirmed that the D6 is the most suitable type of tractor for the work; the caterpillar track is essential and there is sufficient power to meet all conditions.

Typical Work Employing the Moledrainer Plough

While the plough was being modified, a careful survey was made in locality "B," and from an examination of the subsoil it was decided that the conditions were favourable for the initial trial. To expedite the progress of the work and to reduce the risk of faults, it was considered that the cables should be laid with a minimum number of joints. To this end, therefore, full drums containing 1,000-yd. lengths of cable, PC. 20 pr./20 lb., were conveyed to the site and laid out at convenient points along the track, which had been staked when the survey was made.

One of the drums of cable was mounted on jacks securely bolted to the floor of the Albion lorry, which was brought into a position alongside the tractor at the starting point. The modified moledrainer was hitched to the tractor with a short length of 7/8 G.I. strand wire, which served as a mechanical fuse to protect the equipment against overload stresses. The cup on the plough was filled with sodium silicate petroleum jelly emulsion, which was also applied to the top layer of cable on the drum. The end of the cable was then threaded through the pipe and anchored on the ground.

¹ P.O.E.E.J., Vol. 34, p. 147.

² I.P.O.E.E., Printed Paper No. 146.

Three men mounted the Albion, two of them taking positions to turn the drum, the other to spread the emulsion evenly over the sheath and guide the cable as it was paid off. The other two men remained on the ground, one to feed the cable into the pipe and attend to the moledrainer, the other to maintain a bight of slack cable behind the moledrainer as a precaution to prevent damage to the cable in the event of a mishap arising. The foreman mounted the tractor near the operator, in a position which enabled him to keep all phases of the work under close observation and from which any start or stop signals were promptly recognised by the whole party.

The tractor and motor vehicle then moved forward side by side at a speed of about 2-3 miles per hour, and a length of about 200 yds. of cable was laid, without hitch, at a depth averaging 12 ins. Operations were then halted while a brief inspection was made to determine the condition of the cable at one or two points. The cable being satisfactory, the work was restarted and continued until the top layer of cable was drawn off the drum, when another halt was made to apply grease to the second layer. These halts afford a period of respite to the men controlling the drum, whose energies are fully taxed to keep pace with the speed of the tractor, especially when the drum is fully loaded. When the complete length was laid, the working party unloaded the empty drum from the motor vehicle and set up a fresh one for the next length.

While the preparations for the following length were proceeding the tractor travelled back along the track, and its weight compressed and levelled the slight "swell" made by the cut. After this the surface of the ground appears practically unaltered, and where there are special reasons for avoiding obvious signs of trenching, this is a particular advantage of the moledrainer method.

The foregoing procedure was followed generally throughout the work where the track was under open grass-land, but at one point between buildings there was insufficient width for the tractor and lorry to travel side by side, and the cable was laid out on the ground in advance of the tractor and moledrainer. It was then lifted and fed into the cable tube as the machine proceeded. Fig. 2 shows cable being passed into the tube of a moledrainer after being laid on the grass. In another short section the surface was too hard for the moledrainer, so, to avoid making joints, the mole was raised and the cable was paid out through the pipe of the mole-drainer at ground level. It was thus laid out along the ground and subsequently lowered into a trench excavated by hand. A somewhat similar method was adopted where a ditch was encountered which could not be crossed by the tractor. The tractor travelled to the brink of the ditch, where it was uncoupled from the moledrainer and taken by another route to the other side of the ditch. The moledrainer was recoupled

with a suitably long length of 7/8 G.I. strand wire and drawn over the ditch on two skid boards. At road crossings, where ducts had been laid in advance, lengths of cable sufficient to reach through the ducts, were passed through the moledrainer pipe before the cable was cut. These lengths were coiled up and drawn in later.

Unforeseen obstructions, such as old foundations and a water-pipe, were encountered, but apart from breaking the fuse and thereby hindering the progress of the work, no serious damage was done to the mole or the coulters. Drawing the machine back from an obstruction on one occasion damaged a short length of cable which had to be cut out, but this can be avoided by excavating to free the cable in the soil before clearing the obstruction. An incident occurred when the Albion lorry was travelling over uneven ground, the tilt of the vehicle causing the cable drum to slide along the spindle; consequently one of the fixing nuts on the cable drum fouled the jack and prevented the drum from turning. Prompt action to stop the operations and the precaution of maintaining a bight of free cable prevented any mishap, and a collar about 3 in. long improvised from 2½-in. steam-pipe fixed on the spindle on each side of the drum has prevented further trouble.

Altogether, during the course of three days' work at locality "B," 2,824 yds. of cable were laid, including 206 yds. where trenches were excavated by manual labour and 150 yds. where the cable was drawn into ducts.

Comparative Costs of the Moledrainer and other Methods.

Having obtained such satisfactory results with the moledrainer in the initial experiment, extended trials were carried out in other localities and, mainly in consequence of the experience gained at locality "B," the results on the subsequent work were even more gratifying. The rate of progress was governed to a considerable extent by the number of occasions it was necessary to cut the cables on account of road crossings or other obstructions and by the number and length of the spur cables, and it is worthy of

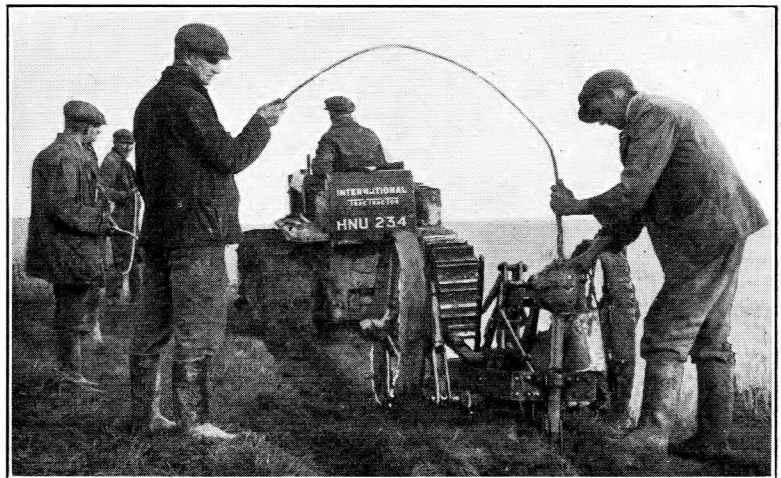

FIG. 2.—CABLE-LAYING WITH MOLEDRAINER.

note that where the conditions were particularly favourable, as much as 3,000 yds. were laid during the course of one working day of 10½ hours. Details of a series of cable works in which the moledrainer was used are given in Table I.

TABLE I
CABLES LAID BY MOLEDRAINER

Locality	Total length laid		Effective Man-hours	Average rates —Manhours		Charges for hire of tractor
	Yds.	Miles		Per yd.	Per mile	
B	2,468	1.402	213	0.036	152	£23
C	3,500	1.989	146	0.042	*73	25
D*	3,150	1.790	216	0.068	121	28
E	4,700	2.670	170	0.036	64	28
F	3,620	2.057	214	0.059	104	24
Total	17,438	9.908	959	—	—	128
Mean	—	—	—	0.055	97	—

* A number of comparatively short spurs were laid and inclement weather was experienced during the course of this work.

From Table I it is evident that the cables were laid much more expeditiously and economically than the cable laid in the trenches excavated with the Killefer equipment at locality "A." At the site where the latter was used the subsoil was a dry heavy clay which was thrown out of the trench in the form of large boulders. Many of these fell back into the trench, and it may be that more than a normal amount of time was required to level the trench and to ensure that the cable was not damaged when the trench was filled in. However, several trenches have been excavated with the Killefer Plough equipment in other localities, and it has been remarked generally that the bed of the trench was very uneven, so it seems probable that some clearing and levelling would usually be necessary. The fact remains, however, that the cable could have been laid with the moledrainer at locality "A" at a rate comparable with those achieved in the other localities and, since the running costs of the Killefer equipment are considerably higher than the charges for the tractor and mole drainer, the above contention as to the merits of the two methods seems well justified.

The works referred to in Table I were scattered over a wide area, and subsoils of clay, fine gravel

and fairly heavy loam were encountered. On one occasion the moledrainer cut through what appeared to be a length of disused brick drain without breaking the fuse or damaging the machine, and the presence of the obstruction was only revealed as a result of an investigation made to determine why the speed of the tractor had been retarded. Although such an event serves to demonstrate the stability of the equipment, it also emphasises the need for making full enquiries to determine the position of any other buried plant when the cable track is being surveyed.

Owing to the abnormal manner in which ordinary lead-covered cables had been laid, special insulation tests were made with satisfactory results on each of the separate lengths before they were jointed, and there is no evidence or reason to believe that the cables have suffered any unsuspected damage during the course of the operations.

Both plain lead-covered and protected cables have been successfully laid with the moledrainer, a mixture of whiting and water being used for the protected type as a lubricant in the tube to prevent the compound sticking.

Conditions on some sites have been such that a wheeled motor vehicle was unable to travel along the track owing to the yielding character of the ground, and this difficulty has been surmounted by laying the cable alongside the route, using the tractor as an aid in pulling out the cable. It has also been expedient to adopt this method for short spur cables, setting up the drum at one end of the spur and pulling off the required length. A further development for work on this class of surface was the construction of a timber sledge on which the cable drum jacks were securely bolted. This was dragged over the ground by the tractor and used not only to get the drums of cable on site but also to pay out cable along the route prior to laying by the machine. On some sections the tractor has pulled both moledrainer and cable sledge and the cable passed from the drum through the pipe into the soil in one operation. This is illustrated in Fig. 3.

From some points of view it may appear to be irrelevant to try to determine the saving in manhours which has accrued as a result of using the moledrainer in lieu of normal methods, but as speed of completion and saving of labour were the main objectives the comparisons given below are of striking interest. In the calculations an attempt has been made to use basic rates consistent with those which would have been obtained if normal methods of construction had been employed, and thus to estimate the time (in man weeks) gained and the expenditure saved on the works scheduled in Table I.

The direct labour cost of these five works is calculated at £110, which, with the cost of tractor hire, gives a total cost of £240. If the trenches had been excavated entirely by hand, the cable laid and the ground restored, it is estimated that the direct labour cost would have been £1,140 for the 9.9 miles.

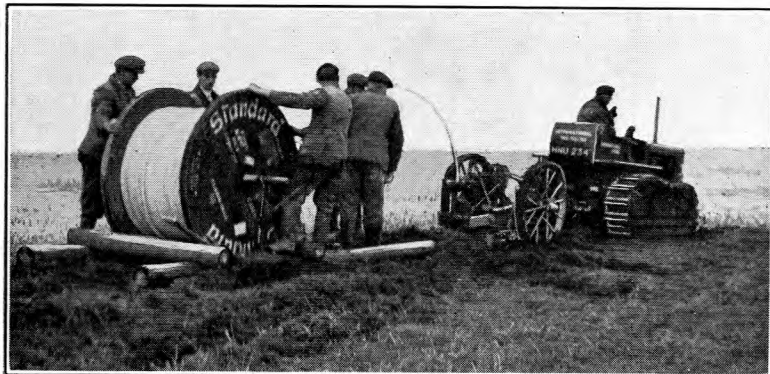

FIG. 3.—CABLE-LAYING WITH MOLEDRAINER AND SLEDGE.

For the purpose of this calculation the observed rate of excavation for such work at locality "B" has been taken where the cable was laid in trenches at the same depth as it was laid by the moledrainer. If, moreover, ducts had been laid and the cable drawn into them, the estimated total cost of direct labour and ducts becomes £2,640. The net saving in cost of the moledrainer method over the hand trenching method is, therefore, £900, or, over the use of ducts £2,400, and this shows significantly the extent to which it has been possible to effect economies by using the moledrainer plough.

The speed in the completion of works is also apparent in that the time taken to do the effective work is only 9 per cent. of that calculated to be required to lay cables in open trenches, or 6 per cent. of that required for duct construction. Actually, the whole of the work in the five localities referred to was completed in the course of 13 working days.

The Ripper Plough

The modification of the ripper plough followed in principle, but varied in design from that of the moledrainer. The ripper plough is very strongly built to carry out its original purpose of removing obstacles, and is essentially a chassis constructed of 1-in. steel plate carrying a ripper blade of section $3\frac{1}{4}$ in. by 8 in., extending below the chassis for a length of 2 ft. 6 in. The weight is approximately $7\frac{1}{2}$ tons. To provide for cable laying two steel plates were welded to the sides of the blade and extended behind the blade to form the parallel sides of a box through which the cable passes. The cable enters the box at the top just behind the blade and passes via two guiding sheaves to the exit tube at the bottom rear. The cable drum in this equipment has been mounted on jacks securely bolted to the rear extension of the chassis, and thus the cable feeds direct into the cable laying device without requiring a second vehicle. The whole is drawn by a tractor of 110 h.p. (D8 type). Fig. 4 shows the plough raised above ground and with the cable drum in place ready for operations, and Fig. 5 shows a near view of the ripper blade with the cable laying modification.

Several works have been carried out with this equipment, but insufficient data is available to quote comparative costs; it is probable that they approach the economies of the moledrainer equipment, but the tractive force required and consequently the running cost is much greater. It has been used to lay cable in soft sandstone. A depth of 2 ft. is easily obtained, and it is obvious that this equipment can be used in difficult soil conditions where the normal moledrainer equipment would be impracticable. On the other hand, very wet conditions have stopped the ripper equipment by reason of the weight—some 9 tons, including the drum of cable—causing

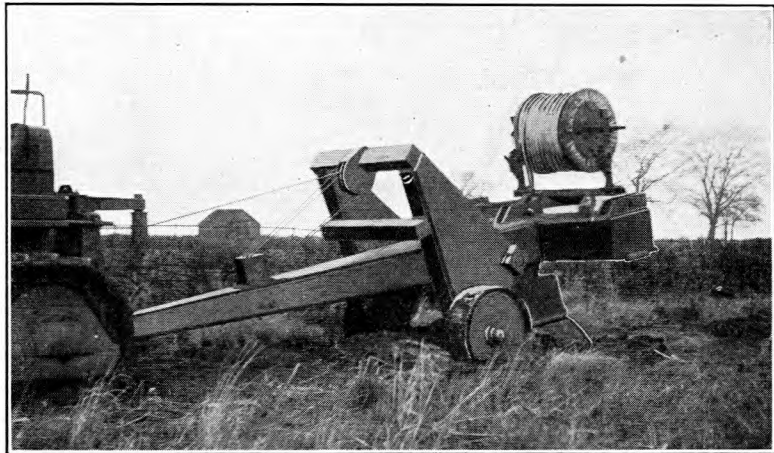

FIG. 4.—RIPPER PLOUGH.

it to sink in the soft ground. Any jamming of the cable in the device has to be carefully guarded against, on account of the extreme tension which can be imparted to the cable when this happens.

Conclusions

It is concluded, from the experience gained, that considerable savings can be effected by the use of mechanical aids, but these must generally be selected to meet, among other factors, the varying conditions of soil. If the conditions permit the use of the modified moledrainer, the greatest savings can be secured by its use. A careful survey by an experienced man must, therefore, be made in advance.

It is worth noting that under open grass conditions all signs of burying the cable quickly disappear, particularly if the moledrainer has been used. For this reason, and to aid maintenance, detailed map records of the position are compiled from frequent measurements taken from permanent recognisable objects. In addition, the standard search coil and head-gear receiver, which picks up the current from a vibrating generator applied to the cable sheath, is a necessary part of the faultsman's equipment.

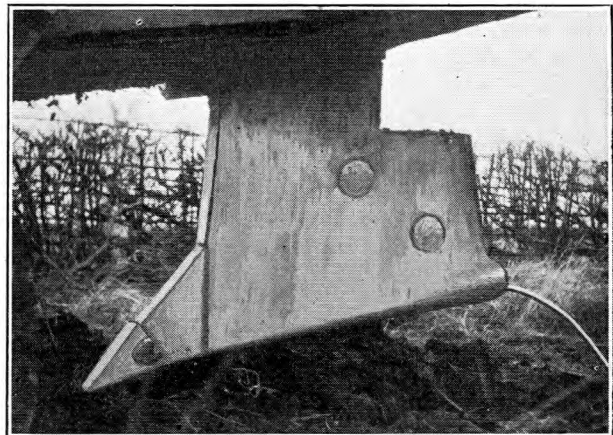

FIG. 5.—RIPPER BLADE WITH CABLE-LAYING MODIFICATION.

The Measurement of the Loss Coefficients of Magnetic Dust Core Materials

V. G. WELSBY, B.Sc.(Eng.)

U.D.C. 621.396.662.2 621.318.322

The author describes a method by which the losses in a toroidal dust-cored coil may be measured and those associated with the winding eliminated to allow the loss coefficients of the core material to be determined.

Introduction.

THE impedance of an iron-cored inductance coil can be represented by an equivalent circuit, shown in Fig. 1, in which the resistance R represents the component causing the power loss in the winding and the magnetic core. The distributed capacitance and leakage of the winding can be regarded as a lumped capacitance and leakage shunted across the coil. The investigation of losses in the core thus involves the determination of the resistance R from measurements of the impedance

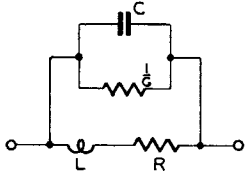

FIG. 1.—EQUIVALENT CIRCUIT OF IRON-CORED INDUCTANCE.

presented at the terminals and the deduction of the components associated with the winding. For any practical coil, in which the effects of self-capacitance and leakage are kept as small as possible, the impedance of the coil may be expressed as $(R' + j\omega L')$

$$\text{where } R' = \frac{R + G\omega^2 L^2}{(1 - \omega^2 LC)^2} \dots\dots\dots (1)$$

$$\text{and } L' = \frac{L}{1 - \omega^2 LC} \dots\dots\dots (2)$$

In addition to the required component R_m due to core losses, the resistance R also includes the D.C. resistance and eddy-current resistance (skin-effect and proximity-effect) of the winding. The core loss component can be separated out by measuring the impedance of a coil similar in every way to the test coil except that it is wound on a former constructed of non-magnetic material. Then, assuming that the wire losses are not changed by the introduction of the magnetic core, it follows that the difference between the values of R obtained for the two coils will be due to losses in the core. The above assumption is justified for a single-layer toroidal¹ coil, but may not necessarily hold for other types of coil. The test coil should always be designed so that the wire eddy-current losses form only a small percentage of the total. It is often possible to avoid winding a second "air-cored" test coil by keeping the wire losses so small that they can either be calculated to a sufficient degree of accuracy², or even neglected altogether. The core loss resistance R_m is then obtained simply by subtracting the D.C. resistance of the winding from the total loss resistance R.

An exact theoretical analysis of the core loss is somewhat difficult, but, by making certain assump-

tions, a simple theory can be developed, yielding results which are confirmed by experiment³. The resistance R_m is split up into the following three components, each of which can be considered separately:—

- (a) Hysteresis resistance, R_h .
 - (b) Eddy-current resistance, R_e .
 - (c) Residual-loss resistance, R_r .
- So that $R_m = (R_h + R_e + R_r)$.

Then, if μ is the permeability of the core material, B_m the maximum flux density in the core, L the inductance of the coil and f the testing frequency, it can be shown that the following relationship exists:

$$R_m = \mu a B_m f L + \mu e f^2 L + \mu c f L \dots\dots\dots (3)$$

$$\text{or } \frac{R_m}{\mu f L} = [a B_m + c] + e f \dots\dots\dots (4)$$

a, e, c, are known as the hysteresis, eddy-current and residual loss coefficients respectively, and it will be seen that the values of these coefficients for a given material enable its losses to be predicted when it is used as a core for an inductance coil and that they also provide a useful basis for the comparison of the performance of different materials.

This article describes the design of apparatus for the accurate measurement of the impedance of suitable test coils and shows how the three fundamental loss-coefficients of the core material may be determined from the results of such measurements.

Test Coils.

The toroid is the most suitable form of test coil for the investigation of the properties of dust-core materials, the disadvantage of the difficulty of winding being outweighed by advantages which may be summarised as follows:—

- (a) The flux-density is practically constant over the cross-section of the magnetic path.
- (b) A toroid is easier to press and more likely to be homogeneous than other less symmetrical types.
- (c) The flux-density, and hence the permeability of the material can be calculated accurately.
- (d) The external leakage field is small.

The maximum flux density B_m produced by a sinusoidal current of I amps. R.M.S. flowing in a uniformly-wound coil of N turns on a toroid of cross-sectional area A square centimetres and effective diameter d centimetres is given by:

$$B_m = \frac{0.4 \sqrt{2} N I \mu}{d} \dots\dots\dots (5)$$

The permeability μ may be obtained from the following relationship:—

$$\mu = \frac{dL \times 10^9}{4N^2 A} \dots\dots\dots (6)$$

¹ Strictly speaking, the term "toroid" refers to a ring of circular cross-section, but it is commonly used to include rings of other shapes.

² W.E., January, 1929, p. 13.

³ B.S.T.J., Vol 15, p. 49. B.S.T.J., Vol. 16, p 212.

where L is the inductance obtained from equation (2).

The effective diameter of the core may be taken as the arithmetic mean of the inside and outside diameters of a thin toroid. For thick toroids the flux-distribution must be taken into account and the effective diameter is slightly less than the mean.

Graphical Analysis of Losses.

To minimise the possible errors, it is usual to make a series of impedance measurements and to evaluate the loss coefficients by a graphical method.

The first step is to evaluate the hysteresis coefficient by measuring the value of R_m at a constant frequency but with different values of the current I flowing in the coil. Then if B_m is calculated from

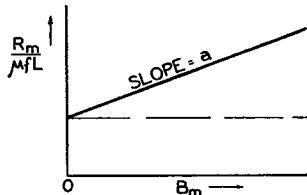

FIG. 2.

equation (5) and plotted against the quantity $R_m/\mu f L$ as shown in Fig. 2, a straight line should be obtained, the slope of which gives the value of the coefficient a .

The remaining coefficients are obtained

by measuring R_m at various frequencies, but keeping the current in the coil constant. Plotting the quantity $R_m/\mu f L$ against f will again give a straight line graph (Fig. 3). The slope will give the eddy-current coefficient e , and the intercept on the $R_m/\mu f L$ axis will be $(aB'_m + c)$ where B'_m is the maximum flux density corresponding to the constant coil current. The value of aB'_m will be obtainable from the graph of Fig. 2, so that the residual loss coefficient c can then be calculated.

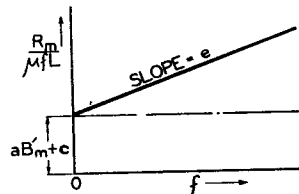

FIG. 3.

Effect of Dielectric Loss.

Referring to equation (1) and re-writing :

$$\begin{aligned} R + G\omega^2L^2 &= R'(1 - \omega^2LC)^2 \\ &= R'(1 - x^2)^2 \end{aligned}$$

where x is the ratio of the testing-frequency to the frequency of self-resonance of the coil. It will be seen that the first stage in the evaluation of the loss resistance R is a simple correction for the self-capacitance of the coil. This gives the value of $(R + G\omega^2L^2)$. The term $G\omega^2L^2$ represents the power dissipated by dielectric losses in the insulating materials which are used in the construction of the coil. Normally, care should be taken to ensure that this loss is negligible.

MEASURING EQUIPMENT

Accuracy.

It will be remembered that the eddy-current and residual loss coefficients are obtained from the slope and zero-intercept respectively of a straight-line graph. The most likely source of inaccuracy in the values of these coefficients will be at the lowest

testing-frequency. This applies particularly to the intercept, which can be changed considerably by small errors in the measurements at the lower frequencies. The apparatus which is to be described was designed to give the value of R' to an accuracy of about ± 0.005 ohm at frequencies up to half a megacycle. This enables the hysteresis and eddy-current coefficients to be evaluated with a possible error of about ± 5 per cent. The possible error in the value of the residual coefficient, particularly when dealing with low-loss materials, was greater, sometimes reaching the order of ± 10 per cent.

Simple Resonance Bridge.

There are several methods which could be used for measuring the impedance of the test coil, but it has been found that an impedance bridge circuit is the most suitable for obtaining the degree of accuracy required. The arrangement of the series resonance bridge in its simplest form is shown in Fig. 4.

The ratio arms P and Q are usually made equal, so that the condition for balance is that the impedances of the arms AE and BE should be equal. Before actual measurements are made, a balance is obtained with the switches S_1 and S_2 closed; a small inductance L_0 and resistance R_0 being adjusted to compensate for the residual impedance of the constant inductance resistance standard R when the latter is set to zero, and incidentally for the impedance unbalance of the connecting leads in the arms AE and BE . The test coil is connected between terminals XY and a new balance obtained with the switches open by adjusting R and C . Then if the impedance of the coil is $(R' + j\omega L')$ the conditions for balance will be

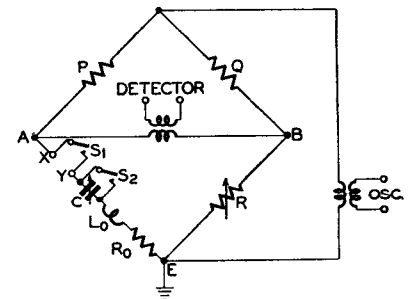

FIG. 4.—SIMPLE RESONANCE BRIDGE.

$$\begin{cases} R' + r = R \\ j\omega L + 1/j\omega C = 0 \end{cases}$$

where r is the effective loss resistance of the condenser C . Since the reactances of the coil and condenser are made equal at balance, it follows that the resistances R' and r are approximately proportional to their respective power factors. Now, at the lowest testing frequency, where the greatest accuracy is required, the power factor of the coil may be of the order of 0.01, so that for an accuracy of ± 1 per cent. in the value of R' it follows that the condenser power factor must be less than 0.0001.

Power factors of this order can be obtained with high-grade air-dielectric condensers of capacitances up to about $0.001\mu F$, but such condensers become unwieldy when large capacitances are required. Thus the simple resonance bridge is not suitable for the measurement of small inductances at low frequencies and a modification of the method is required.

The Partial-substitution Resonance Bridge.

To reduce the tuning capacitance required, a "ballast" coil L_o is used (Fig. 5). The bridge is

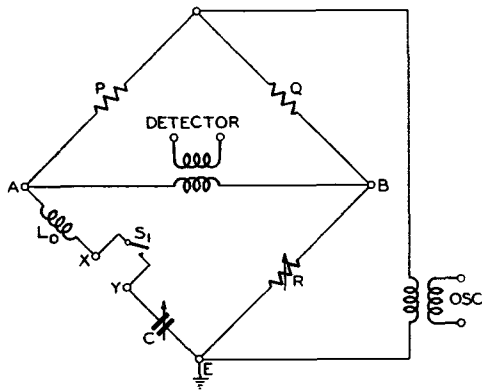

FIG. 5.—RESONANCE BRIDGE WITH BALLAST COIL.

first balanced with switch S_1 closed and the condenser and resistance settings C_1 and R_1 noted. The test coil is then connected between the terminals X and Y and a new balance obtained with the switch S_1 open. If C_2 and R_2 are the new condenser and resistance settings, the conditions for balance are as follow :

$$\begin{cases} R' &= R_2 - R_1 \\ L_o &= \frac{1}{\omega^2 C_1} \\ (L' + L_o) &= \frac{1}{\omega_2^2 C_2} \end{cases}$$

so that $L = \frac{1}{\omega^2} \left(\frac{1}{C_2} - \frac{1}{C_1} \right)$

The condenser losses have been neglected, since it is now assumed that a high-grade air-dielectric condenser can be used. It can be seen that C_2 must be less than C_1 so that the maximum capacitance of the tuning condenser is now determined only by the value of L_o . L_o can conveniently take the form of a set of plug-in coils, one for each testing frequency, their inductances being chosen so that C_1 always falls near the maximum capacitance of the tuning condenser.

The effect of condenser losses is further reduced by the fact that it is only the increment of the loss resistance between the settings C_1 and C_2 which can affect the result of the measurements.

Description of Apparatus.

In the above discussion, the effects of stray capacitances and magnetic couplings have been neglected, but in practice these are of considerable importance and careful screening becomes necessary. A schematic diagram of a complete bridge circuit is shown in Fig. 6.

The potentiometer r and differential condenser c are used to trim the balance of the bridge output transformer to ensure that connections to the secondary of the transformer can have no influence on the bridge readings. This initial adjustment

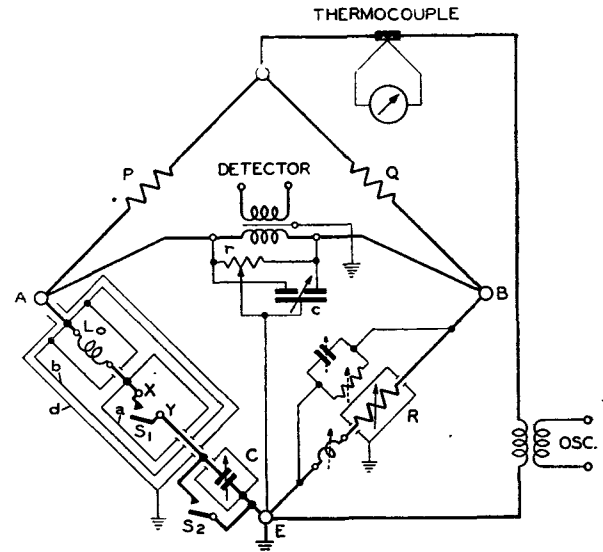

FIG. 6.—PARTIAL-SUBSTITUTION RESONANCE BRIDGE.

should be checked at each testing frequency with the bridge arms AE and BE disconnected. The screening of the coils is designed so that the capacitances

between the screens can be allowed for. It consists of three copper boxes, one inside the other, and connected as shown. Fig. 7 shows the equivalent circuit of the arm AE, including the various stray capacitances and their associated conductances. The suffixes a, b, d, refer to the screens as indicated in Fig. 6. C_{ab} and G_{ab} are shunted across the ballast coil L_o and merely modify its apparent impedance without affecting the measurements, while $C_{v,1}$ and G_{bd} can be compensated by a pre-set condenser and resistance connected across the arm BE. The latter correction is not at all critical, owing to the low tuned-impedance of the bridge arm, and can often be omitted altogether. The capacitances C_3 and C_4 , between the terminals X and Y and between terminal Y and earth, respectively, must be taken into account as corrections. C_3 can be kept small by ensuring that X and Y and their leads are air-spaced as far as possible; the value of the capacitance will generally be less than $1 \mu\mu\text{F}$ with a negligible conductance. This capacitance may need to be taken into account when considering the effect of the self-capacitance of the test-coil, but it can be measured accurately and the correction is generally small.

FIG. 7—EQUIVALENT CIRCUIT OF ARM AE (FIG. 6).

C_4 can be allowed for quite simply, since it is in parallel with the tuning condenser and merely means that a constant correction has to be added to the nominal capacitance of the condenser. The conductance associated with C_4 introduces a troublesome correction which varies with the setting of the tuning

condenser and with testing frequency. Fortunately, this correction can be made negligibly small by careful design and the use of low-loss insulating materials at the points where the lead from the terminal Y passes through the various screening boxes.

To sum up: the only corrections which need to be applied when making measurements are those for C_3 and C_4 , both of which are constant capacitances and which can easily be allowed for.

Fig. 8 shows the arrangement of the screens in the arm AE and also the form of the plug-in ballast coils. Inside the inner screen are the mercury cups which form the terminals X and Y. Each of these cups has a small projection at the bottom which dips into a third mercury cup on a pivoted arm, forming the switch S_1 . A typical test-coil is shown in position for measurement.

Use of Bridge.

Where it is possible to make measurements with the simple bridge (Fig. 4) the ballast coil is replaced by a short-circuiting link and a small coil is inserted in the arm BE to balance the inductance of the leads in the screened arm. This adjustment is part of the process of setting up the bridge and should not require further attention. The coil can, of course, be left in position when using the partial substitution method. The simple bridge must always be used for hysteresis measurements, since the other

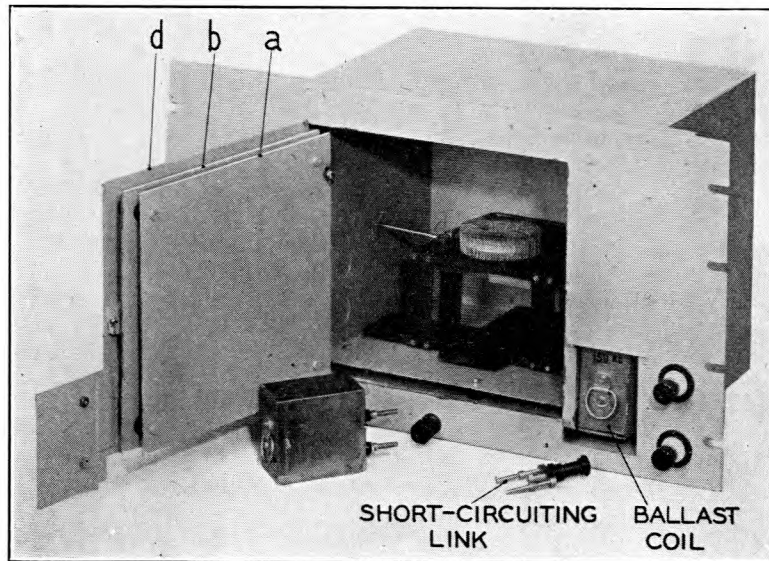

FIG. 8.—ARRANGEMENT OF SCREENS AND BALLAST COIL IN ARM AE (FIG. 6).

method uses dust-cored ballast-coils which would upset the results. The measurement of current is carried out by a thermocouple meter in the feed to the junction point of the bridge ratio-arms. When the arms AE and BE are disconnected there will still be a small current flowing via the earth capacitances from the points A and B. This leakage current can be measured and used as a correction where necessary,

although it can usually be made negligible by minimising the stray capacitances concerned. At balance, the bridge current divides equally into the two ratio arms.

Then, since no current flows in the output transformer, it follows that half the measured bridge current flows through the test coil. It should be pointed out that errors will be introduced if the output of the driving oscillator is not sinusoidal, since the bridge will be balanced at the fundamental frequency only, whereas the thermocouple meter will indicate the R.M.S. value of the current wave flowing into the bridge. This difficulty can be overcome quite simply by introducing a tuned circuit between the oscillator and the bridge input.

Auxiliary Equipment.

In addition to the oscillator and the bridge itself, some form of detector is required to provide an aural or visual indication of the degree of balance. A visual indicator of the "magic eye" type can be used, but this suffers from the disadvantage that it gives no discrimination between the signal and unwanted circuit noise. The signal may be swamped by noise near the balance point, resulting in an apparent reduction of sensitivity. Aural methods may be rather more tiring to the operator, but since the ear is capable of picking out a single-frequency signal in the presence of considerable interference, better results can usually be obtained. The audible note is obtained by the well-known heterodyne principle, the unbalance signal from the bridge being used to modulate the output of a variable oscillator whose frequency is adjusted to be 1,000 c/s away from the testing-frequency. The resulting 1,000 c/s tone is amplified and fed into headphones or a loudspeaker. A tuned H.F. amplifier must be connected between the bridge and the detector to ensure that harmonics of the testing-frequency, generated in the oscillator or in the test-coil itself, are not passed on into the detector. If such harmonics are allowed to enter the modulator circuit of the detector, they will produce difference-products, the frequency of some of which will obviously coincide with the fundamental frequency. Thus it may happen that even when the bridge is exactly balanced, a spurious signal will be heard.

Conclusion.

A method has been described whereby the fundamental loss coefficients of a core material can be determined. The values of these coefficients are of considerable importance in the development of core materials, since they indicate how the components of the core loss are affected by changes of grain size, moulding pressure, etc., and enable the most suitable materials to be selected for particular purposes.

The Application of Welding to Repair Work

C. W. BRETT, M.Inst.W.
(Erimar, Ltd.)

U.D.C. 621.791

After an outline of some recent developments in welding practice the author instances a number of typical repairs carried out in the factory and by mobile repair gangs to illustrate the wide range of repairs made possible by modern welding methods.

Introduction.

THE two main systems of welding in use to-day are the electric arc and oxy-acetylene processes, although there is some forge work done in the blacksmith's shop, and Thermit welding is of great value for certain highly specialised operations.

The experienced welding engineer rarely has any doubt as to whether the electric arc or the oxy-acetylene process is the one to use for any particular work, although in an article like this it is hardly possible to lay down hard and fast lines. Speaking generally, cast iron, brass, copper, aluminium, and thin sheet metal should be welded by the oxy-acetylene process, whereas mild steel, the high carbon steels, steel alloys, "semi-steel," and cast steel are welded more readily by the electric arc method.

Most of the components of motor vehicle engines—the cylinders, cylinder heads, crank cases and gear boxes—are repaired by the oxy-acetylene process, and this method of repair has been of inestimable value to owners of all kinds of mechanical road transport. The same process is used for the repair of stamping press bodies, crane bed plates, steam engine cylinders, condensers with cast-iron shells, machine tools and marine engine parts. The chief exceptions among motor vehicle components are crankshafts, axles and other steel parts, for which the electric arc process, as depicted in Fig. 1, is employed. For practically all kinds of steel fabrication the electric process is used, and this sphere now

embraces the steel framework of buildings, as well as bridge construction.

A great deal of the plant in the super-electric power stations erected within the last few years has been of welded construction, and welding in some circumstances has proved much more satisfactory than riveting, especially for steel condenser shells.

The fabrication of plant by electric welding is in its infancy, but already its utility is recognised in many branches of engineering, because of the saving it shows in time and material. It is unlikely that welding will ever replace foundry work of a repetition nature; but for single, or even a few, units it is much more economical, as it avoids the expense of patterns. It is, however, in regard to general repair work that the greatest opportunities probably exist. Toward this field of usefulness much technical research has been directed with gratifying results.

Modern Developments.

It is not too much to state that astounding success has been gained in the welding together of dissimilar metals. For some time past it has been practicable to weld steel to cast or malleable iron, regardless of the difference in the co-efficients of expansion of the two materials. Still greater variation in this respect was regarded as an insuperable barrier, but it has not proved to be so. Only a few months ago a process was commercialised which enables ferrous and non-ferrous metals to be welded together, even when the combination is most divergent in primary characteristics. In short, if it is necessary, then steel and aluminium can be brought into welded union. Test pieces of work of this kind reveal that the breaking strain at the joint is invariably above that of the weaker metal, thus proving that a true weld is accomplished. This new method is being applied to repairs of many kinds.

Less spectacular, but equally important, advances have been made in the direction of cost, with the result that the already low price of repair work has been reduced still further. This is on account of methods by which the operator requires less time to complete a given job than hitherto. This remark applies particularly to work upon cast or malleable iron which no longer always needs heating in a muffle furnace before the actual repair can be commenced. Such a preliminary was at one time essential because of the risk of creating stresses in the metal due to unequal expansion and contraction in the vicinity of the weld. Such danger has been eliminated by the use of improved

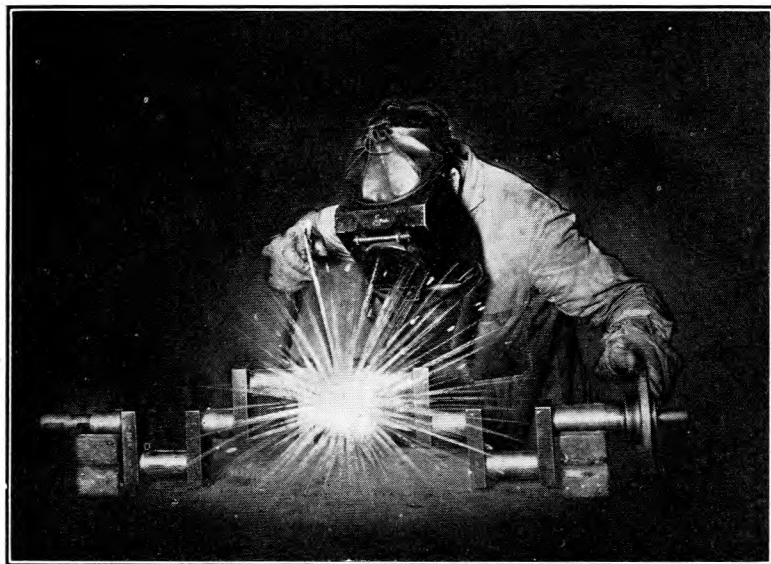

FIG. 1.—ELECTRIC WELDING OF CRANKSHAFT JOURNAL.

apparatus enabling a close regulation of the heat-flow to be obtained with certainty. To within such strict limits is the high temperature area reduced, that if operations be ceased momentarily it is actually possible to touch close up to the point of fusion without fear of being burned.

The use of a hydrogen "field" process has been of considerable value in the welding of worn or fractured steel components. Although any competent welder can obtain the necessary strength in a steel weld, molten steel enters into chemical combination with the oxygen and nitrogen in the air, resulting in the formation of oxides and nitrides in the steel. Not only do these lessen the resistance to corrosion, but they are the cause of pit marks which cannot be

out by a skilled operator in the manner described is virtually unknown. Of some 750 crankshafts reconditioned after fracture and kept under observation, only one broke a second time, and this was due to a flaw in the forging at a point remote from the weld.

These crankshafts vary from some of small size to others up to 16 ft. in length. The majority belong to petrol and Diesel engines (including a number belonging to postal departments) with a fair sprinkling of steam engine cranks, such as the one shown in Fig. 2, belonging to a railway locomotive and weighing nearly $1\frac{1}{2}$ tons. Welding has proved to be a most economical means for the general maintenance of road vehicles used in the postal service.

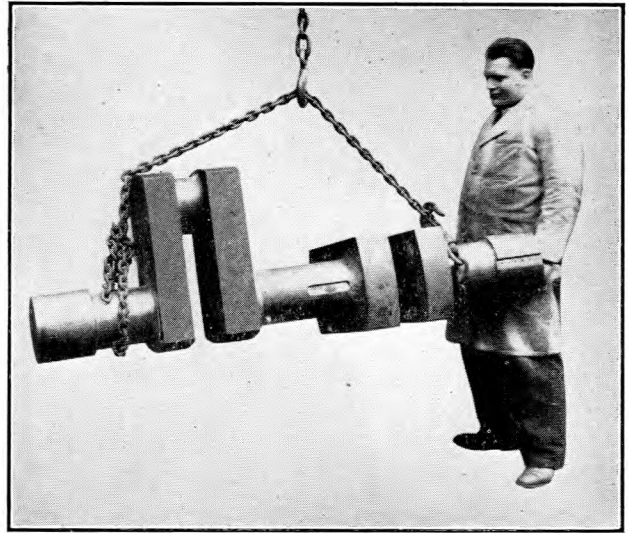
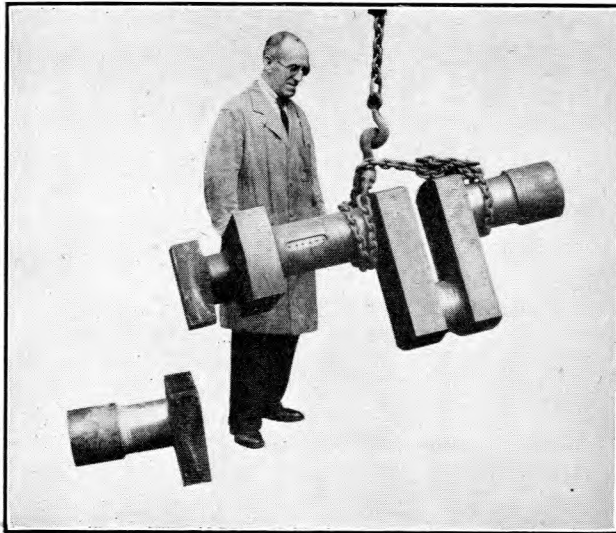

FIG. 2.—REPAIR OF $1\frac{1}{2}$ TON LOCOMOTIVE CRANKSHAFT.

tolerated upon a surface that must be machined to a superfine finish. If, however, the metal during fusion can be protected from contact with the atmosphere, then blemish is avoided and the quality is maintained. This is secured by doing the welding inside a "field" of hydrogen; thus ductility of the weld together with highly satisfactory tensile strength are assured.

The increased thickness of the metal welded nowadays is a matter that has passed without general notice, but progress has been steady in this direction. The cumulative effect of the experience gained is that fractured castings having a section of 6 in. or even more are tackled in the ordinary course and they are not regarded as offering a problem which is in any way extraordinary.

Typical Repairs.

Crank Shafts.—To illustrate the advantages of this repair process and the reliance placed in electric welding, mention should be made of the large number of crankshafts which have fractured, usually through a web, and have been reunited by welding. It would be difficult to imagine any component part that is more highly stressed, but the failure of a weld carried

Upon a cost basis a saving of up to 80 per cent. is shown in contrast to the policy of purchasing replacement parts. Welding repairs also contribute to the national need for conserving supplies of new metal for direct armament purposes.

Gear Wheels.—Even gear wheels that are fractured and partially stripped, the teeth being lost oftentimes, are far from being beyond re-conditioning by welding. When such work is carried out on a scientific basis, the part concerned is at least equal to a replacement; often it is actually better, for in the event of wear having taken place, the new material that is welded on before machining afresh is far better calculated to resist wear.

Diesel and Petrol Engines.—In regard to generating sets, particularly those embodying Diesel engines, re-conditioning by welding methods has reached a very high standard. For example, cracked cylinder heads can be repaired efficiently. In most instances it is useless to weld fractures, which are most common between valve seatings, without regard to the condition of the metal. The high temperatures consequent upon combustion can de-naturise the casting locally to such an extent that it is advisable

to cut out the doubtful area entirely and replace it with new metal welded in position. In other repairs a new piece is cast and welded in place. When this is done the repair is absolutely dependable.

The procedure just described is followed when fracture has been brought about by high explosion temperatures after long periods of duty. External cracks in water jackets can be dealt with more directly, but in no event is there risk of distortion; in fact, when dealing with precision parts, which may be thrown out of truth by reason of a smash, it is customary for the welding engineer to guarantee the original accuracy after welding to within a tolerance of one-thousandth part of an inch. Steam plant has its own peculiar ills, but for each and every one of these a fusive remedy is available.

It is found that cylinder blocks are liable to be split from end to end and large pieces broken out; but notwithstanding this, not one of the very large number of accidents of this kind which have come to the personal attention of the writer has been beyond completely satisfactory restoration by welding skill. Sometimes a new side has to be cast for the water jacket and welded in, but even in the most difficult repairs it is virtually impossible to detect where any fracture has occurred when the repair is completed. A typical repair of this nature is illustrated in Fig. 3.

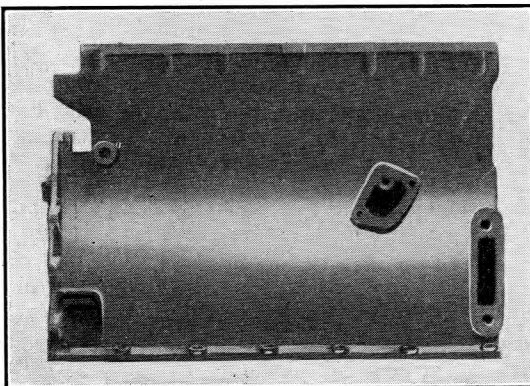
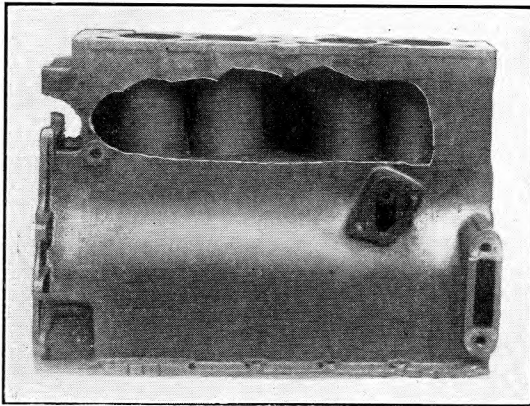

FIG. 3.—REPAIR OF MOTOR VEHICLE CYLINDER BLOCK.

Boilers.—Welding applied to boilers is another important application and one that is approved fully by the insurance companies. It can be used with unqualified success for correcting grooved and otherwise weakened plates. The results are so dependable that riveted patches are now regarded as obsolete. This is because rivets require a lap joint, thus forming unwanted ledges. These offer an invitation to scale with the threat of further trouble on account of the unequal expansion and contraction. In contrast to these objections welding permits the use of a butt joint, leaving a perfectly clean surface both inside and out together with any margin of strength that may be desired. Sometimes it is unnecessary to renew a section of plate at all, for weakened areas can be restored to their original thickness simply by the internal or external application of new metal welded in position.

In regard to the smaller types of boiler, welding is often useful as an aid to the conversion from solid to liquid fuel. In this connection the sectional boilers used at some post offices have had the lowermost portions cut away, the open ends being blanked off by steel plates welded in position. Conversions of this type have proved most successful.

Not long ago preliminary tests were about to take place at a new power station equipped with turbo-generators. The construction of these was such that at certain points the casing, subjected to steam pressure, was riveted. When the sets were started up considerable leakage occurred, and careful caulking did nothing to reduce the trouble to any material extent. It was essential to overcome the fault with the least possible delay, therefore it was decided to seal the riveted seams by welding, notwithstanding the fact that at one point the operator had to work in extremely cramped quarters. The result, however, amply justified the difficulties involved, leakage being overcome entirely.

Conclusion.

Important progress can be recorded in regard to the welding of non-ferrous metals of all kinds including those having a high magnesium content and therefore actually inflammable in the form of swarf or filings. Sufficient has been said, however, of the application of welding to work that is of direct interest to electrical engineers in the service of the Post Office to indicate the great extent of the resources that are available.

Welding repair service is highly organised in this country, and for work which, owing to bulk or weight cannot be removed to the shops of the specialist for attention, operators are always in readiness with suitable portable equipment to deal with emergency needs. The value of this squad can hardly be over-estimated in war time, their activities being most noteworthy and an important contribution to the national effort. It should be emphasised that repair work is absolutely dependable when the necessary degree of skill and experience are forthcoming; but notwithstanding the high stage of development to which welding apparatus has attained and the present vastly improved technique, the personal element is still a factor which must not be overlooked.

Delayed Call Formulæ when Calls are Served in Random Order

S. D. MELLOR, B.Eng., A.M.I.E.E.

U.D.C. 519.2:654.153.4

Formulæ are developed to enable the effect of introducing queueing facilities for waiting calls, to be estimated.

General.

THE addition of queueing facilities (i.e. facilities for serving delayed calls in the order in which they originated) to delayed call systems involves the provision of special equipment which is comparatively complicated. In the absence of such facilities, calls which do not immediately obtain connection are served in random order, resulting in a poor distribution of delays. In a queueing system a call arriving when all trunks are engaged and no other calls are waiting, would be allotted to the first trunk to fall free. With random selection such a call, if persistently unfortunate, might fail to pick up a free trunk until a large number of calls originated later had all been served.

That individual calls can be delayed for long periods before being connected is a matter of experience, particularly on auto-manual and manual-manual connections where the operator loading is high, and on connections to highly loaded trunk lines operating under demand conditions (under delay conditions an element of queueing is introduced). It is important to be able to estimate in such cases what improvement would be effected by providing queueing facilities. Formulæ for the distribution of waiting times when delayed calls are served in order of origination are well known. A formula for the case when calls are served in random order is given below. Pure chance traffic, exponential distribution of holding times and full availability conditions are assumed.

Symbols.

N = Number of trunks in full availability group.

A = Traffic offered to (and carried by) the group in T.U.

h = Average holding time.

P_x = Probability of exactly x trunks being simultaneously engaged ($x < N$).

P_{N+q} = Probability of all N trunks being engaged and q calls waiting.

$P(>0)$ = Probability of a call being delayed

$$= \sum_{q=0}^{\infty} P_{N+q}$$
 (it is assumed that there is no upper limit to the number of calls which may be simultaneously delayed).

$P(>t)$ = Probability of a call being delayed longer than time t .

M = Average delay on all calls.

General Delay Formulae.

The following relations hold in whatever order delayed calls are served (proofs are given in the references quoted at the end of the article) :—

$$\begin{aligned} A. P_{x-1} &= x \cdot P_x \\ \text{i.e. } P_x &= \frac{A^x}{x!} \cdot P_0 \dots \dots \dots (1) \end{aligned}$$

$$\begin{aligned} A. P_{N+q-1} &= N \cdot P_{N+q} \\ \text{i.e. } P_{N+q} &= \left(\frac{A}{N}\right)^q \cdot P_{N+0} \\ &= \left(\frac{A}{N}\right)^q \cdot \frac{A^N}{N!} \cdot P_0 \dots \dots (2) \end{aligned}$$

$$\begin{aligned} \sum_{x=0}^{N-1} P_x + \sum_{q=0}^{\infty} P_{N+q} &= 1 \\ \therefore P_0 &= \frac{1}{\sum_{x=0}^N \frac{A^x}{x!} + \sum_{q=1}^{\infty} \left(\frac{A}{N}\right)^q \cdot \frac{A^N}{N!}} \\ &= \frac{1}{\sum_{x=0}^N \frac{A^x}{x!} + \frac{A}{N-A} \cdot \frac{A^N}{N!}} \dots \dots \dots (3) \end{aligned}$$

$$\begin{aligned} P(>0) &= \sum_{q=0}^{\infty} P_{N+q} \\ &= \frac{A^N}{N!} \cdot P_0 \cdot \frac{N}{N-A} \\ &= \frac{\frac{A^N}{N!} \cdot \frac{N}{N-A}}{\sum_{x=0}^N \frac{A^x}{x!} + \frac{A}{N-A} \cdot \frac{A^N}{N!}} \\ &= \frac{B}{1 - (1-B) \frac{A}{N}} \dots \dots (4) \end{aligned}$$

where $B = \frac{\frac{A^N}{N!}}{\sum_{x=0}^N \frac{A^x}{x!}}$

This is an extremely useful expression, as B represents the grade of service on a lost call basis when A is the traffic offered to the group of N full availability trunks, and frequently can be obtained directly from published curves or tables.

$$\text{Average delay } M = P(>0) \cdot \frac{h}{N-A} \dots \dots (5)$$

Delay Distribution—waiting calls queued.—If delayed calls are served in order of origination, the proportion delayed more than time t

$$= e^{-\frac{(N-A)t}{h}}$$

The proportion of all calls delayed more than time t

$$= P(>t) = P(>0) \cdot e^{-\frac{(N-A)t}{h}} \dots \dots (6)$$

Delay Distribution—waiting calls served in random order.—Consider a call which has been waiting for

time t . The probability of there being $q-1$ other calls also waiting, i.e. q calls in all

$$= P_{N+q}$$

The chance of one of the engaged trunks falling free in the subsequent small interval of time δt , and of the call under observation picking up the free trunk $= \frac{1}{q} \cdot N \cdot \frac{\delta t}{h}$ (since any of the q calls has an equal chance of picking up the free trunk).

Let $P_q(>t)$ = the probability of the call still waiting after time t

$P_q(>t+\delta t)$ = the probability of the call still waiting after time $(t + \delta t)$.

$$= P_q(>t) \times \text{chance of call not being served in interval } \delta t$$

$$= P_q(>t) \left[1 - \frac{N}{q} \cdot \frac{\delta t}{h} \right]$$

$$\therefore \frac{P_q(>t+\delta t) - P_q(>t)}{\delta t} = -\frac{N}{qh} \cdot P_q(>t)$$

Let $\delta t \rightarrow 0$

$$\text{Then } \frac{d}{dt} P_q(>t) = -\frac{N}{qh} \cdot P_q(>t)$$

$$\therefore P_q(>t) = C_q \cdot e^{-\frac{Nt}{qh}} \text{ where } C_q = \text{constant of integration}$$

$$P(>t) = \sum_{q=1}^{\infty} P_{N+q} \cdot P_q(>t) \\ = \sum_{q=1}^{\infty} P_{N+q} \cdot C_q \cdot e^{-\frac{Nt}{qh}}$$

To obtain the value of C_q , put $t = 0$

$$P(>0) = \sum_{q=1}^{\infty} C_q \cdot P_{N+q}$$

$$\text{But, } P(>0) = \sum_{q=0}^{\infty} P_{N+q} \\ = P_{N+0} \sum_{q=0}^{\infty} \left(\frac{A}{N}\right)^q \\ \text{(from equation (2))}$$

$$= \frac{N}{A} \sum_{q=1}^{\infty} P_{N+q}$$

$$\therefore C_q = \frac{N}{A}$$

$$\text{and } P(>t) = \sum_{q=1}^{\infty} \frac{N}{A} P_{N+q} \cdot e^{-\frac{Nt}{qh}} \\ = \frac{N}{A} \cdot P_{N+0} \sum_{q=1}^{\infty} \left(\frac{A}{N}\right)^q \cdot e^{-\frac{Nt}{qh}} \\ = P(>0) \cdot \frac{N-A}{A} \sum_{q=1}^{\infty} \left(\frac{A}{N}\right)^q \cdot e^{-\frac{Nt}{qh}} \dots \dots \dots (7)$$

As a check on the correctness of the formula, evaluate the value of the average delay M .

$$M = \int_0^{\infty} t \cdot P(t) \cdot dt \text{ where } P(t) \cdot dt \text{ is the chance}$$

of a call being delayed for more than time t but less than time $t + dt$.

$$\text{i.e. } P(t) \cdot dt = P(>t) - P(>t + dt) \\ \text{and } P(t) = \frac{P(>t) - P(>t + dt)}{dt} \\ = -\frac{d}{dt} \cdot P(>t)$$

Thus, integrating by parts,

$$M = \left[-t \cdot P(>t) \right]_0^{\infty} \\ + \int_0^{\infty} P(>t) \cdot dt \\ = \int_0^{\infty} P(>t) \cdot dt \\ = \left[-P(>0) \cdot \frac{(N-A)h}{NA} \sum_{q=1}^{\infty} q \cdot \left(\frac{A}{N}\right)^q \cdot e^{-\frac{Nt}{qh}} \right]_{t=0}^{\infty} \\ \text{from equation (7)} \\ = P(>0) \cdot \frac{(N-A)h}{NA} \sum_{q=0}^{\infty} q \cdot \left(\frac{A}{N}\right)^q \\ = P(>0) \cdot \frac{h}{N-A} \text{ i.e. the same as equation (5)}$$

Since equation (5) can be shown to be correct irrespective of the order in which the delayed calls are served, this can be regarded as a satisfactory check.

Evaluation of Formula.

It is convenient to evaluate the distribution formula (7) in terms of the two parameters A/N and Nt/h . If $a = A/N$ and $b = Nt/h$, the formula can be written:—

$$\frac{P(>t)}{P(>0)} = \frac{1-a}{a} \sum_{q=0}^{\infty} a^q \cdot e^{-\frac{b}{q}}$$

For large values of A/N the series converges slowly and evaluation is somewhat laborious. The following method illustrates the method of evaluation in the case of $A/N = 0.6$ and $Nt/h = 1$ and 2 .

q	(0.6) ^q	Nt/h = 1		Nt/h = 2	
		1/e ^q	(0.6) ^q · e ^{-1/q}	e ^{2/q}	(0.6) ^q · e ^{-2/q}
(1)	(2)	(3)	(2) ÷ (3)	(4)	(2) ÷ (4)
1	0.6	2.72	0.2205	7.4	0.0811
2	0.36	1.65	0.2182	2.72	0.1324
3	0.216	1.398	0.1548	1.95	0.1109
4	0.1296	1.286	0.1007	1.65	0.0785
⋮	⋮	⋮	⋮	⋮	⋮
17	0.000172	1.06	0.0002	1.125	0.0002
18	0.000103	1.06	0.0001	1.118	0.0001
19	0.000062	1.05	0.0001	1.111	0.0001
20	0.000038	1.05	—	—	—
Σ		—	0.8608	—	0.5450
P(>t)/P(>0) = 2/3 Σ		0.574		0.364	

Fig. 1 shows the variation in $\frac{P(>t)}{P(>0)}$ with Nt/h up to $Nt/h=100$ for values of A/N from 0.1 to 0.9

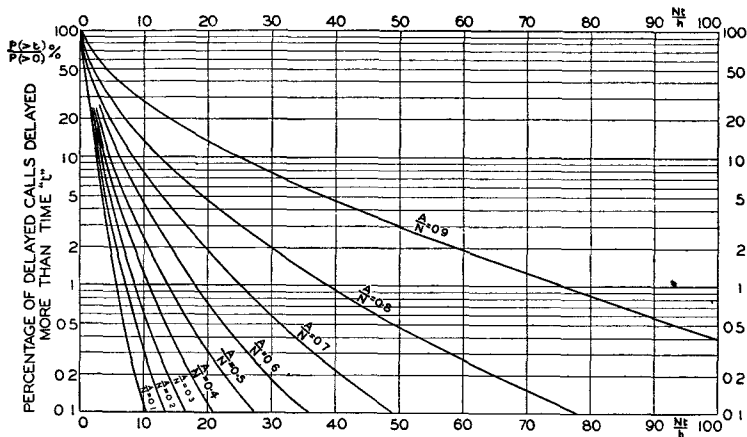

FIG. 1.—DELAY DISTRIBUTION OF CALLS SERVED IN RANDOM ORDER.

in steps of 0.1. Knowing A , N , t and h in a particular case A/N and Nt/h can be calculated and the value of $\frac{P(>t)}{P(>0)}$ read off directly or by interpolation. Thus if $A = 4$ T.U. and $N = 10$, the curve relating to $A/N = 0.4$ applies. For $\frac{t}{h} = 1$, and $\frac{Nt}{h} = 10$, the curve gives $\frac{P(>t)}{P(>0)} = 1.25$ per cent., i.e. 1.25 per cent. of the delayed calls are delayed for a period greater than the average holding time. If it is desired to know the value of $P(>t)$ it is necessary to obtain $P(>0)$ either from published curves or by calculation from equation (4).

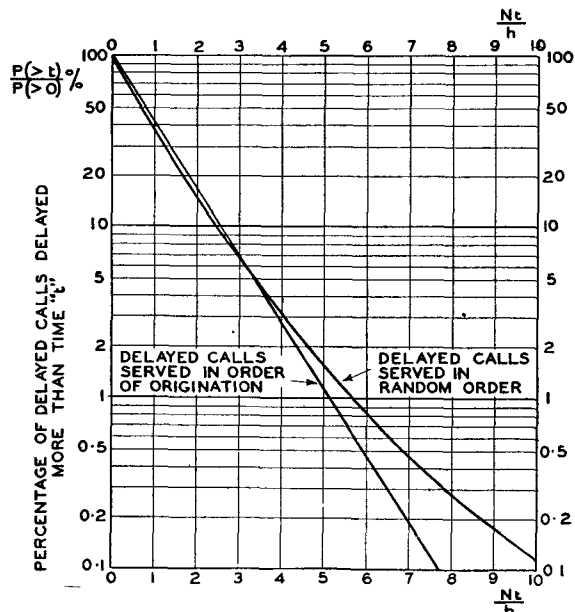

FIG. 2.—COMPARISON OF SERVING CALLS IN RANDOM ORDER AND IN ORDER OF ORIGINATION ($A/N = 0.1$)

Comparison with "Queueing" Distribution Formula.

The curves for $A/N = 0.1$ and 0.9 are reproduced in Figs. 2 and 3 respectively, together with the corresponding curves for the condition where delayed calls are queued (equation (6)). Writing $a = A/N$ and $b = Nt/h$ as before, equation (6) becomes:—

$$\frac{P(>t)}{P(>0)} = e^{-b(1-a)}$$

As would be expected, the "random distribution" curve shows a larger proportion of calls delayed for long periods than the "queueing" curve, the difference being more marked for the larger values of A/N . Thus for a group of 20 trunks carrying 18 T.U., $\frac{P(>t)}{P(>0)} = 3$ per cent. for $Nt/h = 50$, ($t/h = 2.5$) in the "random distribution" case, i.e. 3 per cent. of the delayed calls are delayed for more than 15 mins., if the average holding time is 6 mins. In the "queueing" condition the corresponding value of $\frac{P(>t)}{P(>0)}$ is 0.7 per cent.,

i.e. less than a quarter the previous figure.

It will be seen that for small values of Nt/h the "random distribution" curve gives smaller values of $\frac{P(>t)}{P(>0)}$ than the "queueing" curve. This follows from the fact that the average delay is the same in both conditions. Since the "random distribution" condition results in a larger proportion of long duration delays it must also give a larger proportion of short duration delays. This implies a smaller proportion of calls delayed for more than short periods. Thus, taking the above example of $N = 20, A = 18$ T.U., $\frac{P(>t)}{P(>0)} = 46$ per cent. and 61 per cent. respectively for the "random distribution" and "queueing" conditions for $Nt/h = 5$, ($t/h = \frac{1}{2}$), i.e. if the average holding time is 6 mins., with random distribution 46 per cent. of delayed calls are delayed more than $1\frac{1}{2}$ mins., the remaining 54 per cent. being served within $1\frac{1}{2}$ mins.

These figures suggest that where it is desirable to dispose of as much delay traffic as possible within a specified short period, it is better not to queue the delayed calls if the disadvantage of having a comparatively large proportion of long delay calls is accepted. To a certain extent these conditions obtain on trunk demand routes where calls are held on the demand positions $1\frac{1}{2}$ mins. before being passed to the delay position for completion. Owing to the fact that a number of demand operators are in competition for trunks falling free in the congested route, conditions of random selection apply at least for the first $1\frac{1}{2}$ mins. of delay. Since the loading of demand routes is of the order of 0.9 T.U. per trunk, the figures quoted in the previous paragraph can be applied approximately and indicate that the number of calls passed to delay positions would be increased by 33 per cent. $\left(\frac{61-46}{46} \times 100\right)$ if facilities were

provided for serving all the delayed calls in order of origination. On the other hand it would be possible to complete calls more rapidly from the delay positions. These conclusions are affected to some extent by the fact that the present procedure is a combination of "random selection" and "queueing," since calls are already served in order on the delay positions.

The "change-over" point increases as A/N increases, occurring at $Nt/h = 3.2$ for $A/N = 0.1$, at $Nt/h = 4.4$ for $A/N = 0.5$ and at $Nt/h = 20$ for $A/N = 0.9$. Since the curves are expressed in terms of Nt/h it is apparent that, as N increases, the value of t/h at the

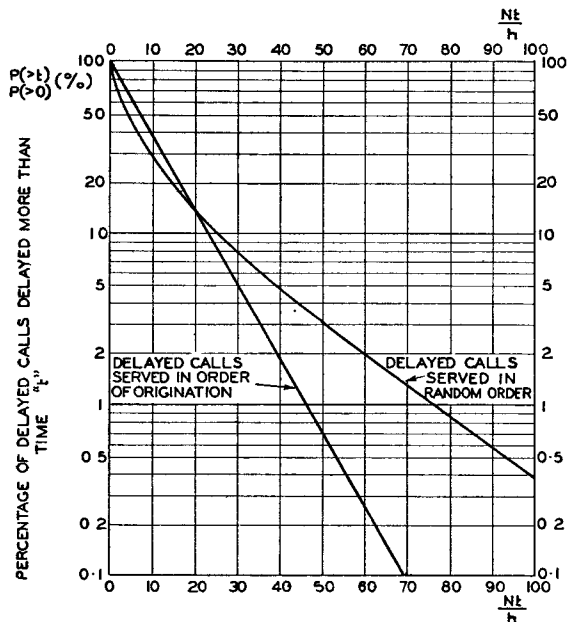

FIG. 3.—COMPARISON OF SERVING CALLS IN RANDOM ORDER AND IN ORDER OF ORIGINATION.

change-over point decreases, provided that A/N remains constant or increases slowly, i.e. the larger the group of trunks the smaller the value of delay above which queueing gives an advantage. For small groups of trunks, on the other hand, queueing only gives reduced values of $\frac{P(>t)}{P(>0)}$ for large delays.

It is interesting to note the effect in the example given above of increasing the period for which completion is attempted from the demand positions. In the U.S.A. a period of 11 mins. obtains, corresponding, on a group of 20 trunks and an average holding time of 6 mins., to a value of Nt/h of 37. If, as before, the group carries 18 T.U., Fig. 3 applies, from which it is seen that 5.6 per cent. of the delayed calls are passed to the delay positions under "random selection" conditions, compared with 2.6 per cent. under queueing conditions. The effect of queueing in

this case is thus not only to reduce the proportion of long delays, but also to reduce the traffic passed to the delay position and hence the number of delay positions and operators required by over 50 per cent.

Application of Formula.

The assumptions made in deriving the delay distribution formula are:—

- Pure chance traffic.
- Full availability.
- Exponential distribution of holding times.
- Full delay, i.e. all subscribers wait until connection is established and do not clear down after waiting for a certain period.
- There is no limit to the number of calls which may be waiting at any instant.

The formula can be accurately applied only where all these conditions apply. The same restriction, however, applies to the "queueing" distribution formula (6) and this is thus equally limited in its application. For comparison purposes, however, the two formulæ may be used to enable the effect of introducing queueing facilities to be estimated approximately in conditions where neither is strictly applicable, e.g. delays on gradings, or delays on incoming positions where circuits are ancillary.

The assumption that full delay conditions obtain is the one most open to criticism, as the subscriber is at liberty in most systems to clear down after waiting unsuccessfully for a time. Generally, however, he will make another attempt immediately afterwards and his call will again join the group of waiting calls, so that the effect on the average delay and the distribution of delays will not be appreciable. With "queueing," however, the second call will have to take its place at the end of the queue and this affects the distribution.

In some systems a combination of "queueing" and "random selection" applies, the discrimination being based either on a definite delay period (as in trunk demand working referred to above) or on a specific number of waiting calls, the first two (say) waiting calls being queued and any further calls served at random. It is apparent that the distribution of delays will be intermediate between the "queueing" and "random" selection cases, but an exact analysis would appear to be excessively complicated. The formulæ given can, however, be used to obtain the limits of the distribution.

References.

- "The Theory of Probabilities applied to Telephone Trunking Problems," E. C. Molinà, *Bell System Technical Journal*, November, 1922.
- "Etude des délais d'attente," C. Palm, *Ericsson Technics*, 1937, No. 2.
- "Probability and its Engineering Uses," T. C. Fry.
- "Delay Formulæ," *P.O.E.D. Trunking Report*, No. 46.
- "Delay Formulæ and Curves," *P.O.E.D. Trunking Report*, No. 54.

New Lamp Signalling P.M.B.X. Switchboard

U.D.C. 621.395.23

J. J. ROCHE and
N. D. SMITH

A new switchboard designed primarily for P.M.B.X. purposes is described. Novel features are the physical construction of the board and the line circuit which dispenses with line and cut-off relays.

Introduction.

THE question of the introduction of a lamp signalling P.M.B.X. was first raised in 1922, but it was considered at that time that the anticipated demand for a switchboard of this type did not justify the work involved. In 1931, however, the question was again raised due to increased demand by the public for a lamp signalling P.M.B.X. and also to the fact that a number of installations outside the capacity of the largest P.M.B.X. switchboard the Post Office had to offer (Sections Switch C.B. Multiple No. 9, ultimate capacity per suite of position, 160 exchange lines, 800 extension lines) were in demand, chiefly for hotels and large establishments in London. An experimental model of a lamp signalling P.M.B.X. was then proceeded with, using the framework of a recovered C.B. No. 1 Section. The whole of the apparatus was accommodated in the rear of the section. This design was abandoned as it proved cumbersome and the layout of the equipment was such that it prevented ready accessibility to the interior of the board.

As a tentative measure demands for lamp signalling P.M.B.X.s were met by the provision of a main exchange switchboard C.B. No. 10. Arrangements were then made to develop, in conjunction with the contractors, a lamp signalling P.M.B.X. The development had practically reached conclusion in September, 1939, but was suspended owing to the outbreak of hostilities. The demands for Sections Switch B.E.C.B. Multiple No. 9 increased with the

outbreak of the war to such an extent that a serious shortage in supplies of this board resulted. It was then decided to introduce the lamp signalling P.M.B.X. in a slightly modified form to augment the supply of multiple type P.M.B.X.s. This decision was influenced by the fact that earlier deliveries of the new board could be effected as all the items used were standard apparatus, whereas the Section Switch B.E.C.B. Multiple No. 9 used non-standard jacks which were in limited supply, and were being manufactured by one contractor only. The new lamp signalling switchboard bears the Rate Book description "Section Switch P.M.B.X. No. 1A."

PHYSICAL DESIGN

A complete installation consists of a suite of two or more sections, closed at each end by cable-turning sections, and one or more apparatus racks (Equipments P.M.B.X. No. 1 or No. 1/35), together with a suitable power plant. Fig. 1 shows the first installation of this type.

Section Switch P.M.B.X. No. 1A.

The section is of wooden construction, normally of mahogany, the ironwork for mounting apparatus being screwed to and supported by the timber frame in contrast to the main exchange practice of having a metal framework to which the wooden parts of the section are attached. The design is modern in that all panelling and cornices have been omitted, giving the completed suite a clean smooth line. The keyboard and pilot rail are covered with red fibre. The remainder of the external surfaces of the section, with the exception of the back door, are polished to the standard finish for P.M.B.X.s.

The dimensions of the section are: height 4 ft. 6 in., width 2 ft. 2 in., depth over keyshelf 2 ft. 6 in. The height of the keyshelf is 2 ft. 6 in. The dimensions of the B.E.C.B. No. 9 section for comparison are 6 ft. 5 in. × 2 ft. 5 in. × 2 ft. 8 in., height of keyshelf 3ft. The low keyboard and also the low overall height of the P.M.B.X. No. 1A makes the provision of special chairs for the operators unnecessary, a great advantage in subscriber's premises.

The face equipment of the section is divided into two panels, the multiple being complete over two sections, i.e. four panels. Each panel is capable of accommodating 30 strips of jacks. The exchange line multiple occupies the bottom of the panel immediately above the pilot rail and consists of jacks and lamps in strips of 10. The extension multiple occupies the

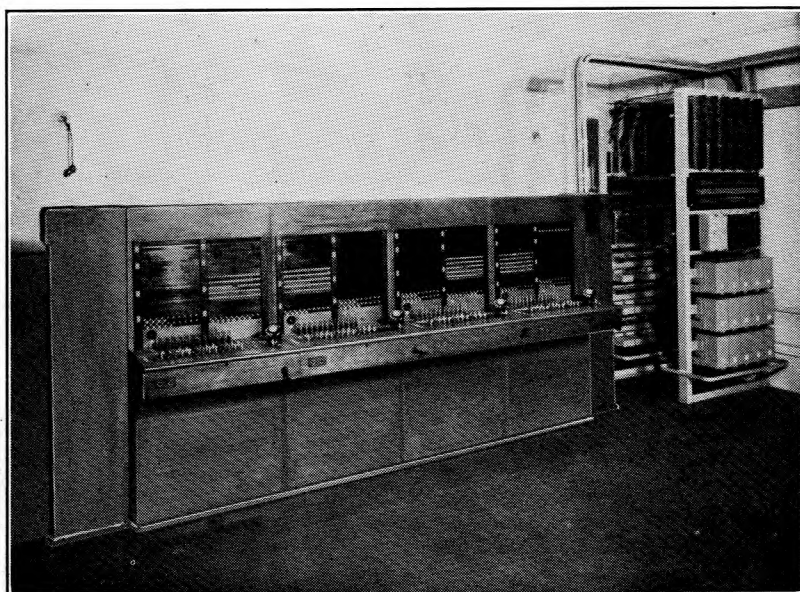

FIG. 1.—TYPICAL INSTALLATION.

remainder of the panel, 20-way jack and lamp strips being used. The stile casings are engraved 0, 2, 4, 6, 8, to indicate the tens of the extension multiple, removable white celastoid labels being provided for the numbering of the hundreds of the extension multiple and the panel numbers of the exchange line multiple. Interswitchboard lines are accommodated in the exchange line multiple field.

The keyboard is initially equipped with 12 cord circuits and has a capacity for 16. Two supervisory lamps and two keys are provided per cord circuit. The keys allow of ringing and dialling on the calling cord and ring-back on the answering cord; the speaking condition is common to both cords. The facilities provided by the keys, the cords and supervisory lamps are clearly marked by engraved labels countersunk into the keyboard.

The hand generator key which connects the hand generator should the power ringing fail, the position coupling key, and the emergency dial key (only fitted if a keysender is in use) are of the push-button type and are accommodated at the top of the multiple field in the right-hand panel. The functions of these keys are indicated on a designation strip. The removal of these keys from the keyboard simplifies the operation of the switchboard in that only keys concerned with individual cord circuit operations are accommodated on the keyboard. A dial is not fitted on the switchboard as issued, but wiring and facilities for fitting are provided. The dial position is on the right-hand side of the keyshelf immediately in front of the hinge, a sloping mounting being used to facilitate dialling.

A pilot lamp is situated in the pilot rail below the multiple field to the right of the centre stile. The usual cord test jack is fitted in the pilot rail of the left-hand panel.

The apparatus for the cord circuits, operator's circuit, pilot and cord test circuits only, is accommodated in the rear of the section (Fig. 2). The relays, which are all of the 3000 type, are mounted on horizontal mountings which cater for three cord circuits each. Five mountings are provided which will take the 12 cord circuits and miscellaneous circuits. A space is provided for an additional mounting to allow of the cord circuits being extended to the full capacity of 16. All condensers are mounted on a shelf at the top of the section. Ringing feeds, battery feeds, position couplings, etc., are terminated on a connection strip immediately below the relay mountings.

The multiple cabling is supported on pins screwed into vertical iron bars fixed to the woodwork of the section. Each pin carries two layers of four cables (four panel multiple) and can be unscrewed and removed to facilitate maintenance on the multiple field. The usual method of jack fastening is provided.

The back of the section is closed by a plain removable door which is held in recesses at the top and bottom of the section. A feature of this door, which is being introduced for all P.B.X. switchboards, is the omission of projecting lifting handles. Finger slots are provided in lieu. This also applies to the door of the cable turning section and to the kicking panels under the keyboard.

The only unusual feature of the cable turning section, apart from the fact that all panelling has been omitted from its construction, is the provision of a pocket on the inside of the door to hold diagrams, relay cards, etc., for the use of the maintenance staff.

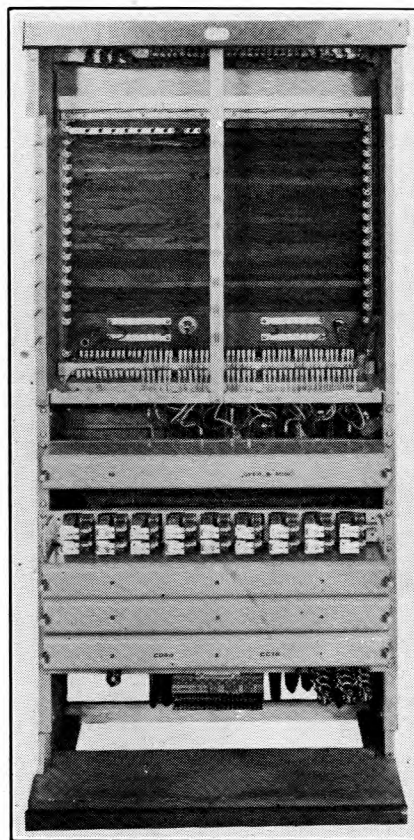

FIG. 2.—REAR VIEW OF SWITCHBOARD.

Auxiliary Apparatus.

All apparatus except that dealt with above is accommodated outside the switchboards on racks. Exchange line and interswitchboard line apparatus is made up in the form of relay sets. As well as the relay sets the apparatus racks carry the rest of the apparatus necessary for an installation. The first of these racks, known as Equipment P.M.B.X. No. 1, consists of an angle-iron framework 7 ft. \times 2 ft. 9 in. \times 5 ft. (Fig. 3), capable of accommodating the apparatus for five positions, 250 extensions, 30 exchange lines or 15 interswitchboard lines. To this end the rack is built up as follows: 18 connection strips can be accommodated at the top. These are used to terminate the apparatus on the rack and also the cables from the switchboard and M.D.F. Underneath these strips is a fuse mounting taking 96 fuses. This fuse mounting feeds battery to all circuits. Below the fuse mounting 250 resistor coils of 250 Ω resistance are fitted in piles of five. These coils form the sleeve resistance for extension circuits. Alongside the mounting for these coils space is

provided for a relay mounting for twenty 600 type relays, to allow of the fitting of relays for extensions exceeding 200Ω resistance. The remainder of the

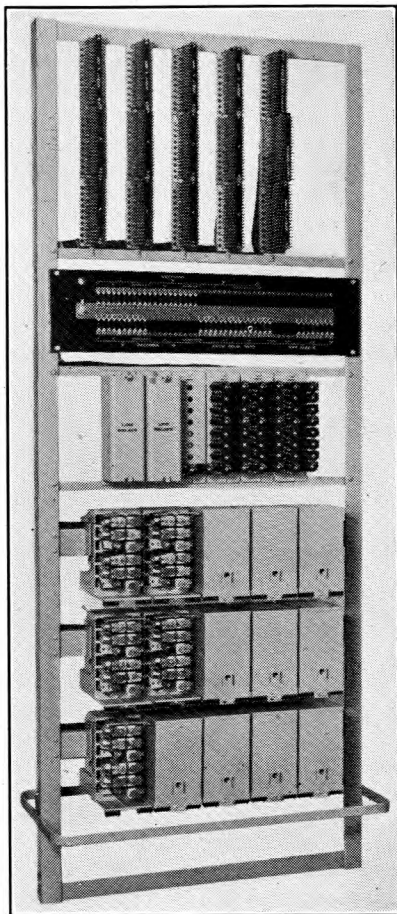

FIG. 3.—APPARATUS RACK (EQUIPMENT P.M.B.X. No. 1).

rack is taken up by three shelves each accommodating five relay sets of the 2000 type. The jacks on these shelves are so wired that they will take either an exchange line relay set (two circuits per base) or an interswitchboard line relay set (one circuit per base).

It will be seen that the maximum of 30 exchange lines per rack is reduced by two for every interswitchboard line fitted.

This rack was originally the only

rack provided for housing apparatus associated with P.M.B.X. No. 1A. Owing to wartime demands for large networks of interswitchboard lines, the provision of Equipments P.M.B.X. No. 1 for interswitchboard lines only became uneconomic, and a second rack (Equipment P.M.B.X. No. 1/35) was introduced which caters for 35 interswitchboard line relay sets only. The necessary connection strips for terminating are fitted at the top of the rack and a separate fuse mounting is provided at the side. The dimensions of this rack are the same as the Equipment P.M.B.X. No. 1.

Cabling.

The sections and associated equipment have been designed with a view to reducing to a minimum the amount of work to be carried out locally on an installation. To this end the apparatus racks are used as the junction point of the M.D.F. and switchboard cables. The connection strips serving the exchange and interswitchboard line relay sets are duplicated, the relay set apparatus being terminated on one set and the multiple cables on the other. By jumpering between the two connection strips an I.D.F. facility is obtained. Fig. 4 gives the cabling arrangement for a typical installation.

Points of interest are :—The extension multiple is run in 80-wire cable. This serves both jacks and lamps. The wiring for the lamps is brought out at each multiple appearance, and where no lamp jacks are fitted it is necessary to maintain a through connection on the two wires to the lamp. Initially these wires were soldered together and insulated, but this gives a very bulky form when these wires are laced in. To overcome this difficulty a new method of stripping and forming the 80 wire cable has been evolved which allows of the lamp wires being left uncut where they are not required. It is a variation of the double stripper method, but is slightly more complicated by the fact that in the 80 wire cable the outer layers of wires are twisted in the opposite direction to that of the wires composing the centre core.

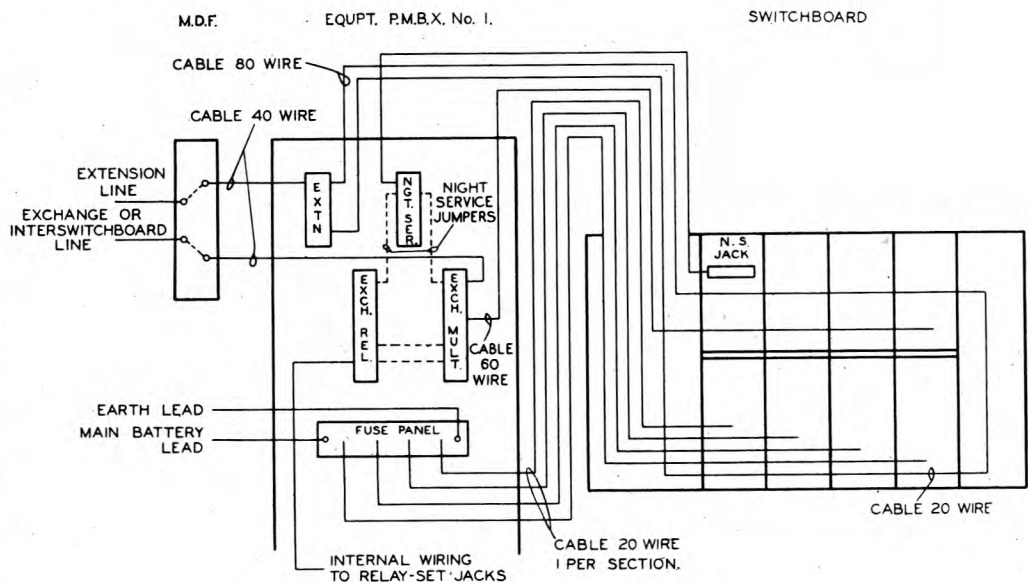

FIG. 4.—CABLING OF TYPICAL INSTALLATION.

The cabling of the extension multiple is so arranged that a long extension line relay can be inserted in any extension circuit. To make this possible the inner spring of the last multiple jack is cabled back to the apparatus rack. This necessitates a 20 wire cable (one wire per circuit) being brought back from the last multiple jacks. This is the reason for the use of two cable turning sections as these 20 wire cables have to be turned and brought along the bottom of the sections.

The night service exchange line interception jacks, usually one strip of 10 jacks is sufficient, are mounted at the top of the multiple field on any convenient section. These jacks are cabled direct to the apparatus rack and terminated on a connection strip. Any exchange line can be given night service facilities by inserting this night service connection strip in the jumper between the two exchange line connection strips on the apparatus rack.

The main battery feed is terminated on the fuse panels and battery is fed to each section by a 20 wire switchboard cable.

Power Supply.

The normal battery supply is a single 24 V battery floated from A.C. mains by a rectifier (No. 38). If A.C. mains are not available then a double battery scheme would be used. The average load for a reasonably busy installation is 10 ampere hours per section per day. Where a rectifier is used a mains failure alarm is fitted in the cable turning section of the suite. This gives immediate advice that the battery has ceased to charge and the operator can report the trouble to the maintenance staff before the battery has been discharged to any extent. Normally the battery capacity is arranged to give a 24 hour standby on a mains failure.

FACILITIES AND CIRCUITS

Extension Line Circuit.

A special lamp (Lamp No. 2.17) has been introduced to eliminate the usual line relay for extension lines not exceeding 200Ω (line resistance). The lamp is connected in series with the line on the battery side

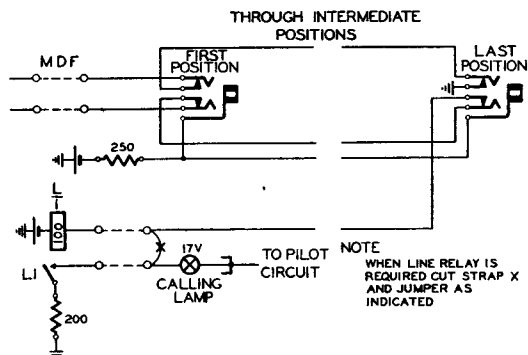

FIG. 5.—EXTENSION LINE CIRCUIT.

of the circuit (Fig. 5), and glows when the extension loop is completed by the operation of the telephone

gravity switch. Amber lamp caps are fitted to equalise illumination over varying line resistances. Provision is made for the inclusion of line relays for long extension circuits. A break jack series multiple is used for extension circuits to obviate the use of a cut-off relay per extension circuit. The answering lamps are associated with the extension multiple jacks, but only one calling lamp may be fitted for any extension line; thus if the calling lamps for extensions 0 to 19 appear in the first multiple appearance, spacing strips are fitted in lieu of lamp jacks on subsequent appearances.

Flexibility, when required, may be obtained by replacing the spacing strip by a lamp jack at the panel to which it is desired to transfer the calling lamps, and removing the lamps from the existing, and fitting them in the new lamp jack. Distribution for exchange lines may be effected in a similar manner, or if required ancillary working can be arranged.

Cord Circuit (Fig. 6).

Double cords are provided with a supervisory lamp associated with each cord, giving double supervision. For extension-to-extension calls and calls to or from extensions completed via inter-switchboard lines, independent battery feeds are provided to both sides of the cord circuit, and the two supervisory lamps give independent supervision to each side. On extension-to-exchange connections, the cord circuit is a through circuit, and both supervisory lamps are joined in parallel, and are under control of the line relay in the exchange line circuit. In effect, the cord circuit functions as a bridge control circuit on extension-to-extension calls, and as a sleeve control circuit on extension-to-exchange calls.

When either cord is inserted into an extension or interswitchboard extension jack, the associated cord circuit sleeve relay (AS or CS) operates to the 250 Ω battery on the sleeve of the jack, but when a cord is inserted in an exchange line jack the associated cord circuit sleeve relay does not operate as the sleeve relay is connected to earth via the auxiliary springs of the exchange line jack.

When the operator inserts an answering plug into an extension (or interswitchboard line) jack in response to a calling signal, and the speak key is thrown, relays SK and SKR operate. These two relays connect relays AS and CS to the sleeve wires of the answering and calling cord, and also connect relays LA and LC to the tip and ring wires.

Relay AS operates via battery and 250 Ω spool on the extension sleeve. Relay AS connects battery and earth via relay LA to the extension instrument. If an extension is required, the calling cord is inserted into the desired jack and relay CS operates; when the called extension answers relay LC operates. With relays AS, CS, LA, and LC operated, a holding circuit is retained for relay SK.

With this relay operated throughout the connection, a divided feed is provided to the extensions. If, however, an exchange call is desired, relay CS does not operate when the calling cord is inserted into the exchange line jack. With relay AS operated, CS normal, LA and LC operated, relay SK will release

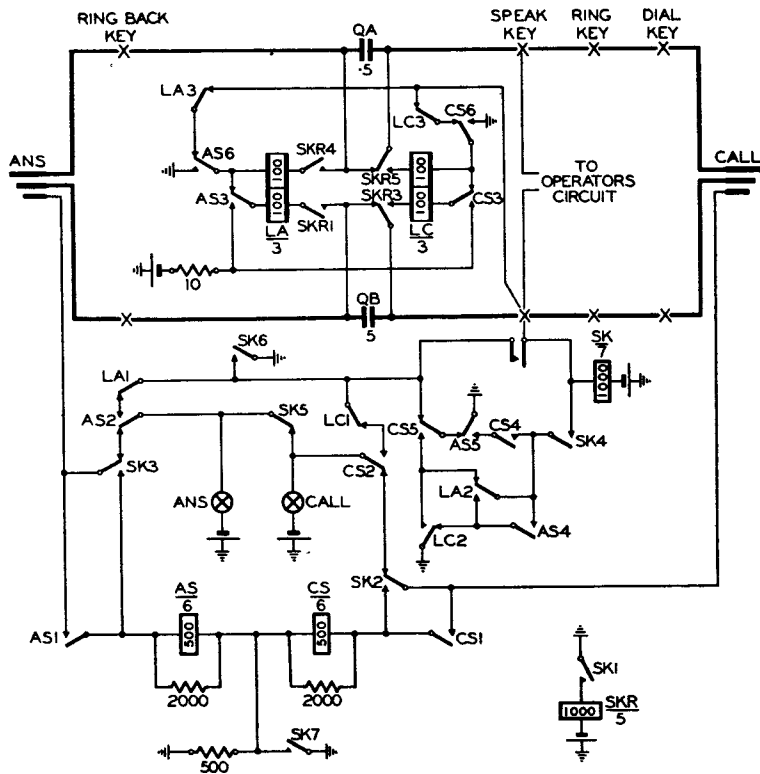

FIG. 6.—CORD CIRCUIT.

and, on releasing, completes a direct metallic path from the extension line to the exchange line relay set.

The Position Circuit.

The operator's circuit is connected to the usual four-way double jack with transmitter across the inner, and receiver across the outer, springs, and the circuit follows normal practice except that provision is made for the transmitter current to flow only when the key is in the speak position. A relay and retard are provided for holding exchange calls when the operator re-enters the circuit.

The standard click engaged test is provided.

A position coupling key is provided on each section to connect the operator's circuit to the next position on the right.

The Exchange Line Circuit.

The exchange line circuit is shown in Fig. 7. There are five relays per circuit whose functions are as follows:—

“AC” for receiving the ringing signal from the main exchange. When this signal is received relay AC operates and locks, lighting the exchange line calling lamps. The insertion of the answering plug into the exchange line jack breaks the locking circuit and the calling lamp circuit.

“LG”—The line guard relay operates when the speaking key is thrown, by current flowing through its windings to a loop on the cord circuit. LG operated places a loop across the exchange line which trips the

ringing and provides a circuit for the operation of relay L.

“L”—The line supervisory relay. This relay removes the short-circuit off the winding of relay LR, the circuit being prepared when the plug was inserted in the jack.

“LR” operates and switches the exchange line to the cord circuit, disconnects relay LG which releases, breaks the holding winding of relay AC, removes the earth on the bush of the jack, replacing it by a 500 Ω resistance connected to earth, thus extinguishing the cord circuit supervisory lamps.

“D” is the operator recall relay; when operated it connects an earth on the sleeve of the jack, thus lighting the cord circuit supervisory lamps. The relay coil has two 15 Ω windings, one winding in series with each line similar to the L relay, but whereas the L relay responds to current in the loop, the D relay is connected with one winding reversed, and will not operate with loop current, but operates when the current of the two lines is unequal. When the extension is through to the exchange the coils of relays “L” and “D” are in series with the line, and add a further 60 Ω to the resistance of the exchange line; each pair of coils is

shunted by a 2 microfarad condenser to by-pass speech currents. The circuit has been designed so that, with a minimum current of 30 milliamperes in the exchange line, relay LR will hold while an extension or operator is dialling.

Operator Recall.

When the extension user presses the operator recall button at the extension point, an earth is applied to the T line which causes about twice the normal current to flow to earth over the wire connected to the exchange battery, and none over the other wire, which is now connected to earth at both ends. Relay D operates and lights the cord circuit supervisory lamps; repeated depression of the button flashes the lamps.

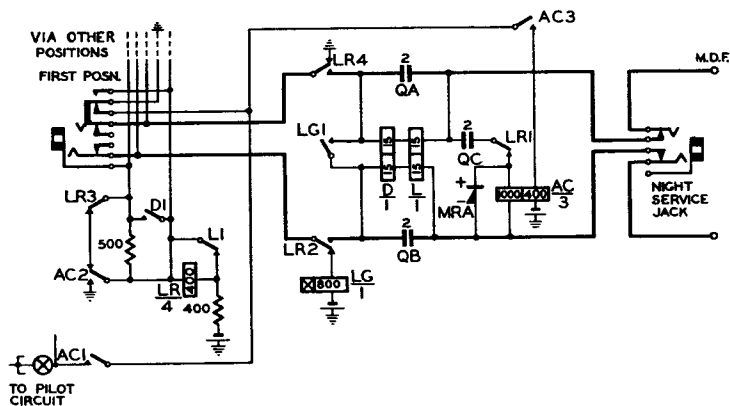

FIG. 7.—EXCHANGE LINE CIRCUIT.

Follow-on-Call Trap.

When the extension has cleared (but not the P.B.X. operator) relays LR; L, LG and AC release, and the cord circuit supervisory lamps light. In this condition an incoming ring operates AC during the ringing period, and extinguishes the lamps which flash to the ringing periods, thus attracting the attention of the operator. The extension bell is not rung as the circuit is broken at the LR relay contacts.

Night Service.

A break jack with the bush disconnected is inserted in each exchange circuit, between the exchange line and the relay set. These jacks are the night service exchange jacks. The insertion of a cord circuit plug into one of the jacks cuts off the exchange calling equipment and the insertion of the associated cord circuit plug into an extension jack joins the exchange line straight through to the extension.

The Interswitchboard Line Circuit.

This is a relay set which will serve both as a termination for an interswitchboard extension and interswitchboard private wire. The relay set serves one circuit only and replaces an exchange relay set which serves two circuits.

When certain "U" points on the jack are strapped it will cater for :—

Generator call and clear.

Generator call and D.C. clear.

D.C. call and clear.

Electrical prohibition of the connection of a private wire to an exchange line.

When an exchange call is extended to a distant P.B.X. the circuit gives through clearing to the exchange from the distant P.B.X. switchboard (but not from the distant extension). The relay set consists of seven 3000 type relays, two retards, two rectifiers and five condensers, together with a transformer.

Conclusion.

Two further developments are in progress. The first is designed to obviate the possibility of a false clear should the operator insert a plug into or withdraw a plug from an interswitchboard line jack while a ringing signal is still being sent from the distant end. The second is the introduction of a simplified interswitchboard line relay set to cater for routes on which D.C. or loop call and D.C. or disconnection clear can be made available at the distant end.

In conclusion, acknowledgments are due to Messrs. Standard Telephones and Cables, Ltd., for the supply of the photographs in this article.

Frequency Division without Free Oscillation

U.D.C. 621.396.615:621.314.26

D. G. TUCKER, B.Sc. (Eng.), A.M.I.E.E., and
H. J. MARCHANT, B.Sc., A.K.C.

A system of frequency division is described which does not involve locked oscillators; very constant phase relations are obtained and the production of an output frequency is dependent on the presence of the input frequency.

Introduction and General Considerations.

THE normal method of dividing frequencies is to lock to the input frequency a multi-vibrator or other type of relaxation oscillator, the natural frequency of which is approximately the output frequency required. It is well known that relaxation oscillators lock readily to frequencies which are approximate harmonic multiples of the natural frequency. Division in one stage can be effected easily in this manner up to a ratio of 10–15 to 1. There are a number of practical difficulties, but there is ample literature¹ on the subject, and the method is generally quite satisfactory.

A normal type of inductance-capacitance oscillator may be locked by a harmonic frequency, and a sine wave output is obtained without filtration. Alternatively, the same result may be achieved by locking the oscillator to a frequency derived by modulation of the input tone with a harmonic of the oscillator. This has been used for synchronising carrier systems.² In the above methods one point arises which may often be a very serious objection. This is the fact

that between the limits of natural frequency of the oscillator at which pull-out occurs, it is possible for the phase relation between the output and input frequencies to vary $\pm 90^\circ$ with reference to the input frequency, i.e. $\pm 90^\circ/n$ with reference to the output frequency, where n is the ratio of frequency division. Some theory of an inductance-capacitance tuned oscillator when $n = 1$ has been given in a previous article³ in this journal. The condition of $n > 1$ follows from this. The possibility of such phase variations occurring can rule out the use of this method of frequency division in some instances. The risk of pull-out occurring is itself often an undesirable feature.

It is quite possible, however, to effect frequency division without the use of a locked oscillator, and consequently the phase variations can be restricted merely to those occurring due to variation of component values in passive networks. Some preliminary information on this subject has been published elsewhere³ by other authors, and the methods described by the present authors, although developed quite independently, will not be found to disagree appreciably with those given in the earlier articles referred to.

¹ *Alta Frequenza*, July, 1938, p. 459; *A.W.A. Review*, 1939, p. 165; *Proc. I.R.E.*, Vol. 29, p. 177.

² *P.O.E.E.J.*, Vol. 33, p. 75.

³ *J.I.E.E.*, Vol. 84, 1939, p. 693; *Proc. I.R.E.*, Vol. 27 p. 446.

Principles of Operation.

The general principle of the scheme will be seen from Fig. 1. If the ratio of division is n , and the required output frequency is f , then the frequency multiplier (or harmonic generator) is designed to give the $(n-1)$ th harmonic of f . This is then

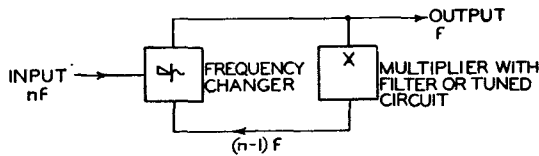

FIG. 1.—PRINCIPLE OF FREQUENCY DIVIDER.

modulated with the input frequency nf , giving the required output frequency f (and in addition $[2n-1]f$, which is, however, readily eliminated). One obvious requirement for continued production of f is that the loop gain shall be slightly greater than unity at the required frequency with a non-linear characteristic. This is conveniently arranged in design as in the example shown in Fig. 2 by considering the input/output characteristics of the frequency changer and

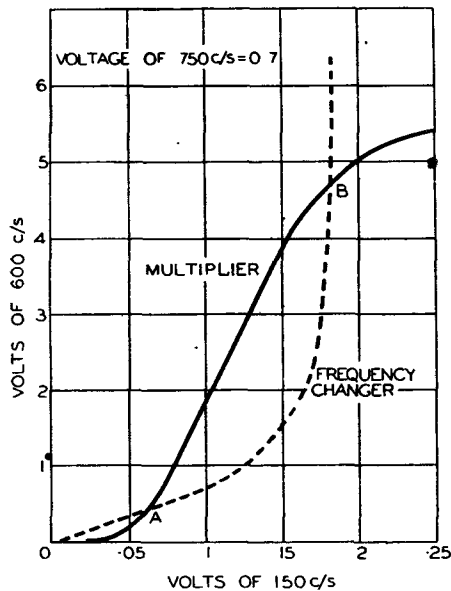

FIG. 2.—LOOP CHARACTERISTIC OF 750 TO 150 c/s DIVIDER.

multiplier units separately. The example chosen is of a 750 to 150 c/s divider in which the multiplier produces and selects the 4th harmonic of 150 c/s.

It will be seen that the curves intersect at two points; this is more or less inevitable, since harmonic generators are not efficient at low input levels. Therefore, for an output frequency to be produced, the circuit must be disturbed artificially to bring the circuit voltages above those represented by intersection A. Above this point there is a gain round the loop circuit, so that the voltages build up until intersection B is reached, where the loop gain is zero. This is the stable working point.

It is not necessary to make any special provision for making the loop phase shift zero or $2n\pi$ at the required frequency. The loop phase shift will automatically adjust itself when operation commences, because of the multiplication of phase in the multiplier and the change of sign in the frequency changer. For example, if ϕ represents the phase of f with respect to the input frequency nf , and if the phase-shifts in the multiplier and frequency changer are θ_1 and θ_2 with respect to their output frequencies, then Phase at output of multiplier

$$= (n-1)\phi + \theta_1$$

Phase at output of frequency changer

$$= -(n-1)\phi - \theta_1 + \theta_2$$

and since this phase has already been defined as ϕ

$$\phi = -(n-1)\phi - \theta_1 + \theta_2$$

or

$$\phi = \frac{\theta_2 - \theta_1}{n}$$

and therefore changes in θ_1 or θ_2 which may occur with amplitude changes affect only the relative phases of the input and output frequencies, but will not otherwise affect the operation.

A feature that is probably fairly evident is that the circuit is effectively a locked oscillator, but with the important properties that (a) if the input frequency fails there is no longer any output and (b) the phase relation between output and input frequencies is fixed only by the nominally constant phase shifts in the networks of which the circuit is composed.

Selectivity Required following Multiplier

Another very important feature that must be considered in design is the selectivity required following the frequency multiplier. This depends to a large extent on how the multiplication is effected. There is a variety of circuits which may be used for harmonic generation; the most convenient circuits

Ratio	Harmonic required	Frequency of harmonic (c/s)	Output frequency (c/s)
2	1st	500	500
3	2nd	666.7	333.3
4	3rd	750	250
5	4th	800	200
6	5th	833.3	166.7
7	6th	857.1	142.9
8	7th	875	125
9	8th	888.9	111.1
10	9th	900	100
11	10th	909.1	90.9
12	11th	916.7	83.3
13	12th	923.1	76.9
14	13th	928.6	71.4
15	14th	933.3	66.7
16	15th	937.5	62.5
17	16th	941.2	58.8

are probably those using metal rectifiers, but the most efficient for harmonics above the 4th or 5th is the system using a saturated iron-cored inductance

together with a condenser-resistance output circuit, as described by Peterson⁴ and others. This system normally generates only odd harmonics, but with a rectifier bridge can be used to obtain even harmonics in a separate group. If a system of generation can be used which substantially suppresses harmonics adjacent to the one required, then evidently less selectivity is required than if all harmonics are present.

The table shows the frequencies which must be selected from the multiplier to effect division of frequency by ratios up to 17, assuming the input frequency to be 1,000 c/s.

Considering one particular case as an example, it is seen that to divide by 15, the 14th harmonic, 933.3 c/s, must be selected. Supposing now the harmonic generator produces all harmonics at about the same level, then if there is still a loop gain at 937.5 c/s, the circuit may be able to divide by 16 instead of 15. The selectivity following the harmonic generator must be sufficient to ensure that there is actually always a loss round the loop at all frequencies but the wanted one. In the above instance, let it be assumed that the maximum loop gain (i.e. the gain when the current is not building up, or, referring to Fig. 2, somewhere between points A and B) is 1.5 voltage ratio. This maximum loop gain should be kept fairly small in practice. Then the selective circuit, tuned to 933.3 c/s, can be designed to give a voltage loss greater than 1.5 at 937.5 and 928.6 c/s.

One special condition calls for comment. With very low ratios of division, it may be possible to make a harmonic generator without any tuning to

produce in quantity only the wanted harmonic—for instance, when dividing by three, a frequency doubler network gives this condition. With a ratio of two, this condition is necessarily obtained. However, it will not be possible to operate the system without some sort of selective circuit, because of the presence of the addition product $(2n-1)f$ after the frequency changer; this must be sufficiently reduced in the circuit, as only the difference product can lead to a stable "oscillation."

Some Practical Designs.

Several frequency dividers have been made according to these principles for use in connection with carrier system synchronisation. A simple example is shown in Fig. 3. In this instance, a pilot frequency of 180 kc/s transmitted on a special carrier system had to be converted to 60 kc/s to work with standard synchronising circuits at the terminal station. If this had been done by a locked 60 kc/s oscillator, there would have been the danger of a free oscillator controlling a whole carrier network if the pilot tone failed. The use of a frequency divider avoids this danger.

The 180 kc/s tone is received by a very selective amplifier connected across the line; the output of this acts as switching current in a ring modulator. The multiplier consists of a metal rectifier frequency-doubling circuit. The 60 kc/s output is taken from the modulator output transformer, through a low-pass filter which largely eliminates the addition product (300 kc/s). Tags are provided on the grid winding of the transformer so that the loop gain may be adjusted to a suitable small value. "Oscillation" starts readily if the H.T. supply is connected after the valves have warmed up.

Frequency dividers with a ratio of 15 have also been constructed. One, dividing 60 kc/s to 4 kc/s, was worked very readily in one stage, since an adequately selective circuit was easily obtainable; but another case, requiring the division of 750 c/s to 50 c/s, was more difficult, since sufficiently stable tuned circuits of high Q are difficult to make for 700 c/s. In any case, extreme phase stability was required, so that high Q circuits were very undesirable. Consequently the division was effected in two stages, one from 750 c/s to 150 c/s, the other from 150 c/s to 50 c/s. It is the characteristics of the former stage that are shown in Fig. 2. The overall performance of this 15/1 divider was as follows: Satisfactory operation over a range of input frequency 725 to 775 c/s; output 0.6 ± 0.025 volt over an input voltage range of 0.4 to above 10 volts; even harmonics of output frequency more than 30 db below fundamental.

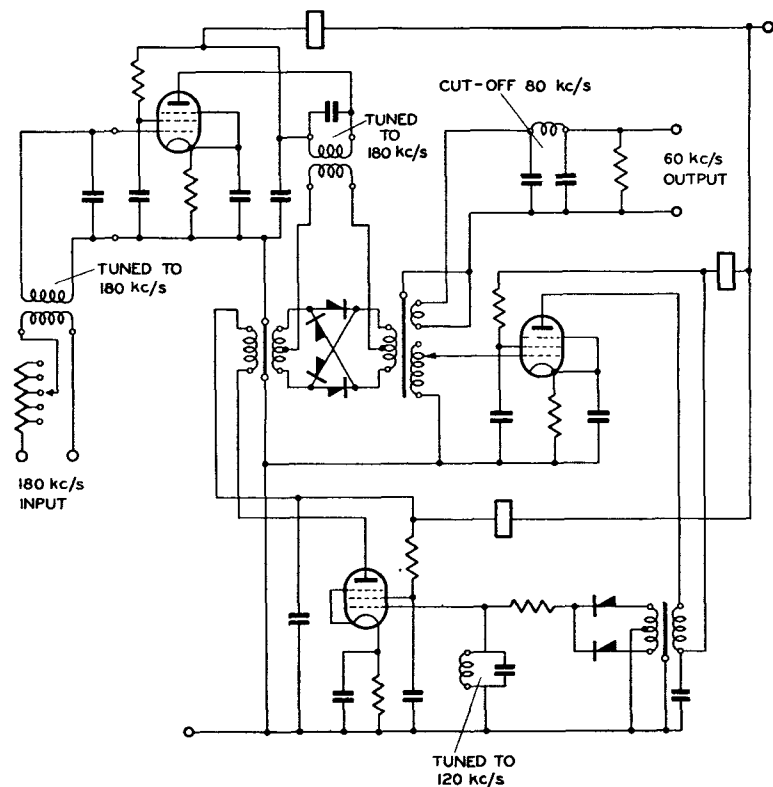

FIG. 3.—180 TO 60 KC/S FREQUENCY DIVIDER.

⁴ B.S.T.J., October, 1937, p. 437.

A Carrier-Frequency Heterodyne Oscillator

K. W. BOURNE.

U.D.C. 621.396.615

A carrier frequency heterodyne oscillator is described having a frequency range 50 c/s to 170 kc/s and developed on similar lines to the earlier Ryall-Sullivan oscillator.

Introduction

THE widespread application of 12-circuit carrier systems, with carrier frequencies up to 60 kc/s, and the further modulation of 12-channel groups to higher frequencies, has caused a considerable increase in the range of testing apparatus required. In view of the usefulness of precision heterodyne oscillators, as exemplified by the Ryall-Sullivan oscillator¹ in development work, it was decided to construct a somewhat similar type of oscillator to cover the lower part of the increased frequency band. The present oscillator is the outcome of this work and has been designed in collaboration with Messrs. H. W. Sullivan. It is in many ways analogous to the Ryall-Sullivan oscillator, but with a frequency range extending over the next higher decade (actually 50 c/s to 170 kc/s); in consequence of the higher frequencies involved, the design has proceeded along rather different lines.

In broad outline, the oscillator follows a familiar plan (see Fig. 1)—two high-frequency oscillators,

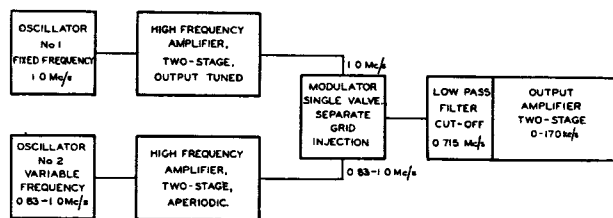

FIG. 1.—BLOCK SCHEMATIC DIAGRAM OF HETERODYNE OSCILLATOR.

high-frequency amplification (separate amplifiers for each oscillator), and modulator, followed by a low-pass filter and output amplifier.

One of the high-frequency oscillators gives an output of 1 Mc/s (with a fine frequency control covering a 1 kc/s band) and the other is variable from 0.83 Mc/s to 1 Mc/s; the outputs are taken off via small pick-up coils (arranged to apply negligible loading to the oscillators) to controlling potentiometers, one of which forms the main output control. The small outputs thus obtained are taken to separate two-stage amplifiers, using H.F. pentodes (Mazda AC/S2 PEN, V.T.106); the amplifier handling the 1 Mc/s output is tuned to keep the harmonic content low, the other has a slightly falling characteristic (about 0.5 db.) from 0.83 to 1 Mc/s to correct for the small rise in level of the oscillator output as its frequency is increased. The amplifiers being quite separate, oscillator interlocking is prevented down

to difference frequencies of less than 1c/s. The amplifier outputs are applied to the control and suppressor grids of a single valve modulator (V.T.106), the 1 Mc/s fixed frequency output (which is varied in level by the volume control) being taken to the control grid.

The difference frequency appearing in the anode circuit is passed through a low-pass filter to eliminate the basic high frequencies which also appear on the anode. Since the volume control is before this point, and does not affect the variable oscillator input to the modulator, this will come through at considerable volume even when the difference frequency output is reduced to a low value; thus considerable filtration is necessary to obtain a good signal/noise ratio at low output levels. A two-stage negative feedback amplifier follows this filter; the output circuit is 600 ohms impedance, unbalanced. Operation is from standard repeater station supplies (130 V and 24 V).

PERFORMANCE OF OSCILLATOR

Frequency Accuracy and Stability

These requirements are very important; in the present oscillator, high initial accuracy is secured by using a large, carefully hand-calibrated dial of the same type as that used on the Ryall-Sullivan oscillator (8½ in. diameter, 205° scale) on the main frequency control, and the long and short period stability ensured by using the highest quality components (including Sullivan-Griffiths temperature compensated coils of similar type to those used in the low-frequency oscillator) in conjunction with a negative trans-conductance oscillator and stabilised high-tension supply. The long period accuracy is estimated at some 0.2 per cent. ± 100 c/s above 10 kc/s (including calibration accuracy and variation over a period of years); the short period stability (over several hours, from two minutes of switching on), has been measured as ± 3 c/s. The oscillator circuit employs a H.F. pentode (V.T.106) using the negative trans-conductance existing at certain voltages between the cathode and the screen and suppressor grids (see below).

Provision is made for considerably improved frequency accuracy by providing the facility for checking against a high-accuracy 1,000 c/s standard frequency and a 1,000 c/s multivibrator, where these are available. The multivibrator output can be connected in parallel with the oscillator output and a rectifier voltmeter; under these conditions, the frequency can be set by visible beat on the meter to an accuracy of better than ± 1 c/s at any multiple

¹ P.O.E.E.J., Vol. 27, p. 213.

of 1 kc/s in the range; the subsidiary 1 kc/s control² on the "fixed" high-frequency oscillator can then be used to interpolate to give a final accuracy of some ± 2 c/s.

Law of Frequency Scale

The scale shape required for a carrier frequency oscillator is not the same as that required for an audio-frequency oscillator. In the latter it is desirable to employ a logarithmic law down to at least about 100 c/s, since this is the natural law of speech frequencies and gives a constant percentage reading accuracy. In using carrier oscillators it is commonly desired to explore similar band widths (e.g., 4 kc/s) with constant accuracy at all parts of the scale; a uniform scale is therefore desirable over the carrier band. In the present oscillator the main scale is linear down to 10 kc/s and approximately logarithmic between 10 kc/s and 100 c/s. This has been done without unduly cramping the scale over the carrier range, since with a logarithmic law at low frequencies it is possible to extend the scale arc beyond 180°; this would have been impracticable with a linear law throughout. It has the advantage of making the oscillator of considerable use for audio frequency testing. The 1 kc/s interpolation scale on the "fixed" frequency oscillator is linear.

Constancy of Output with Frequency

This desirable quality is to a large degree inherent in a heterodyne oscillator, due to the natural constancy of the primary variable high frequency oscillator when varied over only a small percentage of its operating frequency. The output in this design is constant to ± 0.1 db. from 100 c/s to 170 kc/s, and to obtain this, slight correction of the oscillator output is needed. This is obtained in the H.F. amplifier; the modulator and output amplifier are made as flat as conveniently possible. The frequency response of the single-valve modulator is inherently flat, since no transformers are used; these are also absent from the output amplifier, thus enabling the gain to be made independent of frequency over the working range. The application of negative feedback to the output amplifier is also of great use in this respect.

Output Stability

Stability of output with change of supply voltages is ensured by the negative feedback on the output amplifier, and the use of a neon tube stabiliser to supply the earlier stages. These precautions reduce the change of output for 10 V change of anode supply to 0.1 db.; the stability for changes in heater supply voltage is not so great, but a satisfactory figure is obtained of ± 0.35 V for ± 0.1 db. change of output. The frequency change for considerable variations of supply voltages is inappreciable.

Harmonic Production and Power Output

It is difficult to secure a considerable power output with an H.T. voltage limited to 130 V; however, a somewhat higher voltage is obtainable by using the

full P.D. from -24 V to $+130$ V: this is very desirable in any case to obtain efficient operation of the neon stabiliser tube. Using an output tetrode designed for low voltages (Osram KT32 modified, V.T.179), some two watts output is obtained, but half of this is wasted in obtaining the correct output impedance. The harmonic production is almost wholly from the modulator and the output amplifier, the first predominating at low output levels. By careful choice of the operating conditions of the modulator, and the application of as much feedback as possible to the output amplifier, the total harmonic is kept below 0.2 per cent. at an output of +15 db. for all frequencies above 1 kc/s, and below 1 per cent. at an output of +25 db. for all frequencies above 200 c/s.

Noise and High Frequency Leak

To obtain a low harmonic content the modulator must be operated at a low level and in common with other heterodyne oscillators employing this principle the signal/noise ratio tends to be high. There is no volume control after the modulator, and hence most of the noise is present whatever the output level. Considerable decoupling has been found necessary as well as a three-stage low-pass filter after the modulator; the noise (when an average battery supply is used) is not measurable on a normal measuring set, and is of the order of -45 db. relative to 1 mW, being mainly high-frequency leak and resistance noise.

Output Impedance

The output impedance is $600 \pm 15 \Omega$ over the range 50 c/s to 170 kc/s. Of this 500 Ω is due to a fixed series resistor, the remainder being due to the valve whose effective impedance is considerably reduced by the voltage feedback.

CIRCUIT ARRANGEMENTS.

High-frequency Oscillators

As stated above, these use high-frequency pentodes: the circuit (Fig. 2) is usually known as the "Transitron"³ oscillator, but was apparently first described by van Ryn in 1924⁴. Its action can be simply explained by the fact that at certain electrode voltages (the anode voltage is not critical, but should be lower than the screen: the suppressor grid should be some 5 V negative to the cathode using a V.T.106), a rise in the voltage of both screen and suppressor

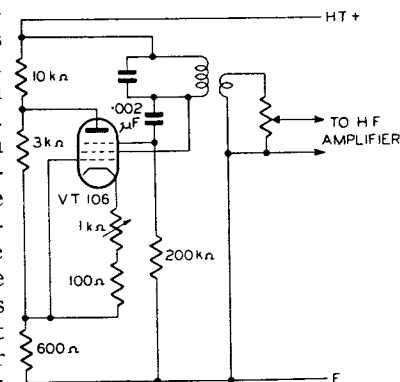

FIG. 2.—SIMPLIFIED OSCILLATOR SCHEMATIC.

² In oscillators intended mainly for testing of crystal filters for carrier systems a special 4 kc/s interpolation dial has been fitted, thus enabling a full 4 kc/s band to be explored on this control only.

³ *Proc. I.R.E.*, Vol. 27, p. 88.

⁴ *Wireless Engineer*, Dec., 1924, p. 134.

grid causes a sudden increase in anode current at the expense of the screen current, so that the screen current actually falls. Thus, if the screen and suppressor grid are effectively connected as regards A.C., a negative resistance exists between these

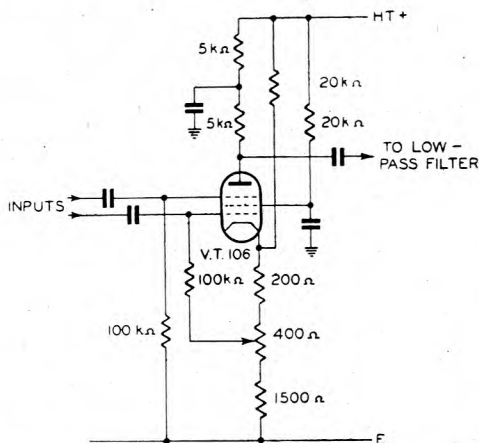

FIG. 3.—SIMPLIFIED MODULATOR SCHEMATIC.

electrodes and the cathode and a tuned circuit, the tuned impedance of which is higher than the modulus of this negative resistance, will be excited to oscillation. This circuit has the advantage over the more usual dynatron circuit that it does not depend upon secondary emission, which is a somewhat variable quantity; also, and this is important in the present design and for high-frequency oscillators generally, it will give a much lower modulus of negative resistance, and can thus be used with tuned circuits of lower impedance.

Modulator

A single valve modulator of the separate grid type was chosen as combining low harmonic output with good efficiency and flexibility in adaptation to the circuit conditions (in these last two respects it is superior to the more usual anode bend modulator) and a frequency response superior to that obtainable from the otherwise attractive copper-oxide modulators of conventional design (e.g., the "ring" modulator). A schematic is given in Fig. 3, showing suitable arrangements for obtaining the necessary bias voltages. These are surprisingly uncritical, but for best results there is an optimum combination of bias and input level to the suppressor grid: this is attained by varying the bias (it is chiefly the control-grid bias which is affected) by the control shown, to obtain a minimum output of second harmonic. This control can be set at a value suitable for a wide range of input level, and can be left untouched for a period of at least several months (probably much longer).

Amplifiers

The high-frequency amplifiers and output amplifier are very much in accord with standard practice. The output amplifier incorporates a considerable amount of negative feedback taken off in parallel with the output; this reduces the impedance looking back into the valve to a low value, and this impedance is made up to $600\ \Omega$ with added resistance as shown in Fig. 4. The load on the valve is about $1,100\ \Omega$,

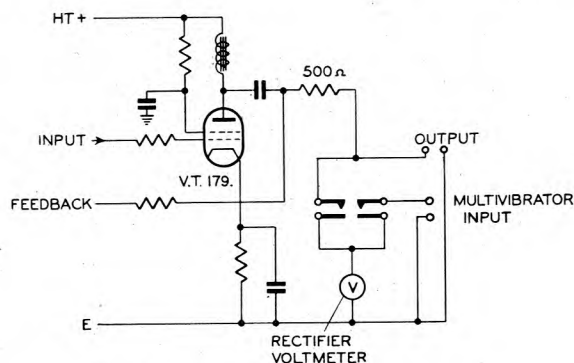

FIG. 4.—OUTPUT CIRCUIT SCHEMATIC.

which is rather low, but not impracticably so. This scheme allows resistance-capacitance coupling to be used throughout, with favourable results on the frequency response and output impedance. The power supply and decoupling circuits follow standard practice, the voltage stabilising circuit being identical with that used in the Ryall-Sullivan oscillator.

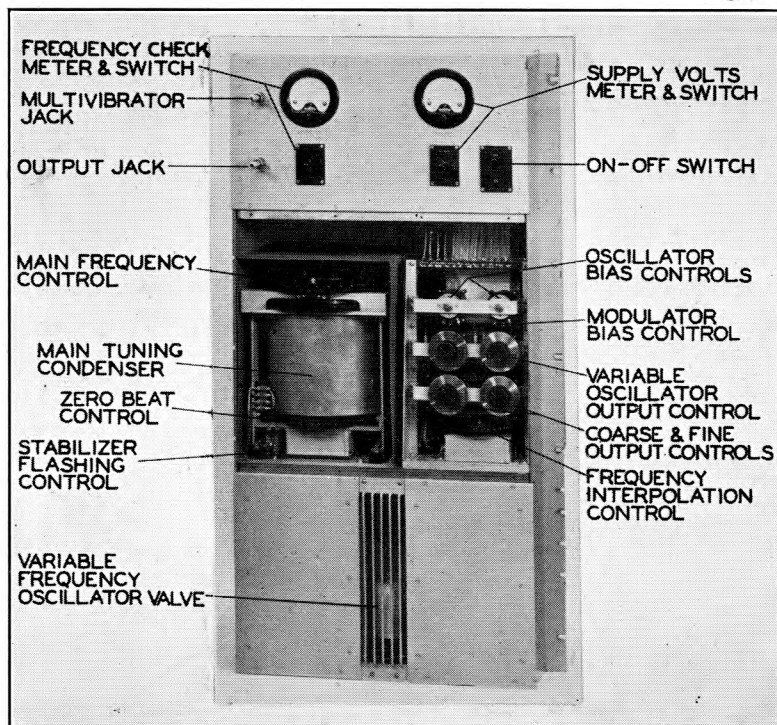

FIG. 5.—FRONT VIEW WITH CONTROLS EXPOSED.

Layout of Oscillator

The general layout of the oscillator follows the same lines as that of the Ryall-Sullivan oscillator and the same chassis is used. Fig. 5 shows the front

view with the controls exposed, the positions of the various controls being indicated. The main tuning coils are in the bottom section exactly as in the low-frequency oscillator.

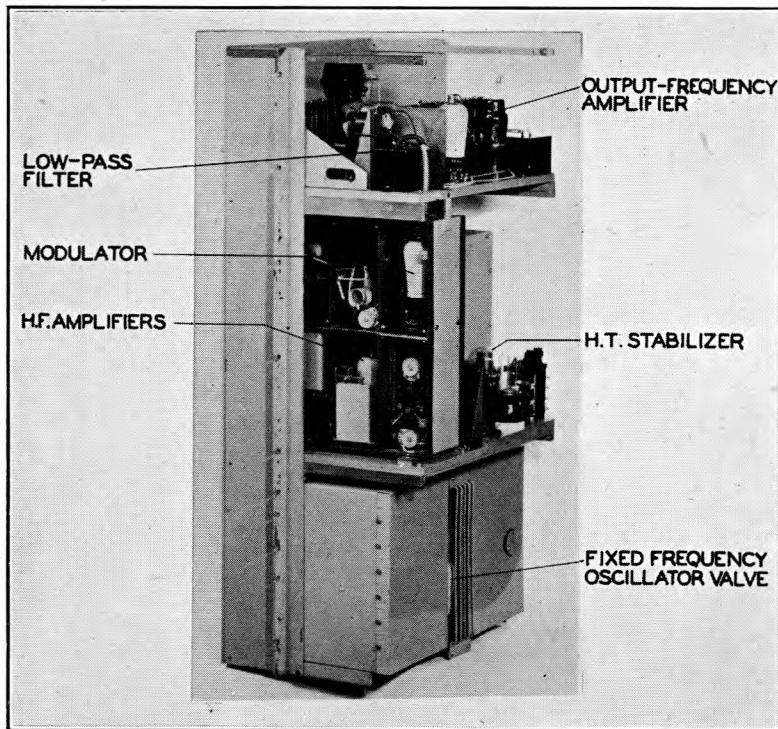

FIG. 6.—HALF REAR VIEW, COVERS REMOVED.

The high frequency amplifiers and modulator are mounted in the middle section to the right of the tuning condenser, as shown in Fig. 6, which is a half-rear view. The low-frequency amplifier and power smoothing circuits are mounted in the top section.

The output is to a coaxial jack, and a similar jack is used for the multi-vibrator input.

Power Consumption

The valve heaters are arranged in two circuits across the 24 V supply. These consume 1.0 and 1.5 A respectively or 2.5 A total. The anode consumption is 160 mA at 130 V.

Conclusion

The oscillator described covers the basic carrier group (60–108 kc/s) and the frequency range likely to be transmitted over multi-pair cable. It is thus very suitable for use in the laboratory and in the testing and servicing of crystal filters. The precision and stability are adequate for most purposes, comparing favourably with other available oscillators.

Notes and Comments

Roll of Honour

The Board of Editors deeply regrets to have to record the deaths of the following members of the Engineering Department:—

While serving with the Armed Forces, including Home Guard

Aberdeen Telephone Area...	Buchanan, E. D....	Skilled Workman, Class II ...	Signalman, Royal Navy
Blackburn Telephone Area	Hall, I.	Unestablished Skilled Workman	Private, Royal North Lancashire Regiment
Brighton Telephone Area ...	Hodgshon, H. B....	Unestablished Skilled Workman	Temp. Sub-Lieutenant, Royal Navy
Cambridge Telephone Area	Webb-Jones, J.	Unestablished Skilled Workman	2nd Lieutenant, Royal Corps of Signals
Canterbury Telephone Area	Upton, A. J. ...	Unestablished Skilled Workman	Private, Royal West Kent Regiment
Cardiff Telephone Area ...	Hall, R.	Unestablished Skilled Workman	Sergeant, Loyal Regiment
Cardiff Telephone Area ...	McLarty, R. S. A.	Unestablished Skilled Workman	Sergeant Air Gunner, Royal Air Force
Cardiff Telephone Area ...	Minks, M. F. ...	Unestablished Skilled Workman	Corporal, Queen's Bays
Engineer-in-Chief's Office	Fantham, F. T. ...	Unestablished Draughtsman ...	Ordinary Seaman, Royal Navy
Engineering Dept. (M.T.) Dundee	Walker, J. T. ...	Mechanic	Captain, Indian Army Ordnance Corp
Engineering Dept., Test Section	Moore, J. A. ...	Unestablished Skilled Workman	Acting Leading Seaman, Royal Navy
Glasgow Telephone Area ...	Flowerdew, S. R. .	Unestablished Skilled Workman	Private, Black Watch
Glasgow Telephone Area ...	Girvan, N.	Labourer	Private, Royal Army Service Corps

Guildford Telephone Area...	Appleford, A. E. ...	Unestablished Skilled Workman	Private, Hampshire Regiment
Guildford Telephone Area...	Elmes, E. S. ...	Unestablished Skilled Workman	Sergeant Pilot, Royal Air Force
Leeds Telephone Area ...	Divine, J. ...	Unestablished Skilled Workman	Signalman, Royal Corps of Signals
Leeds Telephone Area ...	Driver, F. ...	Unestablished Skilled Workman	Signalman, Royal Corps of Signals
Leeds Telephone Area ...	Ellison, J. A. ...	Unestablished Skilled Workman	Driver, Royal Artillery
Leeds Telephone Area ...	Harrison, H. ...	Unestablished Skilled Workman	Private, Royal Army Ordnance Corps
Leeds Telephone Area ...	Thompson, J. ...	Unestablished Skilled Workman	Driver, Royal Corps of Signals
Leicester Telephone Area ...	Lewis, E. R. G. ...	Unestablished Skilled Workman	Sergeant, Royal Air Force
Lincoln Telephone Area ...	Griffiths, D. ...	Unestablished Skilled Workman	Signalman, Royal Corps of Signals
London Postal Region ..	Collier, W. J. De C.	Skilled Workman, Class II ...	Able Seaman, Royal Navy
London Telecommunications Region	Fiddaman, C. R.	Skilled Workman, Class II ...	Able Seaman, Royal Navy
London Telecommunications Region	Holmes, A. J. ...	Unestablished Skilled Workman	Signaller, Royal Corps of Signals
London Telecommunications Region	Jordan, H. F. ...	Unestablished Skilled Workman	Able Seaman, Royal Navy
London Telecommunications Region	Mills, F. E. ...	Unestablished Skilled Workman	Ordinary Seaman, Royal Navy
London Telecommunications Region	Ord, R. W. E. ...	Labourer	Leading Seaman, Royal Navy
London Telecommunications Region	Osborne, T. C. ...	Unestablished Skilled Workman	Sergeant, Royal Air Force
London Telecommunications Region	Owen, G. E. ...	Unestablished Skilled Workman	Signalman, Royal Corps of Signals
London Telecommunications Region	Reid, J. W. ...	Unestablished Skilled Workman	Aircraftman Class II, Royal Air Force
London Telecommunications Region	Vinton, R. H. ...	Labourer	Private, Middlesex Regiment
London Telecommunications Region	White, W. G. ...	Labourer	Chief Petty Officer, Royal Navy
Newcastle - on - Tyne Telephone Area	Coutts, L. G. ...	Unestablished Skilled Workman	Signalman, Royal Corps of Signals
Newcastle - on - Tyne Telephone Area	Lunam, T. ...	Unestablished Skilled Workman	Private, Durham Light Infantry
Newcastle - on - Tyne Telephone Area	Nairn, J. K. ...	Unestablished Skilled Workman	Signalman, Royal Corps of Signals
Newcastle - on - Tyne Telephone Area	Nicholson, A. C. ...	Unestablished Skilled Workman	Signalman, Royal Corps of Signals
Newcastle - on - Tyne Telephone Area	Renton, J. P. ...	Unestablished Skilled Workman	Gunner, Royal Artillery
Newcastle - on - Tyne Telephone Area	Smith, M. ...	Unestablished Skilled Workman	Private, King's Own Scottish Borderers
Newcastle - on - Tyne Telephone Area	Thompson, C. W. B.	Skilled Workman, Class II ...	Corporal, Royal Air Force

While serving with the Civil Defence Forces or on Post Office Duty

H.M.C.S. Borthwick, G. ... Chief Engineer

Recent Awards

The Board of Editors has learnt with great pleasure of the honours recently conferred on the following members of the Engineering Department :—

While serving with the Armed Forces including Home Guard

Oxford Telephone Area	Dalton, W. J.	Unestablished Skilled Workman	Sergeant Pilot, Royal Air Force	Distinguished Flying Medal
Plymouth Telephone Area	Lobb, S. H.	Unestablished Skilled Workman	Lance Corporal, Royal Corps of Signals	Military Medal
Liverpool Telephone Area	Ward, J.	Unestablished Skilled Workman	Telegraphist R.N.V. (W) R.	Mentioned in despatches

Regional Notes

Scottish Region

CALEDONIA STERN AND WILD

The maintenance of communications during the severe winter snow in the North of Scotland is largely due to local initiative and resource. Little outside help is possible until the snow clears from road and rail. During the January and February snowfall, two novel expedients were adopted to keep exchanges alive when the power supplies failed with little prospect of early restoration.

In one case the only approach to an isolated town was by sea. Despite rough weather causing the ports to be closed, a 2-kW emergency engine was shipped to the beleaguered exchange by a drifter. In another case the local omnibus service could not run, but one bus was hired, brought to the exchange, temporary leads run from the 24-volt dynamo and the batteries were re-charged. Service was continued in both exchanges until the power supply was restored.

EXCHANGE CONSTRUCTION COURSE FOR FEMALE ASSISTANTS

Early this year a four weeks' course on exchange construction was held in the Scottish Regional engineering training school. The girls on this course had previously attended a subscriber's fitting course at the Regional school and had progressed some way beyond their early researches when they recorded that the requirements for assembly of a primary cell were: a carbon rod, a sink and plenty of excitement.

It was decided that the girls would install two small exchanges, one C.B. manual and one automatic, which would be all their own work. Each girl was given a full set of diagrams for the proposed exchanges:—

- (1) Routing and Equipment.
- (2) Cabling Layout.
- (3) Power and Ringing Distribution.
- (4) Cord Circuit schematic.
- (5) C.B. Subscriber's L. & K. schematic.
- (6) Manual O/G to Auto schematic.
- (7) Manual I/C from Auto schematic.
- (8) Night Alarm schematic.
- (9) Ringer Start schematic.
- (10) Operator's circuit schematic.
- (11) Automatic Selector schematic.

As the equipment required could not be obtained as assembled sets from the Stores Department, the instructors prepared the circuit diagrams on the basis of available stores and displayed a considerable amount of ingenuity both in circuit design and the improvisation of suitable mountings for the equipment. Most of the equipment used was provided by the Stores Department from the old stock bins.

A small M.D.F. of the P.B.X. type was converted into a combined main and intermediate distribution frame; apparatus racks and shelves were made of wood; an old table did duty as a manual board; each cord circuit being assembled as a complete unit on a strip of wood

which was screwed to the table with sufficient overhang for free working of cords and pulleyweights while the multiple and answering jack fields were built into vertical frames fixed to the table.

The automatic exchange had a 10-line multiple on standard uniselectors which served as single digit selectors and provided basic facilities, i.e. stepping under dial control, ringing called subscriber, ringing trip, transmission bridge and self-drive return to normal.

During the first few days of the course, the girls wired multiple and answering jacks and became familiar with the switchboard cable colour scheme. The jacks were placed in position on the manual suite. Unit wiring of cord circuits, relay sets, etc., commenced during the second week. Each girl wired a unit, ran cable, power leads and did shelf wiring, and at the end of the third week the exchanges were completed, the subscribers connected and junctions between "auto" and "manual" with both-way facilities provided. A slightly modified house exchange external extension unit provided ringing on a start-stop basis.

Throughout the three weeks construction period, the girls had practised relay adjustment as well as wiring and were able to make the necessary adjustments when the power was connected and testing of their own work commenced. Instructors and students derived a great deal of satisfaction from the results of their efforts, and having built and assembled the units into a working system, the students discussed with confidence the functions of the various items.

The disadvantages of improvisation—necessary because of the stores limitations—were offset by demonstration visits to regular service equipment and lectures dealing with magneto, C.B.S.1, C.B.S.2, C.B. and regular auto non-director systems. The sleeve control cord and line terminations were dealt with in an elementary manner.

The holding of these courses at Regional Training Schools has since been regularised by the issue of E.I. Staff General I. 0542.

OPENING OF NEW TOLL B EXCHANGE

A new exchange comprising 99 sleeve control manual positions has recently been brought into service to complete the replacement of an older type bridge control exchange handling incoming toll calls to the automatic and manual exchanges in the London 10-mile circle which had been started by the conversion to seven digit dialling of some seven hundred Toll B circuits (see Regional Notes in April, 1942 JOURNAL).

The outgoing multiple, with about 1,345 new junction circuits, was provided and tested out in advance of the opening. The exchange was opened by simultaneously cutting over one-third of the incoming junction routes (463 circuits) on a Saturday afternoon. The remaining incoming routes (508 circuits) were changed over, one route at a time, at quiet periods during the following two weeks. The outgoing junction circuits remained on the old exchange and were ceased after completion of the transfer.

S. M. E. R.

Staff Changes

Promotions

Name	Region	Date	Name	Region	Date
<i>From Exec. Engr. to Asst. Staff Engr.</i>			<i>Insp. to Chief Insp.</i>		
Potts, E.	E.-in-C.O.	2.3.42	Parker, K. L.	E.-in-C.O. to Test Section, Birmingham	7.12.41
Barlow, T. F.	N.E. Reg.	6.5.42	Bryant, J. W.	N.E. Reg.	22.2.42
Hibberd, W. A.	E.-in-C.O. (Seconded to Factories Dept.)	22.4.42	Mullard, R.	E.-in-C.O. to Test Section, Birmingham	7.12.41
Phillips, R. S.	N.E. Reg. to E.-in-C.O.	31.5.42	Walker, A. H.	L.T.R.	4.1.41
<i>From M.T.O. II to M.T.O. I.</i>			*Waite, D.	N. Ire. Reg.	9.9.41
Malcolm, A. L.	E.-in-C.O.	18.3.42	Fleetwood, C. H. J.	E.-in-C.O.	28.1.42
<i>From Asst. Engr. to Exec. Engr.</i>			Kibble, R.	N.W. Reg.	4.3.42
Cooper, W. D.	E.-in-C.O.	12.2.42	Satterthwaite, H.	Test Section (Birmingham)	28.12.41
Pirie, H. A.	E.-in-C.O.	6.2.42	McDonald, T. H.	N. Ire. Reg.	9.9.41
Styles, G. E.	E.-in-C.O.	6.2.42	Pooley, A. B.	Baldock R/S to E.-in-C.O.	22.3.42
*Hawking, W.	W. & B.C. Reg. to S.W. Reg.	6.2.42	Leek, T. W.	W. & B.C. Reg. to S.W. Reg.	8.3.42
*Ingram, C. P.	S.W. Reg.	6.2.42	Williams, W.	E.-in-C.O.	15.6.41
Prickett, W.	S.W. Reg.	6.2.42	Head, G. F.	W. & B.C. Reg.	17.3.42
*Barnett, H. E.	E.-in-C.O. to H.C. Reg.	6.2.42	Birrell, R. C.	Scot. Reg.	17.3.42
McNeill, A.	H.C. Reg.	6.2.42	<i>From Mech. in Charge, Grade I, to Tech. Asst.</i>		
Davies, B.	Scot. Reg. to N.W. Reg.	1.3.42	Hutchinson, A.	Manchester	19.4.42
Coote, F.	Scot. Reg. to S.W. Reg.	27.3.42	<i>S.W.I. to Insp.</i>		
*Huff, W. C.	N.W. Reg. to E.-in-C.O.	27.2.42	Mills, L. R. W.	S.W. Reg. to E.-in-C.O.	1.2.42
Magnusson, L. E.	E.-in-C.O.	27.2.42	Whiteley, R. G.	S.W. Reg. to E.-in-C.O. (Seconded to Contracts Dept.)	8.3.42
Nicholls, C. A. L.	E.-in-C.O.	29.2.42	Allen, T. R.	E.-in-C.O.	8.3.42
<i>From Asst. R.M.T.O. to R.M.T.O.</i>			Daymond, A. C.	E.-in-C.O.	1.4.42
Allen, J. E.	Edinburgh	7.4.42	Dutton, K. W.	H.C. Reg. to E.-in-C.O.	1.3.42
<i>From Chief Insp. to Asst. Engr.</i>			*Dipple, J. A.	Test Section (Birmingham) (on munitions) to Test Section (London)	8.2.42
Creed, H.	H.C. Reg.	15.3.42	Yates, W. E. C.	Test Section (London)	8.2.42
Such, R. C.	H.C. Reg.	4.3.42	Wheeler, S. T. H.	Test Section (B'ham) to Cable Test Sect. (Ldn.)	18.1.42
Dixon, J.	W. & B.C. Reg. (Seconded to Contracts Dept.)	17.3.42	Hall, G. H.	Scot. Reg. to Darlington R/S	15.7.40
Coulson, J. N.	N.W. Reg.	17.3.42	Allen, L. M.	H.C. Reg. to E.-in-C.O.	15.3.42
Moxon, T.	Scot. Reg.	17.3.42	Birrell, C. F.	Cable Test Section	19.4.42
*Hall, G. K.	N.E. Reg. to Scot. Reg.	3.4.42	Poole, S. R.	Test Section (London)	8.3.42
Lockie, J.	Scot. Reg.	3.4.42	<i>Insp. to Asst. Traffic Supt.</i>		
Cope, H. G.	N.E. Reg. to N.W. Reg.	1.5.42	Park, W. D.	Scot. Reg. to L.T.R.	19.1.42
<i>From Tech. Asst. to Asst. R.M.T.O.</i>			<i>S.W.II to Cable Foreman.</i>		
Fraser, A. V. O.	Manchester to Edinburgh	19.4.42	Greenstreet, F. P.	E.-in-C.O. (Dover Cable Depot)	2.9.40
<i>Chief Insp. to Chief Insp. with Temp. Allee.</i>					
Chapman, C. W.	H.C. Reg.	12.4.42			

* Promoted "in absentia." All promotions "acting."

Retirements

Name	Region	Date	Name	Region	Date
<i>Asst. Staff Engr.</i>			<i>Chief Insp.</i>		
Bastow, F.	E.-in-C.O.	31.5.42	Young, W.	H.C. Reg.	25.5.42
Beattie, W.	Mid. Reg.	31.3.42	Richards, T.	N.E. Reg.	7.5.42
<i>M.T.O.I</i>			<i>Insp.</i>		
Benzies, A.	M.T.O. Class I, E.-in-C.O.	7.3.42	Collenette, L. T.	L.T.R.	5.4.42
<i>Exec. Engr.</i>			Gray, F.	L.T.R.	14.4.42
Irwin, A.	E.-in-C.O.	31.3.42	<i>Fourth Officer.</i>		
Clark, H. V.	E.-in-C.O. (ill-health)	25.4.42	Smith, L. H.	H.M.T.S. (Resigned)	25.4.42
<i>Asst. Engr.</i>			<i>Cable Foreman.</i>		
Jackson, J. M.	N.W. Reg.	10.4.42	Campbell, G. P.	Dalmuir Depot	25.5.42

Deaths

Name	Region	Date	Name	Region	Date
<i>Asst. Engr.</i>			<i>Insp.</i>		
Douglas, J. H.	E.-in-C.O.	21.4.42	Upton, S.	E.-in-C.O.	23.2.42
<i>Chief Insp.</i>			Martin, J. W.	L.T.R.	10.4.42
Forster, J. H.	L.T.R.	31.3.42	Geldart, D. F.	Mid. Reg.	16.3.42
			Johnstone, A. N.	Scot. Reg.	26.3.42

Transfers

Name	Region	Date	Name	Region	Date
<i>Reg. Engr.</i>			<i>Chief Insp.</i>		
Hines, R. J.	N.E. Reg. to Mid. Reg.	12.4.42	Shephard, A. C.	E.-in-C.O. to Kingsbury R/Stn.	23.3.42
<i>Exec. Engr.</i>			Foulsham, R.	Mid. Reg. to H.C. Reg.	16.3.42
Hibbs, A.	S.W. Reg. to E.-in-C.O.	23.3.42	<i>Insp.</i>		
<i>M.T.O.II</i>			Abbott, F. E.	Cable Test Sect. (London) to S.W. Reg.	8.3.42
Wright, F. V.	Edinburgh to E.-in-C.O.	7.4.42	Andrewartha, C. J.	Test Section to L.T.R.	19.4.42
<i>Asst. Engr.</i>			Cameron, J. W.	Scot. Reg. to E.-in-C.O.	1.4.42
Gay, S. G.	Mid. Reg. to S.W. Reg.	16.3.42	<i>Cable Foreman.</i>		
Birnie, R. C.	E.-in-C.O. to Scot. Reg.	11.5.42	Greenstreet, F. P.	Dover Cable Depot to Dalmuir Cable Depot	18.5.42

BOARD OF EDITORS

A. J. GILL, B.Sc., M.I.E.E., M.I.R.E., Chairman.
 F. E. NANCARROW, A.R.C.Sc., M.I.E.E.
 P. B. FROST, B.Sc., M.I.E.E.
 A. H. MUMFORD, B.Sc.(ENG.), M.I.E.E.
 C. W. BROWN, A.M.I.E.E.
 G. H. S. COOPER.
 H. LEIGH, B.Sc.(ENG.), A.M.I.E.E., Acting Managing Editor.
 G. E. STYLES, A.M.I.E.E., Acting Assistant Editor.

Copyright

The entire contents of this JOURNAL are covered by general copyright, and special permission is necessary for reprinting long extracts, but Editors are welcome to use not more than one-third of any article, provided credit is given at the beginning or end thus: "From the *Post Office Electrical Engineers' Journal*."

The Board of Editors is not responsible for the statements made or the opinions expressed in any of the articles in this JOURNAL, unless such statement is made specifically by the Board.

Communications

All Communications should be addressed to the Managing Editor, *P.O.E.E. Journal*, Engineer-in-Chief's Office, Alder House, Aldersgate Street, London, E.C.1. Telephone: HEADquarters 1234. Remittances should be made payable to "*The P.O.E.E. Journal*" and should be crossed "& Co."

Binding Cases

Cases for binding are available, and may be obtained from the Local Agents for 1s. 9d. Subscribers can have their copies of Volumes bound, at a cost of 3s., by sending the complete set of parts to the Local Agents or to the *P.O.E.E. Journal*, Engineer-in-Chief's Office, Alder House, Aldersgate Street, London, E.C.1. Orders for binding for Vols. 1-19 should indicate whether the original binding case with black lettering, or the later pattern with gold, is required. Cases with gold lettering are the only type stocked from Vol. 20 onwards.

Back Numbers

The price of the JOURNAL, which is published quarterly, is 1s. (1s. 3d. post free) per copy, or 5s. per annum post free. Back numbers can be supplied, subject to availability of stocks, at 1s. each (1s. 3d. post free). Orders for back numbers may be sent to the Local Agents or to the Publishers.

Advertisements

All communications relating to space reservations should be addressed to the Advertisement Editor, *P.O.E.E. Journal*, Alder House, Aldersgate Street, London, E.C.1. Communications regarding advertisement copy, proofs, etc., should be addressed to the Publishers, Messrs. Birch & Whittington (Prop. Dorling & Co. [Epsom], Ltd.), 49 Upper High Street, Epsom, Surrey.

owing to war conditions are advertised in this Journal should not be taken as an indication that they are necessarily available for export.

'AVO'
Regd. Trade Mark

46-range Model 7
Universal AvoMeter

40-range Model 40
Universal AvoMeter

Meters that Matter

FROM years of intensive research in the design and manufacture of electrical testing equipment has grown the range of world-famous "AVO" Instruments. To-day, wherever rapid precision testing is demanded, there will be found the meters that matter—"AVO" Meters.

Sole Proprietors and Manufacturers

THE AUTOMATIC COIL WINDER & ELECTRICAL EQUIPMENT Co. Ltd.
Winder House, Douglas Street, London, S.W.1

Phone: VICtoria 3404-7

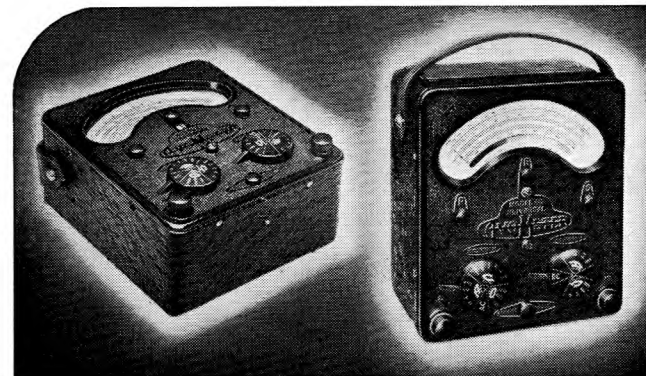

FREQUENCY BRIDGE TYPE D - 101 - A

*A Bridge for the measurement of audio frequencies
—simple to operate—direct reading—outstandingly
accurate—reasonably priced.*

A complete description of this Bridge is given in Bulletin B-526-A, which will be sent on request.

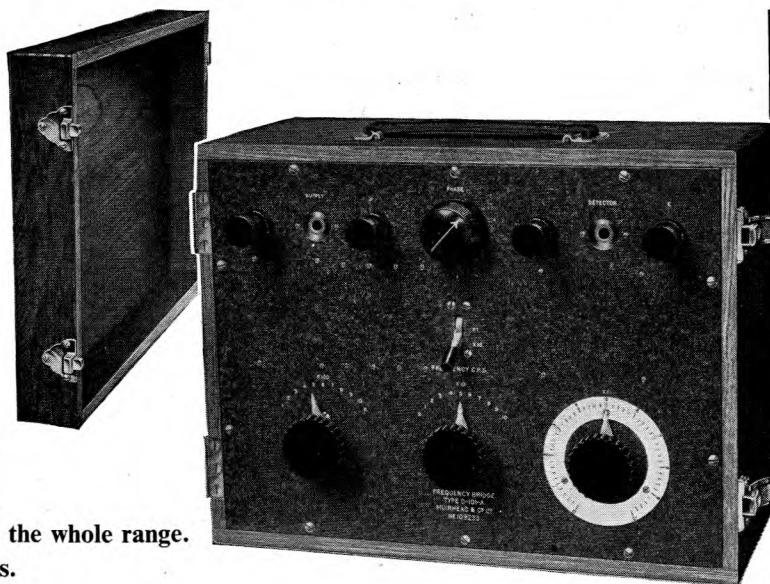

- ★ Frequency range, 100 c.p.s. to 12,100 c.p.s.
- ★ Direct reading on two decade dials and a third continuously variable dial.
- ★ Measuring accuracy $\pm 0.25\%$ ± 1 c.p.s.
- ★ Reading accuracy—better than 0.05% over the whole range.
- ★ Accuracy unaffected by stray magnetic fields.
- ★ Input impedance 400-1,500 ohms unbalanced.
- ★ Telephones form a suitable detector for most measurements.
- ★ Light and easily portable.

MUIRHEAD & CO. LTD., ELMERS END, BECKENHAM, KENT.
TELEPHONE: BECKENHAM 0041-2.

MUIRHEAD

FOR OVER 60 YEARS DESIGNERS AND MAKERS OF PRECISION INSTRUMENTS



There are

15 YEARS' RESEARCH AND DEVELOPMENT

behind every one of the thousands of

WESTINGHOUSE METAL RECTIFIERS

used by Telecommunication Engineers
throughout the world.

Write for descriptive pamphlet No. I1H to Dept. POEJ

WESTINGHOUSE BRAKE & SIGNAL CO. LTD.
PEW HILL HOUSE, CHIPPENHAM, WILTS.

PROGRESS IN TELEPRINTER TRANSMISSION

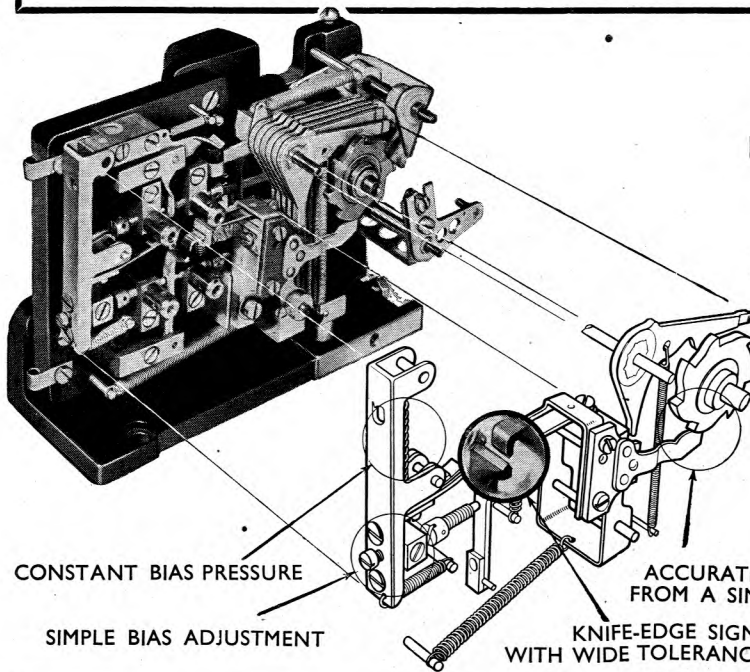

CONSTANT BIAS PRESSURE

SIMPLE BIAS ADJUSTMENT

ACCURATE TIMING
FROM A SINGLE CAM

KNIFE-EDGE SIGNAL SELECTION
WITH WIDE TOLERANCE OF BIAS VARIATION

**IMPROVED PERFORMANCE WITH
REDUCED MAINTENANCE**

**THE NEW
CREED
TELEPRINTER
TRANSMITTING
UNIT S2184**

CREED & COMPANY LIMITED



TELEGRAPH HOUSE, CROYDON

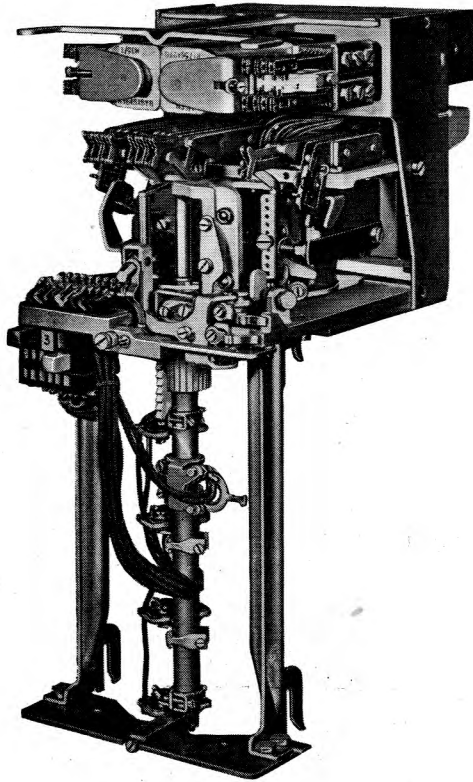

A
QUICK
“SWITCH”
FOLLOWING
A
BLITZ

**STROWGER CONTRIBUTES
TO ONE OF BRITAIN'S
MINOR TRIUMPHS!**

Among the stories which cannot be fully told till the war is over is that of a city's telephone service restored following damage by enemy action.

For the time-being, the city shall be nameless, and the extent of the damage must not be disclosed. It can be said, however, that by bold decision and unflagging effort, the service of a considerable number of subscribers was restored in a few weeks, when the task had appeared impossible.

The principal contributing factor was the characteristic flexibility of Strowger Automatic Telephone Exchange Equipment, which enabled apparatus manufactured for another area to be readily adapted to the needs of the "blitzed" city. Developed essentially as an amenity of civilisation, Strowger Equipment, because of its high operating speed and reliability, is contributing in no small measure to the evolution of the Allies' fighting machine which will bring victory to the freedom-loving nations.

AUTOMATIC TELEPHONE & ELECTRIC CO. LTD.

MELBOURNE HOUSE, ALDWYCH, W.C.2

'Phone, Temple Bar 9262 • 'Grams, "Autelco, Estrand, London"

STROWGER WORKS, LIVERPOOL, 7

'Phone, Stoneycroft 4830 • 'Grams, "Strowger, Liverpool"



FOR JOBS OF NATIONAL IMPORTANCE



THEY CHOOSE

TUDOR

ACCUMULATORS

Tudor Accumulators are doing a big job in the control room of Broadcasting House, and in many other places all over the country Tudor Accumulators are relied upon for jobs of high importance. In many of Britain's power stations, for instance, Tudor Accumulators are installed. Where complete reliability is essential, therefore, no better choice can be made than Tudor.

SAFETYLYTE

(Licensed under Patent No. 313248). The Tudor Emergency Lighting System completely meets the risk of a sudden plunge into darkness. Should the normal supply be interrupted through causes beyond the control of Electricity Undertakings, the control panel that keeps the Tudor Accumulator charged automatically brings it into circuit.

THE TUDOR ACCUMULATOR CO., LTD.
50 GROSVENOR GARDENS, LONDON, S.W.1

Telephone: SLOane 016819. W.T.6

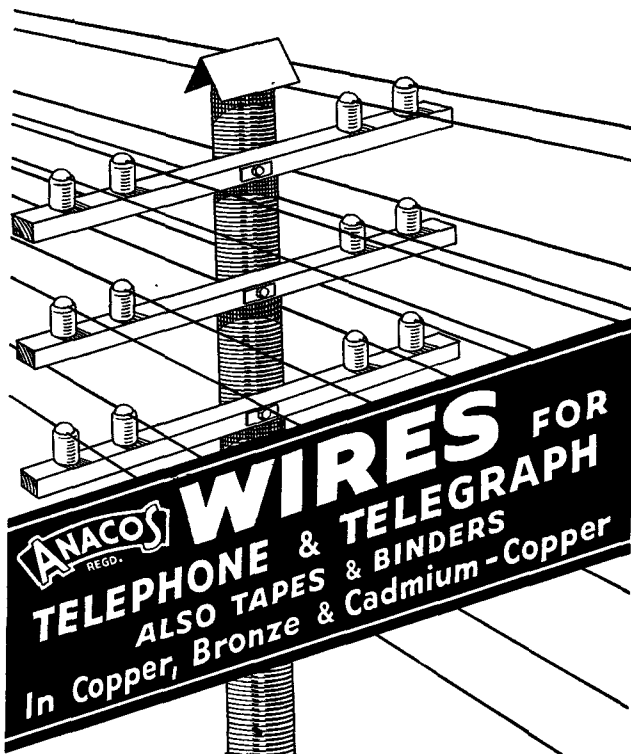

ANACONDA WIRE FOR
TELEPHONE & TELEGRAPH
ALSO TAPES & BINDERS
In Copper, Bronze & Cadmium-Copper

FREDERICK SMITH & CO. LTD. (Incorporated in The London Electric Wire Company and Smiths, Limited.)

ANACONDA WORKS, SALFORD, 3, LANCs.

Telephone :
BLACKFRIARS 8701 (8 lines)

Telegrams :
"ANACONDA" MANCHESTER

High Quality mouldings

Ebonestos have produced many of the finest mouldings manufactured in compositions, Bakelite, Urea, Diakon, and other synthetic resins. For the past 42 years, our reputation for finish and accuracy has been second to none. Let us know your moulding requirements, and we shall be pleased to send one of our technical experts to discuss the matter with you, or, if you prefer it, meet you at our factory.

Moulders to the General Post Office, Admiralty, Air Ministry and other Government Departments.

EBONESTOS

INDUSTRIES LIMITED

EXCELSIOR WORKS, ROLLINS STREET,
LONDON, S.E.15 Telephone: New Cross 1913 (6 lines)

SIEMENS PRODUCTS

MADE IN ENGLAND

Contractors for the manufacture, laying and maintenance of Submarine and Land Cables for Telegraphy and the Electric Transmission of Power, for the erection and maintenance of Overland Telegraph, Telephone and Power Transmission Lines, Public and Private Telephone Exchanges and Carrier Equipment for Telephone Lines.



*Backed by over
80 years experience!*

**ELECTRIC
WIRES & CABLES**

**CABLE
JOINT BOXES**

TELEPHONE CABLES
Aerial, Underground, Submarine

**OVERHEAD
LINE MATERIAL**

CELLS & BATTERIES
Dry, Fluid & Inert

**MARINE
APPARATUS**

**ELECTRIC
LAMPS**

**PRIVATE
TELEPHONE SYSTEMS**

**PUBLIC
TELEPHONE EXCHANGES**

**ELECTRIC
TOTALISATORS**

**MEASURING & RECORDING
INSTRUMENTS**

SIEMENS BROTHERS & CO., LTD

WOOLWICH, LONDON, S. E. 18

ESTABLISHED 1858

Telephone: WOOLWICH 2020

**ELECTRICITY
METERS**

Ericsson



MODERN TELEPHONE APPARATUS...

The new automatic telephone No. 1002 has a casework of moulded bakelite. It incorporates a sliding instruction tray and renewable writing pad. Dimensions $5\frac{1}{2} \times 9\frac{1}{4} \times 7$. Weight 6 lbs. Full particulars from makers.

ERICSSON TELEPHONES, LTD., Head Office: 56 Kingsway, London, W.C.2. Phone: HOLborn 6936

capco

REGISTERED TRADE MARK

Quartz Cutting Machine

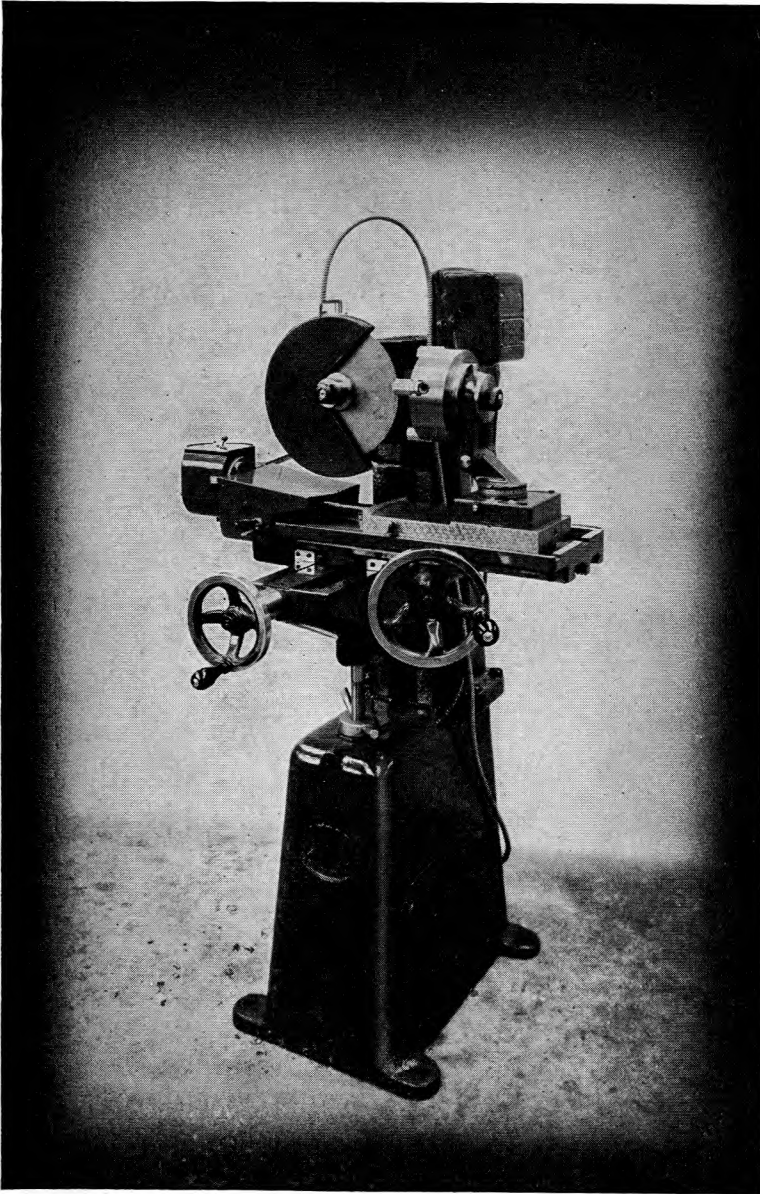

Designers and Manufacturers of Capco Sound-on-Film recorders and equipment. Capco built recorders are in use at Elstree, Pathe News and British Talking Pictures, etc. Patentees and Manufacturers of Capco Enamelled Wire cleaning machines.

Illustration shows latest Model of the Quartz Cutting Machine developed and designed in collaboration with engineers of the Radio Branch of the Post Office.

Similar machines have been supplied to the Post Office and to the leading Telephone and Radio Manufacturers.

Standard and heavy duty cutting machines with high rates of cutting to accuracies of .001 in.

Fixtures to hold any shape of crystal can be supplied.

Heavy Duty Machine can now be supplied with nine rates automatic feed through specially designed gear box, sensitive instantaneous stop through specially designed clutch.

Acknowledged to be the finest machines of their kind for this class of work.

Manufacturers :

CAPLIN
ENGINEERING CO. LTD.

Precision Engineers

BEACONSFIELD RD., WILLESDEN
LONDON, N.W.10

Telephone :
WILlesden 0067-8.

Cables :
Caplinko, London.

ESTABLISHED 1918

Sole Agents: CAPCO (SALES) LTD.

NIFE

COUNTER E.M.F. CELLS

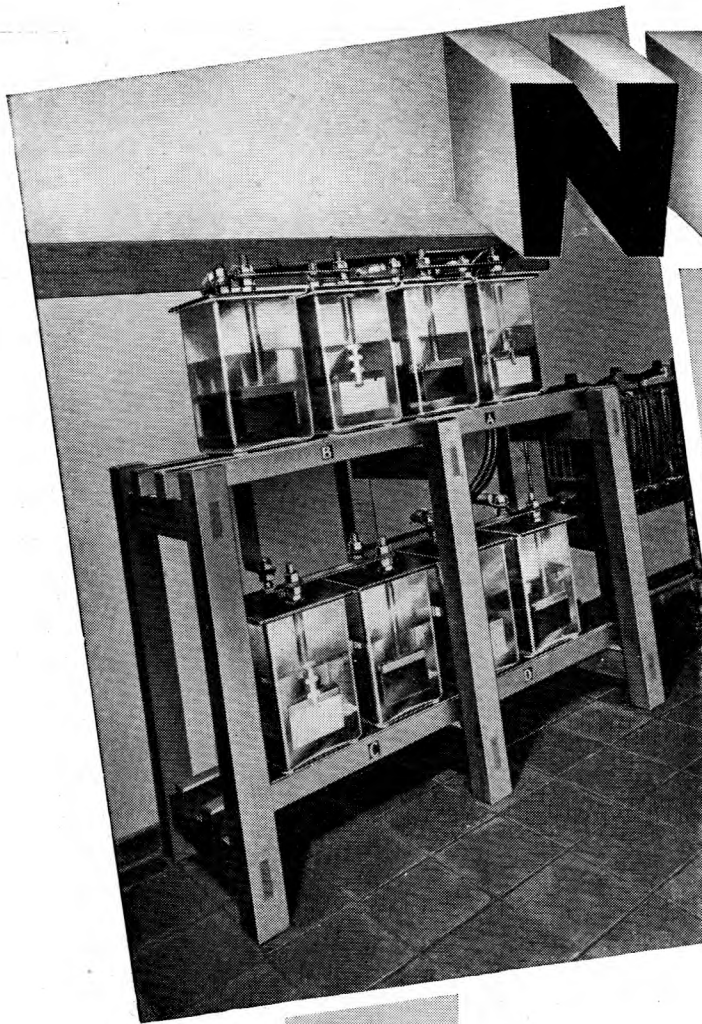

Alkaline with Inert Plates.

Very level voltage characteristic independent of direction and almost independent of magnitude of current.

Zero capacity and complete absence of formation giving prolonged life to switch contacts.

No corrosive fumes allowing installation adjacent to either lead acid or alkaline batteries without detriment to either:

Very low maintenance.

Extremely long life.



NIFE BATTERIES LIMITED

HUNT END • REDDITCH • WORCESTERSHIRE

SALFORD ELECTRICAL INSTRUMENTS LTD.
 PEEL WORKS, SALFORD, 3. Telephones : BLAckfriars 6688 (6 lines). Telegrams and Cables : "Sparkless, Manchester"
 PROPRIETORS: THE GENERAL ELECTRIC Co. Ltd., OF ENGLAND

U.I.C.

CONDENSERS & COMPONENTS

For Modern Radio Technique

- 1 CERAMIC PEARL TYPE CONDENSERS
- 2 CERAMIC COIL FORMERS
- 3 SILVERED MICA (Tropical Type) CONDENSERS
- 4 POT CONDENSERS
- 5 FIXED CERAMIC CONDENSERS
- 6 CERAMIC TRIMMER CONDENSERS

Full details and advice gladly given.

CONTRACTORS TO G.P.O. & GOVERNMENT DEPARTMENTS.
 ON A.I.D. APPROVED LIST.

UNITED INSULATOR CO. LTD.
 12-20, LAYSTALL ST., LONDON, E.C.1.
 'Phone : TERminus 7383.
 'Grams : "CALANEL, SMITH, LONDON."

The Pioneers of Low Loss Ceramics

MAINTAINING EFFICIENCY

THE HIGH STANDARD OF EFFICIENCY
OF PIRELLI - GENERAL TELEPHONE
CABLES IS MAINTAINED BY THE
CONTINUOUS RESEARCH WORK OF
AN EXPERIENCED TECHNICAL STAFF.

TELEPHONE:
SOUTHAMPTON
2141 (5 lines).

PIRELLI-GENERAL
CABLE WORKS, Ltd., SOUTHAMPTON.

TELEGRAMS
"PIGEKAYBEL"
SOUTHAMPTON."



AVOID DANGER of H.R. or DRY JOINTS

The experiences of the leading manufacturers of Radio and Electrical Equipment have shown that only by using ERSIN MULTICORE SOLDER WIRE, which contains three cores of non-corrosive Ersin Flux (A.I.D. Approved) and the correct soldering technique, can they ensure that H.R. or Dry Joints are avoided.

If you are engaged on Government Contracts write for Technical information and free samples of Ersin Multicore. For the present, supplies of Ersin Multicore are restricted to such firms, and the Ministries.

MULTICORE SOLDERS LTD.
BUSH HOUSE, LONDON,
W.C.2

Tem 5583/4

IN THE NATIONAL INTEREST. *Even if you do not yet enjoy the advantages of Multicore, in the National interest endeavour to use an alloy containing a lower tin percentage. We are glad to give technical assistance in overcoming difficulties.*