

THE POST OFFICE ELECTRICAL ENGINEERS' JOURNAL

VOL. 36

APRIL, 1943

PART I

CONTENTS

	PAGE
A COMPACT, TWO-UNIT CATHODE RAY OSCILLOSCOPE— B. M. Hadfield, B.Sc., A.M.I.E.E.	1
THE PRODUCTION OF FIXED CARBON RESISTORS—F. C. Carter, B.Sc.(Eng.), A.M.I.E.E.	6
MODIFICATIONS TO THE AUTOMATIC POWER SUPPLY CHANGE-OVER EQUIPMENT AT KING EDWARD BUILDING SUBSTATION—J. B. Murray, B.Sc.(Eng.), A.M.I.E.E.	10
SOME ASPECTS OF CROSSTALK BETWEEN UNBALANCED CIRCUITS—H. Stanesby, A.M.I.E.E., and E. W. Ayers, B.Sc.	14
SIMPLIFIED METHOD OF UTILISING THE SINGLE MEAN “t” TEST—A. H. Mumford, B.Sc.(Eng.), M.I.E.E.	18
AIR RAID DAMAGE TO POST OFFICE TELECOMMUNICATIONS —PART III—The Second Great Fire of London—E. C. Baker	20
THE RESTORATION OF TELEPHONE APPARATUS AFFECTED BY ENEMY ACTION—C. E. Richards, F.I.C., and D. W. Glover, M.Sc., F.I.C.	25
BOOK REVIEW	27
NOTES AND COMMENTS	28
REGIONAL NOTES	29
STAFF CHANGES	31

Price 1/- net

THE INSTITUTION OF POST OFFICE ELECTRICAL ENGINEERS

**SILVERED CERAMIC
FIXED CONDENSERS**

PEARL TYPE
0.5 pF to 5 pF.
Max. Dimensions 7 × 9 mm.
Test Voltage 1500V. D.C.
Loss Factor -20×10^{-4}
Mechanical and electrical stability
whatever the climatic conditions
Type approved

MULTUM IN PARVO



UNITED INSULATOR CO. LTD.
12-20 LAYSTALL STREET, LONDON, E.C.1.
Phone: TERminus 7383

*The Pioneers
of Low-Loss
Ceramics*

Grams: Calanel, Smith, London.

★
TELEGRAPH APPARATUS
for
MORSE SYSTEMS

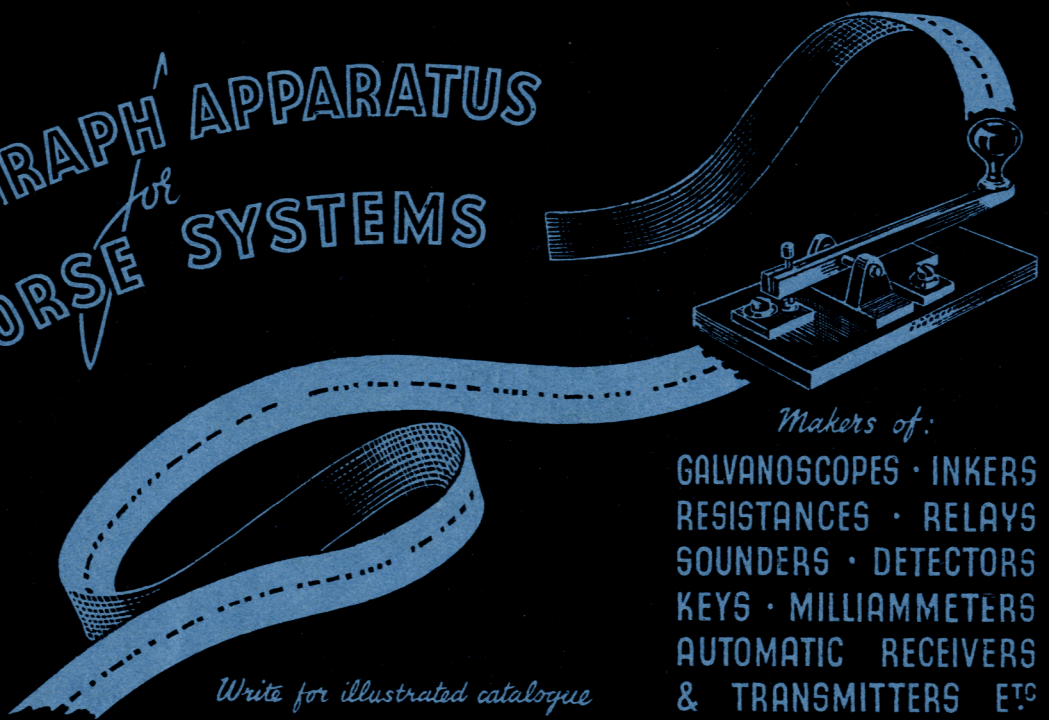

Makers of:

- GALVANOSCOPES · INKERS
- RESISTANCES · RELAYS
- SOUNDERS · DETECTORS
- KEYS · MILLIAMMETERS
- AUTOMATIC RECEIVERS
& TRANSMITTERS ETC

Write for illustrated catalogue

ELLIOTT BROTHERS (LONDON) LTD. CENTURY WORKS, LEWISHAM, S.E.13

THE POST OFFICE ELECTRICAL ENGINEERS' JOURNAL

Vol. XXXVI

April, 1943

Part I

A Compact, Two-Unit Cathode Ray Oscilloscope

U.D.C. 621.317.755

B. M. HADFIELD/B.Sc., A.M.I.E.E.

The author describes the design and construction of an oscilloscope of the minimum dimensions consistent with a reasonable and accurate display, having a test axis sensitivity of from 2 cm./V to 0.04 cm./V with a frequency range from zero to 200 kc/s, a stable, linear time base deflection over a range of 1 c/s to 10 kc/s with independent amplitude control and shift controls on both axes operating independently of the input giving shifts of ± 2 cm. from the screen centre.

Introduction.

THE design and construction of the cathode ray oscillograph equipment to be described was undertaken more than three years ago. At that time there was not available on the commercial market any equipment which satisfied all the requirements for use in the laboratory or field, as listed below. Even to-day commercial equipment falls considerably short of most of the requirements.

During these three years equipment of the type described, with some slight modifications, has been continuously in use both in the laboratory and field with complete satisfaction. For investigations requiring knowledge of waveforms, apparatus of this type is well-nigh essential. Furthermore, if designed and constructed with a view to accuracy of reproduction and an individual calibration supplied, it can replace many of the more common measuring instruments to a sufficient degree of accuracy.

Up to the present time, the equipment has been largely used in the laboratory on development work in connection with two-frequency and direct current signalling. It has also been used in the field for rapid fault location on voice frequency circuits, and the success attending this use has led to the demand for equipment of this type at Zone and Group centres. There is little doubt that the proper transmission and reception of impulses of any type and over any form of medium will be greatly facilitated by the use of this equipment.

General Design Requirements.

Experience with several forms of commercial equipment showed that they suffered from one or more of the following defects:—The size and weight were too great, the control of the oscillogram was insufficient, the reproduction accuracy was bad for large displays, the operation on direct current was nil or only obtainable at a reduced sensitivity, and here was no attempt at calibration.

The following points in the present design therefore received special attention:—

- (1) The oscillograph unit to have the minimum dimensions, so that the bench area used was

similar to a 6-in. scale meter. The screen to be tilted conveniently for viewing, and the terminals to be easily accessible.

- (2) Freedom from all normal forms of oscillograph distortion, such as origin, trapezium and defocusing distortions. The deflection to be linear over the screen at least on a visual basis.
- (3) The deflectional sensitivity to be the same for D.C. and A.C. inputs, and controllable over a wide range on a logarithmic basis by a single variable. The maximum sensitivity to be of the order of 2 cm. deflection for 1 V input.
- (4) Provision of shift controls for both vertical and horizontal axes, entirely independent of the input and having no delay in operation. The design to be such that no matter how the shift and gain controls are set, no non-linear distortion due to overloading appears on the screen.
- (5) Elimination of all spurious forms of pick-up derived from the apparatus itself, such as mains frequency deflection or spot modulation at any frequency. Direct pick-up of electrostatic or electromagnetic fields from nearby apparatus under any adjustment conditions to be minimised.
- (6) Provision of a linear time base deflection with a sweep frequency range from 1 c/s up to at least 10,000 c/s.

The Oscillograph Tube.

At the time when this design was formulated, a commercial tube having a 3-in. diameter screen became available*, having a length of $6\frac{1}{2}$ in., a high vacuum, and electrostatic deflection by two pairs of

* This type of tube has now been withdrawn from production owing to Service production standardisation. It has been replaced by a tube (VCR 139A) having substantially the same electrical characteristics but with a much larger base and a length of 8 in. Fortunately the screen diameter is the same, and owing to the intentional recession of the original tube behind the front panel, the increased length could be accommodated. An advantage is that the sensitivity of both pairs of plates is now the same and equal to the greater value for the original tube, namely 17/E cm. per volt between the plates.

deflection plates all individually terminated. The spot diameter was very small (about 0.5 mm.), compared favourably with gas-focused tubes, and its brilliance was also comparable for anode voltages of reasonable magnitude (500–800 V). The screen was much flatter than usual so that despite the smaller diameter the reproduction over the whole screen was as good as for the usable portions of higher diameter tubes. The diameter to length ratio was 0.48, which is nearly as good as for the more modern magnetically deflected television tube.

Being of the high vacuum type it did not suffer from origin distortion, although trapezium and defocusing distortion were bad when used with an asymmetrical deflection plate voltage. When used with symmetrical voltages (i.e. push-pull with respect to the final anode) neither trapezium nor defocusing distortion was apparent, the deflections on each axis were linear over the whole screen, and "pin cushion" effects were not marked.

This tube satisfied all the requirements and particularly those of dimensions, since this factor always sets the limit to the whole oscillograph unit.

The focusing of this tube is obtained by adjustment of the voltage of the focusing element (known as the first anode) between limits of 140 and 200 V with respect to the cathode. Spot brilliance can be varied by control of the grid voltage between 0 and -30 V with respect to the cathode. Other things being equal, however, the intrinsic spot brilliance is a function of the cathode current, which is proportional to the final anode voltage, as for a thermionic valve. The deflectional sensitivity of the plates is inversely proportional to the final anode voltage, however, so that a compromise between the two must be effected. In view of the fact that the apparatus was for use in surroundings where there would be normal lighting, it was thought better to err on the side of spot brilliance, so that a final anode voltage of 700 was used. The sensitivity of the plates is then $12/E$ and $17/E$ cm. per volt between the plates respectively, i.e. 0.17 and 0.24 mm./volt where E is the final anode voltage of 700. The heater rating is 4 V at 1 A.

The Amplifiers.

Freedom from tube distortion can be provided only by applying equal and opposite voltages to a pair of deflection plates. This infers a push-pull type of amplifier, with a reasonable degree of feedback to ensure linearity over the screen on a visual basis.

The deflectional sensitivity requirement can be met only by having a direct-coupled amplifier, i.e. no intentional reactive impedances. Although this demand makes the amplifier design unusual, it facilitates the layout in a compact form, since all the coupling impedances can be small composition resistances. As an input transformer cannot be used and one of the test points may have a low impedance to the amplifier supply voltage (i.e. between earth and chassis, for instance); it follows that the input to the amplifiers must be asymmetric. Consequently the push-pull effect must be obtained by a phase reversing value of unity gain (i.e. a paraphase valve stage).

The fourth requirement regarding the shift control can be met only by alteration of the anode potentials of the amplifier, since the deflection plates will be directly connected thereto. To maintain the requirement of equal and opposite plate voltages, such anode potential variations must also be equal and opposite. In addition it is desirable that these variations shall be accomplished entirely within the anode circuits, and without alteration of the steady anode currents, as otherwise the operating conditions of the grid circuits will be affected and will require primary consideration from this viewpoint. For instance, the use of a variable D.C. input (obtained from the supply busbars) as a shift control was discarded for the following reasons:—

- (a) The input grid circuit would have a variable impedance due to the inclusion of the shift control;
- (b) The shift effect might alter with the gain control setting; and
- (c) The potential of the test terminals might be variable with respect to the chassis, so that the common connection of the earthing terminals of the X and Y deflections could not be effected when necessary.

It follows that the push-pull valves must be of pentode type, since this is the only type which permits large changes in the steady anode potential without change of anode current, and the equal and opposite steady anode potential changes for shift purposes must be obtained by equal and opposite changes in the anode resistances.

If a single anode/screen supply voltage is desired, on the grounds of economy in design, and the amplifier is to be direct coupled, then not more than one amplifying valve per plate can be used. The order of gain required can be computed from the third requirement. Using the most sensitive axis of the original tube, the required 2 cm. deflection for 1 V input will need 83 V between plates, which will be shared equally by each plate. Hence the gain per plate or anode will need to be about 42.

The general form of the deflection amplifier is now clear. It will consist of two pentode valves, having direct couplings to the plates and input, functioning as a paraphase amplifier with resistive impedances throughout, a gain per valve of about 40, with a shift control consisting of equal and opposite variations of the anode resistances. The next section will describe the specific circuit used.

So that both axes may be used under similar conditions of sensitivity if required, and to permit the expansion of the display on the time axis when the time base is used, it was considered desirable that similar amplifiers should be provided for both deflectional axes.

Description of the Amplifier Circuit.

Fig. 1 shows the circuit using two pentode valves V1 and V2 whose anodes are connected directly to the deflection plates D1 and D2 of a given axis. The asymmetric input is applied to the grid of V1 via the series variable resistance R_s and shunt resistance

R_{10} . The grid circuit of V2 is fed in paraphase manner from the anode of V1 via the potentiometer R_6 , R_7 . The ratio of this potentiometer from anode to grid is the reciprocal of the gain of V1, so that owing to the phase inversion due to V1, the grid input to V2 is equal to that of V1, but of reversed sign. Hence, assuming that the two valve circuits are identical, the anode voltage changes due to an input will be equal and opposite.

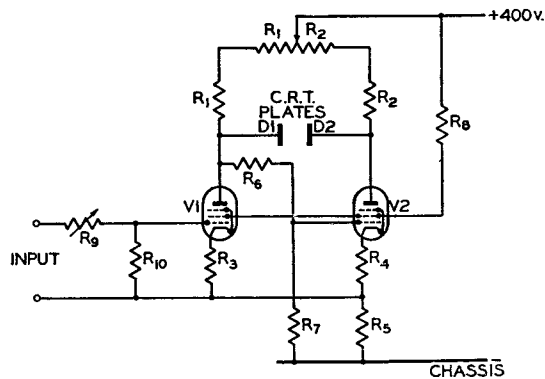

FIG. 1. AMPLIFIER CIRCUIT.

The anode and screen current changes will also be equal and opposite, so that their sum is constant. Thus the steady voltage on a common resistance, such as R_8 , will not vary with the input. It is therefore permissible to use this voltage to neutralise the inevitable steady D.C. voltage obtained from R_7 of the coupling potentiometer, so that the nominal operating conditions of the grid circuits of the valves are the same. Furthermore, the larger the gain of V1, the less will be the degree of neutralisation required and the less will be the wastage of the supply voltage incurred by R_5 . It is the use of these mutually favourable circumstances which permitted the economical and simple design of this amplifier.

The voltage on a common screen resistance such as R_8 will also be independent of the input, so that any value of steady screen voltage can be used, and this also facilitates the design of the amplifier for the necessary gain.

The anode resistances R_1 and R_2 are nominally equal but are comprised in part by a potentiometer, to the arm of which is connected the positive pole of the supply. Movement of the arm permits the steady anode potentials to be altered by equal and opposite amounts from normal, and thus provides a means of shifting the display at will. Such movement does not materially alter the overall gain or the anode currents, so that the display is not otherwise affected. This is strictly true only if the coupling between the valves is removed and they are fed with a push-pull input, but it can easily be shown that for a shift of the order of ± 2 cm., alterations of gain or anode currents are relatively immaterial in the present circuit.

The cathode resistances R_3 and R_4 are also equal and serve the dual purpose of biasing the valves and providing the only admissible form of feedback.

It will be noticed that the "earthy" lead of the input is not connected to chassis, and for this reason the chassis is not earthed. This is inevitable if

neutralisation of the unwanted positive grid voltage on R_7 is to be effective, but as R_5 only sustains a small constant D.C. voltage no ill effect results. Other methods of neutralisation, dispensing with R_5 are possible, but not so convenient.

The input gain control is of somewhat unusual type, in that the grid voltage across R_{10} is varied by a series resistance R_9 . This type of control was adopted instead of the more conventional potentiometer of constant total resistance, for several reasons. It maintains the grid impedance of V1 more constant with different gain settings and hence permits the reduction of unwanted pick-up from surrounding fields, by careful positioning of R_{10} in conjunction with the grid input impedance R_7 of V2. It also ensures the highest input impedance of the circuit, consistent with sensitivity. Hence R_{10} has been made $100,000 \Omega$ and R_7 is of the same order. This value is restricted by the magnitude of the pick-up, and by the availability of a convenient series variable resistance for R_9 to give an adequately large range of gain control. Using a 5 megohm variable for R_9 , a 50 : 1 range is obtained which is adequate for most purposes; external resistances can be used for extending the range. This control is made approximately logarithmic in action, to facilitate setting at around the maximum sensitivity.

This type of control has been found in practice to fit in with normal requirements, since the investigation of low voltages requiring the maximum gain is nearly always carried out across circuits possessing a low impedance, and vice-versa.

The amplifiers have been designed on somewhat novel lines, known as the limiting gain principle, by which method the operating conditions are clearly and simply established without specific knowledge of the values of the circuit parameters. For instance, the choice of suitable valves becomes entirely one of balancing excessive steady current drain against improved high frequency response. In this connection the design covers a range of 0 to 200,000 c/s., with a maximum deviation of 3 db. at the highest frequency, for a current drain of only 4 mA for each of the deflection axis amplifiers.

Description of the Time Base Circuit.

The requirements of this circuit are that it shall generate a waveform which has a constant slope with time (i.e. is linear) for the major portion of a cycle, an amplitude independent of the cyclic time (or speed), and a frequency variable over a range of 1 to at least 10,000 c/s. The frequency must also be stable at any setting with supply voltage and valve changes, and easily controlled.

Fig. 2 shows the form of this circuit, which employs two valves V1 and V2, the former being a gas-filled triode. The required waveform is obtained from the voltage across the condenser C, which is charged from the positive busbar via V2 at a constant current i . The pentode valve V2 exhibits a constant current anode characteristic for changes in anode voltage produced by the charging of C, this effect being enhanced by the large degree of current feedback produced by the cathode resistance R_1 . R_9 is a small resistance whose effect on the charging action is

negligible. The gas valve V1 has a large negative bias on its grid produced by the voltage drop on R_2 , with respect to the positive busbar. Hence it remains non-conducting while C is charging, until the anode/cathode potential due to the voltage on C is nearly equal to the grid bias on R_2 . When this occurs V1

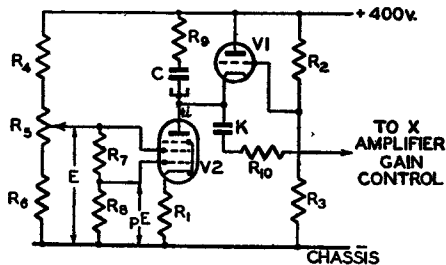

FIG. 2. TIME BASE CIRCUIT.

conducts and remains so until it has discharged C to a voltage below the ionisation voltage of the gas filling. V1 then ceases to conduct and the charging function resumes control of the voltage on C. In the conducting function of V1, the anode/cathode path resembles a battery in characteristics, so that the time taken to discharge C is dependent as regards time constant, only on the external circuit resistance, as is also the discharge current. Although the minimum of discharge time is desired, so that the "flyback" of the spot on the cathode ray tube screen shall be imperceptible, yet the maximum discharge current must be limited to avoid unduly rapid destruction of the cathode material of V1. Resistance R_9 is inserted to perform this function. The time base deflection voltage across C is applied to the X axis amplifier via condenser K, since it is desired that the deflection shall be equally positive and negative with respect to the negative busbar. R_{10} limits the maximum amplitude which can be applied to the X amplifier, to a value giving approximately one-third of the screen diameter with minimum gain setting. A large voltage is necessary across C to reduce to negligible proportions the inevitable leakage of 50 c/s ripple from the supply voltage busbars via the condenser C, especially when the latter is large in value.

It is also desirable that the voltage on C shall be large, because the maximum stability against variations in V1 is then obtained. These variations are (a) the discharge voltage drop of about 20 V, and (b) variations in the control ratio or μ of the valve. As regards (b) it can be shown that the anode/cathode voltage at which the valve will "strike" is $\mu/(\mu + 1)$ times the voltage drop on R_2 , so that provided μ is large, variations will produce negligible effect. The grid/cathode circuit of V1 is in fact a form of cathode follower as is shown by the above familiar ratio. To all intents and purposes, therefore, the voltage amplitude on C is determined solely by the voltage drop on R_2 .

The rate at which C charges is determined by the value of the current i , if the amplitude is fixed. The frequency will be proportional to i and by controlling the current, it may be altered within limits. This control is brought about by simultaneous variation of the positive voltages E and pE applied to screen and control grids respectively, in order that

a maximum of anode current shall be obtained at any setting, without incurring the possibility of grid current at the higher settings, which would reduce the linearity of the waveform. The upper and lower limits are fixed by R_4 and R_5 , the whole being fed from the same supply busbars as for the amplifiers, so that R_5 gives a range of anode currents of at least 10 : 1. The variation of the charge current i with the fine speed control (R_5) is linear, and constitutes a decade range. Four condensers C are fitted and selected by a switch known as the coarse speed control, each of which is one-tenth of the capacitance of the preceding one. In this manner a speed (i.e. frequency range) of 1 to 10,000 c/s can be covered.

It will be noticed that at any given setting of R_5 , the time base frequency is substantially independent of the supply busbar voltage; for the charge current i is proportional to the supply voltage, but so is the voltage at which V1 conducts (i.e. the bias on R_2). Since the charging is linear with time then the frequency is given by $f = i/CV$ which becomes proportional to $1/C$ only, with this circuit. This stability is of great importance in the investigation of waveforms.

It is possible to fit a simple synchronising control, operated by a toggle switch, and consisting of a resistance joined between one of the Y deflection amplifier anodes and the grid of V1. This control, which is not affected by the gain setting, neither does it affect the input impedance, enables normal displays of from 0.2 cm. peak deflection upwards to lock the time base frequency, and hence to give a stationary picture.

The Power Pack and Tube Voltage Supply Arrangements.

It can be shown that the relationship between the amplifier supply and tube voltages can have a minimum ratio of 0.5 with this type of amplifier circuit, and advantage was taken to design a simple power pack on the voltage doubler principle, needing only one high voltage secondary winding H_s , on the mains transformer, as shown in Fig. 3. To avoid defocusing, the potential of the second anode A2 must be the same as the deflection plates, with no input, and this is provided by the potential drop on R_1 . Adjustment of the potential of A1 at around one-fifth of the potential on A2 by R_3 , provides the means of focusing the spot on the screen. The

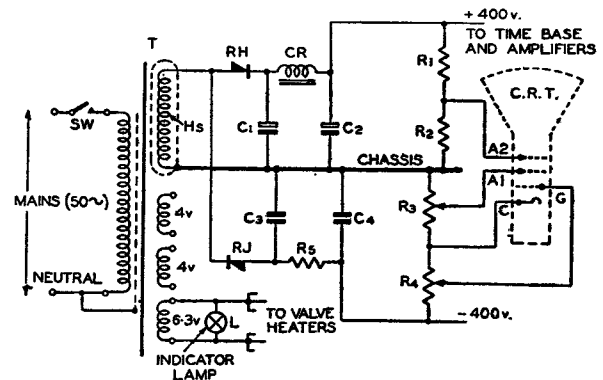

FIG. 3. POWER SUPPLIES.

spot brilliancy is controlled by R_4 , giving negative potentials on the grid over a range of about 30 V.

As the current taken by the tube is only of the order of 0.15 mA, these potentiometers can be of high resistance, and in particular permit of simple resistance/capacitance smoothing for the -400 V busbar. In view of the small current consumptions, even from the $+400$ V busbar at about 10 mA, it is possible to use metal rectifiers for RH and RJ, which makes the power pack much more robust and gives it a longer life.

It will be noticed that both the primary and high voltage windings on the transformer are thoroughly screened. This has been found necessary to eliminate spurious mains frequency deflection and defocusing or modulation of the spot.

General Layout and Mechanical Design.

To satisfy the requirement that the bulk of the working part shall be small, the power pack has been separated from the oscilloscope proper. The power requirements are in any case a necessary evil, and provided they are designed on robust lines, there is no reason why they should waste valuable working space by being incorporated in the tube unit. Furthermore, by placing the power pack out of the way—generally on the floor—there is not the same necessity for screening the tube against magnetic fields from the mains transformer. This normally needs the use of a special alloy, such as mumetal. Again, if the power pack is out of the way, it cannot produce similar interference with the test apparatus.

Fig. 4 is a photograph of the complete equipment, the dimensions of which can be gauged from the large squares on the ruled grating over the tube screen, these being of 1 cm. side. The power pack is on the right, and the tube unit on the left, both being provided with carrying handles. Connections between them are made by a 9-way cable, well protected by heavy gauge rubber tubing, terminated on a plug which fits in the socket of the power unit.

The general mechanical construction is cheap, yet effective. A simple plate of metal (formerly of

aluminium) is bent up at the ends, and forms the backbone. Angle pieces are welded or screwed along the edges for affixing the remaining sides. The top is a simple plate, and the two sides are of perforated sheet, thus giving mechanical protection with adequate heat dissipation. The same length of plate is used for the backbones of both units, but the ends of the tube unit are of different lengths. The longer end, which forms the main control panel, and accommodates the tube screen, is inclined to the base at a convenient viewing angle of 75° , whereas the smaller end is also inclined parallel to the longer and forms the mounting plate for the tube and valve sockets. The overhang of the smaller end is used to accommodate two connection strips mounted vertically, upon which all the composition type resistances are connected, so as to be readily accessible. A sheet-metal cover, hinged to the top plate, protects these resistance panels.

With regard to the tube unit controls, immediate accessibility of those constantly in use is catered for by mounting them under the tube cowling. The right- and left-hand pairs are the gain and shift controls of the Y and X axes respectively, the middle pair being the coarse and fine time base "speed" controls. The Y gain control is individually calibrated in volts/cm. spot deflection, and it is arranged that the Y deflection is upwards for a positive voltage applied to the grid of the Y axis amplifier (i.e. the Y terminal positive to the EY terminal). The coarse and fine range time base indicating arrows are arranged to point towards a vertical line between the knobs; with the former on range 1 and the latter also pointing towards this vertical line, the time base "speed" is 10 i.p.s. Two lines inclined on either side of the vertical one also indicate the fine knob position for "speeds" of 8 and 12 i.p.s. This arrangement is particularly useful when testing automatic impulsing circuits. These "speeds" are approximately multiplied by 10, 100, and 1,000, when the coarse knob is set to ranges 2, 3 and 4, and also form useful location points for general testing. These "speeds" are only approximate because the range condensers are not accurately selected to be in decade multiples.

The remaining controls are the focus and spot brilliancy and, being infrequently used, are mounted on the top panel. They also have friction clutches fitted to them, and an indication of the usual setting, because random use at too high a brilliancy will cause a rapid deterioration in the life of the tube. To facilitate use in normally lit surroundings, the tube screen is mounted within a blackened cowl to a depth of about 2 in.

Only two test terminals and leads are at present provided, to avoid confusion, but a further pair for the X axis can easily be accommodated, together with a time base terminal and strap for disconnection when required.

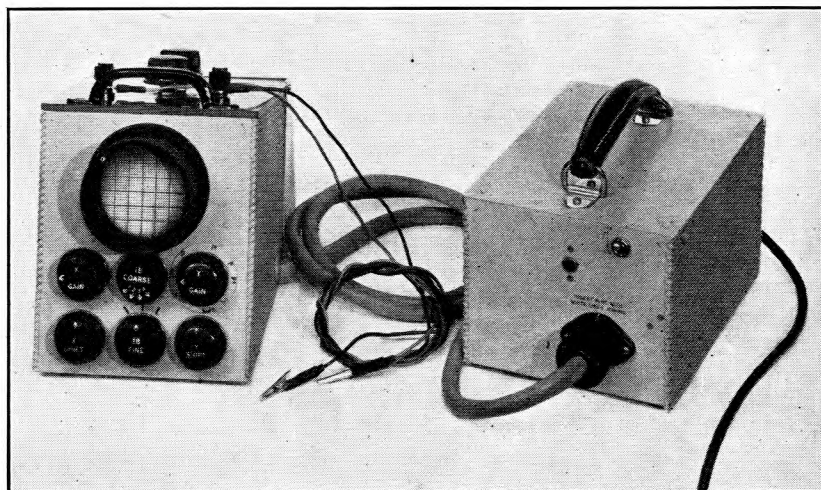

FIG. 4. TUBE UNIT, POWER PACK AND CONNECTING CABLE,

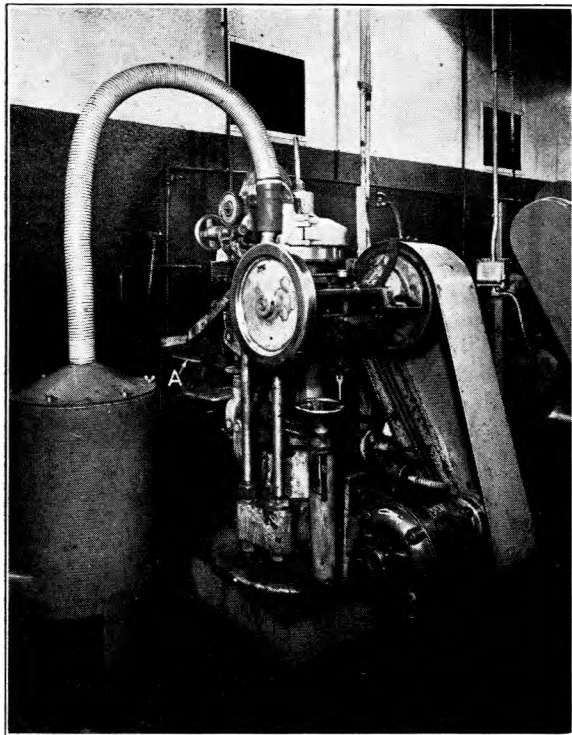

FIG. 2.—MULTI-STAGE PRESS.

Wheatstone bridge and depending upon its actual value is automatically sorted and released into one of a number of compartments or bins. The selection and release operations are performed by a valve operated relay controlled from the Wheatstone bridge. This test equipment provides facilities for selection into any one of ten compartments and one machine is capable of handling and sorting 8,000 pins per hour. It is obviously very uneconomic to set up this machine for less than 100,000 resistors of the same basic value.

The next operation is to spray on to each end of the pin a thin coating of copper. The purpose of this operation is twofold, firstly to provide a good metallic connection for the end cap which is fitted subsequently and secondly by careful control of the axial length of spray to reduce the resistance value to that required. The amount of spray that can be tolerated is limited, however, by the voltage that the resistor will have to withstand, and pins having a resistance value considerably in excess of the target value are set aside against other demands for these higher values.

The pins are then graded again in the automatic sorting machine, all items which are outside the specified limits being set aside for other demands. Those pins that are within the required resistance range are now ready for assembly.

The Insulating Tubes.—The insulating tube that is to house the pin may be made of any good non-conducting material capable of

fabrication or machining to close limits and at the present stage of the art a ceramic material appears to be as good as any. The ohmic value of the finished resistor is indicated by its colour code, and it is convenient to paint the tube before assembly. The colour code internationally adopted is as follows:—

COLOUR CODE.

Number	Colour equivalent
0	Black
1	Brown
2	Red
3	Orange
4	Yellow
5	Green
6	Blue
7	Purple
8	Grey
9	White

Colour of Body == First significant figure.
 " " End ring = Second " "
 " " Centre = Number of noughts following second significant figure.

Resistance Tolerance Code.

± 5% Gold spot on one end.
 ± 10% No special marking.
 ± 20% Silver spot on one end.

As the insulating tube may be little more than 0.5 in. long it will be appreciated that the problem of applying a 3-colour code to it is no small one. As a result of continued development in this problem, however, machines have now been developed which do this automatically. The machines are similar in principle to those used in the spinning industry. In the present application the ceramic tubes are fed automatically on to rotating spindles which in turn are mounted upon a rotating table. Paint is sprayed

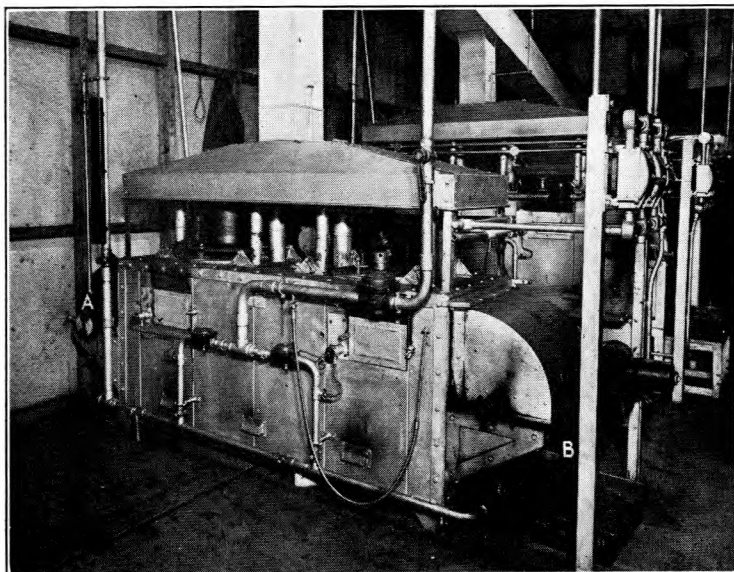

FIG. 3.—CONVEYORISING FURNACE.

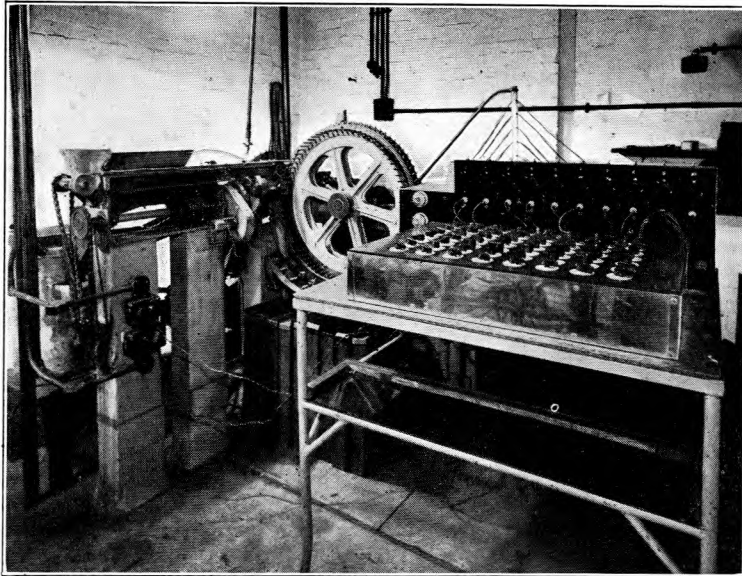

FIG. 4.—AUTOMATIC SORTING MACHINE.

on to the tubes from fixed positions so that the three colours can be applied during one revolution of the table. The tubes are removed from the table by pneumatic means dry and ready for assembly.

The third item in the assembly is the end cap and lead (Fig. 1). This consists of a spun brass cap fixed to a 2 in. length of tinned copper wire. It is made by "bumping up" the copper wire about $\frac{1}{16}$ in. from one end to form a shoulder. The brass cap is then threaded on to the wire against the shoulder and riveted over. The whole operation is performed automatically in one machine.

Assembly.—The next phase in the production is the assembly. A carbon pin is inserted in a tube and a cap with lead affixed pressed on to each end. The dimensions of the parts are chosen so that although the pin is a loose fit in the tube it is trapped in position by the brass caps. The assembled units are then fed on to a belt conveyor and each end in turn filled with a quick drying cement. The size of the conveyor is such that after one cycle of travel the cement is sufficiently dry to permit the assembly to be removed without damage. The assembly is then stored for a minimum of four hours for the cement to harden off. The complete assembly is then thoroughly dried off by baking in an oven for two hours at a temperature of about 100°C.

On removal from the oven the assemblies are vacuum impregnated with a suitable non-hygroscopic wax under a pressure of about 80 lbs. per sq. inch. It is interesting to note that in this operation the wax penetrates the ceramic tube and fills solid the space between the pin and tube. After cooling off every article is inspected and tested for resistance value.

Non-Insulated Type. (Fig. 5.)

The method of production of the carbon pin for this type of resistor is very similar to that for the

insulated type. The chief difference is that of physical dimensions and therefore of the proportions of the various grades of raw materials used in the original mix. The connection leads are automatically affixed to the pin by spinning $1\frac{1}{2}$ turns of approved soft tinned copper wire round each end of the pin which is then automatically fed through a resin flux and solder bath, which ensures a robust joint and good contact. The unit at this stage is inspected for freedom of excessive solder and then vacuum impregnated entirely in a similar way as for insulated units. As there is no insulating sleeve the colour code has to be painted directly on to the body of the resistor, using a resin bound paint to limit as far as possible humidity effect, but it will be evident from the foregoing that this type of resistor is less suitable than the insulated type for use in humid situations.

THE CARBON DEPOSIT TYPE.

The method of production of this type of resistor depends upon an entirely different principle from that used in the solid carbon rod type. As the name implies the process consists essentially of the deposit of a conducting medium upon a high grade insulating rod, and although several different manufacturing techniques may be employed they can all be classified broadly into the two following main groups:—

1. Cracked film type;
2. Synthetic coated type.

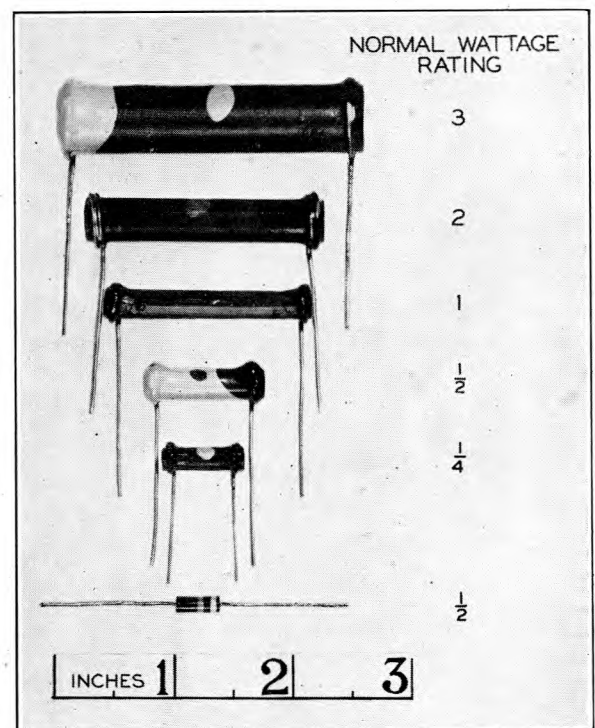

FIG. 5.—SOLID CARBON ROD RESISTORS (NON-INSULATED INCLUDING LATEST AXIAL TYPE)

Cracked Film Type.

One of the methods of production consists of feeding the insulating rod (usually ceramic) through a carburising furnace in a controlled atmosphere. The atmosphere might be a mixture of one of the hydro-carbon groups such as benzine and oxygen at an elevated temperature. This process allows the rods to become coated with a grey carbonaceous medium and the resistor so produced is known as a cracked carbon type, in view of the breakdown of the carburising vapours. The target of ohmic value of the unit so produced immediately after the furnace operation must always be lower than the required final ohmic value since subsequent operations allow for the cutting of spiral tracks of varying pitch which increase the length of the resistance track from one end of the tube to the other. Terminal connection is made usually by cap and connection lead in a similar way to that described earlier on the solid carbon rod types.

Synthetic Coated Type.

The process employed in the production of the synthetic coated type consists essentially of mixing prepared carbon blacks and other solutions in a wet form and the resultant "paint" is then applied to the insulating rod by spraying or dipping and baked at an even temperature. Adjustment of this film can be made by cutting spiral grooves as described above, but it also can be controlled within certain limits by variations in the basic coating material.

It is usual in both types to add an additional low resistance contact material to the ends of these resistors before making the cap connections to ensure a good contact to the terminals.

Both types of units are then painted for standard colour code or coated in a grey synthetic enamel with the resistance value stamped on the outside of the body.

GENERAL.

Stability.

Although a careful control on quality of production is exercised at all stages of manufacture, it must not be overlooked that the stability of the final product depends ultimately upon the contact resistance of carbon particles, which as all telephone engineers are aware from their experience with microphones and lightning arrestors, to mention only two examples, is inherently unstable. In view of the variations in voltage, temperature, and humidity in which these resistors are sometimes expected to operate it is essential to allow some margin to cover this inherent instability. Under ordinary working conditions it is fairly safe to assume that the drift from the manufactured value will not exceed 5%, but a 10% margin will cover all possible known and unknown variations.

Preferred Values.

It will be evident from the foregoing that the manufacturing processes involved lend themselves particularly to bulk production methods but these methods can be employed effectively only if the users of the resistors restrict their demands to a limited number of different values. As already stated the large majority of requirements are for use with thermionic valves where the resistance value is not at all critical. The use of an arbitrary range of resistance value therefore should not restrict unduly the communication engineer in the development of new circuits and facilities.

The Service Ministries and the Post Office have now agreed as a war time measure to three arbitrary ranges of resistance values and tolerances as detailed in the following table:—

PREFERRED LIST OF RESISTANCE VALUES.

± 20% Tolerance	± 10% Tolerance	± 5% Tolerance	
10	10	10	36
15	12	11	39
22	15	12	43
33	18	13	47
47	22	15	51
68	27	16	56
100	33	18	62
	39	20	68
etc. x10, 10 ²	47	22	75
10 ³ , 10 ⁴ , 10 ⁵ ,	56	24	82
	68	27	91
	82	30	100
	100	33	
	etc. x10, 10 ² ,	etc. x10, 10 ² ,	
	10 ³ , 10 ⁴ , 10 ⁵ ,	10 ³ , 10 ⁴ , 10 ⁵ ,	

The ± 20% tolerance range should cover nearly all normal requirements. Where intermediate values are essential the ± 10% tolerance range is available.

Manufacturers are also prepared to produce for special purposes resistance values in the ± 5% tolerance range but in these cases prior technical approval by the appropriate Supply Department design authority is necessary. The limitations of carbon resistors as regards stability should however be closely considered before resistors in this range are specified.

Conclusion.

In conclusion the author would like to record his thanks to Erie Resistor Ltd., the Mullard Wireless Service Co., Ltd., and the Morgan Crucible Co., Ltd., for kindly supplying information and illustrations.

Modifications to the Automatic Power Supply Changeover Equipment at King Edward Building Substation

J. B. MURRAY,
B.Sc. (Eng.) A.M.I.E.E.

U.D.C. 621.316.5 621.311.8 : 621.395.8

Difficulties experienced with the original change-over equipment are discussed and the new circuit is described. Some notes on the operation of oil circuit-breakers are included.

Introduction.

THE high voltage substation in King Edward building, London, which forms the intake point for the duplicate power supplies for various P.O. buildings and the P.O. (London) Railway, was described in an earlier article.¹ Briefly to recapitulate, the two supplies are led into the building at 11,000 V

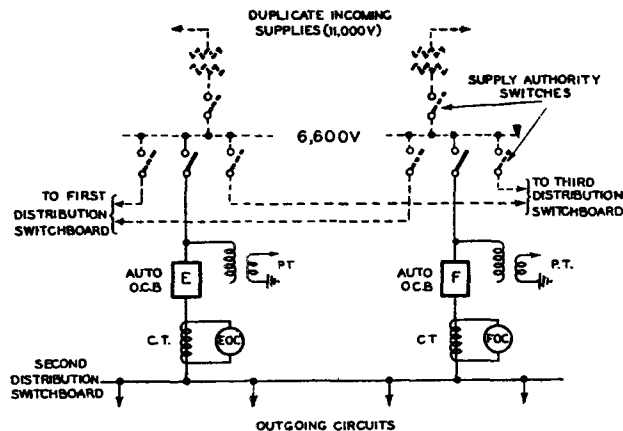

FIG. 1.—SCHEMATIC DIAGRAM OF MAIN POWER SUPPLY DISTRIBUTION.

and transformed to 6,600V by the Supply Authorities' equipment, and are metered and distributed over the P.O. feeders at the lower voltage. These feeders are supplied from three independent distribution switchboards, each of which can take its

supply synchronous machinery and the third static plant. This separation was made so that the time interval between the failure and the restoration of the supply could be suited to the different types of plant. For instance, the supply to the static equipment—which is for the most part lighting—can be restored as quickly as the circuit-breakers will operate, and in practice the delay is reduced to about 5 seconds. The two automatic oil circuit-breakers on each distribution board are solenoid-operated and interlocked mechanically and electrically so that only one can be closed at a time. The closing circuits are arranged so that in the event of the supply connected to the closed circuit-breaker failing, this circuit-breaker would be tripped and the other one would be closed after a predetermined time interval. This process is reversible and continues so long as at least one incoming supply is alive.

The Oil Circuit-Breakers.

In this present article the operation of the original operating circuit for these automatic oil circuit-breakers will be discussed, together with the considerations which led to this circuit being replaced by one with differing characteristics. Before this is done, however, a digression will be made to explain the operation of oil circuit-breaker mechanisms and the precautions that are necessary when they are adapted to solenoid operation. Fig. 2(a), (b) and (c) are single-line diagrams of a typical circuit-breaker mechanism and are intended to illustrate the mechanical details of the closing and tripping mechanisms.

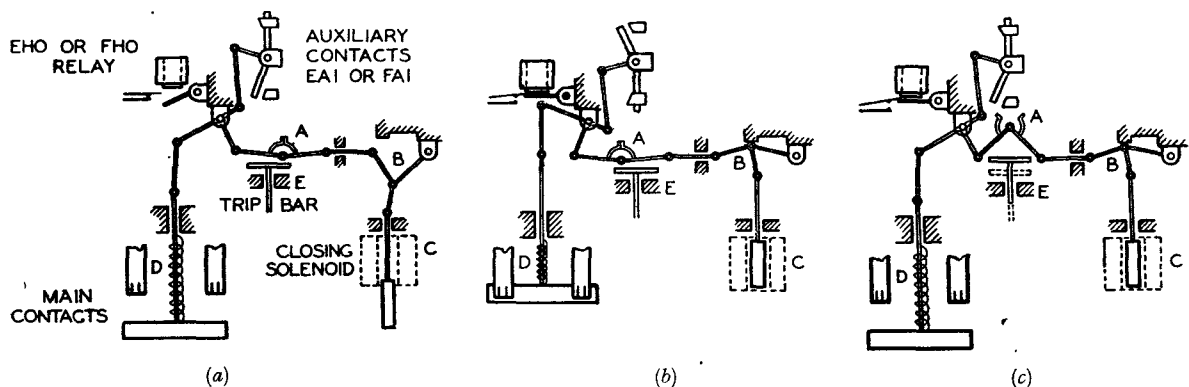

FIG. 2.—OPERATING MECHANISM OF OIL CIRCUIT-BREAKER (a) SET. (b) CLOSED. (c) TRIPPED.

supply from either of the incoming supplies via one of a pair of automatic oil circuit-breakers, as shown in Fig. 1. Two of the distribution switchboards

A and B are toggles which are held slightly over dead centre by projections on the two arms and by a fixed stop respectively.

Fig. 2(a) indicates the mechanism in the set position, i.e. main contacts open and toggle A in the rigid

¹P.O.E.E.J. Vol. 27 p. 225

position ready for closing. To close the circuit-breaker the solenoid C is energised. This lifts the plunger and moves toggle B over to the rigid position ; where it is held, as shown in Fig. 2(b), by the thrust of spring D. The mechanism is self-sustaining in this position, and there is therefore no necessity for the solenoid to remain energised. Its circuit is broken, as will be explained later, when the main contacts are in their fully closed position. When the trip bar E is raised to the position shown in Fig. 2(c) the toggle A is pushed over dead centre from its rigid position and is broken. The spring D is then unopposed and the main contacts return to the open position, Fig. 2(c). It will be observed that the raising of the trip bar E will break the toggle A even when the closing stroke is incomplete and irrespective of the position, in the closing stroke, that the mechanism may have reached. The mechanism is therefore defined as "trip free." When over-current tripping is required the trip bar is raised to the tripping position by a solenoid, energised either directly from current transformers in the main circuit or from a battery through contacts of a relay operated from these current transformers. Direct under-voltage tripping is obtained by energising a solenoid from a potential transformer and arranging that this solenoid restrains a spring or weight-operated device from raising the trip bar. When the mechanism has been tripped, as in Fig. 2(c), the retaining thrust is removed from toggle B. The closing solenoid plunger is thus allowed to drop to its original position and, providing the trip bar has returned to normal, the toggle A resets in its rigid position.

As stated above, the closing solenoid is de-energised when the main contacts are closed. This cannot be done by a simple auxiliary contact connected directly to the circuit-breaker and arranged to open on the last closing movement of the main contacts. The reason will be apparent if the sequence of events is considered when the closing solenoid is energised and a fault exists in the main circuit of sufficient magnitude to operate the tripping mechanism, or when for some reason toggle B fails to remain in the rigid position shown in Fig. 2(b). It will be seen that the solenoid will repeatedly close the circuit-breaker and will continue to do so until the mechanism or the main contacts break down. In the case where a fault existed, the result would probably be disastrous. The method adopted in the Reyrolle circuit-breakers that are used in this substation is shown diagrammatically in Fig. 2. Relay EHO or FHO has its winding energised when the closing solenoid is energised. The air gap of this relay is too great to allow sufficient flux to be produced to attract the armature when it is in its open position. When the circuit-breaker is closed, part of the mechanism is arranged to reduce mechanically this air gap so that the armature then pulls up and remains closed so long as relay EHO or FHO is energised. The contacts on this relay open the closing solenoid circuit without affecting the relay circuit, and thus if the circuit-breaker is

tripped while the closing solenoid circuit is still complete external to the circuit-breaker, it is not reclosed. A reference to the circuit diagram in Fig. 3, which will now be explained, will make this clear.

Automatic Change-over Circuit.

Fig. 3 is the diagram of the automatic change-over circuit that was originally installed and is drawn with the various contacts in the position they take up when

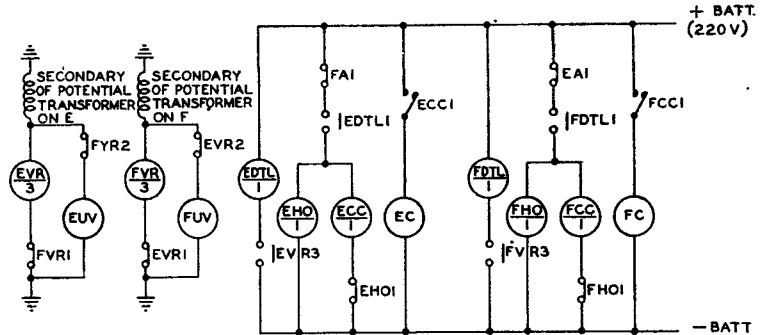

FIG. 3—SCHEMATIC DIAGRAM OF AUTOMATIC CHANGE-OVER CIRCUIT AS INSTALLED ORIGINALLY.

the relay coil is unenergised or the circuit-breaker is open.

The letter E or F included in the relay description indicates the circuit-breaker with which it is associated.

The overcurrent tripping of the circuit-breakers is by direct-acting solenoids with oil dash-pot time lags, and the wiring of these is not shown. The coils EUV and FUV are the direct acting under-voltage trips also fitted with oil dash-pot time lags. The relays EVR and FVR are connected in parallel with the EUV and FUV coils and operate without time lag, contacts on these relays being arranged as interlocks to ensure that only one VR relay and its associated UV coil can be energised at any one time. The relays EDTL and FDTL are of the induction disc type. They are fast to release and operate with a delay which is adjustable from 1 to 10 seconds or from 10 to 60 seconds according to the distribution switchboard concerned. These relays, which start to operate on the operation of EVR or FVR, are used to provide the time delay between the failure of one supply and the closing of the circuit-breaker on to the other supply. The completion of the operation of EDTL or FDTL operates the contactor ECC or FCC, which controls the heavy current circuit of the appropriate closing solenoid EC or FC. EA1 and FA1 are auxiliary contacts on the circuit-breakers (see Fig. 2) which in this circuit provide the electrical interlock to prevent both breakers being closed at the same time. The purpose of the relays EHO and FHO has already been explained. It will be noted that the contacts of these relays are, in practice, connected in the circuits of the auxiliary contactors and not in the main circuit of the closing solenoids, as was stated earlier. It will also be noted that when a voltage failure occurs the release of the VR and DTL relays on the closed circuit-breaker allows the HO relay to reset as soon as this circuit-breaker is tripped.

Circuit Limitations.

Experiences with this circuit indicated the following points :

(1) A voltage surge lasting up to about 2 seconds may operate the undervoltage releases on motor starters, etc., but it is unnecessary to change over the supplies for failures of this duration. Referring again to Fig. 3, it will be observed that, supposing circuit-breaker E to be closed, a voltage failure need last only while EVR releases and FVR operates—a period measured in milliseconds only—to ensure that the changeover takes place.

(2) The actual interval between the opening of one circuit-breaker and the closing of the other depends upon the difference between the timing periods of the DTL and UV relays. The timing mechanism of the latter is not of a type which admits of accurate setting, and cases have occurred in use when the UV timing period exceeded that of the DTL relay. Under these circumstances the incoming circuit-breaker was closed by the operation of contact A1 on the opening breaker and the changeover was instantaneous. As the two supplies were not in general in phase this usually resulted in a flash-over on the rotary convertors or other synchronous machinery when it occurred in conjunction with the circumstances stated under (1).

(3) The circuit arrangements are such that at no time is it safe to interfere with the VR relay on the open or the closed circuit-breaker without risk of tripping the latter, and maintenance of these relays was therefore extremely difficult.

(4) The occurrence of a fault in the zone protected by the automatic oil circuit-breakers, i.e. the busbars and connections of the distributing switchboards, would undoubtedly cause a voltage drop during the period taken for the circuit-breaker concerned to trip. The result of this would be that although the circuit-breaker would be tripped by the operation of its overcurrent release the voltage relay might also fall off and initiate the sequence of events for closing the other circuit-breaker, which would then close on to the fault, trip and probably initiate the reclosing of the first circuit-breaker. This process might continue until the voltage and currents surges set up tripped the backing-up circuit-breakers on the Supply Authority's switchboard.

Considerations in Redesign of Changeover Circuit.

The circumstances detailed under (4) above have never occurred in practice and those under the other headings have occurred only on rare occasions for the most part during the test operations which are made regularly at monthly intervals. However, since the whole object of installing the automatic apparatus was to ensure certainty of the changeover operations under all circumstances together with all possible safeguards for the continuity of this important supply, it was considered advisable to redesign the equipment to accord with more recent practice. Analysis of the circuit indicated that the troubles experienced under (1), (2) and (3) above were caused because the failure of the voltage on the potential transformer of the closed circuit-breaker actually initiated two separate sequences of operations—the first to trip the closed

circuit-breaker and the second to close the other—each of which proceeded independently of the other. The only safeguard being the auxiliary contacts EA1 and FA1, which ensured that only one circuit-breaker could be closed at a time. The basic circuit of the equipment was therefore modified to that shown in Fig. 4, from which it will be observed that the timing

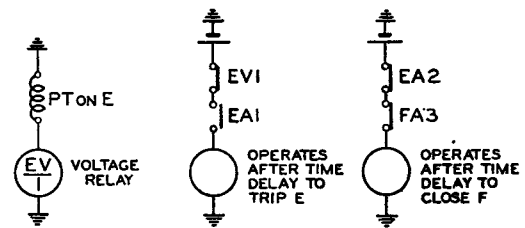

FIG. 4.—BASIC CIRCUITS OF REDESIGNED CHANGE-OVER EQUIPMENT.

period for the closing of the second circuit-breaker does not commence until the first circuit-breaker has completed its opening movement.

Direct operating overcurrent releases were replaced by a relay of the induction disc type, which gave overcurrent and earth leakage protection with an operation delay which had a definite minimum value and varied inversely with the magnitude of the current. This characteristic was required to give improved discrimination between the various circuit-breakers under fault conditions. This relay trips the circuit-breaker via a battery-operated solenoid. The same solenoid is used for tripping on under-voltage.

The other main points that were considered in redesigning the circuit were the following :—

- (a) For maintenance reasons all relays, except of course the voltage relay connected to the supply in use, should be safe to handle and operate at all times, except when changeover is taking place, without risk of tripping the circuit breaker.
- (b) As a corollary to (a) and as a measure of economy, all relays should as far as possible be unenergised in the normal state of the circuit.
- (c) Auxiliary contacts on the circuit-breakers are considerably more robust and are less likely to develop faults than the contacts of the best designed relays, and for this reason preference is given to the former throughout the circuit.
- (d) On no occasion is it necessary to trip or to close both circuit-breakers at the same time, and it is therefore possible to use one timing relay for each purpose which is common to both circuit-breakers. By doing this, two relays, which are of the induction disc type and comparatively costly, can be dispensed with on each switchboard.

Redesigned Changeover Circuit.

The circuit that was finally evolved is given in Fig. 5. EV and FV are the voltage relays connected to the appropriate potential transformers. They are fast in operation and arranged to release at about

65% of the nominal supply voltage and to operate at about 90%. EOC and FOC are the over-current and earth leakage relays. ET and FT are the solenoids which operate the tripping mechanisms of the relative circuit-breakers. EFL is fast to operate and is the lock-out relay which renders the circuit inoperative on operation of either OC relay. EFT and EFC are the relays for timing the tripping and closing operations of the two circuit-breakers E and F. They have the same characteristics as the EDTL and FDTL relays in Fig. 3. The remainder of the relays, etc., have the same function as in Fig. 3.

interlock which only allows one circuit-breaker to be closed at a time. Contact EV3 prevents FOC1 operating ET.

The operation of EOC by an over-current or earth leakage trips circuit-breaker E through ET by means of EOC1. At the same time EOC2 closes to operate EFL, which via EFL1 opens the circuit to EFC and prevents this latter relay operating when EA5 closes. Thus under these conditions, i.e. fault tripping, the automatic changeover does not take place until EOC is reset by hand.

The failure of the voltage of the supply to E causes

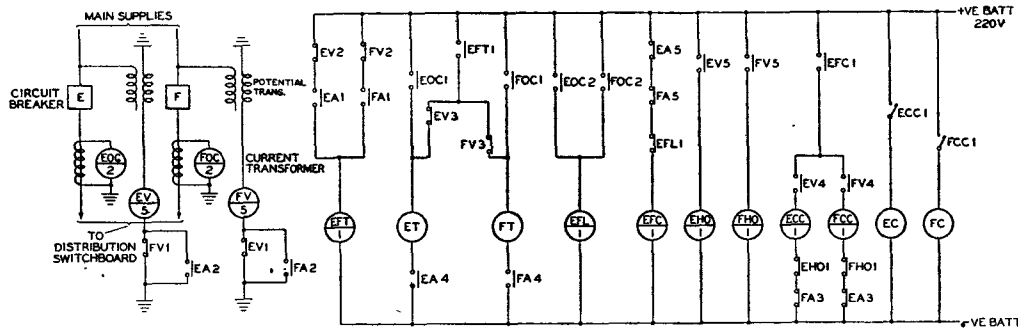

FIG. 5.—SCHEMATIC DIAGRAM OF REDESIGNED CHANGE-OVER CIRCUIT.

The operation of this circuit will now be described. Assume that initially the two circuit-breakers are open, that EOC, FOC and hence EFL are not operated and that there is no voltage on the two potential transformers, EFC will therefore be operated and EFC1 prepares the circuit for the operation of ECC or FCC. If the supply to the circuit-breaker E is now made alive EV will operate. EV4 will complete the operating circuit of ECC to energise EC via contact ECC1. EV5 energises EHO, which operates when circuit-breaker E closes. EV1 opens to prevent FV operating when the supply to circuit-breaker F is subsequently made alive. EV2 and EV3 open but are not effective at this point. The closing of circuit-breaker E operates the auxiliary contacts. It should be pointed out here that the normally open auxiliary contacts make before—and those normally closed, break after—the main contacts of the circuit-breaker make. EA1 prepares the circuit for the operation of EFT by EV2 when EV releases. EA2 short-circuits FV1 to prevent interference with EV by this contact. EA3 is an interlocking contact to prevent the energising of FCC by any means while circuit-breaker E is closed. EA4 prepares the tripping solenoid circuit and is included to prevent the continuous operation of ET after the circuit-breaker has tripped by the operation of EOC. EA5 opens to release EFC. It should be noted that with the circuit in this condition, as it normally is, all relays except EV are unoperated and that any relay can be operated manually without risk of tripping the closed circuit-breaker with the exception of EV and EOC, which are the controlling relays. The operation of FCC would not close circuit-breaker F, since as an additional safeguard there is a mechanical

EV to release. EV1 completes the circuit for FV, but at this stage the contacts of this relay do not affect the circuit. EV2 completes the circuit for EFT, which commences to time, and EV3 prepares the circuit for EFT1 to operate ET to trip circuit-breaker E. EV4 disconnects ECC from EFC1 and EV5 de-energises EHO, so that it will release when the circuit-breaker opens. Should the voltage on E be restored before EFT finishes its timing period EV reoperates, EFT is released and resets and the circuit resumes its normal state.

If the voltage on E is not restored EFT1 closes after a period which can be adjusted from 0-3 seconds and operates ET to trip the circuit-breaker. When it opens, EA2 opens the operating circuit of EV (since FV1 is now open). EA1 releases EFT, EA3 prepares the circuit for FCC and EA5 completes the circuit for EFC, which commences to time. After the timing period, which is adjustable from 1-10 or 10-60 seconds, EFC1 closes to complete the operating circuit for FCC, which energises FC via FCC1 to close the breaker. The circuit is now in its normal state again except that now the controls for circuit-breaker F are in operation instead of those for E.

Acknowledgments.

The author desires to acknowledge the assistance he has received from the engineering staff of the London Postal Region, who have been responsible for the operation of the plant described in this article and by whom the majority of the suggestions regarding the characteristics of the new circuit were made. The author also desires to acknowledge his indebtedness to Mr. G. H. Fowler, of the City of London Electric Lighting Co., Ltd., for his helpful advice.

Some Aspects of Crosstalk between Unbalanced Circuits

H. STANESBY, A.M.I.E.E., and
E. W. AYERS, B.Sc.

U.D.C. 621.395.8

The authors discuss certain aspects of crosstalk between unbalanced circuits carrying radio-frequency currents. Particular consideration is given to methods of terminating coaxial cables used for bay and panel wiring and to the influence of earth connections on crosstalk.

Introduction.

THERE are, of course, many factors which may contribute to crosstalk between high-frequency circuits. Although most of these potential sources of trouble are well understood and steps are taken to guard against them, this does not appear to apply where terminal and earth connections on unbalanced circuits are concerned. Most of the high-frequency crosstalk experienced when short lengths of light gauge coaxial cable are used for panel or bay wiring is due to the method of making the end connections rather than to the cable itself. There is, therefore, little point in substituting better cable, where trouble is found, unless care has already been taken to eliminate other sources of coupling. This article will describe some of the points that should be observed in making coaxial cable connections, with special reference to panel, bay and interbay wiring.

Preliminary Discussion.

Before describing some typical ways in which crosstalk can arise, it will perhaps be helpful to mention some facts about the high-frequency behaviour of coaxial cables and the circuits in which they may be used.

In a coaxial cable, the go and return currents in core and sheath respectively, behave, generally speaking, as if they attract each other. Without going into details, this may be attributed to the currents following paths which make the total

impedance a minimum. The result is that the go and return currents tend to flow on the outside of the core and the inside of the sheath, respectively, and the current distribution in the conductors is generally similar to that shown in Fig. 1 (a). If the sheath were a perfect conductor all the return current would flow on its inner surface, and the outside would remain an equipotential surface. In practice, even on the cables used for panel and bay wiring, this equipotential condition is approached very closely. As an illustration the voltage drop measured along the outside of the sheath of a length of such cable, for a given current I flowing inside the cable, is compared, below, with that across an ordinary tag, and in an earth return circuit in a steel mounting plate, carrying the same current I in each case.

TABLE I

Conductor	Relative Voltage Drop	
	100 kc/s	2 Mc/s
10 ft. of coaxial cable; sheath carrying return current:—		
With double-braided sheath	2	1
With single-braided sheath	32	.56
Tag (No. STA.36) commonly used for interpanel and interbay connections	7	126
Steel mounting plate, 19 ins. by 5¼ ins. by ½ in. connections on C/L, 18 ins. apart.	79	224

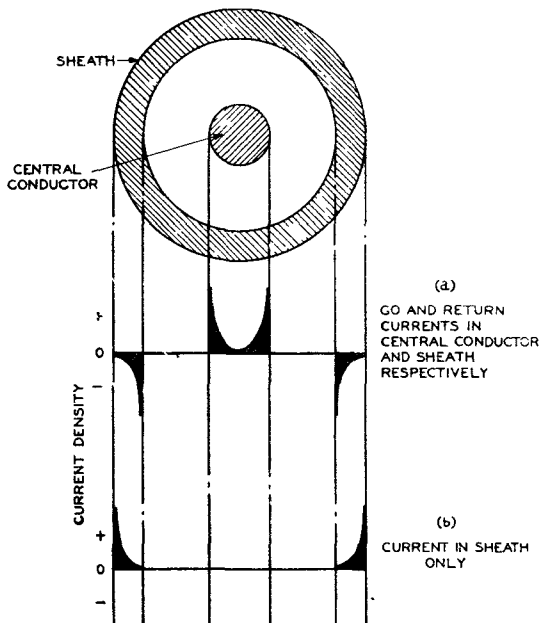

FIG. 1.—DISTRIBUTION OF CURRENT IN A COAXIAL CABLE.

It may be thought that the impedance of 10 ft. of cable sheath cannot possibly be less than that of a tag¹ or a mounting plate. This is quite true if the sheath alone is considered. But the reason for the small voltage drop along the outside of the cable sheath is that the current flowing in the sheath is a return current, equal and opposite to the go current in the core; it therefore flows almost entirely on the inside of the sheath. If the sheath current were due to a source connected to the two ends of the sheath, and there were therefore no equal and opposite current in the central conductor, the current would tend to flow on the outside as shown in Fig. 1 (b), instead of the inside, and the voltage drop on the outside of the sheath might well be 1,000 times as big.

When the central conductor of a length of coaxial cable is carrying high-frequency currents the return

¹ As normally used the inductance of a tag STA36, approximately 1¼ ins. by ⅝ ins. by ⅜ in. is of the order of 0.01 μH, nevertheless this has a reactance of more than 0.1 ohm at 2 Mc/s.

currents are constrained to flow back in the sheath even if an alternative, low impedance path is available. This is emphasised by the results obtained in the following experiment. A 30-yd. length of coaxial cable, the outer conductor of which was covered with insulating braid, was coiled on a drum. The effective inductance and resistance at one end were measured at 100 kc/s with the opposite end short-circuited. The two ends of the sheath were then placed in contact so that a direct path was available for the return current, and the measurements were repeated. The results are given below :—

TABLE 2

	Series Resistance	Inductance
Normal	2.17 ohms	12.9 μ H
Change with sheath shorted	<0.005 ohm	+0.002 μ H

It will be seen that the inductance and resistance values are substantially the same for both conditions, which indicates that the current path is not changed when opposite ends of the sheath are put directly in contact. At first sight it seems surprising that the return current should still flow in the sheath when there is an alternative path of virtually zero impedance. The reason why it does is that the current takes that path which makes the impedance of the *whole circuit* a minimum; when the current returns in the sheath the complete cable circuit is relatively non-inductive, whereas if it were to take the direct path the go current would still flow along the central conductor and the whole circuit would present a much larger inductive reactance.

The general remarks made on the tendency for the return current to flow on the inside of the sheath, and for the outside to remain an equipotential surface, apply equally to any screen which totally encloses the high potential side of a circuit. Screens will not often be referred to explicitly in subsequent parts of the article, but, in view of this similarity in behaviour, statements made in respect of cable sheaths can usually be taken to apply equally to screens.

Sources of Crosstalk.

Perhaps the most familiar causes of crosstalk are magnetic and electric coupling, i.e. inductive and capacitive coupling. It is not, however, proposed to discuss the more obvious ways in which such couplings can arise. Instead, attention will be drawn to crosstalk which results from part of an incidental voltage drop in one circuit being transferred to another via earth connections, panel returns, etc. It is not perhaps generally realised how insidious such crosstalk may be if proper precautions are not taken, and that it may occur between circuits which are not adjacent to each other.

It is nearly always desirable to tie the low potential side of an unbalanced circuit down by an earth connection at some point, as this provides a low impedance path to ground for unwanted longitudinal currents and prevents them from raising the potential

of the whole circuit. Although earthing an unbalanced circuit at both ends tends to increase certain types of crosstalk, it is usually more convenient to do this in practice. Unfortunately, the earthing of unbalanced circuits sometimes induces engineers to use single wire connections and earth or panel returns, with bad results where crosstalk is concerned. In considering the ways in which crosstalk may arise in practice, those conditions will be studied first where no earth return circuits are involved, either intentionally or otherwise.

Minimum Crosstalk Conditions.

Consider two independent unbalanced circuits, each comprising an unbroken length of coaxial cable connecting a source to a load and, to make the example clearer, let the cables follow roughly the same path. It will be assumed that the earth connections are taken directly to the cable sheath as

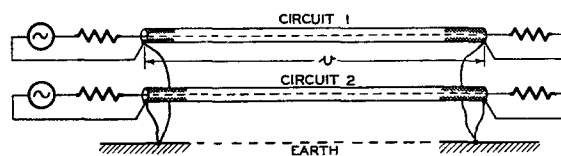

FIG. 2.—CABLE SHEATHS EARTHED DIRECT.

shown in Fig. 2. From what has already been written it should be clear that the return currents will be carried almost entirely on the insides of the appropriate cable sheaths. Consider what happens in circuit 1. With no earth connections a voltage drop of a certain value, although usually very small, will be developed along the outside of the outer conductor. When the earth connections are added this drop will not be reduced to zero, owing to the impedance of the earth system between the two connections. Part of the voltage drop that remains will be applied to the sheath of the second cable, via the common impedance between the earth connections of one cable and those of the other, and will give rise to a certain amount of crosstalk. These conditions—where the go and return paths are provided, respectively, by the inner and outer conductors of a coaxial cable, earth connections are made direct to the cable sheaths, and the sheaths themselves are uninterrupted—are those which yield least crosstalk.²

From this it appears that the common impedance between the earth connections of one circuit and those of the other is a source of coupling through which energy is transferred. Although it is not the only one it is normally by far the most important, and is an essential factor in all the crosstalk considered here. Some common impedance is inevitable when there are two earth connections to each circuit, and it becomes greater the more nearly the two circuits follow the same route. At the same time unnecessary common impedance, due to the use of very long earth wires shared by two or more circuits, should be avoided.

² The crosstalk can actually be made lower still by making only one earth connection to each cable sheath, but this is usually inconvenient, especially where circuit flexibility is desired.

Impedance in Series with Cable Sheath.

If the earth connections at either or both ends of a circuit are taken to points in the main current path separated from the ends of the cable sheath by a length of wire, or even a tag, crosstalk is likely to be much worse. Consider that this occurs in an

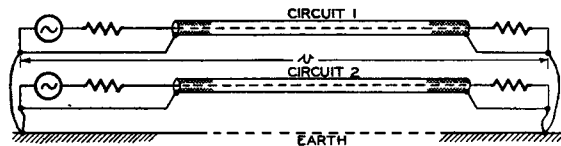

FIG. 3.—CABLE SHEATHS EARTHED VIA SERIES IMPEDANCES.

interfering circuit, as shown in Fig. 3. For a given return current the voltage drop between the earth connections will be greater than before, as the data quoted in Table 1 show, and the interfering E.M.F. introduced in a second circuit via the earth connections will be correspondingly increased. Reciprocity considerations show that crosstalk from the second circuit to the first will deteriorate to the same extent. A moment's thought will show that the use of wire or tags in the low potential return side of a circuit, between the points at which earth connections are made, will have a similar effect, no matter whether it be at the ends of a length of coaxial cable, between two lengths, or whether coaxial cable form part of the circuit or not.

Using the term "crosstalk" in a special sense, serious crosstalk may occur between different parts of the same circuit when big level differences are involved. A very simple case is illustrated in Fig. 4.

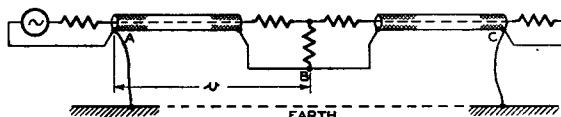

FIG. 4.—CROSSTALK DUE TO LARGE LEVEL DIFFERENCES.

A source is shown connected to a load via a high loss attenuator and, as usual, the circuit is earthed at each end. A voltage drop due to the return current in the input circuit will appear between the points A and B. Since C is joined to A via the earth connections, a voltage will appear between C and B and give rise to crosstalk in the low level part of the circuit. If a high gain repeater were substituted for the attenuator, crosstalk might well occur in the opposite direction.

To avoid crosstalk the unit at B should be enclosed in a metal screen and each return path, between the corresponding earth connection and the point at which the low potential sides of the input and output circuits are joined, should be made up of cable sheath and screen, which together totally enclose the high potential side of the circuit.

Earth Return Circuits.

Because the low potential side of an unbalanced circuit is usually at, or near, earth potential, there is a tendency to use earth return circuits in place of separate return conductors, especially in panel wiring. But unless special care is taken with them, earth returns should be avoided.

When earth returns are used in two or more circuits on the same panel there is a likelihood of spurious coupling because the return paths do not usually surround the corresponding go conductors completely, and so screen one from another.

Coaxial cable is often terminated on a tag block raised some distance from the mounting plate, and the shortest connection from panel to cable sheath is usually several inches long. When an earth return is used on the panel the connection will carry the main return current and the voltage drop along it will contribute, via the earth system, to the voltage developed across the low potential sides of other circuits. In other words the earth, i.e. panel, connection will be made at a point in the main circuit separated from the cable sheath by a short length of wire, which will cause crosstalk in the way described in the previous section. If earth returns cannot be eliminated the trouble may be mitigated by putting the cable sheath itself in direct contact with the panel. Even so the possibility of crosstalk within the panel will remain.

At times some return current is allowed to flow through an earth connection inadvertently. One such case is illustrated in

Fig. 5. The primary winding of an output transformer introduces a high impedance in the anode circuit of a valve; the secondary is connected to an unbalanced circuit earthed on one side. If there is appreciable capacitance between the

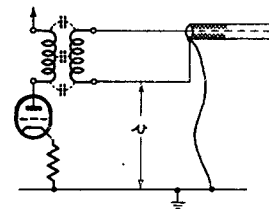

Fig. 5.—CIRCUIT CONDITION LIKELY TO GIVE RISE TO CROSSTALK.

high potential end of the primary winding and any part of the secondary, some of the high-frequency current in the anode circuit will flow through this capacitance, via part of the secondary winding and the earth connection, back to the cathode. The consequent voltage drop in the earth wire is likely to give rise to crosstalk, especially if this wire is used to earth several circuits. The trouble may be cured, or at any rate reduced, by: (a) putting the low potential side of the secondary circuit, namely the cable sheath, in direct contact with the mounting plate, or (b) using a capacitance screen between the primary and secondary windings.

Recommendations.

It is, of course, impracticable to describe all the ways in which crosstalk may arise if unbalanced circuit connections are not made correctly. It is possible, however, to mention several broad principles that should be observed if undue crosstalk is to be avoided:—

- (a) Earth return circuits should not be used; in other words each unbalanced circuit should be complete before earth connections are added.
- (b) As far as possible the low potential side should totally enclose and isolate the high potential side in all parts of an unbalanced circuit, especially between the points at which earth

connections are made. Where this cannot be arranged the go and return conductors should be run as close to each other as possible.

- (c) Common earth wires should not be used when crosstalk is to be reduced to the absolute minimum, especially when they may carry appreciable currents.
- (d) Where common earth wires are used they should be short.

Some practical methods of terminating coaxial cable connections, which conform with these principles, are shown in Fig. 6, with examples of methods that should be avoided. A way in which interpanel and interbay connections are often made is shown at (A). The method is bad, especially for interbay cables, which usually have earth connections on the units at each end. The interruption in the sheath allows a voltage drop to develop between the earth connections, and the external field around the tags may induce voltages directly in other circuits. A much better method, in which these shortcomings are nearly, but not quite, eliminated, is shown at (B). When the most stringent crosstalk requirements must be met the arrangement shown at (C) may be

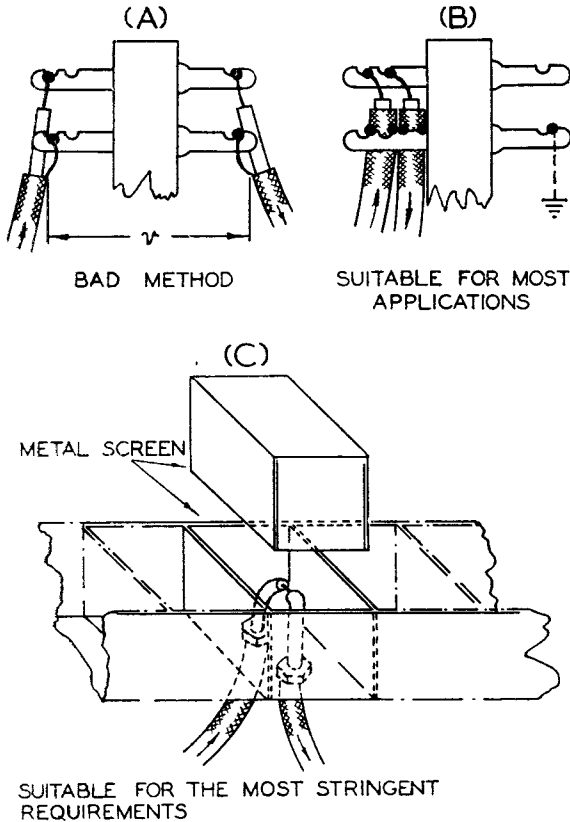

FIG. 6.—METHODS OF TERMINATING COAXIAL CABLES.

used. This is virtually perfect from the crosstalk point of view, but is rather more expensive.

To assess the crosstalk introduced by these three methods of connection, two short lengths of coaxial cable were laid side by side with the sheaths joined

together at each end. Joints were then introduced in the middle of each length of cable and the crosstalk was measured for each of the three methods of connection shown at (A), (B) and (C) in Fig. 6. For (A) and (B) the two pairs of tags carrying the connections were $\frac{11}{16}$ in. apart in a direction at right angles to the view shown.

The results are given in Table 3, with figures for crosstalk attenuation between two continuous 30 ft. lengths of cable.

TABLE 3

Condition	Crosstalk	
	100 kc/s	2 Mc/s
Two 30-ft. lengths of double-braided cable	db. 143	db. >170
With joints as at (A) Fig. 6 ..	84	60
" " " (B) " ..	115	73
" " " (C) " ..	>130	>130

Two other examples shown in Fig. 7 refer to interpanel connections only. One method, often used on panel tag blocks, is shown at (A). It has two weak points: a length of wire in the main circuit, between the earth connection and the cable sheath, and a panel return. Both of these undesirable features are absent in the example shown at (B). If there is a possibility of direct inductive or capacitive crosstalk within the panel itself, the internal connection from the tag block to transformer should also consist of coaxial cable, joined to the

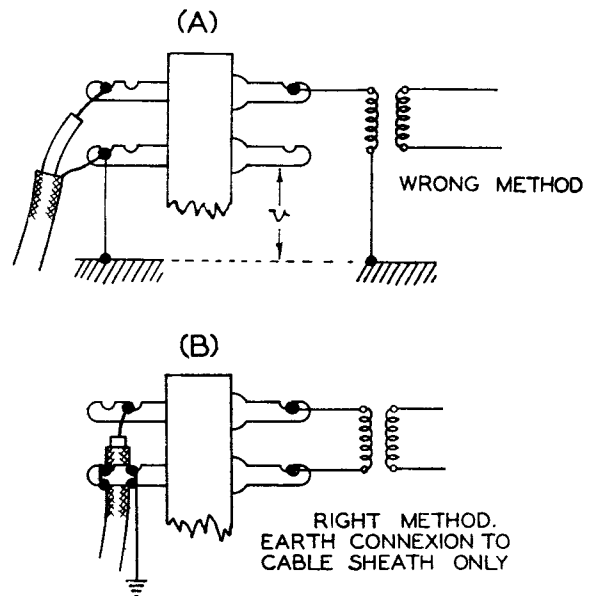

FIG. 7.—TERMINATING COAXIAL CABLES ON PANEL TAG BLOCKS.

external cable as shown in Fig. 6 (b). The free end of the tag carrying both cable sheaths could then be used for picking up an earth connection.

Simplified Method of Utilising the Single Mean "t" Test

A. H. MUMFORD, B.Sc.(Eng.), M.I.E.E

U.D.C. 519.2

A simplified method of applying the single mean "t" test is described which eliminates a large proportion of the arithmetical work normally associated with such a test.

Introduction.

A RECENT series of articles¹ in this JOURNAL introduced readers to the use of statistics in telecommunications engineering, but many may have been deterred from applying the methods owing to the tedious calculations which seem at first sight to be necessary.

In an application of particular interest to the writer the correct value was known for certain check observations, which the observer was required to make from time to time amongst his other normal observations, and the actual error of the checks was, therefore, readily computed. Testing the significance of small groups of these check observations by the single mean "t" test gave a measure of confidence with which to use the normal observations, for which the error was quite unknown and likely to remain unknown for an indefinite time. By this means the development of equipment faults and the tendency of certain observers to be biased in making their observations could be detected and checked at an early stage. This was a particularly valuable feature since the observer was called upon to exercise considerable judgment and discretion in making his observations, which had then to be combined with corresponding results from other observers before obtaining the required answer to the problem; considerable reliance had then to be placed in the accuracy of this answer.

The significance of the error of the check observation is assessed by determining a statistic t the value of which is given by the following equation :

$$t = \frac{\bar{x} - M}{s} (N - 1)^{\frac{1}{2}}$$

where \bar{x} = mean value of the sample.

M = mean value of the population.

s = standard deviation of the sample.

N = number of readings.

For the use under consideration this can be simplified to

$$t = \frac{\bar{y}}{s} (N - 1)^{\frac{1}{2}} \dots \dots \dots (1)$$

Where $\bar{y} = \bar{x} - M$ is the mean error.

Having determined the value of t it is then compared with tabulated values of t at the 5 per cent. and 1 per cent. probability levels for the particular value of N concerned.

Simple Method of Calculating \bar{y}/s .

Starting with the definition that the standard deviation $s = \left(\frac{\sum (y - \bar{y})^2}{N} \right)^{\frac{1}{2}}$ and expanding the

right-hand side of the equation :

$$s = \left[\frac{1}{N} \sum (y^2 - 2y(\bar{y}) + (\bar{y})^2) \right]^{\frac{1}{2}}$$

$$= \left[\frac{\sum (y^2)}{N} - 2(\bar{y}) \frac{\sum (y)}{N} + (\bar{y})^2 \right]^{\frac{1}{2}}$$

Since $\bar{y} = \frac{\sum (y)}{N}$ the equation reduces to the simple form

$$s = \left[\frac{\sum (y^2)}{N} - \left(\frac{\sum (y)}{N} \right)^2 \right]^{\frac{1}{2}}$$

which can be easily evaluated numerically and does not involve summing the squares of a number of differences. Alternatively the equation may be re-written :

$$s = \frac{1}{N} \left[N \sum (y^2) - (\sum (y))^2 \right]^{\frac{1}{2}} \dots \dots \dots (2)$$

An obvious way of setting out this computation is to arrange all the errors in columns, thus :

Error	writing alongside	Square of the error
y_1		y_1^2
y_2	"	y_2^2
y_3	"	y_3^2
y_n	"	y_n^2
$\sum (y)$		$\sum (y)^2$

giving the values of $\sum (y)$ and $\sum (y)^2$ required for equation (2). It may be noted that this table can be prepared concurrently with the taking of the observations, if necessary, since the mean value \bar{y} of the complete series is not required.

$$\text{Then } \frac{\bar{y}}{s} = \frac{\sum (y)}{Ns}$$

Substituting the value of s from equation (2)

$$\frac{\bar{y}}{s} = \frac{\sum (y)}{N} \cdot \frac{N}{[N \sum (y^2) - (\sum (y))^2]^{\frac{1}{2}}}$$

$$= \left[N \cdot \frac{\sum (y^2)}{(\sum (y))^2} - 1 \right]^{-\frac{1}{2}} \dots \dots \dots (3)$$

Simplification of the Application of the Test.

In the original article the statistic t is then determined by multiplying the value of \bar{y}/s by $(N - 1)^{\frac{1}{2}}$.

¹ P.O.E.E.J., Vol. 34, pp. 36, 79, 139 & 173.

If the value of t so computed is :

- (1) less than the tabulated 5 per cent. figure, i.e. $P(|t| > t) \geq 0.05$ then the readings are considered not significant ;
- (2) between the tabulated 1 per cent. and 5 per cent figures, i.e. $P(|t| > t) \geq 0.01$ and < 0.05 , then the readings are significant ;
- (3) greater than the tabulated 1 per cent. figure, i.e. $P(|t| > t) < 0.01$, the readings are highly significant and need immediate examination.

If, however, the calculation of the statistic t is to become a routine procedure it is worth while minimising the arithmetical labour involved in each analysis and an obvious simplification can be made if the table is rearranged to show the value of

$\frac{t}{(N-1)^{\frac{1}{2}}}$ i.e. $\frac{\bar{y}}{s}$ instead of t for the two probability levels, since this will eliminate the necessity of determining $(N-1)^{\frac{1}{2}}$ for each series of observations and multiplying it by $\frac{\bar{y}}{s}$. Further savings can be effected as follows :

A division can be avoided by tabulating $\frac{(N-1)^{\frac{1}{2}}}{t}$, i.e. $\frac{s}{\bar{y}}$ instead of t , since $\frac{s}{\bar{y}} = \left[N \frac{(\sum y)^2}{(\sum y^2)} - 1 \right]^{\frac{1}{2}}$ and further processes avoided each time by tabulating $\frac{N-1}{t^2}$ i.e. $\left(\frac{s}{\bar{y}}\right)^2$, since $\left(\frac{s}{\bar{y}}\right)^2 = \left[N \frac{\sum (y^2)}{(\sum y)^2} - 1 \right]$; by tabulating $\frac{N-1}{t^2} + 1$, i.e. $\left(\frac{s}{\bar{y}}\right)^2 + 1$, since this is given by $N \frac{(\sum y)^2}{(\sum y^2)}$, and finally by tabulating $\left(1 - \frac{1}{N}\right) \frac{1}{t^2} + \frac{1}{N}$ i.e. $\frac{1}{N} \left[\left(\frac{s}{\bar{y}}\right)^2 + 1 \right]$ which is given

by the simple expression $\frac{\sum (y^2)}{(\sum y)^2}$, since both numerator and denominator may be simply derived, as described earlier. A table giving the value of this expression for the probability levels of 1 per cent. and 5 per cent. for various values of N has therefore been prepared and is given in Table 1.

TABLE 1.

Values of $\frac{\sum (y^2)}{(\sum y)^2}$ for probability levels of 1 per cent. and 5 per cent.

N	5%	1%	N	5%	1%
2	0.5031	0.5001	26	0.2651	0.1623
3	0.3694	0.3401	27	0.2649	0.1617
4	0.3241	0.2720	28	0.2647	0.1613
5	0.3038	0.2377	29	0.2647	0.1610
6	0.2927	0.2179	30	0.2645	0.1606
7	0.2860	0.2052	31	0.2643	0.1602
8	0.2814	0.1965	35	0.2643	0.1595
9	0.2783	0.1801	40	0.2637	0.1584
10	0.2759	0.1852	45	0.2633	0.1574
11	0.2741	0.1814	50	0.2631	0.1567
12	0.2726	0.1784	60	0.2625	0.1556
13	0.2713	0.1758	70	0.2622	0.1549
14	0.2705	0.1738	80	0.2619	0.1544
15	0.2695	0.1720	90	0.2616	0.1539
16	0.2690	0.1704	100	0.2615	0.1536
17	0.2682	0.1691	125	0.2613	0.1530
18	0.2677	0.1680	150	0.2611	0.1526
19	0.2673	0.1670	200	0.2609	0.1521
20	0.2669	0.1661	300	0.2607	0.1517
21	0.2665	0.1653	400	0.2606	0.1514
22	0.2661	0.1646	500	0.2605	0.1512
23	0.2659	0.1639	1,000	0.2605	0.1510
24	0.2655	0.1633	10,000	0.2601	0.1505
25	0.2654	0.1627	∞	0.2603	0.1507

NOTE :—If computed value is *greater* than tabulated 5 per cent. value the case is not significant.

If computed value is *less* than tabulated 1 per cent. value the case is highly significant.

Conclusion.

The data given in the above table has also been plotted in Fig. 1, and most engineers will find it easier to use this drawing in determining the degree of significance to be attached to the observations being analysed and sufficiently accurate for their purpose. It will doubtless be agreed that the procedure outlined in this article removes much of the drudgery formerly attached to the use of this particular statistic, although still enabling the standard deviation to be derived quite readily from the expressions utilised. It is believed that similar simple methods may well be derived for many of the other tests described in the original article.

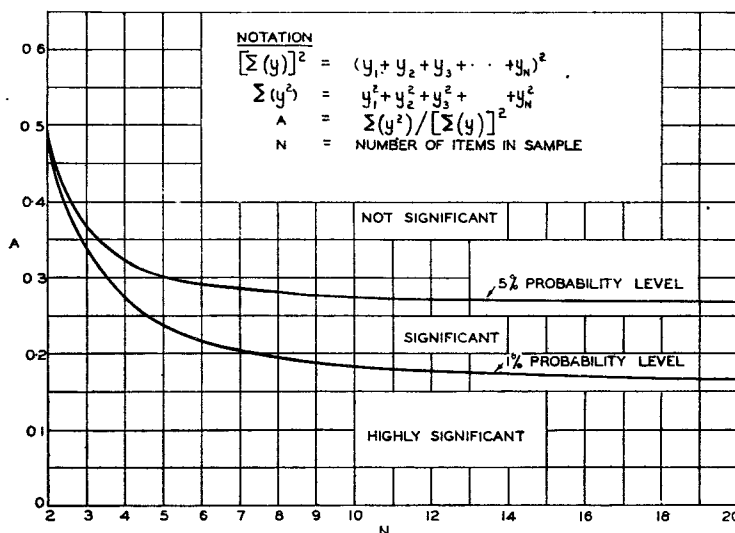

FIG. 1.—SINGLE MEAN "t" TEST PROBABILITY CHART FOR 5% AND 1% LEVELS

Air Raid Damage to Post Office Telecommunications

E. C. BAKER

U.D.C. 623.45 : 621.395.722 621.315.68

Part III.—The Second Great Fire of London

In this third article of the series dealing with air raid damage to Post Office telecommunications the author describes the damage caused by the fire following the raid on London on December 29th, 1940. In this fire considerable damage was caused to the important Wood Street building, and the author describes the methods adopted to restore service.

Introduction.

"THE fire . . . appeared more and more, and in corners and upon steeples, and between churches and houses, so far as we could see up the hill of the City, in a most horrid malicious bloody flame . . ."

Samuel Pepys might well have been writing of the second great fire of London on the 29th December, 1940, 274 years later. On that night within a few minutes of the "imminent danger" signal at 6.20 p.m. incendiary bombs were falling on the City. More than a hundred German planes, we are told officially, showered incendiary bombs on the crowded centre of the City for just over three hours. About 1,500 fires were started and were fanned by a strong south-west wind. In a short time some of these developed into conflagrations which burned out six sections and, in addition, caused sixteen major fires, in one of which the Central Telegraph Office was involved. The greatest of the six conflagrations covered half a square mile in the Moorgate-Aldersgate Street area, which remains to-day the largest area of air-raid destruction in all Britain. It was here that Post Office telecommunications plant suffered its most severe blow of the war. For in this area was the large modern steel-framed Wood Street building, containing three automatic exchanges (London Wall, Metropolitan and National) serving that part of the City, as well as the Headquarters P.A.B.X. and hundreds of repeaters for circuits passing through to terminate at Faraday Building.

Damage to the Wood Street Building.

Incendiary bombs which fell on the Wood Street building were extinguished by members of the engineering staff on duty, who used fire-hoses to prevent fire jumping across from an adjoining building, while others played their hoses on the doors at ground floor level. Before long the water pressure fell off. By that time the public power supply and the emergency supply had failed, so that it was impossible to use the power-driven "booster" pump to increase the pressure.

Just before seven o'clock the blast from a nearby H.E. bomb blew in doors, window shutters and screens; fire embers swirled in through these openings and the staff had to patrol the building to stamp out the small fires

started by the rain of embers. While the engineering staff were thus occupied the operating staff were handling emergency calls in the shelter switchboard; the overflow being answered by an engineer in the switchroom on the sixth floor, which was rapidly becoming untenable through heat and smoke. Outside the building the fire was becoming fiercer, and all the surrounding buildings were well alight. It was clear that the staff could not hold on much longer. At 10 p.m. Police and Fire Brigade officers ordered everyone out of the building. The only exit then available was through a small well at the rear of the building.

Four engineers remained with three members of the London Fire Brigade to continue their efforts to save the building. For a further two hours they fought (without water, for the supply had failed altogether) outbreaks of fire until, at about 12.30 a.m., the chief officer of the Fire Brigade withdrew his men and abandoned the building. Attempts later by members of the Area Control to re-enter were prevented by burnt-out buildings collapsing across the streets, and it was manifest that the Fire Brigade could not be asked to undertake the suicidal risk of approaching the building.

The fire raged throughout the next day, thus making impossible a complete survey of the building until December 31st, when it was found that the only plant to escape complete destruction was the repeater



FIG. 1.—I.D.F. GENERAL VIEW OF DAMAGE.

equipment and batteries on the ground floor and the power plant on the first floor.

Diversion of Circuits.

The Ministry of Works advised that the steelwork of the building was sound, subject to an examination of the structural bolts, but that extensive repairs would be necessary on the upper floors. To install

be constructed in a long straight run. The wooden floor was stripped and the machine beds levelled off after the four machines had been removed. Each machine weighed 14 tons, and as the gantry did not appear to be safe they were taken to pieces and the load distributed over the floor. The cables were found to be undamaged at the first floor level, except for 20 which were soaked with water from the floor above.

One of the greatest difficulties met with in the early stages of restoration was the torrent of water pouring into the cable chamber and tunnel. There were many fractured water pipes in the vicinity, and the basements of the wrecked buildings all round were flooded. After the water supply had been cut off, the water level in these basements was lowered with Post Office pumps. Water continued to pour into the cable tunnel through the cement grouting holes in the segments of the tunnel casing. These were temporarily plugged with lead wool. It was then possible to descend the slope from the cable chamber when 4 ft. of water was found in the horizontal portion of the tunnel about 40 ft. below the road surface: here submersible pumps were brought into operation.

Arrangements were made with the Regional Commissioner for a Company of the Pioneer Corps to clear debris from the streets, and demolish dangerous ruins, to enable vehicles to reach the building. A party of them also assisted to remove the ruined equipment from the building. At this time was to be seen the bizarre sight of these soldiers manhandling the burnt-out equipment, the metal of which had sagged, collapsed and melted under the intense heat, and pitching it through the vacant windows. They removed over 500 tons of scrap metal to clear the four



FIG. 2.—SELECTOR RACKS. THIRD FLOOR.

complete new equipment, after clearing away the tangle of damaged apparatus (Figs. 1, 2 and 3), was out of the question if an early restoration of service was to be achieved. It was, therefore, arranged to give service from other exchanges connected by junction cable to the building and to run new cables to two manual exchanges that it was proposed to bring into service. To do this it was necessary to construct a main distribution frame on which to terminate the 60 cables entering the building. To avoid re-arranging these in the cable chamber—a lengthy job—the junction cables were to be terminated on both sides of the central section of the frame, and subscribers' cables on both sides of the end sections.

The cables enter the building by way of a tunnel and manhole in the street outside, and are carried in steel pipes up the wall of the battery and test rooms on the ground and first floors, to be terminated on solid plugs on the second and third floors, where the original main frames were situated. These cables were burned out above the second floor level. The new main frame had to be installed on the first floor in the testing and service observation rooms and in the power room, the dividing walls of which were removed to enable the main frame to



FIG. 3.—AUTO-MANUAL SWITCH ROOM. SIXTH FLOOR.

upper floors preparatory to making the building weather-proof and habitable.

It was obvious from the devastation all around that a large percentage of the 14,099 direct exchange lines which had terminated in the building prior to the fire would not be required. A detailed survey by members of the L.T.R. Sales Division showed that two-thirds only of these lines would be necessary in future. It was found, too, that they could all be transferred to other exchanges. An examination of the spare equipment at five exchanges connected by junction cables to the building disclosed that about 3,000 subscribers could be accommodated by them without utilising more than three quarters of their spare plant. The old Clerkenwell manual exchange—from which the equipment had not been removed, although it was taken out of service when the new automatic exchange for that area was opened—was fortunately available, and it was planned to transfer 4,500 subscribers to this exchange, to which four full-sized cables had to be laid to enable this to be done. This exchange was renamed "Kelvin."

It was also planned to connect all London Wall subscribers to spare equipment at Avenue exchange. Here, outgoing equipment was to be made common to Avenue and London Wall, but incoming traffic would be directed to either exchange as appropriate. There were insufficient cable pairs from the Wood Street building to transfer all the London Wall subscribers, so three 1,000-pair cables were laid from Avenue to a distribution frame at Salisbury House, which had served as an intermediate frame for the Wood Street exchanges. These new cables made it unnecessary to take London Wall subscribers' circuits to Wood Street.

To restore service to Headquarters Exchange the existing Federal lines there (which passed through Wood Street) were diverted and additional extensions provided so that within two or three days there were 100 of these lines working. At the same time it was decided to install a P.B.X. in Headquarters building of 25 P.M.B.X.1 A positions. By January 10th three positions with about 50 extensions were in service.

Method of Restoring Service.

To connect the subscribers' cables to the junction cables and the new cables, by which these were to be extended to the relieving exchanges, was a straightforward task! This work had, however, to be organised and co-ordinated to complete it in the shortest possible time. With such extensive damage to subscribers' premises the arrangement of changed number schedules and the allocation of junction pairs on which subscribers' lines were to be extended to new exchanges constituted a difficult problem, as did the provision of power leads, ringing leads, through private wires, through junction circuits, extensions, and new subscribers' lines. The arrangement finally decided upon to ensure the restoration of all these circuits was necessarily intricate.

It is interesting to see how these conditions were met. In the first place two records of the subscribers on the Wood Street exchanges at the date of the fire were available—the fault cards, and the cable and D.P.

cards. It had to be decided which gave the more accurate basis on which to build the complicated operation of subscribers' line transfer. In an area such as the City, where the "pairs changed over" work both for new lines and fault diversions had been heavy for many years, it was considered that the fault record was the more likely to be accurate as each pair changed-over meant the provision of another jumper by the exchange staff, and a more or less automatic amendment to the fault card. The amendments to the cable records, on the other hand, were likely to be correct where the change-over had been initiated by the Installation Office staff, which was responsible for these records, but less accurate where diversions due to faults were made by the maintenance staff since the amendments to the cable and D.P. records were dependent upon the circulation of the appropriate advices from the jointer to the installation officers. The fault cards possessed the added advantage of a record of the apparatus fitted at the subscribers' premises—information required for changed-number allocations.

The particulars of the subscriber's name and address, telephone number, type of installation and cable-pair number on each fault card were therefore copied on to individual dockets, together with other relevant details, such as the number of lines in a P.B.X. group. These dockets were then sorted into cable order and finally into cable pair order. At the same time a survey of the Area was made and all destroyed premises recorded. A list of the lines in these premises was obtained from the street directory at Directory Inquiry and dockets relating to these lines withdrawn.

A cable schedule was prepared from the remaining dockets, the old number, name and address of each subscriber being entered opposite the relative cable pair, together with other relative particulars such as P.B.X. with additional lines, and the type of equipment. The new number allocated to each subscriber was then entered into the appropriate column. The spare equipment position at each exchange of P.B.X. groups, barred trunks and the like, had to be carefully examined.

The line resistance of the most distant pair on each subscriber's cable plus the junction pair resistance to each gaining exchange was computed and with Kelvin (where the permissible exchange loop resistance was likely to be exceeded by certain combinations of junction pairs with some types of subscribers' apparatus) arrangements were made for all single instruments, Plan Nos. other than 5, 5A, 7, 7A and all cordless boards to be extended to Kelvin from Wood Street on $6\frac{1}{2}$ lb. conductors, Plan Nos. 5, 5A, 7 and 7A, all switchboards $\frac{5+20}{50}$ and upwards on 10 lb. conductors and all circuits routed via Salisbury House to Wood Street and then to Kelvin on 20 lb. conductors to give the best possible transmission conditions.

These cable schedules were then passed to the engineering division to insert private wire and power lead particulars against the pairs allocated for these purposes, this information being obtained from the

private wire and power lead cards. Next, junction cable pairs to the gaining exchanges were inserted on the schedules and copies made for each gaining exchange of the entries relating to the particular exchange.

On receipt of these cable schedules at the outlying exchanges the local staff prepared jumper schedules. At the same time jumper schedules were issued to the Wood Street staff and a cable-tick record was prepared and held at Wood Street. On this record telephone advices of the running of the jumpers at Wood Street and at the gaining exchanges were recorded as were the clears.

The gaining exchange referred all faulty circuits back to Wood Street; here the external staff was advised, if necessary, as was the staff dealing with the cable-tick record. Clears were reported to the gaining exchange and to the cable-tick record. "O.K. Can't Get" cases were reported by the gaining exchange engineering staff to the traffic staff, who called the circuit for one day, and if still unable to obtain a reply arranged for a visit to be made. The traffic staff allocating new exchange numbers also prepared exchange numerical cards and forwarded them to the traffic staff at gaining exchange at the same time as the cable schedules were sent to the Wood Street staff; this facilitated a daily check between the test desk and the exchange numerical records of the gaining exchange.

Wood Street dealt with through junctions and private wires in their entirety, advising the controlling exchange, prepared jumper schedules and proved private wires through. The controlling exchanges reported to Wood Street when clears had been received, and from there the Area Office was advised.

Cessations notified by subscribers before circuits had been restored caused difficulties, as did the fact that premises which had not been notified or recorded in the surveys had been destroyed. Cessation advices to the Sales Office were passed to the traffic staff allocating new exchange numbers, who passed the information right through the organisation to keep the records up to date. In the same way bombed-out premises found by engineering staff were reported to the exchange number allocation staff and that information transmitted throughout the organisation, a bombed-out or ceased-service subscriber being treated as a clear. Cessations received after a circuit had been restored were dealt with in the normal way by the exchange on which the line terminated and were not, of course, carried into the restoration figures.

As a final overall check a multiple card was prepared by the traffic staff from the exchange equipment schedules, every number having the pencil number of the line allocated to it, a spare pair or "directory barred" entered against it. As the exchange gave advice of the restoration of subscribers' lines these pencil numbers were converted into ink entries. When the work was completed these cards were carefully examined and any remaining pencil entries investigated.

Restoration Work.

To undertake all the engineering work in the area a large staff had to be brought in. It was found

impossible for these men to obtain food locally. They also found it difficult to bring food from home, particularly those on 12-hour shifts who were on loan from the provinces. The workmen's canteen in the building was enlarged to enable it to provide at least one hot meal a day, and cold meals as required, for all the men working in the building. No gas, of course, was available, so electric cookers were installed. The Metropolitan Water Board supplied water by a temporary main through some devastated buildings. Facilities to buy rationed foodstuffs were obtained with the help of the Regional Commissioner. The canteen was kept open for 24 hours a day and served about 5,000 meals a week. To meet the needs of the jointers working outside in the manholes the London County Council readily granted the loan of a mobile canteen. This was manned by Post Office staff and handed over to the workmen's canteen committee. From this canteen jointers were able to buy hot tea and a variety of snacks quite cheaply. Because of the difficulty of travelling during the black-out, sleeping accommodation was found in the building refuge for about 50 men.

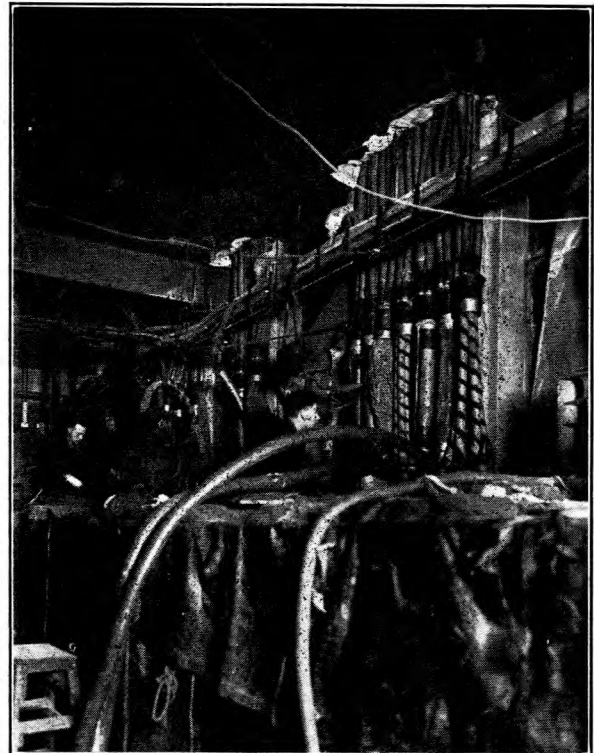

FIG. 4.—PREPARATION OF CABLE TAILS IN BATTERY ROOM BELOW M.D.F.

Jointing on the new cables being laid was carried throughout the 24 hours, volunteers undertaking the work in the streets during black-out. Within the building, to employ the maximum of men on jointing at any one time, the work was split between the main frame room and the battery room immediately below. (Fig. 4.) For a time jointers were also working in the cable chamber below that, renewing lengths of the 20 cables that had been damaged by water. Stages

were erected on both sides of the main frame to enable the internal staff to work in two decks tagging "silk and wools" to fuse mountings.

Later, when jumpering became necessary and the numbering-out of most of the cables had been completed, the bulk of the jointers re-made and pieced out joints in the streets during the day to leave the main frame as free as possible for the internal staffs tagging and jumpering. During the night the jointers were there in force jointing silk and wool terminations at the back of the frame while the internal staff worked, as far as possible, on the other side of the frame.

To speed up restoration work more jointers were borrowed from the provinces. These men were all given sleeping accommodation in the refuge of the building. Experience showed that care was necessary when forming jointing units from them if more than one pair was to work in co-operation. To have a Welsh pair at one end of the cable and a Highland pair at the other tended to slow down such work as numbering circuits. Slight differences in method seemed to add to the effect of dialect difficulties. The difficulties were not so noticeable when either pair worked opposite a London pair.

Speed of completion.

Service for some of the more important subscribers was arranged by temporary circuit diversions at the earliest possible moment. Telephone bureaux (Fig. 5) were opened for the general public. The first two were brought into service on January 9th, in Cheapside and Moorgate Street, with 50 telephones in each.



FIG. 5.—EMERGENCY TELEPHONE BUREAUX.

By January 21st service had been restored to 700 subscribers, 126 power leads, 65 private wires, and 204 extensions on the new Headquarters P.B.X. On the following day Kelvin Exchange was opened with 30 subscribers, the installation of the first of the new cables being practically completed. A tie cable between Kelvin and Clerkenwell main frames and spare pairs on Clerkenwell junction cables gave a nucleus of 150 junctions with which to begin.

By March 25th the work of service restoration had progressed to the following extent:—

D.E.L.s jumpered	9,077
" cleared	8,039
Faults	453
" O.K. Can't Get "	67
D.E.L.s awaiting cessation Advice Notes..	518

The faults remaining were all due to premises having been destroyed or vacated.

The total amount of work carried out is indicated by the following figures:—

Miles of new maximum size cable laid in the streets	7.3
Wet cables replaced in the building—yds.	776
Number of joints made in main cables ..	235
Number of pairs of wires jointed in cables	250,000
Number of pairs of wires tagged and jointed on main frame.. .. .	88,000
Number of jumpers run	23,000
Number of soldered jumper joints—about	100,000
Miles of jumper wire used—about	300

In the last of his reports on this work the Deputy Director of the London Telecommunications Region, Mr. R. G. de Wardt, paid tribute to the excellent work, often in dangerous circumstances, of all the staff engaged on the restoration. He felt that their attitude to this work was clearly expressed by a South Wales jointer to whom he spoke on the day that the jointer was returning home. "This is the biggest job I've ever been on, and I've never worked harder," said the jointer, "living has been hard, with none of the comforts that I have at home, but I wouldn't have missed the job for anything. To finish it in the time has been a man's job."

The Restoration of Telephone Apparatus affected by Enemy Action

C. E. RICHARDS, F.I.C. and
D. W. GLOVER, M.Sc., F.I.C.

Several methods are described for restoring telephone apparatus which, though mechanically undamaged, has been rendered useless by dirt or water.

U.D.C. 621.395.65 : 623.45 : 6.004.6

Introduction.

ONE of the urgent problems which arose during the heavy bombing of 1940-41 was the rapid restoration or recovery of exchange apparatus which, although mechanically sound, had been rendered useless owing to either or both of the following causes :

- (1) Mechanical clogging of moving parts by dust due to nearby bomb-bursts.
- (2) Mechanical clogging and low insulation resistance due to the formation of corrosion products between live springs, contacts tags, etc., following wetting.

The methods described below have been devised and in some cases successfully applied to the clearing

reasonably cleaned by using brushes dipped in paraffin oil, this was a very tedious operation and would have taken many weeks to complete. An ordinary hand spray of the "Flit" type was then tried, and gave such encouraging results that two inexpensive foot-operated spray guns (such as are used for spraying cellulose lacquers) were obtained. These gave completely satisfactory cleaning, but were tiring to use for long periods ; it was obvious, however, that power-driven spray pistols would be effective items and two such equipments were constructed.

The actual units now used (Fig. 1) consist of electrically-driven air compressors, each capable of supplying enough compressed air at 30-40 lb./sq. in. to keep three or four spray guns operating intermittently, and there is adequate hose to permit the operators to work over a whole suite of equipment without moving the compressor. All this apparatus—including the four spray guns—is housed in a wooden travelling case, ready for transport at short notice, and suitable spare motors are held so that any unusual voltage can be used without trouble.

It was mentioned earlier that good results were obtained using a paraffin oil spray ; this material has not been extensively used, but has been replaced by the synthetic "Dekalin" which has most of the solvent properties of paraffin and is less inflammable, having a higher flash point. It is reasonable to ask why this more expensive material has been selected when some fire risk remains, and why an inflammable substance is used at all, since there are so many non-inflammable ones available. The truth is that it is most difficult to find an ideal

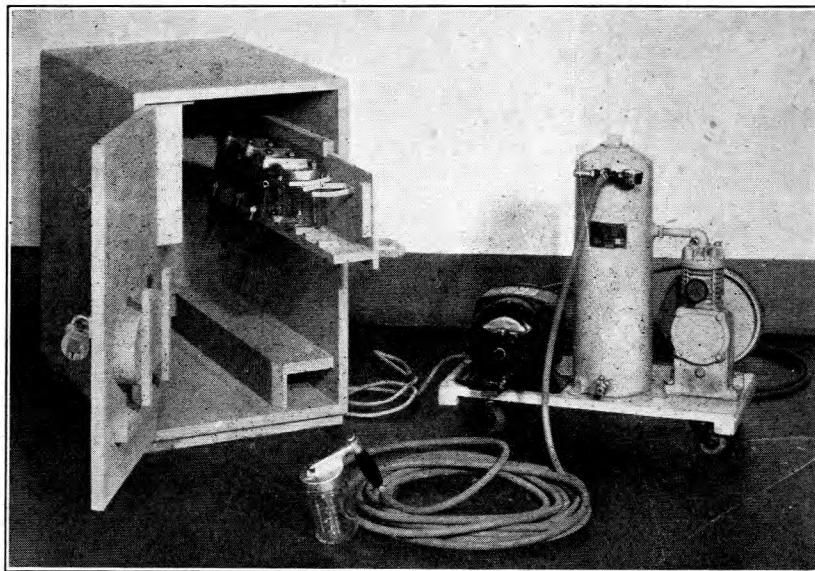

FIG. 1.—DEKALIN SPRAY CLEANING APPARATUS.

of such faults. They are largely complementary, the one more suitable for dealing with any specific incident depending upon the nature and extent of the damage and other circumstances peculiar to the case.

Mechanical Clogging of Moving Parts by Dust.

In one of the early cases of damage, restoration was much delayed by large quantities of brick and plaster dust which had been blown into the apparatus room and had settled on the selector switches.

This was very difficult to remove, as many of the switches had oiled banks, which tenaciously retained the dirt in spite of careful wiping. A few experiments showed that although the mechanism could be

solvent ; the "non-flam" solvents are all halogenated bodies such as carbon tetrachloride and tri-chlor-ethylene, which, when breathed in large quantities, may result in unpleasant internal effects ; other solvents have a serious effect on the eyes or give off explosive vapours at ordinary temperatures. Dekalin was selected, in spite of its peculiar smell, as being the most harmless of all the suitable solvents, and is, in fact, a substance against which there are no records of unpleasant after-effects.

Most of the dust and grit causing trouble lodges in the selector banks and clogs the wipers. To remove this the best technique found has been :

- (1) Remove dry dust by air-blast.
- (2) Soak the remaining sticky grit with Dekalin spray.

- (3) Leave the selector for about half an hour for the solvent to be absorbed by the sticky grit.
- (4) Using the full force of the spray gun, flush out the grit from the banks with Dekalin, aiding the operation if necessary by using a brush.

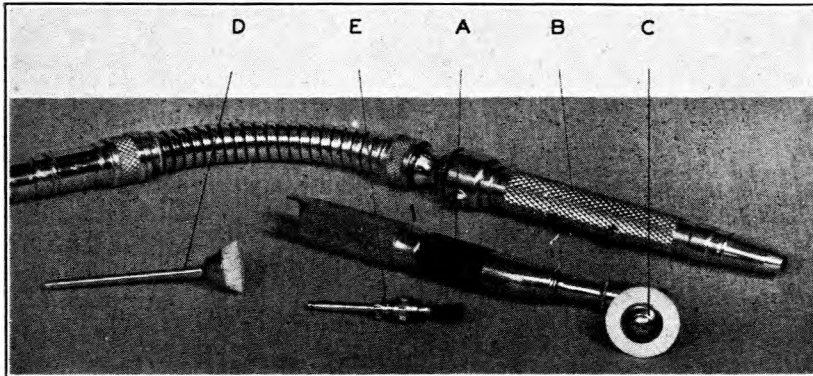

FIG. 2.—DENTAL CHUCK AND BRUSHES.

(Special brushes are provided, but if one is not available a good substitute can be made from an ordinary plastic-handled tooth brush, bent to the right shape after steaming for a few seconds.)

- (5) Blow off excess Dekalin with air-blast.

When the first experiments were in progress, final selectors were being cleaned, and it was most interesting to observe selectors which had previously been quite unable to rotate over the bank contacts immediately start to rotate when the filth was flushed out of the banks. It is unlikely that the subscriber concerned appreciated his good fortune in being able to get his call through at all, bearing in mind the earlier condition of the apparatus.

Mechanical Clogging of Moving Parts and Low Insulation Resistance caused by Electrolysis Products.

When water which is being used for fire-extinguishing gets on to working equipment, large masses of corrosion products are formed between closely spaced live terminal tags, relay, switch and jack springs, bank contacts, etc; depending upon the amount of water involved, the damage may vary from minor effects on isolated items to the complete mechanical clogging of the moving parts of whole racks.

The two extremes constitute separate problems, as in the first case restoration *in-situ* may be well worth attempting, whereas in the second the apparatus will generally have to be removed for treatment. Although the Dekalin spray may often be useful, corrosion products are sometimes too firmly attached to the metal on which they have developed to be removed by it. In such circumstances the following devices have been found useful.

Treatment of Isolated Minor Damage.—Rotating brushes held in a flexible shaft-driven dental chuck are convenient for cleaning spring sets, terminal tags and other small and inaccessible parts. These pieces of apparatus are illustrated in Fig. 2; the brushes may be held either directly in the chuck B or in the 90° conversion drive A, which may be quickly attached to B.

Experience indicates that the disc brush C which is $\frac{3}{8}$ in. in diameter, is the most useful.

Figs. 3 and 4 illustrate a somewhat larger and more robust apparatus of similar kind which has been specially made for cleaning bank contacts. Both tools may be driven by a motor (Motor, Electric, AC/DC No. 13), which will work from any mains or a 50 V battery.

Exchange staff who have used both machines strongly favour the adoption of the large one for normal maintenance work.

Two dental outfits and one of the larger type are available for emergency use, and more of the latter are being made.

Treatment of Heavy and Intensive Damage.—Small numbers of miscellaneous items, including selector switches, which appeared fit only for the scrap heap, have been restored by steel shot blasting. The corrosion produce is moved almost instantaneously by the direct impact of the shot, though a somewhat longer exposure is needed to clear the more intricate crevices, but even for these the time required is not sufficient for the base metal of nickel-plated parts to be exposed, and insulating materials are quite undamaged. Electrically, and at first sight visually, the cleaned equipment is indistinguishable from new, but inspection shows the metal parts to be slightly "frosted."

It is necessary before treatment to dismantle and degrease all sliding and rotating movements, as otherwise it is impossible to get rid of the shot completely.

There is no reason why sand-blasting should not be equally satisfactory.

As the plant necessary for carrying out the operations is quite common in most towns, it would

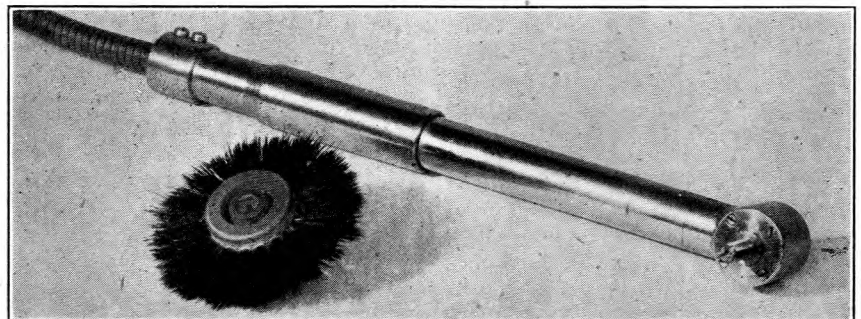

FIG. 3.—BANK CLEANING BRUSH AND TOOL.

probably be best to arrange for the whole process to be carried out under Post Office supervision at a suitable nearby works.

In one instance it was proposed to apply the method on a considerable scale, but unfortunately the exchange concerned was completely destroyed before the plans could be put into effect.

It is found in practice that there is but little tendency for appreciable amounts of water to get into the relay coils, though this may happen occasionally. In such cases, provided that no water from the sea or grossly polluted sources has been used, these can be dried out satisfactorily at a temperature

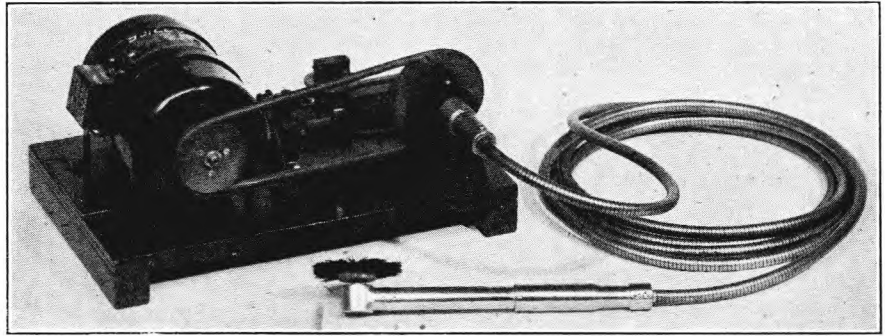

FIG. 4.—GENERAL VIEW OF BANK CLEANING TOOL AND ITS DRIVE.

of about 60° C. Coils restored in this way will undoubtedly be more prone to failure than new ones, particularly if they are wound with very fine wire, but their re-use is fully justified under war conditions.

Book Review

“Electrical Engineering Practice.” By G. J. W. Meares and R. E. Neale. Volume 2. 5th Edition. 590 pp. Combined index for all three volumes. 276 ill. Chapman & Hall, 35s. net.

The present volume, a revised and enlarged edition of its predecessors, is one of a series of three, and itself comprises three sections, the transformation and conversion of electrical energy, its distribution in branch circuits and its application to lighting, heating, cooking, air conditioning and electric welding and cutting. There is also a chapter on storage batteries.

The section on transformation and conversion includes the theory and construction of the standard types of transformer, rotary converters and transverters, and mercury arc, electrolytic, valve and other methods of rectification.

The chapter on secondary cells gives the essentials of the lead and alkaline batteries with guidance for efficient maintenance.

The distribution section sets out and compares the standard systems of supply and follows on to service lines and installations. Wiring systems in use, conduit, lead covered and the various systems on the market under trade names, with their necessary accessories are dealt with fully and there is a detailed guide to the I.E.E. rules referring. This section contains a standard specification compiled by one of the authors for high-

class wiring work in India, and elsewhere in the book there are references to specific Indian or tropical practice as they arise. The full chapter on electric lighting includes the mercury vapour and fluorescent lamp.

The third section gives detailed information on domestic heating and cooking and devotes considerable space to industrial heating; there is also a full chapter on welding.

A noticeable feature of the book is that the fundamental principles of the subject being dealt with are set out in so clear and concise a manner that they can be grasped easily, and there are bibliographies for the reader who wishes to go into any subject in greater detail. The relative British Standard Specifications are stated in all cases and there are references to Home Office, I.E.E. or other regulations. The volume is an excellent summary of up-to-date practice and as such should be generally valuable to engineering students; the engineer who may be called upon to advise on or undertake electrical work outside his ordinary line will find it specially useful and he will appreciate the technical and financial comparisons of available methods given in many cases. Students will find the clear statement of fundamentals and the readable manner in which the book is written of considerable help to them.

The production of the book is excellent.

H. R. M.

Notes and Comments

Roll of Honour.

The Board of Editors deeply regrets to have to record the deaths of the following members of the Engineering Department :—

While serving with the Armed Forces, including Home Guard

Bedford Telephone Area ...	Marsh, F. W. ...	Labourer	Trooper, Hussars
Belfast, Telephone Area ...	Thompson, W. ...	Unestablished Skilled Workman	Sergeant, Royal Air Force
Birmingham Telephone Area	Hill, C. B.	Labourer	Gunner, Royal Artillery
Brighton Telephone Area	Barber, D. L. F. ...	Unestablished Skilled Workman	Sub-Lieutenant, Royal Navy
Bristol Telephone Area ...	Lucas, F. ...	Skilled Workman, Class II ...	Leading Telegraphist, Royal Navy
Canterbury Telephone Area	Farmer, D. G. ...	Unestablished Skilled Workman	Sergeant, Royal Corps of Signals
Cardiff Telephone Area ...	Alderman, N. F. ...	Unestablished Skilled Workman	Signalman, Royal Corps of Signals
Coventry Telephone Area	Patrick, N. F. ...	Unestablished Skilled Workman	P/Lance Corporal, Royal Corps of Signals
Edinburgh Telephone Area	Gordon, S. A. B.	Unestablished Skilled Workman	Pilot Officer, Royal Air Force.
Engineering Department ...	Cooper, L. H. ...	Clerical Officer	Sergeant, Royal Air Force
Engineering Department ...	Davie, C. W. H. ...	Unestablished Skilled Workman	Sergeant Pilot, Royal Air Force
Engineering Department ...	Harford, R. J. ...	Mechanic	Sergeant, Royal Army Ordnance Corps
Engineering Department ...	Kent, R. W. G. ...	Motor Mechanic... ..	Sergeant, Royal Air Force
Home Counties Region ...	Slingo, F. W. ...	Inspector	Sergeant, Royal Air Force
Liverpool Telephone Area...	Barber, J. L. ...	Unestablished Skilled Workman	Lance Corporal, Royal Armoured Corps
Liverpool Telephone Area...	Edmondson, F. ...	Unestablished Skilled Workman	Lance Corporal, Scots Guards
Liverpool Telephone Area...	Herring, G. R. ...	Skilled Workman, Class II ...	Gunner, Royal Artillery
London Telecommunications Region	Anderson, A. I. P.	Unestablished Skilled Workman	Sergeant, Royal Air Force
London Telecommunications Region	Beckett, J. F. ...	Unestablished Skilled Workman	Sergeant, Royal Air Force
London Telecommunications Region	Berry, W. H. L. ...	Unestablished Skilled Workman	Lance Bombardier, Royal Artillery
London Telecommunications Region	Brotherick, D. D. ...	Unestablished Skilled Workman	Aircraftman Class II, Royal Air Force
London Telecommunications Region	Eagling, W. E. ...	Skilled Workman, Class II ...	Able Seaman, Royal Navy
London Telecommunications Region	Howard, W. E. ...	Skilled Workman, Class II ...	Able Seaman, Royal Navy
London Telecommunications Region	Thompson, W. J. ...	Unestablished Skilled Workman	Leading Seaman, Royal Navy
London Telecommunications Region	Vaughan, J. M.	Skilled Workman, Class I ...	Private, Royal Army Service Corps.
Manchester Telephone Area	Toy, T. C. ...	Unestablished Skilled Workman	Flight Sergeant, Royal Air Force
Newcastle-on-Tyne Telephone Area	Turner, R. ...	Unestablished Skilled Workman	Company Quartermaster-Sergeant, Royal Corps of Signals
Norwich Telephone Area ...	Reeve, G. R. ...	Unestablished Skilled Workman	Lance Corporal, Royal Corps of Signals
Portsmouth Telephone Area	Ball, W. A. H. ...	Unestablished Skilled Workman	Flight Engineer, Royal Air Force
Portsmouth Telephone Area	Lovell, A. E. ...	Skilled Workman, Class II ...	Gunner, Royal Navy
York Telephone Area ...	Hunter, K. B. ...	Unestablished Skilled Workman	Cadet, Royal Air Force

Recent Awards.

The Board of Editors has learnt with great pleasure of the honours recently conferred on the following members of the Engineering Department :—

While serving with the Armed Forces, including Home Guard

Edinburgh Telephone Area ...	Campbell, A. B.	Unestablished Skilled Workman	Flight Sergeant, Royal Air Force	Distinguished Flying Medal
Engineering Department ...	Bartram, W.	Motor Cleaner	Stoker Petty Officer, Royal Navy	Distinguished Service Medal
Engineering Department ...	Beechey, A. F.	Motor Mechanic	Flight Lieutenant, Royal Air Force	Distinguished Flying Cross
Glasgow Telephone Area ...	Kennedy, A.	Unestablished Skilled Workman	Signalman, Royal Corps of Signals	Military Medal
London Telecommunications Region	Sears, H. F.	Skilled Workman, Class I	Captain, Home Guard	Member of the Order of the British Empire
London Telecommunications Region	Turpin, F. W.	Skilled Workman Class II	Leading Seaman, Royal Navy	Distinguished Service Medal
Portsmouth Telephone Area	Makin, W. E. D.	Skilled Workman, Class II	Pilot Officer, Royal Air Force	Distinguished Flying Cross
Reading Telephone Area ...	Hillyard, E. G.	Unestablished Draughtsman	Sergeant, Royal Air Force V.R.	Mentioned in Dispatches
Southend Telephone Area ...	Hensey, E. H.	Unestablished Skilled Workman	Telegraphist, Royal Navy	Distinguished Service Medal

New Year Honours.

The Board of Editors offers its sincere congratulations to the following members of the Engineering Staff who have been honoured by the King in the New Years' Honours List

Guildford Telephone Area ...	Perkins, B. H.	Chief Inspector	Member of the Order of the British Empire
H.M.C.S. ...	Aldrich, L. E.	Cable Jointer	British Empire Medal
Liverpool Telephone Area ...	Loftus, J.	Skilled Workman, Class I	British Empire Medal
London Telecommunications Region	Hornsby, G.	Inspector	British Empire Medal
Newcastle Telephone Area ...	Cromarty, A. S.	Skilled Workman, Class I	British Empire Medal
Norwich Telephone Area ...	Hamblett, R.	Inspector	British Empire Medal
Southampton Telephone Area ...	Baker, Z.	Skilled Workman, Class I	British Empire Medal

Regional Notes

Home Counties Region

The photograph below is of the Spitfire provided by voluntary contributions from the Staff of the Home Counties Region. All ranks of the Engineering, Clerical and Postal staffs, totalling approximately 35,000, have



played their part in providing this fighter, a "striking" example of their devotion to the National cause and determination to assist in the attainment of final victory.

We wish the Home Counties Region Spitfire 'God-speed, and may all who fly in her help in retaining the supremacy of the air so magnificently won in the Battle of Britain and other superbly gallant achievements.

PIPE LAYING BY MOLE-DRAINER

An interesting development in the use of the mole-drafter recently tried in the Home Counties Region is the laying of metal water-pipes. The mole-drafter used was a proprietary model adapted for cable laying by local Post Office engineering staff, and towed by a D.4 army type tractor. The trial was undertaken by military personnel under the advice of Post Office engineers.

The subsoil in which the experiment was carried out consisted of loam overlaying chalk containing varying proportions of flints. There was a fall of approximately 1 ft. in 65 ft., and work was carried out down hill in all cases. The total length of pipe-line laid was 6,500 ft. at a depth of 2 ft. The route was sited carefully to avoid irregularities of surface. The pipe used was 1½ in. internal diameter screwed water barrel in standard lengths of 18 ft. The sketch depicts how the mole-plough was modified and adapted to pull in the pipes.

To start the mole-plough at the correct level a trench was excavated to a length of 20 ft.; later results indi-

cated that this length could be reduced to 12 ft. The mole was first pulled through without pipes, taken back to the starting point, pipes attached, and no difficulties whatever were experienced in pulling the pipes through on the second run. The pipes were pulled through in lengths of 204 yards, i.e., 34 standard lengths jointed together before pulling through. When laying a length

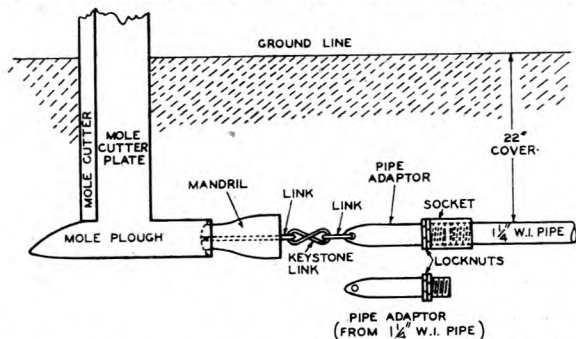

of pipe the tractor also towed a second length above ground. The 204 yard lengths were finally jointed by connectors. There were doubts at first as to whether the joints would stand the strain of the pull, but as the first pipe was connected to the mole-plough by means of a screw thread at the point where the maximum strain occurs it was possible to see that no damage occurred, and it also seemed that there was little strain on the pipe throughout. The pipes seemed sufficiently flexible to follow the uneven surface of the ground to some extent. The tractor time averaged one hour per 130 ft. run.

Further experiments were made using 3 in. pipes, and 90 ft. of 3 in. pipes were drawn in and drawn out again quite satisfactorily. By using a heavier type of tractor the mole-drainer would operate in any type of subsoil other than rock.

South-Western Region

WASHING MACHINE FOR TELEPRINTER PARTS

A very useful machine, as shown in the sketch, has recently been constructed in the Plymouth telegraph overhaul centre for washing teleprinters during repairs and overhauls.

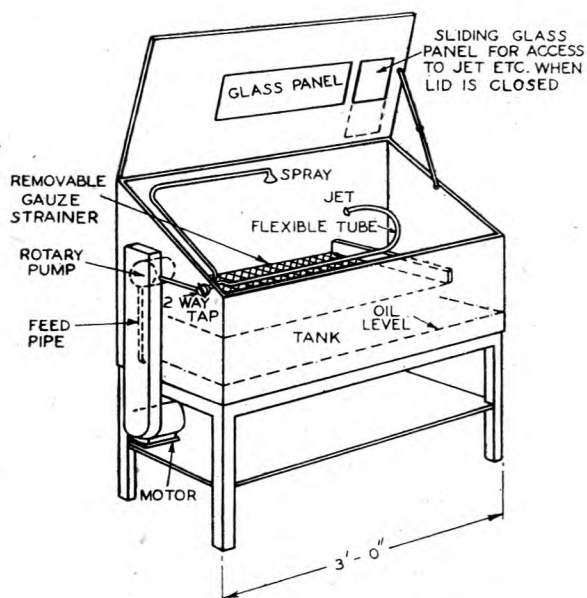

The items to be washed are placed on the gauze tray and sprayed with white spirit. The pump is motor driven, and by using an adjustable spraying nozzle continuous attention is not needed. It has been confirmed by experience that the machine enables a substantial saving of time to be effected on overhauls.

A two-way tap enables an alternative jet on a flexible tube to be used. This is useful when cleaning teleprinter parts which have not been completely dismantled. The pressure from the pump is sufficient to enable this to be really effective.

AERIAL CABLE JOINTING

A 16 mile length of 122/20 and 150/20 aerial cable is in course of provision by direct labour in a very exposed part of Cornwall. Aerial cables of this size are comparative newcomers in the Post Office, and to enable jointing and plumbing work to be carried out efficiently it is found essential to provide accommodation "up aloft" comparable with that in manholes.

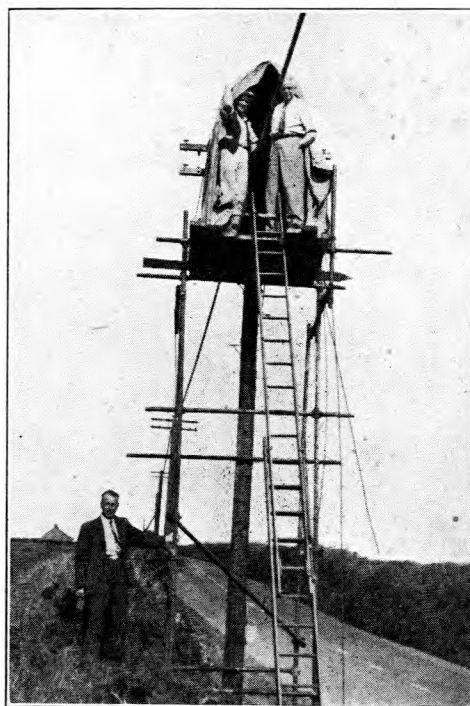

The illustration shows a standard jointer's tent erected round the cable. The tent stands on a platform at the top of a tower constructed of steel scaffolding tubes hired from a local building contractor, and the whole arrangement has proved highly satisfactory. The standard of insulation maintained during the jointing work, which was carried out during extremely wet and cold weather, is comparable with the best obtained on underground work.

The working quarters have found favour with the staff, and on one occasion when a full gale was blowing a working party secured lunch-time accommodation in a tent in preference to the less comfortable lorry.

Although the steel framework varies in construction according to the proximity of trees, hedgebanks, etc., it is possible for two towers to be erected and dismantled daily by one three-man party, and the time taken in this work is more than compensated by the improved standard of jointing.

Staff Changes

Promotions

Name	Region	Date	Name	Region	Date
<i>A.S.E. to Staff Engr.</i>			<i>Insp. to Chief Insp.—cont.</i>		
Aldridge, A. J.	E.-in-C.O.	1.1.43	Shepherd, C. . . .	Mid. Reg. . . .	8.11.42
<i>Exec. Eng. to A.S.E.</i>			Mackie, G. W. . . .	E.-in-C.O. . . .	29.11.42
Morrell, F. O.	E.-in-C.O.	20.1.43	Balfour, A. . . .	L.T. Reg. . . .	27.12.42
<i>Area Engr. to T.M.</i>			Northeast, S. G. . . .	E.-in-C.O. to Mid. Reg. . . .	6.12.42
Luxton, W. G.	S.W. Reg. to Chester	1.1.43	Lipscombe, J. E. . . .	E.-in-C.O. to Scot. Reg. . . .	1.12.42
<i>Asst. Engr. to Exec. Engr.</i>			Davies, H. S. . . .	W. & B.C. Reg. . . .	1.1.43
*Harnden, A. B.	L.T.R.	11.12.42	Brewer, F. . . .	W. & B.C. Reg. . . .	1.1.43
Maddocks, D. C.	L.T.R.	11.12.42	Rowe, J. F. . . .	S.W. Reg. to E.-in-C.O. . . .	27.12.42
Hayward, A. E.	S.W. Reg. to L.T.R.	30.11.42	Groom, D. E. . . .	E.-in-C.O. . . .	28.12.42
*Lee, W. H.	E.-in-C.O.	12.12.42	Banyard, S. C. . . .	H.C. Reg. . . .	17.1.43
Thwaites, J. E.	E.-in-C.O.	12.12.42	Lawson, A. J. . . .	L.P. Reg. . . .	10.1.43
Bordeaux, N.	E.-in-C.O.	1.1.43	Hazlewood, S. . . .	N.E. Reg. . . .	8.5.42
Seaman, E. C. H.	E.-in-C.O.	12.12.42	Dyson, L. V. . . .	H.C. Reg. . . .	13.12.42
Knight, E. W.	H.C. Reg. to S.W. Reg.	8.1.43	Charles, E. E. . . .	Mid. Reg. to E.-in-C.O. . . .	10.1.43
*Taylor, F. J. D.	E.-in-C.O.	20.2.43	Marshman, R. C. . . .	N.E. Reg. to E.-in-C.O. . . .	18.1.43
Cooper, W. H. B.	E.-in-C.O.	20.2.43	Hotham, J. W. . . .	E.-in-C.O. to H.C. Reg. . . .	3.1.43
<i>Chief Insp. to Asst. Engr.</i>			McLeod, J. . . .	Scot. Reg. . . .	31.1.43
Fisher, S. W. . . .	L.T.R. . . .	11.12.42	<i>S.W.I. to Insp.</i>		
Hills, J. E. . . .	H.C. Reg. . . .	13.12.42	Newman, W. L. . . .	E.-in-C.O. . . .	21.11.42
Buckingham, L. J. . . .	E.-in-C.O. . . .	3.12.42	Mason, M. T. . . .	E.-in-C.O. . . .	21.11.42
*Thwaites, H. J. . . .	E.-in-C.O. . . .	3.12.42	Eustace, C. G. . . .	Test Section (London) . . .	15.11.42
Corke, R. L. . . .	E.-in-C.O. . . .	3.12.42	Hitch, F. . . .	Test Section (B'ham) to Test Section (London) . . .	12.10.42
Lowry, W. R. H. . . .	E.-in-C.O. . . .	3.12.42	Warnock, W. T. . . .	Scot. Reg. to E.-in-C.O. . . .	27.5.42
Pitham, S. . . .	E.-in-C.O. . . .	3.12.42	<i>Asst. R.M.T.O. to R.M.T.O.</i>		
Prichard, F. E. . . .	Mid. Reg. to N.E. Reg. . . .	29.12.42	Whitehurst, J. F. . . .	Manchester to Leeds . . .	22.11.42
Pitts, H. E. . . .	H.C. Reg. . . .	20.12.42	<i>M.T.O. Class II to M.T.O. Class I.</i>		
Woods, A. E. . . .	E.-in-C.O. to S.W. Reg. . . .	7.12.42	Unitt, A. T. G. . . .	E.-in-C.O. . . .	1.12.42
Lafosse, L. P. . . .	E.-in-C.O. . . .	7.12.42	<i>Tech. Asst. to M.T.O. Class III.</i>		
Butters, W. . . .	H.C. Reg. . . .	13.12.42	Sturrock, E. S. . . .	E.-in-C.O. . . .	13.12.42
Marshall, W. J. . . .	E.-in-C.O. . . .	7.12.42	<i>Mech. I/C to Tech. Asst.</i>		
Shearing, M. R. . . .	E.-in-C.O. . . .	1.3.43	Pounder, L. . . .	Nottingham to Birmingham	3.1.43
†Myers, H. G. . . .	E.-in-C.O. . . .	21.12.42	<i>Third Officer to Second Officer.</i>		
Atkinson, J. . . .	H.C. Reg. . . .	19.1.43	Dixon, J. . . .	H.M.C.S. . . .	3.7.42
Clarke, T. M. . . .	Scot. Reg. to S.W. Reg. . . .	10.1.43	<i>Senior Draughtsman to Drawing Office Supervisor.</i>		
<i>Chief Insp. to Chief Insp. with Allce.</i>			Lennon, F. T. . . .	H.C. Reg. to E.-in-C.O. . . .	1.1.43
Jennings, J. . . .	Scot. Reg. . . .	1.1.43	<i>Draughtsman Cl. I to Senior Draughtsman.</i>		
Wright, C. T. . . .	H.C. Reg. . . .	25.10.42	*Martin, T. . . .	N.E. Reg. to H.C. Reg. . . .	18.2.43
Love, R. C. . . .	Scot. Reg. . . .	1.11.42	Wainwright, S. W. . . .	H.C. Reg. . . .	18.2.43
<i>Insp. to Chief Insp.</i>					
Durston, E. A. . . .	S.W. Reg. . . .	17.11.42			
Warburton, E. . . .	N.W. Reg. . . .	6.12.42			
Scholes, W. . . .	E.-in-C.O. . . .	13.10.42			

* Promoted in absentia.

† Loaned to another Government Department.

Retirements

Name	Region	Date	Name	Region	Date
<i>Regl. Engr.</i>			<i>Chief Insp.—cont.</i>		
Gray, H. C. . . .	H.C. Reg. . . .	31.1.43	Tombs, T. R. . . .	W. & B.C. Reg. . . .	31.12.42
<i>Asst. Engr.</i>			Haveron, T. . . .	Scot. Reg. . . .	25.2.43
Cuthbert, C. T. . . .	E.-in-C.O. . . .	14.11.42	<i>Insp.</i>		
Missen, H. . . .	E.-in-C.O. . . .	31.12.42	Boal, J. V. . . .	L.T. Reg. . . .	31.12.42
Buften, C. W. M. . . .	S.W. Reg. . . .	31.12.42	Phillips, A. J. . . .	W. & B.C. Reg. . . .	21.12.42
Kilburn, G. A. N. . . .	L.P. Reg. . . .	17.1.43	Scott, C. B. . . .	N.W. Reg. . . .	16.2.43
Smith, B. J. . . .	S.W. Reg. . . .	23.2.43	Clary, G. W. . . .	L.T. Reg. . . .	3.2.43
<i>Chief Insp. with Allce.</i>			Higson, E. . . .	N.W. Reg. . . .	14.3.43
McPhail, W. S. S. . . .	Scot. Reg. . . .	31.12.42	House, R. . . .	L.T. Reg. . . .	27.2.43
Mealing, W. P. . . .	N.E. Reg. . . .	31.10.42	<i>Cable Foreman.</i>		
<i>Chief Insp.</i>			Beer, J. F. . . .	H.M.C.S. . . .	31.12.42
Whibley, P. W. . . .	H.C. Reg. . . .	31.12.42	<i>Draughtsman Cl. I.</i>		
Davies, L. . . .	W. & B.C. Reg. . . .	31.12.42	Formosa, A. C. . . .	E.-in-C.O. . . .	1.1.43

Death

Name	Region	Date	Name	Region	Date
<i>Chief Insp.</i>					
Monk, A. J. . . .	Test Section, London . . .	15.2.43			

Transfers

Name	Region	Date	Name	Region	Date
<i>Asst. Engr.</i>			<i>R.M.T.O.</i>		
Burr, A. H. ..	E.-in-C.O. to L.P. Reg...	19.1.43	Daft, W. E. ..	W. & B.C. Reg. to H.C. Reg. ..	1.12.42
<i>Proby. Asst. Engr.</i>			<i>M.T.O. Cl. II.</i>		
Truslove, E. H. ..	L.T. Reg. to E.-in-C.O. ..	21.12.42	Collman, E. L. ..	Leeds to E.-in-C.O. ..	27.11.42
<i>Insp.</i>			<i>M.T.O. Cl. III.</i>		
Parker, W. J. ..	E.-in-C.O. to L.T. Reg. ..	1.12.42	Green, G. A. ..	E.-in-C.O. to Manchester	23.11.42
Shaw, W. H. ..	E.-in-C.O. to N.W. Reg...	4.2.43	<i>Tech. Asst.</i>		
			Cadge, E. R. ..	B'ham to E.-in-C.O. ..	29.12.42

CLERICAL GRADES

Promotion

Name	Region	Date	Name	Region	Date
<i>From C.O. to E.O.</i>					
Shaw, A. E. (Miss) ..	E.-in-C.O. ..	1.1.43			

All Promotions Acting.

BOARD OF EDITORS

A. J. GILL, B.Sc., M.I.E.E., F.I.R.E., Chairman.
 F. E. NANCARROW, A.R.C.Sc., M.I.E.E.
 P. B. FROST, B.Sc., M.I.E.E.
 A. H. MUMFORD, B.Sc.(ENG.), M.I.E.E.
 C. W. BROWN, A.M.I.E.E.
 G. H. S. COOPER.
 H. LEIGH, B.Sc.(ENG.), A.M.I.E.E., Acting Managing Editor.
 G. E. STYLES, A.M.I.E.E., Acting Assistant Editor.
 A. J. BAKER, Secretary-Treasurer.

Copyright

The entire contents of this JOURNAL are covered by general copyright, and special permission is necessary for reprinting long extracts, but Editors are welcome to use not more than one-third of any article, provided credit is given at the beginning or end thus: "From the *Post Office Electrical Engineers' Journal*."

The Board of Editors is not responsible for the statements made or the opinions expressed in any of the articles in this JOURNAL, unless such statement is made specifically by the Board.

Communications

All Communications should be addressed to the Managing Editor, *P.O.E.E. Journal*, Engineer-in-Chief's Office, Alder House, Aldersgate Street, London, E.C.1. Telephone: HEADquarters 1234. Remittances should be made payable to "*The P.O.E.E. Journal*" and should be crossed "& Co."

Binding Cases

Cases for binding are available, and may be obtained from the Local Agents for 1s. 9d. Subscribers can have their copies of Volumes bound, at a cost of 3s., by sending the complete set of parts to the Local Agents or to the *P.O.E.E. Journal*, Engineer-in-Chief's Office, Alder House, Aldersgate Street, London, E.C.1. Orders for binding for Vols. 1-19 should indicate whether the original binding case with black lettering, or the later pattern with gold, is required. Cases with gold lettering are the only type stocked from Vol. 20 onwards.

Back Numbers

The price of the JOURNAL, which is published quarterly, is 1s. (1s. 3d. post free) per copy, or 5s. per annum post free. Back numbers can be supplied, subject to availability of stocks, at 1s. each (1s. 3d. post free). Orders for back numbers may be sent to the Local Agents or to the Publishers.

Advertisements

All communications relating to space reservations should be addressed to the Advertisement Editor, *P.O.E.E. Journal*, Alder House, Aldersgate Street, London, E.C.1. Communications regarding advertisement copy, proofs, etc., should be addressed to the Publishers, Messrs. Birch & Whittington (Prop. Dorling & Co. [Epsom], Ltd.), 49 Upper High Street, Epsom, Surrey.

NOTE.—The fact that goods made of raw material in short supply owing to war conditions are advertised in this Journal should not be taken as an indication that they are necessarily available for export.

46-range Mode 7
Universal AvoMeter



'AVO'
Regd. Trade Mark

Meters that Matter

THE world-wide use of "AVO" Instruments is striking testimony to their outstanding versatility, precision and reliability. In every sphere of electrical test work they are appreciated for their dependable accuracy, which is often used as a standard by which other instruments are judged. There is an "AVO" Instrument for every essential electrical test.

Some delay in delivery of Trade Orders is inevitable, but we shall continue to do our best to fulfil your requirements as promptly as possible.

Sole Proprietors and Manufacturers

THE AUTOMATIC COIL WINDER & ELECTRICAL EQUIPMENT Co. Ltd.
Winder House, Douglas Street, London, S.W.1

Phone: VICTORIA 3404-7

WIDE-RANGE TRANSFORMERS



TYPES D-106 & D-139

For Modern Communications Equipment

- **FREQUENCY CHARACTERISTICS**
Practically linear from the lower audio frequencies to over 100 Kc/s.
- **IMPEDANCE RATIOS**
Many impedance ratios are available, from 1 : 1 to 500 : 1.
- **POWER**
Types D-139 will handle up to one watt AC power above 40 c.p.s. Types D-106 are designed as input and interstage transformers where the power is negligible.
- **SCREENING**
All types double screened against electromagnetic and electrostatic interference.
- **DIMENSIONS**
2 $\frac{3}{8}$ " \times 3 $\frac{1}{2}$ " \times 3" high overall.
- **WEIGHT** 2 $\frac{1}{2}$ lb.

MUIRHEAD

Full information is given in Bulletin B-538-A which will gladly be sent on request.

MUIRHEAD AND COMPANY LIMITED, ELMERS END, BECKENHAM, KENT. BECKENHAM 0041-0042

FOR OVER 60 YEARS DESIGNERS AND MAKERS OF PRECISION INSTRUMENTS

Clip-on

FOR EASY CURRENT MEASUREMENTS

in Busbars, Fuses and Cables up to 2½" diam.

- DUAL RANGE WITH SELECTOR SWITCH
- FULLY INSULATED CORE AND HANDLE

FERRANTI

DUAL RANGE

Clip-on AMMETER

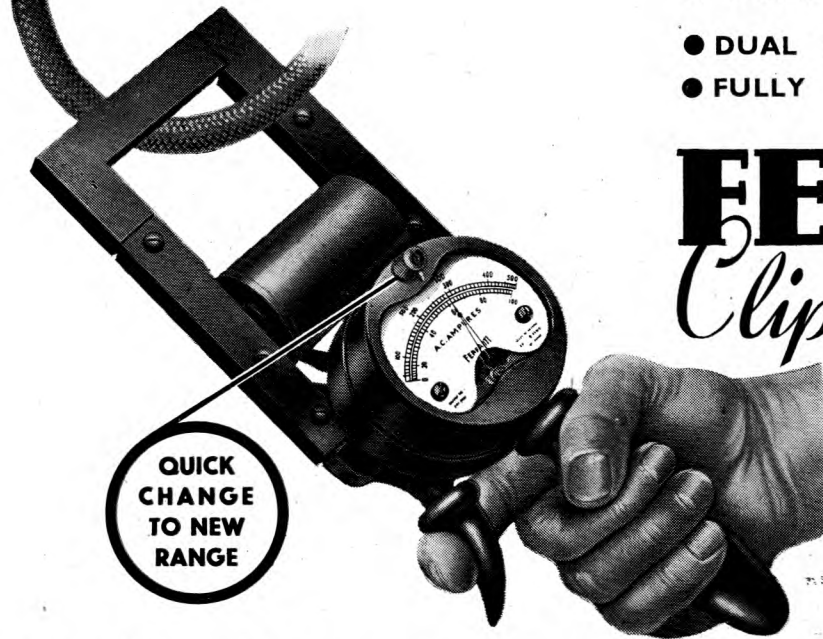

QUICK CHANGE TO NEW RANGE

- RANGES**
- 0—10—50 Amps.
 - 0—20—100 Amps.
 - 0—50—250 Amps.
 - 0—100—500 Amps.
 - 0—200—1000 Amps.

FI50a

FERRANTI LIMITED, Hollinwood, Lancs.

London Office: Bush House, Aldwych, London, W.C.2

TURNER DIFFERENTIAL MILLIAMMETERS G.P.O. No. 17 & No. 18

Meet the most exacting demands for balancing currents in multiplex telegraph circuits.

A quality product of outstanding merit

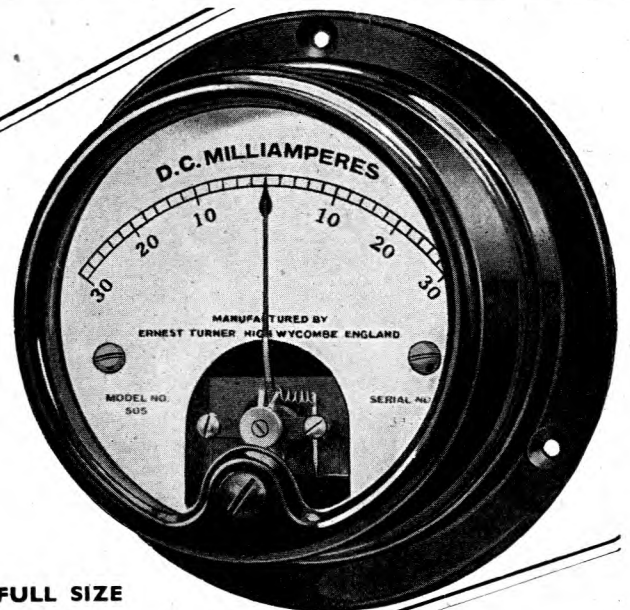

FULL SIZE

Also manufacturers of G.P.O. Detector No. 4, and a comprehensive line of instruments for precision electrical measurements.

ERNEST TURNER ELECTRICAL INSTRUMENTS, Ltd.

CHILTERN WORKS,
49-73 TOTTERIDGE AVENUE,
HIGH WYCOMBE,
BUCKS, ENGLAND

Telephone: High Wycombe 1301, 1302.
Telegrams: Gorgeous. High Wycombe.

The National Interest demands Standardisation

These "Standard Values" cover every Resistance Value from 10 ohms to 10 Meg.

±20%	+10%	★±5%	±20%	+10%	★±5%	±20%	+10%	★±5%
10	10	10	1000	1000	1000	100000	100000	100000
	12	11		1200	1100		120000	110000
	13	12		1300	1200		130000	120000
15	15	15	1500	1500	1500	150000	150000	150000
	16	16		1600	1600		160000	160000
	18	18		1800	1800		180000	180000
	20	20		2000	2000		200000	200000
22	22	22	2200	2200	2200	220000	220000	220000
	24	24		2400	2400		240000	240000
	27	27		2700	2700		270000	270000
	30	30		3000	3000		300000	300000
33	33	33	3300	3300	3300	330000	330000	330000
	36	36		3600	3600		360000	360000
	39	39		3900	3900		390000	390000
	43	43		4300	4300		430000	430000
47	47	47	4700	4700	4700	470000	470000	470000
	51	51		5100	5100		510000	510000
	56	56		5600	5600		560000	560000
	62	62		6200	6200		620000	620000
68	68	68	6800	6800	6800	680000	680000	680000
	75	75		7500	7500		750000	750000
	82	82		8200	8200		820000	820000
	91	91		9100	9100		910000	910000
100	100	100	10000	10000	10000	10 Meg	10 Meg	10 Meg
	110	110		11000	11000		11 Meg	11 Meg
	120	120		12000	12000		12 Meg	12 Meg
	130	130		13000	13000		13 Meg	13 Meg
150	150	150	15000	15000	15000	15 Meg	15 Meg	15 Meg
	160	160		16000	16000		16 Meg	16 Meg
	180	180		18000	18000		18 Meg	18 Meg
	200	200		20000	20000		20 Meg	20 Meg
220	220	220	22000	22000	22000	22 Meg	22 Meg	22 Meg
	240	240		24000	24000		24 Meg	24 Meg
	270	270		27000	27000		27 Meg	27 Meg
	300	300		30000	30000		30 Meg	30 Meg
330	330	330	33000	33000	33000	33 Meg	33 Meg	33 Meg
	360	360		36000	36000		36 Meg	36 Meg
	390	390		39000	39000		39 Meg	39 Meg
	430	430		43000	43000		43 Meg	43 Meg
470	470	470	47000	47000	47000	47 Meg	47 Meg	47 Meg
	510	510		51000	51000		51 Meg	51 Meg
	560	560		56000	56000		56 Meg	56 Meg
	620	620		62000	62000		62 Meg	62 Meg
680	680	680	68000	68000	68000	68 Meg	68 Meg	68 Meg
	750	750		75000	75000		75 Meg	75 Meg
	820	820		82000	82000		82 Meg	82 Meg
	910	910		91000	91000		91 Meg	91 Meg
						10.0 Meg	10.0 Meg	10.0 Meg

★ See note (1) in Text

In the Fixed Composition Resistor Field "STANDARD VALUES" is the Solution

For a long time now the range of values demanded in Fixed Composition Resistors has been increasing until it has now reached an uneconomic and wasteful figure exceeding 800. This position has produced unavoidable delays in delivery because of the time expended in special sorting and colour-coding, and the consequential hold-ups in the manufacture and servicing of important equipment. In order to regularise the position the Services, the Manufacturers, their Engineers and Laboratories have co-operated in rationalising the range to the 255 STANDARD VALUES listed in the accompanying table, without any loss of efficiency. Tolerance $\pm 20\%$ should be used wherever possible; $\pm 10\%$, should be used only where essential: whilst for $(1) \pm 5\%$ prior authorisation is required and should be sought by the Development Authority through the appropriate Supply Department Design Authority. The schedule applies only to new development projects, and not to existing contracts, spares for same or repeat orders for either. Your co-operation in using only STANDARD VALUES of resistance is vital if your demands are to be met on time.

"STANDARD VALUES"

- GIVE**
 - Increased Production
 - Quicker Delivery
 - Speedy Servicing
- SAVE**
 - Valuable Raw Materials
 - Labour
 - Dangerous Delays

A limited number of "Quick Reference" STANDARD VALUES charts at 3d each is available from manufacturers of Fixed Composition Resistors to those engaged in work of National Importance

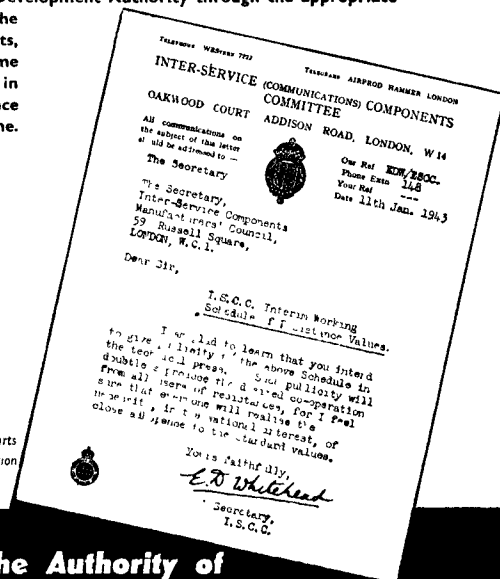

Issued under the Authority of
INTER-SERVICE COMPONENT MANUFACTURERS' COUNCIL
 59, Russell Square, W.C.1. Tel: MUSEum 4031-2

Electrical Standards for Research and Industry

Testing and Measuring Apparatus
for Communication Engineering

BRIDGES — Capacitance
Inductance
Resistance

RESISTANCES

INDUCTANCES

CONDENSERS

OSCILLATORS

WAVEMETERS

H. W. SULLIVAN
— LIMITED —

ALL TYPES — ALL FREQUENCIES — ALL ACCURACIES

London, S.E.15

Tel. New Cross 3225 (Private Branch Exchange)

Hall Telephone Accessories (1928) Limited

Suppliers to the British Post Office, Air Ministry,
Admiralty, War Office and Foreign Government
Departments.

Manufacturers of prepayment telephone
multi-coin collectors, gas leak
indicators, precision instruments,
automatic stamp selling and ticket
selling machines, automatic slot
machines and fire alarm apparatus.

Registered Office:

**70, DUDDEN HILL LANE, WILLESDEN,
LONDON, N.W.10**

Tel. WILLESDEN 5141/2/3.

Also SOUTH WALES

LONDEX RELAYS

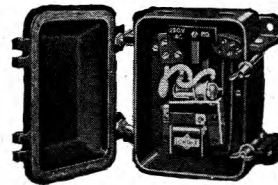

This Relay type
LQA is approved
by the G.P.O. for
use in Telephone
Lines

FLOATLESS LIQUID LEVEL CONTROL

for

- PUMPS
- VALVES
- SIGNALLING
- RECORDING
- DRAINAGE
- STORAGE

“LECTRALEVEL”
SYSTEM

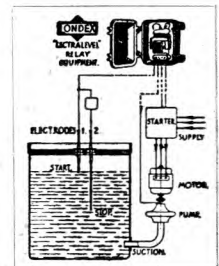

ASK FOR LEAFLETS SPN & 94/PO

LONDEX LTD

*Electrical Remote Control.
Engineers & Manufacturers.*
Anerley Wks, 207 Anerley Rd, London, S.E.20
Phone: SYDENHAM 6258-9

SIEMENS PRODUCTS

backed by over 80 years' Electrical Experience

Contractors for the manufacture, laying and maintenance of Submarine and Land Cables for Telegraphy, Telephony and the Electric Transmission of Power, for the erection and maintenance of Overland Telegraph, Telephone and Power Transmission Lines, Marine Wireless Telegraph and Telephone Installations, Public and Private Telephone Exchanges and Carrier Equipment for Telephone Lines.

Manufacturers of

Electric Lamps of all types for Domestic, Industrial and Street Lighting, including "Sieray" Electric Discharge Lamps, Fluorescent Tubes, Motor Car Lamps, Projectors, etc.



**ELECTRIC
WIRES & CABLES**

**CABLE
JOINT BOXES**

TELEPHONE CABLES
Aerial, Underground, Submarine

**OVERHEAD
LINE MATERIAL**

CELLS & BATTERIES
Dry, Fluid & Inert

**ELECTRICAL
MARINE APPARATUS**

**ELECTRIC
LAMPS**

**PRIVATE
TELEPHONE SYSTEMS**

**PUBLIC
TELEPHONE EXCHANGES**

**CARRIER-CURRENT
EQUIPMENT**

**WIRELESS EQUIPMENT
FOR SHIPS**

"ZED" FUSES
L.T. SWITCH & FUSE GEAR

SIEMENS BROTHERS & CO., LTD.
WOOLWICH, LONDON, S.E. 18

SIEMENS ELECTRIC LAMPS & SUPPLIES LTD., 38-39 UPPER THAMES STREET, LONDON, E.C. 4

**PREPARATION OF
METALLURGICAL SPECIMENS
FOR THE MICROSCOPE**

Purity and correct grade of materials are of paramount importance in the manufacture of WESTINGHOUSE METAL RECTIFIERS. One of the preliminary processes is the examination of crystal formations by means of the microscope, for which the specimen is first ground and then polished to provide an optically flat surface.



In spite of greatly increased production we are unable to supply Westinghouse Rectifiers as freely as we would wish. We hope customers will understand and accept our assurance that the constant research now going on in our laboratories and designing departments, is resulting in Rectifiers of remarkably advanced design which will be available after the war.

*Westinghouse
Rectifiers*

**WESTINGHOUSE BRAKE & SIGNAL CO. LTD.
PEW HILL HOUSE - CHIPPENHAM - WILTS**

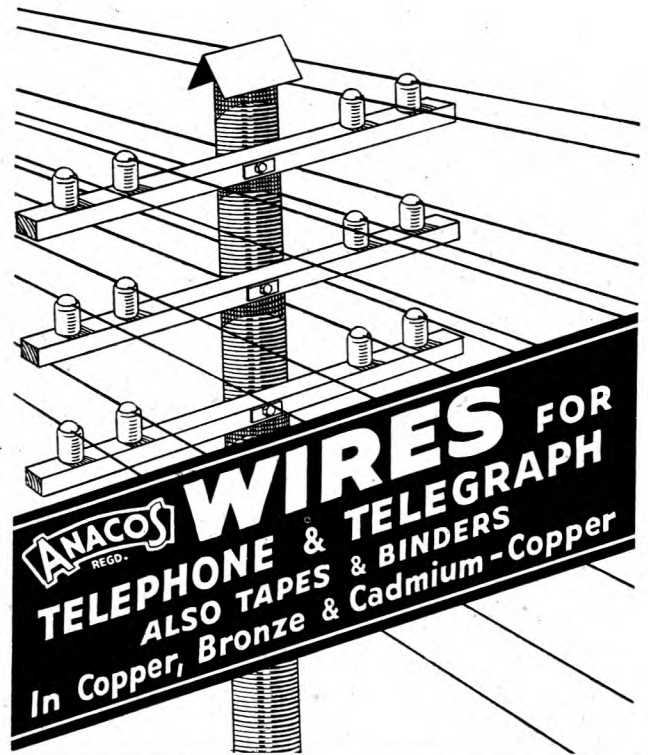

FREDERICK SMITH & CO. LTD. (Incorporated in The London Electric Wire Company and Smiths, Limited.)
ANACONDA WORKS, SALFORD, 3, LANCS.
Telephone : BLACKFRIARS 8701 (8 lines) Telegrams : "ANACONDA" MANCHESTER

**INSTALLED
WEEKS
AHEAD OF
SCHEDULE**

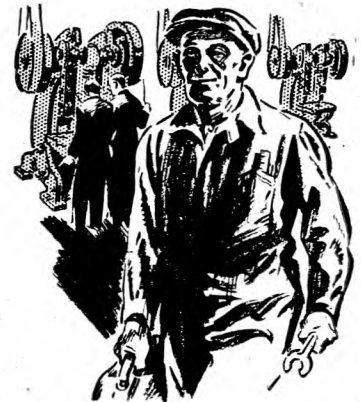

Work of the first importance is being started much sooner by the aid of Rawlplug Fixing Devices; work varying widely in type—from the fixing of light wiring to the installation of the heaviest machinery. The speed and efficiency of Rawlplug Fixing Devices are appreciated more than ever these days.

Rawlplugs, Rawldrills, Rawltools, Rawlbolts, Rawldrives, Rawlplastic, White Bronze Plugs, Bolt Anchors, Screw Anchors, Cement in Sockets, Boring Tools, Tile Drills, Electric Hammers, Mechanical Hammers, Soldering Irons, Toggle Bolts and many products of Industrial and Domestic utility. Write for Technical Literature.

Contractors to His Majesty's Government
THE RAWLPLUG CO. LTD., CROMWELL ROAD, S.W.7

The World's Largest Manufacturers of Fixing Devices

B290





Shipwrecked sailors find a banquet

For five successive days the crew of a Dutch vessel fought off waves of Nazi war planes until with ammunition exhausted their ship was sunk. Rather than risk captivity on the Nazi-occupied Norwegian coast the survivors turned their lifeboats towards inhospitable Nova Zembla, 13° south of the North Pole, where they landed frostbitten and weak from exhaustion and hunger. Bleak as were their prospects of fighting death by starvation, one—the third Engineer—who must be nameless, realised that for survival the will alone is not enough. With a loop of string on a stick he “noosed” over a hundred ducks, the birds being too surprised by flight, their land not having been visited by human beings since Barentz, the explorer, discovered it four hundred years before. Safely back in England the heroic band of Dutchmen were last reported with but one wish . . . that of so many other gallant men after similar ordeals . . . a speedy return to sea to continue the fight against the Nazis.



The Will alone is not enough—

The instinct of self-preservation, fierce though it may flame, is not sufficient in itself. We may, in times of stress, prolong our existence with tools and weapons as primitive as those of our ancestors, or in more normal circumstances triumph over Nature with such achievements as giant ocean liners and fast-flying planes. But, archaic or advanced, the existence of tools or instruments, equipment or machinery is proof that the brain is behind the hand. And modern brains are very good indeed. In the field of electrical signalling and communications they have surpassed themselves. Automatic telephone systems link-up remote individuals and widely-scattered communities. Street Fire Alarm systems enable swift, accurate notifications of out-breaks to be transmitted to a fire-station from any street point. Vehicle-actuated Street Traffic Signals keep traffic flowing swiftly and eliminate road-accidents while Supervisory Remote Control equipment enables switchgear throughout electricity power networks to be remotely controlled and supervised. For details of these and other products which brain-power has evolved, communicate with



Automatic Telephone & Electric Co. Ltd.

LONDON & LIVERPOOL

Manufacturers of · Strowger Automatic Telephone Equipment · Carrier Current and Transmission Equipment · Street Traffic Signals · Street Fire Alarm Apparatus · Supervisory Remote Control Equipment for Power Networks · Mine Telephones and Signalling Apparatus, etc.



*manufacturers
of High Grade
telephone
communication
equipment . . .*

G.E.C.

T E L E P H O N E • W O R K S
T H E G E N E R A L E L E C T R I C C O . , L T D .
Head Office • MAGNET HOUSE • KINGSWAY • LONDON • W.C.2.

SALFORD METAL RECTIFIERS

For Radio and Telecommunication, X-ray H.T. Rectifiers, Relay and Contactor operation, Electrical Precipitation equipment, Surge Absorbers, Metallic Sputtering apparatus, H.T. and E.H.T. Insulation Test equipment, Instruments and Power applications, etc.

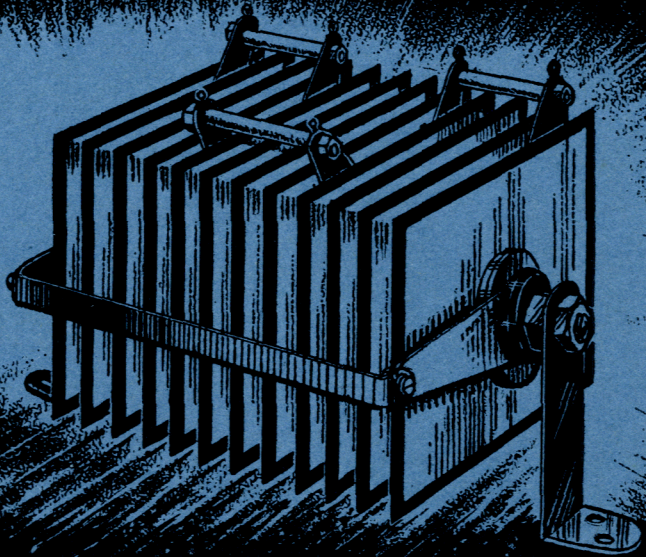

SALFORD ELECTRICAL INSTRUMENTS LTD.

PEEL WORKS, SALFORD, 3. Telephones : BLAckfriars 6688 (6 lines). Telegrams and Cables : "Sparkless, Manchester"
 PROPRIETORS: THE GENERAL ELECTRIC Co. Ltd., OF ENGLAND

EDISWAN

TELEPHONE LINE PROTECTOR PANELS

EDISWAN-SHOTTER-GREETHAM PATENT

(British Patent No. 353924)

for the protection of telephone systems against surges induced by faults on neighbouring power lines

Of the difficulties attendant upon the employment of overhead systems one of the most serious is to ensure uninterrupted working of the telephone system, by providing adequate protection against induced surges caused by switching or line faults in adjacent power lines or by lightning.

The Ediswan Patent Protectors provide the solution. They are inert at the normal working pressure of the telephone line, they keep the voltage on the line down to a pre-determined figure by providing a path of low resistance to earth whereby the surge is cleared and they again become inert immediately the surge is cleared.

They ensure simultaneous discharge of both lines and are capable of clearing heavy discharges without detriment to the system or the protector.

Ediswan Telephone Line Protectors have now been in use by Supply Companies for many years.

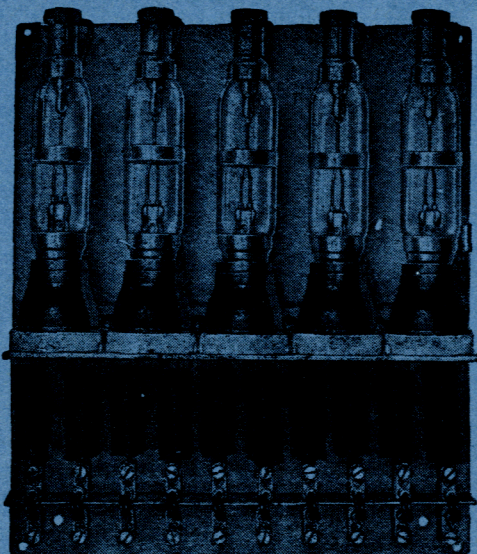

5-circuit panel for overhead lines incorporating choke coils, spark gaps, etc.

THE EDISON SWAN ELECTRIC CO. LTD., 155 CHARING CROSS ROAD, LONDON, W.C.2

MAINTAINING EFFICIENCY

THE HIGH STANDARD OF EFFICIENCY
OF PIRELLI - GENERAL TELEPHONE
CABLES IS MAINTAINED BY THE
CONTINUOUS RESEARCH WORK OF
AN EXPERIENCED TECHNICAL STAFF.

TELEPHONE:
SOUTHAMPTON
2141 (5 lines).

PIRELLI-GENERAL
CABLE WORKS, Ltd., SOUTHAMPTON.

TELEGRAMS
"PIGEKAYBEL"
SOUTHAMPTON."

**WHAT BIT TEMPERATURE SHOULD
BE USED FOR 40/60 ALLOY?**

This and numerous other queries are answered in reference sheet 2 of "Technical Notes on Soldering," published by the manufacturers of Ersin Multicore—the A.I.D. approved solder wire with three cores of non-corrosive Ersin activated flux.

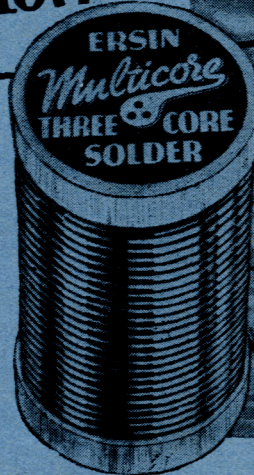

ERSIN MULTICORE

The Solder Wire with 3 cores of non-corrosive Ersin flux.

★ Firms engaged on Government contracts are invited to write for a copy of this reference and samples of ERSIN MULTICORE SOLDER WIRE.

MULTICORE SOLDERS LTD., BUSH HOUSE, LONDON, W.C.2. TempleBar 5583/4