

THE POST OFFICE ELECTRICAL ENGINEERS' JOURNAL

VOL. 38

APRIL, 1945

PART 1

CONTENTS

	PAGE
A FIVE CHANNEL CARRIER TELEPHONE SYSTEM FOR THE SERVICES—L. S. Crutch, B.Sc.(Eng.), M.I.E.E.	1
CRYSTAL FILTERS—Part 2.—Reactance Circuits and Lattice Filters—R. L. Corke, A.M.I.E.E.	7
THE EQUIPPING OF THE RECONSTRUCTED CENTRAL TELEGRAPH OFFICE—E. J. C. O'Brien	11
A DELAYED-ACTION LEVER TYPE KEY—W. H. Blois and J. M. Fleming	16
AERIAL CABLE SUSPENSION BY THE SPINNING METHOD—C. A. Mitchell, A.M.I.E.E.	19
CABLE SPLICING AND RECONDITIONING—L. C. Langford	22
NOTES AND COMMENTS	25
REGIONAL NOTES	27
STAFF CHANGES	30
JUNIOR SECTION NOTES	32

Price 1/- net

THE INSTITUTION OF POST OFFICE ELECTRICAL ENGINEERS

GE CALLOY

RADIO CORES

Send for
New List
1944

SALFORD ELECTRICAL INSTRUMENTS LTD.

PEEL WORKS, SALFORD, 3. Telephones: BLACKFRIARS 6688 (6 lines). Telegrams and Cables: "Sparkless, Manchester"
PROPRIETORS: THE GENERAL ELECTRIC Co. Ltd., OF ENGLAND

EDISWAN

TELEPHONE LINE PROTECTOR PANELS

EDISWAN-SHOTTER-GREETHAM PATENT

(British Patent No. 353924)

**for the protection of telephone systems
against surges induced by faults on
neighbouring power lines**

Of the difficulties attendant upon the employment of overhead systems one of the most serious is to ensure uninterrupted working of the telephone system, by providing adequate protection against induced surges caused by switching or line faults in adjacent power lines or by lightning.

The Ediswan Patent Protectors provide the solution. They are inert at the normal working pressure of the telephone line, they keep the voltage on the line down to a pre-determined figure by providing a path of low resistance to earth whereby the surge is cleared and they again become inert immediately the surge is cleared.

They ensure simultaneous discharge of both lines and are capable of clearing heavy discharges without detriment to the system or the protector.

**Ediswan Telephone Line Protectors have now been in
use by Supply Companies for many years.**



5-circuit panel for overhead lines incorporating choke coils, spark gaps, etc.

THE EDISON SWAN ELECTRIC CO. LTD., 155 CHARING CROSS ROAD, LONDON, W.C.2

THE POST OFFICE ELECTRICAL ENGINEERS' JOURNAL

Vol. XXXVIII

April, 1945

Part I

A Five Channel Carrier Telephone System for the Services

L. S. CRUTCH, B.Sc.(Eng.), M.I.E.E.
(Siemens Bros. and Co. Ltd.).

U.D.C. 621.395.44

This article gives an account of the adaptation of a civil multi-channel carrier telephone equipment to meet Service needs for a robust and portable equipment to give good communication facilities. It deals with the problem of providing these channels over aerial lines or cables, over short and long distances and under conditions peculiar to Service use. The equipment described has had extensive use by the Army and Royal Air Force in India, Africa, Italy and North-Western Europe.

Introduction.

THE Post Office Carrier System No. 4 is in use on a number of routes in the United Kingdom and in this form it has already been described in this Journal¹. It is a five channel carrier telephone system in which one channel is obtained by simple voice frequency apparatus and four channels from the modulation of carrier frequencies between 6 and 16 kc/s. The four carrier frequencies are 6 kc/s, 9.2 kc/s, 12.5 kc/s and 16 kc/s and the lower sideband is selected in each case by band filters, passing a frequency range equivalent to the transmission of voice frequencies between 300 and 2,600 c/s. From these four band filters the combined outputs are amplified before transmission to line. The receiving equipment is similar; the incoming frequency bands are amplified to a suitable level before passing to the receiving band filter which selects the band corresponding to the individual channels. The demodulator is similar to the modulator and the resulting voice frequency output is again amplified in each channel before passing to the exchange line. As described, the system was intended for use on unloaded underground trunk cables.

Six years ago discussions took place between the authorities concerned, with a view to producing a system for service use on aerial lines and embodying the main features of P.O. Carrier System No. 4. At this stage the contractors who had supplied the equipment for the latter system were called in, and detailed discussions ensued on the necessary and desirable features of a new system.

Basically the decisions reached were as follows:—

1. The equipment was to be transportable and mounted on bays similar to P.O. standard type but shorter and of special construction.
2. Open wire operation on a group frequency basis so that four carrier channels in the frequency range of 3.4 kc/s to 15.7 kc/s should be group modulated into the frequency range of 32 to 19 kc/s to form the return circuit for the low frequency group.

3. The equipment was to be capable of satisfactory operation under extreme climatic conditions and the general design and construction sufficiently robust to withstand the rough handling to which it would be subjected under service conditions.

Prototype equipments were constructed and subjected to very thorough tests. One of these prototypes served with the B.E.F in the Flanders campaign of 1940, and the main production equipments were first used in the North African campaign. Even before this equipment came into general use, it was realised that the rapid movement of modern warfare demanded equipment which was smaller and more readily transportable, and attention was given to the design of an equipment which should be much smaller than formerly but yet embody the same performance, and have more general application under varying conditions which might occur in service. From this study the company with which the writer is associated put forward proposals for the equipment to be described which has since been manufactured in considerable quantities. A comparison of the features of the first and second equipments, the Apparatus Carrier Telephone (1+4) Mk.1 and Mk.2 respectively, is therefore interesting.

In the first place a considerable reduction in bulk has been obtained. The Mk.1 terminal equipment occupies three bays each 5 ft. 6 ins. high by 20½ ins. wide by 16½ ins. deep, weighing in all 11¼ cwts. and occupying about 52 cubic feet. The Mk.2 equipment occupies two bays 2 ft. 10½ ins. high by 20½ ins. wide by 1 ft. 2½ ins. deep, weighing 6 cwt. and occupying 18 cubic feet.

Whereas the Mk.1 terminal was intended for open wire line operation and could be used on cable circuits only by adding additional panels to the third bay, the Mk.2 terminal can be converted for either type of working by re-arranging U-links, an operation carried out in a few moments.

The Mk.1 equipment had a fixed group carrier frequency of 35 kc/s so that with more than one system on a route, the crosstalk between systems depended on the quality of the line. The Mk.2 equip-

¹ P.O.E.E.J. Vol. 29, pp. 226 and 294.

ment provides alternative frequencies of 35 and 33.8 kc/s so that a frequency staggering is obtained with consequent improvement in privacy and signal-to-noise ratio.

The generator equipment and associated power supply bay necessary for the operation of the Mk.1 equipment is dispensed with in the re-designed equipment where all power is derived from A.C. mains or accumulators. This has been made possible by a considerable reduction in the power required mainly due to the use of lower consumption valves.

The signalling has been modified to a valve operated system of much greater sensitivity, so that the range of the equipment should never be limited by signalling, with the result that under emergency conditions considerable extension of line attenuation is possible.

Since the Mk.1 equipment was soon superseded by the Mk.2 and exists only in much smaller quantities, it is not intended to describe it, but to confine this account to the later version and the repeater equipments developed to work with it.

Immediately under this panel on Bay No. 1 is the test panel, where one U-link field controls the connections for open wire (2-wire)² or cable (4-wire) working and a second set of links brings in a spare line amplifier in each direction in the event of failure. A source of 500 c/s tone and attenuation pads brought out to sockets on this panel can, when used with the decibelmeter shown on the right of the panel, provide measuring apparatus for setting up the terminals at each end of a connection without the use of portable testing apparatus. The voltmeter at the left of the panel is used for checking valves by measurement of cathode current.

Below this panel is the line equaliser, comprising sections for different lengths of open wire line and cable together with resistance pads for overall gain adjustment in relatively coarse steps.

Immediately under the equaliser is the power supply panel for the bay. An A.C. mains transformer, rectifier, smoothing and vibrator are provided for the line amplifiers and group frequency oscillator, and a

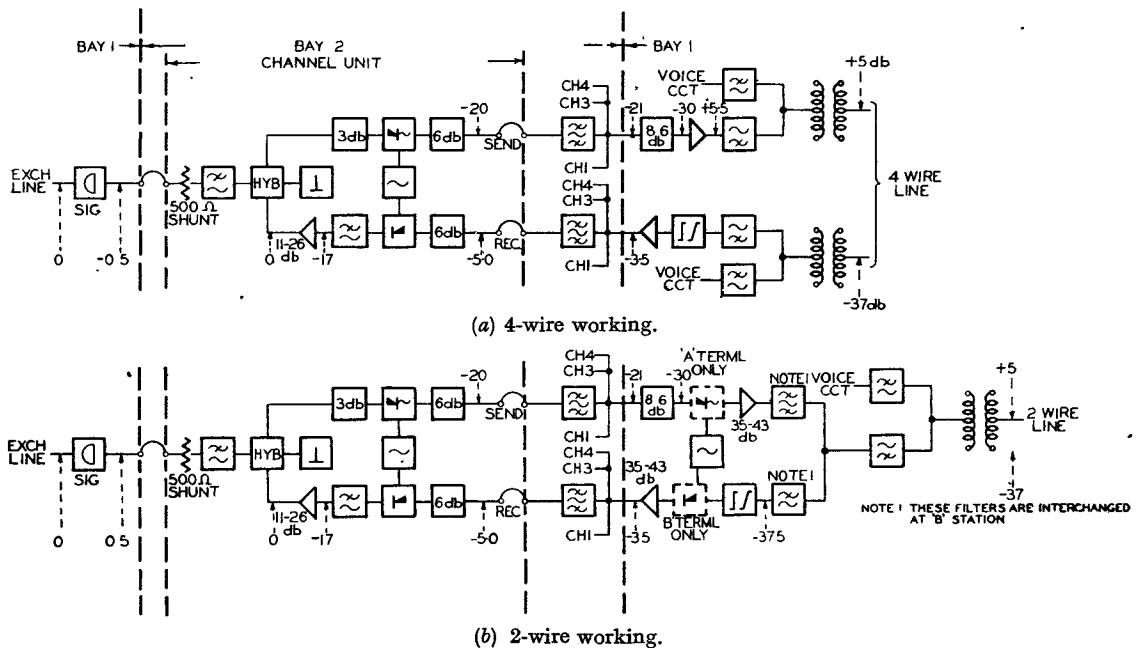

FIG. 1.—BLOCK SCHEMATIC OF ONE TERMINAL.

Description of Equipment.

Fig. 1 is a block schematic of the system, and also shows the distribution of the component items between the two bays which go to make up a terminal.

Fig. 2 shows a Mk.2 terminal, comprising the two bays, mounting apparatus on standard P.O. type 19-in. panels with individual and removable dust covers. The left-hand bay carries the common equipment, voice channel filters and signalling panels and the right-hand bay the modulation and demodulation apparatus and band pass filters for the four carrier channels.

All connections between the bays, and external connections for exchange lines, trunk line and power are made from the terminal panel at the top of each bay. The connecting cords are not shown in the

duplicate set of apparatus for the signalling panels. A change over from A.C. mains connection to 12 V battery is made by the two 8-pin plugs shown at the right-hand side of this panel. A similar plug changes the power supply connections from the normal to the spare line amplifier. This arrangement is simple and less liable to dirty contact trouble than a more elaborate multi-point change-over switch. "H.T. fail" "L.T. fail" and "Relay Supply fail" relays are fitted, each being associated with an alarm indication lamp.

² Throughout this article the term "2-wire" is used to denote the open wire line condition when all circuits (both audio and carrier) use the same 2 wires for both directions of transmission. This differs from the usual use of the term since the carrier circuits utilise different frequency bands for transmission in the two directions.

At the foot of the bay are the normal and spare line amplifiers. Each panel mounts two amplifiers each of two stages, used for the go and return directions of transmission. The layout shows the valves segregated at each end of the panel to assist heat dissipation and simplify ventilation; the associated transformers, condensers and gain controls are mounted adjacent to each pair of valves but separated from them by a metal screen. It will be seen that the

being fed to the signalling panels. Local ringing current is generated by a self-interrupting tuned relay working at about 20 c/s and fed through a tuned transformer providing a suitable waveform and source impedance. The signalling panels each mount two signalling receivers. The receiver has two valves, the first acting as a limiter and the second as a D.C. amplifier actuating a relay of the high speed type, which in turn controls a slow release relay in the local ringing circuit.

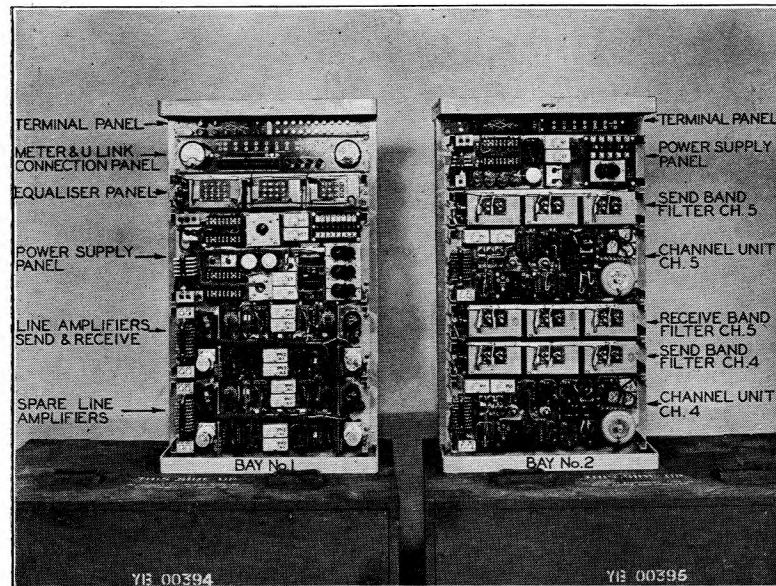

FIG. 2.—BAYS 1 AND 2, COMPRISING C.T. (1 + 4) Mk.2.

gain control is a U-link switch having eight positions which varies the gain from a maximum of 43 db. down to 35 db. in steps of 1 db. Relays for indication of failure of any one valve and associated alarm indication lamps are included on the panel.

On the rear of the bay mount the line filters for separation of the voice circuit from the carrier channels; the group oscillator and frequency changer, signalling oscillator and local ringing generator, mounted on one panel; and below two signalling panels each mounting two signalling receivers, thus providing one receiver per carrier channel.

Two line filters are provided, one only being required for a 2-wire open wire line circuit but two for a 4-wire cable circuit. These filters are identical and are complementary high- and low-pass structures cutting off around 3 kc/s.

The group frequency oscillator can generate either 35 kc/s or 33.8 kc/s and feeds directly into the ring modulator which acts as frequency changer for the transfer of the 3-16 kc/s group into the 32-19 kc/s range. It is followed by a low-pass filter which removes the upper side band and attenuates the carrier by some 40 db. Alternative strap connections on the oscillator tuning unit and the filter provide the correct circuit connections for either 35 kc/s or 33.8 kc/s group modulation. The 500 c/s oscillator for signalling is of conventional design and its output is interrupted by the local ringing generator before

The bay No. 2 mounts the equipment for the four speech channels and their power supply apparatus. The basic circuit arrangements for the production of a carrier sideband from a voice input and for its demodulation to give back a voice output are well known and need not be described. Each carrier circuit comprises a channel unit panel and two band pass filters, the sending filter for selecting the lower sideband of modulation and the receiving filter for selecting the wanted sideband to the exclusion of all others. The arrangement of these band filters is shown in Fig. 1. The channel unit panels are all identical and interchangeable, and with the correct strap connections on the tuning unit, can generate any one of the four carrier frequencies of 6.0, 9.2, 12.5 or 16 kc/s.

Each panel thus comprises :—

1. The 2-wire connection to the hybrid coil, which contains a simple low pass filter for restricting carrier leak in the exchange lines.
2. A modulator of the ring type fed from a single valve oscillator of high stability, and working between suitable attenuation pads.
3. A demodulator of similar type fed from the same oscillator, and having a filter to exclude unwanted demodulation products and carrier leak from the channel amplifier.
4. A single stage amplifier for raising the demodulated signals to a suitable level for feeding to the 2-wire line via the hybrid coil. The maximum gain is about 23 db. with variation in steps of 3 db. down to 11 db. The input transformer is combined with the demodulator sideband output transformer; and the output transformer with the hybrid coil.

A check frequency key provides for sending the carrier frequency of a particular channel to line, where at the receiving end it beats with the local carrier in the demodulator; the resulting low frequency difference beat being indicated on the voltmeter on the test panel.

The sending and receiving band filters are identical for each channel and are ladder networks using coils and condensers of conventional type for equipment of this nature. They provide for substantially uniform transmission of sidebands corresponding to modulating frequencies between 300 and 2,600 c/s, with

attenuation outside the band of about 60 db. It will be seen from the photograph that each filter is divided into three cans. This arrangement provides a perfect seal for the coils and condensers against moisture and mechanical damage, but divides the structure into units of reasonable weight, any one of three being replaceable in the event of a fault.

The layout of the apparatus on the two bays was chosen to need the minimum number of interbay connections. Six double ended twin cords are used, four of which carry voice frequency currents at approximately zero level and connect the carrier equipment to the signalling panels; and two carry the "Go" and "Return" sidebands between the band filters and common amplifiers. These two operate at different levels but any crosstalk which does occur only affects the stability of individual channels and does not cause interference between them.

Repeater Equipment.

To extend the working range between terminals, 2-wire and 4-wire repeaters have been provided. As far as possible these repeaters have been built from the same parts as the terminals and have certain important panels in common, as for example, line amplifiers and directional filters. This practice is economical in manufacturing effort and reduces the number of spare parts which have to be transported and stocked. The general construction of the repeaters is similar to the terminal equipments but since they comprise less apparatus the overall bulk is reduced. Fig. 3 shows the 2-wire unit known as Repeater C.T. No. 1 (Mk.1). The 4-wire repeater is of similar construction and appearance but is smaller on account of the omission of the directional filters. Both units have

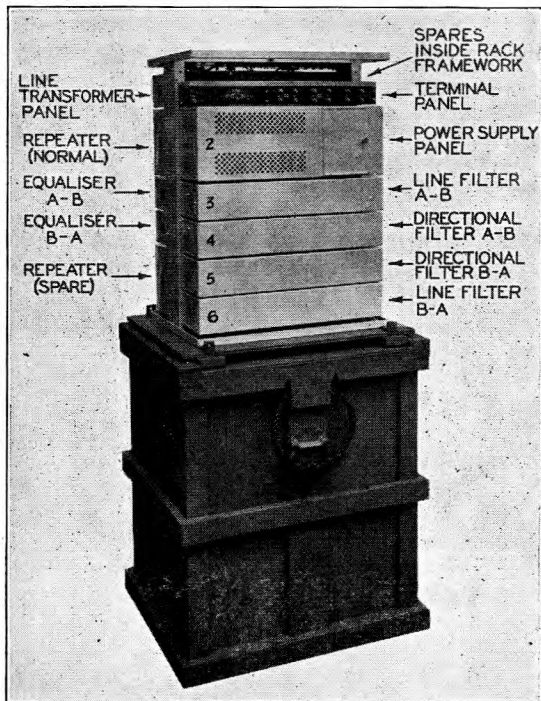

FIG. 3.—REPEATER C.T. No. 1, Mk.1.

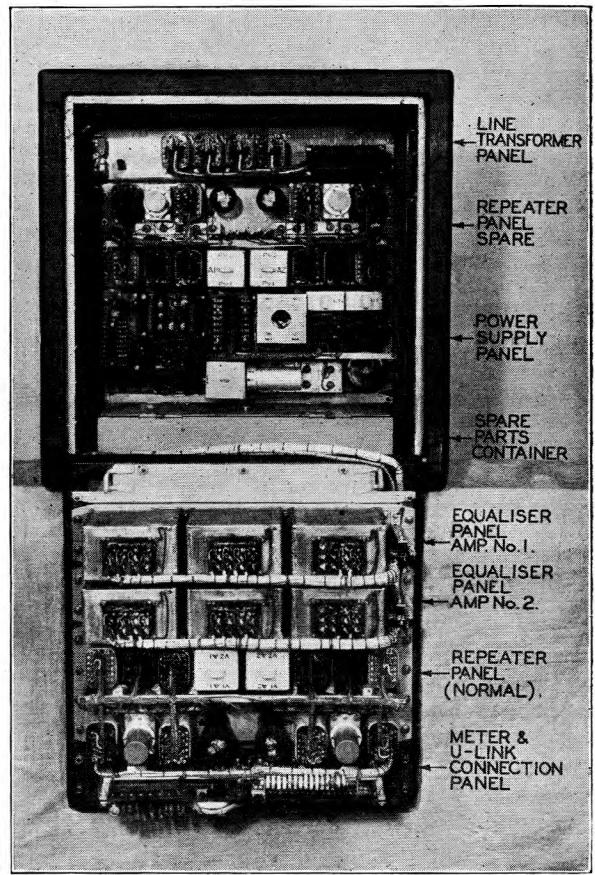

FIG. 4.—REPEATER C.T. No. 3.

apparatus panels mounted on light frameworks and standing on a substantial wood base, the whole having a cover which acts as a transit case, or as a stand to mount the unit at a convenient height. Fig. 3 shows the unit standing on the transit case in the usual working position. The apparatus panels are similar in appearance to those of the terminal equipment (see Fig. 2) and do not merit separate description.

The line amplifiers being common with the terminal equipment have a maximum gain of 43 db. This gain is usable as a 4-wire repeater on cable circuits but as a 2-wire repeater it cannot be realised without more elaborate directional filters than normal circumstances warrant. The equalisation networks associated with the repeater contain attenuation pads, so that the maximum insertion gain is restricted to 28 db. at the highest working frequency. Higher gains can be obtained without instability, but the frequency characteristic will no longer be level. Control of gain in small steps of 1 db. up to a maximum of 8 db. is provided as on the terminal amplifiers. This serves to set the gain for the desired output level per channel and also provides for a manual control to take account of changes in the line due to temperature and weather. No pilot frequency with means for changing automatically the repeater gain with line attenuation changes is provided on this system, as the circuits on which most of the equipment would be used were not of such a length as to require these facilities.

Separating filters are provided on the 2-wire repeaters, and have similar characteristics to the units fitted on terminals. In this way the voice circuit may be by-passed round the repeater, or a separate voice frequency repeater having a maximum gain of 26 db. can be inserted.

The power handling capacity of the amplifiers is the same as the terminal equipment and the sending level per channel is nominally + 5 db. This is quite adequate for cable circuits but to meet the need for a higher sending level on noisy aerial lines, a new unit known as Repeater C.T. No. 3 is being provided which when used with a separate filter unit known as Filter Line and Directional No. 1 can transmit levels up to + 17 db. per channel (ref. 1 mW) and give a higher insertion gain than the former repeater.

Fig. 4 shows the repeater unit. It will be seen that the form of construction has been changed to mount the apparatus in a pressed steel case of a type standardised for other portable service equipment. In this form of construction the apparatus panels are mounted on frames which hinge about the base of the case. The normal working position is with both frames shut. The filter unit is of similar construction and carries filters in sealed cans adapted to the frame method of mounting.

The division of the 2-wire repeater into two separate units was necessary to fit the apparatus in standard sizes of this steel case, but has the added advantage that the repeater without the filter unit is a complete 4-wire repeater and with the filter unit is a complete 2-wire repeater. Increased gain and power handling capacity have been provided so that as a 4-wire repeater 48 db. is available in place of 43 db. previously and the directional filters allow an insertion gain of 40 db. as a 2-wire repeater instead of the 28 db. on the earlier unit. The units have an additional function in that they can be used as auxiliary equipment with existing terminals to raise the sending level to line from +5 db. per channel to +17 db. per channel.

By-pass Equipment.

It may happen that when carrier channels are used to provide a group of circuits between two points,

circuits are also needed to branch off from the main route, or to give access for linemen to communicate with adjacent stations. To meet this need it is most economical to use the voice circuit and a by-pass unit is accordingly provided for insertion in the route at any point where the voice channel needs to be separated from the carrier channels. This is a simple unit, and in the form shown in Fig. 5 it can be mounted on a pole or hung on a wall. It contains complementary high and low-pass filters of the same type as used in the terminal and repeater equipment together with isolating line transformers and condensers from which an earth phantom telephone circuit can be derived. As shown in the photograph, the apparatus mounts on a tray which slides into the box, a flap letting down over the terminal connection panel when external leads are joined. As a protection against weather this terminal panel faces downwards when the unit is hung up. No reference has so far been made to phantom circuits, but all terminal and repeater units provide for the mid-point of the line to be accessible either from a transformer mid-tapping point or from balanced condensers so that an earth phantom service connection can be set up. A particular form of earth phantom through condensers is used on the terminal equipment, so that the carrier line transformer can be isolated from low frequency ringing currents, which then pass directly into the low pass filters in the voice circuit.

When 4-wire carrier circuits are obtained from field quad cable, there is of course the choice of one full phantom metallic circuit of good quality or two earth phantom circuits which will probably be noisy.

Summary of Performance.

The gain provided in each terminal equipment was required to be sufficient for 2-wire circuits of 4 db. equivalent to be obtained from aerial line or cable circuits having 40 db. attenuation at the highest frequency transmitted; namely 31.4 kc/s for aerial and 15.7 kc/s for cables. The gains are such that with all conditions normal, 4 db. circuits can be set up over a line attenuation 5 db. in excess of the basic requirements; and the ringing sensitivity is such that circuits of 20 db. equivalent can be worked in emergencies. A 40 db. attenuation represents about 100 miles of army air line with about 10 db. allowance for entrance and interruption lengths of cable. On civil lines of more elaborate construction greater ranges between terminals are possible, depending upon the weight of copper conductors in the line.

Approximately 14 db. more gain is available for 4-wire working on cables, since group frequency-changers are not used. The equipment was intended to work over loaded field-quad cable having an attenuation of about 1 db. per mile at 15.7 kc/s, giving approximately 40 miles range without intermediate repeaters. However the available gain can extend this distance up to about 55 miles, provided that the near-end crosstalk in the cable is satisfactory.

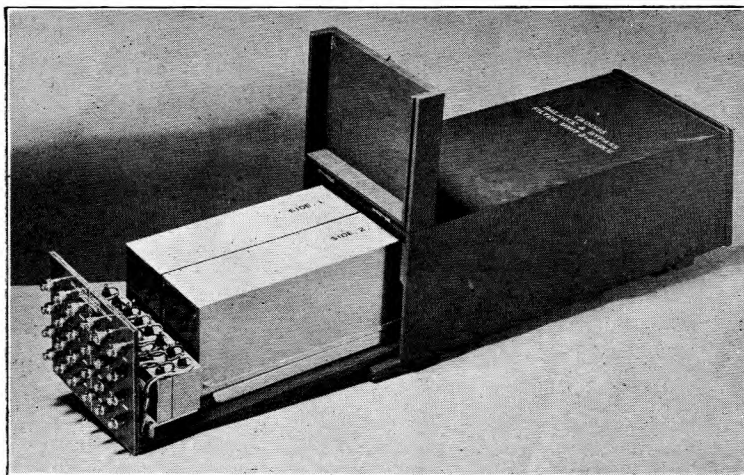

FIG. 5.—BALANCE AND BY-PASS UNIT.

The nominal sending level to line is +5 db. per channel but this can be increased to +12 db. per channel at the expense of the signal to noise ratio. Typical values obtained are as follows:—

- Sending at +5 db. per channel.
- Far-end Crosstalk average 69 db., worst 67 db.
- Near-end Crosstalk average 62 db., worst 54 db.
- Sending at +12 db. per channel.
- Far-end Crosstalk average 62 db., worst 58 db.
- Near-end Crosstalk average 62 db., worst 51.5 db.

Any attempt to extend the length of line by raising the sending level will of course always be at the expense of the near-end crosstalk, and the figures quoted above are for a 30 db. non-reactive line taking no account of the effect of equalisation in modifying the crosstalk obtained when working over a physical line.

On open wire lines, provided that the frequency groups always transmit in the same direction, far end crosstalk will be the main result from couplings between pairs carrying separate systems. The equipment provides for alternative group carrier frequencies of 35 and 33.8 kc/s, so that the resulting sidebands in the upper frequency group are staggered by 1,200 c/s with respect to one another. This makes the inter-system crosstalk unintelligible and gives at least 10-12 db. improvement on a volume basis.

The quality of transmission is within the former C.C.I.F. requirements for carrier systems on aerial

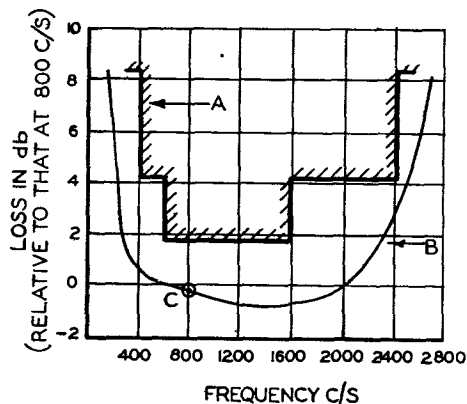

- A. C.C.I.F. Values for 4-wire circuit.
- B. Typical characteristic for 2-wire-2-wire connection.
- C. 800 c/s reference point.

FIG. 6.—QUALITY OF TRANSMISSION.

lines, the frequency response for a complete connection being as shown on the block chart in Fig. 6. Clearly the carrier frequency spacing does not allow of realisation of a band-width extending the response to 3,400 c/s.

The group and channel carrier frequency oscillators have been designed for a high degree of stability and the frequency drift with temperature has been kept as small as possible. At 16 kc/s the variation of frequency with 10 per cent. change in H.T. and L.T. supply is about 1 c/s and the change of frequency

with temperature is in general less than 1 c/s per degree centigrade change. For the channels below 16 kc/s the changes are smaller and in rough proportion to the frequency.

At the group carrier frequency of 35 kc/s, the effect of the supply voltage stability is again so small as to be negligible and the change of frequency with temperature is less than 1½ c/s per degree centigrade temperature change. The signalling receivers have a band pass characteristic about 25 c/s on either side of the nominal 500 c/s signalling frequency, and failure due to carrier frequency drift is not likely to occur until the drift has exceeded 20 to 30 c/s, a frequency difference which is noticeable on speech. Although the equipment was not intended to transmit voice frequency telegraphs over the carrier channels, this can readily be done on cable circuits where group modulation is not used, and has in fact been carried out on open wire lines with group modulation in many instances with quite successful results. Should drift occur, the synchronisation of the carrier frequencies between terminals is so easily carried out that no trouble arises in maintaining the circuits.

Power Supply.

All the equipments described have been intended primarily for operation from alternating current mains with an accumulator battery as a standby or for those situations where no generator source of supply is available. In all equipments the principle adopted has been to provide transformers connected to the mains giving low tension supply from secondary windings and a rectified and smoothed H.T. supply through dry plate rectifiers and choke and condenser smoothing. When due precautions are taken the circuit noise is little worse than when supplied from station batteries. Operation from batteries in the field must be from low tension accumulators and 12V is universal. The battery then supplies the low tension direct, so that all connections of 6 V valve heaters are made in pairs. Accordingly on A.C. the step-down transformer windings provide 12 V. For H.T. supply from accumulators, current is fed to the mains transformer through a vibrating interrupter of the "car radio" type. With a suitably proportioned winding on this transformer, usually common with the A.C. heater winding, the same effective voltage is induced into the H.T. winding feeding the rectifier system as occurs when the primary is joined to the A.C. mains. The rectifying and smoothing equipment is then used for either source of supply and self rectifying vibrators are not necessary. Unless due precautions are taken, this arrangement can cause considerable circuit noise and radiate interference to nearby radio sets from all conductors connected to the system. Since the life of the vibrators can be very short under incorrect operating conditions the circumstances of vibrator sparking, useful life and radio interference have to be considered together. In earlier equipments precautions were taken merely to reduce sparking at the contacts without paying any special attention to radiation. It was, however, found that sensitive radio receivers could not be operated at anything near their full gain when in

close proximity to the equipments or to the exchange or trunk lines connected to them. Later equipments are fitted with low-pass filter networks in the vibrator leads and the whole unit comprising vibrator and filters enclosed in an earthed screening case. In these circumstances the interference in nearby radio receivers is only some 6-10 db. above the background arising in the receiver itself.

Maintenance and Spare Parts.

Equipment for service use has to withstand rough handling with transport under difficult conditions and may have to operate under climatic conditions much more severe than experienced by permanently installed civil equipment in fixed locations. Considerable attention was devoted to these physical and mechanical questions when the prototypes of the Mk.1 terminal equipment were built and the experience then gained has been incorporated in all the later equipments. Important components are enclosed in sealed cans, where possible small components working in close proximity, such as the interstage elements between two amplifying valves, have been mounted in small cases similar to transformers. All wiring is in flexible lead and rigidly supported at frequent intervals where the run exceeds a few inches.

Maintenance of equipment can be divided between the routine checking and replacement of consumable

items like valves, vibrators, fuses, lamps and cords, and the replacement of faulty components. The Mk.1 terminal equipment carried a large selection of consumable and general spares in a separate carrying case. On later equipments the principle of carrying spares on the equipments themselves rather than in separate cases has been followed. On Mk.2 terminals, the carrying case is constructed to include a spares compartment in the form of a flat tray below the runners carrying the bay framework. This compartment cannot be opened while the bay is in the case, but when the bays are out and standing normally on the case, the side flap can be taken out, the lid of the tray opened and the spares are exposed to view.

Conclusion.

The equipment described has proved very useful for service communications, where the small bulk has been of advantage in transportation and the simple procedure for putting into service has enabled new circuits to be set up and worked in a short time. Large quantities of equipment have been and are being supplied with only minor alterations since the prototype stage, which testifies to its suitability for the use for which it was designed. The grade of transmission provided is high, and satisfactory circuits have been set up over distances very much longer than envisaged for the equipment at the time of design.

Crystal Filters

R. L. CORKE, A.M.I.E.E.

Part 2.—Reactance Circuits and Lattice Filters

U.D.C. 621.318.7 621.392.52

Two-terminal reactance circuits are dealt with in more detail than in Part 1. Then follows a description of simple methods of determining the properties of lattice filters.

Reactance and Susceptance Curves.

THE final paragraph of Part I contains three general rules concerning the behaviour of two-terminal reactance circuits. These rules are most easily applied to more complicated circuits if the circuits are in either of the two standard forms shown in Fig. 1. Any reactance circuit, however,

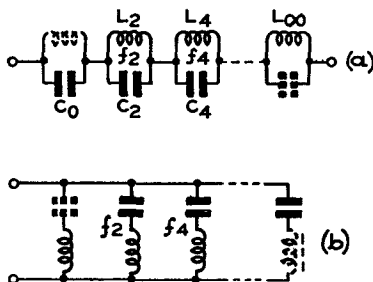

FIG. 1.—STANDARD FORMS FOR REACTANCE CIRCUITS.

can be reduced to these forms by circuit transformations¹. Circuits in these standard forms are free from redundant elements and they can be dealt with

simply by using Foster's Reactance Theorem which will be explained later in this article. In Fig. 1 (a) the form is a series connection of a number of parallel connected pairs of inductors and capacitors except on the left where an inductor, shown dotted, has infinite value, and on the right a capacitor, also dotted, has zero value. These dotted elements have been indicated to preserve the symmetry and also to emphasise how the reactance at zero frequency and infinite frequency due to the left- and right-hand pairs respectively can be regarded as an anti-resonance. The circuit of Fig. 1 (b) has the inverse form, being a parallel arrangement of series connected inductors and capacitors; the dotted elements indicate that the left-hand pair limits to an inductor only, resonant at zero frequency, and the right-hand pair limits to a capacitor only, resonant at infinite frequency. For brevity the following description will deal mainly with circuits of the type shown in Fig. 1 (a), but since the two standard forms are inverse networks it follows that consideration of the reactance of one standard form will also suffice for the susceptance (the inverse of reactance) of the other form. In Fig. 1 (a) the tune frequencies of the centre pairs are labelled as f_2 and f_4 , at which frequencies the reactance is infinite. At zero frequency and at

¹c.f. "Transmission Circuits for Telephonic Communication," by K. S. Johnson, Appendix D, Part 2.

infinite frequency the remaining elements shown provide infinite reactance so that the complete circuit will exhibit anti-resonances at these four frequencies. Bearing in mind that the reactance/frequency curve must always have a positive slope this means that it is not possible to have two adjacent resonances or anti-resonances, but that a frequency of resonance must be preceded and followed in the frequency scale by an anti-resonance, and so on. Thus the reactance and susceptance curve of Fig. 2

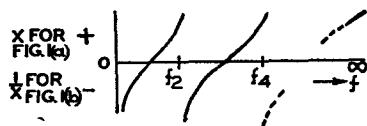

FIG. 2.—REACTANCE AND SUSCEPTANCE CURVE.

The dotted lines in Fig. 1. The foregoing has illustrated the three rules for sketching reactance curves of given circuits. As a further example Fig. 3 shows the

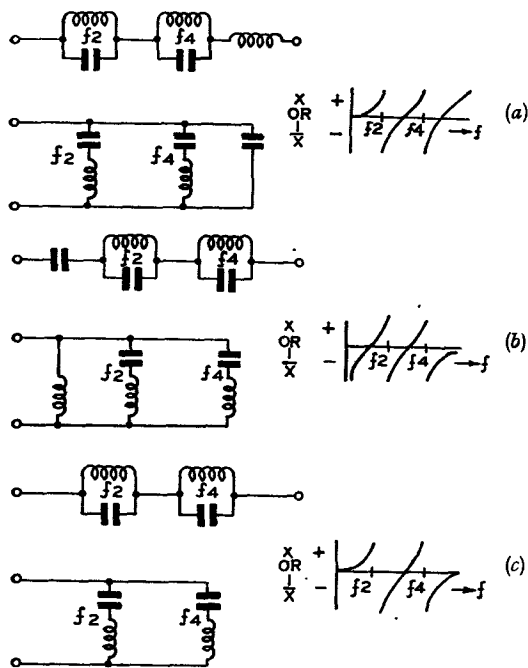

FIG. 3.—REACTANCE AND SUSCEPTANCE CURVES OF VARIOUS CIRCUITS

reactance/susceptance curves for different circuits obtained by successive simplification of Fig. 1. Application of the same principles enables circuits to be drawn corresponding to any given reactance or susceptance/frequency curve.

Foster's Reactance Theorem

In addition to being able to tell the general form of the reactance curves of any two-terminal reactive circuit, it is, of course, necessary to be able to calculate the reactance at any frequency as well as the values of inductance and capacitance to produce any

desired result. The simplest method of calculation involves the use of Foster's Theorem² which shows first how the reactance can be expressed in terms of the critical frequencies and of one of the elements in the network, and second, how all the other elements may be determined in terms of this element and the critical frequencies. In this article it will be necessary to make use of the first part only of the theorem; the second part is of value in the design of filters of which little can be said here.

The first part of Foster's Theorem states that the impedance Z of a reactive two-terminal circuit at any frequency f is given by

$$Z = \frac{H (\omega_1^2 - \omega^2) (\omega_3^2 - \omega^2) (\omega_5^2 - \omega^2) \dots}{j\omega (\omega_2^2 - \omega^2) (\omega_4^2 - \omega^2) (\omega_6^2 - \omega^2) \dots}$$

in which $\omega/2\pi = f$, $\omega_1/2\pi = f_1$, $\omega_2/2\pi = f_2$, etc.

f_1, f_3, f_5 , etc., are frequencies of resonance,
 f_2, f_4, f_6 , etc., are frequencies of anti-resonance,

$$0 < f_1 < f_2 < \dots$$

and H is a positive constant related to one element in the circuit. (H can be zero, but discussion of this condition is omitted for simplicity). For example, the expression for the impedance of the circuit in Fig. 4 with the critical frequencies numbered as shown in the reactance curve is

$$Z = \frac{2\pi L}{jf} \cdot \frac{(f_1^2 - f^2)(f_3^2 - f^2)(f_5^2 - f^2)}{(f_2^2 - f^2)(f_4^2 - f^2)}$$

If the capacitance C is omitted from the circuit the frequency f_1 will move to zero (see Fig. 3 (a)) and the expression for the impedance will become

$$Z = j2\pi Lf \frac{(f_3^2 - f^2)(f_5^2 - f^2)}{(f_2^2 - f^2)(f_4^2 - f^2)}$$

This is obtained from the previous equation because

$$\frac{2\pi L}{jf} (-f^2) = 2\pi Lf \cdot \frac{(-1)}{j} = j2\pi Lf$$

since $j = \sqrt{-1}$

From the foregoing it is clear that it is possible to sketch the general shape of the reactance (or the susceptance) curve of a two-terminal reactive circuit

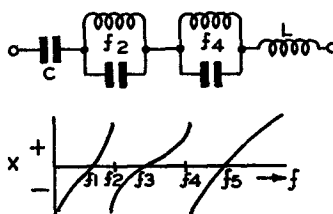

FIG. 4.—EXAMPLE FOR FOSTER'S THEOREM.

in the standard forms irrespective of the number of elements involved, and further by a simple application of Foster's Theorem, to write down an expression for the reactance (or the susceptance) of the circuit. With these aids it will now be possible to examine in some detail the characteristics of lattice

²B.S.T.J., April, 1924, p. 259.

filter sections with more complicated arms than the simple low pass section so far described.

Lattice Filter Sections.

It will be recalled that in Part I it was shown that the pass band of a lattice section embraces all those frequencies at which the reactances of the series and lattice arms are opposite in sign and that attenuation regions exist where the reactances have similar sign. In particular, infinite attenuation develops at those frequencies for which the reactances of the series and lattice arms are equal. Suppose a filter has the

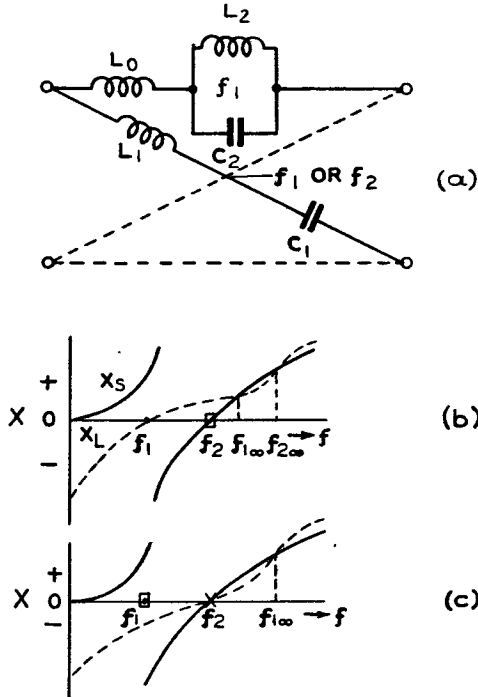

FIG. 5.—LOW PASS FILTER WITH ALTERNATIVE CHARACTERISTICS.

configuration shown in Fig. 5 (a). The full lines in (b) and (c) show the type of reactance curve for the series arms. The reactances of the lattice arms have the general shape shown by the dotted lines, and these can be related in the two ways shown at (b) and (c) to give the conditions for a low-pass filter. In (b) f_1 is a frequency of resonance for the lattice arms and of anti-resonance for the series arms. In this case therefore f_2 , the resonant frequency of the series arms, marks the edge of the pass band, and is thus the cut-off frequency. The pass band is continuous from zero to f_2 , since at all frequencies in this band the arm reactances are opposite in sign. For the alternative arrangement in Fig. 5 (c) f_1 is the cut-off frequency and the attenuation band is continuous for all frequencies above f_1 , since the reactances in this range have the same sign throughout. Both arrangements of the same filter circuit therefore result in low-pass sections, but the characteristics of the two are very different. To find out how they differ, each will be taken in turn and expressions found for the characteristic impedances and for the number and location of any frequencies of infinite loss.

From Fig. 5 (b) and using Foster's Theorem the impedances Z_s and Z_L of the series and lattice arms respectively are

$$Z_s = j2\pi L_0 \cdot f \cdot \left(\frac{f_2^2 - f^2}{f_1^2 - f^2} \right)$$

$$\text{and } Z_L = \frac{2\pi L_1}{j f} (f_1^2 - f^2)$$

Therefore

$$Z_0 = \sqrt{Z_s Z_L} = 2\pi \sqrt{L_0 L_1} (f_2^2 - f^2)$$

and the nominal value of Z_0 at zero frequency is

$$R_0 = 2\pi f_2 \sqrt{L_0 L_1}$$

which is obtained by making f zero,

$$\text{and therefore } \frac{Z_0}{R_0} = \sqrt{1 - \frac{f^2}{f_2^2}}$$

This last expression is a convenient form for determining the nature of the impedance curve.

Turning next to the peaks of loss, these occur at the frequencies f_∞ when $Z_s = Z_L$, as explained in the first part of this article. Thus the condition is given by the equation

$$j2\pi L_0 f_\infty \frac{f_2^2 - f_\infty^2}{f_1^2 - f_\infty^2} = \frac{2\pi L_1}{j f_\infty} (f_1^2 - f_\infty^2)$$

Simplifying and rearranging, this equation, a quadratic in f_∞^2 , becomes

$$f_\infty^4 \left(\frac{L_1}{L_0} - 1 \right) - f_\infty^2 \left(\frac{2L_1}{L_0} f_1^2 - f_2^2 \right) + \frac{L_1}{L_0} f_1^4 = 0$$

and the two values for f_∞^2 may be found by using the ordinary solution for a quadratic equation. The most significant fact for the moment is that there are *two* frequencies of infinite loss (at positive frequencies) shown diagrammatically in Fig. 5 (b) at $f_{1\infty}$ and $f_{2\infty}$, which are the points of intersection of the reactance curves.

The alternative arrangement for this filter, Fig. 5 (c), has arm impedances of

$$Z_s = j2\pi L_0 f \cdot \left(\frac{f_2^2 - f^2}{f_1^2 - f^2} \right)$$

$$\text{and } Z_L = \frac{2\pi L_1}{j f} (f_2^2 - f^2)$$

$$\text{so that } Z_0 = 2\pi \sqrt{\frac{L_0 L_1}{f_1^2 - f^2}} (f_2^2 - f^2)$$

$$\text{and } R_0 = 2\pi \sqrt{L_0 L_1} \frac{f_2^2}{f_1}$$

$$\text{Hence } \frac{Z_0}{R_0} = \frac{1}{\sqrt{1 - \frac{f^2}{f_1^2}}} \left(1 - \frac{f^2}{f_2^2} \right)$$

This expression is somewhat different from that of the previous example. A comparison of the two characteristic impedances is shown in Fig. 6. At f_2 , the cut-off frequency in Fig. 6 (a) (corresponding to the arrangement of Fig. 5 (b)) the impedance is zero, whereas at the cut-off frequency f_1 in Fig. 6 (b)

(corresponding to the arrangement of Fig. 5(c)) the impedance is infinite. At frequency f_2 (Fig. 6) (b) the impedance is zero. The position of this frequency in relation to f_1 controls the shape of the curve in the pass band. It will be found that the characteristic

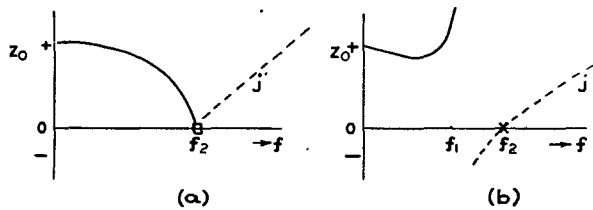

FIG. 6.—ALTERNATIVE IMPEDANCES.

impedance of (b) (Fig. 6 (a)) is the same as that of a series-terminated constant-K low pass ladder filter³, and that of (c) (Fig. 6 (b)) corresponds to that of an m-derived shunt terminated low-pass ladder filter⁴.

Further analysis of the m-derived lattice filter shows that there are two frequencies of infinite loss; one corresponds to f_2 and the other occurs elsewhere at the intersection of X_s and X_L as shown in Fig. 5 (c). Equating Z_s and Z_L gives

$$f_\infty = f_2$$

and

$$f_{1\infty} = \frac{f_1}{\sqrt{1 - \frac{L_0}{L_1}}}$$

The latter expression is similar to one found for the section in Fig. 2 of Part I.

Examination of other circuits will demonstrate that the rules which follow for ascertaining the nature of the characteristic impedance and the number of peaks of infinite loss are true for all lattice-filter sections. A distinction will be made between the two kinds of frequencies of infinite loss. The first kind, as in Fig. 5 (b), are those that can occur due to intersections of Z_s and Z_L away from the frequency axis. The second kind, which will be known as impedance controlling frequencies, includes all those that correspond to a critical frequency in the attenuation region, as does f_2 in Fig. 5 (c). The rules are these:—

- (1) The total possible number of peaks of loss of the first kind is equal to the number of intervals into which the pass band or pass bands are divided by critical frequencies.
- (2) The number of impedance controlling frequencies determines the nature of the characteristic impedance of the filter. (When the number is zero the impedance is related to that

of the constant-K ladder filter. When the number is one or more the impedance characteristic is modified.)

Two examples will serve as a summary. Fig. 7 (a) gives an arrangement of reactance curves which

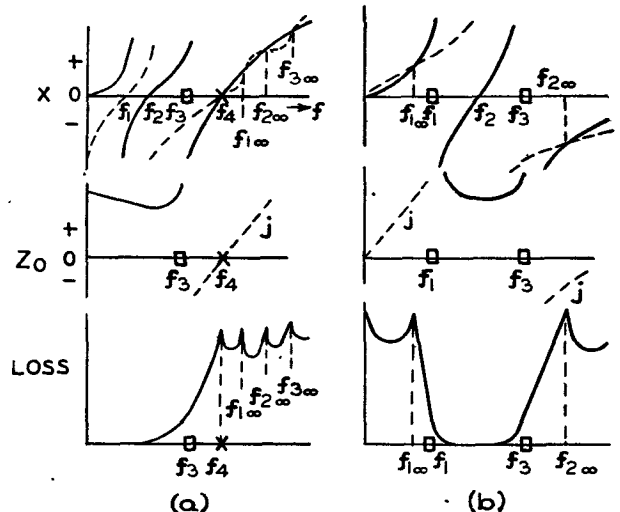

FIG. 7.—LOW PASS AND BAND PASS FILTER CURVES.

inspection shows gives a filter with the following characteristics:—

- (i) Low pass, cut-off frequency f_3 .
- (ii) Derived mid-shunt impedance with f_4 the impedance-controlling frequency.
- (iii) Three intervals in pass band, i.e. 0 to f_1 , f_1 to f_2 and f_2 to f_3 , and therefore three peaks of loss (with f_4 additional).

Fig. 7 (b) shows the reactance of a filter with the following:—

- (i) Band pass, cut-off frequencies f_1 and f_3 .
- (ii) Constant-K impedance (mid-shunt), since there are no impedance-controlling frequencies and the impedance is infinite at the cut-off frequencies.
- (iii) Two intervals in the pass band and therefore two peaks of loss. These have been shown in the loss diagram with one in each attenuation band, but they can both be designed to appear on the same side of the pass band if this is desired.

The circuits of these two filter sections can be deduced by applying the principles of two terminal reactance circuits, already described.

Part 3 will describe the nature and characteristics of quartz crystal resonators and will show how they can be incorporated in filter networks.

^{3,4} Ladder filters are series terminated at an end when a series or longitudinal branch of the network is connected to a terminal, and shunt terminated at an end where a shunt branch is connected across a terminal pair. The ladder filter with m-derived impedance has at least one frequency of infinite loss which, according to its frequency, controls the impedance curve as does f_2 in Fig. 6(b). The constant-K version is a special case in which, for the low pass case, the impedance controlling frequency has infinite value.

The Equipping of the Reconstructed Central Telegraph Office

E. J. C. O'BRIEN

U.D.C. 621.394.722

The author describes the re-equipping of the Central Telegraph Office following its destruction by enemy action.

Introductory and Historical.

IN connection with the following description, it is thought that some reference to the C.T.O., its historical background and unique association with the development of telegraphs might be of general interest.

The forerunner of the present C.T.O. was founded about 90 years ago in a small room in Founders Court, Lothbury, when the Electric Telegraph Company acquired the patent rights of Messrs. Cooke and Wheatstone's system of telegraphy. In 1860 the company moved to Little Bell Alley off Moorgate. The name of this alley was changed to Telegraph Street and its initials "T.S." have since been the telegraphic call signal of the C.T.O. By the Telegraph Act of 1870 the Government acquired the various telegraph companies then operating, and in 1874 the C.T.O. building (Fig. 1) was erected on

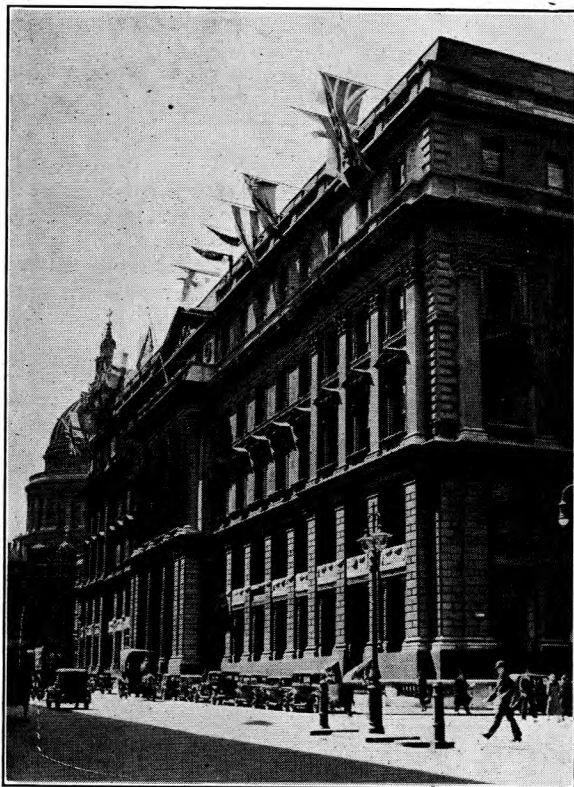

Fig. 1.—C.T.O. BUILDING IN 1935.

its present Newgate Street site. An additional floor was added in 1884 and another in 1925. From the time of the transfer to 1920 the staff had grown from 1,500 to over 5,000 and the systems in use were mainly Morse, Wheatstone automatic, Baudot,

Creed, Murray and the Hughes system. From this period onwards the staff gradually decreased, mainly due to the introduction of the teleprinter and traffic zoning. In July, 1917, the building was struck by an enemy bomb, causing structural damage, and suffered similarly during the present conflict in September, 1940. Later the same year, in December, the building was almost completely destroyed and for the first time in 70 crowded years messages ceased to flow through the galleries.

Telegraph traffic, however, did not stop. The possibilities of an occurrence of this nature had been foreseen and preconceived engineering arrangements whereby circuits were switched and diverted to reserve offices functioned immediately. The bulk of the traffic was carried by C.T.O. "R" and C.T.O. "X."

Salvage and reconstruction of the damaged C.T.O. was commenced promptly and the derrick crane which towered above the building was a familiar sight for many months. By this process the top three floors were removed until only one floor above street level remained, and the outer walls of this portion stand to-day (Fig. 2), squat and bomb-scarred, the only outward recognisable part of the original C.T.O. Inside, however, structural alterations have effected what must be considered a general improvement. The basement has been modernised and although the Newgate Street side still accommodates the original M.D.F., apparatus room and engineering quarters in much the same location as before, the workshops, corridors and spaciousness of the battery and power rooms are distinctly changes for the better. The whole of the ground floor is given over to office accommodation, and the first floor to instrument galleries.

Preliminary Work on M.D.F.

The initial phase of reconstruction was the modification of the main distribution frame. This was complicated by the fact that under the emergency arrangements which were brought into use at the time of the fire, all circuits were re-routed to the reserve offices by cable pairs from this frame. This took up the whole of the external side of the lengthy M.D.F. and at the same time rendered the internal side which accommodated heat coils and protectors redundant. The arresters were accordingly recovered and 25 of the verticals modified to take fuse mountings of the low loss type (No. 4028). Thus a double sided M.D.F. capable of terminating 10,000 pairs was obtained. Silk and cotton ends (5,000 pairs) were terminated and teed into external cables. In addition the concentration of the fuse mountings at one end necessitated the recovery and re-terminating of 3,000 pairs of silk and cotton ends on the original

internal side of the frame. The task of diverting practically every circuit was carried out while the above work was in progress and not the least formidable aspect of the job was maintaining service.

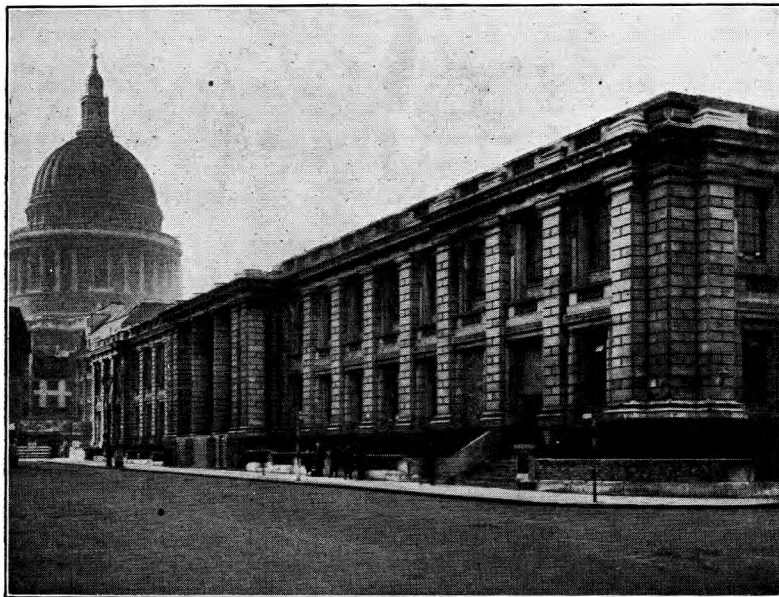

FIG. 2.—PRESENT C.T.O. BUILDING.

The re-signwriting of the whole of the M.D.F. and amending all records was also an undertaking of some magnitude. Of the remaining verticals now spare 15 were modified on both sides to take connection strips and serve as an I.D.F. Those remaining were recovered to provide much needed space.

Special Arrangements.

Owing to war-time conditions one of the facilities considered necessary for re-opening the C.T.O. in the reconstructed building was the ability to switch circuits back into the reserve office every night as a routine, or at short notice under emergency conditions. To provide this "switching jacks" were installed on the Engineering Control Board. The arrangement is such that the insertion of a disconnection peg will disconnect the line to the office to be vacated.

Summary of Main Equipment.

It was decided at the outset to cable and wire the ultimate capacity of the whole of the Inland galleries and to equip as and when required. Accordingly arrangements were made to install the following:—

- 1 Engineering control board with equipped capacity for 960 line circuits, 960 instrument circuits and 260 switching jacks.
- 1 Traffic control board with equipped capacity for 960 line circuits and 960 instrument circuits.

- 220 Teleprinter positions wired for No. 3 X machines.
- 16 Teleprinter positions wired for No. 7 B machines.
- 32 Printergram positions.
- 3 Power bays for signalling current distribution.
- 8 T. & O. and 2 repair bench positions.
- 160 Filters, Frequency.

The whole of the main cabling was carried out in switchboard cable and with maximum flexibility as the major consideration all "line" and "instrument" cabling was taken to the I.D.F.

Engineering Control Board (Fig. 3).

This consists essentially of a jack field whereby every circuit coming into the building is concentrated at one point for engineering test purposes and is an adaptation from its prototype the D.C. test rack seen in repeater station and V.F. terminals.

Panel 1 has been allocated for switching jacks with an equipped capacity of 11 sets of triple jacks ("Line," "C.T.O." and "C.T.O. R") with availability for switching 220 circuits. On each of the

remaining panels 12 sets of double jacks ("Line" and "Instrument") are terminated, giving a total accommodation for 960 circuits. Two testing positions are provided with voltmeter and testing keys in Panels 2 and 5.

It will be observed that the lower portions of Panels 1 and 4 accommodate miscellaneous jacks. These consist of test and interception jacks, engineering speakers, lines to the public telephone

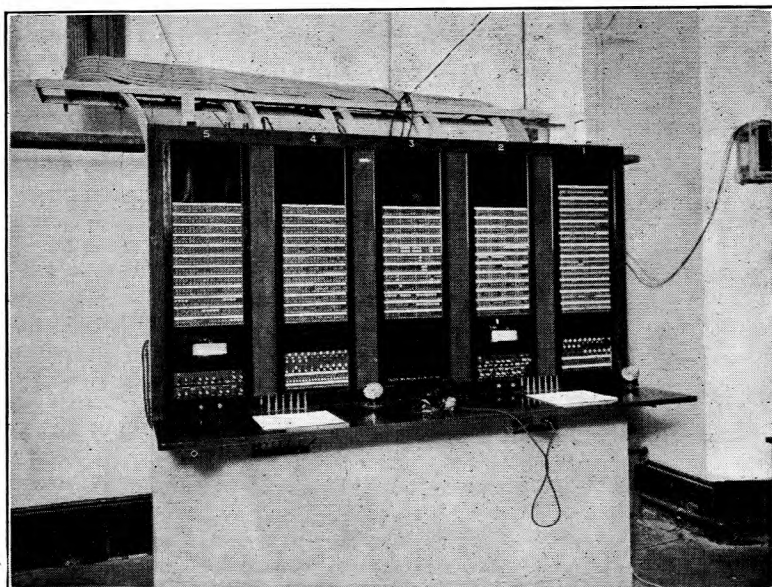

FIG. 3.—ENGINEERING CONTROL BOARD.

network, and access to test and observation sets, and the synchroscope. Panel No. 3 serves as a filing cabinet for fault cards.

Traffic Control Board (Fig. 4).

The traffic control board is located in the control room, situated in the south-west corner of the first floor and is adjacent to bench test positions accommodating test panels for teleprinters (Panels No. 18), test and observation positions (Testers TG 803) and synchrosopes. To meet the requirements of the Telegraph Branch all circuits have been arranged

layout of apparatus which, being mounted on removable traps, facilitates maintenance and allows maximum room for operating the teleprinter. The right hand trap accommodates the jack for the teleprinter plug and one socket outlet for the teleprinter motor plug with another in parallel for operating the time recorder, the terminal block being the connecting point for the half-minute impulse. The timing facility is extended to the left-hand trap, whereby both "receiving" and "sending" time recorders can be operated. The "sending" and "receiving" milliammeters mounted as one unit and housing condensers and resistors complete the left-hand trap.

Wiring Details.

All teleprinters are driven by 150-170V D.C. motors. One ten way iron clad distribution board located at the gangway end serves each table. A concentration block is mounted at the delivery end of the table which serves as the connecting point for send and receive lines and signalling current, the latter being fed via resistor bulb units known as Panels Telegraph No. 63. These are rack mounted in strips of 20 Bulbs Resistor No. 11, 100Ω. Associated with each strip are current limiting resistors and shunted condensers in strips of 10, termed Panels Telegraph No. 67A. This method of signalling current distribution is a recent development and the compact units located in one place possess obvious advantages, not the least of which are the saving of space on instrument tables and ease of maintenance. The above methods of wiring

obtain for the Teleprinter 7B and printergram installations in the East Gallery with, of course, the obvious circuit differences. Of the printergram installation it is noteworthy that the apparatus is located in the basement apparatus room and cabled throughout in switchboard cable with the exception of the 1,500 c/s tone lead, for which an individual screened conductor for each position has been em-

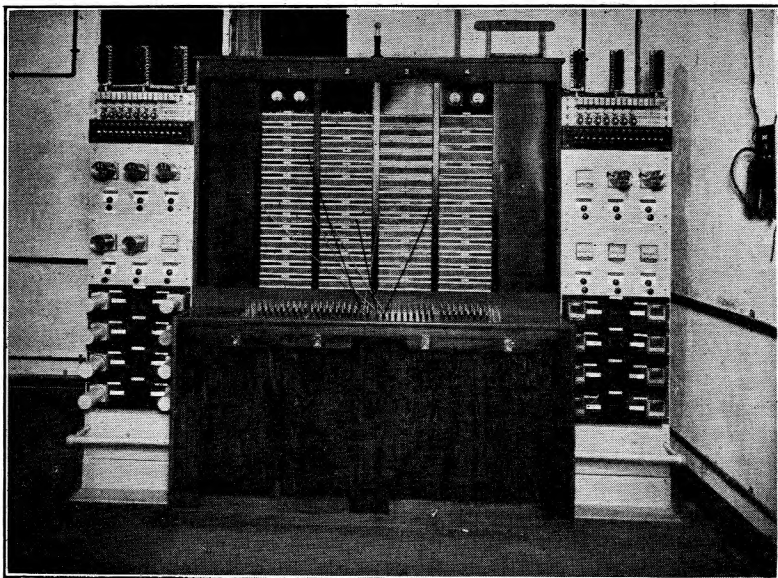

FIG. 4.—TRAFFIC CONTROL BOARD.

to be accessible at this point before cross-connecting to the instrument tables.

A noteworthy departure in design will be observed in the introduction of four panels. By this means considerable ease of operating is effected, as two or if necessary three operators may have access to the board simultaneously and reach the top jacks with minimum effort. Eighty double ended cords for patching and monitoring are located on the cord shelf, two at either end having their connections reversed to be used as an expedient for effecting a line reversal.

Instrument Tables

These are of wooden construction and standard design, 22 ft. in length and 4 ft. wide and each accommodates eight teleprinter positions, four on either side, the space apportioned to each operator being 5 ft. 6 in. On the centre line a Table V type conveyor belt is located, which disposes of telegraph forms to a floor V conveyor and thence to sorting tables.

Fig. 5 gives a general view, showing

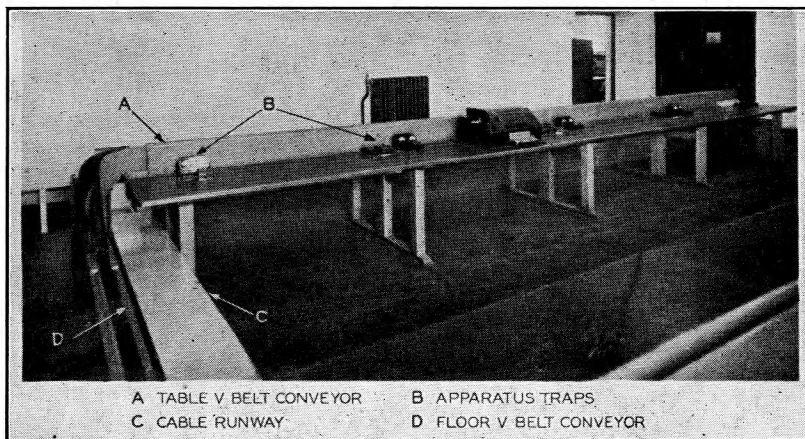

FIG. 5.—INSTRUMENT TABLES.

ployed. The converters are of the A.C. mains supply type and are mounted five on either side of 10 ft. 6 in. apparatus racks, each convertor being fed from a 10-way fuse box located at the bottom of the rack. The inclusion of the relays also make each rack into

West. The generators are by Crompton Parkinson.

Four rectifiers of the Westalite type are available, each of which operates on the input side at 220/250 V 50 c/s and delivers an output of 15/7 A at 80/110 V positive to earth and a similar output on the negative side.

The batteries are cabled to a main power board of standard design with facilities for floating or charge-discharge working. Power is distributed from the power room by four main feeders cabled in 19/963 cable in screwed conduit and taken on the outer walls three feet from floor level right round the galleries. Opposite each instrument table on the wall the conduit is passed in and out of a straight-through conduit box containing a pair of 10 A fuses which feed the local distribution fuse box for driving the teleprinters on that table. A feature of the scheme is that continuity is not broken, the taps for the 10 A fuses being clamped mechanically. For signalling current one main is tapped by a separate pair of 15 A fuses which feed apparatus racks on which are mounted bulb resistor units (Panels Telegraph No. 63) feeding individual tables.

Circulation.

The method of circulating the telegraph forms is from the instrument tables by table V belt message form conveyor, to floor V belt conveyor and thence to sorting and circulation

centres. Drag bands will be installed in the near future.

The table conveyors are individually driven by electric motors situated at the gangway end under each instrument table and enclosed in a stout wire mesh grille. The tensioning head and grease cup lubricators are also housed at this end. The floor V's are driven similarly, each gallery having its own conveyor, the motor and tensioning head being at each extremity of the belt. Control throughout is by press button, using the well-known Allen West start and stop control units.

Main Earth.

No trace of the original main earth was found after the fire, so accordingly it was decided to install a new system. After consultation with the architect and building authorities, who were somewhat apprehensive about an excavation owing to the proximity of tubes, water and the general difficulties of the site, two vaults in the basement of the St. Martins-le-Grand side of the building were selected, one for the telegraph and the other for the power earth. The excavation was commenced, but for a considerable depth the strata were found to be unsatisfactory, the first 3 ft. being concrete and then 4 ft. of nondescript rubble and then about 2 ft. 6 in. of loamy clay running into sharp sand and ballast

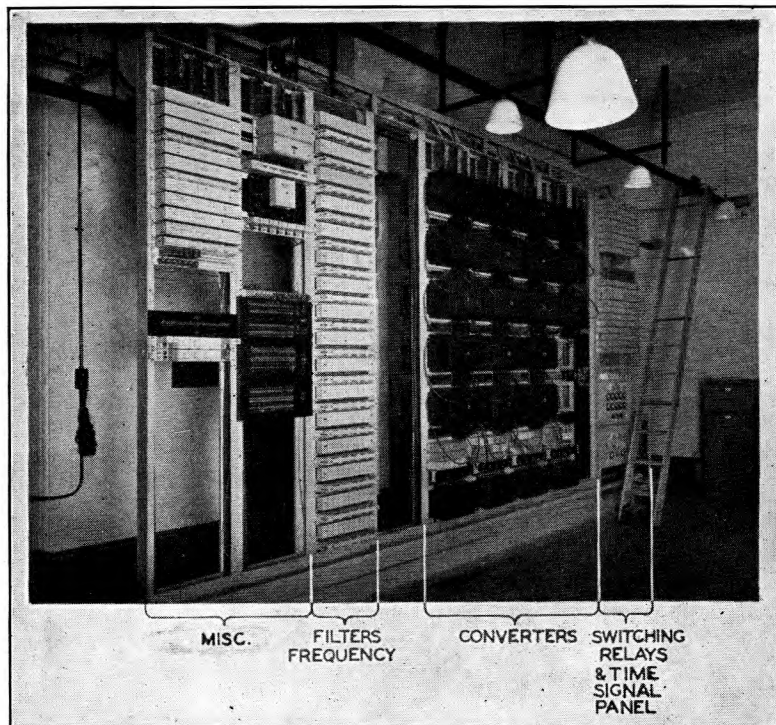

FIG. 6.—PART OF APPARATUS ROOM.

a self-contained unit for 10 circuits. Fig. 6, bays 5-8, show the layout and convey a general impression of the apparatus room.

Power Distribution.

Owing to war conditions the main batteries, charging and control gear which were installed for the opening may be regarded as a temporary installation. The cells are by the D.P. Company and consist of two batteries each of 82 D.P. Kathanode LKC-29 type cells centre-tapped to earth, whereby 80 V positive and 80 V negative to earth are obtained—this being the supply for telegraph signalling current. The full terminal voltage of the battery, approximately 160 V, being available for driving the teleprinters.

The capacity of the cells is 588 Ah at the 5-hour rate and normal charging current is 56 A, maximum 112 A and is carried out by motor-generators augmented by rectifiers. The positive and negative batteries are separately charged, the respective generators having an output of 80/110 V 24.2/18.2 A and located at either end of a single bedplate driven by a centrally disposed 7.5 H.P. 400/440 V A.C. motor at 1,430 r.p.m. Control gear for the motor is of the 3 position "off," "start" and "run" ironclad type with press button master control by Allen

with water present. By the time an excavation of 32 ft. from street level had been made it became apparent that conditions would not improve, as the water was coming in faster and pumping had been resorted to. It appeared that the subterranean lake which is reputed to be the source of supply for the historical Roman Bath on the adjacent site had been reached, as the excavation being outside the main walls of the C.T.O. was not protected by the 6 ft. concrete raft on which that building was erected. After observing that the water came to a certain level and remained static it was decided to import heavy clay and seal the water off with a clay pan in the bottom of the excavation. The electrodes were then placed in position and more clay punned in, until the plates were covered. Filling then continued with the excavated material until the loamy clay band was reached. At this point six Earth Spikes No. 1 were driven laterally and equidistantly round the perimeter of the hole, the tails being protected by lead piping, jointed and finally connected by a solid joint to the main 37/16 earth lead in the

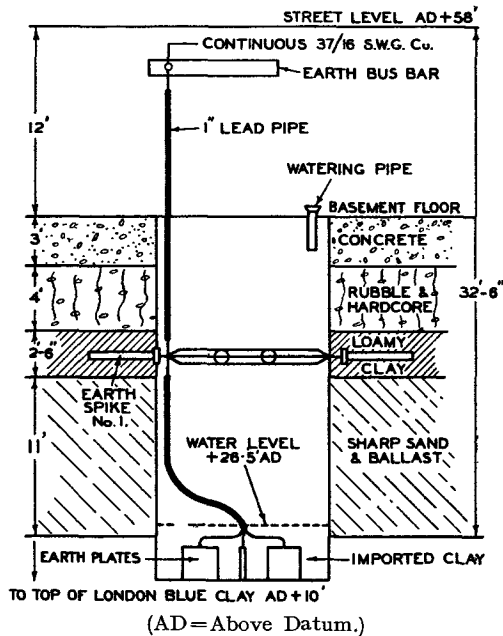

FIG. 7.—C.T.O. MAIN EARTH.

manner shown in Fig. 7, which also illustrates the strata and general scheme. The resistance of this combination measured 2.5Ω on completion.

Public Address System.

This, an innovation as regards telegraph offices, consists of a public address unit by Parmeko of Leicester and is capable of 30 W undistorted output feeding thirteen loud-speakers. These are placed in south and west galleries at selected points and the reception is satisfactory in spite of a considerable noise from teleprinters. The installation has been of great value during rush periods and emergencies, being used for important announcements, and instructions to staff on occasions when time is of vital importance.

General.

Apart from the considerable modifications to the M.D.F. mentioned earlier in this article, the mezzanine platform was modernised and suspended by a method more suitable to the modified frame. The main racking carrying cables from the basement to the instrument galleries was specially designed with an artificial turn to obtain the correct numerical "drop off" of the cables. A further complication was introduced by the whole of the cabling being taken through one cable hole, and on reaching the first floor branching respectively north and south and the racking having to be reduced to 9 in. in width. This was necessitated by the racking in the instrument galleries being installed 6 in. from the floor in the narrow gap between the floor V-band conveyor and the table ends, the advantage claimed for this method being the elimination of a large number of racks dropping down from high level to the tables and also cabling for the main part without ladders and trestles. An interesting feature of the cable racking is the fact that it is of welded construction throughout, mass produced in the L.T.R. workshops and cut to requisite lengths and fish-plated together on site. Approximately three-quarters of a mile of 9 in. racking, the framework of two control boards and associated woodwork, 20 apparatus racks and miscellaneous fittings were designed and installed by the L.T.R. Power Section in collaboration with the City Area Construction Staff.

Features of the installation from a construction angle are:—

Approximately 12 miles of switchboard cable, some individual lengths being over 200 yards in length, eight miles of jumper wire and ten miles of miscellaneous wire used.

In addition some 2,000 pieces of apparatus were mounted for teleprinter positions alone.

From these figures it will be seen that the undertaking may be considered a major one and noteworthy that it was planned on site and the whole of the telegraph construction work carried out by departmental staff, 20 per cent. being female engineering assistants. The installation was completed and ready for service in slightly under four months.

Pre-transfer testing was carried out on an organised scheme whereby distant offices all over the country passed testing traffic on main and reserve lines and spare channels, the Telegraph Branch co-operating and contributing in a great measure to the successful opening on June 1st, 1943. Since this date further equipment in the shape of a complete phonogram installation and high speed telegraph apparatus in the Overseas Section has been completed.

Conclusion.

The foregoing article has been written to mark an occasion rather than to describe anything novel in the equipment. At the same time the description of well-tried telephone exchange construction technique as applied to telegraphs is of interest and may possibly exert an influence on future design and development.

A Delayed-Action Lever Type Key

W. H. BLOIS and
J. M. FLEMING

U.D.C. 621.316.542.1 621.394.652

The authors describe a lever type key which, when depressed, returns to its normal position slowly under the action of a coiled clock spring and centrifugal governor and delays the re-operation of the contacts for a period up to seven seconds.

Introduction.

THE delayed action key described in this article has been developed for use at teleprinter out-stations with a view to simplifying the operating procedure when it is required to give a clearing signal to the teleprinter switchboard. The existing practice, when using a standard non-locking lever-type key, is for the operator to hold the key in the operated position for a period of five seconds to ensure satisfactory operation of the clearing supervisory circuit at the switchboard. With the delayed action key, however, the operator is required merely to depress and release the key handle, which then restores to normal under the control of a centrifugal governor. The key may be pre-set to give a signal of any desired duration up to a maximum of seven seconds, although, for the present application, a standard clearing signal of five seconds will be employed.

Following an initial field trial with experimental models, delayed-action keys have been adopted as standard items of equipment for use in connection with the inland telegraph manual switching scheme, and an improved model is now in course of production.

An Experimental Key.

The experimental delayed action keys used for the field trial were designed for manufacture on a small scale, and their production was undertaken by the Post Office Factories Department. In view of the small quantity required, it was desirable that standard parts should be used as far as possible, and the key was therefore designed to incorporate the governor and gears of a telephone dial, with certain

additional parts from a coin box escapement, and a large lever-type key frame to provide a firm mounting for the assembled mechanism, shown in Fig. 1.

The essential features of the key are shown in schematic form in Fig. 2. The main gear is in the

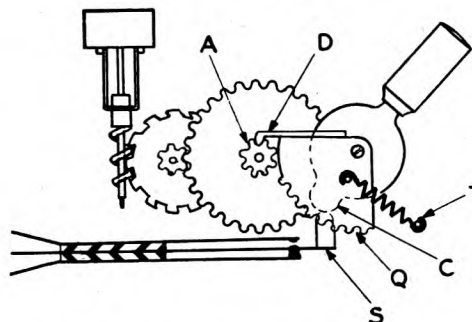

FIG. 2.—ESSENTIAL FEATURES OF KEY.

form of a quadrant *Q* attached to the key lever, and is normally retained in the position shown by the tension spring *T*.

In order that the key handle may be depressed freely, a helical spring friction clutch, as used in a telephone dial, is interposed between the pinion *A* and the gear wheel on the same spindle which allows the pinion to be rotated in one direction by the main gear without disturbing the governor. When the handle is released at the end of its travel, the spring *T* restores the mechanism to its normal position, the speed of the return movement being controlled by the governor.

The moving contact spring *S* is normally held operated by the key cam *C*, but restores when the handle has been rotated a few degrees from its rest position, and remains thus until it is re-operated as the cam reaches the corresponding point during its return movement.

For use as a "clearing" key it is essential that the transit time of the moving spring, when the contacts are re-operated, shall be reduced to a minimum. This requirement has been met by arranging that the main gear is released from the restraint of the governor immediately before the change-over is due to occur, and the resulting "snap-back" of the cam ensures positive operation of the contacts. Disengagement from the governor is effected by the removal of several teeth from one end of the main gear quadrant, and it will be seen from Fig. 2 that a small detent *D* is provided for setting the pinion in position for smooth re-engagement when next the key is operated.

The result of the field trial of the experimental keys, which was carried out at a selected manual switching area office, was very encouraging, and the

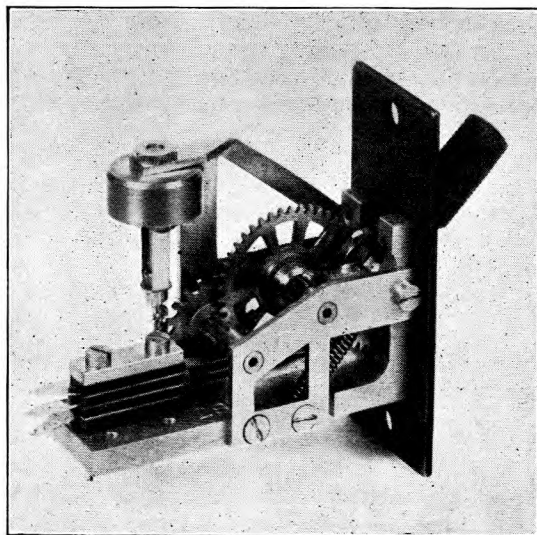

FIG. 1.—MECHANISM OF DELAYED ACTION KEY.

redesign of the key in a form suitable for production on a larger scale was therefore undertaken.

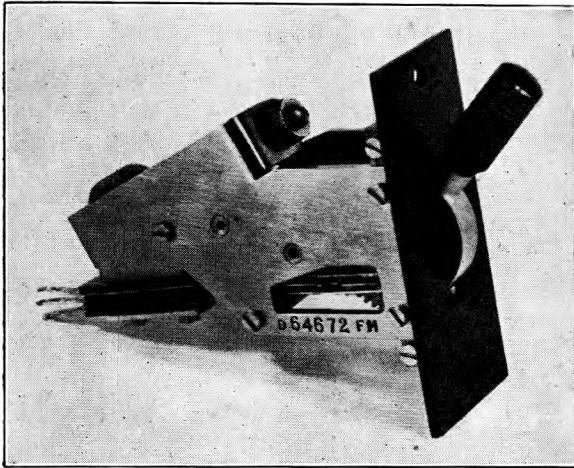

FIG. 3.—PROTOTYPE MODEL OF KEY D64672.

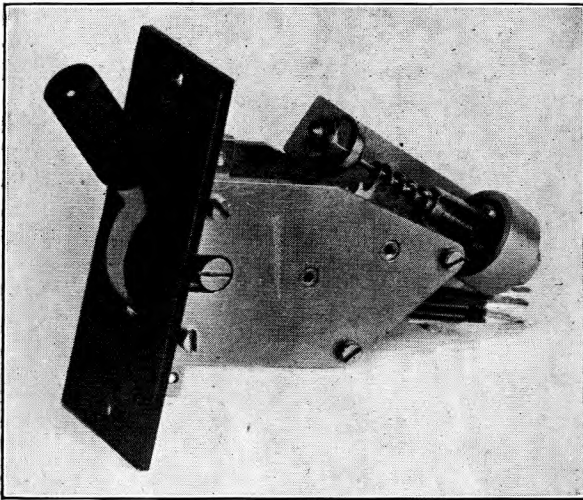

FIG. 4.—AS FIG. 3, VIEWED FROM OTHER SIDE.

The Production Model.

The characteristics of the improved key, which has been designated Key D64672, are similar to those of the experimental model, but, as will be seen from the illustrations, considerable changes in the general layout and details have been effected to make use of pressings and die castings designed for rapid and accurate assembly.

Figs. 3 and 4 illustrate the prototype of the production model. The design allows the pre-assembly of the various components into two self-contained units, shown in Fig. 5, which may then readily be associated and secured by four screws.

The Governor Unit.

The governor unit, which is shown on the left of Fig. 5, is of straightforward construction, consisting of pressed sheet metal side plates, connected by distance pieces. One of the plates is formed to provide brackets for the accommodation of the contact spring assembly, and the governor cup and bearings, respectively. The gear train is similar to that of the experimental model, but, in view of the larger quantities now involved, it has been permissible to depart from the exclusive use of standard parts, and to design gears and pinions to suit the particular requirements of the improved key. The governor itself is of the standard pattern, but it has been found desirable to employ an enlarged governor cup to obtain the requisite speed control without resorting to unduly fine adjustment of the governor.

The contact spring assembly, which provides a change-over spring combination, is built up from 600-type relay springs having twin contacts, but, owing to the difficulty of fitting a satisfactory buffer block, it has been necessary to incorporate buffer springs to facilitate adjustments and to prevent contact bounce. Contact pressures of 18-20 grams are obtained in nominal adjustment, with adequate contact follow and clearances. The assembly is secured between clamping plates and forms a self-contained spring set for attachment to the governor unit.

The Handle Unit.

The second unit, shown on the right of Fig. 5, comprises the handle and return-spring sub-assembly mounted in a die-cast frame. A coiled clock spring, as used in the telephone dial, is employed for restoring the mechanism after each operation, the spring being contained in a hollow brass drum, hot-pressed in one piece with the operating handle and the main gear.

A steel pin, covered for part of its length by an ebonite sleeve, is fitted on one side of the spring drum for operating the moving contact spring. As in the experimental key, the spring set is held operated when the key handle is at rest, and the method of

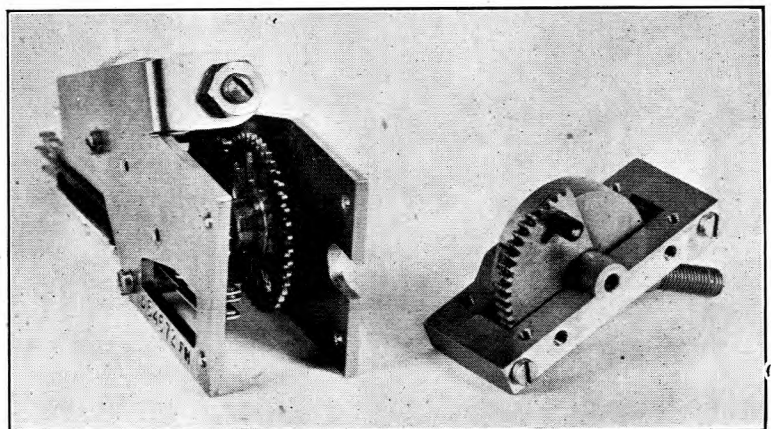

FIG. 5.—GOVERNOR AND HANDLE UNITS.

achieving quick re-operation as the handle approaches the end of its return motion is also unchanged.

The device for ensuring that the main gear re-engages smoothly with its pinion differs, however, from that employed in the experimental keys. It consists of a second gear quadrant loosely mounted on the same spindle as the main gear and engaging with the same pinion, with which it always remains in mesh; the contact-operating pin protrudes through a slot in the quadrant, and is made to perform the additional function of limiting the relative movement of the quadrant with respect to the main

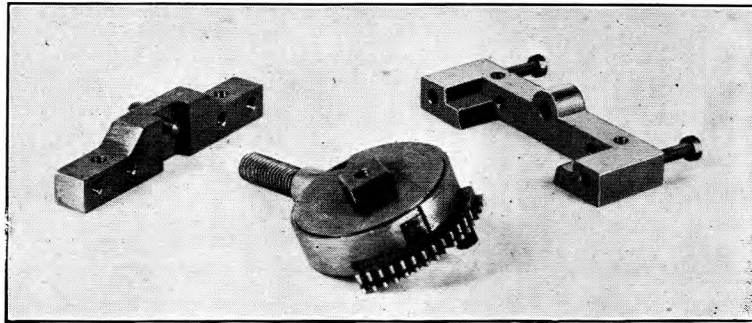

FIG. 6.—COMPONENT PARTS OF HANDLE UNIT.

gear. The position of the slot is such that the teeth of the main gear come into alignment with those of the permanently-meshing quadrant prior to re-engaging with the pinion.

The components of the handle unit are illustrated in Fig. 6, from which it will be seen that the frame has been designed for manufacture in two pieces to facilitate assembly, each part being die-cast in "Mazak 3" alloy. The smaller die-casting has a recess into which the squared end of the spring-drum spindle is fitted; the larger casting provides an additional support for the spindle, and forms end stops to limit the movement of the main gear quadrant.

The inner and outer ends of the clock spring are secured in slots formed in the spindle and spring-drum respectively, and, by first attaching the spindle to the smaller frame casting by a screw, a convenient winding lever is provided for imparting the required amount of initial tension to the spring. On subsequently screwing the two halves of the frame together, a rigid assembly is obtained, which may then be attached to the governor unit without requiring any further adjustment.

The overall dimensions of the key-plate, which is of orthodox design apart from the enlarged handle aperture, are $2\frac{5}{8}$ in. by $1\frac{1}{8}$ in. and the delayed-action key is therefore interchangeable with any standard lever-type key fitted with a key-mounting of similar size.

Application.

The key described above, in its application to the

inland telegraph manual switching scheme, as a "clearing" key, is required to be mounted on bench type teleprinter positions and to be so located that it may readily be accessible to the operator.

The most satisfactory means of meeting these conditions was found to be by the use of the box type mounting shown in Fig. 7, which supports the key at a convenient angle for operation. The mounting, which is known as "Key-mounting D64673," has been designed for production in bakelite, and includes brass inserts tapped to receive the fixing screws of the key mounting plate.

Conclusion.

The key in its present form has been designed to meet a specific requirement, but, for certain applications, it is appreciated that the release of the moving contact spring during the period when the handle is being depressed by the operator may be a disadvantage. The key is capable of being modified, however, to prevent the release of the contact spring taking place before the handle is fully depressed, so that the time lag is independent of the short period taken for the operation of the handle. A further refinement, which might then be desirable, would be to arrange for the spring-drum, with the contact-operating pin, to be freed from the handle

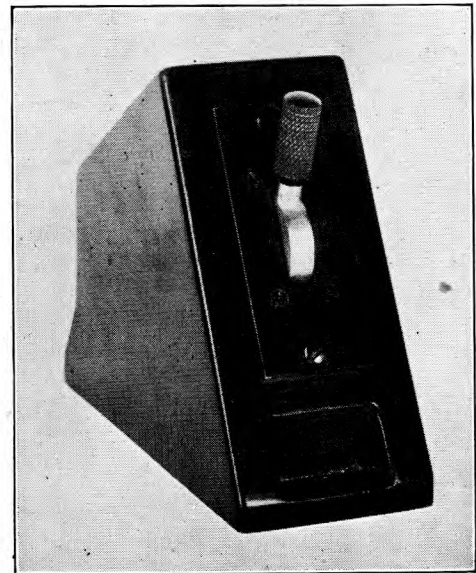

FIG. 7.—KEY MOUNTING D64673.

itself during the return movement to eliminate the possibility of the action being retarded by accidental interference from the operator.

In addition to its use for giving a single long pulse of current, the key might also be adapted for transmitting a series of shorter impulses in the form of a code.

Aerial Cable Suspension by the Spinning Method

C. A. MITCHELL, A.M.I.E.E.

U.D.C. 621.315.242

This article describes a method of supporting aerial cable from a suspension wire, which replaces individual suspension units by continuous open lay windings of wire round both the cable and suspension wire. The method is undergoing trial and conclusions regarding the relative merits of this and other methods have not yet been reached.

Introduction

OF all the components used in the erection of aerial cables, that by which the cable is attached to the suspension wire has been produced in the greatest variety of design. The reason for this is the difficulty in devising a fitting which embodies all the desirable features. Ideally, the device should be as durable as the cables and suspension wires themselves, otherwise renewal will be necessary from time to time and occasions will arise when impending failure will not be detected, with the result that a section of cable will be found in an unsupported condition. The device should not, however, be so hard and unyielding, or the method of using it such that the cable sheath is damaged as a result of movement and vibration imparted to the system by wind. Moreover, the variation in length of a cable due to seasonal temperature changes being greater than that of its suspension wire, the suspension device should permit the cable to expand uniformly throughout its length and so avoid the accumulation of slack at a few isolated points, where restraint is weakest, a condition known as "bowing." Finally, installation cost should not be so high as to be out of proportion to any advantages conferred by a particular system.

Methods of attaching cables to suspension wires may be divided into two groups :

- (1) those using individual suspension units such as raw hide or marline suspenders and steel cable rings, and
- (2) those using a continuous suspension, by an open lay binding of metal tape or wire round both the cable and suspension wire.

Many of the methods in the first group are already well known in this country but those in the second group have not been used by the Post Office except for the experimental length of cable at Caxton, near Cambridge, described by W. H. Brent in this Journal.¹ In that experiment the cable and suspension wire were supplied from the factory already bound together by two high-purity iron tapes.

Spinning Methods

Means whereby a suspension wire already erected on poles had cable bound to it with marline running from a cylinder which was drawn along the wire were used in America many years ago. In more recent years the idea of a cylindrical device for binding together cable and suspension wire with galvanised iron wire has been developed and improved machines have been produced in that country. Some machines are designed to be drawn along the suspension wire by a rope, whereas others are propelled by a man

riding in a chair which is part of the appliance.

It is possible that the method may result in less sheath cutting and bowing than is experienced when cable rings are used. On the other hand it appears to suffer from the disadvantages that the life of the single strand of No. 14 S.W.G. wire used for spinning may be expected to be short relative to that of the 7/8, 7/10, 7/12 or 7/14 strand suspension wire and the cable, and that the breakage of the spinning wire at any one point due to local defect or general deterioration would let down a whole span of the cable.

It is only by field trials extending over a sufficiently long period that positive information can be obtained, and when an offer was extended by Pirelli General Cable Works, Ltd., to use a "Neale spinner," which they had obtained from America, on a short section of a cable they were about to erect for the Post Office, it was gladly accepted. The machine was subsequently used by the Pirelli General Co. on other sections of cable for which alloy E (containing 0.4 per cent. tin and 0.2 antimony) was the only material immediately available for the cable sheath at the time when an urgent requirement arose. This alloy is softer than alloy B (0.8 per cent. antimony) which is generally used by the Post Office for aerial cables. To afford a comparison of sheath cutting tendencies under the different conditions, some lengths were erected in rings and others by the spinner. The firm was also good enough to loan the machine to the Post Office for the experimental erection of some 20 spans of 25 pr. 10 lb. cable in an exposed situation in the South Western Region.

The "Neale Spinner"

Fig. 1 shows the Neale spinner resting on its packing case. Its weight, complete with the operator's chair, is 65 lbs.

The crank handle on the right of the machine is connected to a spindle carrying two wheels, one of which rides on the suspension wire and the other, being a sprocket wheel, carries a roller link chain, connected to a similar sprocket at the left of the machine. To the spindle on which the latter sprocket wheel is mounted is also attached a second riding wheel and a bevelled gear wheel A.

The two wheels which ride on the suspension wire are grooved about their peripheries and at the bottom of the grooves are hard rubber inserts which increase the grip between wheels and wire imparted by the joint weights of the operator and the machine itself. A ratchet and pawl is associated with one of the riding wheels to prevent the machine from running backwards and so relaxing the tension on the binding wire.

¹P.O.E.E.J., Vol. 26, p. 219

The bevelled wheel A engages with a smaller bevelled wheel B which is mounted on a spindle to the other end of which is attached a gear wheel C and this, in turn, engages with teeth on the periphery of the cylinder D. The other end of the cylinder is flared out to form a disc E the periphery of which

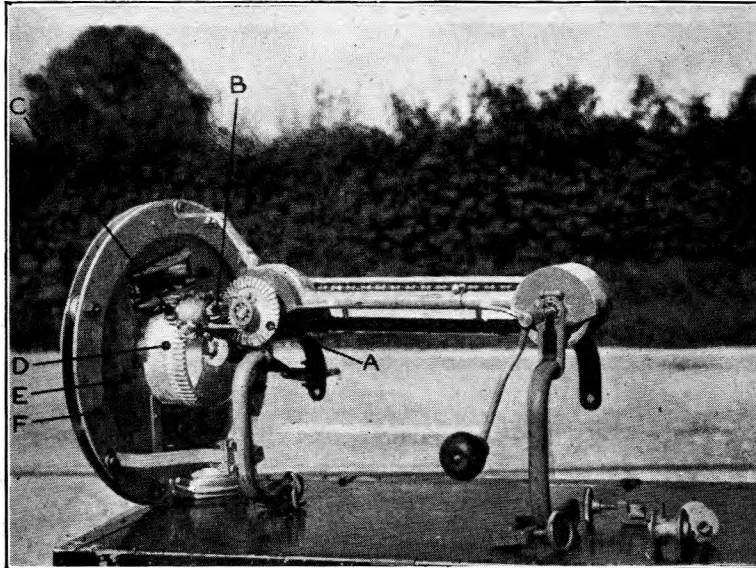

FIG. 1. THE NEALE SPINNER.

revolves on rollers in a stationary framework F. The disc carries a drum loaded with binding wire which revolves when the wire is drawn from it as the machine moves along. Two grooved tensioning wheels, over which the binding wire is fed to the cable at a tension of approximately 35 lb., are mounted near the drum and can be seen at the top of the disc in Fig. 2.

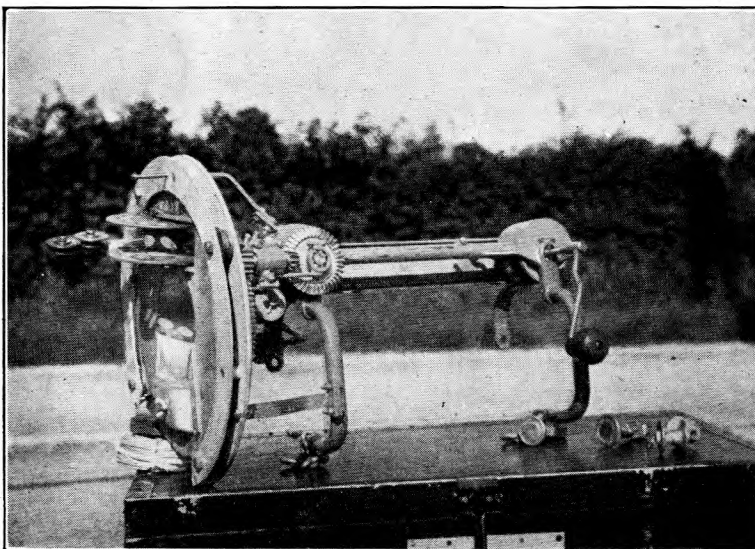

FIG. 2. THE NEALE SPINNER (SHOWING TENSIONING WHEELS).

Opposite the drum is a removable segment of the disc and cylinder which enables the machine to be placed on and taken off the suspension wire and cable at the

beginning and end of each span. An adjustable jockey wheel, fixed below the suspension wire and adjacent to the second grooved riding wheel, raises the cable into close contact with the suspension wire in advance of the application of the binding wire. Jockey wheels of several sizes to suit cables of different diameters are provided, and those not in use are seen lying on the top of the case. Cables upon which the machine was used during the trials referred to in this article, ranged in diameters from 1.67 in. to 0.72 in.

Operation of the Spinner

A cable having first been erected in rings in the normal manner, the machine is hoisted up a pole and placed in position with its running wheels resting on the suspension wire, the removable segment of the disc having been taken out for this purpose. The operator's chair is placed in position and the operator takes his seat. The jockey wheel is adjusted by means of a knurled nut on a threaded spindle to raise the cable into position. The disc segment is carefully replaced so that the teeth on its inner edge complete the cylindrical driving ring, and the end of the binding wire is fed from the drum through the grooved tensioning wheels and secured to the suspension wire at the pole. This hoisting and preparatory

work occupies some 25 minutes.

By turning the handle the operator propels the machine along the suspension wire (Fig. 3), the disc carrying the drum of binding wire revolving at the same time and causing the wire to be paid off in a spiral with a lay of between 12 ins. and 14 ins. The operator has to stop to remove each cable ring as

he reaches it, and as the rings have to be opened sufficiently to allow them to be withdrawn from both the cable and suspension wire, the operation is more difficult than that of placing the rings on the wire initially. The spinning of a span including the removal of rings fixed at the normal spacing of 20 ins., occupies about ten minutes. Rings fitted temporarily immediately in advance of spinning could be more widely spaced, and the spinning time for a span would then be slightly reduced. A partly completed span of 1.67 diameter cable is shown in Fig. 4.

On reaching the pole at the end of a span, it is necessary to secure the binding wire temporarily until the machine has been transferred to the next span after which the last few spirals of the wire are completed by hand and permanently terminated. The actual transfer of the machine from one side of the pole to the other, though somewhat similar to transferring a ringing chair, is a con-

siderably more difficult operation. Additionally, it is necessary to remove the disc segment and free the jockey wheel from the machine on one

side of the pole and replace them on the other. The empty wire drum also needs to be changed for a full one or removed and recharged with binding wire as it will only carry enough wire for a 60 yard span. The changing of the drum in mid-span is a difficult job and in any case joints in the

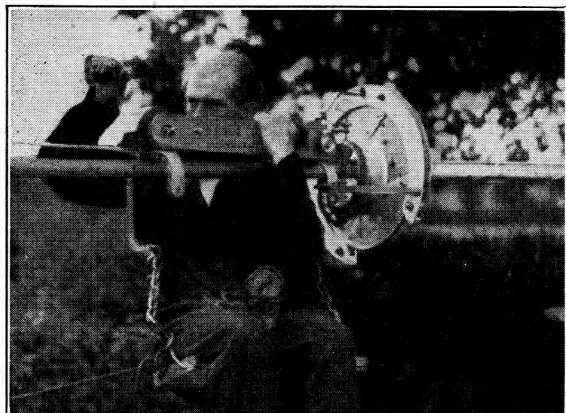

FIG. 3. OPERATION OF SPINNER.

wire within spans are undesirable. All operations involved in the transfer of the machine from one side of the pole to the other take approximately 20 minutes.

In the experiment carried out by Post Office staff a length of a small cable (.72 ins. diameter) was erected by feeding it from a drum, carried on a vehicle, to the spinning machine by way of a pulley

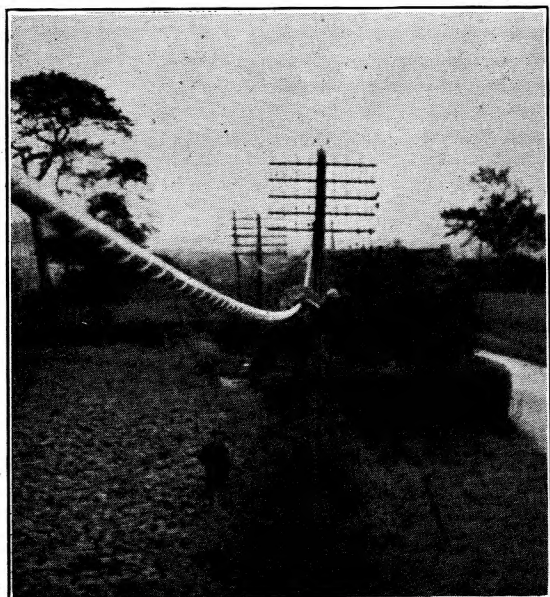

FIG. 4. CABLE SPAN PARTLY COMPLETED.

and loops attached to a rope by which the lorry drew the machine along the suspension wire. The initial erection of the cable in rings was thus dispensed with. This method which could be employed only when the cable was on the road-side of the poles and no obstructions existed, was found to be successful on straight pulls. When a straight pull was not possible the machine became unstable and the suspension wire became jammed between the wheels and framework. It is understood that the Pirelli General, Ltd., have since devised means of mitigating this difficulty.

Binding Wire

The binding wire used for the largest cable was No. 12 S.W.G. galvanised iron, but this was too stiff for the smaller cables erected subsequently, and No. 14 S.W.G. charcoal-annealed galvanised iron wire was used. If the correct size and type of wire is used the cable is bound close to the suspension wire unless the cable has any sets in it due to handling, etc., when gaps between the cable and the suspension wire appear.

Conclusions

Where a cable has to be erected in rings in advance of the use of the spinner it is clear that the spinning is an additional operation and the initial cost is greater than for ordinary ring suspended cable. Information from the U.S.A. confirms this. It also shows that the spinning method is slightly less in initial costs than ring suspension, where it is possible to effect the placing and spinning of the cable in one operation, and expert operators of the machine are employed. No information is yet available as to the length of life of the spinning wire. Recovery or replacement of cable erected by the spinning method would, of course, be more difficult than similar operations on ring supported cable.

The erection of cable in rings is an economical form of construction and Post Office cables erected in this manner over 20 years ago are still giving good service. Where ring-cutting has been experienced there has usually been a traceable cause, such as upward air currents, to account for it, and various devices for coping with such conditions are under field trial in different parts of the country. It is already known that some aerial cable suspending devices which have been introduced both in this country and abroad to overcome certain troubles have themselves produced new problems in the course of time. It is therefore desirable that long term experience of various methods should be gained, and it was to secure experience of the operation of the current type of spinning machine, and to enable information as to the life and behaviour of the completed installation to be available in due course, that the recent trials were undertaken.

Cable Splicing and Reconditioning

L. C. LANGFORD

U.D.C. 621.315.687.1

The article describes the steps taken to recondition recovered cable so that the maximum amount may be used. A feature is the use of "unidiameter" joints which enable short lengths to be pieced together.

Introduction.

IN peace-time the volume of new construction works ensured an adequate supply of junction and subscribers' cables from which any emergency could be met, but for trunk cables small emergency stocks were held. When war broke out it was evident that these reserve supplies had to be increased, but, on the other hand, manufacturing capacity was fully occupied with war requirements and the necessity to conserve materials rendered it necessary to restrict the demand for new cables as much as possible. It was therefore decided to make the maximum possible use of recovered cable and arrangements were made to recondition all lengths of recovered cable containing 50 or more pairs and exceeding 20 yards in length, the lengths being jointed by "unidiameter" joints so that they could be drawn through pipes or ducts. The aim was to produce standard lengths of approximately 180 yards containing only one joint. In this manner stocks of cable suitable for restoration works could be provided from what would otherwise have been mainly scrap.

Pre-war a depot existed at Birmingham for jointing together short lengths of stock cable so that requisitions could be met from one or more short lengths which would otherwise be scrapped. Increase in requirements and the desirability of saving transport led to the opening of a similar depot in London in December, 1940. This consisted of an inspector's office, a large brick-built shed and a covered walk in the yard under which the cleaning could be carried out. Instructions were issued for all recovered cables from the London Region to be sent to this depot.

In consequence of damage to the depot by enemy action and an increase in the amount of recovered cable, it became necessary to open an additional depot in London, and since then further depots have been established in other parts of the country. A cable gang is employed at each depot for cleaning and measuring the cables, plumber jointers for making spliced joints, and other skilled workmen and labourers for testing, etc. The following tools are provided:—

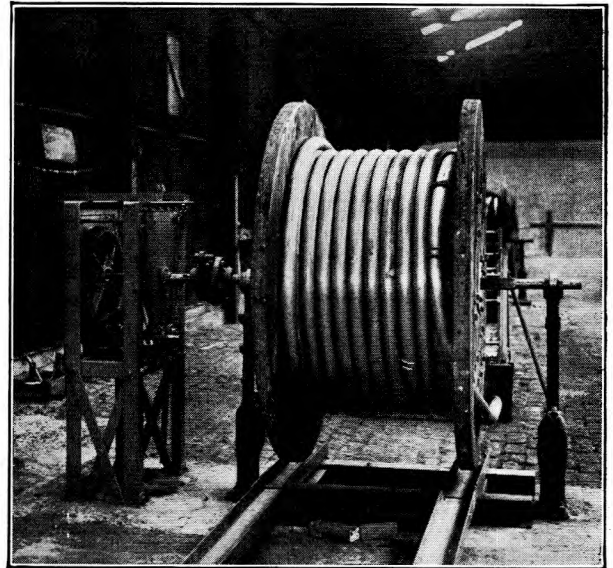

FIG. 2.—CABLE DRUM AND WINDING MACHINE.

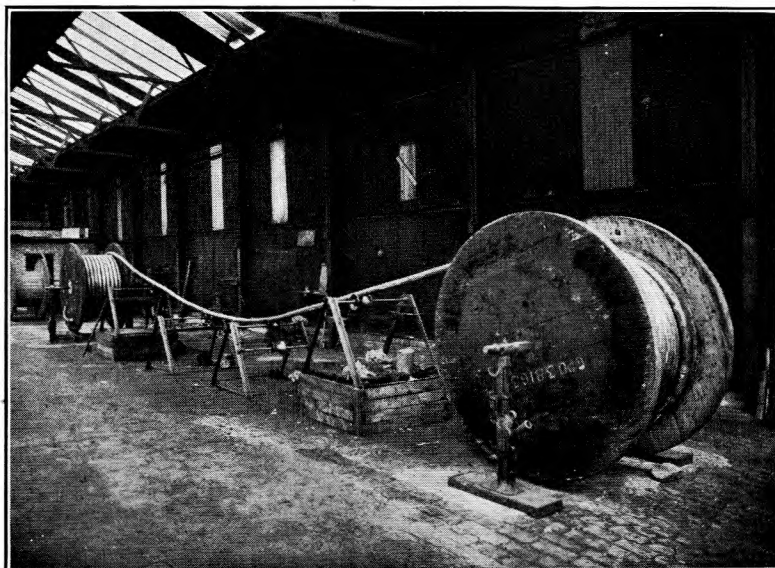

FIG. 1.—CABLE IN POSITION FOR RECONDITIONING.

Jointing kits, axes, cable grips, ratchets and tongs, desiccators, jacks and drum spindles.

Cable rollers, drying ovens, drum winding machine, swages, etc.

Oxyacetylene welding sets.

Ohmmeters, detectors and vibrator units.

Reconditioning Operations.

Upon arrival of each length of cable, visual inspection is made as to its general condition, having regard to the type and size. A few inches of lead sheathing is stripped, and a sufficient length of the paper insulation exposed so as to enable a decision to be made as to whether reconditioning is justified.

The drum of cable is set up on jacks with an empty drum in position, about thirty feet away. Four specially constructed cable rollers (see Fig. 1) are placed in line between the

drums so that the cable can be laid on them. The bobbins of the rollers are designed to move laterally along their spindles and are about three feet from the floor, this being a convenient height for cleaning, which is carried out by hand, using cotton waste saturated with kerosine. During this process, the sheathing is carefully examined for damage, corrosion, etc., mis-shaped portions being beaten out with boxwood dressers. Any unsound portions are cut out and scrapped, the rest being carefully measured and recorded and wound on to the empty drum.

The cleaned length is subjected to a full insulation test and, if below standard, carbon dioxide gas is passed through it. When the insulation test is satisfactory every wire is checked for continuity, the cable ends sealed by lead burning and the sheathing subjected to a pressure test of 24 lb. per square inch for over 24 hours. When the reconditioning is satisfactorily completed, a lead label is burnt on the sheathing at one end to indicate type, size and length; the clockwise end is painted red and one red ring is painted on the sheathing at both ends to indicate second-hand cable.

The cleaning operation, although heavy and dirty, is performed with minimum effort, as the drum spindles are fitted with ball bearings and a drum winding machine is used (Fig. 2) which can be operated by two men. The machine was improvised by inverting a cable winch in a steel framework, its spindle being coupled to that of the drum. For drums with round holes, a special coupling attachment was devised.

A weekly return of reconditioned cables is forwarded to the Chief Regional Engineer, who arranges distribution to the various storage sites.

Splicing.

Short lengths of reconditioned cable are joined at

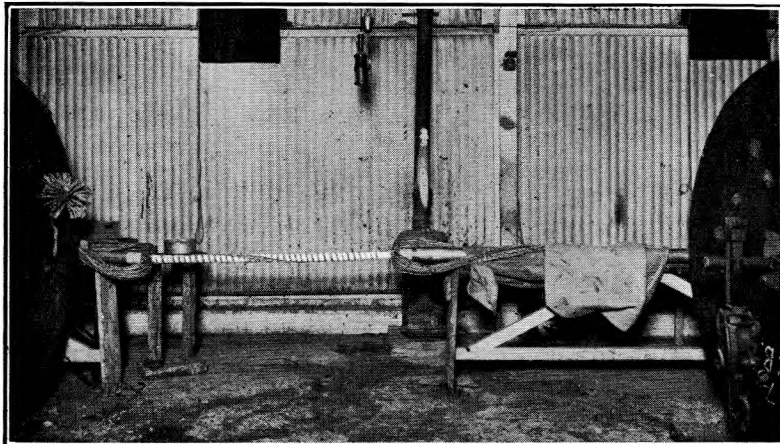

FIG. 3.—“UNIDIAMETER” JOINT PARTIALLY COMPLETED.

the London depots by so-called “unidiameter” joints, which ensure that the completed cable can be passed through the duct or pipe. This is done by using two drums containing cable set up at right angles to the jointing position (Fig. 3), the cable ends being so arranged that the cores are in correct rotation in relation to each other. The cables are stripped for a joint of 4 ft. 11 in. for large cables and for a slighter shorter joint for smaller ones. A 5 ft. length of lead tube with a diameter slightly larger than the cable is placed over one end of the cable for the final cover. Before jointing is commenced,

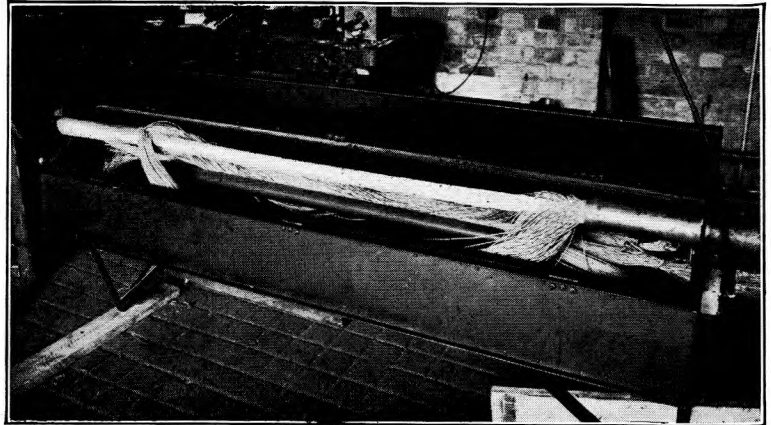

FIG. 4.—BAKING OVEN.

both cables are anchored to the wall or cable drum by cable grips, and ratchets and tongs, as it is essential that the finished joint should be tight and compact. The centre cores are jointed straight across the joint, the twists being evenly staggered over its length. Each twist is tipped with solder, covered with a paper sleeve and pressed down with its end toward the shorter of the two lengths of cable. The centre core of jointed quads is bound with half-inch insulating paper, the subsequent layers of jointed wire being given a symmetrical turn to simulate the lay of the wires in the cable. All cotton wrapping, with the exception of that of the “marker” and “reference,” is removed from the quads, and each completed layer is bound with insulating paper and checked over before the next layer is commenced. To maintain the high insulation of the joint it is placed in a baking oven (Fig. 4). This oven is a specially constructed steel box containing non-luminous heaters and the joint is placed in the oven during meal times, nights and week-ends. The completed core is tightly bound with two-inch insulating paper and the lead sleeve pulled over the joint, one end (chamfered to reduce the thickness) being lightly welded to the sheathing. At the other end a mark is made at a point 6 in. from the butt of the cable for reference during the swaging operation.

The sleeve is brushed with soapy lather and a special tool, namely, a swage, made of boxwood or lignum-vitæ (Fig. 5), clamped to it. When spirally rotated along the tube this tool reduces the external diameter of the sheath by extending its length. When the desired dimension is reached the surplus sheathing at the unfixed end is removed, leaving about half-inch for welding, lead sheet cut into thin strips being used for this purpose. As both drums

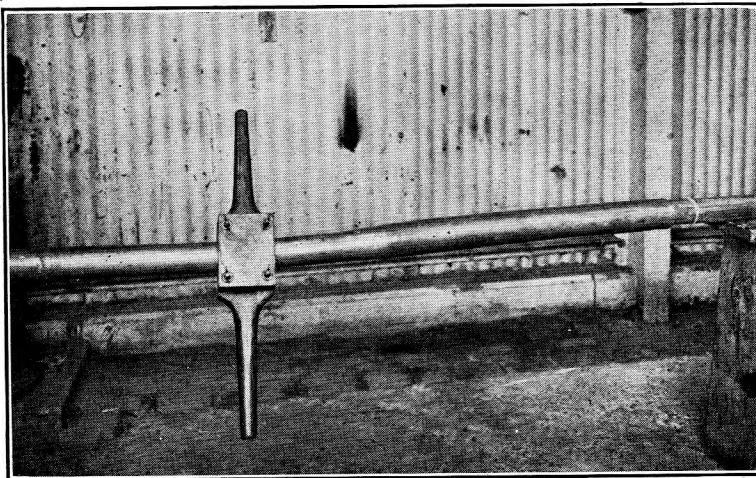

FIG. 5.—SWAGE CLAMPED TO CABLE.

are placed at right angles to the jointing position it is possible to jack them up and carefully rotate through an angle of 180° , so that the welding can be completed all round the joint. The method used in making the spliced joint secures that lead burning is kept to a minimum, thus reducing the liability to fracture.¹ The lead burning process, which is adopted for all the operations involved in this class of work, has also enabled a considerable saving in plumbing metal to be effected.

The method of jointing used at the Birmingham depot is similar to that described above, except that they prefer to use a split sleeve as, in their opinion, the swaging process does not give such a good mechanical joint.

¹P.O.E.E.J., Vol. 28, page 37.

After jointing, the cable is wound upon one drum, namely, the one containing the shorter of the two lengths, to limit the strain on the joint during the drawing-in operations. After this a pressure test of 40 lb. per square inch is applied for 24 hours. If the pressure test is satisfactory, insulation and conductivity tests are made, after which both ends are sealed and a lead label burnt on to one end. This label indicates the size and length of the spliced joint with the distance of the splice from the running end. The clockwise end of the length is painted red and three red rings are painted at each end to indicate that it contains a spliced joint.

The smallest joint undertaken is that for 24 pair 40 lb. carrier type cable. Successful results have been obtained on all sizes up to and including 1,400 pr/6½ lb. cables, together with joints on protected cables.

A careful record has been kept of the location of all spliced lengths drawn in and very few have failed to withstand the strain of the cabling operations.

General.

In addition to reconditioning and splicing, the depots have undertaken experimental work for the Engineer-in-Chief in connection with the desiccation of joints, the fitting of sealing ends to coaxial cable lengths and the examination and minor repairs to loading pots.

The value to date of cable reconditioned and brought into stock in the London Region alone is approximately £180,000 and the total weight of cable condemned as unsuitable for further use is nearly 600 tons.

The organisation of the work has been interesting and generally the staff, which includes several Belgian refugees, has shown great initiative in introducing labour-saving devices to build up reserve stocks of cable.

A recent detailed cost investigation has shown that the work is being carried out on sound economic lines.

Notes and Comments

Roll of Honour

The Board of Editors deeply regrets to have to record the deaths of the following members of the Engineering Department :—

While serving with the Armed Forces or on Post Office Duty.

Aberdeen Telephone Area	Johnson, P.	..	Skilled Workman, Class II	..	On Post Office Duty.
Belfast Telephone Area	Johnston, J. O.	..	Skilled Workman, Class II	..	Sergeant, R.A.F.
Birmingham Telephone Area	Adlington, J. T.	..	Skilled Workman, Class II	..	Signalman, Royal Signals
Birmingham Telephone Area	Chatwin, F. R.	..	Skilled Workman, Class II	..	Pilot Officer, R.A.F.
Birmingham Telephone Area	Hands, J. E.	..	Skilled Workman, Class II	..	Flight Sergeant, R.A.F.
Birmingham Telephone Area	Purvey, H. A.	..	Skilled Workman, Class II	..	Flight Sergeant, R.A.F.
Blackburn Telephone Area..	Jackson, A. C.	..	Skilled Workman, Class II	..	Sergeant, R.A.F.
Blackburn Telephone Area..	West, R. A.	..	Unestablished Skilled Workman	..	Flying Officer, R.A.F.
Bradford Telephone Area ..	Porrelli, J.	..	Skilled Workman, Class II	..	Sergeant, R.A.F.
Bradford Telephone Area ..	Siddle, F. V.	..	Unestablished Skilled Workman	..	Signalman, Royal Signals
Bristol Telephone Area ..	Hooper, L. W.	..	Unestablished Skilled Workman	..	Sergeant Pilot, R.A.F.
Cambridge Telephone Area..	Crane, G. C.	..	Labourer..	..	Lance Corporal, Beds. and Herts. Regt.
Cambridge Telephone Area..	King, A. J.	..	Unestablished Skilled Workman	..	Sub-Lieutenant, Fleet Air Arm
Cardiff Telephone Area ..	Gale, E. G.	..	Unestablished Skilled Workman	..	Signalman, Royal Signals
Chester Telephone Area ..	Cairns, P.	..	Skilled Workman, Class II	..	Corporal, Welsh Guards
Chester Telephone Area ..	Goldring, R.	..	Skilled Workman, Class I	..	Flight Sergeant Navigator, R.A.F.
Dundee Telephone Area ..	McHardy, G. L. P., D.F.C.	..	Draughtsman	..	Flight Lieutenant, R.A.F.
Dundee Telephone Area ..	McKillop, J.	..	Skilled Workman, Class II	..	Lieutenant, Black Watch
Edinburgh Telephone Area	Finlayson, W. D.	..	Skilled Workman, Class II	..	Signalman, Royal Signals
Edinburgh Telephone Area	Russell, J. A. C.	..	Skilled Workman, Class II	..	Warrant Officer, R.A.F.
Engineering Department ..	Cody, J.	..	Cleaner	..	Private, South Wales Borderers
Engineering Department ..	Gardner, J. W.	..	Mechanic-in-Charge, Grade I	..	Major, Royal Electrical and Mechanical Engineers
Engineering Department ..	Harrison, J. H.	..	Staff Officer	..	Lieutenant, Green Howards
Engineering Department ..	Levens, E. D.	..	Unestablished Skilled Workman	..	Flying Officer, R.A.F.
Engineering Department ..	Peacock, F. J.	..	Unestablished Skilled Workman	..	Pilot Officer, R.A.F.
Engineering Department ..	Tingay, K. A.	..	Unestablished Skilled Workman	..	Leading Aircraftsman, R.A.F.
Glasgow Telephone Area ..	Clark, D.	..	Skilled Workman, Class II	..	Signalman, Royal Signals
Glasgow Telephone Area ..	Sheridan, C. H.	..	Unestablished Skilled Workman	..	Warrant Officer, R.A.F.
Glasgow Telephone Area ..	Soutar, R. A.	..	Unestablished Skilled Workman	..	Sergeant, R.A.F.
Guildford Telephone Area ..	Kearey, S. W.	..	Unestablished Skilled Workman	..	Warrant Officer, R.A.F.
Lincoln Telephone Area ..	Pratt, D.	..	Unestablished Skilled Workman	..	Sergeant Air Gunner, R.A.F.
Liverpool Telephone Area ..	Faragher, C. R.	..	Skilled Workman, Class II	..	Signalman, Royal Signals
Liverpool Telephone Area ..	Lewis, A.	..	Skilled Workman, Class II	..	Flying Officer, R.A.F.
London Telecommunications Region	Bright, R. W.	..	Skilled Workman, Class I	..	Electrical Artificer, R.N.
London Telecommunications Region	Cocks, W. E.	..	Unestablished Skilled Workman	..	Flight Sergeant, R.A.F.
London Telecommunications Region	French, E. D. G.	..	Labourer..	..	Private, Highland Regiment
London Telecommunications Region	Harman, J. H.	..	Unestablished Skilled Workman	..	Sergeant, R.A.F.
London Telecommunications Region	Jackson, D. H.	..	Unestablished Skilled Workman	..	Flight Sergeant, R.A.F.
London Telecommunications Region	Jacques, M. B.	..	Skilled Workman, Class II	..	Sergeant, R.A.F.
London Telecommunications Region	Lowes, W. J. L. S., D.F.C.	..	Skilled Workman, Class II	..	Flight Lieutenant, R.A.F.

London Telecommunications Region	Paddison, J. E. . .	Tradesman Wireman	Flight Sergeant, R.A.F
London Telecommunications Region	Pemberton, D. S.W.	Labourer	Bombardier, Maritime R.A.
London Telecommunications Region	Rowe, J. E. . .	Skilled Workman, Class II . .	Sergeant, Essex Regiment
London Telecommunications Region	Taylor, E. C. . .	Labourer	Private, South Wales Borderers
London Telecommunications Region	Vince, D. T. . .	Unestablished Skilled Workman	Sergeant, R.A.F.
London Telecommunications Region	Waters, V. A. . .	Unestablished Skilled Workman	Sergeant, R.A.F.
Manchester Telephone Area	Kenyon, A. T. . .	Unestablished Skilled Workman	Pilot Officer, R.A.F.
Middlesbrough Telephone Area	Cotton, E. R. . .	Skilled Workman, Class II . .	Sergeant, R.A.F.
Newcastle-on-Tyne Telephone Area	Fender, J. D. . .	Unestablished Skilled Workman	Lance Corporal, Royal Signals
Nottingham Telephone Area	Casajuana, R. D.	Unestablished Skilled Workman	Flight Sergeant, R.A.F.
Oxford Telephone Area . .	France, R. C. . .	Unestablished Skilled Workman	Pilot Officer, R.A.F.
Peterborough Telephone Area	Thorne, N. W. . .	Inspector	Sergeant, Royal Signals
Scotland West Telephone Area	Davidson, A. B.	Skilled Workman, Class II . .	Sergeant, Royal Signals
Scotland West Telephone Area	Middleton, D. . .	Skilled Workman, Class II . .	Captain, Royal Artillery
Southampton Telephone Area	Poynter, H. R.	Youth-in-Training	Sub-Lieutenant, Fleet Air Arm
Stoke-on-Trent Telephone Area	Genno, E. N. . .	Unestablished Skilled Workman	Sergeant Air Gunner, R.A.F.
Tunbridge Wells Telephone Area	Seaward, G. L. . .	Unestablished Skilled Workman	Driver, Royal Signals
York Telephone Area . .	Townshend, E.	Inspector	Commissioned Gunner, R.N.

Recent Awards

The Board of Editors has learnt with great pleasure of the honours recently conferred on the following members of the Engineering Department :—

While serving with the Armed Forces, including Home Guard, or on Post Office Duty.

Aberdeen Telephone Area . .	Byers, W. S. . .	Skilled Workman, Class I	Sergeant (now Lt.), Royal Signals	Mentioned in Despatches
Birmingham Telephone Area	Parker, F. G. . .	Skilled Workman, Class II	Flying Officer, R.A.F.	Distinguished Flying Cross
Bradford Telephone Area . .	Askew, E. A. . .	Skilled Workman, Class II	Flying Officer, R.A.F.	Distinguished Flying Cross
Brighton Telephone Area . .	Laker, W. J. J. .	Draughtsman, Class II	Staff Sergeant, Home Guard	British Empire Medal
Bristol Telephone Area . .	Frampton, H. F. J.	Skilled Workman, Class II	Sergeant, Royal Signals	Military Medal
Engineering Department . .	Calverley, C. E.	Executive Engineer	Lieut.-Col., Royal Signals	Officer of the Order of the British Empire
Engineering Department . .	Stonebanks, A. M.	Assistant Engineer	Major, Royal Signals	Member of the Order of the British Empire
H.M.T.S.	Leech, W. H. . .	Commander . .	On Post Office duty	Distinguished Service Cross
H.M.T.S.	Nairne, I. U. D.	Second Officer . .	On Post Office duty	Distinguished Service Cross
H.M.T.S.	Oates, J. G. B.	Commander . .	On Post Office duty	Distinguished Service Cross
Hull Telephone Area . .	Thompson, W. H., M.M.	Inspector . .	Major, Home Guard	Member of the Order of the British Empire
Lancaster Telephone Area . .	Gilpin, F. A. . .	Unestablished Draughtsman	Sub-Lieut., R.N.V.R.	Distinguished Service Cross

Lancaster Telephone Area ..	Tweddle, W. D.	Skilled Workman, Class I	Flying Officer, R.A.F.	Distinguished Flying Cross Military Medal
London Telecommunications Region	White, R. J. ..	Labourer.. ..	C.Q.M.S., Royal Signals	
Manchester Telephone Area	Connoly, C. F. ..	Skilled Workman, Class II	Sergeant, Royal Signals	Mentioned in Despatches
Norwich Telephone Area ..	Ball, H. J. ..	Chief Inspector ..	Major, Home Guard	Member of the Order of the British Empire
Oxford Telephone Area ..	Gillies, J. J. ..	Skilled Workman, Class II	Sergeant, Home Guard	British Empire Medal
Portsmouth Telephone Area	Neill, H. F., M.M.	Skilled Workman, Class I	Major, Home Guard	Member of the Order of the British Empire
Taunton Telephone Area ..	Canever, R. B. ..	Skilled Workman, Class II	Flight Lieutenant, R.A.F.	Distinguished Flying Cross
Taunton Telephone Area ..	Harrison, H. G.	Inspector ..	Major, Home Guard	Member of the Order of the British Empire
York Telephone Area ..	Jones, F. ..	Telephone Manager	Brigadier, Royal Signals	Commander of the Order of the British Empire

Regional Notes

Home Counties Region

LEAD COVERED CABLE ATTACKED BY WOOD WASP

An interesting and somewhat unusual cause of faults in underground cables occurred during December, 1944, in the locality of Rackheath, near Norwich. The larva of the wood wasp (*Sirex gigas*) had bored three holes in the lead sheath of a piece of 14/20 lead cable, causing a low insulation fault.

The construction was non-standard inasmuch as the 14/20 cable was buried direct in the soil and terminated at about 3 ft. above ground level on a terminal block fixed to an uncreosoted larch pole which had probably been felled 12 months previously, and the larva eating its way from within the larch pole eventually reached the lead cable 3 in. below ground where it was touching the pole. The lead sheath was pierced and the fault developed.

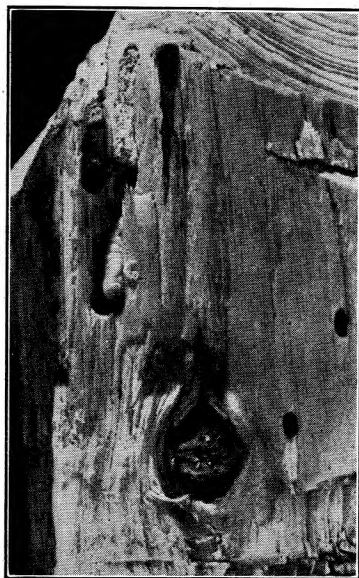

FIG. 1.—EFFECT OF LARVA ON TIMBER.

The female wood wasp is equipped with an ovipositor about $\frac{3}{4}$ in. long and two minute saws with which it is able to saw into the wood and deposit its eggs, generally five to seven. It takes about four weeks for the larvæ to eat their way out of the eggs after which they proceed to bore a tunnel at right angles to the original egg tunnel,

and in approximately $2\frac{1}{4}$ to 3 years each grub will eat a tunnel from 6 to 12 in. long.

From the larval stage it enters the pupal stage, and for the last five or six weeks occupies a pupal cell about $\frac{3}{4}$ in. beneath the surface.

In the particular case in question it appears that the larva had reached the surface late in the year due to its being below ground, and carried on gnawing into the lead. The surface of 9 ft. of pole had holes at 3 or 4 in. spacing throughout its entire area. The photographs (Figs. 1 and 2) show very clearly the effect of the larva on timber and lead, but do not show one of the main characteristics of the larva which is a sharp point at the tail end, which is sketched in Fig. 3.

This case is not isolated as a similar incident occurred when the Norwich-Coltishall-North Walsham cable was laid in June, 1939. The contractors had perforce to use wood bearers as a temporary measure, and by chance a wood wasp was emerging from the pupal stage and gnawed its way from the wood through the lead sheath of the cable, and was carrying on into the copper conductors when its presence was detected by the low insulation. It was killed by electrocution when the

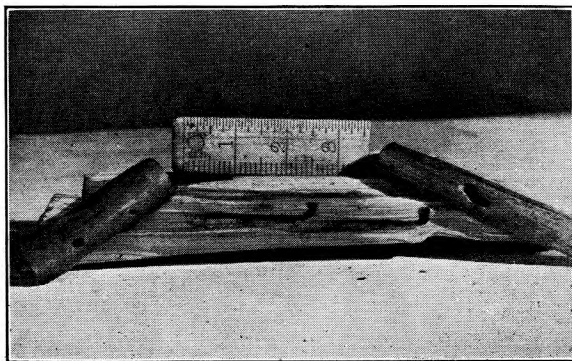

FIG. 2.—EFFECT OF LARVA ON LEAD.

500 V megger was applied to localise the fault. The cable had not been accepted by the Post Office, and the cable company (The Southern United Telephones Cables, Ltd.) retained the samples.



FIG. 3.—LARVA OF WOOD WASP.

From fairly recent correspondence with the Post Office Stores Department on the subject of another wood-eating grub, it would seem that the lead boring habit of larvæ is not uncommon as a failure of a telephone line in Springfield, Massachusetts, led to the discovery of three large larvæ of the broad-necked root borer, *Pri uns laticollis*, in one side of an underground wooden telephone duct, made of southern pine. The lead covering of the cable inside the duct had a hole chewed through it at a point where the insect-injured wood occurred. Apparently a somewhat similar incident occurred in the adjacent town of Longmeadow in the previous year.

Assistance in the classification of the specimen causing the fault near Norwich was freely given by the Curator of the Norwich Museum.

E. H.

Scottish Region

STORM DAMAGE

A snowstorm of exceptional severity swept the whole of the Scottish Region on 17th/18th January, and caused widespread damage, many rural districts being completely isolated. Roads were everywhere blocked, and although the main roads were quickly cleared, minor roads remained impassable due to a continuance of the severe weather with further snowfalls. The continued bad weather resulted in a constant stream of additional faults and isolation of exchanges, and the highest totals recorded were 6,000 subscribers' lines faulty and 142 exchanges isolated.

The fault position had been much improved by 29th January, but on this day a further gale with heavy snow affected the whole of the west of Scotland, including the Outer Isles. Many exchanges, only just restored to service were again isolated, and some districts previously little affected now had their share of damage. Damage to electricity supply mains resulted in difficulties in battery maintenance.

Unusual methods of travelling were adopted in some cases. In the Island of Skye, an agricultural tractor was used to cover roads otherwise impassable, and in one case the lineman travelled on horseback. In a coastal area, the Naval Authorities placed a motor launch, with its crew, at the disposal of the local Inspector, and areas otherwise isolated were reached by coastal landings in very stormy weather.

All areas were normal by 7th February, with the exception of two island localities where exceptionally heavy damage had been done and road conditions were bad. Seven exchanges remained isolated, and the last of these was cleared on 19th February, completing the temporary repairs.

A heavy programme of permanent repairs remains to be tackled during the spring and summer.

J. L.

FICTITIOUS TESTS WITH TESTER No. 36.

During corrosion investigations on the land cables leading to the submarine cable hut at Sinclair Bay, Wick, sheath current was found flowing towards the cable hut and out to sea on the armouring of the submarine cables. The neighbourhood is entirely of rock with a shallow covering of sand, and the submarine cable armouring is used as the cable hut earth, bonded to the land cables.

Testing with a No. 36 tester, a sheath current of several hundred milliamperes on the land cables was found to have increased to 4.5 amperes on the armouring of the submarine cables.

Investigations indicated that there was no possibility of additional pick-up of current in the vicinity of the hut, and it appeared therefore that the results obtained with tester No. 36 were fictitious. It seemed probable that at the contact between the copper test wire and the iron armouring of the cable, the presence of a film of sea water would lead to the generation of a small voltage, to cancel which would require a heavy current from the battery of the tester. Careful drying of the armouring, and care in making the connections resulted in steady sheath currents approximating to those measured on the land cable sheaths and confirmed this view.

J. L.

North-Eastern Region

MAGNESIUM LIMESTONE DEPOSIT ON O/H WIRES

The illustration is not, as might be expected, one of ice formation, but of a unique coating of magnesium limestone on the Department's 40 lbs. O/H wires at the works of the Conisborough Cliff Co. At these works magnesium limestone is quarried, and after crushing and screening is burnt for approximately 24 hours at a temperature between 1600-1700 C. This has the effect of driving off carbon dioxide, the resulting product of magnesium and calcium oxides being known as dolomite. This, when further crushed and mixed with tar, is used for the lining of smelting furnaces producing basic steel.

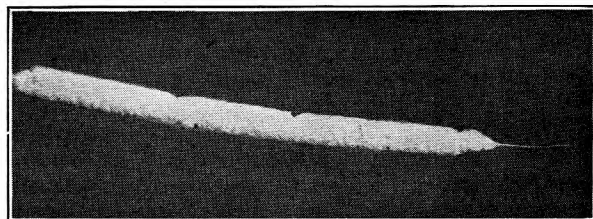

The formation on the wires is produced from the first screening below 4 in. to 6 in. which is rolled, dried and then crushed in a ball-mill down to a fineness to pass a 240 mesh. This dust is then taken to coalmines where it is used for laying coal dust and so assists in preventing explosions. As the dust is somewhat comparable to cement, it clings to damp wires and quickly builds up the formation shown. The time taken to produce a covering 1 in. diameter is between three and six months, depending on the weather.

J. W. S.

AN UNUSUAL EXTERNAL JOB

A direct labour job, outside the normal run of Departmental work, has recently been successfully carried out by staff from the Lincoln Telephone Area.

The work consisted of building a manhole (Type B2c) and transferring to it, from an adjacent cable hut, working cables (both submarine and land) and an

associated loading coil case. The cables and case were transported "en bloc" by an overhead beam and tackle, the slack being taken up by "snaking" the shore end

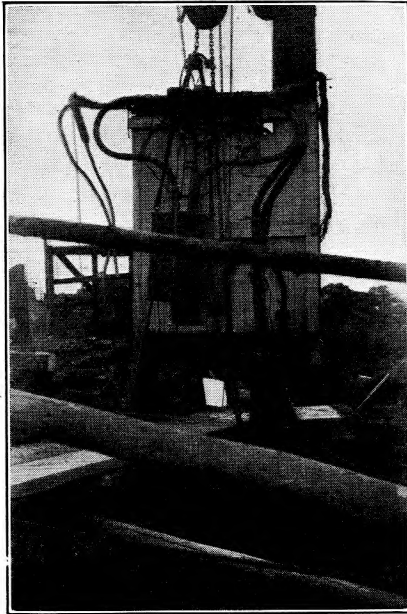

FIG. 1.

of the cable. They were then lowered into the manhole excavation, and positioned on a prepared reinforced concrete base, after which the manhole was built around them.



FIG. 2.

The stages of the work are illustrated in the two photographs. Fig. 1 gives a general view of the partially demolished cable hut and the method of handling the loading coil case, and shows the strutting and lashing used to ensure that the stub and cable joints were not

damaged. Fig. 2 shows the loading coil and cables being lowered into position prior to the manhole being built around them.

The manhole has been made watertight by fitting seals, clay plugging the outside, and building a shaft so that the entrance is above the highest tides. The work was carried out without any interruption of service and the M/H gives adequate space, both for the additional cable and loading coil case now being installed, and also for any further future development.

T. N. L.

South Western Region

THE USE OF THE CHAIN PULLER IN CASES OF CABLE CREEPAGE

Cable creepage occurred recently in the Bristol Telephone Area, where a main cable was found to have moved over seven consecutive lengths and the joints had in some instances commenced to enter the duct mouths. Before anti-creepage devices could be fitted it would be necessary either to build an extension to each of the carriageway joint boxes, or to draw back the cable to its original position. In view of the high cost of the first proposal, it was decided to draw back the cable to its original position, making use of the chain puller.

As only two chain pullers were available, one was placed at the end from which the cable had crept and the other at an intermediate joint box approximately at the halfway point. The chains were anchored to wood arms placed in the joint boxes and arranged to provide a straight pull on the split cable grips which were fixed to the cable behind the joints as shown in the sketch.

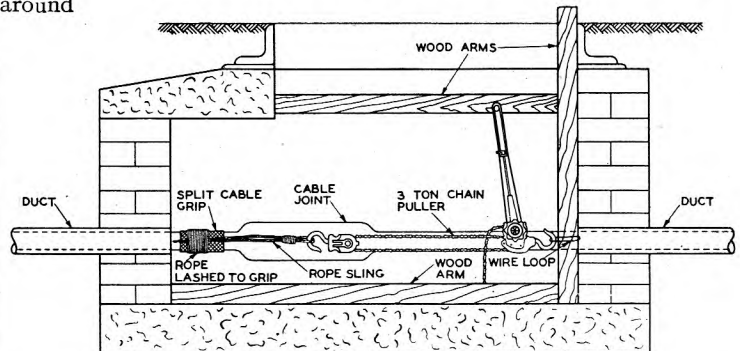

Men were posted to watch the intermediate joints, and the two chains were operated simultaneously. The movement of the cable was slow and steady and the cable was gradually restored to its original position. It should be mentioned that the cable was jointed straight across the intermediate joint boxes, and that the duct track follows a straight line.

The joints were then pressure tested with satisfactory results, but as on examination two showed signs of strain they were replumbed. There was no evidence of crippling of the cable sheath by the split grips. The cable concerned was a 54 pr/20 P.C.Q.T.

The use of the chain puller for this class of work is strongly recommended as the pull is slow and steady, and can be easily controlled. It is considered that to avoid any risk of straining joints or cable shafting the number of chain pullers should be increased to at least one in every alternate joint box, or where the track is not straight, to one in each joint box.

E. W. K.

Staff Changes

Promotions

Name	Region	Date	Name	Region	Date
<u>Regl. Eng. to T.M.</u>			<u>Insp. to Chief Insp.</u>		
Procter, W. S.	.. Scot. Reg. to Glasgow	7.2.45	Bell, R. J. B.	.. H.C. Reg. to Scot. Reg.	17.12.44
<u>Area Eng. to T.M.</u>			Hulcoop, G. J.	.. Mid. Reg. to H.C. Reg.	31.12.44
Hopps, F.	.. N.E. Reg. to Middlesbrough	28.11.44	**Pearcey, J. F. H.	.. N.Ire. Reg. ..	31.21.44
Scarborough, W. H.	.. L.T.R. to Canterbury	31.4.45	**Thornton, F. R.	.. E.-in-C.O. ..	17.12.44
<u>Area Engr. to Regl. Engr.</u>			Goff, A. A.	.. L.T.R. to N.Ire. Reg.	31.12.44
Straw, J. G.	.. L.T.R. to Scot. Reg.	7.2.45	Bolus, E. H.	.. L.T.R. to N.Ire. Reg.	1.1.45
<u>Asst. Engr. to Exec. Engr.</u>			Clifford, F. G.	.. E.-in-C.O. ..	17.12.44
Pettitt, V. R.	.. E.-in-C.O. ..	1.12.44	Hutton-Penman, P. R.	.. E.-in-C.O. ..	16.10.44
Fogg, G. H.	.. E.-in-C.O. ..	18.1.45	Hayman, H. W. S.	.. S.W. Reg. to W. & B.C. Reg.	31.12.44
Leach, F.	.. N.W. Reg. ..	15.12.44	Lugg, J. V.	.. S.W. Reg. to W. & B.C. Reg.	31.12.44
Pyrah, F.	.. E.-in-C.O. ..	21.12.44	Bogg, A.	.. E.-in-C.O. ..	31.12.44
Devereux, R. C.	.. L.T.R. ..	10.1.45	Pullen, L.	.. Mid. Reg. ..	3.1.45
Corkett, H.	.. E.-in-C.O. ..	12.2.45	Cleary, E. J.	.. N.W. Reg. ..	14.1.45
Branson, J. W.	.. Scot. Reg. ..	7.2.45	Hodgkinson, A. A. A.	.. E.-in-C.O. ..	1.1.45
Jeynes, E. H.	.. L.T.R. ..	31.1.45	Freshwater, R. A. A.	.. L.T.R. ..	4.2.45
<u>Chief Insp. to Asst. Engr.</u>			Cooper, R. S.	.. S.W. Reg. ..	25.2.45
Kidd, C.	.. E.-in-C.O. ..	18.1.45	<u>D'sman, Cl. II, to D'sman, Cl. I.</u>		
Cheetham, H.	.. N.W. Reg. ..	14.1.45	Nowlan, N. N.	.. L.T.R. ..	1.1.45
Bavin, A. E.	.. L.T.R. ..	26.1.45	<u>S.W.1 to Insp.</u>		
<u>Chief Insp. to Chief Inspec. with Allce.</u>			Courtman, J. C. S.	.. E.-in-C.O. ..	21.11.44
Thompson, J. G.	.. N.E. Reg. ..	1.2.45	<u>2nd Officer to Chief Officer</u>		
Verney, J. P. S.	.. S.W. Reg. ..	1.1.45	Garnett, F. J.	.. H.M.T.S. ..	18.9.44
Arran, H.	.. L.T.R. ..	1.1.45	Bates, O. R.	.. H.M.T.S. ..	25.7.44
Henderson, W. G.	.. N.Ire. Reg. ..	1.1.45	<u>3rd Officer to 2nd Officer</u>		
<hr/>					
**Promoted "In Absentia"					
<hr/>					
Retirements					
<hr/>					
Name	Region	Date	Name	Region	Date
<u>Exec. Engr.</u>			<u>D'sman, Cl. I.</u>		
Maddocks, D. C.	.. L.T.R. ..	31.12.44	Hillis, J. B.	.. N. Ire. Reg. ..	31.12.44
Vickers, G. H.	.. E.-in-C.O. ..	17.1.45	Wake, E. G.	.. L.T.R. ..	31.12.44
<u>Asst. Engr.</u>			<u>Insp.</u>		
Bardwell, W. J.	.. H.C. Reg. ..	31.12.44	Rowell, W. T.	.. L.T.R. ..	31.8.44
Reeves, T. F.	.. H.C. Reg. ..	31.12.44	Webber, R. N.	.. L.T.R. ..	6.12.44
<u>Chief Insp. with Allce.</u>			Harrison, L. J.	.. L.T.R. ..	7.12.44
French, W. S.	.. N.Ire. Reg. ..	31.12.44	Green, C. H.	.. N.E. Reg. ..	31.12.44
Messenger, C. W.	.. L.T.R. ..	31.12.44	Honeywill, T. C.	.. S.W. Reg. ..	31.12.44
Sceats, F. W.	.. S.W. Reg. ..	31.12.44	Winson, T. H.	.. Mid. Reg. ..	31.12.44
Beaumont, H. R.	.. N.E. Reg. ..	31.1.45	Forrstal, E. J.	.. N.E. Reg. ..	31.12.44
<u>Chief Insp.</u>			Johnston, J.	.. N.W. Reg. ..	31.12.44
Lynch, W. J.	.. L.T.R. ..	17.11.44	Barber, W.	.. N.W. Reg. ..	31.12.44
Traviss, F. D.	.. S.W. Reg. ..	31.12.44	Sargent, F. J.	.. L.T.R. ..	31.12.44
Howcroft, A.	.. N.W. Reg. ..	31.12.44	Springett, H. J. G.	.. L.T.R. ..	4.1.45
Edwards, W. W.	.. Mid. Reg. ..	2.1.45	Cartwright, C. N.	.. Mid. Reg. ..	4.1.45
			Sansome, P. V.	.. Mid. Reg. ..	9.2.45
			Briggs, F. J.	.. N.W. Reg. ..	14.2.45
			Mullis, H. R.	.. W. & B.C. Reg. ..	21.2.45
			Henry, A. G.	.. L.T.R. ..	27.2.45
			Barnsdall, A. W.	.. Mid. Reg. ..	28.2.45
			Plumbly, V. G.	.. L.T.R. ..	28.2.45

Transfers

Name	Region	Date	Name	Region	Date
<i>Exec. Engr.</i>			<i>Insp.</i>		
Coleman, W. L. A.	.. E.-in-C.O. to S.W. Reg.	26.11.44	Pariser, F. A. A.	.. Cable Test Section to Mid. Reg.	4.12.44
Bevis, W. F.	.. E.-in-C.O. to N.E. Reg.	3.1.45	Colburn, J. T.	.. Mid. Reg. to Cable Test Section	4.12.44
Smith, G. E.	.. Scot. Reg. to L.T.R.	7.2.45	Seager, E. F.	.. E.-in-C.O. to H.C. Reg.	18.12.44
<i>Asst. Engr.</i>			Everett, A. A. F.		
McWalter, W. V.	.. Mid. Reg. to Scot. Reg.	14.2.45	Turner, W.	.. Cable Test Section to E.-in-C.O.	28.12.44
<i>Chief Insp.</i>			.. E.-in-C.O. to Mid. Reg.		
Brown, E. H. K.	.. E.-in-C.O. to S.W. Reg.	26.11.44	Corrin, W.	.. E.-in-C.O. to London Test Section	8.1.45
<i>D'sman, Cl. I.</i>			Digby, W.		
Barrett, R. E.	.. H.C. Reg. to S.W. Reg.	13.11.44	Roach, J. D.	.. London Test Section to E.-in-C.O.	11.1.45
				.. E.-in-C.O. to W.& B.C. Reg.	15.1.45

Appointments

Name	Region	Date	Name	* Region	Date
<i>Prob. Insp. to Insp.</i>			<i>Prob. Insp. to Insp.—continued.</i>		
Cooper, H.	.. E.-in-C.O.	1.1.44	Martin, F. N.	.. E.-in-C.O.	1.1.44
Driver, E. R.	.. E.-in-C.O.	1.1.44	**Newham, K. C.	.. L.T.R.	1.1.44
Leask, D. R.	.. E.-in-C.O.	1.1.44	Allery, G. D.	.. E.-in-C.O.	1.1.44
Low, F. A.	.. E.-in-C.O.	1.1.44	Howells, A. W.	.. E.-in-C.O.	1.1.44
Redman, F. W. G.	.. E.-in-C.O.	1.1.44	Faulkner, R. A. R.	.. E.-in-C.O.	1.1.44
Arnold, G. F.	.. E.-in-C.O.	1.1.44	Anderson, J. G.	.. E.-in-C.O.	1.1.44
Milne, F. A.	.. E.-in-C.O.	1.1.44	Fletcher, J. L.	.. E.-in-C.O.	1.1.44
Archbold, R. B.	.. E.-in-C.O.	1.1.44	Barton, R. W.	.. E.-in-C.O.	1.1.44
Brown, W. A.	.. E.-in-C.O.	1.1.44	Fleming, J. M.	.. E.-in-C.O.	1.1.44
Davis, E.	.. E.-in-C.O.	1.1.44	Crosby, E.	.. E.-in-C.O.	1.1.44
Jeffery, N. E.	.. E.-in-C.O.	1.1.44	Foster, F. W.	.. E.-in-C.O.	1.1.44
Frost, E. J.	.. E.-in-C.O.	1.1.44	Hall, R. R.	.. E.-in-C.O.	1.1.44
Garlide, J.	.. E.-in-C.O.	1.1.44	Graty, H. J.	.. E.-in-C.O.	1.1.44
Hutter, J.	.. E.-in-C.O.	1.1.44	Deville, C. W. A.	.. E.-in-C.O.	1.1.44
Pember, A. L.	.. E.-in-C.O.	1.1.44	Edwards, A. J.	.. E.-in-C.O.	1.1.44
Glanville, J. H.	.. H.C. Reg.	1.1.44	Brough, R.	.. Scot. Reg.	1.1.44
Varrall, J. E.	.. E.-in-C.O.	1.1.44	Nesbitt, W. R.	.. S.W. Reg.	1.1.44
Heeson, S. D.	.. E.-in-C.O.	1.1.44	Sinclair, B. R.	.. H.C. Reg.	1.1.44
Mallett, T. H.	.. E.-in-C.O.	1.1.44	Ayling, S. R.	.. E.-in-C.O.	1.1.44
Allan, T.	.. E.-in-C.O.	1.1.44	Farmer, W. H.	.. E.-in-C.O.	1.1.44
Hince, E. W.	.. E.-in-C.O.	1.1.44	Cooper, G.	.. E.-in-C.O.	1.1.44
Homes, A. C.	.. E.-in-C.O.	1.1.44	Thomas, J. F. P.	.. E.-in-C.O.	1.1.44
Lilley, M.	.. E.-in-C.O.	1.1.44	Glazier, A. W.	.. E.-in-C.O.	1.1.44
Walesby, H. N.	.. E.-in-C.O.	1.1.44	Dickson, J. S.	.. E.-in-C.O.	1.1.44
Warburton, D.	.. E.-in-C.O.	1.1.44	Parks, F.	.. E.-in-C.O.	1.1.44

** In Absentia.

Deaths

Name	Region	Date	Name	Region	Date
<i>Asst. Engr.</i>			<i>Exec. Officer.</i>		
Dodge, J. C.	.. E.-in-C.O.	26.11.44	Parker, J. A. T.	.. E.-in-C.O.	Death presumed 28.1.44
<i>D'sman, Cl. I.</i>			<i>Insp.</i>		
Fletcher, W. J.	.. E.-in-C.O.	11.2.45	Bradley, E. A.	.. N.Ire. Reg.	22.11.44
			Mantle, A. L.	.. Mid. Reg.	2.12.44
			James, G. E. C.	.. H.C. Reg.	10.2.45

Junior Section Notes

Aberdeen Centre

We are pleased to report that the membership is now over 100, a record for the Centre.

This session has also extended to members in Kirkwall and Inverness a novel method in participating in the meetings. This has been made possible by using 4-wire circuits with suitable terminal amplifiers and microphones so that both-way speech is obtainable. The arrangement has proved very successful and has created a *tête-a-tête* atmosphere at the meetings.

We have decided to hold a film night on Sunday, 25th February; the selection of films is being loaned from the Central Film Library. It is hoped that out-station members will be free from "emergencies" so that they can avail themselves of seeing this interesting show.
S. D. F. B.

Leeds Centre

The Leeds Centre of the Junior Section of the I.P.O.E.E. was re-formed on the 10th January, 1945, when a meeting was held at the Regional Conference Room, when the following officers were elected:—

Chairman : Mr. Couch (Area Engineer)
(Internal).
Vice-Chairman : Mr. A. Lodge.
Secretary : Mr. L. Smith.
Treasurer : Mr. T. Whitaker.

BOARD OF EDITORS

A. J. GILL, B.Sc., M.I.E.E., F.I.R.E., Chairman.
F. E. NANCARROW, O.B.E., A.R.C.Sc., M.I.E.E.
P. B. FROST, B.Sc., M.I.E.E.
A. H. MUMFORD, B.Sc.(ENG.), M.I.E.E.
C. W. BROWN, A.M.I.E.E.
G. H. S. COOPER.
H. LEIGH, B.Sc.(ENG.), A.M.I.E.E., Acting Managing Editor.
G. E. STYLES, A.M.I.E.E., Acting Assistant Editor.
A. J. BAKER, Secretary-Treasurer.

Copyright

The entire contents of this JOURNAL are covered by general copyright, and special permission is necessary for reprinting long extracts, but Editors are welcome to use not more than one-third of any article, provided credit is given at the beginning or end thus: "From the *Post Office Electrical Engineers' Journal*."

The Board of Editors is not responsible for the statements made or the opinions expressed in any of the articles in this JOURNAL, unless such statement is made specifically by the Board.

Communications

All Communications should be addressed to the Managing Editor, *P.O.E.E. Journal*, Engineer-in-Chief's Office, Alder House, Aldersgate Street, London, E.C.1. Telephone: HEADquarters 1234. Remittances should be made payable to "*The P.O.E.E. Journal*" and should be crossed "& Co."

Committee : Mr. S. Lancaster.
Mr. T. Barker
Mr. R. Willans.

The programme arranged for the session ending April, 1945, is:

21st February: "Wayleaves," Mr. A. E. Lancaster.
27th March: "The New Leeds Automatic Exchange," Mr. T. Barker.
10th April: Annual General Meeting.

Tunbridge Wells Centre

The inaugural meeting was held at Tunbridge Wells on September 23rd, 1944, and a committee of six was elected as follows:—*Chairman*, C. T. Polhill; *Vice-Chairman*, R. A. Evans; *Secretary*, D. L. Bendall; *Treasurer*, A. E. Chapman; *Committee*, T. W. Lusted and F. W. Scott.

The Centre has a membership of thirty, and the programme for second half of the 1944-45 session is as follows:—

27th January, 1945: "Thermionic Valves," by F. Lambert, read by R. P. Coleman.
24th February, 1945: "Underground Works," by J. Aldred.
7th April, 1945: "Drawing Office," by A. G. Fagg and W. H. Sturges.
April 4th, 1945: Film display and Annual General Meeting.

C. T. P.

Binding Cases

Cases for binding are available, and may be obtained from the Local Agents for 1s. 9d. Subscribers can have their copies of Volumes bound, at a cost of 3s., by sending the complete set of parts to the Local Agents or to the *P.O.E.E. Journal*, Engineer-in-Chief's Office, Alder House, Aldersgate Street, London, E.C.1. Orders for binding for Vols. 1-19 should indicate whether the original binding case with black lettering, or the later pattern with gold, is required. Cases with gold lettering are the only type stocked from Vol. 20 onwards.

Back Numbers

The price of the JOURNAL, which is published quarterly, is 1s. (1s. 3d. post free) per copy, or 5s. per annum post free. Back numbers can be supplied, subject to availability of stocks, at 1s. each (1s. 3d. post free). Orders for back numbers may be sent to the Local Agents or to the Publishers.

Advertisements

All communications relating to space reservations should be addressed to the Advertisement Editor, *P.O.E.E. Journal*, Alder House, Aldersgate Street, London, E.C.1. Communications regarding advertisement copy, proofs, etc., should be addressed to the Publishers, Messrs. Birch & Whittington (Prop. Doxling & Co. [Epsom], Ltd.), 49 Upper High Street, Epsom, Surrey.



The AvoMeter is one of a useful range of "Avo" electrical testing instruments which are maintaining on active service and in industry the "Avo" reputation for an unexcelled standard of accuracy and dependability—in fact, a standard by which other instruments are judged.

ONE INSTRUMENT
measures:—
Current, A.C. and D.C. (0 to 10 amps.)
Voltage, A.C. and D.C. (0 to 1,000 v.)
Resistance (up to 40 megohms)
Capacity (0 to 20 mfd.)
Audio-frequency Power Output (0 to 4 watts)
Decibels (—25 Db. to + 16 Db.)

Orders can now only be accepted which bears a Government Contract Number and Priority Rating.



Meters that Matter

THE Model 7 Universal AvoMeter is the world's most widely used combination electrical measuring instrument. It provides 50 ranges of readings and is guaranteed accurate to B.S. first grade limits on D.C. and A.C. from 25 to 100 cycles. It is self-contained, compact and portable, simple to operate and almost impossible to damage electrically. It is protected by an automatic cut-out against damage through severe overload, and is provided with automatic compensation for variations in ambient temperature.

Sole Proprietors and Manufacturers

THE AUTOMATIC COIL WINDER & ELECTRICAL EQUIPMENT Co. Ltd
Winder House, Douglas Street, London, S.W.1
Phone: VICTORIA 3404-8

POWER LEVEL INDICATORS

POWER LEVEL INDICATORS—TYPES D-152-A and D-152-B

Embodying a simple resistance bridge, self-balancing at a pre-determined power level—Robust—Accurate—Inexpensive.

Type D-152-A indicates a fixed power level; D-152-B is variable over a limited range.

Equally accurate on D.C. or A.C. Accuracy is independent of wave form and frequency up to 50 Kc/s.

With A.C., telephones will indicate balance to better than 0.1 db; a reasonably sensitive galvanometer (e.g. 100-0-100 μ A) gives equivalent discrimination with D.C.

Cannot be damaged by overloads up to 1,000 %.

Indispensable to Transmission Engineers, Meter Manufacturers and others requiring a standard power level.

STANDARD TYPES

TYPE NUMBER	POWER INDICATION Ref. 1 mW	INPUT RESISTANCES	DIMENSIONS	WEIGHT
D-152-A	+20 db \pm 0.1 db	600 μ \pm 1%	6" \times 5" \times 5 $\frac{1}{2}$ "	3 lbs.
D-152-B	+10 to \pm 22 db \pm 0.2 db	600 μ \pm 5%	8" \times 5" \times 5 $\frac{1}{2}$ "	4 lbs.

Full particulars are given in Bulletin B-540-A a copy of which will gladly be sent on request.

MUIRHEAD & CO. LTD., ELMERS END, BECKENHAM, KENT
Beckenham 0041-0042.
FOR OVER 60 YEARS DESIGNERS & MAKERS OF PRECISION INSTRUMENTS.

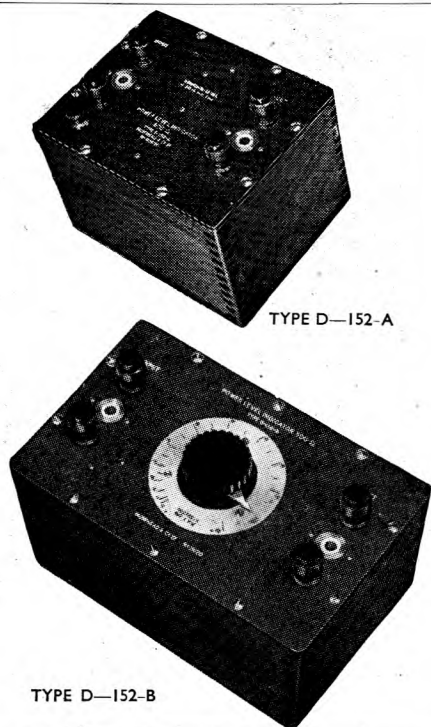

MUIRHEAD

FOR EASY CURRENT MEASUREMENTS

in Busbars, Fuses and Cables up to $2\frac{1}{8}$ " diam.

- DUAL RANGE WITH SELECTOR SWITCH
- FULLY INSULATED CORE AND HANDLE

FERRANTI

DUAL RANGE

Clip-on AMMETER



RANGES

0—10—50 Amps.
 0—20—100 Amps.
 0—50—250 Amps.
 0—100—500 Amps.
 0—200—1000 Amps.

FI50a

FERRANTI LIMITED, Hollinwood, Lancs.

London Office : Kern House, Kingsway, W.C.2

TURNER DIFFERENTIAL MILLIAMMETERS

G.P.O. No. 17 & No. 18

Meet the most exacting demands for balancing currents in multiplex telegraph circuits.

— A quality product of outstanding merit —

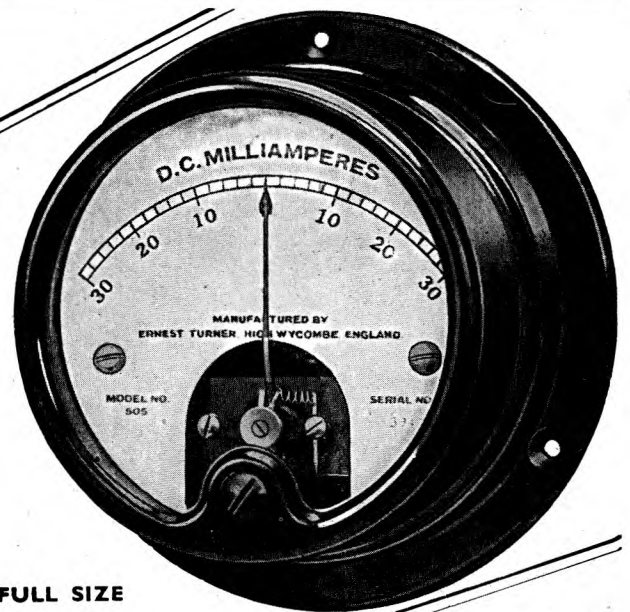

FULL SIZE

Also manufacturers of G.P.O. Detector No. 4, and a comprehensive line of instruments for precision electrical measurements.

ERNEST TURNER ELECTRICAL INSTRUMENTS, Ltd.

CHILTERN WORKS,
 49-73 TOTTERIDGE AVENUE,
 HIGH WYCOMBE,
 BUCKS, ENGLAND

Telephone : High Wycombe 1301, 1302.
 Telegrams : Gorgeous High Wycombe.

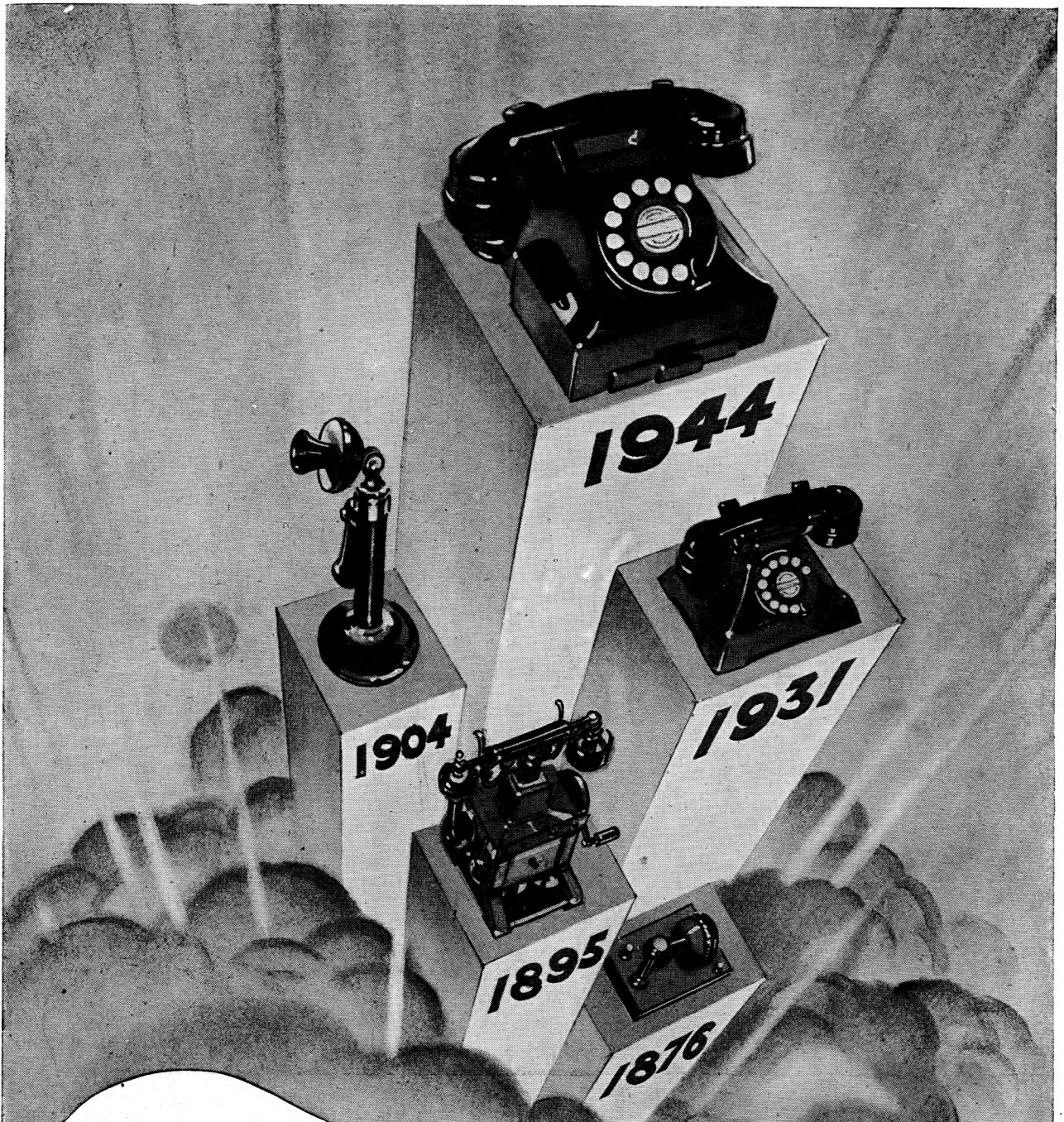

Ericsson

66 years of steady progress in telephony and its applications sees Ericssons in their extensive plant to-day utilising Modern Plastics for the improvement of telephone design and efficiency.

Ericssons have unrivalled experience in

the production of telephone equipment required to function under tropical and similar extreme conditions—taking full advantage of the application of Plastics in this connection.

Enquiries welcomed.

ERICSSON TELEPHONES LTD., Head Office: 56, Kingsway, London, W.C.2. Tel.: -HOL. 6936.

Works Beeston, Notts.

H. T. A. LIMITED

Formerly Hall Telephone Accessories (1928) Limited.

Contractors to H.M. Post Office, Admiralty, M.A.P., M.O.S., and Dominion and Foreign Administrations.

Precision Engineers & Instrument Makers

Manufacturers of Prepayment Telephone Multi-Coin Collectors, Gas Leak Indicators, Automatic Stamp Selling and Ticket Selling Machines, Automatic Slot Machines and Fire Alarm Apparatus.

Enquiries Invited.

Registered Office and Works :—

**DUDDEN HILL LANE, WILLESDEN,
LONDON, N.W.10**

Tel. WILLESDEN 5141, etc. Also DOWLAIS, GLAM.

RELAYS

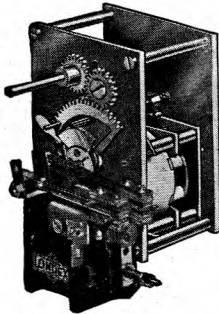

The illustration shows mechanism of Time Delay Relay PRL driven by synchronous motor (without base plate and cover). Six types cover between them a range from 2 seconds to 28 days. All types reset instantaneously.

Wide range of other relays for A.C. and D.C.

Ask for leaflet 97/PO.

PROCESS TIMERS

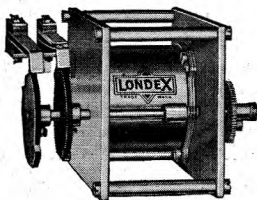

The illustration shows mechanism of Process Timer PR/S driven by synchronous motor (without base plate and cover). This type as well as a wide range of others are fitted with easily interchangeable gearing. Up to 20 circuits can be controlled, each circuit with different time characteristics.

Ask for leaflet 92B/PO.

LONDEX LTD

Electrical Remote Control
Engineers & Manufacturers.
Anerley Wks, 207 Anerley Rd, London, SE 20
Phone SYDENHAM 6258-9



SILVERED MICA CAPACITORS

*for Carrier Current Telephony
and for Instruments*

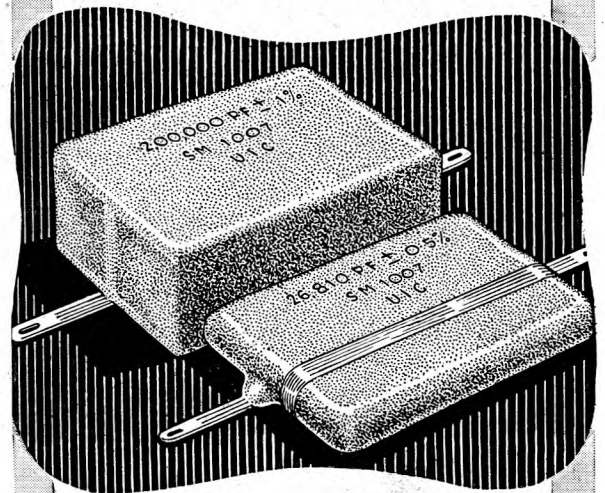

*High stability filter capacitors 0.001
to 0.2 mfd. tolerance $\pm 0.5\%$ or
wider. Full details on request.*

**UNITED INSULATOR CO. LTD.
12-22, Laystall St., E.C.1**

Telephone : Telegrams :
TERminus 7383 (5 lines) Calanel, Smith, London

THE PIONEERS OF LOW LOSS CERAMICS

SIEMENS

TELECOMMUNICATION EQUIPMENT

for service in all parts of the world

PRIVATE
TELEPHONE SYSTEMS

...
PUBLIC
TELEPHONE EXCHANGES

...
CARRIER - CURRENT
EQUIPMENT

...
TELEPHONE INSTRUMENTS
OF ALL TYPES

...
PROTECTIVE APPARATUS

...
RELAYS

...
TELEPHONE CABLES

...
CARRIER - CURRENT
CABLES

...
LOADING COILS

...
CELLS & BATTERIES
Dry, Fluid & Inert

Contractors for
the supply and installation of complete
Automatic and Manual Telephone Exchanges
for Public and Private Service, Automatic
and Manual Trunk Exchanges, all types of
Telephone Cables for Trunk and Local Service,
and Carrier-Current and Repeater Equipment
for Telephone Lines.

Siemens Telecommunication Equipment is
giving thoroughly efficient service in all
parts of the World.

SIEMENS BROTHERS & CO, LTD

WOOLWICH, LONDON, S. E. 18

ESTABLISHED 1858

Telephone : WOOLWICH 2020

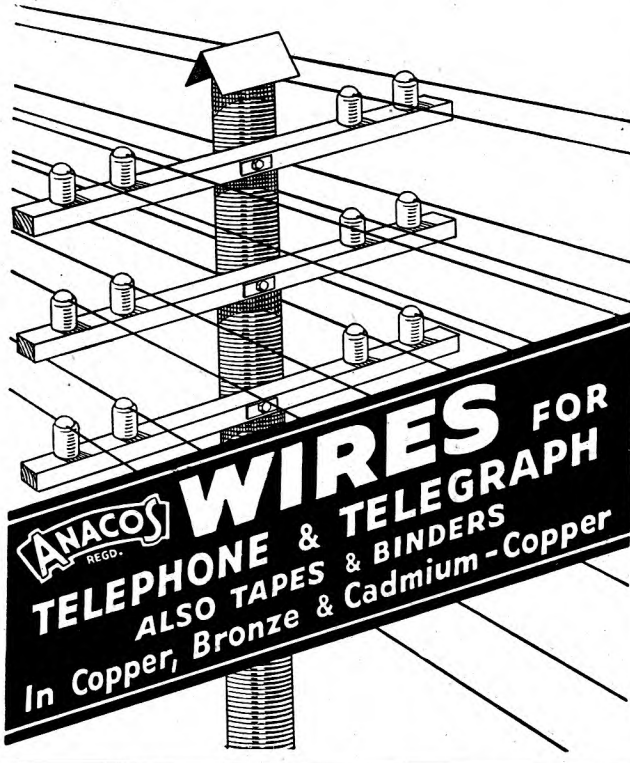

ANACOS REGD. **WIRES FOR**
TELEPHONE & TELEGRAPH
 ALSO TAPES & BINDERS
 In Copper, Bronze & Cadmium-Copper

FREDERICK SMITH & CO. LTD. (*Incorporated in The London Electric Wire Company and Smiths, Limited.*)
ANACONDA WORKS, SALFORD, 3, LANCS.
 Telephone : **BLACKFRIARS 8701 (8 lines)** Telegrams : **"ANACONDA" MANCHESTER**

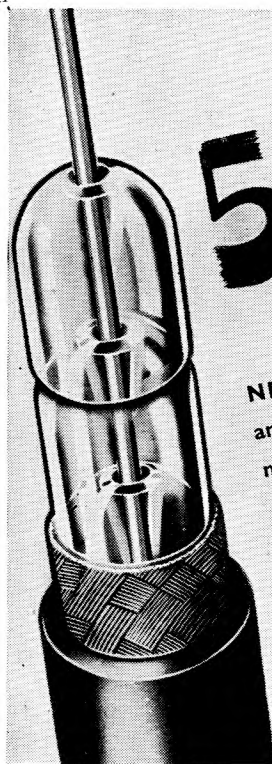

5 mmf/ft

NEW LOW LEVELS in capacity and attenuation of CO-AX Cables mean new possibilities in electronic equipment design both for the war effort and for the post-war electronic age.

BASICALLY BETTER AIR-SPACED

CO-AX LOWLOSS CABLES
TRANSRADIO LTD. 16 THE HIGHWAY-BEACONSFIELD-8-BUCKS.

design for reliability & efficiency

Westinghouse Metal Rectifiers more than meet G.P.O. standards of reliability and efficiency. Every unit, including the latest "Westalite" selenium-compound rectifier, has behind it the experience of eighteen years' rectifier technique and development and is built up to a standard and not down to a price.

Illustrated is a Mobile Power Unit for V.F. Telegraph Equipment, 24 and 130 volts output, incorporating "Westat" Constant Potential System.

Descriptive pamphlet No. 11 H describes the principles of many circuits employed in communication engineering in which Westinghouse Metal Rectifiers play a prominent part. We shall be pleased to send a copy to any interested Post Office Engineer

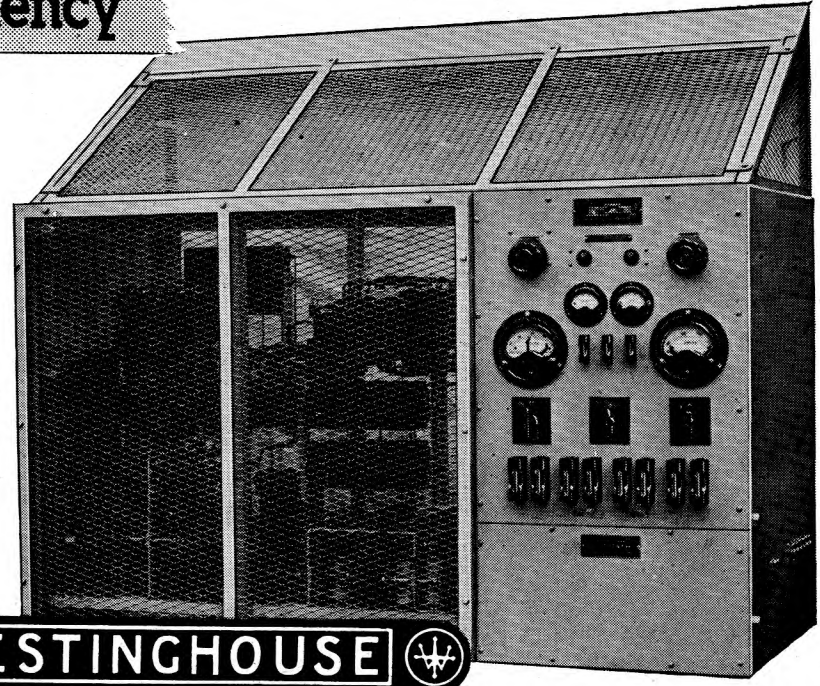

WESTINGHOUSE

METAL RECTIFIERS

WESTINGHOUSE BRAKE & SIGNAL CO. LTD.,
 Pew Hill House, Chippenham, Wilts.

COMPLETE CONTROL

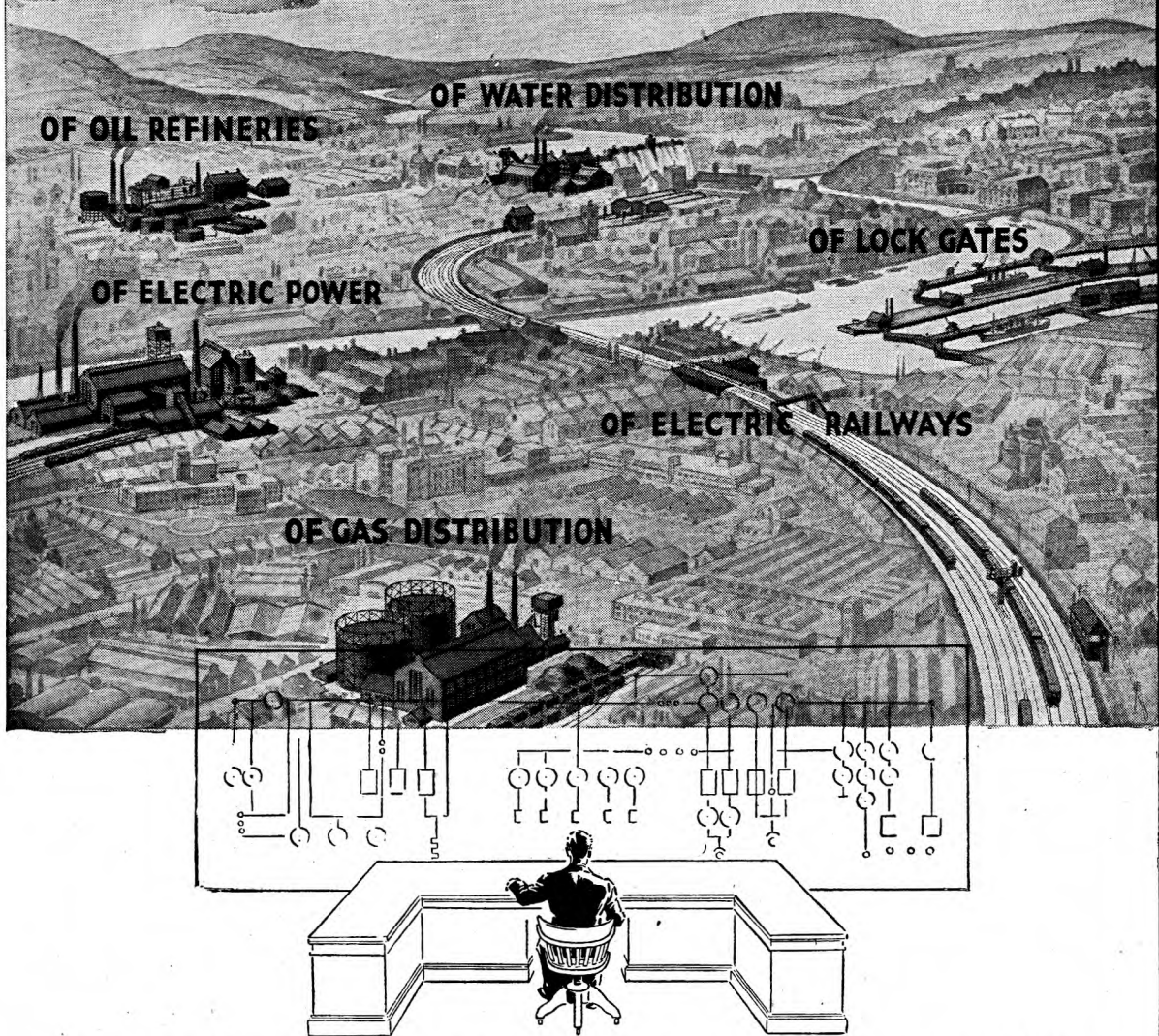

Ingenious combinations of relays, uni-selectors and other electro-mechanical devices are now being extensively employed for the conservation of man-power. This further application of the basic components of Strowger Automatic Telephony is but another example of the inherent flexibility of equipment already providing profitable public and private telephone service to large and small communities in over seventy countries.

For Telecommunications and control requirements specify—



STROWGER AUTOMATIC TELEPHONE EQUIPMENT

AUTOMATIC TELEPHONE & ELECTRIC CO., LTD.
 Norfolk House, Norfolk Street, London, W.C.2. TEMple Bar 9262.
 STROWGER WORKS, LIVERPOOL 7

TALKING OF TODAY

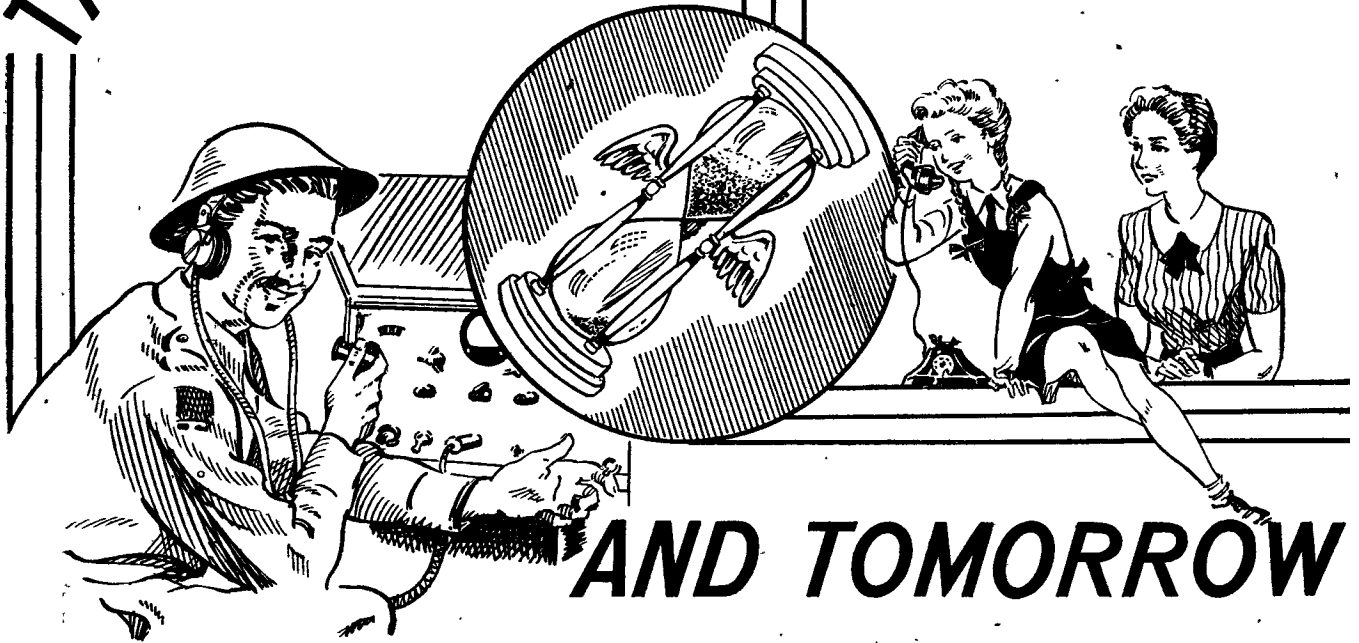

AND TOMORROW

Our fighting men must have telephone communication equipment that will work anywhere, whether in tropic heat or arctic cold, in the sands of the desert or on the landing beaches after the dash through the surf. They must have equipment they can trust at all times and under any conditions.

Today G.E.C. Telephone production is devoted entirely to this and to other essential tele-communication

equipment, but we hope that the day is not far distant when the progress and development of the past five years will be available in our post war designs.

In the meantime our expert advice and specialised knowledge of the design and manufacture of all types of tele-communication equipment, particularly for use in tropical climates, is always at your disposal.

For Public or Private Telephone Exchanges, Telephone Repeater Equipment for Long Lines, Carrier Telephone Systems, Railway Control Telephones, Voice Frequency Telegraph Equipment, Power Line Communications, and Light Current Signalling Systems of all types, specify—

G.E.C. TELE-COMMUNICATION EQUIPMENT

ADVT OF THE GENERAL ELECTRIC CO. LTD. HEAD OFFICE: MAGNET HOUSE
KINGSWAY, LONDON, W.C.2. TELEPHONE WORKS: COVENTRY, ENGLAND

WAVEMETERS

OSCILLATORS

CONDENSERS

INDUCTANCES

RESISTANCES

H. W. SULLIVAN
— LIMITED —

London, S.E.15

Tel. New Cross 3225 (Private Branch Exchange)

Electrical Standards for Research and Industry

Testing and Measuring Apparatus
for Communication Engineering

BRIDGES ——— Capacitance
Inductance
Resistance

ALL TYPES — ALL FREQUENCIES — ALL ACCURACIES

★
TELEGRAPH APPARATUS
for
MORSE SYSTEMS

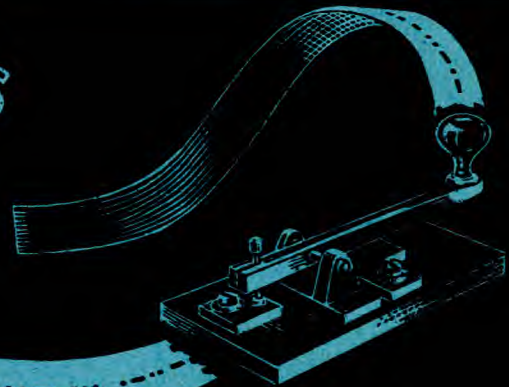

Makers of:

GALVANOSCOPES · INKERS
RESISTANCES · RELAYS
SOUNDERS · DETECTORS
KEYS · MILLIAMMETERS
AUTOMATIC RECEIVERS
& TRANSMITTERS ETC

Write for illustrated catalogue

ELLIOTT BROTHERS (LONDON) LTD. CENTURY WORKS,
LEWISHAM, S.E.13

MAINTAINING EFFICIENCY

THE HIGH STANDARD OF EFFICIENCY
OF PIRELLI - GENERAL TELEPHONE
CABLES IS MAINTAINED BY THE
CONTINUOUS RESEARCH WORK OF
AN EXPERIENCED TECHNICAL STAFF.

TELEPHONE:
SOUTHAMPTON
2141 (5 Lines)

PIRELLI-GENERAL
CABLE WORKS, Ltd., SOUTHAMPTON.

TELEGRAMS
"PIREKAYBEL"
SOUTHAMPTON.



It's always there!

Do not jeopardise production by taking the risk that the core of flux may be missing from the solder-wire you use. Be safe. Use Multicore 3-Core Solder. You will have, **always**, three cores of Ersin Flux—the fastest-action, non-corrosive, safety flux which "makes "dry" or "H.R." joints impossible. Multicore is approved by A.I.D. and G.P.O. If you are engaged upon Government contracts write for technical information and samples.



ERSIN MULTICORE

The Solder Wire with 3 Cores of Non-Corrosive Ersin Flux

MULTICORE SOLDERS LTD. COMMONWEALTH HOUSE, NEW OXFORD ST., LONDON, W.C.1. Tel: CHAncery 5171/2