

THE POST OFFICE ELECTRICAL ENGINEERS' JOURNAL

VOL. 39

JULY, 1946

PART 2

CONTENTS

	PAGE
A QUARTZ CLOCK—C. F. Booth, M.I.E.E.	33
A SIMPLIFIED CABLE BALANCING INSTRUMENT—Part 1— Description of the Instrument—H. C. S. Hayes, A.M.I.E.E., and E. D. Latimer	38
THE REPAIR AND INSTALLATION OF TELECOMMUNICA- TIONS POWER PLANT IN THE L.T.R.—C. A. R. Pearce, M.Sc., A.M.I.E.E.	44
REUTERS' WIRELESS SERVICES—W. West, B.A., M.I.E.E.	48
MODERN VIBRATORY POWER CONVERTERS—L. S. Distin, A.M.I.E.E.	53
COMPUTATION PROBLEMS IN CIRCUIT DESIGN—G. T. Baker, M.Sc.	58
THE UNIT BAY 1B COAXIAL CABLE TRANSMISSION SYSTEM— Part 4—The Installation and Operation of Unit Bay 1B Systems— R. A. Brockbank, Ph.D., B.Sc., A.M.I.E.E., and C. F. Floyd, M.A., A.M.I.E.E.	64
MINIATURE RELAYS—J. S. Young, A.M.I.E.E.	66
TWO METHODS OF LOCALISING CABLE FAULTS—J. M. Allan	70
NOTES AND COMMENTS.	73
BOOK REVIEWS	76
REGIONAL NOTES	77
JUNIOR SECTION NOTES	77
STAFF CHANGES	78

Price 1/- net

THE INSTITUTION OF POST OFFICE ELECTRICAL ENGINEERS

GE CALLOY RADIO CORES



Send for
New List
1944

SALFORD ELECTRICAL INSTRUMENTS LTD.
PEEL WORKS, SALFORD, 3. Telephones : BLAckfriars 6688 (6 lines). Telegrams and Cables : "Sparkless, Manchester"
PROPRIETORS: THE GENERAL ELECTRIC Co. Ltd., OF ENGLAND

*For large scale
Electrical
Purposes*



It is noteworthy where Tudor accumulators are to be found fulfilling the most important duties: over 500 British Power Stations installed Tudor. Many Tudor installations rank among the largest in the land and have an enviable reputation for long-lived reliability. No matter whether they were installed only yesterday, or over thirty

years ago—as many of them were—they are to-day functioning with consistent efficiency.

SAFETYLYTE is the Tudor Emergency Lighting System, which is automatic and instantaneous in operation. It is installed in thousands of schools, hospitals factories and other large buildings.



TUDOR ACCUMULATORS

THE TUDOR ACCUMULATOR CO. LTD
50 GROSVENOR GARDENS, LONDON, S.W.1

THE POST OFFICE ELECTRICAL ENGINEERS' JOURNAL

Vol. XXXIX

July, 1946

Part 2

A Quartz Clock

C. F. BOOTH, M.I.E.E.

U.D.C. 621.396.611.21 : 529.786

The development of the quartz clock by radio engineers and its application by astronomers are discussed, the design and performance of representative units are outlined, and brief details are given of equipment now being produced by the Post Office for the Royal Observatory.

Introduction.

THE absolute standard of time is set by the rotation of the earth, and the astronomer, after determining by stellar observation the period of the earth's rotation, uses special clocks to sub-divide this period, and these clocks become the working standard of time. From such time standards, radio time signals are broadcast in many countries and the rhythmic signals transmitted by Post Office transmitters at Rugby and Leafield may be taken as representative. (These signals, which are generated by the Royal Observatory, are much more accurate than, and should not be confused with, either the six-pip signal transmitted by the British Broadcasting Corporation or with TIM.)

During the past few years the radio engineer has written another chapter in time measurement by his development of a new type of clock, known as the quartz clock, which, on account of its very constant and predictable rate, is now being used by astronomers in preference to the pendulum clock.

Before considering the detailed design of a quartz clock it is proposed to outline briefly the calibration of a frequency standard to illustrate how the radio engineer has been able to improve the mechanism which the astronomer uses to sub-divide the period of the earth's rotation.

The process of calibrating a frequency standard in terms of radio time signals is accomplished with the aid of a time indicator driven by an output from the standard, the overall design being such that when the standard maintains its prescribed frequency the time indicator has a mean solar time rate. An increase of frequency will cause the clock to gain and vice versa, and hence, from a knowledge of the clock rate, the standard frequency is determined. Assuming that the frequency of the standard is 100.00001 kc/s, i.e., 1×10^{-7} above the nominal value, and that a precise 24-hour calibration interval is utilised—say, between successive 10.00 hr. signals from Rugby, then, since there are 86,400 seconds in one day the clock will gain $86,400 \times 10^{-7}$ seconds or 8.64 milliseconds over the interval. It is evident that the accuracy of calibration is dependent on the exactness of the 24-hour interval given by the radio time signals, and should this be in error by $\pm m$ milliseconds, the error introduced in the determina-

tion of the standard frequency in parts in 10^7 is $\pm (m \times 10^7)/(86,400 \times 1,000.)$

With improved frequency standards of the crystal-controlled type it became necessary to employ longer and longer calibration intervals, since the actual error in the astronomer's determination of the interval is sensibly independent of its duration. Thus an increase from one to ten days in the calibration interval will reduce the error to one tenth. One disadvantage of lengthening the calibration interval is that the calibration is in terms of *mean* frequency of the standard over the interval and gives no information of excursions about the mean. Although other methods, which will be discussed later, are available to determine the frequency variations during the interval, the radio engineer found some inconvenience in having to employ excessively long calibration intervals to obtain the accuracy required in the calibration of his frequency standard—an accuracy which was imperative to enable him to meet the ever tightening frequency tolerances demanded in new equipment designs. However, astronomers were quick to realise that, in view of major improvements, the rate of a time indicator associated with a high-grade frequency standard was proving capable of a more constant short period rate than the best pendulum clock, and they took steps to incorporate this new type of clock—known as the quartz clock—into their time departments. It will be appreciated that the development is a most important one to the astronomer and it is particularly gratifying to radio engineers that in their efforts to provide and to improve communications the comparatively new sciences of radio and electronics have contributed to one of the oldest sciences—astronomy.

The technique of time determination is proper to the astronomer and is extremely complex. It is not proposed to consider the subject in this article, which only deals in broad outline with the design and performance of quartz clocks produced by the Post Office.

General

In its simplest form a representative quartz clock, Fig. 1, comprises a crystal-controlled oscillator, nominal frequency 100 kc/s, and electronic frequency dividers providing a signal of one-hundredth of the

standard frequency. This 1 kc/s signal is used to drive a phonic motor and this in turn operates a time indicating mechanism through special gear trains, the overall design being such that while the oscillator frequency remains precisely 100 kc/s, the clock maintains a mean solar time rate. Accurate pulses at one second intervals are obtained from a contact mechanism on the seconds shaft of the clock.

It is apparent that the "heart" of the quartz clock is the quartz crystal, the function of which is to provide a controlling oscillation of constant period just as the pendulum and the balance wheel control the rates of the pendulum clock and chronometer respectively.

The mounted crystal is associated with a circuit which translates the electrical energy from the associated power unit into a form appropriate to cause the system to self-oscillate at a frequency determined by the crystal. The mechanism of the drive circuit is such that, by virtue of the electro-mechanical coupling inherent in the piezo-electric crystal, the circuit oscillates at the natural resonant frequency of the selected mechanical vibration of the quartz element. The advantage of the crystal-controlled oscillator¹ is that the frequency is determined almost solely by the quartz element, being sensibly independent of variations in the associated electrical circuit, and, since quartz is a very stable substance, capable of a very low frequency-temperature co-efficient of vibration and possesses an extremely low decrement of vibration, the frequency stability achieved is of a much higher order than is possible at present with any other mechanical or electro-mechanical system.

One major difference between the clock pendulum and the chronometer balance wheel on the one hand and the quartz vibrator on the other, is that whereas the frequency of both the clock pendulum and the balance wheel is usually about 1 c/s, that of the best quartz controlled oscillators at the present time is in the region of 100 kc/s. This circumstance does represent a disadvantage to the astronomer, inasmuch as fairly complex electronic dividing circuits are necessary to give him a frequency of 1 c/s. However, the position will probably be improved when work is completed on special quartz crystals of

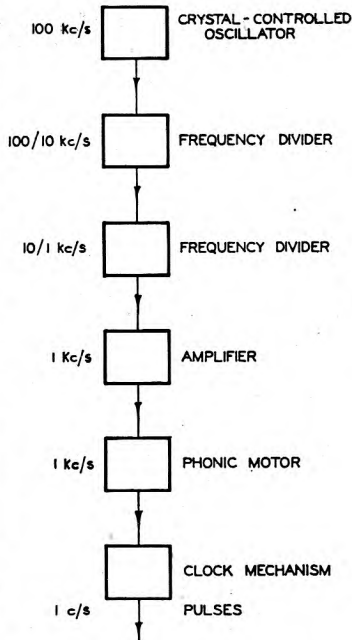

FIG. 1.—SIMPLIFIED SCHEMATIC DIAGRAM OF QUARTZ CLOCK.

frequency down to 4 kc/s, which, it is possible, will eventually be capable of the stability now being achieved at the higher frequencies.

Crystal-Controlled Oscillator.

The mounting of the quartz crystal element is of great importance if the potential frequency stability of the crystal is to be achieved. The metal electrodes necessary to apply the electric stress to the crystal are of gold, plated direct on the two major surfaces, and the crystal is mounted either in an evacuated metal container or in a glass envelope. In the latter

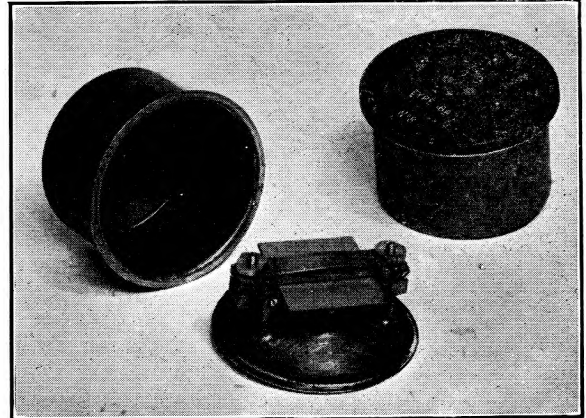

FIG. 2.—CRYSTAL PLATE MOUNTED IN EVACUATED METAL CONTAINER.

case the crystal is supported by wires soldered direct to the two electrodes and the pressure of the air in the envelope is reduced to about 0.0001 mm of Hg. Fig. 2 illustrates the mounting of a clamped 100

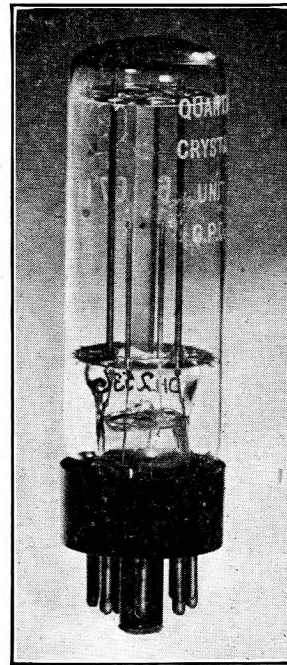

FIG. 3.—CRYSTAL BAR MOUNTED IN EVACUATED GLASS ENVELOPE.

kc/s crystal plate in a metal container and Fig. 3 that of a 100 kc/s bar supported by soldered wires in a glass envelope. It is of interest to note that the effective Q of a representative mounted crystal is about 300,000. The angle of cut of the quartz plate with reference to the natural crystal and its dimensions are such that the maximum frequency-temperature co-efficient of the selected 100 kc/s vibration is about $1 \times 10^{-7}/1^\circ\text{C}$. However, despite this low co-efficient it is necessary to stabilise the temperature of the mounted crystal which is contained in a thermostatically controlled oven. The control² is accomplished with a resistance bridge balanced at 50°C . and a temperature stab-

¹ P.O.E.E.J., Vol. 38, p. 65.

² P.O.E.E.J., Vol. 35, p. 8.

ility approaching $\pm 0.005^\circ\text{C}$. is achieved for an ambient range of some 22 to 25°C .

The drive circuit which maintains the crystal in vibration is of the bridge stabilised type, the mounted crystal, a metal filament lamp and two fixed resistors forming the bridge, Fig. 4, which is connected to

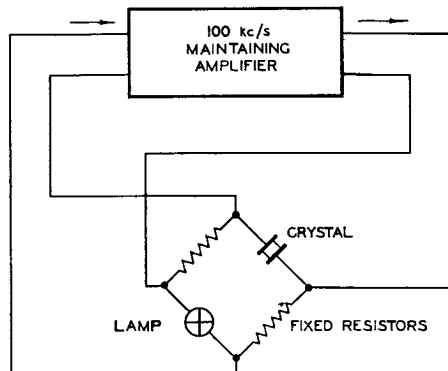

FIG. 4.—SCHEMATIC DIAGRAM OF CRYSTAL-CONTROLLED OSCILLATOR.

the input and output of a two-stage maintaining amplifier. The bridge is balanced at the series resonant frequency of the crystal and oscillation is maintained when the amplifier gain exceeds the bridge attenuation. Amplitude stabilisation is achieved by the lamp, and in a typical unit the power dissipated in the crystal is less than 1 mW. The effect of valve and supply voltage changes on oscillator frequency are extremely small. A 10 per cent. change of H.T. or L.T. voltage results in a frequency change of less than 3×10^{-10} and change of amplifier valve rarely gives a frequency change exceeding 2×10^{-6} .

Frequency Dividers.

Frequency division from 100 to 1 kc/s is accomplished with dividers of the regenerative modulator type, each of the two decade steps being carried out in two stages, 2/1 and 5/1. This type of divider has already been discussed in the JOURNAL³ and will not be considered here.

Phonic Motor and Time Indicator.

The 1 kc/s control signal from the frequency divider chain is amplified and fed to the phonic motor, of which several designs are available. In one type giving mean solar time rate the rotor, carrying 100 teeth on its periphery, is mounted on a vertical spindle and rotates 10 times per second under the influence of an electromagnet excited by a direct polarising current plus the 1 kc/s control current, hunting being minimised by a damping device. Through a 10/1 worm gear the rotor drives a shaft rotating once per second and the clock hands are controlled through an auxiliary gear train. Seconds pulses are obtained via a contact which is operated by the 1 r.p.s. shaft.

General Assembly.

Since the calibration, in terms of the earth's rotation, of the crystal-controlled oscillator in the quartz clock gives only a measure of the mean frequency over the calibration interval, and no informa-

tion of the frequency excursion about the mean, it is usual to set up a group comprising at least three oscillators and to intercompare the oscillators continuously to obtain information on their short period stabilities.

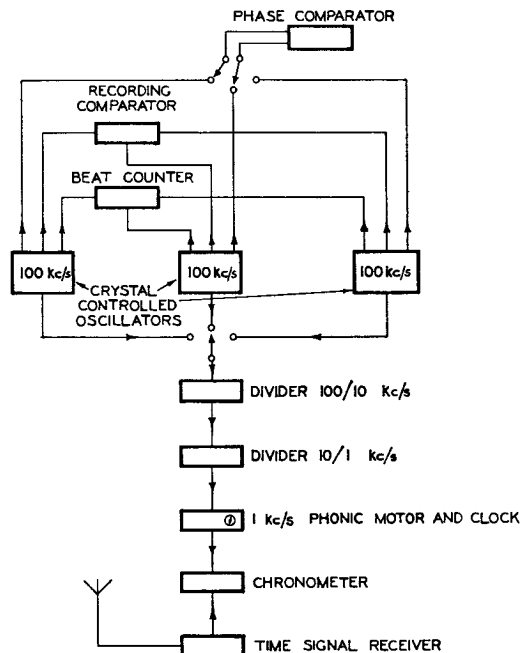

FIG. 5.—SCHEMATIC DIAGRAM OF TYPICAL QUARTZ CLOCK INSTALLATION.

A typical installation as illustrated in Fig. 5 comprises three 100 kc/s crystal controlled oscillators, four comparators and a frequency dividing train through the medium of which one of the crystal oscillators drives a clock. The functions of the comparators are respectively:—

- The comparison of the clock rate with standard time signals,
- The automatic comparison of the frequencies of any pair of oscillators every few seconds by the phase comparator to an accuracy of $\pm 1 \times 10^{-10}$,
- The automatic recording of the frequency difference between each pair of oscillators every two minutes to an accuracy of $\pm 5 \times 10^{-6}$,
- The automatic counting of the beats between pairs of the three oscillators.

Detailed analysis of these several records gives the mean frequency of each oscillator in terms of the time signals and also indicates the second-to-second and daily stabilities of the individual oscillators. The assembly, less the comparators, is illustrated by Fig. 6.

Although there is no standard method of mounting it is advantageous to install the crystal-controlled oscillators in a temperature-controlled room remote from the associated equipment, the main accommodation requirements being a fairly constant temperature, freedom from mechanical shock and vibration and freedom from unwarranted interference.

³ P.O.E.E.J., Vol. 35, p. 62.

Equipment for the Royal Observatory.

As already indicated astronomers found it essential to incorporate quartz clocks in their mean clocks, and in this country the Post Office is now providing the Royal Observatory with equipment which includes 18 crystal-controlled oscillators and miscellaneous associated equipment. The design of the equipment follows broadly on that outlined in this article and will not be discussed in detail. However, reference to Fig. 7, which illustrates in schematic form part of the equipment being provided, clearly demonstrates the importance which is being attributed by the astronomer to the application of quartz clocks to time measurement.

Performance.

At present there is an ageing effect with quartz crystal controlled oscillators which generally takes the form of a small frequency drift. The magnitude of the drift is greatest over the first few weeks of oscillation and the rate of drift slowly decreases. Thus, whereas the measured drift of one crystal was some 2×10^{-6} in the first three months, the value was reduced to 0.5×10^{-6} over the next three months, and during the next year was only 0.2×10^{-6} . Although this phenomenon has been, and still is, the subject of close study by many investigators its true mechanism is not yet fully appreciated, but is believed to be due primarily to the settling down of the quartz plate, electrodes and mounting system. The effect of frequency ageing on quartz clocks is not so serious as the reader may imagine, since, apart from the initial drift during the first few months—and the effect of this can be largely eliminated in the final assembly by employing mounted crystals which have been previously aged—the rate of drift is usually closely predictable, and appropriate corrections can be made to compensate for the ageing rates. Thus, although the astronomer is interested in mean solar and mean sidereal times he can, knowing the clock rate, apply the appropriate rate correction.

It should perhaps be pointed out that it is possible, by the frequency comparisons already discussed, to determine the respective daily rates of the individual clocks comprising a group to better than 0.0001 seconds.

The actual performance of one of a group of three 100 kc/s quartz clocks over a period of one year is illustrated by Fig. 8 (b). For simplification, the results are given in terms of frequency, and clearly demonstrate the unique stability which can be achieved despite the second order long term frequency drift. The clock had been in operation for about $1\frac{1}{2}$ years when the tests started and the total frequency drift of the associated crystal-controlled oscillator over the

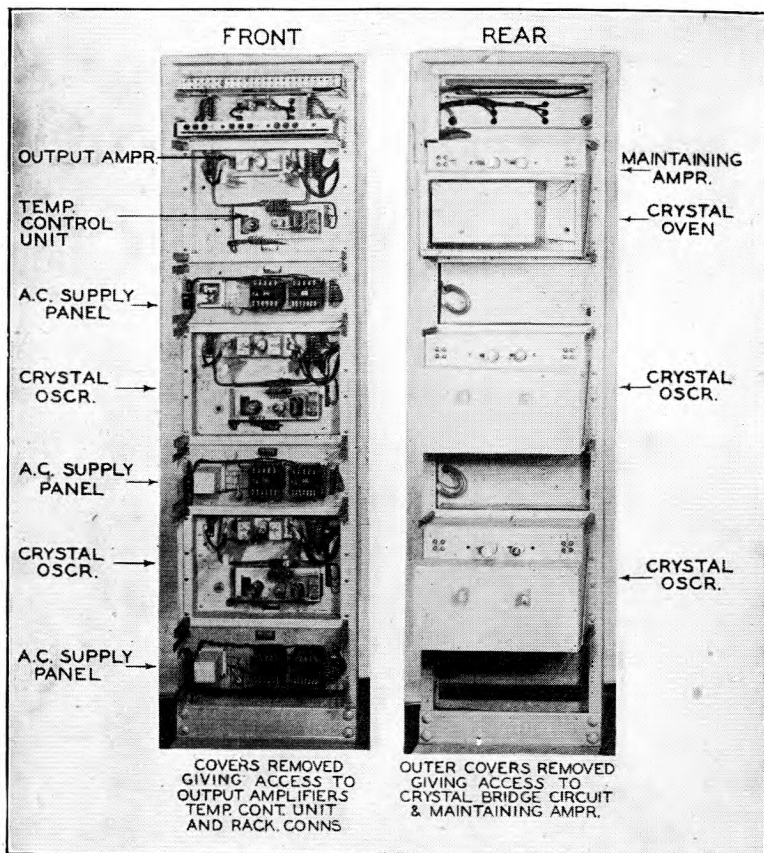

FIG. 6.—QUARTZ CLOCK OSCILLATOR RACK.

subsequent year was only $+2 \times 10^{-7}$. This represents a change in the daily rate of the clock of about $+17.24$ milliseconds between the beginning and end of the year. Or, putting it another way, the gain of the clock in one year in terms of an ideal clock of zero rate, would be some 3.15 seconds over a period of 31,536,000 seconds. Some idea of the short period stabilities of the oscillators will be obtained from Fig. 8 (a), which shows the measured frequency difference between a pair of oscillators over six hours. Maximum variation about the mean difference frequency was less than 1×10^{-9} .

It will be appreciated that special precautions are necessary in the design to minimise the risk of a failure in a quartz clock, since, in addition to losing "time" the rate of the clock may take some weeks to settle down again, during which period accurate rate predictions are not practicable. Special care is taken with components which are all of best quality and are under-run, and the clock is made semi-independent of the supply mains, float battery operation being employed.

Future Developments.

Although great strides have been made in the development of high-grade quartz controlled oscillators and in their application to time measurement, much remains to be accomplished. In particular, a reduction of the ageing phenomenon associated with

No 1 STATION

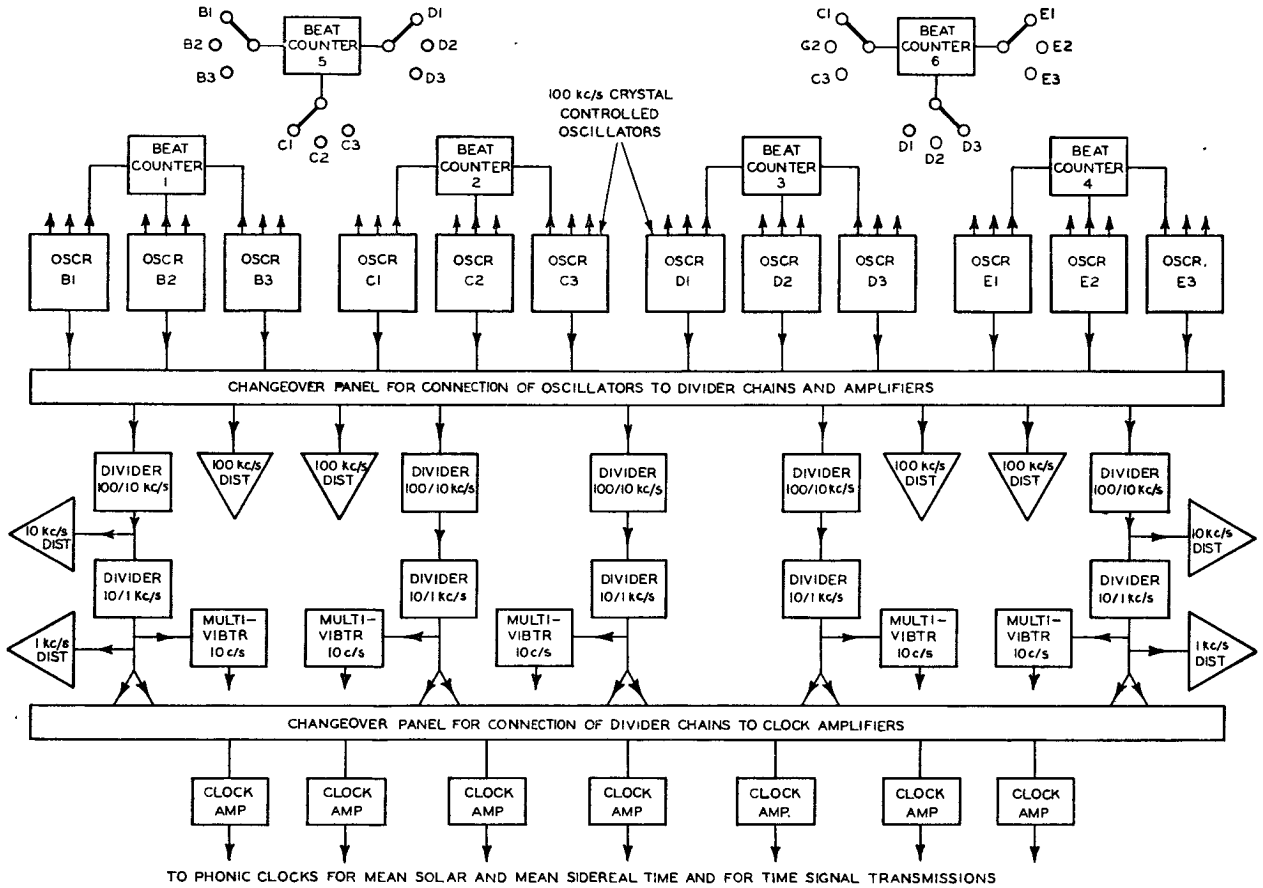

FIG. 7.—SCHEMATIC DIAGRAM OF QUARTZ CLOCKS AND ASSOCIATED EQUIPMENT FOR THE ROYAL OBSERVATORY.

all quartz-controlled oscillators and the achievement of the frequency stability now practicable at 100 kc/s

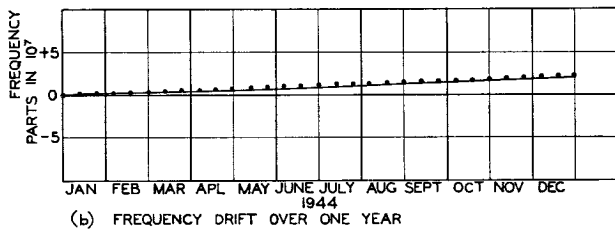
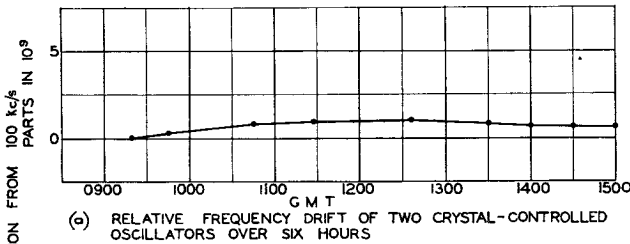

FIG. 8.—PERFORMANCE OF A 100 KC/S CRYSTAL-CONTROLLED OSCILLATOR IN A QUARTZ CLOCK.

on the very low frequencies whereby the complexity of the quartz clock and its maintenance can be simplified, are matters which are now receiving attention.

It may be thought that sufficient finality in terms of frequency stability to meet the needs of the radio engineer has already been reached. However, this is not so; there are applications to-day which call for frequency measurements accurate to within $\pm 1 \times 10^{-8}$, and experience has clearly demonstrated that the knowledge gained in improving present standards is, in many cases, capable of direct and useful application by the engineer who is concerned with the general design and development of oscillators for use in the Post Office line and radio system.

In conclusion, the author wishes to point out that it has not been possible to convey in this article more than a very brief outline of a complex and specialised subject, but is hopeful that the picture given may be of interest to many people who have been curious during the past few months regarding the origin and application of that new device, the quartz clock.

A Simplified Cable Balancing Instrument

H. C. S. HAYES, A.M.I.E.E., and
E. D. LATIMER

U.D.C. 621.317.34

Part I.—Description of the Instrument

Capacitance unbalances accumulate when lengths of cable are jointed together "straight," and this article shows how accumulation within-quad can be prevented by the use of a simple cable balancing instrument. Reduction of unbalances to the same extent as with normal balancing methods is not possible, but nevertheless, the reduction obtained is quite sufficient for certain classes of cables. A model of the instrument incorporating switching keys to enable specific unbalances to be dealt with and crosstalk to be measured is described in detail.

Introduction.

WHEN a cable is being balanced by normal methods some 12 single lengths making up a balancing section are first jointed into four quarter sections, each consisting of three lengths. In each quarter section adjacent quads in one length are systematically jointed to non-adjacent quads in the adjoining length with the object of limiting capacitance unbalances between quads, the wires within the quads being jointed straight, i.e. A-A, B-B, C-C and D-D. This straight jointing of the wires produces in a quarter section within-quad capacitance unbalances which are, in general, greater than those of a single length. The five within-quad capacitance unbalance characteristics, i.e. side-to-side, phantom-to-each-side and each side-to-earth, are next measured on each of the four quarter sections and a quadruple selection made with the object of reducing all of these five unbalances to a low level in the complete balancing section, particular attention being paid to the side-to-side characteristic, upon which depends the amount of overhearing between the two pairs of a quad.

After much experience of balancing work on these lines it seemed clear that easier selection and a generally improved over-all balance would result if in addition to test selection at the quarter sections the jointer were to introduce wire crosses into the joints between the three single lengths making up each quarter section in such a way that the side-to-side unbalance characteristics of the quads reduced one another. A simple instrument to enable him to do this seemed a possibility and the idea was toyed with for a number of years. It was not until 1942, however, that a trial balancing instrument was made which, so far as was practicable, was designed to be as simple to use and as easy to maintain as a hand-driven ohmmeter; switching keys were incorporated so that accumulation of phantom-to-side or side-to-earth, in addition to side-to-side, unbalances might be reduced. Field tests were carried out to demonstrate the extent to which accumulation of unbalances could be prevented by using the instrument not only between the single lengths of a quarter section, as originally intended, but in addition at the three remaining joints between quarter sections. The results of these tests (described and discussed in Part 2 of this article) justified the making of a second instrument (Fig. 1) provided with crosstalk measuring facilities and a number of refinements not included in the trial model.

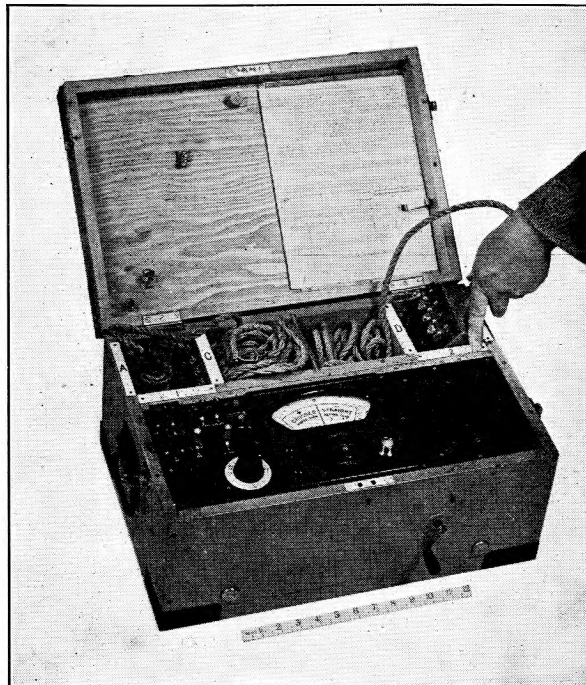

FIG. 1.—CABLE BALANCING AND CROSSTALK MEASURING INSTRUMENT.

PRINCIPLE UPON WHICH THE INSTRUMENT OPERATES

Basically the instrument operates as follows:—

(1) *Cable Balancing.* For side-to-side balancing (Fig. 2) the output from an oscillator is applied to

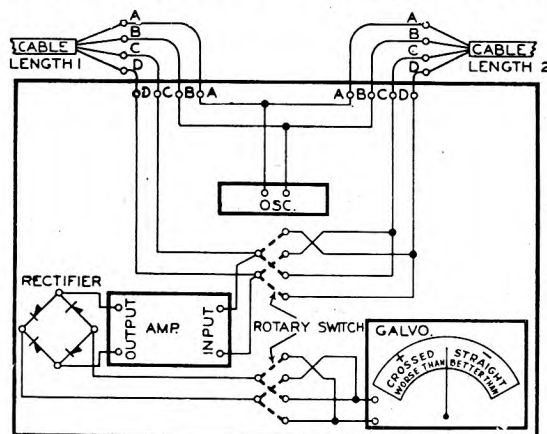
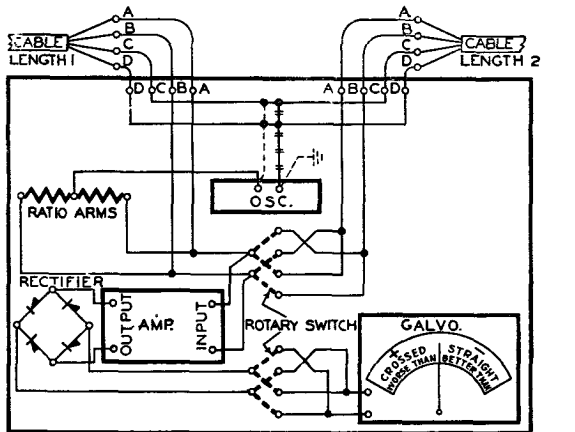

FIG. 2.—CONNECTIONS FOR BALANCING, SIDE TO SIDE.

the AB pairs of two quads to be jointed together, and the input terminals of an amplifier are connected to the CD pairs which are connected together, "straight" and "crossed" alternately by contacts on a rotating switch. By virtue of the side-to-side capacitance unbalance characteristics existing in the quads there is developed across the CD pairs (and hence across the amplifier input terminals) a voltage which is different in the "straight" and "crossed" conditions because the capacitance unbalance characteristics add in the one condition and subtract in the other. The output current from the amplifier is passed via a rectifier and further contacts on the rotary switch to a centre-zero galvanometer, the scale of which is engraved "Straight" to the right of zero and "Crossed" to the left. The contacts on the rotary switch are so arranged that the change-over of the CD pairs from "straight" to "crossed" is accompanied at the same instant by a reversal of the connections between the galvanometer and the rectifier. Thus the rectified current resulting from the "straight" connection of the CD pairs tends for a period of time to deflect the galvanometer needle to the left (i.e. the side engraved "Crossed"), whereas that resulting from the "crossed" connection tends for an equal period of time to deflect the needle to the right (i.e. the side engraved "Straight"). Since the switch is continuously rotating during the test at the rate of about ten revolutions per second the needle takes up a position to the right or left of zero, dependent upon the relative magnitudes of the deflecting currents and so shows which of the two deflecting currents resulting, respectively, from the "straight" and "crossed" conditions is the smaller. The better method of jointing to prevent accumulation of the side-to-side capacitance unbalance is thus directly indicated by the galvanometer needle deflection. Phantom-to-side and side-to-earth unbalances may be similarly treated by simple changes of the circuit connections, as shown in Fig. 3.



NOTE :-
 - - - - - CONNECTIONS FOR PHANTOM TO SIDE (AB) MEASUREMENT
 - - - - - CONNECTIONS FOR EARTH TO SIDE (AB) MEASUREMENT
 - - - - - CONNECTIONS FOR MEASUREMENT TO SIDE CD SIMILAR BUT WITH PAIRS AB AND CD REVERSED.

FIG. 3.—CONNECTIONS FOR BALANCING, PHANTOM TO SIDE AND EARTH TO SIDE

(2) *Measurement of Crosstalk.* The output terminals of an oscillator and a crosstalk meter are connected to the AB pair of a quad of which the side-to-side crosstalk is to be measured (Fig. 4). The crosstalk

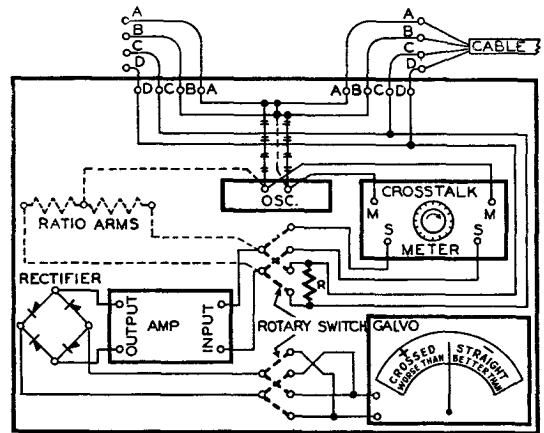

NOTE -
 - - - - - CONNECTIONS FOR SIDE TO SIDE.
 - - - - - CONNECTIONS FOR PHANTOM TO SIDE CD.
 - - - - - PHANTOM TO SIDE AB SIMILAR BUT WITH AB AND CD PAIRS REVERSED

FIG. 4.—CONNECTIONS FOR MEASUREMENT OF CROSSTALK.

meter (described in detail later in this article) is calibrated so that the ratio of the potential difference across the terminals SS to that across the terminals MM is known for various settings of the meter. The input terminals of an amplifier of high input impedance are connected alternately and for equal periods of time to the CD pair of the quad and to the terminals, SS, of the crosstalk meter. This switching is effected by means of contacts on the rotary switch, further contacts of which are arranged to reverse the connections between the galvanometer and rectifier in unison with the change of connections to the input terminals of the amplifier. Thus the rectified amplifier output current resulting from the voltage applied to the amplifier input terminals when connected to the CD pair tends for a period of time to deflect the galvanometer needle to the left (i.e. the side engraved "Worse Than"), whereas that resulting from the voltage applied to the amplifier input terminals when connected to the crosstalk meter tends for an equal period of time to deflect the needle to the right (i.e. the side engraved "Better Than"). Since the switch is continuously rotating during the test, the needle takes up a position to the right or left of zero dependent upon the relative magnitudes of the deflecting currents, but by adjustment of the crosstalk meter the galvanometer needle can be restored to zero by arranging that these deflecting currents are of equal strength. This setting of the crosstalk meter thus indicates the crosstalk between the AB and CD pairs of the quad. The engravings "Worse Than" and "Better Than" enable an operator to determine simply, without adjusting the crosstalk meter, whether the cable crosstalk is worse or better than that indicated by the meter setting. Fig. 4 also shows the alternative circuit arrangement for the measurement of phantom-to-side crosstalk.

Cable crosstalk due to a capacitance coupling of constant value is directly proportional to the impedance of the cable pairs, and therefore special steps must be taken if the measured crosstalk, due to a particular value of capacitance unbalance, is to be very nearly constant for different lengths of cable under test. The expedient adopted in this machine to ensure practically constant impedance over cable lengths ranging up to 2,000 yards is to terminate the "receive" pair with a resistance, R, of low value compared with the impedance of the cable pair. Further, the value of R is so chosen that, for any particular capacitance unbalance, the measured side-to-side crosstalk is equal to that which would occur, at 1,300 c/s, between two electrically long lines each of 1,100 ohms characteristic impedance (i.e. the characteristic impedance of 20 lb. cable loaded with 88 mH coils at 2,000 yards spacing) with such a capacitance unbalance concentrated at the point of measurement.

(3) *Check Tests.* Two artificial cables, each simulating about 176 yards of actual cable, are accommodated in the instrument for the purpose of verifying that it is functioning correctly before commencing any cable tests. Confirmation that the instrument is functioning correctly in its cable balancing capacity is obtained by connecting the artificial cables to the instrument test leads first "straight" and then with crossed connections, and noting that the resulting galvanometer deflections are in accordance with those predicted from a knowledge of the signs and values of the capacitance unbalance characteristics of the artificial cables. A check of the accuracy of the instrument as a crosstalk measuring device is obtained by connecting the instrument test lead used for crosstalk measurements to one of the artificial cables, and measuring the side-to-side crosstalk resulting from the known capacitance unbalance of the artificial cable. The measured crosstalk in db. should be that which would be obtained by calculation from the formula

$$20 \log_{10} \frac{8 \times 10^{12}}{2 \pi f Z_0 K}$$

where f = frequency in c/s i.e. 1,300

Z_0 = characteristic impedance in ohms, i.e. 1,100
and K = capacitance unbalance in $\mu\mu\text{F}$.

(4) *Determination of the Signs of Capacitance Unbalance Characteristics.* The instrument in its cable balancing form can be used to determine the signs of capacitance unbalance characteristics by connecting one of the instrument test leads to the cable quad under test, and the other test lead to one of the artificial cables. Since the signs of the artificial cable characteristics are known the galvanometer deflections either to "Straight" or "Crossed" serve to indicate the signs of the characteristics of the cable quad. For example, if the sign of the side-to-side unbalance characteristic of the artificial cable is +, and a galvanometer deflection to "Crossed" is obtained when a cable quad and the

artificial cable are connected to the instrument, it is clear that the sign of the cable quad side-to-side characteristic is +, since a "crossed" joint is required between cable lengths having unbalances of the same sign if accumulation of their unbalances is to be prevented. The galvanometer scale is therefore engraved "+" on one side and "-" on the other side of the centre line, in addition to "Straight" and "Crossed."

DESCRIPTION OF THE INSTRUMENT

For convenience, items readily obtainable from stock have been used, wherever possible, in the construction of the instrument and in consequence the whole assembly is larger and heavier than if

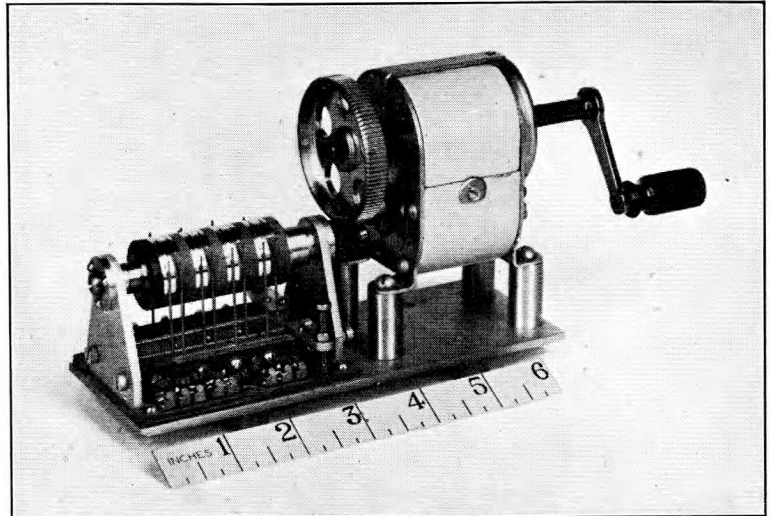

FIG. 5.—HAND GENERATOR AND ROTARY SWITCH.

the individual components had been designed specially for the purposes they serve.

Hand-driven Generator (Fig. 5). The 17 c/s (approx.) output voltage from this generator, after suitable transformation, provides the power necessary for the operation of the oscillator and amplifier valves, and the machine is thus quite independent

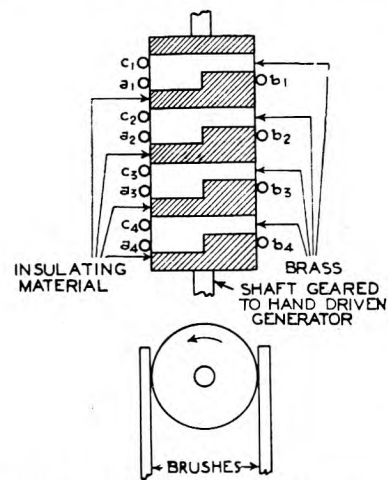

FIG. 6.—ROTARY SWITCH ARRANGEMENT.

of batteries, with the exception of two small cells used for detecting earths and contacts. Since the valves are directly heated only a few turns of the generator handle are required for each reading taken.

Rotary Switch.

The mechanism of this item is shown in Fig. 5 also, and is illustrated diagrammatically in

Fig. 6. For one half of a revolution of the switch barrel the contact strips c_1 and a_1 are in electrical contact and for the following half revolution the strips c_1 and b_1 are electrically connected (and similarly for the strips $c_2, a_2, b_2; c_3, a_3, b_3; c_4, a_4, b_4$). The switch barrel is geared to the handle shaft of the 17 c/s generator so that it rotates at about $3\frac{1}{2}$ times the handle speed (i.e. at about 10 revolutions per second when the handle is turned at normal speed).

Power Pack (Fig. 7). The output terminals of

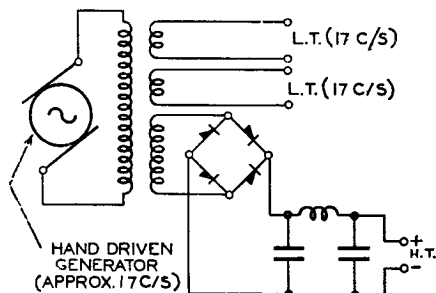

FIG. 7.—POWER PACK.

the generator are connected to the primary winding of a transformer provided with three separate secondary windings, two of which are connected directly to the filaments of the oscillator and amplifier 2 V valves, the third being connected via a full-wave metal rectifier and smoothing circuit to the H.T. circuits of these valves. The A.C. filament and D.C. anode voltages developed when the generator is rotated at normal speed are approximately 1.8 and 140 respectively. The rise in these voltages occurring with increased speed of rotation of the generator is not sufficient to damage the valves.

Oscillator (Fig. 8). This is of normal type, grid

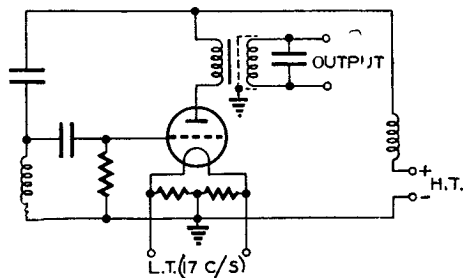

FIG. 8.—OSCILLATOR.

bias being obtained by the grid-leak and condenser. The load which is presented to the oscillator is almost a pure capacitance, which varies according to the length of cable under test. The nature of the output circuit is therefore a matter of compromise, and is such that for any length of cable up to 2,000 yards a satisfactory voltage is developed across the cable pair to which the oscillator is connected. The secondary winding of the output transformer is balanced and screened.

Amplifier (Fig. 9). When the instrument is used for cable balancing, a load which is almost a pure capacitance is connected to the input terminals of

the amplifier. This capacitance, however, varies according to the length of cable under test, and to limit the range of capacitance presented to the step-up input transformer (balanced and screened) series condensers are inserted between the input terminals and the primary winding of the trans-

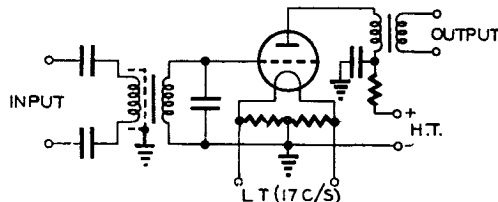

FIG. 9.—AMPLIFIER.

former. Across the secondary winding of the transformer is connected a condenser of such value that resonance with the secondary winding inductance occurs when a mean condition prevails as regards cable length. In this way sufficient sensitivity is obtained for the balancing of short lengths of cable or of lengths comprising a full balancing section of 2,000 yards.

When measuring crosstalk the cable pair connected to the input terminals of the amplifier is terminated with a resistance, which necessarily reduces the sensitivity of the amplifier. This reduced sensitivity is, however, sufficient for crosstalk measurements down to 100 millionths (80 db.).

Centre-Zero Galvanometer. A unipivot galvanometer with a scale engraved as shown in Figs. 2-4 is used. The clamping device fitted to the galvanometer is automatically brought into operation when the lid of the instrument is closed.

Galvanometer Rectifier. The output current from the amplifier is rectified before passing to the galvanometer, and for this purpose a full-wave metal rectifier of the instrument type is used.

Ratio Arms. 1,000 ohms non-reactive ratio arms are incorporated in the instrument for the purpose of phantom-to-side and side-to-earth tests.

Crosstalk Meter. This item comprises a 1,000 ohms, continuously variable, wire wound slide wire and two fixed condensers joined up as shown in Fig. 10.

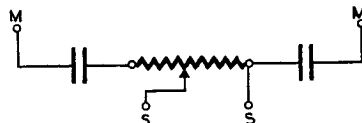

FIG. 10.—CROSSTALK METER.

Crosstalk in short lengths of cable is directly proportional to frequency, and in order that the measured value should be unaffected by small changes of the oscillator frequency, condensers, instead of resistances, are used in the crosstalk meter. At the mean oscillator frequency the reactance of each condenser is 50,000 ohms, which is the figure upon which the calibration (millionths and decibels) is based. Since the reactance of a condenser is inversely proportional to frequency the meter reads "high"

if the oscillator frequency, and therefore the cable crosstalk, decreases, and "low" if the frequency increases. Effective compensation for frequency changes is thus obtained.

Keyboard Panel. The functions of the keys mounted on this panel are as follows:—

- (1) To make the circuit changes necessary for conversion from a cable balancing to a crosstalk measuring instrument.
- (2) To make the necessary connections for measurements involving any of the within-quad capacitance unbalance characteristics (i.e. side-to-side, phantom/AB, phantom/CD, earth/AB, or earth/CD).
- (3) To shunt the output from the oscillator when measurements are made on quads having very large capacitance unbalance characteristics. Before the shunt is applied, large unbalances produce jerky movements of the galvanometer needle; this is a valuable feature, because it enables large unbalances due to incorrect clipping of the cable wires to the test leads to be detected and removed.
- (4) To connect a watch receiver (mounted underneath the keyboard panel) to the oscillator output terminals, and to disconnect all other wiring from these terminals. By listening to the tone an operator can verify that the oscillator is functioning when the generator is rotated. Furthermore, the disconnection of the "sent" tone provides a means, during crosstalk tests, of determining whether or not any extraneous voltage is vitiating the measurements.
- (5) To provide a means of determining whether or not the four wires of the quad or quads under test are free from contacts with each other and from earth. By operating the appropriate keys a galvanometer deflection is obtained if any such contact exists (two small dry cells are incorporated in the instrument for the purpose of this test).

Balancing Condensers. Capacitance unbalances existing in the test leads and wiring are balanced out by small condensers housed in a separate compartment of the instrument box. Since the accuracy of the results obtained with the instrument are dependent upon its freedom from capacitance unbalances, it is most important that once the balancing condensers have been adjusted subsequent changes to the disposition of the wiring should be avoided.

Testing Leads. These are flexible and of quad construction, and have very small unbalances. Each lead is terminated at one end permanently on the instrument wiring, and at the other end on a spring clip for connection to the cable wires. For cable balancing both clips 1 and 2 are used for connecting to the cable, but for crosstalk measurement clip 2 only is used, clip 1 being either left "free" or as explained later, placed in contact with the terminals of an artificial cable for determining the sign of the unbalance giving rise to the crosstalk.

Artificial Cables. A high degree of stability of the capacitance unbalance characteristics of the artificial cables is clearly essential, and it is a matter of interest that it was not found possible to achieve the requisite stability (and at the same time meet the limitations as regards size) by using fixed condensers only in the construction of the artificial cables. Stability of a very high order was finally achieved by following to some extent the principles of cable manufacture. Four lengths of fine insulated wire were laid up in multiple twin formation and the resulting 4-wire unit wound in layers on to a metal bobbin, metal foil being interposed between layers 2 and 3, 4 and 5, etc., to make the wire-to-earth capacitances very nearly equal to those of an actual cable. A soldered connection was made between the metal foil and the bobbin, to which an earth wire was soldered. The length of 4-wire unit chosen was such as to simulate about 176 yards of cable. To render the artificial cable stable and moisture-proof it was impregnated with ceresin by long immersion in a bath of the molten wax. Small silvered mica condensers were then connected to the appropriate wires of the artificial cable to give the required capacitance unbalance characteristics. Fig. 11

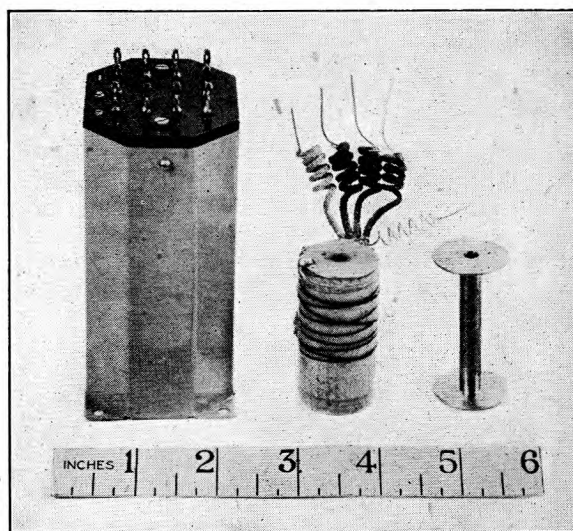

FIG. 11.—CASE HOUSING TWO ARTIFICIAL CABLES, MULTIPLE TWIN UNIT AND BOBBIN.

shows the metal bobbin, the completed 4-wire unit after impregnation with ceresin, and the case in which two such units, together with a number of silvered mica condensers are housed.

The artificial cables are wired to sets of contact strips mounted in the compartments provided for the accommodation of the instrument test clips; the strips being labelled "A," "B," "C" and "D." Reference to Figs. 1 and 12 shows how each test clip can be connected to the artificial cables either "straight" or "crossed" merely by inserting the clip one way or the other in the compartment. The signs and values of the capacitance unbalance characteristics of the artificial cables are such that when the test clips are in their compartments rotation of the generator handle at normal speed should, if

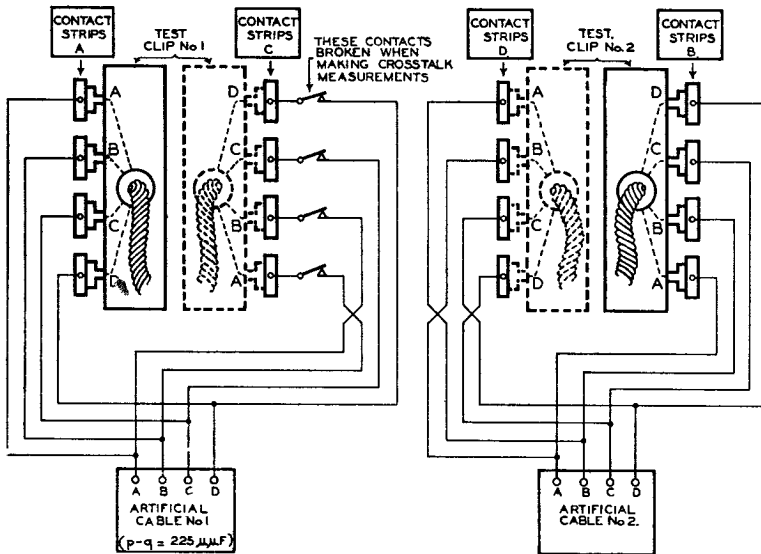

FIG. 12.—CONNECTIONS TO THE ARTIFICIAL CABLES.

the instrument is functioning correctly in its cable balancing capacity, produce approximately $\frac{1}{2}$ scale deflections in accordance with Table 1.

TABLE 1. CABLE BALANCING CHECK TEST BY MEANS OF ARTIFICIAL CABLES.

Terminals of Test Clip No. 1 in contact with Contact Strips labelled	Terminals of Test Clip No. 2 in contact with Contact Strips labelled	Galvo. Indications (approx. $\frac{1}{2}$ Full Scale Deflections)				
		AB/CD	+ / AB	+ / CD	Earth/AB	Earth/CD
A	B	"Crossed"	"Crossed"	"Crossed"	"Crossed"	"Crossed"
A	D	"*"	"Straight"	"*"	"Straight"	"*"
C	D	"Straight"	"*"	"*"	"*"	"*"

* These positions need not be checked

The value of the side-to-side capacitance unbalance characteristic of artificial cable No. 1, is $225 \mu\mu\text{F}$, which, by calculation from the formula previously quoted, gives rise at 1,300 c/s to 72 db. of crosstalk between two uniform and electrically long lines of 1,100 ohms characteristic impedance. The accuracy of the instrument as a crosstalk measuring device can therefore be readily checked by making a crosstalk measurement with test clip No. 2 making contact with the strips labelled "A." A red check

line at 72 db. is engraved on the dial of the crosstalk measuring potentiometer.

When making crosstalk measurements, test clip No. 2 is connected to the cable under test and test clip No. 1 may be placed in the left-hand compartment with its terminals in contact with the strips labelled "C" (as shown in Fig. 12 the connections between these strips and artificial cable No. 1 are broken when the instrument is being used for crosstalk measurements). If, after making a crosstalk measurement, it is desired to know the sign of the capacitance unbalance characteristic giving rise to the crosstalk it is only necessary to operate the key used to convert the instrument to a cable balancing device and rotate the generator handle. The operation of this key completes the connections between artificial cable No. 1 and the contact strips labelled "C," and therefore rotation of the generator handle results in a galvanometer deflection either to the right (i.e. the side engraved "-") or left (i.e. the side engraved "+") of zero dependent upon the relative signs

of the capacitance unbalance characteristic of the cable quad under test and that of artificial cable No. 1.

Part 2 of this article will (a) describe field tests carried out to demonstrate the extent to which accumulation of unbalances can be prevented by the use of such an instrument and (b) in the light of the results obtained discuss the types of cable which are likely to be balanced satisfactorily by means of the instrument.

The Repair and Installation of Telecommunications Power Plant in the L.T.R.

C. A. R. PEARCE, M.Sc., A.M.I.E.E.

U.D.C. 621.395.668 : 621.312 621.355

Following a description of the type of work undertaken in the London Telecommunications Region in connection with the repair and installation of telephone exchange and repeater station power plant the author gives details of some of the mechanical aids which have been developed to assist this work.

General.

THESE are in the L.T.R. about 270 telephone exchanges, as well as many large P.B.X.'s, repeater stations, etc. All these are concentrated in an area, every part of which is easily accessible from central London. It is, therefore, profitable to specialise in the L.T.R. to a degree not always economical in other Regions. In particular, although the operation and day-to-day maintenance of the telecommunications power plant throughout the Region is the responsibility of the respective Telephone Managers, most of the repairs and much installation work falls to the Power Engineer. This article describes the organisation and some of the equipment used to carry out this unusual side to the work of the L.T.R. Engineering staff.

Scope of Work.

Repair work is particularly unsuited to contract procedure. Frequently the extent of the work cannot be gauged until a substantial amount of dismantling has taken place. In addition, most repairs to exchange power plant have a degree of urgency attached to them. Nevertheless, at one time, plant, space and staff restrictions made it necessary to let out to contract many of the power plant repairs. Now, however, there is little occasion to call on the services of contractors.

The only parts of the general run of repairs not at present done by direct labour are "rewinds," and it is hoped that when the labour situation eases, even these will also be carried out by Post Office staff.

It has for many years been customary in the L.T.R. to carry out all classes of repairs and replatals of batteries by direct labour. Exchange batteries of up to 10,000 Ah are regularly replated by Post Office staff. Since the war, however, staff shortage has made it necessary to call on contractors for assistance, but as staff becomes available it is hoped to return to the pre-war position, in which all battery work, other than that of equipping new exchanges, was carried out by Post Office staff.

Until the period immediately prior to the outbreak of war, the construction and installation of telecommunications power plant was restricted to P.B.X.'s and special cases, but with the abnormal conditions of the last few years came other demands on the installation staff which considerably extended their operations. Among jobs carried out recently have been the installation of complete new repeater station power plants such as that shown in Fig. 1. This plant is standard equipment, and was installed entirely by direct labour. The Engineer-in-Chief's staff subjected it to exactly the same acceptance tests as would have been applied to a contractor's work.

Organisation and Staff.

The work is carried out for the most part by battery, electrical and general fitters and wiremen, working under Inspectors in the usual way. A few tradesmen, and, since the war, female assistants, are also employed on the work and in all, the three Inspectors concerned supervise a staff of about 60.

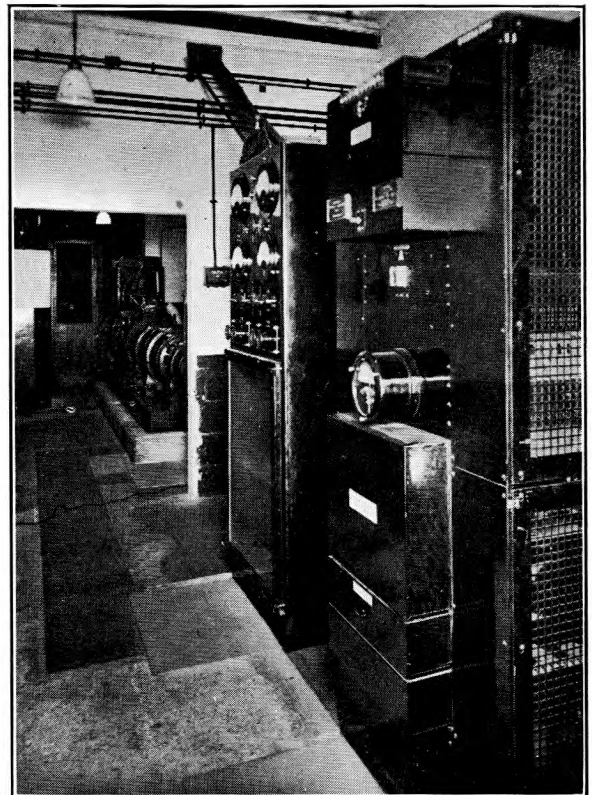

FIG. 1.—REPEATER STATION POWER PLANT.

The respective loads of the Inspectors are :—

1. Battery installation, repair, and replatal.
2. Power plant installation.
3. Power plant repair.

For power plant repairs the aim is to have electrical fitters available for giving immediate attention to faults and repairs which can be cleared up on site, to bring other work into the shops, and then to carry out as much of the mechanical fitting and machining as possible by general fitters.

Typical Repair Jobs.

The only parts of a motor generator which are subjected to wear are the bearings and the commu-

tator or slip rings, and it is natural, therefore, that many of the repairs coming into the shops are associated with bearing or commutator trouble. Typical jobs are the repair of bearings which have seized or are showing signs of seizing, the skimming and undercutting of commutators, the building up of shafts, the overhauling of starters and circuit breakers, including renewal of contacts, etc., and repairs to ringer drums.

Fig. 2 illustrates a typical case of a seized bearing, the machine concerned being a 3-phase induction

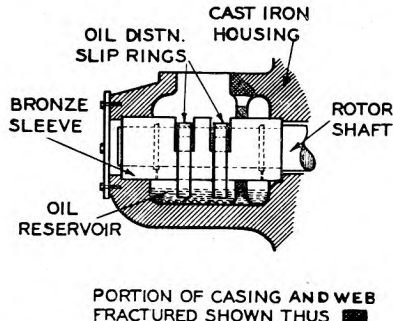

FIG. 2.—REPAIR OF SEIZED BEARING.

motor driving a motor generator set, and having a rated output of 145 h.p. The bearing concerned seized, and in the excitement of the moment the officer in charge of the set shut it down and somewhat foolishly poured cold oil into the oil well. The result was that the brass so securely gripped the shaft that it was found impossible to remove it by force, and the rotor had eventually to be mounted in the lathe and the sleeve turned from the shaft. The cold oil falling on the cast iron housing of the sleeve, cracked it at the points marked, and this casting had to be welded and the interior surface machined so as to form a new locating surface for the sleeve. The surface of the shaft, which was badly scored, was ground smooth. A new casting for the sleeve was obtained, and machined to fit the new sizes of the shaft and housing. The rotor in question weighed nearly half a ton, and was some 17 in. outside diameter and 6 ft. or so long.

Another typical job was to replace the wedges closing the slots of a large D.C. armature which somewhat unusually had two commutators, one at either end of the winding. The original wedges, which were of wood, had weakened with age and heat, so that they were virtually bursting from the ends of the slots, and were in a dangerous condition. The steel wire binding was removed, and new wedges constructed in the Section's woodwork shops, and the whole reassembled and the armature rebound in the lathe.

A very common repair is the "building up" of the worn shafts of motor generator and ringer arma-

tures. This is done with electric arc welding plant. Generally the "runs" of the weld are longitudinal, as indicated in Fig. 3 (a), but if the shaft

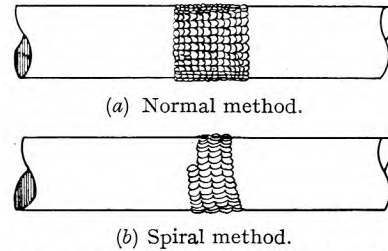

FIG. 3.—"BUILDING UP" OF WORN SHAFTS.

is of small diameter, or the "building up" extensive, the "runs" are made circumferentially, as in Fig. 3 (b), the shaft being turned continuously throughout the process. This second method is more laborious to carry out, but it has the merit of minimising the distortion of the shaft due to the local heating from the arc. There is now a wide variety of electrodes available for arc welding, and these provide a corresponding degree of control over the nature of the weld metal. Generally, of course, the surface of a built-up shaft is not quite as good as the original, but it need not be markedly inferior. In one recent repair, the two halves of a broken stainless steel shaft from an acid pump were joined by arc welding with stainless steel electrodes, and a satisfactory result obtained.

Workshop and Testing Plant.

The workshops are equipped with one 8½ in. and one 6 in. lathe, and a universal milling machine in addition to drilling machines. To relieve the back centre of the 8½ in. lathe from some of the weight of the heavy rotors with which it is required to deal, an auxiliary bearing has been designed and con-

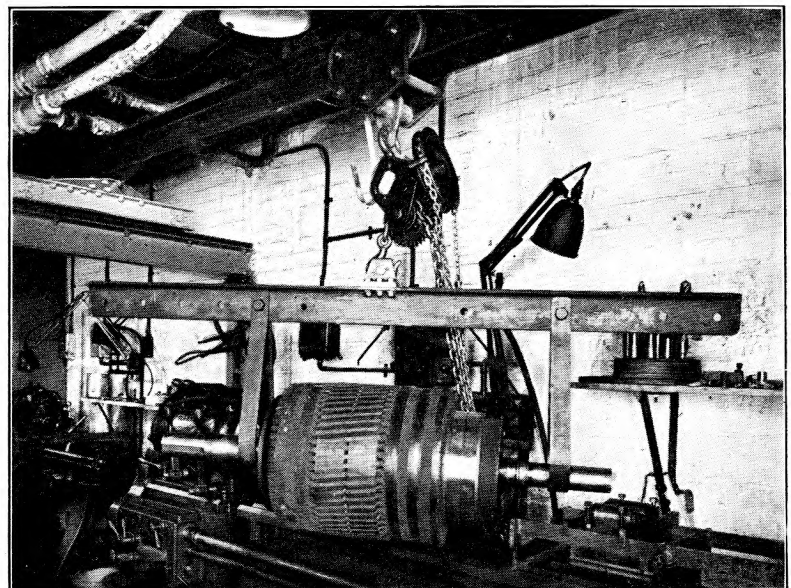

FIG. 4.—WORKSHOP LATHE AND MECHANICAL AIDS.

structed and is shown in Fig. 4 with other mechanical aids associated with the lathe.

The main item of testing gear provided for power plant repairs is a motor-generator set which is capable of delivering up to 300 A and 400 V D.C. It consists of two independent motor-generator sets mounted on a common bed. The motors besides being each direct-coupled to a D.C. generator, are provided with a grooved pulley for endless belt drive, so that they may run in mechanical parallel. The function of this device is to reduce the motor capacity necessary to obtain full output from either set. With testing gear of this sort, it seldom happens that a generator is required to deliver its full rated

may therefore be run light, or partly loaded. A.C. is obtained direct from the mains.

This equipment was designed and constructed in the Section, the bed being fabricated from standard sections by the arc welding process.

A 2,000 V flash tester is also provided in addition to the ordinary measuring instruments, etc. It will, no doubt, be readily understood that a great deal of other testing gear might be of occasional use, for example, if an alternator providing 100 c/s were available it could be used for applying the standard double voltage test to any plant of which the inter-coil insulation was in doubt, but it will also be appreciated that the workshop is not a testing or research

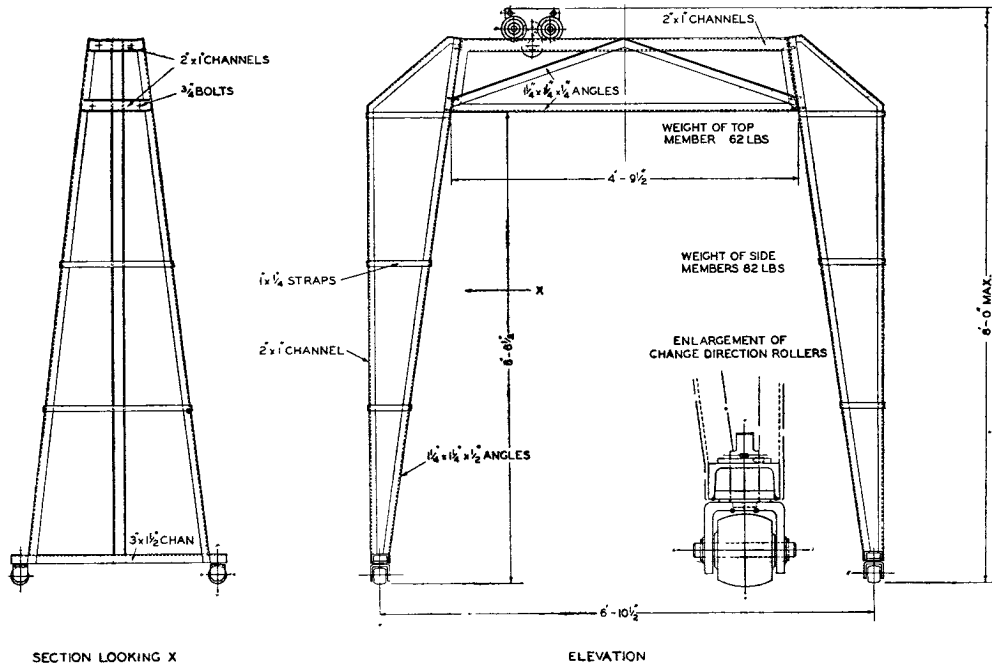

FIG. 5.—SECTIONAL LIFTING FRAME.

current and voltage simultaneously, and it is therefore wasteful to couple it to a motor capable of delivering its full output continuously. Instead, therefore, each generator is coupled to a motor of half its own capacity. If either generator is required to give full output, the two motors are run in mechanical and electrical parallel by fitting the driving belts. A jockey pulley is used to simplify belt adjustment.

To obtain the full range of voltage from the D.C. machines, they are used as separately-excited generators, the field current being obtained from rectifiers working from the mains. Previous plant used in the shops included self-excited generators, but the shunt characteristic rendered it virtually impossible to obtain a steady voltage from a machine at anything less than about half the maximum. One of the generators will deliver any voltage up to 30 V and currents up to 300 A, and is suitable for carrying out drop tests on the largest of armatures. The second machine will deliver any voltage up to 400 V and currents up to 10 A, and almost any D.C. motor

station, and that gear has not been provided for which an everyday use has not been evident.

Lifting Tackle and Mechanical Aids.

Since the power plant is the heaviest part of the equipment of a telephone exchange, it naturally follows that the work involves a considerable amount of heavy lifting, and this is not only tiring to the staff who are called upon to undertake it, but can be very wasteful of Departmental time unless it is organised on the best possible basis. Certain aids have therefore been introduced to this end. One of the most useful is that illustrated in Fig. 5. This frame, which is capable of lifting and shifting one ton, can be erected in a few minutes. It is made up from three units, two vertical members, and one horizontal, and can be assembled in the room in which it is required to be used. It will be seen that it is mounted on swivelling wheels, and provided with a runner along the top member. It will be readily appreciated how its use enables a heavy machine to be shifted from its base, and moved

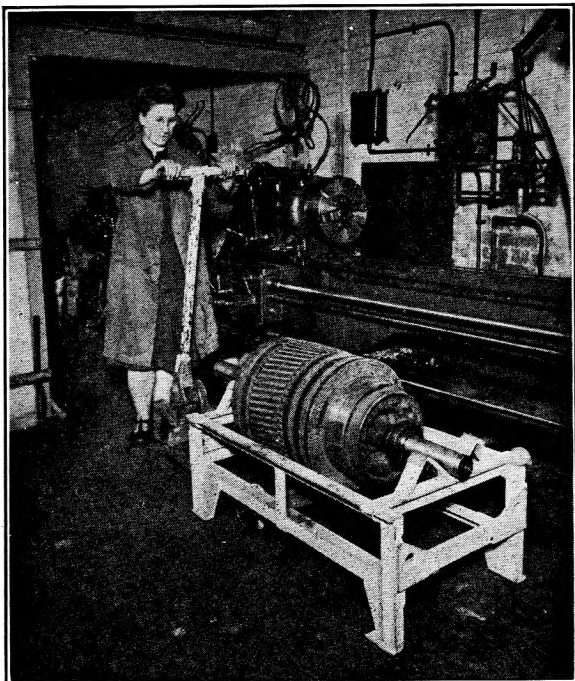

FIG. 6.—“SLINGSBY” TYPE TROLLEY.

about with a minimum of effort. The lifting frame was designed and constructed by Power Section staff.

Another useful item is the “Slingsby” type trolley, which enables one person to move suitable loads of up to a ton unaided. The load is deposited on to a platform, and it is then easy to insert the “Slingsby” trolley under the platform, and move the load as required. Fig. 6 shows the trolley being used to shift an armature on a specially designed frame.

The same frame is used to support the armature, while the commutator is undercut, or any other repair effected, and so handling is reduced to a minimum. Other platforms carry smaller machines, such as ringers, at heights convenient for work to be carried out.

In the repair of batteries, much of the work is heavy or unpleasant, and there is still much to be done to eliminate some of these features. The manhandling of material is an important factor in efficiency, and here again the “Slingsby” trolley is of assistance. Large battery plates can be mounted on wooden platforms as they are delivered, and need not be handled again until they are removed from the pile for straightening and placing in position in the tanks. Other aids which help to eliminate some of the unpleasant features of the work are acid pumps, of which the most satisfactory pattern used to date has been the diaphragm type, and plate presses, of which there is still a demand for a pattern which will press wet plates or large plates in a single operation.

Conclusion.

The capital values of exchange and repeater station power plants may not be large in relation to the equipments which they supply, but these plants undoubtedly have a key position as factors in the maintenance of service, and this, in the author's opinion, warrants the application of considerable thought and attention to their maintenance and repair. In London, because of the concentration of the power plant, there is an opportunity for ensuring this which does not always arise elsewhere, and it is hoped that this article has conveyed an adequate picture of what has been done so far in this direction.

Speaking Clock. Ten Years of Service

On 24th July, 1946, the speaking clock installation at Holborn Exchange, London, will be 10 years old and will have given the time accurate to 0.1 seconds to the 325 million calls made to it during this period. The clocks have been working continuously except for a few momentary stoppages due to the interruption of the power supply, while the service to the public has, on only a few occasions, had to be withdrawn due to cable damage caused by enemy action.

Prior to the introduction of the service 26,000 time enquiries were made each week in the London Area, but owing to the popularity of the speaking clock, this figure has increased steadily to 500,000 calls each week. During the 10 years the service has been extended to thirteen provincial towns, at which a further 500,000 calls are made each week. The accuracy and continuity of the announcements provided by the speaking clock is of use to the fighting services and a direct feed has been provided to the R.A.F. Central Exchange.

The peak calling rate to the service is not during the normal exchange busy hour, but occurs between 12 noon and 1 p.m., with smaller peaks ending at 9.30 a.m. and 5.30 p.m. The holding time of most calls is between 10-15 seconds, with an overall average of 20 seconds.

The clock equipment has been seen by visitors of practically every nationality, who have been unanimous in their admiration of the reliability, accuracy and design of the installation.

As no major overhaul or detailed inspection of the installation has been made during the 10 years, it is now proposed to examine each part of the mechanism and replace any that are worn. During this period the duplicate installation at Liverpool will supply the announcements to the whole of the country. Further extensions to additional centres in the country are also being engineered.

J. M. R.

Reuters' Wireless Services

W. WEST, B.A., M.I.E.E.

U.D.C. 621.396.3

An account is given of the principal developments connected with Reuters' distribution of news from Post Office radio transmitters. A brief description of the Hell-schreiber system of telegraphy is included.

Historical Outline.

IN November, 1923, Reuters, Ltd., commenced a broadcast service of news distribution in morse to European countries, renting radio transmitting facilities from the Post Office for the purpose. The example was soon followed on a small scale by other senders of news. The progressive policy which Reuters have adopted towards this service has led not only to very healthy growth and expansion of the service, but also to some interesting developments in telecommunications technique, some account of which will, it is thought, be of interest to readers of this Journal.

An outline view of the manner of growth of the service may perhaps best be seen from a brief review of the principal features since its inception. In July, 1928, the emissions were transferred from Northolt to Rugby radio station for a "World" broadcast service of news, sent in code, from the powerful radio-telegraph transmitter on 16 kc/s (GBR). The keying centre was transferred from the Central Telegraph Office to Reuters' offices in November, 1929, though the operating was still carried on by Post Office staff. The service was remodelled for sending uncoded messages and extended by the addition of two high frequency transmitters, with omni-directional aerials, at Leafield radio station, keyed simultaneously with the Rugby long wave transmitter GBR; following a short experimental period this new "World" service was introduced on March 23rd, 1931. A supplementary service to European countries was started on an experimental basis on July 22nd, 1935, Hell-schreiber signals being emitted from a low-frequency radio-telegraph transmitter at Leafield (GIX, 43.2 kc/s). A brief description of the Hell-schreiber system is given later; the system provides a facility similar to that obtained by receiving on teleprinter instead of by morse. To improve reception of Hell-schreiber signals at the more remote European centres, a high-frequency transmitter at Leafield was added, and a visit was made in June, 1938, during the experimental period of these emissions, to test reception at Budapest, Prague, Belgrade and Bucharest. The years immediately preceding the war were of grave difficulty for Reuters' wireless services, on account of severe competition from foreign services subsidised for propaganda reasons. The war brought controls by the Ministry of Information; it also necessitated many and frequent rearrangements of transmitters and frequencies used for Reuters' services, arising from military requirements and from the needs from time to time for various emergency services from Post Office radio transmitters. During the first half of 1941 replacement of the one very-low frequency plus two omni-directional high-frequency emissions for Reuters' "World" service by four or five beamed high-frequency emissions was com-

pleted, and testing with a view to the introduction of Hell-schreiber signals on these emissions has now commenced. In January, 1944, special aerials designed for the high-frequency emissions to Europe (and parts of N. Africa and Asia Minor) were brought into use.

A fairly definite pattern can be traced in these developments: a service is started for Europe only, on a low frequency transmitter, then extended by means of high frequencies. For purposes of presentation, discussion will be continued under the two broad headings, "World" and "European" service, with an extra section on the Hell-schreiber system. It will be appreciated that the type of service supplied for Reuters by the Post Office is essentially multi-destination (i.e. it is a broadcast service intended for reception at more than one point) as distinct from point-to-point, so that advantage of close technical liaison with the recipient is not available; at the same time the number of recipients in any one high frequency beam may be relatively small, and attention to individual needs, e.g. in selection of frequencies, can sometimes be given. The recipients are news distributors, not wireless engineers, and their reports on reception of the signals are generally of a broad qualitative nature (especially if an important message has been badly mutilated in transmission or not received at all); too often it is not even possible to interpret from the report whether poor reception was due to abnormally low field strength or to interference or other local trouble at the receiving end.

"World" Service.

A powerful low-frequency radio transmitter gives good and reliable signals over a very wide area, but the equipment and the aerial are expensive and the signals are subject to atmospheric interference, especially where electrical storms are prevalent. A high-frequency transmitter with much lower power and less costly aerial system can give as good, though somewhat less reliable, signals at even greater distances, provided that the frequency is right for propagation at the time and to the place concerned. A single omni-directional emission at high frequency is quite inadequate for world coverage; several emissions at different frequencies give a better chance of reception at any point. If there are to be several simultaneous emissions it is better for each transmitter to radiate from a directional aerial to cover a particular receiving area, so that the best frequency at any time for propagation to that area can be used. For Reuters' service, such an arrangement has also the advantage of permitting specialisation in editing and timing messages for different parts of the world.

After consultation with Reuters as to their probable

future requirements an aerial system for radiating six beams was planned and erected at Leaffield radio station. The aerials are arrays, with reflectors, suspended from triatics between 180-foot steel towers; there are about four for each direction (or beam), each tuned to a separate, preselected, frequency. Most of the arrays are horizontal, but some for the longer wavelengths are vertical; they have generally a nominal beam width $\pm 16^\circ$, i.e. at 16° away from the axis, the field strength in free space has fallen 6 db. from the maximum. The map, Fig. 1, shows the great-circle paths of these six beams

changing propagation conditions—as can be done in point-to-point working—and it is necessary to arrange a schedule of frequency changing for each beam, based on calculations from radio propagation data and theory. Forecasts, of which Fig. 2 is an example, are regularly prepared by the Post Office to show which of the frequencies available for the service is likely to be best to use at any time for a period some months ahead. These forecasts vary, in a not very regular manner, not only with time of day and season of year, but also with the phase in the sun-spot cycle. In addition, of course, reports

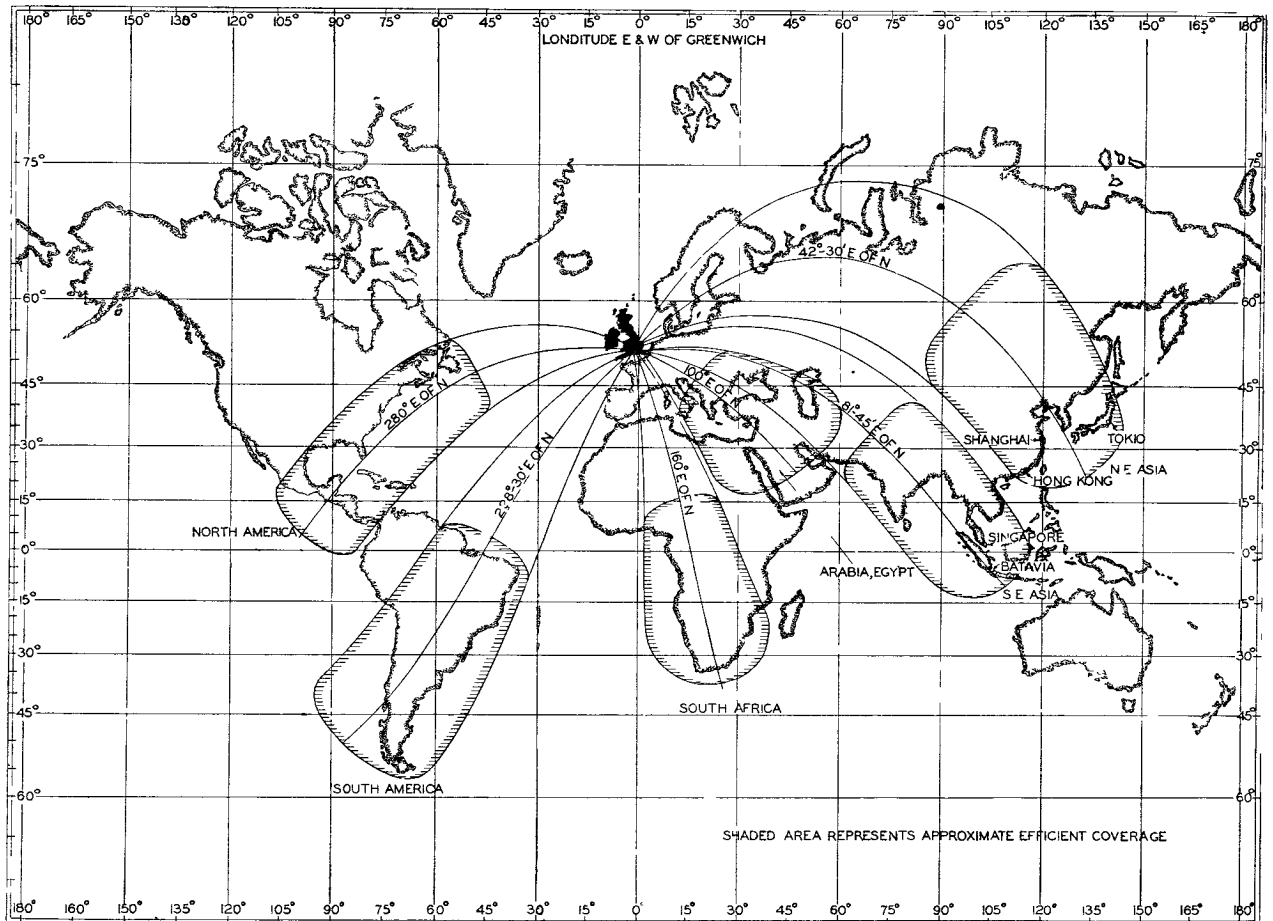

FIG. 1.—ARRANGEMENT OF HIGH-FREQUENCY BEAMS FOR REUTERS' SERVICES.

and the principal regions which they were designed to cover. The beams are shown 32° wide, but in practice the cut-off at the edges is not as sharp as is indicated by this simple method of illustration; any of the beams can fairly easily be doubled in width by alteration of the arrays, if required. New transmitter construction enabled most of the beams to be operated from Leaffield, in addition to the European service, in 1941, but during the course of the war some rearrangements of these services have from time to time been necessary and not all of the beams are in use.

With a multi-destination service it is not possible to make frequency changes at short notice to follow

of reception are taken into account in arranging the frequencies to be used.

From the start of the war the time available on the big Rugby transmitter GBR for Reuters' services became less and less, so these had to depend more and more, and soon entirely, on the Leaffield low-frequency transmitter GIX for serving the nearest centres and on high-frequency emissions for the more distant centres. GIX compares with GBR roughly as follows:—frequency ratio 11 to 4; output power ratio 1 to 6; aerial height ratio 3 to 8; it gives reasonably adequate coverage of Europe on morse. The use of the aerials of both these transmitters was temporarily lost due to ice loading in

January, 1940¹; the damage to GIX was the more quickly repairable.

Hell-schreiber System and Apparatus

The Post Office were approached by Reuters (in July, 1933) to co-operate in investigating the possibilities of application to their wireless service of a new type of telegraph printing system ("Dr. Hell's System"), being developed by Siemens & Halske, of

as the tape passes the printing head. The marks forming a letter are so close together that, when viewed at normal reading distance, they appear as a letter rather than as separate marks.

In the Hell-printer each mark is made by pressure on the tape between the inked face of a helical tooth on the printing wheel and a straight edge which is parallel to the axis of the wheel. The straight edge is attached to the armature of an electromagnet, which is energised by the incoming signals, in accordance with which the straight edge is moved towards the wheel to mark the tape. The obliquity between the tooth and straight edge is such that the area of contact between the tape and the inked tooth is small. The duration of the shortest signal is such that the corresponding mark occupies one of the 25 frame elements. A complete vertical line, as in the letter I, is formed by a signal duration of five times the shortest; the speed of the tape is slow relative to the peripheral speed of the helical tooth, so that the line so formed is nearly, though not quite, perpendicular to the edge of the tape. The width of tape is sufficient to accommodate two letter frames and the spacing between the helical teeth is such that each operation of the straight edge makes two similar marks (one by each of two adjacent teeth) at corresponding positions in each frame; thus two parallel lines of printing are produced, to avoid need for exact synchronism with the Hell sender. If synchronism is not exact, the lines of print do not run parallel to the tape, but one or other can always be read.

Before the war Hell-printers and senders were obtained from Germany, and when this source of supply failed the Post Office undertook to arrange for production in this country. Stocks of Hell-printers were then quite inadequate for supplying new subscribers to Reuters' service, which could not therefore be expanded until supplies of these items became available. As there then were requirements for both 7-line and 12-line printers, design of a printer which could accept either was produced by the Post Office. Fig. 3 is a photograph of an early model; the printing wheel with the helical teeth is just above the printing point on the tape, above it is the inking roller and below it the box containing the electro-magnet and the straight edge. To change from 7- to 12-line, or vice versa, the printing wheel only has to be changed.

At the normal speed of operation, five characters per sec., the signalling speed is 245 bauds for 7-line or 500 bauds for 12-line working. Such speeds are too great for transmission over standard Post Office voice-frequency telegraph channels with only 120 c/s spacing. For passing the signals from the Hell sender in Reuters' office to the radio transmitter at Leafield, terminal equipments have therefore been installed at these two points to provide three one-way high-speed channels, each 600 c/s wide, and one two-way order wire within the frequency band occupied by the 18-channel V.F. system. The three 600 c/s channels are centred at 900, 1,500 and 2,100 c/s and the two 120 c/s channels for the order wire at 420 and 540 c/s, i.e. they are the two lowest frequency channels of the standard system.

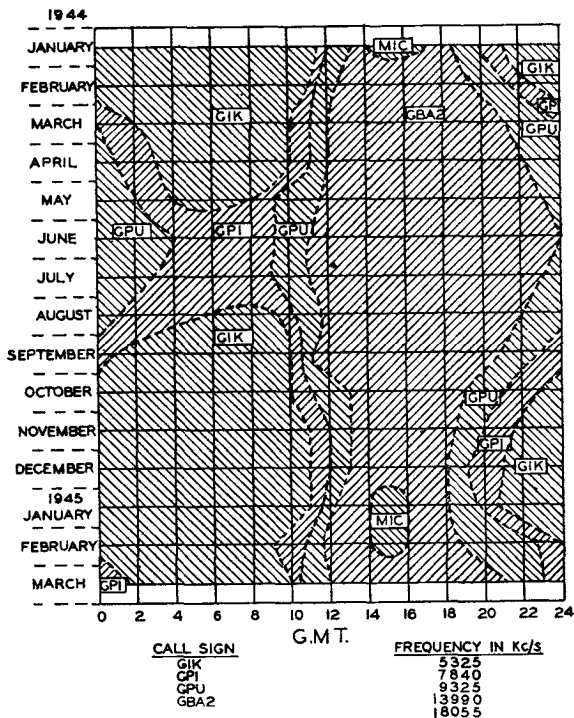

FIG. 2.—1944 FORECAST OF FREQUENCIES FOR USE ON REUTERS' SERVICE TO N. AMERICA.

Berlin. The system was given the name of Hell-schreiber, commonly abbreviated to Hell. Equipments were obtained from Germany and tests were made at Dollis Hill and over radio paths from Leafield (GIX) to Baldock, Dollis Hill and Berlin in June, 1934. The system then used came to be known as the 12-line system, to distinguish it from a later development, the 7-line system which is now in general use. The great advantage of the 7-line over the 12-line system lies in the use of fewer elements per letter, hence a narrower frequency band of radio emissions and a reduced liability to cause or suffer interference.

The Hell system is essentially facsimile, i.e. the characters are not printed from type face, but are built up by a series of marks. In the 7-line system each letter frame is divided into seven vertical strips (of which two are left blank to form spaces between letters) and seven horizontal strips (of which two are left blank to form marginal spaces above and below the words formed on the tape). The frame for the letter proper thus comprises 5 x 5 (i.e. 25) elements, in any one of which a mark can be made by the received signals

¹ P.O.E.E.J. Vol. 33, pp. 33 and 134.

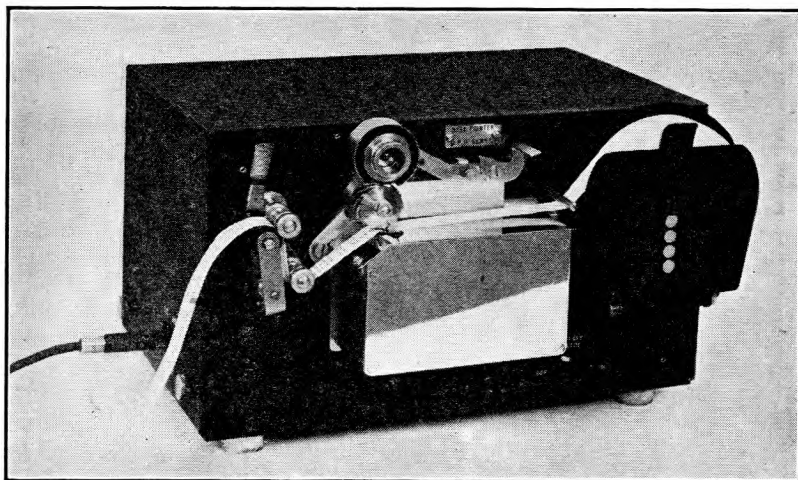

FIG. 3.—HELL PRINTER (P.O. MODEL).

One other feature of the Hell system deserves mention: the motor of the printer is started and stopped automatically by signals from the sender, of approximately $\frac{1}{2}$ sec. and 10 sec. respectively, which are inserted at the beginning and end of Hell emissions. Attended operation at the receiving point is therefore unnecessary, at any rate under reasonably steady conditions of radio reception.

"European" Service

Difficulties with reception of Hell emissions from the low-frequency transmitter GIX were, at the start, reported by many of Reuters' agencies on the Continent. A visit was therefore made, in July and August, 1936, to Oslo, Stockholm and Copenhagen to carry out investigations at these receiving points. Before the introduction of the Hell system it had been the practice to receive Reuters' news service in morse at points outside a city and to relay the messages to the agency offices in the city. In taking advantage of the unskilled operation offered by the Hell system the news agencies were anxious to effect further economies by locating the radio receivers in their own offices in the heart of the city, and generally the services were being handled by non-technical staff, with technical assistance obtained locally as and when required. The difficulties with the Hell receptions arose primarily from the inadequacy of the technical assistance in relation to the problem of radio reception of the Hell signals with the limitation of aerial efficiency and in the presence of heavy local interference due to the location of the receiving point in a city office. By careful attention to technical details the visiting officers demonstrated that even under these conditions satisfactory reception was quite practicable at all three centres; samples of the slip, taken at Oslo before and after modifications were made to the receiving equipment, are shown in Fig. 4. Following this investigation, reports in the form of answers to a questionnaire were obtained from other agencies.

Although satisfactory service with the Hell system was then given by the low-frequency transmitter GIX to the nearer European reception centres, the

field strength was too low for proper reception at the more remote centres. A programme of test emissions from a high-frequency transmitter at Leafield was therefore arranged in conjunction with a visit to study reception at Budapest, Prague, Belgrade and Bucharest in June, 1938. Satisfactory results were obtained at the agency offices in all four cities, using a frequency of about 11 Mc/s during day-time, and an enlarged service was introduced by Reuters, with simultaneous Hell emissions from GIX and one high-frequency transmitter, during the political crisis in September, 1938.

Close study was at about that time being given to the relative merits of the 12-line and the 7-line Hell systems. From all the evidence which was available it was concluded that the

substantial advantages accruing from the lower signalling speed of the 7-line system outweighed all other considerations, and Reuters' service was therefore changed from 12-line to 7-line on August 20th, 1939.

Perhaps the greatest effect of the war on engineering technique in connection with Reuters' Hell service resulted from the threat of loss of use for this service of the low-frequency transmitter GIX. Apart from the strain to which the radio transmitting facilities of the Post Office were being subjected and the possibility of damage to this rather large and powerful (and therefore not readily replaceable) equipment, the emissions were of the kind which could assist navigation of enemy aircraft and were liable to be shut down at short notice. Accordingly arrangements were made in November, 1939, to reinforce the 11 Mc/s Hell emissions by another high-frequency transmitter, using a frequency about 7 Mc/s. On occasions when the low frequency trans-

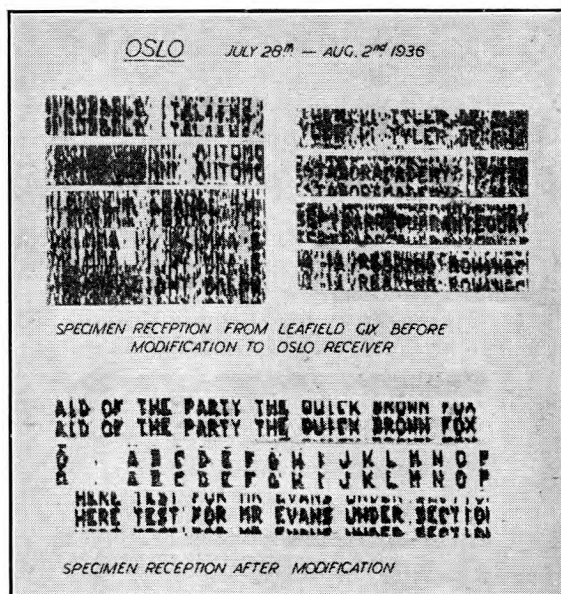

FIG. 4.—HELL PRINTER SLIP.

mitter was not in use, trouble was encountered by the nearer reception centres (who were relying on this transmitter) in getting good results from the high-frequency signals. The difficulty was aggravated by the absence at that time of any high-frequency radio receiver really suitable for a service of this kind in commercial production in this country—a deficiency which has since been rectified. A visit was paid to the Scandinavian and Low Countries in February, 1940, to help in overcoming difficulties in high-frequency reception, not least of which arose from variations in radio path conditions. A certain amount of semi-skilled attention (of a kind not normally required for receiving a low frequency) to controls on the receiving equipment produced a considerable improvement in the grade of service. This visit, in common with the earlier ones, by technical personnel to the agencies abroad was useful, not only in direct results, but also in stimulating interest in the various technical matters discussed.

The course of the war reduced the number and altered the geographical distribution of subscribers to Reuters' Hell service, but it did not thereby ease the problem of supplying the service; on the con-

trary, it raised the question of radiating high frequencies efficiently to points so scattered as Stockholm, Moscow, Berne, Ankara, Tangier, Madrid and Lisbon. To improve the service on high frequencies, therefore, aeriels were designed to distribute radiation fairly uniformly within a wide horizontal angle (of about 220°) at vertical angles ranging from about 15 to 45° to the horizontal, to the exclusion, as far as possible, of radiation in other directions. The design takes the form of two horizontal radiating elements at right angles to each other, each a half-wavelength long with a reflecting element behind. Aerials to this design were brought into use at Leafield on Reuters' service in January, 1944.

Conclusion.

These few notes on the technical developments are necessarily incomplete; if the plans mature for applying Hell-schreiber signals on all of Reuters' services, a chapter of development will have been closed, but it can confidently be predicted that further chapters dealing with extensions or improvements of the services will follow sooner or later in the future.

Temperature Indicating Materials

In many cases where heat is applied to or generated in materials either in manufacture or in use, it is necessary in the original design to be able to measure the temperatures reached under test conditions and in certain cases the use of the standard temperature indicators, such as liquid thermometers, thermocouples, etc., is either impracticable or unsatisfactory. A typical example is the design of a process sequence for the sealing of wire-supported quartz crystal elements¹ into valve type envelopes. In such a process the weak spot is the low melting point solder ($180^\circ\text{C}.$) used to connect the support wires to the burnt-on silver spot on the crystal and it is necessary to adjust the temperature gradients occurring in the sealing process to ensure that the solder-joint shall never reach softening temperature.

In solving this problem, use has been made of the properties possessed by various organic and inorganic compounds by virtue of which certain observable physical changes occur at well defined temperatures. A whole range of such substances has been developed and these are vended in various forms, the chief ones being:—

- (a) Paints which may have one or more mainly irreversible colour changes with increase of temperature. The transition temperatures may vary according to the rate of temperature change, but if this is determined the transition

temperature does not vary by more than a few per cent. It is possible to determine in this way some scores of spot temperatures in the range $180^\circ\text{F}.$ to $1,800^\circ\text{F}.$

- (b) Lacquers which change from matt to glossy surface at $25^\circ\text{F}.$ intervals in the range $125^\circ\text{F}.$ to $350^\circ\text{F}.$ and at $50^\circ\text{F}.$ intervals in the range $350^\circ\text{F}.$ to $1,600^\circ\text{F}.$ with a quoted accuracy of ± 1 per cent.
- (c) Pellets which melt or sublime at the same sharply defined temperatures as in the case of the lacquers.
- (d) Crayons, in stick form for marking surfaces, which are otherwise similar to pellets.

Paints are marketed in this country by I.C.I., Ltd. (Thermetric Colours) and by J. M. Steele, Ltd., London (Thermindex Colours), and the latter firm also supplies lacquers, pellets and crayons under the trade names "Tempilaq," "Tempil Pellets," and "Tempilsticks."

There is a fairly wide literature on the subject, but it is probable that the information is not generally known to telecommunications engineers, who may nevertheless find the materials useful in many applications.

Some further information may be obtained from British Standards No. 1041.

J. L. C.

¹ P.O.E.E.J. Vol. 38, page 65.

Modern Vibratory Power Converters

U.D.C. 621.314.5

L. S. DISTIN, A.M.I.E.E.
(Ericsson Telephones Ltd.)

The author outlines the principles on which vibratory power converters operate with reference to both rectifying (D.C.-D.C.) and non-rectifying (D.C.-A.C.) types. A new unit specially developed for use under Service conditions is then described and performance details given.

Introduction

CONVERTERS of the vibratory type have long been used for obtaining the necessary high tension voltages on battery operated radio equipment. Their most satisfactory application, however, has been found where the power demands have been moderate—a condition which is largely governed by the power handling ability of the vibratory mechanism (or vibrator) which forms an integral part of converters of this type.

During the early stages of the recent war the Services desired to extend the use of converters, but owing to the severity of requirements it was evident that the development of a new type of vibrator would be necessary. Accordingly an appropriate programme was undertaken by Ericsson Telephones, Ltd., in collaboration with the Royal Aircraft Establishment. This resulted in the production of a vibrator of the necessary standard of performance and which moreover is of simple design, compact, and suitable for use in all climates and at high altitudes.

This new unit is known as the Air Ministry Vibrator type 14, and differs in many respects from other types, but in common with them has a wide field of application. It is considered, therefore, that a description of this unit, together with an outline of the principles on which modern vibrators operate will prove of general interest.

In essentials, a vibratory converter consists of a group of components, including, as a rule, a vibrating switch of the tuned reed pattern (referred to in future as a vibrator), a transformer, spark suppression devices and, in some cases, a rectifying unit such as a metal rectifier or its equivalent. Modern practice, however, on the grounds of compactness and efficiency, aims at eliminating the separate rectifying unit and effecting rectification by extra contacts fitted to the vibrator. A typical converter of this type is shown in Fig. 1. Its D.C. output is 300 V at 100 mA.

Methods of connecting the components, together with general descriptions, are given later, since it is considered that a brief description of the vibrators upon which so much of the whole converter design depends, would be of advantage at this early stage.

Vibrator types.

Broadly speaking, vibrators fall into two classes, viz., non-rectifying and rectifying, typical examples of which are shown in

Fig. 2. The non-rectifying (or non-synchronous) type is the simpler and consists of a free steel reed (1), to which is attached a soft iron armature (2), which is attracted by the electro-magnet (3). A pair of tungsten contacts (4) is attached to the reed, and when the mechanism is functioning engage intermittently with the fixed contacts (5).

The rectifying (or synchronous) type is similar, but has an additional set of contacts (6). These contacts operate in synchronism with the first set (5), but are arranged to make later and break earlier. The object of this sequence is to increase contact life, and is dealt with more fully later when the operation of the complete converter is under consideration. Both types of vibrator have a further contact (7) fitted for driving purposes. This contact is usually made from platinum or platinum/iridium alloy and is connected in series with the magnet winding. When the reed is stationary this contact is closed, hence when the magnet is energised and the reed moves towards the poleface, the magnet circuit is opened and oscillation of the system is sustained in a manner very similar to the principle of the electric trembler bell. The frequency of oscillation is determined for all practical purposes by the

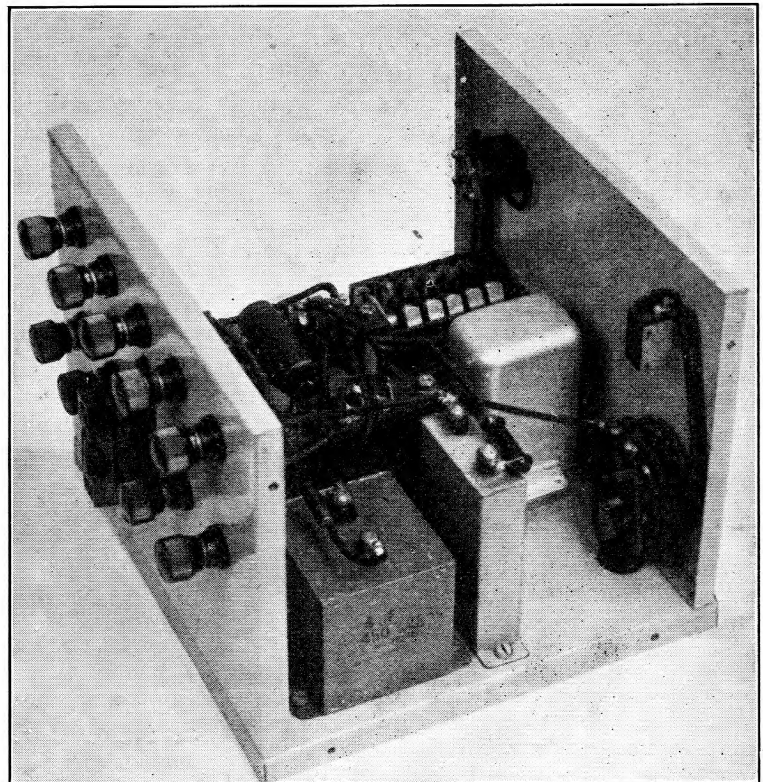

FIG. 1.—D.C.-D.C. VIBRATORY CONVERTER. OUTPUT 300 V. 100 mA.

mechanical characteristics of the whole reed and contact system, and is usually of the order of 100 cycles per second when contact pressures and "follow" are of the right order.

Vibrators fitted with the separate drive contact are referred to as separately driven types and on account of their better reliability are mostly used for important applications in preference to vibrators of the self-driven type. The latter are not fitted with a separate drive contact but rely on the intermittent short-circuiting of the magnet winding by one of the main tungsten contacts for sustaining oscillation. Owing to waning popularity, however, it is proposed not to deal further with this driving principle.

For reference purposes a table showing various types of vibrators in use to-day is given below:—

Type	Reed and Contact Arrangement
(a) Non-synchronous self-driven	Single changeover contact set, no driving contact.
(b) Non-synchronous separately driven	Single changeover contact set. Drive contact fitted and electrically connected to the main contact set.
(c) Synchronous self-driven	Two changeover sets of contacts fitted. The centres are electrically connected via the reed. No drive contact fitted.
(d) Synchronous separately driven	As (c) but driving contact fitted.
(e) Synchronous, split-reed separately driven	Two changeover sets of contacts, no electrical connection between them. Drive contact fitted.

All the above vibrator types can be, and in many cases are, built around one type of magnetic circuit.

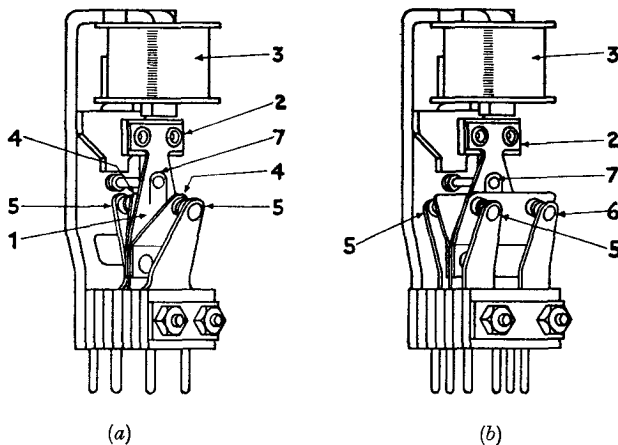

FIG. 2.—(a) NON-RECTIFYING VIBRATOR.
(b) RECTIFYING VIBRATOR.

Those shown in Fig. 2 are typical and form the basis of a number of well-known makes of vibrator.

The heavy duty Services unit mentioned in the introduction to this article is a special form of the type classified under (e) in the table. A description of this unit is given later, after the principles on

which complete converters operate have been discussed. In this way it is felt that the reasons for various design features of the new unit will, to all intent, be self-evident.

D.C. to A.C. Converter.

Turning to the general principles of converter operation, Fig. 3 shows the basic circuit of a typical

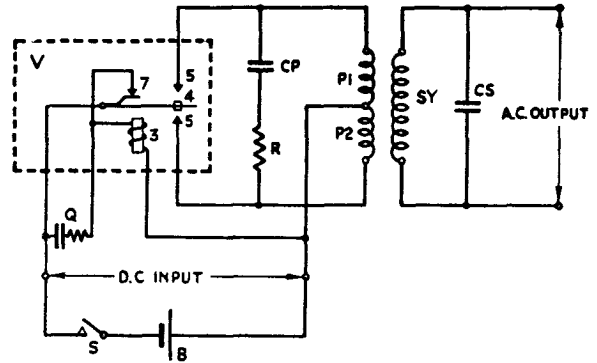

FIG. 3.—CIRCUIT SCHEMATIC OF TYPICAL D.C.-A.C. CONVERTER.

present-day converter for producing A.C. from D.C.

The vibrator V is of the non-rectifying separately driven type, with external spark quench Q. When the switch S is closed, operation occurs as previously explained, at a frequency of 100 c/s approximately.

Contacts 4 and 5 on the reed now intermittently close the transformer primary circuits P1 and P2 via the battery B. These primary windings are similar, hence the transformer core is subjected to one pulse of magnetisation in one direction and one in the other for each excursion of the reed. The core flux is hence of an alternating nature and is symmetrical. This flux links with the secondary turns SY, and in accordance with the well-known laws of electrical induction, produces an alternating voltage in this winding of a frequency equal to that of the vibrating reed. The transformer is thus in effect a means for separating the output voltage from the supply voltage, and it is obvious that by choosing a suitable ratio of primary to secondary turns a secondary voltage of almost any desired value can be obtained.

The waveform of this voltage is of the form shown in Fig 4, which is a reproduction of an oscillogram taken of the no-load unrectified output of a typical converter of approx. 45 V.A. output. The rectangular waveform shown is very suitable for rectification, since it requires less filtering than a sinusoidal form of the same mean value. The problems of waveform and spark suppression are to a certain extent interdependent, and the secondary condenser CS together with the resistance/capacitance circuit across the transformer primaries are provided for dealing with them. The value of the secondary condenser is so arranged that when the converter is operating at its rated load, electrical resonance is approached in the secondary circuit, hence producing optimum conditions in the system at this load value,

particularly as regards electrical efficiency, waveform and contact arcing.

The spark suppression circuit, composed of resistor R and condenser CP, moderates the rate of decay

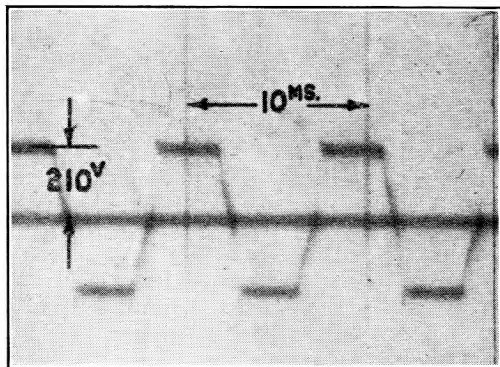

FIG. 4. OUTPUT VOLTAGE WAVEFORM OF D.C.-A.C. CONVERTER.

of primary current at the instant of contact break, and, with the assistance of the secondary condenser CS, assists in limiting the magnitude of undesirable voltage peaks in both primary and secondary circuits. Resistor R limits the rate of dissipation of stored reactive energy at the primary switching contacts and so prolongs life.

The above notes indicate how a simple D.C.-A.C. converter produces alternating current from direct current. For a majority of radio communication applications, however, it is necessary to both rectify and filter the A.C. output voltage so that a smooth supply of anode current for the various electronic devices is available. Rectification is frequently performed by thermionic valves or metal rectifiers, but these methods, for reasons already touched upon, are being displaced rapidly by the self-rectifying vibrator and therefore do not come within the scope of this article.

The advantages offered by the self-rectifying vibrator, i.e., low rectification losses, compactness, etc., have been recognised for a considerable time, but difficulties in the direction of life have been serious hindrances to its adoption for really important applications. These have now been overcome, with

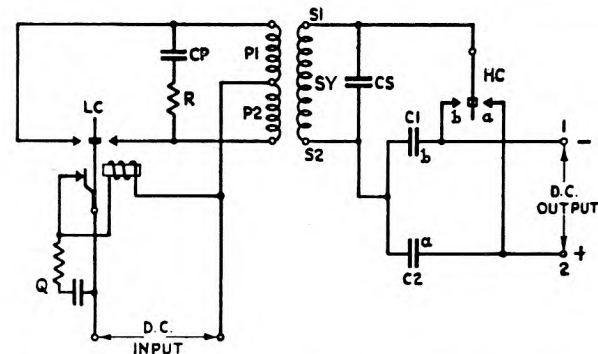

FIG. 5.—CIRCUIT SCHEMATIC OF TYPICAL D.C.-D.C. SELF-RECTIFYING CONVERTER.

the result that really reliable converters are available using this type of vibrator.

D.C. to D.C. Converter.

A typical self-rectifying converter circuit as used for airborne equipment is shown in Fig. 5, and incorporates voltage doubling facilities on the secondary side of the transformer. This circuit is similar to the one shown in Fig. 3, but in addition includes the rectifying contacts HC and energy storage condensers C1 and C2.

As far as the generation of high tension alternating voltage is concerned this circuit functions similarly to the one shown in Fig. 3. The additional voltage doubling and rectifying processes, however, are effected in the following way.

Referring to Fig. 5, LC and HC are respectively the primary switching and synchronous rectifying contact sets of the vibrator. Let it be assumed that the directions of the transformer windings and battery potential are such that during operation the rectifying contact "a" on springset HC closes when the secondary terminal S1 is positive, and contact "b" closes when this terminal is negative. Also it must be borne in mind that due to the synchronism of contacts LC and HC the polarity of the secondary terminals, S1 and S2, reverses in synchronism with the operation of springset HC.

It is convenient to trace what happens during operation on the secondary side by starting at the instant contact "b" breaks. When this occurs, condenser C1 will be charged so that its plates "b" will be at negative potential equal to the transformer charging potential. Contact "a" now closes and simultaneously the polarity S1 reverses to a positive potential. The voltage now occurring across the D.C. output terminals 1 and 2 will be the sum of the transformer secondary voltage and the voltage across the charged condenser C1 and will be of the polarity shown. Condenser C2 is meanwhile being charged across the transformer secondary in a direction such that plates "a" are at positive potential. Contact "a" now breaks leaving condenser C2 in a charged condition. Contact "b" closes and the secondary voltage also reverses, so that terminal S1 is again negative. The voltage across the output is now the sum of the secondary voltage and the voltage across the condenser C2, and will be of the same polarity as for the first half cycle. It is thus seen that for one excursion of the reed two unidirectional pulses are delivered to the D.C. output terminals. This process continues throughout operation, thus maintaining a unidirectional source of supply at the output terminals.

The ratio of the D.C. output voltage to the transformer secondary voltage is dependent on the balance between transformer regulation, the capacitance of condensers C1 and C2 and load values. Figures for a converter of 30 W output are approximately 2 : 1 at no load, falling to 1.6 : 1 at full load. Oscillograms showing the unidirectional output at no load and full load are shown in Fig. 6.

For anode supply purposes, etc., it is necessary to smooth the output further by low-pass filtering (not shown in the figure), so that under load conditions the

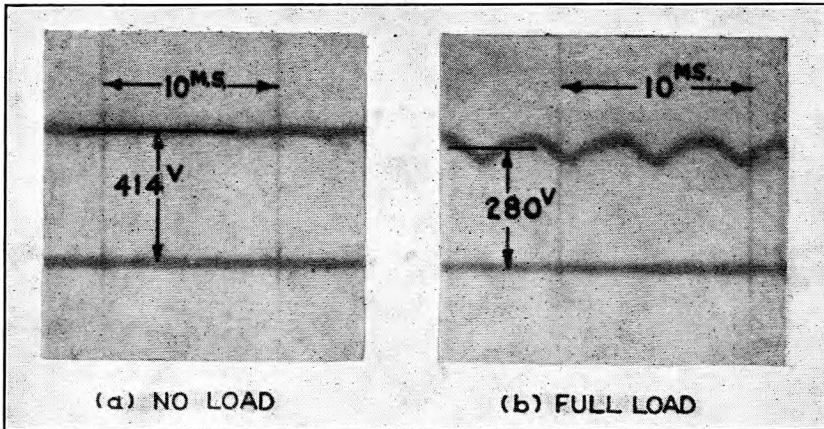

FIG. 6.—OUTPUT VOLTAGES OF SELF-RECTIFYING CONVERTER.

ripple voltage does not increase appreciably above the no load level. To increase the life of the primary switching contacts the timing of the LC and HC contacts is so arranged that the secondary circuit is closed slightly after the primary contacts make, and broken before these contacts break. In this way a considerable lowering of the primary current occurs before the primary contacts function.

Electrical interference is another aspect of performance which has to be taken into account. This is affected by conditions surrounding the use of converters, e.g., class of load, proximity of components, etc. It is usual, therefore, to treat circumstances on their merits, using established methods of suppression when doing so. The metal cover of the vibrator is always connected to the equipment chassis.

With regard to the part played by the vibrator itself, consideration will show that it has a difficult task to perform. For example, the primary switching contacts both make and break the heavy current primary circuits of the transformer 100 times a second for hours on end with no possibility of maintenance attention; moreover, output is sensitive to contact deterioration. This combination of circumstances, together with the need for close frequency control in some types of converter, were the main factors prompting the development of the vibrator type 14 referred to at the commencement of this article.

Air Ministry Type 14 Vibrator.

This new unit is classed as a synchronous, split reed, separately driven vibrator and is illustrated in Fig. 7. Some tabulated details of performance and features of interest are given below:—

- (a) Frequency 110 cycles \pm 2.5 cycles at nominal battery voltage.
- (b) Driving system arranged for 6 and 12 V operation with voltage limits of \pm 25 per cent. For higher voltages a suitable impedance may be connected in series with the drive coil.

- (c) Reed driving power 1.7 W maximum.
- (d) Time efficiency of the switching contacts:
 - L.T. springset—39 per cent. make period.
 - H.T.—34 per cent. make period.
 - Minimum overlap period—3 per cent.
- (e) Contact bounce limited to 5 per cent. of the total make period.
- (f) Life a minimum of 1,000 hours when operating a 12 V converter delivering 30 to 40 W unidirectional output.

- (g) Ambient temperature range—40° C to + 70° C.
- (h) Standard of robustness capable of meeting Services shock and vibration tests.
- (i) Container pressure sealed and filled with dry air at 1 atmosphere.

Referring to Fig. 8, the foundation of the unit consists of the comparatively heavy magnet framework (1). The layout of this is arranged with three main objects in view, viz:—

- (a) To provide an efficient iron circuit.
- (b) To provide a winding of good copper efficiency.
- (c) To accommodate an efficient anti-vibration suspension system.

The result of (a) and (b) is reflected in the low amount of driving power required (1.7 W), a value which is no greater than for vibrators carrying

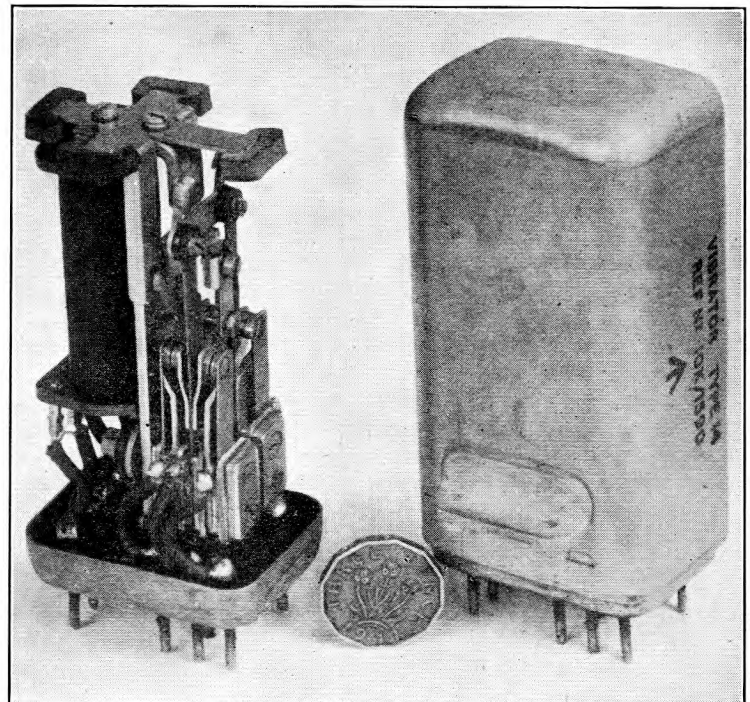

FIG. 7.—AIR MINISTRY TYPE 14 VIBRATOR.

much lighter reed systems. The magnet winding is divided into two equal sections so that winding efficiency (and hence power consumed) remains the same whether on a 6 or 12 V supply.

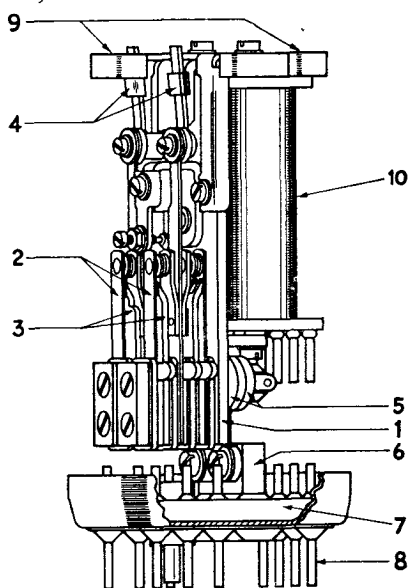

FIG. 8.—AIR MINISTRY TYPE 14 VIBRATOR—KEY DIAGRAM.

The magnet frame carries the reed and contact assembly. This contact system is of heavier construction than has been usual, and when operating develops contact pressures of the order of 100 gms. with sufficient movement to lift the contact springs (2) well clear of the rigid buffers (3); tungsten contacts are fitted. The tips of the buffers are shaped to ensure good mating with the contact springs and are brought well up to the contacts to provide stabilisation and to assist contact cooling. A good clearance between springs facilitates adjustment—tension in particular. Control of this is desirable so that all contacts operate with uniform and known pressures. This feature also contributes towards uniformity of stiffness of the whole reed system and so materially assists towards obtaining the close frequency limit quoted. Final frequency trimming is obtained by positioning the sliding weights (4). Mica insulation is used between springs.

Owing to the robust action of the moving system correspondingly high reactionary forces are generated,

and to prevent undue vibration from being transmitted to the chassis, the unit is suspended on a specially designed rubber mounting. This incorporates two mechanically insulating suspension joints interposed in tandem between the vibrator framework and the container base. The first of these consists of rubber grommets (5) placed in a position on the magnet framework, about which the reactionary forces of the vibrating reed and the magnet system (which also oscillates slightly in accordance with well-known laws) are approximately equal. This state of balance is the condition when minimum mechanical energy is transmitted from the moving system to the mounting block (6) and means that chassis disturbance also will be a minimum. The second energy absorbing joint is formed at the bonded junction of the mounting block and the rubber base pad (7) and serves to reduce chassis disturbance further. This base pad also carries the ten brass contact pins (8), all of which are bonded to the rubber. The pad itself is bonded to the container and so forms a pressure seal.

Fouling of the container is prevented by the four Sorbo rubber buffers (9) on the head of the vibrator.

Conclusion.

Converter design has been for many years the subject of a good deal of attention, with the result that there are many types of vibrators and converters in existence. The designs described in this article, however, are good examples of present day practice, and their comparative simplicity serves well to illustrate general principles.

Present development, in the main, aims at increasing electrical output and producing equipment for specialised purposes. Designs in which the output voltage is stabilised against battery voltage and load variation have been very successful, while converters of 1 kW output, using multi-contact vibrators, are claimed to be operating satisfactorily. At the other end of the scale, miniature high frequency vibrators for use in life saving and kindred equipment have also given satisfactory service.

Acknowledgment.

The author extends his best thanks to the Ministry of Aircraft Production for permission to publish details of the type 14 vibrator described, and to Ericsson Telephones, Ltd., in whose laboratories it was developed, for their kind assistance with the preparation of this article.

Computation Problems in Circuit Design

G. T. BAKER, M.Sc.
(Automatic Telephone and Electric Co., Ltd.)

U.D.C. 518.1 : 621.3

This article analyses certain computation processes and reproduces these in physical terms, using telephone type apparatus. The technique is illustrated by an application to time measurement problems.

Introduction.

IN the course of time, the circuit engineer encounters a wide variety of computation problems. Some of these are of obvious construction, but more often than not they are disguised as something quite different. The method of attack given herein is relatively simple to apply, since it consists of a literal translation into physical terms of the written methods studied in childhood.

Written computation work is based entirely upon breaking down an extensive problem into a series of elementary units. Each unit represents a simple operation which is performed, usually mentally, on part after part of the total problem in a defined sequence. As an example, consider the addition of the two numbers,

$$\begin{array}{r} 98,765 \\ 43,210 \\ \hline 141,975 \end{array}$$

Each column is treated as a separate summation, the only connection between the various columns being "carry" digits. The same layout will be apparent in all computation methods, subtraction, multiplication, division, finding square roots, etc.

The technique to be described reproduces these stages exactly. A circuit is designed, using relays and other standard telephone apparatus, to perform the elementary unit operation. Then uniselectors are used to apply this circuit to part after part of the total problem, in a sequence defined by the computation method under consideration.

THE BINARY SCALE

Scales of Notation.

When any number, such as 13,579, is written, these digits imply,

$$1 \times 10,000 + 3 \times 1,000 + 5 \times 100 + 7 \times 10 + 9.$$

Stating this mathematically, numbers are commonly expressed in the form,

$$a_n \cdot 10^n + a_{n-1} \cdot 10^{n-1} \dots a_2 \cdot 10^2 + a_1 \cdot 10^1 + a_0 \cdot 10^0.$$

Where $a_n, a_{n-1}, a_2, a_1, a_0$ all are integers less than 10.

In the above examples, 10 functions as the radix or base of the scale, and this scale has now been universally adopted. For special purposes, however, other scales may be used, e.g. e ($= 2.71828$), while the base 2 has particular attractions for use in computing apparatus.

A number in this scale is written as

$$a_n 2^n + a_{n-1} 2^{n-1} \dots a_2 2^2 + a_1 2^1 + a_0 2^0$$

Where $a_n, a_{n-1} \dots a_2, a_1, a_0$ are either 1 or 0. Thus 1010101 represents $64 + 0 + 16 + 0 + 4 + 0 + 1 = 85$.

The advantages of this scale lie in the simplicity with which it can be represented physically, and

the fact that all computation problems involve only a single basic operation, i.e. the addition of "one" and "one."

Physical Representation.

The relay used in telephony has two positions, i.e. operated and non-operated. Hence, numbers in the binary scale can be expressed directly by one relay per digit, the operated position indicating "1," and the normal position indicating "0." Other scales have a greater range of digits and consequently a number of relays are required to express each one. The decimal scale requires four relays to reproduce its ten digits, these being operated singly or in combination.

The digit or storing relays are required in quantity in most problems, and accordingly should be as

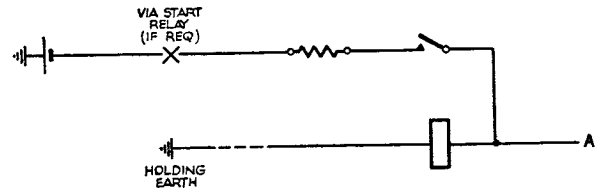

FIG. 1.—STORAGE RELAY.

simple as possible. Fig. 1 shows the unit that will be assumed in all the circuits given later. One make combination is required and the relay can be of a miniature type. The relay is locked via a resistance spool to negative battery in order that it can be controlled over the single wire marked A. Battery potential on this wire operates the relay, and a full earth releases it by short-circuit. When testing the condition of the relay, the operated position of the relay is denoted by battery potential on A. With very slight modification of the circuits, the relay can be replaced by a condenser in a charged or discharged condition.

Binary Computation.

Since the average reader will be unfamiliar with the binary scale, the following examples will show its resemblance to the decimal scale, and illustrate the general procedure.

Addition and subtraction are exceedingly simple, the process being column by column, and 2 in any column is carried as 1 into the next. For example, adding 85 (1010101) to 37 (100101),

$$\begin{array}{r} 1010101 = 85 \\ 100101 = 37 \\ \hline 1111010 = 122 \end{array}$$

Reversing the operation to illustrate subtraction,

$$\begin{array}{r} 1111010 = 122 \\ 100101 = 37 \\ \hline 1010101 = 85 \end{array}$$

Similarly in multiplication, the multiplicand is operated on digit by digit of the multiplier, and the results added.

The division process is also identical to the decimal equivalent, e.g.

$$\begin{array}{r} (85) \quad (3,145) \quad (37) \\ 1010101 \overline{) 110001001001} \quad (100101) \\ \underline{1010101} \\ 1101010 \\ \underline{1010101} \\ 1010101 \\ \underline{1010101} \\ 1010101 \end{array}$$

It should be noted that in division the sequence is from highest units to lowest, whereas, in addition, subtraction and multiplication the operations are conducted in the reverse order.

Addition Circuit.

This is shown in Fig. 2. The two numbers, set up on relays, are connected to the banks of the unselector at A and B. The relay on any contact

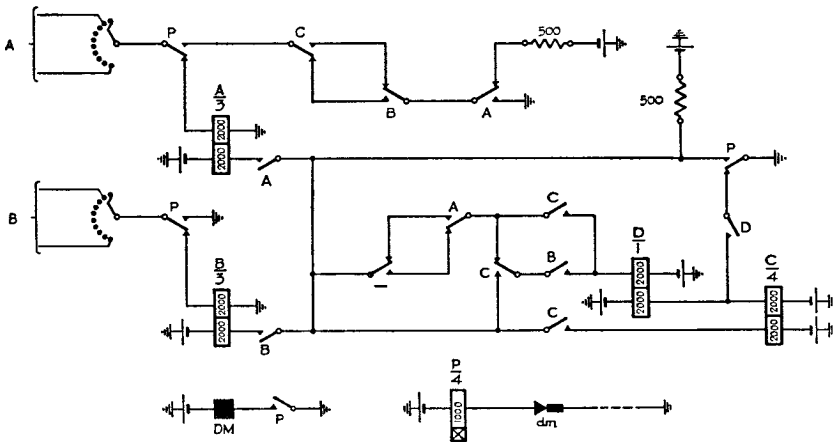

FIG. 2.—BINARY ADDITION AND SUBTRACTION CIRCUIT.

represents double the value of the relay on the preceding contact, i.e. the power of the implied radix increases as the wipers step.

The stepping is caused by the inter-action of relay P and the driving magnet, and on each contact the action may be divided into two stages. The wipers reach the contact with relay P normal, and relays A and B are set up according to the conditions already existing on the contacts. Relay C has already been set according to whether there has been a carry forward from the preceding contact.

When relay P operates, the relays on the bank are re-set. B is in all cases released since its value has been transferred to A. If relays B and C are both

released, or both operated, the relay on A is unaltered, but if either B or C is operated the relay on A is reversed, i.e. operated if it were already normal and vice versa. Relay D is operated if any two of relays A, B and C are energised. When P releases, the wipers step on to the next contact, and the condition of relay D is transferred to C.

The action on this contact is repeated exactly as on the preceding contact and it will be apparent that the number set up on B is progressively added to that on A. Since B is cleared down each cycle, a new number can be set up, and a series of numbers accumulated on A.

The changeover contact marked (—) is covered in the next section. The resistance across the P locking contact gives the relays a slight release lag to cover the transit period of relay P. If the locking resistors on the B storage relays are taken to the battery via a common pilot relay, this can be used as a start condition, and since the action is completed when all the B relays are normal, the pilot relay would then stop the cycle, and provide a self-interrupted drive for the unselector to return to the home position.

Subtraction Circuit.

If the change-over combination marked (—) is moved to an operated position, Fig. 2 will now function to subtract number B from number A.

Provided the number of storage relays fitted on bank A is in excess of that required on an actual problem, a negative condition presents no difficulty. In this case, all the later relays would be in an operated condition, and the energisation of the last relay could give an indication of a negative result. If, due to a further addition, the result becomes positive, the later relays are cleared down and the correct result given. In this manner the circuit can be used for mixed additions and subtractions, even though the result on A varies between negative and positive values.

Multiplication Circuit.

The physical reproduction again follows closely the written method; the multiplication proceeds digit by digit, and the results are summed. The circuit is shown in Fig. 3, where the numbers whose product is required are connected to banks A2 and B1 and the product is given on bank A1.

The best way to study the operation of this circuit is by means of an example, say, 37 on A2 and any number on B1. 37 is 32 + 4 + 1, or written in the binary scale 100101, hence operated relays will be located on the 6th, 3rd and 1st contacts of bank A2. These relays would be fed via a pilot as described earlier, and this would start the operation of the circuit. Since a storage relay is energised on the home contact of A2, relay SW will be operated and both unselectors will step forward together. When

P operates, the relay on the home contact is shunted down. On the second contact ON energises and disconnects bank A2 which plays no further part in this cycle. Banks A1 and B1 and the remainder of the circuit function exactly as the addition circuit,

Division.

This can be built up from two uniselectors with wiper displacement as for multiplication. This time, however, the wiper of B starts several steps in front of the wiper of A, and loses a step in the

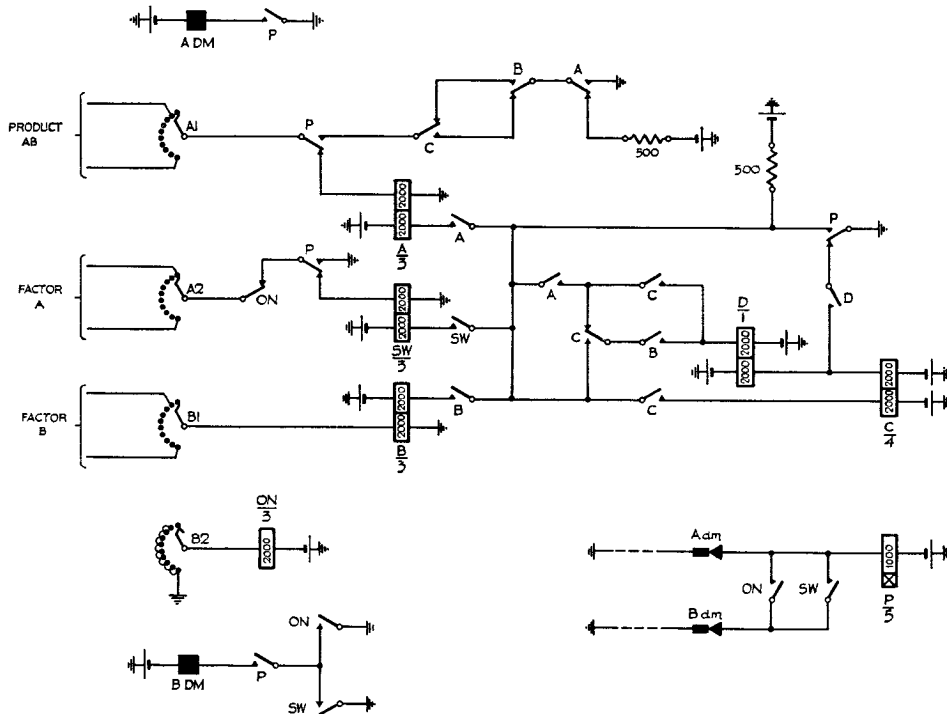

FIG. 3.—BINARY MULTIPLICATION CIRCUIT.

Fig. 2. The number on B1 is virtually multiplied by 1, and set up on A1. When the uniselectors reach the home position, relay ON releases and breaks the stepping circuit of uniselector B, since relay SW is now normal. Uniselector A continues to step until the third contact is reached. At this point SW re-operates (due to the operated relay on the third contact of A2) and completes a circuit for uniselector B to move off home.

Relay ON again operates and the two uniselectors step together, but this time the wiper of A is two contacts in front of the wiper of B. Hence, when this additive cycle takes place, a relay representing "1" on B1 is added to A1 as "4"; "2" as "8," etc. Thus the number on B1 is multiplied by 4 and added to A1. The number on A1 is now 5 times B1.

When uniselector B reaches its home position, relay ON releases, and this time A steps alone until the 6th contact. Here, relay SW is operated and causes uniselector B to step as previously described. Uniselector A is now 5 contacts in front of B, and multiplies the number on B1 by 32 and adds this on to A1. The total on A1 is now 37 times the number on B1 and since all the relays connected to A2 have been released the operation ceases.

Fractions can be handled on this circuit provided the binary (equivalent of decimal) point is placed in the same position on banks A2 and B1.

home position every cycle. The number on B1 is subtracted from A1 and this leads to an apparent difficulty; the circuit will carry out the subtraction even in those cases where "it won't go." This difficulty can be overcome as follows:—Carry out the cycle in all cases, and where this leads to a negative result on A1 set up "0" in the quotient. Displace the wipers as usual and carry on to the next cycle, but make this an additive process. If this brings A1 positive, set up "1" in the result and subtract on the next cycle. If the result is still negative, set up "0" and continue to add. The correctness of this process can be demonstrated by working through some examples and it enables division to proceed as a straight cycle without any "trial" attempts.

CIRCUITS FOR OTHER SCALES

General.

Circuits for other scales can largely follow the methods given in the preceding section, the only difference being in complexity, since more than one relay is required to express each digit. When the normal computation method proceeds digit by digit, the circuit to simulate this can be built up quite readily and the result incorporated into the main total by the arrangement given in the next section. Failing this, circuits can be designed for converting any number into the binary scale, carrying out the

necessary manipulation, and then re-converting to the original scale.

Addition and Subtraction.

The particular combination of relays used to represent any digit is usually immaterial to the problem and often the cheapest and most convenient method is to use the binary code within each digit. Then the operation can follow the binary process and it is only necessary to carry out a correction between digits.

An example of this method of attack is shown in Fig. 4, which adds, in a direct manner, numbers expressed in the ordinary or decimal scale. Four relays, designated W, X, Y and Z, are used to express each digit, and the combinations used are shown on the diagram. The operation on any digit, occupying the first four of each five contacts on the uniselector, follows Fig. 2 exactly, but on the fifth contact relay

though not the most convenient, is shown on B.P.O. Diagram AT. 4356. Uniselectors C and D would be located by the received digits and the result given on the bank wiring of D. The quickest arrangement would be to use a selector of the cross-bar type and feed one digit on to the "row" magnets and the other on to the "column" magnets. The result could be taken off directly in code from the intersecting, operated spring combination. This would be in the form of one or two digits and would be added into the main total by a circuit as shown in Fig. 4. In this way a high-speed multiplication circuit can be built up since the lay-out of these problems presents no difficulty.

Division.

The methods detailed in this article break down in this case, since long division does not proceed digit by digit, but involves the complete divisor at each

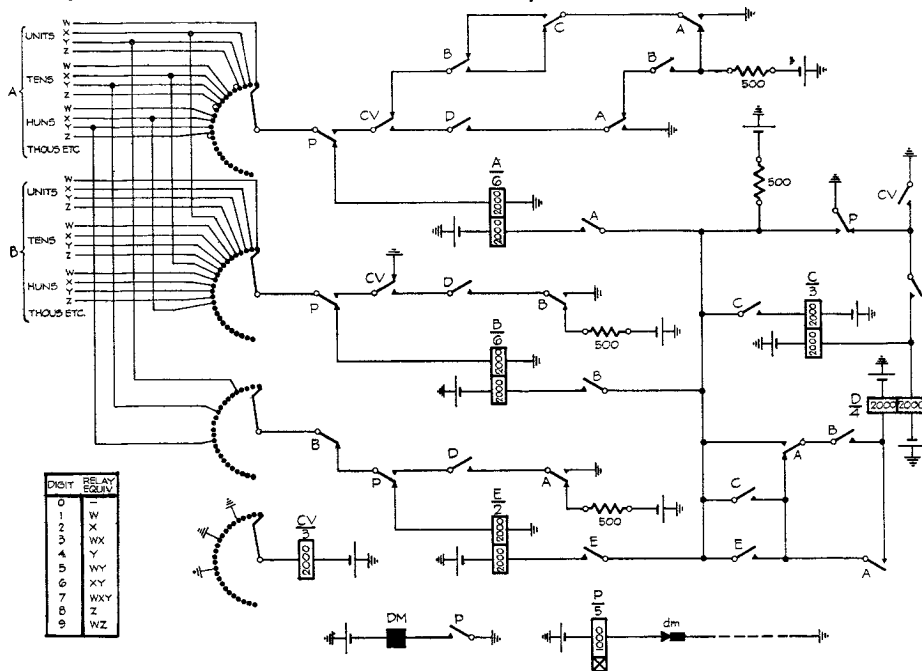

FIG. 4—DECIMAL ADDITION.

CV energises to perform the necessary correction. The circuit ensures that any "carry-over" to the next digit is equivalent to 10, any difference being fed back to the digit preceding.

A full description of all the possibilities of this circuit is somewhat lengthy, and the operation can be deduced quite readily by working through an example. If two numbers are set up on banks A and B respectively, it will be seen that after one cycle of the uniselector, the number on B is cleared down and its value added on to A.

The equivalent subtraction circuit can be evolved without difficulty, and uses almost the identical contact arrangements.

Multiplication.

A circuit for multiplying two digits can be achieved using relays and two uniselectors. One method,

stage. Conversion to the binary scale is feasible but slow, and it seems necessary to recourse to approximation methods adapted to each particular problem. In one practical case encountered, a circuit was evolved for conversion of a number to its logarithm, expressed in the binary scale, subtracting by the Fig. 2 circuit and then re-converting to the decimal scale. The complexity, however, was such as to render the arrangement inferior to mechanical methods based on levers and cams.

A PRACTICAL APPLICATION.

Time Measurement.

A very wide field was available from which to select an example of the practical application of these principles. Time measurement has been chosen because it is a problem frequently encountered, and

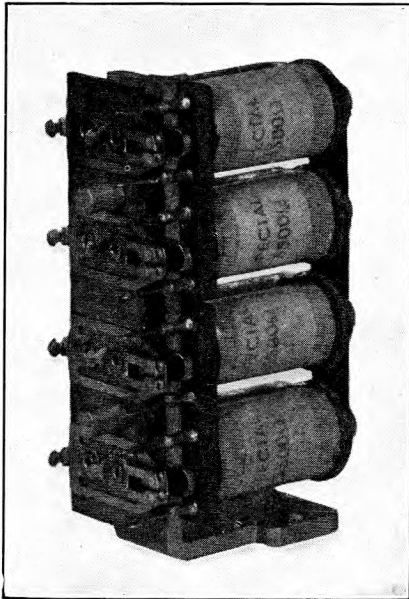

FIG. 5.—TYPICAL GROUP OF STORAGE RELAYS.

For time measurement, two things are required :

- (a) A counting circuit.
- (b) A time unit.

The Counting Circuit.

These circuits involve a visual or written display and, therefore, to avoid conversion, the decimal scale is used. Four relays are required at each digit stage, but the requirements of these are extremely simple, an operating coil and a single make contact. They can be made quite small, and four units have been combined on a single mounting to provide a complete digit storing device.

A typical group is shown in Fig. 5, which has been designed to mount in a single 3,000 type relay space. The four relays are electrically independent, being operated singly or in pairs, each combination representing one of the integers of the decimal scale.

These relays are connected to the banks of the counting circuit shown in Fig. 6. The wipers arrive on a contact with PR normal and relays W, X, Y and Z are set in accordance with the storage relays on the bank contacts. Relays P and PR operate from the driving pulse, lock W, X, Y or Z and extend potentials on to the controlling wires, which reset the storage relays to the combination representing

one that is likely to be of direct interest to all telephone engineers.

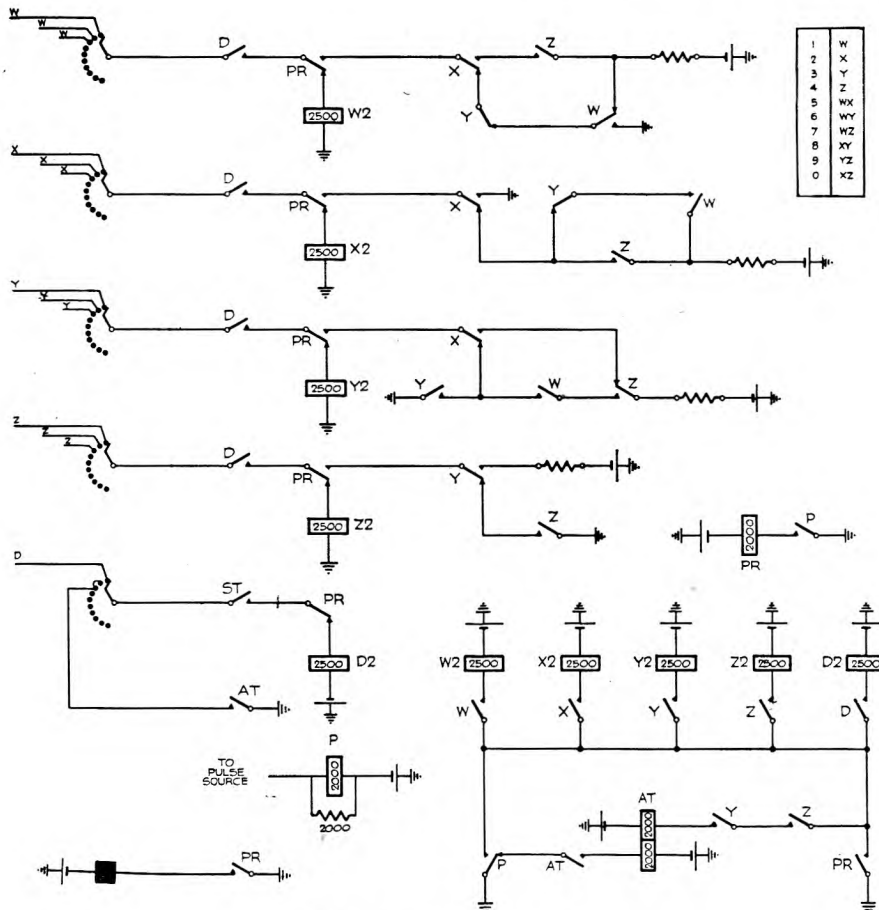

FIG. 6.—COUNTING CIRCUIT.

(NOTE: W2, X2, etc., indicates that the relay has two windings.)

the next integer. PR also energises the uniselector magnet to step the wipers around the bank.

It will be apparent that the operation is ineffective unless D contacts are closed. In the first, or units position, relay D is energised via the D wire and bank, this being the external control for the circuit. On subsequent contacts, relay D is energised by relay AT, which responds to combination "Y + Z," i.e. the digit "9." When this integer is received, the storage relays are set to "0," and "1" is carried to the next digit. Relay AT is locked from normal contacts of relay P and is thus maintained on to the bank contact subsequent to that on which it was operated. Here it energises D relay, and causes the addition of "1" as required. An electrical equivalent of the Veeder principle is thus obtained.

If all the uniselector bank is allocated to one circuit, with a storage relay on each of the 25 contacts, and if this combination is used to count 6-second periods as described later, the total time measuring capacity, i.e. 6×10^{25} seconds, or 2×10^{18} years,

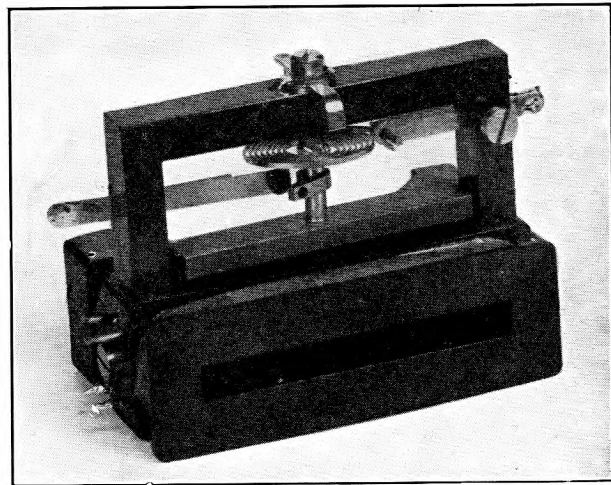

FIG. 7.—GALVANOMETER RELAY.

gives a fairly good approximation to eternity. It is, therefore, possible to connect several counting sets to the banks of the uniselector, i.e. one counting circuit can serve a number of individual conversational circuits, the counting on each being completely independent.

The apparatus involved on a connection is, therefore, limited to the storage relays, and the counting circuit caters for 8, 12 or 25 trunks, according to whether 3, 2 or 1 storage group is fitted per circuit.

The uniselector wipers move at a steady speed over all the individual circuits, but unless an earth is received on the D bank, no action takes place. If, however, the circuit is in an operative, e.g. a talking condition, this is indicated by the earth on D, and one unit is added to the storage count at each rotation.

The Time Unit.

The length of this unit is governed by two opposing factors. It must not be too long, otherwise the timing is inaccurate, since the counting circuit, working in integers, can introduce an error whose maximum is equal to the unit employed. If the unit is small, the counting circuit becomes complicated and expensive due to the large number of units involved. A compromise value of the order of 6 to 15 secs. is usually adopted.

The wipers must be connected to each of the individual circuits at fixed time intervals to increase the reading by one unit. A convenient way of achieving this is to provide a relay-interrupted drive to the uniselector, so adjusted that the time taken for a complete cycle is somewhat less than the required time interval. The wipers then rest on the home contact until a start pulse is received from the exchange clock. These clocks, however, are expensive items to instal in small exchanges and it is advantageous to have a self-contained timing mechanism that avoids their use.

Such an item is already available in the galvanometer relay that has been extensively used in the "Rythmatic" system of remote switching. This is shown in Fig. 7 and consists of a pair of cobalt steel magnets pivoted on a common shaft to form an astatic combination. One of the magnets is almost completely enclosed by a pair of deflection coils. The periodic time is controlled by a spiral hair spring as in a clock mechanism, various thicknesses of spring being used to provide differing oscillation times. Jewel bearings are used, ensuring extremely long life and absence of friction. A robust silver contact, arranged to close at the end of the swing, is connected to an interrupter relay, which extends the pulses to the controlled circuit and also passes a current impulse through the deflection coils in order to maintain the oscillation.

Extensive tests indicate that the maximum error under normal exchange conditions is of the order of ± 1 per cent. This amounts to a couple of seconds in a three-minute call and is, therefore, well within the usual commercial tolerances.

The Unit Bay 1B Coaxial Cable Transmission System

R. A. BROCKBANK, Ph.D., B.Sc., A.M.I.E.E., and
C. F. FLOYD, M.A., A.M.I.E.E.

U.D.C. 621.395.44

Part 4.—The Installation and Operation of Unit Bay 1B Systems

In the previous three parts the complete repeater system and its terminal repeater bays have been described. The fourth, and last, article describes installation and maintenance procedure.

INSTALLATION OF SYSTEMS

Installation of Equipment.

VARIOUS non-standard repeater systems have been built during the war to meet urgent traffic requirements with the minimum amount of equipment. Because of these conditions it was necessary for the complete installation, lining-up, testing and final responsibility for their working to be undertaken by laboratory staff. With the introduction of the standard Unit Bay 1B, and as a result of the experience gained during the provision of these earlier routes it has become possible for these duties to be undertaken by the P.O. staffs normally concerned with transmission installations. In future, Unit Bays will arrive on site complete and will already have been fully tested. The bays will then be installed by Regional staff, who will make the necessary connection of coaxial tubes, telephone pairs and power leads.

Testing and Lining-up.

A standard Unit Bay 1B Repeater System is lined-up in the following order:

- (a) A.C. power is connected at each power feeding station and the voltages at the dependent stations are adjusted to the specified values.
- (b) The general operation of each bay is checked.
- (c) The supervisory circuits are lined-up.
- (d) The H.F. circuits are lined-up.
- (e) The necessary sub-equalisers are fitted and the operation of the control and supervisory equipment is checked.

Stages (c), (d) and (e) require co-operation between the terminals and each station on the route in turn.

Overall Acceptance Tests.

Acceptance tests are now conducted to obtain the performance of the wideband transmission path.

(a) Overall measurements are made on the H.F. circuits in both directions of transmission: these include attenuation frequency response, harmonic production, overload characteristics, crosstalk between "go" and "return" and noise.

(b) All ancillary equipment at each station is checked and tests are made to see that the correct fault indications are received at the control terminal for various fault or operating conditions on the route. The most important test results in each bay are recorded in a framed table at each station for reference during maintenance.

After the repeater system has passed its acceptance

tests it is connected at each end to the terminal translating equipment so that overall circuit tests can be made.

OPERATION IN SERVICE

Maintenance.

Experience has shown that repeater equipment which has been properly designed, manufactured and inspected gives more reliable service if it is allowed to work undisturbed than if it is subjected to frequent routine maintenance testing. An annual maintenance routine only has therefore been instituted at intermediate repeater stations and, when once a system has been passed into service, no additional attention beyond fault repair should be necessary.

The overall performance of the H.F. path is logged regularly at the terminals, where various daily, weekly and monthly readings are called for. At the intermediate repeater stations monthly visits for superficial inspection only are advisable. An important item in the annual routine examination concerns the valves: all valves in the H.F. repeaters are replaced by new stock, but the valves in the remainder of the equipment are tested and replaced as necessary.

Fault Procedure.

The staff at the control terminal are advised immediately by the alarm system or by traffic control of any fault condition on the system, and they should generally be able to identify the type of fault and its location. The Regional maintenance officer concerned is then advised directly and he immediately visits the station. Spare equipment, often in the form of a complete bay, is held at not less than one strategic point on the route so that the speedy replacement of any faulty panel or component is assured. The Regional and terminal staff should work in close contact via the speaker circuit and the wider experience of the control terminal engineer—who is nominally in charge—is then available for special maintenance. He is also responsible for testing the system before handing it back into service.

If the fault is found to be in a section of cable the Regional staff undertake the location and repair.

TEST EQUIPMENT

High-frequency testing of coaxial repeater equipment is required for:—

- (a) adjustment and testing during inspection at manufacturer's works;

- (b) testing and lining-up the overall system during installation; and
- (c) routine maintenance and fault repair during service.

In this article attention will be concentrated on (c), for which the H.F. Transmission Measuring Set (H.F.T.M.S.) (Fig. 1) has been specifically designed.



FIG. 1.—H.F. TRANSMISSION MEASURING SET.

Tester WL 56265.

A design for a H.F.T.M.S. was put in hand several years ago so that models could be well tested in the field before large scale manufacture commenced. The complete set, contained in a single case, is known as Tester WL 56265 and sufficient are now becoming available for all routes to be equipped. It consists of :

- (1) A seven-frequency oscillator with an output variable in 10 db. steps from zero to -50 db. relative to 1mW in 75 Ω . The source impedance is 75 Ω .
- (2) A receiving element capable of measuring terminated-levels from -41 to +31 db., through-levels from -21 to +31 db., and in conjunction with (1) gains up to 81 db. and losses up to 41 db. The levels are with reference to 1mW in 75 Ω .

The set is self-calibrating, as the characteristics of the receiving element, which includes a negative feedback amplifier, remain constant under all normal operating conditions. The receive levels are measured on three dials calibrated in tens, units and tenths of a db. respectively. Filters are incorporated for measuring either the 300 kc/s or upper frequency pilot in the presence of traffic signals and there are facilities for using an external oscillator.

The tester weighs 32 lbs. complete and operates from the 250 V D.C. and 4 V A.C sockets provided on the Unit Bay. The accuracy of the tester is ± 0.2 db. for level measurements and for small gains and losses, but towards the limit of measurement the error may increase to ± 0.5 db. This instrument is also used for many of the tests required in (a) and (b) above.

For routine maintenance purposes two other test panels are provided on each Unit Bay—the Valve Test Panel and the L.F. and D.C. Test Panel.

Valve Test Panel.

The valve to be tested is inserted in the panel test position and with a fixed bias voltage the anode current and mutual conductance is measured. The latter is indicated from the output voltage when about 0.25 V at 50 c/s is applied to the grid. Only one type of valve, the VT.150 is used on the Unit Bay.

Test Panel W4/112.

This panel has measuring ranges of 3, 30, 300 and 3,000 mA and 300 V D.C. and the input lead can be plugged into the various test positions provided on the equipment. A low-frequency voltmeter is also included with ranges of 1.0 and 5.0 V.

FAULT LIABILITY OF SYSTEMS

In the design of equipment for the early experimental routes it was difficult to decide which components or portions of the equipment would prove to be most susceptible to breakdown under normal operating conditions. It was concluded that the H.F. repeaters would have to be provided with standbys, but it was considered that with due care in design, manufacture and inspection it should be possible to obtain a high degree of reliability in the remainder of the equipment. Experience on these and more recent systems installed during the war has not appreciably modified the early views. Analyses of fault returns show that at the moment there is an approximately equal division of traffic interruption time between cables, power supplies and repeater equipment. Faults in the main/standby repeater combination are now very rare and the facility introduced on the Unit Bay of being able to switch main or standby repeaters to any station from the control terminal has proved to be most valuable in giving an immediate check on any repeater for gain, intermodulation or, in particular, noise without interfering with traffic. Inferior cable jointing on the earlier cables is still a source of trouble and it may be some time before the weaker joints are replaced by the stronger modern joint. The reliability of the power supplies has not improved since the war to the extent envisaged, so that power-changeovers from the mains to the standby engine set are comparatively frequent, but not, at present, completely reliable.

An analysis of all the factors contributing to the fault records of coaxial systems is continuously under review and the rate of progress which has been made since the first London—Birmingham experiment in improving the reliability of coaxial systems promises to be maintained.

U.D.C. 621.318.5

One of the requirements occasioned by the war was for small, light-weight, telephone type relays of reliable performance which would withstand extremely severe conditions of use. The author describes the relays produced to meet these needs.

Introduction

THE requirements of airborne and parachute troops, carrier aircraft and advanced infantry units in jungle country, in addition to the need for greater compactness in army vehicles, small naval craft, mines and a host of other war machines, made it imperative to reduce the size and weight of radio and telecommunication equipment for the fighting services. To assist in this task of miniaturisation the Inter-Service Miniature Components Sub-Committee (I.S.M.C.S.C.), a sub-committee of the Inter-Service Components Technical Committee, was set up. Relays were among the components to receive special consideration and the Inter-Service Component Manufacturers' Council was approached with a view to the development, in collaboration with the I.S.M.C.S.C., of miniature relays to replace, so far as possible, the existing telephone equipment types for miniature equipment.

The Council allocated the work to its Relay Panel, which consisted of representatives of the British telephone manufacturers. After preliminary discussion of the requirements this Panel decided that the work fell into two distinct sections, viz. :—

- (a) General Purpose Relays.
- (b) High Speed Relays.

and could be conveniently handled by two manufacturers so as to share the load and thus expedite completion.

The work of development for the general purpose relays was allocated by the Panel to the General Electric Co., Ltd., and the high speed type to Messrs. Siemens Brothers & Co., Ltd. At the request of the I.S.M.C.S.C. the G.P.O. furnished an officer experienced in relay design work to act as liaison with the manufacturers' designers.

The severe conditions under which Service components were required to function presented many new and difficult problems for relay designers. The relays were required to function satisfactorily over a voltage range of ± 20 per cent. from nominal, a temperature range of -40°C. to $+100^{\circ}\text{C.}$ and an air pressure range of 1,500 mm. to 120 mm. of mercury, equivalent to an altitude of below sea level to 40,000 ft. They should not be adversely affected by immersion in 3 ft. of water, by salt spray, dust clouds, accelerative forces of 9 g, shocks of 12 g or vibrations of $\cdot 002$ in. at frequencies varying from 10 to 100 cycles per second.

An exceptionally good tropical test performance was required, the rate of change of temperature catered for being 2°C. to 3°C. per minute and the rate of change of air pressure of 10 mm. of mercury per second. The combination of these changes and high humidities produces condensation to the point of saturation on the surfaces of the relay.

Sealing of Relays

One of the best ways of ensuring that the relay would withstand the above conditions was to seal the relay hermetically. There were differences of opinion as to whether the relay or the set in which the relay was used should be sealed. It is not always practicable to seal sets, e.g. because of forced cooling, and it is also required that spares (a certain number of spare components are generally ordered for servicing sets) should be sealed during transport to, and storage in, any part of the world. The relay manufacturers were therefore requested to seal individually each relay.

The technique of glass to metal sealing in the manner required for relays was at this time in the very early stages of development, whereas compressed or sandwiched rubber seals, similar to those mentioned later, had achieved some measure of success. The I.S.M.C.S.C. therefore suggested that rubber type seals be employed if no better method had been found.

The anticipated possible repercussions due to sealing the relays were :—

- (a) Increase in temperature.
- (b) Enclosure of sparking contacts in a damp atmosphere would result in production of nitric acid.
- (c) Evolution of organic vapours from insulating materials and finishes and their combustion by sparking contacts would result in severe pitting of the contacts and coating with carbon deposit.

With regard to (a) the additional temperature rise due to enclosure was expected to be very small in comparison with the normal temperature rise of the relay due to operation. The amount of nitric acid likely to be produced was considered to be unimportant, but did indicate the need for having dry air in the relay case. The pitting of contacts and deposit of carbon was considered to be a real danger and to counteract this and at the same time obtain temperature stability it was stressed that all materials used should be inert and suitably cured. Ceramics were favoured wherever possible.

Important factors which had to be borne in mind when considering the seal were the external surface distance between terminal pins, the separating surface material and type of surface. These now became potential points of weakness when the relay was subjected to high humidities.

It is well known that one of the contact materials least affected by vapours and oxidation is platinum. For this reason it is also a good material to use for contacts carrying speech currents when there is no D.C. potential present. Platinum contacts are used for all miniature relays where currents up to one ampere are carried.

Types of Relays Required

The types of miniature relays required for operation on 1.2V, 6V, 12V, 24V and 48V together with their contact actions and ratings were as follows:—

- (a) Normal relays (G.E.C.) with 1C, 2C, 2C2K or 4C contact units¹, the contacts to be capable of carrying 1A at 12V, 100mA at 300V. D.C., or 100mA at 250V A.C.
- (b) Low loss, low capacitance relays (G.E.C.) with 2C contact units, the capacitance of spring to spring or of spring to case or relay frame not to exceed 4 pF at 1 Mc/s; the springs and contacts to be capable of handling 100 mA at 50V at a frequency of 300 Mc/s as well as 1A at 12V D.C.
- (c) Heavy duty relays (G.E.C.) with 1C contact units, the contacts to be capable of carrying 10A at 12V. After preliminary investigation the contact current rating was reduced to 4A and the contact units changed to 1M1B (equivalent to 1C), 2M or 2M2B.
- (d) High speed relays (S.B.) with 1C contact unit, the contacts to be capable of carrying 0.5A at 50V; the relays to operate at a speed of 150 w.p.m. (i.e. 120 bauds at a maximum of 20 per cent. distortion). This speed was subsequently reduced to 116 w.p.m. (i.e. 93 bauds at 20 per cent. distortion).

The original target figure for the operating power of the relays was 100 mW, but this was increased to cover relays having the maximum number of contact units which might be adjusted to the upper limit of the adjustment range. The relays were initially required to be of the plug-in type, but this requirement was subsequently waived to simplify and expedite production.

Normal Relay (G.E.C.)

The general construction of the relay without the seal is shown in Figs. 1 and 2. The magnetic circuit may appear rather generous for the size of the relay, but is necessary to approach the required sensitivity. The armature is not pivoted in the usual manner, but is fixed to two $\frac{3}{16}$ in. wide hinge springs clamped between the yoke and spring-set. No residual stud is provided as the armature fixing springs exert a restoring force on the armature. An extension of the armature carries a moulded armature block which lifts the lever springs when the armature is operated, thus eliminating lifting pins, bushes, etc. An armature ratio of approximately 3 to 1 is obtained. There is a slight clearance between the armature block and lever springs when the armature is unoperated. The lever springs are tensioned against the thick break springs and the make springs are tensioned

against shoulders on distance pieces fixed into the break springs. When the relay is operated the make spring is moved away by the lever spring from its supporting shoulder on the distance piece. As the relay is sealed and therefore free from normal dust troubles, single contacts are fitted to the springs. Although of different construction the principle of independent spring supports and spring clearances, as given by the buffer block on the P.O. 3,000 type relay, is provided. The spring tensions and contact clearances are the same as for the 3,000 type relay.

Five unsealed relays having 2C contact units for each of the voltages 1.2V, 6V, 12V, and 48V were tested by the P.O. Circuit Laboratory in comparison with equivalent general purpose 600 type and 3,000 type tropical relays, with the following results:—

- (a) The miniature relay operates in approximately 40 per cent. of the time for the 3,000 type relay and 60 per cent. of the time for the 600 type relay. (It should be pointed out that by suitable combination of parts and of adjustments the 3,000 type relay can be made much faster than the miniature relay.)

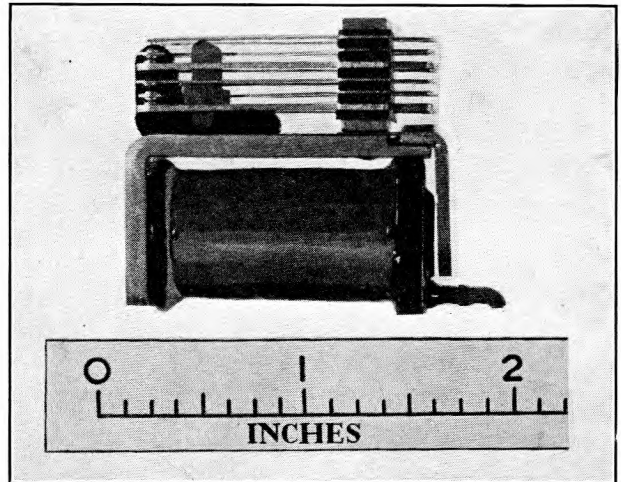

FIG. 1.—NORMAL RELAY (G.E.C.) WITHOUT SEAL.

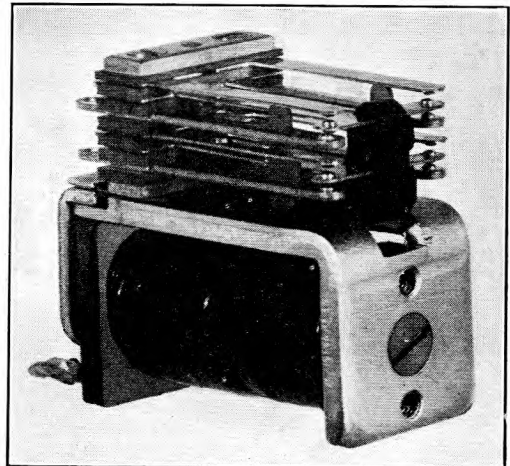

FIG. 2.—ANOTHER VIEW OF RELAY SHOWN IN FIG. 1.

¹ C = change-over, K = make-before-break change-over, B = break, M = make.

- (b) The 3,000 type relay is the most sensitive of the three and the miniature relay the least sensitive, though this is not always a disadvantage. Approximate average wattages for the relays in average adjustment are 3,000 type relay 66 mW, 600 type relay 83 mW and miniature relay 86 mW. When the relays are fitted with 4C contact units the miniature relay is slightly more sensitive than the corresponding 600 type.
- (c) Although the miniature relay has less contact bounce than the 600 type relay but more contact bounce than the 3,000 type relay, the total duration of the contact bounce of the miniature relay is less than either of the other two.

The above results are based on the mean of tests of the relays in their respective adverse adjustments.

Fig. 3 shows the sealed relay with fixing lugs and Fig. 4 a cut-away view of the sealing arrangement. The present seal consists of a bakelite terminal plate which clamps a rubber gasket to the surrounding metal frame. The gasket is placed under pressure when the surrounding metal frame is soldered to the

relay case. Each terminal pin, consisting of a shouldered tube, has an individual rubber gasket which is compressed when the terminal pin is spun over on to the terminal plate. The terminating wires are passed through the pins and soldered with high melting point solder. The bare terminating wires are covered with insulating sleeving when wired into the equipment.

The magnet coil and bakelite insulating parts are thoroughly dried out and cured before assembly into the relay. After assembly and prior to final sealing the relays are subjected to a high temperature vacuum stoving process, at the conclusion of which dry air is admitted to the oven. When the relays have cooled to room temperature and pressure they are removed from the oven and finally sealed.

The replacement of the compressed rubber seals by ceramic or glass seals is being pursued, but this work has not been allowed to delay the development of the relay.

Low Loss, Low Capacitance Relay (G.E.C.)

As will be seen from Fig. 5, the magnetic circuit of this relay is identical with that used for the miniature normal relay, but there is a slight change in shape of the armature block. A cellular type of spring-set assembly with greater spring separation has been adopted for this design, thus reducing the capacitances and power factor to a minimum. The overall size of the spring-set assembly is a little greater than that of the 4C contact unit unsealed miniature normal relay. It was found that enclosing the relay in a metal case increased the spring capacitance by 1 pF, and a further $\frac{1}{2}$ pF was added by the sealed terminal and internal wiring. It was decided therefore to use the low loss relay unsealed and steps were taken to ensure a good tropical performance from unsealed relays. The power factor of the springs was 0.56 when measured at a frequency of 1 Mc/s and the capacitance between any one spring and all the others connected together and framed (i.e. measured under worst conditions) was 3 pF when measured at a frequency of 30 Mc/s.

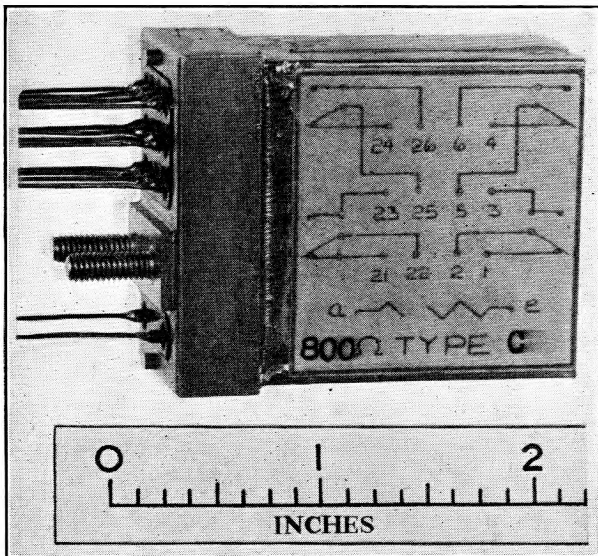

FIG. 3.—NORMAL RELAY (G.E.C.) SEALED AND WITH FIXING LUGS.

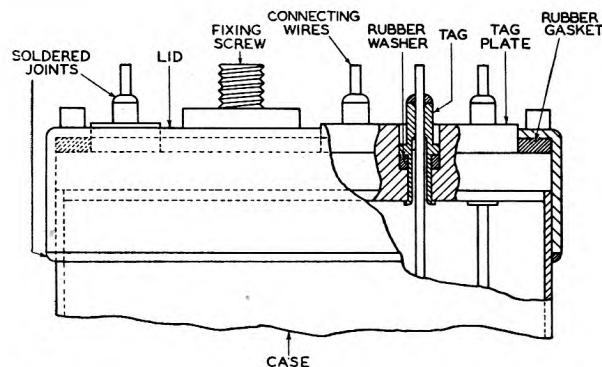

FIG. 4.—SEALING ARRANGEMENTS FOR NORMAL RELAY.

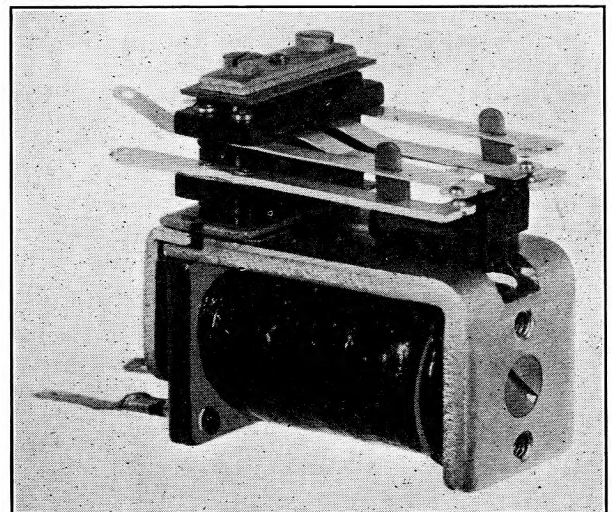

FIG. 5.—LOW LOSS, LOW CAPACITANCE RELAY (G.E.C.)

Heavy Duty Relay (G.E.C.)

In this design the coil, yoke, armature and armature block are the same as the miniature normal relay. The spring-set also is similar, but the nickel silver springs of the normal relay are replaced by phosphor bronze and the platinum contacts by large Elkonite D 56 (sintered silver nickel) contacts. M and B contact units only are used, the lever springs of M contact units being tensioned against the armature block. Samples tested have completed more than three million operations without failure with the contacts carrying a non-inductive load of 4A at 12V D.C.

High Speed Relay (S.B.)

Figs. 6 and 7 show the unsealed relay with the front protection block removed. This relay is covered in this country by British Patent 569268 and by patents applied for overseas. The coils are the same size as used for the major high speed relay and the effective part of the core is of the same dimensions but the "U" shaped core is fixed to the relay frame. The make and break springs are tensioned on to the ceramic supporting studs. Lorival studs were used on the early samples and found to be unstable at 100°C. All three contact springs are clamped by both of the spring-set assembly screws, which have insulating sleeves in addition to the separating insulating washers. The moving spring, to which the armature is fixed by four rivets, is channelled towards the front to give rigidity and has three limbs at the rear, the two outer limbs being clamped by the spring-set screws and the end of the middle

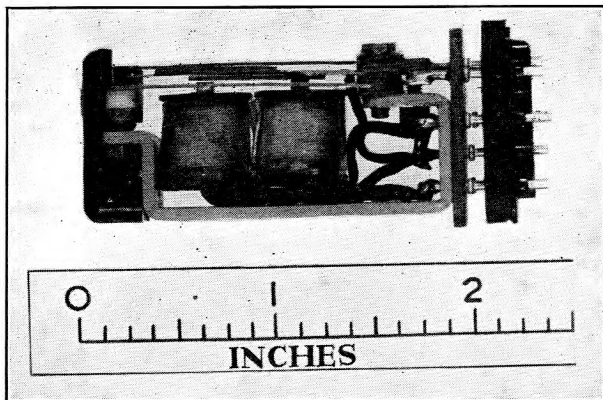

FIG. 6.—HIGH SPEED RELAY (S.B.), UNSEALED.

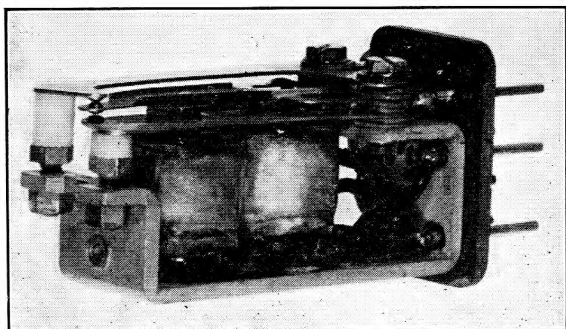

FIG. 7.—ANOTHER VIEW OF RELAY SHOWN IN FIG. 6.

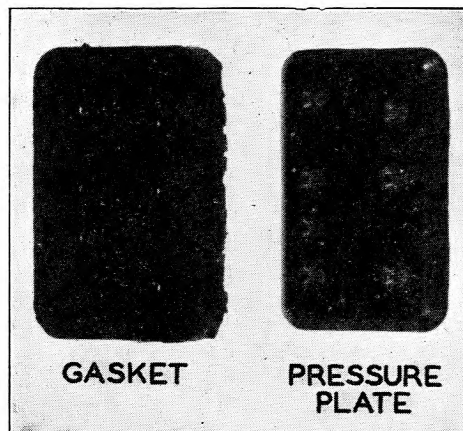

FIG. 8.—MOULDED PERBUNAN SEAL AND BAKELITE PLATE.

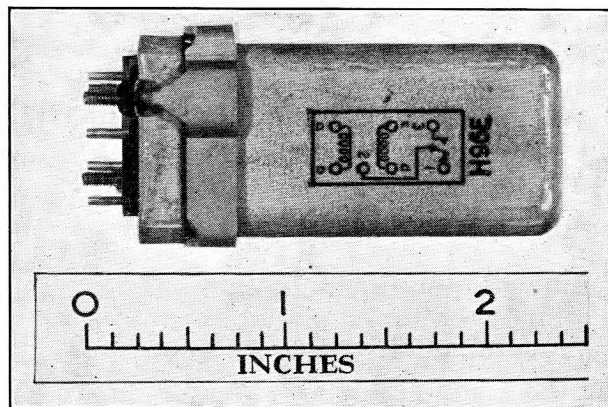

FIG. 9.—HIGH SPEED RELAY (S.B.), SEALED AND WITH CLAMPING RING.

limb, which extends behind the others, is associated with an adjusting screw to give the necessary spring tension against the break (upper) spring. The armature rests against the rear edge of the rear pole face. The contact clearance and lever spring tension are the same as for the major high speed relay.

Unsealed miniature high speed relays were tested in comparison with the major high speed relays. The results indicated that the operating lag of the major high speed relay was 0.5 to 1mS greater than the miniature relay and the releasing lag was also slightly greater. Of ten miniature relays tested six were free from contact bounce. Impulsing tests at 50 operations per second showed slightly less distortion with the miniature relays.

As a result of these tests modifications were made by the manufacturer to the design of the contact springs of the miniature relay and the amount of contact bounce was considerably reduced without adversely affecting any other feature.

Fig. 8 shows the moulded perbunan seal and the outer moulded ribbed bakelite plate. The seal is compressed when the edge of the case is spun over the bakelite plate. The complete relay, with clamping ring for fixing the relay to the chassis, is shown in Fig. 9. After the relay has been assembled and prior to placing in the case it is baked at 100°C. for a minimum of 5 hours. After cooling all screws are

tightened and the relay adjusted and tested. A wrapping of bakelised paper is put round the relay before it is placed in the cover. Prior to pushing the cover home it is passed through an oven at 160°C. for 3 minutes and then the cover is closed down.

Marking of Relays

Due to the closeness of the terminals of the normal relay and the ribbed reinforcement of the outer plate of the high speed relay it was impracticable to mark the terminals. Consequently a diagram, showing the terminal positions and associated internal connections, is stamped on the side of the relay cover, as shown in Figs. 3 and 9.

Maintenance of Relays

It was decided during the early development of the relays that should a relay fail the whole relay

would be replaced and hence the design does not cater for replacement of piece parts or readjustment under service conditions.

Conclusion

The development of miniature relays represents no mean portion of the relay manufacturers' contribution to the war effort. It was carried out at a very difficult stage in the war when shortage of manpower, both technical and manual, was most acute, and while they were struggling to meet the very heavy demands of the Services for increased output. It is to their credit that satisfactory designs were produced in spite of these handicaps. It is also gratifying to note that miniaturisation has been achieved without loss of reliability in the product.

Thanks are due to the General Electric Co. and Messrs. Siemens Bros, for kindly supplying samples to illustrate the article.

Two Methods of Localising Cable Faults

J. M. ALLAN

U.D.C. 621.317.333.4

This article shows how localising difficulties due to transient currents may be overcome. A means of localising a fault when no good wire is available is also described.

Introduction.

IN the Varley test for localising a cable fault, the good pair used is that which has the highest insulation resistance in the same cable. When all the wires are faulty, a good pair in another cable has to be used. It is often found in such circumstances that the Wheatstone bridge is difficult to balance because of varying induced currents in the good and faulty wires.

One method of eliminating the disturbing effects of the currents is by using a differential galvanometer (Galvanometer No. 27A), which has been designed for this purpose. The author has devised a different method of nullifying the disturbing effects of these currents, and it has the advantage that the ordinary type of reflecting galvanometer can be used. Two variable resistance boxes in addition to the one normally incorporated in the bridge are required.

When no good wire in the cable or in any other cable to the distant end is available, then a different test must be employed. The impedance/frequency test, the Poleck test, or that described by G. H. Metson¹ may be used in such a case.

One other test has been used by the author and as far as he knows has not been used elsewhere. Unlike the other tests, this one depends upon there being a certain amount of battery leakage from other circuits to the pair under test. If there is not sufficient leakage then this must be purposely made.

NEW TYPE OF VARLEY TEST

When a Good Wire in another Cable is available

When the Wheatstone bridge is connected to the good and bad wires in the normal way it is often experienced that varying currents originating from the good and bad wires cause the galvanometer

needle to move very irregularly on either side of zero. It is often hopeless to balance the bridge with any degree of accuracy under these conditions.

The varying current in the loop is induced by the transient currents of unbalanced telegraph and signalling circuits. The fluctuating field of the current in tramway rails, etc., which may run parallel to the cable for miles is also a cause. The varying fault resistance contributes in a lesser degree to the disturbing currents. As the wires in one cable are not influenced to the same extent as those in the other, it is not surprising that induced current should appear in the loop.

It has been found that the irregular currents in a loop consisting of the A-wires of the good and bad pairs are identical in direction and strength to those in the loop of the B-wires. Fig. 1 shows how

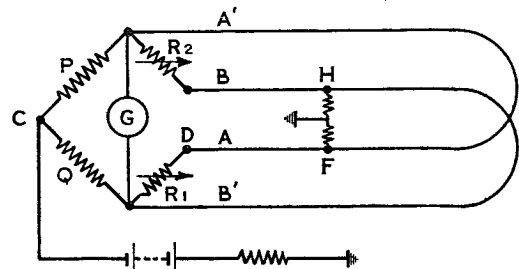

FIG. 1.—A B = FAULTY PAIR.
A' B' = GOOD PAIR IN SEPARATE CABLE.

advantage is taken of this fact in cancelling out the disturbing currents in the bridge galvanometer. The value of R_2 is always made the same as R_1 . To obtain the Varley reading P and Q must be equal and the resistance R_1 and R_2 are adjusted in step until the bridge is balanced. The value of R_1

¹ P.O.E.E.J. Vol. 30, p. 99.

when the bridge is balanced is the Varley reading. As will be seen later from the theory of the test, the insulation resistance of the faulty A-wire should not be identical to that of the B-wire. In practice this condition is easy to comply with, especially in "third-stage" faults. It is also assumed that there are no high resistance faults in any of the conductors.

The Determining of the Faulty Conductor Resistance and the Resistance to the Fault

The disturbing currents prevent the loop resistance of the A-wires from being found with accuracy. The B-wires and R_2 have still to be used to keep the galvanometer needle steady. It will be apparent from Fig. 1 that the loop resistance cannot be found by connecting the battery between points C and D. If the battery were so connected and the bridge balanced, the value of R_1 or R_2 would depend on the fault resistance. The lower the fault resistance the greater would be the difference between R_1 and the true value of the loop. If, however, the fault resistance were as high as 2 megohms, such a connection between points C and D would be permissible.

A method of obtaining the faulty conductor resistance no matter how low the fault resistance may be is shown in Fig. 2.

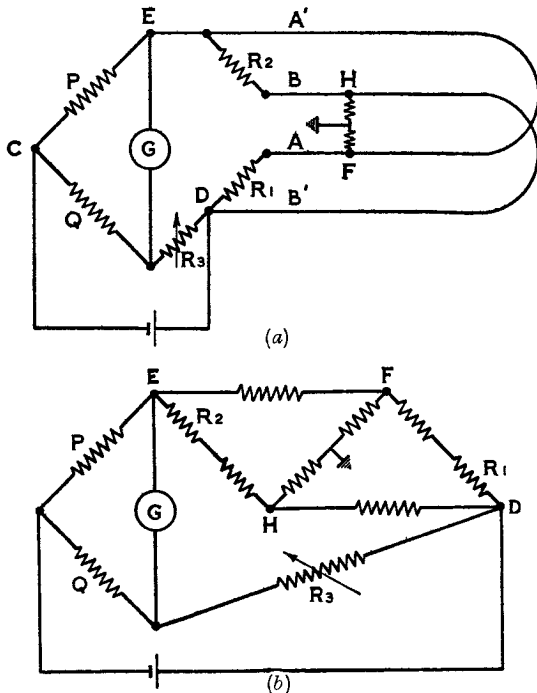

FIG. 2.—A B = FAULTY PAIR.
A'B' = GOOD PAIR IN SEPARATE CABLE.

The resistance boxes R_1 and R_2 are each fixed at the Varley reading. The variable resistance R_3 is adjusted until balance is obtained. In Fig. 2 (b) the resistances R_1 , R_2 and both loops form a network of four equal resistances, namely, EF, FD, DH, and HE. The value of the fault resistance between F and H can have no effect on the balance of the bridge. Even if battery leakage from other faulty circuits produced a P.D. between F and H,

there would still be no P.D. between E and D except that due to the battery of the bridge.

Let V = Varley reading

R_3 = value of variable arm of bridge in Fig. 2 (a).

R_4 = resistance of good conductor.

R_5 = resistance of faulty conductor.

then in Fig. 2 (a) or (b)

$$R_3 = \frac{R_4 + R_5 + V}{2} \text{ since } P = Q$$

$$\therefore R_5 = 2R_3 - (R_4 + V)$$

The loop of the good and bad wires

$$= R_4 + R_5 = 2R_3 - V$$

The resistance to the fault

$$= \frac{2R_3 - V - V}{2}$$

$$= R_3 - V$$

If X = distance to the fault in miles

and L = length of the faulty cable in miles

$$\text{then } X = \frac{(R_3 - V) L}{2R_3 - (R_4 + V)}$$

Theory of New Type of Varley Test

Let the value of R_2 be always made the same as R_1 .

In Fig. 3, N_1 and N_2 are the normal insulation resistances of the good wires, and N_3 and N_4 are the

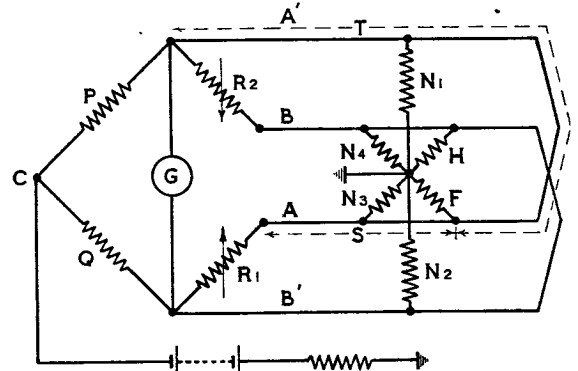

FIG. 3.—AB = FAULTY PAIR.
A'B' = GOOD PAIR IN SEPARATE CABLE.

normal insulation values of the faulty wires. F and H are the fault resistances. Suppose F and H did not exist and $N_1 = N_2$ and $N_3 = N_4$, then it is evident that the bridge would balance for all values of R_1 and R_2 . In practice it is generally possible to choose wires such that $N_1 = N_2$ and $N_3 = N_4$. When faults F and H appear the bridge can only be balanced by one value of R_1 and R_2 . The bridge galvanometer is therefore only influenced by currents flowing through F and H and not by currents through the normal insulation. In such circumstances no "correction factor" is required. It is also evident from Fig. 3 that F and H must have different values. This condition is not difficult to comply with, as an incipient fault tends to affect one wire differently from another.

To prove that F must not be equal to H, let Fig. 3 be represented by Fig. 4 (a). It is assumed that $N_1 = N_2$, $N_3 = N_4$. The normal insulation can therefore be neglected.

The symbols p, q, r, s and t in Fig. 4 (a) represent

conductances corresponding to resistances P, Q, R₁, S and T in Fig. 3. By the star mesh transforma-

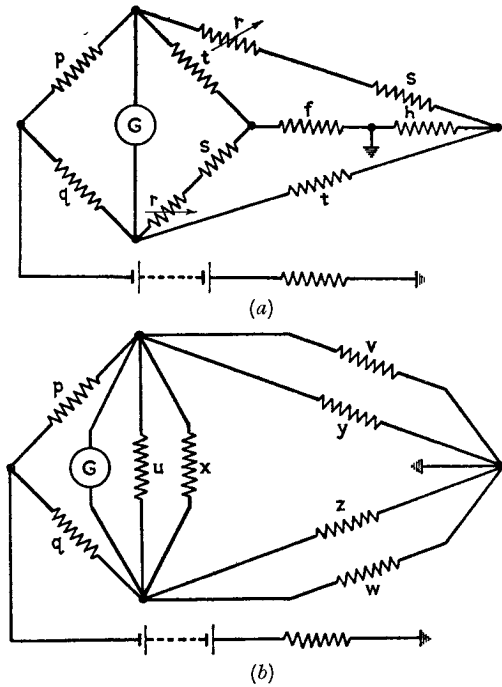

FIG. 4.

tion theorem, Fig. 4 (a) may be represented by Fig 4 (b), where

$$u = \frac{t \frac{rs}{r+s}}{\frac{rs}{r+s} + t + f}, \quad v = \frac{tf}{\frac{rs}{r+s} + t + f}, \quad w = \frac{f \frac{rs}{r+s}}{\frac{rs}{r+s} + t + f}$$

$$x = \frac{t \frac{rs}{r+s}}{\frac{rs}{r+s} + t + h}, \quad y = \frac{h \frac{rs}{r+s}}{\frac{rs}{r+s} + t + h}, \quad z = \frac{th}{\frac{rs}{r+s} + t + h}$$

Balance is obtained when $w + z = y + v$

$$\text{i.e. when } \frac{f\{rs-t(r+s)\}}{rs+(t+f)(r+s)} = \frac{h\{rs-t(r+s)\}}{rs+t(+h)(r+s)}$$

It can be seen from the above equation that balance can be obtained when $f = h$ no matter what the value of r may be. If $f \neq h$ then balance can be found only when $rs = t(r+s)$.

i.e. when $t = \frac{rs}{r+s}$ or resistance $T = R_1 + S$.

This is the condition for balance in the Varley test. The value of R_1 is therefore the Varley reading.

The test begins to suffer from insensitivity when F becomes nearly equal to H (Fig. 3). By careful selection of the faulty pair this handicap can be avoided. When there is a heavy earth fault on a cable, F is always sufficiently different from H. The shunting effect of the conductances u and x (Fig. 4 (b)) on the galvanometer also introduces a certain amount of insensitivity. This disadvantage is far outweighed by the advantage of being able to use the most sensitive type of reflecting galvanometer.

TEST WHEN NO GOOD WIRE IS AVAILABLE

In this test advantage is taken of the fact that in multiple twin or in star-quad cables the wires are maintained in quad formation from one station to the other. If the paper insulation of the cable is wet, then a battery connected to the C and D wires of a quad, as in Fig. 5, will cause a small current to

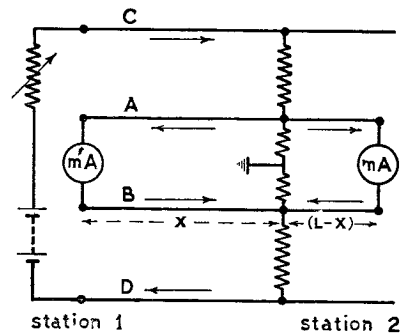

FIG. 5.

circulate in the A and B wires and milliammeters. Before using the milliammeters they should be checked to give identical readings when placed in series.

Let d_1 = deflection in meter at Station 1 at a given instant.

d_2 = deflection in meter at Station 2 at the same instant.

p_1 = length of cable with same loop resistance as meter at Station 1.

p_2 = length of cable with same loop resistance as meter at Station 2.

L = length of cable.

Then distance to fault from Station 1

$$= X = \left\{ \frac{d_2 (L + p_1 + p_2)}{d_1 + d_2} \right\} - p_1$$

It is assumed that the gauge of the A and B wires is uniform between the stations.

This test has the advantage that a large number of pairs of simultaneous readings can be noted to find the mean value of $d_2/(d_1+d_2)$. It has been found that a milliammeter with maximum full scale deflection of 0.5 mA gives the most satisfactory results. The test is not made inaccurate by leakage from other circuits as long as that leakage does not vary rapidly. If sufficient leakage is obtained, then the circuit on the C and D wires is not required.

Conclusion

The first method shows how, by careful selection of the good and faulty wires, a high insulation resistance fault can be localised from one end of the cable only, and without a correction factor. The test has the advantage of saving time in precision testing, and it is hoped that it will be of use to those engaged on this work. Although the second method depends upon two meters being identical, it has the advantage that no slide wire is required. The test, which is more accurate for short cables than for long ones, is useful when other tests become inaccurate because of polarisation and battery leakage.

Notes and Comments

Roll of Honour

The Board of Editors deeply regrets to have to record the deaths of the following members of the Engineering Department :—

While serving with the Armed Forces.

Birmingham Telephone Area	Handy, J. B. ..	Unestablished Skilled Workman	Pilot Officer, R.A.F.
Blackburn Telephone Area ..	Lucas, R. P. ..	Unestablished Skilled Workman	Sergeant, R.A.F.
Bristol Telephone Area ..	Tombs, W. H. ..	Labourer	Pte., Yorks. & Lancs. Regt.
Cambridge Telephone Area ..	Metcalfe, A. A. C.	Skilled Workman, Class II ..	L/Corporal, Royal Signals
Cardiff Telephone Area ..	Jenkins, R. S. ..	Skilled Workman, Class I ..	Major, Royal Signals
Engineering Department ..	Dooner, E. ..	Labourer	Corporal, R.A.S.C.
Engineering Department ..	Glaysher, V. R. ..	Unestablished Skilled Workman	Flight Sergeant, R.A.F.
Engineering Department ..	Higgins, W. ..	Unestablished Skilled Workman	Flight Sergeant, R.A.F.
Engineering Department ..	Meigh, T. D. ..	Unestablished Skilled Workman	Flight Sergeant, R.A.F.
Engineering Department ..	Wooll, C. W. ..	Cleaner	Corporal, Suffolk Regiment
Glasgow Telephone Area ..	Griffin, G. ..	Unestablished Skilled Workman	L/Corporal, Royal Signals
Guildford Telephone Area ..	Luff, W. C. ..	Unestablished Skilled Workman	Pilot Officer, R.A.F.
Guildford Telephone Area ..	Nicholls, G. F. ..	Unestablished Skilled Workman	Flying Officer, R.A.F.
London Telecoms. Region ..	Barker, A. H. ..	Skilled Workman, Class II ..	Signalman, Royal Signals
London Telecoms. Region ..	Linehan, W. C. M.	Skilled Workman, Class II ..	L/Sergeant, Royal Signals
London Telecoms. Region ..	Ratcliffe, F. P. ..	Unestablished Skilled Workman	Signalman, Royal Signals
London Telecoms. Region ..	Robinson, R. C. ..	Unestablished Skilled Workman	Petty Officer, R.N.
London Telecoms. Region ..	Saunders, R. R. ..	Skilled Workman, Class II ..	Signalman, Royal Signals
London Telecoms. Region ..	Taylor, F. A. ..	Unestablished Skilled Workman	Flight Sergeant, R.A.F.
Nottingham Telephone Area	Hall, T. A. ..	Skilled Workman, Class II ..	Flight Sergeant, R.A.F.
Preston Telephone Area ..	Wilkinson, J. N.	Skilled Workman, Class II ..	Bombardier, R.A.
Scotland West Tele. Area ..	Arnott, J. ..	Unestablished Skilled Workman	L/Sergeant, Royal Signals
Scottish Region	Nunn, J. J. ..	Unestablished Draughtsman ..	Flying Officer, R.A.F.
Sheffield Telephone Area ..	Sanderson, D. W.	Unestablished Skilled Workman	Sergeant, R.A.F.
Taunton Telephone Area ..	Connibeer, H. E.	Unestablished Skilled Workman	Sapper, R.E.
York Telephone Area ..	Greenwood, L. E.	Unestablished Skilled Workman	Pte., Gloucestershire Regt.

Recent Awards

The Board of Editors has learned with great pleasure of the honours recently conferred upon the following members of the Engineering Department :—

Aberdeen Telephone Area ..	Buchan, C. M. ..	Skilled Workman, Class II	Corporal, Royal Signals	Military Medal
Bedford Telephone Area ..	Mills, M. W. ..	Skilled Workman, Class II	Flight Lieutenant, R.A.F.	Distinguished Flying Cross
Belfast Telephone Area ..	Craig, G. ..	Draughtsman, Class II	Staff Sergeant, R.A.S.C.	British Empire Medal
Birmingham Telephone Area	Pyatt, J. H. ..	Skilled Workman, Class I	C.Q.M.S., Royal Signals	Mentioned in Despatches
Birmingham Telephone Area	Rees, A. S. M. ..	Skilled Workman, Class II	Sergeant, Royal Signals	Mentioned in Despatches
Bradford Telephone Area ..	Neill, J. H. ..	Skilled Workman, Class I	Sergeant, Royal Signals	Mentioned in Despatches
Bristol Telephone Area ..	Lucas, F. R. ..	Skilled Workman, Class II	C.Q.M.S., Royal Signals	British Empire Medal and Mentioned in Despatches
Bristol Telephone Area ..	Mansfield, A. L.	Skilled Workman, Class II	Captain, Royal Signals	American Bronze Star and Mentioned in Despatches
Canterbury Telephone Area	Elderkin, D. R.	Unestablished Skilled Workman	Sergeant, R.A.F.	Distinguished Flying Medal
Coventry Telephone Area ..	Heawood, R. H.	Skilled Workman, Class II	Warrant Officer, R.A.F.	Distinguished Flying Cross
Dundee Telephone Area ..	Strachan, D. F.	Skilled Workman, Class II	Lance Corporal, Royal Signals	Mentioned in Despatches

Edinburgh Telephone Area..	Aitchison, J. K.	Inspector		Captain, Royal Signals	Chevalier of the Order of Leopold with Palm, and Croix de Guerre 1940 with Palm Class 4 (Belgian) Military Cross
Engineering Department ..	Armstrong, R. G.	Assistant Engineer		Lieutenant, Royal Signals	
Engineering Department ..	Gifford, S. J. ..	Mechanic	..	Chief Motor Mechanic, R.N.	Mentioned in Despatches
Engineering Department ..	Heayel, W. J. ..	Mechanic	..	Chief Motor Mechanic, R.N.	Mentioned in Despatches
Engineering Department ..	McMillan, D. ..	Executive Engineer		Colonel, Royal Signals	Officer of the Order of the British Empire
Engineering Department ..	Ogden, R. S. I.	Inspector	..	Captain, Royal Signals	Member of the Order of the British Empire
Engineering Department ..	Redington, F. D.	Assistant Engineer		On Loan to M.A.P.	Member of the Order of the British Empire
Engineering Department ..	Smith, W. O. ..	Mechanic, Leading Hand		Sergeant, R.A.F.	Mentioned in Despatches
Engineering Department ..	Toft, G. ..	Inspector	..	Flight Lieutenant, R.A.F.	Mentioned in Despatches
Engineering Department ..	Taylor, A. H. ..	Motor Cleaner	..	B.Q.M.S., R.A.	Mentioned in Despatches
Engineering Department ..	Taylor, F. J. D.	Executive Engineer		Major, Royal Signals	Member of the Order of the British Empire and American Bronze Star
Glasgow Telephone Area ..	Mole, H. H. R.	Inspector	..	Major, Royal Signals	Member of the Order of the British Empire and Mentioned in Despatches
Glasgow Telephone Area ..	Milligan, W. J...	Skilled Workman, Class II		Sergeant, Royal Signals	Mentioned in Despatches
Lancaster Telephone Area ..	Bushby, J. H. ..	Skilled Workman, Class II		Warrant Officer, R.A.F.	Distinguished Flying Cross
Leeds Telephone Area ..	Biggin, C. ..	Skilled Workman, Class II		S.Q.M.S., R.A.C.	Mentioned in Despatches
Leeds Telephone Area ..	Cook, R. B. ..	Skilled Workman, Class II		Captain, Royal Signals	Mentioned in Despatches
Leeds Telephone Area ..	Gavins, R. R. ..	Skilled Workman, Class I		Signalman, Royal Signals	British Empire Medal
Leeds Telephone Area ..	Hollings, D. ..	Skilled Workman, Class II		Signalman, Royal Signals	Mentioned in Despatches
Leeds Telephone Area ..	Lee, E. ..	Skilled Workman, Class II		Signalman, Royal Signals	Croix de Guerre, with Bronze Star
Leeds Telephone Area ..	Newton, F. ..	Skilled Workman, Class II		Sergeant, Royal Signals	Mentioned in Despatches
Leicester Telephone Area ..	Jones, H. C. ..	Skilled Workman, Class II		Signalman, Royal Signals	Mentioned in Despatches
Lincoln Telephone Area ..	Green, W. H. R.	Unestablished Skilled Workman		Flying Officer, R.A.F.	Mentioned in Despatches
Liverpool Telephone Area ..	Bolan, N. ..	Skilled Workman, Class II		Corporal, Royal Signals	Mentioned in Despatches
Liverpool Telephone Area ..	Davies, A. O. ..	Skilled Workman, Class I		C.S.M., Royal Signals	British Empire Medal
Liverpool Telephone Area..	Darbyshire, H...	Skilled Workman, Class II		Signalman, Royal Signals	Military Medal

Liverpool Telephone Area ..	Jackson, R. ..	Inspector	Lieut.-Colonel, Royal Signals	Member of the Order of the British Empire
London Telecommunications Region	Willshire, G. F.	Skilled Workman, Class II	Driver, R.A.S.C. ..	Military Medal
Manchester Telephone Area	Barclay, D. ..	Skilled Workman, Class II	Sergeant, Royal Signals	Military Medal
Manchester Telephone Area	Baxter, C. J. ..	Skilled Workman, Class II	Flight Sergeant, R.A.F.	Distinguished Flying Medal
Manchester Telephone Area	Grimshaw, G. E.	Skilled Workman, Class II	Sergeant, Royal Signals	Mentioned in Despatches
Middlesbrough Telephone Area	Little, C. ..	Skilled Workman, Class II	Sergeant, Royal Signals	Mentioned in Despatches
Nottingham Telephone Area	Durant, D. L. ..	Skilled Workman, Class II	Corporal, Royal Signals	Mentioned in Despatches
Oxford Telephone Area ..	Fletcher, R. T. . .	Draughtsman, Class II	Sergeant, R.A.F. ..	Mentioned in Despatches
Plymouth Telephone Area ..	Connell, G. G. ..	Skilled Workman, Class II	Lieutenant, R.N. ..	Distinguished Service Cross and Mentioned in Despatches
Plymouth Telephone Area ..	Hehir, J. S. ..	Skilled Workman, Class II	Corporal, Royal Signals	Military Medal
Scotland West Telephone Area	Horne, F. A. ..	Inspector ..	Major, Royal Signals	Member of the Order of the British Empire and Mentioned in Despatches
Sheffield Telephone Area ..	Hellely, H. ..	Inspector ..	Lieutenant, Royal Signals	Mentioned in Despatches
Shrewsbury Telephone Area	Turner, M. G. ..	Draughtsman, Class II	Lance Corporal, Royal Signals	Mentioned in Despatches
Southampton Telephone Area	Clubb, N. A. C.	Skilled Workman, Class I	Major, Royal Signals	Member of the Order of the British Empire
Stoke-on-Trent Telephone Area	Griffiths, W. ..	Unestablished Skilled Workman	Sergeant, R.E. ..	Mentioned in Despatches
York Telephone Area ..	Hill, S. ..	Skilled Workman, Class I	R.S.M., Royal Signals	Member of the Order of the British Empire
York Telephone Area ..	Snaith, J. ..	Skilled Workman, Class II	Sergeant, Royal Signals	British Empire Medal

Recent Appointments.

The Board offers its congratulations to the following engineering officers in their recent appointments.

Col. H. B. Somerville, O.B.E., to be Regional Director, Northern Ireland Region; Mr. W. West to be Staff Engineer, Research Branch; Mr. H. R. Harbottle, O.B.E., to be Staff Engineer, Training Branch; Mr. F. C. Carter to be Staff Engineer, Subscribers' Apparatus Branch; Capt. W. H. Leech, D.S.C., to be Staff Engineer, Submarine Branch; and Mr. W. F. Boryer to be Chief Regional Engineer, London Postal Region.

The Board is also pleased to note the appointment of the following ex-engineering officers to Regional Director posts: Col. H. Carter, T.D. (W. & B.C. Region) and Col. F. Reid, C.B.E., M.C., T.D. (N.E. Region).

Earth Currents in Submarine Cables.

It has long been known that submarine cables are subject to earth currents of varying magnitude, often of sufficient intensity to interfere seriously with the location of faults. In a letter to *Nature* (published in the 8th June, 1946, issue) Messrs. D. W. Cherry and A. T. Stovold, of the Post Office Cable Test Section, have shown that the fluctuations of the earth currents in three cross-channel cables are semi-diurnal and are directly connected with the change in direction of the tidal stream over the cables.

From the direction of the current flow in relation to the tidal flow, the inference is drawn that the earth currents in these cables are due to the sea water, acting as an electrical conductor, cutting the earth's magnetic field, the electric current flow being in the direction given by Fleming's right-hand rule.

Scientific Film Association.

The Board has been asked by the Scientific Film Association to draw attention to a catalogue of industrial films which they are preparing and to invite readers to assist them in their work by advising them of the title of such films, the source from which they may be hired or borrowed and any other relevant particulars. Information on these points should be sent to the

Hon. Secretary,
Industrial Committee,
Scientific Film Association,
34 Soho Square, London, W.1.

The Association has already prepared a preliminary list, copies of which may be obtained from

Book Reviews

"Heaviside's Electric Circuit Theory." H. J. Josephs, M.I.E.E. 115 pp. 15 ill. Methuen & Co. 4s. 6d.

Every student of alternating current theory is nowadays taught the Steinmetz method of obtaining the steady state solution of alternating current problems, but if he is taught anything of methods for obtaining the transient solution the "classical" method of solving the differential equations involved is generally the only one to which he is introduced. This method is unfortunately only applicable to comparatively simple circuits. There are at least three other methods available, namely, the Heaviside operational calculus and the Fourier transformation and Laplace transformation methods. In the last few years, a number of books have appeared, of which the book by H. J. Josephs is an example, which have attempted to interpret these methods, particularly the Heaviside method, to engineers. Many readers may think that the gap has not been closed sufficiently in the present book, and that the approach is still too much from the point of view of the mathematician, but the author has made a real attempt to explain the use of the Heaviside method without introducing complex integration until the last chapter.

The first chapter considers the steady state solution for the currents in a linear network and the classical transient solution. After showing the practical limitations of the latter the author introduces the reader rather abruptly to the Heaviside method. The Expansion Theorem is introduced in the second chapter, where it is shown that this is of practical use only in comparatively simple networks. Chapter 3 deals with Heaviside's power series solutions, pointing out their wider application, which is further extended to ladder networks in Chapter 4. Chapter 5 introduces impulse functions and attention is drawn to an important theorem of Heaviside's which appears to have escaped notice by engineers. The author shows in this and later chapters how it is possible to deduce rigorously from this theorem the Heaviside operational processes, and shows the close relation to the work of Carson and Bromwich.

Brief mention of the Fourier integral is made in the last chapter, but no mention of the Laplace transformation method preferred by some writers, e.g., Gardner and Barnes in "Transients in Linear Systems." This method appears to have several important advantages over the Heaviside operational method and the author's views on this subject would have been of value. The author appears to have made a careful study of Heaviside's original works and more specific references to

the above address at a nominal charge of 2s. per copy.

Increased Size and Circulation.

The Board of Editors is pleased to announce that the allocation of paper to this JOURNAL has been increased and that it is now possible to accept additional subscribers. Orders should be placed with the local agents or direct with the publishers, Birch and Whittington (Prop. Dorling and Co. (Epsom), Ltd.), 49 Upper High Street, Epsom.

The increased allocation of paper will also enable an increase in size of the JOURNAL and it is hoped progressively to restore it to its pre-war number of pages.

these and a short bibliography would have been useful to the reader anxious to study the subject further.

R. F. J. J.

"An Introduction to the Theory and Design of Electric Wave Filters," by F. Scowen, B.Sc., A.Inst.P. 164 pages. 60 ill. Chapman & Hall, Ltd. 15s.

Electric wave filters are used so frequently now in almost all types of telecommunications equipment that any additions to existing literature on the subject is a matter of considerable interest, particularly when the publication is a British product. The author is backed by a wide practical experience which makes itself apparent in this book.

The treatment of the subject is very logical, commencing with an introduction to the mathematics and electrical theory required, followed by chapters on constant K sections, and leading to "m" derived sections of all types. After dealing quite fully with the general theory of all normal types, a number of examples of actual design are given. Points of interest in this part are the use of templates to determine the number and types of sections to give a specified total attenuation and two useful nomograms; one for the calculation of attenuation of dissipative filters in and around the pass band and the other for the calculation of insertion loss and phase shift of a four-terminal network. There is a short chapter on a subject of importance in modern telecommunications equipment—the parallel and series connection of filters.

The chapter on lattice filters deals very briefly with the Cauer method of design and touches on crystal filters. In view of the great and increasing use and importance of crystal filters, more space might with advantage have been devoted to them.

The final chapter deals with practical considerations in filter construction and measurements on actual filters. This matter is very rarely dealt with in any of the existing standard works, and since at the higher frequencies the method of construction has considerable effect on the performance of a filter, this information should be of considerable use to designers.

The author states that the book is not intended to replace any of the standard works on the subject but it can well be recommended both to the student and to the telecommunications engineer, who may occasionally find it necessary to design a filter. In this connection the text might well be improved by the addition of a list of symbols.

The serious student of the subject will find the presentation clearer than in many other books on the subject, but it should not be inferred from this that the book is by any means light reading.

H. W.

Regional Notes

London Telecommunications Region

BYRON AND HARROW AUTO MANUAL BOARD

In connection with the conversion of Harrow exchange to automatic working, a 22-position sleeve control auto manual board has been installed, together with a 6 volt power supply for free line signalling at Byron exchange. The work was carried out by Standard Telephones and Cables, Ltd., in conjunction with an extension of the Byron automatic equipment. The board will cater for the requirements of both Byron and Harrow auto exchanges.

It was successfully cut over and brought into service on Saturday, 2nd March, 1946.

It was decided to bring the new board into service before the opening of Harrow auto for two reasons, viz., to release certain M/B 1st code selector rack space associated with the old bridge control board for modification by the contractor, and thus provide an increase to the Byron auto plant, and also to give training to the operating staff in sleeve control working prior to the opening of Harrow auto.

Some 64 I/C and 143 O/G circuits were involved in the change-over, but these will be increased to approximately 158 I/C and 161 O/G circuits on the conversion of Harrow.
E. R. S.

Welsh and Border Counties Region

MAGNETIC STORM AFFECTS SIGNALLING

On the morning of 27th March several complaints were made in the Cardiff Area of false calls on junction circuits using battery signalling. On test, it was found

that a variable D.C. voltage appeared on the line when testing via the balanced relay to earth at the far end. The effect was not confined to one exchange or direction, but was more noticeable on the circuits leaving Cardiff for the North and North East. Generator signalling circuits were not subject to the trouble and, therefore, it was thought that the cause was induction from magnetic disturbance. Further tests proved that there was not an induced voltage, but that the voltage was the difference of earth potentials at the two ends.

The Engineer-in-Chief was advised and voltage tests were carried out in the afternoon every 15 minutes on nine circuits. These showed large variations up to 17 volts and rose to 30 volts at 21.45 hours on East and West routes. At the same time the North-South voltage was negligible, but rose to 10 volts after a quarter of an hour.

During the night there was no trouble. The same effect was noticed the following day and to a lesser degree on 29th March.

Observations were made on overhead and cable circuits in the Swansea Area. There was no appreciable difference between overhead and underground routes in the same direction. It was, however, noticed that when the circuits to the North were affected, those to the West were not disturbed and vice versa.

In other areas it was found impossible to get through on direct circuits, but possible via intermediate points. This indicated that there was a voltage gradient between the earths.

From reports in the daily press, submarine cable circuits of Cable and Wireless, Ltd., were unworkable on the 27th March. This lends support to the suggestion that the differences of earth potential were due to a magnetic storm.
G. R. T.

Junior Section Notes

Doncaster Centre

An interesting evening was recently spent by the Doncaster Junior Centre members when they visited a nearby airfield and were introduced to radar.

A number of interesting talks were given and some of the sets were demonstrated to them.

The talks covered a wide field, including radar time, the advantages of pulse modulation over frequency modulation and the essential features of the two basic types of radar, namely, primary radar where no co-operation is required from the object to be located, except that it reflects energy, for example, aircraft and ships, or ionosphere soundings, and secondary radar where use is made of range/time measurements but not reflection, for navigational aids and homing devices. Measuring methods using the cathode ray oscillograph with various types of display, for single-sided time base, etc., were demonstrated.

A. E. D.

London Centre

The London Centre has been reformed on an Area basis with the following representation on the Central Committee :—

Chairman, C. A. Hayes ; Vice-Chairman, A. P. Fleming ; Secretary, E. L. Tickner ; Assistant Secretary, H. E. Williamson, Financial Secretary, E. Davis ; Senior Section Liaison Officer, C. A. Pride ; Committee : G. E. Haslam (Centre), W. Bates (City), L. G. Laycock (West), W. W. Mott (East), E. R. Pilton (S.E.), E. J. Hookway (S.W.), R. C. Gray (N.W.), E. E. Paul (N), G. L. Mack (Cct. Lab.), J. A. Towell (Training Schools),

W. R. Blakebrough (Power), R. G. Stanesby (L.D.), F. R. Brand (Radio and Research), S. W. Martin (N. Postal), L. W. Kirk (S. Postal), H. T. Longman (Test Section, Studd St.), P. H. Ashfold (Visits Secretary).

Newcastle-upon-Tyne Centre

On 25th January, 1946, the above Centre was visited by the President of the Junior Section, Mr. D. Smith, B.Sc., A.M.I.E.E., who was welcomed by a good attendance. Mr. Smith gave an informal talk on "Training," which was well received, and a lively and interesting discussion ensued, the President ably dealing with the various questions that were asked.

The following evening the Junior Section held a Dinner in the County Hotel, Newcastle, when Mr. Smith was again present. Lt.-Col. F. N. Lucas, B.Eng., A.M.I.E.E., the Area Engineer, ably occupied the Chair for the evening. Music and humour were provided by Messrs. Murdy, Mark and Charlton.
W. D. C.

Rochdale Centre

The 1945-46 session was brought to a close on 16th April, when Mr. J. H. Seale of Heywood gave a cine show of P.O. educational films. All the meetings have been extremely well attended and many thanks are due to Mr. Rothwell and assistants of Birch Hill Institution, the management of Ferranti's and Kemsley Newspapers for the able way in which our parties were conducted.

The interest shown is reflected in the fact that members enrolled well on into the session and the final membership reached a total of 45, which is excellent for an outstation the size of Rochdale. The committee thank all members for their support and hope to see them again in the 1946-47 session.
N. L.

Staff Changes

Promotions

Name	Region	Date	Name	Region	Date
<u>Asst. Contr. (Eng.) to Chief Regional Engr.</u>			<u>Chief Insp. to Asst. Engr.</u>		
Boryer, W. F.	L.P.R...	29.4.46	Crooks, R. H.	L.T.R.	15.5.46
<u>Dep. C.R.E. to Staff Engr.</u>			Stevens, E. C. C.	E.-in-C.O.	15.5.46
Harbottle, H. R.	L.T.R. to E.-in-C.O.	12.5.46	Shepherd, C.	Mid. Reg.	15.5.46
<u>A.S.E. to Staff Engr.</u>			Oldacre, A. G.	N.W. Reg. to Scot. Reg.	22.5.46
Carter, F. C.	E.-in-C.O.	28.5.46	Howarth, H.	N.W. Reg.	9.5.46
West, W.	E.-in-C.O.	1.5.46	Larner, F. L.	E.-in-C.O.	9.5.46
<u>Comdr. to Sub. Supt.</u>			Trimmer, W. J.	S.W. Reg.	9.5.46
Leech, W. H., Capt., D.S.C.	H.M.T.S. Iris to E.-in-C.O.	1.4.46	Stovold, A. T.	E.-in-C.O.	9.5.46
<u>Asst. Sub. Supt. to Comdr.</u>			Smith, G. J.	N.W. Reg.	9.5.46
Finlayson, I. R.	E.-in-C.O. to H.M.T.S. Iris	8.5.46	Brown, E. B.	L.T.R.	9.5.46
<u>Regl. M.T.O. to M.T.O. I.</u>			Kirkham, W. D.	H.C. Reg.	9.5.46
Wood, Col. E. W.	Scot. Reg. to E.-in-C.O.	1.5.46	<u>Insp. to Chief Insp.</u>		
<u>Regl. Engr. to Dep. C.R.E.</u>			Deamon, T. E.	Mid. Reg.	25.3.46
Moffatt, C. E.	S.W. Reg. to L.T.R.	19.5.46	Linsell, W.	L.T.R.	6.5.45
<u>Exec. Eng. to A.S.E.</u>			Taylor, A. E.	Mid. Reg.	19.10.45
McMillan, D.	E.-in-C.O.	1.3.46	Kemp, F. G.	H.C. Reg.	13.1.46
Chew, W. G. N.*	E.-in-C.O.	28.5.46	Meredith, W.	Mid. Reg.	1.1.46
Helman, S. L.	E.-in-C.O.	28.5.46	Wallington, F. S.	S.W. Reg.	3.9.45
Lewis, N. W. J.	E.-in-C.O. to S.W. Reg.	23.5.46	Roberts, E. W.	W. & B.C.	7.4.46
Davis, L. H.	E.-in-C.O.	1.4.46	Wood, T.	N.E. Reg.	10.3.46
<u>Area Engr. to Telephone Manager</u>			Barnsdall, M. G. W.	Mid. Reg. to E.-in-C.O.	2.9.45
Knapman, D. E.	W. & B.C. Reg. to Cambridge	1.5.46	Jenkinson, H. C.	E.-in-C.O.	25.3.46
<u>Asst. Eng. to Exec. Engr.</u>			Johnson, E. S.	Mid. Reg. to E.-in-C.O.	19.3.46
Turley, T. G.	L.T.R.	1.5.46	Savage, A.	N.W. Reg.	1.5.46
Clarke, E. F. S.	E.-in-C.O.	23.5.46	Barron, H.	N.W. Reg. to S.W. Reg.	19.5.46
<u>Asst. Engr. to P.R.O.</u>			<u>Insp. to A.T.S.</u>		
Endecott, A. H.	E.-in-C.O. to Mid. Reg.	25.4.46	Dymott, G. W. T.	E.-in-C.O. to L.T.R.	20.11.45

*In absentia.

Retirements

Name	Region	Date	Name	Region	Date
<u>Sub. Supt.</u>			<u>Asst. Engr.</u>		
Firmin, Capt. E. W., O.B.E.	E.-in-C.O.	31.3.46	Ind, G. E.	E.-in-C.O.	31.3.46
<u>Staff Engr.</u>			Baillies, D. C.	Scot. Reg.	31.3.46
Aldridge, A. J.	E.-in-C.O.	30.4.46	Cain, S. J.	H.C. Reg.	30.4.46
Walmsley, T.	E.-in-C.O.	27.5.46	<u>Chief Insp. with Allce.</u>		
<u>M.T.O., Class I</u>			Bennett, S. Y.	S.W. Reg.	31.3.46
Strachan, L. D.	E.-in-C.O.	30.4.46	Budd, W. C.	L.T.R.	31.3.46
<u>Exec. Engr.</u>			Harris, R.	S.W. Reg.	31.3.46
Morice, L. F.	E.-in-C.O.	3.3.46	<u>Chief Insp.</u>		
Romain, W. A. B.	L.T.R.	30.4.46	Pattinson, B. C.	Mid. Reg.	22.3.46
Taylor, H. M.	S.W. Reg.	31.3.46	Wilson, C. F.	E.-in-C.O.	22.3.46
			Curnin, H. R.	E.-in-C.O.	31.3.46
			<u>Insp.</u>		
			O'Malley, E. C.	N.E. Reg.	28.2.46

Retirements—continued.

Name	Region	Date	Name	Region	Date
<i>Insp.—continued</i>			<i>Insp.—continued</i>		
Noble, J. ..	N.Ire. Reg. ..	10.3.46	Chislett, G. C. ..	W. & B.C. Reg. ..	30.4.46
Seach, G. E. ..	H.C. Reg. ..	18.3.46	Jeans, C. W. ..	L.T.R. ..	20.5.46
Knox, A. ..	Scot. Reg. ..	27.3.46	<i>Senior Draughtsman</i>		
Gallacher, F. ..	Leafield Radio Station	12.3.46	Lawrence, J. W. H. ..	E.-in-C.O. ..	3.3.46
Bradley, V. A. F. ..	Mid. Reg. ..	31.3.46	Bulley, T. H. ..	E.-in-C.O. ..	31.3.46
Lovell, R. W. R. ..	L.T.R. ..	31.3.46	Cross, C. A. ..	E.-in-C.O. ..	31.3.46
Nicoll, D. A. D. ..	Test Section ..	31.4.46	<i>Draughtsman, Class I</i>		
Hayes, H. E. ..	L.T.R. ..	31.3.46	Smith, W. ..	E.-in-C.O. ..	31.3.46
Morse, A. E. ..	Mid. Reg. ..	15.4.46	Tocher, H. ..	L.T.R. ..	30.4.46
Munn, C. ..	L.T.R. ..	30.4.46			
Smith, W. T. ..	L.T.R. ..	30.4.46			

Resignations

Name	Region	Date	Name	Region	Date
<i>Asst. Engr.</i>			<i>Insp.—continued</i>		
Atkinson, G. ..	L.T.R. ..	11.3.46	Brown, W. J. ..	E.-in-C.O. ..	15.3.46
Simmonds, J. C. ..	E.-in-C.O. ..	16.3.46	Bennett, G. ..	N.E. Reg. ..	23.3.46
Stoneman, F. W. ..	N.W. Reg. ..	1.3.46	Price, C. A. ..	S.W. Reg. ..	31.3.46
<i>Insp.</i>			Clarke, T. E. ..	E.-in-C.O. ..	30.4.46
Meades, G. ..	Scot. Reg. ..	14.2.46	Dain, G. T. ..	E.-in-C.O. ..	30.4.46

Transfers

Name	Region	Date	Name	Region	Date
<i>Asst. Engr.</i>			<i>Insp.—continued</i>		
Harding, T. C. ..	Mid. Reg. to L.T.R. ..	15.4.46	Green, J. ..	Criggion R/S to E.-in-C.O.	15.3.46
Ireland, J. C. ..	H.C. Reg. to E.-in-C.O.	8.4.46	Nicholson, T. ..	Mid. Reg. to E.-in-C.O.	31.3.46
James, M. H. ..	E.-in-C.O. to L.P.R. ..	29.4.46	Webb, P. B. ..	N. Ire. Reg. to N.E. Reg.	31.3.46
Glover, R. P. ..	E.-in-C.O. to S.W. Reg.	5.5.46	Walker, S. H. ..	E.-in-C.O. to N.E. Reg.	1.4.46
Hayward, R. K. ..	Mid. Reg. to E.-in-C.O.	13.5.46	Reeves, L. N. ..	Scot. Reg. to E.-in-C.O.	1.4.46
Woodhouse, T. ..	N.E. Reg. to N.W. Reg.	20.5.46	Wicks, A. G. W. ..	E.-in-C.O. to L.T.R. ..	30.4.46
<i>Chief Insp. with Allce.</i>			North, G. W. ..	L.T.R. to E.-in-C.O. ..	1.5.46
Baldey, C. ..	Mid. Reg. to L.T.R. ..	1.4.46	Cowan, R. T. B. ..	E.-in-C.O. to Scot. Reg.	7.5.46
<i>Chief Insp.</i>			Behets, F. J. ..	E.-in-C.O. to N.W. Reg.	13.5.46
Stevens, E. C. C. ..	N.E. Reg. to E.-in-C.O.	10.3.46	Stamp, R. G. ..	Mid. Reg. to H.C. Reg.	13.5.46
Bennett, H. V. ..	E.-in-C.O. to N.W. Reg.	21.5.46	Gill, T. ..	E.-in-C.O. to N.E. Reg.	20.5.46
<i>Insp.</i>			Scotten, R. J. ..	L.T.R. to H.C. Reg. ..	20.5.46
Higson, R. P. ..	E.-in-C.O. to N.W. Reg.	11.3.46	Ridgway, H. ..	Criggion R/S to N.W. Reg. (S.W.1 at own request)	13.4.46
Ash, F. J. ..	E.-in-C.O. to Mid. Reg.	11.3.46			
Lewis, R. E. ..	E.-in-C.O. to Criggion R/S	12.3.46			

Deaths

Name	Region	Date	Name	Region	Date
<i>Chief Insp. with Allce.</i>			<i>Insp.—continued</i>		
Ralph, H. P. ..	L.T.R. ..	11.4.46	Stafford, D. E. H. ..	Mid. Reg. ..	29.3.46
<i>Insp.</i>			Turner, A. C. ..	L.T.R. ..	10.5.46
Hannah, C. R. ..	N.W. Reg. ..	13.3.46	Menzies, W. C. K. ..	Scot. Reg. ..	10.5.46
Smith, J. ..	N.E. Reg. ..	26.3.46	Ballard, W. ..	W. & B.C. Reg. ..	15.5.46

CLERICAL GRADES

Promotions—Nil.

Transfers

Name	Region	Date	Name	Region	Date
<u>S.O.</u>			<u>E.O.—continued</u>		
Topley, W. C., Major	E.-in-C.O. to Contracts Dept.	1.4.46	Binmore, H. P. . .	E.-in-C.O. to Contracts Dept.	1.4.46
<u>E.O.</u>			Haley, M. R. (Miss) . .	E.-in-C.O. to Contracts Dept.	1.4.46
Crane, D. G. . .	E.-in-C.O. to Contracts Dept.	1.4.46	Palmer, W. J. . .	E.-in-C.O. to Contracts Dept.	1.4.46
Page, G. R. J. . .	E.-in-C.O. to Contracts Dept.	1.4.46			

Death

Name	Region	Date	Name	Region	Date
<u>E.O.</u>					
Dickinson, P. R. . .	E.-in-C.O.	30.4.46			

BOARD OF EDITORS

- A. J. GILL, B.Sc., M.I.E.E., F.I.R.E., Chairman.
- F. E. NANCARROW, O.B.E., A.R.C.Sc., M.I.E.E.
- P. B. FROST, B.Sc., M.I.E.E.
- A. H. MUMFORD, O.B.E., B.Sc.(ENG.), M.I.E.E.
- C. W. BROWN, A.M.I.E.E.
- C. E. C. SKUSE.
- H. LEIGH, B.Sc.(ENG.), M.I.E.E., Managing Editor.
- G. E. STYLES, A.M.I.E.E., Assistant Editor.
- A. J. BAKER, Secretary-Treasurer.

Copyright

The entire contents of this JOURNAL are covered by general copyright, and special permission is necessary for reprinting long extracts, but Editors are welcome to use not more than one-third of any article, provided credit is given at the beginning or end thus: "From the *Post Office Electrical Engineers' Journal*."

The Board of Editors is not responsible for the statements made or the opinions expressed in any of the articles in this JOURNAL, unless such statement is made specifically by the Board.

Communications

All Communications should be addressed to the Managing Editor, *P.O.E.E. Journal*, Engineer-in-Chief's Office, Alder House, Aldersgate Street, London, E.C.1. Telephone: HEADquarters 1234. Remittances should be made payable to "*The P.O.E.E. Journal*" and should be crossed "& Co."

Binding Cases

Cases for binding are available, and may be obtained from the Local Agents for 2s. Subscribers can have their copies of Volumes bound, at a cost of 7s. 6d. by sending the complete set of parts to the Local Agents or to the *P.O.E.E. Journal*, Engineer-in-Chief's Office, Alder House, Aldersgate Street, London, E.C.1. Orders for binding for Vols. 1-19 should indicate whether the original binding case with black lettering, or the later pattern with gold, is required. Cases with gold lettering are the only type stocked from Vol. 20 onwards.

Back Numbers

The price of the JOURNAL, which is published quarterly, is 1s. (1s. 3d. post free) per copy, or 5s. per annum post free. Back numbers can be supplied, subject to availability of stocks, at 1s. each (1s. 3d. post free). Orders for back numbers may be sent to the Local Agents or to the Publishers.

Advertisements

All communications relating to space reservations should be addressed to the Advertisement Editor, *P.O.E.E. Journal*, Alder House, Aldersgate Street, London, E.C.1. Communications regarding advertisement copy, proofs, etc., should be addressed to the Publishers, Messrs. Birch & Whittington (Prop. Dorling & Co. [Epsom], Ltd.), 49 Upper High Street, Epsom, Surrey.

Getting Down

to
it!

OF course you don't have to take us too literally, but we assure our innumerable friends that we *are* pressing on with the production of all the well-known "Avo" Testing Instruments with a view to speeding up delivery dates as time goes on.

Meanwhile, we have not neglected to use the advances perfected during the war years, and the several new Instruments scheduled for early production will measure up to the traditional "Avo" standards of accuracy and reliability.

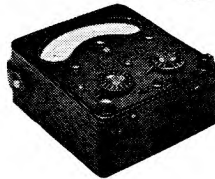

The 50-range Model 7 Universal AvoMeter is the leader of the world-famed range of "Avo" Electrical Measuring Instruments which are appreciated for their compact portability, dependability, and a steadfast accuracy which is often used as a standard by which other instruments are judged. Fully descriptive pamphlet available on application.

Sole Proprietors and Manufacturers:

THE AUTOMATIC COIL WINDER & ELECTRICAL EQUIPMENT Co. Ltd
Winder House, Douglas Street, London, S.W.1

Phone: VICtoria 3404-8

These dials will interest you:—

DIALS & DRIVES: TYPES D-115-A & D-206-A.

TYPE D-115-A employs a 20:1 worm reduction gear providing a right-angle drive for two components. TYPE D-206-A employs a 20:1 spur reduction gear providing a single in-line drive.

OUTSTANDING FEATURES:—

- High reading and setting accuracy by means of a dial embodying an adding mechanism—effective scale length over 12 ft. with 500 divisions.
- Gears spring-loaded to reduce backlash.
- Rugged die-cast construction and substantial bearings for long and continuous service.
- Shafts: $\frac{1}{4}$ in. diameter and $\frac{3}{8}$ in. projection.
- Finish: gunmetal with engraving filled white.
- Weight: 2½ lb.

Dial manufactured under licence from the
Sperry Gyroscope Co. Ltd.
Pat. No. 419002.

Full description in

Bulletins B-532-B and B-556-A

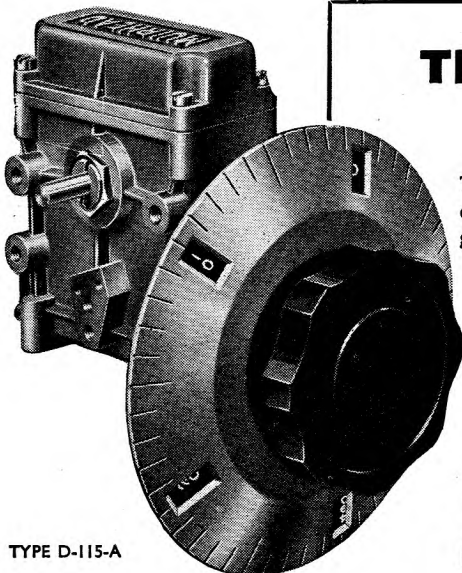

TYPE D-115-A

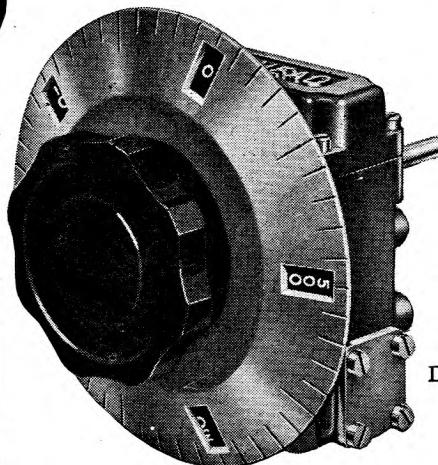

TYPE D-206-A

MUIRHEAD

MUIRHEAD & COMPANY, LTD., ELMERS END
BECKENHAM, KENT · BECKENHAM 0041-2

FOR OVER 60 YEARS DESIGNERS AND MAKERS OF PRECISION INSTRUMENTS.

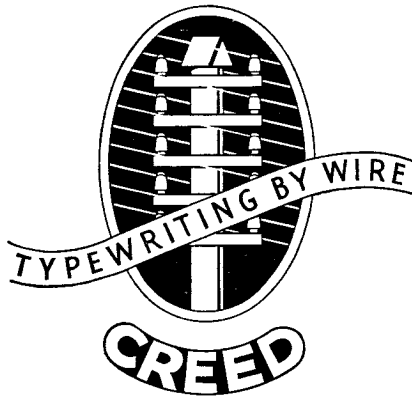

PRINTING TELEGRAPH APPARATUS

TELEPRINTERS
HIGH SPEED MORSE INSTRUMENTS
RELAYS
AND REPEATERS

CREED AND CO. LTD
CROYDON



Change of Address

Customers are requested to note that all works and administrative departments formerly at 12-22 Laystall Street, E.C.1, are now installed at our factory at Tolworth, Surbiton, Surrey. This move will involve no hold-up in the flow of deliveries. Henceforth, all communications should be sent to this new address.



UNITED INSULATOR CO., LTD
Oakcroft Road,
Tolworth,
SURBITON, Surrey
Tel: Elmbridge 5241 (6 Lines)

Unsurpassed In Ceramics

LINK THE WORLD'S RESOURCES . . .

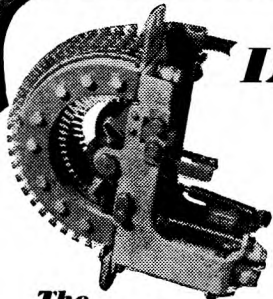

IN THE GREAT PORTS

The Strowger Uni-selector.

- has a contact selecting device with a uni-directional motion.
- has semi-circular "levels" each with 25 contacts spaced radially 7° 12' apart.
- has a varying number of "levels" up to a maximum of eight.
- has wipers which are normally double ended and are arranged in pairs so that two connections are made on each contact. If 50 outlets are required, single ended wipers can be fitted mounted 180° to each other.
- has means by which wipers having tips which "bridge" adjacent contacts can be fitted as an alternative to the non-bridging type if necessary.
- has often a "homing" arc fitted to provide a simple method of bringing the wipers to the "home" position after use.
- has the reverse drive principle of working.
- has been designed to work on 22, 40 & 50 volts.
- has, for any 50 volt uni-selector, a minimum speed of 50 complete revolutions per second, when the magnet circuit is self-interrupted.

Where bays and indentations occur in coast lines, shelter from the force of wind and waves is available. There ships can load and unload cargoes and passengers can embark and disembark; docks and wharves are constructed, warehouses and office buildings are erected, and the terminus points of rail and roadways are located. The seaport is a vital link connecting land and sea routes. Telephone services, within it and extending to the many centres from which export material is drawn or to which imports are distributed, are essential. Long distance trunk calls are frequently necessary and through-connections are required with the minimum delay. The provision of "on demand" service enables a trunk call to be routed direct to the distant exchange without need for the calling subscriber to replace his telephone handset and await a revertive call from the exchange operator. "On demand" service can be obtained by Strowger Automatic Telephone equipment working in conjunction with sleeve control cord circuits which, being identical on all trunk switch board positions, enable any operator to complete a call in a group with an equivalent saving in time.

WITH

STROWGER

TELECOMMUNICATIONS

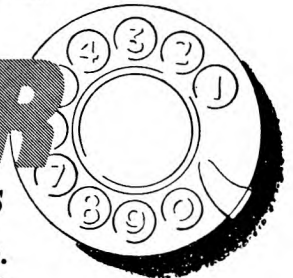

AUTOMATIC TELEPHONE & ELECTRIC CO. LTD.

Export Dept.—NORFOLK HOUSE, NORFOLK ST., LONDON, W.C.2

TEMPle Bar 9262

STROWGER WORKS, LIVERPOOL, 7, ENGLAND

Rectifiers

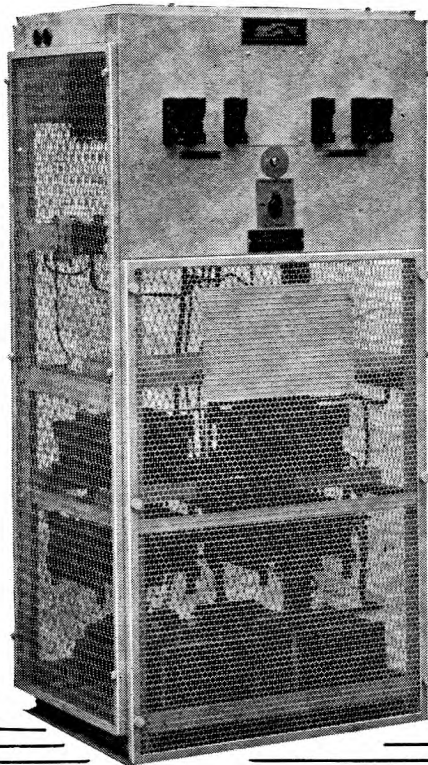

FOR TELEPRINTER OPERATION

The latest practice in teleprinter operation from A.C. supplies is to employ separate Westinghouse metal rectifiers to feed the motor and provide power for the telegraph apparatus.

Large installations may be powered by 80+80 volt batteries, which are "floated" by special "Westat" constant voltage charging equipments in conjunction with "standby" and "recharge" rectifiers. An 80+80 volt 6.75 ampere power unit for teleprinter operation is illustrated.

WESTINGHOUSE WESTALITE METAL RECTIFIERS

Write or descriptive pamphlet No. M.R.9 to Dept. P.O.E.E.J.

WESTINGHOUSE BRAKE & SIGNAL CO. LTD.,
82 YORK WAY, KING'S CROSS, LONDON, N.1

CAPCO

REGISTERED TRADE MARK

QUARTZ CUTTING MACHINES

Q.2.B Machine. This is the original Q.2, but re-designed, giving full protection to all slides, lead screw, etc. New type gear box enlarged and strengthened.

Light and Heavy Duty Machines have been Re-designed and Improved. Latest Development, Hand and Automatic Notching Machines. Details are now available.

Cutting can now be carried out in a totally enclosed clear view splash guard enclosing the whole table. There are other new and interesting features too—details on request.

CAPLIN ENGINEERING CO. LTD.

25 years of service to the engineering and allied trades.

Well over one thousand "CAPCO" machines in use to-day, including hundreds of special machines and apparatus. "CAPCO" is synonymous with accuracy.

Designers and manufacturers of Capco Sound-on-Film recorders and equipment. Capco built recorders are in use at Elstree, Pathe News and Universal Talking News, etc. Patentees and manufacturers of Capco Enamelled Wire Cleaning machines.

BEACONSFIELD RD WILLESDEN, LONDON, N.W.10

Sole Agents : CAPCO (Sales) LTD.

Telephone : WILlesden 0067-8

SIEMENS

TELECOMMUNICATION EQUIPMENT

AUTOMATIC TELEPHONE EXCHANGES
including the following types

Trunk	T.A.X.
Main	M.A.X.
Rural	R.A.X.
Unit	U.A.X.
Private	P.A.X.
Private Branch	P.A.B.X.

MANUAL EXCHANGES
of all types

CARRIER TRANSMISSION EQUIPMENT

TELEPHONE INSTRUMENTS
of all types

TELEPHONE SWITCHING EQUIPMENT

PROTECTIVE DEVICES

RELAYS

TELEPHONE CABLES, WIRES & CORDS

LOADING COILS

MARINE RADIO EQUIPMENT

SHIPS' TELEGRAPHS & TELEPHONES

CELLS & BATTERIES
Dry, Fluid and Inert



*Designed for service
in all parts of the world*

BY close attention to technical detail the Company has maintained its position in the forefront of Telecommunication Engineers throughout its long experience. Its products enjoy a world-wide reputation for sound design and technical excellence.

The Company undertakes the supply and installation of complete Automatic and Manual Telephone Exchanges for Public and Private service, Automatic and Manual Trunk Exchanges, all types of Telephone Cables for Trunk and Local Service, Carrier Transmission Equipment and Cables, Radio Equipments for Ships.

SIEMENS BROTHERS
& CO., LIMITED
WOOLWICH
LONDON, S.E.18

Achievement...

by

Ericsson



ERICSSON TELEPHONES, LTD., Head Office : 56 Kingsway, London, W.C.2. Phone: HOLborn 6936



ANALOGY ON THE GOOSE STEP

There are various kinds of goose step - here we show the delicate tread of dear old mother goose herself; there is also the gentle Prussian variety which did so well for a time until old Joe objected.

The only thing these two goose steps have in common is that each step is identical, in fact just like the Transformers we delight in producing, whether it is one or ten thousand they are all identically the same - giving exactly the same ????? - not the slightest variation to cause trouble at a later stage.

To us it is a stirring sight to see our beloved Transformers goose stepping along the production lines and if you saw them for yourself you would no longer wonder how it is that we produce the best Transformers so swiftly and economically . . .

PARMEKO of LEICESTER.
Makers of Transformers.

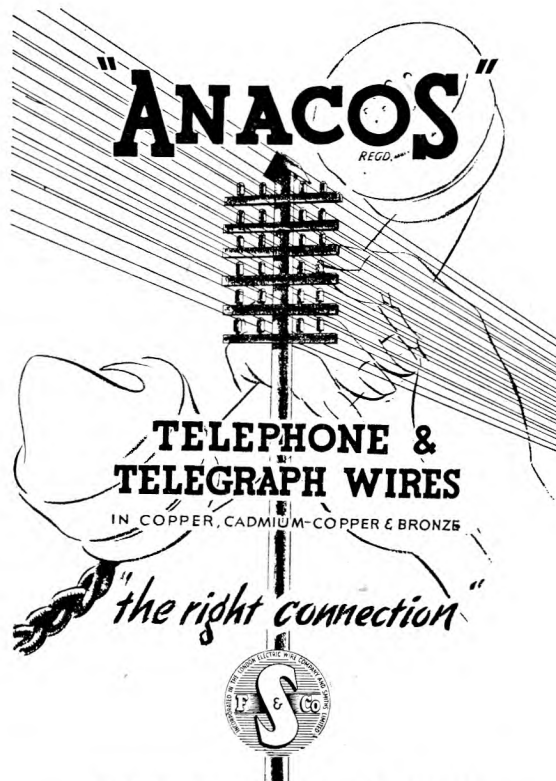

FREDERICK SMITH & COMPANY
(Incorporated in The London Electric Wire Company and Smiths, Limited)
ANACONDA WORKS, SALFORD 3, LANCS.
Phone : Blackfriars 8701 (9 lines) • Grams : "Anaconda," Manchester

for **HIGH • HIGHER and HIGHEST FREQUENCIES!**

TENAPLAX Co-axial Cable



SOME TENAPLAX CABLES HAVE

60% AIR INSULATION

Patented method of construction reduces losses to a minimum.

- _____ • Plastic Cover
- _____ • Electrical Screening
- _____ • Alkathene Sleeve
- _____ • Braided Alkathene Filaments
- _____ • Conductor

We also make : **RADIO SLEEVING • INSULATING TUBING**
SPECIAL TUBING FOR CONVEYING LIQUID FOOD, ETC.
COVERED WIRES AND CABLES Write to :

TENAPLAS WORKS, UPPER BASILDON, PENBORNE, BERKS.

Phone : UPPER BASILDON 228 & 269

STANDARD WITH THE BRITISH POST OFFICE

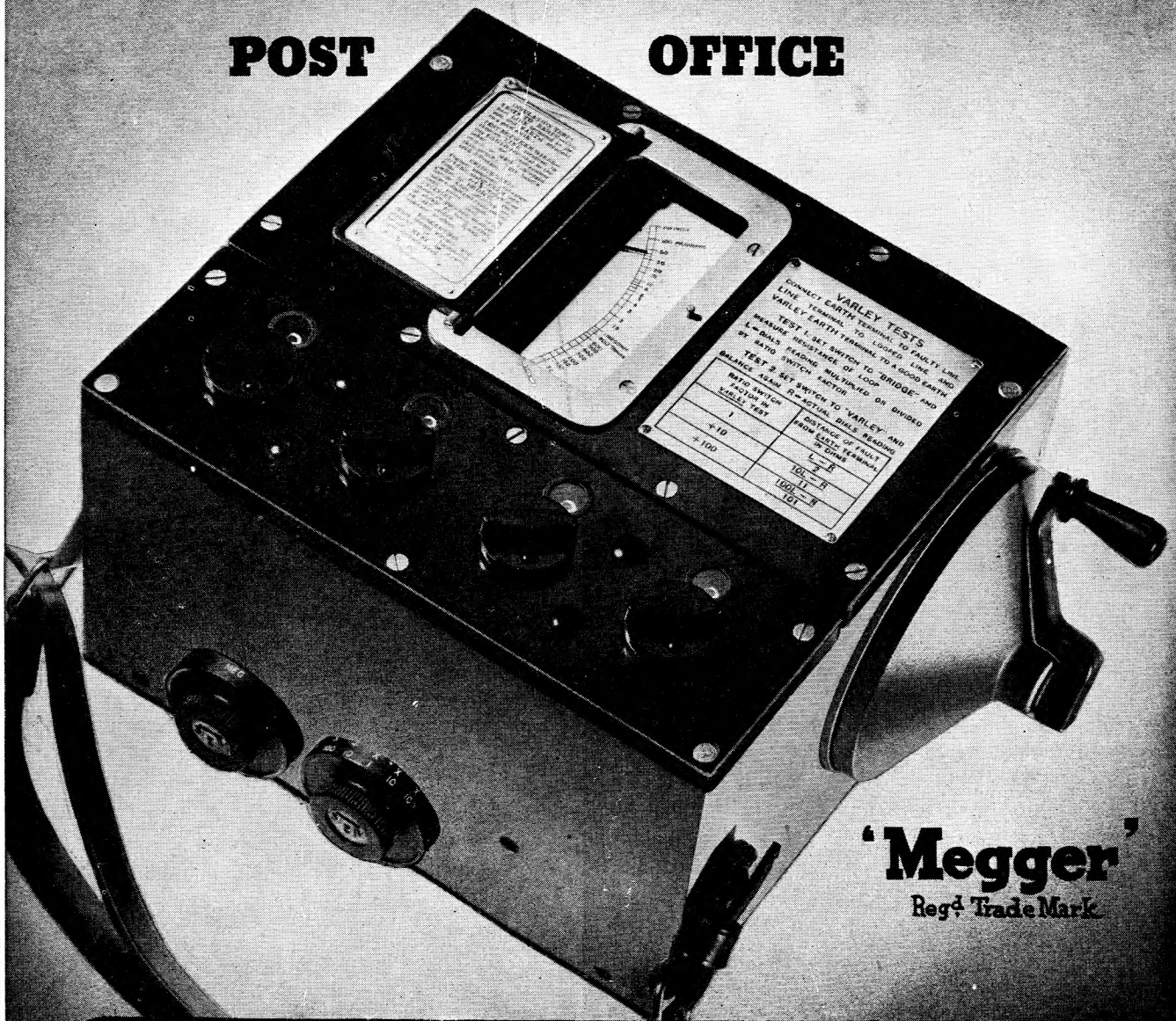

'Megger'
Regd Trade Mark

THE BRIDGE-MEG TESTING SET used by the British Post Office is a portable, self-contained instrument combining the functions of an Insulation Tester and a Wheatstone Bridge; it can be used for fault location by the Varley Loop method. Facilities can also be provided whereby, with the use of an external galvanometer and resistance box, the instrument may be used for making Murray Loop tests. Insulation range 100 megohms at 500 volts. Bridge range 0.01 to 999,900 ohms. Size $7 \times 8\frac{3}{4} \times 12$ ins. Weight $12\frac{3}{4}$ lbs. Mains operated instruments are also supplied to the British Post Office. Ask for list X 267.

EVERSHED & VIGNOLES LTD., CHISWICK, LONDON, W.4
TELEPHONE: CHISWICK 1370 * TELEGRAMS: "MEGGER" CHISK, LONDON

MORE POWER TO LOCHABER!



Despising all other weapons, the clansman trusted to his claymore and superb swordsmanship

THE old-time history of Lochaber is that of highland clans, highland feuds and the 'forty-five'. But today the power of this wild and picturesque district no longer lies in the claymore; it comes instead from one of the greatest industrial developments of recent times which, promoted at a cost of millions of pounds, harnesses the waters of the countryside to generators that give an immense output of electrical power. A new page to highland history indeed! . . . and one in which it is recorded that an Alton battery has been installed in the hydro-electric station for emergency and other important duties.

ALTON

BATTERIES OF MERIT

THE ALTON BATTERY COMPANY LTD., ALTON, HANTS

Sole Suppliers of Fuller Stationary Batteries

Telephone: Alton 2267 and 2268 Telegrams: 'Battery, Alton'



MAINTAINING EFFICIENCY

THE HIGH STANDARD OF EFFICIENCY
OF PIRELLI - GENERAL TELEPHONE
CABLES IS MAINTAINED BY THE
CONTINUOUS RESEARCH WORK OF
AN EXPERIENCED TECHNICAL STAFF.

TELEPHONE:
SOUTHAMPTON
2141 (5 lines)

PIRELLI-GENERAL
CABLE WORKS, Ltd., SOUTHAMPTON.

TELEGRAMS
"PIREKAYBEL"
SOUTHAMPTON "

THE SOLDER WITH 3 CORES OF NON-CORROSIVE FLUX,
PREFERRED BY LEADING MANUFACTURERS OF TELEPHONE
EQUIPMENT • SUPPLIED UNDER CONTRACT TO THE G.P.O.

ERSIN MULTICORE

The Leading manufacturers of Telephone apparatus realise that ERSIN MULTICORE SOLDER is superior to all other types of Solder for assembly and maintenance purposes. The 3 cores of non-corrosive flux ensure flux continuity, extra-rapid melting and speedy soldering. High precision standard of soldered joints is obtained with the utmost economy of labour and material. ERSIN MULTICORE SOLDER

is made in a wide range of alloys and gauges to meet all specifications. If you do not already enjoy the advantages of ERSIN MULTICORE SOLDER please write for comprehensive technical information and free samples.

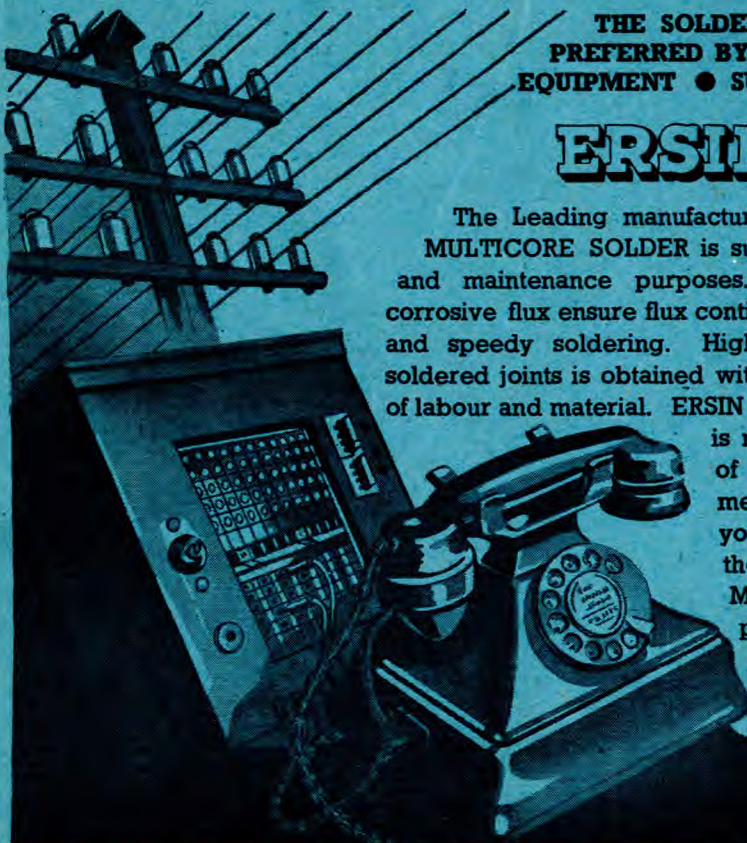

MULTICORE SOLDERS LTD., MELLIER HOUSE, ALBEMARLE ST., LONDON, W.1. Tel: REGent 1411 (P.B.X. 4 lines)

MULTICORE SOLDERS LTD., Mellier House, Albemarle Street, London, W.1. Telephone: REGent 1411 (P.B.X. 4 lines)