

This document was generated by me, Colin Hinson, from a document held at R.A.F. Henlow Signals Museum and is believed to be out of copyright or Crown Copyright . It is presented here (for free) under the Open Government Licence (O.G.L.) if under Crown Copyright and this version of the document is my copyright (along with the Crown Copyright) in much the same way as a photograph would be. If you believe the document to be under copyright, please contact me.

The document should have been downloaded from my website <https://blunham.com/Radar>, if you downloaded it from elsewhere, please let me know (particularly if you were charged for it). You can contact me via my Genuki email page:

<https://www.genuki.org.uk/big/eng/YKS/various?recipient=colin>

**You may not copy the file for onward transmission of the data nor attempt to make monetary gain by the use of these files. If you want someone else to have a copy of the file, point them at the website. It should be noted that most of the pages are identifiable as having been processed by me.**

---

I put a lot of time into producing these files which is why you are met with the above when you open the file.

In order to generate this file, I need to:

1. Scan the pages (Epson 15000 A3 scanner)
2. Split the photographs out from the text only pages
3. Run my own software to split double pages and remove any edge marks such as punch holes
4. Run my own software to clean up the pages
5. Run my own software to set the pages to a given size and align the text correctly.
6. Run Omnipage (Ultimate) on all the pages to OCR them.
7. Generate a searchable Acrobat pdf file.

Hopefully after all that, I end up with a presentable file, though I can't guarantee there aren't errors in the OCR. If you find missing pages, pages in the wrong order, anything else wrong with the file or simply want to make a comment, please drop me a line (see above).

It is my hope that you find the file of use to you personally – I know that I would have liked to have found some of these files years ago – they would have saved me a lot of time !

Colin Hinson

In the village of Blunham, Bedfordshire.



# THE POST OFFICE ELECTRICAL ENGINEERS' JOURNAL

**VOL. 41**

**APRIL, 1948**

**PART I**

## CONTENTS

	PAGE
ALDEBURGH-DOMBURG No. 6 SUBMARINE CABLE SYSTEM— J. Rhodes, M.B.E., B.Sc.(Eng.), A.M.I.E.E. . . . .	1
NOTES ON THE EXPONENTIAL DISTRIBUTION IN STATISTICS —N. W. Lewis, Ph.D.(Eng.), M.I.E.E. . . . .	10
PULSE TECHNIQUES IN COAXIAL CABLE TESTING—F. F. Roberts, B.Sc.(Eng.), A.M.I.E.E. . . . .	13
PRINCIPLES OF OVERHEAD LINE CONSTRUCTION—P. R. Gerry, A.M.I.E.E. . . . .	18
THE POTENTIALITIES OF THE VOCODER FOR TELEPHONY OVER VERY LONG DISTANCES—J. Swaffield, Ph.D. . . . .	22
THE MANUFACTURE OF STAR-QUAD TELEPHONE CABLE— Part 3—Quadding and Stranding Lays, Acceptance Tests and Sheath Defects—J. E. Deering . . . . .	29
IONOSPHERIC DISTURBANCES—G. H. M. Gleadle, M.Sc.(Eng.), A.M.I.E.E. . . . .	34
INTERNATIONAL TELEX—Part 1—Signalling System, Subscribers' Station Equipment and Line Terminations—H. E. Wilcockson, A.M.I.E.E., and A. H. T. Waldram, B.Sc.(Eng.), A.C.G.I., D.I.C., A.M.I.E.E. . . . .	39
THE EFFICIENCY OF GRADINGS—Part 1—Determination of General Formulae; Small Grading Elements—H. A. Longley . . . . .	45
THE EUROPEAN SWITCHING PLAN . . . . .	50
HEADQUARTERS NOTES . . . . .	52
JUNIOR SECTION NOTES . . . . .	54
NOTES AND COMMENTS . . . . .	55
REGIONAL NOTES . . . . .	57
STAFF CHANGES . . . . .	60
BOOK REVIEWS . . . . .	28, 44, 56

Price 1/6 net

**THE INSTITUTION OF POST OFFICE ELECTRICAL ENGINEERS**



# THE POST OFFICE ELECTRICAL ENGINEERS' JOURNAL

Vol. XLI

April, 1948

Part I

## Aldeburgh-Domburg No. 6 Submarine Cable System

J. RHODES, M.B.E., B.Sc.(Eng.), A.M.I.E.E.

U.D.C. 621.315.28 : 621.395.5

A new Anglo-Netherlands submarine cable of the coaxial type was formally opened in December 1947. This article gives constructional features of the cable, a brief account of the laying operation and details of the terminal equipment. The present capacity of the cable is for seven 12-circuit groups working in the range 24-372 kc/s for the "Go" and 456-804 kc/s for the "Return" direction, the equipment design being such that circuits are extended on 12-circuit systems in each country without reduction to audio level at the coastal repeater stations.

### *Introduction.*

THE Anglo-Netherlands submarine cable route provides a very good illustration of the progress made in telephone transmission during the past 25 years. Each cable laid has marked a further step in submarine cable telephony and the No. 6 cable recently brought into service is perhaps one of the greatest.

The first cable, laid in 1922, was a four-core gutta-percha cable, coil loaded at 1 naut intervals. This was followed in 1924 by the No. 2, which was a four-quad paper-covered double lead sheath cable with continuously-loaded conductors of 165 lb. copper. The cable was worked on a two-wire repeated basis and provided 14 circuits. The No. 3 cable was laid in 1926 and was generally similar to the No. 2 but incorporated a centre wire in addition to the four quads. The route was one of the first to employ carrier circuits, a number of 1+1 carrier systems being fitted on some pairs of the No. 2 and 3 cables in 1934.

In 1937 the No. 4 and No. 5 cables were laid; these cables were of the coaxial type with paragutta dielectric and had an outer conductor diameter of 0.62 in. They were the first of this type to be laid round the British Isles. Carrier equipment was installed at Aldeburgh and Domburg and the cables were worked on a four-wire basis, i.e. all "Go" channels on one cable and all "Return" channels on the other, and provided 17 circuits. Consideration was being given at the outbreak of war to increasing the number of circuits by the use of high-powered transmitting amplifiers and by fitting compandors on the higher frequency channels, but apart from experiments these projects did not materialise, and in May 1940 all cables on the route were cut.

The route was reopened in 1945 for military circuits by the repair of the No. 4 cable followed shortly afterwards by that of the No. 5 and No. 2 cables. The original equipment for the No. 4 and No. 5 cables had been used on other projects during the war and completely new equipment was provided after the initial military phase. The demand for both military and civil circuits was heavy and special endeavours

were made to obtain as many circuits as possible. The cables were again worked on a four-wire basis and two 12-circuit groups in the frequency range 12 to 108 kc/s were fitted. Also, to utilise the frequency band 0-12 kc/s 1+2 carrier systems were fitted on a duplex basis on each cable, thus providing a total of 30 circuits on the two cables together. The circuits on the duplex carrier systems were, of course, the equivalent of two-wire circuits, and since the attenuation of the top channel on these systems was 39 db. at 9 kc/s, it was necessary to obtain a return loss of 45 db. on the balance against the cable. At 108 kc/s the attenuation of the cables is 123 db. and therefore the signal-to-noise ratio on the higher channels was less than the accepted standard.

The No. 3 cable has not been used since the war as it was found to be faulty at a number of points in areas not yet completely swept of mines, and repairs have in consequence been impossible.

### THE NO. 6 CABLE

Owing to its length of 82 nauts, the Anglo-Netherlands route is one on which it has in the past always been difficult to provide economically all the circuits required. The new cable has, however, gone a long way to solving this problem since this alone will provide 84 circuits, which is more than the five earlier cables taken all together.

### *Constructional Details.*

The cable is of the coaxial type but has a unique construction with a dielectric partly air and partly polythene. The coaxial pair is also much larger than that of the No. 4 and No. 5 cables with an outer conductor diameter of 1.7 in. A cross-section of the cable is shown in Fig. 1. The central conductor is a single copper strand surrounded by 10 copper wires and is covered with polythene up to a diameter of 0.443 in. The inner coaxial conductor is then applied and consists of six copper tapes, laid helically, over which a single copper tape is applied longitudinally to form a cylinder which after application is crimped at approximately  $\frac{1}{2}$  in. intervals to make the tube so



formed more flexible. The longitudinal tape forms a smooth surface for the high-frequency currents which flow mainly on the surface of the tube. These currents would tend to "spiral" and follow a longer path if the inner coaxial conductor consisted of the six tapes only. A cylindrical rod of polythene 0.22 in. diameter is then wound over the inner coaxial conductor to form a helix with a lay of approximately 1 in. This helix provides a support for the tube of polythene which is next extruded over it up to a diameter of 1.7 in. Then follows the outer conductor consisting of six copper tapes applied helically with a suitable lay followed by two open helical lappings of wider tape to act as binders. The remaining construction follows conventional lines, consisting of two lappings of tarred jute yarn to form a bedding for the armouring wires which are next applied and consist of 23 No. 2 S.W.G. galvanised iron wires; after coating with compound, two servings of tarred jute yarn are applied to finish off. The appearance of the completed cable is shown in Fig. 2. The weight of the cable is approximately 19 tons per naut, and it is interesting to note that the weight of the No. 2 cable providing only 14 circuits was 23 tons per naut. The table below gives the principal dimensions:—

	Size (in.)	Weight (lb./naut)	D.C. Resistance (ohms/naut)
<b>Central Conductor</b>			
Inner wire ..	0.068 dia. }	250	4.78
Outer wires ..	0.030 dia. }		
<b>Insulation</b>			
Air-spaced type ..	0.443 dia.	345	
Solid type ..	0.348 dia.	202	
<b>Inner Coaxial Conductor</b>			
Air spaced {	0.0075 thick	248	2.38
6 Helical tapes	0.0075 thick	255	
Solid type {	0.0075 thick	191	3.05
6 Helical tapes	0.0075 thick	202	
<b>Insulation</b>			
Air spaced {	0.22 dia.	190	4,030
Helix	1.7 dia.	5,240	
Tube	1.7 dia.		
Solid type ..			
<b>Outer Coaxial Conductor</b>			
6 Helical tapes ..	0.015 thick	1,885	
2 Binding tapes ..	0.004 thick	846	

The shore ends to a distance of approximately  $\frac{1}{2}$  naut out to sea and also the land extensions to the terminal repeater stations on each side have a solid polythene dielectric. In order that these sections of the cable shall have the same characteristic impedance as the main section, the inner coaxial conductor has been reduced in diameter by approximately 20 per cent. The land sections of the cable are protected by steel tape armour. From the terminal repeater stations to the end of the shore ends approximately  $\frac{1}{2}$  naut out to sea, the outer conductor is insulated by an extruding of polythene to a thickness of 0.1 in. The main coaxial pair so insulated, together with the armouring wires, thus form a double coaxial construction. This was adopted to reduce external interference, since extraneous land currents are prevented from flowing in the outer coaxial conductor, and in addition the armouring provides a partial screen against interference by radio signals

which often give trouble on land extensions of submarine cables owing to the very low incoming signal levels at these points.

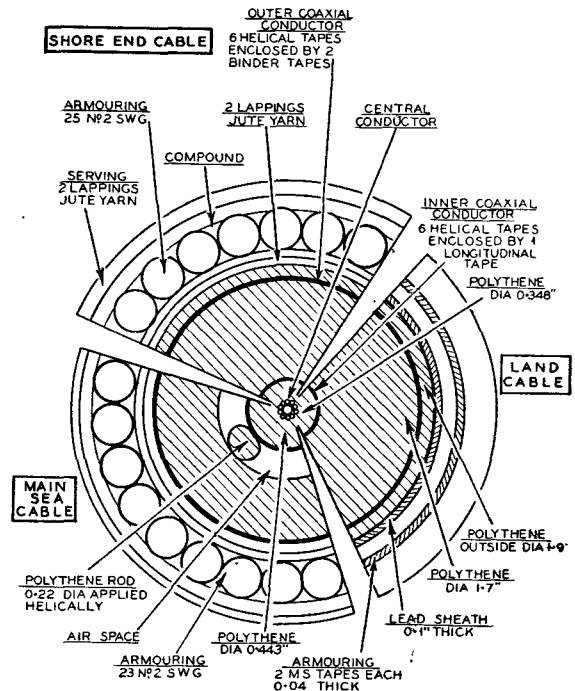

FIG. 1.—CROSS SECTIONS OF THE THREE PARTS OF THE CABLE.

Since the cable has an air space it has been necessary to provide stoppers of solid polythene at approximately 750-yard intervals to prevent water flowing along the whole length of the cable when a fault occurs. The signal currents are carried on the inner and outer conductors, the centre wire not being used for communications purposes, but during the manufacture and works tests. The characteristic impedance of the cable is approximately 60 ohms and the attenuation after laying is shown in Fig. 3, on which the attenuation of the Nos. 4 and 5 cables is also given for comparison.

#### The Laying Operation.

The land sections of the submarine cable were laid out well in advance of the main operation and terminated in each repeater station ready for the shore ends. The shore end at Aldeburgh was laid on the 11th October, 1947, by H.M.T.S. *Alert*, which was able to get close to the shore at Aldeburgh, and the cable was floated ashore on barrels drawn firstly by a lorry and later by a winch when the pull became too great. The *Alert* then steamed seawards and laid approximately two nauts of cable and then cut and buoyed the end. The joint between the land section and the shore end was made the following day. The operation was repeated on the Domburg side on the 15th October, but in this case, owing to shallow water, nine nauts of cable were laid out before cutting and buoying. The laying of the shore ends in advance was necessary since the larger ship required for laying the main section of the cable would not be able to come



close into shore. Also it was expected that the main section would be ready for laying in November when rougher weather was more probable and it was considered advisable to lay the shore ends as soon as possible. Fig. 4 shows the laying of the shore end at Domburg.

The main length of the cable was laid by H.M.T.S. *Monarch*.<sup>1</sup> This ship, owing to her great size, was well suited for the task and was easily able to hold the whole length of the cable, weighing 1,400 tons, in only two of her four tanks. After loading at the manufacturers' works, she left Greenwich at 10 a.m. on the 24th November and steamed to Aldeburgh. On the 25th November, the *Monarch* proceeded to buoy the route, laying five buoys in all at approximately 10 naut intervals. Advantage was taken of two convenient navigation buoys at points close to the intended route. During the laying of the buoys a gale sprang up and the last two were laid under difficult conditions. The ship then returned to Aldeburgh in a full gale and anchored for the night. On the next day the gale had subsided sufficiently for the main

task of laying the cable to commence and the buoyed end of the previously laid shore end was brought on board and the joint between this and the main section in the ship's tanks commenced.

In making a joint on this type of cable the two ends are firstly plugged solid with polythene to form stoppers. This is done by injecting molten polythene under pressure into the air space. The centre conductor and the inner coaxial conductor are then joined through and the joint placed into a mould which is 1.7 in. diameter. Molten polythene is then injected into the mould under pressure. After cooling the joint is removed, the outer conductor tapes replaced and jointed and the armouring wires spliced.

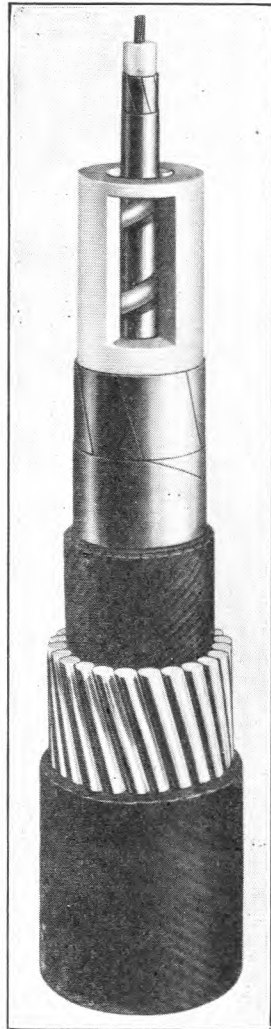

FIG. 2.—CONSTRUCTION OF THE CABLE. (THE POLYTHENE ROD CAN BE SEEN THROUGH THE "WINDOW".)

The ship commenced to pay out at 6.55 a.m. on the 27th November and continued at the rate of five knots until 25.4 nauts had been laid, when she stopped in order that a faulty joint could be cut out and a new

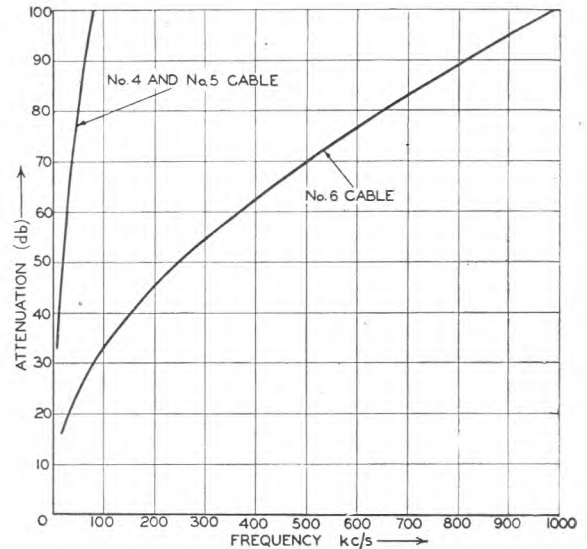

FIG. 3.—ATTENUATION OF NO. 6 CABLE AFTER LAYING, COMPARED WITH THAT OF NOS. 4 AND 5 CABLES.

one made. She commenced to pay out cable again at 11.30 p.m. the same evening, and at 9.55 a.m. on the following day was close to the buoy marking the Domburg shore end. This was then hauled aboard and the final joint commenced. The joint and splice were completed at 10.18 p.m. that evening and the final bight was slipped at 10.53 p.m. A view of the cable being paid out is given in Fig. 5.

During the whole period of the laying, tests were continuously made from the ship to Aldeburgh repeater station and later to Domburg repeater station when the shore end at this side had been brought on board. After the final bight had been



FIG. 4.—H.M.T.S. *Alert* LAYING SHORE END AT DOMBURG.

<sup>1</sup> P.O.E.E.J., Vol. 39, p. 129.



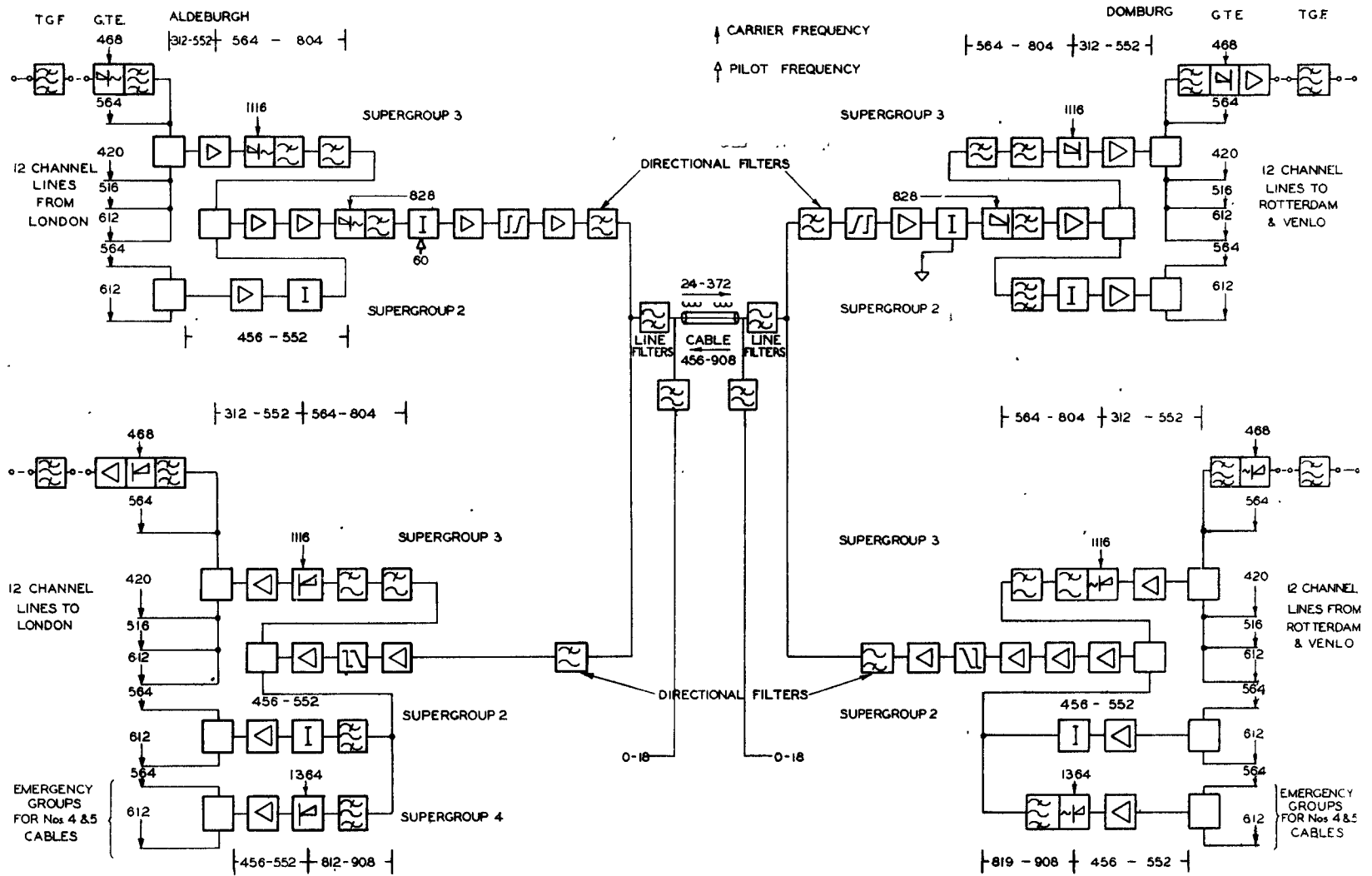

FIG. 7.—SIMPLIFIED BLOCK SCHEMATIC OF TERMINAL EQUIPMENTS. (ALL FREQUENCIES IN KC/S).



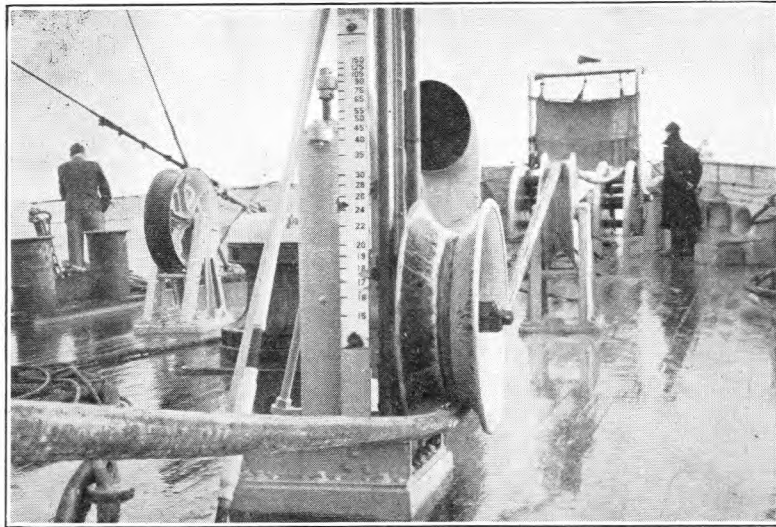

FIG. 5.—FOREDECK OF H.M.T.S. *Monarch* WHILE PAYING OUT CABLE.

slipped, through-tests of insulation and conductor resistance were immediately taken from the ends and a signal sent to the ship that the cable was satisfactory. The ship then proceeded to Flushing, where she anchored for the remainder of the night. On the following day the *Monarch* proceeded to recover the buoys laid to mark the route. The last two buoys had to be picked up in darkness since the lights on them had been extinguished. The fact that the ship could

be brought so close that the buoys could be found in the beam of a search-light is an indication of the very accurate navigation of the ship throughout the whole operation. After anchoring for the night off Aldeburgh the *Monarch* returned to the Thames but was fogbound in the estuary on the 1st December and docked at Greenwich in the afternoon of 2nd December.

The final length of the cable between the two terminal repeater stations at Aldeburgh and Domburg is 81.438 nautical miles, and the final test figures are:—Conductor resistance with the inner and outer coaxial conductors looped at the distant end, 186 ohms ;

insulation resistance between inner coaxial conductor and earth, 12,850 megohms absolute, corresponding to the very high figure of 1,046,000 megohms per nautical mile. The capacitance of the inner to the outer coaxial conductor is  $11.04 \mu\text{F}$ . Fig. 6 shows the submarine cable termination panel at Aldeburgh with the covers removed.

#### The Terminal Equipment.

The cable is worked on a "grouped" basis, that is, the "go" and "return" channels are carried over the same conductors in different frequency ranges, and with the present terminal equipment has a capacity of seven 12-circuit groups, i.e. 84 circuits. In the direction Aldeburgh to Domburg, the seven groups occupy the frequency range 24 to 372 kc/s and in the return direction the range 456 to 804 kc/s. The attenuation at 804 kc/s between the two repeater stations is 89 db. Fig. 7 shows a simplified diagram of the circuit arrangements at the terminal repeater stations.

In designing the terminal equipment for assembling the circuits into the carrier frequency range for transmission over modern submarine cable systems, endeavours are usually made to employ as much equipment of a standard nature as possible. This principle has been followed and on this system one bay only of special equipment is necessary at each submarine terminal station. Following the group distribution frame where the 12-circuit groups are in the frequency range 60 to 108 kc/s, five such groups, after modulation, are first combined via standard group translating equipment to form one supergroup in the basic supergroup range 312 to 552 kc/s. This supergroup then passes through a further stage of modulation to translate it into position 3 of the standard supergroup spectrum, i.e. the frequency range 564 to 804 kc/s. The remaining two groups also pass via standard group translating equipment to provide a band occupying two-fifths of a basic supergroup in the frequency range 456 to 552 kc/s which is then combined with the complete supergroup in position 3 to form a complete spectrum of seven groups occupying the frequency range 456 to 804 kc/s. The signals so combined then pass into the special submarine system bay. Fig. 8 shows in diagrammatic form the stages of modulation from the G.D.F. to the submarine cable. For the direction Domburg to Aldeburgh no further modulation process is required and the signals pass to line in this frequency range. For the direction Aldeburgh to Domburg, however, a further stage of modulation is necessary. This modulation employs a carrier frequency of 828 kc/s and translates the combined group to the frequency range 24 to 372 kc/s for transmission over the cable.

The output level to the submarine cable of the top channel at Domburg in the high frequency direction is +20 db. and over the transmitted band of 456–804 kc/s, 10 db. of pre-equalisation is provided and thus the lowest channel at the frequency of 456 kc/s is

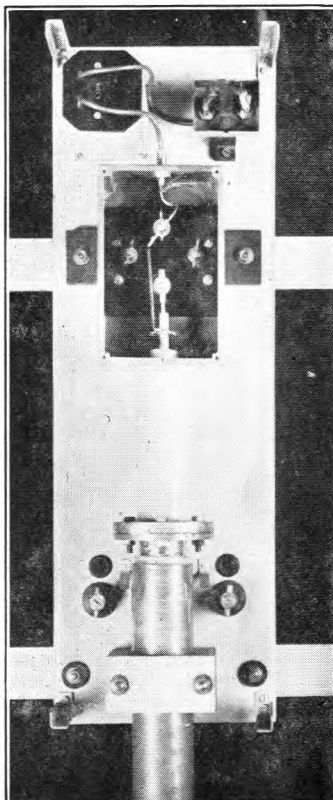

FIG. 6.—CABLE TERMINATION PANEL.

transmitted at +10 db. Pre-equalisation is provided to reduce the total loading on the transmitting amplifier and also to reduce the amount of equalisation necessary at the receiving end. This has the further

maintenance level measurements. Spare amplifiers are mounted on each side of each bay and may be connected into circuit via coaxial change-over jacks. All power supplies to each amplifier are taken through

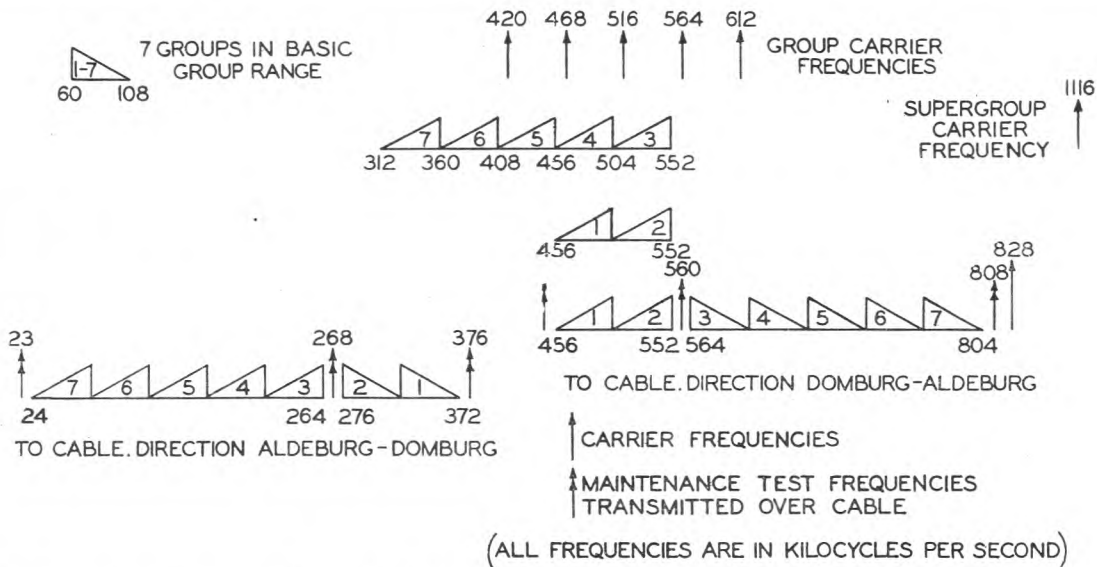

FIG. 8.—MODULATION STAGES AT TERMINAL EQUIPMENT (EMERGENCY EQUIPMENT FOR NOS. 4 AND 5 CABLES OMITTED).

advantage that all the equalised sections at this end may be placed after the first receiving amplifier, which thus immediately follows the directional filters. The received signals do not therefore suffer any reduction in level at this point, where they are at their lowest value, as would be the case if one or more sections of the receiving equaliser preceded the first receive amplifier. In the lower frequency direction of transmission the output level of the top channel at Aldeburgh is +5 db., and here also pre-equalisation to the extent of 10 db. over the range 24–372 kc/s is provided.

All amplifiers on the submarine system bays are of the same type for both the high and low frequency bands with the exception of the transmitting amplifier for the 456–804 kc/s band at Domburg. The former amplifiers have three stages and are fully screened. The gain has a fixed value of 40 db. with feedback. Without feedback the gain is 74 db. The valves used are of the CV 1091 type throughout and each stage is equipped with two valves in parallel, but the amplifier will give the specified performance with one valve only in each stage. Fig. 9 gives a view of this amplifier. The transmitting amplifier at Domburg has two stages, the first having two CV1091 valves in parallel and the second stage four CV1947 valves in parallel. This amplifier also will give the required performance with half the valves in each stage. The normal gain is 25 db. and without feedback is 50 db. The overload point is a little over +40 db. The input and output impedance of all amplifiers is 75 ohms unbalanced. In addition to the normal input and output coaxial jacks which are situated under the covers, input and output level coaxial jacks are provided projecting through the covers for normal

screwed connectors mounted on the main panels and as the whole amplifier is mounted on a sub-panel it may easily be taken off the bay for maintenance. The H.T. supply is at 250 V. As this is not a standard repeater station supply, the whole power feed of each submarine system bay is supplied from A.C. power panels fitted on each side of the bay. All leads from the power panels are taken via connecting strips so

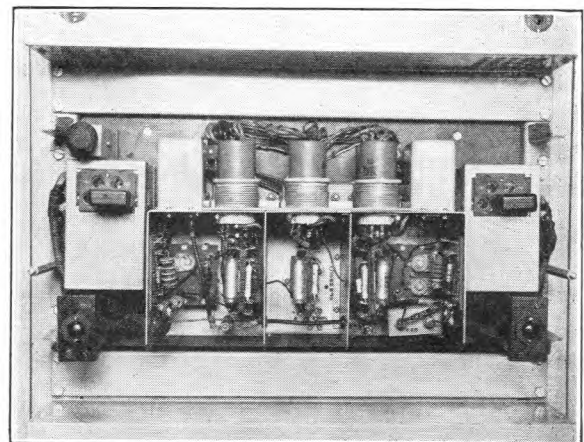

FIG. 9.—40-DB. AMPLIFIER (COVERS REMOVED).

that a faulty panel may be rapidly disconnected and a spare one substituted. Interlocks are fitted on all power panels but not on the amplifiers which have covers held on by knurled screws. Special precautions have been taken at the high- and low-level portions of the circuit against external interference and crosstalk,



and at each terminal the line filters, directional filters and receive equalisers have been built with double copper screens. The directional filters (see Fig. 10),

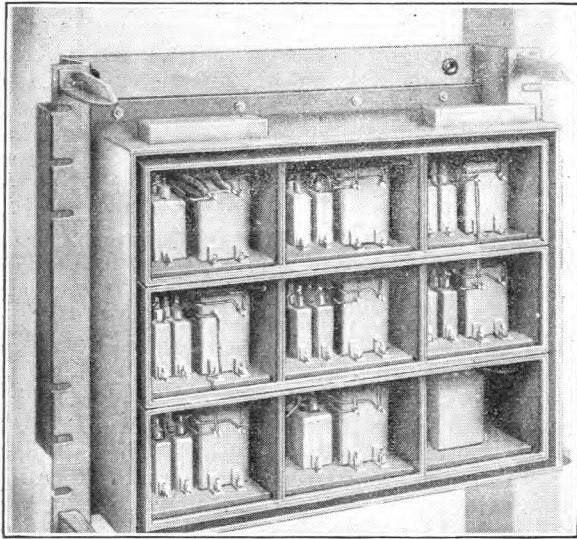

FIG. 10.—DIRECTIONAL FILTERS (COVERS REMOVED).

which are one of the most important components of a single cable submarine scheme, and are therefore duplicated, are fitted with air-cored coils throughout. The normal practice on lower frequency systems is to use toroidal wound coils for these filters, but in this case solenoidal coils have been used. This type of coil can be wound and adjusted more easily than the toroidal type but has a greater external field. Owing to the high frequency involved on this system the inductance values are comparatively small, and since the coils must be adjusted to very close limits, fractional turns can be more easily obtained on a solenoidal coil. These have naturally required more efficient screening, but the  $Q$  obtained has been at least as good as with toroidal coils. The directional filters have a suppression greater than 110 db. in their stop ranges and the high-pass filter and low-pass section have been mounted back to back on each side of the bay in order that the connecting lead may be as short as possible. This reduces to a minimum the possibility of mutual impedance in the earthed conductor of the lead connecting the two. The line filters separating the audio band from the main transmission band are constructed on the same lines as the directional filters. Fig. 11 indicates the earthing and screening arrangements

adopted at each terminal. It will be seen that coaxial chokes have been inserted in the main coaxial pair at each side between the terminal equipments and the cable. These chokes are mounted on the submarine cable termination panels, and serve the purpose of isolating the sea earth from the system earth, thus allowing the system earth to be placed at the junction of the directional filters which is the optimum point for suppression in their stop ranges. The chokes also prevent any longitudinal currents and radio signals (which flow along the outer coaxial conductor of the cable) from entering the terminal equipment. The equalisers are of the conventional constant impedance type and are adjustable to enable small changes of attenuation slope of the cable, due to winter and summer temperature changes, to be corrected. Line filters have been fitted to enable the frequency band 0–18 kc/s below the main frequency spectrum to be used either for a music or speaker circuit. All circuit impedances throughout the submarine system bay have been standardised at 75 ohms with the exception of the line and directional filters, which are designed to 60 ohms impedance to match the cable. A 60 kc/s pilot frequency is transmitted from Aldeburgh to Domburg to synchronise the frequency generator at the latter station. Fig. 12 is a view of the special submarine bay with covers removed and Fig. 13 shows the terminal equipment at Aldeburgh.

#### *Emergency Arrangements for the Nos. 4 and 5 Cables.*

Development of the cable and the terminal equipment proceeded simultaneously, and at the start a conservative estimate had to be made of the total attenuation of the cable when laid. On systems where the cable attenuation can be determined accurately in the early stages of the equipment design it is usual to allocate the frequency bands so that the attenuation of the top channel at the highest frequency is 100 db. With a transmitting level of +20 db. this enables the signal-to-resistance noise in the worst channels to be predetermined accurately to be 57 db. (i.e. 2 mV psophometric E.M.F. at a zero point). On this basis the new cable could carry 108 circuits, and if no change in the cable attenuation occurs, the terminal equipment may be converted to carry an extra 24 circuits at some time in the future. Use will be made of the extra bandwidth available above 804 kc/s, however, in the event of a cable fault on one of the existing No. 4 or No. 5 cables. Modulation equipment has been provided (not shown on Fig. 8 but indicated on Fig. 7), which will allow a further band of frequencies in the range 812–908 kc/s to be transmitted over the new cable in the Domburg-Aldeburgh direction. Thus in the future, if either the No. 4 or 5 cable suffers a fault, the undamaged cable will be arranged as a "Go" cable carrying two 12-circuit groups in the Aldeburgh-Domburg direction, and for the return direction of transmission, these groups will be modulated into the frequency range 812–908 kc/s and will be transmitted over the No. 6 cable.

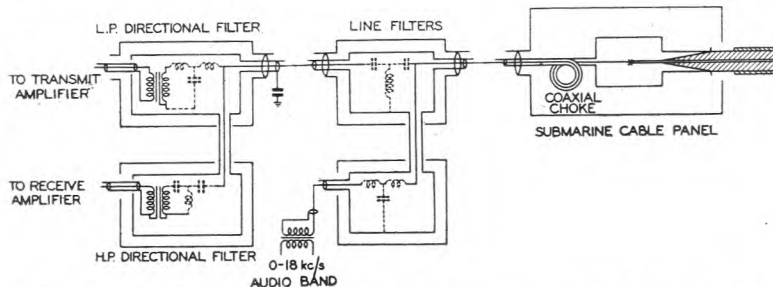

FIG. 11.—EARTHING AND SCREENING ARRANGEMENTS AT ALDEBURGH.

In the past it has always been difficult to free a submarine cable for special tests, and even then only for a short period. This is likely to be one of the problems in fitting submerged repeaters to working

cable is also an international cable, i.e. it crosses a frontier, and therefore the frontier envelopes of the 12-circuit groups must be maintained in accordance with C.C.I.F. regulations.

For the line-up and day-to-day maintenance of the submarine system itself facilities are provided so that test currents may be sent on three frequencies covering the band of frequencies in each direction. In the low-frequency direction, these frequencies are 23, 268 and 376 kc/s, and in the high-frequency direction they are 452, 560 and 808 kc/s. It will be observed that these test signals are either just above or below the signal frequency ranges or are in the gap produced by a standard assembly of supergroups. At each coastal terminal station, selective apparatus is provided capable of measuring individually the level of any of these frequencies whilst all channels of the system are in traffic. This will enable the submarine system to be kept under observation and maintained satisfactorily within the necessary limits. In addition, fully selective measuring sets have been provided at each terminal repeater station. These sets, which have a selective bandwidth of approximately 2 kc/s, can measure any test signal on the system throughout the whole range of frequencies transmitted. One of their main uses will of course be the checking of the envelopes of each of the twelve-circuit groups to ensure that it is set up and maintained within the limits laid down for the frontier levels of 12-circuit systems, in accordance with C.C.I.F. regulations. They will also be available for special tests and for the localisation of more difficult faults which may occur. This system is only

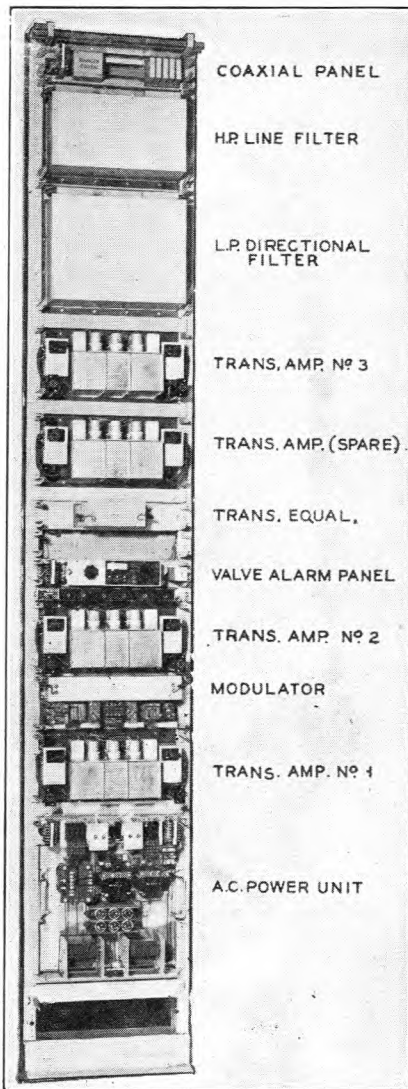

FIG. 12.—SUBMARINE SYSTEM BAY (COVERS REMOVED).

submarine cables in the future when a period of weeks may be required with the cable out of traffic. The scheme described above will help to solve this problem on this particular route.

#### Testing Arrangements.

A very necessary requirement of all transmission systems is the provision of facilities and testing equipment for lining up and maintenance. On wide band carrier systems this is a problem which has many difficult features, particularly if a system is a link between two other high-frequency systems. The new Aldeburgh-Domburg cable system is one of these, since the circuits are extended by 12-circuit carrier systems in each country without passing through the audio range at the coastal repeater stations. The

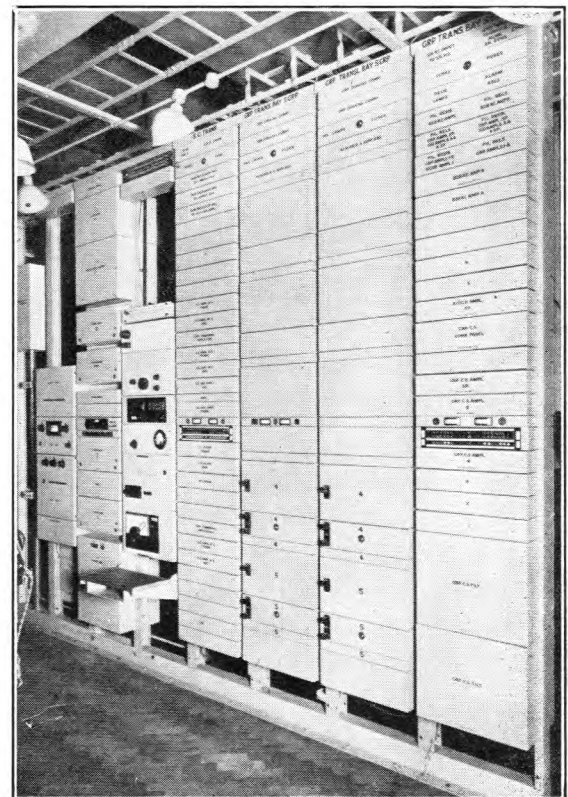

FIG. 13.—GENERAL VIEW OF EQUIPMENT AT ALDEBURGH.

the second international high-frequency system between this country and the Continent carrying 12-channel groups from London to distant terminal stations on the Continent, the first system being the London-Dover-Calais-Paris circuit. The experience obtained in the maintenance measurements on this earlier system has been of very valuable assistance in determining the procedure to be adopted on such systems, and the results on this new system will be watched with interest.

#### *Lining Up and Overall Tests.*

After completion of the tests on the cable, the terminal equipments were connected and lining up commenced. The first stage was that of adjusting the submarine system bays for levels and equalisation and was carried out by sending H.F. tones over the system from the input of the submarine system bays. When all the necessary adjustments had been made on these bays the group and supergroup translating equipment was connected and adjusted to the standard levels of  $-8$  and  $-37$  db. at the G.D.F.

Channel equipment was then connected to each 12-circuit group in turn and the system was checked for radio and other extraneous noise. None could be detected on any channel, although, as a more stringent check, the received gain was temporarily increased from 75 db. to 95 db. Psophometric noise measurements with the system idle were then taken at both ends on each of the 84 channels. The figures on the highest group at Aldeburgh, the most severe direction, are given below.

Static Noise at a Point of Zero Level.

Channel Noise Voltage (Millivolts P.D.)	1	2	3	4	5	6
	0.63	0.63	0.63	0.57	0.63	0.63
Channel Noise voltage (Millivolts P.D.)	7	8	9	10	11	12
	0.57	0.57	0.57	0.57	0.57	0.57

This corresponds to a signal-to-noise ratio of approximately 62 db.

The system was next tested for intermodulation. The first test was made by transmitting over the system a number of pure tones at normal test level and measuring the noise on the channels in which the second and third intermodulation products of the tones would fall. The second test was rather unusual. Due to the fact that two 12-circuit groups are working on the Nos. 4 and 5 cables, it was possible to obtain a sample of live traffic being carried over one of these groups. Arrangements were made to leak off the

signals by means of a high impedance tap, amplify them to normal level, and then lead them via a six-way branching network over six of the seven groups of the new system. This was carried out at Aldeburgh and at Domburg, the "Go" of each group was looped to the "Return." Psophometric noise measurements were then taken on each channel of the seventh group. The tests were repeated until all combinations of six out of the seven groups had been loaded. The test can be regarded as very much more severe than normal conditions of traffic in which the speech peaks over the six groups would have a more random distribution, but in no case did the noise figures exceed 1 mV P.D. at a zero point.

On completion of the tests at the two coastal terminal stations, lining up of the through 12-circuit groups was commenced from London. The initial allocation of the groups is three London-Venlo groups, three London-Rotterdam groups and one Aldeburgh-Rotterdam group. The twelve circuits on the latter group are extended to London on audio cables, the reason for this being twofold, namely it enables the maintenance staff at Aldeburgh, which is the submarine system control station, to monitor the channels, and secondly, it provides a small measure of alternative routing in this country in the event of a fault on the inland carrier cable.

The cable was formally opened on the 11th December, 1947, when simultaneous ceremonies were held in London and the Hague, and the Postmaster-General exchanged greetings with the Director-General of the Netherlands Administration.

#### *Acknowledgments.*

A large international system such as this one could not be brought to completion without the co-operation of many parties. The author's thanks are due especially to all the engineers of the Netherlands Administration who have co-operated so helpfully through the whole work and also to Submarine Cables, Ltd., who manufactured the cable; to Standard Telephones and Cables, Ltd., who provided the terminal equipment at both sides; to the Submarine Superintendent and the Captain, officers and men of H.M.T.S. *Monarch*, and also the Captain, officers and men of H.M.T.S. *Alert*; to the Test and Inspection Branch who were responsible for the tests during manufacture and final test after laying; to the Research Branch, who designed and built the fully selective measuring sets; and lastly to the staff of Aldeburgh repeater station, and the author's many colleagues in the Main Lines Branch of the Engineer-in-Chief's office.



# Notes on the Exponential Distribution in Statistics

N. W. LEWIS, Ph.D. (Eng.), M.I.E.E.

U.D.C. 519.2: 621.385.1

Written in terms of the life statistics of electronic valves, the article gives some elementary notes on the exponential distribution and indicates its relation with the Poisson distribution.

## Introduction.

FEW text-books on probability or statistical theory devote much space to the exponential distribution or indicate its relation with the better-known Poisson distribution.<sup>1</sup> Yet the subject is of practical importance and some elementary notes on it may be of interest to students. It is not proposed to offer a rigorous mathematical treatment but merely to consider the more practical aspects in terms of a particular application, the life-distribution of electronic valves. This choice of theme was suggested by the fact that a recent study of life-records of a certain type of valve used under continuous service conditions in line transmission equipment showed that the distribution of life was approximately exponential. Such an unexpected result, valve lives being generally assumed to tend towards normal distributions, aroused interest in the various implications of the exponential distribution.

The actual results for about 700 valves of the type mentioned are shown by the dotted points in Fig. 1,

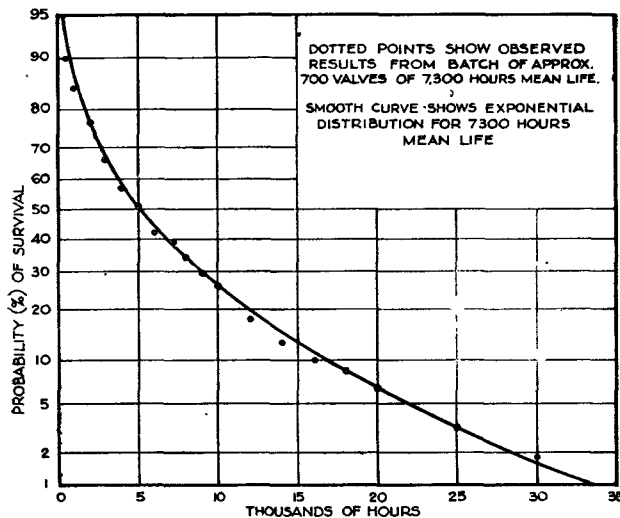

FIG. 1.—EXAMPLE OF EXPONENTIAL LIFE—DISTRIBUTION

and the corresponding theoretical exponential distribution is shown by the smooth curve. An "arithmetic probability" scale is used to indicate the departure from a normal distribution, which would have appeared as a straight line. It will be shown later that the exponential distribution meant, in effect, that the valves failed at random. The practical importance of this conclusion is that it implied lack of control, probably in the conditions of service or rejection of the valves. Further investiga-

tion and corrective action were thus shown to be necessary in the interests of economy and reliability of service.

Although the discussion is restricted to this one somewhat academic application, the principles will be understood to apply also to a wide variety of other subjects.

## Exponential Distribution.

In its simplest form, the exponential distribution is given by :

$$p(t) = \frac{1}{T} e^{-t/T}$$

where  $e$  is the base of natural logarithms,  $T$  is a time-constant (the mean life) and  $t$  is a time-variable which may be given any positive value between zero and infinity. The interpretation of this equation may be indicated by writing :

$$p(\tau) \cdot d\tau = \left( \frac{1}{T} e^{-\tau/T} \right) d\tau$$

to show that the differential probability  $p(\tau) \cdot d\tau$  of, for example, a valve failing at some instant between  $t = \tau$  and  $t = \tau + d\tau$  (having been in service since zero time) is given by the area of a segment under the curve, as illustrated in Fig. 2.

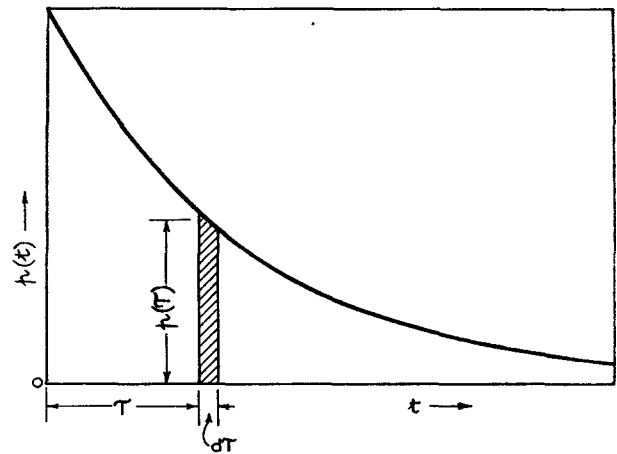

FIG. 2.—EXPONENTIAL DISTRIBUTION.

The probability of a valve failing at some instant between  $t=0$  and  $t=\tau$  is given by :

$$\int_0^{\tau} \frac{1}{T} e^{-t/T} \cdot dt = 1 - e^{-\tau/T}$$

This expression represents an "expiry" curve showing the probability of the life of a valve being less than any given value. Valve-life statistics are

<sup>1</sup>Doust and Josephs, *P.O.E.E.J.*, Vol. 34, p. 139.

more commonly expressed, however, by a "survival" curve showing the probability of a valve exceeding any given life. This is the simple complement of the "expiry" curve, i.e.  $e^{-t/T}$ .

It will be seen that the exponential distribution has only a single parameter, the time-constant  $T$ . This is equal to the mean life because, in the usual form :

$$\left\{ \int_0^{\infty} \left( \frac{1}{T} \cdot e^{-t/T} \right) t \cdot dt \right\} / \left\{ \int_0^{\infty} \left( \frac{1}{T} \cdot e^{-t/T} \right) \cdot dt \right\} = T$$

Also,  $T$  is equal to the standard deviation of the distribution because :

$$\left[ \left\{ \int_0^{\infty} \left( \frac{1}{T} \cdot e^{-t/T} \right) (t-T)^2 \cdot dt \right\} / \left\{ \int_0^{\infty} \left( \frac{1}{T} \cdot e^{-t/T} \right) \cdot dt \right\} \right]^{1/2} = T$$

Table 1 gives a number of points on the generalised exponential "survival" curve. It shows, for example, that if the lives of valves follow an exponential law only 36.8 per cent. of a batch may be expected to survive the mean life of the batch, and that 39.3 per cent. may be expected to fail within half the mean life.

TABLE 1

Proportion of mean life		Probability of survival	
0.020	1.00	0.98	0.368
0.051	1.20	0.95	0.30
0.105	1.50	0.90	0.223
0.223	1.61	0.80	0.20
0.358	2.00	0.70	0.135
0.500	2.30	0.607	0.10
0.510	3.00	0.60	0.05
0.693	3.92	0.50	0.02
0.916	4.60	0.40	0.01

The undesirability of the exponential distribution may be emphasised by considering the case of a valve manufacturer asked to guarantee that not more than 5 per cent. of his valves shall fail before giving 10,000 hours' (1.14 years) continuous service. If he assumed an exponential distribution, he would have to design his product for a mean life of no less than  $1.14/0.051 = 22.4$  years. He might, however, be encouraged by the reflection that about 1 per cent. of the valves could be expected to outlive  $22.4 \times 4.60$  years—more than a century!

Fig. 2 shows that a valve is more likely to fail during any given interval than during any equal later interval, or in other words a valve is more likely to "die young." This does not mean, however, that there would be any advantage in applying a pre-service ageing process, i.e. in operating a batch of valves for some period under dummy-load conditions to eliminate short-lived individuals. To make this clear a simple numerical example is given in Table 2, showing the results to be expected from a batch of valves having a mean life of two years.

The last column shows that although 39.3 per cent. of the batch would be eliminated by a one-year pre-ageing process, still 39.3 per cent. of the survivors would fail during the next year, and so on.

TABLE 2

Year	Number surviving at end of year, expressed as proportion of whole batch	Number failing during year, expressed as proportion of whole batch	Number failing during year, expressed as proportion of number surviving at beginning of year
1st	.607	$1.00 - .607 = .393$	$.393/1.00 = .393$
2nd	.368	$.607 - .368 = .239$	$.239/.607 = .393$
3rd	.223	$.368 - .223 = .145$	$.145/.368 = .393$
4th	.135	$.223 - .135 = .088$	$.088/.223 = .393$

An alternative form of expression of this characteristic of the exponential distribution, indicating its random nature, is that the probability of a valve failing is independent of the length of time it has already been in service. For example, the probability that a valve which survives until noon on one day will fail before noon on the next day is constant, determined only by the parameter  $T$ .

Another conclusion that may be drawn from the foregoing is that the practice of replacing working valves by new ones at fixed intervals is useless as a means of reducing the risk of failing in service, assuming that the valves would follow exponential distributions if undisturbed.

#### Relation with Poisson Distribution.

Considering a set of points distributed individually and collectively at random along a line, with an average of  $k$  points per unit length, it may be shown that the probability of exactly  $r$  points occurring in any line-length of  $x$  units is given by the Poisson distribution :

$$P(r, x) = (kx)^r \cdot e^{-kx} / r!$$

A full discussion of the significance of the phrase "individually and collectively at random" has been given by T. C. Fry<sup>2</sup>, but for the purpose of these notes it may be taken as meaning simply "entirely at random."

The points on the line may be regarded as a series of events occurring at random instants along the axis of time, with a mean interval  $T$  between consecutive events. Then, writing  $t$  instead of  $x$ , and  $1/T$  instead of  $k$ , the Poisson distribution becomes :

$$P(r, t) = (t/T)^r \cdot e^{-t/T} / r!$$

giving the probability of exactly  $r$  events occurring during any period of length  $t$ .

The differential probability of an interval of length  $t$  to  $t+dt$  occurring between consecutive events is given by the product of the probability of no events occurring during a period  $t$  and the probability of one event occurring during a period  $dt$ , i.e. :

$$p(t) \cdot dt = P(0, t) \times P(1, dt) \\ = e^{-t/T} \times (dt/T) \cdot e^{-dt/T}$$

which becomes, in the limit, the equation of the exponential distribution, viz. :

$$p(t) = \frac{1}{T} \cdot e^{-t/T}$$

<sup>2</sup>Probability and Its Engineering Uses. D. Van Nostrand, 1928.

The random nature of the exponential distribution is thus again indicated by the foregoing demonstration that the intervals between consecutive random events are distributed exponentially. The converse is not necessarily true, but if, for example, a single-valve amplifier is kept in continuous service with a batch of valves of exponential life-distribution, each valve being left in service until it fails, then the successive replacements may justifiably be assumed to be a series of random events following a Poisson distribution.

#### Alternative Causes of Failure.

Consider a batch of valves of which each individual is liable to fail from two alternative causes, e.g. "emission failure" and "heater failure," and assume that each cause operates independently in accordance with an exponential distribution, the time-constants being  $T_1$  and  $T_2$  respectively. Then the overall life-distribution, combining both causes of failure, will also be exponential with a mean life—

$$T = T_1 T_2 / (T_1 + T_2).$$

The number of valves expected to fail from each cause will be inversely proportional to the respective time-constants, i.e. the life-records of the batch would be expected to show a proportion  $T_2 / (T_1 + T_2)$  of emission failures and a proportion  $T_1 / (T_1 + T_2)$  of heater failures. It is to be noted that a separate analysis of the lives of valves recorded as failing from either cause would show the same exponential distribution (with mean life  $T$ ) as would analysis of the whole batch.

In general, for  $n$  alternative causes of failure, of time-constants  $T_1, T_2 \dots T_n$ , the overall time-constant is given by:

$$T = 1 / \sum_{r=1}^n 1/T_r$$

As another simple illustration, consider the incidence of faults due to valve-failures in a 3-stage amplifier, assuming that each of the three valves is kept in service until it fails and is then replaced by a new one. If all the valves have an exponential life-distribution with a mean life of two years, the intervals between consecutive faults will be distributed exponentially with a mean interval of eight months, and the faults may therefore be expected to follow a Poisson distribution with an average of 1.5 faults per year.

#### Combined Life of a Group of Valves.

Each amplifier-stage of a submerged repeater may be provided with three valves used successively, the second being switched into service when the first fails, then the third when the second fails. The total life of the stage is therefore the combined life of the group of three valves. It is unlikely that the lives of submerged-repeater valves will follow exponential distributions, but the problem of finding the combined life-distribution of such groups is of more general interest because of its similarity to the elementary

sampling problem of finding the distribution of the means of a series of samples each containing three valves.

The effect of grouping valves of exponential life-distribution may be demonstrated in a simple form by making use of the relation with the Poisson distribution. In general, the differential probability that the combined life of a group of  $n$  valves will fall between  $t$  and  $t+dt$  is given by the product of the probability of  $n-1$  failures occurring during a period  $t$  and the probability of one failure occurring during a period  $dt$ , i.e.:

$$p(t).dt = P(n-1, t) \times P(1, dt)$$

which leads to the results shown in Table 3.

TABLE 3

n	Combined life of group of n valves		
	p(t)	Mean	Standard deviation
1	$\frac{1}{T} \cdot e^{-t/T}$	T	T
2	$\frac{1}{T^2} \cdot t \cdot e^{-t/T}$	2T	$\sqrt{2}T$
3	$\frac{1}{2T^3} \cdot t^2 \cdot e^{-t/T}$	3T	$\sqrt{3}T$
4	$\frac{1}{6T^4} \cdot t^3 \cdot e^{-t/T}$	4T	2T

These distributions, shown plotted in generalised form in Fig. 3, afford a striking demonstration of the fact that the distribution of the means of samples taken from almost any non-normal population tends to become normal as the size of sample is increased. It will be seen that even a group of three shows

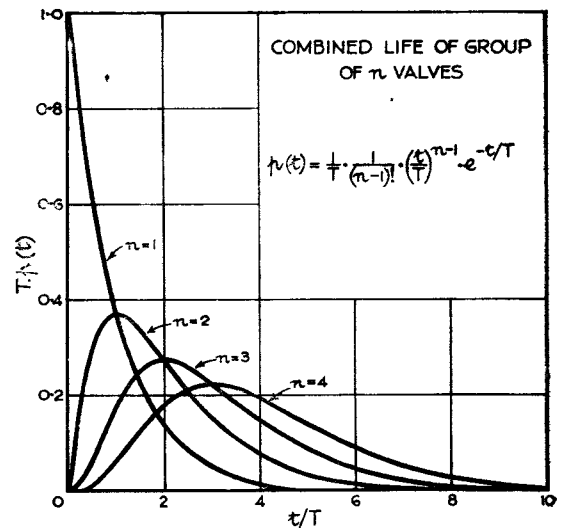

FIG. 3—COMBINED LIFE OF GROUP OF VALVES—DISTRIBUTION CURVES

considerable progress in the evolution from the original unsymmetrical exponential curve towards the symmetrical bell-shaped curve of a normal distribution.



# Pulse Techniques in Coaxial Cable Testing

F. F. ROBERTS, B.Sc.(Eng.), A.M.I.E.E.

U.D.C. 621.317.333.4 : 621.315.212.029.6

An explanation is given of the principles of fault location by pulse technique methods parallel with those employed in radar. The application of the technique utilising 3 microsecond D.C. pulses and a cathode-ray tube display makes possible the rapid location of intermittent faults on coaxial cables. Reference is made to equipment of later design, employing pulses of 20 Mc/s carrier, developed for measuring small impedance irregularities under conditions which can be correlated with those obtaining in long distance television relay systems.

## Introduction.

IN addition to the two coaxial tubes, the standard type of coaxial cable now in use for long distance multi-channel telephony contains a number of paper-insulated audio pairs for supervisory purposes. The insulation of the tubes is normally very high and in practice any ingress of moisture into the cable is detected and located by D.C. tests on one of the audio pairs. A permanent short-circuit fault in one of the tubes would be most readily located by a D.C. test on the tube, and a permanent open-circuit fault would be quite simply located by a low-frequency capacitance test on the tube, or even by a measurement of A.C. charging current when the 50 c/s power voltage is applied to the cable through a suitable transformer. A series resistance, due for example to a dry soldered joint in the inner or outer conductor of a coaxial tube, could not, however, readily be located by either of these methods, but would require a sequence of impedance measurements at one or other end of the cable section, to be made at a sufficient number of frequencies to determine the outline of the impedance/frequency characteristic. The damped sinusoidal variations of impedance with frequency could then be interpreted as due to reflections occurring at one or more points in the cable. Fig. 1 illustrates the impedance/frequency characteristics obtained in this way respectively for one and for several simultaneous points of reflection. In the latter case, if the several faults are all of small magnitude, the deviation of the resultant sending end impedance of the cable-length from the mean at any frequency approximates to the vector sum of the deviations that would be obtained with each fault singly. Conversely, from a given characteristic, such as that of Fig. 1 (b), the periodicities and amplitudes of the separate sinusoidal components can be derived by Fourier analysis, and these enable the distance and the magnitude respectively of the impedance mismatch causing each reflection to be calculated.

A considerable number of impedance measurements is required to determine the distance of even a single mismatch with useful accuracy. If the cause of the mismatch, e.g. a faulty cable joint or termination, is intermittent, this method of testing is of no value except in its most recent form employing a rapidly-sweeping oscillator frequency and a cathode-ray oscilloscope for continuous impedance indication. When it is desired to obtain

information as to the magnitude and distribution of the numerous small impedance irregularities inherent in any cable, even if the continuously-swept oscillator

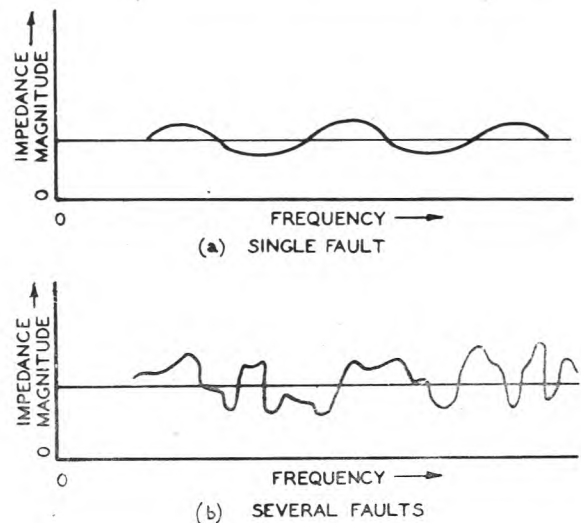

FIG. 1.—TYPICAL IMPEDANCE/FREQUENCY CHARACTERISTICS

technique is used, the analysis of the results to obtain this information becomes a complex task.

By the application and development of pulse techniques parallel with those employed in radar, a tester for the rapid location of intermittent faults was produced during the war, and, more recently, equip-



FIG. 2.—CABLE FAULT LOCATOR.

ment has been developed for the direct measurement of very small impedance irregularities in cables intended for television transmission.

### SIMPLE FAULT LOCATION.

The principles of fault location using the pulse technique will be described with reference to the instrument developed in 1942 (Fig. 2). A block schematic diagram of the arrangement of the test circuits with the faulty cable is shown in Fig. 3, and

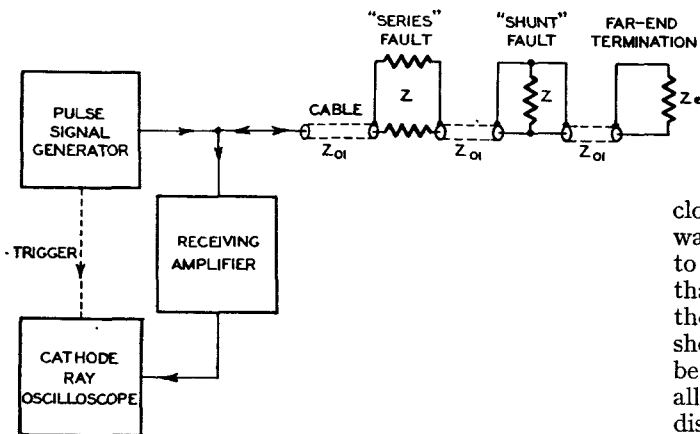
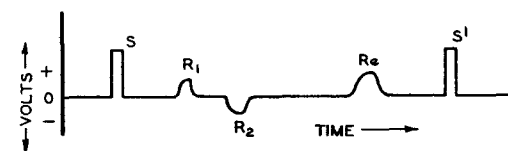

FIG. 3.—ARRANGEMENT OF TESTING EQUIPMENT.

Fig. 4 shows the general appearance of the voltage waveform across the sending end of a faulty cable.

The transmitted pulses  $S$ ,  $S^1$  are equivalent to connecting a 1-volt battery through 75 ohms to the



- $S$ ,  $S^1$ —SUCCESSIVE TRANSMITTED PULSES.
- $R_1$ —RECEIVED PULSE FROM SERIES FAULT.
- $R_2$ —RECEIVED PULSE FROM SHUNT FAULT.
- $R_e$ —RECEIVED PULSE FROM FAR-END OPEN-CIRCUIT.

FIG. 4.—VOLTAGE WAVEFORM AT SENDING END OF CABLE.

cable for about 3 microseconds, with intervals of about 90 microseconds during which the E.M.F. is short-circuited. The resulting 3-microsecond D.C. pulse travels along the cable at nearly the speed of light and is partially reflected by any series resistance fault in the conductors or by any shunt leakage fault across the dielectric. If the cable is open- or short-circuited at the far end, a complete reflection of the pulse occurs there. The time delays of the echo pulses ( $R$ ) can readily be measured with the help of a suitable time-base on a cathode-ray tube. The distance of the fault is then obtained by comparing the echo times from the fault and from the far end of the cable, or, if the velocity of propagation on the cable is accurately known, by the echo time from the fault alone.

It is helpful for understanding the mechanism of reflection at an impedance change to consider a "unit-step" voltage applied to a cable having a

single sudden change of characteristic impedance, as shown in Fig. 5 (a). Since the characteristic impedance of a coaxial cable approximates to a constant resistance at all frequencies, each section of the cable could be properly terminated in this way by the resistance  $R_2 = Z_{02}$  as shown, and let the "unit-step" voltage be applied by suddenly switching on a 1-volt battery through a resistance  $R_1 = Z_{01}$  to the near end of the cable as shown in

Fig. 5 (a). Immediately after the switch has been closed, and before the voltage wave has had time to travel as far as the impedance discontinuity (B), conditions at the sending end A may be represented by the equivalent circuit of Fig. 5 (b). It is clear that the voltage across the cable input terminals is 0.5 volt.

Now consider the situation a long time after the closing of the switch—long enough for all transient waves to have subsided and for the final steady-state to be established on the whole cable length. Assuming that the D.C. resistance of the cable is negligible, the steady-state equivalent circuit is evidently that shown in Fig. 5 (c), from which the voltage at A must be  $Z_{02} / (Z_{01} + Z_{02})$  volt. If the cable is loss-free at all frequencies, and has an air dielectric, then all disturbances are propagated along it without distortion and at the speed of light. The voltage at A as a function of time takes the form shown in Fig. 5 (d), commencing at 0.5 volt and jumping suddenly to the

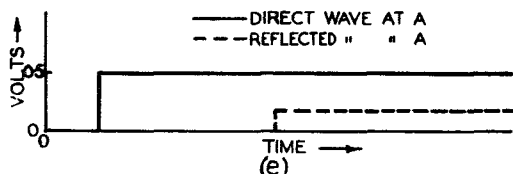
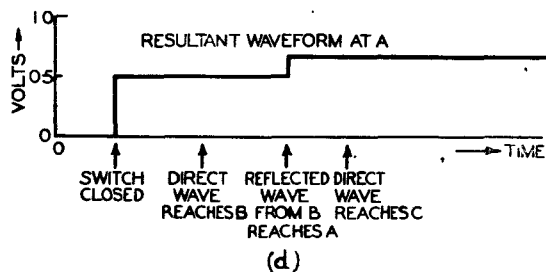
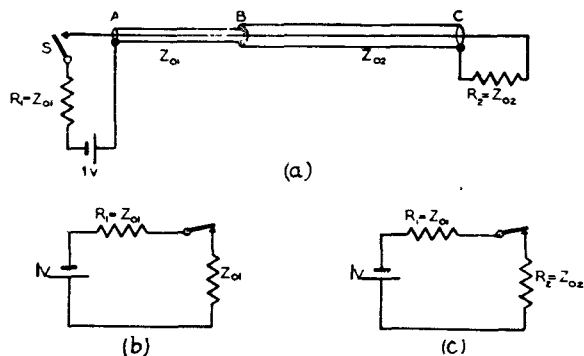

FIG. 5.—"UNIT-STEP" WAVES ON MISMATCHED CABLES.

value  $Z_{02} / (Z_{01} + Z_{02})$  at the moment the reflection from B arrives back at A. The resultant waveform at A may thus be expressed as the sum of the direct wave of 0.5 volt and a reflected wave given by

$Z_{02} / (Z_{01} + Z_{02}) - 1/2 = \frac{1}{2} (Z_{02} - Z_{01}) / (Z_{01} + Z_{02})$  volt, as shown in Fig. 5 (e). The reflection coefficient of the mismatch at B is defined as the voltage ratio of this reflected wave to the direct wave :

$$\text{Reflection coefficient} = \frac{Z_{02} - Z_{01}}{Z_{01} + Z_{02}}$$

The "return loss" at the mismatch point is defined as the decibel equivalent of the voltage reflection coefficient :

$$\text{Return loss} = 20 \log_{10} \left| \frac{Z_{01} + Z_{02}}{Z_{02} - Z_{01}} \right|$$

The reflection coefficient can have a positive or negative sign, according as the second cable has the higher or lower impedance. The return loss is of course always positive or zero.

Since a rectangular pulse may be considered as the voltage difference of two "unit-step" waves displaced in time by the duration of the pulse, it is readily seen that the above laws of reflection apply equally to pulses, under the same condition of zero cable loss.

In practice, of course, the cable losses are not negligible, and the attenuation constant, expressed in decibels per mile, increases very nearly as the square root of the frequency, being of the order of four decibels per mile at a frequency of one megacycle per second for present types of long distance coaxial cable. When the short test pulses are repeated continuously, as they must be to give a flicker-free picture on the cathode-ray tube display, the resulting periodic waveform may be shown by Fourier's theorem to contain the fundamental and all the harmonics of

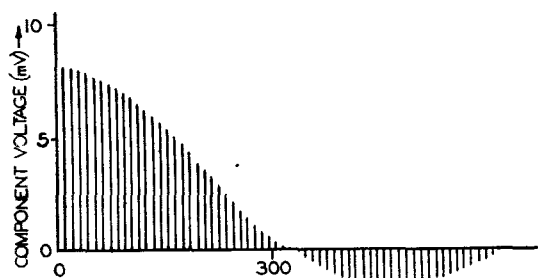

(a)

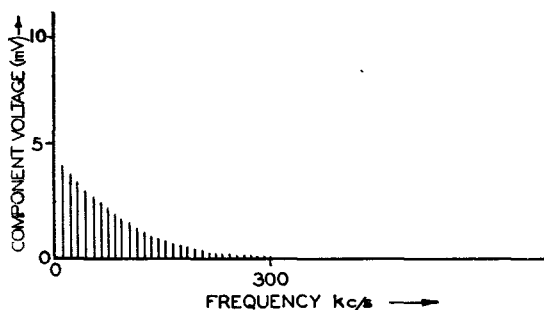

(b)

FIG. 6.—EFFECT OF CABLE ATTENUATION ON FREQUENCY SPECTRA.

the pulse repetition frequency, at amplitudes which remain important up to a frequency (e.g. in c/s or Mc/s) about equal to the reciprocal of the pulse-length (in seconds or microseconds respectively). The spectrum of the transmitted pulse employed for the fault locator is shown in Fig. 6 (a). Clearly this spectrum will suffer considerable distortion after transmission through 10 miles of cable (see Fig. 6 (b)), and the shape of a pulse reflected from an impedance mismatch five miles away must therefore also be considerably distorted.

In principle, the new pulse shape is computed by synthesis from the new values of the Fourier components as modified by the cable attenuation. For cables obeying the attenuation law above, however, a general expression has been found<sup>1</sup> for determining the pulse distortion directly. A number of typical cases are shown in Fig. 7.

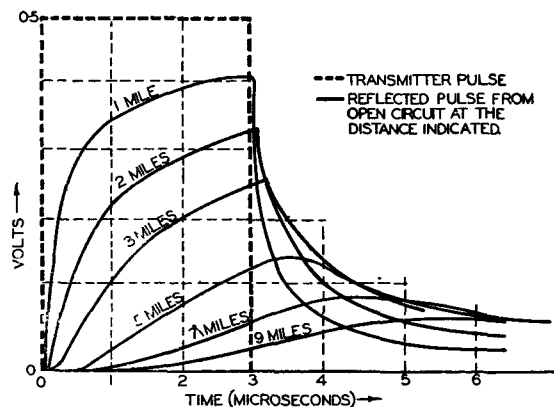

FIG. 7.—DISTORTION OF PULSE DUE TO CABLE ATTENUATION.

Such pulse distortion could be largely overcome by the introduction of a suitable attenuation equaliser either at the pulse signal generator output, at the receiving amplifier input, or incorporated in the amplifier itself, though such equalisation could not be satisfactory for echoes from all ranges simultaneously. For practical fault-locating purposes on existing coaxial cables pulse-equalisation has not been found essential.

In considering the mechanism of reflection above with reference to Fig. 5, it should be noted that the magnitude of the reflected wave does not depend on the nature of the impedance  $Z_{02}$ , which may, for example, consist of a series or parallel combination of another cable of impedance  $Z_{01}$  with an impedance totalling  $z$  in series or  $Z$  in parallel—thus representing the "series" and "shunt" faults on an otherwise uniform cable as in Fig. 3. The corresponding reflection coefficients then become  $z / (z + 2Z_{01})$  and  $-Z_{01} / (2Z + Z_{01})$  respectively. It may be noted that a 7.5 ohm series fault or a 750 ohm shunt fault on a 75 ohm cable would each produce a return loss of 26 db. at the point of reflection, whereas each would cause at most a transmission loss of 0.5 db. to normal steady signals.

<sup>1</sup> *J.I.E.E. (III)*, Nov. 1946, p. 395.



### Equipment.

It was for faults of this order of magnitude that the original Cable Fault Locator was designed. The other major requirement was a range-accuracy sufficient to locate a fault to within one joint-length (176 yards) of cable. The instrument was to be used primarily on the standard 75 ohm main cable, and was to be portable and of low power consumption.

Since the transmission time once to and fro over a single joint-length of cable is just over one microsecond, a pulse-length of one microsecond would be desirable to obtain a clear reflected pulse from a fault at the first joint away from the testing point. But as such a fault can be located with sufficient clarity even when the echo is superimposed upon the transmitted pulse, the length of the latter has been made 3 microseconds, to gain the advantage of clearer echoes from long-distance mismatches.

The realisation of the necessary range-accuracy depends, apart from the limitation set by pulse-distortion at long range, entirely upon the degree of expansion and the accuracy of measurement or calibration of the timebase on the cathode ray tube display system. Two types of display are provided on the fault locator, namely, a linear timebase with conventional "Y-deflection" for the pulse waveform, and a circular timebase with brightness modulation. Both timebases are of the straightforward continuously running type, the main object of the circular display being the inherent 3-to-1 expansion of scale-length obtained, and the simplicity combined with reliability of the range measurements.

The essential circuit of the fault locator is shown in Fig. 8. In operation, the 11.1 kc/s oscillator V1

"differentiating" the sinusoidal voltage from the oscillator. Squaring is caused by overdriving an amplifier valve V2, and differentiation by passing the square wave through a short time-constant C-R coupling circuit. (An ideal differentiating circuit would produce an output voltage which varies with time according to the differential coefficient with respect to time of the input voltage. The circuit used gives an adequate approximation to this performance.) The resulting alternate positive and negative pulses are amplified sufficiently in V3 so that only the positive-going pulses are effective in controlling the output valve V4, which therefore feeds only negative-going pulses to the cable on test. To match the cable and thus to absorb any incoming echoes and to prevent their reappearance as spurious "fault" echoes after a second passage to and fro along the cable the effective load of this valve is approximately 75 ohms. The receiving amplifier consists of two parts, both fed from the cable terminal. The first part, consisting of the three valves V5, V6 and V7, amplifies pulses from "series" type faults to modulate the instantaneous spot-brightness of the cathode-ray trace while the circular timebase is in use. The mean brightness is adjusted so that no trace is visible except at the positions on the CR tube corresponding to the transmitted and the echo pulses. The second part of the receiving amplifier, which is used only in conjunction with the linear timebase display, is formed by the two amplifier stages V8 and V9 incorporated in the double-beam oscilloscope—the two stages being connected in cascade to the "Y1" beam for this purpose by the selector switch on the instrument. When the circular timebase is in use, these same two

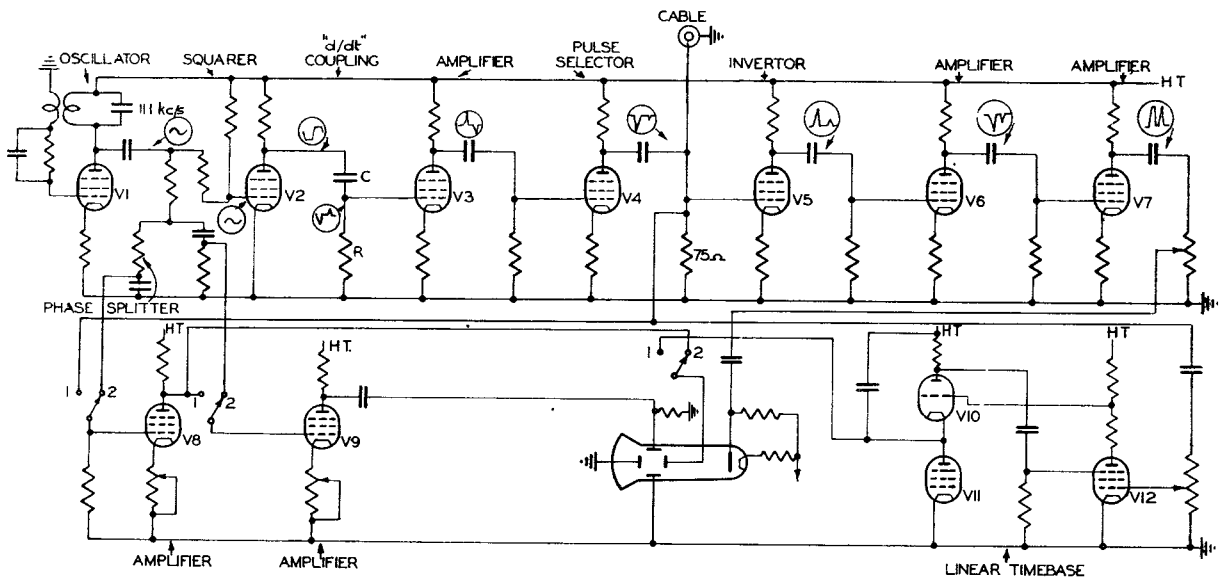

FIG. 8.—CIRCUIT OF CABLE FAULT LOCATOR.

controls the rate of transmission of the pulses and also provides the timebase drive voltages for the circular display via the two phase-shifters of  $+45^\circ$  and  $-45^\circ$  respectively; the 3 microsecond transmitted pulse is obtained by "squaring" and then

amplifier stages are employed to amplify the two-phase sinusoidal voltage from the phase-splitter, the two outputs then being separately connected via suitable switches directly to the "X" and "Y1" plates of the CR tube, as indicated in Fig. 8. The

linear timebase is provided by valves V10, V11 and V12 incorporated in the oscilloscope, synchronism being ensured by the trigger voltage obtained from the cable terminal as shown.

In normal operation, the equipment is preferably connected directly to the cable terminal and initial observations made on the linear timebase display. After a fault has been identified, the circular timebase display is brought into use to obtain an accurate location, either in terms of actual echo time-delay in microseconds as read off the circular scale, or from the ratio of the delays of the fault echo and the echo from the far-end of the same or another cable of known length (of the same type).

Experience has shown that the required accuracy can be realised if the fault is not too small in magnitude. An open-circuit can be fixed within one joint length at 10 miles range. The sensitivity is sufficient to reveal a 5 ohm series fault or a 1,000 ohm shunt fault at this range. Intermittent faults both in cable joints and in terminating units have been located with this equipment—feats that would be impossible by any of the older methods.

#### CABLE IRREGULARITY MEASUREMENT.

As the sensitivity of the test equipment is increased, very small echoes are revealed in a cable which would normally be considered fault-free. These echoes are due to small impedance irregularities, inherent in the mechanical construction of the cable. They may be randomly scattered along the length of the cable or they may recur at regular intervals set by some characteristic of the cable-making machinery. An important periodic type of irregularity is that occurring at the joints between adjacent drum-lengths of cable. This particular irregularity can be of two kinds. Thus if the adjacent drum-lengths have different characteristic impedances, no design of joint apart from a dissipative network or an ideal transformer can eliminate the mismatch over a wide range of frequencies. On the other hand, even if the adjacent drum-lengths have identical impedances, an imperfect joint design will introduce a lumped reactance, producing an echo of increasing importance at high frequencies.

Experience to date suggests that the randomly spaced irregularities occurring within drum-lengths also behave largely as lumped reactances, indicating that the physical deformations causing them occupy relatively short lengths of cable, though this may not prove true for all types of cable design.

Although echoes of these types may be individually negligible, their likely occurrence throughout some hundreds of miles of cable will result in spurious signals being received at the end of the system (due in fact to double echoes between pairs of irregularities or between irregularities and terminations). The measurement of the individual echoes therefore becomes important, particularly if the cable is to be used for frequencies above 3 Mc/s.

#### Equipment.

Since several irregularities can occur within one drum-length of cable, the testing pulse must be of

short duration, considerably less than 1 microsecond, so that the separate echoes can be resolved. A D.C. pulse of such a short length will, however, be appreciably distorted, even for a cable somewhat larger than  $\frac{3}{8}$  in. diameter. For example, if the time scale is divided by 10 in Fig. 7, the same curves are correct for a 0.3 microsecond pulse on a cable of about 1.2 in. diameter. More important reasons for abandoning the D.C. pulse in favour of a pulse of high-frequency carrier are (a) the fact, already noted, that the cable irregularities behave mainly like lumped reactances and therefore produce stronger echoes for high frequency pulses, and (b) the simpler correlation of cable test results with system performance when frequencies of the same order are employed for testing as for ultimate operation.

An improved equipment has been developed for the purpose of measuring the individual irregularities, under conditions that can be readily correlated with those obtaining in long distance television relay systems. The output from this equipment consists of 0.3 microsecond pulses of a 20 Mc/s carrier. The peak amplitude is about 1 volt as before, the interval between pulses being about 500 microseconds. The transmitted frequency spectrum is similar to that shown in Fig. 9. Echoes received 1 microsecond or

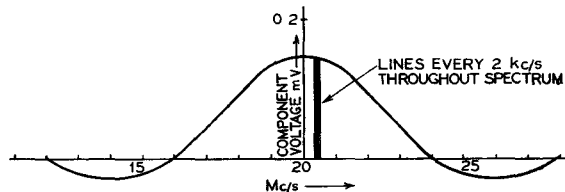
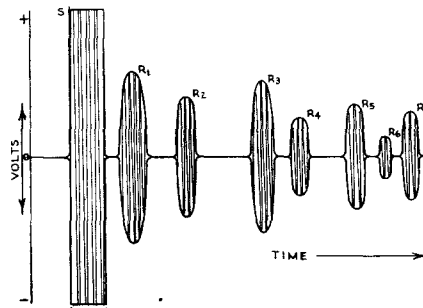

FIG. 9.—SPECTRUM OF FREQUENCIES TRANSMITTED FOR THE MEASUREMENT OF CABLE IRREGULARITIES.

more after the transmitted pulse, and of amplitudes down to about 90 db. below it, can readily be measured to within 2 db. Echoes from all joints at normal spacings, and several echoes from cable irregularities between such joints, may usually be clearly resolved and independently measured.

Fig. 10 illustrates the voltage waveform at the end



S—TRANSMITTED PULSE (SATURATING BY 60 DB.)  
R, ETC.—ECHO PULSES FROM JOINTS AND IRREGULARITIES.

FIG. 10.—VOLTAGE WAVEFORM AT THE SENDING END OF CABLE.

of the cable, as observed through a high gain, high frequency amplifier. In the equipment itself, this waveform is rectified and further amplified so that the final observations are made on D.C. pulses as in the fault locator.

# Principles of Overhead Line Construction

P. R. GERRY, A.M.I.E.E.

U.D.C. 621.315.17

A description is given of the present-day design standards which affect the stability of an overhead line. The standards are compared with those published in the 1894 issue of Technical Instructions, XIII.

## Introduction.

**R**IGIDITY and stability are essential features of a satisfactory pole line. Lack of stability upsets the symmetry of the open wires and this leads to crosstalk or inductive interference between the circuits and causes excessive stresses in the wires and/or cable on the poles. To construct lines which would remain stable under all conditions would be uneconomic and design standards for Post Office lines have always sought to provide reasonable stability under normal conditions only, and, when abnormally severe conditions occur, for the damage to be restricted, as far as practicable, to the more easily replaced plant.

The design standards in use at the present time have emerged from experience over many years. The original standards were published as circulars, each of which generally dealt with one particular aspect of the work. The growth of overhead line work and the consequent need for standardisation resulted in a large number of circulars being issued. In 1894, the information in the circulars was collected and published in book form—the first issue of Technical Instructions, XIII. A description of the design standards which affect line stability and which were included in the 1894 publication is given in the following paragraphs with details of the present-day standards.

## Wind Pressure.

The principal stress concerned in the selection of suitable poles is the wind pressure on the wires, cables and poles which must be balanced by the resisting moment of the unstayed poles. The earlier standard specified that, for normal situations, a maximum pressure of 17 lbs. per square foot of exposed surface should be assumed, the effective area of the wire, cable or pole being taken as two-thirds of the diameter multiplied by the length. Since the introduction of this standard experiments have been carried out in the wind tunnel at the National Physical Laboratory as a result of which it was found that, for cylindrical surfaces,

$$P = KV^2D$$

where  $P$  = the pressure in lbs. per foot,

$K$  = a coefficient whose value depends on the product  $VD$ ,

$V$  = the velocity of the wind in miles per hour,

$D$  = the diameter, in inches, of the wire, cable or pole.

This formula is used in present-day design work. The value of  $V$  varies according to the degree of exposure of the line which is classified as sheltered, normal, or exposed, and for each classification the following maximum wind velocity is assumed:—

Sheltered situations 40 m.p.h.

Normal situations, i.e. ordinary inland, undulating or level country 60 m.p.h.  
Exposed situations such as coast roads or elevated moorland 80 m.p.h.

The value of  $D$  is taken, in all cases, as the full diameter without ice.

The total wind pressure per foot on all wires and cables is multiplied by the number of feet in adjacent half spans to give the total pressure imposed on a single pole. This value is then converted into a bending moment by being multiplied by the height above ground of the resultant point of the wind load. The wind pressure per foot in lbs. on wires of various sizes, and for normal situations, calculated on 1894 and 1948 standards is shown in Table 1.

TABLE 1  
Wind Pressure on Wires in lbs. per foot run for Normal Situations.

Size of Wire	40 lb.	70 lb.	100 lb.	150 lb.	200 lb.	300 lb.	400 lb.	600 lb.	800 lb.
1894	·047	·062	·075	·002	·106	·130	·149	·182	·211
1948	·037	·050	·062	·077	·091	·116	·134	·168	·197

Considering the additional data that have become available since the earlier standard was introduced, the disparity between the values for the two standards is surprisingly small.

No variation in the 17 lbs. per square foot pressure was employed, in 1894, for sheltered or exposed lines. The reduced or increased wind pressure was allowed for by adjusting the factor of safety for the poles.

## Bending Strength of Poles.

The bending strength of poles is now expressed in terms of resistance moments, i.e., fibre stress multiplied by the section modulus. The calculated moment at which the pole would fail is divided by 3·5 and then reduced by a value equal to the bending moment on the pole itself due to a wind of 80 m.p.h. striking its surface; the resulting resistance moment for all poles (i.e., the safe working value) is published in tabular form as shown in Table 2.

In 1894, the bending strength of poles was expressed in cwt. for cylindrical beams of various diameters from 6 to 20 in., and 1 ft. in length. The breaking stress of an actual pole was found by dividing the value given by the distance, in feet, from the ground line to the resultant load point.

The main difference between the old and new standards is in the factor of safety employed. The value of 3·5 used now is considered sufficient to allow for the usual irregularities in timber of pole form and also for some deterioration in strength due to decay. The 1894 instruction, however, read as follows:—

“For poles upholding wires on roads or railways a factor of ten (10) may be considered as providing sufficient margin. . . . For special cases where wires are



TABLE 2  
MOMENT OF RESISTANCE OF POLES

Class of Pole	Safe Moment of Resistance (in lb.-ft.)											
	Length of Pole in feet.											
	16-20	22	24	26	28	30	32	34	36	40	45	50
Light	3,800	4,300	4,900	5,400	5,800	6,400	6,800	6,900	7,300	7,200	6,800	5,800
Medium	—	—	9,000	9,800	10,600	11,200	12,000	12,700	13,200	12,700	14,500	12,300
Stout	—	—	—	—	18,200	20,400	22,700	22,500	23,500	24,600	25,000	21,700

erected on lofty heights or where they are exposed to excessive transverse stresses, necessary allowance must be made. On the other hand, when so placed as to be sheltered from wind effects, the factor may be reduced."

The following extract from the same instruction demonstrates the effect of the high factor of safety.

"Light poles to be used for from 1 to 5 wires.

Medium poles to be used for from 6 to 10 wires.

Stout poles to be used for above 10 wires.

Care should be taken in every case to see that the authorised factor of safety is maintained."

#### *Buckling Strength of Poles.*

This factor need be considered nowadays only when the line is to carry an aerial cable. The downward thrust imposed on angle and terminal poles by the combined effect of the tensions in the suspension wire and in the stay wire may be sufficient to cause the pole to buckle. The present-day methods of determining the imposed buckling load and the buckling resistance of poles have been dealt with in detail in a previous article.<sup>1</sup>

The only mention of buckling in the 1894 instruction reads :—

"Poles at sharp angles should have sufficient diameter to prevent buckling should the stay or strut not act exactly at the resultant point."

The use of high tensile steel suspension wire was obviously not envisaged in the earlier instruction, but even if such wire had been used it would not have been necessary to consider buckling stresses because poles having a factor of safety of 10 for the bending stresses would have had ample buckling resistance.

#### *Length of Span*

In present design span lengths are made as uniform as practicable. For open wire main lines a span length of 55 yards is stipulated and for subsidiary lines the length is increased to 63 yards. For lightly loaded lines in rural areas the span length may be increased to 80 yards. Uniformity of span length facilitates the maintenance of good regulation and the 55-yard and 63-yard spacing enables transpositions to be made in the wires at the required regular intervals.

For new aerial cable lines, where transposition is not required, the spans are still made as uniform as practicable, but their length varies according to the ultimate load the poles are to carry.

Two types of line were specified in 1894, and the instruction on the length of span read :—

"On light extensions upon roads it is only necessary to provide 22 to 24 poles to the mile (73-80-yard span) but

on main through lines which will ultimately carry the maximum number of wires, 30 poles to the mile (55-60-yard span) should be catered for. But the number of poles to the mile, or, in other words, the length of the span, depends very much on the character of the road, the obstacles to be encountered, etc. Thus, in very exposed places or on sharply curving roads the supports must necessarily be more numerous and stronger than in favourable localities, but the experience and judgment of the

engineer who is in charge of the work must, to a great extent be exercised in dealing with each individual survey."

#### *Staying.*

Stays or their equivalent are now fitted to meet the following conditions :—

- (a) to prevent bending of the poles by the tension in the line wires, i.e., terminal or angle stays,
- (b) to reduce the bending and rocking of the poles by wind, i.e., transverse stays,
- (c) to limit the extent of a pole-line collapse under breakdown conditions, i.e., in-line or longitudinal stays.

The staying requirements to meet each of the above conditions are as described in the following paragraphs.

#### *Terminal Stays.*

The horizontal component of the breaking load of the stay is made equal to the total breaking loads of all the line wires, including, when fitted, the aerial cable suspension wire. In other words, when all the line wires break simultaneously the tension in the stay should not exceed its breaking weight. This standard has proved satisfactory in meeting the fundamental requirement that the poles shall remain intact under conditions which are sufficiently severe to cause overstretching or even fracture of the open wires. To meet this requirement, it is necessary for the stay to remain intact when the line wires break, and in practice this does occur because the line wires do not break simultaneously; the wires on the upper arms break before those on the lower arms, and where both open wires and aerial cable suspension wire exist on the same line the former are the first to break. This applies when the wires are broken by a falling tree; severe icing conditions never cause the open wires to break simultaneously.

Aerial cable suspension wires are of sufficient strength (breaking weights from 5,700 to 22,000 lbs.) to resist breakage under any icing conditions likely to arise, and would need to be struck by a very heavy tree to be fractured.

Although it is known that simultaneous breaking of all wires does not occur, it is not possible to predict what will be the maximum stress in the stays during the period of fracture. It is not practicable, therefore, to design the stays so that a specific factor of safety will be provided. Experience over a number of years, however, shows that the present standard of making the horizontal component of the stay equal to the total breaking weight of all the line wires provides a

<sup>1</sup>P.O.E.E.J. Vol. 37, p. 70.

sufficient margin of strength in the stay to ensure that the poles remain standing when the line wires break. The standard has the added advantage of being simple and convenient to apply.

Staying was covered in considerable detail in 1894 although the methods specified were not so precise as those in use at the present time. The rule for the strength of stay for a terminal pole, for example, read :—

“ In staying terminal poles either solid rods or  $\frac{7}{8}$  stay wire may be used. When the latter is selected, either V or parallel stays may be fixed, and if the stay rod enters the ground at a distance from the base of the pole equal to the height at which it is fixed, an approximate rule which will give a sufficient factor of safety is to use, in forming the combined stays, twice as many strands as there are 400-lb. line wires carried by the pole. Where this would involve an abnormal number of stays then iron rods of suitable dimensions should be used.”

#### *Angle Stays.*

The present standard lays down that for severe angles ( $60^\circ$  deviation or more) the poles should be fitted with stays in line with both directions of the line, and the stays in each direction should be designed as terminal stays. For angles smaller than  $60^\circ$  the stay should be placed in line with the bisector of the angle.

The horizontal component of the stay load where the stay bisects the angle should be equal to

$$2 T \sin \frac{\theta}{2} + PL$$

where T is the total breaking load of all the line wires, including, if fitted, the suspension wire,

$\theta$  is the angle of deviation,

P is the total wind pressure per foot on all open wires, suspension wire and aerial cable (with rings) and

L is the length, in feet, of one span.

The wind is assumed, for convenience, to blow at right angles to the line on both sides of the pole. P will vary with the degree of exposure of the situation.

There is obviously no direct relationship between the ultimate breaking load of the line wires and the ultimate strength of angle stays placed in line with the bisector of the angle. If all the line wires were broken near such an angle pole, the latter would be deflected and probably broken whatever the strength of the stay. The standard does, however, ensure that the angle pole will remain stable under normal working conditions.

The size of stay required for both terminal and angle poles is readily found from a specially designed slide rule which is in the form of two discs fixed concentrically but which can be revolved independently. The rule gives a direct indication of the size of stay required for various line deviations, for base-height ratios of the stay from 4/1 to 1/10 and for a total breaking weight of line wires up to 60,000 lb. Determining the size of stay required for an angle pole in 1894, was, however, a very tedious operation. The equivalent of the horizontal component of the stress in the stay was found by referring to a table of values indicating the stress in cwts. exerted by ten 400-lb. wires for various angles of deviation when the spans

varied from 35 to 110 yards in length. The stress in the stay was then found by ascertaining from another table the multiplying factor applicable to the base-height ratio of the stay.

#### *Transverse or Wind Stays.*

Although the unstayed poles in a line should withstand the pressure created by the wind they will, during windy spells, be deflected, and this may result in frequent and excessive bending in straight sections of the line. This rocking of the poles which results in fatigue stresses in the line wires and cables, and disturbs the foundation strength, is checked by fitting stays on opposite sides of a pole in a direction at right angles to the line. To reduce the effects of rocking to a minimum it would be necessary to fit wind-stays to all poles in the straight, but it is found that the effects can be kept to a reasonable level if the horizontal component of the load upon each stay is made equal to the total wind pressure on all wires and cable (if any) in adjacent halves of a transverse stayed section. The wind load on the poles in the section is not taken into account. Light stays at frequent intervals (e.g., on every pole in the straight) are obviously preferable to heavier stays at less frequent intervals.

The fitting of transverse stays is often difficult due to lack of space at the foot of the pole, but the cost of providing over-road stays or even struts is justified in view of the increased stability which results.

No mention of transverse stays is made in the 1894 instruction. This is to be expected in view of the high factor of safety adopted which would result in a very small deflection of the heads of the poles during periods of high wind.

#### *In-Line or Longitudinal Stays.*

These stays are nowadays fitted at  $\frac{1}{4}$ -mile intervals in straight sections of open wire lines. They should be designed as terminal stays and fitted on both sides of the pole in the direction of the line, so that if the line wires break on one side of a pole, the consequential damage will be confined to one  $\frac{1}{4}$ -mile section. In general, some poles will be broken but the rest will only be deflected.

Line stays are also fitted to poles at rail and road crossings, but in these cases they are fitted only on the side remote from the crossing and are provided to prevent the poles deflecting or falling towards the crossing.

Breakages of the open wires may be caused by relatively light tree branches falling across them, but experience shows that the fracturing of an aerial cable suspension wire is a very rare occurrence and the provision of in-line stays on lines carrying aerial cables is not, therefore, adopted except at crossings of railways and important roads.

The 1894 instructions on the fitting of line stays read :—

“ Double longitudinal stays (in the direction of the line wires) should be fixed on all main lines which carry over 12 wires at each side of road crossings so as to limit the range of a breakdown during snowstorms. Where road crossings are infrequent such stays should be provided at every quarter of a mile. Longitudinal stays in

one direction are also required where heavy wires terminate and are continued by light copper conductors for sections through towns, etc."

#### *Wire Regulation.*

The tension at which wires should be erected varies according to the type and size of the wire and the temperature prevailing at the time the wires are erected.

For all but very exposed situations the erection tensions for all types of open wire and for all spans are calculated so that at 20° F in still air, the tension shall not exceed one quarter of the breaking load for copper or iron or one third for cadmium copper or bronze. These bases of design ensure that under the worst conditions which it is considered necessary to assume (i.e., 80 miles per hour wind and no ice at 20° F), the tension in a wire shall not exceed half the breaking load. The tensions also ensure adequate clearances and moderate sags at high temperatures (100° F) to provide against contacts during wind.

For very exposed situations wires of a gauge heavier than is required to meet transmission requirements are used. In addition, the erection tensions, at 20° F, for copper and iron wires are reduced to one-sixth of their breaking loads. For cadmium-copper and bronze wires normal erection tensions are used; the smaller separating distance between wires normally provided on cadmium-copper and bronze wire lines does not permit of the increase in sag which would result from a reduction in erection tension.

When wires having different characteristics are erected on the same line, the tension values are adjusted to provide, as nearly as practicable, the same sag in all wires during periods of average temperature. This requirement has an important influence on the erection tensions adopted.

The tensions which should be applied are given in table form for various lengths of span and for the range of erection temperatures from 20° F to 100° F. The values can also be read direct from the standard thermometer issued to staff engaged on the erection of wire. The thermometer has a revolvable cylinder which has engraved on it separate scales for each type and size of open wire. By setting the cylinder to the appropriate position the tension to be applied is shown opposite the temperature reading on the thermometer.

For *aerial cable suspension wire* the tension at which the wire should be erected before the cable is placed in position varies with the size of wire, length of span and temperature. The values, which are printed in table form, are calculated so that when the cable is in position, the temperature is 20° F and an 80 m.p.h. wind is blowing, the stress in the wire will not exceed half its breaking weight. For the strongest suspension

wire, however, the tension is limited so as not to exceed the capacity of the standard tensioning tackle which has a safe working limit of 3 tons.

The tensions at which wires should be erected were also shown in table form in 1894, and were based on the same standards. The tensions at low temperatures were approximately the same as present-day values, but at the higher temperatures they were appreciably lower. The reason for this is given in the following extract from the paragraph on regulation of wires:—

"Elasticity has been designedly ignored. The result of this omission is that new lines erected in summer will at low winter temperatures have a larger factor of safety and somewhat greater sags than the tables indicate."

#### *Aerial Cable Lines.*

Extensive alterations have been made in recent years in the methods of designing pole lines to be used for supporting aerial cables. The revised methods were evolved to secure a more accurate assessment of the loads imposed on the poles and of the safe load the poles would carry. The use of these methods, which have been described in detail in a previous article,<sup>2</sup> enabled unnecessary strengthening work on the lines to be avoided, and this effected an appreciable saving in labour and material at a time when the utmost economy in the use of both commodities was essential. It is not possible, however, to make a comparison between current and 1894 standards as aerial cable on pole lines has not been in general use for more than 25 years.

#### *Conclusions.*

The behaviour of pole lines over the years has shown where some of the earlier standards could be relaxed. Relaxations have also been possible due to improvements effected in the material and fittings used for the construction of the lines. The specifications and drawings, with which these items should comply, have undergone considerable change over the period concerned, with the result that higher quality and more reliable items are now obtained. In addition to relaxations, some of the methods of applying the standards have been simplified and in some cases specific values have been adopted for values which were not known in 1894, or had to be left to the discretion of the engineer-in-charge on the work.

Apart from aerial cable lines and the adoption of the transposition in place of the twist system for neutralising the effect of inductive disturbances, there has been no important change in the principles of overhead line design during the past 54 years, a fact which reflects great credit on those responsible for the early design standards.

---

<sup>2</sup>*P.O.E.E.J.* Vol. 37, pp. 44 and 70



# The Potentialities of the Vocoder for Telephony over Very Long Distances

J. SWAFFIELD, Ph.D.

U.D.C. 621.395.47

The requirements of a commercial telephone system over very long distances are shown to lead naturally to the idea of telephony by speech analysis and synthesis. The vocoder, a practical example of an analysis-synthesis system, first developed in America, gives speech transmission of fair quality in a bandwidth of a few hundred cycles per second. The design and performance of a typical vocoder are described.

## Introduction.

THE exploitation of carrier technique is rendering line telephony commercially practicable over ever longer distances. For a sufficiently long line the circuit cost tends to be predominantly line cost, and the cost of an individual speech circuit then tends to become proportional to the bandwidth it occupies. How long in physical distance the circuit has to be before these conditions arise depends on the type of system; a few hundred miles of submarine cable may present more onerous conditions than much greater distances overland. So far as this country is concerned, the field of very long distance economics is entered only with international, or possibly only with intercontinental, calls.

In the very long distance field, then, the question "How wide a band of frequencies is necessary to transmit speech?" assumes a particularly direct importance. Telephone engineers have been apt to assume that since the important part of the speech spectrum extends continuously from about 300 to 3,000 or 4,000 c/s, it is necessary to provide for at least this bandwidth in the transmission. This assumption is only true if the system must be capable of transmitting *any* kind of arbitrary signal that could be constructed using components from 300 to 3,000 or 4,000 c/s. But a telephone system is normally only required to handle speech. This would be a considerable limitation if it did no more than restrict the possible signals to the limited variety of sounds which the human vocal organs can produce; the restriction is actually even narrower than this. The analogy with television may clarify the argument. The visible electromagnetic spectrum extends over a bandwidth of about  $3 \times 10^{14}$  c/s which, to say the least of it, represents a formidable transmission problem. But these high frequencies merely represent frequencies to which the eye is responsive and are no guide to the complexity of pattern and rate of movement which the brain can perceive. So the transmission engineer merely analyses the picture, uses his system to transmit only the coded analytical description and ultimately, at the receiving end, synthesises the picture from a local light source controlled in accordance with the received description. Thus the actual bandwidth needed over the line can be adjusted to be just sufficient to reconstruct the scene at the rate at which it is capable of changing (or, if less, the rate at which the eye can follow the

changes). In this case the process of analysis and synthesis effects a bandwidth economy of at least  $10^8 : 1$ .

Any argument that 4,000 c/s is inherently essential for commercial speech confuses the audible spectrum of the sounds themselves with the bandwidth needed for a running description of their construction and variation. Economy comparable to that for television is, of course, out of the question and very little is possible at all unless severe restrictions are imposed on the type of input sounds; fortunately this is just what can be done in telephony. The problem therefore reduces to finding the simplest way of transmitting a running description of speech sounds. One theoretically simple way would be to exploit the fact that there are only 40-50 different speech sounds, by transmitting merely a code sufficient to define from instant to instant which one is in use. Reconstruction at the receiving end might be from recorded versions of individual speech sounds. This rather extreme form of analysis is hardly practicable, though the bandwidth needed might be less than 50 c/s. A more profitable approach is to recognise that the real restricting element is the limited rate at which the vocal organs can articulate speech and possibly also the rate at which the brain can formulate its ideas into sentences. This approach leads directly to the conception of the vocoder.

## The Mechanism of Speech Production.

The mechanism of speech production can be divided in two stages, (1) the sound source, and (2) the mouth, tongue and lips, here referred to as the modulating parts. Speech sounds are produced by air from the lungs being forced up through the larynx. The larynx contains the vocal chords which may vibrate and chop the airstream at a rate which may be as low as 90 c/s for a deep-voiced man and as high as 300 c/s for a shrill-voiced woman. For certain speech sounds the vocal chords do not vibrate; the spectrum is then continuous instead of consisting of a harmonic series. Sounds which normally have their source in the vibrating chords are referred to as "voiced" sounds; those (such as S and CH) which are merely the simple breath noise are referred to as "unvoiced." In practice some voiced sounds also normally contain breath energy; little, if anything, of interest is lost if such sounds are reproduced from a purely larynx type of energy.

As these sounds pass out through the mouth the characteristics of speech are impressed upon them by two types of modulating processes. The first, best described as a shaping of the energy-frequency distribution, is achieved by the passage of the sound

<sup>1</sup> The material of this article is partly taken from a paper, "Analysis-Synthesis Telephony with Special Reference to the Vocoder," read by R. J. Halsey and the present author jointly before the Institution of Electrical Engineers on 1st April, 1948.

through the multiple resonance chamber formed by the mouth and tongue; further shaping may be effected by the lips and teeth. The "continuants," which are sounds that can be produced continuously, depend on such modulation for their character. The stop consonants are formed by a second type of modulation; their main characteristics are transient and they are made by using the tongue, lips, etc., to hold up or "stop" the sound pending its sudden release.

In speech the larynx frequency varies only slowly and the range of variation is small in any one speaker's voice. These pitch variations do not contribute to the meaning of individual words, though they do affect the general sense.

### PRINCIPLE OF THE VOCODER

Substantially complete synthesis of the speech can be made from information describing the variation with time of (a) the shape of the spectrum, (b) the type of energy (i.e. continuous or harmonic) of which the spectrum is constructed, and (c) the pitch of the voice. Of these (a) is the most important and defines the articulation; (b) and (c) add emotion and naturalness and so assist communication of ideas, but, of course, contribute little or nothing to articulation.

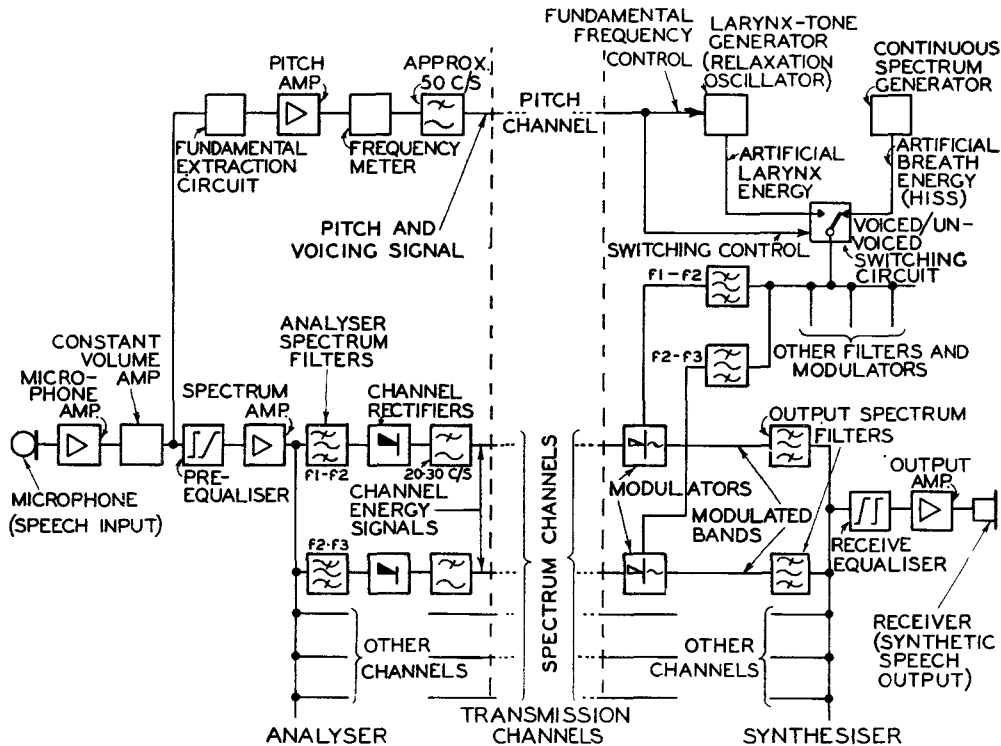

FIG. 1.—BLOCK SCHEMATIC DIAGRAM OF THE VOCODER.

Synthesis of individual speech sounds by purely acoustic means (e.g. coupled resonators) is of great antiquity and the idea can readily be extended to synthesis by analogous electrical circuits. Such devices are usually of extremely restricted performance, but speech study at the Bell Telephone Laboratories enabled Homer Dudley in 1936 to demonstrate a complete electrical system for the analysis and

subsequent synthesis of speech. In 1939 (at the New York World's Fair and elsewhere) a manually-controlled speech synthesiser, the "Voder" (Voice Operated DEMonstratoR)<sup>2</sup> was shown; this was substantially unrestricted in versatility. Meantime the complete analyser-synthesiser, now christened the "Vocoder" (VOICE CODER) had been further developed and a description was published in 1939.<sup>3</sup>

Development in the Post Office started from this stage and thereafter proceeded independently of American work.

### The Analyser.

In the analyser, incoming speech from a microphone passes to a bank of about 10 band-pass filters which, together, cover most of the speech spectrum and so segregate the energy into a number of channels (Fig. 1). Thus the output from each filter, when suitably rectified and smoothed, defines the total energy in the corresponding part of the speech spectrum. Each smoothed output gives a point on the energy-frequency distribution curve; provided there are enough channels, these points will sufficiently define this curve and its variations with time.

The other function of the analyser is to define the type of source in use and the fundamental frequency

(if any) from instant to instant. This information is conveyed as one signal by defining the fundamental frequency by the magnitude of the signal voltage;

<sup>2</sup> Dudley, H., Riesz, R. R., Watkins, S. S. A.: "A Synthetic Speaker." *Journal of the Franklin Institute*, 1939, 227, P. 739.

<sup>3</sup> Dudley, Homer: "Remaking Speech." *Journal of the Acoustical Society of America*, 1939, 11, p. 169.

a zero output signifies that the speech is not, at that instant, voiced (i.e. harmonic) and that, accordingly, it is to be synthesised from continuous spectrum noise. The output from the analyser thus consists of a number of code channels which define the energy-frequency distribution (the spectrum channels) plus another code channel which defines the type of source and, at such instants as the speech is voiced, the fundamental frequency (the pitch channel).

The fluctuations of energy in speech are sufficiently slow for the spectrum-channel signals to pass through a low-pass filter of 20–30 c/s cut-off with little distur-

artificial larynx since (a) it produces an output having a long series of harmonics of almost equal amplitude, and (b) the fundamental frequency is easily varied by a bias control provided by the incoming pitch-channel signal; thus the pitch of the artificial larynx may be varied in sympathy with that of the speaker. When there is no voltage on the pitch-channel, the hiss generator is connected to the synthesising modulators; this occurs during silent intervals as well as during unvoiced sounds, but in the former condition the simultaneous absence of signals on all spectrum channels as well as on the pitch-channel,

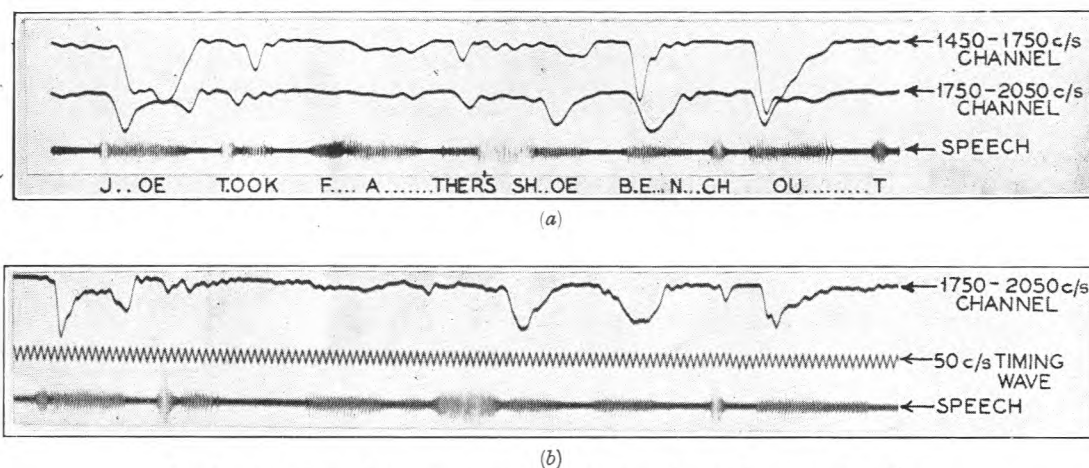

FIG. 2.—SPECTRUM-CHANNEL SIGNALS. (a) WITH 25 c/s CHANNEL CUT-OFF. (b) WITH 50 c/s CHANNEL CUT-OFF.

tion. Fig. 2 shows typical signals after this filtration. The spoken signal in each case is the test sentence “Joe took Father’s shoe bench out.” In Fig. 2 (a) the actual speech wave-form is shown alongside the channel signals on two adjacent channels dealing with the frequency ranges 1,450–1,750 c/s and 1,750–2,050 c/s; these signals are for a cut-off of 25 c/s. Fig. 2 (b) shows a similar signal (the same voice and words but a different occasion) for the 1,750–2,050 c/s channel but with a 50 c/s cut-off. Although the fluctuations are seen to be sharper, there is no significant difference in articulation between a vocoder with 25 c/s and one with 50 c/s cut-off on all channels. In view of the rapidity with which changes as between voiced and unvoiced sounds occur, a somewhat higher cut-off frequency is desirable on the pitch-channel. Thus the vocoder transmission system could theoretically occupy a total bandwidth of as little as 300 c/s (250 c/s for, say, ten 25 c/s spectrum channels and, say, 50 c/s for the pitch channel); the actual signals are, as they stand, inconveniently arranged for assembly on a sub-audio carrier system (single side-band transmission is impracticable owing to the slowly varying nature of the signals).

#### The Synthesiser.

In the synthesiser a continuous-spectrum (or hiss) generator and a relaxation oscillator act as sources of energy (see Fig. 1). The hiss generator gives a very satisfactory simulation of breath energy and the relaxation oscillator is almost ideally suitable as the

ensures that (apart from leakage) there is no audible output. When a voltage appears on the pitch-channel a switching circuit operates to connect the relaxation oscillator in place of the hiss generator; the magnitude of the pitch-channel voltage then determines the oscillation frequency.

The output from the relaxation oscillator or hiss generator is divided by filters into frequency bands corresponding with those used at the analyser, and the energy from each filter is used as a carrier supply to a carrier-suppressing modulator whose signal input is the slowly varying voltage which has arrived over the corresponding spectrum channel. Thus the output of each modulator consists of a signal corresponding in composition (continuous spectrum or discrete harmonics), pitch (if any) and magnitude, with a particular frequency band in the original speech. These outputs combined thus represent the speech in every relevant respect within the frequency range covered by the spectrum filters.

The complete equipment is not unduly bulky; one terminal, exclusive of transmission equipment, needs both an analyser and synthesiser (each occupying a 6 ft. 6 in. double-sided bay) if both-way conversation is required. An analyser and synthesiser are shown in Fig. 3.

#### VOCODER DESIGN

A high quality microphone is used to ensure as much energy as possible at the low frequencies of the male pitch. Operation from the public network appears to be quite feasible but requires regeneration

of the fundamental which in the ordinary way is, of course, attenuated by the carbon transmitter, cord circuits, etc.

It is important that each spectrum channel should show overall linearity over the full range of levels to which its band of speech subjects it. This range of

and a range of 35-40 db. for  $\pm 1\frac{1}{2}$  db. departure from linearity can be achieved for the overall spectrum channel performance, i.e. from spectrum filter output at the analyser to spectrum filter input at the synthesiser.

The optimum manner for subdivision of the speech

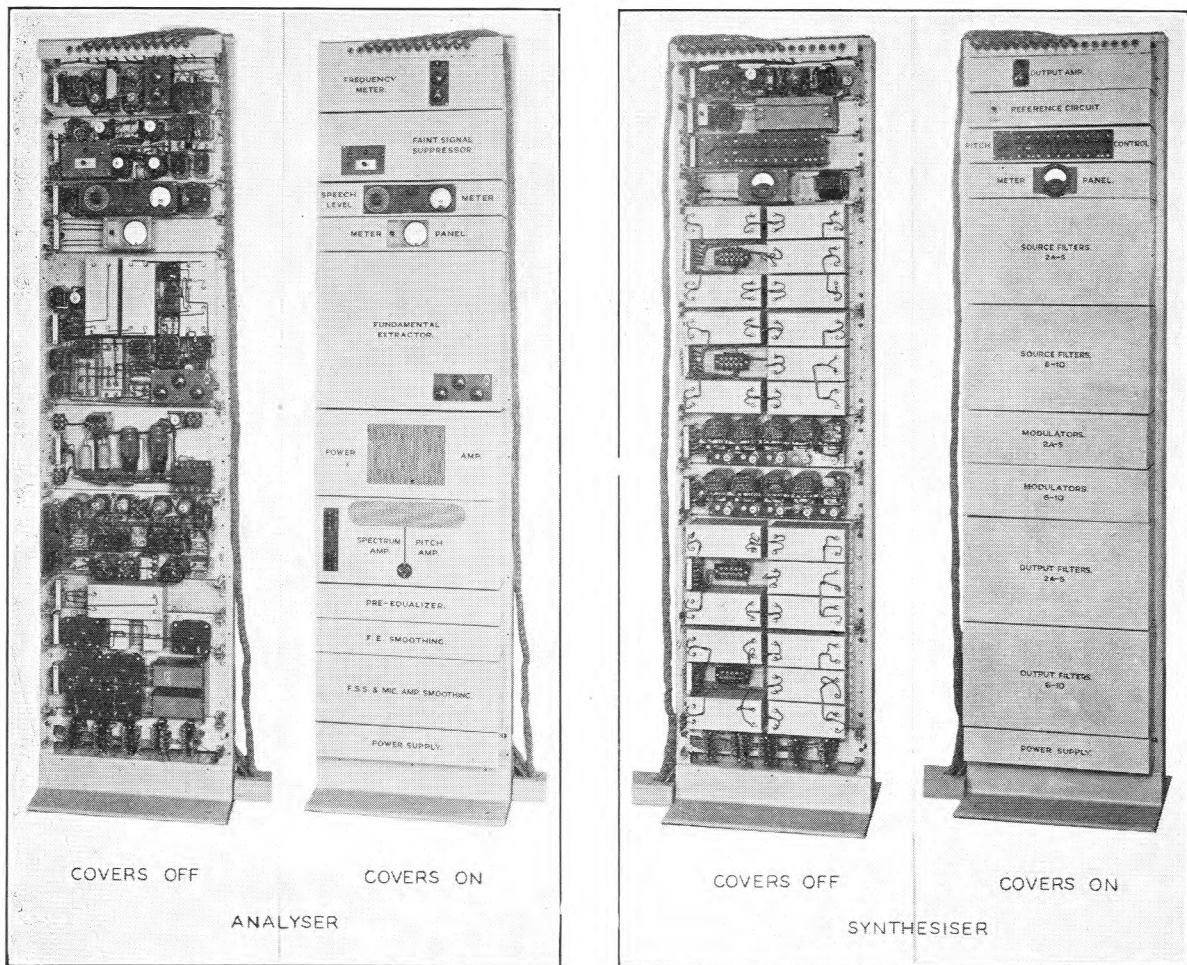

FIG. 3.—ANALYSER AND SYNTHESISER BAYS.

levels is of the order of 30 db. for a single speaker (largely irrespective of the channel position), but, of course, there is considerable speaker-to-speaker variation and, furthermore, the mean level in each channel depends on its position in the speech spectrum. These factors together call for a range of about 80 db, which is quite impracticable. The method adopted is to pass the speech through a frequency weighting network (the "pre-equaliser" curve in Fig. 4) before application to the spectrum filters and to subject the synthesised speech to a similar network of inverse characteristic (the "receive equaliser" curve in Fig. 4) before reproduction. These curves are designed to ensure that the mean level on all channels is the same. Speaker-to-speaker variations are reduced by the constant volume amplifier (Fig. 1).

Either metal rectifiers or diodes can be used as a basis for both channel rectifiers and modulators; usually, on balance, the former are more attractive,

spectrum into 8 to 10 spectrum channels is not easy to determine. Other things being equal, the contribution which a channel makes increases as it gets wider, but there is a limiting width above which the channel can actually detract from the intelligibility of the whole vocoder. An arrangement of ten channels which appears to be nearly optimum is shown in Table 1.

There is little call for sharp cut-off in the spectrum filters and Fig. 5 shows the insertion-loss characteristics of a typical set of spectrum filters.

The problem of deriving the pitch-channel signal is perhaps the least attractive in the vocoder. A number of methods are available, but that based on fundamental extraction and frequency metering has been found the most satisfactory. The fundamental frequency is extracted from the speech by a circuit which discriminates against second and third harmonics as such (e.g. 270 c/s is rejected if it is the



TABLE 1

Channel	Frequency range c/s	Bandwidth c/s
1	250- 400	150
2	400- 600	200
3	600- 850	250
4	850-1,150	300
5	1,150-1,450	300
6	1,450-1,750	300
7	1,750-2,100	350
8	2,100-2,500	400
9	2,500-2,950	450
10	2,950-3,500	550

second harmonic of 135 c/s or the third of 90 c/s, but not if it is the fundamental). Frequencies above 290 c/s are always rejected. The principle, illustrated

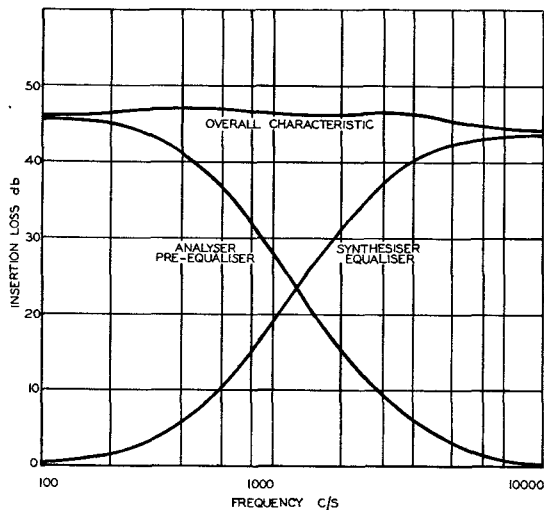

FIG. 4.—SPECTRUM EQUALISATION.

in Fig. 6, is as follows :—Two low-pass filters of 155 c/s and 290 c/s cut-off are effectively in parallel ; when

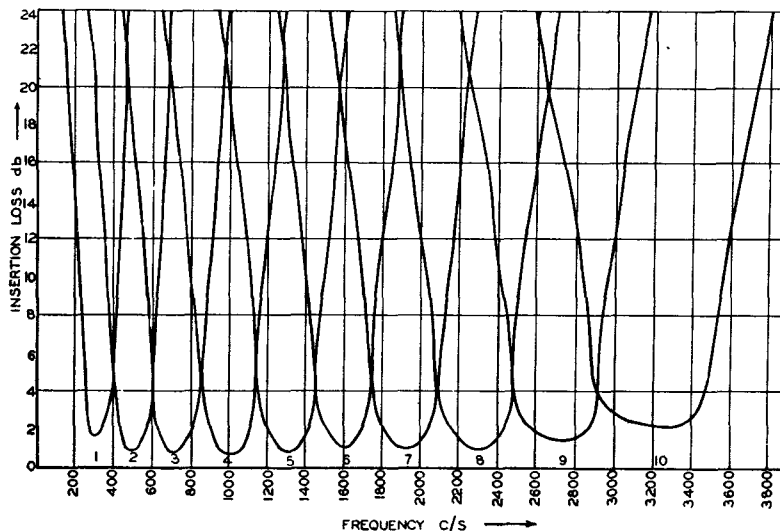

FIG. 5.—INSERTION-LOSS CURVES OF THE SPECTRUM FILTERS.

an output is obtained from the first, the output of the second is blocked. Any fundamental passing the first filter, i.e. lower than 155 c/s, will have its second (and possibly third) harmonics within the pass band of the other which will, however, be blocked by the action of the output of the first filter. Larynx tones

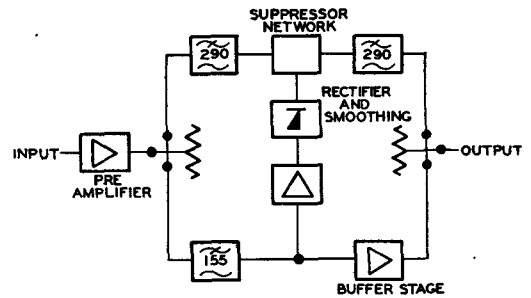

FIG. 6.—PRINCIPLE OF FUNDAMENTAL EXTRACTOR.

whose fundamentals exceed 155 c/s must have their fundamental but no harmonics within the range of the second filter. It has been found that very few female voices go beyond 290 c/s in normal speech, and so more elaborate schemes using three paths instead of two are not justified. The fundamentals which pass through upper and lower paths correspond respectively, and very roughly, with female and male ranges, although male voices frequently slightly exceed 155 c/s. The variable-attenuation network used for blocking the 290 c/s filter is controlled by a current derived from the 155 c/s filter output via an amplifier, rectifier and smoothing. An experimental fundamental extraction panel is shown in Fig. 7.

The pitch signal itself is derived by impressing the fundamental upon a further set of circuits arranged to produce a "steady" output proportional to the frequency but independent of the amplitude of the applied fundamental.

The energy sources (hiss and larynx-tone generators) of the synthesiser present no exceptional problems, and the circuit used for selecting from instant to instant the appropriate source is shown in principle

in Fig. 8. The incoming pitch-control voltage applied to the grid of one of a pair of bridge-arm valves controls the value of the current circulating through the two suppressor networks which are arranged so that whichever one is open the other is closed. In the absence of a pitch signal, the hiss suppressor is open ; a voltage on the pitch circuit reverses the situation. Fig. 9 gives the suppression of hiss and larynx tone as a function of pitch-channel voltage. The changeover (3.5V) corresponds to a pitch frequency of about 40 c/s. An oscillogram of the switching circuit output during a voiced sound, showing switch-over at each end, is shown in Fig. 10.

#### PERFORMANCE.

In the present state of development of the vocoder, its performance, regarded

as a potential system for commercial speech transmission, is quite good, and, measured in terms of articulation efficiency, compares well with many commercial circuits actually in use. In its present form<sup>4</sup> it gives reliably a syllable articulation of 83–85 per cent.; this compares with the 90–91

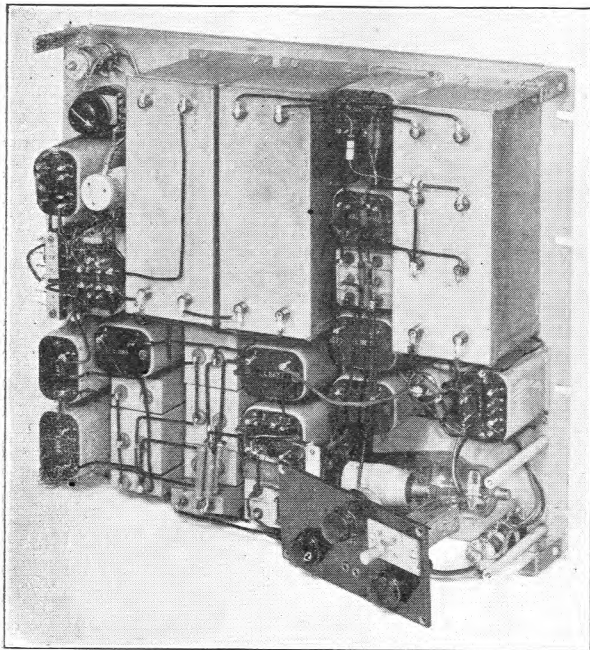

FIG. 7.—EXPERIMENTAL FUNDAMENTAL EXTRACTION PANEL. (CONTROL PANEL PARTLY REMOVED).

per cent. given by a high-quality circuit degraded by restricting its band to 250–3,000 c/s, i.e. to that band from which the vocoder draws its energy. The latter articulation thus represents the maximum that a vocoder drawing its energy from this band could achieve if perfect. The highest syllable articulation achieved on commercial circuits is limited (mainly by the carbon microphone) to about 83 per cent., and articulations down to 50 per cent. are acceptable commercially.

The obvious grounds on which to criticise the vocoder is the crudeness of its definition of energy-frequency distribution. The spectrum of speech as normally heard is smooth and may include one to three major and other minor resonances. The vocoder offers a stepped spectrum in which only ten different amplitudes can occur no matter how many harmonics exist; in particular, two or three adjacent harmonics which fall within the compass of one channel will necessarily be reproduced at equal amplitude since they are regulated by the same channel modulator. How little the ear objects to these irregularities is shown by the articulation achieved with vowel sounds (which are primarily

<sup>4</sup> The performance quoted refers to a ten-channel vocoder covering the band 250–3,000 c/s. Unfortunately it has not yet proved possible to carry out the necessary speech tests, which are somewhat lengthy, on a vocoder incorporating the most recent improvements.

determined by spectrum definition, i.e. the ear appreciates energy-frequency rather than energy-time relationships when listening to vowels). The mean vowel articulation efficiency (weighted for rates of occurrence in English) is over 95 per cent. Five vowels, EE, Ī, Ī, OÖ and EW, were never received incorrectly throughout two tests totalling 15,000 sounds. Only four vowels, AR, Ā, Ē and OÖ, had articulation efficiencies of less than 95 per cent. Bearing in mind that less than half the sounds of speech are vowels, it is evident that the scope for further overall improvement by increasing vowel articulation is small. Even this, however, refers only to *articulation* and it is well known that vowel sounds are, in any case, largely redundant in conveying intelligence. It is quite evident that little useful purpose would be served by more accurate definition of the spectrum. What evidence there is is all the other way and tends to show that little would be lost by reducing the number of spectrum channels to seven or eight.

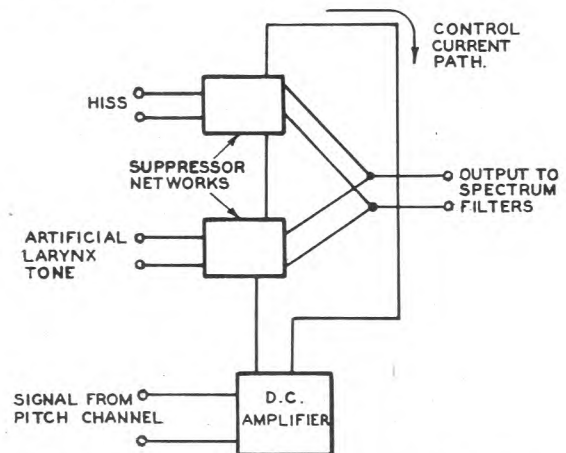

FIG. 8.—PRINCIPLE OF THE SWITCHING CIRCUIT.

The problem is therefore essentially one of consonant articulation. Final consonants come off fairly well; the commonly occurring N and L both exceed 95 per cent. The one final consonant which is badly reproduced, TH (about 52 per cent.), is fortunately of rare occurrence. Sound articulations of initial consonants range from: H, R, W and SH, all 100 per cent., and N, 99 per cent., down to P, 77 per cent., and F, 74 per cent., which is the lowest except again for TH, which fortunately occurs most commonly in unimportant words.

Fletcher's correlation between syllable articulation and intelligibility of ideas<sup>5</sup> points to an idea intelligibility of 99 per cent., but there is no certainty that the relationships hold for synthetic speech where factors other than human are specially liable to influence intelligibility and leave articulation unaffected. Effective communication depends largely on the sympathy of expression that can be established between talker and listener and this in turn depends on qualities which come fully into play only in practical two-way conversations.

It is instructive to note that, as would be expected

<sup>5</sup> Fletcher, Harvey: "Speech and Hearing" (1929)

from the previous remarks on speech synthesis, the articulation of the vocoder is barely affected if the pitch circuit is disconnected altogether, causing the

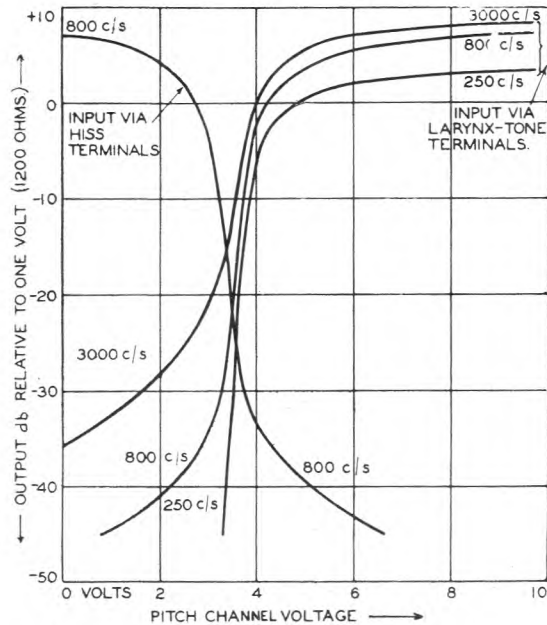

FIG. 9.—TYPICAL SWITCHING CIRCUIT CHARACTERISTIC.

speech to be reproduced in a hoarse whisper ("laryngitis effect"). If the larynx-tone generator is fixed at a constant pitch, so that the synthesised speech will appear as a monotonous chant ("sermon

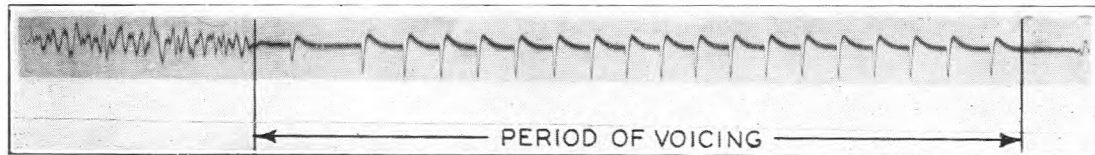

FIG. 10.—OUTPUT OF SWITCHING CIRCUIT FOR DURATION OF A VOICED SOUND.

## Book Review

"Radar System Engineering." Volume 1 of the Radiation Laboratory Series (Massachusetts Institute of Technology, U.S.A.) edited by Louis N. Ridenour; 748 pp. 445 ill. McGraw-Hill Publishing Co., Ltd. 45s.

In November 1940 the Radiation Laboratory of the Massachusetts Institute of Technology was formed to carry out microwave radar development, and in 4½ years the staff rose from 40 to 4,000. A vast fund of information was accumulated, and towards the end of the war it was wisely decided that because the information was so valuable it should be written up and published. Accordingly a *magnum opus* of 28 volumes was planned covering practically every aspect of radar and associated techniques, and a small army of specialists worked for months writing this encyclopedia, of which "Radar Systems Engineering" is the first instalment. This book, which is the work of 34 co-authors, is an excellent and generally well balanced survey of those forms of radar that involve the emission of signals and the reception of echoes at the same point. The treatment of highly

effect"), the articulation is again unaffected. These effects emphasise clearly that the human pitch conveys emotion rather than articulation.

## Conclusion.

It has not been possible in this article to discuss practical transmission systems for the vocoder. There are various alternatives to a double-sideband carrier system for the channel signals, but the only attractive one from a purely band-economy viewpoint is a quadrature system which would enable the theoretical bandwidth of 300 c/s to be approached.

Whether the vocoder could reproduce under commercial conditions anything like the utility for ordinary conversation which its articulation efficiencies suggest, is controversial, but it is certainly true that the vocoder establishes as practicable a standard of speech transmission much greater than had previously been believed possible within a bandwidth of a few hundred cycles per second. If it is agreed that the vocoder offers a standard potentially satisfactory to the subscribers, the question of its field of application becomes an economic one to be considered as part of the general development of telephony over very long distances.

## Acknowledgment.

The author's thanks are due to Mr. R. J. Halsey, under whose guidance the Post Office vocoders have been developed, and who collaborated with the present author in producing the fuller account of the development work to which reference has already been made.

organised position finding systems like Gee and Loran is reserved for other volumes.

Attention is about evenly divided between adequate, but not profound, theoretical treatments of various aspects of radar, and description of many different radar systems and component parts thereof. Very little is written about gun laying, i.e. fire control, radar, however. The high lights of the book are the treatments of the properties of radar targets, of systems for eliminating echoes from fixed targets, and an excellent series of pictures of P.P.I. displays. Only one error has been noticed, that in equation 18, p. 31.

As is to be expected, practically all the photographs and considerations of detail refer to U.S. equipment, but acknowledgments of the pioneer work of this country appear not only in the Foreword and the Introduction, but in many other parts of the book. Indeed, as far as the reviewer is aware, this text book, written in the United States, is the first to give a technical appreciation of the way in which radar information was handled at R.A.F. Fighter Command Headquarters, Stanmore, during the Battle of Britain!

The book can be recommended as an excellent up-to-date survey of the radar field.

H. S.

from the previous remarks on speech synthesis, the articulation of the vocoder is barely affected if the pitch circuit is disconnected altogether, causing the

effect"), the articulation is again unaffected. These effects emphasise clearly that the human pitch conveys emotion rather than articulation.

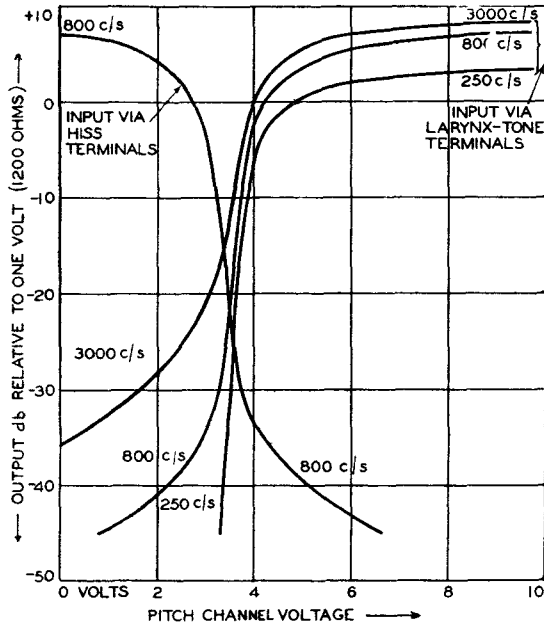

FIG. 9.—TYPICAL SWITCHING CIRCUIT CHARACTERISTIC.

speech to be reproduced in a hoarse whisper ("laryngitis effect"). If the larynx-tone generator is fixed at a constant pitch, so that the synthesised speech will appear as a monotonous chant ("sermon

### Conclusion.

It has not been possible in this article to discuss practical transmission systems for the vocoder. There are various alternatives to a double-sideband carrier system for the channel signals, but the only attractive one from a purely band-economy viewpoint is a quadrature system which would enable the theoretical bandwidth of 300 c/s to be approached.

Whether the vocoder could reproduce under commercial conditions anything like the utility for ordinary conversation which its articulation efficiencies suggest, is controversial, but it is certainly true that the vocoder establishes as practicable a standard of speech transmission much greater than had previously been believed possible within a bandwidth of a few hundred cycles per second. If it is agreed that the vocoder offers a standard potentially satisfactory to the subscribers, the question of its field of application becomes an economic one to be considered as part of the general development of telephony over very long distances.

### Acknowledgment.

The author's thanks are due to Mr. R. J. Halsey, under whose guidance the Post Office vocoders have been developed, and who collaborated with the present author in producing the fuller account of the development work to which reference has already been made.

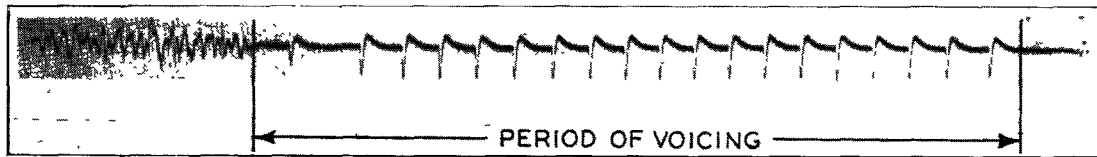

FIG. 10.—OUTPUT OF SWITCHING CIRCUIT FOR DURATION OF A VOICED SOUND.

## Book Review

"Radar System Engineering." Volume I of the Radiation Laboratory Series (Massachusetts Institute of Technology, U.S.A.) edited by Louis N. Ridenour; 748 pp. 445 ill. McGraw-Hill Publishing Co., Ltd. 45s.

In November 1940 the Radiation Laboratory of the Massachusetts Institute of Technology was formed to carry out microwave radar development, and in 4½ years the staff rose from 40 to 4,000. A vast fund of information was accumulated, and towards the end of the war it was wisely decided that because the information was so valuable it should be written up and published. Accordingly a *magnum opus* of 28 volumes was planned covering practically every aspect of radar and associated techniques, and a small army of specialists worked for months writing this encyclopedia, of which "Radar Systems Engineering" is the first instalment. This book, which is the work of 34 co-authors, is an excellent and generally well balanced survey of those forms of radar that involve the emission of signals and the reception of echoes at the same point. The treatment of highly

organised position finding systems like Gee and Loran is reserved for other volumes.

Attention is about evenly divided between adequate, but not profound, theoretical treatments of various aspects of radar, and description of many different radar systems and component parts thereof. Very little is written about gun laying, i.e. fire control, radar, however. The high lights of the book are the treatments of the properties of radar targets, of systems for eliminating echoes from fixed targets, and an excellent series of pictures of P.P.I. displays. Only one error has been noticed, that in equation 18, p. 31.

As is to be expected, practically all the photographs and considerations of detail refer to U.S. equipment, but acknowledgments of the pioneer work of this country appear not only in the Foreword and the Introduction, but in many other parts of the book. Indeed, as far as the reviewer is aware, this text book, written in the United States, is the first to give a technical appreciation of the way in which radar information was handled at R.A.F. Fighter Command Headquarters, Stanmore, during the Battle of Britain!

The book can be recommended as an excellent up-to-date survey of the radar field.

H. S.



# The Manufacture of Star-Quad Telephone Cable

J. E. DEERING

U.D.C. 677.73 : 621.315.213

## Part 3.—Quadding and Stranding Lays, Acceptance Tests and Sheath Defects

The concluding part of this series discusses the considerations involved in selecting suitable lays for quadding and stranding, outlines the acceptance tests made on completed cable and gives a brief account of typical defects encountered in lead sheaths.

### *The Choice of Quadding and Stranding Lays.*

THE mutual electrostatic capacitance (M.E.C.) of a cable pair within a star quad is a function resolved from such factors as the area of the conductor, area occupied by air, spiral length of the paper and string, percentage overlap of the paper dielectric, and the composite dielectric constant arising from the quality of the paper and string, etc. The effect of quadding four insulated conductors does not in itself cause a marked change in the M.E.C., but the spiral effect of stranding introduces a deviation in the M.E.C. of, say, any pair in the outside layer compared with any pair in the centre. This is due to the increase in conductor length as the core diameter builds up. In large cables this increase can be as much as 2 per cent. The basic reason for quadding is to reduce parallelism which would result in abnormal interference between quads; at the same time quadding presents a state of symmetry between the four conductors forming a four point star network.

The Post Office does not specify the length of lay to be employed, but states that the lays of the conductors forming quads shall be so chosen as to ensure that crosstalk is as small as possible. The manufactured cable must conform with the specified limits imposed for capacitance unbalance, etc. To reduce interference, adjacent quads in each layer differ in length of lay. If the number of quads in a layer is odd, the least number of different lengths of lay in that layer is three. Due to the close proximity of quads in the centre (which never exceed four), the length of lay of each of the quads differs and these lengths of lay are so chosen as to differ from that of any quad in the first layer. This brings the total different lengths of lay to seven. Although adjacent layers are stranded in alternate directions, it is usual to adopt the same quadding lay for quads in the odd layers, and employ a different group of lays for the quads in the even layers. This can be achieved by introducing one other quadding lay, bringing the total to eight. This practice is more often employed in trunk type cable where the capacitance unbalance limits are more stringent. In carrier type cable each of the twelve quads is different in lay, due to an even more stringent specification limit.

From an electrostatic and economical standpoint, the use of long lays is an advantage, but lays over 10 in. are liable to suffer derangement, such as the centre bedding string moving from its central position, which in itself would upset the original object of symmetry between conductors in a quad, and give rise to high capacitance unbalance. Therefore the choice of quadding lays is usually less than 10 in.

The choice of stranding lays is dependent on two features which are directly opposite in effect. To manufacture a cable which is flexible and free from kinking troubles, it is necessary to use a comparatively short stranding lay, but from an electrostatic and economical viewpoint, the stranding lay should be as long as possible. A reduction in the length of lay increases the linear length of the individual quads in a layer and hence increases both the capacitive effects and the weight of materials. Therefore a compromise is adopted by the manufacturers. An example of the quadding and stranding lays for a P.C.Q.T. 542 Pair/20lb. cable is given in Table 1.

### *Capacitance Unbalance.*

The star formation on which a quad is designed has for its object a geometrical and electrostatic symmetry. Departure from symmetry throughout a cable causes electrical interference between pairs, and therefore

TABLE 1  
DIRECTION AND LENGTH OF LAYS

LAYERS	Centre	1st	2nd	3rd	4th	5th	6th	7th	8th	9th
	Left	Right	Left	Right	Left	Right	Left	Right	Left	Right
Length of quadding lays, inches										
1st quad "Marker" .. ..	5	5½	5	5½	5	5½	5	5½	5	5½
2nd, 4th, etc.; quads .. ..	6	6½	6	6½	6	6½	6	6½	6	6½
3rd, 5th, etc.; quads .. ..	8	5½	5	5½	5	5½	5	5½	5	5½
Last quad "Reference" .. ..	7	7½	7	7½	7	7½	7	7½	7	7½
Length of stranding lays, inches	18	18	18	24	24	24	30	30	36	36

the Post Office specifies the limits of unbalance in capacitance permitted within any quad, and between any two quads. Unbalance which occurs regularly along the cable length may be due to a bias in the quadding machine, such as tension or persistent irregularity of one of the components. For example, if the 'A' conductor of a quad were regularly lapped with a thicker paper than its associated 'B' conductor, its capacitance to earth would be different from that of the 'B' conductor. The unbalance to earth, which

is the difference between the capacitance to earth of the 'A' and 'B' conductors, would vary with the cable length. Such unbalances are generally the largest in the cable. Other types of unbalance due to normal irregularities in the dimensions and properties of the paper, string, cotton, wire, etc., may not be regularly disposed, or regularly affect any one conductor of the quad. Therefore such unbalances will not be persistently positive or negative, and their magnitude will not be proportional to the cable length.

When a factory length of cable is measured for capacitance unbalance, the arithmetical mean of each characteristic is obtained ignoring the signs. Therefore if two cables both of the same quality and mean unbalance be jointed together, the arithmetical mean then obtained would not be double that of one single length. Such a condition could only be arrived at by jointing pairs so that the negative values add to negative values, and similarly with the positive values. Likewise zero unbalances would be obtained only when pairs with unbalances of opposite signs but equal magnitude were jointed together. With random jointing of the pairs in the two cables, the resulting unbalances would fall somewhere between zero and double those of the single length. With such a random combination the mean unbalances on the greater length would probably be related to those of the single length by the square root of the ratio of the lengths. As a result of this, cable lengths are specified to meet capacity unbalance limits after the measured values have been corrected by a factor based on the theory of probability, which allows for the unbalances to vary somewhere between the square root and linear functions of the length (L yds.). The measured values for the P-Q characteristic are divided by the factor  $\frac{1}{2}(L/176 + \sqrt{L/176})$ . Similarly the unbalances to earth are corrected by dividing the measured values by  $L/176$ , which is a direct law factor.

#### TESTS AFTER MANUFACTURE.

##### Electrical Tests.

Each manufactured cable length is tested electrically before it is finally approved by the Post Office inspecting officer. The tests are shown in Table 2.

TABLE 2  
TYPE OF CABLE

Electrical tests, conducted on	P.C.Q.L.	P.C.Q.T.	P.C.Q. Carrier
(1) Insulation resistance .. ..	✓	✓	✓
(2) Conductor resistance .. ..	✓	✓	✓
(3) Mutual electrostatic capacitance ..	✓	✓	✓
(4) Capacitance unbalance .. ..	✓	✓	✓
(5) Resistance unbalance .. ..	—	✓	✓
(6) Mutual impedance .. ..	—	—	✓
(7) Self inductance .. ..	—	—	✓
(8) Ringing through .. ..	✓	✓	✓

Test (1) is taken with a D.C. voltage of not less than 300V. after electrification for one minute at a temperature of not less than 10° C (50° F).

Tests (2) and (5) are corrected for the temperature of the cable at 15.6° C (60° F).

Tests (3) and (4) are made at a frequency of 800 c/s at 10° C (50° F).

On carrier cables tests (2) and (7) are made at a frequency of 60 kc/s, and (6) at 5,000 c/s in addition to the D.C. tests.

As the final electrical test each length is completely rung through. It is here that all the wires are checked for continuity, correct conductor markings and correct position relative to other wires of the same quad at both ends of the cable length.

Typical faults found are :—

- (a) Misplaced quads.
- (b) Wrong cotton whipping.
- (c) Cotton whipping missing.
- (d) Quads incorrectly laid up.
- (e) Two conductors marked with the same identification at one or both ends.
- (f) Insulating paper reversed at one or both ends.
- (g) No insulating paper on conductor.
- (h) Conductors incorrectly arranged in quad.

Such faults are investigated if frequent, and are included on a fault label attached to the drum flange. Cables of over 75 pairs with 6½ and 10 lb. conductors have one extra pair per 100 to allow for any mechanical or electrical faults. The approved cable must contain the ordered number of good pairs.

##### Mechanical Tests.

General inspection during the manufacture is carried out by the inspecting officer. All raw materials are sampled periodically, or at stated intervals where a particular stipulation is made, such as for lead alloy, which is spectrographically analysed after each extrusion.

The annealed copper wire is visually examined for freedom from defects, such as "spills," "sucks," "waves" etc., and periodical elongation tests are taken. Also samples of jointed conductors (due to accidental breakage) are measured for conductivity and tensile strength.

Insulating paper is examined for clarity and correctness of markings. The quality should be such that it withstands the mechanical and drying processes of manufacture. It must be of uniform thickness and texture and free from metallic and deleterious substances. A strip of 1 in. width should support a weight of 4 lb. for each 0.001 in. thickness. The insulating paper used to be made from Manila hemp, but nowadays cellulose fibres from wood are used.

Sheathing material is subjected to an air pressure test of 75 lb./sq. in. after the cable has been manufactured. This is a good general test although a bad join or weak seam will not always open with pressure, and only on subsequent bending of the cable when drawing in will the defect be revealed. The sheath is checked for

Intermediate between these two states are those alloys—and these are by far the most numerous—in which the state of the metal solution is partially maintained in the solid state. Some alloys containing up to a certain limiting proportion of the second constituent crystallise according to group (a) above as solid solutions without any separation of the constituent metals, but alloys containing a higher proportion of the second constituent than the limiting proportion undergo partial separation during freezing, the excess of the second metal above the limit of solid solution being separated as crystals of a separate constituent. These alloys are related to group (b) above except that the two kinds of crystals present in them are not those of the pure constituent metals but consist of solid solutions of each of the metals in the other.

During the crystallisation of some binary alloys the separation of solvent and dissolved metal from one another only occurs finally at the moment of complete solidification, that portion of the alloy which crystallises last containing both metals, and these in freezing separate from one another in the form of minute crystal plates or granules thus forming a fine-grained duplex constituent. The alloy which consists entirely of this duplex constituent is known as the eutectic alloy

As an example it will be shown how the above facts can be related to an alloy of lead and antimony containing 1 per cent. of the latter metal, which is specified by the Post Office for sheathing some of its cables. At a sufficiently high temperature there is complete miscibility of the two metals, but as the melt begins to cool off a certain amount of lead begins to crystallise and this continues until a temperature is reached when the antimony and lead in the proportions found in the eutectic alloy completes the solidification. From the moment when the lead begins to separate to that when the separation of the eutectic alloy brings about solidification, the metal will be in a more or less pasty condition, and it is while in this condition that the alloy is extruded in cable manufacture. The structure of the alloy following extrusion and complete solidification will vary with the conditions existing throughout the plant, and it was for this reason that an early reference was made to the need for careful control to ensure uniform conditions and results.

#### *Typical Sheath Defects.*

If the temperature of the lead or lead alloy is too high and the metal has been kept at this elevated temperature for too long a period, the resultant structure will consist of large crystals. This state of affairs must be avoided, particularly with lead, since the boundary walls are comparatively weak and can be ruptured or weakened by vibration or stress (Fig. 2). This weakness is avoided by the introduction of antimony, tin or tellurium, but if the structure of such alloys is of large crystals, the same weakness exists although to a somewhat lesser extent. Provided the structure consists of small crystals these alloys offer, among other characteristics, greater resistance to fatigue than pure lead and are therefore

employed for specific purposes where subjection to fatigue is expected.

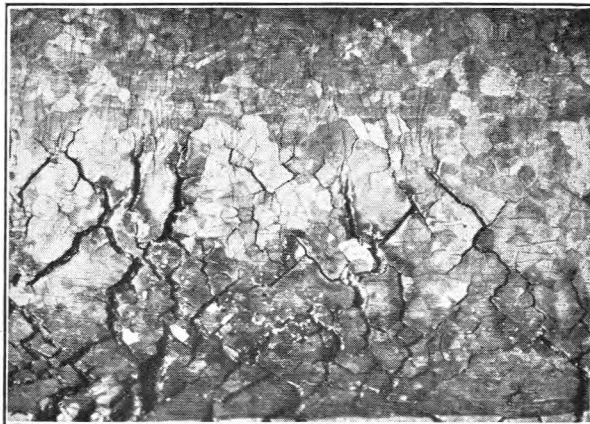

FIG. 2.—FATIGUE CRACKS DUE TO LARGE CRYSTALS (MAG.  $\times 5$ ).

It may be noted here that very small additions of metals which were at one time regarded as undesirable impurities have a beneficial effect in lead on account of the increased strength they impart to the lead.

Having seen how the crystals form and solidify to produce the finished sheath and how lack of control of temperature can lead to unsatisfactory results, it may now be of interest to turn to a few other faults or defects which may occur.

It is possible during the extrusion process for seams to fail to knit or weld, and so to produce mechanically weak areas which sometimes reveal their presence under vibration and even during jointing operations.

Transverse cracking on the surface of a sheath results primarily from intergranular weakness in the crystal structure and can be brought about by too high an extrusion temperature and also through deformation immediately after extrusion. It is the

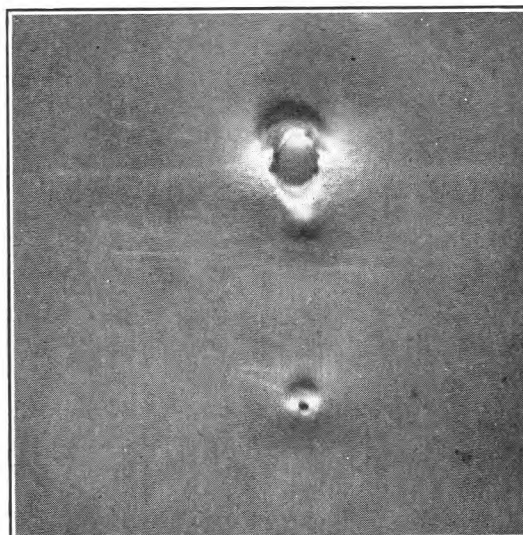

FIG. 3.—BLISTERS CAUSED BY THE INCLUSION OF AIR IN THE LEAD CHARGE.

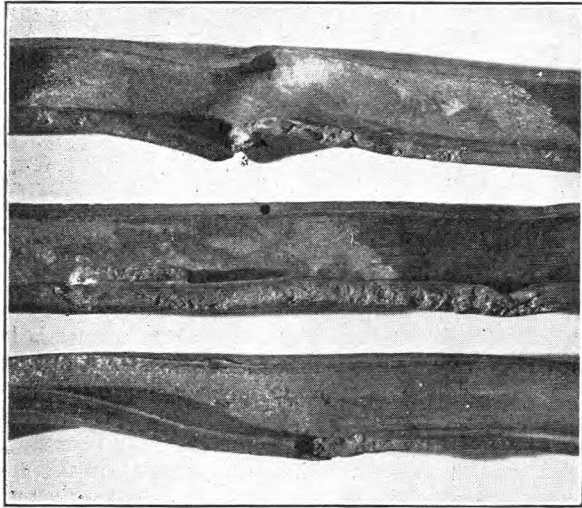

FIG. 4.—EXAMPLE OF RED LEAD EXTRUDED IN THE SHEATH OF A CABLE.

general custom to cool the extruded sheath as it emerges from the press and this practice also avoids, in alloys, the formation of small amounts of eutectic alloy at the die opening where friction is high.

It sometimes happens in recharging the supply pot that small amounts of air or gas may become occluded in the molten metal which may lead to the formation of blisters or pinholes in the sheath (Fig. 3). These faults are generally detected when subjecting the

sheathed cable to the pressure test and to immersion in water before the application of electrical tests.

Apart from air inclusions causing blisters it is essential that when recharging the supply pot the new metal shall coalesce with the metal left in the pot. Small quantities of oxide or grease may be included and these will contaminate the molten metal and prevent thorough and complete mixing. These faults can be carried forward through the extrusion press and may be revealed in the finished sheath in a variety of ways (e.g. see Fig. 4). They may lead to a tongue appearing in the sheath or the layer may be carried forward inside the sheath and revealed only when the cable is bent or during pressure test. Fig. 5 clearly shows how these layers exist in the finished sheath according to the manner of flow of molten metal and its passage through the press. It will be obvious that unless the weld is good the region around it constitutes a serious weakness and the sheath may be easily split over a considerable distance.

#### *Acknowledgments.*

Grateful acknowledgment is made to officers in the Cable Test Section and Construction Branch for advice and assistance given in the preparation of this series. Thanks are also due to numerous telephone cable contractors for information supplied, and in particular to Messrs. Johnson and Nephew and W. T. Henleys for helpful co-operation and for permission to reproduce certain of the illustrations.

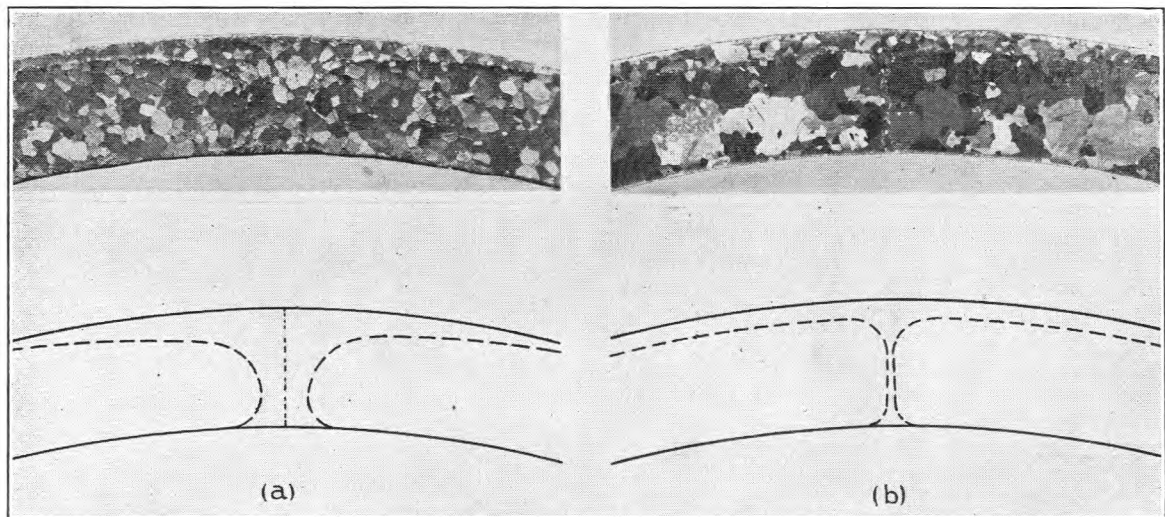

(a) Shows a tongue of new charge; the radial weld is faint and does not bisect crystals.

(b) A radial weld.

FIG. 5.—LAYERS FORMED IN CABLE SHEATH DUE TO NEW CHARGE BEING ADDED (MAG.  $\times 5$ ).



# Ionospheric Disturbances

U.D.C. 621.396.11

G. H. M. GLEADLE, M.Sc. (Eng.), A.M.I.E.E.

A brief outline is given of the nature of the two main kinds of ionospheric disturbance that upset long-distance, short-wave radio communication and the steps that can be taken to mitigate their effects. As an example, the disturbances that accompanied the great solar flare of July, 1946, are described.

## Introduction.

IN an earlier article<sup>1</sup> a brief description was given of the methods that are used to predict the best frequency for long-distance, short-wave radio communication between any two points. In that article attention was confined to "normal", undisturbed conditions, but here a description will be given of the two main kinds of ionospheric disturbance which upset radio transmission, the Dellinger Effect and the Auroral Storm, and of the steps that may be taken to mitigate their effects.

## Dellinger Effect.

The first kind of ionospheric disturbance that will be described is the "Dellinger Effect" (named after its discoverer), sometimes known as a "catastrophic fade-out" or "ionospheric irruption." This disturbance coincides with the appearance of bright flares on the Sun, which, it is thought, are accompanied by great increases in ionising radiation (chiefly ultra-violet radiation). Below the normal E-Layer, at heights of the order of 80 kilometres, or even less, ionisation during such disturbances becomes much more intense than usual, but the E- and F-Regions appear to be little affected. This abnormal ionisation causes severe absorption of high-frequency radio waves during their passage through this region on their way to and from the reflecting layers above. Only those paths which traverse the sunlit hemisphere are affected by this type of fade-out. The disturbances are more intense the higher the altitude of the Sun over the path in question, and usually occur very suddenly, the intensity of radio signals decreasing sometimes to less than one-hundredth of the undisturbed value within one or two minutes. Such interruptions usually last from a few minutes up to about half an hour, though in severe cases conditions may not return to normal for several hours. Since the absorption of a high-frequency wave passing through a given ionised region is inversely proportional to the square of the frequency, the effect is the more pronounced the lower the frequency. However, low- and very-low-frequency radio signals are reflected at the lower boundary of the abnormal absorbing layer and so avoid the absorption normally experienced in higher layers, with the result that such transmission may, therefore, be improved during the fade-out of high-frequency signals. Thus, it is frequently possible to maintain communication during the abnormal condition by changing from high to low frequencies, i.e. from short to long waves. Dellinger Effects do not show any well-defined seasonal changes, although it might be expected that such fade-outs would be more pronounced in summer than in winter. The frequency of occurrence of the fade-outs varies in phase with the sunspot cycle, since solar flares are nearly always

associated with sunspots. The fade-outs are often accompanied by a considerable rise in radio noise which, as shown by Appleton,<sup>2</sup> appears to originate in the Sun.

It will be appreciated that the fade-out is not due to absence of reflection from the ionosphere, but is a result of severe absorption. For the reason already given, a reduction in the operating frequency in the high-frequency band would serve no useful purpose since the attenuation would be increased still further. In fact, the only possibility of maintaining communication when an interruption occurs on a high-frequency circuit, due to a fade-out, is to raise the frequency, unless, of course, a low-frequency circuit is brought into use. The drawback to increasing the frequency is that the next higher frequency allocation available may be above the Maximum Usable Frequency (M.U.F.) for the normal E- and F-Layers, in which case the wave would probably pass through the ionosphere and not be reflected back to Earth. However, there is often a substantial increase in Sporadic-E ionisation and it is sometimes possible to restore communication by resorting to higher frequencies than those normally used. (Sporadic-E ionisation is the term given to small intense clouds of ionisation that occur within the normal E-Layer. It is probable that they are due to ionisation caused by particles shot out of the Sun, or to meteor showers.) The use of a low-frequency circuit is, however, the most likely method of providing communication during the disturbance.

An interesting example of Dellinger Effect is illus-

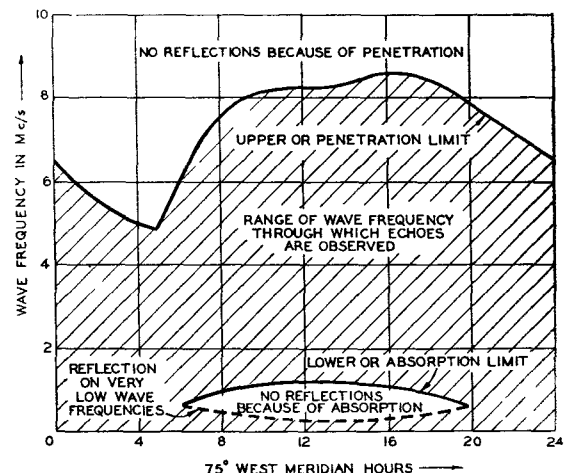

FIG. 1.—WAVE FREQUENCY BOUNDARIES GIVING REFLECTION LIMITATION DURING NORMAL CONDITIONS FOR SIX CONTROL-DAYS NEAR DAY OF FADE-OUT OF 31-7-1937.

trated in Figs. 1, 2 & 3 which are due to L. V. Berkner<sup>3</sup> and his colleagues. Fig. 1 shows the average iono-

<sup>1</sup> P.O.E.E.J., Vol. 40, p. 76.

<sup>2</sup> *Philosophical Magazine*, February, 1946.

<sup>3</sup> *Physical Review*, Vol. 55, March 15, 1939.

spheric conditions at Kensington, Maryland, U.S.A., for six undisturbed days near the day of a fade-out, the shaded area indicating the range of frequencies throughout the 24 hours on which echoes could be observed when radio waves were projected vertically upwards and reflected back to Earth from the iono-

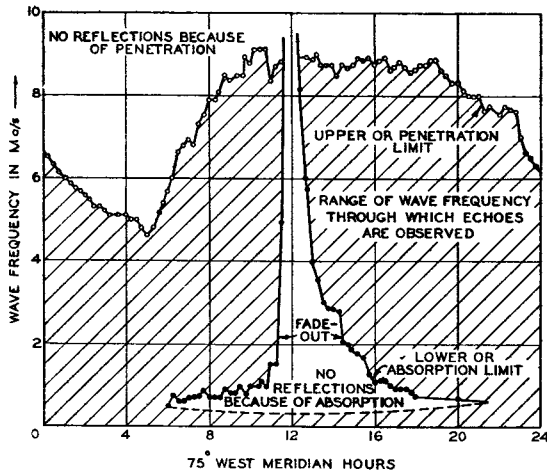

FIG. 2.—WAVE FREQUENCY BOUNDARIES GIVING REFLECTION LIMITATION DURING FADE-OUT; ILLUSTRATING UPWARD PROJECTION OF LOWER OR ABSORPTION LIMIT FOR FADE-OUT OF 31-7-1937.

sphere. During the day normal D-Layer absorption prevented echoes from being observed on a certain range of low frequencies. Fig. 2 clearly shows the effect of the fade-out, no echoes at all being observed on any frequency (apart from the very lowest fre-

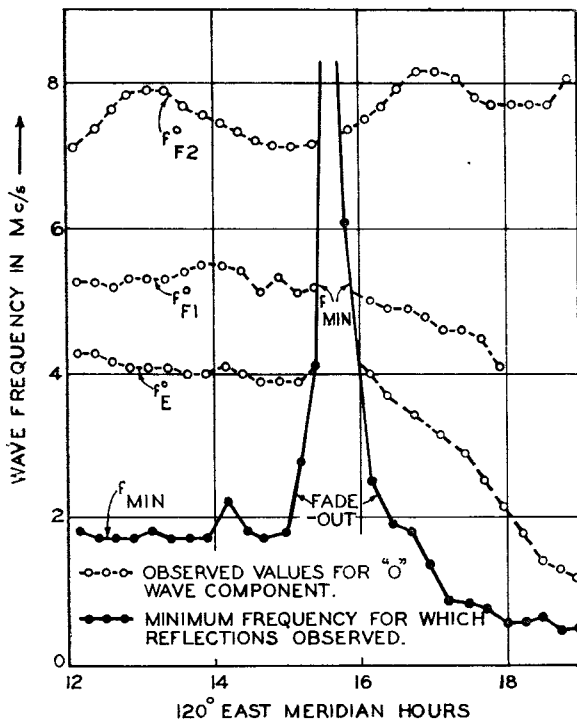

FIG. 3.—CRITICAL FREQUENCIES OF THE IONOSPHERE SHOWING RADIO FADE-OUT, 26TH NOVEMBER, 1938, DETERMINED FROM AUTOMATIC MULTI-FREQUENCY AND FIXED FREQUENCY REGISTRATIONS.

quencies) for about half an hour. The graph also indicates the tendency for the effect to be more prolonged on the lower frequencies. Fig. 3 is a record of measurements made on a different date at Watheroo, Australia, and shows that the normal E- and F-Layers are probably unaffected during a fade-out since the critical frequencies ( $f^{\circ}E$ ,  $f^{\circ}F1$  and  $f^{\circ}F2$ )<sup>4</sup> immediately before and after the fade are nearly the same. This conclusion is also supported by measurements of layer height.

It is of interest to note that the ionospheric effects during Dellinger fade-outs have their counterpart in characteristic disturbances which occur in the Earth's magnetic field.

#### Auroral Storm.

The other main kind of ionospheric disturbance is called an "Auroral Storm," although it is sometimes referred to as a "Magnetic Storm" or "Ionospheric Storm." The disturbance is thought to be due to the effect of charged particles shot out from active regions of the Sun at the same time as the occurrence of a major solar flare. The particles, however, have a far smaller velocity than the ultra-violet and visible radiation from the flare and reach the ionosphere 17 to 36 hours later. Moreover, it appears that the particles are usually shot out within a fairly narrow cone approximately at right angles to the surface of the Sun, so that they are not likely to hit the Earth unless the active region is near the centre of the Sun's disk, i.e. near the Central Meridian Passage (C.M.P.) and not too far removed from the solar equator. As the particles come into the Earth's magnetic field they follow a spiral course and spread around the geomagnetic poles on both the dark and light sides of the globe. Turbulence is produced in the F-Layer, the density of ionisation decreases, at times profoundly, and the virtual height of the layer increases rapidly. During severe storms the particles may penetrate lower into the ionosphere and sometimes an abnormal absorbing layer may be produced in the neighbourhood of the E-Region. At night this gives rise to auroræ. These ionospheric disturbances are most pronounced, not at the magnetic poles themselves, but in comparatively narrow zones where auroræ are most frequent, called the Auroral Zones, which surround the poles at a mean radius of about 1,500 miles. High-frequency radio circuits whose paths traverse these regions may at times be severely affected, and, with violent storms, the effects gradually spread to lower latitudes. Unlike the Dellinger Effect, the frequency with which auroral storms occur does not vary precisely in phase with the sunspot cycle but lags it by about one to two years. This is due to the fact that during the years of sunspot maximum the spots occur most frequently in two bands, 10 to 15 degrees north and south of the solar equator and are, therefore, not favourably situated for particle emission to hit the Earth. Later in the cycle, although there are fewer

<sup>4</sup>The Earth's magnetic field renders the ionosphere doubly-refracting, so that a radio wave is split into two components (the ordinary and extraordinary rays) during its passage through the ionosphere. The superscripts "o" and "x" are used to indicate the ordinary and extraordinary components, respectively.

active areas, they occur nearer to the solar equator. Auroral storms often follow Dellinger fade-outs after an interval of one to two days if the active region is near the centre of the Sun's disk. High-frequency radio circuits whose paths traverse the auroral zones are affected by these storms not so much because of absorption but because the radio waves are not reflected from the F-Layer, or in less severe storms are reflected irregularly, which causes fading, echo, and distortion of the received signal.

Auroral storms are also accompanied by disturbances in the Earth's magnetic field. The magnetic storms that follow the appearance of major solar flares after an interval of one to two days usually commence very suddenly, but do not last as long as the ionospheric effects. The horizontal and vertical components of the Earth's field show rapid changes followed by irregular fluctuations, while the declination may change by as much as two degrees. There is, however, another though smaller class of magnetic storm that accompanies appreciable ionospheric disturbance. These particular storms do not follow solar flares and do not commence very suddenly. They are most frequent during sunspot minimum years, and their cause is still obscure.

The tendency for auroral storms to have their peak a year or two after the maximum of the sunspot cycle has been confirmed from a recent analysis of the lost circuit time, due to ionospheric disturbances, on the Post Office overseas radio telephone circuits for the years 1937 to 1939. Unfortunately, all regular circuits had to be closed down at the outbreak of war, so that long-term trends cannot be traced very far. However, all the circuits whose paths traverse the auroral zones (those to Canada, U.S.A., Japan and Iceland) show continuing increases in lost time after the peak of the last sunspot cycle in 1937, whereas all the other circuits, except that to India (those to South America, Egypt, South Africa, Australia, Portugal and Kenya), which are largely affected only by Dellinger Effect, show a fairly flat characteristic. Their lost time rises slightly in 1939, due, presumably, to auroral storms which would have their peak about two years after the sunspot maximum in 1937. This is illustrated in Fig. 4, which shows the sunspot number<sup>5</sup> and the average annual lost time for two representative circuits, one to Canada (representing a circuit traversing the north auroral zone) and one to South America (representing a circuit which is largely free from the effects of auroral storms).

Operating staff at a receiving terminal often recognise that an auroral storm is beginning by the violent fading, echo and distortion of the signals that accompany the disturbance in the F-Region. In these circumstances, it is advisable to reduce the operating frequency in the hope that reliable reflections may be obtained from the reduced ionisation of the F-Region or perhaps from the E-Region. If the storm is severe, and additional absorption takes place, then the signal

<sup>5</sup>The sunspot number is an index of the number of spots occurring on the Sun's disk, and is compiled from the formula  $C(10G + N)$ , where C is a "seeing" factor for the observatory concerned, and depends upon weather conditions, equipment etc.; G the number of sunspot groups; and N the number of separate spots.

may disappear altogether due to attenuation. When this happens there is little that can be done, such as raising the frequency, since the higher frequency necessary to overcome absorption would not be reflected back to Earth. However, the additional absorption does not usually persist as long as the disturbance in the F-Region, and after it has disappeared it should be possible to restore communication on a lower frequency until the F-Layer has returned to normal.

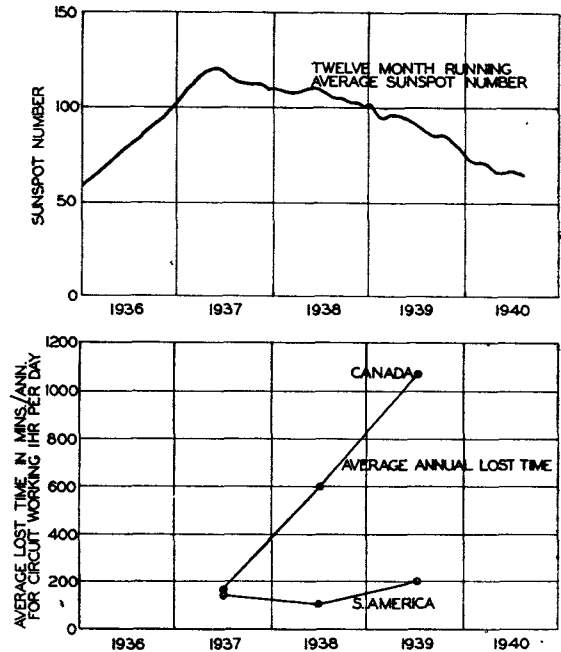

FIG. 4.—COMPARISON BETWEEN SUNSPOT NUMBER AND AVERAGE ANNUAL LOST TIME.

#### SOLAR ACTIVITY DURING JULY, 1946.

As an example of the disturbances that occur on long-distance, short-wave radio circuits when a major solar flare appears, a brief analysis has been made of circuit performance during the latter part of July, 1946, a period of intense solar activity.

On the 20th July, 1946, the Royal Observatory advised that a large spot was on the Sun's disk in latitude 21°N. Its position was such that it should have been visible from the Earth between 19th July and 2nd August. Provisional measurements of its area on the 20th July gave a figure of 2,500 millionths of the Sun's visible hemisphere, and later the spot increased to a maximum of about 4,600 millionths on the 27th July. (Most sunspots do not exceed about 1,000 millionths.) The C.M.P. was expected to occur at noon on the 26th July. On the 25th July it was reported from Greenwich that at about 1615 G.M.T. an intense solar flare associated with the sunspot had been observed at Sherborne, Dorset, by Dr. M. A. Ellison and also by the Solar Physics Observatory, Cambridge. The flare rose to an intense maximum at about 1627 G.M.T. on the 25th July and did not finally subside until about 0900 G.M.T. on the following day. (The most intense flares rarely last for more than two hours.) At the time of the flare, the sunspot

was about 15 degrees away from C.M.P. Smaller flares associated with the spot were recorded at Greenwich and elsewhere on certain days prior to the great flare.

Fig. 5 is a photograph of the great solar flare taken at Meudon Observatory, Paris. This photograph was

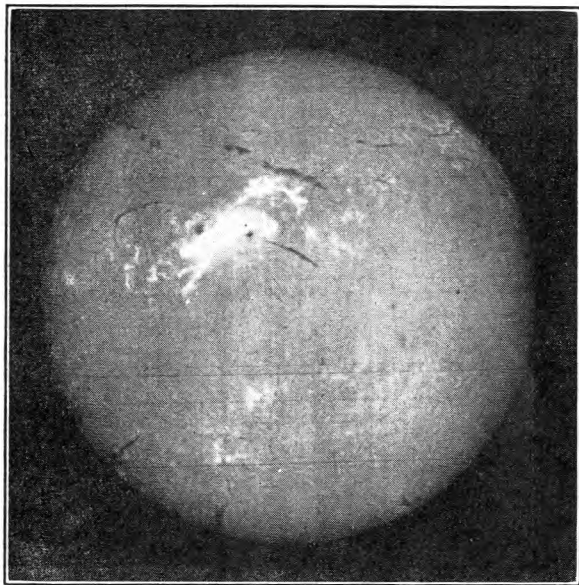

FIG. 5.—THE GREAT SOLAR FLARE OF 25TH JULY, 1946.

taken in the light of the hydrogen alpha line of the solar spectrum at 1732 G.M.T. on the 25th July, 1946. The magnitude of the flare at its most intense phase can well be imagined when it is appreciated that the photograph was taken over an hour after the peak, which occurred at 1627 G.M.T.

Subsequently, the National Physical Laboratory advised that exceptionally severe D-Region absorption was measured at Slough between 1500 and 1800 G.M.T. on the 25th July (the day of the flare) and less severe absorption was measured on the following day. Ionospheric measurements showed that between 2300 G.M.T. on the 26th July and 0900 G.M.T. on the 28th July, an auroral storm was in progress. An aurora was seen in Great Britain during the early hours of the 27th July.

The Abinger magnetograms of the Royal Observatory showed that a great geomagnetic storm began sharply on the 26th July at 1846 G.M.T. and continued until 2200 G.M.T. on the 27th July. Later, an appreciable but not a large magnetic disturbance began at about 1400 G.M.T. on the 28th July, and ended at 1700 G.M.T. on the 30th July.

#### *Ionospheric Disturbance Records.*

The transmission data that have been used in this example are the ionospheric disturbance records prepared by the Radio Telephony Terminal of the British Post Office. These data are compiled from the log-sheets of the various radio circuits and care is taken to exclude any disturbance due to other causes, e.g., apparatus faults or operation, usually for particular reasons, on frequencies far removed from the optimum working frequency.

The disturbed periods on five circuits that were operated for a substantial proportion of the 24 hours are plotted as histograms in Fig. 6, which shows the total disturbed periods for each day from 15th July to 6th August, plotted as percentages of the operating

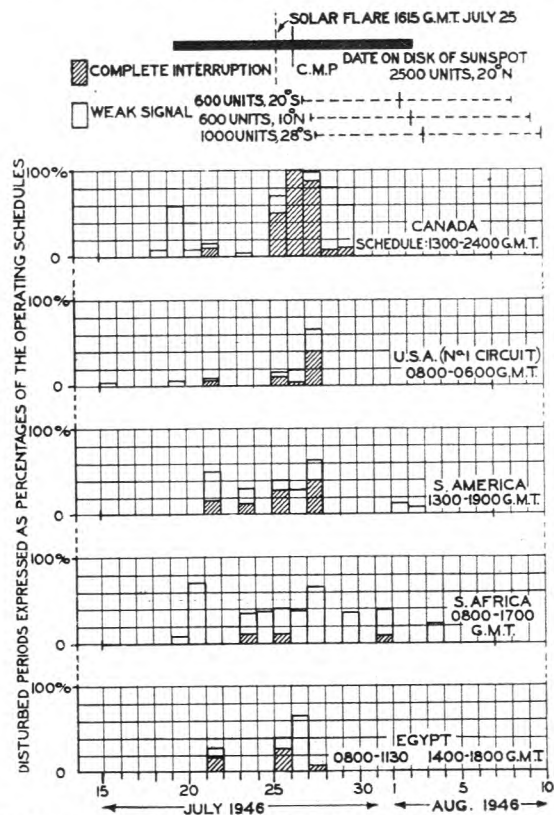

FIG. 6.—DAILY PERIODS OF DISTURBANCE ON FIVE RADIO CIRCUITS.

schedules of the various circuits. The incidence of the major sunspot and the great solar flare is also shown. The presence of other spots, greater than 500 units, on the disk during the period in question is indicated by dotted lines at the top of the figure. Fig. 7 shows the disturbed periods in more detail for each hour of operation of the five selected circuits for the four days, 25th to 28th July.

#### *Interruptions Due to Dellinger Effect.*

The transmission data (not reproduced here) show that all the circuits in use, i.e., those to U.S.A., Canada, South America, South Africa, Egypt and Portugal, went out of action at about 1620 G.M.T. on the 25th July, just when the solar flare was reaching its maximum intensity. The only circuit on which any signal could be detected was that to South Africa. The paths of all these circuits were then in daylight. The interruptions were so complete that it is not possible to deduce directly that, in general, the more southerly circuits were more affected than, say, those to Canada and U.S.A., as might have been expected. The South Africa circuit appeared to be the least affected since faint signals were audible throughout this phase, but it should be noted that this circuit is more reliable than most, largely on account of the small difference in longitude between the terminals.



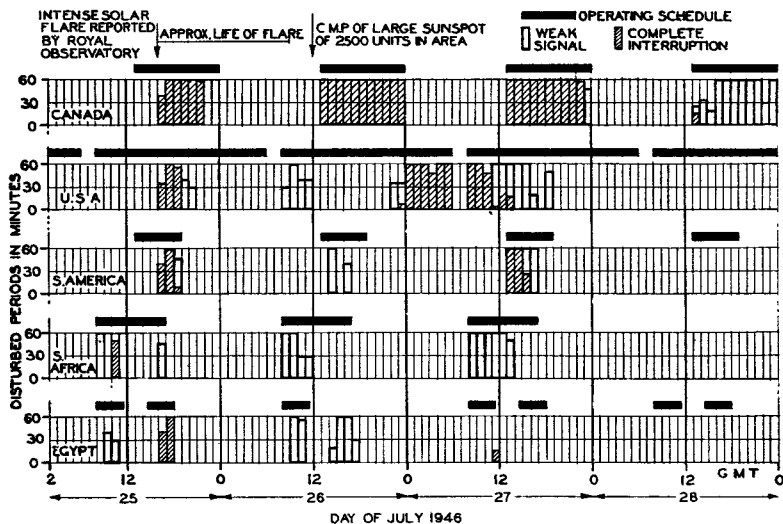

FIG. 7.—HOURLY RECORD OF DISTURBANCES. (SAME CIRCUITS AS IN [FIG. 6.]

The circuits to South America, South Africa and Egypt all remained disturbed until the end of their schedules on the 25th July. Signals began to be faintly audible again on the U.S.A. circuit at 1924 G.M.T. and on the Canadian circuit at 2200 G.M.T. These circuits continued to improve as the radio paths began to pass out of sunlight into darkness. This effect could not be observed on other circuits because they were not in operation when their paths were in darkness. From about 2030 until 0600 G.M.T. on the next day, 26th July, the U.S.A. circuit, the only one in operation, remained normal, the bulk of the path being in darkness throughout this period. Between 0600 and 0800 G.M.T. the circuit was closed for maintenance purposes, but at about 0830 G.M.T. "weak signal" conditions were experienced again, due, it is thought, to less severe Dellinger Effect associated with the last vestiges of the solar flare. Similar poor conditions were recorded on the circuits to South Africa and Egypt as these were brought into operation at 0800 G.M.T.

#### *Auroral Storm Disturbances.*

Throughout the latter part of the 26th July, disturbances began to be recorded again on all circuits except that to Portugal, which is usually extremely reliable. These disturbances probably indicate that the auroral storm was beginning. The interval between the first appearance of the solar flare and the onset of the auroral disturbances on the U.S.A. circuit was 29½ hours, which is a little longer than the average figure of 26 hours. The commencement of these disturbances agrees very closely with the ionospheric disturbances that the N.P.L. reported as having commenced at 2300 G.M.T. on the 26th

July. From this time onwards and throughout the next day, 27th July, the more northerly circuits to Canada and U.S.A. were, on the whole, more affected than the southerly circuits, as shown by the histograms. In fact, no signals were heard on the Canadian circuit for nearly 10 out of the 11 hours of operation on the 27th July. It is noteworthy, too, that the U.S.A. and Canada circuits were affected by night as well as by day during the auroral storm. During the 28th and 29th July, all circuits continued to improve, though signals on the Canadian circuit were for considerable periods still too faint for commercial operation. This phase probably represents the dying away of the auroral storm and the end of disturbances caused by the solar flare on the 25th July. The main effects are not as clear-cut on the histogram as could

be desired, and some disturbances occurred occasionally before the incidence of the intense flare. These disturbances were most probably due to earlier and smaller flares associated with the great sunspot and possibly due to other smaller, active regions on the Sun's disk.

#### *Conclusions.*

It is often possible to decide whether a disturbance to a high-frequency circuit is a fade-out or an auroral storm by noting at the beginning whether the absolute noise level, as distinct from noise/signal ratio, increases, or the first indications are fading, distortion and echoes. If the disturbance is of the former type the frequency should be increased when communication becomes difficult; if of the latter type, it should be decreased. Although in the daytime there may be some doubt as to which disturbance is occurring, in which case the best course would be to increase the frequency, during the night only auroral storms can occur and there can be no doubt that the best course to follow is to reduce the frequency.

#### *Acknowledgment.*

The author has much pleasure in acknowledging the kindness of Mr. L. V. Berkner in giving permission to make use of Figs. 1, 2 and 3, and wishes to thank Dr. L. d'Azambuja of the Meudon Observatory, Paris, for permission to reproduce the photograph shown in Fig. 5. Acknowledgment is also made to the Royal Observatory, Greenwich, for co-operation in providing solar and geomagnetic data.

## Part I.—Signalling System, Subscribers' Station Equipment and Line Terminations

U.D.C. 621.394.34

A description is given of the signalling system employed to reopen the telex service between subscribers in the United Kingdom and the Continent, prefaced by a historical survey of the development of the service, and the influence of C.C.I.T. recommendations. The equipment provided at subscribers' stations and for switchboard line terminations is also described. Part 2 will deal with the remainder of the switching and related equipment.

### *Introduction.*

WHILST the main purpose of this article is to describe the equipment provided in Great Britain for the reopening of the telex service between this country and the Continent, nevertheless some account is given of the reasons for employing the signalling system described, which is new to this country but conforms to C.C.I.T. (Comité Consultatif International Télégraphique) recommendations.

A national telex network was inaugurated in 1932,<sup>1,2</sup> and aimed at providing teleprinter intercommunication between any subscribers connected to the telephone network. Calls between subscribers to the system were first set up as for a telephone call, after which both parties switched to "teleprinter," the teleprinter signals being transmitted over the telephone network by pulses of alternating current in the voice frequency range. A frequency of 300 c/s was employed initially, but in 1936 a change was made to the internationally agreed standard of 1,500 c/s.

Service to the Continent was first opened in 1936, to Holland, in which country a telex system using alternating currents at 1,500 c/s was also in operation, the calls being routed via special telex positions of the telephone trunk suites at Faraday Building, London, and at Amsterdam. Extension of the service to the German telex network was effected in 1937, but as the German system was based on the use of an exclusive, automatically switched, telegraph network, direct circuits were not employed, calls being routed via Amsterdam trunk exchange, and "telex convertor switchboards" existing in the same building, which provided conversion facilities from A.C. to D.C. methods of signalling, and gave access to the German dialling network.

This, then, was the position in 1939, except that development was proceeding on the design and provision of "convertor" switchboards for installation in the C.T.O., in order that conversion from A.C. to D.C. signalling could be effected in this country, and telegraph channels employed for direct connection to countries, such as Germany, using D.C. signalling methods, with resulting economies in the cost of the provision of the international circuits. In this connection it is interesting to note that the first 18-channel V.F. telegraph system to be employed between this country and the Continent was opened for traffic in 1936 on the London-Paris route.

After the dislocation of the war years, discussions on the resumption of the International Telex Service became active early in 1946, as a result of which a

decision was taken in May that the post-war international service from Great Britain should be based on the use of an exclusive telegraph network using D.C. signalling methods, thus facilitating the employment of telegraph channels for the international circuits.

In conformity with this decision, and having regard to the desirability of reopening the Continental telex service as early as possible, development of the necessary subscribers' equipment and telex switchboard proceeded on an urgent basis, and after successful tests of a laboratory set-up, specifications were drawn up in September for the adaptation of an existing standard type of floor-mounted teleprinter switchboard, construction of associated rack equipment and of subscribers' units by adaptation of existing standard table units. By the adoption of these expedients, construction and installation of the switchboard equipment was completed in December, 1946, and engineering tests to the Dutch telex network commenced.

The Continental telex service was reopened on 24th March, 1947, between subscribers to the Continental telex service in this country and telex subscribers in Holland, and was subsequently extended to France and Belgium on 5th May, 1947. Calls to these countries are set up on a manually switched basis via manual telex switchboards in Amsterdam, Paris and Brussels respectively and hence dialling facilities were not required, and were not provided initially, on the telex switchboard in London.

Dialling facilities are, however, now available on this switchboard, and also on the second switchboard, which was brought into service on 26th January, 1948, to carry the additional traffic to and from the Swiss telex network, which employs Siemens & Halske automatic switching equipment. Calls to Swiss subscribers are thus directly dialled by the London telex operator, over direct V.F. channels between London and Zurich. By specific agreement, calls in the reverse direction are also controlled by the London telex operator, Swiss subscribers dialling a special code (014) which gives direct access to a calling appearance at the London switchboards.

Further expansion of the service, which is already approaching the 1939 level in terms of paid time over the Continental circuits, can confidently be anticipated, as well as extension to other countries not previously connected, when the requisite telegraph circuits become available.

### *C.C.I.T. Recommendations.*

With the application of switching systems to

<sup>1</sup>P.O.E.E.J., Vol. 25, p. 177. <sup>2</sup>P.O.E.E.J., Vol. 29, p. 290.

telegraphy to provide a subscribers' "teleprinter exchange" (telex) service, introduced in 1932, the technical problem of ensuring satisfactory inter-working between different national switching networks, previously confined to telephony, was extended into the telegraph field, complicated, perhaps, by the fact that the two fundamentally different systems previously mentioned were already in process of development.

The C.C.I.T., which on international matters serves the field of telegraphy on very similar lines to the C.C.I.F. in telephony<sup>3</sup>, ratified, at its 5th Plenary Session at Warsaw in 1936, a number of *Avis* framed to facilitate satisfactory inter-working between countries employing telex systems over telephone networks, and which had been the subject of investigation by a joint commission of the C.C.I.T. and C.C.I.F. at the Hague in 1935. These recommendations included the standardisation of the frequency at 1,500 c/s for the transmission of teleprinter signals over completed telex connections, as well as the level at which the A.C. signals were to be transmitted; the precautions to be taken to prevent interference between the telegraph and telephone equipment, viz., the ringing equipment and echo suppressors on telephone trunk circuits liable to be used for telex connections; and also the modifications to be carried out and special operating procedure to be applied at the specially assigned positions at both local and trunk exchanges through which telex calls were established, to prevent speech, or V.F. signals of any kind being connected to a telex call in progress.

The first step on the wider issues involved was taken at the International Telegraph Conference held at Cairo in 1938, at which it was recommended that "the question of the regulations for the subscribers' telegraph service by start-stop apparatus in the

<sup>3</sup>P.O.E.E.J., Vol. 29, p. 38.

European regime should be studied by a commission of C.C.I.T. rapporteurs with a view to preparing a draft of technical and operating regulations. . . ." A first meeting of this Commission was held at the Hague in 1939; the second in November, 1946, at which the regulations were completed in draft form for submission to the 6th Plenary Session of the C.C.I.T., to be held at Brussels in May, 1948.

It would be outside the scope of this article to give full details of these proposals, but the following summary indicates the fundamental plan to which the International Telex Service should ultimately conform, and which will influence the development projects of participating countries meanwhile.

- (1) That the International Telex Service be effected, preferably by means of *direct telegraph* circuits between the systems of countries operating the service.
- (2) That the number of circuits between two countries and the number of staffed telex switchboards should be calculated, as far as possible, to give a *demand* service.
- (3) That the national telex systems be organised preferably for *automatic switching*, so that subscribers may be dialled directly by the controlling operator in the country of origin.
- (4) That where these conditions exist, the operator at the international telex positions in the country where a call originates should control and time that call.
- (5) That the equipment of the telex positions in the country of origin should meet the technical requirements of the country of arrival, to which end full technical and operating details of the distant equipment should be made available to the originating country.

Recommendations are also included, mainly to cover the interim stages of development, whereby

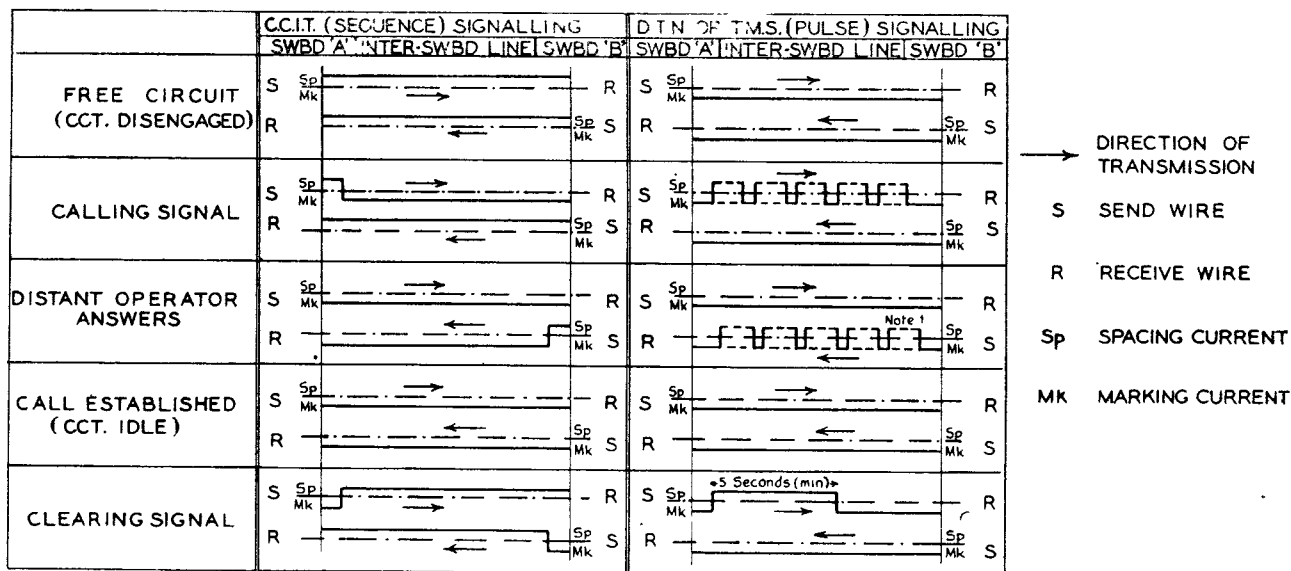

Note 1: Teleprinter signals, 7½ unit code, comprising "start" element of 20 mS spacing current, 5 code elements each of 20 mS marking or spacing current, according to character sent, and "stop" element of 30 mS marking current.

FIG. 1.—BASIC SIGNALLING CONDITIONS—SEQUENCE AND PULSE SIGNALLING SYSTEMS.

national telex networks employing manual switching should nevertheless provide a "demand" service, and permit of the control and timing of calls in the country of origin. Furthermore, by agreement between the Administrations concerned, the employment of direct dialling between subscribers to their respective systems, or the control and timing of calls in the country of arrival, or the use of telephone circuits in telex connections, is permissible.

In addition to the foregoing fundamental recommendations, others relating to essential facilities necessary for satisfactory inter-working have been established in principle, although not in technical detail, such as the provision of full supervisory signalling at the telex switchboards, the prevention of follow-on calls, precautions against the answer-back unit of the switchboard operator's teleprinter causing interference during the monitoring of an established connection, and safeguards, on automatic switching systems, against the establishment of fortuitous connections as a result of line interruptions. Proposals for the operating procedure to be employed at telex switchboards, and operating directives for participating subscribers are also incorporated.

#### Signalling Conditions.

The necessity of obtaining the maximum degree of unification between the signalling systems used by participating countries was fully recognised by the C.C.I.T. Commission concerned, and a recommendation for the calling and clearing signals has been established, which may be expressed as follows:—

The free condition of a line will be characterised by a signalling condition corresponding to the start signal of the International Telegraph Alphabet No. 2; calling, by an inversion of that condition (marking), and the clearing condition by reversion to the same condition as that for a free line (spacing) for a period of at least 300 mS duration.

The circuit arrangements of a switching system designed to meet these requirements differ radically from any previously employed for teleprinter switching in this country, as will be clear from Fig. 1 which contrasts the C.C.I.T. (sequence signalling) conditions against the pulse signalling conditions utilised for the D.T.N.<sup>4</sup> and T.M.S.<sup>5</sup> networks. One result of employing the sequence signalling system is that signalling relays are required at the teleprinter terminations, although overall service benefits should accrue as a result of the more positive nature of the calling and clearing conditions.

It will be noted in the description of the auto-manual line equipment which follows, that signals additional to the basic calling and clearing signals above defined are necessary where automatic switching systems are involved (e.g., "proceed-to-dial" signal), and the extension of the scope of the C.C.I.T. recommendations to cover these auxiliary signalling conditions is a matter for further study by the relevant Commission.

In accordance with proposal (5) of the preceding section, the dialling facilities provided in the London telex switchboards to provide access to the Swiss

network meet the requirements of the system installed at Zurich, i.e. Siemens & Halske TW39 teleprinter automatic switching system. Similar equipment is also to be found in Czechoslovakia, Denmark, Sweden, and, of course, Germany, and hence the dialling facilities already provided in London would technically permit of early extension of the service to all of these countries.

#### Telex Station Equipment.

The station equipment, illustrated in Fig. 2, of a subscriber to the Continental telex service comprises

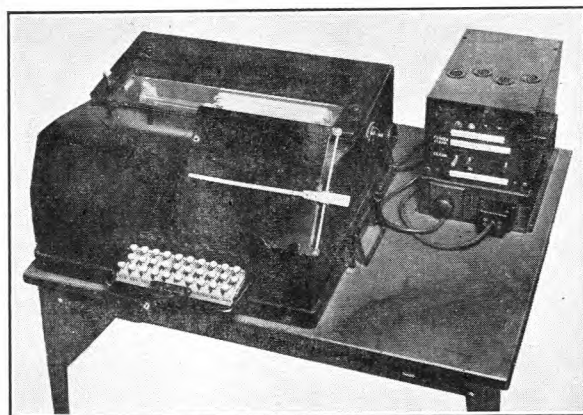

FIG. 2.—SUBSCRIBER'S STATION EQUIPMENT.

a standard steel teleprinter table, 2 ft. 6 in. by 3 ft., carrying the Teleprinter No. 7B (page), and the table unit containing the requisite keys, lamps and relays for signalling purposes. The teleprinter operates on a double-current, two-wire simplex basis, a local copy of all transmitted messages being obtained via the teleprinter send-receive switch. Power for the teleprinter motor and 80+80 V signalling supplies are derived from Rectifiers 43A and 22C respectively, mounted under the table. Where the mains supply is D.C., a Dynamotor No. 22 is also supplied to convert from D.C. to A.C.

Fig. 3 gives in simplified form the circuit arrangement of the terminal equipment, which is contained in the table unit seen to the right of Fig. 2. It will be seen that in the free (disengaged) condition of the line connecting the subscriber to the telex switchboard, spacing battery (+80 V in Great Britain) is connected to the S wire, via key KC1 normal. Spacing battery is also received from the telex exchange equipment over the R wire. The teleprinter electromagnet is, however, maintained in the marking or rest condition by the connection of marking battery (−80 V in Great Britain) over a local circuit governed by contact C1.

To originate an outgoing call the lever type call key KC is operated, and at contact KC1 the calling condition (marking battery) is connected to the S wire, thus lighting the calling lamp at the telex switchboard. The operation of relay M at contact KC3 starts the teleprinter motor. When the switchboard operator answers the call, marking battery is also returned over the R wire, causing contact R1 of the

<sup>4</sup>I.P.O.E.E., Printed Paper, No. 189. <sup>5</sup>P.O.E.E.J., Vol. 40, p. 102.



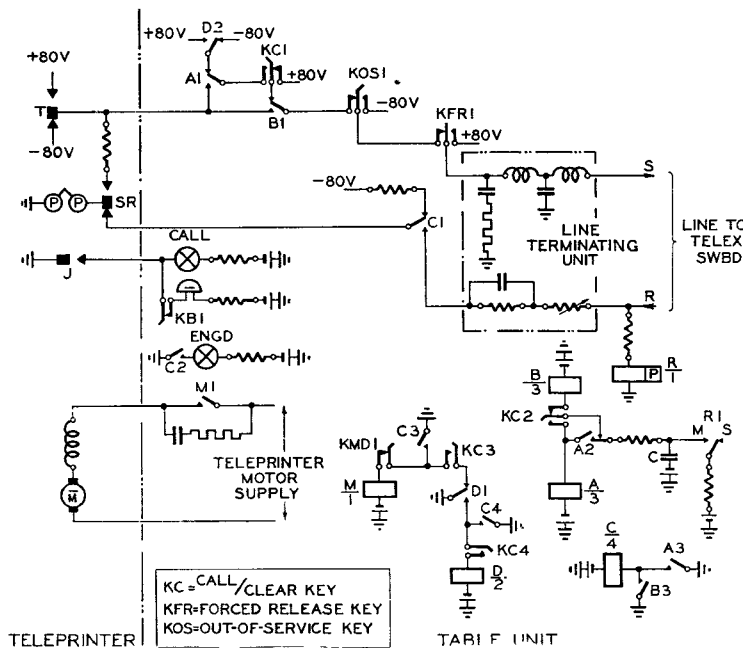

FIG. 3.—CIRCUIT SCHEMATIC OF SUBSCRIBER'S STATION EQUIPMENT.

polarised telegraph relay R to move to the marking side, and operation of relays A, C and D. The teleprinter is switched to line at contacts A1 and C1 operated, the circuit now being prepared for the transmission of teleprinter signals in either direction. The red "engaged" lamp also lights at this stage, and remains so until the call is cleared. At the completion of transmission, clearing is effected by returning the call key (KC) to its normal position, thus at KC1 connecting spacing battery to the S wire and forward transmission path. This automatically ensures the glowing of the answering supervisory lamps at the telex switchboards in circuit, and the restoration of the distant teleprinter to a "free" condition, after which event a spacing battery is returned over the backward transmission path to the R wire of the originating telex station equipment. This condition causes the calling supervisory lamps at the telex switchboards to glow, giving the requisite "double-clear" signal on the cord circuits involved, and contact R1 in the calling subscriber's equipment to move to its spacing contact. Relay A releases after a nominal delay of 300 mS (the slow release feature being controlled by condenser C), releasing in turn relays C and M, and restoring the station circuit to its "free" condition, with motor stopped.

An incoming call to a telex station is signalled by the inversion of the polarity on the R wire from spacing to marking, the consequent change-over of contact R1 operating relay B, via KC2 normal, followed by relays C and M. The teleprinter is thus connected to line at contacts B1 and C1, the motor started, and the red "engaged" lamp lighted, which condition will be maintained until the receipt of a clear signal over the R wire. The clear signal (spacing battery for not less than 300 mS) causes relay B to release after a nominal 300 mS and at B1 to return spacing battery over the S wire and backward trans-

mission path for the purposes above described in relation to an incoming call. Relays C and M at the called subscriber's station are also released by the release of relay B, and the equipment restored to the "free" condition.

It should be noted that during the transmission of teleprinter signals over an established connection, the line condition alternates between marking and spacing in conformity with the characters being signalled, and hence signals passing over the transmission path associated with the R wire of a station circuit will be reproduced at contact R1 of the associated polarised relay R. The clearing relay associated with this contact (relay A on originated calls; relay B on incoming calls) will not, however, be released by the disconnections offered by R1 during spacing periods, because of the delay feature introduced by condenser C, which ensures satisfactory holding of the relay under the most onerous conditions which can be imposed, viz., 120 mS spacing, 20 mS marking, continuously repeated, with maximum adverse signal

distortion in the transmission path. Conversely, the "clear" relays are arranged to release on receipt of a true clearing signal, i.e., spacing battery maintained for not less than 300 mS. If, during the progress of a call, the transmission path in either direction is broken by line irregularity, equipment fault or operating error for a period in excess of 300 mS, the "clear" relays will, of course, release, thus stopping the teleprinter motors and extinguishing the engaged lamps at the subscribers' stations concerned. The transmitting telex operator is thus immediately made aware of the interruption to service, and the possibility of errors is much reduced.

From the foregoing description it will be clear that a call may be established, a message transmitted and the call cleared without intervention by an operator at the distant station. In some circumstances, however, the caller may wish for a teleprinted comment or acknowledgment from the distant station, and to attract attention the caller depresses the figure shift key, followed by the "J" key, on the teleprinter, and thereby causes the "J" contacts at the distant teleprinter to close. It will be seen from Fig. 3 that this causes the white "call" lamp to glow, and the alarm bell to sound, unless the "bell off" key (KB) on the table unit is operated, when the bell only is disconnected. The "J" contact on the teleprinter remains closed until a further teleprinter signal is keyed on either machine.

In some circumstances a called station may need to release an incoming call. This may be effected by throwing the "forced release" key, KFR, which at KFR1 connects a spacing battery to line, and thus establishes the same clearing effect as from a calling station. The key is released when the connection is cleared as instanced by the extinguishing of the engaged lamp.

The "out of service" key, KOS, is operated after a

line has been extended to a special "hold" jack at the telex switchboard, in order that the teleprinter may be changed, or given maintenance attention. The teleprinter transmitting contacts are disconnected from line at KOS1 operated, and marking battery substituted. The teleprinter may thus be tested in local without transmitting signals to line, and when the equipment is again ready for service the restoration of KOS1 causes the cord circuit supervisory lamp to glow.

#### Switchboard Line Equipment (Manual).

The manual line equipment, the circuit of which is shown in Fig. 4, is applicable as a termination for all

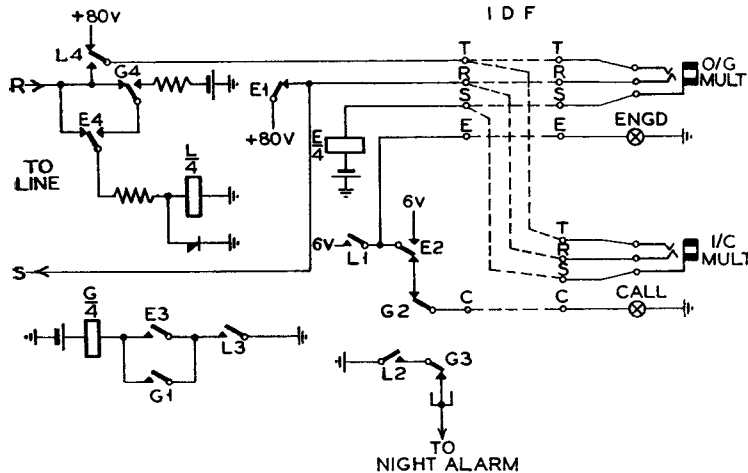

FIG. 4.—CIRCUIT SCHEMATIC OF MANUAL LINE EQUIPMENT.

subscribers' station lines, and also for bothway inter-switchboard circuits. The relays and associated components for 40-line equipments are strip mounted on standard 6 ft. 6 in. by 1 ft. 8½ in. racks, the fuse panels for power distribution being mounted at the bottom of the rack.

Separate appearances of the incoming and outgoing line jacks in the switchboard multiple field are catered for, with a calling lamp for the incoming jack, and either V.E.S. or F.L.S. lamp signalling for the outgoing appearance, the latter option being arranged for by alternative strappings on connection strips mounted on the line-equipment rack. As shown in Fig. 4 the line equipment is arranged for V.E.S. working, the preferred arrangement for small groups of circuits.

In the free (disengaged) condition of a circuit, the R wire is terminated on the calling relay L, which is so polarised by a metal rectifier as to be inoperative to the spacing battery being received over it; spacing battery is also connected to the S wire to hold the distant equipment at rest. When a call is originated from the distant end, the R wire polarity is reversed to marking, operating relay L, and causing the call and engaged lamps to glow. When the call is answered at the incoming multiple jack by the switchboard operator, the sleeve relay E operates, followed by relay G. The call lamp is extinguished, but the engaged

lamp continues to glow as relay L is held operated by a local circuit after being disconnected from line. The line is switched through to the multiple jack, and the spacing battery on the S wire of the line equipment is disconnected, being replaced by marking battery from the cord circuit. The calling and switchboard operators can thus teletype one to the other.

When a call is set up by the switchboard operator plugging into the outgoing jack, the sleeve relay E operates, thus lighting the engaged lamp, and disconnecting the spacing battery from the S wire, which is replaced by marking battery fed from the cord circuit. The calling condition is thus extended to the distant equipment, and in the event of this being a telex station equipment, marking battery will be returned immediately over the R wire (from the teleprinter transmitter contact), operating relays L and G, L holding as before to the local marking battery. Should the line into which the operator plugs be an inter-switchboard circuit, an equipment giving similar conditions to the line equipment now being described may be assumed to exist at the distant end, from which it follows that the return of marking battery over the R wire, and the above cycle of operations, will be delayed until the distant switchboard operator answers the call. During this period, spacing battery is returned to the cord circuit via contact L4 of the line equipment, and hence the calling supervisory lamp glows until the call is answered, thus giving full supervisory signalling conditions to the switchboard operator.

The clearing condition of a call produces no direct circuit operation in the line equipment, but when the switchboard operator clears by withdrawing the cord circuit plug, relay E releases reconnecting the L relay to the R wire; L then releases to the spacing battery, followed by relay G.

#### Switchboard Line Equipment (Auto-Manual).

This equipment, the circuit of which is given in Fig. 5, has been designed to meet the requirements of the Siemens & Halske TW39 system, and its first use was on the international telex circuits to Switzerland. At the distant end, Zurich, the circuits are terminated on a bothway relay set giving access to and from the automatic exchange equipment, and hence the Swiss dialling network. A fully equipped 6 ft. 6 in. by 1 ft. 8½ in. standard rack will accommodate 12 auto-manual line equipments, including the requisite fuse panels for power supplies.

It will be seen that the line equipment provides for the same terminations on the switchboard multiple jack field as does the manual equipment previously described. It will also be appreciated that in order to meet the agreed signalling code, similar disengaged, calling and clearing, line signalling conditions are applied. Additional relays are, however, incorporated, firstly to return a short marking signal over the backward transmission path to the distant auto equipment on seizure by an incoming call, a signal which provides

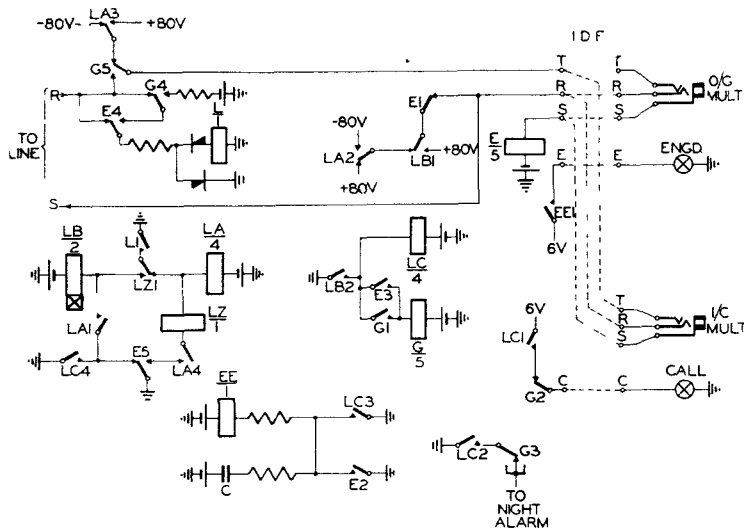

FIG. 5.—CIRCUIT SCHEMATIC OF AUTO-MANUAL LINE EQUIPMENT.

a "continuity" test of the international telex circuit concerned, and in the absence of which the call is released at the distant end: secondly, to detect the short marking signal returned from the incoming group selector at the distant end on an outgoing call, and which provides a "proceed-to-dial" indication to the London switchboard operator; and finally a guard relay to ensure that a call is not offered to the auto equipment until it has fully released from a previous call.

The operation of the circuit is briefly as follows:— An incoming call reverses the polarity on the R wire to marking battery, operates relay L, and then relays LA and LB. Contact LA2 disconnects spacing and applies marking battery to the S wire, and LB1 reverses this condition some 25 mS later, thereby generating a 25 mS nominal marking pulse for the line "test" pulse. Contact LB2 operates relay LC, and contact LC3 relay EE, thus the calling and engaged lamps are caused to glow by contacts LC1 and

EE1 respectively. When the call is answered by the switchboard operator relays E and G operate, thus connecting it to the multiple jack and cord circuit, from which marking battery is now returned to the S wire. At the termination of the call, and withdrawal of the plug from the incoming jack, the guard relay EE will be last to release, maintaining the "engaged" lamp in the outgoing multiple alight at contact EE1 for about 1½ seconds. It will be noted, however, that should a further call be offered from the distant end during this period, relays L to LC will be caused to re-operate, and the call lamp lighted at contact LC1.

The insertion of the plug in the outgoing jack when setting up an outgoing call operates relays E and EE and causes the engaged lamp to light, but the cord circuit calling supervisory lamp remains darkened due to the spacing battery extended from contact LA3 to the tip of the jack. Marking battery is seized the distant automatic equipment. When the incoming selector is prepared to receive dialling impulses, a mark pulse of some 25 mS is returned over the R wire, operating relay L momentarily via contact G4 normal, E4 operated. Relay LA operates during the period contact L1 is closed, and relay LZ operates in series with relay LA via contacts LA4 and E5 operated, when contact L1 restores to normal. The polarity of the tip of the jack is reversed at contact LA3, and the calling supervisory lamp glows to indicate to the operator that dialling may proceed. At the completion of dialling the connection of the called subscriber is signalled by a reversal of polarity at the R wire, thus operating relays L, LB and G, connecting the line to the jack and cord circuit, and extinguishing the supervisory lamp. When the plug is withdrawn from the outgoing jack at the end of the call, relay EE applies the same guarding conditions as described above for the incoming call.

## Book Review

"Very High-Frequency Techniques" (Vols. 1 and 2).  
Radio Research Laboratory (Harvard University).  
McGraw-Hill Publishing Co. 1057 pp. 935 ill.  
84s. per set.

This work, which for the convenience of the reader has been published in two volumes, has been compiled by the staff of the Radio Research Laboratory, Harvard University, under the general editorial direction of Herbert T. Reich. This large laboratory, which has Dr. F. E. Terman for its director, was established by the office of Scientific Research and Development for the U.S.A., and had the task of developing countermeasures against enemy radar. It was concerned in a major way with the extension of continuous-wave technique to the high radio frequencies used in radar work.

The book does not pretend to be a textbook or a comprehensive treatise covering all aspects of the ultra-high-frequency field, but there is no doubt that it will be welcomed by engineers as a handbook and reference

work. The material included is fundamental and new and whilst much of it originated with the Radio Research Laboratory staff, the many authors have not hesitated to draw upon the work of the numerous N.D.R.C., industrial and Service groups with whom the laboratory worked in close association. The 35 chapters deal with broadband, cone, cylinder, sleeve and slot antennae; horns and reflectors; impedance matching; direction finding and homing systems; triode and pentode U.H.F. oscillators; the principles of magnetron operation and the operating characteristics of continuous-wave magnetrons; reflex klystrons; coaxial line power amplifiers and oscillators; modulation; detectors and mixers; receivers and intermediate-frequency amplifiers; the principles and design of transmission line filters; U.H.F. measurements and measuring equipment for testing receivers. The authors of the different sections have obviously been closely associated with the subject of the section for which they have been held responsible and the work can well be recommended to the engineer working in the very-high-frequency field.

A. H. M.

# The Efficiency of Gradings

## Part I.—Determination of General Formulæ Small Grading Elements

H. A. LONGLEY  
(Telecommunications Department)

U.D.C. 621.395.341.8

A technique for dealing with traffic problems is described and applied to small grading elements to determine a general formula for the grade of service given by gradings, in which certain factors are individual to each grading arrangement. In Part I the efficiencies of various types of grading element are compared. Part II will deal with gradings of the size met with in practice.

### Introduction.

TELEPHONE channels working from the banks of selectors are "graded" when the number of channels required to carry the traffic exceeds the number of outlets that can be served from the selector level. An arrangement similar in essence to grading results where a group of junctions or trunk lines is worked partially on a bothway basis. From a service point of view the main features of grading are that (a) the traffic offered to a graded group is split into two or more parts (usually equal) and (b) the channels comprising the group are split into a similar number of divisions, some of the channels being commoned so that they are accessible to two or more divisions of the traffic. Grading introduces a number of problems the solution of which is of considerable importance. Although the theory of the behaviour of fully available groups when offered pure chance traffic can be regarded as solved for all time by Erlang's loss formula, the theory of graded groups has hitherto defied attempts at its discovery, owing to the complex behaviour of the traffic when divided and re-united in the grading.

There are three main traffic problems to be solved, namely:—

- (a) to determine the most efficient type of grading arrangement;
- (b) to determine the traffic capacity of any particular grading arrangement at a given grade of service;
- (c) to determine the traffic carried by each channel in a grading.

In the absence of more exact information, investigators of these problems have been obliged to base their conclusions on hypotheses and approximations to obtain solutions required for practical purposes. Such hypotheses have served a valuable purpose for many years, but attention has recently been focused on the problems afresh by results obtained with an artificial-traffic creating machine by the Bell Telephone Manufacturing Co. in Antwerp.<sup>1</sup>

It is clear that, if problem (a) above can be solved, the other two problems are considerably circumscribed, since they need be solved only in respect of the most efficient grading arrangement. By a technique, developed by the author and N. A. Hawkins, also of the Telecommunications Department, for a study of fully available groups under certain conditions, it is possible to analyse the effect of traffic on a group of channels under a great variety of conditions.

When this technique is applied to gradings, very complex expressions are obtained, which are different for every grading arrangement, but by analysing a number of the resultant expressions a general expression for the grade of service given by gradings has been obtained in which certain factors are individual to each particular grading arrangement. A study of these factors enables the relative efficiencies of certain families of gradings to be compared.

### Analysis of Fully Available Group.

Before proceeding to the main investigation, it will be convenient to illustrate the technique referred to and to demonstrate its validity, by applying it to a small fully available group to obtain Erlang's full availability loss formula. The underlying assumptions are those used in the conventional proof of Erlang's formula, and the basic principle is the same; that is, a group of channels in statistical equilibrium is examined. Instead, however, of considering only the conditions when any one, any two, etc., channels are engaged, consideration is given to the conditions when each one, each combination of two, three, etc., channels are engaged.

Consider a group of channels which is receiving traffic arriving in a random manner. Sometimes none, sometimes one, two, or more channels will be engaged at any given moment. In Fig. 1 are shown all the possible conditions of engagement through which a group of three channels can pass; similar diagrams can be drawn for any size of group. The group changes from one condition to another due to two kinds of event—the arrival of calls and the cessation of calls.

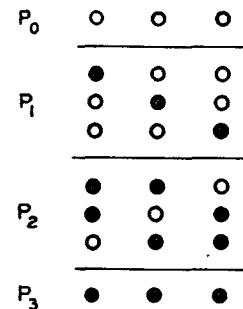

○ REPRESENTS A  
FREE CHANNEL  
  
● REPRESENTS AN  
ENGAGED CHANNEL.

FIG. 1.—POSSIBLE CONDITIONS OF ENGAGEMENT OF GROUP OF THREE CHANNELS.

The group changes from one condition to another due to two kinds of event—the arrival of calls and the cessation of calls. Fig. 2 shows how the arrival of calls causes the condition of such a group to change when it is tested in one direction only. It will be seen from Fig. 2 (a) that a call arriving when no channels are engaged, i.e., during condition  $p_0$ , causes condition  $p_{1a}$ ; and a call arriving when the first channel is engaged, i.e., during condition  $p_{1a}$ , engages the second channel, causing condition  $p_{2a}$ ; and so on. Fig. 2 (b) gives a complete

<sup>1</sup> *Electrical Communication*, Vol. 23, No. 2.



picture of how the arrival of calls will cause the condition of a group of three channels to change. In a

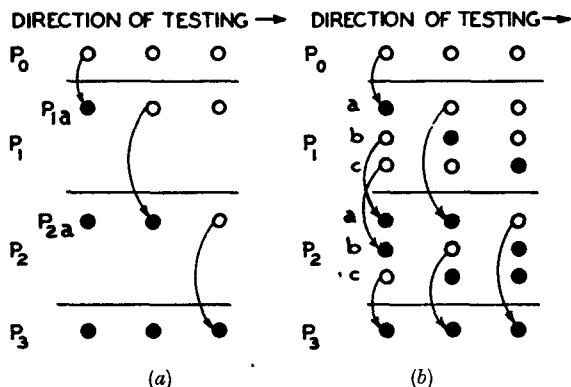

FIG. 2.—ARRIVAL OF CALLS CAUSING THE CONDITION OF A GROUP TO CHANGE.

similar manner Fig. 3 shows how calls ceasing cause the condition of the same group of three channels to

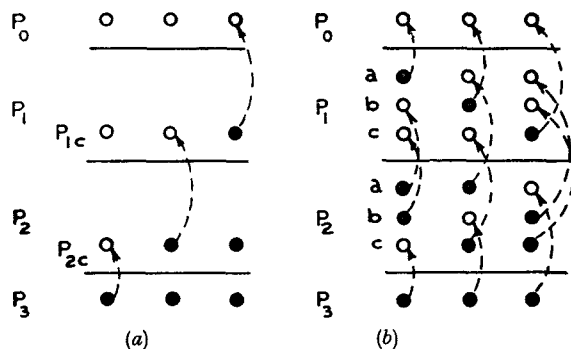

FIG. 3.—CESSATION OF CALLS CAUSING THE CONDITION OF A GROUP TO CHANGE.

change. If the calls in Fig. 2 (a) ceased in the same order as they arrived the group would pass successively through conditions  $p_3, p_{2c}, p_{1c}, p_0$ , as shown in Fig. 3 (a). Fig. 3 (b) gives a complete picture of how the cessation of calls changes the condition of the group.

In Fig. 4 the arrivals and cessations shown in Figs. 2 and 3 are combined. A group of three channels receiving traffic with a pure chance incidence will change continually, from one condition to another, along any one arrow at a time. Assuming the number of sources of traffic to be large the incidence of traffic is unaffected by the condition of the group of busy hours every con-

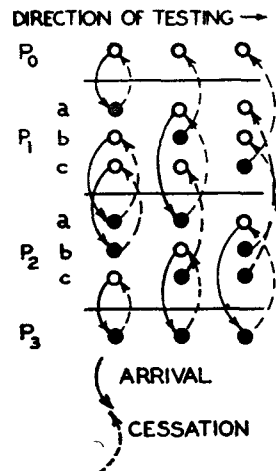

FIG. 4.—ARRIVALS AND CESSATIONS COMBINING TO CHANGE CONDITIONS OF GROUP

dition will therefore receive traffic with the same average intensity, which will be the average rate of arrival of traffic per unit time, and will be equal to the traffic offered,  $A$ , expressed in traffic units.

The symbols  $p_0, p_1, p_2$ , etc., represent the proportions of the time that 0, 1, 2, etc., channels are engaged, and  $p_{1a}, p_{1b}$ , etc., the values of the components of  $p_1, p_2$ , etc., as shown in Fig. 4. Since the values  $p_0, p_1$ , etc., are proportions of the total time,

$$p_0 + p_1 + p_2 + \dots + p_x = 1$$

where  $x$  is the number of channels. In a group subject to pure chance incidence with a constant underlying density over an infinite number of busy hours these proportions will be fixed and determinate, and the system is said to be in statistical equilibrium. In such a system the forces operating to increase and to reduce the proportion of time the group is in a given condition are equal and opposite: in other words, the amount of traffic which by arriving or ceasing tends to create a given condition of engagement must be equal to the traffic which by arriving or ceasing tends to destroy the condition.

In Fig. 5 are shown the operative factors responsible for the magnitude of one of the component conditions ( $p_{1a}$ ) of a group of three channels. The factors tending to increase condition  $p_{1a}$  are:—

- (1) the arrival of traffic during  $p_0 (= Ap_0)$ ;
- (2) the cessation of traffic during  $p_{2a}$  and  $p_{2b} (= p_{2a} + p_{2b})$ .

The factors tending to decrease condition  $p_{1a}$  are:—

- (1) the arrival of traffic during  $p_{1a} (= Ap_{1a})$ ;
- (2) the cessation of traffic during  $p_{1a} (= p_{1a})$ .

As, for a group in statistical equilibrium, the factors tending to increase and decrease the proportion of time a given condition exists are equal and opposite, the equation determining the magnitude of condition  $p_{1a}$  is

$$Ap_0 + p_{2a} + p_{2b} = Ap_{1a} + p_{1a}$$

In Fig. 6 are shown the eight basic equations for a group of three channels, each equation being set

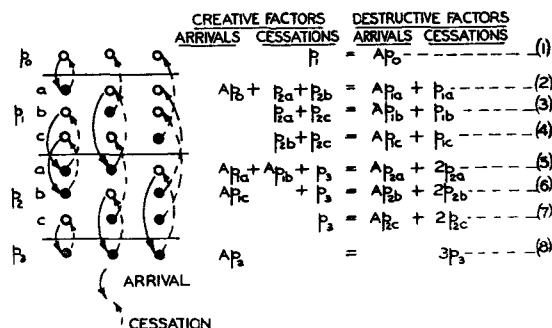

FIG. 6.—BASIC EQUATIONS FOR GROUP OF THREE CHANNELS, FULL AVAILABILITY.

against the condition to which it corresponds. The traffic that arrives when all three channels are engaged is lost, and therefore does not appear in equation (8).

From the equations in the figure it is deducible by simple algebra that

$$Ap_0 = p_1 \quad \text{or} \quad p_1 = Ap_0$$

$$Ap_1 = 2p_2 \quad \text{or} \quad p_2 = \frac{A}{2}p_1 = \frac{A^2}{2!}p_0$$

$$Ap_2 = 3p_3 \quad \text{or} \quad p_3 = \frac{Ap_2}{3} = \frac{A^2p_1}{2 \cdot 3} = \frac{A^3p_0}{3!}$$

$$\text{Now } p_0 + p_1 + p_2 + p_3 = 1$$

$$\therefore p_0 + Ap_0 + \frac{A^2p_0}{2!} + \frac{A^3p_0}{3!} = 1$$

$$p_0 = \frac{1}{1 + A + \frac{A^2}{2!} + \frac{A^3}{3!}}$$

$$\text{and } p_3 = \frac{\frac{A^3}{3!}}{1 + A + \frac{A^2}{2!} + \frac{A^3}{3!}}$$

A set of basic equations and their derivatives can be developed for any size of group and the results will be found to be consistent with those already obtained; the general expression for the proportion of lost calls, or the grade of service, is therefore :—

$$\frac{\frac{A^x}{x!}}{1 + A + \frac{A^2}{2!} + \dots + \frac{A^x}{x!}}$$

where  $x$  is the number of channels in the group.

This is the well-known "loss" formula, first developed by A. K. Erlang of Denmark, and used by the British Post Office to determine the number of channels required whenever pure chance traffic is offered to a fully available group.

#### INVESTIGATION OF GRADINGS.

The analytical method having been illustrated, and its validity demonstrated, it will now be applied to the investigation of grading problems. The investigation is arranged on the following lines :—

- To develop a formula, for the grade of service given by graded groups, which is a generalisation of Erlang's loss formula, and which includes a series of factors whose values are special to each grading arrangement ;
- To determine the exact value of these factors—which are referred to as "K factors"—for a number of typical grading elements ;
- To compare the efficiencies of the grading elements ;
- To use the "K factors" as a means of studying the efficiencies of "straight" gradings ;
- To consider the effects of introducing "slipped" and "cyclic" arrangements.
- To consider, in the light of the results so obtained, those recently obtained with the artificial traffic machine.

#### Analysis of Graded Groups.

In Fig. 7 are shown the basic equations appropriate

$$p_1 = Ap_0 \quad \text{----- (1)}$$

$$\frac{A}{2}p_0 + p_{2ab} = (A+1)p_{1a} \quad \text{----- (2)}$$

$$\frac{A}{2}p_0 + p_{2ac} = (A+1)p_{1b} \quad \text{----- (3)}$$

$$p_{2bc} = (A+1)p_{1c} \quad \text{----- (4)}$$

$$\frac{A}{2}p_{1ab} + p_3 = (A+2)p_{2a} \quad \text{----- (5)}$$

$$\frac{A}{2}p_{1ac} + p_3 = \left(\frac{A}{2} + 2\right)p_{2b} \quad \text{----- (6)}$$

$$\frac{A}{2}p_{1bc} + p_3 = \left(\frac{A}{2} + 2\right)p_{2c} \quad \text{----- (7)}$$

$$Ap_{1a} + \frac{A}{2}p_{2bc} = 3p_3 \quad \text{----- (8)}$$

$$\left[ p_{2ab} = p_{2a} + p_{2b} \right]$$

FIG. 7.—BASIC EQUATIONS FOR GRADED GROUP OF THREE CHANNELS, AVAILABILITY TWO.

to a simple graded group of three channels with an availability of two. Traffic is lost not only during the time three channels are engaged, but also during part of the time that two channels are engaged, that is, during  $p_{2b}$  and  $p_{2c}$ . In fact, half the traffic arriving during conditions  $p_{2b}$  and  $p_{2c}$  is effective, and all the traffic arriving during condition  $p_{2a}$  is effective. Only that part of the traffic that is effective has any influence on the relative magnitude of the components represented by  $p_0, p_1$ , etc.

The eight equations in the figure reduce to the following :—

$$Ap_0 = p_1 \quad \text{or} \quad p_1 = Ap_0$$

$$Ap_1 = 2p_2 \quad \text{or} \quad p_2 = \frac{A^2p_0}{2!}$$

$$Ap_{2a} + \frac{Ap_{2bc}}{2} = 3p_3 \quad \text{or} \quad p_3 = \frac{A^3K_2p_0}{3!}$$

$$\text{where } K_2 = \frac{p_{2a} + \frac{1}{2}p_{2bc}}{p_2} = 1 - \frac{\frac{1}{2}p_{2bc}}{p_2}$$

In general, the factor  $K_r$  is used to represent the proportion of traffic effective during condition  $p_r$ , where  $r$  is a number of channels equal to or greater than the availability.

From the foregoing equations the following formula for the grade of service ( $\beta$ ) is obtained :—

$$\beta_{3,2} = \frac{(1 - K_2)\frac{A^2}{2!} + \frac{K_2A^3}{3!}}{1 + A + \frac{A^2}{2!} + \frac{K_2A^3}{3!}}$$

$$\text{or } 1 - \frac{1 + A + \frac{K_2A^2}{2!}}{1 + A + \frac{A^2}{2!} + \frac{K_2A^3}{3!}}$$

where, in the particular example considered,

$$K_2 = \frac{3A^2 + 9A + 9}{5A^2 + 14A + 12}$$

The formula for  $\beta$  applies equally to any other arrangement of three channels with an availability of two, but the value of  $K_2$  is different for each arrangement.

Solution of the basic equations for a group of four channels with an availability of two, derived in a similar manner to the above (that is, by consideration of the appropriate component diagram) gives the grade of service as

$$\beta_{4/2} = 1 - \frac{1 + A + \frac{K_2 A^2}{2!} + \frac{K_2 K_3 A^3}{3!}}{1 + A + \frac{A^2}{2!} + \frac{K_2 A^3}{3!} + \frac{K_2 K_3 A^4}{4!}}$$

In this example there are two  $K$  factors, which respectively represent the probabilities that calls arriving during conditions  $p_2$  and  $p_3$  will be effective. Here, again, the values of the  $K$  factors differ for each of the possible arrangements, the number of which is quite appreciable even within the narrow limits that apply.

#### General Expression for Grade of Service Given by Graded Groups.

The formula for the grade of service given by graded groups in terms of the  $K$  factors is the same for all groups with a given number of channels and availability. A general formula can be obtained by adopting a  $K$  factor for every one of the conditions  $p_0, p_1, p_2, \dots$ , in which case the factors for conditions corresponding to a number of engaged channels less than the availability will be equal to unity, while  $K_x = 0$ . The number of  $K$  factors with values lying between 1 and 0 is equal to the difference between the number of channels and the availability. The general expression for the grade of service given by a graded group is then:—

$$\beta_{x/a} = 1 - \frac{1 + K_1 A + K_1 K_2 \frac{A^2}{2!} + \dots + (K_1 \dots K_a) \frac{A^a}{a!}}{1 + K_0 A + K_0 K_1 \frac{A^2}{2!} + \dots + (K_0 \dots K_{a-1}) \frac{A^a}{a!} + \dots + (K_1 \dots K_{x-1}) \frac{A^{x-1}}{(x-1)!} + \dots + (K_0 \dots K_{x-1}) \frac{A^x}{x!}}$$

where  $A$  is the traffic offered,  $a$  is the availability, and  $x$  is the number of channels.

The calculation of the  $K$  factors themselves involves considerable tedious algebra: the number of simultaneous equations to be solved is equal to  $2^x$  where  $x$  is the number of channels in the group, and their solution becomes a formidable task when the number of channels is greater than five or six. For a given number of channels and availability there are, of course, many ways of arranging a grading; the pairs, commons, etc., may be placed first or last or intermingled with the individuals; in addition to the conventional "straight" grading there are also various "slipped" or "cyclic" methods of grading and each arrangement has its own special set of  $K$  factors. In Fig. 8 are illustrated a number of simple grading

DIRECTION OF TESTING →	PROPORTION OF CALLS EFFECTIVE WHEN $\gamma$ CHANNELS ENGAGED = $K_\gamma$		MAXIMA AND MINIMA OF $K$			
	$K_2$	$K_3$	$A \rightarrow 0$	$A \rightarrow \infty$	$A \rightarrow 0$	$A \rightarrow \infty$
(a) [ STRAIGHT	$\frac{3(A^2+3A+3)}{5A^2+14A+12}$		750	600		
(b) [ REVERSED STRAIGHT	$\frac{3(A+2)}{5A+12}$		500	600		
(c) X SLIPPED	$\frac{2}{3}$		667	667		
(d) [ [ STRAIGHT	$\frac{2(2A^3+11A^2+25A+21)}{6A^3+31A^2+64A+48}$		875	667		
(e) X SLIPPED	$\frac{3}{4}$		750	750		
(f) [ [ UNGRADED	$\frac{3}{4}$	$\frac{1}{2}$	750	750	500	500
(g) X SLIPPED	$\frac{3(6A+13)}{2(11A+24)}$	$\frac{1}{2}$	813	818	500	500
(h) [ [ OR [ ] CYCLIC	$\frac{2(9A^4+78A^3+267A^2+414A+252)}{22A^4+119A^3+648A^2+984+576}$	$\frac{1}{2}$	875	818	500	500
(i) [ [ STRAIGHT	$\frac{2(15A^3+82A^2+172A+144)}{3(3A^3+69A^2+138A+108)}$	$\frac{2(A+9-\frac{4}{3})}{5A+18}$	889	769	500	400

FIG. 8.—PROPORTION OF CALLS EFFECTIVE DURING VARIOUS CONDITIONS OF GRADING ELEMENTS.

arrangements of the various types referred to, together with the algebraic expressions for their appropriate  $K$  factors, the expressions being reduced to their simplest form. The  $K$  factors may also be expressed as continued fractions or series, but no uniformity, sufficient to enable a general expression to be derived, is apparent. It will be noted that each  $K$  factor has a maximum and minimum numerical value (when  $A \rightarrow 0$  and  $A \rightarrow \infty$ , though not necessarily respectively) and these values are indicated in the figure.

#### Efficiency of Grading Elements

The efficiency of any particular grading arrangement can be best expressed relative to the number of channels in a fully available group which gives the same grade of service as the graded group. Thus, for example, a group of, say, 20 channels in a graded formation might be equivalent to 15 channels arranged as a fully available group, and the efficiency of the graded group might then be expressed as  $15/20 = 75$  per cent. The fully available group (called by some administrations a "perfect" group) is the most efficient arrangement possible, and its efficiency on this basis is obviously always 100 per cent. The efficiencies, measured in this way, of some of the small grading arrangements considered above are shown in graph form in Figs. 9 and 10 which apply to three- and four-channel arrangements respectively. To determine the efficiencies of small graded groups it is necessary to employ the hypothetical conception of a number of channels, in a fully available group, which may not be a whole number; for example, the graded group of Fig. 7 when offered two traffic units,

is equivalent to 2.65 fully available channels. The equivalent number of fully available channels was determined for purposes of Figs. 9 and 10, in respect

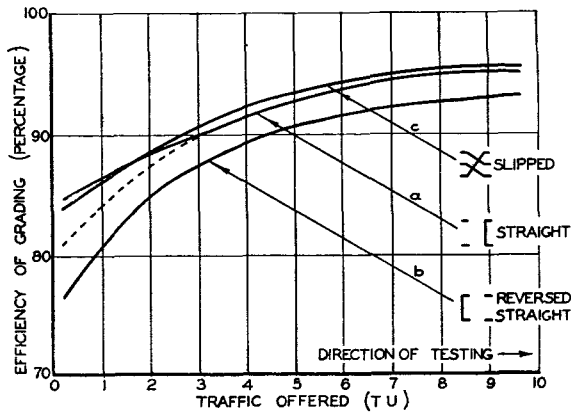

FIG. 9.—RELATIVE EFFICIENCY OF 3-CHANNEL GRADING ELEMENTS.

of the simple grading arrangements considered above, by a graphical interpolation.

The graphs show the efficiencies, for various densities of traffic offered, of the grading elements depicted at the right-hand side, and the letters identifying the elements correspond with the lettering in Fig. 8. It is apparent that (g) and (h) are more efficient than (f), for all values of traffic; (b) is less efficient than (a) and (c) for all values of traffic. The relative efficiencies depend, in the other examples, on the density of traffic offered.

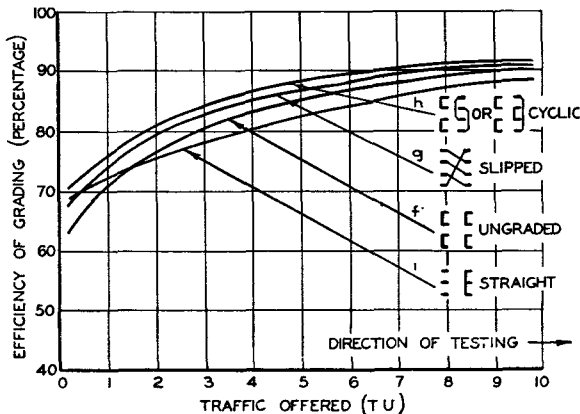

FIG. 10.—RELATIVE EFFICIENCY OF 4-CHANNEL GRADING ELEMENTS.

The grading arrangements considered in Figs. 8, 9, and 10 are some of the elements from which practical gradings are built up, and facts which can be established about the elements will be true, within limits, of the larger gradings met in practice. The graphs of Figs. 9 and 10 reveal the following important facts:—

- (a) The efficiency of a given grading varies with the amount of traffic offered; the efficiency is greatest when the traffic is heavy, that is, when the grade of service is low. This is fairly obvious: when the traffic is infinitely great all arrangements would be equally efficient.
- (b) The relative efficiencies of given grading arrangements may vary with the amount of traffic offered.
- (c) Any grading arrangement in which a common is tested before an individual must be less efficient than the reverse arrangement for all levels of traffic. Such grading arrangements will therefore be excluded from further consideration.
- (d) "Cyclic" and "slipped" grading elements are more efficient than "straight" elements, except when the traffic offered is light, in which case the reverse sometimes applies. One reason for the difference in the relative efficiency of cyclic or slipped as against straight gradings can be appreciated by considering elements (f) and (g) of Figs. 8 and 10: the arrangement of the channels in (f) is such that as much as one-half of the traffic offered can be lost when two channels are engaged, but with the arrangement in (g) not more than one-quarter of the traffic offered can be lost when two channels are engaged. That there is a difference between the efficiencies of the slipped and cyclic arrangements can be seen by considering the arrival of consecutive calls in different divisions: the slipped arrangement introduces a degree of interference, absent in the cyclic arrangement, which increases the probability of loss on subsequent calls.

The result of applying the well-known Lubberger theory to the simple arrangement of Fig. 7 is shown by the broken line in Fig. 9, from which it may be concluded that the Lubberger method tends to underestimate the efficiency of a grading, but is sufficiently accurate for practical purposes when used to estimate the traffic carried by the earlier choices of a grading.



# The European Switching Plan

U.D.C. 654.16

The article gives a résumé of the work of a mixed commission of the Comité Consultatif Internationale Téléphonique, set up to formulate a general plan for the connection of telephone calls in Europe.

## General.

FROM time to time readers of this Journal are kept informed of the progress of matters of general interest discussed on the C.C.I.F. One of the Commissions has now reached a stage in its deliberations when it is of particular interest at the present time to record the position reached.

Before the late war a mixed Commission was set up with the object of recommending a "General Switching Plan for Europe," and a good deal of technical work was carried out on the stability of circuits, use of echo suppressors, and other matters concerned with the switching of circuits, including operating procedure.<sup>1,2</sup> The present plan is, of course, a manual one and involves not more than two international circuits in tandem for the completion of a call.

## Circuit Provision.

After the war, in October 1945, a Plenary Assembly was held in London and this Commission was urgently revived under the chairmanship of M. Gastebois (France), together with a sub-committee composed of members of the Operating and Signalling Commissions to get the shattered international networks into operation as soon as possible. At this meeting countries agreed on the numbers of circuits which would be provided on a short term basis.<sup>3</sup> During the course of the work of the main committee a suggestion was made by Mr. Chamney, of the British delegation, that the international telephone network of Europe should take full advantage of advances made during the war and plan a high velocity network. This suggestion was taken up very seriously by all the nations with the result that at the Plenary Assembly at Montreux in November 1946, a map (Fig. 1) was

<sup>1</sup> P.O.E.E.J., Vol. 30, p. 32.

<sup>2</sup> "Réunions D'Oslo," Tome 1, Ter, pp. 29-81.

<sup>3</sup> Livre Rose, C.C.I.F. XIIIth Plenary Assembly, Oct. 1945, p.73.

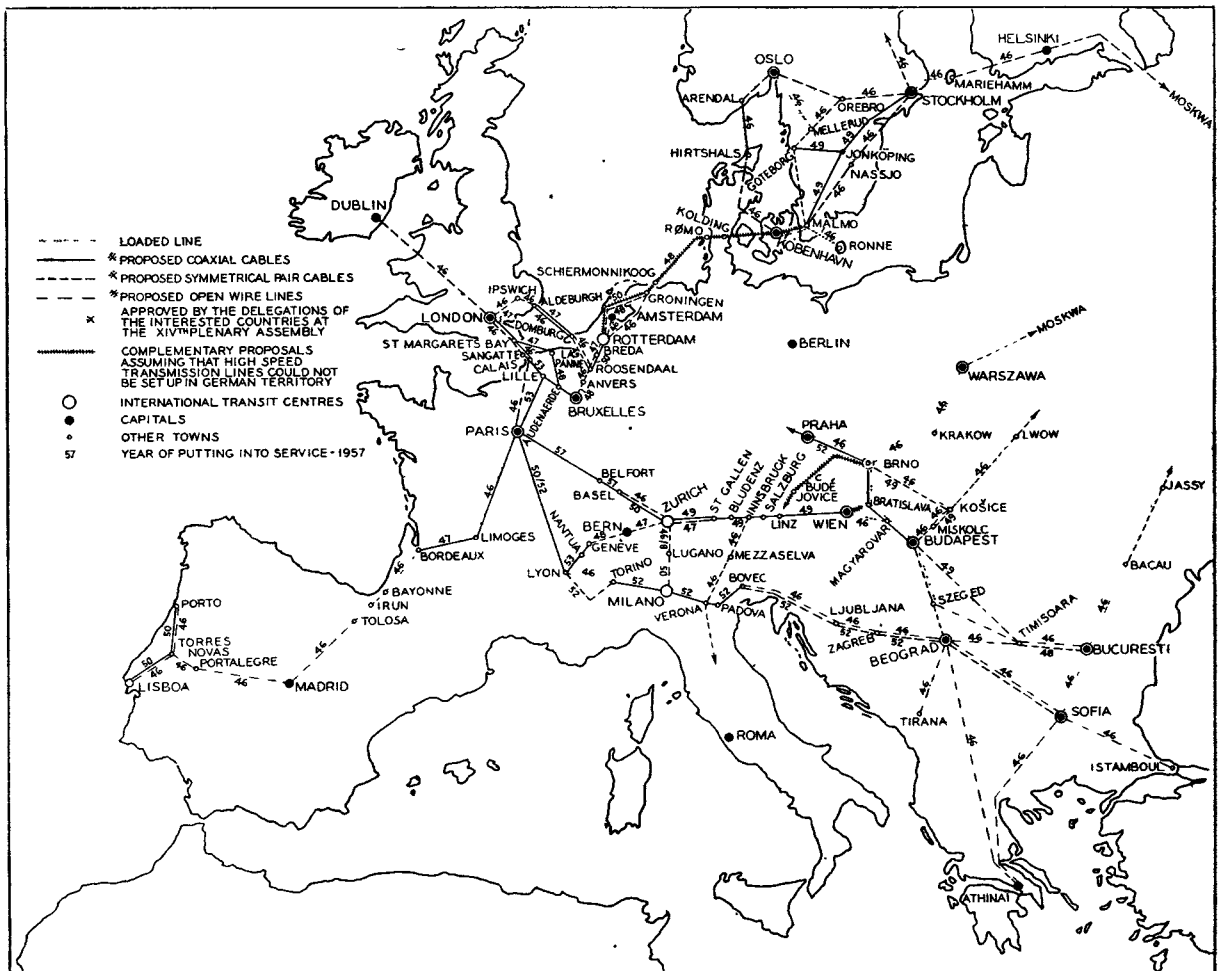

FIG 1.—MAP SHOWING EUROPEAN NETWORK OF HIGH-SPEED TRANSMISSION LINES (C.C.I.F. GENERAL TELEPHONE SWITCHING PLAN 1947-1952).

produced and agreed showing the cables and lines which the countries propose to construct.<sup>4</sup>

The No. 6 Anglo-Dutch cable recently laid is part of this scheme and forms a part of the British and Dutch Governments' contribution. Two new cables have now been laid to Eire from Holyhead in its furtherance.

### Signalling and Dialling System.

During the Plenary Assembly in 1945, a combined meeting of engineers, making a review of the old signalling questions, and anxious to take advantage of recent advances in signalling techniques, decided to reopen questions on the international signalling and dialling system.<sup>5</sup> In this connection one of the most important changes contemplated was to raise the frequency of the signalling current. This enables a signalling receiver of much greater speech immunity to be used, reduces the number of false signals and allows a faster system to be employed. At Montreux, levels of such currents for various frequencies were agreed. A question which could not be resolved, however, was whether the system should be a single or double frequency system, and, therefore, codes of signals have been drawn up for both systems, each giving the required facilities.

At the meeting in London in 1945, Dr. Osborne, chief engineer of the American Telephone and Telegraph Co., New York, invited the sub-committee to America to study the Bell Toll system and the proposals for the automatization of the Bell network. This generous offer was accepted, and in July 1947, representatives of many nations under the presidency of M. Lambiotte (Belgium), travelled to New York and undertook the study. The study was very interesting and instructive. Fig. 2 shows members of



FIG. 2.—LAYING A COAXIAL CABLE BY GIANT PLOUGH.

the study trip watching a new giant plough laying an 8-tube coaxial cable, part of the Philadelphia-Washington cable.

Technically there are several broad differences

<sup>4</sup> "Programme Général D'Interconnection Téléphonique en Europe."—C.C.I.F., Montreux 1946.

<sup>5</sup> The present recommendations regarding signalling and dialling are embodied in "Réunions D'Oslo," Tome I, Ter, pp. 83-93.

between the Bell proposals and those proposed for the European Switching Plan. The code of signals proposed for Europe is based on "pulse signals," but the Bell code for V.F. signalling and dialling is based on a type of direct current signalling employed extensively in America at the moment and uses interrupted continuous line tone. A typical sequence of operations indicating the Bell codes is shown in Table 1.

TABLE I  
Signals on line for typical sequence of operations

Conditions	Systems using frequencies in voice band		Systems using segregated direct current channel	
	Tone "calling" to "called"	Tone "called" to "calling"	"Calling" to "called"	"Called" to "calling"
Trunk idle .. .. .	On	On	G	G
Operator seizes trunk ..	Off	On	B	B
Wait for dial signal ..	Off	Off	B	B
Start dialling .. .. .	Off	On	B	G
Dialling .. .. .	On-Off*	On	G-B*	G
Called subscriber answers	Off	Off	B	B
Re-ring .. .. .	On-Off*	Off	G-B*	B
Called subscriber hangs up	Off	On	B	G
Connection taken down ..	On	On	G	G

G = Ground. B = Battery.

\* Shifts between the two conditions at dialling or flashing rate.

No reason is seen, therefore, for abandoning the pulse system as proposed for Europe which, being entirely new, is not required to work into an existing international system. The Bell system engineers, although aware of the advantages to be gained by raising the signalling frequency, decided not to raise it too high because a large number of narrow bandwidth circuits (approximately 1,700 c/s) are in use for emergency purposes. They have decided therefore on a single frequency of 1,600 c/s for 4-wire circuits.

For the future European plan the actual choice of signalling system has not yet been decided, but a number of fundamental decisions have been made:

1. The maximum number of international circuits in tandem will be two.
2. Switching at transit points will be 4-wire to 4-wire.
3. The signalling system will be a "pulse" system.
4. No echo suppressors will appear in the signalling portion of the circuit.
5. If a two-frequency system is used, the frequencies will be 2,040 and 2,400 c/s. If a single-frequency system is decided upon, the frequency will lie between 2,000 and 2,400 c/s.

To determine whether a single or double frequency system is adopted, it is proposed to make a fairly extensive trial on a number of international routes and a restricted working party of engineers, under the presidency of Captain Legg, Assistant Engineer-in-Chief, has been set up to co-ordinate the design, manufacture and installation of the equipment for the trial.

H. W.

# Headquarters Notes

## Training

### Correspondence Courses.

The preparation and issue of lessons, questions and answers, has been augmented this year by two preliminary grade subjects. Although it has only been possible to guarantee the issue of Lessons up to and including No. 10, before the end of April, it is, nevertheless, expected that later lessons will be available before that date. The number of students taking this course reached a total of approximately 5,000; the number of subject enrolments being about 11,000.

### City and Guilds of London Institute.

An analysis of the examination results in Telecommunication Engineering for the 1946/47 session is given in the table below.

Subject	Candidates	Pass	1st Class	2nd Class	Failure
Elementary Telecommunications Practice ..	2,691	—	991 (37%)	895 (33.5%)	805 (29.5%)
Mathematics for Telecommunications 2 ..	1,710	1177 (68.8%)	—	—	533 (31.2%)
Mathematics for Telecommunications 3 ..	280	222 (79.3%)	—	—	58 (20.7%)
Telecommunications (Principles) 1 .. ..	4,285	—	663 (15.4%)	1550 (36.2%)	2072 (48.4%)
Telecommunications (Principles) 2 .. ..	2,066	—	309 (14.9%)	776 (37.6%)	981 (47.4%)
Telecommunications (Principles) 3 .. ..	763	—	105 (13.8%)	298 (39%)	360 (47.2%)
Telephone Exchange Systems 1 .. ..	968	—	302 (31.2%)	337 (34.8%)	329 (34.0%)
Telephone Exchange Systems 2 .. ..	493	—	178 (36.2%)	144 (29.2%)	171 (34.6%)
Telephony Grade 3 .. .. .	302	—	100 (33.2%)	100 (33.2%)	102 (33.6%)
Telegraphy 1 .. .. .	364	—	114 (31.3%)	141 (38.7%)	109 (30%)
Telegraphy 2 .. .. .	250	—	73 (29.2%)	86 (34.4%)	91 (36.4%)
Radio 1 .. .. .	1,817	—	381 (21%)	960 (52.8%)	476 (26.2%)
Radio 2 .. .. .	1,146	—	199 (17.4%)	591 (51.5%)	356 (31.1%)
Radio 3 .. .. .	576	—	36 (6.2%)	203 (35.2%)	337 (58.5%)
Line Plant Practice 1 .. .. .	490	—	76 (15.5%)	227 (46.3%)	187 (38.2%)
Line Plant Practice 2 .. .. .	64	—	18 (28.2%)	29 (45.2%)	17 (26.6%)
Transmission and Lines Grade 1 (Old Syllabus)	400	—	114 (28.5%)	131 (32.7%)	135 (38.7%)
Transmission and Lines Grade 2 (Old Syllabus)	156	—	51 (32.7%)	61 (39.1%)	44 (28.2%)

### Central Training School.

Instruction is now being given at the Central Training School, Stone, and the subsidiary schools at Dollis Hill and Birmingham in 70 different courses covering automatic switching, transmission and other aspects of Telecommunication Engineering. The average number of students in attendance is 580.

### Visual Aids.

A sound film on "Cable Jointing," having a duration of approximately 20 minutes, has been completed and a copy is held by the Central School and each Regional School. A partner film on "Plumbing," also

of the same duration, is nearing completion, and should be available shortly. Other films to be included in this series, for early issue, are "Accident Precautions" and "Overhead Line Construction."

The projectors are of the 16 mm. type, and a number of operators have been given a course of instruction on this equipment. Each of the foregoing schools has been supplied with a projector and these are available for loan by a local arrangement.

Film strips, as a means of superseding and replacing slides, are being prepared. These are of the 35-mm. type, and will supplement the instruction given in the various subjects. The projector has a 500-watt lamp, air-cooled by a motor-driven fan. A subsidiary motor-driven "feed" enables the lecturer to control the forward and backward movement of the film strip, at a distance from the projector. The complete equipments will shortly be available for issue.

## Telephones

### New Signalling and Impulsing Systems.

With a view to attaining conditions where only one operator (outgoing) shall be engaged in setting up any trunk or toll call, together with the desire to dispense with impulse regeneration on tandem connections, the two following new systems have been developed up to the laboratory stage.

*Single Commutation D.C. Impulsing System.*—This is a new form of Long Distance D.C. Dialling (L.D.D.C.) which derives its title from the fact that impulsing consists of a series of reversals of earth and battery by a single change-over contact which in effect

provides double current signalling by commutating the battery. It is virtually distortionless over circuits up to 100 miles of 20-lb. 4-wire amplified cable or a loop resistance of 5,000  $\Omega$ . It is primarily intended for use on the longer circuits—other than carrier circuits, which require V.F. signalling—which are outside the limits of the normal loop-disconnect impulsing system.

Further details of the system will be found in I.P.O.E.E. Printed Paper No. 184.

*Separate Signalling System.*—In this system, which is intended for signalling on carrier and co-axial circuits in the trunk network, a normal speech circuit is appropriated as a separate signal circuit to serve up to 20 speech circuits. The frequency spectrum of the signal circuit is divided into 20 signal channels each of 100 c/s spacing with each sub-channel (go and return) serving the signalling requirements for one speech circuit.

The speech circuits are permanently associated with their relevant signal sub-channels by means of relays at each end of the line.

The primary advantages over the existing 2 V.F. system are immunity from false signals due to speech operation; avoidance of echo suppressors in the signalling path and the resultant relative simplicity of design. Arrangements for a field trial of the system are in hand.

#### *Automatic Trunk Charge Calculator.*

As a contribution to labour-saving by machine accounting an automatic calculating machine consisting of relays and motor-driven uniselectors has been developed for the purpose of computing trunk charges from the particulars entered on the ticket by the operator, e.g. basic charge for 3-minute call, duration, time of day, and any special charges, after they have first been transferred manually into punched card form.

Arrangements are in hand for a field trial of the equipment in association with punched card machinery.

It is hoped to publish an article on the subject in a later issue of this Journal.

#### *Trunk Mechanisation—Development of Cordless Switchboard.*

The main details of physical design and the facilities to be afforded by a cordless type switchboard for future trunk and auto-manual exchanges have been determined.

Apart from the inherent abolition of cords, jacks and multiple will be the use of a flat top type position, the feeding of calls to positions through a queue and the use of key-sending.

#### *Relay Director.*

With a view to improving the service in Director areas a new type of Director known as a "Relay Director" has been developed. The item comprises 3,000-type relays and a Siemens motor unselector, both of which possess relatively low fault liabilities. A comprehensive field trial alongside existing Directors fitted with a new heavy-duty unselector is planned.

#### *Party Line Service.*

In alleviation of difficulties in providing service for new subscribers due to shortage of plant, arrangements have been in existence for some time for the provision of a non-secret, automatic two-party line service, with selective ringing but without selective metering. This necessitates one of the subscribers accepting responsibility for payment of the local calls account for both subscribers. To overcome this disability a simple automatic selective metering system has recently been developed and is at present undergoing field trials.

#### *Uniselectors.*

A new heavy-duty unselector mechanism has been developed which gives promise of increased life and reduced maintenance costs as compared with the present standard. The item is now in production for field trial.

### **Local Lines and Wire Broadcasting**

In post-war years new methods of design and provision of local line plant have been introduced. Executive Engineers have been appointed in each Region, with the object of ensuring that the up-to-date practices are carried into effect.

On September 1st, 1947, a second step was taken when the Local Lines and Wire Broadcasting Branch of the Engineering Dept. (Engineer-in-Chief's Office) was set up. The branch is in the charge of a Staff Engineer (Mr. A. Morris) assisted by two Assistant Staff Engineers. One A.S.E. (Mr. T. W. Baker) is responsible for local line planning, the other A.S.E. (Mr. F. Hollinghurst) undertakes development work in connection with wire broadcasting.

At present the lines side of the work of the new Branch is restricted to those matters originally carried out by the former L2A and L2D groups of the Transmission and Lines Branch.

### **Main Lines**

#### *Coaxial Cable Provision and Utilisation.*

For the development of the main trunk communications network a long term plan for the provision of coaxial cables has been drawn up. As a first stage, the following coaxial cables are under construction:—

- (i) London-St. Margaret's Bay, 4-tube coaxial.
- (ii) Guildford-Aldershot, 2-tube coaxial.
- (iii) Guildford-London, 4-tube coaxial.
- (iv) London-Slough, 4-tube coaxial.
- (v) Birmingham-Coventry, 4-tube coaxial.
- (vi) Birmingham-London, 6-tube coaxial.

For items (i) to (v) the coaxial tubes are being enclosed within layers of audio quads which will be used in the provision of circuits on shorter routes. Items (iii), (iv) and (v) are the advance stages of bigger schemes, extensions being planned to Southampton, Bristol and Leeds, respectively, the advance provision being necessitated by the need for audio pairs.

In addition, orders for the following two coaxial cables were placed in 1947 but actual construction has not yet begun:—

London-Tunbridge Wells, 4-tube coaxial.

Tunbridge Wells-Eastbourne (Eastbourne-Hailsham section), 4-tube coaxial.

The coaxial tubes in all of these cables (except for



the television tubes) are of standard type, that is, a central copper conductor of 0.104 in. diameter, and an outer conductor formed of a single copper tape folded to form a cylindrical tube of inner diameter 0.370 in., the two conductors being positioned by hard rubber discs and the whole tube wrapped with two steel tapes. This type of construction has superseded the older type in which the outer conductor was formed of interlocking copper tapes.

The Birmingham-London six-tube coaxial cable is a cable of novel design being laid to form the first link in the extension of the B.B.C. television services as well as to provide for additional trunk telephone circuits from London to the North. For television purposes the cable contains two coaxial tubes, roughly 1-in. overall diameter, of entirely new design, and for telephony, four 0.370-in. tubes of conventional design. The remainder of the space inside the outer sheath is occupied by eight 40-lb. screened pairs (for programme transmission), sixteen 40-lb. and eighteen 20-lb. audio pairs (for the control of the coaxial repeater equipment).

The television tubes are constructed with an inner conductor in the form of a tube made by the longitudinal folding of a copper tape. The inner conductor

is surrounded by spigot-ended polythene thimbles which interlock to build up an articulated tube round which the outer conductor of corrugated copper tape is folded. The outer conductor is held in position by lapping with two steel tapes and the complete tube insulated with tape. The complete composite cable is lead-sheathed with an outer protection of compounded hessian tape to minimise corrosion. For the major portion of its length the cable will be drawn into a conduit from which the old Birmingham-London No. 2 cable is being withdrawn.

Repeater stations will ultimately be provided at a nominal spacing of 3 miles throughout the route, in order that the television tubes may be capable of transmitting a bandwidth suitable for television pictures with definition up to 1,000 lines. Initially, these tubes will be repeated at a nominal 12-mile spacing permitting the transmission of pictures with the present B.B.C. definition of 405 lines. The 0.370-in. tubes will be repeated at a nominal six-mile spacing allowing for the standard provision of 10 supergroups and 600 circuits.

Laying of this cable is now in hand from the London end, and by the end of February about 17 miles had been laid. Completion of cabling is expected by the end of 1948.

## Junior Section Notes

### Brighton Centre

The 1947/48 session opened with a visit to the Southern Railway signal box at Brighton station, where a good company of our members showed keen interest in the operation of the coloured light signalling system.

"Recording" was the subject of a talk, given at our first meeting in October, by Mr. H. M. Wells, A.M.I.E.E., and dealing with steel wire and magnetic tape recorders, as well as the gramophone disc.

At our November meeting, Mr. D. C. Blair, A.M.I.E.E., gave an impromptu talk on various aspects of "Staff Problems" and "Work Units," which was extremely interesting, and enjoyed by all members attending.

"Motoring" was the subject at our December meeting and Mr. H. H. Bishop gave an expert account of the technical side of motoring, illustrated by sound films.

A talk of outstanding interest, called "From Sound Track to Speaker," was given at our January meeting by Mr. N. W. Wooderson (British Acoustic Films Ltd.) who dealt with various problems of 16-mm. sound equipment. The latest type 16-mm projector was demonstrated, and a film "How the Talkie Talks" was shown.

The session concluded with "Trunk Lines, from Copper Wires to Coaxial Amplifiers," by Mr. F. N. Charles, A.M.I.E.E., in February, an account of the development of trunk lines up to coaxial working, and finally a film show in March.

Our membership this session has reached 115, with an average of 40 per cent. attendance at each meeting.

R. F. J. B.

### Harrogate Centre

The following officers were elected for the 1947/48 Season:—

Chairman: J. T. Winspear.

Secretary and Treasurer: L. Webster.

Committee: Messrs. E. G. Horsley, S. Smith, D. R. Lewis, J. L. Bagley, G. Leckenby, J. G. Cameron.

The programme, now nearing completion, included the following:—

"Basic Auto," J. T. Winspear.

"Film Show," Central Office of Information.

"Timber and its Uses in the Post Office," G. F. Young.

"The Teleprinter," L. Webster.

"Film Show," Central Office of Information.

"Mechanical Aids," J. W. Barratt.

"Protection and Earthing," T. A. Slater, A.M.I.E.E.

"Remote Control of Fire Bells," S. B. Watkins.

The papers, which were very interesting, gave rise to most helpful discussions at well-attended meetings.

J. T. W.

### York Centre

The current season of the York Junior Centre is drawing to a close and a well-balanced programme, catering for a diversity of tastes, has so far proved of exceptional interest and has attracted an average attendance of 25 out of a total membership of over 50.

The papers contributed to date have included the following:—

"Generation of Electric Power," H. Hollis (York Corporation).

"Aspects of Post Office Research," P. Barton.

"Telephone Area service in Rural Areas," J. E. Collins.

"Outlines of Modern B.B.C. Stations," D. R. Steen.

"Film Show," including Cathode Ray and the Manufacture of Lead-covered Cable.

The running of the Centre is in the capable hands of the following, who are all in their second year of office:—

Chairman: C. S. Mills.

Secretary: L. Chapman.

Treasurer: D. M. Peacock.

Assistant Secretary: J. N. Richardson.

Committee: Messrs. P. Barton, W. Foster, H. Johnson and A. Steventon.

L. C.

# Notes and Comments

## Recent Awards

The Board of Editors has learnt with great pleasure of the honours recently conferred upon the following members of the Engineering Department :—

Birmingham Telephone Area	Harvey, A. G.	..	Assistant Engineer	Major, Royal Signals	Member of the Order of the British Empire
Bradford Telephone Area	..	Thurlow, C. A.	..	Technician	Corporal, Royal Signals
Dundee Telephone Area	..	Duncan, J.	..	Skilled Workman, Class II	Sergeant, Gordon Highlanders
London Telecomms. Region	..	Burgess, D. W. H.	..	Skilled Workman, Class II	Signalman, Royal Signals
London Telecomms. Region	..	Isles, A. R.	..	Assistant Engineer	Captain, Royal Signals
Nottingham Telephone Area	Jubb, R. R.	..	Clerical Officer	Bombardier, R.A.	Royal Netherlands Bronze Cross
Swansea Telephone Area	..	Phillips, G. D.	..	Skilled Workman, Class II	Corporal, Royal Signals
Engineering Department	..	Nash, R. W.	..	Hostel Manager	Formerly Squad. Ldr., R.A.F.
Sheffield Telephone Area	..	Filton, J. H.	..	Higher Clerical Officer	For services to M.O.S.
					Croix de Guerre with Palm
					Member of the Order of the British Empire

## New Year Honours

The Board of Editors offers its congratulations to the following members of the engineering staff of the Post Office honoured by H.M. The King in the New Year's Honours List :—

Engineering Department	..	Daly, G.	..	Staff Officer	..	..	..	..	Member of the Order of the British Empire
Northern Ireland Region	..	Worthington, C. E.	..	Executive Engineer	..	..	..	..	Member of the Order of the British Empire
Liverpool Telephone Area	..	Foote, F. W.	..	Inspector	..	..	..	..	British Empire Medal
London Telecomms. Region	..	Hardy, R. H.	..	Inspector	..	..	..	..	British Empire Medal
Shrewsbury Telephone Area	..	Holbrook, W.	..	Technician	..	..	..	..	British Empire Medal
Southampton Telephone Area	..	Cavill, J. S.	..	Skilled Workman, Class I	..	..	..	..	British Empire Medal
Southend Telephone Area	..	Hince, Miss B. E.	..	Female Assistant, Grade I	..	..	..	..	British Empire Medal
Tunbridge Wells Telephone Area	..	Bennett, J. C.	..	Skilled Workman, Class I	..	..	..	..	British Empire Medal

## Royal Humane Society Awards

The Board notes, with pleasure, that the Royal Humane Society has recently presented its Testimonial on Parchment to the following members of the Engineering Department, in recognition of gallant conduct in rescue from drowning :—

Exeter Telephone Area	..	..	..	Flay, R. J.	..	..	..	..	Technician
London Telecomms. Region	..	..	..	Lang, V. T.	..	..	..	..	Skilled Workman, Class II
Taunton Telephone Area	..	..	..	Moses, W. W.	..	..	..	..	Technician

## Journal's 40th Birthday

Vol. 1 Part 1 of this Journal was published in April, 1908, and with the current issue we start on our 41st year of publication. Commencing with a circulation of about 3,000 copies per issue publication has been continuous, in spite of the incidence of two world wars. The circulation to-day is well over 18,000 and is world-wide.

In welcoming the appearance of the first issue, Sir John Gavey, the then Engineer-in-Chief, wrote :—

“ A new Electrical Journal is commenced to-day which we hope will not only have a long and prosperous

career, but which is destined to have a potent influence for good on the large body of men whom it is intended to represent directly . . . In wishing success to our new Journal let us not forget that success will depend on our support which should be given in an ungrudging spirit.”

His words are alike a spur to those concerned in producing the Journal and a reminder to members of the Institution that the success of the Journal is ultimately dependent on their efforts. The Board of Editors, having in mind the many conflicting claims on limited leisure time, takes this opportunity of expressing its appreciation to all those who have contributed in the past, and its confidence that similar support will be forthcoming in the future.

## W. S. Procter, M.I.E.E., F.R.S.E.

Mr. W. S. Procter, Telephone Manager, Glasgow, has been appointed Chief Regional Engineer, London Telecommunications Region.

A native of Halifax, Yorkshire, Mr. Procter entered the Post Office Engineering Department in 1914. After a period of service in the R.N.V.R. in 1918-19 he became one of the original team engaged on cable balancing and loading tests. In 1926 he was appointed Assistant Engineer at Preston, and later served in the

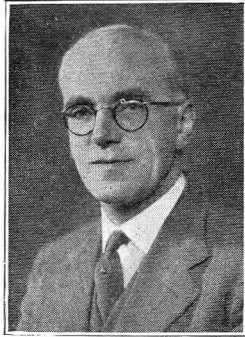

Engineer-in-Chief's Office, London, where, for three years, he was Assistant Editor of this Journal. In 1935 he was appointed Sectional Engineer, Dundee, and Area Engineer on the formation of Dundee Telephone Area. In 1938 he was appointed Regional Engineer at Post Office Headquarters, Edinburgh. He became Telephone Manager, Glasgow, in February 1945.

Keenly interested in music, Mr. Procter was for 2½ years organist and choirmaster at St. Peter's, Lutton Place, Edinburgh. While in Glasgow he was responsible for the encouragement of the musical activities of his staff, resulting in the expansion of the activities of the male voice choir and the formation of a ladies' choir, a light orchestra and a light operatic club.

Mr. Procter is the joint author of the standard textbook "Telephony" as well as being the author of several other textbooks on the subject. He is a Member of the Institution of Electrical Engineers and a Fellow of the Royal Society of Edinburgh.

Mr. Procter brings to his new appointment, in addition to high technical qualifications, a wealth of experience in staff management which has for long been one of his major interests. His friends in all parts of the country wish him every success in his new sphere.

H. C.

## Book Review

"British Time." D. de Carle, F.B.H.I. 199 pp. 104 ill. Crosby Lockwood & Son, Ltd., 15s.

The author states that his aim is, "... to describe the means of recording time, and its distribution in the mass; i.e. the distribution of time to the public, ..." and the main sections of the book each have brief historical introductions followed by accounts of visits by the author to the institution or installation described. Chapters are included on early methods of time determination, Greenwich and Kew observatories, the evolution of clocks, Big Ben, electric clocks, time signals and TIM. The author does not interpret his aim too rigidly and devotes chapters to such matters as daylight saving, unusual clocks and the clock and watch industry.

The book is written in a popular narrative form and is well provided with drawings and photographs to make it attractive to the non-technical reader. The first chapters, on the observatories and the development of clocks, are brief and mainly historical; they are

## Capt. C. F. Booth, O.B.E., M.I.E.E.

After serving an apprenticeship at Messrs. Ruston & Hornby, Capt. C. F. Booth entered the Engineering Department as Probationary Inspector in January, 1923. Little did he realise when he was welcomed into the Radio Branch laboratories at Dollis Hill that he would make his home there for just over 25 years. During this period, he has tackled most phases of the radio art but has become best known for his work on frequency standards, quartz crystals and the "quartz" clock. An ardent Territorial for many years, he was re-called from the Army in 1940 to enable his specialised knowledge to be applied to the development of quantity production of high grade crystals for military purposes, in particular for the GEE navigational aid system. From 1942, he acted as technical adviser to the Telecommunication Quartz Committee of the Radio Production Executive



and ran the Technical Sub-Committee, which involved co-ordinating the requirements of the Service ministries and of the production of quartz crystals by the manufacturers. As a result of this work, the U.S. Signal Corps invited him to visit the U.S.A. in 1943 to observe the development and production of crystals in the U.S.A.

He has been a frequent contributor to this Journal and the *Journal of the Institution of Electrical Engineers*. Elected a member of the Radio Section Committee of the I.E.E. for 1941-1945, he was again elected in 1947 for a further three years.

Gifted with the ability to size up a situation quickly, a well developed and appropriate sense of humour and an insatiable appetite for work, he will find unique opportunities of applying these gifts in his promotion to Staff Engineer in charge of the Radio Development Branch, and his success is assured.

A. H. M.

followed by a full account of the manufacture and performance of Big Ben. The next chapter, on electric clocks, deals with the Shortt free pendulum clock, mentions A.C. mains synchronous clocks and presents a confused account of quartz clocks. Thus Morrison's clock is referred to but not described, Essen's crystal is described and illustrated as part of a quartz clock but is not attributed, and the supply of 18 clocks to the Royal Observatory is mentioned but without making it clear that these clocks use a different circuit and form of crystal vibrator from that described. Again, a short period frequency stability of  $1 \times 10^{-11}$  is mentioned, which presumably refers to the N.P.L. tests for evidence of Fitzgerald-Lorentz contraction, but it is not stressed that this was a *relative* stability over a very short interval. The chapter on TIM is largely an acknowledged reprint from this Journal's articles on the same subject.

The book can be recommended to those, with little previous knowledge of horology, who are interested in clocks and time determination.

F. J. M. L.

# Regional Notes

## Home Counties Region

### NON-STANDARD LOADING COIL MANHOLE

Road re-surfacing operations necessitated laying a six-way multiple duct, part of which passed through thoroughfares badly congested with other undertakers' plant, the demolition of an existing manhole and the construction of a new manhole 14 ft. 6 in. long, 7 ft. 6 in. wide, and 7 ft. 6 in. deep, the bottom of which was to be 11 ft. from ground level. This latter requirement involved the shifting and piping of two very ancient culverts, a number of electric light mains and a traffic signal. (See Fig. 1.)

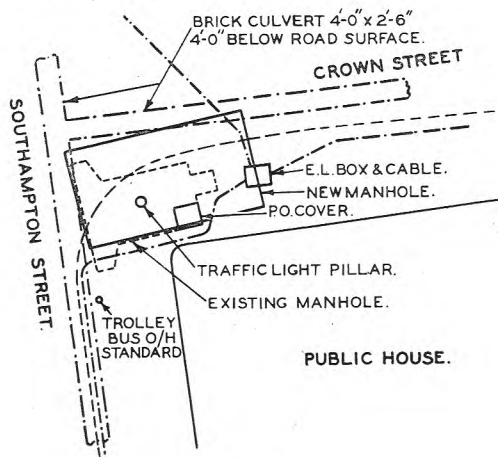

FIG. 1.

Passing through this manhole were two 542/20 pr. cables and a number of other trunk, junction and subscribers' cables which made it most congested and prevented operations being carried out in an effective manner on account of lack of space. The installation of two loading coils was necessary and there were possibilities of a further two being required at a later date, together with other trunk and tie cables between the repeater station and the exchange. The new manhole is situated approximately 2 ft 6 in. from an adjacent building, and the thoroughfares are subjected to extremely heavy vehicular traffic especially between London and the West of England.

After a number of discussions between the execution and planning staff it was decided to proceed with the proposals for the new manhole. A special design was prepared, but on inspection by Headquarters staff it was decided that there was a possibility of the building collapsing during the operations. Advice was then sought from consulting engineers, who recommended the underpinning of the foundations of the building for approximately 16 ft. and the shoring of the building at three points during the progress of the work. Headquarters concluded at this stage that the conditions were too onerous and suggested that alternative arrangements be made.

It was eventually established that the only possible alternative arrangement was more costly, and conditions at this manhole would still be most unsatisfactory, and after further discussions it was finally agreed to proceed with the original proposal. The Borough Surveyor then became very interested and requested a wayleave agreement which was to embody certain stipulations regarding the new manhole. An agreement was negotiated by the P.O. solicitor with the Town Clerk which was subject to

the work of shifting the culverts, electric light mains and traffic signal being undertaken by the Council.

The P.O. contractor's agent who inspected the site prior to the operations commencing pointed out certain difficulties regarding the shoring of the building and it was agreed that this could be dispensed with providing the existing manhole wall adjacent to the building was left intact and underpinned before the remainder of the manhole was demolished. The underpinning of the wall was carried out by breaking out a portion of the floor, excavating under the wall, and filling in the space with concrete. The change in procedure also meant that it would only be necessary to underpin the foundations for a distance of approximately 4 ft. adjacent to the length by which it was proposed to extend the new manhole

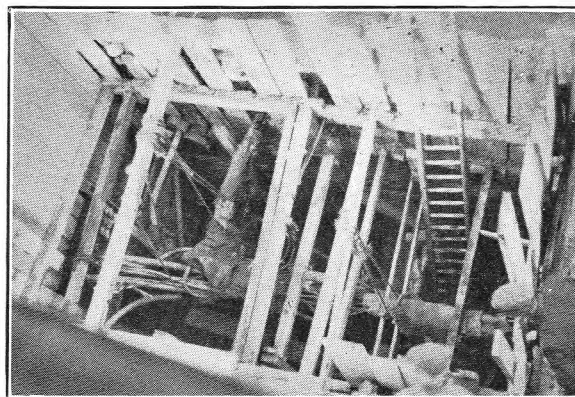

FIG. 2.

beyond the existing manhole. Fig. 2 shows a section of the former under construction.

In spite of the difficulties and delays the new manhole has been built, the building shows no signs of collapsing and, although the work will prove to be somewhat expensive, it is considered that in the circumstances it has been amply justified. The "straightening up" of existing cables to be supported on new centre standard bearers has yet to be completed, but there is ample space for this and future operations to be carried out. These latter, it is now known, will involve the drawing-in and jointing of a co-axial and a 1,100 pr. cable and the installation of two additional loading coils.

A period of 15 months elapsed between the commencement of the design and the completion of the construction work and much credit is due to the Works Supervisor who so successfully brought to completion what was a most hazardous, difficult and trying task. F. G.

## North-Eastern Region

### RECOVERY OF THE ALTHORPE-BURRINGHAM TELEPHONE MASTS

Erected for the Post Office in 1895, two steel masts 120 ft. high and with a span of 280 yds. have carried trunk wires over the River Trent for 53 years. With the advent of sub-aqueous cables their useful life ended and they have now been dismantled to swell the salvage drive. The work of cutting them down was undertaken by specially trained staff of the Radio Branch in conjunction with staff of the Lincoln Telephone Area.

It is interesting to recall a few reminiscences of their history. They were erected by a Worcester firm as part of the first Grimsby-Scunthorpe-Sheffield route at a time when Scunthorpe boasted one of the few G.P.O. exchanges in the country. This was a one-piece



C.B.S. No. 1 board located in a small post office in Holme Street and in service before Scunthorpe became famous for its iron smelting industry. The original wires were of 400-lb. copper. The method adopted to get a wire across was to hire a boat and start paying out from a point a quarter mile up-stream from the masts; in the time taken to row across the river the boat was usually a quarter mile down-stream. As each wire was pulled up it left the water with a loud report and sprang up some 50 to 60 feet into the air. In 1913, the first 150-lb. bronze wires were erected and the task of regulating these with the copper wires presented a nice mathematical problem. Owing to the sag being of the order of 30 feet, any chance of regulating them by inspection was out of the question.

Climbing the masts was no easy matter near the top, for the cross-bracing made it possible for only the toe-cap of a boot to be inserted.

During the last war, an aeroplane flying low took off the top twelve wires but did not crash. It speaks well for the design of the masts that this sudden shock and unbalancing of the load left them unaffected.

Now that they have gone their loss will perhaps be felt most by river craft which have for years used them as a landmark on this tortuous river. J. W. S.

### Welsh and Border Counties Region ENGINEERING REGIONAL TRAINING SCHOOL

Prior to August, 1947, all engineering training for the W. & B.C. Region in Regional School subjects was carried out by the Midland Region at their school in Birmingham, but the anticipated heavy demand for post-war training coupled with the unsuitability of the Birmingham premises for further expansion rendered desirable the establishment of a school in the W. & B.C. Region.

Authority for this course of action was given by the Engineer-in-Chief in February, 1945, and the search for a suitable site and premises was begun. This proved no easy task, but after lengthy enquiries and negotiations which extended until February, 1946, a disused U.S. Army Hospital Camp was offered by the Ministry of Works. Many hindrances were encountered subsequently with the result that the accommodation was not ready for training purposes until August 1947.

The school is situated in the seaside residential town of Penarth, three miles south of Cardiff, and consists of a number of huts of the "Standard M.O.W." and "Nissen" types (Fig. 1) laid out in four acres of ground which had

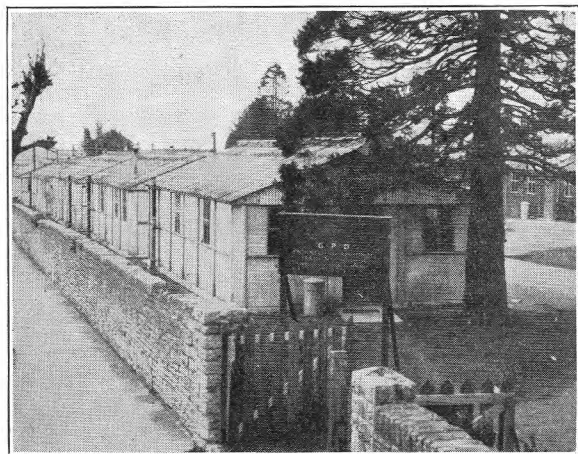

FIG. 1.

formerly belonged to a large mansion. The lecture, demonstration and practical rooms have been housed in the "Standard" huts and the "Nissen" huts have been reserved for storage purposes. One large "Nissen" hut is used as an overhead covered way and has been invaluable in that it has enabled overhead training to be performed in wet weather and in the failing light of winter afternoons.

The construction park is equipped with the usual dwarf and medium height pole routes for wiring and other overhead practice, and in addition has a miniature exchange distribution network radiating from the Equipment hut. The cable layout serves cabinets and pillars which in turn feed D.P.s and subsidiary poles spread in various parts of the grounds, and the entire network can be linked to exchanges of the automatic, C.B. or C.B.S. type so that students may gain experience of working on "live" plant. At one point on the system a duplicate cabinet is tied into the normal cabinet, this second cabinet being housed in the Underground practical room; this arrangement not only allows detail work to be carried in the cabinet in all weathers but permits a further extension of the distribution network via a dummy cable layout prepared by the students in their practical room.

The Underground practical room is fitted with a double row of "jointing stalls" erected in concrete block-work, each stall being equipped with cable bearers and arranged so as to simulate normal working conditions in a joint-box or manhole (Fig. 2). A small self-contained



FIG. 2.

cable scheme is constructed in this room by trainee jointers on their initial course and is modified on a subsequent advanced course to incorporate cabinets and pillars.

The lecture rooms are designed to accommodate 24 students and are fitted with a raised dais for the lecturer. One 60-ft. hut has been adapted as a lecture theatre and a 16-mm. sound-film projector has been housed in an operating booth constructed by the school staff. The addition of a lighting dimmer and one or two other refinements has enabled the film shows to be conducted in quite a professional manner. The lecture theatre is



used for showing the official instructional films and for holding fortnightly evening shows of documentary and interest films which are loaned by the Central Office of Information. These shows, which are a regular feature of the school's activities, have proved very popular with the students and help to make a material contribution towards education in its broader sense.

The welfare arrangements include a library and a recreation room equipped with table-tennis, darts, and sub-size billiard table, and, of course, a radio set. The canteen is of paramount importance in any school at which the majority of students are living away from home, and in this respect the Penarth School has been extremely fortunate. A pleasant dining-room and a well-equipped kitchen have been provided and the management, consisting of a committee formed from the school staff, were lucky in securing the services of a first-class cook and helpers.

The training undertaken so far has been confined to the Youths' Courses and, in general, to the basic stages of the remainder of the Regional School curriculum, but as the teaching staff gain more experience and the school becomes more fully equipped it will be extended to encompass the full range of courses.

The average intake to the school is reckoned to be 75 students at a time, with a maximum of 100, and possessing, as it does, the distinction of being the only Regional School by the sea it is confidently predicted that, at least in the summertime, Penarth will have little difficulty in reaching its target.

H. C. A. L.  
C. W. C. R.

### **London Telecommunications Region**

#### **STANFORD-LE-HOPE (ESSEX) U.A.X.14**

The conversion of the Stanford-le-Hope exchange area to automatic working was completed at 1.30 p.m. on Wednesday, 21st January, 1948, when a new U.A.X.14 was opened to replace the existing C.B.S.2 manual exchange. An initial multiple capacity for 600 subscribers was provided and the exchange opened with 393 working subscribers and 67 junctions. The parent exchange is at Tilbury, a C.B.10 exchange, where three positions have been converted for U.A.X. working.

Standard parallel battery automatic type charging plant was provided with two 300 Ah batteries charged by 15 A rectifiers.

The equipment contractors for the U.A.X. were Ericssons and the rectifiers were supplied by the Electric Construction Co.

A. W. C.

### **Scottish Region**

#### **AYR NON-DIRECTOR AUTO: NON-STANDARD EXTENSION**

Early in 1947, it became apparent that, owing to building difficulties, the exchange extension programme would not be completed in time to cater for the ever increasing list of applicants for telephone service and it was decided that some measure of interim relief must be provided. In order to provide 300 subs. multiple and calling equipments, the following rather unorthodox modifications to existing equipment were made.

Ayr Non-Director Auto has a few single-sided racks but most of the equipment is of the line-switch and final unit type, the bank multiple on the final side being a multiple of 16 banks on two shelves. To provide

additional final numbers, a careful scrutiny was made of traffic records and overflow meter readings, and it was decided that the banks of two final units could be split without adversely affecting the grade of service to these units, thus making available bank multiples for 200 final numbers. The bank multiple on each unit was split into two, leaving one shelf of eight banks for the existing numbers, and one shelf of eight banks for the new numbers, the latter being cabled to a temporary I.D.F.

For the third hundred the traffic records and overflow meter readings were again scrutinised, and it was found that one shelf on a 200-outlet final rack could be made available by disconnecting the tie cable between shelves B and C; thus, shelf C was made available and one hundred of this bank multiple was cabled to the temporary I.D.F. The full 200 could not be utilised as the traffic would have been too heavy for the number of switches which could be accommodated.

The final selectors for the first 200 were obtained by robbing final units which were not heavily loaded; the final selectors for shelf C of the 200-outlet final rack were supplied by the E-in-C from surplus equipment. Test finals were not provided for these subscribers, but trunk offering facilities were provided by modifying three final selectors.

Three hundred subscribers' calling equipments were provided by the contractor, as an advance portion of the exchange extension, 100 on an existing rack, and a new rack of 200, which was fitted in a temporary position, these being cabled to the temporary I.D.F.

All the work, cabling, grading, etc., except the cabling of the uniselectors, was carried out by the Department's staff.

T. W. D.

### **North-Western Region**

#### **KIRKHAM (LANCS.) EXCHANGE TRANSFER**

A unit automatic exchange of the No. 14 type was opened for service on Thursday, 4th December, 1947, thus replacing the C.B.S. No. 1 exchange which had been in service for many years. The transfer involved 284 subscribers' lines and 44 junctions.

The equipment was provided and installed by Siemens Bros. and the work was taken over from the Engineer-in-Chief's Office in May, 1939, when contract equipment works were devolved on the North-Western Region. On the review of outstanding works soon after the outbreak of war, it was decided to complete the manufacture of the equipment and store it on site in the new U.A.X. building which had already been erected. Due to the lapse of time between design and the transfer, additional equipment was required and, after manufacture, this was installed in conjunction with the stored items on site. The new exchange is parented on Preston, and access to subscribers on ten other automatic exchanges is obtained through the parent exchange by dialling. A non-parent route to Blackpool gives access to 13 exchanges via the auto-manual board. Three other non-parent routes serve two automatic exchanges and one manual exchange, while calls to two manual exchanges are routed through the parent automatic equipment.

The territory served by Kirkham exchange is largely rural and some lines of considerable length exist in the area.

The engineering staff carried out all the preparatory work in a praiseworthy manner, thus ensuring a successful transfer.

W. O.

# Staff Changes

## Promotions

Name	Region	Date	Name	Region	Date
<u>Tel. Man. to C.R.E.</u>			<u>S.W.I. to Inspector</u>		
Procter, W. S.	.. Scot. Reg. to L. T. Reg	1.1.48	Nokes, W. J.	.. L. T. Reg. .. ..	12.11.46
<u>A.S.E. to Staff Engr.</u>			Adams, W.	.. N. E. Reg. .. ..	4.1.47
Booth, C. F.	.. E.-in-C.O. .. ..	13.1.48	Samuel, J. H.	.. N. E. Reg. .. ..	4.1.47
<u>A.S.E. to Asst. Secy.</u>			Druce, J. E.	.. W. & B. C. Reg. ..	31.1.47
Hibbs, A.	.. E.-in-C.O. to Personnel Dept. .. ..	4.1.48	Gray, A.	.. L. P. Reg. .. ..	12.3.47
<u>Exec. Engr. to A.S.E.</u>			Payne, A. J.	.. L. P. Reg. .. ..	12.3.47
Anderson, E. W.	.. E.-in-C.O. to H.C.Reg.	31.12.47	Martin, H. W. B.	.. L. P. Reg. .. ..	12.3.47
Mitchell, H. T.	.. E.-in-C.O. .. ..	22.1.48	<u>Sen. Chem. to P.Sc.O</u>		
Creighton, J. L.	.. E.-in-C.O. .. ..	22.1.48	Linch, R.	.. E.-in-C.O. .. ..	1.1.46
<u>Area Engr. to Principal</u>			Hourigan, H. F.	.. E.-in-C.O. .. ..	1.1.46
Bland, F. E.	.. Scot. Reg. to Min. of Health .. ..	12.1.48	Downes, A. D. W.	.. E.-in-C.O. .. ..	1.1.46
<u>Engr. to Exec. Engr.</u>			<u>Exec. Engr. to P.Sc.O.</u>		
Angus, J. L.	.. Scot. Reg. .. ..	12.1.48	Coombs, A. W. M.	.. E.-in-C.O. .. ..	17.12.47
Easterling, C. E.	.. E.-in-C.O. .. ..	26.11.47	<u>Phys. or Chem. to S.Sc.O.</u>		
Lawrence, J. A.	.. E.-in-C.O. .. ..	1.1.48	Bull, R. L.	.. E.-in-C.O. .. ..	1.1.46
Burgess, A. G.	.. E.-in-C.O. .. ..	26.11.47	Walker, E. V.	.. E.-in-C.O. .. ..	1.1.46
Harding, T. C.	.. E.-in-C.O. .. ..	26.11.47	Rickard, E. F.	.. E.-in-C.O. .. ..	1.1.46
Phillips, S. A.	.. E.-in-C.O. .. ..	26.11.47	Garrett, F. S.	.. E.-in-C.O. .. ..	1.1.46
Sharpe, H. T. A.	.. L. T. Reg. .. ..	2.12.47	<u>Phys. or Chem. to S.Exp.O.</u>		
Carrette, A. D.	.. N. E. Reg. .. ..	1.1.48	Peirce, J. G.	.. E.-in-C.O. .. ..	1.1.46
Piggott, E. C. C.	.. Mid. Reg. .. ..	1.1.48	Taylor, E. A.	.. E.-in-C.O. .. ..	1.1.46
Glass, C. G.	.. L. T. Reg. to N.W.Reg.	2.12.47	Rayner, L. W. W.	.. E.-in-C.O. .. ..	1.1.46
Lewis, S. G.	.. E.-in-C.O. .. ..	19.12.47	Bowcott, H. J.	.. E.-in-C.O. .. ..	1.1.46
Rudeforth, S.	.. E.-in-C.O. .. ..	19.12.47	Edwards, W. T.	.. E.-in-C.O. .. ..	1.1.46
Macpherson, A.	.. E.-in-C.O. .. ..	8.2.48	<u>T. Fem. Phys. to S.Exp.O.</u>		
Hedges, E. W.	.. E.-in-C.O. .. ..	8.2.48	Lovett, Miss C. M.	.. E.-in-C.O. .. ..	1.1.46
Hawkins, C. F. W.	.. L. T. Reg. to E.-in-C.O.	23.1.48	<u>Exp.O. to S.Exp.O.</u>		
O'Roark, A. F.	.. S. W. Reg. to H.C. Reg.	8.2.48	Paul, W. A. J.	.. E.-in-C.O. .. ..	12.5.47
<u>Asst. Engr. to Engineer</u>			<u>Asst. Chem. to Exp O.</u>		
Butcher, W.	.. N. W. Reg. .. ..	12.1.48	Terrett, L. E.	.. E.-in-C.O. .. ..	1.1.46
Wadson, D. E.	.. Scot. Reg. to S.W. Reg.	15.12.47	Taylor, P. E.	.. E.-in-C.O. .. ..	1.1.46
Smallwood, W. K.	.. E.-in-C.O. .. ..	8 2 48	Woodward, J. A. W.	.. E.-in-C.O. .. ..	1.1.46
Davis, A. T.	.. Mid. Reg. .. ..	10.2 48	<u>Technician to Exp.O.</u>		
<u>Asst. Engr. to Prob. Engr.</u>			Hancock, A.	.. N.E.Reg. to E.-in-C.O.	19.1.48
Partridge, J. G.	.. N. Ire. Reg. to E-in C.O. .. ..	1.12.47	<u>Tech. Asst. to A.R.M.T.O.</u>		
Tattersall, R. L.	.. Scot. Reg. to E.-in-C.O.	1.12.47	Longwood, A. L.	.. H. C. Reg. .. ..	11.2.48
Hudson, G. K.	.. N.E.Reg. to E.-in-C.O.	5.1.48	<u>Mech. i/c to Tech. Asst.</u>		
Burton, R. N.	.. N. E. Reg. to E.-in-C.O.	5.1.48	Coppin, W. L.	.. N. W. Reg. to London	26.11.47
<u>A.T.S. to Prob. Engr.</u>			Thwaites, J. B. H.	.. London to E.-in-C.O.	11.1.48
Fenemore, R. W.	.. H.C.Reg. to E.-in-C.O.	15.12.47	Short, R.	.. N.W.Reg. to E.-in-C.O.	26.11.47
<u>Tech. to Asst. Engr.</u>			Brown, G.	.. Mid. Reg. to London	28.12.47
Thompson, C. F.	.. N.E. Reg. .. ..	10.2.47	<u>Sec. Off. to Ch. Off.</u>		
Boon, W. H. H.	.. N. E. Reg. .. ..	31.5.47	Marshall, J.	.. H.M.T.S. Ariel ..	8.9.47
<u>S.W.I. to Asst. Engr.</u>			<u>Fourth Off. to Third Off.</u>		
Stansfield, R.	.. N. E. Reg. .. ..	4.1.47	Hoar, W. A.	.. H.M.T.S. Monarch to H.M.T.S. Ariel ..	9.2.48
McCutcheon, A.	.. W. & B. C. Reg. ..	31.1.47	<u>Fifth Engr. to Fourth Engr.</u>		
King, E.	.. N. E. Reg. .. ..	4 2.47	Clews, E. S.	.. H.M.T.S. Iris to H.M.T.S. Alert ..	23.6.47
<u>Tech. to Inspector</u>			Creighton, E. S.	.. H.M.T.S. Monarch to H.M.T.S. Iris ..	10.1.48
Wade, C. W.	.. H. C. Reg. .. ..	10.1.47	<u>D'man Cl. II to D'man Cl. I.</u>		
Agutter, S. J.	.. H. C. Reg. .. ..	10.1.47	Smith, G. H.	.. E.-in-C.O. .. ..	21.12.47
Dodgon, S. W.	.. H. C. Reg. .. ..	11.2.47	Taylor, E. W. E.	.. E.-in-C.O. .. ..	28.12.47
Gunner, C.	.. H. C. Reg. .. ..	11.2.47	Prior, H. W.	.. E.-in-C.O. .. ..	7.3.48
Waters, F. J.	.. H. C. Reg. .. ..	11.2.47			
Lawson, J. M.	.. H. C. Reg. .. ..	17.2.47			
Sykes, R. P.	.. H. C. Reg. .. ..	17.3.47			
Martin, S. W.	.. L. P. Reg. .. ..	12.3.47			
Penn, E. E.	.. L. P. Reg. .. ..	12.3.47			
Newton, C. B.	.. L. P. Reg. .. ..	12.3.47			
Roe, R. J.	.. H. C. Reg. .. ..	11.4.47			

### Transfers

Name	Region	Date	Name	Region	Date
<u>C.R.E.</u>			<u>Asst Engr. — continued</u>		
Morris, A.	.. L.T.Reg. to E.-in-C.O.	1.1.48	Brooker, H. J.	.. E.-in-C.O. to South African P.O.	4.12.47
<u>Exec. Engr.</u>			McNab, A. M.	.. E.-in-C.O. to Scot.Reg.	10.12.47
Armstrong, R. G.	.. N.W.Reg. to E.-in-C.O.	2.12.47	Clark, R. M.	.. E.-in-C.O. to Scot.Reg.	10.12.47
Young, J. E.	.. E.-in-C.O. to L.T. Reg.	1.1.48	Heath, F. J.	.. E.-in-C.O. to Scot.Reg.	10.12.47
<u>Engineer</u>			Coulman, A. H.	.. S.W.Reg. to E.-in-C.O.	1.1.48
Goldsmith, F. H.	.. E.-in-C.O. to Scot.Reg.	28.11.47	Tinsley, W. S.	.. E.-in-C.O. to L.T.Reg.	18.1.48
Chapman, S. D.	.. E.-in-C.O. to S.W.Reg.	1.12.47	Ratchiff, D. J.	.. E.-in-C.O. to S.W.Reg.	1.1.48
Hopkinson, E.	.. E.-in-C.O. to N.E.Reg.	1.1.48	Woodward, G. W.	.. E.-in-C.O. to Foreign Office	1.2.48
Hull, J. A.	.. E.-in-C.O. to N.E.Reg.	1.1.48	Johnston, E. J.	.. N.W.Reg. to E.-in-C.O.	1.2.48
Neal, C. W. B.	.. E.-in-C.O. to Adm'alty	1.1.48	Anderton, M. F. D.	.. E.-in-C.O. to N.E.Reg.	8.2.48
Haley, G.	.. L.T.Reg. to E.-in-C.O.	24.1.48	Scholey, D. H. A.	.. E.-in-C.O. to Colonial Service	14.2.48
Draper, J. H. P.	.. E.-in-C.O. to Min. of Trans.	2.2.48	Foskett, G. E.	.. Scot. Reg. to E.-in-C.O.	22.2.48
Collins, P. T.	.. L.T.Reg. to South African P.O.	11.2.48	<u>Inspector</u>		
Waldram, A. H. T.	.. E.-in-C.O. to South African P.O.	11.2.48	Boast, T. W.	.. E.-in-C.O. to N.E.Reg.	15.12.47
<u>Asst. Engr.</u>			<u>Tech. Asst.</u>		
Attree, V. H.	.. E.-in-C.O. to Min. of Supply	16.5.47	Elder, D.	.. London to S.W.Reg.	1.12.47
			<u>D'man Cl. I</u>		
			Holt, J. V. O.	.. Scot. Reg. to N.E. Reg.	29.2.48

### Retirements

Name	Region	Date	Name	Region	Date
<u>Exec Engr.</u>			<u>Inspector</u>		
Preston, S.	.. N.E. Reg.	31.12.47	Hishon, C. H.	.. H.C. Reg (Resigned)	31.7.47
Thorn, B. K.	.. Mid Reg.	31.12.47	Godden, A. J. R.	.. H.C. Reg.	19.9.47
Freestone, A. G.	.. L.T. Reg.	31.12.47	Brient, A.	.. L.T. Reg.	2.8.47
Chapman, F. G.	.. E.-in-C.O.	7.2.48	Boys, W. E.	.. L.T. Reg.	4.10.47
<u>Engineer</u>			H'shon, D.	.. H.C. Reg.	6.10.47
Bellairst, G. F.	.. E.-in-C.O. (Resigned)	17.12.47	Rastall, G. H.	.. N.E. Reg.	10.10.47
Davey, H. B.	.. W. & B.C. Reg.	31.12.47	Hankin, J.	.. H.C. Reg.	23.10.47
Stark, W.	.. Scot. Reg.	31.12.47	Kelt, W.	.. Scot. Reg.	7.12.47
Chany, F. T.	.. N.W. Reg.	31.12.47	Galloway, J.	.. Mid Reg.	31.12.47
Smith, A. E.	.. H.C. Reg.	31.12.47	Denton, W. T.	.. H.C. Reg.	31.12.47
Moon, F. H.	.. N.W. Reg.	31.12.47	Court, A. F.	.. H.C. Reg.	31.12.47
Murgatroyd, A.	.. N.E. Reg. (Resigned)	31.12.47	Farrow, A. W.	.. H.C. Reg.	31.12.47
Johnson, R. P.	.. Mid Reg.	3.2.48	Chisholm, H.	.. Scot. Reg.	31.12.47
Reid, W. A.	.. Scot. Reg.	13.2.48	Pascall, E.	.. L.T.Reg.	31.12.47
<u>Asst. Engr.</u>			Gould, H.	.. L.T. Reg.	31.12.47
Harris, K. E.	.. H.C. Reg. (Resigned)	19.9.47	Connor, J.	.. N.I. Reg.	17.1.48
Griffith, D. A. C.	.. L.T. Reg. (Resigned)	30.11.47	Gadd, C. A.	.. L.T. Reg.	26.1.48
Evans, W. P.	.. Mid Reg.	31.12.47	Gardiner, E. R. B.	.. Mid Reg.	31.1.48
Humphreys, H. L.	.. L.T. Reg.	31.12.47	Vernon, C. H.	.. W. & B.C. Reg.	18.2.48
Dawson, R. E.	.. N.W. Reg.	31.12.47	Holden, W.	.. N.W. Reg.	19.2.48
Choldcroft, E.	.. E.-in-C.O.	31.1.48	Hunt, A. A.	.. Mid. Reg.	21.2.48
Middlemiss, W. A.	.. Scot. Reg.	14.2.48	<u>Asst. Exp. Officer</u>		
			Falkner, Miss E. C. S.	.. E.-in-C.O. (Resigned)	17.1.48
			<u>D'man Cl. I.</u>		
			Sabine, D. C. W.	.. S. W. Reg. (Medical Gds.)	9.11.47

### Deaths

Name	Region	Date	Name	Region	Date
<u>Engineer</u>			<u>Asst. Engr.—continued</u>		
Naylor, W. H. G.	.. H.C. Reg	19.11.47	Harbage, H.	.. Mid. Reg.	19.12.47
Martin, B. R.	.. E.-in-C.O.	5.12.47	Foott, W. E.	.. E.-in-C.O. (T.S.)	24.12.47
<u>Asst. Engr.</u>			<u>Inspector</u>		
Pritchard, H.	.. W. & B.C. Reg.	11.11.47	Lanfear, E.	.. S.W. Reg.	6.12.47
			Milburn, T. J.	.. N.E. Reg.	6.12.47

CLERICAL GRADES

Promotions

Name	Region	Date	Name	Region	Date
<i>E.O. to H.E.O.</i>			<i>C.O. to E.O.—continued</i>		
Norris, S. A.	.. E.-in-C.O. .. ..	9.2.48	Griffiths, Miss O. A.	.. E.-in-C.O. .. ..	1.11.47
Sawtell, G. K.	.. E.-in-C.O. .. ..	1.3.48	Coomber, E. J.	.. E.-in-C.O. .. ..	1.11.47
<i>C.O. to E.O.</i>			Jones, H. P.	.. E.-in-C.O. .. ..	1.11.47
Vipond, G.	.. E.-in-C.O. .. ..	1.11.47	Ellingham, J. B.	.. E.-in-C.O. .. ..	1.11.47
Henderson, H. F.	.. E.-in-C.O. .. ..	1.11.47	Yearley, R. R.	.. E.-in-C.O. .. ..	1.11.47
Sturges, A. F. R.	.. E.-in-C.O. .. ..	1.11.47	McCready, R.	.. E.-in-C.O. .. ..	1.11.47
Merrony, A. E.	.. London Test .. ..	1.11.47	Morris, J.	.. E.-in-C.O. .. ..	26.1.48
Rainbow, H. R.	.. E.-in-C.O. .. ..	1.11.47	Diamond, W. B.	.. E.-in-C.O. .. ..	26.1.48
Faulkner, N. L.	.. E.-in-C.O. .. ..	1.11.47	Page, W. G.	.. E.-in-C.O. .. ..	25.2.48
			Holliday, J. H.	.. E.-in-C.O. .. ..	25.2.48
			Rainbird, F. C.	.. E.-in-C.O. .. ..	25.2.48

Transfers

Name	Region	Date	Name	Region	Date
<i>Staff Officer</i>			<i>Exec. Officer—continued</i>		
Walker, F. H.	.. E.-in-C.O. to Min. of Nat. Ins. .. ..	9.2.48	Jones, A. E.	.. E.-in-C.O. to Min. of Nat. Ins. .. ..	1.3.48
<i>Exec. Officer</i>			Lewis, E. T. S.	.. E.-in-C.O. to Min. of Nat. Ins. .. ..	1.3.48
Yearly, R. R.	.. E.-in-C.O. to P. & T. Gold Coast .. ..	9.1.48	Pearson, K.	.. E.-in-C.O. to Min. of Nat. Ins. .. ..	15.3.48

BOARD OF EDITORS

- H. FAULKNER, B.Sc., M.I.E.E., Chairman.  
 F. E. NANCARROW, O.B.E., A.R.C.Sc., M.I.E.E.  
 P. B. FROST, B.Sc., M.I.E.E.  
 A. H. MUMFORD, O.B.E., B.Sc.(ENG.), M.I.E.E.  
 C. W. BROWN, A.M.I.E.E.  
 C. E. C. SKUSE.  
 G. E. STYLES, A.M.I.E.E., Managing Editor.  
 J. P. HARDING, B.Sc.(ENG.),  
 A.M.INST.C.E., A.M.I.E.E. } Assistant Editors.  
 F. WARREN, A.M.I.E.E.  
 A. J. BAKER, Secretary-Treasurer.

Copyright

The entire contents of this JOURNAL are covered by general copyright, and special permission is necessary for reprinting long extracts, but Editors are welcome to use not more than one-third of any article, provided credit is given at the beginning or end thus: "From the *Post Office Electrical Engineers' Journal*."

The Board of Editors is not responsible for the statements made or the opinions expressed in any of the articles in this JOURNAL, unless such statement is made specifically by the Board.

Communications

All communications should be addressed to the Managing Editor, *P.O.E.E. Journal*, Engineer-in-Chief's Office, Alder House, Aldersgate Street, London, E.C.1. Telephone: HEADquarters 1234. Remittances should be made payable to "*The P.O.E.E. Journal*" and should be crossed "& Co."

Binding Cases

Cases for binding are available, and may be obtained from the Local Agents for 2s. Subscribers can have their copies of Volumes bound, at a cost of 7s. 6d., by sending the complete set of parts to the Local Agents or to the *P.O.E.E. Journal*, Engineer-in-Chief's Office, Alder House, Aldersgate Street, London, E.C.1. Orders for binding for Vols. 1-19 should indicate whether the original binding case with black lettering, or the later pattern with gold, is required. Cases with gold lettering are the only type stocked from Vol. 20 onwards.

Back Numbers

The price of the JOURNAL, which is published quarterly, is 1s. 6d. (1s. 9d. post free) per copy, or 7s. per annum post free. Back numbers can be supplied, subject to availability of stocks, at 1s. 6d. each (1s. 9d. post free). Orders for back numbers may be sent to the Local Agents or to the Publishers.

Advertisements

All communications relating to space reservations should be addressed to the Advertisement Editor, *P.O.E.E. Journal*, Alder House, Aldersgate Street, London, E.C.1. Communications regarding advertisement copy, proofs, etc., should be addressed to the Publishers, Messrs. Birch & Whittington (Prop. Dorling & Co. [Epsom], Ltd.), 49 Upper High Street, Epsom, Surrey.

## MODEL ANSWERS

TO

CITY AND GUILDS OF LONDON  
INSTITUTE EXAMINATIONS

NOW AVAILABLE

**TELECOMMUNICATIONS (PRINCIPLES) I**

**TELEPHONE EXCHANGE SYSTEMS I**

NOW PRINTING

**TELEGRAPHY I AND RADIO I**

Copies may be obtained at 2/6 each (2/9 post free)

FROM

THE MANAGING EDITOR

POST OFFICE ELECTRICAL ENGINEERS' JOURNAL

ALDER HOUSE, ALDERSGATE STREET, LONDON, E.C.1

## INDEX TO ADVERTISERS

	<i>Page</i>
Alton Battery Co., Ltd., The .. .. .	vii
Automatic Coil Winder & Electrical Equipment Co., Ltd. ..	iii
Automatic Telephone & Electric Co., Ltd. .. .. .	xii, xiii
Bennett College, The .. .. .	iv
British Institute of Engineering Technology .. .. .	viii
Creed & Co., Ltd. .. .. .	v
Edison Swan Electric Co., Ltd., The .. .. .	ii
Ericsson Telephones, Ltd. .. .. .	xx
Evershed & Vignoles, Ltd. .. .. .	x
Ferranti, Ltd. . . . .	xv
General Electric Co., Ltd., The .. .. .	xvii
Great Northern Telegraph Co., Ltd., The .. .. .	xvi
H. T. A., Ltd. .. .. .	vi
International Correspondence Schools .. .. .	xviii
Marconi Wireless Telegraph Co., Ltd. .. .. .	xi
Muirhead .. .. .	xv
Neill, James, & Co., Ltd. .. .. .	vii
Neosid, Ltd. .. .. .	xviii
Parmeko, Ltd. .. .. .	iv
Pirelli-General Cable Works, Ltd. .. .. .	xxii
Pitman, Sir Isaac, & Sons, Ltd. .. .. .	xxi
Salford Electrical Instruments, Ltd. .. .. .	ii
Savage, W. Bryan, Ltd. .. .. .	xxi
Siemens Brothers & Co., Ltd. .. .. .	xiv
Smith, Frederick, & Co. .. .. .	iv
Standard Telephones and Cables, Ltd. .. .. .	ix
Sullivan, W. H., Ltd. .. .. .	xxii
Telephone Manufacturing Company, Ltd. .. .. .	vi
Tungstone Products Ltd. .. .. .	xix
Turner, E. .. .. .	xvi
United Insulator Co., Ltd. .. .. .	viii
Westinghouse Brake & Signal Co., Ltd. .. .. .	xi
Winn & Coales, Ltd. . . . .	xviii

*Time limits*  
**OF ACCURACY**

The 50-range Model 7 Universal Avometer, the pioneer of the comprehensive range of "Avo" Precision Instruments, is the world's most widely used combination Electrical Measuring Instrument. Fully descriptive pamphlet available on application to the Sole Proprietors and Manufacturers:

**THE AUTOMATIC COIL WINDER & ELECTRICAL EQUIPMENT CO. LTD.**  
Winder House, Douglas Street, London, S.W.1

Phone: VICToria 3404-9



*Electrical  
Measuring  
Instruments*



THE PARMEKO  
**MERCURY**  
SERIES

Announcing this amazing  
new range of Parmeko  
Hermetically sealed  
Transformers and Chokes.

Developed to operate  
under abnormal  
conditions.

PARMEKO OF LEICESTER  
Makers of  
Transformers.

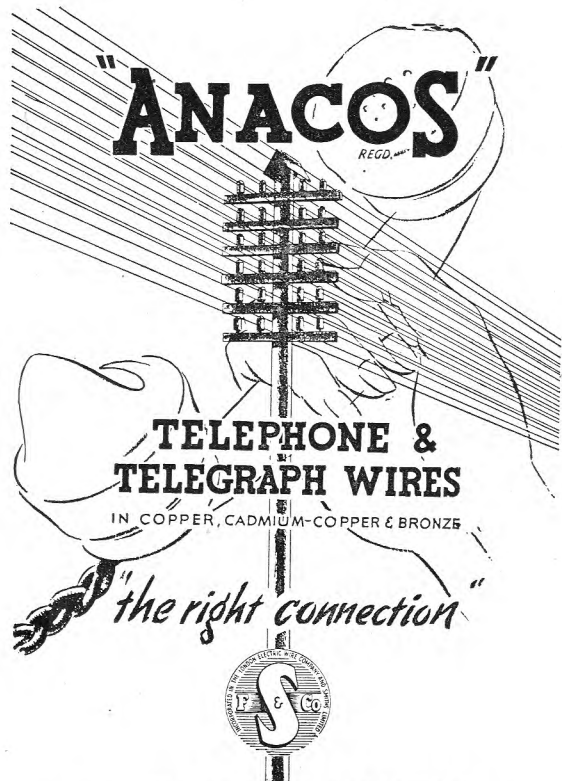
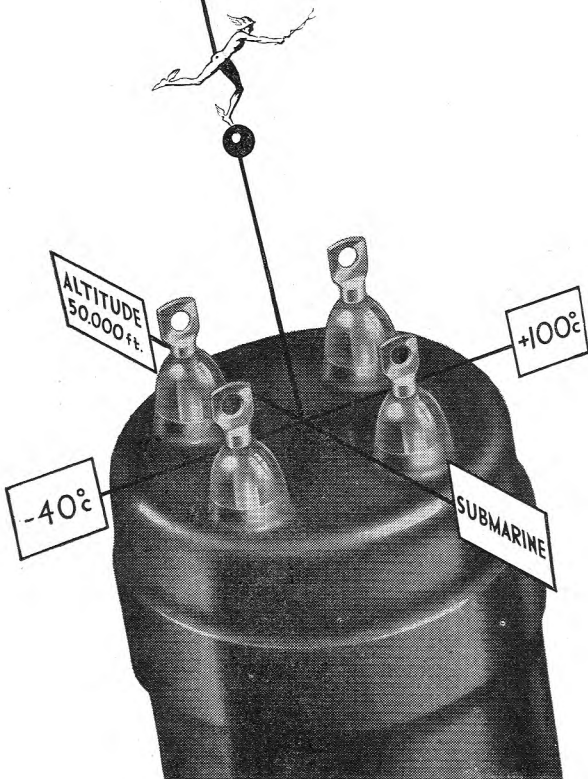

**TELEPHONE &  
TELEGRAPH WIRES**

IN COPPER, CADMIUM-COPPER & BRONZE

*"the right connection"*



**FREDERICK SMITH & COMPANY**

(Incorporated in The London Electric Wire Company and Smiths, Limited)

**ANACONDA WORKS, SALFORD 3, LANCS.**

Phone: Backfriars 8701 (9 lines) • Grams: "Anaconda," Manchester

STUDY  
AT  
HOME

You Can Have a College Training  
For a Few Shillings Monthly

IN YOUR  
SPARE  
TIME

FOUNDED 1900

40 YEARS OF SUCCESS

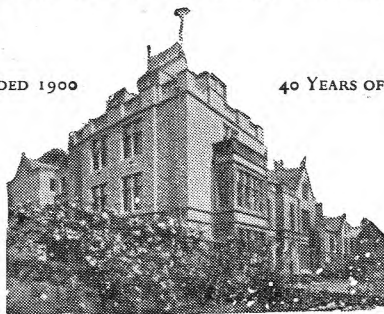

**CITY and GUILDS (Telecom-  
munication) EXAMINATIONS**

To every student we send  
a written Guarantee of  
Tuition until the  
examination is  
actually  
passed

Our tuition  
is so graded that  
each stage is reached  
without difficulty.

Personal attention is given  
to every student.

FULL PARTICULARS AND  
ADVICE SUPPLIED FREE.

WE TEACH BY POST IN ALL PARTS  
OF THE WORLD.

*The most progressive and most successful  
Correspondence College in the world*



Dept. 24, THE BENNETT COLLEGE, SHEFFIELD

No. **47** TAPE MODEL  
**TELEPRINTER**

FOR —

**MODERN TELEGRAPHY—**

A NEW PRODUCT



*Creed*

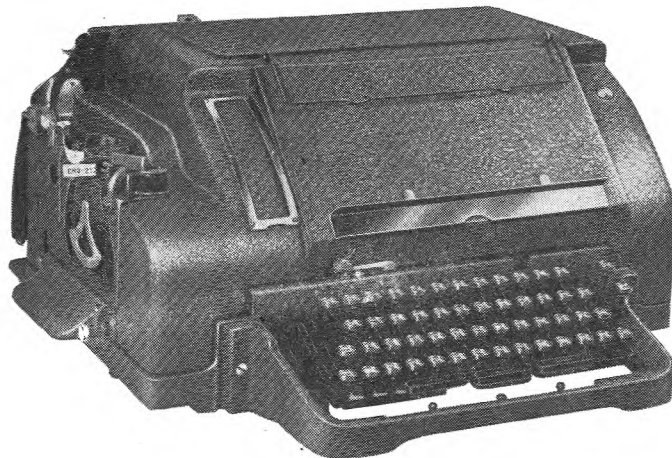

- Printing point is in ideal position on left side.
- Accessible printing unit using typewriter ink ribbon.
- Receiving cam orientation device facilitates optimum adjustment.
- Answer-back unit (20 characters).
- Conforms to C.C.I.T. recommendations.
- A cover attachment for accommodating message forms, etc., can be provided for handling heavy traffic.
- Tape and ink ribbon are replenished without removing cover.
- Simplified maintenance with unit construction.
- Quiet in operation.

***Creed and Company Limited***

TELEGRAPH HOUSE • CROYDON • ENGLAND

TELEGRAMS : "CREDO, TELEX, CROYDON."  
TELEPHONE : CROYDON 2121 (7 lines).

● CABLES : "CREDO, CROYDON."  
● TELEX : CROYDON, TELEX 1082

# A Typical Example of H.T.A. DESIGN

Included in the range of H.T.A. Products are Telephone Coin Collectors, Stamp Selling Machines, Autodials, Commodity Vending Machines, Coin Operated Mechanisms, Kitchen Control Units, Gas Leak Indicators and Ticket Printing and Issuing Machines of which the model illustrated is a typical example.

★ *This H.T.A. all-electric Ticket Issuing Machine prints and dates each ticket when coin is inserted*

Designed for selling of railway travel and platform tickets this model can be adapted for a variety of other purposes.

Tickets are printed and dated on the insertion of the appropriate coin or coins from a roll of blank paper, the size of the ticket issued being approximately 3" x 1 $\frac{1}{4}$ " x .015" thick. The machine is electrically operated and full details and specification will be supplied on request.

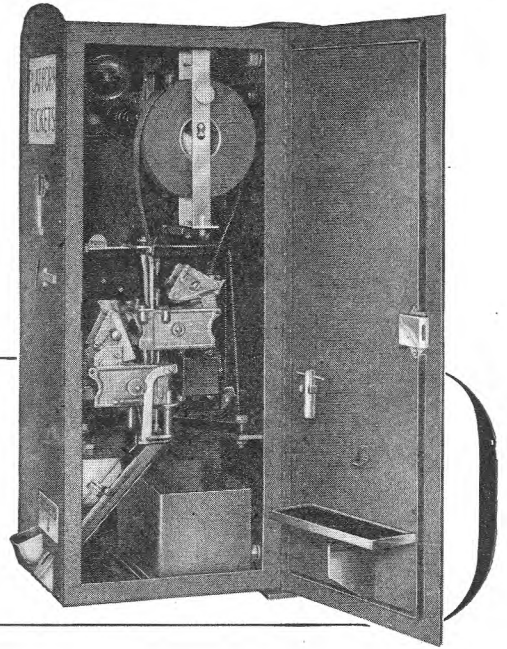

## H.T.A. LIMITED

FORMERLY HALL TELEPHONE ACCESSORIES (1928) LTD

*Precision Engineers & Instrument Makers*

DUDDEN HILL LANE • WILLESDEN • LONDON • N. W. 10

PHONE: WILLESDEN 5141

# CARPENTER

## High Speed Polarised

# RELAY

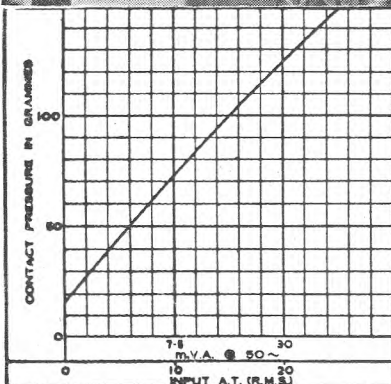
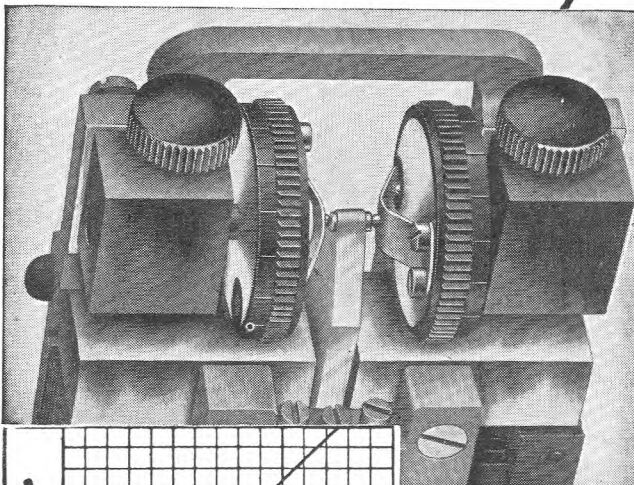

● Contact mechanism of Relay showing damped compliant mountings of side contacts.

● Graph showing contact pressures developed at 50 c/s against mVA and ampere turns input for type 3E Carpenter Relay.

The Carpenter Relay in its standard adjustment reproduces, with a 5AT input, square pulses from less than 2 milliseconds upwards with a distortion of 0.1mS, i.e., 5% for 2mS pulses or 1% at 10mS.

This unequalled performance is due to inherent features of the design of the relay, ensuring short transit time, high sensitivity and low hysteresis. There is complete absence of contact rebound at any input power and contact pressures are exceptionally high (*see graph*). Adjustment can be made with great ease. Moreover, since the armature is suspended at its centre of gravity, the relay has high immunity from effects of mechanical vibration and there is no positional error. Effective screening is provided against external fields. Because of these characteristics, the Carpenter Relay has many applications in the fields of measurement, speed regulation, telecontrol and the like, in addition to the obvious use in telegraph circuits; details of models suitable for such purposes will be supplied willingly on request.

DIMENSIONS IN COVER: 2 $\frac{3}{8}$  x 1 $\frac{1}{8}$  x 4 $\frac{1}{2}$ .

WEIGHT with standard socket: 22 ozs.

Ask for booklet 1017 P.O.

## TELEPHONE MANUFACTURING CO. LTD.

HOLLINGSWORTH WORKS • DULWICH • LONDON • S.E.21

Telephone: GIPsy Hill 2211 (10 lines)





## FROST WARNING

*'Possible danger, eh? Shouldn't have thought there'd be frost at tree level tonight, whatever the radio says. Still—better switch on. Silly to take any risks, now that we've got the current . . .'*

Not very far ahead of us now lies the Electric Age—with universal, unlimited supplies of electricity. When that age is established, peace will at last begin to count her victories. Farmers will find new weapons against the wasteful treachery of the weather. City dwellers will break free from smoke and dirt and disease. Better days for all. And for us, here in Alton, where we make the batteries for generating stations all over the world, busier days than ever. Hydro-electric, Atomic or what you will, the new generating stations will all need batteries. Good batteries. The kind we have always made at Alton.

# ALTON

## BATTERIES OF MERIT

THE ALTON BATTERY COMPANY LTD • ALTON • HANTS

Sole Suppliers of Fuller Stationary Batteries

Telephone: ALTON 2267 & 2268 • Telegrams: 'BATTERY, ALTON'

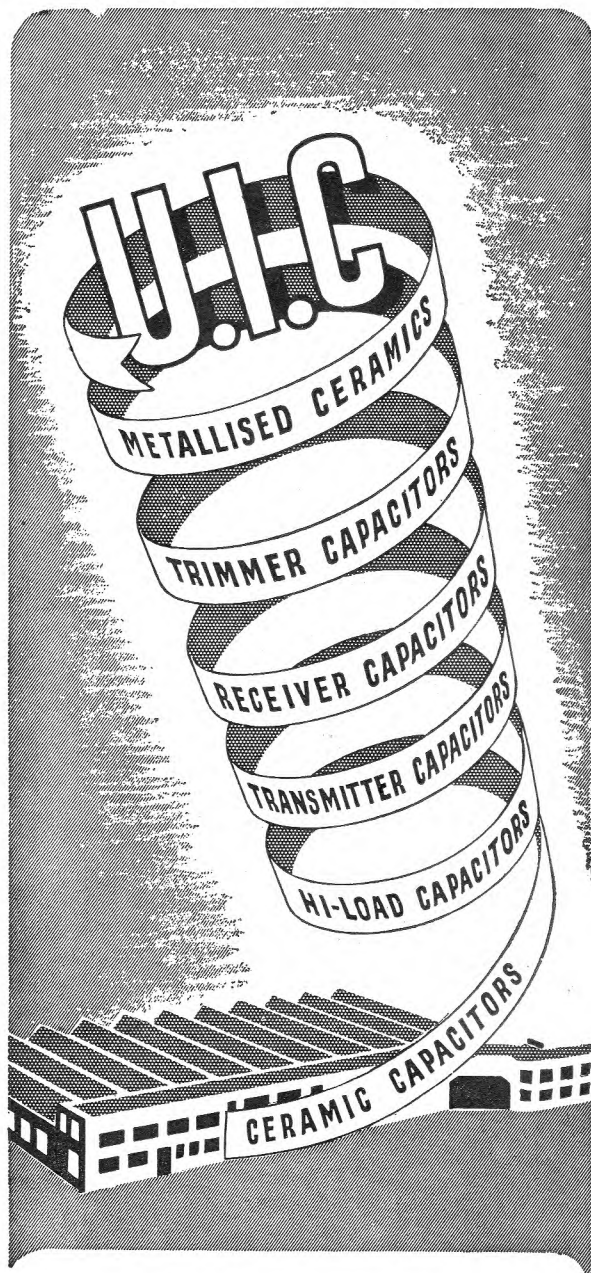

**UNITED INSULATOR CO. LTD.**

OAKCROFT RD., TOLWORTH, SURBITON, SURREY

Telephone: Elmbridge 5241

Telegrams: Calanel, Surbiton

Unsurpassed  
in  
Ceramics

## A PRACTICAL PLAN for EARLY PROMOTION



Valuable Free Handbook Tells You  
How to Pass Your C. & G.  
or Promotion Exam. at *First Attempt!*

All Post Office Engineering personnel who are anxious to obtain early promotion should at once send for a copy of our handbook "**ENGINEERING OPPORTUNITIES**," which, among other intensely interesting matter, describes our unique methods of preparation for **TECHNICAL APPOINTMENTS IN THE POST OFFICE** (Assistant Engineer—New Style and Assistant Traffic Superintendent), **A.M.I.E.E., CITY AND GUILDS EXAMINATIONS** in Principles of Telecommunications (1-5), Radio (1-4), Telephone Exchange Systems (1-3), Telegraphy (1 and 2), Line Transmission (1 and 2), Lines Plant Practice (1 and 2), Mathematics for Telecommunications (1-5), Electrical Engineering Practice (Prelim. Inter. and Final), and outlines a wide range of non-examination courses in all branches of Electrical, Mechanical, Civil, Automobile, Aeronautical and Radio Engineering.

We definitely guarantee  
"NO PASS—NO FEE"

If you intend to make the most of to-day's opportunities, you cannot afford to miss reading "**ENGINEERING OPPORTUNITIES**." It tells you everything you want to know to secure advancement, and describes many opportunities you may now be missing through lack of information. Send for your copy to-day—**FREE** and without obligation.

**BRITISH INSTITUTE OF ENGINEERING TECHNOLOGY**  
369, SHAKESPEARE HOUSE, 17-19 STRATFORD PLACE, LONDON, W.1

**Eclipse** PERMANENT  
MAGNETS

IN  
TUNGSTEN · CHROME  
COBALT · ALNI · ALNICO  
& ALCOMAX

Our Technical Development Section  
will be pleased to advise on any  
problem connected with applied  
magnetism

Made by the manufacturers of  
"ECLIPSE"  
PERMANENT MAGNET CHUCKS

EM 7

**JAMES NEILL & CO. (Sheffield) LTD., SHEFFIELD, ENGLAND**



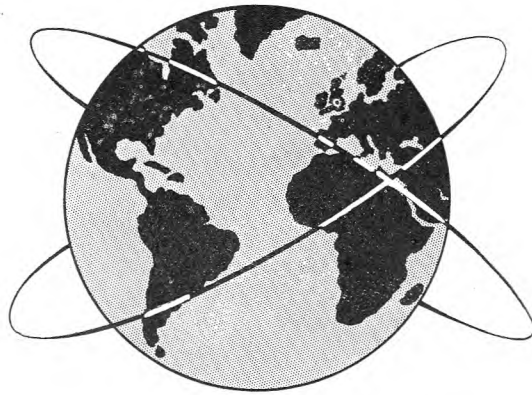

**four-fifths  
of the world's  
COMMUNICATIONS  
by line  
are carried by  
paper  
insulated  
cables**

*Standard* Paper Insulated Cables are used in telephone and telegraph systems throughout the world, fulfilling transmission requirements with complete reliability.

*Standard Telephones and Cables Limited*

TELECOMMUNICATION ENGINEERS, NORTH WOOLWICH, E.16

# STANDARD WITH THE BRITISH POST OFFICE

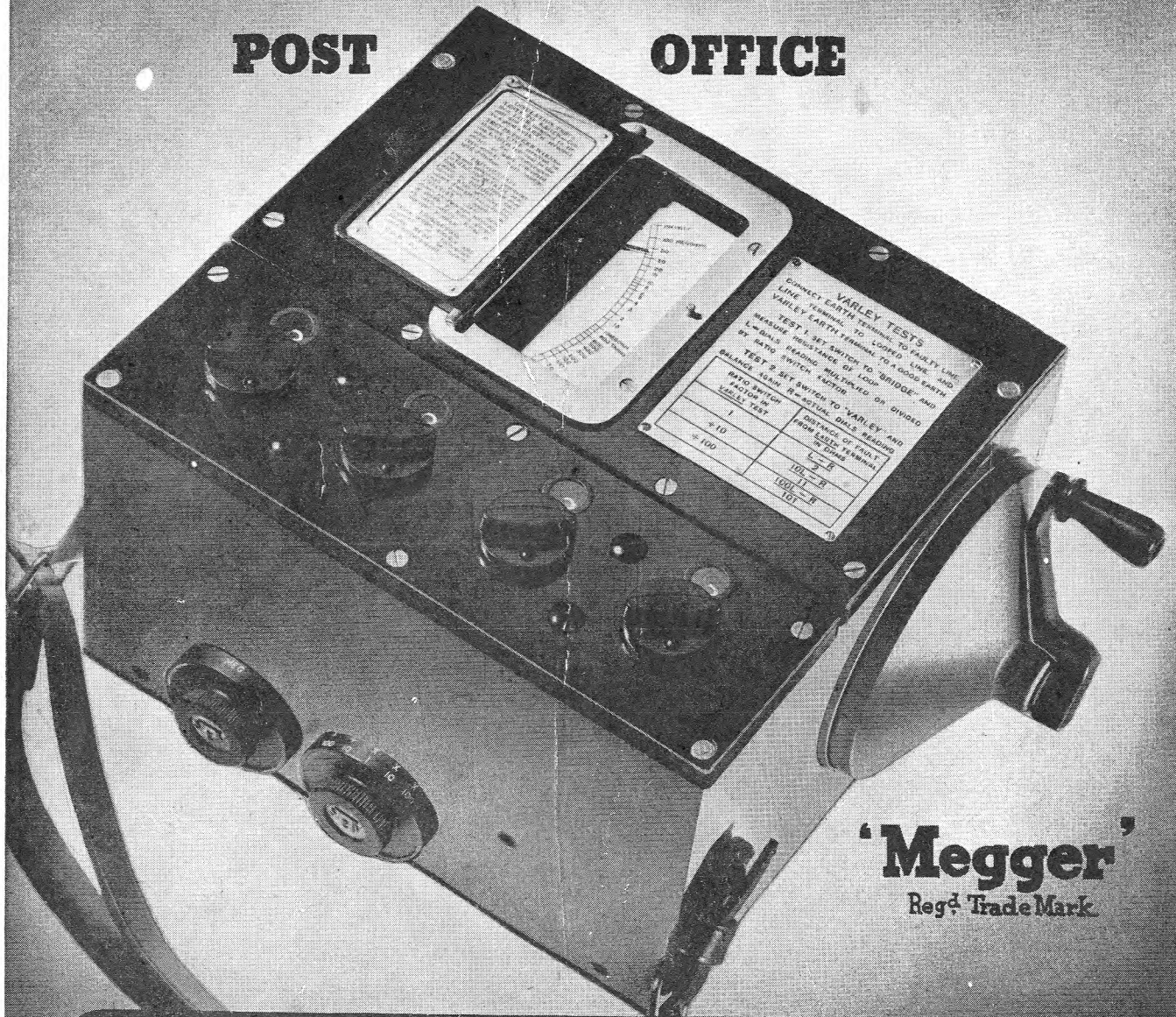

**'Megger'**  
Reg'd Trade Mark

**THE BRIDGE-MEG TESTING SET** used by the British Post Office is a portable, self-contained instrument combining the functions of an Insulation Tester and a Wheatstone Bridge; it can be used for fault location by the Varley Loop method. Facilities can also be provided whereby, with the use of an external galvanometer and resistance box, the instrument may be used for making Murray Loop tests. Insulation range 100 megohms at 500 volts. Bridge range 0.01 to 999,900 ohms. Size 7x8 $\frac{3}{4}$ x12 ins. Weight 12 $\frac{3}{4}$  lbs. Mains operated instruments are also supplied to the British Post Office. Ask for list X 212.

**EVERSHED & VIGNOLES LTD., CHISWICK, LONDON, W.4**  
TELEPHONE: CHISWICK 1370 \* TELEGRAMS: "MEGGER" CHISK, LONDON





# Great cities of the world rely on Strowger telecommunications

## DURBAN

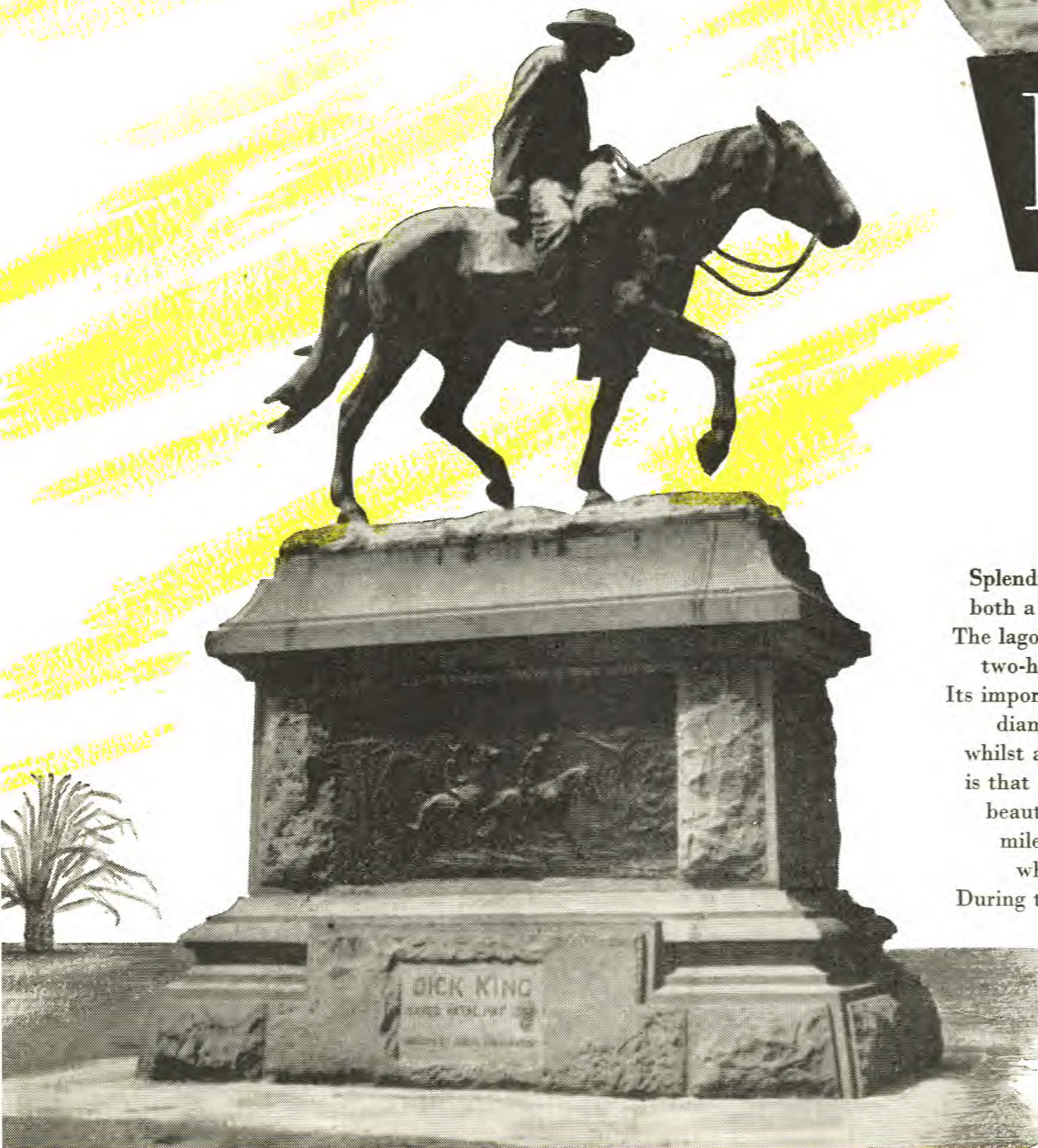

Splendidly situated on the Natal coast, Durban is both a busy seaport and a popular holiday resort. The lagoon harbour is screened from the sea by the two-hundred-foot-high Bluff, and by sand dunes. Its importance was greatly increased when gold and diamonds were found in the rich interior-lands, whilst among the seafaring activities located there is that of whaling. Along the ocean front runs the beautifully laid-out Embankment; there are five miles of bathing beaches and a fine racecourse, whilst Berea is a pleasant residential district. During the three centuries which have passed since Charles II obtained it for a time for a regular payment of ten pounds, Durban has become one of the world's greatest and most attractive cities.

The Dick King Statue, Durban  
(Photo: Courtesy South African Railways)

### STROWGER AUTOMATIC ROUTINERS

- ★ They carry out automatically almost the whole of the routine tests usually required on the automatic equipment.
- ★ They subject each selector or circuit to a series of thorough functional tests.
- ★ They function with extreme rapidity and test each selector in turn. They stop whenever a defective selector is encountered and give indications of both the selector affected and the nature of the defect.
- ★ They function within finer limits than normally exists under working conditions and thus detect any deterioration before it can give rise to a fault in service.

The Durban automatic telephone network provides service for subscribers throughout a wide area which extends some distance beyond the boundaries of Durban itself. The Durban Corporation is responsible for exchange within the city limits, whilst the Government of South Africa operates those outside the town boundaries. In consequence, Strowger engineers were faced with a number of unusual operating and trunking problems. For example, in the Corporation area many call office lines with a high calling rate are required, but in the Government area the number of such lines is comparatively small. Again, certain special services such as local enquiry, test clerk, and complaints, need to be duplicated so that one appropriate set is available to subscribers in each area. The latest development in the area is the provision of an automatic trunk exchange which is in process of design and manufacture and whose function is to link the Durban automatic area with the remainder of the Union.

### AUTOMATIC TELEPHONE & ELECTRIC CO. LTD.

Norfolk House, Norfolk Street, London, W.C.2  
Temple Bar 9262. Cables: Autelco, London.  
STROWGER WORKS, LIVERPOOL, 7, ENGLAND



A7333-AZ2

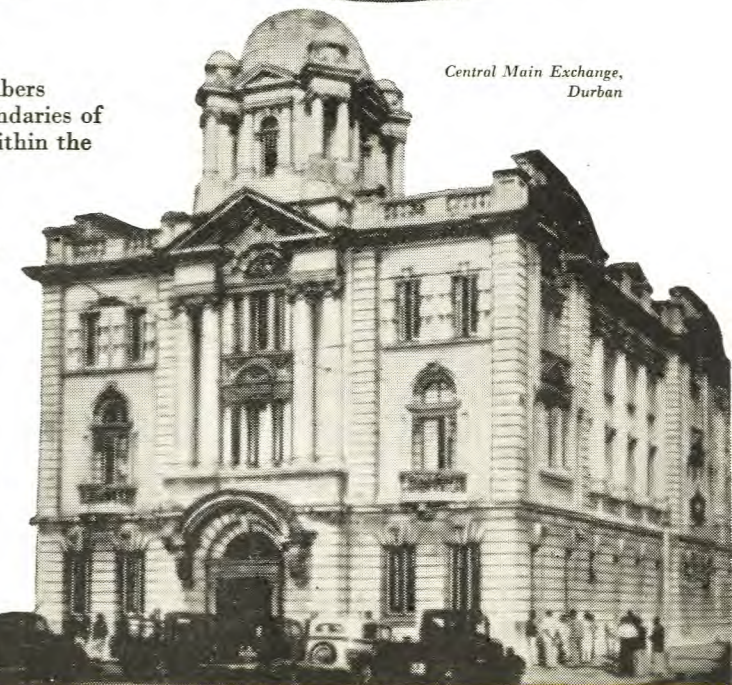
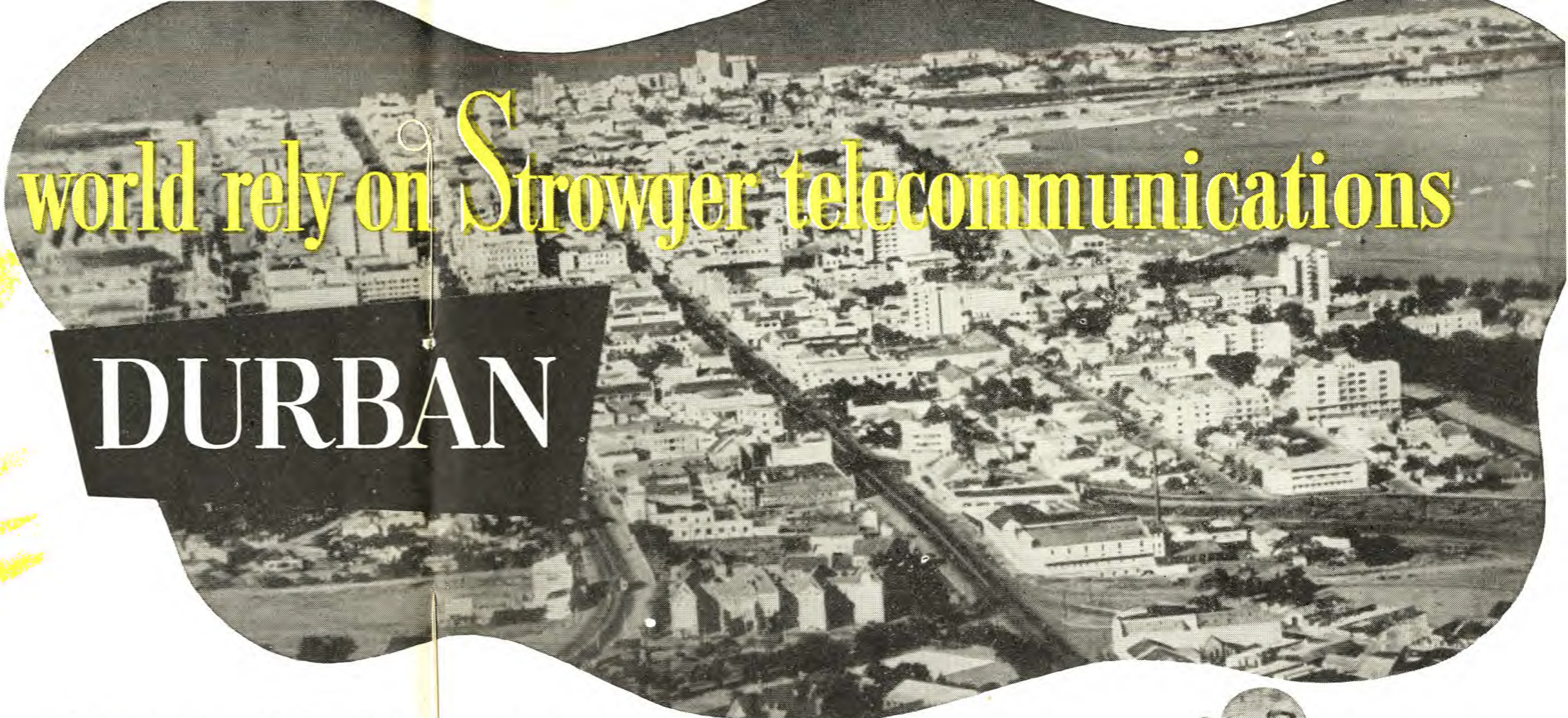

Central Main Exchange,  
Durban



### THE DURBAN NETWORK

1. Durban North
2. Stamford Hill
3. Overport
4. Central
5. Tollgate
6. Congella
7. Rosburgh
8. Fynnlands
9. Malvern
10. Pinetown

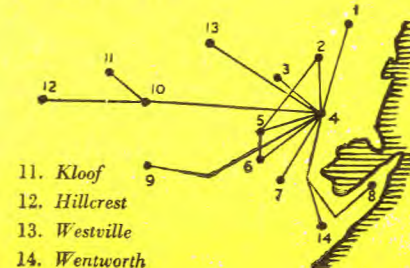

11. Kloof
12. Hillcrest
13. Westville
14. Wentworth



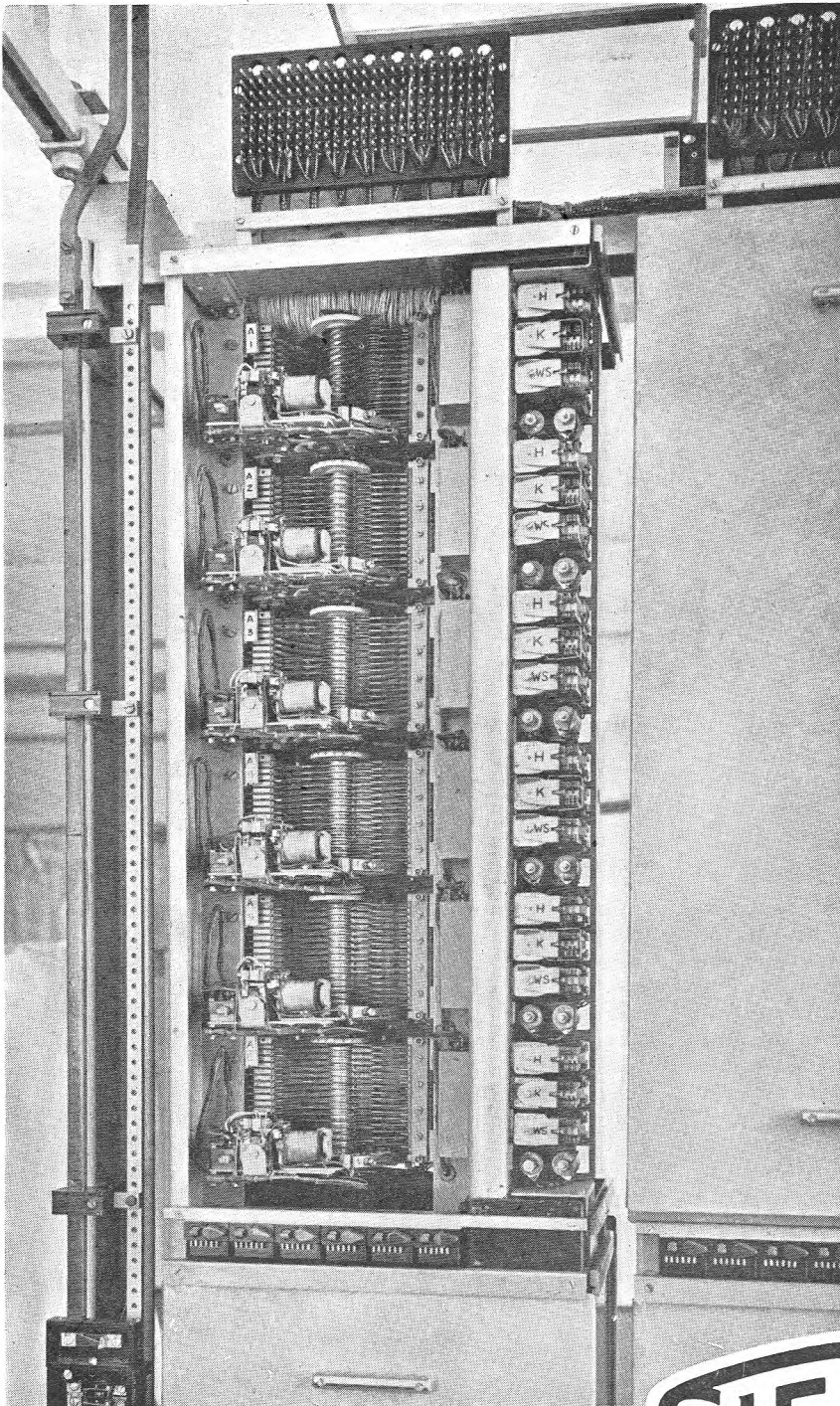

# SIEMENS

## No. 17 SYSTEM

Front view of a Selector Rack with one cover removed. This is typical of all linefinders and local selectors throughout this new automatic telephone exchange system.

**SIEMENS BROTHERS & CO., LIMITED**  
 WOOLWICH • LONDON • S. E. 18.



# R.F. ATTENUATOR TYPE D-239

DELIVERY FROM STOCK

## BRIEF SPECIFICATION

ATTENUATION RANGE : TYPE D-239-A: 0—61.5 db variable in steps of 0.5 db. TYPE D-239-B: 0—80 db variable in steps of 1 db. CHARACTERISTIC IMPEDANCE : 75 ohms ("T"-network). PERFORMANCE : At frequencies up to 5 Mc/s and for any setting of the switches the error in attenuation will not exceed  $\pm 0.2$  db. Reasonable accuracy is maintained up to 10 Mc/s. TERMINATIONS : Coaxial connectors. INPUT : 3 volts maximum. DIMENSIONS :  $6\frac{1}{2}$  in.  $\times$   $2\frac{3}{8}$  in.  $\times$   $5\frac{1}{4}$  in. WEIGHT :  $2\frac{1}{2}$  lbs.

Manufactured to a design of the Radio Branch of the Post Office Engineering Department.

Full details are given in Bulletin B-562-A, a copy of which will be sent on request.

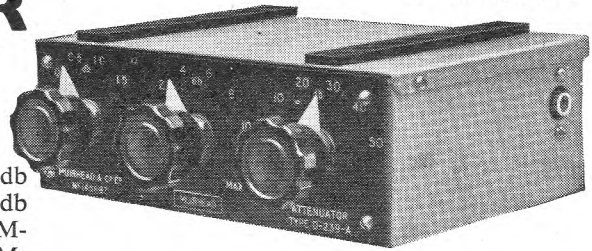

THIS small compact attenuator is characterized by a relatively high insertion loss and outstanding accuracy of attenuation at high frequencies. Wire wound resistance elements ensure accuracy, good stability and freedom from noise. It can be used as a bench instrument or for incorporation in other apparatus where its small size is a considerable asset. Two types, giving alternative values of total attenuation, are available.

## MUIRHEAD

Muirhead & Co. Ltd., Elmers End, Beckenham, Kent. Telephone: Beckenham 0041-2.

FOR OVER 60 YEARS DESIGNERS AND MAKERS OF PRECISION INSTRUMENTS.

C.R.C. 63b

# 7-Range

## CLIP-ON AMMETER

Seven ranges in  
one instrument

Thumb-operated switch

Fully insulated

Accuracy within  
3% of full scale

Weight . . 3lbs.

**RANGES :**

- 0-10 Amps.
- 0-25 Amps.
- 0-50 Amps.
- 0-100 Amps.
- 0-250 Amps.
- 0-500 Amps.
- 0-1000 Amps.

Can be applied to bare or insulated conductors up to  $2\frac{1}{4}$  ins. diameter.

Write for List In. 17a.

# FERRANTI LTD.

HOLLINWOOD · LANCS.

London Office : KERN HOUSE, KINGSWAY, W.C.2

Delivery can be made from stock

F162a

# UNIVERSALLY ADOPTED

## G.N.T.Co. TRANSMITTER MODEL 112

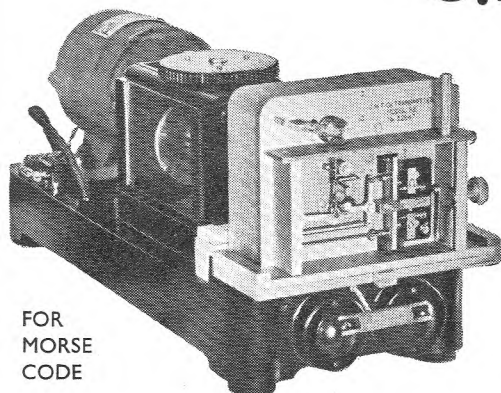

FOR  
MORSE  
CODE

13-250 words per minute without gear changes  
or readjustments.

Absolutely constant speed at all settings not-  
withstanding large voltage variations.

Noted for its easy maintenance.

Supplied with A.C. or D.C. motors as required.

**THE GREAT NORTHERN TELEGRAPH CO. LTD.**  
OF DENMARK

KONGENS NYTORV 28  
COPENHAGEN K. - DENMARK

AND

5, ST. HELEN'S PLACE,  
LONDON, E.C.3

**ELECTRICAL MEASURING  
INSTRUMENTS  
OF THE HIGHER GRADES**

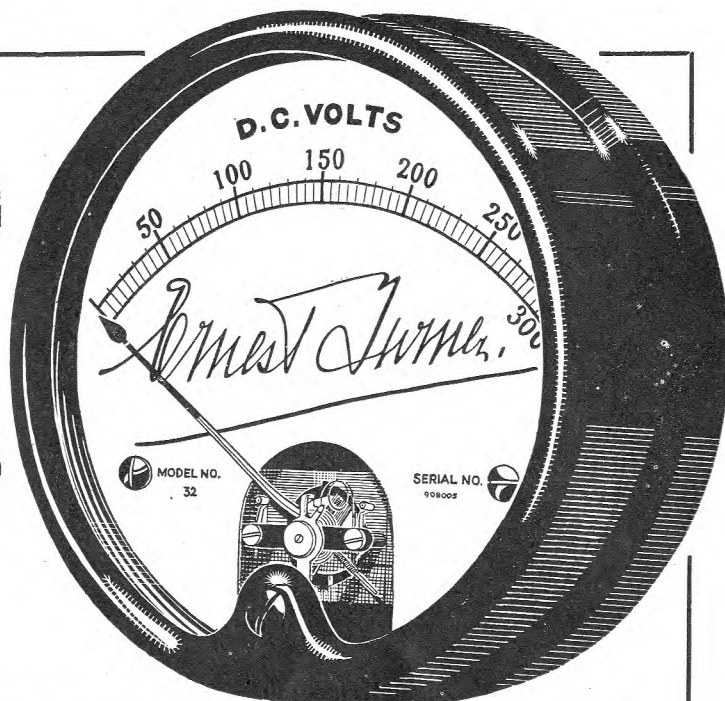

**ERNEST TURNER ELECTRICAL INSTRUMENTS LTD.**  
CHILTERN WORKS, TOTTERIDGE AVENUE, HIGH WYCOMBE, BUCKS.

Telephone: High Wycombe 1301/2

Telegrams: Gorgeous, High Wycombe

TELEPHONE TRANSMISSION EQUIPMENT  
SUBSCRIBERS' TELEPHONES • LOADING COILS  
AUTOMATIC AND MANUAL EXCHANGES  
TRUNK AND LOCAL CABLES • OVERHEAD LINES  
TEST EQUIPMENT OF ALL KINDS

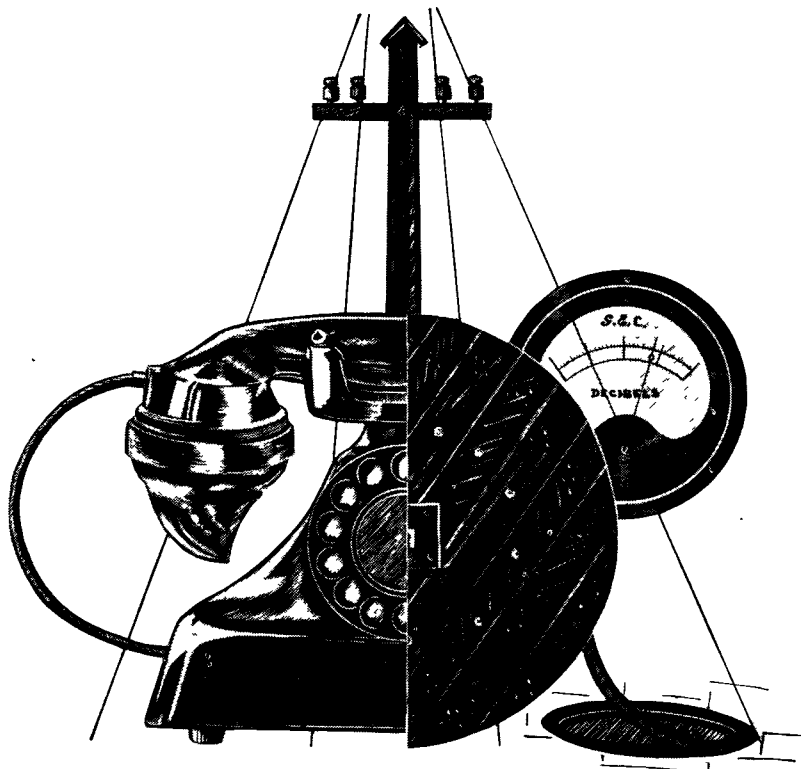

*Telecommunication*  
*Equipment*  
by *G.E.C.*

THE GENERAL ELECTRIC CO. LTD. OF ENGLAND  
HEAD OFFICE: MAGNET HOUSE, KINGSWAY, LONDON

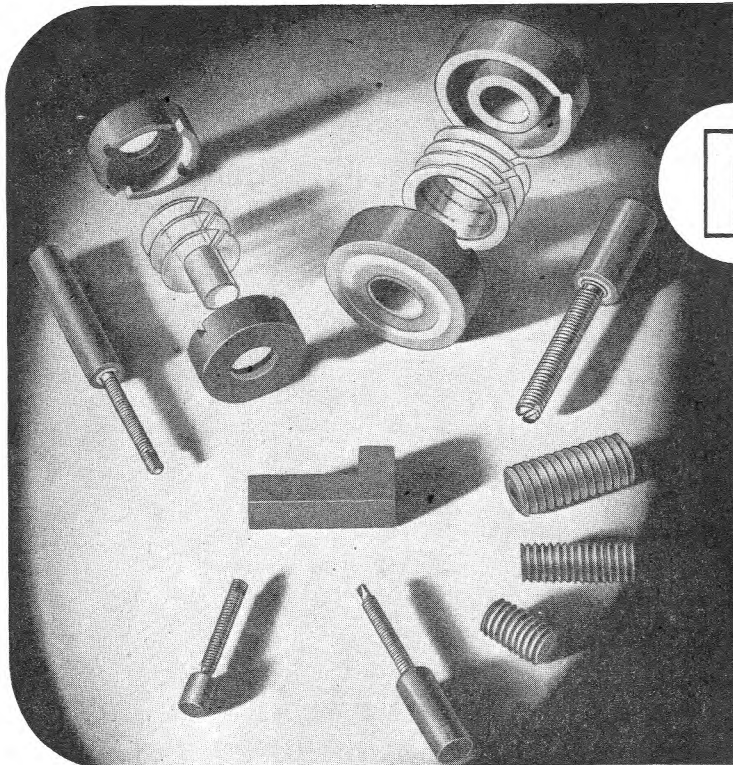

# neosid

## IRON DUST CORES

High performance : Strength : Stability  
Close electrical and mechanical tolerances  
Grades to suit various applications



23 and 25 Hyde Way, Welwyn  
Garden City, Herts.

Tel : Welwyn Garden 925

P.O.I.A.

# DENSO TAPE

*for Protection against Corrosion*

Denso Tape—for emergency sealing of cable ends . . . for protection during jointing process . . . a permanent safeguard against chemical and electrolytical corrosion on cables, conduits, etc. . . . ready for instant use without heating. Denso Tape is just one of a wide range of Denso anti-corrosive products.



**Denso**  
PERMANENTLY PLASTIC PROTECTION

DENSO—to be sure.

*Write for Specification and price list*  
**WINN & COALES LTD**  
TERMINAL HOUSE, GROSVENOR GARDENS, LONDON, S.W.1  
Telephone: Sloane 6264      Telegrams: Denselte, Sowest, London

# SOUND INSTRUCTION by Postal Method

The I.C.S., largest school in the world devoted to spare-time training by the postal method, offers you highly specialised Courses of Instruction for the following Examinations:

**P.M.G. Certificates in Wireless Telegraphy Associate Membership of I.E.E.**

**C. & G. Electrical Engineering Practice, Installation and Telecommunications.**

**Graduateship of the B.I.R.E.**

Other Courses meet the requirements of all who desire to qualify for responsible positions in Electric Power, Illumination, Heating and Traction Systems. Equally successful is our instruction for Telegraph Engineers, Radio Engineers and Radio Servicemen.

Instruction is by correspondence from textbooks specially prepared by many experts.

**WRITE FOR OUR SPECIAL BOOKLET** and state the particular subject or Examination in which you are interested. *I.C.S. Examination students are coached till successful.*  
..... **YOU MAY USE THIS COUPON** .....

## International Correspondence Schools Ltd.

Dept. 108, International Buildings, Kingsway, London, W.C.2

Please send me, free of charge, your special booklet on.....

Name..... Age.....

Address.....





# POWER BEHIND THE LINES

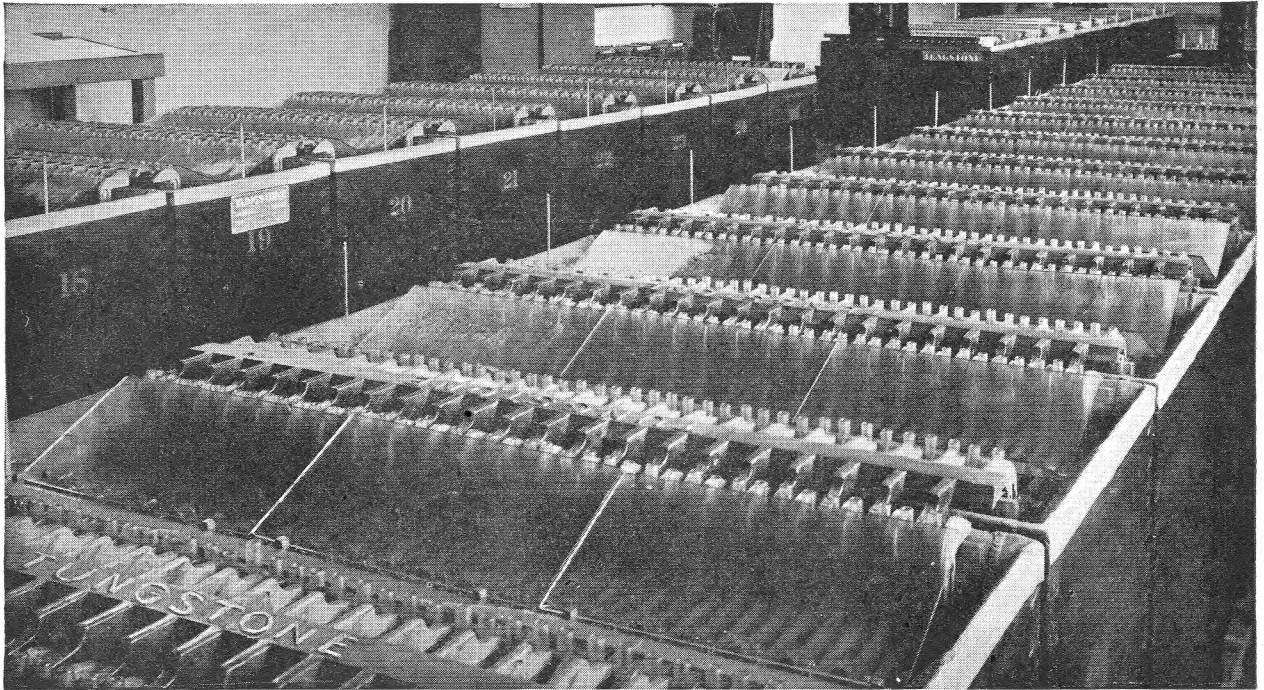

Tungstone Planté cells are being supplied to the British Post Office and to Posts and Telegraph departments abroad and conform fully to *G.P.O.* and *British Standard* specifications. Delivery is reasonable on all types and sizes.

#### *Open type cells*

Similar to the illustration above, these are available in glass and/or lead-lined wooden boxes, in capacities from 100 a.h. to 5000 a.h.

#### *Replatal*

We are in a position to supply plates for the replatal of any size of existing Planté batteries.

#### *Overseas Enquiries*

Export customers are invited to cable or write their enquiries for batteries or parts. Visitors to London are welcome at our offices.

#### *Enclosed cells*

Illustrated on the right, these are in sealed glass boxes, in capacities from 10 a.h. to 200 a.h., delivered in the U.K. filled and charged.

#### *Technical Service*

We are glad to advise on most suitable types and layouts for any installation and for any purpose.

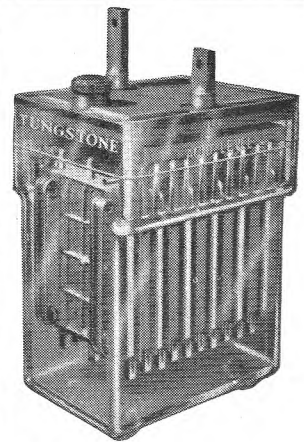

ENCLOSED TYPE CELL

# TUNGSTONE *Batteries*

For further particulars write: **TUNGSTONE PRODUCTS LIMITED,**

St. Bride's House, Salisbury Square, London, E.C.4. Telephone: CENtral 8156 (4 lines.).

Cables: DILUTUM, London Works: Market Harborough, Leicestershire.

**TO EASE YOUR MAINTENANCE PROBLEMS**

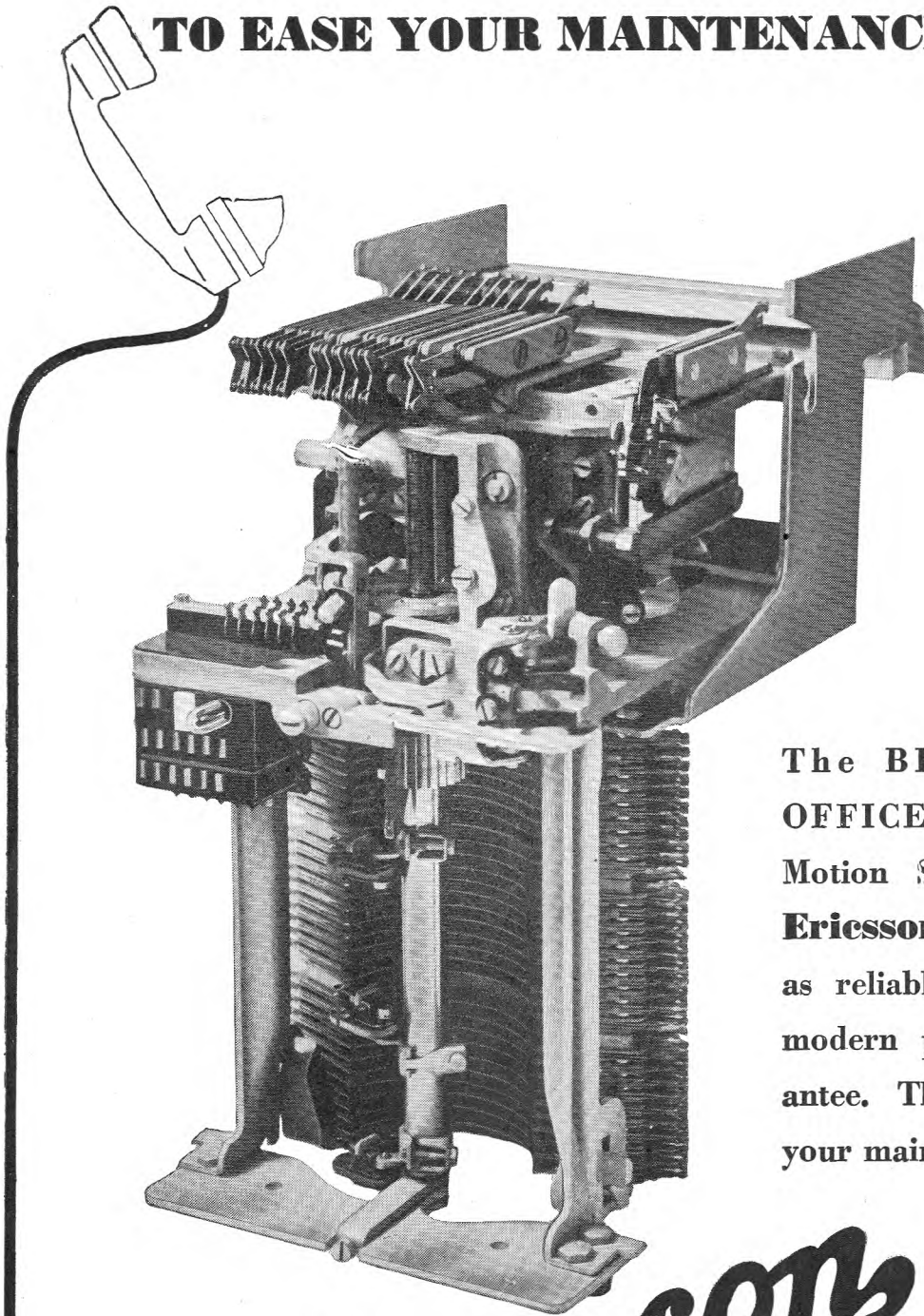

The **BRITISH POST OFFICE** Type 2000 Two-Motion Selector made by **Ericssons** shown here is as reliable and efficient as modern practice can guarantee. This efficiency eases your maintenance problems.

**Ericsson**  
**SWITCHES**



# *A new series of* **SAVAGE AMPLIFIERS**

FOR BROADCAST RELAY

With output of 250, 500 & 1,000 watts, these amplifiers incorporate the latest technique in electrical and mechanical design.

*Specification of the Savage Mark II Kilowatt Amplifier*

Output	- - - 1,000 watts	Gain	- - - - - 84 dB
Output regulation	- 9% (0.8dB)	Noise level	- - - - - -72 dB
Total Distortion		Frequency response	
@ 1,000~	<0.75%	50-10,000~	±1 dB

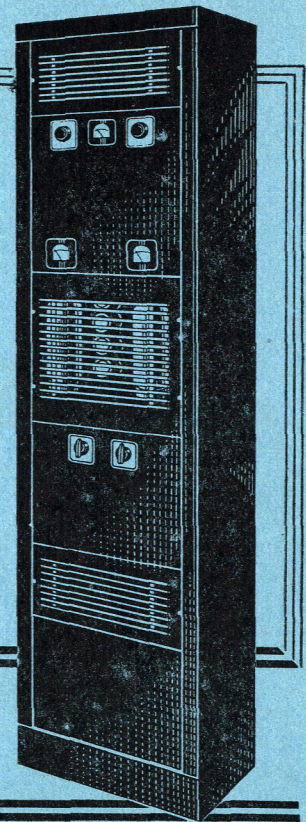

**W. BRYAN SAVAGE LIMITED**

WESTMORELAND ROAD • LONDON, N.W.9 • Phone: Colindale 7131

*Once again available*

## **A Handbook of TELECOMMUNICATION**

By Bertram S. Cohen, O.B.E., M.I.E.E., F.Inst.P.

Edited by F. G. C. Baldwin, O.B.E., M.I.E.E. An important and much needed book describing in full technical detail and with numerous illustrations, present practice and the latest developments in telegraphy and telephony. Information, much of which has hitherto been unpublished, is not confined to British practice, but includes accounts of techniques in use in other European countries and in the U.S.A. An invaluable book for Post Office electrical engineers, lecturers and students. 30s. net.

***Pitman Books***

Pitman House, Parker Street, Kingsway, London, W.C.2

## **Whittaker's ELECTRICAL ENGINEER'S Pocket Book**

Edited by R. E. Neale, B.Sc. (Hons.), A.C.G.I., A.M.I.E.E. The most amazing collection of practical and up-to-date information including diagrams, tables and data relating to every kind of electrical work. Entirely written by specialists in each particular branch in electrical engineering. Seventh edition. 30s. net.



# TELEPHONE CABLES

OUR LATEST BROCHURE No. 9E (1947)  
IS NOW AVAILABLE, GIVING INFOR-  
MATION AND SPECIFICATIONS FOR A  
WIDE RANGE OF TELECOMMUNICA-  
TION CABLES MANUFACTURED BY US.  
COPIES WILL BE SENT ON REQUEST.

TELEPHONE:  
SOUTHAMPTON  
2141 (5 lines)

**IRELLI-GENERAL**  
CABLE WORKS, Ltd., SOUTHAMPTON.

TELEGRAMS  
"PIGEKAYBEL"  
SOUTHAMPTON "

## DECADE RESISTANCES

in 3 Grades guaranteed

0.01%    0.03%    0.1%

SUPPLIED BOXED OR FOR  
CLIENT'S OWN PANEL

HIGHLY LAMINATED BRUSHES

LOWER DECADES OF ABSOLUTELY  
CONSTANT INDUCTANCE

EQUALLY SUITABLE FOR HIGH FREQUENCY  
LOW FREQUENCY OR DIRECT CURRENT

**H. W. SULLIVAN**  
— LIMITED —

LONDON, S.E.15

Telephone: New Cross 3255 (P.B.X.)

## Electrical Standards for Research and Industry

Testing and Measuring Apparatus  
for Communication Engineering

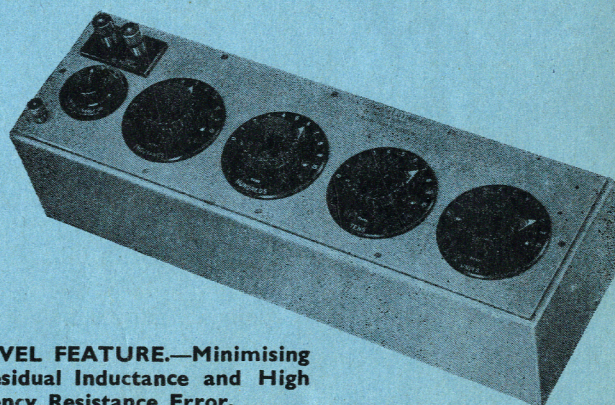

**A NOVEL FEATURE.—**Minimising  
the Residual Inductance and High  
Frequency Resistance Error.

A patented method of reactance compensation is employed on the higher decades which compensates automatically for the screen capacitance and so renders the effective residual inductance sensibly independent of the method of screen connection. In addition, the user may, at will by the simple operation of a switch, adjust the reactance or resistance error sensibly to zero at the higher frequencies.