

This document was generated by me, Colin Hinson, from a document held at R.A.F. Henlow Signals Museum and is believed to be out of copyright or Crown Copyright . It is presented here (for free) under the Open Government Licence (O.G.L.) if under Crown Copyright and this version of the document is my copyright (along with the Crown Copyright) in much the same way as a photograph would be. If you believe the document to be under copyright, please contact me.

The document should have been downloaded from my website <https://blunham.com/Radar>, if you downloaded it from elsewhere, please let me know (particularly if you were charged for it). You can contact me via my Genuki email page:

<https://www.genuki.org.uk/big/eng/YKS/various?recipient=colin>

**You may not copy the file for onward transmission of the data nor attempt to make monetary gain by the use of these files. If you want someone else to have a copy of the file, point them at the website. It should be noted that most of the pages are identifiable as having been processed by me.**

---

I put a lot of time into producing these files which is why you are met with the above when you open the file.

In order to generate this file, I need to:

1. Scan the pages (Epson 15000 A3 scanner)
2. Split the photographs out from the text only pages
3. Run my own software to split double pages and remove any edge marks such as punch holes
4. Run my own software to clean up the pages
5. Run my own software to set the pages to a given size and align the text correctly.
6. Run Omnipage (Ultimate) on all the pages to OCR them.
7. Generate a searchable Acrobat pdf file.

Hopefully after all that, I end up with a presentable file, though I can't guarantee there aren't errors in the OCR. If you find missing pages, pages in the wrong order, anything else wrong with the file or simply want to make a comment, please drop me a line (see above).

It is my hope that you find the file of use to you personally – I know that I would have liked to have found some of these files years ago – they would have saved me a lot of time !

Colin Hinson

In the village of Blunham, Bedfordshire.



# THE POST OFFICE ELECTRICAL ENGINEERS' JOURNAL

VOL. 42

JANUARY 1950

PART 4

## CONTENTS

	PAGE
AN ELECTRONIC TRAFFIC ANALYSER—S. W. Broadhurst and A. T. Harmston, B.Sc.(Eng.), A.M.I.E.E. . . . .	181
USES OF A NEW ADHESIVE IN PRODUCTION OF PIEZO-ELECTRIC VIBRATORS . . . . .	187
FAULT LOCATION IN TRANSMISSION EQUIPMENT BY VIBRATION TESTING AND CONTINUOUS MONITORING—H. G. Myers, B.Sc. . . . .	189
A PARCEL LABEL MACHINE—M. H. James, D.F.H., A.M.I.E.E. . . . .	198
A SURVEY OF MODERN RADIO VALVES—Part 3—Receiving Valves for Use Below 30 Mc/s—K. D. Bomford, M.Sc., A.M.I.E.E. . . . .	201
A NEW DESIGN OF WHEATSTONE BRIDGE—W. L. Surman, A.M.I.E.E. . . . .	209
THE THAMES RADIO SERVICE—J. Neale, B.Sc.(Eng.), A.M.I.E.E., and D. W. Burr, A.M.I.E.E. . . . .	213
PHONOGRAM AUTOMATIC DISTRIBUTION—Part 2—Basic Circuit Features—H. E. Wilcockson, A.M.I.E.E., and H. Walker . . . . .	221
OPENING OF THE LONDON-BIRMINGHAM TELEVISION RADIO-RELAY SYSTEM . . . . .	227
THE POST OFFICE EXHIBIT AT RADIOLYMPIA, 1949—J. Atkinson, A.M.I.E.E. . . . .	228
THE INSTITUTION OF POST OFFICE ELECTRICAL ENGINEERS	232
NOTES AND COMMENTS . . . . .	233
REGIONAL NOTES . . . . .	236
JUNIOR SECTION NOTES . . . . .	242
STAFF CHANGES . . . . .	243
INDEX TO VOL. 42 . . . . .	246
BOOK REVIEWS . . . . .	197, 200, 212

Price 1/6 net

THE INSTITUTION OF POST OFFICE ELECTRICAL ENGINEERS





Announce  
 THE CELEBRATION OF  
**FIFTY YEARS**  
 SUCCESS IN TRAINING BY POST

It is with pardonable pride that we announce the FIFTIETH ANNIVERSARY of the founding of The Bennett College, Sheffield.

This success can be attributed to just one main factor—EFFICIENCY. We believe that The Bennett College teaches with a thoroughness that is unequalled in any other source of tuition. That this home study is highly successful is proved by the 50 years of continuous progress and prosperity, and the ever-growing number of successful students who have passed through the College to reach posts of high responsibility, and big salaried appointments in every field of commerce and industry.

To our students, in every part of the World, we send our Cordial Greetings on this memorable occasion in the history of The Bennett College. To the many men and women whom we are yet to welcome as students, we extend a hearty invitation to join NOW. There is still room at the top for The Bennett College trained man.

*Free!*

OUR FRIENDLY ADVICE ON  
 ANY CAREER IS YOURS  
 FOR THE ASKING

- |   |  |                                      |
|---|--|--------------------------------------|
| Aviation (Engineering and Wireless)                   | Engineering. All Branches, Subjects and Exams. | Quantity Surveying                   |
| Blue Prints   | General Education                              | Radio Service Engineering            |
| Boilers   | Heating and Ventilating                        | Salesmanship                         |
| Book-keeping, Accountancy and Modern Business Methods | Institute of Housing                           | Sanitation                           |
| Building, Architecture, and Clerk of Works            | Inst. Mun. Eng.                                | Secretarial Examinations             |
| Cambridge Senior School Certificate                   | Journalism                                     | Shorthand (Pitmans)                  |
| Carpentry and Joinery                                 | Languages                                      | Short Story Writing                  |
| Chemistry   | Mathematics                                    | Structural Engineering               |
| Civil Service   | Matriculation                                  | Surveying (R.I.C.S. Exams.)          |
| All Commercial Subjects                               | Mining   | Teachers of Handicrafts              |
| Commercial Art  | Motor Engineering                              | Telecommunications (City and Guilds) |
|   | Plastics                                       | Television                           |
|   | Play Writing                                   | Transport Inst. Exams.               |
|   | Plumbing                                       | Wireless Telegraphy and Telephone    |
|   | Police Special Course                          |                                      |

If you do, not see your own requirements above, write to us on any subject. Full particulars free

WRITE NOW TO DEPT. 24c,

THE **Bennett College** LTD.  
 SHEFFIELD

THE MOST SUCCESSFUL & MOST PROGRESSIVE

CORRESPONDENCE COLLEGE IN THE WORLD

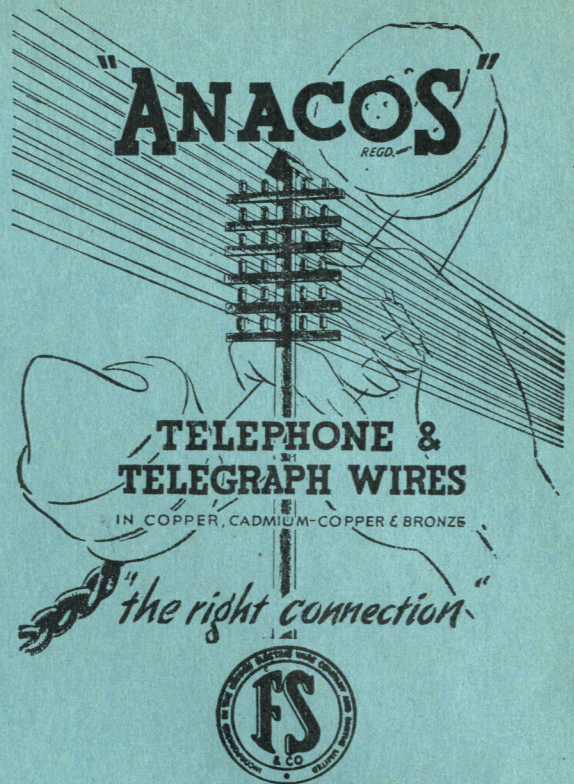

**FREDERICK SMITH & COMPANY**  
 (Incorporated in The London Electric Wire Company and Smiths, Limited)  
**ANACONDA WORKS, SALFORD 3, LANCs.**  
 Phone : Blackfriars 8701 (9 lines) • Grams : "Anaconda," Manchester

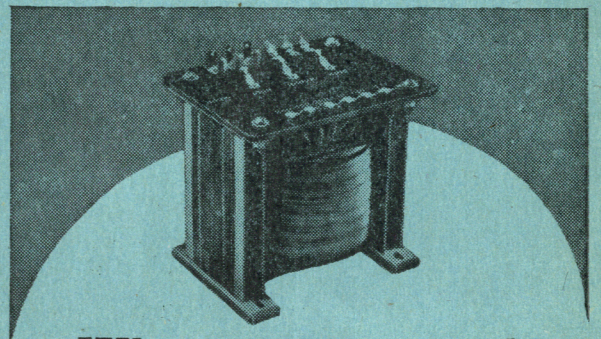

When an unusual  
 Specification  
 is required.

We can give you the benefit of 20 years' experience in transformer construction and design. We manufacture quantities but we do NOT mass produce. Every Instrument is built to suit your most exacting individual specification.

Send your enquiries for the personal attention of our Mr. W. Bryan Savage.



SAVAGE TRANSFORMERS LTD. • NURSTEED ROAD, DEVIZES, WILTS.



# THE POST OFFICE

## ELECTRICAL ENGINEERS' JOURNAL

Vol. 42

January, 1950

Part 4

### An Electronic Traffic Analyser

S. W. BROADHURST and  
A. T. HARMSTON, B.Sc.(Eng.), A.M.I.E.E.

U.D.C. 621.395.663.2 : 621.395.341.8 : 621.38

This article describes an analyser, using entirely electronic principles, which has been constructed to investigate the traffic carrying capacity of various schemes of interconnection of outlets. The article gives details of some of the proposed applications, the electronic principles, the layout of the equipment and the technique of its use. The results of a test are also given. The use of the analyser represents considerable saving as compared with the manual methods hitherto employed.

#### Introduction.

WHEN a certain volume of traffic is offered to a group of trunks, the proportion of lost calls is given by the Erlang formula<sup>1</sup>. This formula assumes that the traffic offered is pure chance and that the trunks are arranged in a full availability group. Where the calls have limited availability to the trunks, the expressions giving the proportion of lost calls are complicated and difficult to evaluate when the number of trunks is appreciably large, and use has been made of the method of artificial traffic to supplement them. In this method, the instant of origination of calls was determined by chance numbers obtained from the London Telephone Directory and the offering of calls to outlets was simulated by means of a record carried out manually. The work involved in carrying out such a record was considerable, however, and in order to save work and also enable more tests to be made, it was decided to construct a machine to carry out artificial traffic tests automatically.

Some typical problems for which it is proposed to use the traffic analyser are:—

*Formation of Gradings.*—Generally, there are a number of possible arrangements of individuals, pairs, commons, etc., of a grading having a particular number of outlets and the traffic capacity of the arrangements differs. The optimum formations of "straight" gradings were determined by earlier work and it is proposed to verify the results with the traffic analyser.

*Traffic Capacity of Gradings.*—The traffic capacities of gradings having 40 availability have recently been derived theoretically for the first time, and it is proposed to verify them by the traffic analyser.

*Subscribers' Unselector Gradings with two "Home" Positions.*—To ensure that consecutive calls made by a subscriber during periods of light traffic have access to different selectors, it is proposed to arrange for the unselector to have two home positions instead of the one as at present. The groups of contacts between the home positions will each be graded. The arrangement is therefore one in which calls are offered to one

grading, and if they are not carried they are offered to a second. The estimation theoretically of the traffic capacity would be difficult.

*Traffic Unbalance on Gradings.*—To ascertain whether equal volumes of traffic are being offered to the groups of a grading in practice, a proposal has been made that the unbalance should be detected by measuring the traffic carried by the individuals and pairs serving the groups of the grading. The traffic analyser will afford a means of studying this problem.

*Congestion Outlets on Motor Uniselectors.*—In the motor unselector, calls are connected to congestion outlets when all the trunks in a group are engaged. These outlets give engaged conditions to the call and are held for a relatively short period. The number of such outlets required is being studied by the aid of the traffic analyser.

The traffic analyser provides for carrying out tests under the following conditions:—

- (a) The calls and traffic offered are pure chance.
- (b) Calls encountering all trunks engaged are lost.
- (c) The holding times of calls are variable and distributed in accordance with the exponential distribution.
- (d) Originating calls may be offered to inter-connection schemes in which a single search only is made.
- (e) The number of originating calls, calls carried by individual trunks, and lost calls may be measured.

#### PRINCIPLE OF THE TRAFFIC ANALYSER

The traffic analyser consists essentially of a means of marking, at random, one of 256 terminals and using the marking condition to represent the beginning or end of a call. It includes outlets which carry the calls and means for offering calls to these outlets.

The marking of one of the 256 outlets is regarded as an "event" and for the purpose of this article the equipment used to produce these random events will be called a "roulette."

Thus, referring to Fig. 1, A represents a roulette having 256 positions, and B1, B2 and B3 represent a group of outlets. The roulette has a certain number of positions, indicated by  $p$ , associated with call originations. Each outlet is associated with an

<sup>1</sup> "An Outline of the Trunking Aspect of Automatic Telephones." G. F. O'dell, *Journal I.E.E.*, February, 1927.



individual position on the roulette as indicated at  $q$  in the figure. The conditions set up are as follows:—

- (a) When the roulette stops on a position indicated by  $p$ , a call is originated and offered to the group of outlets B1, B2, B3 in that order.
- (b) When the roulette stops on a position associated with an outlet, a call on the outlet is released (if it is engaged).
- (c) When the roulette stops on any of the other positions, there is no change.

Thus, in a succession of operations of the roulette,

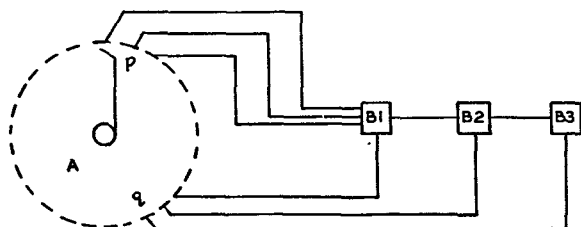

FIG. 1.—DIAGRAM ILLUSTRATING THE PRINCIPLE OF THE ANALYSER.

calls are offered to the group of outlets B1, B2 and B3 and calls being carried by the outlets are released.

With the arrangement as described, it will be of interest to calculate the average holding time of calls carried by outlets and the average value of traffic offered to the groups.

#### Average Call Holding Time.

Consider a call that has just been set up on an outlet. The chance that the roulette does not stop on the position associated with this outlet on the first occasion

$$= \left(1 - \frac{1}{256}\right)$$

Similarly, the chance that the roulette does not stop on the position on either the first or second occasions

$$= \left(1 - \frac{1}{256}\right)^2$$

Also, the chance that the roulette does not stop on the position on either the first, second or third occasions

$$= \left(1 - \frac{1}{256}\right)^3$$

The above correspond to the call having a holding time greater than one, two or three times the interval between successive roulette operations.

Denoting this interval by  $h$ , we have—  
proportion of calls having

$$\text{holding times greater than } h = \left(1 - \frac{1}{256}\right)$$

$$\text{'' '' '' '' } 2h = \left(1 - \frac{1}{256}\right)^2$$

$$\text{'' '' '' '' } 3h = \left(1 - \frac{1}{256}\right)^3$$

Hence, by subtraction,  
proportion of calls having

$$\text{holding times of } h = 1 - \left(1 - \frac{1}{256}\right)$$

$$\text{'' '' '' '' } 2h = \left(1 - \frac{1}{256}\right) - \left(1 - \frac{1}{256}\right)^2$$

$$\text{'' '' '' '' } 3h = \left(1 - \frac{1}{256}\right)^2 - \left(1 - \frac{1}{256}\right)^3$$

Thus, the average holding time

$$= h \left[ 1 - \left(1 - \frac{1}{256}\right) \right] + 2h \left[ \left(1 - \frac{1}{256}\right) - \left(1 - \frac{1}{256}\right)^2 \right]$$

$$+ 3h \left[ \left(1 - \frac{1}{256}\right)^2 - \left(1 - \frac{1}{256}\right)^3 \right] + \dots$$

$$= h + h \left(1 - \frac{1}{256}\right) + h \left(1 - \frac{1}{256}\right)^2 + h \left(1 - \frac{1}{256}\right)^3 + \dots$$

$$= h \left[ \frac{1}{1 - \left(1 - \frac{1}{256}\right)} \right] = 256h.$$

#### Traffic Offered.

The traffic offered to a group, in traffic units, may be defined as the average number of calls arriving in the average holding time. The average holding time has been found to be  $256h$ . As  $h$  is the interval between successive roulette operations this corresponds to 256 roulette operations. The traffic offered is therefore equal to the average number of calls originating in 256 roulette operations.

Suppose  $p$  positions of the roulette are associated with call originations.

Then, when the roulette stops,

$$\text{chance of a call origination} = \frac{p}{256}$$

$$\text{chance of no call origination} = \left(1 - \frac{p}{256}\right)$$

Hence, in 256 roulette operations,

$$\text{chance of no call originations} = \left(1 - \frac{p}{256}\right)^{256}$$

$$\text{'' '' 1 '' ''} = 256 \left(\frac{p}{256}\right) \times \left(1 - \frac{p}{256}\right)^{255}$$

$$\text{'' '' 2 '' ''} = \left(\frac{256 \times 255}{1 \times 2}\right) \times \left(\frac{p}{256}\right)^2 \left(1 - \frac{p}{256}\right)^{254}$$

$$\text{'' '' 3 '' ''} = \left(\frac{256 \times 255 \times 254}{1 \times 2 \times 3}\right) \times \left(\frac{p}{256}\right)^3 \left(1 - \frac{p}{256}\right)^{253}$$

Thus, the average number of call originations

$$= \left(1 - \frac{p}{256}\right)^{256} \times 0 + 256 \left(\frac{p}{256}\right) \left(1 - \frac{p}{256}\right)^{255} + 2 \left(\frac{256 \times 255}{1 \times 2}\right) \left(\frac{p}{256}\right)^2 \left(1 - \frac{p}{256}\right)^{254} + \dots$$



$$\begin{aligned}
&= 256\left(\frac{p}{256}\right) - 256\left(\frac{p}{256}\right)255\left(\frac{p}{256}\right) + \\
&\quad 256\left(\frac{p}{256}\right)\left(\frac{255 \times 254}{1 \times 2}\right)\left(\frac{p}{256}\right)^2 - \dots \\
&+ 2\left(\frac{256 \times 255}{1 \times 2}\right)\left(\frac{p}{256}\right)^2 - \\
&\quad 2\left(\frac{256 \times 255}{1 \times 2}\right)\left(\frac{p}{256}\right)^2 254\left(\frac{p}{256}\right) + \dots \\
&+ 3\left(\frac{256 \times 255 \times 254}{1 \times 2 \times 3}\right)\left(\frac{p}{256}\right)^3 - \dots = p
\end{aligned}$$

Thus the traffic offered in traffic units is equal to the number of positions of the roulette associated with call originations.

It will be seen from the foregoing that the traffic offered is independent of the speed of the roulette and the analyser is dimensionless. The arrangement described was first suggested by Mr. T. H. Flowers, of the Engineering Department of the Post Office.

It may be shown that when the traffic is offered to a full availability group of trunks, the average proportion of calls carried by individual trunks and the average proportion of lost calls are the same as those given by the Erlang formula.

Similarly it may be shown that with the arrangement as described the average proportion of lost calls with a scheme of interconnecting is the same as that obtained theoretically on the assumption of pure chance traffic and exponential distribution of holding times.

#### GENERAL DESCRIPTION OF ANALYSER

The problem of developing an artificial traffic analyser has been occupying the attention of various Administrations for some time. The best-known machine is that developed by Dr. Kruithof, of the Bell Telephone Co. of Antwerp<sup>2</sup>; this machine is wholly electro-mechanical, even in respect of the generation of its random events for which a mechanical dice box is used. No fully developed electronic traffic analyser other than the Post Office model is known, although it is understood that Dr. Kostin, of the Netherlands P.T.T., is working on the problem using a rather different method from that now to be described.

Electronic switching is sufficiently established for the reliability of many of its techniques to be beyond question, and although extremely high speed is not an essential requirement of the machine, reliability is, particularly when hundreds of thousands of "calls" may have to be offered to a grading during any one test. It is not possible to tolerate mechanical wear and the certainty of contact failures under such conditions. Experience has shown that the decision to use electronic equipment was fully justified and the number of valve and component failures has been negligible.

The essential elements of the analyser are:

1. The sources of random events.

2. The electronic elements corresponding to the physical contacts wiped over by the hunting action of a selector (these are known as "contacts").
3. The electronic elements corresponding to the outlets connected to the contacts. These contain the means for busying their associated contacts and facilities for passing to later outlets, calls which are offered when the outlet is engaged. These elements are known as "registers."
4. The call-counting meters which can be associated with any register or used to count the number of overflows.
5. The control element which arranges to switch the random events, one at a time at fixed intervals, into the grading under test.
6. The cross-connection field.

The analyser is capable of dealing with any arrangement of up to 130 outlets connected to a maximum of 300 contacts. All possible methods of interconnection can be used; each unit, i.e. contact, meter or register, is terminated on pluggable connections.

#### Production of Random Events.

The random element is derived from the noise voltage developed by eight sets of neon tubes (Fig. 2). Associated with each tube is an amplifier the input of which is biased so that the noise peaks above a certain level are selected at the rate of about 3,000 per second. Each amplifier feeds into a pulse-shaping trigger driving a two-position electronic counter. These counters have two outputs, one of which is positive and the other negative (with respect to earth), the condition of the output wires being determined by the position of the counter.

In order that the roulette may be as accurate as possible, it is necessary that the chance of odd and even number pulses received by the counter should be equal. On the assumption that the peaks of current from the neon tubes follow a Poisson distribution, an average of 10 peaks between pulses suffices.

The outputs from the neon amplifier counters are grouped in four pairs, the four outputs from each pair of counters operating on a 1 in 4 distribution table in which a unique output is marked for every one of the 2<sup>2</sup> combinations. The 1 in 4 tables are also grouped in pairs and operate on two 1 in 16 distribution tables each of which has a unique output for each of the 2<sup>4</sup> combinations so obtained. The outputs from the two 1 in 16 tables can be combined on the final 1 in 256 table to give a unique condition for every one of the possible 2<sup>8</sup> combinations of the eight neon amplifiers. The distribution tables are, in effect, the electronic equivalent of contact "trees."

The sources of random events (calls originating or calls releasing) are derived from pulses generated at the 256 output terminals of the ultimate distribution table. Owing to the design features of the analyser, it is necessary that at fixed intervals of time a pulse shall be generated at one and only one of these outputs at random. Hence, it is convenient to arrange that although the neon noise is continuously generated

<sup>2</sup> "Rotary Traffic Machine." K. J. Kruithof.



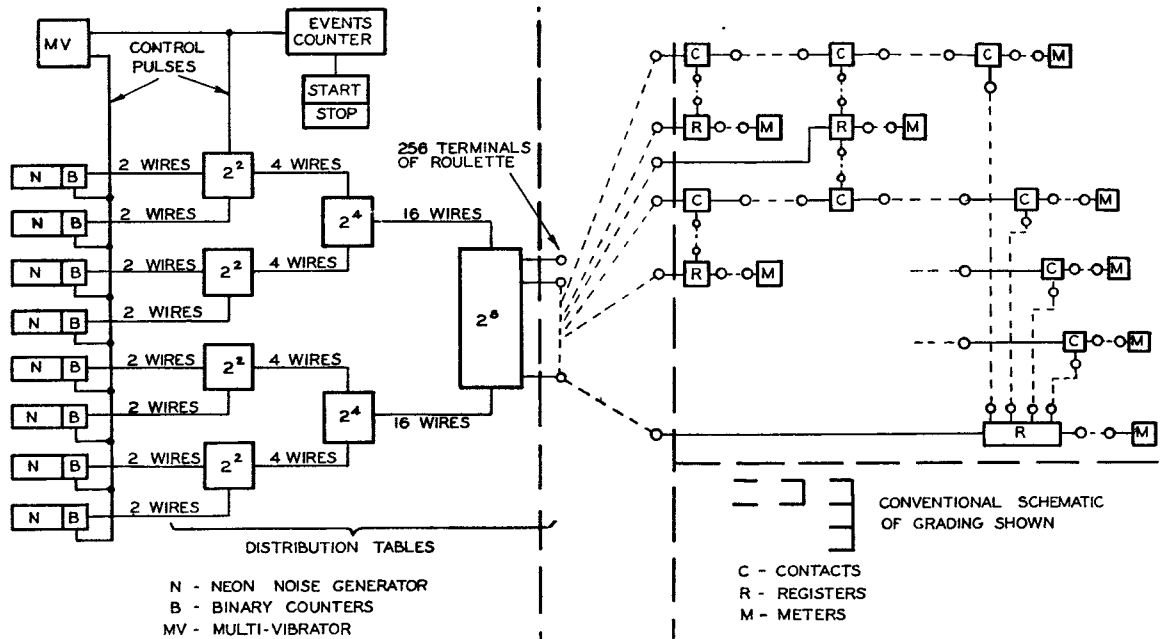

FIG. 2.—BLOCK SCHEMATIC DIAGRAM OF THE TRAFFIC ANALYSER.

the counters associated with the neon amplifiers are prevented from operating on the distribution tables except when an "events" pulse is required to be generated.

The master control circuit contains a multivibrator running at a frequency of either 10 or 300 c/s as determined by a key. At fixed time intervals controlled by the multivibrator, a pulse is generated which inhibits, for a short period, the operation of the binary counters associated with the neon noise amplifiers. During this period an examining pulse is applied to the distribution tables to cause the tables, and hence the roulette, to take up a position corresponding to the combination marked on the stationary neon counters. This action causes an events pulse to appear at the particular roulette terminal which happens to be marked at that instant. As the selection of the terminal is random there is a 1 in 256 chance of an event being generated at any particular terminal. Any number of terminals may be connected together to give any desired volume of traffic.

Every examining pulse is counted on an electronic counter and the analyser can be preset to stop after 12,800, 25,600, 51,200 or 819,200 examinations of the roulette so that the probable number of events operating on the grading under test can be predetermined.

### The Electronic Grading.

The electronic grading, which is illustrated on the right-hand side of Fig. 2, is composed of contacts and registers. The contacts correspond to the contacts of a grading while the registers correspond to the outlets. A register may be associated with a number of contacts. Thus, when a contact is associated with one register only, that contact is an individual. When two contacts are associated with a register,

then the contacts form pairs, and so on. The figure shows a typical arrangement of contacts and registers and the corresponding schematic representation of the grading.

As will be seen from the illustration, the events, corresponding to call originations, are offered to the first contact. If the register associated with this contact is free, then the pulse causes it to become engaged. If the register associated with the first contact is engaged, then the first contact transmits the pulse to the second contact. If the register associated with the second contact is free, then the pulse causes it to become engaged. If the register associated with the second contact is engaged, then the second contact transmits the pulse to the third contact and so on. It will be seen that each register has a connection to a terminal on the roulette. An event occurring on one of these terminals causes the release of a call on the register, if it is engaged. It will be seen that meters may be associated with the registers in order to count the number of calls carried by them.

The two-valve circuits corresponding to the contacts of a grading are shown in Fig. 3. If the contact element (V1, V2) is used as the first contact of a group of outlets its input *p* is connected to one or more of the roulette terminals, and every time an event occurs at one of these particular points a negative-going pulse causes the potential on the grid of V1 to be lowered so that the valve is cut off and its anode potential rises towards the anode supply voltage. In so doing, it raises the potential of the grid of V2, which valve, if its suppressor grid were at its cathode potential, would conduct and regenerate a negative-going pulse at the contact output *b*.

The suppressor grid of V2 is, however, connected by a cord to terminal *e* of a register and is normally maintained at a low negative potential.



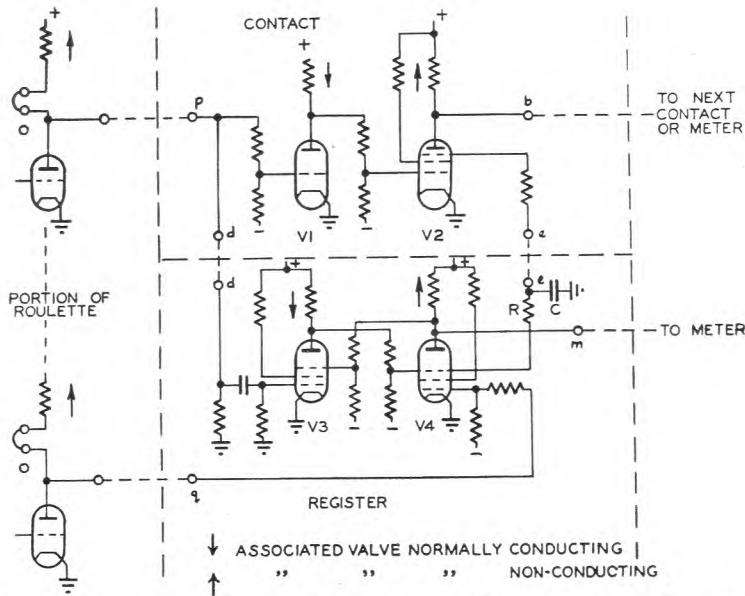

FIG. 3.—SIMPLIFIED CIRCUIT DIAGRAM OF A CONTACT AND A REGISTER, CONNECTED AS THE FIRST "INDIVIDUAL" OF A GRADING.

The function of the register is to control the busying of its associated contact or contacts. (A number of contacts in a grading may share a register because the register corresponds to an outlet from a grading.) Pulses received on the  $p$  terminals of the contacts are also applied to the grid of V3 in the associated register, terminals  $d$  and  $p$  being connected together. V3 and V4 constitute a normal locking trigger circuit having two stable states. A negative-going pulse on the grid of V3 causes that valve to be cut off and the resulting rise of its anode potential causes V4 to become conducting by raising the potential of V4's suppressor grid. (Its control grid is normally at earth potential.) Once the changeover has occurred, further negative pulses on V3 can have no effect on the register. When V4 changes over a negative-going pulse is applied to the meter wire  $m$  in order that the call can be counted.

The suppressor grid of V4 is connected via a time delay circuit, CR, to terminal  $e$  and thence to the suppressor grids of the associated contact valves such as V2. The time delay element is long enough to ensure that the potential of point  $e$  is not raised sufficiently to enable V2 to conduct until after the pulse applied at  $p$  has disappeared.

Should now further pulses appear at  $p$ , the register is unaffected and the contact (V1, V2) merely acts as a pulse regenerator to pass the pulse on to the next contact in the chain or, if the contact concerned is the last, to an overflow meter.

It will be recalled that one and only one event can occur at every examining interval so it follows that after the register has changed over there must be at least one unit time interval before another event can occur.

Terminal  $q$  in the register is also cross-connected to one of the roulette terminals. If a pulse appears at this terminal, V4 is cut off. This causes the trigger V3, V4 to reset to its normal condition in which the

associated contact valves such as V2 are no longer able to conduct and the register is again able to receive a call.

#### Layout of Equipment.

The equipment (Figs. 4 and 5), which contains about 2,000 valves, is mounted on four double-sided 19 in. by 8 ft. 6 in. racks. An additional rack is used for the power supply. On the front of the racks are mounted the neon noise generators, the distribution tables (which take the whole of the front side of rack 1), the control unit and the 14 high- and 90 low-speed meters. The latter are ordinary 100 type meters and require to be operated from timed pulse triggers which are mounted on the front of racks 3 and 4. The high-speed meters are simple binary counters fitted with a neon indicator at each stage and allowing for the reading without ambiguity of numbers up to 511. However, keys are provided to enable

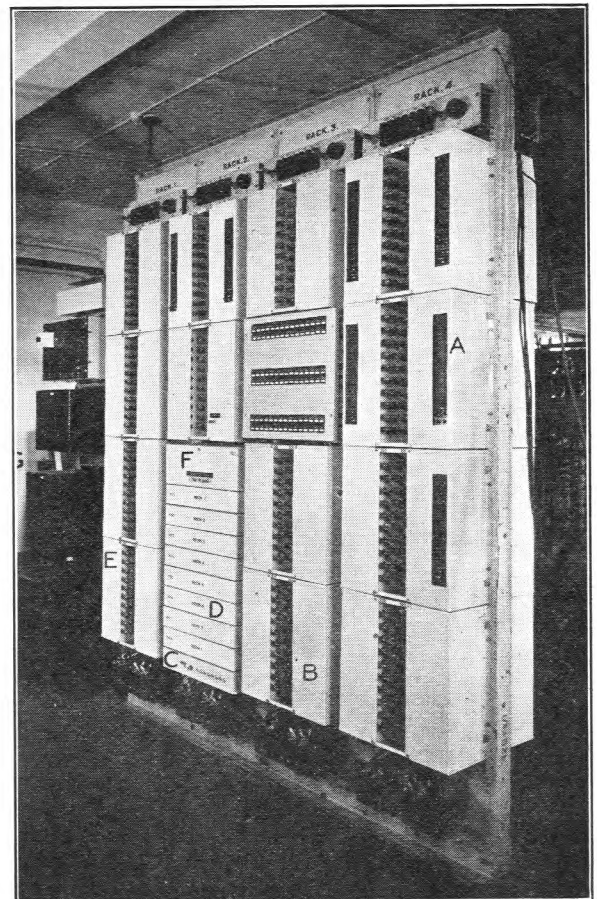

A—HIGH-SPEED METER (2). D—8 RANDOM ELEMENTS.  
 B—LOW-SPEED METER CONTROLS. E—DISTRIBUTION TABLES.  
 C—TEST GEAR. F—CONTROL.  
 G—POWER SUPPLIES.

FIG. 4.—TRAFFIC ANALYSER, FRONT VIEW.

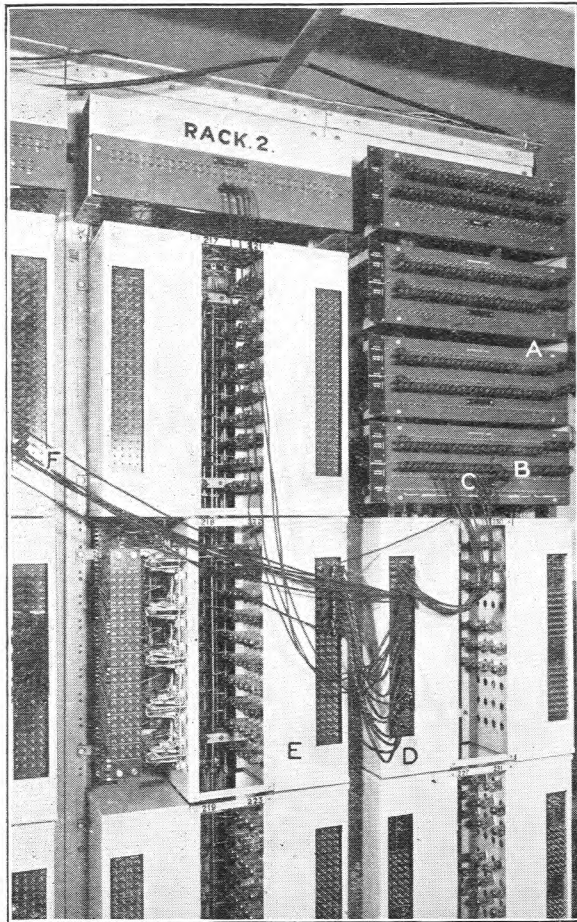

A—ROULETTE TERMINALS.      D—REGISTERS.  
 B—p OUTLETS.                E—CONTACTS.  
 C—q OR RESET OUTLETS.    F—CORDS TO METERS.

FIG. 5.—TRAFFIC ANALYSER, REAR VIEW, SHOWING 10-OUTLET FULL AVAILABILITY GROUP OFFERED 4 T.U.S.

the output of one counter to be fed to the input of the next so that very high numbers can be read. The electronic meters are provided with reset keys.

The rear of the equipment houses the 300 contacts and 130 registers. As each of these units is separately terminated on pins, any arrangement of 300 contacts trunked to 130 outlets can be tested. Some of the 256 terminals of the roulette are shown on the right-hand side of Fig. 5. The terminals are arranged to facilitate the commoning together of numbers of them to provide a greater traffic flow. The illustration shows four terminals commoned together and plugged over by a single cord to the first of 10 contacts connected in series to simulate a simple full availability group. Each contact is connected to a separate register and each register to a separate output from the roulette terminals immediately above. Each register is also connected

to a separate meter, the meter terminations appearing at the top of the racks.

Each panel such as those on rack 2 accommodates 25 contacts on its right- and 20 registers on its left-hand side.

The method of mounting the valves was adopted in order to save space and provide for easy access to the other components. The construction also causes the valves to project into a space which is easily adaptable for use as a ventilating duct. It has, however, not been found necessary to take any special precautions to dissipate the heat generated by the valves.

#### Technique of Use.

Experience has shown that faults are rare. The few which have occurred caused a complete break in the flow of pulses and were rapidly detected without leading to acceptance of false results. To ensure the reliability of results, the following procedure is carried out:—

- (a) After plugging up the grading and checking the roulette, counters are connected to all outlets and the analyser is run for a short time. By checking the total of calls carried and overflowed against the total calls offered, the operation of all contacts and registers may then be verified.
- (b) Because of the large number of counters required, those of the mechanical type are used, and so the test has to be made at low speed.
- (c) The main test is then carried out for sufficient time to obtain results of the required degree of accuracy. Usually there are sufficient electronic counters for this test and the high speed may be used.
- (c) The short test is repeated to ensure that no fault has appeared during the main test.

Owing to the random nature of the "drive" controlling the machine, it is necessary to provide

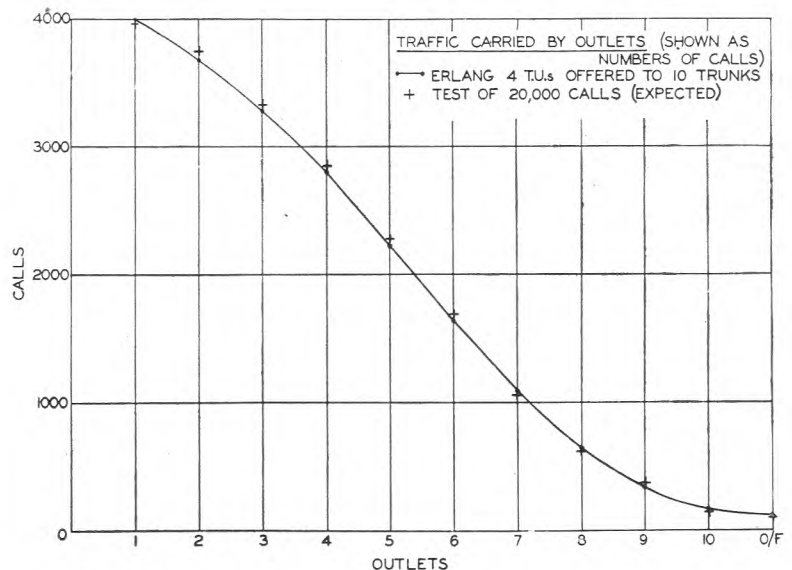

FIG. 6.—RESULTS OF A TYPICAL TEST WHEN 4 T.U.S WERE OFFERED TO 10 TRUNKS IN A FULL AVAILABILITY GROUP.



special routine test facilities which enable the sequence of events operating the machine to be accurately predicted. For this purpose a small routine test panel is arranged to step the roulette in a pre-determined cycle and thus, when a grading has been plugged up, the correct functioning of the circuit elements can easily be observed. Facilities are also provided for the testing of the cords for continuity or reversals.

#### *Results of a Typical Test.*

The test consisted of offering a traffic of 4.0 T.U.s to 10 trunks arranged in a full availability group. The expected number of calls offered during the test was 20,000. The number of calls carried by each trunk and the number of lost calls are shown in Fig. 6.

The theoretical results derived from the Erlang formula are also shown. It will be seen that the agreement is good.

#### *Acknowledgments.*

The equipment was designed and built in the Research Branch and the authors are indebted to their colleagues in this Branch who were concerned in its development and construction and to those in the trunking group of the Telephone Branch concerned with its testing. They would like specially to record the work carried out by Messrs. R. K. Hayward and R. T. Mayne in connection with this development. Acknowledgments are also made to Mr. C. W. Brown and Mr. R. L. Bell, to whom the initial idea of constructing a traffic analyser is due.

---

## Uses of a New Adhesive in Production of Piezo-electric Vibrators

U.D.C. 621.396.611.21 : 668.3

**T**HE new thermo-setting adhesive, Araldite,\* has found applications in the technique of production of crystal vibrators for use in telecommunications. This substance is capable of making very strong joints between surfaces of glass, ceramics and metals, provided that they can be heated to the curing temperature, which is anywhere between about 160° and 240°C. So strong is the joint between glass and metal that in a destructive test the glass will fracture before the joint.

Distinctive features of the material are that it can be applied in powder form to the surfaces which are to be joined, and afterwards melted by heating these surfaces; it can be kept in the molten state for some hours, cooled and remelted several times provided that its temperature does not reach the curing temperature; and the joints can be cured with heat only, i.e. there is no need to use pressure.

In early experiments with Araldite a small hole in a glass beaker was filled with the molten adhesive and the repair was properly cured by heat. Various solvents and reagents available in the Radio Branch crystal laboratory were afterwards put into the beaker to test the repair, e.g. boiling water, trichloroethylene and chromic acid, and they had no detrimental effect on the repair.

In the crystal laboratory the adhesive has been used in two ways, (a) for the attachment of thin wires to crystal elements to form supports and connections to the electrodes, and (b) in the production of abrasive wheels for cutting synthetic piezo-electric crystals.

#### *Wired Crystal Elements.*

The normal method of producing wire-supported quartz vibrators is first to fire a silver coating, usually a small spot, to the quartz surface, using special silver paste and heating to 540°C, and then to solder to this

spot a thin phosphor-bronze wire. The electrodes are thin films of gold or silver deposited on the quartz surface by cathode sputtering or by evaporation of the metal in a vacuum, and the supporting wires which are soldered to the silver spots act also as connections to the electrodes.

Phosphor-bronze wires 0.01 in. in diameter, having flat heads 0.045 in. diameter formed upon them, can be joined to quartz plates with Araldite and the joints can be properly cured, since the quartz can safely be heated to 240°C. Such joints will withstand a straight pull on the wire equal to 3,000 grams before breaking, a strength equal or superior to that of the soldered joint. With this method of attachment, if the wire is to act as an electrode connection as well as a support, the electrode metal, which in this case may be gold, silver or aluminium, must be deposited over the wire, the cemented joint and the quartz surface.

Crystals of other piezo-electric substances which can be grown from solutions have received much attention respecting their uses as possible alternatives to quartz. Notable among these is ethylene diamine tartrate (EDT), and in the production of resonator plates of this material Araldite has been used for the attachment of the support wires. Here the problem is more difficult since the crystal itself cannot safely be heated to a high enough temperature to cure the adhesive properly, and thus only partial curing has been possible. The development of a variety of the adhesive with a lower curing temperature may contribute to the solution of this problem.

#### *Abrasive Cutting Wheels.*

For cutting quartz the use of diamond-charged discs rotating with a peripheral speed of some 6,000 ft. per minute has become universal. Discs of steel, bronze or bakelite are common and the diamond grit may be held in small radial slots in the periphery, may be bound in a matrix which is attached to the

---

\* Marketed by Aero Research, Ltd., Duxford, Cambridge.

disc by riveting or welding, or may be moulded on the wheel in the case of the bakelite type. To ensure a long life for the cutting edge and economy of diamond, the grit is usually firmly held, the quartz itself being hard enough to wear down the matrix material and expose the diamond particles.

In the cutting of the relatively soft water-soluble crystals, it is convenient to use similar machines to those used for quartz cutting, and it is advantageous to employ a cutting agent which, while it need not be so hard as diamond, is freely exposed to the crystal. For this purpose fairly coarse carborundum powder cemented to the edge of a metal disc with Araldite has been found to work very well.

Cutting wheels have been made in the laboratory from 0.03-in. mild steel plate edged with carborundum No. 80 powder. Wheels of other thicknesses, made from other metals, and coated with other abrasives, for example, boron carbide, could readily be constructed in a similar manner.

The disc is cut from sheet metal in the usual way with a centre hole to suit the machine spindle. After flattening it is degreased and heated on a hot plate or in a suitable oven to a temperature of 120°C or thereabouts. Araldite in rod form is then applied to the edge of the disc and to an annular area on each face to a radial depth of about  $\frac{1}{8}$  in. The Araldite melts and forms a sticky coating at the edge of the disc. Care is required to obtain a coating of uniform thickness and radial width. While hot, the disc is immersed in a tray containing washed and dried carborundum powder of the desired grade. The disc may either be laid flat in the tray or may be rotated with only its edge dipping into the powder. The sticky layer of Araldite becomes completely coated with the powder, and provided that the adhesive is of uniform thickness and radial depth, a uniform abrasive surface is obtained.

The adhesive is then cured by heating the disc in an oven or over a hot plate to a temperature of 200°C or thereabouts for 40 minutes. The state of the cure can be indicated by a small sample of adhesive placed in proximity to the disc. After cooling the disc, loose particles of abrasive are shaken off and the disc is ready for use. The particles are firmly held by the adhesive, and the presence of the abrasive layer on the sides of the disc near the edge ensures that a clearance is provided in the cut so that the disc does not bind or generate undesirable friction in cutting. An enlarged view of a portion of a disc treated with carborundum is shown in Fig. 1.

In the plunge cutting method, Fig. 2(a), the work is fed against the saw along a diameter, and to make a complete cut the saw must progress into the mounting plate to a depth dependent upon the size of the crystal. The carborundum Araldite-cemented saw suffers damage, however, if allowed to cut glass,

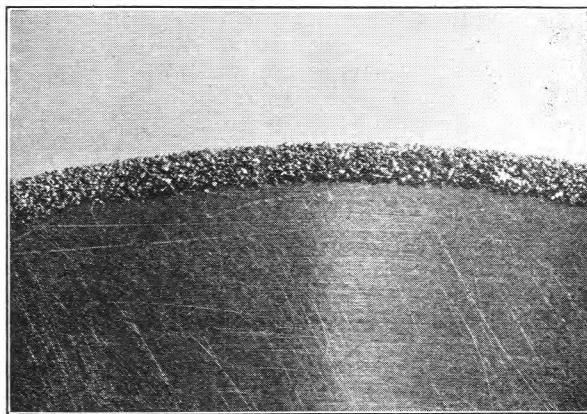

FIG. 1.—PART OF RIM OF METAL CUTTING WHEEL WITH ABRASIVE CEMENTED TO RIM WITH ARLDITE (MAGNIFIED 3 TIMES).

and when the crystals are mounted on glass plates, it is necessary to prevent the saw from entering the glass. It is therefore preferable to adopt the method illustrated by Fig. 2(b), adjusting the relative positions of the work and saw so that the latter just clears the glass mounting plate. This method entails a rather longer traverse of the work table.

A cutting speed of 20 sq. in. per hour, using the method of Fig. 2(b), has been achieved with satisfactory results.

In the case of quartz cut by diamond saws, the cut surfaces are often damaged by fine cracks extending into the cut surface to a depth of some 0.1 mm. The

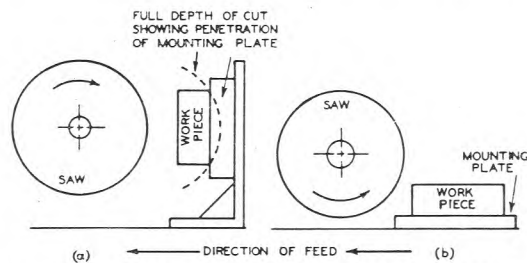

FIG. 2.—TWO METHODS OF CUTTING CRYSTAL USING ABRASIVE DISC.

corresponding damage to EDT crystal produced by cutting with a carborundum Araldite-cemented saw using No. 80 carborundum is of the same order. The tapering of slices, or wedging effect, is of the order of 0.03 to 0.08 mm. in a cut 50 mm. deep, which is similar to that experienced with quartz.

It is easily seen that the method of charging a metal cutting tool with abrasive in this way lends itself to the preparation of other forms of cutter, such as trepanning tools and band-saws or wires, and to the charging of lapping surfaces, either flat, spherical or of some other predetermined shape.

J. E. T.



# Fault Location in Transmission Equipment by Vibration Testing and Continuous Monitoring

H. G. MYERS, B.Sc.

U.D.C. 621.317.333.4 : 621.317.74 : 621.395.5

This article describes equipment and methods developed to locate faults of all types, especially intermittent short duration faults, which occur on transmission equipment before and after being put into service.

## Introduction.

TOWARDS the end of the war attention was being given to methods of improving the circuit performance of the trunk network. The loss of trained and experienced staff and the consequent staffing difficulties, the installation of 12-circuit carrier and coaxial systems, some of which were of experimental types, the rapid expansion of the network and the manufacturing difficulties during the war, all tended to degrade the electrical performance of the network.

The proposed introduction of the teleprinter automatic switching scheme involved an investigation to determine whether the existing design and maintenance of V.F. telegraph circuits to be associated with the scheme would give the required standard of service. It was anticipated that any investigation into the performance of these circuits would also expose weaknesses in trunk circuits.

The investigation as first planned has largely been completed and has shown, for a number of audio and carrier circuits of different types and lengths, that many equipment design, manufacturing and installation defects required attention. It has also shown that the methods of setting-up and maintaining circuits, as applied, did not reach the high standards required.

Contact defects are, undoubtedly, one of the major causes of instability and short interruptions on circuits. These defective electrical connections are liable to be introduced at all stages from the design and manufacture of a component to the time the circuit is put into service. Although the clearance of a contact defect is straightforward its location may present many difficulties: the type of defect which causes intermittent short duration faults is particularly difficult to locate. The seriousness of the difficulty, with the maintenance methods available, can be appreciated when it is realised that a London-Glasgow circuit routed over a 12-circuit carrier group has approximately 7,000 soldered connections and 6,000 pressure contacts (U-links, valveholder connections, etc.), distributed over 24 repeater stations, many of which are unattended.

Experimental equipment for the location of contact defects has been developed and extensively used in the investigation referred to above. In due course, more sensitive standard equipment will be available for general application of the technique to all classes of equipment.

The investigation has shown that preventive maintenance methods for locating a defect before a service failure occurs need revision, the most important of which is the introduction of continuous

monitoring over a period at several points on a circuit in service. This enables a defect or recurring fault to be located to a repeater station with certainty and in the shortest possible time, without withdrawing the circuit or system from service.

## Contact Defects.

The family of contact defects so far encountered includes many which are unwittingly cleared, temporarily, by the application of normal maintenance methods. The degradation of service due to them has not been fully revealed in normal fault data. The types of contact defects found include :—

Unsoldered joints; defectively soldered joints ("Dry joints" or "H.R.s").

Variable wire-wound potentiometers.

Defective spot welding of resistance wires and valve electrodes.

Valveholder contacts and valve pins.

U-link springs and sockets.

Dry riveted and screwed connections.

Plug and jack sleeve or springs.

Spring contacts in jacks and keys.

Unwetted relay contacts.

Broken wires in loose mechanical contact.

Spurious contacts between wires, or between wires and earth.

Loose connections on copper oxide rectifiers.

Bad contacts on pressure-mounted crystals in crystal filters.

Poor connection of screened conductors.

Poor connections on heat coils and mountings.

Poor connection between line fuses and mountings.

The performance of a transmission system is generally assessed in terms of the failure of the service to the user or operating service. This may give rise to a fault report and the cause will not be found unless the fault persists long enough to be located by transmission measurements. Because of the time factor many contact defects, which degrade the service, may cause a series of fault reports over a period of months before location is possible by the maintenance engineer. During this period needless out-of-service time and expenditure of engineering effort is incurred.

A clean contact connection such as that between U-link and socket or a clean wire wrapped tightly round a clean tag, will cause no degradation of circuit performance until atmospheric corrosion, dirt, damp or mechanical fatigue produces contact resistance. The contact defect then becomes unstable and the slightest displacement of the contact may either partially restore the electrical connection or cause a

complete disconnection. A greater displacement will sometimes temporarily clear the defect so that it will lie hidden until sufficient time has elapsed to allow the contact resistance to develop again.

A very troublesome contact defect in line plant is the type which may be temporarily cleared when a normal testing power of 1 mW is applied to the circuit. A few defects have been found, particularly in crystal filters and rectifiers, which could be temporarily cleared by a testing power as low as 10 db. below the normal level. These faults invariably recur.

## VIBRATION TESTING TECHNIQUE

### *Principle of Test.*

Without special testing equipment the location of contact defects is often a matter of chance. Unless inside a component, most unsoldered connections can be located by very careful visual examination; this is the only way of locating a clean, tight, unsoldered connection. On the other hand, a dry soldered connection often looks perfect yet gives rise to a series of short duration faults the clearance reports for which are "Right when Tested" or "Found O.K."

To achieve the design performance of a circuit it is essential that every contact defect be eliminated. This can be done by first applying a vibration test to every point in the circuit, followed by a very careful visual inspection, and then by making continuous observation of a signal on the circuit for at least 24 consecutive hours during weekdays by means of a recording decibelmeter. If the overall loss of the circuit is not stable further tests are made to locate the cause of the variations.

The principle of vibration testing is to pass a signal through the equipment to be examined and apply, in stages, gradually increasing intensity of vibration to each part of the equipment. The sidebands, resulting from the disturbance of a contact defect, are then detected by a suitable device connected to the output of the equipment under test.

For audio frequency equipment the sidebands are passed to a high gain loudspeaker amplifier and there produce audible clicks. For carrier and coaxial equipment it is necessary to detect the sidebands and reduce one of them to the audio frequency band before connection to the loudspeaker amplifier.

In the particular case of amplifiers, except for the input and output circuits, a contact defect is associated with D.C. from the normal power supplies. Vibration of a contact defect in a D.C. circuit generates a square-top waveform and a wide band of frequencies results. These may be detected as clicks in a loudspeaker. To detect contact defects in the input and output circuits of amplifiers and other equipment where no D.C. flows it is essential that the contact passes a "wetting" A.C. signal.

### *Test Signals.*

Some dry-soldered connections and contact defects due to crystal mountings in filters, that have completely failed a transmission path, have been cleared by the application of the normal testing power of

1 mW, but no defect has yet been encountered which could be cleared with a power lower than 10 db below 1 mW. If this type of contact defect is to be located it is advisable in the first stage of the vibration test to ensure that at no point in the transmission path under test is the level of the "wetting" signal higher than -10 db. (ref. 1 mW). In the final stage the power may be raised to the maximum that the equipment under test will transmit without overloading.

It is essential that the equipment under test should effectively transmit the test frequency. The sideband energy developed by disturbing a contact defect is a function of the A.C. voltage across the defect and the ability to detect it depends on the effective gain between the defect and the loudspeaker. For shunt resonant circuits, such as those in equalisers which affect the transmission most at a particular part of the transmitted frequency spectrum, some increase in sensitivity can be obtained by choosing a test frequency in this part of the band.

### *Fault Detection.*

The resistance of a good soldered connection measured with low level A.C. is of the order of 0.001 ohm, whilst that of a dry soldered connection may be anything between 0.1 ohm and infinity, depending upon its condition and the period that has elapsed since it was last disturbed. In the early stages of development the contact defect may have a relatively low resistance and if it exists in a high impedance path the sideband energy developed when the defect is disturbed may be below the noise level of the equipment. It is essential therefore that the detecting device shall be as sensitive as possible. A suitable apparatus developed for this purpose is the Loudspeaker-Amplifier, 6B, described below.

*Loudspeaker-Amplifier 6B.* This portable, mains-operated loudspeaker-amplifier (Fig. 1) employs a conventional three-stage R-C coupled negative feedback circuit with wafer-type control switch allowing the gain to be reduced 40 db. in steps of 8 db.; a toggle switch allows a further reduction of 30 db. for monitoring speech or music circuits. At maximum gain, with an input voltage of 17.4 mV at 1,000 c/s, the output voltage across 3 ohms is 1.74 volts with a harmonic content less than 2 per cent. The frequency response of the amplifier has a spread of 3.5 db. from 300 c/s to 10,000 c/s. With the input closed with 600 ohms and at maximum gain the noise level across 3 ohms is less than 6 mV unweighted, and 1 mV when measured with a broadcast weighting network.

Under normal room noise conditions an input signal 96 db. below 1 mV at 1,000 c/s can be heard 2 yards from the loudspeaker.

In the design the size (13½ in. × 9½ in. × 5½ in.) and weight (7 lb.) have been reduced to a minimum by the use of a wafer type loudspeaker and electrolytic decoupling capacitors.

Although the loudspeaker is very close to the valves the choice of a non-microphonic valve for the first stage eliminates the risk, with such high gain, of an acoustic howl between the loudspeaker and

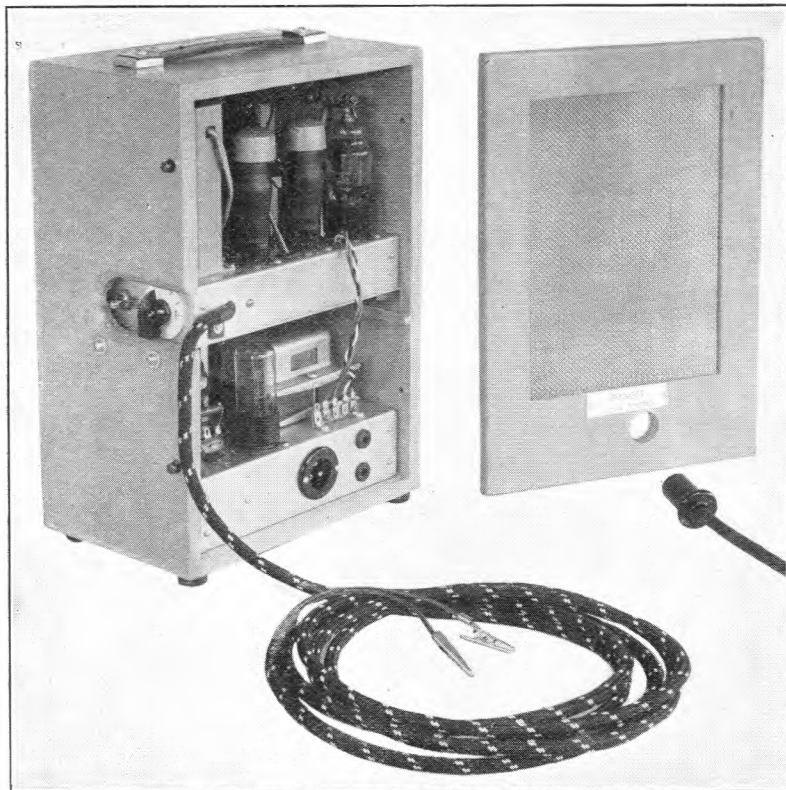

FIG. 1.—LOUDSPEAKER-AMPLIFIER, No. 6B.

components are gently touched (not tapped) whilst listening for clicks from the loudspeaker. A click may be heard when a connection is lightly touched but may not recur when touched a second time because the defect has been broken down. However, such a defect might be revealed at a later stage in the test.

The procedure is then repeated, very lightly tapping all connections, tags, components (including valves) and the cause of any clicks is investigated. When located the defect is cleared before continuing the test. Valves that are abnormally microphonic or have loose electrodes are replaced.

The procedure is then repeated a third time, tapping harder so that contact defects mechanically held by resin or rivets are disturbed and so that sufficient vibration is transmitted from cans to components and wiring inside the can.

Finally, all wires and tags are pulled gently both ways along the axis of the wire and at right angles to it. This detects rigid mechanical joints which are unsound electrically. The pull is adapted to the type of wire and component involved so that no damage is caused. Wire "nicked" in the process

of removing insulation or wire brittle with age may easily be fractured by this process, but it is preferable that this fracture occurs whilst the equipment is under observation rather than during cleaning operations by non-technical staff. A fractured wire still in electrical contact would in due course corrode and develop into an unstable defect. Carbon resistors and small capacitors suspended in the wiring, that are liable to touch tags, earth points or covers when lightly disturbed are repositioned.

#### *Method of Applying Vibration.*

When testing equipment which uses valves, the power supply connections also are tested. Defects in bus-bar connections, fuses and voltage regulators give rise to clicks in the loudspeaker when disturbed. When the equipment has been freed from all defects the cover is replaced and struck quite hard with a closed hand and no clicks should be heard from the loudspeaker.

Completely sealed crystal filters using pressure-contact crystal mountings are gently struck with the closed hand along the length of the cover. Excessive vibration, however, may either temporarily clear an existing defect or completely displace a crystal in its mounting.

When testing equipment which uses valves, the power supply connections also are tested. Defects in bus-bar connections, fuses and voltage regulators give rise to clicks in the loudspeaker when disturbed. When the equipment has been freed from all defects the cover is replaced and struck quite hard with a closed hand and no clicks should be heard from the loudspeaker.

A small wooden-handled screwdriver weighing about 2 ounces is suitable for applying vibration to the equipment but, unless the handle is covered with rubber, it may not be possible to distinguish between the direct noise due to tapping and simultaneous faint clicks from the loudspeaker. Generally, however, the ear can discriminate between a click expected at the moment of tapping and random clicks, even in the presence of steady noise.

Experience has shown that components and wiring on panels are best tested in a systematic sequence, e.g., variable gain-controls are rotated slowly, valves displaced carefully and slowly with a very slight rotary action in the valveholders, then with the aid of a small insulated tool, such as the handle of a screwdriver, cable form, tags, soldered connections and

of removing insulation or wire brittle with age may easily be fractured by this process, but it is preferable that this fracture occurs whilst the equipment is under observation rather than during cleaning operations by non-technical staff. A fractured wire still in electrical contact would in due course corrode and develop into an unstable defect. Carbon resistors and small capacitors suspended in the wiring, that are liable to touch tags, earth points or covers when lightly disturbed are repositioned.

Completely sealed crystal filters using pressure-contact crystal mountings are gently struck with the closed hand along the length of the cover. Excessive vibration, however, may either temporarily clear an existing defect or completely displace a crystal in its mounting.

When testing equipment which uses valves, the power supply connections also are tested. Defects in bus-bar connections, fuses and voltage regulators give rise to clicks in the loudspeaker when disturbed. When the equipment has been freed from all defects the cover is replaced and struck quite hard with a closed hand and no clicks should be heard from the loudspeaker.



A special pair of pliers with long flexible insulated jaws has been designed. This tool produces a tweezer action for gripping a wire from the normal grip action applied to the handle.

#### Acoustic Coupling between Loudspeaker and Equipment under Test.

Some difficulty is experienced when vibration testing is applied to equipment having microphonic valves. Although clicks can be heard above the microphonic noise the high gain in the loudspeaker-amplifier necessary to detect small contact defects is liable to set up an acoustic howl between the loudspeaker and the valves. This may be overcome by the use of an extension valve adaptor, consisting of a valve base wired with 9 in. flexible leads to a valveholder.

The valve and valveholder are first vibration tested and the valve is then carefully removed from the panel. The valve base of the adaptor is inserted in the equipment valveholder and the microphonic valve in the extension valveholder. This eliminates microphonic noise which would otherwise occur when the equipment is tapped. The valve is enveloped in cottonwool to reduce the acoustic coupling.

#### APPLICATION TO TRANSMISSION TESTING

##### Audio Frequency Equipment.

The use of a very low-level signal, just above the equipment noise level, and a simple, high gain loudspeaker-amplifier has the disadvantage of a continuous audible tone from the loudspeaker and a very low-level "wetting" signal passing through the contact defect.

By introducing a low-pass filter before the loudspeaker-amplifier to cut off the testing frequency and its harmonics, the level of the test signal through the contact defect can be increased in proportion to the suppression of the test signal by the filter, with a corresponding increase in sideband level. However, the maximum value at any point in the equipment should not be greater than  $-10$  db. (reference 1 mW) or exceed the overload point of a component.

Fig. 2 shows the arrangement of the testing equipment.

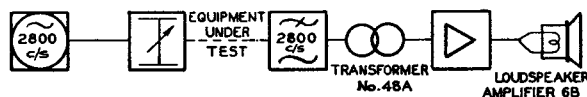

FIG. 2.—BLOCK SCHEMATIC DIAGRAM OF FAULT DETECTOR FOR AUDIO FREQUENCY EQUIPMENT.

Pending development of standard equipment a low-pass filter giving an attenuation of 65 db. at 2,800 c/s and 5,600 c/s (second harmonic) has been constructed from standard equaliser components. This filter is used with a 2,800 c/s testing signal from a standard audio-frequency oscillator through a variable attenuator. After an initial vibration test at a level not exceeding  $-10$  db. at any point in the equipment under test, a test is made at the maximum level the equipment can handle, with a corresponding increase in sideband level.

For testing 2-wire repeaters, a test signal of 1,900 c/s and a low-pass filter with a cut-off frequency of 1,900 c/s are necessary.

##### Multi-Channel Voice Frequency Telegraph Equipment.

The low-level "marking" tone is used as the test frequency appropriate to the looped telegraph channel. Due to the unsmoothed H.T. supply to the detector-amplifier and the narrow bandwidth of the filters the detection of the sidebands generated when a minor defect is disturbed is difficult. Experiments have shown that defects of sufficient importance to affect the performance of the telegraph system can be detected by taking off the sidebands developed across the anode decoupling condenser, through a  $0.1 \mu\text{F}$  capacitor and 100 c/s low-pass filter to the loudspeaker amplifier.

##### Carrier and Coaxial Line Equipment.

The experimental equipment in Fig. 3 has proved

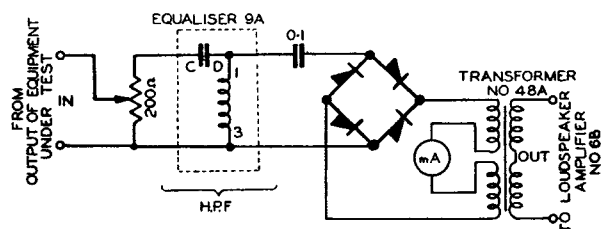

FIG. 3.—CIRCUIT DIAGRAM OF FAULT DETECTOR FOR CARRIER FREQUENCY EQUIPMENT.

effective in detecting defects in carrier line equipment. The 40 kc/s test signal is derived from the test equipment normally provided at unattended carrier stations. This is fed through an attenuator to the equipment under test and the output connected to the detector.

The experimental detector is made up from standard components. It incorporates a high-pass filter for suppressing microphonic noise below 16 kc/s, a bridge rectifier for detecting the sidebands generated when a contact defect is disturbed, and a loudspeaker-amplifier. The meter is included so that the test signal level from the equipment under test can be adjusted to ensure that the rectifiers are not overloaded, and that they operate on the most sensitive part of their characteristic. Tests with half-wave rectifiers of the Westector type showed that frequently under field conditions they were permanently damaged by high level signals.

With an output level of  $-10$  db. (reference 1 mW) from the equipment under test, the gain control is adjusted to give 0.1 mA steady rectified current. Under these conditions 0.1 db. change in level can easily be detected with the Loudspeaker-Amplifier No. 6B.

Coaxial line equipment and group and supergroup equipment have been vibration tested using a coaxial connection direct to the bridge rectifier. If a defect was located to a panel whose components and wiring were inaccessible with the panel on the rack, the final location had to be made on a test bench.

### Carrier and Coaxial Terminal Equipment.

For vibration testing both 12-circuit carrier and coaxial terminals the equipment must be made spare by withdrawal from service. The equipment is looped at the H.F.R.D.F. or G.D.F., and audio frequency vibration testing technique applied at the channel ends. All equipment in the transmission path is tested with the oscillator and detector connected to each channel in turn. For modems in which both directions of transmission are on one panel, it is advantageous to test both at the same time. Equipment common to all channels is tested only once by observing on one channel.

The carrier frequency generating equipment may be tested when observing on the appropriate channel. Alternatively, where no terminal equipment is available, the detecting equipment shown in Fig. 3 can be used straight across the output of the carrier frequency generating equipment. The setting of the gain control is at minimum initially, and is then increased to give the appropriate rectified current.

### Typical Test Results.

With the aid of experimental vibration testing equipment, coupled with visual inspection, the defects on line equipment eliminated by the Area Transmission Efficiency Officers and their staffs between March 1948 and March 1949 were 219,239 on 24,218 bay sides. This represents an average of 9.0 defects per bay side. Based on the percentage of the work completed it may be anticipated that the total defects eliminated in Great Britain and Northern Ireland will be of the order of 350,000.

A broad classification of the defects is given in Tables 1 and 2.

TABLE 1  
Average number of defects per bay side (or vertical).

Coaxial	12-Circuit Carrier	Audio Equipment	M.C.V.F. Telegraph	Distribution Frames
10.2	8.9	12.1	5.4	4.6

TABLE 2  
Average number of defects per bay side (including frames).

	Wiring	Valves	Components and Miscellaneous
Carrier Equipment	5.6	0.7	3.1
Audio Equipment	9.3	1.7	2.3

### Proposed Application to New Equipment.

Application of vibration testing to new equipment has shown that some contact defects have escaped detection at all stages in production from component tests to final acceptance tests, and have become a maintenance liability until finally cleared as a result of fault reports.

It has been shown that by eliminating defects prior to functional tests the time for acceptance tests can

be reduced and programmes of acceptance testing arranged with reasonable accuracy.

Factory experiments are being carried out with a view to eliminating faulty components after the panel wiring stage. The time between the manufacture of components and completion of a wired panel may be several months and dry soldered connections in components may have had time to develop, and can be located by a vibration test.

With a view to new equipment going into service with a reduced fault liability it is proposed to include vibration testing in the specification for installation of transmission equipment. A trial of this nature has been carried out on all the equipment provided on a London-Manchester route which was converted from 12-circuit to 24-circuit working. Vibration tests followed by observations on recording decibelometers have shown that a very high degree of stability has been achieved.

### CONTINUOUS MONITORING

#### General Arrangements.

Vibration testing is a highly skilled operation, but even with qualified staff the elimination at the first attempt of all contact defects on the equipment used in a circuit is not certain. Continuous observation on a circuit is therefore most desirable to confirm that the circuit is free from fault. Such observations are made on circuits by means of a test tone and one or more recording decibelometers (Decibelometer No. 14).

The decibelometer (Fig. 4) is a moving-coil recording

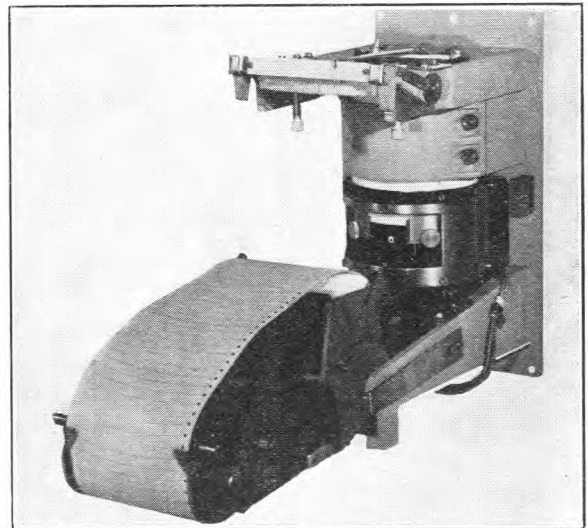

FIG. 4.—DECIBELMETER NO. 14.

meter which has a range of  $-10$  to  $+5$  db., relative to 1 mW in 600 ohms, over the frequency band 50 c/s to 12 kc/s.

The chart, calibrated in decibels, is driven by a synchronous motor at a speed of 1 in. or 6 in. per hour, and the pen system allows interruptions of 10 mS to be recorded as approximately  $\frac{1}{8}$  in. movement of the syphon pen. High and low level adjustable alarms are incorporated, operated by the movement.



If the circuit to be monitored is spare, a stabilised test tone at a level of 20 db. below 1 mW is applied to the circuit and the decibelmeter, preceded by a suitable amplifier, is connected to the circuit at the distant end.

Provided a transmission path is free from contact defects and unstable components and provided the equipment is operated from stabilised power supplies, then the variations in level on the path are due to fundamental changes such as the variation in attenuation with temperature of coaxial and carrier cable. For audio frequency circuits the temperature effect is very small and therefore it would be expected that day-to-day changes in level of a test signal transmitted over the transmission path would also be small.

The use of the recording decibelmeter has shown that if a circuit is free from defects the changes in level over long periods may vary between 0.2 db. and 1 db., depending on the length of the circuit and type of amplifying equipment. A 400-mile circuit using Amplifiers No. 32 should not vary by more than  $\pm 0.2$  db. A circuit with contact defects, faulty components or valves shows considerable variation in level over short periods, and if the defects are disturbed, transient changes occur which may disconnect a circuit for a few milliseconds. A contact defect in the feed-back path of an amplifier may cause momentary rises in recorded level.

In general, a defect likely to affect the overall loss of a circuit behaves in a characteristic manner and exhibits a characteristic trace. It is sometimes possible, therefore, to diagnose the type of defect from a record taken over a period of time on a decibelmeter.

#### Continuous Monitoring on Transmission Paths in Service.

One contact defect of a recurring transient nature can be, and often is, the cause of the bad fault record of a circuit. From the point of view of the mainten-

ance and operating staffs, however, it is unsatisfactory to withdraw a circuit from service for vibration testing and continuous monitoring for long periods, to find perhaps only one defect; this aspect is even more serious when the H.F. path of a carrier or coaxial system is concerned.

Continuous monitoring on transmission paths in service is, therefore, attractive from both the service and the maintenance points of view. It allows lost circuit time due to faults to be reduced and improvement in circuit performance to be made between reported faults. It permits the maintenance engineer to carry out his work in clearing faults without being pressed to restore a circuit or system to service before he is satisfied it is fault free. It also allows him periodically to check the performance of circuits in service, and to detect and clear a defect before service is seriously affected or a fault reported.

#### M.C.V.F. Telegraph Circuits.

Fig. 5 shows a method of monitoring both directions of a V.F. telegraph circuit in service. It utilises a band-pass filter  $2,580 \pm 50$  c/s (Filters, Frequency 38A), and a monitoring test signal of 2,580 c/s. This signal is capable of being transmitted by Tariff E circuits and will not interfere with the V.F. telegraph channels. The bridging loss of the monitoring equipment to V.F. telegraph channels is negligible.

A similar arrangement to that shown at the receiving end may be connected at various points in the circuit. All recording decibelmeters on the circuit up to the defect will show a straight line record and those beyond should show the same irregular trace.

#### Speech Circuits.

One monitoring arrangement, shown in Fig. 6, is similar to that used on V.F. telegraph circuits except that additional filters are required to prevent the

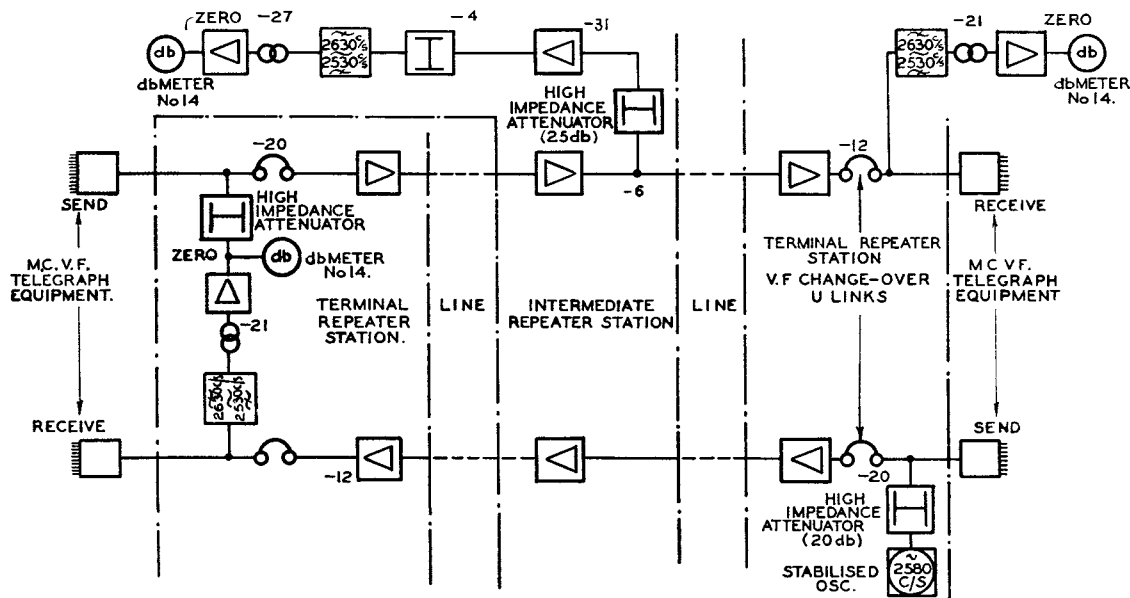

FIG. 5.—BLOCK SCHEMATIC DIAGRAM OF EQUIPMENT FOR MONITORING M.C.V.F. TELEGRAPH CIRCUITS IN SERVICE, INDICATING LEVELS OF TEST TONE.

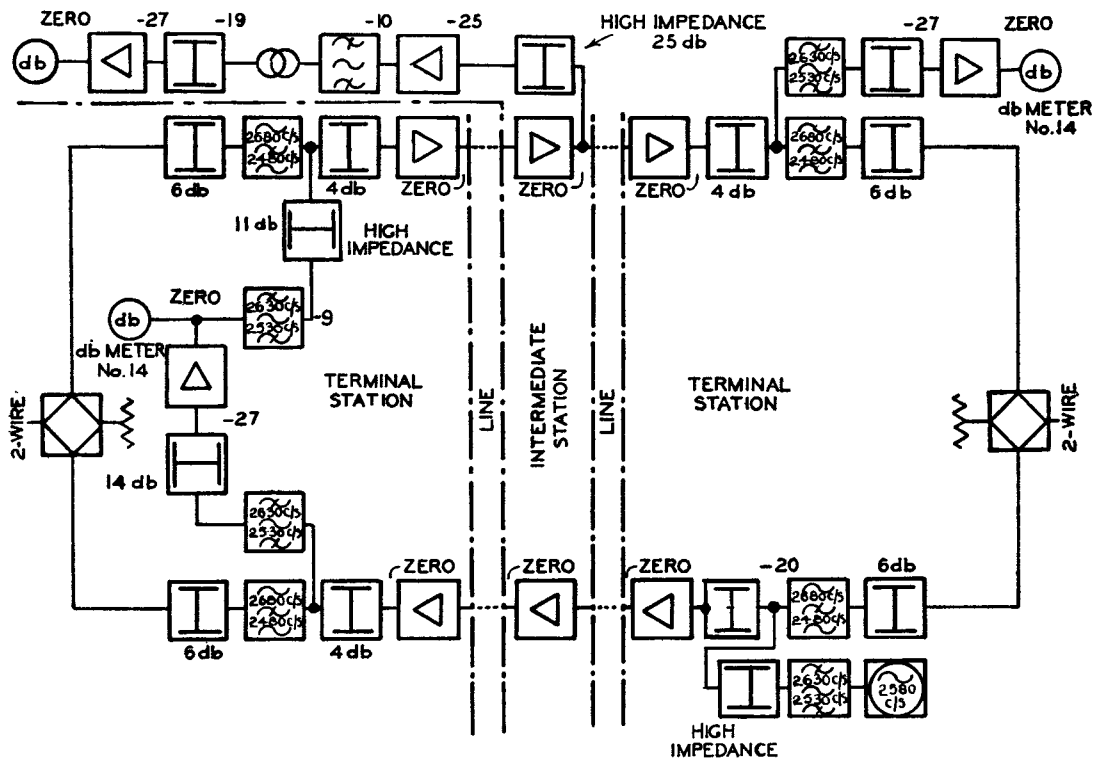

FIG. 6.—BLOCK SCHEMATIC DIAGRAM OF EQUIPMENT FOR MONITORING ON SPEECH CIRCUITS, INDICATING LEVELS OF TEST TONE.

monitoring signal reaching the subscriber and prevent speech frequencies entering the monitoring circuit. The additional filters are band-stop,  $2,580 \pm 100$  c/s, and one is required at each end of each direction of transmission.

ends, and connecting on the line side of these filters a band-pass filter  $3 \text{ kc/s} \pm 50 \text{ c/s}$  at one end and  $3.2 \text{ kc/s} \pm 50 \text{ c/s}$  at the other end (Fig. 7).

*Speech Circuits Routed over Carrier Channels.*

Equipment similar to that shown in Fig. 6 or Fig. 7 is connected in the channel ends. This arrangement will check the stability of the channel, but if there is a defect on the H.F. path it can only be located by pilot monitoring equipment at all amplifying points.

Experimental equipment which monitors a  $60 \text{ kc/s}$  pilot injected at the sending end of the H.F. path has proved a reliable method of locating contact defects.

*Music Circuits.*

As these circuits are unidirectional only one set of composite filters is necessary.

Experiments have been made using a  $10 \text{ kc/s}$  low-pass filter in the music path and a  $12 \text{ kc/s}$  high-pass filter for taking off the monitoring signal of  $12 \text{ kc/s}$  at the receiving end (Fig. 8).

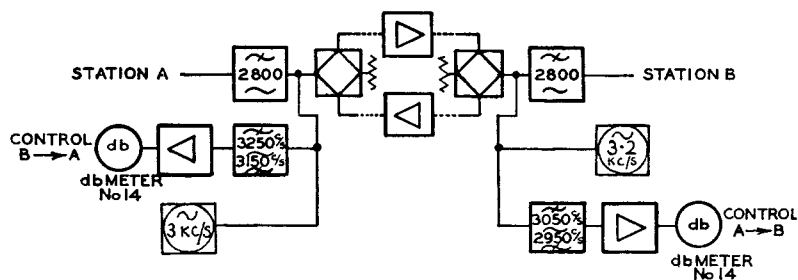

FIG. 7.—BLOCK SCHEMATIC DIAGRAM OF EQUIPMENT FOR SIMULTANEOUS MONITORING IN BOTH DIRECTIONS ON 2-WIRE ENDS OF SPEECH CIRCUITS.

Alternatively, "Filters, Composite, Speech + Duplex" may be used. These filters incorporate a band-stop filter ( $1,470 \text{ c/s}$  to  $2,030 \text{ c/s}$ ) and a band-pass filter ( $1,560 \text{ c/s}$  to  $2,000 \text{ c/s}$ ), the frequency of the monitoring signal being  $1,740 \text{ c/s}$ .

For monitoring one direction of transmission at a time the composite filters can be connected in the 2-wire path but if echo-suppressors are used in the circuit they have to be rendered inoperative and the circuit degraded by 3 db. From a maintenance aspect it is preferable to monitor each direction of transmission separately from the 2-wire side and to place the responsibility for checking circuit performance at the receiving end where the recording decibelmeter provides the performance data. This can be achieved by introducing  $2,800 \text{ c/s}$  L.P. filters in both the 2-wire

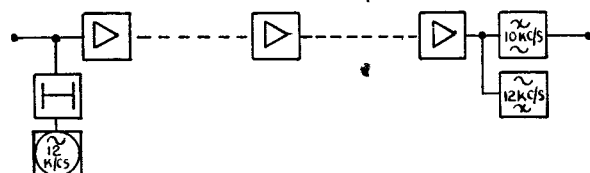
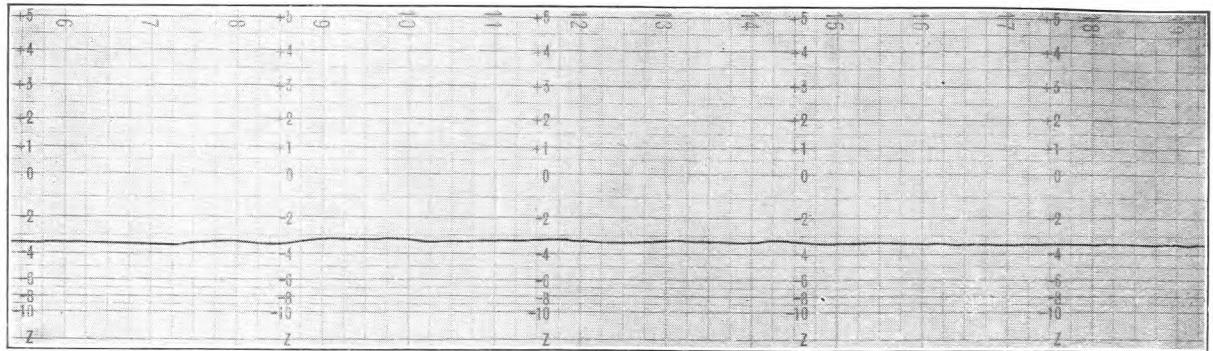
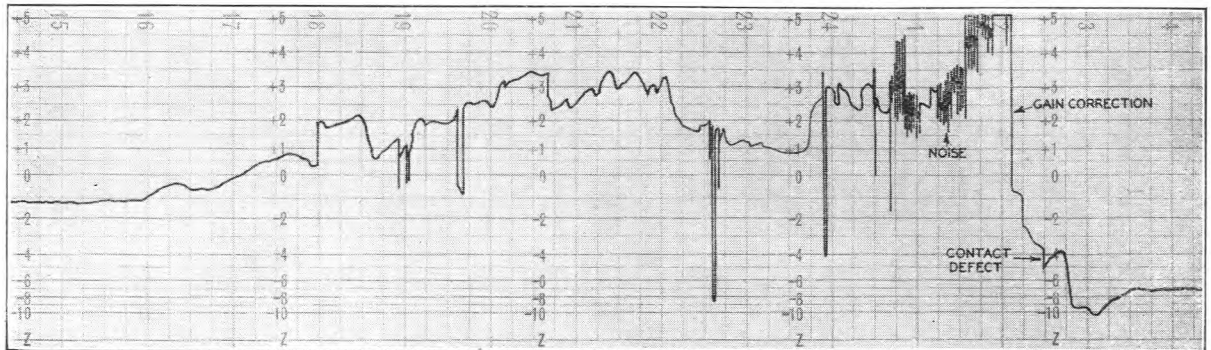

FIG. 8.—BLOCK SCHEMATIC DIAGRAM OF EQUIPMENT FOR MONITORING MUSIC CIRCUITS.





(a) Taken on 400-Mile Looped Audio V.F. Telegraph Circuit 2 1/2 Years after Vibration Testing.



(b) Taken on 450-Mile Carrier Circuit.

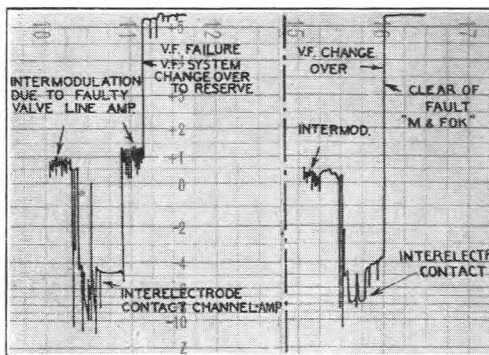

(c) Traces Produced by Inter-electrode Contact in Valve in a Carrier Channel Panel.

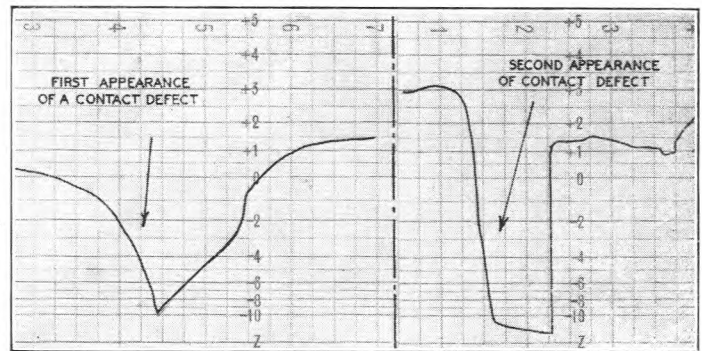

(d) Traces Produced by a Contact Defect.

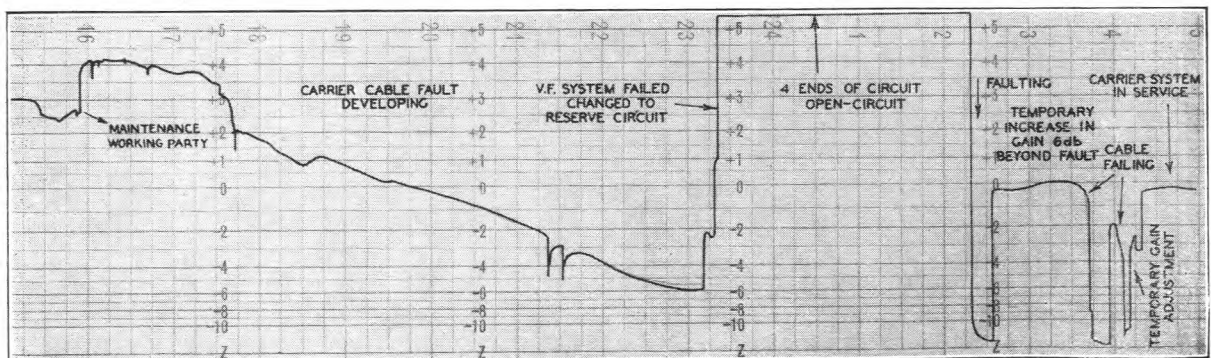

(e) Trace Produced by Typical Carrier Cable Fault.

FIG. 9.—TYPICAL TRACES RECORDED ON CIRCUITS IN SERVICE.

For music circuits which cut off at 8 kc/s or 15 kc/s other filter combinations will be required.

### *Interpretation of Chart Records.*

Typical specimens of the traces on circuits in service are shown in Fig. 9.

Fig. 9a shows the trace of a 400-mile looped audio V.F. telegraph circuit 2½ years after overhaul using vibration testing.

Fig. 9b shows the trace of a 450-mile carrier circuit routed over 250 miles of 12-channel carrier and 200 miles of coaxial path. Using 60 kc/s pilot monitors defects were observed on the 12-circuit carrier path and finally located by vibration testing. The coaxial path was overhauled at all stations, involving the withdrawal of the system from service every week-end for 6 months.

Fig. 9c shows the trace of successive failures of a V.F. system on a carrier channel due to interelectrode contact in the valve in the carrier channel panel. The clear of the fault in both cases was recorded as "measured and found O.K."

Fig. 9d shows successive failures from a contact defect which was located at an unattended repeater station. The duration of the failure and the time at which it occurred made diagnosis and location of the

fault extremely unlikely by normal fault procedure and transmission measurements.

Fig. 9e shows the effect of a typical carrier cable fault.

### *Conclusions.*

Work is proceeding on equipment designed to give improved facilities and greater sensitivity in fault detection, and a new mains-operated H.F. fault detector developed by the Research Branch will enable a defect causing a level change of 0.01 db. to be located. Standard oscillators of the neon-stabilised milliwatt type are being designed for use on continuous monitoring; these will replace the modified Oscillator No. 13 employed at present.

Meanwhile, there seems no doubt that vibration testing will help to reduce the faults due to line plant and improve the performance of line plant in the period between successive faults. Elimination of contact defects in new equipment will enable a true measure of the design performance to be assessed.

Continuous monitoring will provide an invaluable aid to the maintenance engineer in solving recurring fault problems. It will also check the stability of new equipment or new circuits. As a means of providing basic data for study of weaknesses in maintenance methods and fault-reporting procedure, it should be of great assistance to the Engineering Department.

---

## **Book Review**

"Microwave Antenna Theory and Design." Samuel Silver. McGraw-Hill Publishing Co., Ltd., London, 1949. 623 pp. 338 ill. 48s.

This book, Vol. 12 in the Radiation Laboratory Series sponsored by the Massachusetts Institute of Technology, is probably the only book at present available dealing solely with the aerial aspect of microwave (chiefly 3,000 to 30,000 Mc/s, Band 10) techniques. The contents are well balanced since they include both the application of field and transmission line theories to aerial problems and the more practical aspects of aerial design; only a moderate acquaintance with transmission line theory and vector analysis is assumed.

Chapters 3 to 7 contain mainly general theory. The field equations are derived and solutions obtained which permit calculation of the radiation patterns of simple linear elements. Geometrical optics, current distribution and aperture field distribution methods for calculating the radiation patterns of reflector type (e.g. paraboloid) aerials and the Kirchhoff diffraction formula for open apertures are given and the effects of different illuminations on the radiation patterns of both rectangular and circular apertures are examined. A short section is devoted to Babinet's principle as applied to electromagnetic fields. ( $H_z$  should be replaced by  $E_z$  in equation (127) in this section).

The general theory of propagation in waveguides and a qualitative treatment of the effects of obstacles and junctions in waveguides and coaxial lines is given in Chapter 7.

Chapters 8 to 13 present more specialised theoretical treatments of various aerial problems together with a considerable amount of practical information; this section of the book is probably the most valuable to engineers.

In Chapter 9, calculation of the radiation patterns of linear arrays is considered using the technique of the associated polynomial developed by Schelkunoff, but the converse problem of beam synthesis is not given as much attention as could be desired. Considerable space is devoted to the theory and practical characteristics of slot radiators. Waveguide and horn primary feeds are fully treated in Chapter 10, the theoretical and practical results presented being particularly useful for design purposes.

Chapters 11, 12 and 13 deal in detail with dielectric and metal plate lenses and reflectors for producing pencil beams and beams of other shapes. Dimensional tolerances and impedance matching are considered in all cases. Unfortunately no mention is made of the metallic delay lenses recently described by W. E. Kock and very little attention is paid to "cheese" aerials.

Chapter 14 considers some aerial installation problems, chiefly spurious reflections from surrounding objects and radomes in airborne radar.

The last two chapters are concerned with aerial measurement techniques and equipment. Impedance measurements by observation of standing waves on the aerial transmission line are considered, with special attention to the precautions necessary when making measurements on radiating elements. The factors involved in choosing a test site for radiation pattern measurements are dealt with in detail. Several methods for the determination of aerial gain are described and a section is devoted to a theoretical treatment of interaction between the transmitting and receiving aerials in such measurements.

This book will, without doubt, be of considerable value and interest to engineers responsible for the development of aerials for radio relay and radar systems.

S. B. M.



# A Parcel Label Machine

M. H. JAMES, D.F.H., A.M.I.E.E.

U.D.C. 383 : 681.17

The use of gummed and franked labels, instead of stamps, for attaching to parcels has advantages for both the public and the Post Office. This article describes a machine which has been developed for operation by counter clerks and which prints and issues gummed, franked labels of the required monetary value.

## *Introduction.*

A S part of a policy aimed at reducing the queues at post office counters by mechanising various counter processes, trials have been carried out with machines designed to print and issue gummed "franked" labels for attaching to parcels instead of ordinary postage stamps. The advantages of such machines include the saving of the time spent in finding and extracting the appropriate stamp or stamps from a portfolio, the elimination of the stamp-cancelling operation, the provision of a legible post-mark containing the name of the despatching office and the date, and simplification of balancing at the end of the counter clerk's shift. When a machine is used, the total value of "stamp" sales during a shift is arrived at by simply deducting the meter readings at the beginning of the shift from those at the end. Another feature of a parcel label machine, which was actually made use of during the trials at Romford, is the fact that, unlike a stamp portfolio, it can easily be used with one hand, thus enabling parcel acceptance duties to be undertaken by a one-armed counter clerk.

## *Trials with Experimental Prototypes.*

Two experimental machines, which were modified by "T.I.M." (Ticket Issue Machines) Limited, Cirencester, from their standard bus ticket machine to make them suitable for Post Office purposes, were installed for trial at Cambridge and Romford in 1947. The duration of this initial trial was about nine months, during which the machines issued 30,500 and 24,600 labels respectively. During this period no

faults occurred and the machines received no maintenance. As a result of this successful preliminary trial, it was decided to proceed with a large-scale trial with 100 machines, which will incorporate the mechanical improvements standardised by the makers in their latest bus ticket machines, as well as a number of modifications which the trials of the two experimental prototypes had shown to be necessary for Post Office purposes.

## *The Production Model.*

Fig. 1 shows two views of the production model parcel label machine (to be known as Parcel Label Machine No. 1) in its stand, in which it is supported on rubber buffers and to which it is secured by two easily released spring clips. The stand is an aluminium sand casting finished in brown crackle enamel and screwed to the counter.

The machine is designed to print labels of 12 different denominations, the range of values on the 100 new machines being 9d. to 1s. 9d. in steps of 1d. omitting 10d., but the design of the machine permits the choice of any 12 values within the range 1d. to 11s. 11d. with the proviso that the lowest value must be less than 1s. Fig. 2 is a full-size facsimile of a typical parcel label printed by the machine.

## *Operation of the Machine*

The denomination of the label required is selected by the operation of a dial somewhat similar to those fitted to automatic telephone instruments but arranged to operate in an anti-clockwise direction.

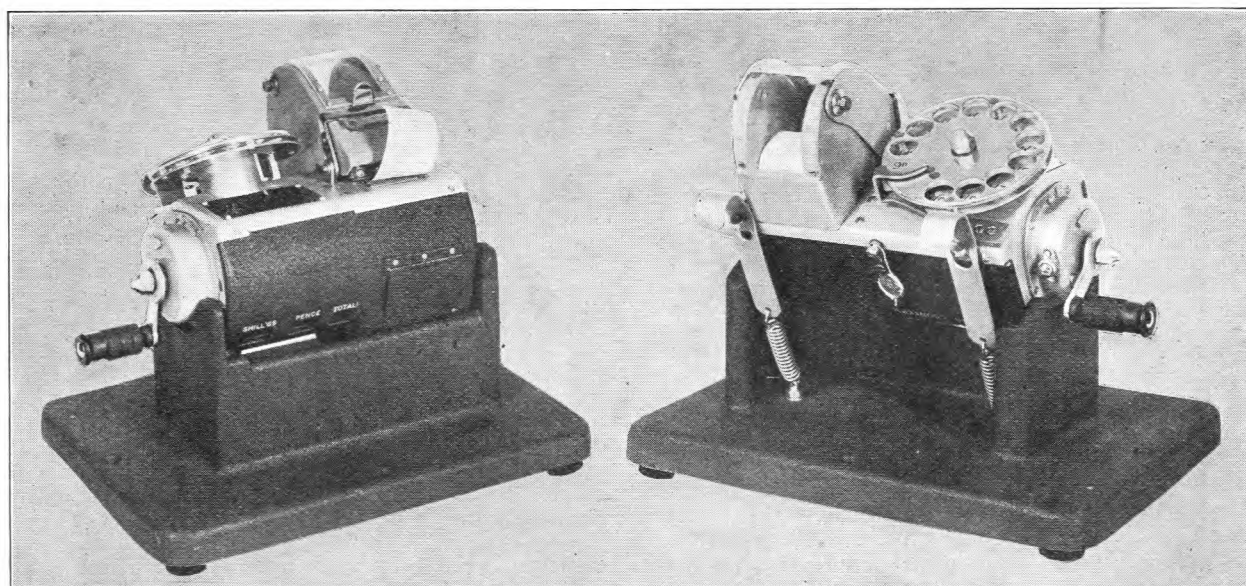

FIG. 1.—TWO VIEWS OF THE PARCEL LABEL MACHINE; LEFT, AS SEEN BY THE PUBLIC; RIGHT, AS SEEN BY THE COUNTER CLERK.

Unlike a telephone dial the dial on this machine is so arranged that pressure of the finger against the finger stop at the end of the anti-clockwise rotation latches the dial at the value selected and the machine will remain set to print this value of label until the dial is released, by moving the fingerstop in the opposite direction, when it will return under the influence of a spring to its normal, or lowest value position. Thus if several labels of the same value are required in

totals on the pence and shillings counters are increased by the appropriate amounts. In this connection it should be pointed out that there is no carry-over from the pence counter to the shillings counter, both shillings and pence being recorded on separate four-figure cyclometer type counters. Duplicate counters arranged to operate in unison are fitted as a check against possible failure of any counter.

#### *The Value Selection and Printing Mechanism.*

The labels are printed by a die plate (Fig. 4) carried on the periphery of a drum mounted on the main spindle. The latter is supported in ball bearings in the two end plates of the machine and carries at its right-hand end the operating handle. The steel die has etched on its surface the design of the label, similar to that shown in Fig. 2 with the exception of the value and date. The date is printed by a series of four small drums carried on a spindle mounted in the main printing drum and arranged so that the engraved characters representing the required date protrude through an aperture in the die. The date can be changed as required by rotating the drums by means of a bone stylus, access being obtained through a small opening in the bottom cover which is normally closed by a sliding shutter.

The value figures are engraved on the 12 facets of the bevelled periphery of a wheel mounted so that the appropriate facet registers with a rectangular aperture in the printing die when the dial is rotated to bring the finger hole, below which is engraved the value required, up to the finger stop. The dial rotation is transmitted to the value wheel through the medium of a rack and pinion mechanism.

#### *Inking Arrangements.*

During the first part of each revolution of the printing drum the die makes contact with a spring-loaded felt roller (Fig. 3) impregnated with ink and thus picks up sufficient ink to print one label. Re-inking of the felt roller is effected through a small aperture in the bottom cover, normally closed by a sliding shutter. In order to spread the ink evenly over the felt roller a spring-loaded steel roller (Fig. 3), which is in contact with it, is provided with a square-ended spindle by means of which it can be rotated by a small handle during re-inking.

#### *The Recording Mechanism.*

In addition to moving the appropriate value facet into the printing position, rotation of the dial also prepares the recording mechanism for adding the value of the label about to be issued to the totals on the shillings and/or pence counters. The counters are driven by ratchet wheels die-cast integral with their Mazak unit wheels, the ratchet wheels being operated by projecting cams on the striker discs (Fig. 4). The



FIG. 2.—FACSIMILE OF PARCEL LABEL.

succession it is only necessary to dial once. Also, if a label of the lowest denomination is required, dialling is not necessary.

The actual printing and issue of the label from a reel of plain gummed paper is effected by a single revolution of the handle at the right-hand end of the machine (when viewed from the operator's position) after pressing the adjacent release button. The printed label which then protrudes from the spool case can be torn off against the serrated edge of the tearer plate (Fig. 3).

During the printing of the label the totals on the numerical counters are advanced by one unit and the

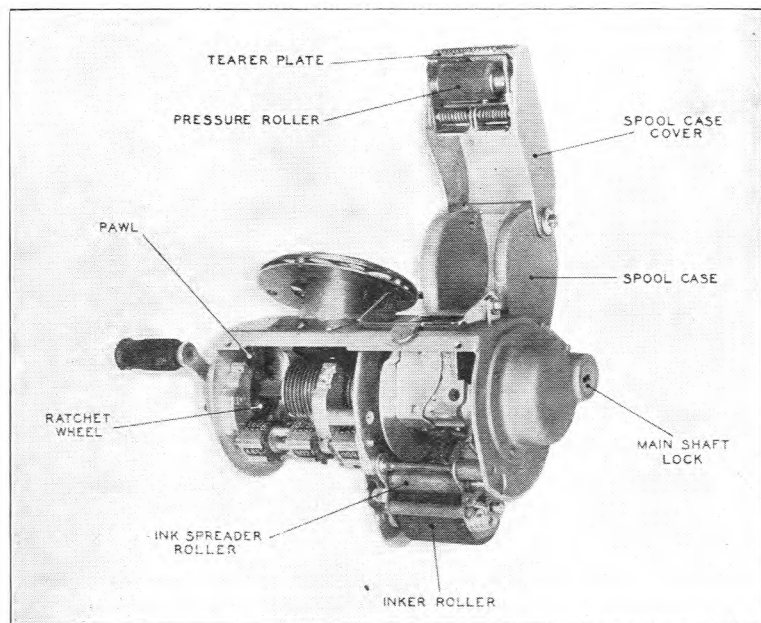

FIG. 3.—VIEW OF THE MECHANISM SHOWING INKING ARRANGEMENTS.



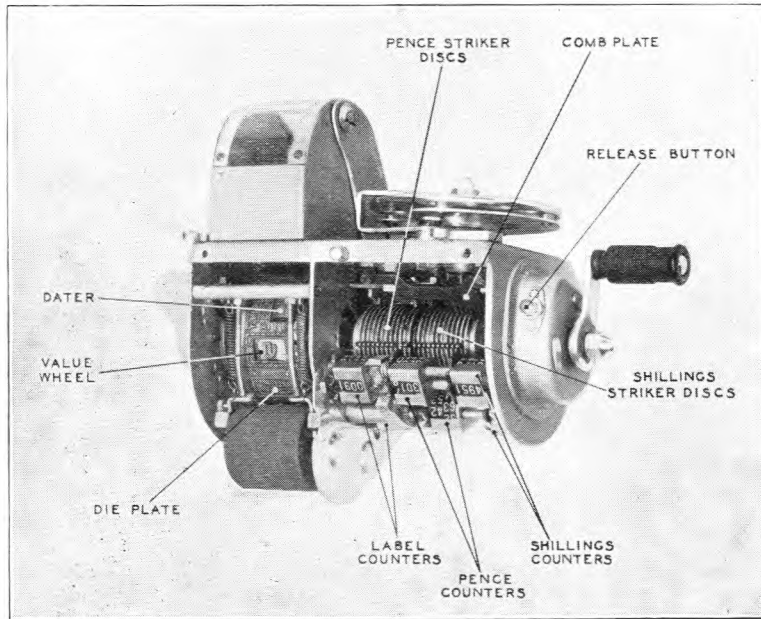

FIG. 4.—VIEW SHOWING VALUE SELECTION AND PRINTING MECHANISM.

latter are thin steel discs, with spacing washers between adjacent discs, mounted on a hub, whose bore is of square section, and which can slide along a squared portion of the main shaft. The hub and striker disc assembly is geared to the dial through a rack and pinion mechanism and the spacing between the striker discs is such that rotation of the dial through one finger hole pitch moves one striker disc out of alignment with a counter ratchet wheel and the adjacent disc into alignment. The striker discs are divided into two groups, one of which operates the shillings counters and the other the pence counters. Each striker disc carries a number of projecting teeth corresponding to the number of shillings or pence in the value represented by the finger hole in the dial with which that particular disc is associated. Thus when, after setting the dial to the value required, the mainshaft is rotated by the handle, a label of the required value is printed and the ratchet wheels of the value counters are rotated through a number of

tooth pitches corresponding to the number of teeth on the relative striker disc which, as already stated, is the same as the number of shillings and/or pence in the value. As there are 10 teeth on the ratchet wheel it follows that each tooth pitch moved by the wheel rotates the units drum one digit, thus the number added to the total on the counter corresponds to the number of pence or shillings in the value of the label being issued.

The numerical counters are operated by a striker fixed to the printing drum which adds one to the total on each numerical counter for every revolution of the drum.

#### *Prevention of Accidental or Deliberate Mis-operation.*

In order to prevent accidental or deliberate mis-operation of the machine a number of safeguards are incorporated; these include:

- (1) Sealing arrangements to prevent unauthorised access to the internal mechanism by removal of the bottom cover.
- (2) Barrel lock (Fig. 3) fitted in the left-hand end plate to allow the main shaft to be locked and the machine thus rendered inoperative during the absence of the operator.
- (3) Pawl and ratchet wheel (Fig. 3) on the main shaft to prevent the operating handle being turned backwards.
- (4) Comb-plate (Fig. 4) with which a number of the striker plates engage as soon as the main shaft begins to rotate from its rest position. By this means axial movement of the striker and hub assembly during the printing of a label is prevented and, as the striker assembly is mechanically geared to the dial and the value printing wheel, both the latter are locked once the printing of a label has commenced. Thus any alteration to the value setting during the process of printing and issuing a label is impossible.

## Book Review

"Electrical Technology." Sixth Edition. H. Cotton, M.B.E., D.Sc., M.I.E.E. Sir Isaac Pitman & Sons, Ltd., London, 1949. 600 pp. 455 ill. 18s.

This well-known text book covering the more important syllabuses in electrical technology, i.e. those for the B.Sc.(Eng.), I.E.E., City and Guilds and National Certificate examinations, has enjoyed a continued and deserved popularity since its first appearance in 1924. The extent of its appeal may be judged from the fact that 15 reprints have been necessary to date, and the book is now in its sixth edition.

For those equipped with a sound basic knowledge of electrical principles and elementary mathematics, it would be difficult to recommend a more useful and well-

written aid to a continuation of studies in this subject. Opportunity has been taken in the new edition to make a few minor corrections, and to add material, particularly to the section on Illumination; the general arrangement of the book is, Part 1—Direct Current (218 pp.), Part 2—Alternating Current (304 pp.), Part 3—Measuring Instruments (20 pp.), Part 4—Illumination (35 pp.).

Students will find the examination questions (with answers) a useful feature. Actually, these have remained substantially unchanged since the first edition, although the textual matter has increased by over 50 per cent.; perhaps the author could consider a revision of the present selection in due course.

G. E. S.

# A Survey of Modern Radio Valves

K. D. BOMFORD, M.Sc., A.M.I.E.E.

## Part 3.—Receiving Valves for Use Below 30 Mc/s

U.D.C. 621.385

The modes of operation of the more widely used types of receiving valve are discussed and contrasted and the various factors limiting their performance are discussed. A considerable amount of data is included on the physical form and the characteristics of modern valves, and some information is given about the time distribution of valve life and the conditions that conduce to long life.

### Introduction.

ORIGINALLY thermionic valves were used only in radio receivers, and when, somewhat later, larger valves came to be used in transmitters they were called "transmitting valves" to distinguish them from the smaller "receiving valves." This nomenclature has persisted to the present day, and although small valves now have innumerable uses, often far removed from radio receivers, the term "receiving valve" by common usage includes all types of small valves whatever their intended application.

The present range of receiving valves is so wide that a useful discussion of valve performance and construction in a short article is only made possible by severely restricting its scope. It is therefore proposed to refer only to vacuum receiving valves intended mainly for telecommunication use at frequencies below 30 Mc/s and to omit such devices as cathode-ray tubes, photoelectric cells, gas-filled valves and crystal detectors. Valves designed for use at frequencies above 30 Mc/s will be covered in later articles.

### THE BASIC VALVE CLASSES





There are five basic classes of thermionic vacuum valve in common use below 30 Mc/s, plus a sixth category covering such valves as triode-hexode frequency changers and other combinations of two valves in one envelope. These basic classes and their more common applications are summarised in Table 1, which also gives some indication of the functional differences by showing the form of the anode current/anode voltage characteristic for each class. The many applications of thermionic valves have naturally produced a large number of type variations within each class; for example, H.F. pentodes are available with several different base connections and assemblies, for mains or battery supplies, with glass envelopes or all-metal construction, with variable- $\mu$  characteristics, with low noise characteristics, and of normal size or in miniature construction.

These several classes of valve will now be considered briefly in turn.

### The Diode.

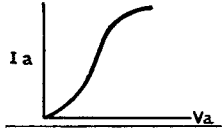
The diode finds wide application as a power rectifier and as a high frequency signal detector. The necessary properties of a power rectifier are adequate emission, high insulation to withstand the inverse cathode-anode voltage, low forward impedance to ensure high efficiency and good regulation, and adequate size so that thermal radiation and convection are sufficient to limit the working temperature to a safe value. The inherent properties of the vacuum diode are such that all these desirable qualities can only be economically achieved for small power

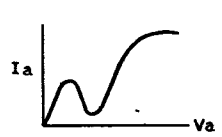
TABLE 1  
Basic Classes and Typical Applications of Valves for use below 30 Mc/s

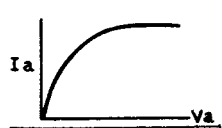
Basic Type	Predominant Characteristics	Typical Applications	Anode current ( $I_a$ )/anode voltage ( $V_a$ ) characteristic
1. Diode	Conducts in one direction only	Power rectifier ; signal detector ; modulator	
2. Triode	Low anode A.C. resistance ; high grid-anode capacitance	Detector ; amplifier ; oscillator	
3. Screen-grid valve	High anode A.C. resistance ; low grid-anode capacitance ; $I_a/V_a$ characteristic affected by secondary emission	Special circuit applications using the negative resistance characteristic	
4. Beam Tetrode	High anode A.C. resistance ; high mutual conductance	Small power amplifiers	
5. Pentode	High anode A.C. resistance ; low grid-anode capacitance	All types of circuit : amplifier ; oscillator ; modulator	
6. Multiple valves	Various	Frequency changer ; detection and amplification by one valve, etc.	

rectifiers, and where a D.C. power output of more than a few hundred watts is required the better efficiency and regulation of the mercury vapour rectifier has eliminated the vacuum diode. The latter is, therefore, only widely used for small powers, and here, too, it must compete with the metal rectifier which offers greater reliability but has a higher first cost.

The other major application of the diode, as a high frequency detector, places a different emphasis on the valve performance. In this case the essential requirements are for low anode-cathode capacitance and generally for small dimensions, in addition to a low forward and high back impedance. Diodes designed for high frequency use usually have an anode-cathode capacitance of only about two micro-microfarads.

Fig. 1 illustrates a small diode for use as a half-wave

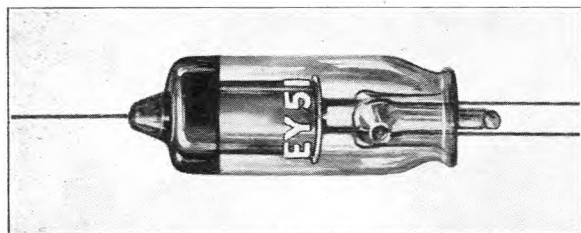

FIG. 1.—SMALL DIODE FOR USE AS HALF-WAVE RECTIFIER.

rectifier for supplying E.H.T. to a cathode-ray tube.

#### *The Triode.*

The performance of a triode valve is largely determined by the following three parameters; (a) the amplification factor,  $\mu$ , which is the ratio of the change in the anode voltage corresponding to a small change in grid volts, when the anode current is held constant; (b) the anode A.C. resistance, given by the ratio of a small change in anode volts to the corresponding change in anode current; and (c) the mutual conductance or ratio of change in anode current to a small change in grid voltage. Typical values of these parameters are given later, and will be discussed when considering the pentode.

In addition to these primary parameters the performance is also influenced by the interelectrode capacitances, input resistance and noise. In particular, the comparatively large anode-to-grid capacitance in the triode produces unwanted coupling between the anode and grid circuits, and although this capacitance may be smaller than the grid-cathode capacitance it is usually subjected to a signal voltage many times greater than that applied between grid and cathode and its effect on the valve input admittance is therefore very important: the effective grid circuit input capacitance is thereby greatly increased and if the anode load is reactive it produces an input resistance in addition. When the anode load is capacitive, energy is fed from the grid to the anode, and the input resistance is positive; if, however, the anode load is inductive energy is fed from the anode to the grid circuit and the input resistance is negative; in this case the circuit will be unstable and prone to oscillation.

Even at audio frequencies the high input capaci-

tance of a triode has appreciable shunting effect on the anode load of the preceding valve and can degrade the high frequency response, while its use in such broad band amplifiers as television video amplifiers is out of the question. For a H.F. amplifier with a tuned anode load the triode can only be used if a neutralising capacitance is added and so connected that it passes a current from grid to anode with exactly the correct magnitude and phase to neutralise the effect of the current in the anode-grid valve capacitance. Such neutralising circuits are required in very high power amplifiers where triodes are still used, but in receiving valves the trouble has been tackled at the source by reducing the anode-grid valve capacitance to negligible proportions.

#### *The Screen-Grid Valve.*

A major reduction in anode-grid capacitance is brought about by the addition of an electrostatic screen between the grid and anode of a triode. This screen grid is of mesh construction and is maintained at a D.C. potential of the same order as the anode potential. The primary electron velocity at the screen is therefore high and only those electrons flowing along paths in direct line with the wires of the screen are intercepted so that the screen current is usually only about one-fifth of the anode current.

Because of its high potential and proximity to the anode the screen can, however, readily attract the comparatively slow-moving secondary electrons released from the anode by the primary electron bombardment and the magnitude of this effect will depend upon the anode voltage. The secondary emission from the anode will increase with anode voltage because of the increased arrival velocity of the primary electrons, but the potential gradient between the screen grid and the anode accelerating the secondary emission electrons to the screen will decrease as the anode voltage is increased from a low value up to a potential comparable with the screen voltage. Over a restricted anode voltage range an increase in the anode voltage actually increases the flow of secondary emission electrons from anode to screen by more than the increase in the primary electron flow, so that the resultant anode current decreases as the anode voltage is increased and produces a negative resistance characteristic. The resulting shape of the anode current/anode voltage curve is shown in Table 1.

The negative resistance characteristic of the screen-grid valve is made use of in various circuit applications, for instance in the dynatron oscillator where it is used to maintain oscillations by neutralising the positive resistance of a tuned circuit. Except for such special applications the screen-grid valve has, however, been totally replaced by the pentode valve.

#### *The Pentode Valve.*

The pentode is a later development of the screen-grid valve in which there is a suppressor grid connected to the cathode, between the anode and screen grid to prevent secondary emission electrons from reaching the screen. The pentode therefore preserves the low anode-grid capacitance of the screen-grid valve while it eliminates the troublesome kink in the anode



voltage/anode current characteristic. The pentode is therefore preferred to triode and screen-grid valves for practically all small power applications and its only disadvantage is that it has a higher shot noise than the triode valve.

Fig. 2 illustrates the construction of typical triode,

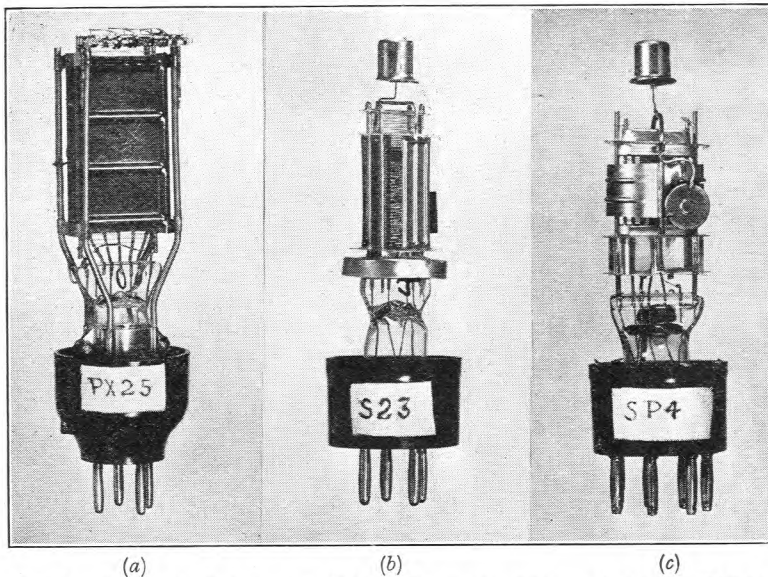

FIG. 2.—TYPICAL RECEIVING VALVE CONSTRUCTION; (a) SMALL POWER OUTPUT TRIODE; (b) SCREEN-GRID H.F. VALVE AND (c) LOW SLOPE H.F. PENTODE.

screen-grid and pentode valves. All these use the glass pinch form of construction which was universal in the past but is now being replaced for H.F. use by flat base envelopes as illustrated later.

A comparison between the values of the more important parameters of typical pentodes and triodes is given in Table 2. The two major differences are the very much higher anode A.C. resistance of the pentode, and the much larger anode-grid capacitance of the triode. The latter leads to a striking difference between the effective input capacitance of a pentode and a triode of otherwise comparable performance. The low slope H.F. pentode, for instance, will have a working input capacitance which is greater by not more than 50 per cent. over the cold grid-cathode capaci-

tance of 7 micro-microfarads, but the medium impedance triode with about the same mutual conductance will have a working input capacitance of about 54 micro-microfarads compared with its cold grid-cathode capacitance of 3.5 micro-microfarads, when used with a high resistive load.

The figures of Table 2 also show that a much higher anode-grid capacitance is permitted for the small power output pentodes designed only for audio frequency use, so that a coarser mesh screen grid can be used and this is reflected in the proportionately smaller screen grid current. The coarser screen grid also allows the anode potential to have some influence on the field near the cathode and this has the effect of reducing the anode A.C. resistance.

#### The Beam Tetrode Valve.

The beam tetrode valve is an alternative to the pentode for small power valves where an anode current of about 40 milliamps. or greater is used, and it effectively suppresses secondary emission from the anode without the use of a suppressor grid. This is achieved by compressing the electron stream into flat beams by suitably placed deflecting electrodes at cathode potential and by aligning the grid and screen grid wires. The electron stream is focused at a point between the screen and anode and the resultant increase in the density of the negatively charged electrons causes a depression in the potential between the screen and anode which

TABLE 2  
Parameters of Typical Receiving Valves

Type of valve	Amplification factor $\mu$	Mutual conductance $g$ (mA/V)	Anode A.C. resistance $r$ (ohms)	Interelectrode capacitances			Anode current at 250V (mA)	Screen current at 250V (mA)
				anode to grid	anode to cathode	cathode to grid		
				(micro-microfarads)	(micro-microfarads)	(micro-microfarads)		
Medium impedance triode	20	2.0	10,000	2.5	3	3.5	5	—
Small power triode	9	3	3,000	3.5	4	7	20	—
Low slope H.F. pentode	6,000	3	$2 \times 10^6$	0.003	8	7	5	1.5
High slope H.F. pentode	7,000	7	$10^6$	0.003	5	8	10	3
Output pentode	64	8	8,000	0.5	7	14	40	5
Small power beam tetrode	140	7	20,000	1.0	10	15	80	6

substantially repels the secondary emission electrons back to the anode.

The anode voltage/anode current characteristic of the beam tetrode differs from the pentode characteristic in that it rises much more steeply at low voltages and has a sharper knee, and the straight part of the characteristic therefore extends over a wider anode voltage range. At first sight this suggests that a larger anode swing is possible with a beam tetrode than with a pentode but in practice the secondary emission is not entirely suppressed for low anode currents in the beam tetrode and this may limit the working anode voltage range to a value no greater than that obtained with a comparable pentode. The amount of distortion produced by both types of valve is about the same; there is therefore generally little to choose between them, except for the minor point that the screen current of the beam tetrode is lower than for a similar pentode valve taking the same anode current.

#### Valve Requirements.

Most receiving valves are used in conventional circuits under reasonably stable conditions and this makes it possible to list the following general requirements. No significance should be attached to the order in which they are quoted, however, and certain requirements do not, of course, apply to diodes.

1. High mutual conductance.
2. Small interelectrode capacitance.
3. Low noise.
4. High input impedance.
5. Low harmonic and intermodulation distortion.
6. Low power consumption.
7. Long life.
8. Uniformity between valves of the same type.
9. Small size.
10. Low cost.

The degree to which these properties are combined in any one valve will, of course, vary because many of them conflict. For instance, a high mutual conductance tends to make the input resistance low at high frequencies while greater uniformity generally involves a higher cost.

When new and unusual applications are involved the stress that must be placed on one particular factor may heavily outweigh that on many others; on the other hand, there are certain requirements that can rarely be ignored, one of which is the need for long life. This is of special importance in the Post Office because of the effect on reliability and maintenance.

#### VALVE PERFORMANCE FACTORS

The magnitude of the mutual conductance and interelectrode capacitances of typical modern receiving valves have already been mentioned and these two factors can be combined to give a comparative indication of the merit of a valve as a high frequency amplifier.<sup>1</sup> The usual factor used is the ratio of mutual conductance to the sum of the input and output valve capacitances ( $g/c$  ratio) and this factor is of particular

value in the case of valves designed for broadband amplifiers where it is a measure of the stage gain that can be realised.

In calculating this performance factor, working values of capacitance are taken which allow for valve holder and wiring capacitances and these are usually assessed at 1.0 micro-microfarads on both input and output. This gives the cold working factor, but in addition the hot working factor which allows for the increase in input capacitance under running conditions is more often used. The figures quoted in this article are for the hot working condition.

The best figure of merit obtainable at the moment is about 0.5 milliamps. per volt per micro-microfarad for a small high-performance H.F. pentode, and as will be seen later this is substantially better than the figure obtainable 10 years ago. The medium slope H.F. pentodes have a  $g/c$  factor of about 0.1 only.

Convenient as it is the  $g/c$  ratio yields only part of the necessary information for assessing the true merit of an amplifying valve. In the first place the valve capacitance is increased by the valve holder and stray wiring capacitances and the larger valve will suffer a smaller percentage increase in effective capacitance than a small valve with the same initial  $g/c$  ratio. On the other hand, the absolute magnitude of the capacitance should be kept to a minimum since it limits the magnitude of the resistance load that can be built up over a given frequency range, and thereby limits the wideband amplification obtainable. With tuned couplings it is also desirable, for stability reasons, that the valve capacitance should form as small a portion of the total tuning capacitance as possible.

For tuned amplifiers with their high input and output circuit impedances the valve input impedance may be a limiting performance factor at frequencies exceeding about 10 Mc/s and its effect will now be discussed.

#### Input Resistance at High Frequencies.

As the frequency is increased above about 10 Mc/s the input conductance between grid and cathode rises rapidly and must be taken into account. This conductance has two components of similar magnitudes; the first arises because the electron transit time ceases to be a negligible fraction of the time for one cycle of the applied signal,<sup>2</sup> and the second is due to the inductive reactance of the cathode lead.<sup>3</sup> This input conductance is a major factor in valve performance at frequencies above 30 Mc/s and will be considered again in a later article. However, its effect below 30 Mc/s cannot be ignored where tuned high impedance couplings are used, and a brief indication of the magnitudes to be expected will be given.

The conductance due to transit time is

$$G_1 = K'g\omega^2t$$

and to cathode lead inductance

$$G_2 = g\omega^2LC$$

<sup>2</sup> W. R. Ferris: "Input Resistance of Vacuum Tubes as Ultra High Frequency Amplifiers." *Proc.I.R.E.*, January, 1936.

<sup>3</sup> M. J. O. Strutt and A. Van der Ziel: "The Causes for the increase of the admittance of Modern H.F. Amplifier Tubes on Short Waves." *Proc.I.R.E.*, August, 1938.

<sup>1</sup> C. Lockhart: "Figure of Merit of H.F. Valves." *Electronics and Television*, March, 1941.

where  $K'$  is a constant depending upon the electrode geometry and potentials,  
 $g$  is the mutual conductance,  
 $\omega$  the angular frequency,  
 $t$  the electron transit time,  
 $L$  the cathode lead inductance  
and  $C$  the cathode to grid capacitance.

The combined conductance is therefore proportional to  $g\omega^2$  or, more conveniently, the input resistance can be expressed as

$$R = K/gf^2$$

where  $K$  is a new constant and  $f$  is the frequency.

As an indication of the magnitudes of the input resistance to be expected, Table 3 shows typical

TABLE 3

*Approximate Input Resistance at 30 Mc/s of Various Types of Receiving Valve*

Type of valve	Input resistance at 30 Mc/s (ohms)
Medium slope H.F. pentode	25,000
High slope H.F. pentode	8,000
High slope, miniature construction, H.F. pentode	20,000
Acorn construction, medium slope H.F. pentode	200,000
High slope power pentode	1,000

values at 30 Mc/s for several types of valve, and as would be expected the smaller valves with their better transit times, and those with low mutual conductance, have the highest input resistance. The magnitude of the valve damping is also illustrated by the curves of Fig. 3, which show how a typical tuned circuit

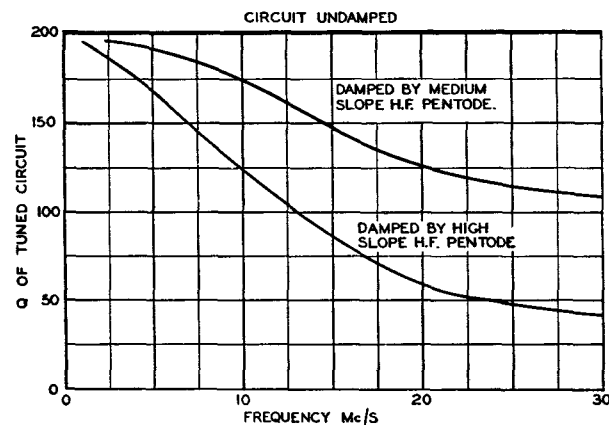

FIG. 3.—VARIATION OF  $Q$  WITH FREQUENCY FOR A TYPICAL TUNED CIRCUIT DAMPED BY THE INPUT RESISTANCE OF A VALVE.

with an undamped  $Q$  value of 200 has its effective  $Q$  reduced when placed in turn in the grid circuits of a high slope and a low slope H.F. pentode. It is worth noting that the reduced damping largely offsets the gain reduction resulting from a lower mutual conductance besides giving a sharper selectivity characteristic.

### Valve Noise.

The random rate of arrival of the electrons at the anode produces a small fluctuating current which appears as a background noise to the required signal and therefore places a lower limit on the input signal level for a given signal-to-noise ratio. The noise energy is uniformly distributed over the frequency spectrum and the magnitude of the fluctuating current,  $i$ , is given by

$$i^2 = F^2 2I_0 e B$$

where  $I_0$  is the emission current,

$e$  the electron charge,  $1.60 \times 10^{-19}$  coulombs,

$B$  the bandwidth in cycles per second

and  $F^2$  a factor depending upon the construction and conditions of operation of the valve.

The factor  $F^2$  has its largest value, of unity, in a diode operated under temperature-limited conditions and the noise current can be calculated with sufficient accuracy to make such a diode useful as a reference noise source for measurement purposes. As mentioned in Part 2 of this series, the presence of the space charge smooths out the variations to an appreciable extent and in a triode operating under space charge conditions  $F^2$  is as low as 0.05. Pentodes are appreciably noisier than triodes and the factor  $F^2$  is dependent upon the ratio of screen to anode current and an  $F^2$  value of 0.3 is common.

For ease in comparing the noise generated by different valves and for estimating the combined valve noise and the thermal agitation noise generated externally in the grid circuit, it is convenient to assess the valve noise in terms of the resistance in the grid circuit whose thermal agitation noise appearing at the anode would equal the valve noise. Such a resistance, at room temperature, has the value

$$R_e = \frac{20,000 I_a F^2}{g^2} \text{ ohms}$$

where  $g$  is the mutual conductance in milliamps. per volt and  $I_a$  the anode current in milliamps. It will be noted that  $R_e$  depends upon  $1/g^2$  and if  $g$  is changed by either valve ageing or alteration in the operating conditions then  $R_e$  must be changed accordingly; in other words, the noise actually originates as a current variation in the anode circuit and is only referred to the grid circuit for convenience.

Typical values of equivalent noise resistance for various classes of valve are shown in Table 4. In the special low noise pentode a lower  $F^2$  factor is obtained by beaming the electron stream to miss the wires of the screen grid, but in order to reduce the screen current effectively in this manner a more open mesh screen must be used. As a result a larger anode-to-grid capacitance and a lower internal resistance must be tolerated. The high noise resistance of the frequency changer illustrates the need for H.F. amplification before the frequency changer in a superheterodyne receiver to achieve a better signal-to-noise ratio, particularly at high frequencies where the step-up that can be provided by a tuned grid circuit is necessarily small.

There are other sources of noise: at frequencies below 100 kc/s oxide-coated cathodes cause noise due to the Flicker Effect, i.e. to variations in the emitting



surface, which may be more troublesome than the shot noise; increased noise also results from a poor vacuum, low insulation resistance and impurities on the inside of the valve envelope.

#### Non-linear Distortion.

The non-linear relation between grid voltage and anode current generates harmonics and intermodulation products of the various frequency components in the signal. For such uses as the amplification of multichannel telephone signals where the intermodulation requirements are unusually severe this distortion is a limiting factor in design. Since the unwanted products arise from the inherent valve characteristics they must, in general, be accepted and restricted to tolerable magnitude by limiting the signal level and by using negative feedback.

TABLE 4  
Equivalent Noise Resistance of Various Types  
of Receiving Valve

Type of valve	Smoothing factor $F^2$	Mutual conductance (Milliamps per volt)	Equivalent noise resistance (ohms)
Medium slope low current triode amplifiers	0.05	2	1,000
Medium slope H.F. pentode amplifier	0.3	2	14,000
Special low noise low slope pentode (with small screen current)	0.08	2	4,000
High slope H.F. pentode amplifier	0.3	9	900
Triode-hexode frequency changer	—	—	200,000

#### Power Consumption.

Although the signal power handled by receiving type valves is generally very small the efficiency of the valve is so poor, often less than 1 per cent., that there is appreciable power dissipation which the equipment designer must take into account. The problem has been accentuated by the introduction of miniature valves in which the decrease in power consumption is far less than the decrease in size, when compared with the normal receiving valves. These miniature valves, with miniature components, have made possible large reductions in equipment size, and designers have naturally exploited this to the full since space is usually expensive. This has been particularly so in the case of airborne equipment where the need for economy in space and weight provides a major stimulus. Since the heat from a valve is dissipated by convection and radiation in roughly equal parts the designer must take care to provide adequate ventilation and sufficient surface area for radiation, and the mechanical design of telecommunications equipment therefore is becoming

more and more influenced by this problem of heat dissipation.

To see the problem in its true perspective it is not sufficient to consider a single unit with only a few valves but it is necessary to visualise closely spaced racks of equipment using, perhaps, up to 100 valves per rack; or, alternatively, to consider electronic computing machines with thousands of valves in a relatively confined space. In such installations heat dissipation is becoming a major consideration and obviously any reduction in power consumption which improved valve design may achieve will be more than welcome.

#### Progress in Valve Development.

As an indication of the progress made in small receiving valves a comparison has been made in Table 5 of the characteristics of typical high mutual conductance pentodes available over the last 15 years. It will be seen that although the mutual conductance has shown no increase, indeed it has fallen slightly, the  $g/c$  ratio, and the input resistance, taking the value at 30 Mc/s as a criterion, have improved appreciably, due mainly to the striking reduction in size. It is doubtful whether the size can be further reduced without an appreciable reduction in power dissipation and close attention to detail will be needed in achieving any further appreciable improvement in performance. It is interesting to note, however, that a new H.F. pentode<sup>4</sup> has recently been described which has a wideband performance factor some 70 per cent. better than the previous best high slope pentode. The valve uses a planar electrode structure with a grid-cathode spacing of only 0.0025 in. and a very close grid winding pitch that necessitates a grid wire of only 0.0003 in. in diameter. This wire, which is so fine that it is described as being one-tenth of the diameter of a human hair, must be wound at a tension of about half its breaking strength in order to obtain a rigid and stable grid structure. Whether such a grid-cathode structure can be economically mass-produced and whether it will be sufficiently reliable for normal use remains to be seen, but it is an indication of the manufacturing problems that must be faced if the performance of the conventional valve is to be appreciably improved.

There remain two very important properties, not listed in Table 5, where considerable improvement can, and it is hoped will, be made, namely, an increase in useful life and greater uniformity between valves of the same type.

#### VALVE LIFE





Valve failures may be conveniently considered under two headings, suddenly occurring failures, and a gradual falling off in emission until the valve must be replaced.

The lives of a large batch of valves all made at the same time and put into service and run continuously under identical conditions, generally conform to the following pattern. During an initial period of about 100 hours there are several failures, some of which

<sup>4</sup> G. T. Ford, "The 404A—A Broadband Amplifier Tube." *Bell Laboratories Record*, February, 1949.

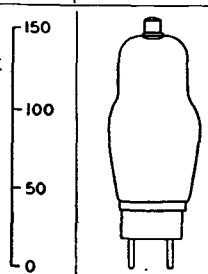
TABLE 5

*A Comparison Showing the Development of High Performance Pentodes over the Last 15 Years*

DATE :—	1935	1938	1940	1945
SCALE (mm)				
Manufacturer's Code	N43	SP41	EF50	—
C.V. No.	CV1675	CV1699	CV1091	CV138
Heater voltage	4.0	4.0	6.3	6.3
Heater current (amps.)	2.0	0.95	0.3	0.3
Anode current at 250V (mA)	40	11	10	10
Screen current at 250V (mA)	10	2.8	3.0	2.5
Total power consumption (watts)	20.5	7.3	5.1	5.0
Mutual conductance, $g$ (mA per V)	10	8.5	6.5	7.5
Input capacitance ( $\mu\mu\text{F}$ )	25	15	10	10
Output capacitance ( $\mu\mu\text{F}$ )	20	5.6	5.6	3
Factor of merit $g/c$ (hot working)	0.22	0.38	0.37	0.50
Input resistance at 30 Mc/s (ohms)	1,000 approx.	5,600	11,000	22,000
Equivalent noise resistance (ohms)	4,000 approx.	850	1,200	800

may occur during the testing and lining-up of the equipment before it is passed into commercial operation. Following this initial shake-down period the performance of the valves in terms of the mutual conductance or anode current often shows a small improvement before the long gradual deterioration sets in. The shape of this performance/time characteristic will be widely different for different valves, and if the end of the useful life is determined by a specified value of mutual conductance or anode current the lives of the individual valves will have a random distribution. In addition, there will be the usual small sprinkling of catastrophic failures due to breakages, burnt-out filaments or heaters, or short-circuits between electrodes, some of which may be due to faults developing in the associated circuit.

It is the lack of uniformity that complicates the maintenance problem and makes it desirable to check one of the significant valve parameters periodically for an indication of when a valve should be changed.

#### *The Exponential Distribution.*

Analysis of the failure of batches of identical valves both here<sup>5</sup> and in America<sup>6</sup> indicates that after the very short initial shake-down period the failures follow an exponential distribution. When this is so, the following important deductions may be made :—

- The rate of failure, expressed as a percentage of the valves remaining, is constant.
- Purely from life considerations there is no point in indulging in preventive maintenance and changing all valves at fixed intervals, because the new valves have the same probability of failure as those they replace.
- The results of tests over a restricted period can be extrapolated into the future to forecast both the expected rate of valve failures and the average life expectancy, the latter corresponding to the time when 37 per cent. of the valves remain in service.

It is by no means certain, however, that all valves under all conditions have an exponential distribution and these deductions must, therefore, be applied with caution.

#### *The Effect of Operating Conditions on Valve Life.*

Valves are generally provided with sufficient emitting material to last for many times the average life normally obtained, and as would be expected from the random nature of the failures, the reasons for cathode poisoning are varied, complex and still not entirely understood.<sup>7</sup>

Much can be done, however, to prolong valve life by careful control of the operating conditions and there is fairly general, but not unanimous, agreement on the following points :—

- It is worth while to pre-age valves by running under normal conditions for about 100 hours to weed out the early failures.
- An improved life is obtained by under-running the heaters by about 10 per cent. on most commercial mass-produced valves.

<sup>5</sup> N. W. Lewis : "Notes on the Exponential Distribution in Statistics." *P.O.E.E.J.*, April, 1948.

<sup>6</sup> D. K. Gannett : "Determination of the Average Life of Vacuum Tubes." *Bell Laboratories Record*, August, 1940.

<sup>7</sup> G. H. Metson : "Poisoning Effects in Oxide-Cathode Valves." *P.O.E.E.J.*, January, 1949.

- (c) All electrode and heater voltages should be as stable as possible.
- (d) A valve that has its supplies periodically switched on and off will have a shorter life than one that is continuously running.
- (e) Valves should be well ventilated and the smaller the fluctuations in ambient temperature the better.

*Valve Construction.*

The salient constructional points of a receiving valve can be appreciated from the sectional drawing in Fig. 4 of a typical modern high performance H.F.

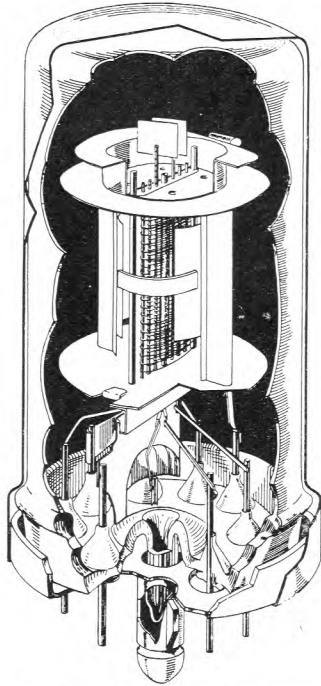

FIG. 4.—SECTIONAL DRAWING OF TYPICAL MODERN HIGH PERFORMANCE H.F. PENTODE.

pentode (type EF50). The most obvious development has been the replacement of the glass pinch, which previously supported the electrode structure, by a flat glass base through which the valve connecting pins pass. This construction has considerably reduced the inductance of the leads between the electrodes and pins, and the capacitance between the leads, with consequent improvement in the high frequency performance of the valve. It will be noticed that despite the shortness of these connections it is worth while reducing the cathode lead inductance still further by using a comparatively large section metal strip for the pin connection to this electrode.

Other features which will be noted are the rigid electrode supporting bracket, the grid cooling fins mounted on a top extension of the grid supporting

wires and the getter container on the metal rim of the upper electrode supporting disc.

A striking feature of contemporary valve construction is the extent to which sizes have been reduced in recent years for certain special applications. These small valves were developed initially to meet war requirements but are now finding many peacetime applications. Fig. 5 illustrates clearly the very

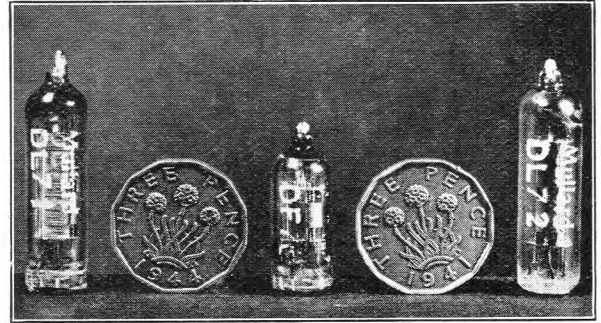

FIG. 5.—SUB-MINIATURE VALVES USED IN "MEDRESCO" HEARING AID, WITH THREEPENNY PIECES FOR COMPARISON OF SIZE.

small size of the so-called sub-miniature valves which still have a performance comparable with the much larger standard type of receiving valve.

*Conclusion.*

Having reviewed the present state of receiving valve performance it is interesting to speculate on the future trend of development. Any appreciable increase in the performance of the conventional types of valve will only be obtained at the cost of a considerable increase in the intricacy of the valve construction, and the increase in mutual conductance obtained by the adoption of a very close grid-cathode spacing and grid winding pitch is a case in point. Whether the difficulties of manufacture will justify the wide use of such a valve is a moot point, but there is no doubt about the need to improve the uniformity and life of the existing types of valve and considerable efforts will undoubtedly be made in this direction.

Conventional valves will also have to meet increasing competition from devices operating on different principles, such as the secondary emission multiplier with its high gain but at present rather indeterminate life. Even more intriguing possibilities are opened up by the comparatively recent advent of the crystal triode, or transistor, which may find widespread application in circuits handling very small powers at frequencies below 10 Mc/s.

*Acknowledgments.*

Acknowledgments are due to Mullard Electronic Products, Ltd., who kindly supplied the photographs of Figs. 1 and 5 and also gave permission for the publication of Fig. 4 which was prepared from a valve of their manufacture.



# A New Design of Wheatstone Bridge

W. L. SURMAN, A.M.I.E.E.

U.D.C. 621.317.733

The disadvantages of the Post Office Box type of Wheatstone bridge have been eliminated in a new design known as Wheatstone Bridge No. 2. The new item described in this article is self-contained, measures resistances from 1 to 9,990 ohms and has an accuracy of  $\pm 0.5$  per cent. to  $\pm 1.0$  per cent. A useful feature of the instrument is that the switch controlling the electrical alteration of ranges is combined with a visual indication of the position of the decimal point.

## Introduction.

FOR as many years as the majority of the staff of the Post Office Engineering Department will remember the loose plug type of Wheatstone bridge, generally known as the Post Office Box, has been used where accurate measurement of resistance is required. It has been felt for a long time, however, that the design of the instrument does not lend itself to modern usage and production methods, and two new bridges have been introduced which, it is expected, will completely supersede the Post Office Box in the course of time.

Of these two, which are known as Wheatstone Bridges Nos. 2 and 3, the No. 3 is a commercial item having accuracy comparable with the Post Office Box but with decade dials. The Wheatstone Bridge No. 2, however, has been developed by the Engineering Department and it is the purpose of this article to describe it in some detail.

## General Requirements.

The Post Office Box is capable of measuring resistance to within  $\pm 0.02$  per cent., but for the greater proportion of tests where a resistance measurement is required, this order of accuracy is unnecessary. The set has the disadvantages of not being self-contained, requiring a separate battery and galvanometer, the loose plugs being easily lost, and the result not being directly read.

The other methods of resistance measurement in general use are the Bridge Megger, the "Voltmeter Deflection" method using either the test desk voltmeter or the Detector No. 4 and, occasionally, a multi-range instrument such as the Avometer. All these methods have considerable disadvantages however. Thus, the Bridge Megger is rather cumbersome and the testing voltage is usually too high. The "Voltmeter Deflection" method relies on the accuracy of two separate readings of voltage, and the estimation of the resistance, either by calculation, or by the use of tables which include only a selected number of resistances, the remainder being obtained by interpolation. It is doubtful whether the accuracy of this method is better than  $\pm 10$  per cent.

The multi-range meter gives a direct reading of resistance value and is very convenient, but only a comparatively small part of the scale can be read and relied upon to better than 10 per cent. The scale on any range extends from zero to infinity and, unless the user realises the limitations of the instrument, he is likely to place unwarranted reliance on the apparent accuracy. While this is adequate for point-to-point testing where an order of resistance only is to be ascertained, it is of doubtful value for the majority of resistance measurements.

It was decided, therefore, that for general use a

simplified Wheatstone bridge was needed and that the following requirements should be met.

- (i) Measurement of resistances from 1-10,000 ohms.
- (ii) Completely self-contained.
- (iii) Reasonably cheap.
- (iv) Capable of measuring resistance to limits of  $\pm 0.5$  per cent. to  $1.0$  per cent.
- (v) Direct reading and simple in operation.
- (vi) To contain, as far as possible, standard Post Office parts.

## Design Considerations.

An accuracy of  $\pm 0.5$  per cent. can be obtained by three significant figures for all values except those commencing with 1, for which three significant figures will give an accuracy of not worse than  $\pm 1.0$  per cent.; it is, therefore, only necessary to provide three decade switches controlling the variable arm of the bridge. As the resistances to be measured range from 1.00-10,000 ohms, this can be met by four ranges 1.00-9.99 ohms, 10.0-99.9 ohms, 100-999 ohms and 1,000-9,990 ohms.

Since the alteration of range consists, essentially, of shifting the decimal point, it was considered desirable that the switch controlling the electrical alteration of range should be combined with a visual alteration of the decimal point. It was also decided that to simplify winding of the coils no individual resistor should be less than 1 ohm, and that to obtain the required sensitivity with a robust commercial galvanometer the maximum ratio to be used would be 100 to 1.

## Circuit Details.

Three fixed ratio arms of 100 ohms-100 ohms, 100 ohms-10 ohms, and 100 ohms-1 ohm are used, the 100-100 being included in the ranges of 100-999 and 1,000-9,990 ohms and the others in the ranges 10.0-99.9 and 1.00-9.99 ohms, respectively.

The actual resistance value of the ratio arms is not critical, but they are wound to have a correct ratio to within  $\pm 0.1$  per cent. which is a reasonably easy condition to obtain. The variable arm consists of nine  $\times 1,000$  ohms, nine  $\times 100$  ohms, nine  $\times 10$  ohms and nine  $\times 1$  ohm resistors each being correct to within  $\pm 0.5$  per cent. The first three groups of these resistors are used in the range 1,000-9,900 ohms and the last three in the remaining ranges.

The selection of the ranges and the adjustment of the resistors is made by means of rotary type switches. The range-selection switch both alters the ratio arms and selects the correct groups of resistors to be used.

Since there are only three dials, it is necessary for the resistors nine  $\times 100$  and nine  $\times 10$  to be connected to two alternative controls; in the 1,000-9,990 range, the 100's and 10's being associated with the

2nd and 3rd dials, respectively, and in the other ranges with the 1st and 2nd dials.

The variable resistance arm is deliberately limited to 3 dials for two reasons:—

- (i) It avoids giving a false impression of accuracy to more than three figures, and
- (ii) it obliges the operator to use the range which gives the best accuracy obtainable.

Schematic diagrams of the four ranges are shown in Fig. 1, and the selection of the groups of resistors in

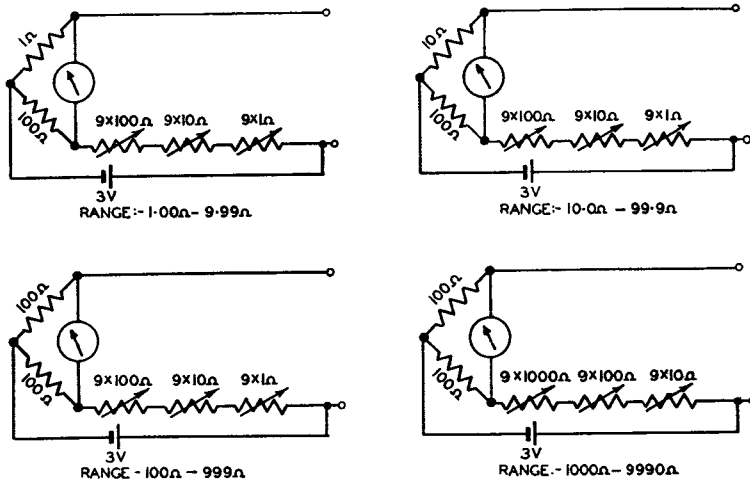

FIG. 1.—CIRCUIT ARRANGEMENTS FOR EACH OF THE FOUR RANGES.

Fig. 2. In these diagrams the essentials only have been shown for the sake of clarity.

The galvanometer used is a moving-coil centre-zero instrument having a full scale deflection of  $12\frac{1}{2}$  microamps. on either side of zero. It was found that the damping exerted by the circuit was more than

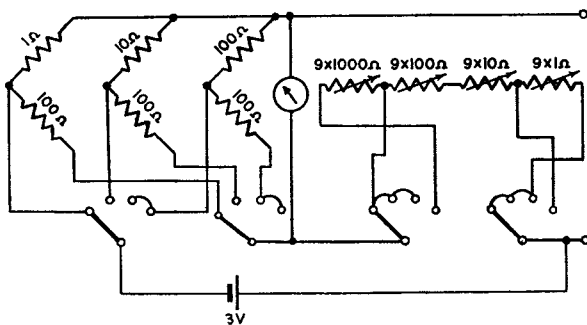

FIG. 2.—DIAGRAM SHOWING CONNECTIONS TO THE RANGE SWITCH.

adequate and it was decided to dispense with the normal metal former for the moving coil and make it self-supporting.

The optimum resistance,  $G$ , for a galvanometer is given by the formula,

$$G = \frac{(P + Q)(R + S)}{P + Q + R + S}$$

where  $P$  and  $Q$  are the resistances of the ratio arms and  $R$  and  $S$  are the resistances of the variable arm and the unknown resistance, respectively.

For the least sensitive condition of the bridge, i.e., when measuring an unknown resistance of the order of 10,000 ohms,

$$G = \frac{(200)(10,000 + 10,000)}{20,200} = 198 \text{ ohms, approx.}$$

It is difficult to obtain a robust commercially produced instrument having a resistance as low as this, and one having a resistance of approximately 350 ohms was adopted as being the lowest practicable value.

In the least sensitive condition, i.e., when measuring a resistance of the order of 10,000 ohms, the deflection of the galvanometer for a 0.5 per cent. difference in resistance is easily detectable as indicated by the following calculation.

From the conditions shown in Fig. 3,

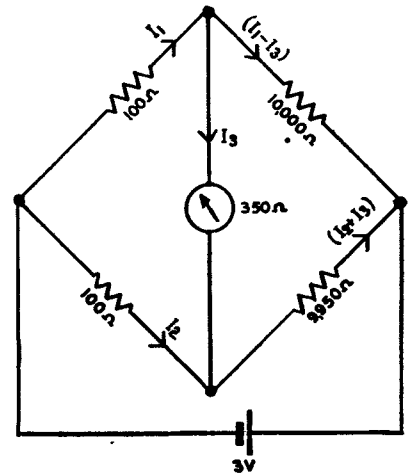

FIG. 3.—CIRCUIT CONDITIONS AT MINIMUM SENSITIVITY.

$$\begin{aligned} 3 &= 100 I_1 + 10,000 (I_1 - I_3) \\ 0 &= 100 I_1 + 350 I_3 - 100 I_2 \\ 0 &= 10,000 (I_1 - I_3) - 9,950 (I_2 + I_3) - 350 I_3 \end{aligned}$$

from which,

$$\begin{aligned} I_3 &= \frac{3 \times 10^6}{11,125,250} \mu\text{A} \\ &= 0.27 \mu\text{A, approx.} \end{aligned}$$

Since the galvanometer has 30 divisions for a full scale deflection of  $12\frac{1}{2} \mu\text{A}$ ,

$$\therefore \text{Deflection} = \frac{30 \times 0.27}{12.5} \text{ divisions} = \frac{2}{3} \text{ division, approx.}$$

This change in deflection can be quite easily detected.

#### Construction.

Fig. 4 shows the layout of the panel. It will be seen that three plastic windows have been inserted above the dials, through which the value of the variable arm can be read. Of these three dials the left-hand one has nine positions reading from 1-9, 0 not being required as values lower than 1,000, 100 and 10 are provided by the lower ranges which give better accuracy, and it is not required to measure less than 1.00 ohm. The remaining two dials are scaled 0.9

and are continuously rotatable to enable smooth transition from, say, 09-10 to be obtained. For the left-hand dial continuous rotation is not necessary as the total reading cannot be increased above 999 nor

bridge is seriously unbalanced. It has been found that quite close approximation can be obtained with the galvanometer shunted, and the unshunted condition is only required for final balance.

A compartment let into the side of the case accommodates the battery which consists of 2 cells DS7.A, 3 volts being adequate for normal testing. When taking Varley tests an additional battery may be necessary, but this can readily be provided by placing additional cells in series with the Varley earth connection or by disconnecting the existing battery and replacing by another of higher voltage. A link included in the battery circuit provides for the Varley earth connection.

The galvanometer has a mirror scale and the scale plate is engraved INCREASE and DECREASE, respectively, on either side of zero, this indicating whether the variable arm needs to be increased or decreased to give balance.

A photograph of the prototype bridge is given in Fig. 5. In the production model the case has been enlarged slightly and the panel size reduced, leaving a compartment in which test cords can be stored. A series of test cords has been introduced primarily for this instrument, but available for all testing equipment, consisting of 0.0017 sq. in. flexible cable with an adaptor at each end into which can be screwed a test prod, a crocodile clip or a spade terminal, the cords being 36 in., 72 in. and 120 in. long.

To check the accuracy of the bridge from time to time, a small unit known as a Tester, SA9085, has been produced, consisting of three resistors of accurately known values. These resistors are so selected as to use each of the ratios and are accurate to  $\pm 0.1$  per cent., including the connecting cords. It is the intention that the bridge shall be checked on site for accuracy at six-monthly intervals.

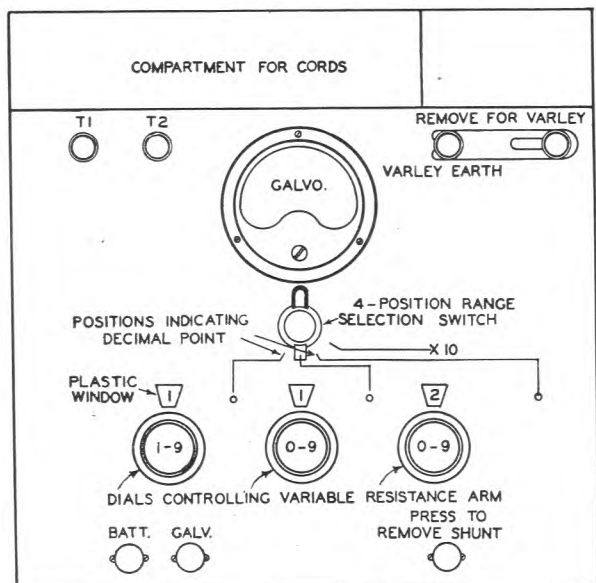

FIG. 4.—PLAN SHOWING LAYOUT OF EQUIPMENT ON TOP PANEL OF WHEATSTONE BRIDGE No. 2.

reduced below 100, and furthermore, switches are not made which have 9 positions only, located at  $40^\circ$  intervals.

The left-hand dial operates a 9-position rotary switch of normal commercial design having positions at  $30^\circ$  intervals, the other two being 20-position switches with  $18^\circ$  intervals, the contacts being multiplied to give a continuous scale 0-9.

The range-selector switch is a rotary type 4-position switch, two banks of which select the ratio arms to be used, the other two banks selecting the group of variable resistors to be associated with the dials. The position of the pointer on this switch indicates the position of the decimal point in the reading, the final position indicating that the reading should be multiplied by 10 to give the 1,000-9,990 range.

Three non-locking keys of the digit type are provided, the two on the left being the normal Battery and Galvanometer keys and the one on the right-hand side removing a 6-ohm shunt from the galvanometer and simultaneously short-circuiting a 300-ohm series resistance which is included to maintain the desensitising of the galvanometer when low resistances are being measured.

The Shunt key is placed a distance away from the main operating keys so that there is less likelihood of the galvanometer being connected in its most sensitive condition when the

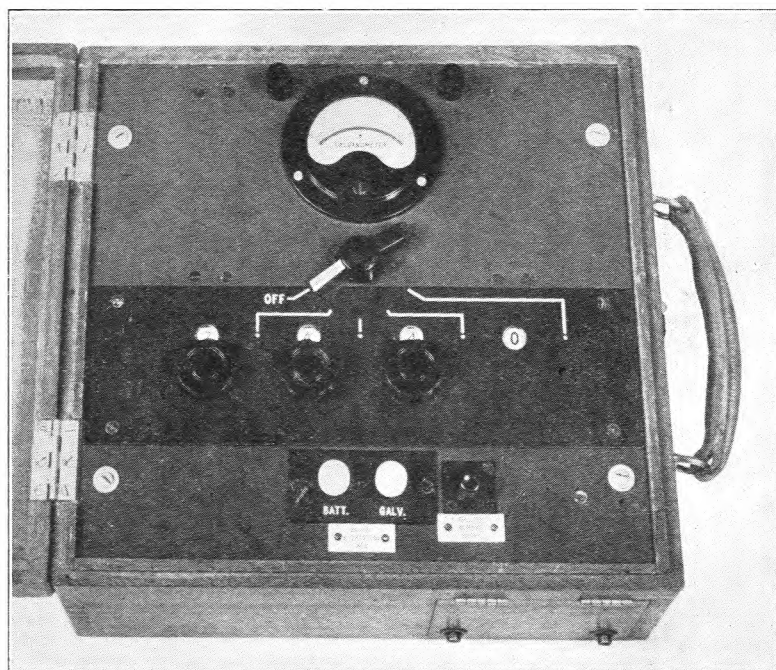

FIG. 5.—PROTOTYPE OF WHEATSTONE BRIDGE No. 2.



### Varley Tests.

The use of the bridge for Varley tests is envisaged and the non-removable link in the battery circuit enables it to be used for this purpose without alteration. These tests are slightly complicated by the fact that the indicated resistance in the variable arm may not be the actual resistance, but the calculation of the fault position is fairly simple.

For the ranges 1,000-9,990 and 100-999 the value "r" in the bridge is the same as the indicated reading "R" since the ratio is 100:100. Then in Fig. 6,

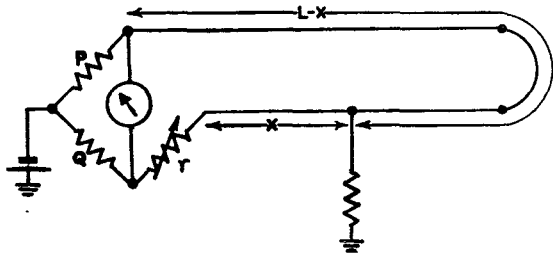

FIG. 6.—CIRCUIT CONNECTIONS FOR VARLEY TESTS.

$$r = R$$

$$\therefore x = \frac{QL - PR}{P + Q} = \frac{L - R}{2}$$

In the range 10.0-99.9,

$$10R = r, P=10, Q=100$$

$$\therefore x = \frac{100L - (10 \times 100R)}{100 + 10} = \frac{100(L - R)}{110}$$

$$= \frac{10}{11}(L - R)$$

In the range 1.00-9.99,

$$100R = r, P=1, Q=100$$

$$\therefore x = \frac{100L - (1 \times 100R)}{101} = \frac{100(L - R)}{101}$$

$$= L - R,$$

as accurately as the bridge can measure, i.e. 1 per cent.

### Conclusions.

The simplified form of Wheatstone bridge described in this article is considered to have substantial advantages over the Post Office Box at present in use, and will, it is hoped, be welcomed in the field as an aid to increased maintenance efficiency. Although the new bridge is not yet available for general use, quantity production is in hand and deliveries are expected in the near future.

### Acknowledgments.

Several members of the Subscribers' Apparatus Branch have been concerned in the development and design work and the author acknowledges their contributions with thanks.

## Book Review

"Electron Tubes," Volume 1 (1935-1941), 475 pp. 234 ill. 15s.; and Volume 2 (1941-1948) 454 pp. 231 ill. 15s. Edited by A. N. Goldsmith, A. F. Van Dyck, R. S. Burnap, E. T. Dickey and G. M. K. Baker. R.C.A. Review, Radio Corporation of America, R.C.A. Laboratories Division.

These two volumes consist of selections from the articles on valves and other specialised electron tubes, written by workers in the Radio Corporation of America and published in various journals between 1935 and 1948. In the two volumes together some 40 articles are reproduced in full, and excellent summaries, of the order of 200 words in length, are given of 50 others. In appendices at the ends of the books there are extensive bibliographies which, together, cover 600 articles on valves and allied subjects, and extend back as far as 1919.

Each volume is divided into four roughly equal parts containing articles and summaries under headings of "General," "Transmitting," "Receiving" and "Special." The articles were, of course, written by different authors at different times and are, for the most part, fairly specialised accounts of contemporary research and development in the R.C.A. There is, therefore, little continuity from article to article and the volumes, valuable though they are, cannot be regarded as a substitute for a text book.

In the earlier volume a number of articles are concerned with the troublesome effects of electron transit-time, and with valves in which transit time is reduced as far as possible. But in other places one can see coming events casting their shadows before them in articles on valves in which transit-time is turned to advantage: there are summaries of two articles on

magnetrons and one on a modified Barkhausen-Kurz, all three following abortive lines as it subsequently appeared. There is also a summary of an article published in 1936, "The Electron-Image Tube, A Means for Making Infra-red Images Visible," a device of which we hear more later.

In the second volume transit-time comes into its own, a quarter of the articles and summaries being devoted to studies of how it can be put into good use, or to valves in which it has already been harnessed, e.g. reflex klystrons. There is one particularly abstruse, but very important theoretical article on a "two-beam growing wave tube" in which the helix of a travelling wave tube is replaced by a second electron beam having a different velocity from the first. It would appear on theoretical grounds that such a tube, little more than 30 cm long, should yield a gain of 120 db. over a band width of 860 Mc/s centred on 3,000 Mc/s.

Valve construction technique receives a great deal of attention and one point of interest is that some sealed-off valves are being made, using vacuum-tight joints with copper gaskets, i.e. without a "Housekeeper" type seal.

In the space available it is impossible to go into much further detail, but for general interest the best article of all is one discussing the military applications, in so far as the United States were concerned, of the infra-red image tube mentioned earlier in this review.

The reviewer cannot forgo this opportunity of complimenting the editors on the excellent summaries, where they precede the articles themselves and where they stand alone. Much time would be saved if the practice of writing adequate summaries were followed more widely and with as much care as in these volumes.

H. S.

# The Thames Radio Service

J. NEALE, B.Sc.(Eng.), A.M.I.E.E.,  
and D. W. BURR, A.M.I.E.E.

U.D.C. 621.396.5

**A public radio telephone service to small craft on the River Thames, using frequencies around 160 Mc/s, has been in operation for some months. This article gives a general survey of the problems involved and describes briefly the equipment used to provide the service.**

## *Introduction.*

THE history of the Thames radiotelephone service dates from August, 1946, when an inquiry was received from the Port of London Authority regarding the possibility of providing communication to their launches. The P.L.A. controls the River Thames between the Nore Buoy and Teddington Lock, but it was stated that if service could be provided between the Nore and somewhere near Chelsea Bridge, most of their requirements would be met. Inquiries were made of a number of tug owners and other bodies to obtain some idea of the probable response if such a service were provided by the Post Office. The number of small craft plying on the Thames is very large and it was evident that, if a fair proportion of them were fitted with radio, a number of channels would be required to carry the traffic. As the response appeared to be encouraging, authority was given in June, 1948 to proceed with the establishment of an experimental service.

Provision was to be made initially for two channels, with scope for expansion up to six channels if justified by traffic requirements. Full duplex telephone service was to be provided; that is, "over-over" working would not be used. After discussions between the Headquarters Departments concerned and the London Telecommunications Region, it was decided to establish the switching centre for the Thames service in the International telephone exchange, Wood Street, but to bear in mind the possibility of shifting it to an auto-manual switchboard at one of the London automatic exchanges if experience indicated that this would prove satisfactory.

It was decided that the owners of boats would have to obtain and maintain the radio equipment at their own expense and the equipment would have to conform to a Post Office specification.

It will be understood that these and other decisions were made only after long and careful study and consultation between the Departments concerned and that some of them were only made after the service was in experimental operation.

## *Frequency Assignments.*

During the war, fixed-to-mobile and mobile-to-mobile radio telephony communication on very high frequencies was developed considerably, particularly for air-to-ground working. It soon became evident that frequencies between 30 and 300 Mc/s possessed certain advantages over lower or higher frequency ranges for this class of work, and when, after the war, new tables of frequency allocations were being settled at international conferences and internal discussions, substantial blocks of frequency space in this region were made available for "fixed and mobile" services. Within these block allocations some small frequency

bands were reserved for general civilian use, and the question arose how to make the best and most economical use of them, bearing in mind the conflicting claims of many possible types of user.

In this article it would be irrelevant to describe the difficulties and uncertainties encountered over the past few years in the matter of frequency allocations, but it was decided in 1946 that frequencies used for radio telephone services operated by the Post Office and connected to the public telephone network would be taken from the band 156-184 Mc/s. This decision has not since been modified and has proved to be a good one from all points of view.

The transmitters and receivers used for these services are designed for spot-frequency operation with crystal control. The nominal carrier frequency allotted to a service is located in the middle of a frequency channel which has to be wide enough to allow for the possible frequency drift both of the transmitters and the receivers. It was decided that frequency channels in the band 156-184 Mc/s should be 100 kc/s wide and recent experience has tended to confirm the wisdom of this choice.

Two-frequency working was envisaged from the outset; i.e., transmission in the two directions on different frequencies, with a separation of several Mc/s. Not only does this enable full duplex speech facilities to be given but, more important in practice, it enables a number of channels to be operated in the same area (even from the same radio station) on adjacent frequency assignments, with a minimum of interference between them.

As a result of the efforts of the planners, a number of adjacent two-frequency channels are available for public radio telephone service to ships, and it is from these channels that the frequency assignments are made for the Thames service. The actual carrier frequencies of the first channel in operation are 157.5 Mc/s for the inward direction (mobile to fixed station) and 161.5 Mc/s for the outward direction. The former frequency is being changed to 157.0 Mc/s very shortly to conform with a recent rearrangement of the frequency channelling scheme. The frequencies for the second channel will be 157.1 Mc/s and 161.6 Mc/s and it will be noted that this constitutes an adjacent channel by virtue of a frequency separation between channels of 100 kc/s, whilst the frequency separation between outward and inward frequencies remains at 4.5 Mc/s.

Finally, it was decided that the first channel of the service would use amplitude modulation. A decision has since been taken to standardise A.M. for marine radio services in the United Kingdom.

## *Choice of Sites.*

Having undertaken to provide service to boats anywhere on the Thames below Chelsea Bridge and

out as far as the Nore Buoy, it was necessary to decide on the number of fixed land stations that would be required, and to find suitable sites for them. Information regarding the propagation of radio signals at 160 Mc/s was at that time very scanty, and a series of field trials was necessary to ascertain the range of such signals over built-up areas. No 160 Mc/s equipment was available, and the trials were therefore carried out with transmitters and receivers which were obtained from the Air Ministry. These operated on approximately 124 Mc/s, and it was thought that the results obtained at this frequency would give sufficient information about the propagation characteristics of frequencies in the 160 Mc/s band.

The lower reaches of the Thames flow through country which is rather flat, and the number of sites even moderately suitable for fixed stations is very limited. A Port of London Authority launch was temporarily equipped as a mobile station, and tests were carried out from every likely position, including the roofs of some of the higher buildings in London. The sites tested included two water towers, one on Shooters Hill near Woolwich and the other at Langdon Hills in Essex. Their positions are shown in Fig. 1

in operation for nearly a year. Since the early field trials the development of equipment for these frequencies has brought about remarkable improvements in performance, and in consequence it has been found that the coverage required can be given adequately from a single fixed station. Only the Shooters Hill station therefore, has been installed and good service is available for suitably equipped boats anywhere below Richmond and well out to sea. The Langdon Hills station will not now be required, unless it is decided to widen considerably the scope of the service.

A block schematic diagram of the existing arrangements is given in Fig. 2.

#### *The Fixed Station.*

At the Shooters Hill radio station the equipment is mainly housed at the foot of the water tower and connected to the aerials by coaxial feeders. There is at present a 12 ft. square wooden hut which is being replaced in due course by a standard Type A brick building. This allows space for working and reserve equipment for as many as six channels, together with auxiliary apparatus. The equipment for one channel

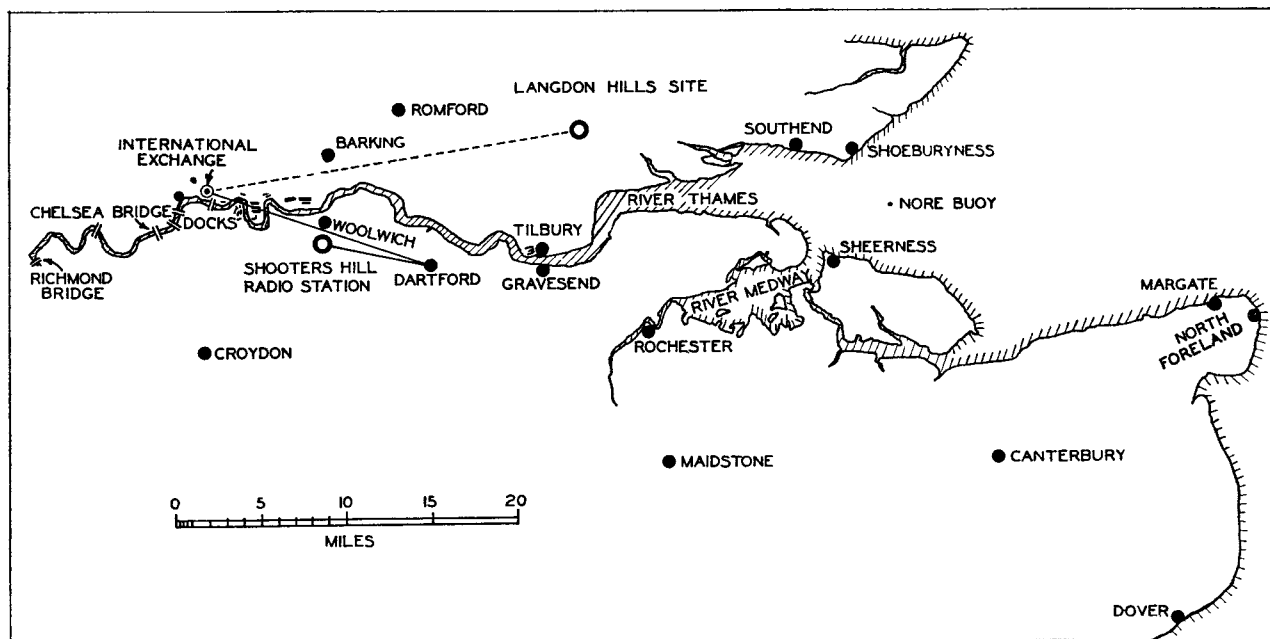

FIG. 1.—MAP SHOWING LOCATION OF RADIO SITES AND EXCHANGES FOR THAMES RADIO SERVICE.

and the tops of the towers are 530 ft. and 446 ft. respectively above low water. From one or the other of these two test sites communication with the launch was possible over practically the whole of the river below Tower Bridge. All other positions tested were unsuitable or ineffective and it was decided to base the initial plans on two stations with the transmitting and receiving aerials on these water towers.

Before describing the equipment in more detail, brief mention will be made of the scheme as it has emerged from the planning and early development stages to the present time. The first channel of the Thames Radio Service, as it is now known, has been

comprises two transmitters, two receivers, monitoring equipment and automatic changeover and alarm gear which maintains the service in the event of a fault occurring.

#### *Aerials and Associated Equipment.*

At present, simple centre-fed vertical dipoles are used and the service was opened with one transmitting and one receiving aerial mounted at the level of the eaves of the tower roof. Later, aerials were mounted on a special structure (Fig. 3) giving a further 20 ft. of height, but the improvement was small. Recently, the receiving aerial has been connected through a



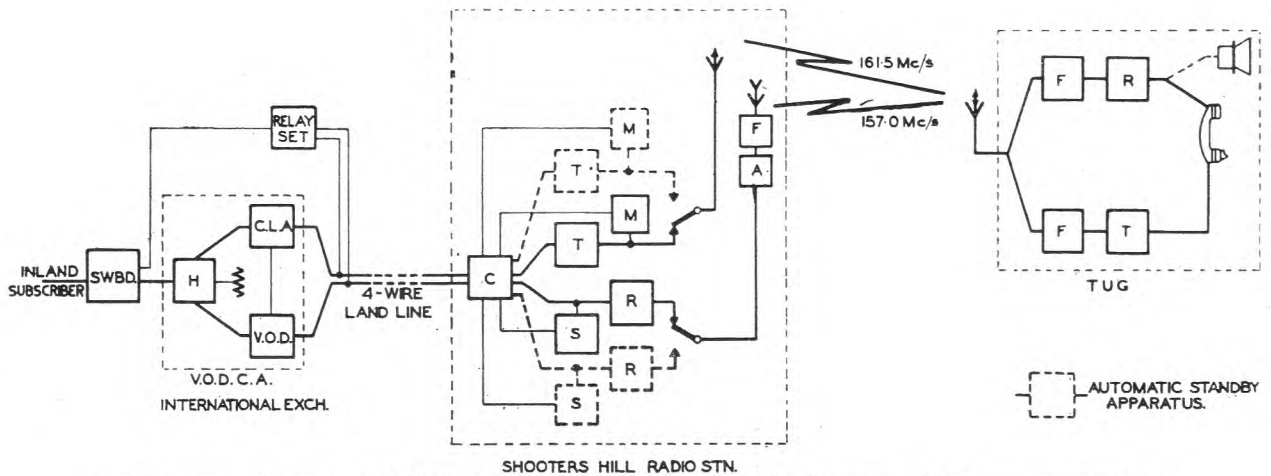

SHOOTERS HILL RADIO STN.  
 A.—R/F Amplifier. F.—Filter. H.—Hybrid. R.—Receiver. S.—Signal Analyser. T.—Transmitter. V.O.D.—Voice Operated Device.  
 C.L.A.—Constant Level Amplifier. SWBD.—Switchboard.

FIG. 2.—BLOCK SCHEMATIC DIAGRAM OF EQUIPMENT.

pre-amplifier, installed at the top of the tower. This amplifier consists of a grounded grid triode with a broadly tuned anode circuit. Power supplies for it are superimposed on the coaxial cable connecting the amplifier to the receivers at ground level. The amplifier has a noise factor somewhat better than that of the receivers and, in addition, avoids the loss of signal in the feeders, thus giving valuable gain in performance in the ship-shore direction of the service.

As the transmitting aerials are within a few feet of the receiving aerials, it is necessary to insert filters in the feeders from the latter to prevent high voltages

being applied to the receiving apparatus. Various types of filter have been examined for this purpose. An attenuation of approximately 30 db. is required at frequencies 4 Mc/s from the pass band, within which an insertion loss of more than 0.5 db. becomes serious. Filters formed by cavities and coaxial lines give the best performance, but tend to be very bulky and expensive. The filters at present in use are of the lumped inductance-capacitance type and give a performance very close to the figures quoted above.

#### Fixed Station Transmitters and Receivers.

The power radiated from the fixed land station can usefully be a little greater than is used by the mobile transmitters, but this increase can only be effective in improving range or quality of service if the fixed station receivers are correspondingly more sensitive than the mobile. At a site which is reasonably free from man-made radio interference, the limit of receiver sensitivity at these frequencies is governed by the noise generated in the first valve. It is, therefore, quite difficult to make a receiver considerably more sensitive than the mobile equipment, even under the relatively ideal conditions of a fixed radio station. Increased sensitivity obtained by using directive aerials is, of course, useful but does not affect this argument, because similar gain can be used for the transmitter. Mobile transmitters have R/F output powers of the order of 10 watts and with these considerations in mind it was decided to provide 50 watt transmitters at the fixed station. It was then necessary to draw up complete specifications, covering the fixed station transmitters and receivers.

Discussions with all the firms manufacturing this type of equipment showed that none could offer anything suitable at that time to operate on the very high frequencies required. It was finally decided to have a standard commercial 80 Mc/s mobile receiver modified for the purpose, but whilst some new transmitters were put on order there was no prospect of delivery in time to open the service as planned. Some surplus 50 watt 124 Mc/s Service transmitters were therefore obtained with a view to modification. These

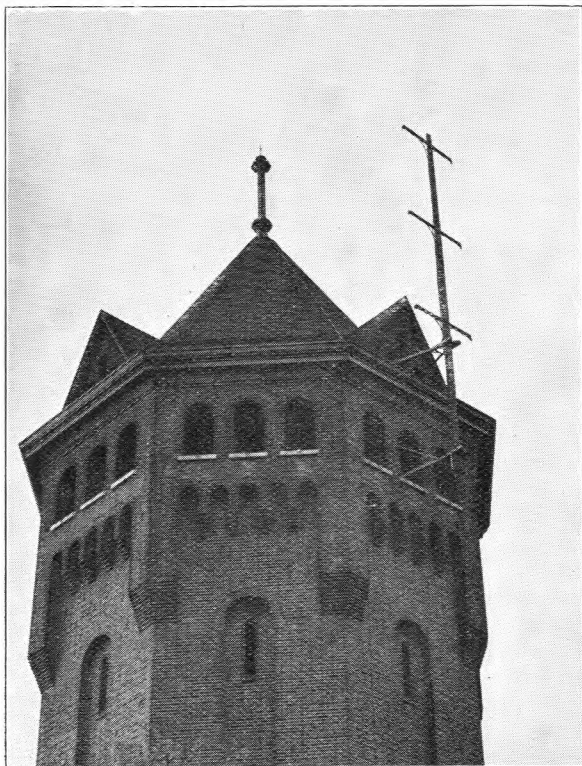
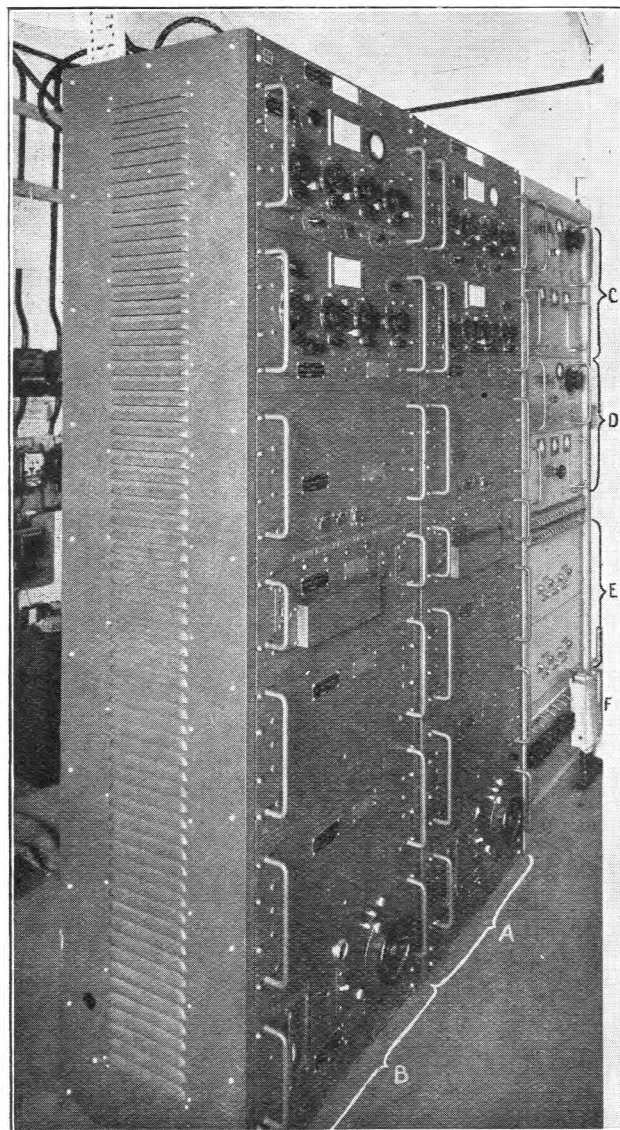

FIG. 3.—THE AERIALS ON THE WATER TOWER.

were fitted with up-to-date types of valves, and the operating frequency increased to 161.5 Mc/s. Various other changes and additions were made, and the drive and output stages were virtually redesigned and rebuilt in the Radio Branch laboratories.

The equipment as installed at Shooter's Hill radio station is shown in Fig. 4.



A.—Main Transmitter. B.—Standby Transmitter. C.—Main Receiver and Analyser. D.—Standby Receiver and Analyser. E.—Control Unit and Spare. F.—Power Distribution.

FIG. 4.—THE EQUIPMENT AT SHOOTERS HILL RADIO STATION.

Various improvements to the receivers have been developed in the Radio Branch laboratories, and, in conjunction with the pre-amplifier, the receivers now have a noise factor of approximately 5 db. Even with the simple aerials at present in use, their sensitivity is sufficient to give an average signal/noise ratio of 15 db. on transmissions from 5 watt mobile equipments anything up to 40 miles away. The frequency stability and band-width are such as to allow ample margin for the rather less stable carrier frequencies of the boats, and at the same time ensure

freedom from adjacent channel interference. The automatic gain control maintains the level at the receiver output constant within  $\pm 1$  db., irrespective of the strength of the incoming signal.

#### Signal Analysers.

Associated with each receiver is a unit called the signal analyser. This has several functions, the most important of which relate to the muting or squelch circuits. These, in effect, examine the quality of an incoming signal and pass it to the operators' switchboard only if it has a signal/noise ratio of 15 db. or more. These circuits also control the calling lamp on the operator's switchboard, in conjunction with a relay set at the terminal, the lamp being illuminated two seconds after the first appearance of a signal from the boat. This delay prevents false calling, due to short bursts of electrical interference or static. The same circuits come into operation if, after a call has been established, the signal/noise ratio falls to less than about 14 db. This occurs if the mobile subscriber closes down or goes out of range. The audio output from the receiver is immediately prevented from reaching the terminal and after five seconds delay, the operator's supervisory lamp is illuminated, indicating that the call can be cleared down. The five second delay in this case avoids false clearing if the signal from the boat fades for a short time.

The signal analyser also maintains a constant check on the receiver performance. It will be appreciated that if no signal is being received, the automatic gain control increases the receiver gain so that radio and valve noise appears at full level in the receiver output, even though the analyser prevents its transmission to the terminal. If neither a signal nor noise appears at this point, the receiver is faulty and the analyser passes a start signal to the automatic changeover gear.

The design of the analyser also includes other functions which are mentioned later.

#### Standby Equipment.

Throughout the system duplicate equipment has been provided and at the radio station, which is of course normally unattended, arrangements are included to bring this reserve apparatus into use automatically in the event of a fault. For each channel a control unit is provided and the appropriate 4-wire circuit from International exchange terminates on it. The transmit pair is connected normally to the "main" transmitter and when the operator at the exchange inserts her answering or calling plug into the circuit, the associated relay set applies battery to the line and the H.T. contactor in the main transmitter closes. Simultaneously, the changeover circuit in the control unit prepares to operate. Associated with each transmitter there is a monitoring circuit which is, in effect, a very simple type of receiver. As soon as the transmitter carrier frequency appears, the monitor prevents the changeover in the control unit. If however, the carrier wave fails, or falls more than 3 db. below 50 watts, the control unit completes the changeover operation and brings the reserve transmitter into action. A coaxial relay is used to change over the transmitting aerial.

As mentioned previously, the performance of the

receivers is checked by the signal analyser. If a fault occurs, the control unit connects the spare receiver at the station and its associated analyser to the "receive" pair of the 4-wire circuit. At the same time, the H.T. supply of the faulty receiver is removed and that for the reserve is switched on. When more channels are brought into operation there will be two receiving aeriels, each with a pre-amplifier and a distributing amplifier. One chain will normally feed all receivers and, if all these receivers appear to fail simultaneously, the reserve aerial circuit will be switched into use.

At the moment there is no standby power supply although this may be necessary when the system develops. There are common power units for relay circuits and alarms, and reserve units are provided with automatic switching in the event of failure.

When any part of the automatic changeover gear has operated, a non-urgent alarm is passed to the fault control, who then advise the maintenance officer. In the unlikely event of a failure of reserve equipment before normal working has been restored, an urgent alarm would be given.

#### *Landlines.*

There is a 4-wire circuit from Shooters Hill radio station to the apparatus room of International exchange. Shooters Hill is seven miles from Wood Street Building as the crow flies but the line was routed via Dartford so that the route mileage is approximately equal to that for the Langdon Hills site which is 23 miles. This was a precaution against difficulties which might have been encountered if it had been necessary to operate both stations and the transmission delay through one station was considerably greater than through the other. It was proposed to complete the delay equalisation by means of switched delay networks. It is possible that in practice the precaution might have proved unnecessary.

#### *Terminal Equipment.*

In the apparatus room of International exchange the usual facilities for testing and monitoring the lines are available, and a special relay unit was designed by the Telephone Development and Maintenance Branch to provide normal sleeve control signalling conditions at the switchboard. The 4-wire speech circuit then passes to a special unit, where it is converted from 4-wire working to 2-wire.

The problem of converting satisfactorily from 4-wire circuits to 2-wire circuits is very old and when the impedance and attenuation of the 2-wire circuits may vary over wide limits there is no completely satisfactory solution. The same difficulties occur with all radio-telephone circuits and because these frequently earn high revenues, very complex voice-operated devices are used to overcome the inherent difficulty. On the Thames Radio Service and similar schemes such expensive apparatus would make call charges prohibitive, and a more economical terminal equipment is necessary.

A design has now been evolved which gives a very good performance, although some of the refinements used on the standard equipment have not been included. It takes the form of a single unit and has been

coded V.O.D.C.A. (voice-operated device and constant level amplifier). If the 2-wire line has considerable loss, as is often the case, the level of speech arriving at the terminal from the inland subscriber may be far below that of the received speech. To cater for such low levels, a constant level amplifier is included in the transmit path so that the transmitter is fully modulated by the outgoing speech. It will be appreciated that, due to variations in the character of the 2-wire circuit, the balance of the hybrid is not usually very good, and speech received from the mobile subscriber will tend to pass along the transmit path, possibly at a fairly high level. The action of the constant level amplifier would then cause the transmitter to be fully modulated by this speech and the side-tone in the mobile subscriber's earpiece would be as loud as the inland subscriber's speech. It must also be remembered that there may be noise superimposed on this re-radiated speech.

To overcome this difficulty, the receive path is normally blocked by a suppressor. Speech from the mobile subscriber opens up the receive path and at the same time reduces the gain of the constant level amplifier to a sufficiently low value to avoid the excessive radiation of side-tone. There are many problems of timing, sensitivity and frequency response in these circuits which require careful attention, but the overall performance is such that full duplex working is possible and the effect is not markedly different from ordinary telephone conversations.

The unit gives "break-through" facilities to the mobile subscriber and also to an inland subscriber whose speech arrives at the terminal at a reasonably high level. The telephone operator who controls the circuit is thus assured of being able to break in when necessary.

Reserve terminal equipment is mounted on the same rack, and there is a comprehensive "U" link field which enables any item to be brought into use quickly. The links also provide full facilities for testing and measuring both the internal equipment and the land lines. The 2-wire circuit of each channel is extended from the voice-operated device to the switchroom where two positions are at present allocated to the service. Dialling-out circuits provide for access to the inland telephone network.

#### *Mobile Subscribers.*

As mentioned previously the mobile subscribers are responsible for the installation and maintenance of their own equipment. It is expected that owners of boats, tugs, etc., will usually devolve this responsibility on to the manufacturers, some of whom have well-established organisations for maintaining ship-borne radio gear in the various ports. So far only two firms have supplied equipment and these have been prototypes so that at present the number of subscribers is limited by lack of equipment. Later it is hoped that a number of firms will enter the market with suitable apparatus at competitive prices. A typical set of mobile equipment is shown in Fig. 5. The Department's responsibility is limited to ensuring that the mobile apparatus does not cause interference to other radio users and that it is capable of providing a good service within the prescribed coverage. All mobile



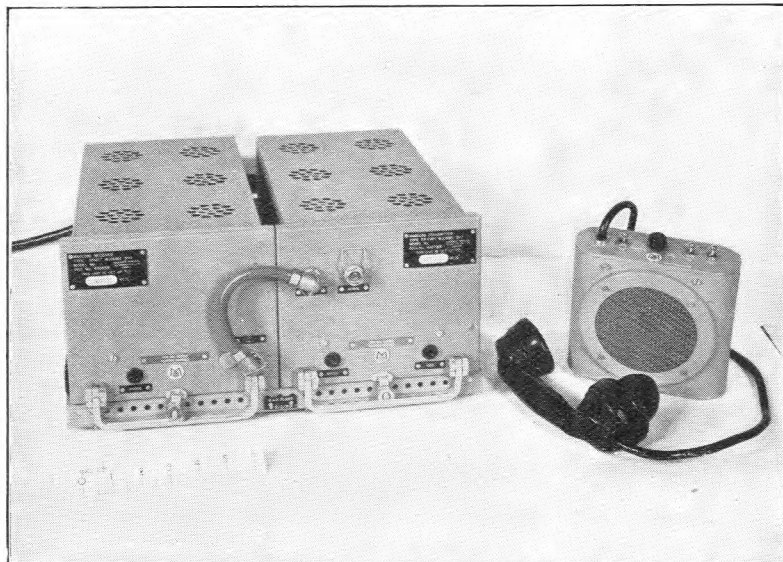

FIG. 5.—TYPICAL EQUIPMENT FOR A MOBILE RADIO STATION.

equipment is therefore required to conform to a specification which has been drawn up in consultation with an association of the interested manufacturers. The limits on the various characteristics covered by the specification represent a most careful compromise between minimum performance necessary to ensure satisfactory service and the initial and maintenance costs.

Fig. 6 shows a block diagram of a typical mobile

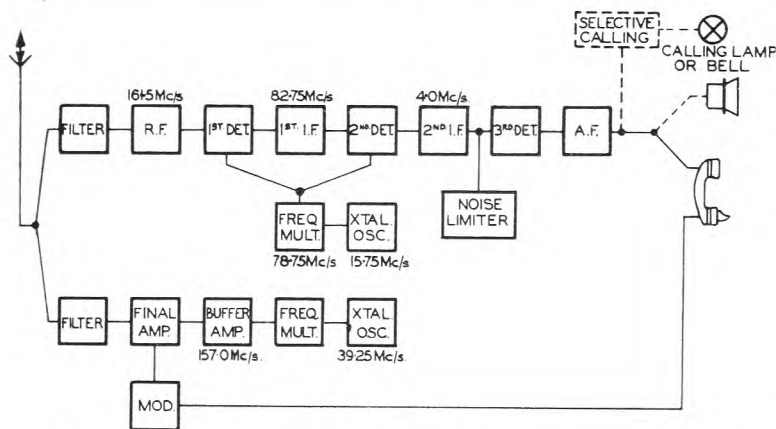

FIG. 6.—BLOCK SCHEMATIC DIAGRAM OF A TYPICAL MOBILE UNIT.

unit and it will be seen that the line-up is similar to mobile V.H.F. equipment such as is used in police cars. The use of frequencies near to 160 Mc/s is however comparatively new and the Thames Radio Service is the first mobile system in this country to use full duplex working with a common aerial for transmitting and receiving. The receivers are fitted with muting relays which are arranged to illuminate a channel engaged lamp in addition to the normal function.

The supply of power to the mobile equipment is in some cases rather a problem as many of the tugs and other river craft wanting to use the service have

no electrical equipment of any sort on board. There are however some very small steam-driven generators available and the possibility of using these is being considered. When the boat already has an electricity supply the problem is relatively simple as in most cases standard power units for A.C. or small rotary converters for D.C. can be employed.

At the present time loud-speaker calling is used and the speaker is fitted in the wheelhouse or bridge, together with the H.M.T. and control box. In some designs the controls are incorporated into the actual transmitter/receiver units in which case the whole equipment is fitted in the wheelhouse. Generally, access to the actual transmitter and receiver is not required and it is convenient to install it in the engine room or other suitable space below deck.

#### Operating Procedure.

The Thames Radio Service is available throughout the 24 hours although the number of calls during the night is small. Boats keep their receivers in operation while they are on the move and at quaysides during the daytime.

If the crew of the boat wish to initiate a call they choose a moment when the channel upon which they work is free and lift the H.M.T. from its hook. This

disconnects the monitoring loudspeaker and brings the mobile transmitter into full operation. The calling lamp at International exchange is illuminated and the operator then inserts her answering plug and announces "Thames Radio Service." The mobile subscriber then identifies himself, asks and waits for the number required.

Inland subscribers making a call to a boat ask for the service and are connected to the appropriate position at International exchange (Fig. 7). The operator then broadcasts a call for the boat required and when a reply is received the circuit is completed.

#### Selective Calling.

The present method of calling and answering is far from satisfactory and it is hoped to introduce selective calling in the near future. Each mobile subscriber will be allocated a signalling code and a small selector will be added to his equipment. The fixed station then transmits the code signal representing a wanted mobile subscriber. The selectors of all the subscribers on the system examine the signal but only the one required responds fully, whereupon a calling bell is sounded. In all the other mobile sets the transmitter is made inoperative so that inward calls are not initiated while the channel is engaged. Some experimental work on this problem has been carried out with promising results but the final choice of system



FIG. 7.—THE OPERATOR'S POSITION AT INTERNATIONAL EXCHANGE.

requires the utmost care as it will govern the cost of the selectors and the reliability of the service for at least several years to come.

#### *Monitoring Station.*

It often happens that the boats do not reply when the operator calls them. This may be due to several causes, e.g., the crew may have forgotten to switch on the receiver, or the boat may have moved out of range. A monitoring station has therefore been set up to enable the operator to make a test call and so ensure that the service is functioning correctly. The station equipment is fitted in the apparatus room near the terminal rack and is operated by the test room staff, who initiate test calls periodically as a further check. This ensures that the quality of transmission and reception remain satisfactory. The aerials are mounted on the roof of the Wood Street building so that the working range is about seven miles.

Much useful work has also been done with a "Morris 8" van which is fitted with mobile equipment. This van (Fig. 8) is used for tests on range and other aspects of the system where the actual conditions of service have to be simulated. All modifications and improvements are checked by means of this van.

#### *Twin-station Operation.*

In the early days of planning for the Thames Radio Service, the range tests made in connection with the choice of sites for fixed stations suggested that two stations would be necessary to cover the river from Chelsea Bridge to the Nore Buoy. A twin-station scheme was therefore proposed and much of the extra equipment necessary was designed. Whilst it is now known that one fixed

station is sufficient to give the required coverage on the Thames, there are other rivers and ports where two or more stations may be required. A few brief details of the proposed method of operating two stations simultaneously may therefore be of interest.

One transmitter and one receiver for each channel would be provided at each fixed station. The two transmitters would operate simultaneously on very slightly different carrier frequencies so that the boats would receive one or both of them without adjusting their receivers, whilst no interference pattern would occur where the field strengths from both stations were equal.

When the boat is near the extremes of the service area, only one receiver would offer a good signal to the terminal equipment, but over much of the range both receivers would have a readable output and as these cannot be combined without loss of signal/noise

ratio, it is necessary to switch from one receiver to the other. This can be done automatically by an electronic switch associated with the terminal apparatus and controlled by signal analysers at each station. Additional circuits for this purpose are included in the signal analysers used on the Thames scheme. A D.C. control voltage is provided by each analyser and its amplitude is proportional to the signal/noise ratio in the output of the associated receiver. This control voltage is superposed on the receive side of the 4-wire circuit from each radio station and passed to the terminal gear. The high speed electronic switch used to select the receive circuits is controlled by the difference in the D.C. control voltages on the lines. Thus the receiver producing the best signal/noise ratio is always connected through to the switchboard, even though the switch may have to change from one line

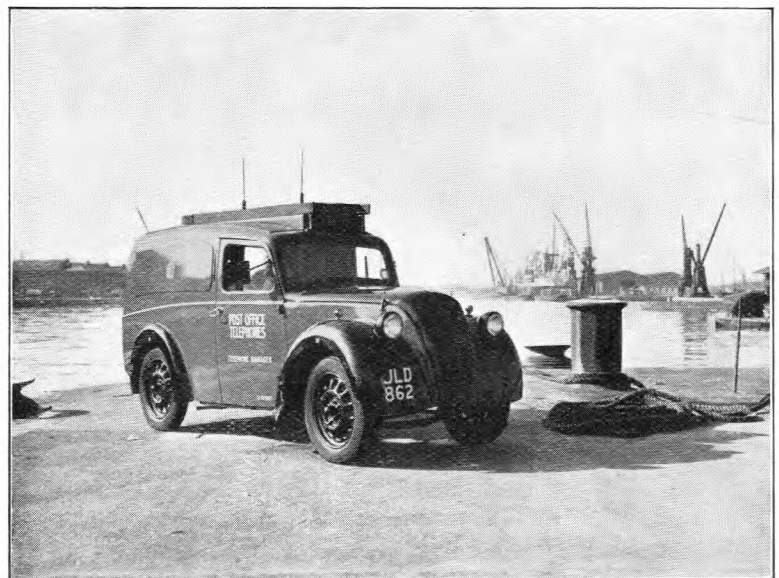

FIG. 8.—"MORRIS 8" VAN FITTED WITH MOBILE EQUIPMENT FOR TESTING.

to the other as frequently as four times per second. Provided that the two signals are in phase, no click is produced on the changeover because the level from one line builds up exactly in time with the fall of level from the other and at one instant both lines provide half the normal level. Even so, the complete transition occurs in considerably less than a millisecond.

#### *Frequency Modulation v. Amplitude Modulation.*

Any article on V.H.F. radio equipment would be incomplete if it did not mention the relative merits of F.M. and A.M. Whilst it was the intention from the outset to open the first channel with amplitude modulation, it had been suggested that the second channel should use frequency modulation to facilitate a comparison between the two systems. However, during some early range trials F.M. radio equipment was temporarily installed both at Shooters Hill and on a tug. The results obtained with the two different sets of equipment were carefully analysed but it should perhaps, be emphasised here that the comparison was between two sets of typical apparatus, each having a performance representing current practice rather than an attempt to confirm the theoretical merits of the two systems of modulation. After adjusting the results to allow for accountable differences in performance, it was found that the F.M. apparatus would have a somewhat better performance within the service area, although it was doubtful whether the extreme range would be much different. This means, in effect, that the use of F.M. would give a somewhat better signal/noise ratio only where it is already sufficiently high with A.M. It was clear from these tests that amplitude modulated equipment was capable of giving adequate coverage of the service area required, and in addition was somewhat cheaper and easier to maintain. Although the Thames service appears not to require a multi-station system some ports and estuaries may, and A.M. lends itself more easily to these schemes. In the light of these and other considerations it was decided to standardise A.M. for Port and River Services throughout the country.

#### *Present Performance.*

It will be appreciated that knowledge and experience of radio communication on these frequencies is growing daily, and new valves and components for this type of equipment are becoming available. During the past few months it has been possible to improve the performance of the fixed station receivers, the mobile test receiver and the mobile transmitters, with a consequent increase in effective range. Recently the mobile equipment normally used in the testing van was

fitted in the M.V. *Daffodil*, which makes daily trips from Gravesend down the River and round the North and South Forelands. During the journey, telephone calls were made to many different subscribers in the Greater London area, and no serious loss of quality occurred until the ship was some 15 miles beyond the boundary of the normal service area. Even when the ship was near North Foreland, some 55 miles from Shooters Hill, successful calls could still be made.

During the first 10 months that the equipment has been in operation the automatic changeover gear has proved of great value. There have been quite a number of faults, but only for two short periods has the service been suspended. One of these faults was in the terminal equipment and the other followed a failure of the main receiver when the standby receiver took over but failed before the first one was repaired.

#### *Further Improvements.*

Apart from the introduction of selective calling mentioned earlier there remains considerable scope for further improvements in the service. Although the actual range is now adequate further improvement, particularly in the upstream direction, would be of value, and experiments are now in hand with directive aerials. A horizontal polar diagram in the form of an elongated figure of eight would be very suitable for the Shooters Hill site. Vertical stacking of aerials should also give improved performance by utilising some of the energy at present radiated at high angles.

Although the existing system of automatic changeover to reserve apparatus has proved satisfactory, there are a few points where faults in the system are not covered. Consideration is being given to an alternative arrangement which will make a routine test of all the apparatus at short intervals without disturbing any calls that may be in progress.

#### *Conclusion.*

The Thames Radio Service is likely to prove the forerunner of many similar systems, not confined to tugs and boats, but available to road vehicles and aircraft. The use of V.H.F. radio communication with vehicles is already regarded as indispensable by many organisations, such as Police, Fire, Ambulance and Taxi Services, but these are private schemes without access to the telephone network, and are only economic for large groups of vehicles. It is envisaged that, within a few years, a network of V.H.F. radiotelephony schemes covering a large part of the country may be required, so that any vehicle or boat can have facilities for making a telephone call.



# Phonogram Automatic Distribution

H. E. WILCOCKSON, A.M.I.E.E.,  
and H. WALKER

## Part 2.—Basic Circuit Features

U.D.C. 621.395.341.8 : 621.394

The previous part of this article described the field trial installation, and the facilities provided. This part describes the basic circuit elements employed in connection with incoming calls, including those concerned with their queueing, storage and distribution and the adjustment of queue size in relation to the number of available staffed positions.

THE predominant features of interest in the design of this equipment are undoubtedly those concerned with the arrangements for the queueing, storage and distribution of *incoming calls*. A brief description of the basic circuit elements employed in this connection is, therefore, given below. Restriction of space has precluded the description of other features, including the means of originating outgoing calls, although the arrangements in this respect will be reasonably apparent from Fig. 3 and the associated text in Part 1 of this article.<sup>1</sup>

The circuits, which employ P.O. standard uniselectors, 3000-type relays and high-speed relays as the major components, have been designed to follow the general lines of automatic telephone exchange practice. Battery-testing arrangements using high-speed relays are employed throughout for the various unselector testing and switching circuits.

### QUEUEING, STORAGE AND DISTRIBUTION ARRANGEMENTS

Fig. 6 shows the basic circuit elements employed for incoming calls and, inset, in block schematic form, the manner in which the various relay sets and uniselectors are inter-connected.

Access to the auto-distribution equipment is over two-wire circuits, phonogram calls from ordinary subscribers being routed from level "90" relay sets at Newcastle telephone exchange, and from C.C.B. subscribers via direct jack-ended circuits from the auto-manual switchboard. Telephone-telegram calls are received either via level "951" relay sets at the auto exchange (i.e., exchange telephone-telegram service for sub-post offices not having sufficient traffic to justify a direct circuit to the phonogram appointed office) or by direct telephone line from sub-post offices with sufficient traffic to justify their provision, but insufficient traffic to warrant a teleprinter circuit.

Each two-wire circuit is connected to an incoming line relay set with associated line unselector, which exercises the joint function of queue and position finder. The common equipment, comprising the queue forming and storage relays, the queue distributor and the position marker, provides the means for arranging and, if necessary, storing the calls in chronological order and for their subsequent distribution to free staffed operators' position circuits in cyclic order. The system is such that all incoming calls enter the queue first and are subsequently discharged to free operators' positions as they arise. The early contacts of the line unselector are used for access to queue storage positions, and the later contacts are used to provide access to the phonogram operators' positions.

The operation of the various circuit elements is as follows.

#### *Incoming Line Relay Set (Fig. 6 (a)).*

From the circuit elements of the relay set it will be seen that relay L operates to the calling condition (which may be loop or battery) and, providing the line unselector wipers are on the home position, completes an operating circuit for relay LL at L1.

Relay LL operating, completes a drive circuit for the unselector driving magnet at LL3 and at LL4 connects the testing relay TRA to wiper P1. The unselector steps to find the bank contact with a marking condition (550 ohm battery via Figs. 6 (b) and (c)) denoting the next available queue storage position. Relay TRA then operates with its windings in series, and TRA1 cuts the drive circuit, at the same time removing the short-circuit from relay H, which now operates in series with the driving magnet.

Contact H1, operated, returns ringing tone to the calling subscriber, and the call is thus held in storage until a free operator's position has been allotted to it by the functioning of the common equipment and the resultant connection of 550-ohm battery (Fig. 6 (d)) to the appropriate P2 bank contact of the line unselector. At the same time the marking battery extended over the P1 bank of the line unselector is replaced by an earth to short-circuit relay TRA which releases. Contact TRA1 via H5 now operates relay HA. Relay H is released at HA2 and at H5 completes a circuit for the unselector driving magnet which again drives and at the P2 wiper searches for the marking battery of the allotted operators' position circuit. Relay TRA again operates when this marking battery is encountered and at TRA1 cuts the drive circuit and also removes a short-circuit from relay K which operates in series with the driving magnet. K2 maintains the holding circuit of relay LL. K3 and 4 release relay L and extend the incoming positive and negative leads to the allotted position circuit. K6 operates relay KR which, among other features, disconnects the ring tone from the circuit.

The provision of "Call Count" and "Time to Answer" meters will be noted, also alarm facilities which operate to indicate PG conditions, or the failure of a call to be taken into the queue within 9 seconds.

#### *Queue Storage Relays (Fig. 6 (b)).*

These relays function to form the queue on the P1 bank of the line unselector, and to hold the calls in storage pending their discharge by the queue distributor (Fig. 6 (c)). As many queue relays are needed as the maximum number of calls to be held in queue storage, although only one relay (and

<sup>1</sup>P.O.E.E.J., Vol. 42, p. 149.

storage position) is available to incoming traffic at any instant, these being opened sequentially either by the successive operation of the queue relay contacts, or the stepping of the queue distributor. At Newcastle, 15 queue storage relays are provided, these being connected to contacts 1-15 of the P1 bank of the line uniselector, and contacts 1-15 of the D1 bank of the queue distributor.

Assuming a period with no calls held in storage, all queue relays would be unoperated, but the contact on which the D1 wiper of the queue distributor is resting would predetermine the queue relay next to be operated. For example, AQ would be operated by the first call, and at AQ2 would connect 150-ohms battery to the next storage relay (BQ), to mark this queue position against the receipt of a further incoming call. Thus subsequent calls are switched to successive queue positions as marked by contacts of preceding queue relays.

The marking condition on the contacts of P1 bank is effectively 550 ohms (NI), composed of 400 ohms (NI) shunting the queue relay, and 150 ohms (NI) connected by the preceding queue relay contact, or wiper D1 of the queue distributor, and it is to this

battery that the high-speed drive-cutting relay TRA in the individual line relay set operates. Earth fed via the low-resistance winding of relay TRA constitutes the effective operating path for the queue relay associated with the marked outlet.

The call at the head of the queue, which is always determined by the position of the queue distributor, is discharged to the next operator's position to become free by the connection of an earth over the D1 bank of the queue distributor, which causes relay TRA to release, and the line uniselector to search for the free position circuit. The queue relay (e.g., AQ) is also released and at AQ2 disconnects the marking battery from relay BQ. Should a further call already be in the queue, however, relay BQ would hold over BQ1 to relay TRA in the line relay set associated with the further call, pending its discharge in the manner above described to the next free position circuit. The queue distributor steps to the next queue relay position on the release of AQ5.

*Queue Distributor and Position Marker (Fig. 6 (c)).*

The queue distributor and position marker exercise independent functions as indicated below, but as the

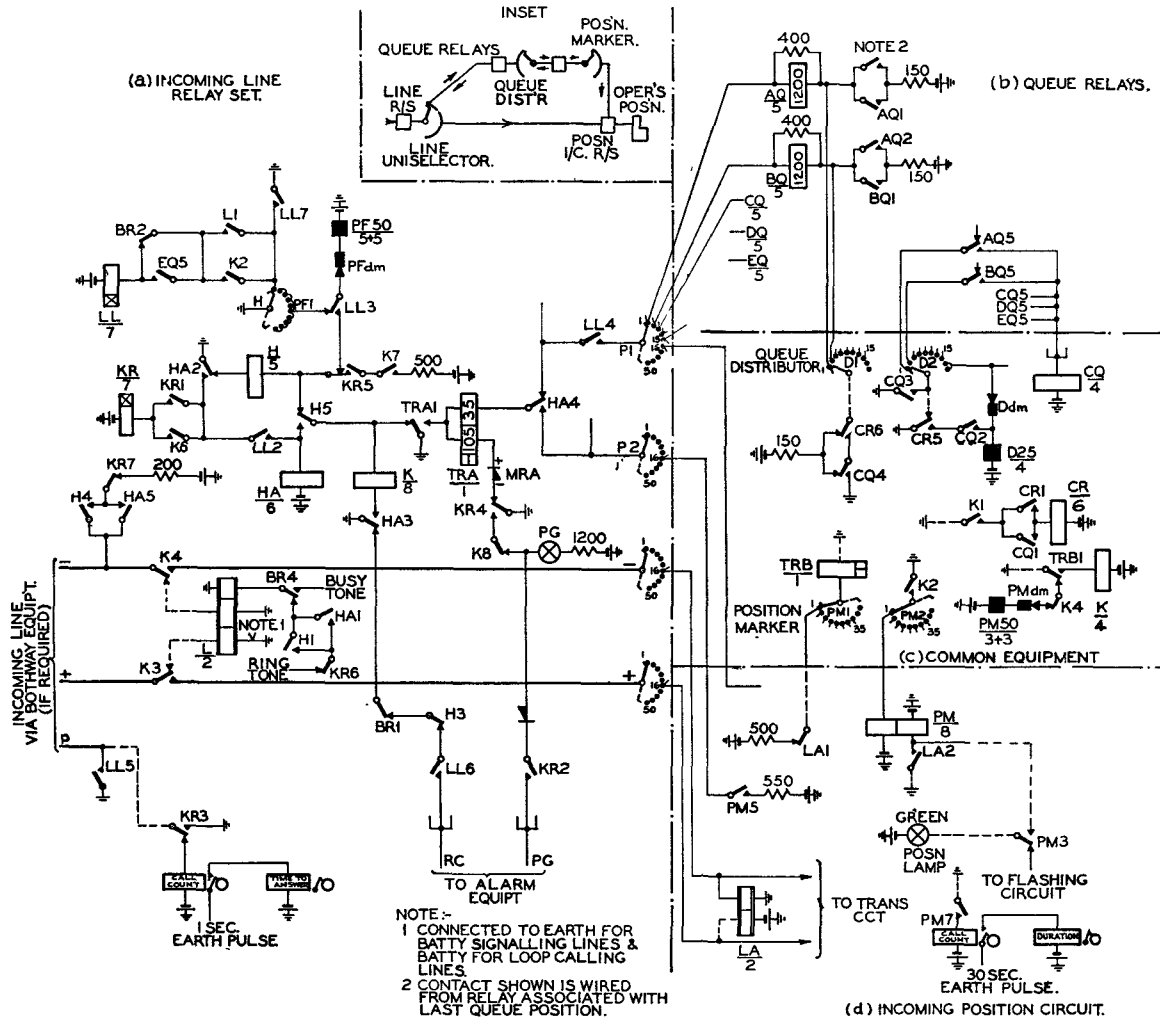

FIG. 6.—CIRCUIT ELEMENTS FOR QUEUE STORAGE AND DISTRIBUTION OF INCOMING CALLS.

controlling relays are closely interconnected, these are mounted on a common relay set base.

The queue distributor controls the initial formation of a queue, and subsequently ensures that all queued calls are discharged in the order of arrival. The bank contact on which the D1 wiper is standing at any instant indicates the head of the queue and the call next to be discharged.

The position marker preselects and marks the first operator's position to become free, and after doing so causes the queue distributor to discharge the call from the head of the queue. This call is then routed to the free position. The queue distributor steps and the next call becomes the head of the queue, awaiting discharge to the next free operator's position, to which the position marker now steps.

Referring to Fig. 6 (c), relay TRB will be operated from contact LA1 (Fig. 6 (d)) of the first free operator's position to which a stored call is to be routed, and at TRB1 cuts the position marker drive circuit and operates relay K. The presence of a call in the queue storage will be denoted by the operation of relay CQ, the operating path for which is completed by a contact (e.g., AQ5) of the queue storage relay at the head of the queue (e.g., relay AQ). CQ1 operated, via K1 operated, completes an operating circuit for relay CR, which locks via CR1, whilst CQ3 prepares a holding circuit for relay CQ against the operation of CR5.

Contacts CR5 and CQ2 energise the queue distributor driving magnet, whilst CR6 and CQ4 connect an earth via the D1 bank of the queue distributor to short-circuit and release relay AQ, and to cause the line uniselector to hunt for the marked free operator's position. The release of AQ5 releases relay CQ, and at CQ2 causes the queue distributor to step to the next contact. Relay CR remains held, however, until the call has switched to the free operator's position, when the operation of relay LA and contact LA1 (Fig. 6 (d)) ensures the successive release of relays TRB, K and CR.

K4 completes a circuit for the position marker to self-drive to the next free staffed position (although arrangements are made for this to be restrained during a period when all staffed positions are engaged), when the re-operation of relay TRB causes the above cycle to be repeated, subject to a call being in queue storage, as denoted by the operation of relay CQ.

For the sake of clarity only one queue distributor and position marker equipment has been shown, but in practice a duplicate, stand-by equipment is provided, with automatic change-over facilities in the event of the failure of the regular equipment. The circuit arrangements are such that the position of the stand-by queue distributor uniselector, upon taking over, is made to agree with that of the regular queue distributor uniselector, thus ensuring that the correct sequence of discharge is maintained for any calls in storage.

#### *Incoming Position Circuit (Fig. 6 (d)).*

The position marker, having preselected the next free staffed operator's position as described above, will cause relay PM of the position circuit concerned to be operated from K2 (Fig. 6 (c)). Contact PM5 connects

550-ohm battery to the P2 level of the line uniselector to mark the outlet to which the next call to be discharged from a queue position should switch. The consequent extension of the calling condition from the calling line to the position circuit causes relay LA to operate. LA2 locks relay PM, and at the same time completes a circuit via PM3 to cause the position lamp (green) to glow. LA1 breaks the operating circuit for relay TRB, allowing the position marker to step to the next free staffed position. The 500-ohm battery condition extended via LA1 normal to the appropriate bank contact of level PM1 of the position marker, to indicate a free staffed position, is disconnected (by contacts not shown) when the position is unstaffed, i.e., plug of the operator's head-set is not inserted in the instrument jack.

The line relay set and position circuit are both held for the duration of the call by the calling subscriber. On the release of the connection by the subscriber, relays LA and PM in the position circuit are released due to the disconnection of the calling condition. PM5, released, removes the negative battery from the P2 level and thereby releases relay TRA in the line circuit. Relays K, LL, HA and KR subsequently release and the line uniselector returns to the home position in readiness for the next call. The position circuit, however, is automatically busied to further incoming calls to enable the operator to complete the form on which the message has been received (i.e., time of receipt, etc.) before a further incoming call is offered. The green position lamp continues to glow until the operation of the position release key by the operator, which also causes the position circuit to be opened for further calls. If, however, the operator fails to operate the position release key within a period of 15 seconds after the clear-down of the calling subscriber, a uniselector timing arrangement, which is individual to the position, causes the green position lamp to change from a steady glow to a flashing signal. The attention of both the operator and the section supervisor is, therefore, called to the excessive guard period and the non-operation of the position release key.

#### ARRANGEMENTS FOR CONTROLLING QUEUE SIZE

The effect of calls held at queue storage positions can be regarded, perhaps, as having a "reservoir" effect in smoothing out short-term inequalities between the supply of operators, and the demand for them occasioned by incoming calls. This effect could, however, in some circumstances be considered undesirable, as for instance where a sustained traffic overload occurs during a period with only a few operators on duty, when the establishment of a queue of maximum size would result in unduly long time-to-answer periods. By limiting the size of the queue in accordance with the number of staffed positions available to incoming traffic, and arranging for the return of busy tone on all calls arriving whilst the queue (as restricted) is full, the time-to-answer period may be itself restricted to an acceptable figure. In determining the relationship between the permissible queue size, and the number of staffed positions, regard has also to be given to the number of



calls which may be lost as a result, a factor which clearly operates in an opposite sense to that of the time-to-answer duration.

Arrangements have been incorporated in the field trial equipment to enable the queue size to be limited, either manually, by means of a rotary switch, at the discretion of the Chief Supervisor, or automatically, in accordance with the number of staffed incoming positions as determined by the Staffed Position Count Circuit.

### Staffed Position Count Circuit.

This circuit, shown in skeleton form in Fig. 7, in

of the operation of the start relay ST, which at ST2 operates relay P. Relay S operates via contact P6 and uniselector arcs C3 and M3 (with wipers on corresponding outlets) which operates relay PW at S1 and relay S holds at PW3. PW4 operates relay B, contacts of which connect the H uniselector driving magnet to the H3 wiper, and relay PC to the H5 wiper, and release relay P at B6.

The H3 and H5 wipers are now connected, via outlet 1, to the HC and C leads of the first operator's position, and if this position is unstaffed, or not available for incoming traffic, then the contacts of the associated OR relay will be normal, as shown.

Earth from OR5 contact is, therefore, connected via H3 wiper to the driving magnet of the H uniselector and the uniselector steps to the next outlet. Should the OR relay of the operator's position connected to this outlet also be normal, the H uniselector again steps, and so on, until an outlet is reached where the OR relay connected to it is operated, which indicates a staffed position available to receive incoming traffic. OR5, operated, disconnects earth from the HC lead, and the H uniselector drive circuit, and connects it to the C lead, thereby operating relay PC via H5 wiper. PC1 energises the C uniselector driving magnet and PC2 energises the H uniselector driving magnet. Relay PC releases when the interrupter springs of the C uniselector open, causing both uniselectors to step to the next outlet.

The H uniselector continues to step as described until outlet 50 is reached, when relay HB operates, operating relay PM and releasing relays B, PW and S, in that sequence, thus disconnecting the uniselector drive circuits and marking the end of the count cycle. Circuit arrangements (not shown) prevent the re-operation of relay P at contact B6 and also cause the H uniselector to step to outlet 1 in readiness for the next count cycle, with consequential release of relay HB. The position of the wipers of the C uniselector, which has stepped once per staffed position, provides the appropriate count indication for extension to the queue limit and lamp display circuits, at wipers C5 and C7 respectively.

After the initial count, subsequent operation of the circuit takes place only when an alteration to the number of staffed positions occurs, this being signalled automatically by the insertion or withdrawal of the

plug of an operator's headset from the position instrument jack, which causes the sequential operation (or release) of relays OP and OR in the position circuit concerned. A pulse earth is thus connected via contacts OP3 and OR4 to the common PU lead, which results in the pulse operation of relay P which locks at P1. The M (marking) uniselector is now caused to drive at contact P3 so that its wipers take up a position corresponding to that of the C (count) uniselector, the drive circuit being cut at contact S1

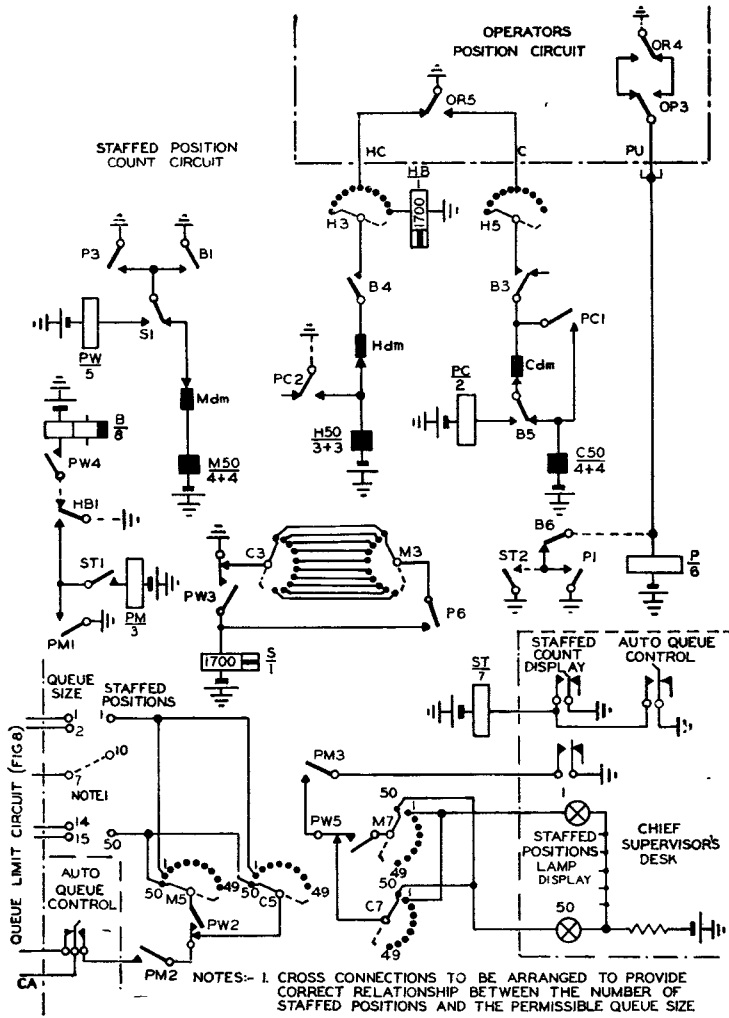

FIG. 7.—THE STAFFED POSITION COUNT CIRCUIT ELEMENTS.

addition to fulfilling its obvious function of counting the number of staffed incoming positions, provides for an appropriate marking condition to be extended to the queue limit circuit when the Auto Queue Control key is operated, in order that the queue size shall be limited to a predetermined value. It also provides for a lamp display to be given at the Chief Supervisor's desk when the Staffed Count Display key is operated. The operation of either or both of these keys causes the initial functioning of the count circuit by reason

due to the operation of the high-speed relay S via contact P6 and wipers M3 and C3. Relay PW is also operated at contact S1; PW2 and PW5 transfer the marking conditions established via wipers C5 and C7 to wipers M5 and M7 respectively. The conditions set up by the initial count are thus maintained during the recount cycle.

The operation of relay B at PW4 is restrained until the C uniselector has been restored to its home position (by circuit arrangements not shown), after which the functioning of the circuit is exactly as described above. The release of relay PW at the end of the recount cycle (PM still being held operated at ST1) restores the queue limit and display circuits to wipers C5 and C7 respectively, which will now be resting at the outlet corresponding numerically with the changed number of staffed positions. The queue size and lamp display will be altered accordingly, and the count circuit will continue to function automatically in this manner so long as one of the control keys on the Chief Supervisor's desk remains operated.

### Queue Limit and Lamp Display Circuit.

The circuit as illustrated in skeleton form in Fig. 8 has two functions, firstly to establish conditions whereby the number of calls accepted into queue storage is limited to a predetermined value, and

secondly to provide a visual indication of the instantaneous value of the queue size, both at the operator's position and the Chief Supervisor's desk.

The first function may be controlled either manually or automatically, as previously mentioned. For the purpose of the initial description, manual control will be assumed, the rotary type switch on the Chief Supervisor's desk being set at position 6, with the object of limiting the size of the queue to six stored calls. It will also be assumed that the wipers of the queue distributor are positioned initially on outlet 1, thereby pre-selecting at wiper D1 (Fig. 6 (c)) queue relay AQ as the next to be operated.

The equipment shown in Fig. 8 is brought into operation only when all staffed positions available to incoming traffic are engaged, when relay PC in the position control circuit is operated, extending an earth at PC2 to prepare for the operation of the start relay ST. An incoming call arriving at this stage will operate queue relay AQ, which at AQ4 operates the common relay QQ. QQ1 completes the operating circuit for relay ST, which locks at ST4, and extends a marking earth to the D4 wiper of the queue distributor. Contact ST1 causes the SA uniselector (which is of non-homing type) to drive until its wipers reach contact 1, where the high-speed relay SA on the SA1 wiper operates to earth via the D4 wiper of the queue distributor. SA1 cuts the drive circuit and connects earth to the SB uniselector which drives in turn to line up with the queue distributor and SA uniselector. Relay SB on the SB1 wiper operates when the SB uniselector reaches contact 1, to disconnect the drive circuit and connect earth to relay LA which operates and locks to ST2. The operation of relay LA causes the first queue display lamps on the operators' positions, and also the Chief Supervisor's desk, to glow via contacts LA2 and LA3 respectively, to indicate that one call is held in storage.

If a further incoming call arrives, the next queue relay in sequence (relay BQ) operates, extending earth via BQ3 to relay LB, via outlet 1 of SA2 arc. Relay LB operates and LB3 transfers earth from lamp No. 1 on the Chief Supervisor's display circuit to lamp No. 2 which now glows, and at LB2 causes the second lamp of the operator's lamp display to glow. Due to the "slipped" bank wiring of the SA2—8 and SB2—8 arcs, succeeding incoming calls operate relays LC, LD, etc., to cause the lamp display at the Chief Supervisor's desk, and the sequence of lamps at the operators' positions, to glow accordingly. It should be noted that the circuit arrangements are such as to ensure that, irrespective of the sequence in which the queue relays are operated, the queue count relays shall, nevertheless, operate in the numerical sequence

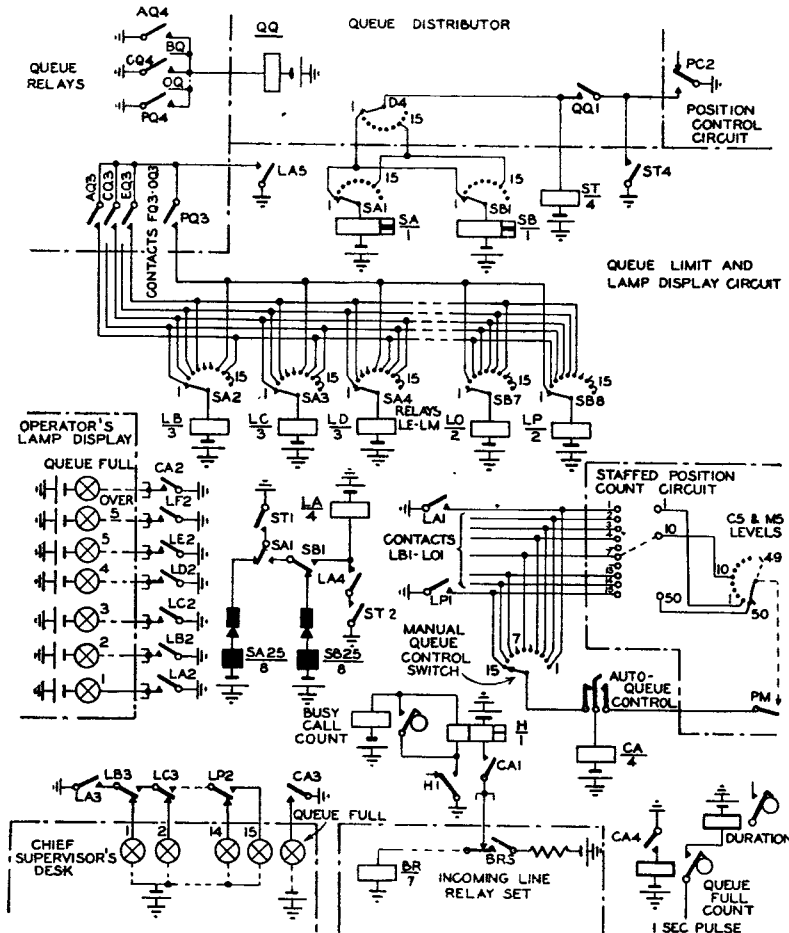

FIG. 8.—QUEUE LIMIT AND LAMP DISPLAY CIRCUIT ELEMENTS.

LA, LB, etc., required for lamp display and queue control purposes.

Relay LF operates when the sixth incoming call arrives, and in addition to lighting the display lamps at LF2 and LF3, also causes relay CA to operate from earth at LF1 contact, via the sixth contact and selecting finger of the manual queue control switch. Contacts CA2 and CA3 operated cause the "Queue Full" display lamps to glow, while CA4 causes the "Queue Full Count" meter and "Duration" meter to operate. CA1 connects relay H to the common lead associated with the BR5 contact of each incoming line circuit to prevent any further calls being stored whilst the queue full condition exists. Thus, any further call arriving would connect the associated BR relay coil in series with the H relay coil, causing both relays to operate. Relay BR locks in the operated condition via BR5 contact and returns busy tone to the calling subscriber. H1 contact operates the "Busy Call Count" meter in series with a holding coil of relay H, the release of both meter and relay being delayed until the meter is fully energised and its contacts short-circuit the H relay winding.

When a position becomes free to accept another incoming call, the longest waiting stored call, as marked by the position of the queue distributor, will be discharged from the queue in the manner described earlier. Thus, relay AQ releases, but relay QQ is held by the remaining operated queue relays. The queue distributor steps to the next contact, thus releasing relays SA and SB and causing uniselectors SA and SB to drive, as previously described, to the corresponding contact (i.e., outlet 2). Due to the effect of the slipped multiple, the stepping of the wipers SA2-SB8 to outlet 2, with the five queue relays BQ-FQ operated, will cause the queue count relay LF only to release, LB to LE being retained operated by contacts CQ3-FQ3, and relay LA continuing to hold via ST2 and LA4 contacts. The release of relay LF also releases relay CA, and the "queue full" condition and lamp display are adjusted accordingly.

The queue distributor uniselectors SA and SB continue to step once for each call discharged from the queue; the discharge of the last stored call releases relay QQ and at QQ1 causes the start relay ST to release. With the release of LA at ST2 the circuit returns to normal to await the next operation of relay PC.

*Automatic Control of Queue Size.*

It will be seen from Fig. 8 that the only effect of operating the Automatic Queue Control key is to transfer the operating path of relay CA from the manually controlled finger of the switch to the automatically controlled wiper C5 of the count unselector in the staffed position count circuit, and thus via a cross-connection field to the LA1-LP1 contacts of the queue count relays. The circuit operation is otherwise exactly as described above except that the automatic adjustment of the C5 wiper to a new position on the bank, as staff changes occur, determines, via the cross-connection field, the appropriate limiting value for the queue size.

*Position Control Circuit.*

One facility required of the system is that calls arriving when all incoming positions are engaged shall first seek a disengaged position among the bothway positions before passing to queue storage. This "overflow" facility, as well as other requirements mentioned below, is provided by the position control circuit shown in skeleton form in Fig. 9.

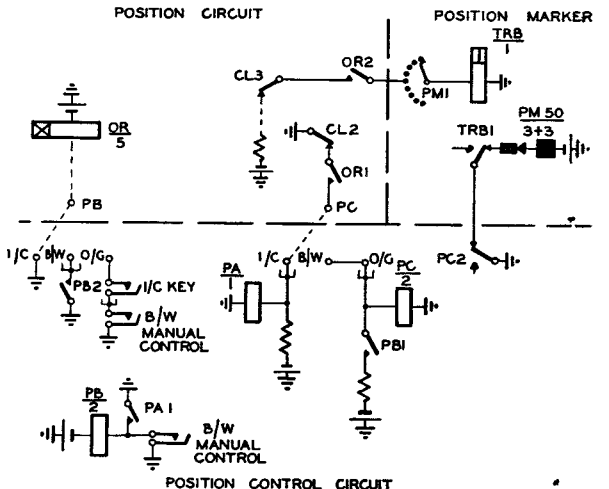

FIG. 9.—POSITION CONTROL CIRCUIT ELEMENTS.

Each operator's position is identical from an equipment viewpoint, but the particular straps employed between the PB and PC terminals of each position and the respective I/C, B/W or O/G terminals of the control circuit predetermine its normal function.

Relay OR in the position circuit is connected to its PB terminal during the period a position is staffed. Thus all staffed incoming positions will have their OR relays operated directly by earth connected from the control circuit, opening them for incoming traffic by extending marking battery via contacts OR2 to the PM1 arc of the position marker. The connection of an incoming call to the position causes relay CL (not shown) to operate and hold during the total position-engaged period, thus removing the marking condition at CL3.

Considering relay PA in the control circuit, this is short-circuited to earth via contacts OR1 operated and CL2 normal until such time as all staffed incoming positions are engaged, when earth is removed at the last CL2 contact to operate and relay PA operates. Contact PA1 operates relay PB, which at PB2 causes the OR relays of all disengaged staffed B/W positions to operate, and to open them at contact OR2 for the receipt of incoming calls.

Contact PB1 prepares an operating path for relay PC, which is short-circuited, however, via the OR1 contacts of B/W positions until all are engaged. The operation of relay PC disconnects at PC2 the drive circuit for the PM unselector (for all available positions are now engaged and further incoming calls are stored) and extends earth to the queue limit circuit (Fig. 8). The release of an incoming or bothway position at this stage causes relays PA and/or



PC to release and the longest waiting call is discharged from the queue (as already described) to the position concerned, when relay PC again operates.

The bothway positions are included in the cyclic distribution of calls by the operation of the "B/W Manual Control" key which, when operated, operates relay PB to operate the OR relays of the free staffed bothway positions. Individual outgoing positions may also be included in the cyclic distribution of calls at this stage by the operation of the I/C key associated with a particular outgoing position. The keys mentioned above are all mounted on the Chief Supervisor's desk.

#### Conclusions.

A further material advance can undoubtedly be claimed in the modernisation of the Telegraph Service with the introduction of the phonogram automatic distribution equipment at Newcastle, which has

functioned satisfactorily in service and meets without qualification the primary objective of eliminating the unfortunate call and of providing an improved service to the public. The employment of cordless type operating positions also enables the phonogram operators to enjoy more congenial working conditions than with the double-tier ancillary switchboard equipment which the automatic distribution equipment replaces.

#### Acknowledgments.

The authors desire to express their thanks to colleagues of the Telegraph and Telephone Branches and Circuit Laboratory for assistance given during the development stages; also to Ericsson Telephones Ltd., and the staffs of the North-Eastern Region and Newcastle Area for their co-operation, without which the early and successful opening of the field trial equipment could not have been secured.

## Opening of the London-Birmingham Television Radio-Relay System

The Postmaster General (The Rt. Hon. Wilfred Paling, P.C., M.P.) and the Vice-Chairman of the B.B.C. (The Dowager Marchioness of Reading, G.B.E.) performed the opening ceremony of the Sutton Coldfield television station on the 17th December, 1949. Since the operation of this second television station in this country is dependent upon an exchange of programme material with London, the Post Office was called upon to provide the necessary

channel, together with the necessary reserve equipment, has been installed; the reversing facility, called for in the contract, has been installed so that transmission in either direction can be obtained as desired. This reversible service has been provided with just over 60 per cent. of the complete radio equipment and without the erection of the final special repeater station towers, and enabled a service to be given some months earlier than would otherwise have been the case.

The radio-relay link is between Museum exchange, London, and Telephone House, Birmingham. The television transmitting stations are at Alexandra Palace, London, and Sutton Coldfield (11 miles from Birmingham), and are connected to the radio-link terminals by coaxial cable.

Readers, particularly those who are already viewers in the London area, will be interested in the photograph showing the B.B.C. television tuning signal as received at Sutton Coldfield during some early tests after transmission over the radio-relay link and coaxial "tails." Attention is drawn to the clarity of the vertical bars in the centre of the clock-face, which require a frequency response in excess of 2.5 Mc/s for their effective resolution. Many viewers will wish that they could obtain such results even from their local stations and possibly many will be surprised to see what detail the centre of the clock-face actually contains.

The television radio-relay system has been built throughout to a most stringent specification drawn up by the Radio Branch of the Engineer-in-Chief's Office. The development, production and installation of this radio system has been a joint effort by the G.E.C. Research Laboratories, Wembley, and the G.E.C. Telephone Works, Coventry. The success of the system will be watched with growing interest far beyond the confines of these islands and will do much to enhance the prestige of British radio the world over. A full technical description of the radio equipment will be given in an early issue of the Journal.

A. H. M.



TUNING SIGNAL AS RECEIVED AT SUTTON COLDFIELD.

facilities. One means of relaying the television signals is by means of a chain of radio links operating at very high frequencies, and a note in the July 1948 issue of this Journal outlined the development of the radio-relay system for the transmission of such signals between London and Birmingham. When fully completed, this radio-relay link, operating on frequencies around 900 Mc/s and employing frequency modulation, will provide for the simultaneous two-way transmission of the 405-line television signals between the two cities, but at the present stage only a single

# The Post Office Exhibit at Radiolympia, 1949

J. ATKINSON, A.M.I.E.E.

U.D.C. 061.4 : 621.396

Some of the many activities of the Post Office were demonstrated at Radiolympia in September, 1949, and this article gives a brief account of particular displays having a special technical interest.

## Introduction.

THE 16th National Radio Exhibition promoted by the Radio Industries Council opened at Olympia on 28th September, 1949. This was the second post-war presentation of Radiolympia, and arrangements were made to display various Post Office activities in the field of general and radio communications. A commanding site of 5,000 sq. ft. on the northern gallery of the National Hall was allocated to the Post Office by the Exhibition Authorities. Various branches of the Engineering Department co-operated in the selection and construction of a series of exhibits, whilst the general design and construction of the stand was undertaken by the Central Office of Information in collaboration with the Public Relations Department of the Post Office. During the ten days run of the exhibition, almost 400,000 people visited Radiolympia. It has been estimated that some 200,000 of these paid a visit to the Post Office stand.

## Layout and Scope of the Exhibition.

The layout and general arrangements of the Post

Office Exhibit are indicated in Fig. 1. The design provided a central island display with supporting exhibits around the boundary walls of the stand, and the exhibits were selected to provide interest to a wide range of technical and non-technical tastes. Apart from the items of general and non-technical interest, the main displays were:—

- (1) A working demonstration of the subscribers' emergency (999) telephone service.
- (2) A display of the submarine cable activities of the Post Office.
- (3) An exhibition of the equipment in a Post Office Coast Radio Station with an interesting demonstration of the method of dealing with distress calls from ships.
- (4) A working demonstration of the transmission of video signals over a microwave radio link.
- (5) An exhibition of the equipment to be used at the terminal and intermediate stations of the London-Birmingham coaxial cable television link.

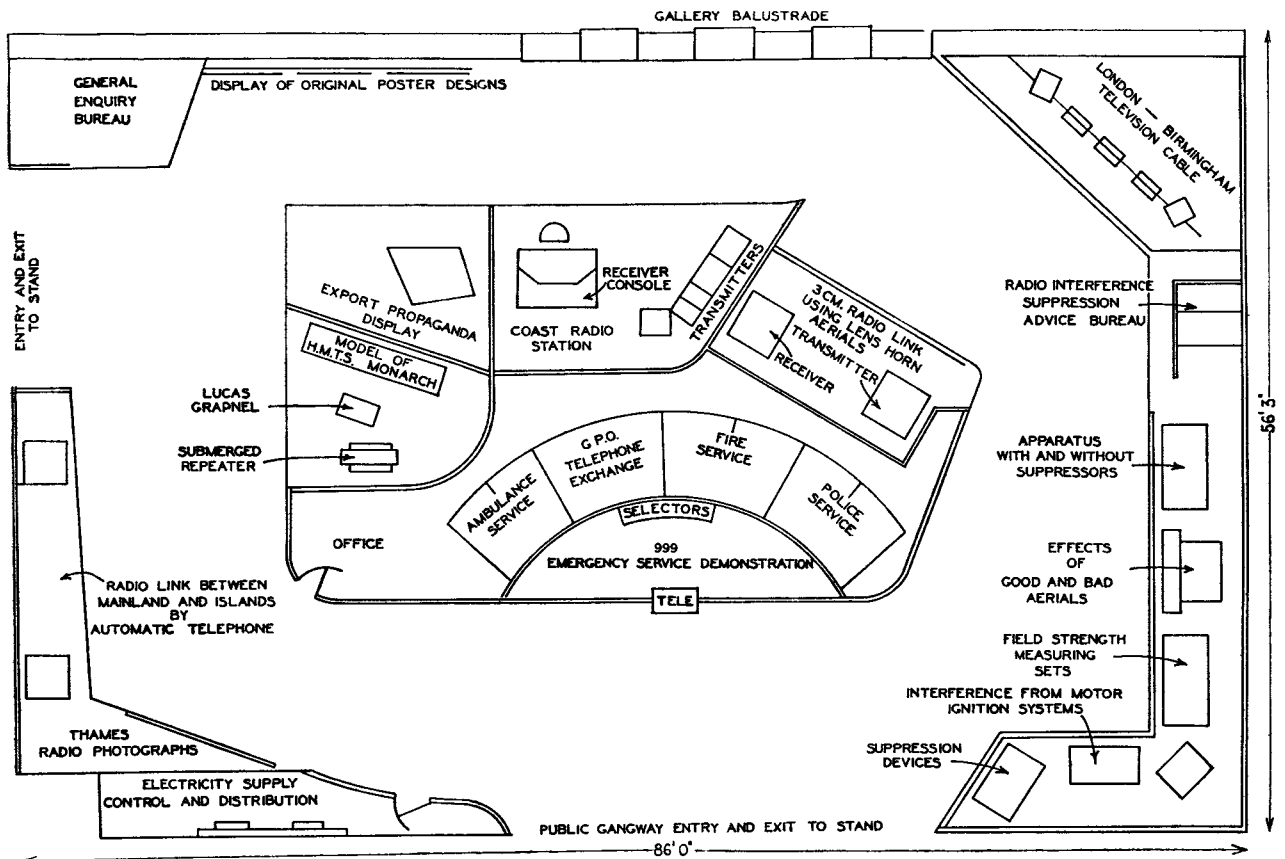

FIG. 1.—LAYOUT OF POST OFFICE EXHIBIT AT RADIOLYMPIA, 1949.

- (6) A comprehensive display of the causes of radio interference, indicating the methods of locating and eliminating such interference.
- (7) A working demonstration of the method of providing telephone service to isolated communities by the use of a radio link to the nearest automatic exchange.

#### The 999 Emergency Service.

This exhibit (Fig. 2) was designed to set out in a



FIG. 2.—DEMONSTRATION OF SUBSCRIBERS' EMERGENCY (999) SERVICE.

simple yet comprehensive fashion the sequence of events that follow the dialling of 999. The stand was divided into four main sections to represent the equipment in use at the local telephone exchange, the Watch Room of the London Fire Service (Lambeth), the Information Room at Scotland Yard and the Control Room of the London Ambulance Service (County Hall). The automatic switching equipment was represented by three group selectors mounted in a suitably partitioned compartment in the foreground. Members of the public were invited to make "emergency" calls from a telephone at the front of the stand and as the three digits were dialled the audience could see the stepping of the group selectors and lighting of the calling lamp, and hear the alarm buzzer at the telephone exchange switchboard. The telephonist then asked for the service required and connected the caller to the Police; Fire or Ambulance service as appropriate. The first part of the Police section of the exhibit contained a replica of the keyboards, maps, etc., as used in the Information Room at Scotland Yard and the second part the radio telephone equipment as used in the Mobile Police cars. The Fire Service was demonstrated by a replica of the switchboard at the London Fire Service Headquarters, whilst, in a separate section, illuminated displays were provided to represent the subsequent action at the appropriate fire station. The circuit arrangements provided for the operation of spotlights

above the various sections of the exhibit to indicate the progress of the call as it was switched from point to point. A realistic atmosphere to the demonstration was provided by the uniformed officers of the three services concerned, and these officers together with the main demonstrator gave advice to callers concerning the correct method of making emergency calls.

#### Submarine Communications.

The Post Office's part in the field of submarine cable communication work was illustrated by a scale model of the cable ship *Monarch*, a model of the "Lucas" cutting and holding grapnel and a submerged repeater. The cable ship and the grapnel have been fully described in the *Journal*.<sup>1</sup> The submerged repeater was of the tandem-operated type which has been expressly designed to enable up to ten such repeaters to be operated on any one cable. With the standard coaxial type of submarine cable the repeaters will be located at 16-mile intervals and will enable a maximum of 60 speech channels to be employed. The frequency bands used range from 24 to 264 and 312 to 552 kc/s, and the repeater has a gain of 60 db. at the highest frequency. The use of a non-linear pulse technique for the identification of a faulty repeater was explained by the demonstrator, and considerable interest was shown by the public in the method of providing the D.C. power supply from the shore terminal to the

repeater.

#### Coast Radio Stations.

The exhibition of the equipment at a Post Office radio station included a complete transmitter of the latest type and a receiver console of recent design (Fig. 3). The transmitter (Type W5) is of the type which can be remotely controlled by the operation of push buttons. These controls enable one of a number of transmitters to be selected and the operator has the choice of various frequencies and output powers. The transmitter provides facilities for CW, MCW or telephony with a maximum power in the order of 3 kW. The frequency range is from 0.35 to 0.5 and 1.5 to 3 Mc/s. The console receiver (Type W20) has been specially designed for coast station work and can be used for a variety of conditions. The receiving equipment provides a coverage of 250-550 kc/s and 1,500-3,750 kc/s.

The transmitter bays and control console were connected together and the circuits energised to enable the remote control of the wave-change and output switches and contactors to be demonstrated.

A considerable amount of public interest was shown in the dramatic and realistic demonstration of the procedure in a coast radio station when a call is received from a ship in distress. A "play-back"

<sup>1</sup>*P.O.E.E.J.*, Vol. 39, p. 129.



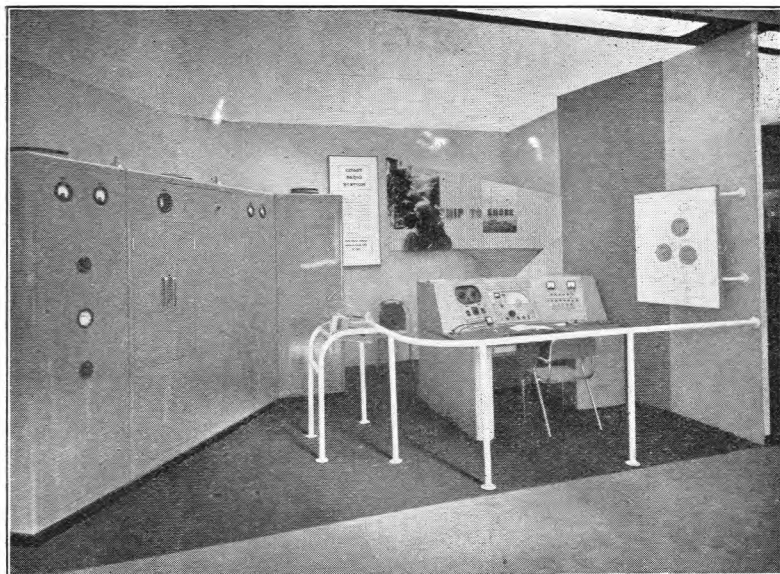

FIG. 3.—COASTAL RADIO STATION.

unit and a loud speaker behind scenes were used to reproduce a special recording of a skipper of a trawler making a distress call, and to augment the operations of the wireless operator at the receiver console. Each demonstration lasted about 15 minutes and very few visitors could distinguish between the recorded and "live" parts of the show.

#### *Microwave Radio Link.*

The more technically-minded visitors to the Post Office stand showed considerable interest in the demonstration of a 3 centimetre (10,000 Mc/s) experimental radio link. Such equipment may possibly have a very extensive field of usefulness in the future for the relaying of television signals or for multi-channel telephony. The working demonstration (Fig. 4) included a transmitter and a receiver, each fitted with a lens-horn aerial and suitable cathode-ray tube equipment for monitoring the input and output signals of the link. The transmitter consists of a low power reflex klystron oscillator which is frequency modulated by the television signal. The output of the transmitter is fed through a wave guide to the lens-horn aerial which produces a narrow beam of radio waves towards the distant receiver. The electro-magnetic wave lenses used in these aerials operate on similar principles to the lenses used in optical equipment but they are made from an artificial dielectric consisting of metal spots sprayed on thin sheets of insulating material. The receiver is of the super-heterodyne type with a reflex klystron local oscillator and a crystal mixer followed by a 60 Mc/s I.F. amplifier, a limiter and a discriminator. To add interest to the demonstration, the public were shown how

microwaves could be efficiently reflected from a sheet of polished copper.

#### *London-Birmingham Coaxial Cable Television Link.*

Until recently, the main public interest in television has been centred on the area around London, but the proposals of the B.B.C. to open the Birmingham television broadcast station had awakened further interest in the extension of the television service to other parts of Great Britain. The exhibit showing the proposed London-Birmingham coaxial cable link therefore attracted considerable attention. (It should be realised, however, that the complete cable system will not be available for some time and the present television transmissions between London and Birmingham are by means of a radio-relay link). This display was so designed that the background of the equipment bays provided a simplified "routing diagram" of the complete London-Birmingham link (Fig. 5).

The exhibit showed the modulating and demodulating equipment at the terminal stations of the link and the amplifiers at an intermediate station on the route. Television receivers connected to the ends of the link enabled the public to see that the picture suffered no visible loss of quality in transmission. The television tubes of the coaxial cable between London and Birmingham are 1 in. in diameter and form part of a composite cable with smaller tubes for multi-channel telephony. The cable also incorporates a number of balanced pairs which can be used for control purposes or for audio programmes. A sectioned sample of the complete cable was available for inspection by visitors to the exhibition. The transmission over the special televi-

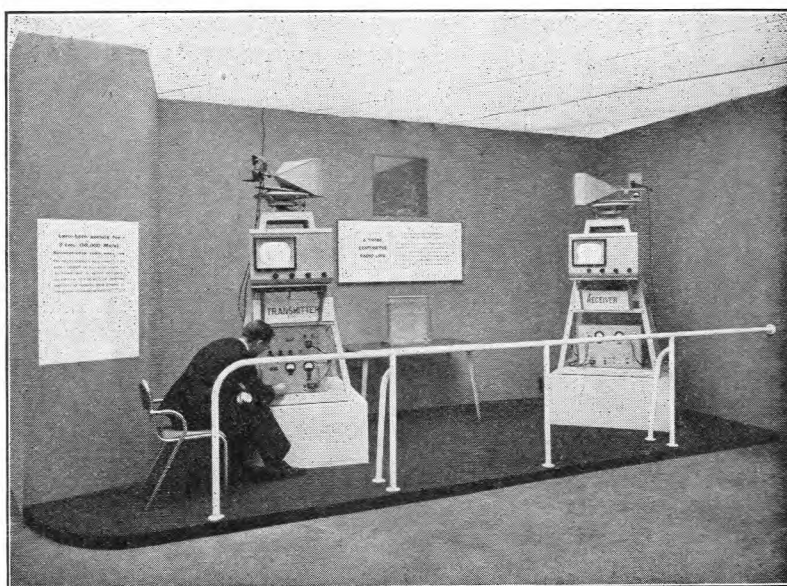

FIG. 4.—3 CM. RADIO LINK.



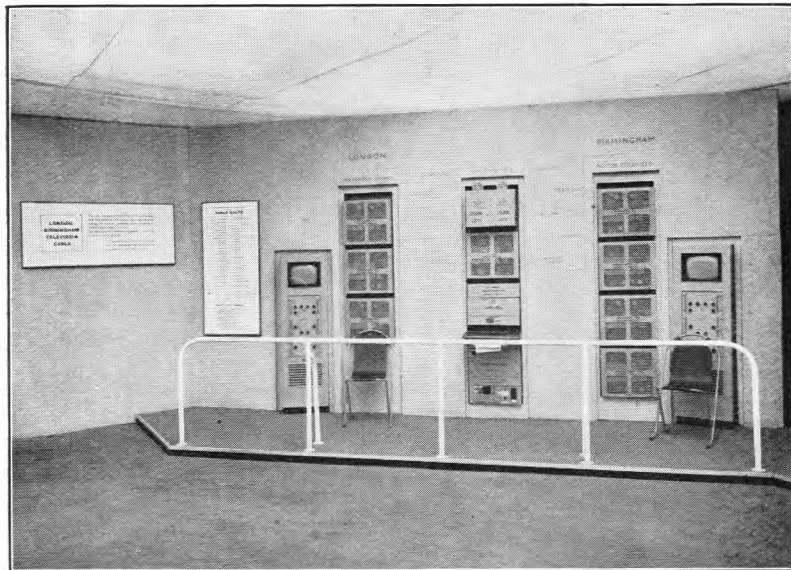

FIG. 5.—LONDON-BIRMINGHAM COAXIAL CABLE TELEVISION LINK.

sion tubes will occupy a frequency range of 3 to 7 Mc/s, video frequencies of up to 3 Mc/s being transmitted on an asymmetric sideband system using a 6.12 Mc/s carrier frequency. The signals will be amplified at intervals of approximately 12 miles along the cable route.

#### Radio Interference.

Almost one complete side of the Post Office stand was devoted to the problem of radio interference. A number of separate exhibits showed how interference was caused and how the use of suppressors can materially help in the minimising of such interference. Possibly the most attractive exhibit was a model house (Fig. 6) completely equipped with a variety of electrical appliances. Various types of aerial were fitted to the house and by means of a group of push buttons, the public could observe the advantage to be gained by a good aerial system. An audio programme circuit was connected to a loud speaker and noise at various levels was injected via the contacts of the push buttons.

Another demonstration of particular interest to the owners of television receivers was provided by a model of a motor car ignition system. By means of switches it was possible to show the extent of the interference on a monitoring television receiver and how this interference could be eliminated by connecting suitable suppressors to the ignition system.

The interference demonstrations were supplemented by exhibits of the equipment used by the Post Office for the detection, location and suppression of interference to radio broadcast reception. The stand also included a bureau where members of the public could discuss any interference problems with the demonstrator. During the ten

days of the exhibition, many hundreds of questions on diverse aspects of radio interference were presented to the officers staffing the bureau. A total of 212 complaints of interference was recorded, and subsequently investigated.

#### Radio Links with Isolated Communities.

As a change from the complex equipment of the television links, the coast radio stations, etc., the demonstration of a new type of low power V.H.F. radio telephone system provided a refreshing contrast (Fig. 7). This system has been developed by the Post Office to provide automatic telephone service to remote communities such as the small islands off the Scottish Coast. The equipment is operated from primary batteries and has been designed to work for long periods without skilled maintenance. To economise

in energy consumption, the transmitters and receivers are fully energised only when a call is in progress. At other times, the receiver operates intermittently to test for a calling signal every half minute. The transmitter is designed for an output of up to 50 mW with a frequency range in the order of 75 Mc/s to 90 Mc/s. Supervisory, ringing and dialling facilities are provided so that the equipment will inter-work with the normal telephone system. The two radio terminal stations of the exhibit were provided with simple  $\frac{1}{4}$ -wave aerials although more efficient aerial systems are normally employed in practice. Arrangements were made so that visitors to the stand could dial over the radio link to an automatic exchange in the London area and thence to a local telephone number.

The Thames Radio Service, by means of which it is

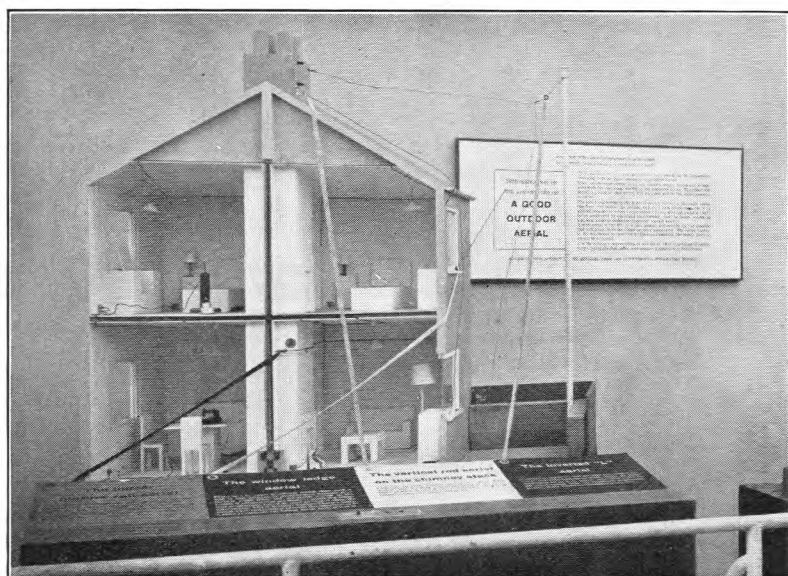

FIG. 6.—MODEL HOUSE FOR DEMONSTRATING ADVANTAGES OF A GOOD AERIAL SYSTEM.

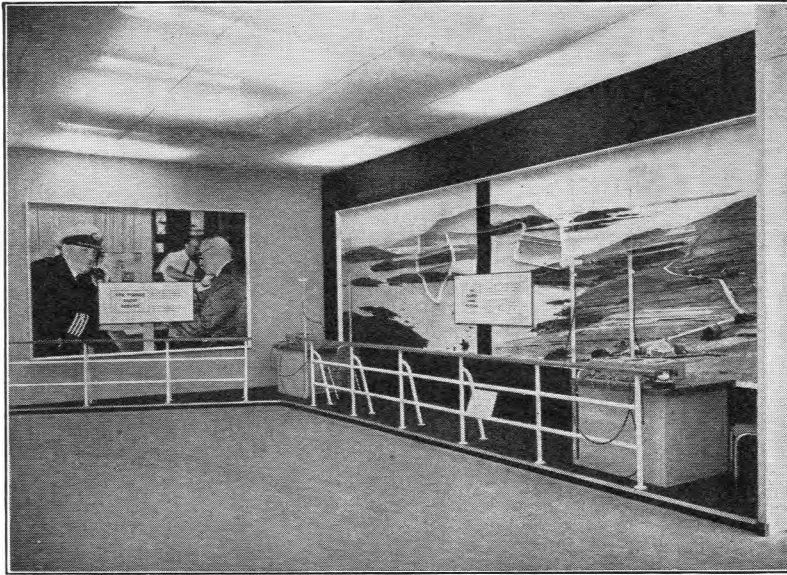

FIG. 7.—RIGHT, RADIO LINKS FOR COMMUNICATION WITH ISOLATED COMMUNITIES ; LEFT, THAMES RADIO SERVICE.

possible to provide communication with various ships in the Thames and Thames Estuary, was publicised by means of a photographic display panel and caption matter (Fig. 7) and not by working apparatus.

#### Conclusion.

As is well known by all who have undertaken exhibition work, the presentation of a large and varied exhibit, involves a considerable amount of

hard work and concentrated effort during the days immediately preceding the opening. The pre-opening turmoil of the 1949 Radiolympia was somewhat worse than usual, due to a strike of the contractors' stand construction staff four days before the opening.

The result of this strike was that 24 hours before the exhibition was due to open, only part of the skeleton of the Post Office stand had been erected, and as the organisers and all exhibitors were determined that the show should open on time, "shock tactics" were employed.

The services of carpenters, joiners and painters were obtained from the London Telecommunications Region, and everyone concerned worked throughout the day and night, almost without pause.

Thanks to a very fine team effort the Post Office stand and exhibits were completed and on display when the exhibition opened to the public at the scheduled time.

Final touches to the show were added during the night period following the opening day.

#### Acknowledgement.

The author is indebted to his many colleagues in the various branches of the Engineer-in-Chief's office who designed, made, installed (under extremely difficult circumstances) and demonstrated the exhibits displayed on the stand.

## Institution of Post Office Electrical Engineers

Recent additions to the Institution Library include the following :—

1827 *Modern Electrical Engineering Mathematics*. S. A. Stigant (British 1946).

An outline of the progress made in the application of the results of pure mathematical research to the solution of problems arising in electrical engineering theory and practice.

1828 *The Photographic Recording of Cathode-Ray Tube Traces*. R. J. Hercock (British 1947).

The object of this booklet is to provide those familiar with the use of cathode-ray tubes with an insight into the photographic techniques necessary to obtain useful records of traces.

1829 *Theory and Application of Microwaves*. A. B. Bronwell and R. E. Beam (American 1947).

A presentation of the underlying theory of microwave systems under the general categories: (1) fundamental electronic concepts and their application in the analysis of microwave tubes; (2) transmission lines and networks, and (3) electromagnetic field equations and their use in the analysis of wave propagation, reflection phenomena, wave guides and radiating systems.

1830 *Shadow and Diffusion in Illuminating Engineering*. K. Norden (British 1948).

This book gives a fairly complete record of our present knowledge and technique regarding the practical application of shadow and diffusion to illuminating engineering problems.

1831 *Radar Engineering*. D. G. Fink (American 1947).

Provides a general compilation of radar information in two parts: (1) fundamental concepts essential to an understanding of radar technology; and (2) components, circuits and structures used in radar equipment.

1832 *Timber, its Structure and Properties*. H. E. Desch (British 1947).

A thoroughly comprehensive work in simple concise language.

1833 *U.H.F. Radio Simplified*. M. S. Kiver (American 1945).

A presentation of the concepts of U.H.F. radio as logical outgrowths of the more familiar low-frequency equipment.

1834 *Records and Research in Engineering and Industrial Science*. J. E. Holmstrom (British 1947).

The object of this book is to serve as a guide to the existing sources of scientific knowledge.

1835 *Hyperfine Structure in Line Spectra and Nuclear Spin*. S. Tolansky (British 1948).

An introduction to the study of fine structure in line spectra for those already familiar with the elements of spectroscopy.

1836 *Low Temperature Physics*. L. C. Jackson (British 1948).

An outline of the subject for readers whose main interest lies elsewhere.

(Continued on page 245)

# Notes and Comments

## Recent Award

The Board of Editors has learnt with great pleasure of the honour recently conferred upon the following member of the Engineering Department:—

Portsmouth Telephone Area	Jackson, A. C.	Assistant Engineer	Capt. (Tem.) Royal Signals	Mentioned in Despatches
---------------------------	----------------	--------------------	-------------------------------	----------------------------

## Special Commendations

The Board learns with great pleasure that the following two officers of the Engineering Department have recently received awards for courageous action:—

Mr. J. Futcher, Technician Cl.IIB, Bradford Telephone Area—Silver Medal of the R.S.P.C.A., for assistance in rescuing animals from a fire at Gargrave.

Mr. M. J. Phillips, Technician Cl.IIB, London Telecommunications Region—Honorary Certificate of the Carnegie Hero Trust Fund; for an attempted rescue from drowning at Rottingdean.

## Recent Appointment

Mr. L. G. Semple, who served in the Engineering Department for many years, and became Superintending Engineer, South Midland District, in 1938, has recently been appointed as Regional Director, North Eastern Region. The Board offers its congratulations and extends to him best wishes for success in this important position.

## Binding for Volume 42

The current issue of the Journal completes Volume 42 and subscribers wishing to have their copies bound are recommended to make early application.

Particulars of the facilities available and method of ordering are given on p. 245 of this issue.

## P.M.G.'S Department, Australia

It is interesting to note from the 38th Annual Report (1947/48) recently issued by the Postmaster-General, Australia, that the 3-year post-war programme expiring in June, 1950, had proceeded satisfactorily. The programme covers capital works, including sites and buildings, to a value of £42,000,000 in respect of the more urgent of the projects designed to overcome arrears and restore a high standard of efficiency. The general position was still critical, however, and all possible means of accelerating progress were being explored.

Although in the year under review a record total of 58,137 telephones was added to the system an extraordinary demand for service continued and arrears of applications tended to increase. In spite of serious problems due to shortage of materials, plant and labour 13 new automatic exchanges were established and 55 carrier-wave telephone systems were installed on trunk line routes.

## Portraits of Telecommunications Pioneers

We have been informed by the Secretary-General, International Telecommunications Union that a series of photographic reproductions of men renowned in the sphere of telecommunications has been pub-

lished during recent years covering such well-known figures as Morse, Bell, Marconi, Baudot, Herz, etc., the latest being that of Faraday.

The reproductions, approximately 9 in. × 7 in., are priced at three Swiss francs per copy and may be obtained on application to the Secretary-General, I.T.U., Palais Wilson, 52 rue des Paquis, Genève (Suisse).

## Circuit Laboratory—Silver Jubilee

An event of unusual interest occurred recently when the Engineer-in-Chief's Circuit Laboratory celebrated the completion of 25 years' service. The occasion was marked in a most appropriate manner by opening the Laboratory to visitors and enabling them to inspect and have explained some 70 exhibits, many of which had been specially staged for the occasion.

In addition to a few items of historical interest which attracted attention, many circuit models of new signalling devices and switching schemes were on show, together with a representative selection of test equipment. It is not possible in these notes to mention specifically more than a few of the exhibits, but amongst those which aroused special interest were an effective set-up showing the origination, routing and reception of a telephone call under Trunk Mechanisation conditions; the new Phonogram Automatic Distribution scheme giving queue formation and queue size adjustment facilities on incoming phonogram calls; the Automatic Traffic Equipment which is already proving of considerable assistance when maintenance investigations are undertaken as a result of service observations; and the Electronic Scaler for relay timing, which may be quoted as typical of the advanced testing techniques now employed in the Laboratory.

The organisers planned for a preliminary "field trial" day on which relatives of those closely connected with the Laboratory were conducted round the exhibits. No doubt the experience then gained helped to ensure the effective arrangements whereby more than 500 official visitors were accommodated during the two "open days" set aside for this purpose. Amongst the many distinguished visitors were Mr. B. L. Barnett, Deputy Director General, Sir Archibald J. Gill, Engineer-in-Chief, and General W. A. Scott, G.O.C., Army Signals. Representatives from numerous organisations outside the Post Office were in evidence and, in common with others, found the Laboratory demonstration staff more than equal to their exacting tasks.

Mr. C. H. Wright, the Officer-in-Charge of the Laboratory, and his assistants are to be congratulated on an exhibition which proved well worthy of the special occasion.



**Brigadier L. H. Harris,  
C.B.E., M.Sc., A.C.G.I., M.I.E.E.**

Brigadier Harris, who has been promoted from Regional Director, Scotland, to Controller of Research, entered the Engineering Department as an Assistant Engineer in 1922, having spent four years with Signals in the Australian Imperial Forces, and graduated at London University from the City and Guilds Engineering College.



He spent the subsequent ten years in the Research Branch during which he obtained a Master of Science degree and twice the Senior Silver Medal of the Institution of Post Office Electrical Engineers. In 1932, he was promoted to Executive Engineer in the Telegraph Branch and to Assistant Staff Engineer in 1936. There he was concerned with the introduction of the V.F. telegraph network and the development of the original teleprinter automatic switching scheme, most of the field trial equipment for which was lost when the Central Telegraph Office was burnt in the London blitz.

Leaving behind the sphere of Research and Development where his work was to have a widespread influence on telephone and telegraph practice, he became Superintending Engineer in the North Midland District in 1938, and on the outbreak of war went to France as a Company Commander of the 44th (H.C.) Divisional Signals.

After Dunkirk, he was appointed Lines Officer at G.H.Q. Home Forces, and then commanded G.H.Q. Signals during the invasion scare period. On promotion to Colonel in 1942, he became involved in the planning and organisation of the cross-channel and continental communications designed to cover any operational plan for the invasion of north-west Europe which might be ultimately decided upon. Without this early preparation of coastal installations, mobile equipments, cable and teams made in conjunction with, and largely provided by, the Post Office,

the complex cross-channel system which was rapidly built up from D-Day could not have been realised.

Such activities naturally led to his inclusion in the team of planners for Operation "Overlord," and to his subsequent appointment to the staff of General Eisenhower in charge of the Telecommunications Section of SHAEF. For these and other services in connection with the rehabilitation of the continental cable network for military use, he was awarded the C.B.E., and honoured by the Allied Governments with the French Legion of Honour and the United States Legion of Merit.

Brigadier Harris has the gift to a remarkable degree of seeing the potentialities of a man and as a result putting the right man in the right place and so forming a keen and hardworking team. Not only his engineering colleagues, but also his many friends in other branches of the Service will wish him, with confidence, every success in his new sphere of activities.

J. R.

**Mr. D. A. Barron, M.Sc., A.M.I.E.E.**

Congratulations to Mr. D. A. Barron on his promotion to Staff Engineer, Telephone Branch.

Mr. Barron has had an exceptionally wide experience of the practice of the art of Telecommunications since he entered the Post Office Engineering Department as a Probationary Engineer, after graduating with Honours at Bristol University, in 1927. Apart



from general experience of both internal and external work as Engineer in the South Western District and, from 1936, as Sectional and Area Engineer at Liverpool, Mr. Barron was particularly concerned with the transfer of Plymouth Area to automatic working, and planning for the transfer of the Liverpool Area to director working. He received special commendation for his work in this connection.

Mr. Barron transferred to the Telephone Branch of the Engineer-in-Chief's Office in April 1940, becoming Asst. Staff Engineer in charge of circuit design,



apparatus and relay design and standardisation and the Circuit Laboratory in January, 1941. It was undoubtedly the exceptional combination of experience of organisation and control in the field of automatic transfers and specialist knowledge of circuit and apparatus design that led to Mr. Barron's selection for a very responsible and heavy task. In 1945, he was seconded to the Telephone Manufacturers of India Limited as chief consultant to the Indian Posts and Telegraphs Department to produce plans and specifications for the conversion of the Calcutta Area to automatic working.

On his return to the Post Office in 1947, his wide experience again led to his selection for a special task—that of taking control of a working party surveying switching methods and plant throughout the world and examining the engineering aspects of subscriber-to-subscriber dialling with national numbering in Great Britain. As part of this task he took a small party to the U.S.A. to study American telephone switching practices and development. He had barely completed his reports on these matters when he was called to undertake the new responsibilities as head of the Telephone Branch.

Mr. Barron has found time in spite of all to pursue his love for games. In his early days he represented the South of England against Canada at lacrosse, and still finds time for a game of tennis, although, as with most of us, gardening tends to take a greater proportion of his leisure. He is also no mean performer at model making and has taken prizes for some of his efforts.

W. J. E. T.

#### **Retirement of Mr. C. W. Brown, M.I.E.E.**

On the 31st October, 1949, Mr. C. W. Brown, Staff Engineer in charge of the Telephone Branch of the E.-in-C.'s Office, retired after about 45 years in the Engineering Department.

In the earlier part of his service, from about the turn of the century until his transfer to the Telephone Section of the E.-in-C.'s Office in the early 20's, he was engaged in the London and in the South-Eastern Districts in the diversity of work required for the provision and running of all types of telephone exchange and area, including the historic first public automatic telephone exchange in the country at Epsom. In the middle of this period, for the duration of the 1914 war, he was also engaged in advising, and lightening the executive burden of the Army Signals formation operating in the all-important south-east corner of England.

With this solid fund of experience, Mr. Brown was transferred to the Telephone Section of the E.-in-C.'s Office, where he was engaged on automatic telephone exchange equipment design work for a year or two, and then became the officer in charge of the newly created school for training students in the construction and maintenance of telephone exchanges, and particularly of automatic exchanges on account of the gathering momentum of growth of automatic working. This commenced a notably constructive period of 12 years for which he was in charge of the Training School, first in King Edward Building and then at Dollis Hill. With no guiding precedents he moulded

the School from its now seemingly modest initial scope through a continuous course of expansion in size and range of subjects to the smooth-running training institutions with a Central and Regional Schools, which set the pattern for the future.

On promotion to the rank of Assistant Superintending Engineer in 1936, Mr. Brown went to the London Engineering District and for the next five years he was in charge, first, of internal construction, during a particularly heavy period of automatic exchange installation, and then as Regional Engineer—and a little later as Deputy Chief Regional Engineer—in charge of external developments.

In 1941 he became Staff Engineer in charge of the Telephone Branch of the Chief's Office, where until his retirement his rich technical and administrative experience, and his deep interest in and understanding of people, enabled him to pilot the Branch through the difficult war and post-war years.

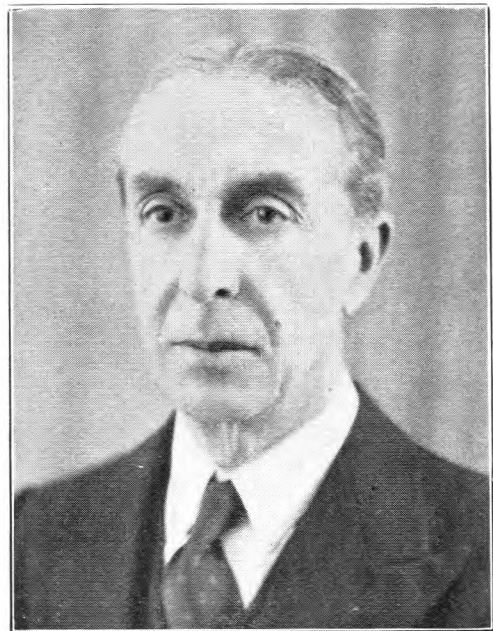

In the post-war years his most prominent responsibilities have been first, the solution of the problems of national semi-automatic trunk-working, and secondly, the preparation of designs, now well in hand, for the field trial of alternative systems of direct operator-dialling between selected European cities, including London, in accordance with technical principles recommended by the C.C.I.F., on which committee he represented the Post Office.

Mr. Brown's long career brought him into contact with many members of the telephone industry at home and in most countries overseas, and he became perhaps the best-known British engineer in the industry. All who know him will surely agree that his high engineering attainments and his delightful personality—his kindness, tolerance, humour and urbanity—made him the perfect "good relations officer" within and outside the Department.

R. L. B.

# Regional Notes

## North-Eastern Region

### EXTENSION OF CABLE TRENCH IN U.A.X. No. 13

The extension of the U.A.X. No. 13 beyond its original capacity of 200 lines, is now standard and is known as U.13X. This involves the fitting of an additional C unit adjacent to the existing unit and standing over the cable trench. Access to the cables and joints is provided by extending the trench in front of the units, the units being supported by R.S.J.

The problem arose as to how to support the weight of the unit, a matter of approximately 7 cwt., during the breaking of the concrete and the fitting of the R.S.J. This difficulty was solved in the York Area by the use of two motor jacks placed in the bottom of the trench and

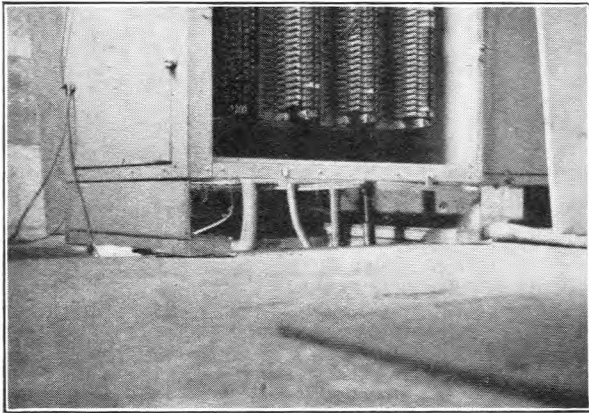

THE UNIT LIFTED.

jacked up to take the weight of the front of the unit. The operation was somewhat delicate as any excessive lifting of the unit would have caused damage to the switchboard cable running into the A unit. The work was further complicated by the presence of the cables in the trench, and by the inaccessibility of the end of the unit farthest from the wall. As this end of the unit does not stand over the trench, it was necessary to take the strain on mild steel bars placed so that the strain was taken by the framework of the unit and not by the cabinet.

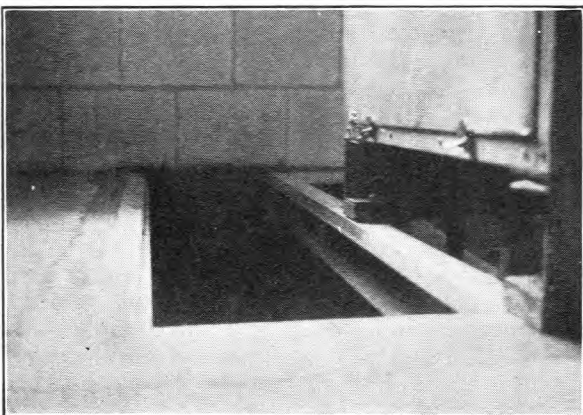

EXTENSION OF CABLE TRENCH WITH R.S.J. IN POSITION.

After the R.S.J. had been set in position, the unit was lowered and the jacks removed. Owing to the small extent of the lift, there was virtually no disturbance to the cabling arrangements of the units. No faults were caused by the operation. W. N. P.

## Home Counties Region

### MAINTENANCE LOAD SCHEDULES, BRIGHTON AREA

There are many arguments for and against territorial maintenance working, but where it is in operation equitable distribution of linemen's loads is regarded as essential. Otherwise, black spots develop because heavily loaded linemen cannot do their routines, or switching linemen to assist outside their own areas becomes common practice and has a bad effect on that "pride of area" feeling. Equitable loading can be approached by careful preparation of load schedules and the method used in the Brighton area may be of interest.

The characteristics of each Maintenance Control are considered when deciding the distribution of "O" and "U" time, e.g., the heavily-wooded Horsham area is given an additional 0.6 mhrs/W.U. for "O" at the expense of the large built-up area around the town of Brighton. The rest of the maintenance subheads are dealt with on a common basis for the whole Area, but with some slight variations to cover local conditions, and the following details illustrate the method used for dividing the 1948-49 manhour allotment, all figures being on the 44-hour week basis:—

AE. Allotment 10.0 mhrs/W.U. U.A.X.s are considered to require about 12 mhrs/W.U. whereas the modern N.D. exchanges can operate at 8 or 9 mhrs/W.U., leaving 9.61 mhrs/W.U. for the Siemens 16 multi-office area in Brighton. The rate allotted to U.A.X.s is further sub-divided to provide for routine overhaul (4.23) and special faults investigation (0.2), leaving 7.39 for the linemen. The rate for routine overhaul would be 50 per cent. of the total if the three-monthly overhaul of common equipment was carried out by the routines officer instead of the lineman.

ME. Allotment 7.92. The large exchanges, i.e., those permanently staffed, are easier to run than the smaller ones, the time being divided thus: large exchanges 7.66, other exchanges 8.0 and special faults 0.5.

SU. Allotment 9.25, which is divided between the linemen (8.55) and special faults (0.7).

TR. Allotment 9.60. The Maintenance Control is given the full rate for all lines which can be tested directly. For other lines the lineman is given 1.2, the remainder going to the Control.

IV. Allotment 6.33. The full amount is given to the linemen or repeater station staff.

TG. Allotment 8.50. There is a Mechanics' Shop in Brighton which maintains many teleprinters itself and overhauls all others in the Area. It also repairs and overhauls stamp-selling machines, clocks, scales, etc. The normal maintenance staff is given 4.6 and the mechanics' shop 3.9.

O. Allotment 7.10. Division of this time varies between each control and also between exchange areas within a control. As an example, in Worthing, gangs employed on tree-cutting and other maintenance works are considered to require 3.62 and special faults 0.7, leaving 2.78 for the linemen.

U. Allotment 7.08. The linemen are given 1.0 to cover testing and co-operation with the jointers, who are allotted the remainder.

F2A. Allotment 7-15. There is a small power maintenance group headquartered in Brighton which undertakes all the work in the Brighton Control and the larger jobs in the other controls. The latter controls therefore make a small contribution to the Brighton Power Group where justified.

F2B. Allotment 10-72. Linemen are allowed 9-0, the remainder going to the Brighton mechanics' shop.

Exchange areas are grouped to make up a load mainly on a geographical basis and can rarely be arranged such that every man is allotted an equal load from the work unit aspect. The following factors, however, are also taken into account:—whether the lineman lives in his area; the size of the area and the amount of travelling involved; the time he is likely to spend on items not covered by work units, i.e., jumpering, meter readings, inspection of power lines; the condition of the plant. Where two or more linemen have the same headquarters the F2A, F2B and TG work can sometimes be grouped and given to one or other to equalise their loads.

Each set of load schedules for the Controls is provided with a facing sheet which summarises how the manhours are allotted to the various maintenance subheads, and gives the controlling officer a clear picture of his maximum anticipated expenditure.

D. C. B.

#### PRESTON (BRIGHTON) T.E.

Preston automatic exchange (Siemens 16, installed in 1927) is a satellite on Brighton with 5,200 working lines. Over the past year, the reported exchange faults have averaged about 0.04 faults per telephone per annum. During each of the weeks ending 2nd and 23rd September, 1949, the exchange excelled itself and the number of reported exchange faults was nil. Is this a record?

D. C. B.

### Scotland

#### ABERDEEN AUTO CONVERSION

Aberdeen was converted to non-director automatic working from C.B.1 (22 V) at 1.15 p.m. on Saturday, 8th October, 1949, almost exactly 40 years after the opening of the C.B. exchange. Four exchanges were concerned: Aberdeen Central, 9,500 multiple; Aberdeen North, 1,800 multiple; Aberdeen West, 5,000 multiple; and Cults, 800 multiple. Cults, being a C.B.S.1 exchange, was modified for C.B. working some time before the transfer. The transfer was originally intended to be effected in 1940, but was deferred due to the outbreak of hostilities and the bulk of the equipment stored. In order to go some way towards the post-war demand for telephone service and also to cope with the increased traffic, three relief manual exchanges had been installed:—

(a) Central, C.B.10—19 positions, April, 1946.

(b) West, C.B.10—4 positions, November, 1945.

(c) North, C.B.1—3 positions, December, 1948.

These also ceased on the transfer date. A five-figure numbering scheme is employed and Cults exchange has lost its identity.

In order to improve the trunk service, affected by serious congestion on the C.B. trunk suites, the 52-position sleeve control auto-manual board was brought into service in April, 1948, some 18 months before the main transfer. All the U.A.X.s parented on Aberdeen were also transferred to this board. Order-wire working was necessary between the two boards and introduced certain operating complications, but there is no doubt that the action taken proved itself well worthwhile during the busy summer season. The introduction of 2 V.F. working on the London, Newcastle, Edinburgh, and Glasgow routes at the same time also played its part in speeding up the service. The advance transfer of the A/M board not only

simplified the ultimate transfer operation but served a very useful purpose in training operators for the transition from C.B. to sleeve control working.

The actual final transfer operation involved 756 junctions and 12,750 subscribers, some 480 of whom are working on a shared-service basis.

At the satellites, 2,000-type discriminators with impulse regenerators are in use. It is hoped to give a more detailed description of the installation and transfer arrangements at a later date.

H. J. R.

### North-Western Region

#### REPAIR TO 3-IN. STEEL PIPE

During recent extensive repair operations on a bridge crossing the River Mersey in the Manchester Area, one of four Post Office steel pipes crossing the bridge was pierced by a pneumatic road-breaker. The drill penetrated the pipe and cut into a 300/10 + 96/40 composite junction cable, the cable being wedged by the jagged edges of the damaged portion of the steel pipe. All the pipes were embedded in concrete, and no spare way was available. Only a portion of the damaged pipe was exposed, and any attempt to remove concrete from the other pipes might have resulted in further damage. Apart from the service aspect, repairs had to be carried out quickly in order not to hold up work on an important main road.

The method of repair in this unusual case presented rather a problem. The damaged cable could not be withdrawn without the jagged edges of the steel pipe damaging the good section of the cable sheath. The following method of repair was adopted:—

An interruption cable was placed overground and the cable changed over. Without further cutting of the pipe the faulty cable was cut through by means of a chisel at the point where it had been pierced, and withdrawn from both ends. These two portions of the cable were immediately spliced at the local Cable Splicing Depot.

It was first decided to cut away the damaged portion of the pipe by means of oxy-acetylene flame and the Department's mechanic was asked to do this. On examining the pipe the mechanic decided not to use the flame method but to employ a diamond-pointed chisel, and successfully removed the jagged portion of the pipe, leaving a clear hole about 2½ in. diameter. He then made a steel patch curved to meet the shape of the pipe and, after removing all rough edges and cleaning out the whole length of the pipe, the patch was welded in place by oxy-acetylene flame, and the pipe was then ready to receive the spliced cable.

This simple operation made a very successful repair and saved a considerable amount of labour. S. B. I.

#### UNDERGROUND PLANT THREATENED BY ROAD ON FIRE

“By shifting tons of earth and roadway from the main Chorley-Wigan road at Birkacre, Lancashire, workmen have removed a threat to an important bridge over the River Yarrow, caused by a two-year-old fire which began creeping towards the bridge in December, 1948.”

This extract from the “Manchester Evening News” of 29th January, 1949, describes an operation of which the Telephone Manager, Preston, had been advised by the Chorley Borough Engineer and Surveyor on 23rd December, 1948. The advice stated that “. . . in order to preserve the reinforced culvert at the Borough boundary at Birkacre, it will be necessary to excavate a section of the road approximately 120 ft. in length and to a depth of 30 ft. This will leave your trunk telephone line exposed and without support . . .” The trunk telephone line referred to in this letter consisted of a 6-way



multiple duct line carrying the old Boston-Preston and the Boston-Carlisle carrier cables, and in view of their importance, immediate action was necessary to divert them and ensure that a continuous service was maintained.

The road to be excavated had been constructed across a natural valley and formed an embankment approximately 60 ft. above the valley level with an angle varying between 60° and 45° at the base. The filling for the embankment was obtained from colliery waste-tips in the vicinity, and this had a high content of combustible material. Spontaneous combustion had occurred, and the result was that a fire was burning underneath 300 yards of roadway; a 12-in. water main and the Post Office underground track being affected by it.



POSITION OF POST OFFICE DUCT IN BURNING FOOTWAY.

Bordering the road embankment is the River Yarrow, and beyond the river a meadow stretching down the valley. The meadow is a collecting ground for water from the adjoining hillside and it has poor drainage. As a result large expanses are marshy and were holding 6 in. of surface water. This meadow land afforded the only possible route for the diversion of the cables, and the known difficulties to be overcome on the proposed route consisted of, (1) an almost vertical descent of 60 ft. from the nearest carriageway into the valley, (2) the River Yarrow, (3) a stretch of marshland and (4) 120 yards of rough scrubby hillside to be traversed to reach the main road again beyond the danger point of the fire.

The obstructions were overcome as follows :—

- (1) By laying 82 yards of Duct No. 6 at right-angles to the main track and building a JF6 as a turning point for the cables. From the JF6 a trench was cut obliquely across the decline into the valley.
- (2) The River Yarrow at winter level is 7 ft. 6 in. in depth and 32 ft. in width at the point decided upon for the crossing, the north bank being 3 ft. above the highest known flood level and 4 ft. 6 in. higher than the southern bank. It was decided to build a JF6 on the north bank above flood level as a jointing point for the cables and to house the steel pipes with which the crossing over the river was to be made. On the southern bank the steel pipes were housed in a surface box, built of stock brick with 9-in. walls and 18-in. footings. This box also served to lower the cables to the new level in the next section.

As a temporary measure the steel pipes were supported across the river on a 55-ft. (S) pole. The butt of the pole was embedded in the north bank and supported and wedged on cylindrical concrete

blocks (ex-wartime road blocks) on the other bank. The question of erecting concrete pillars in the river bed was discussed and abandoned at this stage due to the wintry conditions and the very



55 FT. (S) POLE AS TEMPORARY SUPPORT FOR STEEL PIPES.

short time allowed to complete the diversion. (The pole has been recovered during the summer months and concrete pillars erected as supports for the steel pipes.)

- (3) The stretch of marshland was virtually impassable to a man on foot, but it was found that the the river 30 yards away provided a good outfall and so it was decided to cut trenches from the marsh downwards to the river, to drain it as far as possible. This was very effective, the surface water being drained away the first day after trenching was completed, and it then became possible, by carefully picking his route, for a man to cross. It was decided to cross the marsh by steel pipes supported on concrete blocks, excavation being made until the blocks rested on solid ground. The pipes at each end were housed in buried boxes covered by concrete flags.
- (4) This was overcome by trenching obliquely across the hillside and removing several trees which obstructed operations.

Having overcome the difficulties in building the route, the next problem was how to handle drums of cable, weighing between 2 and 2½ tons, over the meadow previously described. Handling was discarded as impracticable and the drums were jacked up on the adjoining carriageway and in line with the JF6 on the river bank, and a footing was dug out and a platform built for an empty drum immediately behind the JF6. The cables were then re-drummed and protection was given to the cables during this operation by running them over ladders covered with tarpaulin sheets, down the descent into the valley and then on wooden rollers to the drum. The winch was then dismantled, carried by hand across the meadow and re-erected at a point approximately 200 yards from the river crossing, and in a direct line with the route. A 3-in. rope was then passed through the pipes crossing the marsh and along the trench, and the cables pulled in over wooden rollers placed and wedged either vertically or horizontally as required in the trench.

The final section of cables presented no undue difficulty, the cable being run from the main road beyond the fire point and pulled into the open trench over



rollers by means of the hand winch, which was in the position it occupied for the pull across the preceding section. A straight pull was maintained on the cables by passing the rope through blocks anchored to trees, etc.

The work was commenced on 31st December, 1948, the carrier cables were changed over on 1st February, 1949, and the 384/20 + 4/40S cable on 2nd and 3rd February, 1949. 306 yards of Ducts No. 9, and 306 yards Cable P.C.Q.T. 384/20 + 4/40S and 412 yards P.C.T. Carrier 24/40, were afterwards recovered, but the manhole at the end of the first section to be recovered had to be abandoned. It is interesting to note that a temperature of 118°F was recorded on the floor of this manhole, and that, during the whole of the jointing operations in the manhole on the south side, ventilation had to be resorted to, due to the heavy gases. The roadway filling-in material is still burning.

### Midland Region

#### A POWER-DRIVEN EARTH AUGER AND POLE ERECTOR

Arrangements have recently been made by the Birmingham Area to hire from the Midlands Electricity Board a power-driven earth auger, in which the tube enclosing the shaft is used as a crane jib so that the machine is suitable for the boring of pole and stay holes and the subsequent erection of the poles. The machine is one of several reconditioned ex-United States Army surplus vehicles which were bought by the Midlands Electricity Board to assist in the rapid provision of new low- and medium-voltage routes in rural areas.

Machines are supplied on a daily hire basis, two skilled operators being provided with each machine. The Midland Electricity Board are responsible at all times for maintenance and running costs.

The earth-auger and crane jib are mounted at the rear of a four-wheeled-drive Chevrolet lorry. The power for the auger is supplied from the lorry engine through two

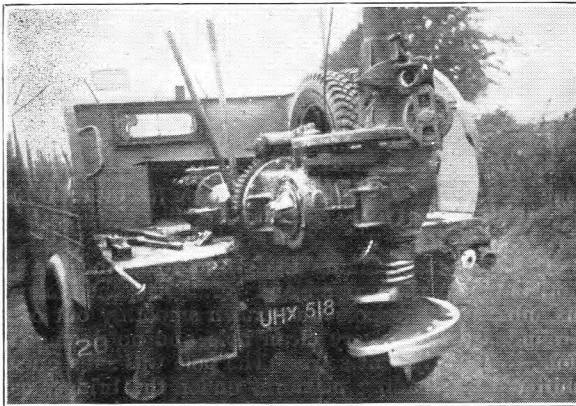

THE EARTH AUGER SHOWING POSITION OF CONTROL LEVERS.

clutches which control the rotation and vertical movement of the auger. The associated control levers are mounted adjacent to the auger and are operated from the lorry body with the auger in full view of the operator. The head of the auger is easily removable, three sizes being supplied as required, viz., 12 in., 20 in. and 24 in. diameter. Holes can be bored to a maximum depth of 8 ft.

The boring shaft of the auger is enclosed by a tubular member which is used as a crane jib, the whole being raised from its rest position on the roof of the driver's cabin by a power-drive from the engine. Final adjustments to ensure that the hole is bored exactly vertical are

made manually. The crane jib is supplied in three sizes (according to the height of poles to be erected) viz., 16 ft. 6 in., 19 ft. 6 in. and 32 ft. from ground level. Jacks are provided for use when lifting heavy loads to ensure that undue strain is not placed on the chassis of the vehicle, but these are not normally required when lifting poles. The 16 ft. 6 in. jib is frequently the most suitable for Post Office use, as this will pass under existing wires and so facilitate the erection of mid-span poles for aerial cable. In other cases, e.g., handling poles up to 36 ft. in length, the 19 ft. 6 in. length would be more convenient.

The winch associated with the jib is driven from the lorry engine, the speed of winding being dependent upon engine speed. Its maximum safe load is 30 cwt.

All pole-hole and stay-hole positions are pegged out prior to the hire of the machine, and the local surveyor's confirmation obtained that no "Services" will be encountered. Poles are laid out adjacent to the pole-hole positions, and the arms, stay-wires, etc., fitted.

The gang foreman, assisted by one other man, accompanies the machine, directing operations, checking depths and helping to guide the poles into the newly-bored holes. Flag-men are posted to control traffic where necessary. The remaining members of the gang (augmented as required) follow-up, setting the poles upright and filling-in the holes.

When stay-holes only are to be bored, the foreman alone accompanies the machine. Two or more vertical holes are bored side-by-side to form one stay-hole; the gang following up the machine then undercut the holes and fit the stayblocks in the normal manner.

The machine, when in position for hole-boring in the road-side, obstructs part of the road. Usually the obstruction is not complete, and a single line of traffic



VIEW SHOWING EXTENT OF ROAD OBSTRUCTION BY THE VEHICLE.

can proceed without delay, but occasionally the pole position may necessitate stopping all traffic while the machine is operating. However, the complete operation of boring a hole and erecting the pole takes only about ten minutes, so the delay is not serious, especially as traffic is usually light on the type of rural roads on which the machine is required to operate.

The chief use for the machine will probably be in connection with the provision or strengthening of routes for aerial cable, and for development schemes in rural areas where a number of poles are required in one locality. It may also prove useful for renewal of dangerous poles, and for the provision of farmers' lines.

A saving of approximately 33 manhours is sufficient to balance the cost of hire of the machine for a day, but the fixed manpower ceiling now operative may make the employment of the machine desirable at an even lower manhour saving than this. The number of hours saved per pole or stay depends on the type of ground and the situation involved, but approximately ten poles and/or stays per day is sufficient to justify the hire of the machine in normal situations. In more difficult ground a smaller number of poles will justify the cost of hire, as the saving in manhours is correspondingly greater. On the trials so far carried out in the Birmingham area, the machine has failed only in Cotswold stone.

In ground considerably harder than normal the following average performance has been obtained:—

Number of poles erected or stays fitted per day .. .. .	15
Manhours per pole erected (including ineffective) .. .. .	4.8
Manhours actually taken on same estimate to erect poles by hand (hard and rocky ground) .. .. .	12
Manhours per stay fitted (including ineffective) .. .. .	5.8
Manhours actually taken on same estimate to fit stays and dig stay holes by hand (hard and rocky ground) .. .. .	14
Estimated manhours saved per day .. .. .	111

The striking economy so far achieved with the use of this machine amply justifies the steps which, it is understood, are now being taken to develop similar British equipment, for employment by the Department.

The use of this machine in conjunction with stainless steel-sheathed aerial cable will undoubtedly achieve a large saving in the cost of the provision of line plant in rural areas. This has been demonstrated in the Birmingham Area where a trial section of stainless steel-sheathed aerial cable has been recently erected and pole routes strengthened in approximately half the time which would have been required by the use of standard methods.

F. H. S.

#### RECOVERY OF A POLE FROM A DIFFICULT POSITION

It was recently necessary to recover a Post Office pole from a difficult position on railway property, just south of the railway station at Peterborough on the London-to-the-North main line, Eastern Region. The pole, a 70-ft. stout, dated 1908, was erected during October, 1912, for a route that passed over the bridge shown in the accompanying photograph. The pole, which was spare, was in a confined situation, being 3 ft. from a railway goods shed, and only 9 ft. from the nearest running rail. The base of the pole, which measured 20 in. across, was adjacent to a sewer manhole. In view of its situation and the dangers involved, normal methods of recovery were considered undesirable, and it was decided to seek the assistance of the railway authorities.

Arrangements were made with British Railways for the use of a 45-ton steam crane stationed at Peterborough. Such a powerful crane was not necessary to cope with the load, but the height of the pole demanded a crane with a jib that could be raised to a sufficient height. The height of the pole was 63 ft. 6 in. above ground level, and slinging at 24 ft. above the ground level was required.

The crane travelled from its shed to the position under its own power, with a normal crew of six men, and the operation of lifting the pole was timed to take place immediately after 9.25 a.m. on the 11th October, 1949, to fit in with train schedules, preliminary work such as recovery of arms and fitting of guy ropes having been carried out by the Post Office.

The whole operation was under the full control of the railway foreman, the Post Office foreman being responsible only for the slinging of the pole and the control of the pole during movement. Two chain slings were used, which were about as much as the two men aloft could lift to put in position.



BRITISH RAILWAYS' 45-TON STEAM CRANE RECOVERING 70 FT. POLE AT PETERBOROUGH.

The time from taking the strain to laying the pole horizontal on the ground and parallel to the rails was six minutes. The pole was drawn smoothly out of the ground, leaving a very clean hole, and no damage was done to the adjacent sewer. The pole was subsequently shifted to a loading platform under the bridge, using the railway crane until the bridge restricted further movement, when the winch of a Post Office 4-ton lorry was used to shift the pole the final few yards to level ground.

The success of the whole operation was largely due to the full co-operation afforded by the railway authorities.

J. D. A.

#### Welsh and Border Counties Region

CARDIFF NEW AUTOMATIC TELEPHONE EXCHANGE—POWER SUPPLIES

The new automatic telephone exchange building at Cardiff is nearing completion, and the installation of power plant to serve the exchange is about to commence.

The building will be served by duplicate high-tension electricity supplies at 6,600 V, and the Post Office will provide its own substation equipment to afford the new national standard voltages of 415 V 3-phase, and 240 V single-phase. The photograph illustrates the arrival of the two 500-kVA transformers on site before removal to their respective cubicles. Each of the transformers is capable of handling the peak load of the exchange in addition to the load of the adjacent Head Post Office. In addition to the duplicate electricity supplies, an emergency diesel-driven generating set developing 375 h.p. or 315 kVA output is being installed by Departmental labour.

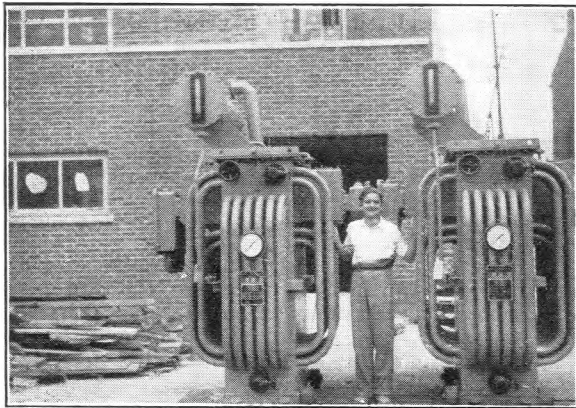

500-kVA TRANSFORMERS FOR CARDIFF EXCHANGE.

This engine set will provide the whole normal load for the telephone exchange in the event of a complete breakdown in mains supplies.  
R. E. R.

#### PROPOSED SWANSEA-CARDIFF COAXIAL CABLE

Nearly 15 months of preparatory work, which involved the demolishing of about 140 joint boxes and manholes of varying size, ranging from JRF4 to RC-type manholes, and the replacement by standard R-type manholes from R0 to R2D, is now nearing completion. The work was performed in the main thoroughfares of several towns and, as might be expected, a number of difficulties were encountered.

The most difficult part of the job concerned the demolition of two RC-type manholes and their replacement by two R2A manholes, the erection of two 4-in. steel pipes across two road bridges crossing railways, an access road leading to a large steel works, and a bridge over the River Tawe. Already existing at these points were six 3-in. steel pipes fixed to the walls of the bridges by iron brackets and supported on the railway embankment by five brick pillars, each of which was to be demolished and rebuilt. In the planning stages of the work, the property owners laid down conditions under which the work was to be performed. The railway company and the local council surveyor ruled that no attachment for the support of the pipes was to be made to the parapet walls of the bridges because of their age and bad state of repair. In addition, no working scaffolding which necessitated fixing to the parapets was to be used. These conditions meant that the new steel pipes crossing over the railway and the river had to be erected underneath the existing formation, and a scaffold of a design to the approval of the railway and council authorities had to be used. Plans of a steel girder scaffold were prepared and submitted for approval, the design of which was such that the girder could be

suspended over the parapets and held in position by its own weight.

The bridges are very narrow and can only accommo-

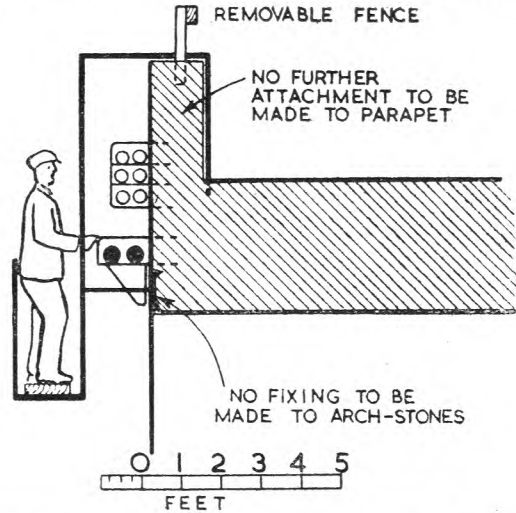

METHOD OF SUSPENDING SCAFFOLDING OVER PARAPETS OF BRIDGES.

date single-line traffic; to the parapet of the river bridge is fitted a removable wooden fence, which is taken down when overhanging loads pass by. It was necessary that the scaffold should not project more than 3 in. over the top and down the road side of the parapet.

During the work of erecting the steel pipes several difficulties were encountered, such as a 12-in. gas main

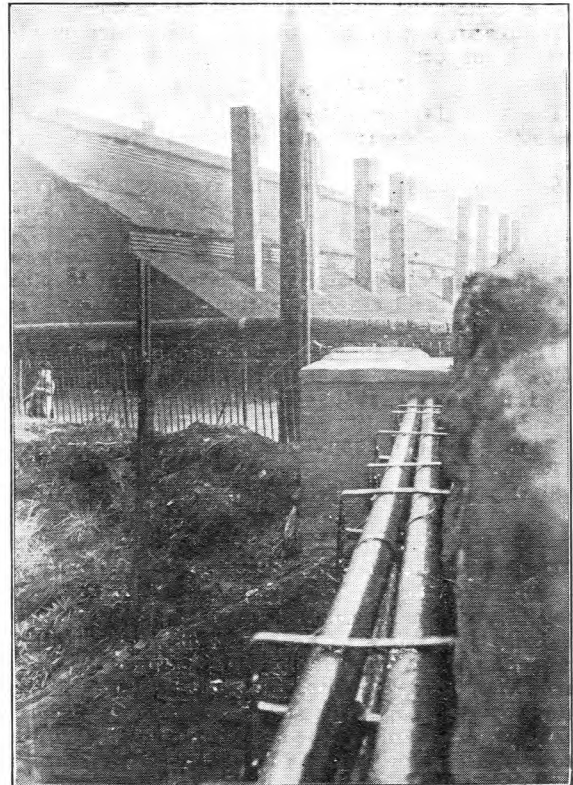

STEEL PIPES IN POSITION SHOWING NEW CABLE SHAFT AT ROAD JUNCTION.



laid in shallow depth, necessitating altering the original run, but this proved to be a blessing in disguise as a better feed into the new manhole was obtained. Another difficulty was that the overhang of the scaffold from one of the railway bridge arches was such that it interfered with the passage of trains underneath and to overcome this a staging suspended by ropes had to be adopted to carry out the work.

The total length of the steel pipes over the bridges was roughly 100 yds., and it was necessary to fleet the scaffold as each two lengths of pipe was placed in position. The drilling of the walls for the brackets was done by means of a compressor, and when cutting the holes for the supporting bars between the existing steel pipes it was necessary to spring them apart with wedges in order to get working room for the drill.

At the junction of the road leading to the Works the pipes from the river and railway bridges are about 4 ft.

above the level of the road, and the cables were fed into the manhole by turning them through a brick shaft built above the manhole. This shaft, together with the old manhole, was scheduled for rebuilding and as the design of the old shaft only permitted feeding of the cables into the manhole through an aperture in the top, opportunity was taken, when building the new shaft, to construct it on the lines of a small manhole above the surface. A channel joint box No. 5 cover has been provided and entry is obtained by steps. Wall-type cable bearers and brackets have been fitted for supporting the bends in the cables.

The arrival of the cable contractor is now awaited with full confidence that all the hard work which has been done will pass its final test without complaint.

Thanks are tendered to Mr. Challenger, Draughtsman-in-Charge, Swansea, for the photograph and drawing.

W. L. J.

## Junior Section Notes

### Scarborough Centre

The first two events on our programme have been duly presented. The first was a return Radio Quiz Competition with the York centre, the result being a draw (20½ points scored by each team after a very enjoyable evening). The second was "question and answer" night, when the questions ranged from Catterick Signals training to the Persian Gulf overhead route, and from car shock absorbers to regenerators.

When the ruling was given that the procedure would be operated in reverse, i.e., the experts asking the audience questions, it proved both amusing and instructive, and if marks had been awarded it was agreed that a photo-finish would have been necessary.

Thanks are due to the visiting Senior Centre members for their support.

### Harrogate Centre

The Annual General Meeting of the centre was held on August 16th, when the following officers were elected for the year:—

*Secretary and Treasurer*: L. Webster; *Chairman*: J. Winspear; *Committee*: P. H. George, D. R. Lewis, M. Jennings, R. Pullman, T. Henderson.

At the conclusion of the business a film show was presented and was greatly appreciated by the members.

On September 1st, a visit to the Harrogate Gas Works was well attended.

The programme for the remainder of the session is as follows:—

12th January, 1950.—The House Exchange System, by H. Clough.

9th February, 1950.—Radio Interference, by G. R. Baston.

9th March, 1950.—Power Supplies, by P. H. George. J. T. W.

### Bradford Centre

The 1949-50 session opened on the 11th October with a visit to Sheffield. The party was welcomed to the Steel City by the Chairman of the Sheffield Centre, who conducted the party to Firth Brown's, Ltd., where an interesting and informative tour of the works was carried out. After an excellent tea the party left the works with many topics for argument and discussion in the future.

The sincere thanks of the centre are extended to Firth Brown's, Ltd., for their cordial hospitality and to the Sheffield Centre on whose invitation the rest of the evening was spent in the Sports and Social Club Room.

On the 15th October, Mr. R. A. Gill read his paper on

"Quartz Crystals" and presented some often overlooked aspects of this subject in a clear and concise manner, adequately illustrated by excellent models of his own construction.

The programme for the remainder of the session is shown below, and an open invitation is extended to all who care to come along and fire questions at the speakers:—

19th January, 1950.—Ship-to-Shore Radio—E. Bauer.

16th February, 1950.—Radio Control for Model Aircraft, by W. D. Priestly.

16th March, 1950.—The Area Contract as Applied to the Erection of Cabinets and Pillars, by A. Entwistle.

20th April, 1950.—Mechanical Aids—J. Peace.

31st May, 1950.—Annual General Meeting.

Suggestions for further visits and offers for short papers or talks will be welcomed by the Committee. A. E.

### Middlesbrough Centre

The 1949-50 session opened on 13th October, 1949, at a local café with a Film Display given by the Central Office of Information.

The films, which were very interesting and instructive

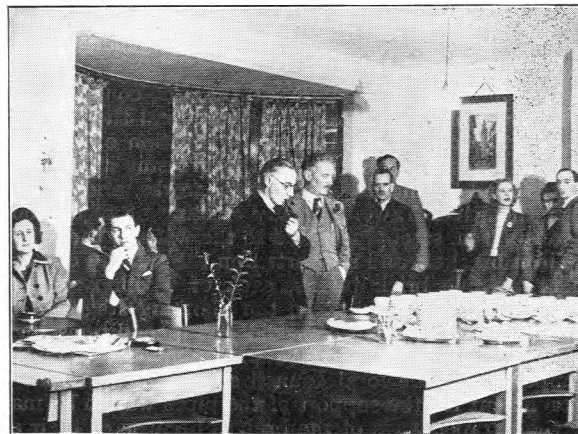

JUNIOR SECTION MEETING, MIDDLESBROUGH CENTRE, 13TH OCTOBER, 1949

to the mixed audience—members, wives and friends—were followed by light refreshments and completed a very pleasant evening.

The illustration shows a group of those present, including the Telephone Manager, Col. J. R. Sutcliffe, in the centre.

# Staff Changes

## Promotions

Name	Region	Date	Name	Region	Date
<i>Reg. Dir. to Contr. of Research</i>			<i>Prob. Engr. to Engr.—continued</i>		
Harris, L. H.	Scot. to E.-in-C.O.	1.10.49	McDowell, D.	E.-in-C.O.	21.10.49
<i>Asst. Staff Engr. to Staff Engr.</i>			Young, S. G.	E.-in-C.O.	16.10.49
Barron, D. A.	E.-in-C.O.	1.11.49	Marsh, S. T.	Scot.	27.10.49
<i>Area Engr. to Asst. Staff Engr.</i>			<i>Asst. Engr. to Engr.</i>		
Spears, G.	L.T. Reg. to E.-in-C.O.	1.11.49	May, E. G. A.	H.C. Reg.	1.10.49
<i>Area Engr. to Asst. T.M.</i>			Hudson, G. J.	E.-in-C.O.	27.11.49
Jeffs, H.	H.C. Reg. to L.T. Reg.	4.9.49	<i>Tech. Off. to Asst. Engr.</i>		
<i>Engr. to Area Engr.</i>			Wileman, G. W.	N.W. Reg. to E.-in-C.O.	5.9.49
Thomas, C. F.	E.-in-C.O. to L.T. Reg.	1.9.49	Evans, R. J. L.	W.B.C. Reg. to E.-in-C.O.	12.9.49
Collins, J. E.	N.E. Reg.	11.9.49	Roberts, E.	N.W. Reg. to E.-in-C.O.	26.9.49
Greenwood, G. C.	H.C. Reg.	23.9.49	<i>Asst. Expt. Off. to Expt. Off.</i>		
Woodhouse, T.	N.W. Reg.	1.11.49	Cowell, G. N.	E.-in-C.O.	5.10.49
Adams, W. E.	E.-in-C.O. to Scot.	13.11.49	Roberts, T. E.	E.-in-C.O.	16.11.49
Arnold, A. F.	E.-in-C.O. to W.B.C. Reg.	20.11.49	Organ, R. M.	E.-in-C.O.	16.11.49
Stead, L. G.	E.-in-C.O.	23.11.49	<i>M.T.O. II to M.T.O. I</i>		
<i>Engr. to Reg. Tng. Off.</i>			Collman, E.	E.-in-C.O.	1.9.49
Mitchell, M.	E.-in-C.O. to L.T. Reg.	12.9.49	<i>Mech. i/c I to Tech. Asst.</i>		
<i>Prob. Engr. to Engr.</i>			Mundy, E. O.	N.E. Reg. to E.-in-C.O.	10.9.49
Welsby, V. G.	E.-in-C.O.	26.8.49	<i>Fourth Off. to Third Off.</i>		
Smith, D. C.	E.-in-C.O.	8.9.49	Tuckwell, R. M.	"Monarch" to "Ariel"	24.10.49
Mansfield, P. M.	E.-in-C.O.	15.9.49			
Gerard, P. S.	E.-in-C.O.	17.10.49			

## Transfers

Name	Region	Date	Name	Region	Date
<i>Executive Engineer.</i>			<i>Asst. Engr.—continued</i>		
Hales, A. C.	Factories Department to E.-in-C.O.	1.10.49	Trask, G. W. F.	Seconded to P. & T. Australia	20.9.49
Jago, W. B.	E.-in-C.O. to L.T. Reg.	1.11.49	Triplow, L. E.	E.-in-C.O. to H.C. Reg.	31.10.49
Casterton, E. J.	E.-in-C.O. to Min. of N. I.	19.9.49	Phillips, A. J.	E.-in-C.O. to Admiralty	1.11.49
<i>Engineer</i>			Skuse, C. E. C.	Seconded to P. & T. Australia	19.10.49
James, L. R.	L.T. Reg. to S.W. Reg.	2.10.49	Best, R. J.	E.-in-C.O. to S.W. Reg.	7.11.49
Roberts, W. J.	S.W. Reg. to E.-in-C.O.	2.10.49	Deaville, J. C.	L.T. Reg. to E.-in-C.O.	1.11.49
Donaldson, A. L.	E.-in-C.O. to N.E. Reg.	13.11.49	Evans, R. J. L.	E.-in-C.O. to W.B.C. Reg.	31.10.49
Mansfield, P. M.	E.-in-C.O. to Scot.	27.11.49	Notley, C.	E.-in-C.O. to L.P. Reg.	14.11.49
<i>Asst. Engr.</i>			Oatley, L. W.	L.P. Reg. to E.-in-C.O.	14.11.49
Pritchard, G. F.	H.C. Reg. to E.-in-C.O.	1.9.49	Henshall, B.	E.-in-C.O. to Mid. Reg.	23.11.49
			<i>Inspector</i>		
			Sugars, E. G.	E.-in-C.O. to Malaya	13.7.49

## Retirements

Name	Region	Date	Name	Region	Date
<i>Staff Engr.</i>			<i>Asst. Engr.—continued</i>		
Brown, C. W.	E.-in-C.O.	31.10.49	Smart, G.	Scot.	7.9.49
<i>Exec. Engr.</i>			Devon, J. M.	N.W. Reg.	25.9.49
Smith, V.*	E.-in-C.O.	27.6.49	Wood, W. H.	H.C. Reg.	30.3.49
<i>Engineer</i>			Smith, W.	H.C. Reg.	23.4.49
McClune, W. J.	E.-in-C.O. (Resigned)	4.9.49	Kesteven, A. S.	H.C. Reg.	31.5.49
Ilett, J. E. W.	H.C. Reg.	30.9.49	Erskine, G. A.	E.-in-C.O. (Resigned)	13.8.49
Standing, F.	E.-in-C.O.	12.11.49	Woodhouse, W. T.	Mid. Reg.	31.5.49
<i>Prob. Engr.</i>			Arthur, C. W.	N.W. Reg.	13.9.49
Sanderson, H. W.	E.-in-C.O. (Resigned)	30.9.49	Davies, L. J. D.	N.E. Reg. (Resigned)	14.10.49
<i>Asst. Engr.</i>			Arundel, G.	Mid. Reg.	30.9.49
Caines, G.	E.-in-C.O. (Resigned)	10.9.49	Sard, G. J.	E.-in-C.O. (Resigned)	12.11.49
			Thistlethwaite, W. R.	E.-in-C.O. (Resigned)	11.11.49
			Fell, S. H.	N.W. Reg.	30.11.49
			Handy, T. A.	Mid. Reg.	13.10.49

\* Incorrectly shown as Principal Scientific Officer in October, 1949, issue.

**Retirements—continued**

Name	Region	Date	Name	Region	Date
<i>Inspector</i>			<i>Inspector—continued</i>		
Brook, B. A.	L.T. Reg.	30.9.49	Hail, G.	Mid. Reg.	31.8.49
Harrex, W. H.	H.C. Reg.	28.2.49	Walker, W. F.	L.T. Reg.	28.11.49
Bridger, A. S.	H.C. Reg.	31.5.49	Quinn, F.	Scot.	4.11.49
South, E. A.	H.C. Reg.	6.6.49	Street, A. D.	N.W. Reg.	11.9.49
Baker, H. P.	S.W. Reg.	31.3.49	<i>Asst. Expt. Off.</i>		
Colbourne, R. W.	S.W. Reg.	28.4.49	Sothcott, M. E. (Mrs.)	E.-in-C.O.	30.9.49
Lambourne, H. L.	S.W. Reg. (Medical Grounds)	13.5.49	<i>Third Officer</i>		
Tapscott, H. F.	S.W. Reg.	3.6.49	McAuliff, E. R.	H.M.T.S. Iris (Resigned)	21.10.49
Harris, C.	S.W. Reg.	4.6.49			
Gilbert, J.	S.W. Reg.	30.6.49			

**Deaths**

Name	Region	Date	Name	Region	Date
<i>Effic. Engr.</i>			<i>Asst. Engr.—continued</i>		
England, A. G.	Scot.	3.10.49	Harbord, F. G.	H.C. Reg.	25.5.49
<i>Asst. Engr.</i>			Crosby, J. J.	Mid. Reg.	8.11.49
Southwell, C. E.	N.W. Reg.	30.8.49	Whitehead, E. H.†	H.C. Reg.	19.8.49
Richards, H.	L.T. Reg.	6.9.49	<i>Inspector</i>		
			Atkins, W. S.	L.T. Reg.	8.9.49

† Incorrectly shown as Inspector in October, 1949, issue.

**CLERICAL GRADES**

**Transfers**

Name	Region	Date	Name	Region	Date
<i>Exec. Off.</i>			<i>Exec. Off.—continued</i>		
Botelle, S. A.	Eng. Dept. to Min. of Agri. & Fish.	15.8.49	Morris, J.	Eng. Dept. to War Damage Comm.	17.10.49
			Carstairs, G.	Eng. Dept. to Air Min.	26.10.49

**Retirements**

Name	Region	Date	Name	Region	Date
<i>H. Exec. Off.</i>			<i>Exec. Off.</i>		
Johnston, A. E.	On loan to War Damage Comm.	31.7.49	Park, W. H.	E.-in-C.O. (Health grounds)	20.8.49

**Death**

Name	Region	Date
<i>Exec. Off.</i>		
Holden, A. G.	E.-in-C.O.	3.11.49



## INSTITUTION'S LIBRARY

(Continued from page 232)

- 1837 *Magnetic Materials*. F. Brailsford (British 1948).  
A comprehensive outline of the present state of knowledge for those concerned with the technological applications of magnetic materials. Reviewed in *P.O.E.E.J.* Vol. 41, p. 233.
- 1838 *Radio Receiver Design (Part II)*. K. R. Sturley (British 1947).  
Part II covers audio frequency amplifiers, the power output stage, power supplies, automatic gain control, push-button, remote and automatic tuning control, overall performance measurements, frequency modulated and television reception.
- 1839 *F-M Simplified*. M. S. Kiver (American 1947).  
A presentation of frequency modulation techniques, design of receivers, commercial applications of various designs, and servicing procedure.
- 1840 *Electronic Devices*. H. A. Millar (British 1948).  
A summary for the student and the electrical engineer not primarily concerned with electronics, of the electronic devices available at the present time.
- 1841 *Microwave Receivers* (American 1948).  
A comprehensive report by the Office of Scientific Research and Development, National Defence Research Committee (American) on Radar and related techniques.
- 1842 *Computing Mechanisms and Linkages*. A. Svoboda. (American 1948).  
Describes the information and the new techniques resulting from the research and development work undertaken at many laboratories in the U.S.A., England, Canada and other Dominions during the development of radar and related techniques during World War II.
- 1843 *Plain Words*. Sir E. Gowers (British 1948).  
A guide to the use of English by officials.
- 1846 *Electrical Network Calculations*. D. E. Richardson (American 1948).  
A book designed to provide students and practical engineers with an efficient arithmetical and tabular tool for use in securing numerical solutions to their electrical network problems.
- 1847 *Fundamentals of Industrial Administration*.  
1848 E. T. Elbourne (British 1947).  
Vols. 1 and 2. These books are designed to assist the student to obtain a thorough preliminary understanding of the subject.
- 1850 Paper No. 9 of the Selected Papers from the *Journal of the Institute of the Electrical Engineers of Japan*—A brief description of the damage done by the earthquake to the wired and wireless telegraph and telephone installations of Japan, by S. Inada (1925).
- 1851 *Plastics for Electrical and Radio Engineers*. W. J. Tucker and R. S. Roberts (British 1946).  
A book designed to classify the various plastics which can be used in electrical and radio apparatus and to give a proper appreciation of their characteristics from an electrical designers standpoint.
- 1852 *Frequency Analysis, Modulation and Noise*. S. Goldman (American 1948).  
A comprehensive discussion of the important subjects of Fourier integral analysis, modulation and random noise.
- 1853 *Textbook of Illuminating Engineering*. J. W. T. Walsh (British 1947).  
The aim of this book is to assist students who are preparing for the examination in Illuminating Engineering (Intermediate Grade) of the City and Guilds of London Institute.

### BOARD OF EDITORS

H. FAULKNER, C.M.G., B.Sc., M.I.E.E., Chairman.  
F. E. NANCARROW, O.B.E., A.R.C.Sc., M.I.E.E.  
P. B. FROST, B.Sc., M.I.E.E.  
A. H. MUMFORD, O.B.E., B.Sc.(ENG.), M.I.E.E.  
W. T. GEMMELL, A.C.G.I., B.Sc., M.I.MECH.E., A.M.I.E.E.  
W. WEST, B.A., M.I.E.E.  
A. F. STOLLARD.  
G. E. STYLES, A.M.I.E.E., Managing Editor.  
W. A. HUMPHRIES, A.M.I.E.E.  
J. P. HARDING, B.Sc.(ENG.) } Assistant Editors.  
A.M.INST.C.E., A.M.I.E.E.  
A. J. HUTCHISON, Secretary-Treasurer.

### Copyright

The entire contents of this JOURNAL are covered by general copyright, and special permission is necessary for reprinting long extracts, but Editors are welcome to use not more than one-third of any article, provided credit is given at the beginning or end thus: "From the *Post Office Electrical Engineers' Journal*."

The Board of Editors is not responsible for the statements made or the opinions expressed in any of the articles in this JOURNAL, unless such statement is made specifically by the Board.

### Communications

All communications should be addressed to the Managing Editor, *P.O.E.E. Journal*, Engineer-in-Chief's Office, Alder House, Aldersgate Street, London, E.C.1. Telephone: HEADquarters 1234. Remittances should be made payable to "*The P.O.E.E. Journal*" and should be crossed "& Co."

### Binding Cases

Cases for binding are available, and may be obtained from the Local Agents for 2s. Subscribers can have their copies of Volumes bound, at a cost of 7s. 6d., by sending the complete set of parts to the Local Agents or to the *P.O.E.E. Journal*, Engineer-in-Chief's Office, Alder House, Aldersgate Street, London, E.C.1. Orders for binding for Vols. 1-19 should indicate whether the original binding case with black lettering, or the later pattern with gold, is required. Cases with gold lettering are the only type stocked from Vol. 20 onwards.

### Back Numbers

The price of the JOURNAL, which is published quarterly, is 1s. 6d. (1s. 9d. post free) per copy, or 7s. per annum post free. Back numbers can be supplied, subject to availability of stocks, at 1s. 6d. each (1s. 9d. post free) Orders for back numbers may be sent to the Local Agents or to the Publishers.

### Advertisements

All communications relating to space reservations should be addressed to the Advertisement Editor, *P.O.E.E. Journal*, Alder House, Aldersgate Street, London, E.C.1. Communications regarding advertisement copy, proofs, etc., should be addressed to the Publishers, Messrs. Birch & Whittington (Prop Dorling & Co. [Epsom], Ltd.), 49 Upper High Street, Epsom, Surrey.

# Post Office Electrical Engineers' Journal

Volume 42, April 1949—January 1950

## INDEX

A	PAGE NO.	E	PAGE NO.
Adhesive in Production of Piezo-Electric Vibrators, Uses of a New .. .. .	187	Electronic Traffic Analyser, An .. .. .	181
Aerial Cables and Their Installation .. .. .	90	Exchange, A 200-Line Mobile Automatic .. .. .	70
Analysers, An Electronic Traffic .. .. .	181		
Anglo-Belgian Route, Laying of Armoured Coaxial Cable on .. .. .	81	F	
Atkinson, J. The Post Office Exhibit at Radiolympia, 1949 .. .. .	228	Fault Location in Transmission Equipment by Vibration Testing and Continuous Monitoring ..	189
Automatic Distribution, Phonogram .. .. .	149, 221	Forrest, J. Hamburg-Hanover Coaxial Cable Scheme	130
		Frequencies, Nomenclature of .. .. .	47
B		Frequency Comparator for 1 kc/s Sub-Standard Tones, A Cathode-Ray Tube .. .. .	61
Benson, D.L., and K. M. Heron. Mechanical Trunk Fee Accounting .. .. .	11		
Boat Race Television Broadcast .. .. .	99	G	
Bomford, K. D. A Survey of Modern Radio Valves (Parts 2 and 3) .. .. .	118, 201	German River and Sea Bed Cable Washing-In Process, The .. .. .	95
Book Reviews 10, 16, 25, 73, 89, 94, 98, 101, 129, 140, 148, 159, 165, 197, 200, 212		Gerry, P. R. Aerial Cables and Their Installation ..	90
Booth, Capt. C. F.			
Nomenclature of Frequencies .. .. .	47	H	
The Receiving System at Cooling Radio Station ..	84	Hamburg-Hanover Coaxial Cable Scheme .. .. .	130
Bridge, A New Design of Wheatstone .. .. .	209	Harbottle, H. R. The Contribution of the Junior Section of the Institution of Post Office Electrical Engineers .. .. .	164
Broadhurst, S. W., and A. T. Harmston. An Electronic Traffic Analyser .. .. .	181	Harmston, A. T., and S. W. Broadhurst. An Electronic Traffic Analyser .. .. .	181
Burr, D. W., and J. Neale. The Thames Radio Service	213	Heron, K. M., and D. L. Benson. Mechanical Trunk Fee Accounting .. .. .	11
		High Frequency Broadcasting Conference, Mexico City, October 1948-April 1949, The .. .. .	166
C			
Cable Washing-In Process, The German River and Sea Bed .. .. .	95	I	
Cables and Their Installation, Aerial .. .. .	90	Institution of Post Office Electrical Engineers	49, 106, 172, 232, 245
Carrier Cables, Music on the Phantoms of 12- and 24- Circuit .. .. .	124	Institution of Post Office Electrical Engineers, The Contribution of the Junior Section .. .. .	164
Carrier Routes, The conversion of, from 12- to 24-circuit working .. .. .	26		
Carter, F. C. Unification of Screw Threads .. .. .	39	J	
Cathode-Ray Tube Frequency Comparator for 1 kc/s Sub-Standard Tones, A .. .. .	61	James, M. H. A Parcel Label Machine .. .. .	198
Channel Islands Communications .. .. .	141	Junior Section of the Institution of Post Office Electrical Engineers, The Contribution of the ..	164
Coaxial Cable on Anglo-Belgian Route, Laying of Armoured .. .. .	81	Junior Section Notes .. .. .	107, 172, 180, 242
Coaxial Cable Scheme, Hamburg-Hanover .. .. .	130		
Collett, W. A. Laying of Armoured Coaxial Cable on Anglo-Belgian Route .. .. .	81	K	
C.C.I.F. Meetings, May and July, 1949 .. .. .	168	Kilvington, T. A New Television Repeater for Telephone Cable Circuits .. .. .	76
Conference for the North-East Atlantic (Loran) January 17th-February 14th, 1949, Special Administrative .. .. .	69		
Conference, Mexico City, October 1948-April 1949, The High Frequency Broadcasting .. .. .	166	L	
Contact Resistance and Its Variation with Current ..	65	Label Machine, A Parcel .. .. .	198
Contribution of the Junior Section of the Institution of Post Office Electrical Engineers, The .. .. .	164	Lafosse, C. E. Sectionalisation of Telephone Repairs	154
Conversion of Carrier Routes from 12- to 24-Circuit Working, The .. .. .	26	Laver, F. J. M. A Cathode-Ray Tube Frequency Comparator for 1 kc/s Sub-Standard Tones ..	61
Cooling Radio Station, The Receiving System at ..	84	Laying of Armoured Coaxial Cable on Anglo-Belgian Route .. .. .	81
Crane, Trunk Pole Recoveries Using a Power-Operated Jib .. .. .	74	London-Birmingham Television Cable, The Part 2. Cable Design, Construction and Test Results .. .. .	33
		London-Birmingham Television Radio-Relay System, Opening of the .. .. .	227
D		(Loran) January 17th-February 14th, 1949, Special Administrative Conference for the North-East Atlantic .. .. .	69
Dickenson, C. R. The German River and Sea Bed Cable Washing-In Process .. .. .	95		
Duerdoth, W. T. A Phase Meter for the Frequency Band 100 kc/s-20 Mc/s .. .. .	43		
Dye, F. W. G. The Conversion of Carrier Routes from 12- to 24-Circuit Working .. .. .	26		

	PAGE NO.
<b>M</b>	
Maps, Ordnance Survey .. .. .	133
Marchant, H. J., and L. R. N. Mills. Music Circuits on the Phantoms of 12- and 24-Circuit Carrier Cables .. .. .	124
McDonald, Col. A. G. Yeading Central Motor Transport Repair Depot .. .. .	1
Mechanical Trunk Fee Accounting Part 2.—Trunk Charge Calculator, Sorting and Tabulating Equipment .. .. .	11
Mexico City, October 1948-April 1949, The High Frequency Broadcasting Conference .. .. .	166
Mills, L. R. N., and H. J. Marchant. Music Circuits on the Phantoms of 12- and 24-Circuit Carrier Cables .. .. .	124
Missen, L. A. A Testing Aid for Subscribers' Apparatus Faultsmen .. .. .	160
Mobile Automatic Exchange, A 200-Line .. .. .	70
Modulators for Amplitude-Modulation Systems, Non-Linear Inductance and Capacitance as .. .. .	156
Monitoring, Fault Location in Transmission Equipment by Vibration Testing and Continuous .. .. .	189
Moore, B. H. Boat Race Television Broadcast .. .. .	99
Motor Transport Repair Depot, Yeading Central .. .. .	1
Music Circuits on the Phantoms of 12- and 24-Circuit Carrier Cables .. .. .	124
Myers, H. G. Fault Location in Transmission Equipment by Vibration Testing and Continuous Monitoring .. .. .	189
<b>N</b>	
Neale, J., and D. W. Burr. The Thames Radio Service New Design of Wheatstone Bridge, A .. .. .	213
New Post Office Standard Uniselector, The .. .. .	17
New Television Repeater for Telephone Cable Circuits, A .. .. .	76
New Utility Vehicle, A .. .. .	22
Nicolson, P. Trunk Pole Recoveries Using a Power-Operated Jib Crane .. .. .	74
Nomenclature of Frequencies .. .. .	47
Non-Linear Inductance and Capacitance as Modulators for Amplitude-Modulation Systems .. .. .	156
North-East Atlantic (Loran) January 17th-February 14th, 1949, Special Administrative Conference for .. .. .	69
Notes and Comments .. .. .	50, 108, 173, 233
Notes, Junior Section .. .. .	107, 172, 180, 242
Notes, Regional .. .. .	52, 109, 174, 236
<b>O</b>	
Opening of the London-Birmingham Television Radio-Relay System .. .. .	227
Ordnance Survey Maps .. .. .	133
<b>P</b>	
Page, A. A., and E. Siddall. A 200-Line Mobile Automatic Exchange .. .. .	70
Parcel Label Machine, A .. .. .	198
Phantoms of 12- and 24-Circuit Carrier Cables, Music Circuits on the .. .. .	124
Phase Meter for the Frequency Band 100 kc/s-20 Mc/s, A .. .. .	43
Phillips, R. S. The Wire Rope Traction Drive .. .. .	102, 144
Phonogram Automatic Distribution Part 1.—Field Trial Installation and General Facilities .. .. .	149
Part 2.—Basic Circuit Features .. .. .	221
Piezo-Electric Vibrators, Uses of a New Adhesive in Production of .. .. .	187
Pole Recoveries Using a Power-Operated Jib Crane, Trunk .. .. .	74
Post Office Exhibit at Radiolympia, 1949, The .. .. .	228
<b>R</b>	
Radiolympia, 1949, The Post Office Exhibit at .. .. .	228
Radio-Relay System, Opening of the London-Birmingham Television .. .. .	227
Radio Service, The Thames .. .. .	213
Receiving System at Cooling Radio Station, The .. .. .	84
Regional Notes .. .. .	52, 109, 174, 236
Repair Depot, Yeading Central Motor Transport .. .. .	1
Repairs, Sectionalisation of Telephone .. .. .	154
Repeater for Telephone Cable Circuits, a New Television .. .. .	76

	PAGE NO.
<b>R (continued)</b>	
Rhodes, J. Channel Islands Communications .. .. .	141
River and Sea Bed Cable Washing-In Process, The German .. .. .	95
Rope Traction Drive, The Wire .. .. .	102, 144
Rudeforth, S. Contact Resistance and Its Variation with Current .. .. .	65
<b>S</b>	
Screw Threads, Unification of .. .. .	39
Sea Bed Cable Washing-In Process, The German River and .. .. .	95
Sectionalisation of Telephone Repairs .. .. .	154
Siddall, E., and A. A. Page. A 200-Line Mobile Automatic Exchange .. .. .	70
Slater, G. H. A New Utility Vehicle .. .. .	22
Sloman, L., and F. Summers. Ordnance Survey Maps Special Administrative Conference for the North-East Atlantic (Loran) January 17th-February 14th, 1949 .. .. .	69
Staff Changes .. .. .	58, 114, 178, 243
Stanesby, H. A Survey of Modern Radio Valves (Part 1) .. .. .	117
Stanesby, H., and W. K. Weston. The London-Birmingham Television Cable .. .. .	33
Subscribers' Apparatus Faultsmen, A Testing Aid for Summers, F., and L. Sloman. Ordnance Survey Maps .. .. .	133
Surman, W. L. A New Design of Wheatstone Bridge Survey of Modern Radio Valves, A .. .. .	209
Part 1.—Introduction .. .. .	117
Part 2.—The Physical Principles of Thermionic Valve Operation .. .. .	118
Part 3.—Receiving Valves for Use Below 30 Mc/s .. .. .	201
<b>T</b>	
Television Broadcast, Boat Race .. .. .	99
Television Cable, The London-Birmingham .. .. .	33
Television Radio-Relay System, Opening of the London-Birmingham .. .. .	227
Television Repeater for Telephone Cable Circuits, A New Testing Aid for Subscribers' Apparatus Faultsmen, A .. .. .	160
Thames Radio Service, The .. .. .	213
Thompson, J. O. The New Post Office Standard Uniselector .. .. .	17
Traction Drive, The Wire Rope .. .. .	102, 144
Traffic Analyser, An Electronic .. .. .	181
Transmission Equipment, Fault Location in, by Vibration Testing and Continuous Monitoring .. .. .	189
Trunk Fee Accounting, Mechanical .. .. .	11
Trunk Pole Recoveries Using a Power-Operated Jib Crane .. .. .	74
Tucker, D. G. Non-Linear Inductance and Capacitance as Modulators for Amplitude-Modulation Systems .. .. .	156
<b>U</b>	
Unification of Screw Threads .. .. .	39
Uniselectors, The New Post Office Standard .. .. .	17
Uses of a New Adhesive in Production of Piezo-electric Vibrators .. .. .	187
Utility Vehicle, A New .. .. .	22
<b>V</b>	
Valves, A Survey of Modern Radio .. .. .	117, 118, 201
Vehicle, A New Utility .. .. .	22
Vibration Testing and Continuous Monitoring, Fault Location in Transmission Equipment by .. .. .	189
<b>W</b>	
Walker, H., and H. E. Wilcockson. Phonogram Automatic Distribution .. .. .	149, 221
Weston, W. K., and H. Stanesby. The London-Birmingham Television Cable .. .. .	33
Wheatstone Bridge, A New Design of .. .. .	209
Wilcockson, H. E., and H. Walker. Phonogram Automatic Distribution .. .. .	149, 221
Wire Rope Traction Drive, The Part 1.—Methods of Roping; Tractive Force; Coefficient of Friction .. .. .	102
Part 2.—Constructional Details and Factors Affecting Operation .. .. .	144
<b>Y</b>	
Yeading Central Motor Transport Repair Depot .. .. .	1



The AvoMeter is one of a useful range of "Avo" electrical testing instruments which are maintaining the "Avo" reputation for an unexcelled standard of accuracy and dependability—in fact, a standard by which other instruments are judged.

**ONE INSTRUMENT**

measures :—

Current, A.C. and D.C. (0 to 10 amps.)  
 Voltage, A.C. and D.C. (0 to 1,000 v.)  
 Resistance (up to 40 megohms)  
 Capacity (0 to 20 mfd.)  
 Audio-frequency Power Output (0 to 2 watts)  
 Decibels (— 25 Db. to + 16 Db.)

*Write for fully descriptive pamphlet.*

**'AVO'**  
 Regd. Trade Mark

*Meters that Matter*

**THE Model 7 Universal AvoMeter** is the world's most widely used combination electrical measuring instrument. It provides 50 ranges of readings on a 5-inch hand-calibrated scale, and is guaranteed accurate to B.S. first grade limits on D.C. and A.C. from 25 c/s to 2 kc/s. It is self-contained, compact and portable, simple to operate and almost impossible to damage electrically. It is protected by an automatic cut-out against damage through severe overload.

Sole Proprietors and Manufacturers :—

THE AUTOMATIC COIL WINDER & ELECTRICAL EQUIPMENT Co. Ltd.  
 Winder House, Douglas Street, London, S.W.1. Phone : VIctoria 3404-9

# EDISWAN

## Telephone Line Protectors

*FOR THE PROTECTION OF LINES OF COMMUNICATION FROM SURGES INDUCED BY LIGHTNING OR FAULTS ON NEIGHBOURING POWER LINES*

Ediswan Telephone Line Protectors have now been in commission for nearly twenty years. They have proved their worth in all parts of the world and are being called for and installed in ever increasing numbers. Many thousands were employed during the war years for the protection of vital lines of communication and were eminently successful. Reports of their outstanding merit and successful operation continue to reach us and in recent years they have proved of particular interest for protection against surges caused by lightning discharges.

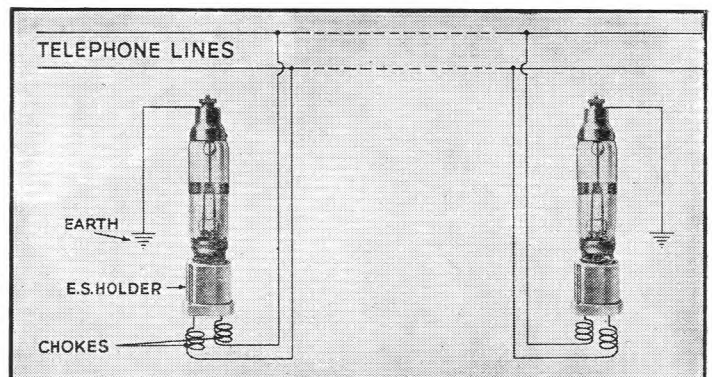

Continued research has enabled us to patent a further improvement which removes any suggestion of delay in operation.

*Further information and prices on application.*

**THE EDISON SWAN ELECTRIC CO. LTD., 155 CHARING CROSS ROAD, LONDON, W.C.2**





TYPE D-197-A

# MEASURE YOUR COMPONENTS on the MUIRHEAD IMPEDANCE BRIDGE

*It gives answers without ambiguity*

- RANGES:** D.C. RESISTANCE: 0.001 ohm to 1.11 Megohms.  
 CAPACITANCE: 1  $\mu$ F to 100  $\mu$ F.  
 DISSIPATION FACTOR: 0.1-2.  
 INDUCTANCE: 1  $\mu$ H to 1000 H.  
 MAGNIFICATION FACTOR: 0-60.

## FEATURES: BUILT-IN

- Provision for use of external generator for A.C. measurements up to 10 kc/s.
- Provision for use of external galvanometer.
- Mechanical interlock between dials displays only one answer.
- Electronically operated Wagner earth.
- All-mains operation.

## Resistance and reactance standards.

- 1 kc/s oscillator and bridge amplifier for A.C. measurements.
- Rectified A.C. source and sensitive centre-zero galvanometer for D.C. resistance measurements.

Full details in Bulletin B-642—which will gladly be sent on request.

Muirhead & Co. Limited, Elmers End, Beckenham, Kent. Tel: Beckenham 0041-2

FOR OVER 60 YEARS DESIGNERS AND MAKERS OF PRECISION INSTRUMENTS

CRC 73b

# BACKGROUND

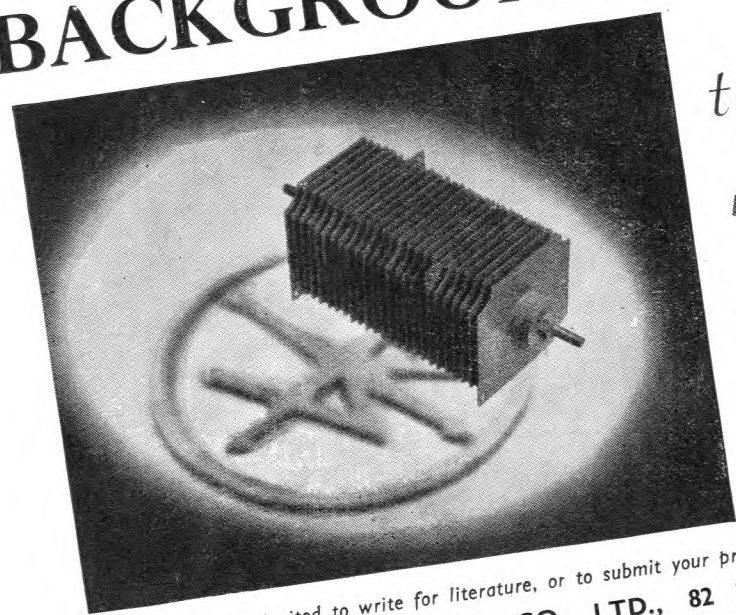

*to efficiency*

## WESTINGHOUSE WESTALITE RECTIFIERS

have the very high efficiency of nearly 90% over a very wide range of loading, and a voltage regulation of only about 5% with a current change from full load to about 1/10th full load.

You are invited to write for literature, or to submit your problems, to Dept. P.O.1.

WESTINGHOUSE BRAKE & SIGNAL CO. LTD., 82 YORK WAY, LONDON, N.1





TELEPHONES

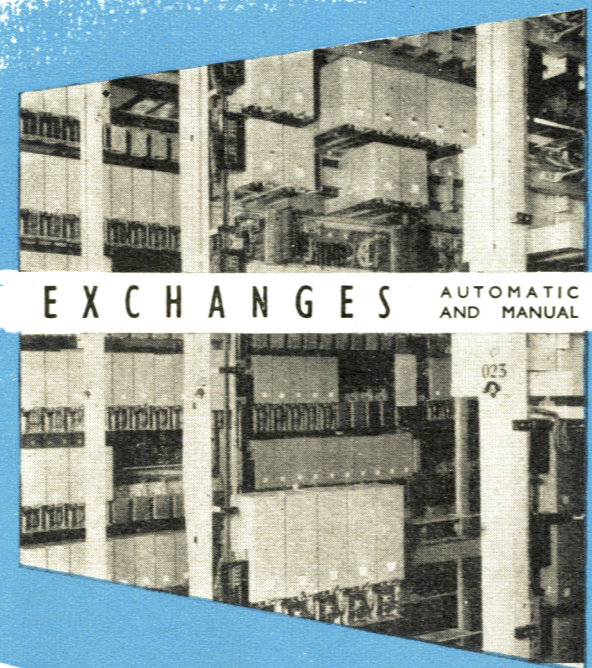

EXCHANGES AUTOMATIC AND MANUAL

FOR A COMPLETE SERVICE

and also

LOADING COILS - METERS

PRECISION TESTING EQUIPMENT

CABLES AND OPEN-WIRE SUPPLIES

THE GENERAL ELECTRIC COMPANY LTD. OF ENGLAND  
TELEPHONE, RADIO AND TELEVISION WORKS · COVENTRY · ENGLAND

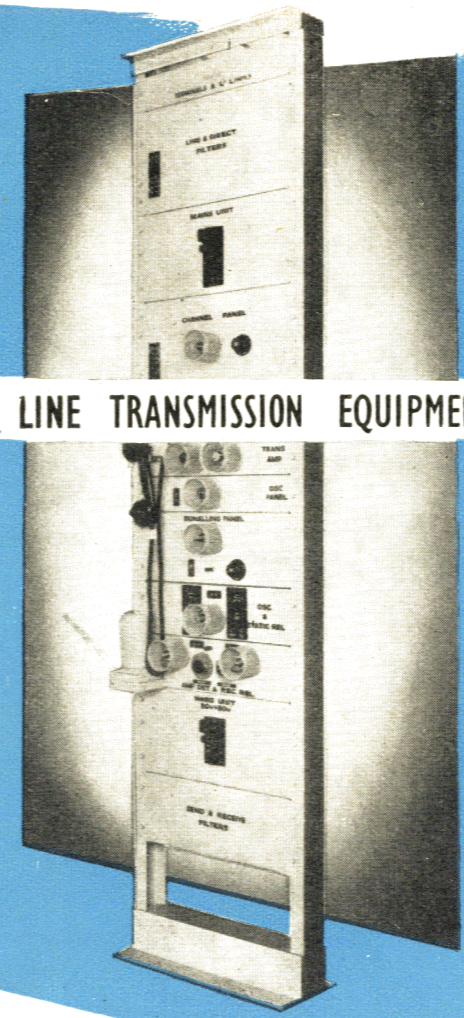

LINE TRANSMISSION EQUIPMENT



TRUNK RADIO EQUIPMENT

CONSULT



HEAD OFFICE, MAGNET HOUSE, KINGSWAY, LONDON, W.C.2

Telephones : Temple Bar 8000 (90 lines) Telegrams : "Electricity, Westcent, London" Cables : "Polyphase, London"



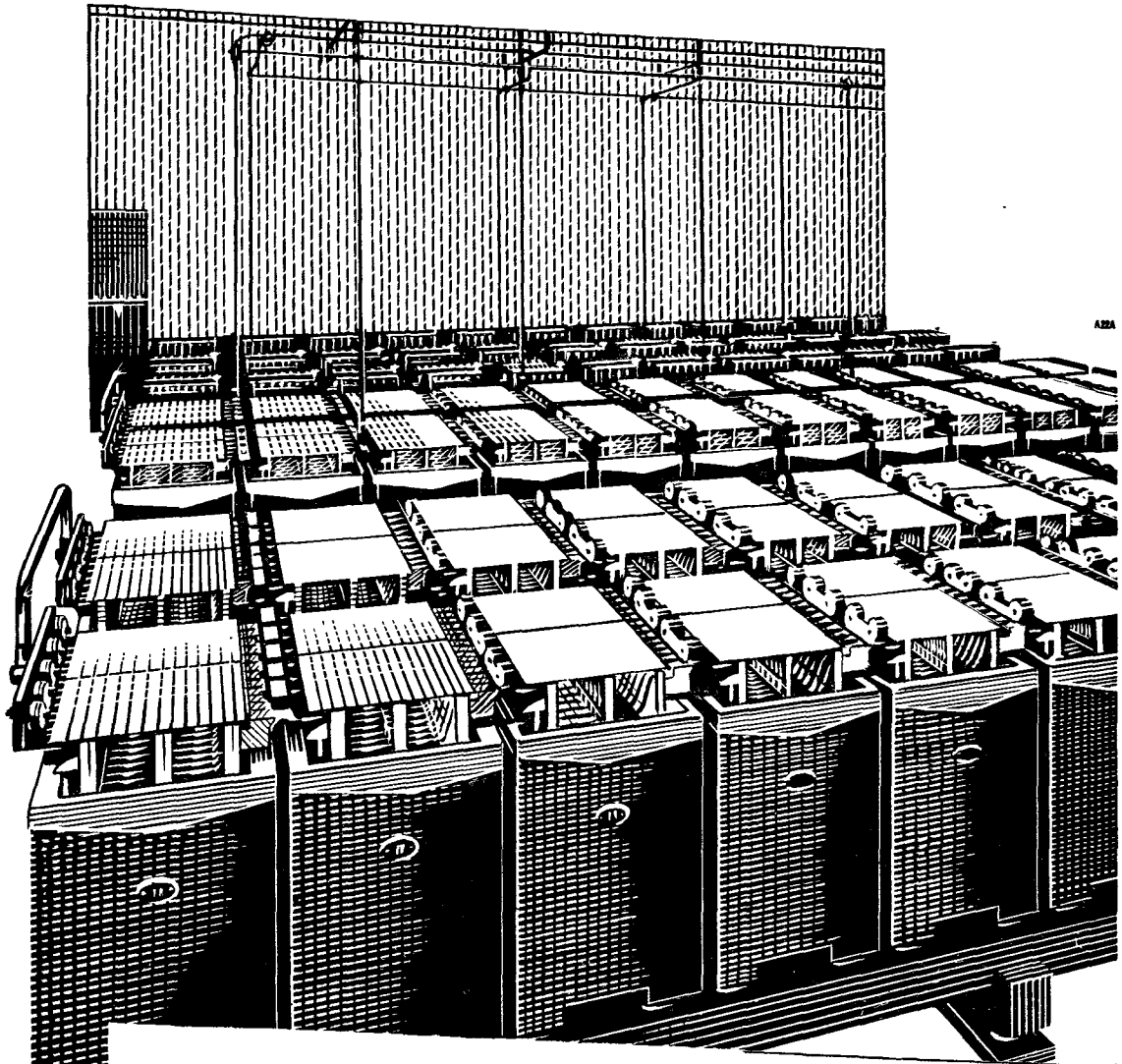

Good batteries giving good service—those are the Alton salesmen in sixty-five countries. They are bringing in orders for batteries ranging in capacity from 10 to 15,000 ampere-hours. Sharply increasing orders: but Alton, long experienced in export, is organised to meet them—with good batteries and firm delivery dates.

# ALTON

*Alton can also supply renewal plates for all makes of battery, British and Continental.*

**BATTERIES OF MERIT**

THE ALTON BATTERY CO. LTD

Alton, Hants. Telephone. Alton 2267 and 2268. Grams: Battery, Alton

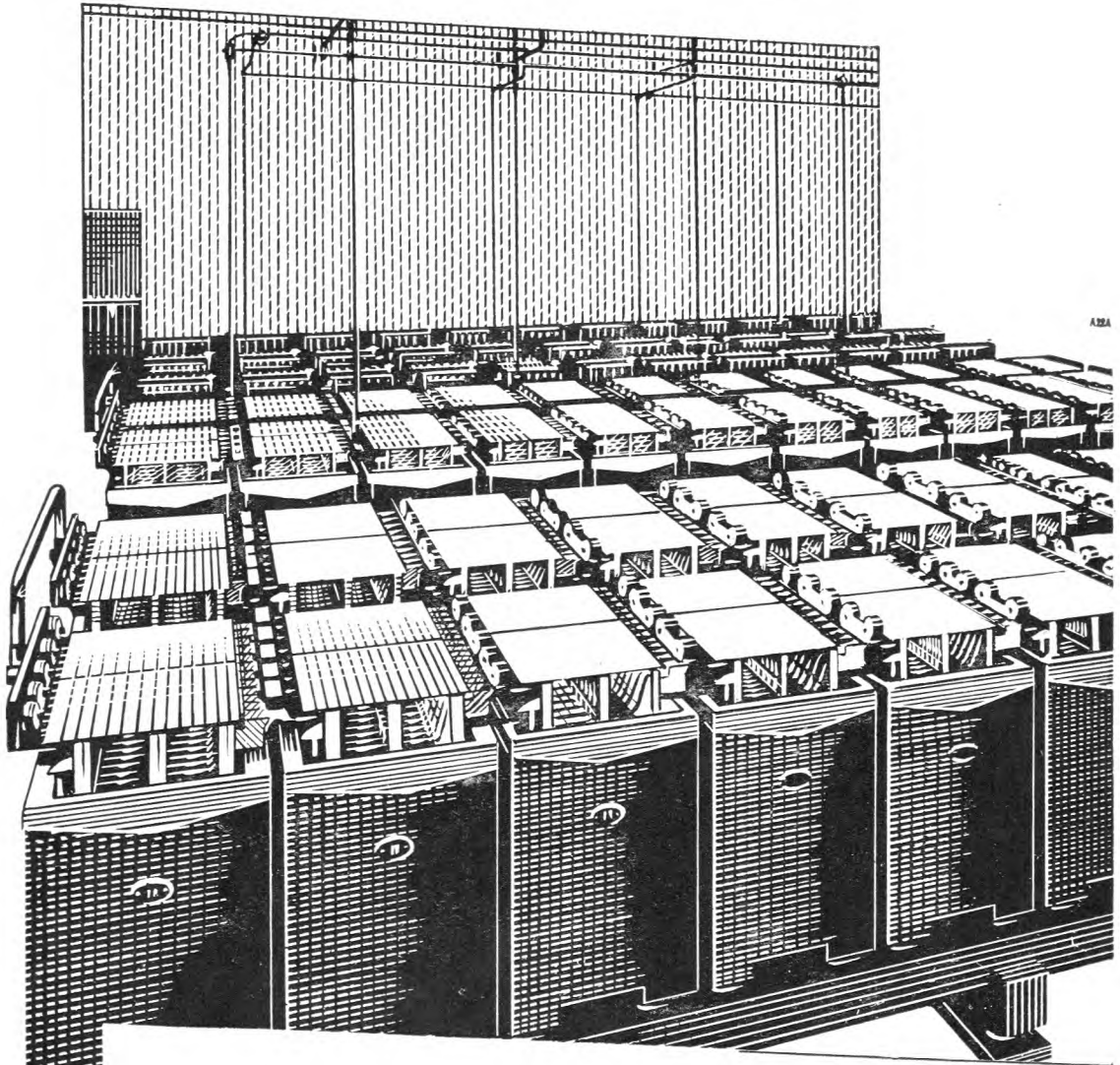

Good batteries giving good service—those are the Alton salesmen in sixty-five countries. They are bringing in orders for batteries ranging in capacity from 10 to 15,000 ampere-hours. Sharply increasing orders: but Alton, long experienced in export, is organised to meet them—with good batteries and firm delivery dates.

# ALTON

*Alton can also supply renewal plates for all makes of battery, British and Continental.*

**BATTERIES OF MERIT**

THE ALTON BATTERY CO. LTD

Alton, Hants. Telephone: Alton 2267 and 2268. Grams: Battery, Alton



## VALUABLE FREE BOOK

Tells You How to Pass Your C. & G. or Promotion Exam. at *First Attempt!*

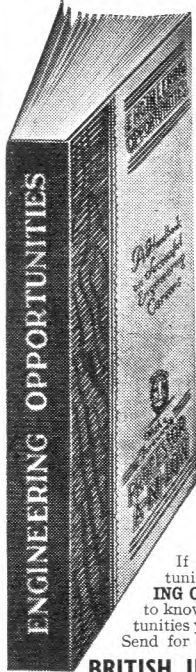

All Post Office Engineering personnel who are anxious to obtain early promotion should at once send for a copy of our handbook "ENGINEERING OPPORTUNITIES," which, among other intensely interesting matter, describes our unique methods of preparation for **TECHNICAL APPOINTMENTS IN THE POST OFFICE** (Assistant Engineer—New Style and Assistant Traffic Superintendent), **A.M.I.E.E., CITY AND GUILDS EXAMINATIONS** in Principles of Telecommunications (1-5), Radio (1-4), Telephone Exchange Systems (1-3), Telegraphy (1 and 2), Line Transmission (1 and 2), Lines Plant Practice (1 and 2), Mathematics for Telecommunications (1-5), Electrical Engineering Practice (Prelim. Inter. and Final), and outlines a wide range of non-examination courses in all branches of **Electrical, Mechanical, Civil, Automobile, Aeronautical and Radio Engineering.**

Assistant Engineer and Assistant Traffic Superintendent. Open competitions now resumed. Age extensions for established Civil Servants. Ask us for full details

We definitely guarantee  
"NO PASS—NO FEE"

If you intend to make the most of to-day's opportunities, you cannot afford to miss reading "ENGINEERING OPPORTUNITIES." It tells you everything you want to know to secure advancement, and describes many opportunities you may now be missing through lack of information. Send for your copy to-day—**FREE** and without obligation.

**BRITISH INSTITUTE  
OF ENGINEERING TECHNOLOGY**  
369 SHAKESPEARE HOUSE,  
17-19 STRATFORD PLACE, LONDON, W.1

# BIET

## Eclipse PERMANENT MAGNETS



IN  
**TUNGSTEN · CHROME  
COBALT · ALNI · ALNICO  
& ALCOMAX**

Our Technical Development Section will be pleased to advise on any problem connected with applied magnetism.

Made by the manufacturers of  
"ECLIPSE"  
PERMANENT MAGNET CHUCKS

EM7

**JAMES NEILL & CO. (Sheffield) LTD., SHEFFIELD, ENGLAND**

## THE PYE *Automatic* VOLTAGE REGULATOR FOR A.C. MAINS

**F**OR efficient operation, modern radio and electronic devices demand a constant input voltage.

The Pye Automatic Voltage Regulator not only ensures such a constant input but also gives a waveform free from distortion, a characteristic not found in other types of stabilizer.

Directors of Research laboratories, of educational institutions, e.g. universities and technical colleges; makers and users of laboratory testing equipment, radio transmitters and radar equipment, facsimile telegraphy apparatus, cinema projectors and sound equipment, telephone apparatus, electronic calibrators, electro-chemical analysis equipment, will find this voltage stabilizer indispensable. It is fully automatic and of special value wherever equipment is installed on unattended sites since it prevents large and sudden changes in the input voltage from causing momentary overloads to equipment.

The regulator is robust, fully tropicalised, and requires little maintenance. It gives constant output voltage of 230 volts or any required voltage within  $\frac{1}{2}\%$  despite an input variation of up to 90 volts, e.g.

230 Volts.  
Output Voltage from Pye Automatic Voltage Regulator.

$230 \pm 1.15$  volts.

Although the mains may vary from 170 — 260 volts.

The regulator is designed for a maximum power output of 4.8 Kilowatts.

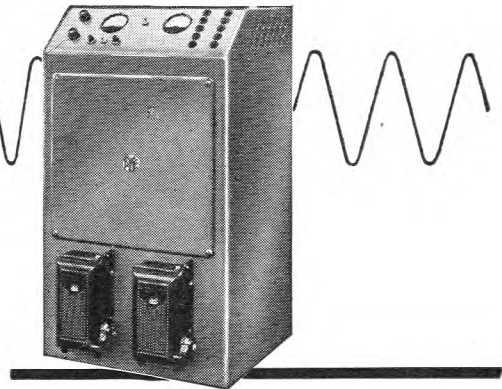

## Telecommunications

CAMBRIDGE

ENGLAND



# SIEMENS

## 4-CHANNEL CARRIER EQUIPMENT

TYPES CS4 and CS4/P

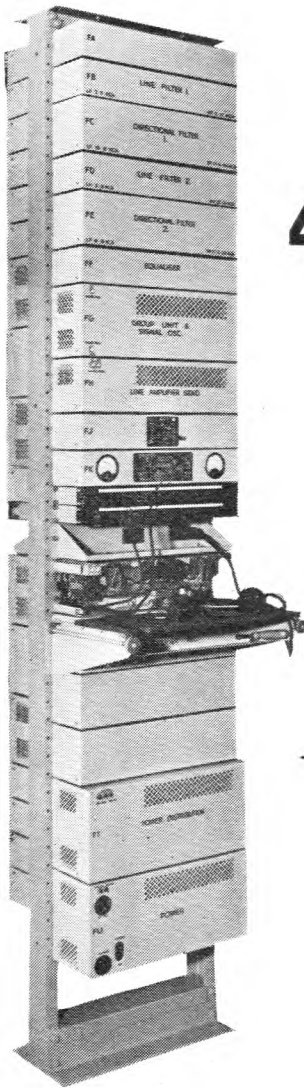

### FEATURES:

*Four additional speech channels in the range 3-32 kc/s.*

*Alternative frequency spectra for 20-32 kc/s channels by change of group modulation frequency.*

*Includes line-filter unit for the voice channel.*

*Complete with 500/20 ringers and power plant.*

**TYPE CS4**—Sending level to line +17 dbm. per channel. Can be used on same route as existing carrier systems. Can be supplied with audio repeaters for the voice circuit. Complete equipment on 8' 6" × 1' 8" bay. A.C. mains operation.

**TYPE CS4/P**—Sending level to line +12 dbm. maximum. Range without repeaters 100-150 miles according to line conductor. Two bays 3' × 1' 8" complete with transport cases and spare parts. Total weight 8½ cwt. Can be set up and put into service in a few hours. A.C. mains operation with 12 volts D.C. standby.

*Further particulars on application*

---



---

**SIEMENS BROTHERS & CO., LIMITED**

WOOLWICH · LONDON · S.E.18

Telephone: Woolwich 2020

---



---

# *A Typical Example of* **H.T.A. DESIGN**

Included in the range of H.T.A. Products are Telephone Coin Collectors, Stamp Selling Machines, Autodials, Commodity Vending Machines, Coin Operated Mechanisms, Kitchen Control Units, Gas Leak Indicators, Ticket Printing and Issuing Machines, also Coin Operated Totalisator Ticket Issuing Machines of which a model is illustrated here.

This machine is an independent ticket printing and issuing unit, constructed to operate on the insertion of a 2/- (two shilling) piece or other denomination of coin. Runner numbers can be varied from 1-99, which enables the machine to be used for both dog and horse betting.

The machine is portable and can, therefore, be moved from one track to another and run from power mains or portable accumulators.

It has two slots, one for "Win" bets and the other for "Place" bets. There are no buttons or other complications on the front of the machine: the public merely have to insert a coin.

The tickets are printed from plain rolls of paper and a warning light is shown when the roll reaches a predetermined minimum—diameter usually equivalent to 100 tickets.

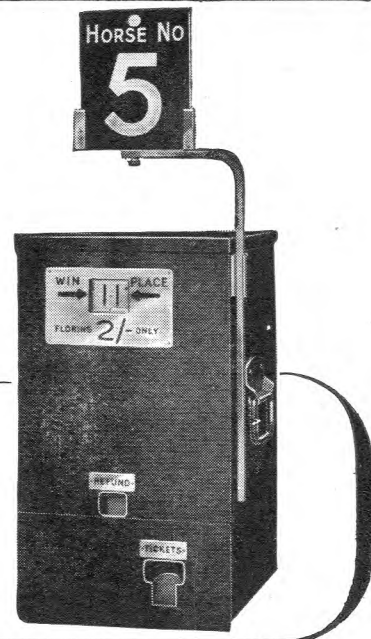

## **HALL TELEPHONE ACCESSORIES LTD**

*Precision Engineers & Instrument Makers*

**DUDDEN HILL LANE • WILLESDEN • LONDON • N. W. 10**

PHONE: WILLESDEN 5141

### HIGH GRADE DECADE ATTENUATORS

0.1% GRADE  
T or H NETWORKS

RANGE 0.1 to 110 db.  
0.01 to 10 nepers

TEMP. COEFF.  
0.0025% C

NO ERRORS UP TO FREQUENCIES OF  
100 Kc/s AND EXTREMELY USEFUL FOR  
FREQUENCIES UP TO 0.5 OR 1 Mc/s

ASSEMBLED INTO A DECADE SERIES  
OR AS PANEL MOULDED UNITS

ALSO SUPPLIED IN PORTABLE  
CARRYING CASES, COMPLYING WITH  
LINE TESTING REQUIREMENTS OF THE  
BRITISH POST OFFICE

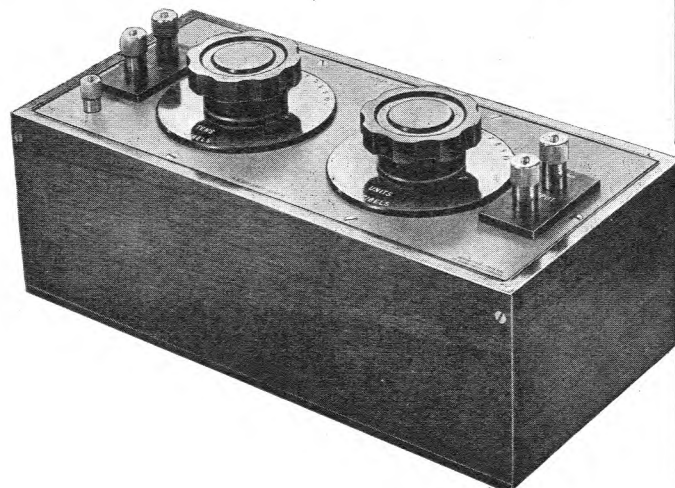

## **H. W. SULLIVAN**

— LIMITED —

LONDON, S.E.15

Telephone : New Cross 3255 (P.B.X.)

**Electrical Standards for  
Research and Industry**  
Testing and Measuring Apparatus  
for Communication Engineering

A SERIES OF METAL CASED HIGH FREQUENCY  
UNITS ARRANGED IN DEGREES OF ATTENUATION  
IN ASSOCIATION WITH SPECIALLY DESIGNED  
SWITCHES HAVING FINELY LAMINATED BRUSHES





# TRACES THE PATTERN OF WORLD TELECOMMUNICATIONS



THE pattern of world telecommunications is varied and complex. Varied because every problem requires an individual approach, involves a new assessment of available knowledge and a fresh consideration of existing methods of solution; complex because of all branches of engineering it is by far the most abstruse, involving in its approach to world communication problems the profoundest researches into physics and the development of special higher mathematical formulæ. This is the scientific background of the vast A.T.M. organisation which has at its disposal the specialised knowledge of over 50 years' experience in the telecommunication art and which has been responsible for many of the major inventions and discoveries in the subject during this period.

The scope of telecommunications is so vast that it requires the Company to employ the services of a large number of specialists in many subjects including acoustics, thermionics, electronics, piezo-electric and photo-electric phenomena, transmission theory, power engineering and measurement; it follows that such a body of collective knowledge is instantly available to deal with any problem for which the application of one or more of these techniques can provide a solution.



The scientific background of the Company is allied to an efficient organisation producing the following:—

#### TELEPHONE EXCHANGES FOR NETWORKS OF ANY SIZE

Director Exchanges for metropolitan and large provincial areas. Non-director main and satellite exchanges  
Automatic and automanual trunk exchanges  
Manual exchanges  
Private automatic exchanges (P.A.X.)  
Private automatic and manual branch exchanges (P.A.B.X. and P.M.B.X.)  
Calling line identification equipment  
Press Button telephone systems from 5 to 15 lines with or without loudspeaker master stations

#### TRANSMISSION EQUIPMENT

Single, three, twelve and twenty-four-channel carrier telephone systems for overhead lines or underground cables. Six, twelve, eighteen and twenty-four-channel carrier telegraph systems  
Loading coils  
Quartz crystals  
Carrier and audio repeaters  
Transmission testing apparatus

#### SIGNALLING EQUIPMENT

V.F. Systems of signalling and dialling using C.C.I.F. codes  
500/20 c/s signalling equipment  
Long-distance D.C. impulsing systems  
50 c/s dialling equipment

#### REMOTE CONTROL SYSTEMS

Systems of remote control with indication and telemetering equipment for the following services:  
Electricity distribution networks  
Electric railways; tram and trolleybus transport undertakings  
Gas distribution networks  
Water distribution networks  
Oil distribution networks  
"Rythmatic" ripple control systems for street lighting, selective load control and other operations

#### LIGHT CURRENT SIGNALLING SYSTEMS

Mine telephones and signalling equipment  
"Electro-matic" vehicle-actuated traffic signals for simple and complex intersections. Interlinked systems

#### ELECTRONIC DEVICES

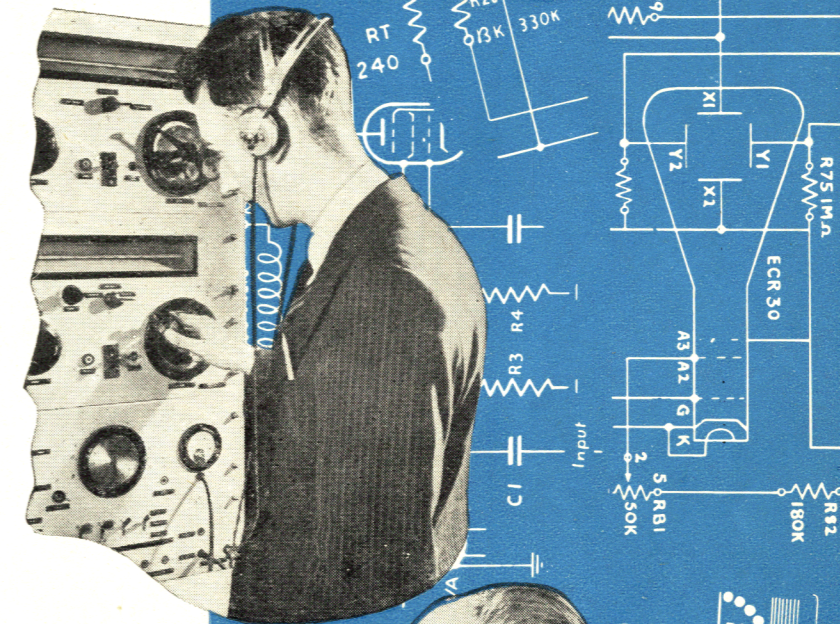
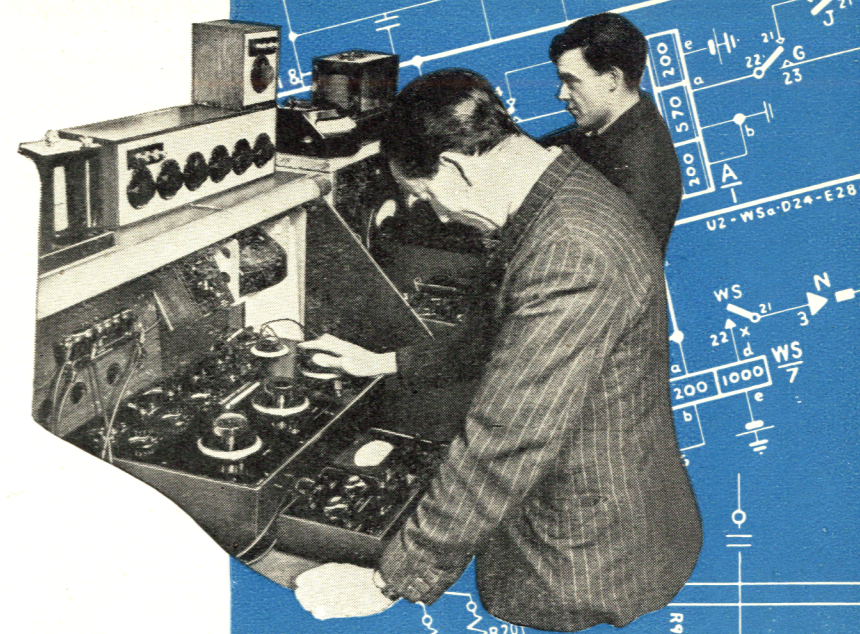

## AUTOMATIC TELEPHONE & ELECTRIC CO. LTD.

Registered Office and Works: STROWGER WORKS, LIVERPOOL 7, England  
Export Department: STROWGER HOUSE, ARUNDEL STREET, LONDON, W.C.2  
Cablegrams: "Autelco, London"  
Agents and Representatives in all parts of the world



# Creed

## TELEPRINTERS

*Built by specialists  
in machine telegraphy~*



N° 47 TAPE MODEL

*Write for  
Bulletin N° 21*

**Creed & Company Limited**

TELEGRAPH HOUSE  
CROYDON, ENGLAND

# CARPENTER Polarized RELAY TYPE 4

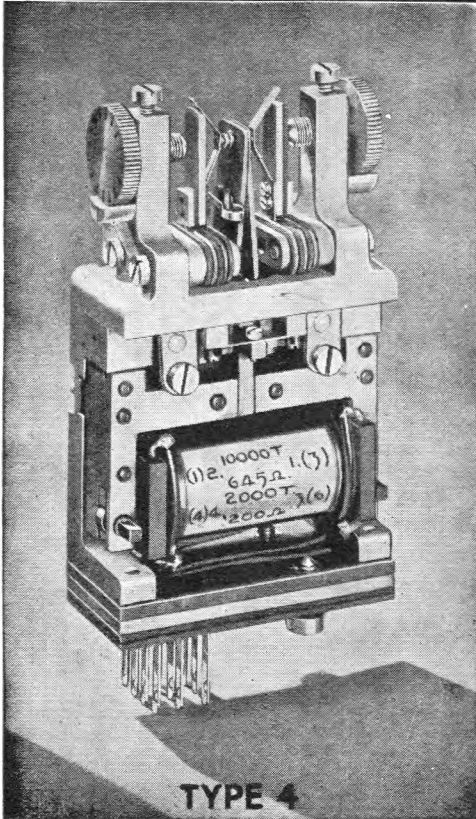

This is a medium speed, sensitive relay with long contact travel designed primarily as a telephone impulsing relay (D.C. dialling up to 100 miles and V.F. dialling on trunk circuits). It has also been successfully adopted for use in Telex systems.

Its sensitivity is such that when the gap is adjusted to .004 in. the relay will just operate at 50 cycles with 4 ampere-turns (corresponding to approximately 1 mVA) or on  $2\frac{1}{2}$  D.C. ampere-turns at low speeds. In service, however, the relay is normally operated at currents substantially larger than the minimum operating current.

Contact chatter is absent if the contact gap does not exceed .004 in. The contact gap is adjustable by means of fine pitch screws with knurled heads marked with .001 in. divisions.

Contacts on the armature tongue are insulated from it and thereby from the frame.

Terminals for soldered connections are fitted as standard.

The relay is supplied with a magnetic screening cover with transparent removable top to facilitate contact adjustment.

Dimensionally the relay is interchangeable with the type "3000" relay and can be supplied to fit directly to the drilling normally provided for the "3000" relay.

**Dimensions of the Type 4 Carpenter Relay are:— (With cover. Excluding wiring tags)**  
 $3\frac{3}{16}$  ins. high  $\times$   $2\frac{3}{16}$  ins. wide  $\times$  1 in. deep. Weight: 13 ozs.

Complete details available on request.

Manufactured by the Sole Licences:—

## TELEPHONE MANUFACTURING CO. LTD.

Contractors to the British Commonwealth and Foreign Governments

HOLLINGSWORTH WORKS DULWICH LONDON, S.E.21

Telephone: GIPsy Hill 2211 (10 lines)

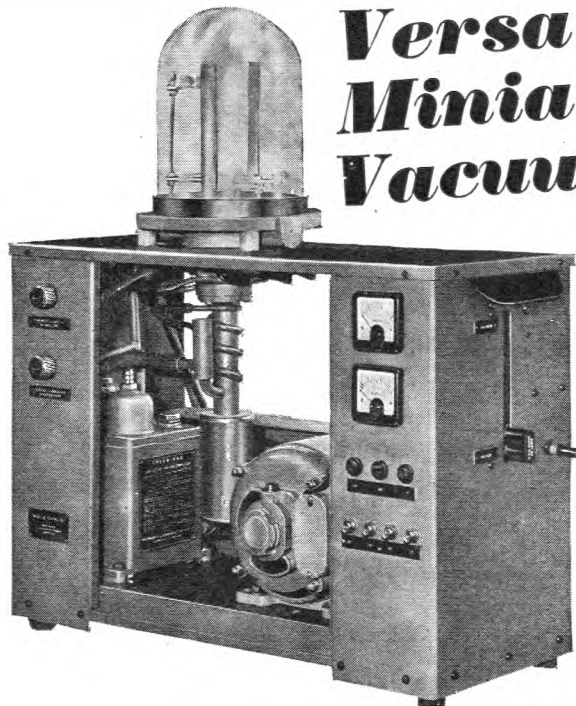

## Versatile! Miniature! Vacuum Coating Unit

Specially developed for the vacuum coating of quartz crystals, optics, photo-cells, etc., and for laboratories not requiring the output of the larger models.

- Unit exhausted from atmosphere down to  $10^{-4}$  mm. Hg in four minutes.
- Baffle isolation valve and by-pass pumping system permit rapid operation cycles and freedom from back streaming.
- Includes cathodic sputtering auxiliary for etching metallurgical specimens for both visual microscopy and electron microscopy replicas.

... For Better Vacuum Service ...

**W. EDWARDS & COMPANY (LONDON) LTD.,**  
 LOWER SYDENHAM, LONDON, S.E.26

Telephone: SYDenham 7026 (8 lines)

Telegrams: EDCOHIVAC, Souphone, London



## PULSE TESTING of *Standard* COAXIAL CABLES



THE measurement of impedance uniformity and the detection of any irregularity in coaxial cables by means of short pulse echoes displayed on the screen of a cathode ray tube represents a significant development in the technique of quality control during manufacture and installation.

The photograph shows such tests being made in a repeater station using pulse echo testing equipment developed by *Standard* for testing their coaxial cables over the entire frequency band used for telephony and television. All measurements are made with great rapidity and form an integral part of *Standard's* endeavour to produce even higher quality telecommunication systems.

***Standard Telephones and Cables Limited*** TELEPHONE LINE DIVISION

NORTH WOOLWICH, LONDON, E.16. Telephone: ALBERT DOCK, 1401

# PERFECTION OF LIAISON . . .

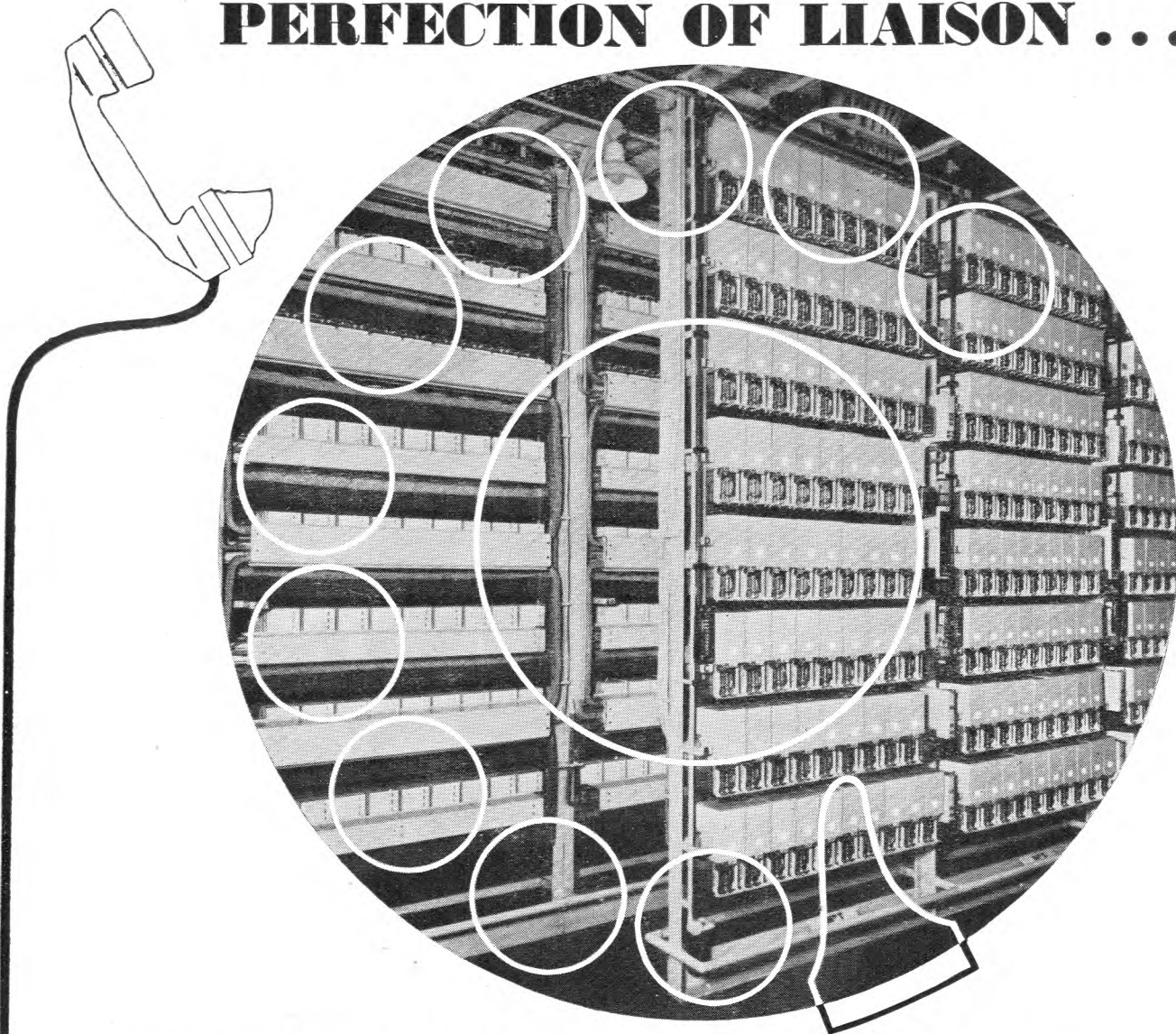

Illustrated are **ERICSSON** British  
Post Office Type 2000 Selector Racks  
made at our Beeston Factory.

As much painstaking care is taken  
in wiring as is expended upon the  
manufacture of the rack. This  
ensures **perfect** connection.

# *Ericsson*

## SELECTOR RACKS

**ERICSSON TELEPHONES LTD.** · Head Office: 22 LINCOLN'S INN FIELDS, LONDON, W.C.2 · Tel.: HOL 6936  
Works: BEESTON, NOTTS.



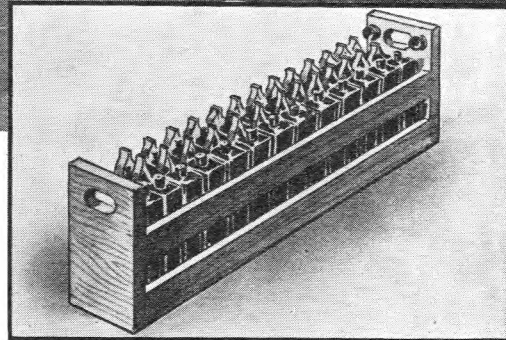
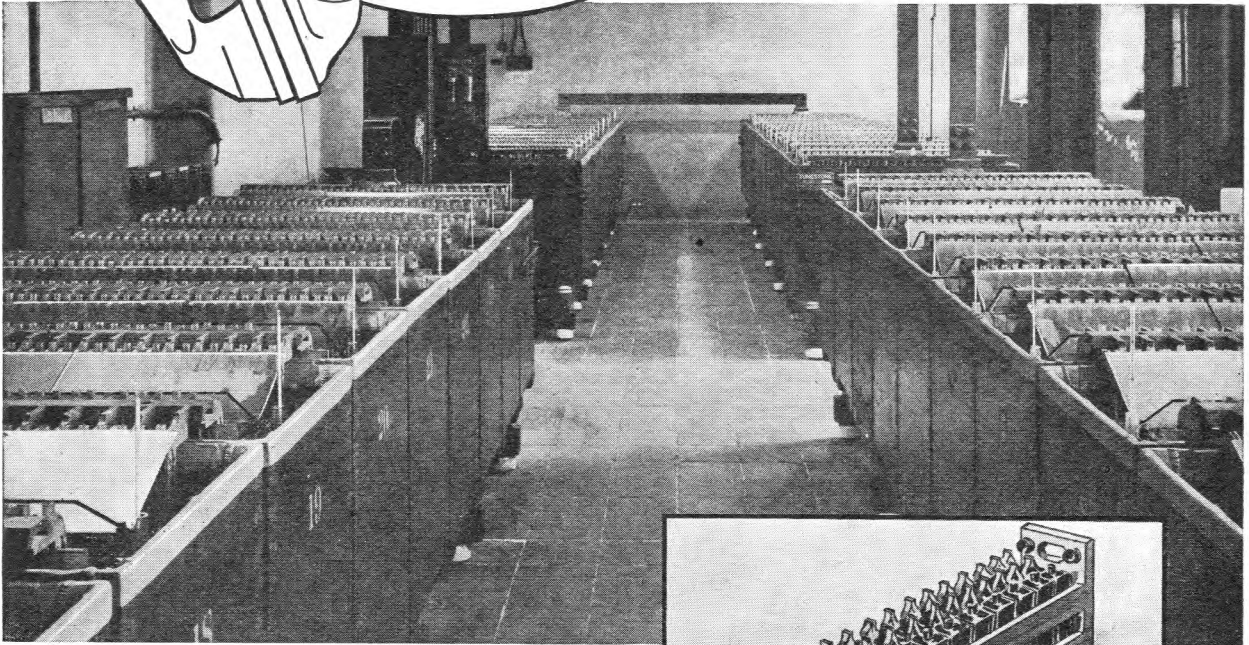
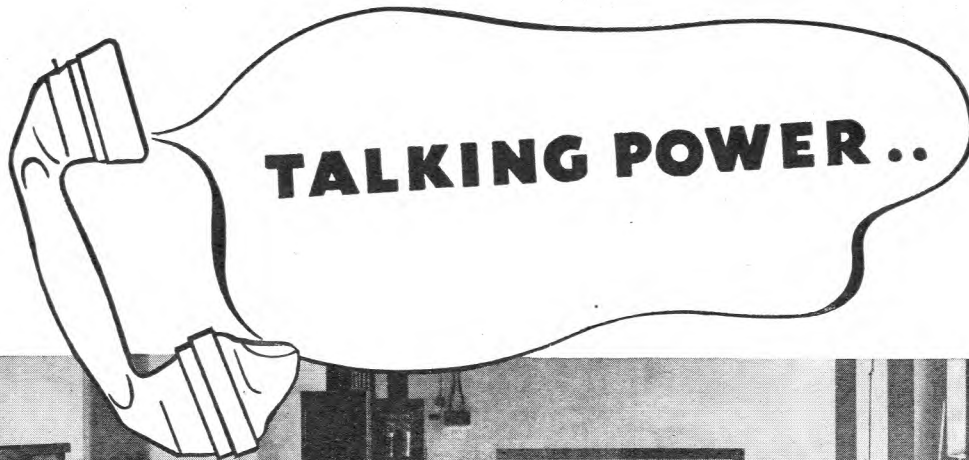

**TUNGSTONE PLANTÉ CELLS** are being supplied to the British Post Office and Post and Telegraph Departments in many countries overseas. They conform fully to G.P.O. and British Standard specifications.

#### OPEN TYPE CELLS

Similar to the illustration above, these are available in glass and/or lead lined wooden boxes in capacities from 100 a.h. to 5000 a.h.

#### REPLATALS

We are in a position to supply plates for replatals of any existing Planté Battery.

#### HIGH VOLTAGE TELEPHONE BATTERIES

As illustrated above. This is a portable type. Standard layout for 50 volts in waxed hard wood crates, exactly to the requirements of the G.P.O.

#### ENCLOSED TYPE CELLS

These are in moulded glass boxes with sealed-in lids. Capacity range from 10 a.h. to 200 a.h

*Overseas customers are invited to cable or write their enquiries for batteries or parts. Visitors to London are welcome at our offices.*

# TUNGSTONE Batteries

For further particulars write : TUNGSTONE PRODUCTS LTD., 10 Salisbury Square, London, E.C.4., England  
Cables : "Dilutum" London.



# How "MEGGER" Insulation Testers are used in the manufacture of High Tension Equipment

Hackbridge and Hewittic Electric Co. Ltd., manufacturers of some of the world's largest transformers, use "Megger" Insulation Testers at various stages in the manufacture of their transformers and rectifiers.

Insulation tests are made progressively during the manufacture of transformers, rectifiers and control panels. All transformers are tested at periodical intervals during drying out and after drying out; before the high tension test, to see if the apparatus is ready for this test; and after the high tension test to see that the insulation resistance has not fallen.

"Megger" Insulation Testers are also used for checking insulation resistance following the drying out of transformers on site before they are put into commission.

The larger (Series 1) "Megger" Insulation Tester in a hard wood case is generally used for these tests, the latest instruments in this series containing many new features, each tester having two ranges, and an effective scale length of  $8\frac{1}{2}$  inches, the full scale reading for a 2,500 volt tester being 50,000 megohms.

SEND FOR PUBLICATION . . . X 051

**NUTS** Drilling sites for artesian wells in Southern Tanganyika have been located by Groundnut surveyors with the "Megger" Geophysical Earth Tester.

## EVERSHED

PROCESS CONTROLLERS  
INDICATORS AND RECORDERS  
REMOTE CONTROLLERS  
**MEGGER** TESTERS

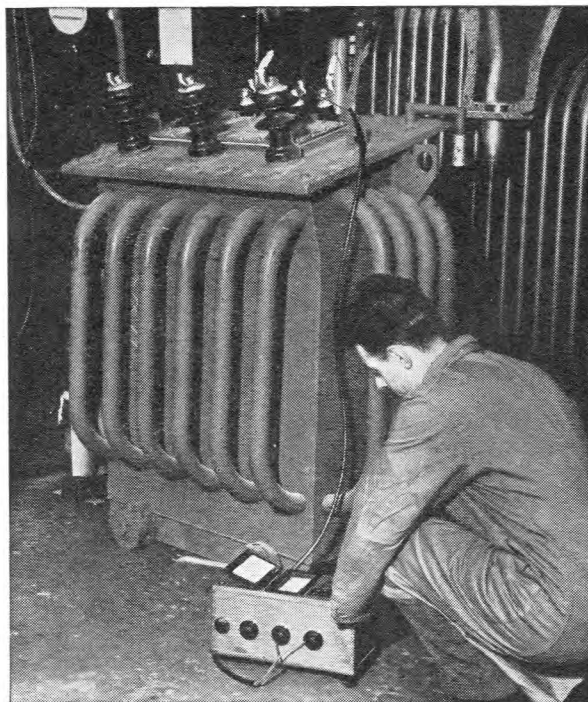

*A "Megger" Series 1 Insulation Tester being used to test a 100 KVA 6000/600/433 volt 3-phase Hackbridge transformer for insulation resistance between H.V. and L.V. windings after the transformer has been lowered into its tank.*

## "DIONIC" TESTERS MEASURE WATER PURITY

"Dionic" instruments provide an extremely simple means of detecting and measuring the amount of inorganic impurities dissolved in water. They supersede to a large extent, the chemical tests associated with this class of work.

There are two types of instrument—the Portable "Dionic" Water Tester which can be used by unskilled operators for testing boiler concentration, or for the control of wash-water in a base exchange process, etc.—and the "Dionic" Water Purity Meter which enables the condition of water in a closed feed system to be kept under constant observation, thus providing immediate warning of cooling water leakage into surface condensers.

SEND FOR PUBLICATION . X 216

## EVERSHED AND VIGNOLES LIMITED

ACTON LANE WORKS · CHISWICK · LONDON · W.4

Telephone : Chiswick 3670 · Telegrams : Megger, Chisk, London

Cables : Megger, London

# For large scale Electrical Purposes

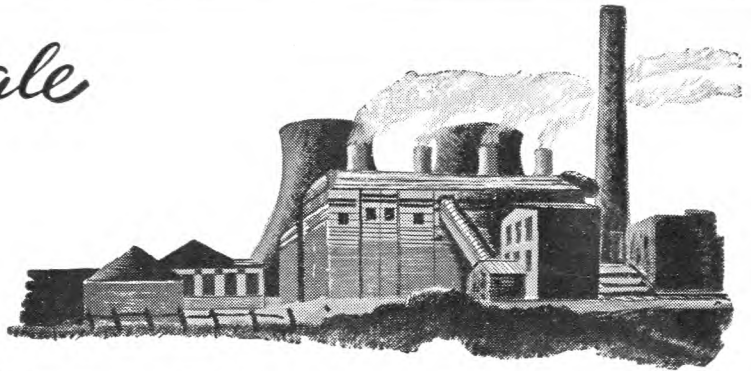

It is noteworthy where Tudor accumulators are to be found fulfilling the most important duties: over 500 British Power Stations installed Tudor. Many Tudor installations rank among the largest in the land and have an enviable reputation for long-lived reliability. No matter whether they were installed only yesterday, or over thirty

years ago—as many of them were—they are to-day functioning with consistent efficiency.

*SAFETYLYTE is the Tudor Emergency Lighting System, which is automatic and instantaneous in operation. It is installed in thousands of schools, hospitals, factories and other large buildings.*



## **TUDOR** ACCUMULATORS

THE TUDOR ACCUMULATOR CO. LTD  
50 GROSVENOR GARDENS, LONDON, S.W.1

WT38/44

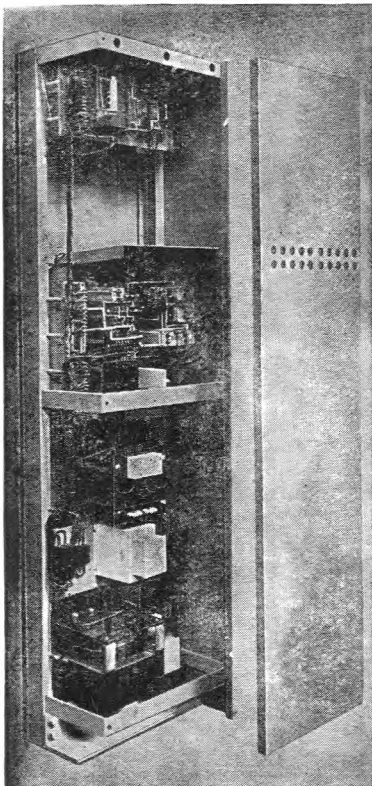

## The Mark II series of **SAVAGE AMPLIFIERS** for Broadcast Relay

● These Amplifiers are examples of what careful design can achieve. A lift-off back panel affords immediate access for maintenance purposes and the removal of six screws releases the side covers of the rack and exposes all the interpanel wiring. Even when the rack is sandwiched between others the side covers can be removed just as easily.

All valves are accessible from the front of the rack, and are protected by quick release grilles. The rack is completely flat fronted. The general appearance is further enhanced by the absence of a projecting front foot, and the masking of all panel fixing bolts. Similar racks carrying auxiliary apparatus can be placed side by side with amplifiers so that the whole installation is uniform in appearance.

Complete specifications  
available on request.

WESTMORELAND ROAD  
LONDON N.W.9  
TELEPHONE: COLINDALE 7131

**W. BRYAN SAVAGE  
LIMITED**



**Take YOUR word for it**

**"Denso**

**will be used  
exclusively"**

An enlightening series of candid opinions of the efficacy of Denso Anti-corrosive and Sealing Products expressed by "Men on the Job."

★ Report by a Cable Contractor dealing with the use of Denso for sealing cable ends :

★ "... Instructions have been received that in future Denso will be used exclusively for protecting cable ends and leaks. This will obviate carrying fires for melting bitumen — and should save valuable time."

**WHAT WE SAY**

**DENSO TAPE**—a permanently plastic wrapping of open-weave textile impregnated and coated with a formula based upon a protective medium known through the centuries for its water- and rust-proofing qualities.

**USES**—Protects Services, Mains, Cables and Metalwork below and above ground against Chemical and Electrolytical corrosion and corrosive atmosphere.

Temporary repairs. Water- and Gas-proofing. An aid to Frost-proofing. Water-proofing temporary cable openings.



Regd. Products

INDUSTRY'S SEAL AGAINST CORROSION

Write for Specification and Price List

**WINN & COALES LTD.**

Terminal House, Grosvenor Gardens, London, S.W.1.

Telephone : Sloane 6146-7. Telegrams : DENSELTE, SOWEST, LONDON

**ELECTRICAL  
INSTRUMENTS  
AND THE CALCULATION OF  
THE ERRORS INVOLVED**

By **D. Karo, Dip. Eng., A.M.I.E.E.**  
Senior Assistant, Northampton Polytechnic

The value of any measurement depends not only on the method used, but on the magnitude of the errors involved. This book compares methods of measurement, discusses the errors, calculates their value, and determines the conditions for maximum accuracy. Part I deals only with D.C. measurements and instruments, but the treatment covers the syllabus of the B.Sc. Part II examination in Electrical Measurements.

106 Diagrams (Part I) 18/- net

**MACDONALD & CO.**  
(Publishers) LTD.

43, LUDGATE HILL, LONDON, E.C.4

**SOUND INSTRUCTION  
by Postal Method**

The I.C.S., largest school in the world devoted to spare-time training by the postal method, offers you highly specialised Courses for the following examinations:

**P.M.G. Certificates for Wireless Operators.**  
**C. & G. Illumination Engineering (Inter.)**  
**C. & G. Electrical Engineering Practice, Installation and Telecommunications.**  
**Graduateship of the B.I.R.E.**

*I.C.S. Examination students are coached till successful.*

Other Courses meet the requirements of all who desire to qualify for responsible positions in Electric Power, Illumination, Heating and Traction Systems. Equally successful is our instruction for Telegraph and Radio Engineers, Radio Servicemen, and in Elementary Radar and Electronics, Advanced Short-Wave Radio and Television Technology.

Instruction is by correspondence from textbooks specially prepared by many experts.

*WRITE FOR OUR SPECIAL BOOKLET* and state the particular subject or Examination in which you are interested.

**YOU MAY USE THIS COUPON**

**International Correspondence Schools Ltd.**

Dept. 108, International Buildings, Kingsway, London, W.C.2

Please send me, free of charge, your special booklet on \_\_\_\_\_

Name \_\_\_\_\_ Age \_\_\_\_\_

(BLOCK LETTERS, PLEASE)

Address \_\_\_\_\_



**Electrical Technology**

By H. Cotton, M.B.E., B.Sc., M.I.E.E. A standard textbook and reference work for electrical engineers and students. Now completely revised, with important new material. Sixth Edition. Illustrated. 18/- net.

**Telephony Vol. I**

By J. Atkinson, A.M.I.E.E., Area Engineer, Post Office Engineering Dept. The first volume of a completely revised edition of Herbert and Procter's great work, universally recognised as the standard guide to telephony. This volume deals with general principles and manual exchange systems. 694 illustrations. 35/- net.

**Radio Frequency Heating  
Equipment**

By L. L. Langton, A.M.I.E.E. A new book by an expert, of first-rate importance to all concerned with this type of equipment. With numerous illustrations. 17/6 net.

**Electrical Measurements and  
Measuring Instruments**

By E. W. Golding, M.Sc.Tech., A.M.I.E.E. A useful textbook covering the syllabuses of the B.Sc.(Eng.) and other examinations. Third Edition. 25/- net.

**Permanent Magnets**

By F. G. Spreadbury, A.M.Inst.B.E. A comprehensive work by an authority dealing fully with recently-developed as well as orthodox materials, with problems of design, and with theory. Profusely illustrated. 35/- net.

**PITMAN, Parker Street, Kingsway, London, W.C.2**



# TELEPHONE CABLES

OUR BROCHURE No. 9E (1949),  
GIVING INFORMATION AND SPECI-  
FICATIONS FOR A WIDE RANGE  
OF TELECOMMUNICATION CABLES  
MANUFACTURED BY US, IS  
AVAILABLE UPON REQUEST.

TELEPHONE:  
SOUTHAMPTON  
2141 (5 lines)

**PIRELLI-GENERAL**  
CABLE WORKS, Ltd., SOUTHAMPTON.

TELEGRAMS  
"PIGEKAYBEL"  
SOUTHAMPTON

## MINIATURE VITREOUS ENAMELLED RESISTOR

TYPE M.V.1

**RATING** 3 watts for 250°C. rise.

**RESISTANCE RANGE** -1-4700 ohms.

Full rated watts over the whole resistance range.

**DIMENSIONS** - 15/32" × 13/64".

Agents in Switzerland: Arnold Kleiner, Zug



Actual size of resistor

TYPE  
APPROVED

**PAINTON**  
of  
**NORTHAMPTON**

KINGSTHORPE, NORTHAMPTON.