

This document was generated by me, Colin Hinson, from a document held at R.A.F. Henlow Signals Museum and is believed to be out of copyright or Crown Copyright . It is presented here (for free) under the Open Government Licence (O.G.L.) if under Crown Copyright and this version of the document is my copyright (along with the Crown Copyright) in much the same way as a photograph would be. If you believe the document to be under copyright, please contact me.

The document should have been downloaded from my website <https://blunham.com/Radar>, if you downloaded it from elsewhere, please let me know (particularly if you were charged for it). You can contact me via my Genuki email page:

<https://www.genuki.org.uk/big/eng/YKS/various?recipient=colin>

You may not copy the file for onward transmission of the data nor attempt to make monetary gain by the use of these files. If you want someone else to have a copy of the file, point them at the website. It should be noted that most of the pages are identifiable as having been processed by me.

I put a lot of time into producing these files which is why you are met with the above when you open the file.

In order to generate this file, I need to:

1. Scan the pages (Epson 15000 A3 scanner)
2. Split the photographs out from the text only pages
3. Run my own software to split double pages and remove any edge marks such as punch holes
4. Run my own software to clean up the pages
5. Run my own software to set the pages to a given size and align the text correctly.
6. Run Omnipage (Ultimate) on all the pages to OCR them.
7. Generate a searchable Acrobat pdf file.

Hopefully after all that, I end up with a presentable file, though I can't guarantee there aren't errors in the OCR. If you find missing pages, pages in the wrong order, anything else wrong with the file or simply want to make a comment, please drop me a line (see above).

It is my hope that you find the file of use to you personally – I know that I would have liked to have found some of these files years ago – they would have saved me a lot of time !

Colin Hinson

In the village of Blunham, Bedfordshire.

THE POST OFFICE ELECTRICAL ENGINEERS' JOURNAL

Vol. 45

APRIL 1952

Part 1

CONTENTS

	PAGE
A NEW COAXIAL CABLE JOINT—E. D. Latimer, A.M.I.E.E., and B. Ash	1
AIR COMPRESSORS FOR EXTERNAL WORKS—J. J. Moffatt, Assoc.I.Mech.E., A.M.I.E.E.	5
THE PUBLIC UTILITIES STREET WORKS ACT, 1950—E. A. Page	8
TRANSATLANTIC TELEPHONE SERVICE—COMMEMORATION OF NOTABLE ANNIVERSARY	10
A POSTAL ORDER PRINTING AND ISSUING MACHINE—P. G. S. Chick, Grad.I.E.E.	11
THERMAL PROBLEMS OF SMALL UNDERGROUND INSTALLATIONS—K. D. Bomford, M.Sc., A.M.I.E.E.	14
NEW-TYPE ROUTINERS FOR AUTOMATIC TELEPHONE EXCHANGE EQUIPMENT Part 2.—General Description of the Control Circuit—L. Green	19
A MILLISECOND TIMING UNIT—J. E. Haworth, A.M.I.E.E.	25
AN APPROACH TO THE STANDARD EQUATIONS FOR A UNIFORM TRANS- MISSION LINE—Part 1.—Propagation of Current and Voltage in Chain of Symmetrical Resistance Networks—H. R. Harbottle, O.B.E., B.Sc., D.F.H., M.I.E.E.	30
C.C.I.F. MEETINGS, FLORENCE, OCTOBER, 1951	35
NOTES AND COMMENTS	39
REGIONAL NOTES	40
JUNIOR SECTION NOTES	45
STAFF CHANGES	47
BOOK REVIEWS	24, 29, 34

Price 2/6 net

THE INSTITUTION OF POST OFFICE ELECTRICAL ENGINEERS

How to make certain of your City & Guilds Certificates



"I guarantee tuition until you have passed"

If you consider taking one or the whole series of C. and G. examinations then I can help you. BY POST, in your own time, one of my Telecommunications specialists will coach you until you pass. He will give you individual attention, he will study you and your problems. And you will be surprised how fast you progress. For The Bennett College has specialised in technical subjects since it was founded 50 years ago. My system of personal postal tuition has helped *thousands* of students through their exams. It can do the same for you.

Send me the coupon to-day. I will send you—without obligation—full information on your subject.

Rep Bennett
GOVERNOR

YOU CAN START ON A BENNETT COURSE FOR ONLY **30/-**

TEAR OUT

with monthly instalments of 15/-

WHICH IS YOUR NEXT STEP?

- Preliminary Course
- Telecommunications Principles I—V
- Telecommunications Practice
- Telephone Exchange Systems I—III
- Radio I—IV
- Telegraphy I & II
- Line Transmission I & II
- Mathematics for Telecommunications I—V
- Radio Servicing Certificate
- Television Servicing Certificate
- A.M.I. Mech.E.
- and many other subjects

The BENNETT COLLEGE

To the Governor, Dept. D24, The Bennett College, Sheffield, England. I would like to have (at no cost) your prospectus and

particulars of

NAME

ADDRESS

AGE (if under 21)

PLEASE WRITE IN BLOCK LETTERS

VALUABLE FREE BOOK

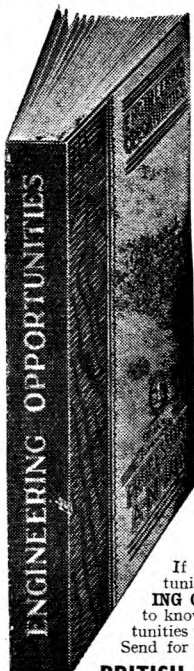

Tells You How to Pass Your C. & G. or Promotion Exam. at First Attempt!

All Post Office Engineering personnel who are anxious to obtain early promotion should at once send for a copy of our handbook "**ENGINEERING OPPORTUNITIES**," which among other intensely interesting matter, describes our unique methods of preparation for **TECHNICAL APPOINTMENTS IN THE POST OFFICE** (Assistant Engineer—New Style and Assistant Traffic Superintendent), **CITY AND GUILDS EXAMINATIONS** in Principles of Telecommunications (1-5), Radio (1-4), Telephone Exchange Systems (1-3), Telegraphy (1 and 2), Line Transmission (1 and 2), Lines Plant Practice (1 and 2), Mathematics for Telecommunications (1-5), Electrical Engineering Practice (Prelim. Inter. and Final), and outlines a wide range of non-examination courses in all branches of **Electrical, Mechanical, Civil, Automobile, Aeronautical and Radio Engineering.**

Assistant Engineer and Assistant Traffic Superintendent. Open competitions now resumed. Age extensions for established Civil Servants. Ask us for full details

We definitely guarantee "NO PASS—NO FEE"

If you intend to make the most of to-day's opportunities, you cannot afford to miss reading "**ENGINEERING OPPORTUNITIES**." It tells you everything you want to know to secure advancement, and describes many opportunities you may now be missing through lack of information. Send for your copy to-day—**FREE** and without obligation.

BRITISH INSTITUTE OF ENGINEERING TECHNOLOGY
369 SHAKESPEARE HOUSE,
17-19 STRATFORD PLACE, LONDON, W.1

BIET



FOR THE RIGHT CONNECTION

FREDERICK SMITH & COMPANY

ANACONDA WORKS, SALFORD, 3, LANCs.

Incorporated in The London Electric Wire Company and Smiths Limited. Associated with The Liverpool Electric Cable Co. Ltd. and Vactite Wire Co. Ltd.

They're worth waiting for...

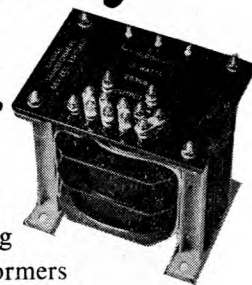

A lot more people than ever before have been ordering a lot more Savage Transformers than ever before. This, and the shortages of raw materials are extending deliveries more than somewhat. As one of our Welsh customers said, however, "Savage Transformers are worth waiting for."



SAVAGE TRANSFORMERS LTD., Nursted Road, Devizes, Wilts.
Telephone: Devizes 536

THE POST OFFICE ELECTRICAL ENGINEERS' JOURNAL

Vol. 45

April 1952

Part 1

A New Coaxial Cable Joint

E. D. LATIMER, A.M.I.E.E., and
B. ASH†

U.D.C. 621.315.212: 621.315.687.1

This article describes a new layout for the coaxial pairs and paper-core quads in the joints of a composite multi-coaxial-pair cable. The adoption of the new layout, which is planned so that access to the coaxial pairs for maintenance purposes is made easy, should minimise the risk of long duration interruption of coaxial telephone or television circuits during cable repairs. The jointing technique to give the new layout has been approved by the Telephone Cable Contractors' Committee.

Introduction.

COAXIAL cables frequently contain several layers of paper core (P.C.) quads laid up over a core of coaxial pairs and P.C. quads or pairs. At jointing points the layer quads are jointed with a certain amount of slack to facilitate access to the coaxial pairs for maintenance purposes; the slack being obtained by jointing the layer quads over a wooden barrel or former (see Fig. 1), which is

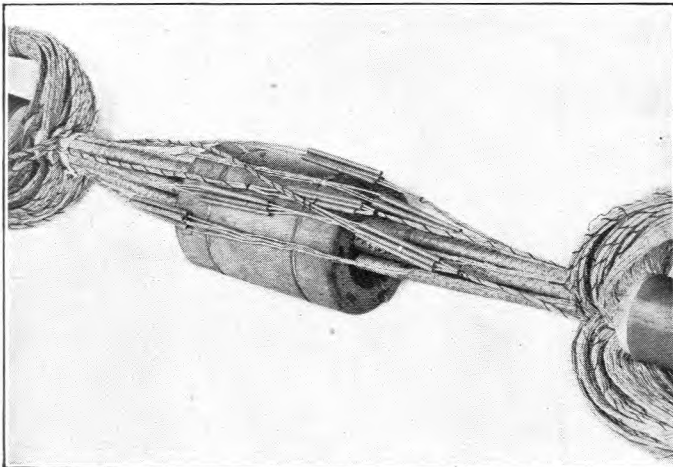

FIG. 1.—BARREL TYPE JOINT IN COURSE OF CONSTRUCTION.



FIG. 2.—BARREL TYPE JOINT COMPLETED; SHOWING LIMITED ACCESS TO COAXIAL PAIRS.

removed after completion of the wire jointing. The wooden barrel is made up of a number of interlocking segments to enable it to be taken apart and removed from the joint. The use of the barrel, however, gives only a very limited access to the coaxial pairs, as is shown in Fig. 2; the criss-crossing of the layer quads resulting from "test-selected" or "systematic" jointing forms a cage-like structure over the coaxial pairs and prevents working access.

Some recent coaxial cable operations, two of which are described below, have shown that an improved type of joint is necessary.

Diversion of Coaxial Pairs from the London-Slough Cable into Museum Telephone Exchange.

To cater for the future transmission of television signals to the West Country by cable, Coaxial Pairs 3 and 4 of the London-Slough cable were, in July 1951, cut in and out of Museum telephone exchange (Post Office Television Terminal, London); the cable make-up is 4 cx. pr. 375* + 408 pr./20 lb. The diversion necessitated the opening of a main joint in the cable so that the two 2 cx. pr. 375 + 16 pr./20 lb. spur cables could be jointed-in. The lead sleeve of the joint measured 30 in. × 5 in., and the jointing gap 26 in. Although the P.C. quads were fairly slack—they had been jointed over a wooden barrel in the standard manner—it was impossible, by separating the quads, to expose the coaxial pairs sufficiently for the jointing work. To obtain the necessary working space around the coaxial pairs the joiner had to resort to the expedient of temporarily piecing-out the P.C. quads, and not until he had pieced-out about half the total number of quads in the cable could he commence work on the coaxial pairs. The work was still further hindered by the difficulty of working on coaxial pairs in close proximity to each other, and although the diversion was satisfactorily carried out it could have been effected in probably a quarter of the time if the main joint had been designed so that adequate access to the coaxial pairs was readily obtainable.

Fault on the Birmingham-Manchester No. 3 Cable.

During October, 1951, a sheath fault in a length developed on this cable (6 cx. pr. 375 + 376 pr./20 lb.) at Stafford. The cable carries the television programme from Birmingham to the North of England, and quick repair was very desirable. It was therefore decided that, as a first step,

† The authors are, respectively, Executive Engineer and Assistant Engineer, External Plant and Protection Branch, E.-in-C.'s Office.
* 4 coaxial pairs, each of 0.375 inch internal diameter.

the faulty length should be by-passed by jointing-in six coaxial interruption cables and three 150 pr./20 lb. P.C. cables drawn into spare bores of the duct. Ideally, to avoid any possibility of breakdown of the television programme, the change-over to coaxial interruption cable should have been carried out immediately after removing the lead sleeve at each end of the faulty length, but access to the coaxial pairs was so restricted, by the criss-crossing layer quads, that they could not be changed over until the maze of wires over them had been cleared by changing over the P.C. quads to interruption cable. Fig. 3 shows this

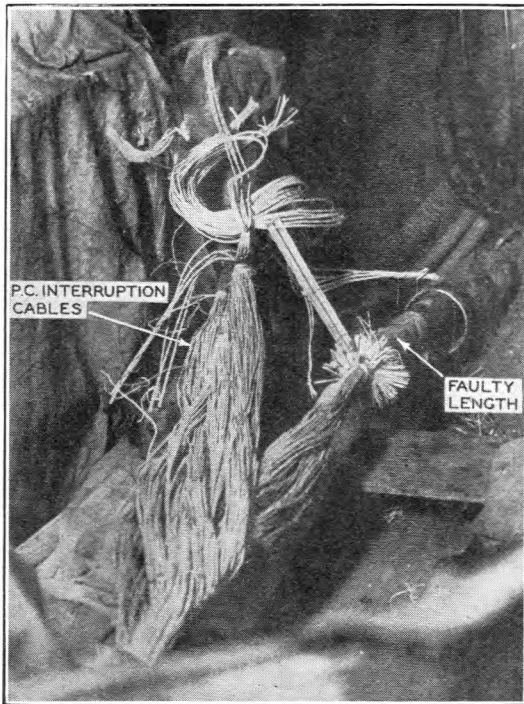

FIG. 3.—FAULT ON BIRMINGHAM-MANCHESTER No. 3 CABLE; CHANGING OVER TO INTERRUPTION CABLE.

latter operation in progress; it took some 48 hours to complete. It is interesting to note that once adequate access to the coaxial pairs had been gained, Coaxial Pair 5, which was in use for television, was changed-over to interruption cable in 21 seconds. The importance of a rapid change-over to coaxial interruption cable under fault conditions on multi-coaxial-pair cable will be appreciated when it is remembered that over the coaxial pairs may be routed a 2-way television circuit and several hundred telephone circuits.

Early Experimental Joints.

During the experimental work, consideration was given to several methods of making a coaxial cable joint in such a way that the difficulty of gaining quick and adequate access to the coaxial pairs was overcome. In the following paragraphs a brief description is given of two methods which, although not adopted, appeared attractive at first sight; the reasons why they were not adopted, are also given.

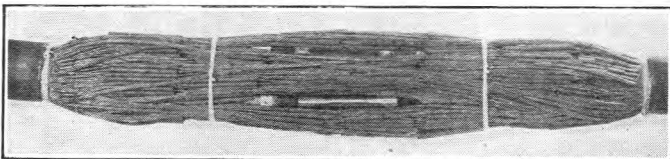

FIG. 4.—EXPERIMENTAL JOINT WITH COAXIAL PAIRS BROUGHT TO THE OUTSIDE.

(1) *Joint shown in Fig. 4.* The coaxial pairs were made to pass over a disc-shaped former at each end of the joint, and were thereby brought to the outside of the layer P.C. quads. They were set so that they were regularly spaced around the joint with a straight portion about 9 inches long after jointing. The straight portion of each coaxial pair enabled the bi-metallic outer conductor ferrule to be slipped over the pair in readiness for jointing.

The method suffers from the disadvantages that,

- (a) considerable skill and care are needed to set the coaxial pairs without kinking them, and
- (b) when breaking down a joint, withdrawal of the last few inner conductor spacing discs from a coaxial pair would be difficult due to the set of the pair (coaxial-pair joints have sometimes to be broken down and discs withdrawn, e.g. for the purpose of removing copper dust accidentally introduced during jointing).

(2) *Joint shown in Fig. 5.* The coaxial pairs were separated from the P.C. quads by making lead plugs at each end of the joint.

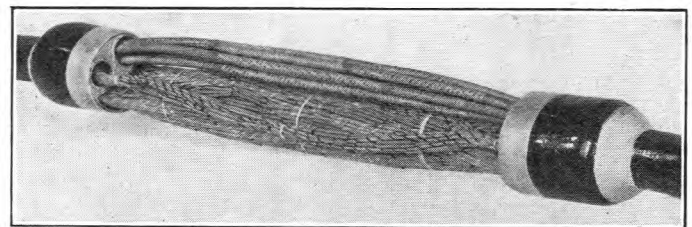

(a) COMPLETED JOINT.

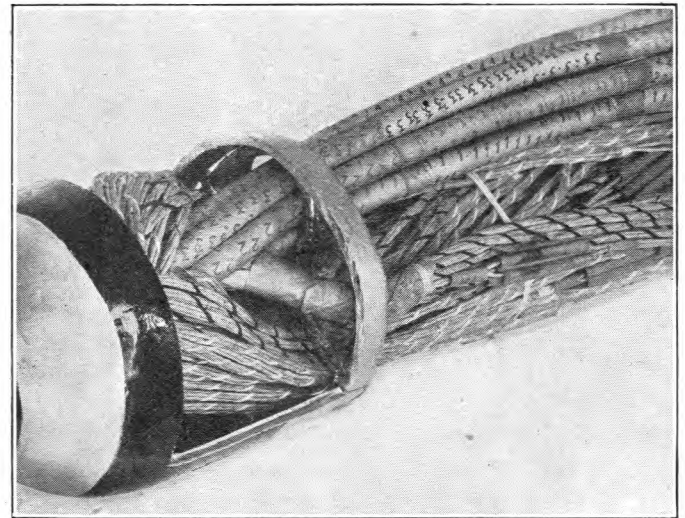

(b) SECTIONAL VIEW OF LEAD PLUG.

FIG. 5.—EXPERIMENTAL JOINT USING LEAD PLUG.

The disadvantages of the method are that

- (a) the coaxial pairs are in close proximity to each other, making work on any one pair difficult,
- (b) work on any coaxial pair situated on the underside of the group of coaxial pairs could only be undertaken after interrupting some of the upper coaxial pairs or piecing-out a number of P.C. quads,
- (c) the coaxial pairs have to suffer a very severe setting in the plug ends, and there is a considerable risk of kinking,
- (d) the joint is considerably larger than normal, and
- (e) layer identification within the jointing gap is lost, and therefore quad numbering on both sides of the joint is essential.

THE NEW JOINT

The jointing technique recommended for all future composite coaxial cables is illustrated in Fig. 6, which shows

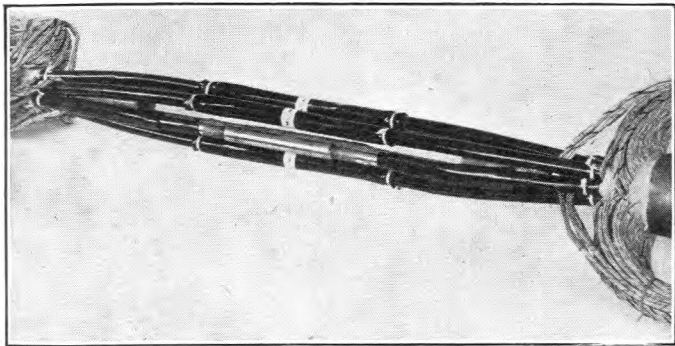

(a) COAXIAL PAIRS JOINTED; PAXOLIN FORMERS IN POSITION.

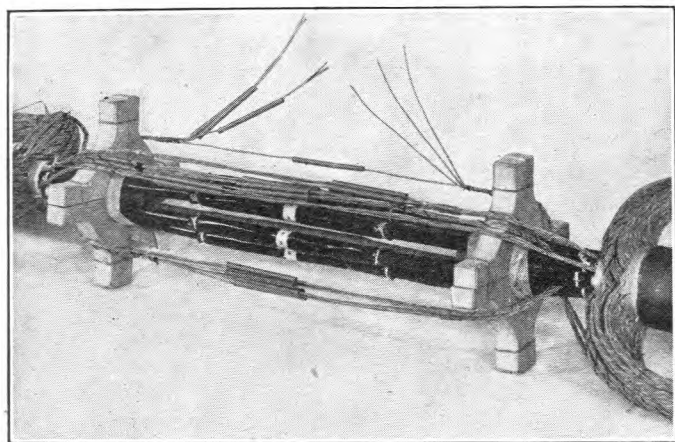

(b) JOINTING P.C. QUADS WITH WOODEN FORMERS IN POSITION.

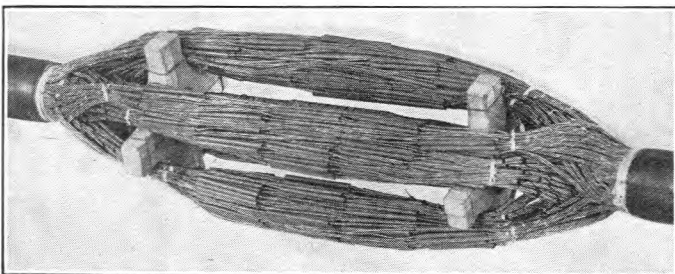

(c) JOINTING P.C. QUADS COMPLETED; WOODEN FORMERS IN POSITION.

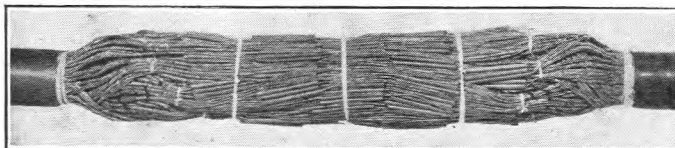

(d) JOINTING COMPLETED, WOODEN FORMERS REMOVED AND P.C. QUADS TIED IN.

FIG. 6.—THE NEW JOINT.

various stages in making a 6 cx. pr. 375+376 pr./20lb. cable joint. The technique was evolved after careful consideration of the following requirements:—

- (a) Easy and adequate access to any one coaxial pair without the need for piecing-out any of the P.C. quads.
- (b) Easy access to all P.C. quads.

- (c) Avoidance of severe setting of coaxial pairs.
- (d) Identification of P.C. quads to be at least as easy as in the present joint.
- (e) The joint to be no bigger than the present barrel type.
- (f) The design of the joint to be such that it can be made under normal jointing conditions.
- (g) The cost of the joint to compare favourably with that of the present type.
- (h) The time taken to make the joint to be no longer than that taken for the present type.

The way in which the new joint is made is described below:—

Jointing the Coaxial Pairs (Fig. 6(a)).

The P.C. quads of each length are folded back, the quads over which the coaxial pairs are laid being passed between adjacent coaxial pairs to bring them into proximity with the layer quads. The coaxial pairs of each length are separated from each other by making them pass over a truncated cone-shaped paxolin former, which is placed so that its narrow end is about 3 inches from the lead sheath. The coaxial pairs are then jointed, and the two formers are left permanently in the joint. It has been the practice, after jointing two coaxial pairs together, to wrap with empire tape the bi-metallic outer conductor jointing ferrule and the portion of the coaxial pairs from which the paper tapes have been removed; the paper tapes are then re-lapped over the empire tape. The empire tape is used to prevent water, which may have entered a coaxial pair in a cable length under fault conditions, from leaking from the coaxial pair at a nearby joint and thence passing into coaxial pairs in the adjacent cable length (the water barrier in the coaxial pair joint prevents direct leakage from one cable length to the next). This wrapping process takes considerable time and it was decided, when making the new joint, to use plastic sheaths over some of the coaxial pairs as an experiment. It is hoped that in the near future it will be possible to make this practice a standard feature of coaxial jointing.

For some years now it has been the practice to joint together similarly numbered coaxial pairs, i.e. Coaxial Pair 1 of one length is jointed to Coaxial Pair 1 of the adjacent length, Coaxial Pair 2 is jointed to Coaxial Pair 2, and so on. This is a good practice, but it sometimes results in the jointed coaxial pairs not being quite in line with the cable within the jointing gap (slight twisting of the cores of the lengths to be jointed is permissible to keep this non-linearity to a minimum). In the photographs the jointed coaxial pairs are exactly in line with the cable sheaths, but the deviations from this ideal met in practice do not in any way interfere with the new jointing technique.

Jointing the Paper-Core Quads (Fig. 6(b) and (c)).

At about 5 inches from each lead sheath a star-shaped wooden former is fixed around the coaxial pairs. Linen binding tape is used to build up the 6 coaxial pair core of the joint so that the formers grip and firmly retain their positions on the coaxial pairs. Each former is made up of four separate segments, and is held together by tying the arms of adjacent segments with string. Interlocking segments have been tried, but the simple design of former shown in the photographs has proved more satisfactory. The quads are passed over the formers and are jointed in the space between them, the jointed quads being parallel to each other and in line with the cable within this space (about 17 inches). As each pair of quads is taken for jointing, the jointer selects a position on the formers to suit both quads as far as possible; this is a matter of compromise as quads to be jointed rarely occupy similar positions relative to the formers ("test selected" and

“systematic” jointing makes it impossible to arrange for similarity of positions). The jointer is also required to arrange that approximately the same number of quads occupy each of the four former positions on completion of jointing. The quads in the cable over which the coaxial pairs are laid are jointed first, and then the layer quads are jointed layer by layer. Quads of the same layer and occupying the same former position are tied together on the lead sheath side of the formers to form separate groups; identification of a particular quad for maintenance purposes is facilitated by this means.

Removing Formers and Completing the Joint (Fig. 6(d)).

The string holding the formers together is cut and the segments are removed separately. The joint is tied and wrapped with paper in accordance with standard practice, and the lead sleeve of the joint is plumbed in position. No increase in the dimensions of the lead sleeve is necessary as the standard 27-in. jointing gap has been retained, and the 5-in. diameter sleeve normally used is amply large enough.

Accessibility of Coaxial Pairs.

Figs. 7 and 8 show the P.C. quads tied back by linen

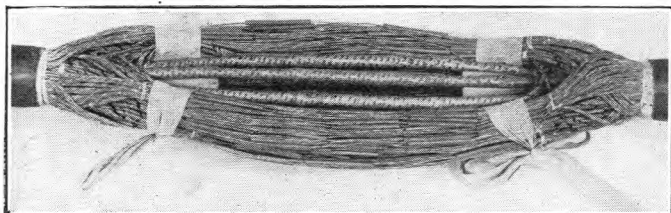

FIG. 7.—NEW JOINT; P.C. QUADS TIED BACK TO OBTAIN ACCESS TO COAXIAL PAIRS.

tapes to give full access to the coaxial pairs; it is interesting to compare these photographs with Fig. 2, which shows the maximum access obtainable with the wooden



FIG. 8.—NEW JOINT; SOLDERING OPERATIONS ON A COAXIAL PAIR.

barrel type of joint. Fig 8 shows the ease with which soldering operations can be carried out on a coaxial pair without the necessity for any piecing-out of the P.C. quads.

Jointing Multi-coaxial-pair Cables, not having Layer P.C. Quads.

The use in joints of the truncated cone-shaped paxolin formers, to separate the coaxial pairs from each other, is recommended also for coaxial cables not having layer P.C. quads. The working space around each coaxial pair, given by the formers, enables the jointer to work with greater ease and speed; on maintenance work speed is important if lost service time is to be kept to a minimum.

Field Trial.

The new joint was used on the Birmingham-Manchester No. 3 Cable when jointing-in the new length required to make a permanent repair of the cable at Stafford, following the temporary repair described earlier in this article. Fig. 9 shows the jointing in progress. No difficulties were

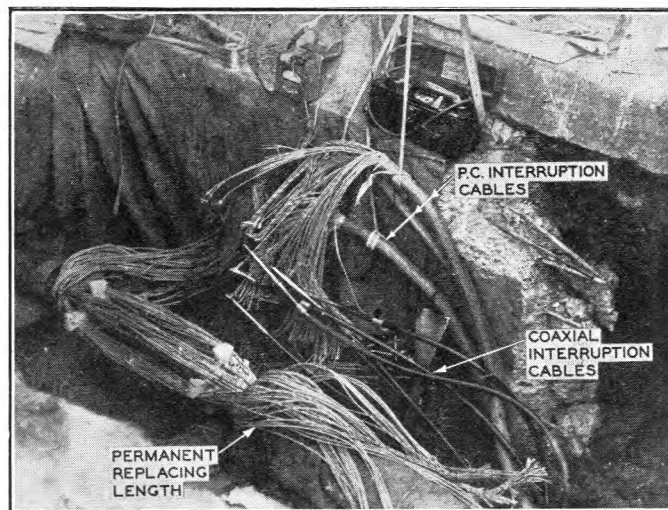

FIG. 9.—THE NEW JOINT IN COURSE OF CONSTRUCTION ON BIRMINGHAM-MANCHESTER No. 3 CABLE.

experienced in applying the new technique.

CONCLUSION

The authors hope that the joint described in this article and recommended for all future composite coaxial cables will lead to a simplification of the jointer's work during cable construction, diversions, and maintenance, and will, in the event of a cable breakdown, facilitate the early restoration of coaxial telephone and television circuits.

ACKNOWLEDGMENTS

The authors wish to express their thanks to Messrs. E. R. Alstin and R. Jones of the External Plant and Protection Branch for their valuable practical work during the design stages of the new joint.

U.D.C. 621.51

This article gives a brief review of a number of the compressor units now available for use on external works. In each case the particular sphere of usefulness is mentioned and details are given of the various pneumatic tools forming part of the unit.

Introduction.

ALTHOUGH it is recognised by engineers that the use of compressed air for the purpose of driving individual tools is less efficient than several other methods, the use of compressed air does offer definite, though small, advantages, both practical and economic, when an overall review of a work is made. The advantages arise primarily from the flexibility, rapidity and ease of application, and the freedom from the need to take special precautions with the leads serving the tools. Thus, the use of compressed air is particularly suited to field work where alternative sources of power may not be available or could only be made available after considerable delay.

Air compressors have been used by the British Post Office on external construction and maintenance works for many years, and this short article reviews the more recently introduced types, indicating the particular field of usefulness, together with the limitations of use, of each type.

The large-capacity compressors are used mainly to serve such pneumatically operated tools as road breakers, hammer drills, clay spades and submersible pumps, and are classified in sizes according to the number of medium-duty road breakers (air consumption approximately 50 c.f.m.) that may be operated simultaneously from one compressor. The air compressors used for this type of work by the British Post Office are in three main divisions, viz., two-tool, self-mobile (i.e. lorry mounted) types; two-tool, trailer-mounted types; and single-tool, trailer-mounted types. In each type a range of tools, etc., is supplied with the machines.

For reasons of standardisation, economy in capital cost, availability of spare parts, etc., the prime-movers (petrol engines) and compressor units are of standard commercial type and hence are not described in detail.

Two-Tool, Self-Mobile Type.

The self-mobile air compressors cater for a large number of disconnected jobs scattered about an area, and provide that extra power which a gang requires for a relatively short period on a specific operation, e.g. breaking through a concrete road to expose a blocked duct or a faulty cable. When such specific operations are completed, the machine may continue to further works, leaving the gang to carry on with their normal operations. The self-mobile units are costly and hence a considerable programme of such works is necessary to warrant the provision of an appliance of this type.

The twin-cylinder compressor is driven by a 32-b.h.p. petrol-engine and operates on the single-stage, sleeve-valve principle, having a piston displacement of 128 c.f.m. and delivering 110 cubic feet of air per minute at 100 lb./sq. in. This method of operation enables reasonably cool air to be supplied via a simple after-cooler to a $4\frac{3}{4}$ -c.f. air receiver, where further cooling takes place and permits the air to be delivered to the tools at a temperature not exceeding 50°F above the ambient temperature.

Each self-mobile air compressor (Fig. 1) is supplied with a tool equipment comprising two medium-duty road breakers, two hand hammer-drills (i.e. rock drills), two clay spades, two rammers (punners), 24 pick steels with moil points, four pick steels with chisel points, 12 drill rods of differing lengths, four asphalt cutters, 24 detachable rip bits, four 50-ft. lengths of heavy-duty air hose, two 10-ft. lengths of light-duty air hose (for use as "tails" for increased



FIG. 1.—SELF-MOBILE AIR-COMPRESSOR AND TOOL EQUIPMENT.

flexibility when using the smaller tools) and the necessary nipples to enable the tools to be used in combination when so desired.

Two of the long lengths of hose are accommodated on reels mounted one on each side at the rear of the unit and within the canopy (see Fig. 2). The two reels are of the live-

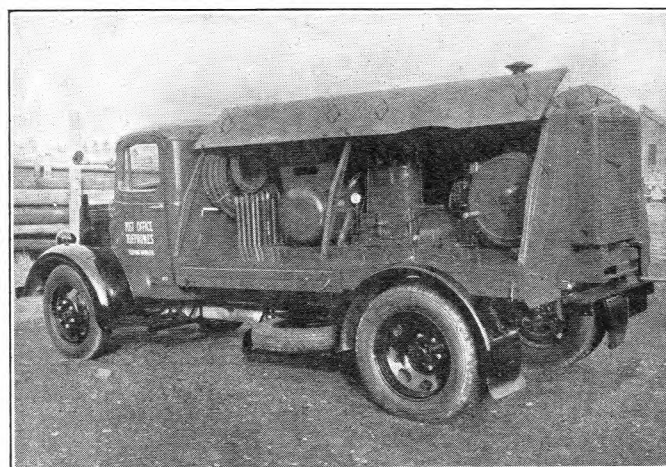

FIG. 2.—SELF-MOBILE AIR-COMPRESSOR WITH SIDE CANOPY OPEN.

centre type, i.e. compressed air is delivered to the centre of each reel and available in the hose without further connections being made. The hoses may be drawn out through apertures in the rear of the unit and are thus ready for use immediately the particular tool has been connected. A total of four air-delivery cocks is provided, in addition to those for the above-mentioned hoses, to enable a multiplicity of smaller tools to be used simultaneously when required. For this purpose, the size of all connections on the hoses, tools, etc., have been standardised at $\frac{3}{4}$ in. B.S.P.

The tools are accommodated in compartments on each side of the unit, while the associated cutting tools, steels, etc., are located transversely across the front of the compressor unit. The tool compartments (Fig. 3) are provided with lids to keep out rain when the appliance is used in such conditions and the canopy sides are necessarily open for the effective cooling of the plant. Operating and day-to-day maintenance instructions are provided in a pocket in one of the compartments.

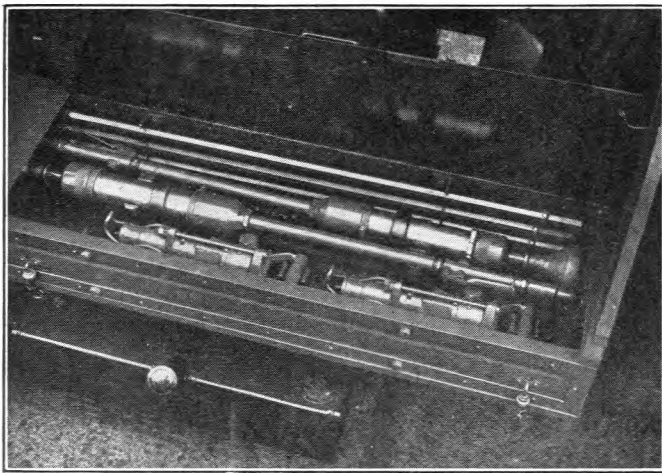

FIG. 3.—TYPICAL TOOL ACCOMMODATION.

The self-mobile units were produced in accordance with a Post Office specification and it is believed that they are the only British-made machines to incorporate live-centre hose reels and certain other points of detail.

Two-Tool Trailer Type.

When much heavy work has to be performed, requiring a considerable amount of time, the two-tool trailer-type machine is employed. As the unit is trailer-mounted and relatively light in weight (approximately 30 cwt.), it may be towed by the vehicle transporting the gang and their equipment and retained by the gang for the duration of the work. The appliance thus provides a suitable means of bringing power to the gang's operations, and eliminates the slow alternative manual methods.



FIG. 4.—TWO-TOOL TRAILER AIR-COMPRESSOR AND TOOL EQUIPMENT.

The two-tool trailer-type air compressor is shown in Fig. 4 and is of the type frequently seen in use by public works contractors on road repairs, etc. The prime mover and air compressor unit are the same type as provided on the lorry-mounted air compressors, as also is the range of tool equipment, but the different kind of work for which these units cater is generally such as not to warrant the provision of special tool accommodation or live-centre hose reels on the trailer type; consequently, the tools are normally transported in the gang's vehicle. In this type, the side panels are removed entirely when the machine is working, to give adequate cooling to the power units (see Fig. 5).

Oil-lamp brackets are fitted in addition to the normal electric rear-lamp to cater for conditions that arise on breakdown work on public roads.

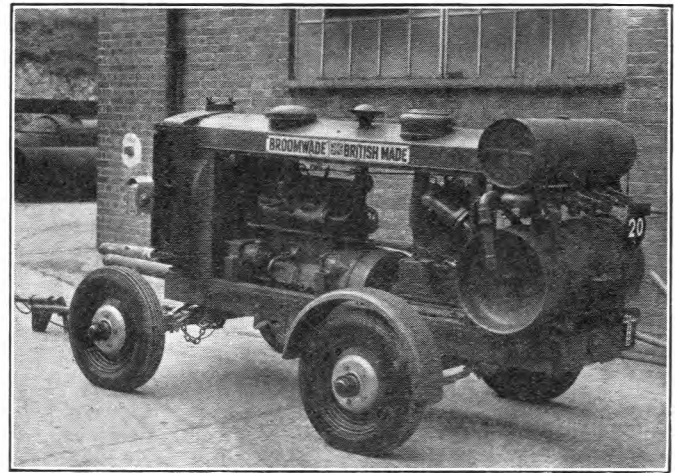

FIG. 5.—TWO-TOOL TRAILER AIR-COMPRESSOR WITH SIDE PANELS REMOVED.

Single-Tool Trailer Type.

This type of trailer-mounted air-compressor is a recent innovation, and meets a considerable need for a compact, yet powerful, tool that may be towed by a gang vehicle and used in urban and rural areas on scattered works. It also caters for the area wherein the volume of heavy work is not sufficient to warrant the provision of either of the foregoing types of machine. The unit is produced in accordance with a Post Office specification, and it is perhaps of interest to mention that the particular manufacturers concerned have now adopted the final arrangements as an addition to their standard commercial range.

Each unit is supplied with a range of tools (see Fig. 6) designed to suit the work undertaken by the users, consisting of one road-breaker, hand hammer-drill and clay-spade together with steels, drill-rods, rip-bits and hoses. This tool equipment is accommodated down either side of the main unit, while the two 25-ft. lengths of heavy-duty air hose are located transversely across the front of the unit, as may be seen from Figs. 7 and 8.

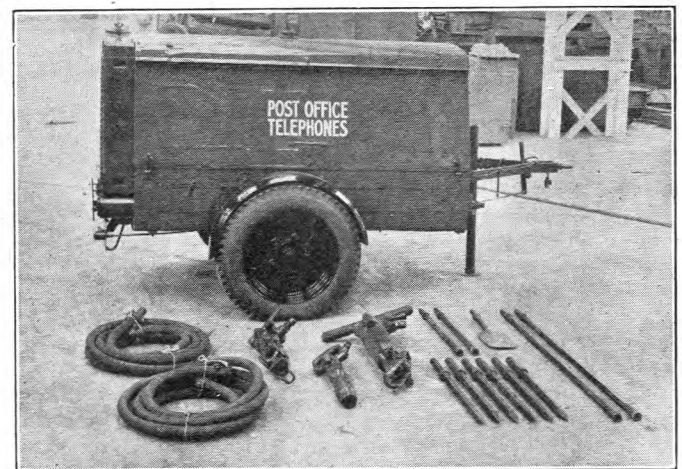

FIG. 6.—SINGLE-TOOL TRAILER AIR-COMPRESSOR AND TOOL EQUIPMENT.

The 24-b.h.p. Standard four-cylinder petrol-engine drives, via a centrifugal clutch, a twin-cylinder, water-cooled, single-stage, sleeve-valve-type compressor having a piston displacement of 78 c.f.m. and delivering 60 cubic feet of air per minute at a pressure of 100 lb./sq. in.

The use of 4-in. diameter steam-quality tubing for the dual purpose of providing the principal trailer-chassis members and also a tubular air receiver greatly assists in maintaining the unit as compact as practicable. The length of

the unit is only 8 ft. 6 in. including the towing bar, and the overall width is 4 ft. 1 in. Although the unladen weight for such a compact unit is considerable (approximately 17 cwt.), careful location of the road wheels and springs has permitted a good balance to be achieved (within the limits imposed by variations due to the presence or absence of items of the tool equipment) for ease of manhandling whenever this is necessary.

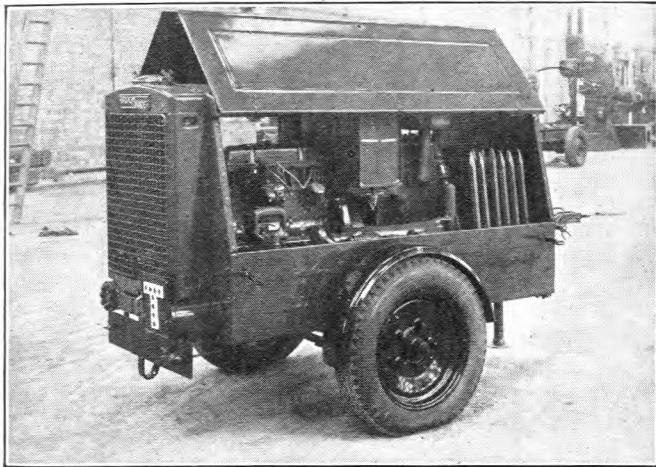

FIG. 7.—SINGLE-TOOL TRAILER AIR-COMPRESSOR; SHOWING AIR-RECEIVER/CHASSIS COMBINATION AND TOOL ACCOMMODATION.

Portable Paint-spraying Outfits.

The portable paint-spraying outfits complete the range of air-compressors used on external works and are provided for use where an appreciable amount of painting work is to be carried out. Similar portable outfits driven by an electric motor are also provided for use in workshops.

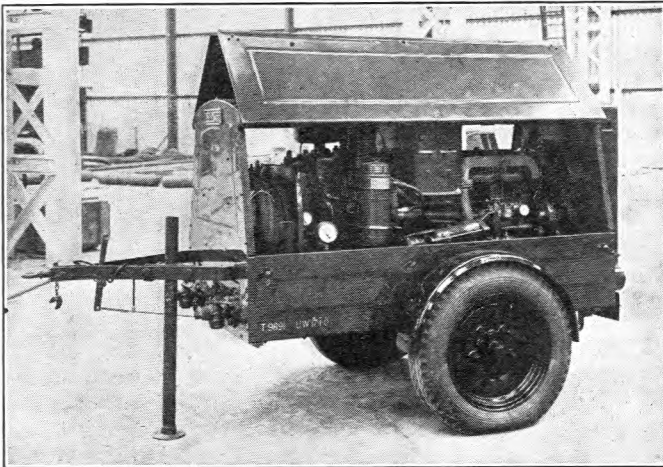

FIG. 8.—SINGLE-TOOL TRAILER AIR-COMPRESSOR; SHOWING AIR-DELIVERY COCKS AND ACCOMMODATION FOR EQUIPMENT.

The air-compressor is designed to supply two full-sized spray-guns operating intermittently or a single spray-gun operating continuously with any type of paint generally used. The single-stage compressor has two cylinders set at 90° giving a total piston displacement of 10 c.f.m. at the normal running speed (880 r.p.m.) and delivering 6.8 c.f.m. at 100 lb./sq. in.

The normal practice employed for air compressors is followed, the air being cleaned before it is compressed and

discharged to a 8½-gallon air receiver. The compressed air is supplied to the guns via a purifier consisting of a reducing valve, a filter, condensation chamber and a separator or rectifier, to enable all undesirable elements, oil, water, etc., to be removed and also to enable the pressure to be varied according to the type of paint being used. Since the pressure required for most types of paint does not exceed approximately 75 lb./sq. in., an automatic unloader is fitted to reduce the speed of the prime mover when this pressure is reached in the air receiver, and to speed up the prime mover when the pressure falls below 60 lb./sq. in. The prime movers in the outfits used on external works are industrial type, air-cooled petrol engines of 2 h.p. and drive the compressors by means of "V" belts.

The equipment supplied with each unit is accommodated (see Fig. 9) within a folding wire-mesh enclosure to ensure that the numerous accessories are not lost in transit, as well as to provide protection against accidents in the vicinity of the belt drive. The equipment supplied with each petrol-engine-driven set includes two paint guns of the siphon/pressure type, two 30-ft. lengths of air hose, four 1-pint paint cups to facilitate rapid changes of colour, tools, gun cleaning kit and operating instructions.

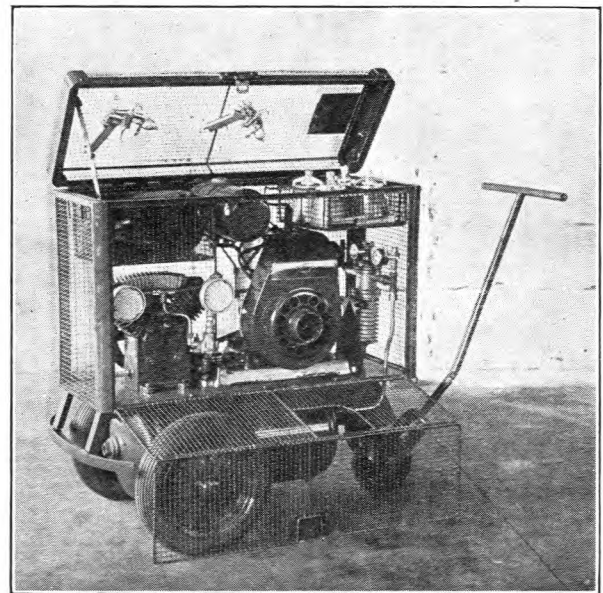

FIG. 9.—PAINT-SPRAYING OUTFIT.

The guns supplied are of lightweight construction (18 ozs.) to reduce fatigue and are fitted with a combination of nozzle, air-cap and needle-size suitable for general-purpose duties. This combination is not, however, suitable for use with cellulose-base paints and such use is discouraged on account of the fume and explosion risks. Manipulation of the controls on each gun enables the operator to work with a small-diameter fine spray, a wide cone-shaped spray or intermediate shapes, according to the need of the work.

The provision of fairly large rubber-tyred wheels, castor wheel and towing bar enables the sets to be readily manœuvred despite their weight (approximately 3½ cwt.).

Although these sets are intended primarily for the application of paint, they are also suitable for the operation of a considerable range of small pneumatically operated hand tools associated with painting work, e.g. paint scrapers, small chipping hammers, etc.

The Public Utilities Street Works Act, 1950

E. A. PAGE †

U.D.C. 351.712

This article first gives a brief historical survey of the legislation covering street-breaking by statutory undertakers with an outline of the considerations leading to the Public Utilities Street Works Act of 1950. The main provisions of the new Act are then explained in simple terms and an indication given of the manner in which these provisions affect the Post Office in its external plant operations.

Introduction.

THE Public Utilities Street Works Act is an Act providing a comprehensive code of procedure for the breaking-up of streets by statutory undertakers, e.g. gas and electricity boards, water undertakings and the Post Office. It also regulates the circumstances arising when undertakers' apparatus is affected by road works, bridge alterations and the like. It applies equally to Government Departments where they operate in the capacity of statutory undertakers (i.e. the Post Office) or as highway authorities (i.e. the Ministry of Transport for trunk roads), and supercedes the corresponding provisions in the many public general Acts and some thousands of private Acts and Orders dealing with undertakers' and highway authorities' works in streets and roads. Agreements governing the exercise of such powers so far as they are inconsistent with the street works code are also invalidated, with the exception of those relating to reinstatement. The Act applies to Great Britain, but not to Northern Ireland, the Isle of Man and the Channel Islands, and for most purposes came into effect on the 26th April, 1951.

Historical Survey.

It had long been recognised that the existing legislation dealing with the breaking-up of streets by statutory undertakers, based largely on Acts over a hundred years old, was, in many respects, inadequate. Advances in the science of road engineering, the growth of road traffic and the development of public utility services had given rise to problems in the relations of statutory undertakers and highway authorities which were not provided for by existing legislation. Considerable diversity also existed between the statutory powers of the different undertakers; the gas and water undertakers, for example, usually having the right, not always exercised, however, to carry out the reinstatement of the disturbed surface themselves, whilst for electricity undertakers and the Post Office the highway authorities could elect to do so. Water, gas and electricity undertakers also had, in general, statutory powers to break open all streets, whether public or private, but the Post Office only had the right to break open public roads.

In 1925, therefore, a Negotiating Committee, consisting of representatives of the various local authorities' associations and the Conjoint Conference of Public Utility Associations representing water, gas and electricity interests, was formed to work out a scheme to regulate the mutual rights and liabilities of the parties concerned. The Negotiating Committee had no power to bind their constituents, but were merely required to arrive at an agreement which could be submitted to the participating associations. Successive drafts of a clause were produced, after prolonged discussions, in 1926, 1928, 1934 and again in 1938 when a final draft was prepared, but none was found acceptable to all parties, the most contentious point by far being the apportionment of the cost of removal or alteration to undertakers' plant rendered necessary by an alteration of the highway. The Post Office was not represented on the Negotiating Committee, but it is of interest to note at this point that, in 1933, it had concluded its own

agreement for the reinstatement of Post Office trenches with the Institution of Municipal and County Engineers, one of the bodies represented on the Committee, and this document has formed the basis of the Department's agreements with the great majority of highway authorities ever since.

Early in 1939, however, a Joint Committee of the House of Lords and the House of Commons, under the chairmanship of Lord Carnock, was formed to consider the various water, gas and electricity Acts involving the breaking-up of streets and to report what modifications were necessary to meet modern conditions. The Negotiating Committee's Clause of 1938 was taken as the basis for consideration and evidence was heard from the parties concerned. The chief point at issue again became the cost of alteration of undertakers' apparatus due to road works. The undertakers argued, on the one hand, that, as they had been authorised by Parliament to lay their apparatus under roads as the only practicable means by which they could carry out their obligations to supply certain necessities of life, it would be unfair to them and their consumers to have to bear the cost of alterations to their plant made necessary by works in the interests of road traffic. The highway authorities, on the other hand, contended that the laying of apparatus under their highways was forced upon them without option and that they ought not to be called upon to bear the additional expense because an alteration of the highway necessitated also an alteration of apparatus in the placing of which they had no choice. On the broad principle, however, that whoever initiated road works requiring an alteration to undertakers' apparatus should bear the cost of such alteration, the Committee finally proposed that the cost of removal or alteration of apparatus made necessary by road improvements should be borne by the highway authority. The Carnock Committee issued a report in the same year, giving their recommendations and detailing the proceedings of the Committee, but owing to the outbreak of the war, further action was suspended. In 1947, however, the matter was revived again when the Post Office and other bodies concerned were asked to give their views on the report, and in 1949 a Bill was drafted, substantially in line with the Carnock Committee's report, which reached Parliament early the following year. It was considered first in the House of Lords and then in the House of Commons, and was finally passed, without any drastic alteration, in the Autumn Session of 1950.

Main Provisions of the Act.

The Act is in four parts. Part I (Sections 3 to 14 and the First, Second and Third Schedules) contains what is described as the street works code, which sets out the procedure regulating the breaking-up of streets by statutory undertakers. The code reproduces the main features of existing codes in the principal Acts governing the operations of statutory undertakers. Undertakers are required to settle plans and sections of their proposed street works (except in most cases of service and overhead telegraphic lines and certain other small works) with those responsible for the street concerned; and if the works are to be done in a street going over or under a bridge or crossing a transport system

† Higher Executive Officer, External Plant and Protection Branch, E.-in-C.'s Office.

(such as a railway or canal), or interfere with a public sewer, they must also settle plans and sections with the bridge, transport or sewer authority, respectively. They must give seven days' notice of the commencement of such works to the street or other authority, and three days' notice for service lines, etc. Special provision is made for emergency works, the submission of plans and sections and notices of commencement being permitted as soon as is reasonably practicable in such cases. Undertakers are required to go about their works in a reasonable way so as to mitigate interference with road traffic and safeguard the public, and interested parties are given the opportunity to supervise works touching their interests. The code also contains three important provisions:—

(1) Street authorities are given the right with all undertakers' works (except most service and overhead telegraphic line works) of carrying out the final reinstatement if they so elect at the expense of the undertakers concerned, but the undertakers are permitted to carry out the temporary restoration up to surface level and the street authority may not disturb this filling-in within 12 in. of the undertaker's plant unless otherwise agreed by the respective parties.

(2) Street authorities can require, in appropriate cases, that the apparatus be laid in controlled land, that is unbuilt-on land alongside a highway which has been earmarked for the eventual widening of the road, instead of in the road itself. This is an important departure from existing codes and is designed to ensure that undertakers' apparatus is laid where it will interfere least with road improvements.

(3) Transport authorities, in view of the peculiar susceptibilities of their systems to damage or danger, may themselves elect to carry out such breaking-up and reinstatement in streets crossing their systems by bridge or otherwise, as the undertaker is permitted to do, at the latter's expense.

With the exception, however, of the second provision mentioned, which extends undertakers' powers in certain circumstances to laying apparatus in land abutting on a road, the street works code in no way increases or extends undertakers' statutory powers to lay apparatus in, or break-up, streets.

Part II (and the Fourth Schedule) of the Act deals with the circumstances arising when it is necessary to move or alter undertakers' apparatus owing to street or bridge alterations, or transport works. As already indicated, this situation had always given rise to a good deal of dispute between undertakers, highway authorities and others, since, apart from the Telegraph Acts which required the Post Office to meet the cost of any removal of their plant consequent on an alteration in the line or level of a road, general legislation had little to say on the point. The Act, however, now lays down that, with certain exceptions, when road or bridge alterations make it necessary for undertakers to move or alter their apparatus, the cost of moving or altering the undertakers' apparatus shall, in these circumstances, fall on the party carrying out the road or bridge alterations or transport works. This was one of the cardinal recommendations made by the Carnock Committee after very full consideration, but the exceptions mentioned are of importance. The first is that where an undertaker's plant has to be altered because of street, bridge or transport works made necessary by subsidence for which the authority concerned is not to blame, e.g. in a mining area, the undertaker cannot claim the cost of alteration from the authority. In the second case it has usually happened in the past that when undertakers came to lay apparatus in a street and knew of any works a street, transport or bridge authority intended to carry out, they placed their apparatus in such a

position as to offset the effects on that apparatus of the proposed works, e.g. by laying it along a different line or at a different depth. The Act endorses this procedure, laying down that if at the time an undertaker submits a plan and section (or notice, where a plan and section is not required) of a proposed work, the street or other authority gives notice and serves a plan and section of impending street or other works which may affect the apparatus, the authority shall be relieved of the liability to pay for any alterations which may then prove necessary to the apparatus if they carry out such works within two years (or up to four years if such extension be subsequently authorised by the Ministry of Transport). The last exception provides for the situation arising when undertakers whose apparatus needs to be altered owing to an authority's works take the opportunity to carry out improvements to their apparatus or are enabled to replace apparatus nearing the end of its useful life. In such cases the costs to be met by the promoting authority are reduced by an amount which represents the benefit accruing to the undertakers. Where, however, the undertaker has to substitute apparatus of greater length than that which has to be moved because of the promoting authority's works or to provide some addition, such as a jointing chamber, the promoting authority has to meet the cost of the additional work.

Part III deals with a number of matters arising from the preceding Parts. One important section provides a code for the mutual protection of undertakers when the operations of one undertaker are likely to affect the apparatus of other undertakers in the same street, requiring, amongst other things, that operating undertakers shall not begin such works (other than those relating to service or overhead telegraphic lines) until they have given due notice of their nature and place to the other undertakers. Operating undertakers are required to comply with the reasonable requirements of owning undertakers for the protection of the latter's apparatus and to meet the cost of making good any damage which occurs.

Another section deals with the restriction of traffic which may be rendered necessary by undertakers' works and the liability of the undertakers for meeting the cost of use of alternative routes, whilst a third section, of considerable importance in view of public reactions on the point, restricts the right of undertakers to break up maintainable highways during the twelve months following the closing of a substantial part of the highway for the execution of road works or resurfacing. The section does not apply to service and overhead telegraphic lines in a part of the highway other than in the carriageway, and provision is made for works in satisfaction of an enactment or agreement already made.

Part IV of the Act deals with questions of procedure. On that of arbitration (for which provision is made in the previous Parts when undertakers and street, etc., authorities are unable to reach agreement on, say, plans and sections or reinstatement requirements), it is laid down that a single arbitrator shall be appointed by agreement between the parties concerned or, in default of agreement, by the President of the Institution of Civil Engineers. The application of the Act to London and Scotland, where special circumstances arise on certain points, is also dealt with. It is of interest to note with regard to London that the street authorities may elect to reinstate in all cases of service and overhead telegraphic lines as well as other works, and that in Scotland, appointment of an arbitrator in default of agreement is made by the Sheriff. For the purposes of the Act, the limitation of a service pipe or line to a length of not more than 100 yds. is laid down, and definitions of the expressions used in the Act are also given. A street, for example, is defined as "any length of a highway (other than a waterway), road, lane, footway, alley or passage, any

square or court and any length of land laid out as a way, whether it is for the time being formed as a way or not, irrespective of whether the highway, road or other thing in question is a thoroughfare or not"—a reasonably comprehensive definition!

Effect on the Post Office.

So far as the Post Office is concerned, whilst the Act does not affect in any way the powers of the P.M.G. under the Telegraph Acts to place telegraphic lines in streets, it does regulate the exercise of those powers in the actual work of constructing overhead and underground lines in streets (the serving of road-opening notices, reinstatement, guarding and lighting, etc.). The Telegraph Acts, which have provided the sole authority for such works for nearly 90 years, have undergone* surprisingly little alteration, confined, apart from a few small amendments, to the cessation of Sections 10, 15 and 17-20 of the Act of 1863 and, so far as works covered by the new Act are concerned, Section 4 of the Act of 1916. It is indeed a tribute to the skill of the drafters of the 1863 Act in particular that so much of it remains to the present day. Consents are still necessary for all overhead plant, except when placed in controlled land under the authorisation of a street authority and for underground plant, in unadopted roads in urban districts. A point of note, however, is that when overhead plant is so placed in controlled land the P.M.G.'s flying wire powers in respect of it remain unaffected. Plans and sections which have now to be furnished to the street authority for all underground plant (other than service lines) to be laid in adopted streets replace the consent procedure for such plant (including settlement of depth, course and position), but it was stressed during the proceedings in Parliament that they should be kept as informal and simple as possible. The work may not, however, be carried out within 12 months of the closing of a substantial part of the highway for road works or resurfacing, save in certain cases.

A major change has taken place with regard to the removal or alteration of Post Office plant resulting from street authorities' works. Under the Telegraph Acts the

Post Office was required to meet the cost of such removal if an alteration in the line or level of the road was involved. The position is now reversed, although it must be borne in mind that the street authority is required to meet only the cost of removal or alteration actually attributable to the plant in situ and that the extent to which the Post Office may benefit by introducing new plant must be allowed for in assessing the costs of the work. Other points of difference are that, whereas formerly the Post Office was required to give the electricity authorities courtesy notice only of projected works and gas and water authorities notice only when alteration to their pipes was likely to be involved, notice now has to be given under the Act wherever other undertakers' plant is likely to be affected. Similarly, other undertakers now have to give the Post Office notice of their works. Also under the Telegraph Acts, highway authorities had the right, although rarely exercised, of carrying out the entire temporary restoration of the trench in addition to the permanent reinstatement, whilst at the same time they could only supervise the actual opening or breaking up of the highway. The position in both cases has now been clarified.

Conclusion.

Some months' operation of the Public Utilities Street Works Act has now been experienced and there has been marked evidence of a desire on the part of the bodies concerned to get the Act working as smoothly as possible. Frequently street authorities have sought a continuation of existing arrangements, whilst on other occasions they have initiated round-table conferences with the undertakers and arrived at reinstatement conditions acceptable to all parties. In a few cases which are proving difficult of solution, it seems, nevertheless, to be agreed that if possible arbitration should be avoided, and with a little give and take on both sides, satisfactory solutions will, no doubt, be found. It is felt, indeed, that much of the value of the Act lies in its emphasis on a reasonable interpretation of its provisions by all concerned.

Transatlantic Telephone Service—Commemoration of Notable Anniversary

U.D.C. 621.396.5: 061.75

MONDAY, the 7th of January, 1952, was the 25th anniversary of the opening of the first commercial radiotelephone service across the Atlantic, which opened in 1927 between London and New York, and the anniversary was marked by an exchange of greetings between Mr. C. F. Craig, President of the American Telephone and Telegraph Company, and Sir Alexander Little, Director-General of the Post Office.

An interesting link with the ceremony of 25 years ago was provided when Mr. Walter S. Gifford, the present U.S. Ambassador in London—who as President of the American Telephone and Telegraph Company at that time made the inaugural call to Sir Evelyn Murray, Secretary to the Post Office—also spoke from the United States to Lord Salisbury, Lord Privy Seal and Leader of the House of Lords.

The opening ceremony was not the first occasion on which a telephone conversation took place across the Atlantic. Speech had been passed from Arlington to Paris in 1915 but the first two-way conversation took place at 4.0 a.m. on Sunday, the 7th February, 1926, from the main transmitting room at the Rugby Radio Station¹. The speech from New York was received at a special receiving station built by the Post Office at Wroughton, near Swindon, where Mr. F. E. Nancarrow was officiating, and was passed

by underground cable through London to Rugby. Speech to New York was from a microphone working directly into the long-wave single-sideband sender at the Rugby Station. A 4-wire circuit was provided throughout as at that time the terminal voice-operated devices, necessary for two-wire working, had not been completed. Ionospheric conditions at the time were very favourable and the quality of the speech in both directions was clear and free from distortion, the voices of the individual speakers being easily recognisable. Those present included Mr. Proctor Wilson of the Western Electric Company, Messrs. Oswald and Knettles, on loan to that Company from the Bell Telephone Laboratories, Mr. C. O. Horn, the Assistant Engineer-in-Charge of the Station, the writer and other members of the Station staff and Sir George Lee who was at that time Staff Engineer in charge of the Radio Section at Headquarters.

The Post Office now operates ten or twelve direct radiotelephone circuits to New York and many other circuits to 27 overseas points through which telephone subscribers in the United Kingdom can be placed in telephone communication with some 75 extra-European countries. Some 4,000 long-distance radiotelephone calls are now dealt with each week at the International Exchange in Wood Street in the City of London, and of these about 1,700 are with the United States of America and Canada. H. F.

⁽¹⁾ *P.O.E.E.J.*, Vol. 19, p. 74.

A Postal Order Printing and Issuing Machine

P. G. S. CHICK, Grad.I.E.E. †

U.D.C. 683: 681.6

This article describes a machine for printing and issuing postal orders at Post Office counters. The advantages of using the machine are stated and a description is given of some of the more important mechanical features.

Introduction.

As a further step towards mechanising the work at Post Office counters, experiments are being carried out with an electrically driven machine (as far as is known the first of its kind in the world) for printing and issuing postal orders on demand. The machine is used with special postal order forms which are made up in strips of 1,000, perforated between orders for easy detachment, and fanfolded together to form packs. All the standard information carried on a postal order is pre-printed (in brown) on the form. The machine completes the postal order by printing, in black ink, the value of the order, the poundage, the date, the name of the issuing office and a code letter which can be used to identify the counter clerk operating the machine.

A postal order of any value from 6d. to 21s. 11d. in penny steps can be printed by depression of the "issue" lever, after setting the shillings and pence values. The value of the postal order is printed in words and figures on the postal order and, in figures only, on the counterfoil. To prevent fraudulent alterations to the value, the printing is of the machine cheque-writing type in which the figures and words are built up of short, horizontal lines which actually perforate the paper. A typical machine-issued postal order is shown in Fig. 1.

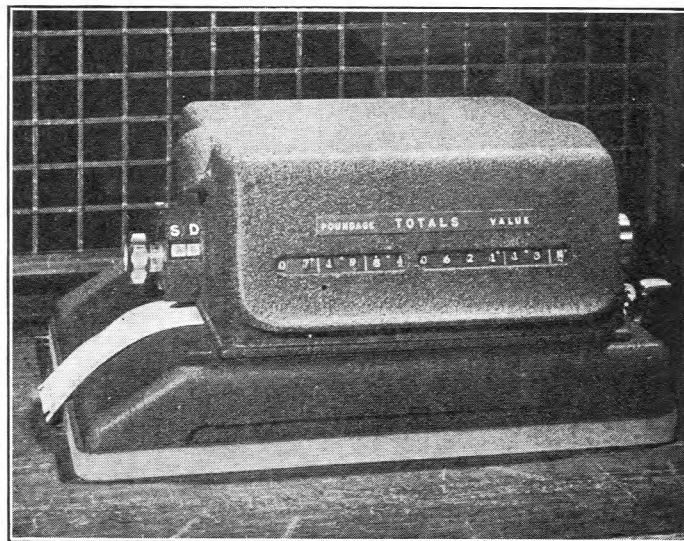

FIG. 2.—THE MACHINE IN PLACE IN A POST OFFICE COUNTER.

The poundage which is, at present, 1d., 1½d. or 2d., according to the value of the postal order, is changed automatically by an arrangement of cams inside the machine.

Separate running totals of the value of postal orders issued and of the poundage are indicated by meters at the front of the machine, check meters also being provided inside the machine. Another meter records the total number of postal orders issued. A purple line is printed on all orders for 10s. or over, to facilitate the sorting of the orders after payment has been made.

A barrel lock is fitted at the front of the machine (see Fig. 3) to prevent unauthorised access to the interior of the machine or to the paper compartment.

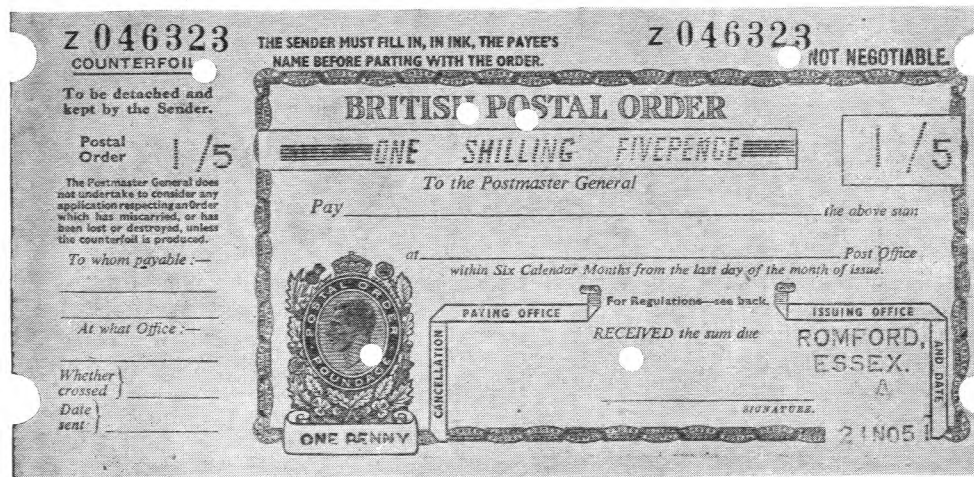

FIG. 1.—A MACHINE-ISSUED POSTAL ORDER.

General Features.

For convenience of operation the machine is partly sunk into the top of the counter (Fig. 2), a removable flap being provided in the counter to enable the counter clerk to get to the paper compartment when loading the machine. The operator sets up the value of the postal order required by means of the shillings and pence knobs at the left- and right-hand sides, respectively, of the machine. The value is indicated by the engraved drums adjacent to the shillings knob. The operator then presses the operating lever at the right-hand side. The completely-printed postal order is delivered at the left-hand side, the operation of the machine taking about 2½ sec. from the instant of pressing the operating lever. The postal order, complete with the counterfoil, is then torn off by hand and given to the customer.

DESCRIPTION OF MACHINE AND OUTLINE OF OPERATION

The machine is made in two sections. The upper section, which contains the dies and meters, can be tilted back and held in position by a strut when the machine is unlocked for loading (Fig. 3), re-inking or when changing the date. This section can also be easily removed for maintenance. The upper and lower sections with their covers removed are shown in Figs. 4 and 5. The upper section has four locating stubs which engage accurately with four locating forks in the lower section when in position.

When the operating lever is pressed, the motor switch closes, the clutch engages and the paper carriage, on which the inking rollers are supported (see Fig. 5), moves to the back of the machine to allow ink to be transferred from the rollers to the dies in the upper section; the carriage then returns to the normal position (as in Fig. 5). Next, the two

† Executive Engineer, Power Branch, Engineer-in-Chief's Office.

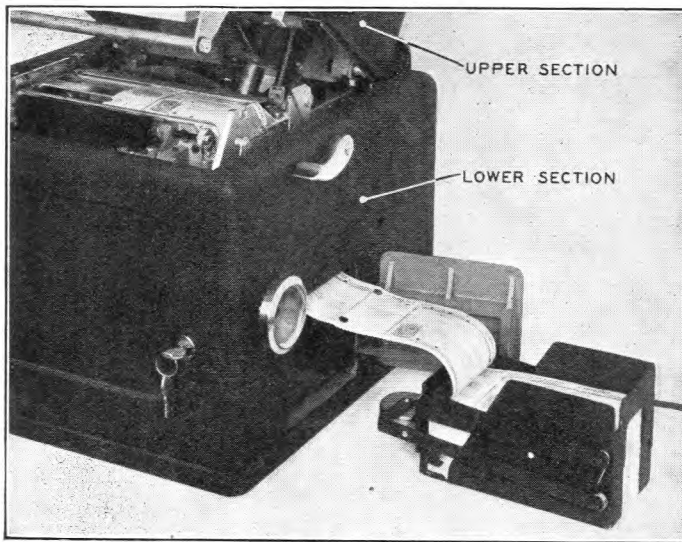

FIG. 3.—MACHINE OPENED FOR LOADING.

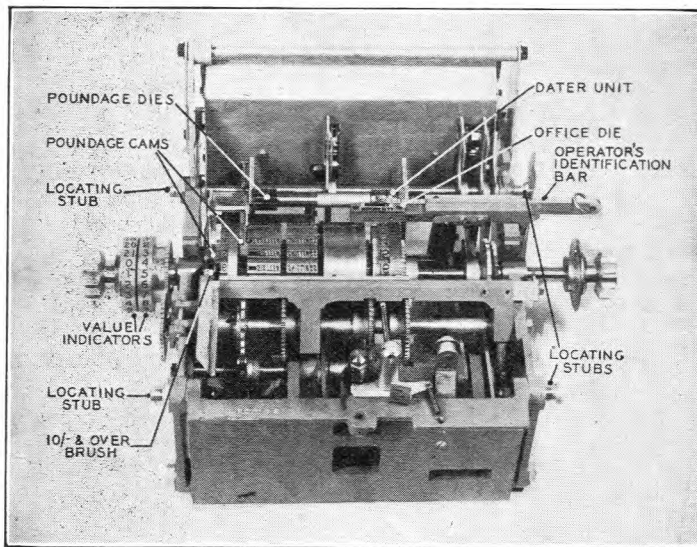

FIG. 4.—UPPER SECTION WITH COVER REMOVED.

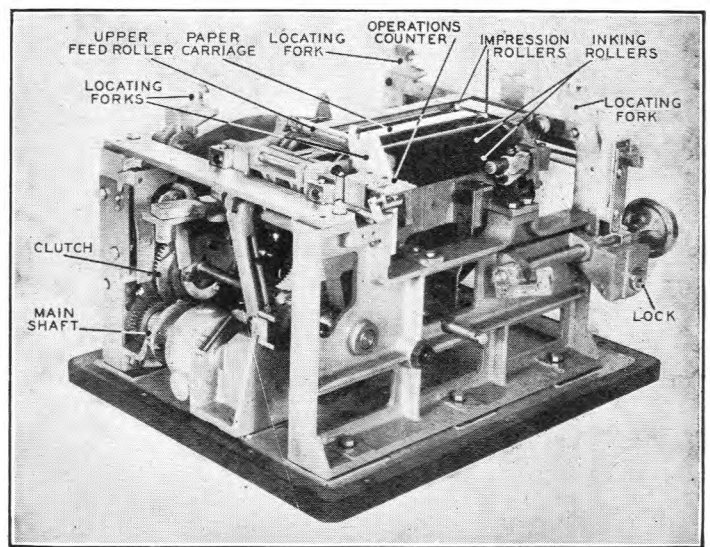

FIG. 5.—LOWER SECTION WITH COVER REMOVED.

impression rollers are driven by an arrangement of levers and cams from right to left underneath the paper, pressing it up against the inked dies. The impression roller which is used to print the cheque-written value has circumferential ridges which mate in similarly spaced grooves in the value dies. The second impression roller is of rubber and this, in conjunction with other dies, prints the date, poundage, office name and identification letter. After printing, the impression rollers are lowered and moved back to their original positions at the right-hand end of the paper carriage. At the same time, the feed rollers rotate, feeding the printed order and counterfoil out of the left-hand end of the machine ready for detaching. The recording of the poundage and value takes place during the printing and issuing stages. Finally, at the end of the cycle, the clutch disengages and the motor switch opens.

The machine is driven through reduction gears by a 1/40 h.p. motor mounted on anti-vibration supports. A handle is provided for manual operation in the event of a mains failure, and for use when testing.

Paper Feed.

The machine is required to print the value, poundage, etc., in the spaces provided on the partly pre-printed forms with a tolerance of $\frac{1}{32}$ in. in any direction. The positioning

of the paper relative to the dies is achieved in the vertical direction by the provision of guides for the upper and lower edges of the paper. In the horizontal direction the positioning is carried out by the arrangement shown in Fig. 6. The upper pressure roller, which holds the paper down against the lower feed rollers, has been omitted in the figure.

Assuming that the first form has just been printed by the machine, the lower feed rollers will rotate, pushing it to the left and drawing the second form into the printing position. The forms will continue to be fed until the positioning holes between the first and second forms reach the feed rollers. At this stage there is no paper between the thin portion of the lower feed rollers and the upper feed roller and the paper, therefore, comes to rest. It remains at rest with the rollers still rotating until the wide shoulders, shown on the periphery of the rollers, pick up on either side of the holes. After feeding the forms forward an additional $\frac{1}{8}$ in., the machine stops. The first form may be detached and the second form is ready for printing.

It will be seen that the position of the second form is determined by the position of the holes between the forms,

and, since the holes are punched at the same time as the pre-printing is carried out, the correct position of the printing spaces relative to the dies is ensured.

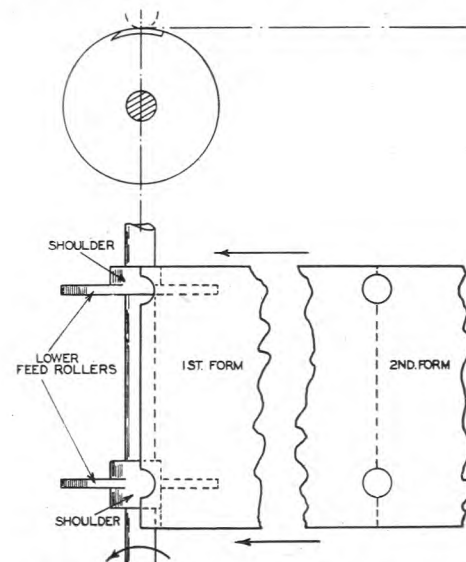

FIG. 6.—THE PAPER-FEED ARRANGEMENT.

"10s. and Over" Device.

A felt brush (Fig. 4) connected to a reservoir of purple ink is contained in the upper section of the machine, with the tip of the brush just clear of the top edge of the paper. When the value is set at 10s. or over, and the machine is operated, the brush is lowered by means of a cam on the shillings die shaft so that it rests on the paper. The feed rollers rotate and draw the paper against the brush, leaving a purple line along the top edge of the issued order. Towards the end of the cycle the brush is raised by means of a second cam.

Value Selection and Recording.

The shillings and pence value setting knobs are connected to the value printing drums by means of concentric shafts, carrying stepped cams which form part of the value recording and poundage control mechanisms. Fig. 7 shows the pence recording mechanism with the stepped cam in the

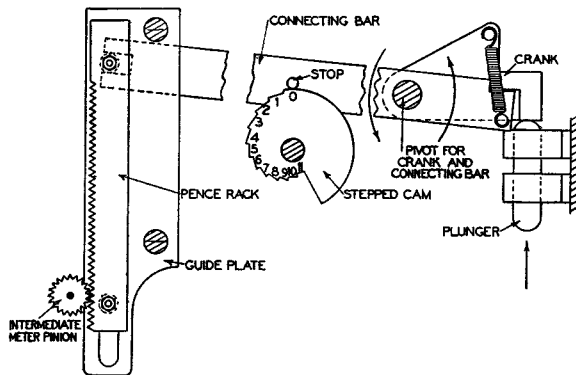

FIG. 7.—THE PENCE RECORDING MECHANISM.

position taken when the pence setting knob is at zero. When the machine is operated, the plunger is pushed upward by an arm in the lower section of the machine, raising the free end of the crank shown. The right-hand end of the connecting bar follows the crank under the action of a spring until the stop engages with a facet of the stepped cam. The left-hand end of the connecting bar depresses the pence rack which, in turn, rotates the intermediate meter pinion. Recording takes place on the upward stroke of the rack after the plunger has been released later in the cycle, the downward stroke being made ineffective by means of a ratchet and pawl fitted behind the intermediate meter pinion.

Similar arrangements are provided for recording the shillings and poundage. The recording of pence and shillings takes place simultaneously in the value meters and a device is provided whereby any shillings to be carried forward from the pence meter are stored until the main recording cycle has been completed before being released into the shillings meter. The duplicate or check meters are driven off the same recording racks.

Sorting.

The machine-issued postal orders are sorted according to their serial numbers only, instead of to their values and serial numbers as is the case with standard postal orders. Sorting holes are drilled in the packs of postal order forms after fanfolding, the positions of the holes being different for each pack. Because the forms are fanfolded, six holes have to be drilled, although only three of these are actually used

for sorting each order. As the positions of the holes differ from those on a normal postal order, a specially modified sorting machine is used. The holes will eventually be punched during the pre-printing process, when only three holes will be required.

Inking Arrangements.

It is necessary to re-ink the machine after about every 5,000 impressions, or about every three days at a busy office. Black ink is evenly applied by means of a brush to the lower of the two felt inking rollers. The two rollers are then rotated together by hand, using the knurled knob at the end of the upper roller to spread the ink and to ensure even impression.

Safeguards.

In order to make the machine as fraud-proof and as proof against misoperation as possible, locking devices are incorporated to make it impossible to operate the machine:—

- (a) without inserting the operator's identification bar (see Fig. 4),
- (b) with the setting knobs incorrectly positioned,
- (c) when there is no paper in the machine,
- (d) when the machine is unlocked.

A locking bar is provided to make it impossible to alter the value setting once the operating lever of the machine has been pressed.

Additional Features.

When there are less than 100 forms left in the paper container a gong is struck each time the machine is operated, thus warning the operator to replenish the supply. A new pack of 1,000 orders can be joined to the end of the pack in the machine very quickly without taking the machine out of service. A special jointing device is provided to make the operation as simple as possible.

When the upper section is tilted back, a lamp is switched on inside the machine, illuminating the dies and inking rollers to assist the operator to carry out the operations of date changing, inking, etc.

CONCLUSION

The first machine is now on field trial at Romford H.P.O. and preliminary results show that some time is saved on each transaction. This is largely due to the fact that it is no longer necessary to make up postal orders for odd amounts by attaching stamps to the 27 standard values. The machine-issued postal orders do not require date-stamping by hand as this is carried out automatically by the machine. There is also an appreciable saving in the time taken to balance the cash taken against issues made during a counter clerk's shift. This is due to the provision of the value and poundage meters. A simple subtraction enables the clerk to determine the value of postal orders sold during the shift. In addition, the arrangements for the supply of postal orders of many different values from stock are simplified by the use of the single type of postal order form.

The scheme and the specification for the machine were initiated by the Post Office and the design and manufacture carried out by the Bell Punch Co., Ltd., Uxbridge. It is hoped to introduce further machines at other Post Offices if the Romford trial proves successful.

Thermal Problems of Small Underground Installations

K. D. BOMFORD, M.Sc., A.M.I.E.E.†

U.D.C. 536.629.7

This article describes theoretical and experimental investigations made to obtain thermal design data for small underground installations housing telecommunications or similar equipment. The theoretical approach is based on the equivalent electrostatic capacitance between two conducting surfaces and it is shown that calculation on this basis provides a useful indication of the temperature rise likely to be experienced in an underground installation of steel construction.

Introduction.

CONDITIONS sometimes arise that make the installation of telecommunications equipment below ground an attractive possibility. The principal advantages that can be claimed for this type of installation are, firstly, a high stability of operating conditions, which is particularly attractive for frequency-standard equipment for example, and, secondly, that it could provide the solution to acute accommodation problems that may arise on telecommunications systems in built-up areas. These advantages may, in certain circumstances, outweigh the inconvenience and maintenance difficulties of such installations, and some consideration has therefore been given to the problems involved in accommodating small units of equipment below ground. It soon became apparent that the dissipation of heat from thermionic apparatus required detailed investigation as it would obviously be a major factor influencing the general design.

The present article is concerned solely with this aspect of the problem and describes the theoretical and experimental investigations that have been made to obtain the required thermal design data. It was decided to consider equipment placed in an underground cylindrical steel tank, buried with its axis vertical and with access provided by a conventional manhole; this shape of tank probably combines ease of construction and installation with the best use of the available volume to a higher degree than any other.

An Outline of the Problem.

The temperature rise of the component parts of the equipment above the ambient temperature can be controlled to a certain extent at the design stage and for thermionic equipment is usually between 20° and 40°C. The actual component temperature during the life of the equipment will then vary in sympathy with the ambient temperature. The air temperature inside a buried steel tank which is dissipating power will be higher than that of the surrounding soil and, since sufficient information exists to enable the actual soil temperature to be predicted with reasonable accuracy, the problem resolves itself into determining the temperature rise of a steel tank above the surrounding medium. The variables involved in the estimation of the temperature rise of a buried cylinder are the diameter and height of the cylinder, the depth of the cylinder below the ground surface, the power dissipation, and the thermal conductivity of the soil in which the cylinder is buried. The dimensions of a suitable cylindrical tank are too large for extensive experiments in which the diameter, height and depth are systematically varied and this made it necessary to study the problem theoretically in an attempt to determine a general relation between the variables concerned.

On the other hand, an experimental check of the analysis

† Armaments Research Establishment, M. of S., formerly Senior Executive Engineer, Radio Experimental Branch, Engineer-in-Chief's Office.

¹ "On the Uniform Motion of Heat in Homogeneous Solid Bodies, and its Connection with the Mathematical Theory of Electricity." W. Thomson. *Camb. Math. Journ.* Feb., 1842.

² "Conduction of Heat in Solids." p. 342. H. S. Carslaw and J. C. Jaeger. Oxford, 1947.

was, perhaps, more than usually necessary, in view of the uncertainty of some of the data. Thus, the thermal conductivity of soil and the dissipation of heat at the surface of the ground are both somewhat indefinite quantities. Experiments were therefore made with three cylindrical tanks of widely different size that were readily available.

THEORETICAL INVESTIGATION

The Electrostatic Analogy.

The analogy between thermal and electrostatic phenomena in the steady state was described by Sir William Thomson in 1842,¹ and it is interesting to note that he used the analogy to solve electrostatic problems from a knowledge of heat flow. To-day the converse process is more usual and a theoretical or experimental determination of the electrostatic capacitance between two conducting surfaces leads directly to a knowledge of the rate of heat flow between isothermal surfaces. Thus, if two isothermal surfaces P_1 and P_2 are maintained at temperatures t_1 °C and t_2 °C, respectively, then the rate of heat flow between P_1 and P_2 is W watts, where

$$W = (t_1 - t_2) / R \dots\dots\dots (1)$$

In this formula R is a thermal resistance factor, which for the units quoted is expressed in "thermal ohms," and it can be shown² that, if C' is the electrostatic capacitance between P_1 and P_2 when separated by a medium of unit permittivity, then the thermal resistance R' between P_1 and P_2 is given by:—

$$R' = \frac{1}{4\pi KC'} \dots\dots\dots (2)$$

where K is the thermal conductivity, in C.G.S. units, of the intervening medium. In equation (2) R' is expressed in °C/cal./sec. and C' in E.S.U. (cms). It is usually more convenient for calculation to express the resistance in thermal ohms, the conductivity in terms of thermal resistivity in thermal ohms per cm. cube,* and the capacitance in micro-microfarads; the appropriate conversion factors yield the formula:

$$R = \frac{S}{4\pi \cdot 0.9 C} = \frac{S}{11.3 C} \dots\dots\dots (3)$$

where R = thermal resistance in thermal ohms
 S = thermal resistivity in thermal ohms per cm. cube
 C = capacitance in micro-microfarads.

The calculation of the temperature rise of a buried cylinder dissipating a given power can thus be made by substitution in equation (1) above, and the appropriate thermal resistance for use in this equation can be determined by equation (3) from a knowledge of the thermal resistivity of the surrounding soil and of the electrostatic capacitance between the tank and the surface of the ground, assuming that a medium of unit permittivity intervenes. The determination of the capacitance to the surface of the ground for the present type of tank, i.e., a cylinder buried with its axis vertical, will now be considered.

* The thermal resistivity, S , in thermal ohms per cm. cube is related to the thermal conductivity, K , in C.G.S. units by the expression: $S = 1/4 \cdot 2K$.

The Capacitance Between a Vertical Cylinder and a Horizontal Plane.

The calculation of the capacitance between a cylinder and a plane perpendicular to its axis is difficult, and a search of the literature did not reveal a general solution. However, a solution having an estimated accuracy of ± 5 per cent., which is considered to be adequate for the present problem, was evolved, as described in the Appendix. The result is expressed as a family of curves, in Fig. 1, in terms of

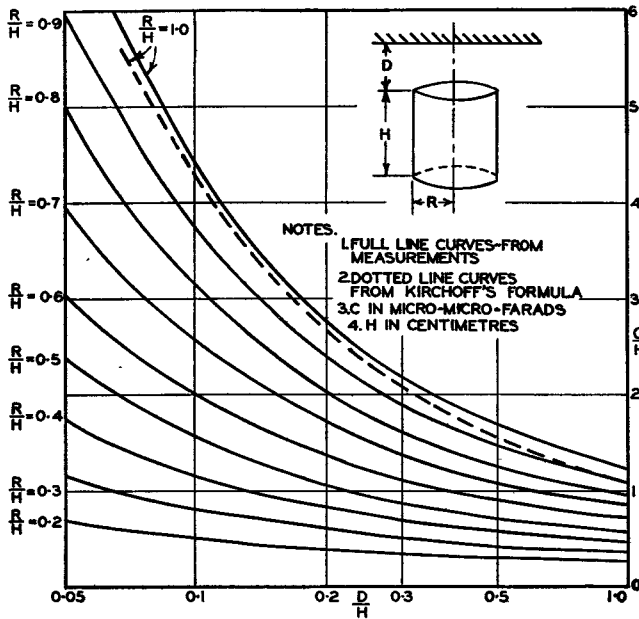

FIG. 1.—CAPACITANCE BETWEEN A CYLINDER AND A PLANE PERPENDICULAR TO ITS AXIS.

dimensionless parameters that are applicable to any size of tank at any depth within the ratios of the dimensions given on the curves.

These curves, in conjunction with equation (3), will give the thermal resistance of a tank of known dimensions, at a specified depth and in a medium of known thermal resistivity. This, in turn, will yield the temperature rise of the tank for a given power dissipation by the use of equation (1). If this solution is to have any real value, however, it is essential to consider the several factors which will, in practice, modify the idealised theoretical analysis so far presented.

Some Factors affecting the Calculated Temperature Rise.

The calculation of the temperature attained in a buried tank is subject to errors that may be classified under two heads, viz., errors of approximation, arising from the inevitable idealisation of the problem, and errors of information, arising mainly from inadequate knowledge of the thermal properties of the soil.

The formulæ already given apply to the flow of heat between two isothermal surfaces separated by a uniform medium, and it is assumed that the surface temperatures are unchanged by the flow of heat, or that equilibrium has been attained. In practice, temperature differences will exist between the extremities of the tank, due to the concentration of its sources of heat, and to the difference in thermal resistance of the paths of heat flow from the different parts of the tank. Furthermore, the temperature of the surface of the ground will not be uniform, for the transfer of heat from soil to air will raise the temperature at the ground surface, and so in the tank, by an amount that will vary with the distance from the tank. The medium

that separates the two surfaces is not uniform, for concrete, as well as different types of soil, will usually surround the tank, and the presence of nearby pipes and cables will affect the flow of heat. Again, for the calculation of its thermal resistance to the ground surface, the tank will usually be assumed to be a simple cylinder, and it may not be possible to allow accurately for the effects of a manhole or cable connections, which will decrease the thermal resistance and cool the tank.

The thermal resistivity of a particular type of soil is found to depend greatly upon its moisture content, and the effect of water appears to be greater than that of soil type, but it is usually sufficiently accurate to assume a resistivity of 100 thermal ohms per cm. cube for any type of soil likely to be met in the British Isles. This assumption is based on the list of soil resistivities given in Table 1.

The assumption has also been made that there is no temperature gradient in the soil except that due to the tank itself, although for the depths at which tanks may be buried, the soil temperature is in fact lower in summer and higher in winter than the surface temperature by an amount that increases with depth. Fortunately, this has only a small effect in the present case. A steel tank buried in soil with a temperature gradient, and with no power dissipation, will assume a temperature intermediate between that corresponding to the depths of its top and bottom surfaces. In practice, the soil temperature difference for depths differing by some 10 ft. (the maximum likely height for a tank) is only about 2°C , if the smaller depth is greater than 6 in., so it is accurate enough to estimate the final temperature by adding the calculated temperature rise to the soil temperature at the mean depth of the tank.

TABLE 1
Specific Thermal Resistance of Various Soils and Materials

Material	Thermal Resistivity in Thermal Ohms per cm^2	Authority
Clay	40-80	1
Clay 28 per cent. moisture by volume	43	3
Sand dry	290	3
Sand dry	350	4
Sand dry	380	2
Sand 8 per cent. moisture	170	2
Sand 10 per cent. moisture	96	3
Sand	100-200 according to season	1
Sandy loam	120	1
Loamy soil	120	1
Soil average	103	2
Concrete	30-80	2
Concrete dry	123	3
Concrete 10 per cent. moisture by volume	82	3
Reinforced concrete	67	3
Brick dry	190	3
Brick 2 per cent. moisture by volume	96	3
Brick (Building)	119	2
Building Brickwork dry	144	4

1. Communicated by E.R.A. Research Laboratory.
2. "Conduction of Heat in Solids." H. S. Carslaw and J. C. Jaeger. Oxford at Clarendon Press, 1947.
3. "Elements of Heat Transfer and Insulation." M. Jakob and G. A. Hawkins. Wiley & Sons, 1942.
4. "Heat Transmission." McAdams. McGraw-Hill.

EXPERIMENTAL INVESTIGATIONS

Description of the Field Trials.

Measurements were required over a wide range of parameters so that a reasonable experimental check on the theoretical analysis could be obtained, and the temperature rises of three underground tanks of widely different dimensions were investigated with appropriate internal power dissipations. The first test was made on a comparatively large underground steel chamber that had been constructed at Baldock Radio Station to accommodate frequency-standard equipment, and which, fortunately, was not only of the desired cylindrical shape with its axis vertical, but had not then been brought into service and

was thus readily available for test. This was followed by measurements at Dollis Hill on a small buried oil drum. In addition to the convenience of making measurements on what was in fact a small-scale model, the oil drum possessed the added advantage that, unlike the other tanks, it was a smooth cylinder directly comparable with the idealised theoretical case. The third series of measurements was made on a prototype underground tank installed at Dollis Hill. The salient features and dimensions of the three tanks tested are shown in Figs. 2, 3 and 4 respectively.

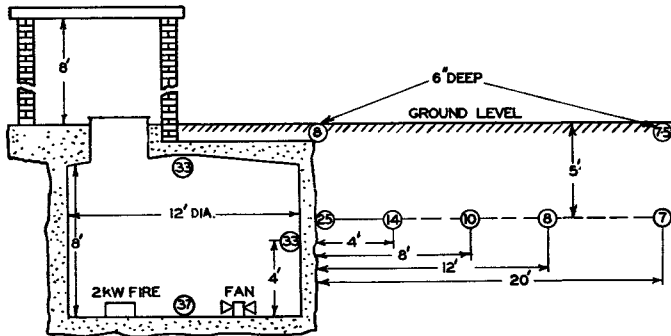

The small circles indicate positions of resistance thermometers. The number gives the temperature in °C at each point, with 1,810 W heating in the tank, when a stable condition had been reached after 80 days.

FIG. 2.—THERMAL TESTS ON UNDERGROUND TANK AT BALDOCK RADIO STATION.

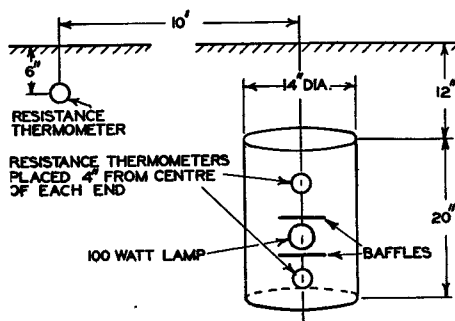
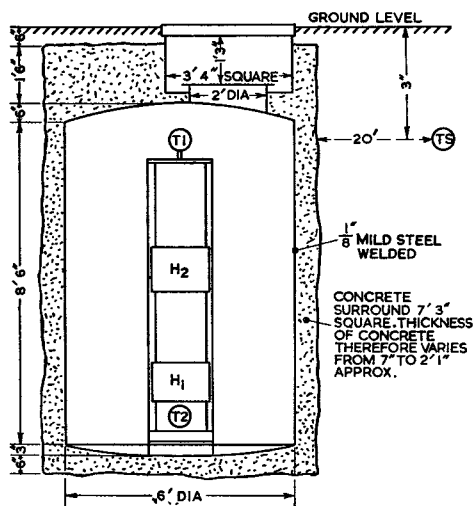

FIG. 3.—ARRANGEMENT OF OIL DRUM FOR HEAT DISSIPATION TESTS.



T1, T2 and TS are resistance thermometers; T1, T2 are 1 ft. from the centre of the top and bottom of the tank respectively. H1 and H2 are 500W heaters, independently controlled and mounted on a 7 ft. 6 in. rack.

FIG. 4.—UNDERGROUND PROTOTYPE TANK AT DOLLIS HILL.

The conditions under which the tests were conducted were substantially the same in each case. Power was dissipated in the tank by suitable electric heaters and temperature measurements were made inside the tank and at points in the surrounding soil, with one measurement at such a distance that it gave the ambient soil temperature. The air temperature in the tank and the soil temperature were determined by resistance measurements of small copper wire coils. These coils occupied a space of about 1 cu. in. and had a nominal resistance of 1,000 ohms. They were calibrated against one standard coil that, in turn, had been calibrated against a thermometer in an oil bath over the temperature range 0 to 100°C. The coils buried in the soil were embedded in wax-filled copper containers for protection, and connections were extended from the coils by heavy leads of negligible resistance to a measuring bridge located in an adjacent building. Measurements were taken at suitable intervals until thermal stability was established.

Results of the Measurements.

The results of the various tests are summarised in Table 2, which gives the temperature after thermal stability had been attained. For the two tests on the Baldock tank it will be noted that the mean temperature rise was proportional to the power dissipation, as would be expected. Measurements of soil temperature in the vicinity also revealed that the temperature at a depth of 5 ft. was affected by the heat from the tank at distances up to about 12 ft. from the side of the tank. Other thermometers buried at a depth of 6 in. indicated a soil temperature rise of less than 1°C immediately above the tank. This supported the belief that the effects of change in soil surface temperature, due to the heat dissipated from the tank, could be neglected.

The distinguishing feature of the oil drum experiment was the comparatively large temperature gradient that existed along the vertical axis of the drum, the temperature being 54°C at the top and falling to 40°C at the bottom.

For the prototype tank at Dollis Hill, the two tests gave a mean temperature rise of 18.5°C with a power dissipation of 480W, and 29°C with a power dissipation of 870W. Heavy rain fell on several days during the second part of the test, to such an extent that the space between the top of the entrance hatch and the manhole cover was found to be full of water at the end of the test. The upper soil was porous and would readily allow water to percolate to a depth of several feet, so that the effective thermal resistance between the tank and soil surface must have been appreciably lower during the second part of the test; this is presumably the reason why the temperature rise did not increase in proportion to the power dissipation.

Calculated Temperature Rise of the Three Tanks.

A comparison was next made between the measured and calculated temperature rises of the three tanks, mainly to assess the accuracy of the theoretical method which it was hoped would be adequate to predict the thermal behaviour of buried tanks in general. The results are given in Table 3.

The calculated capacitance of a simple cylinder of the same dimensions as the Baldock tank is 365 micro-microfarads, to which was added 78 micro-microfarads for the equivalent capacitance of the relatively large man-hole entrance, making a total of 443 micro-microfarads. This addition was determined experimentally by capacitance measurements on a model. As already stated, the thermal resistance, R in thermal ohms, is related to the electrostatic capacitance, C in micro-microfarads, by $R = S/11.3 C$ (equation (3)) where S is the soil thermal resistivity in thermal ohms per cm. cube. The value of S can be estimated from a knowledge of the soil and the resistivities of various soil types given in Table 1. Excavation to a depth of 6 ft.

on the site at Baldock showed that the soil was a mixture of sand and chalk in a moist condition and bearing in mind the large amount of reinforced concrete, which would have a somewhat lower thermal resistivity than soil, the equivalent soil resistivity was estimated at 90 thermal ohms per cm. cube; the thermal resistance of the tank is, therefore, 0.018 thermal ohms. The temperature rise is then given by equation (1).

The oil drum was sufficiently similar to a pure cylinder for the capacitance to be obtained directly from the curves of Fig. 1. The soil surrounding the drum was an average loam containing about 5 per cent. by volume of clay in a fairly moist condition and the estimated soil resistivity that was used to calculate the temperature rise was, therefore, taken as 100 thermal ohms.

TABLE 2
Summarised Results of Thermal Tests on Three Different Buried Steel Tanks

Description of Tank <i>D</i> = depth from ground to top of tank <i>H</i> = height of tank <i>R</i> = radius of tank	Power Dissipation in the Tank Watts	Temperature inside the tank			Ambient Soil Temperature °C	Mean Temperature Rise °C	Approximate time taken to reach Thermal Stability
		near the roof °C	near the floor °C	mean °C			
1. Underground Tank at Baldock Radio Station (<i>D</i> = 2 ft. 9 in. mean, <i>H</i> = 8 ft. 3 in., <i>R</i> = 6 ft.)	942 1810	25 33	27 37	26 35	11 7	15 28	30 days 40 days after power was increased
2. Oil Drum (<i>D</i> = 12 in., <i>H</i> = 20 in., <i>R</i> = 7 in.)	98	54	40	47	13	34	60 hours
3. Prototype Tank (<i>D</i> = 2 ft. 3 in. mean, <i>H</i> = 8 ft. 6 in., <i>R</i> = 3 ft.)	480 870	28.5 37	27.5 35	28 36	9.5 7	18.5 29	13 days 20 days after power was increased

TABLE 3
Comparison between Measured and Calculated Temperatures of the Three Tanks

Tank	Calculated Capacitance (C) microfarads	Estimated Soil Thermal Resistivity (S) Thermal ohms per cm ³	Thermal Resistance $R = S/11.3C$ Thermal Ohms	Power Dissipation <i>W</i> Watts	Calculated Temperature Rise $T = WR$ °C	Measured Mean Temperature Rise °C	Per cent. Increase of Calculated Over Measured Temperature Rise Per Cent.
Baldock Tank	443	90	0.018	942 1810	16.9 32.6	15 28	13 16
Oil Drum	23	100	0.385	98	38	34	12
Prototype Tank	180	100 80	0.049 0.039	480 870	24 35	18.5 29	30 21

The prototype tank was also assumed to be a simple cylinder and the effect of the relatively small entrance hatch was ignored. The surrounding soil structure was examined while excavations were being made for the installation of the tank and the first 4 ft. was a made-up soil of sandy loam merging during the next 3 ft. into gravel that changed quickly to solid clay for the remaining 5 ft. The estimated thermal resistivity of this soil, including the concrete surrounding the tank, is 100 thermal ohms per cm. cube under the fairly dry conditions of the first part of the test, and 80 thermal ohms per cm. cube after the heavy rain in the second part of the test.

The comparison made in Table 3 between the measured and calculated temperature rise figures shows that the calculated temperature rise was consistently higher than the measured figure by from 12 to 30 per cent. In view of the unavoidably large number of approximations and assump-

tions in a thermal investigation of this type, this agreement is considered reasonable, and it would appear that the theoretical approach based on the equivalent electrostatic capacitance provides a useful indication of the temperature rise likely to be experienced.

PERMISSIBLE POWER DISSIPATION IN THE PROTOTYPE TANK

The theoretical calculation of the temperature rise of an underground tank will now be used to determine the permissible power loading in the prototype tank. Since in practice the depth at which the tank will be buried may depend upon local conditions, the solution will be presented as a function of depth. The first requirement is to specify the maximum permissible working temperature in the tank.

Maximum Working Temperature in the Tank.

Although the maximum ambient temperature that can be tolerated within the tank is a function of the type of equipment, a close estimate of the permissible figure is nevertheless possible. Measurements on typical thermionic equipment showed a maximum temperature rise within the equipment of 30°C above the surrounding room temperature. If it is assumed that components with tropical rating would be used, having a permissible working temperature of 71°C, then a maximum air temperature of 41°C could be allowed.

Soil Resistivity and Temperature.

The worst values of soil resistivity and soil temperature likely to be encountered in practice must also be decided upon before the permissible power loading of the tank can be determined. The thermal resistivity of soils varies widely with the type of soil and with the water content, as shown by the typical values listed in Table 1. It is regarded as unlikely, however, that a figure of 100 thermal ohms per cm. cube for the medium surrounding a buried tank would be exceeded for any prolonged period in this country, bearing in mind the normal rainfall and the fact that an appreciable part of the medium would be concrete, possibly reinforced with steel.

Regarding the maximum soil temperature that should be assumed, one authority³ quotes measurements for the London area for the year 1939 that gave the maximum temperature at a depth of 4 ft. as 16°C in September; at the same time the temperature at a depth of 1 ft. was also 16°C. Additional information is furnished by measurements of the resistance of L.F. pairs in the Manchester-Newcastle coaxial cable over the period 1940-1944, which gave a maximum temperature of 17°C at a depth of 2.3 ft. It is considered that a safe working figure for the maximum soil temperature is therefore 18°C, and it would appear that it is substantially independent of depth over the first few feet at the period when the maximum exists. The permissible temperature rise in the tank over the soil temperature is therefore (41 - 18)°C, or 23°C.

³ "The Thermal Insulation of Structures" (p. 47). G. Gale Pitts, Charles Griffin & Co., Ltd. 1941.

Calculated Power Dissipation in the Prototype Tank at Various Depths.

The electrostatic capacitance of the prototype tank of Fig. 4 has been evaluated from the data of Fig. 1 for various depths from 2 to 8 ft. between the top of the tank and the soil surface.

The power dissipation that produces a temperature rise of 23°C in the tank has been calculated for each depth, assuming a soil resistivity of 100 thermal ohms, and the result is shown plotted as a function of depth in Fig. 5. It will be noted that the depth has a very marked effect on the thermal behaviour of the tank and should, therefore, be kept to a minimum.

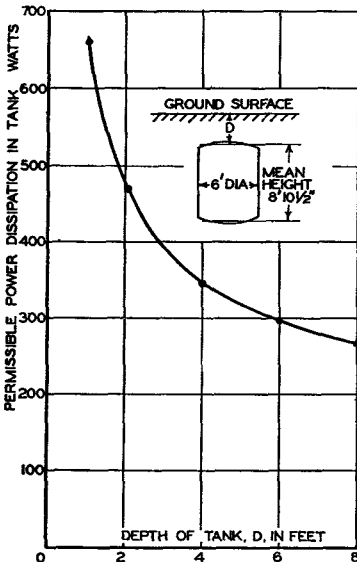

The power dissipation is calculated for a soil resistivity of 100 thermal ohms per cm. cube, a temperature rise in the tank of 23°C above a maximum soil temperature of 18°C and for various depths.

FIG. 5.—THEORETICAL PERMISSIBLE POWER DISSIPATION IN THE PROTOTYPE TANK.

Equipment Loading in the Prototype Tank.

Having determined the permissible power dissipation in the prototype tank, it is also necessary to consider the size of the equipment that will dissipate this power in relation to the size of the tank. The most efficient rack layout in a circular chamber is probably achieved when the equipment is mounted on single-sided racks arranged around the wall. In the proposed 6-ft. diameter tank the number of single-sided racks that can be arranged in this way is six, leaving about 4 ft. of wall space clear for the entrance ladder and such items as telephone, power supply and notice boards. The power consumption of a 7 ft. 6 in. single-sided rack of transmission equipment averages about 150W. From the point of view of space alone, the tank could, therefore, accommodate equipment dissipating 900W, whereas it is shown in Fig. 5 that at a depth of only 2 ft. the dissipation is limited by the temperature rise to 468W. The amount of equipment in this tank would, therefore, be restricted by thermal considerations rather than by space.

Further Considerations.

The present investigation has not considered the possibilities of forced cooling or improving the heat dissipation by increasing the surface area of the tank by some form of finning. These are not, however, solely technical problems. Forced cooling could undoubtedly be made effective, but it would have to be economical, extremely reliable and automatically supervised, and these factors must be set against the simple alternative of installing a larger tank. Again, the addition of some form of finning may not be much more effective than a larger tank having equivalent excavation problems, although a single conduct-

ing mat buried near the surface and effectively bonded to the tank would be worth considering where no high reinstatement charges, e.g., of a road surface, are involved.

The possibility of increasing the heat dissipation would, therefore, have to be considered separately in the light of the particular circumstances of each installation.

Acknowledgments.

The co-operation of various colleagues in the Radio Experimental and the Construction Branches during the progress of this work, and in particular the collaboration of Mr. F. J. M. Laver in the later stages of the investigation, is acknowledged with pleasure.

APPENDIX

THE CALCULATION OF THE CAPACITANCE BETWEEN A VERTICAL CYLINDER AND A HORIZONTAL PLANE

Kirchoff gives an expression for the capacitance between two thick discs which is, of course, one-half of the capacitance between a similar disc and a perpendicular plane midway between the discs. The expression is not directly applicable to the present case, however, because it is only accurate when the thickness of the discs and the separation are both small compared with the radius. Two expressions are given, depending on whether both discs are insulated or whether one is earthed: and from these two formulæ the capacitance of a single disc to an earthed plane can be deduced. For a disc or cylinder of radius R cm. and height H cm., with its nearer surface D cm. from a plane perpendicular to its axis the capacitance, C cm., between cylinder and plane given by Kirchoff's expression is:

$$C = \frac{R^2}{4D} + \frac{R}{2\pi} \log_e \frac{4\pi R(2D+H)}{D^2} + \frac{RH}{4\pi D} \log_e \left(1 + \frac{2D}{H}\right)$$

or, expressing C in micro-microfarads:

$$C = 0.278 \frac{R^2}{D} + 0.177R \log_e \frac{4\pi R(2D+H)}{D^2} + 0.0884 \frac{RH}{D} \log_e \left(1 + \frac{2D}{H}\right)$$

Several measurements of the capacitances between vertical cylinders and a horizontal plane were made in order to determine the errors that occur in the use of Kirchoff's formula when the height of the cylinder and its separation from the plane are not small compared with its radius. The cylinders used were copper screening cans supported on lengths of small-diameter thin-walled paxolin tubing, and a correction was applied for the extra capacitance due to the presence of this support. The plane was represented by a copper sheet 5 ft. square, which check measurements showed to be sufficiently large to avoid errors. The measured capacitances were all greater than the values calculated from Kirchoff's formula. As could be expected, the percentage difference increased as either H or D was increased with respect to R , with the smallest ratios of H/R and D/R , i.e., 1.01 and 0.12 respectively, the calculated capacitance was only 7 per cent. lower than the measured, but with $H/R = 5.94$ and $D/R = 1.92$ the difference was 47 per cent.

The results of the capacitance measurements have been expressed in terms of the dimensionless parameters C/H , D/H and R/H , and are shown in a convenient form in Fig. 1 and these curves can be used to calculate the capacitance for a wide range of tank dimensions.

Kirchoff's formula may also be expressed in terms of these parameters, thus:

$$\frac{C}{H} = 0.278 \frac{R}{H} \left[\frac{R/H}{D/H} + \frac{2}{\pi} \log_e 4\pi \left(\frac{2R/H}{D/H} + \frac{R/H}{(D/H)^2} \right) + \frac{1}{\pi (D/H)} \log_e \left(1 + \frac{2D}{H} \right) \right]$$

and this expression has been evaluated for $R/H = 1.0$, which is the measured condition that most nearly approached Kirchoff's assumptions; the results are plotted on the curves of Fig. 1 for comparison. It will be noted that the general form of the calculated and measured curves is similar.

It is estimated that the capacitance between a vertical cylinder and a horizontal plane may be assessed to within ± 5 per cent. with the aid of Fig. 1, which is quite accurate enough for the calculation of thermal resistances.

New-type Routers for Automatic Telephone Exchange Equipment

L. GREEN†

Part 2.—General Description of the Control Circuit

U.D.C. 621.395.365

This article describes the control circuit designed for use on all new-type routers. It is shown that with this circuit as the standard basis the requirements for individual routers for various types of telephone exchange equipments can be catered for by the addition of testing elements fitted on a unit basis.

General.

A SIMPLE conception of the arrangements standardised for the new-type router is given in the block schematic diagram of Fig. 1. It will be seen that the Routine Control provides through-connection for the test

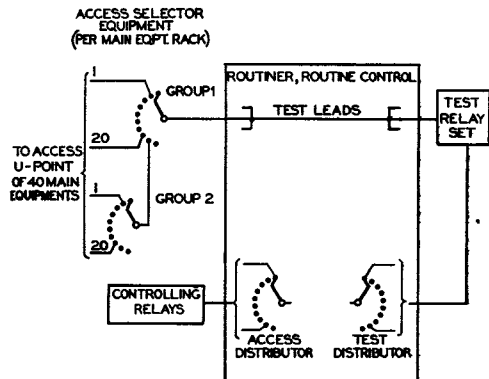

FIG. 1.—SIMPLIFIED BLOCK SCHEMATIC DIAGRAM OF NEW-TYPE ROUTER.

leads between the access selector equipment, selected by the access distributor, and the test relay sets, selected by the test distributor. These arrangements allow access selector equipments and test relay sets to be varied according to the individual testing requirements of the main equipment; the Routine Control circuit being the same for all routers. Thus the router rack assembly and rack wiring is universal, and includes the maximum wiring requirements and shelf positions for the test relay sets. A full description of this rack was given in Part 1 of this article.*

Because the Routine Control circuit is universal, a description of the circuit arrangements is an essential prelude to the circuit and testing principles of individual routers.

Router Access Points.

Hitherto, the access U-points used for router tests have been U-points which existed for the normal circuit connections of jack-in equipment and, because these were not necessarily the best testing points, considerable limitation was imposed on the design and scope of the tests. Arrangements have now been made whereby all new main circuit developments are examined in the draft stages to determine the essential testing requirements and allocate suitable testing points. In this way the access points are more closely related to testing needs, and additional U-points for tapping into the circuit are now included in the manufacturing requirements of the main equipment.

Access Selector Equipment.

From the testing aspect, the access selectors serve as distributors for extending the testing leads from the

router to allotted U-points of the main equipment. By accommodating the access selectors on the same rack as the main equipment considerable cabling economy is effected, and this method is adopted whenever a suitable rack layout can be achieved without reduction of the total rack capacity. For this reason uniselectors were chosen for use as access selectors.

The access selector circuit serves equipment on a rack basis; thus, the total number of uniselectors per access circuit is dependent upon:—

- (a) the number of test leads per item, and
- (b) the number of items per rack.

Because more than one uniselector is necessary to cover (a), a "group" of uniselectors is used in which the magnets are stepped in unison.

The total rack capacity determines whether one or more "groups" is necessary, because a single group of 25-point uniselectors will only serve 20 equipments. Further groups are added as required and the adoption of 25-point or 50-point uniselectors is determined from the economics of the individual case.

ROUTINE CONTROL CIRCUIT

This circuit exercises control of the progress and sequence of testing in all its stages, and the general layout is shown in block schematic form in Fig. 2.

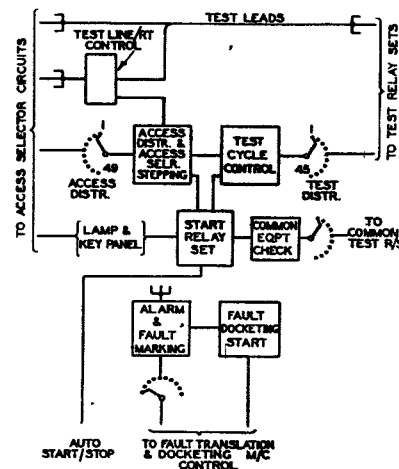

FIG. 2.—BLOCK SCHEMATIC DIAGRAM OF ROUTINE CONTROL.

It will be observed that the test leads are direct connections between the access equipments and the test relay sets; a maximum of 39 such leads is provided. Certain leads, which provide for switching and holding "test lines," or control of RT (routine test) relays, are extended via appropriate controlling relay sets.

Connection to the test leads is controlled, on one hand, by the access distributor, which selects one of 49 racks, and, on the other hand, by the test distributor which controls the connection of up to 45 test relay sets in sequence.

† Executive Engineer, Telephone Development and Maintenance Branch, E.-in-C.'s Office.

* P.O.E.E.J., Vol. 44, p. 147.

Routining may be started either by manual (key) operation or from an automatic (clock) start signal; in the latter case the control circuit is prepared for the automatic docketing of faults.

Automatic Testing Sequence.

The "clock" start signal initiates start conditions for the following sequence of operations:—

(1) *Docketing.* A docket is printed with date, time and serial number, followed by the routiner designation, main equipment rack position number and the start characters "STRT."

(2) *Access selector normal test.* Check is made that access selectors on all racks are normal, i.e., in the home position. This is necessary because each test lead is common to the wipers of access selectors on all racks; the home position outlet being unwired isolates that rack equipment from the test leads.

(3) *Access distributor stepping.* If the distributor, which is non-homing, is standing on an unequipped rack position, it is stepped to the next equipped position.

(4) *Access selector stepping.* The access selectors of the rack selected under (3) above, are moved off-normal to the first equipped position on the rack, counting from shelf position A1.

(5) *Access selector normal guard.* A guarding circuit is applied to ensure that all access selectors, other than those in use by the routiner, remain in the normal position throughout testing.

(6) *Common test equipment check.* Test is made that each common test relay set is working correctly and within tolerance limits.

(7) *Test distributor stepping.* Each test relay set is connected to the test leads in sequence, the start test condition of each relay set being dependent upon the clear-down of the previous test relay set. (At this stage the tests are applied to the main equipment from the test relay sets.)

(8) *Alarm delay.* Either 30-60 sec. or 3-6 min. delay period may be introduced under fault conditions according to the test being made.

(9) *Fault indications.* Faults are classified under two headings: "routine fault" and "routiner fault." The former is indicated as one of four faults in each of 45 test relay set positions. The routiner faults are printed under one of seven sub-classifications.

(10) *Fault docketing.* Completion of the alarm delay period applies conditions for the printing of a docket, giving, for routine faults, the date, time, serial number, routiner designation, rack number, shelf, shelf position, test relay set number and fault number; for routiner faults, the date, time, serial number, followed by the abbreviation "RTR" and one of seven abbreviated fault conditions are printed.

The circuit elements for the routiner control sequences just described are given in the following sections. The elements are extracts from the routiner control circuit and serve as a guide to the circuit operation and demonstrate the step-by-step method whereby localisation of routiner failures may be indicated. Notes on the operation of each element and an explanation of the circuit principles are given, but these do not necessarily explain in detail the functions of all relays and contacts.

Automatic Start and Docket Printing Start (Fig. 3).

Automatic start is initiated by the operation of relay AS from the clock start lead. Relay ST then prepares the various elements for use (hence, contacts of relay ST will appear in Figs. relating to other circuit elements).

Relay DM is operated and locked, and extends a docket marking earth to indicate printing of the start characters "STRT;" DM also operates relay PT which applies the starting earth for docketing. With completion of the print-

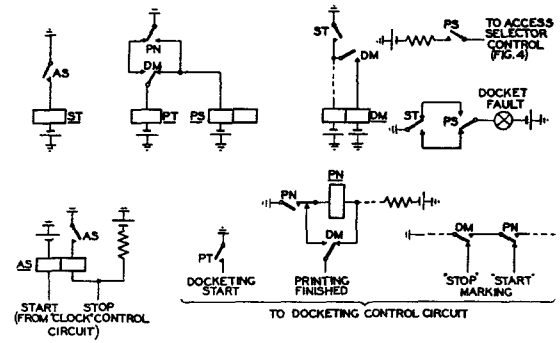

FIG. 3.—AUTOMATIC START AND DOCKET PRINTING START.

ing operation by the docketing machine, earth is returned to operate relay PN which is then locked. PN releases relay PT which removes the docketing start condition and operates relay PS to provide a signal for the commencement of the next sequence. Failure to print a docket for any reason will prevent the operation of PS and a "docket fault" lamp indication is given.

Relays AS, ST, DM, PN and PS remain held until the end of the testing period, when the clock stop signal applies earth to short-circuit the holding coil of relay AS. Relays ST and DM release; the latter prepares the "STOP" marking to the docketing machine and re-operates relay PT to start printing. At the end of the printing operation the "printing finished" earth signal now short-circuits relay PN, allowing release of relays PT and PS, and restoring the circuit to its normal condition.

Access Selector Normal Test (Fig. 4).

The operation of relay PS from the previous automatic

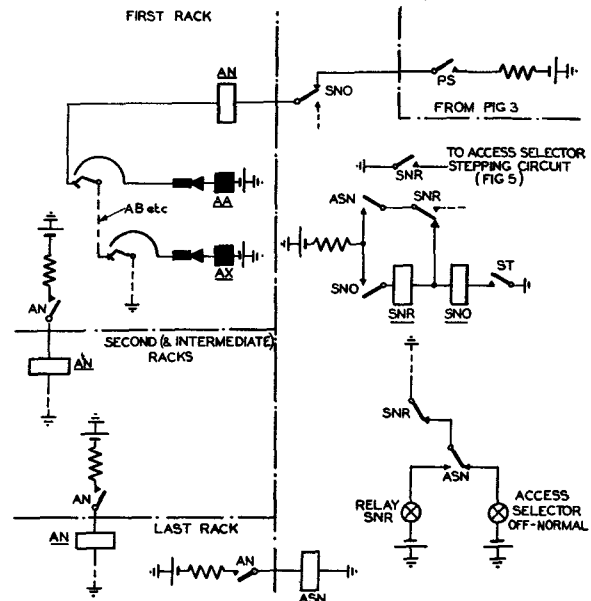

FIG. 4.—ACCESS SELECTOR NORMAL TEST.

start sequence, extends battery to the AN relay of the access selectors on the first rack of equipment. With the access selectors normal, relay AN operates via the home contacts and wipers of each uniselector on the first rack, and extends a battery signal to the AN relay of the second rack, and so on, the last AN relay signal being returned to operate relay ASN. The operation of relay ASN is registered by operating relay SNO, which disconnects the PS battery, thereby releasing all access selector AN relays. The resulting release of relay ASN is registered by the operation of relay SNR in series with SNO; SNR starts the next sequence.

This preliminary release of relay ASN proves that the operating conditions were not due to a fault; for example, a battery contact, or AN contact short-circuited, would hold the whole or part of the chain and give permanent "operate" signal conditions, this being indicated on the "relay SNR" alarm lamp. Failure to operate relay ASN, due to any disconnection in the chain circuit, results in "access selector off-normal" fault lamp indication.

Access Distributor Stepping (Fig. 5).

The use of non-homing uniselectors facilitates the appli-

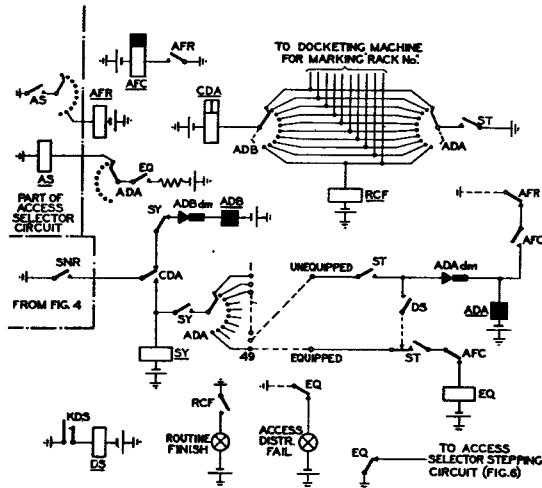

FIG. 5.—ACCESS DISTRIBUTOR STEPPING.

cation of automatic start/stop, a routine being recommenced from the point of its previous termination. Because two uniselectors are necessary to give the required number of arcs, the circuit includes arrangements for maintaining their synchronisation, together with the facility for stepping over outlets which may not be equipped initially.

The operation of relay SNR in the previous element completes a driving circuit for the ADB magnet dependent upon relay CDA which operates with synchronisation of the two uniselector positions. The SNR earth is then extended to the unequipped or equipped terminals, an unequipped strapping causing a step to be made on ADA magnet and re-synchronisation follows, this continuing until an equipped position is reached when relay EQ is operated. Seizure signal is applied by EQ to the selected rack access equipment AS relay. The circuit remains in this condition until all items on the rack have been tested, when a (rack completed) signal applied to relay AFR allows release of EQ and provides a step to the ADA magnet; re-synchronisation on an equipped rack follows.

When all racks have been tested, the operation of relay RCF, on the last outlet of arc ADA, prepares for recommencing the control sequences and provides for the docket marking "routine finished." A failure in the operation of the circuit is indicated by the continuous glowing of one of the classified fault lamps.

Manual positioning of the distributor preparatory to testing is effected by key KDS. With relay DS operated, a continuous stepping circuit for the distributors is completed. The distributor position is given by lamp display on the control panel and enables any rack to be selected for testing.

Access Selector Stepping (Fig. 6).

With the access distributor positioned on the rack to be tested, the operation of EQ (Fig. 5) releases relay TFA, which was pre-operated by the start condition. This releases the cyclic relays AD, AR and AC, giving a pulse to relay SA to step the access selectors; interaction on the

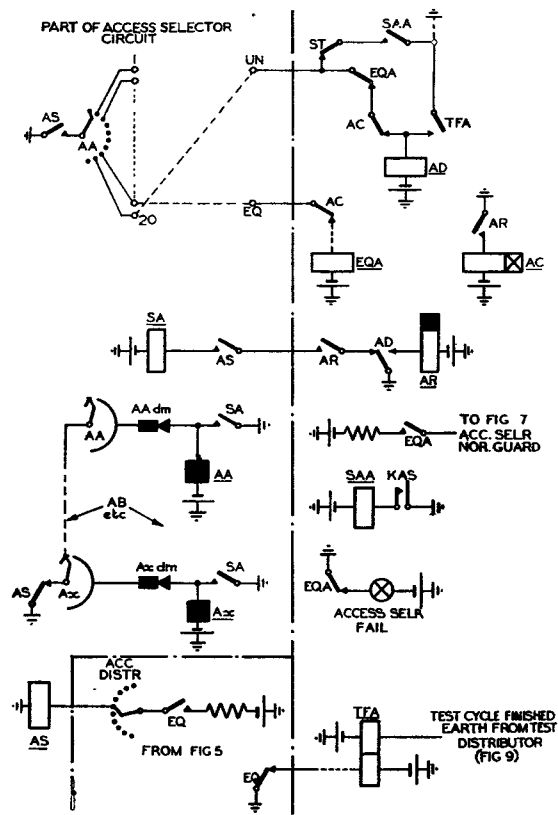

FIG. 6.—ACCESS SELECTOR STEPPING.

cyclic relays is maintained by earth from the UN (unequipped) terminal until an equipped position is reached, when the earth operates relay EQA which then applies a battery signal to start the next sequence (see Fig. 7).

The circuit remains in this condition until the cycle of tests has been made when the test distributor (Fig. 9) extends earth to re-operate relay TFA. Re-operation of the cyclic relays follows and relay EQA is released. The release of EQA releases the next sequence (Fig. 7) in readiness for the next test cycle, and the test distributor homing releases relay TFA which then frees the cyclic relays to step the access selectors.

Manual positioning of the access selectors preparatory to testing is effected by key KAS. With relay ST normal, relay SAA completes a circuit for the interaction on the cyclic relays. The access selector position is displayed on the control panel in terms of shelf and shelf position, enabling any item to be selected for test.

Access Selector Normal Guard (Fig. 7).

The operation of relay EQA when an item has been selected for test, provides battery to re-operate the access selector AN relay chain, described under Fig. 4. Since, however, the rack in use has its selectors off-normal, an alternative path is now provided by the bank wiring on the distributor arcs. It will be observed that the wiring between these arcs is "slipped" so that the position on which the distributor stands is bridged by the control circuit. This completes a circuit for the AN relay chain and relay ASN is operated and extends a start signal to the circuit of the stage following, but, should any other access uniselector be moved off-normal testing is stopped by the release of ASN and alarm indication is given.

Common Test Equipment Check (Fig. 8).

With the operation of relay ASN in the previous element, start conditions are applied to this circuit to

of SX follows and a start condition is now applied via arc TB2 to the second test relay set.

This method of controlling test relay sets in two stages provides the facility for maintaining hold conditions to the equipment under test between successive tests, and ensures that a subsequent test is not applied before the test leads have been cleared from previous test conditions. In addition, the use of AM relay on the AL lead forms part of the "self test" feature of test relay set circuits which will be referred to later.

The failure to synchronise, or the failure of a test relay set to release, gives appropriate fault lamp indications.

When the distributor is stepped from the position of the last test relay set, relay TF is operated via arc TB4, and its contact applies earth to the access stepping circuit (Fig. 6, relay TFA); this results in the release of relay STA and allows the distributors to home in readiness for the next test cycle.

Alarm Delay.

During the setting up of the routiner and the subsequent application of test conditions, as outlined in Figs. 3 to 9, a delay is required to "hold-off" the alarm during the time for successful completion of the tests. This alarm delay is provided by a circuit within the routiner which arranges for two delay periods; the shortest, 30-60 sec., covers the majority of test conditions, whilst 3 to 6 min. caters for those instances where the test is in itself longer than 30 sec.; for example, waiting on a busy circuit, or forced release tests.

In either case the circuit operates the alarm relay at the end of the appropriate period, the relay then locking dependent upon:—

- (a) step-on conditions (at the end of docketing),
- (b) re-set of the test cycle (by manual control),
- (c) clear of the fault.

In the latter case the alarm circuit is released by the operation of the magnet alarm pilot relays of either the "check" unselector or the test distributor, this also re-sets the time pulse between successive tests. From this it follows that the preliminary operations "access selectors normal," "access distributor stepping" and "access selector stepping" are expected to be completed within 30 sec. and the alarm is then reset by the first step of the "check" unselector.

Fault Indications.

In the foregoing description of the circuit elements used for control, an attempt has been made to show that the stages are in a progressive sequence in which a failure breaks the sequence and stops the routine. Moreover, the failure is localised to the point at which the sequence is broken, and indicated accordingly. The circuits so far described have been wholly concerned with the preparation of the routiner for the application of tests and a failure in these circuits is classified under the general heading of "routiner faults," the sub-classifications being provided by the particular indications as shown in the diagrams.

The design of individual test relay set circuits arranges for the selection of one of four fault lamps to indicate a failure on the main equipment, and the provision of a pilot relay in the lamp leads switches the alarm classification to "routine fault." A fault on the main equipment is thus indicated as any one of four in any of the 45 test relay set positions, a total of 180 possible fault indications. This improved fault indication should be of considerable assistance to maintenance officers, the fault being localised to an element of the circuit requiring attention.

As customary with routiners, fault indications are provided at a main panel. With the increase in the displayed

faults the use of individual lamps and labels has been abandoned in favour of an improved label panel. Lamps provide the marking for test relay set numbers 1 to 45 horizontally, and faults 1 to 4 vertically, these forming "x and y" co-ordinates locating one particular label.

For the indication of "routiner faults" the use of individual lamps and labels has been retained.

Main and Auxiliary Control Panels (Fig. 10).

The circuits for manually controlling the routiner have

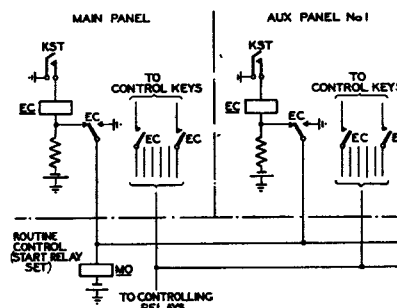

FIG. 10.—MAIN AND AUXILIARY CONTROL PANELS.

been designed to operate with auxiliary panels, the essential arrangement being that controlling keys operate relays to give the necessary circuit control. This readily permits the "teeing" in of other panels as required and interference between panels has been avoided by a guarding circuit which gives exclusive control to the panel by the operation of its "start" key.

A simplified circuit is shown in Fig. 10. It will be seen that each panel has a connecting relay for associating its keys with the appropriate controlling points. The operation of a start key at any panel operates its EC relay provided that no other EC relay is operated. The operation of an EC relay applies an earth to shunt the operating path of the other relays and operates a relay in the control circuit to permit manual operation to be made independently of automatic start/stop and docketing conditions.

The fault lamps and control keys are repeated at each panel, and lamp indication is given of the panel taking control. A "speaker" circuit provides means for co-operation between users at different panels.

FAULT TRANSLATION AND DOCKETING CONTROL

The routiner circuits have been designed for fully automatic operation; this has necessitated the addition of "clock" start and stop signals, and docket recording of faults.

The developments of the routiner and a docketing machine (to be described in a later article) have progressed concurrently. For the purposes of this description, it will be sufficient to say that the machine provides for the printing of any of 45 characters, these covering the letters of the alphabet, numerals 1 to 10, and a number of miscellaneous characters. The control circuit limits the number of characters printed to 23 per docket. Printing is started by the operation of a start relay. The marked character, i.e. one of 45, is found by hunting action and the type-head is carried to the printing position; the operation of a magnet then imprints the docket. The printing magnet springs provide a signal for the next character to be marked and so on. With the completion of 23 characters, a "docketing completed" signal is given.

The machine is controlled from a fault translation circuit which includes a routiner hunter enabling one machine to serve up to 16 routiners. The general principle of the operation is shown in Fig. 11, in which the printer characters have been depicted in the form as printed on the docket and

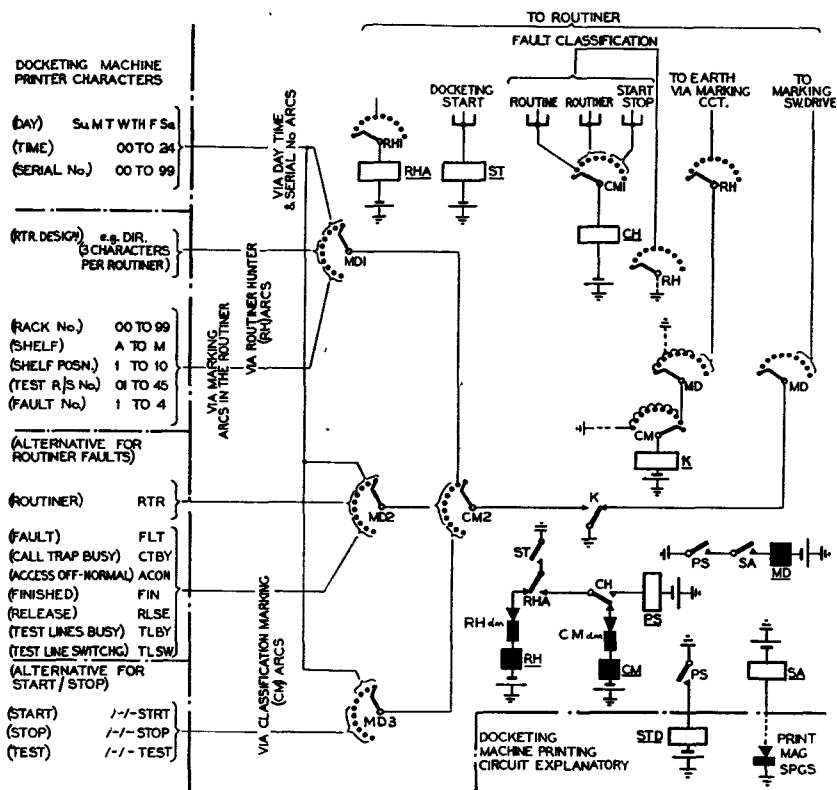

FIG. 11.—FAULT TRANSLATION AND DOCKETING CONTROL.

in the order of printing. The sequence of circuit operation is started by the operation of a routiner alarm relay which marks the routiner hunter bank (RH1) and applies starting earth to relay ST. The routiner hunter (RH), arriving at the calling position, is stopped by the operation of relay RHA, which transfers driving conditions to a classification marking switch (CM). This switch hunts for one of three main classifications (two of which include sub-classifications) marked by the routiner concerned. When this marking is found the operation of relay CH disconnects the drive and prepares the docketing machine by the operation of relay PS. At this stage relay K is operated, its operating path being dependent upon the selected classification which requires that certain characters be derived via a marking switch in the routiner. The operation of relay K extends earth via arc CM2 to the docketing machine, where the marked character is printed on a docket; successful completion of this action provides a stepping circuit for the MD magnet by the operation and release of relay SA, thereby marking the next character.

(To be continued)

Book Review

"A Guide to Plastics." C. A. Redfarn, B.Sc., Ph.D., F.R.I.C. Iliffe. 112 pp. 32 ill. 7s. 6d.

Dr. Redfarn opens with a statement that this is not a textbook, but rather a condensed guide for the reader who wants some general information on what plastics are and what they can be used for. This is a modest description; a large range of plastic materials is described in sufficient detail to give anyone who is interested a fair idea of their performance and possible applications. A later section gives a sufficient description of current methods of fabrication.

The author has chosen his way deliberately, but the treatment is not always consistent; for example, on page 37, "The acetic acid for the production of vinyl acetate is obtained

The CM switch determines which of three marking arcs on MD are used. The first arc marks information appropriate to "routine faults"; the second arc marking "routiner faults" under one of seven sub-classifications; and the third arc marking the start, stop or test indications. In all cases the first information printed is: the day, time and docket serial number, derived via other uniselectors which are separately controlled; day and time being controlled from clock signals, and the serial number switch being stepped progressively each time the control circuit is used.

In the last position of the MD switch, and irrespective of the MD arc used for marking, a "printing finished" signal is extended to the routiner when the docket has been fed from the machine. This signal following a "routine fault," steps the access selectors to the next main equipment and clears down the test cycle; when, however, the classification is "routine fault" the routiner is locked to the fault alarm because there is no purpose in continuing the routine until the fault is cleared. The docketing machine and the control circuit are freed for use by other routiners.

TESTING CIRCUITS

Part I of this article referred to the fact that tests applied to equipment should be "positive." In addition, it is required that the testing circuit should be "self-testing," that

is, a fault condition arising in the testing circuit should not go undetected, because of the probability that such a condition would neutralise the positive testing feature. These basic requirements have influenced test relay set circuit design so that, although the circuits differ in the details of their tests, they have a similarity in their circuit principles. Some of the tests require the use of devices which could not be accommodated within a test relay set even if it were economical. For example, timing tests would require the timing device on each test relay set concerned with such measurements; to avoid this, a common timing device has been provided and made available to test relay sets as required. Circuits in this category have been made available to any test relay set and are referred to as "common test relay sets."

In the next part to this article, outline principles of test relay set circuits will be given and also the principles adopted for the common test circuits, the latter being arranged so that any particular type of test uses a standard circuit with application to any routiner.

by the oxidation of ethyl alcohol obtained by the fermentation of molasses or starch," but on page 30 acetic acid for the production of cellulose acetate is just mentioned by name. Other similar examples occur and it might have been better to group the raw materials together and briefly describe how they are made—or to leave this out altogether.

The reader should be careful about temperatures; sometimes they are Celsius (Centigrade) and sometimes Fahrenheit; after reading that P.T.F.E. shows decomposition at 200°C (page 43); it was startling to read that nylon mouldings can be used under load at 275°F (page 46). The reviewer's mental adjustment to the change of scale was not immediate.

An excellent and readable guide for those who need an acquaintance with the field of plastics, but not complete enough for the professional.

C. E. R.

A Millisecond Timing Unit

J. E. HAWORTH, A.M.I.E.E.†

U.D.C. 531.76: 621.389

The author describes an electronic timing unit designed to count intervals up to 10 seconds in half millisecond units with an accuracy of ± 0.5 millisecond in a full count of 10 seconds. The recording meters step to zero and continue counting at the expiry of 10 seconds so that any time interval may be measured if the number of 10-second periods is separately recorded by the operator.

Introduction.

IN voice-operated switching equipments, such as are used at the Radio Telephony Terminal, it is important that the "operate" and "hang-over" times should be accurately measured, and the timing unit here described was developed to make such measurements as may be necessary during the installation and for the maintenance of the equipment. The instrument operates by counting the number of cycles of a timing wave that occur in the interval to be measured and is a particular application of the electronic switching technique described in recent issues of the Journal.^{1,2}

CIRCUIT DESCRIPTION

General.

The unit has been designed to measure the time interval between two particular events where each event may be:—

- arrival of a tone, usually 1,000 c/s,
- cessation of a tone,
- application of an earth,
- removal of an earth,
- change of potential from 0 to $-50V$ with respect to earth potential, or
- change of potential from -50 to $0V$ with respect to earth potential.

For (e) and (f) the $-50V$ is obtained from a battery having its positive terminal earthed. It is also possible to measure the duration of a tone from its application to removal or, if a continuous tone is applied, to measure the duration of a break of the tone from its cessation to restarting. The operation can probably best be followed by reference to Fig. 1. If we consider that the incoming signals are tones,

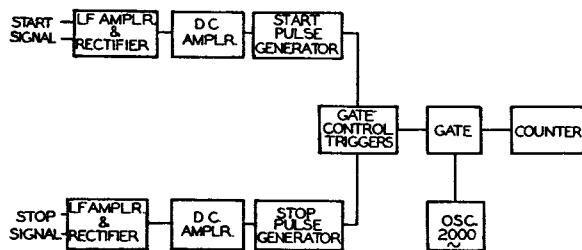

FIG. 1.—BLOCK SCHEMATIC DIAGRAM OF MILLISECOND TIMING UNIT.

then the two signals will be connected to the start and stop L.F. amplifiers. On the arrival of the start signal it is first amplified and then rectified and applied to a D.C. amplifier which operates the start-pulse generator, thereby producing a sharp negative pulse. This negative pulse operates the gate-control trigger circuit which opens the gate circuit, thereby allowing the output from the 2,000 c/s oscillator to be connected to the counter circuit. On the arrival of the stop signal the stop-pulse generator produces a similar negative pulse which now closes the gate and the 2,000 c/s oscillator is cut off from the counter circuit. During the time that the 2,000 c/s oscillator is connected to the counter, each cycle of oscillation operates the counter and the total

count is recorded on the meters. Since each cycle represents an interval of half a millisecond the meters count in units of half a millisecond, and a total count of 10 sec. can be recorded. After the full count all the meters return to zero and carry on counting so that there is no limit to the time interval that can be measured if the number of full counts is recorded separately. The accuracy of the count is absolute and any timing inaccuracy is due to the time delay in the amplifiers and the frequency inaccuracy of the 2,000 c/s oscillator. These errors, however, are small compared with 0.5 mS so that the accuracy of timing can be guaranteed to 0.5 mS in a full count of 10 sec.

A reset key, manual start and stop keys and a slow-count facility for monitoring purposes are included.

The CV 1988 double-triode valve is used throughout, except for the power rectifiers and diodes. This one type has been adopted to simplify maintenance; the small improvements that might have been obtained by using other types of valve for the amplifier and oscillator did not warrant their use. Where these valves are used in trigger or counter circuits in the diagrams illustrated, the half which passes current when the unit is in the RESET condition is shown by an arrow, thus \uparrow . This has been done so that the operation of the circuits can be more easily followed.

Input Amplifiers and Pulse Generators.

The circuit diagram of the amplifiers is shown in Fig. 2 and

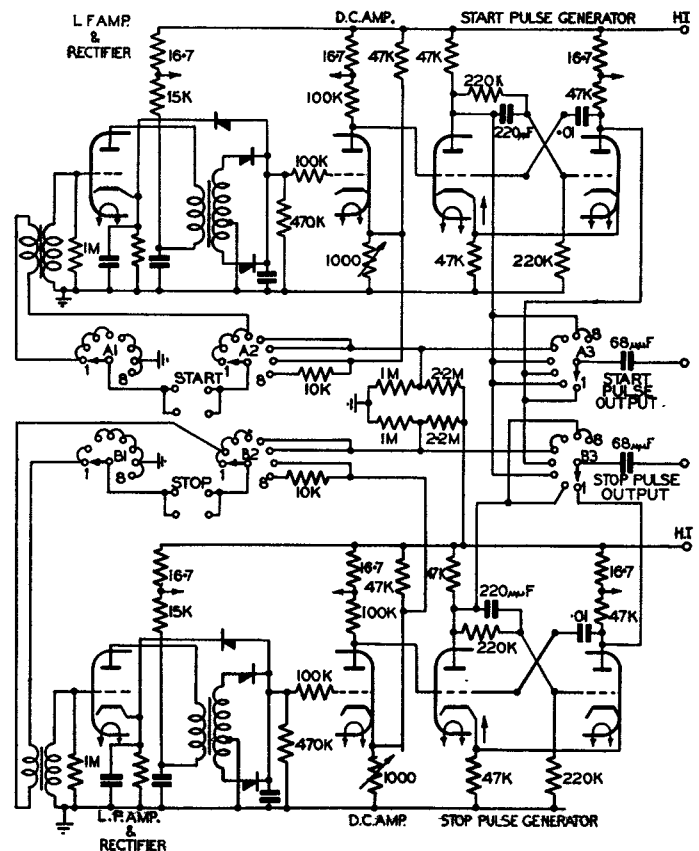

FIG. 2.—CIRCUIT OF INPUT AMPLIFIERS AND PULSE GENERATORS.

† Executive Engineer, Transmission and Main Lines Branch, E.-in-C.'s Office (formerly with the Radio Experimental and Development Branch).

¹ T. H. Flowers. "Introduction to Electronic Automatic Telephone Exchanges." *P.O.E.E.J.*, Vol. 43, p. 61 and p. 177. Vol. 44, p. 10.

² K. M. Heron, H. Baker and D. L. Benson. "An Experimental Electronic Director." *P.O.E.E.J.*, Vol. 44, p. 97.

To ensure the build-up of oscillations, it is necessary to make the loop phase-shift 2π radians (this is provided by the valve and crystal) and the loop gain greater than unity. If the loop gain is very much greater than unity, there is danger of overdriving the crystal and breaking it, whereas if the loop gain is only sufficient to maintain oscillations under normal conditions, there is a risk of failure if the power supply is low or the valve ages. To overcome both these defects the oscillator has been designed to have ample gain to ensure oscillation under adverse conditions, but the amplitude of oscillation is controlled by a simple form of automatic gain control. Since purity of waveform is not required the buffer valve is allowed to pass grid current and the D.C. voltage developed is used as grid bias to control the gain of the oscillator valve. The double-triode valve used is particularly suitable for this circuit, as it not only provides a compact arrangement but it is impossible to remove the buffer valve, thereby removing the A.G.C. and endangering the crystal, without at the same time stopping the oscillator.

The Counter Circuit.

In order to measure and display from one-half milli-second to 10 sec. a counter is required which will record up to 20,000 units and this has been provided by using one binary circuit and four decades, the binary being combined with the first decade to register a count of 20 units. The main essential of a counter of this description is reliability, and to this end it should be independent of valve changes, power-supply fluctuations or normal component ageing. The counter should also be easy to maintain and repair, so it should contain as few valves as possible, and the required component values should have wide tolerances. It is considered that the counter that has been developed meets these requirements.

The basic binary circuit that has been adopted is shown in Fig. 4 and the component values have been chosen to give

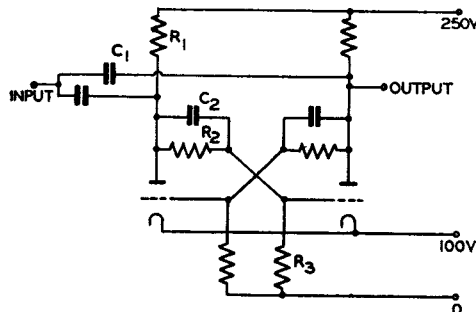

FIG. 4.—BASIC CIRCUIT OF BINARY COUNTER.

a bi-stable trigger circuit. On receipt of a negative pulse the passing valve is blocked, the circuit potentials relax and are controlled by the time-constants $R_1 C_1$ and $R_2 C_2$, $R_2 C_2$ being much longer than $R_1 C_1$, so that the valve which was previously blocked reaches the passing condition first and a second stable condition is reached. On receipt of the second

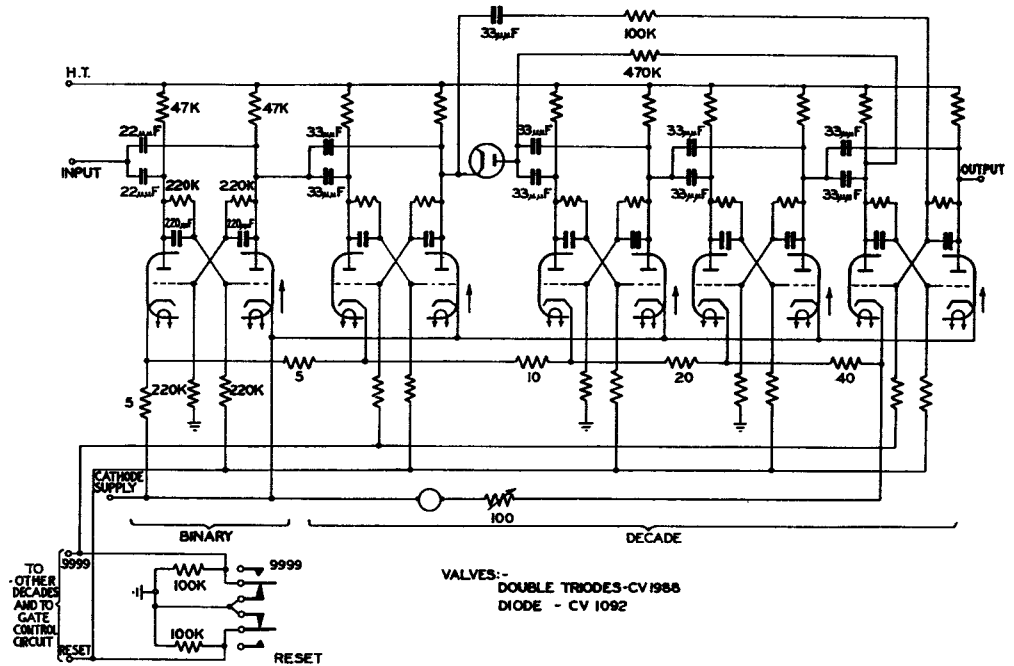

FIG. 5.—THE COUNTER CIRCUIT.

negative pulse the circuit reverts to its former condition, thus giving a count of two. The initiating pulses are supplied from the gate circuit which passes one negative pulse per cycle of oscillation, i.e. one negative pulse per half milli-second, when in its open condition. The operation of a decade counter is as follows:—

When the RESET key is pressed the second valve of each pair will be in the passing condition, as indicated by the arrows in Fig. 5. When a negative pulse is received the first counter stage will trigger and take up a stable condition with the first valve of that pair passing. A positive pulse is generated at the second valve anode, but, as the following binary circuit is insensitive to positive pulses, it remains in the condition indicated. The first valve of the first counter circuit is now passing and a count of one unit is indicated on the meter, as explained later. On receipt of a second negative pulse the first counter reverts to its original condition and in so doing a negative pulse is generated in the anode circuit of the second valve which causes the second binary stage to trigger. The meter now indicates a count of two.

Continuing in this manner and assuming that the meter will indicate four if only the third stage is triggered and eight if only the fourth stage is triggered, it will be seen that with four stages a count of 2^4 is possible in unit steps. To convert this to a decade count the diode gating circuit is introduced. Normally the diode is passing freely but, on the eighth pulse being received and the fourth stage triggered, the valve is blocked by the D.C. potentials. The ninth pulse operates the first stage in the normal manner, but the tenth pulse which restores the first stage cannot trigger the second stage; it does, however, trigger the fourth stage, and so all stages are back to the original condition. Various methods of coupling between binary stages have been devised by various workers, but the direct coupling between anodes which is used has been found simple and reliable.

The circuit can be set to its initial state and prepared for the next count by pressing the RESET key which simply applies a positive potential to the second valve of each binary circuit.

The tolerances of the components in the counter circuits are not critical and changes of more than ± 20 per cent. can be tolerated without affecting the counting action, whilst

changes of over 50 per cent. in the components associated with the diode-gating valve can be tolerated without upsetting the gating action. The valves act only as switching units, and valve changes have no effect on the counting action, or on the current flowing in the valve when in the passing condition. The valve current is, however, dependent on the H.T. supply voltage, as explained later, although the counter will continue to count with an H.T. supply ranging from under 150V to more than 300V.

Register of Count.

Several methods of registering the count of this type of circuit have been devised,^{3,4,5} the most common being some form of neon lamp arrangement. For the present purpose it is required that the display should be easily and rapidly observed so that a series of measurements will not prove tiring to the operator. For this reason it was decided that the most suitable form of display would be to register the count of each decade on a meter calibrated from 0 to 9, with the last meter registering the count of the binary plus decade unit marked in half unit steps to register half milli-seconds.

The method of metering of each decade, developed for use with this unit, can be followed from Fig. 6, and it will be seen

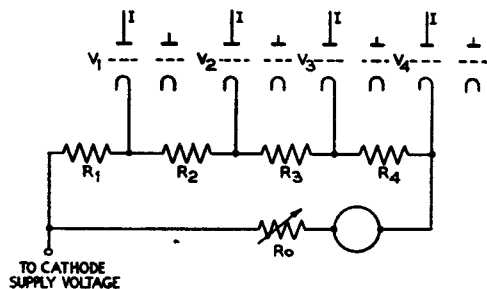

FIG. 6.—PRINCIPLE OF METERING CIRCUIT.

that, in effect, the meter measures the potential across the cathode resistors. It can be shown that to obtain an accurate register and to ensure that the meter reading increases in unit steps, say i , according to the combination of valves, each of which passes a current I , the following conditions must hold:—

$$\begin{aligned} R_2 &= R_1 \\ R_3 &= 2R_1 \\ R_4 &= 4R_1 \\ I &= i \left(\frac{R_0}{R_1} + 8 \right) \end{aligned}$$

and so for finite values of R_0

$$i < \frac{I}{8}$$

The valve current I is of the order of 3 mA and the meter current increases by 100 μ A per count.

If the meter reading is to be easily read the needle should not be more than one-third of a division away from the registered number, so that a reading accuracy of better than 4 per cent. is required on the full-scale deflection. Some degree of compensation can be made by adjusting R_0 of Fig. 6, and, although this scheme cannot be used to make all readings correct, it proves useful; R_0 has been made a preset screwdriver control easily adjustable from the front of the instrument. Arrangements have been made to set the

count to 9999 when desired and each meter can be adjusted to read correctly for this condition. All other readings can then be read with accuracy. This preset adjustment compensates for H.T. voltage changes.

The accuracy of the readings is also dependent on the stability of the valve current I . If we consider the valve current when in the stable condition with reference to Fig. 4, then, provided $R_1 \ll R_2 + R_3$, the valve current I is almost inversely proportional to R_1 and directly proportional to the supply voltage, and is in fact almost independent of the valves. R_1 has therefore been made a Grade 1 high-stability resistor and, as mentioned above, supply-voltage changes can be compensated by the meter series resistor R_0 .

Monitoring.

A useful feature of this timing unit is the ability to observe the operation of each part of the circuit so that maintenance and fault-finding are simplified. The meter associated with the fourth decade can be switched to measure the H.T. supply or the current flowing in the valves, the circuit being shown in Fig. 7.

The counter unit is more or less self-monitoring, but to enable the incremental steps of the meters to be observed more easily, arrangements have been made to substitute the 2,000 c/s timing wave by the 50 c/s mains supply.

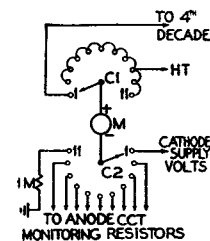

FIG. 7.—CONNECTIONS OF MONITORING SWITCH.

Power Supply.

The power supply circuit is shown in Fig. 8. A 200/250V

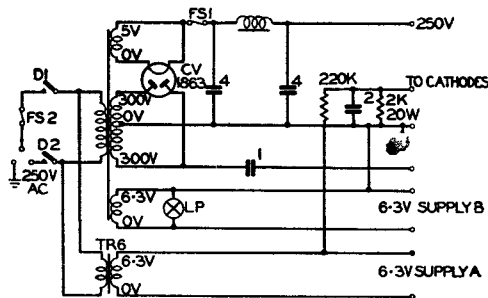

FIG. 8.—POWER SUPPLY CIRCUIT.

50 c/s supply of about 150W is required and the power unit is designed to supply 250V, 80 mA for H.T. supply and 6.3V, 16 amps. for heater supply. The cathodes of the valves in the gate and control circuits and the counter circuits, shown in Figs. 3 and 5, are connected to earth through a 2,000-ohm resistor to provide a bias voltage of 100V. Two heater supplies are provided since the maximum recommended cathode/filament potential of a CV 1988 valve is 90V. The 6.3V supply to the heaters of the gate, gate-control and counter circuits is maintained at the 100V cathode supply potential, the remaining valves being directly connected to earth.

The 50 c/s supply required for the slow-count condition is taken from the transformer secondary via a 1 μ F capacitor.

Construction.

The appearance of the unit can be seen in Fig. 9. The unit is mounted on a 19-in. \times 12 $\frac{1}{4}$ -in. steel panel under a 10 $\frac{1}{2}$ -in. deep dust cover.

Two pairs of input sockets are provided, being connected in parallel on both start and stop circuits, so that if a terminated measurement has to be made the terminating resistor can easily be plugged into the second pair of

³ Grosdoff. "An Electronic Counter." *R.C.A. Review*, Sept. 1946, p. 438.

⁴ West. "An Electronic Decimal Counter Chronometer." *Electronic Eng.*, January 1947, p. 3; February 1947, p. 58.

⁵ Baker. "A Direct Reading Indicator for Electronic Counters." *Electronic Eng.*, April 1948, p. 112.

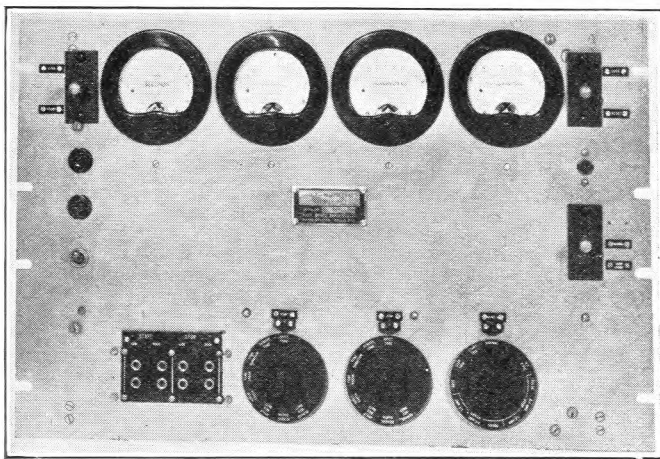

FIG. 9.—FRONT VIEW OF THE TIMING UNIT.

terminals. The start and stop input selector switches are independent and the start and stop signals need not be of the same kind. The START-STOP key and the RESET key are both non-locking and the SLOW-COUNT key switches the timing wave from 2,000 c/s to 50 c/s for monitoring. Below each meter can be seen the screwdriver control for adjusting the full-scale reading of the meter. The valves are mounted on a sub-panel which is hinged for maintenance purposes. The crystal holder, which is a glass envelope somewhat longer than a normal valve, is sunk below the panel for protection and mounted at the bottom of the panel to prevent large

Book Review

"Electronics in Engineering." W. Ryland Hill, M.S., E.E. McGraw-Hill Publishing Co., Ltd., London. 274 pp. 224 ill. 30s.

This book has been written to meet the need of advanced engineering and science students who want an understanding of electronic techniques in order that they can be applied to the various fields of engineering and to physiology. It is the result of the author's experience in developing a course of studies for students in the University of Washington and is an excellent book, both as regards subject matter and its treatment, which is initially analytical, followed by practical applications to illustrate the uses of electronics in various engineering fields. Whenever possible, the mathematical approach is accompanied by graphical analysis and examples are worked out using typical circuit values.

The sixteen chapters of the book are, as far as possible, self-contained so that they can be studied in any order. The short introductory chapter deals with atomic structure, energy levels, ionisation and conduction, and discusses the physics of electron emission, including secondary and photoelectric emission. Then follow two chapters on practical emitters, diodes and contact rectifiers, and circuits incorporating rectifiers and smoothing circuits. The graphical approach is very effective in illustrating the operation of such circuits. The next chapter on grid-controlled vacuum tubes deals first with the triode and all its properties, and then with the tetrode and pentode in a way which is logical and easy to follow. It should leave the reader with a complete understanding of the operation of such valves, which understanding he can prove to himself by working out the problems which are set for this purpose at the end of each chapter. A description of the operation of gas-filled discharge valves, including the voltage regulator, thyatron and mercury arc rectifier, and a chapter on photosensitive devices conclude the portion of the book dealing with electronic devices; the remainder of the book—except for a very good chapter on the cathode-ray tube and oscilloscope—deals with practical electronic circuits.

temperature changes. The D.C. amplifier cathode control is mounted on this sub-panel and is a screwdriver control. All valves can easily be removed after first removing the dust cover. The power plug is inserted through the dust cover so that the dust cover cannot be removed without first disconnecting the power supplies.

The temperature rise above ambient at the hottest part of the unit is about 19°C, but the temperature rise in the vicinity of the crystal is only some 5°C.

FUTURE DEVELOPMENTS

Experience with the first two units constructed shows that although faults have been few and easily corrected, some improvements may be made in any future models.

The CV 1988 valve requires 0.6 amp. heater current at 6.3V and when a large number of valves are used, as in this case, a large saving of power and consequently a smaller power supply unit and lower temperature rise could be obtained if a suitable valve with a smaller heater current consumption, such as is now available, was used.

The normal frequency of operation of the counter is 2,000 pulses per sec., but it will operate at a much higher pulse repetition rate than this and there is reason to think that with more attention to the time-constants the frequency of operation could be increased to about 100 kc/s which is more suitable for standard frequency operation.

Alternatively, since the later decades operate at less than 100 pulses per sec. the valves could be replaced with cold-cathode gas-filled counters with a consequent saving of heater power.

A chapter on electronic control circuits is limited almost entirely to thyatron devices, and a description of some hard valve control and pulse circuits, including the Eccles-Jordan trigger circuit, such as are used in high-speed electronic computing devices and pulse transmission technique is an omission which we hope will be rectified in a later edition.

The description of practical amplifier circuits follows conventional lines except that the graphical presentation is used very effectively in conjunction with the text.

In the chapter on feedback, it is pleasant to find that the implications of feedback are discussed in relation to mechanical and electro-mechanical control systems, and also that the student is made to realise that negative feedback has its pitfalls. "It is not a panacea for the ills of all amplifiers; properly designed circuits offer great improvements, but improper applications may cause more harm than good."

The operation of resonant circuits and tuned amplifiers leads to a study of oscillators, including crystal control and R-C oscillators with both positive and negative feedback.

The chapter on amplitude modulation is confined to the simplest form of modulation. Balanced-type modulators might have been mentioned together with an introduction to frequency modulation.

The descriptions of some of the many forms of transducers are valuable in that they not only introduce the reader to so many of the electrical phenomena known to physics but show how they have been applied to produce practical engineering instruments. The description of the vacuum tube voltmeter, with its wide applications in electronic physics and engineering, appropriately concludes the book.

An Index is provided, but a bibliography or reference to more advanced text books that the student may wish to study would also be a useful addition.

The author is to be congratulated on producing such a readable and concise book. In achieving his purpose, as set out above, he has produced a book which should be of great value to many telecommunication engineers who hitherto have not had the opportunity to become closely acquainted with electronics in engineering.

L. E. R.

An Approach to the Standard Equations for a Uniform Transmission Line

H. R. Harbottle, O.B.E., B.Sc., D.F.H., M.I.E.E. †

Part I.—Propagation of Current and Voltage in Chain of Symmetrical Resistance Networks

U.D.C. 621.3.09

In this article the author derives the standard equations for a uniform transmission line in a manner which avoids the use of differential calculus. The propagation of current and voltage in a chain of similar symmetrical resistance sections is considered in Part 1. Part 2 will show how the results obtained are applied to the general case of propagation through a chain of impedance sections, simulating the uniform transmission line.

Introduction.

THE subject of this article formed the basis of a recent informative talk to members of the London Junior Centre of the Institution of Post Office Electrical Engineers and the suggestion was made then that the subject matter should be published so that students who were not familiar with the solution of differential equations would be enabled to obtain a better appreciation of transmission line theory. The difficulties encountered by students who are preparing for the City and Guilds of London Institute's examinations in this and allied subjects have become increasingly apparent since the introduction of the revised syllabuses in Telecommunications Engineering, and it is felt that the following comparatively simple exposition may prove to be of some assistance. In order to reduce the length of the article, it has been assumed that the reader possesses a working knowledge of alternating current theory so that he can extend the arguments developed from consideration of pure resistances to the more general case of impedance networks.

CHARACTERISTIC RESISTANCE OF A SYMMETRICAL NETWORK OF RESISTANCES

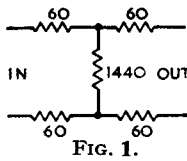

Consider the network of resistances in Fig. 1. The resistance measured across the input terminals, when the output terminals are open-circuited, as shown, is obviously

$$R_{oc} = 60 + 1,440 + 60 = 1,560 \text{ ohms.}$$

When the output terminals are short-circuited, the resistance measured across the input terminals will be

$$R_{sc} = 60 + \frac{120 \times 1,440}{120 + 1,440} + 60 = 230.8 \text{ ohms.}$$

It should be noted that the geometric mean, $\sqrt{R_{oc} \cdot R_{sc}}$, = 600 ohms.

When two such sections are joined in tandem, as in Fig. 2(a), and the output terminals are open-circuited, then,

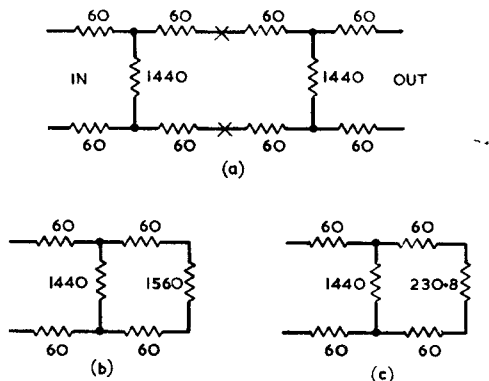

FIG. 2.

as far as resistance measured across the input terminals is concerned, the second section can be replaced by a resistance

† Staff Engineer, Training Branch, E.-in-C.'s Office.

of 1,560 ohms connected across the output terminals of the first section. In this case (Fig. 2(b)),

$$R_{oc} = 120 + \frac{1,680 \times 1,440}{3,120} = 895 \text{ ohms.}$$

Again, when the output terminals are short-circuited, the circuit can be resolved to that of Fig. 2(c), from which

$$R_{sc} = 120 + \frac{350.8 \times 1,440}{1,790.8} = 402.2 \text{ ohms.}$$

Here also, $\sqrt{R_{oc} \cdot R_{sc}} = 600$ ohms.

By adding successive sections the results given in Table I would be obtained.

TABLE I

No. of Sections	R_{oc}	R_{sc}	$\sqrt{R_{oc} \cdot R_{sc}}$
0	∞	0	600
1	1,560	230.8	600
2	895	402.2	600
3	715	504	600
4	650	554	600
		etc.	

If these results are plotted as in Fig. 3, it will be readily

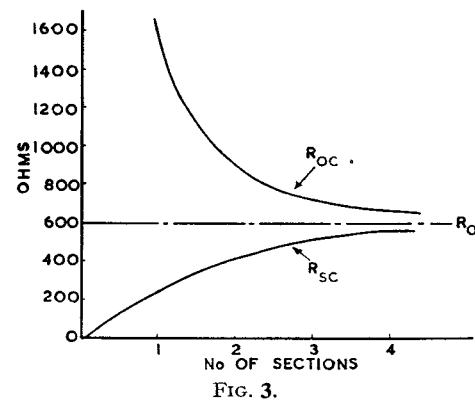

FIG. 3.

observed that both the curves for R_{oc} and R_{sc} are asymptotic to a resistance value of 600 ohms, i.e. with a large number of sections in tandem the resistance measured across the input terminals would be 600 ohms irrespective of the resistance which is connected across the output terminals. The Characteristic Resistance, R_0 , of the network is, therefore, 600 ohms and it will have been observed that $\sqrt{R_{oc} \cdot R_{sc}}$ is also 600 ohms.

i.e. $R_0 = \sqrt{R_{oc} \cdot R_{sc}}$ or R_0 is the geometric mean of R_{oc} and R_{sc} . (The student should check that the resistance measured across the input terminals of a single section is 600 ohms, if the output terminals are closed by a resistance of 600 ohms.)

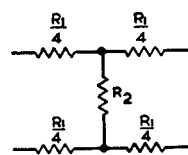

FIG. 4.

In the general case of a symmetrical resistance network (Fig. 4), it will be seen that:—

$$R_{oc} = \frac{R_1}{2} + R_2$$

$$\text{and } R_{sc} = \frac{R_1}{2} + \frac{\frac{R_1}{2} \times R_2}{\frac{R_1}{2} + R_2}$$

$$\therefore R_0 = \sqrt{R_{oc} \cdot R_{sc}} = \sqrt{\frac{R_1^2}{4} + R_1 R_2}$$

PROPAGATION OF CURRENT AND VOLTAGE IN A CHAIN OF SYMMETRICAL RESISTANCE NETWORKS

Returning to the original resistance network of Fig. 1, when the output terminals of a single section are closed by the characteristic resistance of the network ($R_0 = 600$ ohms) the resistance measured across the input terminals will be the characteristic resistance, 600 ohms, also. Any source of electrical power connected across the input terminals will have internal resistance and it will now be shown that maximum power will be delivered to the load when the resistance of the load is equal to the resistance of the source.

Let the internal resistance of the source be R_0 ohms and its e.m.f. e volts (Fig. 5). The power, W watts, delivered to a load of R ohms will be:—

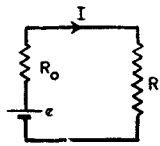

$$W = I^2 R = \left(\frac{e}{R_0 + R} \right)^2 R$$

$$= \frac{R_0^2}{R^2 + 2R_0 R + R^2} e^2$$

FIG. 5.

To find when W is maximum, assume that:—

$$y_1 = R$$

$$\text{and } y_2 = \frac{R_0^2}{R} \quad \text{or } y_2 \cdot R = R_0^2$$

The curves of y_1 and y_2 have been plotted in Fig. 6, with R

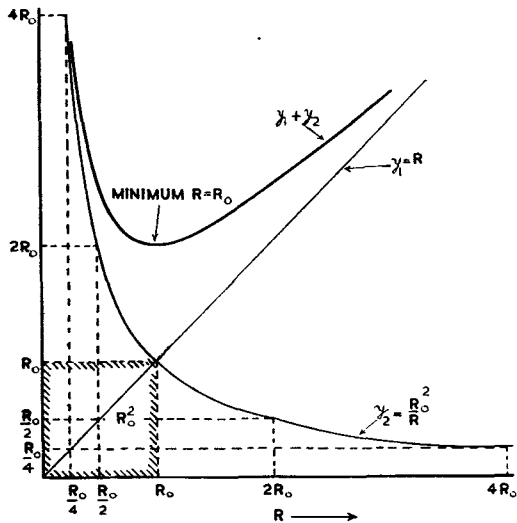

FIG. 6.

as the independent variable. The first will be a straight line through the origin and the second a rectangular hyperbola.

It will be observed that $(y_1 + y_2)$ and, therefore $(y_1 + y_2 + 2R_0) - R_0$ being regarded as fixed—will have a minimum value when $R = R_0$. For this condition, W is maximum.

With such a source, the input current to the single-section resistance-network (Fig. 7(b)) terminated in its characteristic resistance $R_0 (= 600$ ohms), will be

$$I_0 = \frac{e}{1,200} \text{ amps. (Fig. 7(a)).}$$

From the point of view of the termination, the output terminals of the network will appear as a source of e.m.f. having an internal resistance equal to the characteristic

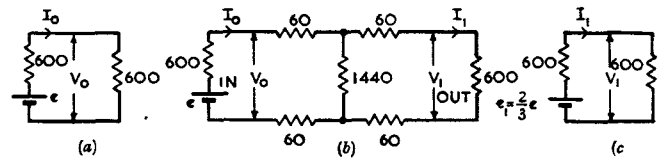

FIG. 7.

resistance $R_0 (= 600$ ohms). The magnitude of the e.m.f., e_1 , will be the same as the potential difference across the output terminals when open-circuited. Hence, (Fig. 8),

$$e_1 = 1,440 \times \frac{e}{2,160} = \frac{2}{3}e$$

This is a particular example of the application of Thevenin's theorem.

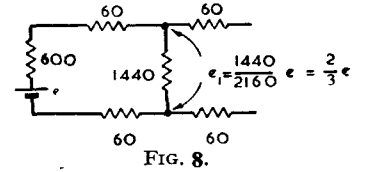

FIG. 8.

The current in the termination R_0 will be

$$I_1 = \frac{\frac{2}{3}e}{2 \times 600} = \frac{e}{1,800} \text{ amps. (Fig. 7(c)).}$$

$$\text{Hence, } \frac{I_0}{I_1} = \frac{1,800}{1,200} = \frac{3}{2}$$

$$\text{Also, } V_0 = \frac{e}{2}$$

$$\text{and } V_1 = \frac{e_1}{2} = \frac{\frac{2}{3}e}{2} = \frac{e}{3}$$

$$\therefore \frac{V_0}{V_1} = \frac{3}{2}$$

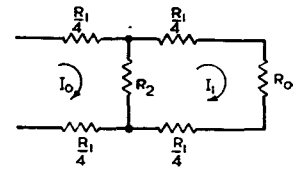

FIG. 9.

Generally, with reference to Fig. 9,

$$R_2 (I_1 - I_0) + \left(\frac{R_1}{2} + R_0 \right) I_1 = 0$$

$$I_0 R_2 = I_1 \left(\frac{R_1}{2} + R_2 + R_0 \right)$$

$$\text{or } \frac{I_0}{I_1} = \frac{\frac{R_1}{2} + R_2 + R_0}{R_2} = 1 + \frac{1}{2} \cdot \frac{R_1}{R_2} + \frac{R_0}{R_2} = r \text{ (say).}$$

N.B.—For the original values of R_1 and R_2 ,

$$r = 1 + \frac{1}{2} \cdot \frac{240}{1,440} + \frac{600}{1,440} = \frac{3}{2}$$

as above.

It should be noted that, although I_1 and I_0 have different magnitudes, there is no phase difference between them, since the network consists of pure resistances only.

When a second similar section, closed in its characteristic resistance $R_0 (= 600$ ohms), is added in tandem to the first section, the resistance measured across the input terminals will still be $R_0 = 600$ ohms and, therefore, the input current from the source will be unaffected, i.e.

$$I_0 = \frac{e}{1,200} \text{ amps.}$$

But, since the output from the first section is equivalent to a source which has an internal resistance of $R_0 = 600$ ohms and an e.m.f. $2e/3$, the output of the second section can be replaced by a source which has an internal resistance of $R_0 = 600$ ohms and an e.m.f.,

$$\frac{2}{3} \cdot \frac{2e}{3} = \frac{4e}{9}$$

Hence, the current in the termination (600 ohms) of the second section will be:—

$$I_2 = \frac{\frac{4}{9}e}{1,200} = \frac{e}{2,700} \text{ amps.}$$

$$\therefore \frac{I_1}{I_2} = \frac{2,700}{1,800} = \frac{3}{2} = \frac{I_0}{I_1}$$

$$\text{and } \frac{I_0}{I_2} = \frac{I_0}{I_1} \cdot \frac{I_1}{I_2} = \frac{3}{2} \cdot \frac{3}{2} = \frac{9}{4}$$

Consequently, if there are n similar sections in tandem, the end one being terminated in its characteristic resistance, R_0 ($= 600$ ohms), the current in this termination will be I_n where

$$\frac{I_0}{I_n} = \frac{I_0}{I_1} \times \frac{I_1}{I_2} \times \frac{I_2}{I_3} \times \dots \times \frac{I_{n-1}}{I_n}$$

$$= \left(\frac{I_0}{I_1}\right)^n = r^n$$

Similarly,

$$\frac{V_0}{V_n} = \frac{V_0}{V_1} \times \frac{V_1}{V_2} \times \frac{V_2}{V_3} \times \dots \times \frac{V_{n-1}}{V_n}$$

$$= \left(\frac{V_0}{V_1}\right)^n = r^n$$

In Fig. 10 the values of the current at the output of each section have been plotted against the number of the section. Provided I_0 ($= e/2R_0$) and r ($= I_0/I_1$) are known, a

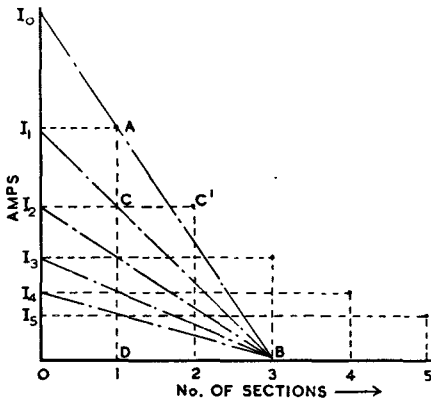

FIG. 10.

graphical construction can be used to determine I_2, I_3 etc., thus:—

Draw a straight line through I_0 and A ($AD = I_1$), cutting the axis of abscissæ in B. The straight line BI_1 cuts AD in C, then $CD = I_2$, etc.

Hence, if we have an infinite number of similar symmetrical resistance sections in tandem, or a finite number, n , terminated in the characteristic resistance, R_0 , the current leaving the m th section (and entering the $(m + 1)$ th section) is given by:—

$$\frac{I_0}{I_m} = \left(\frac{I_0}{I_1}\right)^m = r^m \quad \text{or } I_m = I_0 r^{-m}$$

Similarly,

$$V_m = V_0 r^{-m}$$

Again, if the current, I_n , in the terminating resistance, R_0 , of the finite number of sections, n , is known,

$$\frac{I_0}{I_n} = r^n \quad \text{or } r = \sqrt[n]{\frac{I_0}{I_n}}$$

Then, the current, I_m , leaving the m th section is:—

$$I_m = I_0 r^{-m} = I_0 \left(\sqrt[n]{\frac{I_0}{I_n}}\right)^{-m} = I_0 \left(\frac{I_n}{I_0}\right)^{\frac{m}{n}}$$

$$\text{Similarly, } V_m = V_0 \left(\frac{I_n}{I_0}\right)^{\frac{m}{n}} = V_0 \left(\frac{V_n}{V_0}\right)^{\frac{m}{n}}$$

PROPAGATION OF CURRENT AND VOLTAGE IN A CHAIN OF SIMILAR SYMMETRICAL RESISTANCE SECTIONS CLOSED IN ANY RESISTANCE

So far we have only considered the distribution of current and voltage in a chain of similar symmetrical resistance

sections terminated in the characteristic resistance, R_0 , of a section. The next problem is to determine the distribution for any terminal condition. This can be done quite readily by employing the Compensation and Superposition theorems.

The Compensation Theorem.

Consider the simple circuit of Fig. 11(a) which might represent a source having an internal resistance R_0 and an e.m.f., E , connected across a resistance of R ohms.

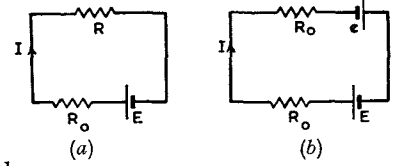

FIG. 11.

$$\text{Obviously, } I = \frac{E}{R + R_0}$$

but the same current would have flowed from the source if the load had been of resistance R_0 and of e.m.f. e (Fig. 11(b)) provided that:—

$$I = \frac{E}{R + R_0} = \frac{E + e}{2R_0}$$

$$\text{or } e = E \left(\frac{2R_0}{R + R_0} - 1 \right)$$

$$= E \frac{R_0 - R}{R_0 + R}$$

The Superposition Theorem.

It should be noted that the current I in the above case is actually the sum of two currents, thus:—

$$I = I_1 + I_2$$

where I_1 is the current due to the e.m.f. E acting alone and I_2 is the current due to e acting alone.

$$\text{For } I_1 = \frac{E}{2R_0} \text{ and } I_2 = \frac{e}{2R_0} = \frac{1}{2R_0} \left(\frac{R_0 - R}{R_0 + R} \right) E$$

$$\therefore I = I_1 + I_2 = \frac{E}{2R_0} \left(1 + \frac{R_0 - R}{R_0 + R} \right) = \frac{E}{R_0 + R} \text{ as before.}$$

Thus, if we have a chain of similar symmetrical resistance sections terminated at either end in any manner, the termination can be reduced to a source of e.m.f. having an internal impedance equal to the characteristic resistance of the section.

For example, suppose a source having an e.m.f., e_s , and internal resistance, R_0 ($= 600$ ohms) is connected to the input terminals of the original network of Fig. 1. When the output terminals are open-circuited (Fig. 12(a)), they can be represented as a source of e.m.f. $2e_s/3$ having an internal resistance of R_0 ($= 600$ ohm) (Fig. 12(b)). If the open circuit is to be replaced by a source of e.m.f., e' , having an internal resistance of R_0 ($= 600$ ohms), then, since no current must flow in the termination,

$$\frac{\frac{2}{3}e_s + e'}{1,200} = 0 \quad \text{or } e' = -\frac{2}{3}e_s$$

Thus, the source of e.m.f., e' , has been shown connected in opposition to $2e_s/3$ in Fig. 12(c). Therefore, the circuit of Fig. 12(c) is equivalent to that of Fig. 12(a), and the current at any point in the circuit can be found by considering the separate effects of e_s and e' . For instance, when the source, having an e.m.f., $e' = -2e_s/3$, and internal resistance R_0 ($= 600$ ohms), which is equivalent to an open-circuit, is connected across the output terminals, the input terminals of the network can be replaced by a source having an e.m.f., e_s , which is dependent on e' , and having an internal resistance of R_0 ($= 600$ ohms).

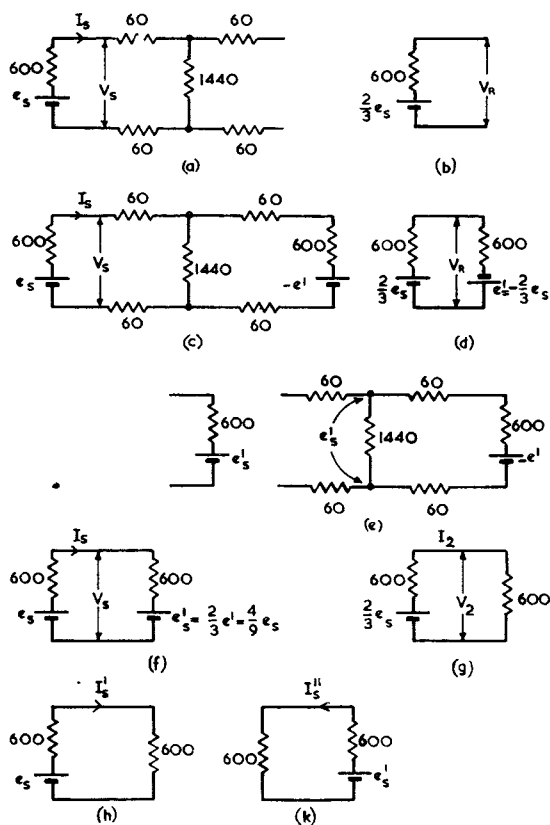

FIG. 12.

From Fig. 12(e) it will be realised that:—

$$e'_s = \frac{1,440}{2,160} e_s = \frac{2}{3} e_s = \frac{2}{3} \left(-\frac{2}{3} e_s \right) = -\frac{4}{9} e_s$$

Hence, the complete circuit at the input of the network can be represented by Fig. 12(f). From this it will be found that:—

$$I_s = \frac{e_s - \frac{4}{9} e_s}{1,200} = \frac{\frac{5}{9} e_s}{1,200}$$

$$\text{and } V_s = e_s - 600 I_s = e_s - 600 \times \frac{\frac{5}{9} e_s}{1,200} = \frac{13}{18} e_s$$

$$\therefore R_{oc} = \frac{V_s}{I_s} = \frac{\frac{13}{18} e_s}{\frac{5}{9} e_s} \times 1,200 = 1,560 \text{ ohms}$$

as was obtained by calculation initially.

It will be apparent that I_s is the algebraic sum of two currents, I'_s and I''_s , where I'_s is the current due to e_s acting alone (Fig. 12(h)) and I''_s is that due to e'_s alone (Fig. 12(i)), thus

$$I_s = I'_s + I''_s = \frac{e_s}{1,200} + \frac{-\frac{4}{9} e_s}{1,200} = \frac{\frac{5}{9} e_s}{1,200}$$

Again, I'_s is the current which would have appeared at the input if the output of the network had been terminated in its characteristic resistance R_0 ($=600$ ohms). Thus, the current I''_s is the current which appears at the input due to the change in output termination from the characteristic resistance R_0 ($=600$ ohms) to an open-circuit. Further, it should be noted that, had the output terminals of the network been closed by the characteristic resistance R_0 ($=600$ ohms) (Fig. 12(g)), the current in this termination

would have been

$$I_2 = \frac{\frac{2}{3} e_s}{1,200}$$

and the voltage $V_2 = \frac{1}{3} e_s$

But, since the output terminals are actually open-circuited, no current is received: therefore, a current I'_2 must in effect, be returned or reflected towards the sending end so that:—

$$I_2 + I'_2 = 0$$

$$\text{or } I'_2 = -I_2 = -\frac{\frac{2}{3} e_s}{1,200}$$

Also, the actual voltage across the open-circuited output terminals is

$$\frac{2}{3} e_s = 2 \left(\frac{1}{3} e_s \right)$$

i.e. double the voltage which would have occurred had the section been terminated in its characteristic resistance.

Again, for the short-circuit condition, Fig. 13(a), the output can be represented as in Fig. 13(b). The short-circuit

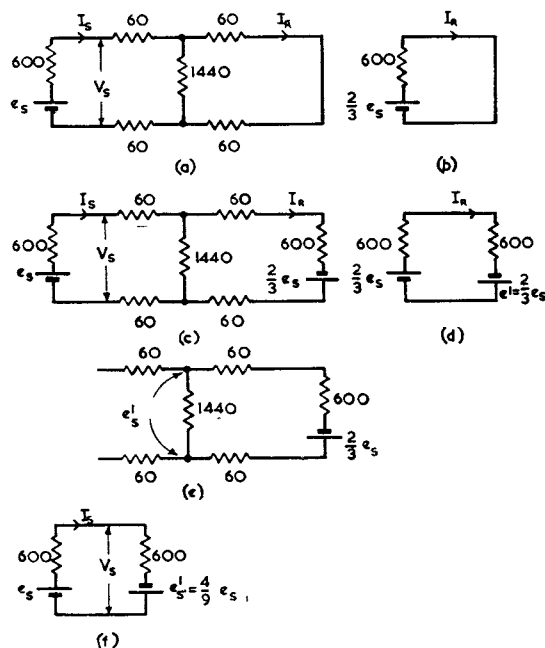

FIG. 13.

can be replaced by a source having an e.m.f., e' , and internal resistance R_0 ($=600$ ohms), provided that:—

$$\frac{\frac{2}{3} e_s}{600} = \frac{\frac{2}{3} e_s + e'}{1,200}$$

$$\text{i.e. } e' = +\frac{2}{3} e_s$$

In other words, e' must assist the effective e.m.f. which appears across the output terminals of the network. This has been shown in Fig. 13(d). The circuit of Fig. 13(c) is, therefore, equivalent to that of Fig. 13(a).

Thus, when the output terminals of the network are short-circuited, the input terminals can be replaced by a source having an e.m.f., e'_s , which is determined by e' , and an internal impedance of R_0 ($=600$ ohms).

From Fig. 13(e) it will be seen that:—

$$e'_s = \frac{1,440}{2,160} e_s = \frac{2}{3} e_s = \frac{2}{3} \left(+\frac{2}{3} e_s \right) = \frac{4}{9} e_s$$

C.C.I.F. Meetings, Florence, October 1951

U.D.C. 061.3:621.395

All of the commissions of the C.C.I.F. with the exception of the 5th met in Florence in October 1951, over a period of about two weeks. These meetings were followed by the XVIth Plenary Assembly at which the recommendations of the technical commissions were endorsed. A short report of the work of each commission is given in these notes. The XVIIth Plenary Assembly will be held in 1954 after the Administrative Telegraph and Telephone Conference.

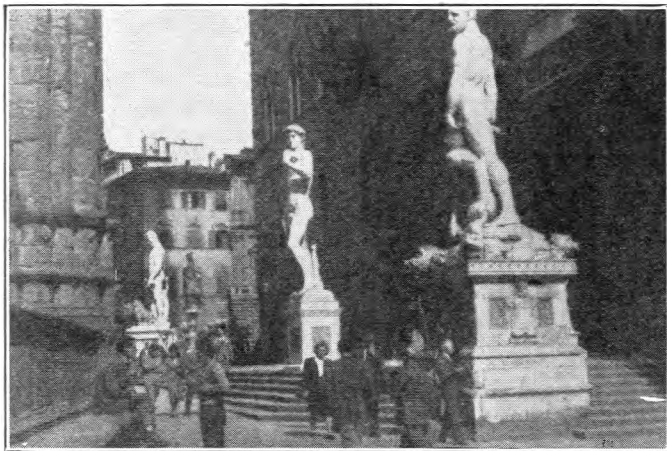

FIG. 1.—ENTRANCE TO THE PALAZZO VECCHIO WHERE THE PLENARY ASSEMBLY WAS OPENED.



FIG. 2.—C.C.I.F. PARTY OUTSIDE ST. PETERS, ROME.

1ST C.E.—PROTECTION FROM INTERFERENCE CAUSED BY POWER LINES

The first Study Group of the C.C.I.F. met under the presidency of M. Collet (France). This Group is entrusted with the examination of problems relating to the electrical protection of communications circuits. Its chief duty is to lay down limits and to recommend practices acceptable to both light current and heavy current electrical engineering interests. To this end, it is necessary for both of these interests to be represented and, in addition to the telecommunication engineers at the meeting, there were representatives of the International Union of the Producers and Distributors of Electric Energy (U.N.I.P.E.D.E.) and of the International Conference of Major Electric Systems (C.I.G.R.E.).

A number of modifications and additions to the C.C.I.F. Yellow Book, Volume 2, Paris 1949, were tabled, including a revised specification for the manufacture of a psophometer for commercial telephone circuits; but the chief work of the Study Group was the drawing-up of a programme of questions to be examined during 1952-53. There are 17 such questions, and of these numbers 7, 12 and 13 are of particular interest to the Post Office.

Question 7.

At present, the allowable limit of parallelism between a power line and a telecommunication line is such that an earth fault on one phase of the power line shall be incapable of producing in the telecommunication line an induced voltage exceeding 430 V. The question is posed as to whether some relaxation of the limit can be agreed for power lines which, by virtue of the nature of their construction, are most unlikely to be subject to earth faults, and which are fitted with such efficient protection and circuit breakers that any earth fault would be cleared in less than 0.5 sec., and the majority (80 per cent.) of such faults in less than 0.1-0.2 sec. This question is a very live one to the Post Office because there are at present cases under consideration in which it seems almost impossible to conform economically to the 430V limit.

Questions 12 and 13.

Questions 12 and 13 relate to the definition, measurement and limitation on trunk and local circuits of electrostatic and electromagnetic earth unbalances, which determine the susceptibility of these circuits to noise interference from power lines. To the Post Office, this is a problem of some moment; one of its facets which comes to mind is the possibility that it may be found that at audio frequencies equipment unbalance so preponderates that cable balancing technique can be simplified without any appreciable degradation of the overall noise interference level. Statistics are to be prepared of measurements on working circuits and these should help to clarify the position.

The edition of the "Directives Concerning the Protection of Telecommunications Lines Against the Damaging Effects of Electric Power Lines (Rome, 1937, revised at Oslo, 1938)" is at present out of print and as there is a demand for these directives it has been decided to set up a committee to revise them. Total revision of the document will take some years but, to meet the need more rapidly, a provisional revision will be made which will incorporate all the modifications of which the principle has already been adopted by the C.C.I.F.

2ND C.E.—PROTECTION AGAINST CORROSION

On the 6th October, 1951, the 2nd Study Group witnessed a demonstration, sponsored by the *Commission Mixte Internationale*, of a double-bridge method of determining the proportion of the current in a rail of an electric traction system which leaks from the rail into the earth. The C.M.I. is a mixed commission of both heavy-current and light-current engineers whose object is to throw light on problems relating to the influence of electric power on telecommunications.

The Study Group commenced its work proper on 8th October under the presidency of M. Collet (France). It considered problems and documentation relating to cable corrosion and the composition of cable sheaths, and drew up a list of nine questions for study during 1952-53. These cover problems relating to alternatives to lead in the con-

Hence, the complete circuit at the input of the network can be represented by Fig. 13(f). Thus,

$$I_s = \frac{e_s + \frac{4}{9}e_s}{1,200} = \frac{\frac{13}{9}e_s}{1,200}$$

$$\text{and } V_s = e_s - 600I_s = e_s - 600 \frac{\frac{13}{9}e_s}{1,200} = \frac{5}{18}e_s$$

(To be continued)

$$\therefore R_{sc} = \frac{V_s}{I_s} = \frac{\frac{5}{18}e_s}{\frac{13}{9}e_s} \times 1,200 = 230.8 \text{ ohms}$$

as calculated originally.

It should be noted that for the short-circuit condition, the voltage across the receiving end terminals is zero, and the current in the short-circuit is twice that which would have been received if the receiving end terminals had been closed by the characteristic resistance R_0 (= 600 ohms).

Book Reviews

"Travelling Waves in Transmission Systems." L. V. Bewley, B.Sc.(E.E.), M.S.(E.E.). 2nd Edn. Published J. Wiley & Sons Inc. (U.S.A.) and Chapman & Hall, Ltd. (U.K.). 543 pp. 246 ill. 96s.

To communication engineers, the title of this second edition of "Travelling Waves on Transmission Systems" may be misleading, since it is mainly concerned with surges on power distribution systems due to lightning. However, since the treatment is mainly theoretical, making extensive use of operational calculus, it can be usefully read by communication engineers concerned with the transient response of transmission lines.

For power engineers, concerned with the design and protection of overhead power lines and terminal transformers, the book is a useful summary of the theories of transient surges, and presents design data in a compact form.

The volume is written in two sections, the first of which treats surges due to direct and induced lightning strokes, switching and arcing earths. Direct lightning strokes are treated in some ten chapters, the remaining causes of surges having a chapter devoted to each of them. The second section is concerned, in six chapters, with surges in transformer windings. Measures for the protection of the system are considered in both parts.

The first chapter deals with generalised solutions of the transmission line equations, and a solution for the infinite line with an applied unit step is quoted. The next chapter is concerned with various wave shapes which may be considered, and their attenuation due to propagation with and without corona formation. Subsequent chapters deal with the reflection of surges at transition points in a line system, and discuss the concept of multi-velocity waves in multi-conductor systems. The theory of the formation of lightning strokes is discussed briefly and a model for lightning stroke simulation is described. The first section then continues with a discussion of earth wires, and counterpoise earthing of the towers. Induced lightning surges, arcing earths, and switching phenomena are then treated. Measures for the protection of distribution systems are discussed at some length.

The second section is devoted to the theory of surges in transformer windings assuming linear transformer characteristics. Various wave shapes are considered. The distribution of voltage throughout the winding, and terminal voltage transients are treated in some detail, on the basis of the windings being considered as a system of transmission lines.

Generally, the book summarises advances made in the theory, design and protection of power distribution systems from the particular aspect of voltage surges. The theoretical treatment is supplemented extensively by details of field work carried out over a number of years. For use as a reference work, the material could, at times, have been presented in a clearer manner; and in particular the numerical examples could have been separated from the main text with advantage, thus clarifying the theoretical treatment, the latter being, at times, extensive. The treatment of earth conduction effects is scanty

and could have been elaborated with advantage. Considerable investigation of the subject has been made since 1930 and it is an important consideration in the treatment of power systems. The author comments in his introduction on the reasons for the scanty references, but, nevertheless, the references are not adequate for a work of this nature. For example, in discussing lightning, reference to the work of Boys, Schonland, Loeb, Meek, Sunde and others could have been made with advantage. In a similar manner, amplification of the references in other topics could have been made.

Apart from these minor defects, the book is a useful addition to the literature on power systems. A complex subject has been simplified and summarised to an extent which permits of application to the design of power distribution systems. For the communication engineer, topics treated in the book have some relevance, in particular the treatment of transients in transmission systems, and of transformer windings as distributed networks.

F.J.

"Theory and Design of Valve Oscillators." H. A. Thomas, D.Sc., M.I.E.E. Second edition, Chapman & Hall. 317 pp. 157 ill. 36s.

This work was first published in 1939 as one of a series of monographs on electrical engineering under the editorship of H. P. Young, M.I.E.E., M.A.I.E.E. This second edition has been revised and enlarged by rearranging Chapters I and II, condensing the material in the original Chapters IV to X into Chapters IV, V and VI, dropping Chapter XI and adding five new chapters. Two of the new chapters are devoted to RC oscillators and crystal oscillators, whilst the remaining three deal with ultra high frequency oscillators, velocity modulated oscillators and magnetron oscillators.

The three additional chapters on the types of valve for use at UHF and above are a useful extension of the original text. However, the treatment in no way compares with that given to LC oscillators and one wonders whether the three chapters could not have been better used in giving a more up-to-date treatment of LC oscillators or even of crystal-controlled oscillators. To devote even one chapter to crystal-controlled oscillators is a change of policy but in no way does justice to the subject, if for no other reason than that it contains only 13 pages.

The dropping of the subject matter of the original Chapter XI, namely, frequency stabilisation by automatic monitoring, seems peculiar in view of the basic nature of the subject and its many applications.

Some surprising statements remain, mainly from the original text. For instance, page 81, where a 1936 reference is considered new; page 87, that oscillation cannot be sustained without the introduction of harmonics; page 89, that C.C.I.R. tolerances are referred to and not the I.T.U.; and on page 214 one finds "such a circuit (transitron) is comparable to the crystal oscillator in stability."

Much pruning of the original text has been carried out and certain information has been added but the pruning could well have been more severe and the whole book made more up to date and realistic.

H. T. M.

struction of cable sheaths, the causes of inter-crystalline corrosion of lead, the protection of cables against lightning, the maintenance of cables under gas pressure and the use of radio-active tracers for locating sheath defects in lead cables. The major part of the Study Group's time, however, was taken up in the completion of a document entitled "Recommendations for the Protection of Underground Cables against the action of Stray Currents arising from Electric Traction Systems (Florence, 1951)."

The above Recommendations have been drawn up by the C.C.I.F. in agreement with the representatives of C.I.G.R.E., U.N.I.P.E.D.E., the International Union of Railways (U.I.C.), the International Union of the Gas Industry (U.I.G.) and the representatives of national tramways associations. It will be appreciated that technical accord between bodies whose operations can cause corrosion and those whose plants suffer it is not easy to secure, and that this has been achieved is felt to be a real cause for satisfaction. The ground covered in the Recommendations is very complete. Good "codes of practice" are prescribed for the construction of both traction tracks and underground pipes and cables; methods of protecting underground plant with protective wrappings, insulating gaps, electric drainage and cathodic protection are described and details of measuring instruments and testing procedures given.

The document just completed refers specifically to corrosion produced by stray currents: it is complementary to the C.C.I.F. document "Recommendations for the Protection of Underground Cables against Corrosion (Paris, 1949)" which treats the subject on more general lines.

3RD C.E.—LONG-LINE TRANSMISSION

Before the meeting in Florence, previous meetings had been held in Geneva, November 1950, and in London in March 1951, so that a good deal of preliminary work had been done. In the following notes an attempt has been made to pick out the most important items in each subject.

Speech Circuits.

Observations made on a number of international circuits over long periods have shown that the equivalent at 800 c/s has a standard deviation of 0.19 Neper and the percentage of measurements outside the limits ± 0.5 Neper is of the order of 7 per cent. To improve this state of affairs a number of remedial measures have been suggested, including the recommendations that adjustments made after periodic measurement shall be as close as possible to the nominal value, and thorough investigations made for incipient faults.

The value of the equivalent of a circuit, when in terminal service, for a semi-automatic international circuit has been fixed at 0.8 Neper. For manual working the equivalent can be of any value not greater than 0.8 Neper.

Music Circuits.

The specification for the new "normal music circuit" giving effective transmission up to 10 kc/s has now been agreed. Such circuits can be provided on carrier systems in which arrangements are made to put the circuit in place of three speech channels.

In this case it is pointed out that the 12-channel groups most suitable are those towards the middle of a supergroup (Nos. 2, 3, 4) and the best supergroups are those with the lowest carrier frequencies.

Carrier Systems.

Many European countries are now interested in 24, 36, 48 and 60 channel systems and recommendations have been made for the partition of line frequencies. The British carrier network is in agreement with the recommendation for "up to 48 circuits."

As mentioned in a previous article,¹ noise limits to be used as a basis of design have been discussed and agreed. For a coaxial system this limit for the high-frequency line is 3 picowatts per km. and the same figure has also been accepted as a provisional guide for carrier systems on unloaded balanced pair cables.

It had been agreed in 1949 that certain reference frequencies should be used for measurements on 12-circuit groups and supergroups.

These were 84 kc/s (in the basic group) and 412 kc/s (in the basic supergroup). It will be noted that these are virtual carrier frequencies and it was known that certain difficulties would attach to their use. This matter has been further discussed and it has now been agreed that two frequencies will be transmitted in place of one, the precise values being as follows:—

	Frequency in kc's	Absolute level of power at a zero level point
Group Reference Frequency	84.08	-20 db.
	84.14	-25 db.
Supergroup Reference Frequency	411.86	-25 db.
	411.92	-20 db.

By agreement between the countries concerned, only one frequency need be transmitted.

Television.

Information on the standards to be adopted internationally for television signals is still awaited from the C.C.I.R. In the meantime, however, a good deal of preliminary work has been done by the agreement of such items as impedance and amplitude at video points, and by consideration of methods of testing and maintaining television circuits.

Telegraph Circuits.

Discussions took place with the C.C.I.T. on a number of questions relative to operation and maintenance, and reserve circuits. For instance, it was agreed that the characteristics of the reserve circuit should be as nearly as possible those of the main circuit.

New Questions.

A very large programme of new questions was approved at the Plenary Assembly, many of which concern inter-connection with radio links. These latter questions have mainly originated with the Mixed Commission which has been considering the Switching Plan for Europe and the Mediterranean Basin.

4TH C.E.—LOCAL TRANSMISSION

Extensive series of articulation tests have been carried out at the C.C.I.F. Laboratory with a view to determining the practicability of obtaining reliable transmission performance ratings of the local ends of a telephone circuit with the facilities available to that laboratory. Five types of commercial telephone sets, supplied by different administrations, were used in these tests.

Results of the tests were considered by the sub-committee for specification of transmission performance (Geneva, October 1950) and by the 4th C.E. (Florence, October 1951). On the latter occasion agreement was reached on outstanding details for obtaining separate sending and receiving transmission performance ratings by measurements of A.E.N. (*Affaiblissement Equivalent pour la Netteté*) relative to the performance of the high-quality reference system, the A.R.A.E.N.² By October 1951, the technique

¹ P.O.E.E.J., Vol. 42, p. 169.

² P.O.E.E.J., Vol. 42, p. 170; and Vol. 43, p. 1.

of measuring A.E.N. values at the C.C.I.F. Laboratory had reached a stage at which it could become no longer experimental but a routine, and in fact four additional types of commercial telephone set had been tested in this way. Arrangements have been made for others to be tested.

The C.C.I.F. has now agreed that the new method of rating transmission, based on A.E.N. values, should be introduced as soon as practicable in national networks of European countries, so that new directives can be decided for the national and international telephone networks of Europe. With this object in view the 4th C.E. has formally posed for study a new question asking what is the maximum permissible limit of transmission performance ratings (expressed in terms of A.E.N.) for a national system from telephone to the terminals of an international line.

Of other questions which are being continued for study, there is space here to mention only two. One concerns the possibility of obtaining transmission performance ratings from objective tests only; some interesting contributions on the calculation of articulation values from data obtained by objective tests have been received. The other deals with transmission impairments due to circuit noise; arrangements have been made for a series of tests to be included in the programme of work of the C.C.I.F. Laboratory with a view to obtaining information on the effects of circuit noise on transmission, in as generalised a form as is practicable.

6TH AND 7TH C.E.S.—OPERATING AND TARIFFS

The 6th and 7th Study Groups reviewed the decisions reached at their meeting in Geneva in 1950 and, in order to implement those decisions, approved modifications and additions to the Operating and Tariff Recommendations in Volume I of the Yellow Book and to the Operating Instructions, which were later agreed by the Plenary Assembly. The main items concerned were: the inclusion in a single recommendation of the generally accepted broad principles for the operation of the inter-continental radio-telephone services; additions to Recommendation No. 21, suggesting rentals for short-period use of international telephone private wires; and the drafting of a booklet on broadcast transmissions, containing instructions for the controlling and accounting staff concerned with such transmissions.

Two new questions which had arisen since the last meeting were also considered. The first related to the priority to be accorded to urgent epidemiological calls, and it was decided that urgent calls booked by the World Health Organisation and its Regional Centres to prevent the possible spread of quarantinable diseases should be considered as distress calls and should be given absolute priority. The second dealt with the question of the free use of emergency routes. There had been complaint of the abuse of this privilege and it was consequently decided to delete from Recommendation No. 11 that part of the recommendation referring to the free use of emergency routes and to substitute a statement to the effect that such calls should be included in the International Accounts for their full chargeable duration.

The Study Groups agreed 19 new questions for study, one of which refers to the possibility of shared use of international telephone private wires. On the general question of the review of international telephone rates, the Study Groups decided to proceed in 1952 with the issue of a questionnaire on the net costs of coaxial cable circuits, but agreed that it was premature at present to proceed with a similar study in connection with radio relay link circuits and the issue of a questionnaire on this subject was accordingly deferred until 1953.

As M. Mockli, Chairman of the 6th Study Group and a founder-member of the C.C.I.F., was due to retire before the next meeting, his colleagues paid a very warm tribute to

him for his direction of the Study Group and for all the work he had done in the C.C.I.F. over so many years.

8TH C.E.—SIGNALLING

The 8th C.E., having already formulated replies to the questions set for study by the XVth Plenary Assembly, met in Florence to consider the revision of Volume V of the Yellow Book, taking these replies into consideration. It also formulated a number of new questions dealing with signalling and switching to be recommended to the XVIth Plenary Assembly for study during 1952 and 1953.

Among the subjects discussed the following may be of particular interest: Section V-2-3-2 of the Yellow Book defined the maximum permissible power level of signals transmitted on international circuits. Some discussion took place on the interpretation of this section and it was decided to add a note to the effect that the figure of 2.5 microwatt-hours, which is the maximum signal energy permitted per circuit during the busy hour, may be regarded as the mean value of signal energy on all channels in the same direction of transmission in a primary carrier group. It is not intended, however, that the power transmitted on any telephone channel of a carrier system should exceed 12,000 microwatt-seconds in one direction.

Section V-2-3-1 of the Yellow Book sets out the advantages and disadvantages of signalling systems which use a signalling path separate from that of speech transmission. It was recognised that, when this text was drawn up, only signalling systems having a completely separate signalling channel were taken into consideration. Systems which can be described as "associated channel" signalling systems, e.g. systems using signalling frequencies situated between the bands of two adjacent telephone channels of a telephone carrier system, may not suffer the disadvantages indicated for systems using an entirely separate signalling channel, particularly in regard to costs. It was decided to add a note in the Yellow Book to make this point clear.

The proposals which the 8th C.E. have recommended for insertion in Section V-2-4-1 of the Yellow Book clearly indicate that each administration will be responsible for the protection of its own national signalling system against interference which can arise when two different national systems using the same, or nearly the same, signalling frequencies are interconnected by an international circuit. Such protection may in practice be difficult to achieve, and it was, therefore, decided to set a new question for study with a view to determining the precautions to be taken in the design of a national signalling system to avoid the type of interference referred to above.

Other questions (13 in number) dealing with various aspects of international telephone signalling and switching were recommended for study by the 8th C.E.; consideration of these, and of the expected report on the field trials of international semi-automatic telephone operation, promises some very interesting discussions for the 8th C.E. in 1952 and 1953.

FIELD TRIAL COMMISSION (FOR SEMI-AUTOMATIC TRIALS)

The C.C.I.F. are planning to carry out field trials of signalling and switching equipment designed for semi-automatic telephone operation on international circuits, the object being:—

- (a) To assess the relative merits of two different signalling systems; one of which uses two signalling frequencies, and the other which uses a single frequency.
- (b) To ascertain the extent to which it is possible to establish calls on a semi-automatic basis without the assistance of an operator at the incoming terminal exchange.

(c) To determine the operating procedure to be employed for international semi-automatic telephone operation.

The Field Trial Commission (C.E.A.) which is responsible for the conduct of these trials, met in Florence to consider the progress made in the construction and installation of the field trial equipment in the countries concerned and to determine the lines on which the trials should be conducted.

It appears from the reports of the participating countries that the 2 V.F. signalling equipment should be ready for service in all centres by the middle of 1952 and the 1 V.F. signalling equipment by about September 1952.

The 2 V.F. equipment in the Scandinavian countries is in the course of installation, or already installed. A few circuits between Oslo, Copenhagen and Stockholm are already in operation on a semi-automatic basis.

In view of the importance attached to the analysis and presentation of the results of the trials, it was decided that all documents recording the results of service observations and faults should be forwarded to the C.C.I.F. Secretariat for examination and for the preparation of a statistical analysis of the results. This work will be carried out under the control of a small working party, established by the Field Trial Commission who will meet as frequently as necessary, preferably in the towns where the field trial circuits terminate.

The Field Trial Commission, also decided to issue four basic documents covering the various aspects of the trials, namely:—

- (1) "Instructions for operators" defining the operating methods to be employed.
- (2) "Equipment Specifications."
- (3) "Conduct of the trials" indicating the lines on which the trials should be put into operation and the observations to be taken.
- (4) "Maintenance Instructions."

VOCABULARY COMMITTEE

A "First draft of the list of definitions of all essential telephone terms" was prepared during the C.C.I.F. meetings in Geneva in 1950, and the observations of the national correspondents upon this draft were collected into a "First list of additions and modifications."

As a result of the work of the Vocabulary Committee, a revised draft of the definitions is now being prepared. All the terms are defined in French and in English, and where there are terms which have no exact equivalent in France, Great Britain and the United States of America, the different terms in use are given together with their definitions.

In addition to the "List of definitions" the Committee revised the "List of telecommunication terms in eight languages," particularly verifying the agreement between French and English terms; in addition, the English terms used in Great Britain and in the United States of America were verified and unessential differences eliminated where there is agreement in usage.

GRAPHICAL AND LETTER SYMBOLS COMMITTEE

Various problems were reviewed, many of which will need further study in co-operation with the C.C.I.T. and C.C.I.R.

A proposal was made that a diagrammatic means should be standardised to show the successive operation of relays in automatic exchange switching circuits. It was decided that this problem should first be reviewed by the 8th Study Group for a decision to be made whether such a diagram is desirable and whether, in the opinion of the auto-switching experts, the operation of the relays in a switching circuit can be shown diagrammatically and so obviate the need of a long written description of the circuit operation.

As regards some of the questions for which an international standard is desirable, a British standard has

already been issued, viz., Letter Symbols for Electronic Valves, B.S. 1409 : 1950, and Graphical Symbols used in Wave-guide Technique, Supplement No. 2 (1951) to B.S. 530 : 1948.

MIXED COMMISSION FOR THE EUROPEAN SWITCHING PLAN

At the meeting of the Mixed Committee for the General Switching Programme for Europe and the Mediterranean Basin, delegates from 21 countries were present as well as representatives from the C.C.I.T., the C.C.I.R., the World Meteorological Organisation and the International Civil Aviation Organisation. Estimated circuit requirements for the public telephone service up to 1954 were prepared and the Committee also took note of the requirements of the public telegraph services and those of the broadcast organisations for broadcast transmission circuits. A list of normal and emergency routes for broadcast transmissions was prepared and this will be reissued from time to time by the Secretariat on information furnished by the various administrations.

Reports were received from the delegates for Switzerland, the United States and the United Kingdom on radio relay links in their inland networks and from France, Italy, Israel and Jugoslavia on their plans for international radio relay links. Representatives of the C.C.I.R. were present to give general guidance and advice on the use of radio links for the international telephone network.

PERMANENT MAINTENANCE SUB-COMMISSION

The Permanent Maintenance Sub-Commission of the C.C.I.F. met from the 3rd to 6th October under the chairmanship of Mr. Visser, of the Netherlands P.T.T.

The main work of the sub-commission was the revision of the programme of maintenance for international telephone circuits in Europe. This programme lists all the international telephone circuits in Europe which transit one or more countries other than those in which the circuits terminate, and the members of the sub-commission agree the dates on which periodical maintenance tests ("routine tests") on the circuits are to be carried out. The programme has to be carefully worked out to provide an even flow of work, and in particular to avoid an overload of work at main transit repeater stations on the Continent, where transit circuits from many countries have to be tested. This is not always easy to achieve and often requires considerable rearrangement of the programme. At Florence the maintenance programme was reviewed and a new programme prepared which was brought into operation on 1st January, 1952.

Other work covered by the sub-commission included a review of the arrangements for setting up and maintaining international carrier systems, and proposals for various modifications to the existing instructions on these matters in the C.C.I.F. publications. The sub-commission also discussed the arrangements for setting up circuits required for international broadcast transmissions. A recommendation was made to the 3rd Commission that a minimum period of 15 minutes should be fixed as the normal duration for the adjustment period (*la période de réglage*) which is used by the engineers of the P.T.T.s for setting up a circuit prior to a broadcast.

CONCLUSION

The arrangements made by the Italian Administration for the Conference and for the comfort and entertainment of delegates and their families were perfect. In addition, many delegates were able to make a four-day visit to Rome as guests of the Italian Administration. There is no doubt that the visit to Italy will long be gratefully remembered by all present.

Notes and Comments

New Year Honours

The Board of Editors offers congratulations to the following members of the Engineering Department honoured by His late Majesty the King, in the New Year Honours List:—

Aberdeen Telephone Area	W. F. Macdonald ..	Technical Officer	British Empire Medal
Engineering Department	F. C. Carter	Staff Engineer	Officer of the Order of the British Empire
Engineering Department	J. W. Portway	Leading Draughtsman	British Empire Medal
Lincoln Telephone Area	J. W. Dickinson	Technician Class I	British Empire Medal
Norwich Telephone Area	M. B. Rogers, M.M. ..	Technician Class I	British Empire Medal
Welsh & Border Counties Region ..	H. C. A. Linck	Senior Executive Engineer ..	Member of the Order of the British Empire

Recent Awards

The Board of Editors has learnt with great pleasure of the honour recently conferred upon the following member of the Engineering Department:—

Reading Telephone Area	F. I. Fuzzens	Inspector	Officer of the Order of the British Empire
------------------------------	---------------------	-----------------	--

Retirement of Mr. F. E. Nancarrow, O.B.E., A.R.C.Sc., M.I.E.E.

The retirement of Mr. Nancarrow means the loss to the Department of a personality well known and highly respected in Telegraph circles both national and international. After engineering training in a naval dockyard, Mr. Nancarrow became a Whitworth Exhibitioner and a Royal Scholar at the Imperial College of Science, and later entered the Department by open competition as an assistant Engineer in 1914.

For 19 years he occupied various posts in the Radio Section at Headquarters, Dollis Hill, and as engineer in charge of the Bodmin Beam Station. One of his many activities during this period was the initiation in the Department of the work on quartz crystals, a sphere in which the Department now occupies a leading position. He was transferred to the Telegraph Branch in 1933 and became Staff Engineer in 1936.

Many important developments in Telegraphy have taken place during his term of office of which the extension of the voice frequency system of transmission, national and international Telex, and Automatic Telegraph Switching are examples.

The prototype of the new Mufax facsimile system, which may well revolutionise sub-office working in the future, came along, much to his delight, a few days before his retirement.

On the outbreak of war Mr. Nancarrow became responsible for directing the planning and provision of the many and varied telegraph requirements of the services, including a very great expansion of voice frequency, teleprinter switchboards and other specialised equipment. It is a remarkable fact that by 1944 there was five times as much telegraph equipment in the country as had existed before the war.

For these war-time services Mr. Nancarrow was, in 1944, decorated with the O.B.E.

Internationally, Mr. Nancarrow was well known owing to the important part he played in the C.C.I.T. of which he was principal Reporter for the study groups on Photo-telegraphy and Telegraph Switching, and led the U.K. delegation at many of the technical conferences from 1936 onwards.

He served with distinction for very many years as a member of the Board of Editors and as a contributor to

this Journal, whose readers will wish him many years of happy and well-earned retirement.

H.F.

Death of Mr. G. A. Abbott

We greatly regret to record the death, early in January, of Mr. G. A. Abbott, who served with distinction as a Member of Council of the Institution from 1949-52 and was actively engaged on the Library and General Purposes Committees. He was also a member of the London Centre Committee from 1936-38 and from 1948-52, representing, during the latter period, the interests of Executive Engineers and Asst. Regional M.T.O.s, London Region.

His untimely death came as a great shock to his Council and London Centre colleagues, who will retain warm memories of the activity and enthusiasm which he displayed in Institution affairs.

Journal Price Increase

Most readers will be aware that the publication world has been very hard-hit in recent years because of the continual increases in the costs of production. Apart from the incidence of several wage awards in the printing industry, the cost of paper has risen alarmingly; in fact, the paper on which this issue of the Journal is printed cost more than double that used in April 1950.

In considering how best to deal with this situation every means of economy which could be adopted without impairing the value of the Journal has been exploited. In spite of these efforts the position is now so serious that the price of 1s. 6d. per copy to Post Office readers can no longer be maintained and we regret to announce that, commencing with the July 1952 issue, the price will be increased to 2s. per copy.

With this arrangement it will be possible to maintain the Journal at its present size and ensure the continued publication of the Supplement with its wide selection of model answers to questions set in the City and Guilds of London Institute examinations in Telecommunications Engineering.

Meanwhile, readers may be assured that as soon as the present conditions improve they will benefit accordingly, because the policy of the Journal has always been, and still is, to run on a non-profit-making basis.

Regional Notes

London Telecommunications Region

YOUTH RECRUITMENT

To stimulate interest in Post Office Engineering as a career the L.T.R. made and staffed a stand, seen in the photograph, at the Schoolboy's Own Exhibition which runs each year in London for a fortnight in the Christmas holidays. Evidence of the extent of the good done will take time to unfold; but without doubt those of the 170,000 visitors who came to the stand were able to see what a career in the Post Office offers.

Against a background of pictures depicting many interesting features of P.O. work and training, the boys—and their elders who came too—could see and operate working models. These included the two-motion switch, motor uniselector, speech scrambler and speaking clock. A teleprinter was set up to print at intervals of a few minutes a recurring message suited to the recruitment drive. These "telegrams" were eagerly collected as souvenirs and will probably lead to the contents being studied elsewhere.

Each likely young fellow was offered verbal advice, answers to questions and printed matter. The most likely of them were



L.T.R. STAND AT SCHOOLBOY'S OWN EXHIBITION.

invited to participate in the 3-times-daily trips from the exhibition to P.O. premises by special P.O. transport, with a free pass re-entry to the exhibition. Thus 33 parties of 7 boys, and their parents in some cases, saw a modern utility vehicle for external work equipped with selected external exhibits, and visited Mayfair and Holborn exchanges. Indoors these parties saw a cable chamber, exchange batteries, and a demonstration set, also the speaking clock, power plant and many other interesting items.

The boys, mostly of the "Grammar-school-type," came from all parts of the country and two from the continent. Careers were well to the fore in their thoughts and many were nearly decided. These had ideas ranging widely (Chef, Architect, Police, &c.) but all went away impressed by what they had seen. Their friends and brothers will benefit, too, from what we had to tell.

It was enthusiasm we sought to stimulate; at times the congestion was our problem! Many compliments were received, from the management of the exhibition and from the holders of other stands—we had done well with a small allocation of space. We naturally expect to do better still next Christmas.

C. E. P. J.

RADIO PICTURES—EXPANSION OF THE AUTOMATIC RELAY FACILITY

During the last hours of the ill-fated "Flying Enterprise" off Falmouth, 9th January, 1952, newspaper agencies were on the spot with portable telephoto equipment ready to wire pictures to Fleet Street.

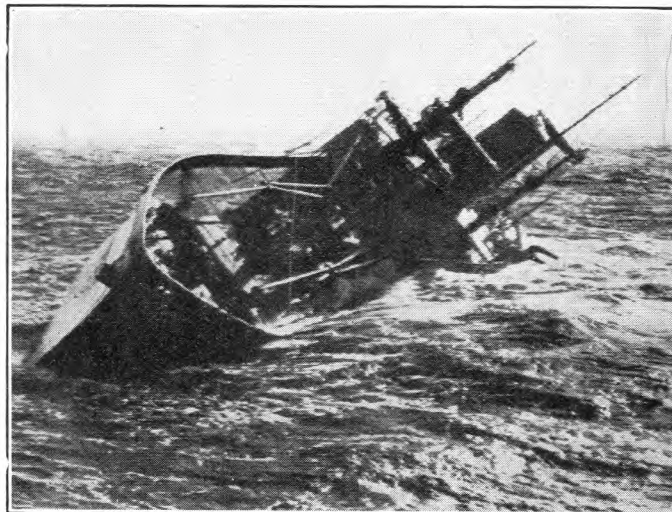

PICTURE AS RECEIVED IN NEW YORK.

An enquiry was made if an automatic relay could be arranged, Falmouth to New York, the agency to transmit their Falmouth signal through to Electra House on the tie line (Fleet St./E.H.), already existing.

Electra House was required to automatically convert the line amplitude modulation to sub-carrier frequency modulation for radio transmission, which presented no technical difficulty, and it was agreed to handle the transmission in this manner.

At 3.15 p.m. G.M.T., the first picture came through, was transmitted to Electra House, converted, and thence to Ongar's single side-band transmitter GLU and cleared to NYK on Channel A. NYK automatically converted the frequency modulation back to amplitude modulation and so through to the customer's New York office where it was fanned out to many U.S.A. cities, including San Francisco.

The picture transmission began at Falmouth at 3.15 p.m. and was simultaneously received in the U.S.A. cities at 3.25 p.m. G.M.T. Other pictures followed and were handled similarly.

A point of great technical interest is the keying speed involved. The agency could operate only at 100 r.p.m., far higher than the usual drum speed of 60 r.p.m., this representing a keying speed approaching 1,000 cycles.

The pictures received in the U.S.A. were of good quality and very little degraded from the original.

W. C. A.

Home Counties Region

AN UNUSUAL METHOD OF USING A MOBILE U.A.X.

Recently four "A" units had to be renewed at Ardingly Unit Automatic Exchange No. 13 type. This was accomplished successfully without interruption to service, by the use of a mobile U.A.X. in an unusual manner.

The mobile U.A.X. used was that described in this Journal in July 1949, with the equipment for the complete exchange located in two vehicles, the "A" vehicle containing the "A" and "C" units, and the "B" vehicle including the "B" units, the termination of the public electricity supply mains, the rectifiers, power panels and batteries. The "A" vehicle only was required at Ardingly. This was not available for delivery to the site until the end of October and, as the complete M.A.X. was required elsewhere by mid-December, the work had to be organised on an urgent basis.

The site to which the M.A.X. had to be delivered was not an easy one to negotiate, having a frontage to a very narrow road which made it difficult to manoeuvre the vehicle. The entrance was by double gates wide enough only for a Morris Minor van. Added difficulties were the presence of a number of trees on the site which could not be lopped or removed, and a sloping run-in. In the short time available, it was not possible to prepare the site to accommodate the mobile exchange by the provision of a concrete base. The gates and posts were removed, together with a short length of fence, and the

site was roughly levelled by using railway sleepers. In spite of the difficulties, the vehicle was backed into the site over the temporary sleeper track and placed in position. It was finally levelled, using jacks, resting on boiler plates to distribute the load.

The "A" vehicle was worked from the permanent U.A.X. power supplies. The wiring from the "C" unit in the permanent building required for bringing the mobile exchange into service, together with all power cabling was passed through an aperture in the building made by the removal of a Hatten vent. Apart from the power supplies, all connections between the permanent and temporary exchanges were carried out in cable with plastic insulation and covering. The wiring to the mobile exchange was completed and all circuits transferred within a week. For the purpose of the transfer, the junction circuits were wired via change-over strips, and all subscribers circuits were "teed" in the permanent exchange.

The four "A" units to be changed were then recovered and replaced by the new units. The entire wiring between units both in the original installation and in the renewal was carried out in plastic cable. In the original case alternative methods of terminating the plastic insulated cables on connection strips were tried, but on the renewal the method found from experience to be the most satisfactory was used throughout. All circuits were restored to the permanent exchange on 3rd. December, the mobile exchange being released a week later.

F. V. P.

EXTENSION OF BEDFORD AUTO-MANUAL BOARD

The opening of a 33-position extension to the auto-manual suite on 12th September, 1951, provides the opportunity to describe a few of the unusual features of the installation.

The original 22-position suite on the second floor of the main exchange was extended in the early part of the war by a 9-position suite on the first floor. The post-war growth of traffic demanded a further extension and the space on the first floor was needed for relay sets. It was therefore decided to provide a new suite of 33 positions on the second floor of Telephone House, some 150 yards away, to work in parallel with the original 22-position suite.

Five 1,000-pair, 10-lb. P.C.Q.L. cables were provided between the two buildings in parallel with the existing outgoing and incoming multiples and the existing junction relay sets were retained in the main exchange. Separate lamp relays, 6-volt transformers and standby 6-volt batteries were provided in Telephone House and the 50-volt supply was extended from the main exchange using four cables each of one square inch equivalent cross-section.

Owing to the critical resistance of the sleeve circuit an overall single-wire resistance of 9 ohms was specified between the relay sets in the main exchange and the ultimate end of the new multiple in Telephone House. This factor alone ruled out any question of fitting the normal protective devices. It was therefore necessary to provide protection in the form of a 6-inch layer of concrete surrounding the new 18-way duct track.

Due to the expected P.D. of up to 0.2 volts between the positive busbar in the main exchange and that in Telephone House it was decided not to provide a separate earth system at the latter building. Consequently all cables between the two buildings have been sheathed over the lead with polythene to prevent electrolytic corrosion.

The configuration of the external duct track, including the risers to the second floor of Telephone House, would normally have necessitated a joint in each manhole in addition to the usual joints between the paper core and the terminating cables. Cabling was further complicated by the fact that manhole No. 3 had to be of non-standard construction to meet obstructions and this resulted in two right-angle bends in each cable within a distance of 3 ft. 6 in.

By adopting the following techniques, terminating joints only were made on the 1,000-pr. cables and none at all on the power cables.

The power cable termination at the main exchange was in the power room on the ground floor and the P.C. cables were to be jointed to the terminating cables in the basement cable chamber. This, together with the fact that the power cables could be bent into a much smaller radius than could the 1,000-pr. cables, demanded two different methods of cabling.

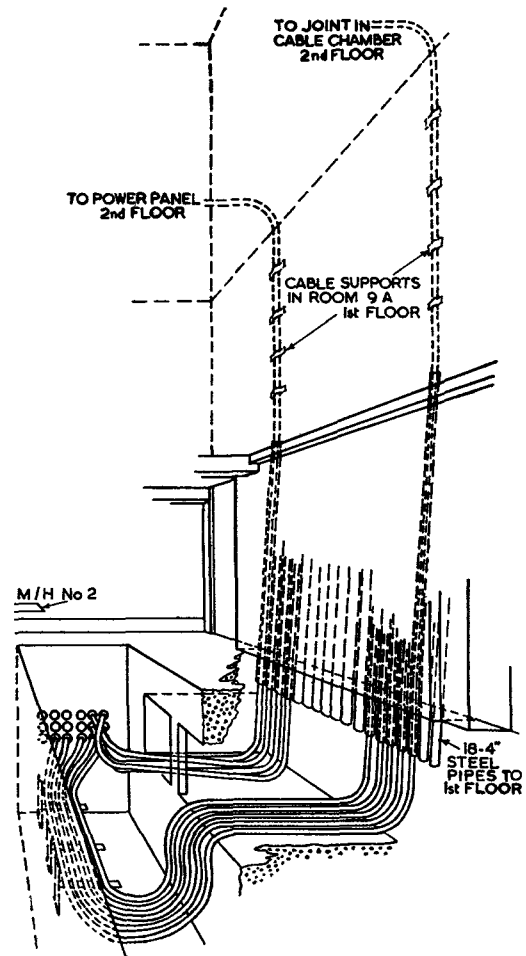

CABLING DETAIL AT MANHOLE NO. 3.

The power cables were drawn in from manhole No. 2 to No. 1 and were "fleeted" through No. 1 as far as the panel in the power room. Sufficient cable was then taken off the drum at manhole No. 2 to reach the power panel on the second floor of Telephone House; it was then cut and coiled in figure-of-eight formation on the roadway. The free end was then passed through the entrance of manhole No. 2, through No. 3 and up the risers by means of snatch blocks and a crab winch located on the second floor. The manhole opening was large enough to permit the final loop being passed through without kinking.

Because the 1,000-pr. cables could not be bent into a radius small enough for the final loop to be passed through the manhole opening it was necessary to fleet sufficient cable through manhole No. 1 into the main exchange cable chamber for it to be fleeted back again through manholes Nos. 2 and 3 and up the risers. To do this meant fleeting 39 yards of cable

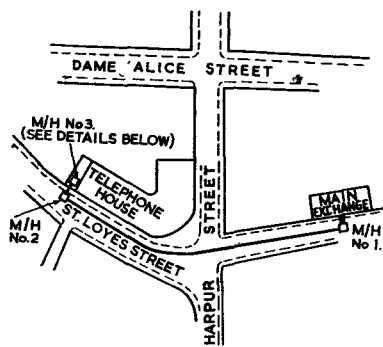

ROUTE OF EXTERNAL DUCT TRACK.

into the cable chamber and the problem here was how to accommodate so great a length.

The staircase and doors to the cable chamber were too small for the passage of a normal drum of the requisite diameter. Therefore, a four-foot drum was set up, fully battened and having wooden "spiders" bolted to its sides, and the 39 yards of cable was wound on over the battens as it was fletted into the cable chamber, using a motor winch at manhole No. 1.

The motor winch was then moved to manhole No. 2 and, with the help of the hand winch on the second floor of Telephone House, the whole length of cable was fletted back until the leading end reached the appropriate point on the second floor. This operation involved very close co-ordination of effort in the cable chamber, the three manholes and in Telephone House and this was controlled over an omnibus telephone circuit together with the usual method of calling down the duct track. The focal point was at the motor winch whence not only the movement of the cable was controlled but also the transfer of manpower as the cable moved from the drum in the cable chamber.

The first lengths were drawn in on Sundays to avoid possible interruptions due to traffic, but experience, and the very keen team spirit shown by all concerned, proved that this precaution was not really necessary and the rest of the cabling work was completed during the normal working week.

The peak staff employed was sixteen men, but their efforts resulted in a saving of over 4,000 manhours because of the reduction in joints from the expected 37 to only ten.

E. W. A.
C. W. R.

THE HUMAN FACTOR IN EXTERNAL WORKS

Two incidents have occurred in the Canterbury Area recently, which, whilst not outstanding in the technical or engineering sense, yet serve to show in what manner difficulties can be overcome when the right spirit prevails.

The first concerns a large, direct-labour, duct-laying job. The circumstances particularly favoured the use of the Aveling-Barford excavator, but the site of work was in an area where both travelling and lodging facilities were difficult. The problem was solved when the only gang having experience of this mechanical aid came forward with the suggestion that they would be prepared to hire a caravan and live on site. The offer was gladly accepted and every facility was provided for towing the caravan and making their stay as pleasant as possible. The job was completed with a remarkably fine performance and the same gang have since carried out two other works under similar conditions. The advantages of this arrangement with experienced men handling a complicated piece of mechanism, the latter under constant watch, and the reduction of ineffective time to the absolute minimum are obvious, but the point it is desired to stress is that the suggestion and offer came from the men themselves.

The second instance concerns the work of a group of Jointers, engaged on a C.B.S.2—M.A.X. transfer. The site is on the

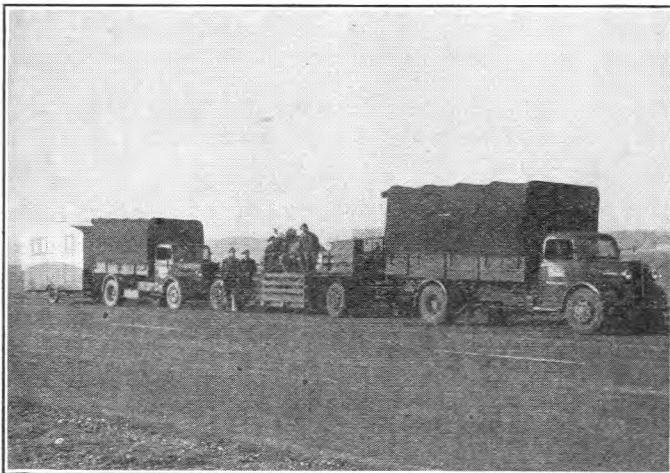

THE EXTERNAL GANG WITH CARAVAN ON TOW.

marshes on the south-east coast and all the land about is below high water level. A 12-inch, open-jointed, storm and foul water drain is adjacent to the duct track and passes close to the exchange manhole. This drain empties to the sea about a mile-and-a-half away through a tide trap, which does not always work.

The combination of a spongy, springy road carrying heavy traffic, an open-jointed drain and an old duct track—with undoubtedly many broken collars—certainly predisposes to flooding. Flooding is an understatement; when the tide reaches the level of the drain, "water" pours in all three ways of the T.R.7 manhole and it takes a Lister-driven 4-inch flood-gate pump all its time to cope with it.

The fact remains that men have been working under these conditions, and made a good job of cutting-in a new exchange.
W. G. C.

North Eastern Region

SOUTH SHIELDS RELIEF EXCHANGE

The subscribers' waiting list at South Shields was the largest in the Newcastle Area due mainly to exhaustion of the exchange equipment. Fortunately, the opening of a new Sorting Office and consequent postal staff rearrangements enabled the old exchange switchroom and apparatus room in the H.P.O. to be extended by minor structural alterations. It was decided to install a relief exchange of twelve C.B.10 positions equipped with 2,000 multiple, 1,500 calling equipments, and 160 outgoing junction multiple. To avoid transfer working between the old and relief exchanges for incoming junction calls, separate junction routes were provided and the relief exchange was given the name of St. Hilda.

The installation of a C.B. 10 exchange in itself is not unusual, but St. Hilda is the largest C.B. exchange so far to be installed by direct labour in the Newcastle Area.

R. C.

EXPLOSION AND CABLE BURN-OUT AT BRADFORD

Following a series of explosions in Leeds Road, Bradford, at about 8 p.m. on January 22nd, 1952, the cover was blown off a manhole from which flames three feet high belched out. Most of the windows in a nearby hotel were blown out but fortunately no one was hurt. Men from the Yorkshire Electricity Board and North Eastern Gas Board worked throughout the night and although a broken 2-inch gas pipe was soon discovered it was not until 9.30 a.m. that the position of the burn-out of the trolley-bus feeder cable was found. The adjacent Post Office manholes, opened at the outset, at first tested clear of gas but on pumping out water to below the duct entries heavy concentrations of gas were encountered. Motor driven blowers were used to clear the air.

At the point of the burn-out, the heat had reduced the P.O. 3-way multiple duct to powder and the cables in it had melted away. In the centre-manhole and at two adjacent manholes lead was melted off all the cables near the duct mouth. On cutting the cables a check showed that the damage was confined to two lengths. Eight damaged 3-way ducts were excavated and renewed. Despite frost and snow, cables were collected from Birmingham by Area transport and delivered on site in time to maintain smooth and rapid restoration work. The carrier cables were completed after 18 hours restoration work, i.e., 32 hours after the explosion. Restoration of the local network followed, an emergency circuit being given temporary service by midnight on the first day by drawing-in a short length of 50 pr. cable and carrying out an interception at a cabinet.

J. McL.

North Western Region

CARLISLE EXCHANGE EXTENSION

The month of December saw the completion of the largest manual extension ever undertaken in the Lancaster Area. The extension of Carlisle manual exchange as originally planned was to be carried out by the Area staff, but subsequently arrangements were made for the Factories staff to do the work under the supervision of a Clerk of Works from the Area. Before completion of this extension the exchange consisted of two separate C.B.10 suites with common sub-

scribers' and trunk and junction multiples. The main suite comprised 12 "A" positions, eight "B" and one T. & P.U. position, and the relief suite, 13 "A" and five "B" positions. The extension catered for the provision of 18 C.B.1 40-volt "B" positions with the subscribers' multiple (0-2799) and the trunk and junction multiples extended from the two existing suites. In addition the new "B" suite accommodates an additional 1500 subscribers' multiple, making the subscribers' numbering range available to the "B" position operator's 0-4299. All "B" positions on the two original suites have been converted to "A" positions, and to facilitate the transfer of calls from these two "A" suites, for subscribers in the numbering range beyond 2,799, two positions on the "B" suite have been modified for S.F.J. working. The O/G lines to the S.F.J. positions appear in the junction multiple on the "A" suites. The cord circuits on the remainder of the new "B" positions were modified on site to trunk type. This was necessary in order to eliminate cut-off troubles at U.A.X's when extended for trunk calls to Carlisle via an A/M group centre. If at Carlisle the call was completed via a G/S trunk using a "B" cord circuit the supervisory conditions returned to the distant U.A.X. were incorrect. The time delay switch there would continue to step whilst the call was in progress and eventually the selectors at the U.A.X. would be force-released. The equipment for these trunk cord circuits is mounted on racks installed in the new switchroom.

To make room for all the additional equipment required it was essential that the apparatus room should be enlarged and this necessitated the removal of the exchange batteries to the basement and the incorporation of the old battery room with the apparatus room. The shifting of the batteries and structural alterations were completed before the Factory staff arrived on site. A combined M. & I.D.F. of 36 verticals, subscribers' equipment racks, S.F.J. racks, etc., were installed in this extension to the apparatus room. Other incidental work included the provision of an additional two-position monitors desk, recovery of a small M. & I.D.F., the rearrangement of all trunk and junction equipment, and the provision of tie cables between the old and new main frames.

To ensure that interruptions to working circuits would be kept to a minimum the engineering of the work was planned to be carried out in three stages. This entailed the preparation of special schedules detailing the work to be done during each stage, and the order in which the different items should proceed. Copies of these schedules were supplied in advance to the Factories Department, together with the works instructions, drawings and diagrams.

The extension is noteworthy, apart from the magnitude of the work, for the introduction of S.F.J. working from the "A" suites to the new "B" suite.

J. N.

Midland Region

LEICESTER RELIEF MANUAL EXCHANGE

In January 1952 a relief manual telephone exchange, known as Granby, was opened to provide service for waiting applicants and various subscribers in the central area of Leicester. A major subscribers' underground development scheme is in progress and new lines are being connected rapidly as underground cable pairs become available. The decision to install a relief manual exchange in an automatic multi-exchange area was taken in 1946 consequent on the exhaustion of the Leicester (Central) exchange and the difficulty in obtaining automatic exchange equipment because of export requirements. In early 1947 recovered C.B. No. 1 equipment from Bradford (Yorks) became available and was earmarked for the relief exchange.

The choice of a building to house the proposed exchange fell on the old National Telephone Company's exchange, advantage being taken of a break in the lease to obtain the premises in 1947. This building presented difficulties in the layout of equipment, cabling, and the provision of welfare accommodation, and considerable ingenuity was required to obtain a satisfactory arrangement. A lift shaft had been cut through all floors and required filling in, with the consequent rearrangement of steel floor reinforcing. On the ground floor, iron pipes for leading underground cables into the M.D.F. had to be arranged to suit the steel girders and filler joists. In

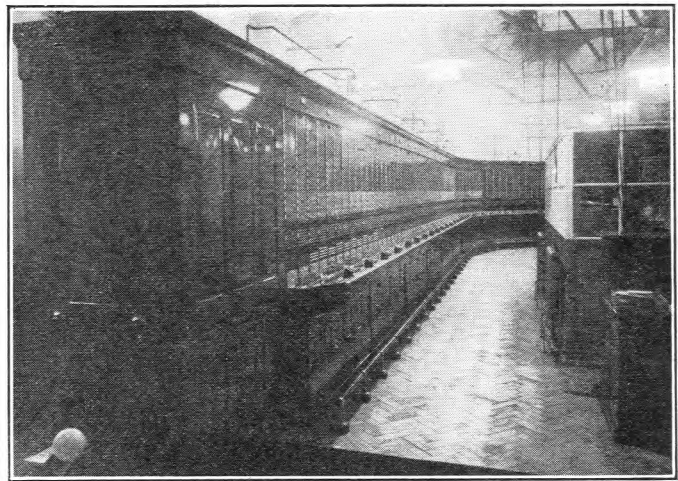

SUITE OF C.B. No. 1 POSITIONS IN GRANBY EXCHANGE.

the basement it was possible to re-use the original cable duct entry into the cable chamber.

It was originally intended that the installation would be carried out by local staff, but owing to a shortage of skilled staff, and the poor condition of the recovered equipment, arrangements were made for the Factories Department to renovate and install the switchboards and associated equipment and for the L.T.R. Power Section to install the power plant. The completed equipment comprises 3,200 subscribers' line multiple, 3,000 calling equipments, 32 "A" positions, 11 "B" positions, 1 filter position, 2 test and plug up, 2 dummy and unequipped positions, 4 monitor positions, 1 supervisor's desk and a 2-position test desk. The junctions have a 6-panel appearance and the subscribers' multiple an 8-panel appearance.

To meet the anticipated additional trunk and junction traffic, a 12-position sleeve control island suite has been installed at Leicester (Central) exchange.

The "B" positions are equipped with 16 cord circuits and a dial, and to cater for shared service lines all positions have reversed ringing facilities.

It should be mentioned that the Leicester A.T.E. remains the distribution point for cabling purposes and all Granby traffic is routed there via tie cables. Although Granby has facilities for testing, the maintenance control centre is housed at the Leicester A.T.E. and a modified fault-reporting procedure has been adopted.

Thanks are due to the engineering officers at Regional and National Headquarters as well as to the staff of the Factories Department concerned and to local traffic and engineering staffs for the valuable help and assistance afforded throughout.

E. S. L.

FIELD TRIAL OF FERGUSON POST-HOLE BORER

The Ferguson Tractor firm market a post-hole boring attachment for fitting to their normal agricultural tractor. The attachment was originally introduced to assist farmers in erection of fences and augers were made to drill two sizes of hole, namely 9-inch diameter and 12-inch diameter.

It seemed possible that the 12-inch auger might be useful in the erection of poles, and when a suitable scheme matured in the Nottingham Area, a Departmental tractor fitted with a 12-inch auger capable of boring to a depth of 3 ft. was borrowed from the Coventry Area, in which Area, incidentally, the tractor had been used extensively for cable laying by the mole-drain method, having a special winch attachment for this purpose.

A new exchange area named Great Cubley has recently been opened in the south-western part of the Nottingham Area, and the external plant lay-out entailed the provision of many miles of overhead route, mainly for aerial cable. Approximately 400 poles have been erected with many associated struts and stays. The routes were along country lanes, mostly rather narrow, and several portions of the aerial cable routes were erected in grass land on the field side of the hedges. When the work first started the weather was good and the machine was found to be a great help for poling. The holes were not quite

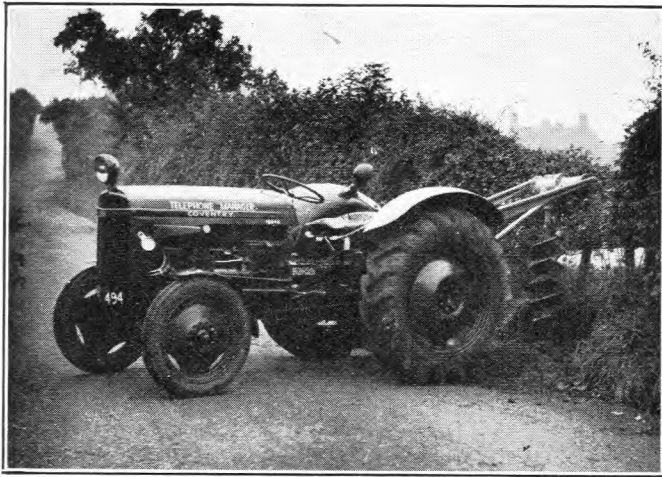

TRACTOR WITH POST-HOLE BORER ATTACHMENT.

deep enough, but were generally easily made deeper, particularly as the majority of the poles were in the light class.

Stay holes were also commenced by boring a series of holes loosening the top soil for a depth of 3 ft. It was found that the machine would not bore in wet clay or in ground where there was a number of large stones. The auger has no downward pressure except its own weight, and pulls itself into the soil by its rotation. When the soil was not suitable the auger would not bore into the ground but just rotated at the particular depth at which the conditions prevented further travel. Generally speaking, however, the borings were quite successful, and there is no doubt that the overhead construction staff were spared a lot of manual labour.

E. H. P.

South-Western Region

"FLYING ENTERPRISE"

There will be few people in this country who are not acquainted with the story of the "Flying Enterprise," the American steamer which in the severe Atlantic gales during the last few days of 1951 developed a list of 60°, and eventually sank on 10th January, 1952, a few miles off Land's End. It is quite certain that the Post Office staff in the West Cornwall port of Falmouth will not quickly forget the activity during the early days of January, when the town was invaded by Press men from all over the British Isles, photographers, the B.B.C., and representatives of newspapers and broadcasting in other countries.

Neither must the Post Office radio station at Land's End be forgotten: this station was the main link with the ships assisting in the rescue, and by 2nd January, 1952, it was the centre for the B.B.C.'s information service, enquiries and radio telephone calls. Recordings were made by a B.B.C. mobile van over the radio link with the U.S. naval vessel "Willard Keith" and the tug "Turmoil," and these were subsequently heard in the news bulletins of the B.B.C. Recordings to and from the "Flying Enterprise" were achieved by relaying through the "Willard Keith." The Film Unit subsequently visited the station and the staff helped in building up a film of the incident.

While preparations were being made for the reception of the two ships, Falmouth exchange became the main centre for picture transmissions. Associated Press photographers arrived at Falmouth on 4th January, 1952, and accommodation was provided in the apparatus room for their equipment, and in the basement for the purpose of developing their films. On 7th January, 1952, two additional transmitting sets arrived, and six more the following day. Pictures were sent almost continuously throughout Tuesday, Wednesday and Thursday. By Wednesday, the invasion was at its peak; there were some 300 reporters, photographers and newsreel men representing newspapers and radio services in all parts of the world. Call offices and street kiosks proved insufficient to carry the traffic and subscribers voluntarily offered their private telephones to the Press.

Following the sinking of the "Flying Enterprise," the Captain and his companion arrived in Falmouth on Friday, 11th January, 1952, and telephone and telegraph traffic and picture transmissions were again very heavy, picture traffic being continued up to nearly midnight.

C. P. I.

Welsh and Border Counties Region

"ARTIFICIAL TRAFFIC EQUIPMENT" AT SWANSEA (SIEMENS 16) EXCHANGE

This exchange was opened in 1924 and although there have been several extensions since that time, by far the greater proportion of the present switching apparatus is that installed at the opening. Naturally the wear and tear over 28 years, coupled with the disturbance of cables, wiring, etc., during extensions, has increased the fault liability of the equipment. Furthermore, the obsolete pattern switches and pip-and-plate relay contacts used on the bulk of the equipment have added to the difficulties of maintaining a high standard of service.

To augment the normal routine testers and supplement the Service Observation results an "Artificial Traffic Equipment."* was installed and brought into use in July, 1951. Briefly, this equipment was developed with two objects in view:—

- (a) to determine by artificial traffic the overall performance of the exchange plant.
- (b) to provide a ready means of tracing "lost calls" to discover the weak spots in the exchange.

The model in use at Swansea was constructed and wired locally to an E-in-C's Telephone Branch design. It is arranged to pass a sequence of calls automatically from 24 selected calling equipments (1st preselectors) to 25 selected spare final selector multiple numbers, in a complete cycle of 600 calls.

Since the introduction of the Artificial Traffic Equipment many faults—some of an elusive nature—have been located and cleared and as a result the standard of service has improved to such an extent that the equipment is considered by the exchange staff, to be an essential maintenance aid, especially as bank multiples, T.D.F. gradings and cabling are checked.

The equipment is in use during the five normal working days of the week. On Fridays it is used under "Observe Service" conditions whereby faults encountered are only recorded; on the other four days it is used under "Faulting Service" conditions. Under these conditions the equipment stops when a fault is encountered; the fault is then localised and cleared.

To gain maximum benefit it has been necessary to employ one T.O. on full-time attendance to the Artificial Traffic Equipment.

The illustration shows the overall improvement in the

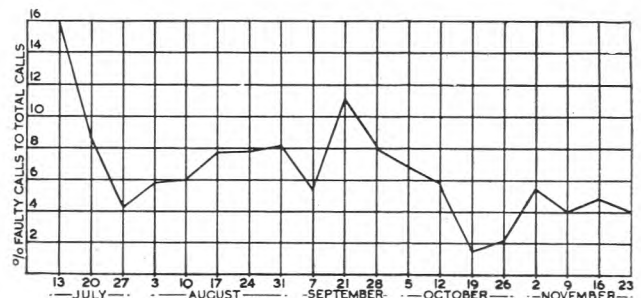

"Observe Service" fault rate since the equipment was brought into use. During this period the percentage of faulty calls has fallen from 16 to approximately 4 per cent. This improvement is also observed in a reduction of the average fault rate in the exchange registered faults.

Due to the number of combinations that can be set up it is not possible at this stage to say when the full benefit of the apparatus is likely to be appreciated. However, the present trend is thought to amply repay the initial difficulties encountered in setting up and staffing the equipment.

G. F.
T. J. D.

*P.O.E.E.J. Vol. 40, p. 159.

Junior Section Notes

Darlington Centre

It is a pleasure to report that our meetings to date have attracted a good average attendance, representative of both the external and internal staffs. "External Telephone Plant and the Law," interpreted by Mr. W. Dodgson, was well received and was followed by a good discussion. "Weights and Measures," by Mr. R. Billings, B.Com., enlightened not a few on the wide field of activities covered by the Post Office Engineering Department. The tour of the Darlington Wire Mills conducted by Mr. F. Wright, Works Manager, who described the firm's specialised work, proved to be very popular.

Our versatile Centre Member, Mr. E. O. M. Grimshaw, gave his fifth talk and this time his subject was "Computers and Calculators." He impressed those who attended with his knowledge of these modern aids and his forecast of their future application.

Prior to the 1951-52 session talks were often given by members without the aid of written papers; they therefore could not qualify for the Institution competition. However, we submitted two written papers covering talks already given by our members, and it was very good news to receive the official intimation that one of these, "Television," by Mr. B. V. Northall, had been selected for the award of £3. 3s. 0d. and the Institution Certificate. At the time of writing it is hoped that the presentation of the coveted prize will be made by the C.R.E., Mr. W. F. Smith, on the occasion of the Darlington v Middlesbrough inter-Centre quiz on Tuesday, 25th March, 1952.

The Centre congratulates the Bath, Lincoln and Belfast Centres on the success of their members in the competition.
C. N. H.

Middlesbrough Centre

On 15th November, 1951, Mr. W. J. Costello gave a most informative talk on "Repeater Station Power." The automatic change-over arrangements were fully explained and one realised that the efficient telephone service given to the public did not depend solely on transmission and auto men; all members of the team play their part.

Mr. E. A. Clark's talk entitled "Photography in General," given on 13th December, 1951, catered for both amateur and professional, and was greatly appreciated by his audience. After viewing about one hundred projected coloured transparencies and slides of various aids to photography, many would realise how far they could progress from the "box camera" stage.

The lecture "Fundamentals of Telephone Cable Design," by Mr. A. C. Holmes, A.M.I.E.E. (Regional Liaison Officer) on 22nd January, 1952, was both educational and interesting. Mr. Holmes dealt with his subject in an able manner. The Standard Telephones and Cables' film showing the manufacture of the London-Birmingham television cable was greatly appreciated.

"Modern Industrial Lighting," given by Mr. H. Carr, on 14th February, 1952, was certainly "illuminating" and once again gave us some idea of the "other man's" job. This aspect was perhaps more striking because Mr. Carr is on Exchange Construction and not E.L. & P. work. Perhaps we in the Department will see some brighter colour schemes not only for walls but for apparatus and machines too, so that full efficiency of illumination is obtained.

Before the meeting closed, the Chairman (Mr. W. J. Costello) asked the audience to stand for one minute as a tribute to our late King George VI.
D. P.

Gloucester Centre

On 19th September, 1951, an invitation was sent to all previous and intending members of the above centre. Their presence was requested at a meeting called to consider the possibility of holding a series of lectures for the coming session.

As a result of a most successful meeting the following officers were elected for 1951-52:—*Chairman*, Mr. J. W. Brookes; *Secretary*, Mr. A. B. Coole; *Assistant Secretary*, Mr. J. Cox; *Treasurer*, Mr. P. Noctor; *Committee*: Messrs. J. Paige, E. Harrison, K. Pople, L. Rea, C. Morgan and B. Hope.

The Committee quickly shouldered their responsibilities and in a remarkably short time produced the following programme:

October, 1951.—"Speech Transmission"—Mr. E. H. Jeynes.

November, 1951.—"Subscribers' Faults—Prevention is better than Cure"—Mr. J. Cox.

December, 1951.—"An Outline to Carrier Telephony"—Mr. R. Hoare.

January, 1952.—"Organisation of a Telephone Area"—Mr. W. Moseley, M.B.E.

February, 1952.—"Transfer of a C.B.S. Manual Exchange to a U.A.X. 13X"—Mr. A. B. Coole.

March, 1952.—"Some Aspects of Staff Relationships"—Mr. T. H. McDonald.

Following the issue of a challenge from the Bath Centre, arrangements have been made to hold a "Quiz"; and it is hoped to provide a pleasant evening's entertainment to all members and visitors who attend this trial of brains and wit.

Arrangements are also in hand for a number of visits during the early spring and summer to the major local industries.
A. B. C.

Cambridge Centre

The programme for the second half of the session was as follows:—

January 9th.—Visit to Goods Control Room and Signalling Systems at Cambridge Railway Station.

February 4th.—Lecture: "Some Aspects of External Development," by Messrs. H. W. Haworth & R. M. Jones.

February 21st.—Visit to Hammond Electric Organ at St. George's Church, Cambridge.

April 8th.—Scientific Interest Film Show by C.O.I. Film Unit, followed by Annual General Meeting.

We are looking forward to an even more successful session for 1952-53.
J. P. W.

Canterbury Centre

At the 1951 A.G.M. the Committee was elected as follows:—*Chairman*, Mr. V. Dungey; *Secretary and Treasurer*, Mr. G. E. West; *Committee Members*: Messrs. S. Cripps, B. Fletcher, H. W. Marsh and A. G. Lee.

The 1951-52 session commenced on 30th October, with a lecture by Mr. B. Winch. His subject was "Call Queueing," illustrated with slides and diagrams. Mr. Cox of the I.T.D. discussed the project from the point of view of his Department.

Mr. W. Seymour described the technique of "Tape Recording" at the November meeting. Practical demonstrations provided great interest.

The title of the December talk given by Mr. A. G. Robins caused many speculations. "Holes in the Road" was in fact a disguise for the Public Utilities Street Works Act, 1950, which was effectively translated into basic English.

On 10th January, 1952, 28 members paid a visit to Chartham Paper Mills. Despite inclement weather an instructive and enjoyable afternoon ensued.

The "Function of the Sales Section" was the subject of Mr. W. J. Gallup on 23rd January, 1952. He proved his ability as a salesman by convincing the members that the Sales Section is really necessary.

The remaining programme for this session was:—

19th February, 1952.—"Cable Balancing"—Mr. V. Dungey.

18th March, 1952.—"Main Cables"—Mr. R. Kent.

22nd April, 1952.—Annual General Meeting.

A visit to a Kent coal mine is being arranged.

There are 60 members in the Canterbury Centre, the average attendance at meetings being 38.
G. E. W.

Maidstone Centre

The officers elected for the 1951-52 session were as follows: *Chairman*, G. T. Cheeseman; *Secretary*, C. Tamc; *Treasurer*, R. W. Wallond. *Committee*: Messrs. P. Lager, J. A. Burrows, V. Bryant, L. A. S. Barham.

Upon the promotion of Mr. Cheeseman the duties of the Chairman were taken up by Mr. L. A. S. Barham on 12th November.

The programme for the session was as indicated below:—
8th October.—"Recruitment of Staff."—F. C. Haliburton.
12th November.—"Jet Engines."—F/Lt. Saywell.

10th December.—“The Provision of Cross-Channel Communications for the Invasion of Europe.”—Col. C. E. Calveley, O.B.E.

14th January.—“The Public Utilities Street Works Act.” A. G. Robins.

11th February.—“Valve Manufacture.”—A. D. Haigh (Edison Swan Electric Co.).

11th March.—“Stage Lighting.”—L. G. Applebee (Strand Electric & Engineering Co.).

7th April.—“2,000-type Selector.”—J. I. Waters.

The attendance at meetings has been a little below the usual standard but the papers given have been well presented and have encouraged useful and informative discussion. It is the desire of the Centre to make its activities as interesting as possible but this cannot be done without the *active* support of its members. It is therefore up to each one to do his utmost to ensure that the Centre is worthy of its connection with the Junior Section.

The continuing goodwill of the Telephone Manager, Mr. W. H. Scarborough, and the active co-operation of the Area Engineers, Messrs. A. G. Robins and F. C. Haliburton, have done much to keep the Centre on the map. The frequent presence of Senior Section members at meetings is a source of great satisfaction, for they are cordially invited at all times.

C. T.

Isle of Wight Centre

By the time these notes appear, the Isle of Wight Centre will be nearing the end of the second session since its reformation in 1950.

The Centre has heard an interesting series of talks, and in addition has taken part in three “Quiz” contests, two with the Portsmouth Centre and one with the Chichester Centre.

Visits have been made to Saunders-Roe aircraft works at Cowes, where the giant “Princess” flying boats are under construction, and to the Pirelli-General Cable Works at Eastleigh.

A visit to the Esso Oil Refinery at Fawley is being arranged.

C. J. S.

Tunbridge Wells Centre

The “Radio and Television Group” is now thriving, with a membership of 22. The activities included a visit to the National Radio Show and two excellent lectures by a senior member on “Stabilised Power Supplies” and “Design and Construction of a Straight Receiver.”

Work in organising the group has been going apace and we now have the use of a first-class workshop.

Future activities are:—Film show on “Electronics,” lecture on the Basic Superhet Receiver, and the construction of a Five-Valve Superhet Receiver.

J. A. V. S.

Bishop's Stortford Centre

A very interesting and varied programme so far has been followed by the Bishop's Stortford Centre during the 1951-52 session. Much interest has been taken in the meetings and attendances have been good, despite some inclement weather.

The first meeting was held on 18th September, when a film show by the C.O.I. was given. This was followed, the same evening, by an extremely interesting talk on “Air Navigation,” very ably given by Mr. G. F. Dann. The following month a practical demonstration of the “Jointing and Testing of Coaxial Cable” was given by Messrs. A. Stanley and R. Fuller. This proved of great interest to those of our members normally employed on internal duties. The demonstration was followed, the same evening, by a talk on “Various Methods of Fault Localisation on Underground Cables,” given by Mr. G. Wyer.

On 14th November a paper on “Railway Signalling” was read by Mr. F. Frecknall. This talk was extremely valuable inasmuch as it was followed, at a later date in November, by a visit to the Signalling Training School of the L.P.T.B., situated at Earls Court Station. A very enjoyable evening

was spent here. No talks were given during the month of December, but an interesting film show was given, on 5th December, by the C.O.I.

The opening of the New Year saw a slight re-arrangement of our programme for the month of January. Instead of a paper on “Simple Radio Circuits,” which was to have been given by Mr. J. Poole, Mr. J. A. Day, A.M.I.G.E. of the Bishop's Stortford Gas Works gave the membership an interesting talk on the production of gas and the by-products of coal. Those who attended were very surprised at the large number of derivatives from coal, and the thousand-and-one applications they have in modern industry. The talk was followed on 22nd January by a visit to the Gas Works at Bishop's Stortford. The tour was conducted by Mr. Day, who went to great pains in showing the various processes the coal gas went through before reaching the consumers' premises. The paper on “Radio Circuits” is to be given by Mr. Poole at a later date.

During March a paper on “Trunk Mechanisation” was read by Mr. A. J. Thompson, followed on 9th April by a talk by Mr. R. Eves on “The Survey and Provision of Local Lines.”

J. S. R.

Guildford Centre

The opportunity to travel and see, if not the world, something of what goes on in industry is one of the advantages of Junior Section membership.

The active co-operation of the Area Engineer and his supervising staff is essential in working out the details which make all the difference between a going concern and a “dead-and-alive” outfit, for nothing is so deadening to individualism as the cold official “toe-the-line attitude.”

We in Guildford count ourselves very fortunate in our Area Engineer, Mr. H. M. Wells, A.M.I.E.E., who has given us every consideration and very active help. We could not have purchased our 16-mm sound film projector without his aid, neither could our extensive factory-visit programme have been so successful. During the past twelve months seventeen visits have been made which have provided 392 member-visits.

An outing for members and their wives to the South Bank Exhibition in June was well attended and a tiring day was had by all!

The lecturers have covered photographic research, power station remote control, promotion and appraisements, the submerged repeaters and oil refining, with an average attendance of 25, which is not so bad considering the usual winter counter attractions.

Our ciné equipment has been used for twelve shows during the four winter months, on subjects ranging from shipbuilding and glass manufacture, to oil refining and supersonic flight.

The factory visits have covered the manufacture of electric lamps, television and gramophones, radio valves, liquid air, motor cars and tractors, the mass production of furniture and foodstuffs, cigarettes, vulcanised fibre, and steam packings. We have also looked over Broadcasting House, Cable and Wireless, Tate and Lyle Sugar Refinery, and seen the production and printing of “Illustrated” at Odhams (Watford) Ltd.

Pirelli-General have shown us the complete manufacture of telephone and very high voltage cables, from the copper ingot to the finished article, in their Eastleigh factory and the production of E.L. cables, flex, and plastic covered wires in Southampton. The Anglo American Oil Co., Ltd., invited us to their new refinery at Fawley and our film shows dealing with oil refining were a great help in understanding the complex business at the actual plant.

Newsprint production was seen at the mill of Bowaters Lloyd Ltd., at Sittingbourne and what a fine organisation they have to convert trees into newspaper.

The goodwill and hospitality shown to us by all these business firms has been very gratifying and it is a matter for some regret that all we have been able to do in return has been a bread-and-butter “thank you” letter and a Christmas card showing the Town Clock!

L. G. W.

Staff Changes

Promotions

Name	Region	Date	Name	Region	Date
<i>Deputy C.R.E. to Stf. Engr.</i>			<i>Asst. Engr. to Exec. Engr.—continued.</i>		
Stratton, J.	L.T.Reg. to E.-in-C.O. ..	22.12.51	Jarman, R. A.	L.T. Reg.	7.11.51
<i>Pr. Sc. Officer to Snr. Pr. Sc. Officer.</i>			Marks, T. A.	H.C. Reg.	1.12.51
Tillman, Dr. J. R.	E.-in-C.O.	12.2.52	Jacobs, G. E. J.	S.W. Reg.	14.11.51
<i>Snr. Exec. Engr. to Asst. Stf. Engr.</i>			McLean, J. C.	L.P. Reg.	4.1.52
Brook, P. R. W.	E.-in-C.O.	24.12.51	Ditchfield, J. A.	N.W. Reg.	18.1.52
Merriman, J. H. H.	E.-in-C.O.	24.12.51	Thom, J. R. H.	Scot.	14.11.51
Barker, H.	E.-in-C.O. (<i>in absentia</i>)	9.11.51	<i>Tech. Officer to Asst. Engr.</i>		
Wilcockson, H. E.	E.-in-C.O.	9.11.51	Elledge, F. J.	E.-in-C.O.	15.12.51
Francis, H. E.	E.-in-C.O.	1.1.52	Hannaford, D.	N.W. Reg. to E.-in-C.O.	29.12.51
<i>Telephone Manager to Asst. Stf. Engr.</i>			Gardiner, R.	N.W. Reg. to E.-in-C.O.	29.12.51
Knight, N. V.	L.T. Reg. to E-in-C O.	21.1.52	Ankers, J. R.	W.B.C. Reg. to E.-in-C.O.	29.12.51
<i>Exec. Engr. to Snr. Exec. Engr.</i>			Young, R. C.	N.W. Reg. to E.-in-C.O.	29.12.51
Banks, W. R.	H.C. Reg.	18.12.51	Dewsnap, S.	N.W. Reg. to E.-in-C.O.	29.12.51
Drew, L. C.	H.C. Reg.	18.12.51	Davis, W. B.	L.T. Reg. to E.-in-C.O.	29.12.51
Owens, W. H.	L.T. Reg.	11.1.52	Cave, K. H.	W.B.C. Reg. to E.-in-C.O.	5.1.52
Benzies, A. C.	N.W. Reg. to N.Ire Reg.	20.1.52	Curtis, F. W.	E.-in-C.O.	4.1.52
Walker, N.	Scot. to E.-in-C.O.	20.1.52	Palmer, J. P.	E.-in-C.O.	4.1.52
Wylie, T. S.	N. Ire. Reg.	10.2.52	Wheatley, S. G.	E.-in-C.O.	4.1.52
Rhodes, W.	E.-in-C.O.	2.12.51	Crampton, J. H.	E.-in-C.O.	4.1.52
<i>Asst. Engr. to Exec. Engr.</i>			Clark, E. H.	Mid. Reg.	5.1.52
Mathewson, J. M.	Scot.	1.1.52	Pope, A. B.	E.-in-C.O.	10.11.51
Hafekost, W. L.	E.-in-C.O.	8.12.51	Gothorp, J. W.	E.-in-C.O.	19.1.52
Bailey, E. A.	L.T. Reg.	13.11.51	Foulkes, R. T.	Mid. Reg. to E.-in-C.O.	26.1.52
Babb, H. E. E.	Mid. Reg.	18.11.51	McCann, E.	N. Ire. Reg. to E.-in-C.O.	26.1.52
			Johnston, C. I.	N. Ire. Reg. to E.-in-C.O.	1.2.52
			Curr, P. F.	Scot. to E.-in-C.O.	7.1.52
			Day, R. F.	E.-in-C.O.	9.2.52
			<i>Tech. Asst. I to Asst. R.M.T.O.</i>		
			White, N. C.	S.W. Reg.	24.1.52

Retirements

Name	Region	Date	Name	Region	Date
<i>Stf. Engr.</i>			<i>Asst. Engr.—continued.</i>		
Morris, A.	E.-in-C.O.	21.12.51	Nock, S. H.	W.B.C. Reg.	1.8.51
Nancarrow, F. E.	E.-in-C.O.	2.1.52	Francis, A. V.	L.P. Reg.	11.7.51
<i>Asst. Stf. Engr.</i>			<i>Inspector</i>		
Bell, R. L.	E.-in-C.O.	31.12.51	Watson, P. A.	Mid. Reg.	1.1.52
Pate, H. S.	N. Ire. Reg.	31.12.51	Stovell, G. P.	L.T. Reg.	31.1.52
<i>Area Engr.</i>			Payne, J.	L.T. Reg.	10.1.52
Wright, C.	N. Ire. Reg.	31.12.51	Judd, C. W.	L.T. Reg.	31.1.52
<i>Exec. Engr.</i>			Hawood, E. H.	L.T. Reg.	20.1.52
Brown, J.	Scot.	31.12.51	Temple, H.	L.T. Reg.	17.2.52
<i>Asst. Engr.</i>			Hayward, A. A.	N.W. Reg.	2.2.52
Moore, B. J.	L.T. Reg.	16.2.52	Lloyd, R. J.	W.B.C. Reg.	19.2.52
Smith, W. C.	Scot.	30.11.51	MacIndoe, T.	Scot.	31.12.51
Harrison, T. W.	Mid. Reg.	6.1.52	Bush, G. F.	H.C. Reg.	9.7.51
Jones, S. K.	L.T. Reg.	18.1.52	Firmin, S. B.	H.C. Reg.	30.9.51
Nightingale, W. H.	L.T. Reg.	13.1.52	Goate, H. E.	H.C. Reg.	7.12.51
Halls, A. N.	H.C. Reg.	29.7.51	Smith, H. A.	H.C. Reg.	31.12.51
Parker, C. E. H.	H.C. Reg.	22.8.51	Jones, H. W.	W.B.C. Reg.	30.11.51
Taylor, C. H.	H.C. Reg.	29.10.51	Clark, Z. C.	N.E. Reg.	31.8.51
Wright, T. D.	W.B.C. Reg.	27.5.51	Johnson, C. C.	N.E. Reg.	3.8.51
			Chalder, E. V.	N.E. Reg.	3.8.51
			Tarelli, F. S.	N.E. Reg.	29.8.51
			Edmondson, T.	N.E. Reg.	19.9.51
			Thompson, A. E.	N. Ire. Reg.	17.12.51

Transfers

Name	Region	Date	Name	Region	Date
<i>Exec. Engr.</i>			<i>Asst. Engr.—continued.</i>		
Beniston, S.	E.-in-C.O. to Min. of Supply	1.2.52	Marchant, A. C.	E.-in-C.O. to Min. of Supply	1.2.52
Proctor, F. H.	E.-in-C.O. to H.C. Reg.	18.2.52	Cowan, R. T. B.	Scot. to P. & T. Dept., Gold Coast	30.5.51
<i>Asst. Engr.</i>			Ogden, R. S. I.	E.-in-C.O. to N. E. Reg.	2.12.51
Dytham, E. T.	E.-in-C.O. to Mid. Reg.	20.12.51	<i>Inspector</i>		
Shinn, E.	E.-in-C.O. to H.C. Reg.	1.1.52	Payne, A. J.	L.P. Reg. to L.T. Reg.	17.11.51

Resignations

Name	Region	Date	Name	Region	Date
<i>Asst. Engr.</i>			<i>Inspector</i>		
Millidge, N. C.	H.C. Reg.	21.8.51	Shepherd, A. H.	N.E. Reg.	12.12.51
Barnes, R. V.	H.C. Reg.	19.9.51	<i>Asst. (Sc.)</i>		
Jones, E. W.	W.B.C. Reg.	1.6.51	Lane, P. S.	E.-in-C.O.	4.1.52

Deaths

Name	Region	Date	Name	Region	Date
<i>Exec. Engr.</i>			<i>Asst. Engr.—continued.</i>		
Abbott, G. A.	L.T. Reg.	29.12.51	Bedley, E. H.	L.T. Reg.	8.1.52
<i>Asst. Engr.</i>			<i>Inspector</i>		
Putland, R. C.	Mid. Reg.	7.12.51	Hunkin, B. W.		
Sandford, W. H.	L.T. Reg.	23.12.51	S.W. Reg.		2.2.52

CLERICAL GRADES

Promotions

Name	Region	Date	Name	Region	Date
<i>C.O. to E.O.</i>			<i>C.O. to E.O.—continued.</i>		
Lee, C. E.	E.-in-C.O. to L.P. Reg.	28.5.51	Davie, C. S. D.	E.-in-C.O. to L.P. Reg.	27.8.51
Ince, G. W.	E.-in-C.O. to L.P. Reg.	25.3.51			

BOARD OF EDITORS

H. FAULKNER, C.M.G., B.Sc., M.I.E.E., Chairman.
W. WEST, B.A., M.I.E.E.
Capt. C. F. BOOTH, O.B.E., M.I.E.E.
L. F. SCANLEBURY, Whit.Sch., A.C.G.I., D.I.C., A.M.I.E.E.
D. A. BARRON, M.Sc., A.M.I.E.E.
E. DAVIS, A.M.I.E.E.
L. CHANT.
G. E. STYLES, A.M.I.E.E., Managing Editor.
W. A. HUMPHRIES, A.M.I.E.E.
J. P. HARDING, B.Sc.(ENG.).
A.M.INST.C.E., A.M.I.E.E. } Assistant Editors.
A. J. HUTCHISON, Secretary-Treasurer.

Copyright

The entire contents of this JOURNAL are covered by general copyright, and special permission is necessary for reprinting long extracts, but Editors are welcome to use not more than one-third of any article, provided credit is given at the beginning or end thus: "From the *Post Office Electrical Engineers' Journal*."

The Board of Editors is not responsible for the statements made or the opinions expressed in any of the articles in this JOURNAL, unless such statement is made specifically by the Board.

Communications

All communications should be addressed to the Managing Editor, *P.O.E.E. Journal*, Engineer-in-Chief's Office, Alder House, Aldersgate Street, London, E.C.1. Telephone: HEADquarters 1234. Remittances should be made payable to "*The P.O.E.E. Journal*" and should be crossed "& Co."

Binding Cases

Cases for binding are available, and may be obtained from the Local Agents for 3s. Subscribers can have their copies of volumes bound, at a cost of 10s. 6d., by sending the complete set of parts to the Local Agents or to the *P.O.E.E. Journal*, Engineer-in-Chief's Office, Alder House, Aldersgate Street, London, E.C.1. Orders for binding for Vols. 1-19 should indicate whether the original binding case with black lettering, or the later pattern with gold, is required. Cases with gold lettering are the only type stocked from Vol. 20 onwards.

Back Numbers

The price of the JOURNAL, which is published quarterly, is 2s. 6d. (2s. 9d. post free) per copy, or 11s. per annum, post free. Back numbers can be supplied, subject to availability of stocks, at 2s. 6d. each (2s. 9d. post free). Orders for back numbers may be sent to the *P.O.E.E. Journal*, Engineer-in-Chief's Office, Alder House, Aldersgate Street, London, E.C.1, or to the Publishers.

Employees of the British Post Office can obtain the *Journal* through Local Agents at the reduced price of 1s. 6d. per copy.

Advertisements

All communications relating to space reservations should be addressed to the Advertisement Editor, *P.O.E.E. Journal*, Alder House, Aldersgate Street, London, E.C.1. Communications regarding advertisement copy, proofs, etc., should be addressed to the Publishers, Messrs. Birch & Whittington (Prop. Dorling & Co. [Epsom], Ltd.), 49 Upper High Street, Epsom, Surrey.

PRINTED PAPERS

The following papers contributed to the proceedings of the Institution have been printed by the authority of the Council and may be obtained, if still in print, from

"THE LIBRARIAN, THE INSTITUTION OF POST OFFICE ELECTRICAL ENGINEERS, G.P.O. (ALDER HOUSE), LONDON, E.C.1."

The price of each Paper is 1s. 6d., plus postage, and in every case Members, Associate Members, and Associates have the privilege of purchasing copies at 1s.

- No. 140. "SOME NON-METALLIC SUBSTANCES AND THEIR CHARACTERISTICS."—Capt. N. F. CAVE-BROWNE-CAVE, B.Sc., A.M.I.E.E. 1931.
- †No. 146. "LAYING ARMoured CABLE BY MEANS OF A MOLE-DRAINER."—L. G. SEMPLE, B.Sc.(Eng.), and R. O. BOOCOCK, B.Sc.(Eng.). 1932.
- No. 148. "STORES SPECIFICATIONS AND ACCEPTANCE TESTING."—Capt. J. LEGG, B.Sc., A.M.I.E.E. 1933.
- †No. 163. "AUTOMATIC EXCHANGE DESIGN."—H. E. FRANCIS. 1936.
- †No. 164. "THE LONDON-BIRMINGHAM COAXIAL CABLE SYSTEM."—A. H. MUMFORD, B.Sc.(Eng.), A.M.I.E.E. 1937.
- †No. 165. "PROPERTIES AND TESTING OF DIELECTRIC MATERIALS."—J. F. DOUST and W. J. SULSTON, M.Sc., A.Inst.P. 1936.
- †No. 166. "CHEMISTRY AND COMMUNICATIONS."—D. W. GLOVER, M.Sc., A.I.C. 1937.
- †No. 169. "CROSSTALK."—H. C. S. HAYES, A.M.I.E.E. R. A. SEYMOUR and P. R. BRAY, M.Sc.(Eng.), Grad.I.E.E. 1938.
- No. 173. "AUDIO-FREQUENCY RIPPLE FROM D.C. POWER SUPPLIES IN COMMUNICATION ENGINEERING."—H. R. HARBOTTLE, B.Sc., D.F.H., M.I.E.E., J.A. SHEPPARD, B.Sc., A.M.I.E.E., and D. L. RICHARDS, B.Sc. 1939.
- No. 174. "METALLURGY AND COMMUNICATIONS."—E. V. WALKER, B.Sc. A.R.S.M. 1940.
- No. 177. "RECENT APPLICATIONS OF THE QUARTZ AND X-RAY SPECTROGRAPHS TO POST OFFICE PROBLEMS."—R. TAYLOR, M.A., Ph.D., B.Sc. 1941.
- No. 178. "LONG DISTANCE D.C. IMPULSING."—S. WELCH, M.Sc.(Eng.), and C. H. J. FLEETWOOD. 1942.
- No. 179. "INTRODUCTION OF U.A.X. MULTI-METERING IN THE LEEDS AREA."—H. G. COPE. 1941.
- †No. 182. "LONDON INLAND TRUNK SERVICES."—W. H. SCARBOROUGH, A.M.I.E.E. 1943.
- †No. 184. "THE FUNDAMENTALS OF DIRECT CURRENT IMPULSING IN MULTI-EXCHANGE AREAS."—S. WELCH, M.Sc.(Eng.), A.M.I.E.E. 1944.
- †No. 186. "TELEPHONE SERVICE OBSERVATIONS."—J. J. PERKINS A.M.I.E.E. 1945.
- †No. 187. "CABLING PROBLEMS IN SUBWAYS AND TUNNELS."—T. G. TURLEY, A.M.I.E.E. 1945.
- †No. 189. "DEVELOPMENT OF TELEGRAPH SWITCHING IN GREAT BRITAIN."—J. A. S. MARTIN, A.M.I.E.E., and J. W. FREEBODY Whit. Schol., B.Sc.(Eng.), D.I.C., A.M.I.E.E. 1944.
- †No. 190. "WIDEBAND TRANSMISSION OVER COAXIAL CABLES."—R. A. BROCKBANK, Ph.D., B.Sc., A.M.I.E.E., and C. F. FLOYD, M.A., A.M.I.E.E. 1946.
- †No. 191. "PIEZO-ELECTRIC QUARTZ AND ITS USE IN TELECOMMUNICATIONS."—C. F. BOOTH, M.I.E.E. and J. L. CREIGHTON, A.M.I.E.E. 1946.
- †No. 193. "IMPROVEMENTS IN TELEPHONE SIGNALLING."—S. WELCH, M.Sc.(Eng.), A.M.I.E.E., and C. H. J. FLEETWOOD, A.M.I.E.E. 1949.
- †No. 194. "MAINTENANCE OF MULTI-CHANNEL CARRIER TELEPHONE SYSTEMS."—F. O. MORRELL, B.Sc., A.M.I.E.E. 1948.
- †No. 195. "THE INTRODUCTION OF AUTOMATIC SWITCHING TO THE INLAND TELEPRINTER NETWORK."—H. E. WILCOCKSON, A.M.I.E.E., and C. W. A. MITCHELL, A.M.I.E.E. 1949.
- †No. 196. "WIRE BROADCASTING."—F. HOLLINGHURST, B.Sc.(Eng.), A.C.G.F.C., M.I.E.E., and W. PRICKETT, A.M.I.E.E. 1949.
- †No. 197. "THE POSSIBILITIES OF SUPER-HIGH FREQUENCY RADIO AND WAVEGUIDE SYSTEMS FOR TELECOMMUNICATIONS."—W. J. BRAY, M.Sc.(Eng.), A.C.G.I., D.I.C., A.M.I.E.E. 1948.
- No. 198. "INTRODUCTION AND APPLICATION OF TRANSMISSION PERFORMANCE RATINGS TO SUBSCRIBERS' NETWORKS."—G. A. E. FUDGE, A.M.I.E.E. 1949.
- †No. 199. "SOME APPLICATIONS OF ELECTRONIC METHODS TO TELEGRAPH APPARATUS."—R. O. CARTER, M.Sc.(Eng.), A.M.I.E.E., and L. K. WHEELER, B.Sc.(Eng.), A.M.I.E.E. 1949.
- †No. 200. "TRENDS IN THE DESIGN OF LINE TRANSMISSION EQUIPMENT."—R. J. HALSEY, B.Sc.(Eng.), A.C.G.I., D.I.C., M.I.E.E. 1949.

† The Council have awarded Institution Medals for these papers.

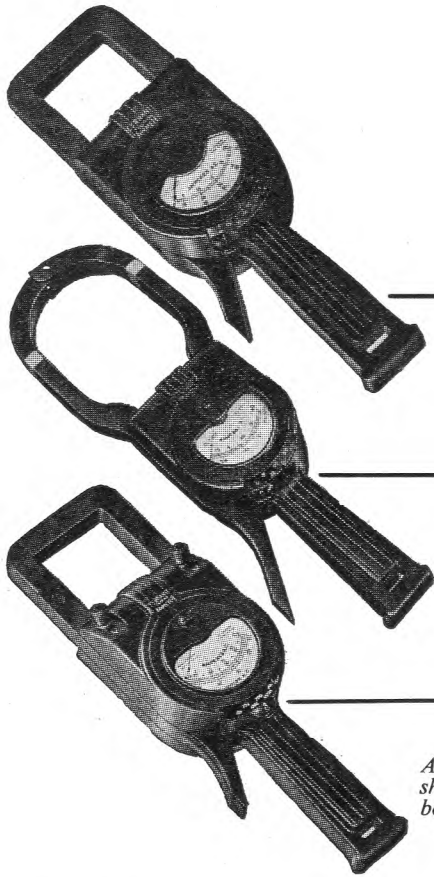

7-Range

CLIP-ON AMMETERS

Type A 7-Range Clip-on Ammeter Type 'A'
0-10-25-50-100-250-500-1,000 amps. Write for List IN.17A.

Type L 7-Range Clip-on Ammeter Type 'L'
0-10-25-50-100-250-500-1,000 amps. Specially designed for use on porcelain-clad fuses and heavy-duty conductors up to 4 in. diameter. Write for List IN.17L.

Type V 7-Range Clip-on Volt-Ammeter Type 'V'
0-10-25-100-250-1,000 Amps and 0-150-600 volts. Write for List IN.17V.

A leather case with shoulder strap can be supplied at an extra price.

FERRANTI LTD.
HOLLINWOOD . LANCASHIRE
London Office: KERN HOUSE, KINGSWAY, W.C.2.



INDEX TO ADVERTISERS

	PAGE
Airmec Laboratories, Ltd.	xxxI
Alton Battery Co., Ltd., The	xxix
Automatic Coil Winder & Electrical Equipment Co., Ltd.	xxiv
Automatic Telephone & Electrical Co., Ltd.	xiv-xv, xviii-xix
Bennett College, The.	ii
British Institute of Engineering Technology	ii
British Power Transformer Co., Ltd.	x
Creed & Co., Ltd.	xxx
De La Rue & Co., Ltd.	xiii
Dexion Ltd.	xxxi
Dubilier Condenser Co. [1925], Ltd.	xxi
Edison Swan Electric Co., Ltd., The	xxxii
E.M.I. Institute	viii
Ericsson Telephones, Ltd.	vii
Evershed & Vignoles, Ltd.	xi
Ferranti, Ltd.	iv
General Electric Co., Ltd., The	xvi-xvii
Great Northern Telegraph Co., Ltd.	xxv
Hackbridge Cable Co., Ltd.	xxv
Hivac	viii
International Correspondence Schools, Ltd.	xxxI
Marconi Instruments Ltd.	v
Marconi's Wireless Telegraph Co., Ltd.	xii
Muirhead & Co., Ltd.	v
Mullard, Ltd.	ix
Painton of Northampton	vi
Pirelli-General Cable Works, Ltd.	xxxii
Pitman, Sir Isaac, & Sons, Ltd.	viii
Savage Transformers	ii
Savage, W. Bryan, Ltd.	xxviii
Siemens Brothers & Co., Ltd.	xx
Smith, Frederick, & Co.	ii
Standard Telephones & Cables, Ltd.	xxii-xxiii
Sullivan, H. W., Ltd.	xxvi
Telephone Manufacturing Co., Ltd.	xxiv
Tungstone Products, Ltd.	xxvii
Turner Electrical Instruments	xxviii
Westinghouse Brake & Signal Co., Ltd.	xxvi
Winn & Coales, Ltd.	iv



Denso Tape provides complete protection for pipes, mains, cables and all metalwork against the combined attacks of chemical and electrolytical corrosion. Permanently plastic—Denso forms a perfect gas- and water-tight seal that withstands the heaviest vibration. Ideal for temporary repairs—**an aid to frost-proofing.**

against **CORROSION**

Write for full details of Denso Anti-corrosive and Sealing Products without obligation, from:—

WINN & COALES LTD.
DENSO HOUSE, CHAPEL ROAD, LONDON, S.E.27
Telephone: GIPsy Hill 4247/8
Telegrams: Denselte, Westnor, London

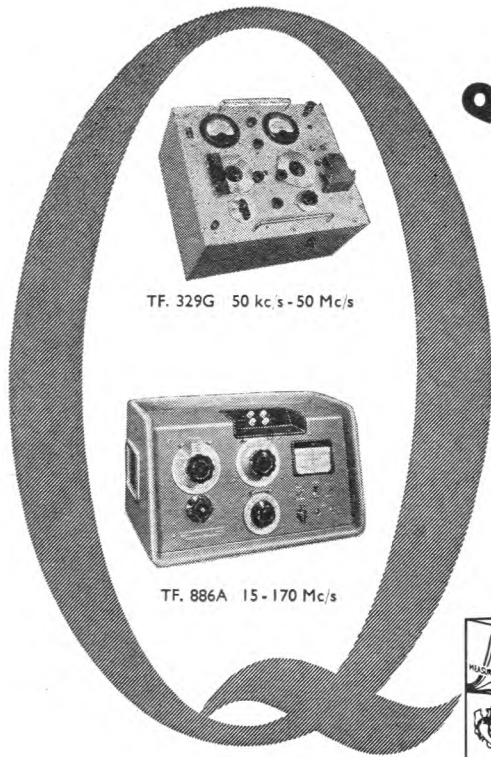

TF. 329G 50 kc/s - 50 Mc/s

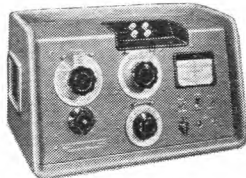

TF. 886A 15 - 170 Mc/s



Q measurement by Marconi

Famous for years in the field of communication measurement, Marconi Instruments offer TF 329G for determinations in frequency range 50 kc/s to 50 Mc/s, and TF 886A for the range 15-170 Mc/s. While both instruments are primarily designed as direct reading Q meters, either may, of course, be employed for a variety of indirect measurements — such as the capacitance and phase defect of condensers — carried out by the normal resonance methods. In addition, special jigs are available for TF 329G for the investigation of dielectrics.

TF 329G 50 kc/s - 50 Mc/s 10 - 500 Q 40 - 450 $\mu\mu$ F.

TF 886A 15 - 170 Mc/s 60 - 1200 Q 12 - 85 $\mu\mu$ F.

May we send you our 44-page booklet "Measurements by Q Meter"?

MARCONI instruments

SIGNAL GENERATORS • BRIDGES • VALVE VOLTMETERS
 FREQUENCY STANDARDS • OUTPUT METERS • WAVE METERS
 WAVE ANALYSERS • BEAT FREQUENCY OSCILLATORS

MARCONI INSTRUMENTS LTD • ST. ALBANS • HERTS • PHONE: ST. ALBANS 6161/7

Midland Office: 19 The Parade, Leamington Spa. Northern Office: 30 Albion Street, Hull. Export Office: Marconi House, Strand, London, W.C.2



The Muirhead-Pametrada Wave Analyser Type D-489

An Analyser for all Waveforms

Whatever the waveform, the Muirhead-Pametrada Wave Analyser can be relied upon to select each component quickly and accurately — quickly because the flat-topped variable bandwidth response curve simplifies tuning — accurately because the stable resistance-capacitance tuned filter circuit ensures constant percentage accuracy at all frequencies.

Features

- | | |
|--|--|
| Wide frequency band—19c/s to 21 kc/s in 3 overlapping ranges | Off-peak response proportional to percentage mistuning |
| Frequency accuracy constant over entire range | Flat-topped response curve—narrow or wide bandwidth selected at will |
| Octave discrimination better than 70db | Electronically stabilized power supplies |

For Full Details Write for Bulletin B-663

MUIRHEAD & Co., LTD.
 PRECISION ELECTRICAL INSTRUMENT MAKERS
 BECKENHAM • KENT • ENGLAND

Phone: BECKenham 0041 Telegrams & Cables: MUIRHEADS ELMERS-END

PRECISION
MUIRHEAD
 ELECTRICAL INSTRUMENTS

SUCCESS?

The demand for qualified technicians to fill well-paid industrial posts grows daily. An E.M.I. course of training is your quickest way to a key position. Our Home Study courses cover all the subjects listed below. As part of the great E.M.I. Group ("H.M.V.", Marconiphone, etc.), we have first-hand knowledge of the Technical Training required in modern industry. No other college can offer you such a practical background of industrial experience.

POST THIS COUPON NOW

E.M.I. INSTITUTES, Postal Division, Dept. 97,
43, GROVE PARK ROAD, CHISWICK, LONDON, W.4.

Please send, without obligation, your FREE BROCHURE
I have marked the subjects which interest me.

Mechanical Eng. Electrical Eng. Draughtsmanship
 Radio Television Production Eng. Automobile Eng.
 Aeronautical Eng. General Cert. of Education (Metric.)
 Civil Service. Also Courses for A.M.I.Mech.E., A.M.I.C.E.,
A.M.Brit.I.R.E., A.F.R.Ae.S., CITY and GUILDS EXAMS. in Mech. Eng.,
Elect. Eng., Telecommunications, etc.

NAME

ADDRESS

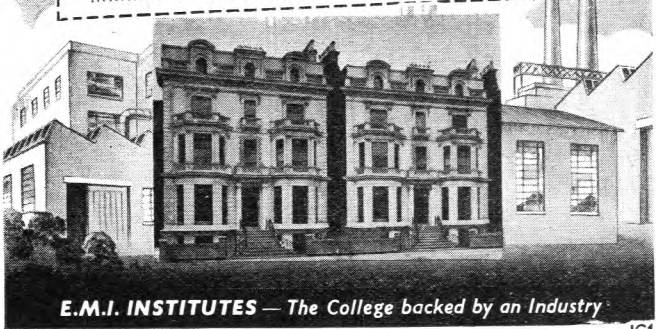

E.M.I. INSTITUTES — The College backed by an Industry

1C1

PITMAN

Earthing Principles and Practice

By R. W. Ryder, B.E., B.Sc., A.M.I.E.E. This is a useful book for all concerned with protective measures. It is a complete guide to the theory and practice of earthing, and includes the I.E.E. regulations for earthing in buildings. With 45 illustrations. 15/- net.

The Practical Engineer Pocket Book

Edited by H. P. W. Moore, B.Sc., A.C.G.I., D.I.C., A.M.Inst.F. A famous pocket book, now in its 64th year, containing technical data, up-to-date articles, etc. Revised edition. Over 750 pages, and numerous illustrations. 12/6 net.
 "This useful little reference book."—*Engineer*.

Telecommunications Principles

By R. N. Renton, M.A.I.E.E. Covers the syllabus for the City and Guilds examinations in Telecommunications Principles, Grades I, II & III. Illustrated. 37/6 net.

"Can be recommended confidently to all students of Telecommunications."—*Post Office Telecommunications Journal*.

PITMAN, Parker Street, Kingsway, London, W.C.2

Cold Cathode Triode

The CC2R is a cold cathode triode on the octal base.

It may be triggered by a power of only a few microwatts and thus provides a means of relay operations from D.C., A.C., or R.F. high impedance sources.

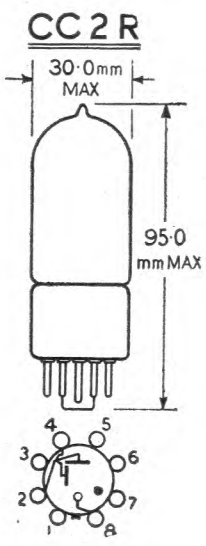

RATINGS

Nominal control gap breakdown	75 V
Minimum main gap breakdown	200 V
Maximum cathode current (continuous) ..	10 mA
Maximum cathode current	30 mA
(Intermittent or pulse)	



GREENHILL CRESCENT,
HARROW-ON-THE-HILL, MIDDLESEX
Telephone: HARrow 2655

MODEL ANSWERS

TO

CITY AND GUILDS OF LONDON INSTITUTE EXAMINATIONS

Students preparing for City and Guilds examinations in Telecommunications will find the Model Answers published in book form a useful aid to study. The questions and answers have been extracted from Supplements to the Journal issued during recent years, and, after careful revision, have been grouped under headings corresponding with the new syllabuses introduced by the City and Guilds in 1947.

Model Answers to questions which, on account of paper shortage, were unanswered in Supplements issued during the war years are also included.

The following books are available :—

TELECOMMUNICATIONS (PRINCIPLES) II

TELEPHONE EXCHANGE SYSTEMS II

TELEGRAPHY I

(PRICE 2/6 EACH POST FREE, 2/9)

TELEPHONE EXCHANGE SYSTEMS I

TELEGRAPHY II

RADIO II

(PRICE 3/6 POST FREE, 3/9)

Orders may be placed with the JOURNAL LOCAL AGENTS or with THE MANAGING EDITOR, POST OFFICE ELECTRICAL ENGINEERS' JOURNAL, ALDER HOUSE, ALDERSGATE STREET, LONDON, E.C.1

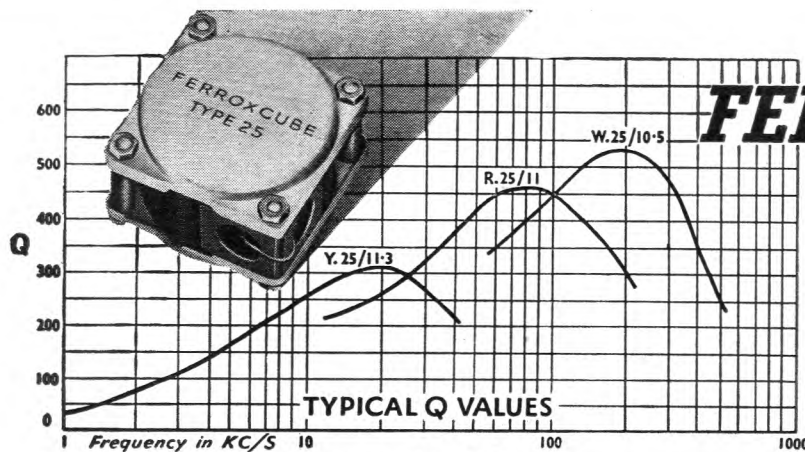

FERROXCUBE

FERROMAGNETIC FERRITE

For Line Communications :

IN THE design of Mullard pot core assemblies type 25 (36) full advantage is taken of the characteristics of Ferroxcube to produce inductances of remarkably high "Q" factors, which, combined with ease of winding, make these cores very suitable for use in filter networks and wherever high quality inductances are required.

Fine adjustment of inductance is obtained by control of the air gap rather than by variation of the turns.

The good screening properties of the Ferroxcube combined with the convenient shape of the assembly, which allows stacking or individual mounting, are features which distinguish these Mullard cores.

OUTSTANDING FEATURES

- | | |
|---|---|
| ★ Low hysteresis coefficient | ★ Self screening |
| ★ High values of inductance | ★ Controlled temperature coefficient |
| ★ Low self capacitance | ★ Operation over a wide frequency range |
| ★ Controllable air gap facilitating inductance adjustment | ★ Ease of winding and tapping |
| | ★ Easily mounted |

PLEASE WRITE FOR FULL DETAILS



Mullard FERROXCUBE

FERROMAGNETIC FERRITE

MULLARD LIMITED · CENTURY HOUSE · SHAFTESBURY AVENUE · LONDON · W.C.2

(MF372)

AUTOMATIC VOLTAGE REGULATORS by B.P.T.

Maintaining a constant voltage unaffected by variation in the supply voltage, frequency, load and load power factor is a problem which can be solved by the aid of our standard range of Automatic Voltage Regulators. For single phase operation there are 11 models from 12½ to 240 amps, for three-phase there are 13 models from 7½ to 150 amps. Three typical models are illustrated from our standard range of wall or floor mounting types.

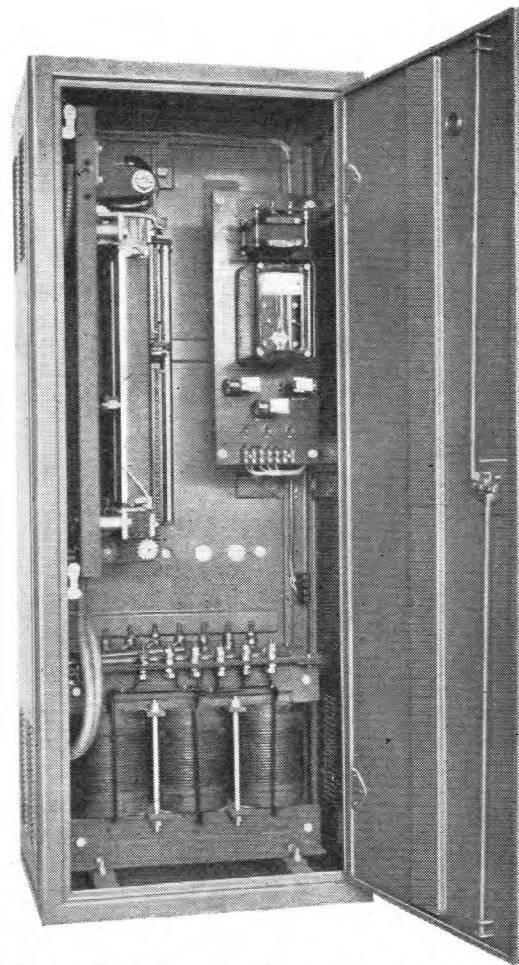

Top: 3-phase, air cooled, floor mounting (cubicle) model. Input 440V ± 10%, output 440V ± 1%, 40 amps.

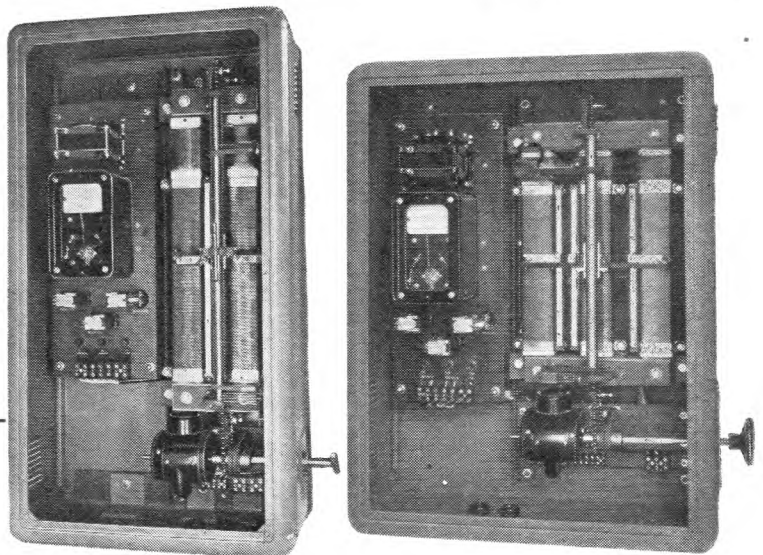

Left: Single-phase, air cooled, wall mounting model. Input 250V ± 15%, output 250V ± 1%. 25 amps.

Right: 3-phase, air cooled, wall mounting model. Input 440V ± 10%, output 440V ± 1%. 7½ amps.

Please write for further information and literature.

BRITISH POWER TRANSFORMER CO. LTD.

QUEENSWAY, PONDER'S END, MIDDLESEX Phone: HOWard 1492 Grams: 'Vitrohm Enfield'

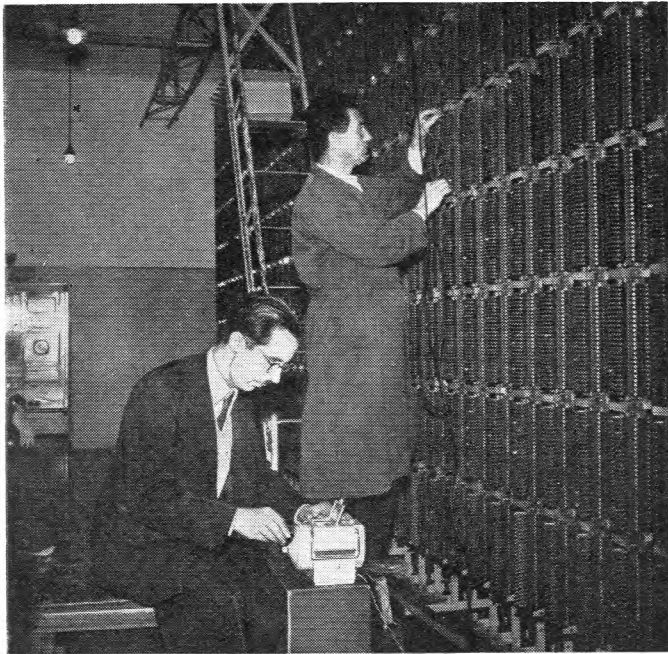

GREECE. This picture shows officials of Telecommunications Organisation of Greece Ltd., using a "Megger" Insulation and Continuity Tester, Series 2, during a routine check at a telephone exchange in Greece.



HOLLAND. "Megger" Testers are used by the Dutch Post Office. This photograph shows Dutch P.O. engineers using a 500 volt Bridge-Megger Varley Testing Set to test a faulty line of a telephone cable in a polder-dike.

"MEGGER" TESTERS SERVE WORLD COMMUNICATIONS

UNITED KINGDOM. 64% of all faults on the 34,000 miles of main underground Post Office cables in the United Kingdom are located by "Megger" Testers.

ITALY. The Societa Telefonica Tirrena, which operates the telephone lines of Liguria (Genoa and the Riviera), Tuscany, Central Italy, the Vatican City and the Island of Sardinia, uses "Megger" Insulation Testers in the maintenance and localisation of faults in cables balanced in groups between cities.

AUSTRALIA. Bridge-Megger Testers prove equally valuable to the Post Office down under. Instruments equipped with Varley fault localisation facilities are used extensively by the Australian Postmaster-General's Department for the location of faults on underground cables. They report that "it is outstanding when used to perform this function."

ALL OVER THE WORLD the famous series of "Megger" Insulation Testers are used by public authorities, industrial undertakings and commercial enterprises because these instruments are more accurate, more reliable and sturdier in use.

For full details send for Publication X051/1-8.



"Megger" is the registered trade mark of Evershed & Vignoles Ltd.
Telephone: Chiswick 3670

EVERSHED & VIGNOLES LIMITED

ACTON LANE WORKS · CHISWICK · LONDON · W. 4

Telegrams: Megger, Chisk, London

Cables: Megger, London

6/76

MARCONI

serves

mankind

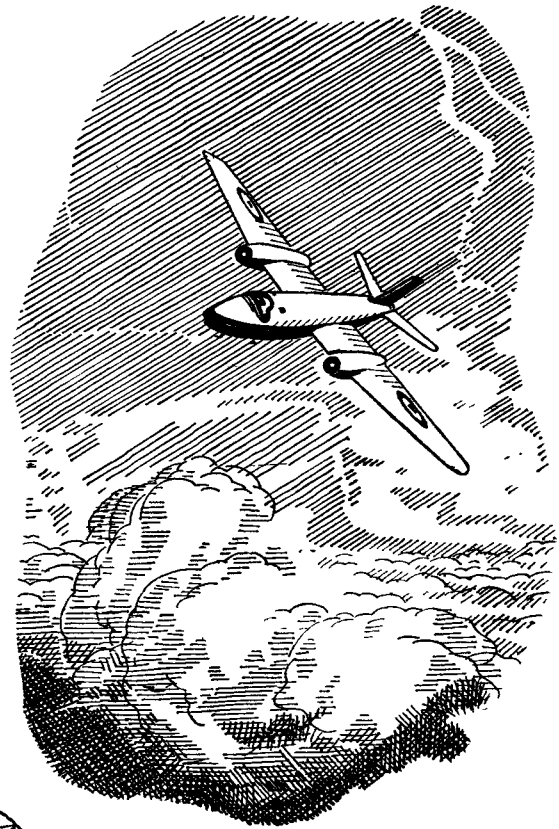

Marconi came into a world in which communications were adolescent. When he left it, the marvels of radio were a commonplace. His name had achieved immortality; his work was established in the service of mankind. It is therefore no coincidence that the Company which he founded should supply communication and navigation equipment for aircraft like the Canberra and Comet, which are the most advanced of their class in the world.

MARCONI

serves

mankind

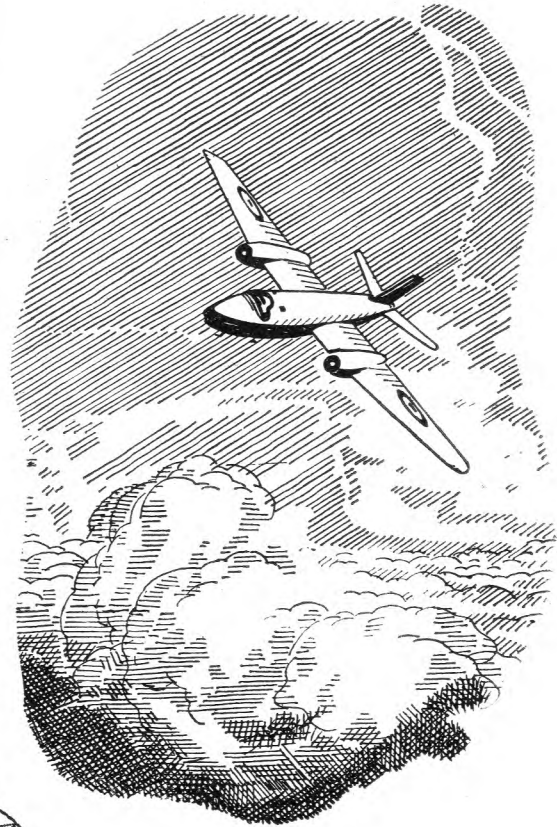

Marconi came into a world in which communications were adolescent. When he left it, the marvels of radio were a commonplace. His name had achieved immortality; his work was established in the service of mankind. It is therefore no coincidence that the Company which he founded should supply communication and navigation equipment for aircraft like the Canberra and Comet, which are the most advanced of their class in the world.

Components made from DELARON LAMINATED PLASTIC possess insulation properties which remain constant within very close limits. Delaron is tough and durable, easy to machine and punch and the range includes grades which conform to all Industrial, British Standard and Ministry Specifications. Delaron is economical too and is supplied in the widest range of board sizes up to 9' x 4'. Our Technical Service Department will be glad to talk over your problems, or if you will send full details, we will let you have samples by return.

We are indebted to our friends in the Radio and Electric Industry for permission to reproduce these components.

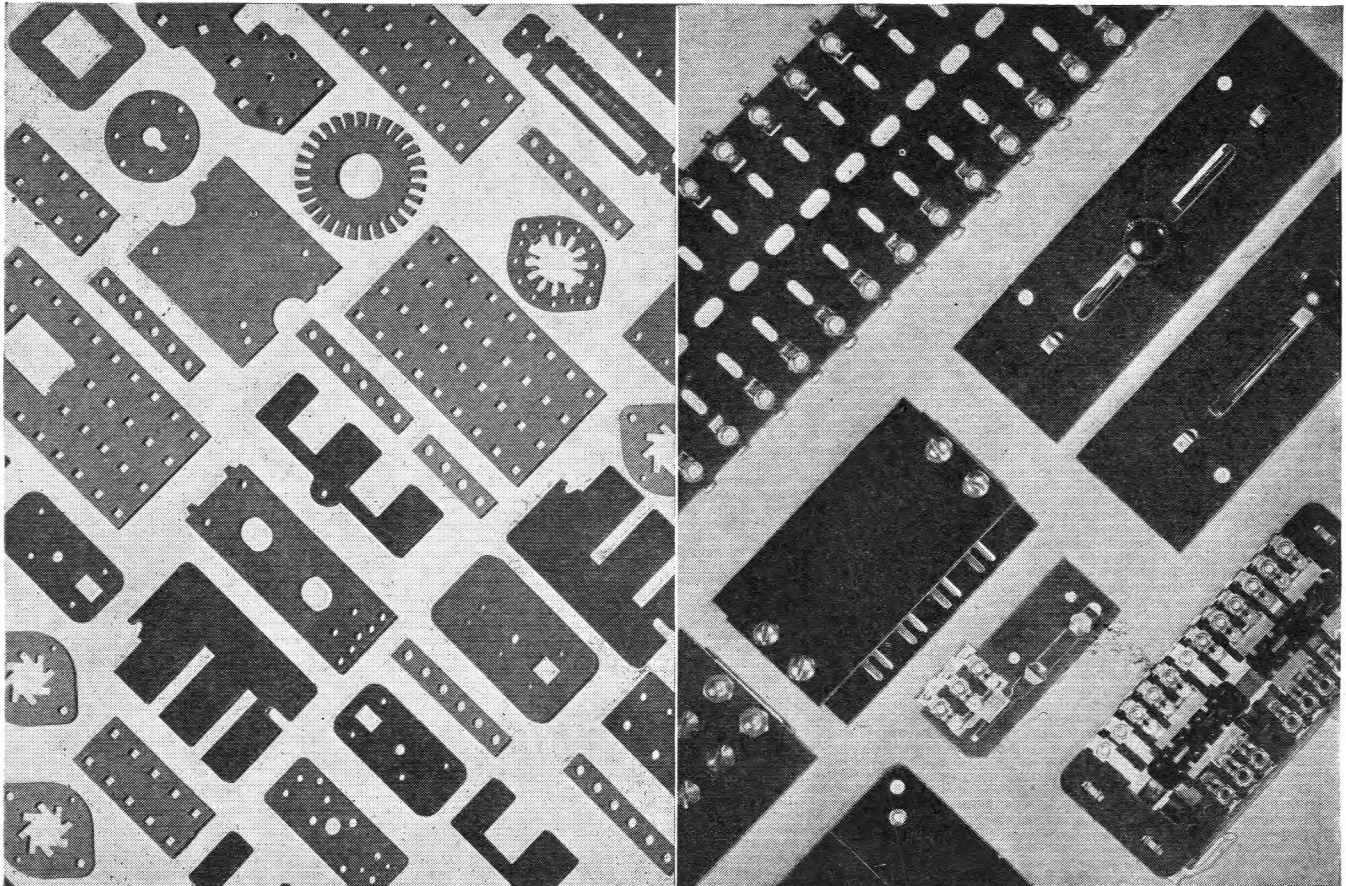

Punched electrical components showing clean finish of edges after machining of intricate parts.

Electrical terminal strips and variable resistors for radio construction.

DELARON

LAMINATED PLASTIC BOARD

THOMAS DE LA RUE & CO. LTD. (*Plastics Group*),
IMPERIAL HOUSE, 84/86 REGENT STREET, LONDON, W.1. Phone: REGent 2901



ANOTHER STROWGER EXCHANGE



LEE GREEN AUTOMATIC EXCHANGE is one of the latest to be commissioned by the British Post Office for the London Director network. Direct dialling facilities are provided for a maximum of 10,000 subscribers to 185 exchanges and

the majority of the 1,500,000 telephones in the area.

Whilst uniselectors are used for the subscriber's line equipment the type 32A (B.P.O. type 2000) two-motion selector is the selecting mechanism and incorporates in its design all the facilities which many years' operational experience has shown to be necessary; the simple straight-forward step-by-step principle of operation characteristic of the Strowger system has been retained. Termed Type 32A Mark II this selector to-day embodies all the qualities of progressive development and offers the most suitable basis for automatic telephone systems of any size. Its simplicity, economy, reliability, and ease of maintenance are the factors of principal appeal to telephone administrations in all parts of the world.



Automatic Telephone & Electric Co. Ltd.

Export Department: Strowger House, Arundel Street, London, W.C.2.

Telephone: TEMple Bar 9262. Cablegrams: Strowgerex, London. Strowger Works, Liverpool, England

AT.7741-AA104

How automatic is a telephone exchange?

In operation it is fully automatic, but there's nothing automatic about its maintenance. Only man-hours expended by skilled personnel will guarantee efficient maintenance.

Since the virtues and failings of a telephone system must depend ultimately on the ease or difficulty of maintenance, the

G.E.C., after years of research, has re-designed apparatus used in the

Strowger system, to obtain greater reliability, maximum ease of adjustment

and instant accessibility. The results are now apparent in the new

G.E.C. two-motion selector, the heavy and light duty uniselectors and the

trigger dial. All of them can now be maintained with much less skill and

in much less time than ever before. Combined with the *electrical simplicity*

exclusive to the Strowger system, these components mean that automatic

exchanges manufactured by the G.E.C. are the most valuable investment

an Administration can make.

SE50 SELECTOR

ACCESSIBILITY — Easy

ADJUSTMENTS — Independent of each other. Permanent. Positive

CONSTRUCTION — Accurate, Simple Stable, Uniform

OPERATION — Consistent, Reliable

WEAR — Negligible

MOUNTING — Interchangeable with British Post Office Type 2000

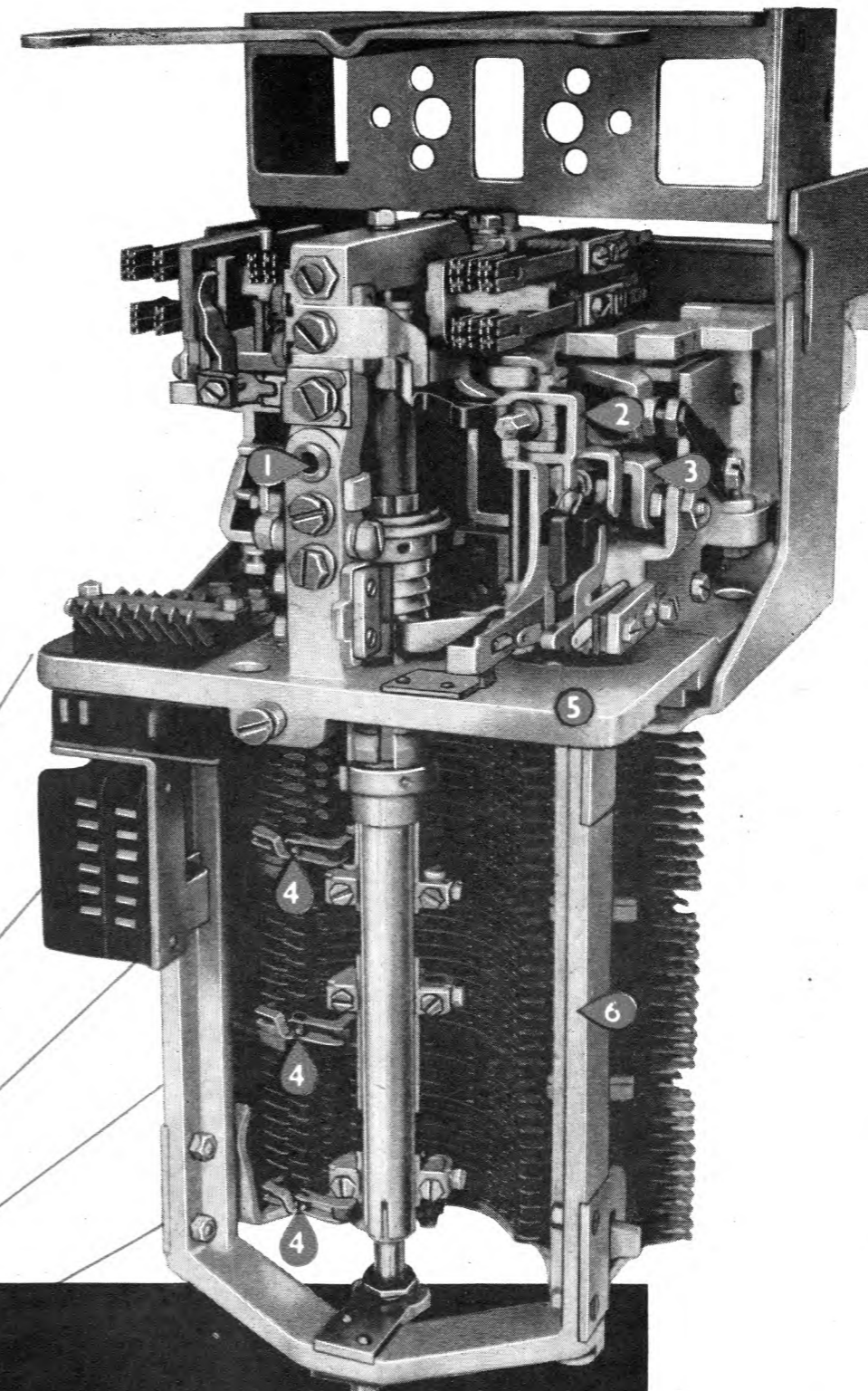

1 Hole for datum pin for uniformity of adjustment throughout the life of the selector.

2 Standard relay-type spring sets, with twin contacts and buffer blocks; usual adjustment technique.

3 Powerful rotary and vertical magnet units self-contained with armature backstops and interrupter springs—pre-adjusted and tested prior to assembly in the selector.

4 Long-life wipers with minimum bounce.

5 Rigid aluminium-silicon frame proportioned and shaped for maximum stability and resistance to wear during service.

6 Rigid aluminium-silicon frame columns to give uniform stability to the selector as a whole.

Full particulars are given in Leaflet SEL.1

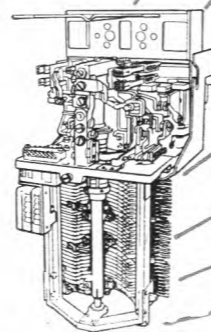
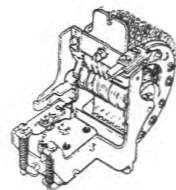
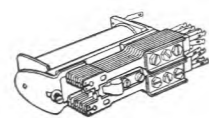

...CUTTING COST OF MAINTENANCE

G.E.C.
OF ENGLAND

THE GENERAL ELECTRIC CO. LTD. OF ENGLAND
Telephone, Radio & Television Works · Coventry

ATE/TMC Type 600 Transmission Precision Measurement of Attenuation

This diagram shows the basic arrangement for measuring the loss of a filter by a comparison method.

A signal derived from the oscillator is sent into the filter and a variable attenuator in parallel. By electronic switching the two attenuated signals which result are presented as adjacent rectangles of light on the screen of the cathode ray tube of the level comparator.

The heights of these rectangles are proportional to the amplitudes of the respective signals. The standard attenuator, contained in the transmission measuring set, is adjusted until the two signals are shown by the comparator to be of equal amplitude. The final attenuator setting gives a direct reading of the loss of the filter.

"Frequency runs" can be taken in a fraction of the usual time, by "sweeping" the oscillator frequency through the desired range and watching for variations of the signals displayed by the comparator. Fortuitous variations of output of the test oscillator are of no consequence since both amplitudes are affected in the same way.

The frequency range of the oscillator is 300 c/s to 160 kc/s, and when used with the level comparator the T.M.S. gives facilities for measurement of loss or gain of 70 db, with an accuracy of ± 0.1 db, in circuits of 600, 140 or 75 ohms impedance.

These three instruments form part of a comprehensive range covering the measurements of impedance, capacitance, singing point and crosstalk. All are arranged for mains or battery operation and are light, robust and portable. They are designed and constructed to the high standard of quality in material and workmanship which is a feature of all "ATM" products.

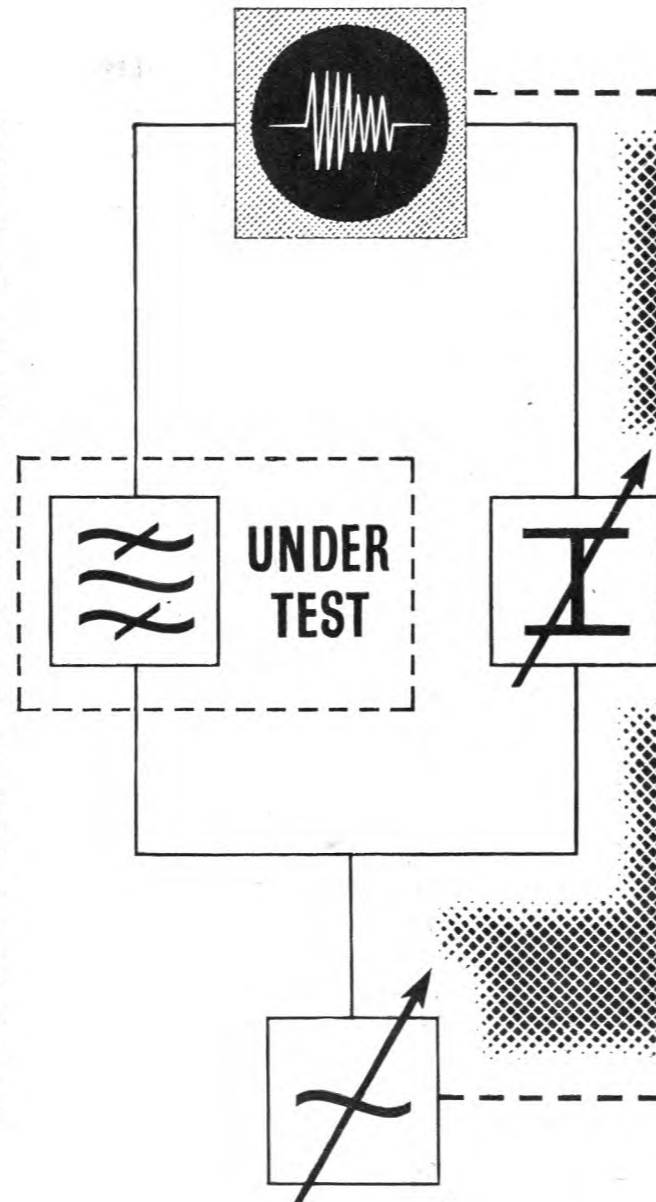

Distributors:—



AUTOMATIC TELEPHONE & ELECTRIC CO. LTD.

Radio and Transmission Division,
STROWGER HOUSE, ARUNDEL STREET, LONDON, W.C.2.
Telephone: TEMple Bar 9262. Cablegrams: Strowgerex, London.

Testing Equipment... or Gain by VISUAL Comparison



LEVEL
COMPARATOR



TRANSMISSION
MEASURING SET



OSCILLATOR

Joint Manufacturers:—

AUTOMATIC TELEPHONE & ELECTRIC CO. LTD., LIVERPOOL & LONDON
TELEPHONE MANUFACTURING CO. LTD., ST. MARY CRAY, KENT.

SIEMENS

MULTI-CHANNEL A.C. TELEGRAPH EQUIPMENT

TYPES CTS/6—CTS/24

FEATURES:

From 6 to 24 channels available.

Mounts 12 channels on one side of a 10' 6" bay.

Additional channels beyond 12 obtained by group modulation.

Associated bays provide duplicate generators or valve oscillators for tone supplies or for channel and group frequencies.

Capacity of bays, 10 systems.

Tone frequencies are 420 to 3,180 c/s at 120 c/s spacing, and equipment complies with CCIT requirements in all respects.

Wide transmission level range for low distortion.

Sending modulator and receiving detector-amplifier panels readily detachable for maintenance by plug and jack connections.

Equipment operates from 24V and 130V batteries or from separate A.C. mains Power Bay.

Testing equipment provided as standard on the Channel Bay.

Further particulars on application

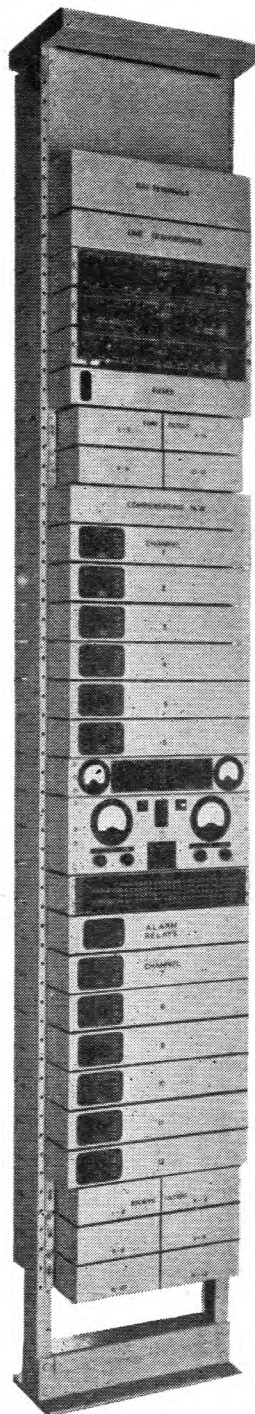

CHANNEL BAY

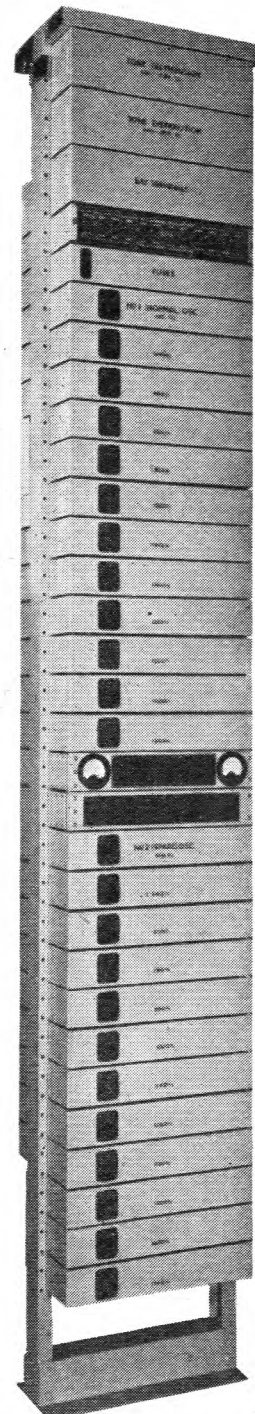

OSCILLATOR BAY

SIEMENS BROTHERS & CO., LIMITED

WOOLWICH . LONDON . S.E.18

Telephone: Woolwich 2020

MODERN CAPACITOR ENGINEERING

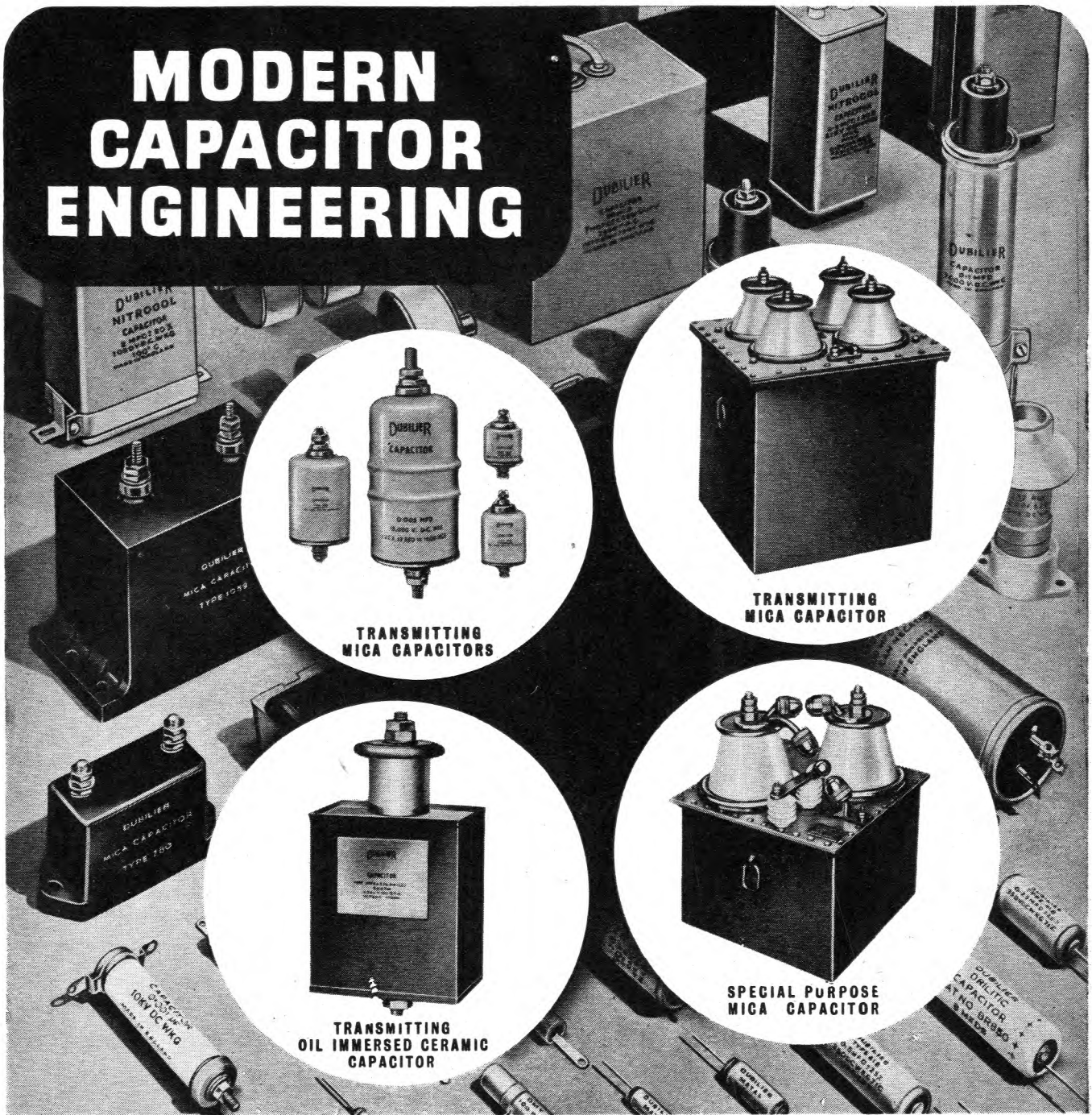

**TRANSMITTING
MICA CAPACITORS**



**TRANSMITTING
MICA CAPACITOR**



**TRANSMITTING
OIL IMMERSED CERAMIC
CAPACITOR**

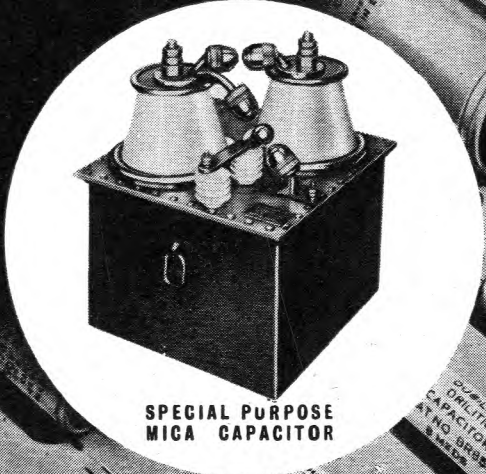

**SPECIAL PURPOSE
MICA CAPACITOR**

DUBILIER CAPACITORS

Dubilier provide the most comprehensive range of Capacitors available today for Radio Transmitting and Receiving, in addition to Capacitors for Electronic and Industrial engineering.

Dubilier Capacitors are designed and manufactured to

a high standard of specification, suitability of purpose and meticulous capacitor engineering, and they satisfy the exacting demands of the British Postal Authorities whom we are proud to number amongst our customers.

Full details and technical service upon request.

DUBILIER CONDENSER CO. (1925) LTD., DUCON WORKS, VICTORIA ROAD, N. ACTON, LONDON, W.3.
 'Phone: Acorn 2241 (5 lines). Cables: Hivoltcon, London. Marconi International Code. 'Grams: Hivoltcon, Wesphone, London.

TELEVISION LINKAGE OF



Standard are proud to have been entrusted with the development, manufacture and installation for the British Post Office of the coaxial television cable linking the London and Midland television transmitters, the coaxial cable and associated Vestigial Sideband terminal equipment linking the Midland and Northern television transmitters, and the microwave radio link between Manchester and the new Scottish television transmitter; these together constitute the longest television relay system in Europe.

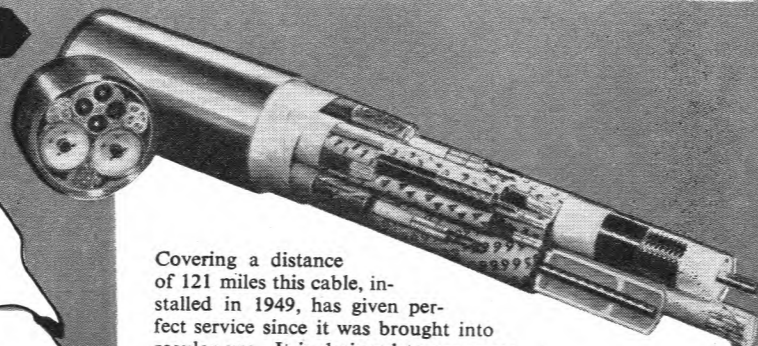

Covering a distance of 121 miles this cable, installed in 1949, has given perfect service since it was brought into regular use. It is designed to accommodate very-high-definition and colour television.

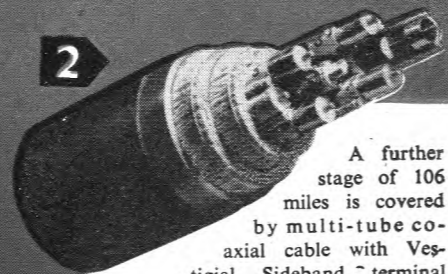

A further stage of 106 miles is covered by multi-tube coaxial cable with Vestigial Sideband terminal equipment.

Standard Telephones
TELECOMMUNICATION
CONNAUGHT HOUSE

ENGLAND AND SCOTLAND

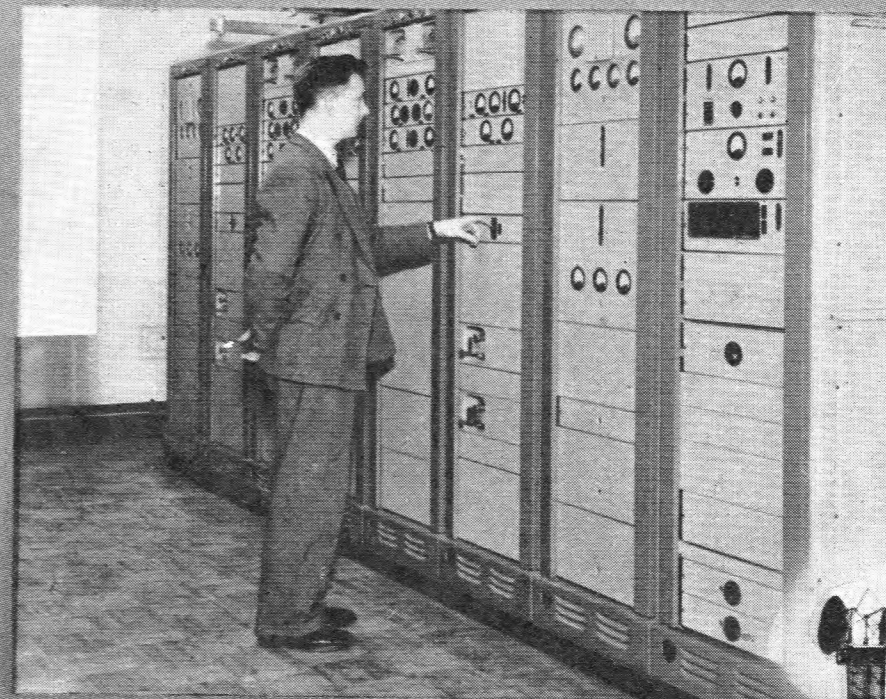

The latest link in the chain carries the signal in eight line-of-sight hops up to the Scottish transmitter. An F.M. carrier of approx. 4000 Mc/s is beamed by 10 ft diameter paraboloids mounted on steel towers. Apart from the paraboloids and the feeder waveguides all the equipment is located at ground level, and full remote control and supervisory facilities are provided at each station. Elaborate precautions are provided for automatic change-over to duplicate equipment.

Above—A standard suite of transmission cubicles installed at one of the seven repeater stations. *Right*—The repeater station at Black-castle Hill near Dunbar on the East coast of Scotland. The height of the steel tower is 200 ft.

and Cables Limited
ENGINEERS
ALDWYCH · LONDON W.C.2

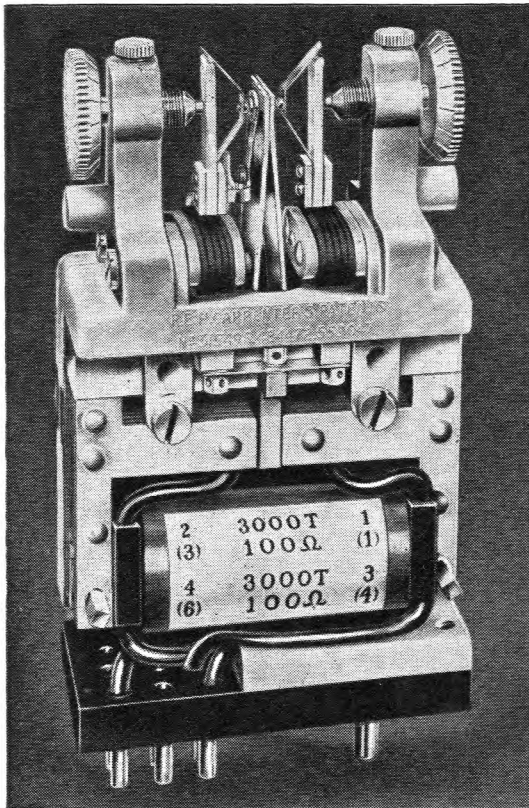

CARPENTER POLARIZED RELAY TYPE 4

The chief characteristics of this relay are low transit time—high contact pressure—freedom from contact chatter and positional error—high sensitivity—stability—symmetrical action—and ease of adjustment.

On V.F. dialling systems its use facilitates the design of sensitive receiving equipment, and on trunk telephone circuits the relay's high sensitivity enables it to respond to D.C. dialled impulses received over unrepeated trunk lines of up to 100 miles long.

It is particularly suitable as an impulse accepting relay when a minimum of signal distortion is imperative, and because of the excellent change-over action and absence of contact chatter the relay is unequalled for impulsing the selector magnets in teleprinter automatic switching systems.

The relay responds satisfactorily to frequencies up to 100 c/s, when the contact gap is adjusted to 0.004 in. nominal, without serious bias disturbance. It can be left connected to line whilst awaiting a clearing signal, there being little distortion of through signals since the total leak can be of the order of 10,000 ohms.

Dimensionally the relay is interchangeable with the "3000" type relay. Terminations can either be made by means of a 12-pin plug base as illustrated, or with soldering tags in place of the pins. Protection is given by a magnetic screen and a transparent cap which is removable for contact adjustments.

Complete details supplied on request.

Manufactured by the Sole Licensees:—

TELEPHONE MANUFACTURING COMPANY LIMITED

Contractors to Governments of the British Commonwealth and other Nations

HOLLINGSWORTH WORKS · DULWICH · LONDON S.E.21 TEL: GIPSY HILL 2211 (10 LINES)

ZEVA

Electric

SOLDERING TOOLS

for SPEED, ECONOMY
and BETTER WORK

The news that this famous range of Soldering Irons and Crucibles is again available has been welcomed in numerous branches of industry everywhere. Zeva Tools are unquestionably without equal for efficiency, economy and trouble-free long life.

- ZEVA heating elements never need renewal. They last the life of the tool.
- ZEVA Irons can be left switched on all day without detriment to the tool.
- ZEVA current consumption for rated temperature is less than any other make of tool.
- ZEVA initial cost is the only cost.
- ZEVA Irons are guaranteed.

Write for complete
Illustrated Catalogue:—

THE AUTOMATIC COIL WINDER & ELECTRICAL EQUIPMENT CO., LTD.
Winder House, Douglas Street, London, S.W.1

Phone: VICTORIA 3404-9

Z1/P2/ZWS

G.N.T.

REPERFORATOR MODEL 457

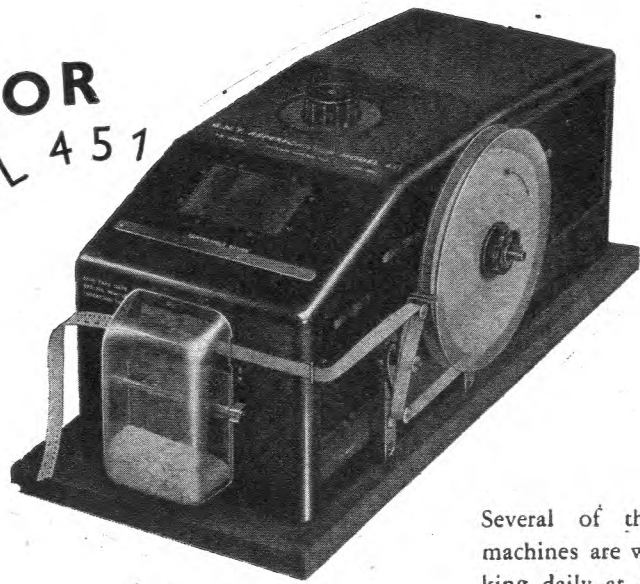

A truly synchronous reperforator for morse code.

Speed range:
40-200 words per minute without gear changes.

Supplied with A. C. or D. C. motor as required.

Several of these machines are working daily at 180 words per minute.

✧ Write for comprehensive catalogue.

THE GREAT NORTHERN TELEGRAPH COMPANY'S FACTORY

4, SYDHAVNS PLADS
COPENHAGEN SV . DENMARK

★ LONDON OFFICE: 5, ST. HELENS PLACE
LONDON E.C.3.

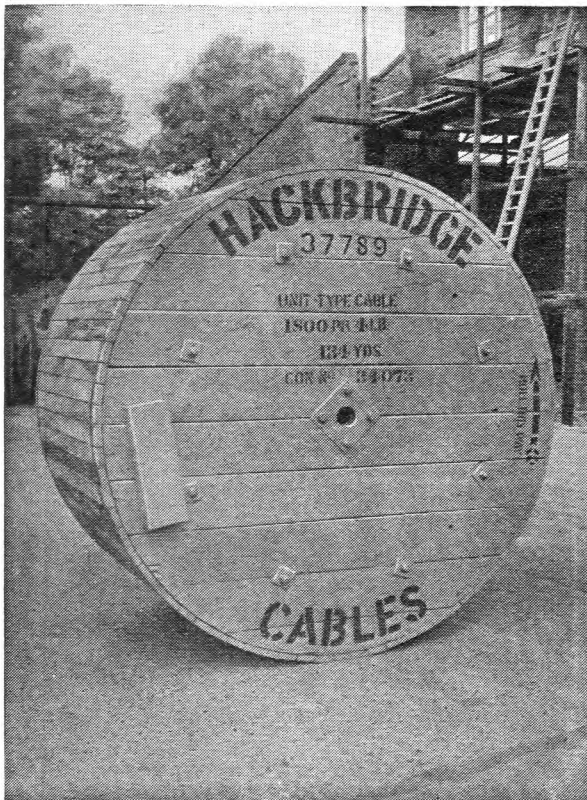

BEYOND THE BUTTON....

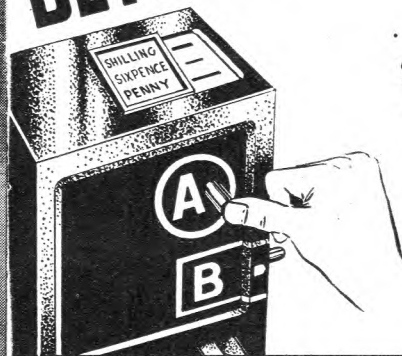

.... Hackbridge underground dry-core air-space lead covered and armoured cable.

Contractors to G.P.O.,
British Railways, British
and Colonial Govern-
ment Departments.



HACKBRIDGE

Cable Company Limited
KELVIN WORKS, HACKBRIDGE, SURREY
in Association with Bryce Electric Construction Company Ltd.
Branches at:
Birmingham, Bristol, Cardiff, Manchester, Newcastle, Sheffield

FOR E.H.T. Supplies

Type 36EHT rectifiers contain high-voltage "Westalite" elements resulting in a greatly reduced length of unit for any given output. They have been developed to meet the demand for small, compact metal rectifiers to provide E.H.T. in many forms of equipment where the current demand is unlikely to exceed 2 mA D.C., as, for example, cathode ray tubes, electron multipliers, condenser storage devices, etc. For further information and tables of outputs of these . . .

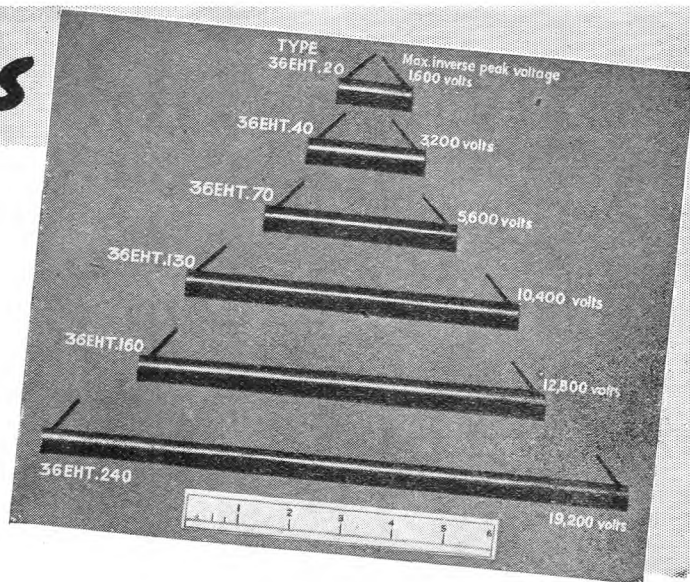

WESTINGHOUSE
WESTALITE

36EHT MINIATURE HIGH-VOLTAGE RECTIFIERS

write for Data Sheet No. 60 to . . .

Dept. P.O.4,

WESTINGHOUSE BRAKE & SIGNAL CO., LTD., 82 York Way, King's Cross, London, N.1

SULLIVAN & GRIFFITHS

**DIRECT READING
VARIABLE CONDENSERS**

WITH NOVEL AIR CAPACITANCE
DECADE RANGE EXTENSION

This air dielectric condenser comprises a decade of air capacitance and a continuously variable air condenser thus giving a scale accuracy ten times that of an ordinary variable condenser of the same range.

Thus a decade of capacitance is provided—permanent in value and entirely free from loss, the only loss present in the complete combination of decade and variable condenser being that due to the solid insulating material which is ordinarily employed in the construction of the latter.

The variable condenser has a range of $100\mu\mu\text{F}$ which is extended to $1100\mu\mu\text{F}$ by ten increments of $100\mu\mu\text{F}$, all adjusted with accuracy so that the decade is absolutely direct reading in $\mu\mu\text{F}$, no corrections or calibration being necessary.

Electrical Standards for Research and Industry

Testing and Measuring Apparatus
for Communication Engineering

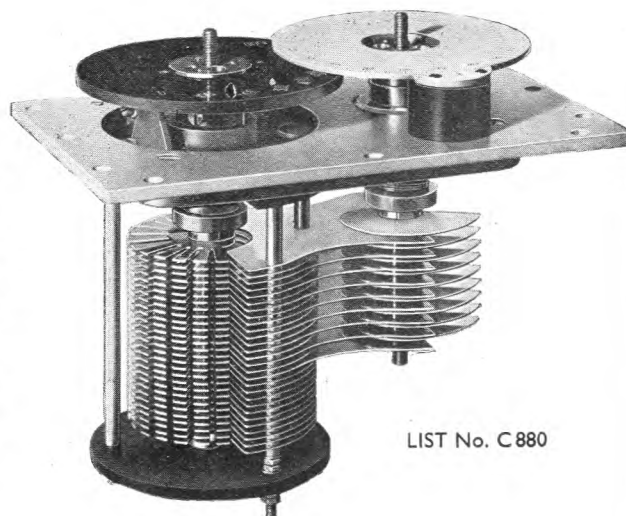

LIST No. C 880

H. W. SULLIVAN, LTD., LONDON, S.E. 15.

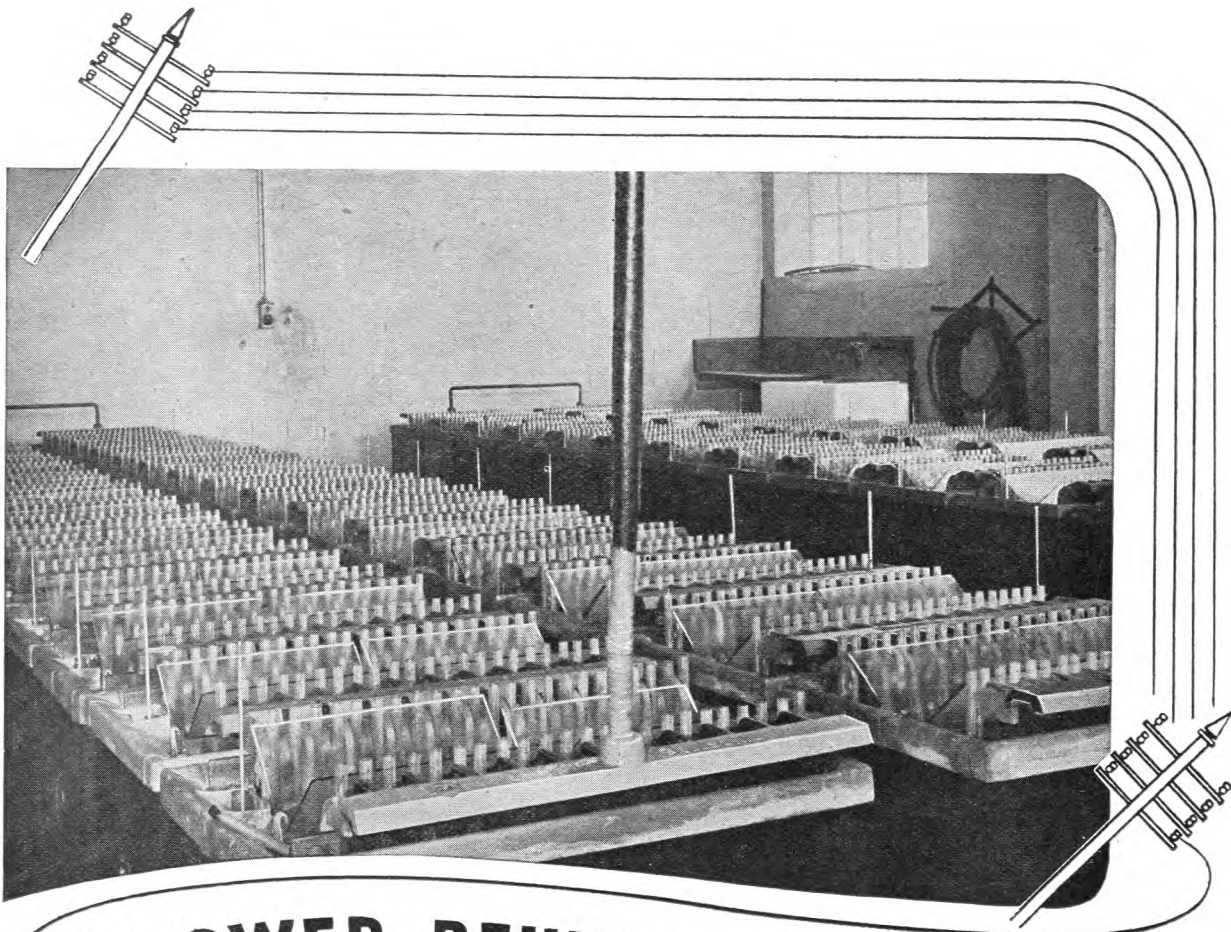

POWER BEHIND THE LINES

TUNGSTONE PLANTÉ CELLS are being supplied to the British Post Office and Post and Telegraph Departments in many countries overseas. They conform fully to G.P.O. and British Standard specifications.

OPEN TYPE CELLS

Similar to the illustration above, these are available in glass and/or lead lined wooden boxes in capacities from 100 a.h. to 500 a.h.

REPLATALS

We are in a position to supply plates for the replating of any existing Planté Battery.

ENCLOSED TYPE CELLS

As illustrated on the right, these are in moulded glass boxes with sealed-in lids. Capacity range from 10 a.h. to 200 a.h.

HIGH VOLTAGE TELEPHONE BATTERIES

Portable Type. Standard layout for 50 volts, in waxed hard wood crates, exactly to the requirements of the G.P.O.

Overseas customers are invited to cable or write their enquiries for batteries or parts. Visitors to London are welcome at our offices.

TUNGSTONE Batteries

For further particulars write : **TUNGSTONE PRODUCTS LIMITED**
10 SALISBURY SQUARE · LONDON · E.C.4 · ENGLAND. Cables: "Dilutum" London.

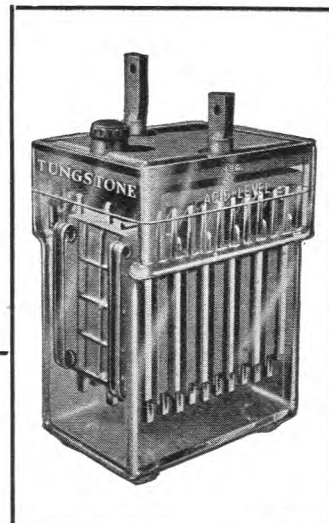

T.B.12

**ELECTRICAL MEASURING
INSTRUMENTS
OF THE HIGHER GRADES**

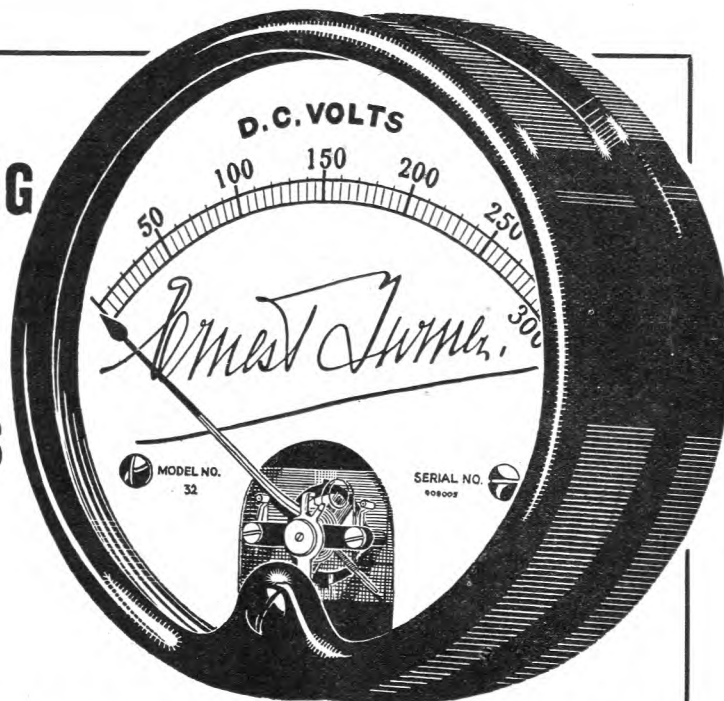

ERNEST TURNER ELECTRICAL INSTRUMENTS LTD.
CHILTERN WORKS, TOTTERIDGE AVENUE, HIGH WYCOMBE, BUCKS.

Telephone : High Wycombe 1301/2

Telegrams : Gorgeous, High Wycombe

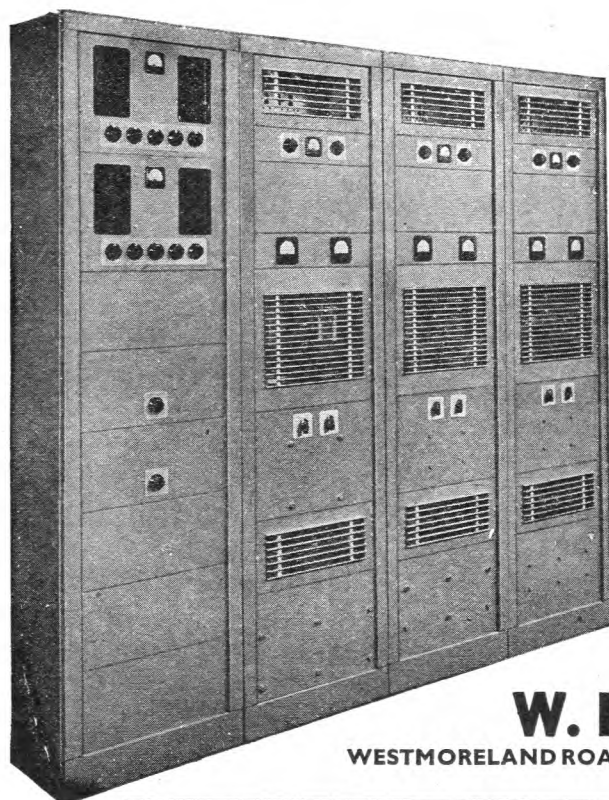

The Mark II series of
SAVAGE AMPLIFIERS
for Broadcast Relay

● These Amplifiers are examples of what careful design can achieve. A lift-off back panel affords immediate access for maintenance purposes and the removal of six screws releases the side covers of the rack and exposes all the interpanel wiring. Even when the rack is sandwiched between others the side covers can be moved just as easily. All valves are accessible from the front of the rack, and are protected by quick release grilles. The rack is completely flat fronted. The general appearance is further enhanced by the absence of a projecting front foot, and the masking of all panel fixing bolts. Similar racks carrying auxiliary apparatus can be placed side by side with amplifiers so that the whole installation is uniform in appearance. Complete specifications available on request.

W. BRYAN SAVAGE LIMITED

WESTMORELAND ROAD · LONDON N.W.9 · TELEPHONE: COLINDALE 7131

This is King's Pond— and its waters almost lap the bricks of the Alton Battery Works' south-west wall. It is part of the Company's property—a 5-acre asset in real estate. And a symbol of assets in wider terms than accountancy covers. Alton is a country town—with a full, rounded, contented life of its own. A town where people have not yet changed to personnel. A town where families take root—and son follows father up to the Battery Works. A place where a man's proper pride in himself and his folk and the life he leads is reflected in doing things just that all-important bit better than 'up-to-specification.' And Alton batteries are made by Alton men

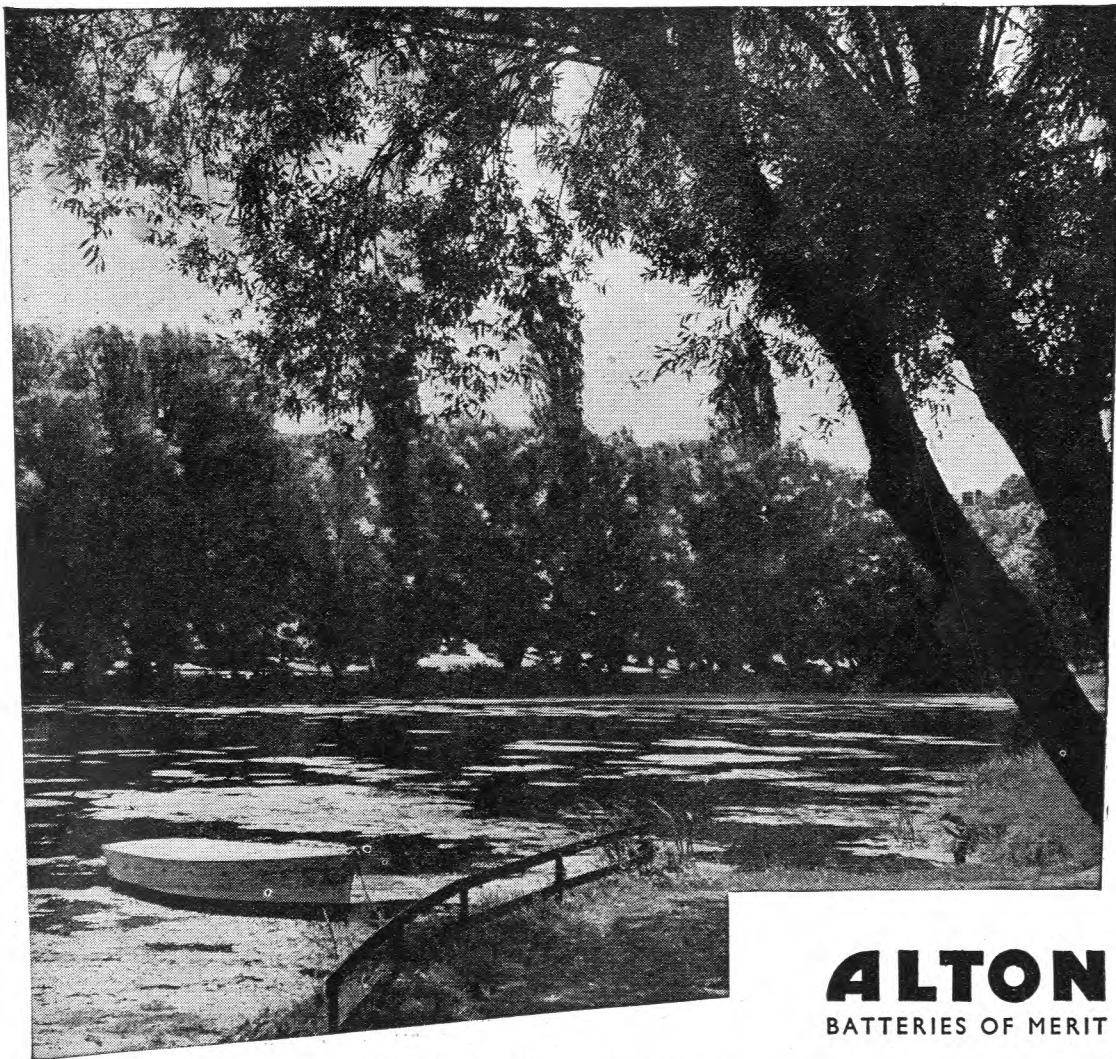

ALTON
BATTERIES OF MERIT

Alton stationary batteries: 10 to 15,000 Ah. Also in regular production, renewal plates for all makes of battery, British and Continental.

A24A

The Alton Battery Company Limited · Alton · Hants · Telephone: Alton 2267 and 2268 Telegrams: Battery, Alton

Creed



No. 47 Tape Model Teleprinter

No. 7 Page Model Teleprinter

**printing
telegraph
systems**

Creed & Company Limited
TELEGRAPH HOUSE · CROYDON · ENGLAND



**Build
your own
equipment**

with

DEXION

S L O T T E D A N G L E

- ★ Can be used over and over again
- ★ No drilling, measuring or painting
- ★ Just cut it and bolt it, that's all!

Write or telephone for illustrated literature p.29

DEXION 189, REGENT STREET
LONDON, W.1
L I M I T E D Telephone: REGent 4841

SOUND INSTRUCTION by Postal Method

The I.C.S., largest school in the world devoted to spare-time training by the postal method, offers you highly specialised Courses for the following examinations:

- P.M.G. Certificates for Wireless Operators.**
- C. & G. Illumination Engineering (Inter.)**
- C. & G. Electrical Engineering Practice, Installation and Telecommunications.**
- Graduateship of the B.I.R.E.**
- C. & G. Radio Servicing Certificate (R.T.E.B.)**

I.C.S. Examination students are coached till successful.

Other Courses meet the requirements of all who desire to qualify for responsible positions in Electric Power, Illumination, Heating and Traction Systems. Equally successful is our instruction for Telegraph and Radio Engineers, Radio Servicemen, and in Elementary Radar and Electronics, Advanced Short-Wave Radio and Television Technology.

Fees are moderate and include *all* books required.

WRITE FOR OUR FREE BOOKLET and state the particular subject or Examination in which you are interested.

Generous Discount to H.M. Forces.

YOU MAY USE THIS COUPON

International Correspondence Schools Ltd.

Dept. 165A, International Buildings, Kingsway, London, W.C.2

Please send me, free of charge, your special

booklet on

Name..... Age.....

(BLOCK LETTERS, PLEASE)

Address

.....



OSCILLOSCOPE - Type 723



- Y Amplifier response flat from D.C. to 5 Mc/s.
- No overloading occurs with full screen deflection over complete frequency range at 2 kV E.H.T.
- Variable E.H.T. voltages of 1, 2 and 4 kV.
- Time base range from 0.5 seconds to 1 micro-second for full screen deflection.
- A 1 cm. deflection ensures rigid synchronisation over whole frequency range.
- Automatic Brilliance Control Circuit.

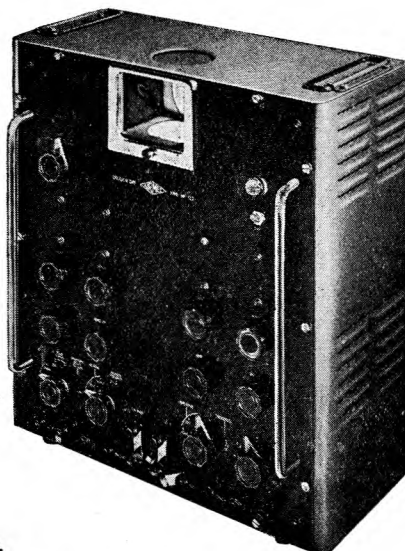

Full details of this or any other Airmec equipment will be provided upon request.

AIRMEC LABORATORIES **LIMITED**

HIGH WYCOMBE • BUCKINGHAMSHIRE • ENGLAND

TEL: HIGH WYCOMBE 2060

CABLES: AIRMEC HIGH WYCOMBE

TELEPHONE DISTRIBUTION

EQUIPMENT

ENGINEERS WHO ARE INTERESTED
IN TELEPHONE DISTRIBUTION EQUIP-
MENT ARE INVITED TO REQUEST
SECTION T.C.13 OF OUR TELECOM-
MUNICATION CABLES CATALOGUE.

TELEPHONE:
SOUTHAMPTON
2141 (5 lines).

PIRELLI-GENERAL
CABLE WORKS, Ltd., SOUTHAMPTON.

TELEGRAMS
"PIGEKAYBEL"
SOUTHAMPTON

EDISWAN

Telephone Line Protectors

*FOR THE PROTECTION OF LINES OF
COMMUNICATION FROM SURGES INDUCED
BY LIGHTNING OR FAULTS ON
NEIGHBOURING POWER LINES*

Ediswan Telephone Line Protectors have now been in commission for nearly twenty years. They have proved their worth in all parts of the world and are being called for and installed in ever increasing numbers. Many thousands were employed during the war years for the protection of vital lines of communication and were eminently successful. Reports of their outstanding merit and successful operation continue to reach us and in recent years they have proved of particular interest for protection against surges caused by lightning discharges.

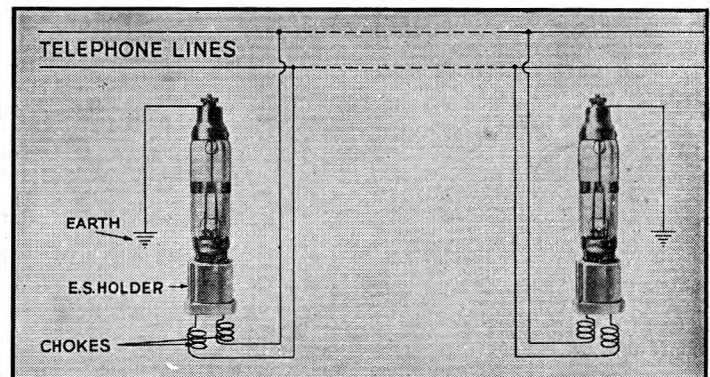

Continued research has enabled us to patent a further improvement which removes any suggestion of delay in operation.

Further information and prices on application.

THE EDISON SWAN ELECTRIC CO. LTD., 155 CHARING CROSS ROAD, LONDON, W.C.2

Member of the A.E.I. Group of Companies

T.E.3