

This document was generated by me, Colin Hinson, from a document held at R.A.F. Henlow Signals Museum and is believed to be out of copyright or Crown Copyright . It is presented here (for free) under the Open Government Licence (O.G.L.) if under Crown Copyright and this version of the document is my copyright (along with the Crown Copyright) in much the same way as a photograph would be. If you believe the document to be under copyright, please contact me.

The document should have been downloaded from my website <https://blunham.com/Radar>, if you downloaded it from elsewhere, please let me know (particularly if you were charged for it). You can contact me via my Genuki email page:

<https://www.genuki.org.uk/big/eng/YKS/various?recipient=colin>

You may not copy the file for onward transmission of the data nor attempt to make monetary gain by the use of these files. If you want someone else to have a copy of the file, point them at the website. It should be noted that most of the pages are identifiable as having been processed by me.

I put a lot of time into producing these files which is why you are met with the above when you open the file.

In order to generate this file, I need to:

1. Scan the pages (Epson 15000 A3 scanner)
2. Split the photographs out from the text only pages
3. Run my own software to split double pages and remove any edge marks such as punch holes
4. Run my own software to clean up the pages
5. Run my own software to set the pages to a given size and align the text correctly.
6. Run Omnipage (Ultimate) on all the pages to OCR them.
7. Generate a searchable Acrobat pdf file.

Hopefully after all that, I end up with a presentable file, though I can't guarantee there aren't errors in the OCR. If you find missing pages, pages in the wrong order, anything else wrong with the file or simply want to make a comment, please drop me a line (see above).

It is my hope that you find the file of use to you personally – I know that I would have liked to have found some of these files years ago – they would have saved me a lot of time !

Colin Hinson

In the village of Blunham, Bedfordshire.

THE POST OFFICE ELECTRICAL ENGINEERS' JOURNAL

Vol. 46

JANUARY 1954

Part 4

CONTENTS

	PAGE
POST OFFICE STANDARD P.A.B.X.s, Part 1—General Review of New Types and Details of P.A.B.X. No. 1—J. J. Roche	159
AN OUTLINE OF THE BRITISH TELEVISION SYSTEM, Part 3—Receiving the Picture Waveform—D. Wray, B.Sc.(Eng.), A.M.I.E.E.	166
THE BIRMINGHAM-MANCHESTER-HOLME MOSS TELEVISION-CABLE SYSTEM, Part 2—High Frequency Line System, Frequency Translating Equipment and Overall Performance—R. J. Halsey, B.Sc., M.I.E.E., and H. Williams, A.C.G.I., M.I.E.E.	171
THE IMPACT OF RECENT SIGNALLING DEVELOPMENTS ON OUT-OF-AREA EXCHANGE SERVICE—R. F. Howard, B.Sc.(Eng.), A.M.I.E.E.	177
A NEW UNI-DIAMETER JOINT—G. F. Arnold, A.M.I.E.E., and S. W. Jennings, A.M.I.E.E.	180
A NEW METHOD OF DIRECT UNDERGROUND DISTRIBUTION—J. G. Donovan, A.M.I.E.E., and J. S. Lanfear	183
THE RATIONALISED M.K.S. SYSTEM OF ELECTRICAL UNITS—R. J. Halsey, B.Sc., A.C.G.I., D.I.C., M.I.E.E.	187
SINGLE-SIDEBAND MULTI-CHANNEL OPERATION OF SHORT-WAVE POINT-TO-POINT RADIO LINKS, Part 4(b)—An Independent-Sideband High-Power Short-Wave Transmitter—Design and Performance—H. E. Sturgess, A.M.I.E.E., and F. W. Newson, A.M.I.E.E.	191
A METHOD OF TESTING COLD-CATHODE TUBES—D. L. Benson, A.M.I.E.E., and D. H. Vogan	196
DETERIORATION OF VALVE PERFORMANCE DUE TO GROWTH OF INTERFACE RESISTANCE—G. H. Metson, M.C., Ph.D., and M. F. Holmes, B.Sc.	198
THE TRANSATLANTIC TELEPHONE CABLE	199
H. FAULKNER, C.M.G., B.Sc.(Eng.), M.I.E.E., F.I.R.E.	200
A. H. MUMFORD, O.B.E., B.Sc.(Eng.), M.I.E.E.	201
VIIITH PLENARY ASSEMBLY OF THE C.C.I.R., LONDON, 1953	202
INSTITUTION OF POST OFFICE ELECTRICAL ENGINEERS	204
NOTES AND COMMENTS	205
REGIONAL NOTES	207
ASSOCIATE SECTION NOTES	211
STAFF CHANGES	213
INDEX TO VOL. 46	216
BOOK REVIEWS	165, 179, 190, 206, 210, 215

Price 2/6 net

THE INSTITUTION OF POST OFFICE ELECTRICAL ENGINEERS



MILLIVOLTMETER TYPE 784

(Wideband Amplifier and Oscilloscope Pre-Amplifier)

- Frequency range from 30 c/s to 10 Mc/s
- Voltage ranges 0-10, 0-100, 0-1000 millivolts
- Cathode follower probe
- Can be used as an amplifier up to 15 Mc/s
- Immediate delivery

THIS instrument consists essentially of a high-impedance probe unit followed by a stable wide-band amplifier and diode voltmeter. Measurements may be made from 1 millivolt to 1 volt in the frequency range 30 c/s to 10 Mc/s. The provision of a low-impedance output enables the instrument to be used as a general purpose amplifier in the frequency range 30 c/s to 15 Mc/s, or as an extremely sensitive pre-amplifier for the Airmec Oscilloscope Type 723.



Full details of this or any other Airmec instrument will be forwarded gladly upon request.

AIRMEC
LIMITED

HIGH WYCOMBE

BUCKINGHAMSHIRE

ENGLAND

Telephone: High Wycombe 2060

Cables: Airmec, High Wycombe

The Ideal Receiver for Point-to-Point
and Ground-to-Air Channels

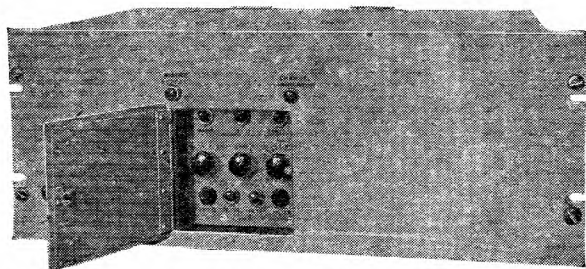

A Fixed Frequency, Single Channel
Receiver covering 2 to 20 Mc/s.

The crystal-controlled R.93 is an important receiver which has been designed to operate over long periods under either temperate, arctic or tropical conditions at unattended sites. A number of R.93's may be stacked in standard 19" racks for multi-channel working on R.T. or W.T. Double or triple diversity racks can also be supplied with suitable terminal equipment for direct teleprinter operation from frequency shift transmission. Enquiries will receive immediate attention.

Redifon

REDIFON LIMITED
RADIO COMMUNICATIONS DIVISION
BROOMHILL ROAD
LONDON, S.W.13
Phone: VANDYKE 7281

DESIGNERS AND MANUFACTURERS OF
RADIO COMMUNICATIONS AND INDUSTRIAL ELECTRONIC EQUIPMENT

How to make certain of your City & Guilds Certificates



"I guarantee
tuition until you
have passed"

If you consider taking one or the whole series of C. and G. examinations then I can help you. BY POST, in your own time, one of my Telecommunications specialists will coach you until you pass. He will give you individual attention, he will study you and your problems. And you will be surprised how fast you progress. For The Bennett College has specialised in technical subjects since it was founded 50 years ago. My system of personal postal tuition has helped *thousands* of students through their exams. It can do the same for you.

Send me the coupon to-day. I will send you—without obligation—full information on your subject.

W. Bennett
GOVERNOR

YOU CAN
START ON A
BENNETT COURSE
FOR ONLY
30/-

TEAR OUT

with monthly
instalments
of 15/-

WHICH IS YOUR
NEXT STEP?

Preliminary Course
Telecommunications
Principles I—V
Telecommunications
Practice
Telephone Exchange Systems
I—III

Radio I—IV
Telegraphy I & II
Line Transmission I & II
Mathematics for
Telecommunications I—V

Radio Servicing Certificate
Television Servicing
Certificate
A.M.I. Mech.E.
and many other subjects

The BENNETT COLLEGE

To the Governor, Dept. A24, The Bennett College, Sheffield, England. I would like to have (at no cost) your prospectus and

particulars of

NAME

ADDRESS

AGE (if under 21)

PLEASE WRITE IN BLOCK LETTERS

THE POST OFFICE

ELECTRICAL ENGINEERS' JOURNAL

Vol. 46

January 1954

Part 4

Post Office Standard P.A.B.X.s

J. J. ROCHE†

Part 1.—General review of new types and details of P.A.B.X. No. 1

U.D.C. 621.395.24

During the past few years much work has been done on the standardisation of P.A.B.X.s and this article, to be published in two parts, describes the developments so far completed. Part 1 introduces the subject, outlines the various types of standard P.A.B.X. now available and covers in some detail the P.A.B.X. No. 1 and its associated cordless manual board. Part 2 will describe the P.A.B.X.s Nos. 2 and 3.

INTRODUCTION

ALTHOUGH the Post Office is concerned primarily with telephone communication on a national basis, the private branch exchange is becoming an increasingly important feature of the general scheme of communications. Indeed, the growing tendency towards the formation of large commercial and industrial groups, together with a greater appreciation of the value of efficient internal communications, is, in many cases, changing the P.B.X. outlook from one of serving as a dispersal point of the main exchange call, to a field of its own, providing an essential self-contained network of communications separate from, but dovetailing into, the main national network.

The private manual branch exchange (P.M.B.X.) has, in the past, been widely used. This may well be continued in the future, particularly for the smaller unit, but with the increasing demand for rapid and efficient 24-hour service and the high cost and scarcity of switchboard operators, the private automatic branch exchange (P.A.B.X.) is being used to a much greater extent than formerly.

Until recently the design of P.A.B.X. equipment was left to the individual manufacturer concerned, with the result that several differing types of equipment have been provided throughout the country. As the number of installations increased it was decided that it would be to the advantage of all concerned and in the interests of efficiency to evolve standard designs.

The development of standard equipment was commenced on the following broad terms:—

- (1) The facilities to be given should be as comprehensive as possible, based upon the past experience of earlier designs.
- (2) For all types of P.A.B.X., both cord- and cordless-type manual boards should be available.
- (3) Up to 50 extension lines the equipment should be designed as a self-contained unit. Above 50 extension lines design would follow main exchange practice.
- (4) Post Office standard components only should be used.
- (5) Equipment up to a size of 1,200 extension lines should be held as a stock item.

Development of the "under 50 lines" type with cordless and cord switchboards, and the "over 50 lines" with cord switchboards, has been completed and equipments are in service. No development has as yet been done on the cordless "over 50 lines" P.A.B.X.

† Executive Engineer, Subscribers' Apparatus and Miscellaneous Services Branch, E.-in-C.'s Office.

The P.A.B.X.s have been titled as follows:—

P.A.B.X. No. 1—maximum capacity, 10 exchange lines, 49 extensions. Cordless manual board (referred to as "attendant's cabinet").

P.A.B.X. No. 2—maximum capacity, 10 exchange lines, 49 automatic extensions, with an additional 30 "manual only" extensions. Cord-type manual board.

P.A.B.X. No. 3—50 extension lines and over, with cord-type manual board.

The original objective of making P.A.B.X. No. 3 up to 1,200 lines a stock item has had to be abandoned and complete standardisation has not been realised. P.A.B.X.s of this type will continue to be supplied and installed by direct arrangement between the manufacturer and subscriber, standardisation being limited to circuits and components. This means that, while there may be slight variations in layout of equipment between one installation and another, there will be no fundamental differences between them.

GENERAL DESCRIPTION OF P.A.B.X. No. 1

The Automatic Equipment.

The automatic equipment is manufactured in four sizes having capacities as shown in Table 1.

TABLE 1

Apparatus	Sizes of Equipment			
	4 + 15	5 + 24	7 + 35	10 + 49
Exchange line circuits	4	5	7	10
Extension line circuits	15	24	35	49
Manual Extension line circuits	2	2	4	4
Inter-Switchboard line circuits	2	2	3	3
Connecting circuits	3	4	6	7
"0" level circuits	2	2	2	2
Enquiry circuits	1	1	1	1

The equipment is enclosed in a cabinet and Figs. 1 and 2 show the arrangement for the 10 + 49 size; the others are similar, except that for the two smallest the cabinet width is reduced. No provision is made for the extension of the smaller sizes; they will be replaced when necessary with a larger unit.

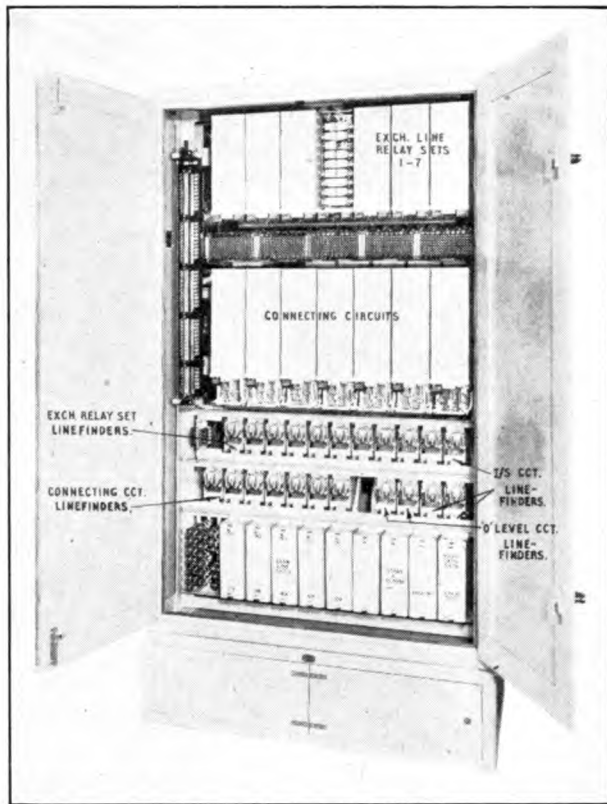

FIG. 1.—FRONT VIEW OF AUTO EQUIPMENT FOR 10 + 49 LINES P.A.B.X. No. 1.

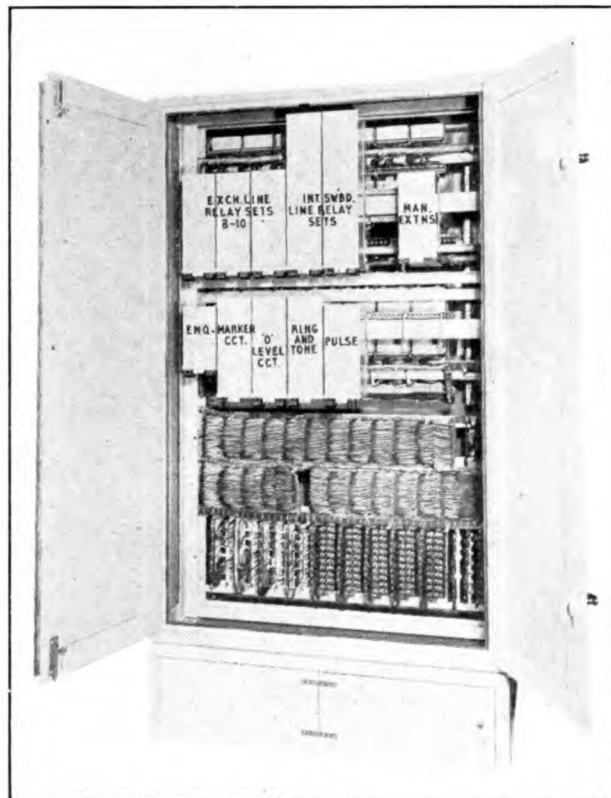

FIG. 2.—REAR VIEW OF AUTO EQUIPMENT FOR 10 + 49 LINES P.A.B.X. No. 1.

The Cordless Switchboard.

The cordless switchboard shown in Fig. 3 is common to all sizes. Exchange circuits appear on the first five keys and lamps, two circuits per key. The next key and associated

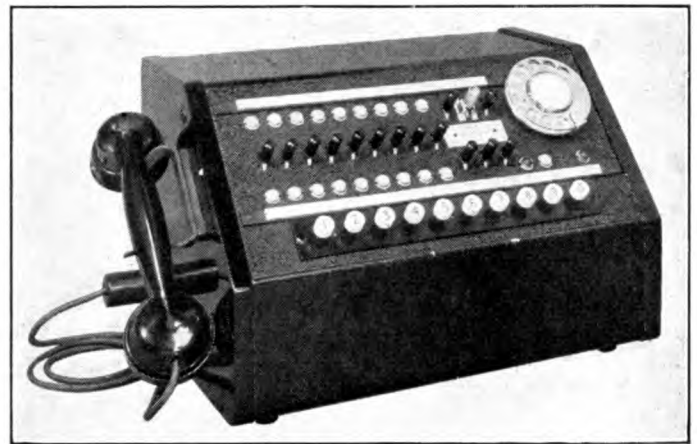

FIG. 3.—THE CORDLESS SWITCHBOARD.

lamps accommodate two inter-switchboard circuits. (A third can be added at the expense of the 10th exchange line.) Four manual extension circuits, and two "0" level circuits, complete the row of keys. A common group of keys and lamps is provided to give the usual operating and miscellaneous facilities required. The dial is used primarily for outgoing calls made by the operator. The digit keys are used for the connection of incoming calls to extensions.

Principles of Design.

Much of the design and circuit operation follows conventional practice and will be referred to only in outline. The main departure from previous designs is to be found in cordless working and the inclusion of special features such as enquiry, transfer, ring when free, dial "8" night service, etc., which will be dealt with more fully later. The general principles followed are interconnection between extensions by means of connecting circuits consisting of 2,000-type two-motion selectors with associated 50-point uniselectors, of the P.O. standard type, as line-finders. Other types of connections are made via the appropriate relay set and line-finder, using the connecting circuit as a selecting device only during the setting up of the call.

Numbering Scheme.

The extensions are numbered 21 to 69, level 1 being left spare. Single-code digits are used as follows:—

- 7—Direct access to inter-switchboard lines.
- 8—Night service access to incoming exchange and inter-switchboard calls.
- 9—Direct access to main exchange, outgoing calls.
- 0—Operator.

OUTLINE OF OPERATION

A brief description of the operation of the equipment can be given by considering in turn the following classes of call:—

- (a) Extension to extension.
- (b) Outgoing, direct access by dialling.
- (c) Outgoing via manual board.
- (d) Incoming via manual board.
- (e) Incoming direct into auto equipment.

A trunking diagram of the P.A.B.X. is given in Fig. 4 and will be referred to in the explanatory outline in the paragraphs which follow.

Extension-to-Extension Calls.

The operation of the line relay in the extension line circuit causes a start signal to be given, via the common start circuit, to a free connecting circuit. The calling extension is found by the associated line-finder (LF) and dialling tone is returned from the connecting circuit. The

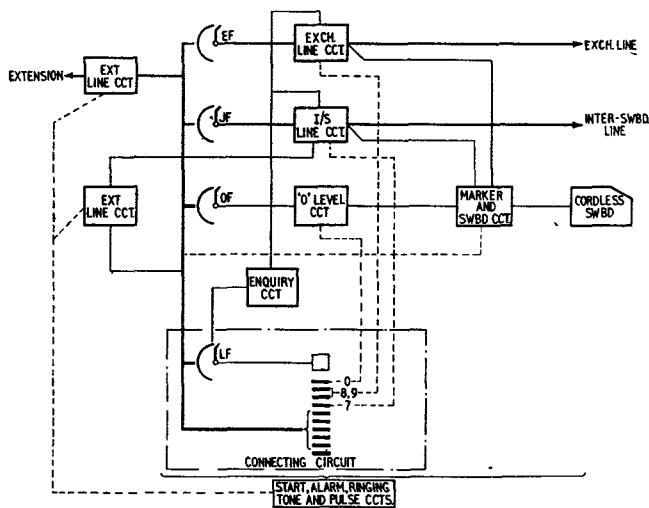

FIG. 4.—TRUNKING ARRANGEMENTS OF P.A.B.X. NO. 1.

required extension is obtained by dialling into the connecting circuit selector, connection being established over the extension line multiple connected to levels 2-6.

Outgoing Calls, Direct Access by Dialling.

Two classes of call are concerned: to the exchange or to another P.B.X. To obtain the exchange, code digit 9 is dialled into the connecting circuit which acts as a "discriminator," causing a free exchange circuit finder (EF) to find the calling extension. The connecting circuit is then released. The caller is thus switched through directly to the exchange and may continue setting up the call as appropriate. The procedure of obtaining access to another P.B.X. over an inter-switchboard line is similar except that code digit 7 is dialled and the call routed via line-finder JF and the inter-switchboard line circuit.

Outgoing via Manual Board.

While it is intended that all types of call should, as far as possible, be completed automatically, facilities are provided whereby the operator can set up the call. Access to the operator is obtained by dialling "0," and the connecting circuit is used to select the "0" level circuit, connection to the manual board being ultimately established via the finder OF and the "0" level circuit. A flicker calling signal is connected to the "0" level line lamp on the switchboard and the operator answers by operating the associated speak key. If the extension requires an exchange or inter-switchboard call, the operator may set up the call using an exchange or inter-switchboard line circuit and then key it to the extension. The circuit switches to the extension and releases the "0" level circuit if this is still held by the extension. Should the caller have replaced his receiver he is automatically rung by the exchange or inter-switchboard line circuit in the normal manner.

Incoming via Manual Board.

All incoming exchange calls are received at the manual board. Inter-switchboard and private circuits where automatic signalling or dialling cannot be used are similarly connected.

When an incoming call occurs, a calling signal is given on the associated line lamp on the switchboard. The operator answers the call by operating the speak key and, after ascertaining the extension required, depresses the digit keys corresponding to the number of the extension required. The exchange line circuit line-finder (EF) is driven to the position corresponding to the extension and, if the extension is free, ringing conditions are applied to the line. If the

extension is engaged, busy flash is given on the line lamp. In either case the operator may retire from the circuit, leaving the call to be automatically connected when the extension becomes free or answers.

Incoming Calls Direct into Auto-Equipment.

This type of connection can only be made over an inter-switchboard circuit. Referring to Fig. 4, an extension line circuit is shown associated with the inter-switchboard circuit. An incoming call over an inter-switchboard line will be connected initially via this extension circuit to a connecting circuit. The wanted extension will be dialled and upon the receipt of the two digits the connecting circuit will cause the line-finder (JF) to find the required number. The connecting circuit will then be released.

OUTLINE OF CIRCUIT OPERATION

It will have been realised from the general description given in the preceding section that, because of the method used in setting up the various classes of connection, the circuits concerned are very closely related and to a large extent functionally inter-dependent on common control equipment.

For automatic calls the connecting circuit provides a discriminating point and controls the routing of the call, taking into account its point of origin and the level and contact dialled. The manual call needs no discrimination because the circuit will be selected by the operator, but such connections are ultimately routed entirely through the automatic equipment, the switchboard having a controlling function only; arrangements must, therefore, be made to enable the operator to exercise such control.

Common-Start Arrangements.

Fig. 5 shows the circuit element of the start connections between line circuits and connecting circuits; the common

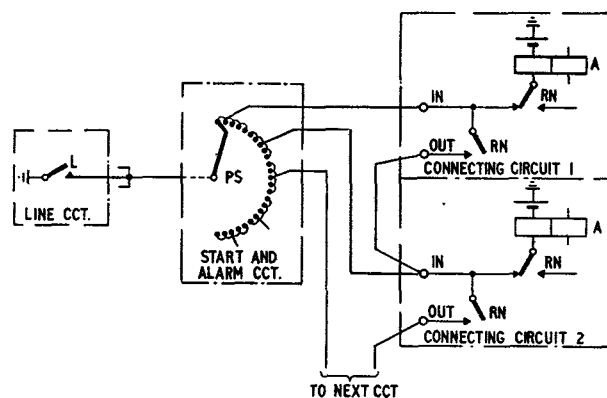

FIG. 5.—START CHAIN BETWEEN LINE AND CONNECTING CIRCUITS.

start circuit connections are shown in outline in Fig. 6. Referring to Fig. 5, a connecting circuit is seized by the operation of its A relay and, when engaged, the operation of RN will cause the common start wire to be connected to the next circuit, and so on. Normally, therefore, the first free circuit will be seized, but the first choice is continually changed by the action of the pulse switch (PS). This switch is non-homing and is provided primarily for the distribution of pulses throughout the equipment. It steps at about 0.4 sec. intervals during the establishment of any connection. Spare arcs are, however, available and wiring the start commons through these, as shown, ensures rotation of the first-choice circuit, thus preventing a faulty circuit being repeatedly picked up during slack periods.

Extension Marking and Discrimination by the Connecting Circuit.

Fig. 6 shows the multiple connections between the line-finders and connecting circuit selectors, excluding the speaking connections. It is over wires HF, BD, H and J that marking and discrimination is done. For the ordinary extension-to-extension call the HF wire and H wire from the selector have functions similar to those of the private circuit in automatic exchange practice.

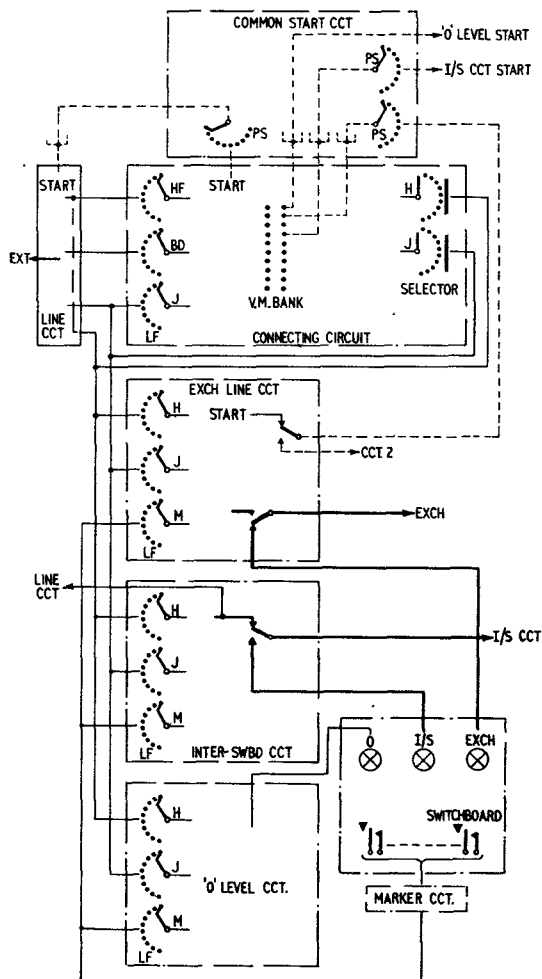

FIG. 6.—ARRANGEMENT OF MARKING AND CONTROL CONNECTIONS BETWEEN CIRCUITS.

When an extension call sets up an exchange call, "9" is dialled into the connecting circuit. The BD connection is used to discriminate whether or not the extension is allowed direct access to the exchange. If allowed, an earth will be extended from the line circuit over this wire and, as a result, the connecting selector will, over the 9th level of the vertical marking bank, apply a start condition to the line-finder of a free exchange circuit via the start chain. At the same time the J wire of the line-finder multiple will be marked with a battery condition by the connecting circuit and this will be found by the exchange circuit line-finder. The exchange line circuit will take over the connection, and, by connecting an earth to the H wire and thence to the HF wire, will not only guard the circuit but also cause the release of the connecting circuit. The extension is thus connected directly to the exchange line.

"0" level and outgoing inter-switchboard calls are similarly switched when "0" or "7" is dialled. On an incoming inter-switchboard call, however, the inter-switchboard circuit is connected, upon seizure, to its own line circuit and thence to a connecting circuit. On the

J wire to the connecting circuit line-finder a condition will be applied which will inform the connecting circuit that the call originates from an inter-switchboard circuit and, as a result, when the extension number has been dialled, the connecting circuit selector will return a marking condition on the J wire of the selector bank. At the same time, over the BD wire, the connecting circuit will return a battery condition, which will cause the inter-switchboard line-finder to rotate, find the called extension and release the connecting circuit from the connection. If "0" is dialled over the inter-switchboard circuit an earth condition will be returned from the connecting circuit over the BD wire and this will cause the line lamp on the switchboard to be lit and the connecting circuit to be released. The operation of the associated speaking key will connect the inter-switchboard line direct to the switchboard.

Control by the Operator.

Exchange line and inter-switchboard circuits are not wired through the switchboard; they are connected to the switchboard and marker circuit over common-access wires by operating the appropriate speaking key. Fig. 7 shows the

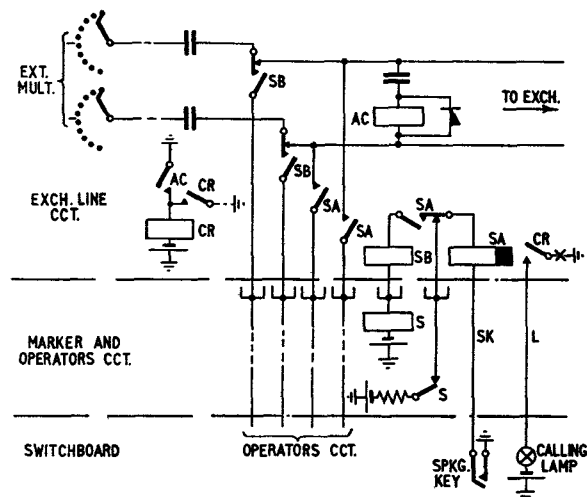

FIG. 7.—CONNECTION OF EXCHANGE LINE CIRCUIT TO OPERATOR.

method of connecting the exchange line circuit to the switchboard, other circuits being similar. It will be noticed that the only permanent connections to the switchboard are the L and SK wires. The operator obtains control of the circuit by operating the speaking key which, assuming no other speaking key is operated, operates the access relays SA and SB. Fig. 7 also shows how the speaking connections are switched, but there are other wires similarly switched to enable the operator to obtain full control. The supervisory conditions given to the operator on the calling lamp are:—

- | | |
|--------------------------|-------------------------------|
| (a) incoming call | — int. earth 0.4 sec. on/off, |
| (b) extension engaged | — busy flash, |
| (c) extension being rung | — steady glow, |
| (d) speaking condition | — lamp out. |

Access to the extension circuits is obtained over the exchange, inter-switchboard and "0" level circuits by keying the required extension number. How this is done will be shown by the help of Fig. 8. The operation of the speaking key operates relays SA and SB as previously mentioned, and the drive circuit of the exchange circuit line-finder is brought under the control of the marker circuit. The operator keys the first digit and it is stored in the "tens" storage group. The digit keys are switched to the "units" storage group by the switching relay RX, and the units digit is keyed.

The storage relays and their associated contact arrangement for marking purposes follow conventional lines and have not been shown in Fig. 8. There is, however, one point

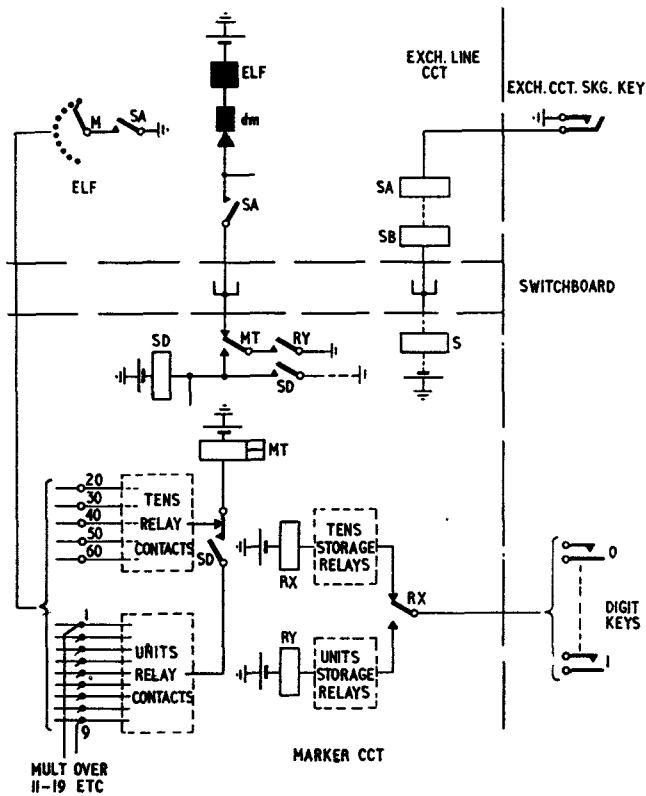

FIG. 8.—MARKING ARRANGEMENTS FROM SWITCHBOARD.

of interest in that the coding chosen differs from that normally used. It is arranged so that as far as possible, on all sizes of the P.A.B.X., keying an unused tens digit will operate a cut-off relay and not result in a wrong number. The operator will be apprised of incorrect keying by the retention of the calling signal on the calling lamp.

The exchange circuit finder (ELF) is set in motion when the units digit is stored, i.e., when relay RY operates. Design economics dictate that the units marking should be common and thus the line-finder must first be positioned on the first contact of the units group concerned. The tens marking is therefore wired to contacts 20, 30, etc., and the operation of the cut-drive relay, MT, will arrest the line-finder on the first contact of the group required. Relay SD will then operate and MT will be connected in turn to the units digit marking. The line-finder will be restarted and will find the units digit. The extension will be rung from the exchange line relay set and the operator releases the marker and position circuit from the connection by the restoration of the speaking key. Alternatively she may fully supervise the call by keeping the speaking key operated until conversation commences.

SPECIAL FACILITIES

When a subscriber makes a call to a P.B.X. further progress of the call is under the control of the P.B.X. operator. The difficulties in recalling the P.B.X. operator for the purpose of transferring the call to another extension, or correcting a mis-routed call, often make it necessary for the calling subscriber to originate a second exchange call to re-establish connection to the P.B.X. operator. As far as possible, the P.A.B.X. No. 1 removes these difficulties. Firstly, an automatic "ring when free" facility is provided and, secondly, enquiry and transfer facilities under the control of the extension user are available on incoming and outgoing exchange, and inter-switchboard calls. Apart from the service advantages gained, the inclusion of these facilities, together with automatic clearing, which is

fundamental to cordless working, does meet a main design objective—that of minimising the switchboard operator's duties.

"Ring When Free."

When an engaged extension is "keyed" by the operator the supervisory lamp of the exchange or inter-switchboard line concerned will flash. If the caller waits, restoration of the speaking key causes the connection to remain set up continually testing the engaged extension circuit and making connection when it becomes free.

The facility is given by arranging for the testing circuit to be continually applied to the engaged circuit as illustrated in Fig. 9. Relays ET and H will not operate when an

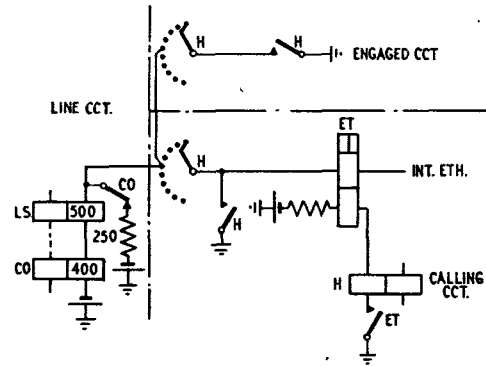

FIG. 9.—"RING WHEN FREE" FACILITY.

engaged condition exists on the H wire and busy flash will be returned to the operator. The testing relay ET is, however, continuously applied and as soon as the circuit becomes free the caller will be connected. Earth pulses 0.4 sec. every 10 sec., are connected to ET because a continuous earth condition would not allow relays LS and CO in the line circuit to release and the 200-ohm testing battery, essential to the operation of ET, would not be reconnected to the H wire.

Enquiry and Transfer.

When connected to an exchange or inter-switchboard circuit an extension user may:—

- (a) Make another call on the same telephone for the purpose of making an enquiry, the original connection being held.
- (b) Return to the original connection or, alternatively, transfer it to another extension.
- (c) Call in the operator.

Each extension instrument is provided with a press button the depression of which will send a discriminating signal into the automatic equipment so that the necessary switching can take place. The sequence of operations can be described with the aid of Fig. 10.

Assuming that extension A is engaged upon an exchange call, depression of A's button will cause the exchange circuit to be held and at the same time seize the enquiry circuit. This enquiry circuit is connected to the first contact of the LF multiple (which is why the P.A.B.X. has a capacity of only 49 and not 50 extensions). A start condition is applied to a free connecting circuit, the enquiry circuit will be found, and A will thus be connected to a connecting circuit. Extension B may be called and, at the conclusion of the conversation, a further depression of A's button will re-establish the original exchange connection. Should A, however, wish to transfer the exchange call to B, A will replace the receiver without depressing the button and this will cause the exchange circuit line-finder to be set in motion, find, and connect to B. Should A require to speak

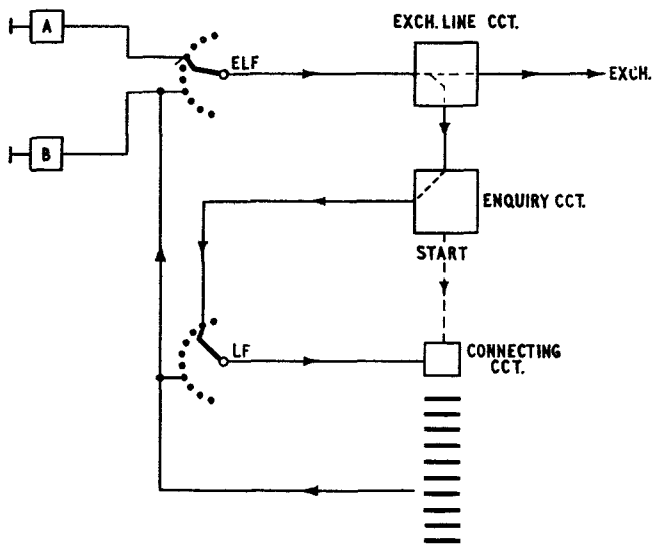

FIG. 10.—ROUTING OF ENQUIRY CALL.

to the operator, a second depression of the button after the enquiry circuit has been seized, i.e., prior to dialling, will cause flicker earth to be connected to the exchange connection switchboard lamp, thus attracting the operator's attention.

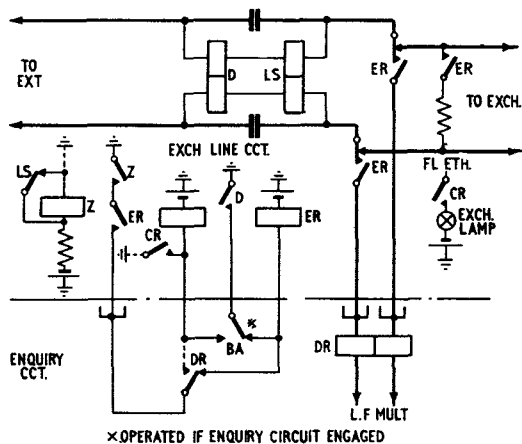

FIG. 11.—CONNECTION TO ENQUIRY CIRCUIT.

Fig. 11 shows the main circuit elements. Essentially the control is vested in the three relays, D and LS in the line circuit and DR in the enquiry circuit. Relay LS remains operated during the call because of the current flowing around the extension loop, but D and DR are differentially connected, operating only when the line is unbalanced by the depression of the telephone press button, which connects both wires to earth.

The following operations are possible:—

(a) *Seizure of enquiry circuit*—operation of relay D, which in turn operates ER and connects the exchange connection to the enquiry circuit. Alternatively, if the enquiry circuit is engaged the lamp on the switchboard is flashed and the operator may take over.

(b) *Call operator*—operation of DR (second depression of push button prior to dialling). Again the call is reverted to the P.A.B.X. operator and the enquiry circuit released.

(c) *Restore to original call after enquiry*—operation of DR releases the enquiry circuit and restores the original connection.

(d) *Transfer original call*—receiver replaced and LS releases. The exchange circuit line-finder rotates to find the

extension called. A marking condition is applied to the LF multiple from the enquiry circuit via the connecting circuit as set up by the extension making the enquiry (this is somewhat involved and is not shown in the circuit element in Fig. 11).

Disconnect-Clearing Equipment.

As the facility of direct dialling to the public exchange is available, it is desirable that the exchange line is entirely free of all connections before it is seized by a P.A.B.X. extension dialling "9". It is possible otherwise for an extension user when making a call to the public exchange either to re-seize the main exchange line before the switching equipment has released from a previous call or if the previous call is controlled by an operator, to seize the line before the operator clears the connection.

Normally the electrical conditions for the free and engaged line condition presented from the main exchange are similar. It is necessary, therefore, to provide equipment at the main exchange, known as "Disconnect-Clearing Equipment," which will give a 600-mS disconnection of the line when the exchange equipment releases. This disconnection is detected at the P.A.B.X. by introducing a high-resistance relay MH across the line when the P.A.B.X. extension user clears.

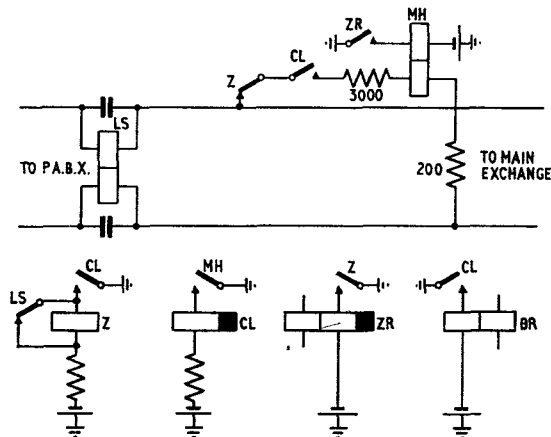

FIG. 12.—ARRANGEMENT FOR BUSYING P.A.B.X. EXCHANGE LINE RELAY SET UNTIL MAIN EXCHANGE EQUIPMENT CLEARS.

The circuit element is shown in Fig. 12. Relay MH is connected across the — and + lines and, when relays LS and Z release, MH will hold until the main exchange equipment releases, thus busying the exchange line relay set at the P.A.B.X.

Night Service.

Service at night (or more correctly, service when a P.B.X. switchboard is unattended) is normally given by connecting the exchange lines to selected extensions. This is known as "direct extension night service" and the extensions concerned operate as direct exchange lines, all P.B.X. switching facilities being lost. The limited communication provided by such means adequately meets the need of many subscribers because their business is such that internal communication is rarely required after office hours.

A subscriber may well justify the additional cost of a P.A.B.X. because he requires inter-communication to be available throughout the 24 hours. Further, it is a particular advantage of the cordless P.A.B.X. that operating attention is reduced to a minimum, an advantage which would be lost

if the retention of an operator was necessary to obtain full continuous service. It is arranged therefore to retain the essential switching facilities during night service conditions without the necessity for an operator.

It is because of the existence of the enquiry and transfer facilities that these night service arrangements are possible. The operation of the night service key on the switchboard brings into operation a bell or number of bells, placed at convenient points, which will ring when an incoming exchange or inter-switchboard call is received. Dialling "8" from an extension will cause the incoming call to be switched to that extension. It can then be dealt with and transferred to another extension as required.

It might well be asked why this arrangement cannot be made a permanent feature and an operator dispensed with entirely. The reason is, of course, that this method of dealing with incoming calls can only be used to handle a limited amount of traffic and can only be operated during slack periods. It may be of interest to mention that some telephone administrations do offer "subscriber attended" P.A.B.X.s, but up to the moment the Post Office has regarded the provision of a switchboard as essential.

Miscellaneous.

Apart from routine visits, P.A.B.X.s are maintained on a fault-reporting basis and essential alarms are, therefore, extended to the switchboards. Mains failure alarm is provided as in standard P.B.X. practice. Automatic equipment release alarms are given in a similar manner to main exchange practice, the alarm lamp being fitted on the switchboard.

A P.G. alarm is also provided to warn the operator when an extension circuit is continuously held, either because of fault conditions or failure to replace the hand-set. A common P.G. pilot alarm lamp is provided on the cordless switchboard, but the operator may locate the extension concerned by using an "0" line circuit and keying extensions in succession. When the faulty circuit is reached, it is indicated by the P.G. pilot and "0" line lamp being extinguished together.

If there is more than one P.G. condition the "0" line lamp only is extinguished and the operator continues to key the remaining extension lines until all P.G. lines have been located.

(To be continued)

Book Reviews

"Television Receiver Design—I. F. Stages." A. G. W. Uitjens. Philips' Technical Library. Distributed in U.K. by Cleaver-Hume Press, Ltd. 177 pp. 123 ill. 21s.

This volume from the Philips Technical Library is listed as one of a series on Electronic Valves but in fact its scope covers a much wider field than this would imply. Earlier volumes in the series have dealt with different types of valve and with their applications in radio receivers; this is the first of a series dealing with the applications of valves in television receivers. The term I. F. Stages in the title is very widely interpreted to include pentode amplifiers operating throughout the range 10-100 Mc/s. Consequently the book covers not only the I. F. Stages of superheterodyne receivers but is also applicable to the pre-detector stages of tuned-radio-frequency receivers for the channels at present used for television in this country.

The necessary ratio of bandwidth to carrier frequency for a television receiver is very much greater than for a sound receiver and the book describes fully the methods of obtaining this bandwidth. With two-terminal coupling networks either damping or stagger tuning may be used. In the former, all the stages of an amplifier are tuned to the same frequency but the tuned circuits are arranged to have a very low Q to obtain the wideband response, and the gain per stage is low. With stagger tuning the different stages of the amplifier are tuned with higher Q circuits to different frequencies "staggered" through the required band. Although each individual stage has a relatively high gain over a restricted band, the combination of all the stages in tandem has the required gain over the required band. Alternatively four-terminal coupling networks may be used between stages and by judicious design enable a flatter response to be obtained over the pass-band. Staggering is also possible with four-terminal couplings but the analysis is very complex and is only lightly touched upon.

The use of negative feedback has not yet been extended to this field of amplifier design and the section of the book dealing with "Feedback" is almost entirely concerned with methods of eliminating unwanted feedback which tends to cause instability in television amplifiers. No fewer than eight possible sources of trouble in this respect are listed, including that very frequent difficulty, the common earth lead, which causes feedback between output and input of a stage or stages. The designer of television amplifiers will do well to pay particular heed to this section.

The treatment throughout the book is mathematical but the non-mathematical reader should not be unduly alarmed by the profusion of symbols and equations that appears on almost every page. All that is required is an average knowledge of mathematics and a little patience in sorting out the symbols. Given these, the engineer engaged on the design of amplifiers

for television receivers will find the book well worthy of close study.

I.P.O.E.E. Library No. 2130.

T. K.

"Communication Theory." Willis Jackson (Ed.). Butterworth's Scientific Publications. xii + 532 pp. 226 ill. 65s.

The symposium held in London in September 1952, on applications of information theory to electrical communication and allied subjects attracted a remarkably stimulating series of contributions from both sides of the Atlantic. The proceedings, including all the original papers in complete form with discussions, have now been collected together by Professor Willis Jackson, the instigator and prime mover of the symposium. A tremendous amount of work has gone into turning the 39 manuscripts into a homogeneous text, and the editor, his collaborators Dr. E. C. Cherry and Dr. D. Gabor, the publishers, and last but not least the printers, are to be congratulated on a superb presentation of worthy material.

The introductory paper by Gabor is a concentrated summary of basic theory intended as a refresher for the non-specialist. The following papers which range from almost wholly mathematical extensions of theory to descriptions of most intriguing pieces of experimental apparatus, are grouped into seven sections. The first section is the largest, and deals with transmission systems and with methods of coding signals to make best use of channel capacity. It includes, for example, Huffman on construction of minimum-redundancy codes, de Jager on delta modulation, and Earp's vernier coding principle.

The second section is concerned with the problem of separating signals from noise, and includes discussions of correlation, integration and related statistical treatments, and of instrumental means of carrying them out. The next group of papers includes one on the synchronising of P.C.M. and allied systems, and three on the propagation characteristics of channels. The three following papers deal with the exploitation of varying "information-density" over a picture in television or facsimile systems. Huggins' paper on his theory of hearing, important in itself, serves also as a fitting introduction to the following section on the analysis, recognition and synthesis of speech signals. The Bell Telephone Laboratories' digit recogniser and Lawrence's formant-controlled speech synthesiser may perhaps be singled out for mention. Other papers deal with the statistical properties of speech and language, and the interaction of a communication channel with its users. A reminder of other uses for information theory, in the form of a paper on resolving power of microscopes, and a record of the concluding discussion at the symposium round off a book which is full of meat from cover to cover.

I.P.O.E.E. Library No. 2143

E. W. A.

Part 3.—Receiving the Picture Waveform

U.D.C. 621.397.5:621.397.62

This article, which deals with television reception, is the last of a series which is intended to provide a simple description of the British television system. In receiving the television waveform and using it to produce a picture on the screen, the domestic receiver virtually performs in reverse order the processes carried out in the camera. Some typical receiver circuits are described, as well as the effects of receiver faults and external interference on television reception.

INTRODUCTION

IN the two previous articles,¹ a description was given of the translation of a visual scene into an electric waveform and its transmission over point-to-point links before being radiated from the transmitters. All this is performed on a national scale by the B.B.C. and P.O. Engineering Departments. It remains for individual domestic receivers to perform the reverse processes of converting the broadcast signal into the video waveform, and then using this waveform to reproduce the pictures on the screen.

Broadly speaking, each stage in the receiver corresponds to a converse process in the generation and transmission of the television signal. Just as the image of the original scene was scanned in the camera by a pencil of electrons, so is the received picture drawn by a similar pencil on the screen, with the brightness of the trace controlled at any instant by the amplitude of the video waveform; the raster in which the electron beam moves is derived from local line and frame scanning generators which are triggered by synchronising pulses extracted from the video waveform—pulses corresponding to those inserted into the original camera waveform to mark the initiation of each scanning line and frame of the raster.

There are now several hundred different television receiver models available commercially in the British Isles; many of these differ in minor points only, but, even so, it is quite impossible to describe every type of circuitry in current use. However, an outline of the more common features in television receiver design is given below.

AERIALS AND FEEDERS

To many people a television receiver and an H-aerial are inseparable corollaries. But an H-aerial is not always necessary for good television reception, and can, on occasion, be positively unsuitable. A wide range of aerials is available for the V.H.F. band, and the selection of the most appropriate for any particular installation will depend on such factors as the distance of the receiver from the transmitter, local topographical features (hills, buildings, gas-holders, etc.) and the strength of any nearby electrical interference; aesthetic factors may also be considered important.

In general, the most suitable aerial is that which delivers a signal with the best possible signal-to-noise ratio to the receiver without overloading it. For television signals "noise" does not necessarily offend the ears; it can be any unwanted electrical turbulence introduced into the vision signal and for our purpose can be taken to include any reflections of the wanted signal. A reflection from an object a few hundred feet away from the receiver may—depending on the orientation of the signals—be delayed sufficiently behind the direct signal to produce a distinct "ghost" image on the receiver screen. The ideal television aerial should have a bandwidth wide enough to cover the required sound and vision channels and be able to discriminate, if necessary, against any unwanted signals or reflections. This has led to

the almost universal adoption of the half-wave dipole as the basis of the receiving aerial, with a transmission-line lead-in to the receiver, having no signal pick-up.

In practice, a dipole is not precisely one half-wavelength of the vision carrier frequency in length. For one thing, there must be a compromise between the vision and sound carrier frequencies (in fact, the design frequency is usually taken as the geometric mean of the highest and lowest frequencies that are to be received); also, the velocity of propagation in the dipole conductor is from 90 per cent. to 95 per cent. of that in free space. However, the length is not very critical: for channel 1 the overall length is about 10 ft. 5 in., and for the other channels the aerial lengths can be calculated by simple proportionality. At the midpoint of the aerial the current is at a maximum and the voltage is low; consequently, the impedance is low at this point and this is usually taken as the signal source to the receiver. The perfect dipole would have an impedance of 72 ohms, but this is affected to a small extent by the diameter of the elements, and quite appreciably by the proximity of the lead-in and surrounding objects.

The dipole, then, is the foundation on which nearly every television aerial is based. It has a circular polar diagram and so is equally sensitive to signals arriving from all directions in the relevant frequency band. The simple dipole is suitable, therefore, for districts where there is a strong field—say, up to 20 miles from a high-powered transmitter—and where there is little electrical interference.

The familiar H-aerial consists of a simple dipole with a reflector mounted behind it on an insulated cross-arm. The reflector is a wire or tube rather less than one half-wavelength long, fixed at a distance of one quarter-wavelength behind the aerial proper. This arrangement has directional properties, and so should normally be "aimed" at the transmitter, but, under certain circumstances, it may be preferable to erect the aerial to give least interference pick-up rather than maximum signal. The gain of such an array is about 4 db. over a simple dipole, and it may be used up to about 60 miles from a high-powered transmitter. Another way of arranging the dipole and its reflector is in the X-aerial, which is really an H-aerial that has been squeezed round the waist. The gain at vision frequencies is about the same as for the H-type, but it has a larger front-to-back ratio, and is therefore useful for rejecting interference originating from one particular source. Aerials with collector elements which subtend horizontal components, however, are particularly liable to interference from aircraft flutter.

For fringe reception, more complicated arrays are used. Once again the basis is the half-wave dipole, but there may be one or two directors in front of the dipole and a reflector behind it. The effect is to further increase the gain at the wanted frequency, to make the array more directional, and to give additional rejection of unwanted signals.

Another variant of the dipole is the folded dipole; in this the collector elements are doubled, becoming, effectively, a simple dipole and a transmission line. Such an arrangement has a wider bandwidth than the simple dipole, but since the latter is quite adequate for the British system this factor is

† Executive Engineer, Radio Experimental and Development Branch, E.-in-C.'s Office.

¹ *P.O.E.E.J.*, Vol. 46, p. 59 and p. 123.

not necessarily advantageous; indeed, it can be a drawback, for it gives a greater signal level of adjacent-channel transmissions; moreover, it has a higher impedance than a dipole and requires a matching transformer to feed the lead-in cable. For high-definition systems, such as the French 819-line service, or when several different channels are available, as in the United States, the folded dipole is very useful. It can be combined, just as the dipole, to give H, X or multi-element arrays.

In districts of high signal-strength, indoor aerials can often give satisfactory reception. Inverted-T and inverted-V aerials, having elements one quarter-wavelength long, and often with flexible elements that can be bent to follow features of the room, are favourite versions of the indoor aerial. They have a directional response, but may suffer from movements of people in the vicinity.

It was stated earlier in this section that the feeder cable or lead-in from the aerial to the receiver should not pick up any signal; for this reason coaxial, or balanced-twin, or even screened balanced-twin, cables are used for the feeders. In the majority of cases, coaxial cable is used with an unbalanced input circuit to the receiver, but this may not be satisfactory if the cable passes through a strong interference field. Balanced-twin cable gives better rejection of local interfering signals and is cheaper than coaxial cable, but a very accurately balanced input circuit in the receiver is necessary.

Correct impedance matching of aerial to feeder and feeder to receiver is rarely important. A mismatch of 2 : 1 will not cause a greater loss than 0.4 db., and a normal length of feeder would not introduce sufficient delay to produce a discernible ghost image. Important delayed images are nearly always caused by reflections from nearby objects, or by multi-path reflections occurring in the line between the transmitter and the receiver.

THE TELEVISION RECEIVER

A few years ago, when Alexandra Palace was the only television transmitter in the British Isles, straight receivers were frequently used for television reception. Now, with five channels in operation, a superhet system is advantageous for it enables a receiver to be tuned to any channel by changing the local oscillator frequency; there are still a few straight models being made, however, in which the complete r.f. coil assembly can be changed for another with the channel frequency desired. For illustration, a superhet receiver is shown in block schematic form in Fig. 1.

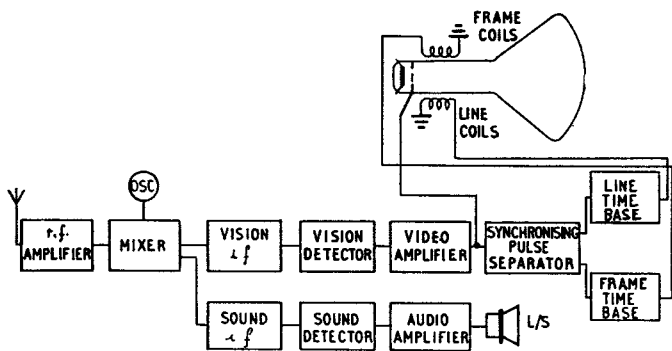

FIG. 1.—BLOCK SCHEMATIC DIAGRAM OF TELEVISION RECEIVER.

It is usual in British sets for there to be one stage of r.f. amplification before the local oscillator and mixer. At this point the vision signal is separated from the sound, each going through its own i.f. stage, and each having its own detector. The vision detector is followed by a stage of video amplification to give sufficient voltage swing to modulate the brightness of the display on the face of the cathode-ray

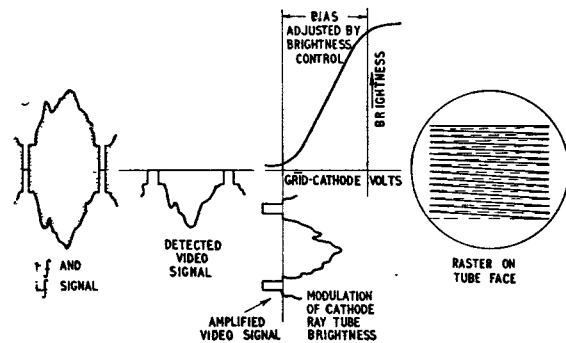

FIG. 2.—PICTORIAL ILLUSTRATION OF PROCESSES IN A RECEIVER.

tube; the audio detector output is amplified and applied to a loudspeaker. A second output from the video amplifier stage is fed to a valve which extracts the frame and line synchronising pulses from the video signal to initiate each sweep of the local frame and line time base oscillators. These processes are shown pictorially in Fig. 2. Each of these stages will now be considered in more detail.

R.F. Amplifier and Frequency-Changer.

The r.f. amplifier valve and the frequency-changer are often mounted on a small sub-chassis, so that the unit tuned to the required channel can be selected and fixed to the main chassis of the receiver. A step-up transformer, balanced or unbalanced according to the nature of the aerial feeder, delivers the received signal to the grid of the r.f. amplifier; this normally has a gain of about 10 : 1. The frequency-changer and local oscillator can either be separate units or combined in one valve; the stability of the oscillator is the most important factor in design considerations. When the receiver is being aligned, the oscillator is usually tuned to give maximum sound output from the audio receiver.

I.F. Stages.

It is unusual for the sound channel to require more than one stage of intermediate frequency amplification in a television receiver, but the vision channel normally requires two or three stages, for the wider bandwidth of the vision channel necessitates a lower gain per stage if distortionless amplification is to be achieved. The i.f. stages are usually simple transformer-coupled stages, with the intervalve transformers tuned to the mid-band frequency; it is the i.f. channel response that determines, in the main, the overall pass-band of the receiver. A typical receiver response is illustrated in Fig. 3. It can be seen that there is a peak of

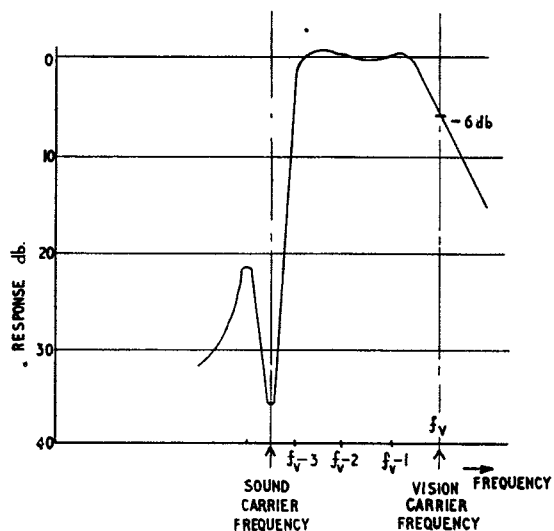

FIG. 3.—OVERALL CHARACTERISTICS OF A TYPICAL RECEIVER.

loss at the sound carrier frequency to prevent the sound channel being detected by the vision detector and appearing on the screen as horizontal streaks across the picture. This "sound rejection" can be achieved either by parallel-tuned circuits in the cathode circuits of the vision i.f. valves (Fig. 4 (a)), or by a combination of high-Q sound rejection and sound take-off circuits between the frequency-changer and the first i.f. valve (Fig. 4 (b)). The choice of frequency for

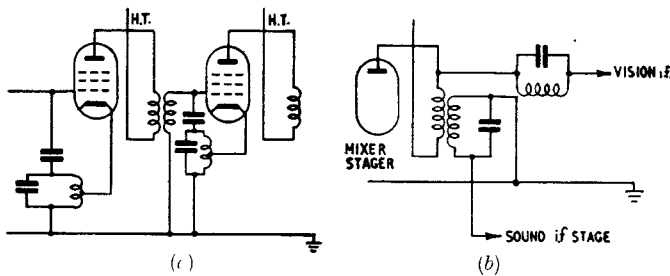

FIG. 4.—TYPICAL RECEIVER CIRCUITS FOR REJECTION OF SOUND CHANNEL.

the i.f. stages varies greatly amongst manufacturers. Until recently the most popular intermediate frequencies were 13.5 and 16 Mc/s, but recent designs favour the 34 Mc/s region. This shift in emphasis is due to the need for receivers, preferably of common design, covering the five different channels at present in use; the oscillator frequency for any one channel should not lie within the pass-band of another, a factor which introduces difficulties at nearly all frequencies below 23 Mc/s, and when harmonics are considered the problem is further complicated. These difficulties are considerably reduced for intermediate frequencies at about 34 Mc/s when the local oscillator frequency is higher than the wanted signal frequency.

The Video Stages.

A conventional second detector is quite satisfactory for extracting the video waveform from the modulated carrier; germanium rectifiers are often used in modern receivers. A choke follows the detector to prevent the intermediate frequency signal overloading the video amplifier valve. Usually a single stage of video amplification is sufficient; any falling-off in gain of the high frequencies due to valve and wiring capacitances is compensated by a combination of cathode feedback and an inductance in the anode circuit. The output of the video amplifier valve, according to its polarity, is applied to either the grid or cathode of the cathode-ray tube and modulates the beam current of the pencil of electrons that are tracing out the picture. Normally a voltage swing of 20 to 30 V is needed to give the full brightness range from black to peak white.

Associated with the video output valve is a diode and potentiometer combination which acts as an interference limiter; this clips off the peaks of the short high-intensity pulses produced by unsuppressed car ignition systems at a voltage just a little above that corresponding to peak

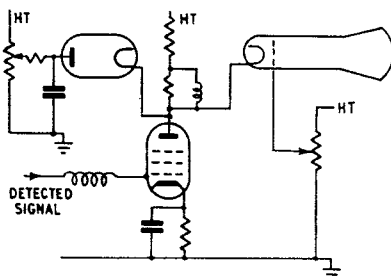

FIG. 5.—TYPICAL RECEIVER VIDEO STAGE CIRCUIT.

white. This prevents ignition interference from producing the brilliant white spots on the picture (often of sufficient intensity to cause serious defocusing), and restricts them to considerably less annoying white dashes. Fig. 5 is a diagram illustrating the video stage of a typical television receiver.

Synchronising-Pulse Separator.

The video signal, in addition to modulating the brightness of the cathode-ray tube display, provides the triggering pulses that initiate the vertical and horizontal deflection of the spot tracing out the raster on the face of the tube. The video waveform output is fed to a high-slope pentode, known as the synchronising-pulse separator or, more commonly, the "synch-separator." This pentode is usually run with a very low screen-grid voltage—perhaps as little as 30 V—which has the effect of reducing the grid base to about 1.5 V, and invests the valve with the property of limiting. As a result the picture waveform is clipped off, and only the synchronising pulses appear at the anode of the valve. A typical circuit is shown in Fig. 6.

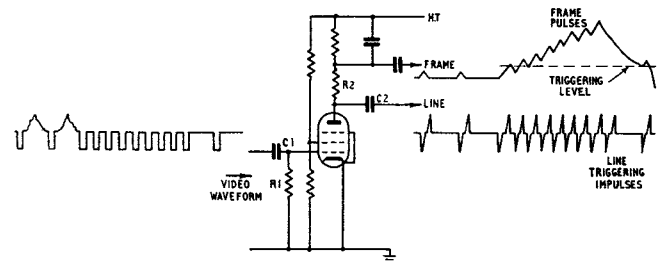

FIG. 6.—TYPICAL RECEIVER SYNCHRONISING-PULSE SEPARATOR CIRCUIT.

The next process is to separate the line and frame pulses from one another. This is often achieved by taking the line pulses through a small capacitor from the anode of the valve. The combination R2C2 differentiates the line pulses in the picture-free waveform, and produces a series of very sharp impulses to trigger the line time-base generator. Fundamentally, the frame pulse is derived by the reverse process—integration. The effects of the differentiating and integrating circuits are sketched in the diagram. In practice, the frame synchronising circuit is rather more complex than a simple integrator if good interlacing is to be assured.

Time Bases and Deflection System.

For a picture to be formed on the face of the cathode-ray tube, the electron beam must be deflected into the same pattern that was used by the camera to scan the transmitted picture (see Part 1). We have seen in the preceding paragraphs how the brightness of the spot on the cathode-ray tube screen is controlled by the video waveform extracted from the received radio signal. The vertical and horizontal deflection of the spot into the standard raster, however, is not derived directly from the received signal but from local time-bases in the receiver itself; the initiation of each vertical and horizontal sweep is controlled by the received signal waveform.

The deflection of the electron beam is achieved by two pairs of deflection coils arranged at right-angles round the neck of the tube; these carry sawtooth-shaped current waveforms—similar to those used by the cameras described in Part 1—with a repetition frequency of about 10 kc/s and 50 c/s for the line and frame coils respectively. These waveforms are produced by separate line and frame scanning oscillator circuits, the sawtooth-waveform generators usually consisting of "blocking oscillators." The frame oscillator is generally followed by a heavy-duty output valve, which is transformer-coupled to the frame deflection

coils. The line deflection coils are often auto-transformer-coupled to the line oscillator output valve circuit. The natural frequencies of the two blocking oscillators are chosen to be near the line and frame frequencies, exact synchronisation being achieved by the pulses received from the preceding synch-separator valve.

A simplified circuit diagram is given in Fig. 7.

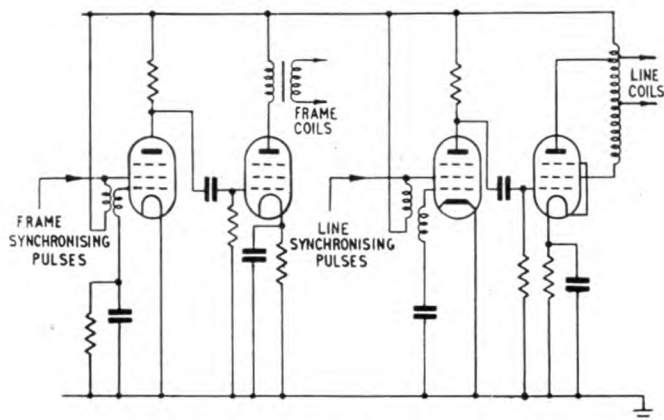

FIG. 7.—TYPICAL RECEIVER TIME-BASE CIRCUITS.

Power Supplies.

In the A.C./D.C. sets available to-day, the heaters of all valves are connected in series with a suitable ballast resistor; special precautions are taken to avoid harmful effects from current surges occurring when the set is switched on. The cathode-ray tube heater is usually at the chassis end of the chain, with the detector valves, then the i.f. and video amplifier valves, then the r.f. and frequency-changer valves and finally the sound output and time-base valves following in succession. The H.T. supply is often derived from a half-wave rectifier circuit, employing a metal rectifier. The much higher voltage supplies required by the cathode-ray tube—often referred to as extra-high-tension supply, or the E.H.T.—can be obtained in a variety of ways: the voltage may be developed by a half-wave rectifier working on the output of a high-voltage winding on the mains transformer; or it may be derived by a diode connected to a winding coupled to the line deflection coils which conducts during the flyback period of the line oscillator. The E.H.T. supply required may be from 2 kV to 15 kV, according to the type and size of the cathode-ray tube employed. The voltage supplies to the cathode, grid, and anodes of the tube are taken from tappings on a voltage-divider resistor chain across the E.H.T. supply; the relative voltage between grid and cathode is made variable, and is used to control the brightness of the picture.

RECEIVER PERFORMANCE AND PICTURE DISTORTION

Every weekday morning the B.B.C. transmits a test film for the benefit of television dealers demonstrating their receivers to prospective customers and for anyone wishing to adjust their own sets. Included in this film are several periods in which a pattern—known as Test Card "C"—is radiated. This test card is a sensitive check of television receiver alignment, for nearly every possible fault and imperfection is seen as a distortion in the reproduction of the card. A photograph of Test Card "C," displayed on a well-adjusted receiver, is shown in Fig. 8.

It is quite a simple matter to interpret the pattern in terms of the electrical performance of the receiver. The large central circle, for instance, together with the grid of white squares across the whole pattern, is a test of the linearity of the line and frame deflection systems, i.e. on the perfection of the sawtooth waveforms, for any defect in

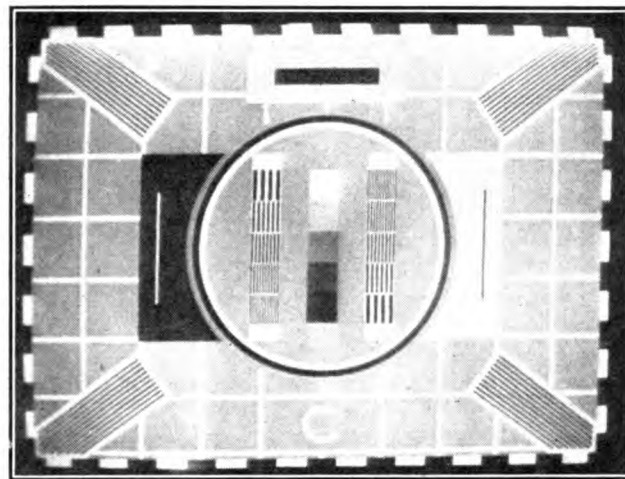

FIG. 8.—TEST CARD "C."

performance is obvious as deformation of the circle and compression or expansion of the grid squares.

Within the circle are three sets of small squares. The outer two sets are marked out in vertical black and white bars which vary from comparatively coarse spacing in the top left and bottom right squares to a very fine gradation in the bottom left and top right squares. The success with which these bars are reproduced is a measure of the overall bandwidth of the receiver, for the frequency by which the electron beam must be modulated to give clearly-defined bars in the picture varies in $\frac{1}{2}$ Mc/s steps from 1 Mc/s for the coarse bars up to 3 Mc/s for the fine bars. Any reduction in bandwidth is seen as a lack of clarity in the higher-frequency bars, which then tend to a uniform greyness.

The central vertical series of squares vary in shade from peak-white to black, and are used as a guide for adjusting the brightness and contrast controls; ideally, there should be an equal change in brightness from square to square. The striped slanting rectangles in the corner of the card are to indicate whether the focus of the spot is maintained over the face of the tube, and the blocks and lines of white and black on contrasting backgrounds show up any deficiencies in the low-frequency performance by giving a streaking effect if such faults exist.

It must be remembered that Test Card "C" is a very stringent test of any receiver, and its perfect reproduction is a rare achievement. Fortunately, the human features, which form such a large part of television intelligence, exist in such variety in nature that any slight distortions added by a television receiver are barely noticeable!

Even when the receiver has been properly adjusted, the reproduced picture may display imperfections; these may be due to faults in the receiver itself, or to conditions external to the receiver.

Receiver Faults.

A common fault in television receivers is sound breakthrough. This is seen as horizontal streaks across the picture which shift and change as the accompanying sound varies in frequency and amplitude, and it is due to imperfect separation of the vision and sound channels after the frequency-changer valve. The solution, usually, is to readjust the sound rejection circuits in the i.f. stages.

One or two horizontal bars across the picture, fixed in position and intensity, suggests a fault in the smoothing of either the H.T. or E.H.T. supplies.

Complete failure of either the line or frame time-base generators results in the picture being condensed into either a single vertical or horizontal line. Severe distortion of the sawtooth waveforms may cause the picture to become badly compressed at one of the edges of the picture.

Imperfect Pictures due to External Conditions.

It has been mentioned in the paragraph on aerials that buildings or large objects in the vicinity of the receiver can cause reflections which appear as "ghost" images on the picture; the ghost image is usually fainter than, and displaced to the right of, the main picture. Varying the orientation of the aerial will usually clear the effect. Reflections of the radio signal from aircraft flying along the line between the transmitter and receiver can cause the picture to flutter in intensity as the direct and reflected signals go in and out of phase. Some receivers are fitted with an a.g.c. system to prevent this annoying feature.

Television pictures may be seriously affected by interference due to radio frequencies in the same frequency band as the required programme. Such interference may be due to harmonics of transmissions lower in frequency than the 40-70 Mc/s band, or to the picking up of sound broadcasting stations by the i.f. stages of the receiver, to r.f. industrial and medical equipment, or to internal-combustion engine ignition systems. The latter are virtually miniature spark transmitters using the leads to the distributor head as aerials. Provided all reasonable care is taken in the receiving installation, interference from outside can only be cured by suppression at the source.

The Post Office has a special group of television interference investigation officers whose services can be enlisted by the public. Their job is to track down any interference to its source and advise as to how it can be suppressed. Apart from ignition interference, which can be cured by fitting a resistor in the leads to the distributor head of the offending machine, external interference is caused chiefly by diathermy and similar electro-medical equipment, industrial r.f. heating apparatus, and harmonics from transmitters working on lower frequencies. For steady-frequency sources, the interference appears as parallel bars across the entire picture, the bars representing the beat frequency between the vision carrier and the interfering harmonics; the bars become disrupted if the transmission is keyed. In diathermy and r.f. heating equipment the frequency is continually varying over a small range, and the interference appears as a "herring-bone" pattern.

Ignition interference is not, of course, a regular transmission, but is an impulsive radiation which causes bright white spots, distributed more or less at random, to appear on the screen. Other sources of impulsive interference are unsuppressed contacts in thermostatic devices fitted in electric irons, water-tanks, etc., and sparks from commutators on electric motors in such things as sewing-machines or hair-driers; these give the appearance of a band of white dashes across the picture. Interference of this type can either be radiated directly or borne along mains supply connections.

The sources of television interference that have been mentioned above are some of the more obvious and common that have been encountered; in fact, there are many possible causes of television interference and their identification and cure can, on occasion, entail arduous and subtle investigation.

FUTURE DEVELOPMENTS

Great Britain was the first country to possess a public television service, and London was the scene of the first television outside broadcast to be radiated. Since then British television has been in the van of all developments and techniques, whether technical, such as in the design of

cameras or transmission systems, or in the scale of its achievements in programme organisation.

Looking now to the future, developments in television can be divided into the tentative and the occult. Fairly safe predictions on some aspects of the British television service, however, can be based on the report of the Television Advisory Committee published in July 1953. In this it is suggested that, in future, television broadcasting should use the frequency bands 174-216 Mc/s, 470-585 Mc/s, and 610-960 Mc/s, in addition to the 41-68 Mc/s band now in use. It is possible that part of the first of these additional bands will be used for extending the coverage of the present B.B.C. programme, the remainder of the 174-216 Mc/s band being devoted to establishing a completely new second programme service. Other television programmes may also be allocated channels in these bands. Obviously, if these higher-frequency bands are to be exploited, a great deal of development work is necessary on both transmitter and receiver circuitry and construction.

A much more distant prospect is the introduction of such luxuries as colour, higher-definition and stereoscopic television. All these things are technically possible and, in fact, have been demonstrable in laboratory models for many years. Colour television will probably be the first of these in general service, for recent work has shown that a colour television system need not employ a greater bandwidth than that occupied by a monochrome service of the same definition; also it has been agreed that any colour service permitted to broadcast in this country would be such that existing receivers could receive the signal and give a satisfactory monochrome picture.

The disadvantage of higher-definition television is that, if present-day techniques are used, it requires a much greater bandwidth than the present standard, though there is intensive investigation into the possibility of devising systems with high definition yet with low bandwidth. Stereoscopic pictures would also require a large bandwidth if the same definition as two-dimensional images is to be maintained, and would require the use of either image-separating spectacles or a slotted viewing mask in front of the pictures.

Other possible future developments, apart from the perpetual advances in receiver and transmission equipment design, may include miniature cameras for newsreel reporting, a further extension of international television exchanges to include trans-Atlantic links, and miniature portable receivers for the handbag or car, using transistors and dry batteries.

ACKNOWLEDGMENTS

In preparing this series of articles numerous publications have been consulted on points of detail. In particular, publications of the British Broadcasting Corporation have been used for this purpose, and the section on Broadcast Transmission (see Part 2) is based on information contained in a number of papers* presented by members of the B.B.C. Engineering Department at the I.E.E. Television Convention, 1952.

Finally, thanks for assistance are due to colleagues in the Radio Experimental and Development Branch; and especially to Mr. T. Kilvington who acted in an advisory capacity throughout the series.

* e.g., Birkinshaw, D. C. "Television Programme Origination: the Engineering Technique." *Proc.I.E.E.*, Vol. 99, Pt. IIIA, (No. 17), 1952.

Bevan, P. A. T. "Television Broadcasting Stations," *ibid.*, (No. 18).

The Birmingham-Manchester-Holme Moss Television-Cable System†

R. J. HALSEY, B.Sc., M.I.E.E.,
and H. WILLIAMS, A.C.G.I., M.I.E.E.

Part 2.—High-Frequency-Line System, Frequency Translating Equipment and Overall Performance

U.D.C. 621.397.242:621.396.65

Part 1* of this article outlined the transmission requirements, general design considerations and cable characteristics of the system. In Part 2 the H.F. line system is described and its measured characteristics are listed. An outline of the frequency translating equipment follows and the article concludes with a review of the overall performance obtained. The authors mention further experimental work on time equalisers (variable waveform correctors) designed to deal with overall distortion of combinations of links.

HIGH-FREQUENCY-LINE SYSTEM

THE general layout of the Birmingham-Manchester-Holme Moss system is shown in Fig. 4. It involves H.F.-line systems in each direction between Telephone House, Birmingham, and Telephone House, Manchester, and thence to Holme Moss. Tail-cable connections are also provided

to the B.B.C. premises at Birmingham and Manchester, where the frequency-translating equipment is installed. The

† This article is a shortened version of the paper of the same title presented at the I.E.E. Television Convention in 1952. Permission to reprint in this form is gratefully acknowledged to the Institution of Electrical Engineers.

* P.O.E.E.J., Vol. 46, p. 118.

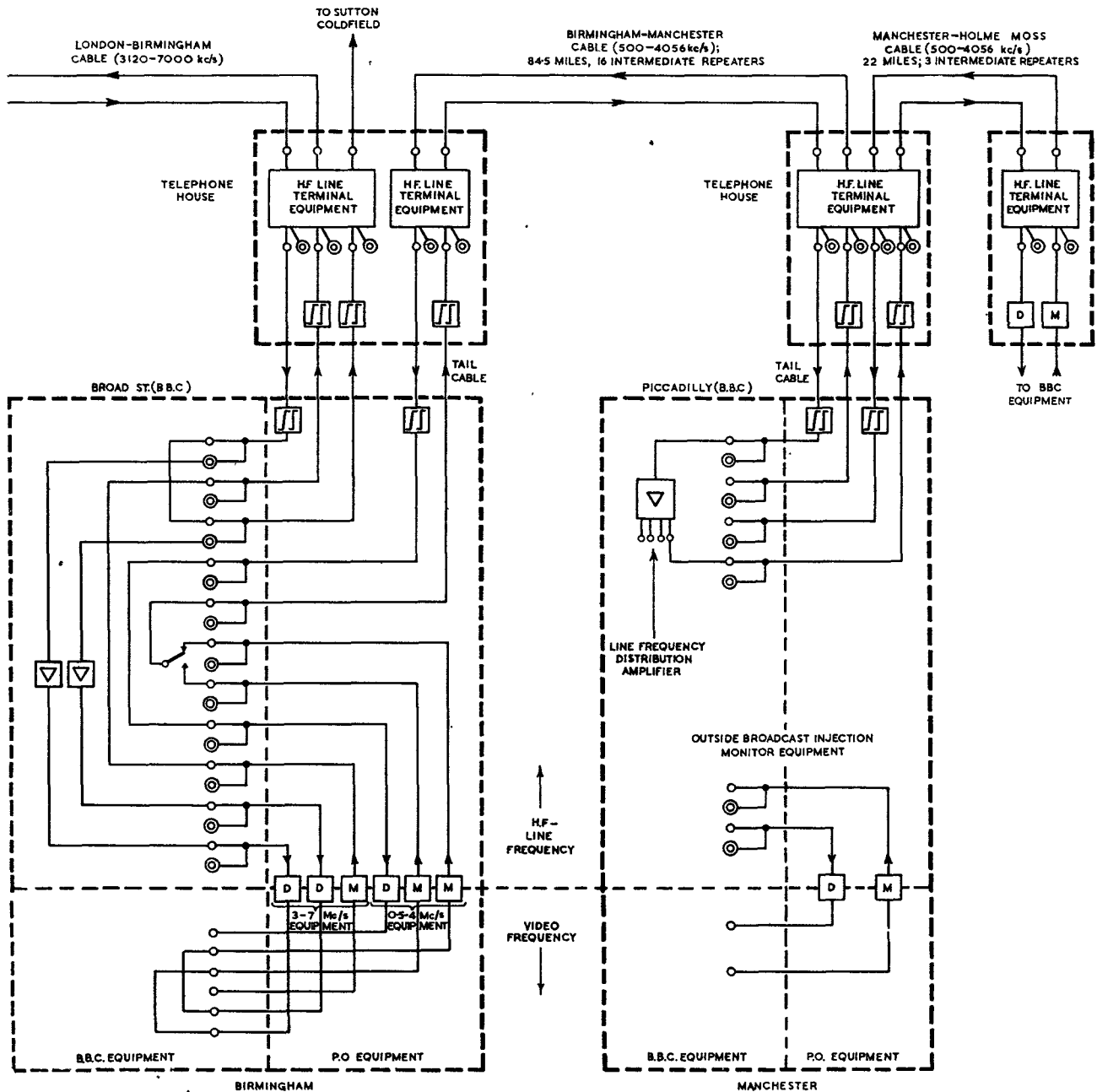

FIG. 4.—BIRMINGHAM-MANCHESTER-HOLME MOSS TELEVISION SYSTEM: GENERAL ARRANGEMENTS. Switching centre connections set up for London-Holme Moss transmission.

Birmingham-Manchester system is 84.5 miles in length with 16 intermediate repeater stations, while the Manchester-Holme Moss system is 22 miles in length with three intermediate stations. Each H.F.-line system is complete with its own terminal equipment, Manchester being the control terminal for each system, with Birmingham and Holme Moss as "remote" terminals.

Each terminal equipment receives or transmits television signals over the appropriate tail cable in the range 500-4,056 kc/s, the carrier levels* being - 10 db. received from, and + 14 db. transmitted to, the B.B.C. premises. At each intermediate and terminal station, normal and reserve line-amplifiers and associated cable simulators are provided, the change-over being effected either automatically, by failure of the 308-kc/s line pilot, or by remote switching from the control terminal. An automatic-gain-control unit at the receiving end of each H.F.-line system controls the gain within ± 0.1 db. as determined by the 308-kc/s pilot; this is effective for input-level variations of ± 3 db.

The gain/frequency characteristic of the line amplifier is designed to compensate for six miles of cable at 22°C, the highest mean cable temperature provided for. At lower temperatures both the gain and the equalisation provided by the amplifiers are excessive. The gain, as indicated by the received level of the 308-kc/s pilot, is corrected by the terminal regulator; excess equalisation, as indicated by the relative level of the 4,340-kc/s pilot, requires the addition of temperature equalisers along the route; this is done in accordance with a planned schedule. Each station is fitted with an additional simulator representing 0.3 mile of cable which serves as a temperature equaliser† and which can be inserted either manually or remotely from the control terminal; in the latter case the equalisers in the two directions of transmission are switched simultaneously.

Power supplies to intermediate stations are obtained, alternatively, over the coaxial cable from a power-feeding station or from a local supply. Up to two dependent intermediate stations may be supplied from each side of an intermediate power-feeding repeater station or from a terminal station.

Terminal Equipment.

A control terminal consists of four 10ft. 6in. bays, of which two are occupied by supervisory and control equipment; only in respect of the control facilities does it differ from the remote terminal, which requires only three bays. At Holme Moss 7ft. 6in. bays are necessary owing to the low ceiling.

The cable-termination bay includes the cable-termination box with precautionary features appropriate to the power supply (350 volts A.C.) to which it is connected, normal and reserve amplifiers for the two directions of transmission and subsidiary panels. The amplifiers transmitting to the H.F. line from the tail cable have a flat gain of 27 db. and include temperature equalisers; those receiving from the H.F. line are identical with the line amplifiers at intermediate stations and include line-simulator and temperature-equaliser units. The remaining bay is fitted with residual and delay equalisers, H.F. regulator, pilot-stop filters and their associated 27-db. amplifiers, pilot-level stabilisers, power panel, test equipment, etc.

The H.F.-regulator panel includes the automatic-gain-control unit, which is thermistor-operated, and an alternative manual control. It also includes pilot-level-deviation

* Transmission levels are relative to 1 mW. Subsequently these levels were adjusted. See later reference to emphasis networks under *Signal/Noise Ratio* in paragraphs dealing with Overall Performance.

† Since dielectric losses are negligible, change in attenuation due to change in temperature can be compensated accurately by a change in effective length. The temperature coefficient of attenuation is about 0.2% per degree centigrade and the equalisers provided correspond to a change in temperature of about 25°C.

meters and a temperature equaliser with switch positions corresponding to 0, $\frac{1}{4}$, $\frac{1}{2}$ and $\frac{3}{4}$ of a normal temperature equaliser for fine adjustment. In the event of the incoming 308-kc/s pilot level varying by more than ± 3 db., thermistor control is automatically rejected and manual control substituted.

The pilot frequencies may be derived from standard carrier-frequency generating equipment, if available, or from local oscillators.

At each terminal station provision is made for a picture monitor to be connected to the circuit without interfering with the transmission. This requires the provision of additional flat amplifiers and frequency-translating equipment at the terminal stations (i.e. at the Post Office premises) for monitoring purposes only. The terminal equipment at Holme Moss is in a screened room to avoid excessive pick-up from the transmitter.

Intermediate Equipment.

The intermediate equipment is mounted on a single 7ft. 6in. bay and is essentially the same as the existing standard equipment used for telephony except in respect of the rearrangement necessitated by the larger amplifiers. The two H.F. panels each carry normal and reserve amplifiers, line simulators and temperature equalisers. In addition there are a relay panel for switching the line amplifiers, a power panel, a power switching panel and supervisory equipment.

The line simulators correspond to cable lengths of 0.2, 0.4, 0.8 and 1.6 miles, thus enabling any length down to 3.0 miles to be built out to 6 ± 0.1 miles. The unit also includes pads of 0.5, 1.0, 2.0 and 4.0 db., and with these facilities the output level from each line amplifier can be adjusted to within ± 0.25 db. in mean level and ± 0.1 mile of cable in slope.

The pilot-selector unit at each intermediate station operates with the normal 308-kc/s pilot level of - 7 db., i.e. the amplifier change-over relay is held operated when the pilot is present at the amplifier output and releases when it fails. When the pilot level is restored the normal amplifier is automatically reconnected. Manual connection of either the normal or reserve amplifier is provided for at each station, while remote switching from the control terminal can lock-in all the normal amplifiers on a route irrespective of the pilot. In addition, the reserve amplifier at any selected station can be switched in by remote control even though the pilot is on the line and the corresponding normal amplifier is not faulty.

The power consumption at an intermediate station is about 400 watts.

Line Amplifier.

The line amplifier has been designed with a gain/frequency characteristic matching very closely the loss in six miles of cable over the frequency range 60-4,400 kc/s, and to give a uniform output over this range. The assumed cable loss is 50.5 db. at 4,400 kc/s and 24 db. at 1,000 kc/s. An allowance of 1.7 db. is made for extra loss which may arise in "mop-up" equalisers.

The amplifier¹² contains six valves and consists, in effect, of two 3-stage amplifiers in tandem, each with separate negative feedback. The first, preceded by a network designed to avoid overloading at low frequencies, gives the required gain/frequency characteristic and is coupled to the second amplifier, which has a substantially flat characteristic; each amplifier section has at least 35 db. of negative feedback. The return-loss against 75 ohms at the input and output of the amplifier exceeds 18 db. at all frequencies within the working band.

The normal output level of the unmodulated carrier is + 15 db., and the overload point is specified to be at least

+ 26 db. Under normal operating conditions the carrier/harmonic ratio is about 83 db. and 88 db. for the second and third harmonics respectively.* Each amplifier is planned to give a phase change of 180° and this provides a considerable degree of cancellation between the second-harmonic products from amplifiers at adjacent repeater stations. The valves employed are selected to have mutual conductances near the means of the specified ranges.

In view of contact troubles which have been experienced with commercial valve-holders for B7G- and B9G-based valves, new low-capacitance valve-holders were designed in which wires, welded to the valve pins, are soldered to tags. Although experience is limited, it is probable that the fault liability of the amplifiers has been reduced by this means.

The 308-kc/s pilot-selector unit, comprising three valves, is mounted on the same chassis as the line amplifier; this chassis is fitted on top of the box in which are mounted the line-simulator units, pads and mop-up equalisers. The temperature equalisers are associated with the relay unit, which is fitted between the normal and reserve amplifiers.

In the method of construction of the H.F. panel particular care has been taken to screen the transmission circuit against external interference.

Flat-Gain Terminal Amplifier.

The flat-gain amplifiers used in the terminal equipment have a gain of 27 db. and consist essentially of the second 3-stage group of the line amplifier, with the addition of an input transformer.

Control and Supervisory Arrangements.

At the control terminal, facilities are provided for switching in the reserve amplifiers at any intermediate station or at the remote terminal, as previously stated, and also the temperature equalisers. A visual indication is provided, showing which amplifier is in use at each station and which temperature equalisers are in circuit. These facilities are provided over two interstice pairs using audio-frequency tones and direct current.

The power supplies and audio-frequency amplifiers at each station have alarm circuits extended back to the control station, and the particular station at which a fault may exist can be determined from the control terminal.

The mean temperature of the cable can be determined at the control terminal by a resistance measurement on a pair of wires looped at the remote terminal.

A 4-wire speaker system is provided throughout the route. The control terminal can ring all stations; the remote terminal can ring the control station; an intermediate station can ring either terminal.

Measured Characteristics.

Attenuation Distortion.—The gain/frequency characteristics of the overall H.F.-line system between Birmingham and Holme Moss are given in Fig. 5. The maximum attenuation

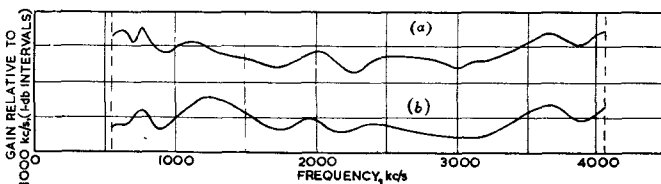

FIG. 5.—H.F.-LINE SYSTEM: GAIN/FREQUENCY CHARACTERISTICS. (a) Birmingham-Holme Moss. (b) Holme Moss-Birmingham

distortion prior to the insertion of the mop-up equalisers was about ± 2 db., and it is of interest to note that response in the two directions of transmission was almost identical, thus indicating the uniformity of the amplifiers and equalisers.

* These figures are changed by the emphasis networks discussed later.

Group-Delay Distortion.—The group-delay distortion of the overall H.F. connections between Birmingham and Holme Moss, relative to the delay at the carrier frequency, is shown in Fig. 6. This includes delay equalisers which were designed

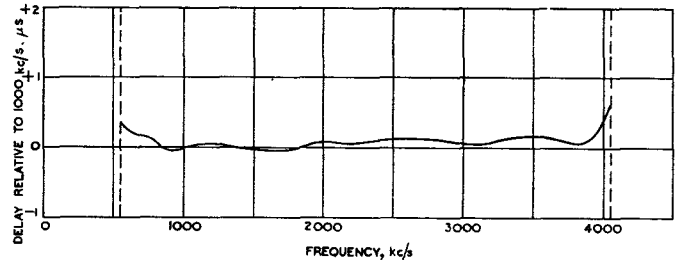

FIG. 6.—H.F.-LINE SYSTEM: GROUP-DELAY/FREQUENCY CHARACTERISTIC. Birmingham-Holme Moss.

as the result of tests over four repeater sections only and which were originally regarded as provisional.

The improvement effected by the delay equalisers is shown in Fig. 7 for the H.F.-line system Birmingham-Manchester. The delay was measured using a modulating frequency of 60 kc/s.

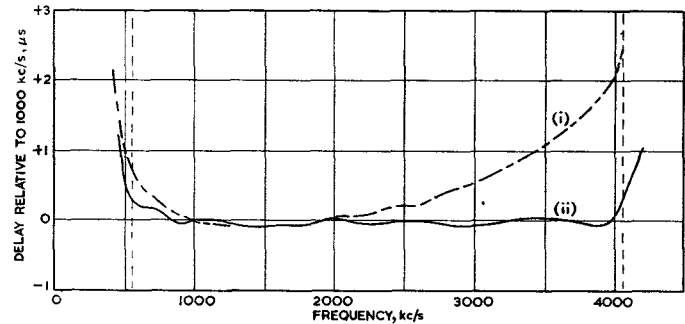

FIG. 7.—H.F.-LINE SYSTEM: GROUP-DELAY/FREQUENCY CHARACTERISTIC SHOWING EFFECT OF DELAY EQUALISERS. Birmingham-Manchester. (i) Without delay equalisers. (ii) With delay equalisers.

Carrier/Noise Ratio.—Measured with a wide-band valve-voltmeter, of approximately square-law characteristic, the carrier/noise ratio is 55 db. on the Manchester-Birmingham system; on the other systems it is 57 db. The peak-to-peak noise voltage will exceed the R.M.S. voltage by 17–18 db.

A frequency analysis of the R.M.S. noise relative to the carrier is shown in Fig. 8 for one long system and one short system.

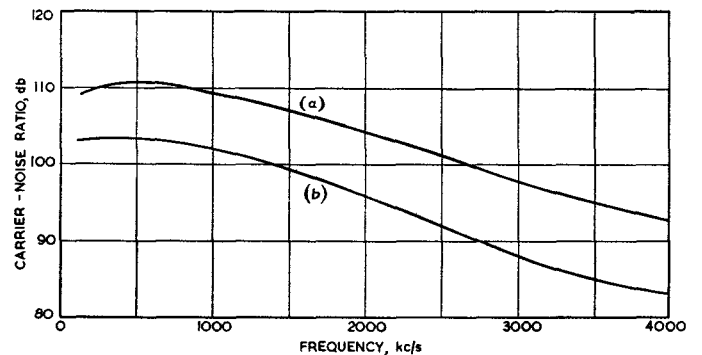

FIG. 8.—H.F.-LINE SYSTEMS: NOISE DISTRIBUTION. (a) Manchester-Holme Moss. (b) Birmingham-Manchester.

Crosstalk between Channels.—The crosstalk between oppositely-directed channels on the same route measured with single frequencies is given in Fig. 9. From its frequency characteristic this crosstalk clearly arises in equipment and not in the cable.

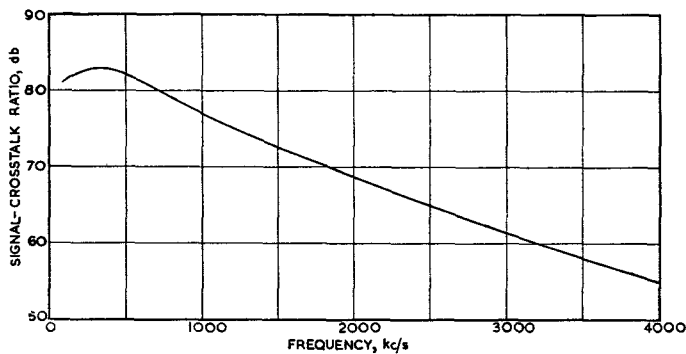

FIG. 9.—H.F.-LINE SYSTEM CROSSTALK BETWEEN OPPOSITELY-DIRECTED CHANNELS.
Birmingham-Manchester

Carrier Harmonic Generation.—The carrier/harmonic ratio, on the four H.F.-line systems, measured with a nominal output level of + 15 db. at each amplifier, ranges from 61 to 71 db. for both the second and third harmonic; the fourth harmonic is below the basic noise level.*

Overload Levels.—The overload point of each system is sharply defined and in every case exceeds + 25 db. at the output of the final line amplifier. This corresponds to a fall in gain of less than 0.25 db.

FREQUENCY-TRANSLATING EQUIPMENT

The asymmetric-sideband frequency-translating equipment was designed to a Post Office performance specification and a full description is given elsewhere.¹³

The equipment receives a video signal of 1 volt peak-to-peak but eliminates the D.C. component and frequencies below about 50 c/s. The band 50 c/s–3,000 kc/s is translated by double modulation to the upper sideband of a 1,056-kc/s carrier. For input frequencies below about 500 kc/s the lower sideband is also partially transmitted, the response between frequencies 500 kc/s above and below the carrier being shaped to give uniform transmission after demodulation at the distant end. This shaping is carried out partly at the sending end and partly at the receiving end.

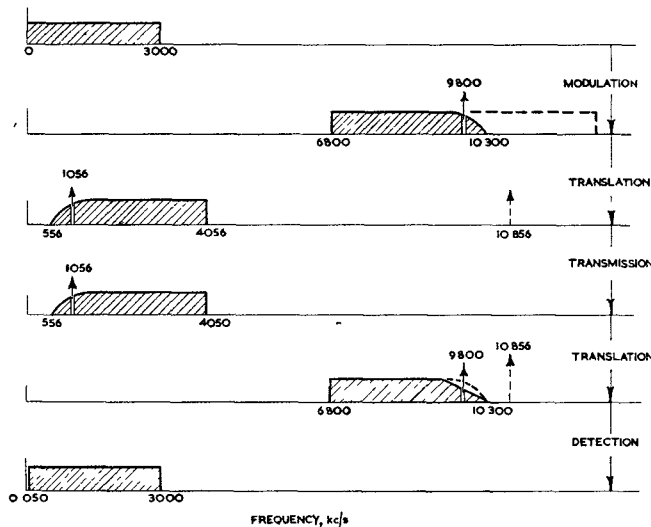

FIG. 10.—FREQUENCY TRANSLATING PROCESSES.

Fig. 10 shows the modulation processes involved. The first modulation is by a single-valve modulator whose output is combined with that of another similar valve which supplies unmodulated carrier in anti-phase and whose output is adjusted to increase the modulation factor to the desired value. The lower sideband, 6,800–9,800 kc/s, and the vestigial upper-sideband are selected and suitably

shaped. The second modulator is of the conventional balanced type, supplied with a 10,856-kc/s carrier, and serves to translate the signal to the range 556†–4,056 kc/s for connection to the H.F.-line equipment. With a modulating signal of 1 volt peak-to-peak and sinusoidal wave form, the modulation factor of the transmitted signal is 42 per cent.; with a full-white picture of the same amplitude, with the D.C. component eliminated, the modulation factor‡ is increased to 60 per cent.

At the receiving end the signal is first translated back to the range 6,800–10,300 kc/s, using a 10,856-kc/s carrier, and after final shaping in the range 9,300–10,300 kc/s, it passes to an envelope detector which restores the video frequencies 50 c/s–3,000 kc/s. The equipment contains no facilities for D.C. restoration, which is done at the television transmitter.

Normal and reserve modulators, each with its own power unit, are mounted on a 7ft. 6in. bay, and change-over is either by local switching or by remote control. A metering panel, which provides an alarm when the anode current in any valve falls below a prescribed limit, completes the equipment. The demodulators are similarly mounted on a separate bay.

As noted in the paragraphs dealing with *Design Problems* in Part 1, the main disadvantage of the system of modulation employed is that the second and third harmonics of the carrier lie within the transmitted band. These carrier harmonics give rise to video frequencies of 1,056 and 2,112 kc/s respectively, and so their level must be at least 50 db. below the signal level even with four links in tandem. In amplifying equipment the necessary linearity can be positively controlled by the amount of negative feedback and choice of output level; in the frequency-translating equipment the same degree of control of linearity is not practicable. The second modulator at the sending end and both stages at the receiving end are likely to contribute to periodic interference. The most troublesome components arise in the second stage of the modulator and the first stage of the demodulator as unwanted products of modulation with the 10,856 kc/s carrier (*A*). For example, when the line carrier of 1,056-kc/s (*B*) passes through the first demodulator stage, it is translated to a frequency 9,800 kc/s (*A–B*). In each half of the balanced demodulator, frequencies 8,744 kc/s (*A–2B*) and 7,688 kc/s (*A–3B*) will be generated owing to the 3rd and 4th-order terms in the demodulator characteristic; at the output, the (*A–2B*) components will tend to cancel while the (*A–3B*) components, like the wanted (*A–B*) components, will be additive. Thus, the (*A–3B*) component, which gives rise to a video frequency of 2,112 kc/s, is a function of the valve characteristic only, whereas the (*A–2B*) component, which gives rise to a video frequency of 1,056 kc/s, is also a function of the demodulator balance. Restricting periodic interference of this type to the required limits has been an important problem in the design of the frequency-translating equipment.

TIME EQUALISERS

The steady-state characteristics specified in Part 1 represent an approximation to those of an ideal low-pass filter, and, with a flexible network of television links, the obvious objective for each link would also be the characteristics of such an ideal filter; these are the only characteristics which can be added together without increasing distortion. The fact that overshoot and ringing

* These figures have been improved by the emphasis networks discussed later.

† This frequency is approximate only as the signal levels are gradually attenuated in this region.

‡ For a television waveform the normal definitions of modulation factor must be replaced by "the difference between the maximum and minimum carrier amplitudes, divided by their sum."

are reduced by a more gradual increase in loss towards cut-off (particularly if the phase distortion increases in this region) appears to be a matter of importance in the design of cameras, television transmitters and broadcast receivers rather than in the design of interconnecting links.

In view of the difficulty of adjusting and maintaining the attenuation and phase equalisation of a single long-distance link to within such close limits that a 4-link connection can be guaranteed to meet the given requirements, it is desirable to consider the possibility of using additional "residual" equalisers to deal with the overall distortion of combinations of links. For this purpose, variable waveform-correctors, or time equalisers, offer the advantage of dealing directly with transient distortion.

A suitable type of time equaliser developed for use, in the first instance, with the present system, is described elsewhere.¹⁴ Briefly, this operates by combining the input signal with a series of both advanced and retarded "echoes" or attenuated replicas of itself, each echo being individually adjustable in amplitude and sign. With certain limitations, the response of a system to a suitable test-signal can thus be corrected rapidly by direct observation of the received waveform on an oscillograph.

The test signal actually employed is a "sine-squared" pulse¹⁵ whose half-amplitude duration (0.17 microsec.) corresponds to the half-period of the highest frequency nominally transmitted by the system. The effect of passing this pulse through an ideal low-pass filter, having a cut-off frequency of 3,000 kc/s, is to increase the half-amplitude duration to 0.23 microsec. and to introduce ringing at 3,000 kc/s with a first overshoot of 13 per cent. The process of equalisation of a link or tandem connection of links consists in adjusting the received waveform until it corresponds as closely as possible to the ideal response. As might be expected the ideal is, in fact, unattainable.

Used in this way, the functions of the conventional attenuation and phase equalisers and the time equaliser seem to be largely complementary. While the bulk of the distortion is best corrected by the more usual steady-state methods, residual distortion is more conveniently dealt with by the time equaliser.

On the Birmingham-Holme Moss link the response with conventional attenuation and phase equalisers was found to meet the B.B.C requirements and additional time equalisers were not provided as a permanent feature. On the longer London-Wenvoe link time equalisers have been provided to gain experience in their use for correcting residual distortion.

OVERALL PERFORMANCE

Steady-State Characteristics.

The gain/frequency and group-delay/frequency characteristics of the complete video-to-video link between Birmingham (B.B.C.) and Holme Moss are shown in Figs. 11 and 12.

Although these characteristics represent a very high technical performance, it is clear that they fall somewhat short of that which would be required if four links were to be connected in tandem. On the average, the distortions on the separate links will add in a random manner, in which case the appropriate limits for one link will be half the total.

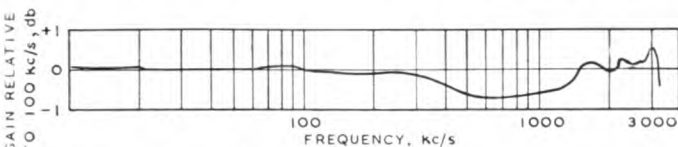

FIG. 11.—OVERALL (VIDEO-TO-VIDEO) GAIN/FREQUENCY CHARACTERISTIC.

Birmingham (B.B.C.)—Holme Moss. Modulator 1 and demodulator 1.

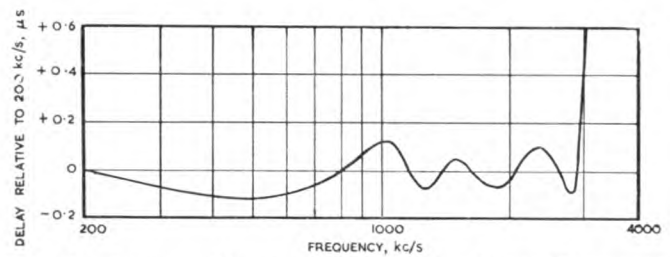

FIG. 12.—OVERALL (VIDEO-TO-VIDEO) GROUP-DELAY/FREQUENCY CHARACTERISTIC.

Birmingham (B.B.C.)—Holme Moss.

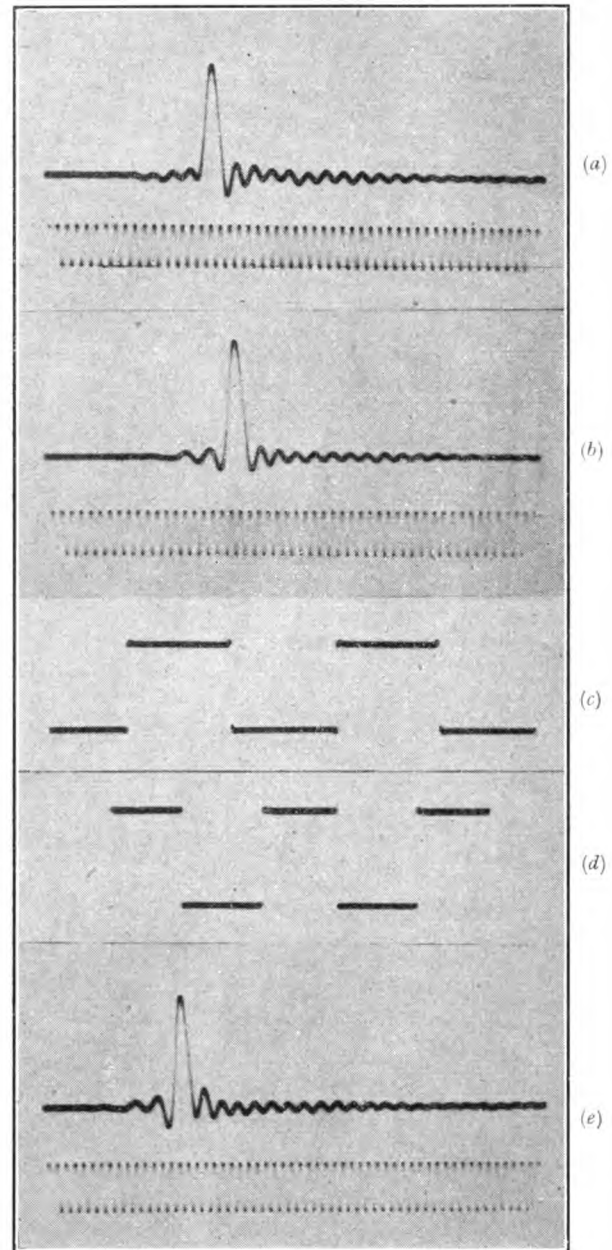

FIG. 13.—RESPONSES TO 0.17-MICROSEC. SINE-SQUARED PULSE AND 10-KC/S SQUARE WAVE.* (TIMING WAVE 6 Mc/s).

- (a) Broad St.—Holme Moss: without time equaliser.
- (b) Broad St.—Holme Moss: with time equaliser.
- (c) Broad St.—Holme Moss: without time equaliser.
- (d) Broad St.—Holme Moss: with time equaliser.
- (e) Alexandra Palace—Holme Moss: with time equaliser adjusted for Birmingham—Holme Moss direction only.

* The square wave is restricted in bandwidth by a network giving a rise time of 0.33 microsec.

In regions of rapid phase-change, i.e. near the upper cut-off of the system, the phase distortion will tend to be directly additive. It may be of interest to note, however, that the overall performance of the London-Kirk o'Shotts system which is made up of 3 different types of links, is within the B.B.C. limits quoted for a 500-mile 4-link system.

Some further improvement of the characteristics could be effected by means of improved delay equalisers and mop-up attenuation equalisers of conventional type; the stability of the system is such as to justify this. However, it is not feasible to obtain ideal flat steady-state characteristics and further information would be required on the tolerable variations in the steady-state response consistent with satisfactory waveform response. Since the latter is the final test of a relay system it appears that time equalisers offer a direct method of waveform response adjustment which may make accurate steady state correction unnecessary. The time equalisers installed experimentally on the London-Wenvoe route have given good results, and experience is being gathered on their long term use.

Pulse Response.

The response of the Birmingham-Holme Moss channel to a 0.17-microsec. sine-squared pulse is shown in Fig. 13 (a). Fig. 13 (b) shows the improvement effected by addition of the time equaliser adjusted to give minimum ringing without increasing the half-amplitude duration to more than about 0.25 microsec. Figs. 13 (c) and 13 (d) show the response to a square-wave of frequency 10 kc/s before and after addition of the time equaliser.

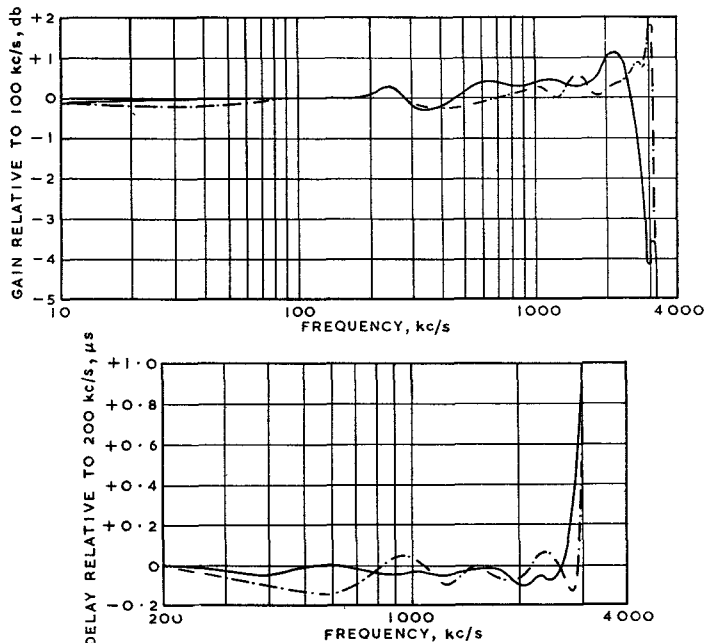

FIG. 14.—OVERALL GAIN AND GROUP-DELAY/FREQUENCY CHARACTERISTICS (BIRMINGHAM-HOLME MOSS) SHOWING EFFECTS OF ADDING A TIME EQUALISER.

— Time equaliser adjusted using 0.17-microsec pulses.
 - - - Without time equaliser.

The gain/frequency and delay/frequency characteristics of the channel before and after the time equaliser had been adjusted as above are shown in Fig. 14; the degradation just below the cut-off frequency emphasises the inadequacy of a steady-state specification for systems transmitting impulsive signals.

Signal/Noise Ratio.

The signal/noise ratio is substantially the same for both directions of transmission. For random noise the ratio between the peak-to-peak picture voltage (excluding

synchronising pulses) and the peak-to-peak noise voltage is 38 db. The frequency distribution of this noise is such that above 500 kc/s the level increases by about 7 db. per 1,000 kc/s.

Periodic noise at 1,056 and 2,112 kc/s is dependent on the balance adjustments of the frequency-translating equipment, typical values for normal adjustment being 50 and 55 db. respectively (peak-to-peak ratios).

As installed, the performance of the line link was quite satisfactory. Unfortunately, after a few months' use deterioration of the harmonic distortion introduced by line amplifiers, brought about by changes in the cathode-heater insulation of valves V1 and V3 made it necessary to apply special corrective measures to limit the 2nd and 3rd harmonic products from the line. As a first approach, emphasis networks giving a lift to the higher line signal frequencies of about 12 db. relative to the carrier, were fitted at the transmitting end of the link and corresponding de-emphasis networks at the receive end. This arrangement gave an immediate improvement of some 12 db. in harmonic production on the line. A further improvement of 6 db. in second harmonic and 12 db. in third, was achieved by a reduction of the carrier level from +15 to +9 db. (ref. 1 mW) at the line amplifier output. As a longer term measure steps have been taken to introduce a simple modification to the line amplifiers giving a suitable bias between the heater and cathode of V1 and V3, which overcomes the phenomenon causing the deterioration described.

CONCLUSIONS

The Birmingham-Manchester-Holme Moss television-cable system has been provided as part of the B.B.C. network of point-to-point links. While it provides a very high standard of transmission, this is barely adequate to meet the overall standard agreed for a 4-link 500-mile circuit, bearing in mind the diverse natures of the various links and the impracticability of interconnecting them at other than video frequencies.

Much of the equalisation, however, has been carried out as a result of tests on part of the system only, and it was originally intended to replace the delay equalisers and mop-up attenuation equalisers when the overall performance was known. Development of time equalisers, suitable for direct correction of a received waveform, has now provided a tool which may make very accurate compensation of the steady-state characteristics unnecessary, but a certain amount of experimental work in this connection remains to be carried out.

The link was made available to the B.B.C. for experimental transmissions in September, 1951, and since the official opening of the Holme Moss transmitter on the 12th October in the same year, the system has been in daily service.

ACKNOWLEDGMENTS

The development and provision of the television link described in the paper has required a great deal of organisation and team work. It has been the privilege and pleasure of the authors to present this account of the work of many of their Post Office colleagues, particularly in the Main Lines and Research Branches of the Engineer-in-Chief's Office.

References.

- ¹² Duerdoth, W. T. "The Design of Amplifiers for the Birmingham-Manchester Coaxial Cable," *Proc.I.E.E.*, Vol. 99, Part IIIA, No. 18, 1952, p. 385.
- ¹³ Roche, A. H., and Weaver, L. E. "Television Frequency-translating Terminal Equipment for the Birmingham-Holme Moss Coaxial Cable," *ibid.*, p. 475.
- ¹⁴ Linke, J. M. "A Variable Time-Equaliser for Video-frequency Waveform Correction," *ibid.*, p. 427.
- ¹⁵ Macdiarmid, I. F. "A Testing Pulse for Television Links," *ibid.*, p. 436.

The Impact of Recent Signalling Developments on Out-of-Area Exchange Service

R. F. HOWARD, B.Sc.(Eng.), A.M.I.E.E.†

U.D.C. 621.395.63

It is Post Office policy to make available a service whereby a telephone subscriber's line may be terminated on an exchange situated at a distance of up to a maximum of about 100 miles from his normal exchange area. Hitherto, such out-of-area service has been provided by using equipment designed to meet the particular conditions encountered. In this article, the author explains briefly how the new Signalling System D.C.2 has now been applied to the out-of-area exchange problem, enabling standard circuit arrangements to be used for automatic exchange subscribers requiring this service.

INTRODUCTION

NORMALLY a subscriber's telephone line is directly connected to a local exchange, and communication with subscribers on other exchanges must be effected by use of the junction and trunk network which connects the exchanges together. The size of the exchange areas and hence the maximum length of a subscriber's line is determined on an economic basis, and is influenced by the costs of external line plant, switching equipment and accommodation, in relation to rental and call charges. It has been shown that generally the number of calls made by subscribers decreases rapidly as the distance to the objective subscriber increases. (The number of calls made is approximately inversely proportional to the square of the distance.) The present subscriber's line resistance limits give a minimum overall cost for the telephone service in so far as present techniques and telephone call distributions are concerned. The normal subscriber's line signalling equipment is therefore just good enough to meet these resistance limits and conditions, with a reasonable margin of safety.

Occasionally, however, a subscriber has an abnormal community of interest, telephonically, with a particular distant exchange area and requires a direct exchange line to that place. Although the special technical arrangements necessary to meet the signalling and transmission requirements lead to a very high rental charge for the service, it is, nevertheless, attractive to the subscriber. In these cases, if a reasonably satisfactory solution to the technical problems can be found, it is the policy of the British Post Office to provide the service.

Before the second World War the demand for this type of circuit was insufficient to justify the development of standard equipment and each case was specially treated according to the circumstances prevailing. Quite naturally, this led to the use of a number of different circuit arrangements, some of which used various items of standard equipment associated together, and some of which employed specially constructed equipment. The arrangements made may, however, be divided into two main classes.

(1) *Service on manual exchanges.*—Here it was usual to make arrangements for some form of C.B. signalling between the subscriber and the exchange, and to use the normal ringing current for calling the subscriber.

(2) *Service on automatic exchanges.*—Here it was usual to arrange for the subscriber to make all his outgoing calls via the auto-manual board, but to permit him to be rung from the final selector multiple.

Most of the line lengths were such that signal repetition was necessary at some point in the circuit, and of course the circuits were nearly all routed in amplified cables.

THE SIGNALLING AND PULSING PROBLEM

The factors which affect the solution of the problem of providing this class of service are discussed in the following paragraphs.

† Executive Engineer, Telephone Development and Maintenance Branch, E.-in-C.'s Office.

Signalling.

At the out-of-area exchange some form of line signalling equipment must be provided which is sensitive enough to operate over very long circuits. The arrangements made for C.B. signalling at manual exchanges are normally sufficiently sensitive to meet the requirements of out-of-area exchange lines connected to manual exchanges, but at automatic exchanges, where loop signalling is normally employed, the subscriber's line circuit is not sensitive enough. Whilst it might be possible to design suitable calling equipment working on a loop signalling basis, the requirements of the selectors in the exchange impose a limit on the maximum line resistance which can be permitted. This limit is not large enough to meet the requirements of many of the out-of-area exchange lines, and, moreover, the use of this method would gravely increase the risk of uniselector chase. (Uniselector chase occurs when a low insulation fault, e.g. high resistance earth on one wire, operates the subscriber's line circuit calling relay, which switches the line to the first selector, but there is insufficient current to operate fully the selector line relay over one of its windings. The connection drops back to the calling equipment the uniselector steps to the next free selector and the cycle of operations is repeated.)

The possibility of uniselector chase occurring could be avoided by introducing into the connection some special form of loop-disconnect pulsing relay set on the lines of an auto-auto relay set, but the maximum line resistance permissible with this arrangement would still not be great enough to meet the requirements of many of the out-of-area exchange lines.

The signal repeating equipment which has been used in the past is unsatisfactory on long underground circuits. This is because the high capacitance of such circuits is sufficient to cause the ringing trip relay in the final selector circuit, or in an automatic-ringing plug-ended junction circuit at a manual exchange, to operate to the first pulse of the interrupted ringing current (17 c/s) and thereby cause a premature cessation of the ringing signal, with the attendant possibility that the subscriber would not be aware that he had been called.

On four-wire amplified cable circuits, the application of a low-frequency A.C. signal to a long line can give rise to considerable noise interference in other circuits. On two-wire circuits, large transformers must be fitted in order that the low frequencies shall not be unduly attenuated, or otherwise special by-passing arrangements must be made. It is therefore advisable to use some form of signalling which does not require low-frequency A.C.

Pulsing.

Where service to automatic exchanges is concerned the pulse distortion introduced by a long out-of-area exchange line must be no greater than that which could be introduced by any ordinary subscriber's line connected to the objective exchange. If this were not so then it would be necessary to restrict the dialling range of the subscriber, which, naturally, would be very undesirable. The use of a loop/

disconnect pulsing relay-set as mentioned above would introduce extra pulse distortion and would therefore be an unacceptable solution to the problem.

Method of Providing the Service.

In these days of increasing automatization of the telephone service, requests for out-of-area exchange service on manual exchanges arise much less frequently than do those for service on automatic exchanges. Consequently, the solution of the problem as far as automatic exchanges are concerned is of far greater importance. It is perhaps fortunate that the advent of Signalling System D.C. No. 2¹ (previously known as Single Commutation D.C. Signalling) has made it possible to provide the service economically on automatic exchanges. It is not considered economical, however, to provide the new equipment for service on manual exchanges, since existing techniques will usually meet the requirements of the few demands that arise.

Signalling System D.C. No. 2 is eminently suitable since:—

(1) The subscriber's line circuit at the objective exchange is not directly connected to the long line and there is therefore no possibility of unselector chase.

(2) The system uses no low frequency A.C. signals on the long line, and the circuit is balanced with respect to earth. These factors naturally avoid the possibility of causing noise interference on other circuits.

(3) The line capacitance cannot affect the ringing trip circuit of the final selector.

(4) The system introduces negligible pulse distortion on lines not exceeding approximately 100 miles of 20-lb. cable. It is rare that a request is received for an out-of-area line on a circuit exceeding this length and the system will therefore meet the great majority of cases.

Signals.

Fig. 1 shows, in circuit elements, the signals which are used in this application of Signalling System D.C. No. 2. Two polarised relays of improved design² (relays A and D in Fig. 1) perform the basic signalling functions. The windings of relay A are connected in series-aiding and those of relay D are connected differentially. Arrows have been inserted in the symbols representing the relays, to indicate

¹ "The Single Commutation Direct Current Signalling and Impulsing System." S. Welch and B. R. Horsfield, *P.O.E.E.J.*, Vol. 44, p. 18.
² "A Polarised Relay of Improved Performance." H. A. Turner and B. Scott, *P.O.E.E.J.*, Vol. 43, p. 85.

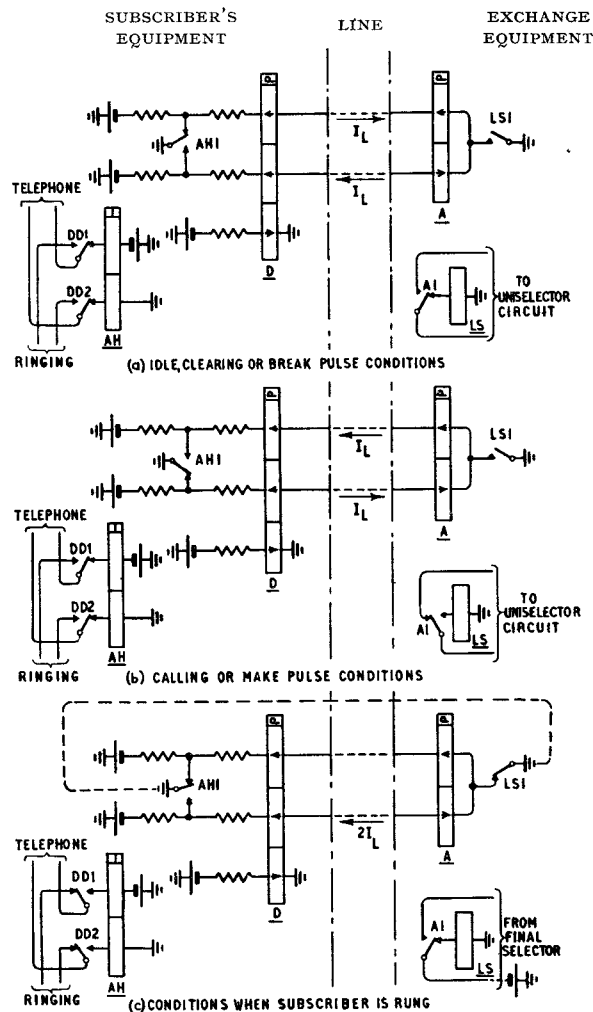

FIG. 1.—SIMPLIFIED CIRCUITS SHOWING SIGNALLING CONDITIONS.

that when a current (flowing from the positive plate to the negative plate) flows in the same direction as the arrows the relay contact moves from "break" to "make" and conversely for a current in the reverse direction.

Thus relay A operates to a given loop current (I_L) or double this current in one winding only, provided, of course,

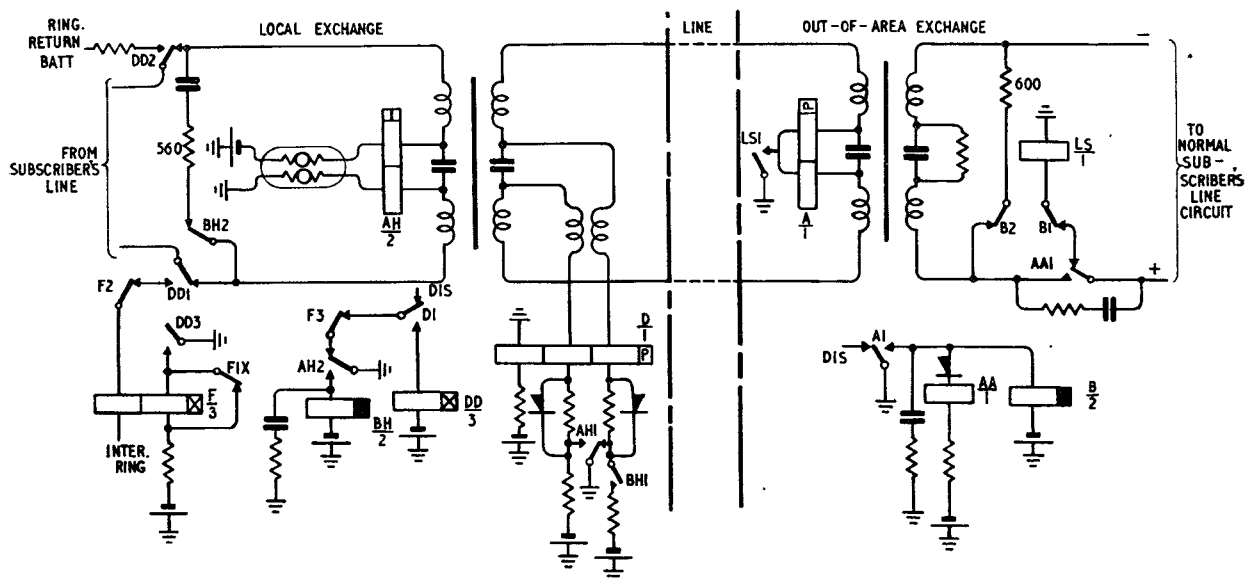

FIG. 2.—BASIC CIRCUIT ARRANGEMENT OF RELAY SETS AT LOCAL AND OUT-OF-AREA EXCHANGE.

that the direction of current flow is as shown for the windings involved. Currents in the opposite direction maintain the relay in the unoperated condition. Relay D operates to a given current ($2I_L$) flowing in either wire of the circuit, current flow being in the correct direction. The third or bias winding on relay D serves to maintain the relay in the unoperated condition when loop currents (I_L) flow in the line windings and produce neutralising fluxes. Fig. 1 indicates in a simplified form, the conditions existing in the main signalling stages. Pulsing from the subscriber's dial causes the conditions to alternate between those shown in Figs. 1(a) and 1(b).

Full Circuit Arrangements.

For satisfactory operation the long line will be provided with amplifiers to meet transmission requirements, and the complete metallic path necessary for the passage of D.C. signals will be provided by the phantom of the amplified circuit. Fig. 2 shows the basic components of the two small relay sets which are used. One of these is fitted at an exchange close to the subscriber's premises (usually his local exchange) and the other at the exchange to which connection is desired.

Outgoing Call.—When the subscriber makes a call the standard two-contact high-speed relay AH operates to the telephone loop and at contact AH1 reverses the line current to operate relay A, and hence relays AA and B, at the out-of-area exchange. At the same time relays BH and B disconnect the terminating impedances at local and out-of-area exchanges, respectively. Contact B1 prevents relay LS from operating, to avoid the possibility of false ringing signals being sent. Contact AA1 completes the loop to the normal line equipment and a free first selector is connected in the usual way.

When the subscriber dials, relays AH, A and AA repeat the pulses and the first selector steps as for a normal call. The remaining trains of pulses are repeated in the same way until the call is established. No called-subscriber-answer

signal is repeated over the long line as metering is, of course, effected at the out-of-area exchange.

At the conclusion of the call relays AH, A, AA, BH and B release, thereby restoring the circuit to normal and preparing it for further use.

Incoming Call.—When a call is made to the subscriber, the ringing return battery from the final selector, connected to the positive wire of the subscriber's line circuit operates relay LS. Contact LS1 connects earth to the centre point of relay A, and the earth current flowing in one wire of the long line operates relay D but not relay A, as explained above. Contact D1 operates relay DD which at DD1 and DD2 connects normal ringing signals (17 c/s) to the subscriber's line.

A standard F relay element is used to trip the ringing signal and release relay DD when the called subscriber answers. Contacts DD1 and DD2 reconnect the subscriber's telephone to relay AH, which operates. The sequence of operations described above for an outgoing call is then repeated, except that instead of operating to a loop current in both windings, the polarised relay A operates to earth current flowing in one winding only (this earth current is double the normal loop current). Contact AA1 closes the loop to the final selector, to trip the ringing signal in the usual way. Relay LS releases and loop current conditions are re-established in the long line. Release is effected in a manner similar to that indicated for an outgoing call.

CONCLUSION

The equipment described in this article is simple and comparatively inexpensive. By its use the necessity for an operator to control the outgoing calls of the subscriber is removed, and thereby a considerable saving of operating charges effected. The equipment is now in use on a number of circuits in different parts of the United Kingdom and is giving satisfactory service.

Book Review

"Information Theory and its Engineering Applications."
D. A. Bell, M.A., B.Sc.(Oxon.), M.I.E.E. Pitman. 136 pp.
30 ill. 20s.

Information theory is still comparatively young, but it has already a considerable body of literature to its credit. Most of this is unfortunately still in the form of learned papers and is not easily accessible to the general reader. Mr. Bell's book, which offers an introductory review in a single manageable volume, is therefore very welcome.

Despite the second half of the title, the book is concerned mainly with fundamentals, and only one short chapter is devoted to practical applications, with examples from the fields of telegraphy, telephony, radar and television. The mathematics has been kept within the scope of the average professional engineer, and the text is both readable and informative. This is partly due to the liberal use of "common-sense" arguments and analogies, but the fare is considerably more solid than that provided by the popular technical press.

The author starts by discussing the definition of information, and the possibility of measuring it. Proceeding from discrete information, which can be dealt with by enumeration of choices, to continuous variables, he introduces the entropy of statistical mechanics as a measure of disorder and the idea of information as its complement or negentropy. Maxwell's demon and his brothers from the underworld appear in an appendix, but are stripped of their supposed power to contravene the basic laws of thermodynamics by Brillouin's demonstration that information cannot be abstracted from a system without causing a finite increase in its entropy.

Consideration of the capacity of a communication channel leads up to the Hartley and Shannon theories relating speed of transmission, bandwidth and signal/noise ratio. The problem of coding the signal to achieve maximum speed over a given channel or minimum frequency of errors is then dealt with, and the apparently paradoxical statement that the best coding for a noisy channel should make the signal as like the noise as possible is explained. After the chapter on practical applications there follows a discussion of the problem of separating signal and noise by linear or non-linear filtering and the design of the optimum filter for given conditions.

I.P.O.E.E. Library No. 2147

E. W. A.

SHORTER NOTICES

"Wireless World Diary, 1954." Iliffe & Sons, Ltd. Leather, 5s. 10d. Rexine, 4s. 1d.

The diary, in its 36th year of publication, includes 80 pages of reference material giving useful formulæ, design data, valve base connections, directory of radio organisations, etc., etc.

"Definitions and Formulæ: Telegraphy and Telephony." E. Mallett, D.Sc., M.I.E.E., M.Inst.C.E., F.Inst.P. (rev. by W. T. Palmer, B.Sc.(Eng.), Wh.Ex., M.I.E.E., A.M.I.Mech.E.). Sir Isaac Pitman & Sons, Ltd. 41 pp. 1s. 6d.

A pocket book 5 in. × 4 in. for students of telegraphy and telephony, including more than 200 definitions and all the formulæ most frequently applied.

"Telecommunications Statistics." A. Hazelwood. Reprinted from Journal of Royal Statistical Society. 12 pp. 2s.

A review of the statistical information on telecommunications as issued by the British Post Office.

A New Uni-Diameter Joint

G. F. ARNOLD, A.M.I.E.E. and
S. W. JENNINGS, A.M.I.E.E. †

U.D.C. 621.315.687.1

This article describes a method of constructing uni-diameter joints which has been developed mainly for in-situ use and results in considerable saving in repair costs.

Introduction.

THE recovery and replacement of cable lengths owing to wet joints and damage other than by corrosion is costly compared with in-situ repairs, especially if the recovered cable is scrapped because of difficulty and damage in withdrawing it. In-situ repair of damage has been customary, but using normal joints has necessitated a box or coupling to accommodate the joint, or if the track is restored by split ducts the joint forms an obstruction to further cabling operations. If a uni-diameter joint (or joints) can be made within the length, the duct can be restored and the duct space maintained as before. Similarly, when water has penetrated from a wet joint to beyond the duct mouth, much saving can result by uni-diameter jointing a few yards of new cable in place of the wet end, rather than renewing the whole cable length, unless only a small cable or a short section is concerned.

Cable splicing has been practised for many years, both by manufacturers for resheathed lengths and by P.O. Regional Depots¹ for making better use of short lengths. In general, however, the existing method of jointing the sheath by lead burning² is not suitable for in-situ repairs as the cable needs turning over to weld the underside. It also requires special equipment and much practice.

For use in field conditions a sleeve-to-sheath seal has been developed which is mechanically strong and can be made by any plumber-jointer with the minimum of special tools. The sleeve is butt-jointed to the sheath by solder and plumber's metal, and reinforced internally by a tinned copper strip surrounding the core inside each butt joint.

The jointing of the conductors in general follows existing uni-diameter jointing practice, the joints being spaced regularly along a sufficient length to avoid increase of core diameter, but some changes have been made to reduce the length of the complete cable joint by about one-third. Over 100 cable joints have so far been made in field and workshop by the new method, and have proved completely reliable.

Jointing Length and Air-space Considerations.

For any given type of cable the minimum length of joint will depend upon the number of conductors that can be jointed at any one point, and will in turn depend upon the amount of air-space available. Modern trunk-type cable is manufactured to a specification which ensures that approximately 40 per cent. of the volume of the cable is air. Local and older-type cables have relatively more air-space and therefore any joint design suitable for trunk-type cables will present no difficulties when applied to the other types.

Experiments have shown that by using undersize paper sleeves fitting tightly over the conductor joints the air-space can be used to best advantage if approximately 4 per cent. of the conductors in any size of cable are jointed at any one point. The present design uses a jointing length equal to 24 wire joints and it is estimated that these occupy about 30 per cent. of the air-space. In view of the probable inaccessibility of uni-diameter joints, the need for complete electrical reliability dictated from the commencement of experiments the necessity for soldering all wire twists,

irrespective of the type of cable. With satisfactory conductivity thus guaranteed, there appeared to be no need to retain the standard length of twist, and a shorter twist, 1 in. long, including one and a half turns of paper at the shoulder, was adopted. The sleeve overlap required to ensure satisfactory insulation was considered to be $\frac{1}{4}$ in. at the soldered end of the twist and $\frac{1}{8}$ in. at the base, but to allow for discrepancies in the actual jointing a sleeve length of $1\frac{1}{2}$ in. is used. The overall jointing length is therefore 36 in., plus 2 in. at each end to allow for tying the layers, insertion of the copper strip, etc., thus giving a total joint length, butt to butt, of 40 in. This length has been found adequate for most types of cable when every conductor is jointed, but can be reduced in special cases, e.g., for coaxial cables, or where only a small number of conductors in a damaged cable have to be pieced out.

Preparing the Lead Sleeve.

As in the established methods of uni-diameter jointing, a piece of sheath from the actual cable to be jointed is used to make the sleeve. This is either expanded by forcing mandrels through it to enable it to slide over the cable, or split longitudinally, using a hacksaw, knife or "cheese-cutter," if the joint has to be seamed.

Mandrels constructed from Maranti, an African hardwood, have been found very durable, and if shaped as shown in Fig. 1 are easier to drive than the older tapered type. The

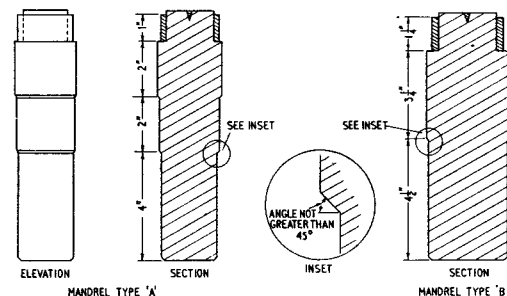

FIG. 1.—SHAPE OF THE MANDRELS.

long parallel lead keeps the mandrel central within the sleeve and helps to ensure even expansion. Russian tallow is used as a lubricant. A set of 13 such mandrels, the smaller ones having two equal steps, and the larger ones one step, dimensioned as shown in Table 1, has been found suitable for most cable sizes in common use. Driving rods, made up of three screwed sections with interchangeable heads, are included with each set of mandrels.

During expansion, Fig. 2, it is important that the sleeve be held clear of the ground, and supported above and below the position of the mandrel. Serious weakening of the sleeve can result if it is inverted and the driving rods "jumped" on the ground. It is not considered worthwhile to expand sheaths of less than $\frac{3}{4}$ in. internal diameter as these tend to buckle during driving; it is better to use a piece of "thin lead" sheath removed from a slightly larger cable. This may also be done for cables greater than $\frac{3}{4}$ in. internal diameter, but it is seldom that the correct size piece of sheath is available, and, also, if normal thickness sheath is used it has the disadvantage that a stiffer joint is produced due to thickening of the sleeve during swaging.

† The authors are, respectively, Executive Engineer and Assistant Engineer, Home Counties Region.

¹ P.O.E.E.J., Vol. 38, p. 22.

² P.O.E.E.J., Vol. 28, p. 37.

TABLE 1
Dimensions of Set of 13 Mandrels

No.	Leading dia. (in.)	Final dia. (in.)	Total increase (in.)	TYPE
1	$\frac{3}{4}$	1	$\frac{1}{4}$	A (Steps to be equal as far as practicable)
2	1	$1\frac{1}{4}$	$\frac{1}{4}$	
3	$1\frac{1}{4}$	$1\frac{7}{16}$	$\frac{3}{16}$	
4	$1\frac{7}{16}$	$1\frac{5}{8}$	$\frac{3}{16}$	
5	$1\frac{5}{8}$	$1\frac{13}{16}$	$\frac{3}{16}$	
6	$1\frac{13}{16}$	2	$\frac{3}{16}$	
7	2	$2\frac{3}{16}$	$\frac{3}{16}$	
8	$2\frac{3}{16}$	$2\frac{3}{8}$	$\frac{3}{16}$	
9	$2\frac{3}{8}$	$2\frac{1}{2}$	$\frac{1}{8}$	
10	$2\frac{1}{2}$	$2\frac{5}{8}$	$\frac{1}{8}$	
11	$2\frac{5}{8}$	$2\frac{3}{4}$	$\frac{1}{8}$	
12	$2\frac{3}{4}$	$2\frac{7}{8}$	$\frac{1}{8}$	
13	$2\frac{7}{8}$	3	$\frac{1}{8}$	

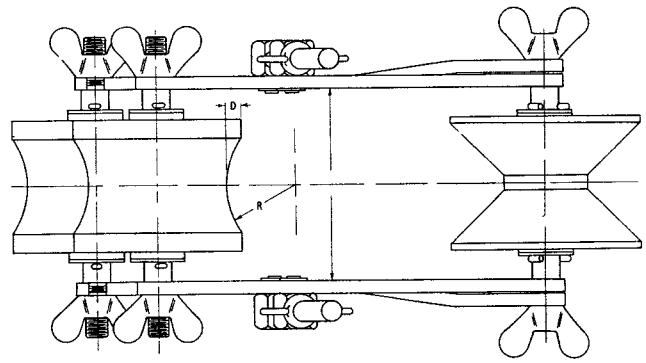

R	$\frac{5}{8}$ "	$\frac{3}{4}$ "	1"	$1\frac{1}{4}$ "	$1\frac{1}{2}$ "	$1\frac{3}{4}$ "
D	$\frac{5}{16}$ "	$\frac{3}{8}$ "	$\frac{15}{32}$ "	$\frac{3}{8}$ "	$\frac{9}{32}$ "	$\frac{7}{32}$ "

FIG. 3.—THE ROLLER SWAGE.

bending tests have shown the complete cable joint to be amply strong. The weakest point is in the cable sheath just beyond the end of the copper tape, where repeated bending will cause the sheath to "concertina" and finally crack, the seal itself remaining intact. A serrated edge to the copper strip, in the shape of a sine wave, would taper the otherwise abrupt change of section and strength at the edge of the copper, but its advantage is not worth the added complexity.

If a split sleeve is used the whole core is wrapped with copper strip and the seam soldered and flush-wiped in the same way as for the end seals. Such uni-diameter joints lack flexibility, however, and are intended only for in-situ repairs where the seamless sleeve cannot be used.

Construction of the Joint.

(a) *The Seamless Type.* The sleeve for this is prepared as already described from a piece of sheath 4 ft. long, the extra length allowing for the considerable contraction that occurs during expansion.

After checking the colour rotation of the cable and selecting the two ends that will ensure a "straight" joint, the prepared sleeve is pushed over the more convenient end until it takes up such a position that it will not impede jointing. Sufficient sheath to give the required jointing allowance is removed from the cable ends and these are rigidly set up so that the butts are $38\frac{1}{2}$ in. apart. Layers are tied for identification purposes and jointing is commenced using the most convenient order for the conditions under which the joint is being made. All cotton whippings are removed as jointing proceeds, except those on the marker and reference quads which are tied near to the butts; all quad twists are taken out. Paper sleeves one size smaller than specified for the conductors being jointed, e.g., 10-lb. sleeves for 20-lb. conductors, are used, cut to just $1\frac{1}{2}$ in. long. The first joint is made as near to one of the butts as possible and successive wire twists are positioned so that their paper sleeves lie in a continuous line right along the joint, without gaps or overlaps. Care is necessary to ensure that no "pips" or droppings of solder are left in the joint during construction.

When jointing is completed a further $\frac{3}{4}$ in. of lead is removed from each butt, the cut around the cable being made as shallow as possible so that the sheath is belled out as the lead is removed, thus facilitating insertion of the copper strip; the exposed maker's paper is not disturbed. After drying out, the whole joint is wrapped very tightly with an unbroken layer of 2-in. wide insulation paper, using a 1-in. lap. This paper extends over the full length of the joint and overlaps, in the same lay, the maker's paper at each end, a light tie holding the finishing end.

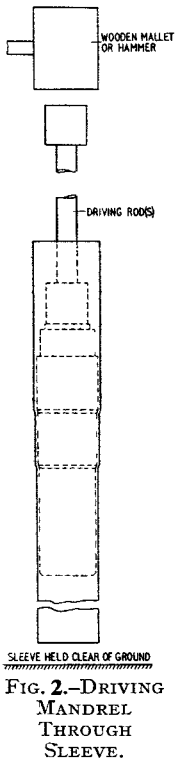

FIG. 2.—DRIVING MANDREL THROUGH SLEEVE.

Reducing the Sleeve to Cable Diameter.

Up to now repair depots have used heavy friction-type swages for reducing the expanded sleeve to its original diameter, but these are not suitable for field use in a confined space as the length of their arms prevents them being rotated round the cable. A roller swage, shown in Fig. 3, overcomes this difficulty and reduces the sleeve to cable diameter by squeezing it between part-circular section rollers. The angle between these and the centre line of the cable has been made slightly less than 90° , thereby providing a small pressure to keep the guide roller in contact with the cable. The rollers are machined, using a form tool, from light alloy castings, and have phosphor-bronze bearings running on $\frac{1}{2}$ -in. diameter mild steel spindles. The working pressure between the constricting rollers is adjusted by wing nuts and care needs to be taken to increase the pressure only gradually. It has been found that six pairs of rollers, with radii of curvature and depth of groove as shown in Fig. 3, are needed for swageing cables between $\frac{1}{2}$ in. and 3 in. diameter,

The Soldered Seal.

The essential feature of the seal is the use of a tinned copper strip to protect the core from hot solder and blow-lamp flame, and to reinforce internally the butt joint. Swageing the joint before sealing ensures that the cable sheath and sleeve fit tightly over the copper strip and stearine flux, and, when the joint is heated and solder applied to the gap, capillary action carries the solder well into the tinned-copper/lead interface on the inside of the seal. A flush wipe of plumber's metal completes the seal, and hence its full strength is given by the soldered butt joint, plus the tensile strength of the copper strip.

This form of seal permits the cable to be drummed and drawn in and out as necessary. Tensile and repetition

Copper strips, $1\frac{1}{2}$ in. wide and 0.005 in. thick, are cut so that they will just go $1\frac{1}{4}$ times round the core and, after rounding the corners with scissors, glass paper is used to remove the burrs and clean the copper before it is tinned on one side. A layer of stearine flux is applied to the tinned surface of the strips before they are inserted, tinned side outermost, between the maker's paper and the cable sheath at each end of the joint. The belling effect previously referred to facilitates this operation, although, if necessary, the cable sheath can be expanded slightly using a small sleeve opener made for the purpose. The copper is positioned so that it will under-lap equally the cable sheath and the sleeve, and, after roughly dressing the expanded sheath back into position, it is retained by means of a light solder tack.

Before drawing the sleeve over the joint a reference mark is made on the cable sheath at a definite distance, say 6 in., from the butt remote from the end of the joint at which the sleeve is first to be compressed. The sleeve is positioned to within $\frac{1}{8}$ in. of the cable sheath at one end and compressed for about 6 in. from this end using the roller swage, until it is the same diameter as the cable; to prevent movement during this operation the far end of the sleeve is lightly tacked to the cable sheath. The seal is then completed as already described.

The tack at the far end is removed and the remainder of the sleeve compressed as before to within about 3 in. of the far butt. It is trimmed, using the reference mark, so that there is a second $\frac{1}{8}$ in. gap, and swaged until it is the same diameter throughout. A second solder seal, flush-wiped, completes the joint except for a pressure test which is applied via the cable sheath near to the joint, or from a nearby standard joint. Fig. 4 shows the sequence of operations.

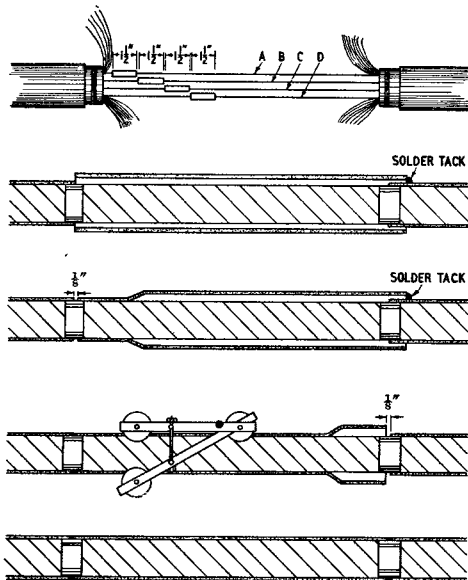

FIG. 4.—STAGES IN CONSTRUCTION OF UNI-DIAMETER JOINT.

(b) *The Seamed Type.* Conductor jointing proceeds as before, but in addition to the copper strips used in the butts an untinned copper strip, 1 in. wide and 0.005 in. thick, is bound tightly, with $\frac{1}{2}$ in. overlap, over the final paper wrapping and lightly tacked in position with solder. The split sleeve, cut to leave $\frac{1}{8}$ in. gap at the ends and along the longitudinal seam, is dressed into position, initially by hand, but it can be finished with the roller swage if available. The longitudinal seam is well fluxed with stearine and the sealing of this and the butt ends is completed using solder and plumber's metal as before. It is important that the gaps should not be much less than $\frac{1}{8}$ in., otherwise penetration of the solder between the sleeve, sheath and copper strip is not fully effective.

Field Use.

The method described has been used so far mainly for trunk and junction cables, where there has been the greatest scope for saving and where the conductor joints have in any case to be soldered. In the latter circumstances it has been found that the time taken need not exceed that for normal jointing by more than about 10 per cent. There is thus little effect on the time out of service, and none if interruption cable is used, although the use of interruption cable should be avoided whenever possible. For local cable repairs with normally unsoldered conductors and shorter section lengths, further investigation and experience is needed before the conditions can be specified for the economic use of uni-diameter jointing in situ. The following comments, therefore, refer essentially to main and junction cables.

For damage, other than by corrosion, within a length a uni-diameter repair and restoration of the track with split ducts is normally preferable to building a box to accommodate a standard joint. Where water penetration is more extensive it may be better to renew the wet section and construct two uni-diameter joints, rather than replace the entire length. If interruption cable has to be used, the provision of a short piece between the breakdown points instead of interrupting the entire length would be much less costly.

For water penetration from, say, a wet joint, to beyond the duct mouth, the track would normally be broken into and a short piece of new cable inserted between the breakdown point and the existing joint to replace the wet section. Construction of a uni-diameter joint at the former, a conventional joint at the latter and restoration of the track by split ducts would complete the repair. Again, if interruption cable is necessary it should preferably be over the short section rather than the whole cable length.

If the track is more than about 3-way or 4-way, or expensive paving is involved, or the presence of P.O. or other plant would impede operations, it is probably best to use one of the following methods, though they almost inevitably involve the provision of interruption cable over the whole length.

- (i) After sealing and fitting a grip to the good end of the cable (in readiness for later use), the length is partially withdrawn towards the wet end and the latter cut off. A short piece of new cable is jointed by uni-diameter methods to replace the wet cable, the joint being made either in the manhole or above ground, and the cable and joint drawn into the duct. A disadvantage of this method is the lack of facilities for proving the conductors before the joint is drawn into the duct, and the following alternative may be preferable.
- (ii) After carefully wrapping the wet end to prevent further penetration of water a short piece of new cable is uni-diameter jointed to the good end. If required the cable can perhaps be drawn slightly towards the good end to provide jointing slack, but enough cable should be left protruding from the duct at the wet end to permit tapping out. After jointing and proving, the length is drawn towards the wet end and the latter cut off as soon as dry cable is reached. This method requires the presence of enough protruding cable in each manhole or jointbox to provide slack for jointing, pulling, and proving the joint. Also, it is essential to complete the work quickly before dampness spreads too far from the wet end.

Acknowledgments.

Much experimental work has been involved and the authors wish to acknowledge the valuable suggestions and enthusiastic co-operation from many colleagues in the Home Counties Region.

A New Method of Direct Underground Distribution

J. G. DONOVAN, A.M.I.E.E.,
and J. S. LANFEAR †

U.D.C. 621.315.236.96

The authors explain the conditions which have led to the need for a new system of providing direct underground distribution, and give details of a method in which plastic-covered cables are buried directly in the ground.

INTRODUCTION

AMONG the many factors which have led to the developments described in this article, the most important have been the large number of waiting subscribers, coupled with the increasing costs of underground line plant and restriction on expenditure for local line construction; the rising objection to poles by local authorities and builders, especially in modern architect-designed estates; and the production of a new type of cable designed for burying directly in the ground.

The only form of distribution which will fully meet the wishes of local authorities to avoid poles is direct underground distribution. The conventional method of drawing lead-covered cable into duct is normally very expensive, but the availability of a polythene-insulated and sheathed cable has opened new possibilities, as it can be safely buried directly in the ground at shallow depths. This type of cable is extremely flexible so that if sufficient slack is left at jointing points it can be jointed above the ground level, the joint and slack cable then being housed in a very small box. This, in turn, has made possible the use of a pre-cast concrete joint box constructed, quite cheaply, in one piece.

Owing to the difficulty of providing additional cables subsequently in the route, ample provision of polythene cables is necessary at the outset.

POLYTHENE IN CABLE MANUFACTURE

The principal physical, chemical and electrical properties of polythene were described in an earlier article in this Journal.¹

Polythene can be used in cable manufacture to reinforce and protect the conventional lead sheath from electrical and mechanical damage; to replace lead entirely; or to replace paper as an insulating material.

Polythene as a Cable Sheath.

The advantages of polythene compared with lead as a sheathing material are:—

- (a) The cable core is effectively insulated from earth.
- (b) Corrosion is avoided.
- (c) The cable is considerably cleaner to handle.
- (d) Owing to its smooth waxy finish the cable is considerably easier to draw into ducts and the recovery of cables from ducts is greatly simplified; this will lead to more economic use of duct space.

The disadvantages of polythene as a cable sheath are:—

- (a) In some situations, especially where petrol, ammonia or detergents are present, it is liable to crack if the sheath is heavily stressed, e.g. at sharp bends. The earlier methods of extruding polythene tended to leave the material stressed in places, but this has now largely been overcome by the inclusion of poly-isobutylene.
- (b) The low melting-point of polythene necessitates the use of special sealing techniques at joints.
- (c) There is an increased fire risk, as polythene is combustible.

A small amount of carbon black is added to polythene

† The authors are, respectively, Executive Engineer and Assistant Engineer, External Plant and Protection Branch, E.-in-C.'s Office.

¹ P.O.E.E.J., Vol. 37, p. 40.

used for cable sheaths to prevent the deterioration which would otherwise occur on exposure to ultra-violet light.

Cable sheaths of thin lead surrounded by polythene have been found to have certain advantages over sheaths of lead wrapped in paper and hessian tapes, but these types of sheath are outside the scope of this article.

Polythene as a Conductor Insulant.

As a conductor insulant the advantage of polythene is that the cable core does not require to be kept perfectly dry, with the result that polythene can be used as the sheath without the addition of a water barrier. The cable mentioned in the opening paragraph, which has now been adopted as a standard, takes this form of construction. Each wire is covered with polythene by an extrusion process and the wires are formed into a cable-core having the conventional twin formation; the core is then lapped with aluminium tapes and sheathed with polythene, again by extrusion.

The aluminium tapes have little value as an electrical screen, and are not made continuous at joints, but have a small advantage in making manufacture easier and also facilitate testing the sheath after manufacture.

The disadvantages of polythene as an insulant, compared with paper, are that polythene-insulated cables are more costly in the large sizes, and more bulky. A 30-pair all-polythene cable costs 20 per cent. more than a similar-sized paper-core lead-sheathed cable and has an overall diameter of 0.74 in. compared with 0.63 in. Nevertheless, in use, the cable can be considerably more economical than the older types, as will be shown later. The additional bulk of polythene cable is of no importance when the cables are buried directly in the ground, but it may be a disadvantage when cables are drawn into ducts.

The cable is at present available in a range of sizes up to 30 pairs. Later, a 50-pair cable will be introduced.

For two reasons, polythene-sheathed paper-insulated cable has not been used for cables laid directly in the ground. Firstly, moisture which passes through the sheath is absorbed and carried away by the paper, so that penetration through the sheath continues, and in from three to six years, depending on the size of the cable, the insulation resistance between conductors will fall below the required minimum. Hence, periodic desiccation would be necessary.

Secondly, in the event of the sheath being damaged, moisture entering the cable would pass fairly quickly along the paper core. By the time the fault had been localised it would usually be necessary to excavate at least several yards of cable on each side of the fault; this would be an expensive operation. With all-polythene cable this difficulty does not occur, as the moisture does not travel appreciably along the core.

JOINTING ALL-POLYTHENE CABLE

The three methods of sealing joints on all-polythene cable which have been examined are: taping, methods using heat, and mechanical joint construction.

The taping method is practicable only for straight-through joints on single cables. Furthermore, the special tape required is expensive and this method is therefore only used for sealing joints on 1-pair cables. A lead sleeve

is first placed over the joint to form a bedding for the tape.

In early experiments directed to finding a method employing heat, both welding and a form of plumbing were tried. Although joints could be sealed by these methods it became evident that to use heat in the field would not be practicable as the amount of heat that could be applied to the sheath of the cable without melting the insulation around the conductor was small and required a degree of control that could not be exercised by jointers working in varying outside conditions.

It is known that the joining of plastics by means of injection moulding is possible but, although the temperature can be controlled within fine limits if the injected material is heated electrically, the equipment required is considerable. A large range of moulds to cover the possible combinations of cables entering a joint would be needed, and a supply of power would be required at each jointing point. A further disadvantage of any method employing heat is that when it becomes necessary to open the joint the added material at the junction of the cable and the sleeve would have to be cut away and, on remaking, a larger sleeve would probably be required since it would be difficult to open the joint without damaging the cable sheath.

Mechanically Sealed Joints.

When the above difficulties were realised, efforts were directed towards finding a mechanical joint which would be:—

- (a) cheap, and easy to install,
- (b) capable of being opened and closed repeatedly,
- (c) able to accommodate any practical combination of the cable sizes available,
- (d) suitable for fitting on a "through" cable without interrupting service on working pairs,
- (e) of a small bulk, and
- (f) suitable for joining polythene cables to lead-covered cables.

Requirements (c) and (d) preclude the use of the simplest form of mechanical joint consisting of a plastic sleeve compressed by jubilee-type clips on to a single cable on each side of the joint.

The present design consists of a rubber plug clamped between a pair of metal plates which can be drawn together by bolts. The cables pass through holes in this assembly which can be sealed into a cylindrical sleeve by tightening the bolts. The detailed drawing of the joint in Fig. 1 shows how the rubber plug and brass plates are cut to allow the plug to be assembled on a cable loop. Using a range of six-plugs, any combination of cables from 0.25 in. to 0.92 in. diameter can be sealed into a sleeve without the use of heat

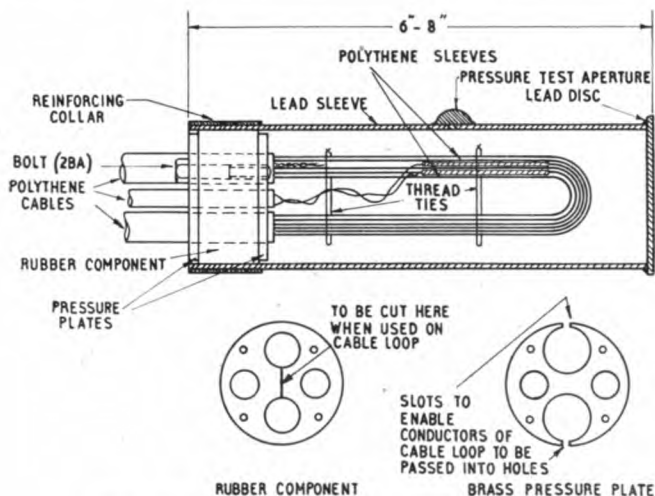

FIG. 1.—DETAILS OF POLYTHENE CABLE JOINT.

or any special skill. Each type of plug can accept two or more cables, spare "ways" being plugged with short ebonite rods.

Single- or double-ended joints can be made, the choice depending on the size and number of cables to be jointed. When jointing lead-sheathed cable to polythene cable the former can be taken through the plug or, if more convenient, the polythene cable can be sealed into one end of a lead sleeve using a plug, the other end of the sleeve being dressed down and plumbed on to the lead cable in the normal way.

When polythene cable is laid, a small amount of slack is left at any point where a joint may later be required to take out a spur cable. Figs. 2 to 6 show the operations of making a joint on a loop of cable. It will be noted that interference to working circuits is completely avoided since it is not necessary to cut the cable to pass it through the holes of the plug. Fig. 2 shows the loop of cable over which has been

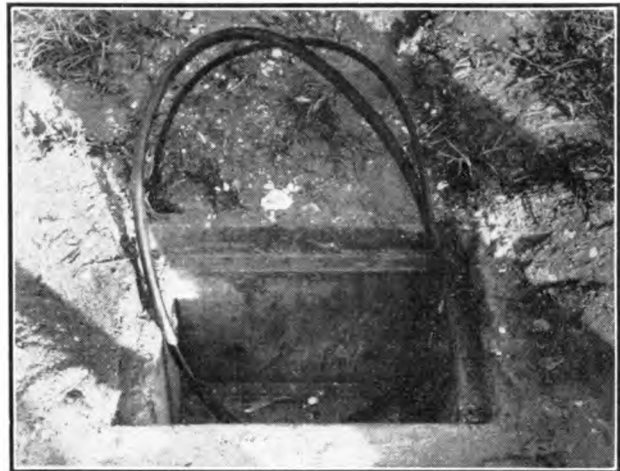

FIG. 2.—JOINT BOX FITTED OVER CABLE LOOP.

placed a pre-cast concrete joint-box with the 1-pair spur cable entering the side of the box. In Fig. 3 some of the cable sheath has been removed, one brass plate has been placed over the cable and the rubber plug, which has been cut between the two holes designed to take the main cable, is being slipped over the cable core. The method of placing the brass plates in position can be seen from Fig. 4. With

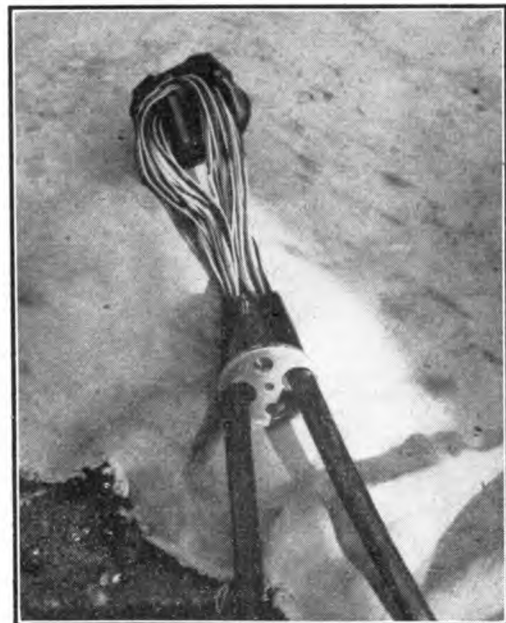

FIG. 3.—FITTING RUBBER PLUG.

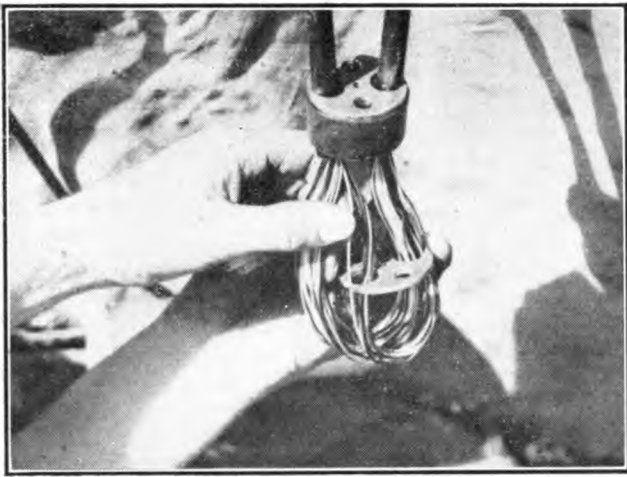

FIG. 4.—FITTING BRASS PLATE.

the plug in position, the pair of wires for the new subscriber is cut and jointed to the 1-pair spur cable, the spare hole is plugged with an ebonite rod and the joint is ready for sealing in the sleeve. After fitting the sleeve and tightening the bolts the joint is pressure tested, and lowered into the joint-box, as shown in Fig. 5.

Experiments are continuing with a view to the use of a plastic sleeve instead of the lead sleeve. The use of a plastic sleeve will not permit a pressure-test of the joint to be done in the conventional manner, but this difficulty can be overcome by making one of the bolts hollow and fitting it with a small nozzle through which air can be pumped.

Jointing of Conductors.

The jointers employed on the various trial schemes experienced no difficulty in stripping the insulation and jointing the wires either to other plastic-insulated wires or to normal paper-insulated conductors. To insulate the wire joints, polythene sleeves are used except when jointing to paper-covered wires, when the cheaper paper sleeve is suitable.

LAYING POLYTHENE CABLE

Methods and Depth of Laying.

The following depths have been found to be sufficient for all-polythene cable buried directly in the ground in public thoroughfares: carriageway, 24 in.; carriageway paving crossing footway, 12 in.; footway, 9 in. The depth of laying in subscribers' front gardens is discussed later.

The method of laying will depend on the availability of machines and of digging labour, the soil conditions, the type of reinstatement, the time factor and the proximity of other undertakers' plant. Four methods are normally available as follows:—

Moledraining.—During the trials of polythene cable laying, moledraining was often found to be unsuitable owing to piles of sand, building materials, etc., impeding progress, which was also held up by large roots of trees and by hard rubbish buried under the footway. Moledraining was found to be economically justified only when lengths of 50 yds. could be laid without serious hold-up. Many modern housing estates are, for aesthetic reasons, laid out using curved roads, and although wide sweeps may look attractive they do not lend themselves readily to hawser-drawn mole-drainers.

The very small area of surface disturbed by mole draining makes the method attractive in grass verges, however, when conditions are suitable.

Trenching.—Several methods of excavating the 9-in.

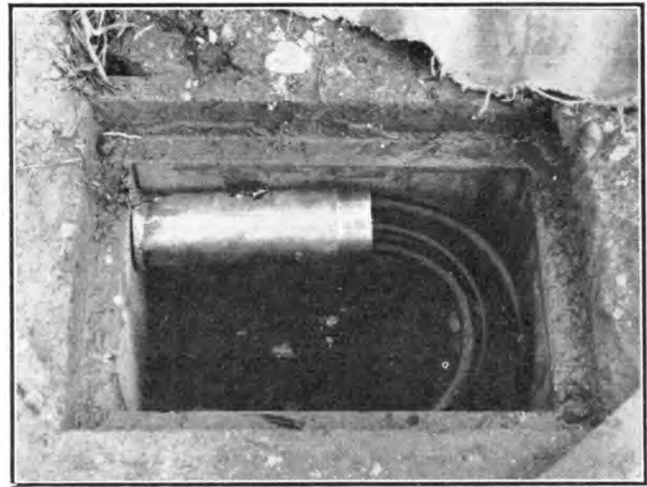

FIG. 5.—SEALED JOINT PLACED IN JOINT-BOX.

trench have been used. Thus, mechanical trenchers are found to be economically suitable when,

- (1) lengths of 100 yds. can be dug fairly continuously;
- (2) the trench is to be excavated under inexpensive surfaces;
- (3) the subsoil is reasonably free from large tree roots and boulders;
- (4) the width of the carriageway or footway is sufficient to allow efficient working.

On some polythene cable-laying trials, bucket excavators have been used, while in other cases tractor-driven rotary hoes were borrowed from farmers, who use excavators of this type for burying small land drains.

Hand-trenching was found to be a speedy method, since a shallow trench allows the work to be done while standing on the surface. Picks and rabbiting spades were used in heavy ground, while in lighter soil draining tools were more popular.

In soil containing a high proportion of sharp flints, a layer of soil free from stones is placed beneath and above the cable as a protective measure.

Cable drawn into Ducts.—When drawing polythene cable into ducts, normal cabling methods were adopted, but no petroleum jelly or other lubricant was used. A 2-in. asbestos-cement duct, laid at 9-in. depth, is sufficient for containing distribution cables up to 50 pairs.

Thrust-boring.—This method can be used either for laying ducts or for drawing the polythene cable direct into the ground. The size of the excavation needed at the "sending" end for housing the machine is often a disadvantage on housing estates.

Jointing Points.

In areas of dense telephone penetration a joint-box to contain the joint outside a subscriber's house is not usually justified; instead, ample cable-pair provision will be made so that access to the joint is not likely to be required, except for maintenance purposes. Joints buried directly in the ground can be protected with a short length of mesh or with halves of grooved ducts, i.e. earthenware ducts manufactured with two longitudinal grooves to facilitate splitting.

On completion of laying, the ends of the polythene cable are sealed, either by melting scrap polythene sheath over the cable-end or by wrapping it with tape.

Teeing for shared service can be carried out either in the pillar, to which polythene schemes are cabled, or in the new 2-pair terminal-block which has been developed for terminating one 2-pair and two 1-pair polythene cables on semi-detached houses.

Joint-boxes.

The cost of a one-piece pre-cast concrete joint-box is considerably less than the cost of a box of the same size built *in situ*, but handling and transport difficulties preclude the use of such boxes in the normal sizes. As explained earlier, the joint-boxes required for housing joints on all-polythene cables can be of smaller size than boxes to contain joints on lead-covered cables, and a pre-cast concrete box, available in two sizes, has been introduced as a part of the scheme for laying polythene cables direct in the ground. Details of sizes, etc., of the boxes are given in Table 1.

TABLE 1
Joint-boxes for use with Polythene Cables

Joint-box No.	Int. dimens. (in.)	Weight (lb.)		Maximum size of joint accommodated
		Box	Lid	
21	12 × 8 × 9	90	20	15 pair
22	22 × 12 × 9	160	55	50 pair

Fig. 6 shows a JF21 joint-box. In some conditions it will be economically desirable to defer installing the box until some time after the cable is laid and, therefore, to allow

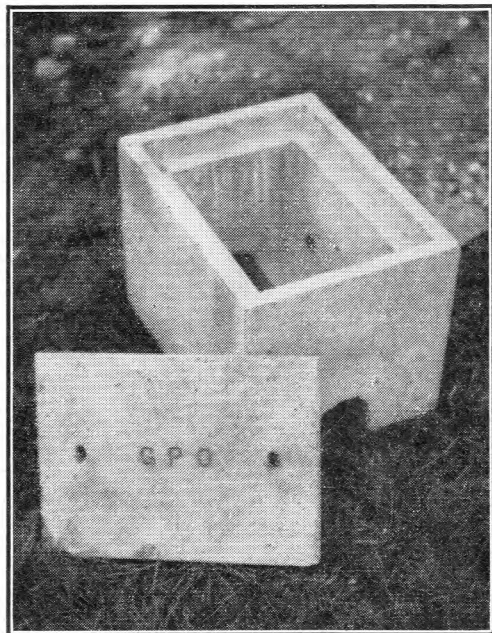

FIG. 6.—JF21 JOINT-BOX.

the box to be fitted over an existing cable without cutting the cable, a slot is provided along the base of the box. The conventional cast-iron frame and cover is not required as the joint-box is provided with a concrete lid.

Leads-in to Subscriber's Premises.

A short length of small W.I. duct, laid from the cable position to a point just inside the subscriber's curtilage, will sometimes be justified, especially when this will avoid the need for subsequently disturbing an expensive paving.

It has been found advisable normally to lay the cable within the subscriber's curtilage at a depth of 18 in., but if a protecting mesh 3 in. wide consisting of 8-ft. lengths of

expanded-metal mesh or heavy wire netting of close mesh is laid above the polythene cable for additional mechanical protection a depth of 9 in. is usually sufficient.

MISCELLANEOUS USES OF ALL-POLYTHENE CABLE

The preceding paragraphs have described the application of polythene cable to direct underground distribution. In addition to this, the cable has been found to have advantages over the normal cable in other circumstances, e.g. for:—

(a) *Outside Broadcasts.*—The cable has been proved very suitable for underground cabling for outside broadcasts, both in radio and television programmes.

(b) *Temporary Cables.*—The flexibility and toughness of the cable allow it to be recovered fit for re-issue after short-term use, e.g. on agricultural show grounds and for temporary repairs following storm damage to open-wire routes.

(c) *Protection from Power Circuits and Lightning.*—When used for underground power crossings the cable avoids the need for duct. It has also been used for cabling in and near high-voltage power stations in place of the previously used cable having rubber insulation over the normal lead sheath.

Polythene cable has been found especially useful in areas where heavy lightning is experienced; in these localities lead-covered cable is liable to damage by lightning surges.

(d) *Resistance to Fatigue.*—The fatigue resistance of polythene is considerably greater than that of lead or lead alloys. This should make all-polythene cable very useful where a small number of pairs are required in conditions of vibration.

(e) *Short Sub-aqueous Crossings.*—Polythene cable has been used with success in providing telephone service to small islands. An example of this type of work has been described in an earlier issue of this Journal.²

(f) *Contaminated Soil.*—On some industrial and experimental sites the ground may be severely contaminated with chemicals which prevent the use of lead-covered cables. On one site where a fairly strong concentration of nitric acid was present, polythene cable was used and is working satisfactorily.

CONCLUSIONS

Until more data are available it is not possible to give a true overall cost comparison between conventional underground distribution (i.e. lead-covered paper-core cables drawn into ducts, using joint-boxes built *in situ*) and polythene cables buried directly in the ground, using small pre-cast concrete joint-boxes.

The saving in the stores and laying costs of ducts and in the cost of joint-boxes is sufficient, however, to make polythene cable distribution economical under most conditions met in residential areas where duct has not previously been laid, e.g. in new housing estates.

Furthermore, there is little doubt that, because polythene cabling usually avoids the use of poles, more co-operation can be expected from local authorities and builders in such matters as providing lead-in ducts through the walls of houses, and in the negotiation of wayleaves.

ACKNOWLEDGMENT

The developments described above have been the result of co-operation with the Local Lines Branch and the authors wish to thank their colleagues in that Branch, and also in the External Plant and Protection Branch, for their help.

² *P.O.E.E.J.*, Vol. 43, p. 161.

The Rationalised M.K.S. System of Electrical Units

R. J. HALSEY, B.Sc., A.C.G.I., D.I.C., M.I.E.E. †

U.D.C. 621.3.081:537.71

In this brief account of the rationalised M.K.S. system of electrical units the author explains how these units are derived, the manner in which they differ from C.G.S. units, and the advantages to be obtained from their use. He points out that following international agreement and in accord with the views of the British Standards Institution and the Institution of Electrical Engineers, the use of the rationalised M.K.S. system of units is to be vigorously encouraged in the Post Office.

List of Principal Symbols

L	Dimension of length.
M	Dimension of mass.
T	Dimension of time.
μ	Dimension of permeability; absolute permeability ($=\mu_r \mu_0$).
ϵ	Absolute permittivity ($=\epsilon_r \epsilon_0$).
μ_0	Permeability of free space.
ϵ_0	Permittivity of free space.
m	Magnetic charge (pole strength).
Q	Dimension of electric charge; electric charge.
d	Separation of charges.
Φ	Total magnetic flux.
B	Magnetic flux density.
H	Magnetic field strength.
Ψ	Total electric flux.
D	Electric flux density.
\mathcal{E}	Electric field strength.

INTRODUCTION

IT is now some 18 years since the International Electro-technical Commission (I.E.C.) made its first recommendation advocating the adoption of the M.K.S. system of electrical units, but it is only in the last few years that the system has started to come into use in Great Britain. In March, 1950, the Institution of Electrical Engineers held a symposium on the subject¹ and the response in favour of the adoption of a rationalised form of the M.K.S. system was almost unanimous. Following the decision by the I.E.C. in July, 1950, to adopt such a system, the B.S.I. and I.E.E., supported by the Post Office among other bodies, decided to encourage its use. In April, 1953, the Post Office reaffirmed and strengthened its policy in this direction and, while the use of the rationalised M.K.S. system is still not mandatory, every effort should now be made to employ it in preference to the C.G.S. electromagnetic systems which it supersedes. In Great Britain, none of the major bodies concerned requires its exclusive use but most of them now prefer and encourage its use; British Universities are also showing this preference in their teaching although the C.G.S. system is still usually being taught as an alternative. In America, adoption of the system is more complete and as early as 1948 the I.R.E. stated that it would henceforth use only rationalised M.K.S. units. The "Proceedings of the I.R.E." for July, 1948, carries a guest editorial by S. A. Schelkunoff, a distinguished worker in the field of electromagnetism, welcoming that "the end is in sight for the age of diverse scientific units—of C.G.S. electromagnetic units, of mixed electrostatic and electromagnetic units, of rationalised and unrationalised varieties of each."

It is the object of the present article to explain the back-

† Staff Engineer, Post Office Research Station.

¹ "Symposium of Papers on the M.K.S. System of Units" (4 papers) *Proc. I.E.E.* 97, Part 1, p. 235. These papers and other publications have been used freely in writing the present article.

² See, for example, "The Fourteen Systems of Units" by Varner (textbook).

§ Two points should be noted here:—

- the apparent incongruity of a "unit" of μ which, unlike the units of L , M and T , is not unity; the term "measure number" has been suggested as an alternative.
- no change in the conception or dimensions of μ is implied.

ground and advantages of the rationalised M.K.S. system and to stimulate interest in its use; it is not concerned with systems of units in general.² Electrical engineers will usually be familiar with three C.G.S. systems, the absolute and practical electromagnetic systems and the absolute electrostatic system as well as the role of the free-space propagation velocity, c , in linking the two absolute systems; present considerations are concerned with electromagnetic systems only. The objectives of the new system are:—

- to adopt new units of length and mass so that all the inconvenient powers of 10 which relate absolute and practical units in the C.G.S. electromagnetic system shall disappear; the units adopted are the metre and kilogram instead of the centimetre and gram.
- to eliminate the irrational quantity 4π from certain equations where it is most inconvenient; it must be clear right from the start that the 4π cannot be made to disappear completely; it can only be relegated to less important positions in the system.

These objectives are completely independent and the rationalised M.K.S. system which is, of course, electromagnetic, achieves both of them. It is both absolute and practical, the usual practical units being retained without change.

BASIS OF THE M.K.S. SYSTEM

The practical electromagnetic units are based on the units of current (ampere) and voltage (volt) which were originally defined more or less arbitrarily in terms of the absolute C.G.S. electromagnetic system. While giving units of a reasonable size for electrical science as then established, the conversion factors involved powers of 10 which are very inconvenient in practice. The dimensions of current and voltage, and the conversion factors in C.G.S. e.m. units are:—

$$\begin{aligned} \text{Current} &= M^{\frac{1}{2}}L^{\frac{1}{2}}T^{-1}\mu^{-\frac{1}{2}}; & 1 \text{ amp.} &= 10^{-1} \text{ C.G.S. e.m.u.} \\ \text{Voltage} &= M^{\frac{1}{2}}L^{\frac{3}{2}}T^{-2}\mu^{\frac{1}{2}}; & 1 \text{ volt} &= 10^8 \text{ C.G.S. e.m.u.} \end{aligned}$$

It follows that:—

$$\begin{aligned} \text{Power} &= ML^2T^{-3}; & 1 \text{ watt} &= 10^7 \text{ C.G.S. e.m.u.} \\ \text{Resistance} &= LT^{-1}\mu; & 1 \text{ ohm} &= 10^9 \text{ C.G.S. e.m.u.} \end{aligned}$$

It is clearly possible to determine new primary units for the quantities M , L , T and μ such that the conversion factors will be unity; the units will then be both absolute and practical. Calling the ratio between the new units and the C.G.S. e.m. units U_M , U_L , U_T and U_μ respectively, this requirement will be satisfied if:—

$$\left. \begin{aligned} U_M \cdot U_L^2 \cdot U_T^{-3} &= 10^7 \\ U_L \cdot U_T^{-1} \cdot U_\mu &= 10^9 \end{aligned} \right\}$$

Obviously there is an infinity of solutions and this is still true if we leave the unit of time unchanged when

$$\left. \begin{aligned} U_M \cdot U_L^2 &= 10^7 \\ U_L \cdot U_\mu &= 10^9 \end{aligned} \right\}$$

Two specific proposals have been made, the first and most important by Professor Giorgi in 1901. He proposed the M.K.S. system with the metre and kilogram as the units of length and mass respectively, thus satisfying the power equation and requiring that μ_0 , the permeability of free space, shall be 10^{-7} (henries/metre) instead of unity (gauss/oersted) as in the C.G.S. system. § There is no particular merit in the choice of permeability as the fourth dimension necessary to define the electrical quantities; Giorgi himself

is said to have favoured the use of resistance with the ohm as the unit, and any other of the electrical quantities could be used equally well. A second system of units meeting the above requirements has been used in Germany; it is the Mie or centimetre-gram⁷-second system.

In 1935, the I.E.C. passed a resolution "That the system with four fundamental units proposed by Professor Giorgi be adopted subject to a fourth fundamental unit being eventually selected"; this amounted to international acceptance of the system.

The reservation in respect of the fourth unit arose from the fact that the internationally agreed values of the various practical units involved small mutual discrepancies. Thus, the international absolute e.m. unit of current was defined as that which will deposit silver at the rate of 0.011180g./sec., while the ohm was defined as the resistance of a column of mercury of uniform cross-section having a length of 106.300 cm. and a mass of 14.4521g. at 0°C. The fourth units mainly favoured were the coulomb and the ohm and it became usual to refer to, say, the M.K.S.-Coulomb system.

A further point left undecided in 1935 was whether rationalised or unrationalised units should be adopted; the latter had first been suggested by Heaviside in connection with the elimination of the irrational 4π from certain commonly used equations. The 4π arises in the closed surface integrals of the normal component of vectors, i.e., as a solid angle; if the radial vector is unity the flux through a sphere is 4π ; if the flux is unity, the vector must be $1/4\pi$. In other words, the 4π must enter into some formulae but we have some choice in deciding which. Further discussion of rationalisation will be left until later since the arguments are in no sense dependent on the basic system of units adopted.

While the M.K.S. system is primarily designed to simplify electrical units it is to be noted that an M.K.S. mechanical system of units is complete in itself and involves a new unit of force (newton), being that required to accelerate 1 kg. at 1 metre/sec.² (= 0.225 lb.). The corresponding unit of work (newton-metre) is, of course, identical with the joule and the unit of power (newton-metre/sec.) is the watt. The fundamental standards used are the same as in the C.G.S. system, viz., the Sèvres metre and kilogram and the mean solar second; hence, no discrepancies between the two systems are possible. It is to be noted that the density of water becomes 1000 kg./m.³ although its specific gravity remains at unity.

While there is no doubt that the electrical system of units is greatly improved by the change, the basic M.K.S. units are sometimes less convenient than C.G.S. units on account of the physical dimensions involved; for example, the unit of magnetic flux density (weber/m.²) may be inconvenient for use in the design of transformers. In such circumstances it may be more convenient to use decimal derivations of the unit of length and it is quite permissible, in the M.K.S. system, to express magnetic flux density in webers/cm.² in the same way that capacitance is commonly expressed in microfarads or picofarads rather than in farads.* The enormous magnitude of the coulomb as an electrostatic charge is demonstrated by the fact that the force between two such charges, separated by one metre, is 9×10^9 newtons or about 900,000 tons!

* It may sometimes even be convenient to use double decimal derivations such as microwebers/cm.².

† The units are, however, unrationalised.

‡ The use of other electrical quantities has certain attractions but, as they are defined in terms of the conditions of experiment, i.e. "in vacuo", μ_0 is more basic.

§ To maintain uniformity between the magnetic and electric aspects the term magnetic charge is used instead of the more usual "pole strength". The conception of isolated magnetic charges or poles is, of course, quite fictitious.

In photometry, the unit of illumination (lux) is already defined in terms of the metre (lumens/m.²) so that it fits naturally into the M.K.S. system†; the definition of the unit of luminosity (candela) is readily adjusted without change of the unit itself.

In 1948, one of the points left outstanding by the I.E.C. in 1935 was resolved completely by a decision by the International Committee of Weights and Measures to adopt the values of the absolute electrical units as international standards. This means that no discrepancies now exist between the various practical units and it is immaterial which one is chosen as a standard in the M.K.S. system. From a technological point of view it is convenient to base the system on the permeability of free space, μ_0 ,‡ which will have a value of 10^{-7} henries/m. in the unrationalised system. From the relationship $\mu_0\epsilon_0 = 1/c^2$, where c is the free-space propagation velocity (= 2.998×10^8 m./sec.), it follows that $\epsilon_0 = 1.113 \times 10^{-10}$ farads/m. in the unrationalised system.

RATIONALISATION

Roget's "Dictionary of Electrical Terms" defines rationalisation of units as "the alteration of the unrationalised systems of electrical and magnetic units so that unit magnetic pole and unit charge respectively should emit unit magnetic and electric flux instead of 4π units."

The problem arises because, unfortunately as it happens, the classical approach to magnetism and electrostatics has been via systems having spherical symmetry. So-called rationalised systems follow naturally from the geometry of a uniform rectilinear field such as exists between two infinite charged planes; so-called unrationalised systems derive from the geometry of a uniformly divergent field such as surrounds a point charge. Irrespective of geometry we have:—

<i>Magnetic</i>	<i>Electric</i>
$H = \text{Force/unit charge} \S = \frac{F}{m}$	$\mathcal{E} = \text{Force/unit charge} = \frac{F}{Q}$
$B = \text{Flux/unit area} = \frac{\Phi}{A}$	$D = \text{Flux/unit area} = \frac{\Psi}{A}$
$B = \mu H$	$D = \epsilon \mathcal{E}$
Eliminating B and H , D and \mathcal{E} ,	
$F = \frac{m\Phi}{\mu A}$	$F = \frac{Q\Psi}{\epsilon A}$

The classical force equations are derived on the basis that unit flux density is that which exists, in vacuo, on the surface of a sphere of unit radius, having unit charge at the centre, whence,

$$\Phi = 4\pi m; \quad \Psi = 4\pi Q.$$

For any isotropic medium the force between two charges at distance d is then

$$F = \frac{m_1 m_2}{\mu d^2}; \quad F = \frac{Q_1 Q_2}{\epsilon d^2}.$$

If, however, we consider parallel planes it is logical to define unit flux density as that produced by unit charge density, when,

$$\frac{\Phi}{A} = m; \quad \frac{\Psi}{A} = Q;$$

or $\Phi = m$; or $\Psi = Q$.

If we derive the force equations on this basis we get the rationalised forms

$$F = \frac{m_1 m_2}{4\pi \mu d^2}; \quad F = \frac{Q_1 Q_2}{4\pi \epsilon d^2}.$$

To effect rationalisation it is necessary to modify the size of one or more units in each force equation and there is clearly an infinite variety of ways in which this could be done. However, changes in the units of d and F would have repercussions far beyond the field of electricity so we

are left with the possibility of changing the units of m and/or μ on the one hand and Q and/or ϵ on the other, always retaining $\mu_0\epsilon_0 = 1/c^2$. Heaviside's original proposals assumed the same values for μ and ϵ in rationalised and unrationalised systems, and so the value of the unit charge, both electric and magnetic, had to be reduced by a factor $(4\pi)^{\frac{1}{2}}$ compared with unrationalised units; such a change in the unit of electric charge required a change in the unit of current which is now extremely undesirable.

In the M.K.S. system, the unit of electric charge remains unchanged, rationalisation being effected by changes in the values assigned to the permeability and permittivity of free space; we substitute $\mu_0/4\pi$ for μ_0 and $4\pi\epsilon_0$ for ϵ_0 in the unrationalised forms, giving rationalised values of $4\pi \times 10^{-7}$ henries/m. and 8.854×10^{-12} farads/m. respectively. The value of the unit of m is consequently decreased by a factor 4π and it follows that the units of H and m.m.f. are increased by the same factor, thus becoming the ampere*/m. and ampere* respectively. Since the work done in moving a unit magnetic charge round unit current (1 ampere) now becomes one joule instead of 4π joules as in the unrationalised system, the unit charge is identical with the volt-sec.; it receives the name weber. The units in most common use—voltage, current, resistance, capacitance and inductance are entirely unaffected.

The arguments for rationalisation were originally based on the presence of the irrational 4π in certain equations where geometry suggests this to be illogical and its absence from certain other equations where, on similar grounds, 4π (or 2π) could logically be expected to appear. Examples of this are:—

- (a) The capacitance of a parallel-plate capacitor of area A is

$$\frac{\epsilon A}{4\pi d}; \text{ in rationalised units, } \frac{\epsilon A}{d}.$$

The capacitance of a cylindrical-plate capacitor, length l , diameters a and b , which should logically involve 2π , is

$$\frac{\epsilon l}{2 \log_e(b/a)}; \text{ in rationalised units, } \frac{2\pi \epsilon l}{\log_e(b/a)}.$$

- (b) The energy per unit volume stored in a magnetic or electric field is

$$\frac{B^2}{8\pi\mu} = \frac{BH}{8\pi}; \text{ in rationalised units, } \frac{B^2}{2\mu} = \frac{BH}{2};$$

$$\frac{D^2}{8\pi\epsilon} = \frac{D}{8\pi}; \text{ in rationalised units, } \frac{D^2}{2\epsilon} = \frac{D\mathcal{E}}{2}.$$

(the rationalised forms $\frac{BH}{2}$ and $\frac{D\mathcal{E}}{2}$ are exactly comparable to the expression for the energy stored in an elastic medium).

- (c) The electric field strength near a surface is $\frac{4\pi}{\epsilon} \times$ surface density of charge (Coulomb's theorem); in rationalised units $\frac{1}{\epsilon} \times$ surface density of charge, whence total flux = total charge.

- (d) The mean energy of a plane wave per unit cube is

$$\frac{\mathcal{E}H(\mu\epsilon)^{\frac{1}{2}}}{8\pi} = \frac{DB}{8\pi(\mu\epsilon)^{\frac{1}{2}}};$$

$$\text{in rationalised units, } \frac{\mathcal{E}H(\mu\epsilon)^{\frac{1}{2}}}{2} = \frac{DB}{2(\mu\epsilon)^{\frac{1}{2}}}$$

and Poynting's vector, the rate of energy flow

* Total amps. i.e., amp.-turns where appropriate.

† Originally proposed by G. A. Campbell.

‡ If we put $c = 3 \times 10^8$ m./sec., this is $\frac{1}{36\pi} \times 10^{-9}$ farads/m., which is more easily memorised.

per unit area, is $\frac{\mathcal{E}H}{4\pi}$; in rationalised units, $\mathcal{E}H$.

- (e) Maxwell's equations in unrationalised units

$$\left\{ \begin{array}{l} \text{curl } \mathcal{E} = -\frac{\partial B}{\partial t} \\ \text{curl } H = 4\pi i + \frac{\partial D}{\partial t} \\ \text{div } D = 4\pi\rho \\ \text{div } B = 0 \end{array} \right\} \text{ become } \left\{ \begin{array}{l} \text{curl } \mathcal{E} = -\frac{\partial B}{\partial t} \\ \text{curl } H = i + \frac{\partial D}{\partial t} \\ \text{div } D = \rho \\ \text{div } B = 0 \end{array} \right\}$$

when rationalised (ρ = volume density of electric charge).

Convincing as these arguments may be, it is the author's opinion that they would not, as they stand, have justified abandoning the long-familiar unrationalised system. To most students of electrical science, the changes would bring little simplification of formulae and would hardly justify the upheaval of thought involved; the fact that m.m.f. = amp.-turns in the rationalised system is perhaps the most helpful feature to the ordinary worker.

The really cogent argument for the introduction of a rationalised system arises from the exploitation of the impedance concept† in wave propagation, primarily by Schelkunoff. In this conception, which has been widely used in recent years, wave propagation has been brought into line with electric circuitry by regarding the electric field strength $\mathcal{E} = \frac{\partial(\text{e.m.f.})}{\partial l}$ and the magnetic field strength

$$H = \frac{\partial(\text{m.m.f.})}{\partial l}$$

respectively. The ratio \mathcal{E}/H therefore has the dimensions and usage of an impedance and is known as the field impedance; it is logical therefore that the unit shall be the ohm; indeed, unless this is so, considerable confusion will arise. In an unrationalised M.K.S. system, \mathcal{E} will be expressed in volts/m. while H will be $4\pi \times$ amps./m. In consequence, the unit of field impedance is

$$\frac{\text{unit of } \mathcal{E}}{\text{unit of } H} = \frac{1 \text{ volt/m.}}{\frac{1}{4\pi} \text{ amp./m.}} = 4\pi \text{ ohm.}$$

In the rationalised system, however, we have the looked-for result that the unit of field impedance is

$$\frac{\text{unit of } \mathcal{E}}{\text{unit of } H} = \frac{1 \text{ volt/m.}}{1 \text{ amp./m.}} = 1 \text{ ohm.}$$

We have already seen that, in the rationalised system, the product $\mathcal{E}H$ is the power flow per unit area in watts (volt-amps. in a dissipative medium); the equivalence between wave propagation and line transmission is therefore complete. The intrinsic field resistance of free space (i.e., its

"characteristic resistance") is $\sqrt{\frac{\mu_0}{\epsilon_0}} = 376.7$ ohms.

In July, 1950, the I.E.C. reaffirmed its 1935 decision to adopt the M.K.S. system and coupled with this a decision to rationalise the units. It was not until June, 1953, however, that it was agreed that the rationalisation should be based on the values of absolute permeability and permittivity in vacuo, viz.,

$$\left. \begin{array}{l} \mu_0 = 4\pi \times 10^{-7} \text{ henries/m.} \approx 1.26 \mu\text{H/m.} \\ \epsilon_0 = \frac{1}{c^2\mu_0} \approx 8.85 \times 10^{-12} \text{ farads/m.} \approx 8.85 \text{ pF/m.} \dagger \end{array} \right\}$$

Table of Rationalised M.K.S. Units.

Table I sets out the names of the various electrical units and their dimensions. It will be noted that when μ is used as the fourth dimension fractional indices occur and it is an advantage of using one of certain other electrical quantities as a fourth dimension, e.g., Q , that such fractional indices do not occur. The last column gives the factor by

which quantities in absolute C.G.S. e.m. units must be multiplied to convert them to rationalised M.K.S. units.

The introduction of values, other than unity, for the permeability and permittivity of free space underlines the essential difference between field strength (H or \mathcal{E}) and flux density (B or D); in the past there has been a tendency in some quarters to regard these quantities as similar in character and to overlook the fact that permeability and permittivity are not dimensionless. In practice it is helpful and certainly usual to write the absolute permeability (or permittivity) of a medium as $\mu_r\mu_0$ (or $\epsilon_r\epsilon_0$); the quantity μ_r (or ϵ_r) is thus dimensionless and is the relative permeability (or permittivity) of the medium; it is numerically equal to what is both the absolute and relative value in the C.G.S. system.

CONCLUSIONS

The decision has been made that use of the rationalised M.K.S. system of electrical units shall be vigorously encouraged in the Post Office; this decision follows agreements made internationally and accords with the views of the B.S.I., I.E.E., the universities and other responsible bodies in this country. In America, the new system is becoming almost exclusively accepted in the sphere of electrical engineering and largely in electrical physics; practically all American textbooks in which communication engineers are interested now use these units.

In this country, change-over will probably be rather slow and must depend largely on teachers. To engineers who are normally concerned only with practical units—and this must embrace the vast majority—no change is involved as these units are unaffected. It is to those working with ferro-magnetic materials that the changes are most significant owing to the new one-to-one ratio between m.m.f. and flux and the new unit of flux; these will require adjustment of thought and data. Those who are in the habit of expressing field strength (i.e., magnetising force) in amp.-turns/cm. rather than in oersteds will need to make least adjustment. More advanced workers, e.g., in the realm of wave propagation, will appreciate the advantages and will therefore be ready to accept the new system. It is hoped that engineers and electrical

physicists operating in fields where the new units give no advantages (possibly even the reverse) will fall into line for the common good. Older workers will probably resent the new system and it is to the younger members of the Post Office and telecommunications industry, therefore, whose habits of thought are not so rigidly formed, that we must look to bring about the change in the technical literature and day-to-day usage of the Department.

It is important that the rationalised M.K.S. system shall not be regarded as "just another system of units"; the ideal is to discard all others. It is hoped that the tendentious word "rationalised" will ultimately disappear and that the controversy which has raged in this connection will be forgotten. The ultimate advantages of employing a single coherent system will be obvious.

TABLE 1
Comparison between C.G.S. and M.K.S. Electrical Units

Quantity	Dimension		Name of Unit			Multiplier. C.G.S. abs. e.m. to M.K.S. rat.
			C.G.S. abs. e.m.	C.G.S. Pract.	M.K.S. Rat.	
Length	L		centimetre		metre	10^{-2}
Mass	M		gram		kilogram	10^{-3}
Time	T		second		second	1
Force	MLT^{-2}		dyne		newton	10^{-5}
Energy	ML^2T^{-2}		erg	joule	joule	10^{-7}
Power	ML^2T^{-3}		erg second	watt	watt	10^{-7}
ELECTRIC						
Charge	$M^{1/2}L^{1/2}\mu^{-1/2}$	Q	abcoulomb	coulomb	coulomb	10
Flux	$M^{1/2}L^{1/2}\mu^{-1/2}$	Q			coulomb	$10/4\pi$
Flux Density	$M^{1/2}L^{-3/2}\mu^{-1/2}$	$L^{-2}Q$			$\frac{\text{coulomb}}{\text{metre}^2}$	$\frac{10^5}{4\pi}$
Current	$M^{1/2}L^{1/2}T^{-1}\mu^{-1/2}$	$T^{-1}Q$	abampere	ampere	ampere	10
E.M.F.	$M^{1/2}L^{3/2}T^{-2}\mu^{1/2}$	$ML^2T^{-2}Q^{-1}$	abvolt	volt	volt.	10^{-8}
Field Strength	$M^{1/2}L^{1/2}T^{-2}\mu^{1/2}$	$MLT^{-2}Q^{-1}$			volt metre	10^{-6}
MAGNETIC						
Charge	$M^{1/2}L^{3/2}T^{-1}\mu^{1/2}$	$ML^2T^{-1}Q^{-1}$			weber	$4\pi \cdot 10^{-8}$
Flux	$M^{1/2}L^{3/2}T^{-1}\mu^{1/2}$	$ML^2T^{-1}Q^{-1}$	maxwell		weber	10^{-8}
Flux Density	$M^{1/2}L^{-1/2}T^{-1}\mu^{1/2}$	$MT^{-1}Q^{-1}$	gauss		$\frac{\text{weber}}{\text{metre}^2}$	10^{-4}
Current	$M^{1/2}L^{3/2}T^{-2}\mu^{1/2}$	$ML^2T^{-2}Q^{-1}$			volt	10^{-8}
M.M.F.	$M^{1/2}L^{1/2}T^{-1}\mu^{-1/2}$	$T^{-1}Q$	gilbert		ampere	$10/4\pi$
Field Strength	$M^{1/2}L^{-1/2}T^{-1}\mu^{-1/2}$	$L^{-1}T^{-1}Q$	oersted		ampere metre	$\frac{10^3}{4\pi}$
Permeability	μ	MLQ^{-2}			henry metre	$4\pi \cdot 10^{-7}$
Permittivity	$L^{-2}T^2\mu^{-1}$	$M^{-1}L^{-3}T^2Q^2$			farad metre	$\frac{10^{11}}{4\pi}$
Capacitance	$L^{-1}T^2\mu^{-1}$	$M^{-1}L^{-2}T^2Q^2$	abfarad	farad	farad	10^9
Inductance	$L\mu$	ML^2Q^{-2}	abhenry	henry	henry	10^{-9}
Resistance	$LT^{-1}\mu$	$ML^2T^{-1}Q^{-2}$	abohm	ohm	ohm	10^{-9}

Book Review

"The M.K.S. System of Units—A Guide for Electrical Engineers." T. McGreevy, M.Sc.Tech., M.I.E.E. Sir Isaac Pitman & Sons, Ltd. 283 pp. 65 ill. 21s.

Two classes of reader have been considered by the author: the practising engineer and the teacher of electrical engineering.

The first five chapters are devoted to the engineer, already familiar with the C.G.S. systems and perhaps not likely to stop using them, who wishes at least to acquire enough knowledge of the M.K.S. system to follow books and papers that use it. It is shown, in more or less the usual way, how the practical units can be made the basis of a unified system, and reasons are given for choosing the M.K.S. system, in its rationalised form, in particular.

Eleven chapters cover very thoroughly the problems of teachers in using the M.K.S. system. Consideration is given to the effect on different types and grades of students, to the mental difficulties of particular ideas, and to the practical difficulties of devising suitable experiments. The author advocates considerable changes in the approach: in particular he recommends abandoning the concept of an "isolated magnetic pole" and stressing the electrical origin of magnetism.

A very practical chapter on dimensions and a summarising chapter complete the text. Appendices contain the tables of formulae, constants, conversion factors, and so on that one would expect and there are also some curves, mostly B/H curves, in M.K.S. units for various metals.

The book is very readable and the numerical examples which occur on nearly every other page, help to drive home the points made.

W. E. T.

Single-Sideband Multi-Channel Operation of Short-Wave Point-to-Point Radio Links

H. E. STURGESS, A.M.I.E.E. and
F. W. NEWSON, A.M.I.E.E.†

Part 4(b).—An Independent-Sideband High-Power Short-Wave Transmitter—Design and Performance

U.D.C. 621.396.41:621.396.61.029.58

This article, the last in the series, gives details of the design and performance of an independent-sideband transmitter (as described in Part 4 (a)), capable of providing a peak power output of up to 70 kW in the frequency range 4-22 Mc/s. Although primarily intended for i.s.b. operation, using the two-channel drive unit described in Part 2 of the series, the transmitter can also be used for double-sideband telephony and C.W. and M.C.W. telegraphy.

DESIGN CONSIDERATIONS

IT will have been appreciated that the type of i.s.b. transmitter described is essentially a means for changing the frequency and power level of the i.s.b. drive unit output of 3.1 Mc/s at 250 mW to that required for radiation from the aerial, in this case 3.85 to 22 Mc/s at a peak envelope power of up to 70 kW. In addition the transmitter must not produce more than a specified amount of non-linear distortion, otherwise appreciable inter-channel cross-talk will occur.

The design of this particular transmitter has also been influenced by the following factors:—

- (a) The desirability of using only those types of valves already in general use in the Department, particularly the large valves.
- (b) The necessity for adhering to the general layout of equipment already adopted for other transmitters at the same radio station.

Influence of Power Output required on Design.

The overall efficiency (ratio of r.f. power output to high-tension and filament heating power input) is least during d.s.b. operation with no modulation applied (i.e., carrier only). The overall efficiency is then only about 20 per cent., the r.f. power output to the aerial being some 15 kW. The total power input to the equipment is about 85 kW of which about 70 kW must be dissipated as heat within the equipment. This power loss is made up mainly by 56 kW loss at the final stage valve anodes and 7 kW for filament heating, with the remainder shared between drive stage valves, load resistors, rectifier losses, blower motors and various control circuit equipment.

The heat loss in the final stage valves is dissipated by circulating sufficient distilled water through the valve water-jackets.

The final power unit and the auxiliary power units for power outputs of the order required in this transmitter occupy a large amount of floor space and it is usual either to assemble the power equipment in a single unit or within two or more small cubicles. The method using two cubicles has been adopted in this case, one of the cubicles being fire-proofed and containing all oil-filled equipment. Extractor fans are also provided to assist in dissipation of the heat generated in the two cubicles.

Influence of Linearity requirements on Design.

A high degree of linearity has been attained in this transmitter by designing amplifier stages and their power supplies to have good voltage regulation, both under slow and transient changes of output load.

The r.f. amplifier linearity is achieved by using push-pull stages employing low-impedance valves operating at a high anode potential and loaded with fixed resistance in addition to the load of the following amplifier. These

requirements necessitate the use of neutralised triodes in all except the early stages where, as no grid current is taken, the following stages constitute a fixed load. Special care must be taken to ensure that the amplifiers are completely stable at all input levels with no tendencies to develop spurious oscillations.

The D.C. power supplies are provided by rectifiers having a good voltage regulation which is improved by a small amount of fixed resistance loading. Satisfactory transient regulation of the smoothed high-tension supply is obtained by the use of inductance-input filters with low-inductance chokes having a low D.C. resistance.

The methods just outlined result in the transmitter having a lower overall efficiency, and in the individual stages having a lower gain than that of similar non-linear amplifiers (e.g., for C.W. emissions). For the transmitter described in this article a good performance can be achieved on i.s.b. emissions with an overall power conversion efficiency of about 30 per cent., whereas a similar non-linear transmitter could have an overall efficiency of about 40 per cent. However, the increased number of stages necessary in an i.s.b. transmitter is to some extent advantageous since the additional tuned circuits required provide further discrimination against unwanted frequencies generated in earlier stages.

The R.F. Circuits. (Fig. 1)

Harmonic generator unit.—The harmonic generator unit must provide a single-frequency feed to the third or final modulator stage (M3) within the range of 4-22 Mc/s when supplied with an input signal in the frequency range of 3.5-7 Mc/s at a level of between about 2.5 and 8.5V across 75 ohms. It is essential that the level of any harmonics or other unwanted frequencies appearing in the harmonic generator (h.g.) output should be very small compared with that of the wanted frequency. This is necessary to minimise the number and level of products produced in the M3 stage. The output stage of the h.g. unit is operated as a class-B amplifier with a very small capacitive coupling to the M3 stage so that the tuned circuit is only very lightly loaded in order to give good rejection of unwanted frequencies.

Third modulator stage.—As stated in Part 4(a), the M3 stage operates in one of three different conditions. When it is operating as a frequency-changer for i.s.b. emissions, special care must be taken to keep the levels of any spurious frequencies generated in the stage to a minimum. This result is achieved by ensuring that:—

- (a) the spurious frequency content of the two input frequencies (i.e., 3.1 Mc/s and the h.g. output) is very low,
- (b) the M3 valve is operating on a suitable portion of its characteristic,
- (c) the level of the h.g. output frequency is always greater than four times that of the 3.1 Mc/s signal when measured at the M3 grid, and

† Until his recent retirement Mr. Sturgess was Senior Executive Engineer, Radio Planning and Provision Branch, E.-in-C.'s Office; Mr. Newson is Executive Engineer in that Branch.

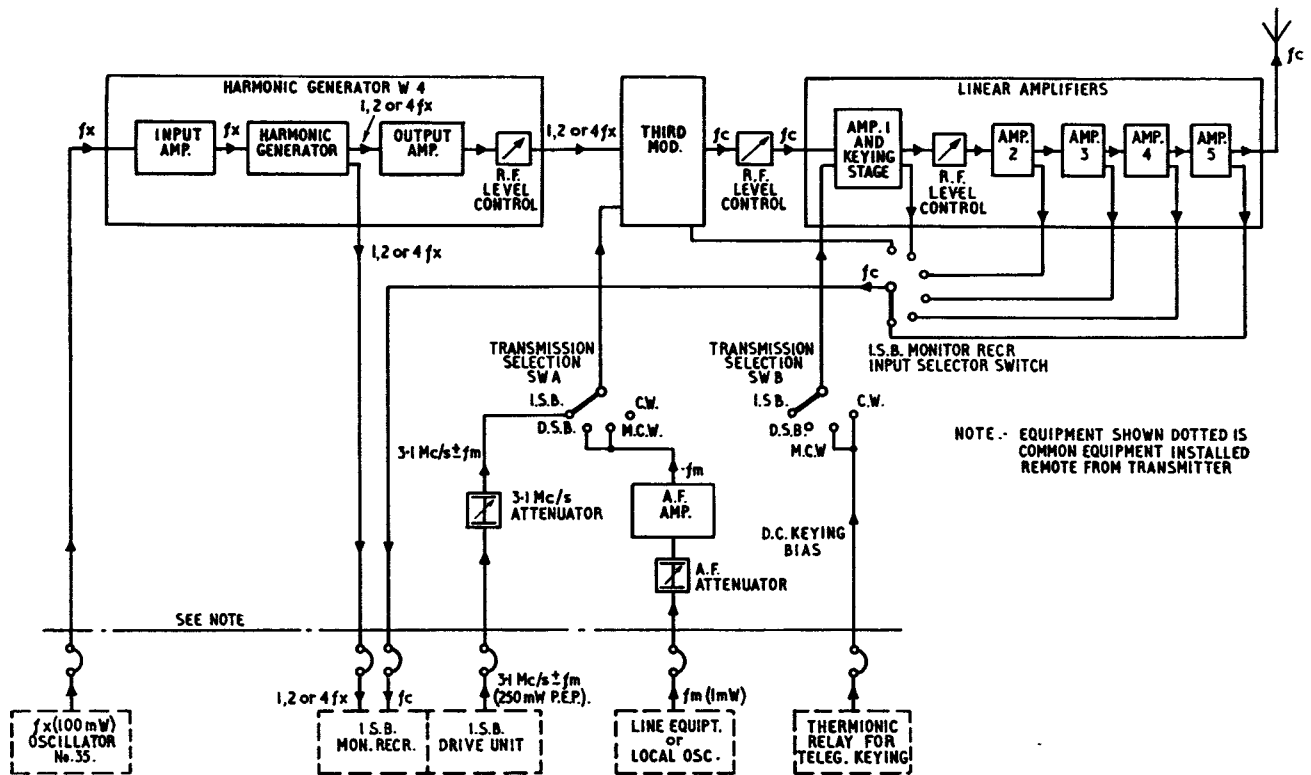

FIG. 1.—BLOCK SCHEMATIC DIAGRAM OF RADIO FREQUENCY UNIT.

(d) the selectivity of the M3 anode circuit is high.

When the M3 stage is operating as a modulator-amplifier or amplifier its gain is reduced to that of a frequency-changer (i.e., output frequency relative to 3.1 Mc/s signal) by the addition of grid and anode resistance loading so that the feed to the following stage (A1) is the same as for i.s.b. operation. The power output at the final frequency from the M3 stage under all operating conditions is about 0.25W.

The gain of the M3 stage under all conditions of operation varies over the frequency range of 4.22 Mc/s from about 12 db. to zero. The coupling circuit to the first amplifier stage (A1) is therefore a variable capacitive potential divider so that the feed can be adjusted to be approximately the same at any frequency and for all types of emissions.

Linear amplifiers A1-A5.—Sufficient power output can be obtained from the first two amplifiers A1 and A2 by operating them without grid current but it is necessary to allow grid current to flow in the later stages. Hence, in spite of their high output impedance, beam tetrodes can be safely used in the A1 stage thus making neutralisation unnecessary and also allowing gain control facilities to be provided by a screen voltage control. Also, for telegraphy operation it is necessary to “on-off” key this stage with a line signal giving zero potential for “mark” and -110V for “space” and this can conveniently be carried out on the control grids. Keying is carried out after modulation, which is effected in M3 stage, in order to maintain a good signal shape. To meet all these requirements the stage must be operated as a class-A amplifier. The second stage (A2) employs low-impedance triode valves arranged to operate as a class-AB amplifier without grid current. With the r.f. drive available from the A1 stage the second stage gives an r.f. output of about 20W with a very low distortion content.

The remaining three amplifier stages increase the r.f. power level from 20W to 50 kW peak envelope power (p.e.p.) with a minimum amount of distortion.

To provide a p.e.p. output from the A5 stage, of at least 50 kW at the highest frequency (i.e., 22 Mc/s) it is necessary

to use four 15 kW water-cooled triode valves connected in parallel-push-pull. The particular valves employed have been chosen because their characteristics are reasonably linear and because they are in general use in a number of P.O. transmitters.

The more important ratings of these valves are:—

Max. anode voltage V_a (up to 15 Mc/s) = 12,000V
 „ „ „ V_a (22 Mc/s) = 10,000V

The peak filament emission for linear operation must not exceed about 2/3 of maximum (11A) for the valve.

Hence $I_o = \frac{2}{3} \times 11 = 7.35A$ per valve.

Max. anode dissipation $W_a = 15$ kW per valve.

Taking into consideration that, under i.s.b. operation, the instantaneous anode potential should not be allowed to swing below 3,000V, the r.f. peak envelope power output (W_p) of the four valves can be calculated as follows:—

$$W_p \text{ (up to 15 Mc/s)} = \frac{E_o I_o}{2} = \frac{9000 \times 2 \times 7.35}{2}$$

$$= 66.2 \text{ kW}$$

$$W_p \text{ (22 Mc/s)} = \frac{7000 \times 2 \times 7.35}{2}$$

$$= 51.4 \text{ kW}$$

where E_o = peak r.f. voltage at valve anodes (i.e., $V_a - 3000$),

$2I_o$ = peak emission for two valves.

The D.C. power input (W_{dc}) to the stage when p.e.p. is being developed is given by:—

$$W_{dc} \text{ (p.e.p.)} = V_a I_{dc}$$

where I_{dc} (four valves in parallel-push-pull)

$$= \frac{4}{\pi} I_o \text{ (per valve).}$$

$$\therefore W_{dc} \text{ (p.e.p.) (up to 15 Mc/s)} = 12,000 \times \frac{4}{\pi} \times 7.35$$

$$= 112.2 \text{ kW}$$

$$W_{dc} \text{ (p.e.p.) (22 Mc/s)} = 10,000 \times \frac{4}{\pi} \times 7.35$$

$$= 93.6 \text{ kW}$$

The power (W_a) to be dissipated in heat at the four valve anodes when peak envelope power is being developed is given by:—

$$W_a \text{ (p.e.p.) (up to 15 Mc/s)} = W_{dc} - W_p \\ = 112.2 - 66.2 = 46.0 \text{ kW}$$

$$W_a \text{ (p.e.p.) (22 Mc/s)} = 93.6 - 51.4 = 42.2 \text{ kW}$$

An i.s.b. transmitter is usually designed to operate continuously at a mean power output which is 50 per cent. of the peak envelope power. This is the condition imposed by the standard two-tone test signal where, without the pilot carrier and neglecting distortion, the envelope of the radiated signal is a series of half-sine waves. Hence, the mean power output (W_m) is as follows:—

$$W_m \text{ (up to 15 Mc/s)} = \frac{W_p}{2} = \frac{66.2}{2} = 33.1 \text{ kW}$$

$$W_m \text{ (22 Mc/s)} = \frac{51.4}{2} = 25.7 \text{ kW}$$

The D.C. power input to the stage when radiating the two-tone test signal is reduced to:—

$$W_{dc} \text{ (2-tone test) (up to 15 Mc/s)} = \frac{2}{\pi} W_{dc} \text{ (p.e.p.)} \\ = \frac{2}{\pi} \times 112.2 = 71.5 \text{ kW}$$

$$W_{dc} \text{ (2-tone test) (22 Mc/s)} = \frac{2}{\pi} \times 93.6 = 59.4 \text{ kW}$$

Calculations of the r.f. power output and D.C. power input have also been made for d.s.b., C.W. and M.C.W. operation; these show that, without re-adjustment of the loading of the stages, satisfactory operation with i.s.b., d.s.b. or M.C.W. operation can be achieved and that C.W. operation can be obtained at an improved efficiency by only slight alteration of loading and a reduction in anode voltage.

The final stage anode efficiency is given by:—

$$\text{Anode efficiency (\%)} = \frac{\text{mean r.f. power output}}{\text{D.C. power input}} \times 100$$

The estimated efficiencies for the various operating conditions are shown in Table I.

TABLE I
Estimated anode efficiency of A5 stage

Frequency range	i.s.b. (2-tone test)	d.s.b. (carr. only)	d.s.b. (85% mod.)	C.W.
Up to 15 Mc/s	46.3%	31.8%	43.4%	59.1%
22 Mc/s	43.3%	29.6%	40.4%	51.7%

The A3 and A4 stages are each operated as class-B push-pull amplifiers employing low-impedance neutralised triodes with resistance loading added to the anode circuits to improve the r.f. voltage regulation. Four 800W valves are connected in parallel-push-pull for the A4 stage and two 350W valves for the A3 stage.

The amplifier anode circuits must be capable of being tuned at any frequency in the range 4-22 Mc/s and must also be adjustable to give the required loading conditions for linear operation. For the final stage the loading must be precise in order to achieve the power ratings given earlier in this section, but with the drive stages the loading must be allowed to vary over a wide range in order to have simple tuning arrangements with means for changing frequency quickly.

The output stage (A5) tuned circuit is a "balanced- π " matching network of the form shown in Fig. 2(a). This circuit has the advantage of not only providing a convenient means of matching the aerial feeder impedance of 600 ohms to the valves but, being a low-pass filter, will also reduce the harmonic content of the final r.f. output. The impedance matching is controlled by the ratio of C_2 to C_1 , and tuning

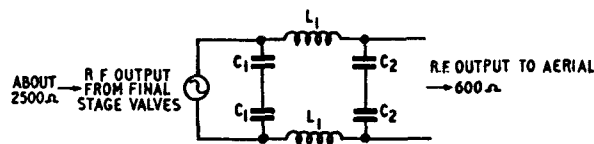

(a) FUNDAMENTAL CIRCUIT OF 'BALANCED- π ' MATCHING NETWORK USED IN FINAL AMPLIFIER STAGE

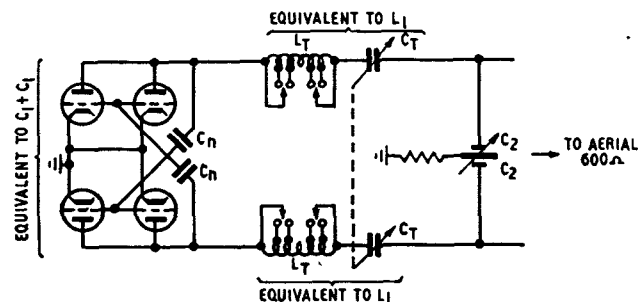

(b) PRACTICAL ARRANGEMENT OF R.F. CIRCUIT OF FINAL AMPLIFIER STAGE

FIG. 2.—TUNED CIRCUIT OF FINAL LINEAR AMPLIFIER STAGE.

is effected by varying L_1 . The practical arrangement of this circuit is shown in Fig. 2(b) where it will be seen that C_1 (Fig. 2(a)) is made up by the valve and neutralising capacitances C_n , C_2 is a variable capacitor for carrying out matching adjustments and L_1 consists of a tapped inductor L_T connected in series with a variable capacitor C_T to give fine adjustment of the overall inductance L_1 .

The anode circuits of stages A1 to A4 are all parallel-tuned circuits with fixed capacitive coupling to the following stage.

Factors affecting Design of Power Supplies.

The total power input to the transmitter is between 80 and 100kW (depending upon the type and frequency of the r.f. emission) of which the main items are:—h.t. supplies—65 to 85 kW, filament heating—about 11kW and grid-bias rectifiers—about 2kW.

The valve filaments are heated from D.C. derived from two three-phase full-wave rectifiers with suitable smoothing to keep the noise level of the r.f. output extremely low.

The grid-bias supplies are taken from single-phase rectifiers having ample smoothing and low-resistance loads connected to give a low apparent internal resistance. In this manner, any potentials developed across the rectifier due to the passage of grid current in the various stages will be small in comparison with the nominal grid-bias voltage.

The high-tension supplies must, in addition to having a very low ripple-voltage content, have a very good voltage regulation for both slow and quick changes of load. In the main 12kV rectifier good regulation for slow changes of load is achieved by use of hot-cathode mercury-vapour valves and a suitable h.t. transformer, and for quick changes by keeping all series inductance (e.g., h.t. transformer, smoothing inductor) to a minimum. Unfortunately, for satisfactory operation of hot-cathode mercury-vapour valves, it is necessary for the series inductance to be high but it can be reduced as the load resistance is decreased. A compromise is therefore effected by using an input-inductance filter comprising an inductor of 1H and capacitance of 40 μ F with a permanently connected load resistor dissipating 4kW. For the 9-kV, 3-kV and 500-V rectifiers a satisfactory performance has been achieved by the use of selenium rectifier elements.

PERFORMANCE CHARACTERISTICS

The transmitter can be operated satisfactorily on all types of emissions specified in the Appendix in the frequency

range of 3.85-22 Mc/s. It is capable of producing an r.f. output of 50 kW p.e.p. at the highest frequency and greater than 70 kW p.e.p. at the lower frequencies on i.s.b., d.s.b. and M.C.W. emissions and greater than 25kW and 35 kW mean r.f. power output on C.W. emissions.

The transmitter can be operated quite satisfactorily by one operator and a change of frequency and type of emission can be effected within 15 minutes (assuming that the i.s.b. drive unit has already been set up ready for use); two operators can effect the change in less than 10 minutes.

A 12-hour heat run on the equipment was carried out with a C.W. emission on a frequency of 6 Mc/s under overload conditions with a continuous "mark" applied, with the results given in Table II.

TABLE II
Increase of temperature during heat run
R.F. power output (C.W.)—39 kW

	Increase of temp. after 12 hours °C
Auxiliary room	13
Fire-proof cubicle	19
R.F. unit (A4 stage)	35
R.F. unit (A5 stage)	16

On i.s.b. emissions the non-linear distortion is lower than specified in the Appendix, even when the peak envelope power is 50 per cent. higher than that specified. Measurements of the levels of intermodulation products made under two-tone test conditions with a spectrum analyser gave the results shown in Table III.

TABLE III
Levels of intermodulation products in two-tone test
R.F. power output .. 50 kW (p.e.p.)
Frequency 10 Mc/s

Product	Level relative to that of f_1 or f_2 db.
3rd order (e.g., $2f_1 - f_2$)	-36
5th order (e.g., $3f_1 - 2f_2$)	-50
7th order (e.g., $4f_1 - 3f_2$)	< -60

Hum on the pilot carrier did not exceed -35 db. (100 c/s) and -42 db. (50 c/s), relative to the pilot carrier level; at hum frequencies above 300 c/s the level was below -60 db.

Under d.s.b. conditions (i.e., when the i.s.b. drive unit is not in use) the a.f. distortion is less than 5 per cent. at 80 per cent. modulation and the audio response over the frequency range of 200-6,000 c/s is uniform within ± 1 db.

Under telegraphy conditions, C.W. or M.C.W., the signal is well shaped and the transmitter can be satisfactorily keyed at over 400 words per min. "Space" radiation is less than -60 db. relative to the power output on "mark."

The performance of the transmitter at nominal maximum output powers at various frequencies under i.s.b., d.s.b. and C.W. conditions is given in Tables IV, V and VI. In each case the power output level shown can be exceeded by 2 db. for short periods without damaging any equipment but, of course, the non-linear distortion will be worsened.

CONCLUSIONS

The high-power transmitter described has operated satisfactorily during the past two years. It is used not only for regular scheduled traffic but also for traffic during the

TABLE IV

Performance under i.s.b. conditions

Test condition	No signal	2 test-tones and pilot carrier		
		4	10	22
Frequency (Mc/s)		4	10	22
A5 I_g (mA)	—	400	400	400
A5 V_a (kV)	12	12	12	10
A5 I_a (A)	1.6	6.1	5.9	5.6
600-ohm line current (A)	—	7.5	7.0	6.25
R.F. output, mean (kW)	—	33.8	29.4	23.4
" " p.e.p. (kW)	—	74.5	64.5	51.5
Distortion* at p.e.p. (db)	—	-30	-30	-28
" " *, -2 db. rel. to p.e.p. (db)	—	-34	-36	-30
A5 stage anode efficiency (%)	—	46	41.5	42
A.C. power input to transmitter (kW)	48	111	110	96
Overall efficiency (%)	—	30.5	26.7	24.5

* i.e., level of 3rd order intermodulation product relative to level of one test-tone.

TABLE V

Performance under d.s.b. conditions

Test condition	No signal	Carrier only	85% mod.	Carrier only	85% mod.
Frequency Mc/s	4	4	4	22	22
A5 I_g (mA)	—	200	420	200	400
A5 V_a (kV)	12	12	12	10	10
A5 I_a (A)	1.6	6.1	5.9	5.6	5.4
600-ohm line current (A)	—	6	7	5	5.75
R.F. output, mean (kW)	—	21.6	29.4	15	19.8
" " p.e.p. (kW)	—	21.6	74	15	51
A5 stage anode efficiency (%)	—	29.5	41.5	26.8	36.7
A.C. power input to transmitter (kW)	48	110	108	90	89
Overall efficiency (%)	—	19.6	27.2	16.7	22.2

TABLE VI

Performance under C.W. conditions

Test condition	No signal	Carr.	Carr.
Frequency (Mc/s)	4	4	22
A5 I_g (mA)	—	610	560
A5 V_a (kV)	10	10	8
A5 I_a (A)	0.4	6.1	5.6
600-ohm line current (A)	—	8	6.5
R.F. output (mean) (kW)	—	38.4	25.4
A5 stage anode efficiency (%)	—	63	57
A.C. power input to transmitter (kW)	32	92	78
Overall efficiency (%)	—	41.7	32.6

times when other transmitters are being serviced; the ease and speed with which the frequency of operation and the type of emission can be changed have been valuable under such conditions.

The large r.f. power output is useful in maintaining services under adverse propagation conditions, whilst the freedom from non-linear distortion permits full loading with multi-channel operation.

ACKNOWLEDGMENTS

The authors' thanks are due to several colleagues in the Radio Planning and Provision Branch, and members of the staff at Leafield Radio Station for the assistance they have given in the design, construction, development and testing of the transmitter.

APPENDIX

Performance specification

The main requirements which the transmitter shall meet are given briefly as follows:—

1. *Types of Emission.*

The transmitter shall be capable of operating on the following types of emissions with or without an independent-sideband drive unit, as required:—

- (a) With independent-sideband drive unit—s.s.b. telephony or any other type of signal which can be generated by an i.s.b. drive unit (e.g., double-sideband telephony, modulated-continuous-wave, continuous-wave and frequency-shift telegraphy).
- (b) Without an i.s.b. drive unit—d.s.b. telephony, M.C.W. and C.W. telegraphy.

2. *Frequency Range.*

The transmitter is required to operate on any frequency in the range 4-22 Mc/s.

3. *Radio-frequency Power Output.*

The transmitter shall be capable of continuous operation at any frequency in the range 4-22 Mc/s when delivering a peak envelope power of not less than 50 kW with a mean power of not less than 25 kW under continuous-wave conditions.

4. *Radio-frequency Inputs.*

(a) *Carrier generating equipment.*

The transmitter is to be suitable for operation via 75-ohm unbalanced coaxial cable from remote crystal oscillators giving an output of between 80 and 500 mW over the frequency range 3.5-7.0 Mc/s.

(b) *Independent-sideband drive unit.*

For i.s.b. emissions the transmitter is to be suitable for operation, via a 75-ohm unbalanced coaxial cable, from an i.s.b. drive unit operating at a frequency of 3.1 Mc/s \pm 6 kc/s and giving an output of 250 mW.

5. *Audio-frequency Input.*

The a.f. input required for d.s.b. or M.C.W. emissions, when not using the i.s.b. drive unit, shall be via a 600-ohm balanced-twin cable at a power level of 1 mW \pm 10 db. over the frequency range 200-6000 c/s.

6. *Telegraph Keying.*

The transmitter is to be suitable for telegraph keying on M.C.W. and C.W. emissions, when not using the i.s.b. drive unit, from a remote thermionic relay having a high impedance output and giving a potential relative to earth of -130V for "space" and of zero for "mark."

7. *Non-linear Distortion.*

Non-linear distortion produced in the transmitter shall be

assessed from the measurement of levels of third-order intermodulation products, i.e., of the type $(2f_1 - f_2)$, when a two-tone test signal is supplied by the i.s.b. drive unit. The level of the third-order $(2f_1 - f_2)$ intermodulation product obtained by demodulating the output of the transmitter in a monitor receiver (included with the i.s.b. drive unit) shall not exceed -26 db. relative to the level of either of the test tones in the demodulated signal. This requirement shall be met for all levels of the applied test tones up to that at which the peak envelope output power of the transmitter is not less than 50 kW.

8. *Carrier Regulation.*

With the level of the pilot carrier adjusted, in the absence of a sideband signal, to -26 db. relative to the peak sideband power corresponding to the peak envelope power of not less than 50 kW, the carrier regulation measured in the output signal of the sender shall not exceed 3 db. when the two-tone test signal is applied at any level up to that at which the peak envelope power is not less than 50 kW.

9. *Unwanted Components Due to Phase and Amplitude Modulation.*

The sum of the r.m.s. powers of unwanted components due to amplitude or phase modulation of the pilot carrier measured in the absence of a sideband signal in a frequency band extending 200 c/s on each side of the carrier frequency shall be not greater than -30 db. relative to the pilot carrier power.

10. *Safety Precautions.*

All high-voltage equipment must be protected so that the risk of authorised operating personnel obtaining an electric shock is reduced to an absolute minimum. To meet this requirement all high-voltage compartments and enclosures must have the power supplies and access doors interlocked both mechanically and electrically. Switches used for electrical interlocks should not include spring-loaded devices.

Normal electrical interlocks must be provided to reduce to a minimum the risk of damage to the sender equipment (including the valves) during operation.

11. *Operation.*

The transmitter shall be designed so that it can be operated, if desired, by one operator unaided. It shall be possible to change frequency in a time not longer than 15 minutes.

12. *Power Supply.*

The transmitter shall be suitable for operation from a 400V, 3 phase, 50 c/s A.C. supply and present a well-balanced load to the supply.

13. *Valve Anode Cooling Water.*

Arrangements shall be made for cooling the valve anodes where necessary from a common distilled water supply at a pressure of about 40 lb./sq. in.

Book Review

"Introduction to Valves." R. W. Hallows, M.A.(Cantab.), M.I.E.E., and H. K. Milward, B.Sc., A.M.I.E.E. Iliffe & Sons, Ltd. 152 pp. 107 diagrams, 1 frontispiece. 8s. 6d.

This text-book should prove useful to any student who is beginning his studies of radio and should have a special appeal to those preparing for the City and Guilds examinations up to and including Radio II and Telecommunications Principles III.

In 12 chapters the authors cover the principles of valves; letter symbols for valves; emission, space charge, the diode; the diode as a rectifier and detector; the triode; main uses of the triode; tetrode and pentode; frequency changers; power output valves; valves for very high and extra high frequencies; valves for special purposes; modern miniature valves. In these 12 chapters the fundamentals of those aspects of radio in which the valve plays a part are covered in outline.

Chapter 2 introduces the B.S.I. system of letter symbols for valves and their associated circuits, and this system is used thereafter. This is a very useful innovation. In the early chapters, which cover the fundamental principles, it is surprising how much information has been included while at the same time the chapters are restricted to the very readable length of about 12 pages. Diagrams are used very liberally and this sets the student a very good example. No complex mathematics appear in the book, and yet the authors do not miss any opportunity of replacing normal circuits by simpler equivalent

ones. The physical principles underlying the operation of valves are amply dealt with. The chapter on valves for special purposes is very brief and makes little more than a passing reference to some of the composite types of valves and to gas-filled valves. The chapter on V.H.F. and E.H.F. valves is a little more detailed but it only touches on this rather advanced aspect of valve technology.

This is not primarily a book for the advanced student, although he may find it useful reading. It can be particularly recommended to students studying on their own.

P. N. P.

SHORTER NOTICES

"Electric Wiring Diagrams." W. P. Maycock, M.I.E.E. (rev. by A. Serner, B.Sc., A.C.G.I., A.M.I.E.E.). Sir Isaac Pitman & Sons, Ltd. 156 pp. 275 ill. 8s. 6d.

A book for the practical man devoted mainly to circuits for electric lighting and power wiring. Includes a brief reference to house telephone circuits.

"Atmospheric Electricity." B. F. J. Schonland, C.B.E., F.R.S. Methuen & Co., Ltd. 95 pp. 20 ill. 7s. 6d.

One of the series of Methuen's Monographs on Physical Subjects. It is intended in this book to supply science students at University level with a compact statement of the modern position concerning atmospheric electricity. Copious references to the literature on this subject are included.

A Method of Testing Cold-Cathode Tubes

D. L. BENSON, A.M.I.E.E.
D. H. VOGAN†

U.D.C. 621.385.1.032.212: 621.317.32

This article describes a method of automatically testing the D.C. breakdown potential of a cold-cathode tube, and circuit detail is given of a tester incorporating this method. Improved accuracy and operational efficiency are claimed for the method compared with manual methods.

Introduction.

AN early experience in operating equipment employing cold-cathode tubes was that failure often occurred when the equipment had been idle for periods of a day or more. This class of misoperation was traced to the cold-cathode tubes, some of which failed to strike unless several attempts were made. Investigation showed that these tubes required an abnormal striker-cathode breakdown potential when they had been left idle for lengthy periods, the tube characteristics returning to normal after the first successful operation. It was by no means clear what proportion of tubes were so affected and to what extent the breakdown potential increased in the affected tubes. Nor was it clear whether the effect was peculiar to one type of tube or to particular batches of tubes. It became essential to establish the extent of this "first-time" phenomenon because equipment was being developed in which tubes might well be left inactive for several days or more and yet be required for immediate use at any time. For such uses circuit design would have to cater for breakdown potentials ranging from the lowest normal figure to the highest first-time figure and it was feared that this range would be too wide to be met by normal circuit designs.

Measurement of Breakdown Potential.

To find the breakdown potential of a cold-cathode tube, the potential across the gap to be tested must be raised slowly until the tube strikes and the potential at the instant of striking noted. When the potential is raised manually by adjusting a potentiometer, errors frequently arise through raising the potential too quickly, the actual breakdown potential being exceeded during the operator's reaction time. If the potential is raised at a speed slow enough to avoid overshoot errors, the whole operation becomes very tedious because the tube may strike anywhere between wide limits. A common manoeuvre to avoid this difficulty is to perform the test twice. In the first test the potential is raised fairly quickly and the approximate breakdown potential noted. In the second test the potential is raised quickly to a value just short of the expected breakdown and then raised slowly until the exact figure is obtained. Even with this procedure errors may occur because of uneven movement of the potentiometer or momentary loss of concentration by the person performing the test. However, in investigating the extent of first-time effects the breakdown potential of each tube had to be determined at the first attempt and determined accurately because once the tube had struck the first-time figure was lost. Thus it was decided to design and construct an auto-

matic tester which would produce accurate results from a single test.

The Automatic Tester.

The basic principle involved, as applied to the testing of triode tubes, is shown in Fig. 1. The central element of the tester is a Miller-integrator circuit which provides a uniformly rising output potential, starting from a low value and rising until stopped by the breakdown of the tube under test. The output of the integrator is connected to the tube under test via a cathode-follower so that there is sufficient power to operate a voltmeter and so that the potential will not alter when current is drawn by the tube after breakdown. To test a tube a test key is operated. This pulse-operates a trigger circuit which in turn provides a signal to the integrator circuit causing the output potential to rise

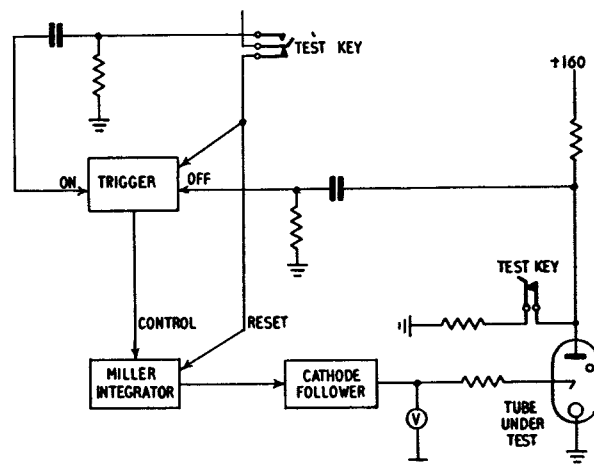

FIG. 1.—BASIC PRINCIPLE OF THE TESTER.

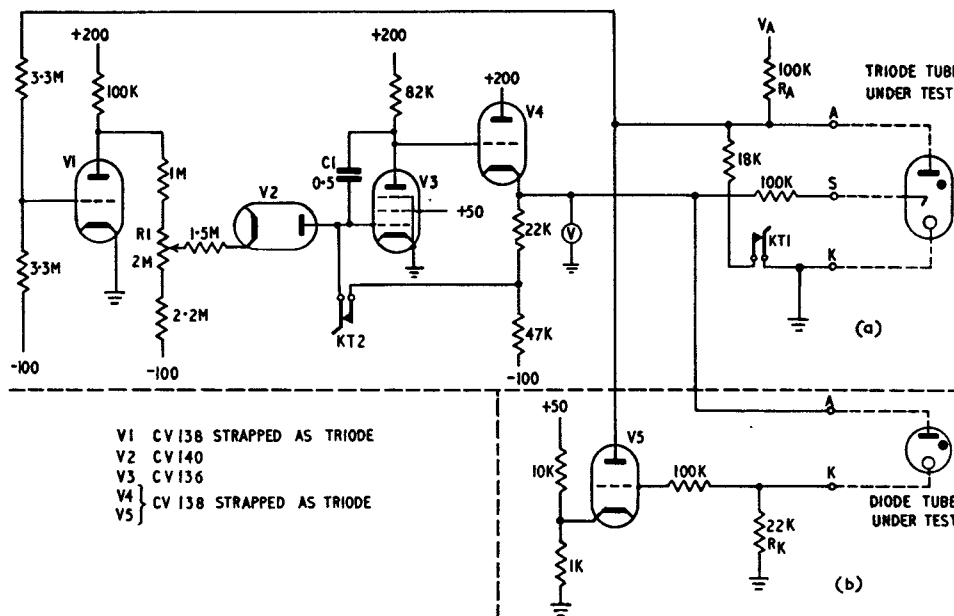

FIG. 2.—CIRCUIT OF THE TESTER.

† The authors are, respectively, Executive Engineer and Assistant Engineer, Telephone Development and Maintenance Branch, E.-in-C.'s Office.

at the predetermined rate. When the tube strikes, the sudden change of anode potential is used to restore the trigger circuit to normal; thereafter the integrator output rises no further and the tube breakdown potential is indicated by the voltmeter. After recording the test figures (stabilise potential may be recorded by a separate meter or by switching the one meter) the test key may be restored to normal to extinguish the tube and reset the integrator circuit ready for another test.

In many circumstances, the tube under test may act as the trigger element and Fig. 2(a) gives circuit details of such a tester. This particular circuit is designed to test the striker gap of triode tubes, and the tester output potential covers a range of 45V to 110V. Thus almost all "coated cathode" tubes may be tested without the need for range switching. While the test key is normal the anode potential for the tube to be tested is shunted to a low value by key contact KT1 so that the tube may be connected safely. In this condition the grid of V1 is held negative so that V1 does not conduct; thus the anode of V1 is at a high potential, the cathode of V2 is at a positive potential and V2 cannot conduct because the anode of V2 is a few volts negative. V3 is the Miller-integrator valve and V4 is the cathode-follower valve. Test key contact KT2 provides a feedback to the grid of V3 so that the output of the cathode follower is normally held at about 40V positive. When the test key is operated, KT2 leaves the grid of V3 dependent on capacitor C1 as in a normal Miller-integrator circuit. Contact KT1 removes the shunt path on the tube under test and the anode potential rises to the supply value V_A . (V_A may be pre-set by a potentiometer.) This raises the grid potential of V1 which now conducts and the consequent lowering of V1 anode potential causes V2 to conduct and therefore charge capacitor C1. Thus the voltage applied to the striker of the tube under test rises until the tube strikes and the anode potential drops to its stabilise value. This drop in potential switches the grid of V1 negative and the resulting increased potential on the anode of V1 raises the cathode potential of V2 so that V2 no longer conducts. Thus capacitor C1 receives no more current and the output potential remains at the breakdown value of the tube under test. Resistor R1 is provided so that the speed of "run up" can be varied as required.

One difficulty encountered in design was the tendency for the output potential to drift after reaching the test figure. This drift is caused by grid current in V3 discharging capacitor C1, and the difficulty was to find a type of valve in which grid current was less than about 10^{-9} A. However, the CV 136 proved a satisfactory type provided that operating conditions limited anode current to less than 5 mA and that a screen potential of 50V to 60V was used. Thus it was not necessary to resort to a special type of valve. With a good-quality capacitor for C1, careful insulation of wiring connected to the grid of V3 and good insulation of contact KT2 the circuit of Fig. 2(a) gives a drift of less than 1V in five minutes, thus providing ample time for the test figure to be read.

A diode tube may be tested by employing an additional valve in the tester. Fig. 2(b) shows the additional circuit involved. The cathode of the additional valve is held at about +5V and therefore current through the valve is cut off. When the diode under test strikes, a potential is

developed across RK which causes V5 to conduct. The anode of V5 is connected to resistor RA and thus the potential at this point is reduced as though a triode tube were being tested. This "diode" test circuit may be used to test the main gap of triode tubes, but a slight rearrangement would be necessary to cater for those tubes which break down at a potential greater than 110V.

The "run-up" tester principle has also been used as part of a cold-cathode tube life-test equipment. In this particular life-test the tubes are operated in counter chains using the well-known circuit shown in Fig. 3. Twice a day striker

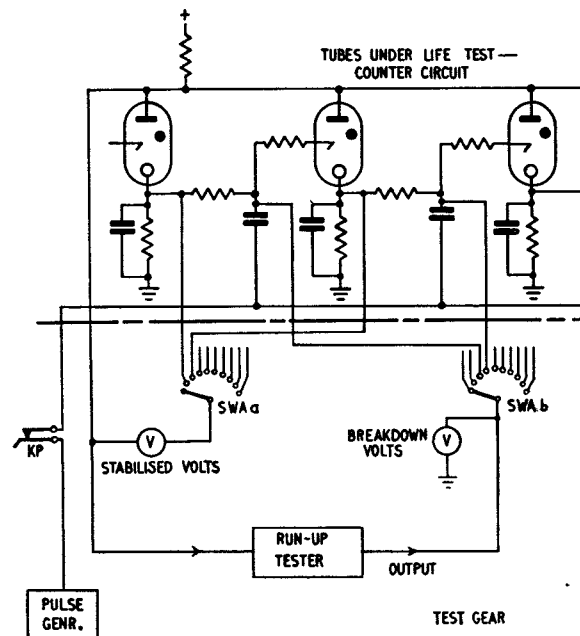

FIG. 3.—CONNECTIONS OF TESTER WHEN USED FOR LIFE-TESTS OF TUBES.

breakdown and main gap stabilise figures are tested with the tubes *in situ*. The driving pulses are first disconnected by a key and then the testing equipment is connected to one tube at a time via a two-arc switch. Each tube is tested by the run-up tester which is started by operating a push-button and stopped by a pulse on the common anode connection (generated by the breakdown of the tube under test).

Breakdown and stabilise voltages are read from the two meters before resetting the tester and switching to the next tube to be tested. Using this method, the array of 50 tubes is tested conveniently and accurately in less than 20 minutes.

Conclusion.

In operation this run-up tester has proved to be a very valuable tool producing results of consistent accuracy and reducing testing time and effort so much that the testing of large batches of tubes is no longer a formidable task. Consequently, testing on a large scale has been possible since the tester was put into service and much has been learned about cold-cathode tubes, such as, batch-to-batch variations, changes of breakdown with life and, in particular, the extent of the first-time effect referred to earlier.

Deterioration of Valve Performance Due to Growth of Interface Resistance

G. H. METSON, M.C., Ph.D.,
and M. F. HOLMES, B.Sc.†

U.D.C. 621.385.13.032.216

This note refers to a recent development which eliminates interface resistance growth in receiving valves. The usual nickel core supporting the oxide cathode is replaced by a core of commercially pure platinum.

Introduction.

THE growth of a resistive interface layer between an oxide cathode and its supporting core is now accepted as one of the prime causes of deterioration of performance of high-slope receiving valves.^{1,2} The cause and general nature of this resistance growth has been described by Child in this Journal³, and the limited object of the present note is to give engineers some idea of the magnitudes involved in practical valves.

Observed Deteriorations.

A common high-slope pentode (CV138) was selected for observation as it is in general production by all of the major English manufacturers and is also made by the Post Office for experimental work on problems of valve life. Batches of samples from five different manufacturing sources were placed on life test under the moderate conditions of anode loading common to Post Office practice and were observed over a period of 4,000-5,000 hours. At intervals during the test period, the magnitude of the interface resistance was measured for each sample by the technique described by Child.

Results are set out in Fig. 1, and show the percentage fall in mutual conductance with time due to the measured growth of interface resistance. Each curve is the average of a group of samples from one of five manufacturers designated A, B, C, D and E. In one case, two groups of samples have been included to bring out a particular aspect.

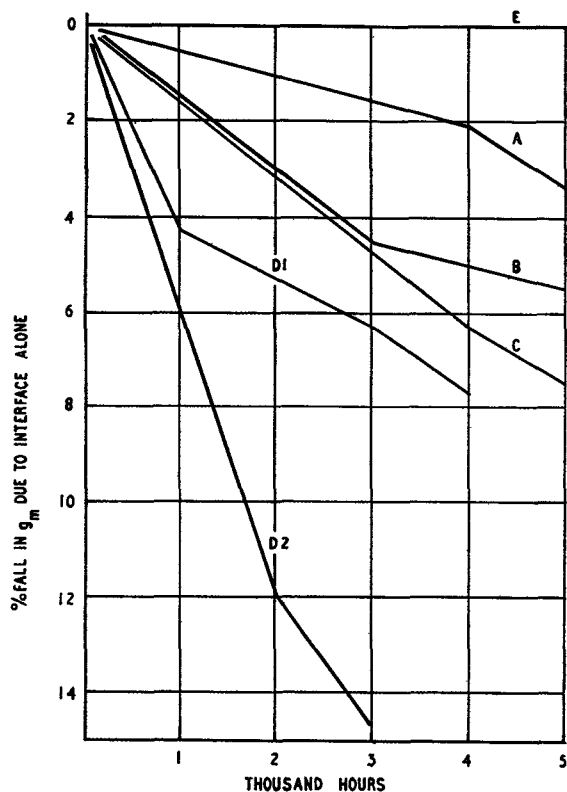

FIG. 1.—FALL IN g_m DUE TO INTERFACE ALONE FOR CV138 TYPE VALVES.

Some General Comments.

Perhaps the first point of interest arising from the curves is that all samples without exception show no measurable interface resistance (< 1 ohm) at the beginning of life. All samples with the exception of the special Group E, develop interface resistance during the test period, and the Groups B, C and D1 can perhaps be regarded as typical. The Group A appears to be rather superior, but investigation showed that the slower rate of growth was due to the fact that the cathode was running at an appreciably lower temperature than the remaining groups. This temperature dependence of growth rate is, of course, a well-known feature of the interface phenomenon.

It might be thought from the curves that the samples from a particular manufacturer could be distinguished by the growth rate, but such does not appear to be the case, and Groups D1 and D2 have been included to show that the rate may vary widely in batches from the same source taken at different time intervals.

Possibility of Controlling the Growth Rate.

A typical core metal used in receiving valve manufacture is nickel containing 0.05 per cent. magnesium and 0.05 per cent. silicon. During processing, the silicon content of the core metal reacts with the oxide matrix to form the interface layer of barium orthosilicate. At the beginning of life this orthosilicate layer is activated by excess barium atoms and it is the progressive deactivation of this semi-conducting layer during the life that leads to the observed rise of interface resistance. The deactivation may occur, either by diffusion of excess barium out of the layer, or by its destruction *in situ* by an invading oxidising gas. The authors are of the opinion that the second alternative is the one that occurs in working valves.

If, indeed, it is a residual gas that attacks the active orthosilicate layer, it would appear possible to eliminate the resistance growth by elimination of all residual gas. Very considerable effort was made at Dollis Hill to bring about such a condition by meticulous pre-processing of piece-parts, use of high-grade bench pumps and lengthy processing schedules. It was found, however, that the growth rate varied from batch to batch, and on the average was no better than that achieved by commercial valves pumped on the common high-speed rotary pumps. Mere betterment of processing detail appears unlikely to lead to elimination of the growth, and it was decided therefore to turn to a core metal free from silicon. The metal chosen was commercially pure platinum and Group E of Fig. 1 is typical of a CV138 type built around a platinum-cored oxide cathode. Tests up to 17,000 hours on such valves have shown no measurable increase in interface resistance.

† The authors are, respectively, Senior Principal Scientific Officer and Principal Scientific Officer, P.O. Research Station.

¹ Metson, G. H., Wagener, S., Holmes, M. F. and Child, M. R. "The Life of Oxide Cathodes in Modern Receiving Valves." *I.E.E. Printed Paper R 1137*.

² Eaglesfield, C. C. "Life of Valves with Oxide-Coated Cathodes." *Electrical Communication*. Vol. 28, No. 2, June 1951.

³ Child, M. R. "The Growth and Properties of Cathode Interface Layers in Receiving Valves." *P.O.E.E.J.* Vol. 44, p. 176.

Future Effort.

Elimination of silicon appears to eliminate the growth of interface resistance, and suitable selection of a core metal will result in a solution to the problem. Present work at Dollis Hill centres around the production of nickel alloys of the following basic composition:

Magnesium 0.05-0.15 per cent.

Silicon < 0.001 per cent.

and with other impurities not greater than are found in such a typical commercial core metal as "O" Nickel. It is

considered that such an alloy would behave satisfactorily on high-speed rotary pumps and would develop no appreciable interface resistance, in two years. Setting an upper limit to the silicon content is a matter of some difficulty and the figure quoted above is based on experience gained with platinum cores of known silicon content.

At a conservative estimate the elimination of the interface resistance growth is thought likely to double the life-span of the common high-slope receiving valve.

The Transatlantic Telephone Cable

ANNOUNCEMENT was made on 1st December of the signing of an Agreement between the United Kingdom Post Office, the American Telephone and Telegraph Company, the Canadian Overseas Telecommunication Corporation and the Eastern Telephone and Telegraph Company of Canada for the construction of the first telephone cable system across the Atlantic Ocean. The cable will provide physical telephone connection between the United Kingdom on the one hand and the United States and Canada on the other.

The decision to lay a transatlantic telephone cable has been made possible as a result of many years' research leading to the development of reliable submerged repeaters, and first place must be given to the work of the Bell Telephone Laboratories, as the American design of repeater will be used on the main crossing between Newfoundland and Scotland (1,950 nautical miles). Cable-laying trials, carried out in the deep water of the Bay of Biscay in 1930 under the direction of Dr. O. E. Buckley led to the decision that these repeaters should be made, in diameter and in flexibility, as much like the cable as possible so that laying could take place without stopping the cable ship. A repeater housing was eventually developed only 2 in. in outside diameter and about 7 ft. long overall. The housing consists essentially of a thin-walled copper tube supported internally by abutting steel rings which are capable of withstanding sea pressure up to 5 tons /sq.in. At each end of the housing is a series of three water-tight seals which taper down to the cable diameter. The whole assembly, about 20 ft. long, runs smoothly around the drums and sheaves of modern cable ships. Development of a housing met, however, only part of the requirement; long-life valves and other electrical components had to be developed to ensure trouble-free service for a period of some 20 years. All this was done, and repeater and cable designs had been completed in 1940 when the war put a stop to active work. Afterwards, the design was reviewed and the result of years of research and laboratory life testing put to the test of practical trial by the manufacture and installation in 1950 of two repeated cables between Havana and Key West (about 120 nautical miles) at a maximum depth of about one mile. These cables each contain three one-way repeaters and the system has given fault-free operation.

British development commenced in the Post Office Research Laboratories in 1938, and the first repeater to be used anywhere in a working cable was designed and constructed in these laboratories and brought into service in 1943. Subsequent developments had as an objective repeaters which, spaced at intervals of 16 to 18 nautical miles, would allow most cables in European continental waters to provide 60 circuits. Nineteen of these repeaters have been installed to date and have a satisfactory record of service up to seven years. More are being constructed. They are in rather large rigid housings and are both too cumbersome and not strong enough for use in very deep

water. A smaller rigid housing has, however, been developed and British-made repeaters to be used for the section of the transatlantic route between Newfoundland and Nova Scotia (310 nautical miles) will probably be in the smaller housings.

A bothway submarine telephone circuit can be provided by two methods. One method requires two cables, one for each direction of transmission; the other divides the total frequency band transmitted by a single cable into two parts and uses one part for each direction of transmission. The second method requires that at each repeater there should be directional filters to separate the two directions of transmission. The American system uses the first method and the electrical circuit of the repeaters is therefore of the simplest possible form. The Post Office system is of the second kind, British practice in home waters having been based on the use of a single cable for both directions of transmission.

The detailed design of the system has not yet been finalised but, as at present envisaged, there will be two one-way cables between Scotland and Newfoundland and a single two-way cable between Newfoundland and Nova Scotia. The system will provide about 36 high-quality telephone circuits any one of which could technically be used to provide a number of telegraph circuits. There will be about 50 repeaters in each of the cables on the main crossing and 13 on the shorter cable. Each repeater will consist essentially of a three-stage feed-back amplifier designed around long-life valves so that there will be between 300-400 valves installed under the ocean, together with nearly 10,000 other electrical components. The success of the system depends on very few of these developing faults during the next 20 years or more.

The repeaters will be energised by direct current supplied over the central conductor of each cable from the terminal stations; this will necessitate there being about 2,000V between the central conductor and the sea at the ends of the long sections. The design of the terminal power plant will give unusual emphasis to current regulation, continuity of service and protection against surges.

The transatlantic cables will be of the coaxial type, 0.62 in. diameter at the outer conductor and with the deep sea sections of about 1.5 in. diameter over the armouring wires. High molecular weight polythene will be used as the cable insulant. Although a great part of the cable will be made in the United Kingdom, manufacture of the cable will be divided between the United Kingdom and the United States where cable meeting somewhat similar requirements was made for the Havana-Key West installation.

The cables will be laid by the Post Office Cable Ship *Monarch* on which the cable-laying equipment will be modified and adapted so as to enable cable and repeaters to be laid as a continuous operation.

H. Faulkner, C.M.G., B.Sc.(Eng.), M.I.E.E., F.I.R.E.



AFTER having completed 40 years' service, during which time he has had a wide and varied experience of Post Office activities, Mr. Faulkner retires on the 5th January, 1954. So closely associated has he been with radio that it may not be generally realised that he served the first two years of his career in the Designs Section of the Engineer-in-Chief's Office. It was not until his return from service during the First World War with the Royal Engineers Signal Corps that he was transferred to the Wireless Section, and added his quota of enthusiasm to that body of enthusiasts who were so soon to embark on the design of the Rugby Radio Station; the birthplace of world-wide radio telegraph transmissions. It was only natural with the opening of this station in 1926 that he should become its first Officer-in-Charge and thereby lay the foundations of that tradition of service associated with the name of Rugby. Returning to Headquarters in 1929 he was a natural choice to take charge of the design and development group of the Wireless Section where he could bring to bear his wide experience of maintenance.

In 1933 he was transferred as Assistant Superintending Engineer to the North Wales District, becoming its Superintending Engineer in 1935 and Deputy Regional Director in 1941. For another 10 years Mr. Faulkner acquired an intimate experience of Regional work and life which has been so useful to him on many subsequent occasions. Never allowed, nor for that matter wishing, to rest for long, Mr. Faulkner was appointed Controller of the Factories Department in 1941, and with his plentiful supply of energy and enthusiasm there was never any doubt about the factory playing its full and proper part in the war effort.

In 1944 he was appointed Assistant Engineer-in-Chief. Responsible for staff matters, negotiations with the Union and Staff Associations, and Chairman of the Standing Joint Committee (P.O.E.U. Questions), the end of the war

found him busily engaged on the many problems arising in the placing of staff returning from the Services, re-organisation of the minor engineering and the motor transport grades. He was also interested in the Lines, Power, Construction and Motor Transport Branches. Promoted to Deputy Engineer-in-Chief in 1947, his interests then became those of the Radio Development and Radio Maintenance Branches.

Having much earlier in his career taken part in the C.C.I.R. meeting at Copenhagen in 1931 and the International Convention at Madrid in 1932, he now began an intensive course of international conference work, starting off in 1948 by leading the U.K. delegation to the Copenhagen Broadcasting Conference. Under his chairmanship the Planning Committee produced the Copenhagen Plan for broadcasting in Europe, thereby bringing some order into a troubled ether. With little respite he was off to Mexico City to take part in the High Frequency Broadcasting Conference, being joint leader of the U.K. delegation with Mr. (later Sir) Thomas Rapp, the then British Ambassador to Mexico. The difficulties which led to adjournment of the Mexico City Conference and its subsequent reassembly, first at Florence and then at Rapallo, have already been recorded in the Journal. His many friends were pleased at seeing his work recognised in the Birthday Honours of 1949 when he was created a C.M.G.

The West European countries became very concerned about television standardisation during the course of the C.C.I.R. Conference at Stockholm in 1948, since many of them were planning television services. Study Group No. 11 of the C.C.I.R. accordingly held meetings at Zurich and London in an attempt to resolve the problem. As leader of the U.K. delegation to these two conferences, Mr. Faulkner made a strong fight for the general adoption of the 405-line U.K. system in which he was a staunch believer. For many years he has served on the Technical Sub-Committees of the Television Advisory Committee and has found much satisfaction in resolving problems arising in the television and broadcasting fields. He was leader of the U.K. Delegation at the Stockholm V.H.F. Broadcasting and Television Conference in 1952.

Chairman of the South Midland Centre of the Institution of Electrical Engineers in 1938-39, Member of Council 1945-48, Chairman of Council of the I.P.O.E.E. and of the Board of Editors since 1947, Chairman of the City and Guilds Advisory Committee for Telecommunications Engineering for many years, no one can doubt that he has served his fellow engineers well. For several years he has been Vice-President of the Post Office Golfing Society. His innate enthusiasm, good humour, good fellowship and geniality have endeared him to all those with whom he has had to live and work and, despite all the trials and tribulations of long international radio conferences, "H.F."—and it is as "H.F." that so many know him—is respected and honoured irrespective of whether he happens to be on the same side or not.

The C.C.I.R. recently held in London its seventh Plenary Assembly, and nothing can have given "H.F." or his many friends more pleasure than to find himself elected Chairman of this Assembly. Others will doubtless detail the work of the conference and it will suffice here to say that Faulkner once more brought into play his undoubted talents and ability for reconciling differing opinions, leaving us feeling that the success of this conference was largely a reflection of his personality; a fitting climax to a glorious career in the Post Office.

A. H. M.

A. H. Mumford, O.B.E., B.Sc.(Eng.), M.I.E.E.



WE offer our congratulations to Mr. A. H. Mumford, who has been appointed Deputy Engineer-in-Chief on the retirement of Mr. H. Faulkner.

Readers will not need to be reminded of Mr. Mumford's long and distinguished career in the radio field of the Department's activities, or of his work during the war years which was recognised by the award of an O.B.E. in 1945. His contributions to the international aspect of radio, and in particular his experience of international conferences are, however, so exceptional as to deserve special mention, particularly as they may not be so widely known in the Department as is his work in the Radio Branch. His activities in the international field commenced nearly twenty years ago, and included the C.I.S.P.R. (Comité International Spécial des Perturbations Radio-électriques) meetings at Berlin in 1935 and 1936, and the earlier C.C.I.F. meetings concerned with coaxial cable systems. In 1946 he attended the Moscow Telecommunications Conference between representatives of the U.S.S.R., U.K., U.S.A., France and China, at which it was recommended that a World Conference on telephone and telegraph communication should be called in 1948. Early in 1947 he took part in a Telecommunications Conference in Paris between the U.S.S.R., U.K. and France, as a preliminary to the long and arduous series of conferences at Atlantic City in which he was a delegate on the International Telecommunication Conference, the Radio Conference and the High Frequency Broadcasting Conference; all three of which were running simultaneously in due course instead of consecutively. Possibly he appreciated most being selected as one of the four members from the Radio Conference as international experts on frequency allocation, and entrusted with the task of detailed drafting of the Atlantic City Frequency Allocation Table; this task he shared with Major Bragin of the U.S.S.R., Mr. Paul

Miles of the U.S.A., and Commandant Loyer of France.

After taking a course at the Imperial Defence College throughout 1948, Mr. Mumford went to Geneva for the Special Administrative Conference for the North-East Atlantic (LORAN) early in 1949 on his return to Post Office activities, and was the leader of the United Kingdom delegation at the two I.T.U. Radio Administrative Conferences for Regions 1 and 3 later the same year, again in Geneva. In 1950 we find him again on a C.I.S.P.R. Conference, this time in Paris. To all these conferences he brought an intimate knowledge of the technical complexities of the subjects to be discussed, which, coupled with his powers of critical analysis and logical debate, caused him to be widely recognised as an international authority.

At home Mr. Mumford has written several papers for, and has long been active in the work of, the I.E.E. and has been a Member of Council since October, 1952. After many years as a Member of the Radio Section Committee (and Chairman of the Section in 1945-46) he is now the Council Representative on that committee. He is also a long-standing member of the Membership Committee of the Institution, was a member of the Education and Training Committee in 1952, and in 1953 a member of the Examinations Committee. As recently as 1952, in association with Mr. G. R. M. Garratt, he gave a paper at the I.E.E. Television Convention on the "History of Television," which paper was awarded a premium. Mr. Mumford has also contributed various papers to the I.P.O.E.E., is an ex-Chairman of the London Centre, and was for many years a member of our Board of Editors.

Since 1950 Mr. Mumford has been very actively engaged on staff matters. Examples of the responsibilities which have come within his province during the last few years are the chairmanship of the boards dealing with promotions to Area Engineer/Senior Executive Engineer, and with promotions to Motor Transport major grades. Also, as many of our more recent entrants to the Executive Engineer grade will know, Mr. Mumford sits with the Civil Service Commissioners Board when the Open Competition selections for Executive Engineers are being made.

Many of Mr. Mumford's activities now bring him into very close contact with the Staff Associations representing Engineering, Scientific, and Drawing Office grades, and to mention that he is Chairman of the Standing Joint Committee dealing with grading questions affecting P.O.E.U. grades is to quote but one of his many contacts with the Engineering Staff Side. He is also a member of the Engineering, Factories and Supplies Departmental Whitley Council, and of the newly formed Joint Production Council (Engineering).

Examples of Mr. Mumford's interests outside the purely technical spheres are those connected with the Engineer-in-Chief's Office Benevolent Society, and the encouragement he has given to the formation of the Engineering Department St. John Ambulance Section, whilst both he and Mrs. Mumford have supported the Engineer-in-Chief's Office Social and Sports Club functions.

Enough has been said to show that in our new Deputy Engineer-in-Chief we have a distinguished professional engineer, with an exceptionally wide national and international experience. To that background he adds, in the words of our last review, "unbounded energy, an analytical mind, and a quality of leadership, all of which are cemented with a ready wit." He carries with him to his new appointment the best wishes of his very many friends and colleagues both at home and overseas.

D. A. B.

VIIth Plenary Assembly of the C.C.I.R., London, 1953

U.D.C. 061.3 : 621.396

AT the VIth Plenary Assembly of the C.C.I.R., held in Geneva in 1951, the United Kingdom Government invited the C.C.I.R. to hold its next meeting in the United Kingdom. This invitation was accepted, and the VIIth Plenary Assembly met accordingly in London from the 3rd September to the 7th October, 1953.

It will be realised that such an invitation entails a considerable amount of extra work by the inviting administration in providing the accommodation and preparing agreements, making the arrangements for hospitality and all the many other administrative details which are necessary. After consultation with the Ministry of Works it was decided to accommodate the meeting in Church House, Westminster, which is the headquarters of the Church of England and is the meeting place of its Convocation. It will be recollected that it was here that the Houses of Parliament met during the heavy bombing attacks in the last war, and it was here that Sir Winston Churchill made some of his most famous speeches, as a plaque on the wall of one of the committee rooms reminded us.

The accommodation at Church House, which was found to be well suited for the purpose of this meeting, was, however, not sufficient by itself, and additional room was found in Sanctuary Buildings, immediately opposite Church House in Great Smith Street. Church House provided accommodation for the plenary meetings and for the two main committee meeting rooms, all of which were fitted for simultaneous interpretation in the four languages used at the conference: English, French, Spanish and Russian. Special

arrangements for providing writing space were made in the plenary hall by eliminating alternate rows of seats. Six of the seven auxiliary committee rooms, together with administrative offices, locker rooms, television and radio lounges, document reproduction arrangements, etc., were provided in Sanctuary Buildings, and proved quite satisfactory.

The VIIth Plenary Assembly was opened by the Postmaster-General, the Rt. Hon. the Earl De La Warr, on the



THE P.M.G., THE RT. HON. THE EARL DE LA WARR, OPENING THE VIIth PLENARY ASSEMBLY OF THE C.C.I.R.



A PLENARY MEETING IN SESSION IN THE MAIN HALL OF CHURCH HOUSE, WESTMINSTER.

3rd September, and the writer had the honour of taking the chair at the plenary meetings. The Conference was attended by some 350 delegates, experts, representatives and observers from 40 member and associate member countries of the I.T.U., 16 private operating agencies, and 12 scientific and other international associations. The Director, Prof. Dr. Balth van der Pol, the Vice-Director, Mr. Leslie W. Hayes, and other officers of the C.C.I.R. Secretariat, the Assistant Secretary General of the I.T.U., Mr. G. C. Gross, Mr. A. J. Gracie and other members of the I.F.R.B., also attended the Conference.

After the first formal plenary session at which various questions of a general nature were discussed, the meeting broke up into the 14 Study Groups into which the C.C.I.R. is divided for study purposes. A Drafting Committee and a Finance Committee were also appointed.

There had been a considerable amount of preparatory work in the period between the VIth and VIIth Plenary Assemblies, and some 300 documents were available for study by the Study Groups. In addition, valuable progress had been made by the following meetings of Study Groups between the VIth and VIIth Plenary Assemblies:—

Study Groups I and III	— The Hague, April, 1952.
Study Groups V, VI and XI	— Stockholm, May, 1952.
Study Group X	— Geneva, August-September, 1952.

The chairmen's reports of all the Study Groups were also available and the Conference lost no time in getting down to the details of its work of framing recommendations, reports, new questions, study programmes and resolutions. Most of the Study Groups were accordingly broken up into working parties and, since the United Kingdom was the home administration, and therefore in a position to maintain a large delegation, the Post Office engineers and their colleagues from other Government Departments and industry were very much to the fore in providing reporters, chairmen of working parties, drafting groups, etc., and there is no doubt that the valuable assistance thus rendered left its mark on the work of the Conference.

This organisation of the work put a good deal of pressure on the accommodation, and the three main committee rooms and the seven smaller rooms were in full use for most of the succeeding four weeks. Considerable pressure was also put on the interpretation staff to cope with this division of the work. With goodwill prevailing, progress was satisfactory and by the time that the plenary meetings commenced on the 28th September, an adequate flow of "pink" copies of documents for final approval had been prepared. Plenary meetings ran almost continuously from that date until on the 7th October, the date scheduled for the closing, the final plenary meeting was held and the work was completed by 11 p.m.

In the end the Conference had made 53 recommendations, 22 reports and 7 resolutions, while 38 questions and 39 study programmes, new or revised, had been tabled to direct the future work of the Study Groups.

The subjects of the recommendations, etc., covered a very wide range and only a few of the more important ones can be mentioned here. They included such items as:—

- (a) The bandwidth of emission and its measurement.
- (b) The reduction in the occupied bandwidth and transmitter power in radio telephony.
- (c) Arrangement of channels in multi-channel transmitters for long-range circuits.
- (d) Frequency shift keying and frequency stabilisation.
- (e) Reduction of harmonics and parasitic emissions from transmitters.
- (f) The selectivity, noise and sensitivity, and frequency stability of receivers.

- (g) The bandwidth required for the output of telephone and telegraph radio receivers.
- (h) Radio propagation questions of all kinds including the production of tropospheric propagation curves, ground wave propagation over mixed paths and irregular terrain, and the revision of atmospheric noise data.
- (i) Standard frequency transmissions and time signals.
- (j) The standard alarm signal for use on the maritime radio distress frequency of 2,182 kc/s.
- (k) Standards for facsimile transmission.
- (l) Telegraphic distortion and other questions.
- (m) Standards for sound recording for the interchange of broadcasting programmes.
- (n) Design of aerials for tropical broadcasting.
- (o) Use of synchronised transmissions in short-wave broadcasting.
- (p) Use of directional antennae.
- (q) Tolerable ratio of wanted to unwanted signals in television.
- (r) Nomenclature of the frequency and wavelength bands used in radio communication.

This short list is probably sufficient to give an idea of the wide range over which the Conference worked. It will be apparent that the objective of finding out how to accommodate the maximum number of radio services in the minimum frequency space was kept well to the fore. This is, in fact, the mainspring of the work of the C.C.I.R., and this Conference has made a considerable contribution to this desirable end.

The present Director of the C.C.I.R., Prof. Dr. Balth van der Pol, world renowned for his work in the sphere of mathematical physics, and a very popular figure, reaches the normal retiring age before the next Plenary Assembly, and the Conference had the pleasure of continuing his period of service by two years, so that he will be available through the next Plenary Assembly.

He was also asked to preside over an Organisation Committee consisting of the Chairmen of Study Groups to consider whether any improvements in the present organisation of the work can be suggested to the next Plenary Assembly.

The United Kingdom holds two Study Group chairs, the Vth on Tropospheric Propagation (Dr. R. L. Smith-Rose, D.S.I.R.), and the IXth on General Technical questions (Mr. H. Stanesby, P.O.E.D.). In addition, two United Kingdom representatives were nominated as Vice-Chairmen of Study Groups: Mr. J. A. Smale (Cable & Wireless, Ltd.) for Study Group III, and Mr. G. Millington (Marconi's Wireless Telegraph Co.) for Study Group VI.

Arrangements were made for the next volume of C.C.I.R. work to contain all the previous recommendations, etc., which still remain valid as well as those adopted in London, and to be provided with a subject index, so that it will be a very valuable reference book for all engaged in the radio art.

A cordial invitation by the delegate of the Polish People's Republic to hold the next meeting of the C.C.I.R. in Warsaw was unanimously accepted.

The arrangements made for providing hospitality for the delegates, both by the Government and by a number of manufacturing firms and operating agencies, were very much appreciated by all, and probably were to some extent responsible for the happy atmosphere and the good will that permeated the Conference.

In conclusion it can be said that the Conference was a very successful one, and one which will leave its mark on the history of the C.C.I.R.

H. F.

Institution of Post Office Electrical Engineers

Annual Awards for Associate Section Papers— Session 1952/3

The Judging Committee has selected the following from the papers submitted by the Local Centre Committees, and awards of £3 3s. 0d. and Institution certificates have been made accordingly:—

B. G. Woods, Technical Officer, London Centre (E.-in-C.O.)—
“Partial Call Queueing for Sleeve Control Exchanges.”

J. E. Sharp, Technical Officer, Lincoln Centre (N.E.R.)—“New Signalling Systems.”

P. E. Smith, Technical Officer, Bath Centre (S.W.R.)—
“Magnetic Recording.”

J. B. Bedford, Technical Officer, Lincoln Centre (N.E.R.)—
“Magnetic Recording on Tape.”

In addition Council has decided both for the current and subsequent years that all papers considered worthy of submission to the Judging Committee for the main awards should be awarded a prize of one guinea each. The above-named, together with the following, will therefore receive the award.

G. J. Hoare, Gloucester Centre—“Britain’s Largest Non-director Automatic Telephone Exchange.”

R. T. Ross, Aberdeen Centre—“An Introduction to Mechanical Engineering.”

A. W. Haddow, London Centre—“The Automatic Teleprinter Concentrator.”

The Council is indebted to Messrs. R. J. Hines, J. G. Straw and F. N. Lucas for kindly undertaking the adjudication of the papers submitted for consideration.

H. E. WILCOCKSON,
Secretary.

London Centre

The programme arranged for the second half of the 1953-54 session is as follows:—

Ordinary Meetings†

6th January, 1954.—“Telex Service.” R. N. Renton, A.M.I.E.E.

9th February, 1954.—“Step-by-step Auto-Exchange Maintenance in the U.S.A.” E. Hopkinson, B.Sc.(Eng.), A.M.I.E.E., and J. Prescott.

9th March, 1954.—“The Theory and Application of Transistors.” F. F. Roberts, A.M.I.E.E., and H. G. Bassett, A.M.I.E.E.

4th May, 1954.*—“Short-Wave Directional Aerial Systems.” D. W. Morris, B.Sc.(Eng.), A.M.I.E.E., W. G. Shaddick and E. W. Thurlow, A.M.I.E.E.

Informal Meetings‡

20th January, 1954.—“Facilities and Novel Features of the Standard P.A.B.X.” P. E. Pettimore and W. Sheldon, A.M.I.E.E.

24th February, 1954.—“Post-war Developments in Call-Office Equipment.” R. T. A. Dennison, A.M.I.E.E.

24th March, 1954.—“Some Aspects of the Efficiency Engineer’s Job.” D. F. Hamilton, A.M.I.E.E.

14th April, 1954.—“TV Receiving Aerials.” G. L. Stephens, A.M.I.E.E. (Messrs. Belling & Lee, Ltd.).

† Held at The Institution of Electrical Engineers, Savoy Place, Victoria Embankment, W.C.2, commencing at 5 p.m.

* This meeting will be preceded by the Annual General Meeting of the Institution commencing at 5 p.m.

‡ Held in the Conference Room, 4th Floor, Waterloo Bridge House, S.E.1, commencing at 5 p.m.

Recent Additions to the Library

2131 *Filter Design Data for Communication Engineers.* J. M. Mole (Brit. 1952).

Concerned generally with the Zobel filter, and designed to assist the practical designer.

2132 *Pictorial Drawing for Engineers.* A. C. Parkinson (Brit. 1953).

Aims at describing the geometrical bases of the various commonly-used methods of three-dimensional drawing,

describes their application to examples graded in difficulty and provides exercise for those who desire to practise the principles involved.

2133 *Dielectric Materials.* D. G. Kiely (Brit. 1953).

A compact statement of the subject designed mainly for science degree students.

2134 *Elementary Telecommunications Examination Guide.* W. T. Perkins (Brit. 1953).

Covers the C. & G. examination in Elementary Telecommunications Practice and Telecommunications (Principles) 1.

2135 *Intermediate Pure Mathematics.* J. Blakey (Brit. 1953).

Attempts to explain adequately and to give practice in all those aspects of Pure Mathematics common to both Inter. B.Sc. and the General Certificate of Education at Advanced level.

2136 *Mechanics for Engineering Students.* G. W. Bird (revised F. J. Batson) (Brit. 1953).

Specially adapted to the needs of third-year students for the National Certificate in Mechanical Engineering.

2137 *British Time.* D. de Carle (Brit. 1947).

Aims at describing the means of recording time and its distribution in the mass (to the public).

2138 *Modern Staff Training.* F. J. Tickner (Brit. 1952).

A simple exposition of what is required to meet the training needs of an undertaking, large or small.

2139 *Circuit Breaking.* H. Trencham (Brit. 1953).

Based on six lectures on the research work on circuit breaking carried out by the British Electrical and Allied Industries Research Association.

2140 *Small Motors and Transformers.* ed. E. Molloy (Brit. 1953).

Provides sufficient data to enable any engineer to undertake the design, construction and rewinding of small motors and dynamos and the design and construction of small power transformers.

2141 *Power Cables: their Design and Installation.* C. C. Barnes (Brit. 1953).

Reviews the many practical and theoretical considerations necessary for the successful design, manufacture and installation of paper-insulated power cables.

2142 *Data and Circuits of Radio and Radio Receiver and Amplifier Valves* (2nd supplement). N. S. Marcus and J. Otte (Dutch, 1952).

Contains descriptions and data of valves brought out by Philips in the years 1945-1950.

2143 *Communication Theory.* W. Jackson (Brit. 1952).

The application of mathematics to communication processes.

2144 *Principles of Electricity.* A. Morley and E. Hughes (Brit. 1953).

Based on the Rationalised M.K.S. System of Units.

2145 *Practical Automobile Engineering.* Odhams Press (Brit. 1953).

A broad but concise coverage of the whole subject of automobile engineering.

2146 *Copper in Instrumentation.* Copper Development Assn. (Brit. 1953).

Covers the use of copper in ordinary industrial instruments and in the ancillary equipment used for automatic control purposes.

2147 *Information Theory and its Engineering Applications.* D. A. Bell (Brit. 1953).

An account of recent developments in the exchange of information in relation to telecommunications and automatic control systems; requiring a knowledge of mathematics not in excess of that reasonably to be expected from the professional engineer.

2148 *Textbook on Sound.* J. W. Winstanley (Brit. 1952).

Covers the first-year work of the University; and the requirements of the General Certificate of Education at Advanced or Scholarship level.

W. D. FLORENCE,
Librarian.

Notes and Comments

Commendation by H.M. The Queen

The Board notes with pleasure that Mr. E. F. Bean and Mr. A. G. Dyer, Technicians, Guildford Telephone Area, have been commended by H.M. The Queen for the courage and determination they showed on 13th March, 1953, when they helped to extricate the pilot of an aircraft that crashed and caught fire at the Royal Aircraft Establishment, Farnborough.

Special Commendations

The Board notes with pleasure that the Postmaster-General has personally commended the following members of the Engineering Department:—

Mr. E. F. Bean, Mr. A. G. Dyer, and Mr. J. W. Ireland, Technicians, Guildford Telephone Area—for their courageous conduct in the incident referred to above.

Mr. T. W. Metcalfe, Youth-in-Training, London Telecommunications Region—for his courageous conduct on 21st September, 1952, when he attempted to rescue two men whose boat had capsized in a sudden storm at Shellness, Isle of Sheppey, an action for which the Royal National Life-Boat Institution has awarded its Bronze Medal.

Mr. H. Faulkner, C.M.G., B.Sc.(Eng.), M.I.E.E., F.I.R.E.

With the retirement of Mr. Faulkner, announced elsewhere in this issue, his Chairmanship of the Board of Editors comes to an end after a term of office which covered most of the post-war years. During this period when ever-increasing production costs forced many publications out of existence, his able conduct of affairs enabled the JOURNAL to continue without interruption, maintain its standards, and eventually achieve again the sound financial position enjoyed in less difficult times.

In tendering our sincere thanks for his valuable services we are confident that in retirement he will continue to be one of our readers and will watch with interest the further development of the JOURNAL to which he contributed so much.

Royal Signals Institution

A Royal Signals Institution has been formed and membership is open to all who are serving, or have served, as officers with R. Signals (regular, or auxiliary and temporary commissions) in the British or Dominion forces, and, in addition, to officers of the W.R.A.C. (or A.T.S.) who have served, or are serving, with R. Signals.

Broadly speaking, the Institution has been formed to further the cultural activities of the Corps and it is hoped to issue the first copy of the *Royal Signals Journal* to all members of the Institution early in 1954.

The subscription for officers of auxiliary forces, retired officers and ex-officers, is 15s. a year, and application for membership should be made to:—

Lt.-Col. N. G. Newell, Hon. Secretary, Ministry of Supply, Room 419, Castlewood House, 77/91 New Oxford Street, W.C.1.

Proposal to Amalgamate the C.C.I.T. and C.C.I.F.

In the note on the Plenary Assembly of the C.C.I.T. published in the October issue of the JOURNAL, reference was made to a resolution passed by the C.C.I.T. to the effect that it would not be in best interests of the Union that the C.C.I.T. and C.C.I.F. should be amalgamated. The votes for and against this resolution were quoted as 17 in favour with 10 votes against. An amendment to the record of the votes cast has since been issued by the Director of the C.C.I.T. indicating that the voting should now be recorded as 16 votes for and 11 votes against.

Capt. C. F. Booth, O.B.E., M.I.E.E.

Welcomed into the Radio Branch laboratories at Dollis Hill in 1923, where he was to remain for just over 25 years, Capt. C. F. Booth achieved the distinction of becoming the first Staff Engineer in charge of these laboratories when they were formed as a separate Branch in 1949. His award of the O.B.E. in 1947 was a well-deserved honour. He is well known for the many articles and papers which he has stolen time to write dealing with various facets of the radio art and particularly for his knowledge of quartz crystals and primary frequency standards about which he is an international expert of repute. His book, entitled "Quartz Vibrators and their Applications," written in collaboration with Mr. P. Vigoureux and published in 1950, is a comprehensive text-book on the subject and is an excellent example of the way a busy man finds time to do even more.



Like so many of his radio colleagues he has frequently, in the last few years, been immersed in the intricacies of international conferences. Thus he was the International Chairman of Study Group IX of the C.C.I.R. dealing with General Technical Questions for about three years; leader of the U.K. delegation to the fifth meeting of the C.C.I.R. at Stockholm in 1948, and to the sixth meeting of the C.C.I.R. in Geneva in 1951. Between whiles, he has attended various meetings of the C.C.I.F. and C.C.I.T. as a radio expert. In 1951 he also attended the Extraordinary Administrative Radio Conference at Geneva as the senior technical delegate of the U.K. At this conference he was faced with solving that most difficult of problems, the individual allocation of frequencies to the many stations requiring to work simultaneously in a limited amount of frequency spectrum. Whilst it would be idle to pretend that the issue is solved, undoubtedly the methods devised for easing this most difficult problem, accentuated by the coming into force of the Atlantic City Frequency Allocation Table, owe much to him.

Leaving Dollis Hill in April, 1951, not only somewhat to his own regret but also to that of the staff there, he took over the Radio Planning Branch where he found a wider scope awaiting him. It caused no surprise when on the setting up of the External Telecommunications Executive

in October, 1952, he became Deputy Director. Given even greater scope for his powers of organisation and applying his personal capacity for work with possibly even more vigour—much as he also likes to see it applied by others—he has done much to prepare the foundations on which his successors can safely extend and improve the activities of the Executive.

Member of the Committee of the Radio Section of the Institution of Electrical Engineers apart from a short interval since 1941 until recently, he was the Section Chairman in the 1950/51 Session, not unnaturally choosing "The Evolution of Frequency Control" as the subject of his Chairman's address. He was awarded by the Institution the Page Thesis Prize in 1932, the Duddell Premium in 1935, the Institution Premium in 1941 and Extra Premiums in 1946 and 1947 for various papers on quartz crystals, frequency measurement and standardisation. A great lover of children, who quickly become his friends, some of us wish that he would commit to paper some of the wonderful stories which he can conjure up so readily for his young friends. No wonder his Christmas lecture in 1948 at the I.E.E. to some hundreds of London County Council school-children on "Telephones, Telegraphs and Television" was so successful.

As we remarked on a previous occasion, "Gifted with the ability to size up a situation, a well-developed and appropriate sense of humour, and an insatiable appetite for work," his promotion to Assistant Engineer-in-Chief should again give him "unique opportunities of applying these gifts" and we wish him well on his return to this Office. A. H. M.

Correspondence on Television Service to Belfast

The Managing Editor,

Dear Sir,

It has been brought to my notice that there was an inaccuracy in my article on the television link to Belfast in the October issue of the JOURNAL. The picture shown in Fig. 6 was not passed by microwave link from Kingston Seymour to Wenvoe but to Bristol; it then traversed a short telephone-pair link set up by a Post Office Television Outside Broadcast team before being passed to London by coaxial cable. So there were, in fact, nine video-to-video links in tandem in the overall circuit to Belfast, and not eight as stated in the article.

Yours faithfully,

T. KILVINGTON,

E.-in-C.O., Radio Experimental and
Development Branch.

Mathematics for Telecommunications

Students preparing for the City and Guilds of London Institute examinations in Telecommunications Engineering will be pleased to learn that, in future, the Supplement will include model answers to questions set in Mathematics for Telecommunications II and III.

For the 1953 examinations, answers to Mathematics II are included in the current Supplement; Mathematics III will be published in the April, 1954, issue which will also include answers to questions set in Radio IV, Telecommunications (Principles) V, Telephone Exchange Systems III, Line Transmission II, and Telegraphy II.

Book Reviews

"Electronic Valves, Book VIII B, Television Receiver Design—Flywheel Synchronisation of Saw-tooth Generators."
P. A. Neeteson. Philips Technical Library. 156 pp.
118 diagrams. 21s.

Flywheel synchronisation, commonly used in American television receivers, is beginning to make its appearance in domestic receivers in this country. When a noisy signal is received, as in fringe areas, impulses of noise sometimes tend to trigger off the line timebase at the wrong time, causing the picture to break up. This trouble is more prevalent with the American system using negative modulation where a noise impulse occurring at any time can have a form similar to that of a synchronising pulse; but it is also experienced in bad receiving points in this country where noise impulses occurring during the line synchronising signal may tend to obliterate this signal altogether.

In the system known as flywheel synchronisation, inertia is added electronically to the timebase so that although the saw-tooth generator operation is controlled by the regularly recurring synchronising pulses in the incoming signal it resists any sudden change of speed such as would be caused by false synchronisation on noise impulses or by the omission of occasional synchronising pulses. The improvement that can be obtained is remarkable and synchronisation can be maintained at signal-to-noise ratios which are so low that the resulting picture is almost unintelligible.

This volume, the second of a series on television receiver design in the Philips Technical Library, deals with the subject in a comprehensive way and also includes a useful ground-work on saw-tooth generators in general and conventional methods of synchronising them. The treatment is mathematical and will undoubtedly prove to be of great value to the specialist in television receiver design.

T. K.

"Principles of Electricity in M.K.S. Units." A. Morley, O.B.E., D.Sc., Hon.M.I.M.E. and E. E. Hughes, D.Sc. (Eng.), Ph.D., M.I.E.E. Longmans, Green & Co. 364 pp. 227 ill. 10s. 6d.

Several excellent elementary engineering text-books have already been written under the joint authorship of Dr. Morley and Dr. Edward Hughes, and many engineering colleges have been accustomed to use their books as part of their normal routine. The recommendation of the International Electrotechnical Committee in 1950, and of the Council of the Institution of Electrical Engineers in 1952, that the rationalised "Metre-Kilogram-Second" (M.K.S.) system of units should replace the systems in current use must have placed engineering teaching establishments in a quandary as it automatically made their favoured text-books on electrotechnology out of date.

This new electrical engineering primer rectifies the situation as it considers the fundamental aspects of electrotechnology entirely in terms of the rationalised M.K.S. system of units. After the opening chapter, in which they explain clearly the fundamental units that are to be used in the following text and their relation to those of the more well-known C.G.S. system, the authors use only the M.K.S. units, which has the effect of accustoming the reader to the new units quite rapidly. A student just embarking on a study of electricity will experience little difficulty with the M.K.S. system. Those who have spent many years with the conventional systems of units will have to alter some of their habits of thought to keep up to date, however, and a few hours spent in reading this book should help them very considerably.

The book covers the basic principles of electrotechnology in D.C. and A.C., up to the standard of approximately Inter. B.Sc., the Ordinary National Certificate or Telecommunications (Principles) II of the City and Guilds of London Institute. It is to be hoped that with this, their latest book, the authors will again achieve a deservedly wide circulation amongst the technical colleges and universities.

C. F. F.

Regional Notes

Wales and Border Counties

AN UNUSUAL CABLING PROBLEM

Considerable difficulty was experienced when drawing a 294/20 P.C.Q.T. cable over the existing 80/20 + 4/40 P.C.Q.T. cable in a 4-in. SA duct line, between Carmarthen and Aberystwyth.

Exceptionally heavy pulling was experienced and in various sections the existing cable was found to have moved 6-24 in., as measured at the winch end of the section, whilst the new cable was being pulled in. Efforts were made to prevent the movement by anchoring the existing cable in the jointing chamber at the feeding-in end of the section, but this did not prove entirely successful.

During the pulling in of one length of 197 $\frac{2}{3}$ yd. between an R2 loading coil manhole and a J.R.C.9 joint box, and after about 80 yd. of the new cable had entered the duct, the anchoring device on the existing cable in the manhole suddenly parted, and the loading coil shot across the manhole for a distance of 4 ft., the stub joint at the same time disappearing up the duct.

Excavations were carried out to locate the grip end of the new cable, and removal of the duct revealed the existing cable to be in the form of a wave. Further excavations were continued along the line of the track and ducts removed to expose the cables, which were found to have become tightly wrapped around each other.

This wrapping was not, however, caused through the cables dipping over and under each other, but apparently by slack in the existing cable which had been pushed forward by the new cable until it was forced by the diameter of the duct to fold itself over the new cable.

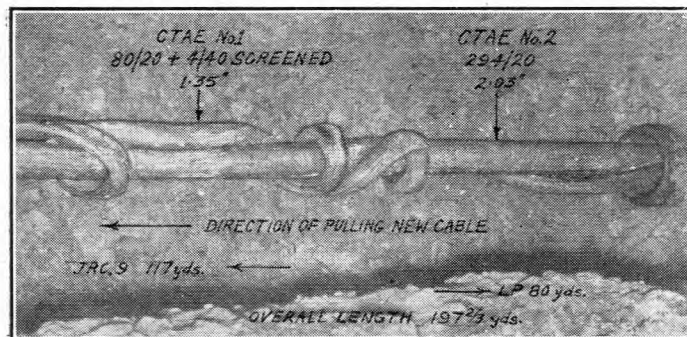

WRAPPING OF CABLE DURING DRAW-OVER OPERATION.

In spite of the severe crippling of the sheath the only fault reported was a contact between the A and C wires of one quad. Examination of the loading coil revealed that a slight crack had occurred in the sheath of one of the stubs.

Cabling operations were resumed with the following precautions. The existing cable was first tensioned using a chain puller and dynamometer at each end of the length with the object of withdrawing any slack which might have existed in the duct. The tension applied was of the order of 700-1,000 lb. A roll of hessian was then made up and saturated with a mixture of colloidal graphite compound and petroleum jelly, and this was drawn through the duct in advance of the new cable but from the opposite direction. This was done to lubricate the existing cable and duct before the installation of the new cable and was additional to the usual lubrication of the cable as it was being drawn in. These methods did not give the full answer to the problem but conditions were considerably improved.

W. L. J.

HEREFORD AUTOMATIC EXCHANGE CONVERSION

Hereford is probably unique for a town of its size in having been served by three automatic exchanges in succession. The first was installed in 1913 by The Canadian Machine Telephone Co., and was known as a "Lorimer System" exchange. This was a revertive impulse system, the impulses being sent back to the subscriber's instrument where they were counted on a

pre-set mechanism. There was no dial, the subscriber's instrument looking something like a cash register. The exchange gave good service until 1927 when, owing to its inflexibility and the general policy to proceed with the Strowger System, it was replaced by a Siemens No. 16 type exchange. This exchange, after extension to the limit of practical possibility, has now in its turn been replaced.

The third automatic exchange was provided under contract by Siemens Brothers & Co., Ltd., and was brought into service on 31st October, 1953. It is of the standard 2000-type with a multiple capacity of 3,400 subscriber's lines. Multi-metering is provided, together with a through-dialling scheme for exchanges in the surrounding country, using impulse regenerators. Hereford is a group centre and the manual switchroom is equipped with 41 controlling and six monitorial positions. The new building, which abuts the old, is pleasantly designed with multi-coloured bricks and hand-cut slates and adds to the amenities of the Cathedral Close which it overlooks.

The transfer arrangements were simplified by the juxtaposition of the old and new buildings. A temporary cable-run was erected between the old and new M.D.F.s and the existing protectors cabled to tagblocks on the new M.D.F. This allowed the external cables to be diverted prior to the transfer and the tees provided by jumpers on the new M.D.F. After the transfer the temporary jumpers and cabling were quickly recovered without interference to service.

S. E. N.

South-Western Region

USE OF MOBILE V.H.F. STATIONS DURING SUBMARINE CABLE BREAKDOWN

The submarine cable providing the link for the only two telephone lines to the small island of St. Agnes, which lies some three miles south-west of St. Mary's (the main island of the Isles of Scillies) was reported cut at 5.38 p.m. on Tuesday, 11th August, 1953, resulting in loss of communication between the island and Scillonia exchange at St. Mary's. This was found to have been caused during sunken buoy dredging operations in St. Mary's Sound by T.H.V. *Satellite*, which is well known in south-west coastal waters as the vessel used by the Trinity House Commissioners for the maintenance of coastal lights and buoys and for reliefs to the isolated lighthouses off the coast.

The Submarine Cable Group was unable to release a cable ship to carry out early repairs to the 4-core cable. Arrangements were therefore put in hand to provide a temporary link for this island community of some 80 people. This community has enjoyed direct communication since 1892, when the original single-core telegraph cable system around the Isles was laid, and telephone service since 1938 when the Scillonia exchange was installed and the telegraph circuits abandoned. It can be well imagined how the need for communication with such a remote island can become urgent. With the heavy seas experienced around these islands the local boats serving them are often unable to put out of harbour.

It was decided that the use of one of the mobile V.H.F. systems recently introduced by the Department would meet the need until the cable was repaired and restored to service.

The apparatus was received at Penzance on the 14th August, and arrangements were made for its dispatch to the Scillies by steamer on the following day. Upon arrival, the base station equipment was fitted without delay, being mounted on a table adjacent to the switchboard in Scillonia exchange. The aerial, a cylindrical type of coaxial dipole, was erected on the chimney stack on the P.O. roof. This building only gave a height of 42 ft. above ground level and this meant that the Garrison Hill of about 120 ft. above sea level was between the base and mobile stations, interrupting the visual line of sight. To check against any difficulties this might introduce, the mobile unit was temporarily mounted on a Morris Minor van and taken around St. Mary's to different localities which offered similar land obstacles, but which were not, of course, so far away as St. Agnes. The results varied, but in all cases were successful enough for good message transmission and reception.

The following day, the mobile equipment, batteries, and associated gear were taken to St. Agnes, where it was decided that the best site for the station would be at the local sub post office. After some difficulty with the mobile set, which was probably caused in transit by open boat, the stations were

tested and handed over for traffic at 6.30 p.m. on Sunday, 16th August, the call signs used being base station—"Scillonia Exchange" and mobile station—"St. Agnes Mobile."

It was arranged that emergency calls could be passed at any time to Scillonia exchange by switching on the mobile set, calling in and passing the message. Should no such calls be necessary, then test listening calls were to be made at scheduled periods. The system worked without any further trouble, and proved admirably suited to the circumstances. The local residents at both St. Mary's and St. Agnes were puzzled by the type of aerial in use and thought of all sorts of descriptions for it, but were highly complimentary to the Department for provision of this standby service in the short time since the cable had gone faulty.

H.M.T.S. *Monarch* subsequently cleared the disconnection by inserting a new length of submarine cable in the deep water channel off Spanish Ledges, between the islands, normal service being restored on 3rd September, 1953.

S. T. S.

HIGHER THAN LEADHILLS!*

For the past 147 years, references to Dartmoor have been mainly associated with events in the famous prison at Princetown, but, for telephone people at least, another not so bleak building has taken pride of place of late.

The telephone needs of the "highest town in England" have for the last 24 years been served by an exchange comprising one Switchboard, C.B.S. 473, $\frac{5 + 20}{70}$ accommodated in the

Post Office and the small band of 47 subscribers has included "The Moor." When the present Postmaster indicated his desire to be relieved of the onus of continuing the manual service, it was decided to proceed with the provision of a U.A.X.12 as this would meet all forecast requirements, and a site was purchased immediately behind the Post Office at an elevation of 1,367 ft. above sea level. In order that the "B" type building would conform with local requirements a flint-spar rough-cast finish was specified together with a slate roof, the finished building toning with the grey surrounding buildings. Moreover, the site was enclosed by a granite wall of great thickness, again more to match the neighbouring property than to deter the ever-wandering Dartmoor ponies.

As soon as the building was weathertight, installation for two Units Auto 12A and one Unit Auto 12B commenced. A mains supply was fortunately available and it was possible to provide electrical heating during the installation period. This was desirable not only for staff welfare in view of the early spring season when snow showers over the town were not infrequent, but also to reduce the humidity within the building. As probably most "old lags" will testify, one of the worst features of Dartmoor is the ever-recurring mist which drenches everything which it contacts. Under such conditions it was difficult to ensure that the standard of insulation required for automatic working was obtained on junctions made up of 6 miles of open wire, and on subscribers' lines often two or three miles from the D.P. It was necessary to take advantage of every brief dry period to get workable test results, but by persevering all was ready for transfer by the end of May, 1953. The transfer had been fixed for 1.0 p.m. on 28th May and to everyone's great relief the morning dawned dry and clear and no faults existed. By 11.30 a.m. all preliminaries had been completed and it was only necessary to wait for 1.0 p.m. to perform the change-over. Shortly after noon it was reported that all junctions were out of action and the lineman sped along the route to ascertain the cause of the trouble, which was readily located at the middle of the route. One pole was down together with all wires, and standing nearby in boggy ground was one R.N. jeep with a very distorted front bumper, complete with crew. Apparently in overtaking another vehicle the jeep had struck a rock which caused it to leave the road, traverse some 40 ft. of rock-strewn moorland and hit one of the 30-ft. medium poles which were spaced a full 60 yd. apart. The pole had yielded at the ground line and the jeep passed through the gap before the remainder complete with arms and wires crashed down.

* Leadhills exchange, Lanarkshire, is situated approximately 1,200 ft. above sea level.

Nearby gangs were hastily summoned to repair the damage, and the transfer was postponed for 30 minutes. However, two gangs were quickly on site and working in conjunction with the lineman, the wires were pulled up and joined through. At 1.30 p.m. precisely the transfer took place with all junctions working. As if to compensate for the apparent lack of consideration by the "Marines," all subscribers were at home and seemed to be waiting by the phone to confirm that all was in order so far as they were concerned.

S. D. C.

North-Western Region

C.C.I.R. VISIT

The Regional Director and the Manchester Telephone Area staff were happy to welcome some 100 members of the Seventh Plenary Assembly of the C.C.I.R., who came to Manchester on the 27th September to see the microwave television link. Standard Telephones & Cables, Ltd., organised the tour, and splendid late summer weather gave the visitors, who had stayed overnight at the Central Training School at Stone, the opportunity to enjoy their coach journey through the hills and to inspect Windy Hill relay station under ideal conditions.

F. W.

CHESTER-OLD BOSTON ROUTE. RIVER WEAVER CANAL CROSSING

The above route follows the Chester-Warrington road to Warrington and at Sutton Weaver a swing bridge carries the road traffic over the canal. At this point it is 34 yd. wide with a maximum depth of 12 ft., reducing to approximately 5 ft. at each bank. The river is navigable from the Manchester Ship Canal to Northwich for barge and power boat traffic.

A cable from Chester to Warrington was provided in 1945 and at the above point the river was crossed by subaqueous cable.

The need for a new cable from Runcorn to Frodsham entailed a further crossing of the river and the Inland Waterways Executive was approached for a wayleave for the work. The wayleave was agreed subject to the existing cable being recovered and laid with the new cable so that there would only be one crossing, thus reducing the section of the river that could not be dredged. In addition the cables were to be laid 5 ft. below the dredging line as an added precaution when dredging was subsequently carried out on either side of the crossing.

During the planning stage a further 542/20 cable from Chester to Old Boston was proposed and finally, in order to cater for future requirements and to carry the existing CS-WA cable, it was decided to lay three 542/20 QT and four 24/40 QT armoured cables.

The river bed is composed of hard clay which rapidly approaches a soft rock formation and in order to reduce the time involved in cutting a new trench it was decided to use the existing crossing. The Waterways Executive insisted that all work on the river should be carried out on Sunday when there is no river traffic. An interruption cable was laid across the river and all circuits from the existing cable diverted. The CS-WA cable was then recovered and the trench re-excavated by the Waterways Executive.

The seven cables were laid on one Sunday, each cable being drawn across individually and positioned by a diver employed by the Waterways Executive. The diver was responsible for the anchorage of the cable in the river bed and the attachment of the protecting baulks on each bank.

No serious difficulties were experienced in the performance of the work.

A. S.

Midland Region

SLEWING A JOINTING CHAMBER AND DUCTS

A case occurred recently in the Leicester Telephone Area where the County Council proposed road improvements which necessitated the moving of Post Office plant, both overhead and underground.

At one point where the road was to be widened the new position for the kerb was through the middle of a J.R.C.1 box. The normal arrangement in such cases is to demolish the existing structure, slew the duct line to its new position and

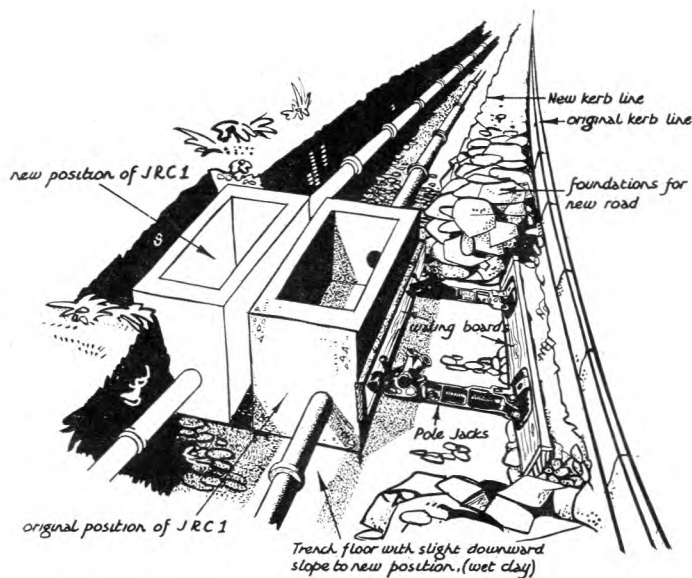

SKETCH TO ILLUSTRATE SLEWING OPERATION.

rebuild the jointing chamber. The County Council were pressing for the moving of Post Office plant to allow the new kerb to be laid but the amount of other work on hand made it difficult to obtain the services of the box-builder just at that time.

At this stage the idea of slewing the J.R.C.1 was suggested and the working parties dealing with the overhead re-arrangements were brought into the picture. Ground on all sides of the box and for a short distance along the length of duct was excavated and two pole jacks set up. By careful operation of the jacks, the box and ducts leading to it were moved to their new positions without any damage to the duct, box or cable. It is perhaps worth mentioning that a bucket of water thrown on to wet clay makes an excellent lubricant to help slide the box to the new position!

The working parties concerned deserve special mention for the patience and skill shown in this unusual operation which seems to suggest that a further U.C.C. item might be required under the heading of "Joint Boxes, Slew'd"!

J. E. R., E. M.

LONDON-BIRMINGHAM RADIO LINK AERIAL TOWERS

An inspection of the London-Birmingham radio-link aerial towers, which are of galvanised steel construction, has revealed signs of corrosion caused by atmospheric pollution.

The towers in this Region have been adversely affected in the following order of severity; (1) Telephone House, Birmingham, (2) Turners Hill, in the Black Country, and (3) Charwelton, which is in remote rural surroundings and is in relatively good condition.

Another factor accounting for the varying degrees of corrosion is that the system opened with the permanent tower at Telephone House and temporary masts at the intermediate stations. The tower at Telephone House, which was erected in 1949, is therefore more aged than the permanent towers now at the intermediates which were built about 18 months later.

The corrosion, although not very advanced, was sufficient to warrant the protective painting of the tower on the roof of Telephone House and this has now been completed. It appears likely that the tower at Turners Hill will require similar treatment within the next year or two, although at the time of erection of the towers it was anticipated that the protection afforded by the galvanising would be effective for at least 10 years.

The work at Telephone House was carried out by contract and consisted of de-rusting, followed by application of red lead primer, aluminium sealer, and aluminium finishing coat.

The main difficulties encountered were due to high winds and defiling of the paintwork before it was dry by hundreds of starlings which attempted to roost at the head of the tower at dusk. The work was carried out in October and the nightly

migration of the starlings to the centre of the city which commences at about this time of the year is the concern of many people. It was necessary for the workmen to remain at the tower-head until dark to scare the birds away. Once darkness had fallen, they had settled elsewhere.

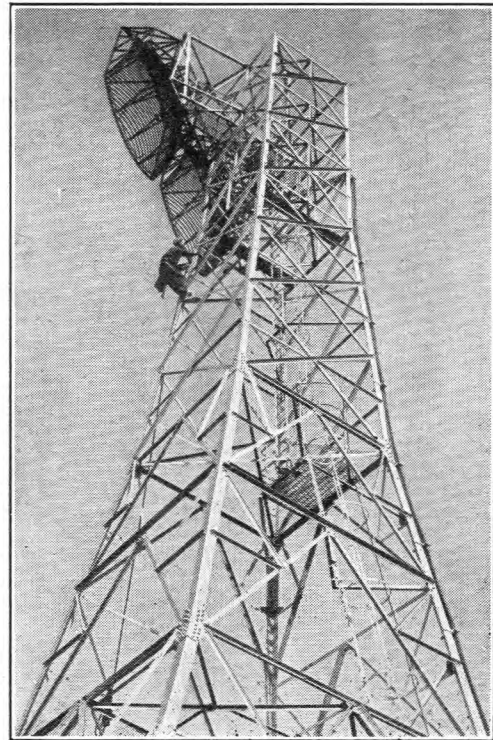

Photo. Courtesy of "Birmingham Post & Mail"

RENOVATION WORK IN PROGRESS ON AERIAL
TOWER, TELEPHONE HOUSE.

In addition, serious corrosion of the aluminium clips fixing the copperclad cables for the de-icing system to the aluminium paraboloid reflector members has occurred. It is suspected that this corrosion is both chemical and electrolytic. There were also signs of slight corrosion at some points where these cables were in contact with the paraboloid members. The original clips have now been replaced at the three stations by stand-off clips which hold the cables slightly away from the reflector members. This was done to ensure that the cables would only need protection against further corrosion over the area of contact with the clips.

These operations were carried out with the reflectors *in situ* and some stages necessitated work being done from within the reflector bowl.

The work on the tower at Telephone House was of sufficient public interest to be featured in the local press.

Thanks are due to staff from Criggon Radio Station who were loaned for this work, and for other items of tower maintenance.

J. W. T., H. H.

RE-USE OF RECOVERED TRUNK POLES

Consideration has been given in the Midland Region to the possibility of converting sound recovered stout poles into timber of more useful sizes. The percentage of recovered stout poles fit for re-use has been found to be high, but the further use of such poles on present-day construction is generally very limited on account of their substantial dimensions. It was considered that by splitting the poles longitudinally it would be possible to produce poles of a strength equivalent to "light" or "extra-light," and that provided they were given a suitable preservative treatment a useful life of 10-20 years could be expected.

The selection and cutting of the recovered timber was accordingly directed towards producing the equivalent of light poles in lengths from 26 ft. to 30 ft. Schedules showing the required dimensions of the poles were prepared and issued to the staff concerned, together with particulars of branding

and drilling requirements; a local firm was found to be willing to undertake the cutting and shaping of the poles, all visible embedded ironwork first being removed by P.O. staff. Experience showed that the most suitable method of cutting is to halve the poles longitudinally—in line with the old arm bolt holes—and afterwards remove the “points” of the D-shaped sections produced so that a “face” of about 3–4 inches wide is formed. To make for easier handling of the “rectangular” section a slight chamfer is formed to remove the resulting sharp corners between the flat faces; the sawn surface is quite as smooth as the original surface of the pole. The steps are fitted to the side faces.



“HALVED” POLE ERECTED.

Tests were carried out on some of the poles produced and the strength was found to be adequate, particularly since a slightly greater cross-section of timber is obtained than in the equivalent standard poles. Tests were also carried out on steps fixed to one of the poles; this was considered advisable as the coach screws are driven at about 45 degrees to the annular rings instead of at right angles to them as is normal. In every case the steps themselves failed before the coach screws or timber showed signs of movement, thus proving the security of the coach screws.

In the first trials it was found that the original creosoting had affected only 1½ in. to 2 in. of the outer sapwood layers, the interior of the pole being white well-seasoned timber; some method of additional preservation was therefore considered necessary in order to ensure a useful future life of the poles. Experiments showed that a fair depth of penetration

could be obtained by completely immersing the cut pole in hot creosote and then transferring it to a bath of cold creosote. The absorption of creosote by this method was considerably in excess of that realised by immersing the section in cold creosote only, although somewhat less than that realised with pressure treatment as given to new poles. Satisfactory results were obtained by using an open-tank process employing two 30-ft. tanks set up side by side under a shelter consisting of poles and tarpaulins. The “hot” tank was provided with a 1 in. thick lagging of straw and a cover, and heating was by means of a suitably arranged immersion element consisting of 400-lb. G.I. wires. For the initial trials a 30-kW petrol-driven D.C. generator was used and the tank containing 200 gallons of creosote was heated from cold to 200°F in just over two hours. Satisfactory penetration of creosote resulted from 1½ hours’ immersion in the hot tank followed by 1½ hours in the cold tank.

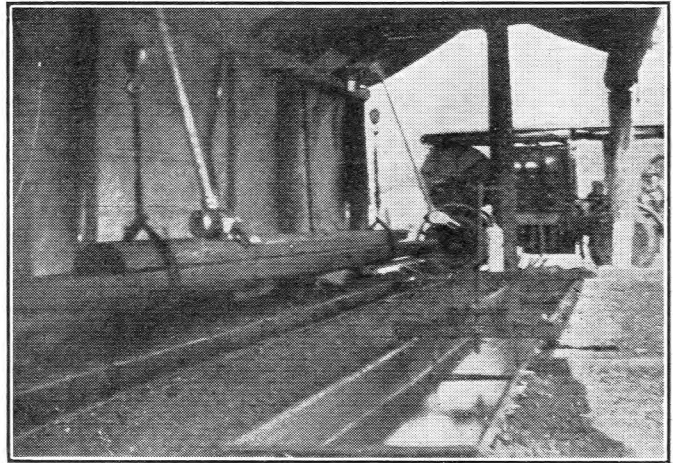

EXPERIMENTAL CREOSOTING PLANT.

Although the creosoting of the converted poles as described above is quite satisfactory as regards the depth of penetration and preservation of the timber, it has now been found possible to have this work done at two timber-creosoting plants in the Region—one in Birmingham and one at Boston—thereby accelerating the conversion process.

The Midland Region already has some hundreds of poles which have been recovered and many more to be recovered; the principle of conversion of recovered stout timber seems sound therefore, and the Forest Products Research Laboratory suggest that the poles so produced should be good for at least 20 years. The cost of conversion, plus the value of the recovered poles (i.e., the price for which they could be sold), is favourable in comparison with the present-day price for poles; even if a long haulage to a creosoting plant is required the costs are still favourable. Several batches of poles have been converted and are proving quite satisfactory in use. The poles are not objectionable in appearance and no wayleave difficulties have been experienced. R. J. C., R. G. T.

Book Review

“Principles of Electronics,” H. Buckingham, Ph.D., M.Sc., A.M.I.E.E., and E. M. Price, M.Sc.(Tech.) Cleaver-Hume Press, Ltd. 335 pp. 266 ill. 15s.

Electronic engineering has now grown to an extent at which it impinges on most branches of engineering. Thermionic valves and vacuum tubes are no longer the special concern of telecommunications and radio engineers only, as electronic devices often form an essential part of much heavy current engineering equipment. Some understanding of the general principles governing the behaviour of valves, amplifiers, rectifiers, cathode-ray tubes and so forth is likely to be valuable to all electrical engineers.

This book, “Principles of Electronics,” has been written for the young engineer trained in general alternating current techniques and network theory to the standard of, say,

Ordinary National Certificate, but who does not intend to proceed to a specialised electronics course. The first five chapters discuss the fundamental physics of electrical conductivity. The behaviour of an electron under the stimulus of various types of magnetic and electric fields is calculated, leading to a discussion of electron lenses and the production of electron beams. From this point the subject matter spreads over a wide field, including the discussion of the principle of operation of many common types of thermionic valve and their simple applications, including photo-electric cells, cathode-ray tubes, and counting circuits.

The authors are to be congratulated on having produced a book with a coverage that many electrical engineers will welcome, and on writing it in a pleasing style that is easy to read.

C. F. F.

I.P.O.E.E. Library No. 2155

Associate Section Notes

Birmingham Centre

This session was opened by Col. Calveley, President of the Associate Section, at a meeting on 17th September when he read a paper entitled "The Present System of Appraisal and Promotion." A considerable amount of information on this subject was given to those present and there were plenty of questions put to the President after the paper. Col. Calveley's visit was very much appreciated by all and it is hoped that he went away satisfied that this Centre is alive and active.

The meeting held in October proved to be extremely interesting; Mr. Spikes, of Joseph Lucas (Gas Turbine Equipment), Ltd., did his utmost to cover, in the short time available, as many aspects as possible of the very wide field represented by the title of his talk, "Jet Propulsion." Question time served to clear up many of the points of doubt still in the minds of those present.

Visits this session are still as popular as ever. The first one was to the Alexandra Theatre to see the stage and electrical gear. This is a very up-to-date installation and a most interesting morning was spent seeing everything. An experience comparatively few people have is to go down a coalmine, but the chance of such an experience was again offered to members of this Centre by a visit to Hamstead Colliery in October. Unfortunately the size of the party was limited to 12 and this only served to satisfy a fifth of those wishing to take part! It is hoped to arrange further parties to both the theatre and the colliery in the near future.

K. G. S. A.

Bishops Stortford Centre

The 1953-54 session of the Centre got off to a flying start on Tuesday, 22nd September, when the A.G.M. was held at South Street. What promises to be a very interesting programme was submitted for the approval of the members. The A.G.M. was followed by a film show consisting of films depicting various aspects of the application of electrical power to industry.

On 13th October a party of members visited the Vauxhall Motor Works at Luton, where an extremely interesting and informative day was spent. All stages in the making of a car were seen, to the time it was driven off the end of the assembly line.

Following this outing, a visit was paid to the B.B.C. Studios at Portland Place during the evening of 23rd October. Many questions were asked, and the answers were ably given by the engineer who showed us round. One could not help noticing the very high degree of co-operation between the various departments concerned in the presentation of this very complex service to the public.

The remainder of the winter's programme is as follows:—
November.—"Radio Valves," by J. S. Rogers. "The Superhet Receiver," by J. Poole.

December.—Paper; and visit to P.O. Wireless Station at Ongar.

January.—Paper; and visit to Coaxial Intermediate Stations (W. Harper).

February.—Visit to Ediswan Valve and C.R.T. Factory at Brimsdown.

March.—Visit to Scotland Yard.

The membership figure is now 55. We would like to see more of the External staff at our meetings; there is plenty of room for everyone.

J. S. R.

Brighton Centre

The activities for this session commenced on Saturday, 5th September, when two motor coaches took a party of members from Brighton and Worthing on a visit to London Airport. The visit, which proved to be a very interesting one, included a conducted tour round the airport, during which we saw many types of aircraft, notably Constellations, Strato-cruisers, D.C.6s, and the jet-propelled Comet. Several members took advantage of the opportunity to have a flight in a D. H. Rapide aircraft. The trip was repeated on 19th September when another coach took a party of our Eastbourne members on a similar visit.

The winter programme is now prepared, and the first meeting was held on 7th October, in Telephone House, taking the form of a film show at which the film "Atomic Physics" was shown. The film tells the story of the development of nuclear fission, with a commentary and animated diagrams, and with comments by such leading scientists as Lord Rutherford and Sir John Cockcroft. Further details of the programme are as follows:—

4th November.—Film Show.

2nd December.—"The Development of the Telephone Business," by a Senior Section Member.

6th January.—"Television," by an Associate Section Member.

3rd February.—"Visit to America," by a Senior Section Member.

3rd March.—"Radio and Television Interference," by an Associate Section Member.

7th April.—Annual General Meeting.

K. E. G.

Edinburgh Centre

Although there has been an encouraging interest in the Centre's activities this winter, attendances at the last two meetings have been disappointing and it is hoped that members will take note and lend their support throughout the remainder of the season.

A full programme has been arranged up to the A.G.M. in April, but suggestions on additional items are always welcomed. Many interesting visits are being negotiated, but if anyone has anything special in mind a word to a member of the committee will set the wheels in motion.

The Centre has room for many more members, so come along to our meetings; there is sure to be some subject in our programme that will appeal to you.

J. R. H.

Glasgow and Scotland West Centre

The Centre has shown a marked increase in numbers and interest in this new session. The membership stands at over 130 (an increase of over 60). This is due in no small measure to having a committee member in each division of the area covered by the Centre and that committee member, by personal contact, doing a grand job stimulating interest.

The opening meeting was conducted by Mr. J. L. Angus, B.Sc., A.M.I.E.E., our chairman, and the distinguished visitor was Dr. A. W. M. Coombs, of the Research Station, Dollis Hill. Dr. Coombs was an instant success and made the intricacies of "Electronic Switching" simple and easily understood with just that dash of humour to make the operation painless! There were about 90 happy patients present.

The proposed visits to a weather ship proved so popular that three separate visits were arranged. They were most enjoyable and instructive.

Messrs. Dobie's, of Paisley, the Four-Square Tobacco Works, provided another interesting and intriguing visit when a party was conducted round the works and saw the processes which convert tobacco leaf to your favourite blend of tobacco or cigarette.

The next meeting gave Mr. Goldie, T.O., an opportunity to address the Centre on "Local Line Planning." This member's paper was well received and resulted in some interesting discussion.

The last meeting of 1953 was addressed by Mr. J. M. Allan, A.M.I.E.E., on the subject of "D.P. Records—a New Method of Verification."

We wish all our members, lecturers, readers and those who have entertained us to visits a Happy and Prosperous New Year.

J. F.

Middlesbrough Centre

The 1953/54 session commenced with an open night on 29th September, 1953. The Chief Regional Engineer was present and presented the National Award and C.R.E.'s prize to two of our members for papers read at the 1951/52 session. Mr. Beer stressed the need for a lively Associate Section and congratulated Middlesbrough Area on maintaining two thriving Centres. After a short interval, when refreshments were served, Mr. F. H. Eccles, a local business man, presented a selection of films. The thrills and spills of the Monte Carlo rally and Le Mans 24-hour car race were followed by an

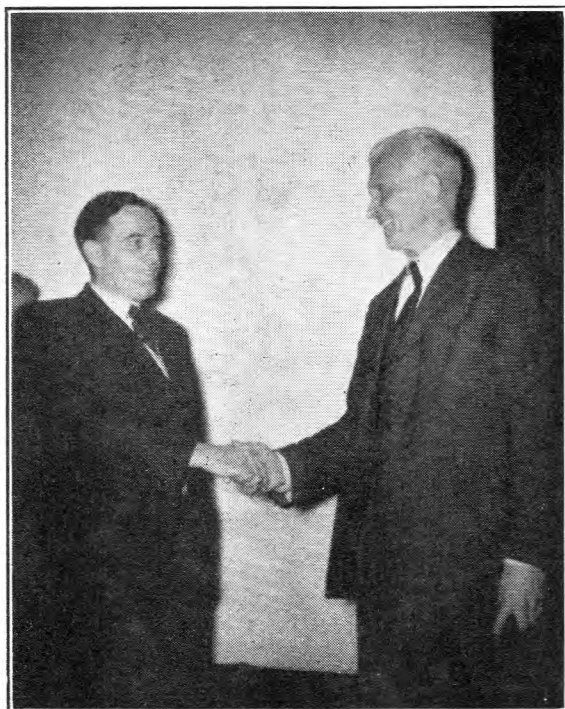

PRESENTATION TO MR. H. CARR, TECHNICAL OFFICER (left), BY THE TELEPHONE MANAGER.

industrial film on the manufacture of razor blades. The evening closed with a film of the Farnborough Air Show.

Our first ordinary meeting was held on 15th October, when two of our members, Messrs. W. E. Torbet and J. N. Graham, gave a talk on "Motor Cycling—Our Hobby." This talk was illustrated by practical demonstrations and a most interesting evening was spent in absorbing information from two well-versed speakers.

The Telephone Manager later presented his prize of £1 1s. 0d. for the 1951/52 session to Mr. H. Carr, Technical Officer, for his paper, "Industrial Lighting."

Members may care to note that there is a vacant date on our programme for this session on 11th March, 1954. Now is the chance for another member to bring further honours to the Centre, so contact the Secretary right away. G. F.

Darlington Centre

27th October, 1953.—The Darlington Centre was off to an auspicious start, when Mr. W. J. Costello gave his talk: "Repeater Station Power." The speaker must be highly satisfied with the reception he received at this enthusiastic meeting.

Without any qualms the undermentioned programme was arranged for the remainder of the session.

17th November, 1953.—"Plastics." J. Wood, B.Sc., Bakelite Ltd.

17th December, 1953.—"Television." B. V. Northall, Grad.Brit.I.R.E.

19th January, 1954.—The "C.I.D." Staff Officer, County Police Headquarters.

16th February, 1954.—"The Area Engineer's Job." F. W. Allan, A.M.I.E.E.

16th March, 1954.—"Thermal Insulation." G. Walker, Chemical & Insulating Co. Ltd.

2nd April, 1954.—"Amateur Radio," with on-the-air demonstration. L. M. Airey (G3 GEN) and H. Walker (G3 CBW).

21st May, 1954.—Annual General Meeting.

High hopes are held for another successful session.

It should be recorded that the Centre was awarded the Regional prize for the paper "Computers and Calculators," given by Mr. E. O. M. Grimshaw.

Mr. Grimshaw has been transferred to Middlesbrough and is now an active member of that Centre. C. N. H.

Colwyn Bay Centre

After a lapse of many years an Associate Section has been formed in the Colwyn Bay area. The attendance at the inaugural meeting on 19th January, 1953, was very encouraging. As a Centre, we are greatly indebted to Mr. T. A. P. Colledge, our Area Engineer, for his guidance and assistance.

An interesting and instructive lecture was delivered by Mr. Paul (Engineering Department, H.Q.) on 4th March, 1953, on "Cine-photography in the Post Office." A high percentage of the members attended and following the lecture the meeting nominated officers and a committee. The officers are:—*Chairman:* Mr. J. Rowlands; *Treasurer:* Mr. J. C. Davies; *Secretary:* Mr. D. Edmund Jones; *Assistant Secretary and Librarian:* Mr. J. C. Roberts.

The Summer programme consisted of the following visits which were well attended.

June, 1953.—Dolgarrog Aluminium Works and Power Station.

July, 1953.—Lewis's Brick Works, Llandudno Junction.

August, 1953.—B.B.C. Transmitting Station, Penmon, Anglesey.

September, 1953.—British Railways Locomotive Sheds, Llandudno Junction.

The Winter programme, which is already well under way, is as follows:—

22nd October, 1953.—"The technique of cable fault localisation with gas testing," by L. E. Grant (Assistant Engineer).

11th November, 1953.—"The present system of appraisal and promotion," Colonel C. E. Calvey (President of the Associate Section).

13th January, 1954.—Film Show.

10th February, 1954.—"Any Questions"; panel formed from three members of the Centre.

10th March, 1954.—"Gas Production," a paper by an officer of the Gas Board. This will be followed by a visit to the local gas works in April, 1954. D. E. J.

London Centre

Earlier this year the London Centre Committee asked the Regional Director, Mr. F. I. Ray, if he would accept the post of President for the London Centre Associate Section. Mr. Ray has very kindly consented to this and on 10th November the committee had the pleasure of meeting their President.

In order to encourage the presentation of papers at meetings the London Centre Committee has decided to offer prizes annually for the best papers read at Centre and Area meetings. For the best paper presented by a member at Centre Meetings the prize will be three guineas. In the event of there being three or more papers presented a further prize of two guineas will be given. For the best papers read at Area Meetings the prizes will be two guineas and one guinea respectively. The judges will be the Chairman, Vice-Chairman, Secretary and the Senior Section Liaison Officer. Both these awards are to be retrospective to September, 1952. The London Centre is endeavouring to capture the interest of the younger members by organising an essay competition for youths. The essay is to be on any aspect of telecommunications or allied subjects and shall not exceed 2,500 words. The first prize will be two guineas and the second prize one guinea.

A Quiz between the City Area team and a Bournemouth Area team is being arranged. The City Area team were the winners of the Inter-Area Quiz held earlier this year. The adjudicator will be Mr. F. C. G. Greening, B.Sc., A.M.I.E.E., Senior Section Liaison Officer, and the Question Master will be Mr. A. W. Lee, a former Secretary of the London Centre.

Two papers read before the London Centre by members during the 1952-53 session have received awards from the Senior Section. A paper entitled "Partial Call Queuing for Sleeve Control Exchanges," by Mr. B. G. Woods, of the Circuit Laboratory, received an award of three guineas; and a paper by Mr. A. W. Haddow, of Cable and Wireless, on "The Automatic Telegraph Concentrator," received a special award of one guinea. E. W. B.

Staff Changes

Promotions

Name	Region	Date	Name	Region	Date
<i>Exec. Engr. to Smr. Exec. Engr.</i>			<i>Tech. Offr. to Asst. Engr.—continued.</i>		
Forster, A. E. T.	E.-in-C.O.	29.9.53	Bushby, W.	N.E. Reg.	30.6.52
McKie, A. N.	E.-in-C.O. (<i>in absentia</i>)	22.9.53	Jones, H.	Mid. Reg.	12.8.53
Marks, D. J.	E.-in-C.O.	22.9.53	Bell, W.	N.E. Reg.	9.3.53
Haworth, J. E.	E.-in-C.O.	12.10.53	Metcalfe, F.	N.E. Reg.	31.7.53
Croisdale, A. C.	E.-in-C.O.	5.10.53	Affleck, C. S.	L.T. Reg.	24.11.52
Smart, J. H. C.	N.W. Reg.	26.10.53	Crake, L. T.	L.T. Reg.	9.2.52
<i>Asst. Engr. to Exec. Engr.</i>			<i>Asst. Engr. (Limited Competition)</i>		
Porter, J. M.	N.I. Reg.	2.3.53	East, W. D.	E.-in-C.O.	5.10.53
Bell, D.	L.T. Reg.	2.10.53	<i>Tech. Offr. to Inspector</i>		
McKendrick, W.	Scot.	30.9.53	Lenton, A. L.	N.E. Reg.	20.4.52
Young, A.	Scot.	30.9.53	McCubbin, I.	Scot.	5.8.53
Lettsome, E. W.	Mid. Reg.	18.11.53	Sharpe, D.	N.E. Reg.	7.6.53
Horner, F. H.	E.-in-C.O.	18.11.53	Rea, A. T.	Scot.	12.9.53
Nelson, J.	N.W. Reg.	18.11.53	<i>Technician I to Inspector</i>		
Price, S. E.	E.-in-C.O.	14.9.53	Jowitt, C.	N.E. Reg.	1.1.53
<i>Exec. Engr. (Open Competition)</i>			Kilduff, W.	N.E. Reg.	31.1.53
Grumwald, H. H.	E.-in-C.O.	26.8.53	Laycock, H.	N.E. Reg.	21.3.53
Leedham, R. V.	E.-in-C.O.	28.9.53	Vincent, R. S.	S.W. Reg.	9.4.53
Medford, R. D.	E.-in-C.O.	28.9.53	Hoare, H. W.	S.W. Reg.	10.8.53
Whorwood, R. W.	Mid. Reg. to E.-in-C.O.	28.9.53	Murphy, J. G.	Mid. Reg.	1.10.53
Boas, S. C.	E.-in-C.O.	1.10.53	Phillips, W.	N.E. Reg.	8.6.53
Luscombe, E. W.	E.-in-C.O.	5.10.53	Nicholson, G.	N.E. Reg.	2.5.53
White, P. S.	E.-in-C.O.	1.10.53	Dalton, E.	N.E. Reg.	1.10.52
Newell, E.	N.W. Reg. to E.-in-C.O.	26.10.53	Drury, L.	N.E. Reg.	2.7.53
McNaul, J.	Scot. to E.-in-C.O.	16.11.53	Lucas, W. D.	N.E. Reg.	20.9.53
Gravett, K. W. E.	E.-in-C.O.	23.11.53	Graham, R. H.	L.T. Reg.	2.2.53
Hillen, C. F. J.	E.-in-C.O.	2.11.53	Larkins, W. C.	L.T. Reg.	12.1.53
<i>Exec. Engr. (Limited Competition)</i>			Lewis, T. R. H.	L.T. Reg.	24.11.53
Baker, D.	L.T. Reg.	2.3.53	McMeechan, G. A.	L.T. Reg.	16.2.53
<i>Inspector to Asst. Engr.</i>			Tait, A. H.	L.T. Reg.	6.10.52
Davis, A.	N.E. Reg.	1.10.52	Cross, J. W.	L.T. Reg.	11.5.53
Roberts, F. K.	N.E. Reg.	8.7.53	Hicks, R. G.	L.T. Reg.	18.3.53
Law, T.	N.E. Reg.	23.9.53	Brown, W. T.	L.T. Reg.	3.9.53
Simpson, E. S.	L.T. Reg.	16.8.53	Kirby, F. W.	L.T. Reg.	1.7.53
Brims, W.	L.T. Reg.	1.1.53	Filmer, S. H.	L.T. Reg.	1.7.53
King, G. O.	L.P. Reg.	11.3.53	Lee, A. E.	L.T. Reg.	5.9.53
Green, G.	L.T. Reg.	18.3.53	Elliott, L. E. A.	L.T. Reg.	17.8.53
Hewitt, H. W.	L.T. Reg.	17.8.53	Smith, E. A.	L.T. Reg.	3.7.53
Cooper, W. J.	W.B.C.	9.6.53	Simmons, H. W.	L.T. Reg.	1.7.53
Williams, A. V.	W.B.C.	14.7.53	Kelly, J.	L.T. Reg.	1.9.53
Allam, F. H.	W.B.C.	14.8.53	Beachey, L. C.	N.W. Reg.	11.5.53
Ball, E.	L.P. Reg.	1.4.53	Dorgan, E.	N.I. Reg.	6.5.53
Scotson, J.	N.W. Reg.	18.7.53	Ware, H.	S.W. Reg.	28.9.53
Gardner, T. H.	N.W. Reg.	23.9.53	Hall, S. J.	W.B.C.	6.8.53
Budgen, F. B.	H.C. Reg.	27.6.53	Ross, A. E.	W.B.C.	12.9.53
Butler, H. F.	H.C. Reg.	7.4.53	Hughes, G. H.	W.B.C.	21.9.53
Myatt, E.	Mid. Reg.	30.3.53	Sheehan, J. D.	L.T. Reg. to L.P. Reg.	13.7.53
<i>Tech. Offr. to Asst. Engr.</i>			Callaghan, J.	Scot.	23.2.53
Gill, W.	N.W. Reg.	13.8.53	Hatto, R.	L.P. Reg.	2.4.53
Turner, F. J.	N.W. Reg.	22.9.53	Clubb, S. H. R.	L.P. Reg.	11.3.53
Blair, A. J.	Scot.	14.2.53	<i>Mechanic I/C to Tech. Asst. II</i>		
Smith, J.	Scot.	31.8.53	Kerr, E.	N.I. Reg.	23.9.53
McKay, C. S.	Scot.	4.10.53	<i>Asst. Engr.—continued.</i>		
Marshall, R.	L.T. Reg. to Scot.	10.11.53	Mason, H. J.	L.T. Reg.	21.11.53
Mew, L. W.	N.E. Reg.	1.7.53	<i>Inspector</i>		
Light, R. A. M.	H.C. Reg.	30.3.53	Haynes, E. R.	Mid. Reg.	9.10.53
Myers, K.	E.-in-C.O.	10.9.53			
Brown, H. W.	E.-in-C.O.	9.9.53			
Buften, C. W.	S.W. Reg.	22.6.53			
Wright, D. K. G. D.	Mid. Reg.	10.8.53			

Deaths

Name	Region	Date	Name	Region	Date
<i>Asst. Engr.</i>			<i>Asst. Engr.—continued.</i>		
Keen, S. R.	E.T.E.	16.9.53	Mason, H. J.	L.T. Reg.	21.11.53
Harrison, R.	N.W. Reg.	19.9.53	<i>Inspector</i>		
Carter, A. T.	N.W. Reg.	26.9.53	Haynes, E. R.	Mid. Reg.	9.10.53
Knowlden, W. A. S.	H.C. Reg.	20.10.53			

Transfers

Name	Region	Date	Name	Region	Date
<i>Snr. Exec. Engr.</i>			<i>Asst. Engr.—continued.</i>		
Turner, H. A. ..	E.-in-C.O. to P. & T. Dept., Sierra Leone	23.2.50	Bell, E. G.	E.-in-C.O. to P. & T. Dept., East Africa	2.2.51
<i>Exec. Engr.</i>			Ashton, E. G.	E.-in-C.O. to L.T. Reg. ..	11.10.53
Winter, F.	Scot. to P. & T. Dept., Nigeria	24.6.50	Lipscombe, J. E. ..	Scot. to E.-in-C.O. ..	4.10.53
<i>Asst. Engr.</i>			Kirby, H. V.	S.W. Reg. to P. & T. Dept., Gold Coast	2.11.50
Stollard, A. C. ..	E.-in-C.O. to N.W. Reg. ..	27.9.53	Cottingham, R. D. ..	E.-in-C.O. to Mid. Reg. ..	29.11.53
Taylor, M. R. ..	E.-in-C.O. to P. & T. Dept., Malaya	27.11.47	McDowell, A.	E.-in-C.O. to Min. of Works	26.10.53
Shaw, M. L.	E.-in-C.O. to P. & T. Dept., Nigeria	10.9.53	<i>Asst. Exptl. Offr.</i>		
			Kelly, L. C.	E.-in-C.O. to R.N. Scientific Service	7.9.53

Retirements

Name	Region	Date	Name	Region	Date
<i>Asst. Staff Engr.</i>			<i>Asst. Engr.—continued.</i>		
Davis, L. H.	E.-in-C.O.	26.9.53	Brookes, G. A.	E.-in-C.O. (Resigned) ..	24.11.53
<i>Area Engr.</i>			Easterby, R. T.	N.E. Reg.	6.8.53
Davies, B.	N.W. Reg.	30.9.53	Kerrison, A. V.	L.T. Reg.	19.9.53
Britton, F. T.	H.C. Reg. (Voluntary retirement)	31.8.53	Baldwin, F.	W.B.C.	13.7.53
<i>Exec. Engr.</i>			Ellis, R.	W.B.C.	13.8.53
Nicolson, P.	Scot.	31.8.53	Misselbrook, R.	L.T. Reg.	17.11.53
Head, G. F.	W.B.C. (Health grounds) ..	13.9.53	Holloway, G. F.	L.T. Reg.	18.11.53
Chadwick, J.	N.W. Reg.	30.9.53	Frizell, C. T.	W.B.C.	18.11.53
McLennan, M.	Scot.	1.5.53	Robinson, A. E.	L.T. Reg.	19.11.53
London, T. G.	E.-in-C.O.	30.9.53	Burnett, H.	N.E. Reg.	19.11.53
Burcher, P.	Mid. Reg.	28.10.53	Cooper, H.	E.-in-C.O. (Resigned) ..	30.6.53
Paul, E. M.	E.-in-C.O.	17.11.53	Berrill, W. G.	H.C. Reg.	31.5.53
<i>Asst. Engr.</i>			<i>Inspector</i>		
Abbott, G. A. O. ..	E.-in-C.O.	15.9.53	Holt, H. J.	L.T. Reg.	2.9.53
McDougall, R. S. ..	Scot.	31.8.53	Sanders, F.	Mid. Reg.	30.9.53
Harvey, S. C.	E.-in-C.O. (Resigned) ..	19.9.53	Barton, J.	Mid. Reg.	30.10.53
Booth, G. W.	N.E. Reg.	21.9.53	Pipe, H.	L.T. Reg.	30.10.53
Gowland, J. W. ..	N.E. Reg.	23.9.53	Stevenson, A.	Scot.	30.6.53
Jones, S. A.	N.W. Reg.	30.9.53	Brown, A.	Scot.	10.7.53
Davies, A. O.	E.-in-C.O. (Resigned) ..	8.10.53	Garrick, J. W.	Scot.	30.7.53
Gunning, W. W. ..	E.-in-C.O.	31.10.53	Walker, J.	L.T. Reg.	17.11.53
Fearn, J.	N.E. Reg.	17.10.53	Vernon, H.	Mid. Reg.	17.11.53
			Pratt, A. W.	L.T. Reg.	24.11.53
			Fuzzens, F. I.	H.C. Reg.	14.7.53
			Norman, H. S.	H.C. Reg.	22.8.53

◆
DRAUGHTSMEN

Promotions

Transfers

Name	Region	Date	Name	Region	Date
<i>D'man to Ldg. D'man.</i>			<i>Ldg. D'man.</i>		
Fuse, S. H.	S.W. Reg. to E.-in-C.O. ..	16.9.53	Harman, J. F.	Fact. Dept. to E.-in-C.O. ..	23.11.53
<i>D'man Cl. II to D'man.</i>			<i>D'man.</i>		
Durward, W.	Scot. to E.-in-C.O.	16.11.53	Mead, S. R.	L.T. Reg. to E.-in-C.O. ..	2.11.53
Tufner, R. H.	E.-in-C.O.	31.8.53	Bliss, F. H.	L.T. Reg. to E.-in-C.O. ..	24.8.53

Retirement

Death

Name	Region	Date	Name	Region	Date
<i>D'man.</i>			<i>Ldg. D'man.</i>		
Palmer, B. L.	E.-in-C.O. (Resigned) ..	30.10.53	Morris, W. A.	E.-in-C.O.	2.10.53

CLERICAL GRADES

Promotions

Transfers

Name	Region	Date	Name	Region	Date
<i>Snr. Exec. Offr. to Ch. Exec. Offr.</i>			<i>Exec. Offr.</i>		
Glover, G.	E.-in-C.O.	15.10.53	Langfield, F. J.	E.-in-C.O. to P.S. Dept. ..	5.10.53
Manning, W. J. ..	E.-in-C.O.	15.10.53	Beckman, R.	E.-in-C.O. to G.C.H.Q. ..	9.11.53

Book Reviews

"Radio Engineering." E. K. Sandeman, Ph.D., B.Sc., A.C.G.I., M.I.E.E. Chapman & Hall, Second Edition, 1953. Vol. 1, 779 pp (illustrated) 60s. Vol. 2, 613 pp. (illustrated) 55s.

According to the Preface this book was "designed so that new-comers with no knowledge of radio technique could acquire familiarity with working principles in the shortest possible time. Subsequently it was extended so as to constitute a book of reference for experienced engineers."

It is the opinion of this reviewer that the book tends to fall between two stools. Firstly, it contains far too much detailed and specialised information to be put in the hands of a beginner; unless carefully guided he would have the greatest difficulty in separating relevant from irrelevant information. Secondly, the experienced engineer would have no need of much of the elementary information included.

The most valuable sections of the book are those dealing with broadcast transmitter design, operation and maintenance, and transmitting aerial design and construction. Here the author writes from long experience with the British Broadcasting Corporation; in this respect the book undoubtedly fills a notable gap in the literature and will be welcomed for the authoritative information it contains.

However, radio engineering now covers a wide range and there are several aspects of the subject which this book either does not refer to at all or deals with inadequately, e.g., point-to-point and mobile communication systems, navigational aids and direction finding, television and radar. On the other hand sound broadcasting, as exemplified by B.B.C. practice, is dealt with very fully. Throughout the book the accent is mainly on L.F., M.F. and H.F. techniques; V.H.F., U.H.F. and S.H.F. techniques are barely touched on.

The Bibliography (p. 515, Vol. 2) is preceded by a statement including the revealing phrase "a very rapid scrutiny of a few periodicals was made and it is impossible to guarantee that important references have not been omitted." This is, if anything, an understatement. Only a small proportion of the references are later than the year 1940, with the result that the Bibliography has serious limitations as a reference source.

It is unfortunate that "Radio Engineering" cannot be recommended for more general use without the foregoing reservations, all the more so since it is evident that much painstaking work has gone into its compilation. Its chief value is perhaps as a source of information on the principles and practice of sound broadcasting, particularly B.B.C. practice in this field of radio engineering.

W. J. B.

"Textbook on Sound." J. W. Winstanley, M.Sc., A.Inst.P. Longmans, Green and Co., Ltd. 239 pp. 154 ill. 4 plates. 12s. 6d.

The book is a good introduction to the science of acoustics and should be suitable for students who are preparing for the general certificate of education at the advanced or scholarship level. It gives a firm grounding in the basic principles using only the simplest of mathematics. The questions and answers to numerical exercises should enable those who by force of circumstance must study at home to consolidate the knowledge gained from the text.

The different symbols used in science and engineering for such basic terms as frequency can often confuse the student. It is suggested that the author might have used the accepted symbol f and not n for frequency in accordance with the British standard glossary of acoustical terms and definitions (B.S. 661 : 1936), and that some mention might have been made of the glossary, if only as an introduction to the fact that there are certain universally accepted symbols and definitions. British Standard 204 : 1943, the glossary of terms used in telecommunications, gives the telephone reference level as 1 mW in the line impedance (nominally 600 ohms) and not 6 mW in 500 ohms as quoted on page 178.

The term mechanical filter (p. 188) is misleading, the filters are in fact acoustical filters made up of acoustical elements of compliance, mass and resonant tubes.

It is not necessary for bone conduction hearing to be via the oval window as is claimed on page 204. In cases of conductive deafness the stapes can be clamped to the oval window by an osseous growth and the transmission is accepted as being through the walls of the cochlea; another method of transmission is through the round window.

Such minor errors as "The average limit of audibility which has been standardised as a sound pressure of 0.0002 dyne per square cm." (p. 179) and the use of the term "sound intensity in decibels" (p. 179) are liable to occur even in second editions and do not detract very much from this, at all times, readable book.

J. Y. M.

SHORTER NOTICE

"Die Laplace-Transformation und ihre Anwendung." P. Funk, H. Sagan and F. Selig. Franz Deuticke, Wien. 106 pp. 18 ill.

This volume, in German, gives a short introduction to the Laplace Transformation and its applications, and is written mainly for engineers and physicists.

BOARD OF EDITORS

H. FAULKNER, C.M.G., B.Sc., M.I.E.E., F.I.R.E., Chairman.

W. WEST, O.B.E., B.A., M.I.E.E.

L. F. SCANTLEBURY, Whit.Sch., A.C.G.I., D.I.C., M.I.E.E.

D. A. BARRON, M.Sc., M.I.E.E.

H. G. BEER, Whit.Sch., A.C.G.I.

E. DAVIS, A.M.I.E.E.

L. CHANT.

G. E. STYLES, A.M.I.E.E., Managing Editor.

W. A. HUMPHRIES, A.M.I.E.E.

J. P. HARDING, B.Sc.(ENG.),

A.M.Inst.C.E., A.M.I.E.E.

A. J. HUTCHISON, Secretary-Treasurer.

} Assistant Editors.

Copyright

The entire contents of this JOURNAL are covered by general copyright, and special permission is necessary for reprinting long extracts, but Editors are welcome to use not more than one-third of any article, provided credit is given at the beginning or end thus: "From the *Post Office Electrical Engineers' Journal*."

The Board of Editors is not responsible for the statements made or the opinions expressed in any of the articles in this JOURNAL, unless such statement is made specifically by the Board.

Communications

All communications should be addressed to the Managing Editor, *P.O.E.E. Journal*, Engineer-in-Chief's Office, Alder House, Aldersgate Street, London, E.C.1. Telephone: HEADquarters 1234. Remittances should be made payable to "*The P.O.E.E. Journal*" and should be crossed "& Co."

Binding Cases

Cases for binding are available, and may be obtained from the Local Agents for 3s. Subscribers can have their copies of volumes bound, at a cost of 10s. 6d., by sending the complete set of parts to the Local Agents or to the *P.O.E.E. Journal*, Engineer-in-Chief's Office, Alder House, Aldersgate Street, London, E.C.1. Orders for binding for Vols. 1-19 should indicate whether the original binding case with black lettering, or the later pattern with gold, is required. Cases with gold lettering are the only type stocked from Vol. 20 onwards.

Back Numbers

The price of the JOURNAL, which is published quarterly, is 2s. 6d. (2s. 9d. post free) per copy, or 11s. per annum, post free. Back numbers can be supplied, subject to availability of stocks, at 2s. 6d. each (2s. 9d. post free). Orders for back numbers may be sent to the *P.O.E.E. Journal*, Engineer-in-Chief's Office, Alder House, Aldersgate Street, London, E.C.1, or to the Publishers.

Employees of the British Post Office can obtain the *Journal* through Local Agents at the reduced price of 2s. per copy.

Advertisements

All communications relating to space reservations should be addressed to the Advertisement Editor, *P.O.E.E. Journal*, Alder House, Aldersgate Street, London, E.C.1. Communications regarding advertisement copy, proofs, etc., should be addressed to the Publishers, Messrs. Birch & Whittington (Prop. Dorling & Co. [Epsom], Ltd.), 49 Upper High Street, Epsom, Surrey.

Post Office Electrical Engineers' Journal

Volume 46, April 1953—January 1954

INDEX

A	PAGE NO.	H	PAGE NO.
A.C. No. 5X, Signalling System	7	Halsey, R. J. The Rationalised M.K.S. System of Electrical Units	187
Arnold, G. F., and S. W. Jennings. A New Unidiameter Joint	180	Halsey, R. J., and H. Williams. The Birmingham-Manchester-Holme Moss Television-Cable System	118, 171
Associate Section Notes	47, 99, 154, 211	Hill, R. E. Telegraph Power Plant using a D.C. Astatic Relay for Voltage Control	25
B		Holmes, M. F., and G. H. Metson. Deterioration of Valve Performance due to Growth of Interface Resistance	198
Barnard, A. J. The Motor Uniselector-type Group Selector for Trunk Switching	108	Hourigan, H. F., J. W. Robinson, and W. T. Edwards. Poor Solderability of Tags, and Dry Joints	134
Barnett, H. E. The Location and Verification of Pairs in Cables	144	Howard, R. F. The Impact of Recent Signalling Developments on Out-of-Area Exchange Service	177
Beaumont, E. B. M., B. H. Moore, and S. M. Rousell. The Provision of Communications for the Coronation of Her Majesty Queen Elizabeth II	71	I	
Belfast, Television Service to	130	Impact of Recent Signalling Developments on Out-of-Area Exchange Service, The	177
Benson, D. L., and D. H. Vogan. A Method of Testing Cold-cathode Tubes	196	Induced Voltage Tests carried out in Conjunction with the London Electricity Board	92
Birch, S., and W. E. Tobin. Satellite Exchange Working in Non-Director Multi-Exchange Systems	1	Institution of Post Office Electrical Engineers	39, 94, 149, 204
Birmingham-Manchester-Holme Moss Television-Cable System, The		Interface Resistance, Deterioration of Valve Performance due to Growth of	198
Part 1.—Transmission Requirements, General Design Considerations and Cable Characteristics	118	Inter-Office Telephone System for the Postmaster-General	33
Part 2.—High Frequency Line System and Overall Performance	171	J	
Book Reviews	6, 12, 18, 36, 38, 49, 58, 64, 70, 78, 82, 85, 88, 111, 133, 139, 165, 179, 190, 206, 210, 215	Jackson, F. G., and R. Collings. The Use of Dry Cells in Subscribers' Premises	37
Brookes, D., and M. B. Williams. A New Cable-Fault Indicator	13	Jennings, S. W., and G. F. Arnold. A New Unidiameter Joint	180
C		Jones, C. E. P., and I. F. Macdiarmid. The Effect of Temperature on the Transmission Characteristics of Carrier Cable	65
Cable, The Transatlantic Telephone	199	K	
Cable-Fault Indicator, A New	13	Kilvington, T. Television Service to Belfast	130
Cables, The Location and Verification of Pairs in	144	L	
Call Queuing Scheme for Sleeve-Control Exchanges, A Partial	29	Lanfeair, J. S., and J. G. Donovan. A New Method of Direct Underground Distribution	183
Carrier Cable, The Effect of Temperature on the Transmission Characteristics of	65	Location and Verification of Pairs in Cables, The	144
C.C.I.R., London, 1953, Seventh Plenary Assembly of the	202	Lowry, W. R. H., and W. N. Genna. Single-Sideband Multi-Channel operation of Short-Wave Point-to-Point Radio Links. (Part 3.)	19
C.C.I.T., Arnhem 1953, Seventh Plenary Meeting of the	121	M	
Cold-cathode Tubes, A Method of Testing	196	Macdiarmid, I. F., and C. E. P. Jones. The Effect of Temperature on the Transmission Characteristics of Carrier Cable	65
Collings, R., and F. G. Jackson. The Use of Dry Cells in Subscribers' Premises	37	Mackie, G. W., and J. L. Cunningham. The Packaging of Telephone Exchange Equipment for Long-Term Storage in Temperate Climates	30
Collins, J. H., and C. E. Easterling. The Teleprinter No. 11	53	Magnetic Materials for Telecommunications, Soft	128
Coronation of Her Majesty Queen Elizabeth II, The Provision of Communications for the	71	Mains-operated Psophometer, A	112
Cunnington, J. L., and G. W. Mackie. The Packaging of Telephone Exchange Equipment for Long-Term Storage in Temperate Climates	30	Manchester-Edinburgh Television Radio-Relay Link, Standby Generating Plant for the	89
D		Marshman, R. C. Standby Generating Plant for the Manchester-Edinburgh Television Radio-Relay Link	89
Deterioration of Valve Performance due to Growth of Interface Resistance	198	May, C. A. The Post Office Standard Motor Uniselector	79
Donovan, J. G., and J. S. Lanfeair. A New Method of Direct Underground Distribution	183	Method of Testing Cold-cathode Tubes, A	196
Dry Cells in Subscriber's Premises, The Use of	37	Metson, G. H., and M. F. Holmes. Deterioration of Valve Performance due to Growth of Interface Resistance	198
E		Midland Region Engineering Training School, The	115
Easterling, C. E., and J. H. Collins. The Teleprinter No. 11	53	M.K.S. System of Electrical Units, The Rationalised	187
Edwards, W. T., J. W. Robinson, and H. F. Hourigan. Poor Solderability of Tags, and Dry Joints	134	Moore, B. H., S. M. Rousell, and E. B. M. Beaumont. The Provision of Communications for the Coronation of Her Majesty Queen Elizabeth II	71
Effect of Temperature on the Transmission Characteristics of Carrier Cable, The	65	Motor Uniselector, The Post Office Standard	79
Engineering Training School, The New Midland Region	115	Motor Uniselector-type Group Selector for Trunk Switching, The	108
F		Multi-Exchange Systems, Satellite Working in Non-Director	1
Faulkner, H.	200	Mumford, A. H.	201
G		N	
Generating Plant for the Manchester-Edinburgh Television Radio-Relay Link, Standby	89	New Cable-Fault Indicator, A	13
Genna, W. N., and W. R. H. Lowry. Single-Sideband Multi-Channel operation of Short-Wave Point-to-Point Radio Links. (Part 3.)	19	New Method of Direct Underground Distribution, A	183
Gibson, W. T. Thermistor Production	34	New Midland Region Engineering Training School, The	115
Goldsmith, F. H., and J. A. Widdicks. A Mains-operated Psophometer	112	New 10-ewt Utility Vehicle, A	86
		New Unidiameter Joint, A	180

N (continued)		PAGE NO.
Newson, F. W., and H. E. Sturgess. Single-Sideband Multi-Channel operation of Short-Wave Point-to-Point Radio Links. (Parts 4(a) and 4(b))	140, 191	
Notes and Comments	39, 94, 149, 205	
Notes, Associate Section.. .. .	47, 99, 154, 211	
Notes, Regional	40, 96, 151, 207	

O		
Outline of the British Television System, An		
Part 1.—Generating the Picture Waveform	59	
Part 2.—Transmitting the Picture Waveform	123	
Part 3.—Receiving the Picture Waveform	166	
Out-of-Area Exchange Service, The Impact of Recent Signalling Developments on	177	

P		
P.A.B.X.s, Post Office Standard	159	
Packaging of Telephone Exchange Equipment for Long-Term Storage in Temperate Climates, The	30	
Pairs in Cables, The Location and Verification of	144	
Partial Call Queueing Scheme for Sleeve Control Exchanges, A	29	
Poor Solderability of Tags, and Dry Joints	134	
Post Office Standard Motor Uniselector, The	79	
Post Office Standard P.A.B.X.s:		
Part 1.—General Review of New Types and Details of P.A.B.X. No. 1	159	
Postmaster-General, Inter-Office Telephone System for the	33	
Production of Very Thin Quartz Oscillator Plates, The	105	
Provision of Communications for the Coronation of Her Majesty Queen Elizabeth II, The	71	
Psophometer, A Mains-operated	112	

Q		
Quartz Oscillator Plates, The Production of Very Thin	105	

R		
Radio Links, Single-Sideband Multi-Channel operation of Short-Wave Point-to-Point	19, 140, 191	
Rationalised M.K.S. System of Electrical Units, The	187	
Regional Notes	40, 96, 151, 207	
Robinson, J. W., H. F. Hourigan, and W. T. Edwards. Poor Solderability of Tags, and Dry Joints	134	
Roche, J. J. Post Office Standard P.A.B.X.s	159	
Rousell, S. M., E. B. M. Beaumont, and B. H. Moore. The Provision of Communications for the Coronation of Her Majesty Queen Elizabeth II	71	

S		
Satellite Exchange Working in Non-Director Multi-Exchange Systems	1	
Seventh Plenary Assembly of the C.C.I.R., London, 1953	202	
Seventh Plenary Meeting of the C.C.I.T., Arnhem 1953	121	
Signalling System A.C. No. 5X	7	
Single-Sideband Multi-Channel Operation of Short-Wave Point-to-Point Radio Links:		
Part 3.—An Independent-Sideband Short-Wave Radio Receiver	19	
Part 4(a).—An Independent-Sideband High-Power Short-Wave Transmitter.—The Radio and Power Units	140	

S (continued)		PAGE NO.
Part 4(b).—An Independent-Sideband High-Power Short-Wave Transmitter.—Design and Performance	191	
Slater, G. H. A New 10-cwt Utility Vehicle	86	
Soft Magnetic Materials for Telecommunications	128	
Solderability of Tags, and Dry Joints, Poor	134	
Staff Changes	50, 102, 156, 213	
Standby Generating Plant for the Manchester-Edinburgh Television Radio-Relay Link	89	
Storage in Temperate Climates, The Packaging of Telephone Exchange Equipment for Long-Term	30	
Sturgess, H. E., and F. W. Newson. Single-Sideband Multi-Channel operation of Short-Wave Point-to-Point Radio Links. (Parts 4(a) and 4(b))	140, 191	
Subscribers' Premises, The Use of Dry Cells for	37	

T		
Telegraph Power Plant using a D.C. Astatic Relay for Voltage Control	25	
Telephone System for the Postmaster General, Inter-Office	33	
Teleprinter No. 11, The	53	
Television-Cable System, The Birmingham-Manchester-Holme Moss	118, 171	
Television Outside Broadcast Service, A Vehicle for	93	
Television Service to Belfast	130	
Television System, An Outline of the British	59, 123, 166	
Thermistor Production	34	
Thwaites, J. E. The Production of Very Thin Quartz Oscillator Plates	105	
Tobin, W. E., and S. Birch. Satellite Exchange Working in Non-Director Multi-Exchange Systems	1	
Toft, G. Signalling System A.C. No. 5X	7	
Transatlantic Telephone Cable, The	199	
Trunk Switching, The Motor Uniselector-type Group Selector for	108	

U		
Underground Distribution, A New Method of Direct	183	
Unidiameter Joint, A New	180	
Use of Dry Cells in Subscribers' Premises, The	37	
Utility Vehicle, A New 10-cwt	86	

V		
Vehicle, A New 10-cwt Utility	86	
Vehicle for Television Outside Broadcast Service, A	93	
Vogan, D. H., and D. L. Benson. A Method of Testing Cold-cathode Tubes	196	
Voltage Control, Telegraph Power Plant using a D.C. Astatic Relay for	25	

W		
Widdicks, J. A., and F. H. Goldsmith. A Mains-operated Psophometer	112	
Williams, H., and R. J. Halsey. The Birmingham-Manchester-Holme Moss Television-Cable System	118, 171	
Williams, M. B., and D. Brookes. A New Cable-Fault Indicator	13	
Wray, D. An Outline of the British Television System	59, 123, 166	



Grinding Mullard 'Ticonal' permanent magnets to required size.

MAGNETIC MATERIALS Extensive research and manufacturing facilities have established Mullard as the leading producers of magnetic materials. They were the first, for example, to introduce Ferroxcube, the world's most efficient magnetic ferrite; 'Ticonal' anisotropic permanent magnets, renowned for their high stability and high energy output; and Magnadur, an entirely new type of permanent magnet with the insulating properties of a ceramic.

The wealth of experience gained from these developments is available to all users of magnetic materials through the Mullard advisory service. An enquiry to the address below will put a team of specialised engineers at your disposal.



Mullard

'TICONAL' PERMANENT MAGNETS · MAGNADUR (Formerly Ferroxdure)
PERMANENT MAGNETS · FERROXCUBE MAGNETIC CORE MATERIAL

MULLARD LTD., COMPONENT DIVISION, CENTURY HOUSE, SHAFTESBURY AVENUE, LONDON, W.C.2.

INDEX TO ADVERTISERS

	PAGE		PAGE
Airmec, Ltd.	ii	Jones, Walter	xxvii
Alton Battery Co., Ltd., The	xv	Muirhead & Co., Ltd.	xxviii
Automatic Coil Winder & Electrical Equipment Co., Ltd.	viii	Neill, James, & Co., Ltd.	iv
Automatic Telephone & Electric Co., Ltd.	vii, xix-xx	Painton of Northampton	v
Bennett College, The.	ii	Pirelli-General Cable Works, Ltd.	xxix
British Electric Resistance Co., Ltd., The.	xxvii	Pitman, Sir Isaac, & Sons, Ltd.	ix
British Institute of Engineering Technology	ix	Pye, Ltd.	xxi-xxii
British Insulated Callender's Cables, Ltd.	xvi	Redifon, Ltd.	ii
Edison Swan Electric Co., Ltd., The	xxix	Siemens Brothers & Co., Ltd.	vi
E.M.I. Institute	xxviii	Skillman, T. S., & Co., Ltd.	xvii-xviii
Ericsson Telephones, Ltd.	xi	Smith, Frederick, & Co.	xxviii
General Electric Co., Ltd., The	xiii-xiv	Standard Telephones & Cables, Ltd.	xxiii-xxiv
Great Northern Telegraph Co., Ltd.	xxv	Sullivan, H. W., Ltd.	xxvi
Hackbridge Cable Co., Ltd.	xxv	Telephone Manufacturing Co., Ltd.	viii
Hivac, Ltd.	ix	Tungstone Products, Ltd.	xii
		Westinghouse Brake & Signal Co., Ltd.	xxvi



Focussing Magnet
ALCOMAX IV



Gramophone pickup Magnets
ALCOMAX III



ALCOMAX II
Loud Speaker Magnet

Permanent Magnets

for the

Radio & T.V. Industry

Made by the makers of
'Eclipse'
Permanent Magnet Chucks

The very latest techniques in permanent magnet manufacture can effect real economies in your production and at the same time contribute further to efficient operation of your products. Consult our Technical Staff at an early stage of design to be certain that you are taking advantage of recent progress.

Send for literature:
Pub. PM108—Loud Speaker Magnets.
Pub. PM112—Permanent Magnets for Television Receivers.



Picture Shift Magnets
in 6% Chromium Steel



Ion Trap Magnet
in 6% Chromium Steel



Ion Trap Magnet
ALNICO



PERMANENT MAGNETS

JAMES NEILL & CO. (SHEFFIELD) LTD.,
SHEFFIELD, 11 ENGLAND



By Appointment to the Professional Engineer

**PLUG AND SOCKET
GO-AXIAL/MULTI CONTACT**

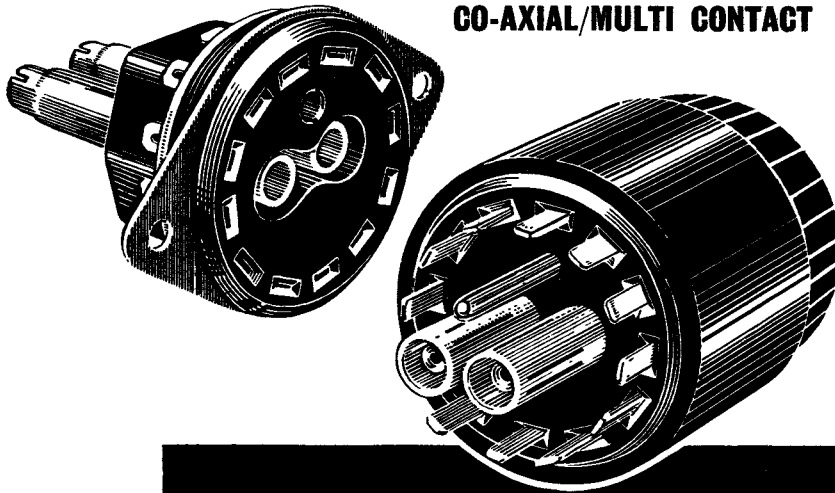

These plugs and sockets have twelve ancillary contacts to carry Audio signals, or power supplies up to 500 Volts/5 Amps. The Coaxial units can connect signals at either Video or Radio frequencies. The combination of these facilities into a single unit has numerous and obvious applications. By eliminating the need for a number of separate and different connectors, wiring problems are eased; and the simplified chassis or panel design has an improved appearance. The "Hammer finished" covers are supplied to match Customers' individual colour schemes.

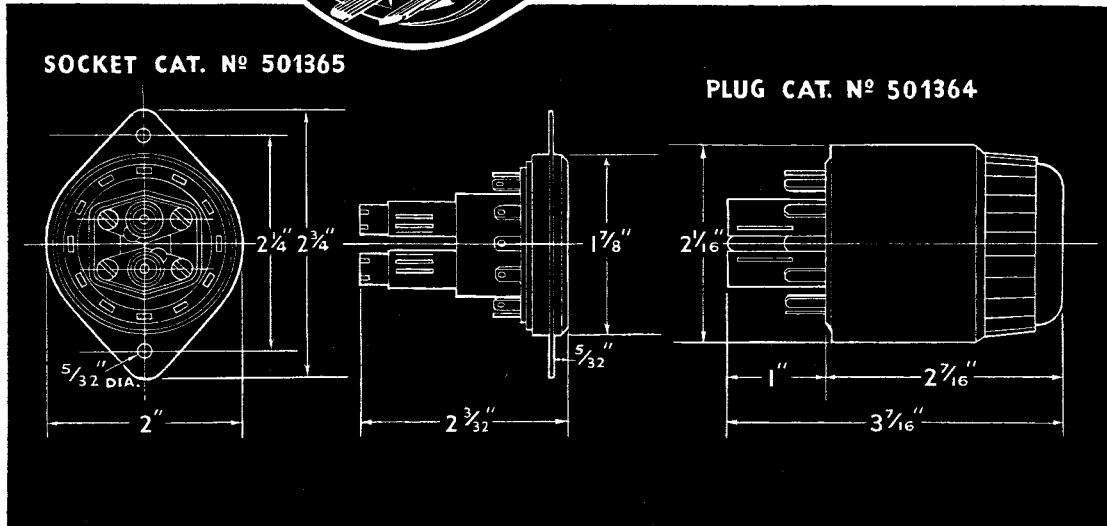

PLUG WITH COVER Type 501364
 PLUG WITH MOUNTING FLANGE . . Type 501544

SOCKET WITH COVER Type 501545
 SOCKET WITH MOUNTING FLANGE . . Type 501365

(A composite cable for the above range has been developed by British Insulated Callenders Cables Limited)

PAINTON
Northampton England

**ATTENUATORS AND FADERS • STUD SWITCHES • FIXED AND ADJUSTABLE WIREWOUND RESISTORS
 WIREWOUND POTENTIOMETERS • MIDGET R.F. CHOKES • HIGH STABILITY CARBON RESISTORS • TERMINALS
 PLUGS AND SOCKETS • KNOBS, DIALS AND POINTERS • TOGGLE SWITCHES • PUSH BUTTON SWITCHES**

SIEMENS 12 Channel

CARRIER TELEPHONE EQUIPMENT

Type CS12/C

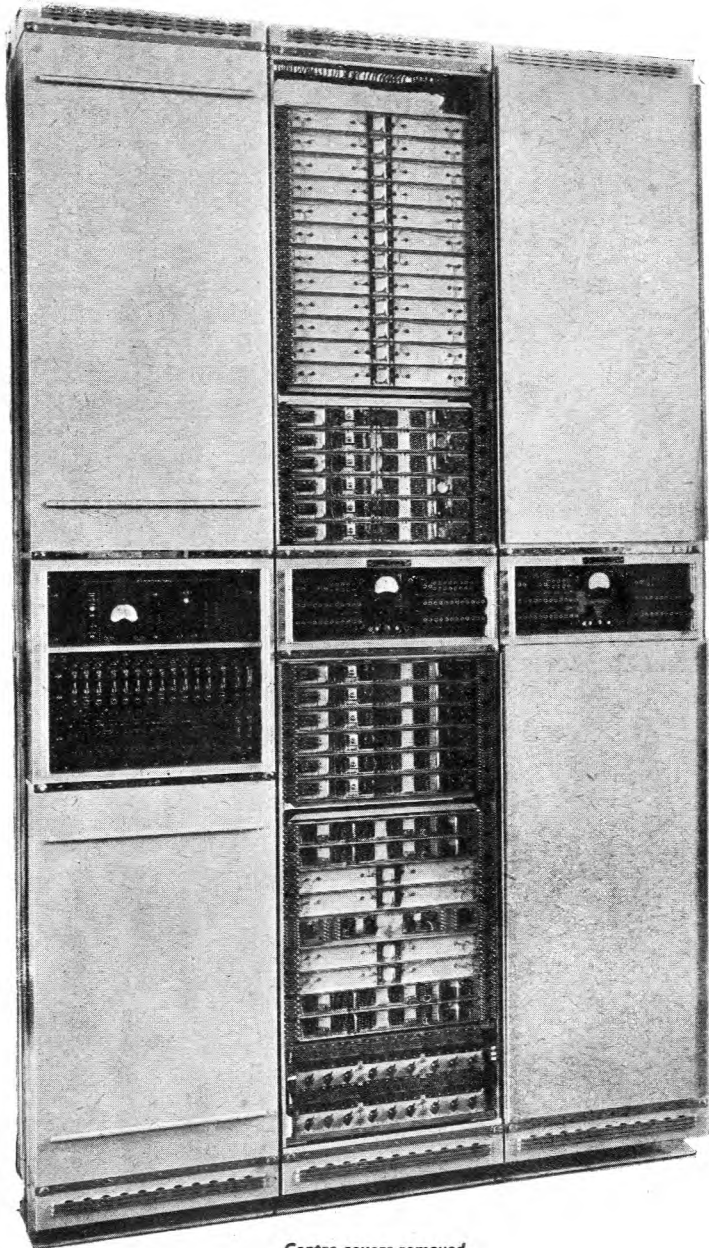

Centre covers removed

THE ILLUSTRATION SHOWS A TYPICAL SIEMENS CARRIER TELEPHONE TERMINAL EQUIPPED FOR 24 CHANNELS COMPLETE WITH CARRIER SUPPLY, LINE AMPLIFIERS AND FILTERS, RINGERS AND TERMINATIONS.

- Complying in all respects with C.C.I.F. recommendations for 12 channel carrier systems.
- Operated from A.C. Mains and suitable for connection to underground cable, overhead line or radio link systems.
- Incorporating the new Siemens method of mounting apparatus to give a compact equipment while providing accessibility and ease of maintenance.

SIEMENS BROTHERS & CO., LIMITED
WOOLWICH • LONDON • S. E. 18.

The fine modern exchange of Remuera, in the Auckland area, New Zealand, is being equipped by Automatic Telephone & Electric Co. Ltd., to the requirements of the Post & Telegraph Department as part of their development plan which standardizes Strowger step-by-step equipment for use throughout the country. Initially, Remuera will be equipped with 7,600 lines and will be the main exchange for a network having five satellites totalling 11,400 lines.

The basic selecting mechanism is the 32A Mark II Selector which incorporates in its design all the facilities which many years operational experience have shown to be necessary, yet retains the simple straight-forward step-by-step principle of operation characteristic of the Strowger system. To-day this selector offers the most suitable basis for automatic telephone systems of any size. Its simplicity, reliability and ease of maintenance are the factors of principal appeal to telephone administrations in all parts of the world.

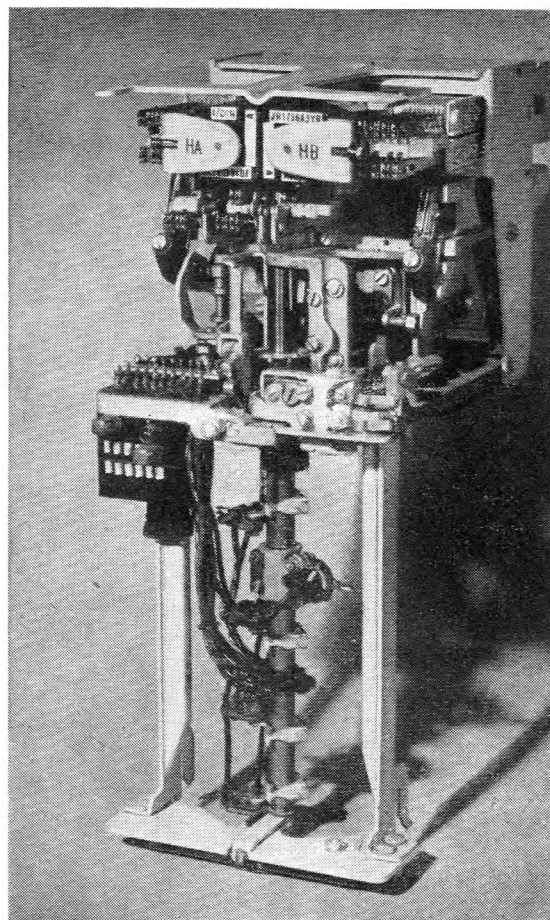

Another Strowger Exchange

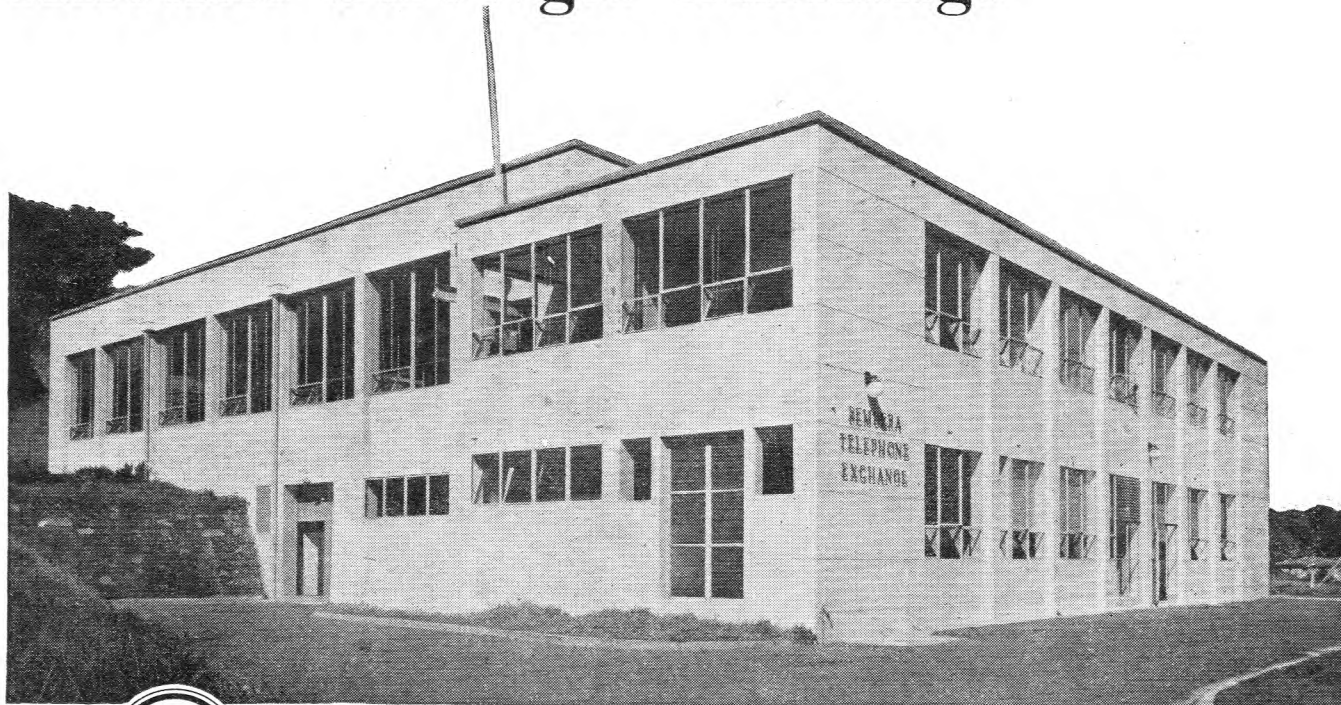

AUTOMATIC TELEPHONE & ELECTRIC CO. LTD., Export Department: Strowger House, Arundel Street, London, W.C.2.
Telephone: TEMple Bar 9262. Cablegrams: Strowgerex London. Strowger Works, Liverpool, England.

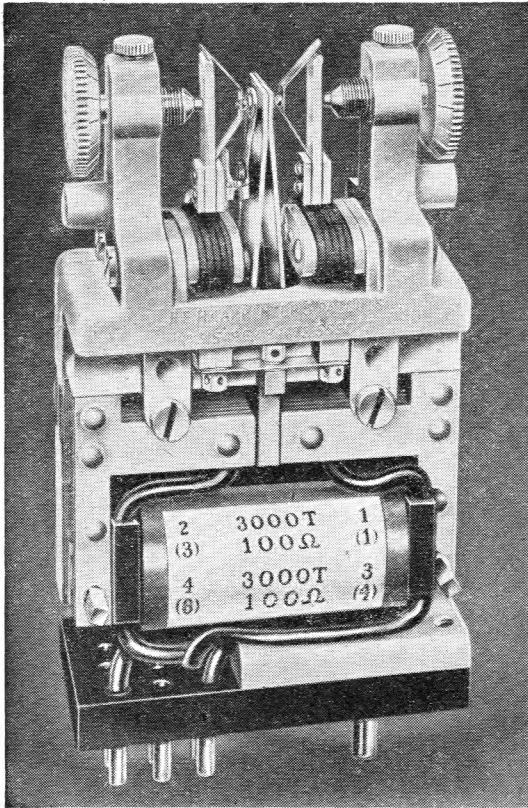

CARPENTER POLARIZED RELAY TYPE 4

The chief characteristics of this relay are low transit time—high contact pressure—freedom from contact chatter and positional error—high sensitivity—stability—symmetrical action—and ease of adjustment.

On V.F. dialling systems its use facilitates the design of sensitive receiving equipment, and on trunk telephone circuits the relay's high sensitivity enables it to respond to D.C. dialled impulses received over unrepeated trunk lines of up to 100 miles long.

It is particularly suitable as an impulse accepting relay when a minimum of signal distortion is imperative, and because of the excellent change-over action and absence of contact chatter the relay is unequalled for impulsing the selector magnets in teleprinter automatic switching systems.

The relay responds satisfactorily to frequencies up to 100 c/s, when the contact gap is adjusted to 0.004 in. nominal, without serious bias disturbance. It can be left connected to line whilst awaiting a clearing signal, there being little distortion of through signals since the total leak can be of the order of 10,000 ohms.

Dimensionally the relay is interchangeable with the "3000" type relay. Terminations can either be made by means of a 12-pin plug base as illustrated, or with soldering tags in place of the pins. Protection is given by a magnetic screen and a transparent cap which is removable for contact adjustments.

Complete details supplied on request.

Manufactured by the Sole Licensees:—

TELEPHONE MANUFACTURING COMPANY LIMITED

Contractors to Governments of the British Commonwealth and other Nations

HOLLINGSWORTH WORKS · DULWICH · LONDON S.E.21 TEL: GIPSY HILL 2211 (10 LINES)



The AvoMeter is one of a useful range of "Avo" electrical testing instruments which are maintaining the "Avo" reputation for an unexcelled standard of accuracy and dependability—in fact, a standard by which other instruments are judged.

ONE INSTRUMENT

measures:—

Current, A.C. and D.C. (0 to 10 amps.)
Voltage, A.C. and D.C. (0 to 1,000 v.)
Resistance (up to 40 megohms)
Capacity (.01 to 20 mfd.)
Audio-frequency Power Output (0 to 2 watts)
Decibels (— 25 Db. to + 16 Db.)

Write for fully descriptive pamphlet.



Meters that Matter

THE Model 7 Universal AvoMeter is the world's most widely used combination electrical measuring instrument. It provides 50 ranges of readings on a 5-inch hand-calibrated scale, and is guaranteed accurate to B.S. first grade limits on D.C. and A.C. from 25 c/s to 2 kc/s. It is self-contained, compact and portable, simple to operate and almost impossible to damage electrically. It is protected by an automatic cut-out against damage through severe overload.

Sole Proprietors and Manufacturers:—

THE AUTOMATIC COIL WINDER & ELECTRICAL EQUIPMENT Co. Ltd,
Winder House, Douglas Street, London, S.W.1. Phone: VICtoria 3404-9

VALUABLE FREE BOOK

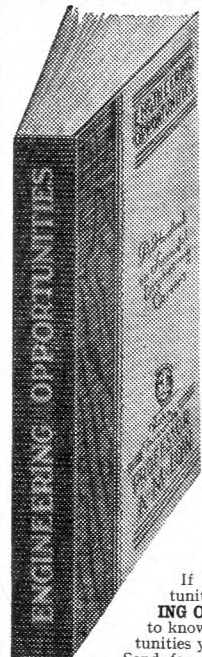

Tells You How to Pass Your C. & G. or Promotion Exam. at First Attempt!

All Post Office Engineering personnel who are anxious to obtain early promotion should at once send for a copy of our handbook "**ENGINEERING OPPORTUNITIES**," which among other intensely interesting matter, describes our unique methods of preparation for **TECHNICAL APPOINTMENTS IN THE POST OFFICE** (Assistant Engineer—New Style and Assistant Traffic Superintendent), **CITY AND GUILDS EXAMINATIONS** in Principles of Telecommunications (1-5), Radio (1-4), Telephone Exchange Systems (1-3), Telegraphy (1), Line Transmission (1 and 2), Lines Plant Practice (1 and 2), Mathematics for Telecommunications (1-5), Electrical Engineering Practice (Prelim. Inter. and Final), and outlines a wide range of non-examination courses in all branches of **Electrical, Mechanical, Civil, Automobile, Aeronautical and Radio Engineering.**

Assistant Engineer and Assistant Traffic Superintendent. Open competitions now resumed. Age extensions for established Civil Servants. Ask us for full details

**We definitely guarantee
"NO PASS—NO FEE"**

If you intend to make the most of to-day's opportunities, you cannot afford to miss reading "**ENGINEERING OPPORTUNITIES**." It tells you everything you want to know to secure advancement, and describes many opportunities you may now be missing through lack of information. Send for your copy to-day—**FREE** and without obligation.

**BRITISH INSTITUTE
OF ENGINEERING TECHNOLOGY** **BIET**
368 COLLEGE HOUSE,
29-31 WRIGHT'S LANE, KENSINGTON, W.8

PITMAN

for books on
Technical Subjects

Telephony (2 Vols.)

By J. Atkinson, A.M.I.E.E., Area Engineer, Post Office Engineering Department. A standard textbook for Post Office engineers and students. With over 1,500 illustrations. Vol. 1 (General Principles and Manual Exchange Systems) 35/- net. Vol. 2 (Automatic Exchange Systems) 55/- net.

Definitions and Formulae: Telegraphy and Telephony

By E. Mallett, D.Sc., M.I.E.E., M.Inst.C.E., F.Inst.P. Second Edition revised by W. T. Palmer, B.Sc.(Eng.), Wh.Ex., M.I.E.E., A.M.I.Mech.E. An up-to-date new edition of this useful reference which provides the student with all the necessary definitions and formulae in convenient form. 1/6.

D. C. Generators and Motors

By J. E. Macfarlane. 8/6 net.

"There has long been a need for a simple and concisely written book such as this . . . This book certainly gives the reader his money's worth."
—*ELECTRICAL REVIEW*.

The M. K. S. System of Units

By T. McGreevy, M.Sc.Tech., M.I.E.E. 21/- net.

" . . . should prove of great topical interest and, at the same time should be of lasting value to electrical engineers and to teachers and students of electrical engineering and physics."—*ENGINEERS DIGEST*

Sir Isaac Pitman & Son Ltd.

PARKER STREET · KINGSWAY · LONDON · W.C.2.

SUB-MINIATURISATION

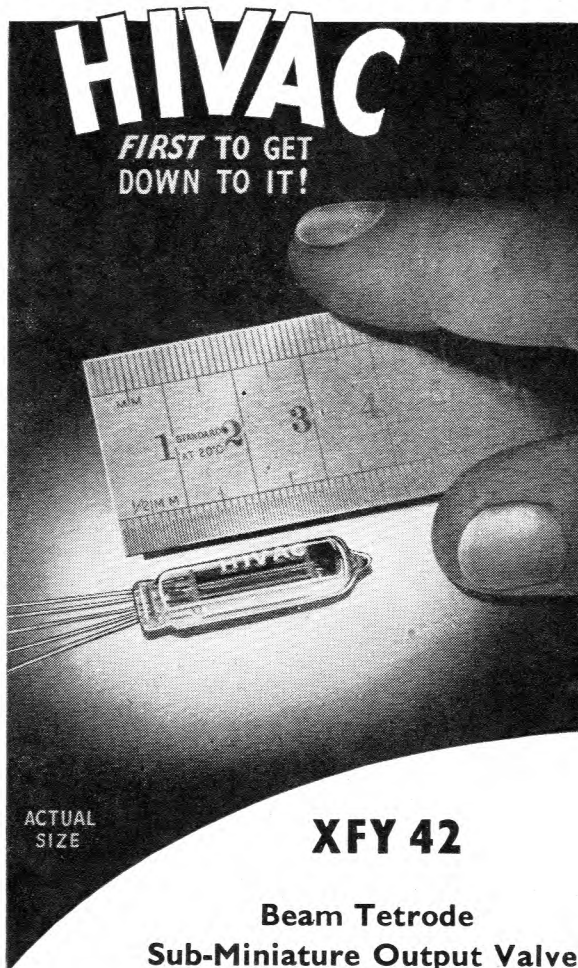

ACTUAL
SIZE

XFY 42

**Beam Tetrode
Sub-Miniature Output Valve
with still lower filament current**

TYPICAL OPERATION

Filament Voltage	1.25	1.25	1.25 V.
Filament Current	10	10	10 mA.
H.T. Voltage	16.25	22.5	30 V.
Control Grid Voltage	0	-1.5	-2.75 V.
Power Output	1.1	2.7	6.0 mW.

The maximum cross-section is only 8 mm. x 6 mm. with a maximum glass length of 35 mm.

A small flat sub-miniature output tetrode with still lower filament current and improved performance at reduced battery voltages.

HIVAC
THE SCIENTIFIC
VALVE

Hivac Ltd.

Telephone: HARrow 2855
GREENHILL CRESCENT, HARROW-ON-THE-HILL, MIDDLESEX

a new
**INDEPENDENT SIDEBAND
RECEIVER**

**... developed to British Post Office
Specification**

THIS new Independent Sideband Receiver type GFR 552 is designed for operation on long-distance, point-to-point, short-wave radio links forming part of the international trunk network. On independent sideband working, the GFR 552 provides facilities for the reception of two single sideband signals, each 6 kc/s wide, one above and one below the frequency of a reduced-level pilot carrier. Each sideband will accommodate either two 3 kc/s wide telephony channels, or several voice frequency telegraph channels. The GFR 552 may also be used for reception of single sideband or double sideband transmission. In the case of the second application this receiver offers two advantages: firstly, the absence of non-linear distortion which occurs in normal D.S.B. receivers when signals are subjected to selective fading conditions; and, secondly, the ability to select upper or lower sideband for demodulation, dependent upon which is freer from adjacent channel interference. The circuit and chassis layout of the GFR 552 closely follows that of the Mullard Receiver GFR 551, which was based on a British Post Office design (Receiver, Radio No. 22).

Special features of the GFR 552 include a high order of oscillator stability and freedom from cross-modulation through which cross-talk between channels or inter-modulation between wanted and unwanted signals might occur. A brief technical summary is given below. More detailed information supplied on request.

FREQUENCY RANGE—4-30 mc/s.

NOISE FACTOR—better than 7 db over the band.

SIGNAL TO NOISE RATIO—25 db for 4 microvolts peak sideband input over the band.

SELECTIVITY—The response is flat within 2 db for sideband frequencies between 100 c/s and 6000 c/s. At 10 kc/s from the carrier frequency the response is -60 db relative to the pass band.

A.F.C.—The A.F.C. system operates effectively with a pilot carrier level of -26 db relative to 1 microvolt (which corresponds to a peak sideband level of 1 microvolt and a signal to noise ratio of 15 db).

NON-LINEAR DISTORTION—Third order intermodulation products which might result in cross talk between sidebands do not exceed -50 db relative to the sideband levels.

OUTPUT—Variable up to +14 db relative to 1 mW into 600 ohms.

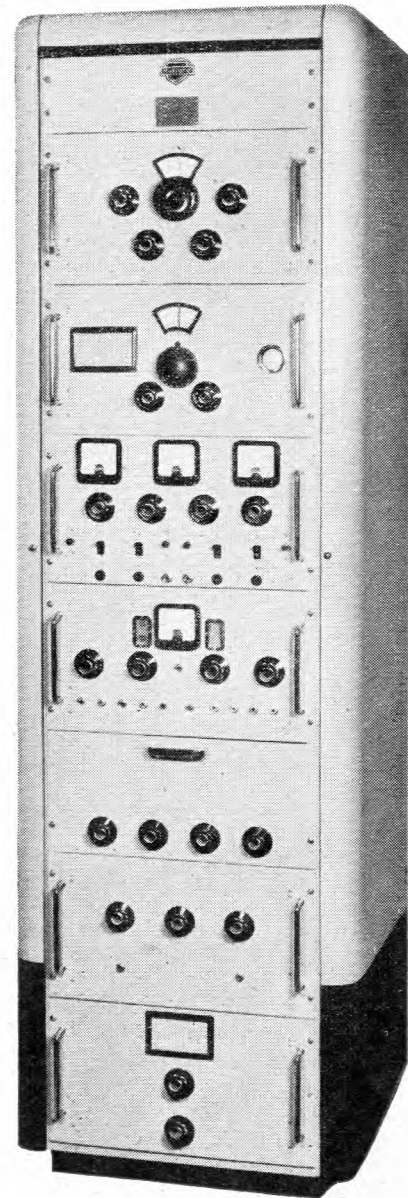

Mullard



SPECIALISED ELECTRONIC EQUIPMENT

MULLARD LIMITED, EQUIPMENT DIVISION, CENTURY HOUSE, SHAFTESBURY AVENUE, LONDON, W.C.2
(MI417)

Cold Cathode Tubes

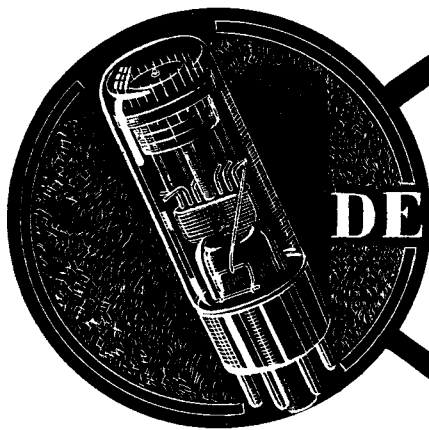

DEKATRONS

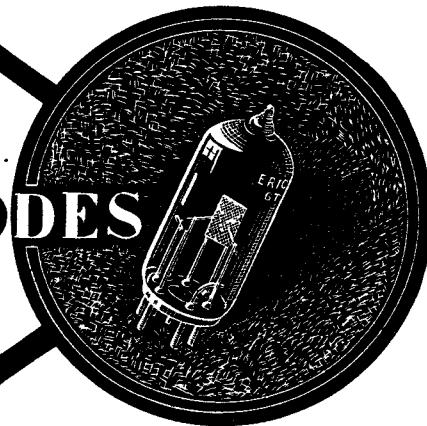

TRIGGER TETRODES

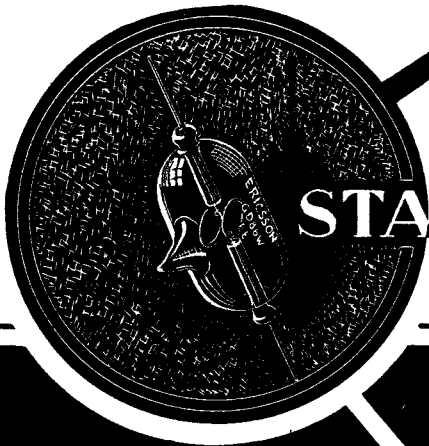

STABILISERS

*Descriptive Catalogue available on
application to:-*

WORKS:
BEESTON,
NOTTINGHAM
Beeston 54225



HEAD OFFICE:
22, LINCOLN'S INN FIELDS,
LONDON, W.C.2
HOLborn 6936

POWER *behind the lines*

TUNGSTONE PLANTÉ CELLS are being regularly supplied to the British Post Office and Post and Telegraph Departments in many countries overseas. They conform fully to G.P.O. Standard specifications.

OPEN TYPE CELLS

Similar to the illustration here, these are available in glass and/or lead lined wooden boxes in capacities from 100 a.h. to 5000 a.h.

REPLATALS

We are in a position to supply plates for the replating of existing Planté Batteries.

ENCLOSED TYPE CELLS

As illustrated below, these are in moulded glass boxes with sealed-in lid. Capacity range from 10 a.h. to 200 a.h.

PORTABLE TYPE BATTERIES

A range of portable type Batteries is in regular production, made to G.P.O. specifications, for ancillary duties.

Overseas customers are invited to cable or write their enquiries for batteries or parts. Visitors to London are welcome at our offices. (Just off Fleet Street.)

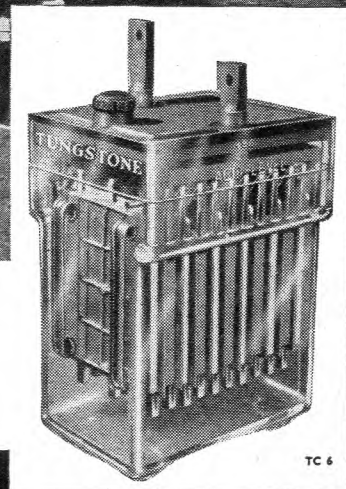
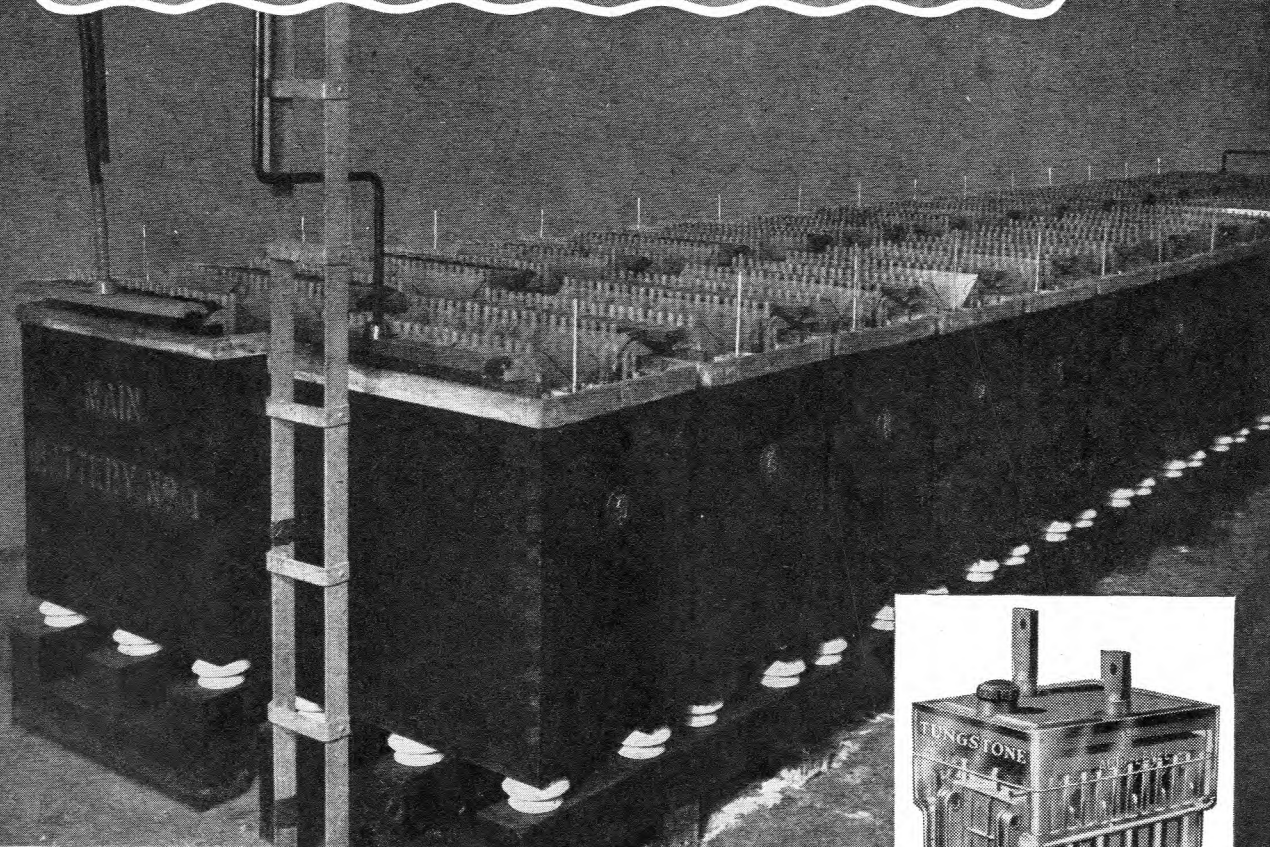

TUNGSTONE *Batteries*

For further particulars write : TUNGSTONE PRODUCTS LIMITED,
10 SALISBURY SQUARE, LONDON, E.C.4, ENGLAND. Cables: "Dilutum" London.

Hearty congratulations

CW 51-151

POST OFFICE
CABLE & WIRELESS

ISSUING OFFICE

NO. 

SENT BY

RECEIVED PARTICULARS

14/10

VIA IMPERIAL

The first line of this Telegram contains the following particulars in the order named: Prefix Letters and Number of Message, Office of Origin, Number of Words, Date, Time handed in and Official Instructions, if any.

TBRUM29 SYDNEY 71/70 14 1427 =
LT SPRINGJACK COVENTRY =

FOR ROBINSON STOP HAPPY TO REPORT COMPLETELY SUCCESSFUL
CUTOVER TENTH OCTOBER OF ST LEONARDS EXCHANGE SYDNEY
NETWORK STOP THIS IS FIRST INSTALLATION USING SE50
SWITCHES SINCE THEIR ADOPTION BY PMGS DEPARTMENT STOP ALL
SWITCHES ENTERED SERVICE WITHOUT LOCAL ADJUSTMENT APART
FROM WIPER SETTING STOP HEARTY CONGRATULATIONS ON THIS
EXCELLENT PERFORMANCE AND YOUR HIGHLY SUCCESSFUL
DEVELOPMENT WHICH CAN BE JUSTIFIABLY REGARDED AS AN EPIC
AND HISTORIC ACHIEVEMENT

SE 50 Selectors installed
in Australian Exchange
without local adjustment

**1912
AUTOMATIC EXCHANGES
STANDARDISED**

St. Leonard's Exchange, north of Sydney, serves at present a residential and industrial area of 3,400 lines. Australian standardisation of the SE50 is due entirely to the merits of the switch, a fact confirmed by a report in *The Age*, Thursday, October 15th, 1953, which reads:

**1953
ACCEPTANCE
AND FIRST
INSTALLATION
OF SE50
SELECTOR**

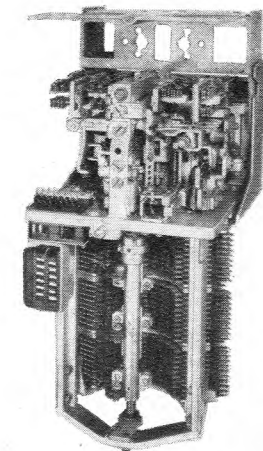

"The Director-General of Posts and Telegraphs (Mr. G. T. Chippendall) said this . . .
"A certain proportion of the older type of switch equipment would still be required by the department, but in all new metropolitan automatic exchanges this new switch, which would be made in Australia, would be installed.
Mr. Chippendall added:
"This new switch has been proved to lower costs of maintenance and reduce faults to a minimum."

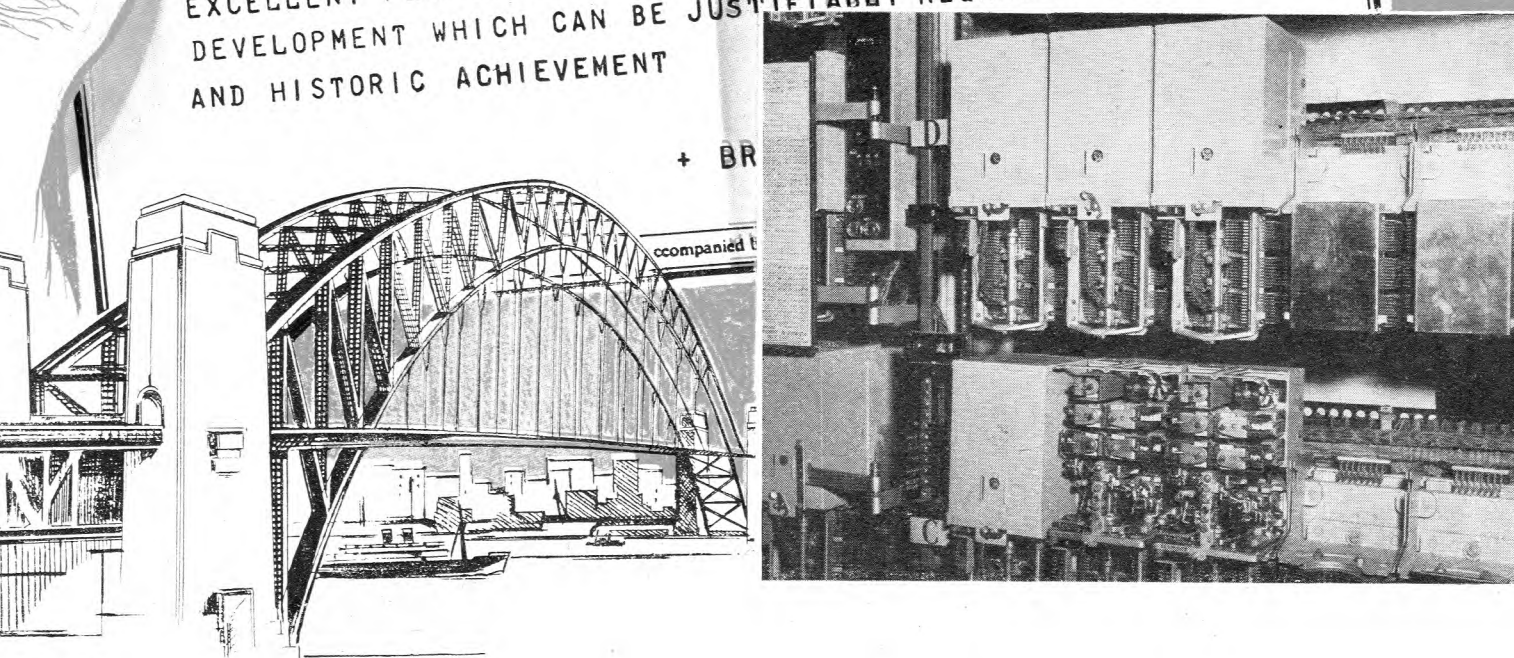

cutting the cost of maintenance

— thanks to

G.E.C.

From Alton go batteries to power stations all over the world. Batteries, as their distant users tell us, that possess a certain distinctive merit all their own. Surprising, in these days of uniformity and standardisation? But Alton, in such an age, is perhaps a surprising place. Alton's a small country town, with a friendly, satisfying life of its own. A natural place unchanged, unspoiled, where the surrounding streams run down through lovely and varied country to feed the river Itchen pictured below. Where a man at leisure can follow his bent, be it sport or hobby or just plain peace of mind. Where a life worth living, a job worth doing are any man's natural right : and pride in himself and the work of his hands is a wholly natural consequence.

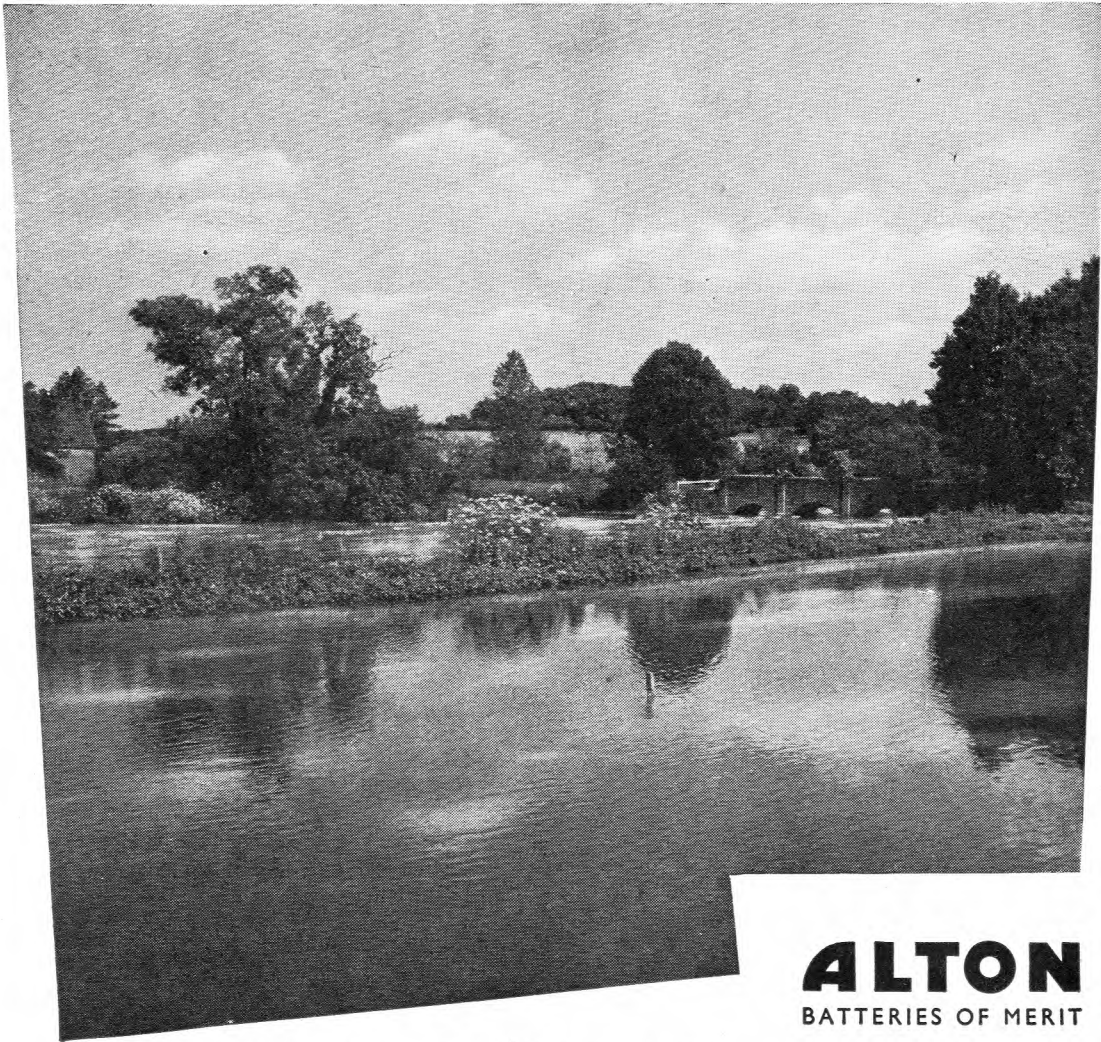

ALTON
BATTERIES OF MERIT

Alton stationary batteries: 10 to 15,000 Ah. Also in regular production, renewal plates for all makes of battery, British and Continental

A23A

The Alton Battery Company Limited · Alton · Hants · Telephone: Alton 2267 and 2268 · Telegrams: Battery, Alton

BICC

PRODUCTS FOR TELECOMMUNICATIONS

BICC are constantly developing new products and improving existing ones to help solve the problems of the telecommunications engineer. The examples illustrated indicate the extent of their research and development work in this field. Like all BICC products, they are made to realistic specifications from the highest quality materials. They will give long, reliable service in any climate.

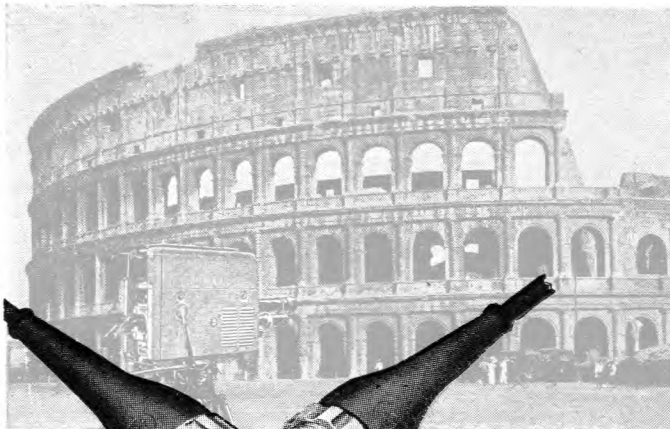

*MOULDED POLYPOLE
CABLE COUPLERS*

These are moulded to the ends of television camera cables in the factory, providing a robust trailing cable system. The cameras supplied by Marconi's Wireless Telegraph Co. Ltd., to the Italian State Broadcasting Corporation—part of the biggest order for television equipment ever placed in Britain—are equipped with BICC cables and couplers.

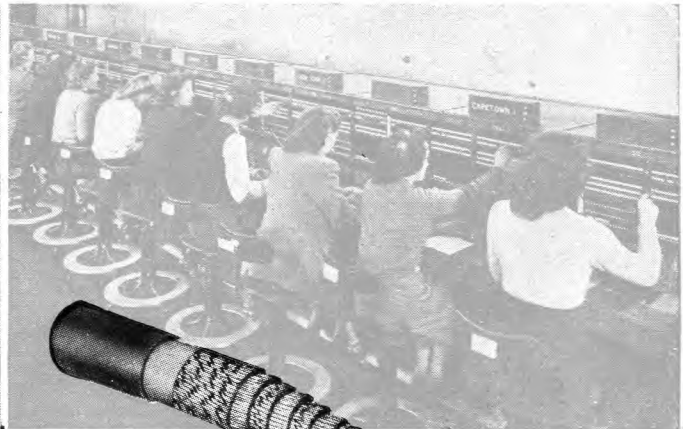

TELEPHONE CABLES

Nearly every type of cable and wire for use in telephone systems is manufactured by BICC. Of particular interest are the spaced polythene disc type co-axial cables for multi-channel operation. Also available are standard dry-core cables for trunk and distribution use, and plastic cables to meet a variety of operating conditions.

Photo by courtesy of H.M. Postmaster-General.

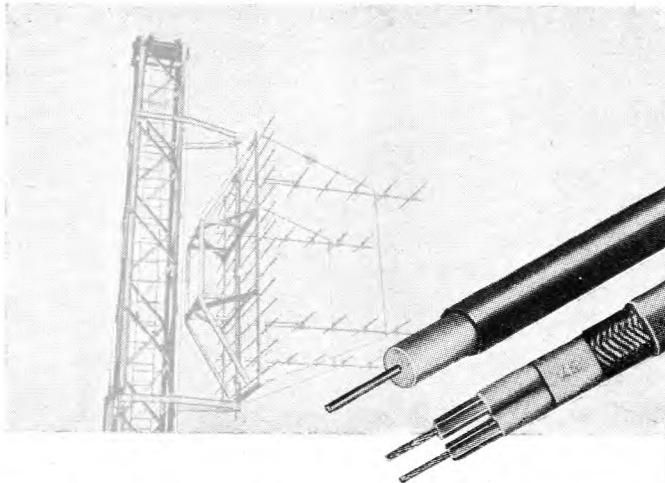

RADIO FREQUENCY CABLES

BICC make a comprehensive range of radio frequency cables. A medium power aluminium-sheathed co-axial cable will provide the main feeder to the V.H.F. aerial installation shown above. The aerial is to be used with equipment designed by the Automatic Telephone and Electric Co. Ltd.

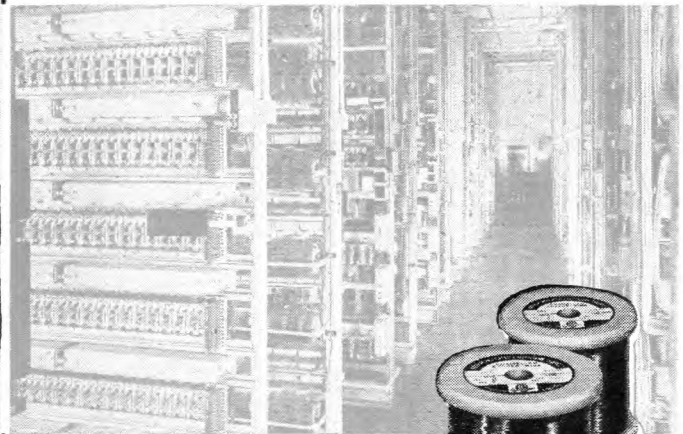

WINDING WIRES

Because of their high space factor and excellent electrical properties enamelled winding wires are highly suitable for small coils and windings. They are widely used in telephone relay coils. BICC manufacture winding wires for all purposes, insulated with oil-base or synthetic enamels, textiles, paper, glass and asbestos.

Photo by courtesy of H.M. Postmaster-General.

Branches and Agents throughout the World.



BRITISH INSULATED CALLENDER'S CABLES LIMITED
21 BLOOMSBURY STREET, LONDON, W.C.1. Museum 1600

SKILLMAN

Short Distance Carrier

4 kc/s Spacing
12-CHANNEL TWO CABLES
6-CHANNEL ONE CABLE

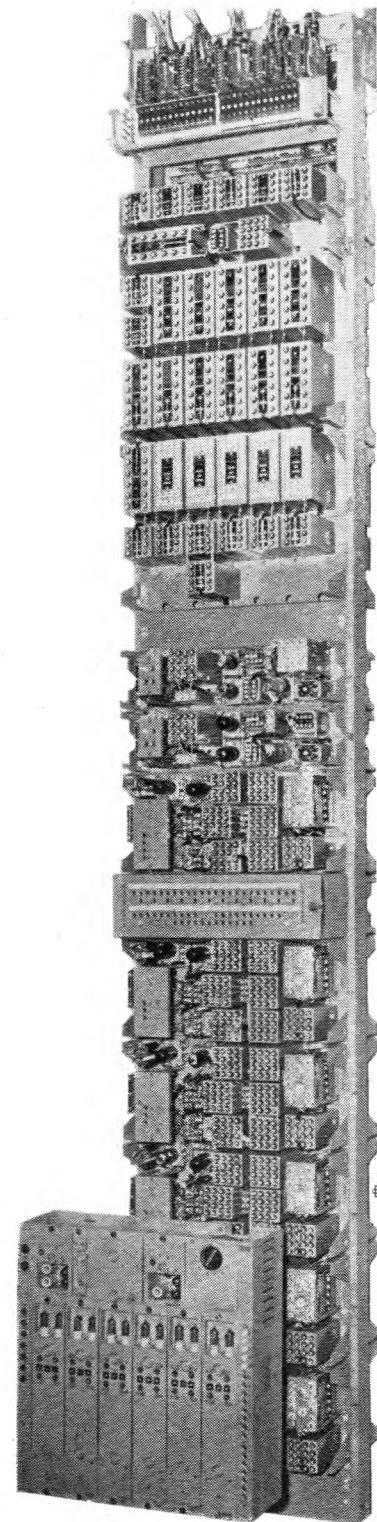

- * Six channels per pair of single cable or twelve channels per pair of double cable. 4-52 kc/s or 12-60 kc/s. Old type inter-exchange cables in city networks can be counted on to give at least 30% pairs suitable for 52 kc/s working; i.e. cable capacity is doubled.
- * No repeaters required on most city networks (see range table opposite). Hence extra circuits obtainable in a few hours.
- * The equipment often proves economic over distances as short as 2 miles by providing temporary extra traffic capacity, and thus delaying investment of funds until traffic has grown enough to occupy a reasonable proportion of new cable capacity (e.g. 12 extra carrier channels may easily be cheaper than the minimum economic new cable providing, say, 100 extra channels).
- * Signalling is by low-level tone, present continuously during speech, and having a frequency of 0 cycles (i.e. the carrier frequency). Thus the circuits are the same as for D.C. paths, and voice operation troubles non-existent.
- * All channels adjustable to low or zero transmission loss, and when required can give a gain.

The small panel on the left is the same as that on the right and replaces the entire bay shown behind.

T. S. SKILLMAN & CO. LTD., Grove Park, Colindale, London, N.W.9

T. S. SKILLMAN & CO. PTY. LTD., Cammeray, Sydney, N.S.W.

SKILLMAN CARRIER EQUIPMENT HAS BEEN SUPPLIED TO ENGLAND FOR OTHER THAN G.P.O. APPLICATIONS, TO AUSTRALIA, NEW ZEALAND, BELGIUM AND EGYPT, AND ENQUIRIES ARE INVITED FOR REPRESENTATIVES ELSEWHERE

SKILLMAN

T. S. Skillman & Co. Ltd. were world pioneers of short haul or "junction" carrier systems. Over £500,000 worth of the old style equipment indicated opposite is in service, much of it for over 4 years.

The miniaturised form is now available, on a 21" panel with 60 channel ends plus power supply on one 19" rack. Installation involves connecting only new junction relay groups, power (A.C.) and carrier supply and deloading the junctions.

Normal copper interoffice line with small relay group for repeating impulses. This is cut at X and reconnected as shown.

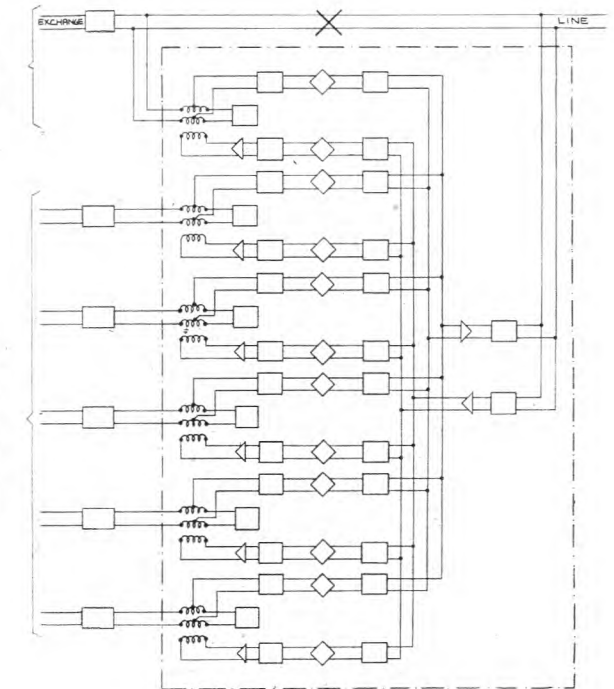

Five new lines indistinguishable from D.C. lines in all respects, except superior speech transmission performance. Relay groups identical with those on D.C.

All the equipment within the dotted lines is mounted on the panel shown below.

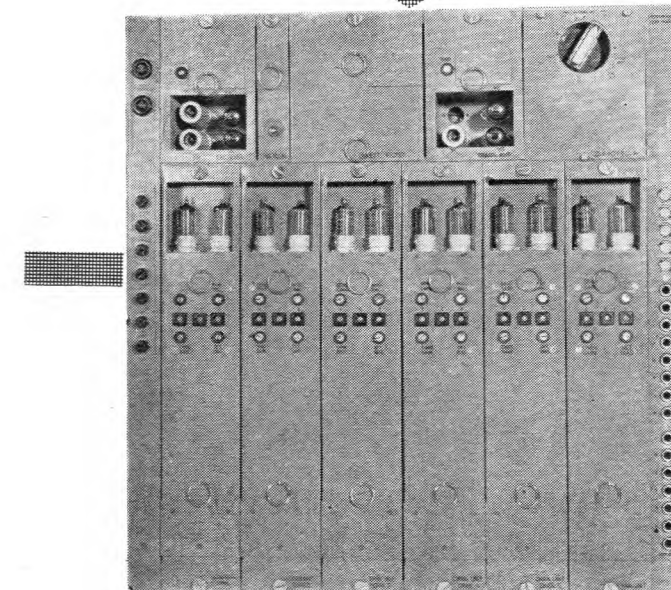

MAXIMUM WORKING DISTANCES		
CABLE	WITH REPEATERS	WITHOUT REPEATERS
20 lbs One Cable	100-200 miles	13 miles
20 lbs Two Cables	100-200 miles	18 miles
40 lbs One Cable	100-200 miles	16 miles
40 lbs Two Cables	100-200 miles	22 miles

DESIGNED
FOR CONTINUOUS
SERVICE

ATE/TMC transmission equipment is designed to offer an operating administration the maximum facility in installation and in subsequent maintenance routines. A bayside can be unpacked, carried, erected and equipped by one man if necessary. Panel frames, fitted with quickly detachable functional units, are of the "jack-in" type, an arrangement which ensures the most rapid form of servicing yet devised. Further information is contained in the brochure "Unit Construction Practice" a copy of which will be forwarded on request.



AUTOMATIC TELEPHONE & ELECTRIC CO. LTD.

Radio and Transmission Division, Strowger House, Arundel Street, London, W.C.2. Telephone: TEMple Bar 9262. Cables: Strowgerex London. Manufacturers:— AUTOMATIC TELEPHONE & ELECTRIC CO. LTD., Liverpool & London. TELEPHONE MANUFACTURING CO. LTD., St. Mary Cray, Kent.

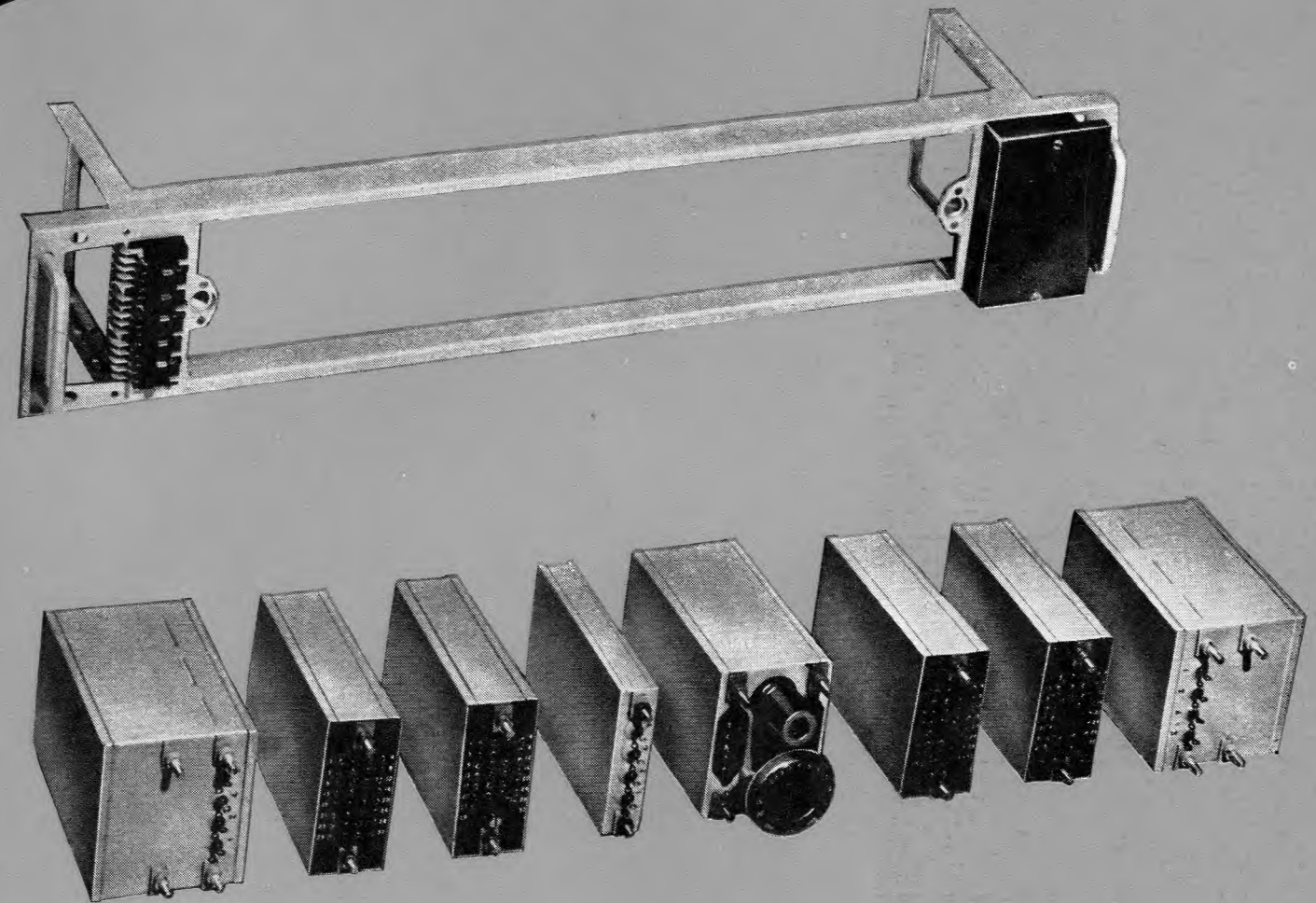

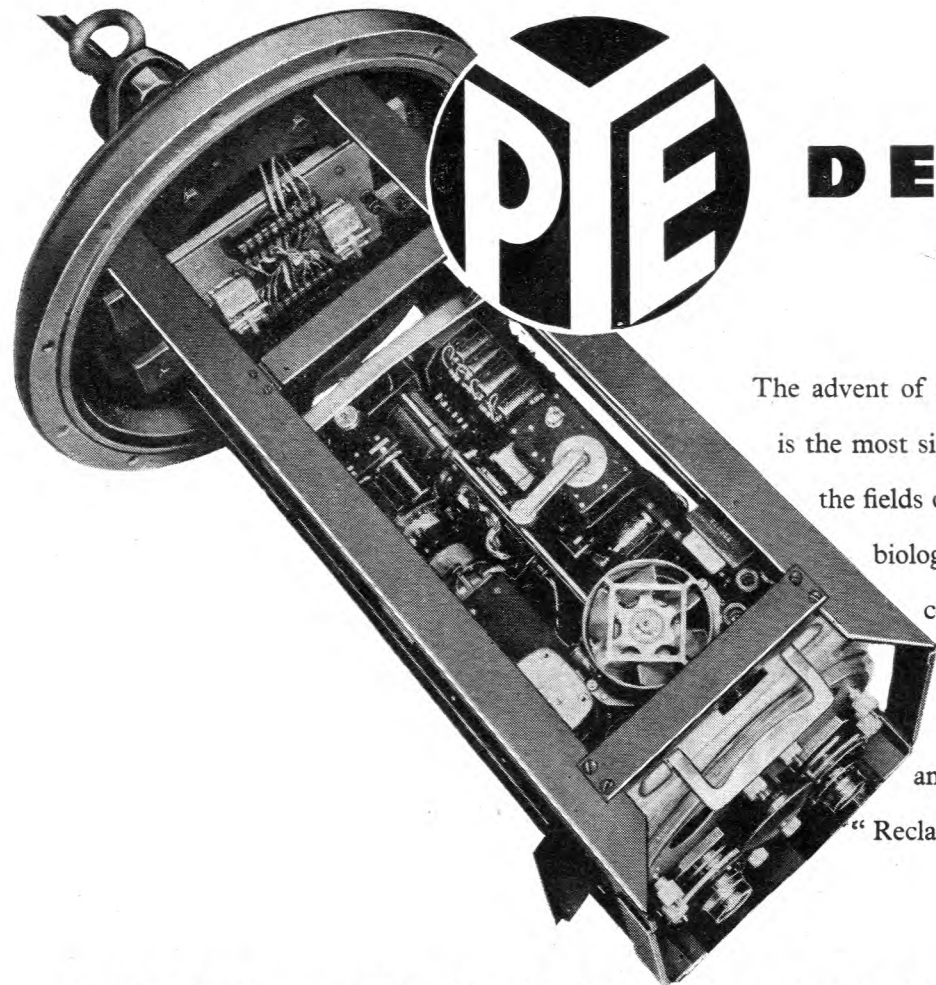

DEEP SEA

The advent of the Pye deep sea television camera is the most significant advance in recent years in the fields of marine salvage and of underwater biological research. Developed in close co-operation with the Admiralty, the equipment is now installed in the Admiralty Research Laboratories and in Deep Diving Vessel H.M.S. "Reclaim".

USED BY THE ADMIRALTY

Direction and angle of elevation through 115 degrees are mechanically controlled from the surface. Alternatively, the elevation angle can be set before submerging, while for prolonged, static observation, the camera can be mounted on the sea bed. All optical and other adjustments are made from the control unit illustrated opposite which fits into the control room on board the deep diving vessel.

For illumination, either a standard Admiralty pattern diver's lamp or a recently developed cold cathode lamp is housed at the base of the camera. Extra light may be derived from subsidiary lamps attached at will on the special framework attached to the camera casing.

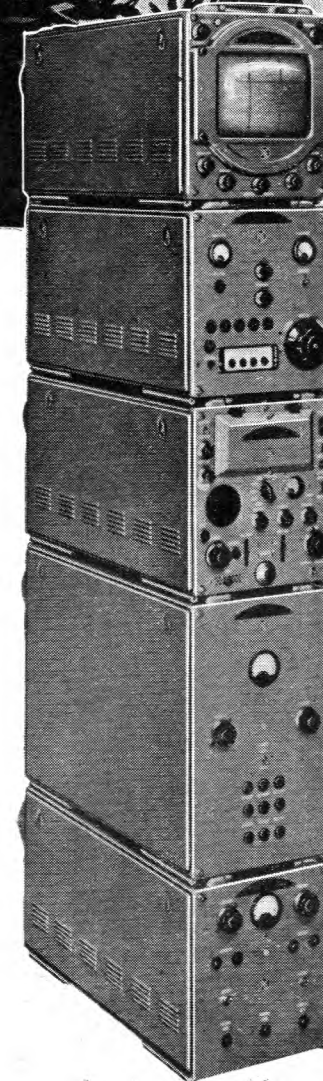
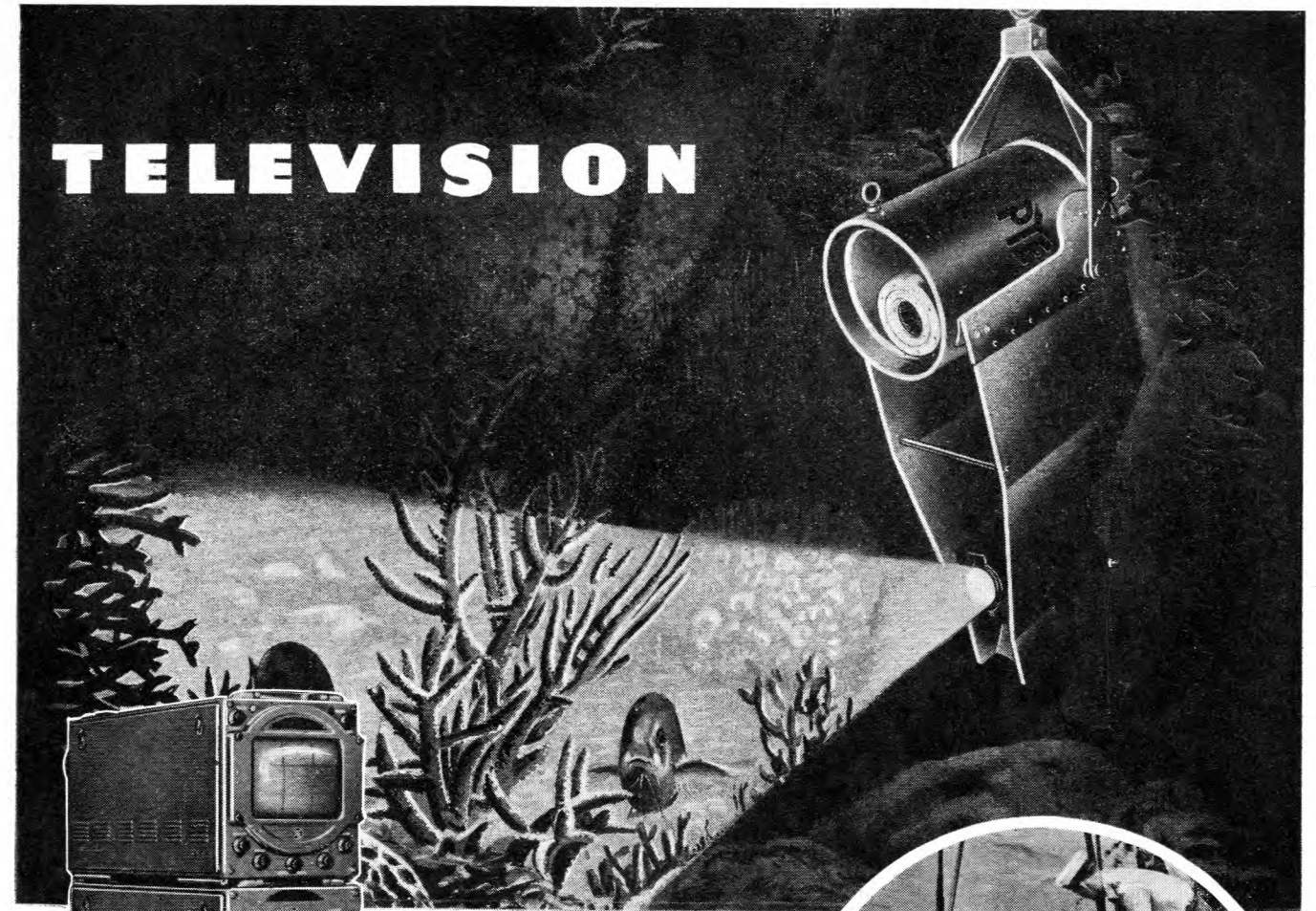
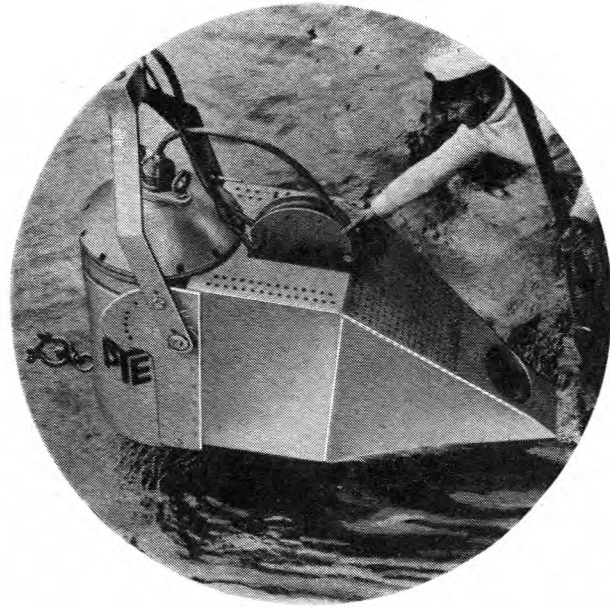

Close-up of Pye deep sea television camera about to be submerged during a salvage operation.

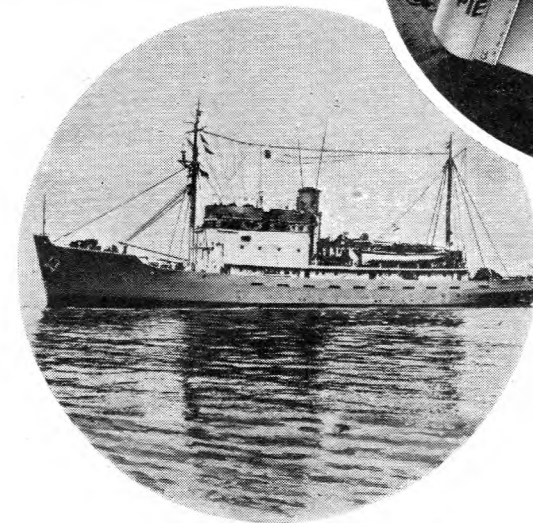
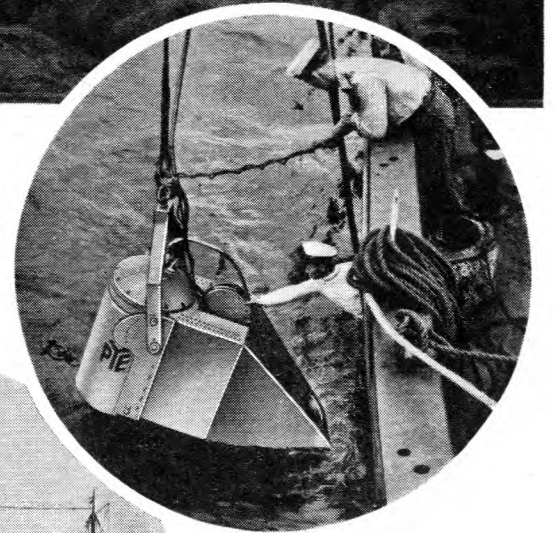

Deep Diving Vessel H.M.S. "Reclaim", specially equipped for Admiralty salvage work, and now fitted with Pye underwater television equipment.

Communication

Standard Systems in Service



A recent example of **Standard's** activity in the field of radio engineering, is the DS.13-40 Kilowatt single side-band radio telephone transmitter designed and manufactured by the Company for the New Zealand P. T. & T. Administration. Made available for carrying H.M. the Queen's Christmas message to Britain and the Commonwealth this transmitter is installed at Himatangi 75 miles north of Wellington. The service with the U.K. constitutes the longest radio telephone link in the world.



A member of the New Zealand P. T. & T. staff making adjustments during installation.



Standard Telephones
(TELECOMMUNICATION)
Connaught House, Aldwych,

Cairo • Dublin • Johannesburg

and Control

Standard systems include:—

Standard's wide resources, their long experience in the design and manufacture of systems and equipment for telecommunications and control, have enabled them to produce an extensive range of apparatus for use in all parts of the world.

These resources and experience are at your service, either for the systems listed or for their development to meet specific needs, as well as for the supply of products including:—

SenTerCel Selenium Rectifiers
Power Factor Correction
Capacitors
Power Cable
Thermionic Valves
Quartz crystals
Magnetic alloys

Telephone
Telegraph
Radio Broadcasting
Radio Communication
Radio Navigation
Sound Reproduction
Remote Control
Remote Indication
Telemetry
Railway Communication
Railway Control
Communication Cable
Airfield Lighting Control
Street Lighting Control
Fire Alarm
Totalisator
Public Indicator
Signalling (Office and Factory)

and Cables Limited

ENGINEERS)
London, W.C.2, England

Karachi • New Delhi • Salisbury



MORSEINKERS MODEL 1515



Motordriven, 110/220 volts A.C., especially designed for radio schools.

Special design of printing wheel gives very distinct record and absence of inking troubles.

✧ Write for comprehensive catalogue.

THE GREAT NORTHERN TELEGRAPH COMPANY'S FACTORY

4, SYDHAVNS PLADS
COPENHAGEN SV . DENMARK



LONDON OFFICE: 5, ST. HELENS PLACE
LONDON E.C.3.

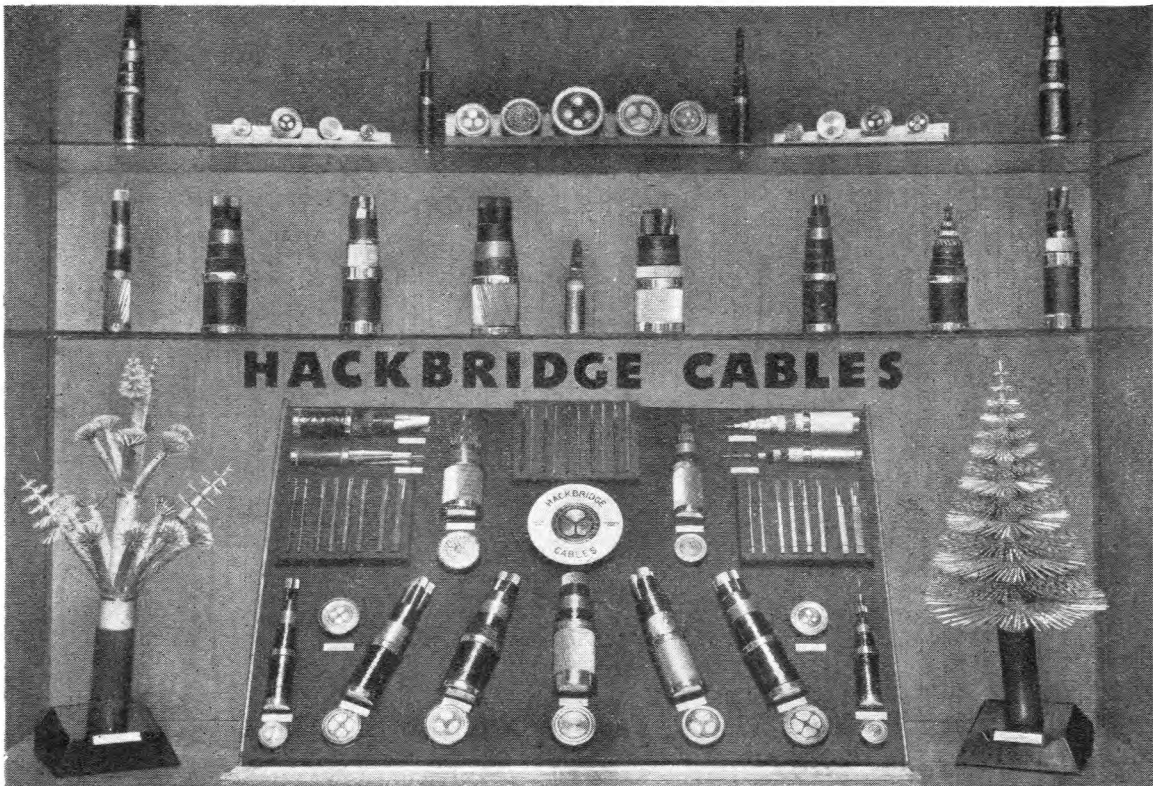

HACKBRIDGE
Cable Company Limited

KELVIN WORKS, HACKBRIDGE, SURREY

In Association with BRYCE ELECTRIC CONSTRUCTION Co. Ltd.

Branches at BIRMINGHAM, BRISTOL, CARDIFF, MANCHESTER, NEWCASTLE, SHEFFIELD

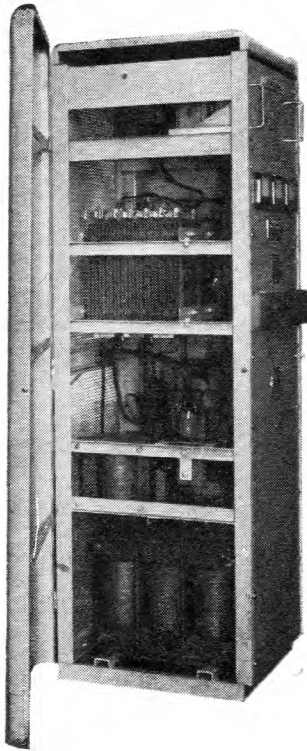

THE TRANSBOOSTER

The Transbooster is an improved method of voltage control, the equipments being produced in either static or mobile housings to suit varying requirements. A range of outputs is available and the illustration here shows a 3 kW model giving an output of 60 amperes at 50 volts nominal, smoothed for telephone exchange use. It is designed to hold D.C. output voltage within limits of $\pm 1\%$ from 1/20th up to full load and is independent of mains voltage variations of -10% to $+6\%$ and frequency variations from 48 to 52 c/s. The applications of this equipment are extensive, and full details of

WESTINGHOUSE
WESTALITE

CONSTANT POTENTIAL RECTIFIERS

can be obtained on request to . . .

Dept. P.O.E.E.J. 1

WESTINGHOUSE BRAKE & SIGNAL CO. LTD, 82 YORK WAY, KING'S CROSS, LONDON, N.1

SULLIVAN & GRIFFITHS

DIRECT READING VARIABLE CONDENSERS

WITH NOVEL AIR CAPACITANCE
DECADE RANGE EXTENSION

This air dielectric condenser comprises a decade of air capacitance and a continuously variable air condenser thus giving a scale accuracy ten times that of an ordinary variable condenser of the same range.

Thus a decade of capacitance is provided—permanent in value and entirely free from loss, the only loss present in the complete combination of decade and variable condenser being that due to the solid insulating material which is ordinarily employed in the construction of the latter.

The variable condenser has a range of $100\mu\text{F}$ which is extended to $1100\mu\text{F}$ by ten increments of $100\mu\text{F}$, all adjusted with accuracy so that the decade is absolutely direct reading in μF , no corrections or calibration being necessary.



LIST No. C 880

Electrical Standards for Research and Industry

Testing and Measuring Apparatus
for Communication Engineering

H. W. SULLIVAN, LTD., LONDON, S.E. 15.

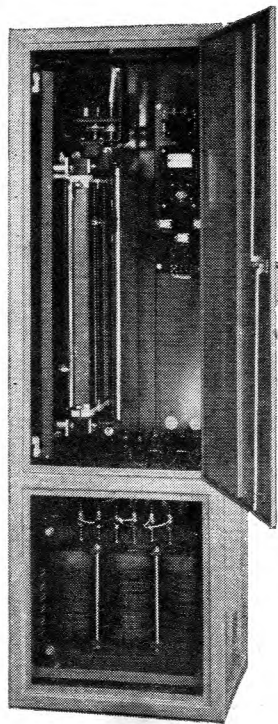

30 KVA three phase cubicle type automatic regulator.

BERCO / *B.P.T. Voltage Control Equipment*

BERCO/B.P.T. voltage regulating and stabilising equipment is designed to afford a constant supply voltage to industrial scientific and electro-medical apparatus — and to all other electrical equipment which is normally sensitive to voltage fluctuation. Standardised sizes and ratings in single, three phase, hand operated and motor driven models meet most requirements but special designs can be made where necessary.

Applications apply to induction heating equipment, electric furnace control, radio and scientific equipment, process control, chemical analysis, X-ray and electro-medical apparatus, meter testing equipment, and wherever a process depends on a constant supply voltage.

Complete details and specifications obtainable without obligation. Please write for booklet 5091.

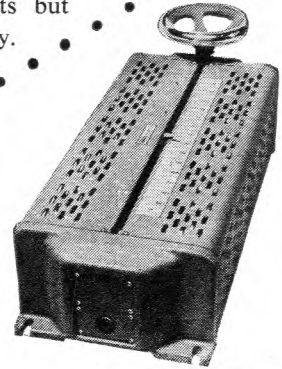

Hand operated BERCO "Regavolt" (single phase).

**THE BRITISH ELECTRIC RESISTANCE CO. LTD.
BRITISH POWER TRANSFORMER CO. LTD.**

Queensway · Ponders End · Middlesex

Telephone: HOWard 1492

Telegrams: "Vitrohm, Enfield"

BR/BP5091/BXH

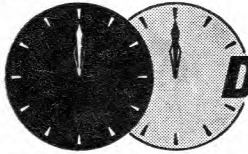

DESIGNED FOR 24 HOURS PER DAY OPERATION

BATTERY DRIVEN CARRIER CURRENT GENERATORS FOR VOICE FREQUENCY TELEGRAPH TRANSMISSION

These generators are the result of many years experience in this field. They are made in three forms for 18, 24 or 27 channel transmission systems. Frequency ranges 420 to 2460 c.p.s., 420 to 3180 or 300 to 3420 c.p.s. in 120 c.p.s. steps. Speed and frequency accuracy $\pm 12\%$ for long periods without maintenance. Input 20 to 28 volt d.c. or 150 to 184 volts d.c.

Comprehensive details from the Manufacturers . . .

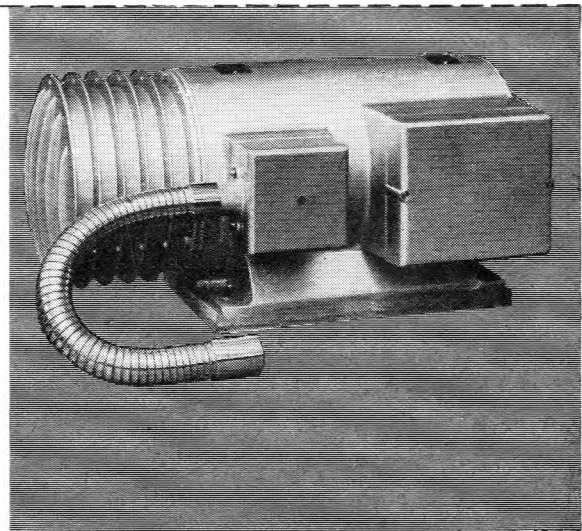

WALTER JONES & Company (Engineers) Limited

**NEWLANDS PARK · SYDENHAM
LONDON · S.E.26 · SYDenham 6264**

TECHNIQUE

MUIRHEAD

A JOURNAL OF INSTRUMENT ENGINEERING

FREE ON REQUEST

**POST
THIS COUPON
TODAY**

MUIRHEAD & CO. LTD. BECKENHAM · KENT · ENGLAND

Please place my name on your mailing list for "TECHNIQUE"

NAME _____

POSITION _____

COMPANY _____

ADDRESS _____

P.O.E.E.J.61

MUIRHEAD & CO., LTD.
PRECISION ELECTRICAL INSTRUMENT MAKERS
BECKENHAM · KENT · ENGLAND

Phone: Beckenham 0041 Telegrams & Cables: MUIRHEADS ELMERS-END

PRECISION

MUIRHEAD

ELECTRICAL INSTRUMENTS



FOR THE RIGHT CONNECTION

FREDERICK SMITH & COMPANY

ANACONDA WORKS, SALFORD, 3, LANCS.

*Incorporated in The London Electric Wire Company and Smiths Limited.
Associated with The Liverpool Electric Cable Co. Ltd. and Vactite Wire Co. Ltd.*

NEW!

**EXPERIMENTAL
OUTFITS**

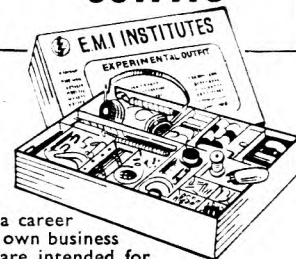

**LEARN THE
PRACTICAL WAY**

Whether you are a student for an examination, starting a new hobby, intent upon a career in industry or running your own business — these Practical Courses are intended for You—and may be yours at very moderate cost.

EASY TERMS FROM £1 A MONTH

With these outfits, which you receive upon enrolment, you are given instructions which teach you in easy stages the basic principles of the subject concerned. A tutor gives individual help and guidance throughout the Course.

COURSES WITH PRACTICAL EQUIPMENT INCLUDE:—Radio (Elementary and Advanced), Television, Mechanics, Electricity, Chemistry, Photography, Carpentry. Also Draughtsmanship, Commercial Art, Amateur S.W. Radio, Languages, etc.

POST THIS COUPON TODAY

Send me your FREE book on Practical Courses.
To E.M.I. INSTITUTES, Dept. 97X, 43 Grove
Park Road, Chiswick, London, W.4.

NAME _____

ADDRESS _____

IC24

EMI

INSTITUTES

*The only Postal
Collegewhich is
part of a world-
wide Industrial
organisation.*

TELEPHONE DISTRIBUTION

EQUIPMENT

ENGINEERS WHO ARE INTERESTED
IN TELEPHONE DISTRIBUTION EQUIP-
MENT ARE INVITED TO REQUEST
SECTION T.C.13 OF OUR TELECOM-
MUNICATION CABLES CATALOGUE.

TELEPHONE:
SOUTHAMPTON
2141 (5 lines).

IRELLI GENERAL
CABLE WORKS, Ltd., SOUTHAMPTON

TELEGRAMS
"PIGEKAYBEL
SOUTHAMPTON"

EDISWAN

Telephone Line Protectors

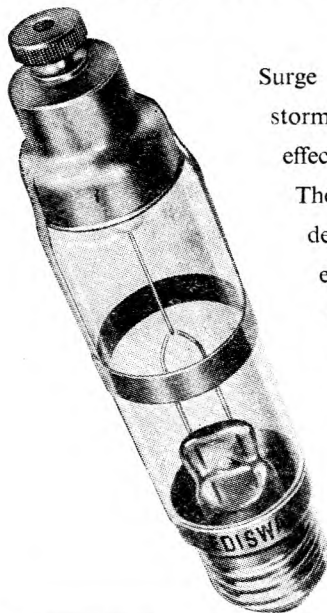

Surge currents induced on telephone lines by electric storms or breakdowns on neighbouring power lines may be effectively controlled by Ediswan telephone line protectors.

These special electrode gas discharge tubes have been developed in collaboration with G.P.O. Engineers to provide economical and effective protection for telephone systems without impairing the service.

Full details of these protectors and their application is given in the Ediswan publication C.1581 which is available on application.

THE EDISON SWAN ELECTRIC CO., LTD.

155 CHARING CROSS ROAD, LONDON, W.C.2

Member of the A.E.I. Group of Companies

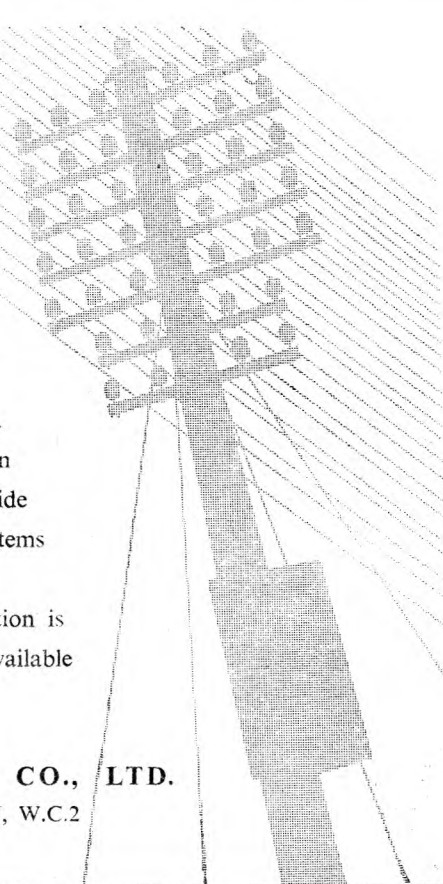

TE107