

This document was generated by me, Colin Hinson, from a document held at R.A.F. Henlow Signals Museum and is believed to be out of copyright or Crown Copyright . It is presented here (for free) under the Open Government Licence (O.G.L.) if under Crown Copyright and this version of the document is my copyright (along with the Crown Copyright) in much the same way as a photograph would be. If you believe the document to be under copyright, please contact me.

The document should have been downloaded from my website <https://blunham.com/Radar>, if you downloaded it from elsewhere, please let me know (particularly if you were charged for it). You can contact me via my Genuki email page:

<https://www.genuki.org.uk/big/eng/YKS/various?recipient=colin>

**You may not copy the file for onward transmission of the data nor attempt to make monetary gain by the use of these files. If you want someone else to have a copy of the file, point them at the website. It should be noted that most of the pages are identifiable as having been processed by me.**

---

I put a lot of time into producing these files which is why you are met with the above when you open the file.

In order to generate this file, I need to:

1. Scan the pages (Epson 15000 A3 scanner)
2. Split the photographs out from the text only pages
3. Run my own software to split double pages and remove any edge marks such as punch holes
4. Run my own software to clean up the pages
5. Run my own software to set the pages to a given size and align the text correctly.
6. Run Omnipage (Ultimate) on all the pages to OCR them.
7. Generate a searchable Acrobat pdf file.

Hopefully after all that, I end up with a presentable file, though I can't guarantee there aren't errors in the OCR. If you find missing pages, pages in the wrong order, anything else wrong with the file or simply want to make a comment, please drop me a line (see above).

It is my hope that you find the file of use to you personally – I know that I would have liked to have found some of these files years ago – they would have saved me a lot of time !

Colin Hinson

In the village of Blunham, Bedfordshire.

# THE POST OFFICE ELECTRICAL ENGINEERS' JOURNAL

Vol. 49

APRIL 1956

Part 1

## CONTENTS

	PAGE
TRANSATLANTIC TELEPHONE CABLE—THE OVERLAND CABLE IN NEWFOUNDLAND, Part 1—Design of the Cable, Survey of Route and Preparations for Laying the Cable—H. E. Robinson and B. Ash .. .. .	1
THE TESTING OF TELEGRAPH MACHINES—J. H. Collins, A.M.I.E.E., and E. G. Collier	7
NEW LINE TRANSMISSION EQUIPMENT—L. W. J. Chilver, Associate I.E.E., and A. H. Watkins, C.G.I.A. .. .. .	12
“MOSAIC”—AN ELECTRONIC DIGITAL COMPUTER, Part 3(b)—The Art of Programming (continued)—A. W. M. Coombs, Ph.D., B.Sc., A.R.T.C... .. .	18
THE DOVER-DEAL EXPERIMENTAL CABLE, Part 2—Measurement of Gas Flow Characteristics during Installation, Gas-Drying and Gas-Pressure Equipment and Tests on Completed Cable—H. C. S. Hayes, M.I.E.E. .. .. .	22
SAFETY ARRANGEMENTS FOR HIGH-POWER RADIO TRANSMITTERS—A. E. N. Wase, A.M.I.E.E., and S. J. Sellwood .. .. .	27
A BURIED FREQUENCY STANDARD—J. S. McClements .. .. .	32
AN EXPERIMENTAL ELECTRONICALLY-CONTROLLED P.A.B.X.—B. F. Yeo, A.M.I.E.E.	34
THE ROCKING-ARMATURE RECEIVER—J. S. P. Robertson, B.Sc.(Eng.) .. .. .	40
A PORTABLE FOOT-PUMP DESICCATOR USING SILICA GEL .. .. .	46
THE INTRODUCTION OF A TELEPHONE WEATHER SERVICE IN LONDON—D. J. Manning .. .. .	47
SUBMERGED TELEGRAPH REPEATERS .. .. .	49
CONTINUOUSLY-VARIABLE ELECTRICAL, ACOUSTICAL AND MECHANICAL IMPEDANCES—J. Y. Morton, A.M.C.T., A.M.I.E.E., and R. A. Jones, B.Sc.(Eng.) .. .. .	50
A PRESSURIZED WAVEGUIDE SYSTEM—J. G. Hobbs .. .. .	52
A NEW POLICE TELEPHONE AND SIGNALLING SYSTEM—W. R. A. Porritt .. .. .	54
THE PRODUCTION OF BEAT FREQUENCIES .. .. .	56
NOTES AND COMMENTS .. .. .	58
INSTITUTION OF POST OFFICE ELECTRICAL ENGINEERS .. .. .	59
REGIONAL NOTES .. .. .	60
ASSOCIATE SECTION NOTES .. .. .	63
STAFF CHANGES .. .. .	65
BOOK REVIEWS.. .. .	6, 11, 17, 21, 26, 57

Price 2/6 net

THE INSTITUTION OF POST OFFICE ELECTRICAL ENGINEERS

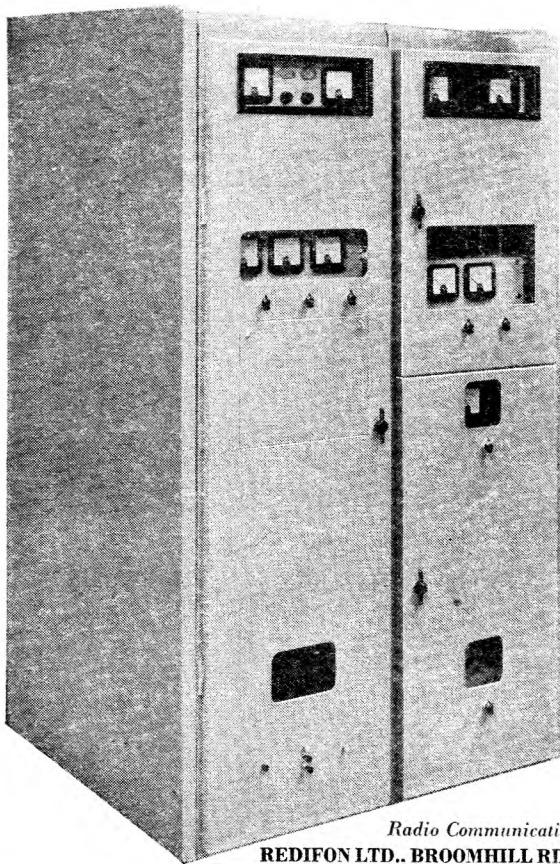

# 10

## SPOT FREQUENCIES

THE ANSWER TO INCREASING  
TRAFFIC DENSITIES

The Redifon G.143 TRANSMITTER for medium distance links meets the need for rapid frequency changing where high traffic density conditions prevail at shore stations, and for conserving engineering staffs at all but the largest centres. It provides ten stabilised crystal controlled frequencies for telegraphy or telephony in the 2.26 Mc/s band and has a power output of 1 kW. Only one pair of lines is required for complete remote control up to 25 miles.

# Redifon G.143 TRANSMITTER

Radio Communications Division  
REDIFON LTD., BROOMHILL RD., LONDON, S.W.18 VAN 7281 A Manufacturing Company in the Rediffusion Group

## PITMAN

### RADIO AND ELECTRONIC COMPONENTS

Vol. 1: Fixed Resistors

By G. W. A. Dummer, M.B.E., M.I.E.E.

The characteristics and specifications of all types of fixed resistors used in electronic equipment are discussed and much information is included on special-purpose and experimental types. Illustrated. 28/- net. Vols. 2, 3 and 4 on Variable Resistors, Fixed Capacitors and Variable Capacitors in preparation.

### ELECTRONICS

By A. T. Starr, M.A., Ph.D., M.I.E.E.

Written by an acknowledged authority, this new book forms a comprehensive treatise on theoretical and applied electronics. Illustrated. 32/6 net.

"This is an outstanding textbook from the viewpoint of both teacher and student and one which is likely to be widely adopted."  
—*The Electrical Journal*

### TELEPHONY (2 Vols.)

By J. Atkinson, M.I.E.E.

This massive two-volume treatise is recognised as the standard work on the subject. An essential book for all Post Office engineers and students. Over 1,500 illustrations.  
Vol. 1 (General Principles and Manual Exchange Systems) 40/- net  
Vol. 2 (Automatic Exchange Systems) 55/- net

PARKER ST., KINGSWAY, LONDON, WC2

## VALUABLE FREE BOOK

Tells You How to Pass Your C. & G. or  
Promotion Exam. at First Attempt!

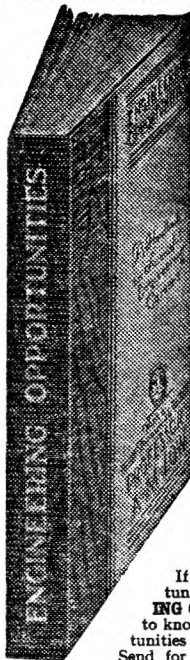

All Post Office Engineering personnel who are anxious to obtain early promotion should at once send for a copy of our handbook "ENGINEERING OPPORTUNITIES," which among other intensely interesting matter describes our unique methods of preparation for TECHNICAL APPOINTMENTS IN THE POST OFFICE (Assistant Engineer—New Style and Assistant Traffic Superintendent), CITY AND GUILDS EXAMINATIONS in Principles of Telecommunications (1-5), Radio (1-4), Telephone Exchange Systems (1-3), Telegraphy (1), Line Transmission (1 and 2), Lines Plant Practice (1 and 2), Mathematics for Telecommunications (1-5), Electrical Engineering Practice (Prelim. Inter. and Final), and outlines a wide range of non-examination courses in all branches of Electrical, Mechanical, Civil, Automobile, Aeronautical and Radio Engineering.

Assistant Engineer and Assistant Traffic Superintendent. Open competitions now resumed. Age extensions for established Civil Servants. Ask us for full details

We definitely guarantee  
"NO PASS—NO FEE"

If you intend to make the most of to-day's opportunities, you cannot afford to miss reading "ENGINEERING OPPORTUNITIES." It tells you everything you want to know to secure advancement, and describes many opportunities you may now be missing through lack of information. Send for your copy to-day—FREE and without obligation.

BRITISH INSTITUTE  
OF ENGINEERING TECHNOLOGY  
369 COLLEGE HOUSE,  
29-31 WRIGHT'S LANE, LONDON, W.8

# BIET

# THE POST OFFICE

## ELECTRICAL ENGINEERS' JOURNAL

Vol. 49

April 1956

Part 1

### Transatlantic Telephone Cable—The Overland Cable in Newfoundland

H. E. ROBINSON  
and B. ASH†

#### Part 1.—Design of the Cable, Survey of Route and Preparations for Laying the Cable

U.D.C. 621.315.28 + 621.315.23

The Transatlantic Telephone Cable is routed overland for a distance of about 60 miles across Newfoundland in a south-westerly direction from Clarenville to Terrenceville. Part 1 of this article describes the preparations made for laying this overland cable, including the development of a suitable type of cable and jointing technique, the survey of the route and training of supervisors and jointers. Part 2 will conclude the article by describing the cable-laying operations in Newfoundland.

#### INTRODUCTION

BEFORE the agreement to provide a transatlantic telephone cable was signed in November, 1953, preliminary studies had been made of the route to be followed and a small party had visited Newfoundland, in March, 1953, to decide where the cable from Scotland should land, and how the system should be extended to connect with the submarine cable link from Newfoundland to Nova Scotia. Alternatives considered were a radio-relay system across Newfoundland, an all-sea cable route round Newfoundland to, possibly, Halifax, Nova Scotia, a land cable route across Newfoundland, and two alternative part-sea part-land routes starting from Trinity Bay, crossing the narrow isthmus to Placentia Bay, and thence either going directly by sea to Sydney, Nova Scotia, or crossing the Burin peninsula into Fortune Bay and thence to Sydney. The numerous factors that had to be taken into account included the maximum allowable lengths of the ocean cable and the cable to Nova Scotia, hazards to sea cables and

† The authors are, respectively, Executive Engineer and Assistant Engineer, External Plant and Protection Branch, E.-in-C.'s Office.

crossings of existing cables, general amenities for the main station and the cost and technical efficiencies of the alternatives. The party recommended that the main station should be at Clarenville, and that a cable should be laid across land to Terrenceville, at the head of Fortune Bay, to connect with a submarine cable to Sydney (see Fig. 1).

In the agreement signed in November, 1953, the British Post Office undertook the responsibility of providing the system between Clarenville and Sydney, Nova Scotia. In order to meet a Canadian request for good cable circuits between the mainland of Canada and Newfoundland, the Clarenville-Terrenceville-Sydney system has been designed to be suitable for transmitting sixty 4-kc/s channels and thus provides capacity from Newfoundland to the mainland of Canada in excess of the capacity of 36 circuits in the main ocean cables.

#### LAND CABLE DESIGN

The route between Clarenville and Terrenceville had to be designed to connect a main transmission terminal, at Clarenville, using cable frequencies of 20 to 164 kc/s, to a submarine cable system using frequencies 20 to 260 kc/s "go" and 312 to 552 kc/s "return" and starting at Terrenceville, a remote settlement where there will be no public power supply in the foreseeable future and which would be most unsatisfactory for staffing.

Standard two-pair or four-pair coaxial cable used normally or as balanced pairs was considered, but an important feature that had to be taken into account was the possibility of interference by static or radio pick-up at the low frequencies used, unless translation to the normal coaxial cable frequencies was planned. Consideration was also given to the use of a specially made polythene quad cable. It was finally decided to have the simplest and most robust construction possible, with no translation or terminal equipment at the junction between land and sea sections at Terrenceville; i.e., to make the land cable a continuation of the sea cable and use submarine-type repeaters on land. This

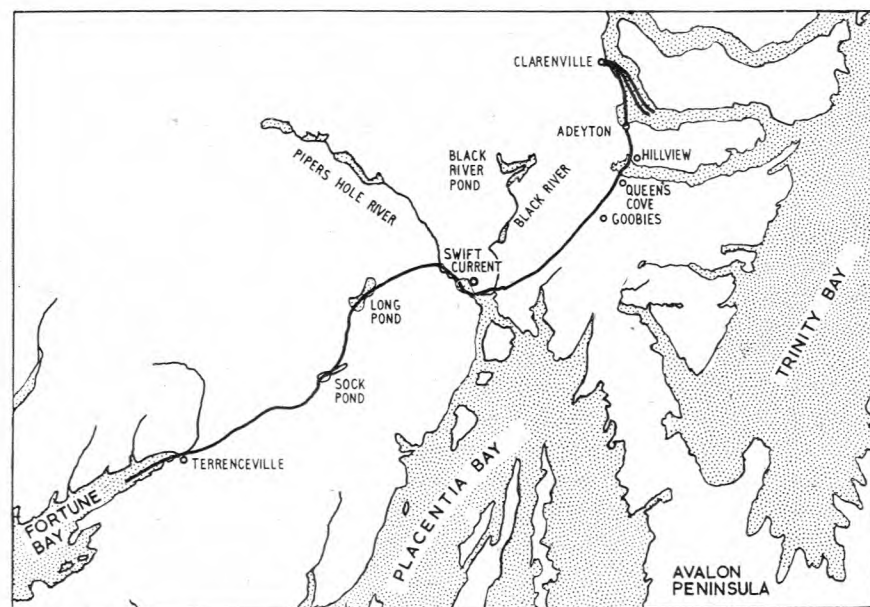

FIG. 1.—ROUTE OF THE CABLE ACROSS NEWFOUNDLAND.

resulted in the use of a solid-polythene-insulated cable with wire armour, highly desirable for the conditions in which it is laid, but left two problems—temperature variations and the equivalent of a 63-mile shore end. The distance from Clarenville to Terrenceville is about  $2\frac{1}{2}$  repeater section lengths.

Temperature equalizers capable of seasonal adjustment could be provided at Clarenville and Terrenceville, but were undesirable at either of the two intermediate repeater points since they would have involved an auxiliary housing that could be made accessible, or the assembly of the (modified) components of a submarine repeater in a repeater hut. With standard submarine repeaters, temperature equalization of the cable section between the two repeaters is not provided. A study of available data indicated that with the cable buried about 30 in. deep (also desirable from a safety aspect) the maximum temperature variation was likely to be well within the range  $\pm 10^{\circ}\text{C}$  about a mean of  $7.5^{\circ}\text{C}$ , corresponding to a change in attenuation of  $\pm 1$  dB at 552 kc/s.

It was therefore decided that, provided the two submarine repeaters were accurately sited, there would be a satisfactory margin against overload in the winter and noise in the summer in all the land section if seasonal adjustments could be made at Clarenville and Terrenceville.

Screening required special consideration and departure from the recognized technique of insulating the outer coaxial conductor from earth with polythene and extruding a lead sheath over the polythene. Cable so insulated and sheathed with lead is used, appropriately armoured, for all shore ends from about half a mile off shore to the cable terminating cubicle, where a coaxial choke is fitted before connecting the cable to the terminating unit. Such cable is expensive and very heavy, and it was judged that its screening properties over long lengths might not be adequate in the event of strong interfering signals at some future date. A new cable was therefore designed using a screen of thin tapes of high permeability iron; four tapes being laid with alternate left-hand and right-hand lays and the fifth tape being wrapped longitudinally round the core. These tapes are laid over the return coaxial conductor with only a light mechanical barrier that does not prevent occasional contacts between the copper and iron. Such contacts have no operating electrical significance but make location of leaks (i.e., earth faults) in the water barrier protecting the iron tapes somewhat difficult by normal d.c. precision-testing methods. This construction presented interesting manufacturing problems, complicated by the fact that the iron tapes, even after special annealing, will lose some of their permeability and hence their screening properties if they are bent and work hardened. A layer of polythene 80 mils thick was extruded over the iron tapes to prevent corrosion and the jointing technique adopted was designed to maintain the water barrier intact. The armouring wire was chosen to give reasonable strength and protection without making the cable too heavy.

Four 1,000-yd trial lengths of cable were made, two lengths screened and two normal sea-type (unscreened), and were laid out on an airfield in such a manner as to pick up, among others, a particular strong radio signal that had been found to give trouble in the past on certain shore-end cables. The conclusions reached were that the new cable, even after a limited amount of handling, should give an improvement in screening at the lower (and critical) frequency of 20 kc/s of about 40 dB compared with an unscreened cable and 15 dB compared with the lead-covered shore-end type of cable. This was regarded as satisfactory and production of the cable was started.

To provide maximum security for the cable, both in transit and during laying, arrangements were made to hire

non-standard Western Electric cable reels of the largest size. They are of prefabricated steel construction, and can be used in conjunction with a standard tracked cable-drum trailer for laying over rough country. On each cable reel it was found possible to put 1,000 yd of cable, giving a total weight of  $4\frac{1}{2}$  tons, and yet retain a minimum barrel diameter of 50 in. to avoid bending the cable screen unduly. This gave a good workable length, with not too many joints to make, and not too heavy a load. In the event, it was found that for the type of country traversed the weight and size were near the upper convenient limit.

#### *The "Speaker" Cable and Guard Wires.*

The use of a submarine-type coaxial cable meant that the conventional speaker circuit, using layer pairs, could not be provided. The submarine system proposed envisaged a speaker system for maintenance between Clarenville and Sydney Mines, using an inferior part of the transmitted frequency spectrum near the filter cross-over point. It would be undesirable to install apparatus at Terrenceville specially to derive this circuit there, nor could the circuit be provided intermediately. Since there are no communications available other than a single-wire telegraph circuit for half the distance from Clarenville, it was desirable to have a speaker circuit that could be tapped at intermediate points. Using the return coaxial conductor or the insulated screening tapes for the speaker circuit would have involved mechanical interference with the structure of the cable at "talker" points, and speech would have been of poor quality. A single overhead "copperweld" wire was not favoured because of maintenance problems, and the local telephone Administration formally stated that they had no interest in having public circuits in a cable laid in the trench used for the main cable. It was therefore decided to use the American equivalent of our "farmer's line," a well-tried type of construction, which is illustrated in Fig. 2,

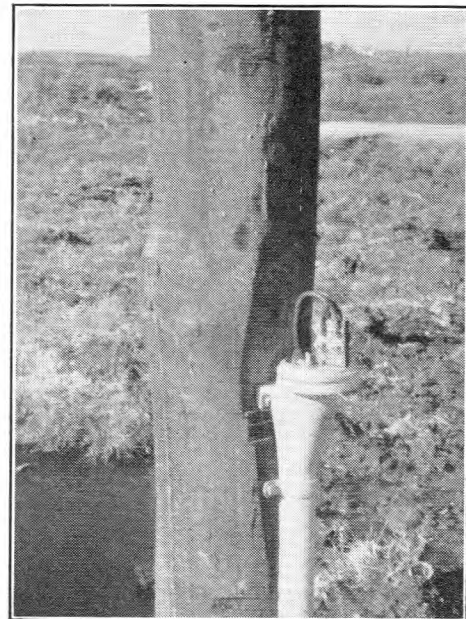

FIG. 2.—AMERICAN "FARMER'S LINE" (COVER REMOVED).

and to loop out to "talker posts," another standard item, at convenient points. This type of line can be loaded and theoretically would give an attenuation at mean speech frequency of about 0.3 dB/mile.

Simultaneously the Americans advised that lightning protection should be provided because of the rocky country, and their standard system was used. This consists of two bare approximately 200-lb copper wires buried about 12 in. apart and 6 in. above the cable.

## JOINTING TECHNIQUES

As soon as the design of the cable had been determined it became necessary to design the joint. Briefly, the accepted technique is as follows:—

- (a) Centre conductor and surrounding tapes—electrically brazed.
- (b) Polythene dielectric— injection moulded.
- (c) Outer-conductor copper tapes—riveted and soft soldered.
- (d) Terebo tape—soft soldered.
- (e) Screening tapes—soft soldered.
- (f) Polythene sheath—taped with “Telcohesive” and “Lasovic” tape.
- (g) Armour wires — interlaced barrel spliced.

It was estimated that some 100 joints would be required. Changes in the size of the armour wire due to sea crossings meant splicing together wires of a different gauge, while at points where the land cable (screened) required jointing to sea cable (un-screened) a water barrier was necessary on the land-cable side of the joint to prevent corrosion of the soft-iron screening tapes.

To appreciate the problems connected with the design of a satisfactory joint it should be mentioned that, normally, submarine cable jointing on a cable ship is done by two parties, (a) the jointer and assistant jointer who joint the cable and (b) an armouring party of six to eight men who are responsible for the armour-wire splice and make an overlay type of splice, which requires a long overlap of cable. Although the making of this submarine-type of splice requires a small gang of men, the lack of restriction on the length of core exposed on a cable having no sheath simplifies many of the jointer's problems.

The desirable features of the land-cable joint, including the armour splice, are that it can be made by one jointer and his assistant, and that it can be completed in such a time that the work of the contractor (back filling) is not held up by the jointing operations. Electrical brazing and injection moulding, although modern techniques, are already a feature of submarine cable jointing and are used for jointing the centre conductor and polythene core of the land cable; the overall time taken by two men to complete a joint depends largely on the methods adopted for the other jointing operations and of these the sealing of the polythene sheath and splicing of the armour wires are the most significant. The joint must be as short as possible to facilitate sealing the polythene sheath and limit the length of disturbed armour wire, and must be kept as thin as possible to facilitate restoration of the armour wire over the jointed cable; i.e., a near uni-diameter joint of minimum length is required.

Although two types of polythene-moulding machine were available, one American and one British, both were too heavy for the field work in Newfoundland, but, fortunately, a portable moulding machine was being developed at the Post Office Research Station. This machine had several advantages for the work in Newfoundland; it was built in three units, each of which could be carried easily by two men, the mould was short and the clamping arrangements for the cable were near the mould ends.

With the new machine (Fig. 3) it was found that the core of the cable could be exposed sufficiently for moulding

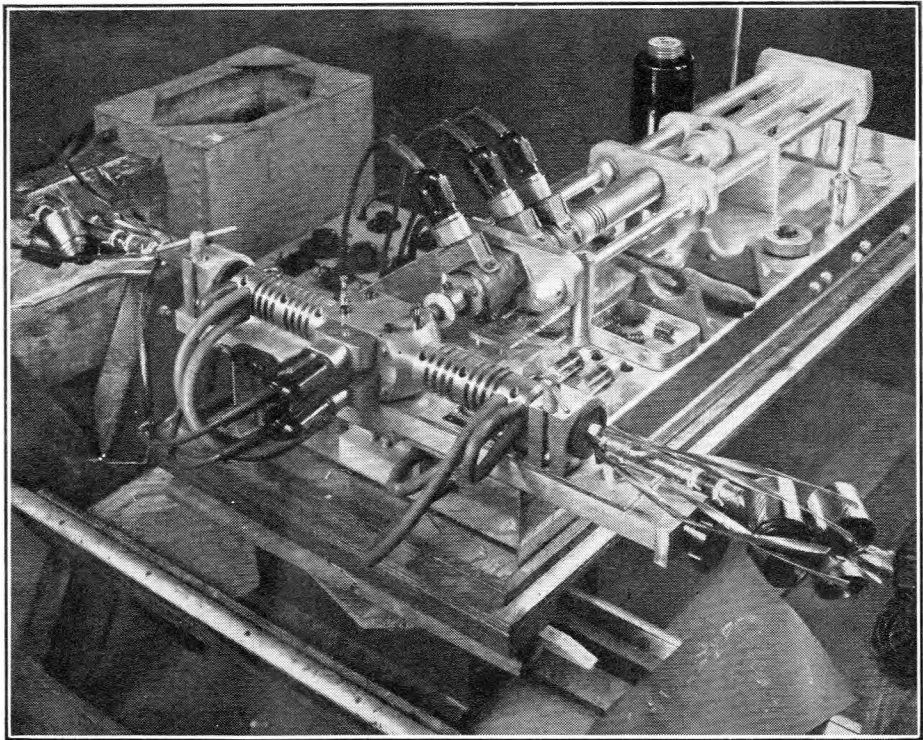

FIG. 3.—POLYTHENE-MOULDING MACHINE.

with a 42-in. jointing gap between the cut ends of the polythene sheath and that with care and skill the brazing, moulding, and jointing of the return tapes, the terebo tape and the screening tapes could be done to almost uni-diameter dimensions. This made the sealing of the joint a simple operation with “Telcohesive” and “Lasovic” tapes. Joints sealed in this manner were inserted in a sealed canister filled with water at a pressure of 200 lb/in<sup>2</sup> and hourly insulation tests showed no change in the insulation resistance between screen and earth over a period of approximately three months.

### *The Armour Splice.*

As the jointing of the cable could be done within a jointing gap of 42 in. the overlap at jointing points was dependent upon the type of splice required for the armour wires. Initially it was thought that a metal coupling similar to those used on local power cables could be used, but this method was rejected as being unnecessarily costly and a splice was devised which was easy to make and well within the capacity of a jointing party of two men. A 9-ft overlap of cable is sufficient for the splice and is therefore considerably less than for the normal submarine cable splice. Some of the stages in making a splice are shown in Fig. 4. The wires from each side of the joint are interlaced inside an 8-in. steel barrel which fits snugly over the interlaced wires. The ends of the wires are then bent back over the steel barrel, and the free ends bound down with 16-S.W.G. galvanized iron wire. A tension test of 4½ tons was applied to a splice of this type in No. 10 S.W.G. armour wire and no measurable movement was observed.

Steel barrels of different diameters cater for armour splices between wires of different gauge or splices of heavier gauge wire, without any change in technique.

## THE LAND-CABLE ROUTE AND SURVEY

When it had been decided in principle that a cable should be laid overland between Clarenville and Terrenceville, the alternative routes available between these places had to be examined, the chosen route surveyed in detail and a

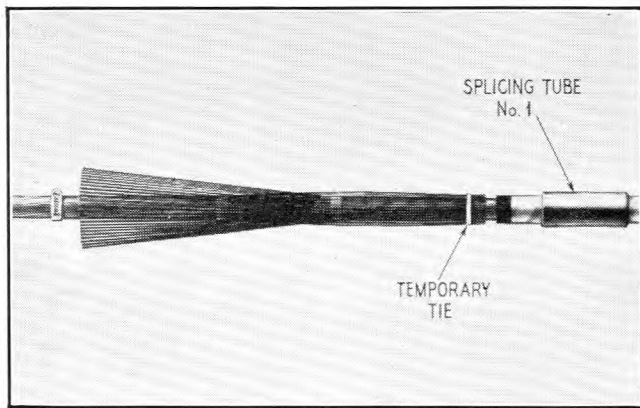

(a) Re-laying the Armour Wires.

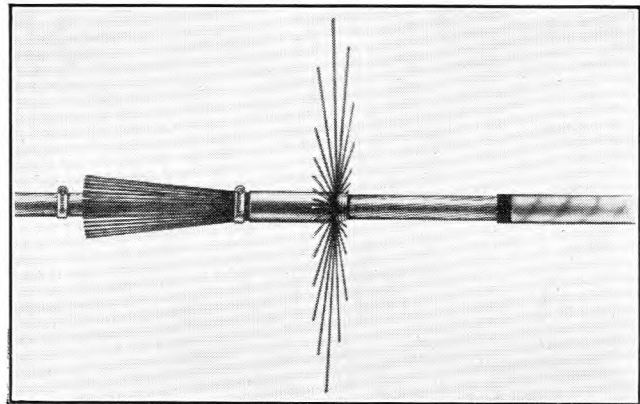

(b) Bending the Armour Wires over the Splicing Tube.

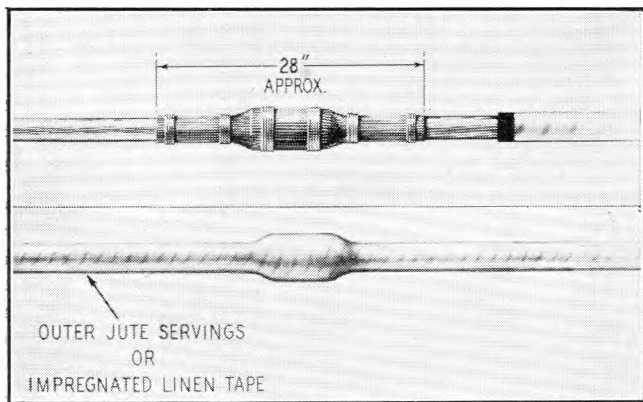

(c) The Completed Splice.

FIG. 4.—THE ARMOUR SPLICE.

record made for association with the cable-laying contract and for the formalities of wayleaves or "easements." This survey was made in the summer of 1954, and involved many miles of very difficult walking. The territory between Clarenville and Terrenceville can be divided geographically into two parts. From Clarenville for about 30 miles the country is hilly and wooded, with numerous lakes and bogs, then, further west and north of the Burin Peninsula the country rises to a plateau approximately 800 ft above sea level, where the terrain changes to barren open country. It was clear that on the plateau the cable route should follow or run parallel to the road, but it still remained for the survey party to examine the alternative routes available through the more difficult wooded country. (Fig. 5, 6 and 7 show typical views of the country at different points on the route.) In June, 1954, the survey party engaged a local guide and, with the aid of a compass and maps prepared



FIG. 5.—RIGHT OF WAY CLEARED BETWEEN ADEYTON AND HILL VIEW.

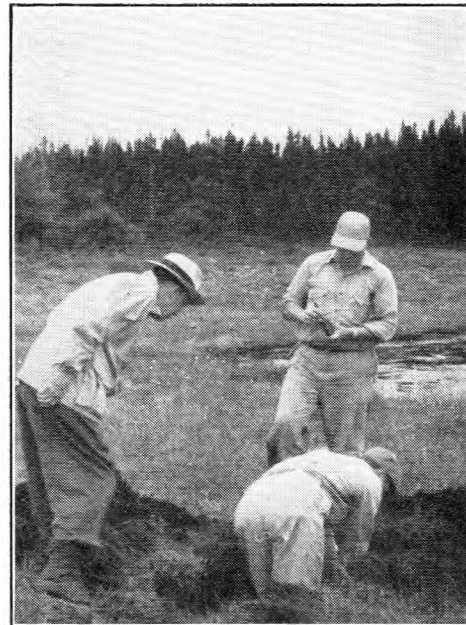

FIG. 6.—DIGGING A HOLE NEAR PIPERS HOLE RIVER FOR MEASUREMENT OF EARTH TEMPERATURE.

by the British Ordnance Survey Department from aerial photographs, they set out to walk the shortest and most direct route from Pipers Hole River to Clarenville. As was envisaged, this journey proved to be most arduous and it soon became evident that to lay the cable across country it would first be necessary to build a road for the movement of machines, stores and equipment. Apart from the heavy capital expenditure, it was realized that such a road would open up fresh logging activities with the consequent risk of tractors damaging the cable. It was therefore decided to look for a more southerly but longer route in the general direction of the high road, and to take advantage of the north-west and south-west arms of Trinity Bay and the upper reaches of Placentia Bay, as indicated by the map in Fig. 1, to by-pass three of the more rugged sections of country.

In the beginning of July the services of a Newfoundland land surveyor were obtained to measure the bearing and distance of the line flagged by the preliminary survey party, who from then on worked with him to make the location survey. In territory covered with timber or scrub a trial survey line 6 ft wide was cut to allow the work to proceed, but the rate of progress was considerably slower than in open country and for this reason it was decided to work

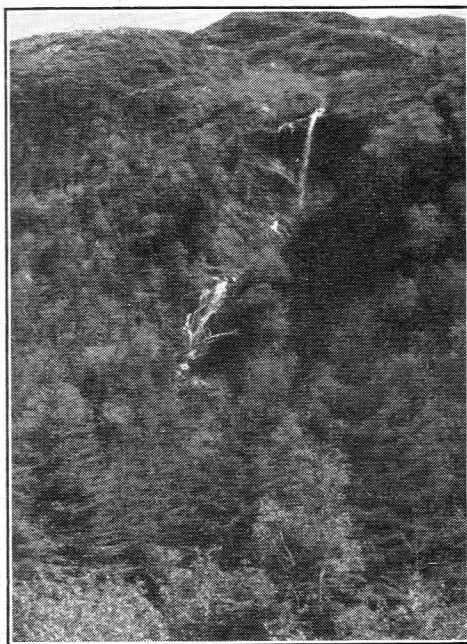
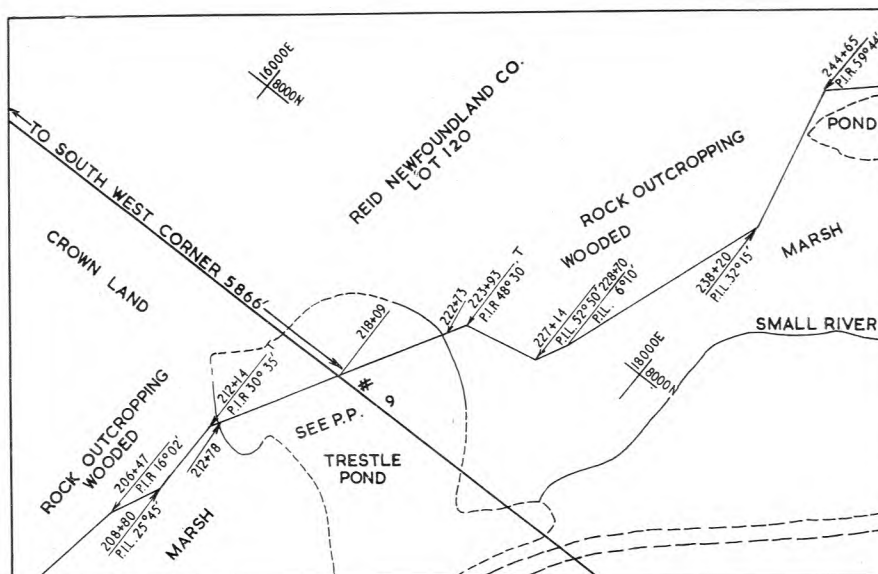

FIG. 7.—TYPICAL COUNTRY NEAR TERRENCEVILLE.



P.I.R.—Point of Interception Right.  
P.I.L.—Point of Interception Left.  
206+47—20,647 ft from commencement of Section of Survey (in this Example from Black River).

FIG. 8.—GENERAL PLAN OF PART OF THE ROUTE BETWEEN BLACK RIVER AND QUEEN'S COVE.

from Terrenceville to give the advance party the opportunity of keeping ahead of the surveyor. For convenience of operation the location survey was made in three separate sections: (1) Terrenceville to Pipers Hole River, (2) Black River to Queen's Cove, and (3) Hillview to Adeyton. Later the order was reversed, combining all sections together. The procedure for making the location survey followed closely the standard American practice for a buried cable route and was briefly as follows: a round stake with a nail driven in to mark an exact reference point (known as a "hub") was driven into the ground on the centre line of the route at each point where the route changes its direction (point of interception) and at 500-ft intervals on a long straight run. A theodolite and graduated chain were used to measure the bearing and distance of the traverse at each hub or station. The information was noted at the time of the survey, in the survey field notebook, and also recorded on a line stake placed adjacent to the hub. Assuming the line of the survey to be in the general direction west to east, off-line stakes were driven in the ground 15 ft to the north and 25 ft to the south of each hub and line stake and marked in such a way that the hub could be re-established if destroyed. The boundaries of the cable right-of-way lie 5 ft to the north and 15 ft to the south of the survey centre line. The off-line stakes therefore lie 10 ft outside the cable right-of-way, and consequently they are reasonably safe when the right-of-way is cleared for cabling.

Three methods were used for measuring the length of the route across rivers and ponds:—

- (1) By stadia. The stadia method is particularly adaptable for measurement across rivers and small ponds (up to 1000 ft across). For this work the theodolite has two parallel horizontal lines which appear in the field of the telescope and are additional to the centring hairline. The telescope is sighted on an ordinary level rod, which is held erect at the point to be measured, and the distance to the rod is obtained by multiplying the length of rod seen between the horizontal lines by a factor which is a characteristic of the instrument.
- (2) By triangulation for distances over 1,000 ft.
- (3) By computation from an open traverse, or meander, line around the shore, in difficult cases.

Soundings were taken at regular intervals from a rowing boat, and to guide the oarsman along the proper course two markers or guides were erected at each end of the pond in line with the route to be followed.

To complete the survey the following plans were prepared:—

- (1) A general plan of the route, of which Fig. 8 shows part of the route between Black River and Queen's Cove.
- (2) A plan and profile (section) of each river, pond and road crossing.
- (3) A plan and description of each piece of private property for which a wayleave was required.

#### THE CONTRACT SPECIFICATION

The specification was written to ensure the safe handling of the cable, with constructional features based upon British Post Office experience, but, as the work was to be undertaken by a Canadian contractor, American methods had to be envisaged and it was not possible to know exactly what equipment the contractor would use, particularly for the pond crossings, and a certain amount of latitude had to be allowed to the contractor in his methods. As will be described in Part 2, it transpired that methods commonly used in this country were followed.

As is customary in the United Kingdom, the work was itemized for record and costing, but there were a few unusual items such as "trenching under water." The basic unit, with different rates for the type of soil, rock or bog encountered, was 1 yd of trench excavated, cables laid, and filled in, all inclusive. Certain of the contractual clauses had to be written to conform to Canadian law and custom and others were inserted or amended to meet American requirements. An endeavour was made to avoid controversies about types of rock and the rate appropriate to a particular job by using all-embracing definitions. Rock was dealt with simply under the definition that it was rock only if it could not be excavated by the digging equipment in use and blasting had to be resorted to. But the attempt to deal with bog raised problems of interpretation. The nature of the country was known to be such that it would be impossible to decide just at which point the ground ceased to be "soil" and became "bog," and there



were bogs of all degrees of consistency. So soil and bog were classed together, leaving it to the contractor to bid an appropriate rate for his operation in soft going, but trenching in shallow water, under 3 ft deep, was treated as a separate item. It was then considered that the definitions were fairly clear, since it was envisaged that the shallow-water rate as distinct from the normal water-crossing rate would apply where the water was too shallow to allow the cable or the equipment to be floated. Unfortunately the shallowness of shallow water, or conversely the point at which bog ceased to be bog and became shallow water were subject to frequent changes during wet weather and the incidence of shallow water gave rise to the most difficulties, particularly as heavy rain quickly turned a piece of bog over which the equipment operated without very great difficulty into a morass in which neither men nor equipment could operate.

#### TRAINING

The contractor estimated that he would be laying cable in the trench at the rate of 6000 yd/week and that, simultaneously with the trench work, operations on the lakes would be in progress. On the basis of this it was estimated that three work supervisors, three jointers and three assistant jointers would be required. It was considered that twice the number of men required for work in the field should be trained, half of them to remain in the United Kingdom as a reserve in the event of casualties among the overseas party. Six work supervisors, six jointers and six jointers' assistants were therefore selected from volunteers from the Telephone Areas in the United Kingdom and these men were called to London for training by the Engineering Department in December, 1954.

The work supervisors were given the details of the signed contract and received training in the records and diary entries applicable to the work. They were also trained in work organization based on the contractor's estimated progress and informed of the terrain difficulties experienced by the survey party. The jointers were given training in all features of the jointing work, particular emphasis being placed on brazing, moulding and armour splicing.

The following brief description of the specification conditions for the centre-conductor joint serves to show the standard of workmanship required.

"The diameter of the centre conductor over the surrounding tapes is  $0.160 \pm 0.005$  in.; over the brazed section it should not be less than that of any adjacent section, nor greater than 0.165 in."

It will be seen from the limits allowed that much skill was required to meet the specification.

Similarly on injection moulding, rigid specification limits were imposed for inclusions in the polythene and for concentricity of the centre conductor, and all joints were examined by X-ray. By this rigid control of the work and an abundance of practice all jointers acquired the necessary skill to qualify, but before qualification each man had to make 10 centre-conductor joints and 10 injection-moulding

joints to specification, regardless of how many satisfactory joints he had made during the training period.

An equal amount of practice was given on all other features of the jointing work and field trials were held to accustom the men to working under actual field conditions. During these field trials the same high standard of workmanship was called for and all joints were X-rayed.

#### VEHICLES, STORES AND EQUIPMENT

During the first three months of 1955 arrangements were made to assemble the vehicles, stores and equipment for use in Newfoundland and to schedule and price each item for shipping and customs formalities.

It was realized that primitive roads in Newfoundland would severely test the vehicles used, and it was considered that four-wheel drive was essential. The two types of vehicle most suited to the conditions are the American Willys Jeep and the British Land Rover. A decision was made to purchase a fleet of nine short-wheelbase Land Rovers, three Willys 1-ton trucks and trailers, and two Karrier test vans; all were fitted with heaters and were equipped for service as follows:—

- Two Land Rovers fitted with power bollards;
- Three Land Rovers fitted with 5-kW alternators;
- Four Land Rovers (two with low-loading trailers);
- Two Karrier test vans converted and equipped as mobile dark-rooms, and
- Three Willys 1-ton trucks and trailers (for the jointing parties).

Power supplies were obtained from two 230V  $2\frac{1}{2}$ -kW alternators (trailer), three 230V 2-kW Onan alternators (portable) and the 5-kW alternators fitted in three of the Land Rovers. Two lightweight 230V 500W alternators were carried in each of the mobile dark rooms and, for lighting, four 24V P.E.D. generators were used.

Standard packing cases were used for the jointing stores, but special cases were made for the shipment of the X-ray cameras, brazing machines, moulding machines and the 40-kV test sets; there were 79 cases in all.

For customs formalities the whole consignment was scheduled under two categories, "B" and "C," and a certificate was given that items under category B (non-consumable stores) would remain the property of H.M. Postmaster-General, and that they were imported into Canada on loan for the duration of the work, after which they would be re-exported to the United Kingdom. A certificate was also given that items under category C (consumable stores) were imported into Canada and that the value shown was a fair market value in the United Kingdom at the time of importation. By mutual arrangement between the British Post Office and the manufacturers of the land cable, Southern United Telephone Cables, Ltd., a cargo ship was chartered to convey cable, vehicles, stores and equipment to Newfoundland, and on the 5th April, 1955, the S.S. *Teeswood* sailed from London to St. Johns.

*(To be continued.)*

## Book Received

"Facilities for Telephones in New Buildings." Issued by H.M. Postmaster-General. 40 pp. 31 ill.

This booklet is a revised version of the 1931 edition. It has again been prepared by Post Office and Royal Institute of British Architects' representatives in collaboration, and sets out the installation requirements for providing telephone service in various types of buildings.

Separate sections of the booklet deal with the telephone facilities required in Office Buildings, Hotels, Flats, Houses, and Hospitals and Factories. Particular attention is given to the problem of concealing wires and cables, while permitting

provision of telephones at any desired position at short notice and allowing rearrangements to be made without damage to the structure of a building or its decorations.

In a foreword to the booklet, the President of the R.I.B.A. commends it to all concerned with the design and erection of modern buildings and draws their attention to the Telephone Manager's function as guide and adviser in these matters.

The Booklet has been issued widely to Architects, Surveyors, Consulting Engineers and others responsible for the planning and erection of buildings, and has been distributed to all Post Office Regional and Area Headquarters. Distribution to the public is in the hands of the local Telephone Manager, to whom all requests for copies of this document should be made. Supplies are limited.

# The Testing of Telegraph Machines

J. H. COLLINS, A.M.I.E.E.,  
and E. G. COLLIER†

U.D.C. 621.394.66

This article reviews the testers and testing techniques used by the British Post Office for checking the performance of teleprinters and associated five-unit-code machines.

## INTRODUCTION

THE maintenance of telegraph machines is of special importance in creating a good impression of the service given to users of a telegraph system, and adequate means of checking the performance of all types of telegraph machines are therefore essential.

When testing telegraph lines it is usually sufficient to connect a "perfect" signal generator at one end of a circuit and measure the distortion of the received signals at the other end, but when testing telegraph instruments, in addition to measuring distortion, it is also necessary to simulate distorted signals and determine the response of receiving equipment to such signals. Measurements of speed and of the response of receiving electromagnets to signals are also required. The testers referred to in this article vary greatly in size, complexity, cost, and accuracy, and range from "standard" testers for use at a comparatively few centralized workshops to portable items developed in recent years for use by staff engaged on day-to-day maintenance.

## SPEED TESTING

Measurement of the mean speed of a telegraph machine involves either direct assessment of the rotational speed of a selected shaft of the mechanism or, if the machine has a transmitter, timing of the signals produced by the transmitter.

### *Mechanical Stroboscopes.*

The simplest method of measuring speed is by viewing stroboscopic markings on a suitably situated shaft through a shutter made to open and close at a frequency bearing a harmonic relationship to the nominal speed of the shaft.

In the older pattern of stroboscope—the "reed" type—the aperture of the shutter is fitted to the open end of a metal tube and the vibrating member is mounted on the free end of a steel reed firmly mounted within the tube. When the reed is set in vibration the line of vision through the aperture is interrupted at a frequency depending on the actual machine for which the instrument is required, e.g., with a Teleprinter No. 7, a 643 vibrations-per-minute stroboscope is used to view a single white segment printed on a boss attached to the typehead spindle, which rotates at 643 revolutions per minute.

This stroboscope has given good service over a period of many years but is inherently of unsound design in that the vibrating system is mechanically unbalanced, and as a result the frequency of vibration is greatly affected by the manner in which the stroboscope is held. Also, it is necessary to have these stroboscopes checked and re-calibrated at regular intervals. A further disadvantage is that the period during which the reed vibrates is too short to determine adequately whether the speed is stable or to make a trustworthy estimate of the speed error.

These considerations have led to the introduction of the "tuning-fork" type of instrument illustrated in Fig. 1. The tuning fork constitutes a balanced system with a nodal point at or at least close to the handle and the natural frequency of vibration is far less susceptible to change when held in different ways. Apart from actual damage to the fork, the frequency is sufficiently stable to make re-calibration at intervals unnecessary. The main advantage over

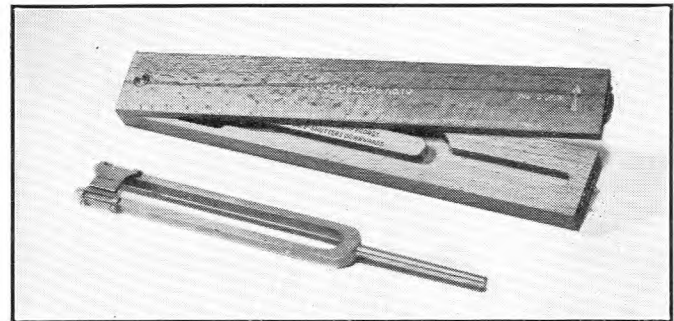

FIG. 1.—TUNING-FORK STROBOSCOPE.

the reed type is the increased viewing time, about 20 sec approximately, compared with 2 or 3 sec, which makes possible some assessment of the steadiness of rotation as well as giving a much more definite stroboscopic display.

The standard tuning-fork (Stroboscope No. 19) has a frequency of 150 c/s and is intended for use with stroboscopic markings on the covers of motor governors which, in standard machines, rotate at either 3,000 or 1,500 rev/min. The fork frequency chosen (which corresponds to a shutter frequency of twice the value) enables a fork of reasonable dimensions to be made with an amplitude of vibration sufficient to open and close the shutter.

The speed of a machine is normally adjusted until the stroboscopic display is virtually stationary and the speed error is then of the same order as the manufacturing tolerance on the fork frequency, namely 0.1 per cent. When making routine checks of speed it is necessary to estimate the speed error. Using a Stroboscope No. 19 a speed error of 1 per cent corresponds to a movement of three "spots" of the stroboscopic display per second past a fixed reference point.

### *Synchrosopes.*

The synchroscope (Panel Telegraph No. 34A) was introduced in the early days of teleprinter working to provide a more accurate and convenient method of checking speed than was provided by reed-type stroboscopes. It consists essentially of a 12-segment rotary distributor, the brush arms of which are rotated once in 300 ms (for 50-baud working) by a synchronous motor connected to the 50-c/s mains supply. Diametrically opposite segments are connected in pairs to six neon lamps arranged in a circle on the face of a panel mounted so that it is visible from all parts of the instrument room. The a.c. supply to the lamps is taken via contacts of a relay controlled by the transmitting contacts of the teleprinter being tested. Continuous transmission of a suitable character (for example, the letter V) causes one of the lamps (or two adjacent lamps) to light twice per revolution of the distributor. If the speed is correct the same lamp or lamps light during every revolution; if there is a speed error the display "rotates," the time and direction of revolution indicating the magnitude and sense of the speed error. An indicator lamp operated from a half-minute pulse circuit enables the rotation to be accurately timed.

The dependence of the synchroscope on the a.c. mains and the introduction of switched telegraph networks has led to its replacement by more convenient testing techniques.

† The authors are Executive Engineers, Telegraph Branch, E.-in-C.'s Office.

### *Speed Test Facilities on Switched Systems.*

In a switched telegraph system it is possible to check teleprinter speeds at outstations by direct comparison with a standard frequency source at the switching centre. This can be achieved by two methods, both of which have been used on the Teleprinter Automatic Switching System for the public telegraph service.

In the first method, "plugged" characters (i.e., characters continuously repeated at full cadence speed) are transmitted from the teleprinter and received on a start-stop electronic T.D.M.S. at the switching centre. The facilities provided by this tester, described in detail in a previous article,<sup>1</sup> permit direct measurement of the speed error by adjusting a calibrated dial until a stationary trace is obtained on the screen of a cathode-ray tube.

The second method<sup>2</sup> involves the provision of standard reversals at 20 c/s at the switching centre to which access is obtained from the outstation by dialling a speed-test number. The 20 c/s reversals are received by a Teleprinter Speed Tester (Tester TG 5181) plugged into the receive line in place of the teleprinter electromagnet. A neon lamp in the tester flashes at 40 c/s, and is used to illuminate a stroboscopic disc mounted on the transmitter shaft of the teleprinter. Interruption of the 20 c/s reversals at 10-sec intervals provides a ready means of timing the rotation of the stroboscopic display and thus determining the speed error. The 20 c/s reversals are generated by one of the signal generators at the switching centre; the generator speed being controlled by a standard 50 c/s signal from a tuning-fork controlled source.

### *Speed Test Facilities for Margin and Distortion Measuring Sets.*

It is a prime requirement of most testers for measuring margin and distortion that there should be no appreciable difference between the speed for which the tester is set and that of the machine under test, and where the speed of the tester is adjustable provision is made for measuring the speed difference.

## DISTORTION TESTING

### *Transmitter Distortion.*

With a few minor exceptions British Post Office 5-unit equipment works at a speed of 400 characters per minute with  $7\frac{1}{2}$  unit signals per character (made up of a 20-ms start signal, five code elements of 20 ms and a stop signal of 30 ms). Accurate timing of the signal elements is essential to ensure that the distortion due to the transmitter, together with that due to the line, does not exceed the maximum which the receiving mechanism is designed to accept.

Imperfections in transmitters such as speed variations, backlash in gear trains and dimensional tolerances on parts, tend to limit the precision of their operation. The normal distortion limit specified for teleprinter transmitters is  $\pm 5$  per cent of the unit signal element, i.e., no individual "characteristic instant of modulation" should be advanced or retarded more than 1 ms from its true theoretical timing with respect to the commencement of the start signal.

### *Standard Distortion Testers.*

The standard method of measuring distortion is to arrange for the "instants of modulation" to be displayed spatially on an accurate reference "time" scale so that the displacements of individual "instants" relative to their nominal positions can be examined. The standard testing equipment in general use, the Teleprinter Distortion and Margin Tester (Testers TG 956/7 and 8),<sup>3</sup> employs a viewing disc carrying a neon lamp and rotating at a constant

speed which is the same as that of the transmitter being tested. The neon lamp is mounted behind a narrow slit in the disc and is arranged to flash at each transit of the transmitting tongue. A visual display of narrow radial flashes corresponding to the "instants of modulation" is thus produced and can be examined against an annular scale calibrated in milliseconds. Since the transit time of the transmitter tongue and contact bounce are also factors contributing to signal distortion by reducing the duration of signal elements, means of indicating these are included. The test circuit for transit time causes the neon lamp to light while the transmitter tongue is not resting on either mark or space contact. A display similar to the distortion display is therefore produced, the angular width of the flashes indicating transit time and spurious flashes indicating bounce.

These testers have been in use for many years at overhaul centres, and when carefully maintained and in the hands of capable staff yield a fairly accurate assessment of the transmitter distortion. Measurement of distortion less than 5 per cent is however virtually impossible and in recent years development has been directed towards an electronic measuring set to enable more accurate measurements to be made. With electronic techniques it is possible to produce a start-stop distortion set which eliminates the need for absolute synchronism; with the older tester, lack of synchronism made reading of the distortion rather difficult due to shifting of the display. The electronic distortion measuring set developed by the Post Office<sup>1</sup>



FIG. 2.—ELECTRONIC DISTORTION MEASURING SET.

is illustrated in Fig. 2 and several other versions are available. All these instruments produce spatial displays of the "instants of modulation" as bright flashes or small lateral displacements on linear, spiral or circular traces on the face of a cathode-ray tube and enable the degree of distortion to be determined by examining the position of the flashes relative to a calibrated graticule.

Maintenance of electronic test equipment requires specialized knowledge not hitherto associated with machine maintenance and this is of importance in deciding the field of use of electronic equipment.

<sup>1</sup> WHEELER, L. K., and TISSINGTON, R. S. An Electronic Distortion Measuring Set for Start-stop Telegraph Signals. *P.O.E.E.J.*, Vol. 43, p. 18, Apr. 1950.

<sup>2</sup> FORSTER, A. E. T. Test Equipment for the Teleprinter Automatic Switching System. *P.O.E.E.J.*, Vol. 44, p. 107, Oct. 1951.

<sup>3</sup> JOLLEY, E. H. Determining the Transmission Efficiency of Telegraph Circuits. *P.O.E.E.J.*, Vol. 26, p. 1, Apr. 1933.

A simple method of assessing distortion, which avoids the need for accurate time measurements, is the determination of the ratio of the total duration of marking elements in a selected character signal to the total duration of spacing elements. A portable Bias Distortion Tester (Tester TG 1132), shown in Fig. 3, has been designed on this



FIG. 3.—BIAS DISTORTION TESTER.

principle and has been introduced at maintenance centres and minor workshops. By examining in turn "plugged" character signals having only one space to mark transition it is possible to assess the distortion of each "instant of modulation," while average distortion can be ascertained by "plugging" the characters R and Y.

The basic circuit of the tester is shown in Fig. 4 and it will

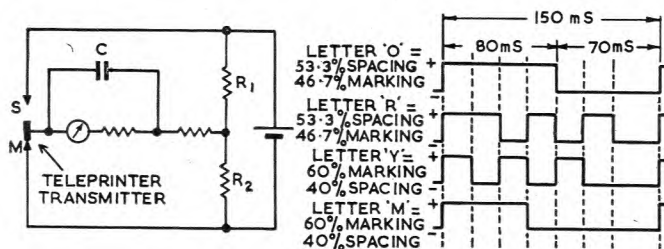

FIG. 4.—BASIC CIRCUIT OF BIAS DISTORTION TESTER.

be seen that it consists essentially of a heavily-damped sensitive galvanometer connected between the transmitting tongue and a pre-set potentiometer with ratio arms,  $R_1$  and  $R_2$ , appropriate to the character to be examined. The circuit forms a simple bridge network which can be shown to be balanced when  $t_m/t_s = R_2/R_1$ , where  $t_m$  and  $t_s$  are the aggregate times during which the transmitting tongue is at rest on the marking and spacing contacts respectively during a period of several complete characters. Distortion produces an out-of-balance current the mean value of which determines the reading on the galvanometer, which is directly calibrated in terms of distortion.

The receiving margin of a telegraph machine is, broadly speaking, the maximum degree of distortion of the input signals that can be tolerated before errors occur. With five-unit receiving mechanisms, it is more precisely defined as the maximum advancement or retardation of any characteristic instant of modulation from its nominal timing (relative to the commencement of the start signal) which can be received without error. In practice the error rate (i.e., proportion of errors) does not change abruptly from zero to 100 per cent. This is mainly due to the fact that with a ratchet clutch on the receiving cam the pick-up time can vary from zero to about 2.2 ms, the actual value on any signal being purely fortuitous. To allow for these variations it is the practice to define the failure point as being the maximum (or minimum) at which not less than 400 consecutive characters are received without error. Synchronous testing (i.e., with no speed difference between the signal source and the receiver) is normally employed when a machine is on the test bench. When testing working installations, however, it is sometimes more convenient and realistic to use test signals at the correct nominal speed but to allow the machine to run with its normal speed error.

The Post Office standard tester for measuring the receiving margin of teleprinters has been the Teleprinter Distortion and Margin Tester (Testers TG 956/7 and 8).<sup>3</sup> This equipment, which, as already stated, caters also for distortion measurements, is of mechanical design. It comprises essentially a means of varying the duration of the start signal elements of test signals fed into the machine under test. All the characteristic instants of modulation can therefore be advanced (or delayed) by increasing amounts until failures begin to occur in the printed record. The maximum percentage increase, or decrease, of the start signal which can be introduced without causing errors is the receiving margin. This should not be less than 35 per cent for standard Post Office machines. These testers have given excellent service as margin testers and can be easily maintained by staff skilled in mechanism maintenance. Apart from laboratory work and the acceptance testing of new machines, they have been used only at telegraph overhaul centres but have probably contributed more than any other single factor to maintaining the standard of performance of teleprinters.

A prototype electronic margin tester giving comparable and in some ways improved facilities and capable of measuring margin more easily and more reliably has been developed but not yet produced in quantity.

#### Signal-Biasing Unit.

As the standard margin-testing equipment is both costly and bulky and needs careful maintenance for accurate results, alternative means of checking or estimating margin are desirable for use by day-to-day maintenance staff. A portable tester (Tester TG 1133), known as the Signal-Biasing Unit, has been developed and is in use at the larger maintenance centres and at minor workshops. As it is used in conjunction with the Bias Distortion Tester already described it has been designed to fit into the same case so that the two form a compact testing unit.

The transmitter of the teleprinter under test (or if necessary of a second machine) is used as the primary source of test signals. This transmitter must be of the striker pattern which has been fitted to all Post Office teleprinters since 1939 and can be relied upon to have an inherent distortion of not more than 5 per cent when all mechanical adjustments are correct.

The principle of operation of the tester is that either all the mark-to-space, or all the space-to-mark transits (but

not both together), generated by the source transmitter are delayed by a regulated amount before being used to actuate the receiving mechanism under test. For this purpose a normal telephone-type high-speed relay, associated with a simple delay network comprising an inductor, a capacitor and two ganged variable resistors, is employed.

The connexions are as shown in Fig. 5(a) for the "long condition" and Fig. 5(b) for the "short condition." In the

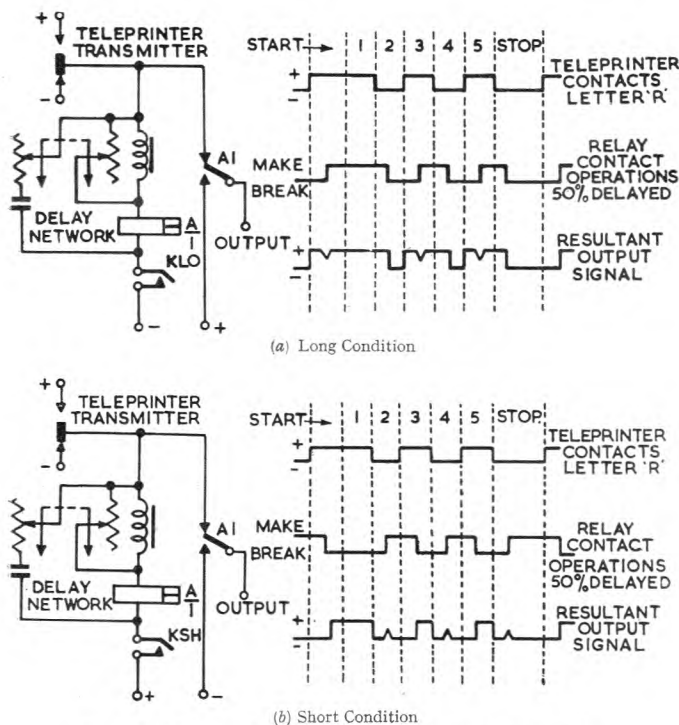

FIG. 5.—BASIC CIRCUIT OF SIGNAL-BIASING UNIT.

first condition the relay has no effect on a mark-to-space transit since it operates a short interval after the transit occurs without affecting the polarity of the signal transmitted. At the ensuing space-to-mark transit the relay remains operated, transmitting a spacing signal (positive) to the receiver for a short interval after the transit, depending on the setting of the delay network. The effect is to lengthen all spacing elements of the signal, including the start element—hence the term "long condition." Marking elements are correspondingly shortened. In the "short condition" the biasing is reversed, spacing elements being shortened and marking elements lengthened.

Before using the tester, the speed of the teleprinter is checked and the transmitter readjusted if necessary. Plugged characters (e.g., R or Y) are then sent from the transmitter via the tester into the electromagnet. With appropriate keys thrown for, say, the "long condition" the setting of the variable resistors of the delay network is increased until printing errors occur, and then reduced to the maximum setting at which no errors occur. The signals are then switched by a key into the associated Tester TG 1132 and their distortion measured as already described. Measurements with the "short condition" and with other characters can be made as desired.

It will be observed that in the long condition marking transients are delayed, and in the short condition advanced, relative to the commencement of the start element. Spacing transients are unaffected. The conditions of test are therefore basically different from those employed in the standard margin tester in which all transients—marking and spacing—are delayed or advanced. This, coupled with the use of a signal source which is not distortionless, prevents exact

correlation of the readings with those of the true margin. The tester does however afford a means of checking the receiving performance and it is possible to assign values of distortion that a properly adjusted machine should accept, although these must be less than the normally accepted figure for margin. Means are also provided in this tester, as in the standard margin tester, for checking the sensitivity and neutrality of the receiving electromagnet.

#### Distorted Message Generators.

With the introduction of switched telegraph networks, and particularly of automatic systems, it became possible to test the receiving performance of teleprinters by means of signals of known distortion generated at switching centres and sent out over extension lines to outstation teleprinters. The method requires that the distortion introduced by the extension line should either be known or should be negligible—neither of which conditions strictly applies in practice. In spite of this the facility has sufficient value to warrant its introduction.

The signals are generated by a Telegraph Signal Generator (Generator, D.C. Signalling, No. 1A), illustrated in Fig. 6,

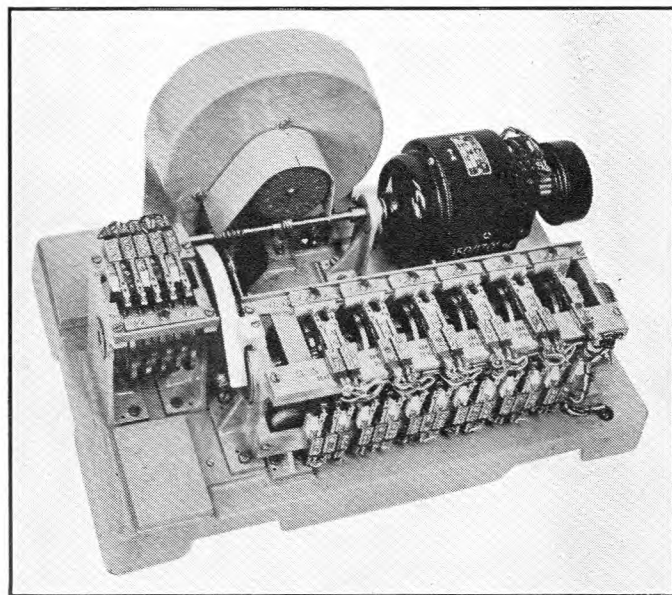

FIG. 6.—TELEGRAPH SIGNAL GENERATOR.

which is one of the suite of three machines normally provided at a telegraph automatic switching centre for producing the various signals required for switching purposes.<sup>4</sup> These units are driven by 160V, 3,000 rev/min d.c. shunt motors, the speeds of which are controlled within very close limits by means of a standard 50-c/s tuning-fork oscillator. The output from this oscillator and that produced by a slip-ring commutator assembly on the motor shaft are fed to a phase-comparator circuit, the output from which is used to regulate the shunt field of the motor and hence its speed. The speed accuracy enables signals of the requisite precision to be produced.

The motor drives the rotating arms of a conventional telegraph distributor and a series of control cams operating springsets which connect appropriate signalling polarities to the distributor segments. The distributor face-plate has four separate pairs of slip-rings arranged concentrically, each pair comprising a segmented ring and a continuous "collector" ring. These enable signals with zero, 20 per

<sup>4</sup> WILCOCKSON, H. E., and MITCHELL, C. W. A. The Introduction of Automatic Switching to the Inland Teleprinter Network. *I.P.O.E.E. Printed Paper No. 195.*

cent, 25 per cent and 30 per cent early and late distortion to be generated.

The test message used is: "THE QUICK BROWN FOX JUMPS OVER THE LAZY DOG + SQSPSO," the final sequence being intended to check the operation of the teleprinter typehead-latching mechanism with long and short throws, i.e., large and small angles of rotations of the typehead between successive printed characters. When the distorted-test-message number is dialled from a teleprinter automatic switching position, the test message is transmitted eight times in succession, twice undistorted, once each with 20 per cent, 25 per cent and 30 per cent early distortion, and once each with 20 per cent, 25 per cent and 30 per cent late distortion. Each transmission of the test message is preceded by three letter shifts, a carriage return and a line feed signal and an "announcement" in the form "TEST DSTN . . .", the whole of this preamble being sent undistorted.

It is not practicable to introduce more than 30 per cent distortion at source since the distortion introduced by the longest extension circuit connected to the system must be allowed for. A further limitation of this test is that there is no check of reception at intermediate values of distortion.

#### *Orientation Device.*

Although the orientation mechanism fitted on certain telegraph machines (e.g., Printing Reperforators and the Teleprinter No. 11) is not strictly a tester it is worthy of mention since it enables an assessment of the receiving margin to be made in the field, a facility which has not hitherto been available on telegraph machines.

The orientation mechanism on the Teleprinter No. 11 has been described in a previous article in the *Journal*<sup>5</sup> and that on printing reperforators differs little. The mechanism allows the selecting periods to be advanced or retarded with respect to the commencement of the start element of incoming signals by moving an adjusting block over a calibrated scale. If the advancement or retardation is sufficient, points are reached at which errors occur, the so-called "orientation limits." If this is done with perfect (undistorted) incoming signals with the speed accurately adjusted, the displacement of the block from the normal position in both directions gives a fairly accurate measure of the early and late margin, within the limits of accuracy of the calibration of the scale.

In practice, and particularly where this method of testing is likely to be resorted to, perfect test signals are

not available. It is possible to use the signals generated by a standard teleprinter transmitter of the striker type provided the adjustments are carefully checked, though this will introduce distortion so that the "margin" measurements will be 5 per cent or so less than those obtained with perfect signals. The exact measurements to expect are difficult to predict and the test is therefore of limited value. It is however capable of detecting a machine which is badly out of adjustment and readings made and recorded at regular intervals would indicate when the margin was beginning to deteriorate.

In determining the orientation limits (as with tests made with margin testers) difficulty usually occurs in fixing the exact point at which errors begin to occur. The usual practice is to make separate determinations with characters R and Y in turn and from the four limits thus determined to select the two inner ones as representing the working margin limits.

#### CONCLUSION

A problem becoming increasingly more common with the growth of world-wide communications is that of working machines at speeds other than 50 bauds, particularly at the American Teletype speed of 45.5 bauds. Machines working at 75 bauds and handling high-speed cross-office traffic at automatic or semi-automatic tape relay centres constitute another class that will require special test facilities in the near future. For these machines, special stroboscopes may be needed for checking speeds, although it is sometimes possible to use standard stroboscopes of the tuning-fork type in conjunction with special stroboscopic markings. Tachometers, apart from being expensive and prone to damage if handled carelessly, are not in general sufficiently accurate for this purpose, nor are they so useful as stroboscopes in detecting speed instability.

The present standard Teleprinter Distortion and Margin Tester cannot be used at non-standard speeds without considerable modification but such facilities are obviously desirable. The electronic T.D.M.S. and Margin Tester will incorporate means of carrying out tests at 45.5 and 75 bauds in addition to 50 bauds. The Bias Distortion Tester can be used in its existing form for distortion measurements at speeds not greatly different from 50 bauds. The Signal Biasing Unit could similarly be used, provided a suitable source of test signals at the appropriate speed were available.

<sup>5</sup> EASTERLING, C. E., and COLLINS, J. H. The Teleprinter No. 11 *P.O.E.E.J.*, Vol. 46, p. 53, July 1953.

## Book Review

"Protective Current Transformers and Circuits." P. Mathews, B.A.(Cantab), A.M.I.E.E. Chapman & Hall, Ltd. 253 pp. 119 ill. 36s.

Very little information has hitherto been available in convenient form on this subject, particularly as regards the response of protective equipment to transient currents, and this excellent book should quickly find its place as a standard reference work for those engaged in transformer design or testing.

The author has wisely omitted information about voltage transformers, which are well catered for in other text books, and by so doing has, in a reasonable compass, been able to offer a full and satisfying treatment of his subject.

The book is divided into two parts, the first dealing with steady state conditions and the second with transient current conditions. The analysis at the beginning of Part 1 is based on the classic theory of coupled circuits and is extended to include ferromagnetic effects. Later chapters cover zonal protection, special applications (such as differential transformers to achieve high ratios), general design considerations and testing. Part 2 starts with an expression for transient

fault currents and proceeds to linear theory of transformation. Later chapters deal with ferromagnetic effects, current summation types of protection and methods of stabilization.

The style of the text and method of presenting this specialized subject are to be commended. The reader is assisted throughout by the generous use of equivalent circuits and similar diagrams, which augment and clarify the text remarkably well. Furthermore, great care has been taken to display each diagram on the same page as the reference in the text and that exasperating "referring-back" that often arises in the study of text books is avoided. There is an appendix giving a list of definitions of all the terms used and another for symbols.

The photographs (there are only four, three of them being different views of a testing plant for operation tests) might, with advantage, have included a complete range of current transformers and auxiliary apparatus to match the text or to illustrate methods of core construction and assembly.

The book should prove invaluable to engineers responsible for the testing and maintenance of protective gear in the field or for those engaged in post-graduate work but it is too specialized for the average electrical engineering student.

G. M. M.

# New Line Transmission Equipment

L. W. J. CHILVER, Associate I.E.E.,  
and A. H. WATKINS, C.G.I.A.†

U.D.C. 621.395.73:621.395.44

This article describes equipment being developed to facilitate the more efficient utilization of existing line plant. Brief descriptions are given of carrier terminal equipments, for operating over medium and short distances, which produce channels with a bandwidth exceeding 4 kc/s, signalling being effected within the channel frequency band. Some of the equipment is for use with conventional carrier or coaxial line links and some is for use with unloaded pairs in audio cables. Reference is also made to the possible future application of transistors and 2-wire negative impedance line amplifiers to the audio network.

## INTRODUCTION

PROGRESS in design and manufacturing techniques has made consideration of methods of increasing the circuit capacity of existing audio cables a matter of some importance. In the United Kingdom the application of carrier telephone systems has previously been confined almost entirely to the trunk network, and within that network to special carrier and coaxial cables. There is now a trend towards a wider application of cheaper carrier systems for operation over shorter distances using line plant not specially designed for carrier telephony. In addition, the cost of terminal equipment on some of the shorter carrier and coaxial cable routes is out of proportion to the line costs. A reduction in the cost of carrier terminal equipment for use on some conventional carrier links therefore appears desirable. To a marked extent this requirement presents problems similar to those of providing carrier systems on audio cables.

Investigations are now being undertaken to determine how the recent advances in these fields, and in the field of semi-conductors, can best be used, and consideration is being given to the following equipment for use in the existing network:—

- (a) Carrier systems for use on existing audio cables.
- (b) 2-wire negative impedance audio line amplifiers.
- (c) Less-costly carrier terminal equipment for use on carrier and coaxial line links.
- (d) 4-wire transistor line amplifiers.

The investigations into the value of these equipments, if applied to the Post Office network, have reached a stage when field trials of the equipment are being carried out or are about to commence. It is thought therefore that an indication of the lines along which development is proceeding would be of interest.

## ECONOMIC CONSIDERATIONS

### Carrier Systems.

The size of the United Kingdom is such that with existing types of carrier equipment the cost of the terminal equipment exceeds that of the cable and the line equipment on the majority of routes. As the length of line increases, the ratio of the cost of terminal equipment to the total cost of the system decreases and, conversely, on an extremely short line the cost of the terminal equipment is predominant.

Analysis of annual charges has indicated<sup>1</sup> that for a 900-mile coaxial system carrying 960 circuits the cost of the terminal equipment is approximately equal to the cost of the line. Circuits of this length, however, are not required within the United Kingdom. For routes of 100 miles in length (which are common) the cost of terminal equipment is approximately 90 per cent of the total cost of the system, and of the terminal costs 40 per cent are attributable to signalling. A reduction in the terminal (including signalling) costs is therefore of great interest to the Administration.

† Mr. Chilver is an Executive Engineer in the Transmission and Main Lines Branch, E.-in-C.'s Office, and Mr. Watkins was an Assistant Engineer in that branch at the time that this article was prepared, but is now in the Home Counties Region.

<sup>1</sup>HALSEY, R. J. Trends in the Design of Line Transmission Equipment. I.P.O.E.E. Printed Paper No. 200, 1949.

Terminal costs have, to date, remained at a high figure due, in the main, to the high cost of channel filters and the cost of elaborate signalling equipment. The cost of channel filters could be appreciably reduced if the present 4-kc/s spacing of channels were increased. Increasing the channel spacing reduces the number of channels that can be accommodated in a given frequency band and there is, therefore, an optimum carrier spacing when considering the cost per circuit for a system of given length.

The relationship between cost per channel, spacing, terminal costs and system length may be determined as follows:—

$$C = T + S + DL \dots\dots\dots(1)$$

where,  $C$  = total cost of system,

$T$  = cost of carrier terminal equipment (excluding signalling equipment),

$S$  = cost of signalling equipment,

$D$  = distance between terminal stations in miles, and

$L$  = cost of line per mile (including cable, repeaters, buildings, etc.).

The line costs per channel are  $DL/n$  where  $n$  is the number of channels and is equal to  $f_o/f_c$ ,  $f_o$  being the total available bandwidth of the system and  $f_c$  the spacing between channel carrier frequencies.

To obtain the cost per channel ( $c$ ) for a given system, equation (1) may be rewritten thus:—

$$c = \left( \frac{T + S}{n} \right) + \frac{DLf_c}{f_o} \dots\dots\dots(2)$$

If equation (2) is plotted for three systems using channel spacings of 4 kc/s, 6 kc/s and 8 kc/s, assuming that terminal and signalling costs are reduced when channel spacing is increased, the line lengths for which each spacing is most economical are readily obtained (see Fig. 1).

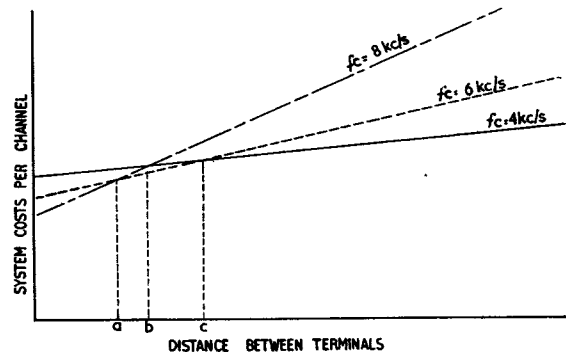

FIG. 1.—COST OF CARRIER CHANNELS WITH DIFFERENT CHANNEL SPACINGS.

From Fig. 1 it will be seen that for less than  $a$  miles the 8-kc/s system would prove cheaper than either the 4-kc/s or 6-kc/s system. For distances less than  $c$  miles the 6-kc/s system is cheaper than the 4-kc/s system. For all distances in excess of  $c$  miles the 4-kc/s system is cheaper than either the 6-kc/s or 8-kc/s systems.

In Fig. 1 the graphs cut the "costs" axis at the total cost of the terminal and signalling equipment. The cost of the

terminal equipment will decrease as the channel spacing increases by virtue of the fact that close channel spacing requires expensive filter arrangements such as crystal filters, or double modulation, whereas the wider the channel spacing the simpler is the filter problem.

For a system using 8-kc/s channel spacing, the cost of the terminal equipment may be reduced still further by transmitting upper and lower sidebands and the carrier frequency. The use of 8-kc/s channel spacing for carrier systems in cable can probably be justified economically only over comparatively short distances and, for this reason, it has no field of application on existing carrier and coaxial lines. With the increasing demand for junction and short trunk circuits the use of this type of carrier system on unloaded 20-lb cables is being investigated.

The attenuation/frequency characteristic of 20-lb P.C.Q.T. cable is shown in Fig. 2. It will be seen that,

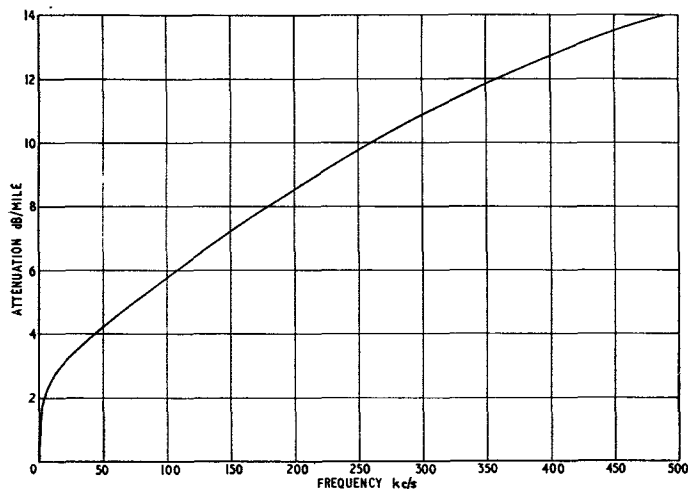

FIG. 2.—ATTENUATION OF 20-LB P.C.Q.T. CABLE

assuming amplifier gains of the order of 60 dB and a repeater station spacing of 6 miles, this type of cable could be used for carrier working up to a frequency of approximately 250 kc/s if crosstalk requirements could be met.

The economics of carrier working on unloaded audio cables is somewhat complicated by the need to "de-load" existing cables before the system can be used to any great extent on the existing cable network. It can be shown, however, that the capital cost of providing additional circuits by this means, including the cost involved in "de-loading" the pairs, is less than that of providing new cable.

#### 2-Wire Negative Impedance Audio Line Amplifier.

Another method of economizing in the use of audio cable is by means of negative impedance amplifiers. The insertion of this type of amplifier at the approximate centre point of a 2-wire, 20-lb line, not exceeding a length of about 30 miles, will reduce the overall loss of the line, at 800 c/s, from about 10 dB to approximately 5 dB. By the use of this type of amplifier many 4-wire junction and short trunk circuits should be convertible to 2-wire working, thus effecting a 50 per cent saving on existing line plant. New planning problems are involved, however, in the application of this equipment to the existing network on a large scale.

The amplifier cannot at present be operated satisfactorily to give an overall circuit loss better than about 4-5 dB, because of the wide range of terminating conditions. On this account its application will be restricted initially to circuits between Group Centres and Minor exchanges and auxiliary routes on which the loss can be tolerated. Under the present transmission plan, Group-Minor and Group-Minor-Dependent circuits are required to have a loss not

exceeding 4.5 dB. The transmission equivalent of 20/88/1.136 cable at 800 c/s is 0.37 dB/mile, which limits 2-wire unamplified circuits of this type to a length of approximately 12 miles. The use of negative impedance amplifiers might raise this limit to 30 miles (approximately). It is estimated that the conversion of a 30-mile circuit from 4-wire to 2-wire working by the use of a negative impedance amplifier would result in an appreciable saving in capital costs. Allowing for an increase in maintenance charges resulting from the possible need to use more complex signalling equipment, as discussed later, there would still be considerable savings on total annual charges.

#### 4-Wire Transistor Line Amplifier.

The development of semi-conductors and, particularly, the increased availability of low-power, low-frequency transistors, raises the question of the field of use of a transistor 4-wire line amplifier in situations where the use of a conventional line amplifier would present difficulties. The low power consumption of a rack of transistor amplifiers would allow it to be installed in an exchange where repeater station power supplies are not available. The use of these amplifiers in such circumstances could effect economies in both accommodation and line plant, enabling standard transmission requirements to be met with light-gauge cables. The provision of standard circuits in these circumstances without the use of transistor amplifiers involves the use of more expensive cables or the provision of repeater station equipment, including power plant and, possibly, new buildings or building extensions.

#### Signalling Equipment.

*Carrier Circuits.*—Existing signalling equipment used on circuits routed in carrier systems is expensive due to the signalling frequencies being within the speech band, which necessitates elaborate precautions to avoid signal imitation by speech. One way of effecting a reduction in signalling equipment costs would be to use a signalling frequency outside the speech band instead of signalling within the speech band. "Within-band" signalling has been necessary for the 4-kc/s spaced systems with the speech band extending from 300 to 3,400 c/s, because there are difficulties in selecting a suitable signalling frequency situated outside the speech band but within the channel band. With the spacing extended to 6 kc/s a signalling frequency of, say, 4.3 kc/s may be readily selected by means of a simple, cheap, coil-and-capacitor filter. In an 8-kc/s spaced system with transmitted carrier, the carrier may be used for signalling, thus saving the cost of signalling oscillators. Recent developments indicate that the production of a 4 kc/s spaced system using a signalling frequency outside the speech band may not be long delayed.

*Physical Circuits.*—A difficulty associated with the use of negative impedance amplifiers is that, although the attenuation of the 2-wire circuit may approximate to that of the 4-wire circuit it replaces, the d.c. signalling path resistance is doubled. This may entail the use on some circuits of more-expensive signalling equipment than that necessary on the 4-wire circuit. It seems likely, however, that for some time the use of the 2-wire negative impedance amplifier will be largely confined to routes which will not require a change of signalling system due to the increased signalling path resistance. Offsetting this signalling disadvantage, to some extent, is the advantage that in the event of failure of the amplifier the circuit continuity is maintained, but with an overall loss slightly exceeding that of the unamplified pair.

#### DESCRIPTIONS OF NEW EQUIPMENT

Brief descriptions of the various equipments that are being tried in the field are given below; only general



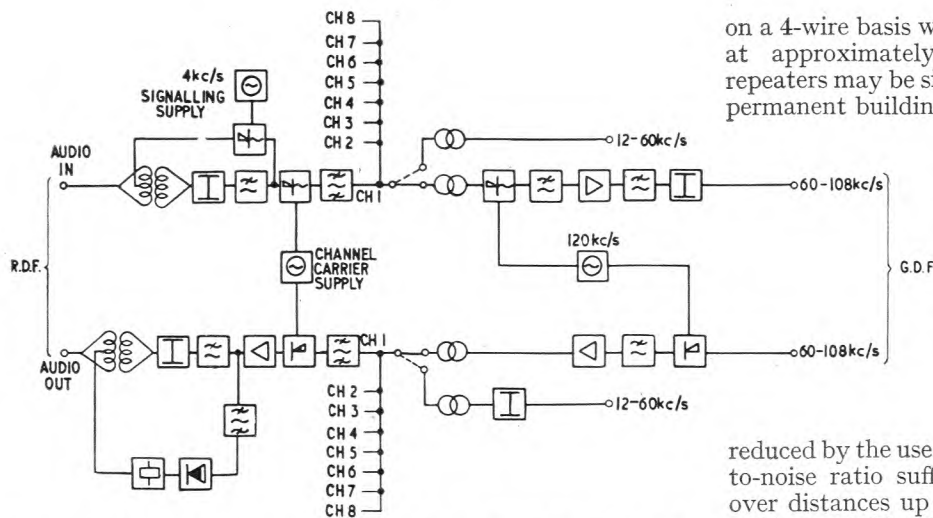

FIG. 3.—MEDIUM-DISTANCE CARRIER SYSTEM FOR USE ON CONVENTIONAL H.F. LINKS.

principles are given as the development of the equipment has not yet reached finality.

#### Medium-Distance Carrier System for Use on Conventional H.F. Links.

This system is designed to assemble eight channels spaced at 6-kc/s intervals in the Primary Group B (60-108 kc/s) frequency range. A block schematic diagram of the equipment supplied by one contractor is shown in Fig. 3. In this equipment the channels are first assembled as a Primary Group A (12-60 kc/s) and further modulated by 120 kc/s to place them in the 60-108 kc/s range. In this particular equipment the Primary Group A is made available for transmission to line. This could be an advantage in that transmission would be possible over an existing 12-channel carrier link which has not been converted to 24-channel working.

The number of 8-channel groups comprising the terminal equipment on one single-sided rack varies with different contractors. At least four groups per rack may be expected on any future production. The equipments under trial have been designed for small-station use and therefore contain their own carrier generating equipment.

Signalling is effected by arranging for the d.c. from the outgoing exchange relay set to modulate the signalling carrier supply. At the receiving end the modulated signalling carrier is applied to a signalling receiver, resulting in the operation of a polarized relay, which provides a d.c. output to the incoming exchange relay set. Supervisory signals are returned by modulating the signalling carrier supply associated with the return channel in the same way. The d.c. signal can be extended over audio cable tails at each end.

The equipment is mounted on 9-ft racks and is of 51-type, formerly known as N.E.P.,<sup>1</sup> or similar construction.

A terminal equipment manufactured by one contractor is illustrated in Fig. 4, which shows one rack-side of equipment with the panel covers removed. Equipment for one complete group of eight circuits is mounted on this particular rack-side, together with carrier and signalling supply oscillators. A second associated rack-side carries equipment for two more complete 8-circuit groups but derives its carrier, signalling and power supplies from the rack-side illustrated.

#### A 12-Channel Carrier System for Use on Unloaded Cable.

This system is designed for operation over distances of 20-100 miles of 20-lb P.C.Q.T. cable. It provides 12 circuits in a line-frequency band of 84 kc/s. The system operates

on a 4-wire basis with intermediate repeater stations spaced at approximately 6-mile intervals. The intermediate repeaters may be situated in roadside cabinets when suitable permanent buildings are not available.

The effect of near-end crosstalk is eliminated by "frequency-frogging," in which the line-frequency band transmitted at any station is arranged to appear as either 24-108 kc/s (Low Group) or 138-222 kc/s (High Group), with the received band at that station appearing as the other group. The high-level signals thus appear in one frequency band and the low-level signals in the other band (see Fig. 5).

The effect of far-end crosstalk is reduced by the use of companders, which improve the signal-to-noise ratio sufficiently to enable the system to operate over distances up to approximately 100 miles.

The assembly of the channels into the two line-frequency groups is shown in Fig. 6, which also shows the line pilots.

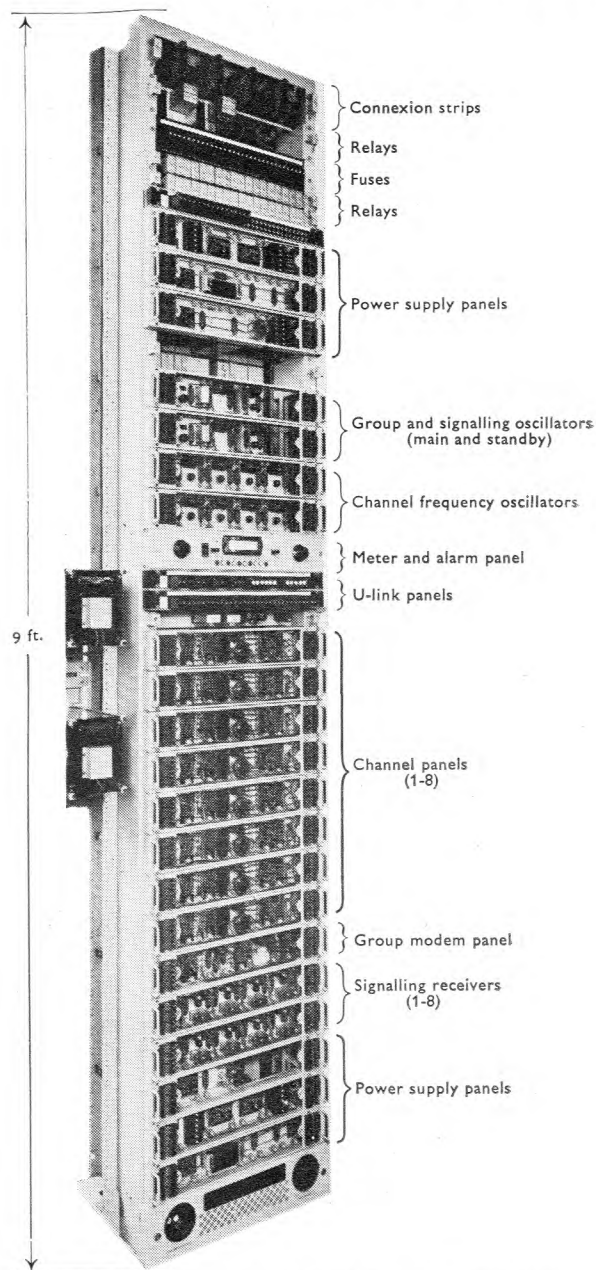

FIG. 4.—MEDIUM-DISTANCE CARRIER EQUIPMENT.

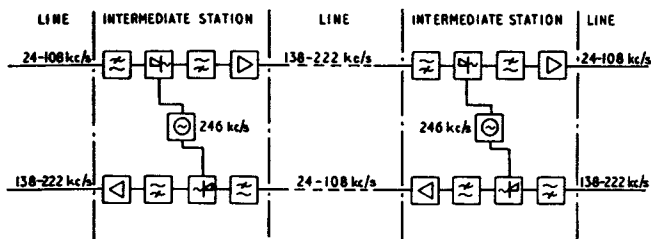

FIG. 5.—PRINCIPLE OF FREQUENCY FROGGING.

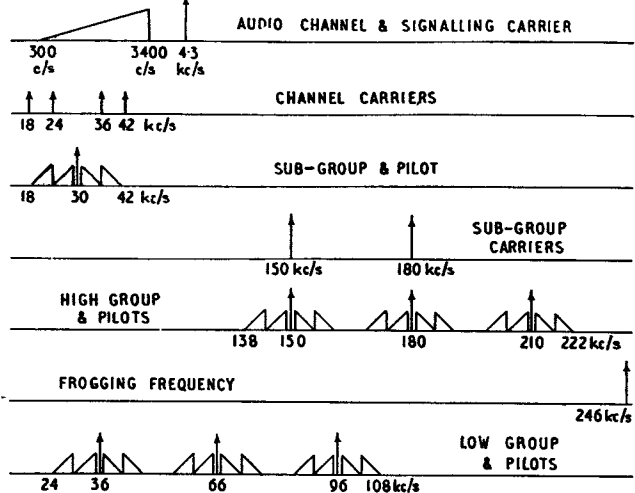

FIG. 6.—FREQUENCY ALLOCATION OF 12-CIRCUIT CARRIER SYSTEM FOR USE ON UNLOADED CABLE.

The channels are first formed into three sub-groups, each of four channels, on carrier frequencies of 18, 24, 36 and 42 kc/s. The sub-groups are next modulated by carrier frequencies of 150 or 180 kc/s to form a line-frequency band consisting of the lower and upper sidebands of the 180 kc/s modulation and the upper sideband of the 150 kc/s modulation, extending from 138-222 kc/s. The lower line-frequency group of 24-108 kc/s is formed by further modulation by a carrier of 246 kc/s (the "frogging" frequency).

A built-in signalling system is provided, using a signalling

carrier frequency of 4.3 kc/s. Pilot frequencies are used to give automatic level control and for frequency synchronization.

A simplified block schematic diagram of the transmission and signalling circuits is shown in Fig. 7.

Power supplies are fed over the cable to dependent stations at a voltage of 130-0-130 volts d.c., the power-feeding stations being situated at approximately 18-mile intervals and feeding one dependent station on each side.

#### *A Proprietary Short-Distance Carrier System for Use on Unloaded Cables.*

A field trial of a proprietary system at present known as the "Q" system is being undertaken. A block schematic diagram of this system arranged for 2-wire operation is shown in Fig. 8. The bandwidth occupied by six circuits is 12-120 kc/s, using 12-60 kc/s for one direction of transmission and 72-120 kc/s for the opposite direction of transmission. Quadrature modulation<sup>2</sup> is employed, both sidebands and the carrier frequency being transmitted. One advantage claimed for quadrature modulation is a saving in filter costs when compared with conventional single-sideband modulation. In addition, the overall channel loss is largely independent of variations in the line loss due to the action of the demodulator and limiter. The output from a demodulator of this type is proportional to the phase of the applied signal and is substantially independent of the amplitude of the signal.

From Fig. 8 it will be seen that the modulator in the channel panel is fed with a carrier frequency via a static relay, controlled from the signalling relay set. In this way the outgoing carrier to line is controlled by the d.c. input to the telephone relay set, and on the receiving side the incoming carrier, which has been modulated by the d.c. signal at the distant end, is rectified and applied to the exchange relay set to operate the supervisory relay. Relay sets of the "jack-in" type are fitted to suit local conditions.

The equipment being tested by the Post Office produces six channels in each direction and is mounted on a single-sided rack, as illustrated in Fig. 9. The equipment is mains-

<sup>2</sup> HOLLOWAY, D. G. New Carrier Equipment for Short Lines. The "Q" System. *The Strowger Journal*, Vol. VIII, Nos. 2, 3 and 4, 1954.

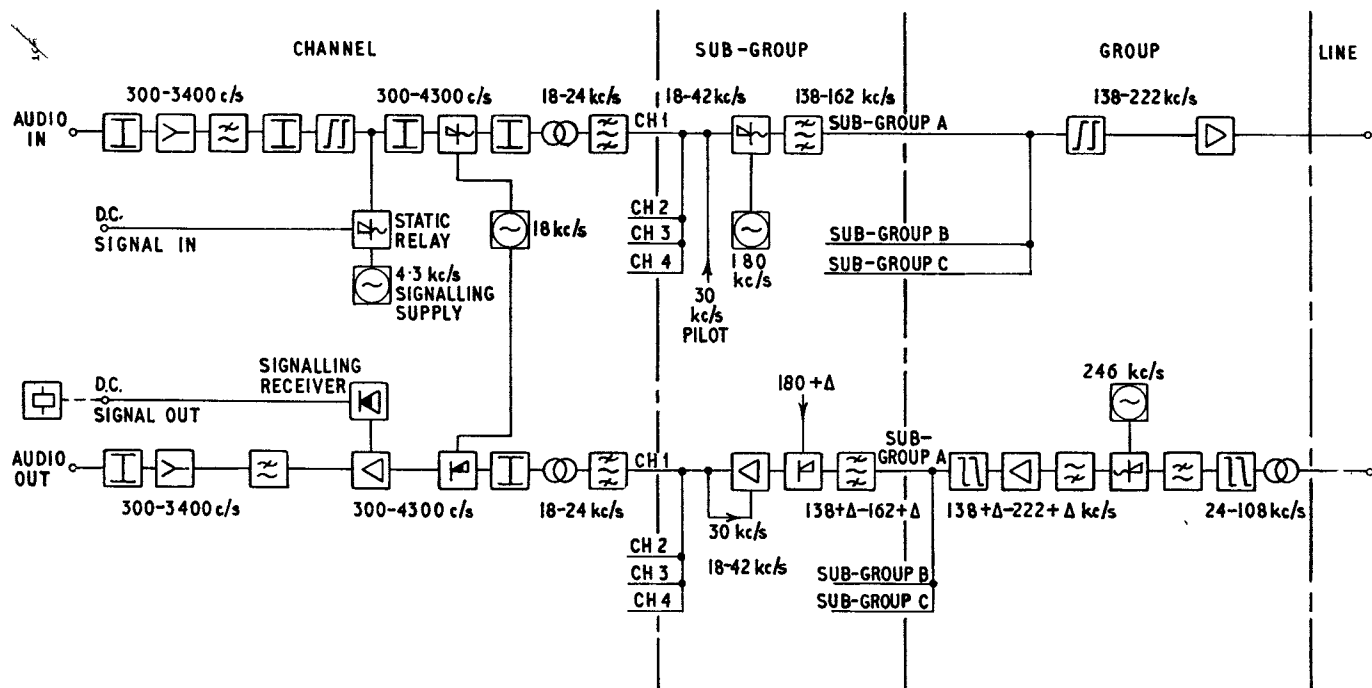

FIG. 7.—ONE TERMINAL OF A 12-CHANNEL CARRIER SYSTEM FOR USE ON UNLOADED CABLE.

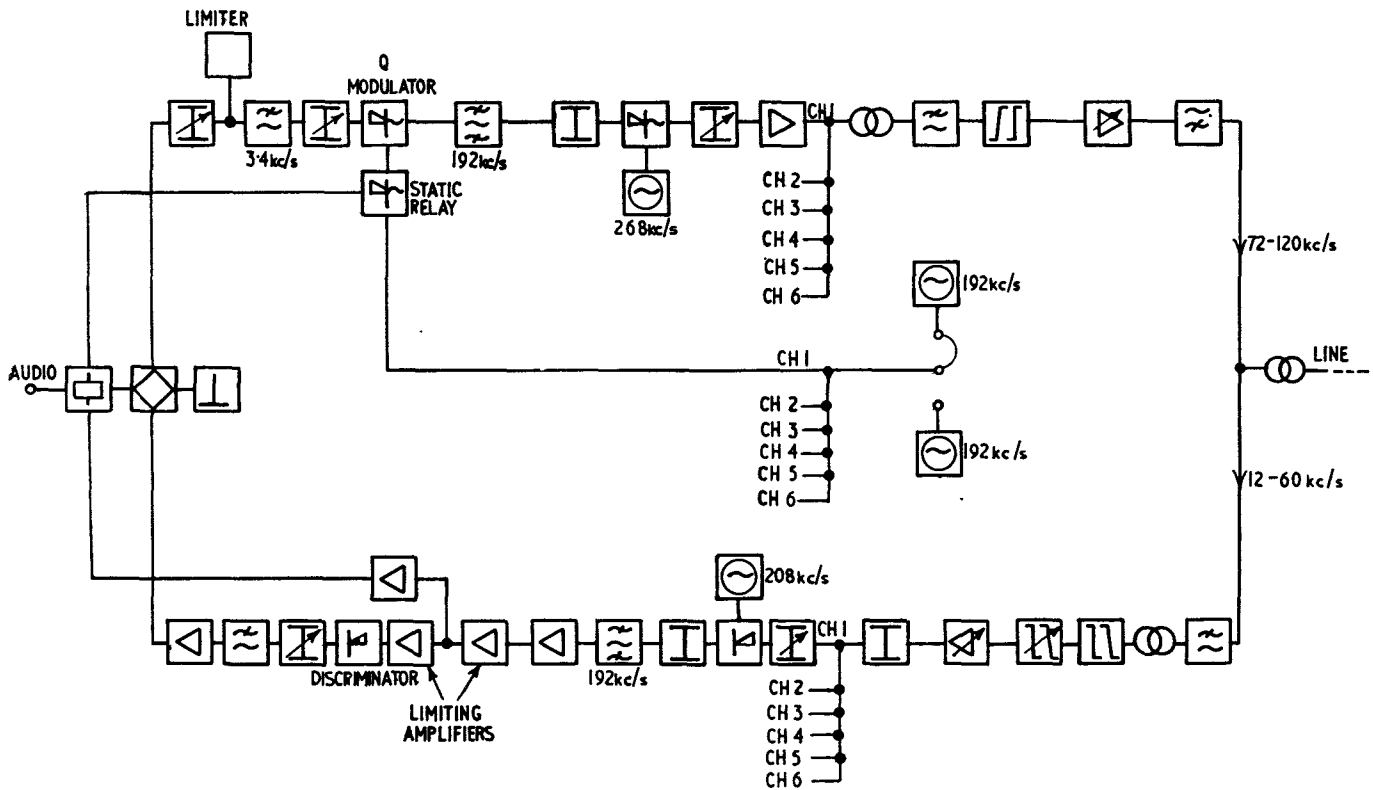

FIG. 8.—A-TYPE TERMINAL OF THE "Q" CARRIER TELEPHONE SYSTEM.

operated and has a power consumption of 270 watts per terminal. A separate 50-V exchange battery supply is required for the relay sets. The maximum route length of 20-lb P.C.Q.T. cable over which the system can operate without the use of intermediate repeaters is eight miles.

#### Negative Impedance Audio Line Amplifiers.

The negative impedance amplifier<sup>3</sup> is basically a device for introducing into a 2-wire line a negative impedance the magnitude of which is approximately that seen at the point of insertion of the amplifier. The impedance between the sending-end and the receiving-end is thereby reduced, with a resulting reduction in the attenuation. Ideally the amplifier should be fitted near the centre of the line and at the centre of a loading coil section.

Due to the impedance/frequency characteristic of the line, caused by irregularities in construction, reflections from the terminations, and different terminal conditions during the setting-up of a call, it is not practicable to match the line impedance at all frequencies. To ensure stability under adverse conditions it is considered necessary to set up the circuit so that it is stable with the ends of the line either open-circuited or short-circuited. Under these conditions the impedance/frequency characteristic of the line will contain "rolls" of appreciable magnitude due to the reflections from the circuit ends.

Negative impedance amplifiers may be connected to the line in "shunt" or in "series." (An amplifier employing a combination of series and shunt negative impedance can give a greater gain, with an adequate safety margin, than is obtained with either the series or shunt type.)

The magnitude of the negative impedance is designed to be greater than the line impedance at all frequencies for the shunt connection, and less than the line impedance at

all frequencies for the series connection. The need to maintain stability and the impracticability of obtaining a complete match between the line and the negative impedance restricts the gain of the device at present to that giving an overall circuit loss of the order of 5 dB.

#### Transistor Audio Line Amplifiers.

An amplifier employing two junction-type transistors in push-pull was described in a recent article in this journal.<sup>4</sup> This type of amplifier has given a performance closely approximating to that of an Amplifier No. 32<sup>5</sup> except in respect of power output. It has a power consumption of approximately  $\frac{1}{4}$  watt and may be operated from an exchange battery of 50 volts.

A low-gain amplifier of similar type is likely to find special applications (e.g. in connection with 4-v. r.f. switching) where a larger gain is not required.

#### PRESENT STAGE OF DEVELOPMENT

To assess the merits of equipment designed for conventional H.F. links and to determine the charges of such equipment, it is necessary to carry out fairly extensive field trials of factory produced equipment. Such field trials are conducted in the following order:

- Installation of the equipment and contract testing.
- Acceptance testing by the Post Office and contractors.
- "Type tests" by the Post Office.
- Traffic tests using dummy traffic.
- Period of approximately 12 months during which the circuits carry live traffic.

The most advanced of the field trials of the new equipment is that of a carrier system using 6-kc/s spacing giving eight channels per conventional group. Equipment has been manufactured in tractors for trial purposes, the routes selected for trials being the Middlesbrough-Newcastle and Birmingham-Leeds routes. Selection of these routes was made with a view to testing the equipment in locations where it would necessarily prove more economic.

<sup>3</sup> TILLMAN, J. R. A Negative Impedance Converter for Use as a Two-Terminal Amplifier. *P.O.E.E.J.*, Vol. 48, p. 97, July 1955.

<sup>4</sup> BASSETT, H. G. The Transistor, Part 6—Applications. *P.O.E.E.J.*, Vol. 48, p. 47, Apr. 1955.

<sup>5</sup> WILLIAMS, H. The New Amplifier No. 32 and Associated Equipment. *P.O.E.E.J.*, Vol. 34, p. 60, Apr. 1941.

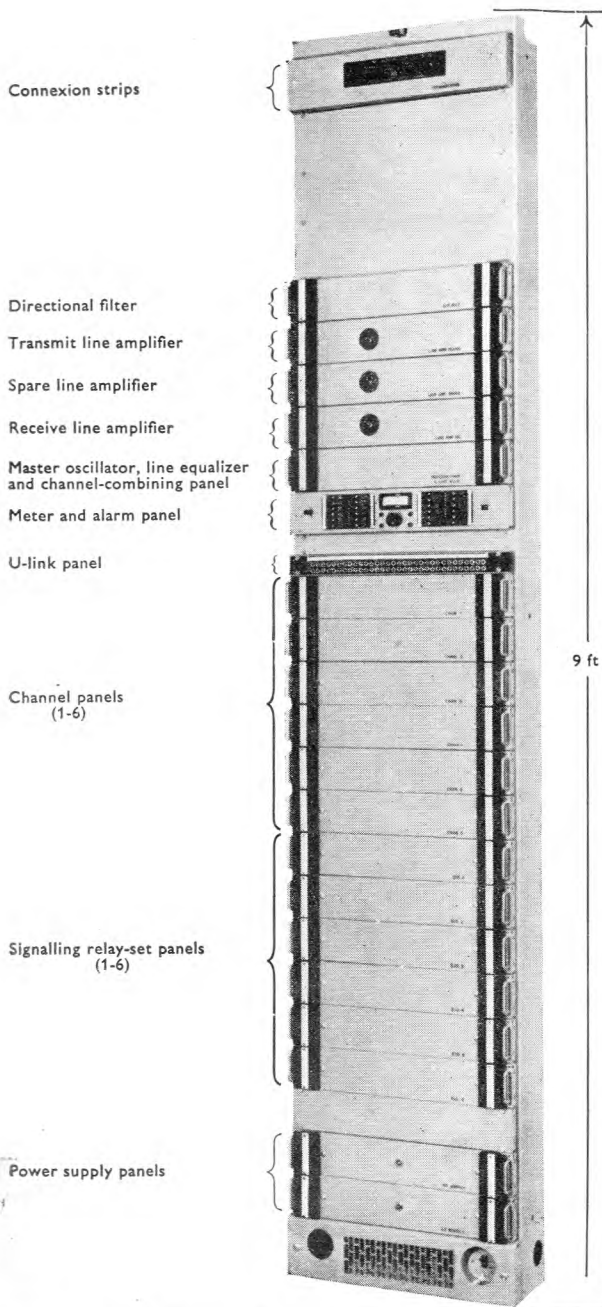

FIG. 9.—“Q” SYSTEM CARRIER TERMINAL EQUIPMENT.

than conventional equipment with 4-kc/s channel spacing, but was influenced by the availability of existing spare line plant and a desire to include routes on which dialling facilities could be made available. These systems, although manufactured by different contractors, are similar in type since they have been designed to meet a common Post Office specification.

A 12-circuit carrier system for operation over unloaded audio cable has been designed by the Post Office Research Station. This system will be the subject of a field trial between Bedford and London.

A proprietary system suitable for operation on similar line plant is to be tested by the Post Office between Leeds and Pudsey. The system is unique in that the signalling relay sets are included with the carrier equipment. This will present new problems in the division of responsibility between repeater station and telephone exchange maintenance staff. In this system the carrier spacing is 8 kc/s, both sidebands and carrier being transmitted and signalling being effected by keying the carrier.

Investigations into the performance of negative impedance amplifiers have been made using experimental amplifiers on 20/88/1.136 cable between London and Weybridge. These tests have shown that losses of the order of 10–15 dB can be reduced to approximately 5 dB with attenuation distortion not exceeding 1 dB between 300 and 2,600 c/s. Arrangements are now being made for the manufacture of two equipments, each comprising 48 amplifiers, for a more extensive field trial. The first of these equipments is expected to be installed at London (Uplands) to provide amplification on 48 experimental London-Dorking circuits.

A 4-wire amplifier using transistors, designed by the Post Office Research Station, has been the subject of laboratory tests and limited tests in the field. In the near future it is proposed to carry out a more extensive field trial with a rack of such amplifiers.

#### ACKNOWLEDGMENTS

Acknowledgment is made to the Automatic Telephone & Electric Co., the Telephone Manufacturing Co., the British Telecommunications Research Establishment and to many of the authors' colleagues in the Research and Main Line Branches who are concerned in the development of the various equipments outlined in this article.

Appreciation is also expressed to the Automatic Telephone & Electric Co. and the Telephone Manufacturing Co. for permission to use photographs and circuit diagrams of equipment developed by them.

#### Book Review

“Explained.” E. A. W. Spreadbury. Trader Publishing Co. Ltd. 37 pp. 25 ill. 2s. 6d.

This booklet covers frequency modulation as applied to public broadcast receivers, and is intended to assist the serviceman in coping with the new problems in receiver design brought about by the inception of the B.B.C.'s frequency-modulated broadcasting service.

Chapter 1 gives a brief account of the history of frequency modulation, and then proceeds to a discussion of the basic principles in non-mathematical terms and with commendably simple explanations. Chapters 2 and 3 deal respectively with the different types of frequency-sensitive detector, or discriminator, and the various amplifying and mixing stages of the receiver. Chapter 4 covers the features of circuit design

involved in combined a.m.-f.m. receivers, and the special components which have been developed for these receivers. The fifth and last chapter deals with the alignment of f.m. receivers by two basic methods; these are the visual method using a frequency-swept signal generator and an oscilloscope, and the non-visual method which calls for less complex equipment.

While the booklet has a purposely limited scope, in that aspects of f.m. which fall outside broadcasting applications are excluded, it can be recommended as a useful introduction to f.m. techniques, and as a valuable survey of current practice in f.m. broadcast receivers. In so far as the competent servicing of such receivers in the hands of the public can make a significant contribution towards the success of the new service, the appearance of this booklet at the present time will be welcomed.

G. F. S.

# "Mosaic"—An Electronic Digital Computer

A. W. M. COOMBS, Ph.D., B.Sc., A.R.T.C. †

## Part 3(b).—The Art of Programming (Continued)

U.D.C. 518.5:681.142

Parts 1 and 2 of this article considered the separate functions of the four main sections of the computer "Mosaic." Part 3(a) dealt with the machine as a whole and introduced the subject of programming and Part 3(b), this part, gives examples of programming for particular problems. Diagrams are still schematic, for it will be in Part 4 only that the major problem of translating the theoretical ideal machine into practical circuitry will be considered.

### PROGRAMMING IN GENERAL

FROM now on, it will be assumed that the input-output routine is satisfactory. Attention will be focused solely on the question "How does a given problem become translated into a list of instructions which the machine can follow and use to solve the problem?" This is the art of Programming; it demands on the part of the Programmer a profound knowledge of numerical processes and of the capacities of his particular machine.

The formulation of a complete computational programme involves several distinct stages of approach. First of all, it must be decided what particular numerical method is to be used. The preference will be given to those processes most suited to the machine, which are not necessarily those which would be used in solving the problem by hand. There will be a preference for "iterative" methods, in which a few instructions are obeyed many times, as opposed to the normal process of many instructions used once each. For the same reason—storage space—sines and cosines will be evaluated from the power series rather than from interpolations in stored tables. Again, it is convenient if "fixed binary point" arithmetic can be used—that is to say, if all numbers appearing in the course of the computation have their binary point in the same place. By so arranging the programme, any numbers can be directly added, subtracted or compared, but of course the absolute range of numbers becomes fixed, and this may involve the extraction of "scale factors" at particular points in the programme.

It is convenient at this stage to draw up a chart of the procedure that is to be adopted. For a short computation, it may be a few written lines indicating the sequence of major operations to be performed; for a long computation it will probably be a Block Diagram, each block covering a whole group of operations, with connecting links showing how the machine is to move through the diagram. In a large programme, each block may be a complete problem in itself (for instance, a long division) and may be used several times; such a block is called a "Sub-routine" and the programme to cover it may well be already available to the programmer, it having been worked out for some other problem. An example of such a diagram will be given later.

It is now necessary to produce a Flow Diagram. This is a more detailed chart showing the path of the computation in machine language—that is to say, it is the problem broken down into simple additions, subtractions, multiplications and comparisons *and nothing else*. The sub-routines themselves may not be indicated in detail, but at least the instructions which enable the machine to get into them and out again must be shown. Particularly indicated are those points where the programme "bends back," or returns to an earlier point in itself, forming a closed loop. Such points occur many times in a programme—for instance, the sub-routine "Divide" might be carried out by continued subtraction of the divisor from the dividend using the same group of instructions each time until

eventually the remainder became negative, which would be the signal to the machine that division was complete, and a "discriminate" instruction would be used to start it off on a new sequence of instructions.

Finally, the flow diagram is put into "machine order"—that is, the instructions are arranged in the order the delay lines will hold them in order to give maximum possible speed, which implies that as many instructions as possible are to be available at the exact moment when they are required. This operation usually requires fairly complicated juggling with characteristics, timing numbers and "next instruction sources."

The whole process will become much clearer if a sample computation be considered as it passes through the various stages. The problem chosen will be quite trivial, and the method of solution certainly not the best from any point of view save that of exhibiting programme formation.

### Sample Problem.

Let there be a positive number  $N$  consisting of up to 40 binary digits. It is desired to find the highest factor of the number  $N$ .

The method of solution is to try various numbers  $a$ , starting with  $a = N - 1$  and working downwards until one number  $a$  turns out to be a factor of  $N$ . Each number  $a$  is to be repeatedly subtracted from  $N$  (so that the successive remainders are  $N - a, N - 2a, N - 3a$  and so on). If eventually the remainder becomes negative, then  $a$  is not a factor of  $N$  and the process is repeated with a value for  $a$  one less than before; if the remainder is ever zero, then the relevant  $a$  is a factor of  $N$ . Each remainder must therefore be tested for three conditions. If it is positive,  $a$  is to be subtracted again; if it is negative, a new trial number ( $a - 1$ ) is to be used; if it is zero, the solution to the problem is the number  $a$ .

The flow diagram for the routine described is illustrated in Fig. 11(a). The three short lines TS1, TS2 and TS3 are to hold respectively the number  $N$ , the current test number  $a$  and the remainder at any given point in the working. The interpretation of the flow diagram, line-by-line, is as follows:—

1. TS1 — P1 → TS2. (TS1 minus P1 to DEST TS2).  
This instruction subtracts 1 from the number  $N$  to provide the first test divisor  $a (= N - 1)$  in TS2.
2. TS1 — TS2 → TS3.  
This subtracts  $a$  from  $N$  and puts the remainder in TS3. As  $a$  is less than  $N$ , the remainder is bound to be positive.
3. TS3 — TS2 → TS3.  
This subtracts  $a$  from the first remainder to give the second remainder ( $N - 2a$ ) in TS3. ( $N - 2a$ ) will certainly be negative for the first test number  $a$ , but in general for later numbers may be positive, negative or zero. Since the same instruction is to be used for all the numbers  $a$ , it is necessary to examine the number now in TS3.
4. TS3 + 0's → D PLUS.  
This is the discriminate instruction for checking

† Principal Scientific Officer, Post Office Research Station.

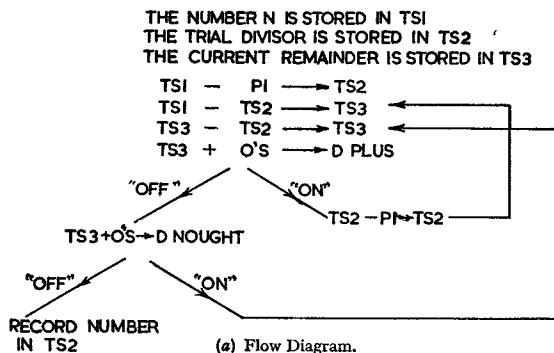

POSITION IN	D.L.I	SI	FN	S2	DEST.	CH & TG	N.I.S.	GO
(16)	0	TS1	-	PI	TS2	i O	I	G
(17)	1							
(18)	2	TS1	-	TS2	TS3	i O	I	G
(19)	3	RECORD THE NUMBER IN TS2						
(20)	4	TS3	-	TS2	TS3	i O	I	G
(21)	5							
(22)	6	TS3	+	O'S	D PLUS	i O	I	G
(23)	7							
(24)	8	TS3	+	O'S	D NOUGHT	d 9	I	G
(24)	9	TS2	-	PI	TS2	d 7	I	G

(b) Storage Order Chart.

FIG. 11.—SAMPLE PROBLEM.

whether the number in TS3 is negative or not (zero being regarded as positive). If "D PLUS" is switched "ON," the number is negative, and the trial number  $a$  must be reduced by one. The next instruction will be No. 5. If "D PLUS" is not switched "ON," the number is either zero or positive, and the next instruction is No. 6.

5.  $TS2 - PI \rightarrow TS2$ .

If this instruction is called for, it means that a new trial divisor ( $a - 1$ ) is to be formed, as explained above. The new divisor is stored in TS2 in place of the old, and the programme re-entered at instruction No. 2 with the new divisor; i.e., a fresh start is made.

6.  $TS3 + O'S \rightarrow D NOUGHT$ .

If this instruction is called for, it means that the current remainder is either positive or zero. Further examination is necessary to find which condition applies. If "D NOUGHT" is switched "ON," the remainder is positive, and the current test divisor, unchanged, must be again subtracted from the remainder; the programme is re-entered at instruction No. 3. If "D NOUGHT" is not switched "ON," the remainder is zero and the solution has been found; it is the current number in TS2. The next instruction is No. 7.

7. "Record the number in TS2."

If this instruction is called for, the solution to the problem is the number in TS2. It might be displayed, typed out or punched on a card. The instruction will call for the appropriate action in the output gear, but is not detailed here.

It will be observed that no characteristics, timing numbers or "next instruction source" numbers have yet been specified. They are in general selected in such a way as to make the programme follow the indicated course with a minimum time lag, and are indicated in the "Storage Order" chart, Fig. 11(b), which will now be considered.

Since the machine proceeds on a 2-beat cycle, there must be at least one minor cycle of "Obey Instruction" between successive "Set-up" beats. Therefore, the minimum spacing of successive instructions is every other minor cycle. It is, of course, possible to get an *apparent* closer spacing by making the Obey beat exactly one

major cycle long, in which case successive instructions may be successively spaced in a long line, but they will not be obeyed in immediate succession. The programme of instructions we shall assume to be destined for storage in Delay Line No. 1. The first instruction may go into the first (or "zero") minor cycle, and there is no reason why it should not be of "Immediate Nought" type. The next instruction source will be Delay Line 1 (as it will be for all the other instructions in this elementary programme).

The next instruction will be in minor cycle No. 2, as the previous instruction called for an Obey beat one minor cycle long. It will also be of "Immediate Nought" type. The next will be in minor cycle No. 4, and the next in minor cycle No. 6, both of "Immediate Nought" type. We have now reached the first discriminate instruction, which may be followed either by the fifth or the seventh instruction in the flow diagram.

The fifth instruction is the one to be obeyed abnormally—that is, if the discriminator circuit "D PLUS" is switched "ON" by the previous instruction. The effect is to add one minor cycle to the Obey beat; therefore the fifth instruction is the next-but-two to the fourth—in minor cycle No. 9. The transfer that it orders—"TS2 - PI → TS2"—is to last for one minor cycle, but to be followed by the setting-up of instruction No. 2 again. That is, the Obey beat is to last until minor cycle No. 2, which holds instruction No. 2, comes round again. There is a period of eight minor cycles between the end of No. 9 and the beginning of the second appearance of No. 2 (which may be called No. 18), and this is the length of the Obey beat. An Obey beat lasting eight minor cycles, and including a transfer lasting one minor cycle, can be obtained with a "Deferred 7" characteristic and timing number, which are accordingly given to instruction No. 5.

The sixth instruction is the "normal" (D PLUS switched off) instruction to follow the fourth, and is therefore in minor cycle No. 8. It is itself a discriminate instruction, calling abnormally for instruction No. 3, in minor cycle No. 4—which on second appearance may be called No. 20. The Obey beat must thus last 11 minor cycles, and since this is the "abnormal" beat it includes the extra minor cycle inserted by the discriminate circuit. The transfer lasts for one minor cycle, therefore we require a "Deferred 9" instruction, giving a normal Obey beat of 10 and an abnormal beat of 11 minor cycles.

When the sixth instruction gives no operation of the discriminate circuit, instruction No. 7 must follow. This condition would give an Obey beat of 10 minor cycles; therefore instruction No. 7 must be placed in minor cycle No. 3.

The storage order chart has been easy to make in this problem for two reasons. First, the numbers to be operated on were all in short lines, and therefore were available at any minor cycle; thus, the only factor fixing the characteristic and timing number was the position of the next instruction. Second, each time a position was needed for an instruction, that position was available. Suppose it had been found that minor cycle No. 3, needed for the 7th instruction, was already occupied. Then instruction No. 7 would have been put in delay line No. 2, 3rd minor cycle, and instruction No. 6 would have called for "Next Instruction Source 2." Therefore, instruction No. 3, called for by instruction No. 6 as an "abnormal" case, would also have required to go in delay line No. 2. Therefore instruction No. 2 which is also followed by No. 3 would have specified delay line No. 2 as next instruction source.

It must be stressed again that this programme is intended to illustrate the principles only. It is a very bad programme for solving the problem. If the number  $N$  were  $2^{38}$ , it would take seven years of continued working to find the answer, which is of course  $2^{37}$ .

### Sub-routines.

Mention has already been made of sub-routines, self-contained computations which may be needed in the course of other and major problems, perhaps several times. Such are for instance the derivation of  $\sin \theta$  and  $\cos \theta$  from  $\theta$ , long division (if no separate divider circuit is provided), square root extraction and interpolation in tabulated functions. A large library of sub-routines is a necessity if programming is to be performed efficiently and rapidly. Most large digital computers spend the first year of their active life in establishing such a library.

The use of sub-routines raises an interesting point in the technique of programming. If a main programme is to call for a sub-routine "A" several times at different places, then how, having got into "A," is the machine going to get out of it again, and return to the main programme at the correct point, which will probably be different each time "A" is used? Clearly, there must be provision for the machine to "make a note of" the point where it leaves the main programme before it starts the sub-routine "A." The operation is called providing a "Link" instruction, and it proceeds along the following lines.

Consider the "cossin" sub-routine—that which derives the cosine and sine of a given angle  $\theta$ .\* "Cossin" is arranged to regard, as the number representing the angle  $\theta$  in radians, the content of a particular short line in the store, and it inserts the cosine and sine values obtained in two other short lines. The last instruction of the sub-routine calls for a particular point of the instruction store (which point we shall designate "x") as the next instruction source. If now the sub-routine is required by the main programme, it must first be ensured that none of the lines called for in the sub-routine is already in use, holding data that must not be lost; if any are, the data must be transferred to some other part of the store. Next, the value of  $\theta$  is inserted in the line appointed. Then the Link instruction is placed, still by the main programme, in the position "x" defined above. It is an instruction which steers the computation back to the main programme, by specifying as "next instruction source" the instruction which is the point of re-entry in the main programme. It may have other useful functions too; for instance, transferring the result of the sub-routine operation to some desired location, thus making the sub-routine line available for its next use, but the vital factor in the Link is the next instruction source it specifies. A Link instruction must be inserted at "x" each and every time the sub-routine is required, and the instruction will be different for differing re-entry points in the main programme.

It is, of course, perfectly possible for sub-routines to employ second order sub-routines, in which case the sub-routine itself acts as main programme, inserting the Link in the second-order

\* It is good practice to make sub-routines as general as possible. The "cossin" routine can be used whether cosine or sine or both are required, and will indirectly provide  $\tan \theta$ .

routine, and so on. When the library of sub-routines is big enough, the main programme may be little more than a few instructions joining in time-sequence a whole battery of sub-routines.

There are many short-cut methods employed by programmers skilled in the art to shorten the labour of making programmes—too many to go into here. One may specify the "relative address" technique, whereby positions of instructions are fixed by the programmer only relative to each other, the absolute addresses being worked out and inserted by the machine itself. Again, increasing the timing number of a serial instruction will cause successive words to be read out of a delay line, and when the timing number passes through the transition 15 to 16, the carry will go to the "source 1" address and increase it by one; thus the same instruction will still serve to feed from the next delay line—just as though the delay lines were joined end to end.

As an example of a practical programme, the description and block diagram of the sub-routine "cossin," already mentioned, will be given.

### Sub-routine "Cossin."

The angle  $\theta$ , in radians, is stored in line TS1;  $\cos \theta$  and  $\sin \theta$  are worked out and stored in TS2 and TS3 respectively. During the calculation, TS4 and TS5 are used for counting "loops," TS6 for temporarily holding the signs of the sine and cosine, and TS7 to hold the "Link." The method is as follows:—

1. Find an angle  $\delta$  such that  $0 \leq \delta \leq \pi/2$ , and such that  $\sin \delta = |\sin \theta|$  and  $\cos \delta = |\cos \theta|$ . Store the signs of  $\sin \theta$  and  $\cos \theta$  temporarily in TS6.
2. Work out  $\cos \delta$  from the formula:—

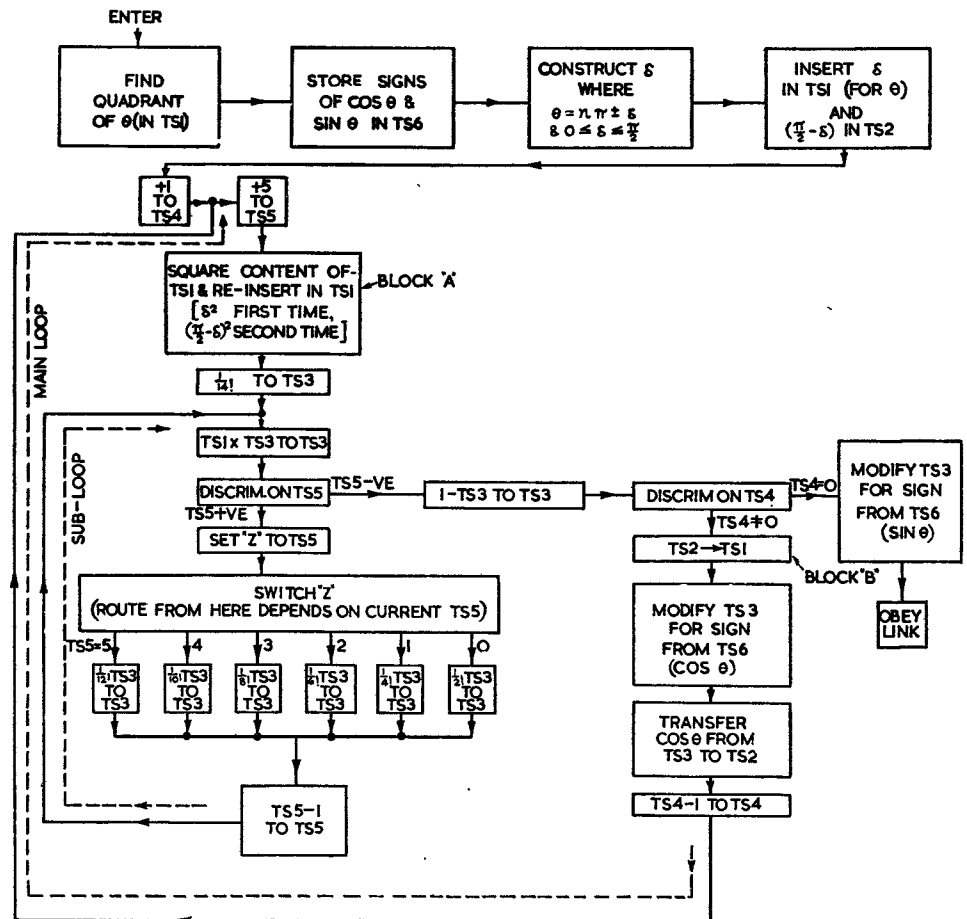

FIG. 12.—"COSSIN" SUB-ROUTINE BLOCK DIAGRAM.

$$\begin{aligned} \cos \delta &= 1 - \frac{\delta^2}{2!} + \frac{\delta^4}{4!} - \frac{\delta^6}{6!} + \frac{\delta^8}{8!} - \frac{\delta^{10}}{10!} + \frac{\delta^{12}}{12!} - \frac{\delta^{14}}{14!} \\ &= 1 - \left( \frac{1}{2!} - \left( \frac{1}{4!} - \left( \frac{1}{6!} - \left( \frac{1}{8!} - \left( \frac{1}{10!} - \right. \right. \right. \right. \right. \right. \\ &\quad \left. \left. \left. \left. \left. \left( \frac{1}{12!} - \frac{\delta^2}{14!} \right) \delta^2 \right) \delta^2 \right) \delta^2 \right) \delta^2 \right) \delta^2 \end{aligned}$$

and  $\sin \delta$  by repeating the calculation for a new angle  $\delta_1$ , where  $\delta_1 = \pi/2 - \delta$ .

3. Correct for the signs of  $\cos \theta$  and  $\sin \theta$ .

The seven constants  $1/2!$  to  $1/14!$  could be worked out by the machine, but it is more convenient in this case to hold them ready and complete in the main store.

The block diagram for the computation is shown in Fig. 12. It must be understood that this diagram represents a sequence of operations—a route through a problem. It does not show the path of a signal through a series of circuits. Some of the blocks represent simple transfers—

(To be continued.)

## Book Reviews

“Principles of Electrical Measurements.” H. Buckingham and E. M. Price. English Universities Press, Ltd. 592 pp. 418 ill. 37s. 6d.

This book is intended not only to meet the requirements of final degree and A.M.I.E.E. examinations, but also to provide a source of reference for practising engineers, and these objectives have been largely achieved.

The authors have, as far as circumstances permitted, avoided attempting to include basic theory in a book dealing essentially with the application of theory. They have wisely and deliberately omitted basic electromagnetic and electrostatic theory, and have thus been free to adopt a presentation of material which is not only more logical in these changed circumstances, but which also provides an easy and systematic reference. Since the authors have—very properly—used the newly accepted M.K.S. rationalized system of units throughout the book, it has been necessary at this transitional stage to provide some instruction both on its use and on the factors leading to its adoption. Hence the inclusion in Chapter 4 of a discussion on systems of units and dimensions. It is hoped that this discussion may be unnecessary in future editions of the book.

The purely descriptive sections of the book are very good, but mathematical analysis is sometimes omitted where its inclusion would have been of real benefit; there is a tendency to use terms that are not explained, and the treatment of important topics is occasionally sketchy and difficult to understand without reference to other sources of information. For example, the extensive use of vector diagrams is to be commended; but in sometimes failing to provide adequate explanation the authors impede the understanding they seek to promote. There is, in fact, an occasional impression that the authors are imparting information rather than understanding. These criticisms do not apply to the major part of the book. They refer only to isolated sections where the otherwise high standard has not been maintained.

Some sections are worth special mention. Chapter 5 on Bridges is well written, well presented, and adequate within the scope of the book; it is indeed a most useful chapter. Chapter 6, on Oscillations and Vibrations, is again well written. The section on the oscilloscope and some of its uses provides a satisfactory introduction to the subject, and contains a great deal of information useful to the graduate engineer. The two pages given to wave-form and its determination do not, however, do justice to the subject. Two other chapters deserve close study. They are Chapter 7 on Methods Using Thermionic Valves and Chapter 8 on Resonance and Heterodyne Methods.

Although the authors may well find it necessary to modify parts of the book in the light of their future experience in its

for instance “TS4 MINUS 1 to TS4”—while others may represent whole groups of operations still to be worked out in detail—for instance, the first block of all. Each block calls for some action to be performed on the content of one or more storage lines, and that same content varies as the computation proceeds. Thus the first time block “A” is reached, TS1 contains  $\delta$  and block “A” therefore calls for  $\delta^2$  to be formed; the second time, TS1 contains  $(\pi/2 - \delta)$ , which was originally stored in TS2 but has in the meanwhile been transferred (block “B,” which calls for TS2 to TS1). Therefore, on the second circuit, the result of the operation of block “A” is to form  $(\pi/2 - \delta)^2$  in line TS1. The line TS2 is used as a temporary store for  $(\pi/2 - \delta)$  because TS2 is not needed to store the final signed value of  $\cos \theta$  until near the end of the first complete loop; the store is thereby used economically. Again, the line TS5 contains a number “5” which is diminished by one on each circuit of the sub-loop, so that eventually the course of the computation is diverted from the sub-loop to the main loop.

use, it is in general excellently presented, authoritatively written and is likely to become a standard work on the subject.

F. T. W.

*I.P.O.E.E. Library No. 2352.*

“Plastics Progress, 1955.” Ed. Philip Morgan, M.A. Iliffe & Sons, Ltd. 440 pp. 172 ill. 50s.

The present volume of “Plastics Progress” contains the papers presented and discussions held at the British Plastics Convention in London at Olympia in June 1955, but the printed text is often substantially longer than the paper read at the Convention. It continues the high standard of subject matter and presentation set by the two previous volumes in 1951 and 1953.

The emphasis of the papers is almost entirely on recent advances, and practically every paper contains information of interest to scientists or engineers.

Considering the sections of the volume in detail, the first gives a survey of new knowledge of the basic structure of plastics, the radiation treatment of plastics, and the measurement and significance of the molecular weight of polythene, from which much may be learned about the causes of the differences between different grades and types of plastics.

The section on foamed plastics includes information on the polyurethane foamed plastics which are capable of being formed by an *in situ* method in many situations, as well as in the conventional moulds. Some types foam at ordinary temperatures and some require heating.

The very high softening point of polytetrafluoroethylene is both a valuable property in some applications and also a handicap in fabricating it. By means of p.t.f.e. dispersions, tough thin films suitable for capacitor dielectrics can now be made, tubes and coverings can be extruded rapidly, and porous materials can be impregnated. In the same section (Thermoplastics) information is given on new nylon polymers and compositions.

The contents of the sections on Extrusion, Work Study and Productivity, and Injection Moulding are largely indicated by their titles.

Foundry resins are principally those used to hold together the grains of sand to make cores or moulds. They were introduced when the traditional binders, mainly linseed oil, were scarce and expensive. Their use is increasing, mainly because of their rapid curing rate, and they make possible various new techniques, such as shell moulding.

Glass (fibre) reinforced plastics, described in the section with that title, form more robust structures than the cotton or asbestos loaded types which preceded them, and are now being used for a variety of objects both large and small, including boats and automobile bodies.

A. A. N.

*I.P.O.E.E. Library No. 2178.*



## Part 2.—Measurements of Gas Flow Characteristics during Installation, Gas-Drying and Gas-Pressure Equipment and Tests on Completed Cable

U.D.C. 621.315.221.8: 678.742.2: 621.315.53: 621.315.211.4

Part 1 of this article described the cable, its installation and jointing, and gave the results of tests on factory lengths of cable. Part 2 concludes the article by describing the measurements of gas flow characteristics which were made during installation of the cable, the gas-drying and gas-pressure arrangements and the results of tests on a loading-coil section and on the completed cable.

### GAS FLOW CHARACTERISTICS MEASURED DURING INSTALLATION

TO supplement the information gained from the gas flow measurements in the factory further tests were made on "slings" of lengths and loading sections in the field. For these tests the cable lengths were sometimes joined together temporarily—the wires being left unjointed but the sheaths extended through by means of the brass sleeves and expanding rubber plugs used later for the permanent jointing.\*

The gas volume and gas flow figures were all observed by means of a volume meter working on the principles often used in the measurement of coal gas. This meter consists essentially of a drum which is divided into compartments and which rotates within a gastight casing partially filled with water. The passing gas causes the drum to rotate and in quick succession each of the compartments fills up with, traps and delivers, a measured volume of gas. The instrument is an integrating one, the dial reading the total volume of gas that has passed, and thus the dial readings have to be related to observed times when rates of flow are under investigation. The work done in rotating the meter is derived from the pressure difference between the inlet and outlet sides, but this difference is so small that it can be neglected without any sensible error. The meter used is depicted in Fig. 10. The capacity of each measuring

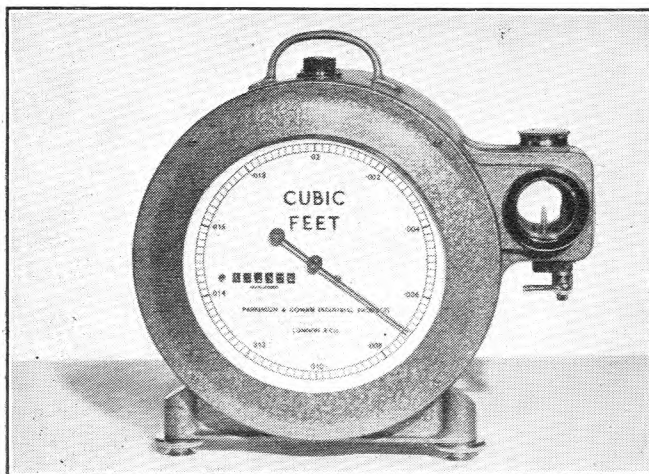

FIG. 10.—VOLUME METER.

compartment is dependent upon the level of the water surface within it, and the sight box, with its index pointer, filler cap and draining tap, shown on the right of the instrument, is to allow the water level to be adjusted to the same height as it was when the meter was calibrated initially. Screw adjusting feet allow the instrument level to be set and there is a small spirit level for reference on top of the case.

† Assistant Staff Engineer, External Plant and Protection Branch, E.-in-C.'s Office.

\* Described in Part 1, Vol. 48, Pt. 4, p. 224.

Fig. 11 shows the measuring equipment connected to the cable at a loading point; the meter is on the left and a pressure gauge on the right.

From Fig. 12, a graph relating gas flow to cable length, it will be noted that, approximately, the rate of flow is inversely proportional to length; in other words, the pneumatic resistance is directly proportional to length.

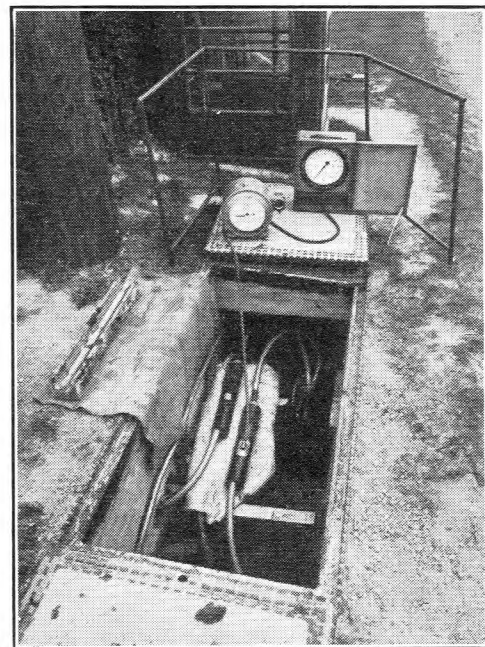
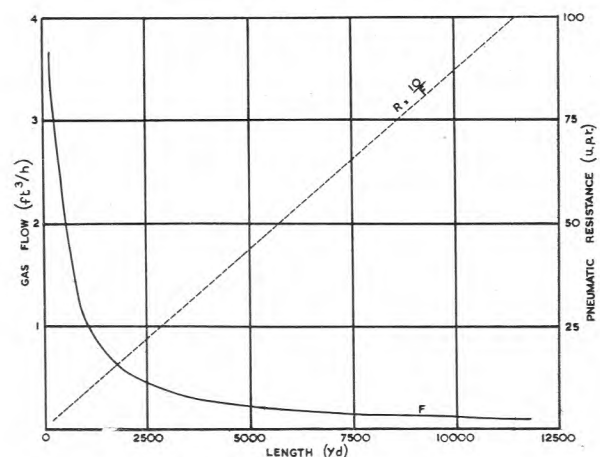
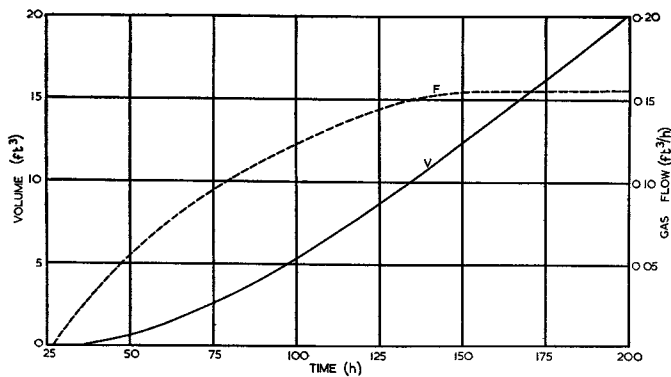

FIG. 11.—VOLUME METER AND PRESSURE GAUGE CONNECTED TO THE CABLE.



Cable type: 54/044.  
Sending pressure: 10 lb/in<sup>2</sup>.  
Receiving pressure: atmospheric.

FIG. 12.—CHANGE OF GAS FLOW (F) AND PNEUMATIC RESISTANCE (R) WITH CHANGE OF LENGTH.



Cable type: 54/044.  
Length: 4.432 miles.  
Sending pressure: 10 lb/in<sup>2</sup>.  
Receiving pressure: atmospheric.

FIG. 13.—RELATIONSHIP BETWEEN RECEIVED VOLUME OF GAS (V), GAS FLOW (F) AND TIME.

When pressure is applied at one end of a length of the cable, some time elapses before any air issues from the distant end, the interval depending on the length. The flow at the distant end commences at a slow rate and gradually builds up until a maximum steady rate is reached. A typical curve showing these features for 4.432 miles of cable is shown in Fig. 13. The full line shows the total volume of gas delivered, as indicated by the volume meter at the distant end, and the dotted line is the gas flow curve derived from it.

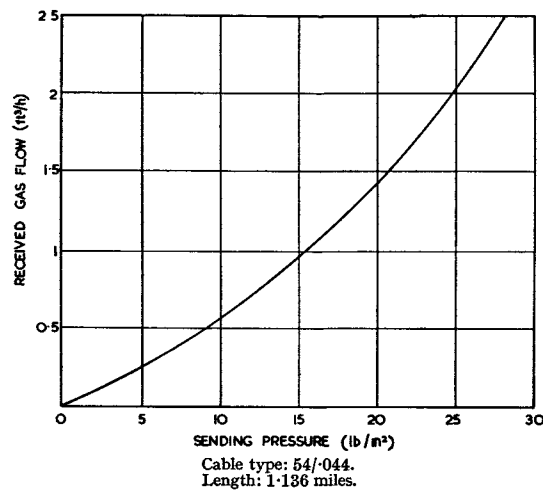

Cable type: 54/044.  
Length: 1.136 miles.

FIG. 14.—RELATIONSHIP BETWEEN SENDING PRESSURE AND RECEIVED GAS FLOW.

An investigation was made to determine how the rate of flow at the distant end varied with applied pressure at the sending end, and it was found that an increase in pressure produced more than a proportional increase in the rate of flow. Sending pressures plotted against rates of flow for a cable length of 2,000 yd are given in Fig. 14. The unexpectedly high rate of flow at the higher pressures is possibly due to a very slight increase in the cable diameter with pressure.

#### LOADING SECTION TESTS

As is usual when installing a loaded cable, electrical check tests were carried out on the 2,000-yd (nominal) loading sections and a summary of the results obtained on a typical section is given in Table 5.

The rate of gas flow from the open end of a 2,000-yd section when a pressure of 10 lb/in<sup>2</sup> was applied at the other end was found to be approximately 0.62 ft<sup>3</sup>/hr when the steady-state condition had been reached.

TABLE 5  
Summary of Tests on a Typical Loading Section (December, 1954)  
(54/044 Cable. Loading Section 5-6. Length 1.148 miles.)

INSULATION RESISTANCE (megohms/mile)  
28,000, after electrification for one minute.

CONDUCTOR RESISTANCE (ohms/loop-mile)  
Max. 85.9 Mean 85.6  
Percentage unbalance between wires of a pair  
Max. 0.3 Mean 0.16

MUTUAL CAPACITANCE (micro-farads/mile)

	Max.	Mean	Min.
Side Circuit . . . . .	0.0649	0.0632	0.0614
Phantom Circuit . . . . .	0.1657	0.1621	0.1580

#### CAPACITANCE UNBALANCE (pico-farads)

Side/Side		Phantom/Side		Side/Earth	
Max.	Mean	Max.	Mean	Max.	Mean
40	12	270	84	280	51

#### FACILITIES FOR GASSING

Provision has been made for gassing, i.e., the passing of dry air through the cable, when required. Two identical sets of compressor equipment have been provided, one at Dover and the other at Deal. A schematic diagram indicating the main items of the equipment is shown in Fig. 15, and a photograph of the set installed at Deal in Fig. 16. The

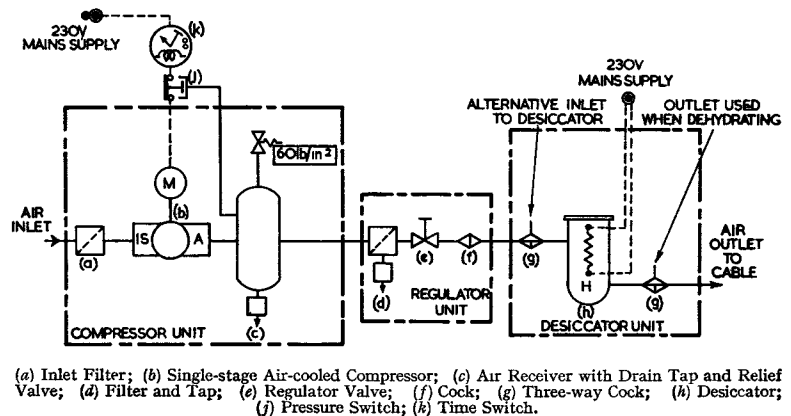

(a) Inlet Filter; (b) Single-stage Air-cooled Compressor; (c) Air Receiver with Drain Tap and Relief Valve; (d) Filter and Tap; (e) Regulator Valve; (f) Cock; (g) Three-way Cock; (h) Desiccator; (j) Pressure Switch; (k) Time Switch.

FIG. 15.—BLOCK SCHEMATIC DIAGRAM OF AIR-COMPRESSING AND DRYING PLANT.

essential features of the set are an electric mains-driven compressor which automatically switches on when the pressure in the storage cylinder drops to 40 lb/in<sup>2</sup> and switches off when the pressure rises to 60 lb/in<sup>2</sup>; a regulator, which drops the pressure to 10 lb/in<sup>2</sup>; and an activated alumina desiccator which can be electrically heated in a flow of air and dried out for use over and over again. A copper tube fitted with a pressure gauge leads to the polythene cable at its junction with the lead-covered E.S. & W. (enamel, silk and wool) terminating cable, which incorporates a wax-filled gas-seal. The gassing equipment is located in the cable chamber of the exchange. It is probable that an additional set of gassing equipment will later be installed at Kingsdown exchange.

As there is no regular air channel through a loading pot, each is fitted with a gas-bypass pipe between the stub cables near the top plate of the pot. The path through the pipe can be opened and closed at will by operating the bypass valve, which can be seen in Fig. 17. All the bypasses are in jointing chambers that are readily accessible without digging.

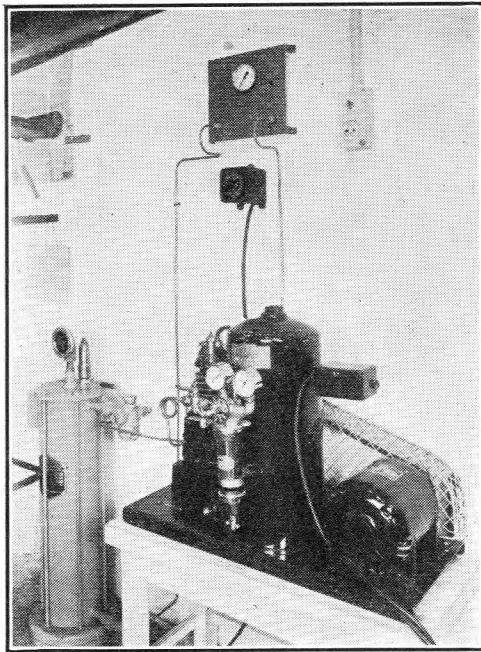

FIG. 16.—AIR-COMPRESSING AND DRYING PLANT AT DEAL.

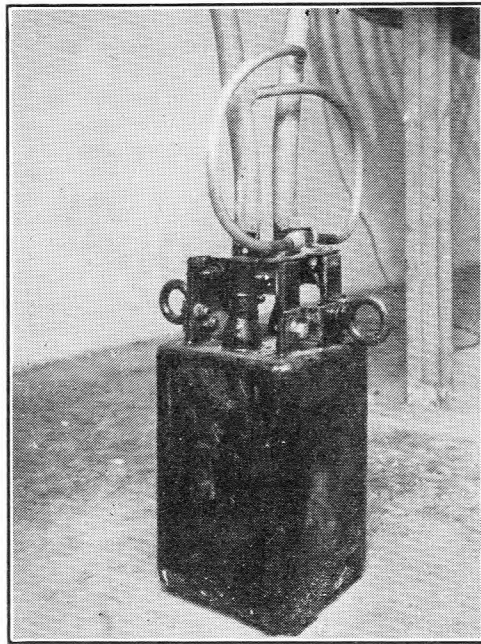

FIG. 17.—LOADING POT WITH GAS-BYPASS PIPE.

Schraeder valves are fitted into the brass jointing sleeves at intervals of approximately 500 yd to enable gassing operations or gas-pressure measurements to be carried out readily. All of these valves are easily accessible at positions where there are jointing chambers with surface entrances. Air can be permitted to escape from the cable at any of the Schraeder valve points. It is to one of these Schraeder valves that the rubber tube from the gas meter is shown connected in Fig. 11.

#### PERMANENT GAS-PRESSURE SYSTEM

The permanent gas-pressure system for detecting and locating defects in the sheath and sheath joints is essentially that described in a previous article in this Journal.<sup>2</sup> The dry air at 10 lb/in<sup>2</sup> pressure along the cable is supplied

<sup>2</sup> KEEP, J. F. Field Trial of Pressurised Cable System. *P.O.E.E.J.*, Vol. 48, p. 7, Apr. 1955.

from the compressors at Dover and Deal. Bellows-type contactors, which short-circuit the A and B wires of a quad when the pressure falls to 6 lb/in<sup>2</sup>, are installed inside the brass jointing sleeves at 500-yd intervals at the same points as the Schraeder valves.

When a contactor operates it brings in an urgent alarm at Dover and starts up a recording voltmeter. The position of the operated contactor is determined by making a Murray loop test, after which the testing officer operates keys on the test panel and prepares the circuit for receiving, on the recording voltmeter, indications of the times, relative to the operating time of the first contactor, when subsequent contactors operate. Operation of a contactor on the near side of the one first operated swings the recording voltmeter in one direction, and operation of a contactor on the far side swings it in the other direction. Study of the times and directions of these swings should allow most leaks to be located to better than 0.1 mile. This localization will be supplemented as found necessary by pressure measurements at the Schraeder valve points, or by introducing a suitable halogen-compound gas into the cable near to the indicated fault point and examining the air at the duct ends in the nearby jointing chambers with a halogen detector for traces of escaped halogen gas.

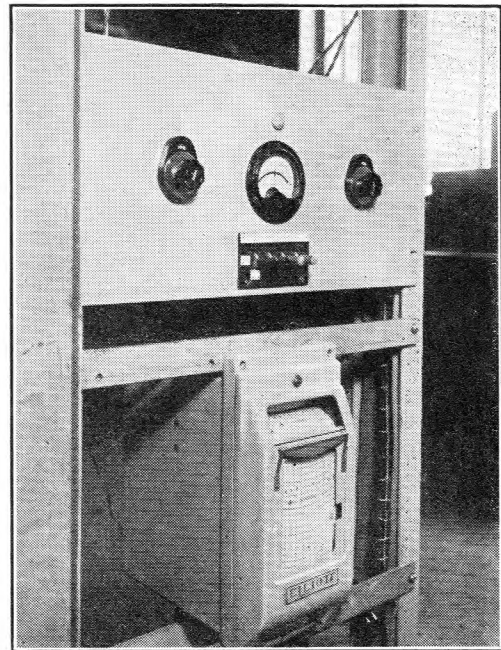

FIG. 18.—THE TEST PANEL AT DOVER.

The test panel at Dover (Fig. 18), which is fitted in the exchange apparatus room, incorporates all the equipment for the alarm and the Murray test and also the recording voltmeter.

#### *Space for Gas within the Cable.*

The cross-sectional area of the core underneath the polythene sheath is occupied by conductors, screen, insulation and air. The air-space volume,  $S$ , within a length of cable was measured by charging the cable to a known steady pressure,  $P$ , above that of the atmosphere,  $A$ , and then allowing the air to discharge from one end through the gas meter until the flow ceased and the pressure in the cable became equal to that of the atmosphere outside. As there is negligible pressure-drop in the meter itself the volume,  $V$ , indicated by the meter, was clearly the volume at atmospheric pressure of the air that flowed out. The air left in the cable at atmospheric pressure and occupying the space,  $S$ , together with the escaped air of volume,  $V$ ,

had occupied the space,  $S$ , when the pressure was at its initial value  $(P + A)$ . Thus, by Boyle's law,

$$(P + A)S = A(S + V)$$

hence, 
$$S = \frac{A}{P} \cdot V.$$

In one test the meter recorded that 20.8 ft<sup>3</sup> of air flowed out from 3,758 yd of 54/044 cable which had initially been pressurized to 8 lb/in<sup>2</sup> above the atmospheric pressure of 15 lb/in<sup>2</sup>, and for this test,

$$S = \frac{15}{8} \times 20.8 = 39.7 \text{ ft}^3.$$

The calculated volume within the polythene envelope for this length of cable is,

$$3,758 \times 3 \times \pi \times \frac{(1.07)^2}{144 \times 4} = 70 \text{ ft}^3.$$

The ratio 39/70 is approximately 0.56, thus about 56 per cent of the volume within the polythene envelope is air space.

Had the length of 3,758 yd been pressurized to 10 lb/in<sup>2</sup> initially, instead of to 8 lb/in<sup>2</sup>, the volume of air which would have flowed out would have been, approximately,

$$39 \times \frac{10}{15} = 26 \text{ ft}^3.$$

since, 
$$S \cdot \frac{P}{A} = V.$$

Conversely 26 ft<sup>3</sup> of air measured at atmospheric pressure would be required to raise the pressure within the 3,758 yd of cable to 10 lb/in<sup>2</sup>. From this data it is concluded that some 115 ft<sup>3</sup> of air at atmospheric pressure (15 lb/in<sup>2</sup> absolute) are required to raise the pressure over the whole cable between Dover and Deal, including the spur to Kingsdown, by 10 lb/in<sup>2</sup>.

#### TESTS ON COMPLETED CABLE

Just before the cable was brought into service in June, 1955, it was subjected to electrical tests and a summary of the principal characteristics, as measured on pairs between Dover and Deal, is given in Table 6. The figures do not call for special comment as they are similar to those to be expected on a standard 54/20 P.C.Q.T. cable.

TABLE 6  
Summary of Characteristics of Completed Cable (June, 1955)  
INSULATION RESISTANCE (megohms/mile)

Test with 500V on bunch of 23 wires to remainder earthed	Miles of wire on test 200 (approx.)	After electrification for:—				
		1 min	2 min	3 min	4 min	5 min
		26,000	30,000	32,000	44,000	44,000

CONDUCTOR RESISTANCE (ohms/loop-mile)  
Max. 91.0 Min. 90.5  
Percentage unbalance between wires of a pair  
Max. 0.56

ATTENUATION (Decibels/mile)

(a) Tested by Mayer Method

Frequency c/s	Max. dB	Min. dB	Frequency c/s	Max. dB	Min. dB
1,140	0.368	0.363	2,500	0.401	0.393

(b) Calculated from open and closed impedance measurements (average values).

Frequency, c/s	1,000	2,400	3,200
dB/mile	0.362	0.390	0.435

#### IMPEDANCE UNBALANCE

Singing Point dB	
Worst	Mean
26.0	28.3

CHARACTERISTIC IMPEDANCE (average calculated from open and closed impedance measurements)

Circuit	Frequency c/s	$ Z_0 $ ohms	$\sqrt{\phi_0}$
Side	1,000	1,078	4° 10'
Side	2,400	866	2° 21'
Side	3,200	644	1° 17'
Phantom	1,300	163	33° 28'

#### NEAR-END CROSSTALK (corrected millionths)

Side/Side		Phantom/Side		Pair/Pair	
Max.	Mean	Max.	Mean	Max.	Mean
76	41	216	150	97	28

#### Watch on the Insulation Resistance.

The insulation resistance of the cable varies with the time of application of the test voltage, and a curve showing this characteristic is given in Fig. 19. The

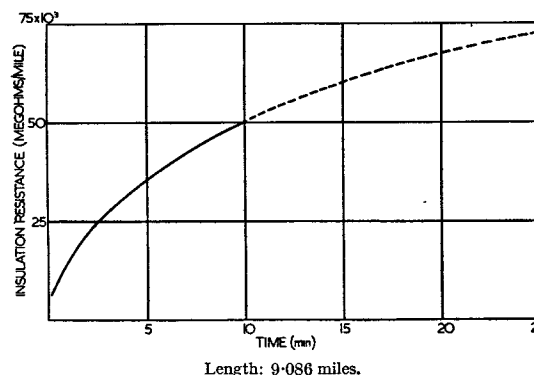

FIG. 19.—INSULATION RESISTANCE OF THE CABLE.

measurements were made in June, 1955, with a 500V ohmmeter of about 250,000 ohms internal impedance on the A-wire of pair 31 with the B-wire connected to earth. All other wires in the cable were free with the exception of eight pairs in use for traffic-carrying or testing purposes. It will be seen that, under the conditions of test, after one minute's electrification the insulation was about 15,000 megohms/mile; with prolonged testing it rises to about five times this value.

To keep the insulation of the cable under strict review a recording ohmmeter at Dover is permanently connected to a selected cable pair.

### *Dielectric Dispersion Tests.*

The condition of the paper insulation is also being kept under review by dielectric dispersion measurements. The British Electrical and Allied Industries Research Association has developed a dispersion meter which was primarily designed to assess the electrical condition of the insulation of equipment used in the power industry, but the Association has kindly consented to carry out periodic tests on this experimental telephone cable. Dispersion tests are valuable adjuncts to insulation tests because they are less dependent upon the distribution of the moisture within the cross-section of the dielectric. It is probable that the loose make-up of this cable would favour an even distribution of any moisture present, but nevertheless the tests should prove of interest. For these particular measurements a 200V rectangular charging pulse of 3-sec duration is applied to a pair (A-wire to B-wire earthed) and this is followed by a short-circuiting pulse of 100-ms duration. At the end of the short-circuiting pulse a recovery voltage will develop across the pair if the dielectric contains some degree of moisture. This recovery voltage will rise to a peak after some milliseconds and then slowly decay. The dispersion is

given by the relation  $D = \frac{V_1}{V_0 - V_1}$ , where  $V_0$  and  $V_1$  are

respectively the charging and peak-recovery voltages. If, on the other hand, the paper is perfectly dry the test pair will be completely discharged at the end of the short-circuiting pulse and will show no recovery voltage, i.e., no dispersion. It was found at the first set of tests taken in June, 1955, that the pairs selected for test did in fact exhibit no measurable dispersion.

### CONCLUSION

It would be premature to attempt to draw any conclusions from a long-term experiment which has only just started, but it may be said that from theoretical considera-

tions and limited field trials there are grounds for hoping that the cable will remain serviceable for several years without resort to gassing. Diffusion is a both-way process, water vapour both entering and leaving the paper core through the sheath, the net rate of ingress depending, among other factors, on the water-vapour pressure-difference between the outside and the inside. At first, due to the absorbing effect of the dry paper, the vapour pressure within is likely to be very small but later, as more and more vapour diffuses through, the pressure will rise and the net rate of ingress will become slower until equilibrium is finally reached. It may even be that equilibrium will be reached before the proper working of the circuits is affected, but to speculate further on this is but to anticipate the result of the experiment.

### ACKNOWLEDGMENTS

This trial has been made possible by the combined effort of the cable manufacturers, United Telephones & Cables Ltd. (Southern), and Post Office staff of the Home Counties Region, especially the Canterbury Telephone Area, and of I, LM, R and Cn Branches of the Engineer-in-Chief's office. It is unfortunately not possible to acknowledge all the contributors, but it is desired to thank those most closely concerned; Mr. L. F. Scantlebury for his valued direction and encouragement; Mr. H. A. Buy of the H.C.R. who undertook the rather difficult task of finding a cable for the trial which was needed to meet traffic expansion but not so urgently as to rule out the making of experiments; Messrs. A. T. C. Moore and H. C. Rivers of U.T.C.(S) who advised and co-operated in deciding the design of the cable; Mr. J. S. Lanfear who very largely developed the special jointing features; Mr. J. F. Keep who planned and arranged all the gas-flow and gas-pressure experiments; and finally Messrs. D. W. Glover, J. Gerrard and E. D. Latimer whose advice and help was called for many times.

## Book Review

"Appareils et Installations Telegraphiques." D. Faugeras. Editions Eyrolles. 564 pp. 340 ill. 3,900 Fr.

The author is well known as a C.C.I.T. delegate particularly experienced in the study of start-stop machines and switching systems. The book gives a fairly detailed account of the techniques adopted in telegraphy by the French P.T.T. and cannot fail to be of the greatest interest to all telegraph engineers.

It is clear that the blood of Emile Baudot courses in the veins of the French telegraph engineer, for whether discussing teleprinters, switching or facsimile there is scarcely a chapter without its mention of Baudot. For example, explanation of the teleprinter is based on the Baudot distributor, using the correcting segments (despite their transposed polarities) to demonstrate the start and stop principle. It is difficult to appreciate the merit of this.

The British reader should beware of the battery symbol, in which the short thick stroke represents the positive pole: unfortunately some confusion arises in the first few diagrams from errors showing batteries with two like poles. It is also well to be clear that stop polarity (mark = repos) is positive.

The author has taken some liberties with circuit symbols and the presentation of circuit diagrams: it is strange that the advantages of detached contacts are not more widely appreciated.

The first section deals with fundamentals and machines. Not all telegraph engineers will agree with a general statement (p. 23 and p. 288) that frequency-modulation will in the near future supersede amplitude-modulation for voice-frequency telegraphy. Four chapters are devoted to early systems (Morse, ABC, Hughes, Baudot) which have been adequately described elsewhere and are no longer in general service.

In a reference to the standardization of 50 bauds, no definition of the baud is given other than the remark that this rate corresponds to a unit interval of 20 ms. Similarly the plunge into statements on distortion and margin seems without adequate preparation.

Descriptions of the teleprinter relate mainly to the Sagem instrument, though some reference is made to the now obsolete Creed No. 3 model, as well as to the No. 7 and No. 47 (B.P.O. No. 11).

The second section on Installations gives little information on telegraph relays, but a great deal on repeaters. One obtains a new evaluation of the merits of that simple and static device, the shunted capacitor, with its considerable saving not only in power consumption but also in the installation and maintenance of large quantities of telegraph relays.

The chapter on maintenance gives interesting descriptions of relay testers, margin and distortion measuring sets and a distortion analyser: it also includes a brief description of a regenerative repeater.

Two interesting chapters are devoted to a comprehensive examination of transit problems and their solution by various switching methods. Tape-relay systems are described, but the author objects to the use of the term "switching centre" when channels are switched together through the medium of reperfors and automatic transmitters, preferring to use "transit centre."

The problems peculiar to switched systems for telex and public telegrams are fully examined: in a consideration of overflow traffic, reference is made to the solution adopted in the B.P.O. An interesting and detailed account is given of the manual telex system. This is followed by what is probably the first published description of the French automatic switching system, now in course of installation, in which selection is

(Continued on p. 31)

# Safety Arrangements for High-Power Radio Transmitters

A. E. N. WASE, A.M.I.E.E.,  
and S. J. SELLWOOD†

U.D.C. 614.825:621.396.7

The methods now adopted by the Post Office to protect staff working on high-power radio transmitters from electric shock are described and details are given of a new method of mechanically interlocking mains power switches, earthing switches and door locks. The main feature of the new method is the design of a special lock for use with a flexible control rod that can be readily applied to existing equipment without major alterations to cubicle frameworks or disturbance of the existing layout.

## INTRODUCTION

A MAJOR consideration in the design of most electrical plant is the protection of personnel from electric shock while carrying out their normal duties. It is necessary to guard against accidental contact with parts carrying dangerous voltages, which, in British Post Office telecommunications installations, are generally defined as any voltages maintained in excess of 100V a.c. (r.m.s.) or 150V d.c. The degree of danger and the nature of the precautions necessary depend upon the particular apparatus concerned and the voltages and powers at which it operates. High-power radio transmitters operated by the Post Office are required to be fitted with a comprehensive safety system to make them as safe as practicable. Good access to component parts of transmitters is always necessary for valve changing, faulting and general maintenance, and the safety arrangements must ensure that access is possible only after all dangerous voltages have been removed. A thoroughly reliable safety system is required because inadequate arrangements can, in some circumstances, be more dangerous than no safety system at all.

## GENERAL PRINCIPLES

The main radio transmitting stations operated by the Post Office are equipped with a variety of transmitters, employing high-voltage amplifiers at powers ranging from a few kilowatts up to half a megawatt. A complete transmitter may be contained in a single metal enclosure or cubicle, but it often comprises a number of physically separated cubicles. The present practice is to employ interlocked mechanical safety systems to lock up and deny access to all live parts of the equipment while the transmitter is in operation. Access to the equipment is permitted, by opening doors, hatches, etc., only after the following action has been taken:—

- (a) The mains power has been disconnected by opening a manually-operated switch.
- (b) The high-voltage connexions have been earthed by closing a switch.
- (c) A mechanical interlock safety system has been operated, to permit access doors to be opened and at the same time ensure that power cannot be re-applied until all doors, etc., are restored to their normal closed positions.

Electrical safety systems are not considered to be sufficiently reliable for the protection of personnel as they are dependent upon gate switches or similar devices, which interrupt a control circuit when any door or panel is opened and thereby close down a transmitter or prevent it coming-up on power. This type of safeguard is inadequate, as it necessarily relies upon the release of relays and contactors. Faulty contactors, failing to release due to a sticking armature or welded contacts, have been known to lead to severe injuries and fatalities to maintenance engineers. Such electrical controls are often incorporated

in equipment designs to give protection against damage to the equipment due to mis-operation or fault, but their function must always be restricted to this purpose and they should not be relied on for protection against electric shock.

## Coded Locks and Keys.

For small installations, such as a single cabinet having only a few access points, the required degree of safety interlocking can be achieved by a system of coded locks and keys. Each door is fitted with a coded lock which can be opened only by the appropriate key, the key remaining trapped in the lock while the door is open. Normally all the door keys are retained in an interlocked key bank associated with a master lock, and the master key is held in a lock associated with the main power switch supplying the equipment. This master key can be withdrawn only when the switch is locked in the "off" position. When the master key is inserted and trapped in the key-bank lock, the individual door keys can be withdrawn to permit opening of the equipment, and the master key remains trapped until all the door keys have been restored and are themselves trapped in the key bank. Fig. 1 shows a typical

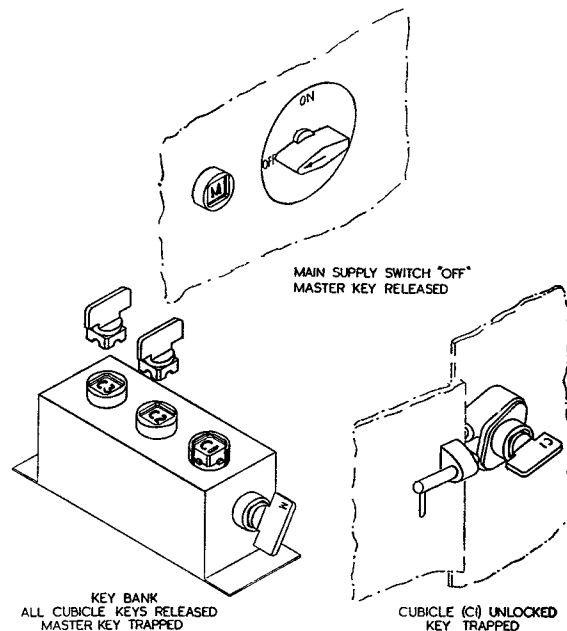

FIG. 1.—TYPICAL ARRANGEMENT OF CODED LOCKS AND KEYS.

arrangement of this type, with a main supply switch interlocked with three cubicle access doors. Coding is effected by embossed letters on the face of the lock which enter into and fit corresponding letters engraved in the inner face of the key.

## Mechanical Interlock Safety Systems.

The system of coded locks and keys is effective but is slow in operation and, for larger installations involving a considerable number of access doors in fairly frequent use,

† The authors are, respectively, Senior Executive Engineer and Executive Engineer, Radio Planning and Provision Branch, E.-in-C.'s Office.

tends to become cumbersome and tedious. It is necessary that a safety system shall be both effective and readily operated in service, so that the maintenance engineer does not feel that his work is unduly hindered by the safety arrangements. A mechanical safety system which unlocks a number of doors simultaneously is generally the current practice for the larger installations. This may also include coded trapped-key locks as the basis of interlocking between cubicles that are separated by an appreciable distance.

It has been Post Office practice for many years to incorporate a mechanical interlock safety system as an integral part of the design and arrangement of transmitter cubicles. This permits convenient grouping of the main interlocked controls for switching-on, earthing and door-locking, and also facilitates the use of coupled locking mechanisms operated from a single control for simultaneously releasing a number of access doors.

A positive directly-acting mechanical system is required to ensure that the three actions of disconnecting power, earthing, and operating the safety system are in fact carried out, and in the correct sequence. A system of rods moved by a rack-and-pinion action, and arranged to engage with slotted discs associated with the power and the earthing switches, is often adopted, in conjunction with a locking device to trap the door-interlock release bars when a door is open. The details of such a system are described later in this article, but it is appropriate here to discuss briefly some of the considerations governing the mechanical design.

The system should be smooth in operation and yet sufficiently robust to withstand mis-operation and to last for the life of the transmitter. Ideally it should not require alignment within fine limits and the design should be such that the reliability of the system is not impaired by subsequent wear, or by distortion of the cubicle framework or doors. It must be fool-proof to the extent that it shall not be possible to readily fake the system and so permit over-riding of the interlock control. For example, a simple plunger attached to a door and arranged to engage or displace a latch when the door is closed is not generally satisfactory, as the insertion of a screwdriver blade or a pencil, imitating the action of the plunger and tripping the latch, would simulate the door-closed condition.

The interlock mechanism should be designed to afford the greatest possible safety margin, such that in the event of failure of any part the system should tend to lock-up and deny access rather than render the equipment unguarded. Assemblies or devices dependent upon springs for their operation should not be used, as failure of a spring may result in the safety system being ineffective. The mechanism connected to the main switch or circuit-breaker should be arranged to control, and be controlled by, the position of the switch blades rather than the position of the switch-operating handle or toggle. All rotatable shafts, including switch shafts carrying blades, should be square in section and square keyed to the bosses. Pinned bosses on circular shafts are less reliable and have been known to shear in service.

The earthing switch should be situated in a well-illuminated position in the equipment, behind an inspection window at about eye level, so that an operator is able to see the action of the blades as he closes the earthing switch and visually check that it has operated satisfactorily.

#### *Special Considerations.*

High-power radio transmitters operate from high-tension d.c. supply voltages of the order of 8 to 12 kV, which are usually derived from 3-phase a.c. mains via an h.t. transformer, rectifiers and an output smoothing filter. Disconnexion of the primary supplies to an h.t.

rectifier system does not ensure that the smoothing capacitors are discharged. An earthing switch connected to the high-voltage supply circuit is necessary to give complete protection against electric shock and the switch must be closed before the interlock arrangement will permit access to the equipment. The short-circuit applied across the capacitors also obviates the risk of shock on a set that has been idle for some time, as capacitors, even after being discharged initially, will over a period acquire static charge from the residual energy stored in the dielectric material if a leakage path is not provided between the plates. The foregoing remarks also apply to other dangerous voltage supplies required in a transmitter, including intermediate h.t. supplies and bias supplies.

The aerial is not normally disconnected from the output stage of a transmitter when the set is shut down and, in consequence, there is always the risk of shock or burns by r.f. voltage induced from an adjacent transmitter aerial. An aerial earthing switch controlled by the safety interlock system can guard against this by preventing access until the output circuit is earthed.

Open-wire transmission lines are used extensively for external h.f. feeders over distances of up to nearly a mile, from a transmitter to an aerial, and breakdown between a final-stage anode circuit and the output coupling to the aerial feeders could cause the full h.t. voltage to be applied to the external lines. To obviate this danger a permanent d.c. earth is provided, either at the central point of the output coupling coil, or alternatively by means of r.f. chokes connected to the transmitter output terminals. These connexions should be capable of carrying the full short-circuit capacity of the h.t. supply. This earthing connexion on the transmitter output also prevents the accumulation of static charges on transmission and aerial systems.

Before commencing any work involving the handling of high-voltage connexions a local earth must be connected, after, of course, having switched off the power by the normal means provided. To enable this additional safeguard to be applied conveniently, it is common practice to provide earthing sticks as part of the normal equipment in high-voltage compartments. The stick comprises an insulated handle, on which is mounted a substantial copper probe or hook, connected via flexible copper braid to a permanent earth. When not in use, the stick may be suspended from a switch-hook which has contacts wired to the transmitter control circuit, to ensure that all sticks are restored to their hooks before power can be switched-on and so to protect the plant from inadvertent damage.

#### *Test Facilities.*

In modern transmitters employing complex control systems for motorized tuning and rapid automatic frequency-changes under remote control, it is necessary to provide test facilities for locally checking the operation of the control circuits. This may be arranged by means of an auxiliary switch, which can be closed when the main switch has been opened and so made to re-apply only low-voltage control supplies without bringing up the transmitter on power. Access can then be obtained to the equipment with the control circuit energized under local control, to facilitate checking and adjustment. The interlock arrangement ensures that this auxiliary switch is restored to the open position before the main switch can be re-closed.

#### *Shrouding.*

When the main switch is in the "Off" position and equipment is accessible, the incoming connexions to the main switch and the auxiliary switch are still live. Also, when the auxiliary switch is closed for the test condition,

mains voltages will be present on the transformers supplying the control voltages. It is necessary therefore to protect all the connexions carrying dangerous voltages by adequate shrouding. Preferably, earthed metal covers should totally enclose all terminals, the covers being secured by at least two screwed fastenings, and warning labels which state the voltage must be fitted to the covers. In addition to a warning notice on covers protecting the incoming mains terminals on a transmitter, it is a recommended practice to state also the location of the isolator or breaker controlling the power supply to the transmitter.

Like much other modern electrical equipment, radio transmitters are generally built in metal cabinets, providing fully earthed enclosures for the major units of a complete installation. All switch handles, control shafts, etc., brought out through panels are earthed or alternatively fully insulated. Panel-mounted meters are connected as far as possible to low or medium-voltage points of the circuit, but where meters are necessarily included in high-potential circuits a set-back insulated mounting behind a safety glass is used.

#### A TYPICAL TRANSMITTER INSTALLATION

An h.f. transmitter with an r.f. output of 70 kW peak envelope power, which is representative of current Post Office practice, has been described in a previous article<sup>1</sup> and the floor layout of the apparatus is shown in Fig. 2.

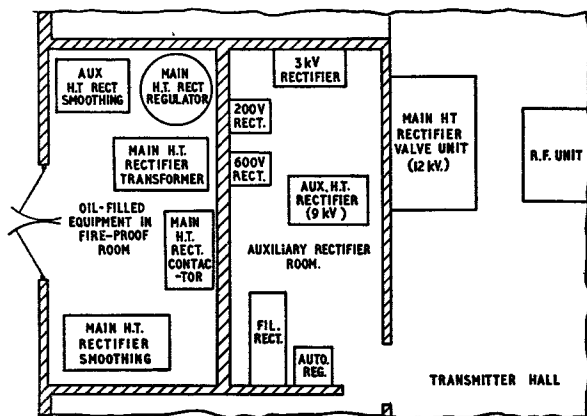

FIG. 2.—TYPICAL LAYOUT OF HIGH-POWER H.F. TRANSMITTER.

The r.f. amplifier and h.t. rectifier valve units are located in the transmitter hall, and the power-supply equipments that require less frequent attention from the operating staff are housed in adjacent rooms. All oil-filled and other units involving a special fire risk are located in a fire-proof room on the exterior of the main building. This room is accessible only from the outside and all cable ducts from it into the main building are sealed and rendered fire-proof; also, the room is equipped with thermally operated fire-extinguishing apparatus which automatically discharges carbon-dioxide gas when a predetermined ambient temperature is exceeded.

The r.f. unit framework has a built-in sliding-rod safety system which is fitted with a combined isolating and earthing switch, to interlock mechanically with the door-control mechanism. The switch disconnects and earths all the high-voltage supply connexions before the doors are released and cannot be reoperated unless all the doors are closed. In addition, for the protection of the plant only, the switch includes auxiliary contacts which are electrically interlocked with the contactors controlling the a.c. supplies to the high-voltage rectifiers, so that these supplies can be connected only when the switch is in the "On" position.

The doors of the main h.t. rectifier valve unit are

mechanically interlocked, by means of coded keys and locks, with the main a.c. switch to the rectifier; and as an additional precaution an auxiliary contact on the door mechanism is electrically interlocked with the primary a.c. supply contactor. The grid-bias and other intermediate high-tension rectifiers have all panels screwed in position and no special mechanical interlocks are provided. These units carry appropriate warning notices and also "Power On" warning lamps.

The external doors to the fire-proof room are also mechanically interlocked, by means of coded keys and locks, with the main a.c. switches supplying the 12,000V rectifier and the 9,000V auxiliary rectifier, so ensuring that all power is disconnected before access can be obtained to the high-voltage equipment.

#### A NEW METHOD OF MECHANICAL INTERLOCKING

To facilitate the application of a modern type of safety system to older transmitters and provide improved and up-to-date safety arrangements, a new type of lock<sup>2</sup> and coupling have been developed. The basis of the new system is a flexible rod of the "Bowden Cable" type, as shown in Fig. 3, with spirally wound outer layers of steel wire (A)

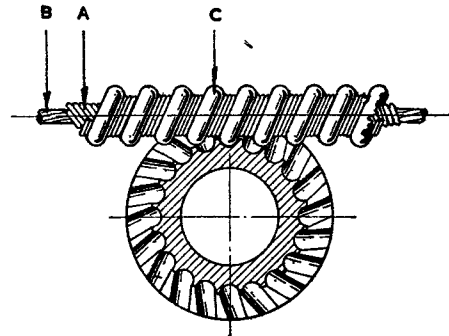

FIG. 3.—FLEXIBLE ROD AND PINION WHEEL.

over a stranded core (B), and with a final outer helix comprising alternate thick and thin wires (C).

The helix is continuous throughout the length of the rod and is in effect a continuous flexible rack, with the thick wire forming the teeth, which engages with pinion wheels for converting longitudinal motion into rotary movement, and vice versa. Movement is imparted to the rod by a control pinion-wheel attached to a hand-wheel, and the longitudinal motion of the flexible rod causes rotation of other pinion wheels in locks and other devices. The flexible rod itself does not rotate but slides in a conduit of soft-drawn brass tubing which can readily be curved and shaped to fit a cubicle framework, and so form a suitable run connecting door locks at convenient points anywhere along its length. Branch rods can be directly coupled to a main run by means of coupling boxes and a large number of locks can therefore be controlled simultaneously by movement of the main rod. The locks are embodied in the control-rod system fitted to a cubicle and engage with captive keys attached to the access doors and hatches. The lock has been designed specifically for this application and is positive in action and does not rely upon springs for any essential function.

Adaptability and ease of application are important advantages of this system, as it can be installed without major structural alterations to cubicle frameworks or

<sup>1</sup> STURGESS, H. E., and NEWSON, F. W. Single-Sideband Multi-Channel Operation of Short-Wave Point-to-Point Radio Links, Part 4—An Independent-Sideband High-Power Short-Wave Transmitter. *The Radio and Power Units, and Design and Performance. P.O.E.E.J.*, Vol. 46, pp. 140 and 191, Oct. 1953 and Jan. 1954.

<sup>2</sup> Provisional Patent Application No. 35283/54.



disturbance of an existing layout, such as a rigid-rod system often entails. The rod and conduit can be bent to avoid obstructions and a single length can couple together several locks which may be situated some distance apart, such as on the front and back of a cubicle. Ease in operation is generally limited by the sharpness of bends, rather than by the total number of bends or the extent of a complete system, and a bending radius sharper than four inches should usually be avoided. A satisfactory system, which will respond readily to the control wheel without any feeling of harshness, can then be obtained with a number of bends, including right-angle turns.

The flexible rod and a variety of fittings, including the pinion gear-wheel and housing, are available commercially for the remote control of windows and similar industrial applications.

#### The Lock.

The lock performs two discrete locking actions. Firstly, it responds to movement of the flexible control rod, in accordance with the positioning of an interlock control operating handle, to permit or prevent unlocking of the access door. Secondly, when the captive door key is turned in a lock and withdrawn to open an access door, the control rod is locked against further movement. A compact design has been achieved and the whole lock mechanism is accommodated in a small diecast housing. The complete lock and key and all the component parts of the lock are shown in Fig. 4, and sectional drawings of the lock under various conditions are given in Fig. 5 to facilitate describing the operation of the lock.

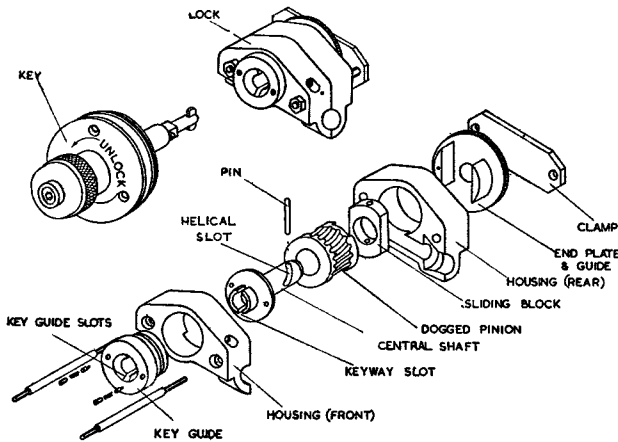

FIG. 4.—EXPLODED VIEW OF THE LOCK.

Fig. 5 (a) shows the central shaft of the lock, which has a helical slot with a sliding block fastened to the shaft by a pin, which passes through the helical slot. The slotted fore end of the shaft provides a key-way to enable the shaft to be rotated when the key is inserted and turned. Rotation of the shaft relative to the block causes the block to slide longitudinally along the shaft and a quarter-turn produces the full travel. The shaft also carries a "dogged" pinion wheel in mesh with the flexible control rod, which directly or indirectly controls the position of the main supply switch. The pinion wheel is free to rotate independently of the shaft when the control rod moves.

Fig. 5 (b) to (d) show the inner mechanism of the lock together with part of the key. The lock is in the unlocked condition in Fig. 5 (b), when the key can be withdrawn through the key guide slots in the lock face, as these slots and the shaft key-way slots are in alignment. In this position the sliding block is seated between the shoulders or dogs on the rear of the pinion wheel. Rotation of the wheel is stopped by the block, which is also partly within the parallel-sided recess formed by the end-plate and guide in

the rear portion of the housing. Under this condition the key is free, but the control rod is locked and cannot be moved. If the key is given a quarter-turn to rotate the lock shaft, the key is trapped and cannot be withdrawn as the slots in the shaft key-way and in the key guide are disposed at right angles to each other and the key blades are restrained against withdrawal. The rotation of the shaft drives the sliding block wholly within the recess in the rear portion of the housing and clear of the dogs on the pinion wheel, which is free, as shown in Fig. 5 (c). This unlocks the control rod which is then free to move. The interlock control wheel can now be used to move the control-rod system and permit switching on of the equipment. Movement of the control rod rotates the pinion wheel in the lock and the dogs move out of alignment with the sides of the block, which is thus obstructed against sliding along the shaft. As shown in Fig. 5 (d), the block is restrained within the recess in the end-plate and guide and so locks the shaft against rotation, preventing unlocking and withdrawal of the door key.

#### The Key.

The key basically comprises a twin-bladed shaft attached to an operating knob which is free to rotate in a retaining bush secured to a cubicle door or apparatus cover. The key shaft has been designed so that it can easily be cut to the length required when the device is fitted, and it is also spring loaded to give a degree of float sufficient to allow for some misalignment between the key and a lock. These and other features are incorporated to facilitate setting up and adjustment of the system. Similarly, installation and adjustment facilities are provided in the lock mechanism.

The key also incorporates a locating mechanism, so that an operator can feel when the key is in the appropriate position to enter the key guide of a lock, before attempting to close the door.

#### Application of the System.

A typical example of the use of the system for equipment

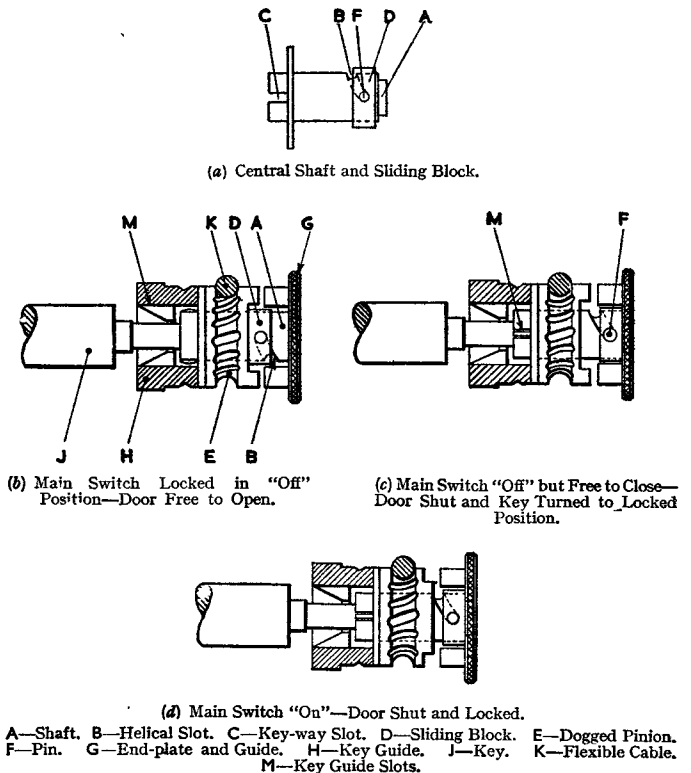

FIG. 5.—EXPLANATORY DIAGRAMS OF THE LOCK.

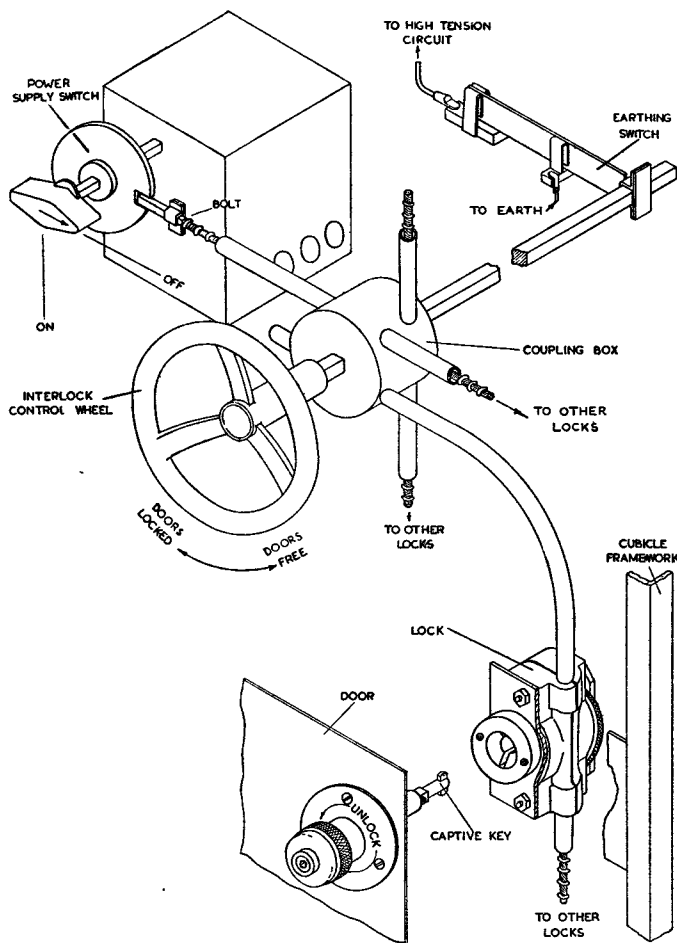

FIG. 6.—TYPICAL APPLICATION OF FLEXIBLE-ROD SYSTEM.

contained in a single cabinet is illustrated in Fig. 6, which shows the rotary-type power-input switch locked "off" and the h.t. circuit earthed, with the interlock control wheel in the "doors free" position, so that the door lock mechanisms are released to permit unlocking the captive keys to give access to high-voltage apparatus. In this arrangement, the square shaft turned by the interlock control wheel directly rotates pinion wheels in the coupling box, to drive the flexible rods in the three limbs of the system; it also carries the earthing-switch blade. The bolt engaged in the slot of the power-supply-switch interlock-disc locks the switch to ensure that power cannot be reconnected until the control system is restored to the "doors locked" position. The door lock is shown in the unlocked condition and the door key shown in the figure has been turned and withdrawn to open an access door. This action locks the control rod at this point, preventing

any further movement of the control-rod system, should an attempt be made to turn the interlock control wheel. The door must be reclosed and the captive key reinserted and turned in the lock before the control wheel can be moved back to the "doors locked" position. Thus, the mechanical safety-interlock system is returned to the working position and the power-supply switch can then be closed to put the equipment in operation.

For installations where a complete transmitter comprises a number of separate cabinets or cubicles, it is generally convenient to equip each cubicle with a mechanical interlock control system of the general type shown in Fig. 6, and to make the separate systems interdependent, by a sequence of locks and removable keys associated with the interlock arrangement on each cubicle. For example, in an installation comprising three cubicles, A, B and C, it may be necessary firstly to obtain the keys from A before access can be obtained to B or C. This requires that the supplies from A shall be switched off and earthed, in order to free the keys required to release the B and C cubicle interlocks. After insertion, these keys are trapped in the latter interlocks so that the A control system cannot be restored to the working condition while any cubicle is open. In these circumstances, a trapped key bank associated with the A cubicle is added to the system shown in Fig. 6. The keys for the B and C systems are retained in this bank until released, when the power-supply switch is interlocked in the "Off" position. Power-supply switches are not required in the B and C cubicles as the supplies to the whole installation are controlled by the switch in the A cubicle. In the control systems for the B and C cubicles, the power-supply switch shown in Fig. 6 is replaced by a lock, which releases the system only when the appropriate key obtained from the A cubicle has been inserted and turned.

#### CONCLUSION

The comprehensive safety arrangements provided in modern radio transmitters have been outlined, but it should perhaps be emphasized that in practice the onus finally rests on each individual engaged on potentially dangerous equipment, to exercise the greatest care for his personal safety by scrupulous adherence to safety rules and precautionary instructions. He must check that the power is off and he should apply a local earth before handling any connexions. To obtain the safest possible conditions all conceivable hazards must be guarded against before commencing work.

#### ACKNOWLEDGMENTS

The authors wish to express their appreciation of the assistance given by colleagues in the Radio Planning and Provision Branch in the development of the new interlock system and in the preparation of this article.

## Book Review

"Appareils et Installations Telegraphiques"—continued  
from p. 26.

initiated by teleprinter keyboard signals instead of the hitherto orthodox dial pulses—a method being used in Holland, and also projected (so the book discloses) for the Italian telex service. References are also made to the Siemens and Halske TW 39 system and to the question of international subscriber-to-subscriber dialling. The book concludes with a chapter encompassing submarine and radio telegraphy, the latter referring to Hell, Verdan and Van Duuren systems; and a final chapter dealing, perhaps too briefly, with photo-

telegraphy and direct-recording facsimile telegraphy.

The text and diagrams are not free from editorial error. The addition of captions to the diagrams would increase their value, and an index would have been useful.

The author invariably gives the clearest description of fundamental principles, and advances arguments for the adoption of particular methods. The presentation is clear and concise, making the book enjoyable to read. It is noteworthy that no mention is made of the semateme family of terms. The publishers are to be congratulated on the excellent clarity both of the many line diagrams and of the clear type on matt white paper. The book is a welcome addition to the somewhat meagre bibliography on telegraphy.

R. N. R.

# A Buried Frequency Standard

J. S. McCLEMENTS†

U.D.C. 621.3.018.4:389.6:621.372.412

A new type of frequency standard which is free from mechanical and thermal shock and also independent of power supplies (all vital factors in the operation of quartz-oscillator frequency standards) has been set up at the Dollis Hill Radio Station. The standard is located 60 ft below ground level, and it is hoped that in a few months' time it will take its place in the Dollis Hill Standard.

## INTRODUCTION

IN a previous issue of the Journal<sup>1</sup> some details were given of quartz-clock equipment supplied by the Post Office to America and Canada and attention was drawn to the growing importance of such standards, and to the sustained efforts to improve technique. To augment the primary frequency standard maintained in the Radio Experimental and Development Branch of the Engineer-in-Chief's Office, at Dollis Hill, a new type of frequency standard known as a "Quartz-Crystal-Resonator Standard" has been developed. This type of standard differs from the conventional quartz-oscillator standard in that, unlike the oscillator, which is in a continuous state of oscillation, the resonator is only excited at infrequent intervals for sufficient time for its frequency of resonance to be determined.

It is known that, providing the temperature of a crystal resonator is maintained at a constant value, its frequency-time performance is similar to that of its oscillator counterpart. Advantage has also been taken of the temperature stability which exists some feet below the surface of the ground. The effect of the ground on penetration of heat waves generated at the surface may be considered somewhat as a transmission problem; i.e., the waves suffer an attenuation and a phase delay. For instance, at a depth of 30 ft a surface temperature change of 10°C will be attenuated to about 0.4°C, and will be delayed about six months, i.e., when the surface temperature is rising in the summer period, the measured temperature at 30 ft down is falling, corresponding to the previous winter temperature fall. It is only the long-term seasonal temperature changes which penetrate to these depths, the daily surface changes being, in effect, completely filtered out.

The Post Office has installed a quartz resonator at a depth of 60 ft below ground level, where the maximum temperature change throughout the year is less than one-tenth of a degree centigrade. As this installation is the first of its kind in Great Britain or the Commonwealth, it is thought that some details of the installation will be of interest.

## THE QUARTZ-CRYSTAL RESONATOR

The quartz resonator has been placed at the foot of a 60-ft deep steel pipe of 6 in. internal diameter; the pipe consisting of a number of sections jointed with screwed sockets and each joint made waterproof.

### *The Crystal.*

A 100 kc/s Essen-type ring is used, suitably dimensioned so that the temperature at which its frequency-temperature coefficient is zero corresponds with the temperature at the bottom of the borehole (at Dollis Hill 11.5°C). It is in all respects similar to its oscillator counterpart and is mounted by a silk-thread suspension system in an evacuated container. A photograph of a typical oscillator unit is given in Fig. 1. Resistance thermometer elements are associated with the crystal so that the working temperature can be monitored at all times.

† Executive Engineer, Radio Experimental and Development Branch, E.-in-C.'s Office.

<sup>1</sup> McCLEMENTS, J. S. Post Office Quartz Oscillators for Use in Time and Frequency Standardisation Abroad. Vol. 48, p. 26, Apr. 1955.

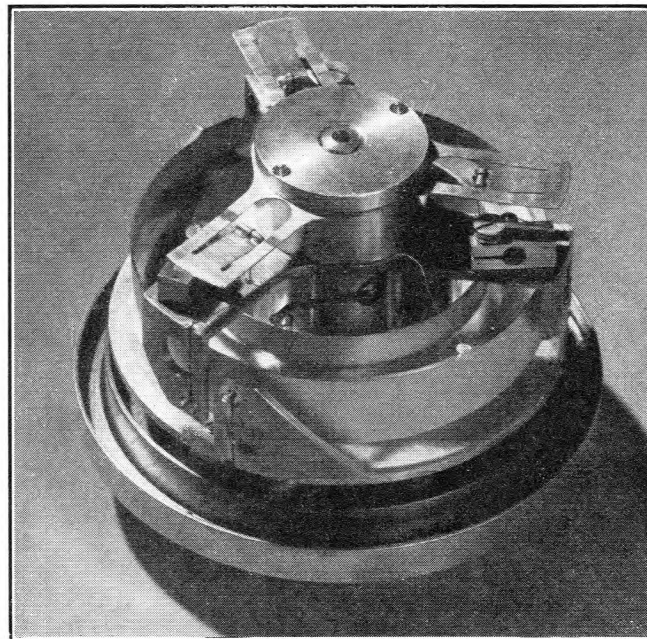

(a) 100 kc/s Z-cut quartz ring, mounted on thread suspension, with cover removed.

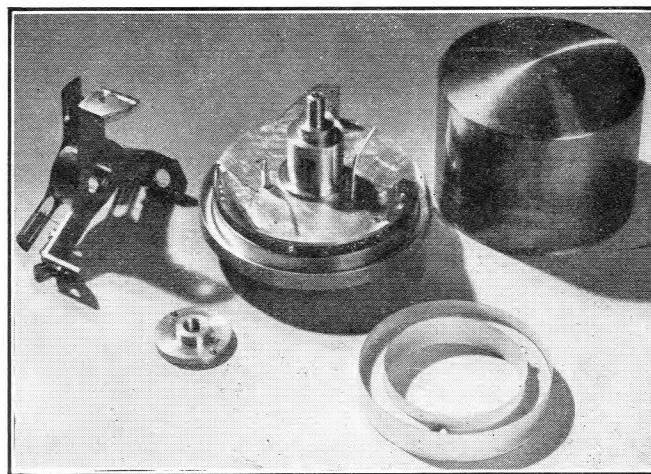

(b) Dismantled oscillator unit.

FIG. 1.—TYPICAL QUARTZ-CRYSTAL OSCILLATOR UNIT.

### *The Resonator Chamber.*

Fig. 2 shows the assembly of the resonator chamber which was lowered down the borehole, the crystal element being mounted in the cylindrical container at the base of the assembly. Coaxial cables carrying the h.f. signals and d.c. control cables can be seen entering the chamber at the top, and changeover relays and calibrating resistance elements are seen about the middle of the assembly. Provision is made for checking the degree of vacuum in the crystal holder and for checking the frequency-temperature coefficient of the crystal.

The complete chamber is sealed with carbon dioxide gas at slightly above atmospheric pressure. Four spring feet at each end of the chamber acted as guides on the pipe walls during the lowering operations.

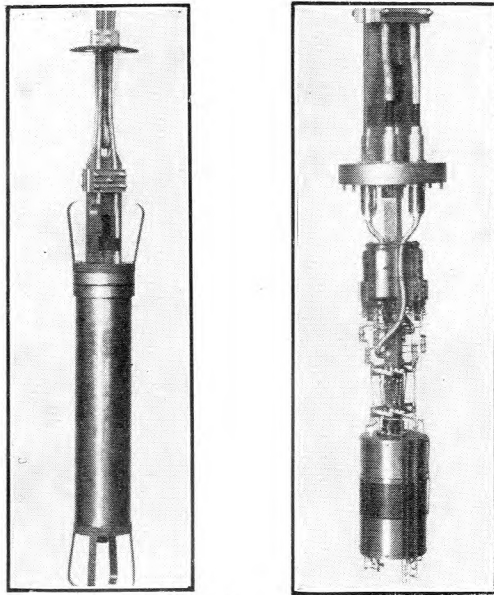

FIG. 2.—THE RESONATOR CHAMBER.

#### Lowering Operations.

Fig. 3 shows the complete assembly suspended above the borehole prior to lowering. The container is suspended on a  $\frac{1}{4}$ -in. diameter steel-wire rope, to which the cables are also clamped at frequent intervals. At intervals of 10 ft the bore pipe is closed by air baffles, also attached to the supporting cable, which reduce the effect of air convection in the pipe. Because of the delicacy of the crystal element, lowering operations were carried out slowly and carefully, cable clamps and air baffles being fitted as the system was lowered. The performance of the crystal was monitored throughout the lowering operation.

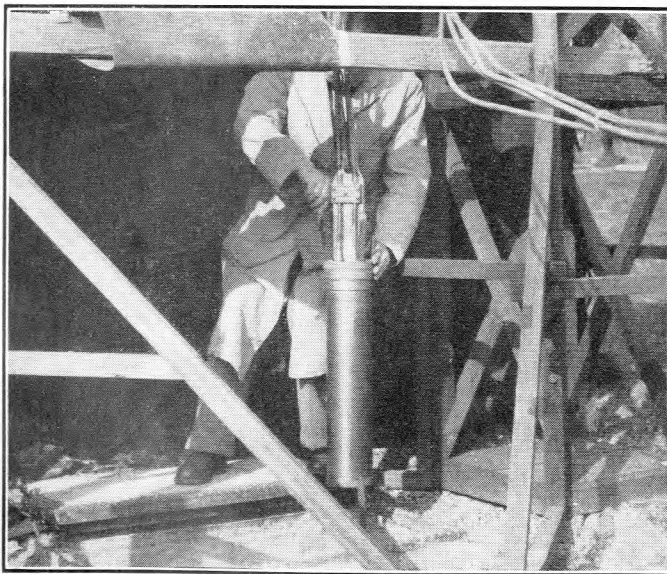

FIG. 3.—RESONATOR CHAMBER SUSPENDED OVER BOREHOLE PRIOR TO LOWERING.

#### Measurement of Frequency.

Advantage is taken of the fact that at the resonant frequency of the crystal its equivalent electrical circuit is a pure resistance. The overall circuit, including cables, is initially aligned at 100 kc/s with an equivalent resistance simulating the crystal. By means of relays the crystal is then switched into the circuit, and the frequency of the driving generator adjusted until the resistive conditions are again obtained. The frequency of the generator then corresponds with the crystal resonance frequency.

#### Performance.

When a crystal oscillator is first installed, the frequency changes rapidly with time, compared with the rate of change after some months of operation. This comparatively large frequency change is known as the "preliminary frequency-ageing" of the crystal; the preliminary ageing may persist for three to six months, during which time a total frequency change of 10 parts in  $10^8$  is not uncommon. A typical ageing curve of a crystal oscillator operating at  $50^\circ\text{C}$  is shown in Fig. 4, curve A. The frequency-time

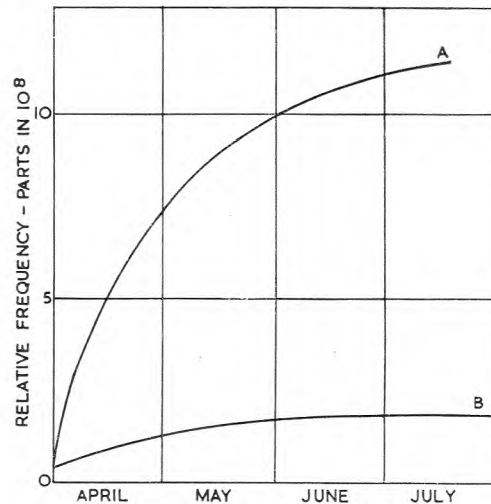

A—Oscillator operating at about  $50^\circ\text{C}$ .  
B—Resonator operating underground at  $11.5^\circ\text{C}$ .  
FIG. 4.—FREQUENCY-TIME PERFORMANCE OF QUARTZ-CRYSTAL OSCILLATOR AND RESONATOR.

performance of the underground resonator since installation is shown in Fig. 4, curve B, which is a mean curve based on daily measurements and fits the measured data within one part in  $10^9$  at all points. It will be seen that the preliminary frequency ageing of the resonator was completed in less than two months and the overall frequency change measured up to the beginning of August was less than 1.5 parts in  $10^8$ .

#### CONCLUSION

The performance of the first Dollis Hill underground resonator, since it was lowered into the earth in March 1955, is very promising, the rate of frequency change with time already being comparable with the best oscillator frequency standards. As is the case with all frequency standards, however, measurements will continue for many months before performance can be sufficiently established to enable the resonator to be used as an effective standard.

# An Experimental Electronically-Controlled P.A.B.X.

B. F. YEO, A.M.I.E.E.†

U.D.C. 621.318.57:621.395.722:621.395.34

**A small electronically-controlled P.A.B.X. has been designed and constructed for use in the Telephone Branch Circuit Laboratory to gain experience in the design and use of electronic circuits and equipment while, at the same time, meeting the internal telephone requirements of the Laboratory. This article describes the facilities provided and the operation of the electronic circuits employed.**

## INTRODUCTION

WHEN the Telephone Branch Circuit Laboratory moved to new premises, in December, 1953, it was necessary to install an intercommunication system for the laboratory staff in the new premises and it was decided to proceed with the design and construction of a suitable system, on the lines of a small P.A.B.X., which would be either wholly or partially electronic. This decision was taken for two main reasons: firstly, it would give valuable experience in the design and costing of electronic switching circuits and equipment, and, secondly, having the system completely under engineering control would assist in obtaining detailed and accurate information about its subsequent performance.

The testing and constructional staffs located in the main laboratory and other rooms are divided into functional groups, each of which is controlled by a supervising officer, the supervising officers being located in a separate common office. Each supervisor must have individual access to any of five exchange lines, common to the office, for incoming and outgoing calls, and must be able to speak to any of his own or other staff and transfer exchange line calls to them. Several supervisors must be able to pick up the same exchange line, if required, for conference purposes. These requirements have been met by the provision of a small switchboard for each supervisor, with individual control over each exchange line and with access to the internal communication system. For convenience, stations where the small switchboards are used have been designated "Office" extensions, while stations with an ordinary two-wire telephone have been designated "Laboratory" extensions. The exchange-line circuits are normally independent of the internal communication system, but may be connected to it under the control of the office extensions.

The main facilities provided are:—

(a) The automatic intercommunication system has a two-digit numbering scheme with full flexibility in which the numbers available are 21-28, 31-38, 41-48, 51-58, 61-68, 71-78, 81, 82.

Restricting the highest digit to 8 allows a slight economy in the register pulse counter and also gives certain advantages in the design of the coincidence field.

(b) Provision is made for 25 laboratory extensions, 21 office extensions, and four circuits which may be used as laboratory or office extensions.

(c) Five exchange-line circuits are provided.

(d) Any laboratory extension can be barred from dialling any office extension, as required, by the insertion of suitable straps associated with the extensions concerned.

(e) All laboratory extensions are barred from direct access from or to the exchange lines.

(f) Office extensions can select any one of the exchange lines by key.

(g) Office extensions can hold an exchange line on either an incoming or an outgoing call and dial a laboratory extension via the P.A.B.X. Conversation between the two extensions is then secret.

(h) At stage (g), the office extension can revert to the exchange line, leaving the laboratory extension held. Conversation between all three parties can then take place.

(i) At either of stages (g) or (h) the office extension can release the P.A.B.X. connexion while remaining connected to the exchange line.

(j) At stage (h) the office extension can transfer the exchange line to the laboratory extension and then clear down. Transfer can take place only if the laboratory extension has answered and is on the line. The laboratory extension cannot dial over the exchange line.

(k) Office extensions can "butt-in" to a busy laboratory extension by operating an appropriate key after dialling the extension and receiving busy tone. A distinctive tone is momentarily connected to the busy extension as a warning that an office extension is butting in.

(l) A combined calling and busy lamp is provided for each exchange line on each office extension switchboard.

(m) A lamp, buzzer and buzzer cut-off key are provided on each office extension switchboard for receiving incoming P.A.B.X. calls.

(n) Incoming exchange line calls can operate either a common call bell, or each line can be given a separate (and distinctive) call bell, if required.

(o) Number-unobtainable tone is provided on spare extension numbers.

## GENERAL PRINCIPLES AND TRUNKING

Preliminary study of the trunking involved showed that with the comparatively large degree of manual control vested in the office extensions, relay switching would be most economical for the office-extension line-circuits. For the P.A.B.X. itself, with such a small installation, the higher operating speeds possible with a wholly electronic system are of little advantage and are off-set by higher initial costs. In view also of the convenience with which relays may be used for battery feeding, ringing and supervisory purposes, it was decided to adopt an electronically controlled mechanical system, confining cold-cathode tubes mainly to the control equipment, where, for pulsing and storage functions, they might be expected to show advantages over relays. Again, for reasons of economy, it was decided to use uniselectors (P.O. type 2), rather than some other electromechanical device, to obtain access to the 50 extension lines.

Fig. 1 shows the trunking layout. The calling loops of both laboratory and office extensions produce a signal, across a common calling resistor RS, which is applied to all registers simultaneously. The registers are brought into use on a "one-at-a-time" basis so that, when one register is dealing with a calling signal, the others are blocked. The seized register extends a seize signal to a link-circuit selector, which allocates and connects a free link circuit to the register. The link circuit is used to connect the two extensions together when the call has been set up. The register extends a start signal to the incoming uniselector associated with the link circuit, and the uniselector hunts for the calling extension, which has an individual marking on the banks of all the incoming uniselectors. If two

† Executive Engineer, Telephone Development and Maintenance Branch, E.-in-C.'s Office.

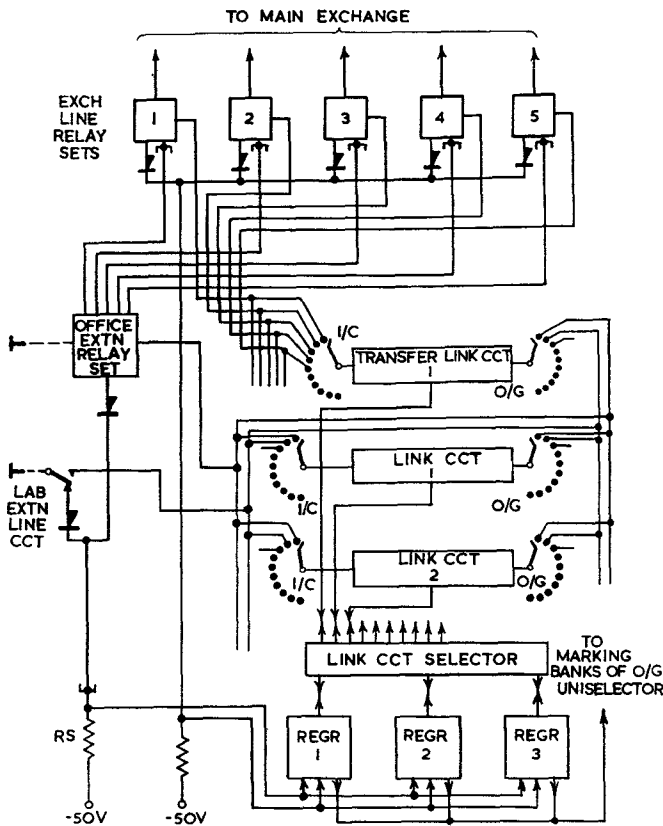

FIG. 1.—TRUNKING DIAGRAM.

extensions originate calls within a short time of each other, then depending on their relative positions around the uniselector bank, the first extension to call is not necessarily the first to be found. When the calling extension has been found, a signal is returned to the register to unblock the other registers. The calling extension is switched through the link circuit and link selector to the register, which transmits dial tone. The caller dials into the register, where the two pulse-trains are stored. Hunting for the called number is controlled from the register, which is allocated its turn in the same way as when finding the calling extension. Each register has a coincidence field which translates the stored number into an individual marking signal which is applied to the banks of all the outgoing uniselectors during the register's turn to hunt for a called number, but the only outgoing uniselector that hunts at any one time is that associated, through the link selector, with the register whose turn is allocated. In this way incorrect connexions of calling and called extensions are prevented. When the called extension has been found the register is released, and testing for busy, ringing and switching, etc., is controlled from the link circuit. If the number dialled is spare, N.U. tone is given from the register, it remains held and the outgoing uniselector does not hunt, but the other two registers are unblocked. Should the caller receiving N.U. tone hold the register for more than 10-20 sec, the register is released by a time-pulse. The average holding time of a register engaged on a normal call is about 3 sec.

The exchange-line relay-sets have access to a separate common start-resistor and the register, recognizing this distinctive calling signal, causes the link selector to select one of two special link circuits (known as "transfer" link circuits) which provide the transfer facilities required only on P.A.B.X. calls set up via the exchange-line relay-sets.

Seven ordinary link circuits, two transfer link circuits and three registers have been provided, with wiring

included to enable an eighth ordinary link circuit to be added if necessary. Traffic meters have been fitted to check the traffic carried over a period and it is expected that the provision of three registers, in particular, will be shown to be generous.

### THE REGISTER

The register is almost entirely electronic, using cold-cathode tubes of the miniature wire-ended type, and larger octal-based cold-cathode tubes where the circuit arrangements demand a heavier current than can be provided by the miniature tubes. Fig. 2 is a block schematic diagram

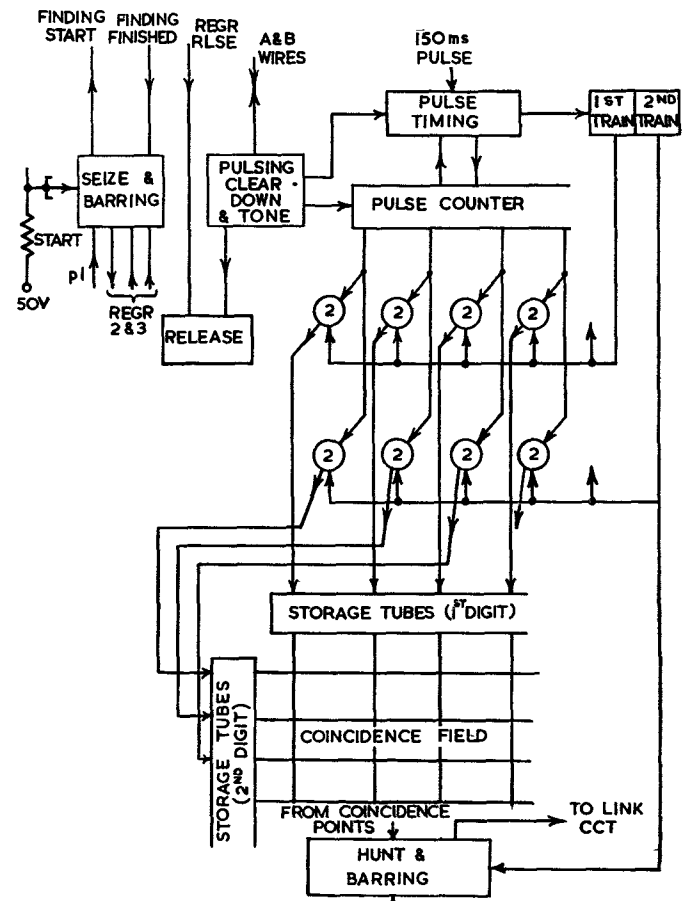

FIG. 2.—BLOCK SCHEMATIC DIAGRAM OF THE REGISTER.

of the register. The seize signal from the common start resistor is applied to the seize and barring circuit, which has connexions to the other two registers, and which is initially brought into use by a pulse  $p_1$ , a pulse voltage of 55V amplitude and 200  $\mu$ s duration, generated with respect to -50V and repeated at 75 ms intervals. The other two registers are supplied with their own individual pulses (the three pulses being separated by intervals of 25 ms) so that although the common start signal is applied to all registers simultaneously, only one is seized at a time. On seizure, the register applies a seize signal to the link-circuit selector, which switches the register through to a free link circuit. A Finding Start signal is then passed to the link circuit and its associated incoming uniselector finds the calling subscriber. A Finding Finished signal is returned to the register to unblock the other two registers. The seized register remains busy while the call is being set up. Should all registers or link circuits be busy, receipt of dial tone is delayed.

The calling loop is now extended to the register via the link circuit, and dial tone is returned from the register. The loop prepares a pulse-counting circuit in the register.

Should dialling not commence within 10-20 sec of the receipt of dial tone, an alarm is given and the register is held so that the calling line can be traced. Should dialling not be completed after it has been commenced, the register is forced-released after 10-20 sec, the calling line seizes another register and eventually causes an alarm. Should the caller clear down before dialling, or before dialling has been completed, the register, etc., are released normally.

Associated with the register pulse-counter is a pulse-timing circuit, controlled by pulses at 150-ms intervals, which detects the inter-train pause and end of dialling. At the end of the first pulse train, the tube in the first row of storage tubes, corresponding to the tube struck in the counter, is fired, and the counter is reset in readiness for the next train. The second digit is then received, timed, recorded, and transferred to the second row of storage tubes, and a signal is applied to the hunt and barring circuit, which controls hunting for the called subscriber. As with the incoming sequence, the hunt and barring circuit is operated by a pulse individual to the register and has connexions to the other two registers so that the coincidence field associated with each register is brought "alive" only when its pulse is incident.

### Seize and Barring Circuit.

Fig. 3 shows the elements of the seize and barring circuit,

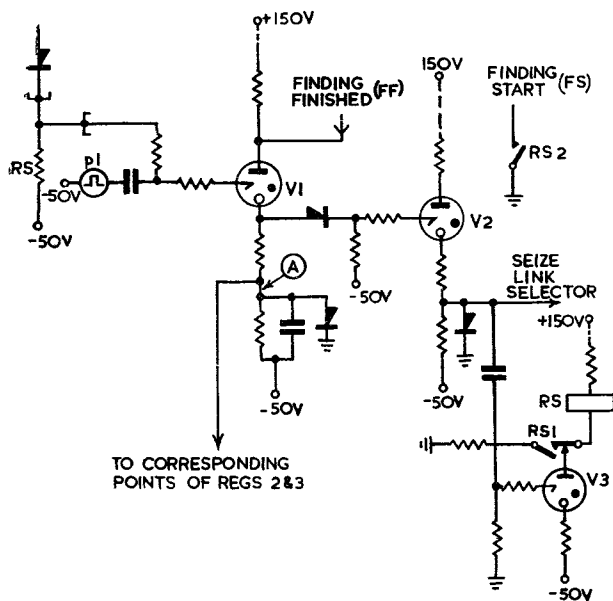

FIG. 3.—REGISTER SEIZE AND BARRING CIRCUIT.

simplified for explanatory purposes. A calling loop causes current to flow through the common resistor RS and raises the potential at its upper end to (very nearly) earth potential. This primes the striker of V1, which is struck by the next p1 pulse. Point A is now raised to approximately earth potential and as this point is common to all three registers, the cathodes of the V1 tubes in registers 2 and 3 also assume earth potential, and the common start signal no longer results in an effective priming on these tubes. In the register under consideration, the cathode of V1 is raised to about 50V above earth and this is sufficient to cause V2 to strike. V2 extends a signal to the link selector to seize a free link circuit, and also strikes V3. The link selector having found a free path, the register is connected to a link circuit. Relay RS operates via V3 and RS2 extends a driving earth through the link selector to the incoming unselector of the link circuit. When the unselector has found the calling line, the link circuit returns an earth on lead FF to extinguish V1. The maintenance

of an earth on this lead during the remainder of the register operations ensures that V1 does not restrike to another start signal. The capacitor connected at A causes the potential at this point to decay comparatively slowly and covers the operation of the calling extension's K relay from the link circuit. If this were not so, another register would sometimes be seized by the same start signal before the K relay had operated to remove it. The rectifier at A acts as a clamp, when V1 strikes, to maintain the potential at this point nominally at just above earth and minimize the spread which might otherwise occur due to tube-to-tube variations.

### Pulsing, Tone and Clear-Down Circuits

Although the pulsing, tone and clear-down circuits may be shown as separate elements, the circuits are to some extent interdependent and it is therefore convenient to show the combined arrangement, as in Fig. 4.

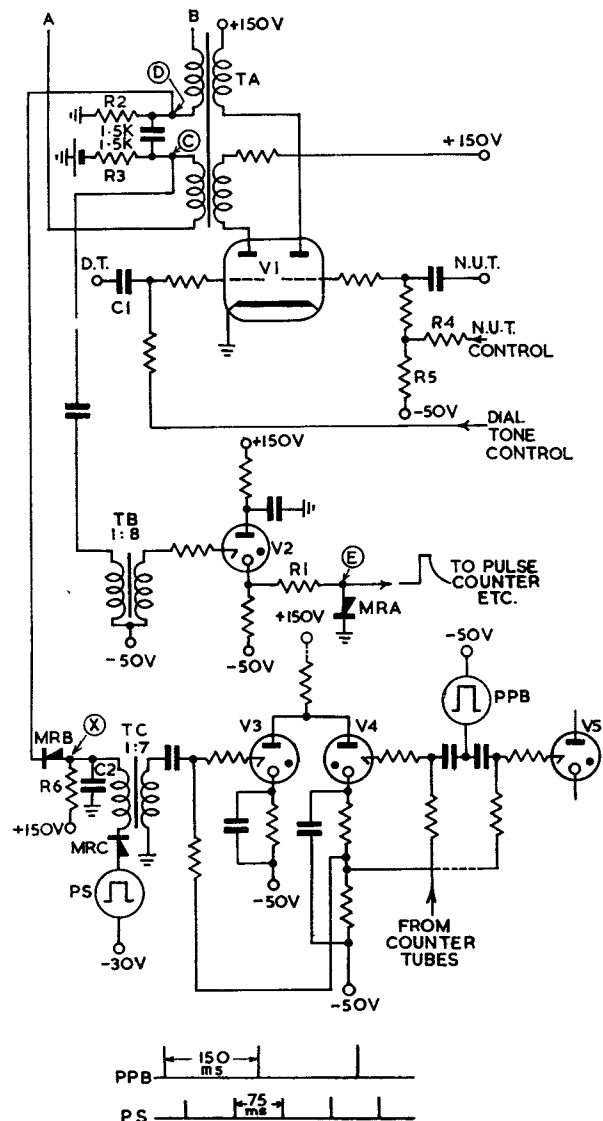

FIG. 4.—REGISTER PULSING, TONE AND CLEAR-DOWN CIRCUIT.

**Pulsing.**—When the calling extension has been switched through the link circuit to the register, the calling loop is connected across the A and B wires. The potential at point C therefore changes from -50V to a less negative value, and this change is increased by the 1:8 transformer TB to produce a pulse of sufficient amplitude to strike V2; i.e. the circuit detects "makes." V2 is self-extinguishing

and develops a cathode output pulse having an exponential decay. The pulse is clamped at E by the resistor R1 and rectifier MRA and its minimum width under load conditions is about 200  $\mu$ s. When dialling commences, make-pulses are detected and repeated via V2 in a similar way. The magnitude of the changes at C due to the making of the dial springs depends on the speed and ratio of the dial, and also on the time taken to recharge the telephone capacitor via the line resistance and capacitance and the feeding resistors at C and D. If this time is long, the potential change at C when a make occurs is small. The values of the feeding resistors are, therefore, a compromise and are chosen to give the highest potential at C under steady-state conditions consistent with the maximum change at C when dialling under adverse conditions. The 1,500-ohm resistors R2 and R3 cater for lines up to about 1,000 ohms and the circuit performs satisfactorily over an artificial line representing 5½ miles of 10-lb cable, dialling at 14 p.p.s., 60 per cent break. The transmitter current, when fed via a total resistance of 3,000 ohms, is less than normal, with the result that the transmitter resistance is high and varies considerably according to the position in which the transmitter is held. The resistance may reach a peak of about 1,000 ohms. On short lines, in particular, this gives rise to a false make-pulse when the transmitter is short-circuited by the dial off-normal springs preparatory to dialling. The circuit must, therefore, discriminate between this unwanted pulse and the initial seize signal from a long line, where the potential change at C is at a minimum.

**Tone Circuit.**—V1 is a double triode controlling the application of dial tone and N.U. tone to the line transformer TA. The control wires are normally at -50V potential and both halves of the tube are cut-off. To switch dial tone, the dial-tone control lead potential is raised positive to earth. The left-hand side of V1 therefore conducts fully and the grid draws current. The dial tone is applied via the capacitor C1 so that the grid swings between cut-off and grid current for wide variations in level of the applied tone. Thus V1 acts also as a limiter. The anode resistor prevents the tone voltage induced in the line windings of TA from rising to a value where it could cause false operation of the pulsing circuit. To switch N.U. tone, the N.U.-tone lead is raised to earth potential and the tone is applied about the resultant potential appearing at the junction of the resistors R4 and R5.

**Clear-Down Circuit.**—This circuit causes the register to release should the caller clear down after being switched through to the register and before dialling has been completed. When the caller is off the line, the selenium rectifier MRB is conducting from +150V via R6 and R2 to earth. As a result, X is at a few volts above earth and the crystal rectifier MRC is cut off to PS pulses, which rise from -30V to earth potential. When the extension loop appears across the A and B wires, point D falls to a negative potential, point X follows it, and the MRC gate is opened to pass a pulse of approximately the same amplitude as the voltage drop across resistor R2. Under long-line and other adverse conditions this is about 12V. The 200- $\mu$ s pulse PS, repeating at intervals of 75 ms, is increased in amplitude by transformer TC to strike V3, which is primed by V4. V4 has previously been operated by PPB (a 200- $\mu$ s pulse repeating at 150-ms intervals) superimposed on a priming potential derived from the counter tubes, which operated when the calling loop was applied across A and B. V3 in striking extinguishes V4. The next PPB pulse restrikes V4 which extinguishes V3. This process continues for as long as the extension loop is connected. If the extension clears, V4 remains struck and primes V5 so that the next PPB pulse strikes this tube. V5 operates the register release and extinguishing circuit.

When the first dial "break" pulse occurs the potential at D rises from a negative value to earth potential. MRB is now cut-off because the potential at point X is held negative by capacitor C2, while it is being recharged through R6. The time-constant of the circuit at X, in conjunction with the timing of pulses PS and PPB, covers the break period and prevents unwanted clear-down. The circuit will cater for dialling at 7 p.p.s. and 75 per cent break over a 1,000-ohm line under adverse voltage conditions.

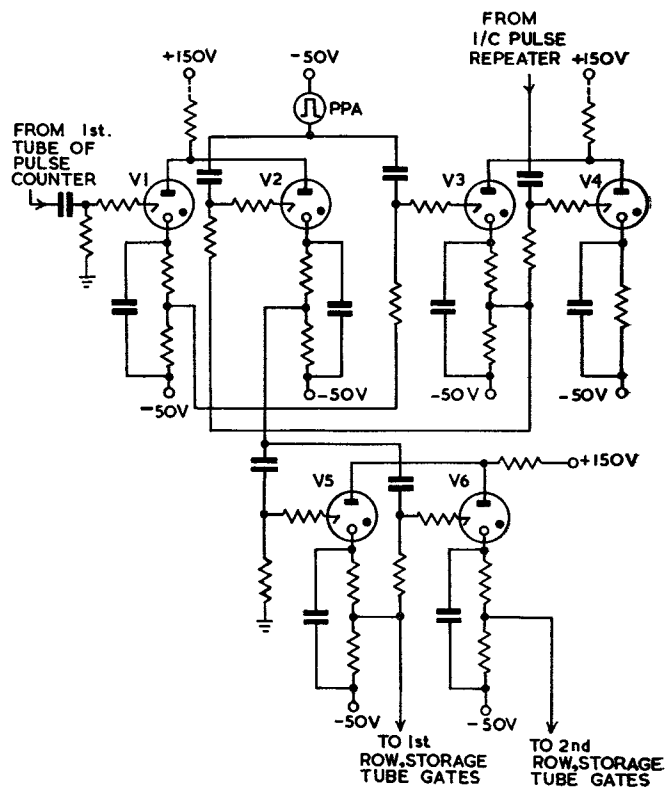

FIG. 5.—REGISTER PULSE-TIMING CIRCUIT.

*Pulse-Timing Circuit (Fig. 5).*

As soon as the register pulse-counter is stepped off normal by the incoming dial pulses, V1 strikes and primes V3. V3 is struck by PPA, which is a 200- $\mu$ s, 55V pulse repeating at 150-ms intervals. V3 primes V2 and V4. Provided dial pulses are still being received, V4 strikes, extinguishes V3 and thus removes the priming from V2 before the next PPA pulse arrives. When dialling ceases, V2 eventually strikes and in turn strikes V5. V5 records the fact that one digit has been received, strikes the appropriate digit-storage tube (not shown) and resets the pulse counter in readiness for the next train. At the end of the next train, a similar sequence occurs except that V2 now strikes V6, which has been primed by V5. V6 extinguishes V5, strikes the appropriate digit-storage tube for the second train, and prepares the one-at-a-time outgoing hunting circuit for operation in due course.

The shortest intertrain-pause period covered by the pulse-timing circuit is 150-300 ms.

*Coincidence Field.*

Fig. 6 shows part of the coincidence network whereby the outputs of the tubes struck in the digit-storage arrays are combined to produce a marking potential individual to the number dialled. The coincident points are not brought "alive" until relay BC operates, and this in turn is controlled by the one-at-a-time allocating circuit. The storage tubes used (CV2174) work at a nominal anode current of about 25 mA and allow a comparatively low value of



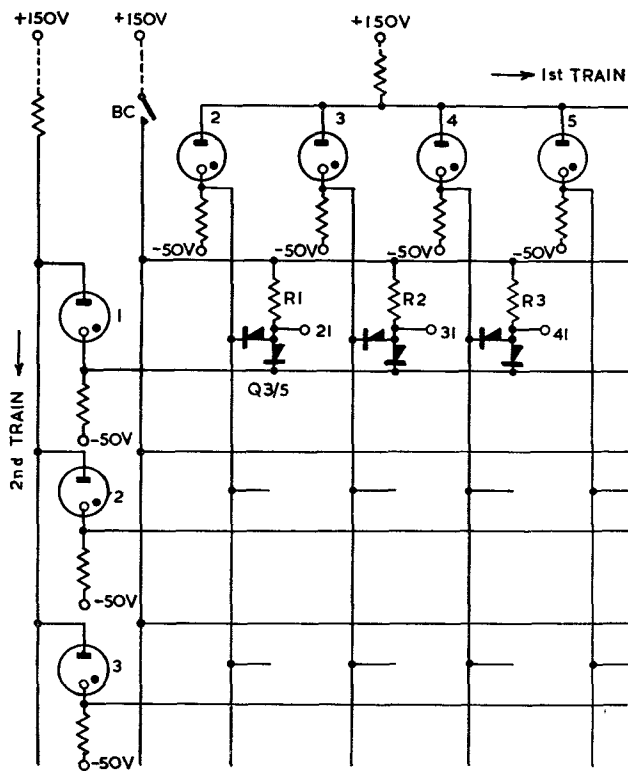

FIG. 6.—REGISTER COINCIDENCE FIELD.

cathode resistor to be employed. When a tube is struck its cathode is at earth potential, and where the potentials of two such tubes coincide, the coincidence point is also raised to this potential. At a point where one tube is struck and the other is normal, the coincidence point takes the lower value of the two potentials, the rectifier connected to the line of higher potential being cut-off.

When BC operates, current flows into each cathode circuit via resistors R1, R2, etc., and the selenium rectifiers. The value of the cathode resistors is small compared with the other circuit values and the cathode potential rises only slightly above  $-50V$  and is insufficient to cause false switching at the unwanted coincidence points.

#### THE LINK SELECTOR AND LINK

Fig. 7 shows part of the link selector, through which connexions from the three registers to three link circuits can exist simultaneously. When the selector is seized, the outlets are tested in sequence, although the commencement of the sequence is at a different outlet for each register. Pulse leads pa1, etc., supply  $8\frac{1}{2}$ -ms, 50V pulses with respect to  $-50V$ . Pulses on any one lead recur at 75-ms intervals and are spaced  $8\frac{1}{2}$  ms from those on adjacent pulse leads. Under normal conditions, with the OSR leads at  $-50V$  potential, none of the tubes is primed and none strikes. If now OSR1 is lifted to earth potential by a seize signal, and pa1 is imminent, the associated tube is primed and pa1 strikes it. AA operates and remains operated while the selector is in use. Contacts of AA extend the first register to the first link circuit; contacts of AB, AC, etc., connect the first register to link circuits two, three, etc. The first tube having struck, the remaining tubes in the same row are prevented from striking to the same seize signal by the fact that, all cathodes having been raised to earth potential via the common cathode-resistor, priming on these tubes is ineffective. To prevent another register seizing the same outlet, barring is applied in a vertical direction by a contact of AA which connects a low impedance  $-50V$  potential to a common bias point for the trigger rectifiers. These rectifiers therefore short-circuit the OSR seize signals

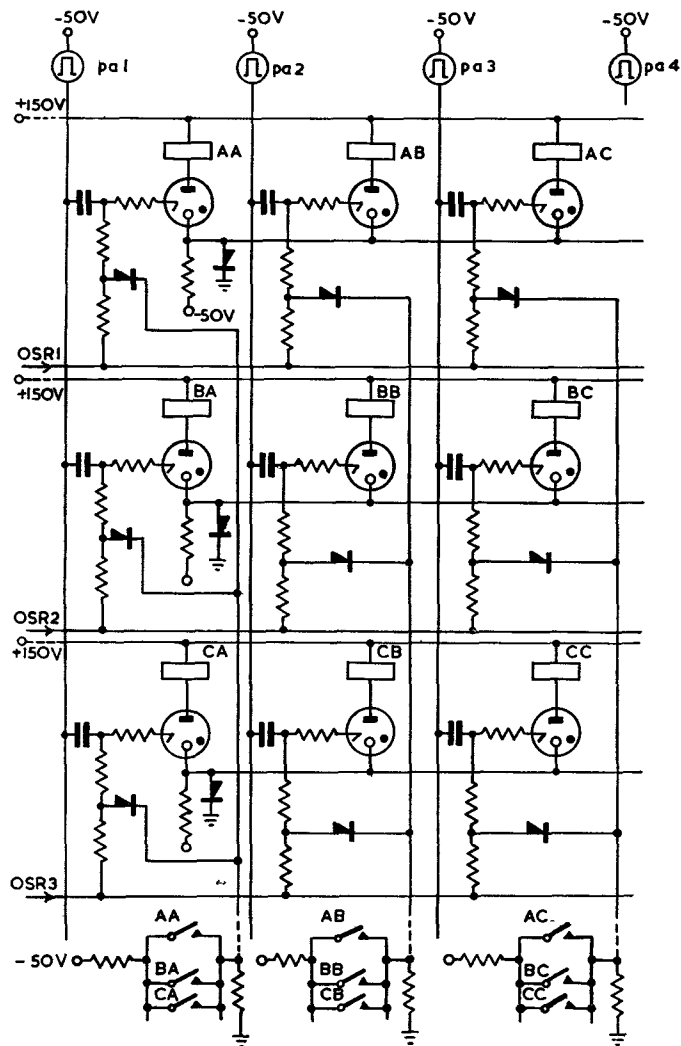

FIG. 7.—PART OF THE LINK SELECTOR.

on the vertical row associated with the first outlet. A connexion to the common bias point is also made from the link circuit so that it appears as a busy outlet after the call has been set up and the register and link selector connexion have cleared down. The 75-ms interval between successive pa1 pulses allows time for relay AA to operate and apply vertical barring before the next pa1 pulse is ready to strike the corresponding tube in the next row. The same principle obtains with the other columns. The average hunting time for the selector is about 110 ms.

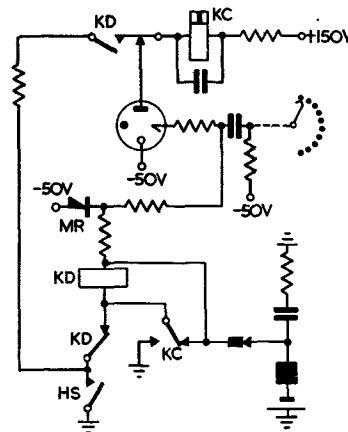

FIG. 8.—UNISELECTOR CUT-DRIVE CIRCUIT.

The h.t. supply to the horizontal row of tubes associated with each register is controlled from the register so that the link circuit connexion clears down with it. The tubes used are CV2174.

Fig. 8 shows the arrangements for cutting the drive of the outgoing uniselectors associated with the link circuits. The use of a cold-cathode tube enables an earth potential of comparatively high impedance to be detected. A start earth, via contact HS, completes a self-drive circuit for the uniselector and at the same time provides a priming potential for the trigger of the cold-cathode tube. The uniselector commences stepping and the testing wiper passes over contacts normally connected to a potential of  $-50V$ . When the wiper reaches the marked contact, the earth potential results in a pulse being applied to the trigger via the trigger capacitor, and the tube strikes. KC operates in series with the tube anode circuit, cuts the drive-magnet circuit, and allows KD to operate by removing the short-circuit from across its coil. KD holds KC to the HS earth and disconnects the tube, which extinguishes. The tube carries the operate current for relay KC during only the time taken for relays KC and KD to operate.

Despite the normal quench circuit, the drive-magnet can generate negative pulses of sufficient amplitude to strike the tube in the reverse direction when the drive-magnet contacts close. Rectifier MR is included to suppress these pulses.

#### POWER AND PULSE SUPPLIES

##### *Power Supplies.*

Apart from the normal  $-50V$  exchange battery and ringing and tone supplies, stabilized supplies of  $+150V$  and  $-50V$  are provided for the electronic equipment. For convenience in splitting the load (about 700 mA maximum) each of these supplies consists of two stabilized power packs, each supplying 350 mA. Each pack is mains operated, with mains transformer, full-wave selenium rectifier and reservoir capacitor, and employs three CV345 tubes (joined in parallel) as a series regulator. With a mains variation of 210-250V, and when one CV345 tube is removed to simulate tube failure, the output voltage is within  $\pm 2.5$  per cent of the nominal when the load changes from zero to a maximum. Normally, the regulation is better than this. A  $-85V$  reference potential for both  $-50V$  and

$+150V$  supplies is derived from a cold-cathode tube (CV449) operated from a separate rectified mains supply.

##### *Pulse Supplies.*

The various pulses used in the system are derived from a cold-cathode counter and taken via self-extinguishing CV2174 tubes acting as pulse-repeaters. The counter is driven by a 120 p.p.s. source consisting of a cold-cathode relaxation oscillator and a pulse-shaper, as shown in Fig. 9. The pulse frequency may be adjusted by means of the potentiometer in the anode circuit of V1, while the pulse width is adjusted to  $200\mu s$  by the grid potentiometer associated with V2. The rectifiers clamp the output pulse between  $-50V$  and approximately earth potential. If the pulse output fails, a similar pulse generator is brought into use to drive the main cold-cathode counter and a deferred alarm is given. Should the standby pulse generator then fail, a prompt alarm is given.

#### CONCLUSION

A general view of the complete exchange is shown in Fig. 10. Although it has not been in service long enough for its reliability to be firmly assessed, results so far have been promising and it is hoped that useful data will eventually be compiled—particularly of the life and performance of the cold-cathode tubes and associated components.

It may be mentioned that fault locating during the initial testing period was helped by the fact that cold-cathode tubes give visual indication of their operational condition.

#### ACKNOWLEDGMENTS

The author gratefully acknowledges the helpful criticism and advice given by colleagues in the Telephone Development and Maintenance Branch, E.-in-C.'s Office; in particular, thanks are due to Mr. A. R. Bartle, who was largely responsible for testing the completed installation, and to the staff of the Laboratory, who carried out the constructional work.

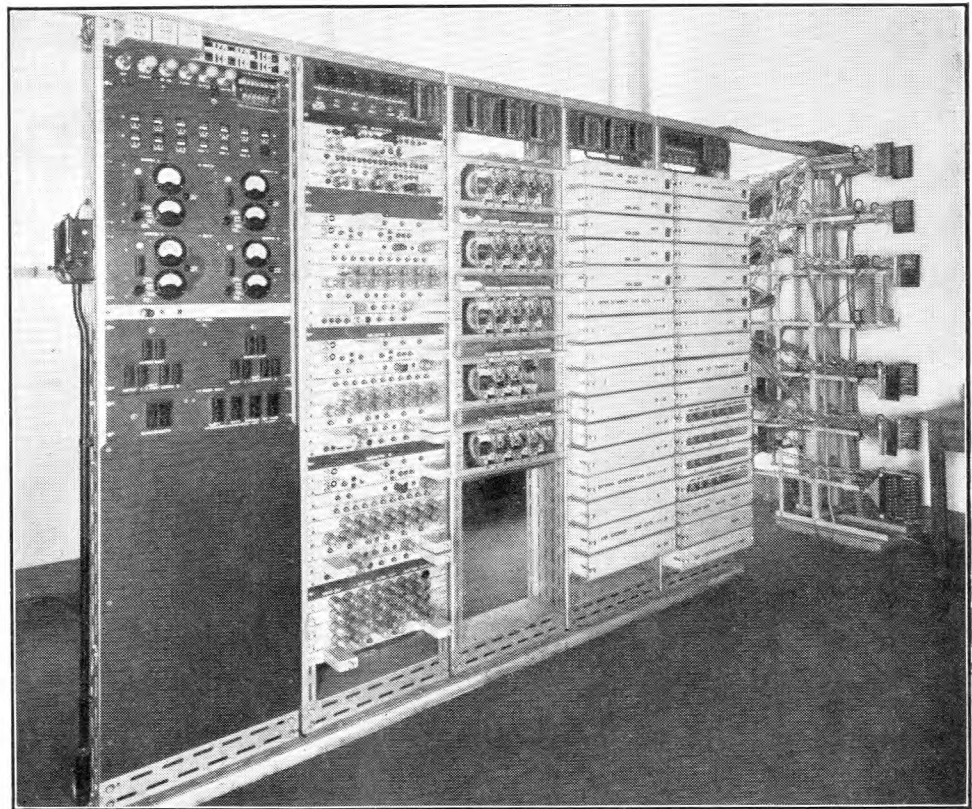

FIG. 10.—GENERAL VIEW OF THE EXPERIMENTAL ELECTRONICALLY-CONTROLLED P.A.B.X.

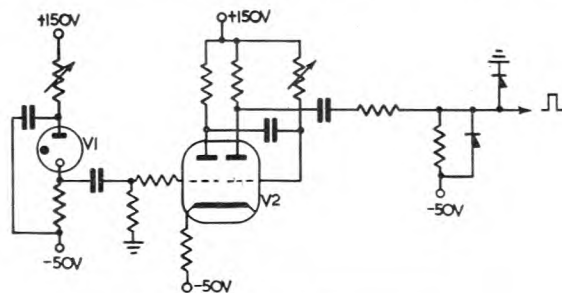

FIG. 9.—120-P.P.S. GENERATOR.

# The Rocking-Armature Receiver

J. S. P. ROBERTON, B.Sc.(Eng.)†

U.D.C. 621.395.62

A new receiver inset (No. 4T) is described. It has been developed, using the rocking-armature principle, to give substantial improvements in sensitivity and frequency response compared with previous Post Office standard receivers, and it has been embodied in the new Post Office standard telephone (700-type) which will be described in a future article in this Journal.

## INTRODUCTION

IN 1950 the Post Office drew up, for the guidance of the telephone manufacturers, a target specification for a more sensitive receiver which would be suitable for inclusion in a projected new telephone. The specification called for a flat sensitivity/frequency response over the range 200-3,400 c/s and removed a maximum limit on the sensitivity of new receivers which had earlier been imposed. This limit was removed because it was realized that sensitivity in excess of that required for purely receiving considerations could be usefully employed in a new telephone to improve sending efficiency by change of the Y ratio of the induction coil.<sup>1</sup> Such exchange of efficiency could be made to give balanced increases in sending and receiving efficiencies, even though a more sensitive transmitter were not available. A balanced increase in efficiencies is essential to obtain economic advantages from the use of a new telephone in the Post Office network.

Standard Telephones and Cables, Ltd., who had already carried out some exploratory work, undertook the development of the new receiver and produced a design which differs greatly from receivers previously used in telephones, employing what has come to be known as the "Rocking-Armature" form of construction. The conventional form of construction for telephone receivers, using a magnetic diaphragm, was abandoned in the design of the new receiver because it was found that little increase of sensitivity was possible even when the most modern materials and manufacturing methods were used. The rocking-armature type of construction uses a bi-polar form of balanced magnetic system giving high sensitivity with simplicity of construction and stability; it derives its name from the fact that the armature rocks, or pivots, on a fulcrum resting on the magnet, which supports it.

When the receiver was designed it was realized that there would be considerable maintenance advantages in changing to a capsule type of construction from the open construction of existing receivers such as the No. 2P Receiver Inset. This open construction, with removable diaphragm, is liable to changes of sensitivity and the collection of dirt at the magnetic air gaps whenever the receiver is opened.

This article describes specifically the No. 4T Receiver Inset, which will be used in the 700-type telephone, to be described in a subsequent issue of this Journal. The same physical design of receiver, wound to different impedances, will find other applications in the Post Office, while a miniaturized version forms part of a lightweight headset for operators, at present under development.

## FUNDAMENTAL FACTORS IN THE RECEIVER DESIGN

Before describing the constructional features of the receiver, the basic factors underlying the design will be reviewed.

### The Magnetic Circuit.

In the present 2P Receiver Inset and similar receivers, the magnetic diaphragm has to perform a dual function in which both its magnetic and acoustical properties are used;

since these conflict in their requirements for highest sensitivity of the receiver, a compromise has to be effected. It was considered important, in the new receiver, to separate these two functions, so the magnetic function is confined to the rocking armature, while the acoustical function is confined to a light flared diaphragm of high effective area coupled to the armature. Fig. 1 and 2 show schematically in elevation the basic elements of the 2P Receiver Inset and the Rocking-Armature Receiver.

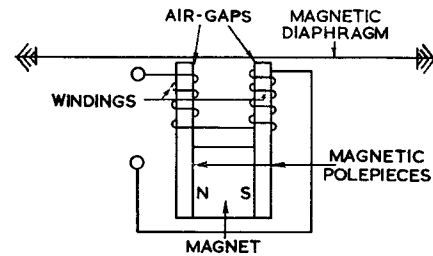

FIG. 1.—BASIC ELEMENTS OF 2P RECEIVER INSET.

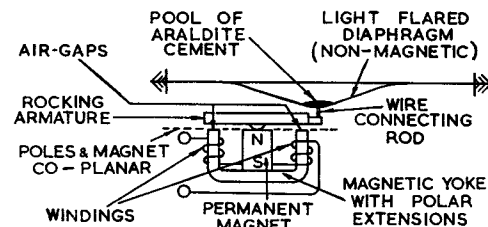

FIG. 2.—BASIC ELEMENTS OF ROCKING-ARMATURE RECEIVER.

Again, in the 2P Receiver Inset and many similar receivers, the high reluctance of the permanent magnet is arranged in series with the alternating flux circuit; this further limits the magnetic sensitivity that can be achieved with such designs. In the new receiver a balanced bridge type of magnetic circuit was chosen in which the permanent magnet is so "bridged" across the alternating flux circuit that its reluctance is excluded therefrom.

The magnetic circuits shown in Fig. 3(a) and 4(a) together with the analogous electrical networks shown in

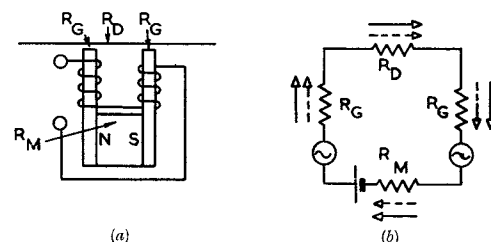

FIG. 3.—MAGNETIC CIRCUIT AND ANALOGOUS ELECTRICAL NETWORK OF 2P RECEIVER INSET.

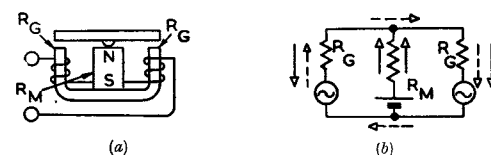

FIG. 4.—MAGNETIC CIRCUIT AND ANALOGOUS ELECTRICAL NETWORK OF ROCKING-ARMATURE RECEIVER.

† Mr. Robertson is with Standard Telephones and Cables, Ltd., London, England.

<sup>1</sup> H. J. C. SPENCER. Some Principles of Anti-Side-Tone Telephone Circuits, *P.O.E.E.J.*, Vol. 48, p. 208, Jan. 1956.

3(b) and 4(b) make clear these differences between the two designs. In these analogous electrical networks, the magnetic reluctances are represented by electrical resistances, the magnets by d.c. batteries and the windings by sources of a.c. The direct and alternating fluxes of the magnetic circuits are represented by the direct and alternating currents (denoted by the full and broken arrows respectively in Fig. 3(b) and 4(b)). It will be noted, in Fig. 3(a) and 3(b) for Inset 2P, that whereas the reluctances of the pole-pieces have been omitted, being negligible, it has been necessary to include the diaphragm reluctance  $R_d$  which is far from negligible because of the compromise already mentioned. In Fig. 4(a) and 4(b) for Inset 4T, on the other hand, only the gap reluctances  $R_g$  are shown, because both armature and yoke reluctances can be made small in comparison. It will at once be apparent that the latter design, which has no swamping reluctances in series with the gap reluctances, offers a much greater reward for reduction of the air-gaps to the minimum consistent with requirements of stability, and control in manufacture.

One of the aims of the rocking-armature receiver design was to achieve this reduction of air-gaps while meeting the other requirements.

#### Control of Air-Gaps.

The two-pole balanced magnetic circuit of the rocking-armature driving system was chosen, in preference to the more usual four-pole balanced magnetic circuit of other receivers, because of its simplicity, leading to much easier control of the small air-gaps in manufacture.

Thus, the length of the two air-gaps of the receiver depends on two manufacturing operations only, both of which are capable of very close control. Firstly, a ridge which forms the fulcrum of the rocking armature is swaged or "coined" upon one of its faces (see Fig. 5) and secondly

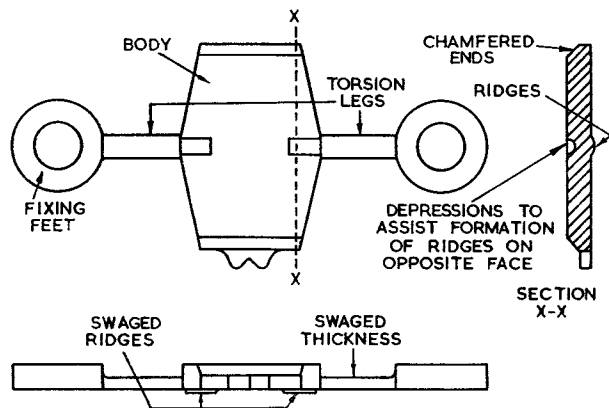

FIG. 5.—THE ROCKING ARMATURE.

the magnet and yoke assembly is ground across the polar faces into a plane (see Fig. 2). When the face of the armature is placed parallel to, and with its coined ridge in contact with, the ground plane, the two controlled air-gaps lie between.

In four-pole designs the length of the four gaps depends on the length of the spacers (sometimes the magnet) which separate the two yokes, on the length of their formed pole-pieces, and on the thickness of the armature which lies between them, three dimensions which may vary in production quite widely.

#### Stability of Rocking Armature.

In balanced magnetic systems, it is important to ensure stability of the armature in the central position of balance, against the high static field force which tends to deflect it

further as it is moved off balance towards either of the poles; this high force is of course inseparable from the conditions for high magnetic sensitivity of the receiver. The ratio of this field force to the displacement of the armature at any frequency is generally denoted by  $s_r$ , and can be regarded as a negative stiffness because the field force has the opposite sense to a restoring force. Because of hysteresis and eddy current effects the absolute value of the field stiffness falls with increasing frequency, and the maximum value  $s_{r,m}$  occurs at zero frequency; i.e., the static condition. It is therefore necessary, for static stability, to introduce a correspondingly high, but rather greater, restoring force to the armature.

In the rocking-armature receiver this is done through the torsional stiffness,  $s_a$ , of the armature side limbs. The condition for static stability of the armature is that  $\int_0^x (s_a + s_{r,m}) dx$  shall be positive for all values of  $x$ , the armature displacement from the balance position. However, the preponderance of restoring force must not be too great, or the net positive dynamic stiffness ( $s_a + s_r$ ) of the armature system will become excessive in the range of working frequencies, causing loss of sensitivity. Hence a nice balance must be kept between the restoring stiffness  $s_a$  of the armature and the static (negative) field stiffness  $s_{r,m}$ ; this calls for good control of both these stiffnesses. The armature torsional stiffness is controlled by making the side limbs of such large dimensions that their stiffness is not unduly affected by normal manufacturing variations; the closest tolerance required is  $\pm 0.001$  in. on the thickness of the side limbs, and this thickness is a swaged dimension and therefore largely tool controlled (see Fig. 5). The field stiffness is largely controlled by the close air-gap control already mentioned, and through a flux adjustment made on the assembled receivers.

In the rocking-armature receiver, the stability under static forces is achieved within the driving system itself, and the diaphragm stiffness which is later added to that of the armature is not essential for this stability.

Further, this added diaphragm stiffness is made as low as practicable compared with the net positive stiffness of the armature under static conditions so that, once the armature air-gaps have been balanced by mechanical adjustment of the side limbs, subsequent slight deflections of the diaphragm which is afterwards connected to it do not appreciably alter the balance.

#### Sensitivity.

The magnetic sensitivity of electromagnetic receivers can be readily shown to be proportional to the field stiffness,  $s_r$ , which equals  $B^2/\pi R_a$  where  $B$  is the polarizing flux density at the pole tips and  $R_a$  is the effective reluctance of the alternating flux circuit to alternating flux. Because of iron saturation,  $R_a$  increases rapidly as  $B$  is increased beyond a certain limit and the expression  $B^2/R_a$  shows a maximum value when plotted against  $B$ . To realize the maximum sensitivity in practice, it is necessary to allow for the variations which occur in the properties of the permanent magnets, and, to a less extent, for the variations in air-gaps and pole-piece-dimensions. It is therefore necessary to provide a magnet having a sufficient surplus of flux above the optimum value to cover all variations, and then to adjust the flux in a progressive demagnetization process until the maximum sensitivity of the receiver is achieved. In the rocking-armature receiver this process must be applied after adjusting the two airgaps for equality, so that the optimum flux value is realized in both halves of the magnetic circuit individually. If the air-gaps are not balanced, a maximum sensitivity with flux variation can be found, but the value is below that obtained for the balanced condition.

Because of the closer balance between  $s_a$  and  $s_r$  at lower frequencies (referred to previously) the net positive stiffness ( $s_a + s_r$ ), by which the receiver sensitivity is judged at low frequencies, is very sensitive to the changes of  $s_r$  brought about by flux adjustment. For this reason, when the flux adjustment is made, the sensitivity is tested at a fairly low frequency.

#### The Drive to the Diaphragm.

High acoustic efficiency is achieved by providing a light diaphragm having the optimum effective area. The diaphragm can be regarded as a transformer linking the mechanical part of the receiver with the acoustical part and the ear. The effective area (about 10 cm<sup>2</sup>) of the diaphragm employed is correct for matching the mechanical impedance of the receiver to the acoustical impedance, over much of the frequency range, of the receiver. A difficult problem was, how to achieve the true piston motion which would yield such a high effective area without thickening the diaphragm unduly, leading to increased diaphragm mass and flange stiffness.

Centrally driven diaphragms are liable to unwanted modes of vibration, or parasitic oscillation of parts of the diaphragm, unless, in the design, careful attention is given to the shape. Experiments made with various diaphragm shapes led to the conclusion that one having a flared form like a shallow trumpet was less liable to break up into unwanted modes than one having a shape based on pure conical forms. This fact is probably due to the flared shape having curvature in two dimensions, whereas the cone has curvature in only one dimension. A further advantage of the flared trumpet shape is that the stiffness is more nearly constant from the central driving region to the end of the trumpet part of the diaphragm. Thus, starting from the central driving region just outside the solid pool of Araldite cement, the slope of the surface is greatest, giving the greatest stiffening, due to the shape, where the section of material (taken normal to the diaphragm axis) is least; as one moves out to the peripheral flange, the slope decreases, but the increasing section adds to the stiffness.

Because of the rocking motion of the armature its end describes an arc of vibration at the point where it is connected to the diaphragm. Therefore, an unwanted lateral movement as well as the desired axial movement would be imparted to the diaphragm, were it not for a wire connecting rod which is flexible enough to bend under the lateral forces but adequately stiff to transmit axial forces.

#### Frequency Response.

In order to obtain a flat frequency response, the mechanical-acoustical system of the receiver was designed with two portions containing essentially reactive elements, leading to two resonances in the response separated by a shallow trough. A third part of the system containing essentially a resistive element was used to damp the resonances, more especially the first resonance. The basic mechanical-acoustical system is shown in Fig. 6 in a sectional view of the receiver in a handset resting against an ear. The corresponding analogous electrical network is shown in Fig. 7(a), in which acoustical elements have dash suffixes and the mechanical elements have not. The acoustical elements are divided into two sections corresponding to the acoustical parts of the receiver behind, and in front of, the diaphragm; each section is coupled to the mechanical portion of the receiver through a transformer of ratio 1 :  $A_e$ , where  $A_e$  represents the effective area of the diaphragm.<sup>2</sup> In Fig. 7(b) the acoustical elements have been transferred to the mechanical sides of the transformers

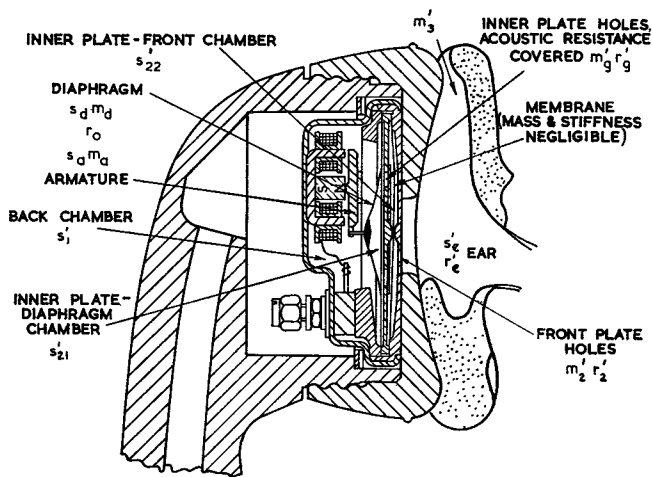

FIG. 6.—SECTIONAL VIEW OF THE 4T RECEIVER INSET (IN THE NEW HANDSET) HELD AGAINST THE EAR, SHOWING MECHANICAL-ACOUSTICAL SYSTEM.

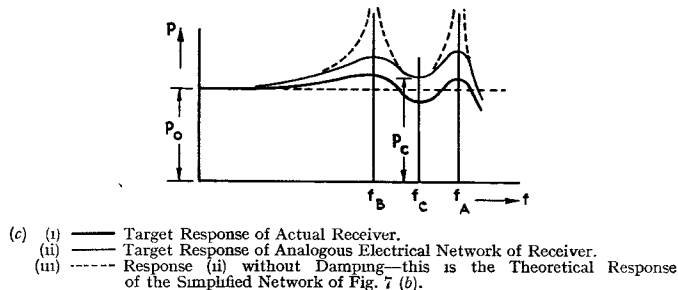
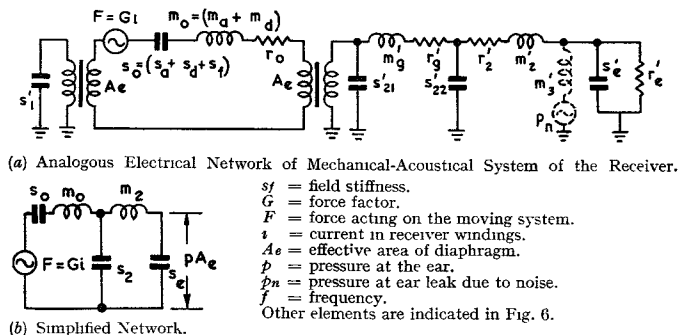

FIG. 7.—ANALOGOUS ELECTRICAL NETWORKS AND RESPONSES OF 4T RECEIVER INSET.

(thus  $s_e = s_e' A_e^2$ , etc.);  $m_g'$ , which is small, and the resistive elements have been omitted, and certain elements consolidated.

An analysis of this simplified network and application of the analysis to the design are given in an appendix to this article, in which reference is made to Fig. 7(c). From this analysis, and from studies made on the more complete analogous network of Fig. 7(a), in which the various elements could readily be changed, it was possible to achieve the network response of Fig. 7(c), curve (ii).

In Fig. 7(c), curve (i) shows the response of a receiver based on the type of mechanical-acoustical system with two damped resonances. The target set for the network study is shown as curve (ii); this differs from curve (i) to compensate for defects of the network analogy as explained in the appendix. Curve (iii) shows a similar response to curve (ii) but without damping; this is the theoretical response of the simplified network (Fig. 7(b)).

#### Weight.

With a view to its use in headsets, and also ultimately for lighter handsets, it was decided to keep the weight of the receiver as low as possible. Light alloys were therefore

<sup>2</sup> BAUER, B. B. Analogues of Diaphragms. *Journal of the Acoustical Society of America*, Vol. 23, No. 6, Nov. 1951.

chosen where possible for the constructional parts, and the magnetic driving system was made as small and light as possible by the use of the best available magnetic materials. It was realized that the light weight would have the advantage of reducing inertia forces which might damage the structure or upset the magnetic balance of the armature should the capsule be subjected to undue mechanical shocks, for example by accidental dropping. It was also desirable to reduce cost by the use of minimum amounts of critical magnetic materials.

#### *Protection of the Mechanism.*

Because of the small air-gaps and the light diaphragm it was essential that adequate protection should be given against entry of dirt, probing through the front-plate

#### THE PRODUCTION DESIGN

The construction of the receiver as designed for large-scale production is shown in the sectional view of Fig. 6, and in Fig. 8. The lower half of the photograph shows an "exploded" view of the piece-parts and unit assemblies making up a receiver; the upper half shows complete receivers and supplementary views of piece-parts not fully revealed by the exploded view.

It will be seen that the capsule receiver is constructed around a diecast frame, has an inner diecast perforated plate, and is enclosed by a diecast perforated front plate and a pressed cover, which is stepped from the crown to provide a low-level platform for terminals.

The receiver comprises, essentially, a small electromagnetic driving unit, mounted towards one side of the



FIG. 8.—THE ROCKING-ARMATURE RECEIVER AND ITS COMPONENT PARTS.

apertures, and abnormal changes of pressure on the diaphragm (for example, by clapping the earpiece on the cupped palm of the hand). The necessary protection has been afforded by the capsule construction which totally encloses the receiver except, of course, at the sound outlet. Here protection is afforded by means of an inner plate in which the perforations are offset from those in the front plate, so that it is impossible to insert pointed objects into contact with the diaphragm. Between the inner and outer plates a membrane is arranged to act as a flap valve, closing the holes in either plate upon a momentary abnormal rise or fall of pressure, but readily transmitting vibrations of normal amplitude. The membrane also serves as protection against entry of moisture or dirt into the driving system of the receiver.

frame, which drives a flared light-alloy diaphragm clamped between the frame and the inner plate. The diaphragm, and the armature of the driving unit, are joined by a thin wire connecting rod, shaped at one end to provide a suitable anchor when fixed by Araldite cement to the apex of the diaphragm; later, after balancing the two air-gaps of the driving unit, the connecting rod is soldered at the other end to a V-recess in a tongue of the armature.

#### *The Magnetic System.*

The two-pole balanced magnetic system of the driving unit uses a small high-energy anisotropic permanent magnet (of Alcomax III) having the shape of a rectangular block, which is mounted centrally between the limbs of a U-shaped yoke of Permalloy B (45 per cent nickel-iron alloy) forming

the two pole-pieces. To avoid loss of section at the corners of the pole-pieces on forming (which was found to be detrimental magnetically), fillets of material are swaged up on the insides of the corners. The yoke and magnet are joined together by a soldering operation after coating both parts with tin. Following this operation, the surface of the magnet, pole-pieces and two side fixing lugs of the yoke are brought closely into one plane by a grinding operation.

#### The Windings.

The windings consist of a pair of spools wound on a common mandrel with a continuous length of wire; a spacer between the spools on the winding mandrel ensures the correct length of wire link for the assembly in the receiver. The ends of the winding wire are brought out for direct soldering to the receiver terminals on final assembly. This procedure eliminates the use of conventional stranded lead-wires and five soldered joints (four to lead-out wires, and one between spools). It is therefore cheaper and gives more reliable windings, but since the winding wire is relatively fragile, the windings are made in the assembly line and placed directly on the yokes of the receivers. They are so wound and connected that when assembled one on each pole piece their effects will be in series aiding around the yoke and armature circuit. The fixing is achieved by using the thermoplastic property of the spool material (Diakon) to mould over mushroom-shaped heads, at the back of the yoke, from projecting studs on the spool cheeks. The heads key into notches swaged in the yoke.

#### The Armature.

The armature, which is also made from Permalloy B, rocks or pivots on the magnet with the end faces of the armature opposed to the two pole-pieces; a ridge, which extends partly across one face of the armature and is of circular section where it bears against the magnet, acts as a fulcrum, and also governs the length of the air-gaps between the armature and the magnet and pole-piece assembly. The ridge is raised up over the sides only of the armature, for better mechanical seating on the magnet and also in order to avoid a magnetic constriction at this section of the armature. Regarding the armature in plan (Fig. 5), it will be seen that the central portion, which constitutes an important part of the magnetic circuit, is tapered from the middle towards the polar ends, allowing adequate section for the magnetic flux at each part of the circuit, combined with minimum effective moving mass. This principle has been followed even in the chamfering of the end-corners, which are unnecessary for carrying flux, resulting in a reduction of six per cent in the armature mass. The side limbs of the armature have shaft portions which provide the required torsional control; equality of the two polar air-gaps is achieved by suitably twisting the shafts near to the supporting lugs, after assembly, so that the shafts take an appropriate set.

#### Assembly and Testing.

Two side lugs on the yoke and two corresponding side lugs on the armature are clamped to the frame by the same pair of screws and nuts. Since the plane of the armature surface and its fixing lugs is displaced (by the height of the ridges, 0.0035 in.) from the plane of the magnet and yoke fixing lugs, this gap must be closed on assembly by the clamping forces of the two fixing screws. These forces, together with the magnetic force added on magnetization, provide a total force of the order of 20 lb, which holds the ridges in firm contact with the magnet. It will be noted that this direct clamping together of the armature and the yoke adds two side shunt paths for the permanent magnet flux, through the yoke lugs and side limbs of the armature. However, owing to the small section of the armature

torsion arms, the leakage flux passing by these paths is small, and the resulting simplification in design (compared with the use of non-magnetic spacers between the yoke and armature lugs) is worthwhile.

The inner plate assembly consists of the perforated die-cast plate, to one face of which a disc of woven silk is secured with Phenolic cement, so as to cover the ring of 12 perforations. Before assembly in the receiver, each plate assembly is tested for acoustic resistance by a flow test under direct air pressure. Between the inner-plate assembly and the front plate is clamped a polythene membrane, which is normally prevented from sagging on to the apertures in either plate by small central bosses raised on the opposing faces.

The assembly consisting of the frame with the driving unit, the diaphragm, inner-plate assembly, membrane, and front plate, is secured for initial adjustment and testing by locally forming the skirt of the front plate into recesses at the rear of the frame periphery. The ends of the windings are soldered to the tags of two terminals encased in a small block of thermoplastic material which fits with a frictional grip into recesses in the frame. The terminals have threaded projections which protrude through holes in the cover of the receiver, and are insulated from it by projections of the moulded block and by an external plate insulator which is added after assembly of the cover.

The back of the receiver is enclosed by the cover, the rim of which is formed over the front plate.

The receiver is then tested for sensitivity within three 500 c/s wide frequency bands suitably chosen to provide a check of the shape of the sensitivity/frequency characteristic. The chosen frequency bands are 450-950 c/s, 1,700-2,200 c/s, and 2,950-3,450 c/s.

#### PERFORMANCE OF THE RECEIVER

Fig. 9 shows the sensitivity/frequency characteristics of the new 4T and older 2P and 1L Receiver Insets, plotted on the basis of constant available power from a

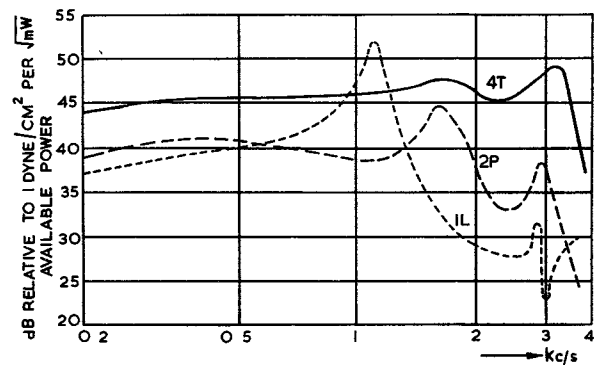

Note.—Measured with Post Office 3-cm<sup>3</sup> Artificial Ear.

FIG. 9.—SENSITIVITY FREQUENCY CHARACTERISTICS OF 4T, 2P and 1L RECEIVER INSETS.

source impedance matched to the receiver impedance at 1 kc/s. In all cases the receivers in the appropriate handset were measured on the Post Office 3-cm<sup>3</sup> Artificial-Ear Coupler. It will be noted that whereas the improvement in the 2P Inset over the 1L Inset was primarily one of shape, the improvement in the 4T Inset over the 2P Inset is both in sensitivity and shape. Thus the effective gain in volume sensitivity of the 4T Inset over the 2P Inset is about 7 dB, while the frequency response curve is flatter, the variation in sensitivity not exceeding about 5 dB over the frequency range 200 c/s to 3,500 c/s. Further, the sensitivity of the 4T Inset rises slightly with frequency, whereas that of the 2P Inset has rather a general falling tendency.

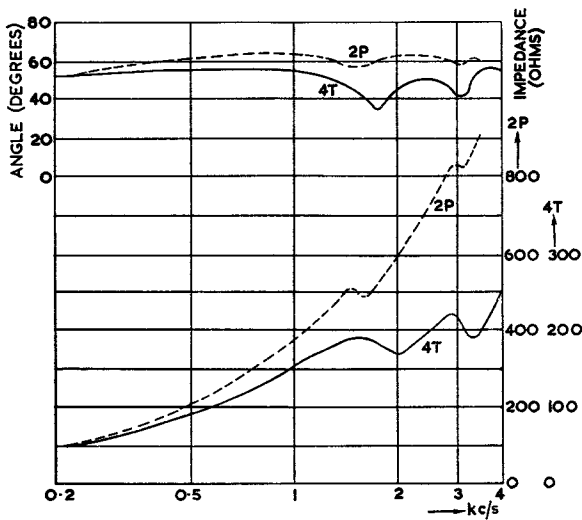

Note:—Measured with Post Office 3-cm<sup>3</sup> Artificial Ear.

FIG. 10.—IMPEDANCE/FREQUENCY CHARACTERISTICS OF 4T AND 2P RECEIVER INSETS.

Fig. 10 shows typical impedance/frequency characteristics for 2P and 4T Receiver Insets measured on the Post Office 3-cm<sup>3</sup> artificial ear; the variations of modulus and phase angle are shown separately. It will be seen that the new receiver has a generally lower phase angle, and a smaller percentage variation of the modulus with frequency, these differences being due largely to the increased "motional impedance" effect in the new receiver. The smaller variation of impedance with frequency of the 4T Inset is advantageous in reducing losses due to mis-matching which occur at all frequencies other than the chosen matching frequency.

The smaller nominal impedance of 150 ohms (at 1 kc/s) of the 4T Inset compared with the 400 ohms of the 2P Inset results from the redesign of the induction coil to meet the requirements of the 700-type telephone.

A feature of the design, which is not apparent from the performance figures, is that the new receiver is less susceptible to the effects of imperfect sealing on the ear, owing to its acoustical impedance being lower, than were the older types of receiver. The effect of an imperfect seal on the ear is shown in Fig. 7(a) by the acoustical mass  $m'_3$  of the leak, and the source of room noise  $p_n$ . It will be clear that, in the new receiver, more of the energy from the noise source will be shunted away from the ear into the lower acoustical impedance of the receiver. Again, in considering the effect of the leak on the signal reaching the ear, it will also be clear that the lower acoustic impedance of the new receiver, which is in series with the ear, means the pressure at the ear is more nearly constant for a given leak. The lower acoustical impedance results partly from the lower effective mass of the mechanical system, and partly because, with the much higher effective area of the diaphragm, consideration of matching between the mechanical and acoustical sections of the receiver demands much lower acoustical impedances of the chambers and outlet holes in the front of the receiver.

ACKNOWLEDGMENTS

The author would like to thank colleagues associated in this development for their assistance, and Standard Telephones and Cables, Ltd. for their permission to publish this outline of the principles involved and research background that have made possible the substantial improvements in sensitivity and response characteristics achieved in the Rocking-Armature Receiver.

Analysis of the simplified network shown in Fig. 7(b)

- Let  $G$  = force factor, defined as the force generated at the diaphragm when unit (a.c.) current flows in the receiver windings,
- $i$  = current in the receiver windings,
- $F$  = the total force generated at the receiver diaphragm, assumed to be constant with frequency, ( $=Gi$ ),
- $A_e$  = effective area of the receiver diaphragm,
- $p$  = pressure developed at the ear (here assumed to consist of a stiffness  $s_e$  only),
- $\omega = 2\pi f$  where  $f$  = frequency.

Then it can be shown, by application of Kirchoff's laws, that

$$p = F s_e s_2 / A_e [\omega^4 m_0 m_2 - \omega^2 (m_0 s_e + m_2 s_0 + m_0 s_2 + m_2 s_2) + s_0 s_e + s_0 s_2 + s_e s_2] \dots (1)$$

This has the form

$$p = 1 / (A \omega^4 + B \omega^2 + C) = 1 / A (\omega^2 - \omega_A^2) (\omega^2 - \omega_B^2) \dots (2)$$

in which  $\omega_A, \omega_B$  correspond with the peaks shown in Fig. 7(c), and where

$$\omega_A^2 + \omega_B^2 = -B/A = (s_0 + s_2) / m_0 + (s_e + s_2) / m_2 = (s_0 + s_2' A_e^2) / m_0 + (s_e' + s_2') / m_2 \dots (3)$$

$$\omega_A^2 \omega_B^2 = C/A = (s_0 s_e + s_0 s_2 + s_e s_2) / m_0 m_2 = (s_0 s_e' + s_0 s_2' + s_e' s_2' A_e^2) / m_0 m_2 \dots (4)$$

and  $A, B,$  and  $C$  have the values defined by identifying coefficients in equations (1) and (2).

To obtain an expression for the response on a power basis, equation (2) must be squared. This yields

$$p^2 = 1 / (A \omega^4 + B \omega^2 + C)^2 = 1 / A^2 (\omega^2 - \omega_A^2)^2 (\omega^2 - \omega_B^2)^2 \dots (5)$$

By differentiation of  $p^2$  with respect to  $\omega^2$  we find from (5) that  $p^2$  becomes a minimum when

$$\omega^2 = -B/2A = \frac{1}{2}(\omega_A^2 + \omega_B^2) = \omega_e^2 \dots (6)$$

Substituting from (6) in (5) and denoting the minimum value of  $p^2$  so obtained by  $p_0^2$ , we have  $p_0^2 = 16/A^2 (\omega_A^2 - \omega_B^2)^4 \dots (7)$  When  $\omega^2 = 0$  we have  $p^2 = p_0^2$ , obtaining by substituting in (5)

$$p_0^2 = 1/C^2 \dots (8)$$

$$\text{From (7), (8), and (4) } p_0/p_0 = A(\omega_A^2 - \omega_B^2)^2 / 4C = (\omega_A^2 - \omega_B^2)^2 / 4\omega_A^2 \omega_B^2 = \frac{1}{4} (f_A/f_B - f_B/f_A)^2 \dots (9)$$

The analysis given above will now be applied to the problem of obtaining a level frequency response with a receiver constructed on the basis of such a mechanical-acoustical network.

In the first place it is important to realize that the analysis of the analogous network assumed that the force  $F$ , i.e., the product  $Gi$ , remained constant with frequency. In the actual receiver,  $G$  falls with rising frequency due to the increasing iron losses, and  $i$  also falls with rising frequency due to the rising electrical impedance of the receiver. (When used in the telephone set, the receiver impedance is normally matched to the source impedance at some frequency in the middle of the voice range, such as 1 kc/s, hence the current falls, as stated.) For this reason, the response measured on an analogous network would have to show a generally rising tendency with frequency in order that the corresponding real receiver response should be level. Fig. 7(c), curve (i) shows the target response of the actual receiver drawn generally level, while curve (ii) shows the corresponding rising target response to be used in studying the design on the analogous network. Both these curves include suitable amounts of resistive damping, which had to be excluded from the network simplified for theoretical analysis. (The amount of damping included, as well as the allowances for defects of the network analogy, do not materially alter the location in frequency of the resonances and trough.) The amount of allowance to be made between curves (i) and (ii) was obtained from measurements on preliminary models of the magnetic driving systems of the receiver. It was found from such measurements that in curve (ii)  $p_0$  should be set 6 dB above  $p_0$ , which corresponds to a ratio  $p_0/p_0 = 0.502$ . The solution of equation (9) for this value of  $p_0/p_0$  yields  $f_A/f_B = 1.94$ . Since the resonance  $f_A$  determines the response near the top of the effective frequency range of the receiver, its value was set at 3,300 c/s; hence  $f_B = 1,700$  c/s (and from equation (6),  $f_e$ , the frequency of the trough = 2,625 c/s).

Substituting these values of  $f_A$  and  $f_B$  in equations (3) and (4) yields two expressions towards the solution of the simplified



network. Of the six quantities to be determined, three,  $m_0$ ,  $s_0$ , and  $A_e$ , were largely fixed by the design of the magnetic driving system and the diaphragm, and a fourth,  $s'_e$ , was known from data on the ear. The remaining two quantities  $m'_2$  and  $s'_2$  were determined by the solution of equations (3) and (4). Several attempts were needed to obtain the best and most suitable values for  $m_0$ ,  $s_0$ , and  $A_e$ ; in particular, it was found necessary to keep  $m_0$ , the total mass of the moving system, as low as possible. This necessitated paring the

armature mass to the minimum required for magnetic reasons, and the use of the thinnest and lightest alloy for the diaphragm consistent with mechanical requirements.

Finally, from a study of the derived mechanical-acoustical system both in actual receivers, and on the analogous electrical network, in which appropriate values for the inherent damping elements  $r_0$  and  $r'_2$  were included, it was possible to select the appropriate resistance  $r'_0$  for the best damping of the resonances.

## A Portable Foot-Pump Desiccator Using Silica Gel

U.D.C. 621.54:542.74

FOR many years the portable foot-pump desiccator has been part of the normal equipment of telephone cable jointers. By means of this unit air is thoroughly dried and then pumped into a newly made joint to verify that it is water-tight; even the smallest hole that may be present in the joint becomes readily apparent by bubbles forming in soap suds applied to the outside of the joint.

The earlier method of drying the air was by pumping it through a cylinder containing a bag of calcium chloride, which was scrapped and a fresh charge inserted after the pump had been used for some time. In practice, however, it was difficult to judge when replacement of the calcium chloride was necessary and checks in the field sometimes revealed the calcium chloride reduced to a sloppy porridge-like mass or in a contracted rock-hard lump and thus useless for drying the air. The only means of determining whether the calcium chloride required changing was by visual examination after removing the top of the cylinder.

To overcome this unsatisfactory state of affairs, without introducing a cumbersome procedure for recording the use and periodicity of recharging of the cylinder, the drying cylinder has been redesigned, and the new design, which has been on satisfactory trial under practical conditions for several months, is shown in Fig. 1. The pump folds up to a position parallel with the drying cylinder for carrying. Silica gel is employed as the drying agent in place of calcium chloride. This gel is coloured with cobalt chloride and is blue when

in a dry and highly adsorbing condition. Silica gel treated in this way progressively changes to pink as atmospheric moisture is adsorbed, thereby giving a visual indication of its condition.

To enable the silica gel to be readily seen, without the need for dismantling the desiccator, the new type of cylinder is fitted with a Perspex window which incorporates a panel of four coloured strips showing a range of colour changes and indicating the condition when the silica gel may and may not be used for drying air.

The new desiccator that will be issued for general use will differ slightly from the prototype shown in Fig. 1 in that the window will be in a protected position on the pressure-gauge side of the cylinder. In this way, the operator can readily note the colour of the gel while looking at the gauge to ensure that the usual 20 lb/in<sup>2</sup> pressure used for this local pressure testing is maintained.

To ensure that the air flow inside the cylinder does not bypass the gel contained in the window recess, partly-porous baffle plates are provided. These baffle plates are mounted on springs to reduce the grinding together of the  $\frac{1}{4}$ -in. gel crystals which may occur due to vibration during transport.

It is a property of silica gel that when it has adsorbed moisture it may be easily reactivated by the gentle application of heat up to approximately 350°F. Hence, when a jointer finds the silica gel is turning a pink colour he can tip it into the baking tin used for drying paper jointing sleeves and reactivate it by the application of heat to the outside of the baking tin, shaking the crystals at the same time to cause air to move over the gel and carry away the moisture that has been released. Advice about reactivation is shown on the Perspex window. Overheating of the gel may cause the crystals to become brown and burnt (a condition that arises at approximately 450°F) or, if heat is applied too rapidly when the crystals contain their full capacity of water, the sudden generation of steam in the extremely fine pores of the gel will cause the crystals to disintegrate.

The ability to reactivate the gel and to be certain that only really dry air is pumped into the joint is of considerable value in the avoidance of incipient low insulation conditions. Loss of effective time in trying to obtain supplies of new calcium chloride—not at all easy in rural areas—is avoided, as also is the cost of fresh calcium chloride. Providing the silica gel is not overheated the adsorption and reactivation cycle may be repeated indefinitely.

J. J. M. R. E. M.

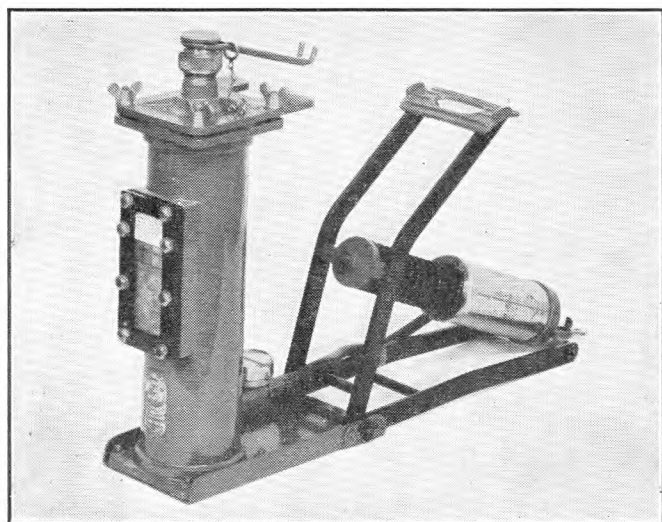

FIG. 1.—THE DESICCATOR, READY FOR USE.

# The Introduction of a Telephone Weather Service in London

D. J. MANNING†

U.D.C. 621.395.91:551.509

A recorded forecast of the weather over an area of about 20 miles radius is now available to telephone subscribers in London by dialling a special number. The author describes the trunking arrangements and a new final selector employed to provide this new service.

## INTRODUCTION

THE provision of a service giving weather-forecast announcements automatically to telephone callers dialling an appropriate code was considered by the Post Office before the war, not long after it became clear that the speaking clock service was a success. During the war, knowledge of the weather over the British Isles or approaching them had to be kept from the enemy, as far as possible, and public weather forecasts were suspended. For some years after the war consideration of a telephone weather service had to remain very low on the list of telecommunication works to be done and it was not until February, 1955 that it was decided to introduce a trial service in London, which has now opened.

In this service, callers hear a continuously repeated announcement, giving the forecast for a central area of some 20 miles radius for a period of about nine hours, usually with some indication of the further outlook. The Meteorological Office reviews the forecast every hour and advises the Post Office recording centre when a change of announcement becomes necessary.

## DIALLING AND ROUTING OF CALLS TO WEATHER ANNOUNCEMENTS

In planning the new service it was thought that, if the initial service, giving forecasts for a central area, proved popular, a demand was likely to grow for forecasts covering surrounding areas; for example, South and East coastal areas within "day-tripping" range. It followed that a simple three-letter dialling code, say "WEA," would be unlikely to suffice for the Weather Service. As there might be several weather services eventually, it was decided that the dialling code for each should be "WEA" followed by four numerical digits. The initial service, giving forecasts for the central area only, is reached by dialling "WEA 2211."

The digits "WEA" route a weather-service call as far as a tandem second selector in either Holborn or Museum tandem exchange. Of the four numerical digits the first two are sufficient to select the particular service required. The remaining two digits, which will be "11" for all services, are not required for routing purposes but to ensure that the director will switch the call. A number consisting of three letters plus figures must contain four figures since, if less than four figures are dialled, the director waits 30 to 60 seconds for the remaining digits and then releases without having switched the call through. The last two digits "11" on a weather service call are pulsed into the announcements, but since the announcement source is an amplifier (of the type used in provincial exchanges for the speaking clock service) having a low effective output impedance of about 1.3 ohms, the disturbing voltages across the amplifier output are low in comparison with the announcement output voltage. The attenuation of the low-frequency disturbing voltages is further increased by connecting each call to the amplifier through a decoupling network consisting of a 2 $\mu$ F capacitor and 700-ohm resistor in series with each wire of the speech pair.

So that the minimum number of selector ranks is required, the two dialled digits which select the required announcement are both accepted on one selector, an information-service final selector. Besides switching the call to the selected announcement, this selector also performs functions similar to those of a speaking-clock terminating relay-set; namely, holding the connexion, returning conditions causing the call to be metered, transmitting N.U. tone and suppressing call-metering when the announcements fail, and providing facilities for the measurement of traffic.

Even if one dialled digit had been considered sufficient for any future announcement selection, this final selector (requiring two digits) would have been economic, being cheaper than the combination of a group selector and terminating relay set. It has the further economic advantage that it can be used in large groups giving access to many different information services, the advantage being increased if the busy hours of the different services do not coincide. It has capacity for 100 services, one service per bank-multiple outlet, each of which would be reached by dialling a 3-letter plus 4-figure code. All services could, if required, be reached either by the same routing digits preceding the announcement-selecting digits, or by any other available routing codes, for example "INF" as well as "WEA."

## THE INFORMATION-SERVICE FINAL SELECTOR

The chief difference between an information-service final selector and a normal final selector is that the former does not busy the outlet to which it switches.

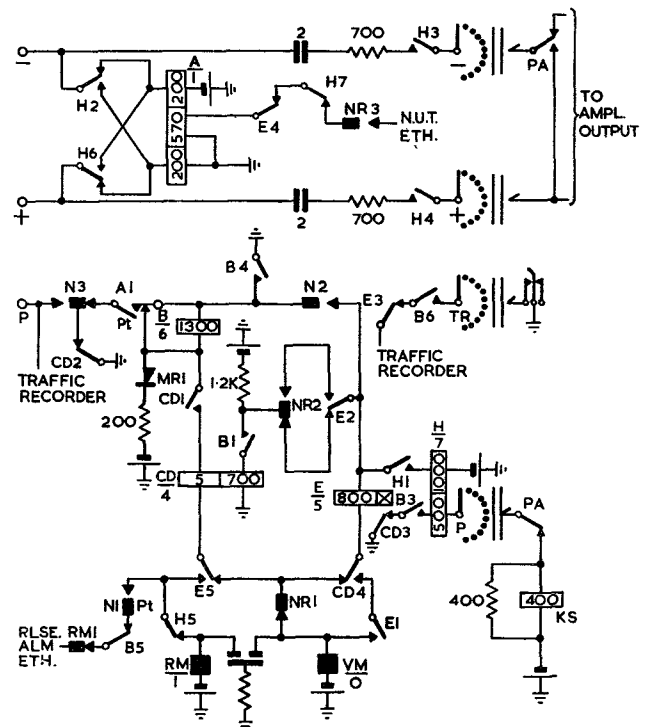

FIG. 1.—THE INFORMATION-SERVICE FINAL SELECTOR.

†Executive Engineer, Telephone Development and Maintenance Branch, E.-in-C.'s Office.

Earth is connected to the P-bank outlet (from contact CD3, Fig. 1) for only about 150 ms at the end of rotary stepping. The release of contact E2 then removes a short circuit from relay CD, which reoperates. The H relay switches during this period to a 200-ohm negative battery condition from a KS relay, one of which is provided per service per rack of 80 final selectors. Five final-selector H relays can switch simultaneously to any one KS relay. The probability of more than five out of 80 final selectors attempting to switch simultaneously to one service when the switching time of each is only 150 ms is so remote that failures to switch due to heavy traffic will be rare (one failure, on average, in a million calls).

The KS relay will operate in series with one or more H relays, and at each operation registers a call on a call-count meter. Overlapping calls arriving so close together that the KS relay cannot release between them cause the call-count meter to under-read, but the degree of inaccuracy is insignificant. Provision is made for two other traffic measurements. There are traffic recorder access points on the incoming P-wire and in the circuit to the TR bank wiper. The first permits measurement of the total traffic to the information-service final selectors, and the second the traffic to any one information service, the appropriate TR bank outlet being earthed by operation of a key.

If a service fails, the amplifier output is disconnected and the leads to the final-selector banks are short-circuited to prevent crosstalk between callers who are already connected to the announcements when they fail. Also, the KS relay for each final selector rack is disconnected so that subsequent calls to the service cannot switch; N.U. tone and non-metering conditions are returned to the callers (Fig. 1, H relay not operated).

#### DISTRIBUTION OF ANNOUNCEMENTS TO FINAL SELECTORS

Theoretically, each service output could be multiplied over the banks of all the final selectors at the information-service switching centre, but in practice not more than three racks of final selectors will be multiplied together. Each multiple extending over three racks (or less) constitutes an "output channel." The primary reason for so limiting the extent of multiplying of a service output is the need to avoid overloading of the amplifier, which could cause an appreciable drop in output voltage and distortion of the speech. As planned, each output channel, connected to one working amplifier, will serve three racks of final selectors, so that the maximum load for the amplifier is 240 calls. Assuming each call is made over a line of 600 ohms impedance, the peak amplifier load will be some 8 ohms. At this load the amplifier output will be only about 3 dB below that when no calls are connected and this drop will not be noticeable to callers. The true instantaneous peak speech voltage output to line on each call will be about 1V when the amplifier output meter is indicating 1.4V on the peak syllables in the announcements, which is the reading to which the amplifier gain is adjusted.

For the initial weather service in London there will be six racks of final selectors at Holborn exchange and three racks at Museum exchange. Thus there are two output channels for "WEA 2211" at Holborn, and one at Museum. Each output channel is served by a pair of amplifiers, one working and one standby. The input of each amplifier is connected to a line from the working announcing machine, located in Holborn exchange building (see Fig. 2). If the working channel-amplifier output fails, either because of a fault within the amplifier itself or because of failure of the input, an alarm relay in the amplifier releases and the service is automatically changed over to the standby amplifier. If the standby channel-amplifier also fails, a prompt alarm is given. The most probable

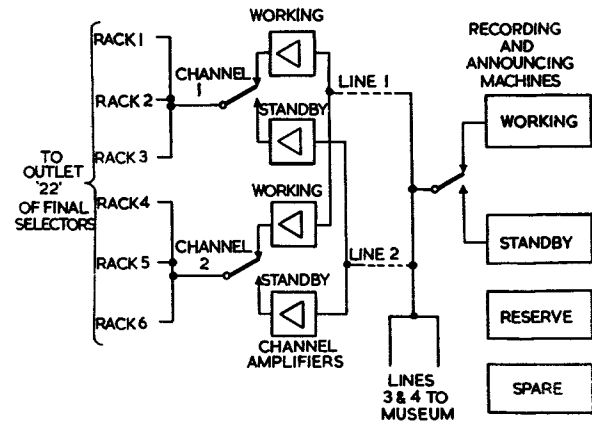

FIG. 2.—DISTRIBUTION OF ANNOUNCEMENTS TO FINAL SELECTORS.

cause of failure of both amplifiers of a channel at Holborn is failure of the working announcing machine, which is in the same building, and therefore in this condition a signal is transmitted to cause changeover of the service to the standby machine.

#### RECORDING OF FORECASTS

When a telephone weather service was considered before the war it was at first envisaged that machines similar to the speaking clocks, but without such close control of speed, would be used, each having several recorded discs carrying announcements of a variety of phrases covering the component aspects of weather. The phrase-tracks would have been selected for continuous playback as required by the forecaster. Such machines were used in Stockholm and elsewhere from 1936. They would have required a minimum of maintenance and changing a forecast would have been a simple and inexpensive procedure. There was, however, always the doubt whether a practicable machine could have given sufficient variety of phrase for accurate description of British weather, and the idea has now been abandoned in favour of using magnetic recording technique, each forecast being freshly recorded as received from the meteorological office.

The London Weather Service is initially being given by using four magnetic tape recording and play-back machines of a well-known commercial make, similar to those used for changed-number announcing.<sup>1</sup> It is possible to select any one of three of these machines as the "working" machine, the others being simultaneously selected as the "standby" and "reserve" machines; the fourth, "spare," machine can be patched-in in place of any of the others that is withdrawn for maintenance. A new forecast is recorded on the standby and reserve machines simultaneously (changeover of the service to the standby machine in case of failure of the working machine being prevented during the process). These two machines are then, after a check play-back of the recording, switched to "working" and "standby."

Normally only the working machine is running. It gives continuously repeated play-back of the forecast announcement, which is between 25 and 30 seconds long and is reproduced from an endless loop of tape of 30 seconds playing time. In periods of settled weather a shorter message may suffice. This will be arranged to be about 13 seconds long and will be recorded twice on the 30-second loop of tape. Until a re-recording becomes necessary the standby machine carries the same recorded announcement as the working machine but normally delivers no output because its motor is stopped. Before recording a new forecast the recording operator must check that the

<sup>1</sup> MANNING, D. J. The Changed-Number Announcer. *P.O.E.E.J.*, Vol. 47, p. 179, Oct. 1954.

speaking time will be between 25 and 30 seconds, and during recording the operator must be careful to keep her message between these limits. If she exceeded the upper limit the end of the message would not be recorded. If she recorded in less than the lower limit of time, callers would have to wait longer than 5 seconds between successive announcements and it is possible that the alarm relays in the channel amplifiers would not hold in.

Since many of the controls are integral parts of the machines, they could not be made suitable, unless considerably modified, for remote control by an operator, and the assistance of a recording engineer is therefore required at each change of announcement. Machines are, however, being designed which will give the operator complete control of the recording process and considerably greater freedom in the matter of message length.

## CONCLUSION

Following speedy completion of all details of switching and control equipment design by the author's colleagues in Telephone Branch, the work of installation was planned, supervised, and executed by engineers of the London Telecommunications Region, and the first automatic telephone weather service in this country was made available to the London public in March, 1956.

Whether other information services will be introduced later will depend on the success of this first weather service. The use of the special final selectors would facilitate the introduction of other services at Holborn and Museum, but if the total traffic would much exceed the 300 Erlangs for which equipment is initially provided it would become necessary to use the subsidiary tandem exchanges as additional distributing centres.

## Submerged Telegraph Repeaters

U.D.C. 621.315.28:621.375.2:621.394.6

Two experimental submerged telegraph repeaters, designed and constructed at the Post Office Research Station for Cable & Wireless, Ltd., were laid during 1955, by the company's cable ship *Recorder*

THE Porthcurno-Gibraltar No. 3 and No. 4 cables, in which submerged telegraph repeaters were laid during 1955, are typical of many older single-core cables in the network of Cable & Wireless, Ltd. They are unloaded, insulated with gutta-percha and armoured. Their maximum duplex operating speed without repeaters, determined by the signal-to-noise ratio at the receiving end, is about 60 words/min for the No. 3 cable and about 85 words/min for the No. 4 cable. Three-condition cable code is used and the word speeds quoted above are obtained at modulation rates of about 20 and 28 bauds respectively.

The basis for the provision of the repeaters is as follows. There are considerable technical and practical difficulties in feeding power to several low-speed repeaters in tandem. However, it is found that almost all the noise is induced in these telegraph cables where they lie in shallow water, the

verno-Gibraltar No. 4 cable was laid on 4th December, 1955, also in about 650 fathoms, 130 nauts from Gibraltar.

The two-stage repeater includes six of the Post Office long-life valves type 6P/12 and its gain is approximately 85 dB at the upper end of its frequency range. The chassis, shown in Fig. 1, which was designed to be encased in a housing generally similar to the Post Office deep-sea telephone repeater, incorporates some large and heavy components, notably the output transformer whose secondary winding has to carry the valve-heater current to a sea earth. The housing is 6 in. longer than those used for the Aberdeen-Bergen telephone cable and provides for two cores to be led through the bulkheads. Twin cable is provided for 25 fathoms on each side of the repeater, so that the sea earths on the main-sea-cable armouring may be well separated to avoid electrical coupling between the input and output. The sea cable between the repeater and

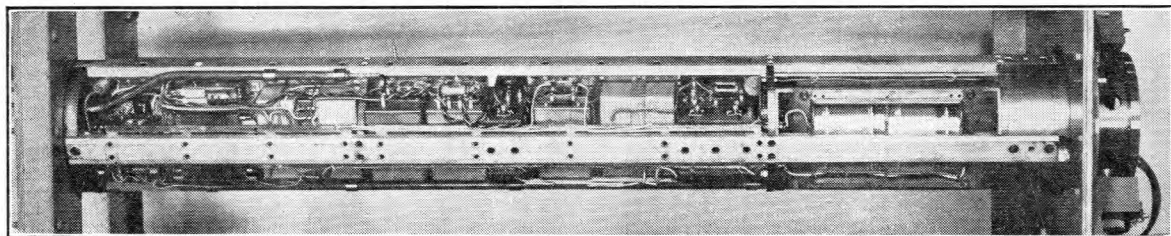

FIG. 1.—SUBMERGED TELEGRAPH REPEATER.

Note. The ironwork at the ends of the repeater is part of the demonstration frame in which it is mounted.

major part of the cable, lying in depths greater than, say, 250 fathoms, contributing negligible noise. A useful improvement can, therefore, be achieved by inserting a single repeater near the receiving end at the point where the sea is beginning to deepen rapidly on the edge of the land shelf. The repeater should also, if possible, be well on the seaward side of any crossings of other cables. Duplex operation is sacrificed, but the maximum signalling speed can be at least tripled, so that the traffic-handling capacity is increased by about 50 per cent. This idea was first exploited by the Western Union Telegraph Co., who, in 1950, inserted a repeater 170 miles from Bay Roberts, Newfoundland, in a cable to Penzance.<sup>1</sup>

The repeater in the Porthcurno-Gibraltar No. 3 cable was laid on 21st July, 1955, in about 650 fathoms, 170 nauts along the cable from Porthcurno, and that in the Porth-

the receiving terminal has been relaid with polythene cable in each case.

The receiving terminal, including the constant-current power-feeding rack, was also designed and constructed at Dollis Hill. The repeater does not transmit d.c., but d.c. restoration is provided in the signal receiver. The receiving terminal feeds power to the repeater, and has facilities for switching the repeater in and out of the cable so that a reversion to low-speed duplex working is possible.

During engineering tests, made in collaboration with Cable & Wireless, Ltd., good signals were obtained at 60 bauds on the No. 3 cable and 90 bauds on the No. 4 cable.

G.N.D.

<sup>1</sup> CRAMER, C. H. Submerged Repeater for Ocean Cable. *Electrical Engineering*, Vol. 70, p. 566, 1951.

# Continuously-Variable Electrical, Acoustical and Mechanical Impedances

J. Y. MORTON, A.M.C.T., A.M.I.E.E.,  
and R. A. JONES, B.Sc.(Eng.)†

U.D.C. 621.3.011.21:534.231.3:531.3

A theoretical basis is given for all three continuously-variable impedances, and is followed by a practical example of the acoustical impedance

## INTRODUCTION

THE design of a continuously-variable acoustical impedance was undertaken with the object of simulating the impedances of a number of individual human ears in connexion with the design of an artificial ear. The principle has a much wider field of application and could be extended to electrical and mechanical problems; it is best explained in electrical terms.

## THEORETICAL BASIS OF CONTINUOUSLY-VARIABLE IMPEDANCES

In Fig. 1 (a) an impedance  $Z$  is connected to the terminals of a network of impedances and generators; the p.d. across  $Z$  is  $V$  and the current flowing through it is  $I$ . In Fig. 1 (b),  $Z$  is replaced by an electrical source  $A$  of

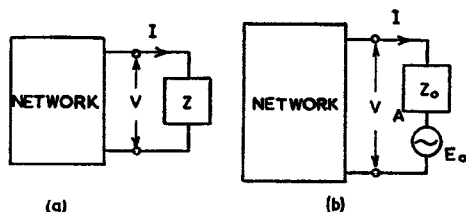

FIG. 1.—CONTINUOUSLY-VARIABLE ELECTRICAL IMPEDANCE.

internal impedance  $Z_o$  whose e.m.f.  $E_o$  is adjusted in magnitude and phase until the current flowing from the network is restored to  $I$ . As there are no changes in the generators and impedances of the network, and the current flowing from it remains the same, the voltage drop to the terminals is unchanged. Hence the terminal voltage  $V$  is maintained and the input impedance of source  $A$  is  $V/I = Z$ . Alternatively, if  $E_o$  is adjusted until  $V$  is restored, it follows that terminal current  $I$  will be restored, and the source  $A$  will still simulate impedance  $Z$ ; in other words, source  $A$  behaves as a continuously-variable electrical impedance (c.v.e.i.).

If the c.v.e.i. is connected to any other network and the current  $I$  flowing through it is restored to its value in Fig. 1 (b) by means external to the c.v.e.i., then the p.d.  $V$  across it will be maintained, for

$$V = Z_o I - E_o \dots \dots \dots (1)$$

Hence, the input impedance will still be  $Z$ . Alternatively, if the terminal p.d.  $V$  is restored by means external to the c.v.e.i., the current  $I$  will be unchanged and the c.v.e.i. will still simulate impedance  $Z$ .

If  $Z_o$  is a linear impedance and the ratio of  $V$  to  $E_o$  obtaining in Fig. 1 (b) is repeated when the c.v.e.i. is connected to the other network, without necessarily repeating  $V$ , the change in  $I$  will be proportional to any changes in  $V$  and  $E_o$  and the input impedance of the c.v.e.i. will still be  $Z$ . Because of the proportionality between  $I$  and  $V$  it is immaterial whether the ratio of  $I$  to  $E_o$  or  $V$  to  $E_o$  is repeated when setting up the c.v.e.i.

From equation (1),  $\frac{E_o}{I} = Z_o - Z \dots \dots \dots (2)$

and  $\frac{E_o}{V} = \frac{Z_o}{Z} - 1 \dots \dots \dots (3)$

Hence, if  $Z_o$  is known and a device to give the ratio of  $E_o$  to  $I$  or  $V$  can be made, that device can be calibrated in terms of  $Z$ .

It can be shown that errors in the impedance of the c.v.e.i. caused by variations in  $E_o$ ,  $V$  and  $I$ , due to instability or poor adjustment, are diminished the closer the simulated impedance value,  $Z$ , approaches the source impedance  $Z_o$ . Errors caused by independent variations of  $Z_o$  are minimized when  $Z_o$  is very much smaller than  $Z$ . As variations in  $E_o$ ,  $V$  and  $I$  are those liable to give the greatest trouble a practical design figure for  $Z_o$  would be of the same order as the impedance to be simulated, but it will be appreciated that the condition is not critical.

## Acoustical Analogue.

In Fig. 2 (a) an acoustical impedance  ${}_aZ$  is connected in an acoustical system and a sound pressure  $p$  and volume current  $U$  exist at the plane of the connexion. This figure is the analogue of Fig. 1 (a) in which  $p$  corresponds to p.d.

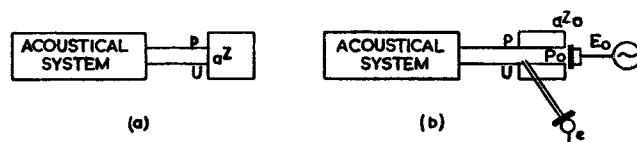

FIG. 2 —ACOUSTICAL ANALOGUE OF FIG. 1.

$U$ , and  $U$  to current  $I$ . By analogy with the electrical circuit of Fig. 1 (b), if  ${}_aZ$  is replaced by a sound source of internal impedance  ${}_aZ_o$ , as in Fig. 2 (b), and the source pressure  $P_o$  is adjusted until  $U$  or  $p$  is restored at the connexion, the input impedance of the sound source will be  ${}_aZ$ .

It follows that the sound source can be adjusted to any required input impedance  ${}_aZ$  by adjusting  $P_o$  and that the source behaves as a continuously-variable acoustical impedance (c.v.a.i.).

As it is more convenient to measure sound pressure than volume current the remainder of the argument in the acoustical case will be confined to that involving a measurement of  $p$ , although it will be appreciated that theoretically a method involving the measurement of  $U$  and not  $p$  should be equally successful. If the c.v.a.i. is connected to another acoustical system and the feed to that system is adjusted until the sound pressure  $p$  at the plane of the connexion is restored, by analogy with the electrical case the input impedance to the c.v.a.i. will still be  ${}_aZ$ . If  ${}_aZ_o$  is a linear impedance and the ratio of  $p$  to  $P_o$  obtaining in Fig. 2 (b) is repeated when the c.v.a.i. is connected to the other system, without necessarily repeating  $p$ , the input impedance of the sound source will still be  ${}_aZ$ . In practice the value of  $p$  used in setting up the c.v.a.i. is repeated when the c.v.a.i. is applied to an acoustical system; this ensures the greatest accuracy. As in the electrical case, the best results are obtained when the source internal impedance  ${}_aZ_o$  is of the same order as the simulated impedance  ${}_aZ$ .

The acoustical equivalent of equation (3) is:—

$$\frac{P_o}{p} = \frac{{}_aZ_o}{{}_aZ} - 1 \dots \dots \dots (4)$$

Hence a device measuring  $P_o/p$  can be calibrated in terms of  ${}_aZ$  if  ${}_aZ_o$  is known. By using linear electro-acoustical

† The authors are, respectively, Executive Engineer and Assistant Engineer, Post Office Research Station.

transducers for the sound source and microphone of Fig. 2 (b), the acoustical measurement can be adapted to an electrical one.  $P_o$  is proportional to electrical stimulus  $E_o$  and e.m.f.  $e$  to  $p$ , hence

$$\frac{P_o}{p} = A \frac{E_o}{e} = \frac{aZ_o}{aZ} - 1 \dots \dots \dots (5)$$

where  $A$  is a constant depending on the properties of the transducers.

It will be noted that even if non-linear transducers and a non-linear source impedance are used the method will still work provided the sound pressure  $p$  obtained in Fig. 2 (b) is repeated on connexion of the c.v.a.i. to a new system.

*Mechanical Analogue.*

In Fig. 3 (a) a mechanical impedance  $mZ$  is connected to a mechanical system and a force  $f$  and velocity  $v$  exist at the point of the connexion. This is the mechanical analogue

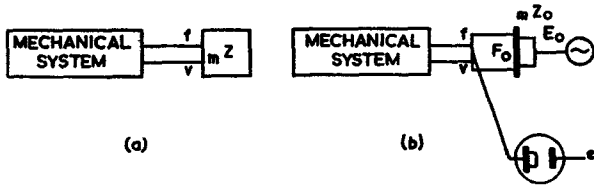

FIG. 3.—MECHANICAL ANALOGUE OF FIG. 1.

of Fig. 1 (a); the force  $f$  corresponds to the p.d.  $V$  and the rectilinear velocity  $v$  to the current  $I$ . By analogy with Fig. 1 (b), a mechanical source of impedance  $mZ_o$  and force  $F_o$ , as in Fig. 3 (b), may be used to simulate impedance  $mZ$  if  $F_o$  is adjusted so that either  $f$  or  $v$  at the point of connexion have the same value as in Fig. 3 (a). As in the electrical case, if  $mZ_o$  is a linear impedance and the ratio of  $F_o$  to  $v$  or  $f$  obtaining in Fig. 3 (b) is repeated when the mechanical source is connected in any other system without necessarily repeating  $v$  or  $f$ , the source will simulate the impedance  $mZ$ . Hence it behaves as a continuously variable mechanical impedance (c.v.m.i.). The condition for greatest accuracy is again when the source internal impedance is of the same order as the impedance to be simulated.

In practice, measuring velocity  $v$  at the point of connexion will be simpler than measuring force  $f$  so the remainder of the argument in the mechanical case will be confined to that involving a measurement of  $v$ . By using linear electro-mechanical transducers for the mechanical source and velocity detector,  $F_o$  is made proportional to electrical stimulus  $E_o$  and e.m.f.  $e$  to  $v$ . Hence, the mechanical analogue of equation (2) can be adapted to electrical measurements,

$$\frac{F_o}{v} = mZ_o - mZ = B \frac{E_o}{e} \dots \dots \dots (6)$$

where  $B$  is a constant depending on the properties of the transducers. It follows that a device measuring  $E_o/e$  can be calibrated in terms of  $mZ$  if  $mZ_o$  is known.

As in the acoustical case, the method will work even if non-linear transducers and a non-linear source impedance  $mZ_o$  are used, provided the value of  $v$  obtained when setting up the c.v.m.i. is repeated when it is applied to a new mechanical system.

COMMON ELECTRICAL EQUIPMENT AND ITS OPERATION IN THE ACOUSTICAL CASE

The variable impedances require electrical circuitry which is common to all three types, electrical, acoustical and mechanical. They all require a method of adjusting  $E_o$  in magnitude and phase and a method of measuring a ratio of two voltages  $\frac{E_o}{V}$  or  $\frac{E_o}{e}$ .

A common electrical circuit is shown in Fig. 4 with

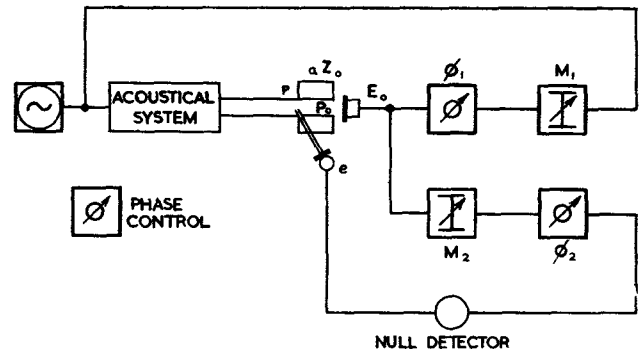

FIG. 4.—COMMON ELECTRICAL CONTROL CIRCUIT (SHOWN WITH ACOUSTICAL EQUIPMENT).

associated acoustical equipment. The modulus and phase controls  $M_1$  and  $\phi_1$  are used to adjust  $E_o$  and hence the sound pressure  $P_o$ . The "null" detector in association with modulus and phase controls  $M_2$  and  $\phi_2$  is used to store and indicate by a "null" a given ratio of  $E_o$  to  $e$  and hence a given acoustical impedance. From equation (5) it follows that  $M_2$  and  $\phi_2$  can be calibrated in terms of acoustical impedance. In practice this calibration is dispensed with because greater accuracy can be obtained by setting up the c.v.a.i., using an acoustical impedance measuring set.<sup>1</sup> The procedure is as follows:—

$M_1$  and  $\phi_1$  are adjusted until the measuring set indicates the required impedance;  $M_2$  and  $\phi_2$  are then adjusted to give a null on the null detector. When the c.v.a.i. is connected to an acoustical system,  $M_1$  and  $\phi_1$  are adjusted, or the feed to the system is adjusted, until the null is restored; the c.v.a.i. then simulates the required impedance.

No attempt has been made to date to build the electrical and mechanical counterparts of the c.v.a.i., but it is probable that in the mechanical case calibrations of  $M_2$  and  $\phi_2$  would give less accurate results than setting up with a mechanical impedance measuring set.<sup>1</sup>

ACOUSTICAL EQUIPMENT

Fig. 5 shows a cross-section of the acoustical equipment. The source transducer, which is a moving coil receiver, is coupled to the source cavity by an annular slit<sup>2</sup> to distribute the sound pressure uniformly over the plane of application of the c.v.a.i. The cross-section of the cavity should be continuous with that in the acoustical system to which it is connected and to that of the impedance measuring set with which it is used. Cavity couplers such

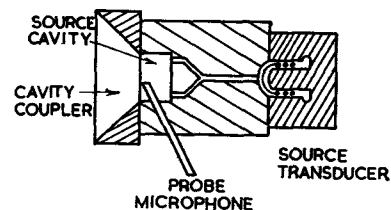

FIG. 5.—SOUND SOURCE AND CAVITY COUPLER.

as the one shown in Fig. 5 can be used to prevent too abrupt a discontinuity at the plane of the connexion. The probe microphone has been described in a previous issue of this journal.<sup>3</sup> Its impedance is part of the source internal impedance  $aZ_o$ .

References

- <sup>1</sup> MORTON, J. Y. A Measuring Set for Acoustical and Mechanical Impedances. Proceedings of the first I.C.A. Congress on Electro-Acoustics, *Acustica*, Vol. 4, p. 117, 1954.
- <sup>2</sup> MAWARDI, OSMAN K. Measurement of Acoustic Impedance. *Journal of the Acoustical Society of America*, Vol. 21, p. 86, 1949.
- <sup>3</sup> ARCHBOLD, R. B. An Experimental Probe Microphone for the Measurement of Sound Pressures. *P.O.E.E.J.*, Vol. 45, p. 145, 1953.

# A Pressurized Waveguide System

J. G. HOBBS†

U.D.C. 621.372.8

The internal surface of a waveguide must be kept dry and clean to ensure satisfactory transmission, and a method of achieving this by maintaining a reasonably constant pressure of dry nitrogen in the waveguide is described.

## INTRODUCTION

WAVEGUIDE is used in most microwave radio systems operating at frequencies above 2,000 Mc/s, the internal "wiring" of those parts of the transmitter and receiver that carry signals at these frequencies usually being in the form of hollow rectangular waveguide. Aerial systems are connected to the equipment by similar waveguide feeders. It is, of course, possible to use coaxial conductors for aerial feeders and this form of conductor is used very successfully at 2,000 Mc/s, but as frequency increases the hollow waveguide becomes increasingly attractive, chiefly because the attenuation coefficient of coaxial conductors increases with frequency rather more rapidly than that of hollow waveguide, and at 4,000 Mc/s and above the favoured type of conductor for feeders is the waveguide.

Waveguide with a rectangular cross-section is usually employed, though there is likely to be an increasing use of waveguide with a circular cross-section for aerial feeders. Very great care must be taken in the construction of the feeder to ensure that it is substantially free from unwanted internal reflections, that the joints are sound and that the waveguide remains in good condition. Irregularities in the waveguide cause reflections which, although they may represent a quite negligible power loss, can introduce echoes which will seriously impair the performance of a frequency-modulated radio system by introducing intermodulation noise when the system is carrying multi-channel telephony signals. Although less susceptible, a television link can be degraded by the same cause. The internal surface of the waveguide must remain dry and clean, because if the surface becomes fouled the attenuation rises: if it becomes wet the condensed moisture will increase the attenuation to a marked extent. It is therefore desirable to prevent the entry of the atmosphere into the waveguide feeder, and essential to prevent water vapour condensing on the inside walls. The obvious solution is to block the waveguide feeder at each end with a window that is transparent to the radio waves but impervious to gases. This article shows that this simple solution would have undesirable results and then describes a sealed waveguide system employed by the Post Office in some installations.

## SEALED WAVEGUIDES

Sealing the feeder from the atmosphere requires a window at the aerial end and another one at the apparatus end of the feeder and, because reflections within the feeder must be reduced to very small amounts, the electrical impedance of the window must be as closely as possible the same as that of the waveguide in which it is fitted. Without dealing in detail with the design of such windows it can be said that the most suitable material appears to be best-quality ruby mica, used in sheets 0.003 in. thick in a mounting that permits compensation for the added capacitance due to the mica. These windows can be made to have a reflection coefficient of 1 per cent or less. The ability of such a window to withstand air pressures is obviously limited, and when used in a waveguide with a cross-section of  $2\frac{1}{2}$  in.  $\times$   $1\frac{1}{4}$  in. the window described will withstand a differential pressure of 1 lb/in<sup>2</sup>. The waveguide, since it is of rectangular form, is easily distorted by internal pressure; a pressure of 1 lb/in<sup>2</sup> will cause the broad face of the guide to bulge by about 0.0013 in. This should be compared with the manufacturing tolerance on this size of waveguide,\* which is 0.003 in.

If the volume in the waveguide between the windows were sealed off, the differential pressure would vary since it would depend upon the ambient temperature and pressure as compared with the conditions prevailing when the feeder was sealed. Because the feeder is unprotected from changes of temperature and at times may be in direct sunlight, pressure differentials of the order of 3 lb/in<sup>2</sup> could be produced in the United Kingdom under extreme weather conditions, which would damage the windows and might produce significant reflections due to dilation or contraction of the waveguide feeder. It is therefore undesirable to seal the feeder without at the same time ensuring that differential pressures do not exceed a safe figure, which has been set at 0.5 lb/in<sup>2</sup>.

The device described below maintains a reasonably constant pressure of dry nitrogen within the waveguide, and is arranged to regulate this automatically within safe limits. It has certain other features which, although incidental, are nevertheless important, such as supplying additional gas when required, eliminating overloads, whether natural or accidental, and making long-term checks for the presence of small leaks in the complete feeder.

## PRESSURIZED WAVEGUIDES

The pressurized waveguide is connected by a small-bore tube to a reservoir, ‡ Fig. 1 (a), in which a liquid is displaced

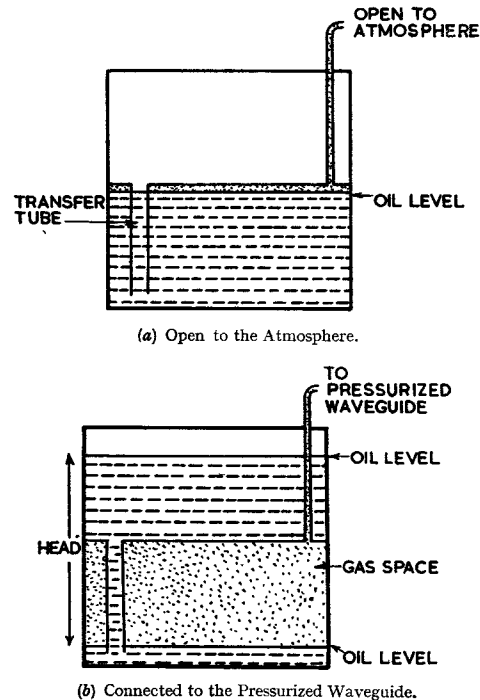

FIG. 1.—PRINCIPLE OF OPERATION OF THE RESERVOIR.

by the gas pressure. The reservoir consists of a container divided horizontally into approximately equal volumes by

† Assistant Engineer, Radio Experimental and Development Branch, E.-in-C.'s Office.

\* Waveguide, seamless rectangular tubing W.G.11. Specification RCL 351 of the Radio Components Standardization Committee.

‡ This device is covered by British Patent Application No. 3850/54, American Application Serial No. 485117 and Canadian Application 680103 in the name of the National Research Development Corporation, Tilney Street, London, W.1.

U.D.C. 621.395.9:351.74

A new standard telephone and signalling system has been developed for use in the provinces; it includes only standard items of telephone equipment.

## INTRODUCTION

**P**OLICE alarm systems were introduced as an aid to both the police and the public for dealing with emergency calls and to assist the police in their duties. They consist essentially of a number of telephones, suitably housed and sited in prominent places in public thoroughfares and directly connected to the police headquarters. They are available for use by both the police and the public to establish contact with the police headquarters in an emergency with the minimum of delay. A signalling device, normally in the form of a lamp, is also provided at the telephone point to enable the switchboard operator to attract the attention of a patrolling policeman for relaying urgent messages.

The "emergency call" value of the police alarm system to the general public was lessened to a considerable extent by the introduction of the "999" service, but it still remains an important part of the emergency services, apart from its special value to the police. To date, several systems have been introduced and are in use in the provinces, in addition to the systems used by the London Metropolitan and City police authorities, which are peculiar to the special requirements of the police authorities in the capital.

The various provincial systems in use have several features which have become outdated, notably:—

- (1) Special switchboards are used, employing many non-standard components, and special stocks of spare parts must be held for maintenance.
- (2) Party line working, which was adopted for reasons of line plant economy, has in actual practice not realised this saving and has sometimes given rise to noise trouble on the circuits. The present tendency to reduce the conductor gauge of distribution cables is also making it difficult to keep such circuits within signalling limits without resorting to bunched cable pairs.
- (3) At the time when the systems were designed, people were not very "telephone minded" and a loudspeaker method of conversation was therefore used for the public side of the call points. Nowadays, the conversations are considered to be too public and unwanted interest is attracted by the loudspeaker and lamp signal when the public side of the call point is in use.

It was therefore decided to introduce a new standard telephone and signalling system for the provincial police which would meet the Home Office requirements and at the same time use only standard telecommunications equipment.

## THE NEW SYSTEM

For the new system, the loudspeaker type of communication has been abandoned and a single hand-microtelephone is provided at each call point for use by both the police and the public (Fig. 1). Each call point is connected by an individual circuit to the switchboard at the police headquarters, which is a standard P.M.B.X., either of the lamp calling type for large installations, or with indicator calling where the installation is small.

### Facilities.

The facilities offered by the new system are:—

- (a) To call the police headquarters from a call point it is only necessary to lift the telephone handset. The



FIG. 1.—STREET CALL POINT.

- (b) For the switchboard operator to attract the attention of a policeman on the beat, a ring key is associated with each call-point circuit termination on the switchboard. These keys are non-locking and momentary operation of the ring key associated with the call point required causes the calling signal to be sent out to the call point. The calling signal consists of ringing current connected in pulses of 0.75 s on and 0.75 s off, and remains locked in automatically until the call is answered at the call point, or is cancelled by a second momentary operation of the ring key. The signal lamp at the call point flashes in response to these ringing pulses. Any number of call points may be called simultaneously. When the call is answered at the call point, the calling signal is tripped, the calling lamp or indicator for that call point on the switchboard is operated and the call proceeds as if it were an incoming call from the call point.
- (c) A "proving" circuit is incorporated in the equipment at the call point, and while the signal lamp is flashing satisfactorily an interrupted earth signal is returned over the line to operate a supervisory signal associated with the call-point circuit on the switchboard.
- (d) Call-point circuits are treated as normal external extensions and as such may be extended to any other extension, private circuit or exchange line circuit terminating on the switchboard, but through dialling from the call points is not provided.

†Assistant Engineer, Subscriber's Apparatus and Miscellaneous Services Branch, E.-in-C.'s Office.



### Sizes of Installation.

A survey of existing installations and outstanding requests for police alarm systems showed a wide variation in the number of call points that may be required to be terminated at any one installation. The call-point circuits have been designed for termination on lamp-calling switchboards, but so that smaller installations may be provided more economically, the call points may also be terminated on indicator-calling switchboards. It was considered that the total number of circuits terminating at a police headquarters switchboard would usually exceed the capacity of both the cordless and 25-line P.M.B.X. switchboards and, therefore, the 65-line Switchboard, AT 3796 has been standardized for use where indicator-calling circuits are required. Table I gives details of the maximum numbers of circuits that can be accommodated on these switchboards.

TABLE I  
Circuit Capacity of Switchboard

Type of Switchboard Installation	Maximum Circuit Capacity					
	Street Call Points		Exchange Lines		Extensions	
	Posn. 1	Posn. 2	Posn. 1	Posn. 2	Posn. 1	Posn. 2
1 Position Indicator Calling (A.T.3796)	20	—	10	—	30	—
2 Positions Indicator Calling (A.T.3796)	20	20	10	10	30	30
	20	40	10	—	30	10
P.M.B.X. 1A Installation	Above 60		Arranged as required			

It will be seen that private circuits, which form an important part of the police telephone network, are not included in this table. They normally terminate in either the extension or exchange-line jack field and consequently their number must be included in the totals for these circuits.

### Switchboard Face Equipment.

Associated with each call-point circuit in the switchboard face equipment is a line jack, calling lamp, ringing-supervisory lamp and non-locking "ring" key. Fig. 2 shows the arrangement of these items in the extension multiple

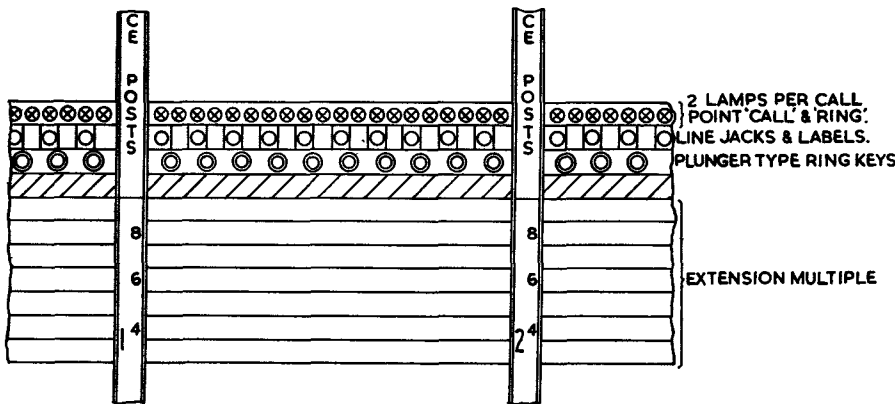

FIG. 2.—ARRANGEMENT OF CALL-POINT CIRCUITS ON THE SWITCHBOARD.

field at a P.M.B.X. No. 1A installation. The face equipment is provided in units of ten circuits, taking up  $1\frac{1}{2}$  in. of multiple space.

When indicator-calling switchboards are used, one indicator serves the purpose of both the calling and ringing-supervisory lamps, the two types of signal being distinguished

by the calling signal being a continuous operation of the indicator and the supervisory signal a flashing operation.

### Equipment Racks.

Special line equipment is necessary in each call-point circuit to enable the automatic signalling, call cancellation, and circuit-proving facilities to be provided. At the switchboard end one or more apparatus racks are required to accommodate this auxiliary equipment.

### Transmission and Signalling Limits.

A central battery telephone is fitted at the call points, the transmission feed being incorporated in the line equipment at the switchboard end of the circuits. The transmission limits for the call points have been assessed on the assumption that calls into the public network, and in particular over the trunk network, will be infrequent. On this basis it has been possible to allow a transmission limit for the call points which is independent of the length of the exchange line or the type of main exchange to which the system is connected. With the normal 24V P.B.X. battery the signalling and transmission limits from the P.B.X. to the call point are 700-ohms loop and 600-ohms T.E.R. respectively, and it is expected that this will enable the majority of circuit requirements to be met. In certain circumstances the limits may be increased to cater for the exceptionally long line, by increasing the voltage applied to line.

### Street Call Points.

The telephone post used by the Metropolitan Police has been adopted as the new standard. A typical example of the type of post in use in the London area is shown in Fig. 1, which gives an indication of the size of the post. It is of simple box-like construction in cast iron, and is larger than the post used in the earlier provincial systems.

The design of the post for earlier provincial systems was such as to make it unsuitable for use with the new system and, in addition, the police authorities were asking for a telephone post which provided them with more room for storing police equipment such as the constable's cape and first aid equipment. The Metropolitan Police post affords these facilities, and was also ideally suitable for accommodating the necessary telephone equipment required by the new system. In addition, it also had the advantage that very little development work was required before production could commence. Patterns for casting the post were in existence, and production could start without the delay that development of a completely new style of post would have incurred.

The post contains three main compartments, which provide for the termination of the electricity supply, space for police use, and the telephone and signalling unit. The signal lamp is mounted on top of the post. It will be seen from Fig. 1 that the door to the central compartment forms a writing shelf when in the open position. This compartment and the lower compartment are fitted with "Yale"-type locks and are normally only accessible to the police.

The notices around the top of the post and in the telephone compartment door are translucent and at night time are illuminated by an internal light.

As an alternative to the post, the call point may take the form of a kiosk. If so, the kiosk is provided by the police authorities, the Post Office being responsible only for the provision of the telephone and associated signalling equipment, which is identical with that fitted in the post.

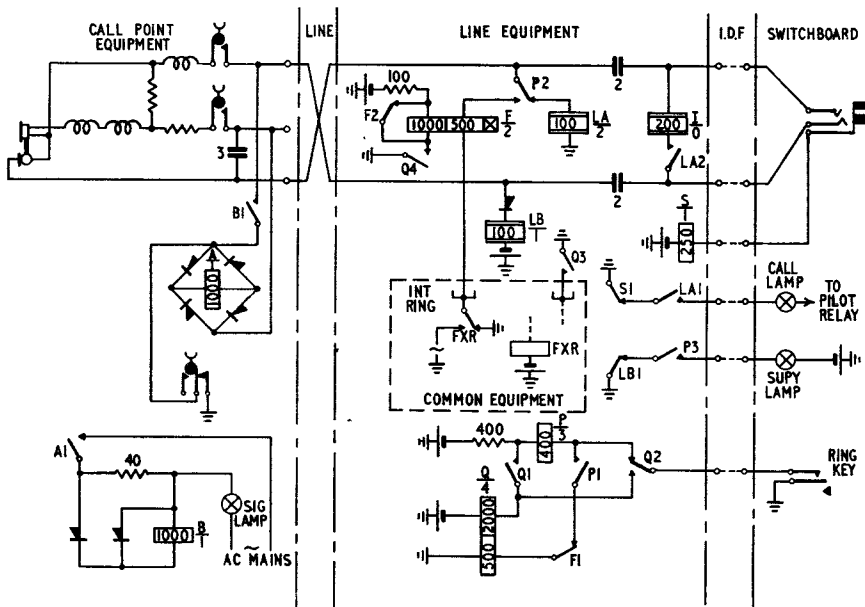

FIG. 3.—CIRCUIT OF A CALL POINT AND ITS SWITCHBOARD TERMINATION.

**Circuit Operation.**

Fig. 3 shows the circuit for a call point connected through to the switchboard.

Operation of the ring key locks in relays P and Q, which extend interrupted ringing over the A-wire to the call point. The high-voltage relay A in the call-point equipment

<sup>1</sup> New Police Telephone and Signal System. Regional Notes, P.O.E.E.J., Vol. 47, Part 4, p. 247, Jan., 1955.

operates to this ringing current and causes the signal lamp to flash. The voltage drop across the 40-ohm resistor in the signal lamp circuit provides an operating voltage for relay B, another high-voltage relay, which returns an earth signal over the B-wire to operate relay LB and hence flash the supervisory lamp associated with the call-point circuit at the switchboard.

Relays P and Q remain operated until released either by the ringing being tripped when the call is answered or by the call being cancelled by a second operation of the ring key.

The incoming loop signal from a call point, when either an outgoing call is answered or an incoming call originated, lights the calling lamp via contact LA1, through clearing being provided by contact LA2.

**CONCLUSION**

At the time of writing, the first stage of an installation at Cardiff has been completed and is working satisfactorily, and a short account of this installation has already been published.<sup>1</sup> Installations are also in hand in three other towns, and it is expected that by the end of 1957 some 21 installations will have been completed, involving the provision of more than 750 call-point circuits, the majority of which will terminate on the new-type post.

## The Production of Beat Frequencies

U.D.C. 534.755.1

Students sometimes have difficulty in interpreting the trigonometrical expression usually advanced to explain the production of beats between two oscillators of different frequencies, because it does not contain a term representing an oscillation at the beat frequency. This article explains briefly how beats are produced, and offers an alternative trigonometrical expression from which the production of a beat can be clearly shown.

**INTRODUCTION**

THE production of beats between two oscillations of different frequencies is a common phenomenon, but telecommunications students sometimes find it difficult to interpret the trigonometrical expression usually advanced in explanation. Thus, representing the two oscillations by  $E \sin \omega t$  and  $E \sin pt$ , trigonometrical addition gives:

$$E \sin \omega t + E \sin pt = 2E \sin \frac{1}{2}(\omega + p)t \cos \frac{1}{2}(\omega - p)t. \quad (1)$$

The right-hand expression appears to correspond to an oscillation at the mean frequency  $\frac{1}{2}(\omega + p)$  rad/s, and having an amplitude varying at  $\frac{1}{2}(\omega - p)$  rad/s, which is *one-half* the difference frequency; whereas the beat frequency is notoriously equal to  $(\omega - p)$  rad/s. This apparent discrepancy is often dismissed by a rather vague reference to the need to use detectors or other non-linear devices for the production of beats. These points are considered briefly below.

**SIMPLE ADDITION OF TWO SINUSOIDAL OSCILLATIONS**

In the simple circuit of Fig. 1 two alternators of nearly equal frequencies,  $\omega$  rad/s and  $p$  rad/s, are connected in series and joined to a lamp load. For simplicity let their peak e.m.f.s be equal. The combined e.m.f. is simply the sum of their separate e.m.f.s; this by simple trigonometry can be

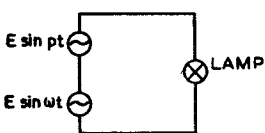

FIG. 1.

represented by equation (1) above, and is shown graphically in Fig. 2. Starting at  $t = 0$  the combined voltage rises to a positive peak value at (a) when the  $\sin \frac{1}{2}(\omega + p)t$  term has its first positive maximum value of +1, and the successive +1 values of  $\sin \frac{1}{2}(\omega + p)t$  give rise to the following series of positive peaks (b), (c). The amplitudes of these peaks are fixed by the remaining term  $2E \cos \frac{1}{2}(\omega - p)t$ , which oscillates between the values +2E and -2E at a frequency of  $\frac{1}{2}(\omega - p)$  rad/s, as shown by the chain-dotted envelope in Fig. 2. When the envelope passes through zero

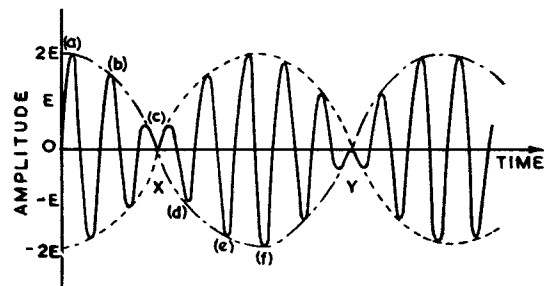

FIG. 2.—ADDITION OF TWO SINUSOIDAL OSCILLATIONS.

from positive to negative the peaks produced by the +1 values of  $\sin \frac{1}{2}(\omega + p)t$  also change from positive to negative values, e.g. (d), (e), (f), etc. This means that the  $\frac{1}{2}(\omega + p)$  frequency oscillation changes in phase by 180° each time that  $\cos \frac{1}{2}(\omega - p)t$  passes through zero, as at X and Y in Fig. 2. The peaks produced by the -1 value of the

$\sin \frac{1}{2} (\omega + \phi)t$  term vary in a corresponding fashion, as shown by the dotted envelope.

The foregoing description shows that the amplitude and phase of the combined e.m.f. vary cyclically at a frequency of  $\frac{1}{2} (\omega - \phi)$  rad/s. However, the amplitude changes in each half cycle of this variation are similar, and so a device which is affected only by amplitude changes, will respond at the half-cycle rate, i.e. at  $(\omega - \phi)$  rad/s. Thus, in the circuit of Fig. 1 the lamp flickers at the difference frequency  $(\omega - \phi)$  rad/s, and not at one-half this rate. Again, when two tuning forks are sounded together beats are heard at the difference frequency because the ear responds only to the amplitude of the combined tone and does not distinguish the phase changes.

The fact that the amplitude variation (irrespective of phase) takes place at the difference frequency can also be shown by an alternative trigonometrical method. Thus, equation (1) may be written:

$$\begin{aligned} E \sin \omega t + E \sin \phi t \\ &= E \{ \sin \omega t + \sin [\omega + (\phi - \omega)]t \} \\ &= E \{ \sin \omega t + \sin \omega t \cos (\phi - \omega)t + \cos \omega t \sin (\phi - \omega)t \} \\ &= E \{ [1 + \cos (\phi - \omega)t] \sin \omega t + \sin (\phi - \omega)t \cos \omega t \} \dots (2) \end{aligned}$$

Expression (2) represents two components in quadrature having a frequency  $\omega$  rad/s and amplitudes  $[1 + \cos (\phi - \omega)t]$  and  $\sin (\phi - \omega)t$ . These are shown in the vector diagram, Fig. 3, and their resultant has an amplitude given by:

$$\begin{aligned} &\sqrt{E^2 [1 + \cos (\phi - \omega)t]^2 + E^2 \sin^2 (\phi - \omega)t} \\ &= E \sqrt{1 + 2 \cos (\phi - \omega)t + \cos^2 (\phi - \omega)t + \sin^2 (\phi - \omega)t} \\ &= E \sqrt{2 (1 + \cos (\phi - \omega)t)} \dots \dots \dots (3) \end{aligned}$$

(since,  $\sin^2 \theta + \cos^2 \theta = 1$ ).

This amplitude varies in sympathy with the  $\cos (\phi - \omega)t$  term, and so oscillates at the difference frequency  $(\phi - \omega)$  rad/s.

The mathematical arguments given above were simplified by assuming equal amplitudes for the two oscillations. When the amplitudes are unequal the envelope waveform changes from the "full-wave rectifier" shape of Fig. 2 and becomes more nearly sinusoidal, but the amplitude variation still occurs at the difference frequency.

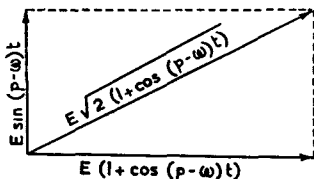

FIG. 3.

#### DETECTION OF THE SUM OF TWO SINUSOIDAL OSCILLATIONS

When two sinusoidal oscillations of equal amplitudes and different frequencies are simultaneously applied to an ideal envelope detector the output produced corresponds to the envelope of the positive peaks in Fig. 2. This resembles

the output from a full-wave rectifier, so that the beat-frequency signals have a very distorted waveform. When one oscillation is much stronger than the other the envelope is almost a sine wave, and the amplitude of the detector's output is then proportional to the amplitude of the weaker oscillation and almost independent of the amplitude of the stronger oscillation.

Most detectors behave something like ideal envelope detectors when dealing with strong signals, but when the signals are weak their output tends to be proportional to the square of the applied signal amplitude. The output voltage  $v$  is then related to the applied voltage  $e$  thus:

$$v = ae + be^2 \dots \dots \dots (4)$$

where  $a$  and  $b$  are constants. The output produced when two equal weak oscillations are simultaneously applied is given by substituting for  $e$  from equation (1) in equation (4) thus:

$$\begin{aligned} v &= a(E \sin \omega t + E \sin \phi t) + b (E \sin \omega t + E \sin \phi t)^2 \\ v &= aE (\sin \omega t + \sin \phi t) + bE^2 (\sin^2 \omega t + \sin^2 \phi t \\ &\quad + 2 \sin \omega t \sin \phi t) \\ v &= aE (\sin \omega t + \sin \phi t) + bE^2 [\frac{1}{2} (1 - \cos 2 \omega t) + \\ &\quad \frac{1}{2} (1 - \cos 2 \phi t) + \cos (\omega - \phi)t - \cos (\omega + \phi)t] \dots (5) \end{aligned}$$

Inspection of equation (5) shows that it contains a term,  $bE^2 \cos (\omega - \phi)t$ , corresponding to the beat frequency, and that terms representing harmonics of the beat frequency are absent, so that the beat-frequency output has an undistorted sinusoidal waveform. An equal output is also produced at the sum frequency  $(\omega + \phi)$  rad/s. A similar result is produced if the two oscillations have unequal amplitudes.

Beat frequencies are also produced by applying two oscillations to separate grids in mixer valves containing six or more electrodes. With these valves the output amplitude is proportional to the product of the amplitudes of the applied signals, thus:

$$v = ke_1 e_2 \dots \dots \dots (6)$$

where  $k$  is a constant. This is sometimes called multiplicative mixing. Whence, substituting  $e_1 = E \sin \omega t$  and  $e_2 = E \sin \phi t$

$$v = KE^2 \sin \omega t \sin \phi t \dots \dots \dots (7)$$

$$v = \frac{1}{2} KE^2 [\cos (\omega - \phi)t - \cos (\omega + \phi)t] \dots \dots \dots (8)$$

The operation of "multiplicative mixer" valves thus resembles the operation of a square-law detector so far as the sum and difference frequency products are concerned, as may be seen by comparing equations (5) and (8). They are not, however, limited to weak signals, and do not necessarily produce second harmonic components having frequencies of  $2\omega$  and  $2\phi$  rad/s.

F. J. M. L.

## Book Review

"Antennen und Ausbreitung." K. Fränz und H. Lassen. Second Revised Edition. Springer-Verlag, Berlin, 1956. 332 pp. 293 ill. D.M.45.

This volume is a revised edition of a work (in German) on Aerials and Propagation published by Springer-Verlag in their series "Textbooks of Wireless Communication Techniques." The work is divided into two sections: the first "The Propagation of Electro-magnetic Waves" is by Prof. H. Lassen and occupies 214 pages; the second "Emission and Reception of Electro-magnetic Waves" is by Prof. K. Fränz and occupies 118 pages.

The treatment of the subjects of both sections is analytical

and mathematical and the subjects are dealt with in a comprehensive manner. A large number of graphs and explanatory diagrams assist materially in understanding the text and in giving a clearly tabulated set of results of the mathematical analysis. The mathematical sections are well set out and straightforward to follow, but for English readers the German convention of representing vector quantities by Gothic characters is unfamiliar. Both sections are provided with a long and comprehensive bibliography.

The book would form a valuable addition to the library of anyone interested in the fundamental analytical aspects of the subjects dealt with.

R. P. F.

# Notes and Comments

## New Year Honours

The Board of Editors offers congratulations to the following members of the Engineering Department honoured by Her Majesty The Queen in the New Year Honours List:

Aberdeen Telephone Area	.. .. Russell, W. S.	.. Inspector	.. ..	.. British Empire Medal
Engineering Department	.. .. Booth, Capt. C. F.	.. Assistant Engineer- in-Chief	.. ..	.. Commander of the Most Excellent Order of the British Empire
Engineering Department	.. .. Sauer, W. T. J. B.	.. Technical Officer	.. ..	.. British Empire Medal
Glasgow Telephone Area	.. .. Jardine, W. M.	.. Technical Officer	.. ..	.. British Empire Medal
London Telecommunications Region	Holliday, R. F.	.. Area Engineer	.. ..	.. Member of the Most Excellent Order of the British Empire
Portsmouth Telephone Area	.. Brown, M. J.	.. Technician Class I	.. ..	.. British Empire Medal

## Death of Mr. F. G. C. Baldwin, O.B.E., M.I.E.E.

We regret to record that Mr. F. G. C. Baldwin died at his home at Bardsey, near Leeds, on 12th January, 1956. Mr. Baldwin entered the service of the National Telephone Company in 1896 and joined the Post Office as a Sectional Engineer in London in 1912. He was Chief Regional Engineer of the North-Eastern Region when he retired from the Post Office in November, 1938. Besides writing many technical articles for the press, he spent years in researches into the history of the telephone and the results of these were published in 1935 in his book, "The History of the Telephone in the United Kingdom." He was an active member of both the Institution of Electrical Engineers and of this Institution; in 1922/23 he was Chairman of the North-Eastern Centre of the I.E.E., and from 1935 to 1938 he was Chairman of the Northern and North-Eastern Centres of the I.P.O.E.E. His other interests were many and varied and during his long retirement he was able to enjoy his diverse hobbies.

## Awards by the Radio Industry Council

Congratulations are offered to the following members of the Engineering Department who have been awarded premiums by the Radio Industry Council for articles published during 1955:—

One premium was awarded for " 'Memory' Systems in Electronic Computers," by A. W. M. COOMBS, Ph.D., B.Sc., A.R.T.C., published in *Communications and Electronics*, March 1955.

Two premiums were awarded jointly in respect of the following three articles published in this Journal:—

"A Frequency Modulator for Broad-Band Radio Relay Systems," by I. A. RAVENSCROFT, A.M.I.E.E., and R. W. WHITE, B.Sc., A.M.I.E.E., F.Inst.P. (July 1955).

"Equipment for Measurement of Inter-Channel Crosstalk and Noise on Broad-Band Multi-Channel Telephone Systems," by R. W. WHITE, B.Sc., A.M.I.E.E., F.Inst.P., and J. S. WHITE, B.Sc.(Eng.), A.M.I.E.E. (October 1955).

"An Instrument for the Measurement and Display of V.H.F. Network Characteristics," by J. S. WHITE, B.Sc.(Eng.), A.M.I.E.E. (July 1955).

## I.P.O.E.E. Jubilee Issue of the Journal

As announced on p.59, the October 1956 Journal (Vol. 49, Part 3) will be a special issue celebrating the 50th anniversary of the foundation of the Institution of Post Office Electrical Engineers. It will be devoted to articles reviewing the development and growth of the British Post Office telecommunications services and of mechanization of postal services, and these articles will include the history of development in each of the main branches of telecommunications engineering, with particular reference

to technical advances in more recent years.

Although it will contain substantially more pages than in normal issues, and the usual Supplement will also be included, the price will not be increased. As it is expected that there will be a heavy demand for this issue of the Journal, subscribers who would like *extra* copies, and readers who are not regular subscribers, are strongly advised to place an order with their local agent or with the publisher, whose address is quoted on page 67, before 1st August, 1956.

## Publication of C.C.I.F. Series of Green Books

The collection of Green Books (destined to replace the former Yellow Books of the C.C.I.F.) constitutes a re-editing of all the C.C.I.F. recommendations and represents the material results of the work of the International Telephone Consultative Committee from 1951 to 1955.

This work is published in French and English, and a Spanish edition is available in mimeographed form; it may be obtained from the Publications Department of the International Telecommunications Union (I.T.U.), Palais Wilson, Geneva. The various volumes are:—

Volume I (574 pages). Minutes of meetings of the XVIIth Plenary Assembly of the C.C.I.F. (Geneva, October 1954)—Organization of the C.C.I.F.—Questions for study. Price Fr.38.55.

Volume II (120 pages). Recommendations of the C.C.I.F. concerning the protection of telephone lines and the constitution of telephone cable sheaths, as well as documents on protection. Price Fr.9.60.

Volume III (about 350 pages) and Book of Annexes of Volume III (a separate volume of some 250 pages). Recommendations of the C.C.I.F. concerning line transmission and maintenance. (Specially specifications for international telephone circuits and international carrier systems). Being printed. Approximate price for Volume III and Book of Annexes of Volume III, Fr.40.

Volume IV (about 200 pages) and Book of Annexes of Volume IV (a separate volume of some 200 pages). General recommendations and measurements of performance rating. Telephone apparatus. Being printed. Approximate price for Volume IV and Book of Annexes of Volume IV, Fr.30.

Volume V (124 pages). Signalling and switching—Specifications for standard international signalling and switching equipment. Price Fr.7.80.

Volume VI (164 pages). Recommendations on operating and tariffs and documents pertaining thereto. Price Fr.11.

## Publication Delay

Because of a recent dispute in the printing trade the publication of this issue of the Journal has been considerably delayed and we regret any inconvenience caused to readers.

# Institution of Post Office Electrical Engineers

I am directed by the Council of the Institution of Post Office Electrical Engineers to draw the attention of the membership to the fact that the 50th Anniversary of the Foundation of the Institution will be celebrated during the forthcoming 1956/57 session. The first Council Meeting of the Institution was held on 6th June, 1906, and the first Local Centre Meeting on the 8th October, 1906.

The Council of the Institution of Post Office Electrical Engineers, in co-operation with the Local Centre Committees, has arranged to celebrate the Institution's Jubilee by holding a commemorative meeting in London, on Monday, 8th October, 1956, and meetings of a similar character at Provincial Centres on dates to be announced. In addition, the October 1956 Journal will be a special Jubilee issue, and the Institution will hold a celebration dinner-dance in London on Tuesday, 9th October, 1956.

Further details of these arrangements will be given in the July issue of the Journal.

H. E. WILCOCKSON,  
Secretary.

## Library Catalogue Supplement (1952-1956)

A supplement showing the books added to and withdrawn from the Library since the 1952 re-issue of the Catalogue is available on request from Honorary Local Secretaries.

### Additions to the Library

2311 *Aluminium Paint and Powder*. J. D. Edwards and R. J. Wray (Amer. 1955).

The manufacture, properties and applications of aluminium paints and powders are fully described.

2312 *Magnetic Alloys and Ferrites*. M. G. Say (Brit. 1954).

Describes the fundamental processes of magnetization and the practical applications of recent developments in magnetic materials.

2313 *An Introduction to Colour Television*. G. G. Gouriet (Brit. 1955).

Deals with colour theory and with the various systems of colour television, with particular reference to the N.T.S.C. compatible system in the U.S.A.

2314 *Workshop Technology, Part I*. W. A. J. Chapman (Brit. 1955).

2315 *Workshop Technology, Part II*. W. A. J. Chapman (Brit. 1954).

2316 *Workshop Technology, Part III*. W. A. J. Chapman (Brit. 1951).

Part I is an introductory course, and covers most of the material required for the C. & G. Intermediate Certificate in machine shop engineering; Part II covers the C. & G. Intermediate and Final Certificates in machine shop engineering, and the Ordinary National Certificate in workshop technology; Part III is an extension of Part II and covers O.N.C. and H.N.C., and the I.Mech.E. examinations in workshop technology, metrology and machine tools, and the C. & G. final examination in machine shop engineering.

2317 *An Introduction to Electronic Analogue Computers*. C. A. A. Wass (Brit. 1955).

Presents the basic principles rather than detailed designs and design methods; some acquaintance with electronic circuits and equipment and a mathematical background being assumed.

2318 *Physics—A Descriptive Interpretation*. C. H. Backman (Amer. 1955).

A new presentation for non-science students of a complete and up-to-date view of the subject in relation to every-day problems; no mathematical background being expected.

2319 *Second Thoughts on Radio Theory*. "Cathode Ray" (Brit. 1955).

A collection of the author's articles in *Wireless World*, arranged in subject order.

2320 *Radar and Electronic Navigation*. G. J. Sonneborn (Brit. 1955).

Gives the general theory, but the emphasis is on the factors of practical use and importance.

2321 *Television Receiver Servicing, Vol. 2—Receiver and Power Supply Circuits*. E. A. W. Spreadbury (Brit. 1955).

Designed mainly for the service radio engineer wishing to embark on television servicing; covers tuning, signal and video-amplifying circuits, and sound and power supply circuits.

2322 *Ultrasonic Engineering*. A. E. Crawford (Brit. 1955).

Collects together and correlates the data on applications and effects of ultrasonic waves, and covers the basic methods of generation.

2323 *Physics for Our Times*. W. G. Marburger and C. W. Hoffman (Amer. 1955).

A general coverage of physics and its applications.

2324 *An Outline of Atomic Physics*. O. H. Blackwood, T. H. Osgood and A. E. Ruark (Amer. 1955).

An exposition of the structure of the atom, nuclear energy, the nature of radiation and of the fundamental constituents of matter.

2325 *Harwell: the British Atomic Energy Research Establishment 1946-51* (Brit. 1952).

The story of the research branch of the British atomic energy effort.

2326 *Photography All the Year Round*. C. Wallace (Brit. 1955).

Describes the technique of photography in any conditions of lighting.

2327 *The Practice of Management*. P. F. Drucher (Brit. 1955).

A practical guide to all connected in any way with management, and for those without direct management experience who wish to know what management is.

2328 *Alternating-Current and Transient Circuit Analysis*. H. A. Thompson (Amer. 1955).

Designed as a first course in a.c. circuit analysis and transient analysis for engineering students; assumes a knowledge of physics and d.c. circuit analysis, and some understanding of differential and integral calculus.

2329 *A.R.R.L. Antenna Book*. Amer. Radio Relay League (Amer. 1955).

Assembles such of the available material on antennas, including associated transmission lines, as may be useful to amateurs.

2330 *Practical Electro-acoustics*. M. Rettinger (Amer. 1955).

Mainly concerns the essential units of audio-communication (microphones, moving coil loudspeakers, mixers, etc.), and is not concerned with amplifiers.

2331 *Optics and Sound*. C. A. Padgham (Brit. 1955).

Meets the requirements of the Intermediate examination in Physics and of final year O.N.C. students.

2332 *Radio Valve Data*. "Wireless World" (Brit. 1954).

Gives the characteristics of 2,000 valves and cathode-ray tubes.

2333 *Ford Engines: Industrial, Agricultural, Marine and Automobile*. J. W. Sandermon (Brit. 1955).

Compiled to meet the requirements of mechanically-minded owners and operators.

2334 *Telecommunications Principles and Practice*. W. T. Perkins (Brit. 1955).

Deals with the basic principles of magnetism, electricity, telephony, telegraphy and radio communication, and covers the syllabus of the C. & G. of London Institute.

2335 *Television and Radar Encyclopaedia*. Ed. W. MacLanachan (Brit. 1953).

A reference book of television and radar terms which are or are likely to be in common use in Great Britain and the United States.

2336 *Experimental Mechanics and Properties of Materials*. C. W. Muhlenbruch (Amer. 1955).

Describes experimental work intended to confirm theoretical relationships, and to help acquire a broad understanding of the mechanical properties of materials commonly used in engineering design.

W. D. FLORENCE,  
Librarian.

# Regional Notes

## North-Eastern Region

### DAMAGE CAUSED BY SNOW-STORM IN THE LINCOLN AREA

A very heavy fall of snow accompanied by gale-force winds occurred during the night 8th-9th January, 1956. The following morning widespread damage to Post Office plant was revealed over the eastern half of the Area, from Scunthorpe and Grimsby in the north to Horncastle and Woodhall Spa in the south, with the greatest amount of damage around Louth between the Lincolnshire Wolds and the coast. It was not possible immediately to assess the whole damage as many roads were impassable.

The snow was of the "wet" variety, causing ice on overhead wires to build up in thickness and weight until, aided by a gale-force wind, 2,500 poles either broke or were dislodged and 5,000 miles of overhead wires were disrupted, causing some 4,500 faults on subscribers' circuits. Widespread failure of electricity supplies resulted in 28 exchanges, most of them U.A.X.s No. 12 and 13, being without power. However, the battery reserve was sufficient at the majority of exchanges to keep them working until the public supply was restored, and at those exchanges where delay occurred in reconnecting the supply (at one or two exchanges the delay exceeded seven days) small charging sets were used to keep the batteries charged.

Storm-work controls were speedily set up in each of the headquarters towns of the maintenance control areas affected, Scunthorpe, Lincoln, Louth and Grimsby, and gangs were moved into the latter two, the worst-hit areas. Development survey teams were immediately at work and restoration, albeit temporary, commenced. The total number of men engaged on storm work during one period was 317, including 10 United States Air Force men from one of the U.S.A.F. bases in Lincolnshire and gangs lent to the Area from Bradford, Leeds, Middlesbrough, Sheffield and Newcastle. The work of restoration was hampered by further snow, sleet and strong winds, but such was the spirit of the men that 1,927 faulty lines had been restored to service by 15th January; further faults had developed during this period and 3,419 faults still existed. By the 25th January this large number of faults had been reduced so that only 600 remained. Some 110 miles of interruption cable were used, much of it being of the polythene-covered type.

All the staff involved worked long hours continuously with the usual extra keenness and initiative shown at times of emergency, and service was restored to all affected subscribers and the number of faults reduced to the normal level by 4th February, 1956.

J. E. S.

## London Telecommunications Region

### OPENING OF WILLESDEN AUTOMATIC EXCHANGE

On the 19th January, 1956, Willesden C.B.1 manual exchange was replaced by a 2000-type director exchange.

The old exchange, built by the American firm of Peel-Connor, was opened in 1910 with nine B and twelve A positions—including one "Electrophone" position for relaying theatre performances to certain specially-equipped subscribers. At the closing of the exchange 45 years later, most of the original equipment was still in service. The original exchange area was very large, and because of the rapid development which has taken place since the earliest days, the whole of four automatic exchanges and substantial parts of four others are now necessary to provide service to the 43,000 subscribers in the original Willesden exchange area.

The new automatic exchange, which is in an extension of the manual exchange building, has a multiple of 7,600, uses the new standard uniselector racks and has a remote manual board at Cunningham Exchange. By a coincidence, the contractor was Peel-Connor's successor in this country, The General Electric Company.

The opening was watched by a large party of civic dignitaries, which included the Mayor. The closing of Willesden manual exchange marks one of the last stages in the conversion to automatic-exchange working of inner London, and removes the last exchange in the North-West Area equipped with Coded Call Indicator equipment.

## Midland Region

### CONVERSION OF BRIDGEMERE U.A.X. 5 TO U.A.X. 12

Bridgemere U.A.X. No. 5, in the Stoke-on-Trent Area, consisted of three units and an open-type M.D.F., housed in an A-type building with a.c. mains power plant.

It was decided to replace this exchange by U.A.X. No. 12 equipment because:

1. The U.A.X. No. 5 equipment had been in service for 24 years and was considered to be approaching the end of its economic life.
2. At Faddiley exchange a few miles distant sufficient recovered U.A.X. No. 12 equipment, only six years old, was available, following conversion of this exchange to U.A.X. No. 13 to cater for abnormal post-war growth. It was considered that the full economic life of the recovered equipment could best be obtained by re-installation at Bridgemere in the existing A-type building.
3. Multi-metering and inter-dialling facilities could be provided, enabling full use to be made of the parent tandem-dialling equipment and so divert traffic from the auto-manual board at Crewe.

The turn-round involved outhousing the U.A.X. No. 5 units to clear the building, and space available at the rear of the building was used for the erection of a battery hut to house the U.A.X. No. 5 units only; the M.D.F. was to remain in the A building but be shifted to a temporary position to allow the U.A.X. No. 12 C-unit to be correctly positioned. Three U.A.X. No. 5 units just fit into a battery hut of internal dimensions 7 ft × 5 ft, and to give access to both sides of the units each side of the battery hut had a door; i.e., the "door" sides from two battery huts were used. This arrangement gave clearances in the battery hut of 9½ in. at each end, 27 in. on the equipment side and 20 in. on the wiring side of the units.

The battery hut was erected end-on to the door of the A building and approximately 10 ft from it to allow ample space for carrying the U.A.X. No. 12 units into the building.

For the removal of the U.A.X. No. 5 units into the battery hut, preparations required prior to the day of removal consisted of running tie cables between the A building and the battery hut. A suspension wire was erected from the corner of the A building to the corner of the battery hut to support the interconnecting cables. Battery and earth and M.D.F. tie cables were extended through the wall ventilator and along the suspension wire to the rear corner of the battery hut, entrance being gained through a gap immediately under the eaves. P.V.C.-type and V.I.R.-type cables were used for this purpose and the cable ends were prepared ready for terminating, the power cables having lugs soldered to them. This initial preparation was accomplished by two men in one day.

On the day of the removal five men were engaged and the operation was planned as follows:—

The tie cables between the A building and battery hut were released from the suspension wire and the battery hut ends of the cables were taken back into the A building through the door. This was necessary to allow the cable to be terminated in the first U.A.X. No. 5 unit prior to being shifted. Two men were employed in disconnecting the existing cable between the M.D.F. and first unit and terminating the extension cables. This was carried out pair by pair to cause as little interference as possible with working circuits during the operation. Working circuits only were changed over and the whole operation took eight man-hours to complete. Simultaneously, the remaining three men were employed in removing the end of the battery hut and raising its roof to gain sufficient height for the easy transfer of the units into the battery hut, and also in preparing the U.A.X. No. 5 units for shifting. Using car jacks and specially-made supporting brackets, the U.A.X. No. 5 units were raised to a convenient height for placing two eight-way arms underneath. To keep the units low enough to pass through the exchange door it was necessary to remove the wooden battens from the feet of the units. Steam pipe of 1-in. diameter cut to 15-in. lengths was used for rollers, the small-diameter pipe being used to conserve height. The ground between the A building and the battery hut was uneven and two 8-in. × 2-in. planks were used to bridge the gap. A ramp into the battery hut was constructed using 4-way arms. The actual

removal of the units into the battery hut presented no problems and a smooth transfer was made in approximately half an hour. The tie cables were re-attached to the suspension wire and the end of the battery hut replaced. The whole operation was completed in approximately six hours (or 30 man-hours) plus assistance by the engineer in charge of the operations.

In order to reduce the work of installing the U.A.X. No. 12 to a minimum, the suite was split between Units A1 and B1, the actual disconnection of tie cables being made in B1 only. The multiple lines and miscellaneous cables were carefully disconnected in Unit B1 and tied back into Unit A1 for transportation. Units C and A1 and Units B1 and A2 remained bolted together in pairs. The selectors and relay sets were removed from the units to lighten them as much as possible. The preparation for transfer of the U.A.X. No. 12 equipment was completed in 1½ days by two men, including the recovery of all jumpers and the disconnection of the surplus Unit B2. The transportation of the units in pairs from the place of recovery to Bridgemere presented no difficulty; they were laid side downwards for ease of handling and a party of ten men completed this phase of the operation in four hours, which included travelling time from headquarters.

The U.A.X. No. 12 units were installed in position and re-termination of the cables between Units A1 and B1 was completed. The remainder of the installation was carried out in the standard manner but an overhaul of all selectors and relay sets, etc., was made to ensure satisfactory operation after transportation.

Teeing between the U.A.X. No. 12 C-unit and the old M.D.F. was carried out using internal P.V.C. cable. This enabled all jointing work in the cable trench to be permanently completed before transfer of the exchange took place.

In general, the method adopted resulted in an inexpensive conversion and is worthy of consideration in any case where a transfer from U.A.X. No. 5 to U.A.X. No. 12 is envisaged.

#### EXTENSION OF WALGRAVE ST. PETERS U.A.X. 12

An alternative to the published scheme for extending U.A.X.s No. 12 was put into operation at Walgrave St. Peters, which is in the Coventry Area, during October, 1955. One additional A-unit has been provided initially in the existing accommodation by moving the existing suite of racks 6 in. along the cable trench, and the M.D.F. requirements have been temporarily catered for in the existing C-unit. Arrangements are, however, in hand to extend the building by an additional 4 ft 6 in., move the racks back to their original position, and then install a further A-unit and a D-unit. The cabling to the new unit is run through the existing units on the existing bearers.

The scheme caters for a full 200-line multiple having standard U.A.X. No. 12 facilities and inter-working is provided between the original and new units. Only minor modifications are necessary to the selector circuits, and the standard junction relay set has been adapted to serve as a link between the multiples. In addition, in order to improve the "pick-up" time, one additional relay has been added to the allotter circuit.

It was appreciated that in considering such a scheme the traffic-carrying capacity of the equipment must be borne in mind. However, a large number of cases have been investigated in the Midland Region, of which Walgrave St. Peters is one, and in each case the equipment which could be provided proved adequate to cater for a grade of service of 1/200.

The equipment has now been in service some months and is functioning satisfactorily. It has the advantages that the order lists on U.A.X.s No. 12 can be cleared quickly and cheaply; surplus U.A.X. No. 12 units can be used and thus reduce the demand for U.A.X. No. 13 units; all subscribers can be given full facilities; and new subscribers can be given either exclusive or shared service with separate metering.

The scheme has, however, the disadvantages that, in order to provide for the link to the new unit it may be necessary, depending upon the amount of traffic, to change two or three existing subscribers' numbers.

J. C.  
R. A.

#### FIRE AT SWADLINCOTE EXCHANGE

On the evening of 15th November an outbreak of fire occurred at Swadlincote Exchange, which is a 1,000-line by-path satellite in the Burton-on-Trent multi-exchange area.

The fire was observed by a passer-by, who notified the fire brigade and the brigade arrived at the exchange shortly before the emergency lineman, who had been called out for what he presumed was a normal fault. Fortunately, no water was used to extinguish the outbreak and after its extinction by fire extinguishers it was found that a rack of line-finders had been destroyed, and that the fire had burnt through all the battery supply cables to the other racks, as the cable run passes immediately over the damaged rack.

A team of maintenance staff and fitters was rapidly assembled and, with supervising staff from Leicester, began to restore service. It was necessary to piece out all the battery cables to restore service to those subscribers not affected by the damaged rack, and this work proceeded with such speed that by 11.00 p.m. all coin-box circuits were working and by 5.30 a.m. the following morning all but 190 subscribers had had full service restored.

Fortunately, the exchange, which is due for transfer in the summer of 1957, had been scheduled for temporary relief by the provision of an M.A.X. 12 and a hard-standing had already been provided. During the night arrangements were made for the transfer of a spare M.A.X. 12 to the site the next day, and this was in place by 7.30 p.m. on the 16th November. In the meantime, polythene cables had been slung between the exchange main frame and the mobile-exchange site.

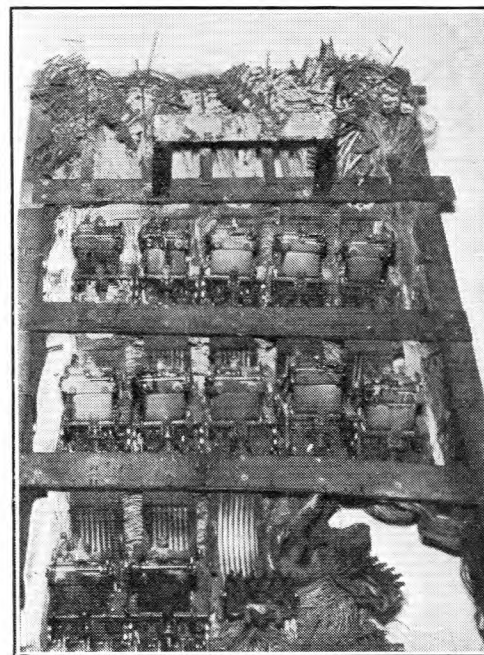

THE UPPER HALF OF THE DAMAGED RACK OF LINE-FINDERS.

To cater for the remaining subscribers, a rack of 100 by-path line-finders was made spare at another by-path satellite exchange and was taken to Swadlincote, with its associated cables to the I.D.F. Installation of the rack was completed by the afternoon of the 17th and all subscribers given service by the evening of the 18th, resulting in a complete restoration of service in approximately 72 hours.

Damage to the building and probably more extensive damage to the equipment was largely prevented by the fact that the ceiling of the exchange was made of asbestos sheeting.

The photograph shows the upper half of the damaged rack, where the fire damage was the most severe.

W. L. S.

#### Home Counties Region

##### 15 TONS OF WATER IN ROOF OF NEW EXCHANGE

The Norwich North satellite exchange building consists of one floor with the main dimensions 100 ft × 36 ft wide and

the roof is constructed of precast prestressed concrete units 38 ft 5 in. long, which are supported only at the side walls.

The cross-section of one roof unit, as seen in the accompanying sketch, is hollow and is obtained in manufacture by

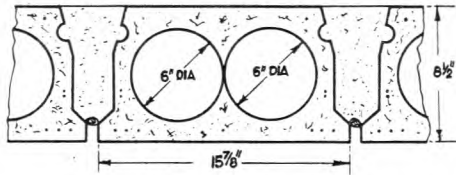

CROSS-SECTION OF ROOF UNIT.

pouring concrete over two rubber tubes inflated with air; the tubes being held in position by rods passing across the unit (not shown in the sketch). The tubes and rods are withdrawn early in the process to enable steam curing to proceed, and the final product contains two circular holes with partial access from one to the other at the point of contact of the rubber tubes used during construction.

The withdrawal of the retaining rods leaves small holes from the side of the unit to the top of the hollow centres, and during the handling and construction it seems that rainwater passed through these holes and became locked in the unit. Each unit is capable of holding some 90 gallons of water, but in fact it varied from almost nothing to as much as 50 gallons per unit, giving an overall loading for the 70 units of some 15 tons.

It is remarkable that the building was completed and all the switching equipment was installed before the trouble was diagnosed. During the warm summer of 1955, and only on hot days, clear water was noticed coming through the plastered painted ceiling at one point. The asphalt waterproofing of the roof was searched for cracks but nothing was found. There were one or two wet days, but no moisture came through the roof on these days. It is now known that on the hot days the pressure of the water vapour imprisoned in the roof unit caused water to come through the ceiling. It is a credit to the concrete used in the construction that in all of this large area the water made itself apparent in only one place.

The Norwich North satellite exchange is one of two buildings constructed as an austerity experiment to ascertain the minimum requirements acceptable for permanent use. One of the main features in this respect was the provision of prestressed unit roof construction which made possible the complete elimination of beams supporting the roof and considerable steel economy generally. There are several methods of producing these units and the successful tenderer for the Norwich contract executed the work generally as described above, which results in a unit with a flat soffit. The circumstances that revealed the water-bearing capacity of one of these units were fortunate in affording an opportunity to justify a test on all the other units, which proved to be constructed with concrete of the full density required, but clearance of the water by drilling the roof with a Kango hammer and collecting water in dustbins, 1 1/2 dustbins per roof unit, was a messy job to be undertaken at such a time in the construction of the exchange. Several exchanges of similar construction have been included in the 1956/57 program and these will profit by the experience gained in the construction of the initial buildings. E. H.

### Scotland

#### TANDEM SWITCHING IN EDINBURGH

For more than 50 years the hub of Edinburgh's telephone system has been the building at 149 Rose Street, known simply as "Rose Street." No other telephone building in Edinburgh approached it in importance. After the war, however, it became clear that the long reign was ending. Modern needs in automatic switching of trunk and junction traffic demanded accommodation the old building could not provide, so a decision was taken to meet these needs by means of a new building (Woodcroft) which would, in due course, reduce Rose Street to the status of a minor exchange in the multi-exchange area. Unfortunately, lack of funds prevented erection of Woodcroft; and meanwhile the growth of trunk and junction traffic demanded urgent attention. Under a revised plan it was decided to get the trunk and junction traffic out of Rose Street in two stages. First, a junction tandem exchange would

be provided immediately in the recently erected Fountainbridge director-exchange building; secondly, a trunk tandem exchange would be provided in Woodcroft when ready. As things turned out a small amount of trunk tandem switching had to be grafted on to the junction tandem and after some hard work by many people the whole installation was brought fully into service on 28th November, 1955, thus marking "the



FOUNTAINBRIDGE DIRECTOR-EXCHANGE BUILDING.

end of the beginning" of the exodus from Rose Street.

Space will not permit of a description of the difficulties encountered and remedies propounded in the design of Edinburgh Trunk/Junction Tandem, Fountainbridge. Edinburgh is about half-way through its conversion from Siemens 16 to director working so, in addition to an already complicated signalling and dialling network, account had to be taken of the Siemens 16 battery-dialling condition. Mention can be made only of the facilities and of a few points of particular interest.

The facilities provided at Fountainbridge are:

(a) Inter-dialling between Edinburgh director exchanges and some 30 directly-connected fringe exchanges, mostly U.A.X.s.

(b) The 30 fringe exchanges dial the Edinburgh Siemens 16 exchanges.

(c) Five directly-connected zone and sub-zone centres dial the Edinburgh group and four other directly-connected group centres; conversely, these five group centres dial the five zone centres and each other.

(d) Eight directly-connected "foreign" minor exchanges dial the Edinburgh group and each other.

All other zone centres and potential group centres directly connected to the Siemens 16 main exchange, Rose Street, dial the director and Siemens 16 exchanges via Siemens 16 levels and, in addition, have dialling access to the Fountainbridge tandem network.

Of the measures of particular interest there are two which have been adopted nationally for similar installations. First, in order to reduce greatly the demand made by the standard U.A.X. terminations on the parent incoming multiple, a line-finder arrangement has been introduced between the U.A.X. 9/0 relay-set and the switchboard termination. Secondly, to reduce demand on the parent outgoing multiple it was decided to dispense with the standard joint-access arrangement by providing facilities for the parent operator to gain access by dialling through the tandem network. For trunk-offering the joint-access facility was retained on the last two choices of each route.

One other point of general interest is the use of level "1" in Siemens 16 main exchange, and of level "1" in the junction tandem for the routes between the two exchanges, allowing a large saving of second selectors and an easily remembered code.

The exodus from Rose Street will be completed when the trunk tandem exchange is provided in the Woodcroft building, on which it is to be hoped a start will soon be made. Rose Street has not seen the end of its usefulness—a director exchange, bearing the proud name Caledonian, is being provided there so a good prospect exists that the old building will yet celebrate its centenary.

J. W. G.



# Associate Section Notes

## Canterbury Centre

The 1955-56 session opened on 26th October with a talk given by Mr. R. W. Palmer, Principal of the Central Training School, Stone, and President of the Associate Section, entitled "Maintenance in Other Countries." He outlined the principles of the more important telephone systems of the world, giving special emphasis to Sweden and America, and compared their maintenance problems and solutions with those of the British Post Office. All members agreed that the talk was one of the finest given to the Centre.

"General Aspects of Power Distribution" was the subject at the second meeting, in November, the speaker being Mr. J. H. Blackmore of the South-Eastern Electricity Board. He described the basis of the supply of electricity from "Coal to Consumer," and gave some examples of the problems encountered in its production and transmission. The talk was well illustrated with diagrams and samples of the Board's line plant.

Canterbury Area is the first Area to adopt, experimentally, a mechanical accounting system for trunk fees, employing punched-cards. Mr. G. H. Greenwood, Chief Clerk, Telephone Manager's Office, gave an excellent talk on this subject, followed by a working demonstration of equipment, aided by the ladies of the staff, at the third meeting of the session. He left members well aware of the possibilities of this type of equipment as an aid to accountancy in a telephone service.

R. P.

## Guildford Centre

At the time of writing, the 1955-56 session of the Guildford Centre is in full swing, with the membership, which now numbers about 140, steadily increasing.

During the past months six film programs of engineering and general interest have been presented at Guildford; each program has also been given at one of our outstations. Attendance at these shows has varied considerably, but special mention must be made of the reception received when a program is taken to Haslemere, an outstation with a comparatively small membership, where an attendance of almost 100 per cent can be relied upon. Two further programs of a similar nature will be presented before the session ends.

On 6th December, 1955, our president, Mr. H. M. Wells, M.I.E.E., Area Engineer, Guildford, gave a very interesting talk to the Centre on "High Speed Photography in Industry," illustrating his talk with both still and motion films.

Our Senior Section Liaison Officer, Mr. R. B. Hoult, has agreed to address the Centre on 15th February, 1956, on "The Control of Engineering Expenditure." The committee hope that this talk will give plenty of opportunity for discussion.

Since the publication of our last notes, visits have been made to Goodmans Industries, Ltd., Wembley; Vauxhall Motors, Ltd., Luton; Pirelli-General Cable Works, Eastleigh; and the Post Office Railway, Mount Pleasant, London. Further visits will be made during the session to The British Electric Transformer Co., Ltd., Hayes; Bush Radio, Ltd., London; and the B.B.C. Television Studios, London.

On the occasion of our visit to Vauxhall Motors, Ltd., we were pleasantly surprised to find a party of members from the Portsmouth Centre visiting the factory the same day. Efforts are now being made to commemorate this meeting by holding an inter-centre "quiz" before the end of this session.

E. N. H.

## Medway Centre

During the 1955-56 session we have had some very interesting evenings together.

Our opening paper was by Mr. W. Collett, A.M.I.E.E., on "The Ear," and proved to be most enlightening to those present. A very controversial paper was presented by Mr. Wraight on "Modern Architecture."

Mr. F. Jenkins presented a paper on "Archaeology," which was very interesting, and a film supplied by "Carborundum," showing their products, has also been seen during this session.

The program includes the following visits: Ford Motor Works; Kent Oil Refinery; Cordless Switchboard, Thanet; and Guinness Brewery. Papers to be presented are "Cables," by Mr. N. Gates, A.M.I.E.E.; "Looking Forward," by the Telephone Manager, Mr. W. H. Scarborough, A.M.I.E.E.; and "Atomic Power," by Mr. W. Collett.

Our membership figures are most pleasing and it is hoped that the programmes arranged will attract large numbers to the meetings.

L. F. P.

## Aberdeen Centre

Although the activities of this Centre have not been recorded in the Associate Section Notes of the Journal for some time, it will be observed from the following account that the Centre is not in any manner an idle one.

At the annual general meeting terminating the 1954-55 session it was decided to ask the membership to come into line with other Centres in the deductions of subscriptions from pay. The response of members in favour of deduction from pay was magnificent and the membership, which stood at a little over 90 last year, including Youths-in-Training, is now nearly 120, excluding Youths-in-Training. About 80 per cent of the members elected to purchase the *P.O.E.E.J.* through this same scheme. This result was very gratifying indeed.

It was also agreed by the committee that Youths-in-Training should be permitted to join the Centre free of charge and that, after their return from National Service, they would automatically become subscription-paying members. This idea ensures that they will still be retained on the register as members, and can therefore resume and take part in our activities on their return from the Forces.

This year's program started with a "quiz," a battle of wits between members stationed at Aberdeen Headquarters and the outstationed members, which the outstationed members won.

A visit by Mr. R. J. Hines, Chief Regional Engineer, Scotland, to present awards was the highlight of the current session. A certificate and prize were awarded to Mr. J. H. Lawrence for his paper, "Remote Control System E for Air-Raid Sirens," read to the Centre in November, 1954. Certificates were also awarded to the Centre for prize-winning papers read in previous sessions by Mr. D. S. C. Buchan, Mr. G. Booth and Mr. R. T. Ross.

The meeting began with a paper read by Mr. Isaacs on "Post Office Finance and the Engineering Department," and a general discussion took place after the paper, in which Mr. Isaacs was questioned on many aspects concerning the paper. Needless to say, Mr. Isaacs knew his job.

The second part of the meeting was devoted to prize-giving, and the photograph shows Mr. Hines presenting certificates to our Chairman. Mr. Hines gave an interesting talk to a

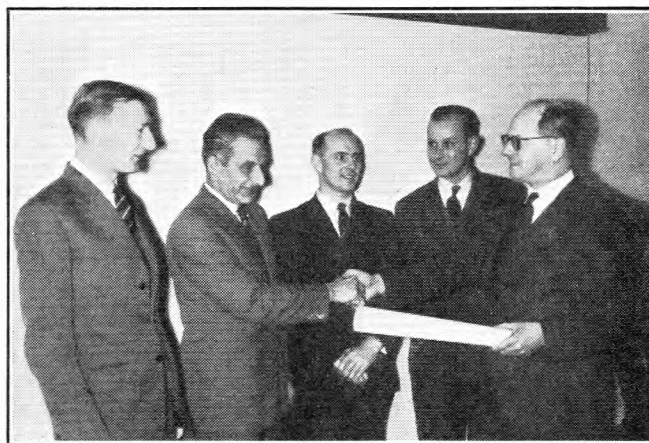

packed meeting, and afterwards presented the certificates. Mr. R. C. Birnie, President of the Centre, warmly welcomed Mr. Hines. The Telephone Manager also spoke and thanked

the Centre for a very interesting evening. Votes of thanks were proposed by Mr. E. T. Ross, Chairman, and the whole party then adjourned to the old conference room for tea. The evening was a success in every way.

Meetings which have yet to take place are:—

18th April.—“Annual General Meeting,” plus “Tape Recording,” by Mr. J. Pike.

28th April.—“Visit to B.B.C. Television Station, Meldrum.”

It is also hoped to arrange a visit to one of the hydro-electric schemes in the Highlands, but this will be arranged for a date nearer the summer.

Office Bearers are: *President*, Mr. R. C. Birnie, M.B.E., Area Engineer; *Chairman*, Mr. R. T. Ross; *Vice-Chairman*, Mr. G. Jack; *Assistant Secretary and Treasurer*, Mr. J. H. Lawrence; *Librarian*, Mr. J. H. Lawrence; *Auditors*: Mr. J. R. Davidson, Mr. R. W. Lord; *Committee*: Mr. G. Ronaldson (Inverness), Mr. G. C. McKee (Elgin), Mr. F. J. Marshall (Huntly), Mr. J. B. Leonard (Aberdeen), Mr. J. Yule (Aberdeen) and Mr. J. G. Philip (Aberdeen).

### Edinburgh Centre

The December meeting of the Centre was in the form of a “quiz,” and all present voted the evening a great success. A visit to the Scotsman Publications, Ltd., was the first outing of the new year and a full quota of members saw some of the hustle and bustle of life in a large newspaper office in the efforts to get the first edition out to the public.

The remainder of the session promises to be extremely interesting as quite a varied program has been prepared. Variety being the spice of life we are offering our members such different topics as talks on “Diving,” “Tape Recording,” “Model Railways” and “Calculating Machines.”

The increase in membership has been most encouraging during the past few months, but many more can be easily absorbed; remember, the bigger our membership the more ambitious our programs can become.

J. R. H.

### Glasgow and Scotland West Centre

At the time of writing we are looking forward to a return visit from Mr. T. Moxon, S.E.E., Edinburgh, who is to speak on “Radio Links,” with special emphasis on the technical advances that will affect the development of telecommunications in remote areas and the Western Isles. The talk in March, by Principal R. H. Garner, Coatbridge Technical College, will be on “The Principles of Colour Television.” The last paper of the session will be given by Mr. S. J. Barker, Technical Services and Development Department of I.C.I., Ltd., on the subject of “Plastics.”

The visits during the summer have been slightly altered, as follows:—

8th May (Tuesday).—Albion Motors, Ltd., Scotstoun.

June.—Kirk o’ Shotts Television Station.

August.—Bus run to Pitlochry Power Station.

October.—Scottish Cables, Ltd., Renfrew.

Now is the time to consider the program for next session. What kind of talks do *you* want? Where do *you* wish to visit? Do you prefer this year’s arrangement of summer visits in place of winter visits? *You* come along to the A.G.M. in May and make next year’s programme even better than this year’s!

J. F.

### Tunbridge Wells Centre

The program arranged for 1955-56 winter session has consisted of the following talks:—

12th October.—“Art for Art’s Sake,” Mr. Hollands.

2nd November.—“Subscribers’ Apparatus,” Mr. Glazier.

6th December.—“The Drawing Office,” Mr. Holding.

11th January.—“The Coaxial Line Link,” Mr. Bridger.

15th February.—Film Show. (Prelude to visit to Isle of Grain oil refinery.)

22nd February.—Visit to oil refinery.

21st March.—“Circuit Provision,” Mr. Waghorn.

During April the 1955-56 program will be concluded with a visit to the Hastings Branch for a “quiz” and social, and the annual general meeting.

The Committee and Members would like to record their sincere thanks to Mr. E. L. English who was Secretary of our Centre for so many years, and did a great deal of spade-work in all our activities and in raising our membership to over 120. We also wish him the very best of success in his new appointment and hope he will long remember the many enjoyable evenings the Centre has spent at the Telephones Club in past years.

G. E. K.

### Hull Centre

Among the many successful events of the 1955-56 session were a talk on “Railway Signalling Systems,” by Mr. W. L. Cartwright, of British Railways, North-East Regional Office; a combined talk and visit to the new Cecil Cinema, conducted by Mr. Brownlee, of the Westrix Co., Ltd.; and numerous presentations of good technical films—that on the “Principles of Ultrasonics” was really outstanding.

At the time of writing, visits are still to be made to the new British Railways Signal Box at York, and to the Northern Radio Show at Manchester. We hope that these will prove as interesting as our visit in May last year to the British Industries Fair at Birmingham.

L. J.

### Middlesbrough Centre

The E.-in-C.’s Office has for some time been investigating the possibility of using electronic devices for automatic exchanges and some results of this work were described in a talk on 16th December, 1955. With the assistance of Mr. Vogan, who ably demonstrated a working model of an electronic register-translator, Mr. J. A. Lawrence, of the E.-in-C.’s Office, explained the basic circuits necessary in such equipment. After light refreshments the audience, which included staff from Traffic, Sales and Clerical divisions, maintained a lively discussion until about 10.15 p.m. The meeting closed with a vote of thanks to the speaker.

G. F.

### Darlington Centre

The session opened on 8th November, 1955, when Mr. G. A. Whitton, A.M.I.E.E., of I.C.I., Ltd., had for his subject, “Electricity in the Chemical Industry.” His talk was followed with keen interest and in the ensuing discussion there was an interesting exchange of views on I.C.I. methods as compared with Post Office practice. Many thanks were accorded the speaker and preliminary arrangements were made for a visit to the I.C.I. Works.

On 29th November, 1955, Mr. W. A. Myers, Chief Reporter of the North of England Newspaper Co., Ltd., gave a talk on “The News in the Newspapers.” Mr. Myers had some quaint and vivid experiences to relate, and held the attention of his listeners with his review of over 40 years spent in journalism. He recalled his first assignment and the limited telephone service and other communications then available and compared them with the facilities offered to-day, when news of national importance is available to the public in a matter of minutes. He described the pathos of his experiences as a war correspondent and in contrast related some very humorous incidents in his career. His talk was warmly appreciated by all.

At the joint Centre meeting with Darlington on 14th December, members heard from Mr. J. A. Lawrence about “Electronics in Telephone Exchanges” and future developments in long-distance dialling.

On 10th January, 1956, Mr. B. V. Northall, A.M.Brit.I.R.E., gave a talk on “The New Broadcasting System.” No introduction of the speaker was necessary as Mr. Northall was a past member of the Centre and had come along as a Senior Section member to give a talk for the third session in succession. His happy knack of putting over his subject again delighted the members and his demonstration of radio reception in this new era was much appreciated.

We record, with pleasure, that Mr. W. J. Costello, who is already an Institution certificate holder, has been awarded a prize of one guinea for his paper given to the Darlington Centre in the 1954-55 session.

C. N. H.

(Continued on p. 67)

# Staff Changes

## Promotions

Name	Region	Date	Name	Region	Date
<i>Exec. Engr. to Sur. Exec. Engr.</i>			<i>Tech. Offr. to Asst. Engr.—continued.</i>		
Partington, E. V.	E.-in-C.O.	28.11.55	Good, D. J.	Mid. Reg.	15 8 55
Stewart, T.	E.T.E.	1.11.55	Slater, P. E.	Mid. Reg.	28.9.55
Gandon, N.	W.B.C.	9.11.55	Musk, E. A.	Mid. Reg.	7.11.55
Hall, A. W.	N.W. Reg.	9.11.55	Caudle, W.	Mid. Reg.	7 11.55
Horne, F. A.	N.I. to Scot.	4.1.56	Hill, B. J. F.	E.T.E.	4.11.55
Irwin, A.	E.-in-C.O.	19.12.55	Leith, W. F.	Scot.	4 12.55
Dixon, W.	Mid. Reg.	9 11.55	Batch, R. G.	H.C. Reg.	5 11 55
Prichard, F. E.	N.E. Reg.	9.11.55	Lansley, R. E.	H.C. Reg.	5 11 55
Waite, D.	N.I.	12.11.55	Kitchener, J. R.	H.C. Reg.	5 11.55
Woods, A. E.	S.W. Reg.	12.11.55	West, G. E.	H.C. Reg.	5.11.55
Gray, H. G.	H.C. Reg. to Mid. Reg.	1.12.55	Taylor, W. K.	Scot.	10.12.55
Arnold, G. F.	H.C. Reg. to Mid. Reg.	2.1.56	Smith, F.	N.W. Reg.	1.12 55
<i>Exec. Engr. (Open Competition).</i>			Sherratt, W. R.	N.W. Reg.	7.12.55
Berry, R. W.	E.-in-C.O.	21.11.55	Calvert, C. P. H.	N.W. Reg.	14.12.55
<i>Asst. Engr. to Exec. Engr.</i>			Jennings, H. G.	H.C. Reg.	15.12.55
Barker, R. C.	E.-in-C.O.	7.11.55	Skinner, T. J.	H.C. Reg.	15.12.55
Stevens, P. F.	E.-in-C.O.	5.11.55	Benefield, P. A.	H.C. Reg.	15.12.55
Heptinstall, D. L.	E.-in-C.O.	7.11.55	De Coster, K. M.	H.C. Reg.	15.12.55
Fletcher, J. L.	N.E. Reg. to N.I.	12.12.55	Mollart, E. L.	H.C. Reg.	15.12.55
Hamilton, F. A.	L.T. Reg.	16.9.55	Berry, B. A.	H.C. Reg.	15.12.55
Mann, H. F.	E.T.E.	7.11.55	Woodward, T. A.	H.C. Reg.	15.12.55
Seager, E. G.	E.T.E.	7.11.55	Shepperd, R. G.	H.C. Reg.	15.12.55
Tarbet, A. G.	Scot. to L.P. Reg.	6.12.55	Button, A. C.	H.C. Reg.	15.12.55
Sharp, J. H. W.	Scot.	20.12.52	Crerar, J.	N.W. Reg.	20.12.55
Palin, F.	H.C. Reg.	14.12.55	Costa, G. G.	Scot.	15.11.55
Willoughby, E.	E.-in-C.O.	9.1.56	Mountford, A.	N.W. Reg.	29.12.55
Grieve, J. W.	Scot.	15.11.55	Davies, G. J. I.	W.B.C.	20.9.54
Porter, D. J.	H.R. Reg. to Scot.	6.12.55	Dulson, G.	Mid. Reg.	12.9.55
Benson, T. A.	Scot.	15.11.55	Richardson, H. E.	Mid. Reg.	30.1.56
Wood, T.	N.E. Reg.	13.12.55	Young, D. C.	Scot. to E.-in-C.O.	28.1.56
Guppy, H. L.	N.E. Reg.	6.12.55	Cave, K. H.	W.B.C.	31.10.55
Capon, S. J.	L.T. Reg.	20.1.56	Robinson, L. R. S.	L.T. Reg.	7.11.55
Houldsworth, G. R.	N.W. Reg.	28.12.55	Blackburn, F. C.	L.T. Reg.	23.11.55
Isherwood, J. E.	L.T. Reg.	20.1.56	Shepherd, R. S.	L.T. Reg.	6.6.55
Adams, A. V. G.	L.T. Reg. to N.I.	9.1.56	Plant, C. G.	L.T. Reg.	16.5.55
Kennedy, M. M.	Scot.	6.12.55	Wenban, K.	L.T. Reg.	31.10.55
Bradley, C.	N.W. Reg.	6.12.55	Benford, C. J.	L.T. Reg.	13 9.55
Longyear, J. W.	S.W. Reg. to Scot.	6.2.56	Thraves, E. A. J.	L.T. Reg.	2 11.55
<i>Asst. Engr. (Open Competition).</i>			Willett, W. H.	L.T. Reg.	16.9.55
Campbell, G. M.	E.-in-C.O.	5.12.55	Clark, A. J.	L.T. Reg.	16.9.55
Pring, D. C.	S.W. Reg.	5.12.55	Shrewsbury, H.	L.T. Reg.	3 10.55
Kerslake, K. W.	S.W. Reg.	5.12.55	Wright, W. O.	L.T. Reg.	12.9.55
Carter, K. R.	E.-in-C.O.	5.12.55	Medcalf, A. F.	L.T. Reg.	9.5.55
Fletcher, F. H.	E.-in-C.O.	5.12.55	Fisher, H. W. R.	L.T. Reg.	31.10.55
Fenner, A. G.	E.-in-C.O.	5.12.55	Stageman, E. J.	L.T. Reg.	1.10 54
Medwell, J. D.	E.-in-C.O.	5.12.55	Monk, E. H.	L.T. Reg.	1 10.54
Taylor, R. C.	W.B.C.	5.12.55	Aldridge, H. G.	L.T. Reg.	31.10.55
Pinnock, D. C.	E.-in-C.O.	5.12.55	Gallacher, D. P.	L.T. Reg.	31 10.55
Nightingale, C. R.	E.-in-C.O.	5.12.55	Lemon, L. F.	L.T. Reg.	31.10.55
Mulcahy, M. C.	S.W. Reg.	5.12.55	Endean, F. C.	L.T. Reg.	22.8.55
<i>Inspector to Asst. Engr.</i>			Goard, R. E.	L.T. Reg.	13.12.54
Carrington, J. A.	N.E. Reg.	12.9.55	Everett, C. S.	L.T. Reg.	22.8.55
Clark, A. H.	L.T. Reg.	30.7.55	Ward, J. W.	L.T. Reg.	31.10.55
Newbury, A. H.	L.T. Reg.	20.8.55	Turnbull, J. H.	N.W. Reg.	16.1.56
Everett, G. J. Y.	L.T. Reg.	19.9.55	Bibby, G. N.	N.W. Reg.	26.1.56
Truine, W. J.	L.T. Reg.	9.9.55	Chadwick, E. H.	N.W. Reg.	31.1.56
Buchanan, D. R.	Scot.	26.11.55	Dowdeswell, A. R.	N.W. Reg.	31.1.56
Johnson, F.	N.W. Reg.	7.12.55	<i>Tech. Offr. to Inspector.</i>		
Schofield, J.	N.W. Reg.	31.1.56	Goater, W. J.	N.I.	21 11.55
<i>Tech. Offr. to Asst. Engr.</i>			McPherson, J. B.	S.W. Reg.	7.3.55
Kilby, G. F.	W.B.C.	1.6.55	Cox, J. W.	S.W. Reg.	22.11.55
Fillmore, W. C.	L.T. Reg.	12.9.55	Daish, L. H.	S.W. Reg.	25.5.55
Beale, J. J.	L.T. Reg.	9.6.55	Bullen, V. W.	H.C. Reg.	17.8.55
Ramsay, J.	Scot.	30.9.55	Short, A. F.	H.C. Reg.	1.9.55
Farmer, K. F.	W.B.C.	28.4.55	Brown, F. W.	Mid. Reg.	3.10.55
Hornsby, H.	H.C. Reg.	24.7.55	Wykes, C. J.	Mid. Reg.	3 10.55
Morton, H. P.	H.C. Reg.	4.10.55	<i>Tech. I to Inspector.</i>		
Bell, L. D.	H.C. Reg.	4 10.55	Found, L.	N.E. Reg.	4.6.55
Whittle, F. R.	H.C. Reg.	19.9.55	Askew, N.	N.E. Reg.	25.6.55
Lampard, P.	H.C. Reg.	4.10.55	Barber, J.	N.E. Reg.	4.10.55
Mason, L. A. S.	H.C. Reg.	4.10.55	Gibbs, F. G.	N.E. Reg.	20.8.55
Carwin, F. T.	H.C. Reg.	4.10.55	Graham, H.	N.E. Reg.	8.8.55
Bailey, K. W. E.	Mid. Reg.	3.10.55	Corrill, H.	N.E. Reg.	12.9.55
Seymour, A. W.	Mid. Reg.	25.5.54	Fordham, H. J.	L.T. Reg.	19.9.55
			Stead, E. E. A.	L.T. Reg.	19.9.55
			Sullivan, J. P.	L.T. Reg.	31.10 55
			Puttinger, J. J.	L.T. Reg.	1.10.55
			Hart, J. G.	L.T. Reg.	10.10.55

Promotions—continued.

Name	Region	Date	Name	Region	Date
<i>Tech. I. to Inspector (continued).</i>			<i>Asst. (Sc.) to Snr. Asst. (Sc.).</i>		
Elder, J. .. ..	Scot. .. ..	28.11.55	Hancock, G. J. .. ..	E.-in-C.O. .. ..	16.1.56
Saunders, D. J. .. ..	H.C. Reg. .. ..	17.8.55	<i>Asst. (Sc.) (Open Competition).</i>		
Lane, R. J. F. .. ..	H.C. Reg. .. ..	5.10.55	Richardson, (Miss) D. .. ..	Birmingham .. ..	16.11.55
Joynson, S. .. ..	N.W. Reg. .. ..	21.11.55	Unsworth, (Miss) M. B. .. ..	Birmingham .. ..	25.11.55
McNairn, T. W. .. ..	Scot. .. ..	27.11.55	James, D. T. .. ..	E.-in-C.O. .. ..	19.12.55
Dunn, G. W. .. ..	W.B.C. .. ..	17.11.52	Garrett, B. V. .. ..	E.-in-C.O. .. ..	28.1.56
Greenaway, A. V. .. ..	L.T. Reg. .. ..	20.8.55	Reynolds, J. D. .. ..	E.-in-C.O. .. ..	1.2.56
Bury, P. S. .. ..	L.T. Reg. .. ..	3.8.55	<i>M.T.O. III to M.T.O. II.</i>		
Eastley, E. G. .. ..	L.T. Reg. .. ..	22.11.55	Horler, R. J. .. ..	E.-in-C.O. .. ..	28.11.55
Taylor, B. B. .. ..	E.-in-C.O. .. ..	1.2.56	<i>T.A. I to M.T.O. III.</i>		
Warman, H. .. ..	L.T. Reg. .. ..	5.11.55	Fisher, P. E. .. ..	E.-in-C.O. .. ..	9.1.56
Martham, W. S. .. ..	L.T. Reg. .. ..	28.11.55	Beeton, F. E. .. ..	E.-in-C.O. .. ..	20.12.55
Butcher, E. G. .. ..	L.T. Reg. .. ..	19.11.55	Mundy, E. O. .. ..	E.-in-C.O. .. ..	9.1.56
Burch, L. J. .. ..	L.T. Reg. .. ..	21.11.55	Mitchell, A. J. .. ..	E.-in-C.O. .. ..	9.1.56
Woodyard, M. L. .. ..	N.W. Reg. .. ..	17.1.56	Ash, H. V. .. ..	E.-in-C.O. to N.W. Reg. .. ..	9.1.56
Williams, L. .. ..	N.W. Reg. .. ..	26.1.56	Williams, C. F. H. .. ..	E.-in-C.O. to Scot. .. ..	9.1.56
Burke, M. A. .. ..	N.W. Reg. .. ..	26.1.56	Payne, F. .. ..	N.E. Reg. .. ..	20.12.55
<i>Exptl. Offr. (Open Competition).</i>			Wilson, H. R. .. ..	Mid. Reg. .. ..	20.12.55
Goodison, H. .. ..	E.-in-C.O. .. ..	21.11.55	<i>Asst. Exptl. Offr. (Open Competition).</i>		
<i>Asst. Exptl. Offr. (Open Competition).</i>			Baker, D. .. ..	E.-in-C.O. .. ..	1.1.56

Transfers

Name	Region	Date	Name	Region	Date
<i>Snr. Exec. Engr.</i>			<i>Asst. Engr.—continued.</i>		
Hamilton, R. N.* .. ..	Loan to War Office to H.C. Reg. .. ..	1.11.55	Meade, J. .. ..	S.W. Reg. to Nigeria (approved employment)	30.11.55
Dolan, W. H. .. ..	E.-in-C.O. to W.B.C. .. ..	9.1.56	Andrews, A. C. .. ..	E.-in-C.O. to War Office (seconded)	1.12.55
<i>Exec. Engr.</i>			Pairman, W. S. .. ..	E.-in-C.O. to Scot. .. ..	1.12.55
Jennings, J. C. .. ..	E.-in-C.O. to Nigeria (approved employment)	17.11.55	Blunden, R. M. .. ..	E.-in-C.O. to C.O. of I. .. ..	1.12.55
Moffatt, J. J. .. ..	E.-in-C.O. to Nigeria (approved employment)	17.11.55	Griffiths, F. .. ..	E.-in-C.O. to Singapore (London) (approved employment)	1.1.56
<i>Asst. Engr.</i>			Rusdeye, E. A. .. ..	H.C. Reg. to M. of S. .. ..	4.1.56
MacBride, J. M. R. .. ..	E.-in-C.O. to Scot. .. ..	28.12.55	Sutcliffe, N. .. ..	N.E. Reg. to Singapore (London) (approved employment)	14.1.56
Polglase, S. A. .. ..	L.T. Reg. to H.C. Reg. .. ..	12.12.55	Edwards, A. J. .. ..	E.-in-C.O. to Min. of Transport and C.A. .. ..	1.2.56
Manuel, W. H. .. ..	H.C. Reg. to L.T. Reg. .. ..	12.12.55	Pagett, F. A. T. .. ..	Mid. Reg. to Cyprus (seconded)	7.2.56
Bell, C. .. ..	E.-in-C.O. to Nigeria (approved employment)	17.11.55	<i>M.T.O. II.</i>		
Linney, P. J. .. ..	E.-in-C. to Nigeria (approved employment)	17.11.55	Dorman, A. E. .. ..	E.-in-C.O. to H.C. Reg. .. ..	28.11.55

\*This transfer cancels that reported in Vol. 48, Pt. 4, Jan. 1956.

Retirements and Resignations

Name	Region	Date	Name	Region	Date
<i>Snr. Exec. Engr.</i>			<i>Asst. Engr.—continued.</i>		
Lawman, G. J. .. ..	E.T.E. .. ..	30.6.55	Fisk, W. A. .. ..	L.T. Reg. .. ..	7.11.55
Legood, F. J. .. ..	E.-in-C.O. .. ..	7.1.56	Musgrave, A. H. .. ..	L.T. Reg. .. ..	22.11.55
Thomas, C. F. .. ..	L.T. Reg. .. ..	24.12.55	Garwood, F. .. ..	L.T. Reg. .. ..	22.11.55
<i>Exec. Engr.</i>			Dommett, S. G. .. ..	N.E. Reg. .. ..	23.11.55
Allison, A. J. .. ..	L.T. Reg. .. ..	26.6.55	Laws, H. .. ..	N.W. Reg. .. ..	30.11.55
Jones, C. W. .. ..	N.W. Reg. .. ..	27.12.55	Edwards, P. K. .. ..	E.-in-C.O. (Resigned)	25.11.55
Fisher, S. W. .. ..	L.T. Reg. .. ..	31.12.55	Pollentine, G. H. .. ..	Mid. Reg. (Resigned)	3.12.55
Ricketts, N. J. W. .. ..	L.T. Reg. .. ..	4.2.56	Hatch, E. F. .. ..	H.C. Reg. .. ..	1.1.56
Earls, J. C. .. ..	E.-in-C.O. (Resigned)	31.8.55	Hall, H. .. ..	Scot. .. ..	5.1.56
<i>Asst. Engr.</i>			Birkby, H. W. .. ..	N.W. Reg. .. ..	12.1.56
Robins, R. E. .. ..	H.C.R. .. ..	1.12.55	Sawyer, E. C. .. ..	H.C. Reg. .. ..	1.2.56
King, E. F. H. .. ..	E.-in-C.O. .. ..	6.12.55	Collins, A. G. .. ..	E.-in-C.O. (Resigned)	28.1.56
Sage, J. W. .. ..	L.T. Reg. .. ..	19.12.55	<i>Inspector.</i>		
Williams, P. A. .. ..	S.W. Reg. .. ..	25.12.55	Price, A. A. .. ..	W.B.C. .. ..	17.12.55
Milford, T. S. .. ..	Mid. Reg. .. ..	31.12.55	Walker, A. .. ..	N.E. Reg. .. ..	17.12.55
Procter, R. .. ..	N.W. Reg. .. ..	31.12.55	Coe, S. P. .. ..	L.T. Reg. .. ..	29.12.55
Catto, A. D. .. ..	Scot. .. ..	31.12.55	Mannooch, E. T. .. ..	E.-in-C.O. .. ..	2.1.56
Roberts, R. .. ..	N.E. Reg. .. ..	31.12.55	Packer, L. .. ..	H.C. Reg. .. ..	31.7.55
Tully, J. .. ..	H.C. Reg. .. ..	5.1.56	Norris, E. J. .. ..	L.T. Reg. .. ..	4.11.55
Beacon, R. L. .. ..	E.-in-C.O. (Resigned)	28.12.55	Cole, J. H. .. ..	L.T. Reg. .. ..	18.11.55
England, R. .. ..	H.C. Reg. .. ..	1.9.55	Smith, A. T. .. ..	H.C. Reg. .. ..	26.11.55
Blakeman, W. W. .. ..	L.T. Reg. .. ..	2.11.55	Green, G. .. ..	N.E. Reg. .. ..	4.12.55
			Neale, A. C. .. ..	L.T. Reg. .. ..	19.1.56

**Retirements and Resignations—continued.**

Name	Region	Date	Name	Region	Date
<i>Exptl. Offr.</i>			<i>Temp Asst. (Sc.).</i>		
Burrells, W. . . . .	E.-in-C.O. (Resigned)	31.1.56	Burties, J. G. . . . .	E.-in-C.O. (Resigned)	16.12.55
<i>Asst. Exptl. Offr.</i>			<i>R.M.T.O.</i>		
Yeoman, K. A. . . . .	E.-in-C.O. (Resigned)	31.12.55	Coventon, A. E. . . . .	H.C. Reg. . . . .	26.10.55
Foster, (Mrs.) R. W. . . . .	E.-in-C.O. (Resigned)	30.11.55	<i>T.A.I.</i>		
Hands, A. L. . . . .	E.-in-C.O. (Resigned)	28.1.56	Hutchison, A. . . . .	N.W. Reg. . . . .	21.11.55

**Deaths**

Name	Region	Date	Name	Region	Date
<i>Snr. Exec. Engr.</i>			<i>Asst. Engr.—continued.</i>		
Stewart, A. D. . . . .	E.-in-C.O. . . . .	25.11.55	Brinkley, A. G. . . . .	H.C. Reg. . . . .	12.11.55
<i>Exec. Engr.</i>			Crew, S. A. . . . .	N.E. Reg. . . . .	8.12.55
Williams, L. A. . . . .	E.-in-C.O. . . . .	27.11.55	Steadman, A. . . . .	L.T. Reg. . . . .	5.1.56
Denny, E. . . . .	L.T. Reg. . . . .	2 12.55	Allibone, G. . . . .	E.-in-C.O. . . . .	23.1.56
<i>Asst. Engr.</i>			Williams, B. G. . . . .	L.T. Reg. . . . .	2.2.56
Mintern, R. K. . . . .	L.T. Reg. . . . .	9.11.55	<i>Inspector.</i>		
			Lawson, W. H. . . . .	L.T. Reg. . . . .	12.12.55

*Correction.*—The reporting, in the October 1955 issue, of the resignation of R. L. Fagg, Asst. Engr., H.C. Reg., was incorrect; although Mr. Fagg resigned on 14.5.55 in order to contest a seat in Parliament at the 1955 General Election, he was, in fact, re-instated later in May 1955, and the resignation should not therefore have been reported in the Journal.

**Associate Section Notes** (continued from p. 64).

**London Centre**

With the end of the 1955-56 session in sight, plans have been completed for the annual general meeting. The meeting will be held in the small hall, I.E.E., Savoy Place, W.C.2, on Tuesday, 29th May, 1956, at 5.30 p.m.; an address to be given by the President of the Associate Section, Mr. R. W. Palmer, M.I.E.E., will precede the normal business of the A.G.M. (further details will be given in a poster).

The lecture on "Colour Television," given by Mr. I. L. Whitlock, of Marconi's, was a great success. The lecturer,

ably assisted by Mr. Dunmow, dealt firstly with the theory of colour, which was illustrated by slides and practical demonstration. This was followed by a description of the methods used to overcome the need for a large bandwidth, and slides taken of the B.B.C. test colour transmissions.

Several times during this session, points have arisen which are essentially of a national basis. Many of these points are dealt with at the Liaison Officers' Annual Conference, but there are still many difficulties which arise. With this in mind the London Centre would welcome the interchange of information in the way of articles and letters in the London Centre Quarterly Journal. P. S.

**BOARD OF EDITORS**

- D. A. BARRON, M.Sc., M.I.E.E., Chairman.
  - W. WEST, O.B.E., B.A., M.I.E.E.
  - L. F. SCANTLEBURY, Whit.Sch., A.C.G.I., D.I.C., M.I.E.E.
  - H. G. BEER, Whit.Sch., A.C.G.I.
  - C. E. CALVELEY, O.B.E., E.R.D., B.Sc.(Eng.), M.I.E.E.
  - A. F. STOLLARD.
  - A. E. BAVIN A.M.I.E.E.
  - W. A. HUMPHRIES, T.D., A.M.I.E.E., Managing Editor.
  - J. H. BROADHURST, A.M.I.E.E.
  - E. DAVIS, A.M.I.E.E.
  - A. J. HUTCHISON, Secretary-Treasurer
- } Assistant Editors.

**Copyright**

The entire contents of this JOURNAL are covered by general copyright, and special permission is necessary for reprinting long extracts, but Editors are welcome to use not more than one-third of any article, provided credit is given at the beginning or end thus: "From the *Post Office Electrical Engineers' Journal*."

The Board of Editors is not responsible for the statements made or the opinions expressed in any of the articles in this JOURNAL, unless such statement is made specifically by the Board.

**Communications**

All communications should be addressed to the Managing Editor, *P.O.E.E. Journal*, Engineer-in-Chief's Office, Alder House, Aldersgate Street, London, E.C.1. Telephone: HEADquarters 1234. Remittances should be made payable to "*The P.O.E.E. Journal*" and should be crossed "& Co."

**Binding Cases**

Cases for binding are available, and may be obtained from the Local Agents for 3s. Subscribers can have their copies of volumes bound, at a cost of 10s. 6d., by sending the complete set of parts to the Local Agents or to the *P.O.E.E. Journal*, Engineer-in-Chief's Office, Alder House, Aldersgate Street, London, E.C.1. Orders for binding for Vols. 1-19 should indicate whether the original binding case with black lettering, or the later pattern with gold, is required. Cases with gold lettering are the only type stocked from Vol. 20 onwards.

**Back Numbers**

The price of the JOURNAL, which is published quarterly, is 2s. 6d. (2s. 9d. post free) per copy, or 11s. per annum, post free. Back numbers can be supplied, subject to availability of stocks, at 2s. 6d. each (2s. 9d. post free). Orders for back numbers may be sent to the *P.O.E.E. Journal*, Engineer-in-Chief's Office, Alder House, Aldersgate Street, London, E.C.1, or to the Publishers.

Employees of the British Post Office can obtain the *Journal* through Local Agents at the reduced price of 2s. per copy.

**Advertisements**

All communications relating to space reservations should be addressed to the Advertisement Editor, *P.O.E.E. Journal*, Alder House, Aldersgate Street, London, E.C.1. Communications regarding advertisement copy, proofs, etc., should be addressed to the Publishers, Messrs. Birch & Whittington (Prop. Dorling & Co. [Epsom] Ltd.), 49 Upper High Street, Epsom, Surrey.

## INDEX TO ADVERTISERS

	PAGE
Adcola Products, Ltd. . . . .	xxxv
Airmec, Ltd. . . . .	xv
Alton Battery Co., Ltd., The . . . . .	xx
Austinlite, Ltd. . . . .	vii
Automatic Coil Winder & Electrical Equipment Co., Ltd. . . . .	xvii
Automatic Telephone & Electric Co., Ltd. . . . .	xi-xii, xiv
British Electric Resistance Co., Ltd., The . . . . .	iii
British Institute of Engineering Technology . . . . .	ii
British Insulated Callender's Cables, Ltd. . . . .	viii
Edison Swan Electric Co., Ltd., The . . . . .	xxx
Ericsson Telephones, Ltd. . . . .	vi
Ferranti, Ltd. . . . .	xxxvii
General Electric Co., Ltd., The . . . . .	xxi-xxii, xxvii-xxviii
Great Northern Telegraph Co., Ltd. . . . .	iv
Hackbridge Cable Co., Ltd. . . . .	xxx
Hivac, Ltd. . . . .	xv
Marconi's Wireless Telegraph Co., Ltd. . . . .	v, ix-x
Marconi Instruments . . . . .	xvi

	PAGE
Muirhead & Co., Ltd. . . . .	xxxvi
Mullard, Ltd. . . . .	xviii
National Salt Glazed Pipe Manufacturers' Association . . . . .	xxiv
Painton of Northampton . . . . .	xix
Pirelli-General Cable Works, Ltd. . . . .	xxxvii
Pitman, Sir Isaac, & Sons, Ltd. . . . .	ii
Redifon, Ltd. . . . .	ii
Siemens Brothers & Co., Ltd. . . . .	xxxii-xxxiii
Skillman, T. S., & Co., Ltd. . . . .	xxxiii-xxxiv
Smith, Frederick, & Co. . . . .	xxxv
Standard Telephones & Cables, Ltd. . . . .	xxv-xxvi, xxix
Sullivan, H. W., Ltd. . . . .	xiii
Telephone Manufacturing Co., Ltd. . . . .	xvii
Tungstone Products, Ltd. . . . .	xxiii
Turner, Ernest . . . . .	xxxv
Westinghouse Brake & Signal Co., Ltd. . . . .	xiii
Winn & Coales, Ltd. . . . .	xxxv

### Now available from stock . . .

**CONSTRUCTION:** Toroidally wound auto-transformers, with tracks formed on one face of the windings.

**CORE:** Wound from a continuous strip of low loss electrical steel in a similar manner to the well-known C core construction.

**INSULATION:** Specially processed plastic mouldings ensure minimum shrinkage due to heat and continuous use, and prevent any possibility of the turns slackening.

**WINDING:** Of high conductivity copper, insulated with a synthetic enamel of the polyvinyl acetal-phenal formaldehyde resin type, giving good space factor, exceptionally high abrasion resistance and prolonged heating resistance.

**FRAME:** Of die cast aluminium, incorporating long spindle bearings and mounting feet to ensure accuracy and rigidity of the mechanism in relation to the fixing holes.

**BRUSHES:** The brushes are of a special carbon chosen for its contact resistance characteristics, shaped to give minimum loss, maximum strength and longest life.

There are 4 models of the Berco Rotary Regavolt available :—

Model	Max. Input Volts at 50/60 cycles	Max. Output Voltage Range at no load	Rated Current	Weight	PRICE		
					£	s.	d.
41A	250	0-250	0.8	4½ lbs.	6	18	8
41B	115	0-135	2.25				
42A	250	0-270	2.0	6½ lbs.	8	5	11
42B	115	0-135	5.0				

The Berco Rotary Regavolt provides a highly economical, compact and reliable means of obtaining a continuously variable output voltage, without the heat losses associated with resistances. Its outstanding advantage over resistance control is that any alternating current load within normal rating can be controlled from zero to full voltage without the necessity of special designing for individual applications. Thus, one rotary Regavolt can be used in place of a number of adjustable resistances. In addition, an increase in voltage, above the main supply, can be obtained with three of the four Regavolt models. This is an especially valuable feature when the supply voltage is low.

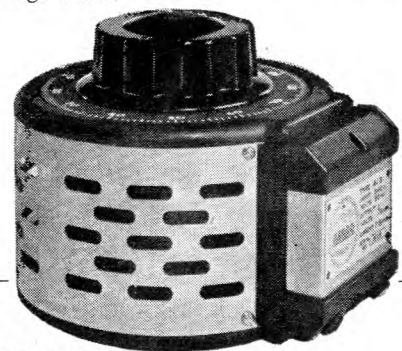

## ...BERCO ROTARY REGAVOLT



★ For full details and prices write to:—  
THE BRITISH ELECTRIC RESISTANCE CO. LTD.,

Queensway, Ponders End, Middlesex, Telephone: HOWard 2411. Telegrams: Vitrohm, Enfield  
Specialists in the control of current and voltage for more than 25 years

BB1251-AH

# G.N.T.

# UNDULATORS

MODELS 309 & 310

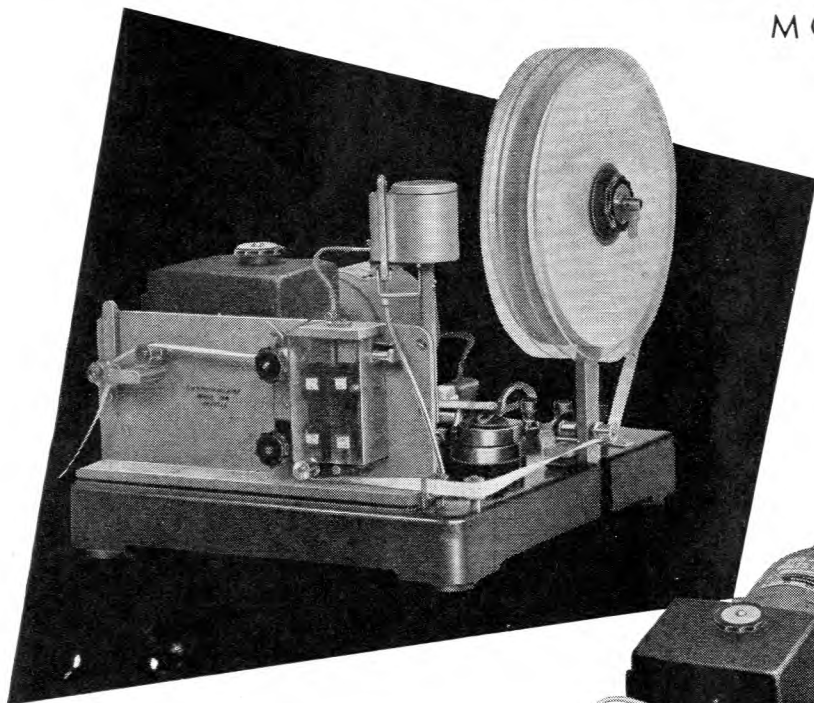

◀ Model 309 with single recording part.

Model 310 with two recording parts.  
▶

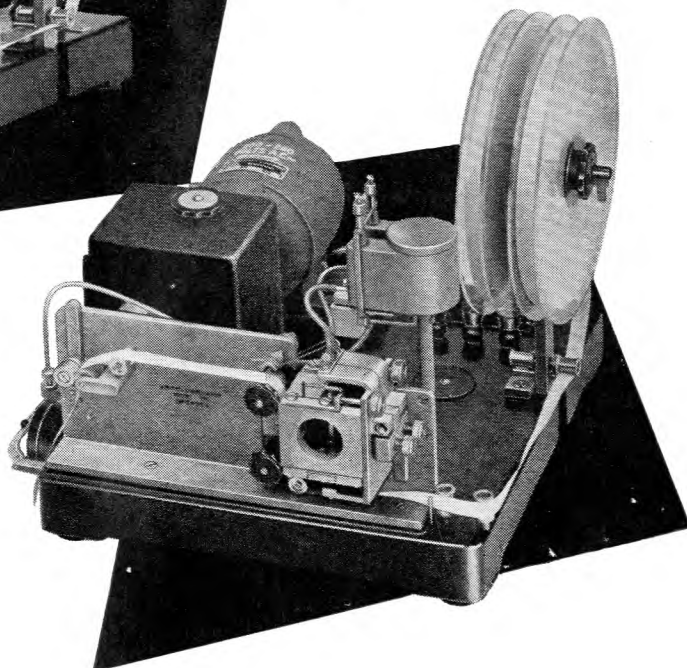

Both models can record signals up to 300 w.p.m. Supplied with A.C. or D.C. motors, as required.

✕

Also manufactured with built-in amplifiers under catalogue numbers 311 and 312 for single and double recording, respectively.

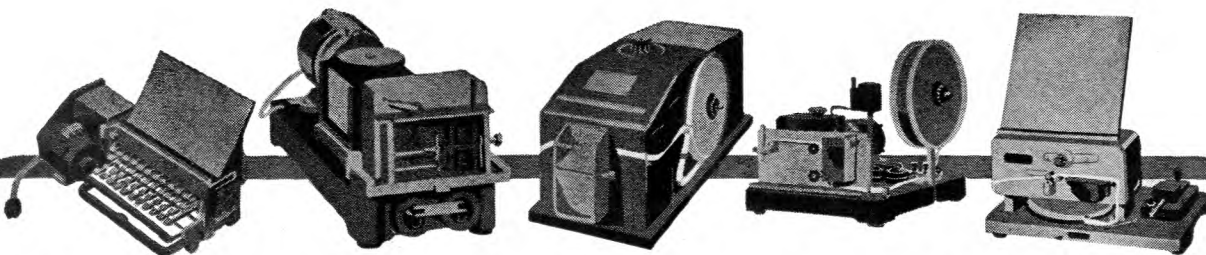

## GREAT NORTHERN TELEGRAPH WORKS

DIVISION OF THE GREAT NORTHERN TELEGRAPH CO. LTD.

4, SYDHAVNS PLADS  
COPENHAGEN SV, DENMARK

LONDON OFFICE: 5, ST. HELEN'S PLACE  
LONDON E. C. 3.

# MARCONI-SIEMENS

## Five Band Split Privacy Radio Telephone Equipment

(Type HW 12)

This equipment, which may be switched in or out of use at the radio terminal, provides a very high degree of privacy for speech on a radio-telephone circuit by:-

- (1) splitting the speech band of 250-3000 c/s into five sub-bands of 550 c/s and recombining them in different relative positions,
- (2) inverting the frequency range of any one or more of the sub-bands, and
- (3) rearranging the combination of the sub-bands simultaneously at both ends of the radio-circuit in accordance with a pre-arranged sequence at controlled intervals between 4 and 20 seconds.

The resulting speech band, which modulates the transmitter, is unintelligible and the frequent regrouping of the sub-bands, with or without inversion precludes any simple method of interception. A reversal of the process at the distant terminal restores the original speech. The processes involved are reversible, thus common channel equipment can be used for both transmission and reception. Amplifiers in the privacy path compensate for the losses in band splitting and recombining. The simultaneous switching system, operates by means of relays under the control of a synchronous motor driven by a high precision crystal oscillator, this does away with the need for a transmitter pilot tone.

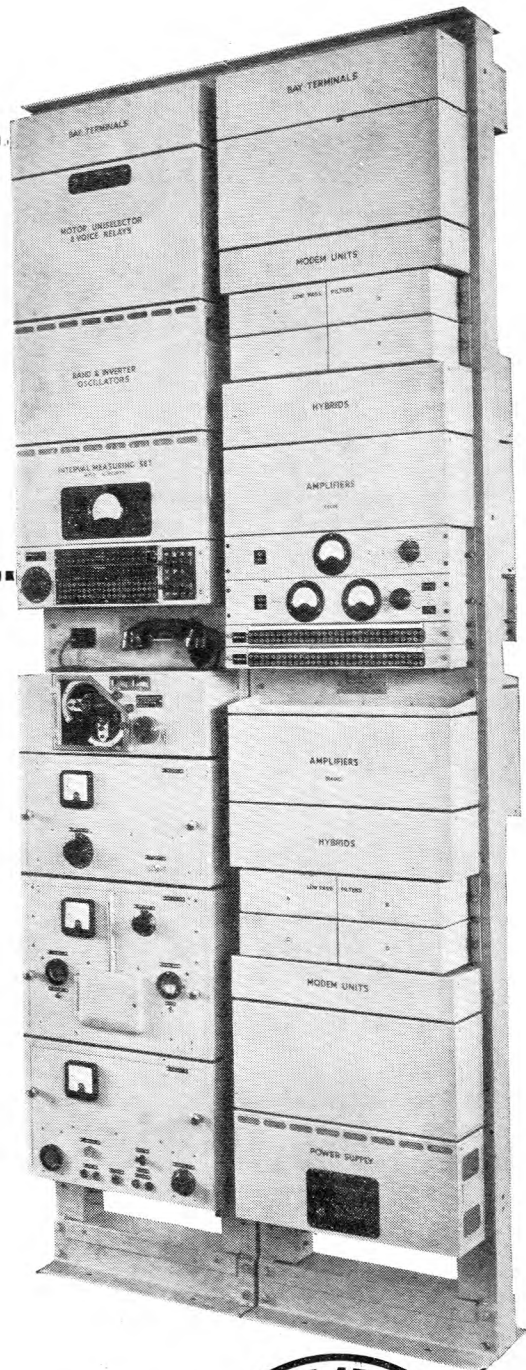

THE LINK BETWEEN RADIO AND LINE COMMUNICATIONS



*Full technical details of this and other Marconi-Siemens equipment, which provides completely integrated radio and line telegraph and telephone systems may be obtained from either*

MARCONI'S WIRELESS TELEGRAPH COMPANY LIMITED, CHELMSFORD, ESSEX  
OR SIEMENS BROTHERS & CO., LIMITED WOOLWICH LONDON S.E.18

MS



'OPTIMUM SOLUM SUFFICIT'

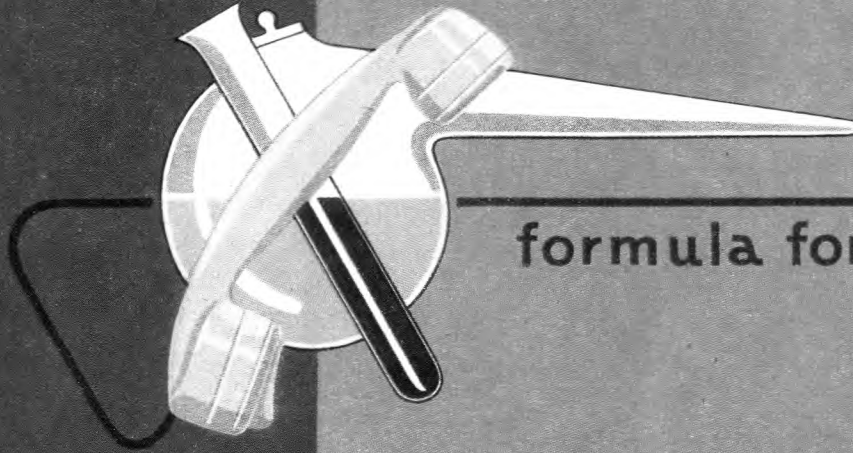

formula for quality

'ONLY THE BEST IS GOOD ENOUGH' is our standard, established as firmly today, as it has been throughout the past. For over half a century, Telecommunication Equipment by ERICSSON has always borne the seal of high quality. Throughout the whole of our Works, appreciation of this has become an endowment that sets a background to every phase of design and production. Modern Plant allied to the highest technical resources is the 'sine qua non' for the exacting standards imposed by modern conditions.

An outstanding example of the unity of these essential ingredients becomes apparent in the finish of all our products. Electro depositions and organic surface coatings are formulated and controlled directly by an extensive PROCESS LABORATORY so that at every stage expert knowledge is applied to ensure the superfine finishes which stand up to the most arduous conditions of service and climate.

What better FORMULA FOR QUALITY?



HEAD OFFICE: 22, LINCOLNS INN FIELDS, LONDON W.C.2  
WORKS: BEESTON, NOTTINGHAM & SUNDERLAND



**Bespoke and Off the Peg**

We can supply, economically, standard types of automatically controlled generating plant that fit many of those jobs in which reliability and continuity of supply are essentials. But our *forte* is tailor-made equipment. Sizes? 1.4 to 250 kVA. Quality? Savile Row. We like the problems other people can't fit. The more difficult they are the better we like them. We are, in short, selling experience and brains as much as generating plant. Austinlite stands for an unbroken flow of power, not some rigid pattern of generator and diesel engine on a base. Where this utter reliability of the power supply is an essential our engineers are prepared to go anywhere in the World to discuss the best means of providing it. And our erecting teams will follow them to get the plant running.

*Austinlite* **AUTOMATIC GENERATING PLANT**  
**Tailor-made by STONE-CHANCE LTD.**

# BICC

# execute

# Major Telecommunication Projects ANYWHERE IN THE WORLD

Consult BICC about the Planning Manufacture and Installation of Telecommunication Projects.

We have had long experience in this kind of work in many parts of the World. A few of our recent contracts are briefly described below.

The following types of BICC Cable are in continuous manufacture for telephone administrations in many countries:— coaxial and balanced pair trunk-route cables for carrier working, audio-trunk cables, paper or polythene insulated exchange-area distribution cables.

We shall be pleased to give you further information from our nearest Branch Office or from our Headquarters in London.



**AUSTRALIA** Electrification of the New South Wales Railway Western Line has necessitated a completely new track-side cable scheme covering the 34 miles from Sydney to Penrith. The main cable comprises 6 pairs for 24 channel carrier working and 60 audio pairs for local telephone and control purposes. Many of the audio pairs are terminated at railway stations, signal huts, power substations, etc., in order to provide local facilities. The installation was undertaken by BIC Construction Co. for the N.S.W. Railways Department, the cables being manufactured by BICC.



**NEW ZEALAND** BICC are supplying a trunk cable between Auckland and Hamilton for the New Zealand Post and Telegraph Department. BIC Construction Co. are supervising the installation and undertaking the progress and transmission testing. The cable consists of 4 coaxial tubes to provide long distance circuits, together with a surrounding layer of 34 pairs of audio quads to give intermediate local service, these circuits being loaded. The cable is buried direct in the ground for most of its eighty-mile route, except when passing through towns, where it is laid in ducts.



**VENEZUELA** BIC Construction Co. have undertaken the jointing and supervision of installation of a 448 pair 20 lb trunk cable to improve the telephone service between Caracas and Maquetia. With a route length of approximately seventeen miles, the cable runs wholly in ducts along the side of a newly-constructed auto-road linking the capital town of Caracas with the coast. This contract has been undertaken for the Compania Anonima Nacional Telefonos de Venezuela, the cable being manufactured by BICC.

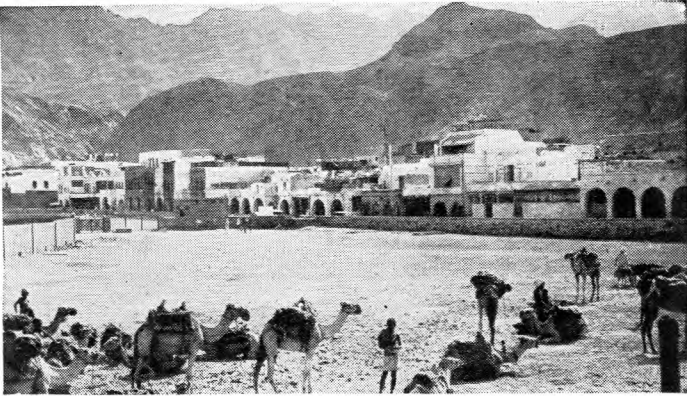

**ADEN** To extend existing facilities and to cater for the Colony's growth, a new distribution network has been installed comprising approximately 44 miles of BICC cables specially protected against soil corrosion. The new network provides an increase of 3,000 lines and consists of cables of varying sizes ranging from 15 to 200 pairs, twin cables, the larger sizes being of the unit twin type. A short balanced and loaded trunk cable was also installed to link the Town with the new refinery site at Little Aden. This contract was undertaken for the Aden Posts and Telegraph Department.

24 channel 24 pair 40 lb. carrier telephone cable.

4-tube composite coaxial cable with 18 supervisory pairs and 195 audio-trunk quads.



Left: a BICC jointer at work on a coaxial cable, cutting the tubes ready for jointing. Two typical carrier-trunk cables are illustrated on right.

BICC manufacture every type of telecommunication cable and undertake their installation—anywhere.

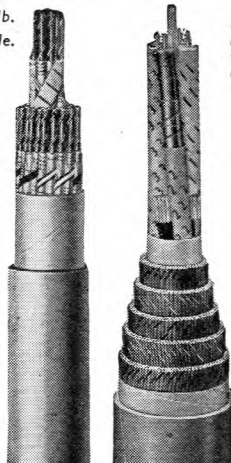

# BICC

**Planning • Manufacture • Installation for TELECOMMUNICATION SYSTEMS**

**BRITISH INSULATED CALLENDER'S CABLES LIMITED**

21, Bloomsbury Street. London. W.C.1



# MARCONI

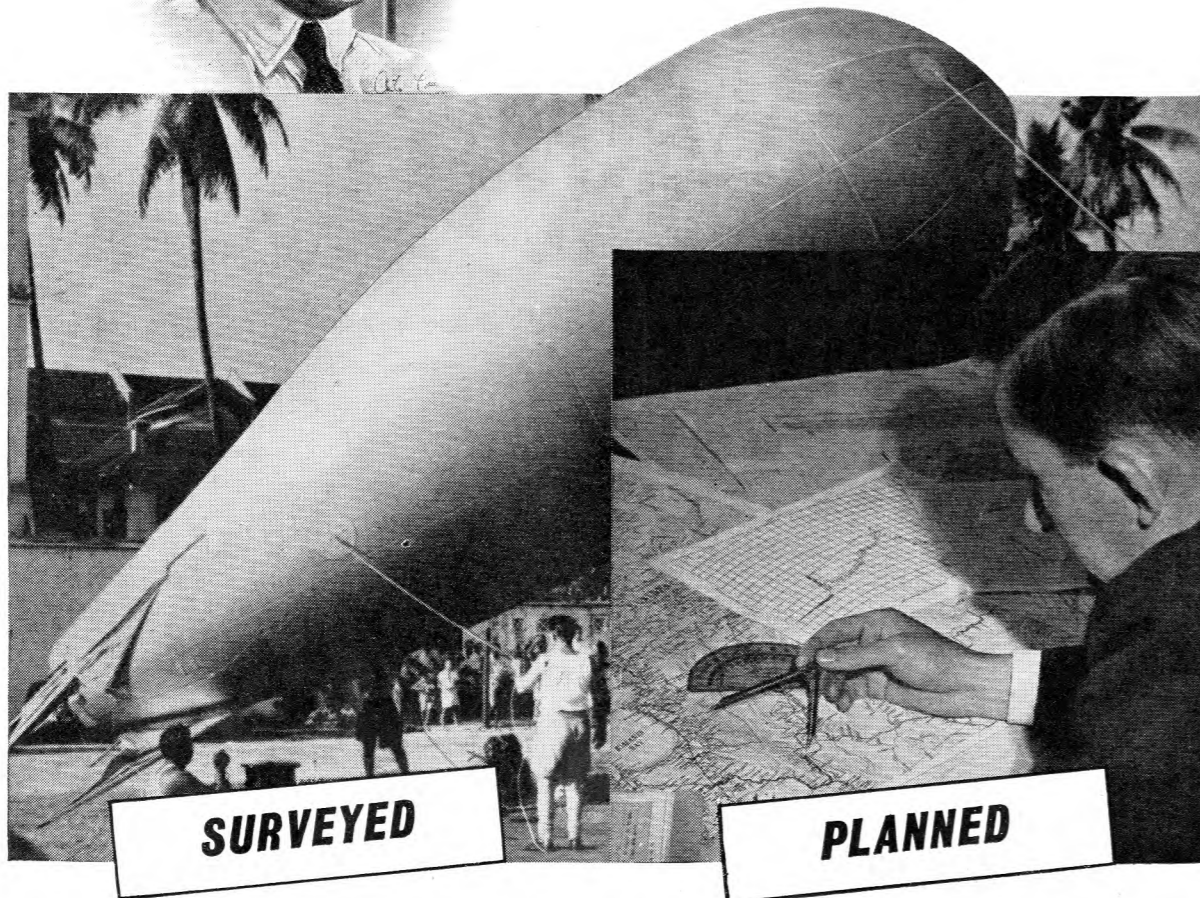

**SURVEYED**

**PLANNED**

## V. H. F. MULTI-CHANNEL SYSTEMS

VHF radio-telephony was welcomed in its early days as an economic means of providing communication over terrain where the cost and difficulty of erecting line or cable routes was prohibitive. Today Marconi's have developed multi-channel systems

which, by employing frequency modulation to widen the bands, provide up to 48 telephone channels and are recognised as being preferable to line systems in many instances on grounds of performance as well as installation cost.

## COMPLETE COMMUNICATION SYSTEMS — *all the world over*



**INSTALLED**

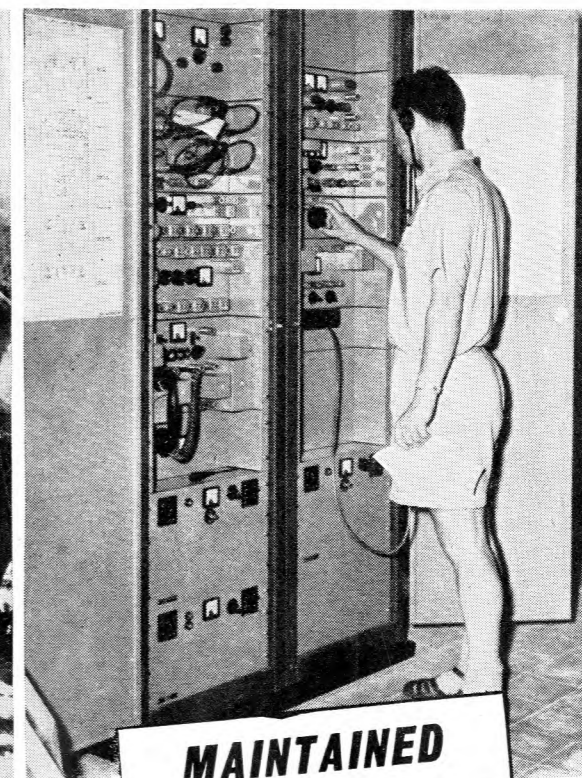

**MAINTAINED**

*Over 80 countries now have Marconi-equipped communication systems. Many of these are still giving trouble-free service after more than 20 years in operation.*



The lifeline of communication is in experienced hands

**MARCONI**  
**Complete Communication Systems**

MARCONI'S WIRELESS TELEGRAPH COMPANY LIMITED, CHELMSFORD, ESSEX.

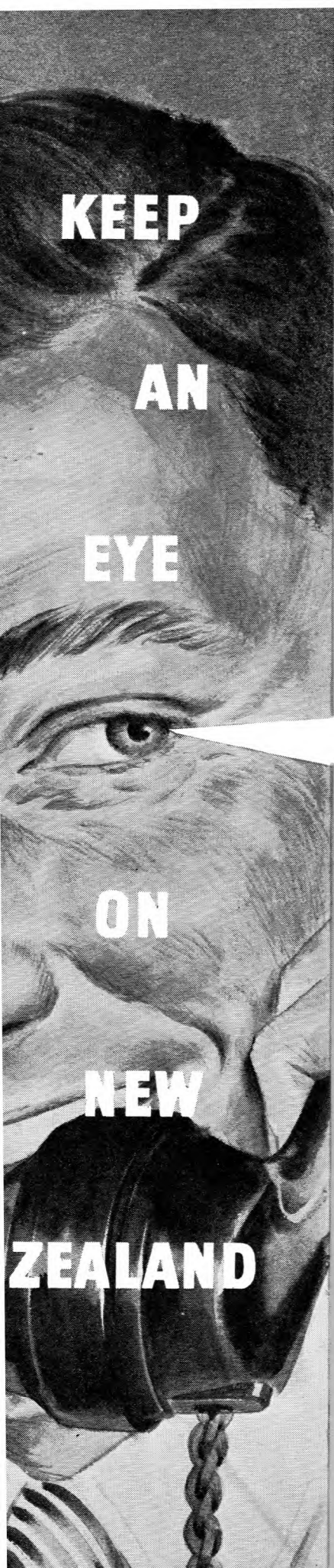

**KEEP  
AN  
EYE  
ON  
NEW  
ZEALAND**

# **COAXIAL CABLE SYSTEM to link Auckland and Hamilton**



The first coaxial cable system in New Zealand will shortly be installed between Auckland and Hamilton to the requirements of the New Zealand Posts and Telegraph Department.

The New Zealand authorities have chosen ATE to supply all terminal and line equipment for the new coaxial system.

The route, which will initially carry 240 telephone channels, replaces the existing 12 channel open wire systems. As traffic demands continue to rise the number of circuits can be increased to an ultimate capacity of 960 channels.

ATE are proud to be associated with this enterprise, making another advance in the expanding trunk network of the nation's telephone services.

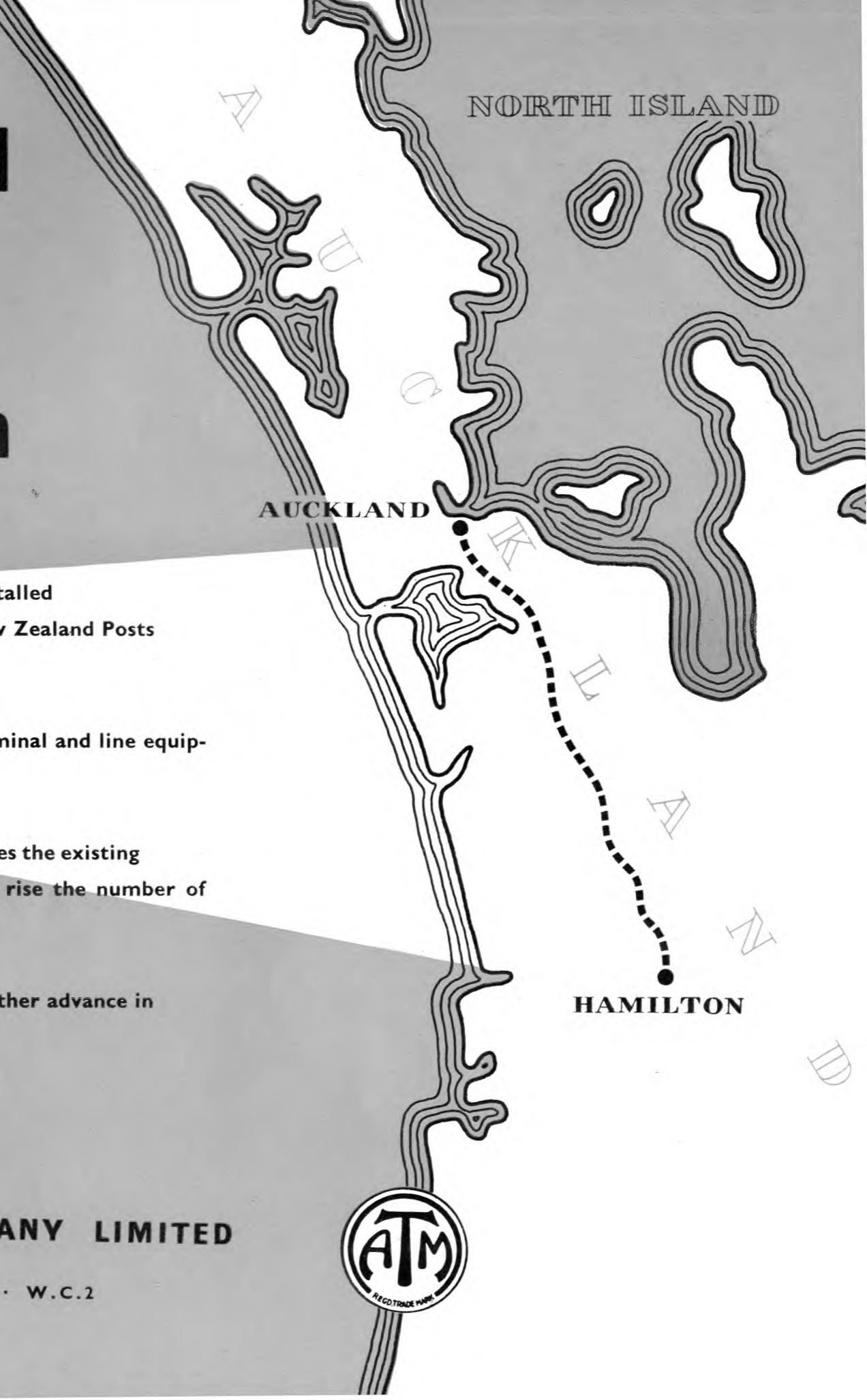

**AUTOMATIC TELEPHONE AND ELECTRIC COMPANY LIMITED**

RADIO AND TRANSMISSION DIVISION

STROWGER HOUSE · ARUNDEL STREET · LONDON · W.C.2

Telephone: TEMple Bar 9262      Cablegrams: Strowgerex, London

AT 8591 - AA 107



# Constant DC Voltage

DC Voltage limits  $\pm 1\%$  despite:—

- \* AC voltage fluctuation of  $- 10$  to  $+ 6\%$ .
- \* Frequency variations of 48 to 52 cps.
- \* Load variations of 5% to 100% and self-protecting on overload.

The above are typical limits of our range of constant DC voltage equipments. Electronic, magnetic or mechanically regulated equipments are available and can also be designed to meet customers' specific requirements. Consult us for the most satisfactory solution to your problems—take full advantage of the WESTINGHOUSE SERVICE.



## CONSTANT POTENTIAL RECTIFIERS

Write for details to:—

Dept. P.O.4, WESTINGHOUSE BRAKE & SIGNAL CO. LTD., 82 York Way, King's Cross, London, N.1

Telephone:— TERminus 6432

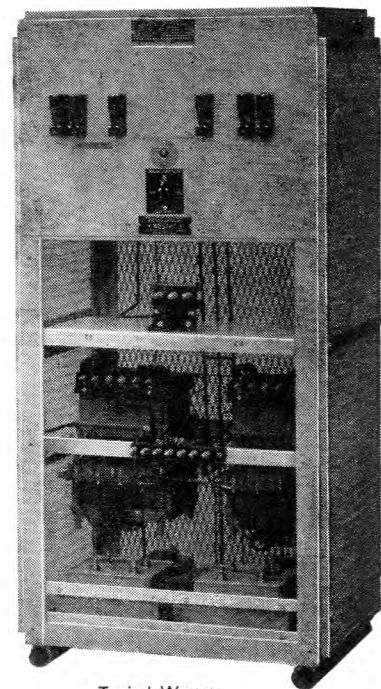

Typical Westat

## IMPROVEMENT IN THE ACCURACY OF DECADE RESISTANCES

We have pleasure to announce that the well-known and novel

SULLIVAN and GRIFFITHS

# DUAL DIAL DECADE RESISTANCE BOXES

FOR ALL FREQUENCIES

Moreover, the windings are now of **Manganin** in order to reduce the temperature coefficient; more important still, to improve the long period of stability and make them as suitable for all direct-current purposes as they are for alternating currents of all frequencies.

**Screened Resistances** of guaranteed accuracy exactly similar to our well-known Decade Resistances but specially arranged so that one box of a given number of dials gives many different values of maximum resistance. Thus a three-dial box (as illustrated) may be used for instance for

three decades of <b>Thousands, Hundreds and Tens</b>	a total of 10,000 ohms.
or three decades of <b>Hundreds, Tens and Units</b>	a total of 1,000 ohms.
or three decades of <b>Tens, Units and Tenths</b>	a total of 100 ohms.
or three decades of <b>Units, Tenths and Hundredths</b>	a total of 10 ohms.

have now been improved in accuracy to

**0.05 PER CENT**

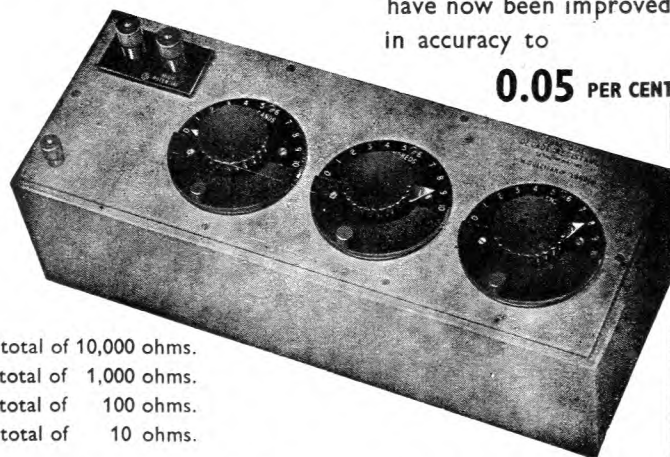

## H. W. SULLIVAN LIMITED

LONDON, S.E.15

Telephone: New Cross 3225 (P.B.X.)

The advantages of such a system will be obvious, for in addition to the economy involved much space is saved and the residual resistance and inductance is much reduced.

The resistances are available in 3-dial, 4-dial and 5-dial types with subdivision of 0.001% down to 0.001 ohm if necessary, depending of course on the number of dials incorporated.

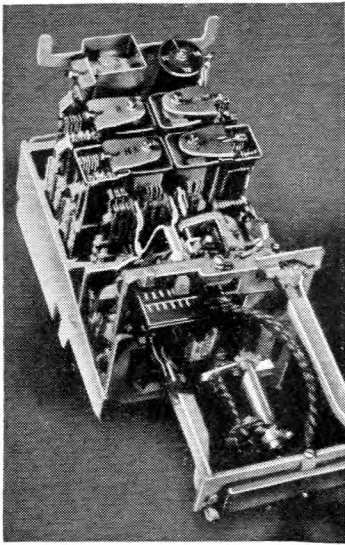

## Another Strowger Exchange

Nakuru is one of the latest exchanges to be commissioned by the East African Posts & Telegraphs Administration as part of its automatisisation plan for B.E.A. It is of 1,600 lines ultimate capacity and is a trunk terminating centre for v.f. circuits from Nairobi and Kampala and for 12-channel v.h.f. radio circuits from Nairobi. Nakuru will ultimately serve as a zone centre for the mechanised trunk working system now being introduced in the area. The Type 32A Mark II Selector is the basic selecting mechanism. Regular lubrication and the performance of simple operational tests are the only maintenance requirements. The observance of these simple routines is all that is required to ensure reliable performance.



AT7931-A

**AUTOMATIC TELEPHONE & ELECTRIC CO. LTD.**  
LONDON AND LIVERPOOL



# PHASE MEASURING EQUIPMENT

## TYPE RX103

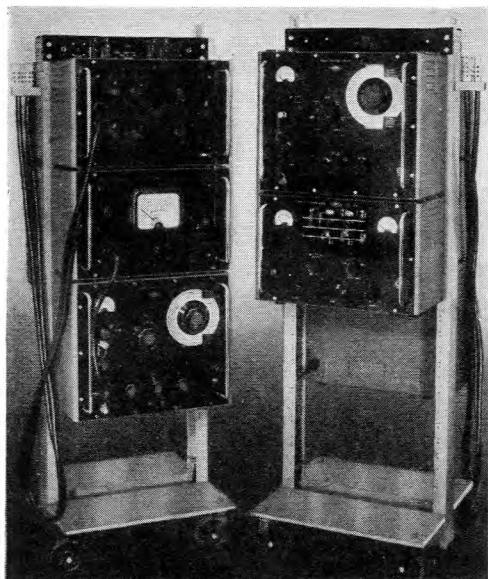

<b>Frequency Range:</b>	50 kc/s-20 Mc/s
<b>Minimum Input Level:</b>	66 db below 1 volt
<b>Maximum Input Level:</b>	27 db below 1 volt
<b>Maximum Level Difference:</b>	39 db between the two points at which measurements are to be made
<b>Accuracy:</b>	Attenuation Measurement $\pm 0.5$ db Phase Measurement $\pm 3^\circ$

**T**HIS equipment has been developed and manufactured to a General Post Office Research Branch design. It was primarily intended for the measurement of the loop phase-shift and gain of feedback repeaters over the frequency range 50 kc/s-20 Mc/s, but it is equally suitable for the measurement of these quantities in amplifiers, filters, equalisers and other four-terminal networks.

*Full details of this or any other Airmec Instrument will be forwarded gladly upon request*

**AIRMEC** HIGH WYCOMBE BUCKINGHAMSHIRE ENGLAND  
L I M I T E D Telephone: High Wycombe 2060. Cables: Airmec, High Wycombe



YOU CAN COUNT ON **Hivac**  
COLD CATHODE TUBES

Continuing development in the field of cold cathode tubes has brought a new

### COLD CATHODE TRIODE XC18

This electrically reliable and mechanically robust tube is contained in a 10mm round bulb, 32 mms in length  $V_{sa} \leq 200V$ :  
 $V_{ma} \approx 70V$ : $V_{st} \approx 68V$ .

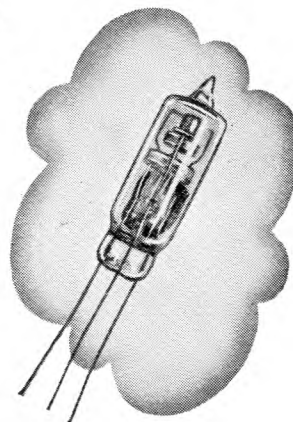

ACTUAL SIZE

DATA SHEET ON REQUEST

## Hivac Limited

Perfection in  
*miniature*

STONEFIELD WAY, VICTORIA ROAD, SOUTH RUISLIP, MIDDLESEX  
Telephone: Ruislip 3366





**Yes, MARCONI'S**  
*have just what*  
*is needed!*

*Marconi instruments include a wide range of Signal Generators designed to meet practically every requirement.*



As the Signal Generator is the basic tool in radio research, it is not surprising that Marconi Instruments have had long and unrivalled experience in this fundamental field. Generators are available which will fulfil practically every requirement, and new types are continually being added to the already large range at present available.

**F.M./A.M. SIGNAL GENERATOR**  
**TYPE TF 1066**

Carrier Frequency Range : 10 to 470 Mc/s. • No spurious sub-multiple outputs ; r.f. oscillator generates direct at carrier frequency on all bands. • F.M. monitored and variable up to 100 kc/s deviation. • A.M. monitored and variable up to 80% depth. • Output Level variable from 0.2  $\mu$ V to 200 mV. • Precision Incremental Tuning with frequency change indicated on a directly-calibrated meter.

**See it and other new designs on Stand 104.**  
**R.E.C.M.F. PRIVATE EXHIBITION,**  
**The Great Hall, Grosvenor House, Park Lane, London, W.1.**  
**APRIL 10th to 12th 1956 INCLUSIVE**

AM & FM SIGNAL GENERATORS · OSCILLATORS · VALVE  
 VOLTMETERS · POWER METERS · Q METERS · BRIDGES  
 WAVE ANALYSERS · FREQUENCY STANDARDS · WAVEMETERS  
 TELEVISION AND RADAR TEST EQUIPMENT · AND SPECIAL  
 TYPES FOR THE ARMED FORCES



**MARCONI INSTRUMENTS LTD., ST. ALBANS, HERTFORDSHIRE. TELEPHONE: ST. ALBANS 6160/9**  
 30 Albion Street, Kingston-upon-Hull, Telephone: Hull Central 16144 19 The Parade, Leamington Spa, Telephone: 1408  
 Managing Agents in Export: MARCONI'S WIRELESS TELEGRAPH CO. LTD., MARCONI HOUSE, STRAND, LONDON, W.C.2. TC75R

# CARPENTER

# POLARIZED RELAYS

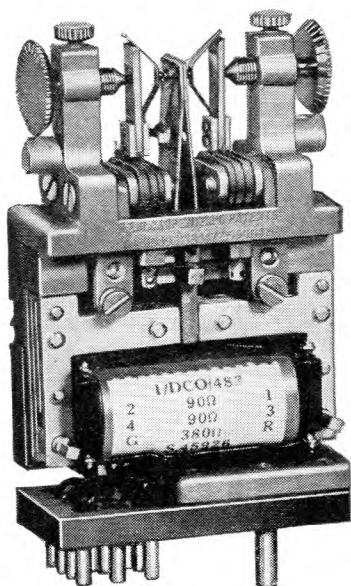

*have these outstanding features*

- HIGH OPERATIONAL SPEED • HIGH SENSITIVITY
- FREEDOM FROM CONTACT REBOUND
- NO POSITIONAL ERROR • HIGH CONTACT PRESSURES
- ACCURACY OF SIGNAL REPETITION
- EASE OF ADJUSTMENT

The Carpenter Polarized Relay will respond to weak, ill-defined or short-duration impulses of differing polarity, or it will follow weak alternating current inputs of high frequencies and so provide a continuously operating symmetrical changeover switch between two different sources.

Dimensionally the Type 4 relay illustrated is interchangeable with the type "3000" Relay and can be supplied to fit directly to the drilling normally provided for the "3000" Relay.

*Manufactured by the sole licensees*

## TELEPHONE MANUFACTURING CO. LTD

*Contractors to Governments of the British Commonwealth and other Nations*



**HOLLINGSWORTH WORKS, DULWICH, LONDON, SE21**

Telephone GIPsy Hill 2211

# ZEVA

*Electric*

## SOLDERING TOOLS

*for SPEED, ECONOMY  
and BETTER WORK*



The news that this famous range of Soldering Irons and Crucibles is again available has been welcomed in numerous branches of industry everywhere. Zeva Tools are unquestionably without equal for efficiency, economy and trouble-free long life.

- ZEVA heating elements never need renewal. They last the life of the tool.
- ZEVA Irons can be left switched on all day without detriment to the tool.
- ZEVA current consumption for rated temperature is less than any other make of tool.
- ZEVA initial cost is the only cost.
- ZEVA Irons are guaranteed.

Write for complete Illustrated Catalogue:—

**THE AUTOMATIC COIL WINDER & ELECTRICAL EQUIPMENT CO., LTD**  
 Avocet House, 92/96 Vauxhall Bridge Road, London, S.W.1      VICtoria 3404 (9 Lines)

ZL/P2/ZWS

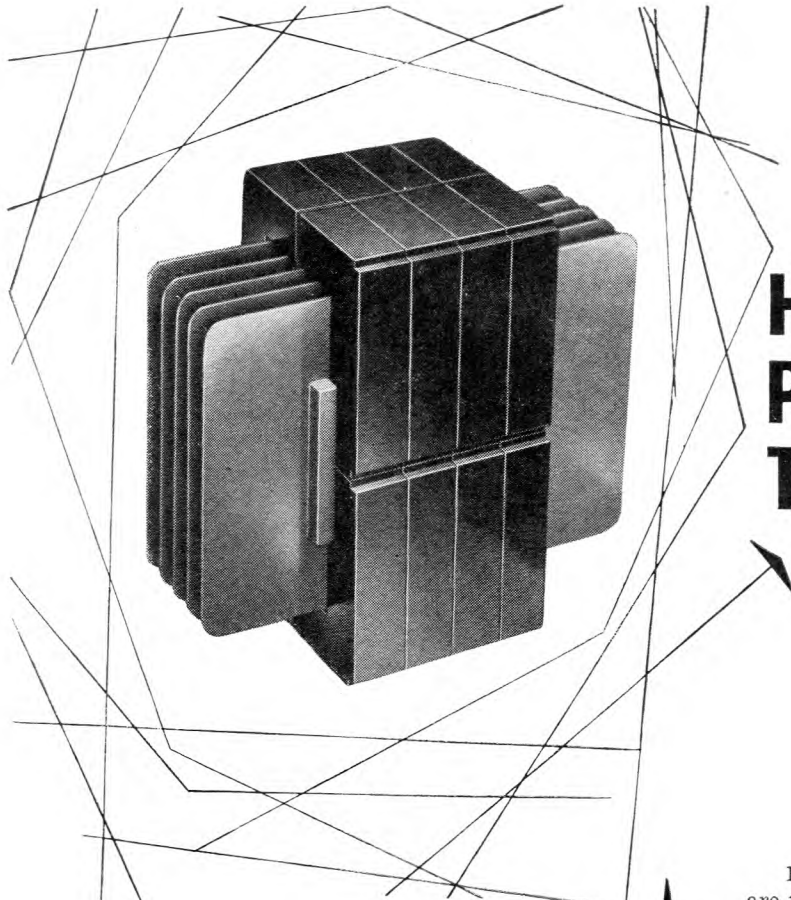

# H.F. POWER TRANSFORMERS

**RATING . . . . . UP TO 2 kW**

**FREQUENCY RANGE . . . . 2 Kc/s to 2 Mc/s**

H.F. power transformers of outstanding efficiency are the latest addition to the Mullard range of high quality components designed around Ferroxcube magnetic cores.

Utilising the unique characteristics of Ferroxcube to the full, Mullard H.F. transformers are smaller, lighter, and less costly than transformers using alternative core materials. These advantages are particularly marked in transformers required to handle powers of up to 2kW, between the frequency range 2kc/s to 2Mc/s.

Mullard transformers are already finding wide use in applications as diverse as ultrasonic H.F. power generators and aircraft power packs operating from an aircraft's normal A.C. supply. In the latter application, the low leakage field of Ferroxcube can eliminate the need for external screening, thereby reducing the size and weight of the transformer even further.

As with all Mullard high quality components, these H.F. power transformers are designed and built to engineers' individual specifications. Write now for details of the complete range of components available under this service.

# Mullard



'Ticonal' permanent magnets  
Magnadur ceramic magnets  
Ferroxcube magnetic cores



*By Appointment to the Professional Engineer*

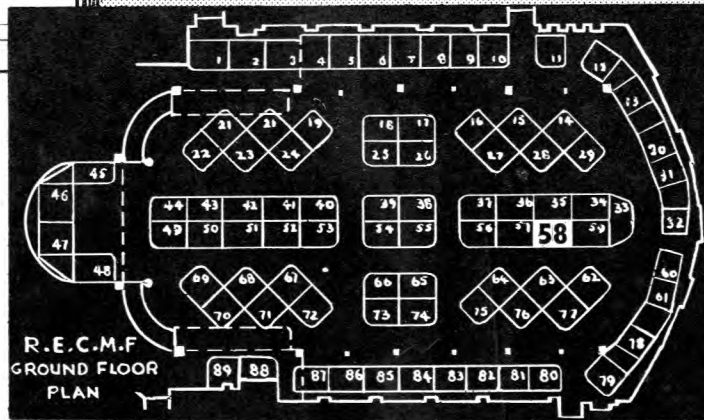
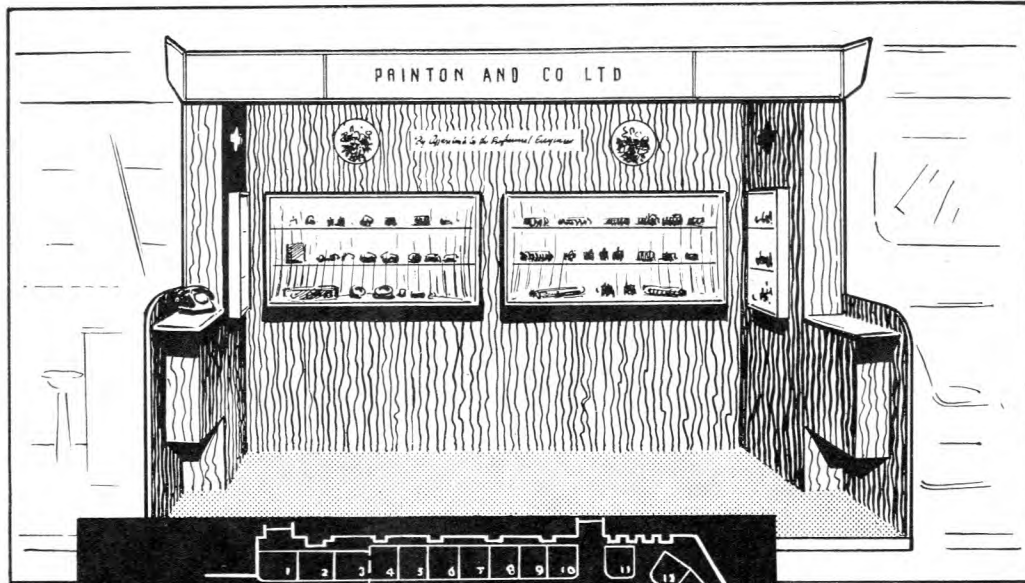

You are cordially invited to visit Stand No. 58 at this year's R.E.C.M.F. Exhibition where the complete range of Painton products will be displayed.

This illustration shows a selection of WIRE WOUND RESISTORS and HIGH STABILITY CARBON RESISTORS from the Painton Resistor range



**PAINTON**  
*Northampton England*

Manufacturers of

ATTENUATORS AND FADERS · STUD SWITCHES · TOGGLE SWITCHES · PUSH BUTTON SWITCHES  
FIXED AND ADJUSTABLE WIREWOUND RESISTORS · HIGH STABILITY CARBON RESISTORS  
'METLOHM' METAL FILM RESISTORS · WIREWOUND POTENTIOMETERS · MIDGET R.F. CHOKES  
KNOBS, DIALS & POINTERS · TERMINALS · PLUGS AND SOCKETS



*Now what on earth,* you may ask, have bluebells to do with batteries? Well . . . if you were with us in Alton this evening it would be easier to explain. That grizzled character at the end of the bar—the one with ‘Prickly—handle with care’ written all over him. Hard to picture him knee-deep in bluebells and picking like billy-oh. But that is how his father saw him, under the beeches in Dogford wood, some distant Sunday in May. As surely as he himself saw his own son—that chap by the dartboard, the one with the light ale. Dogford wood is an Alton custom—as old as the Hampshire hills. Life, do you see, still has continuity down here. Continuity in birthplace and occupation. Continuity in manual skills and a man’s solid pride in them. Continuity, as the years have proved, in the workmanship that Alton men put into Alton batteries.

## **ALTON** *Batteries of Merit*

*Alton stationary batteries: 10 to 15,000 ah. Also in regular production, renewal plates for all makes of battery, British and Continental.*

THE ALTON BATTERY COMPANY LIMITED, ALTON, HANTS • Telephone: ALTON 2267 and 2268 • Telegrams: BATTERY, ALTON

A27



# SE50 Selector... ..now cutting maintenance

## costs in South-East Asia!

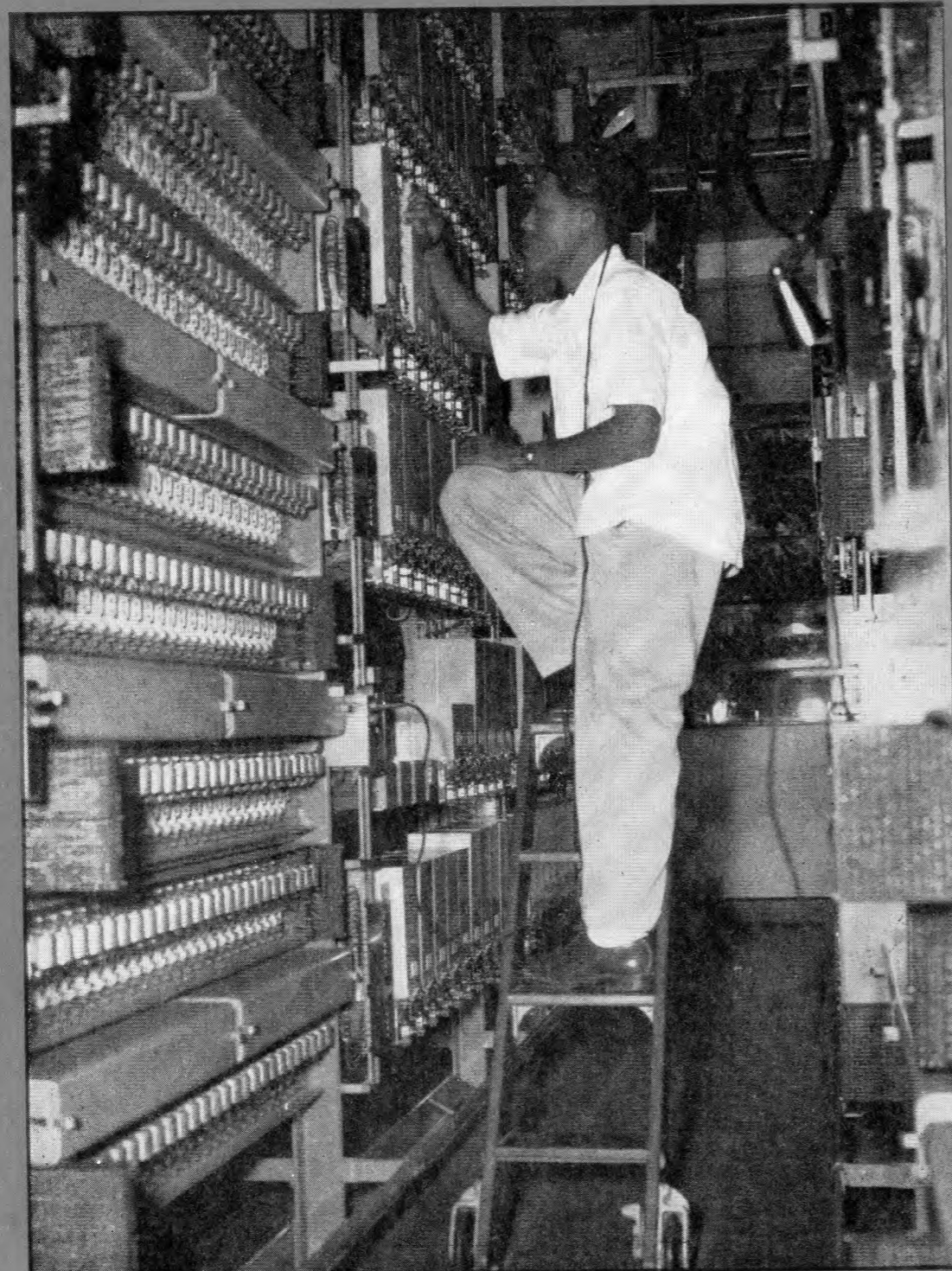

**T**HE NEW automatic exchange at Kuching, Sarawak, in the Island of Borneo, is the first main exchange using SE50 Selectors to be commissioned in South-East Asia. The initial capacity of the exchange is 800 subscribers, but it is designed to have a capacity of 2,000 subscribers. SE50 Selectors have been life-tested to five times the British Post Office requirements for two-motion selectors, and their remarkable life, extraordinary reliability and ease of maintenance render them particularly suitable for an installation of this kind. The SE50 sets new standards in automatic exchange equipment. The mechanism is robust and simple; all adjustments are independent and can be made without disturbing those previously carried out. These characteristics mean that the SE50 can be maintained by less-skilled staff—providing yet another saving in maintenance costs.

- ★ Each unit can be removed from the frame for adjustment and replaced without affecting its own or other settings.
- ★ Drift adjustments are eliminated and all adjustments are independent.
- ★ Auxiliary contact spring/sets are identical with those used in G.E.C. P.10 type relays (British Post Office 600 type). No special adjustment technique is required.

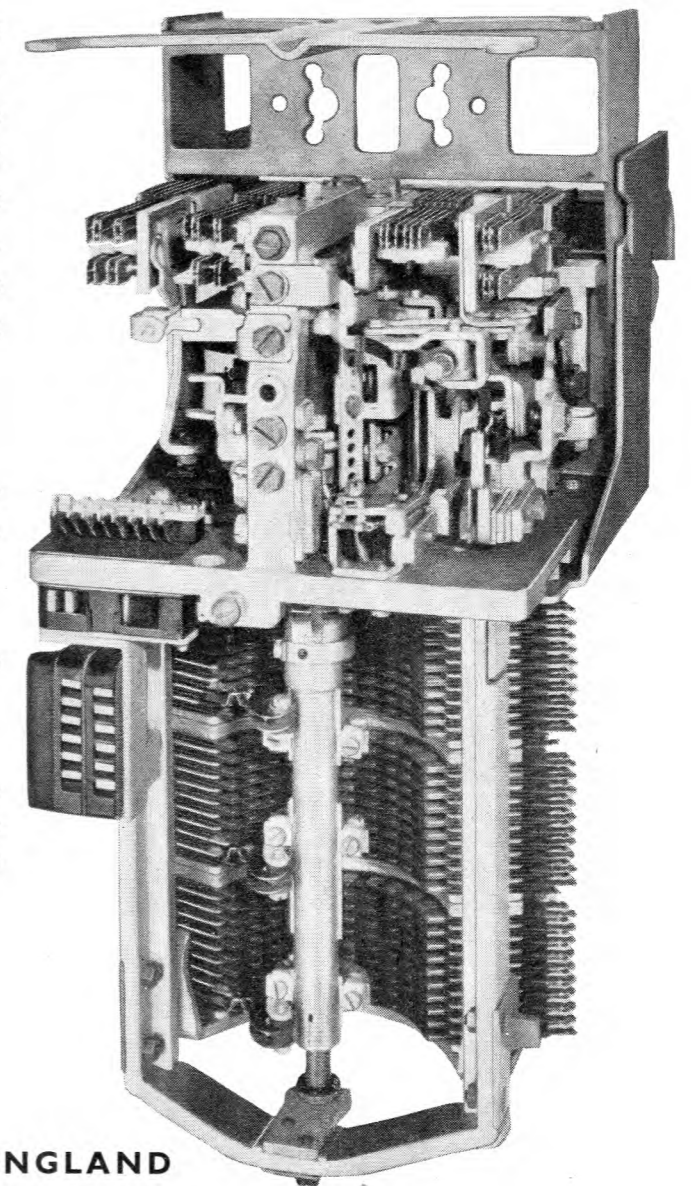

**THE GENERAL ELECTRIC CO. LTD. OF ENGLAND**  
TELEPHONE, RADIO AND TELEVISION WORKS, COVENTRY, ENGLAND.

Local technician at work on the new exchange at Kuching—the first exchange to use SE50 Selectors in S.E. Asia.

# POWER *behind the lines*

TUNGSTONE PLANTÉ CELLS are being regularly supplied to the British Post Office and Post and Telegraph Departments in many countries overseas. They conform fully to G.P.O. Standard specifications.

#### OPEN TYPE CELLS

Similar to the illustration here, these are available in glass and/or lead lined wooden boxes in capacities from 100 a.h. to 5000 a.h.

#### REPLATALS

We are in a position to supply plates for the replating of existing Planté Batteries.

#### ENCLOSED TYPE CELLS

As illustrated below, these are in moulded glass boxes with sealed-in lid. Capacity range from 10 a.h. to 200 a.h.

#### PORTABLE TYPE BATTERIES

A range of portable type Batteries is in regular production, made to G.P.O. specifications, for ancillary duties.

*Overseas customers are invited to cable or write their enquiries for batteries or parts. Visitors to London are welcome at our offices. (Just off Fleet Street.)*

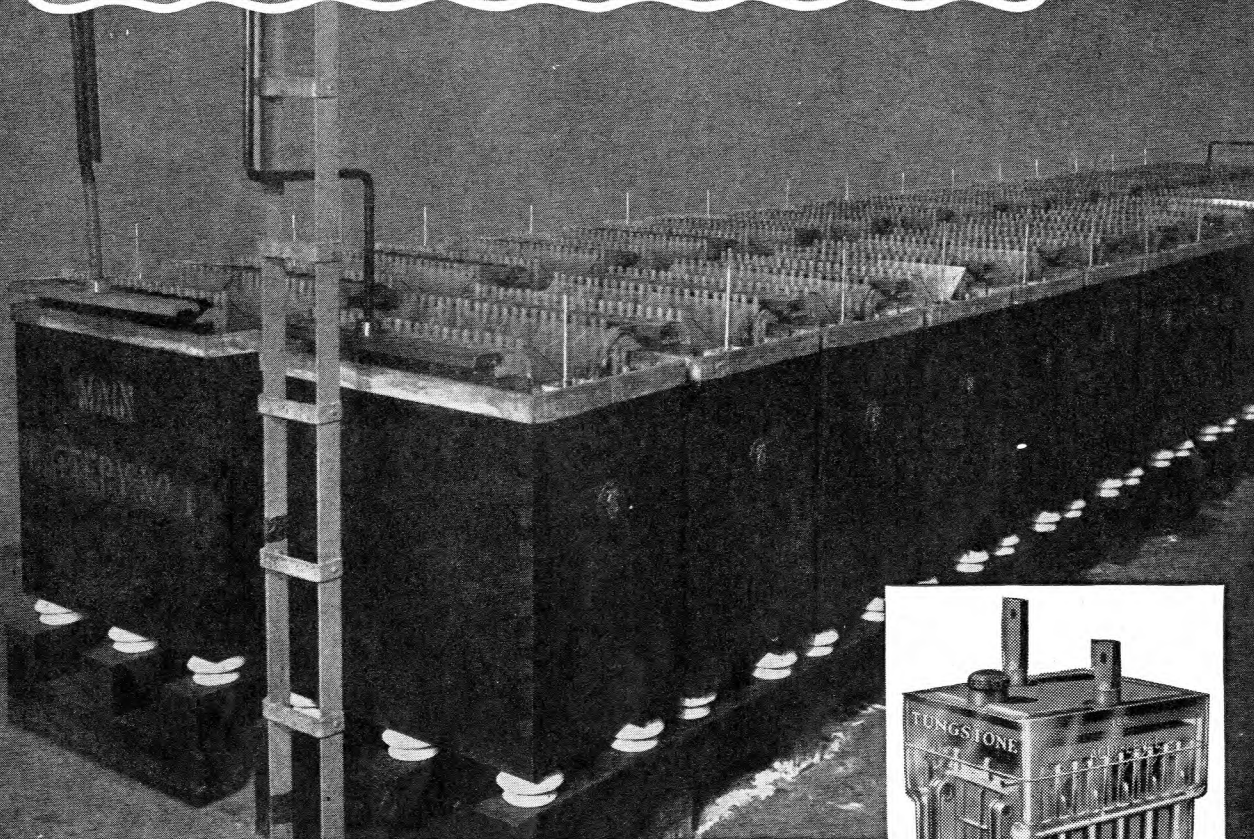

## TUNGSTONE *Batteries*

For further particulars write : TUNGSTONE PRODUCTS LIMITED,  
10 SALISBURY SQUARE, LONDON, E.C.4, ENGLAND. Cables: "Dilutum" London.

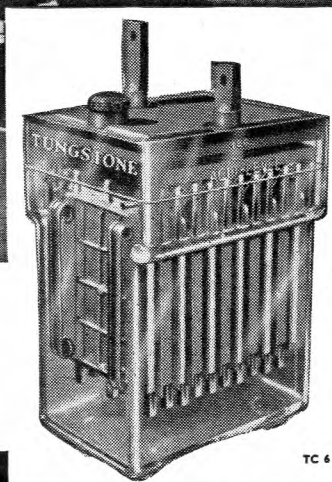

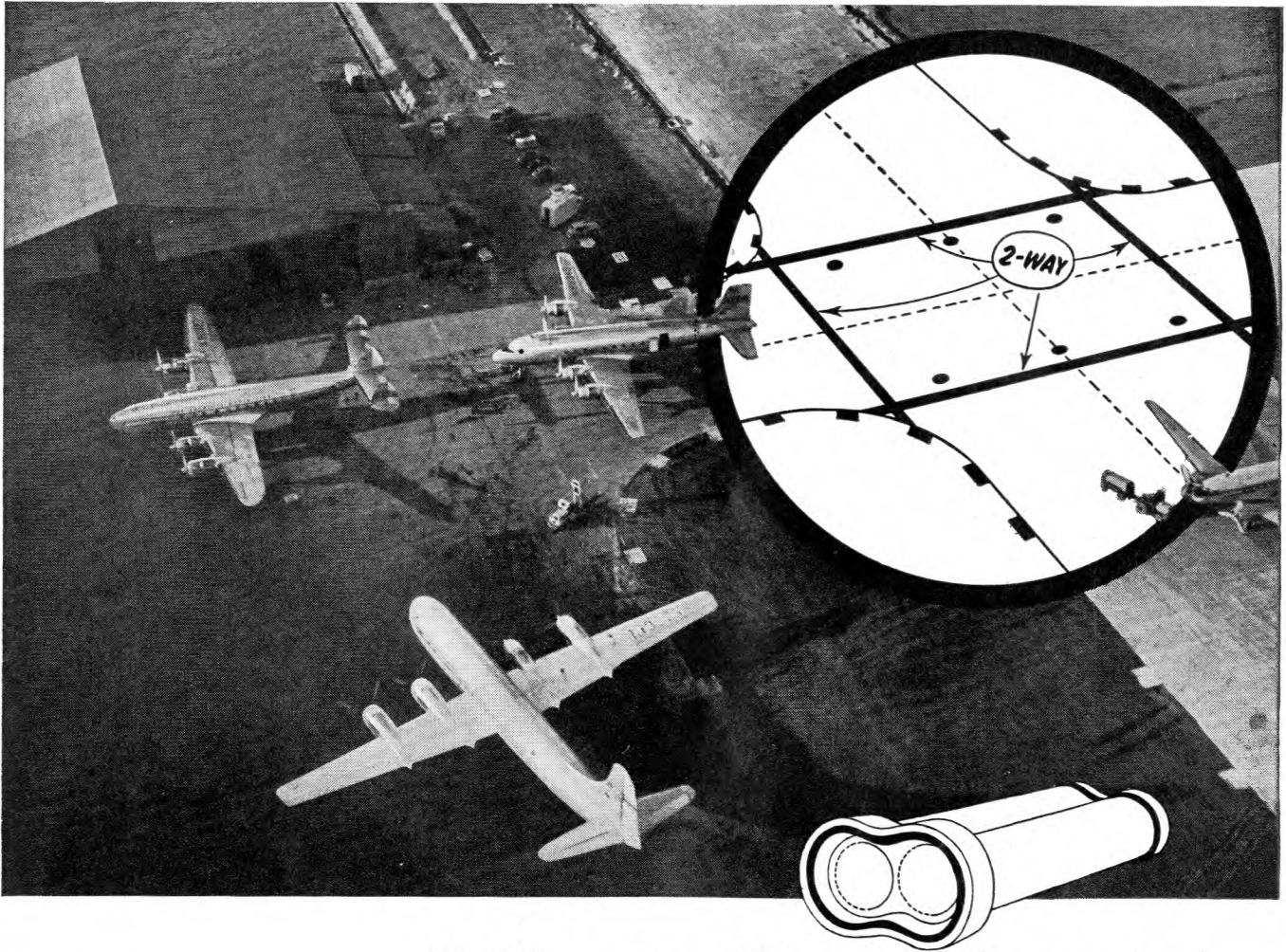

## Under an Airport Runway

***If you never  
want to have  
to dig them  
up again  
put down***

This is a key point in an airport runway pattern. You lay electric cables under here, to serve the runway lights. Those cables must be easy to get at, easy to service. So you run your cables through conduits — in this case 2-way conduits.

If anything goes wrong with those conduits, if they have to come up again — think of the chaos. Think what would happen at a big airport. Last year *in August alone* London Airport handled nearly 9,500 aircraft and 210,000 passengers. A lot depends on those conduits — you never want to have to dig them up again.

That's why, at London Airport, they put down conduits of salt glazed vitrified clay.

Salt glazed conduits are glassy smooth and hard as nails. They are acid-resisting. Sulphates in the soil cannot corrode them. They go down for good! The same applies to the hundreds of salt glazed *drainpipes* that are out there too. Safe and efficient, salt glazed conduits and pipes can — and do — stay down for centuries.

***Salt Glazed***



***pipes and conduits***

NATIONAL SALT GLAZED PIPE MANUFACTURERS' ASSOCIATION



# Communication

*Standard Systems in Service*

An extension of the permanent television transmission network in Great Britain, the S H F link to the North of Scotland has been manufactured and installed by **Standard Telephones & Cables, Ltd.**, for the General Post Office. Illustrated, is the tower and buildings of the terminal transmitting station at Craig Owl, near Dundee.

*Inset: Equipment at Bruxie Hill, one of two unattended repeater stations on the route between Dundee and Aberdeen.*

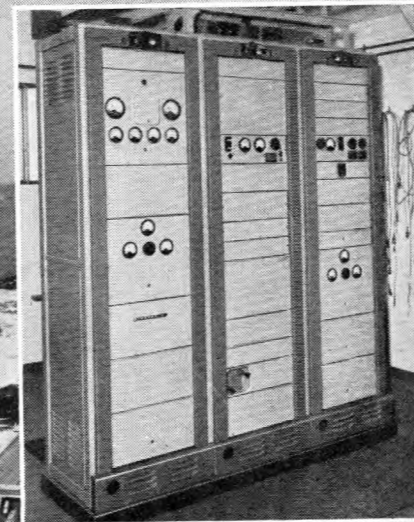
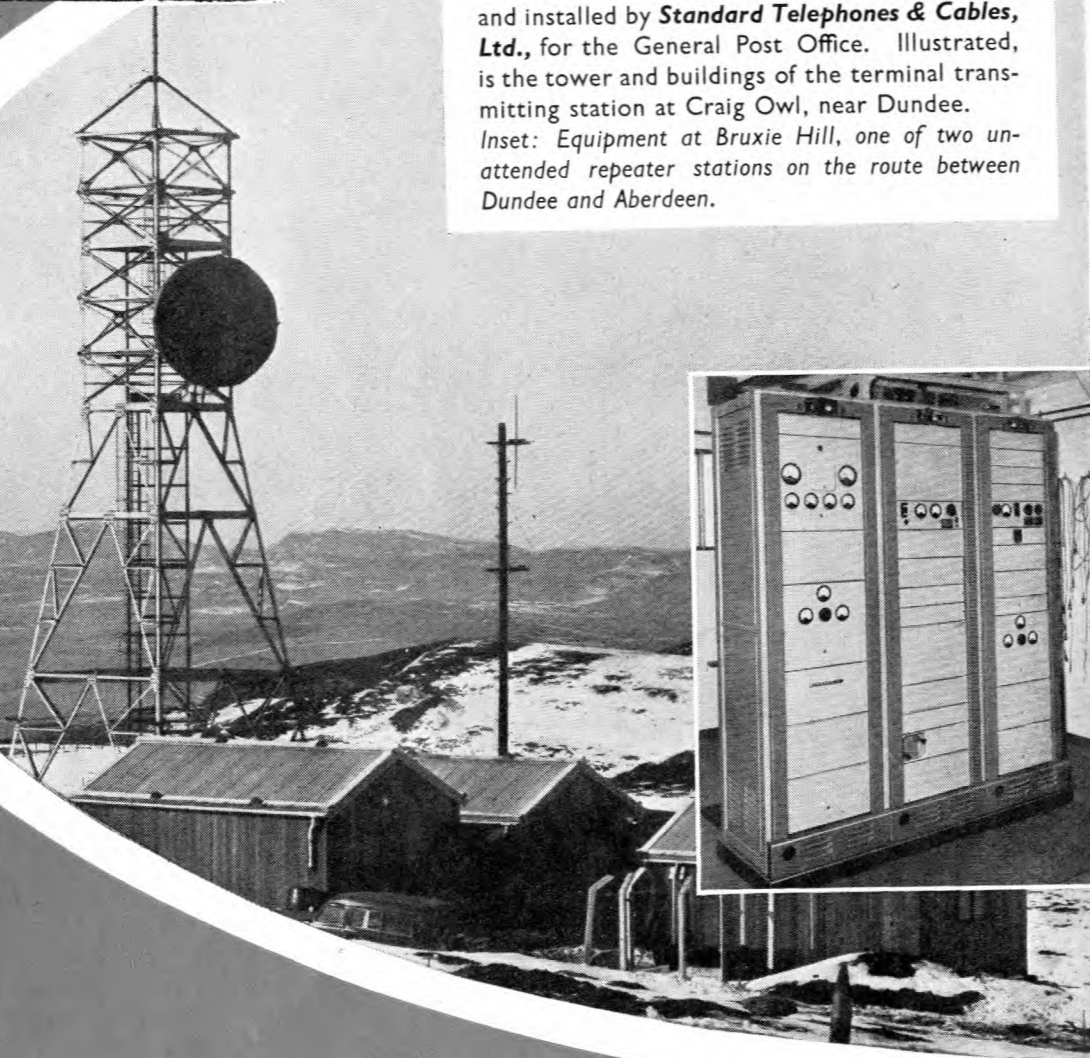

**Standard Telephones**

(TELECOMMUNICATION)

**Connaught House, Aldwych,**

Cairo • Dublin • Johannesburg

# and Control

*Standard products include:-*

One of the largest telecommunication engineering organisations in the British Commonwealth **Standard Telephones and Cables Limited** is engaged in research, and the development, manufacture and installation of all types of communication and control systems. Concerned with every aspect of telecommunications engineering, the Company is in an unrivalled position to undertake, within its own organisation, the co-ordinated planning of complete communication projects involving interdependent systems of various types.

#### Systems:—

Telecommunications Line Transmission  
Radio Broadcasting, Communication and Navigation  
Railway Communication and Control  
Telephone and Telegraph  
Supervisory and Remote Indication and Control  
Sound Reproduction  
Municipal and Industrial Fire Alarms  
Street and Airfield Lighting Control  
Signalling (Office and Factory)  
Submerged repeaters and terminal equipment  
Communication Cable  
Power Cable

#### Equipment:—

SenTerSet Selenium rectifier equipment  
Power Factor Correction  
Heat Treatment  
Transmission Testing apparatus  
Cable Testing equipment  
Loading Coils

#### Components:—

Quartz Crystals  
Transistors  
Capacitors and Interference Suppressors  
Germanium Rectifiers and Photoelectric Cells  
Thermionic Valves

#### Magnetic Materials

Thermistors  
Relays  
SenTerCel Selenium Rectifiers  
Rubber, Plastic and Textile insulated cables and wires

**and Cables Limited**

ENGINEERS)

**London, W.C.2, England**

Karachi • New Delhi • Salisbury



Britain's microwave leaders announce

# The New 60/120-CIRCUIT U.H.F. TELEPHONY SYSTEM SPO 5500

THIS FREQUENCY-MODULATED SYSTEM, conveying either 60 or 120 circuits, operates in the 1700-2300 Mc/s band. Long systems show a minimum of modulation distortion since non-demodulating repeater stations are used. The system handles two super groups of 60 circuits each, with a total signal/noise performance in the worst channel only 6 db. below that recommended for C.C.I.F.

international coaxial-cable networks. The most modern construction practice permits all panels to slide into place on guides, being connected into service by plug-in sockets. Wiring is not disconnected for the removal of a panel.

Each rack has a meter panel, giving readings of anode and grid currents, crystal currents, RF amplifier output power, and all non-mains

voltages.

No voltage higher than 300V is encountered in the equipment.

The use of coaxial cable for feeders eliminates the expense of wave-guides.

A rack complete with transmitter and receiver is single-sided, so that two racks may be mounted side-by-side or back-to-back. They are economical of floor space, occupying only 20½ in. × 8½ in.

★ Conveying one super-group of 60 circuits, the SPO 5500 system achieves, in all respects, the performance laid down by C.C.I.F. for international coaxial-cable networks.

★ In addition, the channel spacing, intermediate frequency and transfer levels comply with the standards laid down in the C.C.I.R. Documents 66 and 69.

★ Spur routes and local base-band traffic are catered for in the design of the system, since at repeater stations any signal from the baseband is injected or extracted without demodulation of the "through traffic."

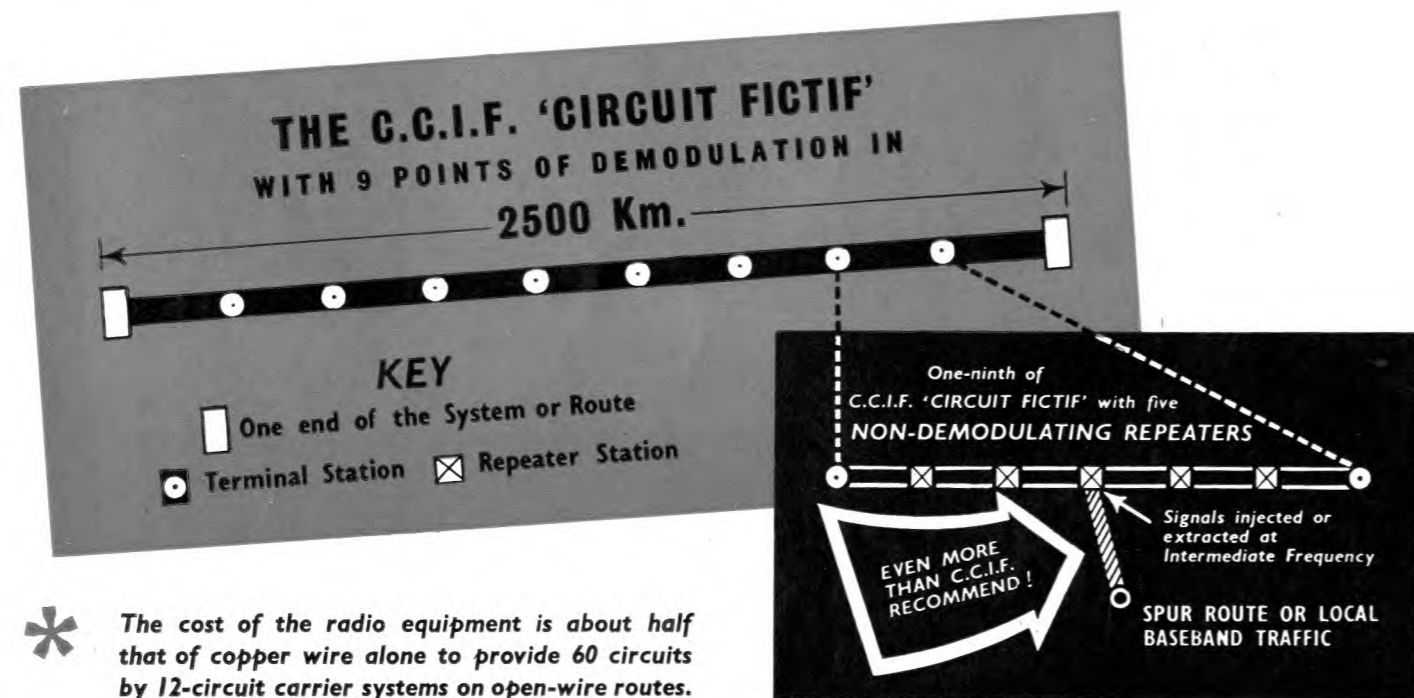
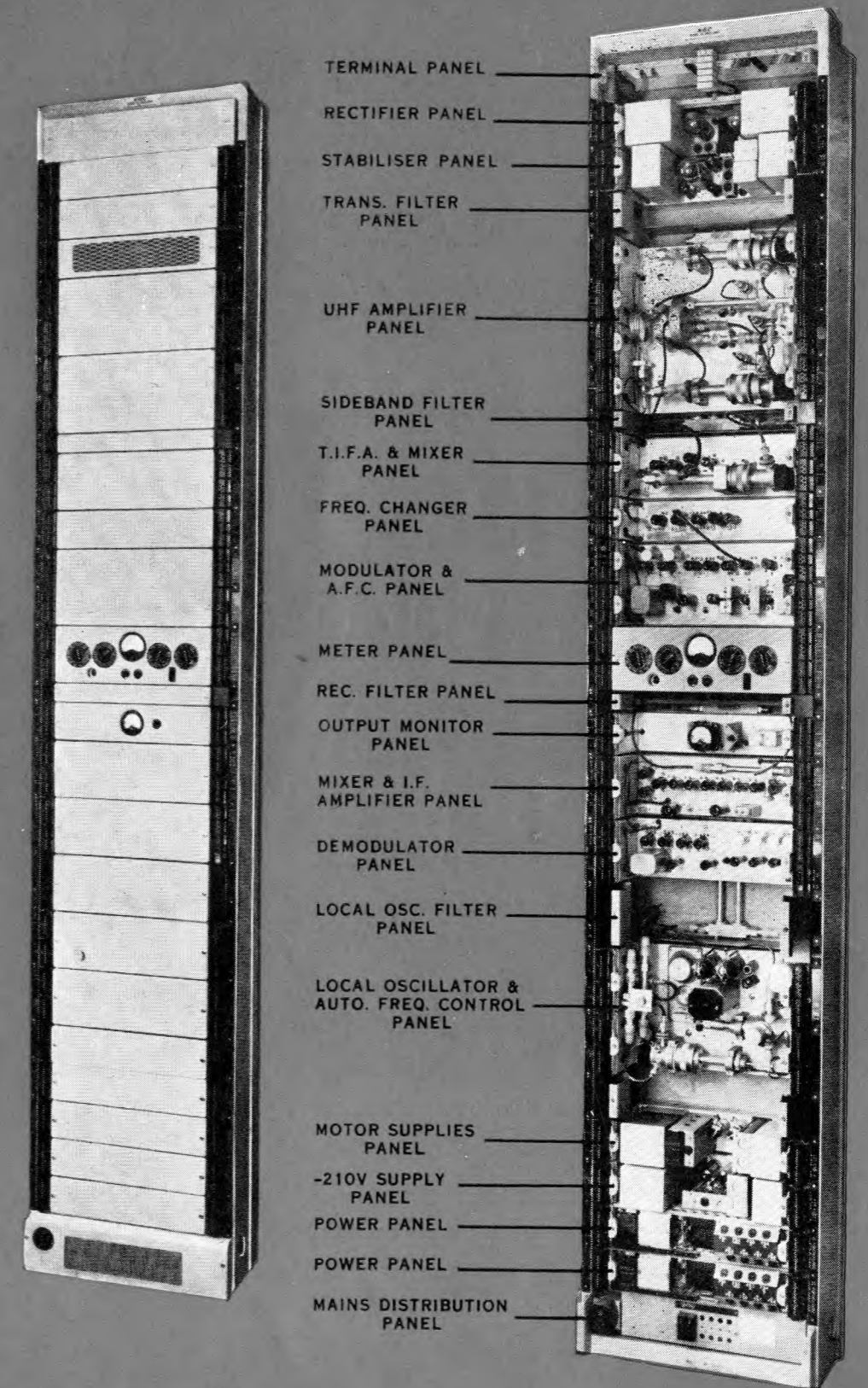

\* The cost of the radio equipment is about half that of copper wire alone to provide 60 circuits by 12-circuit carrier systems on open-wire routes.



lead the march of progress in the microwave radio field.

In addition to telephony, G.E.C. television links are playing vital roles in many national and international networks, and are in continuous manufacture both at home and abroad. Up-to-date equipment design promotes economy of space, accessibility of components, and ease of maintenance in all G.E.C. telephone and television transmission equipment.

**good magnetic  
characteristics**

*demand*

# **PRECISE ELECTRICAL INSPECTION**

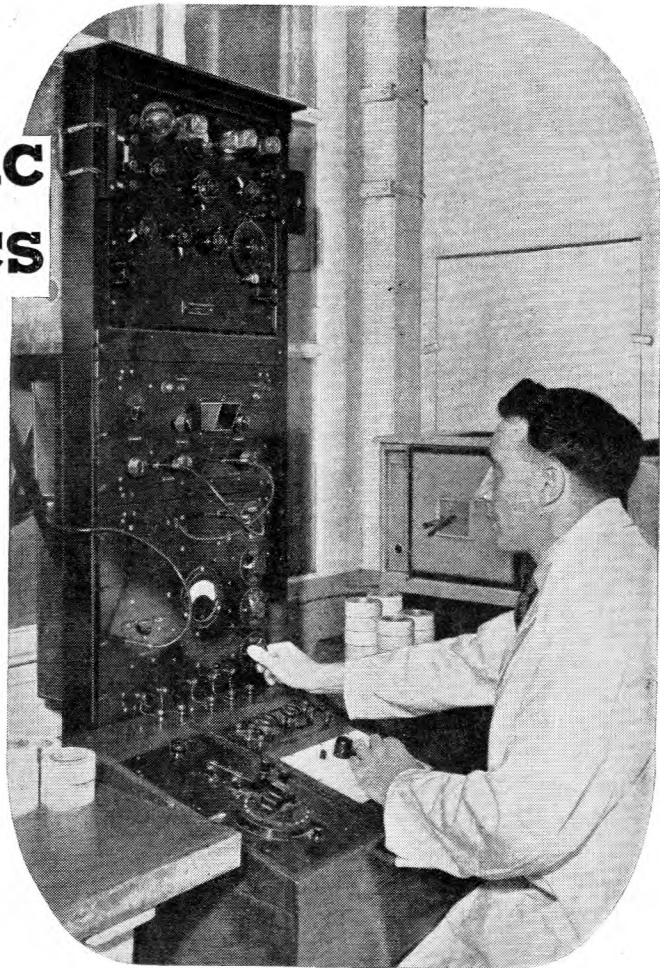

*Standard* maintains its established leadership in the manufacture of high permeability magnetic alloys by constant vigilance in the control of each and every production process, one of which is illustrated here. Produced by a Company which has the unique advantage of being a large-scale user of its own magnetic materials, a long experience of the applications of these materials gives full appreciation of the properties essential for uniform electrical characteristics and stable performance. It will pay you to investigate the capabilities of *Standard* magnetic alloys with relation to your specific requirements.

① FERMALLOY 'C' for highest initial permeability, useful for wide-band frequency transformers, current transformers, chokes, relays and magnetic shielding.

② FERMALLOY 'B' has lower initial permeability than Fermalloy 'C' but higher values of flux density. Suitable where high permeability to alternating field is required superimposed upon a steady polarising field.

③ PERMALLOY 'D' for very high resistivity without undue lowering of the maximum density. Variation of permeability with frequency is small. Ideal for H.F. applications.

④ PERMALLOY 'F' for high flux density, very rectangular hysteresis loop, with a retentivity of at least 95% of its saturation value and low coercive force. Ideal for saturable reactors, magnetic amplifiers, digital computers, memory devices, etc.

● V-PERMENDUR for high permeability with a very high value of maximum flux density. Finds special application for use as high quality receiver diaphragms, also motor generators and servo-mechanisms in aircraft where weight and volume are important factors.



***Standard Telephones and Cables Limited***

Registered Office: Connaught House, Aldwych, W.C.2

**TELEPHONE LINE DIVISION : North Woolwich, London, E.16**

# HACKBRIDGE CABLES

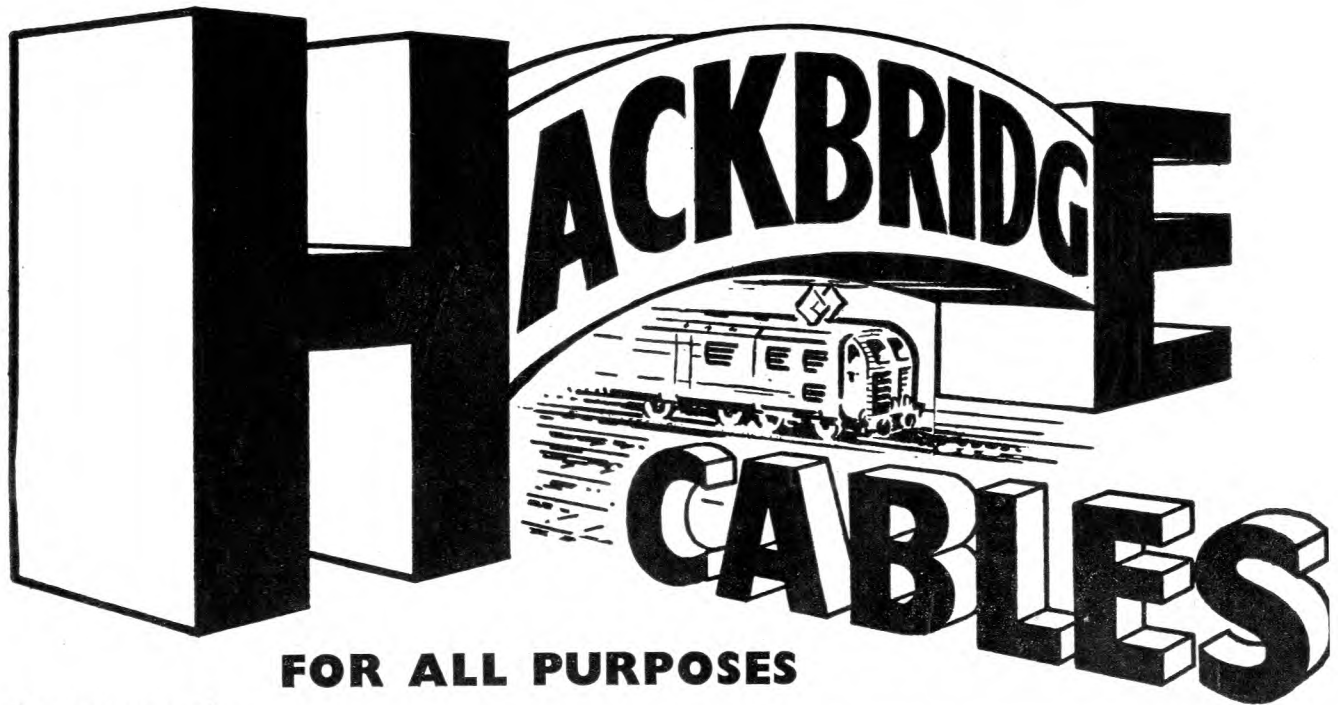

**FOR ALL PURPOSES**

*Contractors to the*

G.P.O. — NATIONAL COAL BOARD — BRITISH RAILWAYS.  
C.E.A. and BRITISH & DOMINION GOVERNMENT DEPTS.

**HACKBRIDGE CABLE CO. LTD.**

KELVIN WORKS — HACKBRIDGE — SURREY

*In Association with* BRYCE ELECTRIC CONSTRUCTION COMPANY LTD.

## EDISWAN

### *Telephone Line Protectors*

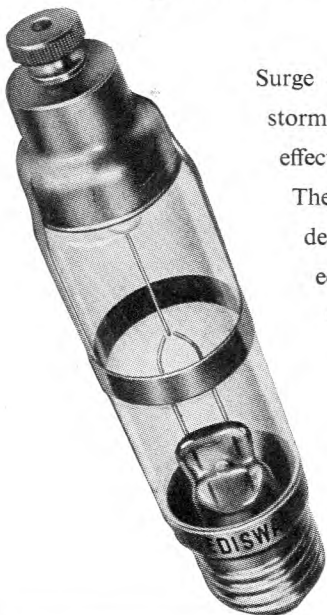

Surge currents induced on telephone lines by electric storms or breakdowns on neighbouring power lines may be effectively controlled by Ediswan telephone line protectors.

These special electrode gas discharge tubes have been developed in collaboration with G.P.O. Engineers to provide economical and effective protection for telephone systems without impairing the service.

Full details of these protectors and their application is given in the Ediswan publication C.1581 which is available on application.

**THE EDISON SWAN ELECTRIC CO., LTD.**

155 CHARING CROSS ROAD, LONDON, W.C.2

*Member of the A.E.I. Group of Companies*



# 1 V.F.

## SIGNALLING & DIALLING SYSTEM

Siemens Brothers Single Voice Frequency (1 V.F.) System has been designed to provide signalling and dialling facilities over commercial speech channels and possesses the following major advantages :—

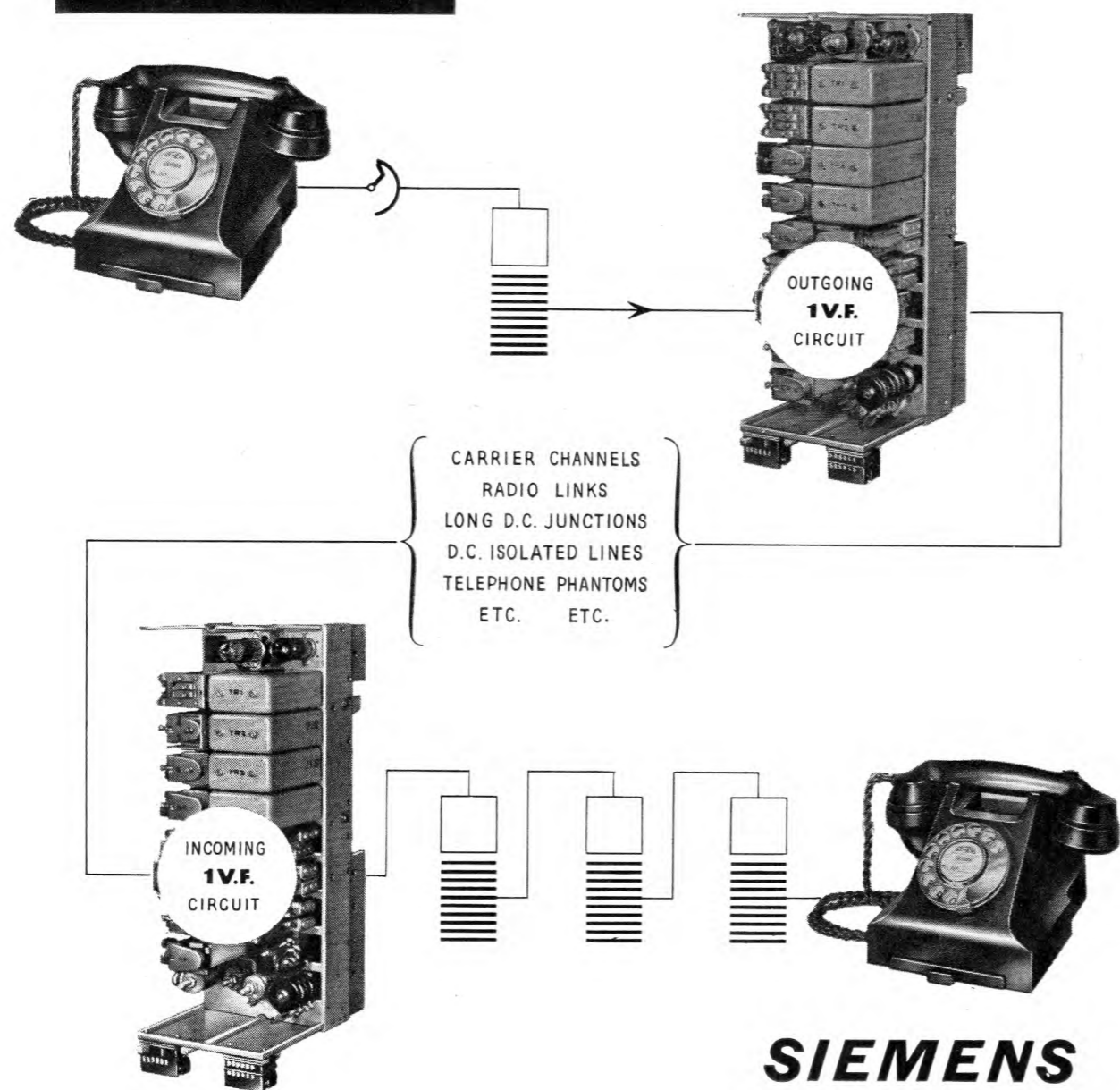

- \* The system can be applied to any speech channel.
- \* The overall loss on single or tandem links can be ignored provided speech is acceptable.
- \* The system is basically simple and does not complicate the line terminal or channelling equipment.
- \* The system conforms to C.C.I.F. performance recommendations.
- \* The standard design is suitable for trunk or junction operation.
- \* The system can be arranged for unidirectional or both way signalling and dialling.
- \* The equipment is relay-set mounted in accordance with latest telephone exchange practice.
- \* The voice frequency receiver is incorporated in the terminal relay set.
- \* The equipment can be installed with the telephone equipment and served from exchange power supplies.
- \* The latest standard components are used throughout.
- \* The system requires negligible maintenance attention.
- \* The system is designed to provide the required facilities on a strictly economic basis.

**SIEMENS**  
TELEPHONE BRANCH.

**BROTHERS & CO. LIMITED**

WOOLWICH, LONDON, S.E.18.

Telephone: Woolwich 2020

*Member of the A.E.I. Group of Companies.*

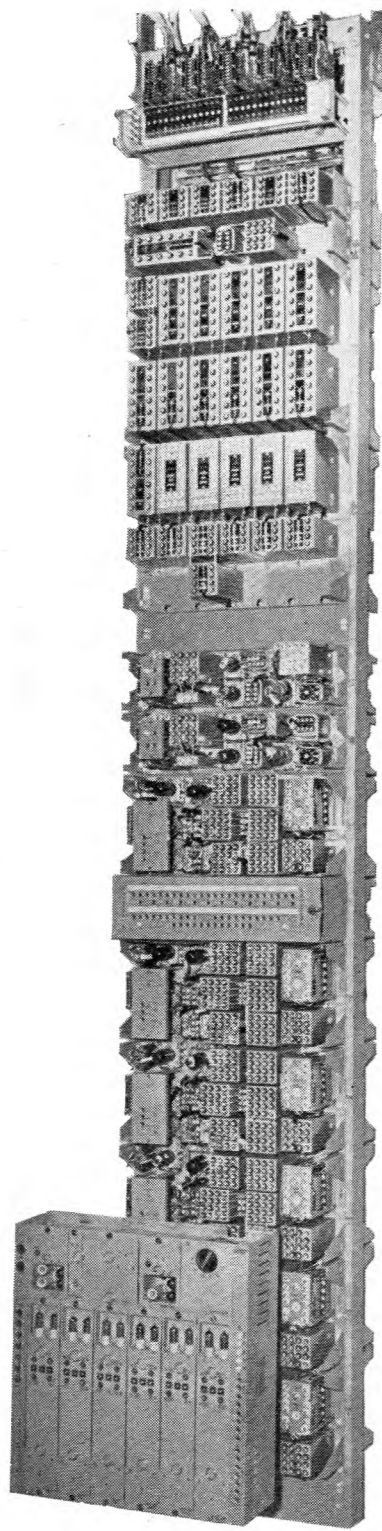

# SKILLMAN Short Distance Carrier

## With UAX/RAX Signalling!

- \* Extra Channels for new or existing Rural Automatic Exchanges with all signalling facilities necessary for parent and dependent exchange working.
- \* Rural exchanges may be converted to dial working without increasing the number of line pairs required for junctions.
- \* Steady-state signals for the basic line signals with ancillary signals by V.F. tones. Complete voice immunity on all signals with no elaborate timing or guard circuits.
- \* For use on cable or open-wire with 4 or 5 kc/s channel spacing, giving circuits of zero transmission loss.
- \* Systems supplied complete with relay sets giving the normal junction signalling conditions of the Unit Automatic Exchange 12, 13 or 14, for connection to the normal junction equipment at parent exchange and U.A.X.

The small panel on the left is the same as that on the right and replaces the entire bay shown behind.

**T. S. SKILLMAN & CO. LTD.,** 199 Uxbridge Road, Hanwell, London, W.7

**T. S. SKILLMAN & CO. PTY. LTD.,** Cammeray, Sydney, N.S.W.

SKILLMAN CARRIER EQUIPMENT HAS BEEN SUPPLIED TO ENGLAND FOR OTHER THAN G.P.O. APPLICATIONS, TO AUSTRALIA, NEW ZEALAND, BELGIUM AND EGYPT, AND ENQUIRIES ARE INVITED FOR REPRESENTATIVES ELSEWHERE



### Full signalling facilities for:

**Bothway Dialling**

**Coin Collecting Box  
Discrimination**

**Routing to Auto or Manual  
Equipment at the Parent  
Exchange**

**Manual Hold on calls to the  
Parent Exchange**

**Trunk Offering to the UAX  
subscriber**

**Dependent Exchange Working**

Normal line from U.A.X. to parent exchange. This is cut at "X" and reconnected as shown

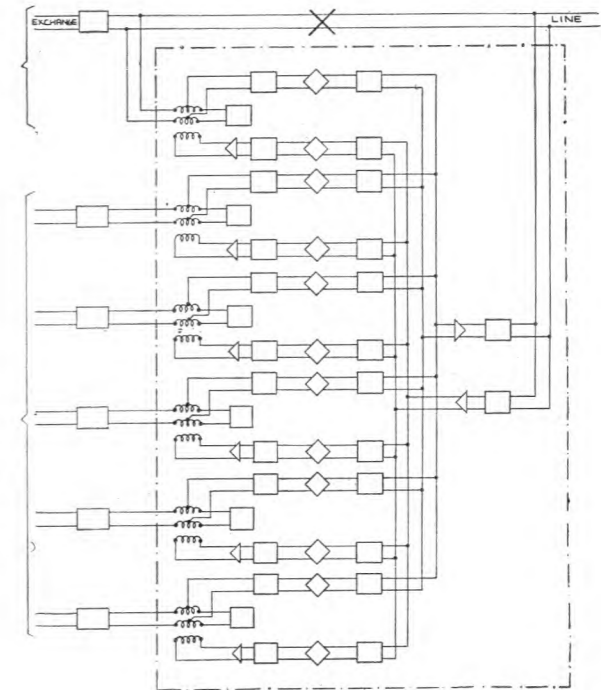

Five new lines with all discriminating facilities and superior transmission. Connections at each end are identical with connections for D.C. Junction.

All the equipment within the dotted line is mounted on the panel shown below.

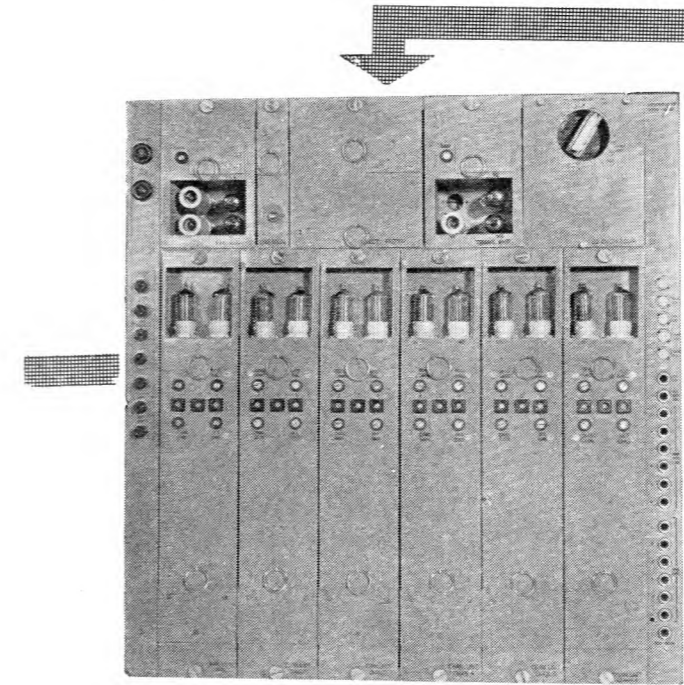

**SKILLMAN'S** are world pioneers of short haul or "junction" carrier systems. Over £500,000 worth of the old style equipment indicated opposite is in service, much of it for over 4 years.

The miniaturised form is now available, on a 21" panel with 60 channel ends plus power supply on one 19" rack. Installation involves connecting only new junction relay groups, power (A.C.) and carrier supply and deloading the junctions.



**DENSO**

Industry's protection  
against CORROSION

Full information from

**WINN & COALES LTD.**

DENSO HOUSE · CHAPEL ROAD · LONDON, S.E.27

Telephone:  
GIPsy Hill 4247  
(3 lines)



Telegrams:  
Denselte, Westnor,  
London.

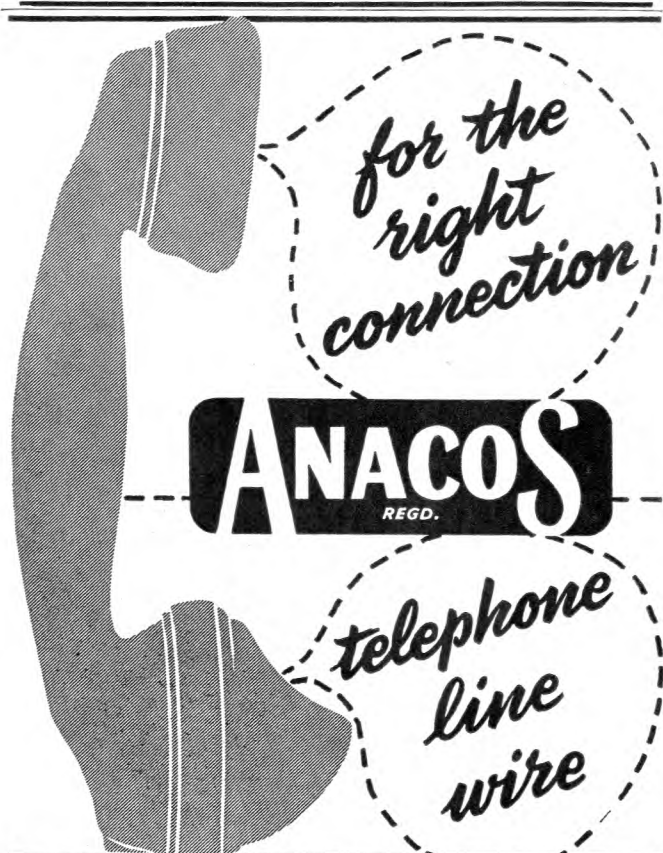

**ANACOS**  
REGD.

**FREDERICK SMITH & COMPANY**  
ANACONDA WORKS, SALFORD, 3, LANCS.  
Incorporated in The London Electric Wire Company and Smiths Limited.  
Associated with The Liverpool Electric Cable Co. Ltd. and Vactite Wire Co. Ltd.

**SOLDERING INSTRUMENTS  
and ALLIED EQUIPMENT by**

**ADCOLA**  
PRODUCTS LIMITED  
(Regd. Trade Mark)

**TRADITIONAL BRITISH QUALITY**

British, U.S.A., Canadian & Foreign Pats.  
Registered Designs, etc.



Reg. Design  
**PROTECTIVE  
SHIELD**  
List 68

$\frac{3}{16}$ " Dia.  
**DETACHABLE  
BIT  
INSTRUMENT**  
List 64  
As illustrated

**SUPPLIED FOR ALL VOLTAGES.  
DESIGNED FOR FACTORY BENCH LINE  
ASSEMBLY RADIO, TV, DEAF AID, ETC.**

Write for Catalogues.....

HEAD OFFICE, SERVICE AND SALES

**ADCOLA PRODUCTS LTD**  
GAUDEN RD., CLAPHAM HIGH ST., LONDON, S.W.4

Phone: MACaulay 3101, 4272

**MUIRHEAD**  
PRECISION  
ELECTRICAL INSTRUMENTS



## A 'NEW LOOK' FOR OUR DECADE RESISTANCE BOXES

The Muirhead 4- and 5-dial boxes, Type A-25, originally made their appearance some twenty-five years ago and have been in continuous production ever since. During the intervening period these boxes have given reliable service, and it is the possibility of all-round improvements using new materials, rather than any particular shortcomings of the old design, which have led us to produce these new instruments.

Features of the new D-825 resistance boxes are: low and constant contact resistance, reduced switch capacitance, improved terminals, and light alloy construction of panel and box leading to reduction in weight. In addition, the switches do not require lubrication, and are designed to give years of trouble-free service without attention. The temperature coefficient, current ratings and accuracy of adjustment are the same as for the Type A-25 boxes.

Further details may be obtained from our Publication No. 1728

**MUIRHEAD & CO. LIMITED · BECKENHAM · KENT · ENGLAND**

184



The

## DETECTOR No. 4 Mk. 10

—a TURNER instrument produced for Post Office engineers and combining a high level of sensitivity with accuracy and robust design for work in the field.

**ERNEST TURNER ELECTRICAL INSTRUMENTS LTD.**

**HIGH WYCOMBE      BUCKS      ENGLAND**

Telephone: HIGH WYCOMBE 1301-2-3

Telegrams: GORGEOUS, HIGH WYCOMBE