

This document was generated by me, Colin Hinson, from a document held at R.A.F. Henlow Signals Museum and is believed to be out of copyright or Crown Copyright . It is presented here (for free) under the Open Government Licence (O.G.L.) if under Crown Copyright and this version of the document is my copyright (along with the Crown Copyright) in much the same way as a photograph would be. If you believe the document to be under copyright, please contact me.

The document should have been downloaded from my website <https://blunham.com/Radar>, if you downloaded it from elsewhere, please let me know (particularly if you were charged for it). You can contact me via my Genuki email page:

<https://www.genuki.org.uk/big/eng/YKS/various?recipient=colin>

**You may not copy the file for onward transmission of the data nor attempt to make monetary gain by the use of these files. If you want someone else to have a copy of the file, point them at the website. It should be noted that most of the pages are identifiable as having been processed by me.**

---

I put a lot of time into producing these files which is why you are met with the above when you open the file.

In order to generate this file, I need to:

1. Scan the pages (Epson 15000 A3 scanner)
2. Split the photographs out from the text only pages
3. Run my own software to split double pages and remove any edge marks such as punch holes
4. Run my own software to clean up the pages
5. Run my own software to set the pages to a given size and align the text correctly.
6. Run Omnipage (Ultimate) on all the pages to OCR them.
7. Generate a searchable Acrobat pdf file.

Hopefully after all that, I end up with a presentable file, though I can't guarantee there aren't errors in the OCR. If you find missing pages, pages in the wrong order, anything else wrong with the file or simply want to make a comment, please drop me a line (see above).

It is my hope that you find the file of use to you personally – I know that I would have liked to have found some of these files years ago – they would have saved me a lot of time !

Colin Hinson

In the village of Blunham, Bedfordshire.

# THE POST OFFICE ELECTRICAL ENGINEERS' JOURNAL

Vol. 49

JULY 1956

Part 2

## CONTENTS

	PAGE
THE NEW, 700-TYPE TELEPHONE—H. J. C. Spencer, A.M.I.E.E., and E. A. Wilson, C.G.I.A., A.M.I.E.E., A.M.Brit.I.R.E.	69
THE NEW CENTRALIZED SERVICE-OBSERVATION SYSTEM—A. J. Barnard, A.M.I.E.E., and E. H. A. Beck	81
ELECTRICAL ACCIDENTS INVOLVING POST OFFICE PLANT AND STAFF—S. J. Little, A.M.I.E.E.	86
A NEW STANDARD POWER PLANT FOR MEDIUM-SIZED 50-VOLT TELEPHONE EXCHANGES—L. H. Catt, A.M.I.E.E.	93
SETTING UP AND TESTING A COAXIAL LINE LINK FOR TELEPHONY—A. H. Watkins, C.G.I.A., A.M.Brit.I.R.E.	98
AN APPLICATION OF DELAY-LINE STORAGE TECHNIQUES TO THE COMMON CONTROL OF DIRECTORS—S. W. Broadhurst, A.M.I.E.E.	104
SOLDERING-IRON HEATERS	109
TRANSATLANTIC TELEPHONE CABLE—THE OVERLAND CABLE IN NEWFOUNDLAND, Part 2—The Cable-Laying Operations in Newfoundland—H. E. Robinson and B. Ash	110
MINISTRY OF TRANSPORT AND CIVIL AVIATION TELEGRAPH CENTRE, LONDON AIRPORT	118
INSTALLATIONS IN AUSTRALIA OF THE BRITISH POST OFFICE SPEAKING CLOCK MARK II—E. F. Sandbach, B.A., B.Sc.	120
AN EXPERIMENTAL RINGING CIRCUIT FOR ELECTRONIC EXCHANGES—R. C. Barker	124
“MOSAIC”—AN ELECTRONIC DIGITAL COMPUTER, Part 4—Circuitry—A. W. M. Coombs, Ph.D., B.Sc., A.R.T.C.	126
I.P.O.E.E. PRINTED PAPER No. 207	132
TIME-TO-ANSWER EQUIPMENT FOR USE IN SLEEVE-CONTROL EXCHANGES—D. R. B. Ellis	133
POST OFFICE JOINT PRODUCTION COUNCIL FOR ENGINEERING AND ALLIED SERVICES	135
NOTES AND COMMENTS	136
INSTITUTION OF POST OFFICE ELECTRICAL ENGINEERS (including Arrangements for Commemoration of 50th Anniversary)	137
REGIONAL NOTES	138
ASSOCIATE SECTION NOTES	142
STAFF CHANGES	144
BOOK REVIEWS	85, 117, 119, 123, 125, 135, 141

Price 2/6 net

THE INSTITUTION OF POST OFFICE ELECTRICAL ENGINEERS

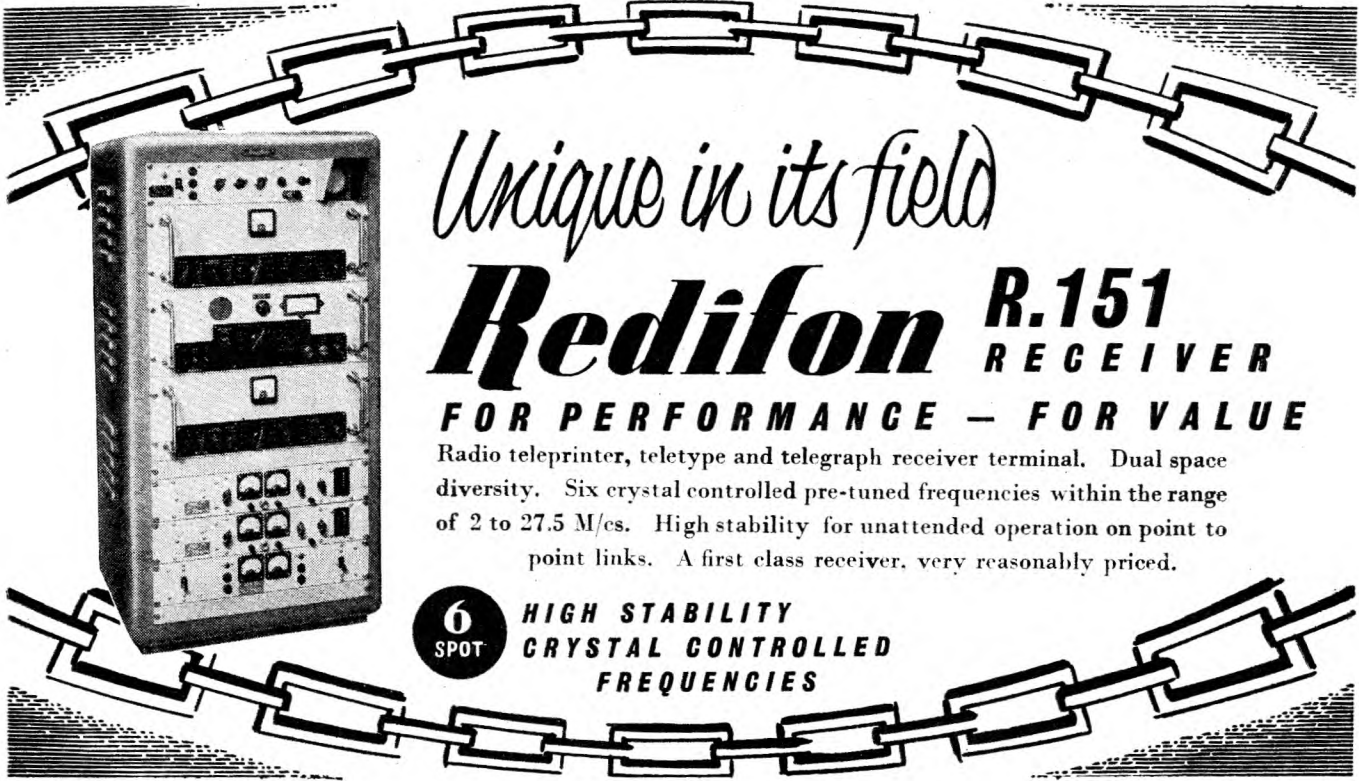

*Unique in its field*

# **Redifon R.151** **RECEIVER**

**FOR PERFORMANCE — FOR VALUE**

Radio teleprinter, teletype and telegraph receiver terminal. Dual space diversity. Six crystal controlled pre-tuned frequencies within the range of 2 to 27.5 M/cs. High stability for unattended operation on point to point links. A first class receiver, very reasonably priced.

**6** HIGH STABILITY  
**SPOT** CRYSTAL CONTROLLED  
FREQUENCIES

Radio Communications Division

REDIFON LIMITED, BROOMHILL ROAD, LONDON, S.W.18. VANDYKE 7231

*A Manufacturing Company in the Rediffusion Group*

## **PITMAN** TECHNICAL BOOKS

### **TELEPHONY (2 Vols.)**

By J. Atkinson, M.I.E.E., Assistance Staff Engineer, Post Office Engineering Department. This massive two-volume treatise is recognised as the standard work on the subject. Volume I is primarily devoted to the signalling and switching of the manual exchange systems. Volume II deals with the complete range of modern automatic switching and gives a detailed treatment of the various circuits and accessory equipment employed.

Volume I. "General Principles and Manual Exchange Systems."

511 pages. 40/- net

Volume II. "Automatic Exchange Systems."

873 pages. 55/- net

### **TELECOMMUNICATIONS PRINCIPLES**

By R. N. Renton, A.M.I.E.E. A useful work covering the syllabus for the City and Guilds examinations in Telecommunications Principles, Grades I, II and III. Illustrated. 45/- net

"Can be confidently recommended to all students of Telecommunications."—*Post Office Telecommunications Journal*

### **TELECOMMUNICATIONS**

By A. T. Starr, M.A., Ph.D., M.I.E.E. This book, included in the Pitman Engineering Degree Series, has been written to cover the syllabus for the subject of Telecommunications in the London University Degree, but the choice of materials should make the book very acceptable to all who are studying the subject. It will provide the student of "light" electrical engineering with a firm foundation for specialisation and advanced study. Illustrated. 35/- net

**SIR ISAAC PITMAN  
& SONS LTD.**

Parker Street, Kingsway,  
London, W.C.2.

## **VALUABLE FREE BOOK**

**Tells You How to Pass Your C. & G. or  
Promotion Exam. at First Attempt!**



All Post Office Engineering personnel who are anxious to obtain early promotion should at once send for a copy of our handbook "**ENGINEERING OPPORTUNITIES**," which among other intensely interesting matter describes our unique methods of preparation for **TECHNICAL APPOINTMENTS IN THE POST OFFICE** (Assistant Engineer—New Style and Assistant Traffic Superintendent), **CITY AND GUILDS EXAMINATIONS** in Principles of Telecommunications (1-5), Radio (1-4), Telephone Exchange Systems (1-3), Telegraphy (1), Line Transmission (1 and 2), Lines Plant Practice (1 and 2), Mathematics for Telecommunications (1-5), Electrical Engineering Practice (Prelim. Inter. and Final), and outlines a wide range of non-examination courses in all branches of **Electrical, Mechanical, Civil, Automobile, Aeronautical and Radio Engineering.**

**Assistant Engineer and Assistant Traffic Superintendent. Open competitions now resumed. Age extensions for established Civil Servants. Ask us for full details**

**We definitely guarantee  
"NO PASS—NO FEE"**

If you intend to make the most of today's opportunities, you cannot afford to miss reading "**ENGINEERING OPPORTUNITIES**." It tells you everything you want to know to secure advancement, and describes many opportunities you may now be missing through lack of information. Send for your copy to-day—**FREE** and without obligation.

**BRITISH INSTITUTE  
OF ENGINEERING TECHNOLOGY**  
369 COLLEGE HOUSE,  
29-31 WRIGHT'S LANE, LONDON, W.8

# **BIET**

# THE POST OFFICE

## ELECTRICAL ENGINEERS' JOURNAL

Vol. 49

July 1956

Part 2

### The New, 700-Type Telephone

H. J. C. SPENCER, A.M.I.E.E. and  
F. A. WILSON, C.G.I.A., A.M.I.E.E., A.M.Brit.I.R.E.†

U.D.C. 621.395.721.1

The development of a new telephone receiver, described in the last issue of the Journal, has made possible the design of a range of new telephone sets with transmission performance substantially better than that of the 300-type telephones which have been the standard instruments used in the British Post Office network for the past 20 years. This article discusses the problems that arise when a new telephone is to be introduced into an existing network, and describes the development of the new, 700-Type Telephone for the British Post Office and the advantages to be gained from it.

#### INTRODUCTION

TO engineers concerned with the transmission of speech a telephone is not so much a particular physical instrument as a collection of transmission components, the transmitter, receiver and induction coil, and the circuit that connects them. The telephone manufactured at the present time for the British Post Office is summed up in the shorthand description "13-2P-27," indicating that its vital components are the Transmitter, Inset, No. 13, the Receiver, Inset, No. 2P and the Coil, Induction, No. 27. This "telephone" exists in a number of different physical forms, but of these the combined-set table-telephone, Telephone No. 332, is by far the most common. This article describes both the development of a new telephone in the general sense of the word and a combined-set table-telephone embodiment of it, Telephone No. 700.

There are many reasons why the design of an administration's telephone should not be changed, but there comes a time when the accumulated improvements in material available and in manufacturing techniques, and the increased knowledge of circuit designers, promises a sufficient improvement in performance, and consequent economy in use, to justify major changes. By the end of the 1939-45 war, Telephone No. 332 was nearly 10 years old, the handset and transmitter being even older, and although little had been done on telephone design during the war it was clear from the progress made in allied branches of the electrical art that more-efficient telephones could be designed. A program was therefore initiated, through the British Telephone Technical Development Committee,<sup>1</sup> to develop new transmitters and receivers as the starting point for a new telephone, and this resulted in a new receiver of greatly increased efficiency becoming available by 1952.

The design of a better transmitter than the Inset No. 13 proved to be more difficult, but the work on transmitters had shown that a significant increase in their output was unlikely; the more likely improvements being greater uniformity of frequency response and less amplitude distortion. Thus, a new transmitter, provided that it was made physically interchangeable with its predecessor, could be included in a new telephone at a later date without appreciably affecting the balance struck between sending and receiving efficiencies. It was decided, therefore, to design a new telephone using the existing standard transmitter, and

to obtain the required improvement in transmission efficiency from the increased efficiency of the receiver and the re-design of the transmission circuit.

Not the least problem in designing a new telephone is deciding the kind of performance that is wanted from it, and this is greatly influenced by the local line network in which it is to be used, by the performance of the telephones already in use and by the method used to plan the network. The early part of this article therefore touches briefly upon these factors, showing how they have influenced the resulting telephone. The remainder of the article describes the components used in the new telephone, its circuit and performance, its design for flexibility in use, and the complete telephone.

#### THE BRITISH POST OFFICE METHOD OF EVALUATING TRANSMISSION PERFORMANCE FOR LOCAL NETWORK PLANNING

##### *Assessment of Transmission Performance.*

The evolution of a new telephone instrument involves many intermediate designs, the difference in performance between successive instruments often being very small. Good design relies upon the ability to compare experimental telephone sets with each other and with the existing telephone so that the value of each improvement can be assessed. The problem is how to compare two telephones, and in what terms. Unfortunately, there is yet no simple solution involving a single method, for, bearing in mind that the only true assessment of the efficiency of a telephone is obtained from human reactions, and considering the enormous ranges of speaking and hearing qualities which are characteristic of telephone users, it is obvious that accuracy is not easily obtainable.

The two instruments can be connected in turn to an exchange line, a connexion set up and comparison made between them for both sending and receiving, but this is not very practical. If the telephones are almost equal in performance, it is quite possible that, in choosing which is the better, a second pair of observers will not have the same preference. Also, the sets are compared under one line condition only, and it can be shown that the performance of a telephone is affected to a considerable degree by the circuit into which it works. Thus, to compare accurately the usefulness of two sets, it is necessary to obtain the mean of many opinions and repeat this whole procedure under several line conditions; a formidable task which has to be eased as much as possible by somewhat artificial but less time-consuming methods.

To this end the British Post Office has so far adopted

† The authors are, respectively, Executive Engineer, Subscribers' Apparatus and Miscellaneous Services Branch, E.-in-C.'s Office, and Executive Engineer, Post Office Research Station.

<sup>1</sup> For numbered references see end of article.

the practice of using articulation tests as a basis for assessing the performance of any telephone on a single specified line and transmission bridge (for convenience, any combination of set, line and bridge will be given the general title "local telephone circuit") relative to that of a "standard" local telephone circuit (defined later). Calculation techniques based on the results of electrical measurements and subjectively obtained data are then used to extend the information to obtain both sending and receiving performances of this set as a function of cable gauge and length, from the single-valued articulation ratings. These relative performances are known as Transmission Performance Ratings.

In the articulation test<sup>2</sup> consonant-vowel-consonant combinations (often meaningless) are spoken into the sending transmitter of the connexion at a controlled vocal level and speaking distance, while listeners record what they think is said. Some 1,500 monosyllables are received over the connexion for each of several junction attenuations, so obtaining a percentage score of sounds correctly received for each setting. The attenuation for an 80 per cent correct score of sounds is then determined. Repetition of the procedure for another connexion enables the necessary comparisons to be made. In this type of test the actual level of listening is made very low because the testing team is highly trained and at normal telephone listening levels on most circuits their scores would approach 100 per cent. To cater for room noise experienced by subscribers, a standard, controlled level of noise<sup>3</sup> is generated by loudspeakers in the rooms in which the listeners are seated.

It will be noted that several artificialities have been introduced into the tests; control of talking level, talking distance, listening level, listening-room noise conditions, and the use of non-representative subjects. These have been introduced in order to obtain reasonable precision with minimum testing. The room noise enables the test to include weighting for the side-tone performance of the instrument, for under noisy conditions poor side-tone suppression adversely affects receiving performance. The noise is presented to the ear by the receiver via the side-tone path, in conjunction with the wanted signal. The signal/noise ratio is thus lower for high side-tone and for loud room noise. In addition, a telephone handset introduces an unnatural transmission path between the mouth and one ear of the user; the subconscious effort made to adjust the voice to the accustomed loudness results in a change in the talker's voice level; for high side-tone levels the voice level is lowered and for low side-tone levels it is raised.<sup>4</sup> For sending, a correction is made for the effect of the side-tone that has been lost by the artificial control of the voice level.

The calculation technique<sup>5</sup> involves pure-tone comparisons wherever these are shown to be practicable; that is, when comparison of the transmission performance of any similar telephone connexion links (e.g. induction coils, subscribers' lines, transmission bridges) by a pure-tone method produces a similar answer to that which would be obtained subjectively. An example is the use of the attenuation of trunk lines at 1,600 c/s as a measure of their speech transmission loss. The number of frequencies to be used in other cases depends on the degree of irregularity in the characteristics being compared.

Thus, the performance of one local telephone circuit can be expressed relative to that of another. If the two local telephone circuits contain the same subscriber's line and transmission bridge, but different telephone sets, then the relative performance of the sets is obtained. By repeating this procedure over a range of line and transmission-bridge conditions, an estimate of the improvement of a new set over any other telephone set can be made.

### *Control of Network Transmission.*

There is obviously a limit to the overall transmission loss which any two subscribers should experience on a call. What constitutes a satisfactory service is a question difficult for a subscriber to answer and almost impossible for an administration to determine when the needs of all its subscribers are considered in conjunction with the balance between cost and service. It is not intended here to consider the problem in detail, but to show simply and briefly the Post Office method of planning so that discussion of the performance of the new telephone will be appreciated.

For transmission planning, the British network is divided into two parts: the local network of subscribers' installations, subscribers' lines and exchange-transmission bridges; and the junction and trunk network. The local network is planned so that no local telephone circuit has a transmission performance worse for either sending or receiving than that of the Standard Local Telephone Circuit. Similarly, the junction and trunk network is arranged so that the total losses do not exceed that value which, when interposed between two of the Standard Local Telephone Circuits, would produce "just satisfactory" transmission performance. Guidance on what constitutes a "just satisfactory" transmission performance was obtained several years ago by asking some 1,700 persons to converse over telephone connexions of various grades of performance so that a relationship between "opinions of usability" and attenuation could be obtained.

Since more-sensitive telephone instruments can tolerate longer or smaller-gauge lines for equivalent transmission performance, the method of determining the lengths of the various gauges of subscribers' cables which, in conjunction with a particular telephone instrument and transmission bridge, will make up a local telephone circuit having a transmission performance equal to that of the Standard Local Telephone Circuit, is of particular interest.

The Standard Local Telephone Circuit consists of a Telephone No. 162 with Bell Set No. 25, connected via 2.56 miles (450 ohms) of 10-lb cable to a 50V Stone transmission bridge with 200 + 200-ohm relays. It has recently become apparent that when telephones with modern anti-side-tone circuits are compared by articulation-testing techniques with the Standard Local Telephone Circuit, which does not include a true anti-side-tone telephone, receiving ratings are consistently obtained which are about 6 dB higher than those obtained by less artificial techniques. (The sending ratings obtained by the different methods of comparison are in reasonably close agreement.) These differences are probably attributable to the artificial nature of articulation tests, although the exact contribution of each of the various subjective factors involved is still being investigated. From this consideration, with others involving international connexions, it has recently become clear that while articulation tests form the basis of line-planning transmission-performance assessments, the receiving limit should be reduced by 6 dB. Telephone No. 332 meets this raised limit for receiving when connected to its limiting line, the limit being set by its sending performance.

Curves are plotted of the Transmission Performance Ratings of any given telephone for sending and receiving relative to the Standard Local Telephone Circuit (with the 6-dB correction for receiving) against line length, for different gauges of conductor. The line lengths at which these curves cross the zero performance line are therefore the maximum permissible. As different maximum lengths are normally obtained for sending and receiving, the lesser one becomes the transmission-planning limit. This is usually quoted in Transmission Equivalent Resistance (T.E.R.),<sup>6</sup> the resistance of the limiting 6½-lb conductor line. Where, in practice, other or mixed gauges of conductor are used,

conversion factors are employed to obtain their T.E.R. Signalling must also be possible for the particular instrument on its limiting line; if not, then the signalling line-limit takes preference.

#### THE DESIGN OBJECTIVES FOR THE NEW TELEPHONE

The increased sensitivity of a new telephone may be utilized in one or both of two ways. It may be passed directly to the subscriber by improving the existing grade of transmission performance, or it may be absorbed by maintaining this grade of performance at lower overall cost by exchanging sensitivity for increase of line length or decrease of conductor gauge. Thus, the introduction of a new telephone with its potentialities of effecting some saving in the provision of underground plant was considered an attractive engineering proposition, especially as its use would often also result in an improved grade of transmission. In addition, longer exchange lines become practicable, with the possibility of larger exchange areas and absorption of very small ones. The saving is not, of course, immediately realizable because line plant changes very slowly, and thus the savings are small at first but progressively increase with time.

It is also important that savings in line plant should not be offset by increased cost of the telephone nor by increased exchange-equipment costs due to changes necessary for efficient signalling over higher-resistance lines. Thus the cost of the new telephone has been as important a factor as performance and the primary design objective became that of obtaining increased sensitivity without significant increase in cost. The whole problem of estimating the savings to be obtained by introducing a telephone of increased sensitivity is extremely complex and is resolved only by considering instrument and exchange costs, the rate of numerical growth of the new instrument in the network and the rate of provision of lines on which the increased sensitivity may be used to advantage, bearing in mind that there is a limit to the practicability of reducing conductor gauge.

From knowledge gained by the critical examination of existing components and the assessment of experimental transmission circuits, the British Post Office was enabled to draw up a target specification for the guidance of telephone manufacturers. This laid down that,

- (i) the impedance of the telephone at 2,000 c/s when carrying 30 mA line current should have a modulus of  $600 \pm 50$  ohms,
- (ii) the signalling resistance should not exceed 300 ohms when measured with 20 mA line current, and gave
- (iii) the desired shape of the pure-tone sending and receiving sensitivity/frequency characteristics for maximum overall intelligibility with the greatest economy of transmitted power,
- (iv) line impedance values on which the set should have minimum side-tone so that the best overall side-tone performance would be obtained in the British network, and
- (v) the proposed method of testing any new handset. It was stated that tests would be necessary using free-conversation techniques so that the transmission difference between the new and existing handsets could be assessed with the handsets held as in normal use, and a correction made, if necessary, to the relative transmission performance ratings found from articulation tests.

In addition, guiding principles were stated for the desirable limits of amplitude and non-linear distortion and control of sensitivity.

No hard-and-fast figure for the increase of sensitivity was given, but the view was expressed that the telephone should

be suitable for use on 1,000-ohm T.E.R. lines when connected to exchanges with 50V ballast Stone transmission bridges.

#### THE COMPONENTS OF THE NEW TELEPHONE

The main objective of the re-design of the telephone was improved transmission performance without significant increases in cost. The transmission performance of a subscriber's telephone is determined entirely by the handset, which includes the transmitter and receiver, and the induction coil with its associated circuit, and it is in these components that the principal differences between the new telephone and its predecessors are to be found. Of these components, the greatest improvement has been made in the receiver, and the better transmission performance of the new telephone springs almost entirely from this source.

#### The Handset.

The new telephone uses a handset of the "hollow-handle" type which has been titled "Handset No. 1." It is illustrated, complete with mouthpiece and earpiece, in Fig. 1,

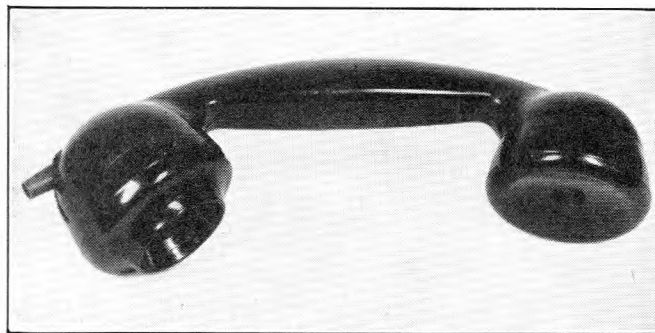

FIG. 1.—HANDSET NO. 1.

and the position of the tunnel through the handle is shown in Fig. 2. The tunnel is formed when the handset is moulded by a tapered core which passes through the cord-entry hole. To allow this core to be withdrawn when the moulding is completed, the tunnel and the cord-entry hole follow a curve of constant radius and this, together with the need to position the mouthpiece and earpiece in the correct relative positions, largely determines the shape of the handset.

In the new handset the cord is connected directly to terminals of the transmitter and receiver (apart from one connexion to the transmitter which is made by a floating spring), the receiver conductors passing through the hollow handle. This method of connexion, together with the use of a screw-on mouthpiece, enables a simple moulding to be used for the handset body without any of the threaded inserts, wires and bayonet fixings that had to be moulded into the previous handset.

The mouthpiece of the new handset is of the screw-on type, and the elimination of the bayonet fixing not only simplifies the body moulding but also enables a simpler moulding tool to be used for the mouthpiece. The thread used on both mouthpiece and earpiece has a coarse pitch

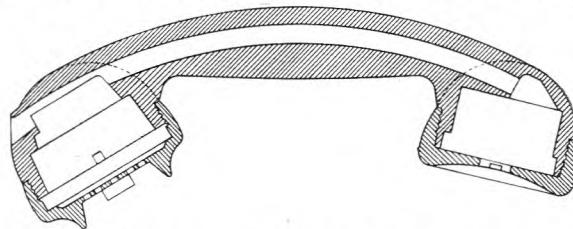

FIG. 2.—CROSS-SECTION OF HANDSET NO. 1, SHOWING THE POSITION OF THE TUNNEL THROUGH THE HANDLE.

and a slight taper, which speed the release of the finished mouldings from the moulding tool. The position of a screw-on mouthpiece relative to the handset body when it is screwed on tightly cannot be controlled accurately, as the position of a bayonet-fitting mouthpiece can, and this means that the mouthpiece must be symmetrical about the thread axis; hence a shaped horn cannot be used.

The shaped horn was an essential feature of the telephone No. 164 handset, as it contributed to some extent to the sending performance, but it had been frequently criticized as unhygienic. While the opinion of the medical profession in this country and elsewhere is that the telephone does not contribute at all to the spreading of germs, the collection of dirt within the horn, particularly in call office telephones, undoubtedly creates a bad impression, and the elimination of the horn is advantageous, although it entails a slight sacrifice of sending efficiency.

To compensate for the loss of a horn the angle of the transmitter diaphragm relative to the axis of the new handset has been increased compared with the Telephone No. 164; bringing the diaphragm more nearly opposite the user's mouth. When the handset is used by the majority of subscribers, the change of angle also results in the transmitter being held at an angle at which it is more sensitive than when used in a Telephone No. 164, giving a greater electrical output for a given speaking level.

Free-conversation tests using a large number of subjects have shown that the electrical output from a Transmitter, Inset, No. 13 is, on average, the same whether used in the new handset without a horn, or in the Telephone No. 164 with its horn. Subjective tests have also been carried out to find the effect of variations in length of the new handset and in the angle between the transmitter and the receiver, and these tests have shown the chosen shape to be the optimum for sending and receiving efficiency.

The bayonet fixing of the mouthpiece on the Telephone No. 164 handset incorporated an elementary form of lock to guard against interference with the transmitter, but no such device was used for the earpiece. Experience has shown that the receiver in the Telephone No. 164 is no more subject to interference than the transmitter, and so no such lock has been provided for the mouthpiece of the new handset.

A rubber sleeve is fastened to the cord to reduce wear where it passes through the rectangular entry hole in the handset. The sleeve is enlarged within the handset and has a rectangular section so that it cannot be pulled through or twisted in the hole, so protecting the cord conductors from strain. The cord is fitted by passing its telephone end through the hole in the handset from inside the transmitter cavity.

For maintenance the new handset will be a considerable improvement over older ones. The direct connexion of the cord to the insets is a big improvement as it eliminates a number of connexion points, each a potential fault; also, the coarse-pitch threads should speed removal of the mouthpiece and earpiece for inspection and prevent the occasional seizures which occur with the present design of earpiece with its fine thread.

#### The Receiver.

The receiver is of the "Rocking-Armature" type and has been titled Receiver, Inset, No. 4T. It is illustrated in Fig. 3, and has been described in a previous issue of the Journal.<sup>7</sup> For circuit-design reasons it has been wound to have an impedance of 150 ohms, measured at 1,000 c/s, and has a d.c. resistance of 20 ohms.

In the rocking-armature receiver the functions of the acoustic diaphragm and of the moving-iron part of the magnetic circuit have been split between two mechanically linked parts, each of which can then be designed for

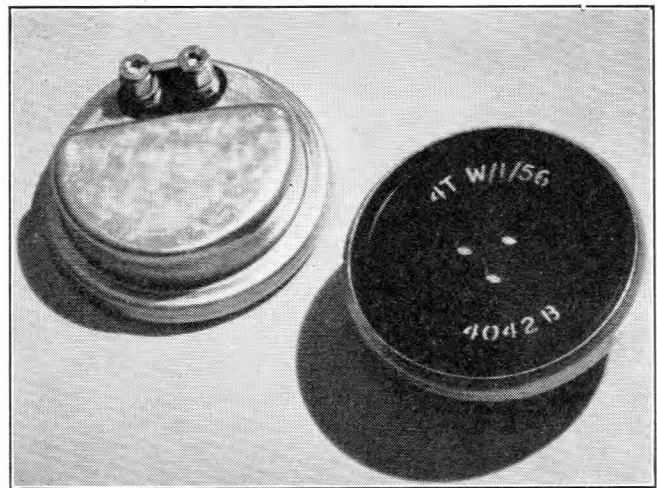

FIG. 3.—RECEIVER, INSET, NO. 4T.

optimum performance of its particular function. Because of this, and because in the magnetic circuit used the reluctance of the permanent magnet is excluded from the path of the alternating flux, the rocking-armature receiver is more sensitive and has a greater frequency range than the magnetic-diaphragm receivers previously used in telephones. The improvement of the new receiver over its predecessors is shown by the curves of Fig. 4.

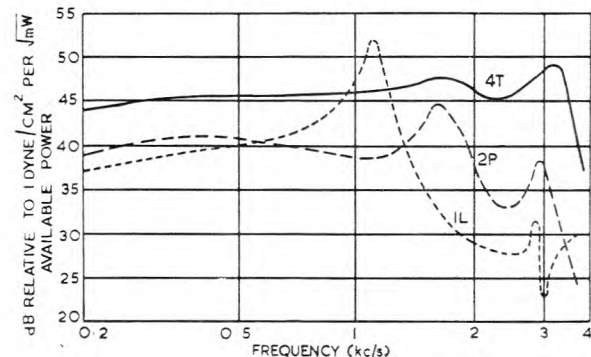

FIG. 4.—SENSITIVITY/FREQUENCY CHARACTERISTICS OF 4T, 2P AND 1L RECEIVER INSETS.

The new receiver is a sealed capsule unit provided with terminals on the rear of its case for the direct connexion of cord conductors. The terminals, like those on the transmitter-connexion springs, have nuts slotted for screwdriver tightening to avoid the use of box spanners. The capsule form of construction should result in the receiver having a more stable performance in service than the open-construction magnetic-diaphragm types, which are always liable to changes of sensitivity after opening due to distortion of the diaphragm and dirt getting in and collecting in the air gaps.

Fig. 5 is a cross-section of the receiver end of the handset showing the fitting of the receiver. It is pressed into contact with the earpiece by a spring ring and at its rear is space for fitting a click suppressor, if required.

#### The Transmitter.

In the absence of a completely developed and proved alternative, the well-tried Transmitter, Inset, No. 13 has been used in the new telephone. This is a development of the No. 10 inset transmitter, which has been described in a previous issue of the Journal.<sup>8</sup> It differs from the No. 10 inset in that it does not have an oiled silk membrane behind the front guard, the diaphragm being protected by a coating of tough flexible enamel. The breathing hole, which in the No. 10 inset was in the diaphragm, has been replaced

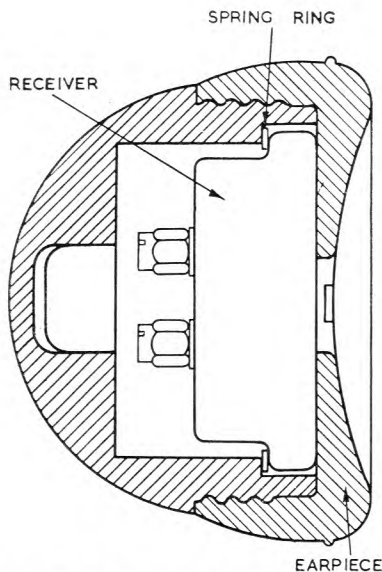

FIG. 5.—CROSS-SECTION OF THE RECEIVER END OF THE NEW HANDSET.

by a hole through the rear electrode. These changes were introduced to improve the resistance of the transmitter to the penetration of moisture.

The Transmitter, Inset, No. 13 was not designed for use with hollow-handle handsets and means have had to be devised for connecting the cord conductors to it. Connexion to the front electrode, which is in contact with the case via the diaphragm, has been made by replacing the usual spring ring on the rear of the case by one which incorporates a terminal post for the connexion of one cord conductor. The new spring ring has a small tongue bent down to engage in a slot in the handset moulding, so preventing the transmitter from turning and straining the cord connexions as the mouthpiece is screwed on. The tongue is split and is wider than the slot in the handset, so that when it is pressed into the slot, the transmitter is held in position, thus facilitating the fitting of the mouthpiece. Contact with the rear electrode is made by means of a loose springy nickel-silver plate within the transmitter cavity of the handset. This plate, which includes a terminal post to which the other cord conductor is connected, has a contacting cone raised in its centre which engages with the hole in the rear

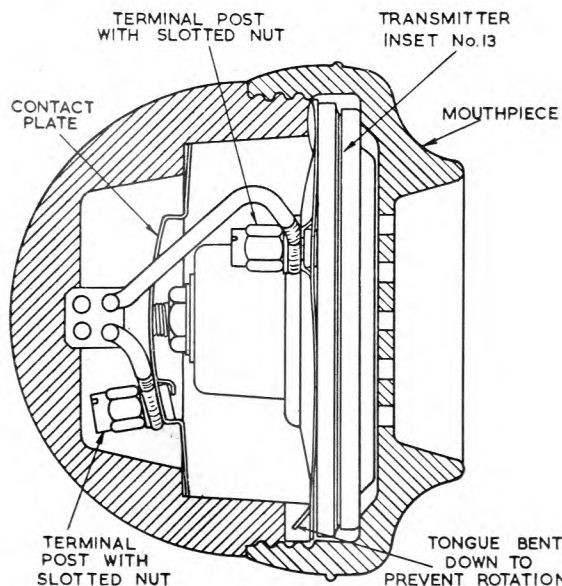

FIG. 6.—CROSS-SECTION OF THE TRANSMITTER END OF THE NEW HANDSET.

of the transmitter. It is held firmly in contact with the transmitter by a step in the side wall of the transmitter cavity in the handset. When flat, the plate is slightly larger than the diameter of the transmitter cavity at the step, and when the transmitter is removed and the pressure on the plate is released, its edges grip the moulding and it is held securely in position; in fact, it is quite difficult to remove. The contacting cone in the plate is perforated to avoid blocking the breathing hole in the rear electrode of the transmitter. Fig. 6 is a cross-section of the transmitter end of the handset, which shows the means of connecting the conductors to the transmitter.

#### The Induction Coil.

The induction coil designed for the new telephone, "Coil, Induction, No. 30," is illustrated in Fig. 7. Its shape and mounting brackets are designed so that the coil is physically interchangeable with the Coil, Induction, No. 27.

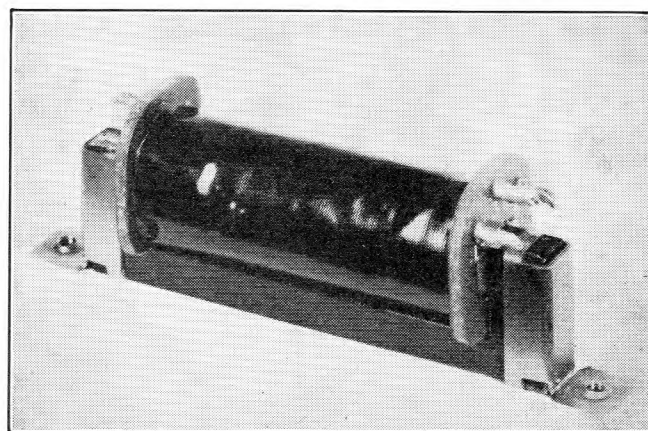

FIG. 7.—COIL, INDUCTION, NO. 30.

The coil has three inductive windings of No. 33 S.W.G. enamelled wire connected in a series-aiding; these windings are:—

Winding	Turns	Resistance (ohms)
1 (line)	1,220	15.0
2	666	10.5
3	420	7.5

In addition, two balance resistors for the transmission circuit are wound non-inductively on the same bobbin.

Design for good side-tone suppression requires windings of high inductance, and for efficiency low winding and core losses are required. These properties have been achieved by use of a closed magnetic circuit of grain-orientated silicon-iron. The grain-orientation process,<sup>9</sup> which consists of cold rolling and annealing silicon-iron strip to orientate the crystal lattices of the grains in the same general direction, results in the material exhibiting much lower core losses together with greatly increased permeability, and at comparatively low cost. Maximum efficiency is obtained when the flux path through the core is parallel to the rolling direction, and the elongated shape of the core (the mean length is almost five times the breadth) makes it particularly suitable for the efficient use of this type of material.

The comparatively high permeability of the core enables the required transformation efficiency to be obtained with fewer turns than are required when the magnetic circuit includes a large air path, as in the Coil, Induction, No. 27. The copper losses and the amount of copper used per induction coil are therefore smaller, partly offsetting the increased cost of the core. The core has a  $\frac{1}{4}$ -in. square cross-section and is built up in two sections, each L-shaped and comprising 18 laminations, 0.012 to 0.013 in. thick, held in place by nickel-silver clamps. A 0.002-in.



aluminium spacer provides a gap in the magnetic circuit to avoid saturation by high line currents, and Fig. 8 shows that there are no large changes of inductance for the most frequently occurring line currents, say 40-100 mA.

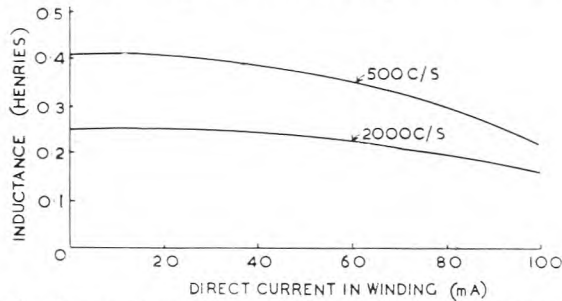

FIG. 8.—INDUCTANCE OF LINE WINDING OF AN EXPERIMENTAL COIL, INDUCTION, No. 30.

The major effect of inductance changes is on side-tone attenuation at low frequencies. The coil and circuit have been designed to give minimum side-tone at 40 mA line current, and a rise to 100 mA increases the 500 c/s side-tone level by 3 to 4 dB. This is of minor importance, however, since the greatest effect of side-tone is experienced when receiving in the presence of room noise and then, because the ear is seldom completely sealed by the receiver, low-frequency noise heard directly via the imperfect seal between receiver and ear is often greater than side-tone. The same change of line current has a negligible effect on side-tone measured at 2,000 c/s.

The two curves of Fig. 8 have been plotted to indicate the fall of inductance with this type of core as frequency rises. This is due to a decrease in incremental permeability, typical values of which are 800 at 500 c/s and 510 at 2,000 c/s, for a line current of 50 mA.

A metal sleeve with synthetic-resin-bonded-paper end-checks forms the bobbin, as shown in Fig. 9; the sleeve is split longitudinally so that it does not form a short-circuited turn.

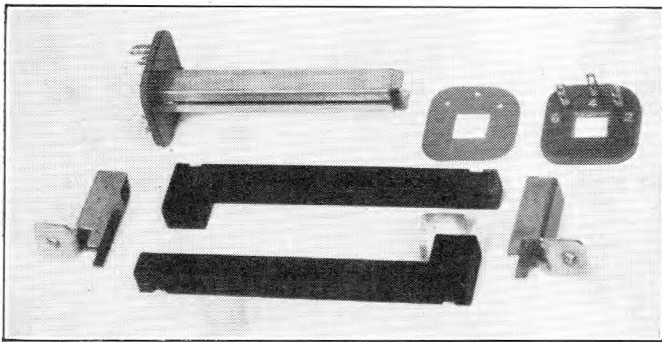

FIG. 9.—COMPONENT PARTS OF THE COIL, INDUCTION, No. 30.

#### The Capacitors.

The circuit of the new telephone has a capacitor in the balance network as well as the one used for blocking d.c., but does not have a capacitor shunting the transmitter. A 0.1- $\mu$ F capacitor was included in the Telephone No. 332 circuit to prevent the modulation and demodulation of r.f. currents that may be induced into telephone lines in regions of very high r.f. field strength, but investigations have shown that such a capacitor is required in only a very few cases, and that it would be more economic to provide it as an extra when required.

To enable the new transmission circuit to be contained initially within the same case as the 300-type telephones without changes to the internal layout, it was necessary to accommodate the d.c.-blocking and balance capacitors in the space previously occupied by a total capacitance

of 2.1  $\mu$ F. The transmission circuit has been designed with this space limitation in mind, and the values of the capacitors have been fixed at 1.8  $\mu$ F and 0.9  $\mu$ F respectively. It has been found possible to manufacture conventional foil and paper capacitors of these values, enclosed for economy in a common can that is small enough for the space available. Two different designs have been produced: one uses the same impact-extruded aluminium can with neoprene seal as is used in the No. 332 telephone for the 2 + 0.1  $\mu$ F capacitors, the increased capacity without increase of volume being obtained by the use of interleaving paper of improved properties. In the second design the capacitors are contained in a rectangular fabricated container which, while having the required overall dimensions, makes better use of the space available in the telephone and contains more space for the capacitor elements.

#### The Dial.

If the improved transmission performance of a telephone allows the use of longer local lines, it is essential that signalling, particularly pulsing, should also be satisfactory over the longer lines. The pulsing performance of a telephone is determined by the distortion introduced by the telephone spark-quench and by the mechanical properties of the dial.

The dial used in the new telephone is the Post Office No. 12 type, a "trigger" dial first introduced into service in 1950. Its predecessor, the No. 10 dial, owes its long popularity to the fact that it provides the inter-train pause before the pulse train, instead of after it, and the dial runs up to its governed speed before pulses are transmitted. The No. 12 dial also has this advantageous feature but avoids the known weaknesses of the slipping cam.

With the No. 12 dial mechanism the pulse ratio is affected during service by wear at the contacts, and between the teeth of the pulse wheel and the trigger. The effects of wear at these two points are compensating, whereas in the No. 10 dial, contact wear and tooth wear are additive: because of this it has been possible to assume greater constancy of pulse ratio in service for the No. 12 dial. Hitherto, both No. 12 dials and No. 10 dials have been used indiscriminately in telephones and it has not been possible to take advantage of the improved pulsing performance, but in the new telephone, No. 12 dials are being used exclusively and the more constant performance offsets the increase of pulse distortion when the telephone is used on a longer local line.

The method of connecting the dial to the telephone has been changed. In earlier telephones it has been the practice to use a separate dial cord, connecting the dial to a terminal strip within the telephone. This practice was followed, not to allow replacement of the dial cord, which gets no wear and should outlast the telephone, but to enable C.B. versions of telephones to be provided. In the new telephone, connexion is made to the dial by flexible conductors included in the cable form. For automatic working this is more economic because it eliminates the terminal strip and the conductors have bound loops at the dial ends only. Where the telephone is not fitted with a dial the new arrangement is not quite so economic as the old; conductors equivalent to a dial cord are provided unnecessarily and a dummy dial which includes a terminal strip is necessary to provide a point at which the telephone loop can be restored, and to prevent conductor ends being left loose in the telephone. New telephones will be used much more as automatic instruments than older telephones have been, partly because manual exchanges are being converted to automatic working and partly because, initially at any rate, the new telephone will be used mainly on long lines connected to new automatic exchanges designed for the higher resistance limits. The saving achieved by eliminating

the terminal strip from the new telephone when it is used with a dial is therefore the more important factor.

### The Bell.

The new telephone uses the same No. 59A bell movement as the Telephone No. 332. The impedance of the ringing circuit, particularly in the most onerous conditions when a number of bells are connected in series to one line, is so high that the extension of line limits allowed by the improved transmission performance does not affect ringing efficiency.

## THE TRANSMISSION CIRCUIT

### Winding Ratios.

The new instrument is designed for an existing, well-established network and it has therefore to work in conjunction with a variety of older instruments. Consider a hypothetical telephone network containing one type of telephone instrument only and assume local-line planning by the present method. If a new instrument has been designed and has a transmission performance better than that of the existing instrument by  $s$  dB for sending and  $r$  dB for receiving, then the transmission performances obtained over the existing limiting connexion for combinations of new and existing sets are:—

- (i) Existing set sending to existing set—transmission performance = 0 dB relative to lower limit.
- (ii) New set sending to existing set—transmission performance =  $+s$  dB relative to lower limit.
- (iii) Existing set sending to new set—transmission performance =  $+r$  dB relative to lower limit.
- (iv) New set sending to new set—transmission performance =  $+(s + r)$  dB relative to lower limit.

Conditions (ii) and (iii) are the most important, for the network will contain the older sets for a very long period, and show that new sets can only be fitted on lines of increased transmission loss to the value of  $s$  or  $r$ , whichever is the smaller. This restriction is necessary since, by introducing a new set with increased receiving efficiency ( $r$ ) greater than the increased sending efficiency ( $s$ ) and by connecting this set to a line with an extra transmission loss equivalent to the improvement in its receiving performance ( $r$ ) the sending performance of the set on that line becomes ( $r - s$ ) below the lower limit.

The economic advantage is clearly a maximum when  $s = r$ , and there is no economic advantage when either  $s$  or  $r$  is zero. Although the assumptions made are not completely valid under all circumstances, the example does indicate the ideal practical condition, that the new set should be better in transmission performance by equal amounts for both sending and receiving compared with the planning standard.

An article in a previous issue of the Journal<sup>10</sup> showed that within the anti-side-tone circuit sending efficiency can be increased if the receiving efficiency is reduced and vice versa. This feature is of great advantage in the design of a subscriber's set, for in the 700-type telephone the added transducer efficiency is almost wholly in the receiver and with no change in the induction-coil circuit (e.g. by continuing to use the Coil, Induction, No. 27) no economic advantage would be realized. In fact, a deterioration would be more likely because the increased side-tone would reduce sending efficiency by causing a lowering of the talker's voice, and the greater receiving loudness might easily become an embarrassment on short lines. Such considerations, followed by experimental design and trial, enabled the  $Y$ -ratio,<sup>10, 11</sup> of the new induction coil to be determined; the final value adopted (3) being a compromise between the degree of transfer of efficiency required and the loss of overall efficiency incurred in the process.

It has been shown that there are 136 possible 3-winding ASTIC circuits that have the same fundamental properties

so far as subscriber's set design is concerned<sup>11</sup>. Of these, many may be rejected as uneconomical because they need additional isolating capacitors; e.g. when a winding forms a d.c. shunt across the line or transmitter. The circuit chosen from the group remaining was determined mainly from the balance-network considerations discussed later, and, for the chosen circuit, knowledge of the  $Y$ -ratio, the line impedance and the transducer impedances enabled the winding ratios to be determined; these are, winding 1/winding 2 = 1.83 and winding 1/winding 3 = 2.9.

The difference between characteristics of the sending and receiving transmission paths of the Coil, Induction, No. 27 and the Coil, Induction, No. 30 are shown in Fig. 10; the

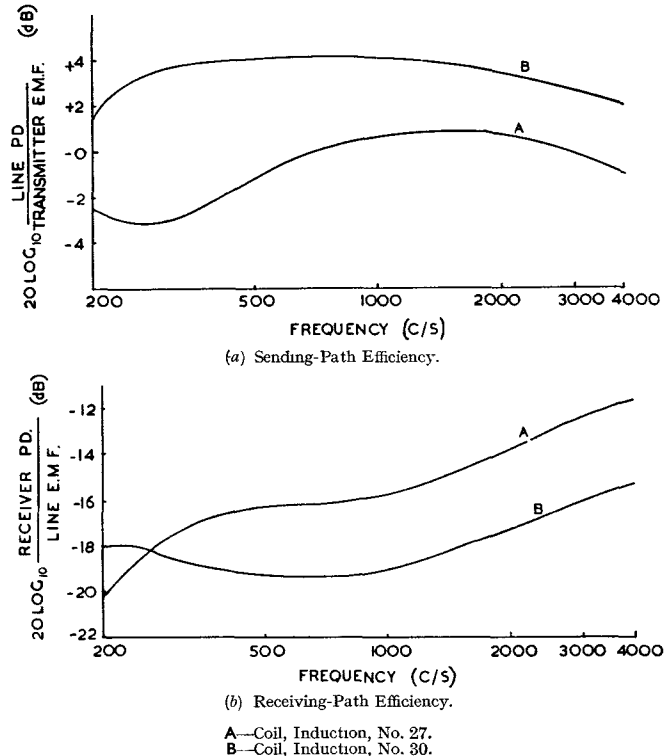

FIG. 10.—SENDING AND RECEIVING CHARACTERISTICS OF COILS, INDUCTION, NO. 27 AND NO. 30.

new coil has a sending-path efficiency about 3.5 dB greater than that of the Coil, Induction, No. 27, but the efficiency of the receiving path is lower by about the same amount for the particular line condition and range of frequencies shown. The change of  $Y$ -ratio from approximately 1, for the 332 circuit, to 3 for the new circuit would theoretically have resulted in the 700-type electrical circuit having a sending efficiency only about 2 dB greater, while the receiving efficiency would have been some 3 to 4 dB less. That the new telephone has efficiencies materially better than this is due partly to the increased efficiency of the circuit and partly to the greater efficiency of the induction coil with its low winding resistances and low core losses.

### Choice of Circuit.

So far, the performance of the new instrument has been compared with that of the existing telephone without reference to the effect of side-tone. By changing to a transmitter or receiver (or both) of greater sensitivity, the overall level of side-tone is increased and by its effect on a talker and on the signal/noise ratio when receiving in the presence of room noise it may partially offset the expected transmission-performance gains. It is thus desirable that the equivalent electrical attenuation of the side-tone path of the new induction-coil circuit should be greater than that of the Coil, Induction, No. 27 by an amount at least

equal to the total sensitivity added.

The degree of side-tone balance obtainable under the practical range of line conditions, and the complexity of the balance network, are important factors affecting the final choice of the induction-coil circuit. The design of the balance network for the group of usable circuits is affected by the magnitude of the self-inductance and mutual inductances of the windings of the induction coil (assuming a type of construction in which leakage inductance and winding resistance are both small), low values resulting in a more costly network. The choice of the circuit within the group is thus dictated by consideration of the balance network and a knowledge of the anticipated physical construction of the induction coil. The complete transmission circuit found to be the best compromise is shown in Fig. 11; it is very similar in configuration to the basic circuit analysed in an article in a previous issue of the Journal.<sup>10</sup>

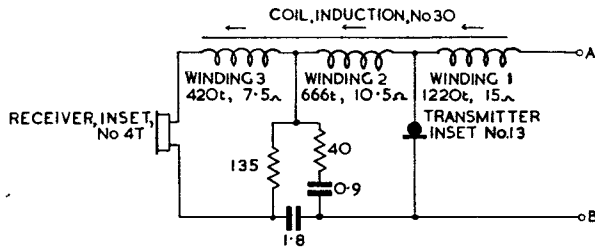

FIG. 11.—TRANSMISSION CIRCUIT OF 700-TYPE TELEPHONE.

#### The Balance Network.

The line impedances to which a telephone set may be connected vary over a wide range, both from installation to installation, due to variation in line gauge and length; and from call to call, due to variation in transmission bridges and junctions. By examining all the impedances that may confront the line terminals of a telephone in the Post Office network (and to a close approximation, many other networks), it was possible to estimate the impedance/frequency characteristic for the termination on which a telephone should have minimum side-tone in order to obtain the best mean side-tone performance. The balance circuit was then designed so that at each frequency the line impedance producing the greatest side-tone path attenuation was as near as was economically possible to that of the design characteristic. The ideal and achieved characteristics (expressed for convenience in terms of the resistive and reactive components) are shown in Fig. 12. The characteristics indicate that the new circuit has a greatly improved side-tone suppression, and this fact is substantiated by a series of actual measurements made on the Telephone No. 332 and 700-type telephone circuits over a typical range of line conditions, as shown in Fig. 13, in which mean side-tone levels over the telephone frequency band are plotted for various subscriber's line lengths and gauges.

The balance network is not a simple two-terminal network; it is complicated by the addition of the d.c.-blocking capacitor, making a three-terminal asymmetrical  $\pi$  network.

The 332-type circuit is especially economical in its use of components; the aim of the 700-type design is similar; i.e. to use certain components to perform both transmission and signalling functions. The position of the d.c.-blocking capacitor and

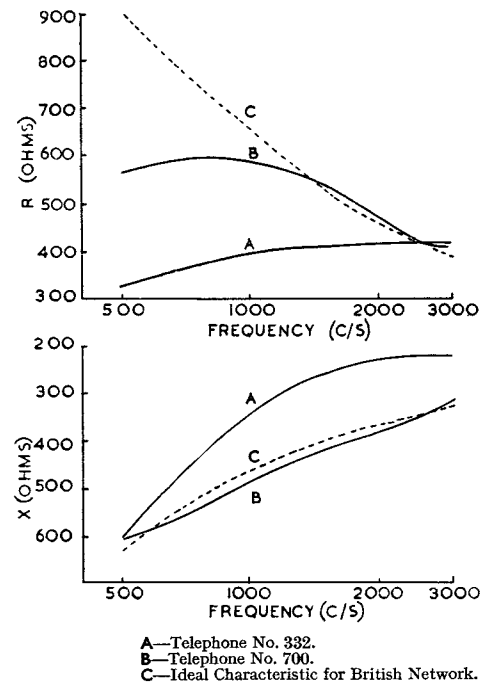

FIG. 12.—LINE IMPEDANCE FOR MINIMUM SIDE-TONE.

its value are, therefore, determined by considerations additional to those of transmission. For example, it was desirable that both the d.c.-blocking and balance capacitors should be contained within the same can, the size of which was limited. From all considerations (transmission, dialling and ringing) it was not possible to reduce the value very much, especially when manufacturing tolerances of some  $\pm 15$  per cent are necessary, but a slight reduction from the existing value of  $2 \mu\text{F}$  to  $1.8 \mu\text{F}$  enabled a balance circuit to be designed to give satisfactory side-tone suppression, while easing the capacitor manufacturing problem.

#### TRANSMISSION PERFORMANCE OF THE 700-TYPE TELEPHONE

Methods of assessing transmission performance that produce the most realistic answers usually entail the greatest amount of work and require considerable time for precision, and as production models of the 700-type tele-

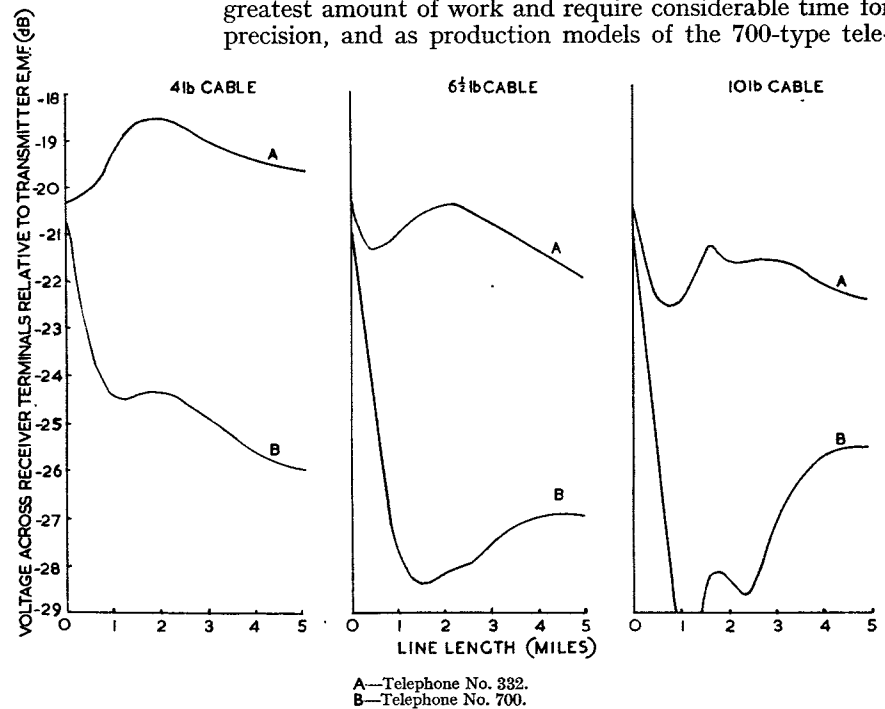

FIG. 13.—SIDE-TONE RESPONSE OF TELEPHONES NO. 332 AND NO. 700.

phone have not been available until recently, only provisional information can be given here. This has been obtained from tests on prototypes only, but while it may be subject to small corrections when comprehensive tests have been completed, it does allow a fairly reliable estimate of the transmission improvement of the new telephone to be made.

For pure-tone sensitivity tests and for subjective tests in which a fixed handset position is used, the angle of the handset and the speaking distance used were determined from a recent series of measurements made on telephone users when holding a handset naturally.

#### Loudness Efficacy.

The loudness efficacies of the 700-type telephone are greater than those of the Telephone No. 332 by about 5 dB for sending and 3 dB for receiving when working directly into a 50V Stone transmission bridge, 600-ohm junction and the appropriate end of the Articulation Reference Telephone Circuit.<sup>12</sup> The same order of improvement is maintained for most practical line conditions.

#### Pure-tone Characteristics.

Pure-tone sending and receiving sensitivity/frequency characteristics are given in Fig. 14. They are shown for one-

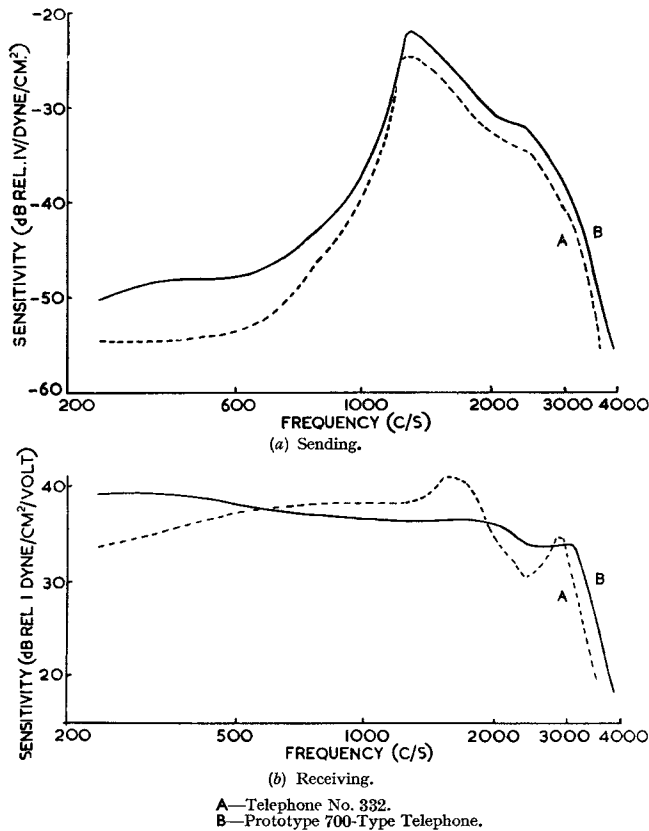

FIG. 14.—SENSITIVITY/FREQUENCY CHARACTERISTICS OF TELEPHONE NO. 332 AND PROTOTYPE 700-TYPE TELEPHONE.

line condition only but are typical of the difference between Telephones No. 332 and No. 700 on all practical lines.

#### Transmission Performance Ratings.

Transmission performance ratings are probably the best method of showing the usefulness of a telephone in a network. A typical series for the 50V ballast Stone transmission bridge comparing the Telephones No. 332 and No. 700 is given in Fig. 15.

It can be seen that the controlling limits are those for sending in all cases (ignoring signalling considerations) and that the original expectation of a telephone suitable for use

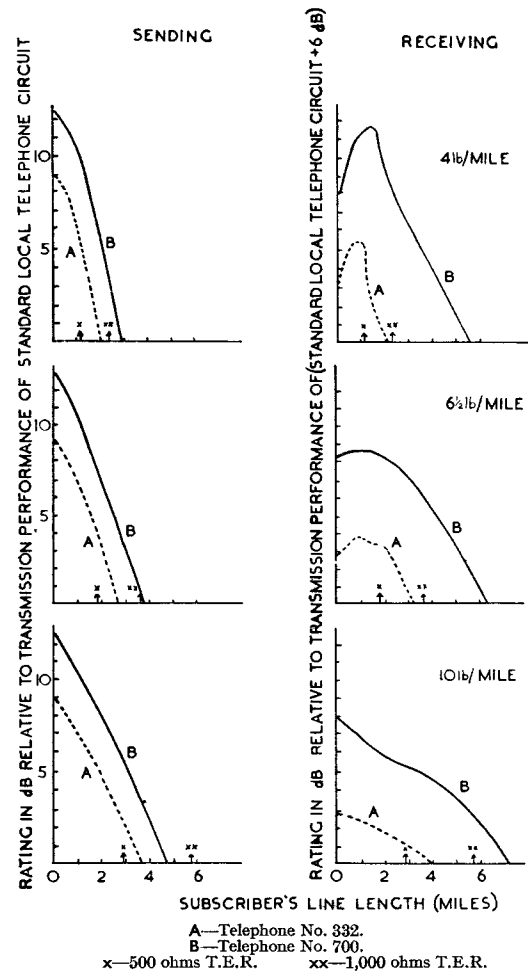

FIG. 15.—TRANSMISSION PERFORMANCE RATINGS OF TELEPHONES NO. 332 AND NO. 700.

on lines having a T.E.R. of 1,000 ohms has been realized, thus allowing greater usable line lengths for the new set to the extent of some 40 per cent. Space does not permit details to be given of the transmission improvement on other types of transmission bridge, but the increases in usable line lengths are of the same order for all.

Alternatively, the new telephone will have transmission performance equal to or better than that of the Telephone No. 332 when used on lines of the next smaller Post Office standard conductor weight; e.g. where Telephone No. 332 requires a 10-lb/mile or 6 1/2-lb/mile conductor, the new instrument can use 6 1/2 lb/mile or 4 lb/mile respectively.

#### THE PRACTICAL CIRCUIT

So far, only the transmission properties of the new telephone circuit have been considered. The practical telephone must perform a number of signalling functions and these require the addition to the transmission circuit of gravity switch contacts, a dial and a bell. In the 700-type telephone these have been added without any sacrifice of transmission efficiency. The rearranged circuit is shown in Fig. 16 and it will be seen that, as in the Telephone No. 332, the d.c.-blocking capacitor of the transmission circuit is also the bell capacitor and the capacitor in the dial spark-quench. With the bell connected as in this circuit a small direct current passes through the receiver when the telephone is in use; although undesirable in principle, this is so small (a fraction of 1 per cent of the line current) that it has no effect on the receiver sensitivity, while it has the advantage of "wetting" contact GS2 which would otherwise carry only small alternating currents. The circuit requires the same com-

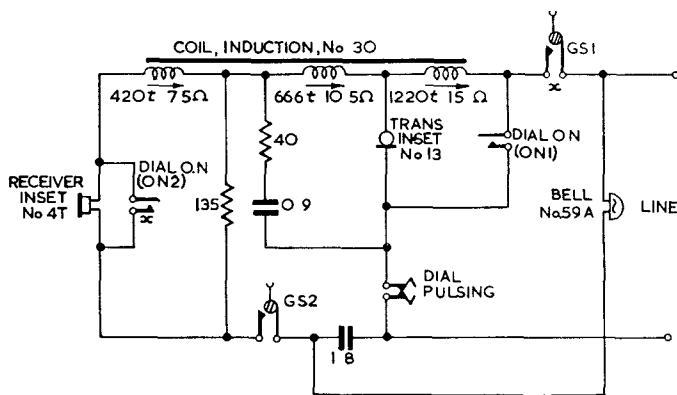

FIG. 16.—COMPLETE CIRCUIT OF TELEPHONE No. 700.

bination of dial off-normal contacts as the Telephone No. 332, so that the same dial can be used for both old and new telephones.

#### Gravity Switch Contacts.

The positioning of the gravity switch contacts exactly follows the practice of the earlier telephone. Two contacts are used to break the telephone loop; contact GS1 breaks the transmitter circuit while GS2 breaks an indirect circuit through the bell. To prevent an objectionable click being heard when the handset is lifted, GS1 is adjusted to make before GS2. Completion of the receiver circuit is thus delayed until the d.c.-blocking capacitor (1.8  $\mu$ F, charged to the full exchange battery potential while the telephone is idle) has discharged via the transmitter circuit. A click is still heard in the receiver due to the coupling between the windings of the induction coil, but its level is reduced so that it is no louder than the clicks caused by the exchange apparatus when the line is switched to a selector.

#### Dial Contacts.

While the method of including the dial in the 700-type telephone circuit follows generally the lines of the 332 circuit it differs considerably in detail. Contact ON1 both completes the low-resistance pulsing loop and prepares the spark-quench for the pulsing contact, leaving ON2 to short-circuit the receiver to prevent dial pulses being heard. The spark-quench formed when the dial is off-normal consists of the 1.8- $\mu$ F capacitor with a series component made up of a network of induction-coil windings, the balance resistors and capacitor, and the transmitter. This network has a d.c. resistance of about 30 ohms, varying slightly with the transmitter; the circuit of the complete spark-quench is shown simplified in Fig. 17.

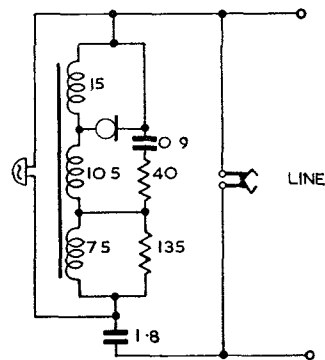

FIG. 17.—PULSING CIRCUIT (DIAL OFF-NORMAL CONTACTS OPERATED).

The presence of capacity in parallel with the pulsing contacts of a dial has the effect of increasing the make/break ratio of the pulses and the exchange apparatus in the British Post Office system is designed to accept pulses from telephone dials with a spark-quench as fitted to the 332 telephone, i.e. 2  $\mu$ F in series with 30 ohms. Use of a spark-quench of a different value would be equivalent to using a dial with a non-standard ratio and would reduce the margin of pulsing performance of the exchange apparatus.

In the present British Post Office non-director automatic system the pulses from subscribers' dials are used, without regeneration, to control calls over several junctions, to the

limit set by the cumulative pulse distortion and the margin of the exchange apparatus. Reduction of this margin would inevitably result in a reduction of the limiting distance over which the direct pulses could be used, requiring the provision of more pulse regeneration equipment at exchanges, and the cost of this equipment might easily offset the savings in other directions obtained by the use of a more efficient telephone. It is important therefore that the spark-quench of the 700-type telephone should have a pulse-shaping effect similar to that of Telephone No. 332.

For this reason the 0.9- $\mu$ F capacitor is connected above the pulsing contact, in Fig. 16, instead of below it; if it were connected below, the capacitor would be in shunt with the contact and would add to the capacity of the spark-quench. Connecting the capacitor in this way does not affect the transmission circuit at all, as when the pulsing contact is closed both sides of it are electrically the same point.

The effect of the spark-quench of the 700-type telephone is difficult to calculate as it contains both inductance and capacitance in the dissipative element, but laboratory tests have shown that its pulse-shaping properties are similar to those of the 332 spark-quench, while it performs the primary object of a spark-quench satisfactorily.

It will be seen from Fig. 17 that, as in the 332 circuit, the bell is shunted during dialling by the resistive component of the spark-quench. This shunt prevents the bell tinkling during dialling without recourse to devices such as bias springs. By the use of a 4-wire connexion between telephones connected in parallel to the same line this feature can be extended so that when any telephone connected to the line dials, tinkling of other bells is prevented.

#### The Need for a 4-way Handset Cord.

In the 332 telephone the basic transmission circuit was rearranged to make one terminal of the transmitter and receiver a common point in the circuit, so that a 3-way handset cord could be used. A similar rearrangement of the 700-type telephone circuit is possible, but has not been made owing to consequent difficulty of providing a satisfactory dial spark-quench without introducing extra components, and because a 4-way cord is more convenient for the type of handset used.

#### Design for Flexibility.

The introduction of a "new telephone" involves much more than the design and production of one type of table telephone. Lines with lengths between the maximum of the older telephones and the new maximum allowed by the superior transmission of the new telephone can only use telephones having the improved transmission circuit and components. Unless an administration is prepared to limit the choice of telephone, and the type of service, for subscribers having lines with lengths between the limits for the old and the new telephones, it is necessary to provide a complete range of new telephones.

The subscriber to-day has a wide choice of physical designs of telephones; two different table telephones, a wall telephone and a number of special-purpose telephones, while the varieties of service and the facilities available can be judged by the fact that a range of nine different versions of the 300-type table telephone is necessary to cater for them. The number of telephones actually stocked is further multiplied by the range of colours offered, and by the alternative dials used, so that the duplicating of the complete range of older telephones by a similar range of new telephones must be avoided if possible.

#### The Case Against a "Universal" Telephone.

The multiplicity of telephones of the older type makes attractive the idea of one "universal" version of each

physical design of the new telephone, the universal telephone being made suitable for any purpose by simple alteration by the installer when connecting it to a line. There are two major difficulties with a universal telephone:

(a) The majority of telephones required are of the simplest type and it would be very wasteful at these installations to provide a universal telephone which, containing unused components, would inevitably cost more than one designed to fulfil the simple function only.

(b) A universal telephone would need holes for fitting the maximum number of push-buttons and for fixing a label, but the "knock out" method of providing holes, used for wiring holes in block terminals, etc., cannot be successfully applied to telephones because it often gives a ragged edge which is both unsightly and bad for push-button operation. Moulded holes would be necessary and when not wanted they would have to be filled by dummies. Since the holes are unwanted on the majority of telephones this is obviously uneconomic besides being aesthetically undesirable; although unobtrusive plastic dummies are now being used, a telephone with no holes will always look better than one having holes filled with dummies.

#### A Compromise Solution.

With the first telephones of the 700 series a measure of flexibility has been achieved and the types to be stocked have been reduced without paying the full price of complete flexibility in a single instrument providing all facilities. A simple telephone, coded Telephone No. 700, has been designed, which will satisfy the majority of requirements and meet the economic and aesthetic objections to the use of a telephone equipped for the installation of push-buttons, on the large number of lines on which the facility is not required. In addition, a "flexible" telephone, coded Telephone No. 704, has been designed to reduce the number of types of telephone which have to be stocked.

The Telephone No. 704 has facilities for fitting the maximum number of push-button keys and has a circuit, shown in Fig. 18, that can be adapted to perform the signalling functions of a number of different telephones in the 300 series. (In Fig. 18 the telephone circuit has been drawn to emphasize the signalling paths.)

The price of flexibility, apart from the provision of holes in the case for push-buttons and of dummies for filling the holes not required, is an extra terminal strip and an additional spring in the gravity-switch set. The additional terminal strip is the one used in Telephone No. 332 for terminating the dial cord. It is used for con-

necting the keys and other components necessary for adapting the telephone to meet various signalling requirements. The additional gravity-switch spring is required when the telephone is used on shared-service lines to disconnect the earthed bell from the rest of the telephone circuit during a call and so prevent line noise.

A typical application of Telephone No. 704 is its use on shared-service lines with separate metering. To make the telephone suitable for this purpose an adaptor unit, comprising a wired assembly of a key, a rectifier and a thermistor, is fixed within the telephone and is connected into the circuit via the auxiliary terminal strip. Fig. 18 shows the telephone with the adaptor, and an experimental adaptor employing a germanium diode in place of the more usual copper oxide rectifier is shown in Fig. 19.

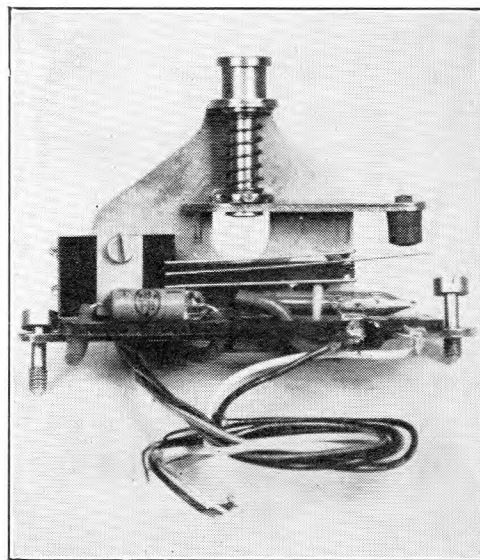

FIG. 19.—EXPERIMENTAL SHARED-SERVICE ADAPTOR.

The Telephone No. 704 is similarly adapted to perform other functions, the added part being often no more than a key. Apart from avoiding the provision of additional components except when they are actually needed, the use of "add-on" units allows facilities not yet thought of to be provided later by the design of simple adaptors rather than complete telephones.

This method of reducing the numbers of stocked types of the new telephone has been applied recently, as a trial, to a new physical design of wall telephone based upon the 332 transmission circuit.

#### THE COMPLETE TELEPHONE

Telephones No. 700 and No. 704 have been designed to utilize the case and chassis of the 300-type telephones, preserving many of their proved features. This has enabled telephones containing the new transmission circuit and components to be made available much earlier than if the complete telephone had been re-designed. These telephones will be used to gain experience of the new circuit and to meet urgent requirements for telephones with an improved transmission performance.

Externally, Telephone No. 700 is identical in appearance with Telephone No. 332, except for the change of handset. Internally the visible changes (see Fig. 20) are the replacement of the old induction coil by one with a closed magnetic circuit and the omission of the dial terminal strip.

The chassis wiring is carried out in P.V.C.-covered tinned-copper wire, as in the most recent production of 300-type telephones; this has better insulation properties than the textile and enamel insulated wire used previously, and reduces the risk of unsoldered connexions.

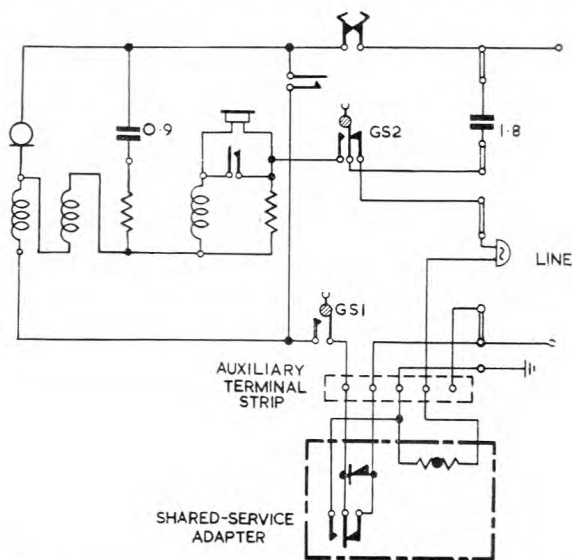

FIG. 18.—TELEPHONE NO. 704, WITH SHARED-SERVICE ADAPTOR.

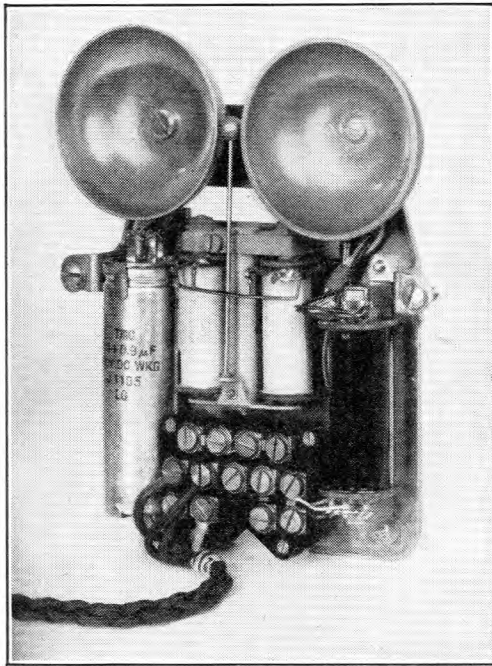

FIG. 20.—CHASSIS OF TELEPHONE No. 700.

#### THE NEW TELEPHONE ON SHORT LINES

The better receiving efficiency of the new telephone might result in its being considered too loud by subscribers on short lines and, when a large proportion of the telephones in service are of the new type, the higher sending efficiency might increase crosstalk and the loading of common-equipment amplifiers on coaxial and carrier equipment. It is probable, however, that these difficulties will not arise because it is known that telephone users lower their voices when the level of side-tone or received speech is high.

To test the reactions of subscribers under these conditions trials are being held in which the telephones are being used as extensions of P.B.X.s on which a large proportion of the calls use very short lines. Pending the completion of these trials, the new telephones will be used on long lines only. If the problem does prove to be a real one it is unlikely that a policy of zoning will be accepted as a final solution since it is uneconomic and undesirable for the telephone industry to produce more than one basic type of telephone, and a regular supply of repaired old telephones for short lines will not continue indefinitely.

If the trial of the new telephone on short lines shows that regulation will be necessary after the initial zoning period, several different methods are possible, some of which have already been tried by other administrations. Possible methods are:—

- (a) Automatic regulators can be included in the telephone circuit. Devices of this type usually regulate receiver or transmitter sensitivity, or both, according to the line current, and utilize either barretters, thermistors or varistors, or combinations of these.
- (b) A fixed attenuator, either included in the telephone or fitted as an addition when required, can be included in the circuit by the installer when connecting the telephone to a short line.
- (c) Graded transducers of varying sensitivity can be fitted to the handset.
- (d) The subscriber can be given control of sensitivity, e.g. by means of a handset switch.

All these methods have disadvantages; it is obviously uneconomic to provide a sensitive telephone and then to provide an expensive device to reduce its sensitivity on short lines. Automatic regulators, besides being expensive,

may have a considerable fault liability, relying as they do on non-linear devices whose characteristics may change over a period of years and, possibly, incorporating vulnerable filaments. Preset attenuators and graded transducers pose a difficult problem when a P.B.X. is connected to a long exchange line and its extensions use short lines. A subscriber-operated control increases fault liability due both to the fallibility of switches and potentiometers when frequently used, and to the possibility of mis-operation.

#### FURTHER DEVELOPMENT

In the immediate future the case of the table telephone will be re-designed to suit better the new shape of handset, with consequent changes to the internal layout of the components. A further objective will be the inclusion of the improved transmission circuit and components in other physical forms of telephones. In this connexion it is of interest that the new wall telephone, with the 332 circuit, recently put into service, was styled so that its case blended harmoniously with the new handset.

A longer-term project for improving the new telephone is the possible replacement of the inset No. 13 by a new transmitter. Tests of the 700-type telephone fitted with an experimental transmitter have shown that the shape of the sending characteristic is considerably improved by its use, and this might result in the articulation efficiency of the telephone being increased, although the experimental transmitter is little, if any, more sensitive than the inset No. 13. Economic advantage could be taken of any increased sending efficiency in the Post Office network because the new telephone at present has a preponderance of receiving efficiency. There would also be physical advantages in the use of a new transmitter; it would be designed to include terminals for direct connexion of the cord and so eliminate the loose contact plate from the handset.

#### ACKNOWLEDGMENTS

The valuable assistance of Engineer-in-Chief's Office colleagues in the preparation of this article is acknowledged. Acknowledgments are also due to Standard Telephones and Cables, Ltd., and to the General Electric Co., Ltd., for their co-operation in the project, and in particular to Mr. A. C. Beadle, of S.T.C., for the fundamental design of the transmission circuit.

#### References.

- <sup>1</sup> PALMER, R. W., and BRIMMER, W. L. The British Telephone Technical Development Committee. *P.O.E.E.J.*, Vol. 41, p. 193, Jan. 1949.
- <sup>2</sup> DE WARDT, R. H. The Conduct of Articulation Measurements. *P.O.E.E.J.*, Vol. 44, p. 159, Jan. 1952.
- <sup>3</sup> HOTH, D. F. Room Noise in Subscribers' Telephone Locations. *Journal of the Acoustical Society of America*, Vol. 12, p. 499, Feb. 1941.
- <sup>4</sup> RICHARDS, D. L. Some Aspects of the Behaviour of Telephone Users as affected by the Physical Properties of the Circuit. *Communications Theory* 1953, Butterworths, London, p. 442.
- <sup>5</sup> BARNES, E. J., WOOD, A. E., and RICHARDS, D. L. Standards of Transmission and Local Line Limits. *P.O.E.E.J.*, Vol. 39, p. 151, Jan. 1947, and Vol. 40, p. 8, Apr. 1947.
- <sup>6</sup> FUDGE, G. A. E. Introduction and Application of Transmission Performance Ratings to Subscribers' Networks. *I.P.O.E.E. Printed Paper No. 198*, 1949.
- <sup>7</sup> ROBERTSON, J. S. P. The Rocking-Armature Receiver. *P.O.E.E.J.*, Vol. 49, p. 40, Apr. 1956.
- <sup>8</sup> ALDRIDGE, A. J., BARNES, E. J., and FOULGER, E. A New C.B. Microtelephone. *P.O.E.E.J.*, Vol. 22, p. 191, 1929.
- <sup>9</sup> Magnetic Alloys and Ferrites. (George Newnes, Ltd.).
- <sup>10</sup> SPENCER, H. J. C. Some Principles of Anti-Side-Tone Telephone Circuits. *P.O.E.E.J.*, Vol. 48, p. 208, Jan. 1956.
- <sup>11</sup> CAMPBELL, G. A., and FOSTER, R. M. Maximum Output Networks for Telephone Substation and Repeater Circuits. *Transactions A.I.E.E.*, Vol. 39, p. 231, 1920.
- <sup>12</sup> SWAFFIELD, J., and DE WARDT, R. H. A Reference Telephone System for Articulation Tests. *P.O.E.E.J.*, Vol. 43, p. 1, Apr. 1950.

# The New Centralized Service-Observation System

A. J. BARNARD, A.M.I.E.E.  
and E. H. A. BECK†

U.D.C. 621.395.364

The existing design of centralized service-observation system has a number of disadvantages which are avoided by the new system described in this article. The new system has been designed to connect into the circuit to be observed at the first selector and so will enable more observations to be made in a given time than does the existing equipment, which is connected to individual subscriber's lines, and also the number of different subscribers' lines on which observations can be made is very greatly increased.

## INTRODUCTION

THE centralized service-observation system is a means of sampling telephone traffic passing through an exchange, for the purpose of assessing the quality of the service.

An outline of the present system, together with a description of difficulties experienced in its use, and proposals for overcoming these difficulties, has already been published.<sup>1</sup> These defects are briefly:—

- (a) Additional pulse distortion is introduced into the observed line and may cause failure of calls under adverse conditions.
- (b) Additional transmission loss is introduced.
- (c) The clip-and-cord connexions, by means of which access to lines is obtained, are a source of faults, and appreciable time is spent rearranging them to change the lines connected for observation.
- (d) The sample of calls obtained is restricted in range and size.

A new observation system for automatic exchanges has been developed to overcome these difficulties, and in addition provides for observing incoming junction traffic. The new equipment introduces negligible pulse distortion and transmission loss into the observed line, access is by jumpered connexions which require very infrequent rearrangement, and the sample of calls obtained is widespread. The rate of taking observations has also been greatly increased so that the required number can be obtained in far shorter time. For example, on trials on subscribers' traffic an average of 275 observations per day was obtained from one exchange compared with 100 per day with the existing type of equipment. The new system is suitable for use in director, non-director main and satellite exchanges, of both 2000-type and pre-2000-type, excepting only certain early non-standard exchanges. An equipment giving similar facilities at automatic trunk exchanges has also been developed.

## GENERAL DESCRIPTION OF THE SYSTEM AND FACILITIES PROVIDED

Fig. 1 shows, in block schematic form, the arrangement of the system. "Tapping" and "access" equipment is provided in each observed exchange and is connected to a centralized observation position, via a junction where necessary.

### Access Equipment.

Access to traffic is made at the incoming negative, positive, private and, where appropriate, meter and coin-box-discriminating leads of the first switching stage, i.e. 1st selectors, 1st code selectors, D.S.R.s, etc.

Selectors on which observation is required are jumpered to the banks of the observation access uniselectors. Four 50-point uniselectors are provided for access to selectors carrying traffic originated by subscribers on the observed exchange, and four for access to selectors carrying incoming

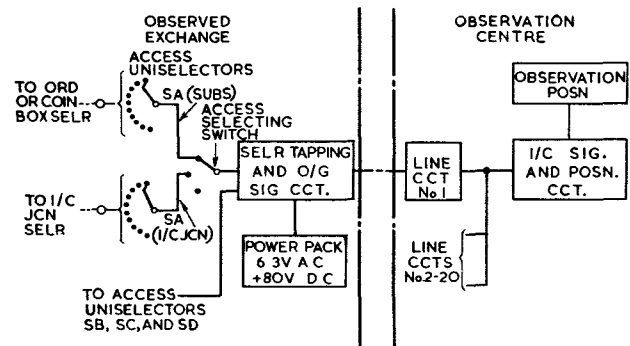

FIG. 1.—BLOCK SCHEMATIC DIAGRAM OF THE SYSTEM.

junction traffic from manual exchanges and small U.A.X.s. Each group of uniselectors has capacity for connexion to a maximum of 192 selectors, and either group may be associated with the tapping equipment by the operation of a rotary switch on the observation equipment rack. This switch will be positioned by engineering officers on request from the Traffic Division.

To ensure an ample number of observations the selectors connected are early choices in uniselector exchanges or directly-connected selectors in linefinder exchanges. By selecting them from all grading or linefinder groups in the exchange a representative sample of calls is obtained.

Flexibility for changing the selectors connected for observation is provided by using jumpers, but changes are only necessary when regrading or extension of equipment occurs.

### Selector Tapping and Junction Signalling Equipment.

The "selector tapping and outgoing signalling" circuit is switched on by a signal from the observation position, under control of the observing operator. The access uniselectors, which are non-homing, are then caused to find outlets to four free selectors, on which they "camp" and wait for calls to occur. When a call is originated on one of these four selectors, the tapping equipment switches to this selector, at the same time preventing interference should calls originate on any of the other selectors. A calling signal is sent to the equipment at the observation position, and a listening connexion is established from the selector negative and positive wires to the observation operator via a high-impedance tapping circuit and amplifier. The amplifier makes good the tapping loss and permits the use of a 2-wire junction to the observation centre with a loss of up to 16 dB. To permit discrimination between traffic of different types, e.g. ordinary or coin-box subscribers' traffic, or manual or U.A.X. junction traffic, two distinctive calling signals are used. The number dialled, and for local subscribers' traffic the metering pulses, are detected by the tapping equipment and repeated to appear as lamp signals on the observation position. On incoming junction traffic the metering facility is ineffective since any metering pulses occurring in the apparatus at the observed exchange are not related to the actual call charge. In place of the metering signal, the Called-Party Answer condition is detected and repeated to the observation position.

†Executive Engineers, Telephone Development and Maintenance Branch, E.-in-C.'s Office.

<sup>1</sup>PERKINS, J. J. Telephone Service Observations. *I.P.O.E.E. Printed Paper No. 186, 1945.*



The observation is terminated by the release of the observed call, or by the observation operator releasing the tapping equipment. In either event the tapping equipment causes the access uniselectors to step on, so preventing successive calls being taken from the same selector and ensuring that the sample of calls taken is spread over the observed selectors.

*Observation Position.*

A new observation position has been designed to accommodate the display and signal lamps and junction and line condition keys. Fig. 2 shows the prototype developed for



FIG. 2.—PROTOTYPE OBSERVATION POSITION.

Carlisle, which will be the first centre where the new equipment will be provided.

The future standard position will differ slightly from that provided at Carlisle, being 3 in. wider and incorporating a book rack at the left side of the knee hole. The height of the turret has been reduced by 9½ in. compared with the existing design, being 1 ft 2½ in. above the writing surface, and the front face of the panel slopes at 15° from the vertical.

The writing surface is flat for a distance of 4 in. from the foot of the panel and then slopes downwards at 8° from the horizontal. Located in the writing surface towards the upper right-hand corner is the junction release key, which is of a flush-fitting plunger type.

All lamps, other than the junction lamps, are fitted behind a translucent screen engraved with their designations.

Each observation junction is connected via a key on the observation position to an incoming line circuit. Operation of this key, with the operator's headset plugged into the position jack, sends the switching-on signal to the tapping equipment associated with the distant end of the junction, and permits calls to be received over the junction. The observation position caters for up to 20 junctions, and any number of the 20 keys may be operated at one time. When more than one junction is connected, the first call to originate seizes the position circuit and guards against intrusion by calls occurring on junctions from other exchanges.

On seizure, a lamp associated with the junction key glows, and, in addition, a "Calling Supervisory" lamp and a discriminating lamp showing the type of call also glow. The number dialled is shown on a digit display panel with capacity for 16 digits. Four meter-fee lamps are provided, which glow in turn as the signals denoting meter pulses are

received, the last one to glow remaining alight until release of the call.

When observing on incoming junction traffic, the meter-fee lamps are rendered ineffective, and instead a lamp glows to indicate that called-party answer conditions have been received. Should the called party clear, this lamp darkens and, similarly, the calling supervisory lamp darkens if the calling party clears. The remaining lamps, once having been lit, remain glowing until the call is released from the position by operation of a plunger-type "Release" key. Until this key has been operated, no other call can be received at the observation position.

OUTLINE OF CIRCUIT OPERATION

*P-Wire and Meter-Pulse Tapping Circuit and Access-Uniselector Control.*

The circuit for controlling access uniselector SA is shown in Fig. 3, together with the metering tapping element. The

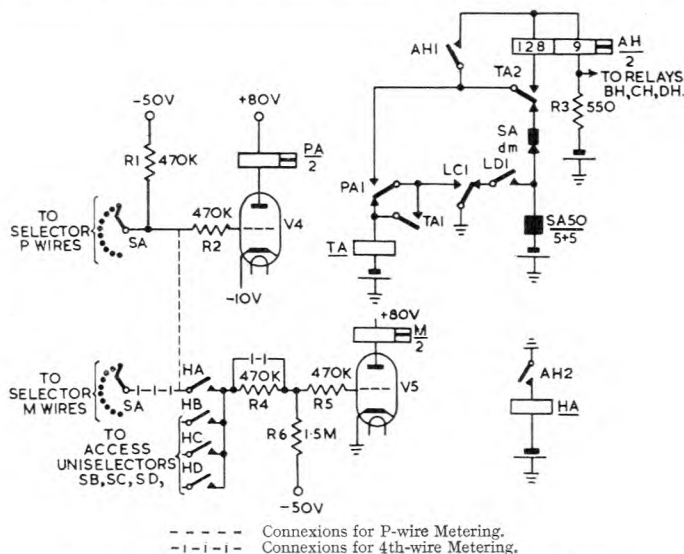

FIG. 3.—P-WIRE AND METER-PULSE TAPPING CIRCUIT.

description is confined to the SA uniselector since the circuit and operation of the other uniselectors are identical.

The switching-on signal from the observation position operates contacts LC1 and LD1 and, if it is assumed that SA is at that time standing on the outlet to an engaged selector, V4 will be conducting due to the earth from the P wire and relay PA will be operated. Earth from LC1 contact via PA1 drives SA until an outlet to a free selector is reached, when V4 cuts off and releases PA. PA1 cuts the drive of SA and operates relay TA, which locks. When a call originates on this selector, earth on the P wire causes V4 to conduct again and PA to re-operate. PA1 operating, with TA2 now operated, operates relay AH, which short-circuits its high-resistance coil and holds via its low-resistance coil, thus lowering the potential from the common resistor R3 to relays BH, CH and DH to prevent their possible operation by other calls. AH2 operates relay HA, causing a calling signal to be transmitted to the observation position, and connecting the selector negative, positive and, where necessary, metering and coin-box-discriminating leads, via the SA uniselector wipers, to the tapping equipment.

The metering circuit can cater for positive-battery or booster-battery metering on the P wire, or negative or earth metering on a separate M wire, by appropriate strapping. Circuit operation for P-wire metering is as follows: with earth on the selector P wire, the potential at the junction of R4 and R6 is -12V and V5 is cut off. When a metering pulse is connected the +50V on the P wire

raises the potential at the grid of V5 to +25V and relay M operates. At the end of the metering pulse relay M releases, and this sequence is repeated for each metering pulse.

At 4th-wire battery-metering exchanges relay M operates to the normal condition on the M wire and releases to the metering pulses, whilst at certain 4th-wire earth-metering exchanges, where unit-fee metering only is provided, relay M operates and holds to the metering condition. Another part of the circuit, not shown, converts these varying conditions into single or multiple signal pulses, of the same sense, for transmission to the observation position.

When the call clears, disconnection of earth from the P wire of the selector releases relay PA. PA releases AH and HA, and a clearing signal is sent to the observation position. Relays LC and LD, releasing in sequence, cause the access uniselectors to step on to the next outlet.

#### Dialled-Pulse Tapping Circuit.

To prevent the introduction of pulse distortion and additional transmission loss into the observed connexion, access to the negative and positive lines is obtained through a high-impedance circuit, the elements of which are shown in Fig. 4. Dialled pulses are detected by V1 as the potential

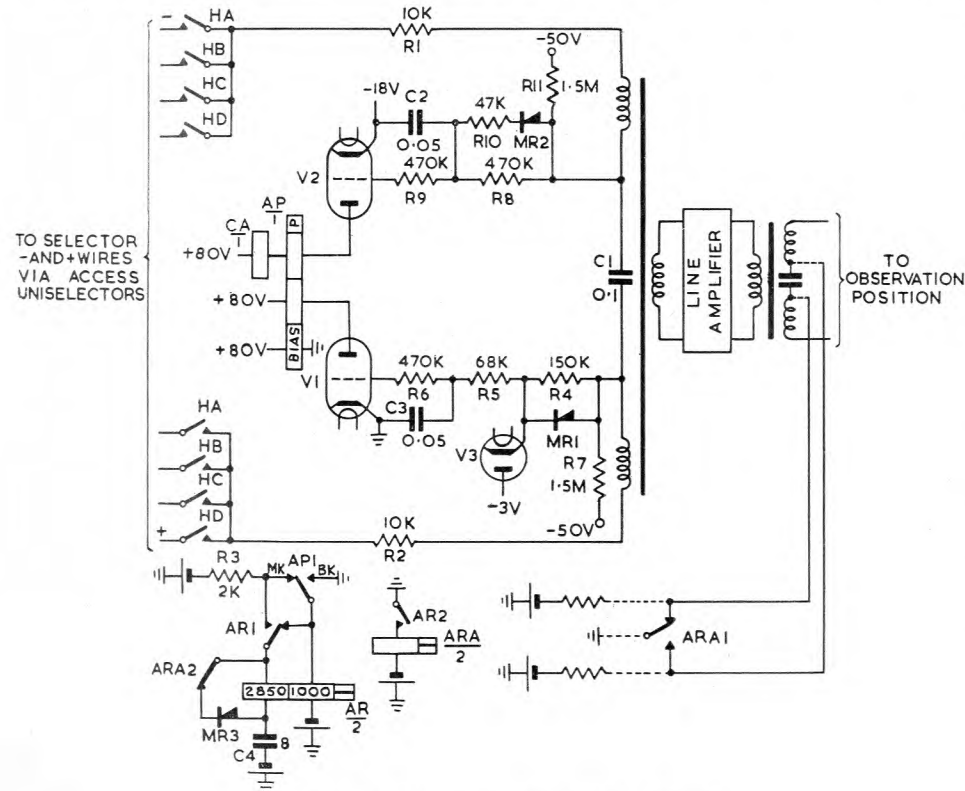

FIG. 4.—DIALLED-PULSE TAPPING CIRCUIT.

changes across the earth-connected coil of the selector or relay-set pulsing relay, and are repeated by relay AP.

With the observation circuit energized, but not connected to a line, valves V1 and V2 are cut off by the negative potential on their grids from resistors R7 and R11, the contact of AP being held to the make side by the current in the bias coil of the relay. When the observation circuit switches to a line the potentials on the grids of V1 and V2 are governed by those existing on the positive and negative wires. At this moment the line is normally looped and the potential on the positive wire is in the range  $-2V$  to  $-25V$ , and that on the negative wire is in the range  $-25V$  to  $-48V$ . Valve V2 remains cut off, whilst V1 is cut off or near cut off depending on the line length, so that relay AP remains on the make side. When the pulsing contacts

open, the potential of the positive line becomes zero and that of the negative line  $-50V$ . V2 remains cut off but V1 conducts, the current being in such a direction and of sufficient magnitude to overcome the effect of the bias current and cause AP to move to the break side. When the pulsing contacts remake, the original line potentials are re-established, and AP returns to the make side.

The circuit is basically simple, but complications arise in

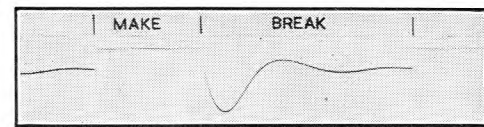

(a) Group Selector—Short Line.

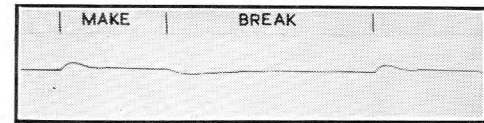

(b) Auto-Auto Relay Set—2,000-ohm Line.

FIG. 5.—WAVEFORM OF VOLTAGE ACROSS PULSING RELAYS UNDER SHORT AND LONG LINE CONDITIONS.

guarding against false operation by various voltage surges. These occur during pulsing and subsequent switching and signalling operations on the observed connexion, due to the inductive effect of line relays and the presence of spark-quench and transmission-bridge capacitors. The oscillograms in Fig. 5 depict typical voltage waveforms occurring across pulsing relays under long and short line conditions, and show the wide range of input signals to which the pulse-repetition element must work. At the same time it must be immune to false operation by surges considerably greater in amplitude than the minimum signals which it is required to detect. This immunity to false operation is achieved in part by the time-constant circuit R4, R5, C3, in the grid circuit of V1 (Fig. 4), which delays the response of relay AP.

To prevent distortion of dialled pulses, equal time-delays should occur for the change from make to break and for the change from break to make. It is not possible to achieve this under all line conditions owing to the wide range and

character of the input signals, but a large measure of compensation is provided by the diode V3, which, in conjunction with R4, acts as a signal limiter. MR1 in parallel with R4, by giving the delay circuit a different time-constant for charge from that for discharge of C3, also assists in minimizing distortion.

Although the grid time-constant circuit suppresses the majority of surges and is necessary to obtain a stable output from AP, some surges occur of such duration that to suppress them by this method would introduce excessive pulse distortion. Such surges are allowed to operate AP, but are suppressed by relay AR, which has an operate lag of 20 ms. This operate lag is obtained from the charging current to capacitor C4 through the 2,850-ohm coil of relay AR, which is connected in opposition to the 1,000-ohm

coil, and hence delays the rise of flux in the relay when AP1 operates. For distortionless repetition the release time should also be 20 ms, but at high pulsing speeds the succeeding make pulse may not be sufficiently long to permit this. The release time of AR is therefore made variable and dependent on the time for which it has been operated.

The variable release time is obtained by AR, when operated, completing a circuit for discharging C4 via the 2,850-ohm coil of AR and resistor R3. When relay AP releases, the 1,000-ohm coil of AR is connected in parallel with R3 and part of the capacitor discharge current then flows in that coil. The direction of current flow is such that the two coils of AR are now aiding, and the relay releases slowly, the release time depending upon the degree to which C1 has been discharged. The time-constant is such that the release time exceeds 20 ms and pulse correction results with break pulses of such length that the succeeding make pulse, even at high pulsing speeds, will be more than adequate for the release of AR. With long break pulses, which imply a short following make pulse if the pulsing speed is high, the release time reduces to a minimum of 7 ms. At some speeds this results in pulse correction, whilst at others distortion is introduced. The output from AR is, however, always adequate for operation of the observation-position digit-display.

A further possible source of false pulses occurs when the observation equipment is used in a non-director exchange. The pulse tapping circuit, which is initially connected to the 1st selector pulsing relay, is switched through as the call progresses to the A relays of successive selectors. If the group-selector switching-relay contacts change over sequentially, a break pulse is given to V1, which may exceed 20 ms on pre-2000-type equipment. Under this condition, however, the grid circuits of V1 and V2 are connected together round the pulsing loop and both valves conduct. The resulting currents oppose in the windings of relay AP, which remains held to the make side by the bias current. The time-constant of the V2 grid circuit is such that the current rise is quicker and decay slower in V2 than in V1, so ensuring that the AP contact remains on the make side.

#### Called-Party Answer Signal.

Valve V2 also serves to detect the "Called-Party Answer" condition. The reversal of polarity on the negative and positive wires raises the grid potential of V2 to the range -2V to -16V, causing V2 to conduct and operate relay CA. Relay CA repeats the signal, via relays not shown, to the observation position.

#### Junction Signalling System.

A 2-wire observation junction will normally be used and the signalling system, the principles of which are shown in Fig. 6, permits a maximum loop resistance of 3,500 ohms. The idle-junction condition is battery on both lines at the tapping equipment from resistors R3 and R4, and disconnection of both lines at the observation centre equipment. When the observation position is staffed, earth is connected to both coils of all LS relays from the incoming signalling circuit. The JUNCTION CONNECT keys (KJ) are operated on the circuits on which it is intended to make observations, and earth via the LS relays operates the LA relays at the distant exchanges. Relay LS is differentially connected and does not operate under these conditions. Relay LA, operating, switches on the power supply circuit of the tapping equipment, and after an initial delay to allow the valves to warm up, calls are accepted for observation.

On seizure of a selector by an originating call, relay HA (or HB, HC or HD), in the P-wire tapping circuit, operates relay PT, which connects earth to either the A or the B line of the observation junction, depending on whether relay D has operated or not. Relay D is operated by either a condition on the coin-box-discrimination lead of the selector under observation or from the access uniselector, and gives discrimination between different types of traffic. Connection of earth to one line at the outgoing end of the observation junction unbalances LS, which operates. Relays K and KK operate and light the junction calling lamp, guard the incoming junction signalling circuit against intrusion by calls on other junctions, and switch the junction to the observation position. Current now flows from the battery and earth at the outgoing end round

the loop provided by relays AL and MA the direction of flow depending upon whether relay D has operated or not. Relay MA operates and relay AL, which is polarized, takes up a position on one contact or the other. Relay MA causes the calling supervisory lamp to glow and MA and AL together operate the appropriate discriminating relay to light the "type of call" lamp. At the outgoing end, relay RV is operated and, by reversing one coil of LA, permits this relay to hold to the changed line conditions. Dialed pulses are transmitted by the Single Commutation Direct Current system, operation and release of relay AR (Fig. 4) reversing the direction of current in the line and causing AL to move from one contact to the other. A relief relay or AL pulses the digit-display uniselectors.

Metering pulses are transmitted as disconnections of earth at the MT contact of the outgoing signalling circuit, which causes MA to release to each pulse, but leave AL unaffected. MA pulsing steps a uniselector via relief relays, which lights the appropriate meter-fee lamp. With multi-metering, the pulses may occur some seconds after the called party answers, depending on the phase of the S and Z pulses, and

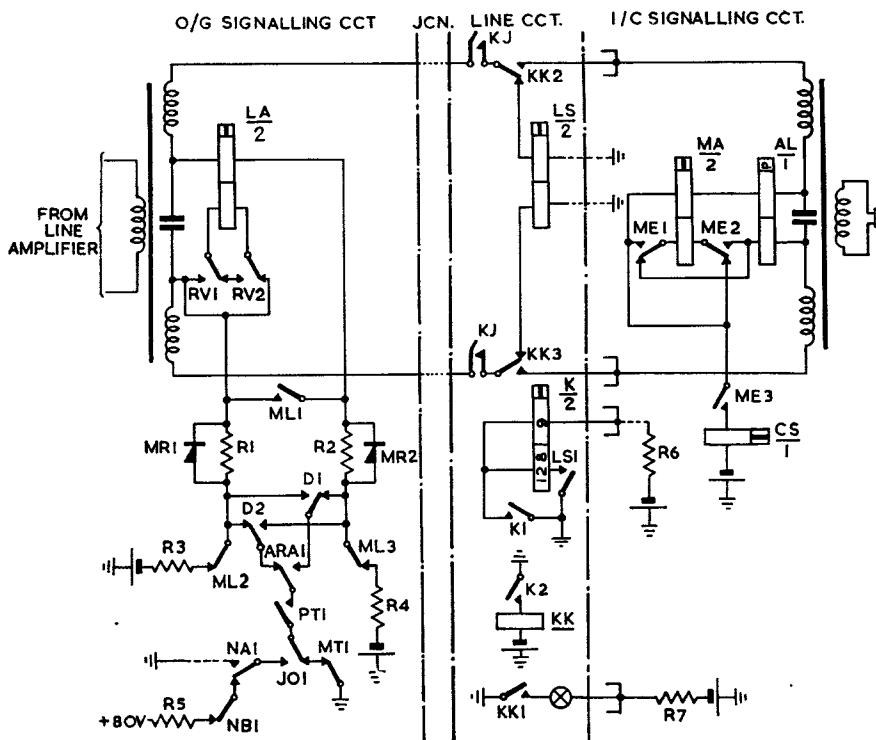

FIG. 6.—JUNCTION SIGNALLING PRINCIPLES.

in order that the metering signals shall not interfere with the observation operator hearing the opening phrases of the conversation, relay ML at the outgoing end, and relay ME at the incoming end, are operated with the first metering pulse and change the line signalling conditions, so that subsequent metering pulses are repeated over both lines in parallel to battery at the incoming end via relay CS, and hence cancel out in the incoming transformer. At the incoming end relay ME reverses one coil of relay MA so that it can hold to the new line conditions, whilst at the outgoing end relay ML releases relay RV to permit LA to hold to the new line condition. Relay CS is used to receive the "Called-Party Answer" signal, and is inoperative to the above condition. When the tapping equipment is in use for incoming-junction-selector observations, relay JO at the outgoing end is operated, switching the signalling circuit from the MT contact to the "Called-Party Answer" signalling circuit. Until supervisory conditions are received, contacts NA and NB are operated and the circuit functions as previously described. Receipt of

the "Called-Party Answer" signal causes NA and NB to release in sequence, first disconnecting earth and then connecting +80V to line. Relays ML and ME are operated as before and, in addition, relay CS at the incoming end operates to the increased line current.

Clearing of the call is indicated by the disconnection of earth from the selector P wire and results in contact PT in the signalling circuit releasing and disconnecting earth from the line. Relay MA releases, extinguishing the calling supervisory lamp at the observation position.

#### CONCLUSION

In addition to the equipment described, of which the first installation will shortly be completed at Carlisle, development is in progress on another tapping equipment, suitable for use in U.A.X.s No. 7 and No. 14. This new equipment will provide the same junction signalling conditions and work into the same observation position as the equipment that has been described.

## Book Reviews

"Fixed Resistors." G. W. A. Dummer, M.B.E., M.I.E.E. Pitman. 183 pp. Illustrated. 28s.

This book is Volume 1 of a series on "Radio and Electronic Components," and in it Mr. Dummer covers the subject of fixed resistors in a most comprehensive fashion. This is not surprising when one realizes that the author is well qualified to write such a book, having been engaged for many years on research and development work on radio and electronic components at the Radar Research and Development Establishment; he is also actively concerned with several committees dealing with the development and standardization of such components.

The book has been written chiefly for the benefit of the user and, to enable him to choose the best type of resistor for his particular requirement, the methods of manufacture and fundamental characteristics of the various types are presented. However, to restrict the book to a reasonable size, no attempt has been made to cover every type of fixed resistor in current use and in those parts of the text that deal specifically with different types of resistor only those standardized for use in the armed services have been treated. This limitation has not appreciably reduced the worth of the book because, although the number of types of commercial fixed resistor is large, they can in general be considered as being variations of the service types.

The first four chapters deal with general matters relating to fixed resistors, such as those covered by the various specifications issued by the British Standards Institution, Radio Industry Council and Service Departments; physical properties of resistive materials; symbols, codes and preferred values; various characteristics of resistors that need to be considered and methods of measurement of these characteristics; wattage, voltage and pulse ratings. The remaining five chapters deal with general-purpose, high-stability and special types of fixed resistor, giving methods of construction, performance characteristics and particular advantages or disadvantages. Various experimental types of fixed resistor are also considered as well as future developments in resistor design. The book finishes with a 17-page bibliography and a very useful chart giving comparative data on the main characteristics of the various types grouped into three categories—mechanical, electrical and climatic.

This book is a mine of information on fixed resistors and one can look forward with enthusiasm to the promised future publication of further books in this series on variable resistors, fixed capacitors, variable capacitors, etc.

D. G. J.

*I.P.O.E.E. Library No. 2370.*

"Television Receiver Servicing, Volume 2: Receiver and Power Supply Circuits." E. A. W. Spreadbury. Iliffe & Sons, Ltd. 308 pp. 172 ill. 21s.

The first volume of Mr. Spreadbury's book was reviewed in the July, 1954 issue of this Journal and it was forecast at the time that the two volumes together would form an invaluable guide for both professional and amateur television servicemen. The view is fully confirmed now that the second volume is available. It will be remembered that the earlier volume dealt with the time-bases and cathode-ray tube—circuitry peculiar to television itself. The present volume covers the radio receiver proper—"front end," intermediate frequency, detector and output stages—component parts of almost any type of radio receiver, although in the case of television they have to have some special properties, notably a very wide bandwidth and the ability to receive and separate the vision signal and the accompanying sound signal.

The detailed circuits encountered in television receivers are dealt with in turn, beginning with the "back end" or video output stage and working through to the front end and aerial. At first sight this order seems a little illogical but in fact it is not, for in the case of an obscure fault it is necessary to begin at the output end of the receiver and gradually work back towards the aerial end, proving the various circuits in turn. Many illustrations of possible circuit variations are given, nearly all taken from the circuit diagrams of well-known domestic receivers, the makes and type numbers being given.

One chapter which is likely to attract a good deal of attention at the present time is that dealing with multi-channel tuners and the conversion of Band I receivers for the reception of Band III signals. Now that Band III programme transmissions are upon us, many viewers will be fitting adaptors to their sets. Much useful information on this subject is given and some of the pitfalls are described.

The purist will find a few terminological inexactitudes (in the literal sense and not that intended by a former Prime Minister!) in this book. For example, on page 11 it is suggested that a video output stage is a true amplifier whereas an audio output stage is not necessarily an amplifier. In fact both are amplifiers, the former a voltage amplifier and the latter a power amplifier, and there would be little point in having them at all if they were not. Then again on page 14, after saying that some of the faults found in television receivers defy obvious kinds of explanation, Mr. Spreadbury goes on: "... but they are awkward cases. We find them sometimes even in radio receivers." Yet surely television receivers *are* radio receivers! However, these are criticisms of detail and not of substance, and the new volume will prove a very useful addition to the television bookshelf.

*I.P.O.E.E. Library No. 2321.*

T. K.

# Electrical Accidents Involving Post Office Plant and Staff

S. J. LITTLE, A.M.I.E.E.†

U.D.C. 614.825

An analysis of electrical accidents reportable under the Factories Acts is published by H.M. Stationery Office for the Ministry of Labour and National Service.\* Most of the electrical accidents involving Post Office plant and staff occur on external plant or on premises to which the Factories Acts do not apply, and this article, after referring briefly to electrical accidents in general, analyses the electrical accidents recorded by the Post Office since 1924 and describes how they were caused.

## INTRODUCTION

THE introduction of electricity into the industrial and domestic life of a nation is, unfortunately, not free from certain risks to the lives and well-being of the consumers and those responsible for generation and distribution, but careful attention to design of equipment and similar measures reduces these risks to a minimum. Nevertheless, so far as the United Kingdom is concerned, records kept over a number of years by Her Majesty's Chief Inspector of Factories appear to indicate that there is a certain minimum number of accidents each year which it is extremely difficult to reduce. If, for instance, British records of "reportable" electrical accidents are tabulated for the 20-year period ending 1953, the latest year for which

statistics are available, the variation will be as set out in Table 1. For the purpose of this table reportable accidents are defined as those in which the victim is disabled for more than three days from earning full wages at the work at which he is employed.

Detailed analysis of these reportable accidents shows that there are certain common causes, as indicated by Table 2, in which the reportable accidents for the year 1953 are analysed in relation to the apparatus involved.

In this analysis, 40 per cent of the fatal accidents and 35 per cent of the total accidents occurred on portable apparatus. Before proceeding further it is advisable to compare the risk of electric shock with that of other day-to-day hazards. It is known for instance that whilst some 800 people lose their lives in the factories of the United Kingdom in each year, nearly 5,000 members of the general public are killed on the roads and 5,500 meet with fatal accidents in their own homes. Of the last, by far the greatest number are due to falls. By comparison, the number of fatal electrical accidents is relatively small, but lives are lost and there is continuous effort to reduce this loss.

### The Phenomenon of Electric Shock.

It is well known that a conductor carrying a potential of, say, 50V d.c. can usually be touched without suffering any unpleasant effects. On the other hand, touching a phase wire of a domestic supply and a good earth connexion simultaneously can be extremely unpleasant and even fatal. It is, however, not the voltage applied, but the current which flows as a result of the application of the voltage which can be dangerous. The time of flow, frequency of supply and the path of the current through the body also have a bearing on the ultimate effects. A current of 30 mA at 50 c/s between the hands for 10 sec may well be fatal, whereas  $\frac{3}{4}$ A at 100 kc/s for the same time will pass through the body giving only a sensation of heat; 0.5A to 1A at 50 c/s applied across the temples will cause unconsciousness but not death. Generally, it can be said that for immediate fatal effects the current must pass through the respiratory tract or upset the rhythm of the heart. It is, however, paradoxical that with very high voltage shocks the victim dies, not as a result of the shock itself, but from the effects of the burns which he almost invariably sustains. A similar situation occurs when a person comes into contact with conductors carrying high radio-frequency voltages: although the electric shock is not likely to be fatal the victim may suffer severe burns which may well cause death, or only heal with difficulty.

### THE CAUSES AND PREVENTION OF ELECTRICAL ACCIDENTS

Turning now to the causes of accidents, it is not possible in one article to analyse Table 2 in detail, but it is instructive to consider the causes of accidents with portable apparatus recorded in that table.

TABLE 1  
Twenty-Year Record of Reportable Electrical Accidents

Year	Fatalities	Total Accidents	Year	Fatalities	Total Accidents
1934	31	380	1944	31	1,072
1935	23	447	1945	31	891
1936	31	520	1946	33	769
1937	36	583	1947	30	734
1938	30	560	1948	43	780
1939	No records due to commencement of hostilities		1949	24	771
1940	32	729	1950	38	778
1941	51	921	1951	34	715
1942	51	1,042	1952	38	721
1943	58	1,255	1953	40	744

TABLE 2  
Reportable Electrical Accidents in relation to Apparatus, 1953

Apparatus	Fatal		Non-fatal		Total
	Men	Women	Men	Women	
<i>Portable apparatus:</i>					
Portable electric machines . .	6	—	43	3	52
Portable heaters and irons . .	—	—	4	5	9
Portable lamps . . . . .	2	—	14	—	16
Portable test sets, inc. lamps . .	2	—	35	—	37
Plugs and adaptors . . . . .	2	—	23	4	29
Cables and flex for portable apparatus . . . . .	3	—	25	4	32
Electric hand welding:					
(a) Shock and/or burns . .	1	—	27	1	29
(b) Eye injuries . . . . .	—	—	162	—	162
<i>Fixed apparatus:</i>					
Electrical machinery . . . . .	—	—	11	—	11
Transformers . . . . .	3	—	3	1	7
Switchgear above 850V . . . . .	4	—	34	—	38
Switchgear below 850V . . . . .	4	—	107	4	115
Fusegear . . . . .	—	—	32	—	32
Crane trolleys . . . . .	2	—	34	—	36
Fixed lamps . . . . .	1	—	14	3	18
Cables for fixed apparatus . .	2	—	45	1	48
Test leads . . . . .	1	1	12	4	18
Apparatus not classified . . .	6	—	47	2	55
Total . . . . .	39	1	510	32	744
			Plus 162 eye flash accidents (welding)		

†Senior Executive Engineer, External Plant and Protection Branch, E.-in-C.'s Office.

\**Electrical Accidents and Their Causes*, 1953, obtainable from H.M. Stationery Office, price 3s.

	<i>Fatal Accidents</i>	<i>Non-fatal Accidents</i>
<i>Portable electric machines, heaters and irons:—</i>		
Faults in the apparatus (insulation faults, brush-gear and switch defects, etc.) . . . . .	1	28
Apparatus made live due to the earth core of the flex touching a phase conductor within the plug, connector, adaptor, etc. (e.g., by being pulled off a terminal) . . . . .	2	14
Apparatus made live by wrong connexions in a plug, connector, adaptor, etc. . . . .	3	7
Apparatus made live by damage to the cable . . . . .	—	6
<i>Portable lamps:—</i> The accidents on portable handlamps were due to a variety of causes, such as lack of a proper guard, damage to the handlamp or cable, use with the wrong supply voltage, metal lampholders, lack of skirt, etc. In addition there were a number of accidents due to the use of a lampholder and leads instead of a properly constructed handlamp.		

	<i>Fatal Accidents</i>	<i>Non-fatal Accidents</i>
<i>Plugs, adaptors, connectors, sockets:—</i>		
Arcing due to a short-circuit, mostly due to lack of barriers, allowing wires to touch, either slack or adrift from terminals. . . . .	—	10
Shock from accessories . . . . .	1	11
Bare wires pushed into contact tubes of sockets . . . . .	—	2
Objects touching live pins of plugs or live contact tubes of sockets . . . . .	1	2
Plug inserted into wrong type of socket . . . . .	—	2
<i>Cables and flex for portable apparatus:—</i>		
Damaged or defective cable and flex . . . . .	3	24
Exposed ends of cables . . . . .	—	5

**Regulations.**

To ensure safety in the application of electricity it has been necessary for statutory and other regulations to be prepared. Typical of these are the Electricity Supply Regulations 1937, the regulations made under the Factories Act, and the non-statutory regulations issued by the Institution of Electrical Engineers. All have the same object—the safe utilization of electrical energy. To achieve this object the regulations quoted require, among other things, that equipment shall be satisfactorily earthed. It must, however, be emphasized that earthing is not an infallible safeguard and it has become increasingly evident that for portable appliances in particular other forms of protection are desirable.

**Earthing.**

Earthing itself presents some difficulty since it is not an easy matter to make a really reliable connexion to earth that will have such a low resistance that the protective device of the circuit will always work under fault conditions. The Electricity Supply Regulations, in an attempt to deal with this point, define the term “connected to earth” as a connexion that will ensure “an immediate and safe discharge of energy.” Regulations under the Factories Act, however, require earthing “to prevent danger,” danger being defined not only as shock but also in terms of burns and fire.

It is evident from the statistics of accidents with portable equipment that earthing is not an infallible safeguard and unless the earth connexion can be kept under continuous surveillance, either by regular frequent inspection or, alternatively, by automatic means, there is an element of risk.

A very large number of metal-cased portable appliances operating at mains voltage (200–240V) are now used in industry and these appliances are often held tightly by an operator whose feet generally make good contact with earthed metalwork or floors. The flexible conductors feeding the appliances are subject to very hard wear and can easily break; if, then, a line or neutral conductor fails this is self-evident as the machine will stop. But, if the earthing lead breaks, this may not become apparent until a fault occurs and the frame of the appliance becomes alive. Fig. 1



FIG. 1.—PATH OF FAULT CURRENT TO EARTH FROM DEFECTIVE TOOL.

illustrates this situation and shows the path of the fault current to earth through the person using a defective tool. Some large organizations have attempted to overcome this danger by systematic inspection and test of their portable appliances and leads.

Even so, a megger test for earth continuity is not sufficient because if the earth lead is only partially worn through and one or two strands are still intact, the earth connexion will appear to be satisfactory but could fail under fault conditions. A heavy current of 25–30A at low voltage should therefore be passed through the conductor for approximately 10 sec. If the wire is partially broken, the high current will melt the few remaining strands. As a further safeguard, the same current should be passed from the tool case to the earth pin on the plug, thereby ensuring that the power plug connexions are in working order.

As an alternative to systematic testing, proprietary systems are now available which keep the continuity of the

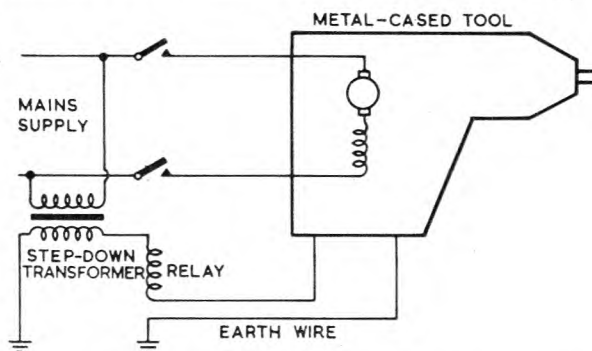

FIG. 2.—SUPERVISION OF CONTINUITY OF EARTHING CONDUCTOR.

earthing conductor under continuous supervision and, should it fail, cut off the supply to the appliance (Fig. 2 shows the basic arrangement of this system), but such protective devices tend to be costly and somewhat elaborate.

Good and reliable earthing of the appliance is not the only requirement, because in some situations associated with faults on the supply system the earthing arrangements can acquire a potential that will render a nominally safe installation dangerous.

#### Low-voltage Apparatus.

Basically, the whole problem can be reduced to a single question—how to restrict the current which will flow through the body of a human being touching a faulty appliance to such a value that it will be harmless.

For portable appliances, the basic object of protection must be that of ensuring that a current very much less than a fatal current passes through the body of a person who handles faulty equipment. Probably the most reliable method of achieving this is to use a reduced voltage and there is now a general tendency towards the use of low voltages for portable industrial appliances. One method of achieving protection in this form is to design the appliance for 50V working and feed it and its flexible lead through a robust step-down transformer. This transformer may have the central point of its secondary winding earthed (Fig. 3), in which case no part of the appliance can, under

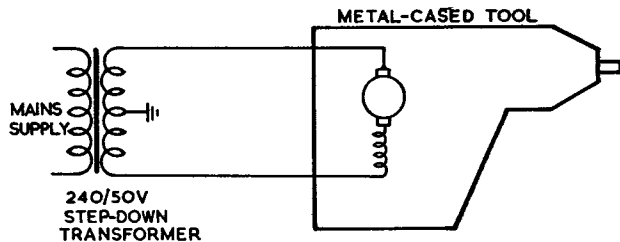

FIG. 3.—LOW-VOLTAGE TOOL WITH CENTRE-TAPPED TRANSFORMER.

fault conditions, acquire a potential exceeding 25V to earth. Alternatively, the appliance may be fed through a 240/50V step-down transformer, the secondary circuit of which is completely isolated from earth.

Methods involving the use of low voltages are probably the most satisfactory safeguards since they eliminate all risks and complications attendant on the use of earthing conductors.

#### ELECTRICAL ACCIDENTS IN THE POST OFFICE

Accidents involving Post Office plant would only rarely come to the notice of H.M. Chief Inspector of Factories since most of them occur on external plant or in premises to which the Factories Acts do not apply. Furthermore, because of the large amount of external plant which the Post Office owns, the public are to a certain extent also subject to some risk of accident.

Records of electrical accidents involving Post Office plant that have resulted in death or injury have been kept since the early part of the present century. Unfortunately, the record is incomplete for the years before 1924, but from that date onwards it has been continuous and Table 3 sets out the electrical accidents that have been reported during the 30-year period for which continuous records are available.

#### Accidents Involving Internal Plant.

For the purpose of this article internal plant is defined as all plant within a building, Post Office or otherwise. Since 1936, 18 accidents involving internal plant have been recorded, including three fatal accidents, all of which took place on subscribers' premises.

TABLE 3

Situation	Fatal		Non-fatal	
	Post Office or Contractors' Staff	Public	Post Office or Contractors' Staff	Public
<i>Internal Plant:</i>				
(a) Portable equipment (electric drills) ..			4	
(b) Improvised hand-lamps ..	1		1	
(c) Defective subscribers' wiring or apparatus	2	1	5	
(d) Defective Post Office wiring or apparatus			2	
(e) Fault on power supply ..			1	
(f) Cleaning switchgear			1	
<i>External plant:</i>				
(a) Contact between covered power conductors and bare Post Office wires ..	3	6	5	3
(b) Contact between bare power or tramway wires and bare Post Office wires ..	1		4	3
(c) Failure of guard wires ..		2		1
(d) Contact between overhead power and Post Office wires where guarding is not specified in the records ..	1	3	1	2
(e) Contacts with high-voltage wires ..	2		4	
(f) Joint use of a route by Post Office and power supply authorities ..			1	
(g) Underground plant			2	

It is not possible to say for certain if there were any accidents on internal plant before 1936. The existing statistics include records of electrical accidents from 1924 onwards, but between that year and 1936 the accidents recorded involved external plant only. It can therefore only be assumed that there were no accidents on internal plant between 1924 and 1936. The accidents that have been recorded can be sub-divided under the six headings of Table 3, and some details of accidents that have occurred under each heading are:—

*Portable equipment (electric drills).*—There have been four accidents due to electric drills and similar plant, it being significant that three have taken place since 1950. The first occurred in September 1941, when a workman received a shock from an electric drill in a garage. Although the drill appeared to be properly earthed, it seems that the earth circuit, comprising the earth continuity conductor in the flexible lead to the plug, the earthing arrangements of the fixed wiring to the socket and the earth connexions to the main earth electrode had excessive impedence. As a result, when a fault appeared on the tool, its outer metallic case acquired an excessive potential which caused a shock to the user.

The next accident involving a portable tool occurred in October 1950, when a contractor's employee working on an apparatus rack suffered a shock. In this instance, a faulty electric drill was being operated from an ordinary lampholder and there were no earthing arrangements; the victim was fortunate that the results were not more serious. The third accident was due to a faulty trigger switch, and the fourth to the use of the tool in a wet cable trench, when, although a shock was received by the

user, tests on the drill did not reveal any faults, and it was concluded that the accident was probably due to water being splashed into the case.

*Improvised handlamps.*—Two accidents have occurred with improvised handlamps. The first took place in April 1943, when two Post Office employees were running lead-covered cables for a switchboard. It was necessary to run the cables below a platform and to feed them through a hole in this platform to a position above. It was dark below the platform and the man working in this position improvised a handlamp consisting of a 5A plug, a length of jumper wire and an old brass combined lampholder and switch. The lampholder and switch should have had a wooden handle and guard, but both had been removed. Unfortunately, the lampholder switch was defective, and one of its terminals was in contact with the metal frame of the holder which, in consequence, became alive. Whilst using the handlamp the victim came into contact with the earthed sheaths of the cables with which he was dealing and was electrocuted.

The second case occurred in November 1949, when a contractor's employee received a shock from a defective improvised handlamp. There are, however, no details of this accident.

*Defective wiring or apparatus in subscribers' premises.*—There have been eight accidents attributable to defective wiring in subscribers' premises; of these, three were fatal. The first recorded fatality took place in 1936, when an accident occurred at a defective socket-outlet in a subscriber's premises; the victim, a member of the public, was electrocuted as a result of touching both the earthed metallic sheath of a Post Office cable and the defective socket itself. The Post Office wiring had been run very close to the socket, in fact almost in contact with it. This accident focused attention on the desirability of using some form of subscriber's wiring having an insulated sheath and, with the introduction of p.v.c. sheathed conductors, this has largely come about.

The next accident involved a female engineering assistant, employed as a subscriber's apparatus fitter, who suffered a fatal shock in May 1944 when running telephone wires under the floor of a private house. In this case, a fault had developed in the house wiring system, as a result of which an unearthed length of metal electric light conduit had become alive at a lethal voltage. It appears that the lead-covered cable which the fitter was running came into contact with this unearthed conduit and as a result the fitter, who was probably in contact with damp ground, received a fatal shock.

In November 1945, another female engineering assistant received a shock and burns when laying out lead-covered cable in a subscriber's premises. On this occasion the lead sheath of the cable came into contact with the live terminals of a broken power point, and at the same time the fitter unfortunately also came into contact with earthed metalwork and received a shock.

Contact between the earth wire of a telephone in a high-voltage sub-station and metalwork alive at a power voltage caused another accident.

An accident, although perhaps not strictly on internal plant, occurred in February 1951, when a Post Office employee fell from a pole after touching a telephone wire alive at mains voltage. The circumstances of the case were that a lineman was sent to investigate a complaint of noise on a subscriber's line, and from the evidence available it must be presumed that he was about to determine whether the source of noise was between the pole outside the subscriber's premises and the exchange, or actually within the subscriber's premises. He climbed the pole to investigate, and it seems that when at the top he received

an electric shock and fell to the ground, but it is not recorded whether his death was a result of the electric shock or the fall. After the accident, examination of the subscriber's premises revealed an earth fault on an electric cooker. In addition, the Post Office earth wire was in contact with the power earth wire, which had become disconnected from its earth plate, and mains voltage was therefore applied to the Post Office earth wire. This caused the lightning arrestors, which are fitted between each wire and earth and which appeared to be partially faulty, to operate in a "backward" direction and thus allowed a mains voltage to appear on the overhead lines. This accident illustrates clearly the necessity of preventing contact between the power and telephone earth systems in a subscriber's premises.

Of the three remaining accidents in subscribers' premises, all of which were fortunately not fatal, one other is of special interest. This occurred in June 1953, when a fitter accidentally overturned an all-metal table-lamp in a private house. On striking the floor the lampholder became detached from the standard, and the fitter did not switch off the supply to the lamp before attempting to pick up the standard. Picking up the standard in one hand and the holder in the other, he received a severe shock, because, although the standard was properly earthed, breakage of the lampholder from the main body of the standard itself had brought a live conductor into contact with the lampholder frame and, on touching both the detached lampholder and the standard, a shock was received. This incident illustrates very well the danger of touching any damaged electrical equipment until the power supply has been disconnected.

The remaining accidents in this category do not present any special points of interest.

*Defective Post Office wiring or apparatus.*—Considering now those accidents that have occurred on Post Office premises and which can be attributed to defective wiring, the first took place in a sorting office in June 1946. Here, a Post Office employee was standing on a trestle and plugging a ceiling prior to hanging a fluorescent lighting fitting. A large metal semi-indirect lighting fitting, of a type used extensively at that time for sorting offices, was causing an obstruction to his work, and the wireman, when attempting to push it clear, suffered a severe electric shock. Although he received burns, was rendered unconscious and fell from the trestle to the ground, he recovered. Subsequent examination showed that, if the semi-indirect fitting was tilted to a marked extent, the flexible cord leading to the lamp could come into contact with a large metal reflector, an insulating ring normally provided at the point where the flexible cord passed through the reflector being missing. Furthermore, the flexible cord was frayed at the point where it passed through the reflector. At the time of the accident the lamp in the lighting fitting was defective, and its controlling switch was in the "on" position. When the reflector was moved into contact with the frayed flexible cord the reflector became alive and the victim received a shock through touching both the live fitting and metalwork at earth potential, probably electric light conduit on the ceiling.

The second case in this category occurred in June 1950, when a Post Office employee received a shock and burns while repairing an electric-lighting fitting. It appears that he was working on the fitting in the belief that the fuses controlling the circuit had been withdrawn when, in fact, they had not and he was actually working on live wires.

*Miscellaneous accidents.*—In the accident shown in Table 3 as a fault on the power supply, a Post Office employee had switched on an electric radiator in a U.A.X. The radiator did not glow after a short interval, and he bent down and put his hands near the element to check



whether it was getting warm. In the confined space of the U.A.X., he overbalanced and one hand came into contact with the element. He was unable to release his contact, but managed to operate the switch controlling the radiator with his foot, but the radiator remained energized. He finally managed to withdraw the plug from its socket and cut off the supply. It was subsequently found that a fault had developed in a joint box of the service cable supplying the U.A.X. This fault resulted in the disconnection of the neutral wire of the supply and there was, therefore, no complete circuit for the flow of current through the radiator element, although its potential above earth was that of the phase conductor of the mains. Furthermore, when the single pole switch controlling the radiator was in the "off" position the potential of the element was maintained through the consumer's meter shunt coil and, until the plug serving the radiator was withdrawn, the element remained alive. Fig. 4 illustrates the situation in diagrammatic form.

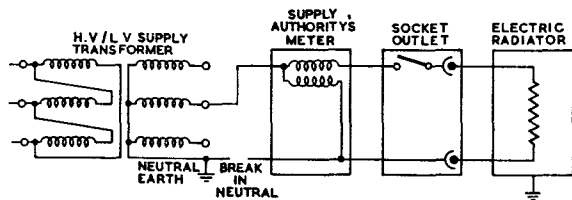

FIG. 4.—FAULT LEADING TO ACCIDENT IN U.A.X.

Finally, the accident due to cleaning switchgear occurred during the war, when a woman cleaner was attempting to dust a 400/230V three-phase main switch. The switch was of an old type, and she came into contact with live metalwork not protected in accordance with modern practice. Fortunately, she received only a relatively slight shock.

#### *Electrical Accidents on Overhead External Plant.*

The record kept since 1924 shows that over the 31 years covered, 11 members of the public, including six children, have been killed and a further nine, including four children, suffered some form of injury such as electric shock or burns due to contact between overhead Post Office wires and overhead power conductors. Six people were killed and three injured when broken Post Office wires fell across or came into contact with braided-and-compounded (P.B.J.) insulated low-voltage power conductors. In a further two cases, both of which took place before 1936, broken Post Office wires fell across tramway or trolley-bus overhead wires and each caused injury to a member of the public. In almost all the incidents involving P.B.J. wire, the general circumstances of the accident were similar. Usually a bare Post Office wire passing over a low-voltage overhead power conductor had broken and fallen across the power wires. Following the then current practice for guarding such crossings, either the power wire or the Post Office wire had a P.B.J. covering. If the power wire had the P.B.J. covering and was below the Post Office wire, there was a serious risk of accident because, when the small-diameter Post Office wire fell on the P.B.J. covering, it tended to cut through it, especially if the Post Office wire was pulled vigorously to clear an obstruction.

Because of the number of accidents that had occurred due to the failure of the P.B.J. covering on low-voltage power conductors, it was decided in 1939 to prohibit the erection of bare Post Office wires over such conductors, and since the introduction of this prohibition there has been an appreciable reduction in accidents from this cause. Such an accident did occur in March 1956, when a member of the public was killed, but prior to this the last fatality occurred in August 1947, when a Post Office lineman working at the top of a pole received a shock, fell

from the pole and was killed. Investigations showed that this accident was due to spare Post Office wires, which were resting on covered power conductors at a power crossing, chafing through the P.B.J. cover on the power conductors. As a direct result of this accident, the Post Office began to recover all spare wires at crossings.

It is interesting to note that, although six incidents have been reported where, due to breakage or sagging of low-voltage power conductors, a power potential appeared on Post Office circuits, no deaths or injuries have been caused either to Post Office staff or to members of the public.

*Accidents to Post Office staff at low-voltage overhead power-line crossings.*—Considering now those cases where accidents have befallen Post Office staff whilst actually working at power crossings, 17 incidents have been recorded in such situations during the last 31 years. These resulted in the deaths of six Post Office employees and shock or burns to 14 others. Most of the earlier accidents occurred when bare Post Office wires were being erected or recovered over low-voltage P.B.J.-covered power conductors or bare tramway wires. From now onwards there should, of course, be few accidents attributable to this cause since this form of construction should no longer be employed. There is, however, still an accident risk when working on or recovering Post Office wires from above existing P.B.J.-covered power conductors. It is inevitable that this form of construction will remain in service, although on a declining scale, for some time, and great care must always be taken on such work. The danger should, however, become progressively less as time passes and old plant is recovered. In fact, it seems that the risk is now very slight since, although one such accident occurred in July 1955, its immediate predecessor occurred 13 years earlier, when a gang were cutting down bare Post Office wires which ran above snow-laden P.B.J.-covered low-voltage power wires. One of the Post Office wires fell across the power line and nearby iron railings, cutting through the P.B.J. covering on the former, which was old and in poor condition, in the process. As a result, the railings became alive and electrocuted a member of the gang who happened to touch them. In an earlier case, a bare Post Office wire came into contact with a P.B.J.-covered low-voltage power conductor whilst being recovered. A Post Office employee working on the wires, feeling a shock, released the wire which he was holding and it fell on a horse, which was electrocuted. Another accident occurred when an aerial-cable suspension-strand was being erected over P.B.J.-covered low-voltage power wires. The suspension strand was being supported by a ladder to clear the power wires below the Post Office route, but unfortunately the suspension strand slipped and touched an exposed power jumper wire and a Post Office employee received a shock from the suspension strand, which rendered him unconscious. The guarding was at fault as the bare power jumper wire should have had a P.B.J. covering; furthermore, the use of a ladder for ensuring separation at the actual point of crossing was not good practice.

Accidents have also occurred at crossings where guarding has taken the form of guard wires between the two sets of plant. In one case, which occurred in July 1926, attempts were being made to erect Post Office wires over tramway wires which had not been provided with permanent guard wires. The foreman in charge of the gang carrying out the work decided to erect temporary guard wires and, although the gang were using the accepted standard method of erecting wires in such circumstances, contact occurred, and a Post Office employee received electrical burns. In December 1929, a similar incident took place; there, the precautions normally adopted for running wires in such circumstances were not being observed and a Post Office employee received a shock.

A more serious accident occurred in 1939, when a lineman was killed by a bare Post Office wire falling across bare low-voltage power conductors. Normally, such construction is permissible if the neutral conductor of the power system is uppermost. In this accident, however, the phase and line connexions on the power system had become reversed and the live conductor was the upper of the two wires. A third case of a similar nature occurred in January 1947, when a labourer received a shock and burns whilst working with a gang who were erecting bare Post Office wire over P.B.J.-covered power wires. This form of construction was, as mentioned earlier, prohibited in 1939, and the gang were in error in attempting to carry out the work.

*Joint Post Office and low-voltage power-line construction.*—The joint use of external overhead plant by the Post Office and power supply authorities has been in use on a fairly large scale since 1951, and although it appears to introduce a particular hazard, experience to date indicates that, if proper precautions are taken, the risks are very small. One form of joint construction, which permits a metal extension piece to be fitted to a Post Office pole for the attachment of not more than two low-voltage power conductors, has been in use since 1939 (Fig. 5). One

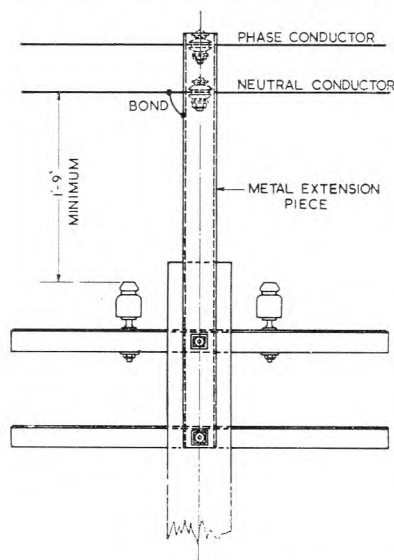

FIG. 5.—ARRANGEMENT FOR CARRYING LOW-VOLTAGE POWER CONDUCTORS ON POST OFFICE POLE.

accident has, however, occurred on these joint construction works. This took place in March 1955, when a survey officer fell from a pole after touching a metal extension piece which was alive because of reversal of the phase and neutral connexions at a nearby feeding point. Normally, the metal extension piece is required to be bonded to the neutral but in this case reversal of the phase and neutral connexions resulted in the extension piece acquiring a dangerous potential. After this accident, a large number of extension pieces were checked, but no further cases of reversal of phase and neutral connexions came to light. Consideration is, however, being given to the possibility of standardizing wooden extension pieces for future use.

*Accidents at high-voltage overhead power crossings.*—There are four recorded cases of accidents at crossings of Post Office plant and high-voltage overhead power lines. The first of these occurred in 1914, when a lineman was killed, but this is not included in Table 3 as it does not fall within the period covered by the table. The accident occurred at a crossing of overhead high-voltage and Post Office routes where a form of construction which has long been obsolete was employed. The actual crossing, which is shown in

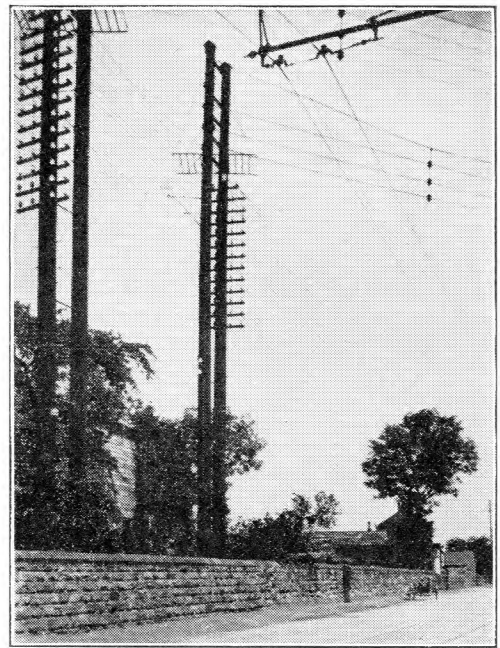

FIG. 6.—HIGH-VOLTAGE POWER CROSSING WHERE ACCIDENT OCCURRED IN 1914.

Fig. 6, consisted of an H-pole structure, with the power lines in vertical formation between, and at the top of, the two poles, the telephone wires being below and at approximately right angles to the power system. The telephone wires were supported by arms in the normal way, these arms being fixed to one of the two members of the H-pole unit. Separation of the power and telephone wires was affected by an earthed metal platform, having its longer axis parallel with the power lines. There was a clearance of 1 ft 4 in. between the lowest power conductor and the top of the platform, and 1 ft between the underside of the platform and the highest Post Office wires. It seems that, at the time of the accident, a Post Office employee was fixing a warning notice just below the platform. He had completed his work and, whilst attempting to climb down over the outside of the arms on the Post Office side of the metal platform, his head came into contact with a power conductor and he was electrocuted. After this accident, the distance between the earthed platform and lowest power conductor was increased to about 4 ft, and there are no further records of electrical accidents on this form of construction.

The next accident at a high-voltage crossing did not occur until June 1941, when, in contravention of standard methods of protection at high-voltage crossings, which required Post Office plant to be placed underground or cradle guards to be provided, rubber covered, braided and compounded (I.R.V., B. and C.) wires were erected between the terminal poles of an underground section of an overhead Post Office route where the latter crossed a 132 kV power line. Initially, it appears that a circuit was diverted to the Post Office route concerned and, there being no good underground spares at the power crossing, lengths of I.R.V., B. and C. wire were strung overhead between the terminal poles, immediately below and crossing the line of route of the power wires. About 12 days after the Post Office overhead wires had been put up at the crossing it was found that leads on the terminal poles had been burned out and that the overhead wires had disappeared. It was assumed that the Post Office wires had been blown into contact with the power conductors and, there still being no good spares available in the underground cable, two P.B.J. wires were erected, again overhead, to restore service. Good spare

pairs became available shortly afterwards in the underground cable at the crossing and the circuit was diverted to the cable and the P.B.J. wires recovered. Within a month, however, two more circuits were required and the expedient of providing these by overhead wires was again adopted. This time a pair of P.B.J.-covered wires and one I.R.V., B. and C. wire were erected, but these were not recovered when the circuits were diverted to the underground cable at a later date. Just over a month after erection of these wires a flashover occurred between one of the high-voltage conductors and the overhead I.R.V., B. and C. wire. This caused damage to exchange and subscribers' equipment in the vicinity and the following day a lineman investigating the fault found that, although the I.R.V., B. and C. wire had been burnt out the P.B.J. wires were intact. He made an attempt to use these to provide a circuit, but whilst working on the wires there was a flash which scorched his face and burnt his clothes and the P.B.J. wires were scattered over the ground in small pieces. Again, faults were caused to subscribers' and exchange equipment in the vicinity.

Unfortunately, the clearance allowed between the high-voltage conductors and Post Office wires at the time of erection is not known, but it is probable that the flash-over occurred when the high-voltage conductors approached the Post Office wires due to expansion during a period of warm weather.

A further and very similar incident occurred in September 1954, when another attempt was made to run Post Office wires below and crossing a 132-kV power line. Again, efforts were being made to restore service to a subscriber who normally used pairs in an underground crossing of the 132-kV line. In this instance, an I.R.V., B. and C. wire was run out along the ground below the high-voltage conductors and between the two poles terminating the underground power crossing. A man then climbed each pole, taking with him an end of the wire. This became caught in an obstruction between the terminal poles and the men pulled strongly in an attempt to release it; eventually it became free, but because of the tension to which it was subjected it sprang upwards and touched a conductor of the 132-kV line. Both men received shocks and one fell from a pole and sustained severe injuries. The other was unable to move from his position on the other pole until assisted by a member of the public. In each case the men were not wearing safety belts.

These two cases illustrate the danger of running overhead wires, insulated or otherwise, below 132-kV power conductors and it cannot be emphasized too strongly that to do so is a most dangerous practice. There is only one satisfactory safeguard for communication circuits when crossing high-voltage power lines and that is to put them underground.

Another and unusual type of accident, which can only be attributed to carelessness and disregard of instructions, occurred when bare overhead wires were being recovered near an 11-kV power crossing. In this case, a man drawing out old wire from an overhead route walked under the power line and up an incline pulling the wire behind him. Ultimately, this wire came into contact with a conductor of the 11-kV power line, and the man pulling the wire was electrocuted. A second man who was paying out seven spans away was also killed and a third man on the terminal pole adjacent to the crossing was rendered unconscious and recovered consciousness hanging head downwards supported by his safety belt. This accident occurred because the

foreman's instructions that the recovered wire should be coiled on a drum placed between the terminal pole and the next pole away from the crossing had not been observed.

Although not strictly an accident at a high-voltage crossing, an accident occurred in July 1939 which illustrates the dangers of working in the vicinity of high-voltage installations. The work concerned was in connexion with provision of service to a subscriber adjacent to a 66-kV sub-station belonging to the Central Electricity Board. As originally surveyed, the proposals were for the new Post Office line to run right across the sub-station compound, a most dangerous procedure, even though there were no overhead power lines entering or leaving the station. The installation gang attempted to carry out the work as surveyed and entered the sub-station compound without, however, first seeking the permission of the Central Electricity Board engineer. They were in the process of erecting the wires across the compound when one was allowed to sag to such an extent that it came into contact with a high-voltage transformer terminal. There was a heavy explosion, an arc was seen from 200 yards away, and there was a prolonged interruption of supplies to the district.

Although members of the gang were actually handling the wire at the time they were fortunate that they received no injuries, a truly remarkable escape as the results of an incident of this kind could have been very serious indeed.

#### *Electrical Accidents Involving Post Office Underground Plant.*

So far as underground plant is concerned the records indicate that the risk of electrical accidents on such plant is very small. Two cases only are recorded as having occurred since 1924. The first of these took place in February 1944, and involved a cable contractor's employee. It is recorded that, at the time of the accident, the victim was clearing a joint hole which had been excavated to reach a split coupling in a Post Office cable. The man had finished his work and prepared to leave the hole, placing his left hand on the footway surface and vaulting up on to the footway itself. Instead, however, of placing his spade in a place of safety, he retained it in his right hand, apparently grasping it by its metalwork. As he sprang upwards, a corner of the spade caught and pierced the sheath of an 11-kV power cable. As a result, a power arc occurred and the victim received shock and burns. The power cable itself was fully exposed to view, having been moved to one side of the excavation by the power supply authority, to facilitate work on the Post Office cable. The power cable was, moreover, unarmoured and had no protection against mechanical damage whatsoever; this was probably due to wartime conditions as it had been laid to give service to a defence site during the early days of the war.

The next case occurred in February 1953, when a Post Office employee received a shock whilst excavating near a street-lighting standard fed by a small armoured low-voltage cable. A spade being used for excavation partly pierced the armoured cable and the man using it received a shock.

#### ACKNOWLEDGMENT

Tables 1 and 2 and the summary of the causes of electrical accidents on portable plant in industry are extracted from "Electrical Accidents and Their Causes, 1953," published for the Factory Department of the Ministry of Labour and National Service by the Controller of Her Majesty's Stationery Office, who has given permission for reproduction of the material.

# A New Standard Power Plant for Medium-sized 50-Volt Telephone Exchanges

L. H. CATT, A.M.I.E.E.†

U.D.C. 621.311.6:621.395.722

A new power plant, designated Power Plant No. 210, has been developed to supersede Parallel-Battery Automatic Power Plants previously used for exchanges with power consumption up to 2,000 Ah/day. The new plant uses rectifier sets incorporating mechanical regulators which are controlled from a voltage-sensitive relay connected across the exchange load.

## INTRODUCTION

CHARGE-DISCHARGE working was the standard method of supplying power for telephone exchanges until about 1935, when new standard schemes were introduced.<sup>1</sup> Larger exchanges were then supplied on a "float" basis; i.e. the exchange load was supplied by an automatically regulated generator. A battery connected across the output of the generator served to maintain the supply in the event of failure of the generator. This battery was intended to be kept in a fully-charged condition but experience has shown that, with the voltage range and number of cells used, small losses occur and the battery requires occasional refreshing charges. Smaller installations, with up to 2,000 Ah/day consumption, were supplied by automatic power plants which allowed the battery to partially discharge (by approximately 4 per cent of its capacity), and charging rectifiers (or motor generators in d.c. areas) were then automatically connected across the load and batteries until the batteries were restored to a fully charged state. The maximum output of the rectifiers was at about the 16-hour rate of charge for the batteries. Thus the method of working was a mixture of "float-charge," "assisted discharge" and float working, depending on the load.

These automatic plants needed only occasional attention compared with the frequent attention needed by charge-discharge working. Experience with the system has indicated the desirability of replacing automatic working by float working for smaller loads than originally envisaged. The main reasons are the unreliability of ampere-hour meters (resulting in incomplete charging of the batteries) and the fact that the life of the batteries, some 6 to 8 years, is little different from that on charge-discharge working, whereas on fully-floating systems battery lives of the order of 12 to 14 years are being obtained. The plant described in this article has been introduced to supersede the existing "Parallel-Battery Automatic Power Plant" (Power Plant No. 207) in districts where a public a.c. supply is available.

## FACILITIES AND CIRCUIT OPERATION OF NEW PLANT

Field trials of rectifier sets incorporating mechanical regulators and without ballast showed that they could be successfully used on "equilibrium" floating duties (i.e. maintaining the batteries at a voltage equal to or slightly higher than the open-circuit voltage) under the control of a voltage relay. The battery losses, which comprise internal losses and slight discharges whilst the regulators are readjusting the rectifier output, are made good at fortnightly intervals.

It was decided to standardize in detail a plant that could easily be increased in size if, as experience at some exchanges has shown, estimated loads are exceeded earlier than expected.

The plant, which has been standardized as Power Plant No. 210, is designed to provide a positive-earthed supply within the limits 46V to 52V under all load conditions, with a peak load capacity of 300A, but the capacity can easily

be increased if found desirable. The plant includes two batteries, which are connected in parallel across the output of one or two rectifiers. A common filter is provided in the output from the rectifiers to prevent the noise level across the load exceeding the psophometric equivalent of 2 mV at 800 c/s. The output of the rectifiers is normally controlled by a voltage-control circuit mounted on the power switchboard, which also accommodates the switching panel for connecting the batteries to the load or the charging circuit, as required. A system of "Prompt" and "Deferred" alarms is provided for connexion to the main alarm system. Alarm lamps mounted on the top panel of the power switchboard indicate the part of the circuit giving rise to an alarm.

When two rectifiers are installed, the circuit is arranged so that Rectifier No. 2 is not brought into use until Rectifier No. 1 is loaded to a predetermined amount. The voltage-control circuit is then transferred to Rectifier No. 2 and the output of Rectifier No. 1 is kept under "current" control; i.e. its output is adjusted automatically if required, to maintain the output within predetermined limits of current. When the load falls the output of Rectifier No. 2 is reduced until its regulator is at the minimum output position. The voltage-control circuit is then reconnected to Rectifier No. 1 and Rectifier No. 2 is switched off.

It is expected that the majority of installations will require only one rectifier, and the relays controlling the change-over of the control circuits to the second rectifier are not fitted initially but the wiring for them is provided ready for use if required.

## Outline of Circuit Operation.

Basically, the plant is controlled by the following circuits:—

- (a) A voltage-monitoring circuit which is connected across the load and causes the voltage regulators to operate and adjust the output of the rectifiers to meet load changes.
- (b) The change-over circuit to control the switching in and out of the second rectifier (where fitted).
- (c) Alarm circuits.

A simplified circuit diagram of the complete power plant is given in Fig. 1. Alarm lamps, indicating meters, fuse-alarm circuit, receiving-attention circuit and the distribution of auxiliary supplies all follow conventional practice and have been omitted from Fig. 1.

The voltage across the load is monitored by voltage relay VA. If the load increases, the voltage falls until LA is operated via the "low" contact of VA1. LA causes the "raise output" signal to be given to the rectifier; i.e. LA2 operates relief relay LAR and LAR3 earths the connexion to relay R in the rectifier; R1 operated completes the regulator-drive circuit. Simultaneously VA is biased by the operation of LAR5 so that VA1 moving contact breaks from the "low" contact and takes up a predetermined position near the "high" contact. The rising output from the rectifier causes the voltage across the load to rise until relay HA is operated from the "high" contact of VA. HA2 operates relay HAR and the "raise output" signal is then disconnected by HAR3 and relay CA is operated via LAR4 and HAR4. Relay CA locks to earth via CA3 and

†Executive Engineer, Power Branch, E.-in-C.'s Office.

<sup>1</sup>JONES, H. C. Modern Tendencies in the Supply of Power to Telephone Exchanges. *I.P.O.E.E. Printed Paper No. 156.*

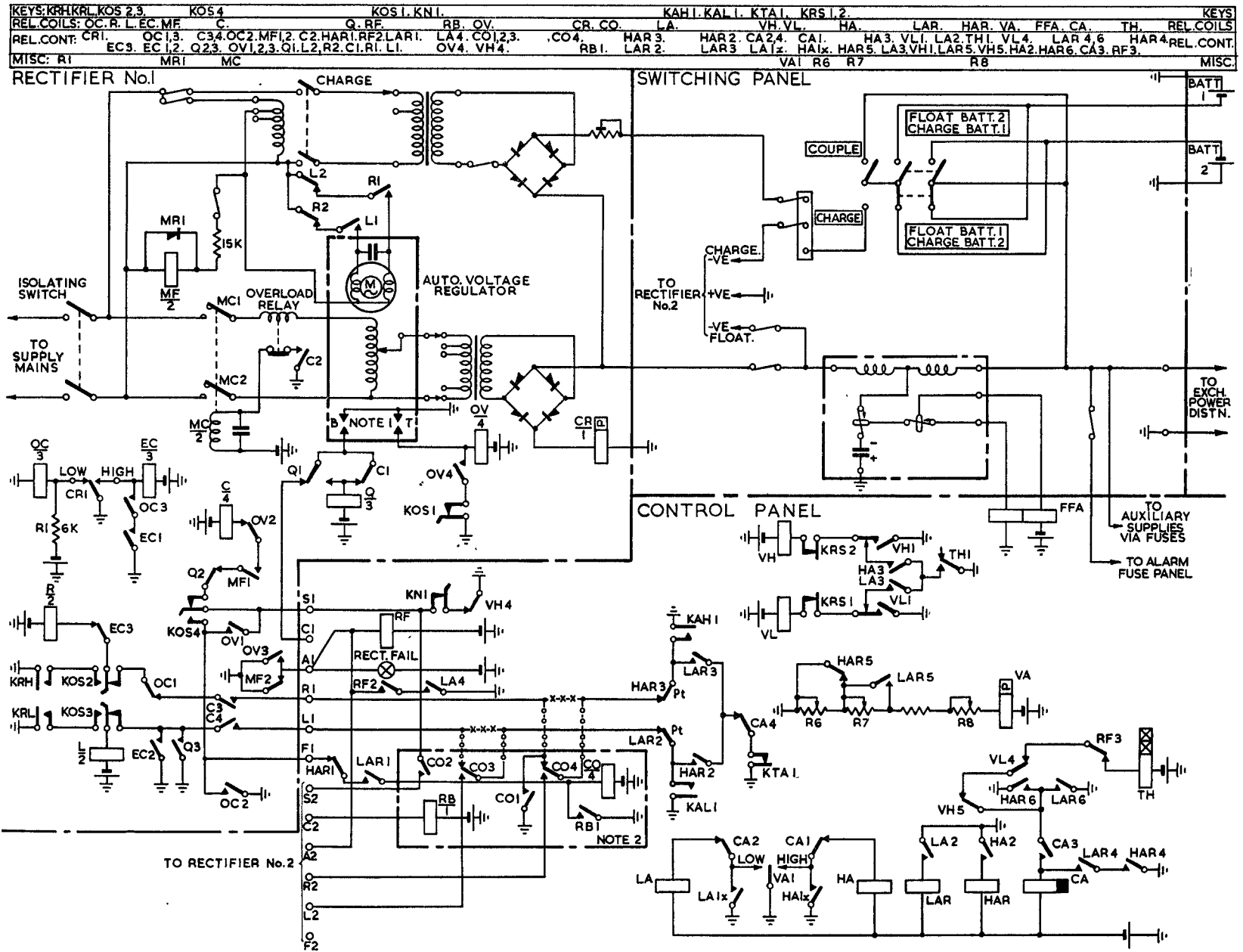

Notes:—  
 1. Contact B is open when the regulator is in the minimum-output position. Contact T is closed when the regulator is in the maximum-output position.  
 2. This part of the circuit is not required when a single rectifier only is fitted. When a second rectifier is fitted, connexions shown thus x-x-x are broken and connexions shown thus 0-0-0 are made.

FIG. 1.—SIMPLIFIED SCHEMATIC DIAGRAM OF THE NEW POWER PLANT.

LAR6 and HAR6, thus guarding against mis-operation by ensuring that all control relays are normal before re-connecting the control circuit.  
 If the load decreases, the voltage will rise and the control circuit operates in a similar manner to that previously described, but the "high" contact of VAI operates relay HA, HA2 operates HAR and HAR2 extends earth to relay L in the rectifier and LI causes the regulator to drive

in the reverse direction. A feature of the circuit is that voltage correction is initiated and terminated by closing contacts on VA, thus ensuring that no circuits are broken through the contacts of the voltage relay.  
 The voltage limits between which the voltage can change without operating the control circuit are determined by the settings of the "high" and "low" contacts of VA. The amounts by which the voltage is automatically adjusted are

determined by the difference between the bias voltage and the voltage difference between the settings of the "high" and "low" contacts of VA. Bias resistors R6 and R7 are adjustable so that the amounts by which VA is biased (and hence the voltage change corrected at any one time) can be set to the most suitable values. During field trials it was found that, using a B.P.O. Voltmeter No. 47 as the voltage relay, a voltage correction of 0.1V with overall variation limits of 0.6V (i.e. a bias of 0.5V) gave the best results on a working exchange load. The actual settings will vary slightly at individual installations owing to the differing characteristics of the various makes of voltage relays and the age and condition of the batteries. Typical figures for the setting of the VA circuit are "high" contact 51.3V, "low" contact 50.7V, bias 0.5V. Adjustments for these settings are provided, together with a series resistor, R8, to enable the operating range of VA to be adjusted over a range of about  $\pm 2\frac{1}{2}$ V.

#### *Rectifier Load Limitation.*

Relay CR, in series with the rectifier, is a current relay of the moving-coil type with adjustable "high" and "low" contacts. The function of this circuit is to prevent damage to the rectifier element when the current rises (e.g. on reconexion to a partially discharged battery following failure of the mains) and to reduce the output should the current tend to rise above the rating of the rectifier elements (e.g. a change of the public mains supply voltage will cause a disproportionately large change in the output current).

When the output current rises above the setting of the "low" contact of CR1 (say 95 per cent output), CR1 breaks from its low contact, allowing relay OC to operate, and OC1 disconnects relay R, thus preventing any further rise in output due to signals on the "R" lead. The output will stay at a value slightly above the preset "low" limit of 95 per cent output unless reduced by signals on the "L" lead. Should the current continue to rise (due to, say, an increase in the voltage of the public supply mains) CR1 will make on its "high" contact and operate relay EC, which causes the output to be reduced (by EC2 operating relay L and L1 completing the regulator drive circuit) until CR1 makes on its "low" contact. The circuit is then restored to normal and if there is an earth on the "R" lead the regulator will drive until cut off again by CR1.

#### *Circuit Operation using Two Rectifiers.*

When two rectifiers are fitted the change-over circuit operates as follows:—

Rectifier No. 1 deals with load changes until it is fully loaded (current limited by operation of CR). As the load continues to rise the control relays of Rectifier No. 2 are brought into use by the operation of relay CO. Rectifier No. 2 then deals with the load changes while the output current of Rectifier No. 1 is maintained within preset limits. When the regulator of Rectifier No. 2 is driven from its minimum position, its B contacts close, earthing lead C2; relay RB operates and RB1 holds relay CO to prevent the control circuit being switched back to Rectifier No. 1 until the output of Rectifier No. 2 has been reduced to zero.

#### *Rectifier Regulator "Homing" Feature.*

If a rectifier is switched off for any reason, such as a mains supply failure or for maintenance attention, the circuit is arranged so that the regulator is driven to its minimum output position before the rectifier is reconnected to the load. This is accomplished as follows:—

Relay C is released by (a) disconnexion of earth from terminal S; e.g. operation of Cut-off key (KN), (b) operation of relay OV (see later), or (c) release of relay MF—failure of a.c. mains supply.

Contact C2 disconnects the earth from the contactor MC,

C3 and C4 disconnect the control wires from relays R and L, and C1 operates relay Q. Q3 operates relay L and causes the output to be lowered until the regulator low-limit contact, B, opens. The circuit is then restored to normal by the release of relay Q.

#### *Mains Supply Failure.*

If the mains supply fails, relay MF releases, MF1 disconnects relay C and MF2 operates alarm relay RF via terminal A. The release of relay C disconnects contactor MC and the mains supply is disconnected from the rectifier transformer by MC1 and MC2. When the mains supply is restored relay MF re-operates and MF1 prepares the circuit for the re-operation of relay C. The rectifier "homing" circuit operates and when the low-limit switch (contact B) on the regulator opens, relay Q releases and relay C re-operates; the control circuit is then restored to normal. The rectifier output continues to rise (subject to the current-limiting arrangement previously described) until the float voltage is again within limits.

When the load is transferred to the battery, VA1 will operate relay LA; LA4 holds relay RF operated and RF3 disconnects relay TH, preventing operation of the low-voltage alarm circuit until the normal float voltage is restored. The purpose of this is to avoid the necessity of special visits to unattended stations merely to restore the voltage alarms since there will inevitably be a low-voltage condition existing for a short period after the restoration of the mains supply.

#### *Voltage Alarm Circuit.*

Should the voltage remain outside the limits set by relay VA for approximately 45 sec without correction, an alarm is given. If the condition is due to a high voltage, the C relay(s) in the rectifier(s) will be released (relay VH operated via HA3 and TH1, and relay C disconnected by VH4) and the rectifiers will be switched off. The reason for this is that this condition can only arise if there has been a failure of one of the control circuits.

If the alarm is due to a low-voltage condition the rectifiers are not switched off.

The alarm condition persists until attention is given. Operation of the reset key (KRS) releases relay VH (or VL). The voltage alarm circuit is inoperative if a rectifier failure is responsible for the condition giving rise to the voltage alarm.

#### *Filter Fuse Alarm Circuit.*

The fuses associated with the capacitors in the smoothing filter are of the alarm type. If one of these ruptures, the spring contact operates relay FFA causing a Filter Fuse Alarm lamp to glow and the Prompt Alarm circuit to operate.

#### *Out-of-Service Facility.*

If it is desired to switch a rectifier out of service to give maintenance attention to the regulator or for investigation of a fault, the "Out-of-Service" key (KOS) is operated. KOS1 disconnects the holding circuit of relay OV (if operated, as described later); KOS2 and KOS3 transfer the operating circuits of relays R and L to test keys (KRH and KRL) and the operation of these relays to "stray" conditions is prevented. KOS4 releases relay C and connects terminal S to terminal F. When two rectifiers are fitted, the bridging of terminals S and F on Rectifier No. 1 causes relay CO to operate and Rectifier No. 2 is brought into service immediately.

The rectifier to be taken out of service is now disconnected from the load (release of relay C disconnected contactor MC) and the regulator can be driven under hand control by the use of the "Test Raise" (KRH) and "Test Lower" (KRL) keys on the rectifier. When the key KOS is restored

the rectifier "homing" circuit operates, since relay Q will have operated if the regulator is not at its minimum output position.

#### Regulator Overdrive.

If the regulator reaches the limit of its travel in the "Raise Output" direction, limit switch T closes and operates relay OV. This condition can arise due to failure of relay OC to operate (coil of OC disconnected or coil of CR disconnected) or excessively low input voltage.

The possibility of damage to the rectifier elements or regulator drive under these conditions is prevented by operation of relay OV. OV1 bridges terminals S and F and, when two rectifiers are fitted, bridging of terminals S and F on Rectifier No. 1 causes relay CO to operate and bring Rectifier No. 2 into service. OV2 disconnects relay C, which releases, and in turn releases the a.c. contactor MC and isolates relays R and L. OV3 applies earth to terminal A, causing RF to operate and give an alarm. When attention is given the maintenance officer can reset relay OV by operating the "Out-of-Service" key (KOS) and the rectifier is held out of service by this key whilst maintenance attention is given.

#### Test Facilities.

Testing is carried out without interrupting the supply to the load and a few simple tests prove the operation of the circuits.

Testing of the main circuit operation is carried out very simply by operating the "Rectifier Cut-Off" key (KN) and restoring it to normal again. KN1, operated, releases the C relays of the rectifiers and the rectifier "homing" circuits are operated. When the regulator of the rectifier is in the minimum output position relay Q releases and relay C re-operates. The rectifier regulator then responds to the low-voltage condition registered by contact VA1, since the load is being carried by the batteries.

Where two rectifiers are fitted, the change-over circuit and "pick-up" of Rectifier No. 2 can be tested by operating the "Out-of-Service" key (KOS) of Rectifier No. 1.

The driving circuits of the regulators can be tested individually by operating the "Out-of-Service" key (KOS) and operating the "Test Raise" (KRH) or "Test Lower" (KRL) key of the rectifier.

The operation of the voltage-control circuit is tested as follows: operation of the "Test HV" key (KAH1) earths the lead to relay R and so causes the rectifier regulator to increase the output current and the voltage across the load rises. When it reaches 51.3V, relays HA and HAR operate and correct the condition. HAR3 isolates the test condition directly HA and HAR operate by removing the earth applied by KAH1 to relay R. The circuit is restored to normal by the operation and release of relays LA, LAR and CA. To test the low voltage condition, "Test LV" key

(KAL1) is operated and the circuit operation is similar. Should either testing key be held in one position the test will repeat continuously, without interrupting service, until the key is released.

The voltage alarm circuit is tested by operating the "Test Voltage Alarm" key (KTA), which prevents normal operation of the control circuit. By operating the "Test HV" or "Test LV" key until relay VA operates, the required alarm condition can be set up. The circuit is restored by restoring the "Test Voltage Alarm" key (KTA1) and operating the "Reset" key (KRS).

#### Battery Charging.

A single-pole knife switch, fitted on the switching panel, is operated to the "charge" position and the rectifier charge circuit is switched on. The battery to be charged is selected by the double-pole knife switch, shown in Fig. 1.

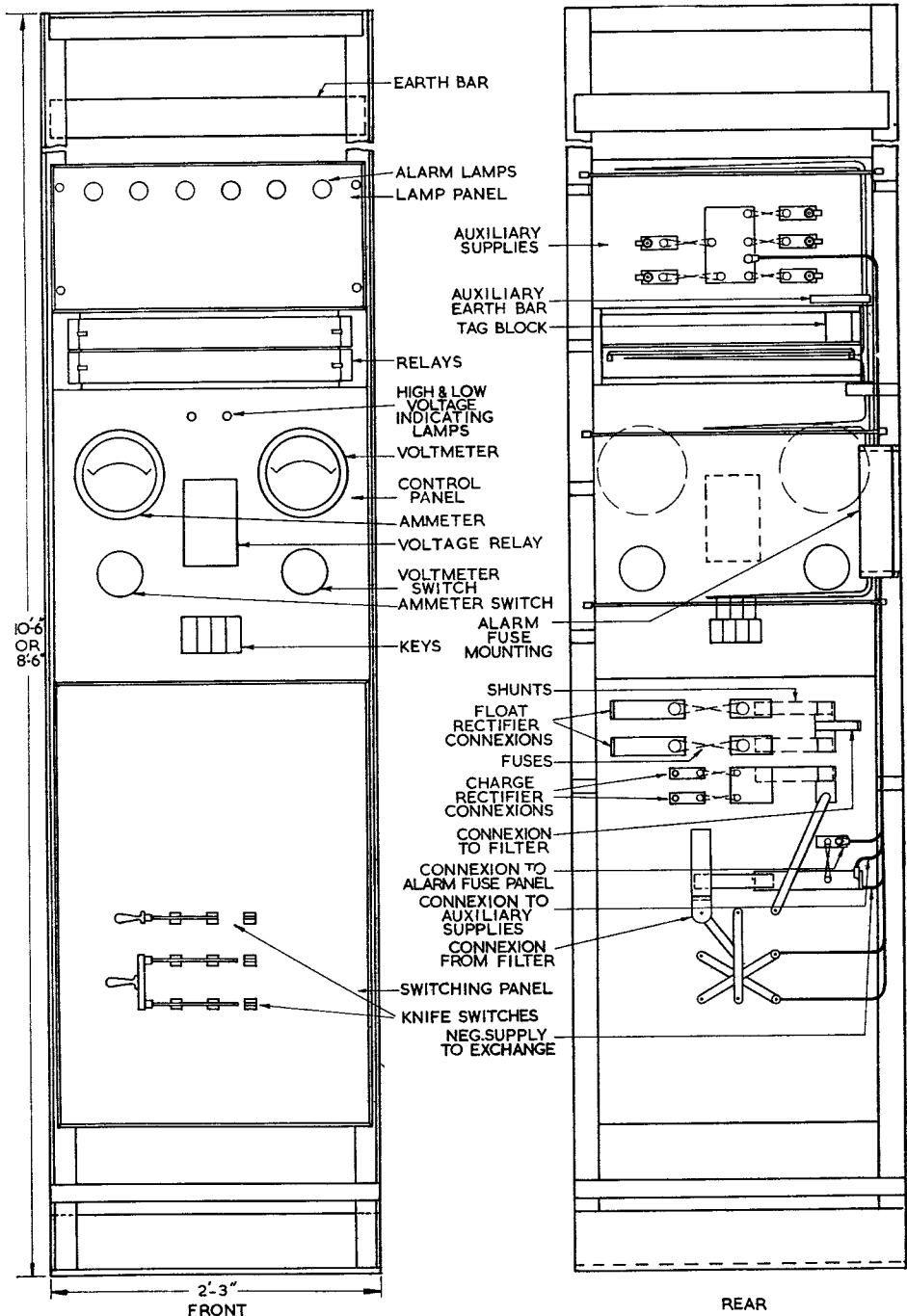

FIG. 2.—THE POWER SWITCHBOARD (SIZE A).

## THE POWER SWITCHBOARD

The power switchboard, Power Switchboard No. 3, has been standardized in two ratings, each of which is supplied in two heights. The "A" size, which is shown in Fig. 2, has a maximum rating of 100A and the B size a rating of 300A. The only difference between the two is in the rating of the ammeter and the main components of the switching panel, and this has been made an item that can be ordered separately under the title Panel, Switching No. 2A or 2B, so that an "A" size switchboard can easily be converted to "B" size.

The framework, which is of similar design to the 2000-type racks used for telephone exchanges, is made in either of the two heights used for exchange apparatus racks. This facilitates installation in combined power and apparatus rooms. Power Switchboards No. 3A and 3B are only 2 ft 3 in. wide and can be installed in line with existing apparatus racks if at least 2 ft 6 in. clear space is left at the front and rear. The control-circuit components and meters are mounted on a sheet-steel panel with two relay mountings above the panel, arranged so that all relays are accessible from the front of the board. The Panel, Switching, No. 2 is fitted below the Control Panel and is of insulating material. It carries all the "current-rated" components (e.g. switches, shunts, etc.), with the exception of the ammeter. The knife switches have been fitted horizontally to reduce the size of the panel and to simplify the busbar layout. To prevent inadvertent short-circuits due to metallic items dropping across the switches, an insulating guard, similar to a shelf, is fitted above them. At the back of this panel are the fuses and shunts, the sizes of which are determined locally for each installation. The fuses and shunts are selected from the Post Office standard ranges. Bolts are provided on the contact blocks across which the load fuse is fitted so that a recording device can be connected in the load circuit when required. Above the relays is fitted an insulating panel carrying the local alarm lamps on the front and five distribution fuses for auxiliary services at the rear. At the top of the rack is the common positive or earth bar. This is drilled for a variety of arrangements, connexion being made by standard soldering sockets (to British Standard No. 91) bolted to the bar. The position of the earth bar reduces the amount of cabling crossing the back of the board when overhead cabling is used.

## THE RECTIFIERS

The rectifier units consist of sheet-steel cubicles containing the voltage regulator, mains transformer, rectifying element and control and testing circuits, plus a charging rectifier unit. Some voltage regulators are of the auto-transformer type, and others of the "double-wound" type, the latter in most cases dispensing with the necessity of providing a separate mains transformer. The rectifying elements are likely to be of the dry-plate type, although mercury-arc elements are not precluded by the specification.

In view of the large number of proprietary regulators and the diversity in their dimensions and contours, the size, layout and circuit detail of the rectifiers are not closely specified. The circuit in Fig. 1 is typical.

The cubicles are arranged for access from front and rear, but need not be side-by-side where two rectifiers are fitted. Each rectifier is a separate entity and is connected direct to the power switchboard. The rectifier need not be fitted near the power switchboard and can, if desired, be fitted in a different room. Each rectifier is provided with keys to facilitate maintenance testing and fault location. The cubicles are designed for overhead cabling.

Rectifiers No. 75 and Rectifiers No. 76 are used. Rectifiers No. 75 can be operated from 50-c/s single-phase supplies within the range 200 to 250V and Rectifiers No. 76 from

50-c/s 3-phase supplies within the range 346 to 440V. These rectifiers have "float" outputs equal to the "peak loads" in Table I. The output of the charge-rectifier unit is equal to one-fifth of the nominal output of the "float" portion of the rectifier. Rectifiers for operation from other mains supplies can be provided where necessary.

## FILTERS

The filters are of the conventional "T" formation, arranged as shown typically in Fig. 1. It is probable that some of the larger sizes will be produced in a vertical arrangement (i.e. chokes one above the other) to economize in floor space and to facilitate overhead cabling. The filter can be placed in any suitable position near the power switchboard, the distance being kept as small as possible as it is desirable to keep the output cable from the filter short and apart from the input and earth cables. The input and earth cables must be kept as close together as possible to minimize inductive disturbance in other circuits.

The range of filter sizes covers each of the standard sizes of Power Plant No. 210 given in Table I, which also shows the values of the components. The shunt arm comprises Post Office standard 500- $\mu$ F capacitors and each capacitor is connected in series with an alarm-type fuse.

TABLE I  
Power Plant No. 210—Main Components

Power Plant No.	Peak Load	Mains Supply	Power Switch-board	Rectifier	Filter		
					Size	Inductor	Capacitor
210A	25 amp	Single-phase	3A	75A	A	8 mH	2,000 $\mu$ F
210B	50 amp			75B	B	8 mH	2,000 $\mu$ F
210C	75 amp			75C	C	7 mH	2,000 $\mu$ F
210D	25 amp			76A	D	3 mH	2,000 $\mu$ F
210E	50 amp			76B	E	3 mH	2,000 $\mu$ F
210F	75 amp	3-phase	3B	76C	F	2 mH	2,000 $\mu$ F
210G	125 amp			76D	G	2 mH	2,000 $\mu$ F
210H	175 amp			76E	H	1.5 mH	4,000 $\mu$ F
210I	300 amp			76D + 76E	J	1 mH	6,000 $\mu$ F
210J							

## BATTERIES

The circuit was designed to operate with two 25-cell batteries having Planté positive plates and acid of maximum specific gravity of 1.220 at 60°F. It is possible to use the system with other types of secondary cells provided that the voltage-regulating limits and/or the number of cells are adjusted to suit the characteristics of the cells used. If other types of cell are used, consideration should be given to the adequacy of the output of the charging rectifier(s). The capacity of the batteries is not important so long as both batteries employ plates of the same size and type; variations of plate characteristics will cause one battery to become discharged whilst the other is maintained fully charged. It is preferable for the two batteries to be identical in all respects.

The size of the batteries is determined individually for each installation. Where standby engine sets provide the main reserve, smaller batteries can be provided than where a full 24-hour reserve, or more, is required. This should save battery-room accommodation at some exchanges, since, with Parallel-Battery Automatic Power Plant it is essential that the relationship between the battery size, rectifier size and load range be adhered to.

## CONCLUSION

A Power Plant No. 210 requires less floor space than a Parallel-Battery Automatic Power Plant of equivalent size and the facility of fitting the rectifiers some distance from the power switchboard should enable the best use to be made of available accommodation.

Although this plant was originally intended for use where the exchange load is between 200 and 2,000 Ah/day, projected developments in rectifiers indicate that it may be possible to extend the range to cover bigger loads.



# Setting Up and Testing A Coaxial Line Link for Telephony\*

A. H. WATKINS, C.G.I.A., A.M.Brit.I.R.E.†

U.D.C. 621.395.44:621.315.212

An account of the procedure used by the British Post Office for setting up and testing a coaxial line link for telephony, with particular reference to links employing Coaxial-Equipment, Line, No. 2B.

## INTRODUCTION

THE procedure for setting up and testing a coaxial line link for telephony is described in this article with particular reference to links employing Coaxial-Equipment, Line, No. 2B, which is typical of the equipment most commonly used at present in the British Post Office coaxial cable network. A "line link" may consist of one or more line-regulated sections, but this article is concerned with a single line-regulated section.

### Coaxial-Equipment, Line, No. 2B.

Coaxial-Equipment, Line, No. 2B, of which Unit Bay 1B Equipment<sup>1</sup> may be considered the prototype, consists of all the line equipment between the supergroup translating points and includes, in addition to the high-frequency (h.f.) amplifying equipment, h.f. supervisory, h.f. control, engineering speaker, and power equipment. The repeater stations are spaced at a maximum of six miles and power is supplied over the centre conductors of the cable from selected stations (power-feeding stations).

*Power-feeding arrangements.*—The power-feeding arrangements for a single power-feeding section are shown in Fig. 1. The maximum loading for a single power-feeding

350V for supplying the local equipment and to 500-0-500V for feeding to line. Power-feeding stations have a diesel generator with facilities for automatic starting if the mains supply fails.

*H.F. transmission path.*—The h.f. transmission path and pilot circuits are shown in Fig. 2, 3 and 4. The bandwidth, 60-2,852 kc/s, will accommodate 11 supergroups, each of 60 circuits, although to date the policy has been to equip only 10 supergroups, in the line frequency band 60-2,540 kc/s.

Changes in cable attenuation due to changes in temperature are compensated by switching networks (temperature equalizers) into, or out of, circuit as the temperature of the cable decreases or increases, respectively.

Two pilot signals are transmitted in each direction of transmission. The level of each pilot is 16 dB above the channel test level, which at the line amplifier output is -13 dB relative to the channel level at the two-wire point. The pilot frequencies are 300 kc/s and 2,852 kc/s; 300 kc/s being used for monitoring the system level at each station, stabilization of the received level at the terminal station, and synchronization of the carrier generating equipment. At terminal stations the 2,852-kc/s pilot is also used to monitor the system level, and provides an indication of when temperature equalizers should be switched.

The system level is monitored by selecting the 300-kc/s pilot at each station and using it to control switching relays in the transmission path. Should the 300-kc/s pilot signal fall to a predetermined level, a standby line amplifier is switched into circuit. At the receiving terminal the 300-kc/s pilot is used to provide an automatic gain control which is, however, rejected if the gain control required exceeds  $\pm 3$  dB. The 300-kc/s pilot is frequency-converted to 60 kc/s at the receiving terminal for synchronization of the carrier supplies. At the transmitting terminal the two pilots are derived from the channel and supergroup carrier generating equipment, the 300-kc/s pilot being derived by frequency conversion from the 60-kc/s carrier supply, and the 2,852-kc/s pilot being obtained direct from the carrier supply for supergroup No. 10.

*Supervisory and control facilities.*—The supervisory and control circuits are arranged so that the control station is always fully informed of the conditions existing at all stations on the line. The supervision and control is provided over a 4-wire audio circuit, which is shown in schematic form in Fig. 5. The control circuit is used for switching the temperature equalizers or changing from main to standby line amplifiers. The supervisory circuit is used for transmitting information to the control terminal to indicate whether the temperature equalizer is in or out of circuit and whether the standby amplifier has been switched into circuit.

Selective voice-frequency ringing is provided on the speaker circuit so that the control terminal can call any station in the line-regulated section. The remote terminal station or any power-feeding station also calls the control station by selective ringing. Dependent stations call the terminal stations by d.c. signals superimposed on the audio circuit to the power-feeding station, which transmits an audio signal to the control station.

Fault location and cable-temperature measurement is carried out by the adjustment of a simple bridge circuit,

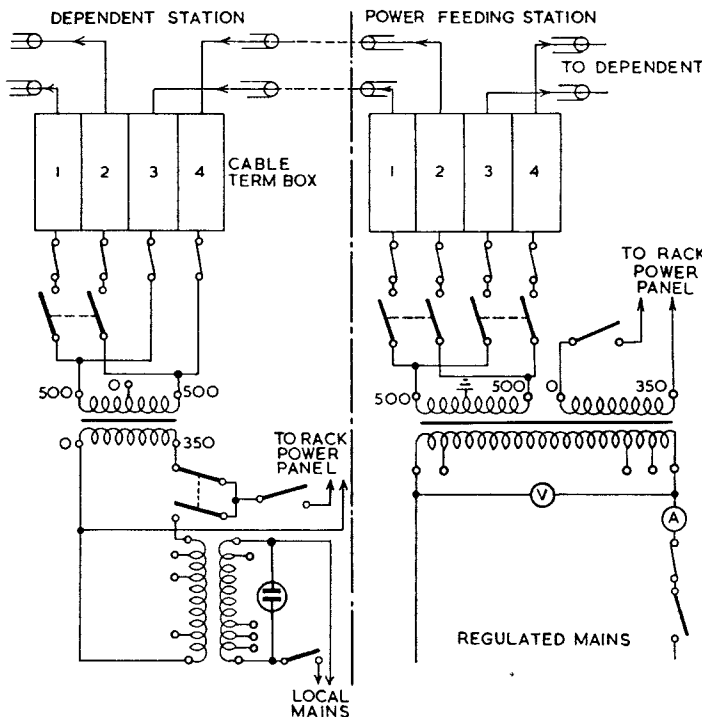

FIG. 1.—SCHEMATIC DIAGRAM OF POWER-FEEDING ARRANGEMENTS.

station is three stations on each side of it. A terminal station feeds a maximum of three dependent stations. The local a.c. supply is voltage regulated and stepped up to

\*This article is a shortened and simplified version of the thesis submitted by the author to the City and Guilds of London Institute in connexion with the Institute's Insignia Award in Technology. Permission to publish in this form is gratefully acknowledged to the City and Guilds of London Institute.

†Assistant Engineer, Home Counties Region, formerly in the Transmission and Main Lines Branch, E.-in-C.'s Office.

<sup>1</sup>For numbered references see end of article.

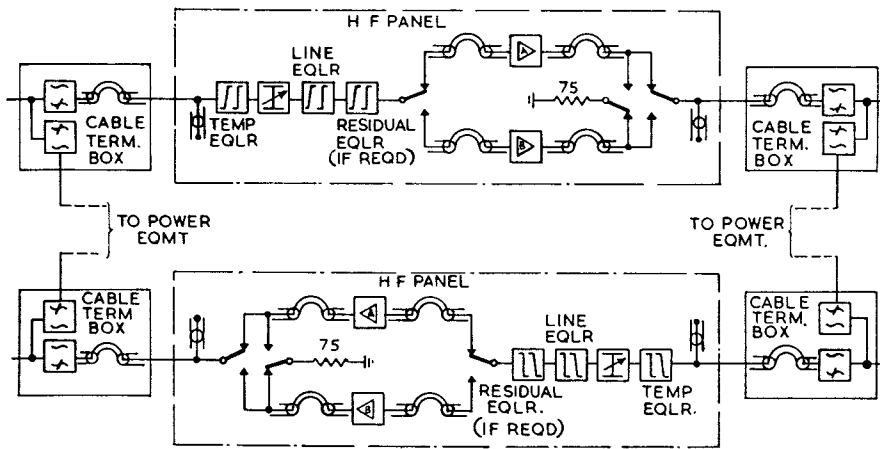

FIG. 2.—H.F. TRANSMISSION PATH AT AN INTERMEDIATE STATION.

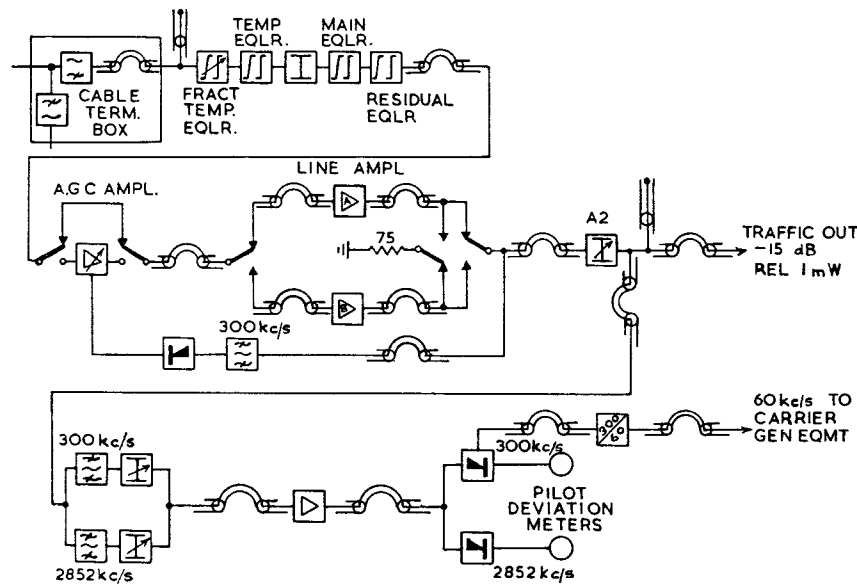

FIG. 3.—RECEIVE H.F. TRANSMISSION PATH AND PILOT CIRCUITS AT A TERMINAL STATION.

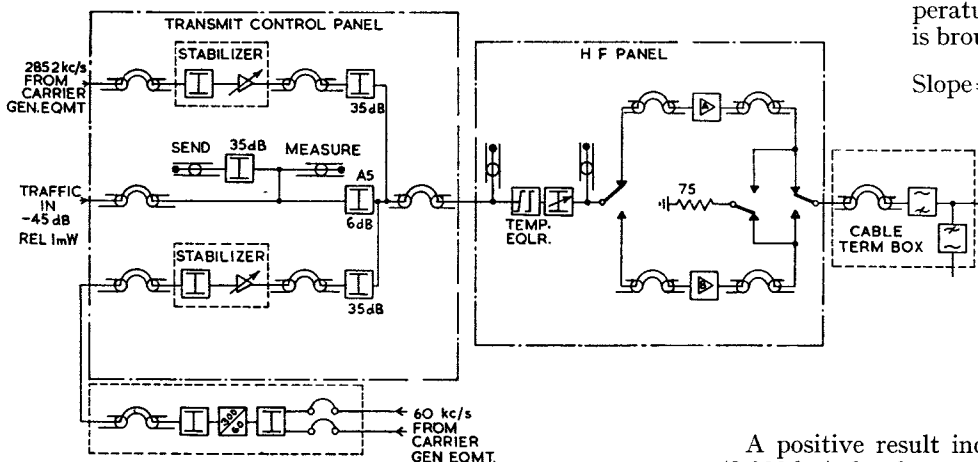

FIG. 4.—TRANSMIT H.F. TRANSMISSION PATH AND PILOT CIRCUITS AT A TERMINAL STATION.

which is independent of cable temperature changes when used for fault location.

#### TEMPERATURE-EQUALIZER SWITCHING SCHEDULE

The networks that are switched into or out of circuit to compensate for changes in cable temperature are equivalent to approximately 0.4 miles of 375A-type coaxial cable. A

Temperature Equalizer Switching Schedule is prepared to determine the order in which the networks are switched, as the temperature falls and rises, to ensure that:—

(a) the changes in the amplifier output levels when an equalizer is switched are kept to a minimum, and

(b) at mid-schedule temperature, the amplifier output level at any station does not differ from the nominal level\* by more than  $1\frac{1}{2}$  times the loss of one temperature-equalizer network; the mid-schedule temperature being that midway between the upper and lower temperatures for the number of temperature equalizers switched into circuit.

#### HIGH-FREQUENCY LEVEL TABLE

The amplifier output level at any station will be dependent upon the number of temperature equalizers in circuit and the amount by which the cable temperature differs from the mid-schedule temperature. During the h.f. line-up it is necessary to know the nominal amplifier output levels at mid-schedule temperature at the time of measurement. This involves correcting the absolute measured level by (a) the change in cable attenuation due to the difference between the cable temperature and the mid-schedule temperature and (b) by the change from nominal level at the station due to the number of temperature equalizers in circuit. A table is therefore prepared showing the corrections at temperatures likely to obtain during the line-up with any number of temperature equalizers in circuit. Table 1 shows part of such a table for one direction of transmission of a typical line.

The table is prepared by calculating the slope† of the output level/frequency characteristic at each station (at mid-schedule temperature) when each temperature equalizer is brought into use, in the following way:—

$$\text{Slope} = \left( \frac{xy}{l} \right) - z \text{ temperature equalizers,}$$

where:—

$x$  = Distance from transmit terminal in miles.

$y$  = Total number of temperature equalizers in circuit.

$z$  = Number of temperature equalizers in circuit between transmit terminal and amplifier output.

$l$  = Distance between terminal stations in miles.

A positive result indicates that an upward slope exists (2,000 kc/s level exceeds 300 kc/s level) at the station in question; conversely, a negative result indicates a downward slope. An upward or downward slope is indicated by

\*In this article the term "nominal level" refers to the level that would exist at the point of measurement if all equipment between that point and the sending point were of its designed gain or loss and the cable were at its designed loss at 25°C.

†Where the term "slope" is used in connexion with the h.f. line-up it refers to the difference in level between two arbitrarily chosen frequencies, namely 300 kc/s and 2,000 kc/s at intermediate stations, and 300 kc/s and 2,852 kc/s at terminal stations.

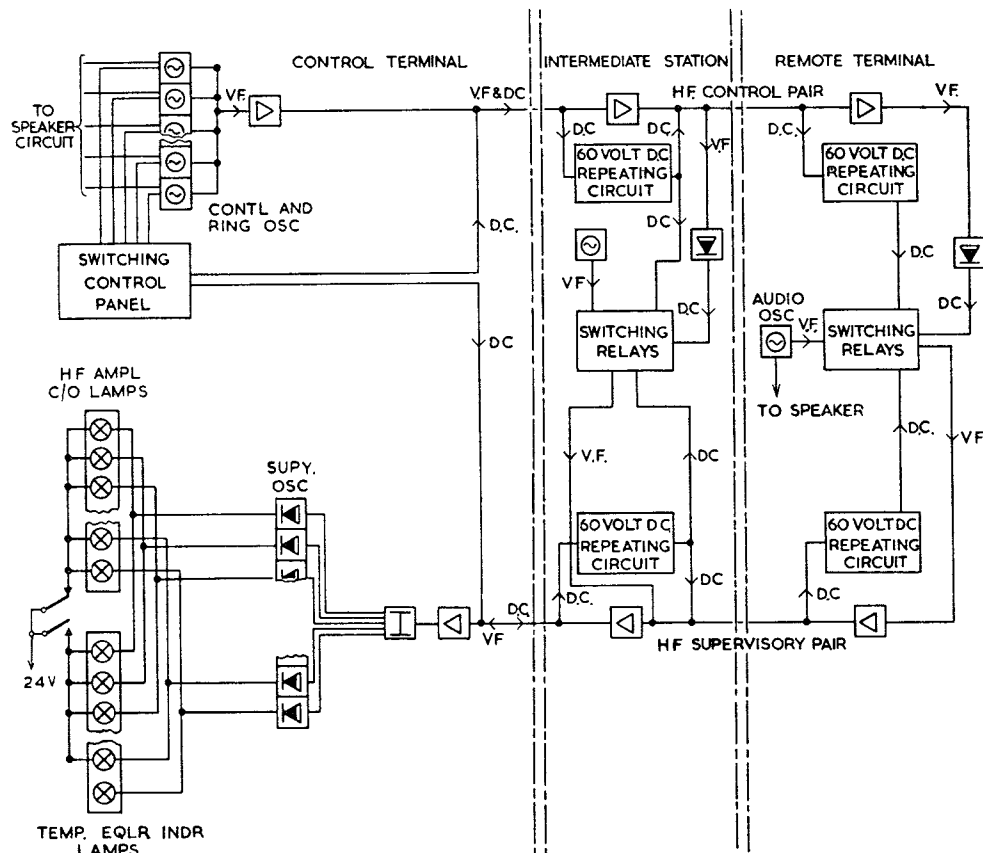

FIG. 5.—BLOCK SCHEMATIC DIAGRAM OF SUPERVISORY AND CONTROL CIRCUITS.

the suffix “u” or “d” against the calculated figure for the station.

The lower portion of Table 1 shows the correction for temperature deviation from mid-schedule temperature.

TABLE 1  
Part of Typical H.F. Level Table

Direction of transmission A-Y											
* Schedule No.	Temperature range °C		Mid-Schedule Temp. °C	Station name	Slope of amplifier output-level/frequency characteristic (in temperature equalizers)						
	Max.	Min.			Station A	Station B	Station C	Station W	Station X	Station Y	
1	24.2	22.6	23.4	Station W.	0	0	0.1u	.....	0.1d	0	0
2	22.6	21.0	21.8	Station D.	0	0.1u	0.2u	.....	0.2d	0.1d	0
3	21.0	19.4	20.2	Station M.	0	0.1u	0.2u	.....	0.2d	0.1d	0
·	·	·	·	·	·	·	·	·	·	·	·
14	3.4	1.8	2.6	Station H.	0	0.4d	0.1u	.....	0.1d	0.5d	0
15	1.8	0.2	1.0	Station Q.	0	0.4d	0.2u	.....	0.2d	0.5d	0
16	0.2	-1.4	-0.6	Station S.	0	0.3d	0.2u	.....	0.2d	0.6d	0
Corrections to be made for variations from mid-schedule (fraction of temperature equalizer)	+0.75°C.			0	0	0	.....	0.4d	0.4d	0.5d	
	+0.5°C.			0	0	0	.....	0.3d	0.3d	0.3d	
	+0.25°C.			0	0	0	.....	0.1d	0.1d	0.2d	
	Mid-schedule			0	0	0	.....	0	0	0	
	-0.25°C.			0	0	0	.....	0.1u	0.1u	0.2u	
	-0.5°C.			0	0	0	.....	0.3u	0.3u	0.3u	
-0.75°C.			0	0	0	.....	0.4u	0.4u	0.5u		

\* “Schedule No.” corresponds to the number of temperature equalizers switched into circuit.

#### TESTING PROGRAM

After installation each rack is tested individually. These tests are known as “In-Station” tests and for equipment supplied under contract are, with certain exceptions, the first acceptance tests carried out by the Post Office.

In-station testing is followed by the “Power Line-Up,” during which power is fed over the cable to the intermediate stations, and all necessary adjustments made.

When the power equipment has been lined up it is desirable to complete adjustments on the speaker circuit so that full intercommunication between stations is available for subsequent tests. The 4-wire circuit which provides the control and supervisory circuits is lined up concurrently with the speaker circuit. Adjustment of the audio oscillators and selectors is next carried out, thus completing all work on equipment other than the h.f. path, which is next lined up and tested between the line terminal stations.

#### IN-STATION TESTING

The in-station tests are not dependent on the cable and may be carried out during installation of the equipment at other stations; they consist of:—

- Visual inspection and vibration testing.
- Relay adjustments.
- Audio amplifier tests.
- H.F. amplifier and selector tests.
- Audio oscillator tests and adjustments.
- Audio selector tests and adjustments.
- Functional testing of supervisory and control circuits.
- Miscellaneous h.f. testing, including testing of pilot stabilizers, gain control circuits, etc. at terminal stations.

All these tests are carried out with power supplies obtained from the normal source or from standby supplies. A temporary adjustment of voltages is made so that the equipment is tested under approximately the same conditions as will exist after completion of the power line-up.

#### POWER LINE-UP

In view of the high voltages used on the cable, 500.0-500V a.c., it was necessary to design the power

system such that points of high potential were not readily accessible to the testing and maintenance staff. This has been achieved by means of a system of locks. Access to the cable terminations can only be obtained via a locked cover, the key of which is kept in an interlocking key box mounted on the wall of the station, adjacent to the equipment. The key can only be removed from the box after insertion of a second key into the box. As the second key controls the 500-0-500V supply to the cable it follows that the high voltage supply must first be disconnected before the key can be removed from the key box to obtain access to the cable terminations. In addition to releasing the key giving access to the cable terminations the second key releases tertiary keys for the use of cable jointers. The jointer who is to open the cable will only proceed after he has obtained possession of the tertiary key, ensuring that power has been removed from the cable.

It is essential that before the power line-up commences all interlocking key boxes be fitted and all power-feeding switches operated by the appropriate keys.

Each complete power-feeding section is lined up in two stages, power being first fed out on one side only of the feeding station and voltages checked and adjusted at each station. At each dependent station the received voltage is a function of the sending-end voltage, section length and load, and is therefore not readily calculated in the field, and to facilitate a check in the field constants relating these variables have been determined.

Simultaneous measurements are made at each end of the section. This is necessary because the regulated voltage at the power-feeding station may, in the limit, change by 4 per cent ( $\pm 2$  per cent from nominal) in the interval between measurements if not made simultaneously, due to tolerances on the voltage regulator.

## SPEAKER, SUPERVISORY, AND CONTROL CIRCUIT LINE-UP AND ADJUSTMENTS

### *Four-wire Audio Circuit Line-Up.*

The speaker, supervisory and control circuits consist of two 4-wire circuits, each equipped with Amplifiers No. 32.<sup>2</sup> The circuits are routed over 20-lb unloaded interstice pairs of the cable.

Line equalization is effected by an impedance mismatch at the input to each amplifier by the use of line transformers producing a reflection and interaction loss/frequency characteristic that is approximately the inverse of the attenuation/frequency characteristic of the line. Using this method of equalization it is found that residual equalization is necessary at approximately every 10 stations and for this Equalizers, No. 9A<sup>3</sup> are used.

The circuits are lined up, using conventional methods, to a nominal zero overall loss and equalized between the limits  $-3$  dB and  $+0.5$  dB, relative to zero overall loss, over the band 300-3,400 c/s.

### *Audio Oscillator Adjustments.*

The audio oscillators are tuned to the frequency allocated to the station for supervisory, control and speaker-ringing purposes against a test oscillator having an accuracy of  $\pm 0.2$  per cent or 2 c/s, whichever is the greater, during the in-station testing. The output levels are adjusted after the 4-wire line-up to  $-6$  dB (Control or Supervisory) and  $+2$  dB (Speaker), both relative to 1 mW in 600 ohms, measured at the line-amplifier output.

### *Audio-Selector Sensitivity Adjustments.*

The tuning of the audio selectors is carried out during the in-station testing in the same manner as the oscillators. It is necessary to set the sensitivity of the selectors 11 dB below the nominal operating level. This margin of 11 dB is to accommodate changes in the level of the received

signal due to the permitted attenuation distortion of the associated line, level changes due to cable temperature variation, effect of voltage changes when working on standby supplies, and tolerances on the initial adjustment of the oscillators.

## THE H.F. LINE-UP

### *Preliminary Adjustment of Line Equalizers and Attenuators.*

The Line-Equalizer Unit consists of five sections, each designed to equalize a given length of 375A-type coaxial pair, the five lengths being 1.2, 1.6, 1.8, 2.0, and 2.2 miles. Combinations of the five sections may be selected to equalize cable lengths of 3-6 miles in steps of 0.2 miles with the exception of 4.4 miles.

The equalizer settings are selected so that at any station the total equalizer mileage between the sending end and the line amplifier at the station is equal to the line mileage between these two points. The attenuator preceding the equalizer is set to a value such that the insertion gain between the amplifier output at the preceding station and the amplifier output at the station is zero at 300 kc/s at a cable temperature of 25°C.

Before the preliminary adjustment of equalizers and attenuators is made a table of mileages of each station from the sending end, and the required equalizer and attenuator settings, is compiled for each direction of transmission. Part of a typical table for one direction of transmission is shown in Table 2. The actual distances are converted to equivalent lengths of 375A cable if the cable is other than 375A. This is because the main equalizers were designed to equalize 375A-type cable.

TABLE 2  
*Preliminary Equalizer and Attenuator Settings for Typical Line-regulated Section*

Station A—Station Y Direction of Transmission							
	Distance from previous station	Equivalent distance for 375A cable	Distance from control terminal	Equivalent distance for 375A cable	Equalizer setting	Total Equalizer miles from control	Attenuator setting (dB)
Station A .	—	—	—	—	—	—	10
Station B .	5.158	4.849	5.158	4.849	4.8	4.8	10
Station C .	4.225	3.972	9.383	8.821	4.0	8.8	18
. . . . .	. . . . .	. . . . .	. . . . .	. . . . .	. . . . .	. . . . .	. . . . .
Station X .	5.164	4.699	118.464	108.584	4.6	108.4	12
Station Y .	4.441	4.041	122.905	112.625	4.2	112.6	16

### *Temperature Equalizers.*

Measurement of the cable temperature is made to determine how many temperature equalizers should be in circuit at the commencement of the line-up, the number for any given temperature being obtained from Table 1. The temperature equalizers are switched in and out of circuit manually in accordance with the temperature equalizer schedule. In addition, all A amplifiers are locked in circuit manually. The locking of temperature equalizers and amplifiers is considered preferable to remote control to avoid any possibility of a temperature equalizer or amplifier being switched without the knowledge of the testing officer responsible for the line-up.

### *H.F. Continuity Tests.*

During the visit to each station for the preliminary setting of equalizers, switching of temperature equalizers and locking of amplifiers, opportunity is taken to check the continuity of the h.f. path at 300 kc/s. In this way, serious faults that may exist are detected and can be cleared before the main line-up commences. This precaution is necessary as it is desirable that once the line-up commences it should proceed as quickly as possible to completion with minimum change in cable temperature.

### *Final Adjustment of Line Equalizers and Attenuators.*

Each station is visited in turn and the following procedure followed:—

- (i) The amplifier output level is measured as a terminated level at 300 kc/s and 2,000 kc/s.
- (ii) Measurements made in (i) are corrected for the slope shown on the H.F. Level Table (Table 1) and for difference between cable temperature at the time the measurement is made and the mid-schedule temperature; a further table (not shown) being used to convert "slope" to dB at the frequency of measurement.
- (iii) Corrected measurements are examined to see if any slope exists which could be reduced by adjustment of the equalizer and whether the level at 300 kc/s is within  $\pm 1$  dB of nominal.
- (iv) The equalizer is adjusted, if necessary, to reduce the corrected slope to not greater than half the slope of 0.2 miles of equalizer.
- (v) The attenuator is adjusted to correct, if necessary, the level at 300 kc/s to within  $\pm 1$  dB of nominal.
- (vi) Investigation is made to find the cause of any adjustment exceeding 0.2 miles of equalizer and 2 dB of attenuator from the settings made during the preliminary adjustments.
- (vii) The terminated amplifier output-level/frequency characteristic is measured over the complete line-frequency band.

As the line-up proceeds station by station in the above manner, irregularities appear in the amplifier output-level/frequency characteristic due to an accumulation of design tolerances. The variations of output level introduced in this manner are not permitted to exceed  $\pm 3$  dB, relative to the nominal output level, to ensure that the overload and signal/noise limits for the line are met. Residual equalization is applied if the attenuation distortion exceeds this limit. Residual equalizers can be fitted to remove a "dip" in the characteristic only if sufficient gain is available at the station to compensate for the loss of the equalizer. In the event of insufficient gain being available at the station, the equalizer is fitted at the nearest station at which gain is available, on the sending side of the station at which the permitted attenuation distortion is exceeded. It is then necessary for the line-up to be repeated at succeeding stations from that where the residual equalizer was fitted.

The line residual equalizers are in general designed and constructed to meet the requirements of each particular case. Experience has shown, however, that the irregularities in the amplifier output-level/frequency characteristic usually occur at approximately the same points in the frequency band. Residual equalizers are stocked for equalization of these irregularities, other irregularities being equalized by residual equalizers designed for the specific purpose.

At the receiving terminal a similar procedure is adopted, and with the Fractional Temperature Equalizer\* set to 0.75, the automatic gain control switched out of circuit and attenuator A2 (See Fig. 3) set to 2 dB, the overall attenuation distortion should not exceed specified limits.

On completion of the adjustment of equalizers and attenuators all measurements are repeated as "through-level" measurements at all stations. The difference between the "through" and "terminated" measurements should not exceed 0.5 dB at any frequency.

### *Adjustment of H.F. Selectors.*

The operate and release level of all h.f. selectors is

\*A special temperature equalizer fitted only at the receiving terminal and capable of being set at fractions of the loss of the complete temperature equalizer fitted at all stations.

measured. Selectors failing to meet the specification limits are re-adjusted.

### OVERALL TESTS

In addition to the overall insertion-gain/frequency characteristics measured at the time of the h.f. line-up the following overall tests are carried out: basic noise, intermodulation, crosstalk, overload, radio interference and stability.

#### *Basic Noise.*

The noise present on the line may consist of components due to thermal noise, valve noise, intermodulation, crosstalk and radio interference or other spurious signals. The combination of thermal noise and valve noise is grouped under the general title of basic noise and is measured in a 4-kc/s band with the automatic gain control in circuit and both pilots transmitted.

Ideally, the basic noise should be measured in the actual channel bands but due to practical difficulties in selecting these bands at line frequencies, 4-kc/s bands distributed over the complete frequency band are selected for measuring purposes. The level of the noise in these bands is obtained by direct comparison with the known level of a single-frequency signal from a test oscillator. The tests are made both with the main, "A," and standby, "B," amplifiers in circuit and should meet specified limits, which depend on the number of stations.

#### *Intermodulation.*

On a line system employing high-level pilots it is the intermodulation between the signal and the pilots that is of greatest importance. Intermodulation products of the two pilots will fall between channels and may therefore be ignored.

The intermodulation tests are carried out firstly with the "A" amplifiers in circuit, and repeated with the "B" amplifiers. The test consists of transmitting a signal with one or both pilots connected and selecting the required second-order and third-order products. Care is taken to ensure that intermodulation does not take place in the testing equipment. Where this occurs a stop filter is connected before the test equipment, to suppress the fundamental signals.

The second-order and third-order intermodulation products have been shown by Brockbank and Wass<sup>4</sup> to consist of the following frequencies, where the fundamental frequencies are  $A$ ,  $B$  and  $C$ :—

$$\text{2nd order terms} = 2A, A \pm B, \text{ etc.}$$

$$\text{3rd order terms} = 3A, 2A \pm B, A \pm 2B, A + B - C, \text{ etc.}$$

Choice of the intermodulation product to be selected for measurement is dependent upon the frequency of the test signal used. A test signal of 500 kc/s is used with the 2,852 kc/s pilot to produce a second-order product, whilst both pilots and a signal of 850 kc/s are used to produce the third-order product.

The test signal is applied at the input to the line at a level of  $-15$  dB relative to 1 mW and is decreased in steps of 1 dB to  $-30$  dB relative to 1 mW, measurements of the intermodulation products being made at the distant terminal at each level of signal.

A change in the test signal level will result in a linear change in the level of second-order and third-order intermodulation products over the major portion of the level range  $-15$  dB to  $-30$  dB relative to 1 mW. This linear change will not occur at the lower and upper levels of test signal due to the proximity of the basic-noise level and overload point respectively.

The level of the intermodulation product with the test signal at channel test level ( $-45$  dB relative to 1 mW at

the input to the line link) is obtained by plotting the above test results and extrapolating the linear part of the graph. The level thus obtained is corrected by 15 dB (channel test level is -15 dB relative to 1 mW at the point of measurement) to express the intermodulation as a signal/intermodulation-noise ratio, which should meet specified limits; these are derived from the line-amplifier harmonic-distortion limits.

#### Crosstalk.

The line crosstalk is measured in both directions of transmission with both pilots connected and the automatic gain control in circuit. First, the "A" amplifiers are locked in circuit and, secondly, the tests are repeated with the "B" amplifiers in circuit. The tests are made at a number of selected frequencies and a narrow band is explored about these frequencies as it has been found that, due to phasing of the multiple crosstalk-paths, rapid changes of the measured crosstalk occur with small changes of frequency.

#### Overload.

The usual method of measuring the overload point of an amplifier (by observing the level of the harmonic content of the output signal with increasing level of input signal) is not used in the overall tests. It has been found more practicable, when testing in the field, to observe the relationship between the output and input level of the fundamental signal. This relationship becomes non-linear at approximately the same output level as the relationship between the harmonic level and the fundamental signal level.

For specification purposes the overload of the line amplifiers is defined as the output level at which an increase of 1 dB in the input level results in a change of output level of 0.75 dB or less. The overload of the line is measured by applying a test signal at the input to the line at a level of -30 dB relative to 1 mW and measuring the level of signal received at the distant terminal; the input level is increased in steps of 1 dB and the changes of output level noted, the overload point of the line being defined in the same way as that for a single amplifier.

The overload point of a single line amplifier is +20 dB relative to 1 mW (output level) within the band 60-2,500 kc/s. As the channel test level at the output of a line amplifier is -13 dB relative to 1 mW it would appear, from the work of Holbrook and Dixon,<sup>5</sup> that there is ample margin to cater for the maximum number of speech channels likely to be in simultaneous use during the busy hour. This margin is, however, necessary due to the permitted attenuation distortion, switching of temperature equalizers, and changes in cable temperature between the times of switching temperature equalizers. At intermediate stations the output level may be 4 dB above the nominal level, due to the permitted attenuation distortion. The temperature equalizer switching schedule permits this level to rise by up to 4 dB at the higher frequencies. In addition to these two deviations from nominal output level there is that due to change of cable temperature between the switching of temperature equalizers, which amounts to half the insertion loss of a temperature equalizer; approximately 1.5 dB at 2.6 Mc/s.

It will be seen that under the most adverse conditions the nominal amplifier output level may increase by up to 9.5 dB, without taking into consideration the effect of carrier leaks, test tones, v.f. telegraphy channels, and line pilots.

The line is tested for overload at a frequency of 300 kc/s and should not overload with an input signal of -14 dB relative to 1 mW, which is equivalent to an amplifier output level of +18 dB relative to 1 mW.

#### Radio Interference and Spurious Signals.

In view of the possibility of interference from radio transmitters and other similar sources, the complete band 60-2,852 kc/s is carefully explored for signals of this nature.

Measurements are made with all "A" amplifiers locked in circuit and both pilots disconnected, any signal in excess of 5 dB above basic-noise level being investigated and steps taken to reduce the level to that of basic noise if the signal falls within a channel band.

#### Insertion-Gain Stability Check.

The final test carried out on the complete line link is a check of the stability of the insertion gain of the overall h.f. transmission path. The test is made by monitoring the 300 kc/s pilot with a recording milliammeter at the "Traffic Out" test point (Fig. 3). The test is carried out over a period of two weeks. During the first week the automatic gain control is not in use and during the second week it is switched into use. During the test the line amplifiers are under the control of the 300 kc/s pilot and all temperature equalizers are under the control of the terminal station. The 300 kc/s pilot is also monitored at the output of the stabilizer to obviate any change of level being incorrectly attributed to the line.

The sensitivity of the recording instruments is such that level changes of 0.1 dB are immediately recorded. The overall stability of the line should be such that, with the exception of changes due to cable temperature, the insertion gain remains constant for the duration of the test.

#### CONCLUSION

The problem of the technique to be adopted in the setting up and testing of a coaxial line system is not one that presents any fundamental technical difficulty; the problems are usually of a practical nature and the technique described has been evolved by the Post Office from practical experience in the setting-up and testing of many of the earlier systems of a similar type. The methods to be adopted are dependent upon the design of the equipment and any fundamental change in design will necessarily result in new methods of setting-up and testing in the field.

#### ACKNOWLEDGMENT

Acknowledgment is made to the author's colleagues in the Transmission and Main Lines Branch of the E.-in-C.'s Office who were concerned over a period of some years in evolving the testing and lining-up procedure on which this article is based.

#### References:

- <sup>1</sup>BROCKBANK, R. A. and FLOYD, C. F. The Unit Bay 1B Coaxial Cable Transmission System. *P.O.E.E.J.*, Vol. 38, pp. 43 and 82, July and Oct., 1945; Vol. 39, pp. 14 and 64, Apr. and July, 1946.
- <sup>2</sup>WILLIAMS H. The new Amplifier No. 32 and Associated Equipment. *P.O.E.E.J.*, Vol. 34, p. 60, July, 1941.
- <sup>3</sup>PYRAH, F. A new Standard Equalizer. *P.O.E.E.J.*, Vol. 37, p. 22, Apr. 1944.
- <sup>4</sup>BROCKBANK, R. A., and WASS, C. A. A. Non-Linear Distortion in Transmission Systems. *Journal I.E.E.*, Vol. 92, Part III, No. 17, 1945.
- <sup>5</sup>HOLBROOK, B. D., and DIXON, J. T. Load-Rating Theory for Multi-Channel Amplifiers. *B.S.T.J.*, Vol. XVIII, No. 4, p. 624, Oct. 1939.

# An Application of Delay-Line Storage Techniques to the Common Control of Directors

S. W. BROADHURST, A.M.I.E.E.†

U.D.C. 621.374.5:621.395.34:621.318.57

Hitherto, electronic equipment designed to replace electromechanical equipment in telephone exchanges has been designed as a direct substitute for electromechanical devices and has thus exploited only one of the features of electronic devices, the absence of mechanical wear. This article discusses, with particular reference to the common control of directors, the design of electronic telephone exchange equipment that exploits also the ability of electronic devices to operate at very high speeds and their potentialities for storing large quantities of information in a small space.

## INTRODUCTION

THE most striking features of electronic as opposed to electromechanical switching are the absence of mechanical wear, its ability to operate at very high speeds and its potentialities for storing large quantities of information in a small space. Hitherto, in the design of replacement equipment for the existing telephone system, it is the first of these features that has been exploited. Thus, in the Richmond experiment<sup>1</sup> electronic components are, in general, employed as direct substitutes for the electromechanical devices used in the original directors, and are operated at speeds comparable with those of the replaced items. Moreover, except in the case of the translator, the duty cycle of each circuit element remains unchanged.

To achieve the maximum economies, it is necessary to exploit fully the other features of electronic switching: its high speed and large storage capacity. At first sight there appears to be little advantage in speeding-up the circuit elements of such a device as a director, whose holding time is largely governed by the speed with which it can be supplied with information, and which has, in any case, to control relatively-slow-acting selector mechanisms. The present directors can, however, be regarded as mechanical operators capable of dealing with only one call at a time; if a common director can be devised which will act as a single operator capable of dealing with all the incoming traffic, the need for high-speed operation becomes apparent. Such an equipment would have to collect traffic from a large number of sources quickly enough to avoid missing any significant change of information from any one of them, and would further have to provide a very high capacity storage in order to assemble and use the mass of information it would receive. Systems of this type have been produced<sup>2,3</sup> and this article describes some of the basic operations involved.

## THE STORAGE PROBLEM

Any control circuit such as a director contains a series of built-in sequences, and the action taken by the circuit is governed by the association of the new information it receives with the knowledge it already has of the past history of the call. Hence, a common equipment substituting a number of directors will have to possess, in addition to digit-storage capacity, an individual memory of the progress of each of the calls it is handling. The sequence control circuits, however, being identical for every director, can be provided on a common basis.

Pulse-storage techniques offer the possibility of recording information in the form of pulse patterns which can be changed as the information changes, so that whereas the state of a call on a normal director may be read by observing the condition of the relays and switches, the state of the electronic equivalent is read by observing the particular pulse pattern at any instant, much in the same way that a

telegraph tape can be read by noting the pattern of the holes.

Suitable pulse-storage devices include magnetic drums,<sup>2,3,4</sup> recording tapes and delay lines of various types. This article will be restricted to discussing the exploitation of delay-line techniques, although the principles to be outlined are applicable to other storage devices.

The principles of a supersonic mercury delay line have already been given in this Journal.<sup>5,6</sup> Another form of delay line which avoids the use of mercury and does not require a carrier supply is the magnetostrictive line,<sup>7,8</sup> consisting of a nickel wire or tape threaded through a coil and having the property that, when a pulse is injected into the coil, a physical constriction occurs in the wire immediately under the coil causing a contraction wave to travel down the wire at a constant speed. At the other end of the wire the wave passes through a receiving coil and a voltage is produced in the coil as the wave passes through it. The wire is terminated and mechanical damping is necessary to avoid excessive reflections from the terminations. The output from the receive coil can be amplified, re-shaped and re-applied to the input to maintain a constantly circulating storage system.

Using this type of delay line well within its capacity, it can store approximately  $2\frac{1}{2}$  "bits" of information per inch, using  $2\text{-}\mu\text{s}$  pulses at the input. Mercury delay lines can operate at much higher speeds and are correspondingly shorter. The system to be described in this article does not relate to any particular type of delay line and the time scale chosen is purely illustrative.

The register-translator functions in the existing director exchanges are spread over the A-digit selectors and directors. Economies can be made if these functions are undertaken by a common register capable of handling 7-digit numbers and translating all of the A B C codes. Registers of at least this capacity will, in any case, be required when long-range subscriber-subscriber dialling is introduced into the non-director network. Assuming that a pulse-storage system operating in the binary code is to be used, the storage of 7 digits will require  $7 \times 4$  storage elements or "bits." To this number must be added the bits required to distribute the incoming digits, to control the sending of the translation and to provide the memories for the sequence circuits. In total, a 7-digit director requires the use of 55 storage elements, so that a delay line holding 1,100 bits could accommodate 20 such directors. A magnetostrictive line of this capacity may require a wire about 36 ft long, which could, however, be coiled to occupy a very small space.

Assuming that a delay line having a capacity of 1,100 bits is provided, and each item of information relating to a particular director is supplied to the delay line as the presence or absence of a pulse at some predetermined point in a time cycle made up of  $2\text{-}\mu\text{s}$  pulses, the whole of the information relating to one of the 20 directors can be made to pass any given point in the circulating system in  $110\ \mu\text{s}$  at intervals of  $2\cdot2\ \text{ms}$ . The delay line can thus be made the equivalent of an operator who can remember the

† Assistant Staff Engineer, Post Office Research Station.

<sup>1</sup> For numbered references see end of article.

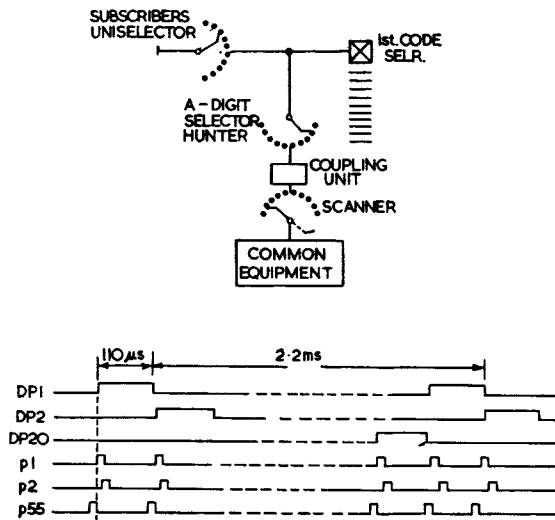

FIG. 1.—A POSSIBLE TRUNKING SCHEME.

history of 20 calls simultaneously and who can, during a period of  $110 \mu\text{s}$ , receive, or receive and change, the information relating to one particular call. The principle is illustrated in Fig. 1.

#### A POSSIBLE TRUNKING SCHEME

Assuming the subscribers' lines are connected to the 1st Code Selectors and the A-Digit Selector Hunters in the usual way, each hunter outlet is connected to a coupling circuit associated with a particular  $110\text{-}\mu\text{s}$  period (DP) allotted to it out of a total time cycle of  $2.2 \text{ ms}$ . During this DP period the coupling circuit concerned is the only one connected to the common equipment. In Fig. 1 the common equipment is shown connected to the coupling circuit by a scanner, represented for the purpose of illustration as a continuously hunting uniselectors. The coupling circuits contain the conversion equipment to convert Strowger signals to their pulse equivalents and vice versa.

Fig. 1 also shows the arrangement and nomenclature of the basic "clock" pulses controlling the system. Pulses  $p_1$ - $p_{55}$  are  $2\text{-}\mu\text{s}$  pulses repeated every  $110 \mu\text{s}$  and the DP pulses 1-20 are the scanning pulses allotted to the individual coupling circuits.

#### PULSE STORAGE

##### *Elementary Principles of Memory Function.*

As previously stated, the sequential operation of any circuit is dependent on its previous history. When, therefore, during a scanning period a change in the state of the pulsing relay in the 1st Code Selector is noted, the information received by the common control must be compared with the information already circulating in the delay line and relating to the same call. A simple case will illustrate this. Suppose that during the time a coupling circuit is being scanned the pulse wire is found to be disconnected; then, either the circuit has not been seized, or it has been seized and the caller has started to dial or is in process of abandoning the call. The action of the common control must obviously depend on whether during a previous scanning period it had detected an earth on the pulse wire. A method of doing this is shown in Fig. 2. Other methods of obtaining the required result are available.

Fig. 2 shows the circulating system to be made up of two delay lines, DLA and DLB. DLB has a delay equal to one unit-pulse time, the remainder of the major-cycle time of  $2.2 \text{ ms}$  being absorbed in DLA. A pulse injected into DLA will leave DLB  $2.2 \text{ ms}$  later (it being assumed that there are no delays in the connecting circuits).

The pulse wire of a 1st Code Selector using a particular coupling unit is connected to a gate G1, which is scanned by a pulse, say DP1, once every cycle. If the pulse wire is earthed the pulse is gated through to the two gates B and M in the common control. Both of these gates are operated on by pulses occurring at time  $p_1$ , but gate B is inhibited so long as G1 gives an output. A make condition of the L relay thus

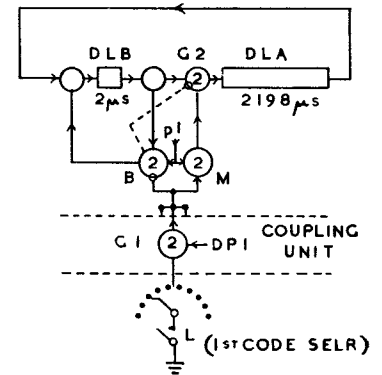

FIG. 2.—PRINCIPLE OF INFORMATION RECORDING.

appears as a pulse condition at the output of M at time  $p_1$  at the beginning of its DP pulse. The pulse enters the circulating system at the input of DLA and continues to circulate indefinitely. At some subsequent scanning period the L relay contact will be found to be normal, and at time  $p_1$  gate B will no longer be inhibited. At this time also the original pulse will be emerging from delay line DLB and the coincidence in gate B of this pulse with the clock pulse  $p_1$  will cause a pulse to be inserted at the input of DLB, so that now there will be two pulses circulating in adjacent positions in the system. Alternatively, if the dotted connexion shown in Fig. 2 be inserted, the original pulse can be deleted by the closing of gate G2 by an output from B, in which case a pulse circulating in position 2, but not in position 1, indicates the reception of a break following a make, whereas in the first case this condition is indicated by the presence of a pulse in both positions.

It should be noted that the gates other than G1 are common to all the coupling units, the stored pulses being spaced out in time by the DP pulses.

##### *Storage of Digital and Other Information.*

The maximum number of items of information that can be noted by the simple arrangement of Fig. 2 is four—no pulses, pulse in position 1, pulse in position 2, or pulses in both positions. The number of items of information necessary to simulate the A, B and C relay circuit is six, and each digit storage will require 11; 10 for the actual digit, and one to be used in connexion with digit distribution, as will be shown later. To record this information in the binary form by the presence or absence of pulses it is convenient to provide a total of four unit-delay elements similar to DLB and to shorten DLA to correspond. The complete system may be regarded as being made up of 220 groups of five pulse positions (Fig. 3), of which each coupling unit is allotted 11 groups; pulse positions 1-5 dealing with the dial pulsing circuit, 6-10 with the storage of the A digit, 11-15 with that of the B digit, and so on. Pulse positions 41-55 are used for translation and sending purposes.

Fig. 3 also shows the elementary circulating system of Fig. 2 expanded to include four unit-delay elements DLB, DLC, DLD, and DLE. Each element is provided with an output gate, O, and an input gate, I, the input gates being provided with suppression or inhibiting leads, S, which can be operated on to prevent any stored pulse from proceeding further down the line. With this arrangement any number of up to five pulses can be put in, read, out or detected simultaneously; that is, the whole of the information relating to a storage group can be read, or read and changed, during the  $2\text{-}\mu\text{s}$  time of one clock pulse.



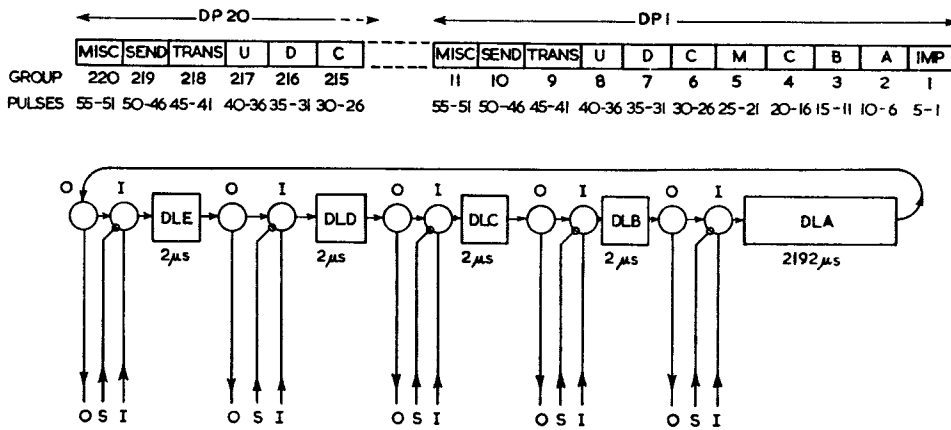

FIG. 3.—A COMPLETE STORAGE SYSTEM.

*Principles of the Dial-Pulse-Accepting Circuit: Sequence and Timing.*

In addition to the memory feature previously discussed, a normal dial-pulse-accepting circuit contains timing elements to distinguish, for example, the make periods of a dial-pulse train from the inter-train pause. With sensitive electronic equipment it is also necessary to distinguish spurious disconnexions from the true dial breaks. Excluding forced

TABLE I

Condition of pulsing relay	Pulse Positions		
	1	2	3
Operated prior to pulsing or re-operated after unaccepted break .. .. .	1	0	0
Released but true break not yet timed .. .. .	0	1	0
Released and timed as true break pulse .. .. .	1	1	0
Operated and inter-train pause timing started .. .. .	0	0	1
Operated after a true break pulse. (Inter-train pause timing not started) .. .. .	1	0	1

release, the conditions may be described by an arbitrary 3-unit binary code, as shown in Table I.

*Timing the Dial Break-Pulse Period.*

In Fig. 4, gates B and M operate in a similar manner to that described with reference to Fig. 2. Gate B, however, is connected to two supplementary gates, B1 and B2, which are used to time the break periods of the L relay contact. While it is possible to achieve extremely accurate timing with a system controlled by 2-μs clock pulses, a less accurate method, using the well-known S and Z pulse system and giving a 2-to-1 range of timings, is probably good enough; this is the method outlined in Fig. 4.

If at time p1 in the relevant DP pulse period the L contact is normal, gate B passes a pulse to gates B1 and B2, and B1 will put a pulse into the input of DLB to suppress the pulse about to enter DLA, providing,

- (a) that a pulse due to a previous make of L is detected at the output of DLB, and
- (b) that a break-timing S pulse (BS) is present coincidentally with pulse p1.

If the break condition of the L contact persists until the break-timing Z pulse (BZ) arrives (say, 11 ms later), then

at time p1 of the appropriate DP pulse, B2 will open to re-insert a pulse into DLA. An acceptable dial break pulse is therefore indicated by the presence of circulating pulses in positions one and two of the group of pulses relating to the particular coupling unit. Arrangements (not shown) are made to avoid any dial break being timed more than once.

Timed dial pulses have to be stored in some later pulse position appropriate to the digit that is being counted. For this reason B2 also gives an output to a locking trigger, TG2, which remembers that a true break pulse has been received. TG2 is, in any event, released before the

next DP pulse arrives.

*Timing the Dial Make-Pulse Period.*

On the initial operation of an L relay, gate M passes a p1 pulse to gate M1, which, in turn, injects a pulse into the input of DLA. At the same time, a trigger, TG1, is operated. Thereafter, as long as pulses are circulating in positions 1, 2 or 3, M1 cannot re-operate, but two additional pulse gates, M2 and M3, are provided to accept the output from M. M2 is used to gate a pulse into position 1 and to delete the pulse circulating in position 2 should the L contact re-make before an acceptable break pulse has been timed; i.e., if no pulse is circulating in position 1, but B1 has put one into position 2 prior to the operation of B2. M3 operates to put a pulse into position 3 (input of DLC) only if M operates at a time when pulses are already circulating in positions 1 and 2; i.e., after B2 has operated. M3 deletes the pulse from position 2.

After a make has been detected following a timed break, it is necessary to look for an inter-train pause condition. This also can be measured by an S and Z pulse system by pulses spaced, say, at 110 ms. Gate M4 opens to delete the pulse circulating in position 1, provided that pulses are already circulating in positions 1 and 3 and the inter-train pause S pulse (ITPS) is present at a time when M is operated.

On receipt of the inter-train pause Z pulse (ITPZ), gate M5

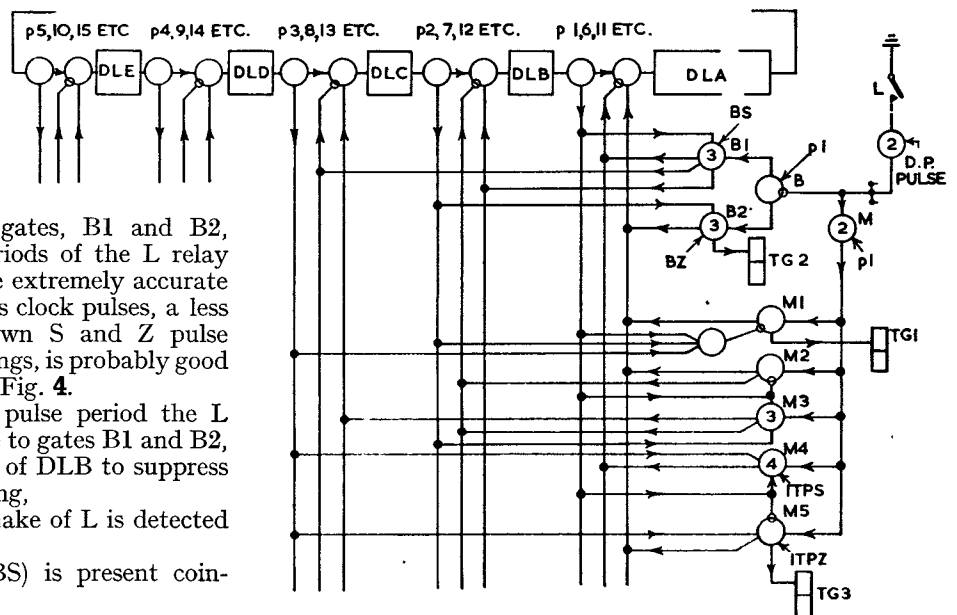

FIG. 4.—PULSING-IN CIRCUIT: TIMING OF DIAL PULSES.

operates to the pulse in position 3 provided there is no pulse in position 1. M5 also operates a trigger, TG3, which is used to control the distribution of the incoming digits.

*Incoming Digit Distribution.*

Each digit dialled by a caller is allotted a group of five pulse positions in the delay-line time cycle, the first position in a group being used as a marker to indicate which storage group is to be used at any time. The A digit occupies positions 6-10, the B digit positions 11-15, and so on. The operation of trigger TG1 (Fig. 4 and 5) when the loop is first detected causes gate DD1 (Fig. 5) to be marked. At time p6 of the relevant DP period, DD1 opens, and a pulse is put into DLA to occupy the sixth pulse position of the series allocated to a particular coupling unit. This pulse marks the beginning of the A-digit storage group. The output of DD1 also resets TG1. The marking pulse continues to circulate in position 6 until trigger TG3 is operated to indicate that the A digit is complete. At the p6 pulse following the operation of TG3, DD2 is operated by the pulse circulating in the storage system. DD2 deletes the pulse circulating in position 6 and, after a slight delay (DL), re-operates TG1. Meanwhile, TG3 is reset. At time p11 following the re-operation of TG1, DD1 gates a pulse into position 11. This pulse continues to circulate until TG3 re-operates after the next inter-train pause has been detected. This sequence may be repeated as many times as necessary under the control of the pulse series connected to the DD gates.

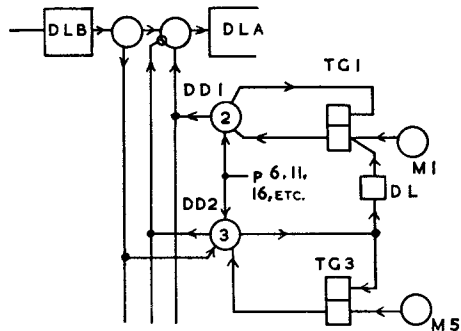

FIG. 5.—INCOMING DIGIT DISTRIBUTION.

*Digit Storage.*

Two alternative methods of counting-in dial pulses in the binary notation are indicated in Fig. 6 and 7. In Fig. 6 the pulses are fed into the circulating system at a single point and distributed in binary form by a system of clock pulses, whereas in Fig. 7 they are fed into one or more of four input positions during the time of one unit pulse. The choice of method is a matter of convenience, but both will be described because, with slight modifications, each can be used either for the storage or the sending of information.

TABLE 2

Digit	Pulse Positions			
	7	8	9	10
1	1	0	0	0
2	0	1	0	0
3	1	1	0	0
4	0	0	1	0
5	1	0	1	0
6	0	1	1	0
7	1	1	1	0
8	0	0	0	1
9	1	0	0	1
10	0	1	0	1

The binary code to be used is given in Table 2.

If the binary numbers are read from left to right as shown in the table, it will be seen that to add one to any of them it is necessary to change all the 1's preceding the first 0 to 0's, and to change the first 0 to a 1, the adding process always finishing with the insertion of a 1.

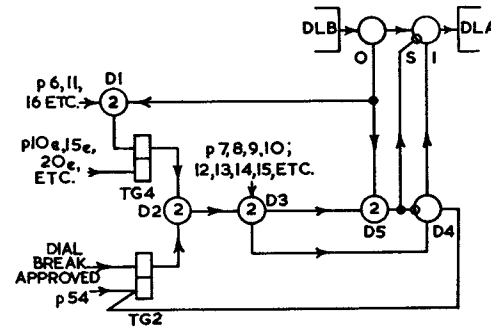

FIG. 6.—COUNTING-IN BINARY-NOTATION DIAL PULSES.—METHOD 1.

Referring to Fig. 6, the digit-distributor circuit described in the previous section will have caused a pulse to be put into the circulating system at one only of the positions 6, 11, 16, etc. Gate D1 enables a pulse to operate trigger TG4,

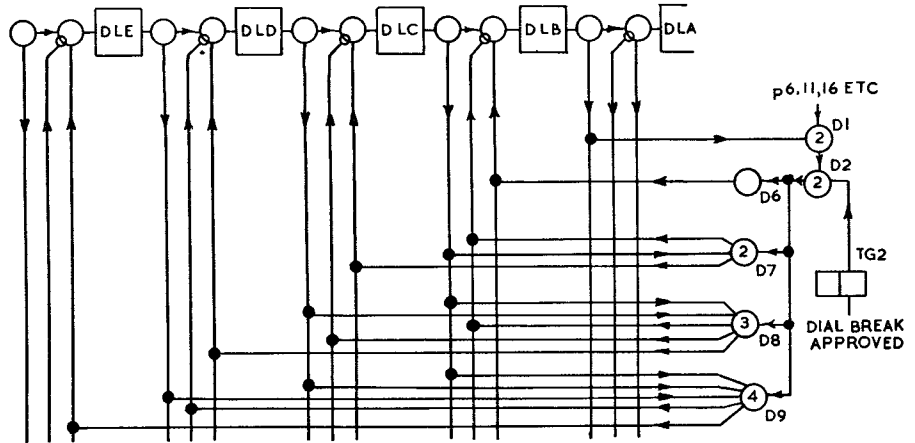

FIG. 7.—COUNTING-IN BINARY-NOTATION DIAL PULSES.—METHOD 2.

when a circulating pulse appears at the output of DLB coincidentally with one of the clock pulses in the series p6, p11, p16, etc. When a true dial pulse has been timed at time p1 (Fig. 4) TG2 operates and the combined outputs of TG2 and TG4 mark gate D3 via D2. Thus, assuming that gate D3 is marked at time p6, then at time p7, D3 will give an output to D4 and D5. If a pulse is already circulating in position 7, D5 will operate and suppress the pulse at the input of DLA. At the same time, D4 is inhibited. Unless D4 is activated TG2 will not release, so that at the next pulse time (p8 in this case) D3 will again attempt to operate D4. Again, if there is a pulse emerging from DLB at time p8, D5 will operate to inhibit D4; if no pulse is detected by D5, D4 will put one into DLA and restore TG2 until the next break pulse has been detected by the dial-pulse-accepting circuit. TG2 is, in any event, reset before the next DP pulse. TG4 is always reset at the clock time indicating the end of the storage group in use.

In Fig. 7, gates D1 and D2 and trigger TG2 have the same functions as the corresponding equipment in Fig. 6. If D1 detects a circulating pulse at the output of DLB at time p6 after TG2 has operated, a pulse is applied via D2 to the four gates D6, 7, 8 and 9 at time p6. Pulses relating to the digit being received may already be circulating in the delay line and may appear simultaneously at

one or more of the outputs of DLA, DLE, DLD and DLC at clock time p6. The arrangement of the gates D6-9 is such that at times p6, 11, 16, etc., depending on which digit storage is marked, D6 will put a pulse into DLB unless D7 detects a pulse leaving DLC, in which case D7 inhibits the input to DLB and puts a pulse into DLC. D8 will put a pulse into DLD only if pulses are about to enter DLB and DLC; it will also suppress these pulses. D9 will gate a pulse into DLE and suppress the remainder only if pulses are about to enter DLB, DLC and DLD simultaneously.

#### TRANSLATION

There is a wide choice of types of common translator which can be used in association with the common director; several have already been mentioned in the Journal.<sup>1,5,6</sup> It would appear that, for service in a Strowger network, particularly for the case in which a translator is not required until a particular number of code digits has been received, a static translator operating from a pulse register is to be preferred. If this method is used the five sets of leads from the circulating system can be extended to the translator and the pulse information gated into the latter by clock pulses. The pulse information can be stored on triggers used to control switching elements such as rectifiers and cold cathode tubes to expand the codes to select a particular code terminal much in the same way that relay contact "trees" are used. The code terminal can be caused to select the appropriate translation, which can then be fed into the appropriate section of the delay line at the correct time by one of the information storage methods already outlined.

The whole of the translation may be put in during the time of one DP pulse or read out one digit at a time as convenient. The second method economizes in delay-line storage, but involves the translator being called in as required so that, in this case, the translator will have to be told which translation to release. In addition to the question of storage space, the choice of translation method is affected by the type of components used in the translator. For example, if cold cathode tubes are used, their long de-ionization time will prevent the translator being used more than once every 10 ms, and this will limit the number of commoned directors having access to a single translator.

#### SENDING

To illustrate a method of sending Strowger pulses, it is assumed that the digit to be sent is stored in binary form in a particular group of four adjacent pulse positions in the delay line; e.g., positions 47-50. To read out the binary number, a "counting-down" process is employed in which

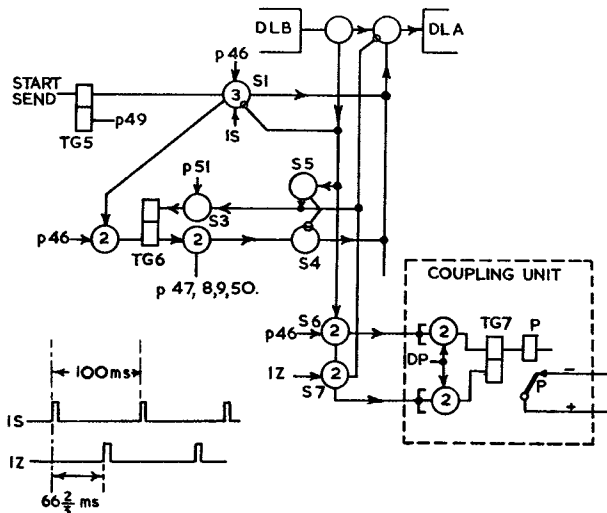

FIG. 8.—SENDING STROWGER PULSES.

one is subtracted from the stored number each time a Strowger pulse is sent to the coupling unit. Referring to Table 2, it will be seen that to subtract one from any binary number, all the 0's preceding the first 1 (reading from left to right) must be changed to 1's, and the first 1 must be changed to 0. This is, of course, the reverse of the reading-in process previously described with reference to Fig. 6. Fig. 8 shows a method of achieving this result.

When a start-send signal is detected, trigger TG5 operates to mark gate S1. To gate S1 is connected a lead, IS, on which a pulse appears every 100 ms. At time p46 after the operation of TG5, S1 operates to the first IS pulse it detects and a pulse is caused to enter the circulating system. This pulse also operates the trigger TG6.

The pulse in position 46 is detected by gate S6 during the next cycle and gates an operate condition to the outgoing loop-control trigger, TG7, in the coupling unit. TG7 operates relay P to open the outgoing pulse loop to the 1st Code Selector.

The operation of TG6 marks S3, which opens at pulse times p47, 48, 49 and 50. If, at time p47, a stored pulse is detected by S4, the output from S3 is prevented from passing S4 and the trigger TG6 is restored. S5, however, deletes the pulse from the circulating system by inhibiting the input gate to DLA. If no pulse had been detected at time p47, S3 would have passed a pulse into DLA, in which case TG6 would not have released until either S5 had detected a pulse in one of the positions 48-50, or the end of the cycle had been reached at time p51.

The pulse circulating in position p46 is continuously applied to gate S6 and through S6 to gate S7. Gate S7 is also connected to pulse lead IZ, over which pulses spaced at  $66\frac{2}{3}$  ms from the IS pulses appear every 100 ms. The first of these pulses following the operation of S6 causes S7 to give an output to the coupling unit to reset trigger TG7 and restore the outgoing loop to the 1st Code Selector. S7 also deletes the pulse from the delay line so that the cycle can be repeated until the stored digit has been completely erased.

#### COMMONING OF LARGER GROUPS

The principles already described can be extended to cover the case of larger groups either by increasing the length of the delay lines, by putting several lines in series, or by using a parallel arrangement of lines. With a parallel arrangement it is possible to circulate the information relating to any coupling unit in several lines simultaneously; the choice of method will, in general, depend on whether delay-line space is to be sacrificed to simplify the gating elements, and on the number of inputs it is required to scan in a particular time cycle.

#### CONCLUSION

The use of high-speed pulse-storage techniques in association with a time-division-multiplex scanning system so reduces the number of individual components that a common-control system using these techniques is likely, when fully developed, to be competitive with any electro-mechanical storage system, even when comparatively small numbers of control units such as directors are commoned together. Because the bulk of the cost will always be in the pulse generator and the translator, the cost per unit tends to decrease as the number of commoned circuits increases. Indeed, this fact may offset the major criticism of common control devices—that a common fault may be catastrophic—because, paradoxically, a common-control system of the type described may, in fact, be cheap enough to be provided in duplicate, and the principle of one component, one job, introduced with advantage. The extremely low cost per unit of storage space enables self-routining features to be readily introduced into this type of equipment because the

whole of the storage system can be monitored by causing a pulse to be circulated continuously in a spare position.

The extension of the use of the common-control principle leads to some interesting possibilities. For example, not only could the principles described be applied to common apparatus such as directors and registers, but also to other apparatus such as impulse regenerators and supervisory relay sets. The principle can be extended to provide a few super controls to control the whole of the exchange switching and supervision, whether the selectors be electronic or electromechanical, the exchange selectors in effect working as slave mechanisms controlled by a few electronic operators permanently monitoring the whole of the incoming lines.

#### ACKNOWLEDGMENT

The author would like to thank his colleagues in the RF Division of the Research Station, in particular, Messrs. M. J. Rubin and N. T. Thurlow for their assistance in experimental work of the type described in this article.

#### References.

- <sup>1</sup> HERON, K. M., BAKER, H., and BENSON, D. L. An Experimental Electronic Director. *P.O.E.E.J.*, Vol. 44, pp. 97 and 169, Oct. 1951 and Jan. 1952.
- <sup>2</sup> MALTHANER, W. A., and VAUGHAN, H. E. An Automatic Telephone System Employing Magnetic Drum Memory. *Proceedings I.R.E.*, Vol. 41, No. 10, p. 1341, Oct. 1953.
- <sup>3</sup> BAKER, G. T. British Patent Specifications 681, 360 and 688, 723.
- <sup>4</sup> WILLIAMS, F. C., KILBURN, T., and THOMAS, G. E. Universal High Speed Digital Computers: A Magnetic Store. *Proceedings I.E.E.*, Vol. 99, Part II, p. 94, 1952.
- <sup>5</sup> FLOWERS, T. H. Introduction to Electronic Automatic Telephone Exchanges: Register-Translators. *P.O.E.E.J.*, Vol. 43, p. 177, Jan. 1951.
- <sup>6</sup> BROADHURST, S. W. An Experimental Register-Translator for Universal Subscriber-Subscriber Dialling. *P.O.E.E.J.*, Vol. 47, p. 97, July 1954.
- <sup>7</sup> BRADBURY, E. M. Magnetostrictive Delay Lines. *Electrical Communication*, Vol. 28, No. 1, p. 46, 1951.
- <sup>8</sup> DE BARR, A. E. Digital Storage Using Ferromagnetic Materials. *Elliot Journal*, Vol. 1, No. 4, p. 116, 1953.

## Soldering-Iron Heaters

U.D.C. 621.365.41:621.791.332

**G**AS-HEATED soldering-iron furnaces were superseded just before the war by electric furnaces, in which a 1-in. diameter alloy liner is surrounded by a nickel-chrome heating element. Two sizes of heater are in use: the 250W model takes one soldering-iron, while the 550W furnace accommodates two irons. When new, the heaters take 10 min to raise the temperature of a 4-oz bit to the melting point of solder, but with age this time gradually increases. Although a switch is incorporated, enabling the heater to be run at a high or a lower temperature, it is found, in practice that, because of the long heating-up time, furnaces are run for long periods at the high temperature; shortening the lives of both heating elements and soldering bits.

Trials have been made of low-voltage furnaces incorporating a thermostat and a gravity switch that operates only when an iron is inserted. The thicker wires of the heating element last longer, but a transformer is required.

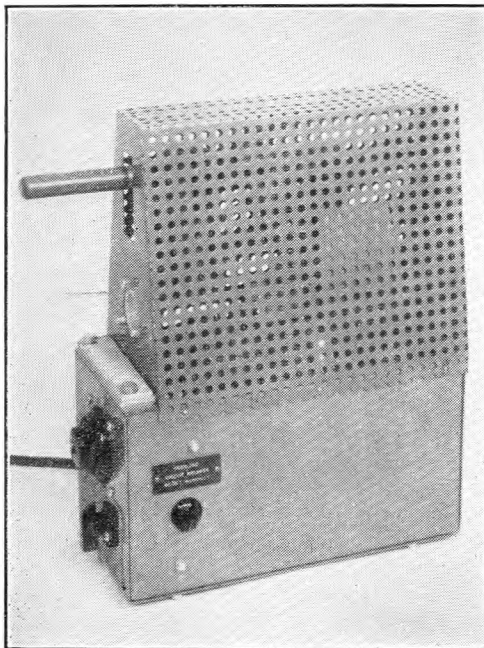

In recent years, several heating devices have appeared on the market which consist of a transformer, in the secondary circuit of which two electrodes (usually carbon) are provided; the object to be soldered is placed between the electrodes and the resulting surge of current raises the object to the required temperature. Several proprietary soldering-irons use this principle; power (usually at 4-6V) is fed to the copper tip by closing two carbon contacts. The tip reaches soldering temperature in a few seconds but, if the control knob is left switched on, bright red heat is soon attained, with a risk of burning adjacent insulation; this is one of several reasons why this type of soldering-iron is unlikely to be generally adopted by the Post Office.

In order to determine whether this principle can be used for heating copper bits, a heater incorporating two electrodes in the form of tongs was investigated, and a bench type with spring-loaded carbon jaws was developed in conjunction with Messrs. Standard Telephones & Cables, Ltd., and is at present undergoing field trials. The contacting action is made by holding a handle downwards against a spring. As illustrated, the heating carbons are enclosed by a perforated metal guard; the guard is insulated from the electrodes to avoid arcing when irons are inserted or removed.

The primary current taken from the mains is between 3.5 and 5.0A, depending on fluctuations in the supply voltage and on whether the carbons are applied to the base or to the tip of the bit. The secondary current when heating a 4-oz bit is approximately 300A. The time required to heat the iron to soldering temperature is from 0.5 to 1.0 min, according to the position of the bit relative to the carbon blocks. Subsequent re-heating of the iron will, of course, be quicker. Power is thus continuously saved, compared with the day-long operation of the standard electric heating ovens.

Since the handle is held down only during the heating, there is no great risk of over-heating, but a circuit-breaker is incorporated to disconnect the primary circuit under overload conditions. It provides both instantaneous and delayed tripping; an electro-magnet acts instantaneously against faults such as short circuits, while a thermal unit caters for prolonged low fault currents.

J. G. D.

# Transatlantic Telephone Cable—The Overland Cable in Newfoundland

H. E. ROBINSON  
and B. ASH†

## Part 2.—The Cable-Laying Operations in Newfoundland

U.D.C. 621.315.235

The Transatlantic Telephone Cable is routed overland for a distance of about 60 miles across Newfoundland. Part 1 of this article described the overland cable and preparations for laying it, up to the stage when the S.S. *Teeswood* sailed from London to Newfoundland, on 5th April, 1955, with the cable, vehicles and stores. Part 2 concludes the article by describing the organization of the work in the field and the actual cable laying, jointing and testing operations in Newfoundland.

### FIELD ORGANIZATION

THE contractor's organization for trenching and laying the cable was as shown in Fig. 9, and the Post Office staff had, therefore, to be organized to provide for supervision of each of the contractor's sub-divisions of the work and also to perform the additional work of jointing and testing and of liaison with the Eastern Telephone and Telegraph Co. (E.T. & T. Co.) and the Canadian Overseas Telecommunication Corporation (C.O.T.C.) representatives.

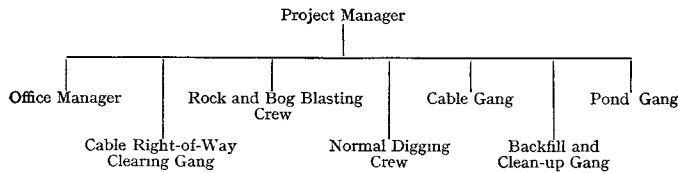

FIG. 9.—CONTRACTOR'S ORGANIZATION.

It was originally intended that the Post Office should send a party of three work supervisors, three jointers and three jointer's assistants to Newfoundland, based on the contractor's estimated average rate of cabling (6,000 yd per week). As progress, week-by-week, would depend on weather and ground conditions, it was expected that there would be periods in which the contractor's estimate would be exceeded, and to ensure effective supervision and prevent delay to the contractor by cable-jointing operations, the Post Office overseas staff was increased (from the reserve) to five work supervisors, five jointers and five jointer's assistants. Two officers from the Cable Test Section, Test and Inspection Branch, E.-in-C.'s Office, who accompanied the party, were responsible for the photographic X-ray examination of joints and the electrical tests on completed lengths of cable.

The Post Office staff were therefore organized as shown in Fig. 10.

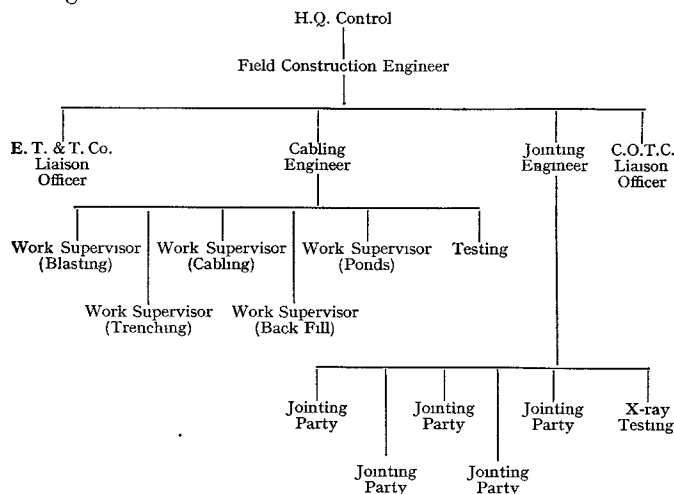

FIG. 10.—POST OFFICE ORGANIZATION.

†The authors are, respectively, Executive Engineer and Assistant Engineer, External Plant and Protection Branch, E.-in-C.'s Office.

### PREPARATORY WORK IN NEWFOUNDLAND

A small party left England in time to supervise the unloading in St. Johns of the cable, vehicles and stores from the S.S. *Teeswood*. With the assistance of C.O.T.C.'s manager in St. John's they dealt with customs formalities, arranged rail transport, temporary accommodation for the main party and a site for the job store at Goobies.

#### The Job Store.

Goobies, a small settlement which lies approximately midway between Clarenville and Swift Current, has a railway siding alongside the road, opposite to which is a suitable piece of ground large enough to park 20 or more vehicles. Because of these facilities, Goobies was chosen as a place for the job store from which to serve working parties over a large section of the cable route. Two box cars were hired from the Canadian National Railways, one for use as a store and the other as an equipment repair workshop, and to prevent inconvenience and possible damage to the equipment by shunting, a private siding was built to isolate the cars from the permanent way. There, while the contractor was assembling his stores and equipment, the Post Office jointing party, with the help of local labour, built two portable wooden cable test huts ("Alder House" and "Leith House"), jointing-tent floorboards, sleighs and field store boxes in preparation for the work ahead. They also built a store for diesel oil, paraffin and petrol, a fire-prevention point and a dump for scrap cable. Later, when the work had progressed beyond Swift Current, the job store was moved to a site near Long Pond and housed in tents provided by the contractor; the box cars and siding were then given up. It is of interest that, due to the unflinching efforts of the staff, the job store was the only tent in the contractor's camp to survive when the hurricane "Ione" swept Newfoundland in September, 1955.

#### Route Reconnaissance.

Although the problems of trenching and cabling had been discussed at some length during the training period in London, it was felt that the work supervisors should be given an opportunity of making a reconnaissance of the route, to reassess these problems for themselves. With the cabling engineer, who was a member of the 1954 survey party, the five work supervisors walked over the 50 miles of cable route between Adeyton and Terrenceville. During this reconnaissance a study was made of the survey traverse under field conditions, the sea-section landing points were studied in detail and methods of cabling the ponds and rivers were discussed. With the aid of the route plan the party surveyed for suitable places of access from the road to the track for each drum length of cable. A few days later the jointing parties were taken on a similar reconnaissance between Adeyton and Goobies and the experience gained was useful in deciding the method of transporting testing and jointing equipment into and out of the jointing positions. Besides giving the staff a thorough knowledge of the route the reconnaissance was good physical training for the months of arduous work ahead.

### Field Trials.

The method proposed by the contractor for cabling the ponds was to use a barge, 24 ft × 12 ft, built up from steel sections 6 ft × 6 ft and powered by two 125-h.p. outboard engines. From observations during the reconnaissance it seemed likely that the use of this cabling barge, requiring considerable manpower to assemble and launch, would delay the work and be costly in ineffective time. Furthermore, it was doubtful whether such a craft could be launched and manoeuvred on the ponds when the water was at its lowest level. It was therefore decided to stage a field trial of cabling the ponds by floating the cable on sealed empty oil-drums. This method proved very satisfactory and did not require a separate pond gang except for Long Pond and Sock Pond. It allowed continuous cabling where otherwise gaps would have had to be left to be cabled later at the contractor's convenience, a situation that was undesirable for the progress of jointing and section testing. The trials also proved that when cabling along narrow ponds the cable ends could be floated off the line of route to a suitable place on the shore for jointing, and afterwards floated back again to be dropped to the bottom in line with the surveyed route. The trials also established that Long Pond and Sock Pond could be cabled in this way, and that the jointing could be carried out on a locally made wooden raft which could be managed by the jointing party.

### CLEARING THE CABLE ROUTE

To clear the cable route for the digging and cabling machines in wooded country, a party of 10 experienced woodcutters went ahead of the trenching party to widen the 6-ft path cleared for the survey line to 20 ft (the width covered by the wayleave, or easement). The trees were cut as near to the ground as possible, leaving the roots undisturbed to assist in maintaining the stability of the subsoil, which would otherwise have become a morass. Leaving the roots also helped to retain the natural drainage channels, so preventing water from spreading over a large area and causing soil erosion in the cable trench after heavy rain. The trees felled were used to support the heavy trenching and cabling equipment when operating over the bogs and soft ground, although it involved considerable labour to move sufficient trees to satisfy working requirements in barren open country.

### TRENCHING

The contract specification called for a trench to be excavated on the survey line to a depth of 30 in. in soil, gravel or bog and 18 in. in rock. On the 18th May two Hyster backhoe trenching machines (Fig. 11) were set in



FIG. 11.—ONE OF THE TRENCHING MACHINES AT WORK.

operation at Adeyton, but at first progress was slow because the ground was waterlogged, and when the surface was broken many boulders were exposed, weighing from a few pounds to several tons. The tree roots did much to consolidate the ground, in spite of being an obstacle to clean digging, but the machines were frequently out of action for many hours at a time, due to bogging down in a quagmire of their own making. Unfortunately, these machines were not equipped with winching mechanisms and, therefore, another tractor had to be used to tow or winch them through the soft places. For a time, the two digging machines worked close together so that, when necessary, one could assist the other, but, as the work progressed, the distance between the two machines increased and the arrangement for mutual assistance was no longer practicable. Although costly, it soon became evident that satisfactory progress could not be maintained unless a tracked towing vehicle (towcat) was used with each machine, and after repeated failure to keep the diggers in operation by any other means the contractors obtained two "D6" tractors fitted with winching gears for use as towcats.

The trenching work was divided between three separate parties, the machine-digging crews, the rock-blasting party, and a gang to clean out and level the bottom of the trench to receive the cable. In the contract specification it had been agreed that the price per yard of trench excavated in rock could be claimed only if the trench could not be excavated by the digging equipment in use and blasting was necessary, so the following procedure was adopted: first, the machine diggers went over the route to clear the overburden and to excavate as much rock as possible; then, if the trench produced was not of the required standard, an assessment of the amount of rock trench for payment purposes was agreed with the contractor and the rock-blasting crew were called in.

Trenching in bog caused the most difficulties, especially after heavy rain, when a piece of bog in which trenching machines could normally operate was changed into a morass that could support neither men nor machines. A procedure was adopted similar to that for the trench obstructed by rock. First, a machine digger assisted by a towcat and supported on spruce logs would be tried; then, if this failed, a party of men would try to dig a trench by hand; and, finally, if this method was not successful, explosives were used. An agreement was reached whereby the shallow-water rate for trenching in bog would apply only if machine and manual digging had been tried and had failed.

In many of the bogs the contractor, for his own convenience, chose to use explosives for opening the cable trench and, at first, he tried the propagation method, which is generally the quickest and most economical way of blasting a trench in bog. In applying this method only one of the charges is primed, the shock from the explosion of this charge is propagated through the wet bog with sufficient force to detonate the adjoining charge, and so on. The velocity of detonation is very rapid, with the result that the entire line of charges explodes almost simultaneously. The distance through which propagation can take place depends on the size of each charge, the sensitivity of the explosive material and the temperature and characteristics of the ground. The ditching dynamite used in Newfoundland was supplied in sticks 1½ in. × 8 in. and should normally propagate satisfactorily when charges are placed 12 in. to 18 in. apart, but due to the large number of boulders which lie just below the surface of the bogs, the chain of propagation was broken and the method had to be abandoned because of misfires. Various alternative methods of blasting in bog were tried, but the one finally adopted was that whereby a detonating fuse, named "Primacord," was

used to detonate each charge individually, the Primacord itself being detonated electrically. One of the problems of trenching by explosives is that the spoil is spread over a large area and cannot be used as backfill; consequently material for reinstating has to be obtained elsewhere. This tends to offset any advantage gained by the use of explosives for trenching in bogs and in soft ground.

In streams and small rivers the trench was excavated to the normal depth of 30 in., but in the large rivers the depth was increased to 4 ft, as a precaution against damage by the pack ice which piles up in the rivers during the winter and would be a hazard to the cable were it not laid deeply, especially in rivers with sandy bottoms.

Where the cable crosses Dunn's River the bed is approximately 150 ft wide and is of solid rock, the river is fast flowing and some 50 yd downstream there is a fault over which the water cascades a hundred feet or more to the valley below. For most of the summer the volume of water was too great for safe working above the falls, and consequently this river could not be cabled until late August when the conditions were favourable; then, as soon as the level of the water began to fall, the contractor started to build sandbag dams to divert the water from the sections of the bed he had planned to blast. Heavy rain delayed this work and it took almost a month to drill the rock and prepare the bed for blasting. Spruce branches were placed in the drill holes to prevent them silting up, and when all the drilling had been finished, some  $3\frac{1}{4}$  cwt. of dynamite, in  $3\frac{1}{4}$  in.  $\times$  8 in. cartridges, was placed in the river bed. When exploded, as shown in Fig. 12, this gave one of the most spectacular sights

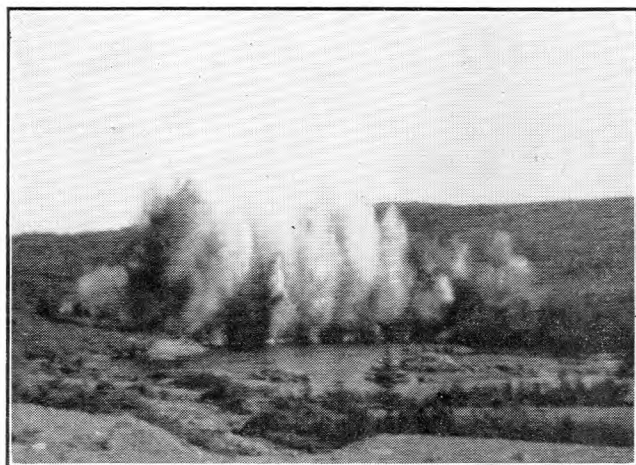

FIG. 12.—BLASTING DUNN'S RIVER.

of the job, as it is estimated that 100 yd<sup>3</sup> of rock were lifted from the river bed by the blast. When the loose rock had been cleared the sandbags used to dam the river were placed in the bottom of the trench to give a soft bed for the cable.

The most costly trenching work of the project was that in the Terrenceville highroad. The road from Swift Current reaches a point at the end of the plateau some three miles from Terrenceville where it drops steeply to sea level. For about 3,500 yd the road is cut in the steep side of the river valley and where the angle is too steep the road is supported on timber and is braced against the side of the hill. Every few years, and particularly after a wet spell, the road collapses and slides down the sides of the valley and into the river. The highways superintendent gave valuable advice based upon his many years of road-building experience, and, with his co-operation, many tons of rock and soil were removed from the road bank so that the trench could be dug to a depth of 4 ft in solid ground. At this depth the cable is safe from all normal road works, including schemes for road drainage.

## CABLING

Wherever possible, the cable was laid directly in the trench from the cable trailer; but in wet weather it was often necessary to make a detour around mud holes and soft places, lay the cable out over the ground and man-handle it into the trench. In bog land, over which the heavy cable-laying equipment could not operate, a light tractor was used to pull the cable off the reel and over the soft ground and, as an aid to this operation, freshly skinned spruce poles were placed on the ground 10 ft apart and at right angles to the trench. The cabling gang followed up and, lifting the cable a few yards at a time, they worked it into the trench, as illustrated in Fig. 13; then, to complete the operation, a man walked along the cable and



FIG. 13.—WORKING THE CABLE INTO THE TRENCH.



FIG. 14.—TREADING THE CABLE TO THE CORRECT DEPTH.

trod it to the required depth (see Fig. 14). With skilled tractor operators it was possible to lay up to 800 yd of cable in one operation across some of the most formidable bog country that is to be found in Newfoundland.

At road crossings the cable was laid at a depth of 5 ft below the crown of the road for the width of the highway right-of-way (100 ft for main and 66 ft for secondary roads), and, as an extra precaution against road works, the cable was protected with timber for a distance of 15 ft on either side of the carriageway. A 4-in. composition duct impregnated with bitumen was laid adjacent to the cable at each road crossing to facilitate repair in the event of a fault under the road.

No special measures were taken to protect the cable in streams and small rivers, but it was considered desirable to lay a spare length of cable with the working cable in each

of the three large rivers, to insure against the possibility of a fault in the working cable in one of these rivers.

The method of cabling the ponds was evolved from the field trials carried out by the Post Office party in Newfoundland. For each pond the cable reels were taken to a vantage point as near to the water as practicable and in line with the route to be followed. A rope was paid out from a motor boat to span the pond and for all except the two largest ponds a light tractor was used to pull the cable across. On the shore a small gang of men lashed 40-gal oil drums to the cable at 20-yd intervals to give it buoyancy during the pulling operation. As soon as the cable was pulled into position on the surface of the pond the drums were progressively released from one end, allowing the cable to sink to the bottom in a manner comparable with that of laying the cable from a barge. The drums were allowed to drift to the shore and were collected later. At first, hand signals, flags and vociferous means were used to control the operations, but later, when cabling Long Pond (5,700 yd) and Sock Pond (3,400 yd), portable short-wave radio sets ("walkie-talkies") were used.

#### *The Cable in Placentia Bay.*

The road from Goobies reaches the head of Placentia Bay where the Black River flows into the sea, and where the Pipers Hole River has emerged from between hills rising steeply to nearly 1,000 ft, into an open basin of mud flats through which the main channel of the river follows a winding course for some two miles. The road has been trenched out of the rock cliff in places, and the country behind is very rugged. From the Black River mouth, the objective was to reach the high plateau beyond Pipers Hole River, and past the settlement of Swift Current lying in the basin. The hazards due to small coastal vessels approaching the pier at Swift Current were judged not to be great, and so it was decided to bridge a very difficult gap in the route by laying the cable in the water. For this purpose a piece of land cable was made in one length of some 11,500 yd, but it was armoured with No. 2 gauge wire, and called "Land Special." Similar pieces were also used across the south-western arm of Trinity Bay from Hill View to Queen's Cove, and off the shore at Adeyton, but these two lengths were laid by *Monarch* while she was there.<sup>1</sup> The Placentia Bay cable weighed 70 tons, and it is of interest to record that the manufacturers (Southern United Telephone Cables, Ltd.) sent this to the dock in a tank on a special transporter, without particular difficulty. On her way to Clarenville *Monarch* sailed into Argentia Harbour and there off-loaded this piece of cable on to a "scow," together with a similar length of D-type cable (deep-sea light-armoured type) for completion of the speaker circuit and to serve as a reserve for the main transmission cable.

The scow is essentially a large flat-topped totally-enclosed tank. This one could support 400 tons. It was equipped with a good motor-driven capstan winch and had a flat bottom, and could therefore run aground safely. An ocean-going salvage tug, *Foundation Vera*, took the scow for 40 miles up Placentia Bay to a point near Black River and handed it over to the skipper of a small local motor boat (4 ft draft) capable of negotiating the shallow waters at the head of the bay, but having the disadvantage of small towing power. As shown in Fig. 15, the cable on the scow was coiled on the deck, in about three layers, around an "eye" built of planks on edge, some 70 ft long and 10 ft wide. The end of the cable passed through a cable sheave, supported by an "A" frame, located amidships, and thence through a braking device (Fig. 16) provided by *Monarch* and lashed in place at the stern. The operation was under

<sup>1</sup>HALSEY, R. J. Transatlantic Telephone Cable—Inaugural Ceremonies and the first Laying Operations. *P.O.E.E.J.* Vol. 48, p. 174, Oct. 1955.

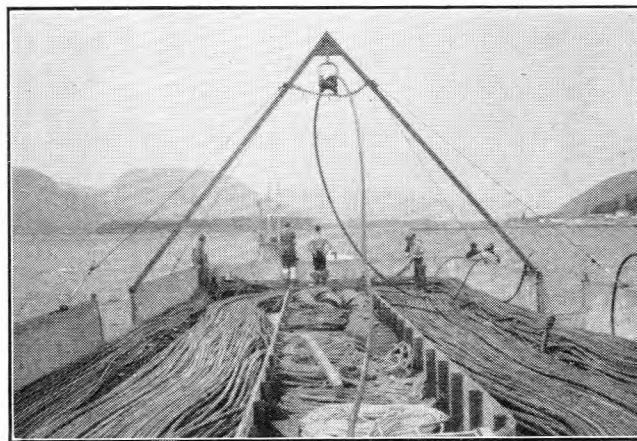

FIG. 15.—THE COILS OF CABLE ON THE DECK OF THE SCOW.

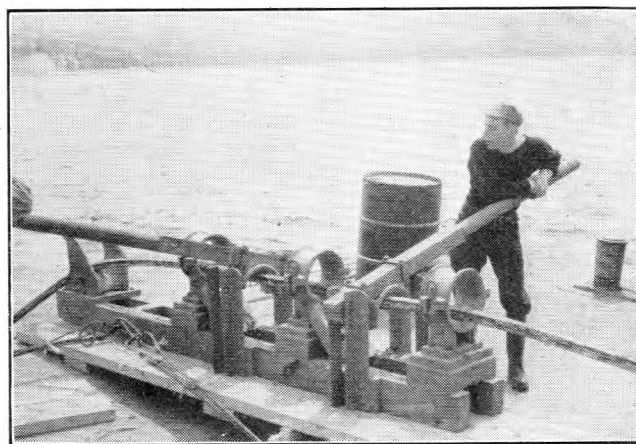

FIG. 16.—THE CABLE-BRAKING DEVICE.

the command of an officer lent by the cable ship and he had as crew two of *Monarch's* seamen cable hands, assisted by an odd collection of engineering staff, local Newfoundlanders, two of the staff of the Canadian Overseas Telecommunication Corporation and the E.T. & T. Co. liaison officer.

In preparation for the laying, the channel had been buoyed with home-made wooden buoys attached to large boulders. In the open water, where there are submerged sandbanks alongside the channel, long wooden stakes were driven in to mark the starboard side of the channel and were the only worth-while markers to survive. The critical part of the operation lay in rounding the sharp bends in the channel, at which points slack water only lasts for half-an-hour at full and low tides. At other times currents of up to 5 knots swirl around and would have made the scow uncontrollable.

A significant, although not critical, factor was that the mud flats at the Pipers Hole River end would only be covered with sufficient water to float the scow for a couple of hours at high water. It was therefore planned to try to reach the river bends at slack tide low water and then to proceed leisurely with the flood to arrive as soon as practicable before high water, giving the maximum time for contingencies. Low water was at noon, so an early start was made at Black River, the end put ashore and laying begun in the open bay at about 1½ knots. Approaching the narrowing part on a falling tide, speed fell until at one place no headway was made for nearly half an hour and it was almost noon. However, the efforts of the small diesel engine prevailed and the three most difficult bends were rounded in fine style just before the turn of the tide. The course in the very narrow deep channel was set by a local man who



knew the river well. Thereafter, the boat and the scow emerged into the broad open part of the river where the channel is narrow and winding and at low water is less than 2 ft deep. The scow by this time was drawing about 30 in. only, but the motor boat required 5 ft. The stakes marking the channel helped the skipper to steer the proper course, but a breeze came up and twice blew the scow aground, so there was a pause for half an hour each time until the rising tide floated it. Finally, just before high water, the motor boat went aground some 600 yd short of the objective and the skipper was unable to go further. Several coils of grappling rope had been put aboard the scow by *Monarch* for contingencies, so it was decided to take a line ashore, anchor it and have the scow complete its journey on its own winch. This took some time and the scow finally came to rest on the mud about 50 yd from shore, on a now falling tide. This upset the plan for laying the surplus main cable parallel to the shore, so it was cut and the end passed ashore. In preparation for the next day the end of the speaker cable was also put ashore, and the ship's officer led his crew off into the dusk for a meal after some 16 hours without a break.

To finish the operation, advantage was taken of the next high tide at about 7 a.m., so the party assembled at dawn and went to the scow, which, to everyone's relief, was floating, with no holes in the bottom. The return trip, paying out the D-type (speaker) cable along a course as nearly as possible 20 to 30 yd from that of the main cable, went without a hitch and the dangerous bends were negotiated at slack high water. The craft arrived off Black River during the morning, the end was passed ashore and both cables were tested. The surplus main cable (about 1,000 yd) and about 500 yd of surplus D-type cable were then streamed out from the scow in succession in a southerly direction into Placentia Bay. The free end of the surplus D-type cable was cast off, and the cable lies in the sea to be picked up if required. The surplus main cable, laid separately, was taken ashore at both ends, buried and its position marked with a post so that it can be periodically tested.

### JOINTING

It was necessary to reinforce the jointing parties with local labour because of the difficult conditions along the route and the amount of stores and heavy equipment required at each jointing position; approximately one ton of tools, stores and equipment had to be carried into and out of each position. The work at each jointing position consisted of surveying a route to the position, preparatory work at the position, jointing, testing, moulding and armouring and, to maintain a satisfactory jointing program, this work was divided among the jointing parties in such a way that they were able to work progressively along the route with the minimum of ineffective time.

A survey party located a suitable route and made an access way from the highway to each jointing position, collected a jointing platform, tent, tarpaulins, jointing bench and table from a completed jointing position and placed them at the junction of the highway and the point of access to the new position. They also decided how power could best be made available at the site and set up the supply accordingly.

A preparation party, following the survey party, transported the equipment from the road to the jointing site and, after preparing the site and erecting the tent, they set up the cable as shown in Fig. 17 and prepared the cable ends for jointing. To do this, both cable ends were cut to give the correct overlap and the appropriately-sized steel barrel was passed over one end in readiness for the armour splice. Next, the jute servings and armour wires were laid back, leaving the polythene sheath exposed. At this stage the

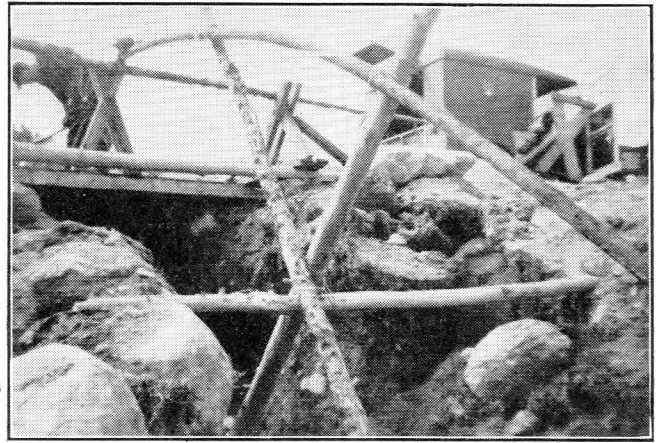

FIG. 17.—SETTING UP THE CABLE FOR JOINTING.

preparation party assisted the testing officers to measure and record the insulation resistance and the conductor resistance of each cable length; the jointing engineer was then advised that the position was ready to receive a jointing party.

The jointing parties were responsible for cutting the exposed polythene-sheathed cable to the correct overlap, setting back the screening, tereido and return tapes to expose sufficient cable core for brazing the centre conductor and for subsequent moulding of the polythene dielectric. When the centre conductor had been brazed and cleaned, the brazed portion of the joint was bridged by four 30-S.W.G. tinned-copper wires helically wound over the conductor and soldered to the tapes on both sides of the joint. This is a safety measure designed to ensure the continuity of the centre conductor in the event of a fault developing in the area of the braze. After jointing the centre conductor the polythene dielectric was trimmed for a distance of  $\frac{1}{2}$  in. on both sides of the joint, to remove any foreign matter, such as copper dust, which had adhered to the ends while cleaning the braze. This operation left a 4-in. gap between the ends of the dielectric for moulding. The injection-moulding machines used in Newfoundland were of British design and construction, and for portability they were built in three separate units; the mould and injection unit, the temperature control unit and the water pump unit (for cooling the ends of the mould). The moulding machine is shown in use in Fig. 18. The polythene was injected into the mould under pressure and at carefully controlled temperature, and the indication that the mould was filled was given by worm-like threads of polythene spewed from two vents in the top section of the mould.

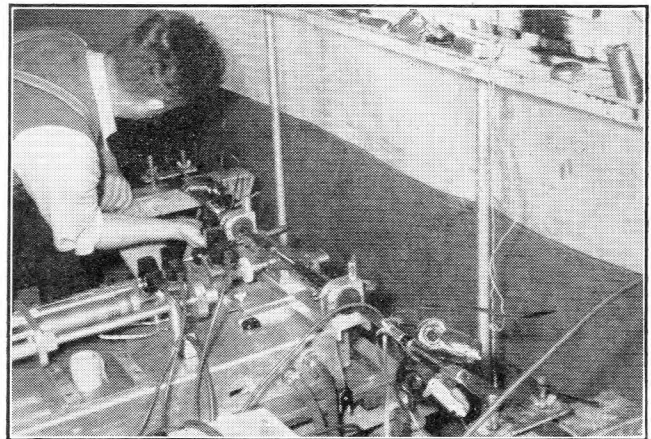

FIG. 18.—A MOULDING MACHINE IN USE.

When approximately 3 in. of polythene appeared the vents were sealed and the mould heaters switched off.

The temperature and the pressure of the polythene in the injection chamber were maintained throughout the period taken for the mould to cool, but as soon as the temperature of the mould had fallen to 50°C the remaining heaters were switched off and the injection pressure released. Then the injection nozzle and water pump connexions were disconnected from the mould and the mould was broken to remove the core. To complete the operation, the polythene projections produced by the injection and spew holes were carefully pared off.

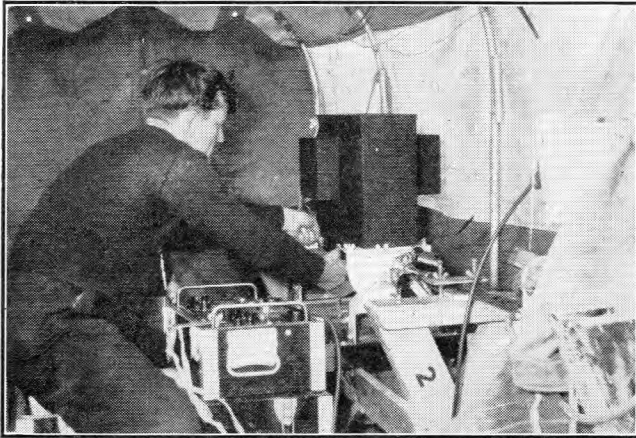

FIG. 19.—TAKING X-RAY PHOTOGRAPHS OF A COMPLETED MOULDING.

The finished moulding was examined by X-ray photographs taken as depicted in Fig. 19 and was subjected to a high-voltage test, but before this was done it was examined for "hard-bake." Hard-bake, as the name implies, is the hardened or charred polythene produced by constantly heating the polythene residue that adheres to the sides of the injection chamber during the process of moulding and, if allowed to accumulate, flakes off and mixes with the new polythene injected into the mould. Inclusions of hard-bake possess a similar chemical structure to that of new polythene and therefore they cannot be detected by radiographic (X-ray) examination. Polythene hard-bake was, however, assessed as foreign material in a moulded joint and it was for this reason that the cable core was given a visual examination in a specially-designed light box. From experience it was found that hard-bake inclusions could be prevented by regular and meticulous cleaning of the machines.

The purpose of the X-ray examination was to detect voids and inclusions of dirt or metal and to check the concentricity of the centre conductor. In this work a high standard of film processing was essential to avoid photographic faults which might be interpreted as genuine faults in the moulding. The high-voltage breakdown test was made by earthing the centre conductor and applying a 40-kV potential to a piece of moistened material wrapped around the surface of the moulding. Approximately 10 per cent of the joints were remoulded because of inclusions of foreign materials in excess of the amount specified for a satisfactory moulding, but no joints failed the high-voltage tests.

As soon as the jointing engineer was satisfied that the moulding was sound, the joint was completed. First, the return tapes were riveted together and soldered, then the copper binder (teredo) tape and the screening tapes were restored and the cable built up to unidiameter with polythene and P.V.C. tapes. Finally, the armouring party made the splice, as shown in Fig. 20. In addition to armouring, this party was responsible for the joints and

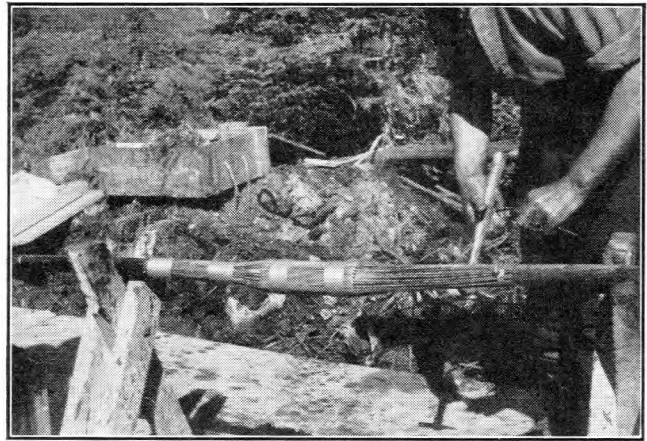

FIG. 20.—COMPLETING A SPLICE.

insertion of loading coils in the speaker cable, the talker post terminations and the installation of the impedance matching transformers in the speaker cable at the junction of the land and sea sections.

In all there were 105 joints in the main cable, and in the speaker cable there were 150 cable joints, 40 talker posts, 90 loading coils and 5 transformer-and-capacitor assemblies.

#### BACK FILL AND THE PLACING OF THE GUARD WIRES

The soil excavated from the cable trench contained a great number of rocks and boulders, and consequently indiscriminate backfilling by machines could not be permitted and a method of reinstating in two stages was devised. The first back fill was carefully carried out by a gang of men who hand-filled the bottom six to eight inches with selected soil; this served both as a protection to the cables and as a soft bed for the copper guard wires. Later, when the guard wires had been laid, the backfill was completed by the machines used for digging and trenching. In small rivers and streams, smooth boulders were placed over the cables to protect them, and on steep slopes and wherever there were signs of erosion, boulder walls or dams were built at suitable intervals in the trench, as shown in Fig. 21, to help to consolidate the soil.

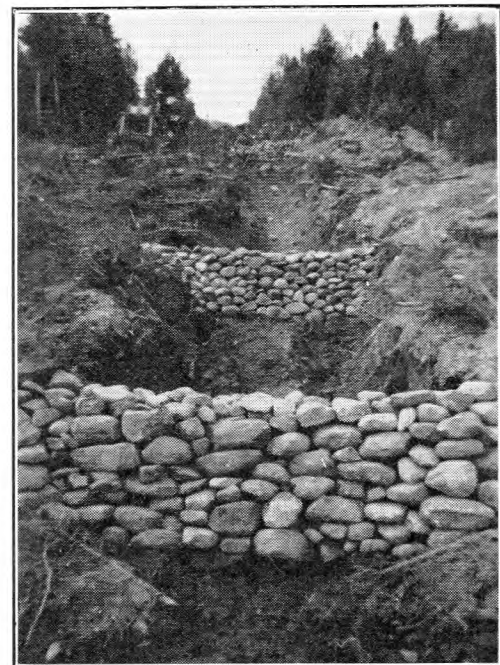

FIG. 21.—BOULDER DAMS IN THE TRENCH NEAR QUEEN'S COVE.

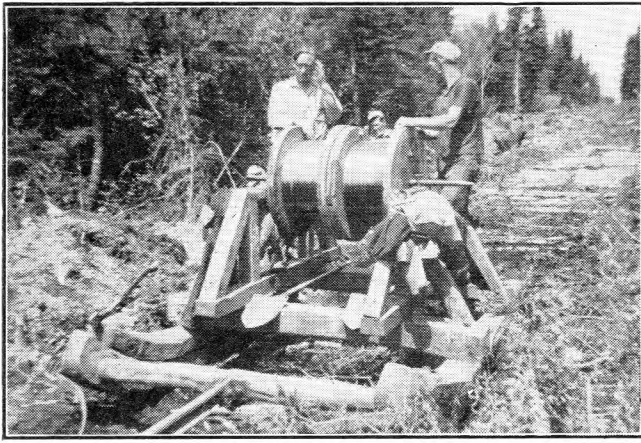

FIG. 22.—LAYING THE COPPER GUARD WIRE.

For convenience of laying, the copper guard wire was supplied on drums in lengths of two miles. The drums were mounted side by side on a wooden sleigh and towed by a light tractor (see Fig. 22). This very simple arrangement enabled both wires to be laid simultaneously, quickly and without serious difficulty in every kind and condition of country. The lightning guard wires are an effective protection to the cables in rock and in high ground, but in the ponds they could be the cause of lightning trouble, particularly if they were allowed to make contact with the cables. In each pond, therefore, the wires were laid divergently out into the water for 50 ft or more; the end of each wire was then fastened around a rock or boulder and buried in the sand. The guard wires were terminated similarly in the large rivers and in each of the three sea sections.

#### THE ROUTE MARKERS

To mark the location of the route, creosoted wooden poles approximately 10 ft long and 9 in. diameter were erected in the right-of-way at all points where the route changes direction, and at ponds, road and railway crossings. For identification with the records the poles were numbered consecutively from Adeyton and were fitted with labels which indicate clearly the position and the direction of the route. At road and railway crossings and at other places where there is a likelihood of future excavations, the poles carry warning notices to notify other undertakers of the existence of the cables and to ask for their co-operation in advising the cable station superintendent of any work that might endanger the cables.

#### INSTALLATION OF THE REPEATERS

It was estimated that the two repeaters would be available about the middle of November, and that if they were shipped by air to Gander it should be possible to install them before the severest winter weather set in. In preparation, therefore, two wooden huts 12 ft by 12 ft were built to accommodate the transmission-measuring equipment and were erected on a site at Fox Pond, near to the pit excavated in the pond for the first repeater, and at a convenient site adjacent to the road approximately 20 nautical miles further west along the cable route. Both huts were equipped with oil-burning heaters and were wired for electric lighting. The exact position for the second repeater could best be determined when the attenuation of the cable had been measured and so a series of pits were excavated at suitable sites (on the edges of ponds) over a distance of 800 yd on either side of the test point. Temporary joints (not armoured) were made in the cable at the first repeater position and at the test point to facilitate cutting and testing. A team of transmission engineers, together with a

jointing party, left England by sea with their equipment early in November and a week later the two repeaters, mounted in specially-designed steel cases, were sent by air to Gander by the manufacturers, Standard Telephones & Cables, Ltd.

A maximum-minimum thermometer and an impactograph were fitted to each repeater case, so that temperatures and the impacts received on each stage of the journey could be measured and recorded. By previous arrangement with a firm of contractors in Gander, and as soon as customs formalities had been dealt with, the repeaters were carefully transported to the railway station for shipment to Clarenville. Meantime the transmission-measuring equipment had been sent by rail from St. Johns, and both consignments arrived in Clarenville about the same time. Without delay the repeaters were taken to the cable station and tested and a certificate confirming that they had arrived safely and in good condition was sent home.

As soon as the tails had been jointed and bolted into the ends of the repeater housings, arrangements were made to move the first repeater to Fox Pond. Fortunately it was possible to hire a lorry and trailer fitted with a power derrick, and this proved to be a very valuable piece of equipment for loading and unloading the repeaters. For the journey, the repeaters were carried on the trailer in their steel travelling cases, but an additional wooden framework was constructed to support the tails. Motor-car tyre tubes were used to cushion the vibration caused by the rough road surface. The site for the first repeater lies downhill approximately 200 ft from the road and, with the assistance of local hired labour, the repeater was manhandled slowly and carefully to the edge of the pond. There it was fastened by a rope to a light tractor to control the weight, and by a co-ordinated effort the repeater was lowered to the bed of the pond.

When jointing the repeater tails (sea cable) to the land cable (screened) a method had to be devised to prevent the penetration of water across the joint and so prevent corrosion of the soft-iron screening tapes. An effective water barrier was made simply by impregnating the joint with a polythene compound. While the first repeater was being jointed into the cable, transmission measurements were made to establish the exact position for the second repeater, and it was found that the measured attenuation of the cable between the first repeater and the second test hut was 59.75 dB at 552 kc/s. As the temperature of the cable was estimated to be about 7.5°C, the annual mean temperature, this fixed the position for the repeater at 175 yd beyond the point of test and very close to the pit prepared on the west shore of "Hargrove Pond." Unfortunately access to the site was not particularly good and when the pit was examined it was found to be silted up. A coffer dam was built to dam the pond and allow the pit to be re-excavated, and then an access road was made to facilitate the conveyance of the repeater. The excavating and digging was done manually and as the weather by this time had become extremely cold, the task of working in icy water was not an enviable one.

Heavy snow falls had made the road almost impassable, and with the weather getting steadily worse the problem was to get the second repeater safely to its site, but this was achieved with the help of the highways department, who sent a grader over the road to clear the snow and to improve the surface. On the day the repeater was moved the weather improved and the 45-mile journey was made without incident, but of necessity the speed had to be reduced to 5 miles an hour in places and consequently it was almost dark when the repeater reached its destination. At sunset the air temperature began to fall rapidly (the lowest temperature recorded that night in Newfoundland

was 12 degrees below zero) and to prevent any possibility of damage to the repeater due to the low temperature it was decided to lay it without delay. Aided by artificial light from current supplied by the diesel generators the repeater was loaded on to a sleigh and towed to the edge of the pit and lowered, in a manner very similar to that employed for the first repeater. Immediately the repeater was in position the coffer dam was broken to flood the pit, and the party returned to Swift Current for a well-earned rest. The following day the jointers made the tail joints, and when this work had been completed, the ends were recovered from the test hut and the final joint in the Newfoundland section of the T.A.T. cable was made.

#### CONCLUSIONS

Although the cable-laying contract specified depths of 30 in. in soil and bog and 18 in. in rock, the contractor, by virtue of the type of digging equipment used, was able to lay the cable nearer an average depth of 3 ft, resulting in extra protection of the cable.

#### ACKNOWLEDGMENTS

The authors desire to express their appreciation for the assistance given by Mr. F. A. Hough in the preparation of this article and to thank Mr. C. H. Ryde, of the Canadian Overseas Telecommunication Corporation, for supplying many of the photographs used in the illustrations.

## Book Reviews

"Ultrasonic Engineering." Allen E. Crawford. Butterworths Publications, Ltd. 344 pp. 222 ill. 45s.

Ultrasonics is a fairly new subject and one that is diverse in its applications. In this very practical book the emphasis is on the applications and effects of ultrasonic waves; in it information and data are collected together from a wide range of sources, and the book reflects its author's close contact with the subject in his association with Mullard, Ltd., on the development and exploitation of high power ultrasonics.

The subject is divided very broadly into three sections; two chapters on Theory, four on Generation and seven on Applications. Adequate knowledge by the reader of the physical theory of acoustics is assumed and the first chapter, on ultrasonic waves, constitutes a general introduction to the book. The second chapter is concerned with the interesting phenomenon called cavitation which is associated with the passage of an intense sound wave through a liquid; about half of this chapter is occupied by illustrations of practical results of cavitation.

The four chapters devoted to transducers and generators, namely piezoelectric, magnetostriction, jets and whistles and electromagnetic transducers, are well treated and include practical and theoretical considerations relative to the design of ultrasonic transducers.

It is the last seven chapters that demonstrate the wide range of known and possible applications of ultrasonics. Nor are all the applications mentioned; an omission which would be noticed by readers of this Journal is the use of ultrasonic waves in mercury for storing information in the form of pulses. Perhaps the applications which are of most direct interest in telecommunications engineering are those described in Chapter 11 which deals with methods of soldering.

The book is easily read and well illustrated; it offers to the non-specialist a reasonably compact account of the up-to-date position with regard to many of the practical developments which are taking place in this new field of engineering.

W. W.

"Second Thoughts on Radio Theory." "Cathode Ray." Iliffe & Sons, Ltd. 509 pp. 266 ill. 25s.

Electrical engineers should feel indebted to "Cathode Ray." For many years his articles have appeared regularly in the *Wireless World*, to enliven and clarify obscure sections of radio theory with brisk comments and neatly turned, friendly phrases.

He has the happy knack of knowing why a problem seems difficult or abstruse, and then of dissecting and re-assembling it in some different order that is much easier to understand. This type of perception is quite rare. It is as valuable a gift as the analytical ability of a good research worker, but in

In spite of slow progress in the beginning, and of the many delays caused by adverse weather and difficult terrain, the contract was successfully completed by the end of September. The success of the operation was made possible by sheer hard work, good will and the determination of all concerned to see "it" through, come what may. To those of the Post Office Engineering Department who were privileged to take part, the Newfoundland cable operation was a unique experience and they will never forget the hospitality and friendship shown to them by the Newfoundland people.

contrast to the latter has the advantage that maturity sharpens its perception and increases its range of accomplishment.

"Cathode Ray" himself explains his book as follows: "I must make it clear that this is not a complete systematic treatise. The topics are for the most part elementary; but the more elementary they are, the more important it is to get clear ideas on them. Most of the difficulties one has at later stages arise from lack of these clear ideas. The urge is to hurry over the basic stuff to get on to something 'practical.' One object of these articles is to help the beginner by putting things perhaps a little differently, or by going more fully into some of the points that are often taken as read. Another is to encourage him to tackle some subjects that seem at first rather forbidding. But however many years we have been at it, when we turn back to the things we supposed we knew there is always room for second thoughts. Are we quite sure about the meaning of Ohm's Law, for instance? What exactly is resonance? Is phase necessarily connected with time?"

The 44 short chapters have all appeared in the *Wireless World* over the past 20 years and some of them have almost an historic interest. The range of coverage of these little essays is considerable—from diagrammatic symbols to Thevenin's Theorem. Simple algebra is included where it is obviously necessary; so are graphs and sketches of circuits. Some problems are included for more serious readers (answers and solutions at the end of the book) and a good index has also been compiled. In fact, this book can be thoroughly recommended. It will not be out of date for a very long time.

C. F. F.

*I.P.O.E.E. Library No. 2319.*

"Modern Clocks, Their Repair and Maintenance." T. R. Robinson, F.B.H.I. N.A.G. Press. 283 pp. 237 ill. 30s.

Interest in machines for the measurement of time has been sustained since the earliest days of mechanics and each generation has added one or more refinements to the art and science of horology. This well-produced book describes all the latest contributions from the British clock industry, which has grown enormously in the last 15 years. "Modern Clocks" is a collection of descriptions, copiously furnished with detailed illustrations, of modern mass-produced clocks, and is written especially for the repair trade. Its contents can be assimilated at once by the expert in "staff pivots, escapements, arbors, pallets, crutches," and the like; however, the novice need not be daunted, but should consult one of the excellent horological dictionaries that are available. The devotion and expert knowledge of the author (in what is his life's work), as described in this eminently practical book, evokes nothing but admiration. The impression left on the reader is that Mr. Robinson must have spent years in workshops discussing the knowledge gained by hundreds of repair-shop craftsmen

(Continued on p. 119)

# Ministry of Transport and Civil Aviation Telegraph Centre, London Airport

U.D.C. 621.394.7

A new telegraph signal centre was opened by the Ministry of Transport and Civil Aviation at London Airport in December 1955. It occupies spacious accommodation on the first floor of the east wing of the central control block and replaces the old centre, which was housed in a temporary building.

**T**HE new centre was built jointly by the Ministry of Transport and Civil Aviation and the Post Office. The Ministry, in consultation with the Post Office, manufactured consoles, cabinets, tables and benches, and the Post Office designed the circuits and provided and installed the machines and associated equipment. Installation was undertaken by the Telephone Manager, City Area, London, and completed within six months of the receipt of the Ministry's order. The centre contains 70 teleprinters, 20 automatic message transmitters, 12 automatic number transmitters, 45 printing reperforators, and power, control and miscellaneous equipment.

Tape-relay technique is used as extensively as possible, but in designing the centre the Ministry had to cater also for the acceptance and despatch of messages by telephone and pneumatic tube. The main centre is, therefore, divided into a tape section for handling purely telegraph traffic and a page section for the transcription of telephoned and manuscript messages into telegraph signals and vice versa. Part of a suite of sending positions in the page section is shown in Fig. 1. Further, compliance with

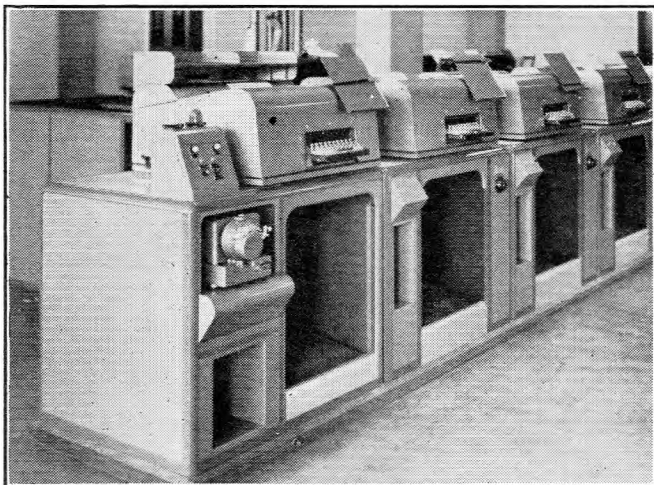

FIG. 1.—SENDING SUITE IN THE PAGE SECTION.

exacting international recommendations for transit times demands that re-transmissions be reduced to a minimum. To this end, messages received other than telegraphically are injected into the national and international civil aviation networks on lines working directly from teleprinters in the page section of the new centre to printing reperforators in the Civil Aviation Communication Centre at Croydon. Similarly, to dispense with tape-to-page conversion at London Airport, signals from Croydon are received simultaneously on tape and page machines for onward transmission by telegraph, telephone or pneumatic tube as appropriate. From a traffic-handling viewpoint the page section may be regarded as a separate sub-centre handling messages for airport offices to which direct telegraph lines cannot, for one reason or another, be economically justified.

The main tape-traffic flow is from Croydon, Northern, Scottish and Southern Air Traffic Control Centres to offices on the airport (delivery traffic), and from the airport

offices to Croydon (despatch traffic). Delivery traffic is received on two suites of printing reperforators occupying opposite sides of a square, and is transferred manually to suites of automatic transmitters forming the other two sides. The despatch section is arranged in the form of a corridor in which signals received on suites of printing reperforators along one "wall" are manually transferred to suites of automatic transmitters along the other.

All transmit lines, whether manual or automatic, are permanently monitored by page teleprinters in two adjacent rooms and all traffic queries are pursued by monitor-room operators. The monitor rooms are connected by bothway cross-office circuits to the main tape centre through which, in consequence, queries pass without disrupting the normal traffic flow.

All tape transmit messages are sequentially numbered automatically both as a check of continuity and for identification. For this purpose automatic number transmitters (No. 4A) have been installed in one of the monitor rooms. They are housed in specially-constructed sound-proof cabinets (Fig. 2) from which they can be withdrawn on telescopic runners for inspection and for resetting the precut number tapes.



FIG. 2.—AUTOMATIC NUMBER TRANSMITTERS.

A jack-field in the monitor room provides facilities for the redistribution of traffic within the centre in exceptional circumstances or for the diversion of lines from faulty machines. The jack-field, which is under the control of the traffic staff, also facilitates occasional monitoring or interception of lines at an adjacent test and monitor position and the extension of lines or machines to the Post Office workshop for test.

Each tape transmit position, shown on the right in Fig. 3, serves three lines and is wired for two three-gang automatic

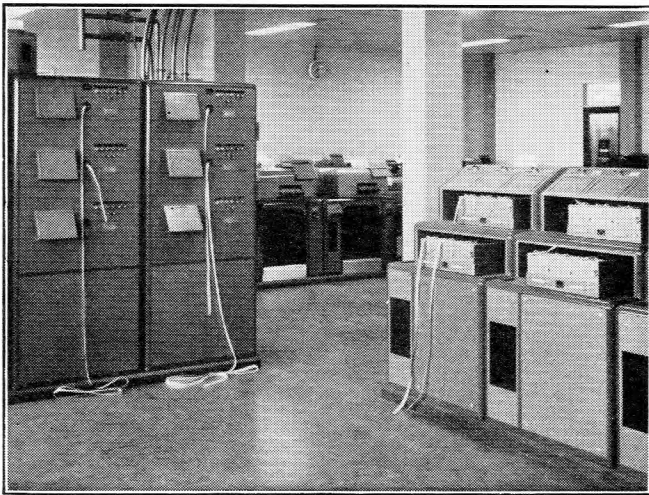

FIG. 3.—PRINTING REPERFORATORS AND AUTOMATIC TAPE TRANSMIT POSITIONS.

transmitters (No. 3A).<sup>1</sup> For lightly-loaded lines, however, only one machine, to give single-headed transmission, has been provided. Where two machines have been provided, they are tier-mounted, each head of the upper machine working sequentially with that immediately below it to give double-headed transmission. In either case, the message transmitters operate sequentially with the remotely-housed automatic-number transmitters. Relays to convert the output of these single-current machines, together with the sequence control equipment, are rack mounted in the Post Office workshop. The loading of a message transmitter with perforated tape starts an associated number transmitter which sends a serial number to line, detects the end of the number and switches the line to the loaded message head, which then transmits. On positions equipped with two transmitters, a second tape loaded into the associated head will, on the completion of the first message, cause the sequence to be repeated automatically. Single-throw keys at the operating position provide a facility for suppressing the number transmission, and an electromagnetic Veeder-type counter, operating in sequence with the number transmitter, informs the operator of the last number transmitted for tick-sheet check purposes.

Receiving printing reperforators are housed in sound-proof cabinets. Two of the cabinets can be seen on the left of Fig. 3, and a rear view of one of the cabinets with the doors open is given in Fig. 4. Each cabinet accommodates three machines which can be withdrawn on telescopic runners for tape renewal and inspection. Alarm relays, circuit breakers, connexion strips and other associated components are mounted in the base of the cabinets on racks that can be withdrawn on hardwood skids for maintenance purposes. The method of housing the equipment and the nature of the traffic have led to the provision of special facilities. Individual visual locking alarms with

<sup>1</sup> EASTERLING, C. E. Automatic Teleprinter Working. *P.O.E.E.J.* Vol. 47, p. 80, July 1954.

## Book Review

“Modern Clocks, Their Repair and Maintenance”—*continued from p. 117.*

in order to have accumulated such a vast amount of detailed information.

In the eight chapters, the mechanism is divided into its main sections and, after the general characteristics of each have been described, the individual features of specific makes of clocks, samples of which are to be found in almost every home, are then described from the repair and adjustment aspect. Every function is considered for both spring and



FIG. 4.—REAR VIEW OF PRINTING REPERFORATORS, SHOWING APPARATUS WITHDRAWN FOR MAINTENANCE.

plunger-type reset keys mounted on the face of the cabinet indicate line failures, the failure of an incoming signal to start the motor, and the receipt of a “J Bell” signal. The “J Bell” is the internationally-recommended signal for urgent and S.O.S. messages, and only this signal operates the station common alarm bell, which rings until the message has received attention. A non-locking lamp indicates that the reperforator tape roll is nearly exhausted and a plunger-type key is provided to run out tape when the end of an incoming message has not been ejected from the cabinet.

Lightly-loaded local delivery lines are simplex. As send and receive terminations at the centre are remote from each other, it is necessary to ensure that send operators cannot transmit when such lines are engaged with incoming signals. To this end, simplex out-stations have been equipped with signalling units similar to those used for subscribers’ telex stations. The out-station operator calls the centre by depressing a “Call” key which locks the in-station transmitter and lights an engaged lamp on the send position. On completing the message the out-station operator depresses a “Clear” key, which releases the in-station transmitter. A plunger-type key is provided on simplex receive positions to release the in-station transmitter should the out-station operator fail to clear.

In conclusion the author wishes to express his thanks to the Ministry of Transport and Civil Aviation (Tels. 9) for assistance in the preparation of this article and for permission to take and reproduce the photographs.

M. E. R.

electrical drives. The final chapter deals with special control clocks, such as time-switches, lighting-controllers, etc. The only shortcomings are an index which is inadequate for a reference book of this type and the lack of a short glossary of specialist terms.

The clock is the “super gadget” of all time and there are few engineers who have not on some occasion assumed responsibility for the repair of a time-keeper. This book should be given a place on the shelves not only of the expert, but of all those who enjoy tackling clock repair work or who are fascinated by ingenious mechanisms.

*I.P.O.E.E. Library No. 2348.*

J. P.

# Installations in Australia of the British Post Office Speaking Clock Mark II\*

E. F. SANDBACH, B.A., B.Sc.†

U.D.C. 621.395.91:681.11

A previous article<sup>1</sup> has described the Speaking Clock equipment and its manufacture and packing. This article describes the installations in Australia and gives details of the performance of the equipment since installation.

## INTRODUCTION

PRIOR to the introduction of speaking clocks, "time-of-day" in Sydney and Melbourne was announced manually by a telephonist reading directly from a clock driven by 1-sec pulses from a source of standard time. The service provided for the time to be announced to a number of subscribers simultaneously. Time announcing is a very monotonous task, for which frequent relief of the telephonist is necessary, and this difficulty, among others, led to the decision to install British Post Office Speaking Clocks which, as well as saving the cost of continuous staffing, are providing a more accurate service with improved intelligibility.

## SYDNEY AND MELBOURNE INSTALLATIONS

In Sydney, the speaking clock has been installed at the General Post Office building in the heart of the city. With a view to minimizing ambient-temperature variations with their consequent effect on the diurnal accuracy of the clock, the control equipment, together with the time-announcing machines and the time-signal generators, were located in a room on the third floor with no wall forming an exterior wall of the building. The general layout of the equipment in this room is illustrated in Fig. 1. The special power plant for the clock has been installed in an adjacent, existing power room.

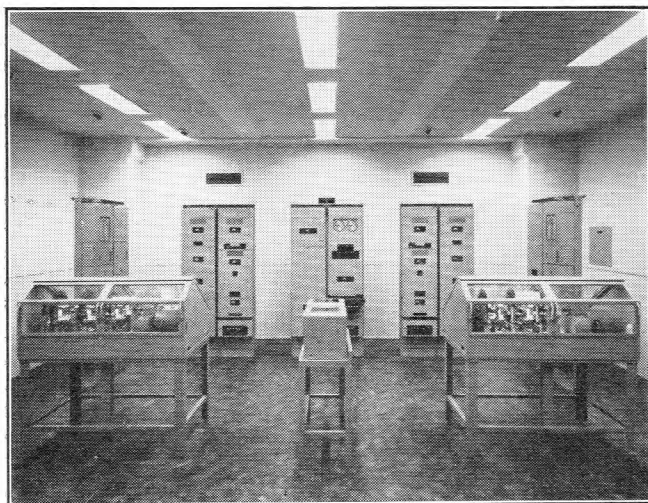

FIG. 1.—SPEAKING CLOCK INSTALLATION IN SYDNEY.

At Melbourne, the clock equipment is located on the first floor of "City West" automatic exchange, which is being air-conditioned, a general view of the installation being given in Fig. 2. The special power plant is installed in the exchange power room in the basement of the building.

In Sydney the distribution of the speaking clock an-

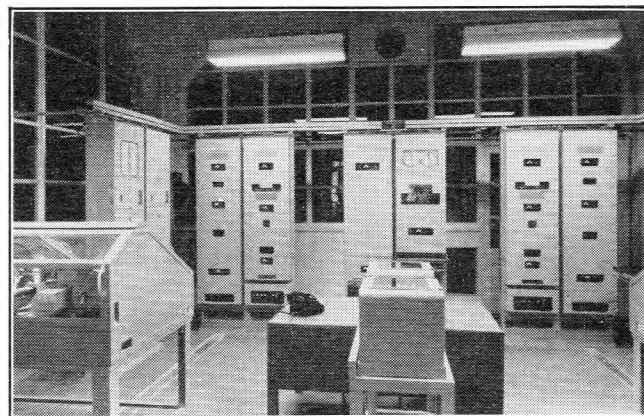

FIG. 2.—SPEAKING CLOCK INSTALLATION IN MELBOURNE.

nouncements to the telephone network is effected via relay sets at "City North" automatic exchange, situated less than a quarter of a mile from the G.P.O. Because of the relatively high speech level transmitted from the clocks to the relay sets, two special cables, one working and one standby, have been provided in the tunnel connecting the two buildings. In Melbourne, the relay sets are located at "City West" exchange, on the same floor as the clock equipment and only a few yards from it.

## Interconnexion of the Sydney and Melbourne Speaking Clocks.

In addition to the reserve facility at each installation of a second announcing machine operated from a different power supply, and as an extra precaution against complete failure of the service in either city, provision has been made for the Sydney and Melbourne clocks to be connected by manually switching a suitable trunk circuit.

## PROVISION OF CORRECTING SIGNALS

Time determination in Australia is the responsibility of the Commonwealth Observatory located at Mt. Stromlo, near Canberra, which measures, each working day, 1-sec pulses from a particular standard quartz clock maintained at the P.M.G. Research Laboratories, Melbourne. As explained later, the results of these measurements are in turn used in the timing correction system of the speaking clocks to ensure that the announced time closely follows Eastern Standard Time as determined by the Observatory. The correction system depends for its operation on the comparison, at specified times each day, of correction signals generated at the Research Laboratories with signals produced by the clocks.

The type of correction signal used in Australia consists of a series of pulses of 2,500 c/s tone of 100 ms duration repeated at 1-sec intervals, the start of each minute being marked by a longer pulse of 500 ms duration. These signals are produced continuously by a correction signal generator coupled to a phonic motor, driven by one of the frequency standards, which can be maintained within a few parts in 100 million of its nominal frequency of 100 kc/s. Timing adjustment to the correction signals, to take account of the observatory measurements mentioned earlier, is carried out by means of variable phase-shifters. The maximum daily adjustment is normally 3 ms.

\* This article was published in the *Telecommunication Journal of Australia*, Vol. 10, No. 4, and is reproduced in a slightly shortened form by kind permission of the Editors of that Journal.

† Divisional Engineer, Australian Post Office Research Laboratories.

<sup>1</sup> FORTY, A. J., MILNE, F. A., and SMITH, R. L. The British Post Office Speaking Clock Mark II. *P.O.E.E.J.*, Vol. 48, pp. 154 and 229, Oct. 1955 and Jan. 1956.

The correction signal generator is provided in duplicate and continuous automatic comparison of the outputs is carried out to detect any time difference greater than 6 ms or the failure of one of them. In the event of either non-standard condition arising, the correction signal is automatically disconnected from the line and an alarm operated.

The correction signals are available continuously at the speaking clock in Melbourne and also at the Melbourne Trunk Exchange, which is in the same building. Sydney obtains the signals by direct dialling, normally using one of two selected trunks. The transmission times of the correction signals over a number of representative trunk circuits from Melbourne to Sydney were measured, and it was found that as long as the choice was restricted to any one of those on a J 12-channel carrier system, the difference between channels was negligible. When setting up the Sydney clock, allowance for this transmission delay was made by advancing the phase of the pip-track an appropriate amount relative to the synchronizing track on disc 3 of the announcing machine.

Correction pulses are switched into the speaking clock equipment at a pre-set time each day during a silent period in the correction signal transmission sequence—in Sydney just before 8.55 a.m. and in Melbourne a few seconds before 9.55 a.m. Signals derived at 1-sec intervals from the synchronizing track of the clock are compared with the correction signals and it is determined whether, at the instant of comparison of the first pair of pulses, the clock is slow or fast. If the clock is found to be slow, then it is advanced by an interval of 1 ms; alternatively, if fast, it is retarded by the same amount. This correction is performed automatically, and is completed before the next pair

of pulses arrive for comparison. The 1 ms corrections continue to be applied at 1-sec intervals, until it is found that the correction signal and the clock signal differ by less than 1.5 ms, when the examination ceases until the next correction check on the following day.

#### SPEAKING-CLOCK TRAFFIC

The fact that there was already a well-established "time-of-day" service in both Sydney and Melbourne made more difficult the estimation of the expected increase of traffic arising from the introduction of the speaking clocks. Provision was therefore made, by supplying 100 relay sets for Sydney and 50 for Melbourne, to handle a little over twice the traffic with the speaking clock, compared with the manual service. Such provision proved adequate except during the first four days of the new service in Melbourne, when 10 of the relay sets used with the former manual service were temporarily installed to help handle the curiosity traffic.

Fig. 3 shows the daily calling rate for the first month of operation in comparison with typical figures for the manual system taken just before the speaking clocks were introduced. Apart from the curiosity traffic during the first week of operation, there has been a permanent increase in the calling rate compared with the manual service. Fig. 4 shows the weekly calling rate for both the Sydney and the Melbourne clocks from the introduction of the new service until the end of January 1955. The effect of the general holiday break over the Christmas-New Year period is clearly seen.

In Table 1, the usage per subscriber of the speaking clock service in Australia is compared with that in various

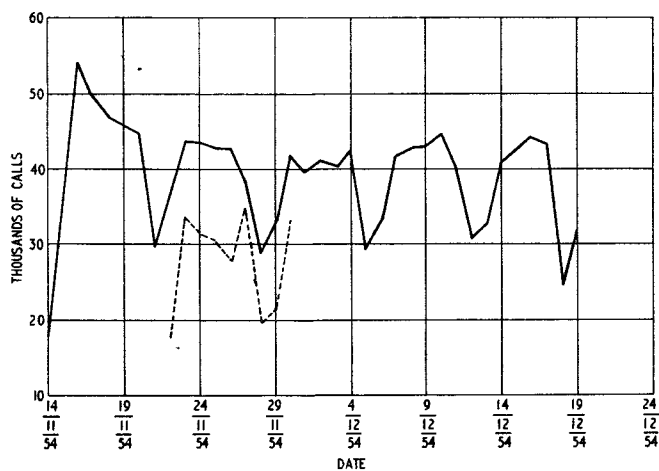

(a) Sydney.

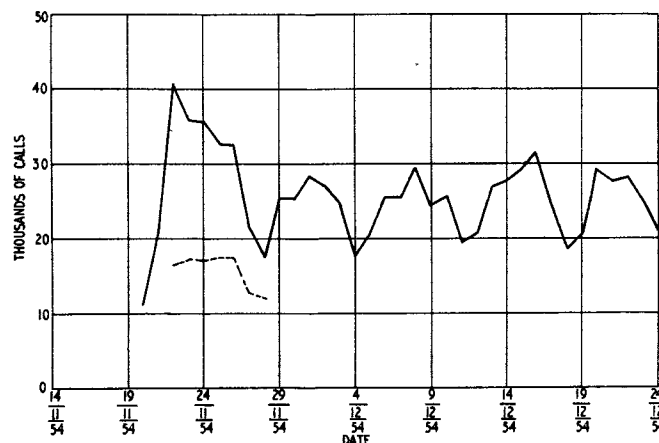

(b) Melbourne.

----- Typical Calling Rate with previous Manual System.

FIG. 3.—DAILY CALLING RATES.

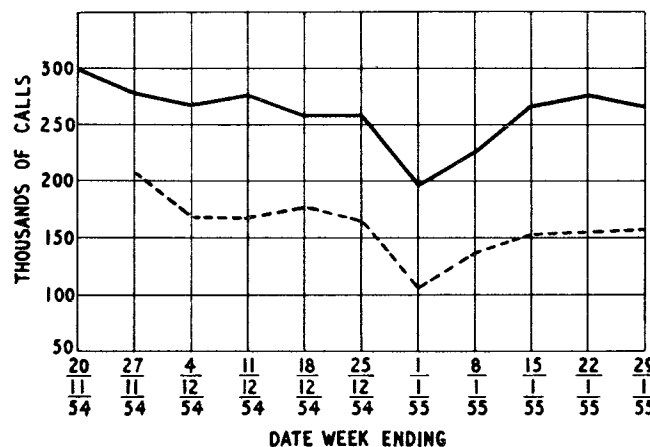

DATE WEEK ENDING

— Sydney.  
- - - Melbourne.

FIG. 4.—WEEKLY CALLING RATE.

TABLE 1  
Comparison of British and Australian Calling Rates for the Speaking Clock

Centre	Number of subscribers	Number of calls per week	Number of calls per subscriber per week
Sydney .. .. .	252,526	269,805	1.1
Melbourne .. .. .	220,339	172,687	0.77
London (Holborn and Museum areas) .. .. .	830,378	665,863	0.80
Glasgow .. .. .	71,427	86,192	1.2
Manchester .. .. .	100,018	102,407	1.0
Sheffield .. .. .	32,357	31,976	0.99
Birmingham .. .. .	89,204	71,504	0.80
Edinburgh .. .. .	55,989	38,886	0.69



locations in Great Britain. The figures for the British clocks were taken in May 1954, and those for Australia in December 1954. This table shows that the use of the speaking clock in Australia is quite comparable with that in Britain.

#### EQUIPMENT PERFORMANCE

The timing accuracy of the clocks is shown by Fig. 5, graphs of the apparent daily errors as determined from the daily "corrections" to each clock. These are the combined effects of two main causes; namely, errors in the clock equipment itself and adjustments to the correction signals required to follow astronomical predictions, as explained earlier. Whilst in three cases in Fig. 5 the maximum cor-

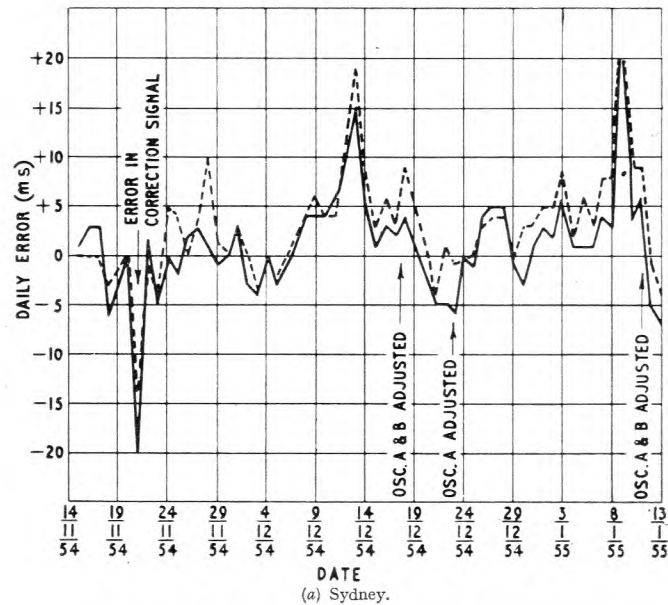

(a) Sydney.

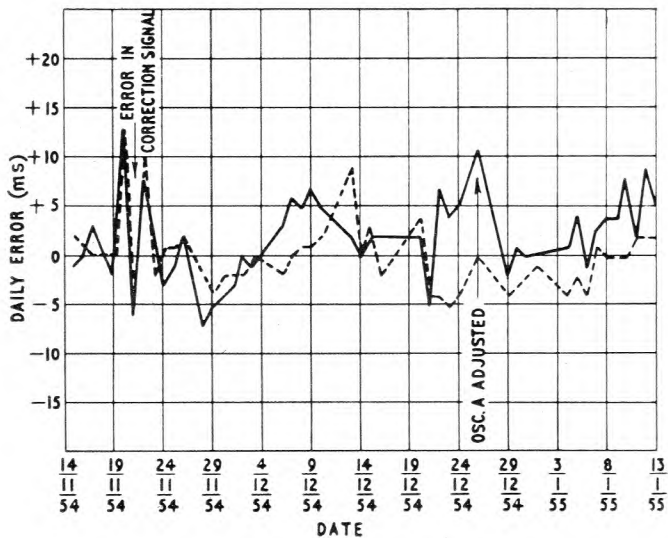

(b) Melbourne.

— Clock A  
 - - - Clock B  
 + Indicates Clock Fast.

FIG. 5.—DAILY ERRORS.

rection required was excessive, two of these can be explained by errors in the correction signals and the third, at Sydney only, by probable non-standard operation of the clock correction system. It should be remembered that for the period shown in Fig. 5 both clock installations and correction signal generators had been in operation for a relatively

short period only and some improvement in the above respects can be expected in addition to some further small improvement due to the settling down of the crystal oscillators.

An impression of the excellent stability possible with these oscillators may be obtained from the record in Fig. 5 of the one driving clock "B" in Melbourne. This oscillator was set up during the installation period and adjusted in frequency on 27th September, 1954. No further adjustment had been necessary in the period up to the end of February 1955. This record represents the best performance of all oscillators included in both the Sydney and Melbourne equipments. Some others have required adjustment at intervals of two or three weeks.

Some modification of the pilot-tone alarm-circuit has been made to take account of battery-voltage variations larger than expected. During conditions of mains failure the 50V exchange battery, operated under floating conditions, drops in voltage with a consequent drop in exciter-lamp brilliancy, which, in turn, has resulted in the operation of the pilot-tone alarm due to the decreased photo-cell output. To avoid this condition, the sensitivity of the pilot-tone alarm has now been reduced by circuit alteration so that this alarm does not operate until the voltage supplied to the equipment drops to 42V. This modified circuit has been operating satisfactorily since February 1955 and during a mains failure it maintains continuity of speaking clock service until the reserve clock is again operating from the standby a.c. supply.

#### TIME-SIGNAL GENERATION AND DISTRIBUTION EQUIPMENT

With each installation of speaking clock equipment, two time-signal generators, called "XNG machines," were provided, one of which is illustrated in the photograph,

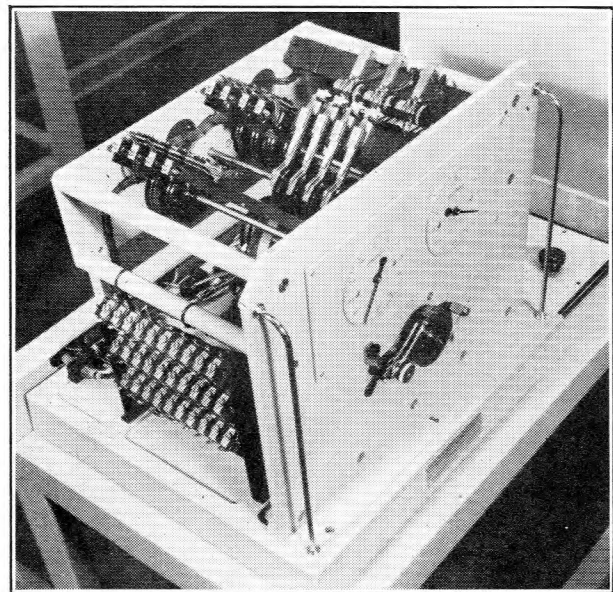

FIG. 6.—XNG MACHINE.

Fig. 6. One XNG machine is driven from the precise 50-c/s supply derived by frequency division from the crystal oscillator that feeds announcing machine A, whilst the other is driven by the supply to announcing machine B. These XNG machines provide four different types of signal, namely:—

- (i) one pip/sec
- (ii) six pips/min
- (iii) six pips/hour
- (iv) XNG marine navigation signal (hourly).

As the precision contacts supplied with the equipment for producing these signals were rated at 10V, 1 mA only, some

heavy-duty contacts for the time signals were required. In addition, provision for the multiple distribution of each type of signal was necessary. Consequently, a unit using 3,000-type relays operated by the anode current of triode valves was designed to give four outlets of signal type (i), six of type (ii), 12 of type (iii) and three of type (iv).

The unit also provides the following facilities:—

- (a) Automatic selection of the XNG machine to follow the associated announcing machine in service; i.e., normally XNG machine A in service simultaneously with clock A.
- (b) Manual control to over-ride the automatic selection of the XNG machine in service. This is provided to handle possible fault conditions where, for example, only the combination of announcing machine A and XNG machine B are available for service.
- (c) Continuous comparison of the one pip/sec outputs of the two machines. Should the time difference exceed 6 ms, the outputs of both machines are disconnected from service and an alarm is operated to call the maintenance technician.
- (d) Connexion to both the aural and the visual (C.R.O.) general monitoring facilities provided, so as to assist in the phasing of the XNG machines when they are started up.

The time-signal distribution equipment described above forms one panel on Rack No. 6 of the speaking-clock

equipment, thus keeping each installation complete in itself.

The use of time signals, and hence of this new equipment, may be illustrated by reference to the scope of the service supplied by the Melbourne equipment, to which there are at present connected 11 permanent subscribers, including the Victorian national radio stations, the commercial radio stations and various Commonwealth and State Government departments and authorities. This service had, for some years past, been rendered on behalf of the Commonwealth Observatory by the Research Laboratories of the P.M.G.'s Department using pendulum clocks lent by the Observatory.

#### CONCLUSION

Judging from the period of operation so far, the speaking clock does all that its designers intended, both in regard to accuracy and reliability. This achievement is particularly noteworthy when it is considered that the equipment is the first production of a basically new design.

#### ACKNOWLEDGMENT

The author desires to record his appreciation of the work performed by Mr. F. A. Milne, Senior Experimental Officer, Research Station, British Post Office, during the installation and the initial operating periods of the speaking clocks.

## Book Reviews

"Germanium Diodes." S. D. Boon. Philips Technical Library, Eindhoven, Holland. 85 pp. 72 ill. 9s. 6d.

This little book will appeal chiefly to the radio and television receiver enthusiast, who will find in its first 32 pages a concise introduction to the principles of conduction in semi-conductors and of rectification at a p-n junction, together with an outline of the method of manufacture of germanium point-contact diodes and of their advantages and disadvantages compared with thermionic diodes. The next 20 pages are reproductions of data sheets and curves for five main types of diode made by the author's company. There follows a compendium (in 16 pages) of 27 circuits, which make use of one or other of the diode types, the more interesting applications including an a.c. voltmeter for the 25 c/s–6 Mc/s frequency range with a sensitivity of 10,000 ohms/volt, a video demodulator, and an f.m. ratio-detector.

An appendix gives maker's data and curves for three types of diode (evidently still of the point-contact type) employing mono-crystalline germanium and having higher power and voltage ratings and closer tolerances than the types detailed in the body of the text (which are presumably made with poly-crystalline germanium, though this is not stated). The last of the three types is described as a computer diode and its specification includes figures for the reverse current at "recovery times" of 0.4 and 3.5  $\mu$ s, details of the relevant test circuit being given. Some explanation of the effects of "hole-storage" on the reverse-current transient response could well have been included earlier in the text, to clarify the need for such a test for diodes that are to be used in fast-switching circuits.

In spite of its title, the book contains no mention of the manufacture, properties or applications of large-area junction diodes, which are now showing such promising characteristics that they may supersede most other types of rectifier in many power applications.

F. F. R.

"Electrical Measurements and Measuring Instruments."  
E. W. Golding, M.Sc. Tech., M.I.E.E., Mem. A.I.E.E.  
Pitman, London. 913 pp. 550 ill. 40s.

Mr. Golding's book, in the well-known Pitman's Engineering Degree Series, was first published in 1933 and soon acquired a considerable reputation with students, who appreciated its thorough treatment of theory and practice, the large number of examination questions (with answers) and the extensive bibliographies concluding each chapter. Evidence of its continued popularity is found in the need for a 4th edition, which has now been met.

The basic material remains largely unchanged, the first section covering, in essence, the measurement of resistance, inductance, capacitance, magnetic quantities, illumination and temperature, together with the determination of wave-forms and consideration of transient phenomena. The remaining chapters are devoted primarily to a detailed description of the principles and construction of instruments used for the measurement of current, voltage, power and energy.

Although the general arrangement of the book remains unchanged, 15 years have elapsed since the third edition appeared and a good deal of revision has been necessary. Thus, descriptions of many newly-developed instruments are now included and a new chapter (35 pp.) has been added to cover the fundamentals of electronics and electronic measuring devices. Modifications and extensions to the text have also been made as a result of recent developments in illumination engineering, high-voltage measurements and cathode-ray oscillography. Another important change is the more detailed consideration of m.k.s. rationalized units; in this matter the author rightly views the present period as transitional between the c.g.s. and m.k.s. systems and, in general, carries both systems through the relevant text as an aid to the student. Finally, all symbols and nomenclature have now been brought into line with the latest recommendations of the responsible bodies.

As with previous editions, the book can be unreservedly recommended to students and will be found a valuable reference work for the practising engineer, particularly if engaged in the power field.

G. E. S.

# An Experimental Ringing Circuit for Electronic Exchanges

R. C. BARKER†

U.D.C. 621.395.632.11:621.395.34:621.318.57

Ringling signals of sufficient power to operate, directly, a magneto bell in a subscriber's telephone connected to an electronic exchange cannot be passed through electronic switches of economic design, and a convertor is required after the switches. This article describes an alternative method of calling the subscriber by applying a low-level audio signal to line to operate a transistor switch in the subscriber's instrument and so operate the bell by direct current from the exchange battery.

## INTRODUCTION

THE present system of calling the attention of a telephone subscriber is only one of several possible methods. The advantages of the magneto bell are that it is cheap, requires little maintenance and, if required, a number of bells can be fitted at points remote from the instrument and extra loud or quiet signals can be provided. Differently-toned gongs can be fitted to the bells of adjacent instruments so that they can be distinguished, and visual indicators can be provided if required. The frequency of the ringing signal (17 or 25 c/s) is low enough to prevent serious crosstalk at the high level transmitted (70–100V).

One of the problems of providing ringing at an electronic exchange is that sufficient power to ring the magneto bell cannot be passed through an electronic switch of economic design, and a convertor is required after the switches. One ringing circuit uses a cold-cathode tube as the convertor<sup>1</sup>; a ringing control signal of 2.5 kc/s is passed at a low level through the switches and applied to the trigger of a cold-cathode tube. The 17-c/s ringing generator is connected to the anode of the tube through one winding of a hybrid transformer. The 2.5-kc/s tone causes the tube to conduct, and thus a 17-c/s signal is sent from the secondary winding of the transformer to the subscriber's line. This method is costly as it requires a 17-c/s transformer for each line, but by using a hybrid transformer a signal can be obtained to check that ringing current is, in fact, being sent out.

## CHOICE OF TRANSDUCER

If the low-level audio signal sent through the switches to ring the line can operate the calling device directly, then conversion at the exchange becomes unnecessary and the exchange equipment is simplified. One possible method of calling is to use a receiver (either the one already provided or an additional one) as the transducer, together with a transistor amplifier. Tests with a receiver type 2P showed

that a reasonably penetrating signal could be obtained in this manner, using a 1,500-c/s tone interrupted at 20 c/s. A high level of output of the receiver presents a danger of injury to a listener's hearing if he has the receiver to his ear at the time, and this cannot be prevented by use of switch-hook contacts as the receiver can be placed to the ear whilst the switch-hook is depressed manually. Hence a separate receiver or possibly a loudspeaker type of transducer is necessary, and this solution is visualized as being satisfactory in many situations where a loud calling signal is not essential. There are circumstances in which a bell is preferable, and for P.B.X. exchange lines an audible signal is inappropriate and a mechanical indicator is much to be preferred.

For subscribers having a mains supply, ringing power can be derived from a mains-operated unit, but then subscribers cannot be rung during periods of mains failure (not uncommon in some rural areas). Local batteries are not subject to this disadvantage, but they require additional maintenance. All these facts being considered, the following method of operating a magneto bell or indicator at the subscriber's station has been devised.

## PRINCIPLE OF OPERATION

The ringing signal consists of an audio signal switched on and off at the ringing frequency (25 c/s) and interrupted at the standard interruption periods (0.4 sec on, 0.2 sec off, then 0.4 sec on, followed by 2 sec off). The audio signal is sent over the line at low level and received by a series resonant circuit, and is then rectified and smoothed. The resultant d.c. is applied to a junction-type transistor, causing it to conduct where it was previously non-conducting. When the audio signal is disconnected the transistor reverts to the non-conducting condition. The transistor thus acts as a switch operated at 25 c/s, enabling d.c. from the exchange battery to be used to ring a magneto bell.

## CIRCUIT DESCRIPTION

Fig. 1 shows the circuit of a telephone No. 332 suitably modified for calling by means of an audio-frequency signal,

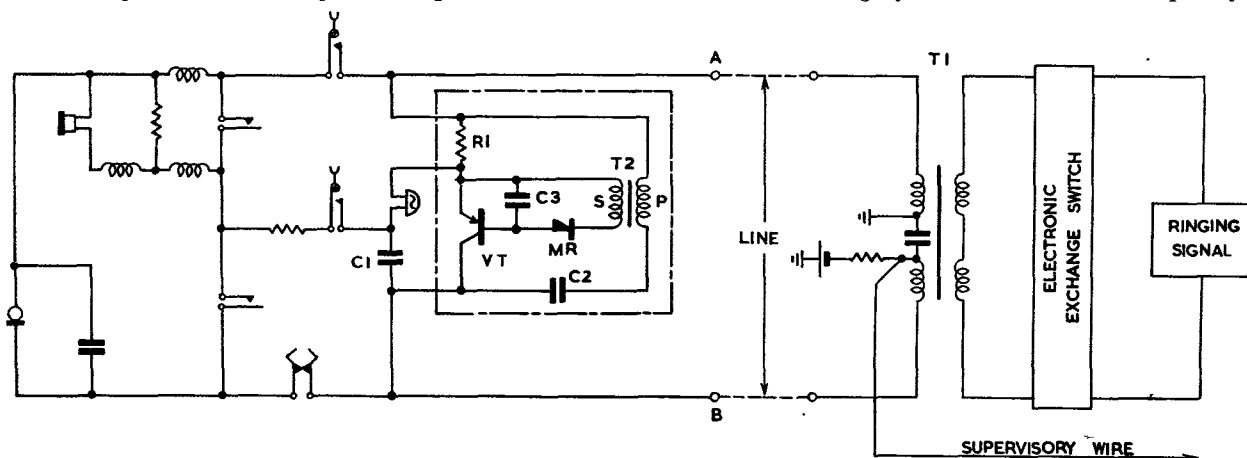

FIG. 1.—SCHEMATIC DIAGRAM OF A TELEPHONE NO. 332, MODIFIED TO RECEIVE AN AUDIO-FREQUENCY RINGING SIGNAL FROM AN ELECTRONIC EXCHANGE.

†Executive Engineer, Post Office Research Station.  
<sup>1</sup>SCOWEN, F. A Small Experimental Electronic Automatic Telephone Exchange, Part 3. *P.O.E.E.J.* Vol. 47, p. 138, Oct. 1954.

the additional equipment being enclosed within the dotted line. The telephone is connected via a line to a transmission bridge at an electronic exchange. Before the ringing signal is applied, the transistor VT is in a cut-off condition because the emitter and base are at the same potential. The line current is limited to the leakage current of the transistor, amounting to a few microamps. The potential drop across the line and resistor R1 is negligible, so capacitor C1 charges to the potential of the exchange battery. The primary winding of transformer T2 and capacitor C2 are tuned to the frequency of the audio component of the ringing signal, and when the audio tone is applied to the line the tuned circuit resonates and an amplified signal appears across the primary winding of T2. The resulting signal in the secondary circuit is rectified and smoothed by rectifier MR and capacitor C3, making the base of the transistor negative with respect to the emitter. The transistor conducts, and the capacitor C1 discharges through the bell coils and the transistor. Because the line current also passes through the transistor and resistor R1 when the transistor is conducting, the transistor must be capable of withstanding the line current as well as the discharge current of capacitor C1. The audio signal is switched at the ringing frequency (for instance, 25 c/s), so after a short period (20 ms) the audio signal is removed. C3 discharges through the reverse resistance of MR, so that the potential difference between the base and emitter of the transistor reduces to zero and the transistor returns to its high resistance state. The capacitor C1 is now recharged to the line potential through resistor R1, and the bell coils are energized in the opposite direction. After a further period of 20 ms the audio signal is re-applied and the transistor conducts again, repeating the cycle. This alternate discharging and charging of C1 through the bell coils causes the bell to ring.

At the time that the circuit was devised, transistors capable of withstanding a potential of 50V between emitter and collector were not available. The tests were made on an experimental ringing circuit, as described, using a 40V supply. Transistors were selected to have a low leakage current at this voltage with emitter and base short-circuited. To provide a satisfactory ring over a 1000-ohm subscriber's line, using a ringing signal of 3 kc/s, required a maximum level of 1 mW into 600 ohms with 6½ lb cable and +1.5 dB relative to 1 mW with 10-lb cable. Lower sending levels were possible with the majority of the transistors used and crosstalk should not therefore be serious.

Subscribers' telephone sets with transistor amplifiers are possible in the future, together with exchange batteries of voltage much lower than 50V. In this event more-sensitive bells would be required by the method described in this article, but exchange indicators would operate with low voltage supplies.

### *Effect of Ringing Circuit on Speech Transmission.*

Telephone transmission articulation tests using a telephone No. 332, modified as shown in Fig. 1, with the ringing control circuit tuned to 3 kc/s show a reduction of the line planning limit of about 12 per cent for 6½-lb cable. Switch-hook contacts can be used, however, either to disconnect the ringing control circuit or to short-circuit the primary winding of the transformer T2. The effect of the ringing circuit on speech transmission is then negligible.

### *Shared Service.*

It is possible to provide separate ringing on shared-service lines by using different ringing-signal frequencies (for instance, 2 kc/s and 3 kc/s) for each of the subscribers. During speech the ringing circuit of the instrument of the subscriber not engaged on a call will be across the line and with the circuit described a small reduction of the speech transmission performance will result.

There is also the possibility that the subscriber making the call may whistle or talk loudly on the line, causing the transistor of the other subscriber's ringing circuit to conduct momentarily but, as the line is looped, there will be insufficient d.c. potential to cause the bell to tinkle.

Bell tinkling due to the other subscriber dialling can be prevented by connecting a thermistor type 1AN in series with the bell, in accordance with present practice on shared-service instruments.

### ADVANTAGES AND DISADVANTAGES

The suggested method solves the problem of calling a subscriber with a low-level audio ringing signal which can be passed through the switches and audio line transformers of an electronic exchange. It retains the advantages of the magneto bell as the calling device and extension bells can be connected in series. As the power for actually ringing the bell is derived from the exchange battery no separate ringing supply is required. Because the circuit is frequency sensitive, little interference should be obtained from line noise and separate ringing signals can be provided for shared-service lines. Additional components are required at the subscribers' premises, but this is not serious if a comparable saving of equipment at the exchange results; the additional components are small and can be accommodated in the telephone instrument. A similar arrangement permits the operation of indicators on P.B.X. lines. Since the effect of the transistor is to open and close the line at the ringing frequency, which is equivalent to very rapid flashing by the subscriber, it serves as a signal that the bell or indicator is in fact being supplied with ringing current.

## Book Review

"Vacuum Valves in Pulse Techniques." P. A. Neeteson. Philips Technical Library. VIII + 170 pp. 147 ill. 27s.

The author recognises in the preface that, although thermionic valves have been increasingly used as switches, analytical treatments of the circuits used have been scanty and rarely applied. He has therefore set himself two tasks, to present a treatment of the valve as a switching element and to follow it with a study of the multivibrator in its three forms, bistable, monostable and astable. There can be little doubt that he succeeds in his aims, but, because he does so using basic methods well known for many years, one wishes he had tried much earlier.

The first four chapters are short and introductory; the fifth briefly states some elements of the operational calculus. The

first task is then undertaken systematically. The effect of grid current and input capacitance on the waveforms obtained in grid circuits during switching is followed by that of anode impedance and load on those in anode circuits. The seventh and last chapter, as long as the other six put together, treats the three types of multivibrator thoroughly; expressions are derived for the waveforms at various points in the circuits and, numerically computed for typical examples, are compared with practice. Everyone who wants to understand multivibrators fully, or to get the utmost out of them, must read this chapter.

The title of the book is not as appropriate as it might be, failing to stress the approach used and the attention given to the multivibrator; here and there in the book the wording leaves something to be desired. But no one need be deterred.

J. R. T.

# "Mosaic"—An Electronic Digital Computer

A. W. M. COOMBS, Ph.D., B.Sc., A.R.T.C.†

## Part 4.—Circuitry

U.D.C. 518.5:681.142

The first three parts of this article have described the essentials of "Mosaic," considered purely as a computer. In this final part, the engineering problem is discussed. Necessarily, the exposition is somewhat sketchy, but at least the broad principles are indicated, including particularly those of Mosaic's novel synchronizing system. The Function Box circuit is used to illustrate the argument.

### INTRODUCTION

MOSAIC is a very large machine, and it would be neither useful nor desirable to describe here its circuitry in minute detail. Nor is it necessary; the technique of design was such that logical symbolic diagrams could for the most part be translated directly into circuits using standard conversion methods—that is to say, the triggers, gates, peaking circuits, etc., are of precisely the same form throughout the machine. Logical diagrams are therefore sufficient to indicate the working of the machine, both in theory and in practice, and in particular, the Function Box typifies so well the electronic and logical system employed that it will be used as a reference circuit in the description that follows. It is hoped that the art of electronic circuit building, at least as interpreted by Mosaic, will thereby be made clear. The logical symbolism is described in the Appendix, and the more important standard unit circuits that the symbols represent are given in the article.

It was apparent from the outset that so large, so fast, and so novel a machine as Mosaic must be based on very sound engineering methods if it were ever to work. As a result, certain basic design principles were laid down, and have proved very successful; unforeseen complications did in fact occur, but all proved capable of solution in terms of the basic concepts. Standardization of all basic circuits, as mentioned above, was one such principle; another was the use of totally enclosed circuits, coaxial interconnecting cables and fully screened and filtered h.t. supplies as a protection against mains-borne or radiated interference. The need for such elaborate protection against false signals arises out of the fundamental digital computer characteristic, that every single binary digit has a meaning or a value, and is not less likely to be distorted or destroyed if its value is great or its meaning highly significant—that is, there is no correlation between intrinsic significance and stability. In terms of communication theory, we may say that there is no redundancy, and therefore there must be no equivocation. The resulting constructional form is illustrated in Fig. 7 (Part 2); here, interest will be more in the circuit principles, particularly in the policy on the use of valves, and in the signal re-shaping and re-synchronizing technique.

### THE USE OF VALVES

A large electronic machine may be regarded as comprising a complex maze of unidirectional "Paths" along which signals may be transmitted, the routes of the signals through the maze being decided by the action of "Gates," or groups of gates, at the interconnecting points of the paths. By and large, the design problem can be reduced to that of finding the most efficient and reliable gating circuits, particularly those which do not interfere with the unidirectional properties of the paths. Gates—and, indeed, switches of all kinds—can be made in two different ways. Either the number of valves\* may be large and the cir-

cuitry simple, or the number of valves may be kept to a minimum at the expense of increased complexity in the circuits. There is a school of thought which regards the valve as the weakest link in an electronic machine—as a short-lived and unreliable structure, to be used sparingly. Such a philosophy favours the second of the above alternatives, and leads to circuits in which, for instance, a single valve may be one of a trigger pair and at the same time required to give output power, two working conditions which may ideally demand quite different valve characteristics; or, perhaps, a single electrode may be required to accept signals from several different sources, with an enhanced danger of interaction between the feeding circuits.

The designers of Mosaic took the directly opposite viewpoint, that circuit troubles were likely to be much more difficult to deal with than valve troubles, and that the complex circuit was therefore the real danger. If a valve be defective, it generally shows a steady fault condition which can readily be traced, and the valve as readily replaced. Complex gate circuits, on the other hand, usually owe their complexity to interconnexion by means of components such as resistors, and failure is due to drifting of these components outside tolerance limits. The fault is then intermittent, giving a troublesome condition known as "pattern sensitivity," wherein an apparently safe circuit fails sporadically due to rare combinations of signals existing ephemerally on other circuits. Such faults are hard to locate, and even harder to eradicate. Valves, by "buffering" and "segregation" (by connexion of different paths to different electrodes), can effectively isolate separate circuits and avoid the danger of interaction; it would appear to be good policy to use them for the purpose, which means using them in profusion.

This is all well and good, but the whole argument breaks down if valves are really unreliable components; a machine with very safe circuits is still useless if it can never work more than a few minutes without a valve failure. The policy of valve multiplication must be accompanied by special precautionary measures. Thus, in Mosaic, the standard valve for general purposes is the CV138 miniature pentode, which has probably been the subject of more research to make it reliable than any other valve, and its characteristics are therefore well known. About 5,000 of the 7,000 valves in the machine are CV138. Then, action to anticipate the three known major causes of failure was taken, as described below:

(a) *Catastrophic Failure.*—This is associated with mechanical defects, and particularly with broken heaters. It is likely to occur, if at all, in the first 1,000 hours of a valve's life. The remedy was preliminary ageing (to show up potential mechanical faults) and, after that, great care in handling. For instance, withdrawal of valves for general routine testing was forbidden; "leave well alone" was to be the rule. Further, it was arranged that heater voltage was applied and withdrawn slowly, over a full minute, under motor control; sudden surges of current and violent temperature changes are likely to cause rupture at weak spots in the wire. Catastrophic failure was virtually eliminated by these precautions.

(b) *Interface Growth.*—After about 10,000 hours' life, a

†Principal Scientific Officer, Post Office Research Station.

\*Mosaic was designed before transistors were available in quantity and quality. It is probable, however, that the arguments adduced here in favour of valves apply with equal force—*mutatis mutandis*—to transistors.

resistive interface will sometimes develop between the cathode core and active matrix in conventional valves, and by automatic-bias action reduce the effective mutual conductance, and therefore the anode current for the same grid bias. The CV138 is at present subject to the phenomenon, but rarely shows more than 70 ohms resistance; the normal load current in Mosaic is 12 mA, so the cathode may rise by about 0.8V above its nominal level. The effect would thus be swamped by arranging the positive grid swings to reach +1V nominal at least, and this technique was adopted.

(c) *Cathode Poisoning.*—During the working life of a valve, the active material on the cathode may be gradually neutralized by residual gas which has escaped contact with the getter, and the result is a fall of mutual conductance. Susceptibility to this form of failure depends very much on the efficiency of the original vacuum-pumping, and particularly on the effectiveness of the gettering process. Valves have been known to fail at an age as low as 3,000 hours, or as high as 60,000. Remedial measures here were the use of the CV138 (which was known to be the subject of intensive research, and therefore likely to improve in the future), and circuit designs using only about two-thirds of the theoretical anode current. A test is available (the  $\delta G$  test) which can indicate whether a given valve is likely to fail early due to gas poisoning; if failure of this type later becomes prevalent, it may be desirable to replace the valves in the machine with units that have successfully passed the test, but as yet such action has not been necessary.

#### SWITCHING AND SYNCHRONIZING

In a large high-speed machine, the time delay suffered by signals in transit from one part of the machine to another may be an appreciable fraction of the signal duration itself. Such delays, for a signal traversing many paths in succession, would be cumulative, and could result in a pair of nominally synchronous signals, which have travelled by different routes, eventually failing to act together when applied at some ultimate combining gate. The delay for a path in Mosaic may amount to one-fifth of the signal period, and the effect is made worse by deterioration of the signal shape in transit. The problem is clearly a real one; it is solved in Mosaic by a system known as "K-pulse switching," the guiding principle of which is that all signals are to be re-shaped and re-synchronized after each and every transit of an interconnecting cable, and after each and every composite switching stage. In this way, no signal is ever allowed to deteriorate in shape beyond a certain point, and the inevitable transit delays, instead of being random, are constrained to proceed in an orderly and predictable manner. The technique will now be described, using Fig. 13 to illustrate the argument.

The fundamental clock frequency of Mosaic is 571 kc/s, so that the spacing between consecutive signals—the signal period—is 1.75 micro-seconds; this period will be referred to as  $T$ . Three separate and staggered trains of synchronizing pulses are provided at all points of the machine; they are called the K1, K2 and K3 trains respectively, and each has a pulse period  $T$ , but K2 is  $\frac{1}{3}T$  later than K1 and K3 is  $\frac{2}{3}T$  later than K2. The ideal signal pulse is  $\frac{2}{3}T$  in length, starting and finishing with K pulses—thus, "K1 to K3," "K2 to K1," or "K3 to K2." The progress of a signal pulse X, originally timed K1 to K3, as it passes through consecutive switching stages or long interconnecting cables (being perhaps combined with other signals at the switching stages), is indicated in the timing diagram, Fig. 13, and the essential K-pulse switches are shown in logical form in Fig. 14.

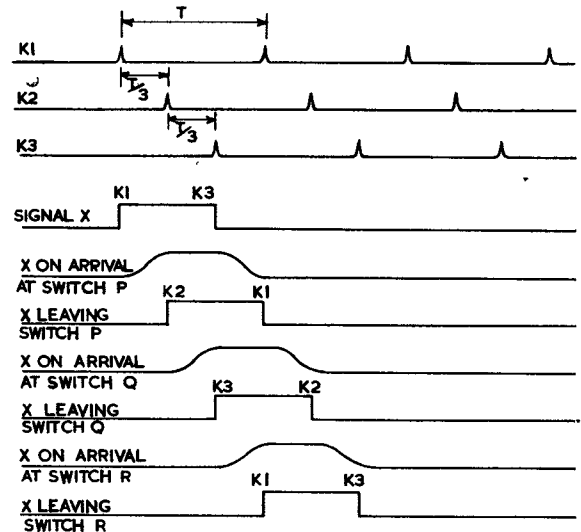

FIG. 13.—PROGRESSIVE TIMING OF SIGNAL PULSE X.

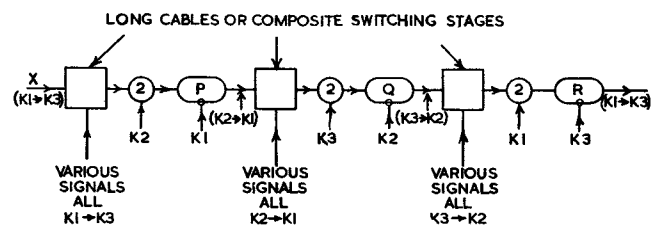

FIG. 14.—LOGICAL K-PULSE SWITCHES.

The most important point to observe is that all signals applied to any one switch must be extant between the same two K pulses. If one of a group of signals has a late nominal timing (say, K3 to K2, where the others are K2 to K1), then the rest of the group must be separately delayed before combination with the exceptional signal; this can be done either by subjecting them to a prior K-pulse stage (since each such stage introduces a delay of  $\frac{1}{3}T$ ) or by passing them through a delay network of the requisite size. It is a matter of convenience which method is used. A second point is that the timing of any one signal changes systematically as the signal passes through the machine; it is convenient to define standard or "synchronous" timing as that possessed by signal pulses which are about to be inserted into the delay lines of the main store, and to refer to all other appearances of the signals as "early" or "late" relative to this. Both the above points may be brought out clearly by consideration of the "Function Box" system, as will now be shown.

#### Function Box System.

A signal in transit from the receiving end of a storage line, through the function box and back to the sending end of the same or any other line, has to follow the route shown in Fig. 15. It will be seen (as was observed in Part 3(a), "The Highways") that the function box forms an alternative path to any re-circulation unit in the entire store. Given that the timing of signals entering a delay line is K1 to K3, and by definition "synchronous," it follows that the timing in other parts of the circuit must be as shown in Fig. 15. The extra delay incorporated in the re-circulation unit to compensate for the transit and switching delays in the parallel path through the function box is  $\frac{2}{3}T$ ; other points worthy of note are that the timing of "Destination Highway" pulses is "K3 to K2, early," and of "Source Highway" pulses is "K1 to K3, early." Further, the timing of signals emerging from a delay line is to be "K3 to K2, extra early," which means that the lines are to be not 640 but 638  $\frac{2}{3}T$  pulse lengths long ( $38\frac{2}{3}$  for short lines); the

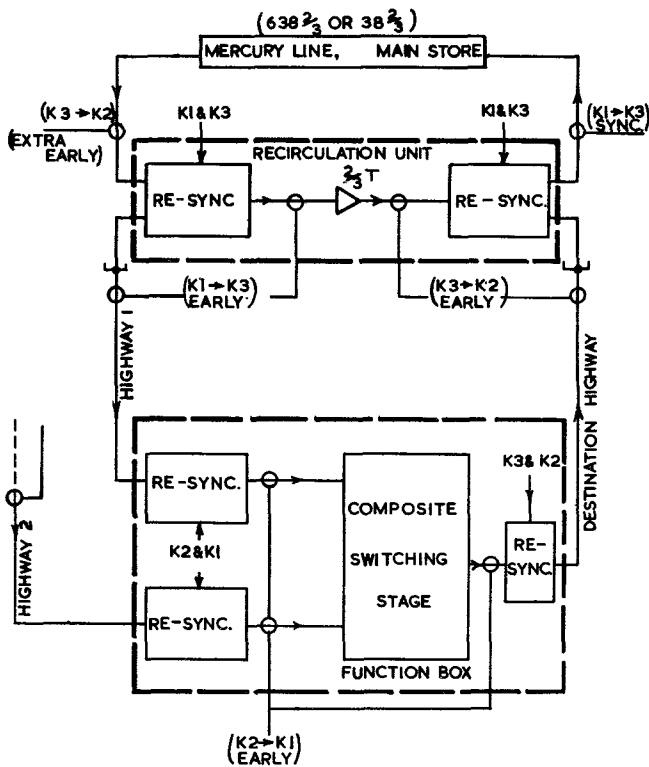

FIG. 15.—FUNCTION BOX SYSTEM.

total re-circulation time including that of the re-circulation unit is still, of course, 640 pulse periods.

The theoretical simplicity of the K-pulse technique makes the synthesis of elaborate switching schemes very easy, but its effectiveness in practice is governed by the fundamental assumption that the K-pulses of any one train are absolutely synchronous at all points of the machine, and that the three trains are genuinely staggered by one-third of a pulse period. Any obvious way of distributing the pulses, however, would itself insert variable relative delays, and thus destroy the required synchronism. The distribution problem will now be discussed.

It is arranged that the K-pulses are generated locally by peaking circuits on each and every panel of the machine, the peaking circuits themselves being driven by distributed

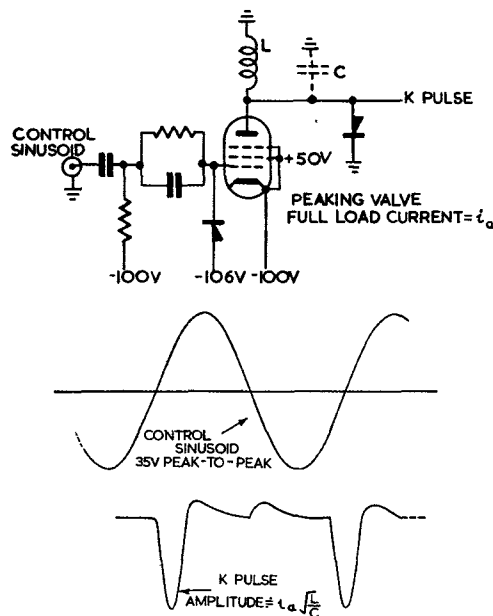

FIG. 16.—K-PULSE PEAKING CIRCUIT.

sinusoids at master-clock frequency. The pulses occur at the negative-to-positive change-over points of the controlling sinusoids, are negative, and of an amplitude proportional to the load current of the peaking valve. The circuit is illustrated in Fig. 16; sudden application of the load current "rings" a resonant circuit consisting of an inductance with stray capacitance, but a rectifier suppresses all except the first negative peak of the resulting oscillation. To provide the three staggered K-pulse trains, three sinusoids in exact three-phase relation are used. The synchronization problem therefore becomes that of providing, for each K-pulse train, a sinusoidal voltage which shall be distributed around the machine and yet be exactly in phase at all panels.

The only form of electrical signal with anything like this property is a standing wave; along such a wave, the voltages are either exactly in phase or 180° out-of-phase, but the amplitude of the voltage swings varies according to a sine

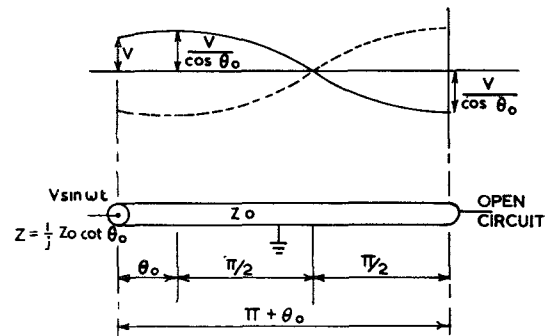

FIG. 17.—STANDING WAVE ON OPEN-CIRCUITED CABLE.

law along the length of the cable. Fig. 17 illustrates a standing wave on an open-circuited cable of length " $\pi + \theta_0$ " electrical radians,  $\theta_0$  lying between 0 and  $\pi/2$  radians. That is, the cable would introduce a phase shift of " $\pi + \theta_0$ " radians between the transmitting and the receiving ends, were it not for reflections from the open-circuited receiving end. If such a cable were to be used for a K-pulse main, then it is true that along the first  $2\theta_0$  radians the voltages would be in phase and of amplitude at least as great as that applied at the transmit end; for the rest of the cable, however, the voltage would be too small, or in reverse phase, or both. However, there is a very easy way to compensate for both unwanted effects at the same time.

Imagine a cable of characteristic impedance  $Z_0$ , and of length  $2\theta_0$  radians at the frequency desired. Further, let the cable for the moment be assumed distortionless (no dissipation). If such a cable be terminated with an inductive impedance of magnitude  $jZ_0 \cot \theta_0$ , and a voltage be applied at the transmit end, then a standing wave having the form shown in Fig. 18 will be set up in it, and the impedance presented to the voltage source will be capacitive, and of magnitude  $-jZ_0 \cot \theta_0$ . A second inductor, of impedance  $\frac{1}{2} jZ_0 \cot \theta_0$  connected to earth at this point will transform the whole network into an impedance of  $jZ_0 \cot \theta_0$ ,

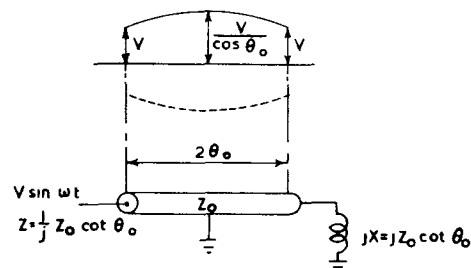

FIG. 18.—STANDING WAVE ON TERMINATED CABLE.

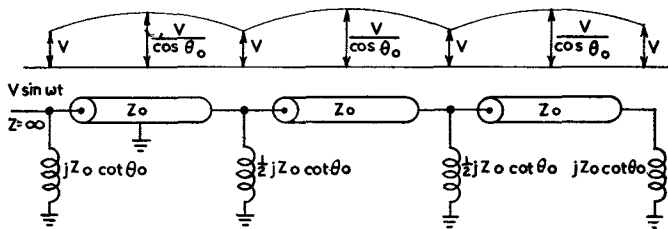

FIG. 19.—STANDING WAVE ON COMPOSITE CABLE.

which can therefore be used to terminate a similar section, and so on; a composite cable of any length can be set up in this way, as shown in Fig. 19, giving a standing wave of absolutely constant phase and of any desired constancy of voltage (the smaller  $\theta_0$ , the more uniform the voltage). The impedance  $j Z_0 \cot \theta_0$  at the transmit end is inserted to make the effective impedance of the composite cable very high.

The effect of dissipation is to reduce the total overall length of cable which can be so made up, for the standing wave phenomenon exists by virtue of equality between the transmitted and reflected waves; dissipation destroys the equality. In Mosaic, the total length of cable required was about  $4\pi/3$  radians (200 yd), and this was conveniently obtained with two composite cables, each of two sections,  $\pi/3$  radians per section, joined at the far end to make a ring main, as shown in Fig. 20. For this case,  $2 \theta_0 = \pi/3$ ,

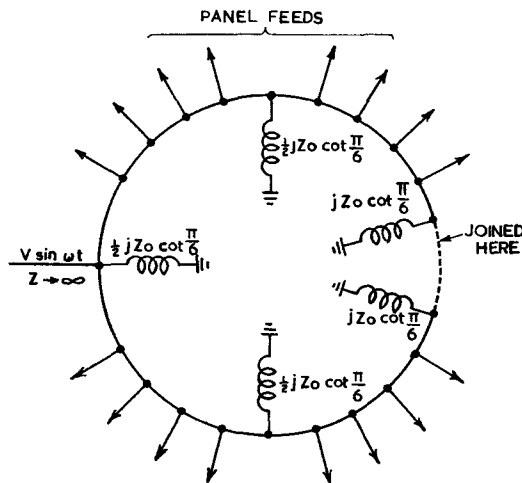

FIG. 20.—MOSAIC'S RING MAIN.

so  $\cos \theta_0 = \sqrt{3}/2$ ; thus the voltage variation along the main was from  $V \sin \omega t$  to  $(2/\sqrt{3}) V \sin \omega t$ , or about 15 per cent. That was quite satisfactory for the job of operating the peaking circuits.

There is a curious analogy between the properties of a standing wave in an uncompensated ring main, and those of an electron in a permitted orbit. An electron can remain in such an orbit, neither emitting nor absorbing energy, but only those orbits are permitted in which the wave-length of the electron, as given by its angular momentum, is an integral sub-multiple of the orbit circumference. A ring main can maintain a standing wave without taking current from the supply point, but only at those frequencies with a wave-length that is an integral sub-multiple of the ring-main circumference. An electron may jump from one permitted orbit to another, and will absorb or emit energy in so doing; the standing-wave frequency can be changed from one permitted value to another, but current (albeit reactive current) will be taken from the supply point during the transition.

The circuit units most in evidence in Mosaic are the "binary triggers" for re-shaping and re-synchronizing, and the "gates" for combining. The description here will be confined to these two. Both illustrate the adopted principle of keeping circuits simple and paths segregated, even though the number of valves may thereby be increased. For reasons both of circuit convenience and economy of current, which will not be elaborated, the signal polarity convention is Negative "ON," Earth or slightly positive, "OFF."

*The Binary Trigger.*

The standard Mosaic trigger uses a pair of symmetrically cross-connected pentode valves (CV138), as shown in Fig. 21. Switching is carried out on the suppressor grids,

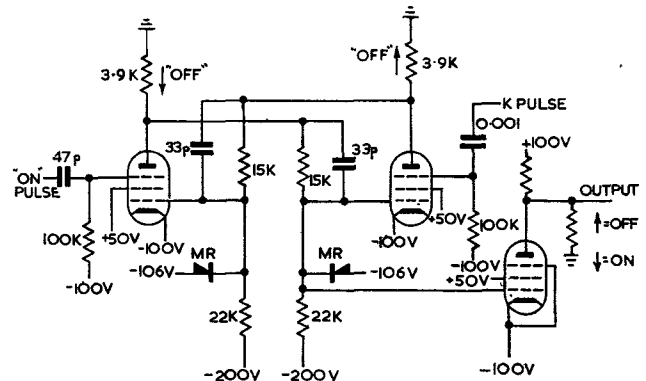

FIG. 21.—BINARY TRIGGER.

usually by a gated K-pulse "ON" and a simple K-pulse "OFF," and the output is obtained from a buffer valve chosen to suit the circuit conditions. Most important are the cross-feed capacitors (33 pico-farads) and the clamping germanium diodes MR; the capacitors improve the high-speed response of the trigger, but without the diodes would lead to a deterioration of the "resolving" or "settling-down" period, which would be governed by their circuit time-constants. The diodes limit the negative excursions of the grids (to just below valve cut-off) and grid current limits the positive excursions; the cross-feed capacitors then discharge or charge to their correct voltages as soon as switching is complete. Further, the diodes ensure that the non-conducting valve is never biased far below cut-off, and this makes the circuit behave as a true trigger—that is, the switching pulses need only *initiate* a change of state, they need not complete it. A 20V suppressor pulse is sufficient for the trigger of Fig. 21.

*The Gates.*

The generalized gate circuit is a logical unit, as described in the Appendix, in which out of  $X$  inputs at least  $N$  have to be activated before an output is provided. Two special forms of the general gate are the "AND" gate ( $N = X$ ) and the "OR" gate ( $N = 1$ ), and in practice it is preferable that all gates should be of "AND" or "OR" type. The reason for this is that the general gate that is neither "AND" nor "OR" almost inevitably involves multiple potentiometer networks, which reduce the effective signal voltage (and in a high-speed machine there is none to spare), draw current from the signal sources, cause a measure of interaction between the feeding paths, and must depend on the stability of inherently unstable resistors; "AND" gates and "OR" gates can be devised which are free of such undesirable characteristics. Fortunately, it is always possible to change a general gate into a composite system of "AND" and "OR" gates alone. It may be observed in this connexion that the gate "A, inhibited by B," may be equivalently described as "A AND (NOT B)"; that is, it is essentially



an "AND" gate with the two controlling signals "A" on the one hand, and "NOT B" (the phase reverse of B) on the other.

Mosaic, with its convention of negative polarity signals, uses three standard gates, two of "AND" type and one of "OR." The normal "AND" gate is a set of cathode followers with a common cathode load, and the normal "OR" gate is a set of diodes with a common anode load, both types being illustrated in Fig. 22. The diode gate is the less satisfactory

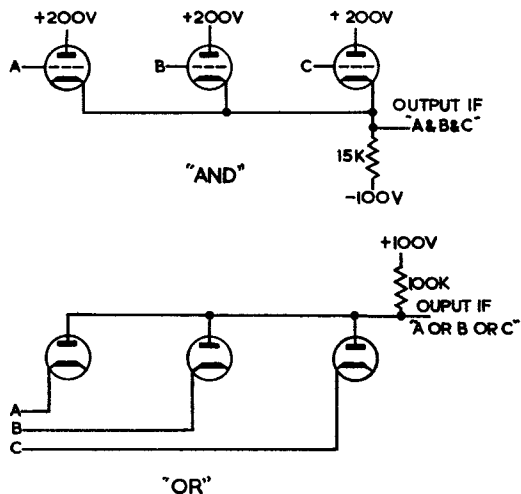

FIG. 22.—NORMAL MOSAIC GATES.

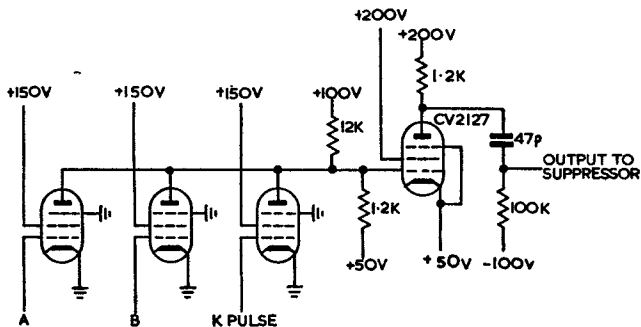

FIG. 23.—TRIGGER-SWITCHING "AND" GATE.

of the two, for it throws a load on the sources of the signals; however, it produces no diminution of signal voltage and does not rely on close tolerance parameters. The second type of "AND" gate is associated solely with trigger-switching. It has been observed that each composite switching stage (and each long inter-connecting cable) is to be

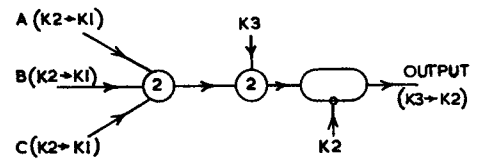

FIG. 24.—LOGICAL "CARRY" CIRCUIT.

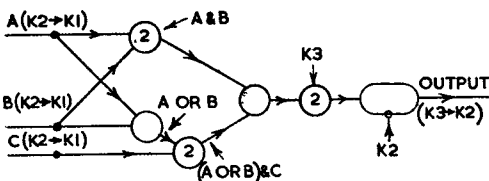

FIG. 25.—MODIFIED LOGICAL "CARRY" CIRCUIT.

followed by re-synchronization; as may be seen from Fig. 14, this means that whatever the law of combination in the composite system may be, the last stage will be an "AND" gate including a K-pulse input, the output being required as a suppressor grid pulse (20 to 30V, negative). The special gate used in the machine for this purpose is shown in Fig. 23, for the case "A AND B AND A K-PULSE." It is a set of valves with anodes commoned, followed by an amplifier of good high-frequency response; all the gate valves must be cut off before the amplifier can operate, and the output (if it exists at all) will therefore be an amplified version of the shortest input signal, the synchronizing K-pulse.

As an illustration of the whole foregoing discussion on synchronizing, triggering and gating, there will be indicated through the various stages of logical, modified logical and practical design, a circuit having the following characteristics:—

"Three signals A, B and C, timed 'K2 to K1' are to be combined on a '2 out of 3' basis, and the output appropriately re-synchronized."

This is, in fact, part of the Function Box "Carry" circuit; the signals A and B are digits of the two numbers being added, and C is a digit carried over from the previous addition. If the sum of A, B and C is at least 2, a carry digit is required for the next addition.

The straightforward logical circuit contains a general gate which is neither "AND" nor "OR" (Fig. 24), and this must be modified into a composite gate system (Fig. 25). The synchronizing pulse in each case is a K3-pulse, with a K2-pulse to restore the re-shaped signal. Note that an output timed "K3 to K2" is provided if any two or all three of the signals A, B and C exist simultaneously with a K3-pulse.

Translation into practical circuitry using the standard gates and trigger is purely rule-of-thumb (Fig. 26). With the output circuit shown, a CV138 buffer valve would give a signal 2.5V positive to 11V negative, which would be ample for most purposes.

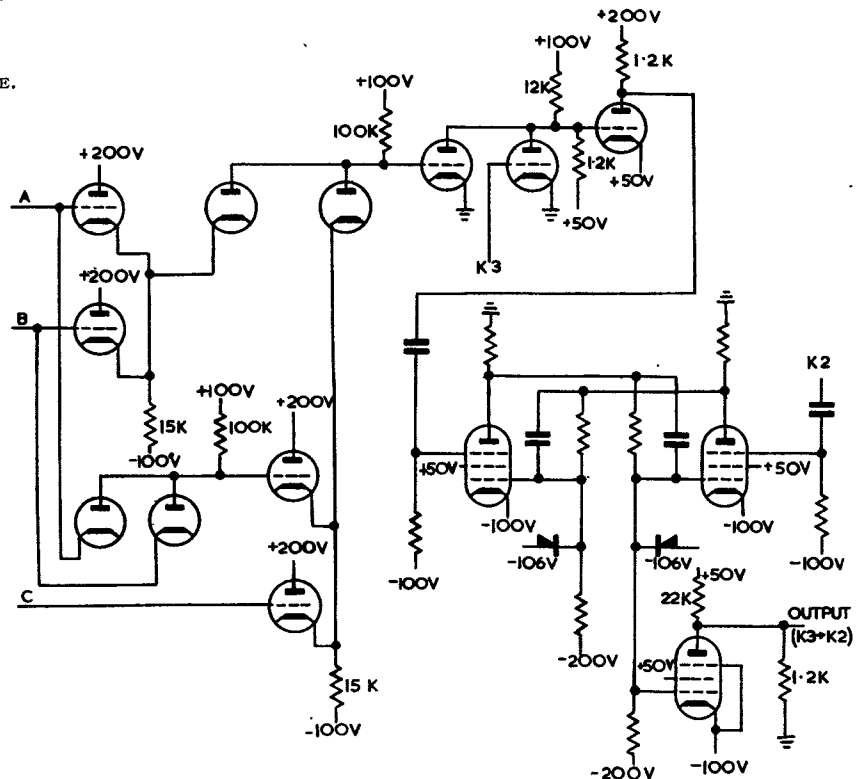

FIG. 26.—PRACTICAL "CARRY" CIRCUIT.

## THE FUNCTION BOX CIRCUIT

As a final example of circuit synthesis on the Mosaic plan, a rather simplified version of the Function Box will be considered. The simplification will consist in this, that the circuit will be capable of single-length (40-digit) addition and the three types of logical comparison only, and it is adopted here because space is limited. It will further be assumed that the "Function" digits of the Instruction Word have been pre-analysed, and that as a result the operation desired is indicated by a signal on one and only one of four controlling leads, "+," "≠," "&," and "OR" (see Table 1, Part 1). The Function Box is required to accept two 40-digit binary numbers A and B (least significant digits first) from Highways 1 and 2 respectively, combine them according to one of the four prescribed laws, and consign the answer, a 40-digit binary number D, to Destination Highway.

### Addition and Logical Operations.

The arithmetical addition of two multi-digit binary numbers involves the possibility of requiring to add, at any stage except the first, three separate binary digits, namely, one from each of the two original numbers A and B, and a possible carry digit C from the previous addition. There cannot and must not be a carry digit at the first stage of addition (the least significant digits); if one exists fortuitously as the result of an irrelevant addition at the 40th stage of the previous numbers fed to the Function Box, it is to be suppressed. The combining unit must therefore accept up to three inputs A, B and C, and produce two outputs D (the answer) and E (the carry digit, to be fed back with unit pulse period delay, and to constitute the C input for the next addition). The sum of the digits A, B and C can have four possible values, each with its own significance, as exhibited in Table 2 below.

TABLE 2  
Binary Addition

SUM A + B + C	ANSWER D	CARRY DIGIT E
0	0	0
1	1	0
2	0	1
3	1	1

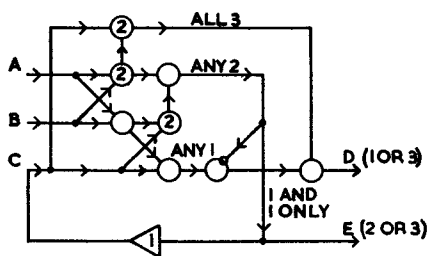

FIG. 27.—LOGICAL "ADDER."

The logical circuit shown in Fig. 27 successfully carries out the required analysis, for D is "1" if the sum be "1 or 3," and E is "1" if the sum be "2 or 3." The make-up of the unit delay, and the method of carry suppression at the first stage of addition, are as yet unspecified.

If all the carry digits are suppressed, the same circuit is capable of discriminating between the three logical operations, because, in that case, output D signifies "1 and 1 only of A and B," while output E signifies "Both A and B simultaneously." Thus, D gives "≠" (not equivalent to). E gives "&" (AND), and the combination of D and E on an "OR" basis gives "A OR B OR BOTH," which is the logical "OR." The whole circuit, taking account of timing, carry

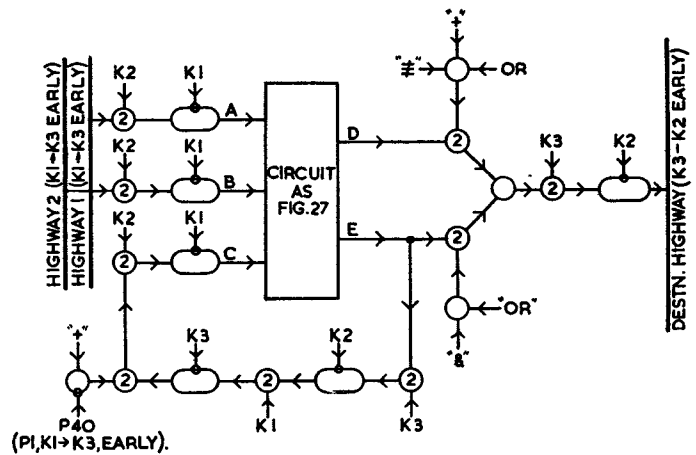

FIG. 28.—SIMPLIFIED FUNCTION BOX.

suppression and control signals may therefore be assembled, and is shown in Fig. 28.

### The Complete Logical Circuit.

The total delay from source highways to destination highway is  $\frac{2}{3}$  pulse period,  $\frac{1}{3}$  for re-synchronizing after the long feed cable and  $\frac{1}{3}$  for re-synchronizing after the composite switching of the Function Box itself (the timing of the highway signals was fixed to accommodate the Function Box requirements, Fig. 15). The unit delay in the "carry" circuit is made up with three successive re-synchronizing stages, one corresponding to the A and B input triggers (K2 → K1, early), and one to the output trigger (K3 → K2, early). "Carry" is to be permitted only if "+" is indicated, and even then not at the first stage of addition, corresponding to the number digit P1 (see Part 3(a), Special Sources); it is therefore ideally controlled by the composite signal "(+) AND (NOT P1)." In practice, control is exercised at a point where the timing of the carry digit is "K1 to K3, early," and the P1 pulse must be similarly timed; it is convenient to use "P40, sync" (which is available) rather than "P1, K1 → K3, early" (which is not). On the output side, the circuit provides D alone for the control conditions "+" and "≠," E alone for control "&," and (D OR E) for control "OR," as required.

### MERCURY-LINE TEMPERATURE COMPENSATION

One of the problems associated with mercury-line storage is that the pulse velocity down lines is variable with temperature. It is, however, vital that a delayed pulse emerging from a line shall be synchronizable by the correct K-pulse of the correct P-digit of the correct minor cycle—that is, that the delay of a long storage line shall be  $638\frac{2}{3}$  pulse periods for Mosaic, within very close tolerance. Therefore, either both temperature and Master Clock frequency must be constant, or else both must vary together according to some rule which will maintain the required equality; Mosaic uses the latter scheme, with one long delay line (No. 0) used as control. It is still necessary that all the lines be at the same temperature, but within limits ( $\pm 30^\circ\text{C}$ ) that temperature may be allowed to vary, the Master Clock frequency being adjusted to suit by signals derived from the controlling line.

The K-pulse technique makes control very simple. In effect, a repetitive standard signal ( $\frac{2}{3}$  pulse period in length) is transmitted down delay line No. 0, and then compared with itself in undelayed form. Ideally, the signal centre lines should be  $1\frac{1}{3}$  pulse periods apart; if they are more than  $1\frac{2}{3}$  or less than 1 period distant from each other, the delayed pulse cannot be synchronized by the correct K-pulse. In practice, the tolerance is made  $\pm \frac{1}{3}$  period; the divergence from ideal is turned into an algebraic voltage by a simple

analogue device, and that voltage is used to bias a valve reactor in the Master Clock oscillator circuit, and so to correct the divergence producing the voltage (as in an error-correcting servo-mechanism).

### CONCLUSIONS

Many high-speed digital computers have been made all over the world, for a variety of purposes, and the output shows no sign of abating. A Soviet machine has been described, for instance, which can translate English text into reasonably grammatical Russian. Perhaps it would be true to say that present interest is largely on machines for commercial use. Mosaic has made its distinctive contribution to the art; it is at present the only 4-address machine in use in this country, and its K-pulse technique, with standing-wave control, resolves very satisfactorily the problem of combined high speed and large size, a problem which was bound to arise sooner or later.

### APPENDIX

#### LOGICAL CIRCUIT SYMBOLS

Any switching circuit may be built up using only four essential units, namely:—

- (1) The "PATH," or route of a signal.
- (2) The "GATE," or switch, the output of which depends in a predetermined way on the signals on a multiplicity of input paths.
- (3) The "NEGATION" unit, which has the effect of changing an "ON" signal to "OFF," and vice versa.
- (4) The "DELAY" unit, which interposes a fixed time-delay on all signals on a given path.

These may be called the "PRIMARY" units, and they are conveniently represented logically by the symbols of Fig. 29.

The symbols represent logical conditions only; the prevalent tendency to make them show more (for instance, circuit parameters or voltage levels) is to be deplored, for the only result is lack of generality and confusion in the diagrams. The same applies in general to multiplication of the symbols for special purposes; nevertheless, some combinations of the primary symbols occur so frequently as to justify such special symbols, and they are shown in Fig. 30. All signals may be of any length in time, with the exception of input "A" of the Scale-of-two trigger and output "B" of the Beginning and End units, which are always understood to be pulses of

No	DESCRIPTION	SYMBOL
1	PATH INDICATES ROUTE OF A SIGNAL ALL PATHS ARE UNIDIRECTIONAL	
2	GATE OF THE "X" INPUTS, ANY "N" OR MORE WILL PROVIDE OUTPUT AT "A" IF N=1, IT IS CUSTOMARY TO LEAVE THE CIRCLE EMPTY	
3	NEGATION SIGNAL AT "A" GIVES NO SIGNAL AT "B", AND VICE-VERSA	
4	TIME DELAY SIGNAL AT "A" APPEARS T UNITS OF TIME LATER AT "B"	

FIG. 29.—PRIMARY LOGICAL CIRCUIT SYMBOLS.

No	DESCRIPTION	SYMBOL
5	TRIGGER (LOCKING SWITCH) TURNED "ON" BY SIGNAL A, THEN GIVES OUTPUT B IRRESPECTIVE OF A.	
6	INHIBITION OR RESET a GATE CIRCUIT PREVENTS GATE BEING OPENED THUS "OUTPUT AT B IF A & D BUT NOT IF E" b TRIGGER CIRCUIT TRIGGER, TURNED "ON" BY A, IS RESET BY E E OVER-RIDES A IF BOTH APPEAR TOGETHER	
7	SCALE-OF-TWO TRIGGER SUCCESSIVE SIGNALS AT A TURN TRIGGER "ON" AND "OFF"	
8	PULSE DEVICES END (E) OR BEGINNING (B) OF SIGNAL AT A PRODUCE PULSE AT D	

FIG. 30.—SECONDARY LOGICAL CIRCUIT SYMBOLS.

predetermined length. The exceptions do not lead to confusion in practice.

The primary and secondary symbols described here were invented by the late Dr. A. M. Turing, then of the National Physical Laboratories.

## I.P.O.E.E. Printed Paper No. 207

"Telex Service." R. N. Renton, A.M.I.E.E. This paper was contributed to the proceedings of the Institution during the 1953-54 session, was awarded the Institution Senior Silver Medal, and printed by the authority of the Council. Copies may be obtained from the Librarian, The Institution of Post Office Electrical Engineers, G.P.O., Alder House, London, E.C.1. The price per copy is 2s. 6d. net (2s. 8d. post free), but members of the Associate Section of the Institution have the privilege of purchasing copies at the reduced price of 1s. 6d. net (1s. 8d. post free). Corporate members of the Institution may also purchase additional copies at the reduced price.

In this paper, the author traces the development of the telex service from its inception in this country up to the present time. An introductory section mentions the factors that enabled such a service to be brought into operation and advances the reasons leading to the decision to make use of the telephone network for the service. A description of the subscriber's 1,500-c/s equipment is followed by a discussion of the experiences and factors that resulted in the proposal to introduce a new telex service based upon the use of a network of telegraph circuits.

The telegraph transmission aspects of such a network are dealt with in some detail, and some results are given of dis-

tortion measurements made over five v.f. telegraph circuits switched in tandem. Details are given of the signalling principles adopted in relation to the recommendations of the C.C.I.T. The equipment at a subscriber's station and at a manual telex exchange is illustrated, and the facilities provided are described with the aid of circuit diagrams. An operational problem of 24-hour staffing at the smaller exchange, and an economic one of serving small groups of remotely-situated subscribers, have both been met by the introduction of a small automatic sub-exchange: a brief description is given of the facilities provided by this unit exchange. The account of the inland telex system is concluded with some reference to the numbering scheme, the printergrams and multitelex services, and the program for conversion from the old to the new system: brief mention is also made of the proposal for early automatization.

The development of the telex service to other countries is described, with brief reference to the systems adopted by other Administrations and the method of operator-to-subscriber dialling from the London switchboard into foreign networks. The telegraph transmission aspects are touched upon, with details of the salient requirements for regenerative repeaters.

The paper concludes with a brief description of the Van Duuren error-correcting equipment used on the London-New York radio telex links.

# Time-To-Answer Equipment For Use in Sleeve-Control Exchanges

D. R. B. ELLIS†

U.D.C. 621.395.361

Traffic Staff have in the past used stop-watch observations for assessing the time taken to answer incoming calls at manual switchboards, but equipment has now been developed that makes the necessary observations automatically, and with greatly increased accuracy.

## INTRODUCTION

INFORMATION concerning the time taken to answer incoming calls at manual switchboards has hitherto been obtained by means of stop-watch observations taken by the traffic staff. A recent experimental installation of partial call-queueing equipment included a means of automatically recording the information on meters. A comparison of the results obtained by the two methods revealed a considerable discrepancy, which has been shown by a mathematical study to be due to the method of sampling. The stop-watch observations, taken at random, were found to be less accurate than those obtained by sequential sampling, by which method every "nth" call to be displayed is timed, "n" being adjustable to meet the conditions existing in a particular exchange, and to obtain an adequate sample. An equipment has been designed for use on selected circuits at sleeve-control exchanges, and from its use additional information about answering times will be made available without the need to install extensive partial call-queueing equipment.

Up to 50 circuits are intercepted and the calls on them are counted. Every "nth" call is connected via an equipment that times the answering-lamp glow in steps of one, three or six seconds, up to a maximum of three minutes duration, and records the call on one of six meters. Hence, the distribution of calls within six predetermined answering periods is ascertained. Coincidentally, the total number of all calls and their total answering time are recorded on meters to give an average answering time for the calls.

## CIRCUIT OPERATION

### Outline description.

Fig. 1 shows a block schematic diagram of the equipment. The existing lamp-wire is intercepted at the I.D.F. and the calling signal from the selector-level relay set connected via the tapping circuit to mark the position of the calling circuit on the linefinder bank and to provide a start signal to the

call-counting and allotter-control circuits, wherein the call is counted.

If it is not the "nth" call, a predetermined linefinder drives to the marked contact, switches and connects a signal to the lamp relay of the tapping circuit, which, in turn, operates the normal lamp relay, to display the call on the switchboard. The call-counting circuit and the linefinder are released to be available for the next call. Subsequent calls, up to and including the next "nth" call, are dealt with by the same linefinder. When the "nth" call is connected, a similar procedure is followed, but in addition the timing circuit associated with the linefinder is brought into use; the linefinder and timing circuit are held by the tapping circuit and the allotter steps to the next free linefinder outlet. When the call is answered, the tapping circuit, timing circuit and linefinder are released in that order, and the call is recorded on the appropriate answering-time distribution meter.

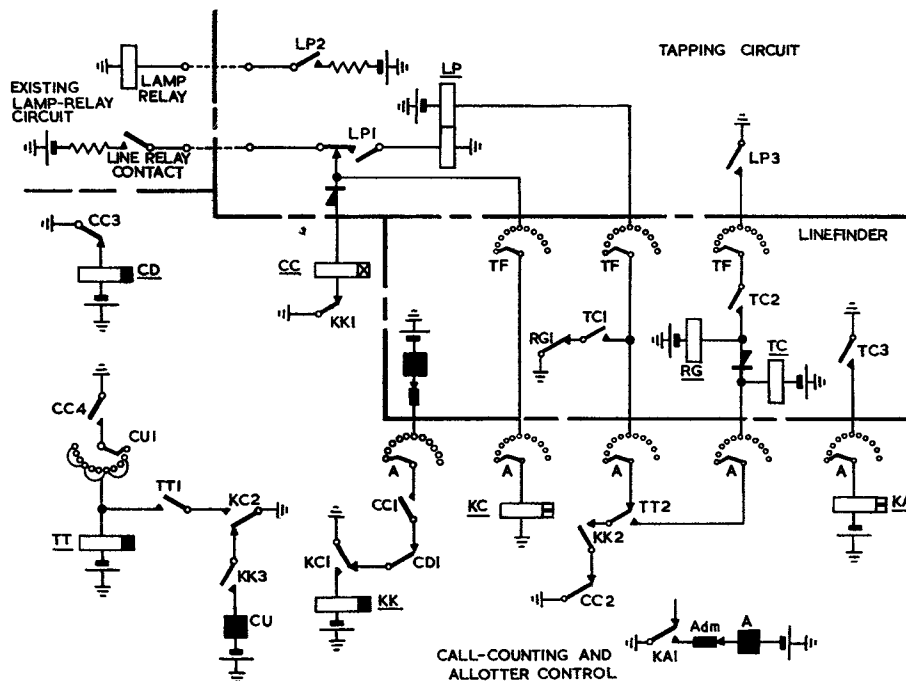

FIG. 2.—TAPPING, CALL-COUNTING, ALLOTTER AND LINEFINDER CIRCUITS.

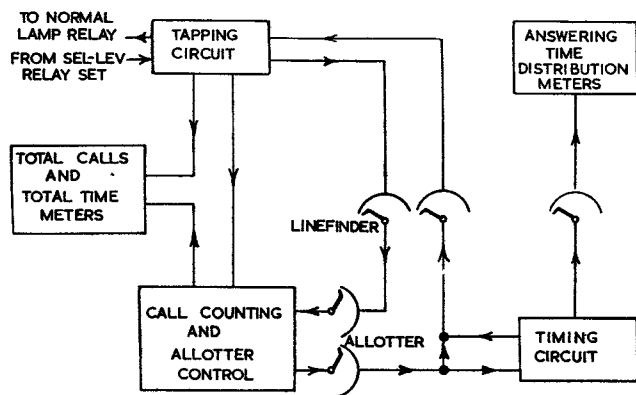

FIG. 1.—BLOCK SCHEMATIC DIAGRAM OF THE EQUIPMENT.

### Tapping, Call-Counting, Allotter and Linefinder Circuits (Fig. 2).

When a call is connected to the equipment, the existing lamp-wire signal from the selector-level relay set is connected via LP1 to mark the position of the tapping circuit on the linefinder bank and, if the call-counting circuit is not dealing with another call, operates relay CC. CC3 releases relay CD and CD1 operates the linefinder magnet. If the call is not to be timed relay TT does not operate. The linefinder wipers drive to the marked contact, and relay KC operates. KC1 disconnects the linefinder magnet and operates relay KK. KK1 releases relay CC and CC2 operates relay LP. LP1 holds relay LP and releases relay KC. LP2 operates the normal lamp relay and displays the

† Executive Engineer, Telephone Development and Maintenance Branch, E.-in-C.'s office.

call. KC1 releases relay KK, KC2 operates the counting uniselector magnet and KK3 releases the counting-uniselector magnet to step the wipers to the next contact.

Every "nth" contact of arc CUI is connected to relay TT, and when the "nth" call is connected, relay CC operates and CC4 operates relay TT. The circuit operation proceeds as before, but when KK2 operates, earth from CC2 is connected via TT2 to operate relay TC. TC1 operates relay LP and LP3 holds relay TC via TC2, and operates relay RG. RG1 disconnects the operate circuit of relay LP, TC3 operates relay KA and KA1 steps the allotter wipers to the next contact.

#### Timing Circuit.

The timing circuit (Fig. 3) comprises a uniselector which steps at 1-sec intervals for 15 sec, at 3-sec intervals from

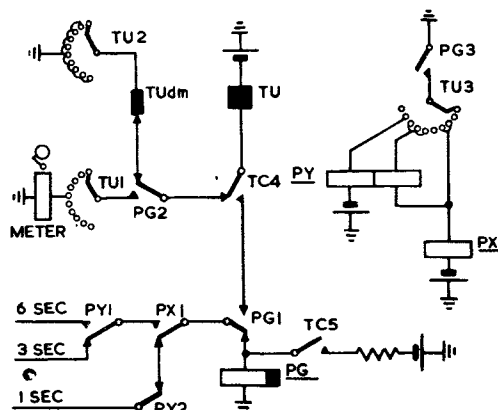

FIG. 3.—TIMING CIRCUIT.

15 sec to 42 sec, and at 6-sec intervals until 3 min, when further timing ceases.

The operation of TC5 operates relay PG, and PG1 connects a 1-sec earth pulse via TC4 to the timing-uniselector magnet. After 15 sec relay PX operates and PX1 changes over the timing-uniselector magnet to the 3-sec pulse wire. After a total of 42 sec, relay PY operates in series with relay PX and PY1 changes over the timing-uniselector magnet to the 6-sec pulse wire. After 3 min, relay PX releases and PX1 disconnects the pulse wire to stop further timing.

When the call is answered, relay LP (Fig. 2) releases and LP3 releases relay TC. TC5 (Fig. 3) releases relay PG and TC4 connects battery via the TU magnet to operate the answering-time distribution meter, during the slow release of relay PG. PG2 completes the self-drive circuit to home the timing-uniselector wipers.

#### Pulse synchronization.

To prevent timing errors due to the 1, 3 and 6-sec pulses not being synchronized, the 3-sec and 6-sec pulses are generated within the equipment by a pulse-counting circuit element, shown in Fig. 4.

One-second pulses from the exchange pulse supplies operate relay PS, and PS1 repeats the pulses to the pulse-counting relays PA . . . PF. The first operation of PS1 operates relay PA and the first release of PS1 holds relay PA and operates relay PB. The second operation of PS1 holds relay PB and releases relay PA. The second release of PS1 holds relay PB and operates relay PC. The sequence continues with each 1-sec pulse until relay PF releases. PF1 re-connects the pulse to relay PA and the sequence is repeated, the whole cycle taking 6 sec. The 3-sec pulse is connected when relay PC or PF is operated, and the 6-sec pulse is connected when relay PF is operated.

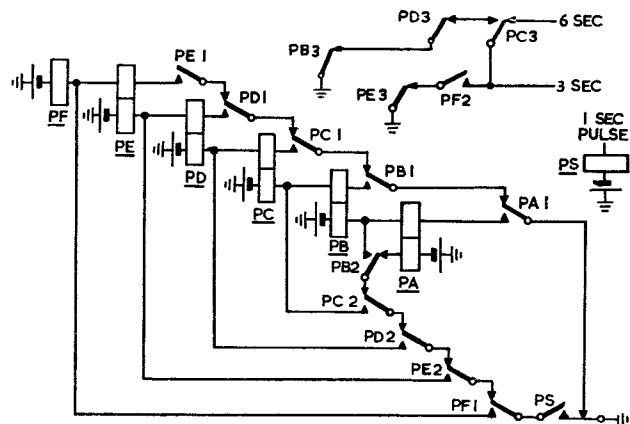

FIG. 4.—GENERATION OF 3-SEC AND 6-SEC PULSES.

#### Total-Time Meter.

To determine the average answering time, the total display time of all calls is recorded on a 100-type meter, each step of which represents 5 sec. Hence, the meter must be operated at a frequency varying between 12/min, when one call is displayed, and 600/min, when 50 calls are displayed. This is achieved by the use of two cold-cathode valves, as shown in Fig. 5.

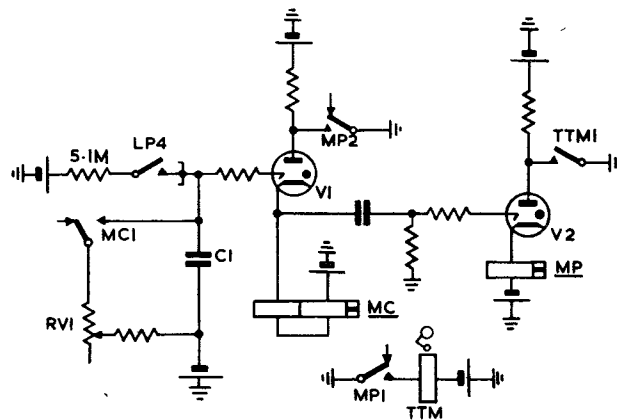

FIG. 5.—CIRCUIT OF TOTAL-TIME METER.

While a call is displayed, LP4 connects 80V positive battery, via a 5.1-megohm resistor, to charge capacitor C1. The potential across C1 rises until such a value is reached that V1 conducts and relay MC operates. MC1 discharges the capacitor via RV1. Simultaneously, the cathode potential of V2 rises, and that valve also conducts, operating relay MP. MPI operates the total-time meter, and MP2 quenches V1, releasing relay MC. MC1 disconnects the shunt across C1, which again charges. TTM1 quenches valve V2, to release relay MP, and MPI releases the meter. If two or more calling circuits are displayed simultaneously, the charging rate of C1 is increased in proportion and the cycle of operations is repeated at a higher frequency. MC1 is operated for the same period of each cycle, irrespective of frequency, and it follows that, because display time is not being recorded while MC1 is operated, a small error might be expected. By adjusting RV1, a small residual charge remains in C1 after MC1 releases, to compensate for such an error, and to provide adjustment to compensate for tolerances in components.

#### CONCLUSION

A prototype of the equipment has been constructed and will shortly be installed in a sleeve-control exchange for traffic tests, which will determine whether the equipment is to be standardized for general use.

## Post Office Joint Production Council for Engineering and Allied Services

**J**OINT Production in the engineering field is by no means new. As long ago as 1928 the Experimental Changes of Practice Committee was set up as one of the first essays in Joint Production for the specific purpose of enabling the staff to get together to discuss ways of carrying out work in the field; since then it has met regularly under the chairmanship of respective Engineers-in-Chief and has done much useful work in a very friendly atmosphere.

Joint Production Committees covering the whole range of

co-ordinate the activities of the regional committees, provide some machinery for joint consultation on suggestions of national importance, and ensure adequate stimulation and encouragement of the Engineering Joint Production movement. Such a body, viz. the Post Office Joint Production Council for Engineering and Allied Services, was formally inaugurated by the Postmaster General on 13th February, 1956, in Room 109, Headquarters Building. The Director General as Chairman of the Council introduced



engineering work have been in operation throughout the country since 1947, when they were set up concurrently with the introduction of the shorter working week. The committees, which provide meeting grounds for the free and joint discussion of performance, problems and suggestions, have up to now been without a counterpart at the national level. For some time, however, the need has been generally recognized for setting up a representative body much on the lines of the Non-Engineering Council, which would

the Postmaster General, who concluded a very interesting speech by wishing the Council every success in its undertaking.

Six panels have been set up to assist the Council in its work, namely, External, Internal, Organization and Procedure, Motor Transport, Supplies and Internal Relations. The first five will consider specialist problems. The Internal Relations Panel will consider and co-ordinate all publicity associated with productivity. Other panels may be set up if necessary.

### Book Review

"Noise." A van der Ziel. Chapman & Hall, Ltd. 450 pp. 97 ill. 60s.

Electrical noise is the name given to unwanted fluctuations of current or voltage; it was observed qualitatively early in the century, but it played no important part in the first years of the history of thermionic valves and active electric circuits. More thorough studies began around 1930; to-day, with engineers striving to take the utmost advantage of components and systems, noise has assumed great importance. It sets the limit to the weakest signal that can be satisfactorily handled in many electrical instruments, in radar, in carrier telephony and in other major applications of electronics.

Prof. van der Ziel has written a comprehensive account of noise in electronic devices, with all the authority proper to his own important contributions in recent years.

Analytical and experimental studies have classified the noise into several components. Two components have fundamental origins. The thermal component of the energy of the mobile charge-carriers in a conductor imparts a random ele-

ment into their motion. The resulting noise is called thermal noise and is dependent on temperature. Shot noise, on the other hand, is due to the finite value of the smallest charge (the electronic charge); it is significant in thermionic valves.

The book begins with general accounts of these two causes and ways of representing them. The measurement of noise has presented problems which are now well understood if not entirely solved. Noise sources required as references are adequately described. Some of the extensions to microwave frequencies are included. A detailed account of the noise generated in thermionic valves includes Schottky's deduction of shot noise; partition noise, so important in pentodes, is dealt with quantitatively. The noise behaviour of valves at very high frequencies has always been a subject of great difficulty and the long chapter devoted to it needs careful reading if the facts presented and the deductions are to be fully absorbed.

The ways of obtaining minimum noise for different valve circuits, single and multi-stage, are well described. Noise in semi-conductors is treated from solid-state theory; both holes

*(Continued on p. 141)*

# Notes and Comments

## Birthday Honours

The Board of Editors offers congratulations to the following members of the Engineering Department honoured by H.M. The Queen in the Birthday Honours List:

Coventry Telephone Area	.. ..	Nixon, G.	.. ..	Executive Engineer	..	Member of the Most Excellent Order of the British Empire
Engineering Department	.. ..	Danks, J. B. R...	.. ..	Technical Officer	..	British Empire Medal
		Jolley, E. H.	.. ..	Staff Engineer	..	Officer of the Most Excellent Order of the British Empire
London Telecommunications Region (City Area)		Steers, W. F.	.. ..	Inspector	.. ..	British Empire Medal
Sheffield Telephone Area	.. ..	Greaves, H. C.	.. ..	Inspector	.. ..	British Empire Medal
Swansea Telephone Area	.. ..	Roe, C. L.	.. ..	Technician, Class I	.. ..	British Empire Medal
Tunbridge Wells Telephone Area	.. ..	Fagg, R. L.	.. ..	Assistant Engineer	.. ..	Member of the Most Excellent Order of the British Empire

## Special Commendation

The Postmaster General has personally commended Mr. W. J. Galland, Technician, Class IIA, Chester Telephone Area, to whom the Royal Humane Society has awarded its Testimonial on Parchment for his courageous conduct on 19th October, 1955, when he rescued a woman from drowning in the River Dee at Chester.

## A. C. Lynch, M.A., B.Sc.

Mr. A. C. Lynch was promoted to Senior Principal Scientific Officer in the Materials Division of the Research Branch in February 1956. He was educated at Emmanuel College, Cambridge, where he read physics and mathematics from 1932-35 and was awarded his B.A. His curiosity in the experimental electrical sciences well aroused, he entered the Post Office Engineering Department as a

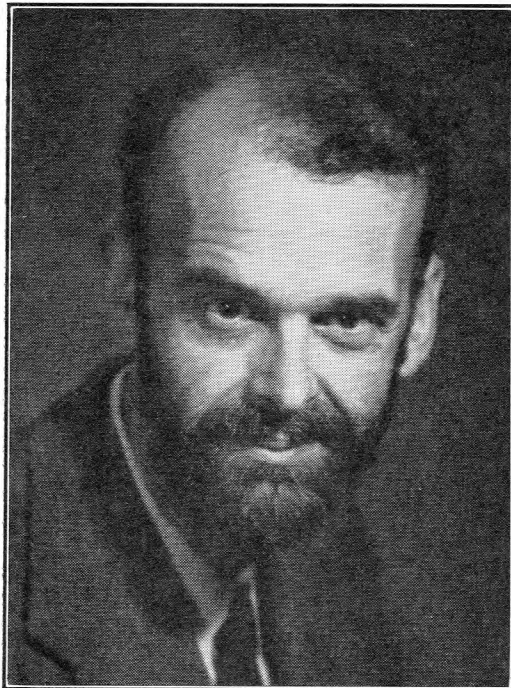

Probationary Inspector in 1936. After a few months' general training he was posted to the Research Branch, where he has made his career ever since. He became a

Probationary Assistant Engineer by limited competition in 1939 and was appointed Senior Scientific Officer when the regrading of parts of the Research Branch took place in 1947. He was promoted to Principal Scientific Officer in 1950, taking charge of the laboratory he had already done much to organize.

From the time he took up his duties at Dollis Hill, he has studied the electrical and magnetic properties of materials used in telecommunications. Thus his early years were very much taken up with studies of dielectric materials, a subject in which he is still active from time to time as needs arise. Since the war, soft magnetic materials have taken up much more of his time and his measurements of their properties have been a major part of the Dollis Hill program of the study of powders and strip; he has been secretary of the relevant inter-departmental committee for many years. He helped organize a conference on soft magnetic materials at Dollis Hill in 1952 and, jointly, edited the subsequent publication. In 1949-50 he made some new measurements on piezo-electric crystals, principally quartz. During the war he undertook other tasks as well, involving the design of electronic equipment for a variety of novel applications.

He has always shown great interest and skill in accurate and sensitive electrical measurements and has turned them to many useful accounts for the Post Office. With claims being made at frequent intervals for new dielectric, ferro-electric, magnetic, magnetostrictive, resistive, etc., materials, engineers often find difficulty in choosing the materials most suitable for their uses. It is here that Mr. Lynch, actively engaged in advance, can continue, and on a widening field, to give the Department advice and guidance.

In private life he has been active in several fields. He has long been a strong chess player, and a regular member of the first team of the Post Office. His interest in orchestral music, and its recording and reproduction, is also long-standing. More recently, and by private study, he has obtained the degree of B.Sc. in psychology from the University of London.

J. R. T.

# Institution of Post Office Electrical Engineers

## Commemoration of 50th Anniversary

In amplification of the preliminary announcement made in the April issue of the Journal, the following details of the arrangements made by the Council of the Institution of Post Office Electrical Engineers to commemorate the Institution's 50th Anniversary of Foundation are given for the information of members:—

### Jubilee Meeting (London)

Arrangements have been completed to hold this meeting at the Institution of Electrical Engineers, Savoy Place, London, W.C.2, on Monday, 8th October, 1956, when the President of the Institution, Brig. L. H. Harris, C.B.E., T.D., M.Sc., F.C.G.I., M.I.E.E., will address an audience of members and distinguished guests on the subject, "Fifty Years of Telecommunications," commencing at 5.30 p.m. A historical exhibition of telecommunications equipment will be on display before and after the meeting. Application forms to attend the meeting will be distributed to members concerned early in July, and those desiring to attend should complete and return the forms by mid-August.

### Provincial Celebrations

The arrangements for celebrating this occasion at Provincial Centres are in the hands of the respective Local Centre Committees, and details will be announced locally.

### Celebration Dinner-Dance (London)

This function has been arranged to take place at the Windsor Room, Corner House, Coventry Street, London, W.1, on Tuesday, 9th October, 1956, at 7.00 for 7.30 p.m. Dancing will continue until 11.30 p.m. Further details, and application forms for tickets, will be distributed to members concerned early in July.

The Postmaster General, Dr. The Rt. Hon. Charles Hill, M.P., has indicated his intention of being present.

### Jubilee Issue of the Journal

The October 1956 issue of the Journal will be a special Jubilee number devoted to articles reviewing the development and growth of the British Post Office telecommunications services and of the mechanization of postal services. These articles will include the history of development in each of the main branches of telecommunications engineering with particular reference to technical advances in more recent years.

H. E. WILCOCKSON,  
*Secretary.*

### Essay Competition, 1955/56—Results

A prize of £5 5s. 0d. and an Institution Certificate have been awarded to the following competitor in respect of the essay named:—

E. F. Taunton, Technical Officer, Perth (Scotland).  
"Problems and Personalities at Maintenance Control."

Prizes of £3 3s. 0d. each and Institution Certificates have been awarded to the following four competitors:—

H. F. Bentley, Technical Officer, Edenbridge (H.C. Region).  
"The Long Arm of Dual Maintenance."

J. R. Haggart, Technical Officer, Edinburgh (Scotland).  
"The Development of the Telephone."

J. O. Rogers, Technical Officer, Rugby Radio Station (E.T.E.).  
"How Far Is Automation a Good Idea?"

J. L. Care, Technical Officer, Eltham (L.T. Region).  
"Conducting the Public Around a Telephone Exchange."

Institution Certificates of Merit have been awarded to:—

R. L. Wood, Technical Officer, Reading (H.C. Region).  
"Observations On the Larger Size of the P.A.B.X. No. 3."

A. H. Strange, Technical Officer, Engineering Dept. (LLB Branch).  
"An Appreciation of High Quality Sound."

J. R. Greenfield, Technician I, L.P. Region (Power Section).  
"Generating and Metering (E.H.T.)."

A. L. Deighton, Technical Officer, Lincoln (N.E. Region).  
"Why Do Accidents Occur and What Should Be Done to Prevent Them?"

The Council of the Institution records its appreciation to Messrs. W. S. Proctor, S. Welch and E. W. Anderson, who kindly undertook to adjudicate upon the essays entered for the competition.

H. E. WILCOCKSON,  
*Secretary.*

*N.B.—Particulars of the next competition, entry for which closes on the 31st December, 1956, and a review of the above-mentioned prize-winning essays, will be published later.*

### Additions to the Library

2337 *Textbook of Servo-mechanisms.* J. C. West (Brit. 1953).  
Assumes a standard of mathematics about that of a first-year University course, and an elementary knowledge of electronics.

2338 *Electromagnetic Principles of the Dynamo.* E. B. Moullin (Brit. 1955).

An academic book for those using the electromagnetic principles of the dynamo as a discipline for mental training.

2339 *Noise (In Electronic Devices).* A. van der Ziel (Amer. 1955).  
Reduces the solutions to most noise problems to an analysis of simple networks.

2340 *A History of Red Tape.* J. Craig (Brit. 1955).

An outline of the constitution, rewards and outlook of the Civil Service from its origin to its present state.

2341 *Principles and Applications of Physics.* O. Blüh (Amer. 1955).

Attempts to provide a comprehensive and coherent understanding of physical science.

2342 *Strength of Materials.* B. B. Low (Brit. 1955).

A fairly elementary textbook.

2343 *Vacuum Valves in Pulse Techniques.* P. A. Neeteson (Dutch 1955).

Indicates the methods of determining the behaviour of a network in which electronic valves are used as switches.

2344 *Practical Wireless Service Manual.* F. J. Camm (Brit. 1955).

Deals with the testing of all types of wireless receiver, and the construction and use of test instruments.

2345 *National Certificate Workshop Technology.* T. Nuttall (Brit. 1955).

Covers primarily the Ordinary National Certificate course, but includes much of the work of the City and Guilds course for fitters and turners.

(Continued on p. 143)



# Regional Notes

## Midland Region STORM DAMAGE

The blizzard that struck the northern part of the Peterborough Area (and affected parts of the Lincoln Area) on Sunday, 8th January, 1956, was distinguished by the damage it did to overhead power lines, simultaneously depriving 33 exchanges in the Peterborough Area of an electricity supply.

The conditions were favourable to the formation of ice and this, combined with the strong wind, resulted in severe damage to trees, roofs of buildings, overhead power wires and, of course, telephone lines. The depth of snow measured in Boston was 15 in.; where drifting had occurred it was much greater and many roads were impassable. The damage to telephone plant amounted to about 3,000 miles of single wire brought down, 150 poles broken, and 2,500 poles deflected or made dangerous. Between 5,000 and 6,000 subscribers' lines and about 100 junctions were faulty.

Thirty-two gangs were borrowed to cope with the enormous task of repair, but even so it was a month later, on 8th February, that the last subscriber's fault attributable to the storm was cleared.

The staff of the Electricity Board were so hampered in their surveys of the damage to power lines (for which they ultimately used a helicopter) that they could give no indication when power was likely to be restored. This was a situation that called for special action. Emergency generating sets are provided on a scale to meet long-duration power failures provided they are confined to a few exchanges; failures of short duration are within the capacity of the exchange batteries.

Power was, in fact, restored gradually but it was 11 days after the storm before the last exchange had a mains electricity supply available. In the meantime, the drain on the batteries at the affected exchanges was minimized by restricting service to those subscribers entitled to "E" attention whose lines were still working.

In spite of loans of 19 emergency generators from other Areas, the number of sets available in the first few days was considerably less than the number of exchanges without power. Batteries were prevented from failing by allotting each emergency set to a group of exchanges and moving it from one to another, giving each battery a partial charge in turn. This was no easy matter owing to the appalling state of the roads. To illustrate this, it took a 4-ton lorry nearly six hours to tow an emergency charging set from Boston to Skegness, a distance of 24 miles.

Unfortunately, the emergency set sent to Skegness broke down and the 22V exchange battery was just saved from complete discharge by connecting to it a "Tiny Tim" lighting set. At two other exchanges, both 50V U.A.X.s, "Tiny Tims" kept things going, two sets being operated in series.

Thanks to the strenuous efforts of the staff operating the emergency sets, who worked under very trying conditions of extreme cold, the number of exchanges out of service due primarily to battery failures was kept very low.

One lesson learnt from the storm was the importance of maintaining the emergency power plant in first-class order. Rigorous routine testing of the plant ensures the reliability of the plant when it is most needed. Only in this way will it be certain that sets can be run immediately they are needed without valuable time being lost in clearing faults.

The question has been raised whether the existing design of emergency power plant meets the requirements at U.A.X.s up to U.A.X. 13X. The staff handling the sets certainly felt the need for a smaller, more easily manoeuvrable, set and proposals are being made for a suitable design.

D. B. A.

## Scotland

### U.A.X. No. 7 DEVELOPMENT

From 1958-59 onward the amount of U.A.X. No. 7 equipment that will be recovered on the conversion of exchanges to non-director working will greatly exceed that required for U.A.X.7 extensions. This surplus equipment would normally be scrapped in spite of still having many years of useful life. In the present circumstances this cannot be tolerated and some U.A.X.s 7 must be kept in use, even though their buildings are full, by catering for growth with a new non-

director exchange. The obvious way of achieving this is to make the U.A.X.7 dependent on the non-director exchange, but the most important objection to this is that the U.A.X.7 invariably bears the name of the town it serves and the new non-director exchange would require a different name, which would almost certainly be opposed locally. In addition, the U.A.X. terminating equipment in the non-director exchange would become scrap on the eventual recovery of the U.A.X.

The following scheme, which has been submitted to the Engineering Department, inter-works the U.A.X.7 and non-director exchange with a common name and numbering range.

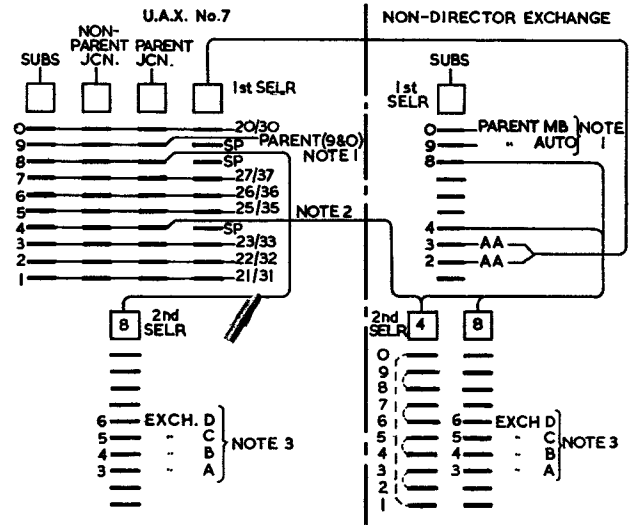

Notes—

1. Separate routes for each exchange.
2. 200 subscribers (24/34) are transferred to non-director exchange to free level 4. Similarly, 200 subscribers (25/35) will be transferred to non-director exchange to free level 5 as non-director exchange grows from 1,000 multiple to 2,000 multiple; level 6 for 2,000-3,000 multiple, etc.
3. This arrangement assumes separate routes from the U.A.X.7 and non-director exchange to non-parent exchanges A, B, C and D. Alternatively, level 8 from the U.A.X. can be routed to the level 8 2nd selectors in the non-director exchange to obtain access to the non-parent routes.
4. Separate trunk-offering is required for the two exchanges, with trunk-offering selectors in the non-director exchange.
5. This arrangement assumes that junction traffic to the non-director exchange circulates via the U.A.X.7. Alternatively, junction 1st selectors could be at the non-director exchange.

### TRUNKING BETWEEN THE U.A.X.7 AND THE NON-DIRECTOR EXCHANGE.

The diagram shows the trunking and distribution of subscribers between the two exchanges. It will be seen that, in cases where all appropriate levels are in use at the U.A.X.7, 200 U.A.X. subscribers must be transferred to the non-director for each 800 "growth" of multiple.

The essence of the scheme is the modification to the U.A.X. 1st selector (AGS 105) which terminates the route from the non-director exchange subscribers to the U.A.X. subscribers. Normally this selector, which includes the U.A.X. transmission bridge, absorbs the initial digits 2 and 3, which are discriminatory digits for subsequently switching the final selector wipers to the required 1,000 group. With the inter-working scheme the "2" and "3" are used at the non-director exchange as routing digits; the modification required to the AGS 105 selector is therefore such as to condition it on seizure to the normal 2nd digit receive stage. The required conditions are that relay WS should be operated for a 3xxx number and relays WS and CB for a 2xxx number. A signal to discriminate between "2" and "3" must, of course, be sent from the non-director exchange, depending upon the digit dialled there, and is achieved by providing a 3-wire junction, the 3rd wire providing an earth from a spare contact of the auto-auto relay set (A.T. 5156) on level 2. Originally, a two-relay unit was to be added to the AGS 105 selector to apply earths to operate relays WS and CB as required. The Engineering Department has, however, suggested a method which saves the relay unit. This is to short-circuit contact W 26,27 (to operate relay WS) and connect the level 2 "discriminating earth" to the CB relay via a U-point.

It is hoped to apply the scheme first to Airdrie, an industrial town within 15 miles of Glasgow, with an existing 1,600-multiple, U.A.X. No. 7.

J. S. W.

### NOVEL METHOD OF RECOVERING POLES

A short section of the old overhead trunk route along the Glasgow-Stirling road, reputed to be the busiest in Scotland, was recently scheduled for recovery, and as very heavy traffic is experienced on this road both by day and night, it was necessary to carry out the work as quickly as possible with the minimum of interference to the free flow of vehicles.

The route was composed of "A" poles with pole braces, and the labour of digging the poles out or cutting them down would have been considerable. As the poles were to be disposed of it was decided to cut them at ground level by means of an explosive charge, and guide them to fall along the grass verge.

Having consulted the County Surveyor and the Road Authorities it was agreed that the best time to carry out the blasting would be between 6.30 p.m. and 9 p.m., the period of the minimum traffic. It was decided to do as much of the preparatory work during normal hours as possible, leaving the blasting and actual felling of the poles to be done during the evening. The method employed was to excavate round each "A" pole, drill two  $\frac{3}{4}$ -in. holes through each leg using a 24V electric drill, driven from a lighting-set generator, and wind about 10 turns of Cordtex detonating fuse round each pole and through the holes in a figure eight formation, as shown in the illustration. When all was ready, an electric detonator was fitted to the end of the detonating fuse and connected to the firing cable and exploder. In order to reduce traffic delays, two "A" poles were felled at the same time, as will be seen from the illustration. The police held up the traffic for a couple of

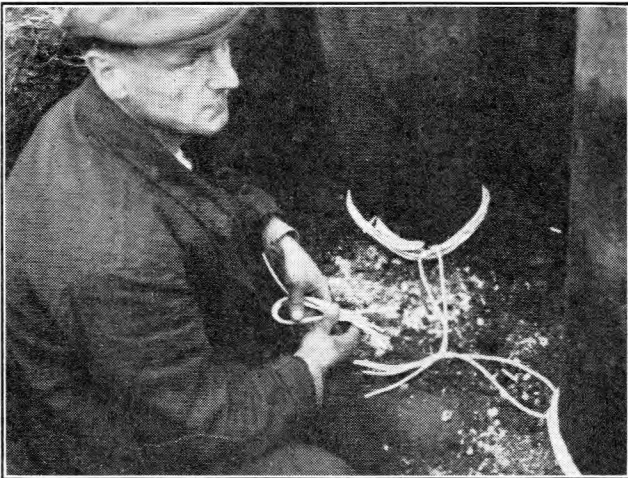

ATTACHING THE DETONATING FUSE TO A POLE.

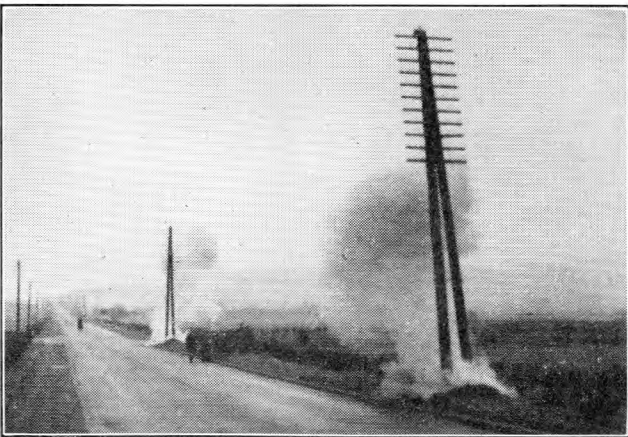

TWO "A" POLES BEING FELLED SIMULTANEOUSLY.

minutes while the actual detonating was in progress, and a couple of men pulling on a rope were easily able to guide the fall of each pole, so that it rested along the grass verge.

During the course of the operation the gang got quite experienced and while 12 "A" poles were recovered the first evening, during the second evening 26 "A" poles were recovered in 90 min.

There was practically no splintering of the poles, or debris thrown up, and in one case where a Post Office duct was discovered only 8 in. away from the pole, it was undamaged by the explosion. Although this method can be strongly recommended for use in open situations it is inadvisable to use it near buildings where damage by blast might occur.

Using this method of recovery it was unnecessary to take the arms and spindles off until the poles had been lowered; they were then dismantled by using oxy-acetylene burner equipment, mounted on a lorry, to burn off the rusted nuts and bolts, the whole operation being performed quickly and economically.

The poles were dated 1899, so they had given good service and their end while swift was nevertheless more economical than if more normal methods of recovery had been employed, a saving of approximately 50 per cent being effected.

F. J. de C.

### London Telecommunications Region

#### AUTOMATIC TESTING OF NEW SUBSCRIBERS' INSTALLATIONS IN AUTOMATIC EXCHANGE AREAS

The testing of newly-installed equipment at subscribers' premises in collaboration with the exchange test-desk before bringing new lines into service is a long-established practice. It is claimed, however, that much of the fitter's time is wasted waiting for the test desk to answer, and various schemes have been tried out to reduce this delay, such as bringing the line into service and testing it later when the completed copy of the advice note is received in the Test Room. During discussion of such a scheme the idea of providing an automatic tester was suggested and the proposal in broad terms was placed on the agenda of the South-East Area Maintenance J.P.C. Sub-Committee. A possible scheme was outlined and a small group was given the task of designing and constructing a prototype tester.

The tester was completed and given its first trial at Eltham exchange. It proved very successful in testing both exclusive and shared lines for both fitting and subscribers' apparatus maintenance staff. The figure shows a block schematic diagram of the arrangement for a director exchange.

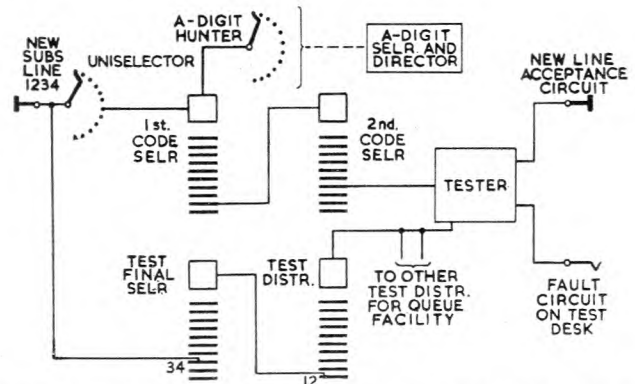

BLOCK SCHEMATIC DIAGRAM SHOWING THE ARRANGEMENT OF THE TESTER AT A DIRECTOR EXCHANGE.

It is essential with this tester that all lines to be fitted be jumpered in the exchange on receipt of the pink copy of the advice note. The fitter completes the installation of the subscriber's equipment and will, on lifting the handset, receive dialling tone. To obtain a test, he dials a code followed by the numerical digits of the line he has fitted (1234 in the schematic diagram). The director routes the call to a code level, giving access to the tester and the numerical digits step the test distributor and test final selector to pick up the line under test. A tone is sent to indicate that the tester has taken the line and on receipt of this the fitter replaces his receiver.

The test cycle then commences and checks insulation resistance line-to-line and line-to-earth, and, if satisfactory, rings out on the line. When the fitter answers, the loop resistance is checked and interrupted dial tone is applied. The fitter then dials figures 1, 3, 5 and 0 and the tester checks the correct pulsing of the digits and the speed of the dial. The fitter then dials a single digit to release the tester. The last digit will vary according to the type of line fitted and whether the

line is to be connected to the new-line acceptance telephone or just to be cleared from the tester. The four conditions are as follows:—

- |  |   |  |
|--|---|--|
| Exclusive line<br>or common metering<br>shared service | } | dial 3—connect to acceptance telephone                     |
|  |   | dial 5—release tester                                      |
| Shared service<br>separate metering                    | } | dial 2 and press button—connect to<br>acceptance telephone |
|  |   | dial 4 and press button—release tester                     |

In the last two conditions the calling-earth resistance is checked.

Associated with the tester is a lamp display showing the test cycle; if the line under test fails to reach the required standard the display halts at the failure point and the call is diverted automatically to a calling equipment on the test desk. The Test Clerk releases the tester and deals with the fitter or subscribers' apparatus man in the normal manner.

The use of a tester of this type has a number of advantages. It ensures a uniform standard of acceptance-testing of new lines, it checks all features of any existing line tested, and may, for example, show a low-insulation fault on a line receiving attention only for a bell complaint, and should thus eventually raise the standard of subscribers' equipment and lines. It is invaluable to the emergency man called out to deal with a line on an unattended exchange.

Another model is under construction for use in non-director areas with discrimination to pick up lines on dependent U.A.X.s No. 14 or satellite exchanges. The whole scheme, although in its experimental stage, shows great promise and should be a valuable aid to fitting and maintenance in automatic exchange areas.

C. H. W.  
W. H. O.

### Northern Ireland

#### ELECTRICITY STRIKE

A strike of electricity workers in Northern Ireland caused a shut-down of the supply on the morning of 14th March. The failure commenced without warning at 8.20 a.m., was 90 per cent effective by 9.00 a.m., and fully effective throughout the Province, except for Londonderry, by 10.50 a.m. A public supply was maintained to Londonderry exchange throughout the strike.

An emergency control was set up in Telephone House, Belfast, at 9.15 a.m., and arrangements were put in hand to operate a preference scheme for subscribers, to distribute emergency generating-sets, to maintain service at essential P.B.X.s, to provide an emergency supply at the H.P.O. Belfast, and to reduce the number of amplified trunk and junction circuits within the Province.

The preference scheme was implemented by means of (a) sash line inserted in the arrestor springs at U.A.X.s No. 14 and all larger exchanges, (b) withdrawal of heat coils or insertion of sash line at small U.A.X.s, and (c) withdrawal of fuses in some small manual exchanges. Although a considerable quantity of sash line had to be purchased on the morning in question and cut into lengths, the preference scheme had been completely implemented in the Belfast multi-exchange area by 2.30 p.m., and was fully effective throughout the Province by 6.00 p.m. Numerous changes to the scheme were required during the day and undoubtedly groups of 20 wedges looped on cords would have been more flexible than sash line and would have caused less trouble with arrestor springs. More preparation beforehand would have been required, however, and, in fact, the amount of trouble caused by the sash lines was remarkably small.

Requests for help with exchange batteries were received quite early in the day. Transport and staff were soon mustered and an initial deployment of all the emergency generating sets was made during the day. It became apparent that, in at least half a dozen cases, there was much less than the nominal reserve available, due mainly to the batteries being near the ends of their lives. In two instances mobile generators would have been required in attendance continuously throughout busy periods. Although all the mobile generators had been recently overhauled, at least three of them gave trouble during the day. These factors must undoubtedly be allowed for when assessing requirements for mobile generators. Fifteen sets of various kinds were available in the Area to deal with about 200 exchanges. It was considered that, allowing for reserves,

double that number would have actually been required to cover all exchanges effectively. A request for reinforcements was speedily answered; five additional sets arrived early next morning on the steamer from Glasgow and nine further ones would have arrived by air during the second day. The trailer-type generators displayed considerable advantages over those which had to be transported in lorries.

Standby arrangements were provided by the Local Authorities for some of the more important P.B.X.s; e.g., hospitals and police. In others, power leads were provided for a 1-kW set used to charge the batteries.

An attempt to reduce the amplifier load at repeater stations met with very little success. Most internal trunks and junctions are amplified at intermediate repeater stations and the allocation of junctions to groups of amplifiers varies at each repeater station. A re-allocation of junctions would be required before many amplifier groups could be switched off.

Information was received late in the evening of 14th March, that the strike had been settled and that power was to be restored. In fact, the power was restored spasmodically during the night, due to the difficulties experienced by the Electricity Authorities in calling out the night shift. Full telephone service was restored in Belfast and the larger exchanges by 9 a.m. and throughout the rural areas by 11 a.m. on 15th March. Relatively few faults were experienced, and all exchange batteries were fully restored during the morning. All time-switches in kiosks were put out of adjustment, however, and it was three days before they had all been readjusted.

Although the strike was of short duration, it enabled a number of useful lessons to be learned and revealed various weaknesses. In spite of these weaknesses, however, essential service was satisfactorily maintained at all exchanges; and this is due in no small measure to the initiative and zeal displayed by the staff concerned.

C. W. B.

### Wales and Border Counties

#### USE OF BAILEY BRIDGE DURING CONSTRUCTION OF EXCHANGE MANHOLE AT SHREWSBURY

The construction of the exchange manhole for the new A.T.E. at Shrewsbury created some unusual problems. The site of the new exchange is just outside the old town walls, with the ducts and lead-in on the town side of the walls. Whichever way the duct track was laid, cutting into the old walls was unavoidable.

On top of the old walls, which vary in height from 8 ft to 14 ft above the land outside, runs a one-way road, which carries main traffic into this medieval town from the English Bridge over the Severn. The road itself is very narrow, being approximately 19 ft wide outside the exchange.

The manhole was kept to a minimum size on account of the difficulties, being designed for cable-turning purposes only. Feeding into it from three diverging directions were a 24-way and two 12-way ducts. To allow for the cables to turn into the exchange, through a 60-way lead-in, it was necessary to have a manhole requiring an excavation, 15 ft × 12 ft, cutting out a large slice of the old walls. Not only would the road be weakened considerably at this point by such an operation (the road being composed of tons of rubble on the inside of the wall), but there would be no possibility of traffic passing during the working operations, unless special arrangements were made.

The main ducts, when laid in 1949, together with other services along the roadway known as Town Walls, had resulted

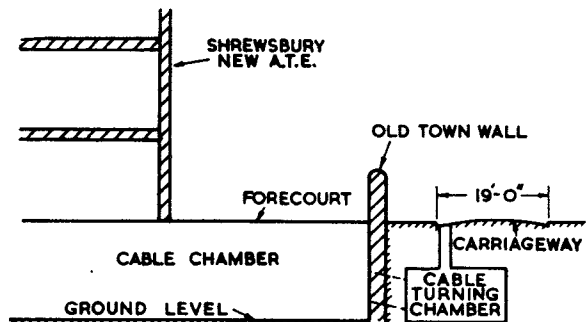

DIAGRAM SHOWING PROXIMITY OF THE NEW A.T.E. TO THE OLD TOWN WALL.

in the road being closed to traffic for eight weeks, and the Post Office at that time gave an undertaking to the Road Authorities that every endeavour would be made to avoid closing the road for any lengthy period in future. It was impossible to construct the exchange manhole at that time because of the considerable weakening of the road and the fact that the property on which the exchange was to be built, with the lead-in through the cellars under the pavement, had not been demolished.

It will be seen from the sketch that the exchange manhole or cable-turning chamber is above the level of the ground on which the exchange is built—a most unusual condition. It might be interesting to observe at this point that the new A.T.E., the usual steel and concrete type of building, will consist of four storeys and the whole has had to be built on approximately 340 piles, varying between 25 ft and 28 ft in length.

The road-weakening problem was met by the decision to build the exchange in proximity to the town walls, and buttress the walls from the outside by the extension of the exchange building and foundations. The cellars of the demolished house (under the pavement just outside the wall) were filled with many tons of weak concrete. These two operations sufficiently strengthened the outside of the wall to enable excavation to take place in safety. The Ministry of Works were asked to construct the exchange manhole in view of its interdependence on the building. This they agreed to do.

It was decided to avoid interrupting the traffic by using a Bailey Bridge. This matter was considered and discussed with Royal Engineers of Western Command and, thanks to their advice and help, it was decided that the project was practicable. This involved the breaking-up of the surface of the road and the erection of a bridge, with sufficient span to bridge the excavation and of sufficient strength to carry the heaviest traffic likely to be using a trunk road. It was subsequently arranged, however, that the bridge should be erected by Messrs. Thomas Storey & Sons, of Stockport, who have now purchased from the Ministry of Supply the sole rights for the manufacture, erection, hiring, etc., of Bailey Bridges. It was necessary that the operation of surface excavation and erection of the bridge should be completed on one Sunday.

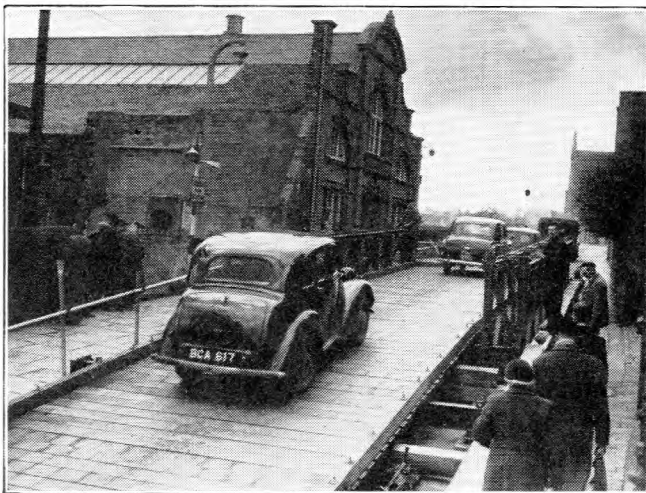

By courtesy of the "Shrewsbury Chronicle."  
THE BAILEY BRIDGE IN USE.

The Bailey Bridge was duly delivered and erected on a Sunday, after which the road was re-opened to traffic. Most of the Journal readers will be familiar, without doubt, with the construction of a Bailey Bridge. Briefly, the strength of the bridge lies in the vertical side frame-work, which can be seen in the photograph. These steel sections are 10 ft long and are pinned together by 2-in. steel pins in machine-faced holes. This makes a simple and strong joint.

The bridge consisted of four sections, which were assembled as the first operation. The ends of the first and last sections were supported on strong steel bases. By means of an assembly of steel girders, supported on transverse steel sections, the frame-work was quickly produced on which to lay the running surface. The latter consisted of 1½-in. planks laid across the longitudinal girders and clamped at the outside ends, each plank fitting into a prepared slot on the main support, designed for that purpose.

The ramp on each side consisted of three transverse girders, similar to those on the span of the bridge itself, with slots for the longitudinal steel members which supported the planks.

The bridge served its purpose in an excellent manner except for one drawback. The longitudinal girders, though very strong, were only loosely fitting. In spite of the end-clamping of the boards, the method employed only succeeded in clamping some of the boards. Even these sprang somewhat in the centre. The others had a certain amount of movement and rattled badly when traffic passed over them. This was particularly noticeable with motor cycles and private cars, which ignored the five miles an hour speed limit which was generally observed by buses and heavy traffic. The noise, particularly at night, was appalling and soon brought the strongest of protests from local residents. This difficulty had been experienced elsewhere when Bailey Bridges were erected on busy traffic routes in the immediate vicinity of residential property. The recommendation for solving this problem was to purchase a large number of 1-in. planks and nail them, at 45°, over the normal planking, thus giving a more-solid running surface. This would be very costly and result in a lot of scrap timber for which there could be little future use.

The problem was largely solved by buying thick carpet felt, unclamping the running boards and tacking the felt on the under-side of them. The running boards were then easily replaced and the noise level considerably reduced. A further improvement, both as regards noise and angle of climb, was effected by coating the ramps and the preceding few feet of roadway with a layer of fine Tarmacadam. The combined effect of the two treatments almost obviated the objectionable noise.

Once the bridge was erected the excavation proceeded from the side and the manhole was constructed in the normal manner. The roof of the manhole was 6 ft below the surface of the road and entrance was obtained from a brick-built shaft.

The whole operation took seven weeks, which was not unreasonable in view of the very great difficulty regarding the reinforcement of the cellars, the nature of the excavation and the rubble to be cleared. The bridge was dismantled and the reinstatement to the excavation completed on the seventh Sunday after the operations commenced.

By using a Bailey Bridge the Post Office was able to meet the reasonable requirements of the Road Authorities and get out of a particularly difficult situation. The co-operation of the Ministry of Works in this problem was very much appreciated.  
G. J. A.

## Book Review

"Noise"—continued from p. 135.

and electrons contribute to shot noise. Excess noise is a less well-understood component whose mean-square current per unit bandwidth usually varies approximately inversely with frequency. It occurs in carbon microphones and resistors, as well as in thin metallic layers, transistors and thermionic valves; some account is given of it. It can be very small in good modern junction transistors, as the appendix states. No detailed explanation of the (frequency)<sup>-1</sup> component is attempted. The descriptions of noise in mixer tubes and in feedback circuits should adequately satisfy engineers. Two mathematical chapters seek a basis for some of the formulae used. Some of the laws of the electronics of thermionic valves

are deduced in another chapter in order to show how analyses of noise have been derived on the basis of dividing up multi-grid structures into several equivalent diodes. A final chapter on the limits set by noise in physical instruments is instructive.

It is difficult to criticize the book at all. Perhaps, in places, it might have been more quantitative; perhaps it might have contained something of the noise components encountered from sources other than within the components. A few typographical errors have been noticed and one might dispute some statements; but nothing should imply that this is other than an excellent book, strongly recommended, particularly to physicists and engineers alike in their task of understanding and minimizing the practical effects of spontaneous fluctuations.  
I.P.O.E.E. Library No. 2339.  
J. R. T.

# Associate Section Notes

## Edinburgh Centre

Another very successful session ended in April with the A.G.M., followed by a most enjoyable dinner, which has now been established as an annual event.

It is regretted that, owing to promotion, we have lost the services of our very able chairman, Mr. W. Irvine; however, we wish him all the best in his new post.

Eight meetings were held and five visits made during the winter, and the committee was greatly encouraged by the increased attendances and the interest shown in our activities. All branches are now represented in our membership; there are more members than ever before, and further increases are expected in the coming year.

Already plans are being made for what should be another varied and interesting program of meetings for the 1956-57 session and, due to the success of last year's venture, visits will again be made from time to time throughout the summer months.

The following members were elected as office-bearers and committee for the new session: *Chairman*, T. J. Potter; *Secretary/Treasurer*, J. R. Haggart; *Committee*, J. Kellard, W. Jager, J. H. Phillips, M. M. Love, F. Willison, G. Henderson. J. R. H.

## Glasgow & Scotland West Centre

The season of talks for 1955-56 is over and the summer season of visits has started. The first visit was on 8th May to the works of Albion Motors, Ltd., Scotstoun, Glasgow, when a small party was conducted round the works and saw the Albion engine at all stages of its manufacture, from the rough casting to the completed engine on road test.

This is to be followed by a visit to Kirk O'Shotts television station on 9th June. Arrangements have been completed for a visit to Pitlochry Power Station on Saturday, 11th August, and the postponed visit to Scottish Cables, Renfrew, will take place in October, when the new machinery for the manufacture of plastic cables will be in full production.

The membership has dropped a little, to 178. The average attendance at meetings has been poor, around 24.

J. F.

## Darlington Centre

The following meetings have been held:—

7th February.—“Some Peculiar Maintenance Problems I have Encountered,” G. B. G. Hart, A.M.I.E.E.

The speaker had indeed encountered some really “sticky” ones during automatic exchange installation, and whilst travelling up and down the country on cable testing.

13th March.—“Motor Sports, with Film Illustrations,” R. Lawson.

The members were treated to a really good show of films depicting the Tulip Rally, motor racing at Silverstone and Pendine Sands, and a six-day motor-cycle trial. Mr. Lawson gave details of the organization of these events.

10th April.—“Frigidaire,” E. J. Naylor (H. C. Troidahl, Ltd.).

Members were enlightened on the various aspects of refrigeration, including its development, up to the ultra-modern condenser units operating in the modern refrigeration plant. Mr. Naylor brought apparatus along with him, and interesting films were shown describing the firm's products. The speaker was accorded a hearty vote of thanks.

Another session has thus concluded; the program has been appreciated and attendances have been maintained. The Centre had the use of the projector from the Training School, and valued this facility. The trouble-free arrangements and efficiency of the operators in charge impressed us.

The Centre is particularly pleased with the I.P.O.E.E. Council's decision to grant framed certificates to Centres whose members have received National Awards. The Darlington Centre certificate has been allotted pride of place in the Lecture Room, and it is hoped will be an incentive to further endeavour.

C. N. H.

## Newcastle Upon Tyne Centre

Our first session as an Associate Section Centre has, it is considered, been a success. We have had five meetings and four visits, which were as follows:—

30th August, 1955.—Visit to W. T. Henley's Telegraph Works cable factory.

8th September.—Visit to Rediffusion (N.E.), Ltd., radio and television establishment.

20th September.—Visit to Central Electricity Authority power station.

27th September.—Meeting, with paper on “Duties, Responsibilities, etc., of an Area Engineer,” given jointly by Mr. J. E. Collins, Area Engineer, and Mr. A. E. Twycross, B.E.M., Area Engineer.

20th October.—Visit to A. Reyrolle & Co., Ltd., electrical engineering works.

2nd November.—Meeting, “Questions and Answers,” a discussion between members on any subject.

30th November.—Meeting, with paper on “The Use of Telecommunications by the C.E.A. and Application of G.P.O. Private Wires to Protection of the Authority's Grid Transmission System,” given by Messrs. A. M. Stevenson and H. N. Hedley, of the Central Electricity Authority, followed by a visit to their control room.

22nd February, 1956.—Meeting and paper on “U.A.X.s” by Mr. J. S. Edmondson, A.M.I.E.E.

21st March.—Meeting, with paper on “Frequency Modulation,” by Mr. T. W. Boast.

At the time of writing, arrangements are in hand for visits to a coal mine, a local television transmitter, and other places of interest, during the summer months.

It is hoped that the incoming committee elected at the annual general meeting will formulate an interesting and varied program for the forthcoming 1956-57 session.

G. D. C.

## Colwyn Bay Centre

Since our last report, which appeared in the January 1954 issue of the Journal, the Colwyn Bay Associate Section has remained active. The membership has increased to the figure of 55, though unfortunately this has not resulted in a corresponding increase in the attendance at our winter meetings.

The 1954-55 winter session was opened by Mr. T. A. P. Colledge, Area Engineer, Chester, who spoke on the building up of financial estimates in the Chester Area and their final presentation to Parliament. Apart from a film show held in mid-February, the talks at the monthly meetings were given by members of the Section; namely, Messrs. Glyn Hughes, J. K. Sinton, H. F. Bennington, J. L. Owen, Raymond Jones and J. C. Davies.

During the summer of 1955 three visits were arranged, the first in April to the British Industries Fair at Castle Bromwich; the second, in May, to the de Havilland Aircraft Factory, Chester; and the third to the John Summers Steelworks, Shotton, all of which proved extremely popular. The attendance in each case was excellent.

The 1955-56 session began with a talk on “Sales Procedure,” by Mr. G. N. Evans. This took place on Friday, 4th November. On Tuesday, 30th November, Mr. R. W. Palmer, Principal of the Central Training School, Stone, gave an interesting talk on “Talks and Speeches—Their Preparation and Presentation.” The talks by Mr. Evans and Mr. Palmer were followed by lively and stimulating discussions. Also in the program were a film show on the 31st January, 1956, and “Any Questions” on 13th March, which was combined with the annual general meeting. To end the winter program, Mr. H. I. Berkeley gave a talk on the “Welsh Himalayan Expedition,” and Mr. E. Whitley gave one on his visit to Holland. D. E. J.

## Bishop's Stortford Centre

The Bishop's Stortford Centre has been actively engaged since Christmas.

In January, M. D. Bass gave a first-class paper on the Post Office P.A.B.X., illustrated with lantern slides lent by the Central Training School.

In February, Mr. W. Watts, of Cambridge repeater station, came to Bishop's Stortford and gave a very instructive paper on “Carrier and Coaxial Cable Systems.”

A visit was made to Odhams Press Limited in March, and a very instructive evening was spent watching the production of a large daily newspaper. In March, also, we were very fortunate in having a talk given by the Liaison Officer of the Harlow Development Corporation, who spoke on the "Administration and Planning of Harlow New Town."

The final visit for the 1955-56 session was made to Standard Telephones and Cables factory at Woolwich, where 18 of our members were privileged to spend a complete day touring all sections of this large factory. A wide range of equipment for telecommunications was seen, from the gold-plating of radio frequency crystals to the making of submarine and coaxial cables.

The annual general meeting of the section took place on 16th May.

J. P.

### Southend-on-Sea Centre

The inaugural meeting of the Southend-on-Sea Centre was held on 13th February, 1956, and the following officers and committee were elected: *Chairman*, C. J. Vann, A.M.I.E.E., Area Engineer; *Vice-Chairman*, R. Wyndham; *Treasurer*, J. Dickson; *Secretary*, D. W. Everett; *Liaison Officer*, C. A. Roberts; *Committee*, B. C. Carter, R. E. Playle, S. T. Ralph, A. G. Trim; *Auditors*, A. P. Padbury, S. I. Restorick.

The successful formation of the Centre was largely due to the efforts and guidance of the Chairman, the Liaison Officer, and Mr. J. Thurbon. At the inaugural meeting, the Centre consisted of 21 members, but we now have 67 members, 56 of whom are subscribers to the Journal.

Although the Centre is only three months old, visits have been made to the factory of Messrs. E. K. Cole (Ekco), and to the Southend Marine Radar Station of Messrs. Kelvin Hughes. One of our own members, Mr. R. Playle, took the bull by the horns and gave the first paper, on "V.H.F. Communications," and it was unanimously agreed that he made a very successful job of it.

Arrangements have been, or are being, made for visits to Ford's works at Dagenham, Lime Grove television studios, and to a British Railway locomotive works. To conclude our summer visits, we intend running a coach to the Radio Exhibition.

The winter program has not yet been definitely decided upon, but it is hoped talks will be given on some of the following subjects: the cordless directory enquiry suite; a guide to car maintenance; promotion; colour television; the detection and prevention of crime; inshore sailing; model engineering; and amateur photography. A film show is also envisaged during the winter session.

Thanks are due to Mr. A. W. Rance for supplying us with a useful foundation for a library, including the complete volumes 29-48 of the *P.O.E.E. Journal*.

So far, so good. Let us hope that all members will continue to give the officers of the Centre active support, and we, in turn, will guarantee the Centre will not meet the same fate as that of a damp squib.

D. W. E.

### London Centre

On Tuesday, 29th May, 1956, the London Centre ended another successful session. On this particular evening the President of the Associate Section, Mr. R. W. Palmer, gave a talk entitled "Speeches and Papers—their Preparation and Presentation." Those present were able to gain many practicable tips from one adept in this field. Amongst the guests present were Mr. Knox, the Home Counties Region Associate Section Liaison Officer, and Mr. C. W. Brown, who was the first President of the then Junior Section, both of whom spoke about the Associate Section in the past and to-day. Prior to this, Mr. R. W. Palmer presented our Chairman, Mr. A. G. Welling, with a wrist watch, given by the London Centre Associate Section as a token of appreciation of Mr. Welling's efforts during the past ten years to promote Associate Section activities.

Although it may appear to most members that the summer is a quiet period, arrangements are being made for the 1956-57 session meetings. Some of the subjects suggested for talks are: electronic switching, the transatlantic telephone cable, photography, computing machines, an interplanetary subject, transistors and television outside broadcasts.

The session will be opened with a lecture on the Trans-Antarctic Reconnaissance Expedition of 1955-56, and a report on the activities of the few who at the moment occupy Shackleton Base near the edge of the Weddell Sea. As this is a general-interest lecture, members have the opportunity of bringing their wives and friends. Interest has already been shown by the Senior Section and a general invitation will be made to them to attend if they wish to. This is merely advance notice; the date and details of distribution of tickets will be made known during July or August.

By the time that this is published, the newly-formed London Power Centre will have been in action three months and as the session approaches we wish them every success this year.

At the annual general meeting, which followed Mr. Palmer's talk on the 19th May, the following officers were elected for the 1956-57 session:

*Chairman*, Mr. A. G. Welling; *Vice-Chairman*, Mr. C. Biddlecombe; *Treasurer*, Mr. W. C. Peck; *Secretary*, Mr. B. C. Hatch; *Assistant Secretary*, Mr. L. E. J. Penney; *Editor*, Mr. P. Sayers; *Librarian*, Mr. S. Challoner; *Visits Secretary*, Mr. M. R. G. Rump.

We are very fortunate in having Mr. F. C. G. Greening as Liaison Officer for a further session. During the past year he has, as always, given us good counsel.

P. S.

### Additions to the Library—continued from p. 137.

2346 *Theory of Machines*. W. G. Green (Brit. 1955).

Designed to meet the needs of students preparing for the external Degree examinations of the University of London, Higher National Certificate examinations, and examinations of the Professional Institutions.

2347 *Hydraulic and Pneumatic Operation of Machines*. H. C. Town (Brit. 1955).

A practical handbook on the use of oil or compressed air for driving and controlling machines and vehicles.

2348 *Modern Clocks: Their Repair and Maintenance*. T. R. Robinson (Brit. 1955).

Covers all the data necessary for a complete understanding of modern clocks, and for their adjustment and repair.

2349 *Builders' Materials*. B. H. and R. G. Knight (Brit. 1955).

Written for all engaged in or studying for examinations on building construction.

2350 *Education and Training in Industry*. J. Wellens (Brit. 1955).

Reviews current practice; propounds the doctrine of integrated training; and includes a chapter on organizational problems as they affect training.

2351 *The Automatic Factory—What Does It Mean?* Institution of Production Engineers (Brit. 1955).

The report of the Conference held in June 1955.

2352 *Principles of Electrical Measurements*. H. Buckingham (Brit. 1955).

Designed for the student and the engineer. Covers the requirements of Final Degree and A.M.I.E.E. examinations.

2353 *The Suppressed Frame System of Telerecording*. C. B. B. Wood, E. R. Rout and A. V. Lord (Brit. 1955).

Summarizes the fundamental and practical aspects of a system designed by the B.B.C. Engineering Research Department primarily to provide additional telerecording facilities in connexion with the Coronation.

2354 *Illuminating Engineering Course*. H. Zizl (Dutch 1955).

Concerned mainly with functional lighting; covers the theoretical principles.

2355 *Radio Receiver Circuits and Handbook*. E. M. Squire (Brit. 1955).

For the practical man; includes only "practical" theory.

W. D. FLORENCE,  
Librarian.

# Staff Changes

## Promotions

Name	Region	Date	Name	Region	Date
<i>Area Engr. to Regional Engr.</i>			<i>Tech. Offr. to Asst. Engr.—continued.</i>		
Rusbridge, E. S.	S.W. Reg.	2.1.56	Gillespie, J. M.	L.T. Reg.	23.11.55
<i>Exec. Engr. to Snr. Exec. Engr.</i>			Newton, R. J.	L.T. Reg.	2.8.55
Warnock, W. T.	Scot.	5.12.55	Drayton, E. H.	L.T. Reg.	7.1.56
Bavin, A. E.	L.T. Reg.	28.12.55	Kiff, B. H.	L.T. Reg.	28.9.55
Morgan, C. A.	L.T. Reg. to E.-in-C.O.	29.12.55	Gabell, F. C.	L.T. Reg.	7.1.56
Gould-Bacon, F. C.	E.-in-C.O.	3.4.56	Howe, F. L.	L.T. Reg.	30.7.55
Richards, C. W. C.	W.B.C.	3.12.55	Antill, J. A.	Mid. Reg.	27.2.56
Clarke, T. M.	S.W. Reg.	9.1.56	Dempsey, N. C.	Scot.	15.11.55
Johnson, L. P.	L.T. Reg.	4.5.56	Mathers, A.	Scot.	12.12.55
Brett, G. E.	L.T. Reg.	4.5.56	Ballinger, N. G.	E.-in-C.O.	18.2.56
<i>Exec. Engr. (Limited Competition)</i>			McPherson, C. J.	Scot.	4.2.56
Kelson, D.	E.-in-C.O.	5.3.56	Inett, C. W. B.	L.T. Reg.	8.11.55
Ready, W. E.	E.-in-C.O.	1.3.56	Bishop, J.	L.T. Reg.	9.1.56
Povey, J. A.	E.-in-C.O.	5.3.56	Oakshott, D. J. F.	L.T. Reg.	31.10.55
Maurer, C. J.	E.-in-C.O.	1.3.56	Baker, W. D.	L.T. Reg.	13.8.55
Wardle, A.	L.T. Reg. to N.W. Reg.	19.3.56	Pearson, H. A.	L.T. Reg.	27.8.55
Parsons, A. P.	E.-in-C.O.	5.3.56	Solley, S. C.	L.T. Reg.	9.9.55
Downing, S. A.	E.-in-C.O. to H.C. Reg.	19.3.56	Jenkins, A.	L.T. Reg.	31.10.55
Gray, R.	L.T. Reg.	12.3.56	Stocker, H. J.	L.T. Reg.	29.12.55
Blanchard, D. T.	L.T. Reg.	12.3.56	Hinchcliffe, K. B.	L.T. Reg.	16.5.55
Selby, G. R.	E.-in-C.O.	3.4.56	Rainger, D. G.	L.T. Reg.	21.1.56
Andrews, J. D.	E.-in-C.O.	3.4.56	Allen, A. W.	L.T. Reg.	26.8.55
Woollett, B. J.	S.W. Reg.	19.3.56	Hedinger, J. F.	L.T. Reg.	10.10.55
Smith, G. L.	E.-in-C.O.	12.3.56	Nott, H. C.	L.T. Reg.	14.11.55
Lowe, B. A.	E.-in-C.O.	12.3.56	Bisson, L.	N.W. Reg.	14.2.56
Dickie, W.	Scot. to E.-in-C.O.	3.4.56	Walker, H.	N.W. Reg.	29.2.56
Meatyard, L. R.	E.-in-C.O.	3.4.56	Whittingham, W. G.	W.B.C.	31.1.55
Harris, B. V.	E.-in-C.O.	3.4.56	Adams, P.	W.B.C.	10.10.55
Bott, A. J.	E.-in-C.O.	12.3.56	Williams, T. H.	W.B.C.	24.9.55
Hornsby, H. C.	Mid. Reg. to H.C. Reg.	19.3.56	Lodge, A.	E.-in-C.O.	1.3.56
Buck, G. A.	H.C. Reg. to E.-in-C.O.	3.4.56	Archer, E. C.	E.-in-C.O.	1.3.56
Edwards, L. B.	Scot.	19.3.56	Mabey, J. E.	E.-in-C.O.	1.3.56
Beck, I. H.	E.-in-C.O.	12.3.56	Francis, R. J.	E.-in-C.O.	1.3.56
Welsh, M. E.	Mid. Reg. to W.B.C.	3.4.56	Fensome, L. D. W.	E.-in-C.O.	1.3.56
Roberts, E.	E.T.E. to W.B.C.	7.4.56	Potts, E. N.	E.-in-C.O.	1.3.56
Goodison, H.	E.-in-C.O.	1.3.56	Brown, K. A.	E.-in-C.O.	1.3.56
<i>Asst. Engr. to Exec. Engr.</i>			Drury, C. B.	E.-in-C.O.	1.3.56
Dearden, T. T.	N.W. Reg. to N.I.	3.1.56	Minta, T. A.	N.W. Reg.	30.3.56
Rolls, H. R.	S.W. Reg.	9.1.56	Sainsbury, T. S.	E.-in-C.O.	1.3.56
Young, J. R.	W.B.C.	25.1.56	Baxter, T. A.	E.-in-C.O.	30.3.56
Bartlett, D. L. G.	S.W. Reg.	9.2.56	Bedford, G. H.	E.-in-C.O.	1.3.56
Robarts, J. C.	H.C. Reg.	9.2.56	Piper, R. J.	E.-in-C.O.	12.3.56
Faithfull, A. D.	S.W. Reg.	15.12.55	Coyte, A.	E.-in-C.O.	1.3.56
Sharpe, C.	E.T.E.	2.3.56	Evans, F. J.	E.-in-C.O.	1.3.56
Rudge, C. H. O. J.	S.W. Reg.	2.3.56	Smith, E. J. S.	E.-in-C.O.	1.3.56
Lilley, F. H.	N.E. Reg.	16.3.56	Smith, N. J. W.	L.T. Reg.	1.3.56
Popplewell, S. R.	N.E. Reg.	16.3.56	Kirkby, R. R.	Mid. Reg.	7.4.56
Winterburn, G. E.	N.E. Reg.	16.3.56	Cockerill, T. A. J.	E.-in-C.O.	30.3.56
<i>Inspector to Asst. Engr.</i>			Green, G. H. C.	L.T. Reg.	1.3.56
Hutchison, J.	L.T. Reg.	30.10.55	Mills, A. A.	E.-in-C.O.	1.3.56
Evans, K.	W.B.C.	21.4.55	Smith, F. A.	N.E. Reg.	10.3.56
Davidson, W. B.	Scot.	6.12.55	Read, C. W.	S.W. Reg.	17.3.56
Powell, W. T.	N.W. Reg.	3.2.56	Lout, J. W.	L.T. Reg.	5.3.56
Smuth, E.	L.T. Reg.	12.12.55	Elliott, H. F.	L.T. Reg.	5.3.56
Broderick, E. C.	L.T. Reg.	29.12.55	Woods, B. G.	E.-in-C.O.	1.3.56
Ewing, R.	L.T. Reg.	24.12.55	Mitchell, J. T. H.	E.-in-C.O.	1.3.56
Payne, A. J.	L.T. Reg.	28.1.56	Saunders, L. E.	E.-in-C.O.	1.3.56
Richards, D. G. W.	S.W. Reg.	18.1.55	Ryles, K. V.	E.-in-C.O.	1.3.56
Osborn, M. G.	S.W. Reg.	2.6.55	West-Robinson, G. W.	L.T. Reg.	1.3.56
Cowell, E. F.	L.T. Reg.	3.4.56	Daniel, R. E.	L.T. Reg.	17.3.56
<i>Tech. Offr. to Asst. Engr.</i>			Orridge, C. E. A.	L.T. Reg.	1.3.56
Davies, R. W.	W.B.C.	12.10.55	Godfrey, K. J. R.	S.W. Reg.	1.3.56
Milford, A. R.	W.B.C.	23.11.55	Snell, B. F. P.	S.W. Reg.	17.3.56
Davis, I. R.	W.B.C.	2.11.55	Stevens, F. W. P.	S.W. Reg.	10.3.56
Pettitt, R. W.	L.T. Reg.	23.1.56	Nickson, J.	L.P. Reg.	10.4.55
Watts, J. R.	L.T. Reg.	31.10.55	Mills, E. J.	W.B.C.	9.2.56
Hebden, H. E. G.	L.T. Reg.	18.7.55	Mills, W. A.	L.T. Reg.	21.1.56
Tyrer, B. S.	L.T. Reg.	31.12.55	Bullen, D. C.	L.T. Reg.	28.1.56
Pallett, S. W.	L.T. Reg.	7.1.56	Bancroft, W. H.	L.T. Reg.	8.8.55
Purdy, F.	L.T. Reg.	20.12.55	Clements, D. H. J.	L.T. Reg.	7.12.55
Peasland, D. P. H.	L.T. Reg.	6.9.55	Ingleby, G. R.	L.T. Reg.	8.8.55
			Walker, D. C.	L.T. Reg.	18.4.55
			Perkins, J. A.	L.T. Reg.	20.6.55
			Pearce, R. J.	S.W. Reg.	18.5.55
			Stokes, E. G. F.	S.W. Reg.	1.1.55
			Holmes, F.	S.W. Reg.	6.6.55
			Matterface, R. J.	S.W. Reg.	22.8.55
			Smallwood, W. G.	S.W. Reg.	12.4.55
			Green, F. G.	N.W. Reg.	14.3.56
			Latham, E.	N.W. Reg.	19.3.56

Promotions—continued.

Name	Region	Date	Name	Region	Date
<i>Tech. Offr. to Asst. Engr.—continued.</i>			<i>Tech. I to Inspector.—continued.</i>		
Bolton, J. M.	N.W. Reg.	19.3.56	Barham, H. W. E.	E.T.E.	1.3.56
Orme, H. L.	N.W. Reg.	23.3.56	Weatherhead, H. J.	E.T.E.	1.3.56
Smith, B. F. M.	W.B.C.	30.8.55	Robinson, P. W. V.	E.T.E.	1.3.56
Redfern, F. C.	W.B.C.	12.3.56	Bower, F.	E.T.E.	1.3.56
Boys, H. C.	L.T. Reg.	1.5.56	Knight, C. J.	W.B.C.	25.3.56
Mills, E. J.	W.B.C.	9.2.56	Haines, L. W.	L.T. Reg.	1.3.56
Adams, R. E.	W.B.C.	25.1.56	Turpin, F. W.	L.T. Reg.	15.2.56
Jones, R.	W.B.C.	3.12.55	Williamson, R. F.	N.W. Reg.	23.4.56
Allan, J. M.	Scot.	2.4.56			
Martin, W. E.	E.-in-C.O.	25.4.56	<i>Prin. Sc. Offr. to Snr. Prin. Sc. Offr.</i>		
Pfeil, J.	L.T. Reg.	23.1.56	Lynch, A. C.	E.-in-C.O.	10.2.56
Dean, R.	L.T. Reg.	9.1.56			
Baker, A. C.	L.T. Reg.	3.2.56	<i>Snr. Sc. Offr. to Prin. Sc. Offr.</i>		
Trinnaman, A. J.	L.T. Reg.	10.11.55	Orchard, H. J.	E.-in-C.O.	3.2.56
Abson, G. J. R.	L.T. Reg.	6.2.56	Bassett, H. J.	E.-in-C.O.	3.2.56
Green, H. M.	L.T. Reg.	2.1.56	Carasso, J. I.	E.-in-C.O.	10.3.56
Burt, A. J.	L.T. Reg.	13.2.56			
Elliott, D. A.	L.T. Reg.	6.2.56	<i>Snr. Explt. Offr. to Prin. Sc. Offr.</i>		
Ansell, J. R.	L.T. Reg.	10.11.55	Chandler, W. W.	E.-in-C.O.	27.2.56
Hadfield, C.	L.T. Reg.	19.12.55	New, A. A.	E.-in-C.O.	27.2.56
Lamberton, A. H.	L.T. Reg.	31.10.55			
Rodgers, F.	E.T.E.	26.3.56	<i>Explt. Offr. to Snr. Explt. Offr.</i>		
Seward, A. W.	E.T.E.	26.3.56	Kingston, F. G.	E.-in-C.O.	15.3.56
Northfield, C. J.	L.P. Reg.	2.3.56			
Adamson, A.	N.W. Reg.	23.4.56	<i>Explt. Offr. (Open Competition).</i>		
Evans, E. A.	N.W. Reg.	23.4.56	Greenaway, P. E.	E.-in-C.O.	14.2.56
			Reynolds, A. E.	E.-in-C.O.	5.3.56
			Sanvoisin, R.	E.-in-C.O.	2.5.56
<i>Tech. Offr. to Inspector.</i>					
Naylor, E. L. H.	N.W. Reg.	1.3.56	<i>Asst. Explt. Offr. (Open Competition).</i>		
Farr, H. J.	L.T. Reg.	24.3.56	Coe, P. A. (Miss)	E.-in-C.O.	28.1.56
Prentice, J. A.	L.T. Reg.	26.3.56	Jefford, J. G. (Miss)	E.-in-C.O.	8.3.56
			James, D. T.	E.-in-C.O.	5.3.56
			Richardson, D. (Miss)	E.-in-C.O.	6.4.56
<i>Tech. I to Inspector.</i>					
Yeates, W. H. F.	W.B.C.	16.7.55	<i>Asst. (Sc.) (Open Competition).</i>		
Roberts, A. E.	W.B.C.	30.1.56	Heard, G. I. (Miss)	E.-in-C.O.	31.1.56
Bell, P. J.	W.B.C.	16.1.56	Levett, A. L.	E.-in-C.O.	31.1.56
Roberts, R. S.	W.B.C.	9.1.56	Brewster, M. (Miss)	E.-in-C.O.	31.1.56
Jones, L. C.	W.B.C.	2.7.55	White, P. M. (Mrs.)	E.-in-C.O.	1.2.56
Sprout, E. H.	L.T. Reg.	30.12.55	Fudge, R. E.	E.-in-C.O.	1.2.56
Kearney, J.	Scot.	23.1.56	Somers, A.	E.-in-C.O.	1.2.56
Burgess, J. L.	L.T. Reg.	20.1.56	Jefts, E. D.	E.-in-C.O.	21.2.56
James, H. E.	L.T. Reg.	10.1.56	Biggs, K. J.	E.-in-C.O.	28.2.56
White, H. V.	L.T. Reg.	21.12.55	Donovan, D. E.	E.-in-C.O.	5.3.56
Fisher, A. C. G.	L.T. Reg.	9.1.56	Moore, P.	E.-in-C.O.	21.3.56
Clark, J.	Scot.	26.2.56	Hodges, L. R.	E.-in-C.O.	27.3.56
Rees, H. T. H.	W.B.C.	3.10.55	Hoyler, J. H. (Miss)	E.-in-C.O.	27.3.56
Betton, F. W.	L.T. Reg.	19.9.55	Beswick, C. A.	E.-in-C.O.	4.4.56
Lewis, G.	W.B.C.	17.10.55	Gorrell, R. W.	E.-in-C.O.	6.4.56
Howells, G. V.	W.B.C.	12.9.55	Agacy, R. L.	E.-in-C.O.	13.4.56
Rutland, A. P. H.	L.T. Reg.	11.12.55			
Natt, V...	L.T. Reg.	1.2.56	<i>T.A. I to M.T.O. III</i>		
Bredemeier, F. M.	L.T. Reg.	20.12.56	Byatt, H. A.	E.-in-C.O.	6.2.56
Cuthbert, T.	Scot.	6.12.55			
Strath, H.	Scot.	8.3.56	<i>T.A. II to T.A. I.</i>		
Veal, B. J.	Mid. Reg.	25.8.55	Fossey, G. H.	H.C. Reg. to E.-in-C.O.	21.4.56
Beasley, W. W.	Mid. Reg.	18.7.55	Shann, D. E. W.	E.-in-C.O.	23.4.56
Pickett, M. G.	Mid. Reg.	26.9.55	Barrett-Jolley, S. R.	N.W. Reg. to E.-in-C.O.	23.4.56
Wheeler, H. F.	Mid. Reg.	24.10.55	Riches, S. J. W.	Mid. Reg.	23.4.56
Fountain, A. G.	Mid. Reg.	2.1.56	Lord, A. C.	E.-in-C.O.	23.4.56
Bradbury, A.	N.W. Reg.	19.3.56	North, H. E.	E.-in-C.O.	23.4.56
Crocker, W.	N.W. Reg.	19.3.56	James, H. S.	E.-in-C.O.	23.4.56
Bath, R. E.	L.T. Reg.	30.10.55	Carruthers, W.	N.W. Reg. to E.-in-C.O.	23.4.56
Dewar, C. G.	W.B.C.	16.7.55	Girling, G. R.	Scot. to N.E. Reg.	21.4.56
Foulkes, W.	W.B.C.	26.2.56	Kirkbv, I. W.	E.-in-C.O.	23.4.56
Chown, R. C.	L.T. Reg.	29.12.55			
Barrett, R. G.	L.T. Reg.	9.1.56			
Brewer, E.	L.T. Reg.	28.12.55			

Deaths

Name	Region	Date	Name	Region	Date
<i>Exec. Engr.</i>			<i>Asst. Engr.—continued.</i>		
Miles, A.	E.-in-C.O.	13.3.56	Black, J. G.	N.E. Reg.	20.3.56
<i>Asst. Engr.</i>			<i>Inspector.</i>		
Frost, F.	Mid. Reg.	29.2.56	Larkins, W. C.	L.T. Reg.	21.2.56
Penn, W. E.	Mid. Reg.	8.3.56	Grime, R.	N.W. Reg.	19.3.56
Smith, A. W.	N.W. Reg.	20.3.56	George, A. W.	H.C. Reg.	22.3.56
			Johnstone, D. K.	Scot.	24.3.56



### Transfers

Name	Region	Date	Name	Region	Date
<i>Exec. Engr.</i>			<i>Asst. Engr.—continued.</i>		
Forrester, H. ..	N.I. to N.E. Reg. ..	12.12.55	Lawrence, C. ..	E.-in-C.O. to L.T. Reg. ..	29.4.56
Marriott, P. E. ..	Nigeria (approved employment) to E.-in-C.O. ..	13.2.56	Nash, L. C. ..	E.-in-C.O. to Colonial Office (Seconded) ..	30.4.56
Lang, W. N. ..	E.-in-C.O. to Scot. ..	13.3.55	Lockton, R. W. ..	E.-in-C.O. to Min. of Supply	1.5.56
Rogers, D. M. ..	E.-in-C.O. to L.T. Reg. ..	30.4.56	Wileman, G. W. ..	E.-in-C.O. to Min. of Transport and C.A. ..	1.5.56
<i>Asst. Engr.</i>			<i>Inspector.</i>		
Colston, I. S. ..	E.-in-C.O. to Min. of Transport and C.A. ..	13.2.56	Hammond, A. E. ..	H.C. Reg. to L.T. Reg. ..	2.4.56
Cook, G. A. ..	E.-in-C.O. to L.T. Reg. ..	14.2.56	<i>T.A.I.</i>		
Hopkins, H. ..	E.-in-C.O. to H.C. Reg. ..	3.4.56	Whitehead, R. H. J. ..	E.-in-C.O. to N.W. Reg. ..	16.4.56
Preece, J. R. ..	E.-in-C.O. to S.W. Reg. ..	14.4.56			
Whittle, A. D. ..	E.-in-C.O. to L.T. Reg. ..	22.4.56			

### Retirements and Resignations

Name	Region	Date	Name	Region	Date
<i>Exec. Engr.</i>			<i>Inspector.</i>		
Counsell, A. J. T. ..	L.T. Reg. ..	4.2.56	Roberts, J. W. ..	Scot. ..	29.2.56
Benham, F. W. ..	L.T. Reg. ..	15.3.56	Smith, A. ..	N.E. Reg. ..	12.3.56
Allen, V. H. ..	E.-in-C.O. ( <i>Resigned</i> ) ..	18.2.56	Irvine, J. ..	Scot. ..	7.3.56
Faulkner, E. B. ..	E.-in-C.O. ( <i>Resigned</i> ) ..	29.2.56	Housley, R. D. ..	N.W. Reg. ..	19.3.56
Tod, D. S. ..	E.-in-C.O. ( <i>Resigned</i> ) ..	17.3.56	Pendleton, H. J. ..	W.B.C. ..	24.3.56
Millard, A. E. ..	S.W. Reg. ..	7.4.56	Swann, P. E. ..	S.W. Reg. ..	31.3.56
Judd, F. W. ..	L.T. Reg. ..	13.4.56	Warman, R. C. ..	L.T. Reg. ..	23.3.56
Wright, J. S. ..	L.T. Reg. ..	16.4.56	Kent, F. J. ..	L.T. Reg. ..	6.4.56
Buckoke, S. ..	L.T. Reg. ..	30.4.56	Sellars, F. ..	N.E. Reg. ..	27.4.56
Wells, H. G. ..	E.-in-C.O. ..	30.4.56	<i>Asst. Exptl. Offr.</i>		
<i>Asst. Engr.</i>			Morris, G. E. ..	E.-in-C.O. ( <i>Resigned</i> ) ..	19.1.56
Richards, B. J. ..	W.B.C. ..	8.2.56	Rowley, J. W. ..	E.-in-C.O. ( <i>Resigned</i> ) ..	16.3.56
Bidgood, O. F. ..	S.W. Reg. ..	10.2.56	Hardcastle, R. A. ..	E.-in-C.O. ..	30.4.56
Wenham, H. ..	L.P. Reg. ..	1.3.56	<i>Asst. (Sc.).</i>		
Shorey, E. E. ..	L.T. Reg. ..	31.3.56	Barnacle, J. W. ..	E.-in-C.O. ( <i>Resigned</i> ) ..	17.3.56
Buckland, S. R. ..	L.T. Reg. ..	31.3.56	Scott, J. (Miss) ..	E.-in-C.O. ( <i>Resigned</i> ) ..	31.3.56
Kemp, F. G. ..	H.C. Reg. ..	31.3.56	Cummings, M. G. ..	E.-in-C.O. ( <i>Resigned</i> ) ..	7.4.56
Vincent, C. F. ..	L.T. Reg. ..	2.4.56	Shepherd, M. B. (Mrs.) ..	E.-in-C.O. ( <i>Resigned</i> ) ..	13.4.56
Poulter, T. J. ..	L.T. Reg. ..	13.4.56	Groves, C. E. (Miss) ..	E.-in-C.O. ( <i>Resigned</i> ) ..	30.4.56
Pepperell, A. J. ..	S.W. Reg. ..	21.4.56			
Bulloch, W. ..	Scot. ..	30.4.56			
Webb, E. E. ..	L.T. Reg. ..	30.4.56			
Sucksmith, A. V. ..	E.-in-C.O. ( <i>Resigned</i> ) ..	13.4.56			
Wood, J. G. ..	E.-in-C.O. ( <i>Resigned</i> ) ..	22.4.56			

### BOARD OF EDITORS

D. A. BARRON, M.Sc., M.I.E.E., Chairman.  
 L. F. SCANTLEBURY, Whit.Sch., A.C.G.I., D.I.C., M.I.E.E.  
 H. G. BEER, Whit.Sch., A.C.G.I.  
 C. E. CALVELEY, O.B.E., E.R.D., B.Sc.(Eng.), M.I.E.E.  
 T. H. FLOWERS, M.B.E., B.Sc.(Eng.), M.I.E.E.  
 R. H. DE WARDT, B.Sc.(Eng.), A.C.G.I., A.M.I.E.E.  
 R. F. WALDEGRAVE.  
 W. A. HUMPHRIES, T.D., A.M.I.E.E., Managing Editor.  
 J. H. BROADHURST, A.M.I.E.E.  
 E. DAVIS, A.M.I.E.E. } Assistant Editors.  
 A. J. HUTCHISON, Secretary-Treasurer.

#### Copyright

The entire contents of this JOURNAL are covered by general copyright, and special permission is necessary for reprinting long extracts, but Editors are welcome to use not more than one-third of any article, provided credit is given at the beginning or end thus: "From the *Post Office Electrical Engineers' Journal*."

The Board of Editors is not responsible for the statements made or the opinions expressed in any of the articles in this JOURNAL, unless such statement is made specifically by the Board.

#### Communications

All communications should be addressed to the Managing Editor, *P.O.E.E. Journal*, Engineer-in-Chief's Office, Alder House, Aldersgate Street, London, E.C.1. Telephone: HEADquarters 1234. Remittances should be made payable to "The *P.O.E.E. Journal*" and should be crossed "& Co."

#### Binding Cases

Cases for binding are available, and may be obtained from the Local Agents for 3s. Subscribers can have their copies of volumes bound, at a cost of 10s. 6d., by sending the complete set of parts to the Local Agents or to the *P.O.E.E. Journal*, Engineer-in-Chief's Office, Alder House, Aldersgate Street, London, E.C.1. Orders for binding for Vols. 1-19 should indicate whether the original binding case with black lettering, or the later pattern with gold, is required. Cases with gold lettering are the only type stocked from Vol. 20 onwards.

#### Back Numbers

The price of the JOURNAL, which is published quarterly, is 2s. 6d. (2s. 9d. post free) per copy, or 11s. per annum, post free. Back numbers can be supplied, subject to availability of stocks, at 2s. 6d. each (2s. 9d. post free). Orders for back numbers may be sent to the *P.O.E.E. Journal*, Engineer-in-Chief's Office, Alder House, Aldersgate Street, London, E.C.1, or to the Publishers.

Employees of the British Post Office can obtain the *Journal* through Local Agents at the reduced price of 2s. per copy.

#### Advertisements

All communications relating to space reservations should be addressed to the Advertisement Editor, *P.O.E.E. Journal*, Alder House, Aldersgate Street, London, E.C.1. Communications regarding advertisement copy, proofs, etc., should be addressed to the Publishers, Messrs. Birch & Whittington (Prop. Dorling & Co. [Epsom] Ltd), 49 Upper High Street, Epsom, Surrey.

## INDEX TO ADVERTISERS

	PAGE
Adcola Products, Ltd. . . . .	xxxii
Airmec, Ltd. . . . .	x
Alton Battery Co., Ltd., The . . . . .	xv
Austinlite, Ltd. . . . .	vii
Automatic Coil Winder & Electrical Equipment Co., Ltd. . . . .	xii
Automatic Telephone & Electric Co., Ltd. . . . .	ix
British Institute of Engineering Technology . . . . .	ii
British Insulated Callender's Cables, Ltd. . . . .	xxix
British Power Transformer Co., Ltd. . . . .	v
Edison Swan Electric Co., Ltd., The . . . . .	x
"Electrical Review" . . . . .	iii
E.M.I. Institutes . . . . .	iii
Ericsson Telephones, Ltd. . . . .	xx
Ferranti, Ltd. . . . .	xxxiv
General Electric Co., Ltd., The . . . . .	xxiv-xxv, xxx-xxxii
Great Northern Telegraph Co., Ltd. . . . .	xxviii
Hackbridge Cable Co., Ltd. . . . .	xxxii
Hivac, Ltd. . . . .	v

	PAGE
Hot Dip Galvanizers Association . . . . .	xxi
Marconi's Wireless Telegraph Co., Ltd. . . . .	vi
Marconi Instruments . . . . .	xi
Mullard, Ltd. . . . .	xiii
National Salt Glazed Pipe Manufacturers' Association . . . . .	xvii
Painton of Northampton . . . . .	xiv
Pirelli-General Cable Works, Ltd. . . . .	xxxiv
Pitman, Sir Isaac, & Sons, Ltd. . . . .	ii
Redifon, Ltd. . . . .	ii
Siemens Brothers & Co., Ltd. . . . .	xxvi-xxvii
Skillman, T. S., & Co., Ltd. . . . .	xxii-xxiii
Smith, Frederick, & Co. . . . .	xxxiii
Standard Telephones & Cables, Ltd. . . . .	iv, xviii-xix
Sullivan, H. W., Ltd. . . . .	viii
Telephone Manufacturing Co., Ltd. . . . .	xii
Tungstone Products, Ltd. . . . .	xvi
Westinghouse Brake & Signal Co., Ltd. . . . .	viii
Winn & Coales, Ltd. . . . .	xxxiii

## Essential to all engaged in the electrical industry

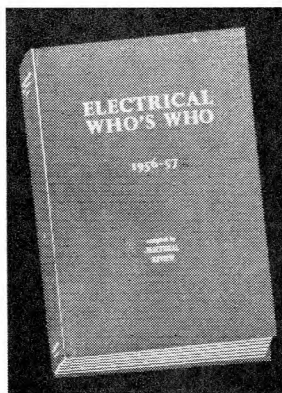

ELECTRICAL WHO'S WHO—the only publication of its kind—is essential to all engaged in the electrical industry.

The fourth edition of this comprehensive personal directory contains some 7,000 biographies of people in all branches of the industry, showing education, training, careers to date, membership of associations and private addresses, with an additional alphabetical listing of firms and organizations in the industry, with their principals.

**NOW READY**  
**The only book of its kind**  
 9" x 6" 454 pp. **21s. net.** By post 22s. 5d.

### ELECTRICAL WHO'S WHO 1956-7

Obtainable from booksellers or from 'Electrical Review'  
**DORSET HOUSE, STAMFORD STREET, LONDON, S.E.1**

## PASS YOUR CITY & GUILDS CERTIFICATES AND P.M.G. CERTIFICATE

We offer comprehensive home training in a wide range of subjects, including P.M.G. Certificates, City and Guilds Grouped Certificates in Telecommunications, A.M.Brit.I.R.E. Examination, Radio Amateur's Licence, Radio and Television Servicing Certificates, General Radio and Television Courses, Radar, Sound Recording, etc. Also Courses in all other branches of Engineering.

With the following Courses, Practical Kits are available.

**Radio, Television, Mechanics, Electricity, Chemistry, Photography, Carpentry; also Draughtsmanship, Commercial Art, Amateur S.W. Radio, Languages, etc.**

*Write now*

for **FREE BROCHURE** stating subjects of interest to:

### E.M.I. INSTITUTES

Dept. 97, GROVE PARK ROAD, LONDON, W.4  
 An Educational Organization serving the E.M.I. Group of Companies, including  
 "HIS MASTER'S VOICE", MARCONIPHONE, COLUMBIA, etc.

10.84 7/56

# Standard VIDEO

# CABLES

The latest advance by *Standard* in the field of communication engineering is the balanced pair cable for video transmission, utilizing expanded polythene as an insulant. This dielectric by its greater mechanical rigidity allows a more uniform location of the conductors than previous designs and gives an improved impedance uniformity, while retaining the characteristics of low attenuation and cross talk. These screened circuits are ideal for short television cable links.

One of the 'Standard' Video Cables is shown being installed at Television House, Headquarters of I.T.A. to connect the studios with the main television switching centre.

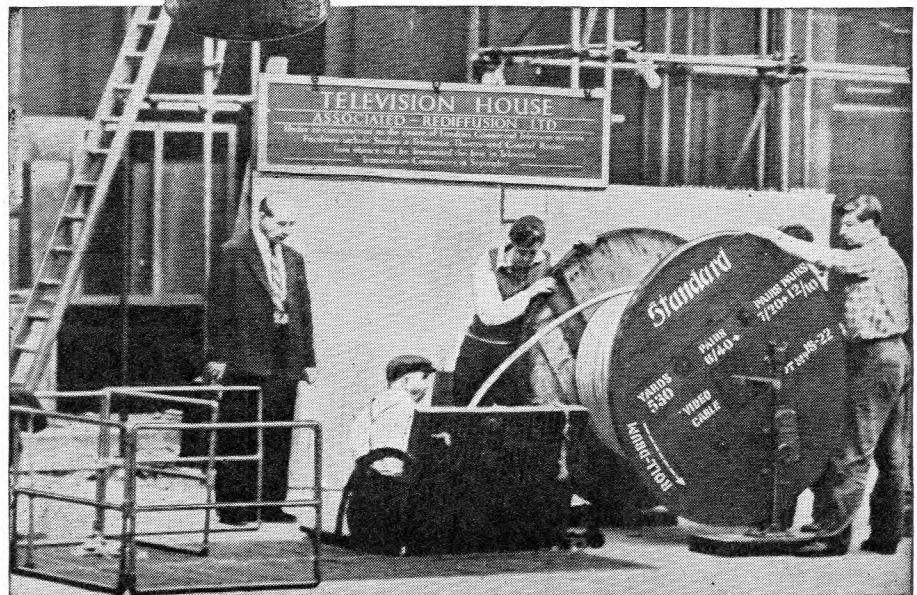

**Standard Telephones and Cables Limited**

Registered Office: Connaught House, Aldwych, W.C.2

TELEPHONE LINE DIVISION: NORTH WOOLWICH • LONDON • E.16

# TO PROTECT EQUIPMENT... AND KEEP OUTPUT CONSISTENT

## THE RANGE OF REGAVOLT CUBICLE TYPE AUTOMATIC VOLTAGE REGULATORS

Consistent supply voltage is essential to industry for manufacturing processes and to extend the life of important electrical plant.

B.P.T. automatic voltage regulators eliminate all variations in supply voltage,

regardless of variations in frequency, load and load power factor.

The following is a list of the standard range of floor mounted, cubicle type equipments, compensating for fluctuations in the supply of  $\pm 10\%$ . Available with early delivery.

SINGLE PHASE, 200/250 volts, 50/60 cycles.

MODEL	Current Amps.	L Ins.	W Ins.	H Ins.	Weight lbs.
A-6NX	90	24	24	60	500

THREE PHASE, 380/440 volts, 50/60 cycles.

A-23BB	30	24	24	60	400
A-43BB	40	24	24	60	500
A-53BB	65	24	24	60	650
A-63BB	100	24	24	60	800

Other standard Regavolt voltage regulators are wall mounted and oil immersed types. Full details will be gladly supplied on request to:

### BRITISH POWER TRANSFORMER CO. LTD.

QUEENSWAY · ENFIELD · MIDDLESEX. TELEPHONE: HOWARD 2411. TELEGRAMS: VITROHM ENFIELD.

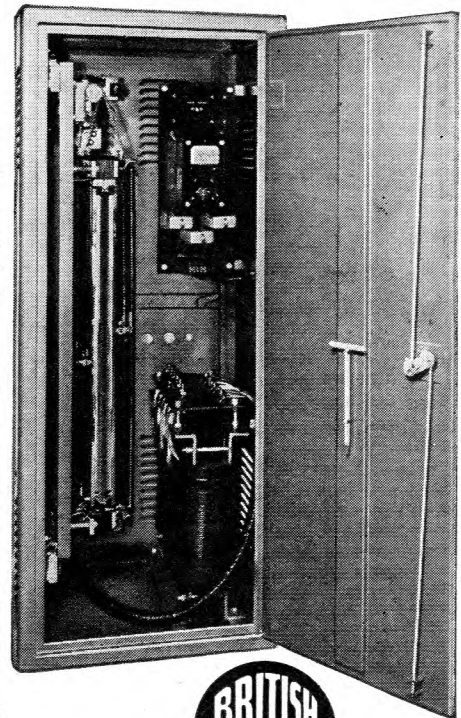

BP 4071-AH

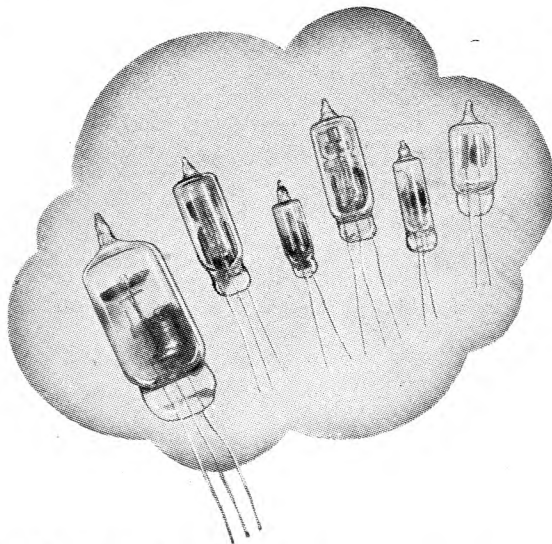

## COLD CATHODE TUBES for TELECOMMUNICATIONS

Continuing development in the field of cold cathode tubes enable Hivac to offer a range of cold cathode diodes and triodes of improved characteristics, and of very small dimensions suitable for performing the complex counting and switching operations required by modern electronic equipment in the field of Telecommunications.

Perfection in  
Miniature

**Hivac Limited**

STONEFIELD WAY, VICTORIA ROAD, SOUTH RUISLIP, MIDDLESEX

Telephone: Ruislip 3366



*The NEW Marconi*  
**GENERAL PURPOSE RECEIVER Type NS. 702**



*Combines exceptional versatility with rugged reliability*  
*—an integral part of an efficient communications system*

- Continuous frequency coverage 15 Kc/s to 28 Mc/s in ten bands.
- Directly calibrated main tuning and band-spread scales with built-in crystal oscillator for precise band-setting. 80 : 1 flywheel action tuning drive, and electrical fine tuning control of  $\pm 3$  Kc/s above 800 Kc/s.
- Magnetostriction filter providing the narrowest of four I.F. bandwidths of 8 Kc/s, 3 Kc/s, 1000 c/s and 100 c/s.
- Unwanted beats between interfering signals minimized by balanced demodulator for C.W. reception.
- Facilities for working with an associated transmitter include desensitizing, either electronically or by internal high-speed relays, and reproduction of transmitter sidetone on C.W., M.C.W., or telephony.
- Very low level of oscillator radiation and spurious whistles.
- Can operate direct on 110v. or 220v. D.C., or 115v. or 230v. A.C. supplies, without vibrator or rotating machine.
- Meets the latest international regulations and complies with the G.P.O. specification for General Purpose Receiver for ships.

*Write for descriptive literature.*



Lifeline of Communication

**MARCONI**

**Complete Communication Systems**

MARCONI'S WIRELESS TELEGRAPH COMPANY LIMITED, CHELMSFORD, ESSEX

LN2



**Difficult to fit ?**

There are generating problems which standard generating plant solves perfectly. There are others so unusual that no standard plant could conceivably fit them. These are the problems Austinlite engineers enjoy most. They are prepared to go anywhere in the world to discuss their solution.

It does not matter whether the plant will be required to run continuously for months without attention ; to isolate

delicate equipment from mains that are subject to voltage surges ; or to take over instantly when a mains supply fails. Provided there is a solution, Austinlite plant can be built which will ensure a steady, unbroken, flow of power. Made-to-measure generating plant is Austinlite's forte. But not the only kind they make. There are standard types of Austinlite Generating Plant which fit many jobs perfectly. Quite difficult jobs. For the idea that links all types of Austinlite plant, standard *or* made-to-measure, is the idea of utter reliability.

*Austinlite* **AUTOMATIC GENERATING PLANT**  
**Tailor-made by STONE-CHANCE LTD.**

# HIGH TEMPERATURE LIGHTWEIGHT RECTIFIERS

- For operation in ambients of up to 85°C
- Elimination of cooling fins for compactness
- Light alloy construction for light weight
- High stability

are some of the salient features of this new range of rectifiers, primarily developed for Service requirements, but now available in production quantities for all applications. Units can be supplied with various finishes to comply with RCS.1000 categories H.1 and H.2.

Details of this new range of



## RECTIFIERS

can be obtained from

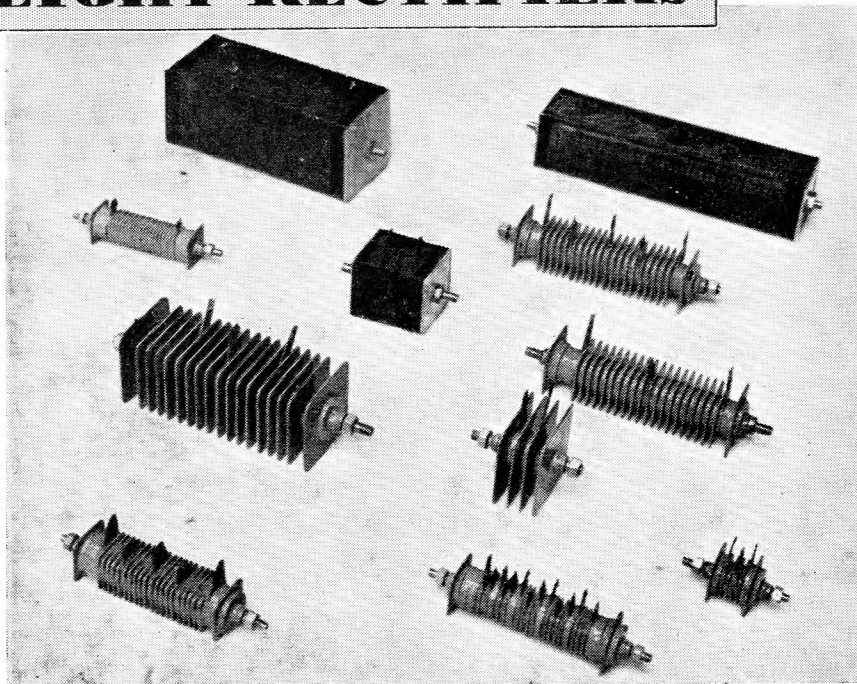

See them on STAND No. 102, Radio Show, August 21st to September 1st

Dept. PO.7, WESTINGHOUSE BRAKE & SIGNAL CO. LTD., 82 York Way, King's Cross, London, N.1. TERminus 6432

## IMPROVEMENT IN THE ACCURACY OF DECADE RESISTANCES

We have pleasure to announce that the well-known and novel

SULLIVAN and GRIFFITHS

# DUAL DIAL DECADE RESISTANCE BOXES

FOR ALL FREQUENCIES

Moreover, the windings are now of **Manganin** in order to reduce the temperature coefficient; more important still, to improve the long period of stability and make them as suitable for all direct-current purposes as they are for alternating currents of all frequencies.

**Screened Resistances** of guaranteed accuracy exactly similar to our well-known Decade Resistances but specially arranged so that one box of a given number of dials gives many different values of maximum resistance. Thus a three-dial box (as illustrated) may be used for instance for

three decades of <b>Thousands, Hundreds and Tens</b>	a total of 10,000 ohms.
or three decades of <b>Hundreds, Tens and Units</b>	a total of 1,000 ohms.
or three decades of <b>Tens, Units and Tenths</b>	a total of 100 ohms.
or three decades of <b>Units, Tenths and Hundredths</b>	a total of 10 ohms.

have now been improved in accuracy to

**0.05 PER CENT**

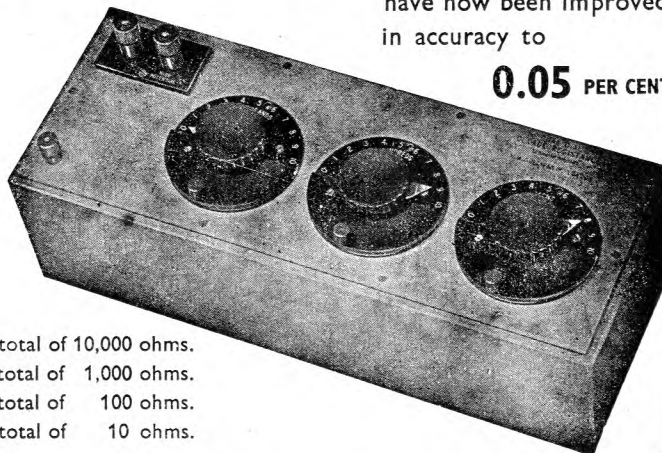

## H. W. SULLIVAN LIMITED

LONDON, S.E.15

Telephone: New Cross 3225 (P.B.X.)

The advantages of such a system will be obvious, for in addition to the economy involved much space is saved and the residual resistance and inductance is much reduced.

The resistances are available in 3-dial, 4-dial and 5-dial types with subdivision of 0.001% down to 0.001 ohm if necessary, depending of course on the number of dials incorporated.

# *Automatic*

## *Exchange ?*

Only the subscriber believes that an automatic exchange is automatic; he is justified, for this is the type of service he gets with unfailing reliability. The Administration, however, thinks in broader terms. It has to maintain the exchange at this high pitch of operational efficiency year after year throughout its useful life, which means at least twenty years and quite possibly forty years of uninterrupted operation. Of the various routines employed the most costly is preventive maintenance, and in order to examine the possibilities of eliminating, or at least, simplifying this routine, A.T. & E. Co. Ltd. recently carried out a lengthy and detailed series of investigations\* on production selectors of the 32A Mark II type. From the results an entirely new conception of maintenance technique has emerged. It may be summed up

in the expression "leave well alone".

Provided the Mark II selector is in proper adjustment to begin with, it should not be removed from its shelf or re-adjusted or re-checked in any way.

The only routines required to attain the essential high standard of performance in service are the performance of simple operational tests, together with lubrication and cleaning at regular intervals.

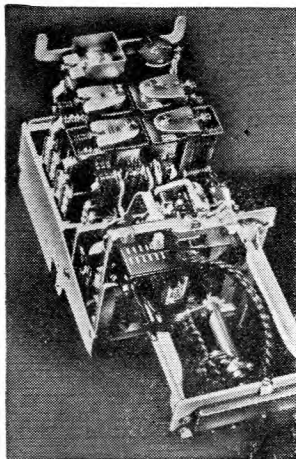

\* These investigations are fully described in a bulletin "The case for a new approach to maintenance". A copy of this will be forwarded on request.



**AUTOMATIC TELEPHONE & ELECTRIC CO. LIMITED.**





# BRIDGE HETERODYNE DETECTOR *Type 775*

THIS instrument is a bridge detector for use over the frequency range 6.5 to 751 kc/s, and its sensitivity is such that out-of-balance bridge voltages down to 1 microvolt may be detected. It operates on the heterodyne principle and consists of a frequency-changer, a beating oscillator, a tuned amplifier, and a detector. The input circuit terminates on a screened and floating transformer winding, making the unit suitable for direct connection to a bridge.

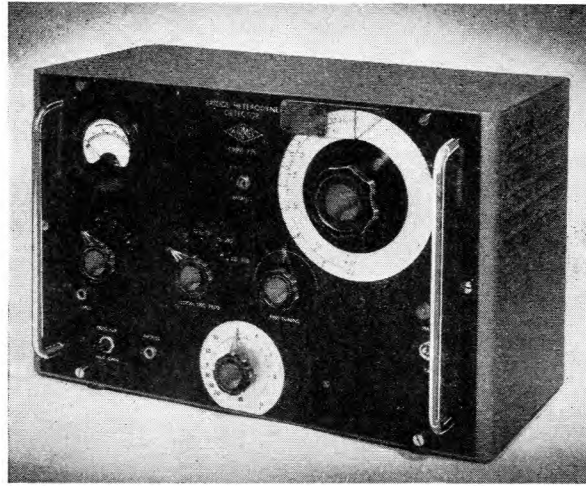

**FREQUENCY RANGE:**  
6.5 to 751 kc/s

**BEAT FREQUENCY:**  
1 kc/s

**SELECTIVITY:**  
Not less than 30 db  
discrimination at 1 kc/s  
off tune

**SENSITIVITY:**  
Readable meter deflection  
for 5 microvolts input  
Audible note in phones for  
1 microvolt input

**ATTENUATORS:**  
0 to 60 db in steps  
0 to 20 db slide-wire

*Full details of this or any other Airmec instrument will be forwarded gladly upon request.*

**AIRMEC**  
L I M I T E D

**HIGH WYCOMBE BUCKINGHAMSHIRE ENGLAND**

Telephone: High Wycombe 2060

Cables: Airmec High Wycombe

# EDISWAN

## Telephone Line Protectors

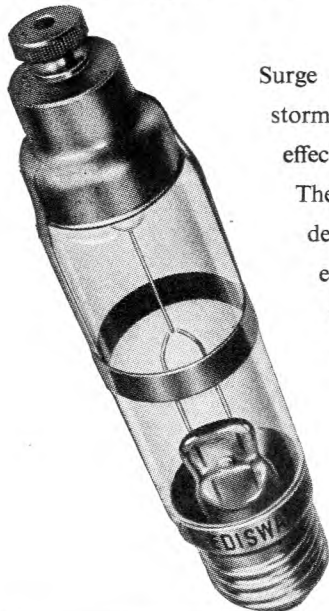

Surge currents induced on telephone lines by electric storms or breakdowns on neighbouring power lines may be effectively controlled by Ediswan telephone line protectors.

These special electrode gas discharge tubes have been developed in collaboration with G.P.O. Engineers to provide economical and effective protection for telephone systems without impairing the service.

Full details of these protectors and their application is given in the Ediswan publication C.1581 which is available on application.

**THE EDISON SWAN ELECTRIC CO., LTD.**

155 CHARING CROSS ROAD, LONDON, W.C.2

*Member of the A.E.I. Group of Companies*

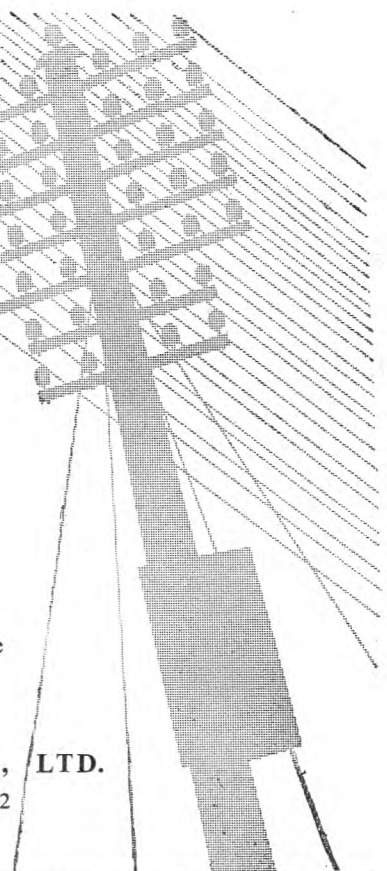

TE107



# MARCONI *instruments* stand the test of time

Originally designed more than ten years ago! Yet the current models of the "144" and "329" are still in demand and readily available.

## THE MARCONI STANDARD SIGNAL GENERATOR Type TF 144G

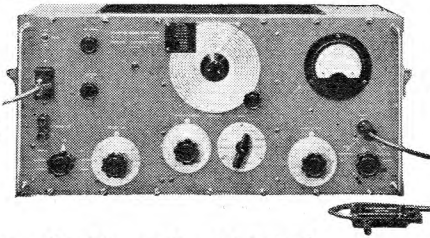

Nearly 6,000 instruments of this well-established series are in use, and the continuing steady demand proves that the design has withstood the test of time. The outstanding features of the latest TF 144G are:— Carrier frequency range, 85 kc/s to 25 Mc/s with alternative ranges down to 20 kc/s. Special models for use up to 70 Mc/s. Dummy aerial for receiver testing. Alternative mains/battery operation. Incremental tuning at all carrier frequencies. Output range, 1  $\mu$ V to 1 volt. Amplitude modulation up to 75% depth measured by fundamental method.

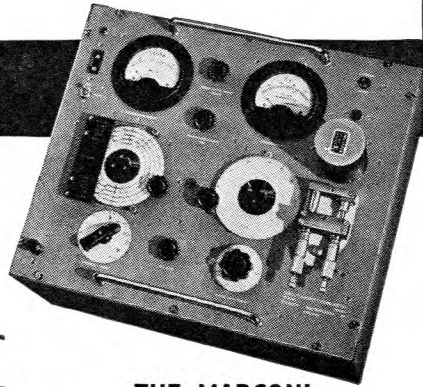

## THE MARCONI CIRCUIT MAGNIFICATION METER Type TF 329G

Another instrument of long standing popularity, the Marconi TF 329G is well known for its reliability and accuracy. The important attributes of the instrument are:— Magnification range, 0 to 500. Internal variable-capacitor range, 40 to 450  $\mu$ F; provision for connecting external capacitor or special-purpose test jigs. Incremental capacitor for Q measurement by bandwidth method. Internal oscillator range, 50 kc/s to 50 Mc/s; direct measurement of Q at lower frequencies by the use of an external oscillator.

*The TF 329G can be used in conjunction with an a.f. oscillator to make direct measurements of Q on television line transformers at 10 kc/s, or indeed on any coils at frequencies down to 50 c/s.*

Send for our booklet: **MEASUREMENTS BY Q METER**

AM & FM SIGNAL GENERATORS · OSCILLATORS · VALVE  
VOLTMETERS · POWER METERS · Q METERS · BRIDGES  
WAVE ANALYSERS · FREQUENCY STANDARDS · WAVEMETERS  
TELEVISION AND RADAR TEST EQUIPMENT · AND SPECIAL  
TYPES FOR THE ARMED FORCES

# MARCONI INSTRUMENTS

MARCONI INSTRUMENTS LTD., ST. ALBANS, HERTFORDSHIRE. TELEPHONE: ST. ALBANS 56161  
(London and the South) Marconi House, Strand, London, W.C.2 Telephone: Covent Garden 1234  
(Midlands) 19 The Parade, Leamington Spa, Telephone: 1403 (North) 30 Albion Street, Kingston-upon-Hull, Telephone: Hull Central 16347  
REPRESENTATION IN MOST COUNTRIES

TC 78

# Telecommunications...

## and the Carpenter Polarized Relay

The Type 4 Carpenter Polarized Relay has been developed primarily for Telephone and Telegraph impulsing circuits where a relatively large gap and ease of contact adjustment are preferable to high operating speeds.

Versions of this relay are in general use in British Post Office equipment.

The operating sensitivity of less than 1 milliwatt enables the relay to be used in impulse circuits over distances of 100 miles of underground cable.

The compliant contact mountings, the moulded base

designed to fit the British Post Office 3000 type relay mountings, and the easily removed contact cover, all make the Type 4 Carpenter relay suitable for use in large scale relay systems.

Full technical data will be sent free on request.

Manufactured by the Sole Licensees:

**TELEPHONE MANUFACTURING CO. LTD**



Contractors to the Government of the British Commonwealth and other Nations

HOLLINGSWORTH WORKS: DULWICH: LONDON S.E.21

TELEPHONE: GIPSY HILL 2211

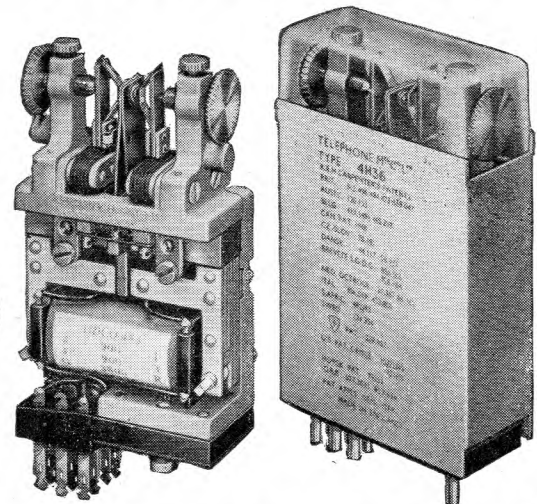

designed for



dependability

Illustrated Brochure available on request.

Sole Proprietors and Manufacturers:—

**The AUTOMATIC COIL WINDER & ELECTRICAL EQUIPMENT CO. LTD.**

AVOCET HOUSE · 92-96 VAUXHALL BRIDGE ROAD · LONDON · S.W.1.

**THE Model 8** is the latest version of the world-famous Universal AvoMeter. In addition to the many well-known AvoMeter features, such as the automatic overload protection cut-out, dual-knob range selection, etc., it has a push-button to obviate the inconvenience of changing over the leads when encountering opposite potentials in respect of a common reference point.

The meter has a sensitivity of 20,000 ohms per volt on all D.C. ranges, and 1,000 ohms per volt on A.C. ranges from 100 volts upwards. Accuracy on D.C. current ranges and A.C. ranges is to B.S. Spec. 89/1954, and on D.C. voltage ranges within 2% of indication from full scale to half scale deflection, and 1% of full scale value below half scale deflection.

VOLTAGE AC/DC: 25mV. to 2,500V.

CURRENT AC/DC: 0.5 microamps to 10 amps.

RESISTANCE:

0.20 megohms with internal batteries,  
0.200 megohms with external D.C. supply.

DECIBELS: -15 Db to +15 Db.

Size: 8½ in. × 7¼ in. × 4½ in.

Weight: 6½ lb (including leads)

List Price **£23 : 10s.**

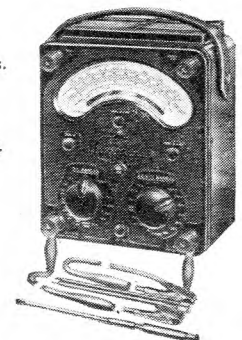

Phone: VICTORIA 3404 (9 lines)

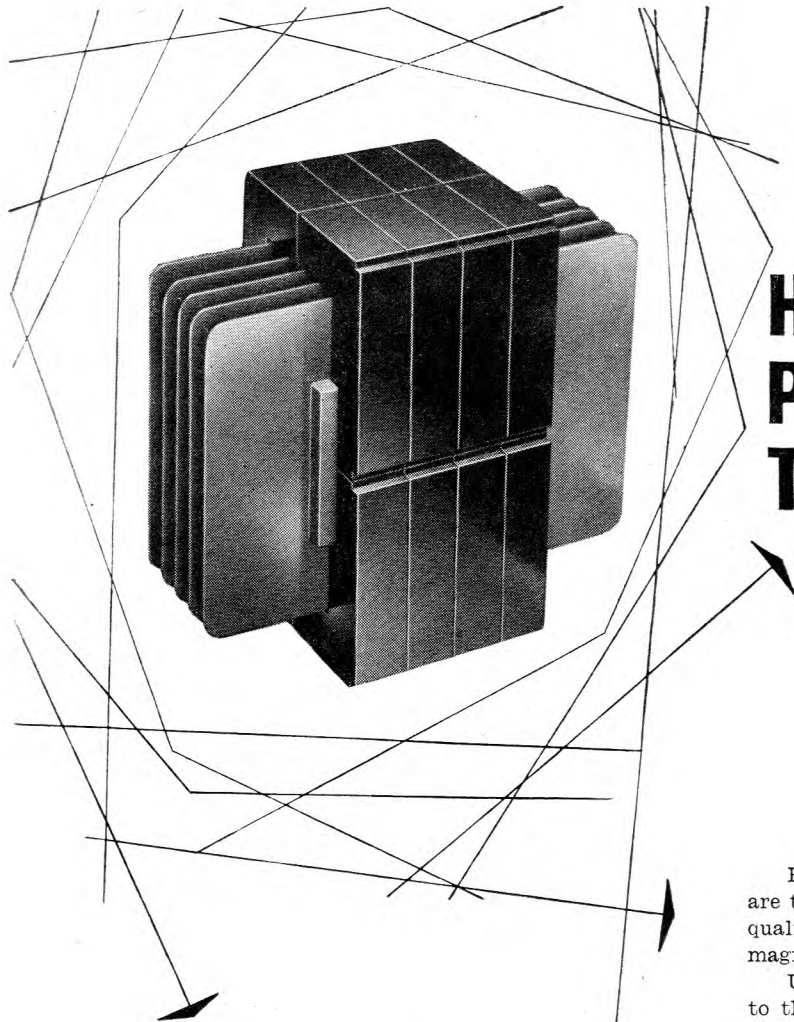

# H.F. POWER TRANSFORMERS

**RATING . . . . . UP TO 2 kW**

**FREQUENCY RANGE . . . . 2 Kc/s to 2 Mc/s**

H.F. power transformers of outstanding efficiency are the latest addition to the Mullard range of high quality components designed around Ferroxcube magnetic cores.

Utilising the unique characteristics of Ferroxcube to the full, Mullard H.F. transformers are smaller, lighter, and less costly than transformers using alternative core materials. These advantages are particularly marked in transformers required to handle powers of up to 2kW, between the frequency range 2kc/s to 2Mc/s.

Mullard transformers are already finding wide use in applications as diverse as ultrasonic H.F. power generators and aircraft power packs operating from an aircraft's normal A.C. supply. In the latter application, the low leakage field of Ferroxcube can eliminate the need for external screening, thereby reducing the size and weight of the transformer even further.

As with all Mullard high quality components, these H.F. power transformers are designed and built to engineers' individual specifications. Write now for details of the complete range of components available under this service.

# Mullard



'Ticonal' permanent magnets  
Magnadur ceramic magnets  
Ferroxcube magnetic cores



*By Appointment to the Professional Engineer*



**HIGH STABILITY CARBON RESISTORS**

$\frac{1}{4}$ W.,  $\frac{1}{2}$ W.,  $\frac{3}{4}$ W., 1W. and 2W. types available at 1%, 2% or 5% Resistance Tolerance.

Type Approved to RCS/112, with RCL/112 reference :

Styles RC2-E to RC2-A for Types 72 to 76 respectively.

For full details please request High Stability Carbon Resistor Leaflet HSC1/3.

Painton High Stability Carbon Resistors are now available with an improved coating protecting the carbon film, and the smaller sizes (Types 72 and 73) can be fitted with a silicone rubber sleeve and supplied as insulated Resistors.

**PAINTON**  
*Northampton England*



*It does you good* to look around you here. You'll never see farms in better heart or villages in better shape or cottage gardens more skilfully tended, than you will from the roads and lanes round Alton. And in Alton itself you'll find plenty of evidence of the local belief that what's worth doing is worth doing well. The reason: Possibly this belief—less widely held than it was, some people think—flourishes best where families take root, and cottager, no less than squire, grows up with a sense of belonging—by right of birth. In the Battery Works son still follows father at the bench—as proud of his skill as his father was, as touchy concerning his personal standard of work. And as proud, and with equal right to be, of the workmanship Alton men put into Alton batteries.

## **ALTON** *Batteries of Merit*

*Alton stationary batteries: 10 to 15,000 ah. Also in regular production renewal plates for all makes of battery, British and Continental.*

THE ALTON BATTERY COMPANY LIMITED, ALTON, HANTS • Telephone: ALTON 2267 and 2268 • Telegrams: BATTERY, ALTON

A.28

# DESIGNED *to meet* G.P.O. specification

TUNGSTONE PLANTÉ CELLS are being regularly supplied to the British Post Office and Post and Telegraph Departments in many countries overseas. They conform fully to G.P.O. Standard specifications.

#### OPEN TYPE CELLS

Similar to the illustration here, these are available in glass and/or lead lined wooden boxes in capacities from 100 a.h. to 5000 a.h.

#### REPLATALS

We are in a position to supply plates for the replating of existing Planté Batteries.

#### ENCLOSED TYPE CELLS

As illustrated below, these are in moulded glass boxes with sealed-in lid. Capacity range from 10 a.h. to 200 a.h.

#### PORTABLE TYPE BATTERIES

A range of portable type Batteries is in regular production, made to G.P.O. specifications, for ancillary duties.

Overseas customers are invited to cable or write their enquiries for batteries or parts. Visitors to London are welcome at our offices. (Just off Fleet Street.)

50 Cells, BSSDW, 25,  
1200 a.h. at the 9-hour rate.  
Installed for the  
General Post Office

# TUNGSTONE

REGD TRADE MARK

## BATTERIES

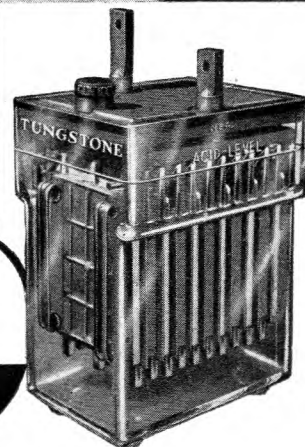

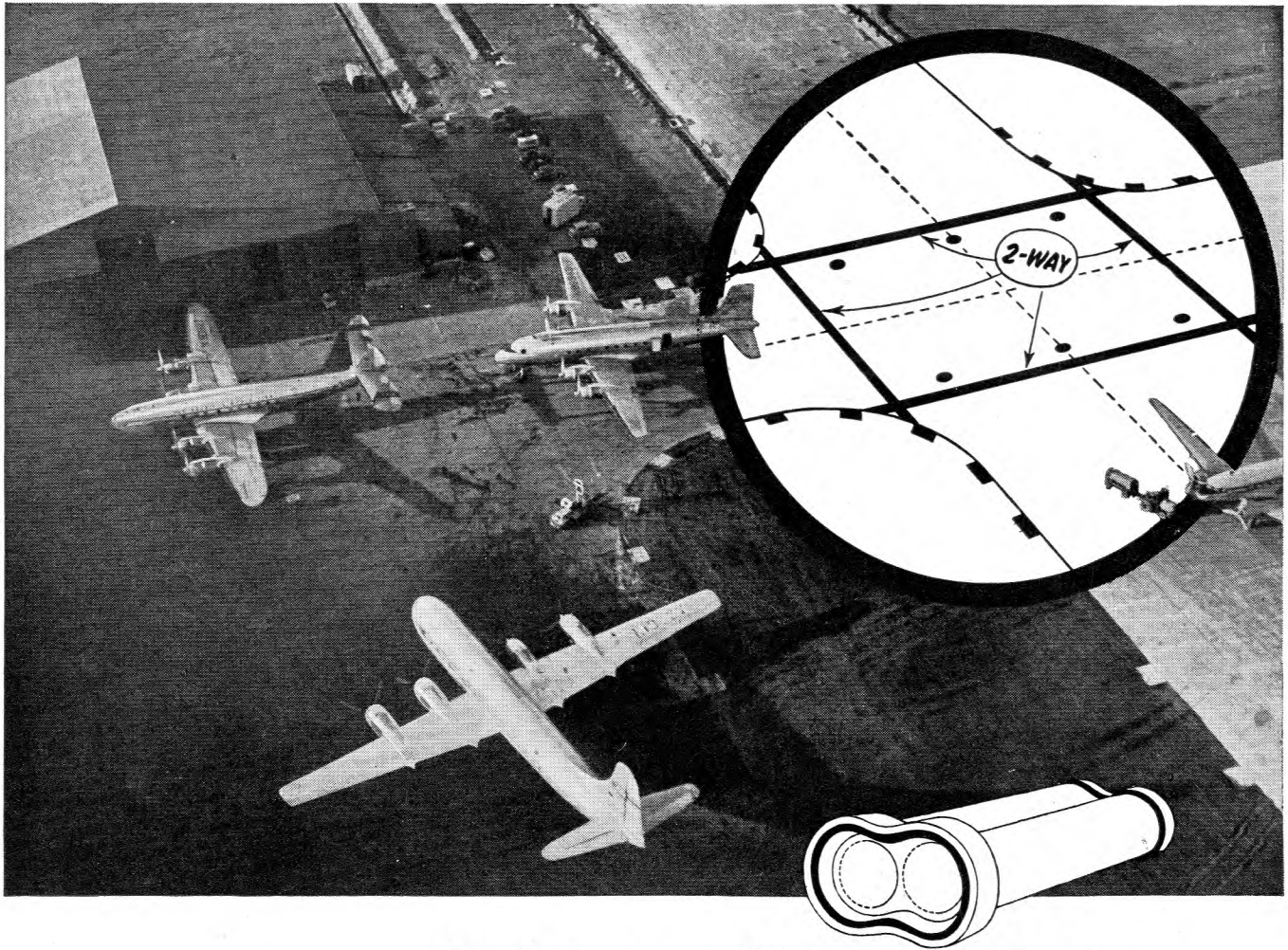

## Under an Airport Runway

***If you never  
want to have  
to dig them  
up again  
put down***

This is a key point in an airport runway pattern. You lay electric cables under here, to serve the runway lights. Those cables must be easy to get at, easy to service. So you run your cables through conduits — in this case 2-way conduits.

If anything goes wrong with those conduits, if they have to come up again — think of the chaos. Think what would happen at a big airport. Last year *in August alone* London Airport handled nearly 9,500 aircraft and 210,000 passengers. A lot depends on those conduits — you never want to have to dig them up again.

That's why, at London Airport, they put down conduits of salt glazed vitrified clay.

Salt glazed conduits are glassy smooth and hard as nails. They are acid-resisting. Sulphates in the soil cannot corrode them. They go down for good! The same applies to the hundreds of salt glazed *drainpipes* that are out there too. Safe and efficient, salt glazed conduits and pipes can — and do — stay down for centuries.

***Salt Glazed***



***pipes and conduits***

NATIONAL SALT GLAZED PIPE MANUFACTURERS' ASSOCIATION



# Standard

# Announce

## the rocking armature receiver

Research and development by Standard engineers in collaboration with the British Post Office has now produced a Rocking Armature Receiver using a bi-polar form of balanced armature, which enables simple construction methods to be employed, producing a robust, reliable, and highly sensitive receiver.

This receiver is now in production at the New Southgate Factory of Standard Telephones and Cables, Limited, and amongst other customers, is to be supplied for the new

### British Post



TELEPHONE DIVISION

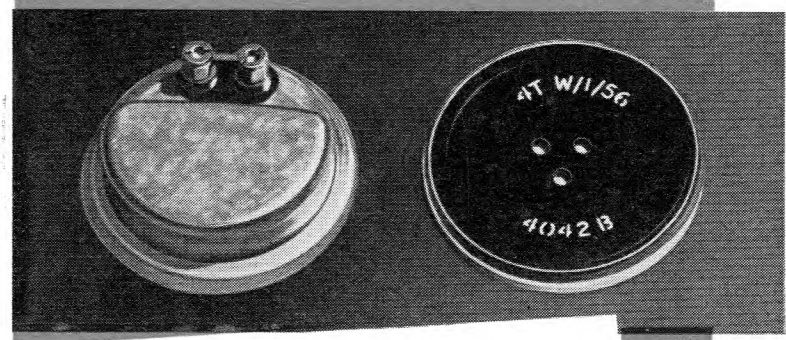

Another advance  
by Standard

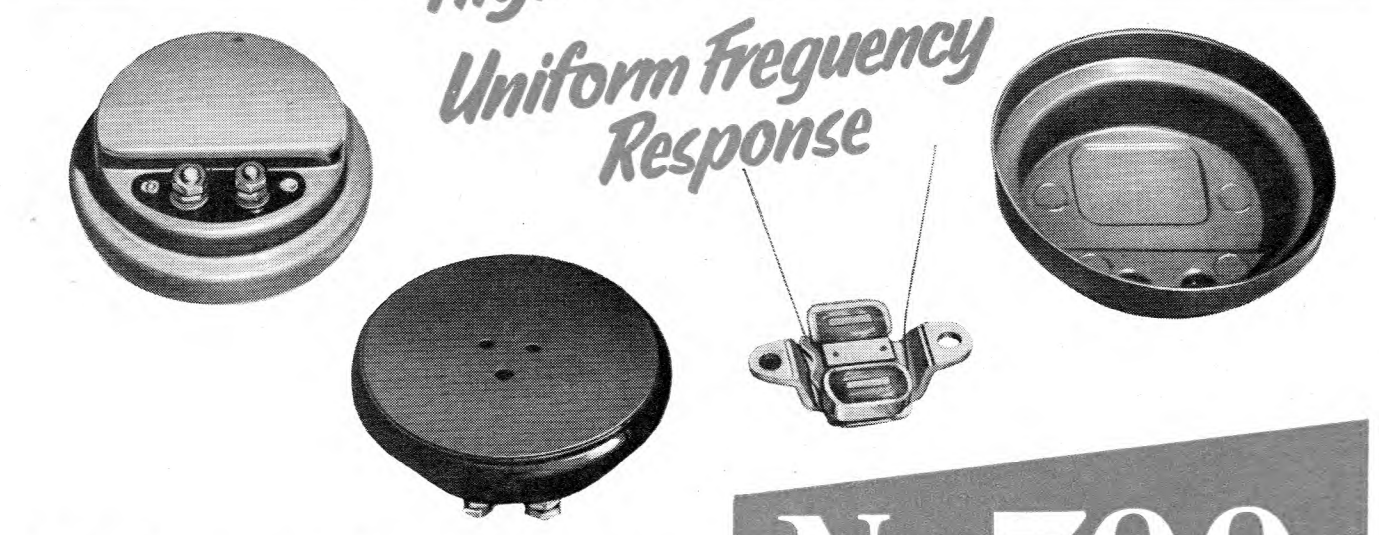
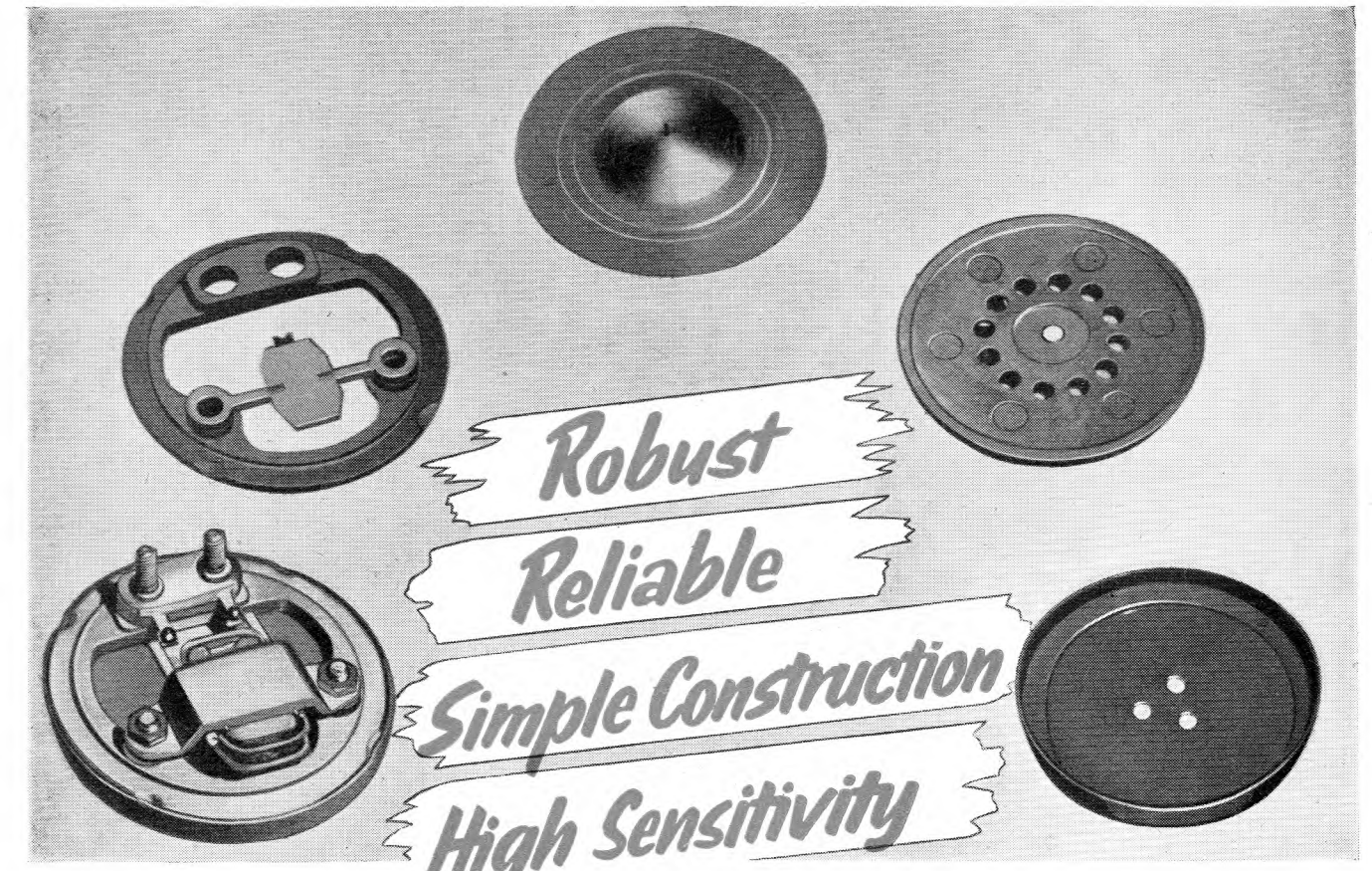

### Office Telephone

# No 700

### Standard Telephones and Cables Limited

Registered Office: Connaught House, Aldwych, London, W.C.2.

OAKLEIGH ROAD · NEW SOUTHGATE · LONDON N.11

'OPTIMUM SOLUM SUFFICIT'

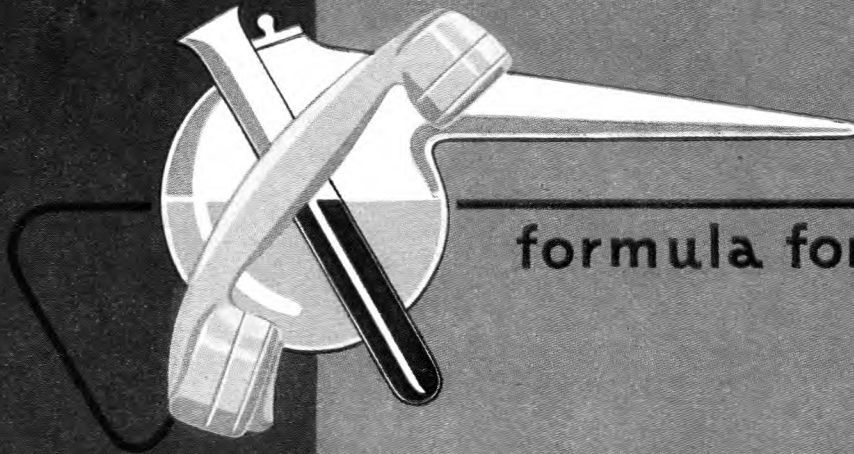

formula for quality

'ONLY THE BEST IS GOOD ENOUGH' is our standard, established as firmly today, as it has been throughout the past. For over half a century, Telecommunication Equipment by ERICSSON has always borne the seal of high quality. Throughout the whole of our Works, appreciation of this has become an endowment that sets a background to every phase of design and production. Modern Plant allied to the highest technical resources is the 'sine qua non' for the exacting standards imposed by modern conditions.

An outstanding example of the unity of these essential ingredients becomes apparent in the finish of all our products. Electro depositions and organic surface coatings are formulated and controlled directly by an extensive PROCESS LABORATORY so that at every stage expert knowledge is applied to ensure the superfine finishes which stand up to the most arduous conditions of service and climate.

What better FORMULA FOR QUALITY?



HEAD OFFICE: 22, LINCOLNS INN FIELDS, LONDON W.C.2  
WORKS: BEESTON, NOTTINGHAM & SUNDERLAND

# HOT GALVANIZING PREVENTS RUST

ASK ANY ENGINEER ABOUT RUST—he knows its dangers on electrical installations. He also knows that hot galvanizing is the surest means of preventing rust—galvanized pylons for instance have enjoyed rust-free life for 20 years or more. In fact, wherever steel is used . . . in factories and mines, on railways and farms . . . there is no substitute for hot galvanizing. The tenacity and durability of *hot* galvanizing ensure lasting protection with minimum maintenance.

## *Protection in Depth*

Hot galvanizing gives defence in depth. The firmly alloyed zinc keeps out rust—tightly sealing crevices and seams. And if the coating *does* get damaged the steel still won't be attacked because the zinc protects it sacrificially. Hot galvanizing *saves* steel—by eliminating the need for large corrosion allowances and the replacement of rusted parts. Hot galvanizing resists normal atmospheric conditions *twenty times better than steel.*



**Hot Dip Galvanizers Association**

*The Hot Dip Galvanizers Association,  
a non-trading body, welcomes enquiries.  
Write to 34 Berkeley Square,  
London, W.1  
Tel. Grosvenor 6636*



*Member of the Zinc Development Association*



**SKILLMAN**

**a new 1+4 or 5 CHANNEL  
system**

**for**

**Open Wires**

**Single Cables**

**Double Cables**

**Radio Links**

- ★ One **QUARTER THE SIZE** as shown by the small unit at the front
- ★ but **IDENTICAL PERFORMANCE** to the old standard system shown behind
- ★ at a **PRICE** hitherto unattainable.
- ★ **REPLACES** the conventional 3 Channel System in all respects
- ★ and will work on routes already using standard 3 Channel.

- ★ Five Star Points *plus* — the most comprehensive range of **SIGNALLING** and other facilities yet offered on such a system.

**5 SPEECH CHANNELS** with any of the following:

**5 DIALLING CHANNELS**

—  
**5 TELEGRAPH CHANNELS**

plus

**5 500-1000/20 RINGERS**

—  
**5 RINGERS** convertible to **DIALLING** later

—  
**5 DIALLING CHANNELS**  
one at the top of each **Speech Channel**

plus

**5 TELEGRAPH CHANNELS**

**at your choice—by simple “plug-in,” interchangeable units!**



**T. S. SKILLMAN & CO. LTD., 199 Uxbridge Road, London, W.7**  
**T. S. SKILLMAN & CO. PTY. LTD., Cammeray, Sydney, N.S.W.**

SKILLMAN CARRIER EQUIPMENT HAS BEEN SUPPLIED TO ENGLAND FOR OTHER THAN G.P.O. APPLICATIONS, TO AUSTRALIA, NEW ZEALAND, BELGIUM AND EGYPT, AND ENQUIRIES ARE INVITED FOR REPRESENTATIVES ELSEWHERE

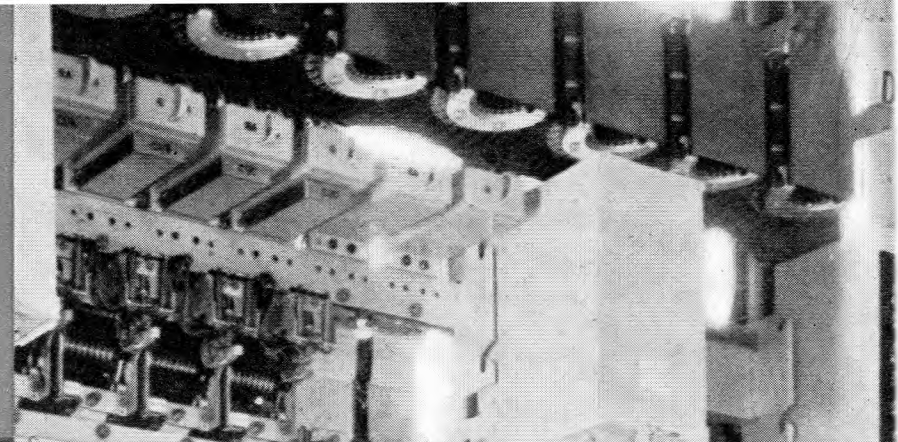

# SE50 SELECTOR

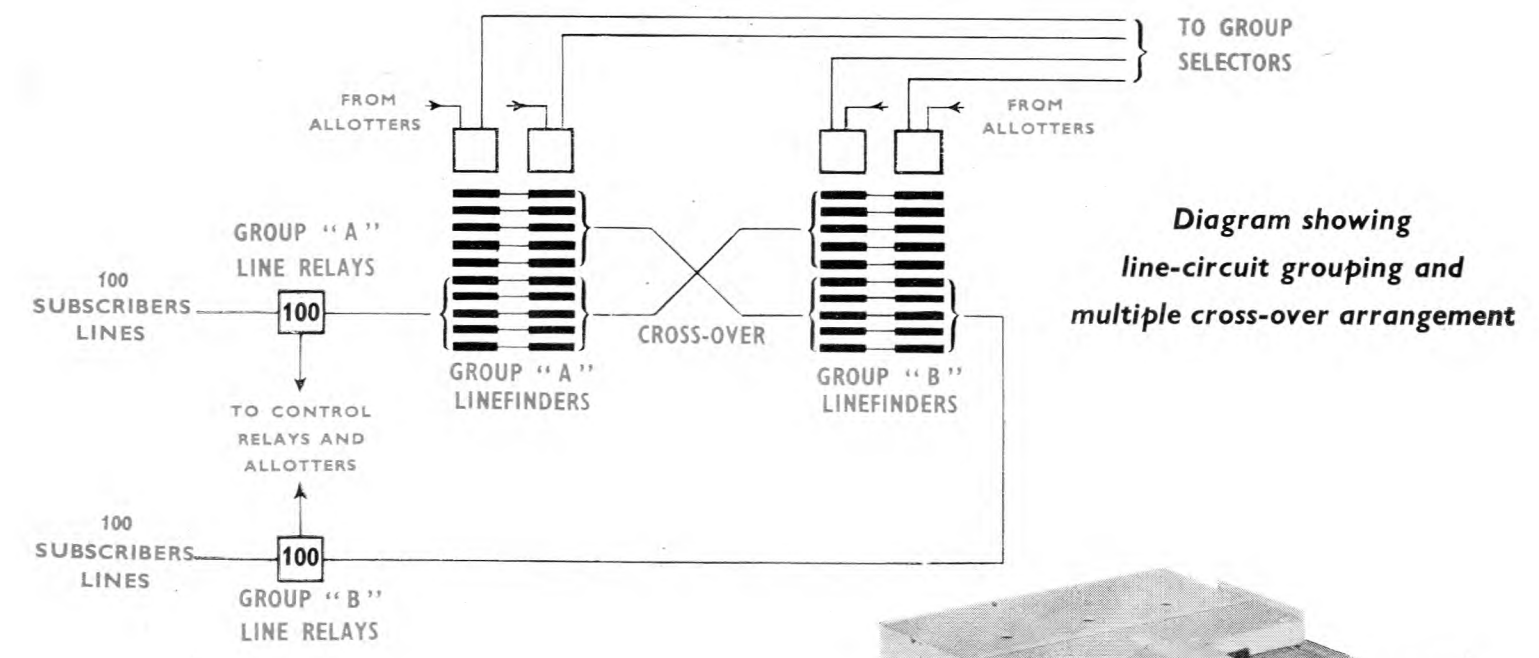

## as a linefinder

The first main exchange to employ SE50 selectors as linefinders was commissioned in December, 1955, at Humboldt, Canada. The compact selector has enabled the complete line-circuit equipment for 600 subscribers to be mounted on one rack 10' 6½" high by 4' 6" wide. The linefinders, which each terminate 200 lines, are provided on a basis of 20 per 200 lines.

The speed of search is increased, and the wear on moving parts reduced, by a simple cross-over in the multiple. This means that a linefinder does not normally have to hunt over more than five bank levels.

The vertical-marking bank is attached to the selector frame and thus does not need separate manipulation when the linefinder is jacked in or out. The vertical wiper gives constant contact pressure during vertical motion, and rotates away from its bank during the rotary motion of the selector shaft, thus eliminating any form of level-marking trouble during rotary hunting.

**LEFT:** Section of Linefinder Rack showing linefinders for 200 lines, 300 sets of line relays, control relay sets and allotters for 600 lines.

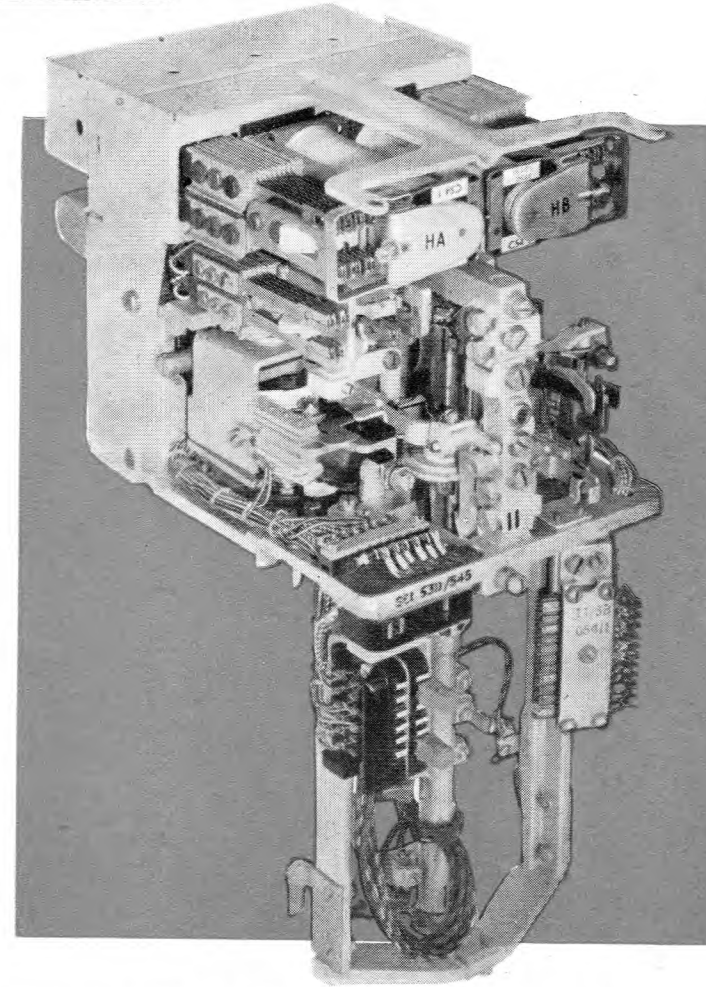

**THE GENERAL ELECTRIC CO. LTD.  
OF ENGLAND**

TELEPHONE RADIO AND TELEVISION WORKS  
COVENTRY · ENGLAND

Cutting the costs of maintenance



## Trunk Mechanisation in Sydney

SIEMENS BROTHERS are proud to feature the Sydney (New South-Wales) Semi-Automatic Trunk Exchange as a major contribution to the development of the Australian Post Office trunk switching plan.

At present in course of installation the Sydney equipment will comprise the largest Cordless Trunk Exchange in the British Commonwealth. An impression of the magnitude of the initial project may be gained from the following:—

Main Operating Positions	—	197
Trunk Lines	—	1020
Local Area Junctions	—	1850

Described opposite are the major features of the equipment but of particular interest is the extent to which automatic switching techniques are employed. The Sydney Trunk Exchange incorporates the experience gained over many years study of the complex problems of trunk mechanisation.

The Australian Post Office is joined by other progressive Administrations throughout the world in recognising the effectiveness of cordless operating positions, in conjunction with our motor uniselector switching apparatus, in meeting the demands of modern trunk switching.



**The Largest Cordless Trunk Exchange  
in the British Commonwealth**



**CORDLESS POSITIONS** economise operator effort and stimulate efficiency. The metal and plastic positions are arranged in convenient small suites.

**AUTOMATIC SWITCHING** is carried out exclusively by our High Speed Motor Uniselector, the ideal trunk switching mechanism. It combines reliability and ease of maintenance with outstanding flexibility of application.

**TRANSIT CALLS**, also calls to the local area are routed without operator intervention. Code translation and automatic alternative routing facilities are available.

**CALL QUEUEING** equipment controls the distribution of incoming traffic to operators who may be assigned to meet fluctuations in route traffic.

**CALL STORAGE** facilities ensure maximum trunk occupancy. Demand service can be maintained despite route congestion.

**KEYSENDERS** are available to all operators and afford code translation and alternative routing facilities.

**TRUNK LINES** of many types are served—Voice Frequency signalling, D.C. dialling, Carrier signalling, etc.

**TRANSMISSION** performance is optimum due to the use of 4-wire switching and automatic pad-control.

**SUPERVISION** of traffic handling and of staff is centralised; the exchange can operate as a trunk switching unit of maximum efficiency.

**SUBSCRIBER TRUNK DIALLING** can readily be added to the system on a progressive basis.

*It is important to appreciate that the many features of our trunk switching system may be applied with equal effect to requirements much smaller than those described.*

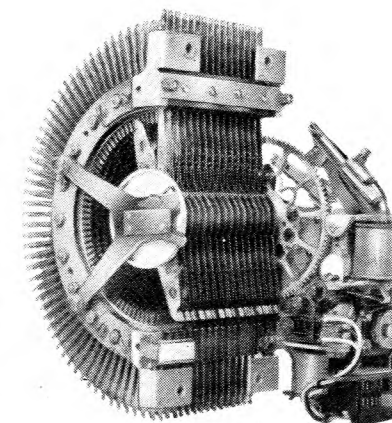

**SIEMENS BROTHERS & CO. LIMITED**

*(Member of the A.E.I. Group of Companies)*

PUBLIC TELEPHONE DIVISION: WOOLWICH, LONDON, S.E.18. Telephone: Woolwich 2020



# G.N.T.

## REPERFORATOR

MODEL 451

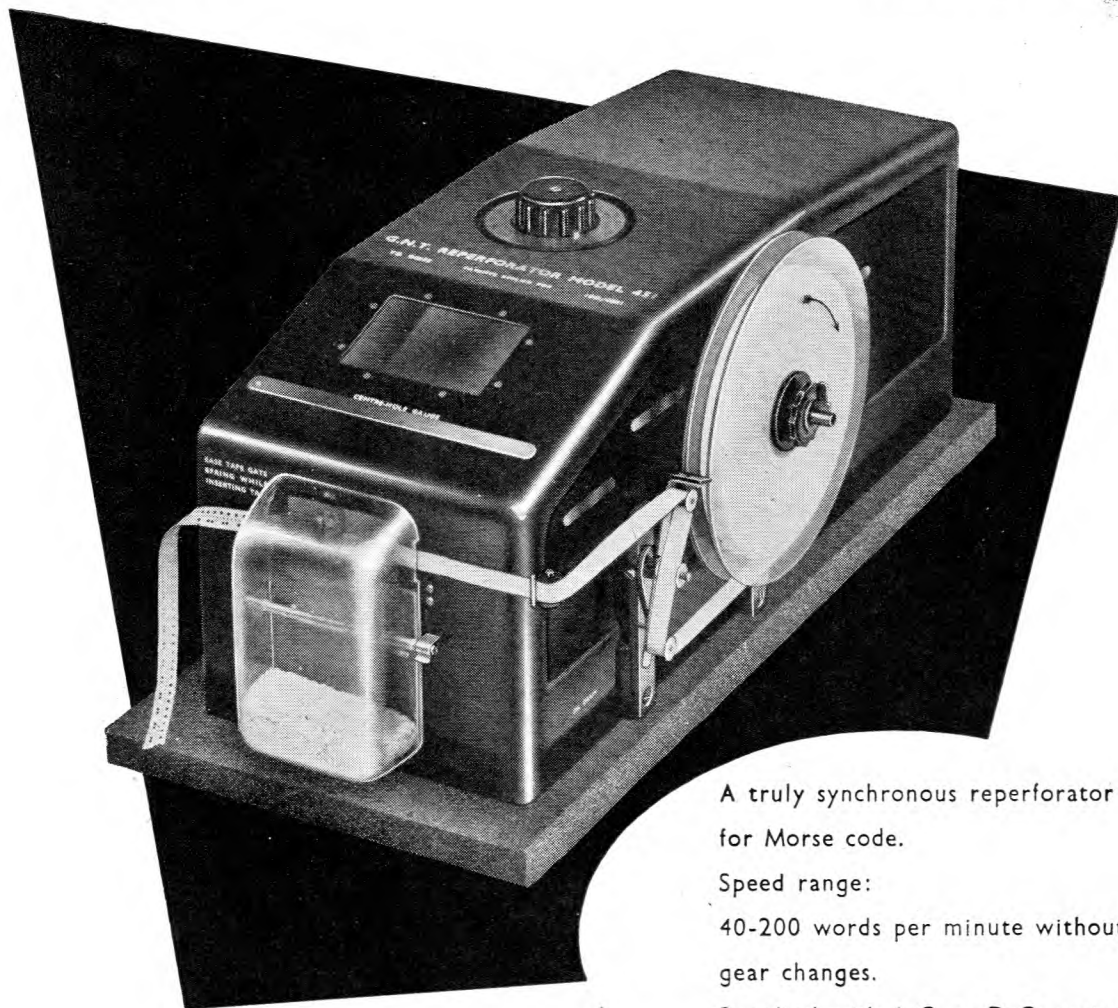

A truly synchronous reperforator for Morse code.

Speed range:

40-200 words per minute without gear changes.

Supplied with A.C. or D.C. motor as required.

*Several of these machines are working daily at 180 words per minute.*

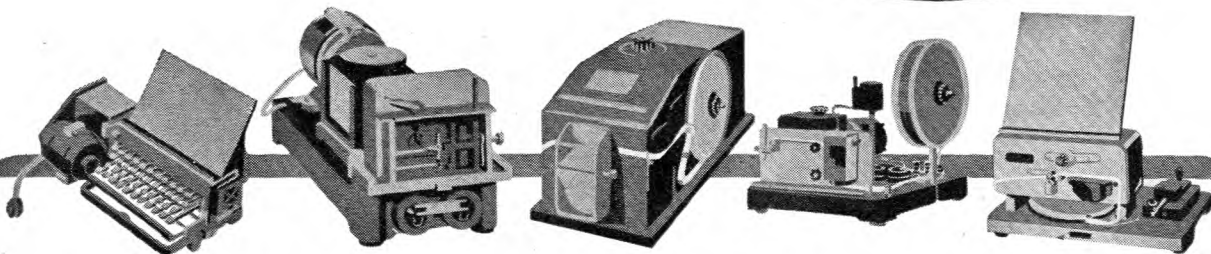

## GREAT NORTHERN TELEGRAPH WORKS

DIVISION OF THE GREAT NORTHERN TELEGRAPH CO. LTD.

4, SYDHAVNS PLADS  
COPENHAGEN SV, DENMARK

LONDON OFFICE: 5, ST. HELEN'S PLACE  
LONDON E. C. 3.

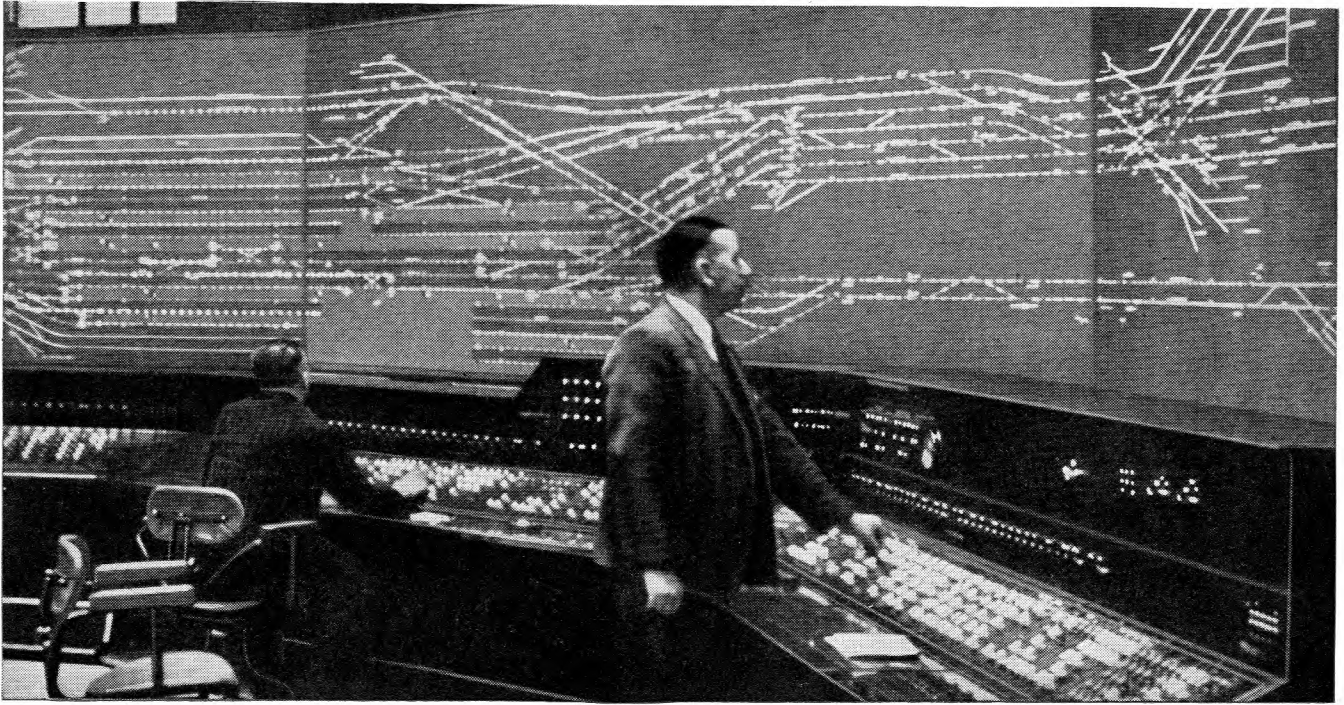

*He's looking where you're going!*

The World's largest Route Relay Interlocking System is centred in the Signal Box at York. It controls the points, signals and indicators for 825 routes. BICC designed and manufactured over 25 miles of armoured, paper-insulated, lead-sheathed Railway Signalling Cables especially for this important installation.\*

We illustrate a 47-core BICC Railway Signalling Cable, one of a range made to British Railways specification and extensively used in this country and overseas. Our research department is continuously developing new cables to meet the most exacting signalling and telecommunications requirements, whether on the railways, in the mines or in industry at large.

If you have a communication problem write to BICC about it. Our engineers will design the cable and, if you wish, install it anywhere in the World.

*\* Main contractors: Westinghouse Brake & Signal Co. Ltd.*



**BICC**

**SIGNALLING CABLES**



**BRITISH INSULATED CALLENDER'S CABLES LIMITED, 21 Bloomsbury St., London, W.C.1**



FIRST WITH LONG-HAUL MICROWAVE TV LINK EQUIPMENT IN BRITAIN



# announce further contributions to the national television network

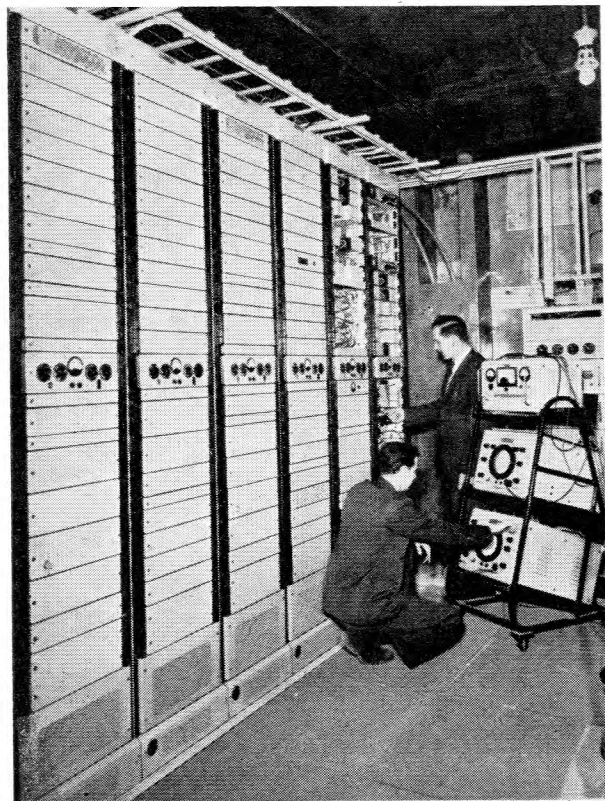

The first British microwave television link was installed some years ago by the G.E.C. between London and Birmingham, for the Post Office. Now, as the map shows, G.E.C. equipment plays a vital part in the growing network of television stations, both by radio link and on coaxial cable. Independent television necessitates separate connecting links and a duplicate network is rapidly developing. Equipment is at present being supplied to the Post Office to carry the I.T.A. programmes from London to Birmingham, Manchester and Cardiff. Translating equipment is also being supplied at Manchester, Carlisle, Glasgow, and for the Scottish independent television transmitter. G.E.C. equipment is also being supplied to extend the B.B.C. coverage with low-power relay stations such as the proposed radio link in West Wales.

Left: G.E.C. equipment undergoing final tests at Lichfield.

THE GENERAL ELECTRIC COMPANY LIMITED OF ENGLAND

## TV LINKS in the United Kingdom

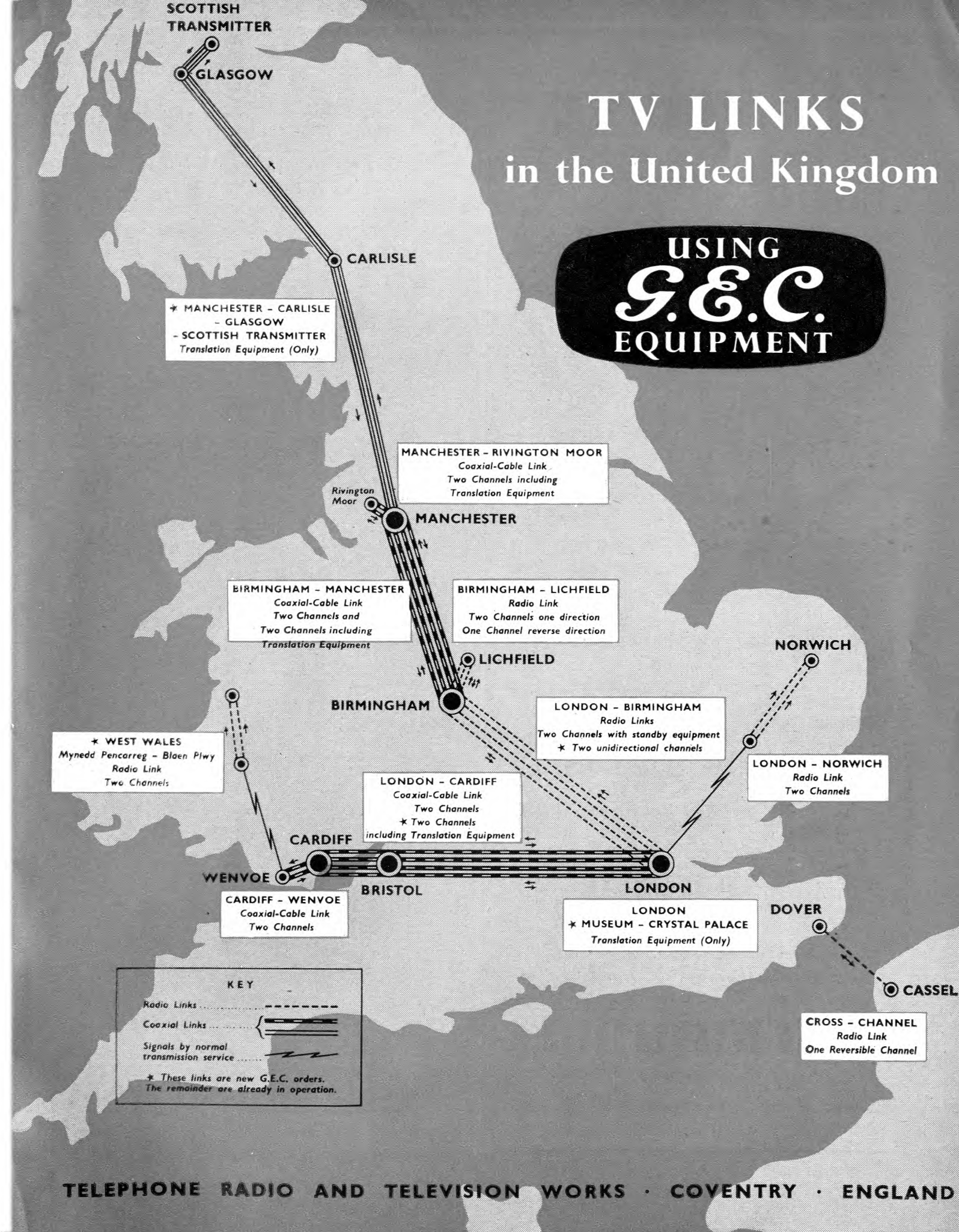

TELEPHONE RADIO AND TELEVISION WORKS · COVENTRY · ENGLAND

# Hackbridge Cables



for  
every  
purpose

Contractors to the G.P.O., National Coal Board, British Railways, C.E.A. and British and Dominion Government Departments.

**HACKBRIDGE**  
*Cable Company Limited*

KELVIN WORKS · HACKBRIDGE · SURREY

In Association with Bryce Electric Construction Company Ltd.

## ADCOLA

PRODUCTS LIMITED  
(Regd. Trade Mark)

FOR

**SOLDERING INSTRUMENTS  
and EQUIPMENT**

SUPPLIED FOR ALL VOLTAGES

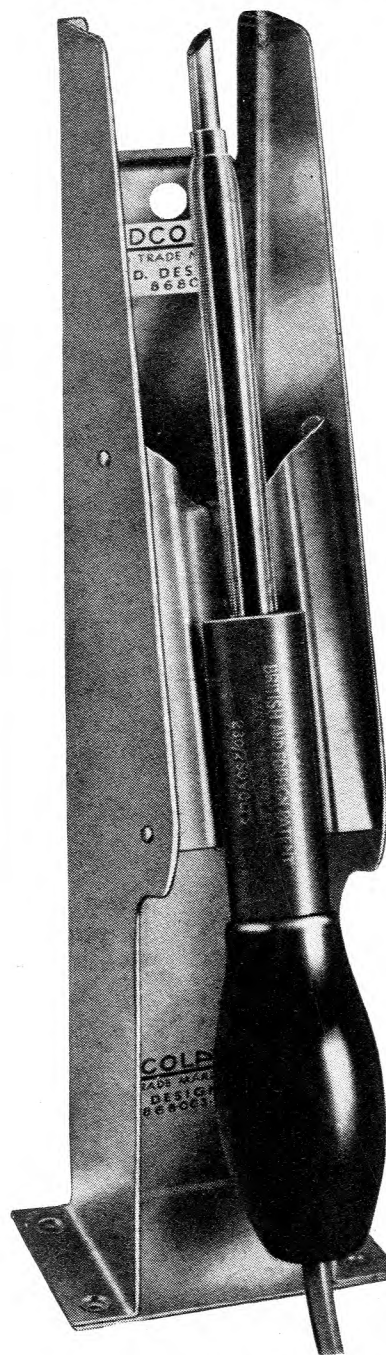

*illustrated*

**DETACHABLE  
BIT**

**MODEL  $\frac{3}{16}$ "**

List 64

**PROTECTIVE  
SHIELD**

List 68

.....Write for Catalogues.....

HEAD OFFICE, SERVICE AND SALES

**ADCOLA PRODUCTS LTD.**  
GAUDEN ROAD, CLAPHAM HIGH STREET, LONDON, S.W.4  
Phone: MACaulay 3101, 4272



**DENSO**

Industry's protection  
against CORROSION

Full information from

**WINN & COALES LTD.**

DENSO HOUSE · CHAPEL ROAD · LONDON, S.E.27

Telephone:  
GIPsy Hill 4247  
(3 lines)



Telegrams:  
Denselte, Westnor,  
London.

for the  
right  
connection

**ANACOS**  
REGD.

telephone  
line  
wire

**FREDERICK SMITH & COMPANY**  
ANACONDA WORKS, SALFORD, 3, LANCS.  
*Incorporated in The London Electric Wire Company and Smiths Limited.  
Associated with The Liverpool Electric Cable Co. Ltd. and Vactite Wire Co. Ltd.*



The

**DETECTOR No. 4 Mk. 10**

—a TURNER instrument produced for Post Office engineers and combining a high level of sensitivity with accuracy and robust design for work in the field.

**ERNEST TURNER ELECTRICAL INSTRUMENTS LTD.**

**HIGH WYCOMBE      BUCKS      ENGLAND**

Telephone: HIGH WYCOMBE 1301-2-3

Telegrams: GORGEOUS, HIGH WYCOMBE

# TELEPHONE DISTRIBUTION

## EQUIPMENT

ENGINEERS WHO ARE INTERESTED  
IN TELEPHONE DISTRIBUTION EQUIP-  
MENT ARE INVITED TO REQUEST  
SECTION T.C.13 OF OUR TELECOM-  
MUNICATION CABLES CATALOGUE.

TELEPHONE:  
SOUTHAMPTON  
22141 (5 lines).

**FIRELLI & GENERAL**  
CABLE WORKS, Ltd., SOUTHAMPTON

TELEGRAMS  
"PIGEKAYBEL"  
SOUTHAMPTON"

# FERRANTI

## Switchboard Instruments

Illustrated here are several Ferranti Switchboard Instruments from a wide range. Shallow pressed steel cases 3½", 3¾", 4", 6" and 8" round or square dial. Projecting or flush mounting. All types of Ferranti switchboard instruments are also available in hermetically sealed cases.

List IN30 and other catalogues supplied on request.

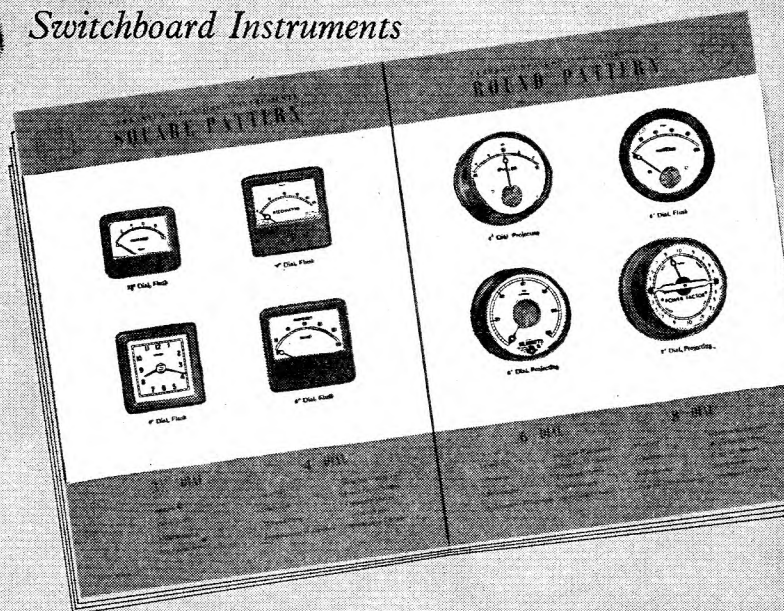

FERRANTI LTD · MOSTON · MANCHESTER 10  
Head Office and Works: HOLLINWOOD, LANCs. London Office: KERN HOUSE, 36 KINGSWAY, W.C.2

F1149