

# THE POST OFFICE ELECTRICAL ENGINEERS' JOURNAL

Vol. 50

APRIL 1957

Part 1

## CONTENTS

|   | PAGE   |
|---|--------|
| "ERNIE"—THE ELECTRONIC RANDOM NUMBER INDICATING EQUIPMENT FOR THE PREMIUM SAVINGS BONDS PRIZE DRAWS—R. K. Hayward, B.Sc.(Eng.), A.M.I.E.E., and E. L. Bubb, B.Sc.(Eng.), A.M.I.E.E. . . . . | 1      |
| A NEW DEEP-SEA COAXIAL CABLE—R. A. Brockbank, Ph.D., B.Sc.(Eng.), A.M.I.E.E., and A. L. Meyers, B.Sc.(Eng.), M.I.E.E. . . . .   | 7      |
| DEEP-SEA TRIALS WITH LIGHT-WEIGHT CABLE . . . . .   | 9      |
| OPERATIONAL RESEARCH IN THE POST OFFICE, Part 1—Sampling by Random Numbers—H. J. Josephs, M.I.E.E., and R. A. Hastie, M.A. . . . .  | 10     |
| THE RUGBY "B" HIGH-FREQUENCY TRANSMITTING STATION—A. Cook, B.Sc.(Eng.), M.I.E.E., and L. L. Hall . . . . .  | 15     |
| A NEW 4-Mc/s COAXIAL LINE EQUIPMENT—C.E.L. No. 6A—M. E. Collier, B.Sc.(Eng.), A.M.I.E.E., and W. G. Simpson, B.Sc., A.M.I.E.E. . . . .  | 24     |
| LOADING IN CABLE JOINTS—S. Rata, E.R.D., B.Sc.(Eng.), A.M.I.E.E. . . . .  | 35     |
| INTRODUCTION OF INCREASED TRANSMISSION AND SIGNALLING LIMITS IN THE DESIGN OF LOCAL LINE NETWORKS—G. A. E. Fudge, A.M.I.E.E., and C. B. Miller . . . . .                                    | 38     |
| AN ELECTRONIC ERROR-CORRECTING MULTIPLEX TELEGRAPH SYSTEM . . . . .   | 44     |
| EIGHTH, AND LAST, PLENARY ASSEMBLY OF THE C.C.I.T., GENEVA, 1956 . . . . .  | 45     |
| THE XVIIIITH, AND FINAL, PLENARY ASSEMBLY OF THE C.C.I.F., GENEVA, DECEMBER, 1956 . . . . .   | 46     |
| THE FIRST PLENARY ASSEMBLY OF THE C.C.I.T.T. . . . .  | 49     |
| ASSOCIATE SECTION NOTES . . . . .   | 51     |
| NOTES AND COMMENTS . . . . .  | 53     |
| INSTITUTION OF POST OFFICE ELECTRICAL ENGINEERS . . . . .   | 56     |
| REGIONAL NOTES . . . . .  | 57     |
| STAFF CHANGES . . . . .   | 64     |
| BOOK REVIEWS . . . . .  | 43, 63 |

Price 2/6 net

THE INSTITUTION OF POST OFFICE ELECTRICAL ENGINEERS



# Valves

FOR **Communication**  
AND **Industry**

*the finest insurance  
against valve  
replacement costs*

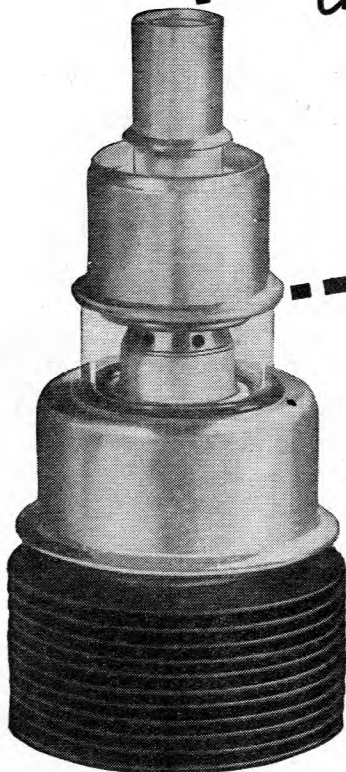

*SV-2C39A Forced air-cooled UHF Triode*

**RECTIFIERS & THYRATRONS**

**TRIODES, TETRODES & PENTODES**  
from 15mW to 150 kW anode dissipation for all  
frequencies from AF to SHF

**GAS-FILLED STABILISERS AND TRIGGER TUBES**

**TRAVELLING WAVE TUBES**

**PULSE MODULATORS**

**VELOCITY MODULATED OSCILLATORS**

**VACUUM CAPACITORS**

**TRANSISTORS**

*Brochure and Technical Data available from:*



**Standard Telephones and Cables Limited**

CONNAUGHT HOUSE

63 ALDWYCH

LONDON W.C.2.





*Unique in its field*

# **Redifon R.151** RECEIVER

**FOR PERFORMANCE — FOR VALUE**

Radio teleprinter, teletype and telegraph receiver terminal. Dual space diversity. Six crystal controlled pre-tuned frequencies within the range of 2 to 27.5 M/cs. High stability for unattended operation on point to point links. A first class receiver, very reasonably priced.



**HIGH STABILITY  
CRYSTAL CONTROLLED  
FREQUENCIES**

Radio Communications Division

**REDIFON LIMITED, BROOMHILL ROAD, LONDON, S. W. 18. VANDYKE 7281**

*A Manufacturing Company in the Rediffusion Group*

## VALUABLE FREE BOOK

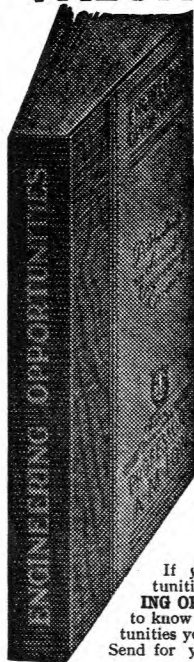

**Tells You How to Pass Your C. & G. or Promotion Exam. at First Attempt!**

All Post Office Engineering personnel who are anxious to obtain early promotion should at once send for a copy of our handbook "ENGINEERING OPPORTUNITIES," which among other intensely interesting matter describes our unique methods of preparation for **TECHNICAL APPOINTMENTS IN THE POST OFFICE** (Assistant Engineer—New Style and Assistant Traffic Superintendent), **CITY AND GUILDS EXAMINATIONS** in Principles of Telecommunications (1-5), Radio (1-4), Telephone Exchange Systems (1-3), Telegraphy (1), Line Transmission (1 and 2), Lines Plant Practice (1 and 2), Mathematics for Telecommunications (1-5), Electrical Engineering Practice (Prelim. Inter. and Final), and outlines a wide range of non-examination courses in all branches of Electrical, Mechanical, Civil, Automobile, Aeronautical and Radio Engineering.

**Assistant Engineer and Assistant Traffic Superintendent. Open competitions now resumed. Age extensions for established Civil Servants. Ask us for full details**

**We definitely guarantee  
"NO PASS—NO FEE"**

If you intend to make the most of today's opportunities, you cannot afford to miss reading "ENGINEERING OPPORTUNITIES." It tells you everything you want to know to secure advancement, and describes many opportunities you may now be missing through lack of information. Send for your copy to-day—**FREE** and without obligation.

**BRITISH INSTITUTE  
OF ENGINEERING TECHNOLOGY  
369 COLLEGE HOUSE,  
29-31 WRIGHT'S LANE, LONDON, W.8**

# BIET

## PASS YOUR CITY & GUILDS CERTIFICATES AND P.M.G. CERTIFICATE

We offer comprehensive home training in a wide range of subjects, including P.M.G. Certificates, City and Guilds Grouped Certificates in Telecommunications, A.M.Brit.I.R.E. Examination, Radio Amateur's Licence, Radio and Television Servicing Certificates, General Radio and Television Courses, Radar, Sound Recording, etc. Also Courses in all other branches of Engineering.

With the following Courses, Practical Kits are available.

**Radio, Television, Mechanics, Electricity, Chemistry, Photography, Carpentry; also Draughtsmanship, Commercial Art, Amateur S.W. Radio, Languages, etc.**

Write now

for **FREE BROCHURE** stating subjects of interest to:

## E.M.I. INSTITUTES

Dept. 97, GROVE PARK ROAD, LONDON, W.4  
An Educational Organization serving the E.M.I. Group of Companies, including  
"HIS MASTER'S VOICE"; MARCONIPHONE, COLUMBIA, etc.

# THE POST OFFICE ELECTRICAL ENGINEERS' JOURNAL

Vol. 50

April 1957

Part 1

## "ERNIE"—the Electronic Random Number Indicating Equipment for the Premium Savings Bonds Prize Draws

R. K. HAYWARD, B.Sc.(Eng.), A.M.I.E.E.,  
and E. L. BUBB, B.Sc.(Eng.), A.M.I.E.E.†

U.D.C. 621.373.43:621.374.3:681.176

The Premium Savings Bonds scheme involves a monthly ballot to select tens of thousands of prize-winning numbers from hundreds of millions of eligible bond certificate numbers. This article describes the principles of operation of an electronic equipment, designed and built by the Post Office, for generating a sequence of random numbers within the range of numbers of eligible bond certificates. The equipment involves the first large-scale use by the Post Office of transistors, rectangular-hysteresis-loop ferrites and printed circuit techniques, and the article gives details of some of the circuits employing these components.

### INTRODUCTION

PREMIUM Savings Bonds are issued in 23 denominations, from £1 to £500. Each bond certificate is numbered serially. Those for £1 have a single serial number; multiple denomination bonds carry a range of serial numbers corresponding to their face value in pounds. In each of the 23 denominations there are at present 100 million numbers—2,300 million in all—from which selections must be made at random to ensure that each bond has an equal chance of winning a prize. At the start of the scheme only a fraction of those ultimately available have been sold and initially the numbering range has been restricted to 30 million numbers in each denomination, i.e. 690 million in all. In subsequent months, as more bonds are sold, adjustments must be made to the range of numbers generated. When more than 30 million numbers are sold in any one denomination, adjustment must be made to 40 million numbers in that denomination and so on. In the first draw, in June, 1957, only those bonds sold in November, 1956, will be taken into account and these cover some 50 million numbers. Each bond has a 6-digit number preceded by a code. The code consists of a prefix numeral to indicate the tens of millions digit, a denomination indicator (one of 23 letters) to declare the bond value, and an alphabetical millions index to signify the unit millions. Thus 2 AZ 123456 is Bond No. 20,123,456 of value A (£1).

### BASIS OF DESIGN

The usual practice for a draw is to have a store of the available numbers and then to make a selection from them at the draw and then discard them. The Premium Savings Bond scheme differs from the usual pattern by having multiple unit certificates as well as units, all of which have to be put into a draw every month irrespective of whether they have been drawn in previous months, and, moreover, the bonds can be encashed and withdrawn in whole or in part at any time. It is not considered a practicable proposition to do this manually nor to write and store some 50 million numbers, each consisting of nine digits, in a machine with the requisite accuracy, bearing in mind the constant alterations attendant upon withdrawals and fresh purchases.

† The authors are, respectively, Senior Executive Engineer and Executive Engineer, Post Office Research Station.

The method chosen is to generate from random number sources the numbers of the prizewinning bonds, which for the first draw amount to some 23,000 numbers each consisting of nine digits. Furthermore, if these numbers are generated successively, then all the problems associated with long-term storage of large numbers are avoided and a much simpler and more reliable machine can be made.

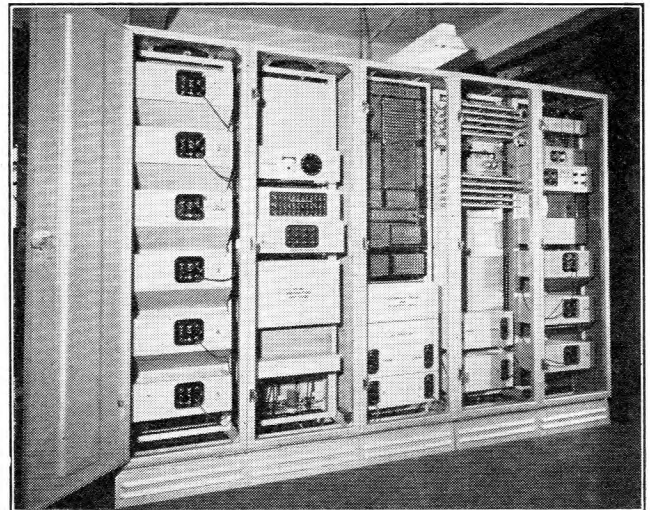

The redundancy table is in the centre cabinet.

FIG. 1.—REAR VIEW OF ERNIE, WITH DOORS REMOVED.

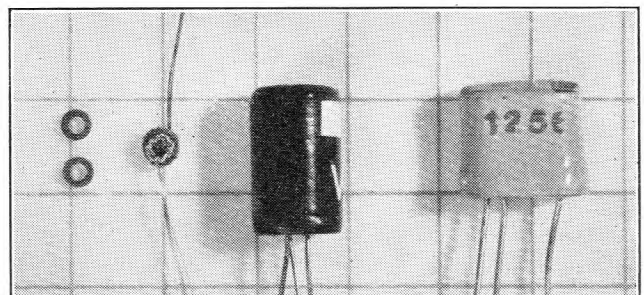

The squares represent 0.25 in.

FIG. 2.—VIEW OF A PAIR OF FERRITE CORES, A WOUND PAIR OF CORES, AND TWO TRANSISTORS.



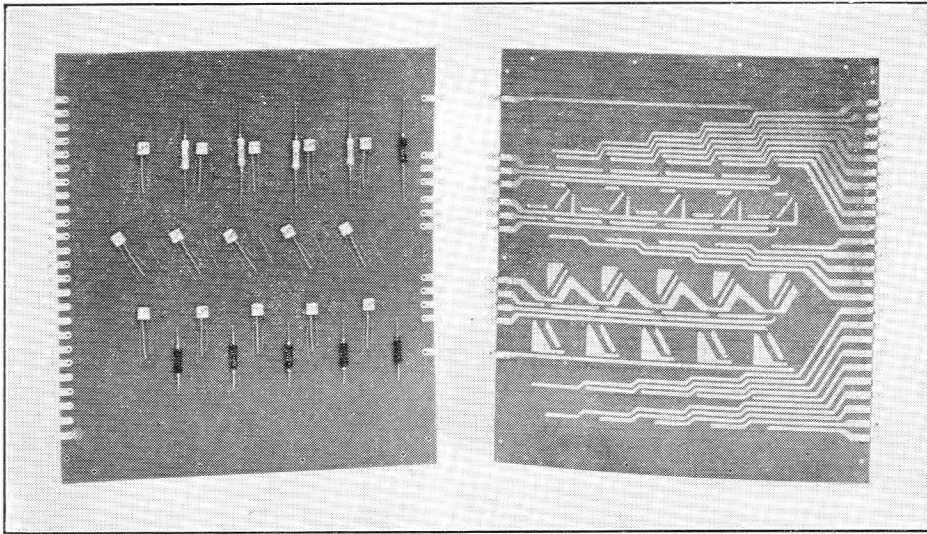

FIG. 3.—FRONT AND REAR VIEWS OF A COMPLETED PRINTED-CIRCUIT ASSEMBLY.

The machine that generates these numbers (Fig. 1) is called the Electronic Random Number Indicator Equipment, or ERNIE, and is of interest as being the first large-scale application by the Post Office of printed circuits, rectangular-loop ferrites and transistors to switching circuits. Fig. 2 shows transistors and ferrite cores, and Fig. 3 shows them mounted on a printed circuit. Owing to the limited time available some sections of the machine were built of conventional electronic design and will not be described in this article.

#### Draw Procedure.

Photo-copies of the bond certificates are filed in numerical order by denominations, and because of the large numbers involved the files occupy a considerable floor area in a number of rooms. Associated with each group of files is a pair of teleprinters to which are sent messages appropriate to the denomination of the bonds. The pair of teleprinters, one of which is a page and the other a tape machine, receive the same message, the two records being essential for the subsequent searching operations.

ERNIE is controlled by an officer of the Savings Department seated at a control desk or console. Although the machine is switched on some time before the commencement of a draw, the draw is started by the operation of a key on the console, whereupon printing of potential winning numbers commences. At the same time a draw-serial-number generator is started. Each printed message consists of the bond number followed by a draw serial number. These messages are printed as a master copy on teleprinters on the console as well as on appropriate pairs of teleprinters distributed among the files. A manual search is then made in the files for photo-copies of the bonds bearing the numbers generated. The photo-copies are extracted and assembled centrally for confirmation of eligibility and subsequent processes. These aspects of the draw and other subsidiary checks, e.g. the processes that ensure that a multiple bond is allotted more than one prize only on the appearance of different random numbers within its bonds number range, are outside the scope of this article. ERNIE continues to issue numbers automatically until it is stopped. Deliberate stopping takes place several times during a draw in order to allow changing of the paper on the teleprinters.

#### Generation of Random Numbers.

The generation of random numbers follows the method

described in an earlier issue of the Journal for an electronic traffic analyser,<sup>1</sup> because this has proved very reliable during several years of service. One of the noise generators is shown in Fig. 4. The noise developed in a neon tube when it is passing current is amplified, and noise peaks above a pre-set level are arranged to operate a pulse trigger, which generates pulses of fixed amplitude and width and with a minimum time separation. In turn, these pulses drive a single-stage binary counter, which generates pulses of a type suitable for operating a counter with an interlaced pulse drive. The counter is thus driven by pulses randomly spaced in time. The counters are of a scale appropriate to the number or letter to be subsequently printed. The first digit is required in a scale of three because 30 million numbers are being generated, the second digit in a scale of 23, one for each denomination, and the other digits in a scale of 10.

Because counters with an interlaced drive must be of an even scale, the first counter is in a scale of six which is later converted to a scale of three. The second counter is in a scale of 24 of which one digit is unused, leaving 23 for the 23 different denominations of bonds. The other counters are in a scale of 10.

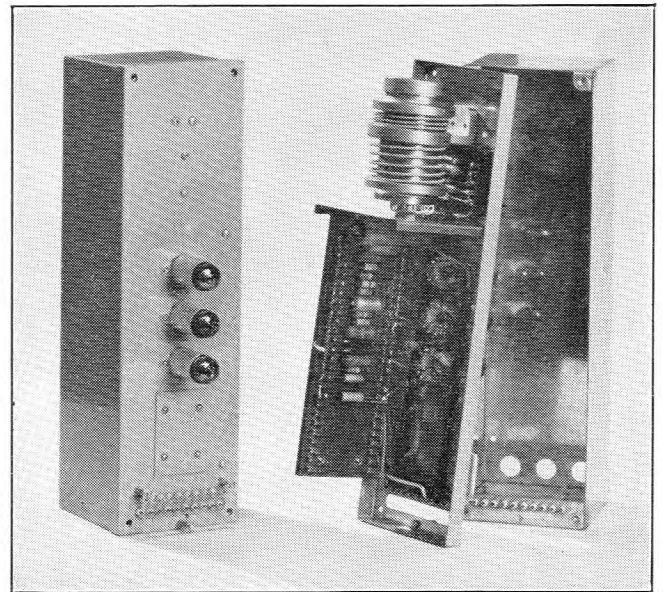

The neon tube in its anti-vibration mounting is seen at the top, with the noise amplifier below.

FIG. 4.—A NOISE GENERATOR AND ITS SCREENING BOX.

Six times a second the noise generators are stopped and the counters are read. With a mean rate of pulse generation of 3,000 pulses/sec the counter in the scale of 24 will have made about 20 revolutions between stops, and the smaller ones many more revolutions. This number is sufficient to ensure that the numbers read from the counters are random.

Such an arrangement as described above is not, by itself, felt to be sufficiently reliable for the purpose because of the possibility that a fault might cause a noise generator to have a cyclic component in its output. This possibility

<sup>1</sup> BROADHURST, S. W., and HARMSTON, A. T. An Electronic Traffic Analyser. *P.O.E.E.J.*, Vol. 42, p. 181. Jan. 1950.

is made more remote by combining the outputs of two counters for each digit, each counter being driven from a different noise generator. The combination is achieved by subtracting one number from the other with the addition of a constant number. The addition arises from the method of subtraction and has no bearing on the randomness of the resulting number. In this way, if either of the noise generators used to produce a digit should have a cyclic component, the resulting number is still random. The new number is in the same scale as the counters from which it originated and is recorded in a temporary store.

It can be seen from the block schematic diagram, Fig. 5, that noise generators can be shared in such a way that two different ones are used for each digit, and that the total number is only one greater than the number of digits.

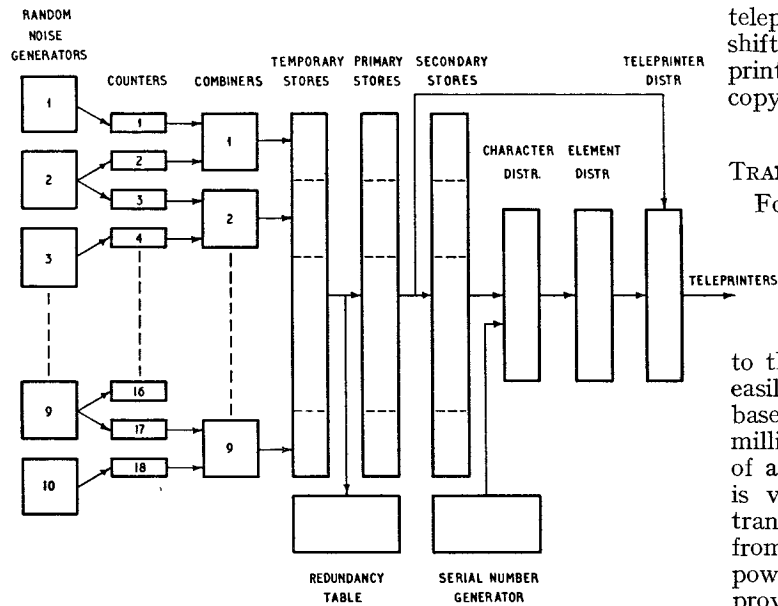

FIG. 5.—BLOCK SCHEMATIC DIAGRAM OF ERNIE.

#### Checking The Number.

The number in the temporary store is read out into a primary store and at the same time into a "redundancy table," described later. Varying quantities of bonds will have been sold in each denomination, but all numbers up to 30 million are generated. The purpose of the redundancy table is to eliminate, as far as possible, the serial numbers of bonds that have not yet been sold and thus avoid unnecessary printing of numbers that would later have to be eliminated by manual processes. Of the 720 million possible numbers presented to it the redundancy table will reject all except 120 million. It is impracticable to discriminate down to the actual 50 million numbers eligible for the first draw, owing to the breaks in the numbering range due to unsold bonds in Post Offices and banks, and it is not worth while to deal with unbroken ranges of less than 100,000 numbers.

The redundancy table is designed in such a way that it fails safe; that is to say that a fault is likely to cause the acceptance of an ineligible number rather than the rejection of a valid number. Adjustment to the table will be made monthly to take account of the new batch of numbers that becomes eligible every month for the draw.

#### Storage of Numbers.

A number rejected by the redundancy table is erased from the primary store, and the next number issued from the counter-combiner is then examined by the redundancy table. When a printable number has been found it remains

in the primary store awaiting printing, which will take place from a secondary store. On completion of the printing of the previous message, the new number is transferred to the secondary store and printing commences. At the same time a search is restarted for a fresh number. If, however, no printable number has been found the printer waits, but this occurs on the average only about once in 25 times.

#### Printing Operation.

On transfer to the secondary store an examination is made of the digit relating to the denomination of the bond, and the pair of teleprinters appropriate to that denomination are switched to receive the message. The message, which consists of the bond number followed by the serial number, is read off character-by-character, converted into teleprinter code and, with suitable spacing, figure and letter shift, and line-feed signals, sent out to the two selected teleprinters. In addition all messages are printed on a master copy at the console.

#### TRANSISTORS AND RECTANGULAR-LOOP MAGNETIC CORES

For switching purposes a transistor can be considered to be a component with the property of having high resistance between emitter and collector when the base is positive with respect to the emitter, and of resembling a battery of about  $\frac{1}{2}V$  between emitter and collector when the base is negative with respect to the emitter. In the latter condition the transistor can easily conduct 50 mA; the current to be drawn from the base to establish such a collector current is only a few milliamps, and the voltage drive on the base a matter of a volt or two. Thus the power to drive the transistor is very small and the power dissipation within the transistor is also small. The transient conditions in changing from one state to the other give rise to an additional power dissipation within the transistor, but this is small provided that the change-over takes place quickly enough.

When the flux in a magnetic core is reversed from one magnetic state of saturation to the other a voltage is induced in any winding on the core during the change-over period. The product of this voltage and its duration is a constant depending wholly on the core (material and size) and the number of turns in the winding. From a core consisting of two commercially available 2-mm diameter rings of rectangular-hysteresis-loop ferrite a pulse of approximately  $8 \mu s-V$  is obtained in a 50-turn winding, and such a pulse applied to the base of a transistor is sufficient to switch the transistor to the high-conduction "on" condition for several microseconds. The resulting current in the emitter-collector circuit may then be used to reverse the magnetization of other cores or perform various other functions.

A core of magnetic material having a high retentivity may be used as an information store by regarding the flux retained after saturation in one direction ("set") as a stored 1 and that retained after saturation in the other direction ("reset") as a stored 0. In either condition no power is needed to maintain the information. To read out the stored information a pulse is applied to a winding on the core in such a direction as to drive the core to the reset condition. If the core is in the set condition (1 stored) the flux is reversed and an output pulse is obtained as described above, while if the core is already in the reset condition (0 stored) the flux change and consequently the output pulse is very small.

In the circuits to be described, combinations of a core and transistor are used as circuit elements, with the core acting as an information store and the transistor as a coupling element when the information is to be transferred



elsewhere.<sup>2</sup> In the intervals between transfer operations no power need be supplied to the circuits because the cores are storing the information magnetically and the transistors are doing no work. In practice small leakage currents of a few microamps per transistor are flowing. In contrast with the Eccles-Jordan type of transistor circuit these leakage currents cause no design problem because the current introduced in the windings of associated cores is very much less than that needed for switching.

The way in which these components are used can be understood by considering a counter such as is employed following the random-noise generators and the binary drive circuit.

### COUNTERS AND COMBINERS

The use of cores of rectangular-hysteresis-loop material is becoming increasingly common but no suitable conventional symbols for circuit diagrams have yet been agreed. The conventions used in Fig. 6 are described below.

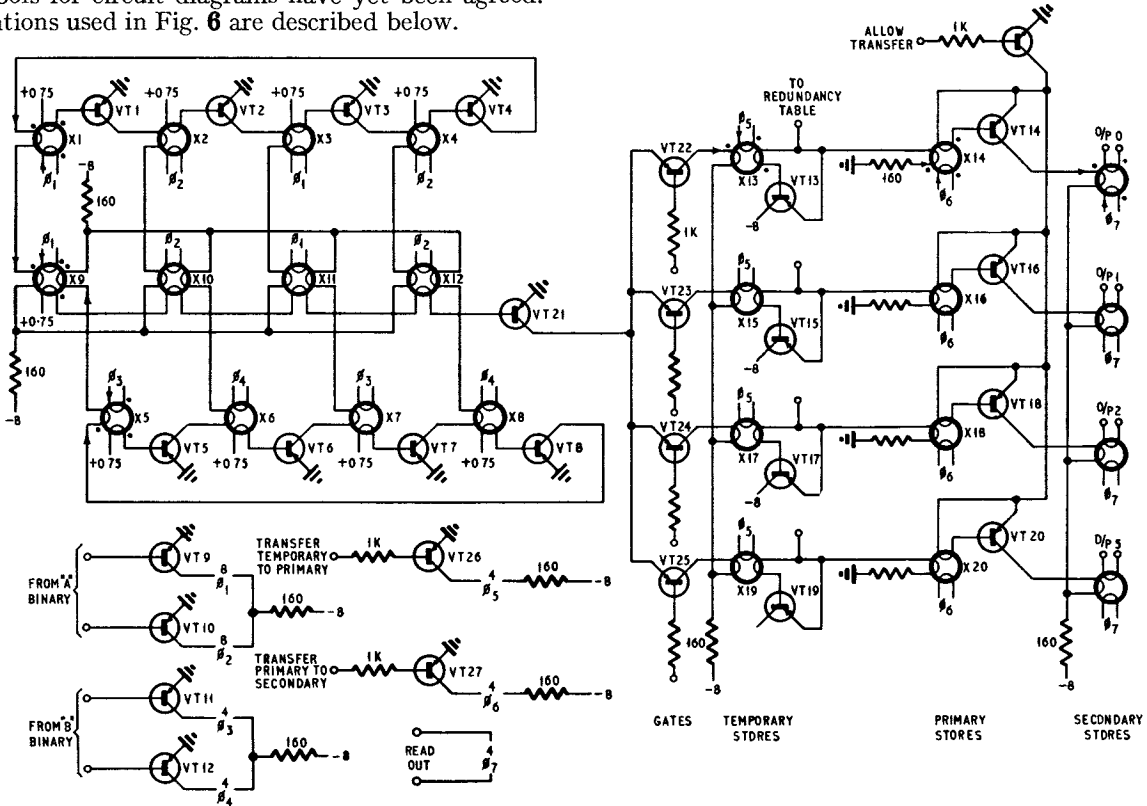

Notes. 1. Windings connected to transistor bases are 50 turns; all others are 25 turns. 2. All cores are double 2-mm Ferroxcube.

FIG. 6.—SCHEMATIC DIAGRAM OF THE COUNTERS, COMBINERS, GATES AND STORES.

The core is represented by a circle and each winding by a single loop crossing the core. The direction of each winding is indicated by a dot adjacent to one end of the winding and indicating that end of the winding by which current must enter in order to drive the core to the "set" condition. Current leaving the winding at the marked end will "reset" the core, i.e. magnetize it in the opposite direction. An arrow on the wire adjacent to the winding indicates the direction of current passed through the winding from the previous component. Where a number of windings are connected in series each carries a symbol, e.g.  $\emptyset 1$ , and in the circuit driving the chain the number of series windings is written above the symbol.

The cores X1, X2, X3 and X4 shown in Fig. 6, together

with the associated transistors, form a 4-way counter. Current pulses from the A binary appear alternately on two leads. The lead marked  $\emptyset 1$  is connected to resetting windings on alternate cores X1 and X3, and the lead marked  $\emptyset 2$  is connected to resetting windings on the other two cores. Suppose that X1 is set and that the remaining cores are in the opposite saturation condition, i.e. reset. Should a  $\emptyset 2$  pulse be the first to arrive it will have no effect on the counter because it tends to reset cores which are already reset and, since no change of flux takes place, no voltages appear on any of the windings on the even-numbered cores. The following  $\emptyset 1$  pulse has the same effect on X3 but causes X1 to be reset and voltages to appear on all its windings. The voltage on the coil connected to the collector of VT4 cannot cause current to flow because this transistor is held non-conducting by virtue of the bias

between its base and emitter. The voltage on the coil connected to the base of VT1 causes the transistor to conduct, thereby permitting current to flow between emitter and collector, and thence through a winding on X2 in such a direction as to set it. Because X2 changes its magnetic state, voltages are induced in the other windings. The voltage on the  $\emptyset 2$  drive winding cannot cause current to flow because the transistor used for the drive is non-conducting. The voltage induced on the base of transistor VT2 is in such a direction as to drive the base positive with respect to the emitter. Very little current can flow in the high impedance between base and emitter with this polarity, and the transistor is driven even more non-conducting between emitter and collector than it is normally.

The final result of the  $\emptyset 1$  pulse is that the set condition originally stored on X1 has been transferred to X2, and core X1 has been reset. Subsequent  $\emptyset 2$  and  $\emptyset 1$  pulses repeat the action and advance the set condition one position for each pulse. In contrast with the magnetic-

<sup>2</sup> These circuits were first described by G. H. PERRY, G. R. HOFFMAN and E. W. SHALLOW in a paper entitled "A New and Simple Type of Digital Circuit Technique using Junction Transistors and Magnetic Cores," read at The I.E.E. Convention on Digital Computer Techniques in 1956.

core counters described in a previous article in the *Journal*,<sup>3</sup> current flows only where it is performing a useful function, and a highly efficient drive circuit results from this.

The B counter (cores X5, X6, X7 and X8) works in an identical manner. The remaining cores (X9, X10, X11 and X12) form a combiner circuit and are used to obtain the difference between the numbers stored in the two counters during the period when the noise generators are blanked off.

The circuit that sets a core in the A counter is extended to a setting winding on a corresponding core in the combiner. The reset windings on the combiner cores are connected in a similar manner to the corresponding cores in the A counter. In this way the setting of a core in the A counter is always accompanied by the setting of the corresponding core in the combiner.

The circuit that feeds a setting winding on a core in the B counter is extended to a resetting winding on the corresponding core in the combiner.

When the generated numbers are to be read (i.e. every 160 ms) the noise generators are blanked off and a single pulse is fed from the master control to the circuits driving the A counters, followed by a train of pulses to the circuits driving the B counters. The single pulse gives a transfer of the A counters and so ensures that one of the combiner cores is in the set condition; without it, all combiner cores could be in the reset condition due to the B counter overtaking the A counter and resetting the corresponding combiner core immediately prior to the blanking of the noise generators.

The train of pulses to the B counter causes this to step through each position in turn. As one of the transfers takes place the marked combiner core will be reset and a pulse will be applied through the series-connected windings to the base of transistor VT21. The number of pulses required to drive the B counter to this position is equal to the difference between the starting positions of the A and B counters (plus one, due to the single pulse to the A counter).

In synchronism with the pulses of the B counter train a sequence of gating transistors VT22 to VT25 is brought by negative base pulses to a state permitting conduction. When the B counter resets the marked combiner core the pulse from the common output transistor will be passed by one of these gating transistors to a setting winding on the corresponding temporary-store core, thus recording in the store one plus the difference between the original A and B counts.

If each gating transistor is operated by two of the pulses a counter operating in a scale of six will store in a scale of three.

After the last pulse of the B counter train all temporary-store cores are reset by a pulse from the master control via transistor VT26. The marked core gives an output to the base of its associated coupling transistor which then sets the corresponding core in the primary store. This transfer occurs simultaneously in all nine sets of cores corresponding to the nine digits of the bond number and as it does so the numbers stored in the first four digits are examined by the redundancy table to detect numbers unsuitable for printing.

Subsequently the stored numbers are rejected if redundant, or passed to the secondary store if suitable for printing.

#### THE REDUNDANCY TABLE

Redundancy of bond numbers is determined to the next complete multiple of 100,000 greater than the highest number sold for a bond denomination. To do this the first

four digits including the denomination digit are examined. Because the bond numbers are issued substantially in sequence, it is not necessary to bring out a separate point for every one of the 6,900 possible combinations of the first four digits. The principle adopted is to examine the digits of a bond denomination in sequence. For each digit a value exists above which all numbers are redundant and below which all numbers are acceptable. To determine the redundancy to a closer limit the following digit must be examined in the same way.

For example, suppose the highest numbered bond sold for a particular denomination is 5,470,976. The first operation is to compare the bond denomination with the first digit, which in this case is "0" (the first digit "0" is generally omitted from the number printed on the bond certificate). For this denomination the table is wired so that "1" and "2" are redundant, and "0" is carried to the next section. Thus number groups 10 and 20 million are made redundant by this operation, and action is deferred on the first 10 million numbers. The second section then compares the first digit "0" with the third digit, i.e. 5 in this example. The wiring is such that the coincidence of "0" with a third digit 6, 7, 8 or 9 gives redundancy, thus disposing of all numbers 6,000,000 to 9,999,999. A third digit 1, 2, 3 or 4 is acceptable, but action is deferred on a third digit 5. The third section of the table then compares 05 with the fourth digit. A fourth digit 5, 6, 7, 8 or 9 gives redundancy but all below 5 are acceptable. The third section is simpler than the previous two because the result is given as a definite redundancy or acceptability. There are only nine possible combinations of redundant groups, i.e. 9 only; 8 and 9; 7, 8 and 9, and so on up to 1-9. This allows commoning of outputs of the second table having the same terminal redundancy. For the example quoted, with the highest number sold being 5,470,976 the table makes redundant all numbers greater than 5,499,999.

The input signals originate from the transistors reading out from the temporary store shown in Fig. 6. Because the emitter current is substantially the same as the collector current, and the input to the transistor has no d.c. bias condition, the output load can be placed in either the emitter or collector leads, giving for the former a negative-going signal and for the latter a positive-going signal. The first section uses signals from the denomination digit (one of 23) and from the "tens of millions" digit (one of three). These signals are applied to the co-ordinates of a matrix formed of transistors (see Fig. 7, which shows parts of the matrices; ERNIE is equipped with matrices  $3 \times 23$ ,  $10 \times 23$  and  $9 \times 9$  triangular). A positive signal corresponding to a bond denomination is applied to the emitters of all transistors in a row; a negative signal corresponding to the "tens of millions" digit is applied to the bases of all transistors in a column. In a marked row the emitters will be at a potential of approximately  $-0.2V$  and in all other rows the emitters will be at about  $-8V$ . In a marked column the bases of the transistors will be at a potential substantially negative and in both of the other columns at about earth potential. There is only one cross-point at which a transistor has its emitter positive with respect to its base. This transistor conducts, its collector potential being raised to very nearly earth potential. The collector is connected to either a row of emitters in a second matrix or to a load resistor and thence to a common transistor which indicates redundancy.

The capacitor in the base circuit and the inductor in the collector circuit improve the shape of the output pulse. The sum of the leakage currents of transistors in a column causes sufficient potential drop across the 4,700-ohm resistor to bring the base potential below that of an emitter in a row receiving a positive pulse; this would cause the conduction of a transistor despite the absence of a base pulse. The

<sup>3</sup> PARKIN, B. G. *Magnetic Materials with Rectangular Hysteresis Loops*. *P.O.E.E.J.*, Vol. 48, p. 1, April 1955.



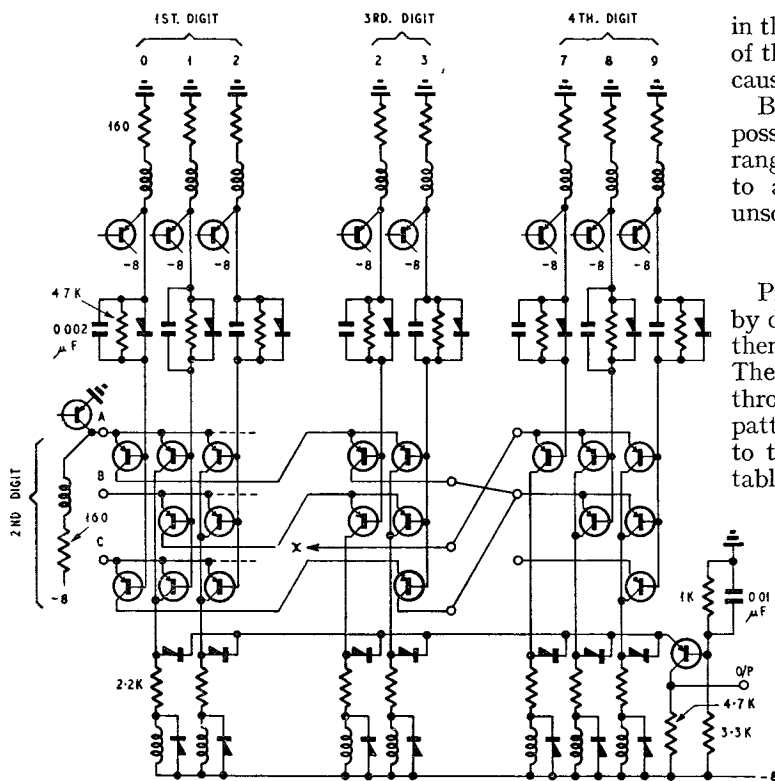

Notes:  
 1. Numbers exceeding 0A 2,799,999, 1B 1,699,999 and 0C 3,799,999 are redundant.  
 2. Point *a* is connected to the collector of the first transistor of the row, which is not shown.  
 FIG. 7.—SCHEMATIC DIAGRAM OF REDUNDANCY TABLE SHOWING PARTS OF THREE MATRICES.

rectifier across the 4,700-ohm resistor prevents this occurring by holding the common base line near earth potential. Separate collector load resistors are used for each column. When the emitter potential of a row of transistors is raised, increased leakage currents flow in the transistors, and these currents would cause a sufficiently large signal in a common resistor to give an output pulse.

The second matrix is formed of transistors in the same manner, with the columns driven by transistors indicating the "millions" digits, and the rows by the transistor which indicates the digit requiring further examination in the corresponding row of the first matrix. Because the voltage drop between emitter and collector of a conducting transistor is very low, the emitters of the transistors in the second matrix are only some 0.2V more negative than those on the first matrix. As in the first matrix, transistors for working numbers are omitted, transistors representing redundant numbers have their collectors taken to a negative potential through a resistor-inductor combination and thence to the redundancy transistor, and transistors representing a number needing further examination are connected to the third matrix.

This differs from the other matrices in being triangular in shape and all collectors have loads which are connected to the redundancy transistor. The first row has nine transistors with their bases operated by fourth digits 1-9, the second row has eight transistors with their bases operated by fourth digits 2-9 and so on. Collectors of transistors in the second matrix are connected as appropriate to one of the emitter rows. The redundancy output voltage from this matrix is some 0.2V less than that of the second matrix which in turn is some 0.2V lower than that of the first matrix.

The redundancy transistor has its base connected to approximately -2V and the operation of any transistor

in the matrices which has a collector load causes the emitter of the redundancy transistor to rise above -2V and hence causes conduction, and a positive output signal.

By simple variations in the circuit as described, it is possible to extract number blocks within the numbering range and make these redundant. In practice this is done to a limited extent to deal with substantial blocks of unsold bonds.

#### CHECKING AND TESTING CIRCUITS

Prior to a draw a cyclic test is made of the machine, by disconnecting the random-noise sources and substituting them with pulse generators delivering trains of pulses. The number of pulses is so chosen that the machine goes through a program, printing numbers sequentially in a pattern such that all parts of the apparatus subsequent to the noise generators are tested. With the redundancy table in operation a check can be made from the printed list that the redundancies have been correctly inserted.

During the operation of the machine a check is made to ensure that the noise generators are producing pulses in excess of a minimum rate. Should any two noise generators fail to do so, the machine automatically stops, because it is no longer possible to produce all the bond numbers with only eight noise generators.

Another circuit checks that a single number has been transferred from each temporary to primary store and if this is not so, stops further printing and indicates which digit is faulty.

#### POWER PLANT

It is essential that there should be no break in the a.c. supply to the electronic equipment and emergency lighting, nor in the d.c. supply to the telegraph equipment. Power plant was specially designed by the Power Branch, E.-in-C.'s Office, to meet this requirement. It consists essentially of a battery with its centre point earthed, which supplies a nominal 80 + 80V d.c. to the telegraph equipment and feeds two motor-alternators in parallel. The motor-alternators provide a 240V 50-c/s supply to the electronic equipment and emergency lighting.

The battery is floated across two mains-fed 3-phase mercury-arc rectifiers in series, with a third rectifier as standby. Each motor-alternator is rated to supply the full load if the other motor-alternator fails. In the event of a mains failure the a.c. supply to the rectifiers is taken from a manually-started engine-alternator, the outputs being maintained by the battery during the change-over period.

The output voltages of the rectifiers and the alternators are automatically controlled but facilities are also available for controlling the plant by hand. Local and extended alarms give indications of failure or misoperation of any part of the plant.

#### ACKNOWLEDGMENTS

ERNIE was designed and built in the Research Branch, E.-in-C.'s Office, and installed at St. Annes by staff of the Preston Telephone Area. The authors are indebted to their colleagues in Research Branch who were concerned in the development and construction of the equipment, and to those in the Telegraph and Power Branches, E.-in-C.'s Office, who were concerned in the provision of auxiliary services and power supplies. In the special circumstances of the project a high degree of teamwork has been called for and this has been achieved by all concerned. Acknowledgment is also made to Mr. S. W. Broadhurst, to whom the initial conception of the machine is due.

# A New Deep-Sea Coaxial Cable\*

R. A. BROCKBANK, Ph.D., B.Sc.(Eng.), A.M.I.E.E.,  
and A. L. MEYERS, B.Sc.(Eng.), M.I.E.E.†

U.D.C. 621.315.212:621.315.28

Development work during the last five years has resulted in a new type of deep-sea coaxial cable which is cheaper and lighter than the present conventional type. It has no external armour and is virtually free from any tendency to kink. Ocean trials are about to take place, and, if successful, the armoured type of deep-sea telephone cable will probably soon become obsolescent.

SINCE the first submarine cables were laid some 100 years ago it has been standard practice to armour them for protection and longitudinal strength with a single layer of steel wires. This armour consists of very heavy wires for shallow depths, where trawls, anchors, rocks, etc., may damage the cable. In ocean depths the wires are reduced to a size which will give adequate tensile strength for laying and recovering the cable. A major disadvantage which has always existed for single-layer wire armoured cables results from the comparative freedom with which the cable twists under tension, thereby tending to throw turns or loops into the cable at a low-tension point, which in practice is normally the sea bed.<sup>1</sup> Under subsequent tension these turns develop into kinks which may seriously damage the cable. The advent of rigid submerged repeaters has further tended to aggravate this trouble. Double-layer wire armour with reverse lays is a cure but only at the expense of greatly increased cost, heavier cable-laying engines and reduced cable capacity in the ship's tanks.

In August 1951 the British Post Office proposed<sup>2</sup> an entirely novel type of construction for a deep-sea coaxial cable. Since steel-wire protection is unnecessary in deep water, where almost perfect quiet reigns, the strength member can be placed at the centre of the inner conductor, which is ineffective in so far as carrier-frequency transmission is concerned. The steel used in this position can have a very high tensile strength and in strand form it can be designed to be balanced, i.e. with no tendency to twist under tension. A further advantage gained from placing the steel at the centre is the complete elimination of any deterioration in the strength of the cable with time, such as occurs to a greater or less extent on conventional cables through corrosion of the armour wires. It was proposed that the steel strand should be enclosed with a longitudinal copper tape to form the inner conductor, and this should prove to be rather more efficient and more stable than the normal type of stranded copper conductor. Polythene insulation was then to be extruded to a suitable diameter and the outer conductor applied in the form of long-lay tapes. An overall protection with a suitable type of non-metallic sheath completed the cable. Aluminium was initially proposed as a satisfactory material for the outer tapes, and because of the resulting very low weight of this new cable, particularly in water, it has since been called the "light-weight" cable.

A submarine cable manufacturer was consulted, and with his active co-operation the first experimental length of a light-weight cable using copper return tapes was produced before the end of 1951. This cable has a core diameter of 0.80 in., an ultimate tensile strength of about 5 tons and a weight in water of about 15 cwt/n.m.,‡ which would have reduced to just over 10 cwt/n.m. if aluminium tapes had been used. The external protection consisted of compounded hessian tapes.

During the next few months a large program of

\* This article is reproduced by permission of The Institution of Electrical Engineers. It first appeared in the *Journal of the Institution*, 1956, Vol. 2 (New Series), p. 572.

† Dr. Brockbank is a Staff Engineer, Post Office Research Station, and Mr. Meyers is with Submarine Cables, Ltd.

‡ n.m. = nautical mile.

tests was carried out to determine the general mechanical and electrical properties of this cable.

Some of the results can be mentioned briefly as follows:

- (a) The centre conductor did not penetrate into the polythene when held for 30 min round a 3½-ft diameter drum at near breaking load.
- (b) The cable withstood several backward and forward bends round a 4½-ft diameter drum, with no observable damage, though round a 2-ft diameter drum a slight wave could be detected on the copper tapes.
- (c) Preliminary soft-soldered steel-strand joints yielded about 60 per cent of the strength of the steel strand.
- (d) Holding the cable with seaman's stoppers would apparently have been quite successful but for the sliding of the compounded hessian protection.
- (e) There was a complete absence of knuckling.
- (f) Intermodulation due to the steel strand could not be detected even at frequencies as low as 2 kc/s.

It was concluded from this series of tests that the cable was a practical proposition and should possess important advantages over existing submarine telephone-cable construction. More development was, however, shown to be necessary, e.g. for improving the balance of the strand, improving the grip of the inner copper conductor on the steel strand and providing a more rigid outer protective sheath. A preliminary study indicated that for the same attenuation the cost of a light-weight cable would be appreciably less than that of an equivalent conventional cable with deep-sea armour.

High stability of the electrical characteristics of a cable is essential in any multi-repeated submarine telephone system. This requirement has become much more severe recently in view of the enormous attenuations now being envisaged for possible future broad-band transoceanic systems. Precision stability measurements on short lengths of cable are extremely difficult, and it is also not easy to simulate the effect of laying operations and ocean bottom conditions. These factors were appreciated when the use of aluminium return tapes was proposed, since this material is notorious for its aptitude to corrode in many situations. It was considered, however, that with suitable precautions corrosion could be kept very low. All possible information on this aspect of the cable was sought, and laboratory and sea tests on aluminium samples were started, but it was evident that none of these data would give a direct answer as to the resultant change in electrical characteristics of the cable. It was provisionally assumed that if there was little visual evidence of corrosion the electrical performance would not be seriously impaired. Experience with copper for outer conductor tapes is considerable and generally satisfactory, and its possible use in this cable was not precluded though it would appreciably decrease the *modulus*, defined as the length in water which the cable strength can support.

Progress in the further development of the cable continued but at a much reduced rate owing to the heavy commitments of both organizations over the transatlantic telephone cable system. Several lengths of cable were manufactured embodying progressively improving techniques of which the most important were as follows. A steel strand was developed<sup>3</sup> which showed less than one quarter of a turn twist in 30 fathoms up to 90 per cent



TABLE 1  
Comparison of Light-weight and Conventional Cable

| Cable type              | Core diameter  | Overall diameter | Relative cost | Weight           |                  | Strength    | Modulus    | Attenuation at 552 kc/s |
|-------------------------|----------------|------------------|---------------|------------------|------------------|-------------|------------|-------------------------|
|                         |                |                  |               | Air              | Water            |             |            |                         |
| Light-weight .. ..      | inches<br>0.80 | inches<br>1.02   | 0.8           | tons/n.m.<br>1.5 | tons/n.m.<br>0.5 | tons<br>5.1 | n.m.<br>10 | dB/n.m.<br>2.60         |
| Light-weight .. ..      | 0.99           | 1.23             | 1.0           | 2.0              | 0.6              | 6.7         | 11         | 2.05                    |
| Transatlantic, Type D.. | 0.62           | 1.27             | 1.0           | 3.1              | 1.8              | 12.5        | 7          | 3.06                    |

of the breaking strength. Still later it was found that the strength of a strand could be increased by a swaging technique. Several methods of applying the copper

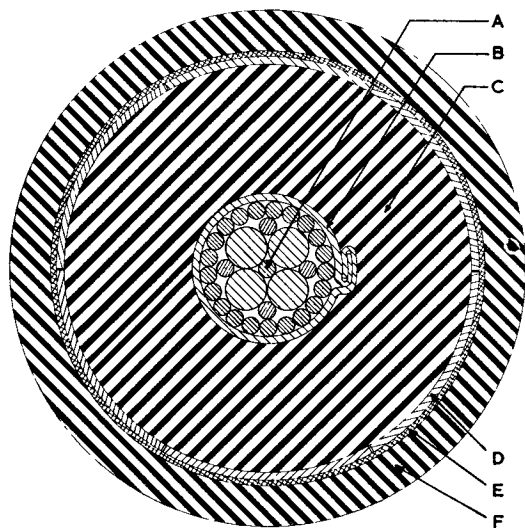

A Torsionally balanced steel strands (26/0.033 in. plus 4/0.080 in).  
B Longitudinal 15-mil copper tape with box seam.  
C Polythene to 0.800 in. diameter.  
D Six 15-mil aluminum tapes.  
E 10-mil cotton tape impregnated with corrosion inhibitor.  
F Polythene sheath, of outside diameter 1.02 in.

FIG. 1.—CROSS-SECTION OF LIGHT-WEIGHT CABLE

conductor were tested: a suitable one appeared to be a tightly applied longitudinal tape closed with a folded box seam, the slight protuberance due to the seam not being considered to be a disadvantage. After a tight application of polythene the aluminium tapes are held closely to the surface of the polythene with a cotton tape heavily impregnated with barium chromate, which experience suggests as being efficacious as a corrosion inhibitor. A tightly extruded sheath of polythene over the cotton tape then completes the cable. Swaging has now displaced soft soldering as a means of jointing the steel strand. Fig. 1 shows a cross-section of a late version of the cable.

Although most development work has been centred on a core diameter of about 0.8 in., a larger cable with a core diameter of 0.99 in. has now been designed. Some interesting comparative data on these two cables and a modern conventional 0.62-in. cable is given in Table 1.

The first ocean trials with a length of light-weight coaxial cable including a rigid repeater are scheduled to be completed before the end of the year. It is confidently expected that the superiority of this type of cable will be demonstrated, in which event the armoured deep-sea type of telephone cable will rapidly become obsolescent.

#### References

- <sup>1</sup> BESLEY, J. C., and HIGGITT, H. V. The Recovery of Deep-Sea Cable. *Journal I.E.E.*, Vol. 72, p. 160, 1933.
- <sup>2</sup> British Patent No. 703782.
- <sup>3</sup> British Patent No. 740647.

## Book Review

"Color Television Receiver Practices." Edited by Charles E. Dean. Chapman and Hall. 200 pp. 96 ill. 36s.

Much of the experimental work in connexion with the development of the system of colour television now in use in the U.S.A. took place at the laboratories of the Hazeltine Corporation. This book is based on a series of lectures presented by members of the Hazeltine staff to visiting engineers from various manufacturing companies, and who could be better qualified to write on the subjects dealt with?

The book opens with a discussion by Mr. A. V. Loughren, former head of research at Hazeltine, of the factors that led to the choice of the N.T.S.C. standards for the U.S. colour system. Whatever may be its shortcomings, the N.T.S.C. system, whereby colour signals are transmitted in a band-width no greater than that used for monochrome signals, is a masterpiece of technical ingenuity and all credit must go to the engineers who developed it. Full details of the F.C.C. specification for the system and a useful set of definitions are given in the second chapter.

Two chapters are devoted to colour display devices, the first in a general way to the various types of display that have been

developed in different places and the second to that incredibly ingenious device, the R.C.A. three-gun shadow-mask tube. It is perhaps to the colour-display-device field that we must look for the most interesting future developments in colour television; a notable omission from this section of the book is any mention of the Philco "apple" tube, which may prove to be a serious rival to the shadow-mask tube.

Approximately half the book deals with the special circuitry required in a receiver for the N.T.S.C. signals; the decoders for extracting the chrominance information from the composite signal and putting it into a form suitable for application to the display device; the special arrangements for synchronizing the local oscillator used for synchronous detection of the chrominance information; and the special requirements in the i.f. and video amplifier performance of the receiver. A final chapter deals with the laboratory test equipment needed for dealing with colour television receivers.

Although dealing entirely with receivers for the American N.T.S.C. system, much of the information contained in the book will be of the greatest value to engineers concerned with the development of colour television receivers for the other systems at present under consideration in different countries.

T. K.

# Deep-Sea Trials with Light-weight Cable

U.D.C. 621.315.285 : 621.315.212

ON 22nd October, 1956, C.S. *Ocean Layer*, owned by Submarine Cables, Ltd., left Greenwich for deep-sea trials in the Atlantic Ocean west of Gibraltar. These trials were jointly sponsored by Submarine Cables, Ltd., the Post Office and Cable & Wireless, Ltd., and also on board were observers of the American Telephone & Telegraph Company, Bell Telephone Laboratories and Johnson & Phillips, Ltd. The primary objective was to determine whether conventional 0.62-in. deep-sea coaxial cable with Post Office rigid-type repeaters could be laid and recovered satisfactorily in depths approaching 3,000 fathoms. It was also required to ascertain the suitability of a caterpillar gear constructed by Johnson & Phillips, Ltd., for such a laying operation. The program was extended at comparatively short notice to include the first-ever trial of a length of light-weight cable with a rigid repeater. For this purpose, lengths of 2.1 and 2.7 n.m. of 0.80-in. light-weight cable were manufactured and joined by a repeater; the strength of the cable being transferred from the centre steel strand to the housing by 25-fathom tails of single-layer wire armour applied over the light-weight cable ends.

The repeaters used in both the conventional and light-weight cable trials were of the telemetering type and they transmitted over the cable to the ship a continuous record of shocks, inclination and rotation of the repeater and attenuation of the cable during the laying and recovery operations.

Tests on the light-weight cable commenced in 600 fathoms and the cable and repeater were laid satisfactorily over the after sheave by the caterpillar gear. The cable end was then transferred to the bows and deliberate attempts were made to form loops and kinks in the cable, e.g. by falling back over a slack cable. Such manoeuvres would have been courting certain disaster with a conventional cable. Subsequent recovery showed the cable to be completely undamaged by these efforts though there was a gash in the outer polythene sheath where the cable had fouled an obstruction on the sea bottom.

The whole operation was then repeated in a depth of 1,500 fathoms and it was again found impossible to damage the cable. There was no further evidence of fouling.

Finally a trial was made in 2,600 fathoms, and since the cable would have been too short for the repeater to touch bottom it was removed and the repeater tails spliced together to give a cable length of 4.8 n.m. Again, despite lengthy efforts in a fair swell to injure the cable, it was recovered in its original condition (Fig. 1).

The evidence given by the telemetering repeaters was most valuable, particularly in one respect. It showed that the light-weight cable repeater in 1,500 fathoms rotated only two turns during the laying operation, whereas with conventional cable in the same depth the rotation would have been over 1,000 turns (3,200 turns recorded in 2,600 fathoms). Even the two turns in the light-weight cable are attributed to the armoured repeater tails. It is due to torque stored up in helically-laid armour wires when under tension that a conventional cable throws loops, usually near the sea bottom, at the slightest favourable provocation. Under tension these loops develop into localized twists or kinks which can seriously damage the cable. This was noticeable during the trials, particularly during one operation when the damage became so severe as to break the cable. These trials confirmed, as expected, that this age-long difficulty has been completely eliminated in

the light-weight cable, and it would seem that a cable ship could stand-to to a light-weight cable for prolonged periods with very little restrictions in respect of weather conditions or angle of cable.

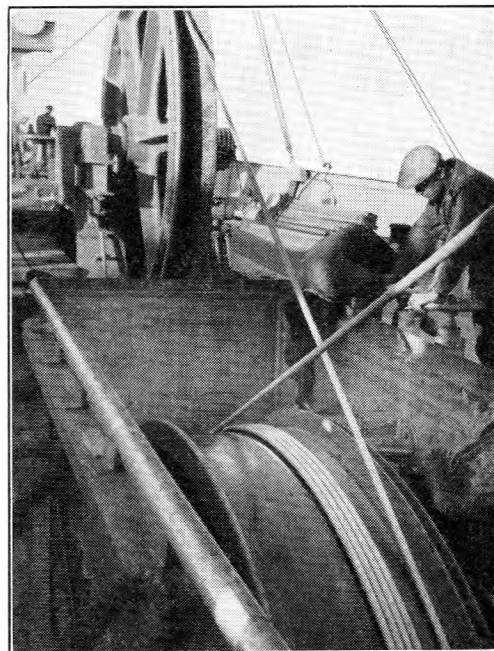

FIG. 1.—RECOVERY OF THE FIRST LIGHT-WEIGHT CABLE FROM 2,600 FATHOMS (3.1 MILES).

Although the major success of the light-weight cable undoubtedly results from its torsionally balanced structure, it was found to possess other admirable properties which greatly endeared it to all on board. It could be recovered quickly with no great increase in tension because it was unnecessary to maintain a forward cable lead. Also, the pick-up lead being desirably fore-and-aft there was no requirement to maintain a suitable "turn-correcting" starboard lead as with conventional cable. The light weight of the cable, coupled with its flexibility, involved very little physical effort on the part of the cable hands both on deck and in the tank. The ever-present liability of injury by broken armour wires on normal cables was non-existent. The cable was at all times perfectly clean and could not soil the clothes and there was no limewash or black compound to foul the ship.

The comparison of electrical tests on the cable in factory tanks before and after the trials is not yet completed, but initial indications are that, at least at 500 kc/s, there is no appreciable change in attenuation.

Whilst the amount of light-weight cable available for these trials was inadequate to carry out fully and realistically all the cable-ship operations involved in laying and repairing a submerged repeater system, it was sufficient to suggest that no unforeseen difficulty should arise in the course of a more ambitious undertaking. In order, however, to establish the fullest confidence and to work out detailed techniques, arrangements are now proposed for H.M.T.S. *Monarch* to undertake a comprehensive series of deep-sea operations involving about 55 n.m. of light-weight cable and two rigid-type repeaters.

R. A. B.

## Part 1.—Sampling by Random Numbers

U.D.C. 31:383/384:519/24

The authors of this article have been consulted on a number of problems to which operational research methods are applicable, and this article is a result of a suggestion to them that some "thinking aloud" on broad lines may be of interest to readers of the Journal. In operational research reliance must be placed only on those measurements or observations to which the mathematical theory of probabilities can be applied. Thus it is apparent that the two mainstays of operational research are scientific sampling and the use of probability models to describe observations; some aspects of these will be discussed in Parts 1 and 2 of this article, respectively. No attempt is made to enter into great detail in either Part since each would need a text-book to do it justice. Instead, the discussion has been kept fairly general and is illustrated by cases chosen not so much for their merit but because work has recently been done on them by the Research Branch of the Engineering Department.

### INTRODUCTION

OPERATIONAL research has been defined by Sir Charles Goodeve<sup>1</sup> as "... the use of the scientific method in providing executive departments with a quantitative basis for decisions regarding the operations under their control."

Obviously the subject is not new but has been practised implicitly for a long time under such names as quality control, market research, trucking and grading theory, etc. It was only during the war that it received explicit recognition when it was applied successfully to problems such as the optimum size of convoys, the interception of enemy planes and the effectiveness of bombing techniques. Since then operational research methods have been developed and used with success in many branches of industry.

Since the war the problems of road and rail traffic have been found to be particularly amenable to the operational research approach. Now the Post Office runs two large traffic concerns, one being the postal service and the other the telecommunications service. Their problems are largely analogous with those of road and rail traffic and operational research methods are likely to be even more effective in dealing with them since Post Office channels are easier to control. From this point of view alone the Post Office offers a wide field for operational research. But there are many other problems for which it can be useful. For example, a vast amount of Post Office plant must be maintained efficiently and operational research can help in deciding how much maintenance is worth while and what form it should take. It may be applied also to problems concerning staff working conditions such as lighting standards, to the setting of realistic specification limits, and so on.

### TYPES OF SAMPLES

Most operational research involves sampling in some way, and this is particularly so when applied to Post Office problems. Any maintenance or traffic problem, for example, must ultimately involve observational data which can be obtained only on a sampling basis.

It is often found that a phrase such as "take a sample" or "a 'representative' sample shows that . . ." has been written in a context which indicates a lack of appreciation of the many different types of samples. A sample may be stratified or unstratified. In the former case, the population (or totality of items or possible observations) is divided into strata, and the sample is formed by taking items from each stratum and combining them. For an unstratified sample the population is considered as a single stratum from which the whole sample is taken.

Unstratified sampling will be considered first. The sampling is not defined completely until three things have been specified, namely,

- (1) whether the sampling is with or without replacement,

- (2) the manner in which sample items are chosen, and

- (3) a rule for deciding when the sample is complete. The sampling is with or without replacement according to whether the sample item is or is not replaced in the population before the next item is selected. Sampling without replacement gives more precise results in the sense that the sample items have smaller "spread" or sampling variance; but, provided the ratio of sample size to population size is small, there is so little difference between sampling with replacement and sampling without replacement that the choice should be made on practical grounds.

In any scientific sampling scheme the items must be chosen either at random or in a defined manner (such as every 10th item). But often in practice the items are chosen in a "haphazard" manner or "without conscious bias," in the belief that this is the same as "at random." As a result the sampling becomes unscientific and wrong conclusions may be reached.

The rule for (3) should state either a sample size or a condition which must be satisfied by the observer before sampling stops. The former method is the more common; but the latter method is used in multiple and sequential sampling schemes for acceptance testing.

Thus there are many different forms of unstratified sampling; likewise, there are as many forms of stratified sampling as there are ways of specifying (1), (2) and (3) for each stratum. Of the various forms of sampling those which are most useful for the Post Office are,

- (a) unstratified random sampling with a fixed sample size, with or without replacement, and
- (b) "representative sampling" in which a random sample is taken, with or without replacement, from each stratum, the size of the sample from each stratum being fixed and proportional to the size of the stratum.

It should be noted that the term "representative sample" has a precise technical meaning and care should be taken not to use it loosely.

### RANDOM SELECTION

The reliability of sampling conclusions will depend largely on the ability to make random selections. "A random selection" means the selection of an item when each item that is available for sampling has the same chance of being selected.

Most people think it an easy matter to select items at random, mainly because they tend to identify random with haphazard or lack of conscious bias. In practice it is impossible for a human being to make random selections unaided. The reader may be familiar with the party trick in which the digits 1, 2, 3 and 4 are written on a sheet of paper and the subject is asked to cross one out "at random." Another sheet of paper face downwards on the table says "You have crossed out 3." A large proportion of people do cross out 3 and are surprised when the sheet is revealed. If asked why they crossed out 3, they tend to suggest that 1 and 4 being at the ends were almost "unrepresentative"

† The authors are, respectively, Principal Scientific Officer and Senior Scientific Officer, Post Office Research Station.



and the choice of 3 in preference to 2 may be due to a right-hand bias.

The same effect has been noticed in postal sampling. An instruction states that a postman shall pick a letter at random from the stack on the bed of his sorting fitting. In practice it is found that he tends to select the letter from near the centre of the stack by associating the randomness of an item with a vague "representativeness" and the latter in turn with "middleness." If the number of letters to be selected is increased, he tends to spread them evenly over the stack in a most unrandom manner.

The difficulty is apparent when random selections are examined, for somehow they tend to look unrandom. Consider, for instance, the following five selections of three numbers in the range 000 to 999:

- (a) 266, 295, 413,
- (b) 279, 979, 992,
- (c) 56, 167, 244,
- (d) 317, 795, 911,
- (e) 167, 415, 952.

If it is necessary to make one selection only, it is unlikely that selections such as (a), (b) or (c) would be chosen, although the five selections are random selections, with replacement, written in ascending order. With (a) and (c) all the numbers lie in one half of the number range, and instinctively this gives a feeling of unrandomness even though one-quarter of such random selections will exhibit this characteristic on the average.

In addition to this position bias, there is item bias if items are not identical in appearance. For example, in a horizontal stack of letters, those which are wider than average tend to get too great a chance of selection; and bias is also introduced by the varying thicknesses of the envelopes and their different colours. Furthermore, an awareness of these dangers is not likely to result in much improvement in the selection of the letters. The above examples can be regarded as illustrations of Borel's theorem, which states that the human mind cannot imitate chance and that when any human element of choice is allowed free play, bias inevitably creeps in.

#### RANDOM NUMBERS

Because of the difficulty of bias, tables of random numbers have been constructed. One such table is due to Kendall and Babington Smith (K. and B.S.)<sup>2</sup>, and an extract of this is given in Table 1.

TABLE 1

|      |      |      |      |
|------|------|------|------|
| 2682 | 5326 | 9319 | 3150 |
| 3914 | 1755 | 7921 | 5226 |
| 7146 | 4773 | 9805 | 6654 |
| 5036 | 5993 | 1144 | 1999 |
| 6924 | 9765 | 3616 | 0132 |
| 0441 | 7622 | 5076 | 8452 |
| 6014 | 0500 | 0735 | 9180 |
| 1962 | 1815 | 6818 | 4451 |
| 2419 | 6778 | 7622 | 5306 |
| 5537 | 8818 | 2108 | 0729 |

This table contains 100,000 digits and has been constructed so that each digit has had the same chance of selection at each trial. As explained later, it may be used as a reliable means of making random selections from the enumerable populations that arise in Post Office investigations.

There are many ways of generating such random number sequences; for example, by noise levels in thermionic valves, by radioactive disintegration<sup>3</sup>, by a large number of arithmetical operations on selected numbers, etc. But how is it known that these numbers are random?

In practice it can never be said that a set of numbers

is "completely random." All that can be done is to set up the hypothesis that the numbers are random and apply probability tests to see whether any evidence can be found for rejecting the hypothesis. The most favourable conclusion is that no evidence can be found for supposing they are not random. If this conclusion can be reached after applying such tests of significance it may be assumed that the numbers are random enough for practical purposes.

The K. and B.S. table has been tested for randomness on the assumption that the digits will be read row-by-row. But in practice there is virtually no danger in reading the digits column-by-column or diagonally or in any way at all, provided that neither the selection of a digit nor its position within the selection depend on its value. For instance the 1st, 2nd, 4th, 16th, . . . digit may be used; so also may the sequence defined by every digit which is preceded by a zero.

#### RANDOM SELECTION FROM A KNOWN POPULATION

In many Post Office applications of random number sampling the populations involved are small. As an example, suppose it is desired to take a random sample of eight telephone sets from a population of 85. The sets are numbered 01 to 85 and pairs of random digits are taken from the extract of the K. and B.S. table given at Table 1, thus

26, 82, 53, 26, 93, 19, 31, 50, 39, 14, . . . .

Crossing out 00 and any number in the range 86-99 leaves

26, 82, 53, 26, 19, 31, 50, 39, 14, . . . .

which is a random sample with replacement from the numbers in the range 01-85. Hence if eight telephones are to be sampled with replacement the telephones sampled are those numbered

19, 26 (twice), 31, 39, 50, 53 and 82.

If the telephones were to be sampled without replacement, any number appearing more than once must be counted as appearing only once, giving

26, 82, 53, 19, 31, 50, 39, 14, . . . .

the first eight numbers in this sequence specifying the telephones to be sampled.

Now suppose that in an investigation of Post Office lighting standards it is wished to sample 25 rooms from a population of 173, and suppose that the sampling is with replacement. In the same way as before the rooms could be numbered 001-173 and random digits taken three at a time, giving

268, 253, 269, 319, 315, 039, 141, 755, 792, 152, . . . .

Any 000's and any numbers in the range 174-999 could then be crossed out, leaving

039, 141, 152, . . . .

This process is obviously wasteful since only three sample rooms have been specified although 10 random numbers have been selected. It can be made more economical as follows. Suppose that the first digit of each number in the original sequence is counted as 0 if it is even and as 1 if it is odd. Then, since the first digits were equi-probable, the modified sequence

068, 053, 069, 119, 115, 039, 141, 155, 192, 152, . . . .

will give a random selection of the numbers 000-199. This sequence is modified as before by crossing out any 000's and numbers in the range 174-199, giving

068, 053, 069, 119, 115, 039, 141, 155, 152, . . . .

so that only one random number out of 10 has been wasted. Alternatively the modification could have been made by counting each first digit as 0 if it lies in the range 0 to 4 and as 1 if it lies in the range 5 to 9. This yields the modified sequence

068, 053, 069, 019, 015, 039, 041, 155, 192, 052, . . . .

which in turn reduces to

068, 053, 069, 019, 015, 039, 041, 155, 052, . . . .

In the above examples it has been assumed that the

populations considered can be numbered readily. This is often the case with Post Office populations where numbering effectively exists on standard forms.

#### Review of Post Office Lighting.

Although random number sampling in the Post Office often involves small populations, cases arise in which large populations are involved. Such a case arose recently when it was desired to find out the extent to which Post Office lighting throughout the country was below the interim standard laid down by the Treasury. It was also desired to find the cost of bringing all the lighting up to that standard and the methods by which it could be most economically achieved. At first it was thought that complete buildings must be taken and thoroughly surveyed, the buildings being chosen in some way assumed to be representative. This, compared with random number sampling, would have been very expensive, for a large number of buildings would have had to be sampled. This is because the variation in lighting standard is mainly between buildings rather than within buildings. An unstratified random sample of lighting points seemed desirable to minimize the task of inspection, provided that questions of cost, etc., could be related in some way to individual points.

Now there is a large number of lighting points in Post Office premises (approximately 600,000) and these are partially numbered on standard forms. A form (A56) shows the number of lighting points in each Post Office building or group of buildings and a list was made giving this information, as in Table 2,

TABLE 2

| Building | No. of points | Numbering Scheme |
|----------|---------------|------------------|
| 1        | 478           | 000,001—000,478  |
| 2        | 22            | 000,479—000,500  |
| 3        | 1,631         | 000,501—002,131  |
| 4        | 103           | 002,132—002,234  |
| :        | :             | :                |

It was estimated that about 1,000 sample points would be needed to find the extent to which the lighting was below standard with sufficient accuracy; and that questions referring to costs, etc., need apply to about 280 points only.

Accordingly, 6-digit random numbers were taken without replacement until a sample of 1,000 points was generated. By reference to the list at Table 2, the distribution of the sample was put into the form,

| Building | No. of points to be sampled |
|----------|-----------------------------|
| 3        | 3                           |
| 7        | 1                           |
| :        | :                           |

there being no indication as yet of the positions of the sample points in the buildings.

For each building with sample points, a list was prepared showing the number of points in each room, corridor, etc., and the sample points were then located as lying in particular positions. For example, three points were required at random from building No. 3 which had 1,631 points. The list of rooms in that building appeared as,

| Room, etc. | No. of points | Numbering Scheme |
|------------|---------------|------------------|
| 1          | 10            | 0,001—0,010      |
| 2          | 25            | 0,011—0,035      |
| 3          | 2             | 0,036—0,037      |
| 4          | 8             | 0,038—0,045      |
| :          | :             | :                |

and three random numbers in the range 0,001—1,631 specified three locations (sometimes less, if more than one sample point appeared in one room). For questions concerning the standard of lighting the room appears as a natural

unit, for the questions cannot be referred to a single point. Accordingly, for each room that contained sample points, enquiries were made concerning the numbers of local and general lighting points, their wattages, whether or not the local lighting as a whole was up to standard and similarly for the general lighting. For 280 of the points (chosen from the 1,000 by taking 3-digit numbers at random from the range 000—999) further enquiries were made concerning the cost of bringing the lighting in the corresponding rooms up to standard, the method by which it would be done and the new wattage required, together with a query concerning why the lighting had not already been brought up to standard.

The data for a sample point in a room was then taken to be the average over all points in the room so that the individual observations were really mean values, giving more information than would normally be obtained from 1,000 independent points. The estimate of 280 points for the cost questions was too low since there were fewer points below standard than expected, and the cost questions were eventually completed for every point below standard.

This sampling survey of a large Post Office population was easily and quickly made; it showed what proportion of the lighting points in the country are below the standard and what proportion are above; it also enabled estimates to be made of the capital cost of bringing the lighting up to the desired level and the resulting annual cost of electricity.

#### RANDOM SELECTION FROM AN UNKNOWN POPULATION

So far random numbers have been used to sample static populations, i.e. populations in which items are available long enough for the items to be numbered before selecting the sample. Some important Post Office populations, however, are dynamic. Two examples are the calls passing through an exchange during a day and the postal items delivered during a year; in these cases, the complete populations are unknown until the end of the day or the year, when most of the items are no longer available. Nevertheless, random samples can be taken from such populations provided certain conditions are satisfied.

As a simple illustration of a dynamic population the transactions made by a counter clerk during a day will be considered. Suppose it is desired to sample these transactions; it is obvious that the total number of transactions cannot be known until it is too late to sample, but it may be felt that it is certain that the total will be less than, say, 300. If a sample of seven is wanted, ten (say) random numbers are taken in the range 001—300, giving the transactions numbered

15, 19, 39, 141, 152, 155, 192, 253, 268, 269.

An attempt is made to sample these but only eight of them are realized if the number of transactions turns out to be 261. A moment's reflection should convince the reader that these eight transactions are nevertheless a random sample of the days transactions since the eight numbers are a random selection from the range 001—261.

It will be noted that a sample of eight was realized instead of seven as desired. An essential feature of sampling dynamic populations by random numbers is that the realizable sample size cannot be predicted but is a random variable. This is a small price to pay. It is usually possible to obtain a larger sample than is absolutely necessary. The excess observations may be thrown away later (on a random number basis) if the data is costly to process; otherwise they should be retained to give more sensitive conclusions.

To enlarge this illustration, suppose it is wished to sample the transactions made by the counter clerk during a year. It will be assumed that there are 310 working days and an upper limit of 300 transactions a day. The possible

transactions may be numbered 00,001–00,300 for the first day, 00,301–00,600 for the second day and so on to 92,701–93,000 for the last day. Random numbers in the range 00,001–93,000 are selected giving, say,

26,825, 32,693, . . . .

and these are interpreted as the 125th transaction on the 90th day, the 293rd transaction on the 109th day, etc. These transactions are looked for and those which actually take place form a random sample of the year's transactions.

A random sample can be specified from any dynamic population by selecting random numbers in the range 00 . . . 001 to  $M$ , provided each item can be represented uniquely as it arises by a number not exceeding  $M$ . More generally, each item can be represented by a set of numbers ( $a; b; c; \dots$ ). A random sample is then specified by selecting a value of

$a$  from the range 00 . . . 001 to  $A$

$b$  from the range 00 . . . 001 to  $B$

. . . etc.,

it being known that the greatest values of  $a, b, c, \dots$  will not exceed  $A, B, C, \dots$ . This form is often advantageous in practice since the components  $a, b, c, \dots$  can lessen the task of locating the item. For example, in the illustration above, ( $a; b$ ) could indicate the  $b$ th transaction on the  $a$ th day, so that the sample transactions would be (090; 125), (109; 293), . . . ; in this case  $A = 310$  and  $B = 300$ . Similarly, if more counter clerks were involved in the investigation, ( $a; b; c$ ) could be used to denote the  $b$ th transaction by the  $c$ th clerk on the  $a$ th day.

The problem of taking random samples from dynamic populations reduces to that of devising a numbering system which will cover all the items that may arise. But the choice of numbering system and the practicability of the sampling depend on,

(i) the ease of locating an item corresponding to a given number, and

(ii) the redundancy of the system, i.e., the proportion of numbers in the system not corresponding to real items.

These factors are not independent, since a greater redundancy usually makes it easier to locate a sample item, but increases the number of sample items to be sought. In practice, a compromise between the two must be made by experience and experiment.

An interesting feature which widens the scope of this form of sampling is that it can be used to determine the size of a dynamic population. Suppose, for example, a numbering system has been set up which contains  $M$  permissible numbers. A sample of  $S$  random numbers is taken and results in the location of  $x$  real items. An unbiased measure of the population size is therefore  $xM/S$  and the precision of this measure may be found readily.

#### Double Register Technique.

The Post Office delivers about 9,000,000,000 items a year. Is it practicable to take an unstratified random sample from this population? Consideration of this problem has led to the development of the double register technique described below.

The numbering system has been based on the delivery process. The main reason for this is that one of the quantities that it is desired to be able to measure is the proportion of items not receiving "due-course" delivery. Nevertheless the delivery process would probably have been chosen anyway since it is virtually the only process that every item goes through just once.

Just before delivery, an item will appear at a place such as a postman's preparation stage, a private box, a checking bay for van deliveries, etc. This "delivery outlet", together with a position within the outlet and the time at which the outlet operates, completely specify the item.

In fitting the specification to a numbering system, the time element must be made discrete. This is done with little redundancy by making each outlet operate once on each weekday and never on Sundays, so that a 3-digit "date number" is sufficient. In consequence any postman's preparation stage which is used for two deliveries a day is considered as two separate outlets operating once a day; and corresponding conventions are used for the other varieties of outlet. Separate numbers for a delivery outlet and the position of an item within it would give too great a redundancy because the outlets differ considerably in magnitude. A "position number" is used to represent an item both by means of national and local registers.

A local register relates to one office and takes the form shown in Fig. 1. On this form each delivery outlet (at the office concerned) is listed under (2) and an overestimate of the greatest number of items taken by each outlet appears under (3). Position numbers are allocated serially to the outlets, each outlet having as many position numbers as its magnitude; the ranges of position numbers are shown in (1). Separate local registers are used for letter correspondence, packets and parcels, and each local register starts with position number 00 . . . 001.

The construction of the national register (which is kept at Headquarters) is shown in Fig. 2.

The local registers are listed under (2), and the magnitude in (3) is found by summing the magnitudes initially on the local register and increasing this by 50 per cent. National position numbers are allocated serially to the local registers as shown under (1).

| (1)<br>Local position numbers |         | (2)<br>Delivery outlet                                      | (3)<br>Magnitude |
|-------------------------------|---------|---|------------------|
| Lowest                        | Highest |   |                  |
| (e.g.)<br>00,001              | 00,720  | (e.g.)<br>Postman's preparation stage No. 1<br>(night-mail) | (e.g.)<br>720    |
| .                             | .       | .   | .                |
| 18,741                        | 19,220  | Postman's preparation stage No. 24<br>(night-mail)          | 480              |
| 19,221                        | 19,600  | Postman's preparation stage No. 1<br>(day-mail)             | 380              |
| 19,601                        | 19,840  | Postman's preparation stage No. 2<br>(day-mail)             | 240              |
| .                             | .       | .   | .                |
| .                             | .       | .   | .                |
| .                             | .       | .   | .                |
| .                             | .       | .   | .                |

Local register: (e.g.) Pontypool—letter correspondence  
Highest permissible position number: (e.g.) 48,180

FIG. 1.—FORM OF LOCAL REGISTER.

| (1)<br>National position numbers |             | (2)<br>Local register      | (3)<br>Magnitude |
|----------------------------------|-------------|----------------------------|------------------|
| Lowest                           | Highest     |                            |                  |
| (e.g.)                           |             | (e.g.)                     | (e.g.)           |
| .                                | .           | .                          | .                |
| .                                | .           | .                          | .                |
| .                                | .           | .                          | .                |
| 092,975,941                      | 092,980,560 | Pol . . . . (letter corr.) | 4,620            |
| 092,980,561                      | 093,028,740 | Pontypool (letter corr.)   | 48,180           |
| 093,028,741                      | 093,031,920 | Por . . . . (letter corr.) | 3,180            |
| .                                | .           | .                          | .                |
| .                                | .           | .                          | .                |
| .                                | .           | .                          | .                |
| .                                | .           | .                          | .                |

FIG. 2.—NATIONAL REGISTER.



In this way an item is specified by a 3-digit date number and a 9-digit position number. The identification of an item corresponding to a number pair such as (176; 092,999,409) is simple. Inspection of the national register shows that the position number refers to the local register for letter correspondence at Pontypool, and the corresponding local position number is 092,999,409-092,980,560 which is equal to 18,849. From the local register at Pontypool this is seen to correspond to the 18849-18740 = 109th item in the outlet formed by postman's preparation stage No. 24 (night-mail delivery). This outlet is examined on the day specified by the 3-digit date number and the 109th item is sought. A rule is needed therefore to enable the position of an item in an outlet to be specified. The rule is that a person may count the items in any order whatever provided he chooses the order before he knows which item is to be sampled.

The double register technique allows the population of delivered items to be numbered and sampled with a tolerable redundancy. The use of local registers gives flexibility to meet the changing pattern of traffic during the sampling period. A local register is retained at its office and may be altered in any way without affecting either the randomness of the sampling or the national register at Headquarters; provided, of course, that the changes do not require the use of more local position numbers than have been allocated. This latter case is unlikely to arise, however, since each local register has been given a liberal allowance of spare position numbers; but an additional safeguard can be arranged by having spare position numbers on the national register at Headquarters.

This sampling technique may be used for measuring with a determinate accuracy any national postal characteristic which is deducible from an examination of the items at their offices of delivery. For example, it will yield:

- (i) the national quality of service index,
- (ii) the average weight of letter correspondence,
- (iii) the ratio of packets to letters,
- (iv) the measurements necessary for the classification of correspondence return,
- (v) the number of ton-miles of parcels carried by the railways in a year,
- (vi) the numbers of printed papers, meter postings, official postings, twopenny stamps used, etc.

Although designed for national measurements the double register technique is also applicable to Regional measurements and special measurements at individual offices but it is not economical for routine local measurements. It is important to note that all the measurements may be made with a sample size of about one item per million delivered.

It is impracticable to give all the details of the postal application here, but sufficient has been given to show the generality and flexibility of the technique. This has been done because the double register technique is applicable to other dynamic populations in the Post Office, such as populations of telephone calls, telegrams, apparatus faults, etc. Preliminary experiments for assessing the practicability of the technique have been completed successfully.

#### SAMPLE SIZE

The above discussion, which stressed the importance of random numbering schemes in Post Office investigations, gave but little information concerning the optimum size of sample. The question as to how large a sample should be enters every sampling problem. The size of the sample depends not only on the precision required but also on other factors such as the nature of the distribution and its

parametric values. Thus the determination of the optimum sample size may be difficult; nevertheless, it is possible to give some rough general guides suitable for the purpose of operational research.

When sampling some variable characteristic an attempt is generally being made to find its mean value  $X$  accurate to  $a$  with  $c$  per cent confidence. Then the sample size  $n$  is given by

$$n \simeq k_c^2 \sigma^2 / a^2 \dots \dots \dots (1)$$

where  $\sigma$  is the standard deviation of the parent population. In this formula  $k_c$  is a parameter depending on  $c$ . When  $c = 90$ ,  $k_c = 1.65$  and when  $c = 95$ ,  $k_c = 1.96$ . Before  $n$  can be calculated from (1) it is necessary to determine  $\sigma$ . For normally distributed characteristics this merely involves plotting the cumulative frequencies of the observations on arithmetic probability paper. The essential features of this determination are illustrated in Fig. 3, in

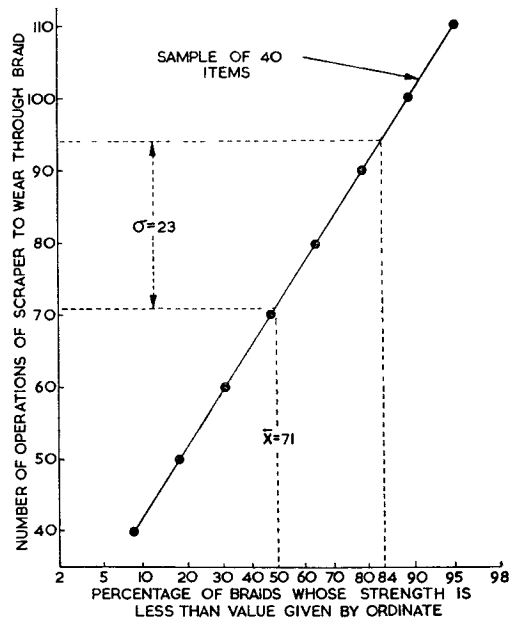

FIG. 3.—DETERMINATION OF STANDARD DEVIATION ( $\sigma$ ).

which the observations refer to a scraper test made to determine the mechanical strength of a new type of cable braiding. Details of this simple process have already been described in the Journal.<sup>4</sup>

In attribute sampling each sample item either does or does not possess a given characteristic  $A$ . Generally it is desired to know the proportion in the parent population possessing  $A$ . If this proportion is about  $P$  per cent and is required accurate to  $a$  per cent with  $c$  per cent confidence, then the sample size  $n$  is given by

$$n \simeq k_c^2 P(100-P) / a^2 \dots \dots \dots (2)$$

for  $5 < P < 95$ ;  $k_c$  is a parameter depending on  $c$ , with the same values as in (1).

(to be continued)

#### References.

- <sup>1</sup> GOODEVE, SIR CHARLES. Operational Research. *Nature*. Vol. 161, p. 377, 13th March, 1948.
- <sup>2</sup> KENDALL, M. G., and BABINGTON SMITH, B. Tables of Random Sampling Numbers (Cambridge University Press, 1939).
- <sup>3</sup> TILLMAN, J. R., REYNOLDS, F. H., and HILTON, P. J. A Method for producing a Random Sequence of Numbers. *Philosophical Magazine*, Ser. 7, Vol. 39, p. 807, Oct. 1948.
- <sup>4</sup> DOUST, J. F., and JOSEPHS, H. J. A Simple Introduction to the use of Statistics in Telecommunications Engineering. *P.O.E.E.J.*, Vol. 34, pp. 36, 79, 139, 173, Apr., July, Oct. 1941 and Jan. 1942.

# The Rugby "B" High-Frequency Transmitting Station

A. COOK, B.Sc. (Eng.), M.I.E.E., and  
L. L. HALL†

U.D.C. 621.396.7.029.58

International communications between the United Kingdom, the Commonwealth and the rest of the world depend on the submarine telegraph network, which has been built up over the last hundred years or so, the radio telegraph and radio telephone systems built up in the last 30 years, and quite recently the repeated submarine telephone cables. The need for long-distance international communications is growing rapidly and is likely to continue to do so in the foreseeable future.

Radio transmission plays an important part in the longer distance interconnexions, and in the course of normal development a new radio-transmitting station has been built at Rugby adjacent to the existing station. The station was formally opened by the Postmaster-General on 28th July, 1955, and by March, 1957, the building had been equipped to its full capacity of 28 high-frequency transmitters of 30-kW power rating, and some 70 aerials had been provided on the site of 700 acres. This article is based on a paper presented to the Institution of Post Office Electrical Engineers during the 1956-57 session.

## INTRODUCTION

A MEMBER of the public in the United Kingdom can communicate with some 95 per cent of the telephone users in the world, and exchange telegrams with many more individuals, via the national and overseas services provided by the Post Office. Radio transmission plays a very important part in the long-distance communications to overseas fixed stations and carries all the traffic in the marine mobile services; 23 Post Office radio stations are employed in the United Kingdom for these purposes. Long-distance point-to-point radio services are established to 66 overseas centres, and over 50 telephone and some 100 telegraph channels are operated, mainly in the h.f. band (3-30 Mc/s). These services are routed through central offices at Electra House, Central Telegraph Office, and the Radio Telephone Terminal,<sup>1</sup> in London, to transmitting stations at Bodmin, Criggion,<sup>2</sup> Dorchester, Leafield, Ongar and Rugby, and from receiving stations at Baldock, Bearley, Brentwood, Cooling and Somerton; the marine services are worked from the Burnham-Portishead receiving/transmitting station and 11 coast stations around the United Kingdom.

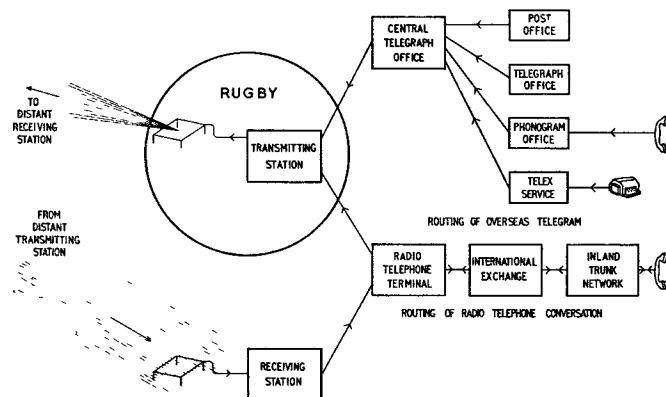

FIG. 1.—POSITION OF RUGBY TRANSMITTING STATION IN THE COMMUNICATIONS CHAIN.

The function of a point-to-point transmitting station in the communications network is shown in Fig. 1. Telegraph traffic from post offices, telegraph offices and the telex network is routed via the central telegraph offices to the transmitting station and thence via radio to the overseas destination. Similarly telephone calls are routed via the International Exchange and the Radio Telephone Terminal to the transmitting station.

Of the equipment required in the United Kingdom for the provision of these services, the numbers of h.f. transmitters installed from 1925 onwards are shown in Fig. 2. The continued growth is clear and, from 1940, the rapid expansion has been associated with considerable improvements in technique which have resulted in still greater

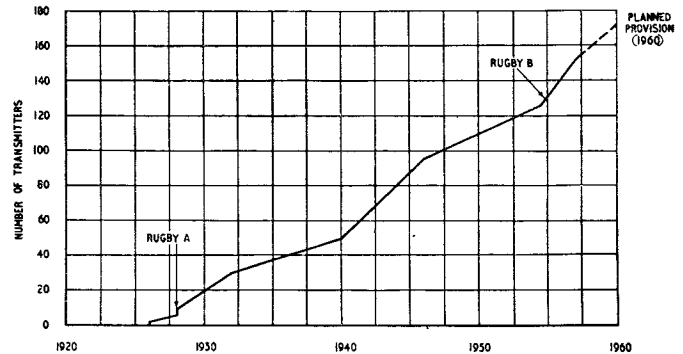

FIG. 2.—GROWTH OF H.F. TRANSMITTERS ON PUBLIC TELEPHONE AND TELEGRAPH SERVICES.

growth in traffic capacity than is indicated by the number of transmitters. Nevertheless, the number of installed transmitters has been recorded since it is this which is of direct interest when considering the provision of a transmitting station.

Although considerable expansion had taken place at all Post Office transmitting stations between 1940 and 1945, the pressing need for additional circuits led to the expansion of the Rugby A station from 11 to 20 h.f. transmitters between 1948 and 1951 and to plans for a new station to house a further 28. After long and careful search it was decided to locate the new station also at Rugby on an adjacent site of 700 acres. Building work was started in 1952 on the new site, now known as the Rugby B station.<sup>3</sup>

## GENERAL FACTORS IN THE DESIGN OF THE STATION

Much traffic and engineering information is taken into account before a new station is planned; the design of the station is determined primarily by the service requirements, contemporary techniques and assessment of development trends, other information determining the more immediate scale and incidence of expansion being only of transient interest.

The new station had to cater for a considerable expansion in radio telephone services, a few multi-destination press services (mostly using single-channel telegraphy) and a variety of single-channel and multi-channel public telegraph services. Fortunately it has been clear for some time that the independent-sideband system<sup>4</sup> of transmission should be used for radio telephone circuits. The variety of telegraph services is, however, considerable and the technical characteristics of each have to be agreed with the different administrations in the distant countries. Standardization of the technical characteristics is being pursued as rapidly as possible but even so the wide range of services to be covered at Rugby necessitates considerable flexibility in meeting the different technical characteristics. Nevertheless, for economic and operational reasons, it is most desirable to standardize the transmitting equipment as much as possible. A most valuable degree of standardization of

† The authors are Assistant Staff Engineers, Radio Planning and Provision Branch, E.-in-C.'s Office.

equipment has been achieved by dividing the transmitters into two parts:—

- (1) low-power drive units, of only two types, to produce all the required forms of signals at a fixed and common intermediate frequency,
- (2) transmitter-amplifiers, all of the same design, which translate the common intermediate-frequency signals to the radiated frequencies and amplify them to the required power.

The transmitter-amplifiers account for 80 per cent of the transmitter costs.

Of the two types of drive unit, one caters for telephony and the other for telegraphy, and an important feature of station design is that both are segregated from the transmitter-amplifiers. This segregation is economical in space occupied, whilst giving considerable scope for developments in drive units without change in the overall design of the station.

To reduce staff costs all the transmitters are operated from a central control position, where 28 small control panels carry the control switches and monitoring signal lamps for the individual transmitters. A simple six-position switch on each panel selects the preset conditions necessary for all normal frequency changes on the transmitters and the associated switching of aerials.

The factors determining the types of aerial used may be of interest. Up to 1938 the larger aerials built by the Post Office were of the Franklin, Kooman's or TW types.<sup>5</sup> These are essentially resonant, and satisfactory performance is achieved over a narrow band of only a few per cent of the frequency of optimum performance, depending on the size of the aerial and the feeder arrangements. For these types of aerial it is therefore necessary to know the working frequency within the same few per cent before designing and constructing the aerials. The tremendous increase in the use of the h.f. spectrum since that time has greatly increased the difficulty of obtaining frequency assignments for new services, and many assignments are only proved feasible after long tests with directional aerials at each end of the required circuit. Thus non-resonant aerials with suitable radiation characteristics over a range of frequencies of one octave or more are now even more attractive than formerly, as they can be designed, erected and used for testing before the exact working frequency has been agreed. The rhombic type of aerial which is in general use nowadays by the Post Office is a good example of the non-resonant type of aerial. As installed in 1938 its performance in service was quite good at frequencies of 15 Mc/s and above, but its deficiencies at frequencies of 10 Mc/s and below became very evident during the sunspot minimum around 1950. The provision of larger and higher rhombic aerials has largely overcome these deficiencies.

Hence at the Rugby B station rhombic aerials have been adopted for point-to-point services with only one exception, i.e. for the New Zealand route, on which the azimuthal angle of propagation varies widely during the effective transmission periods. For this service stacked arrays of dipoles are used to give a horizontal radiation pattern controllable in three switched steps to cover the very wide variations in angles of transmission whilst retaining a moderate gain by restricting the vertical radiation pattern.

Over 70 aerials have been envisaged as a possible future requirement, and the switching of 28 transmitters to this large number of aerials is a major problem. It could be minimized by restricting the operation of each transmitter to one service only, but even so, it would be necessary to cater for daily frequency-changes which for most services would require the switching of the transmitter between two aerials. The restriction of each transmitter to use on one service only is a handicap in making maximum use of the equipment and in any case additional facilities must be

provided to cater for breakdowns of transmitters. If, in contrast to the restriction of one transmitter to one service, all transmitters were made immediately available to all services a complex and massive switching system would result, the complexity and size being proportional to the product of the number of transmitters and the number of aerials. The arrangement adopted at the Rugby B station lies between these extreme solutions; up to six aerials can be made available to each transmitter by manual pre-selection, and the transmitters are switched automatically to each of their available aerials as required. Any aerial can be connected to any transmitter and any transmitter substituted for another by manual changes of the connexions on the switches. These facilities can also be used in the event of a breakdown of equipment or for temporary traffic and test transmissions.

The choice of the type of feeder connecting the transmitters to the aerials via the switching mechanism depends upon several considerations such as economics, safety of personnel, convenience and freedom from interaction. The aerials are all of the balanced-to-earth type and have input impedances of the order of 600 ohms. Open-wire lines can be readily designed to have the same impedance and also for a given loss are much cheaper than coaxial cables. In addition, it is necessary to ensure that excessive energy is not fed from one transmitter feeder to another, in order to avoid intermodulation in the transmitters and consequent generation of unwanted products. A further reason for avoiding such coupling is that the energy transferred would be radiated from other aerials and would be likely to cause interference. Although the open-wire lines are inferior to coaxial cables from the aspect of "crosstalk", it must be remembered that the feeders are connected to aerials which themselves interact to some extent. Open-wire lines are therefore satisfactory if, as has been done, the crosstalk between feeders is kept to the same order or less than that between the aerials, and they are therefore desirable for the long external section of the feeders. Within the building, however, the problem of accommodating and switching such a large number of lines in a confined space, with due regard to safety of personnel and freedom from crosstalk, can be best solved by the use of coaxial cables. The consequential problem of matching internal coaxial feeders to external open-wire lines was considered and after some preliminary experiments it was decided that a cheap and simple form of exponential line could be constructed to match balanced impedances of 200 ohms and 600 ohms. The matching of balanced to unbalanced impedances at a power of 30 kW appeared to be relatively difficult and uneconomic. Thus pairs of coaxial cables have been adopted inside the building and open-wire feeders outside, thereby obtaining the advantages of both where they are most important.

#### SITE AND BUILDING

The site, shown in Fig. 3, is of flat, mixed arable and pasture land of 700 acres extent adjacent to the existing station, and the layout of the aerials and feeders has been arranged to interfere as little as possible with the agricultural use of the land.

The site area and shape have been chosen so that the foreseen requirements for aerials are met, together with a moderate allowance for future developments. Between 1949 and the present the Post Office has doubled the length, height and breadth of rhombic aerials and, even so, the site area required per aerial system might not yet have reached an economic limit.

The close proximity of the new station to the original site permits joint administration, staffing, emergency power supplies, land-line communications and transport, with consequent economies.



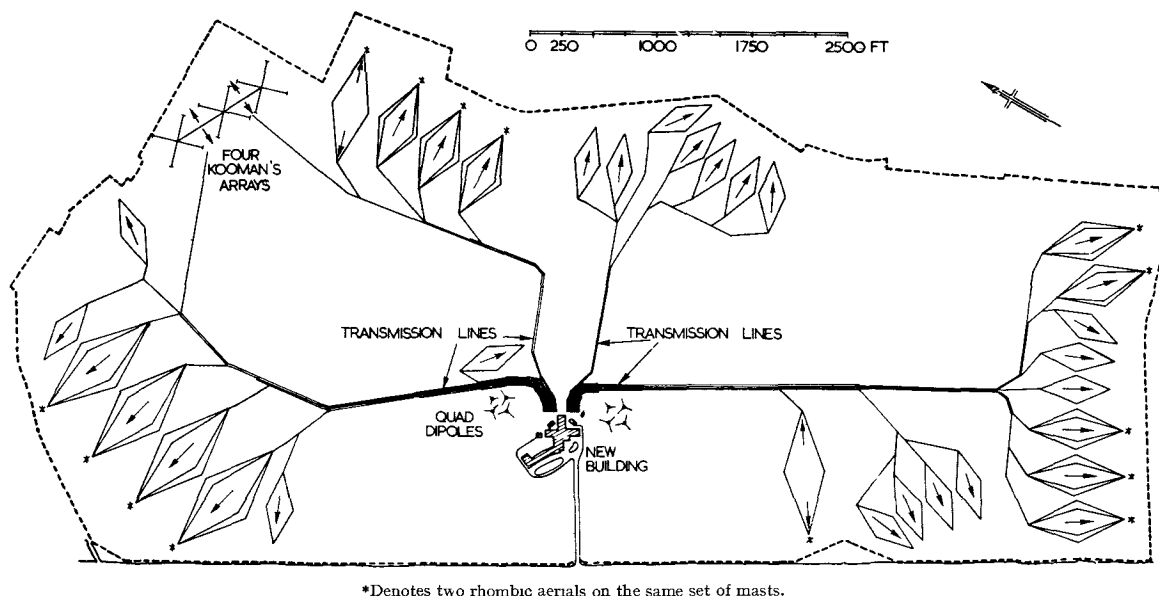

FIG. 3.—SITE PLAN OF THE NEW RUGBY RADIO STATION.

The building, shown in plan in Fig. 4, is divided functionally into four main areas; one, the single curved wing which contains the administration and welfare rooms; a second, which is labelled the rack apparatus room; the third, which consists of three wings containing the transmitter-amplifiers; and finally the area at the centre of the cruciform section, housing the control position. The main entrance is at the junction of the curved wing and one arm of the cruciform section.

Thus the whole of the operational equipment is concentrated in the four wings radiating from the Central Control Position (C.C.P.), which forms the nerve centre of the station where the operational control and supervision of all the transmitters is exercised. The C.C.P. is housed in a glazed structure raised some 2 ft above the general floor level.

The three transmitter wings are each 105 ft long and 30 ft wide; and in wing 3 there are five transmitters on each side. In wings 1 and 2 the arrangement is almost identical except that four transmitters only, making 28 in all, are accommodated on the west sides where the fourth arm of the cruciform structure joins the central area. The three transmitter wings are flanked by fire-proof cubicles for oil-filled equipment and, alternating with these, cubicles for air-cooling plant for each transmitter.

On the fourth side of the central hall are two transmitter-aerial switchrooms and the adjacent rack-apparatus room. The latter is 48 ft × 44 ft and contains drive and monitoring equipment for the transmitters and also repeaters and terminal apparatus for land-lines. The transmitter-aerial switchrooms project above the roofs of the transmitter wings, and coaxial feeders are led out through the rear walls and along the roofs of the transmitter wings.

#### INTERNAL EQUIPMENT

The internal equipment includes a wide range of units, which have been segregated into several groups, as follows:—

- (a) Repeater and terminal equipment for land-lines.
- (b) Drive units for transmitters.
- (c) Frequency-control (or carrier-generating) equipment.
- (d) Transmitter-amplifier units.
- (e) The Central Control Position (C.C.P.).
- (f) Test, supervisory and monitoring equipment.

From these groups, chains of equipment can be set up for transmission using independent-sideband telephony (A3b), double-sideband telephony (A3) and on-off or frequency-shift telegraphy (A1, A2 or F1). Multi-channel frequency-division telegraph signals generated in the voice-frequency range are applied to the independent sideband (i.s.b.) equipments. Such a chain of equipment with alternative choice of drive units for telephony and telegraphy is shown in Fig. 5.

Telephone signals from the Radio Telephone Terminal arrive at the station on audio-frequency land-lines having a band-width of 0.1 to 6 kc/s, and after equalization and amplification are applied to the inputs of i.s.b. drive units. Each audio line can carry two telephone channels, which are associated at the Radio Telephone Terminal in the frequency range 0.25 to 6 kc/s. Two audio-frequency lines are connected to each drive unit, in which the input from each line is translated into a single-sideband signal with a suppressed carrier at 3,100 kc/s; one resulting in an upper sideband and one a lower sideband relative to the carrier. The output of the drive unit comprises the two i.s.b. signals and a reintroduced low-level pilot carrier of 3,100 kc/s, and is extended via a 75-ohm cable to the transmitter-

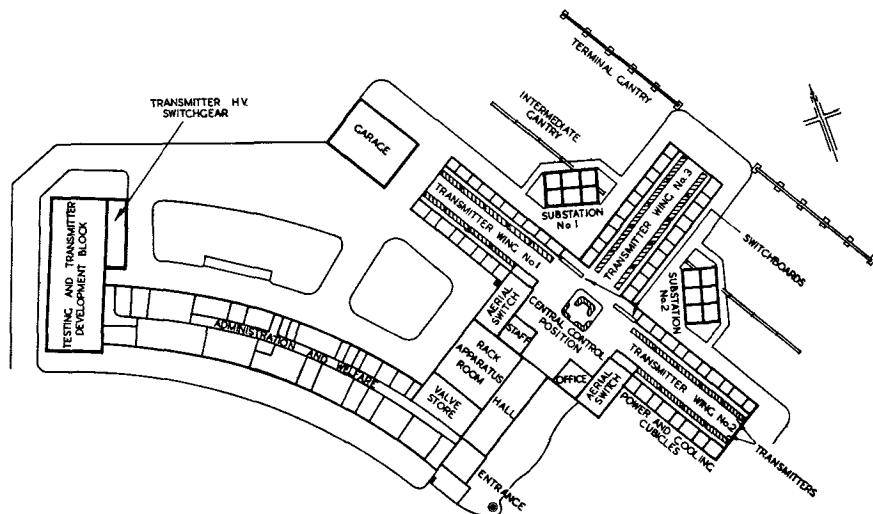

FIG. 4.—PLAN OF THE NEW BUILDING.

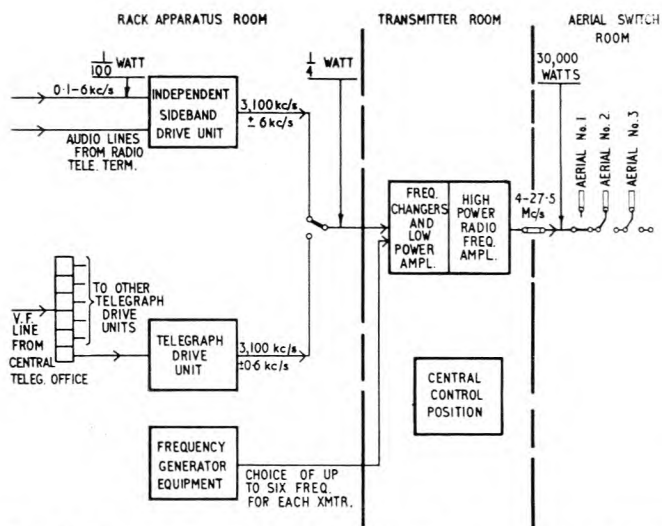

FIG. 5.—BLOCK SCHEMATIC DIAGRAM OF TRANSMITTING CHAIN.

amplifier. Here the signal is first translated to the final radio frequency with the aid of stable carriers from crystal oscillators in the carrier-generating equipment, and then amplified. The signal, at its final frequency (4–27.5 Mc/s) and at full power is then extended to the aerial, thus completing the transmitting-station chain.

It might be noted here that the radiated signals referred to above have the same form of modulation, band-width and relative levels of components as those of the audio-frequency signals applied at the input. The position is somewhat different in the case of single-channel telegraph signals. As shown in the lower half of Fig. 5, several channels from a central telegraph office arrive as a complex voice-frequency signal which has to be separated into the individual channels for transmission to their several destinations. Each channel is then extended as a d.c. signal to a telegraph drive unit and modulates a 3,100-kc/s carrier. The drive unit can be switched to provide outputs which are modulated either for A1 or A2 emissions or frequency modulated for F1 and duplex emissions. In these cases the form of the radio-frequency emission is determined in the drive unit. As for the i.s.b. emissions the signals are extended via 75-ohm coaxial cables to the transmitter-amplifiers and thence to the aerials.

Twenty telephone and 20 telegraph drive units have been installed; both telephone and telegraph drives being available on switches for 12 of the transmitter-amplifiers, telephone drives only for eight, and telegraph drives only for the remaining eight transmitter-amplifiers. A sufficient degree of flexibility has thus been provided for considerable changes in the relative demands for telephone and telegraph types of emission, and the standardization of the fixed intermediate-frequency permits the use of standardized frequency-translation and filtering techniques.

#### Frequency-Generating Equipment.

The radiated frequency of a telephone signal depends on three frequency-changers having carrier frequencies of 100 and 3,000 kc/s in the i.s.b. drive units and  $f_c \pm 3,100$  kc/s in the final modulator, where  $f_c$  is the mid-band frequency of the radiated signal. The 100-kc/s and 3,000-kc/s supplies are derived from a 100-kc/s oscillator maintained within  $\pm 1$  part in  $10^8$  of its nominal frequency. The supplies are fed via distribution amplifiers at a power of 100 mW to the 20 drive units. Change-over to a standby is effected automatically when the main supply fails.

The final frequency-changer (the third for i.s.b. emissions) is the input stage of the transmitter-amplifier and changes in output frequency are required daily to

meet the varying propagation conditions. The frequency-generating equipment supplying the carrier to this frequency-changer is centralized in the rack-apparatus room and comprises a group of up to six crystal oscillators mounted on one 19 in.  $\times$  15 $\frac{3}{4}$  in. panel (i.e. one panel per transmitter). The basic frequencies are generated in the range 3.4–7 Mc/s and fed to the transmitters before being doubled or quadrupled in harmonic generators in the transmitter. The oscillators (Post Office Type No. 35) are quite simple and each is mounted on a strip 12 in.  $\times$  1 $\frac{1}{2}$  in.

The crystals are not temperature controlled except in so far as the room is heated in winter for personal comfort. In these conditions the frequency stability is better than  $\pm 10$  parts in  $10^6$  and in many cases it is much better. The resulting stability of the final radiated frequency depends on whether the frequency is above or below 10 Mc/s, owing to a convention whereby above 10 Mc/s the required harmonic of the crystal frequency ( $m.f_x$ ) is  $f_c - 3.1$  Mc/s and below 10 Mc/s it is  $f_c + 3.1$  Mc/s. Above 10 Mc/s the stability is better than  $\pm 10$  parts in  $10^6$ ; at just below 10 Mc/s better than  $\pm 130$  c/s; and at 4 Mc/s better than  $\pm 70$  c/s.

A rack-mounted frequency-counter is provided and any of the frequency generators can be checked to an accuracy of 1 c/s.

A number of audio-frequency tones are available for test purposes such as the measurement of distortion on the drives and transmitter-amplifiers under two-tone loading conditions. Crystal-controlled oscillators, with gapped-ring crystals vibrating at fundamental frequency, feed distribution amplifiers serving the suites of cabinets in the rack-apparatus room.

#### Transmitter-Amplifiers.

A view of one side of a transmitter wing is shown in Fig. 6; the length of the framework for each transmitter

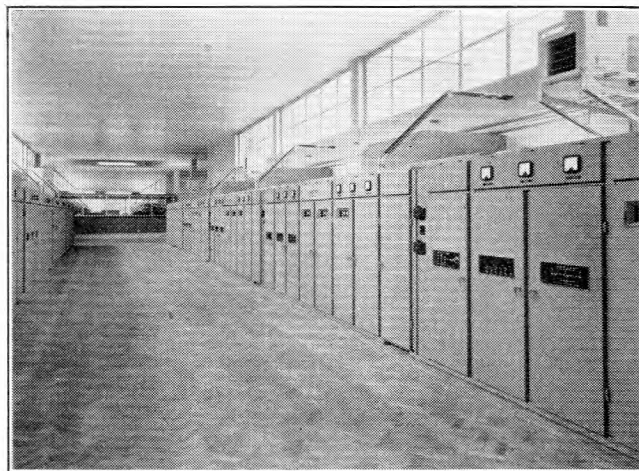

FIG. 6.—ONE SIDE OF A TRANSMITTER WING.

being 20 ft; the height, 7 ft; and the width to the rear, 3 ft 9 in. A transmitter consists of a number of cabinets which are bolted together end-to-end on site. Access along the rear is continuous for the whole length of the room.

The doors to the cabinets of each transmitter are mechanically interlocked with the main power switch on the transmitter and a system of Castell keys prevents access to the high-voltage equipment in the associated cubicles unless the switch is in the "safe" position; in this position an earth is also applied to various supply leads in the transmitter. Filament supplies and power to some of the low-power units may be applied for test purposes via an auxiliary switch, which may be operated with the main switch in

the "safe" position. Limited access is then available but no points are operated above 230V and the mains supply terminals are shrouded.

A block schematic diagram of the transmitter-amplifier is shown in Fig. 7. The input signal at a mid-band fre-

quency  $f_c$  are not greater than  $-56$  dB relative to peak envelope power. Outputs at the second harmonic of the radiated frequency  $f_c$  and the frequency  $m.f_x$ , which are sufficiently far removed from the wanted frequency  $f_c$  to be adequately suppressed in the subsequent tuned amplifier circuits, are at higher levels, i.e.  $-40$  dB and  $-50$  dB respectively, relative to peak envelope power.

Following the frequency-changer are eight linear amplifiers in tandem to give the required output power. In Fig. 7 the first three linear amplifiers are shown inside a rectangle with the frequency-changer and harmonic generators, since separate equipments up to and including the third amplifier are provided for each of six operating conditions. These six units are mounted in pairs on three chassis in one of the transmitter cabinets. The chassis can be withdrawn on roller guides and tilted for ease of maintenance and adjustment.

The further five amplifier stages are re-tuned during frequency changes, and a simplified schematic circuit of these is shown in Fig. 8. The fourth amplifier is a push-pull stage, its output being applied to one diagonal of a capacitance bridge of which the grid-cathode capacitance of the fifth stage forms one arm. A feedback circuit is connected to the other diagonal. The tuning of the fourth and fifth stages is by motor-driven capacitors with mechanically-coupled coil-changing mechanisms.

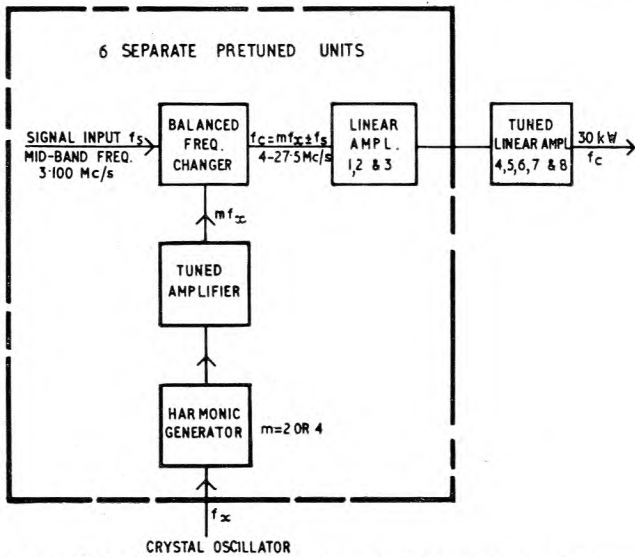

FIG. 7.—BLOCK SCHEMATIC DIAGRAM OF TRANSMITTER-AMPLIFIER.

quency of  $3.1$  Mc/s ( $f_s$ ) is applied to a balanced frequency-changer which is also fed with a carrier  $m.f_x$  via a tuned amplifier and harmonic generator ( $f_x$  being the frequency of the crystal oscillator). In any frequency-changer which depends on a non-linear process unwanted terms are produced in addition to the wanted terms. Some of these unwanted terms may fall near to the frequency required. Products that are well removed from the wanted frequency ( $f_c$ ) may be suppressed in the radio frequency amplifier but those which are near to  $f_c$  cannot. The value of the intermediate frequency ( $3.1$  Mc/s), which is fairly high, assists in reducing the number of values of radiated frequency  $f_c$  for which unwanted components are near to  $f_c$ . The unwanted products involve terms  $p.f_s \pm q(m.f_x)$ , where  $p$  and  $q$  are any integers, and if the carrier supplied to the frequency-changer includes unwanted harmonics of  $f_x$  (in addition to  $m.f_x$ ) the problem is aggravated. The levels of components of frequency other than  $m.f_x$  supplied to the frequency-changer are adequately reduced by a tuned amplifier following the harmonic generators. The use of a balanced frequency-changer also reduces some of the unwanted products as compared with an unbalanced unit, and further products, usually high-order terms, are reduced by the use of a large ratio of carrier/input-signal and an approximately square-law characteristic. This design has ensured that products which, on certain radio frequencies,

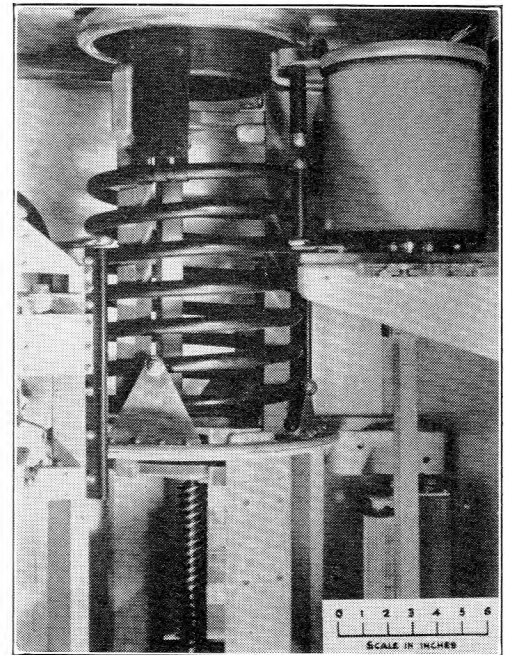

FIG. 9.—VIEW OF R.F. CIRCUIT SHOWING VARIABLE INDUCTOR AND CAPACITOR.

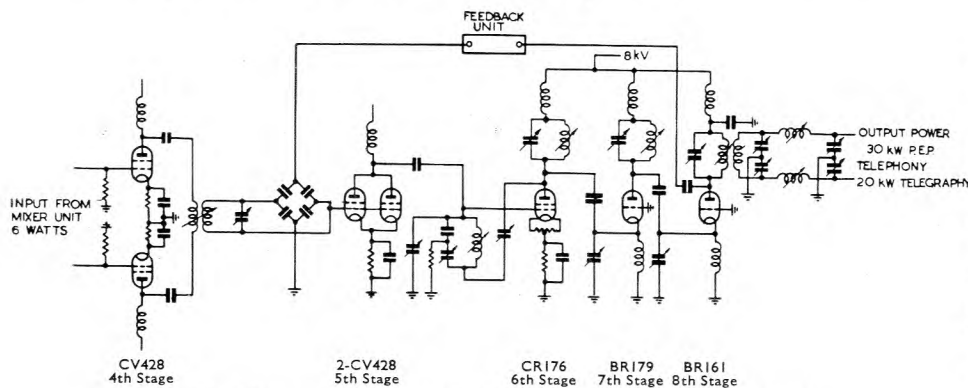

FIG. 8.—SIMPLIFIED SCHEMATIC DIAGRAM OF LINEAR AMPLIFIER.

A tetrode is used in the sixth stage and grounded-grid triodes in the seventh and eighth stages. Voltage feedback occurs in each of the grounded-grid stages as a result of electronic coupling in the valves. Of the  $2.8$  kW available at the anode circuit of stage 7,  $2.3$  kW is fed forward and combines with the power of  $27.7$  kW generated in stage 8 to give the total output power of  $30$  kW.

The range of frequency over which the transmitters can be tuned is  $4$  to  $27.5$  Mc/s, i.e. a minimum/maximum



ratio of 1/6.875, and on units that are physically large it is not easy to avoid unwanted resonances in connecting leads or cabinets over the whole frequency range. The performance achieved in this respect is extremely good and is due in large measure to the compactness and simplicity of the circuit arrangements. In stages 6, 7, and 8, the inductors and capacitors are of interest and a photograph of stage 6 is shown wherein both are readily visible from the rear (Fig. 9). The coil, of 0.75-in. diameter copper tube, is fixed and the upper end is connected directly to the metal support of the valve anode. A single-ball contact mounted on a beryllium-copper spring riveted to a short-circuiting ring determines the number of turns in use. Three subsidiary contacts spaced at one-quarter turn intervals are similarly mounted and make the mechanical pressures symmetrical.

The capacitor also is continuously variable and the contractor has developed an extremely compact unit. Sulphur hexafluoride, a stable and inert gas, is used as the dielectric and has an electric strength at a pressure of 30 lb/in<sup>2</sup> equal to that of nitrogen at 200 lb/in<sup>2</sup>. Each electrode comprises five concentric cylinders of burnished copper and one electrode can be moved axially. The container is a Vitrosil cylinder with end caps of Invar affixed by araldite. With an initial gas pressure of 35 lb/in<sup>2</sup>, the capacitors are expected to have an indefinitely long life.

In the last stage a 2-turn coupling coil encircles the upper turns of the tuning coil and is fixed in position. The turns can be connected in series or parallel and are extended to the feeder coupling circuit mounted in the adjacent cabinet. This circuit is balanced to earth and caters for standing wave ratios (s.w.r.) up to 2:1 on the nominal 200-ohm feeder. This provides an ample margin on the values of s.w.r. normally expected in service, which are better than 1.2:1. The output circuit is also designed to be an efficient harmonic filter, and on full power the harmonic power is generally less than 20 mW (less than -50 dB relative to the fundamental component).

Reverting to stage 8, feedback is taken from the anode of the valve by a capacitor to a feedback unit at the front of the preceding cabinet. In this unit the level and the phase of the feedback signal can be adjusted and thence the signal is extended via a coaxial cable to the capacitance bridge at the input to stage 5. The amount of feedback is not large, being 8 dB when expressed as a reduction of gain of the last four stages. At full power the third-order intermodulation products are -36 dB relative to either tone of a two-tone test. Without feedback the corresponding figure is -28 dB.

A further feature of the transmitter design is the layout of the larger auxiliary power-supply units. Large oil-filled units such as the transformers for the various rectifiers have been segregated in fire-proof cubicles adjacent to the transmitters.

The rectifying elements for the 8-kV h.t. supply to the high-power stages are grid-controlled mercury-arc rectifiers; six single-anode valves mounted in two rows in one of the transmitter cabinets form a very compact unit and are readily accessible. The grid-control is used for initial switching of the h.t. supply in steps of one-third, two-thirds, and full voltage, and also high-speed suppression of overloads with automatic re-application of the voltage. The reduced voltage on initial switching is applied for a few milliseconds only, and if subsequently three overloads occur in quick succession the high voltage is removed until action is taken to clear the fault condition and the unit is re-set.

Heat corresponding to the cathode heating power of 1.5 kW and some 14-kW anode dissipation has to be removed from the anode of the final stage, under peak-envelope-power conditions, and smaller amounts of heat have to be

removed from the preceding stages. For this purpose, filtered air is drawn into the top of the cabinets, around the cathode and grid seals, through the valve anode fins, past the tuning coils and thence into a duct below the transmitter, by a slow-speed fan mounted in a cubicle behind the transmitter. The air discharged from the fan can be directed either outside the building or back into the transmitter hall to give direct heating of the transmitter wings.

#### CENTRAL CONTROL AND MONITORING

In the preceding description of the transmitter mention has been made of motor-driven tuning devices. Motor drives are also fitted on the amplitude and phase control of the feedback unit, the output-feeder matching circuits and on all units requiring adjustment during a change of frequency. All these motors can be operated from a control panel on the face of the transmitter for initial line-up and testing. Each driving mechanism incorporates a spindle carrying six cams which can be preset to stop the driven component in any one of six positions as required. Automatic control of the transmitter can be effected either at the transmitter or, as in normal service, from the Central Control Position.

#### *Central Control Position.*

With only rare exceptions the traffic from the station is transmitted on frequencies and under conditions which are known well in advance; some of the transmissions are on prearranged time schedules, and on others the general trend of the traffic and wave-changes are known, only the exact incidence of wave-changing being unknown. Thus the transmitters are set up for preselected conditions and brought into use under switch and push-button control at the central control position (Fig. 10). Thirty transmitter

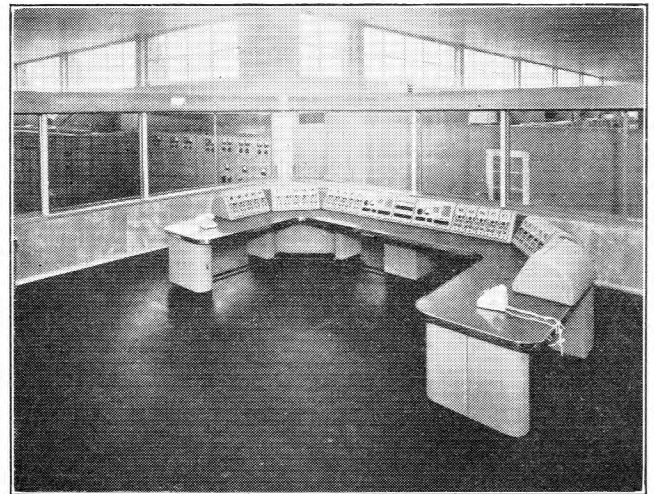

FIG. 10.—THE CENTRAL CONTROL POSITION.

control panels (two are spare) are mounted in a U-shaped console. On other panels centrally placed on this console, facilities are provided for communication by telephone order-wires to the London telegraph and telephone terminals, to various points of the transmitting station and by loud-hailer to staff in the transmitter wings. The control officer can listen to any one of the transmissions but the burden of monitoring is carried by automatic monitoring equipment. Each transmitter control panel is fitted with a six-position switch and on-and-off push-buttons, together with lamp indicators, to show:—

- (a) that the switching operations required have been completed, and
- (b) the presence of either a fault or of an abnormality in the transmission chain by an urgent or a non-urgent alarm.

The indications of faults or abnormalities are initiated in a variety of equipments. Automatic monitors compare the radiated signals with the corresponding land-line signals; the level of the pilot carrier of each i.s.b. emission is monitored by equipment built into the i.s.b. drive unit; and the reflection coefficients on the coaxial cables at the outputs of the transmitters are measured by reflectometers.

Thus the controlling officer can effect the starting and frequency-changing operations on all the transmitters and has a clear picture of the state of affairs at any moment. In the event of a fault or abnormality he can call for remedial action.

#### Monitoring and Test Equipment.

The automatic signal-monitors, provided for checking the operation of the transmitters on single-channel telegraphy and on telephony, have two inputs; one taken from the incoming land-line signal and one from the output of the transmitter after conversion to the same form as the land-line signal. For telegraphy the signals are in direct-current form and the two signals cause charges to be built up on two resistor-capacitor circuits, and whenever the difference in potential on these networks exceeds a predetermined value the event is recorded on a counter; a second counter is also operated and if more than four such events are recorded in half a minute an alarm relay is operated. The same counting units are used for monitoring telephone signals, the input circuits being modified so that the envelopes of the two audio-frequency input signals are compared.

A variety of test equipment is provided for checking levels on land lines and other parts of the equipment and as far as possible this equipment follows normal Post Office practice. A trolley-mounted spectrum analyser, developed initially to measure the spread of any radio-frequency emission in the range 3 to 30 Mc/s, is used to measure the intermodulation products. It is essentially a narrow-band receiver which is repeatedly tuned through the spectrum of the signal under examination and gives a display of the components on a cathode-ray tube. The vertical trace is logarithmic over a range of 30 dB and the horizontal trace is linear with frequency. The range of scan can be adjusted from 300 c/s to 40 kc/s, and the period of scan in three steps of 1, 10 and 30 sec. Three narrow-band filters are available (6, 30 or 150 c/s band-width) to suit the range and rate of sweep. After adjustment of the maximum level to be used as a reference, the vertical display can be switched to show levels from 0 dB to -30 dB or -30 dB to -60 dB relative to the reference. This equipment has proved extremely useful as a general test instrument at 3.1 Mc/s and throughout the final radio frequency range; two equipments are available as maintenance tools.

#### EXTERNAL AND AERIAL-SWITCHING PLANT

About 70 aerials have so far been provided and space has been reserved for more. The requirements of some radio circuits are easily met by aerials of moderate gain operating over a moderate frequency range away from the lower end of the h.f. spectrum and not radiating at very low angles of elevation. For these circuits aerials suspended from spliced poles are provided. Other circuits, however, are much more difficult to work satisfactorily, and require aerials of the highest practicable

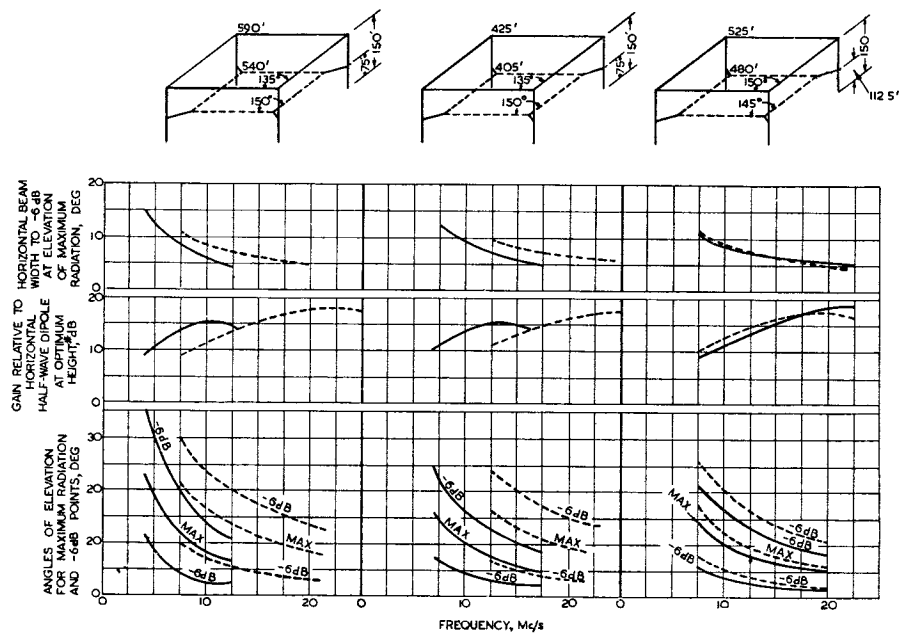

\*This gain is 6 dB less than the gain referred to a dipole in free space.

FIG. 11.—CHARACTERISTICS OF LARGE RHOMBIC AERIALS.

gain covering substantially the full h.f. spectrum and radiating at low angles of elevation. To achieve a sufficient gain at a frequency of about 4 Mc/s aerials of twice the size of those referred to above are necessary, and to keep the angle of elevation of the main beam low the aerials have to be supported at considerably greater heights. It is for such cases that pairs of large concentric rhombics are used, the larger and higher ones covering the lower part of the frequency spectrum and the somewhat smaller and lower ones covering the upper part of the spectrum. The pairs of rhombics used for transmission to Australia are also made reversible, because propagation conditions are sometimes better on the long route than on the short route. The characteristics of three designs of pairs of large rhombics are given in Fig. 11. Because of the height of these aerials, light steel masts are used for their support.

The sides of all rhombics are constructed of three wires, the spacing of which is varied along the aerial to preserve constancy of impedance and thus avoid reflection of power. The power that reaches the far end of a rhombic aerial has to be absorbed in a dissipative resistance, which, for high-power transmitting rhombics, takes the form of a 2-wire line built of highly-magnetic iron wire.

For the New Zealand circuits, on which deviations in the direction of propagation of up to  $\pm 30^\circ$  from the mean direction have been observed, resonant aerials giving wide angular coverage in azimuth are provided. By de-phasing these aerials (under remote control from the station building) the normal beam can be split into two beams lying one on each side of the mean direction, and by further switching the direction of transmission can be reversed. These aerials are suspended from three 325-ft masts.

The open-wire transmission lines to all aerials are constructed of 400 lb/mile hard-drawn copper wire and have an attenuation of about 1 dB/1,000 yd at 10 Mc/s. To minimize electrical discontinuities the insulators are of low capacitance and binding-in wires are not used.

The two-wire transmission lines are terminated mechanically at a steel gantry which is parallel to, and 135 ft from, the building; there they are connected to the exponential matching lines which continue to the building parapet, where connexion is made to the coaxial feeders from the internal switching-mechanisms. The layout of the feeder and matching-line system at the building is shown in

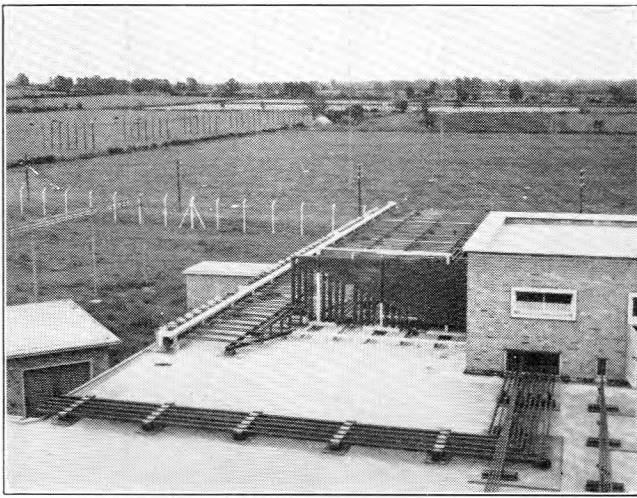

FIG. 12.—LAYOUT OF THE FEEDER AND MATCHING-LINE SYSTEM.

Fig. 12, which shows the coaxial feeders on the building roof, the intermediate and terminal gantries supporting the exponential lines, and gantries on the route of a transmission-line in the background. The exponential lines are of 4-wire construction, tapered in elevation and in plan, and give a close approximation to an exponential gradation of impedance.

The coaxial feeders are built of copper tubes, the cores being 0.3-in outside diameter and the sheaths having an inside diameter of 1.5 in. Three-leg ceramic insulators soldered to the cores at 1-ft intervals preserve concentricity of the conductors, and sliding joints in the cores at appropriate points cater for differential expansion. The attenuation of this type of feeder is 0.063 dB/100 ft at 10 Mc/s, and is closely proportional to the square-root of the frequency.

One of the two aerial switches is illustrated diagrammatically in Fig. 13 (a). It comprises 14 "decks," to each of which the twin coaxial feeder from one transmitter is connected. Twin coaxial cables (forming the indoor ends of the transmission lines to the aerials) hang vertically on each side of the switch and by telescopic terminations any of these aerial cables can be manually connected to any switch deck.

Each deck consists essentially of a twin coaxial feeder in which switching units can be mounted at any points for connexion to the selected aerial cables. In each switching unit, switch blades either divert the cores of the deck feeders to the aerial cables connected to the sides of the unit or connect them to the next unit. This is indicated schematically in Fig. 13 (b), which shows three switch units located at desired points in a deck by means of make-up pieces of twin coaxial feeders. With the blades in the position shown, the transmitter is connected to one of the three aerials available to it and the temporarily unwanted connexions to the other two are broken.

The switch units are automatically operated by a motor at the end of each deck, the motors being controlled by signals from the associated transmitters. Revertive check signals ensure that a transmitter cannot be energized until all switching operations have been correctly completed. To cater for emergencies, cross-connexion facilities have been provided to enable any transmitter feeder to be connected to any deck, and any two transmitters and any two aerials to be connected to the other switch. Arrangements are in hand for the demountable parts of the switch and feeders to be air pressurized so that inadvertent separation of working parts will automatically stop the associated transmitter.

External construction work on site was preceded by a considerable amount of detailed surveying, and a network of trigonometrical survey-stations covering the whole site is permanently marked by concrete obelisks. From these the positions for all aerial-supporting structures have been determined.

For the smaller aerials, about 70 spliced poles 80-90 ft high have been erected. The larger rhombic aerials are supported on 65 steel masts 150 ft high, and the New Zealand aerials on three 325-ft masts. Over a thousand 24-ft poles have been provided for carrying 50 miles of 2-wire transmission and absorber lines, and for other purposes. A pole-hole borer was of inestimable value, and it enabled up to 120 holes to be excavated in one day. The 150-ft light steel masts, which are triangular in section and stayed at four levels, were specially designed for supporting the large rhombic aerials. The masts are supplied in pre-fabricated lengths of 12 ft 6 in., which can easily be carried by two men; twelve of these sections are bolted together end to end on the ground and raised by a "falling derrick." Portability and ease of assembly and erection were dominant features in the design.

The 325-ft masts were erected piecemeal with the aid of a floating derrick supported within the top of the completed portion of a mast.

#### POWER SUPPLY ARRANGEMENTS

For supplying the new station with power, the high-voltage distribution system at the old station was rearranged and extended. Two 11-kV power cables from the old station follow separate routes to the new station, each being capable of handling the maximum load of 1,400 kVA. As shown in Fig. 14, the two feeders supply two interconnected substations at the rear of the new station building, one of the feeders also supplying the transmitter testing and development block. Additional engine generators have been installed in the power house at the main station to cater for the new station load in emergencies.

Owing to the limitation on fault-clearance time imposed by the supply authority, a balanced-current feeder-protection system has been adopted in which the feeder system is divided into overlapping zones any one of which is automatically isolated in the event of a fault occurring in it, without affecting the supply to the others.

Power is distributed to groups of transmitters by bus-cables from two medium-voltage switchboards. As the

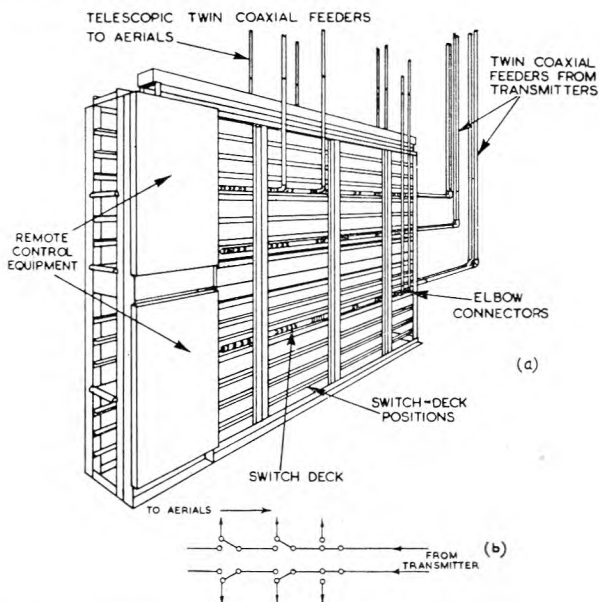

(a) Three switch decks in position, two being connected to two aerials.  
(b) Schematic diagram showing three switch units in one deck.

FIG. 13.—AERIAL SWITCH.



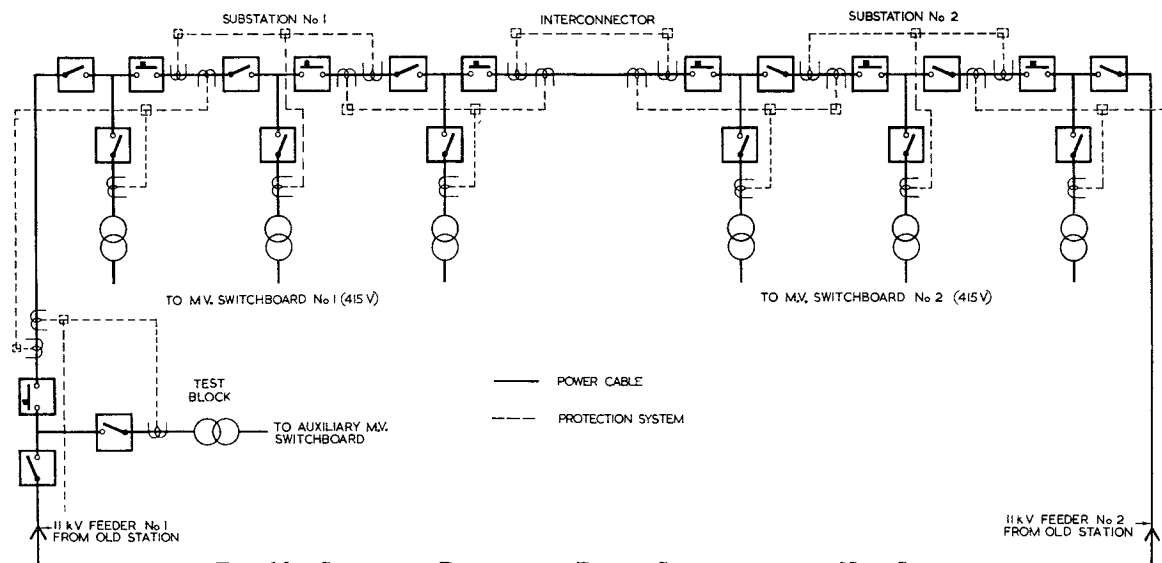

FIG. 14.—SCHEMATIC DIAGRAM OF POWER SUPPLIES AT THE NEW STATION.

grid-controlled mercury-arc rectifiers in the transmitters will clear overloads more quickly than can any circuit-breaker, the medium-voltage bus-cables have to be protected against catastrophic failure only, and this is achieved most simply by high-rupturing-capacity fuses in the group and individual feeders to the transmitters.

#### ACKNOWLEDGMENTS

Many Branches and individuals in the Post Office Engineering Department, the External Telecommunications Executive and several Regions contributed in this work. The contribution of the Ministry of Works stands out, and also that of the main engineering contractor, the Marconi Wireless Telegraph Co., Ltd., whose co-operation during

the work has been much appreciated, and to whom acknowledgment is due for permission to publish the photograph in Fig. 9.

#### References

- <sup>1</sup> SOWTON, C. W., and BALCHIN, D. B. The New London Radio-Telephony Terminal. *P.O.E.E.J.*, Vol. 44, p. 25, April, 1951.
- <sup>2</sup> WEST, W., COOK, A., HALL, L. L., and STURGESS, H. E. The Radio Transmitting Station at Criggon. *Journal I.E.E.*, Vol. 94, Part IIIA, p. 269, 1947.
- <sup>3</sup> BOOTH, C. F., and MACLARTY, B. N. The New High-Frequency Transmitting Station at Rugby. *Proceedings I.E.E.*, Part B, p. 263, 1956.
- <sup>4</sup> BRAY, W. J., and MORRIS, D. W. Single-Sideband Multi-Channel Operation of Short-Wave Point-to-Point Radio Links: Part I.—General Survey. *P.O.E.E.J.*, Vol. 45, p. 97, Oct. 1952.
- <sup>5</sup> WALMSLEY, T. "An Investigation into the Factors Controlling the Economic Design of Beam Arrays." *Journal I.E.E.*, Vol. 74, p. 543, 1934.

## Book Reviews

"Correcting Television Picture Faults." John Cura and Leonard Stanley. Iliffe. 69 pp. 149 ill. 3s. 6d.

This is a most useful little paper-backed handbook with 149 photographs illustrating the many different forms of distortion and interference that can appear on a television picture due to incorrect setting of the controls, faults in the receiver, or interference from external sources. The pictures are by John Cura, who has made a considerable name for himself by photographing pictures from the television screen; the accompanying text, on the adjustment of receiver controls and assisting in the diagnosis of faults and the identification of sources of interference, is by Leonard Stanley.

On the whole the pictures are excellent illustrations of the effects they represent, but the very first two pictures on page 1 are open to some criticism. These purport to show the B.B.C. and I.T.A. tuning signals correctly reproduced, but in fact the I.T.A. signal has been compressed a little in the vertical direction so that its aspect ratio is wrong. As the two illustrations appear side by side the error is particularly noticeable. But apart from this the booklet will prove most helpful in enabling the uninitiated to identify troubles occurring in their television receivers.

T. K.

"Introduction to Color TV." M. Kaufman and H. E. Thomas. Chapman & Hall. 156 pp. 87 ill. 25s.

The authors introduce their subject by posing a number of questions of interest to the layman—and giving the answers. In reply to the question "How much will a colour television receiver cost?" they suggest that it would not be surprising to see a table model at less than \$500 before the end of 1956. In this their judgment is good, for a model is now (October 1956) advertised at \$499.95!

They go on to discuss in a simple and clear manner the fundamentals of colour as far as is necessary for colour television, and follow with a description of the N.T.S.C. system adopted for use in the U.S.A. The major portion of the book is devoted to a description of colour television receiver circuitry with particular reference to the differences between monochrome and colour receivers. Included are the complete circuit diagrams for the C.B.S. Columbia Model 205 and the R.C.A. Model CTC 4 receivers.

The final chapter of the book deals with the adjustment of colour television receivers. Without going into great detail the chapter gives an idea of the complexity of adjustment of colour receivers—one of the major problems to be faced when a colour television service is introduced in this country. The book will serve as an excellent introduction to those who have to deal with this problem.

T. K.



# A New 4-Mc/s Coaxial Line Equipment —C.E.L. No. 6A

M. E. COLLIER, B.Sc. (Eng.), A.M.I.E.E.  
and W. G. SIMPSON, B.Sc., A.M.I.E.E.†

U.D.C. 621.395.44:621.315.212.029.56

The coaxial line equipment described in this article (C.E.L. No. 6A) is the first equipment not of Post Office design to be adopted for large-scale use in the United Kingdom. It is suitable, without alteration, for the transmission of either 16 telephony supergroups (960 circuits) or a 405-line television signal. C.E.L. No. 6A differs from systems of Post Office design in that a single amplifier with most components duplicated is used instead of duplicate amplifiers with automatic change-over; also, the compensation of changes in attenuation due to changes of cable temperature is effected by varying the gain/frequency characteristic of the amplifier instead of by inserting and removing fixed equalizing networks. These features enable a very simple supervisory system to be used. The equipment is of 51-type construction and is operated entirely from an a.c. mains supply; power being fed over the cable to a maximum of six dependent stations on each side of a power-feeding station.

## INTRODUCTION

THE extensive coaxial cable network in the United Kingdom has, in the past, been fitted almost exclusively with line equipments of Post Office design. Following the trial system put into service between London and Birmingham in 1938<sup>1</sup> and extended in 1940 to Manchester, standardized systems were developed—Unit Bay 1B,<sup>2</sup> Coaxial-Equipment, Line, (C.E.L.) No. 1, 1A, 2, 2A and 2B—which were suitable for installation on standard  $\frac{3}{8}$ -in. coaxial cable pairs with repeater sections not exceeding 6 miles long; these systems provided a working transmission band from 60 kc/s to 2,540 kc/s with a capacity of 600 speech circuits, i.e. ten 60-circuit supergroups. With the exception of three links equipped with a British manufacturer's design of line equipment, these systems are at present providing all the telephone circuits on the coaxial cable network.

Later developments have been C.E.L. No. 3<sup>3</sup>—a system for the transmission of a 3-Mc/s television signal using line frequencies in the range 3–7 Mc/s—and C.E.L. No. 4,<sup>4</sup> 4A and 5. C.E.L. No. 4 is a system for the transmission of a 3-Mc/s television signal using line frequencies in the range 60 kc/s to 4,340 kc/s, and C.E.L. No. 4A is an improved equipment which is equally suitable for the transmission of 17 telephony supergroups. C.E.L. No. 5 is a simplified version of C.E.L. No. 4 for use on short television links.

Coaxial Equipment, Line, No. 6A—the line equipment to be described in this article—is the first equipment not of Post Office design to be adopted for large-scale use in the Post Office coaxial cable network. It has been derived from a system designed by Standard Telephones & Cables, Ltd.,<sup>5</sup> which is in service in a number of overseas territories. The design follows that of an earlier 2.6-Mc/s line equipment, first produced in 1946, which has been used for telephone service on two routes in the United Kingdom and has given very satisfactory performance. An installation of the early Standard Telephones & Cables, Ltd., 4-Mc/s equipment was made in the United Kingdom in 1952 and was subjected to an extensive field investigation of its performance. As a result of this experience the new system—Coaxial Equipment, Line, No. 6A—was developed to meet Post Office requirements. The early equipment was subsequently modified to be suitable for the transmission of 405-line television signals and in 1955 was placed in service as the first part of the permanent B.B.C. television link to Europe.

C.E.L. No. 6A transmits a band of frequencies from 60 kc/s to 4,092 kc/s and is suitable, without change to the line equipment, for the transmission of either 16 telephony supergroups (960 circuits) or a 405-line television signal. It is intended for use on  $\frac{3}{8}$ -in. coaxial pairs with repeater-station spacing not exceeding 6.125 miles and conforms to the recommendations of the C.C.I.T.T. (formerly C.C.I.F.) for such line systems. There are two important differences

between the existing systems of Post Office design and C.E.L. No. 6A. First, C.E.L. No. 6A does not use duplicate amplifiers with automatic change-over but has a single amplifier with most of the components in each valve stage duplicated; arrangements for manual change-over to a spare amplifier are, however, provided for maintenance purposes. Secondly, the compensation for changes in cable attenuation with temperature is effected by varying the gain/frequency characteristics of the line amplifiers instead of by inserting or removing fixed equalizing networks. The variation is controlled automatically by the level, at the output of the line amplifier, of a 4,092-kc/s line pilot signal. As a result of these features only a very simple supervisory system is needed and remote control of intermediate stations is eliminated. Greater reliability in the supervisory system is thereby achieved and the power consumption of the stations is reduced, thus allowing more stations to be fed from a power-feeding station. The reduction in the number of power-feeding stations contributes to increased reliability of the system as well as to reduction in cost.

The power-feeding circuit of the C.E.L. 6A system is balanced to earth, using the centre conductors of the two directions of transmission with a potential difference of 1,000V r.m.s., 50 c/s (500V between each centre conductor and earth), and up to six stations can be fed on each side of a power-feeding station.

All the equipment is of 51-type construction, and there are three types of repeater station equipment:—

- (i) Terminal stations, identical equipments being used at each end of the line link.
- (ii) Power feeding, or "main," stations, used as intermediate power-feeding stations and giving facilities for the insertion and extraction of circuits, if required.
- (iii) Dependent, or auxiliary, stations, used at all other intermediate stations.

## DESIGN OF THE SYSTEM

The equipment has been designed for use primarily on the present Post Office standard type of coaxial cable (type 375E), which has an outer conductor of 0.375 in. internal diameter and polythene disk separators. The attenuation/frequency characteristic of the cable is as shown in Fig. 1. At frequencies above 1 Mc/s this may be represented very closely by,

$$3.75\sqrt{f} + 0.01f \text{ dB/mile at } 10^\circ\text{C},$$

where  $f$  is the frequency in Mc/s.

The term involving  $\sqrt{f}$  represents the losses due to the effective resistance, and the term involving  $f$  represents the losses due to leakage. The resistance term increases with increasing temperature, the temperature coefficient being 0.21 per cent/°C, half that of the resistance of copper. The leakage term has a small temperature coefficient and as this term itself is small it can be neglected, at least up to 4 Mc/s, resulting in the attenuation changes with temperature being almost exactly proportional to  $\sqrt{f}$ .

† Mr. Collier is with Standard Telephones & Cables, Ltd., Woolwich, and Mr. Simpson is an Executive Engineer in the Transmission and Main Lines Branch, E.-in-C.'s Office.

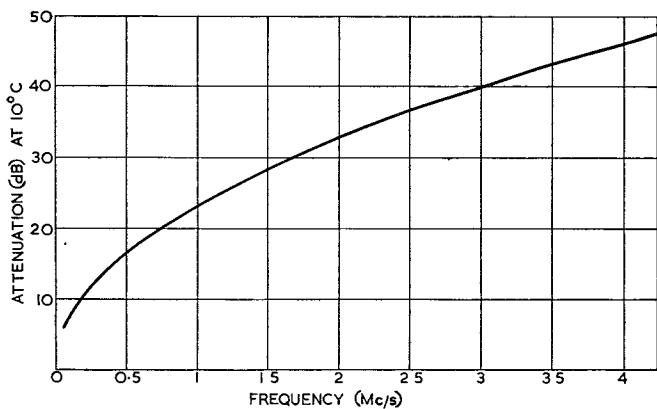

FIG. 1.—ATTENUATION OF 6.125 MILES OF 375E-TYPE COAXIAL CABLE.

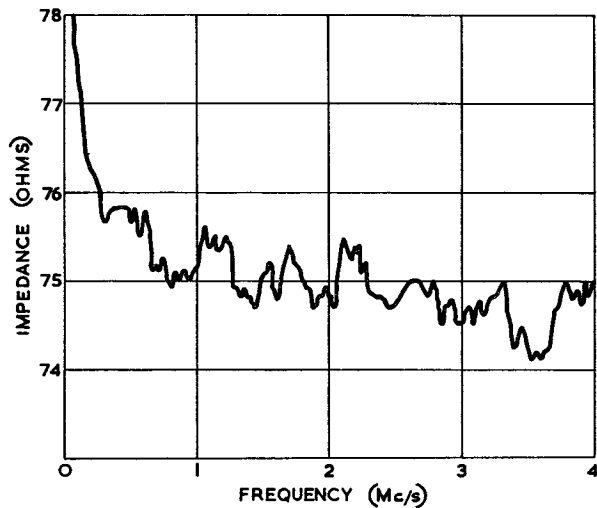

FIG. 2.—TYPICAL IMPEDANCE/FREQUENCY CHARACTERISTIC OF 375E-TYPE COAXIAL CABLE.

A typical impedance/frequency characteristic for a repeater section of the cable is shown in Fig. 2. The irregularities, due to minor reflections caused by impedance mismatches at joints and between manufacturing lengths, are normally well within the specified maximum deviation of 3 per cent from a smooth curve.

#### Principles of Design of the High-Frequency Path.

The most important characteristic limiting the design of long-distance high-frequency cable systems is usually noise. Noise is contributed by all the equipment in a system, frequency-translating equipment and line equipment, and hence the signal/noise ratio on a given circuit depends on the number of line amplifiers, i.e. on the length of the line, and the number of frequency-translation processes at terminal and intermediate points. To assist designers the C.C.I.T.T. has therefore specified a "hypothetical reference circuit"<sup>6</sup> for carrier telephone circuits routed over coaxial cable pairs containing a defined number of frequency translations, the number being reasonably great but not the largest number that could be obtained in extreme cases. This reference circuit is shown in block schematic form in Fig. 3 and has a length of 2,500 km (1,560 miles), which gives an average of 280 repeaters in each direction of transmission for circuits using Coaxial Equipment, Line, No. 6A. The mean psophometric power at a point of zero relative level on a telephone channel routed over the reference circuit, with a psophometer including the 1951 telephone circuit weighting network,<sup>7</sup> should not exceed 10,000 pW (— 50 dBm\*) during any hour.

\*dBm—decibels relative to 1 mW.

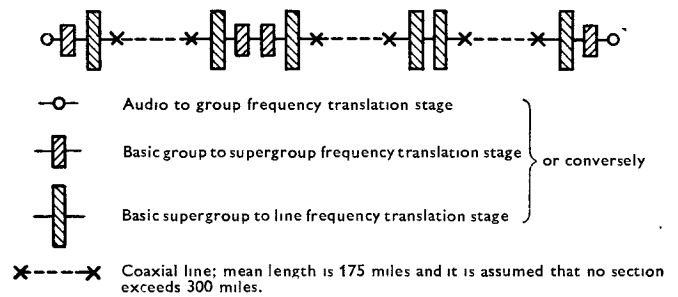

The circuit is 2,500 km (1,560 miles) in length and comprises three audio to-audio links in tandem, each having the circuit formation shown above.

FIG. 3.—C.C.I.T.T. HYPOTHETICAL MAXIMUM-LENGTH CIRCUIT ON COAXIAL CABLE.

Of the total noise, one quarter is allocated to the frequency-translating equipment, and the remaining three quarters to the high-frequency line. This means that the average psophometric power produced by the line during any hour should not exceed 3 pW/km (4.7 pW/mile) when measured at a point of zero relative level.

Noise arises in carrier systems from three main sources: basic noise, comprising thermal-agitation and valve noise; intermodulation noise due to non-linearity; and induced noise (including crosstalk) from external sources. On carrier systems in symmetrical pair cables and on open-wire lines noise induced from external sources and other systems is an important contributor to the total noise, but in coaxial cable systems induced noise is negligible because of the extremely good self-shielding properties of the coaxial pairs at the relatively high frequencies used. The total permissible noise in a coaxial cable system is therefore divided between basic and intermodulation noise, and for C.E.L. No. 6A approximately equal values are allocated to each source.

The relative contributions of thermal-agitation and valve noise to the total basic noise of the line amplifier is determined by the step-up ratio which can be achieved by the transformer network coupling the line to the grid of the first valve and the noise performance of the input valve. For wideband amplifiers suitable for use as line amplifiers in coaxial cable systems this usually results in the total amplifier basic noise being about 2-3 dB higher than the thermal noise in the resistance closing the input. From this, and the basic noise allocation, is determined the lowest test level to which a signal may be allowed to fall. For a telephone channel and with a repeater spacing of about 6 miles this is of the order of — 60 dB. (Test level being the level at a point in a transmission system, resulting from the application of a signal of 1 mW at the point of origin, usually the two-wire side of the hybrid coil.)

Intermodulation noise is a consequence of non-linearity in the transmission path, primarily in the output stage of the line amplifiers, and is dependent in a complex way on the total load (speech, pilot signals, signalling tones, v.f. telegraph channels, etc.) being carried by the path at any instant. Several methods of estimating the total noise power resulting from intermodulation have been proposed and it is of interest that two of these methods<sup>8,9</sup> with different approaches agree closely when the same fundamental data are used. The intermodulation-noise power produced by a line amplifier, determined by the distortion coefficients of the valves in the output stage and the amount of negative feedback which can be applied at the highest frequency used, increases rapidly as the output level is raised and sets the upper limit to the level at the amplifier output. As discussed later, the total power to be delivered by the output stage of the C.E.L. No. 6A line amplifier is reduced by the use of an output-coupling network giving maximum transference of power at the highest frequency. It will be

seen that consideration of these two main sources of noise establishes the maximum repeater section loss that can be used, which for this system is 48 dB and at 4.1 Mc/s corresponds to a section length of 6.125 miles—the length already in use on existing coaxial cables in the United Kingdom.

For television transmission, basic noise is a limiting factor but, as the vestigial sideband method used in the British network<sup>10</sup> employs a high level of transmitted carrier, non-linearity mainly results in a pattern interference by the second and third harmonics of the 1.056-Mc/s carrier. To reduce the magnitude of this interference a shaping network that reduces the level of the carrier relative to the video sideband by some 18–20 dB is inserted in the output of the television translating equipment at the transmitting terminal, and an inverse network is placed in the output of the receiving line terminal.

Although crosstalk does not make an appreciable contribution to the circuit noise of telephone channels, intelligible crosstalk between the two directions of transmission of a system becomes significant for music (program) circuits. The C.C.I.T.T. recommendations for such circuits 1,000 km (621 miles) in length is 74 dB crosstalk ratio, and C.E.L. No. 6A has been designed with this in mind.

#### Equalization.

Equalization, the correction of the variation of cable attenuation with frequency, may be carried out either by using passive equalizer networks having an attenuation/frequency characteristic that is the inverse of the cable characteristic, or by shaping the line-amplifier gain to equal the loss of the cable at all frequencies. A “shaped-gain” amplifier is used in the C.E.L. 6A system; the shaping being provided by the input and output networks, which together equalize the loss of 6.125 miles of 375E cable at frequencies above 2 Mc/s. Compared with flat-gain networks, a greater step-up ratio can be obtained for the highest transmitted frequency at the input and more power can be transferred to line at the output, resulting in an improved basic noise performance and a reduced power-handling requirement, respectively. Further advantages in these respects are also obtained in the C.E.L. No. 6A amplifier by not providing 75-ohm amplifier input and output impedances. The system is designed so that approximately equal intermodulation noise power is produced in all channels and this is achieved by having equal signal voltage for all channels at the grids of the output stage. As a result of the shaping given by the output network the relative level\* at the amplifier output varies with frequency, as shown in Fig. 4. The equalization at frequen-

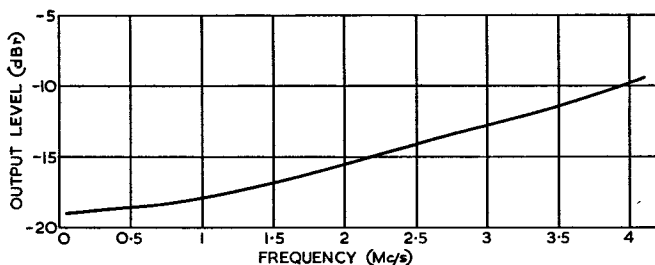

FIG. 4.—TELEPHONY RELATIVE LEVEL AT LINE AMPLIFIER OUTPUT.

cies below 2 Mc/s is provided by external constant-impedance networks, which also improve the return loss of the equipment impedance presented to the cable at the lower frequencies, where the low loss of the cable makes it important to minimize end-to-end reflections.

The amplifier gain can be varied by altering the resistance

\* Relative level (dBr) is the ratio, in decibels, of the power at a point in a line to the power at the origin of the circuit (usually the 2-wire point).

of a thermistor element forming part of the feedback network. The deviations from nominal gain are proportional to the square root of the frequency and are used to compensate for the changes in cable attenuation with temperature.

The nominal amplifier gain, modified by the loss of the external equalizer networks, is designed to compensate for the loss of a repeater section of 6.125 miles of 375E coaxial pair at 10°C, and, for section lengths less than this, line simulators build out the electrical length to this value.

#### Stability of the Overall Gain of the System.

An important requirement of any long-distance transmission medium is that the overall loss shall remain constant within close limits. The margin against singing that has to be allowed on a telephone channel is determined by the variations in loss that are likely, and this margin is only obtained by increasing the nominal loss of the circuit and hence degrading the transmission.

The most important causes of variations in the loss of a line link are:—

- (a) The change in the attenuation of the cable due to a change in its temperature.
- (b) The effects of ageing of valves.
- (c) The effects of variations in power supplies to the amplifier.
- (d) The effects of changes in ambient conditions of the equipment (temperature, humidity, etc.).

The change in cable attenuation is the largest effect and for a change in temperature of 20°C (the normal maximum range encountered in this country) amounts to a 4 per cent change, this being some 33 dB/100 miles at 4 Mc/s. This change is big enough to warrant compensation at intermediate repeater stations so as to avoid increasing the basic noise or intermodulation noise. As mentioned above, this is done by varying the negative feedback of the line amplifier and is controlled by measurement of the level of a 4,092-kc/s pilot signal, a deviation from the nominal level causing a change in the power supplied to the heater of the thermistor in the feedback network. This pilot, and one of 308 kc/s (used for monitoring the system stability and for frequency comparison of the master oscillators in the carrier-generating racks of the translating equipment) are transmitted at a level 10 dB below the relative level of the adjacent telephone channels. With this method of compensation it should be noted that an error in the corrected pilot level at one station, or even a complete failure to regulate, will be corrected at the subsequent stations and the overall accuracy of correction at the pilot frequency is dependent only on the performance of the regulator at the receiving terminal station and the stability of the transmitted pilot. Because of this a more accurate regulator is used at the terminal and a second regulator is used to monitor the performance of the working regulator and be available as a spare in the event of a fault. Another feature resulting from the use of tandem regulated amplifiers is that, owing to the delay inherent in the controlling loop at each station, a periodic variation in pilot level at a particular low frequency may be amplified by the regulating action instead of reduced, and with a long line containing a large number of regulated amplifiers a large amplitude of variation could be produced. In this system dynamic stability is ensured by having relatively coarse regulation at intermediate stations, and by careful control of the phase relationships of the control loop.

A manually adjustable equalizer is fitted at the receiving terminal to compensate for the effects of valve ageing, though at the present time the effect is reduced by a regular replacement of valves, staggered in time so that the average age of the valves on a given route remains fairly constant.

With the use of stabilized mains supplies, power-supply

variations are a second-order effect and on routes of normal length in the United Kingdom the effects of changes in the ambient temperature of equipment are not large enough to require correction. The use of hermetically sealed units and careful choice of components minimizes the effects of changes in ambient conditions.

## DESCRIPTION OF HIGH-FREQUENCY EQUIPMENT

### *The Line Amplifier.*

The line amplifier is a 3-stage negative-feedback amplifier with a nominal gain of 48 dB at 4.1 Mc/s, each stage comprising two CV2000 (soldered-in) valves in parallel. Allowing for the insertion loss of equalizer networks, power separating filters, and bay cabling, this nominal gain is equal to the loss of approximately 6.125 miles of 375E-type coaxial pair at a temperature of 10°C. The nominal gain/frequency characteristic of the amplifier is shown in Fig. 5, and refers to the insertion gain between impedances of 75 ohms, but the amplifier itself was not designed to have 75-ohm input and output impedances, as discussed earlier.

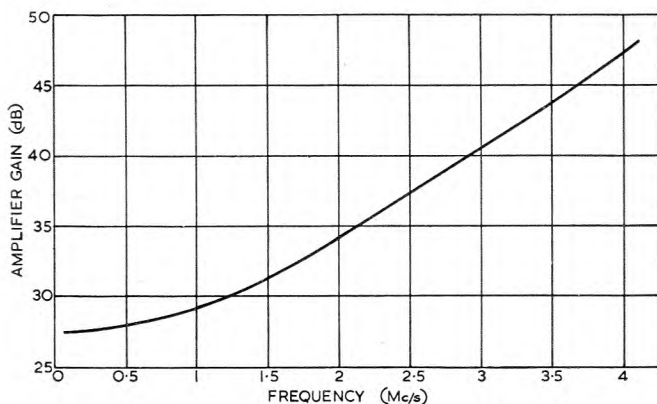

FIG. 5.—GAIN/FREQUENCY CHARACTERISTIC OF LINE AMPLIFIER.

The amplifier operates nominally with a constant voltage at all frequencies at the grid of the output valves, to give optimum intermodulation performance. The active part of the amplifier within the feedback loop has a nominally flat gain/frequency characteristic, and the required overall frequency characteristic is obtained from the networks associated with the input and output transformers, approximately one-half of the shaping being applied at each end. At the transmit terminal a separate pre-emphasis network is used in front of the amplifier to give the required nominal amplifier output levels (shown in Fig. 4).

The feedback circuit contains a network the attenuation of which can be made to vary according to a "square root of frequency" law, under the control of a thermistor. With a thermistor resistance of 40 ohms, requiring a thermistor heater voltage of approximately 1.8V, the amplifier assumes its nominal gain/frequency characteristic. The maximum and minimum values of the amplifier gain at 4.1 Mc/s are 54 and 42 dB, which correspond to thermistor resistances of 8 and 200 ohms, respectively, the appropriate thermistor heater voltages being approximately 3.0 and 1.2V. Thus the gain control range is approximately  $\pm 6$  dB at 4.1 Mc/s and correspondingly less at other frequencies down to 60 kc/s. This range is more than enough to deal with all conditions normally encountered. By means of a U-link the thermistor can be replaced by a fixed 40-ohm resistor for testing purposes.

The amplifier is constructed as a 3-unit panel in accordance with 51-type equipment practice and is illustrated in Fig. 6 (the sizes of panels are usually expressed in units of the vertical height of rack that they occupy, the unit being  $1\frac{3}{4}$  in.). It comprises three sealed cans, containing the input

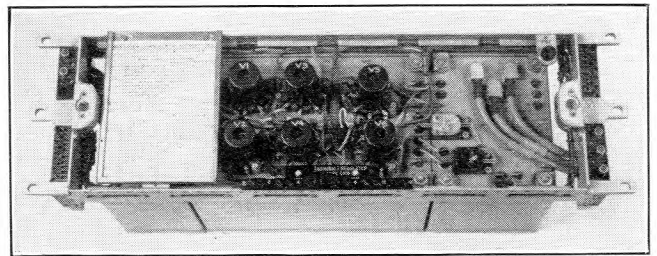

FIG. 6.—LINE AMPLIFIER.

network, amplifier proper, and output network. The centre can has a "dished" lid mounting the six valve-holders, thus keeping all high-frequency connexions to the valves as short as possible. Trimmer capacitors for adjustment of gain are mounted on the lids of the input- and output-network cans. The panel has two paralleled input and two paralleled output coaxial jacks, which in conjunction with a switching panel permit an amplifier to be changed with a negligible break in transmission; the panel also has a low-impedance pilot output.

### *The Flat-gain Amplifier.*

The flat-gain amplifier is used at terminal stations only. It is a 3-stage amplifier using two CV2000 and one CV2006 valves, giving a gain of 30 dB, and is a 2-unit panel.

### *Pilot Regulators.*

The 4,092-kc/s pilot regulator for intermediate stations comprises a narrow-band-pass crystal filter, to select the pilot frequency; a two-stage amplifier, using two CV2000 valves; a germanium rectifier circuit; and a critically biased 2-kc/s oscillator, using one CV2000 valve, that provides the heater supply to the thermistor in the line amplifier. A cold-cathode voltage stabilizer (CV2029) is used to provide a stable reference voltage against which the d.c. voltage from the rectifier stage is compared; the resultant difference-voltage controls the effective grid bias applied to the oscillator valve. A d.c. output is taken from the rectifier stage to operate a meter-type relay mounted on the amplifier change-over panel and used to give an alarm indication if the pilot level should deviate from nominal by more than 2 dB.

The gain of the amplifier stage is adjusted to give a current of 200  $\mu$ A in the relay and then the bias-control of the 2-kc/s oscillator is adjusted to give the required heater voltage for the thermistor in the feedback path of the line amplifier. Subsequent increases in the level of the received pilot signal tend to increase the negative bias on the oscillator and decrease its output to the thermistor heater; the resistance of the thermistor element increases and thus the amplifier gain is reduced until the correct output level is restored; decreases in level of the received pilot signal have exactly the reverse effect. The control ratio of the regulator and amplifier, i.e. the ratio of input level variation to regulated amplifier output variation, may be varied by changing the position of a U-link. A value of approximately 6:1 is used at intermediate repeater stations and 14:1 at terminal stations; the lower value is used to maintain a stable dynamic characteristic. The crystal filter is designed to afford sufficient discrimination against speech or television frequencies to prevent interference from traffic signals; for television signals a complementary narrow-band-stop filter is used at the transmitting terminal to suppress television signals at 4,092 kc/s.

The regulator, illustrated in Fig. 7, occupies a 2-unit panel, the filter, amplifier and oscillator each comprising a separate sealed unit.

Small variations in signal level at intermediate stations



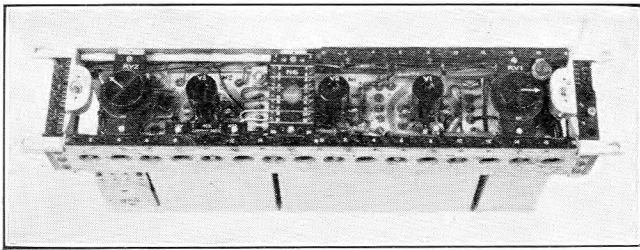

FIG. 7.—GAIN-CONTROL UNIT (REGULATOR).

are unimportant, as they are corrected by subsequent regulators, but the terminal regulator determines the overall stability of the link, and a special regulator panel is employed there. It is very similar to the intermediate regulator but is a 3-unit panel and has a 3-stage negative-feedback amplifier (three CV2000 valves); a double-diode valve rectifier (one CV2004 valve) instead of a germanium crystal, for improved temperature stability; and the input filter is selected for the small variation of its characteristics with temperature. The voltage reference valve is a CV2012 and is fed from a CV2027 voltage stabilizer valve.

#### Pilot Oscillator/Stabilizers.

The 4,092-kc/s pilot signal may be derived either from the associated terminal carrier supply equipment or, more usually, from separate oscillators. The C.E.L. No. 6A terminal station equipment includes a pair of pilot supply panels, one working and one standby, with automatic change-over. Each panel is a self-contained crystal-controlled 4,092-kc/s crystal oscillator with a stabilized output level of  $-2$  dBm. When an external carrier supply is used the pilot oscillator stage is used as an amplifier and the panel becomes only a stabilizer, giving the same output level of  $-2$  dBm. The frequency stability is approximately  $\pm 50$  c/s for normal variations of temperature and the output-level stability is approximately  $\pm 0.1$  dB under normal conditions.

Each panel includes a marginal meter-type relay which gives a continuous indication of the output level, and gives an alarm and initiates a change-over to the standby panel when the level changes by approximately  $\pm 0.5$  dB. The change-over is effected by a solenoid-operated switch, the transit time of its contacts being only 2 or 3 milliseconds. The output from the change-over panel is  $-14$  dBm.

Each oscillator, and the change-over panel, occupy separate 2-unit panels.

The terminal equipment is provided also with a 308-kc/s oscillator/stabilizer panel. This frequency can be used, in conjunction with 60/308-kc/s and 308/60-kc/s converters, for comparison or synchronization of the carrier frequency supplies at terminal stations; also, the level of the 308-kc/s signal is recorded to give a continuous indication of the stability of the system.

The 4,092-kc/s panel employs a Clapp oscillatory circuit, and the 308-kc/s panel a Butler oscillatory circuit. Stability of the output level is achieved by the comparison of a d.c. voltage obtained from the output signal with a reference voltage from a neon stabilizer, the difference in voltage being used as grid bias for an amplifying valve.

The two frequencies are combined and injected into the transmission path via resistive combining circuits.

#### The Amplifier Change-over Panel.

A special amplifier change-over panel is provided between each pair of line amplifier positions ("working" and "standby"). It comprises essentially a high-speed change-over switch which is connected in parallel with the normal amplifier input and output circuits, the arrangement being shown in Fig. 8. Auxiliary contacts are used to

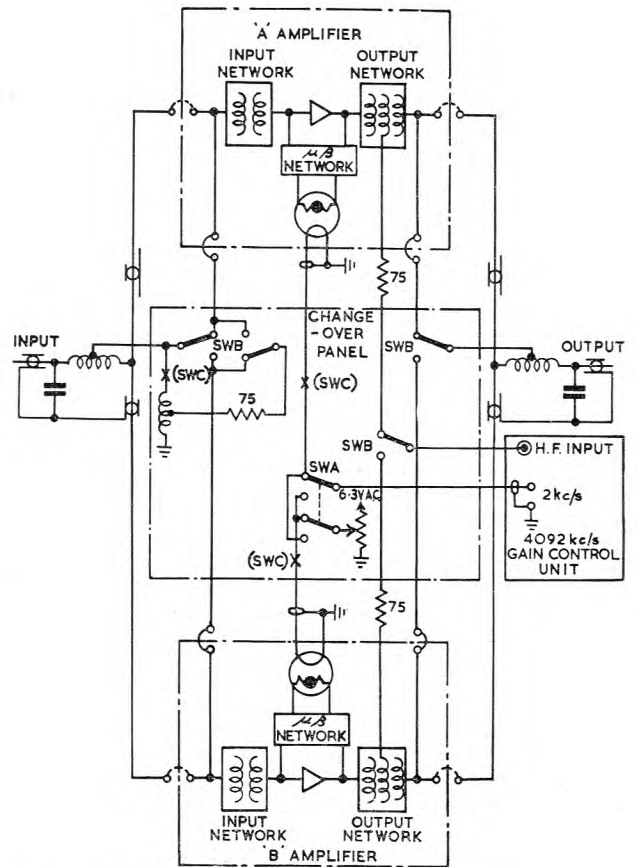

U-links shown dotted are removed during change-over.

FIG. 8.—SIMPLIFIED SCHEMATIC DIAGRAM OF AMPLIFIER CHANGE-OVER CIRCUIT.

inject a known portion of the input signal into the standby amplifier (at 20 dB below the input level to the working amplifier). Before changing over, the gain of the standby amplifier is set by means of a 50-c/s manually adjusted supply to the thermistor heater so that the output level of 4,092-kc/s pilot (as read on a selective level measuring set) is 20 dB below that of the working amplifier. Thus the gain of the standby amplifier is set to that of the working amplifier. An alternative, approximate, method for adjusting the gain of the standby amplifier is to set the 50-c/s voltage applied to the heater of the thermistor to the same value as the 2-kc/s voltage on the working amplifier, using the meter provided. The change-over time is approximately 1 ms. Change-over of the flat-gain amplifiers at terminal stations and fixed-gain amplifiers at main stations is less complicated and requires only a simple fast change-over switch.

The change-over panel, which mounts also the meter-type relays associated with the pilot regulators, occupies a 3-unit panel.

#### The Line Equalizer and Power-separating Filters.

The main line equalizer is split into two units, one equipped at the output and one at the input of the line amplifier. The output equalizer is designed with particular attention to its impedance at very low frequencies.

The main design requirement for the equalizers is that the sum of the line amplifier gain and equalizer loss should equal the loss of 6.125 miles of 375E-type coaxial cable at a temperature of  $10^{\circ}\text{C}$ , plus the losses in the wiring, and power-separating filter and reflection losses. They comprise constant-impedance bridged-T sections, and are contained in sealed units.

The power-separating filter is designed to separate the 60–4,100-kc/s frequency band from the 50-c/s power-

feeding supply, and to produce the minimum of distortion in the h.f. band. Each filter operates at 500V r.m.s. to earth, and the series capacitors in the high-pass section are of a special type designed to withstand several thousand volts, and to have an ionization-inception voltage of not less than 1,000V. Each filter is contained in a sealed unit, and the power supply and line terminals are specially screened to prevent accidental contact.

A coaxial choke is inserted in each side of the repeater, between the power-separating filters and the cable terminals, to reduce any longitudinal crosstalk which may arise from imperfect earthing. Each coil comprises a few turns of flexible connecting cable round a toroidal permalloy core.

#### Pre-emphasis and De-emphasis Networks.

A pre-emphasis network precedes the transmit terminal line amplifier to give the required level/frequency characteristic at the output of the amplifier. The amplifier gain/frequency characteristic has a slope of approximately 21 dB between 1 and 4 Mc/s, the gain increasing with frequency. The attenuation/frequency characteristic of the pre-emphasis network has a slope of approximately 11 dB, loss increasing with frequency; the amplifier output-level/frequency characteristic then has the required slope of 10 dB, as shown in Fig. 4. A de-emphasis network at the receiving terminal restores the levels to a flat characteristic, this network having a slope of approximately 10 dB with loss increasing with frequency.

A pair of these networks is included at main repeaters to provide a point of flat level/frequency characteristic for supergroup derivation and to facilitate residual equalization.

The networks are of the constant-impedance bridged-T type and are contained in sealed cans.

#### Delay Equalizers.

Delay equalizers are equipped at terminal stations in the receive direction only, although facilities for adding them to the transmit direction and at main repeater stations are provided. A range of separate equalizing units is available for selection on site. A unit for equalizing the distortion due to pilot-stop filters is also available. The method of design takes account at the outset of the magnitude of the ripples in the delay characteristic that will be introduced by equalization, when determining the number of equalizer sections to be used. To ensure the stability necessary to achieve a smooth overall group delay/frequency characteristic each unit is in a sealed can and great care has been taken in the mechanical layout to minimize the effects of stray inductance and capacitance.

#### Pilot-Stop Filters.

Band-stop filters for 308 kc/s and for 4,092 kc/s are equipped in the transmit and receive terminal paths. The transmit filters serve to suppress television signal frequencies that would interfere with the pilot signals, and prevent such frequencies reaching the line from other sources (e.g. from other types of coaxial system interconnected with the C.E.L. No. 6A). The receive filters suppress the pilot frequencies to prevent interference with television signals or with the pilot signals of other systems.

To facilitate switching between telephone and television working, all four filters are in circuit continuously. Telephony demands very narrow stop-bands to avoid interference with adjacent speech channels and consequently crystal filters are required. All spurious resonant "spikes" of the crystals occurring within the transmitted band have been suppressed.

## POWER SUPPLIES FOR THE EQUIPMENT

To avoid the necessity for reliable and stable local power supplies and standby plant at all repeater stations, power for the dependent repeaters is fed over the coaxial pairs from a terminal or main repeater. In this way mains supplies are required only at intervals of some 80 miles, although in practice for geographical reasons the spacing is often closer than this. An a.c. "constant-voltage" system is used, 200–260V r.m.s. being derived at all dependent repeaters to feed the power units serving individual rack-sides of equipment.

#### "Rack-side" Power Units.

The power units on the individual rack-sides of equipment are of conventional design, employing selenium rectifiers, and operate from 200–260V 50-c/s supplies. They provide 220V d.c. h.t. and 6.3–0–6.3V a.c. heater supplies; separate units provide 130V d.c. for signalling and alarms, and 12V for charging the microphone battery and operating relays.

Sockets are fitted in the standby amplifier positions to provide h.t. and l.t. supplies for the portable selective level measuring set.

#### Power Feeding of Dependent Repeaters.

Each terminal repeater can feed power to a maximum of six dependent repeaters, and each main repeater six on each side. The arrangements are shown in Fig. 9. Two power-feeding transformers are used, with their primary windings connected in parallel, and their secondary windings connected in series with the centre point earthed, to give a line voltage of 1,000V r.m.s., balanced to earth. Two transformers are employed to divide the weight

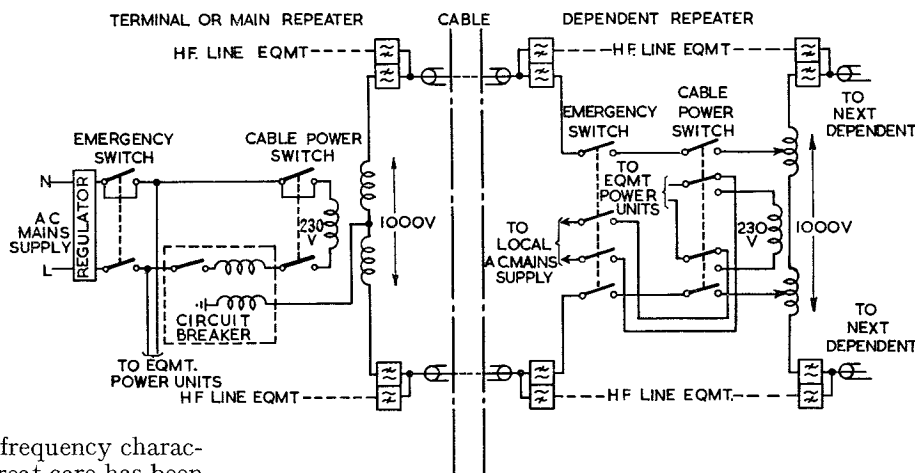

FIG. 9.—POWER-FEEDING CIRCUIT.

between two units of equipment and to utilize standard core sizes compatible with mounting on the 51-type rack-side framework. The nominal rating of a pair of transformers is 1.2 kVA.

At each dependent repeater a transformer raises the incoming cable voltage to 1,000V for onward transmission to the next repeater, using the primary winding as an auto-transformer, and derives a 200–260V supply for the local rack-sides via a secondary winding. The 200–260V supply is adjusted to equal the nominal local mains supply voltage, if such a supply is available, as switching facilities are provided to enable local supplies to be used in an emergency. There is no centre-tap earth at dependent repeaters. Discs of Metrosil, a material whose resistance varies inversely approximately as the fourth power of the voltage across it, are fitted across the transformer secondary winding to limit voltage surges, which can occur under some switching conditions.

The relatively high voltage of 1,000V was chosen to reduce the line current and thereby reduce voltage changes due to changes of load and cable temperature.

#### *Line Circuit Breakers.*

A circuit breaker is equipped at all power-feeding points to switch off power from the cable automatically under fault conditions, such as serious overload or an open-circuit cable. The breaker is of the magnetic type with two trip coils, one coil in the transformer primary circuit and one in the connexion to earth from the centre-tap of the secondary winding. The former coil responds to overloads connected between the two "legs" of the power-feeding circuit, and the latter to unbalanced overloads between one leg and earth or to an open-circuit of one coaxial tube.

Operation is retarded for a few seconds by a thermally operated delay device to avoid accidental tripping when switching on.

#### *Power Consumption.*

Typical power consumptions for fully equipped rack-sides, but excluding test gear and standby amplifiers, are,

|                    |         |
|--------------------|---------|
| Terminal Repeater  | 450 VA, |
| Main Repeater      | 200 VA, |
| Dependent Repeater | 150 VA, |

and the additional total load at a terminal or main repeater for feeding power to six dependent repeaters is approximately 1.1 kVA. The voltage drop in the coaxial cable is approximately 10V in the last section over which power is fed, 20V in the last but one section, and so on. The power factor is approximately 0.9, there being some compensation between the inductive loads of the rack-sides and the capacitive load of the cable.

#### *Precautions Where High Voltages Are Used.*

The relatively high voltage transmitted over the cable demands similar precautions to those used on previous coaxial systems to ensure the safety of men engaged on maintenance and cable repairs. At each repeater station the cable-sealing-end is contained within a cable terminal box which is locked, and can be opened only with a key that is kept in a wall-mounted key-box (a different key being required for each cable terminal box).

Also, a cable-power switch that can be operated only with a key is mounted on a rack-side at each station. The key can only be removed when power is switched off and it is then used to release the keys of the cable terminal boxes from the wall-mounted key-box. (At dependent stations, switching off the power feed to the cable also connects local mains supplies to the station equipment, as shown in Fig. 9.) The keys of the cable terminal boxes associated with one system can be released only by the key that operates the cable-power switch of that system. There are also "token" keys that can only be released when the keys of all cable-power switches serving systems on one cable are freed, i.e. when the power feed to all coaxial pairs in the cable has been switched off. Cable repair staff do not work on the cable unless they have in their possession the appropriate token keys for the cable section on which they are working.

The power-separating filters are carefully designed to withstand high voltages. All high-voltage wiring in the rack-sides has extra-thick insulation covered by a tinned-copper braid, and the dust covers of all panels that carry high voltages incorporate safety links that disconnect the power when the cover is removed.

### THE SUPERVISORY EQUIPMENT

The supervisory equipment comprises a 4-wire audio-frequency telephone circuit and d.c. calling and alarm circuits, the latter permitting location of faulty repeater

stations. Although a total of 14 interstice wires are required, this arrangement has the merits of simplicity and reliability.

#### *The Speaker Circuit.*

The speaker circuit is provided over two interstice pairs, and is equalized over the frequency band 300–3,400 c/s. The attenuation of these pairs is approximately 1.0 dB/mile at 800 c/s and 1.8 dB/mile at 3,400 c/s. Amplifiers are inserted at every alternate repeater station (i.e. approximately every 12 miles) and a standard repeater equipment includes one such amplifier, which is strapped into the "A to B" or "B to A" direction of transmission at alternate stations. The amplifier is a single-stage feedback amplifier employing one EF 37 valve and has a maximum gain of 37 dB. Together with an equalizer (of Post Office No. 9, universal, type) and repeating coils for the non-amplified direction of transmission, the amplifier occupies a 2-unit panel. A relay in the anode circuit of the valve automatically by-passes the amplifier in the event of valve or power failure, thereby permitting a degraded service under fault conditions.

Every repeater station is equipped with a microtelephone handset with a platform-type switch recessed into the rack-side. A 5V nickel-iron battery provides the micro-telephone voltage; it can be charged when required from the 12V relay-power supply unit.

#### *Calling Circuits.*

Calling equipment is operated from the 130V power units equipped at all terminal and main repeater stations. The phantom of one pair of the speaker circuit serves all intermediate repeaters simultaneously, and the phantom of the other pair serves only the terminal stations; a single interstice wire is used as a common return path. To determine the direction from which a call is originated, two parallel relays with associated rectifiers are fitted at each intermediate station. One of these relays operates and automatically connects the telephone to line in the direction of the calling station, and control from the other direction is rendered inoperative when the handset is removed from its platform. A bell and alarm lamp are equipped at every intermediate station and only a lamp at terminal stations. The bells are operated from the microphone battery in the event of power failure. All calling signals are repeated at main stations.

At terminal stations facilities are provided for through connexion of calls and speech on a 2-wire or a 4-wire basis and for extending a 17-c/s ringing signal from a switchboard as a d.c. calling signal to line. At main stations facilities are provided for connecting the speaker circuit to "spur" routes on a 4-wire basis. A "conference" facility at terminal stations permits speaking and listening in both directions from intermediate stations by unbalancing the hybrid coil.

#### *Alarm Circuits.*

Faults occurring at any station operate or release relays which apply short-circuits to interstice pairs, provide closed loops for connexion to the station alarm circuit, and light rack-side alarm lamps. The following conditions cause alarms to be given:—

- (a) Power-Fail Alarm, operated from a relay connected across the 12V power unit.
- (b) Pilot-Fail "A-B," operated from a relay controlled by the marginal meter-type relay in the 4,092-kc/s pilot regulator for the "A-B" direction of transmission, or from the marginal meter-type relay of the 4,092-kc/s pilot oscillator/stabilizer at terminal stations.
- (c) Pilot-Fail "B-A," as for (b) above but for the other direction of transmission.

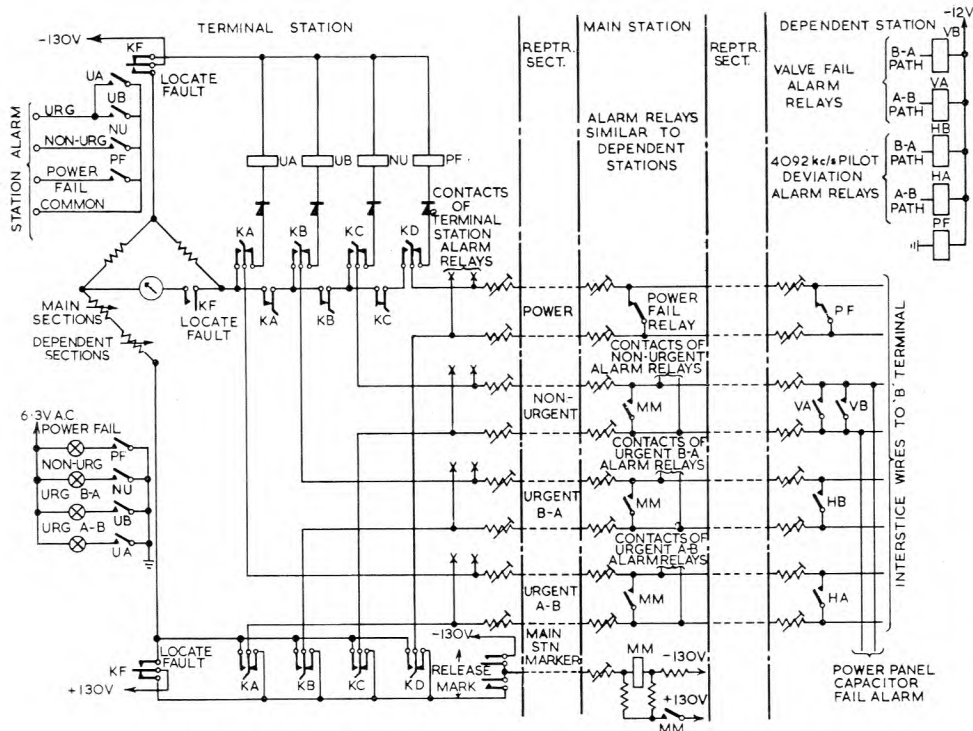

Keys KA—KD are Alarm-Locate/Receiving-Attention keys associated with each of the alarms.

FIG. 10.—SIMPLIFIED SCHEMATIC DIAGRAM OF THE ALARM CIRCUITS.

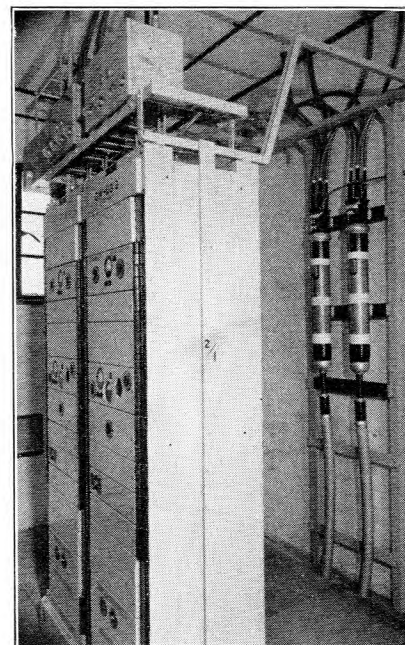

The installation shown is for four coaxial tubes.

FIG. 11.—DEPENDENT REPEATER.

(d) Non-Urgent Alarm, including failure of a valve, operated from the normal valve-failure alarm panel, and failure of a smoothing capacitor, operated from a relay on the h.t. smoothing unit.

At terminal stations, where duplicate pilot oscillator/stabilizers and pilot regulators are equipped, a simultaneous alarm from both panels of a pair gives a separate indication to denote complete pilot failure. On failure of a working terminal regulator, a preset 50-c/s supply is switched to the thermistor heater.

The station, or stations, originating alarms are located by means of a Wheatstone bridge circuit equipped at terminal stations, and operated from the 130V alarm-circuit power supply. The arrangements are illustrated in Fig. 10. Any one of the four alarm pairs can be connected to the bridge. The variable arm of the bridge includes two variable resistors, one of 3,000 ohms maximum resistance fitted with a dial divided into three sections to locate the appropriate main repeater section, the other of 1,000 ohms maximum resistance with a dial divided into 13 sections to locate the appropriate repeater station. A "main-station marker" facility is included whereby artificial alarms may be applied temporarily at a main repeater station by remote control from a terminal station to permit accurate calibration immediately prior to the location of a distant alarm. An additional variable resistor is provided to permit routine compensation for the change in the resistance of the alarm pairs with change of cable temperature.

The alarm-location system will operate over a maximum route length corresponding to three main repeater sections.

#### EQUIPMENT—RACK-SIDE AND STATION ARRANGEMENTS

##### Dependent Repeaters.

The equipment for a 2-way dependent repeater is mounted on two 6-ft rack-sides (Fig. 11). The h.f. panels (i.e. amplifier, equalizer, power-separating filter, pilot regulator and change-over panels) for each direction of transmission are mounted on separate rack-sides, and the common power and supervisory panels are equipped partly on one and partly on the other rack-side. Six-foot rack-sides

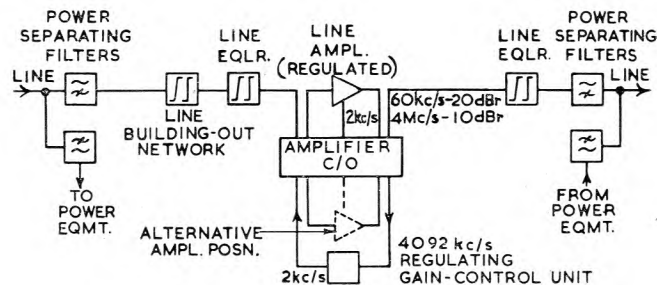

One direction of transmission only is shown; the other is identical.

FIG. 12.—BLOCK SCHEMATIC DIAGRAM OF DEPENDENT REPEATER.

allow the use of standard small repeater-station buildings. Fig. 12 is a block schematic diagram of the h.f. path.

##### Main Repeaters.

The equipment for a main repeater occupies three 9-ft rack-sides (Fig. 13). The h.f. panels (as above, together with a second line amplifier and a network panel for residual equalization and pre-emphasis and de-emphasis) are mounted on two rack-sides, one for each direction of transmission, and the power-feeding and supervisory equipment is mounted on the third rack-side. A block schematic diagram of the h.f. path is given in Fig. 14.

##### Terminal Repeaters.

Each terminal repeater occupies four 9-ft rack-sides. The first C.E.L. 6A equipment (installed on the Glasgow—Oban route) had the terminal equipment on three rack-sides and is illustrated in Fig. 15. The h.f. equipment for the receive direction is mounted on two rack-sides, one including the receive line amplifier, first flat-gain amplifier, pilot regulators, power-separating filters, line equalizer, de-emphasis network and residual equalizer; the second including the second flat-gain amplifier, phase equalizer and pilot-stop filters. The third rack-side mounts the h.f. equipment for the transmit direction, including the pilot oscillator/stabilizer and 60/308-kc/s convertor. The fourth rack-side



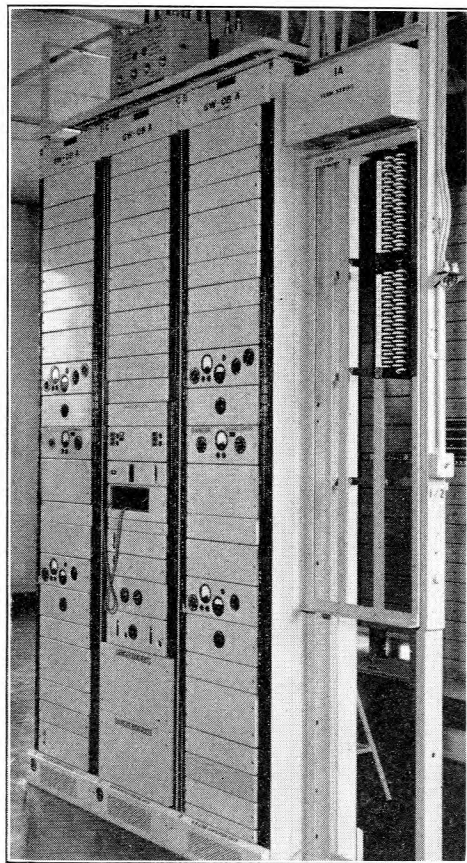

FIG. 13.—MAIN REPEATER.

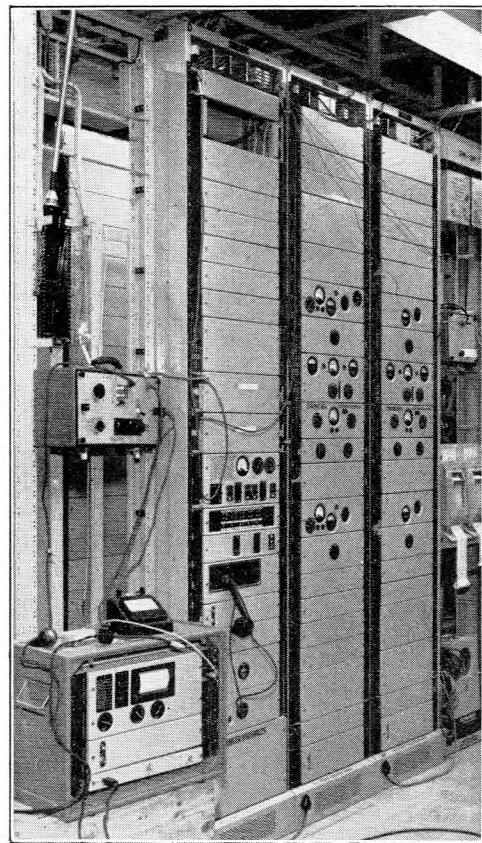
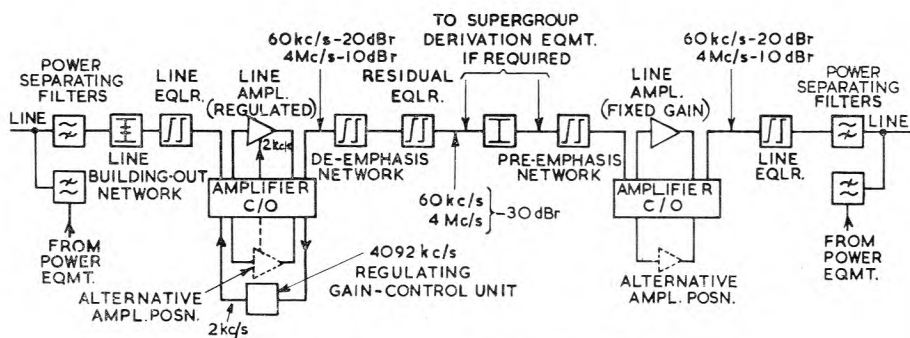

FIG. 15.—OBAN TERMINAL REPEATER DURING INSTALLATION.



One direction of transmission only is shown; the other is identical.

FIG. 14.—BLOCK SCHEMATIC DIAGRAM OF MAIN REPEATER.

mounts supervisory equipment, together with 4,092 kc/s and 308-kc/s pilot-monitoring panels and the 308-kc/s converter. Fig. 16 is a block schematic diagram of the h.f. path.

#### Cable Termination.

In earlier designs of coaxial repeater equipment it has been customary to terminate each coaxial pair directly within the power-separating filter. This has involved running lead-sheathed tail cable from the segregating joint, across cable racking to the rack, and providing the power-separating filter with a framework heavy enough to accommodate a sealing-end for the cable.

With C.E.L. No. 6A, all coaxial pairs are terminated inside separate cable terminal boxes which may be mounted on cable racking, on an equipment rack-side, or on a wall, connexion to the power-separating filter being made by a length of treble-screened flexible coaxial cable; the cable has a carefully controlled impedance of 75 ohms. The terminal box has locked doors (as discussed earlier), together

with neon lamps to indicate when power is on the cable.

The interstice wires are terminated separately on a cable terminal block with U-link test points.

#### INSTALLATION TESTING AND LINING-UP

Every effort is being made to reduce the time spent testing equipment in the field, and with the advent of a 51-type coaxial line system with panels that are easily removed, advantage has been taken of the fact that a considerable proportion of the total testing can now be carried out at a central testing point. At this point high-precision insertion loss or gain measuring sets (74505-type repeater testing equipment (R.T.E.)) are provided, on the basis of one or two per route, for the measurement of amplifier gains, network losses, etc. By this means it is now possible to reduce the amount of time spent travelling along the route from station to station and the time spent by testing staff in unheated isolated dependent-station buildings. The dependent-station racks and all the panels for the route are therefore shipped direct from the factory to the central testing point (usually a terminal-station building) and there receive a visual examination, checks of point-to-point wiring and relay adjustments, and comprehensive tests of performance using the 74505 R.T.E. On the satisfactory completion of these tests the racks are transported, with all panels removed, in containers lined with shock-absorbing material, to the dependent stations. The amplifiers and other panels are distributed along the route in a similar manner. The racks are then re-checked *in situ*, but the time spent on these final tests is comparatively short. Another innovation, adopted to minimize testing

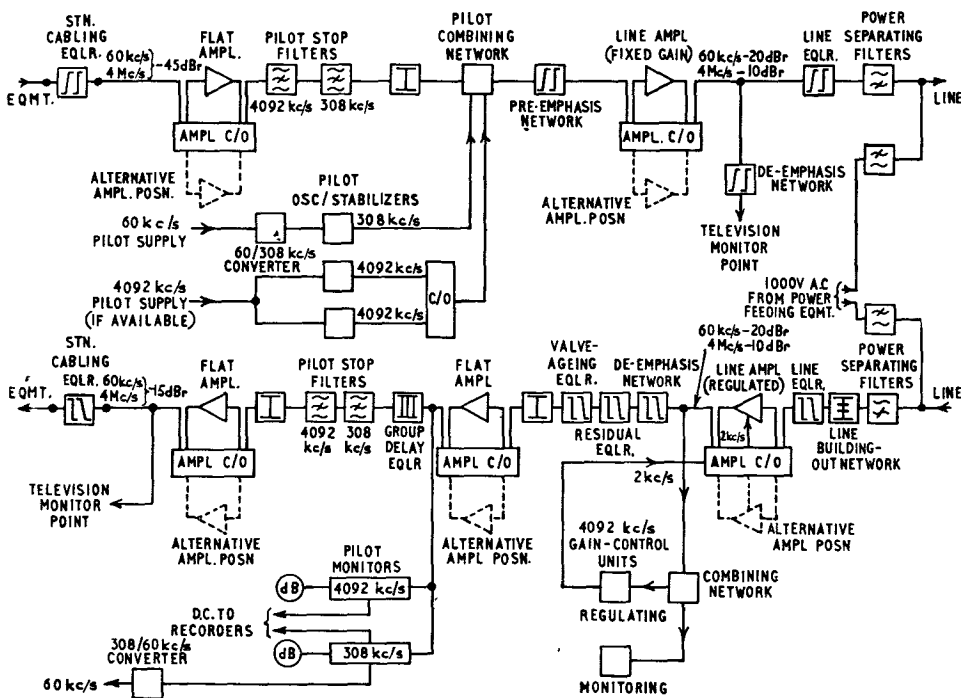

FIG. 16.—BLOCK SCHEMATIC DIAGRAM OF TERMINAL REPEATER.

time, has been the use of factory test results in the field. The aim is to use these results to reduce the amount of field testing by using sampling techniques and so allow the Post Office specification to call for fewer field tests.

#### Method of Line-up.

The following is a brief description of the method of line-up at present used on C.E.L. No. 6A routes:—

- (a) The 4,092-kc/s and 308-kc/s pilot levels are measured at all stations up to the first main station, with the line amplifiers set to nominal gain. The results are compared with the measured rack gains and the calculated cable losses.

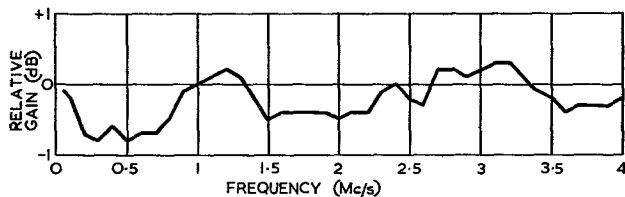

FIG. 17.—TYPICAL OVERALL GAIN/FREQUENCY CHARACTERISTIC.

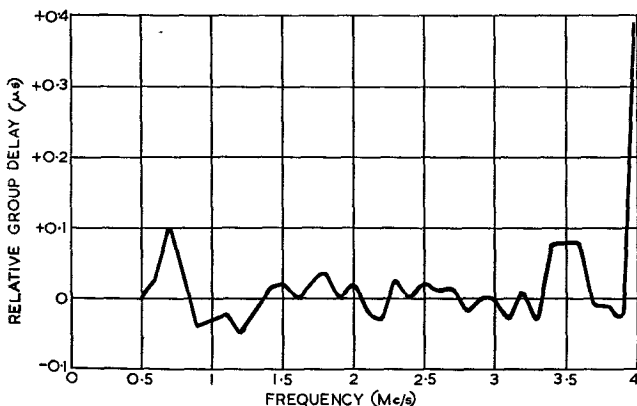

FIG. 18.—TYPICAL OVERALL GROUP-DELAY/FREQUENCY CHARACTERISTIC.

- (b) The insertion-gain/frequency characteristic of the first main section (from the transmit terminal to the “flat” point at the first main station) is measured with the amplifiers set to nominal gain.

- (c) The line amplifiers at every station in the first main section are in turn put into the regulated-gain condition. At the same time the output-level/frequency characteristics for each dependent station are measured.

- (d) The insertion-gain/frequency characteristic of the first main section is measured at small intervals of frequency and the result is compared with that measured in (b). A residual line equalizer is then designed and inserted at the main station.

- (e) While the residual equalizer is being designed and fitted, the pilot levels are measured at all stations in the second main section with the amplifiers in

this section set to nominal gain. The results are compared with estimated values as in (a). Operations (b) to (d) are then carried out on the second main section.

- (f) A line residual equalizer is designed and fitted at the second main station, and the procedure is repeated for each main section until the receive terminal is reached.

It will be noted that much use is made of comparisons with estimated results or previous measurements; this is most valuable as a check against possible faults arising during the line-up. A typical overall gain/frequency characteristic is shown in Fig. 17, and an overall group-delay/frequency characteristic in Fig. 18.

#### MAINTENANCE

Maintenance processes may be considered as falling into three divisions: preventive maintenance, fault location and repair of equipment.

Preventive maintenance is designed to detect defects and known ageing or seasonal processes in advance of their causing reported faults on circuits. On the earlier types of coaxial line links the seasonal effect of temperature on cable attenuation was the main change to be controlled by suitably timed measurement and adjustment. As described earlier, this is done automatically on C.E.L. No. 6A, but introduces the complication that a fault may be compensated by the regulator, this compensation being proportional to the square root of the frequency. Faults, which are usually not of root-frequency shape, are detected by a test at a frequency remote from the controlling pilot, e.g. by monitoring the 308-kc/s pilot level. Regulator faults can be detected by monitoring the level of the 4,092-kc/s pilot signal, and with the aid of the dependent station pilot alarms. Thus the overall tests carried out are, a check of the variability of the gain, using recording decibel-meters to indicate the levels of the pilots, and periodic checks of gain/frequency response. Additionally it may be desirable to make overall intermodulation tests.

To detect ageing components, equipment tests are also made as follows:—

- (a) Checks of panel supply voltages, to detect ageing of power-supply rectifiers and increase the significance of the other tests.
- (b) Checks of valve anode currents to detect valve ageing.
- (c) Periodic overhauls, using vibration test methods, to remove deteriorated connexions. Such overhauls will be made when the pilot recorder charts show them to be necessary.

The only other regular maintenance work required is the regular calibration of the fault-locating panel, charging of speaker batteries and adjustment of the manual setting of the terminal regulator.

Fault location within a line link requires varying methods according to the nature of the fault. Power failure and complete failure of the h.f. path are indicated and located by the system supervisory equipment. Changes of gain/frequency characteristic are located using inter-supergroup pilot signals and selective pilot measuring equipment which allows the gain/frequency response from the terminal to any intermediate station to be measured without taking the line out of service. In addition it has been found useful to record and check the variation of thermistor heater voltages on the line amplifiers at each dependent station as a means of tracing amplifier and regulator faults.

Equipment repair is mainly to be done at one or two of the larger repeater stations on each route, where equipment such as the 74505 R.T.E. is provided to enable faults on amplifiers and regulators to be traced to a unit or component and to enable these panels to be re-aligned after clearance of a fault or change of valves. Spare parts and units are held at these centres for replacement purposes. For major overhauls, and the clearing of faults within sealed units, the equipment is returned to the Test and Inspection Branch of the E.-in-C.'s Office for repair.

## ACKNOWLEDGMENTS

The valuable assistance of the authors' colleagues in the preparation of this article is acknowledged. Acknowledgment is also due to Standard Telephones & Cables, Ltd., for permission to publish information contained in this article and the photographs in Fig. 11, 13 and 15.

## References.

- <sup>1</sup> MUMFORD, A. H. The London-Birmingham Coaxial Cable System. *P.O.E.E.J.*, Vol. 30, pp. 206 and 270, Oct. 1937 and Jan. 1938; Vol. 31, pp. 51 and 132, Apr. and July 1938.
- <sup>2</sup> BROCKBANK, R. A., and FLOYD, C. F. The Unit Bay 1B Coaxial Cable Transmission System. *P.O.E.E.J.*, Vol. 38, pp. 43 and 82, July and Oct. 1945; Vol. 39, pp. 14 and 64, Apr. and July 1946.
- <sup>3</sup> KILVINGTON, T., LAVER, F. J. M., and STANESBY, H. The London-Birmingham Television Cable System. *Proceedings I.E.E.*, Vol. 99, Part 1, p. 44, 1952.
- <sup>4</sup> HALSEY, R. J., and WILLIAMS, H. The Birmingham-Manchester-Holme Moss Television Cable System. *Proceedings I.E.E.*, Vol. 99, Part IIIA, p. 398, 1952, and *P.O.E.E.J.*, Vol. 46, pp. 118 and 171, Oct. 1953 and Jan. 1954.
- <sup>5</sup> ELLIOT, T. W., and PAOLA, N. I. Coaxial Cable Carrier Telephone Systems in South Africa. *Transactions South African I.E.E.*, Vol. 43, p. 295, Nov. 1952.
- <sup>6</sup> *Livre Vert du C.C.I.F.*, Tome III, p. 92.
- <sup>7</sup> *Livre Vert du C.C.I.F.*, Tome IV, p. 123.
- <sup>8</sup> JACOBSEN, B. B. The Effect of Non-linear Distortion in Multi-Channel Amplifiers. *Electrical Communication*, Vol. XIX, p. 29, July 1940.
- <sup>9</sup> BROCKBANK, R. A., and WASS, C. A. A. Non-linear Distortion in Transmission Systems, *Journal I.E.E.*, Vol. 92, Part III, p. 45, 1945.
- <sup>10</sup> ROCHE, A. H., and WEAVER, L. E. Television Frequency-Translating Terminal Equipment for the Birmingham-Holme Moss Coaxial Cable. *Proceedings I.E.E.*, Vol. 99, Part IIIA, p. 455, 1952.

## Book Reviews

"Television Engineering, Vol. 2: Video-Frequency Amplification." S. W. Amos, B.Sc., A.M.I.E.E., and D. C. Birkinshaw, M.B.E., M.A., M.I.E.E. Iliffe. 272 pp. 156 ill. 35s.

This book is the second in a series of B.B.C. engineering training manuals dealing with television. The first dealt with fundamental television principles, camera tubes and optics, and was reviewed in the April 1954 issue of this journal. The present volume deals with video-frequency amplification. It may seem surprising to the uninitiated that a whole volume can be written on this subject, but it is not, of course, confined to the video-frequency amplification found in television receivers. There are many points in the complete television signal generating and transmitting chain at which high-quality video amplification is required.

The first chapter of the book is devoted to a discussion, in the simplest possible terms, of the requirements of a good video amplifier and the effects that distortions in the amplitude-frequency and phase-frequency characteristics have on the transmitted waveform. The different types of distortion are illustrated both by means of step-response diagrams and also by an excellent series of photographs of Test Card C showing the effects of the various distortions on the picture.

The main body of the book contains an analysis of the simple RC intervalve coupling, together with methods of compensating for its inherently falling gain characteristic at the upper frequencies. Simple shunt-inductance compensation is dealt with fully and more complicated circuits using four or five compensating elements are briefly touched upon. Series-inductance filter couplings and cathode compensation are also described.

An all-too-short chapter is devoted to the very interesting subject of the distributed amplifier, which enables prodigious band-widths to be obtained with conventional valves. Such amplifiers are now coming into use in some oscilloscopic work. The phase-compensation of video amplifiers, the low-frequency response, and such practical matters as decoupling are discussed, while the final chapters are devoted to the use of feedback in video amplifiers and the problem of amplifier noise.

The book is a very worthy companion to Volume 1 and should find its place on the bookshelf of every television engineer.

*I.P.O.E.E. Library No. 2394.*

T. K.

"Electric Wiring Diagrams." G. E. Stubbs. Second Edition. E. and F.N. Spon, Ltd. 50 pp. 83 ill. 4s. 6d.

The title does not reveal that the chief contents of this pocket booklet are 54 circuit diagrams showing how to connect standard switches to control electric lamps, bells, heaters and small motors. The simpler circuits would be helpful to the novice and the more complex form a ready reference for the experienced wireman. There are also a list of abbreviations commonly used in wiring diagrams and details of identification lettering of the terminals of 2-phase and 3-phase motors.

A few elementary circuit diagrams for battery charging, rectifiers, testers, fluorescent lamps, an earth leakage circuit breaker and a 13-A ring main complete the 50 pages, but the associated explanations are insufficient for the student. An index instead of "Contents" and the descriptive matter on the same pages as the diagrams would improve ready reference, the purpose for which the booklet is intended.

D. J. H.

U.D.C. 621.372.55: 621.395.52: 621 315 2

A previous article<sup>1</sup> in the Journal dealt with the provision of circuits suitable for occasional outside broadcasts, by cable pairs loaded at intervals shorter than 2,000 yd. This article describes the development of loading coils suitable for installation in cable joints at loading points additional to those, at 2,000-yd intervals, where normal manhole-type loading pots are used. The article then describes the installation in cable joints of "unicoils," the type of loading coil that was finally standardized.

## INTRODUCTION

TO enable circuits on audio pairs in telephone cables to be used for high-grade circuits it was necessary to reduce the spacing between loading coils in such pairs from the normal 2,000 yd to 1,000 or 500 yd. At the 2,000-yd intervals the loading coils could be included in the manhole-type loading pots used for loading the normal audio pairs in the cable, but at the intermediate points a method of loading up to four pairs within a joint was required. The first solution to the problem was the development, by the end of 1949, of a canister containing four loading coils, but it was found that this had several disadvantages. The design of an improved type of canister was discussed but the desired reduction in size could not be attained and development turned to individual coils in screening cans; this type of loading, known as "unicoil," was finally standardized.

## CANISTER LOADING

The canister consists of a metal container, approximately 14 in. × 3 in. × 2 in., containing four loading coils, each in a metal case about 2 in. diameter and 1 in. high. The coils are laid flat and side by side within the canister (Fig. 1); connecting "tails" from the coils being led out in four lead-covered cables soldered to one end of the canister. Fig. 2 shows the canister complete with the four tail cables. In

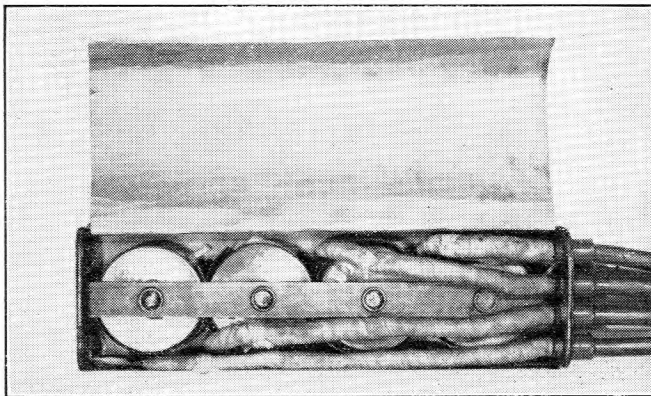

FIG. 1.—CANISTER CONTAINING FOUR LOADING COILS.

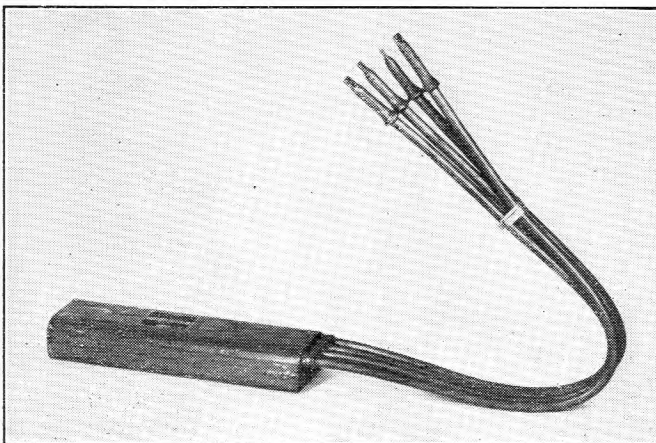

FIG. 2.—THE CANISTER COMPLETE WITH TAIL CABLES.

this form the canister takes up a considerable amount of space when contained within a joint, and installation difficulties vary with the size of the cable.

## Large Audio Cables.

When dealing with large audio cables, joints with half-moon-shaped sections are necessary to ensure that the audio pairs and canister are central within the lead sleeve (Fig. 3). Without the aid of a former to control the

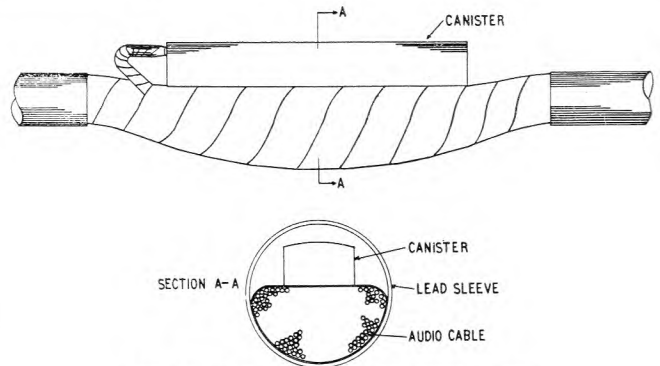

FIG. 3.—CANISTER IN AUDIO-CABLE JOINT.

length of the pairs, jointing of the layer pairs at the varying lengths necessary to achieve a satisfactorily shaped joint is very difficult, and could quite easily result in inferior work which would impair the efficiency of the insulating paper on individual wires.

## Small Audio Cables.

When installing a canister in a joint in a small audio cable, the lead sleeve required is of a size far in excess of that normally used. This heavy and bulky sleeve on a small cable has led to cable sheath faults near to the cable supports or adjacent to the plumbed wipes, where insufficient lateral support has been provided within the jointing chamber.

Extra support for joints is not easily arranged in many of the existing jointing chambers owing to the difference of duct level between one route and another. The larger lead sleeves required to house these canisters also add to maintenance and installation difficulties at fully cabled jointing points and often lead to congestion where reasonable access would otherwise exist.

## Coaxial Cables.

In cables containing coaxial pairs the use of canisters would have led to difficulties because of the limited bending radius of the coaxial pairs. It would not have been possible to position the canister within the joint as in an audio cable, and it was concluded that either the canister should be redesigned to be smaller or an alternative method of loading would be necessary. The first alternative considered was to house the canister in a lead sleeve adjacent

† Executive Engineer, External Plant and Protection Branch, E.-in-C.'s Office.

<sup>1</sup> MORGAN, J. L. W., and ASH, W. S. Program Circuits on Cable Pairs Loaded at 500-yd Intervals. *P.O.E.E.J.*, Vol. 47, p. 193, January 1955.



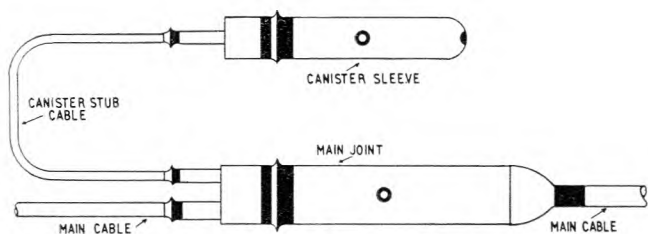

FIG. 4.—HOUSING THE CANISTER IN A SEPARATE LEAD SLEEVE.

to the main joint and connected to it by a short stub cable, in the manner of the auxiliary joint (Fig. 4). This method would have overcome the difficulty of housing the coils in the main joint, but would have introduced additional liability to faults and increased the congestion at the jointing point. Nevertheless, without a radical change in the design of the canister it would have been the only practicable method of canister-loading a few audio pairs in cables carrying coaxial pairs. This method of canister-loading could be justified if a larger number of coils were involved, e.g. to replace the smaller-type manhole loading pots, but development for such a purpose is outside the scope of this article.

#### LOADING WITHOUT USING A CANISTER

It had been generally agreed by both the Post Office and the cabling contractors that the existing canister left much to be desired and should be redesigned at the earliest opportunity. At the same time the loading-coil manufacturers were developing new core materials which would enable much smaller coils to be produced. In anticipation of these smaller coils a new type of canister was discussed in which the individual coils would be mounted axially on a former, the leads brought out to "tag boards" at each end of the canister and cable pairs connected directly to the tags. It was thought that this type of canister would have many advantages and would be of a shape far more suitable for installation in audio-cable joints than the previous design of canister.

The new coils were not as small as originally expected and it followed that the cylindrical canister would still have been a bulky addition to an audio-cable joint and impossible to install in a coaxial-cable joint without recourse to the "auxiliary" joint referred to above. The installation of individual coils in joints was proposed as an alternative method to canister loading and the advantages afforded were immediately apparent. After consultation with the loading-coil manufacturers it was proposed to carry out installation trials with individual coils in screening cans with flexible lead-out wires. Some manufacturers were already using this type of screened coil for installation within manhole-type loading pots, and it was thus a simple matter to obtain samples of this type of coil for installation trials.

#### Unicoils.

Fig. 5 shows the final design of one type of uncoil now being fitted throughout the country where loading of individual pairs in joints is required. The coils are toroidally

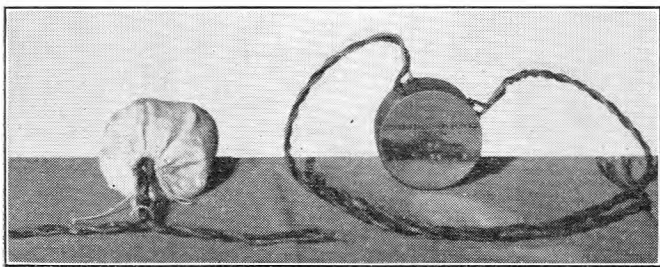

FIG. 5.—ONE TYPE OF UNICOIL.

wound and supplied in cylindrical screening cans, which are not more than  $2\frac{3}{4}$  in. in diameter and  $1\frac{1}{4}$  in. high. In fact, the uncoils at present supplied are considerably less than these maximum dimensions. The coils are available either with screened or unscreened tail cables, according to the cable requirement, and the entry into the can is through either a single- or two-hole grommet. After assembly each coil is filled with wax and sealed.

A linen bag large enough to accommodate the coil and the length of tail cable is supplied with each uncoil.

#### INSTALLATION OF UNICOILS

Experiments were carried out on the installation of four uncoils in a 254-pair, 20-lb cable. It was found that four Grade IA uncoils could easily be inserted in a joint of a 254-pair, 20-lb audio cable and wired to the required pairs. During the development of the jointing technique the maintenance aspect was given a great deal of consideration. While it was necessary to have the uncoils neatly placed in the joint to enable the minimum size of lead sleeve to be used, it was also essential that in the event of a cable fault the coils could be removed from the joint and placed away from the cable pairs without disconnexion. Fig. 6 shows the

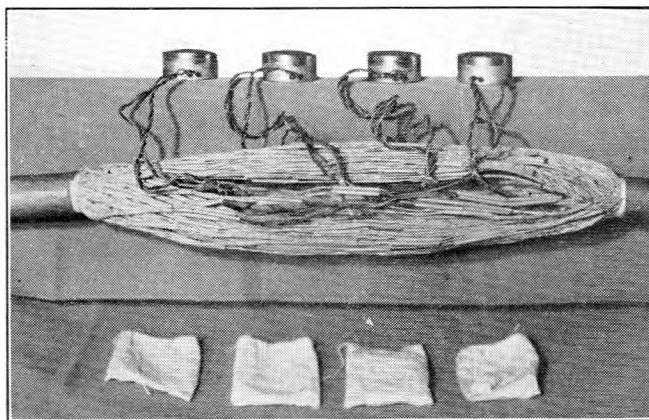

FIG. 6.—COILS REMOVED FROM THE JOINT FOR MAINTENANCE PURPOSES.

four uncoils placed above the joint, as would occur when access to the cable pairs was required. It was found that a tail 14 in. long was necessary to enable the coils to be easily removed from the joint.

An audio joint in which uncoils are to be installed has to be made with the pairs jointed more loosely than is normal. In practice a uniform slackness throughout the joint was found difficult to achieve but the use of wooden formers at each end of the joint improved the jointing technique considerably. With the formers in position the pairs could be jointed with the normal tension and still leave the centre of the joint open for entry of the uncoils. Various types of former may be used to keep the pairs split at the centre, and the original trials were carried out using the star-type former, as used in making the coaxial cable joint previously described in the Journal.<sup>2</sup> The uncoils are placed horizontally in the space between the audio pairs.

It was found that with the 14-in. tail required for easy removal of the coil from the joint and access to the inner pairs, it was necessary to place the coil in a linen bag large enough to accommodate the tail. Fig. 7 (a) and (b) show the appearance of the coils in their bags inside a joint and the completed joint ready for plumbing the sleeve.

The first trials of uncoils in joints in audio cable were made on a spur off the Grantham-Peterborough cable.

<sup>2</sup> LATIMER, E. D., and ASH, B. A New Coaxial Cable Joint. *P.O.E.E.J.*, Vol. 45, p. 1. April 1952.

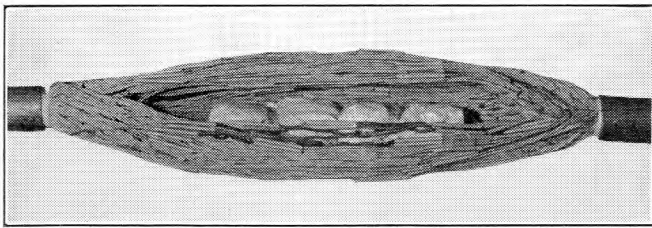

(a) The Coils in Position in the Joint.

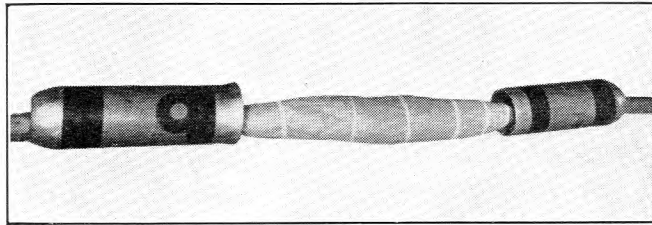

(b) The Completed Joint, ready for Plumbing the Sleeve.

FIG. 7.—CONSTRUCTION OF A JOINT CONTAINING UNICOILS.

The photographs at Fig. 7 demonstrate the very little difference the presence of coils makes in the diameter of the completed joint. In this particular joint the lead sleeve was  $\frac{1}{2}$  in. greater in diameter than that which would normally be used.

During the development of the joint for use in coaxial cables it was found that the spacing of the coaxial pairs was such as to allow the insertion of four and possibly more un coils. Fig. 8 shows the un coils in a coaxial-cable joint,

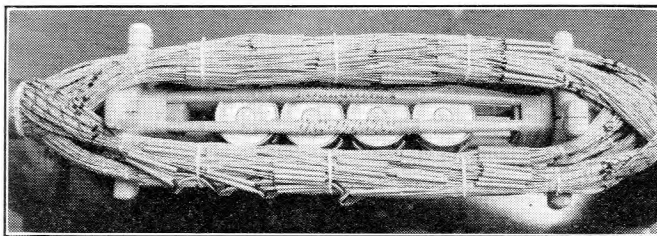

FIG. 8.—UNICOILS IN A COAXIAL-CABLE JOINT.

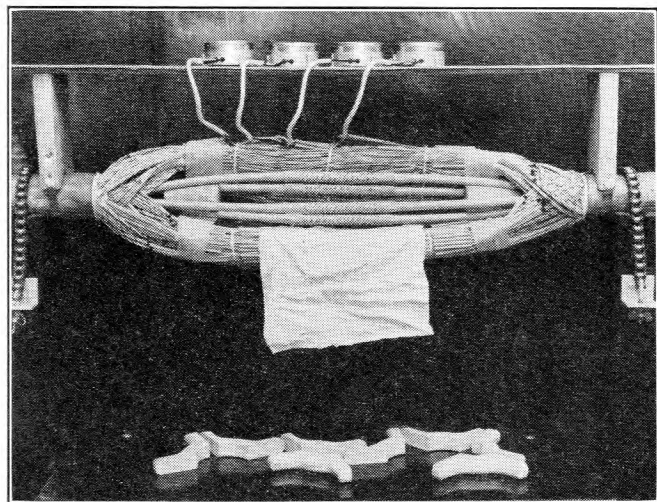

FIG. 9.—COAXIAL-CABLE JOINT WITH THE COILS REMOVED FOR MAINTENANCE PURPOSES.

and Fig. 9 shows them removed for maintenance purposes. For the sake of clearness, the linen bags have been omitted in the picture, but the coils and tails would normally be placed in linen bags as described for the joint in audio cable.

At the same time as the un coils were fitted in the joints

of an audio spur off the Grantham-Peterborough cable, four un coils were fitted in the required coaxial joints on the main portion of this cable.

#### Building-Out Capacitors.

With the increasing use of loading at 500-yd spacing it became necessary to build-out the cable at intervals with capacitance.<sup>1</sup> When building-out in joints in audio cable the capacitors are attached to the sides of the un coil and inserted in the linen bag; the installation is then similar to that previously described. For building-out audio pairs in coaxial cables it was found that, due to the increased thickness of a un coil fitted with capacitors, it was not possible to insert the coil between the tubes as described previously. It was, therefore, decided to mount the capacitors on flat insulating boards in the joint, apart

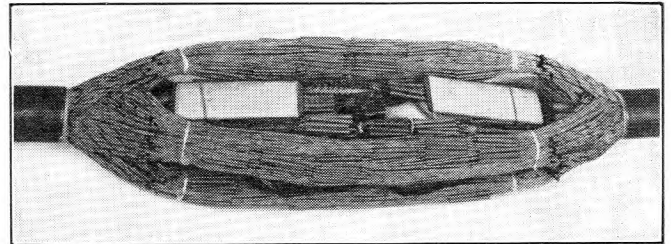

FIG. 10.—JOINT CONTAINING FOUR UNICOILS, A GAS-PRESSURE CONTACTOR AND CAPACITORS.

from the un coils. Fig. 10 shows a joint containing four un coils, a gas-pressure contactor and building-out capacitors mounted on boards and wrapped in paper.

#### FUTURE DEVELOPMENTS

The loading-coil manufacturers are endeavouring to reduce sizes of coils by the use of modern core materials, which will result in a reduction in the overall dimensions of the un coil. Fig. 11 shows the latest size being developed.

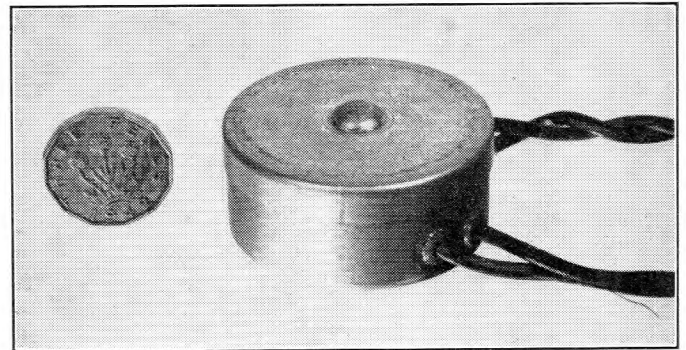

FIG. 11.—LATEST SIZE OF UNICOIL.

It is hoped in future to increase the number of coils that can be installed in a joint and already cases exist where six un coils have been installed in a joint in audio cable. A method of installing up to four un coils in a 6-tube coaxial cable has been approved and installation will commence shortly.

#### ACKNOWLEDGMENTS

The author wishes to express thanks to the members of the Loading-Coil Manufacturers Association for their assistance and co-operation during the development of the un coil. Thanks are also due to Mr. B. Ash, of the External Plant and Protection Branch, E.-in-C.'s Office, who was responsible for the initial development work on the installation of un coils in both audio and coaxial cables.

# Introduction of Increased Transmission and Signalling Limits in the Design of Local Line Networks

G. A. E. FUDGE, A.M.I.E.E.,  
and C. B. MILLER†

U.D.C. 621.3.091.1: 621.395.743

In anticipation of the introduction of the new telephone<sup>1</sup> of superior transmission performance, a review was made of the transmission and signalling limits to be observed in the design of local line networks. As a result of this review, it was decided that the transmission limits for all automatic and common battery (C.B.) exchanges and the signalling limits for some automatic exchanges could be increased. This article outlines the present policy of the Post Office, discusses the effect of the increased limits on the design of the local line network, and describes the modifications to exchange equipment required because of the increased signalling limit.

## INTRODUCTION

IN 1946, the normal transmission limit for automatic exchanges having 50V ballast transmission bridges was 600 ohms (T.E.R.)\* and the signalling limit 650 ohms.† In certain circumstances a transmission limit of 720 ohms (T.E.R.) was permitted but, in general, the design of the network was to the lower transmission limit. Different limits applied to other types of exchange. In 1951, a committee was set up to guide the development of a new telephone instrument, and to determine the future policy regarding the planning limits to be observed in the design of local line networks. Some electrical prototypes of these new telephones, known as the 700-type, have now been produced. The committee decided that:—

- (i) The transmission limit for automatic exchanges having 50V ballast transmission bridges was to be raised to 860 ohms (T.E.R.) in 1953; later, in 1955, when the probable performance of the new telephone had been more accurately estimated, the limit was further increased to 1,000 ohms (T.E.R.).
- (ii) The transmission limits for other types of automatic and C.B. exchanges were to be increased to be equivalent to the 1,000 ohms (T.E.R.) limit for 50V ballast exchanges, i.e. 50V non-ballast, 920 ohms (T.E.R.); 40V C.B. manual, 880 ohms (T.E.R.); 22V C.B. manual, 700 ohms (T.E.R.).
- (iii) With the adoption of the 1,000 ohms (T.E.R.) limit, certain of the older and less efficient types of telephone were to be restricted in use to the shorter lines in the network.
- (iv) The increased limits were to be adopted immediately, in advance of the availability of the new telephone, so that some economic advantages could be obtained for the large program of work then in hand.
- (v) The signalling limit was to be raised to 1,000 ohms line resistance for all new automatic exchanges of the 2,000-type (director, non-director and U.A.X.s No. 13 and 14), and all new U.A.X.s No. 12 (50V non-ballast). Subsequently, "new" exchanges were defined as those ordered after June 1955.
- (vi) Where economically justified, existing exchanges were to be modified to permit the adoption of the 1,000-ohms signalling limit.

Except for (iii), the foregoing decisions have been implemented.

The increase in transmission limits was occasioned by the projected introduction of the new telephone of superior performance. But, because of the use in the network

† Mr. Fudge is an Executive Engineer in the Local Lines Branch and Mr. Miller is an Assistant Engineer in the Telephone Development and Maintenance Branch of the E.-in-C.'s Office.

\* The Transmission Equivalent Resistance (T.E.R.) of any line of given length and gauge of conductor is defined as the d.c. resistance of a 6½-lb line of the same grade of transmission. The T.E.R. of a line is thereby expressed in ohms and its magnitude is equal to the magnitude of the d.c. resistance of the line multiplied by a factor.

† Unless otherwise stated, the transmission limits quoted are for automatic exchanges having 50V ballast transmission bridges and the signalling limits are for 2,000-type automatic exchanges.

in increasing numbers of the current type of telephone (No. 232/332 with Receiver Inset No. 2P) which affords better performance than those telephones considered in determining the previous (1946) limits, and because it takes several years for a change of planning limits to become effective, it was decided to adopt the increased limits in advance of the new telephone. To obtain the maximum benefit from the increased transmission limit it was essential that the signalling limits should be increased also.

Arising from the foregoing major decisions, other changes followed, namely:—

- (a) The raising of the exchange plus extension line signalling resistance limits for P.B.X.s, when the limitation was not set by the P.B.X. equipment.
- (b) The introduction of a new switchboard, N. 1070 (65-line cord board), which has a better signalling performance than, and gives similar facilities to, the AT 3796 switchboard.
- (c) The raising of the transmission limits for local-feed P.B.X.s and for auxiliary signalling units (i.e. where the P.B.X. battery supplies the transmitter current to the extension on exchange calls). The transmission allowance remains unchanged for the standard exchange-feed type of P.B.X. (i.e. where the public exchange battery supplies the transmitter current to the extension).
- (d) The discontinuance of the use of local-battery telephones on P.B.X. extensions in C.B. and automatic exchange areas.
- (e) The use of one common set of multiplying factors for all types of exchange in place of a set for each of the four main types, and one conversion table, slide rule, and one value for feed-cable mileage. The multiplying factors are required for calculating the T.E.R. value of the various conductor gauges (the multiplying factors are, 0.8 for 4lb; 1 for 6½ lb;

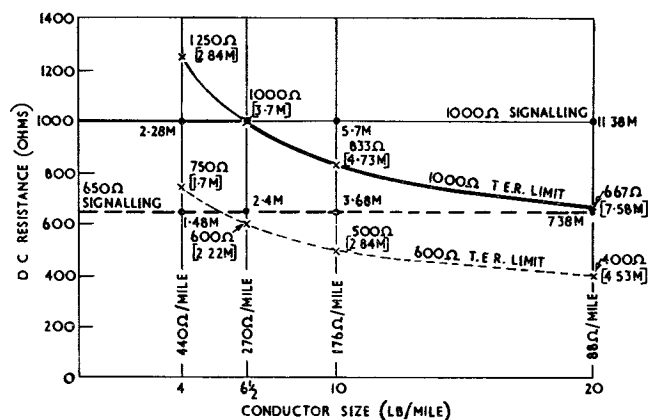

— Limiting condition for new and modified exchanges having a 1,000-ohm signalling limit.  
- - - Limiting condition for existing exchanges having a 650-ohm signalling limit.

FIG. 1.—TRANSMISSION AND SIGNALLING LIMITS FOR VARIOUS GAUGE CONDUCTORS (50V BALLAST EXCHANGES).



1.2 for 10 lb; 1.5 for 20 lb; thus, for example, the T.E.R. value of 1,000 ohms of 4-lb conductor is 800 ohms (T.E.R.).

The effect of the increased transmission and signalling limits on the design of the local line network can be seen from Fig. 1, which shows the transmission limit for each gauge of conductor, appropriate to the present 1,000 ohms (T.E.R.), and the previous 600-ohms (T.E.R.) limits, together with the 650-ohms and 1,000-ohms signalling limits.

### TRANSMISSION

The transmission performance ratings of three telephone circuits, for various values of line resistance in  $6\frac{1}{2}$ -lb conductor (i.e. the T.E.R. value), are shown in Fig. 2.

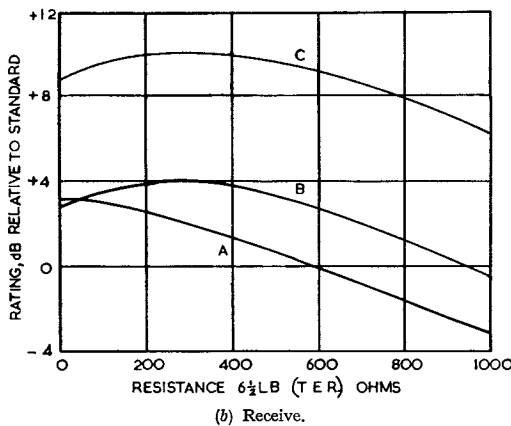
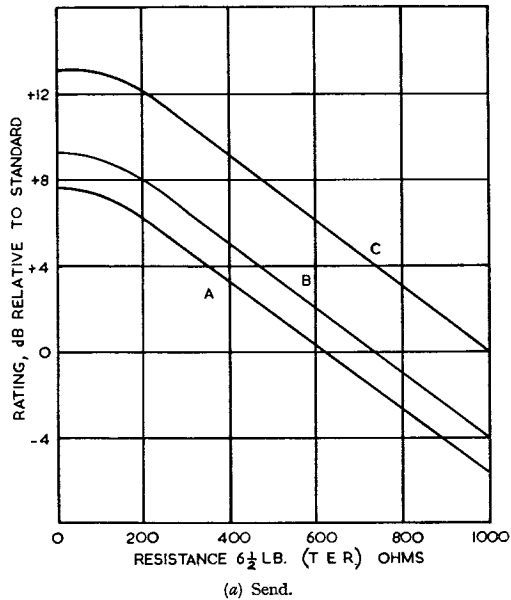

A—Telephone No. 162.  
B—Telephone No. 332 with 2P receiver (or similar type).  
C—700-Type Telephone (estimated).

FIG. 2.—TRANSMISSION PERFORMANCE RATINGS (50V BALLAST EXCHANGES).

Each circuit includes an exchange transmission bridge of the 50V ballast type, and the three telephones are (a) Telephone No. 162 with Bell Set No. 25, having a transmitter No. 13, a receiver 1L and an induction coil No. 18.35A; (b) Telephone No. 332, or similar type, having a transmitter No. 13, a receiver inset No. 2P and an induction coil No. 27, and (c) the new, 700-type telephone (as estimated at present). The performance ratings are relative to the Standard Local Telephone Circuit<sup>§</sup> and are based on articulation tests, with a 6-dB correction for the 332- and 700-type telephones in the receiving direction of transmission. This

correction has been applied recently and is explained elsewhere.<sup>1</sup>

The send and receive ratings<sup>2,3</sup> of the telephone normally differ; the lesser of the two line resistances at which the curves cross the zero axis (Fig. 2) being regarded as its limiting value. Thus, for the 700-type telephone, the limiting resistance value is 1,000 ohms of  $6\frac{1}{2}$ -lb conductor (3.7 miles), i.e. 1,000 ohms T.E.R.—the value adopted for future planning.

Cabling designed to this limiting value would also serve existing types of telephone. Fig. 2 shows that for short lines having a T.E.R. value less than 600 ohms, the performance of the three telephone circuits is better than standard in both directions of transmission but, as the line resistance increases towards the limiting value of 1,000 ohms, circuits with Telephones No. 162 and 332 are below the transmission standard. The performance of a connexion between any two subscribers' installations in this country—apart from the inter-exchange trunk and junction links—can be appraised by combining the respective send and receive ratings of the two telephones. Thus, if two 700-type telephones are interconnected, each on a limiting local line of 1,000 ohms T.E.R., the send rating (0 dB) and receive rating (+6 dB) give an overall rating of +6 dB relative to the Standard Local Telephone Circuit in both directions of transmission. Interconnexions involving the use of the other types of telephone on similar lines will afford lower combined ratings. The lowest rating will be when two Telephones No. 162 are interconnected, when the combined rating will be -9 dB in both directions. There are a few older types of telephone in service with even lower performance ratings. Thus, as far as the local line network is concerned, the transmission performance afforded by a subscriber's installation will be influenced very much by the type of instrument and the T.E.R. value of the line. It will also be observed that there is a wide difference between the combined ratings of two 700-type telephones on short lines and two Telephones No. 162 on long lines.

In appraising these ratings against the performance of the national network, it is necessary to consider the probability of calls being set up which have varying combinations of telephones, local lines, and trunk and junction links. Such consideration must include the future trend as well as the existing state of the three components of a connexion. Some aspects of the distribution of these three components are discussed in the following paragraphs.

*Telephones.*—The quantity and distribution of telephones in the network cannot be accurately assessed. There are no fewer than eight types of telephone, each with different combinations of transmitter, receiver and induction coil and with differing transmission performance rating. The 332-type of telephone (and types having similar transmission components) is in current supply and this type, together with telephones having ratings slightly less than the Telephone No. 332, predominate in number. The Telephone No. 162 and other older and less efficient telephones are available for re-issue and will continue to be for some considerable time.

*Local lines.*—The distribution of subscribers' lines differs in each exchange area and is largely dependent upon the size and location of the area. At one extreme, there are the few congested small areas—such as those in the centre of London—where no lines approach the previous limit of 600 ohms and where little, if any, advantage can be obtained from the increased limits with the use of present gauge conductors. At the other

<sup>§</sup> The Standard Local Telephone Circuit comprises a Telephone No. 162 with Bell Set No. 25, connected by a line of 10-lb conductor of resistance 450 ohms (2.56 miles) to a 50V non-ballast automatic-exchange transmission bridge having 200 + 200 ohm relays.



extreme there are the exchange areas, mostly provincial, having long lines and large telephone growth at the boundary. A study was made in 1954 of the distribution of subscribers' lines in 62 exchange areas of various sizes and locations. This study indicated that the national average T.E.R. value was of the order of 250 ohms representing a send rating of +5 dB and receive rating of +2 dB for circuits having Telephones No. 162. It also showed that approximately 3 per cent of the exchange connexions were around the limiting transmission value.

The adoption of the increased limits in designing local line networks will take a long time to have any effect. First, a period of at least 12 months usually elapses between the planning and execution of a scheme. Secondly, development schemes planned in 1955 to the 1,000-ohms T.E.R. limit were somewhat limited by the then overriding signalling limit of 650 ohms. Schemes making full use of both the 1,000-ohms T.E.R. and 1,000-ohms signalling limit are at present few in number but some lines of high T.E.R. value will shortly begin to appear in the network.

*Trunks and Junctions.*—Local telephone circuits having sub-standard ratings (see Fig. 2), would yield satisfactory transmission on local calls, but should two inferior telephones, each on a limiting local line, be interconnected on a long-distance call, there would be a big risk of unsatisfactory transmission. This would be particularly likely where the trunk or junction route is operating on or near its limiting transmission value. In practice, these calls form a very small proportion of the daily total.

From the foregoing paragraphs it will be gathered that with the present network the probability of setting up calls between local telephone circuits having sub-standard rating is extremely remote. Nevertheless, it is necessary to consider the future network planned to 1,000-ohms T.E.R. and to reduce the risk of sub-standard calls to a minimum. With this object in view, consideration is being given to the introduction of a procedure for some degree of zoning of telephone installations according to their respective transmission efficiencies. Broadly, this would mean that the new, 700-type telephone would be used on long lines and the other telephones on short lines.

The practical application of zoning is now being studied. Its adoption would gradually improve the transmission performance of the network, and would reduce the wide differences between the ratings of connexions.

#### Light-Gauge Conductor.

At present 4-lb/mile conductor is the lightest in use in the network, but some thought is being given to the development of 2½-lb conductors in order to take advantage of the increased limits. The field of use for 2½-lb conductor may be in large local cables in sections near the exchange and especially in congested areas in London and the larger cities, but the provision of this conductor may, under certain circumstances, interfere with the provision of miscellaneous and external extension circuits.

#### Crosstalk.

The effects of the 700-type telephone, lighter gauge conductors and perhaps longer lines will tend to worsen crosstalk in the network. The volume efficiencies of the 700-type telephone are greater than those of the current telephone No. 332 with receiver 2P, by approximately 5 dB in the sending direction and 3 dB in the receiving direction, and thus it may be inferred that two adjacent circuits having 700-type telephones in place of Telephones No. 332 would result in 8 dB worsening of crosstalk. This worsening would, however, be tolerable for a vast

majority of connexions and would be noticeable only in the few cases where conditions were already onerous. The use of a conductor one gauge lighter worsens crosstalk by approximately 2 dB and longer lines increase the risk of crosstalk by a slight amount. The consequent increased risk of crosstalk is, to some extent, being offset by the adoption of Paper Core Unit Twin (P.C.U.T.) cable instead of Paper Core Quad Local (P.C.Q.L.) cable for new work. A study of crosstalk performance, as shown by field tests in local line networks, proved that the crosstalk attenuation of P.C.U.T. cable was some 10 dB greater (better) than that for P.C.Q.L. cable. There is, however, a considerable amount of P.C.Q.L. cable in the network which, with the new telephone, could give rise to an increased risk of crosstalk.

#### LINE PLANT SAVINGS

The application of the increased transmission and signalling limits to the design of the local-line cable network enables economies to be effected by the use of cables having lighter gauge conductors than used hitherto. In general, except where 4-lb conductors are already in use, conductors of the next lighter gauge can now be used.

The amount of the savings for new cable work is largely influenced by the length of the cable route. The greater the route length, the greater the opportunity for taking advantage of the increased limits and for using light-gauge conductors. For route lengths less than about 1.5 miles, no saving can be achieved as this length of the minimum gauge conductor, 4 lb/mile, already meets the earlier limits of 600-ohms T.E.R. and 650-ohms signalling. As the length increases beyond 1.5 miles, the savings also increase; there being a broad relationship between the savings and route length.

In 1952, a detailed study was made to determine the line plant savings. Twenty-four exchange areas were selected and line plant layouts were designed to cater for the 20-year development on the basis of (a) the then existing limits (transmission, 600-ohms T.E.R.; signalling, 650 ohms), and (b) a transmission limit of 860-ohms T.E.R. and a signalling limit of 1,000 ohms; the cost differences gave an indication of the line plant savings. (Subsequently, the effect of the 1,000-ohms T.E.R. limit was pursued, showing a further slight increase in the savings.) From the study, the percentage savings in present value of annual charges (P.V. of A.C.) per added line for varying lengths of cable route were as shown in Fig. 3. The percentage savings for similar

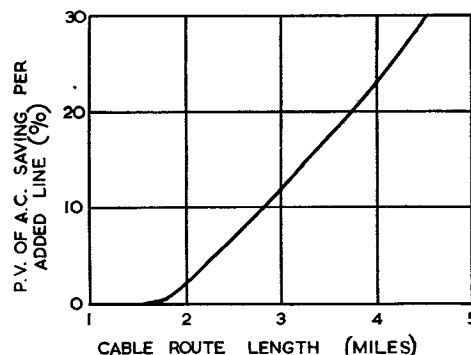

FIG. 3.—SAVING PER ADDED LINE (CABLE WORK ONLY).

lengths of route differed, especially for the longer routes; the curve shown representing the best fit of the 78 routes studied.

By relating this curve to the percentage distribution of added lines (anticipated) with respect to cable route length for director and non-director and for U.A.X. areas—including the routes below 1.5 miles, where no savings are obtained—the average savings per added line (P.V. of A.C.,

cable work only) were calculated as approximately 7 per cent for director and non-director exchange areas and 11 per cent for U.A.X. areas. The percentage savings of inclusive capital cost were of the same order.

A further saving will be achieved in conserving duct space by the use of smaller-diameter cables or by using a cable of more pairs in a duct way. For example, the maximum-diameter cable that can be drawn into a  $3\frac{3}{8}$ -in. self-aligning duct is 3.0 in. This space can be filled with either 800 pairs, 10-lb; 1,200 pairs,  $6\frac{1}{2}$ -lb; or 1,800 pairs, 4-lb P.C.U.T. cable.

Against the savings shown above must be set the additional costs incurred in the provision and maintenance of more sensitive exchange equipment capable of giving satisfactory performance with subscribers' lines of 1,000 ohms.

#### *Size of Exchange Area.*

As a result of the increased limits, either economies can be made in the line plant costs of an area or the area can be enlarged for the same line plant cost. The size of an exchange area depends upon many other factors, e.g. growth, exchange equipment, accommodation, junctions, tariffs, state of existing plant, etc. As the existing plant in any area has been provided after such consideration of economics, the effect of a change in any one of these factors can only be gradually realized over a very long period. However, in the case of small-size exchange areas, it is more likely that line plant cost will have an immediate influence on the determination of the size of the area. Thus, in these cases, it may prove economical to eliminate a small automatic or manual exchange and transfer its area, or parts of the area, to a neighbouring exchange (or exchanges).

### SIGNALLING

The signalling performance of certain items of existing automatic exchange equipment does not permit an increase in the subscribers' line signalling limit from the present value of 650 ohms. Such items are those which, in general, have been designed to work solely in conjunction with subscribers' lines. In this category are 1st code selectors, final selectors, subscribers' line circuits and some miscellaneous circuits. Other items, such as auto-to-auto relay sets, which can be seized by either a junction or a subscriber's line and which have been designed to meet the more stringent signalling requirements of junction working, will adequately cater for subscribers' lines of 1,000-ohms loop resistance. A study was undertaken to determine the extent of the essential changes to director, non-director and U.A.X. equipment necessary to permit the use of subscribers' lines of 1,000 ohms, and the costs of these changes were assessed. The following factors were taken into consideration in determining the limiting performance of the existing types of equipment and in designing more sensitive equipment where required:—

- (i) A subscriber's line of 1,000-ohms loop resistance.
- (ii) A telephone instrument signalling resistance of 350 ohms at 15 mA, 330 ohms at 20 mA, and 300 ohms at 30 mA.
- (iii) An earth resistance of 150 ohms in cases where the most onerous calling condition is that extended by a shared-service telephone.
- (iv) The lower limit of exchange battery voltage.

#### *Subscribers' Line Circuit in Director and Non-Director Exchanges.*

The subscriber's line circuit in standard director and non-director exchanges employs unselector calling principles and incorporates 600-type relays. The sensitivity of the existing subscriber's line relay is not such that it will

meet, with full safety margins of operation, the requirements of a 1,000-ohms line. The use of a more sensitive single-coil line relay would, however, increase the risk of what is termed "unselector chase" under fault conditions.

An earth fault on the B leg of a subscriber's line may cause the subscriber's line relay to operate and the faulty line to be connected to the line relay of a 1st code selector or 1st selector in the normal manner. Only the battery-connected winding of the selector line relay will be energized and if the resistance of the fault to earth is above a certain value, the selector line relay may fail to operate. This being so, the selector will not be seized and a holding earth will not be connected to the subscriber's line circuit via the P wire, and consequently the switching relay, K, in the line circuit will release and the faulty line will be reconnected to the subscriber's line relay. This cycle of events will be continuously repeated with the result that either the subscriber's unselector is driven round its bank from contact to contact, or the relays in the subscriber's line circuit interact continuously, the unselector remaining on a particular contact.

With the most onerous adjustments applied to existing subscribers' line equipment, and 1st code selector or 1st selector, the range of earth-fault resistance over which unselector chase may occur is 750 to 5,000 ohms for director exchanges and 1,600 to 5,000 ohms for non-director exchanges. The lower resistance limit is governed by the sensitivity of a 1st code selector or 1st selector line relay energized over one winding and the upper limit by the sensitivity of the subscriber's line relay. This upper limit would be raised if the sensitivity of the relay were increased.

The subscriber's line relay in director and non-director exchanges has a release lag to cover the delay that occurs between the disconnection of the line relay and the connection of a holding earth to the K relay from the 1st code selector or 1st selector. It was found that if the standard subscriber's line circuit is operated from a line of resistance greater than 650 ohms, the reduction in line current, together with the short energization time that is obtained when the subscriber's line circuit switches to an early outlet, could result in the release lag of the line relay being insufficient for satisfactory operation of the circuit. A more sensitive single-coil 600-type line relay would have, of necessity, an even smaller release lag than the standard design because improved sensitivity could only be obtained by increasing the winding space at the expense of the space available for the slug. It is, therefore, essential that, if a single-coil 600-type line relay is used with a subscriber's line of up to 1,000-ohms loop resistance, some means must be adopted to ease the release timing requirements of the relay. This can be done by providing what is called a "fast guard" facility in subscribers' 1st code selectors and 1st selectors.

When a 1st code selector or a 1st selector of existing design is taken into use, a guarding and holding earth is connected to the incoming P wire by a contact of a relay that is dependent for its operation on a contact of the selector line relay. If it is arranged that the earth is connected to the P wire earlier in the seizure sequence, directly by a contact of the selector line relay, satisfactory switching of the existing standard subscribers' line equipment can be obtained when associated with lines of 1,000-ohms loop resistance. Fig. 4 shows the basic circuit elements of 1st code and 1st selector equipment that provide this facility.

#### *Subscribers' Line Circuits in U.A.X.s No. 12, 13 and 14.*

The subscribers' line circuits in U.A.X.s No. 12, 13 and 14 incorporate 600-type relays and are associated with linefinder equipment. The line relays will not cater for subscribers' lines of 1,000 ohms with full factors of safety.

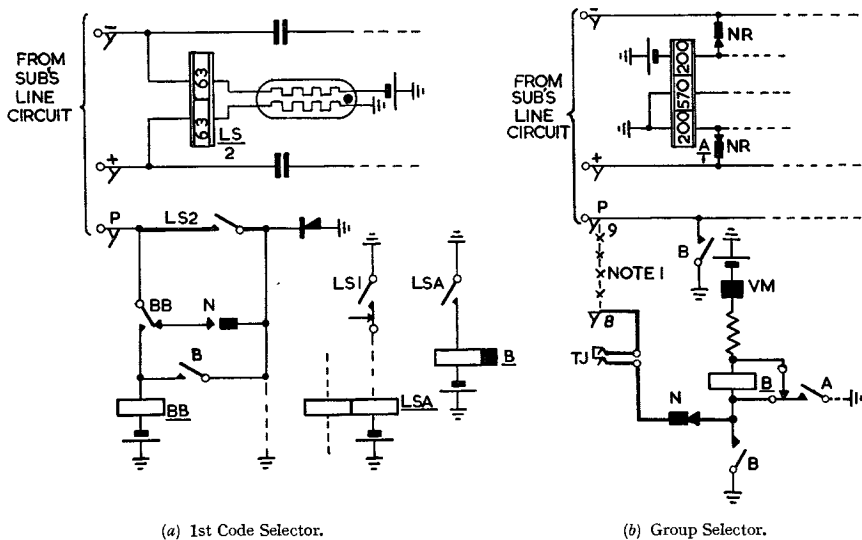

Notes: 1. The strap shown in (b) between U-points 8 and 9 is inserted when the selector is used as a subscriber's 1st selector in a uniselector exchange.  
 2. Modifications to existing equipment are shown by bold lines.

FIG. 4.—BASIC CIRCUIT ELEMENTS PROVIDING FAST GUARD FACILITY.

In exchanges employing linefinder principles, a condition of "linefinder chase" may occur under line fault conditions. Linefinder chase is similar to uniselector chase except that, as the line relays of 1st selector equipment associated with linefinders are pre-operated, these relays have only to be held and not operated by earth-fault currents. In consequence, the ranges of earth-fault resistance over which linefinder chase may occur are less than those for uniselector chase. On the other hand, the effect of linefinder chase is more serious as it results in increased wear of linefinder and common control equipment, which is costly to replace. Whilst linefinder chase may occur in a U.A.X. No. 14 over a range of earth-fault resistance dictated solely by the relative sensitivities of subscribers' line and 1st selector relays, the risk of chase is reduced in a U.A.X. No. 13 and obviated in a U.A.X. No. 12 by the fault-lock-out feature incorporated in the subscribers' line equipments in these exchanges. The use of more sensitive subscribers' line relays to cater for the increased line limit would increase the risk of linefinder chase occurring in U.A.X.s No. 13 and 14.

#### Consideration of Designs of Subscribers' Line Relays.

There are several possible ways by which the sensitivity of subscribers' line relays could be increased to meet the requirements of 1,000-ohm subscribers' lines.

- (i) A 3,000-type relay could be designed to have the desired sensitivity and to give sufficient release lag to be able to dispense with the need for the provision of fast guard facilities in 1st selectors. Such relays are, however, larger than the present line relays, and line equipment racks and U.A.X. units would have to be re-designed, and more accommodation would be required.
- (ii) New 600-type line relays could be adopted, attendant on the provision of fast guard facilities in 1st selectors. The risk of uniselector and linefinder chase could be minimized by the adoption of two-winding line relays, one winding being connected to each leg of a subscriber's line. Earth-fault currents would flow only through the battery-connected winding, and the relay would therefore be less sensitive to these currents than a single-coil relay. The risk of chase could not be completely eliminated as there would be a limit to the minimum sensitivity of the battery-connected winding of such a relay, dictated by the more onerous earth-calling conditions extended from a shared-service telephone. Further-

more, the adoption of a two-winding relay would necessitate modifications being made to other exchange equipment, such as final selector circuits, in order to prevent the unwanted operation of the line relay over its earth-connected winding by the ringing return battery on an incoming call. Any major changes to the design of the present 600-type line relay would involve departures from present manufacturing practices, and it is probable that the cost of a new design with extra features would be somewhat greater than that of the present 600-type relay.

- (iii) The existing designs of subscribers' line relays can be retained and narrower limits of permissible adjustments accepted. It was found that the existing subscribers' line relays will meet the requirements of 1,000-ohm subscribers' lines, except when they are in the most onerous permissible adjustment, provided that associated 1st code selectors or 1st selectors give a fast guarding earth on the P wire.

The last solution has been adopted as it offers considerable economic advantages. Existing designs of subscribers' line relays have not been changed, but, when necessary, these relays are adjusted individually to meet the requirements of subscribers' lines of loop resistance in the range of 650–1,000 ohms. The range of earth-fault resistance over which uniselector or linefinder chase may occur will not be worsened, but the chances of it occurring will be increased to some extent as more subscribers' line relays will tend to be in light adjustment. Fast guard facilities are being provided in 1st code selectors in director exchanges and in 1st selectors in non-director exchanges. In non-director exchanges switching difficulties might result if group selectors, other than those used as subscribers' 1st selectors, gave a fast guard earth, and therefore, in order to avoid the provision of a special design of subscribers' 1st selector, the fast guard facility is an optional feature on new group selector equipment, provided by the strapping of shelf jack U-points when required (see Fig. 4). Since U.A.X. subscribers' line circuits employ linefinder principles, fast guard facilities will not be required from U.A.X. 1st selector equipment.

#### Re-Design of Other Exchange Equipment.

In addition to the changes required to 1st code selectors and 1st selectors to provide fast guard facilities, changes are being made to the designs of the following relays in order to obtain the required performance with 1,000-ohm subscribers' lines:—

Ring-trip relays (F) in final selectors in U.A.X.s No. 12, 13 and 14, director and non-director exchanges and in miscellaneous equipments such as service interception and linemen's ring-back circuits.

Supervisory relays (D) in final selectors in U.A.X.s No. 13 and 14 and director and non-director exchanges. [The existing D relays in U.A.X. No. 12 selectors operate satisfactorily with 1,000-ohm subscribers' lines.]

Line relays in 1st code selectors, certain selector-level relay sets and circuits associated with test equipment, e.g. relays LA in test interception circuits in director and non-director exchanges.

Consideration is also being given to the changes required to test-desk, test-rack and test-case equipment in order that maintenance tests may be made on subscribers' lines of the higher order of resistance, and on the exchange equipment associated with these lines.

### *Effect of Increase in Subscribers' Line Limit on Pulsing Performance and Limits.*

The present limits for loop-disconnect working were based on a subscribers' line limit of 600 ohms, which was later increased to 650 ohms. The limits were determined under adverse conditions assuming the output of a subscriber's dial to be 63 per cent to 72 per cent break ratio. The effect of an increase in the subscribers' line limit will be to increase distortion in such a sense as to cause an increase of the pulse break periods. Tests have shown that the additional distortion resulting from an increase of line resistance to 1,000 ohms is of the order of 2 ms and introduces some increase in the risk of failure should all factors affecting pulsing be simultaneously adverse. It is expected that this increase in distortion will be offset by the rapidly increasing use in the telephone network of the new trigger-type dial, the pulse output of which is expected to remain more constant over long periods than that of the earlier type of dial, due to the compensatory effects of wear on different parts of the pulsing mechanism.

### *Application of the Increased Line Limits to Existing Exchanges.*

The application of the increased signalling limit to existing exchanges gives rise to certain difficulties; for example, pre-2,000-type 1st selectors and D.S.R.s cannot be readily modified to give a fast guarding earth. It has therefore been decided that the new signalling limit can be applied to existing exchanges only when a detailed study has demonstrated that the overall savings would be sufficiently high to justify such action, and when the exchange equipment concerned falls into one of the following categories:—

- (1) Exchanges with wholly 2,000-type equipment (including U.A.X.s No. 13 and 14).
- (2) U.A.X.s No. 12.
- (3) Linefinder exchanges with pre-2,000-type selectors employing 3,000-type relays.
- (4) As (3) but which are extended by uniselectors and 2,000-type selectors. In these exchanges, uniselectors that are trunked out to pre-2,000-type 1st selectors or D.S.R.s cannot be used on lines with loop resistances exceeding 650 ohms.

The question of increasing the signalling limit retrospectively at manual exchanges is still receiving consideration but it has been found possible to increase the limit from 500 ohms to 700 ohms for direct exchange lines connected to certain types of 40V C.B. exchanges.

#### ACKNOWLEDGMENT

The authors wish to acknowledge the help received in the preparation of this article from colleagues in the Local Lines and Telephone Development and Maintenance Branches of the E.-in-C.'s Office, who have been concerned in the implementation of the measures described in this article.

#### References.

- <sup>1</sup> SPENCER, H. J. C., and WILSON, F. A. The New, 700-Type Telephone. *P.O.E.E.J.*, Vol. 49, p. 69, July 1956.
- <sup>2</sup> FUDGE, G. A. E. Introduction and Application of Transmission Performance Ratings to Subscribers' Networks. *I.P.O.E.E. Printed Paper No. 198*, 1949.
- <sup>3</sup> BARNES, E. J., WOOD, A. E., and RICHARDS, D. L. Standards of Transmission and Local Line Limits. *P.O.E.E.J.*, Vol. 40, p. 8, Apr. 1947.

## Book Reviews

"Musical Acoustics." (Fourth Edition.) Charles A. Culver. McGraw-Hill Book Co. 297 pp. 215 ill. \$6.00.

Being a fourth edition, and very largely re-written as a result of experience with earlier editions, this is undoubtedly a good book for its main purpose, namely "as a text for use by music majors in colleges and universities." It is easy to read and takes for granted from its reader little knowledge of either music or acoustics. It can therefore be of interest to a much wider public, to anyone who enjoys music and is not daunted by a little very elementary physics.

The elementary physics is introduced in the first four chapters with little use of mathematical expressions. Then follows a chapter on hearing, which includes the concepts of intensity and the decibel scale as well as some notes on the structure of the ear and its sensitivity in different circumstances. Thereafter the physical and the psychological aspects of acoustics are closely interleaved; thus "resonance" precedes "pitch," "quality" includes methods of recording and analyzing waveform, and short discussions of vibrating strings, air columns and rods and plates precede the descriptions of the corresponding groups of musical instruments. The human voice is properly included with the wind instruments in this section. A chapter on "musical intervals and temperament" introduces the section on musical instruments; it deals with the arithmetic of musical scales and chords and exposes some mysteries of the piano-tuner's art. Chapters on recording and reproducing sound and on architectural acoustics conclude the book—superficial, of course, but evidently done from considerable knowledge and with a good sense of proportion.

The book is well written, well produced and generously illustrated. The selection of illustrations is open to criticism (from a general reader's point of view) in that the photographs of the musical instruments are too few and too small to be of much use for illustrating the detail in the text. On the other hand there are a number of oscillograms of the waveform of sustained sounds which do not seem to serve a useful purpose. They are additional to charts of spectra of the sounds, which

show the relative magnitudes of the different harmonics; the text is not concerned with the relative phases, even if one could read them from the waveform.

Those who teach may find useful the few simple questions and problems at the end of many of the chapters. All can benefit from the book if the author's belief is correct "that a knowledge of the means and processes by which music is produced, recorded and transmitted will serve to contribute to the greater enjoyment of this, the noblest of the arts."

W. W.

"Hi-Fi from Microphone to Ear: Modern Sound-recording and Reproduction Technique." G. Slot. Philips Technical Library. Cleaver Hume Press Ltd. 169 pp. 118 ill. 17s. 6d.

This little volume is an English translation of a publication from Philips of Eindhoven, and is concerned mainly with the high-fidelity reproduction of gramophone recordings. The author disarms criticism by his explanation in the foreword that the book is written for "music lovers without technical training whose aim is to reproduce music and speech as faithfully as they can," and with that aim in view the emphasis throughout is on the simple non-technical explanation.

After an introductory discussion of the general principles of disc recording, detailed chapters follow on the characteristics of the various types of pick-up, and on the frequency response required for reproducing modern recordings. Other sections deal briefly with amplifiers and loudspeakers, and there is a short chapter on the principles of tape recording.

Although the communications engineer will find little that is new in the book, it is nevertheless written in a very readable style, and it should prove very popular with the type of reader for whom it is intended. It is excellently illustrated, and if an occasional phrase jars—such as the use of "richness of tone" to describe a quality of a gramophone pick-up (on page 33)—perhaps difficulties of translation should be blamed rather than the author.

*I.P.O.E.E. Library No. 2414*

F. E. W.



# An Electronic Error-Correcting Multiplex Telegraph System

U.D.C. 621.394.14 : 621.394.441

As a palliative to overcome the mutilations which inevitably occur to a greater or lesser degree in the radio transmission of telegraph signals, the employment of protective codes and automatic repetition has grown over the past 20 years, particularly during the post-war period. In the late 1930's Moore and Mathes introduced, for use with the Radio Corporation of America multiplex system, a 7-unit code in which the characters were each represented by permutations comprising three marking and four spacing elements, this enabling mutilations, other than those which might be fortuitously self-compensating, to be detected and indicated as errors in the received copy. Van Duuren (of the Netherlands P.T.T.) adapted this basic code-form and extended its usefulness by devising means of automatic translation from, and to, the International Alphabet No. 2 used for teleprinters. [The teleprinter code comprises 32 5-unit permutations, and for switched working (e.g. telex) two other conditions, continuous mark or space, require to be transmitted. Seven-unit code gives 128 permutations of which 35 have the required characteristic (3M and 4S).] He also conceived the idea of automatic error-correction by repetition of the faulty character when an error in reception is detected. The 35th code permutation (or RQ signal) is transmitted back to the originating station when an error is detected, and causes the character, which is automatically stored for a period sufficient to cover the double transmission time, to be sent again. During this period for repetition, normal transmission is suspended and printing is resumed only when the character that has been rejected is received again and conforms to the correct code ratio. Other forms of protective code are known, but the van Duuren code and repetition system is the most widely used at present.

During recent years, much attention has been given to the possibility of replacing electro-mechanical apparatus by electronic equipment and, in the cause of investigating the merits of various forms of protective code, an electronic error-correcting multiplex system has been developed by the Post Office Research Branch, using the basic principle of automatic repetition (ARQ) mentioned above.

The apparatus is a 2-channel synchronous time-division multiplex system for the interconnexion of teleprinter networks operating at the international standard speed. The circuit techniques employed comprise thermionic valve and cold-cathode tube elements. In general, the former are used for control and drive-circuits and the latter for pulse distributors, counting and signal storage. The common apparatus consists of the time-division multiplex proper, including the basic time generator, transmitting and receiving distributors with synchronizing correction and both manual and automatic initial phasing of elements and channels at the receiver; code-converters for translation from teleprinter code to the protective code and vice versa; and the error detector. Individual channel apparatus comprises: at the transmitter, the character store, which stores up to the last four characters transmitted; input control circuits; and the repetition sequence counter, which controls the store during a repetition cycle; and at the receiver, a start-stop signal generator which accepts, from the decoder, retranslated 5-unit permutations derived from incoming 7-unit signals that have been found correct and sends them out as standard teleprinter signals.

The basic timing supply is provided by a crystal oscillator via several stages of frequency division (the first of which provides a four-phase output) to give a pulse-repetition

frequency equal to the required aggregate modulation rate (93½ bauds). This pulse train drives the transmitting distributor directly, the resultant seven pulse trains being gated by the coder, according to the permutation to be transmitted. A channel distributor is stepped at the end of each 7-unit cycle so that the input of the coder is connected to the next channel in the sequence.

The input to each channel is by a 6-wire system, five wires for the normal code permutations and the sixth to indicate supervisory conditions, from a tape reader (which can be part of a receiving-reperforator-retransmitter). At the commencement of the character cycle, the channel input is transferred to the first rank of the store (comprising cold-cathode triodes) which, via the channel gates, controls the coder. When the character has been transmitted, it is transferred to the next rank of the store, and so on to the last rank in succeeding character cycles, and then, if no repetition has been demanded, it is discarded. But if a repetition has been requested, or a faulty character has been detected by the corresponding return channel, a pulse actuates the repetition sequence counter. This suspends temporarily the operation of the tape reader, sets up the RQ combination for transmission on the channel and loops the store so that all the characters in the store are retransmitted in their original sequence. The capacity of the store in this equipment can be readily varied to cater for loop propagation times up to 450 milliseconds.

The received signal, reinverted for one of the channels, gates pulses from the receiving distributor to record the received 7-unit permutation in the register. The optimum phase-relationship between the received signals and the distributor drive is maintained by a correction system which integrates algebraically the early and late instants of restitution of the signal and, when the integral exceeds a certain number, causes the divider chain feeding the distributor to be connected to an advanced or retarded phase of the 4-phase divider mentioned earlier. Whilst the signal is being registered, the number of marking elements in the permutation is counted and if this is correct (three) at the end of the cycle, the resulting output of the coder is transferred to the appropriate (determined by the channel distributor) channel start-stop transmitter. Should the count be wrong, no character is retransmitted, but the repetition sequence circuit of the corresponding return transmitting channel is actuated to initiate a repetition cycle, and the output remains blocked until the cycle (or, if necessary, subsequent cycles) is complete and the character has been received again correctly. An additional protection is provided by a "tested RQ" facility which checks that, during a repetition cycle, the RQ permutation and subsequent characters are received correctly, and should this not be so, continues the repetition process. ARQ operation necessitates a 2-way circuit, but this apparatus can be switched to give error-indication instead, if unidirectional operation should be desired, in which case the detection of an erroneous permutation prevents the decoder output from being transferred to the channel start-stop generator and substitutes permutation No. 32 (five spaces), which may be used to print an error-sign.

The automatic phasing depends on the fact that, if the system is out of phase, although each terminal will be generating RQ signals, none will be received correctly. After a predetermined delay period of no RQ signals, the receiving distributor is retarded in phase by one element period, at intervals of the RQ cycle, until the RQ permutation is detected.

L.K.W.

# Eighth, and Last, Plenary Assembly of the C.C.I.T., Geneva, 1956

U.D.C. 061.3:621.394

## INTRODUCTION

THE International Telegraph Consultative Committee (C.C.I.T.) held its Eighth, and last, Plenary Assembly at Geneva in December, 1956. The meeting of the Plenary Assembly was preceded by meetings of all the Study Groups to prepare final reports on their work for submission to the Plenary Assembly. The meeting of the Eighth Plenary Assembly of the C.C.I.T. was immediately followed by the First Plenary Assembly of the new International Telegraph and Telephone Consultative Committee (C.C.I.T.T.), which combines the functions of the old separate committees for telegraphy and telephony.

Since the Seventh Plenary Assembly of the C.C.I.T., held in Arnhem in May, 1953,<sup>1</sup> the work of the C.C.I.T. has been carried on through the medium of the Study Groups set up by the Plenary Assembly. Each of these Study Groups has met at least once during the intervening period to study the 80-odd questions remitted to them by the Plenary Assembly.

## TECHNICAL DISCUSSION

In general the work of the technical Study Groups of the C.C.I.T. has been concerned with problems associated with the expanding use of switched telegraph services in the international field and the integration of wire- and radio-telegraph services. Broadly, the problems fall into three categories: transmission, telegraph apparatus, and switching apparatus.

In the field of transmission, work has been done with a view to improving and extending the technique and definitions relating to telegraph transmission so as to take better account of the requirements for the measurement, prediction and specification of telegraph distortion and telegraph transmission performance on tandem-connected telegraph channels. These requirements arise mainly from the need for the greatest possible accuracy in the difficult transmission conditions imposed by the international telex service and the need to take account of the different transmission conditions affecting radio circuits as compared with wire-line circuits. As a part of the attack on the problems concerned, the definitions have been extended to include matters concerned with error rates, the probability of the distortion on a circuit exceeding an assigned value, and the effect of signal mutilation as distinct from signal distortion.

Other problems tackled have been the analysis of the various factors contributing to the distortion and signal mutilations arising on international telegraph circuits, and the best methods of measuring, observing and specifying the performance, both of the individual telegraph channels and of the international trunk circuits carrying the multi-channel telegraph systems. This latter aspect of the work has, of course, been undertaken in co-operation with the C.C.I.F. One of the more important points under consideration is the extent to which the performance of the telegraph channels is being degraded by transitory effects leading either to sudden changes in the level, phase or frequency of the transmitted signals or to the transitory occurrence of high-level noise. A strong recommendation has been made that Administrations should actively pursue all practical measures to reduce these disturbances, which ultimately limit the accuracy of transmission possible on international switched telegraph services.

So far as the telegraph channels themselves are concerned, apart from the question of improved testing techniques,

methods of improving the performance of amplitude-modulated voice-frequency telegraph systems have been studied as well as factors affecting the introduction of frequency-shift-modulated voice-frequency telegraph systems. While experience must yet be acquired in the use of systems of the latter type in the international service before full standardization can be achieved, it has been recognized that there are potential advantages to be gained from their use, and agreement has been reached on those standards necessary to enable Administrations to proceed to their introduction by mutual agreement. Other questions coming under review included the use of start-stop regenerative repeaters, transmission conditions in national telex networks in relation to the international service, and improvement of fault location and maintenance arrangements and of the facilities for the speedy withdrawal of faulty circuits and equipment from service.

In the field of telegraph apparatus there has been some further standardization of detail, and standards have been agreed in relation to the use of 7-unit error-correcting systems on the radio part of combined wire- and radio-teleprinter communications. The question has been studied of more accurately determining the transmission performance of telegraph apparatus installed at subscribers' premises, by means of measurements carried out at the telex exchange. Among the new questions set for study is one related to a possible need for extending the facilities offered by the present 5-unit telegraph alphabet, perhaps by the introduction, under agreed conditions, of a 6-unit code.

In telegraph switching the most important problems under study were those related to the introduction of subscriber-to-subscriber dialling in the international telex service. Despite the fact that two somewhat different systems of signalling, with individual variants, have come into use—one normally (although not necessarily) associated with dial selection, and the other normally associated with teleprinter keyboard selection—a large measure of standardization has been agreed upon as well as a basis on which the different systems can co-operate. This should allow the process of providing full subscriber-to-subscriber dialling in the international telex service to proceed without undue technical difficulty. Further standardization is, however, desirable and the study is being continued to this end. Recommendations have also been issued in connexion with numbering schemes, standardization of dial pulses, and the utilization, in switched telegraph services, of circuits including radio links employing error-correcting systems. New questions for study include the means of barring certain classes of international communication in automatically-switched networks, methods of selectively inserting regenerative repeaters, and signalling standards for the proposed European switching network for the general public telegraph service.

A special mixed exploitation and technical Study Group was set up at Arnhem to consider the problem of establishing a switched network for the general public telegraph service in Europe. The problem was complicated by the fact that some countries were already operating a combined switched network for their telex and national general telegraph services, while others had separate switched networks for the two services. In addition, some countries envisaged the connexion of the national switched networks to the international general telegraph switched network, while others envisaged connexions to the international network only by means of specialized exchanges. The setting up of a network incorporating all these possibilities has therefore had to be catered for. A number of important recom-

<sup>1</sup> *P.O.E.E.J.*, Vol. 46, p. 121, Oct. 1953.

mendations have been issued covering the principles upon which the the proposed network should be established and operated, and these are sufficient to enable a start to be made with the building up of an international service. As a result, the work of the mixed Study Group has been considered as terminated, outstanding problems being left for study by the appropriate exploitation or technical Study Group. On the technical side, the more important problems outstanding are the standardization of the signalling conditions and agreement as to the technical means to be adopted to prevent telex subscribers obtaining access to telegraph offices in another country.

In the field of facsimile and photo-telegraphy a revision was undertaken of the existing recommendations to bring them up to date and, in particular, to take account of the possible use of frequency modulation as an alternative to amplitude modulation. Means of increasing the speed of photo-telegraph transmission on modern carrier telephone circuits have also been considered, but further experience is necessary. The question of the facsimile transmission of weather charts was also studied and a report on the subject prepared for transmission to the World Meteorological Organization. An important recommendation was issued defining the direction of scanning for all direct recording facsimile systems. New questions set for study relate to such subjects as the possible use of asymmetric sideband

operation on metallic telephone circuits for increasing the speed of facsimile transmission, methods of recording facsimile signals with a view to their re-transmission, and the possible introduction of a new international service for the facsimile transmission between subscribers of business documents.

#### CONCLUSION

The Plenary Assembly of the C.C.I.T. was immediately followed by the First Plenary Assembly of the new International Telegraph and Telephone Consultative Committee (C.C.I.T.T.), at which the Study Group organization for the new Committee was determined. From the telegraph point of view the main changes were that, as part of a plan to reduce the number of Study Groups, the facsimile and photo-telegraph group was amalgamated with the telegraph apparatus group, and the whole of the Study Groups dealing with exploitation and tariffs for telegraphs were combined as one Sub Study Group of a main Study Group charged with the co-ordination of all exploitation and tariff questions. To improve the co-ordination of transmission problems a sub-group of the main Study Group for line transmission was established to deal with questions related to the use of international lines for telegraphy.

E. H. J.

---

## The XVIIIth, and Final, Plenary Assembly of the C.C.I.F., Geneva, December, 1956

U.D.C. 061.3:621.395

#### INTRODUCTION

THE International Telephone Consultative Committee (C.C.I.F.) held its XVIIIth, and final, Plenary Assembly at Geneva in December, 1956. The Plenary Assembly was preceded by meetings of all the Study Groups of the C.C.I.F., and a brief account is given in these notes of the work of the Study Groups since the XVIIth Plenary Assembly<sup>1</sup> at Geneva in October, 1954. After the XVIIIth Plenary Assembly of the C.C.I.F., the First Plenary Assembly was held of the new Committee that now combines the functions of the old C.C.I.F. and C.C.I.T.—the International Telegraph and Telephone Consultative Committee (C.C.I.T.T.).

In addition to the winding-up of the C.C.I.F., the closing stages of the XVIIIth Plenary Assembly was the occasion for a formal farewell to M. Georges Valensi, Director of the C.C.I.F., who was retiring from International Telecommunication Union activities.

#### FIRST STUDY GROUP—PROTECTION FROM INTERFERENCE CAUSED BY POWER LINES

This Study Group pursued the study of 24 questions. Its work was primarily concerned with the co-existence of power transmission and distribution systems, including electrified railways, and telecommunication lines. Current developments in the transmission of electric power by very high voltage a.c. and d.c. systems, including long undersea links, and the increasing use of 50-c/s a.c. for railway traction, are typical matters that engaged the attention of this group. Another question considered was the risk to which underground telecommunication lines are exposed when high earth potentials, due to power system faults, occur in their vicinity. This question is of particular interest when

telecommunication circuits are taken into power stations or high-voltage switching stations.

A further matter considered was the elimination of noise in telecommunication circuits in cables when the sheaths of the cables are connected to power cables, water or gas pipes, pipe lines or electrified railways to effect a communal cathodic protection scheme.

In addition to the above, a sub-committee of the group had been revising the current "Directives concerning the protection of telecommunication lines against the adverse effects of electric power lines." Three meetings of this sub-committee had been held since 1955. The work will be carried to completion by the appropriate study group of the new organization.

Other work in hand was the revision of the current Volume II of the C.C.I.F. Green Book, setting out the recommendations for the protection of telecommunication lines and the constitution of telephone cable sheaths. This work was being carried out in co-operation with Study Group 2.

#### SECOND STUDY GROUP—PROTECTION AGAINST CORROSION

The program of this Study Group covered a range of 19 questions. Of these, that dealing with the impregnation of wooden poles seems to have given rise to considerable interest. It has been suggested that it would be useful to publish a summary of information on this subject. This task will be undertaken by a working party of the new C.C.I.T.T. study group concerned.

Consideration was also given to the problems of cables with entirely plastic sheaths; cables having the conductors insulated with paper and plastic materials were dealt with separately. A further subject under study was the problem of protecting underground cables against lightning.

<sup>1</sup> P.O.E.E.J., Vol. 47, p. 239, Jan. 1955.

It has recently been decided that the current "Recommendations for the protection of underground cables against corrosion (Paris, 1949)" and "Recommendations for the protection of underground cables against the action of stray currents from electric traction systems (Florence, 1951)" should be brought up to date and reprinted as quickly as possible. This undertaking has been handed on to the C.C.I.T.T. organization.

### THIRD STUDY GROUP—LONG LINE TRANSMISSION

The 66 questions dealt with ranged as usual over the whole field of telephone and television transmission. Only the major points of interest can be mentioned here.

It was agreed to adopt a standard power loading on a carrier channel in designing new systems. This value (32 microwatts at a zero-level point) is a long-term mean power and is divided into 10 microwatts for signalling tones and 22 for speech and all other signals carried. This figure will be used in future noise calculations; and in this respect the figure of 7,500 pW for the total line noise on a 2,500-km system is now to be taken as the average value over the busy hour. This is in agreement with a C.C.I.R. proposal and will therefore apply both to radio and line systems. It has not yet been possible to agree on a maximum figure or a statistical distribution for the noise power. More precise recommendations were also made concerning the hypothetical reference circuit for symmetrical pairs and for coaxial systems.

Two frequency allocations were agreed for 120-circuit systems. Both employ supergroup No. 2 (312–552 kc/s) for the upper supergroup, but one employs 12–252 kc/s and the other 60–300 kc/s for the lower supergroup. Other recommendations made concerned the stability of the many pilots now used on coaxial systems, symmetrical-pair systems and group and supergroup reference pilots. It was not possible to make a firm recommendation for the stability of inter-supergroup frequencies, but the specification of the through-supergroup transfer equipment was so arranged as to reduce interference between these pilots. A complete recommendation for the characteristics of supergroup transfer equipment was put forward, including the supergroup demodulating equipment as well as the through-supergroup filter. The specification for the through-group filter was also modified to include all group transfer equipment.

In the cable field, recommendations were made for the limits of regularity and also for the characteristic impedance both for repeater sections and for manufacturing lengths of coaxial cable. It was also agreed that a voltage of 1,000V r.m.s. and current of up to 5 amp might now be used on the standard coaxial cable for power feeding. The recommendations concerning the use of telephone circuits for voice-frequency telegraphy were brought up to date, to include the use of frequency-modulated telegraph systems. Slightly lower power levels per channel were specified than for amplitude-modulated systems, except in the case of circuits routed on long open-wire systems. The specification of the variation of the loss with frequency of a telephone circuit used for telegraphy was also made more precise.

Much time was spent on proposals to extend the frequency range of coaxial systems above 4 Mc/s. Preliminary proposals were formulated for a 6-Mc/s line, more particularly for carrying 625-line television, but many points remained outstanding. In addition, a frequency allocation for extending the range up to 12 Mc/s was tentatively agreed; and Administrations are required to confirm by July, 1957, that they can accept the proposals. This frequency allocation uses the existing spectrum up to and including supergroup No. 16 (4,028 kc/s). Above this

range, the assembly is by means of six master-groups, each consisting of five supergroups, which are translated from a basic master-group in the range of supergroups No. 4–8 (812–2,044 kc/s). Two fairly wide gaps, of approximately 300 kc/s, have been left—one between supergroup No. 16 and the first master-group, and the other at approximately 8 Mc/s with three master-groups on each side. The purpose of the wide gaps is to make direct filtration possible at line frequency. The gaps between other master-groups are 88 kc/s. In addition to wholly telephone use, it is intended that the system shall be suitable for the simultaneous transmission of television and telephony. Many new questions concerning the system were placed for study.

In the field of television transmission, the group studied the C.C.I.R. proposals (which included much of the C.C.I.F.'s past work) for the performance of a television link and methods of testing it, and suggested some modifications. These proposals applied to a 1,000-km circuit, and it will be the function of a joint C.C.I.T.T. and C.C.I.R. study group in the future to continue the study and extend the limits to apply to a 2,500-km circuit. Various recommendations were made concerning television terminal modulating equipment for line transmission, to enable systems to inter-work satisfactorily.

In addition to the above, many other questions were covered, ranging from the more precise specification of the performance of sound broadcast circuits to crosstalk in repeater-station cabling.

### FOURTH STUDY GROUP—LOCAL TRANSMISSION

Much of the time of Study Group 4 was devoted to studying the effects of circuit noises of various characters arising from power induction, carrier and coaxial circuits, radio links and so on. This study began with articulation tests, but it has led on to a new method, suggested by the British Post Office, of determining the degradation of speech transmission, based on the collection of opinions expressed by ordinary telephone users taking part in special conversation tests. Several administrations have carried out a program of tests and useful results are being obtained.

The A.E.N. clauses in the C.C.I.F. Green Book were clarified; and it has been made clear that there is every reason to expect that the A.E.N. technique will eventually be superseded by a method based on objective measurements. Suitable objective measuring methods, particularly of transmitters and receivers, will be elaborated by the corresponding study group of the C.C.I.T.T., together with the development of a reliable calculation technique.

The use of new telephone sets of greater sensitivity may lead to difficulties, not only by providing excessive loudness of received speech, but also by overloading transmission equipment; and the question of suitable maximum sensitivities will require further consideration.

### FIFTH STUDY GROUP—INTERCONNECTION OF LINE AND RADIO SYSTEMS

The fifth Study Group was largely concerned with co-ordination between line and radio systems. Under that head, the group reviewed new recommendations and wishes of the C.C.I.R. and of C.C.I.F. Study Groups 3 and 9, in addition to considering specific questions of its own.

Particular points considered include the following:

- (a) Compatibility of wideband line and radio systems in respect of the interconnection of standard assemblies of channels, groups and supergroups. The "master-group" (equal to five supergroups, or 300 channels) introduced on coaxial cable systems appeared as a new unit of flexibility to be considered in radio systems.



- (b) Noise requirements on line and radio systems. The group contributed some useful observations to the project of Study Group 3 and the C.C.I.R. for determining the permissible statistical distribution of noise.
- (c) Various topics relating to service requirements for radio systems incorporated in the main trunk network (e.g., service channels, reserve channels, switching interruption etc.).

Questions to be studied by the group's C.C.I.T.T. successor concern the interconnexion of television channels on radio and line systems, including arrangements for simultaneous or alternative transmission of telephony and television, and problems arising from the possible introduction of tropospheric-scatter radio links.

#### SIXTH AND SEVENTH STUDY GROUPS—OPERATING AND TARIFFS

These groups dealt, respectively, with operating and tariff questions. As these notes are limited to a brief account of engineering aspects of the work of the XVIIIth Plenary Assembly, it is not proposed to enter into any detail of the work of these two groups, although it will be appreciated that they had a heavy and interesting program. Included among the many matters considered by these groups were such questions as operating procedures, bases of circuit provision, routing of international traffic, semi-automatic operation, the ordering and charging arrangements for international television relays, the costing of semi-automatic calls and of calls on v.h.f. radio links, and preliminary consideration was given to the charging aspects of international subscriber dialling.

#### EIGHTH STUDY GROUP—SIGNALLING AND SWITCHING

Much of the work carried out by this Study Group and its associated Sub-Commission for Rapid Operating Methods was directed towards consolidating the ground previously prepared for the introduction of international semi-automatic telephone operation. The result is that the signalling and switching specifications contained in Volume V of the C.C.I.F. Green Book remain substantially unaffected; and the modifications and additions decided upon have for their object a clarification rather than a change in the previous recommendations.

The sub-commission established a plan for the routing of international semi-automatic telephone traffic in Europe, which shows that the majority of European countries plan to introduce semi-automatic operation on international routes by 1960. The plan also makes provision for a substantial amount of international transit operation, with the establishment of important international transit switching centres at Belgrade, Frankfurt, Copenhagen and other convenient points. The inclusion in the European telephone network of transit switching facilities brings to the fore the possibilities of the alternative routing of international telephone traffic. Both the group and the sub-commission made studies of the various methods used for calculating the number of direct and indirect circuits required under alternative-routing conditions; and although this can be a complicated process if very accurate results are required, it was found possible to recommend two methods of calculation that are relatively easy to apply and reasonably accurate in their results.

Such is the speed at which automatic telephone operation is developing in Europe that, before the plans for the introduction of international semi-automatic operation have had time to mature, the emphasis on future studies within the new C.C.I.T.T. is being placed on problems associated with international subscriber dialling. These studies have acquired some measure of urgency, not only

because in certain countries favourable conditions exist for the early introduction of international subscriber dialling but because of the desirability of taking this into account in the development of national subscriber-trunk-dialling schemes.

#### NINTH STUDY GROUP—MAINTENANCE OF INTERNATIONAL CIRCUITS

Up to 1954, questions concerning the maintenance of international circuits were dealt with by the Permanent Maintenance Sub-Commission, a Sub Study Group of Study Group 3. At the 17th Plenary Assembly of the C.C.I.F. in Geneva, 1954, the sub-commission was raised in status and became Study Group 9. This group reported directly to the Plenary Assembly for the first time in 1956.

A major task of the group during the period 1955-56 has been the revision of the maintenance instructions for international circuits. The initial drafting of the revised instructions was entrusted to a working party, which met in Geneva in June, 1955, the revised text being completed at a meeting of the study group in Paris in October, 1955. The instructions are published as part of Volume III of the C.C.I.F. Green Book and are also available as a separate book entitled "Maintenance."

A working party set up by the group has carried out further work on the study of the variation of loss with time on international circuits in the European network. Two series of tests were carried out, each of three or four months' duration, on selected international circuits of relatively simple constitution, i.e. circuits in direct carrier groups without demodulation to audio frequencies at intermediate points. The tests were made using level recorders to record the level of an 800-c/s signal at the sending and receiving ends of each circuit, supplemented by daily measurements using transmission measuring sets. The tests have shown that for direct circuits on carrier groups in the European network, standard deviations for the variation of circuit loss with time of the order of 1 dB for circuits of 350 to 400 miles can be achieved.

Other questions studied covered various aspects of maintenance for circuits in carrier and coaxial systems; and the conclusions reached have been incorporated in the revised maintenance recommendations.

A draft text giving recommendations for lining-up and maintaining circuits for international television transmission has been prepared. The general organization and arrangements for setting-up these circuits have, as far as possible, been made similar to corresponding arrangements which the C.C.I.F. recommend for setting-up international circuits for sound program transmissions. The recommendations for international television transmissions will be included in a future issue of the "Maintenance" book.

Questions concerning the maintenance of radio-relay links forming part of the international telephone network have been studied, taking account of the relevant recommendations made by the C.C.I.R. at its VIIIth Plenary Assembly (Warsaw, 1956). The study of these problems will be continued by the maintenance study group of the new C.C.I.T.T.

#### TENTH AND ELEVENTH STUDY GROUPS—SYMBOLS AND VOCABULARY

At these meetings approval was given to modifications and additions to graphical symbols for voltage-limiting devices (consistency with proposals for similar classes of items dealt with at a recent International Electrotechnical Commission (I.E.C.) meeting being achieved) and to those for symbols for various types of free and controlled selectors. Proposals were also tabled for other additions and modifications to the list of graphical symbols provisionally agreed

upon at the XVIIth Plenary Assembly, including proposals recently made by the I.E.C.

The study of the guiding principles for the use of graphical symbols and of symbols for waveguides was continued, and agreement was registered on a form of equivalence chart for relay operations, for use by those requiring them. On the classification of diagrams according to their purpose it was decided to await the publication of the I.E.C. document which is now circulating for the agreement of National Committees.

The need to set up a Joint Commission of the C.C.I.s of the I.T.U. for the purpose of preparing a list of graphical symbols for telecommunications to be submitted for the consideration of the I.E.C. was recognized and recorded for action by the First Plenary Assembly of the new C.C.I.T.T.

Modifications and additions to relay terms included in the Draft List of Essential Telephone Terms were recommended by Study Group II, and approved by the Plenary Assembly, which also approved that study should continue of further amendments and additions necessary to bring up to date the list that was approved in Florence in 1951. The combination of this list with the Draft List of Telegraph Terms is the next step, but in the meantime the individual Draft Lists will be taken into account by the I.E.C. in considering the section of its vocabulary covering Telephone and Telegraph terms. Thus, a great measure of co-ordination between the I.T.U. and I.E.C. should be practicable with the resultant benefit of a single agreed definition of each term appearing in international vocabularies.

#### PRESENTATION TO M. GEORGES VALENSI

M. Valensi's services to the telephone world were outlined by Mr. Gnome, of Italy, the oldest delegate, who referred to his important original research on telephone engineering problems and to his early treatise on telephony ("an epoch-making volume on which all technical progress in telephony since then has been based") and spoke of the great achievements of the C.C.I.F. under the ægis of its Director.

Mr. Barron, Assistant Engineer-in-Chief of the British Post Office Engineering Department, followed with a valedictory speech, in which he referred in warm terms to M. Valensi's personal qualities.

Mr. Barron said that he had no fear of sounding insincere through over-praising the Director, for it was impossible to overstress the value of the contribution made to the C.C.I.F. by M. Valensi; and the warmth and sincerity of the delegates' feelings for him were abundantly clear.

Nearly ten years before, when Mr. Barron had first become associated with the C.C.I.F., he had looked forward with considerable interest to meeting this man, who was then already almost a legendary figure. He remembered, with appreciation, the courtesy and warmth of the welcome he had received at M. Valensi's hands, from which had sprung an association and a friendship that he would always value. In this experience he knew that he was by no means alone, for nobody who had had the privilege of knowing the Director could have failed to realize that he was truly an outstanding and altogether exceptional man.

M. Valensi had not only been the architect of the C.C.I.F. edifice; he had taken part in the practical building work and was familiar with all the activities being pursued, on every floor and in every room. Unlike many men in high office, who either fell into the error of concentrating overmuch on detail to the detriment of wider issues, or, in their preoccupation with high policy and administration, found it impossible to have much knowledge of the more detailed operation of their organizations, M. Valensi had the rare gift of combining administrative ability of a high order with a capacity for retaining mastery of detail. This was the secret of his success in coping with the heavy demands made on him by the C.C.I.F., an organization with many complications and a wide technical span.

The departure of this engineer, administrator and (in the best sense) politician, with his fluency in languages, his efficiency, humour and humanity, would be a grievous loss.

The farewell speeches concluded with the presentation by the Chairman of a silver tray and some flowers on behalf of all M. Valensi's associates.

In the course of his reply, M. Valensi likened the world telecommunication network to a road system. There were, he said, already many paths and alleyways and quite a few city streets and secondary roads, but certainly not enough inter-urban long-distance routes. Furthermore, the existing roads would shortly be too narrow to cope with traffic. True, plans had been made to increase the width of certain major roads (from 4 Mc/s to 12 Mc/s) but we should have to build real motor highways earlier than might be thought. A lot had already been done in investigating the possibilities of a highway 500 Mc/s wide, equivalent to 80 × 900 telephone circuits plus 80 television circuits. This would take the form of a tube some two inches in diameter, filled with (for example) purified nitrogen and carrying millimetric waves modulated by coded pulses. These pulses would faithfully carry millions of human thoughts and emotions from one end of the tube to the other, where they would be reproduced as vocal sounds, music, written pages or moving coloured pictures.

---

## The First Plenary Assembly of the C.C.I.T.T.

U.D.C. 061.3:621.394/5

**T**HE question of the fusion of the C.C.I.T. and C.C.I.F. was the subject of discussion at the Plenary Conferences at Atlantic City (1947) and Buenos Aires (1952), and in consequence of a resolution adopted at Buenos Aires it was further discussed by the Plenary Assemblies of the C.C.I.T. and C.C.I.F. and finally approved by the Administrative Council after consultation with the countries that are members of the International Telecommunication Union. The first Plenary Assembly of the new combined committee, named the C.C.I.T.T. (Comité Consultatif International Télégraphique et Téléphonique), was held in Geneva in December, 1956.

The first task of the Assembly was to appoint a Director for the new organization. Neither M. Valensi, Director of the C.C.I.F., nor Mr. Townshend, Assistant Secretary-General of the I.T.U., who had been acting as interim director of the old C.C.I.T., was available to serve in the new capacity, and M. Rouvière, Director-General of Telecommunications of the French P.T.T., was appointed to the vacant post.

The next task of the Assembly was to approve the Study Group organization of the new Committee. A meeting of chairmen and vice-chairmen of the existing Study Groups had already made a detailed examination of this question

TABLE

## C.C.I.T.T. Study Groups and Sub-Groups

| Study Group | Title   | Previous Study Groups       |          | Remarks   |
|-------------|---|-----------------------------|----------|---|
|             |   | C.C.I.T.                    | C.C.I.F. |   |
| 1           | CO-ORDINATION OF STUDIES OF LINE TRANSMISSION AND GENERAL TRANSMISSION PROBLEMS<br><i>Sub Study Groups.—</i><br>1/1 Specification of trunk lines<br>1/2 Use of international lines for telephony<br>1/3 Use of international lines for telegraphy<br>1/4 Use of international lines for transmission of sound and television programs | II (in part)                | 3        |   |
| 2           | GENERAL CO-ORDINATION FOR OPERATION AND TARIFFS (including regulations relating to leased circuits and private networks)<br><i>Sub Study Groups:—</i><br>2/1 Telegraph operation and tariffs (including telex)<br>2/2 Telephone operation and tariffs<br>2/3 Costing<br>2/4 Telephone semi-automatic and automatic operating          | VIII (in part)<br>IX, X, XI | 6, 7     | Sub-Group 2/4 works in co-operation with Study Group II (Telephone Switching and Signalling)  |
| 3           | INTRODUCTION OF RADIO RELAY LINKS INTO THE GENERAL LINE TELECOMMUNICATION NETWORK. LINKING-UP OF RADIO CIRCUITS TO THE GENERAL NETWORK  |                             | 5        | Works in co-operation with C.C.I.R.   |
| 4           | MAINTENANCE OF THE GENERAL TELECOMMUNICATION NETWORK  |                             | 9        |   |
| 5           | PROTECTION AGAINST DANGERS AND DISTURBANCES OF ELECTROMAGNETIC ORIGIN<br><i>Sub Study Group:—</i><br>5/1 Revision of Directives   |                             | 1        |   |
| 6           | PROTECTION AND SPECIFICATIONS OF CABLE SHEATHS AND POLES<br><i>Sub Study Group —</i><br>6/1 Revision of Recommendations   |                             | 2        |   |
| 7           | DEFINITIONS, VOCABULARY, SYMBOLS  | VI                          | 10, 11   |   |
| 8           | TELEGRAPH APPARATUS AND LOCAL CONNECTING LINES. FACSIMILE AND PHOTO-TELEGRAPHY  | III, IV                     |          | Works in collaboration with Study Group MP  |
| 9           | QUALITY OF TELEGRAPH TRANSMISSION, SPECIFICATION OF CHANNEL EQUIPMENTS, AND DIRECTIVES FOR MAINTENANCE OF TELEGRAPH CHANNELS  | I, II                       |          |   |
| 10          | TELEGRAPH AND TELEX SWITCHING   | VII,<br>VIII (in part)      |          |   |
| 11          | TELEPHONE SWITCHING AND SIGNALLING  |                             | 8        | Works in co-operation with Sub Group 2/4  |
| 12          | TELEPHONE TRANSMISSION QUALITY AND LOCAL TELEPHONE NETWORKS   |                             | 4        | Responsible for the laboratory for telephony  |
| MP          | JOINT C.C.I.T.T.-C.C.I.R. COMMITTEE FOR PHOTO-TELEGRAPHY  | V                           |          | Reports to Plenary Assemblies of C.C.I.R. and C.C.I.T.T., but is administered by C.C.I.T.T. Works in collaboration with Study Group 8 and with C.C.I.R. Study Group 3   |
| PLAN        | GENERAL PLAN FOR DEVELOPING THE INTERNATIONAL NETWORK   |                             |          | A Committee outside the normal Study Group organization of the C.C.I.T.T. It contains representatives from the C.C.I.R., I.B.O., E.B.U., I.C.A.O., I.A.T.A. and W.M.O. Although it will be administered by the C.C.I.T.T., it does not submit recommendations to a Plenary Assembly but confines itself to the drawing-up of the program and plan for developing telecommunication networks |

and produced proposals directed to meeting the general desire to limit the number of Study Groups and avoid overlapping. These proposals, with some further modifications, were adopted by the Plenary Assembly. They entail the retention of 12 Study Groups with 10 Sub Study Groups and two special committees outside the normal Study Group structure.

The Study Groups and Sub-Groups of the C.C.I.T.T. are listed in the Table, together with the C.C.I.T. and C.C.I.F. Groups whose work and responsibilities have been taken over by the new Groups.

A further task for the Assembly was that of approving Rules of Procedure for the new Committee. The working methods of the old C.C.I.s were similar in many respects but there were some important differences and the new rules were drafted by the meeting of chairmen and vice-chairmen. One of the chief differences was related to the duties of the chairman, and appointed "rapporteurs," in connexion with the reporting of the work of the Study Groups, *vis-à-vis* the use of the Secretariat. There were also some differences in regard to the translation and distribution of documents. Recommendations were made as regards

using the C.C.I.F. methods, which called more extensively on the services of the Secretariat in connexion with reporting and analysing the work of the Study Groups. As regards the question of translation of working documents, provision has been made so that at the discretion of the chairman, in agreement with the members of his Study Group, the documents may be distributed in the original working language and translation into the other working languages dispensed with.

The old C.C.I.s had submitted to the new C.C.I.T.T. various proposals for the continuing study of existing questions and the setting for study of new questions, including the setting up of working parties to deal with specific problems. The changed organization involved some modifications in the attribution of questions between the various Study Groups; however, these changes were not of a character such as to affect, to any extent, the working arrangements which had already existed for co-operation between all interested parties in the prosecution of particular studies. It now remains for the new C.C.I.T.T. so to order its activities that both telegraphy and telephony will secure the maximum benefit from the new arrangements.

## Associate Section Notes

### London Power Centre

The London Power Centre has now completed its first year as an independent Centre of the Associate Section.

The 1956-57 session opened to a good start with the presentation of the Institution's certificate of merit to Mr. J. Greenfield for his paper "Generating and Metering (E.H.T.)"; the ceremony being performed by the Sectional Engineer (South Postal Engineering Section), Mr. D. W. Roy. Mr. Roy complimented the Centre on its achievements to date and wished members every success for the future. He said he was particularly pleased to officiate on this occasion because he was making a presentation to one of his own men.

The first Session has been a creditable one, all of the following papers having been produced and formally presented at Ordinary meetings:—

"Control and Voltage Regulation of D.C. Generators," by R. Finden (Senior Section).

"Static Capacitors for Power Factor Correction," by P. J. Froude (Associate Section).

"Principles of Photography," by B. Cramphorn (Associate Section).

"Planning a Low-Pressure Hot Water Central Heating System," by T. Mitchell (Associate Section).

"The Construction and Maintenance of Secondary Cells," by P. Bryant (Associate Section).

"Maintenance in a Mechanical Era," by J. S. Liptrott (Associate Section).

"The Maintenance of Electrical Machinery," by P. Maguire (Associate Section).

"Electricity Supply Metering," by J. Greenfield (Associate Section).

In addition to these papers, the Centre has published two useful technical pamphlets entitled "Notes on Oil-Fired Boilers," by J. T. Robinson (Senior Section), and "Notes on K.E.B. Sub-Station," by E. Bettany (Associate Section).

The Committee, having decided to award £2 2s. 0d. for the best paper written by a Youth-in-Training, were pleased with the response; four papers have been received for adjudication, as follows:—

"Electric Motors," by B. A. Parry.

"Electric Lifts," by L. V. Adams.

"Fluorescent Lamps," by B. A. Baker.

"Stamp Cancelling Machines," by J. E. Lavender.

The publication of the "Newsletter" every two months continues, and a good supply of material has been obtained to ensure its continued success. The Committee have decided that future prize-winning papers shall also be published through this medium.

Visits have averaged one per month and they have been found both an education and a pleasure.

Our thanks are due for the valuable guidance given by our Liaison Officer, Mr. Mascall, and Area Liaison Officers, Mr. Short (L.T.R. Power) and Mr. Patrick (L.P.R.).

We would welcome correspondence on Associate Section matters from other Centres. The address is, The Secretary, I.P.O.E.E./L.P.C., c/o Engineering Branch, London Postal Region, King Edward Building, London, E.C.1.

P. B.

### Canterbury Centre

The 1956-57 Session is almost at an end, and looking back we have had a fairly successful year, with a slight increase in membership and a full and varied program.

The winter session opened on the 2nd October with a visit to Bowater Lloyds Paper Mills at Sittingbourne, and was followed one month later by a very successful visit to the Kent Oil Refinery at the Isle of Grain, where we were given a very interesting tour of the plant and very substantial refreshment. A further visit, to London Airport, had to be cancelled due to the petrol crisis.

Our first evening meeting, on 6th November, was a film show of general engineering interest. The next meeting, on 4th December, consisted of a talk by one of our own members, Mr. Green, who expounded on "Sailing" with the enthusiasm known only to the yachtsman. On 8th January we held a speaking contest, always a popular feature, and received a good attendance at a local pub. A talk by Mr. Collett, Executive Engineer, on "atomic energy" followed on 5th February, and provided an excellent insight into this fascinating subject.

Talks for the remainder of the session include "Concrete Construction," by Mr. Haliburton, Area Engineer, and "Valves," by Mullard Valves, Ltd., followed by the annual general meeting and dinner in April or May.

J. C. L.

### Portsmouth Centre

The present session opened with a well-attended visit to the Farnborough Air Display on 8th September, which proved to be a very enjoyable occasion. The next event, which took place on 17th November, was a Quiz with Bath Centre. General and technical questions were answered in an atmosphere of high-spirited rivalry, but Bath managed to secure the winning point. Those present derived much enjoyment from an entertaining evening, and we thank Mr. F. Gibbs, our Quizmaster, for his great interest in our affairs.

On 29th November, a talk entitled "The Development of the Telephone Area" was given by Mr. S. Paterson, Mr. F. Gibbs, and Mr. G. W. Dootson at the Air Balloon Hotel. Mr. Paterson



spoke about "telephone development" from the traffic angle, whilst Mr. Gibbs and Mr. Dootson explained the engineering planning and constructional aspects. This talk was well attended and most ably presented.

A visit to Morris Motors factory at Oxford, attended by 37 members, took place on 5th December. The tour of the plant was skilfully arranged, and many very interesting manufacturing techniques were to be seen. This visit was so much enjoyed by our members that another visit is contemplated in the future.

On 30th January Mr. Newnham, B.Sc. (Vice-President of the Radio Society of Great Britain), gave a talk on "Some Aspects of Amateur Radio," at the Station Hotel. The speaker dealt enthusiastically with radio as a hobby, and illustrated his talk with film strip.

Other events were:—

27th February. Quiz with Guildford Centre.

21st March. Film Show.

28th March. Quiz with Bath Central.

W. L. H.

### **Bishop's Stortford Centre**

The 1956-57 session of the Bishop's Stortford Centre started last July, when a visit was made to the Rye House generating station.

In August, after extensive negotiation, a small party were privileged to visit the B.B.C. television studios at Lime Grove, and in September a very pleasant afternoon was spent visiting the London Fire Brigade Headquarters and the River Brigade.

In October a very good talk was given on photography by a professional photographer from Great Dunmow, and in November a party visited the R.A.F. Station at North Weald for a very interesting talk on weather forecasting by the R.A.F. meteorological experts.

A full program was planned by the committee for the winter months, of both technical and non-technical subjects, and we are pleased to report that the section is still running smoothly and is well supported by all grades.

J. P.

### **Tunbridge Wells Centre**

The Tunbridge Wells Centre has the distinction of having Institution Certificates awarded for two papers submitted during the 1955-56 session:—

"The Coaxial Line Link," by J. E. Bridger.

"Some aspects of Circuit Provision," by W. T. Waghorne.

The awards are to be presented at the April meeting of the Tunbridge Wells Centre, when it meets its near neighbour, Hastings, for the Annual Quiz.

H. F. C.

### **Huddersfield Centre**

In August, 1956, a meeting attended by more than 40 members of the engineering staff in the H.P.O. at Huddersfield decided to start an Associate Centre of the I.P.O.E.E. Already the centre has a membership of nearly 70 out of a total staff numbering approximately 100.

The activities of the Centre to date have been a film show, the main film showing the Automatic Telephone & Electric Co. constructing automatic telephone equipment for the Post Office, followed by two visits. One of these was to the repeater station at Manchester, the other to a local engineering works that specializes in electronic testing equipment.

The two remaining meetings of the current session have been devoted to a paper on "The Departmental Approach to Efficiency," given by Mr. R. Powell, and a full-day visit to the cable works of British Insulated Callender's Cables, Ltd., near Liverpool.

Office bearers are:—

*Chairman:* Mr. P. H. Wade; *Secretary:* Mr. B. Haigh; *Treasurer and Librarian:* Mr. B. B. Howell; *Committee:* Messrs. H. Burden, P. Holroyd, T. F. Johnson, D. M. Lee, B. Stephens, and L. Thwaite.

B. H.

### **Glasgow and Scotland West Centre**

The Transatlantic Cable lecture was well received and attracted the largest attendance so far this session. Mr. Boag gave a most interesting description of the project in all its

phases and confidently answered all the questions fired at him afterwards. Mr. J. R. Atkinson (University of Glasgow Lecturer) made atomic energy seem very simple during his talk on "Energy and the Atom." His analogies and explanations were gems of description and enabled us to explore with him the realms of electrons, protons, neutrons, etc., with ease. The Telephone Manager's illustrated talk on a Holiday in North America was so much enjoyed (until 11 p.m. by some!) that arrangements are being made for it to be repeated.

Some of the work of the E.-in-C.'s Circuit Laboratory was most interestingly explained to us by Messrs. E. W. C. Hubbard and G. L. Mack in their talk "Mechanical Developments in Telecommunications." The high-speed photography of selector mechanisms that failed to work provided some excellent and instructive photography. This talk has whetted our desire to know more about the E.-in-C.'s Office and the developments tested and carried out there.

J. F.

### **Edinburgh Centre**

At the February meeting of the Edinburgh Centre, Mr. D. Lambert gave an interesting talk on "Model Railways," the practical demonstrations being of particular appeal. Although the session is drawing to a close there are still one or two interesting items left on the program.

A visit has been arranged in March to the Salvage and Refuse Depot. Visits to the various public utilities have proved popular and among the most interesting of our outdoor tours.

There has been a slight falling off in enthusiasm for the Centre's activities during the past year but it is hoped that this is only temporary and that there will be bigger attendances next session.

J. R. H.

### **Sheffield Centre**

A visit was made on 4th December, 1956, to the Department of Glass Technology, Sheffield University, where a very interesting lecture and film show was given by Mr. M. Parkin on the technique of making and processing glass. We were very pleased to have one of our own members, Mr. S. Brasher, give a really excellent talk and demonstration on "Tape Recorders," on 24th January, 1957, and a visit was made to a modern power station at Rotherham on 21st February, 1957, which was very successful. Great interest was created by the visit of Messrs. J. A. Lawrence, F. L. Samuels and G. S. Gregson, who gave a talk and demonstration on "Electronic Circuitry" on 21st March, 1957. The present session will end with a talk on a very controversial subject "Promotions and Appraisements" to be given by the Telephone Manager, Mr. Loosemore, on 11th April, 1957. The Annual General Meeting will be held some time in May and members are urged to attend so that all points of view can be fully discussed and a new committee elected.

J. McC.

### **Sunderland Centre**

Since the last notes were published the following visits and meetings have taken place.

On Saturday, 17th November, 1956, nine of our members toured the factory of Ericsson Telephones, Ltd., Southwick, Sunderland. The number attending was small but consequent benefit was had from the four guides available to the party. A wide range of products for the home and overseas market was shown to our members, and it was most informative to observe the assembly and the rapid adjustments of components into their complete and familiar shape. It was apparent that much thought had been given to the question of placing the right type of person to the right type of task and the impression gained was of a smoothly run community.

On 5th December, 1956, Mr. F. M. Inglis of the Edison-Swan Electric Co. gave an informal talk with demonstrations on magnetic tape recording. Mr. Inglis was ably assisted by Mr. Gales and the 21 members present were keenly interested. All members recorded their voices and while the play-back was remarkably truthful it was indeed enlightening and surprising to "hear ourselves as others hear us." We are indeed grateful to Mr. Inglis for his visit on this occasion.

A visit to the Henley's Telegraph Cable Works at Birtley, Co. Durham, on 12th December, 1956, was very interesting

(Continued on p. 66)

# Notes and Comments

## New Year Honours

The Board of Editors offers congratulations to the following members of the Engineering Department honoured by Her Majesty The Queen in the New Year Honours List:—

|                                  |       |                               |       |                             |       |   |
|----------------------------------|-------|-------------------------------|-------|-----------------------------|-------|---|
| Cardiff Telephone Area           | .. .. | Spearey, F...                 | ..    | Inspector                   | .. .. | British Empire Medal  |
| Engineering Department           | .. .. | Betson, Capt. J. P. F.        | ..    | Commander, H.M.T.S.         | ..    | Officer of the Most Excellent Order of the British Empire               |
|                                  |       |                               |       | <i>Monarch</i>              |       |   |
| Engineering Department           | .. .. | Day, J. E.                    | .. .. | Assistant Engineer          | ..    | Member of the Most Excellent Order of the British Empire                |
| Engineering Department           | .. .. | Halsey, R. J.                 | .. .. | Assistant Engineer-in-Chief |       | Companion of the Most Distinguished Order of St. Michael and St. George |
| Engineering Department           | .. .. | Pantenay, R. A. W.            | ..    | Technician Class I..        | ..    | British Empire Medal  |
| Engineering Department           | .. .. | Perrins, E. V. T.             | ..    | Technical Officer           | .. .. | British Empire Medal  |
| London Postal Region             | .. .. | Hough, Lt.-Col. F. A., M.B.E. |       | Chief Regional Engineer     | ..    | Officer of the Most Excellent Order of the British Empire               |
| London Telecommunications Region |       | Cutts, W. J.                  | .. .. | Inspector                   | .. .. | British Empire Medal  |
| London Telecommunications Region |       | Keech, R.                     | .. .. | Technician Class I..        | ..    | British Empire Medal  |

## G. H. Metson, M.C., Ph.D., A.M.I.E.E.

The Government Paper (Cmd 6679) on the Scientific Civil Service provided for an increase in posts at levels above Principal Scientific Officer for the promotion of individual research scientists of exceptional quality, without necessarily expecting them to carry administrative responsibilities. In fulfilment, a panel of eminent scientists has, each year since 1947, examined nominees for departments employing scientists, and recommended a few promotions. In 1956 the Post Office put forward a nominee, Dr. G. H. Metson, for "Special Promotion on Individual Merit" to Deputy Chief Scientific Officer; the panel considered his claims and duly concurred. We can therefore congratulate Dr. Metson on receiving a promotion which carries a special mark of distinction, particularly amongst government scientists.

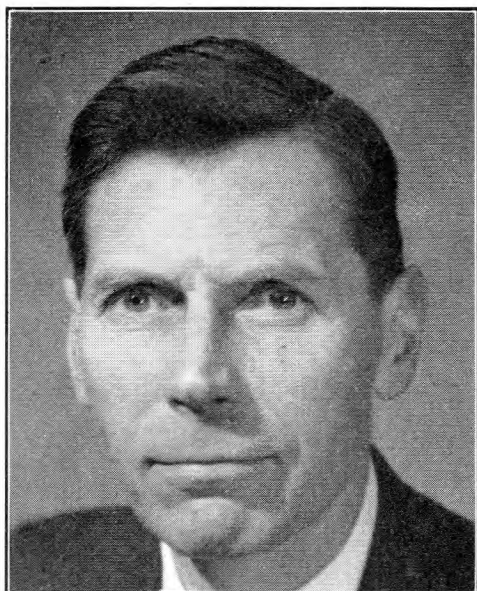

Dr. Metson joined the Post Office many years ago but his first researches were carried out at Queen's University, Belfast, in the late '30s, where he received the degrees of M.Sc. (1937) and Ph.D. (1940)—he had taken his bachelor's degree at London some years earlier. He served in the Royal Corps of Signals throughout the war, being awarded

the M.C. and attaining the rank of Lt.-Col., and was posted to Dollis Hill on his return to the Post Office in 1946. He was soon given the formidable task of developing a long-life thermionic valve for use in submerged repeaters. As a preliminary study he investigated the causes for failure in commercial valves, and with an enthusiastic team to follow up his ideas he devised electrical, electronic, mechanical and vacuum techniques for overcoming them. For some years now his production line has been the main source—very nearly the only one—of valves for British submerged repeaters. Continuing and increasing demands for valves at first made it impossible to concentrate on a valve incorporating all the best features simultaneously and compatibly but recently that project has been undertaken and a valve of integrated electrical and mechanical design is now being produced.

Dr. Metson was promoted to Senior Principal Scientific Officer in 1951; he has published many papers on his subject, particularly in the Proceedings of The I.E.E., for which he has received premiums from the Institution, and is widely recognized as an expert on the oxide-coated cathode—that key feature of the thermionic valve.

J. R. T.

## W. J. E. Tobin, B.Sc.(Eng.), A.C.G.I., D.I.C., A.M.I.E.E.

Mr. Tobin, who has been appointed Staff Engineer, Telephone Branch, entered the Post Office Engineering Department through the Open Competitive examination for probationary Assistant Engineers in 1931. A product of the Royal Dockyard at Portsmouth, he spent three years at the City and Guilds Engineering College, including one year on post-graduate work, prior to entering the Post Office.

After a probationary period of 12 months in London, Mr. Tobin moved to south Lancashire where he completed his probation and served as an Assistant Engineer (old style) for 5½ years. He was attached to the Technical Section of the then Superintending Engineer's Office in Manchester and carried out a variety of duties covering many aspects of external and internal construction and maintenance. Whilst up north he was Local Secretary of the I.P.O.E.E., South Lancashire District, for three years. In 1937 he returned to London to organize the London Regional Training Schools, then after a period on exchange planning he was promoted Area Engineer, West Area, London Telecommunications Region, in 1939. During the

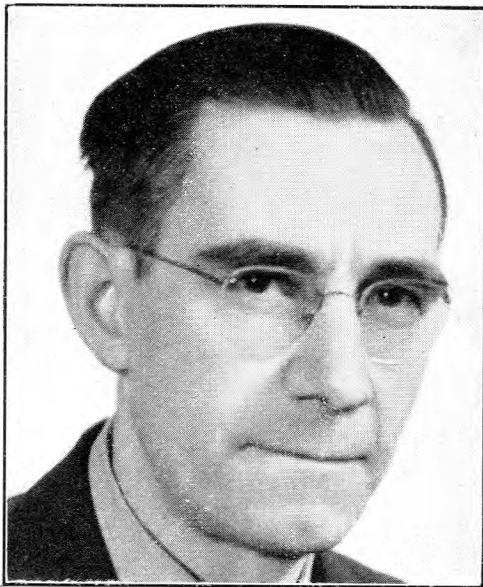

war years he was responsible for the construction of a number of important defence installations including the Headquarters No. 11 Group, Fighter Command, from which the Battle of Britain was directed; the installation for G.H.Q. Home Forces at St. Paul's School, Hammersmith, and the A.A. Gun Operations Room, Brompton Road, Kensington.

Mr. Tobin's next promotion, in 1947, took him to Headquarters as Assistant Staff Engineer, Telephone Branch. After a period spent in charge of the maintenance section, he took over responsibility for the design of exchange signalling systems and the application of electronic techniques to exchange switching. The signalling duty brought Mr. Tobin into the oversea deliberations of the C.C.I.F. and there his logical mind and analytical reasoning, together with a good knowledge of the French language, soon brought him to the fore. He was made Chairman of the Working Party of the 8th C.E. charged with the duty of preparing and issuing full specifications for the signalling and switching equipment to be used for international semi-automatic telephone working, a task that gave him considerable satisfaction. During the development of the transatlantic telephone cable, which was designed to open on a generator signalling basis, the problem of dialling over the cable came up for consideration and Mr. Tobin accompanied Mr. Barron to New York for preliminary discussions on the subject with the American Telephone & Telegraph Co. In the home field, he has been concerned with the first application of electronic methods to exchange switching in this country, i.e. the design, introduction and field trial of electronic directors at Richmond Exchange in the L.T.R. Other entirely new concepts in the telephone field that have come his way are the application of magnetic drums and ferrites to the storage of digital and metering information and the introduction of transistors to exchange signalling and switching circuits.

In the handling of his staff, Mr. Tobin displays a deep human understanding which makes him well liked and respected. Having no time for side in others, he displays a disarming modesty about his personal contribution to the telecommunications art. He is endowed with a shrewd sense of humour and tells a story in a colourful Hampshire accent of which he was blissfully unaware until he heard his recorded voice.

Backed by a wide background of district experience, Mr. Tobin brings to bear on his work at Headquarters an alert mind and a flair for deductive reasoning which make him a worthy choice for the chieftainship of Telephone Branch at a revolutionary period in telecommunications history

when the shaping of the electronic future has to be determined. He carries with him to his new appointment the best wishes of many friends and colleagues at home and abroad.

G. S.

#### **Lt.-Col. F. A. Hough, O.B.E., M.Sc.(Eng.), A.M.I.E.E.**

In 1930, at the conclusion of his studies of Electrical Engineering at the University College, Nottingham, Col. Hough graduated with an honours degree of London University, and in 1932 he gained an M.Sc.(Eng.) degree. He entered the Post Office in January, 1932, through the old-style Assistant Engineer open competition, after a brief period as a graduate apprentice with Metropolitan-Vickers at Trafford Park.

Following the initial training period of a few months in London he was posted to Scotland to complete his probationary period, during which he was attached for short spells to most of the Sections and to the District office. He spent the whole of his time as an established Assistant Engineer in Scotland, in the course of which he assisted on such important jobs as the preparations for conversion of Glasgow to automatic working. He was an active member of the Territorial Army and the Supplementary Reserve, and was called up for service in August, 1939, with the result that he just missed taking up his appointment as Efficiency Engineer in the North-Western Region, which was dated 12th September, 1939.

He served with G.H.Q. Signals Regiment in France in 1939-40 and later in Home Forces. For a period of 15 months in 1941-42 he was seconded to the Ministry of Supply to assist with the design and development of signals equipment. He returned to command 12 L. of C. Signal Regiment and then 21 Army Group Signal Regiment

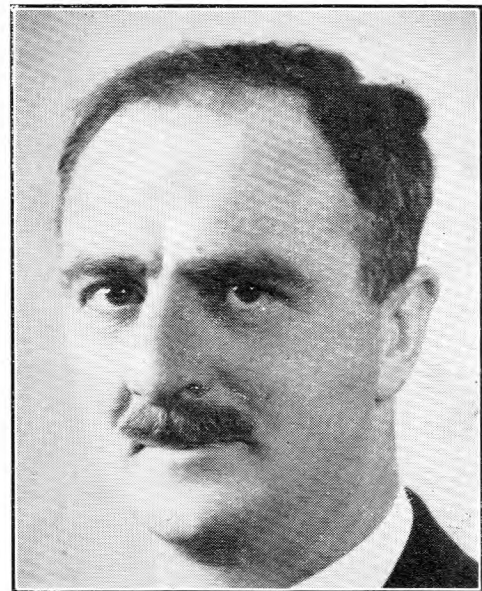

for operation "Overlord" in 1944. For the last nine months of the war he commanded 12 L. of C. Signal Regiment again, on the construction of the main carrier cable link from Holland into Germany. He was awarded the M.B.E. (Military) in 1940 and was mentioned in despatches in 1944.

In January, 1946, Colonel Hough resumed duty with the Post Office and was appointed Area Engineer, Bournemouth Telephone Area, where he stayed until the 1st April, 1949. He was then promoted to Assistant Staff Engineer in the Engineering Organization and Efficiency Branch of



the Engineer-in-Chief's Office, where he was responsible for questions affecting the minor engineering grades.

Early in 1953 the first steps were being taken towards the practical realization of the transatlantic telephone cable and an officer had to be selected to carry out a survey of the possible landing points on the Newfoundland coast and the route to be followed across that island, and who would subsequently have responsibility for seeing the work completed inside the schedule, which it was realized would be very tight. Doubtless in view of his wide and varied experience, his restless energy, his unsparing devotion to duty and his ability to get along with people at all levels, Colonel Hough was chosen for this interesting and important post. He was transferred to the Transmission and Main Lines Branch of the Engineer-in-Chief's Office for this purpose in March, 1953. In recognition of the valuable part he played in the successful completion of the first transatlantic telephone cable Colonel Hough was awarded the O.B.E. In October, 1956, he was promoted to Chief Regional Engineer in the London Postal Region.

Outside his official duties Colonel Hough is an enthusiastic cricketer—a driving force in his local club and a valued member of the Engineer-in-Chief's Office cricket club—and an energetic golfer, as many members of the Engineering Department Golfing Society well know. He still retains his close connexion with the Supplementary Reserve, in which he commands the No. 3 Signal Construction Regiment.

His latest promotion is a great delight to his many friends in and out of the Engineering Department and they wish him the best of luck in his new job and for his future.

E. F. H. G.

#### **Retirement of Mr. A. E. Penney, M.I.E.E.**

The retirement of Mr. Penney, the Staff Engineer in charge of the Power Branch of the Engineer-in-Chief's Office, on 13th August, 1956, due to health reasons following difficulty with his sight and after a serious operation at the age of 50, is recorded with very deep regret.

Mr. Penney, with 30 years' service in the Department, had established himself as an authority on matters pertaining to power work and ancillary services and indeed had spent the whole of his career in various ranks on different phases of the work.

He entered the Post Office in 1926 as a result of the open competition for Probationary Inspectors, after having served an apprenticeship with the Gillingham (Kent) Corporation Electricity Department. The first three to four years of his service were spent on power duties in the old London Engineering District, Technical Section, after which he took charge of one of the two power groups there in 1930 as a result of success in the old style Probationary Assistant Engineers' examination. He continued on power duties for postal buildings for another 14 years, during which he was promoted in 1938 to the old-style Executive Engineer grade in the London Postal Region. In this capacity he acted as deputy to the Assistant Controller (Engineering) of the London Postal Region on all engineering services, including the Post Office Railway.

He again received promotion in 1944, when he was appointed Regional Engineer in the London Telecommunications Region. In this position he was responsible for all telecommunications-power work, including much original work on special schemes, and in addition dealt with the engineering work associated with telegraphs, radio interference problems and the provision of outside broadcast facilities for the B.B.C.

In June, 1951, he was appointed Staff Engineer in charge of the Power Branch of the Engineer-in-Chief's Office. In this capacity he covered a wide range of interests and directed many experiments and investigations with a view

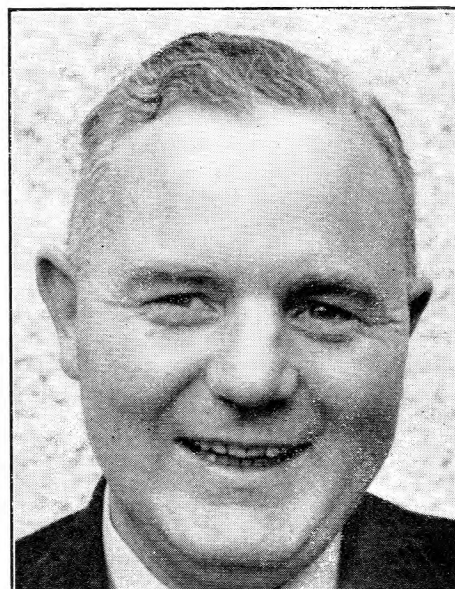

to securing improved equipment and more efficient methods. Among many other items, investigations were made into various types of lighting, including fluorescent, which were essential to enable decisions to be taken on future Post Office policy; experiments were carried out on mechanization of sorting offices, letter-sorting and stamp-cancelling machines, automatic stokers, etc.

In 1951 a start was made on the task of centralizing the design of all telecommunications-power plant in Power Branch, and new standard power plants for exchanges with up to 2,000 ampere-hours daily load were introduced. With coaxial systems and transatlantic telephony, the need for power supplies free from interruptions cannot be over-estimated, and during Mr. Penney's tenure of office, advance was made in securing a high degree of continuity under mains failure conditions.

It was typical of Mr. Penney's demeanour and courage that when he learnt that his colleagues wished him to accept a tribute from them on his departure, he insisted that he should come back to receive it in person. This he did in company with Mrs. Penney on 3rd December, 1956, when, among some hundreds of his colleagues, Mr. Mumford, after wishing him well, presented him with a parting gift. We sincerely wish him a long and happy retirement in company with his family.

G. S. B.

#### **Obituary—Mr. A. E. Morrill, B.Sc., A.C.G.I., A.M.I.E.E.**

Albert Morrill, B.Sc., A.C.G.I., A.M.I.E.E., Chief Regional Engineer, South-Western Region, died suddenly on 22nd January, 1957, after a short illness.

Born at Plumstead in 1897, he interrupted his education and apprenticeship to enlist in the London Regiment, 47th Division. Serving in France he was awarded the Military Medal in September, 1916, when only 19 years of age, for maintaining communications during an attack at High Wood on the Somme. After four years' service he resumed his broken apprenticeship and studies before proceeding to the City & Guilds Engineering College where he obtained his B.Sc. and college diploma.

He entered the Post Office in 1926 as an Assistant Engineer and was appointed to the London Engineering District, South-East External Section. After seven years he was transferred to the External Plant and Protection Branch of the Engineer-in-Chief's Office, and from there he was promoted, in 1936, to Executive Engineer (Old Style) in the Eastern District. At first he was in charge of the Technical





Section but later he went as Area Engineer in the Colchester Telephone Area. In 1940 he moved to the West Country as Regional Engineer, South-Western Region, where his wide knowledge and experience of external plant proved invaluable in the planning and execution of extensive underground programs, both during the war and afterwards. His appointment as Chief Regional Engineer, South-Western Region, in September, 1955, was most popular amongst his colleagues.

He was by training and experience a first-class engineer whose ability and sound judgment was recognized by his

colleagues, by Post Office contractors and by the many other public authorities with whom he came in contact. His shrewd handling of staffing problems and sincere human outlook encouraged staff at all levels to consult him on their social and domestic problems. As a staunch supporter of the British Legion and his Old Comrades Association, he found many outlets through these and other organizations for service to his fellows.

Once a keen hockey and football player—he represented his college in 1923-4, he devoted his interest in later years to bowls, representing the Victoria Club, Weston-super-Mare, on many occasions. He was Chairman of the Regional Sports Club from 1943 until his death.

He was a happy and contented family man and leaves a widow, a stepson and two married daughters. He had a lifelong interest in the Congregational Church, serving as Deacon and Treasurer of the Boulevard Congregational Church, Weston-super-Mare. Albert Morrill was a quiet and unassuming man of simple tastes who, by his generous and kindly actions and very apparent sincerity, made many friends by whom he will be sadly missed.

A. C. W.

### Board of Editors

Mr. A. J. Hutchinson resigned from the Board of Editors on 1st January, 1957, after having served as Secretary and Treasurer for seven years, and Mr. C. E. Calveley, O.B.E., E.R.D., resigned on 9th January, 1957, following a change of his official duties. The Board wish to express their appreciation of the services rendered to the Journal by Mr. Hutchinson and Mr. Calveley.

Mr. B. Farr has been appointed to fill the vacancy caused by Mr. Hutchinson's resignation and Mr. W. J. E. Tobin has been co-opted to the Board.

## Institution of Post Office Electrical Engineers

### Supplement to Library Catalogue (1952-1956)

A supplement showing the books added to and withdrawn from the library since the 1952 issue of the Catalogue is available, on request, from Honorary Local Secretaries.

### Additions to the Library

- 2368 *The Electronic Office*. R. H. Williams (Brit. 1955).  
Concerned with the practical aspects of the use of digital computers for routine office work.
- 2369 *Electrical Interference*. A. P. Hale (Brit. 1956).  
Covers the theoretical and practical aspects of suppressing interference.
- 2370 *Fixed Resistors*. G. W. A. Dummer (Brit. 1956).  
Designed to help the designer and user to select the best components for particular requirements.
- 2371 *Studio Engineering for Sound Broadcasting*. Ed. J. W. Godfrey (Brit. 1955).  
A B.B.C. training manual which includes much on audio-frequency engineering of general interest.
- 2372 *Atoms and the Universe*. G. O. Jones, J. Rotblat and G. J. Whitrow (Brit. 1956).  
A presentation in simple language of the basic experimental work and concepts of nuclear physics and the relation of nuclear physics to the larger and fascinating problems of the universe and its development.
- 2373 *Introductory Applied Physics*. N. C. Harris and E. H. Hemmerling (Amer. 1955).  
Intended to provide the groundwork leading to an understanding of the technical problems encountered in industry.

- 2374 *Magnetic Amplifiers*. H. F. Storm (Amer. 1955).  
Explains the fundamentals underlying the operation of magnetic amplifiers and illustrates their principal uses.
- 2375 *Technology of Heat*. H. W. Baker (Brit. 1956).  
Leads from a general introduction and the simple basic theories to an appreciation of the more complicated facts upon which present and future developments of both theory and practice are and must be based.
- 2376 *Psychology of Personnel in Business and Industry*. R. M. Bellows (Amer. 1956).  
Attempts to provide a link between research and the application of its results to personnel problems in business and industry.
- 2377 *High Fidelity*. G. A. Briggs and R. E. Cooke (Brit. 1956).  
Explains simply why special equipment is required for high-quality reproduction from radio and records, and gives guidance on the choice of equipment.
- 2378 *Applied Electricity*. A. W. Hirst (Brit. 1956).  
Written for the student of Applied Electricity in Pt. 1 of the University of London B.Sc.(Eng.) examination—also suitable for similar examinations, e.g. Electrical Technology in the Graduateship Examination of The I.E.E., and Electrical Technology and Machinery of H.N.C. (The M.K.S. system of units is used.)
- 2379 *Germanium Diodes*. S. D. Boon (Dutch 1956).  
Discusses the basic nature and structure of germanium diodes, and then examines in detail their electrical properties in so far as they affect correct application and operation.

W. D. FLORENCE.  
Librarian.

# Regional Notes

## Northern Ireland

SNOWSTORM, 25TH DECEMBER, 1956

Christmas holidays in Northern Ireland were rudely interrupted when a snowstorm on the afternoon of Christmas Day caused widespread damage to overhead plant throughout the Region. The storm itself was not prolonged, lasting only a few hours, nor was the snowfall particularly heavy. Nevertheless, cold winds combined with wet snow caused a rapid build-up of ice and snow on overhead wires. As a result, 68 exchanges were isolated, and 270 junctions and 9,000 subscribers' lines were put out of action. In addition, important railway signalling systems, which in Northern Ireland are maintained by the Post Office, were extensively damaged. Immediate steps were taken to muster all available staff, and the B.B.C. co-operated by broadcasting a request to all men on leave to report for duty.

The work of restoration was hampered by widespread interruptions of power supplies as the overhead electricity supply lines suffered the same fate as the overhead telephone routes, and 34 exchanges were left without power. As a result, the heavy drain on exchange batteries caused by "P.G.s" made it necessary at some exchanges to impose restrictions on service. In addition to the emergency charging sets in the Region, five sets were borrowed from the N.W. Region and these were flown across to Northern Ireland by chartered aircraft on 27th December. By operating these charging sets on a rota system, each set charging the batteries at a number of exchanges in turn, it was possible to keep isolations due to battery failure to a minimum.

With the help of 17 gangs borrowed from other Regions the work of temporary clearance proceeded apace, all isolations being cleared by 1st January, and service was restored to practically all subscribers within three weeks of the storm. This work was greatly facilitated by the use of many miles of polythene interruption cable—notably 10-pair—which proved much more suitable than the standard "Cable I.R. Aerial" for quick restoration of service, because of its greater ease of handling. Final assessment of the damage revealed that 11,810 miles of wire had been brought down, 500 poles broken, and 5,328 poles deflected.

Many months will elapse before permanent repairs will be completed. Strong winds around the end of January, 1957, caused further damage and, in particular, a severe gale on 4th February isolated 36 exchanges and put approximately 2,500 subscribers' lines out of order. Falling trees were mainly responsible for this trouble.

The storm damage occurred against the background of I.R.A. activity in Northern Ireland, Post Office plant having suffered from the activities of members of this organization. One U.A.X., which had been isolated and restored, was subsequently again isolated, this time by malicious damage to the junction route by raiders who attacked the local police station. Nevertheless, the strenuous efforts of the staff, many of whom worked extremely long hours under very arduous conditions, enabled all difficulties to be speedily overcome in a way that hardly seemed possible at the outset.

G. W. H. L.

## Midland Region

### FAULT ON LEICESTER-NOTTINGHAM No. 3 M.U. CABLE

At 5.15 p.m. on 25th September, 1956, the Leicester-Nottingham No. 3 cable was reported faulty with several pairs disconnected, in contact and earthing. The fault was located and an opening made  $3\frac{1}{2}$  miles from Leicester, but it was decided to suspend operations until morning.

When work was resumed it was found that the local Water Department had mistaken the Post Office iron pipe for their water main and had attempted to connect to it a service pipe for a new house. With the aid of a special tapping machine a neatly threaded hole had been cut in the pipe, lead sheath and conductors. When the workmen realized the mistake, the hole was sealed by screwing in a brass plug; apparently, they thought that this was a first-class repair job, as the incident

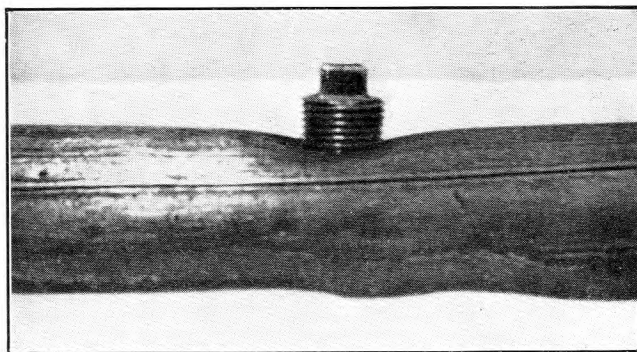

DAMAGED SHEATH OF LEICESTER-NOTTINGHAM No. 3 M.U. CABLE.

was not reported to the Post Office.

It is known that Post Office duct lines are regarded as excellent land drains but this is the first known case in the Midland Region of an attempt to use a main cable to augment the local water supply.

E. A.

## North-Western Region

### AN UNUSUAL TELEVISION OUTSIDE BROADCAST

The sketch shows the video links required by Granada Television, Ltd., for a program about the Manchester Fire Brigade, when, in response to a "999" call, the brigade turned

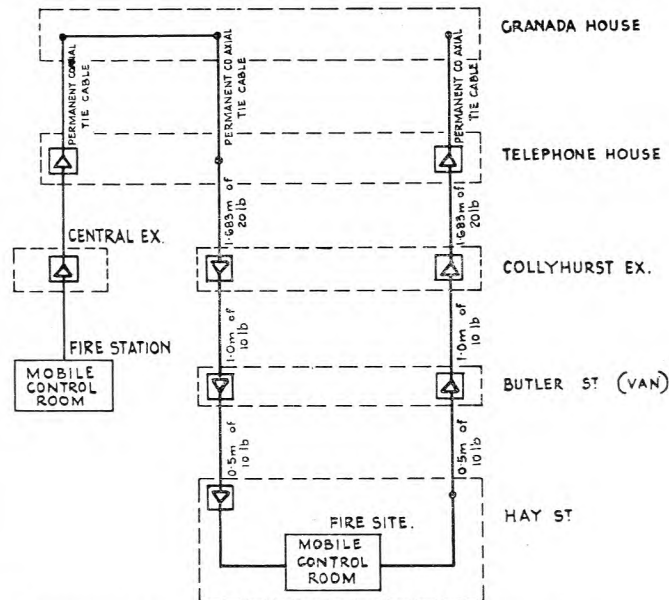

TELEVISION LINKS FOR A PROGRAM ABOUT THE MANCHESTER FIRE BRIGADE.

out to deal with a fire specially started in old property in the Collyhurst district. An unusual feature was that production was controlled in the mobile control room at the site of the fire and not, as would be expected, at the program-switching centre in Granada House. Under these conditions video signals from the cameras attached to the mobile control room located at the fire station passed through eight Amplifiers No. 98A\* in tandem to reach the program switching point and, unfortunately, it was not possible to separate the two directions of transmission between Telephone House and the site of the fire into different cables. In addition to the risk of serious crosstalk between the pairs transmitting in opposite directions, hazards were introduced by "flashing" interference on the pairs between Collyhurst Exchange and Telephone House, by radio-frequency (692 kc/s) pick-up between Collyhurst Exchange and Butler Street, and by the use of a diesel

\* WILLIAMS, M. B., and SEWTER, J. B. The Provision of Circuits for Television Outside Broadcasts, Part 1. *P.O.E.E.J.*, Vol. 48, p. 166, Oct. 1955.



engine generator set to provide power for the amplifiers at Butler Street.

Uncertainty as to the location of the site of the fire until approximately 30 hours before transmission time added to the difficulties of this broadcast, and left little opportunity for tests prior to handing over the circuits, which were, however, quite satisfactory to the renter.

Normally, high-level send amplifiers would have been used to swamp the flashing but the two-way transmission precluded this arrangement; it was possible, however, to increase the balanced outputs of the Amplifiers 98A, in the section subject to radio interference, from 2V peak-to-peak to 4V without serious effect on crosstalk, leaving a radio-frequency pattern which was only just visible on a monitor connected to the looped two-way transmission path. The best equalization possible on each leg of the loop was between 5 and 6 dB down at 2.7 Mc/s, and the crosstalk between the legs measured on a high-speed oscilloscope was less than 1 per cent.

H. C., and F. L.

#### BROUGHTON-IN-FURNESS (LANCASHIRE)

##### U.A.X. No. 13; DAMAGE BY LIGHTNING

Considerable damage was done to Post Office plant on 6th February, 1957, between 8.5 and 8.18 a.m., by an electric storm of unusual intensity. In addition, the electricity supplies were cut along the west coast from Askam to Bootle, and lines, switch-gear and consumers' equipment were seriously damaged. Apart from the darkness of the sky there was little or no warning of the storm and the trail of damage is practically the only evidence of it. It appears that two or three discharges were localized to the immediate neighbourhood of Broughton and were fed to other areas along the power cables.

Broughton U.A.X. was first reported isolated at 8.48 a.m., when it was found that the junctions from the parent exchange (Barrow), which are underground throughout, were all disconnected. It was found that all the junction M.D.F. protectors were "blown," and there were signs of excessive heat on the mountings.

Testing, followed by visits, revealed that about 80 per cent of the subscribers on the exchange were out of service. About half of these needed new protectors and a few had had their bell-sets destroyed. The most obvious external damage was to a 20/10 lashed aerial cable on the Broughton-Coniston Road. Tests later revealed faults throughout its length (806 yd) and the joints at each end were charred. It appeared to have been struck on the crest of a hill where three spans were down. The suspension wire and a stay were burned through. Samples of the damaged cable show a perfect mould of the suspension and lashing wires, due to the melting of the lead. The pole nearest the strike was badly damaged near the



POLE DAMAGED BY LIGHTNING STRIKE.

foot and a trench about 9 in. deep was left between the pole and the tarmac. A similar trench was produced at the pole on the other side of the strike, but this pole was undamaged.

Replacement of the damaged section by self-supporting cable, as an interruption length, failed to clear the faults and further tests showed extensive damage to the whole of the underground system of the exchange. Numerous wires were disconnected or in contact with others, and many circuits were faulty in more than one place. To ensure a speedy restoration and enable localizations to proceed it was necessary to insert an additional 1,000 yd of 30-pair interruption cable.

L.A.T., and A.D.S.

#### CARLISLE TRANSFER AND THE OPENING OF THE MECHANIZED TRUNK EXCHANGE

At 1 p.m. on Saturday, 26th January, with the opening of the new Carlisle automatic exchange, a further stage was reached in the mechanization of the country's trunk system.

The new exchange is housed in a modern four-storey building in Cecil Street and is one of the most up to date in the country, consisting of a trunk unit, local unit and 51-position auto-



By Courtesy of Cumberland Newspapers, Ltd., Carlisle.

CARLISLE AUTOMATIC TELEPHONE EXCHANGE.

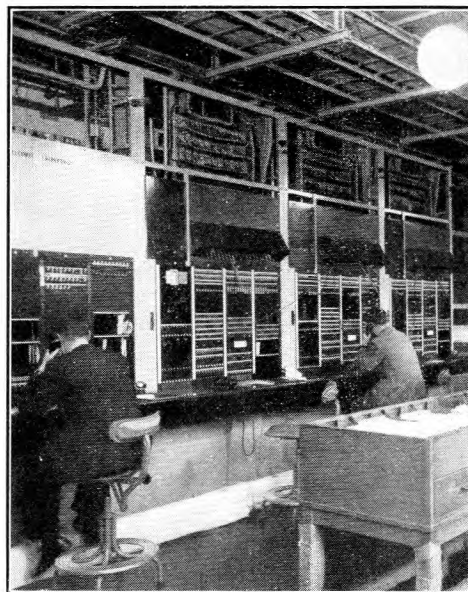

By Courtesy of Cumberland Newspapers, Ltd., Carlisle.

TRUNK AND LOCAL TEST POSITIONS.

manual switchboard. The trunk unit, equipped with motor uniselectors, is accommodated on the ground floor and gives access to eight zone centres and six group centres. The local unit, which has a multiple capacity of 5,700 lines, covers the whole of the first floor. The divided-battery-float power plant occupies the greater part of the second floor and the auto-manual switchboard the whole of the third floor. Noteworthy features of the exchange are the latest-type trunk test racks, the directory inquiry suite with call-queueing facilities, and the verbal delay-announcing facilities.

The preliminary work in connexion with the transfer was complicated by a late decision to turn into the new exchange certain audio cables from the west, north and east, which necessitated the provision of amplifying and terminating equipment. A single-break-jack scheme had been designed to cut out the old exchange, but in order to maintain the trunk service at the old exchange prior to transfer, it became necessary to introduce double break-jacks for all amplified circuits. A further result of the installation of amplifying equipment in the exchange was the decision to transfer all emergency circuit and part-time private wire switching from the repeater station to the exchange, the switching jacks being installed on the trunk test rack adjacent to the "busying keys." Due to there being three frames to take into consideration—the M.D.F. on the ground floor, the I.D.F. on the first floor and the R.D.F. on the second floor—the jumpering arrangements for many of these circuits were complicated, one particular circuit requiring over 40 jumpers. Fortunately the Area was able to meet all its commitments by the 26th November, 1956, the completion date of the call-through test.

End-to-end testing of all circuits connected to both the trunk and local units commenced on 27th November, with a target completion date of 29th December. This latter date was vital, for it had been decided to commence the transfer of the U.A.X. junctions to the new exchange on Wednesday, 2nd January, and to open the trunk exchange for restricted working on the same date. Thanks to the excellent co-operation received from distant Regions and Areas the trunk testing proceeded at a most satisfactory rate and was completed, including traffic tests, by the evening of 21st December. Testing of the junction circuits connected to the local unit also made excellent progress and all work was completed in advance of the target date.

Carlisle is the parent exchange for 25 U.A.X.s, and the transfer of the 222 U.A.X. junctions to the new exchange commenced at 8 a.m. on Wednesday, 2nd January, and was completed without incident by noon on Friday, 4th January. Simultaneously with the commencement of the U.A.X. transfer, approximately one-third of the circuits connected to the trunk unit were changed over, and during the next few days these were augmented until, by Monday, 7th January, half the trunk circuits had been transferred. No further transfer of trunks took place until Friday, 25th January, and the mid-morning of Saturday, 26th January; at that stage 80 per cent of all circuits connected to the trunk exchange had been changed over and tested. A number of circuits to and from dialling-in exchanges connected to the local unit were also changed over during the first week in January. The second stage of the U.A.X. transfer—tandem dialling testing—commenced on Tuesday, 8th January, and was completed in just over one week. This was much quicker than had been expected, bearing in mind the limited staff available and the fact that the majority of U.A.X. dialling code lists contained from 20 to 30 codes. The call offices were transferred in the three weeks preceding the 26th January.

To cater for traffic between the old and new exchanges, 100 transfer circuits were provided between them, 50 in each direction. Due to the limited opening of the trunk exchange, which allowed the operating staff to dispose of trunk traffic from U.A.X.s and call offices direct from the auto-manual suite, the number of transfer circuits proved adequate. Additional relief was provided for the Carlisle operating staff by permitting the group centres, from the 4th January, to dial their own U.A.X. calls via the trunk unit.

The transfer of the 4,000 subscribers' lines and the remainder of the trunk and junction circuits was accomplished smoothly and efficiently at 1 p.m. on 26th January. The opening ceremony was somewhat unusual as, owing to the restricted space in the ground floor apparatus room, it was necessary for the guests to be accommodated on the fourth floor of the

building. They included the Mayor and Town Clerk of Carlisle, the Lord Lieutenant of the County, the Regional Director and many other civic and departmental representatives. To enable them to follow the progress of the transfer, a system of remotely controlled lamp signals was installed which, aided by an "effects" loudspeaker, proved eminently satisfactory. The signal to commence the transfer was given by the Mayor, who subsequently made the first call to "TIM."

At a luncheon held immediately after completion of the transfer, fraternal greetings were passed between the civic leaders of Carlisle, England, and Carlisle, Pennsylvania, U.S.A., via the new transatlantic telephone cable. Arrangements for this call were made by the External Telecommunications Executive.

These notes would be incomplete without reference to the General Electric Co., who installed the exchange equipment and whose staff co-operated so whole-heartedly with the Post Office to ensure what the Telephone Manager afterwards called "the very successful transfer of the Carlisle Exchange."

L. A. T., and J. N.

## Home Counties Region

### UNUSUAL EXPORTS

"One day late last October a big lumbering crane rolled awkwardly down a quiet English country lane, past quaint thatched-roof cottages, on a strange assignment."

So began a report written by American press-men following an unusual bit of Post Office export business to the dollar countries.

It all began with an article in a British timber magazine a few years ago, stating that some 8,000 telegraph poles installed well before the turn of the century were still in service. That article was read by Mr. R. Holmes, Vice-President and General Manager of the Tar Products Division of Koppers Co., Inc., Pittsburgh, U.S.A., who then started proceedings to purchase some of these poles and transport them to America for research and exhibition.

Mr. Holmes contacted the English creosote firm of Messrs Burt, Boulton & Haywood, Ltd., and they in their turn made arrangements with the Post Office Supplies Department and the External Plant and Protection Branch of the E.-in-C.'s Office to trace where some of these venerable old poles still stood. Some were found to be still in use after 80 years, but the Post Office did not have the purchase records to prove it. Attention was drawn to the village of Dorchester within the Oxford Telephone Area.

Two poles, one with a strut, were visited and photographed, showing the dates of pressure creosoting to be 1893 and 1894. They were part of the main Oxford to Henley route, built between 1895 and 1900, but now only serving the local telephone network.

The next stage was to replace these poles and excavate the old poles ready for the ceremonial recovery. Both poles and strut were blocked, the strut block being in a very "dog-eared" condition, but the blocks recovered from the poles were perfect, as were the poles—except for innumerable scars of linemen's spikes.

Late in October, in the very distinguished company of Mr. Holmes, the Telephone Manager, Oxford, and representatives from Messrs. Burt, Boulton & Haywood, Ltd., the E.-in-C.'s Office and the Supplies Department, together with a reporter and photographer from the United Press, the poles were hauled out of the ground by means of a crane. Subsequent examination showed—in addition to the three crowns and 36 stamped on the base of the poles—the letters B.H. & Co., clearly discernible, this being a trademark used by an old-established Norwegian pole-shipping firm. During all these operations, numerous photographs were taken.

The poles were then stacked to await transport to London Docks, where they were loaded on to the M.T. *Evma* and shipped to the port of Norfolk, Virginia. On arrival there, on 17th November, they were taken to Koppers Research Laboratories at Verona, P.A., where they were studied to determine how much creosote still remains in the cellular structure of the poles after their long and successful battle against the ravages of time, the elements and other normal enemies of wood. Later they will be used in a permanent exhibition, demonstrating the long-lasting preservative qualities of creosote.

J. J. C.



## A CURE FOR INSOMNIA

A recent fault on a junction cable was located approximately at the junction of the overhead and underground cable sections, and it was decided to inspect the overhead section. On removing the capping from the pole the cause was immediately apparent. A dormouse had built a nest on the cable and had taken a good meal of the lead sheath, presumably

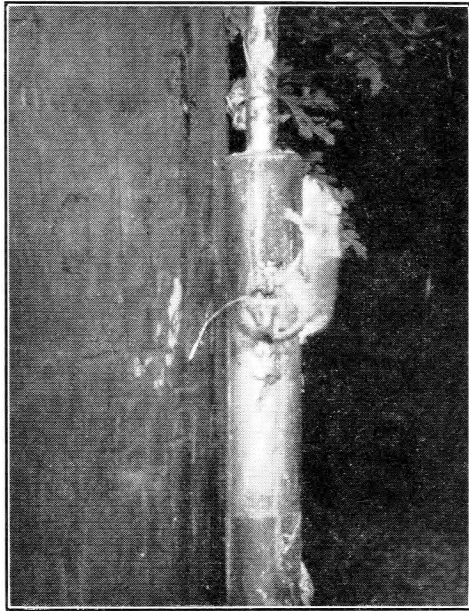

DORMOUSE ASLEEP ON CABLE LEADING UP POLE.

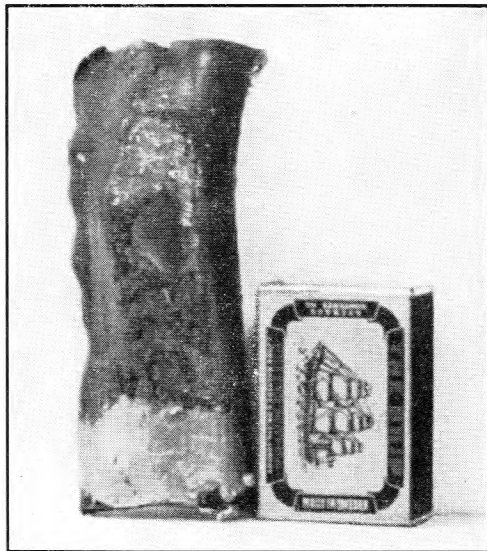

DAMAGE DONE TO CABLE SHEATH BY DORMOUSE.

to enable him to settle down for the winter. The animal remained asleep during the taking of the photograph, and ran away immediately it was removed from the cable and placed on the ground. The hole in the cable sheath was about the size of a shilling and several conductors had also been damaged.

L. W. B.

## AN UNUSUAL METHOD OF CLEARING A FAULT ON A MAIN UNDERGROUND CABLE

On 25th October, 1956, when routine tests were made, an incipient fault was found to exist on the London-Hastings cable. One pair only appeared to be affected, and a single-ended Varley test was made, the fault being proved into a 910-yd length of the route. While identifying the pair in the joint the fault was found to be a contact between two pairs

in different quads, one quad being on the outside layer of the cable, the other quad being on the second layer in.

The London-Hastings cable is very full, its size being 4/40 screened + 384/20 pr. P.C.Q.T. protected. There was no possibility of changing the circuits concerned over to spare pairs, and therefore a means of clearance had to be decided. To renew the length or to make a unidiameter repair to a cable of this size would be very costly. It was also known that attempts had been made recently to renew a length of this cable close by, with great difficulty, the cable finally being taken out in short pieces. It was therefore decided to clear the fault *in situ*. A double-ended Murray test was made over the 90-yd length, the fault being pin-pointed to 1.7 yd from the nearest joint. A deep excavation was made adjacent to the manhole housing this joint, and the cable exposed by breaking out the six-way duct. A careful measurement was made from the joint to the position of the fault and an arrow was chalked on the sheath 1.7 yd from the joint. Using the oscillator of a Tester 9001, tone was connected to one of the faulty pairs, and using the amplifier No. 55A and probe No. 3, the pair was traced and its position chalked on the sheath.

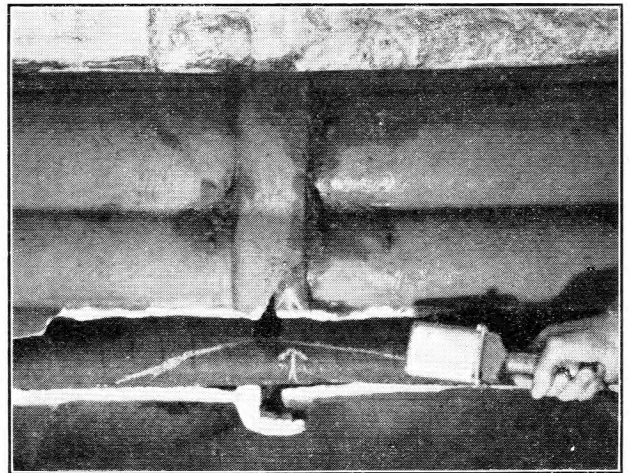

MEASURED POSITION OF FAULT.

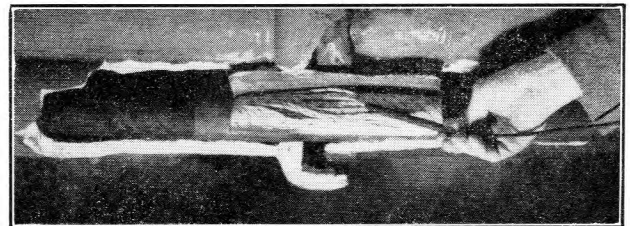

"DOOR" CUT IN LEAD SHEATH.

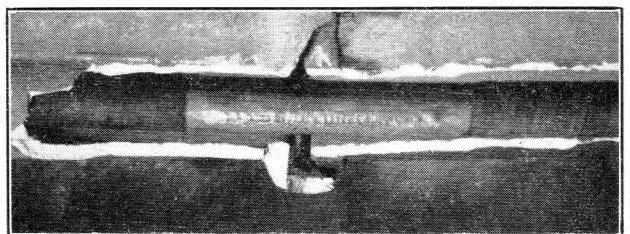

"DOOR" REPLACED AND JOINT LEAD-BURNED.

The tone was then connected to the other faulty pair, another line being chalked to indicate the position of this pair. The lays were right and left handed. The protection was taken off the cable for about 1 ft at this point and a 9-in. "door" cut in the lead sheath, 4½ in. on each side of the fault position. By tearing away the outer insulation paper the quads were exposed. Then, by means of the oscillator and small probe No. 5, the two faulty quads were identified again so that there could be no doubt that the correct quads were exposed. A small discolored spot could be seen on one conductor where

the quads crossed but no damage or distortion could otherwise be felt. Dry insulating paper was then carefully placed between the two quads, a further layer being placed on the outside of the core and slipped under the lead sheath. The lead door was gently dressed back into position, the cut edges being lead-burned so that the diameter of the cable was not affected. The joint was freshly protected and the six-way duct repaired with single-way split ducts, a layer of cement being placed on the outside of the duct. The whole operation was spread over four days, only two men being employed for the practical work.

F. W. G.

### North-Eastern Region

#### TEST MATCH INFORMATION SERVICE AT LEEDS

The Leeds Area staff were asked on 27th June, 1956, to provide a Test Match Information Service, to be ready for use on Tuesday, 10th July, the date of the third Test Match. No engineer could fail to accept this challenge, and by dint of hard work and improvisation a preliminary message by Johnny Wardle, of the Yorkshire C.C.C., went "on the banks" at 8 a.m. on that date. The service remained in use for the succeeding matches of the tour.

In Leeds, the Weather Service type of equipment was not available but there were group selectors and racks, recently thrown spare during the conversion of satellites to group

selector working; spare relay sets of various types, scattered over many racks; and two changed-number announcers. The diagram shows how these were used to give the service. It was decided to trunk the service from level 61, and to ensure that metering conditions were set up when certain relay sets were in circuit, an extra digit was added and the advertised code became 611. The choice of this level ensured that, at the majority of the satellite exchanges, it was possible to trunk the service directly to the announcer, instead of combining it with, and overloading, the normal routes to the central exchange.

Level 6 at Leeds has working levels 63-68, serving exchanges in the linked numbering scheme, and to carry this traffic the arrangement was 160 switches carrying the ordinary and C.C.B. traffic (the latter estimated as equivalent to 20 switches) and one complete rack for the D.I. group. All these share a common grading, so that the first problem was to isolate the C.C.B. and D.I. groups from the 61 level and augment the switches provided in the ordinary group up to 280. Two hundred trunks were provided from level 61, which is typical of the generous provision made to carry the expected traffic on this service. The cabling and terminating for this part of the work was confined to a small part of the exchange. When it was done the work was more widely spread and many more men could be employed on it.

The outlets from level 61 were connected to relay sets of various types giving an earth "A" and battery "B," so reversed jumpers were run to ensure metering on seizure. In some cases battery and earth had to be temporarily disconnected at the relay tags to avoid unwanted relay operations when connected to the loop condition presented by the announcer; in others, ring tone had to be removed. Call-count meters were connected to the P wire of each relay set, the meters on the traffic recorder rack being used for this purpose. Had there been time, it would have been preferable to have obtained a separate rack of meters so that the traffic recorder could have been used to measure the traffic handled while the service was in operation.

The final connexion to the announcer from the relay sets was via a 200-ohm  $\frac{1}{2}$ W carbon resistor in each leg to prevent crosstalk. The photograph shows how the resistors were hastily mounted on wood. Each amplifier normally carried half the load, it being arranged that, under fault conditions, each could be switched to take the full 310 outlets.

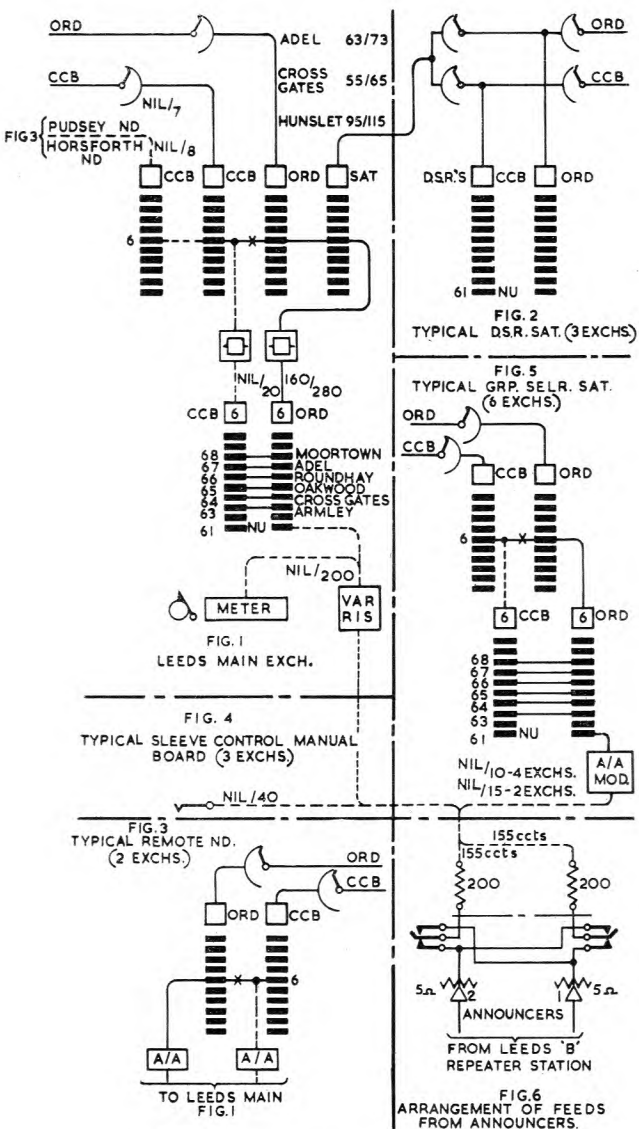

Notes:  
 X—existing trunking disconnected.  
 --- new trunking.  
 63/73—number of trunks before/after modifications.

TRUNKING FOR TEST MATCH INFORMATION SERVICE AT LEEDS.

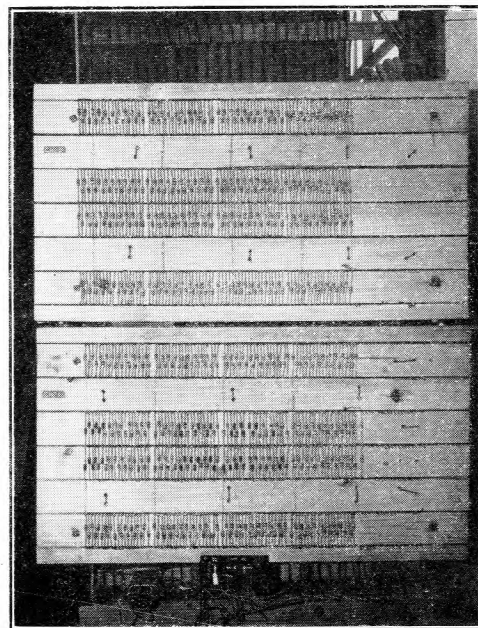

MOUNTING OF 200-OHM CARBON RESISTORS.

The satellites did not present so great a problem as Leeds, at most only regrading being necessary. Sufficient spare underground cable pairs were available to supply enough announcements from the verbal announcer to the outlets at those satellites where it was required.

The provision of the manual board circuits was kept as simple as possible. An engaged test was not provided on the manual board circuits, full dependence being placed on the free-line signalling. All calls were ticketed.

It gave great satisfaction to everyone to know that "611" carried an eighth of a million calls, comfortably handling all the traffic offered, as the overflow meters indicated. In the busiest half-hour there were 3,800 calls, and 60 erlangs were estimated to be offered. E. H.

#### YORKSHIRE I.T.A. TRANSMITTER

Emley Moor, the Independent Television Authority's new television station in Yorkshire, came into full program service on 3rd November, 1956.

This new station, 850 ft above sea-level, is situated 6 miles from Huddersfield. Its 445-ft self-supporting transmitting tower carries twin 8-stack high-gain aerial arrays, providing an effective radiated power of 200 kW on channel 10, beamed for maximum radiation 70° east of north.

In order to link the transmitter with the I.T.A. studios in Manchester a broadband radio-relay link was planned by the Post Office for the vision signal between Telephone House, Manchester, and Emley Moor, with an intermediate repeater station at Windy Hill (an existing radio-relay station on the Manchester-Edinburgh television route). The path between Manchester and Windy Hill was to use existing aerial paraboloids, interference with the Edinburgh route being prevented by the use of waveguide filters. For a satisfactory radio path between Windy Hill and Emley Moor a 325-ft mast was required at Windy Hill, with the paraboloid at Emley Moor 100 ft up the I.T.A. tower.

The necessary aerials and waveguide feeders were installed but the permanent radio equipment was not available to meet the opening date. To provide service, four mobile outside-broadcast s.h.f. equipments were fitted to form a single-hop link, giving two vision channels from Manchester to Emley Moor with both channel signals demodulated to video at Windy Hill. These temporary equipments were coupled to the permanent aerial waveguide feeders and separation of the two channels, at frequencies of 4,052 and 4,500 Mc/s, was achieved by waveguide filters.

At Emley Moor the video channels are passed to the I.T.A. equipment at IV peak-to-peak as two separate signals, the particular channel used for modulating the transmitter being selected by means of a key on the I.T.A. control desk. A similar arrangement is used for sound, two independently routed sound circuits from Manchester being supplied to the I.T.A. Lost program time, due to failure of either the sound or vision circuit supplying the transmitter, is thus reduced to a minimum, the I.T.A. control desk operator having only to operate a key to bring in the second channel.

Overall tests on the video links are made daily by Post Office staff from Manchester and Leeds, using waveform response techniques. Initially full-program-hours staffing was employed at all three link stations because the long-term stability and reliability of the temporary equipment was questionable. A six-weeks' trial period showed satisfactory results and only a daily attendance was found necessary to check the response of the link and carry out minor adjustments to bring the circuits up to the initial "K" ratings. Three months' operation of this temporary equipment has produced only two actual breaks in programs attributed to the link, each break being only the two or three seconds necessary for the I.T.A. controller at Emley Moor to change to the alternative channel.

The permanent radio equipment is now being installed and consists of two independent parallel radio channels from Manchester to Emley Moor and one channel in the reverse direction, with no standby or reserve equipment at any of the three stations. The single aerial paraboloids at both Emley Moor and Windy Hill are to be used for both directions of transmission, waveguide branching filters separating the channels. P. T.

#### Wales and Border Region

##### TRUNK AUTOMATIC SWITCHING.

##### FIRST PROVINCIAL UNIT OPENED AT SWANSEA

Swansea is not a new place for pioneering in the telephone service. It was there in 1881 that the first Post Office exchange

was opened and, in 1924, that the first Siemens No. 16 type of main automatic exchange was brought into service. It is therefore appropriate that on the 5th January, 1957, the first provincial trunk switching equipment should have been put into service there, and that it should have been manufactured and installed by Messrs. Siemens Bros. & Co., Ltd., using the motor uniselector developed by them. A function, attended by civic officials and other prominent persons, was held to inaugurate the equipment, and both the Telephone Manager and the Mayor of Swansea gave addresses in which progress of the trunk service was the theme. Prior to this, on 1st December, 1956, a new local automatic exchange, to which the trunk unit forms an addition, had been successfully opened. The local unit is equipped with 5,200 subscribers multiple, with provision for extension to 10,000, and gives multi-metering on calls up to four unit fees. It is the central exchange in a linked numbering area that includes five satellite exchanges.

The trunk unit, which carries the traffic from 25 exchanges, is composed of three ranks of motor-uniselector group selectors giving access to 16 trunk routes. Delay announcement facilities are provided for through-dialling operators. The A.C.1 and D.C.2 systems of signalling are used on the main trunk routes, and differential or generator signalling from selector levels to the several manual exchanges waiting conversion to automatic working. The trunk and local units have a common M.D.F. and equipment I.D.F., the latter being arranged to grow in one direction for extension of the local exchange and in the other for extension of the trunk unit.

The new switching equipment, together with a terminal repeater station, maintenance control and a suite of trunk test racks, is housed in a newly erected building, but the manual switchboard and many of the associated relay sets have been retained in the Head Post Office, which is situated across the road. Interconnexion is by four 1,040-pair quad cables, run between the equipment I.D.F.s in the two buildings. The usual M.D.F. protecting devices have not been provided for these cables, the short distance involved and the careful construction methods used making them unnecessary. The convenience of having the pairs terminated on the I.D.F.s and the need to keep the resistance as low as possible were factors influencing the decision to make this arrangement. The resistance of the exchange earth at the two buildings is greater than that of the lead cable sheath between them, so that the greater part of the return signalling currents flows in the sheath. To avoid corrosion the cables have an additional polythene sheath.

The whole of the replaced Siemens No. 16 equipment has been allocated for use elsewhere and a program of recovery and shipment has been worked out with the receiving parties to ensure that it will be in service again in the course of a few months.

S. E. N.

#### Scotland

##### EVACUATION OF WISHAW EXCHANGE

On the 26th November, the telephone exchange at Wishaw was evacuated and service withdrawn from about two thirds of the subscribers' lines. This step was taken to meet a situation described at the time as one of real and imminent danger. Wishaw is an industrial town situated in the Lanarkshire coalfield. Mining has been carried out in the area for many years, and from time to time subsidence has occurred due to the collapse of old workings. The danger to the building containing the Post Office and telephone exchange first became apparent when test bores were made 50 yards away on the new exchange site. Investigation under the Post Office itself revealed that it was only the arching of the clay subsoil that was preventing the collapse of the surface ground. The Consulting Engineer, who made the examination, reported on 19th November that the site could be consolidated and the building made safe by a process known as cementation, but this would take several months to complete, and in the meantime there was a grave risk of collapse. Immediate action was necessary. The Post Office, on the ground floor of the building, had to be evacuated to allow the consolidation work to proceed. The problem was what to do about the manual exchange on the first floor. The Consulting Engineer's report emphasized the danger of



the situation, and there was always the possibility that the risk would increase for a time during the consolidation work. In view of this the decision was taken on 22nd November to abandon the exchange until the building was made safe. The date set for evacuation was 26th November.

Wishaw exchange is an 11-position C.B.12 with 1,300 exchange connexions and is the parent for two U.A.X.s. In the time available it was impossible to provide a complete replacement exchange. Initially, service had to be restricted to about one-third of the exchange connexions, and when the exchange was evacuated the situation was as follows:—

- (i) U.A.X.s were reparented on Motherwell and Lanark.
- (ii) 53 emergency service lines and 33 call office lines (including the London Telecommunications Region's 10-line mobile call office unit) were connected to Motherwell exchange.
- (iii) 342 lines were connected to a 3-position C.B.S.2 switch-board in a trailer on the new exchange site. The power was supplied from Wishaw exchange batteries and the subscribers' and junction lines were connected by polythene cable direct from Wishaw M.D.F.
- (iv) The remaining subscriber's lines were disconnected.

This was the first stage of the emergency arrangements. The second stage aimed at a complete restoration of service using an 8-position C.B.S.2 exchange installed in suitable accommodation. There was, however, the difficulty of obtaining safe accommodation in an area where every building was more or less suspect, and the best that could be done was to adapt a garage in the Post Office yard. The garage is a light single-storied structure, and although quite close to the Post Office it provided a much safer location for a manual exchange than the main building or any available alternative. It also had the advantage that the existing power plant and M.D.F. could be used, as it was thought that the risks involved in occasional maintenance visits to the main building were justified. Installation of the 8-position C.B.S.2 exchange commenced on 29th November, and the exchange was opened and service completely restored, with some compulsory sharing, on 10th December. The U.A.X.s remain parented on Motherwell and Lanark to keep the load within the compass of eight positions.

The whole operation, from the evacuation of the exchange to the complete restoration of service, was carried out at very short notice. Tribute must be paid to the efforts of the staff in the field who worked round the clock, partly in very cramped conditions, and to the special contributions made by the Ministry of Works, who, after the investigation of various other possibilities which proved abortive, provided the garage with a new wall where the doors had been and completely lined walls and ceiling between Saturday, 24th November, and the following Wednesday; the Factories Department, who augmented from 60 to 120 the subscribers' equipment of the three C.B.S. 2 positions that were installed in the trailer to form the first stage of the replacement, and then followed with a similar operation on a further eight positions which were

installed in the garage to form the second stage replacement exchange; the Engineer-in-Chief's Office, who arranged the above with the Factories Department and made available the trailers that were used for the first-stage replacement exchange; and the Supplies Department, whose close co-operation in the supply of cable and miscellaneous stores ensured that at no stage was any time lost through their not being available.

M. M. K.

#### THE RAILWAY TRAIN AS AN ADJUNCT TO POLE RENEWAL WORKS

An overhead trunk line from Inverness to the West follows the railway track through a salt-marsh for a distance of 2 miles along the south shore of the Beaully Firth. Access by road is extremely difficult and, when it became necessary recently to replace a number of decayed poles of the medium class on this section, the problem of laying out stores was overcome in an unusual manner—by hiring a railway train.

The train, consisting of one flat-platform wagon and a brake-van, was hauled by one of the ubiquitous Class 5 locomotives, which do such sterling work in the Highland Section of British Railways' Scottish Region, and the competence of the crew contributed in no small way to the speed and success of the operation.



UNLOADING STORES FROM THE TRAIN.

The decayed poles had previously been marked with chalk for the benefit of the train crew, and the wagon was brought gently to a halt where necessary and the stores dropped beside each marked pole. Such a stage in the operations is shown in the photograph, in which the difficult nature of the terrain on either side of the railway track can be seen.

A. R. F.

## Book Review

"Television Explained." (Sixth Edition.) W. E. Miller and E. A. W. Spreadbury. Iliffe & Sons, Ltd. 182 pp. 107 ill. 12s. 6d.

This most successful book, first published in 1947, has already run through five editions. In its original form Mr. Miller was the sole author. The sixth edition, just published, has been brought up to date by the new co-author, Mr. Spreadbury, in order to cover recent developments. The last four years have brought about great changes in the design of domestic television receivers; for example, the opening of the second program by the I.T.A. has made switched tuning necessary, automatic gain control has become more common, and the very-high-frequency transmissions used by the I.T.A. have necessitated more advanced circuit and constructional techniques.

The authors describe, in completely non-mathematical form,

the working and circuit performance of nearly all aspects of domestic television receivers. They start with a chapter on resonant aerials, showing the methods of obtaining directivity by adding elements to the half-wave dipole. No polar diagrams are given: the emphasis is rather on constructional aspects of the aerials and feeders. The second chapter, describing the television signal and explaining how the width of the video signal frequency band is related to the number of scanning lines and frame repetition rate, is likely to interest the less technical reader. From this point onwards the circuitry of typical multi-channel television receivers is described, first in block diagram form and then in more detail, stage by stage.

The treatment is elementary, as it is intended to suit readers not expert in the practice of radio techniques. It is practical, because the authors wish to help service men and ambitious home constructors. The book is well illustrated and produced, especially considering the relatively low price at which it is being sold.

C. F. F.



# Staff Changes

## Promotions

| Name   | Region                   | Date      | Name  | Region                  | Date    | Name   | Region                  | Date     |
|--|--------------------------|-----------|---|-------------------------|---------|--|-------------------------|----------|
| <i>Regional Engr. to Chief Regional Engr.</i>    |                          |           | <i>Asst. Engr. (Limited Competition)—continued.</i> |                         |         | <i>Tech. Offr. to Asst. Engr.—continued.</i> |                         |          |
| Banes, J.  | N.E. Reg.                | 1.6.56    | Grav, H. J.   | L.T. Reg.               | 4.6.56  | Poole, N. C. G.                              | W.B.C.                  | 4.7.56   |
| <i>Asst. Staff Engr. to Chief Regional Engr.</i> |                          |           | Dieckmann, D. J.                                    | E.-in-C.O.              | 4.6.56  | Mack, G. L.                                  | E.-in-C.O.              | 8.9.56   |
| Hough, F. A.                                     | E.-in-C.O. to L.P. Reg.  | 29.10.56  | Warburton, J. E.                                    | E.-in-C.O.              | 4.6.56  | Thornton, T. C.                              | L.T. Reg. to E.-in-C.O. | 8.9.56   |
| <i>Asst. Staff Engr. to Staff Engr.</i>          |                          |           | Farmer, P.  | Scott.                  | 4.6.56  | Martin, R. W.                                | L.T. Reg. to E.-in-C.O. | 8.9.56   |
| Tobin, W. J. E.                                  | E.-in-C.O.               | 2.1.10.56 | Barker, A. L.                                       | E.-in-C.O.              | 4.6.56  | Stroud, L. J.                                | L.T. Reg. to E.-in-C.O. | 8.9.56   |
| <i>Area Engr. to Regional Engr.</i>              |                          |           | Parker, D. J.                                       | E.-in-C.O.              | 4.6.56  | Henshaw, J. H.                               | E.-in-C.O.              | 1.10.56  |
| Hawkins, W.                                      | N.E. Reg.                | 16.6.56   | Phillips, J. L.                                     | E.-in-C.O.              | 22.5.56 | Purslow, J. E.                               | L.T. Reg.               | 19.3.56  |
| Warren, F.                                       | N.W. Reg. to W.B.C.      | 2.7.56    | Millner, D.   | E.-in-C.O.              | 4.6.56  | Brackey, E. H.                               | L.T. Reg.               | 1.10.56  |
| <i>Snr. Exec. Engr. to Asst. Staff Engr.</i>     |                          |           | Childs, A. J.                                       | L.T. Reg.               | 4.6.56  | Thorpe, T. W.                                | L.T. Reg.               | 18.4.56  |
| Broadhurst, S. W.                                | E.-in-C.O.               | 14.8.56   | Atkinson, T. L. H.                                  | N.E. Reg.               | 4.6.56  | McLeod, W. A. L.                             | L.T. Reg.               | 9.1.56   |
| Wheeler, L. K.                                   | E.-in-C.O.               | 17.8.56   | Warner, D. G.                                       | Mid. Reg.               | 4.6.56  | Bower, M. G.                                 | L.T. Reg.               | 8.6.56   |
| Scowen, F.                                       | E.-in-C.O.               | 14.8.56   | Treacher, R. J.                                     | L.T. Reg.               | 4.6.56  | Thulborn, R. A.                              | L.T. Reg.               | 14.4.56  |
| Hales, A. C.                                     | E.-in-C.O.               | 14.8.56   | <i>Inspector to Asst. Engr.</i>                     |                         |         | Bhight, M. G.                                | L.T. Reg.               | 9.4.56   |
| Watt-Carter, D. E.                               | E.-in-C.O.               | 10.9.56   | Anthiff, J. E.                                      | S.W. Reg.               | 14.1.56 | Preston, L. A.                               | L.T. Reg.               | 1.4.56   |
| <i>Exec. Engr. to Area Engr.</i>                 |                          |           | Hughes, G. H. P.                                    | S.W. Reg.               | 31.2.56 | Stern, L. R.                                 | L.T. Reg.               | 12.3.56  |
| Watling, C. E. C.                                | L.T. Reg.                | 12.10.56  | Bond, W. T.   | S.W. Reg.               | 3.4.56  | Browne, V. J.                                | L.T. Reg.               | 12.3.56  |
| Masters, E. J.                                   | H.C. Reg.                | 1.5.56    | Watkins, R.   | S.W. Reg.               | 2.1.56  | Dellar, K. G.                                | L.T. Reg.               | 19.3.56  |
| <i>Exec. Engr. to Snr. Exec. Engr.</i>           |                          |           | Baylis, D. F.                                       | S.W. Reg.               | 2.1.56  | Breeze, K. S.                                | L.T. Reg.               | 5.3.56   |
| Castellano, E. J.                                | E.-in-C.O.               | 12.7.56   | Bonothan, R. J.                                     | S.W. Reg.               | 2.5.55  | Campbell, A.                                 | Scott.                  | 3.9.56   |
| Haley, G.  | E.-in-C.O. to Fac. Dept. | 29.6.56   | Barker, J.  | S.W. Reg.               | 2.1.56  | Ferguson, J. G.                              | Scott.                  | 14.5.56  |
| <i>Exec. Engr. (Open Competition)</i>            |                          |           | Leach, B. O.  | S.W. Reg.               | 6.2.56  | Brown, D.                                    | Scott.                  | 3.9.56   |
| Bartlett, G. A.                                  | E.-in-C.O.               | 18.5.56   | Marrriott, J. D.                                    | Mid. Reg.               | 1.4.56  | Mackenzie, D.                                | Scott.                  | 3.9.56   |
| <i>Asst. Engr. to Exec. Engr.</i>                |                          |           | Davies, D. T. B.                                    | W.B.C.                  | 23.2.56 | Searle, W. F.                                | E.-in-C.O.              | 8.9.56   |
| Pearson, G. D.                                   | L.T. Reg.                | 11.6.56   | Tennvson, A.  | W.B.C.                  | 27.2.56 | Sheppard, K. W. C.                           | E.T.E. to E.-in-C.O.    | 24.9.56  |
| Davies, H. C.                                    | L.T. Reg.                | 1.6.56    | Cannon, T. T.                                       | L.T. Reg.               | 11.6.56 | Wise, J. H.                                  | E.-in-C.O.              | 8.9.56   |
| Orchard, G. A.                                   | L.T. Reg.                | 1.6.56    | Naylor, N. V.                                       | L.T. Reg.               | 18.5.56 | Shupman, L. V.                               | E.-in-C.O.              | 8.9.56   |
| Powell, J. E. H.                                 | L.T. Reg.                | 1.6.56    | Waddell, T. W. F.                                   | Scott.                  | 23.4.56 | Longman, H. T.                               | E.-in-C.O.              | 8.9.56   |
| Griffin, S. J.                                   | L.T. Reg.                | 1.6.56    | Tompkins, F. R.                                     | S.W. Reg.               | 1.8.56  | Craddock, N. W.                              | E.T.E. to E.-in-C.O.    | 24.9.56  |
| Murray, A. J.                                    | E.T.E. to L.T. Reg.      | 11.6.56   | Clear, P.   | H.C. Reg.               | 3.7.56  | Biddlecombe, C.                              | E.-in-C.O.              | 8.9.56   |
| Maynard, L. W.                                   | L.T. Reg.                | 1.6.56    | Bartholomew, R. F.                                  | H.C. Reg.               | 3.7.56  | Wills, G. J.                                 | E.T.E. to E.-in-C.O.    | 29.9.56  |
| Chapman, G. W.                                   | L.T. Reg.                | 1.6.56    | Jackson, J.   | N.W. Reg.               | 7.8.56  | Vaughan, R. T.                               | E.-in-C.O.              | 8.9.56   |
| Moon, W. J.                                      | L.T. Reg.                | 1.6.56    | Ellerbeck, A. J.                                    | W.B.C.                  | 1.6.56  | Hathaway, H. A.                              | E.-in-C.O.              | 8.9.56   |
| Rose, S.   | L.T. Reg.                | 1.6.56    | McBane, C. F.                                       | L.T. Reg.               | 1.8.56  | Wilson, N.                                   | E.-in-C.O.              | 8.9.56   |
| Fife, E.   | L.T. Reg.                | 25.6.56   | West, J.  | L.T. Reg.               | 18.6.56 | Parker, A. E.                                | E.T.E. to E.-in-C.O.    | 29.9.56  |
| Parkinson, S.                                    | N.W. Reg.                | 26.6.56   | <i>Tech. Offr. to Asst. Engr.</i>                   |                         |         | Heath, G. S.                                 | E.T.E. to E.-in-C.O.    | 13.10.56 |
| Hale, C. S.                                      | S.W. Reg.                | 17.7.56   | Newman, J. M.                                       | H.C. Reg.               | 17.4.56 | Chamberlain, K. T.                           | E.T.E. to E.-in-C.O.    | 24.9.56  |
| Moore, H. C.                                     | N.W. Reg.                | 29.6.56   | Norton, H. C. W.                                    | H.C. Reg.               | 17.4.56 | Graham, A. S.                                | E.-in-C.O.              | 8.9.56   |
| Weedon, N. W.                                    | H.C. Reg.                | 7.8.56    | Hannocks, E. A.                                     | H.C. Reg.               | 17.4.56 | Fountain, V. A. E.                           | E.-in-C.O.              | 8.9.56   |
| <i>Asst. Engr. (Open Competition)</i>            |                          |           | Butler, G. A. L.                                    | H.C. Reg.               | 17.4.56 | Piesing, J. E.                               | E.-in-C.O.              | 8.9.56   |
| Manning, F. N.                                   | E.-in-C.O.               | 27.8.56   | Bushby, R. N.                                       | H.C. Reg.               | 17.4.56 | Ward, S. A. L.                               | E.-in-C.O.              | 15.9.56  |
| Bond, B.   | N.E. Reg.                | 2.7.56    | Underhill, R. J.                                    | H.C. Reg.               | 17.4.56 | Kendall, P. C.                               | E.-in-C.O.              | 8.9.56   |
| <i>Asst. Engr. (Limited Competition)</i>         |                          |           | Podmore, E. V.                                      | Mid. Reg.               | 1.10.55 | Burns, A. P.                                 | W.B.C. to E.-in-C.O.    | 8.9.56   |
| Soutar, D.                                       | Scott.                   | 7.5.56    | Parkinson, A. R.                                    | Mid. Reg.               | 18.7.55 | Hovse, K. R.                                 | S.W. Reg. to E.-in-C.O. | 8.9.56   |
| Ham, D. M.                                       | E.-in-C.O.               | 7.5.56    | Roberts, G.   | Mid. Reg.               | 26.6.56 | Holmes, A. D.                                | N.W. Reg. to E.-in-C.O. | 8.9.56   |
| Aitken, J. F.                                    | E.-in-C.O.               | 7.5.56    | Reaves, E. W.                                       | E.-in-C.O.              | 25.6.56 | Tucker, A. A.                                | E.-in-C.O.              | 8.9.56   |
| Wright, P. G.                                    | E.-in-C.O.               | 10.5.56   | Hooper, W. F.                                       | W.B.C.                  | 5.3.56  | Wardle, R. K.                                | E.T.E. to E.-in-C.O.    | 22.9.56  |
| Ledger, D.                                       | H.C. Reg.                | 7.5.56    | Hallett, F. C.                                      | E.-in-C.O.              | 18.7.56 | Smith, G. W.                                 | E.-in-C.O.              | 8.9.56   |
| Brain, J. E.                                     | S.W. Reg.                | 7.5.56    | Smale, I. V.  | Mid. Reg.               | 2.7.56  | Fenning, J. C.                               | E.-in-C.O.              | 8.9.56   |
| Allan, J. A. W.                                  | E.-in-C.O.               | 7.5.56    | Taylor, R. S.                                       | Mid. Reg.               | 18.6.56 | <i>Tech. Offr. to Inspector</i>              |                         |          |
| Dowson, F. H.                                    | E.-in-C.O.               | 7.5.56    | Snead, C. G. W.                                     | Mid. Reg.               | 9.1.56  | Haydock, R. W.                               | H.C. Reg.               | 13.1.56  |
| Hammett, A. H.                                   | S.W. Reg.                | 7.5.56    | Kelly, J. J.  | L.T. Reg.               | 1.3.56  | Gladwell, W. T.                              | H.C. Reg.               | 13.1.56  |
| Disley, C. G.                                    | E.-in-C.O.               | 7.5.56    | Smith, W. P.  | L.T. Reg.               | 23.3.56 | Pavne, F. J.                                 | H.C. Reg.               | 17.4.56  |
| Pink, D. J.                                      | H.C. Reg.                | 7.5.56    | Beard, A. E.  | L.P. Reg.               | 1.4.56  | Caunt, G.                                    | N.W. Reg.               | 24.5.56  |
| Herford-Alley, H. E. D.                          | Scott.                   | 7.5.56    | Dixie, J. A. E.                                     | L.P. Reg.               | 1.4.56  | Peacey-Nash, J. T.                           | S.W. Reg.               | 18.7.56  |
| McNeill, W. N.                                   | Scott.                   | 7.5.56    | Burgess, H. C.                                      | L.P. Reg.               | 7.4.56  | Kelsey, S. A.                                | H.C. Reg.               | 9.8.56   |
| Scott, P. A.                                     | L.T. Reg.                | 7.5.56    | New, R.   | L.P. Reg.               | 7.4.56  | Austin, G. W.                                | H.C. Reg.               | 9.8.56   |
| Pavey, J. C.                                     | L.T. Reg.                | 7.5.56    | DeBoltz, B. W.                                      | H.C. Reg.               | 3.7.56  | Perrin, L. J.                                | L.T. Reg.               | 13.7.56  |
| Nafzger, R.                                      | L.T. Reg.                | 7.5.56    | Pope, J. W.   | H.C. Reg.               | 3.7.56  | Milkins, A. E.                               | L.T. Reg.               | 9.7.56   |
| Glazbrook, J. W.                                 | E.-in-C.O.               | 22.5.56   | Tame, C.  | H.C. Reg.               | 3.7.56  | Parfitt, W. G.                               | L.T. Reg.               | 9.7.56   |
| Jones, I. O.                                     | E.-in-C.O.               | 7.5.56    | Swatton, H. L.                                      | H.C. Reg.               | 3.7.56  | Vardigans, A. G.                             | S.W. Reg.               | 14.1.56  |
| Rogers, W. A.                                    | Mid. Reg.                | 7.5.56    | Briggs, E.  | N.W. Reg.               | 4.7.56  | Jackson, K. D.                               | S.W. Reg.               | 1.8.56   |
| Wilson, J. S.                                    | Scott.                   | 7.5.56    | Balcomb, F. J.                                      | N.W. Reg.               | 4.7.56  | <i>Tech. I. to Inspector</i>                 |                         |          |
| Theobald, F. W.                                  | E.-in-C.O.               | 22.5.56   | Perdrix, R. L.                                      | Scott.                  | 4.6.56  | Houghton, C. W. T.                           | H.C. Reg.               | 13.1.56  |
| Hayes, J. M.                                     | L.T. Reg.                | 22.5.56   | Pinner, L. E.                                       | Scott.                  | 1.5.56  | Sykes, W. W.                                 | H.C. Reg.               | 17.4.56  |
| Elvidge, J. E. H.                                | E.-in-C.O.               | 22.5.56   | Donaldson, S. C.                                    | Scott.                  | 11.8.56 | Varney, G. T.                                | H.C. Reg.               | 17.4.56  |
| Foster, G. J.                                    | E.-in-C.O.               | 4.6.56    | Balfour, A.   | Scott.                  | 3.4.56  | Reims, J. F.                                 | Mid. Reg.               | 17.5.56  |
| Emery, S. R.                                     | H.C. Reg.                | 4.6.56    | Barefield, K. J.                                    | H.C. Reg.               | 9.7.56  | Rees, T. H.                                  | Mid. Reg.               | 3.10.55  |
| Dolan, E. P. D.                                  | H.C. Reg.                | 22.5.56   | Shirt, A. I.  | N.W. Reg.               | 20.7.56 | Cotterill, F. F.                             | Mid. Reg.               | 24.10.55 |
| Pine, R.   | H.C. Reg.                | 22.5.56   | Powell, A. W.                                       | E.T.E.                  | 26.7.56 | Kirkham, C. E.                               | Mid. Reg.               | 5.12.55  |
| Golding, A. W.                                   | E.-in-C.O.               | 22.5.56   | Wheatley, R. T.                                     | E.T.E.                  | 26.7.56 | Marshall, R. A.                              | L.T. Reg.               | 7.4.56   |
| Revill, E.                                       | N.W. Reg.                | 22.5.56   | Brown, G. P.  | S.W. Reg.               | 6.2.56  | Wellington, P. F.                            | L.T. Reg.               | 3.4.56   |
| Churchus, D. B.                                  | E.-in-C.O.               | 22.5.56   | Kohli, R. V. B.                                     | N.W. Reg.               | 29.8.56 | Lever, F. S.                                 | L.T. Reg.               | 12.3.56  |
| Childs, R.                                       | E.-in-C.O.               | 22.5.56   | Watson, E. A.                                       | E.-in-C.O.              | 8.9.56  | Jones, H. T.                                 | L.T. Reg.               | 30.4.56  |
| Brenton, M. E.                                   | E.-in-C.O.               | 22.5.56   | Colley, R. W.                                       | E.-in-C.O.              | 8.9.56  | Ellis, S.                                    | L.T. Reg.               | 18.2.56  |
| Wardman, D.                                      | N.E. Reg.                | 22.5.56   | Reynolds, A. St. J.                                 | E.-in-C.O.              | 8.9.56  | Roberts, G. W.                               | Mid. Reg.               | 27.5.56  |
| Duffy, P. S. J.                                  | E.-in-C.O.               | 29.5.56   | Bishop, G.  | E.-in-C.O.              | 8.9.56  | Smith, J. T.                                 | Mid. Reg.               | 21.5.56  |
| Burville, P. J.                                  | H.C. Reg.                | 22.5.56   | Lander, A. C.                                       | E.-in-C.O.              | 8.9.56  | Petrie, R.                                   | H.C. Reg.               | 3.7.56   |
| Lloyd, E. G.                                     | Mid. Reg.                | 22.5.56   | Holligon, E. R.                                     | N.E. Reg. to E.-in-C.O. | 15.9.56 | Allcorn, P. H.                               | H.C. Reg.               | 3.7.56   |
| Crudge, I. J.                                    | E.-in-C.O.               | 22.5.56   | Smith, J. A.  | L.T. Reg. to E.-in-C.O. | 8.9.56  | Mansfield, G. H.                             | H.C. Reg.               | 3.7.56   |
| Glover, L. O.                                    | L.T. Reg.                | 4.6.56    | Poultou, W. G.                                      | S.W. Reg. to E.-in-C.O. | 8.9.56  | Huxley, A. V.                                | Mid. Reg.               | 21.11.55 |
| Harp, A. B.                                      | W.B.C.                   | 4.6.56    | Kingdom, D. J.                                      | S.W. Reg. to E.-in-C.O. | 8.9.56  | Rigglesford, N.W.A.                          | Mid. Reg.               | 24.10.55 |
| Bell, K. F.                                      | L.T. Reg.                | 4.6.56    | Green, P. K.  | E.-in-C.O.              | 8.9.56  | Bebington, G.                                | N.W. Reg.               | 4.7.56   |
| Hughes, L. E.                                    | L.T. Reg.                | 4.6.56    | Tambin M. P.  | E.-in-C.O.              | 8.9.56  | Dawson, E.                                   | N.W. Reg.               | 4.7.56   |
| Brind, R. R. L.                                  | L.T. Reg.                | 4.6.56    | Westaway, H. E.                                     | E.-in-C.O.              | 8.9.56  | Traynor, J.                                  | Scott.                  | 3.4.56   |
| McGowan, R.                                      | N.W. Reg.                | 4.6.56    | Izzard, A.  | E.-in-C.O.              | 8.9.56  | Ferguson, J. H.                              | Scott.                  | 17.8.56  |
| Holroyd K.                                       | E.-in-C.O.               | 22.5.56   | Hopton, R.  | E.-in-C.O.              | 8.9.56  | Crumley, J. A.                               | Scott.                  | 1.7.56   |
| Noble, A.  | N.E. Reg.                | 4.6.56    | Young, D.   | Mid. Reg. to E.-in-C.O. | 8.9.56  | Bass, N. G.                                  | H.C. Reg.               | 9.7.56   |
| Quick, J.  | W.B.C.                   | 4.6.56    | Higgs, G. C. C.                                     | S.W. Reg. to E.-in-C.O. | 8.9.56  | Kingswood, G. E.                             | H.C. Reg.               | 9.7.56   |
| Moncrieff, A. W.                                 | E.-in-C.O.               | 22.5.56   | Wallingford, J. F.                                  | E.-in-C.O.              | 8.9.56  | Roast, B. G. R.                              | H.C. Reg.               | 9.7.56   |
| Hornsby, R. J.                                   | L.T. Reg.                | 4.6.56    | Kite, C. R. A.                                      | E.-in-C.O.              | 8.9.56  | Goswell, R. A.                               | H.C. Reg.               | 9.7.56   |
| Feldens, J.                                      | E.T.E.                   | 4.6.56    | Hammersley, S.                                      | E.-in-C.O.              | 8.9.56  | Gardner, E.                                  | Scott.                  | 1.8.56   |
| Chambers, J. A.                                  | E.-in-C.O.               | 4.6.56    | Christian, K. A.                                    | E.-in-C.O.              | 15.9.56 | Nutt, J. A. J.                               | Scott.                  | 3.9.56   |
| Still, L. A. H.                                  | L.T. Reg.                | 6.6.56    | Counsell, P. H.                                     | E.-in-C.O.              | 8.9.56  | McGachie, D.                                 | Scott.                  | 12.7.56  |
| Tiddy, K.  | S.W. Reg.                | 4.6.56    | Reilly, P.  | L.T. Reg. to E.-in-C.O. | 8.9.56  | Medford, A. O.                               | N.W. Reg.               | 19.7.56  |
| Doerr, J.  | L.T. Reg.                | 4.6.56    | Bates, R. V.  | E.-in-C.O.              | 8.9.56  | Jones, F.                                    | N.W. Reg.               | 7.8.56   |
|  |                          |           | Goodman, E. T. J.                                   | E.-in-C.O.              | 8.9.56  | Knight, J.                                   | H.C. Reg.               | 10.8.56  |
|  |                          |           | Stephens, J.  | E.-in-C.O.              | 8.9.56  | Fitt, C. J.                                  | H.C. Reg.               | 10.8.56  |
|  |                          |           | Pendlebury, N. H.                                   | N.W. Reg. to E.-in-C.O. | 22.9.56 | Burrows, S. D.                               | N.W. Reg.               | 14.8.56  |
|  |                          |           | Garrick, P.   | N.E. Reg. to E.-in-C.O. | 8.9.56  | Kent, J. C.                                  | L.T. Reg.               | 18.5.56  |
|  |                          |           | Loomes, B. J.                                       | E.-in-C.O.              | 8.9.56  | Morris, W. S.                                | L.T. Reg.               | 1.8.56   |
|  |                          |           | Crewes, C. R.                                       | E.-in-C.O.              | 15.9.56 | Wheeler, N. W.                               | L.T. Reg.               | 19.8.56  |
|  |                          |           | Bunnis, A.  | E.-in-C.O.              | 15.9.56 | Williams, H. C.                              | S.W. Reg.               | 31.1.56  |
|  |                          |           | Long, M. G.   | E.-in-C.O.              | 8.9.56  | Graham, S.                                   | S.W. Reg.               | 30.1.56  |
|  |                          |           | Weller, D. C.                                       | E.-in-C.O.              | 8.9.56  | Radford, R. G.                               | S.W. Reg.               | 14.8.56  |
|  |                          |           | Ryan, W. A.   | E.-in-C.O.              | 8.9.56  | Jones, C. O.                                 | S.W. Reg.               | 8.5.56   |
|  |                          |           | Culley, L. J.                                       | W.B.C.                  | 8.9.56  | Potentier, L. J. T.                          | S.W. Reg.               | 2.7.56   |

**Promotions—continued.**

| Name  | Region     | Date     | Name   | Region     | Date    | Name  | Region     | Date     |
|---|------------|----------|--|------------|---------|---|------------|----------|
| <i>Tech I. to Inspector—continued.</i>              |            |          | <i>Explt. Offr. (Open Competition)—continued</i> |            |         | <i>Asst. Explt. Offr. (Limited Competition)</i> |            |          |
| Parker, L. P.                                       | S.W. Reg.  | 28.12.55 | Lister, C.                                       | E.-in-C.O. | 25.6.56 | Schroder, C. R.                                 | E.-in-C.O. | 17.9.56  |
| Stevens, J. M.                                      | S.W. Reg.  | 1.10.56  | Jones, S. J.                                     | E.-in-C.O. | 30.7.56 |   |            |          |
| Womson, K. H.                                       | S.W. Reg.  | 13.2.56  | Morris, F.                                       | E.-in-C.O. | 10.9.56 | <i>Asst. (Sc.) (Open Competition)</i>           |            |          |
| Drake, E. S.  | S.W. Reg.  | 17.9.56  | Lazenby, F.                                      | E.-in-C.O. | 5.10.56 | Clifton, T. P.                                  | E.-in-C.O. | 16.7.56  |
| McCarty, J. W.                                      | S.W. Reg.  | 31.1.56  |  |            |         | <i>M.T.O. III to M.T.O. II</i>                  |            |          |
| <i>Snr. Prin. Sc. Offr. to Dep. Chief Sc. Offr.</i> |            |          | <i>Asst. Explt. Offr. to Explt. Offr.</i>        |            |         | <i>McConnell, D. A.</i>                         |            |          |
| Metson, G. H.                                       | E.-in-C.O. | 1.7.56   | Hauser, T. V.                                    | E.-in-C.O. | 31.5.56 | <i>Mech. in Charge to T.A. II</i>               |            |          |
| <i>Sc. Offr. (Open Competition)</i>                 |            |          | <i>Asst. Explt. Offr. (Open Competition)</i>     |            |         | <i>Rover, E. V.</i>                             |            |          |
| Brook, V. S. (Miss)                                 | E.-in-C.O. | 23.8.56  | Harrington, D.                                   | E.-in-C.O. | 18.6.56 | Woolley, G. R.                                  | Mid. Reg.  | 22.10.56 |
| <i>Explt. Offr. (Open Competition)</i>              |            |          | <i>Fudge, R. E.</i>                              |            |         | <i>Twycross, W. J.</i>                          |            |          |
| Clarke, A. A.                                       | E.-in-C.O. | 9.5.56   | Fleury, S. J. (Miss)                             | E.-in-C.O. | 13.8.56 | <i>Mountney, G. H.</i>                          |            |          |
| Scott, G. C.  | E.-in-C.O. | 15.6.56  | Biggs, K. J.                                     | E.-in-C.O. | 1.11.56 | <i>Boulton, H. G.</i>                           |            |          |

**Retirements and Resignations**

| Name                       | Region     | Date     | Name                         | Region     | Date    | Name                        | Region     | Date     |
|----------------------------|------------|----------|------------------------------|------------|---------|-----------------------------|------------|----------|
| <i>Chief Regional Engr</i> |            |          | <i>Asst. Engr—continued.</i> |            |         | <i>Inspector—continued.</i> |            |          |
| Beer, C. A.                | N.E. Reg.  | 31.5.56  | Harris, K. T.                | E.-in-C.O. | 26.6.56 | Webber, J. P.               | L.T. Reg.  | 31.7.56  |
| <i>Staff Engr.</i>         |            |          | <i>(Resigned)</i>            |            |         | <i>Caseley, R. G.</i>       |            |          |
| Penney, A. E.              | E.-in-C.O. | 13.8.56  | Glasby, P. A.                | E.-in-C.O. | 30.6.56 | Sanford, A.                 | H.C. Reg.  | 31.8.56  |
| <i>Area Engr.</i>          |            |          | <i>(Resigned)</i>            |            |         | <i>Raftery, F. J.</i>       |            |          |
| Lyddall, A. G.             | L.T. Reg.  | 2.10.56  | Childs, R. S.                | E.-in-C.O. | 30.6.56 | Field, W. G. P.             | L.T. Reg.  | 18.8.56  |
| <i>Snr. Exec. Engr.</i>    |            |          | <i>(Resigned)</i>            |            |         | <i>Menage, E. A.</i>        |            |          |
| Fox, P. C.                 | E.T.E.     | 21.6.56  | Nalder, A. G.                | L.T. Reg.  | 14.7.56 | Judge, W. V.                | Mid. Reg.  | 15.9.56  |
| <i>Exec. Engr.</i>         |            |          | <i>(Resigned)</i>            |            |         | <i>Jones, E.</i>            |            |          |
| Guest, F.                  | H.C. Reg.  | 28.5.56  | Nelson, L. C.                | E.-in-C.O. | 17.7.56 | Barr, A. W.                 | L.T. Reg.  | 23.9.56  |
| Deighton, C. F.            | N.E. Reg.  | 31.5.56  | Cowley, F. H.                | H.C. Reg.  | 29.7.56 | Gaughan, G. W.              | N.E. Reg.  | 30.9.56  |
| Rogers, A. H.              | W.B.C.     | 31.5.56  | Ostn, P. C.                  | W.B.C.     | 30.7.56 | Yates, J. T.                | Mid. Reg.  | 3.10.56  |
| Hey, H. E.                 | N.E. Reg.  | 31.10.56 | Small, S. R.                 | L.T. Reg.  | 31.7.56 | <i>Snr. Sc. Offr.</i>       |            |          |
| House, L. F.               | H.C. Reg.  | 14.6.56  | Mellors, H. R.               | L.T. Reg.  | 6.7.56  | Parkin, B. G.               | E.-in-C.O. | 31.8.56  |
| Dafforn, D. G.             | W.B.C.     | 10.6.56  | (Resigned)                   |            |         | <i>(Resigned)</i>           |            |          |
| Clarke, P. B.              | E.-in-C.O. | 31.10.56 | Stephens, J.                 | S.W. Reg.  | 31.7.56 | <i>Explt. Offr.</i>         |            |          |
| (Resigned)                 |            |          | Bradby, T. J.                | E.T.E.     | 31.7.56 | Trafford, D. J.             | E.-in-C.O. | 30.9.56  |
| Avery, H. C. T.            | S.W. Reg.  | 7.6.56   | Martindale, W. P.            | N.W. Reg.  | 7.5.56  | <i>(Resigned)</i>           |            |          |
| Field, J. A. R.            | E.-in-C.O. | 31.7.56  | Whiteley, H.                 | N.E. Reg.  | 25.8.56 | <i>Sc. Offr.</i>            |            |          |
| <i>Asst. Engr.</i>         |            |          | <i>(Resigned)</i>            |            |         | <i>Kitching, R.</i>         |            |          |
| Logan, H. D.               | H.C. Reg.  | 8.4.56   | Collyer, F. H.               | H.C. Reg.  | 31.8.56 | (Resigned)                  | E.-in-C.O. | 15.10.56 |
| Kinnear, D. J.             | Scot.      | 8.5.56   | Ashworth, W.                 | N.E. Reg.  | 6.9.56  | Acton, R. A.                | E.-in-C.O. | 24.10.56 |
| West, G. A.                | L.T. Reg.  | 17.5.56  | Wilson, A.                   | N.W. Reg.  | 7.9.56  | <i>Asst. Explt. Offr.</i>   |            |          |
| Thompson, R.               | L.T. Reg.  | 17.5.56  | McGovern, M. P. P.           | Scot.      | 7.9.56  | Richell, D.                 | E.-in-C.O. | 16.6.56  |
| Saunders, S. T.            | L.T. Reg.  | 25.5.56  | Kerslake, K. W.              | S.W. Reg.  | 6.9.56  | (Resigned)                  |            |          |
| Bliss, A. R.               | L.T. Reg.  | 27.5.56  | (Resigned)                   |            |         | <i>(Resigned)</i>           |            |          |
| Smerdon, J. H.             | L.P. Reg.  | 30.5.56  | Liddiard, F. E.              | H.C. Reg.  | 31.1.56 | <i>Asst. Explt. Offr.</i>   |            |          |
| Wilson, L.                 | L.T. Reg.  | 31.5.56  | Gardner, E.                  | L.T. Reg.  | 31.8.56 | Hansson, O. K. H.           | E.-in-C.O. | 31.5.56  |
| Simpson, J.                | Scot.      | 31.5.56  | Townsend, J.                 | L.T. Reg.  | 31.8.56 | (Resigned)                  |            |          |
| O'Sullivan, P.             | W.B.C.     | 31.5.56  | Kennedy, D.                  | L.T. Reg.  | 17.9.56 | <i>Kendrick, M. S.</i>      |            |          |
| Regan, F. M. C.            | L.T. Reg.  | 1.6.56   | Young, G. F.                 | N.E. Reg.  | 18.9.56 | (Mrs.) (Resigned)           | E.-in-C.O. | 31.5.56  |
| Gosling, A. H.             | L.T. Reg.  | 1.6.56   | Whittaker, W. N.             | N.W. Reg.  | 26.9.56 | Dingain, M. E.              | E.-in-C.O. | 30.6.56  |
| Taylor, T. A.              | N.W. Reg.  | 18.6.56  | Stafford, A. F.              | N.E. Reg.  | 30.9.56 | (Miss) (Resigned)           | E.-in-C.O. | 30.6.56  |
| Reeves, H. S.              | L.T. Reg.  | 29.6.56  | Cartwright, H. T.            | E.-in-C.O. | 5.10.56 | <i>Asst. (Sc.)</i>          |            |          |
| Lord, T. N.                | N.E. Reg.  | 30.6.56  | Smith, D. A.                 | E.T.E.     | 31.8.56 | Bradshaw, J. M.             | E.-in-C.O. | 5.10.56  |
| Jones, R. A.               | Mid. Reg.  | 30.6.56  | (Resigned)                   |            |         | (Mrs.) (Resigned)           | E.-in-C.O. | 31.10.56 |
| Woodcock, W.               | L.T. Reg.  | 30.6.56  | Inspector                    |            |         | Davies, J. L.               | E.-in-C.O. | 31.10.56 |
| Barnes, T. C.              | L.P. Reg.  | 2.7.56   | Cooper, W. G. R.             | H.C. Reg.  | 30.1.56 | (Resigned)                  |            |          |
|                            |            |          | Gannon, J.                   | N.E. Reg.  | 21.5.56 | <i>Asst. Reg. M.T.O.</i>    |            |          |
|                            |            |          | Soutar, J. B.                | Scot.      | 30.6.56 | Williams, S. A.             | W.B.C.     | 26.7.56  |
|                            |            |          | Crisp, W. R. H.              | L.T. Reg.  | 6.6.56  |                             |            |          |
|                            |            |          | Cleghorn, A. H.              | L.T. Reg.  | 28.6.56 |                             |            |          |
|                            |            |          | Myatt, J. W.                 | W.B.C.     | 10.7.56 |                             |            |          |
|                            |            |          | Parker, J.                   | Mid. Reg.  | 31.7.56 |                             |            |          |

**Transfers**

| Name                                       | Region                            | Date     | Name                                 | Region                                      | Date    | Name   | Region                                   | Date    |
|--|-----------------------------------|----------|--------------------------------------|---|---------|--|--|---------|
| <i>Chief Regional Engr. to Staff Engr.</i> |                                   |          | <i>Exec. Engr.</i>                   |   |         | <i>Asst. Engr.—continued.</i>                    |  |         |
| Phillips, R. S.                            | L.P. Reg. to E.-in-C.O.           | 29.10.56 | Spratley, E. W. F.                   | E.-in-C.O. to H.C. Reg.                     | 1.10.56 | London, A. G.                                    | E.-in-C.O. to Min. of Transport and C.A. | 2.7.56  |
| <i>Staff Engr. to C.M.T.O.</i>             |                                   |          | <i>(Resigned)</i>                    |   |         | <i>Hetherington, T.</i>                          |  |         |
| Calvey, C. E.                              | E.-in-C.O.                        | 29.10.56 | Harms, P. M.                         | E.-in-C.O. to Min. of Housing and Loc. Gov. | 3.9.56  | Pember, A. L.                                    | E.-in-C.O. to E.-in-C.O.                 | 8.7.56  |
| <i>Asst. Staff Engr.</i>                   |                                   |          | <i>(Resigned)</i>                    |   |         | <i>Harding, F. J.</i>                            |  |         |
| Merriman, J. H. H.                         | E.-in-C.O. to Treasury (seconded) | 1.8.56   | <i>Exec. Engr. to Snr. Sc. Offr.</i> |   |         | <i>Sanders, R. V.</i>                            |  |         |
| <i>Area Engr. to Efficiency Engr.</i>      |                                   |          | <i>Ross, J. D.</i>                   |   |         | <i>(Resigned)</i>                                |  |         |
| Wells, H. M.                               | H.C. Reg.                         | 29.3.56  | Ross, J. D.                          | E.-in-C.O. to Min. of Supply                | 1.10.56 | Goff, A. P.                                      | N.I. to E.-in-C.O.                       | 27.8.56 |
| <i>Snr. Exec. Engr. to Area Engr.</i>      |                                   |          | <i>Asst. Engr.</i>                   |   |         | <i>Adair, J. C.</i>                              |  |         |
| Rossiter, G. E.                            | E.-in-C.O. to S.W. Reg.           | 4.6.56   | Langridge, F. R. J.                  | E.-in-C.O. to Gold Coast                    | 9.10.52 | Marshall, N. E.                                  | E.-in-C.O. to Pakistan (seconded)        | 18.8.56 |
| Morgan, C. A.                              | E.-in-C.O. to L.T. Reg.           | 3.10.56  | Crawford, A.                         | Nigeria (approved employment) to E.-in-C.O. | 22.5.56 | Edwards, A.                                      | E.-in-C.O. to H.C. Reg.                  | 18.8.56 |
| <i>Snr. Exec. Engr.</i>                    |                                   |          | <i>(Resigned)</i>                    |   |         | <i>Glass, V. G.</i>                              |  |         |
| Swaffield, J.                              | E.-in-C.O. to Admiralty           | 22.3.56  | Jones, S. I.                         | E.-in-C.O. to Min. of Transport and C.A.    | 22.5.56 | Vicar, C. D.                                     | L.T. Reg. to E.-in-C.O.                  | 9.9.56  |
| Truslove, E. H.                            | Factories Dept to E.-in-C.O.      | 29.6.56  | Cook, R. B.                          | E.-in-C.O. to G.C.H.Q.                      | 4.6.56  | <i>Asst. Engr. to Asst. Postal Controller II</i> |  |         |
|  |                                   |          | Summerland, L. A.                    | E.-in-C.O. to Malaya                        | 25.7.51 | Collings, R.                                     | E.-in-C.O. to W.B.C.                     | 16.7.56 |
|  |                                   |          | Barnett, R.                          | E.-in-C.O. to L.T. Reg.                     | 17.6.56 | <i>Asst. Engr. to Welfare Officer</i>            |  |         |
|  |                                   |          | Mowlem, B. A.                        | L.T. Reg. to Min. of Transport and C.A.     | 18.6.56 | McChesney, J.                                    | E.-in-C.O.                               | 12.3.51 |
|  |                                   |          | Spokes, F. K.                        | E.-in-C.O. to Min. of Transport and C.A.    | 2.7.56  | Pulcher, C. J. F.                                | L.T. Reg.                                | 2.4.51  |

**Deaths**

| Name                    | Region     | Date    | Name                          | Region     | Date    | Name                    | Region     | Date    |
|-------------------------|------------|---------|-------------------------------|------------|---------|-------------------------|------------|---------|
| <i>Snr. Exec. Engr.</i> |            |         | <i>Asst. Engr.—continued.</i> |            |         | <i>Inspector</i>        |            |         |
| Jones, C. E. P.         | L.T. Reg.  | 1.6.56  | Sanderson, J. C.              | L.T. Reg.  | 11.6.56 | George, A. W.           | H.C. Reg.  | 22.3.56 |
| <i>Asst. Engr.</i>      |            |         | <i>(Resigned)</i>             |            |         | <i>Henderson, W. C.</i> |            |         |
| Colburn, J. T.          | E.-in-C.O. | 10.5.56 | Beatte, N. W.                 | E.-in-C.O. | 15.6.56 | Jackson, A. E.          | L.T. Reg.  | 1.10.56 |
| Culf, A. E.             | N.W. Reg.  | 26.5.56 | Pye, H. J.                    | L.T. Reg.  | 17.6.56 | <i>Chief M.T.O.</i>     |            |         |
|                         |            |         | Gillard, J. A.                | L.T. Reg.  | 18.6.56 | McDonald, A. G.         | E.-in-C.O. | 11.2.56 |
|                         |            |         | Carter, R.                    | S.W. Reg.  | 1.9.56  |                         |            |         |

## Associate Section Notes—Continued from p. 52

and most informative to the 14 members who took part. Commencing with the wire drawing department, the processes of annealing, tinning and stranding were observed, followed by the covering of the conductor by three different methods, lapping, longitudinal and extrusion. The use of British and American machines for covering jumper wire was next observed and though creating a lot of noise was certainly intriguing. The visit was completed at the armouring section where heavy drag cables for coal mines were being armoured.

On Saturday, 12th January, 1957, 10 of our members visited the printing works of the *Sunderland Echo and Shipping Gazette*, Bridge Street, Sunderland. Heads of various departments met the members and explained the processes. Unfortunately, the press wasn't "rolling" for the final stage of the visit but the *Echo* made it clear that we would be welcome to call again to witness this another day.

The Centre next met on 25th January, 1957, and on this occasion Mr. J. Edmondson of the Senior Section came to visit us and gave a talk on U.A.X.s, which he amplified with diagrams and slides. There followed a period for discussion, questions and refreshments, which proved beneficial to all present.

I am pleased to say that our centre is now really alive, the membership having increased by 25 per cent since the initial meeting in October last.

D. A. C.

### Leeds Centre

The inaugural meeting of the re-formed Leeds Centre was held on the 14th November, 1956, at the Griffin Hotel, Leeds.

The speaker was Mr. R. W. Palmer, M.I.E.E., President of the Associate Section, who gave an illustrated talk on "Maintenance Abroad." Aspects of maintenance methods in the U.S.A. and Sweden were dealt with and great interest was shown in the different approaches to mutual problems. Afterwards an informal discussion took place and Mr. Palmer ably answered all the questions put to him.

The Centre has had a successful start and up to date over 120 members have been enrolled. The successful formation of the Centre has been largely due to the efforts and guidance of our Area Engineers, Mr. E. Hopkinson and Mr. F. E. Wright, and the Area and Regional Liaison Officers, Mr. Hamel and Mr. Holmes.

Visits have already been made to the B.B.C. North Regional transmitters, Automatic Telephone and Electric Co.'s works at Liverpool, John Smith's Brewery, Tadcaster, and Ledston Luck Colliery, near Castleford; and talks have been given on the Supervisory Control of Power Distribution, by Mr. C. E. Dadson, A.M.I.E.E. (Yorkshire Electricity Board), who discussed the various methods of controlling remote sub-station equipment, with particular reference to the Leeds area. Mr. Dadson extended an invitation to members to visit the main control room of the Yorkshire Electricity Board.

Visits will be arranged throughout the summer months instead of having a closed season.

The Committee for the 1956-57 session is: *Chairman*: Mr. L. Smith; *Secretary-Treasurer*: Mr. A. A. George; *Members*: Messrs. Baker, Bateman, Bates, Crowther, Newton and Senior.

The Centre will welcome communication with other Associate Centres and the Secretary is available through the Telephone Manager's Office, 28 Park Place, Leeds, 1, or telephone, Leeds 32811.

A. A. G.

### Colchester Centre

The Colchester Centre was formed by an interested group of 12 members of the engineering staff of the Area, who met on the evening of the 31st October, 1956, and subsequently elected the following committee and officers: *Chairman*: Mr. A. F. O'Roark, Area Engineer; *Vice-Chairman*: Mr. R. G. Cocker; *Secretary*: Mr. T. T. Shanks; *Treasurer*: Mr. J. W. Jaggard; *Committee*: Messrs. J. W. O. Baker, M. H. Martin, A. J. Russell and T. G. Whitehead; *Auditors*: Mr. J. W. Bare and Mr. E. G. Piper.

The inaugural meeting, with Mr. O'Roark in the chair, was held on the 5th December, 1956, and was well attended. The program consisted of a very interesting talk by Mr. A. H. C. Knox on "Promotion," followed by open discussion

and then a short series of films of general interest. A tentative program for the remainder of the winter session was announced at the meeting and two of the items have already been completed; the first, in January, was a talk by Mr. D. W. Pyle (Assistant Engineer), on "Photography as a Hobby," illustrated by prints and colour slides, and in February a paper entitled "Some Aspects of Long Distance Signalling" was read by Mr. S. A. Watcham (T.O.). The paper was followed by a demonstration on the actual equipment in Colchester automatic exchange by Mr. J. G. Honneyman (T.O.). Both these meetings were highly successful and well supported by the members.

A talk, with the aid of film, entitled "A Simple Approach to Television," by Mr. T. T. Shanks, was scheduled for March and Mr. A. F. O'Roark has promised to contribute a paper in April, which will probably coincide with the Annual General Meeting.

Arrangements for visits are in hand, including one to Marconi's Wireless Telegraph Co., Ltd., at Chelmsford in mid-April. This will be a whole-day visit with lunch at the works and has evoked considerable interest and not a little difficulty in deciding who will be among the 20 members to go.

A very useful technical library has been formed and is in the capable hands of Mr. J. W. Bare, co-opted as librarian. We are indebted to members of the Senior Section, the Liaison Officer, Mr. L. A. Farrow, and our own members, for the many gifts of books and papers. Much of the success of this initial stage of our venture is due to the practical help and guidance of Mr. O'Roark and Mr. Farrow, both of whom have shown an enthusiasm that is very encouraging and makes the project very much worth while.

The membership to date is 104, which is very nearly half the total staff in the Area who are based on Colchester.

T. T. S.

### London Centre

Since its last report, the London Centre has completed two-thirds of the current session, and is making provisional plans for the next.

We were honoured by the presence of the President of the Associate Section, Mr. R. W. Palmer, at our opening meeting on the 12th September, 1956, when he kindly took the chair to welcome Capt. G. S. Tuck, D.S.O., R.N., of the Trans-Antarctic Expedition staff, who gave an illustrated talk entitled "The Trans-Antarctic Expedition." In this he covered the reconnaissance expedition of 1955-6, the objects of the expedition proper in the International Geophysical Year, and reports of the men stationed at Shackleton Base, who, because of adverse weather conditions, had lost their hut and had had to improvise the packing case of a Sno-cat vehicle as workshop and dining-room, and sleep in tents. The talk proved to be of such interest that Capt. Tuck has promised to follow-up when the main party returns in 1958-59.

The next talk was "Cinephotography in the Post Office," by Mr. W. A. J. Paul, F.R.P.S., who dealt with the development of the use of photography in the Post Office and illustrated his talk with a film that must surely include many historical excerpts. On the 7th October, Dr. P. R. Bray and Mr. G. T. Crank gave a talk entitled "Electrical Tests during the Manufacture of the Transatlantic Telephone Cable," which dealt with the manufacturing processes and the tests carried out at each stage and on the completed cable in its storage tanks until it was loaded on to H.M.T.S. *Monarch*.

Mr. J. M. M. Pinkerton gave a most interesting talk on the 5th December entitled "The Electronic Digital Computer," outlining the basic principles, and progressed to the up-to-date techniques incorporated in "LEO" Mk 2, of which Mr. Pinkerton is the chief designer. In January, history was made inasmuch that Mr. W. L. Newman, the Executive Engineer in charge of the Television Control Centre at Museum Exchange, used a closed-circuit television "hook-up" between Waterloo Bridge House and Museum Exchange on the 24th January when he gave a talk entitled "The Post Office Television Distribution Network." The purpose of the closed link was to show the audience much of the equipment that he had been talking about. Our thanks go out to Pye, Ltd., for their co-operation and assistance in this venture.

On the 19th February, Mr. D. H. Jones, a member of the Post Office Research Station staff, lectured to our members on

"An Introduction to Transistor Circuits." In this lecture Mr. Jones dealt with the physical and mechanical properties of germanium, and went on to the practical uses of transistors, mentioning their known limitations. The success of this lecture has prompted us to ask Mr. Jones to present it in a series of articles in our Quarterly Journal, to which he has agreed.

Our lecture on the 12th March, 1956, was arranged for those members who complain of being fed-up with the job as subject matter for lectures. It was "Some Medical Problems of Interplanetary Travel," given by Mr. C. R. Armstrong. On the 9th April, Mr. P. W. Goodwin will give a lecture entitled "An Introduction to Standard P.A.B.X.s," and on 30th April a lecture—"Electronic Circuitry—Are Diagrams Really Necessary"—will be given by Messrs. J. A. Lawrence, F. L. N. Samuels and G. S. Gregson. The Annual General Meeting will again be held in the Small Hall of The Institution of Electrical Engineers on Thursday, 30th May. The Annual General Meeting will be preceded by a lecture entitled "Colour Television," to be given by Mr. I. J. P. James, of E.M.I.

Research Laboratories.

This session will see the forwarding of at least three papers read by Associate Section Members for adjudication by the Senior Section, one of which has already been read. This one merits attention, inasmuch that the lecturer, Mr. K. O. Verity, of the Long Distance Area, was requested to give his paper, "Power from Nuclear Fission," a second reading to the members of Stone Centre. This is only the second occasion that a member of London Centre has read a paper in another Centre.

The session 1957-58 will see the occasion of the Silver Jubilee of the Associate Section (or the Junior Section as it was originally called). To mark this occasion the London Centre intend to hold an Exhibition. The title is "Communications, Past, Present and Future"—the venue, Hotel Metropole Ballroom, Northumberland Avenue, S.W.1; the date 2nd, 3rd, and 4th October, 1957.

Further information will be available by early summer.

P. S.

### BOARD OF EDITORS

D. A. BARRON, M.Sc., M.I.E.E., Chairman.  
 L. F. SCANTLEBURY, Whit.Sch., A.C.G.I., D.I.C., M.I.E.E.  
 H. G. BEER, Whit.Sch., A.C.G.I.  
 T. H. FLOWERS, M.B.E., B.Sc (Eng.), M.I.E.E.  
 W. J. E. TOBIN B.Sc.(Eng.), A.C.G.I., D.I.C., A.M.I.E.E.  
 R. H. DE WARDT, B.Sc (Eng.), A.C.G.I., A.M.I.E.E.  
 R. F. WALDEGRAVE.  
 W. A. HUMPHRIES, T.D., A.M.I.E.E., Managing Editor.  
 J. H. BROADHURST, A.M.I.E.E.  
 E. DAVIS, A.M.I.E.E. } Assistant Editors.  
 B. FARR, Secretary-Treasurer.

### Copyright

The entire contents of this JOURNAL are covered by general copyright, and special permission is necessary for reprinting long extracts, but Editors are welcome to use not more than one-third of any article, provided credit is given at the beginning or end thus: "From the *Post Office Electrical Engineers' Journal*."

The Board of Editors is not responsible for the statements made or the opinions expressed in any of the articles in this JOURNAL, unless such statement is made specifically by the Board.

### Communications

All communications should be addressed to the Managing Editor, *P.O.E.E. Journal*, Engineer-in-Chief's Office, Alder House, Aldersgate Street, London, E.C.1. Telephone: HEADquarters 1234. Remittances should be made payable to "The *P.O.E.E. Journal*" and should be crossed "& Co."

### Binding Cases

Cases for binding are available, and may be obtained from the Local Agents for 3s. Subscribers can have their copies of volumes bound, at a cost of 10s. 6d., by sending the complete set of parts to the Local Agents or to the *P.O.E.E.J. Journal*, Engineer-in-Chief's Office, Alder House, Aldersgate Street, London, E.C.1. Orders for binding for Vols. 1-19 should indicate whether the original binding case with black lettering, or the later pattern with gold, is required. Cases with gold lettering are the only type stocked from Vol. 20 onwards.

### Back Numbers

The price of the JOURNAL, which is published quarterly, is 2s. 6d. (2s. 9d. post free) per copy, or 11s. per annum, post free. Back numbers can be supplied, subject to availability of stocks, at 2s. 6d. (2s. 9d. each post free) except for Vol. 49, Part 4 (January 1957), the Transatlantic Telephone Cable issue, the price of which is 12s. 6d. (post free). Orders for back numbers may be sent to the *P.O.E.E. Journal*, Engineer-in-Chief's Office, Alder House, Aldersgate Street, London, E.C.1, or to the Publishers.

Employees of the British Post Office can obtain the *Journal* through Local Agents at the reduced price of 2s. per copy.

### Advertisements

All communications relating to space reservations should be addressed to the Advertisement Editor, *P.O.E.E. Journal*, Alder House, Aldersgate Street, London, E.C.1. Communications regarding advertisement copy, proofs, etc., should be addressed to the Publishers, Messrs. Birch & Whittington (Prop. Dorling & Co. [Epsom] Ltd.), Depot Road, Epsom, Surrey.

## INDEX TO ADVERTISERS

|  | PAGE             |
|--|------------------|
| Adcola Products, Ltd. . . . .                                  | xxxiii           |
| Airtec, Ltd. . . . .   | xxxvi            |
| Alton Battery Co., Ltd., The . . . . .                         | iii              |
| Austinlite, Ltd. . . . .                                       | xiv              |
| Automatic Coil Winder & Electrical Equipment Co., Ltd. . . . . | xxviii           |
| Automatic Telephone & Electric Co., Ltd. . . . .               | x                |
| British Electric Resistance Co., Ltd., The . . . . .           | xxx              |
| British Institute of Engineering Technology . . . . .          | ii               |
| British Insulated Callender's Cables, Ltd. . . . .             | iv               |
| Cathodeon Crystals, Ltd. . . . .                               | xxvii            |
| Dale Electric (Yorkshire), Ltd. . . . .                        | xx               |
| Edison Swan Electric Co., Ltd., The . . . . .                  | xxxiv            |
| E.M.I. Institute . . . . .                                     | ii               |
| Ericsson Telephones, Ltd. . . . .                              | v-vi             |
| Ferranti, Ltd. . . . .   | xviii            |
| General Electric Co., Ltd., The . . . . .                      | vii-viii, xv-xvi |
| Great Northern Telegraph Co., Ltd. . . . .                     | xxix             |
| Hallam, Sleigh & Cheston, Ltd. . . . .                         | ix               |
| Hivac, Ltd. . . . .  | xxxii            |
| Hot Dip Galvanizers Association . . . . .                      | xiii             |

|  | PAGE           |
|--|----------------|
| Lustraphone, Ltd. . . . .                                      | xviii          |
| Marconi's Wireless Telegraph Co., Ltd. . . . .                 | xxv-xxvi       |
| Marconi Instruments . . . . .                                  | xxiii          |
| Mullard, Ltd. . . . .  | xix            |
| National Salt Glazed Pipe Manufacturers' Association . . . . . | xxxii          |
| Painton of Northampton . . . . .                               | xvii           |
| Pirelli-General Cable Works, Ltd. . . . .                      | xxxvi          |
| Pitman, Sir Isaac, & Sons, Ltd. . . . .                        | xxxiii         |
| Rawplug Co., Ltd. . . . .                                      | xxiv           |
| Redifon, Ltd. . . . .  | ii             |
| Siemens Brothers & Co., Ltd. . . . .                           | xxi-xxii       |
| Smith, Frederick, & Co. . . . .                                | xxxiii         |
| Standard Telephones & Cables, Ltd. . . . .                     | xi-xii, xxxvii |
| Sullivan, H. W., Ltd. . . . .                                  | xxx            |
| Telephone Manufacturing Co., Ltd. . . . .                      | xxxv           |
| Tungstone Products, Ltd. . . . .                               | xxxiv          |
| Turner, Ernest, Electrical Instruments, Ltd. . . . .           | xxviii         |
| Westinghouse Brake & Signal Co., Ltd. . . . .                  | xxx            |
| Winn & Coales, Ltd. . . . .                                    | xx             |





*Farmers sometimes grumble,* it's said, about quite a number of things.

But you never heard a farmer say 'Trouble with the land, is work-shy men'. You never will—while his men are countrymen. Nobody stands at the countryman's elbow to see that he sticks to the job. Nobody needs remind him that this job or that will call for patience and skill. Nobody had to persuade him to welcome the Machine. All he has said of each new box-of-tricks is 'show me how to work it'. Alton, where Alton batteries are made, is a country town where men are countrymen. Men who haven't yet learnt to believe that what's near enough right is well enough done. Men who are happy to marry the old hand skills to the use of modern machines. Men whose personal standards of workmanship have helped to build a world-wide reputation for Alton Batteries.

## **ALTON** *Batteries of Merit*

*Alton stationary batteries: 10 to 15,000 ah. Also in regular production, renewal plates for all makes of battery, British and Continental.*

THE ALTON BATTERY COMPANY LIMITED, ALTON, HANTS · Telephone: ALTON 2267 and 2268 · Telegrams: BATTERY, ALTON

A.30



**BICC**

**R·F CABLES**

If you are designing electronic equipment for radio and television, navigational aids for shipping and aircraft, or controlling impulses for automatic devices, remember there are BICC R.F. cables for every application—guaranteed for efficiency,

economy and long life.

For out-of-the-ordinary jobs, BICC can usually develop specialized cables to meet your requirements.

Full details of all our standard R.F. cables are contained in Publication TD T 23. We will be pleased to send you a copy on request.

**BRITISH INSULATED CALLENDER'S CABLES LIMITED**

**21 Bloomsbury Street, London, W.C.1**





*a new design*



IN

TELECOMMUNICATIONS



At every stage, in the design and production of these compact and elegant Cordless Switchboards, careful consideration has been given to the requirements of simple and positive operation.

The smooth lines and pleasing contours typify their efficiency, and make them a worthy addition to the wide range of modern Telephone Equipment manufactured by this Company.

Attractive colours and handsome styling will blend so well with the decor of modern offices and reception rooms, yet harmonize pleasantly with less contemporary surroundings.

The combination of dependability and low maintenance requirements, inherent in all Ericsson products, is clearly evident in these new switchboards, ensuring a service you will find hard to ignore.



**MODERN BUSINESS  
DEMANDS MODERN  
COMMUNICATIONS**

The use of new components and materials has very considerably reduced the size of these modern Cordless Switchboards, making them particularly suitable for easy operation on table or desk. Their beauty will complement the most handsome office.

The styling and construction follows contemporary practice, having a 'drop on' cover with moulded ends and aluminium centres finished in an attractive mottle enamel. Components are mounted on a two-way hinged metal chassis and cast baseplate, providing trouble free operation and easy maintenance.

All inter-connections are made by keys with indicators providing positive supervision. Exchange line indicators are manually restored by depressing the transparent covers. In addition to the latest moulded hand-micro an auto dial is provided, mounted at the front of the key panel for automatic working. A hand generator at the right-hand side is used for calling extension telephones and a buzzer gives audible alarm when any indicator is actuated.

Two models are available at present :  
2 Exch. Lines                      3 Exch. Lines  
4 Extn. Lines                      or                      9 Extn. Lines  
3 Connecting cets.                      5 Connecting cets.

The size of both switchboards is :—  
13" × 13" × 8½"

With an alternative colour scheme :—  
Grey-green, Brunswick green and Black.  
Grey-green, Brunswick green and Biscuit.

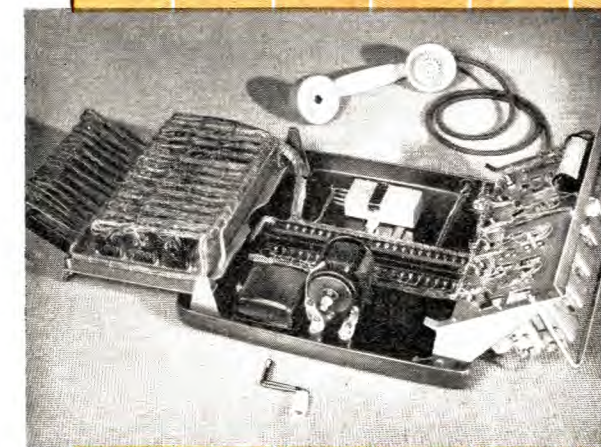
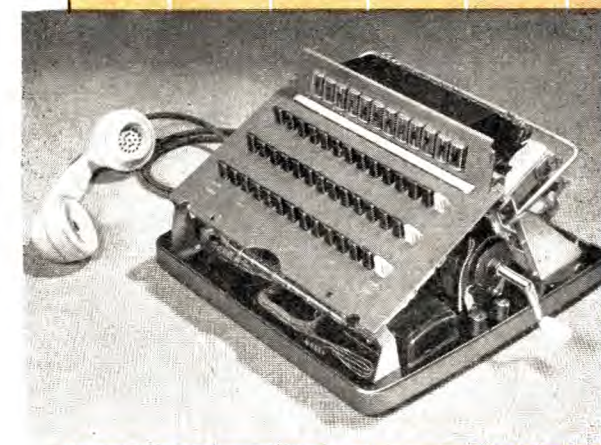

**FULL PARTICULARS ARE AVAILABLE ON REQUEST**

**ERICSSON TELEPHONES LIMITED**

HEAD OFFICE: 22 LINCOLNS INN FIELDS, LONDON, W.C.2. TEL: HOLBORN 6936  
WORKS: BEESTON, NOTTINGHAM & SUNDERLAND



# The G.E.C. 1000

In the "G.E.C. 1000" Telephone new components in a new circuit give a standard of performance that is unsurpassed by other telephones available to-day.

## PERFORMANCE

The rocking-armature receiver has an excellent frequency response and an output 10dB higher than its predecessors. Part of this improvement is transferred by the induction coil to the sending side, giving a resultant improvement in performance of 6dB on sending and 4dB on receiving.

This improved performance means that the new G.E.C. telephones will operate over a local-line loop of 1,120 ohms of 6½lb cable (.5mm conductor) with a performance equal to that of previous telephones operating over a local-line loop of 660 ohms, i.e. a local line may be extended by 70%. Alternatively, the new telephones will operate over a length of 4-lb cable (.4mm) with a performance equal to that of a previous telephone operating over the same length of 10-lb cable.

Despite the increased level of performance, the maximum amount of sidetone suppression has been retained



## COLOUR

In addition to the normal black instrument, a range of two-tone telephones can be supplied in which the case is coloured and all other parts, including the dial, are black. The range of colours is red, green and ivory. The two-tone telephones have the following advantages over the all-colour telephones:

More delicate shades can be used since shade matching is eliminated.

The number of spare parts required to be held by an Administration using more than one colour of instrument is greatly reduced.

*The colour*

# TELEPHONE

The appearance has been redesigned to blend with modern styles of decoration, whilst retaining the dignity essential to office furnishings.



*of a telephone can be changed simply by changing the case*

## APPEARANCE

The pleasing appearance is achieved by blending a number of curved lines and surfaces to form outlines for the case and handset that are in complete harmony with one another. The camber of the sloping front houses the dial in the automatic telephone and the dial dummy in the C.B. set. The incline of the telephone front is such that the telephone is easy to use, and the dial numbers easy to see, whether the user is in a standing or sitting position.

A curved insert is fitted in each side of the case in front of the cradle to provide finger-tip grips for lifting and carrying the instrument. When resting in the cradle, the

curved handset gives the telephone a domed silhouette in accord with the remainder of the instrument. The increased curvature of the handset over previous types gives greater comfort to the user, and tilts the transmitter to a more sensitive position.

## TROPICALISATION

The three G.E.C. features—special insulation, ventilation, and protection against moisture and insects—are incorporated in all telephones supplied to tropical areas.





# Widney Dorlec for Universal Application



We are using Widney Dorlec to construct our main display stand at the R.E.C.M.F. Exhibition and extend a welcome to you to see a practical application of this system on Stand 136 (Gallery), Grosvenor House, Park Lane, London, W.1. The Exhibition is open from 8th-11th April inclusive for Manufacturers only. Requests for tickets should be made direct to the Secretary, Radio & Electronic Component Manufacturers Federation, 21 Tothill Street, London, S.W.1.

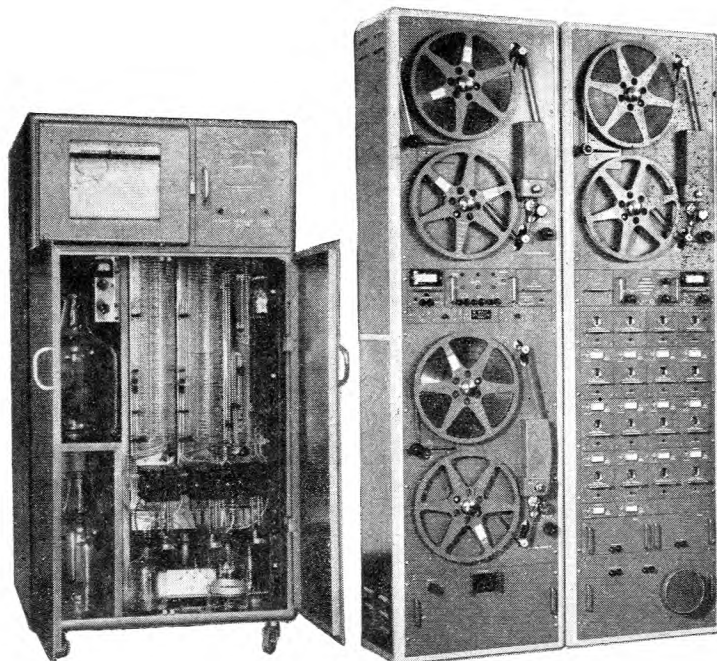

## Widney Dorlec

## Cabinets

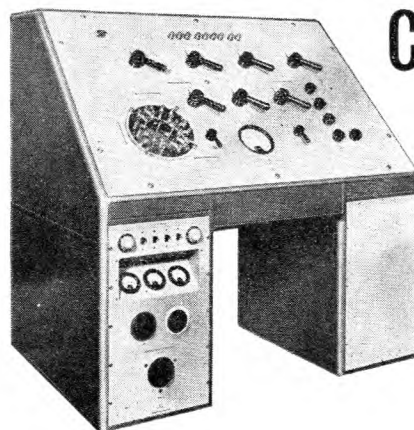

With acknowledgments to Harold Kruger Instruments, California. (American Agents—British Industries Corporation, 80 Shore Road, Port Washington, New York.) Wolfgang Assmann, Bad Homburg. (German Agents—

R. H. Suss & Co. K. G. Groningerstr, 25 (ASIA-HAUS), Hamburg, 11.) H. Tinsley & Co. Ltd., London.

Widney Dorlec appeals to those who are discriminating in their choice of a cabinet for housing their products. It is suitable for a wide range of applications and is available throughout the world. The above three illustrations show typical examples from England, America and Germany of such diverse applications as Airport Tape Recorders, Electrical Measuring Apparatus and Chemical Equipment.

**HALLAM, SLEIGH & CHESTON LTD.** WIDNEY WORKS, BIRMINGHAM 4. 'Phone: ASTon Cross 0914  
SALES OFFICE:  
OLDFIELD ROAD, MAIDENHEAD, BERKS. 'Phone 4311

**STROWGER**

*and the pattern of world  
telecommunications*

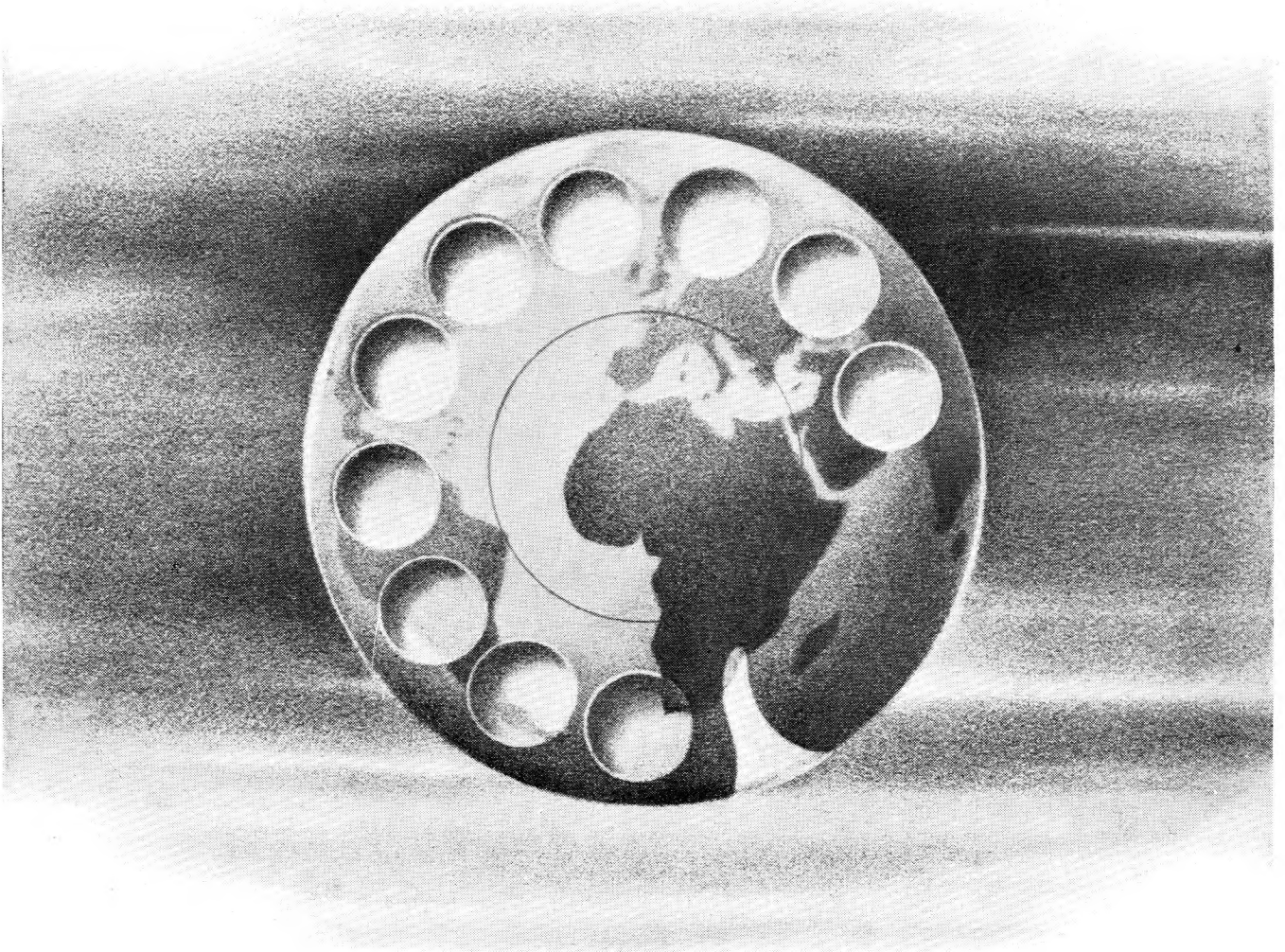

It is not difficult to prophesy the trends of development in telecommunications during the next 25 years. Side by side with local telephone service to even the most isolated subscribers will be long distance calls set up entirely by automatic means from city to city, from country to country. Administrations should consider whether their present equipment is capable of adaptation to future needs, otherwise replacement will be inevitable. Strowger equipment has proved its flexibility and its adaptability to changing circumstances. These qualities have demonstrated their worth in the 50 years' active history of the system to date—and they are the qualities which will be maintained in the future.



*Strowger—designed and built for continuous service*



# Progress in communication cables

ON THE LONDON-BIRMINGHAM ROUTE

Often in the past half-century the cable route between London and Birmingham has been in the limelight of technical interest as successive cable installations have illustrated stages in the development of the art of long-distance communication cable.

Latest in a series of cables installed by S.T.C. between London and Birmingham is a new coaxial type capable of providing over 8,000 speech channels on the coaxial tubes, plus intermediate voice frequency circuits on the layers of quads—a great increase in space utilisation over the earlier cables.

When equipped with modern S.T.C. repeaters at a spacing of approximately three miles, and operating over a band width of 12 Mc/s, the coaxial tubes can provide facilities for over 8,000 speech channels or for one or more high-definition colour television channels plus a reduced number of speech channels.

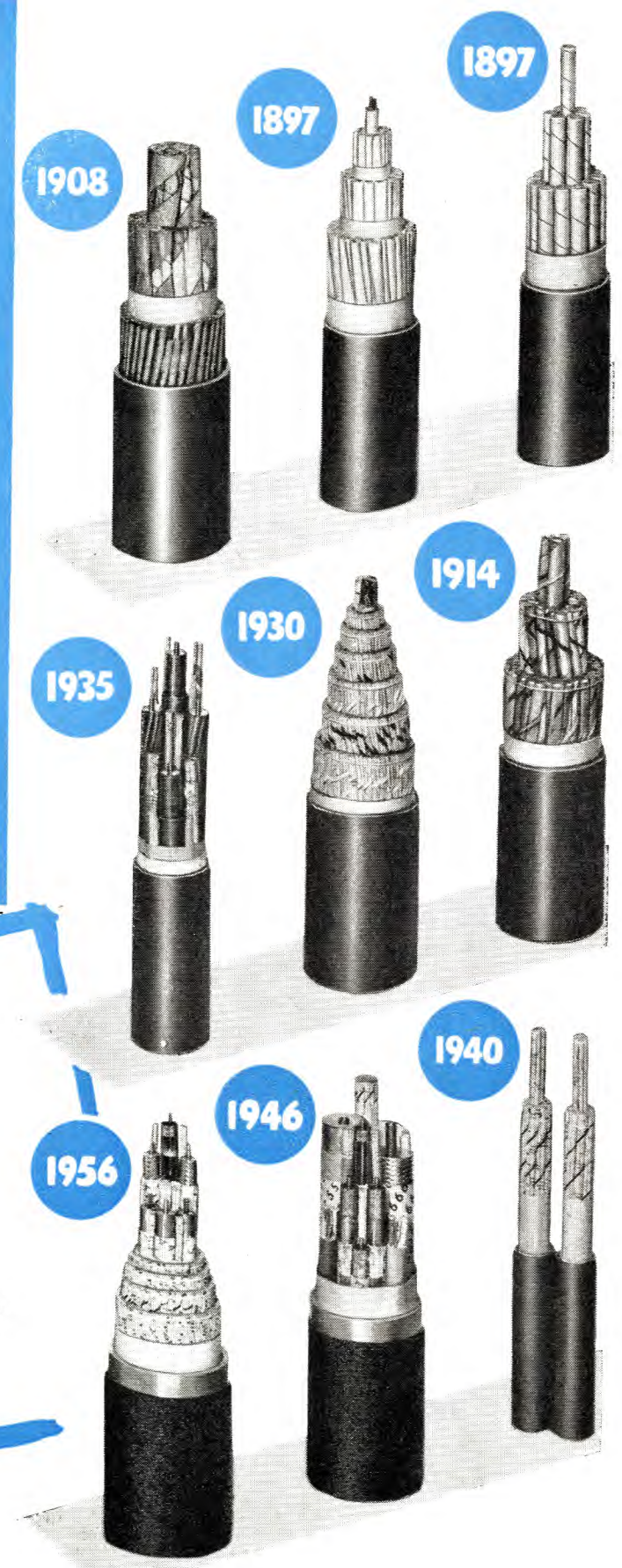

## ROUTE IN RETROSPECT

- 1897 — 38 Speech Circuits
- 1897 — 38 Speech Circuits
- 1908 — 45 Speech Circuits and 34 Telegraph Circuits
- 1914 — 78 Speech Circuits
- 1930 — 4 Radio and 176 Speech Circuits
- 1935 — 4 Radio and 1,200 Speech Circuits
- 1940 — 576 Speech Circuits
- 1946 — 2 Television and 1,920 Speech and 8 Radio Circuits
- 1956 — 4 Radio and 8,272 Speech Circuits



A length of the new S.T.C. coaxial cable during installation at Stratford-on-Avon.



Standard Telephones and Cables Limited

CONNAUGHT HOUSE · ALDWYCH · LONDON WC2 · ENGLAND



# HOT GALVANIZING PREVENTS RUST

ASK ANY SAILOR ABOUT RUST—he knows the dangers of rust on ships. What he may not know is that the surest means of preventing rust is hot galvanizing. Hull plates to handrails, anchors to davits—all need galvanizing. In fact, wherever steel is used . . . in factories and mines, on railways and farms . . . there is no substitute for hot galvanizing. The tenacity and durability of *hot* galvanizing ensure lasting protection with minimum maintenance.

## *Protection in Depth*

Hot galvanizing gives defence in depth. The firmly alloyed zinc keeps out rust—tightly sealing crevices and seams. And if the coating *does* get damaged the steel still won't be attacked because the zinc protects it sacrificially. Hot galvanizing *saves* steel—by eliminating the need for large corrosion allowances and the replacement of rusted parts. Hot galvanizing resists normal atmospheric conditions *twenty times better than steel*.

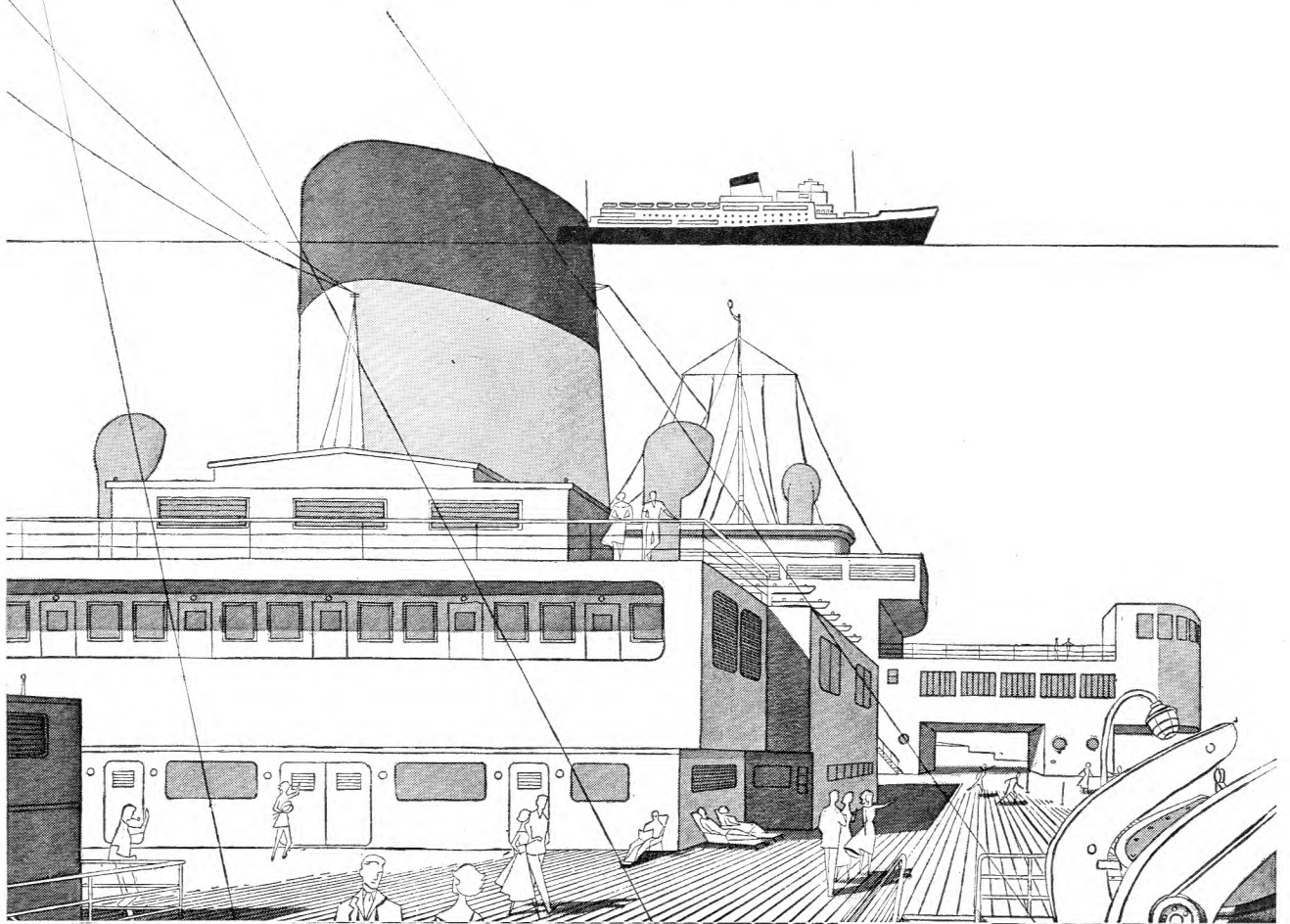

## Hot Dip Galvanizers Association

The Hot Dip Galvanizers Association,  
a non-trading body, welcomes enquiries.  
Write to 34 Berkeley Square,  
London, W.1.  
Tel: Grosvenor 6636.



Member of the Zinc Development Association

**Quality, Sir, is a matter of detail.**

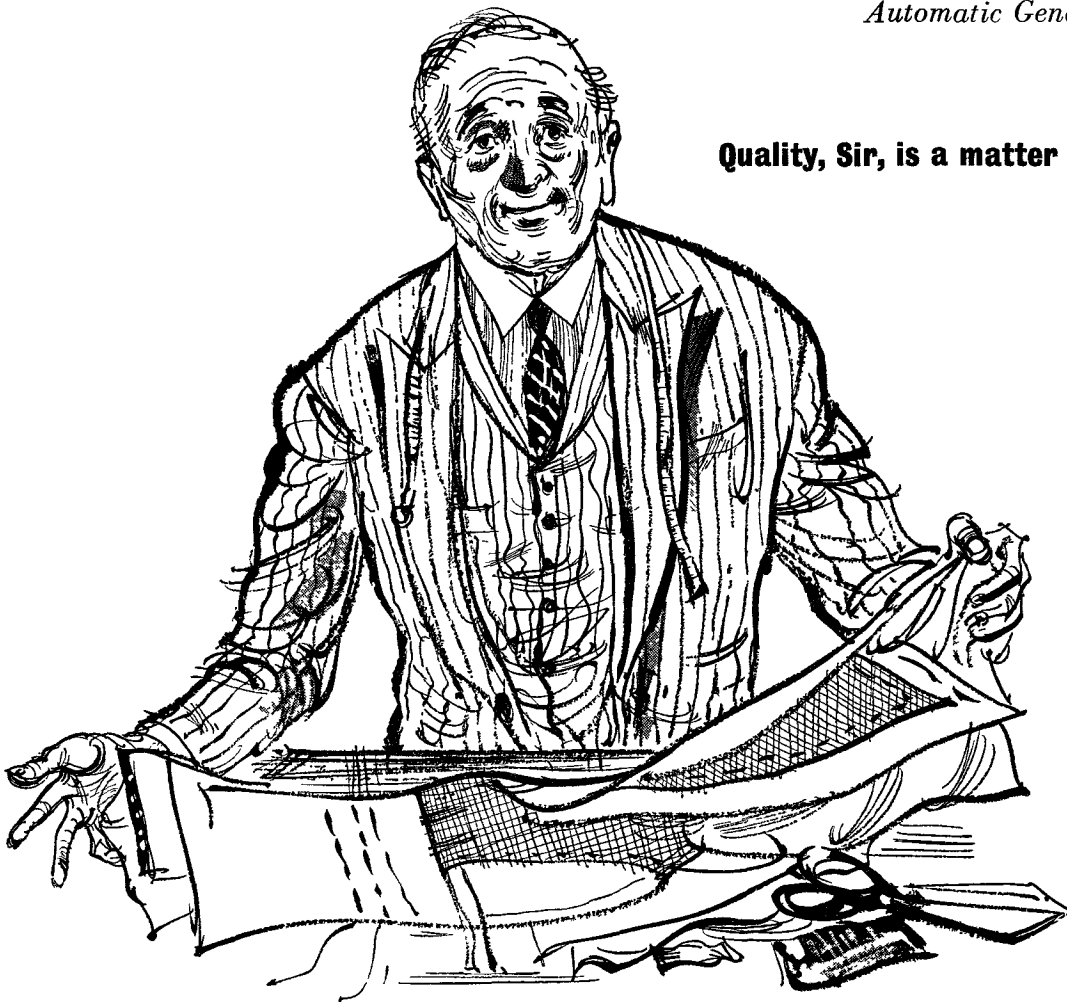

Take a diesel engine and an alternator, bolt them down to a bedplate, couple them together and supply some switchgear. There you have a generating plant. Good enough for some jobs, perhaps, but not for the kind of job Austinlite plant is designed to do.

To see the difference you have to look closely. At the solid steel bearing housings with their special high speed bearings; at the patented bearing wear detection system; at the subsidiary emergency bearings which only come into play in the very unlikely event of main bearing failure; at the electrical equipment specially 'tropicalised' by methods developed as a result of much experience in the supply of plant designed to operate dependably in hot, humid climates.

It is detail of this kind which accounts for the high reputation of Austinlite wherever reliability is an essential. That, and one thing more; Austinlite engineers always enjoy tackling the jobs other people cannot fit. Because, although we make many standard types of generating plant, made-to-measure plant is our forte.

*Austinlite* **AUTOMATIC GENERATING PLANT**  
**Tailor-made by STONE-CHANCE LTD.**



# Bridging the gap with

## MULTI-CIRCUIT

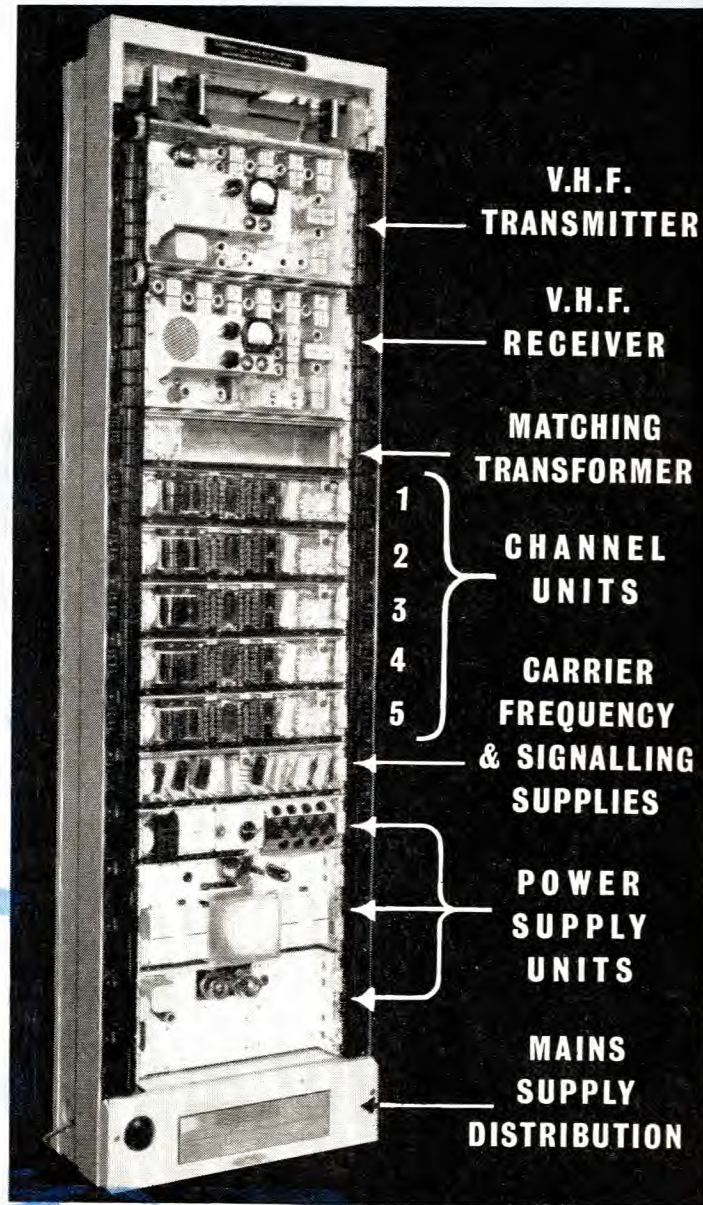

# VHF RADIO

## JUNCTION RADIO EQUIPMENT

An event that illustrates the versatility of G.E.C. 5-circuit junction-radio equipment occurred during the early months of 1956. A severe sleet storm in Northern New Brunswick caused havoc to open-wire telephone lines. The emergency measures undertaken by the New Brunswick Telephone Company to restore communication as soon as possible included the temporary installation of two

G.E.C. 5-circuit VHF radio links to bridge gaps of about twelve and ten miles. Although there was not time to carry out the usual propagation tests, and the equipment had to be installed in such places as a school, a house, a hospital and a store, highly successful operation was maintained during the emergency.

## G.E.C. 5-CIRCUIT JUNCTION RADIO EQUIPMENT

*for permanent or temporary operation*

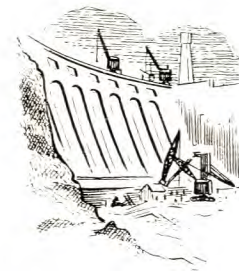

The equipment provides up to five circuits by frequency-division-multiplex operation over the frequency-modulated VHF radio link, and has the advantage of a narrow occupancy in the congested VHF band. All equipment panels are of the slide-in type, easily accessible for maintenance, and can be packed separately and assembled on site, so making transport to difficult sites easy.

Whether the job is a new oil refinery, a massive dam, an airfield or some other project, the engineer must know what's happening on site *when it happens*. Efficient movement of materials and personnel, and logistical operations become impossible without reliable communications. Especially when the terrain is difficult, G.E.C. 5-circuit junction-radio equipment provides the answer. The normal range is about 50 miles, but this can be extended by radio relays. **Small—Inexpensive—Available for quick delivery.**

*For further information write for Standard Specification SPO5050*

### Other G.E.C. Transmission Equipment includes:

Single-circuit, 3- and 12-circuit equipment for operation over open-wire lines; 12- to 60-circuit equipment for operation over non-loaded carrier cables. Coaxial-line equipment for television and telephony. Power-line carrier equipment. Coaxial cable terminal equipment for television (405-, 525-, and 625-line systems) and telephony (960 circuits). Wide band UHF trunk radio systems for television and telephony up to 720 circuits.



*“Everything for Telecommunications by open-wire line, cable and radio, single and multi-circuit and T.V. link, short, medium and long haul. Automatic and manual exchanges.”*

THE GENERAL ELECTRIC COMPANY

LIMITED OF ENGLAND, TELEPHONE, RADIO AND TELEVISION WORKS, COVENTRY





*By Appointment to the Professional Engineer*

## HIGH STABILITY CARBON RESISTORS

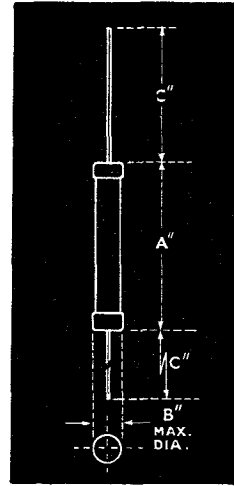
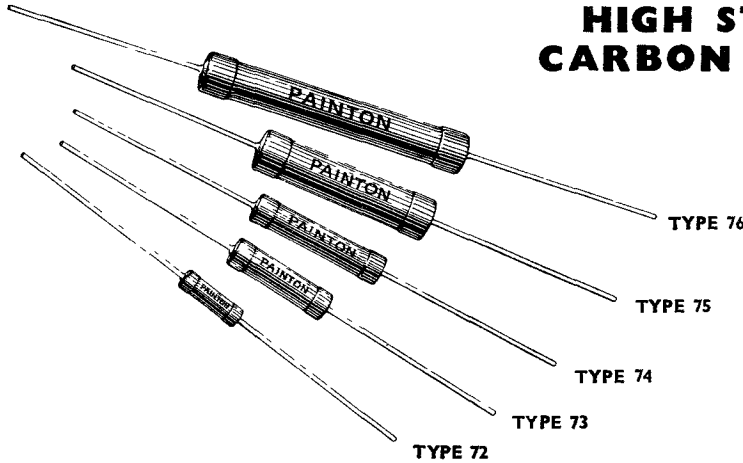

### ELECTRICAL CHARACTERISTICS

The electrical characteristic of a High Stability Carbon Resistor depends upon the physical size of the units and upon the ohmic value. All the data given below relates to the Type 73 Resistor. To obtain the equivalent ohmic values to which the information is applicable in the other four sizes of Resistor the following factors should be applied

Type 72 x  $\frac{1}{2}$       Type 74 x 2      Type 75 x 4      Type 76 x 8

### FULL LOAD STABILITY

Up to 100 K.ohms the resistance change at full load with an ambient temperature of 70°C. is less than 0.75% (average 0.25%) after 1,000 hours operation. At 1 Megohm the change is less than 1% (average 0.75%).

**N.B.** On D.C. loading the maximum voltages stated in RCL 112 should be observed.

### AGEING AND SHELF DRIFT.

Up to 100 K.ohms the average change is 0.25% in 12 months (never greater than 0.75%). For 1 Megohm resistors the average change is 0.6% in 12 months (never greater than 1.25%).

### CLIMATIC

Exposure to the two cycles of H.I. humidity as laid down in RCS 112 shows a change of less than 0.7% (average 0.4%) up to 100 K.ohms. At 1 Megohm the change is less than 1% (average 0.7%).

### TROPICAL EXPOSURE

Eighty-four days exposure to the standard 25°C./35°C. 100% humidity cycling shows a change of less than 1% (average 0.5%) up to 100 K.ohms. At 1 Megohm the change is less than 2% (average 1.6%).

### TEMPERATURE COEFFICIENT

The temperature coefficient is less than 0.04%/°C. up to 100 K.ohms. At 1 Megohm the coefficient is approximately 0.055%/°C.

### NOISE

Noise which is generated in a resistor, as the result of a direct voltage applied across it, varies according to the ohmic value of the resistor, the noise decreasing as the ohmic value increases. The noise is also influenced by factors such as the size of the resistor.

For noise which falls within frequency range of 0 to 10 Kc./sec., the Painton high stability resistors have noise levels which are between 0.05 and 0.4 microvolts of noise per applied direct volt, when the resistor is dissipating power at its maximum wattage rating.

### VOLTAGE COEFFICIENT

Not exceeding 0.002% per volt D.C.

### DERATING FOR AMBIENT TEMPERATURES EXCEEDING 70°C.

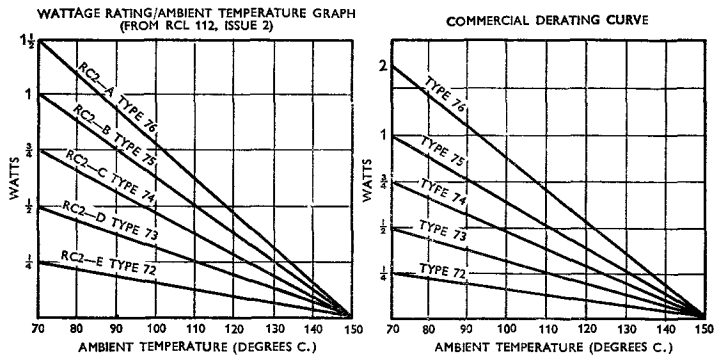

| TYPE                                | RESISTANCE RANGE (ohms) | VALUES OUTSIDE THIS RANGE MAY BE QUOTED FOR SEPARATELY. |                 |                 |                 |                 |
|-------------------------------------|-------------------------|---|-----------------|-----------------|-----------------|-----------------|
|                                     |                         | 72  | 73              | 74              | 75              | 76              |
| 72                                  | ±1% 4—700K              | ±2% 4—10M   | ±5% 4—2.5M      |                 |                 |                 |
| 73                                  | ±1% 4—1.0M              | ±2% 4—2.0M  | ±5% 4—5.0M      |                 |                 |                 |
| 74                                  | ±1% 20—2.0M             | ±2% 20—4.0M   | ±5% 20—10.0M    |                 |                 |                 |
| 75                                  | ±1% 20—3.0M             | ±2% 20—5.0M   | ±5% 20—10.0M    |                 |                 |                 |
| 76                                  | ±1% 20—5.5M             | ±2% 20—9.0M   | ±5% 20—50.0M    |                 |                 |                 |
| TYPE                                |                         | 72  | 73              | 74              | 75              | 76              |
| Normal Commercial Rating 70°C—watts |                         | $\frac{1}{2}$   | $\frac{1}{2}$   | $\frac{1}{2}$   | 1               | 2               |
| R.C.S.C. style                      |                         | RC2-E   | RC2-D           | RC2-C           | RC2-B           | RC2-A           |
| R.C.S.C. Rating at 70°C—watts       |                         | $\frac{1}{2}$   | $\frac{1}{2}$   | $\frac{1}{2}$   | 1               | 1 $\frac{1}{2}$ |
| R.C.S.C. Rating at 100°C—watts      |                         | $\frac{1}{2}$   | $\frac{1}{2}$   | $\frac{1}{2}$   | $\frac{1}{2}$   | $\frac{1}{2}$   |
| DIMENSIONS IN INCHES                |                         | A   | $\frac{1}{2}$   | $\frac{11}{16}$ | $\frac{1}{8}$   | $\frac{11}{16}$ |
|                                     |                         | B   | $\frac{3}{16}$  | $\frac{3}{16}$  | $\frac{3}{16}$  | $\frac{3}{16}$  |
|                                     |                         | C   | 1 $\frac{1}{2}$ | 1 $\frac{1}{2}$ | 1 $\frac{1}{2}$ | 1 $\frac{1}{2}$ |

**PAINTON**  
*Northampton England*

# FERRANTI

## Switchboard Instruments

Illustrated here are several Ferranti Switchboard Instruments from a wide range. Shallow pressed steel cases 3 1/4", 3 1/2", 4", 6" and 8" round or square dial. Projecting or flush mounting. All types of Ferranti switchboard instruments are also available in hermetically sealed cases.

List IN30 and other catalogues supplied on request.

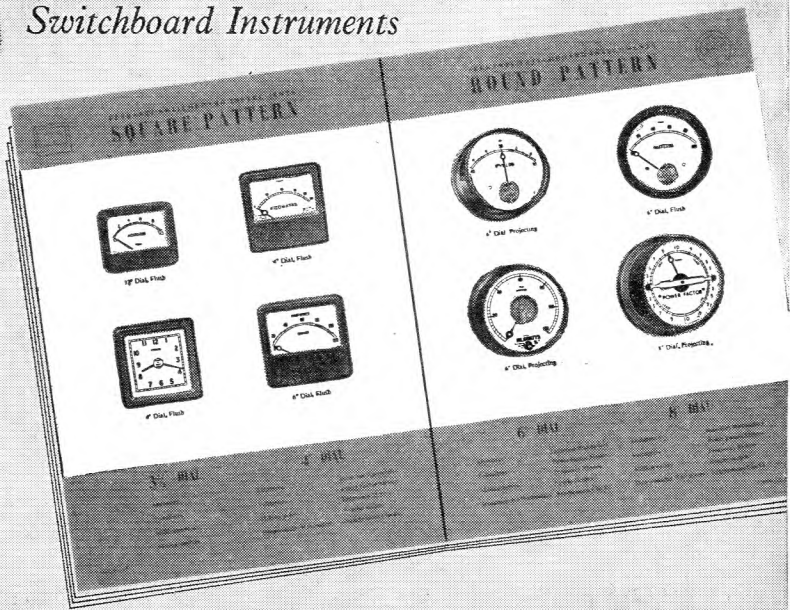

FERRANTI LTD · MOSTON · MANCHESTER 10

Head Office and Works: HOLLINWOOD, LANCS.

London Office: KERN HOUSE, 36 KINGSWAY, W.C.2

F1149

# there's a Lustraphone microphone for every purpose

## A COMPLETE SERVICE TO THE TELECOMMUNICATIONS INDUSTRY

### Microphones for Broadcasting, Public Address and Recording

#### MODEL

- VR/53** Ribbon Velocity. High fidelity, studio class, all impedances.
- LFV/59** Full Vision; dynamic; high fidelity. With flexible positional tube. All impedances.
- LFV/H59** Dynamic, pencil; hand-held model, all impedances.
- C.48** Dynamic; high fidelity. Low impedance. Stand model with or without switch.
- C.51** General-Purpose, stand model. Dynamic, all impedances. Carbon, single or double button. With or without switch.
- CH.51** Dynamic, all impedances. High-quality model for hand or stand use.
- LX.55** Crystal, high quality.
- LD/61** Dynamic microphone for tape recorders.

### Microphones for use in Telecommunications

#### MODEL

- H.51** Carbon, single or double button for fixed or mobile stations. Hand model; rotary switch in case.
- LC.51** Carbon, single or double button for fixed stations. Stand model.
- HD.54** Dynamic, low impedance for mobile stations. Hand model. Lightweight case, with switch.
- HC.54** Carbon, single or double button for mobile stations. Hand model, light-weight case, with switch.
- CI.51/HMT & DI.56/HMT** Dynamic hand microtelephone for fixed and mobile stations, with or without pressel switch.
- VC.52** Dynamic noise-cancelling microphone for all locations of high ambient noise. Special fittings, handles, booms, telephone headsets.

Microphone inserts for intercommunication equipment.

Floor stands: plunger, fixed and folding portable stands, table stands and bases.

Matching transformers, switches, plugs and sockets.

Cables, Mixer and Gain Control Units.

**PLUS A UNIQUE RANGE OF TRANSISTOR PRE-AMPLIFIERS, POWER TRANSISTOR AMPLIFIERS AND PORTABLE TRANSISTORIZED PUBLIC ADDRESS SYSTEMS.**

Full details and illustrated literature available on request.

ALL LUSTRAPHONE PRODUCTS ARE BRITISH IN DESIGN AND MANUFACTURE, ARE FULLY GUARANTEED AND BACKED BY THE LUSTRAPHONE TECHNICAL ADVISORY AND AFTER-SALES SERVICE. LUSTRAPHONE LTD. ARE FULLY EQUIPPED TO UNDERTAKE DEVELOPMENT WORK TO MANUFACTURERS' SPECIFICATIONS.

**LUSTRAPHONE LIMITED** St. George's Works, Regent's Park Road, London, N.W.1. Tel: PRImrose 8844



LGB

**NEW  
GRADE  
OF  
FERROXCUBE  
RESULTS  
IN**

**HIGHER EFFICIENCY POT CORES FOR AUDIO FREQUENCIES**

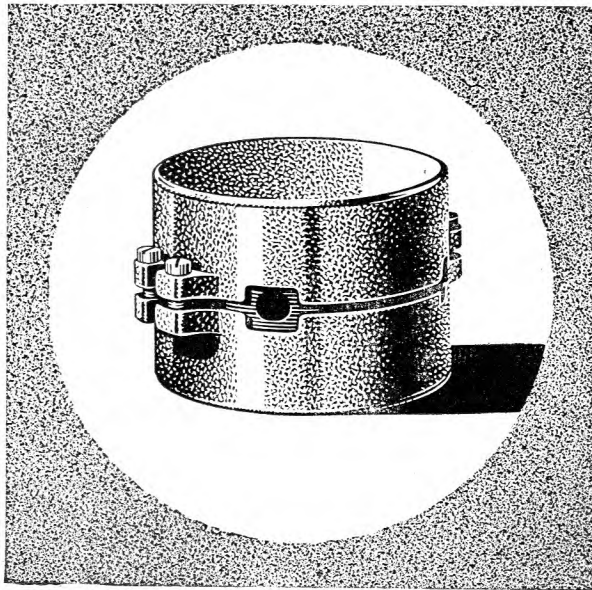

Following the development of audio frequency grades of Ferroxcube, Mullard now introduce a series of 30mm pot cores with exceptionally low losses and high effective permeabilities.

Initial permeability  $\mu_0$  of 1,400 with a loss of  $\tan \delta$  of  $2.5 \times 10^{-6}$ .

The added advantages of simple construction and light weight make them specially suitable for use in cable splicing and audio frequency output transformers.

Designers requiring full technical details on this new series of high efficiency pot cores are invited to write to the address below.

**Mullard**



'Ticonal' permanent magnets  
Magnadur ceramic magnets  
Ferroxcube magnetic cores

MULLARD LTD., COMPONENT DIVISION, MULLARD HOUSE, TORRINGTON PLACE, W.C. 1

MC256a



The Roll-a-Drum is a simple, inexpensive device which, operating from *ground level*, does away with the clumsy, potentially dangerous old method of hoisting cable drums on jacks. It operates swiftly on smooth-running rollers easing distribution in a truly revolutionary way. Compared with the price of jacks of the same lifting capacity, the Roll-a-Drum is a very economical proposition indeed at £11.10 or £23 according to size. Please write for details of discounts and leaflet containing all information you need.



AWKWARD...LABORIOUS...DANGEROUS...

TRY THE NEW WAY

# ROLL-A-DRUM

SUPPORTS CABLE DRUMS WITHOUT JACKS

FOR A SMALL OUTLAY THE ROLL-A-DRUM SAVES ENDLESS TIME, TROUBLE AND WORRY

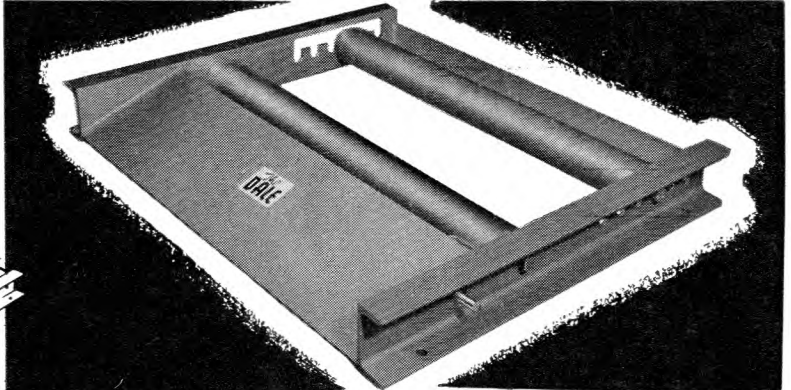

**DALE ELECTRIC (YORKSHIRE) LIMITED**

ELECTRICITY BUILDINGS

FILEY

YORKS

Tel: 2301 (3 lines)

*Setting the Seal on it with*

# DENSO PLAST

You can be safe and sure with DENSO PLAST the invaluable medium for sealing junction boxes, cable ducts and for plugging spare ways. One of the range of Denso Anti-Corrosion Products, the Plast will never harden or crack, and when used for plugging spare ways it can be re-used to seal inserted cables. Denso Plast is suitable for many similar sealing or caulking purposes.

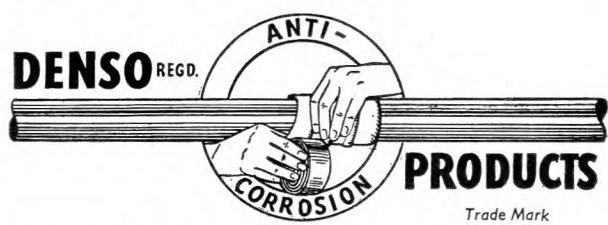

Whatever your corrosion problem consult:—  
**WINN & COALES LTD.**

**DENSO HOUSE, CHAPEL ROAD, LONDON, S.E.27**  
Telephone: GIPsy Hill, 4247 (4 lines)    Telegrams: Denselte, Westnor, London

# number seventeen system

**SIEMENS BROTHERS** No. 17 Automatic Exchange System is rapidly establishing a reputation for a reliability which is quite outstanding, particularly when compared with the performance of present day bimotional systems. The attention paid by our engineers to apparatus design, circuit technique, operating facilities, finish, etc., has been entirely justified by the trouble-free service which characterises all No. 17 System installations.

**Statistics** from working exchanges provide evidence of the very low fault rate achieved. Even in the largest public exchanges it is not unusual for periods of two or three days to pass without the occurrence of a single fault attributable to a defect in the system.

**Telephone Administrations** who are concerned at the high proportion of total operating costs expended on fault clearance, preventative maintenance and routine cleaning of their present exchange equipment are invited to discuss with us the way in which our No. 17 System offers a very significant reduction in such maintenance effort.

*A reputation for reliability*



**SIEMENS BROTHERS & CO. LIMITED**

PUBLIC TELEPHONE DIVISION · WOOLWICH · LONDON S.E.18

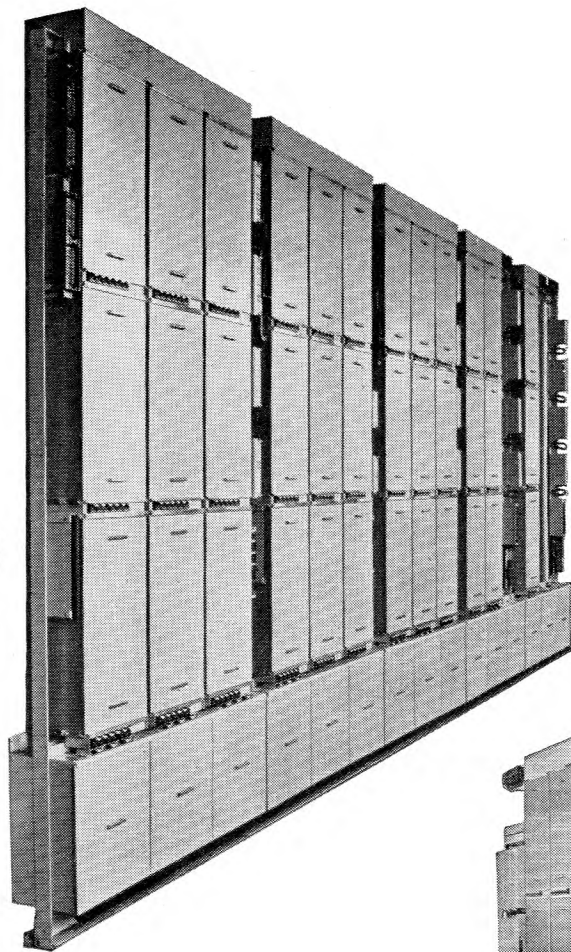
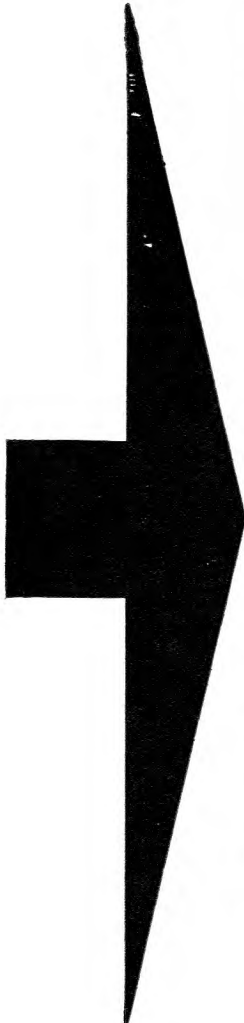

The equipment racks include every refinement for ease of maintenance—automatic call trace facilities, ribbon bank multiples, etc.—and are totally enclosed to minimize the effects of dust. The racks illustrated are 10 ft. 6 ins. in height.

An alternative unit construction is available which often proves more convenient for locations with restricted height or means of entry. The units illustrated are 8 ft. 9 ins. in height and this equipment has found much favour for private installations.

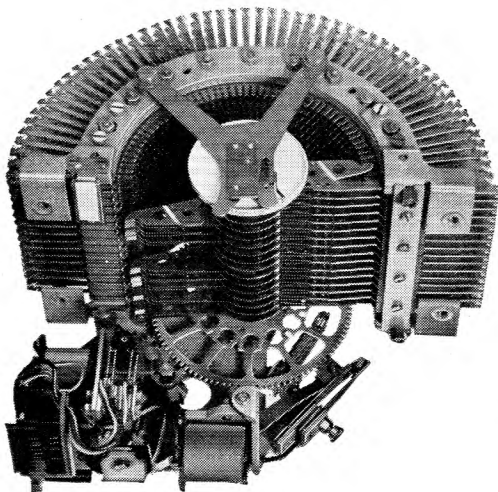
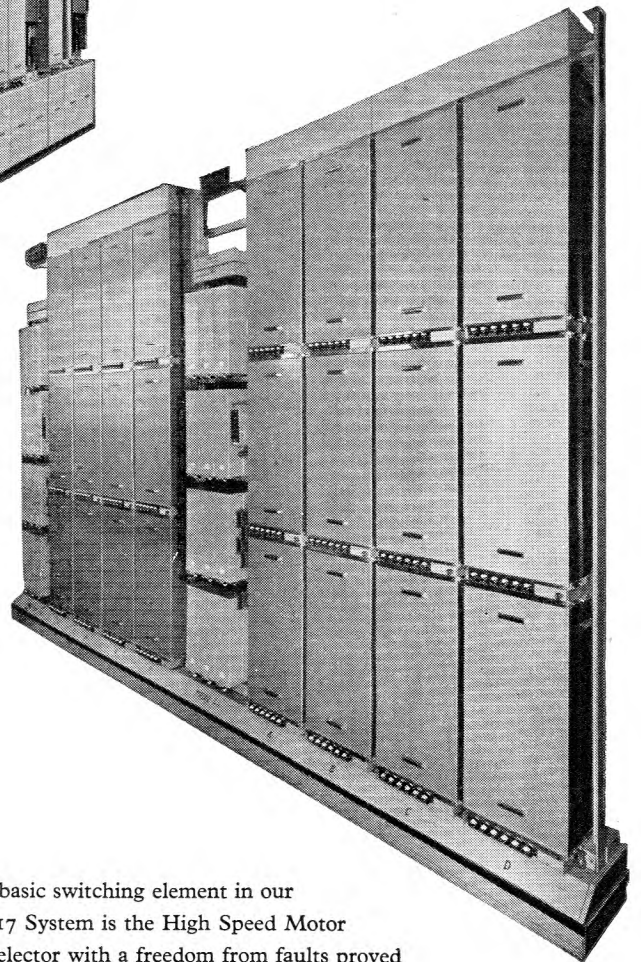

The basic switching element in our No. 17 System is the High Speed Motor Uniselector with a freedom from faults proved to be at least ten times greater than that of a bimotional mechanism. Such features as twin contact wipers, a vibrationless drive, and the elimination of wiper cords and complex mechanical actions, combine to ensure this very high degree of reliability.



**Precision Audio  
Measurement**  
calls for the very best in  
test equipment



**An unrivalled Range of  
Marconi Instruments**

Measurements of audio performance to modern standards call for the very best in test equipment. Marconi's offer an unrivalled range of instruments to meet the most exacting requirements at every stage in the design-production cycle. From first evaluation of laboratory models to final testing in the factory, there is a Marconi instrument to meet the need.



**BEAT FREQUENCY OSCILLATOR TYPE TF 195M**

A reliable, low-distortion signal source for all audio measurements. Frequency range: 10 c/s to 40 kc/s. Up to 2 watts can be delivered into loads of either 600 or 2,500 ohms. At 0.5 watt output, individual harmonics are less than 0.2%.

**BEAT FREQUENCY OSCILLATOR TYPE TF 195M/5**

A wide-range instrument, the TF 195M/5 covers from 50 c/s to 200 kc/s in one band. Its output circuit includes a resistive step attenuator and a continuously-variable slide wire.

**DISTORTION FACTOR METER TYPE TF 142F**

Measures total spurious content, up to 30 kc/s, of inputs within the fundamental frequency range 100 c/s to 8 kc/s. Distortion measurement range: 0.05 to 50%. The input can be at any level between 500 mV and 500 volts.

**WAVE ANALYSER TYPE TF 455E**

Gives amplitude and frequency of individual components of either audio signals or the modulation envelopes of r.f. signals. Its a.f. range is 20 c/s to 16 kc/s and its amplitude measurement range is 30  $\mu$ V to 300 volts.

**OUTPUT POWER METER TYPE TF 893**

A wide-range absorption-type power meter for use in the frequency range 20 c/s to 35 kc/s. The power measurement range is 20  $\mu$ W to 10 watts and the input impedance can be set to any of 48 different values between 2.5 ohms and 20 k $\Omega$ .

- AM & FM SIGNAL GENERATORS • AUDIO & VIDEO OSCILLATORS
- FREQUENCY METERS • VOLTMETERS • POWER METERS
- DISTORTION METERS • FIELD STRENGTH METERS
- TRANSMISSION MONITORS • DEVIATION METERS
- OSCILLOSCOPES, SPECTRUM & RESPONSE ANALYSERS
- Q METERS & BRIDGES

**MARCONI INSTRUMENTS LTD • ST. ALBANS • HERTFORDSHIRE • TELEPHONE: ST. ALBANS 56161**

*London and the South: Marconi House, Strand, London, W.C.2. Tel: COVent Garden 1234*

*Midlands: Marconi House, 24 The Parade, Leamington Spa. Tel: 1408*

*North: 30 Albion Street, Kingston-upon-Hull. Tel: Hull Central 16347*

**WORLD-WIDE REPRESENTATION**

A  **HEAVY DUTY FIXING DEVICE**

# RAWLBOLTS

There is no waiting for cement to harden when you use Rawlbolts. The holes are drilled with a Rawltool to the exact size, the Rawlbolts dropped in and after the machine has been positioned the bolts are tightened. The expansion of the members locks the bolts in the holes. They cannot work loose through vibration or shock. The machine can be put into operation immediately.

Rawlbolts have earned a sterling reputation for strength and reliability throughout the world—they are used by the million every month. Rawlbolts grip by *expansion*—their strength as a fixing is based on the enormous compressive strength of concrete itself.

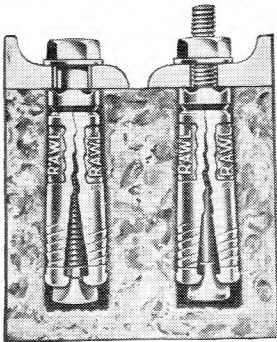



## RAWLBOLTS ARE MADE IN TWO TYPES

For fixing heavy machinery to floors there is the Loose Bolt type of Rawlbolt which enables the machine to be slid into position after the Rawlbolt has been inserted. For wall fixings use the Bolt Projecting type which will position the fixing before tightening up.

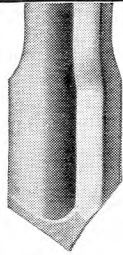

Please write for Chart and descriptive literature.

**Tools that save time** For hole boring there is a big range of high efficiency Rawlplug tools for use by hand, electric and air power.

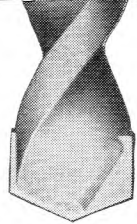
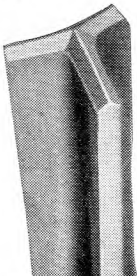
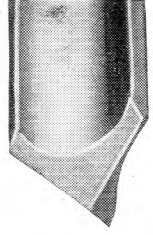
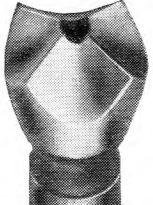
|  |   |   |   |  |   |
|--|---|---|---|--|---|
|  <p><b>RAWLDRILLS</b></p> <p>For hand boring for Rawlbolt sizes A to G.</p> | <p><b>STARDRILLS</b></p> <p>For hand boring for all Rawlbolt sizes.</p>  |  <p><b>DURIUM MASONRY DRILLS</b></p> <p>For use in hand and electric drills for Rawlbolt sizes C to G.</p> | <p><b>TRIFORM DRILLS</b></p> <p>For use in electric hammers for Rawlbolts sizes C to K.</p>  |  <p><b>DURIUM HAMMER DRILLS</b></p> <p>For use in electric hammers for Rawlbolt sizes C to J.</p> | <p><b>P. H. BITS</b></p> <p>For use in pneumatic hammers for Rawlbolt sizes E to K.</p>  |
|--|---|---|---|--|---|

B545





# MARCONI

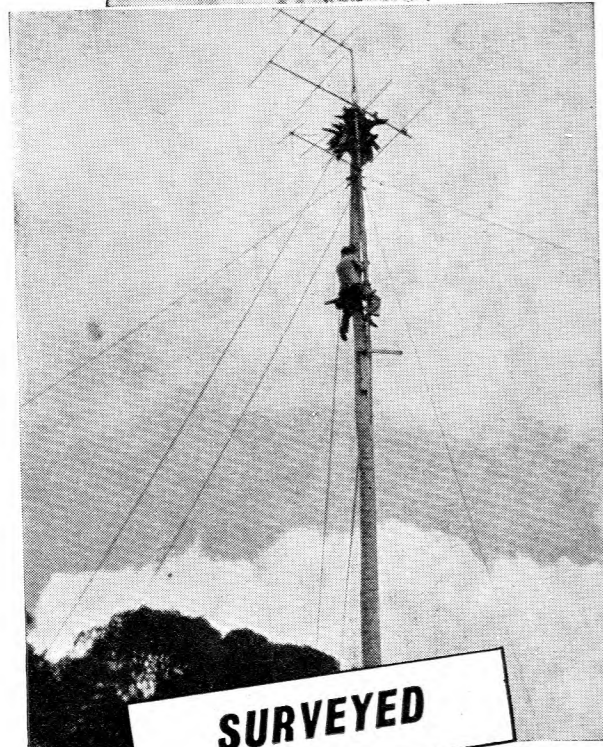

**SURVEYED**



**PLANNED**

## COMPLETE COMMUNICATION SYSTEMS – *all the world over*

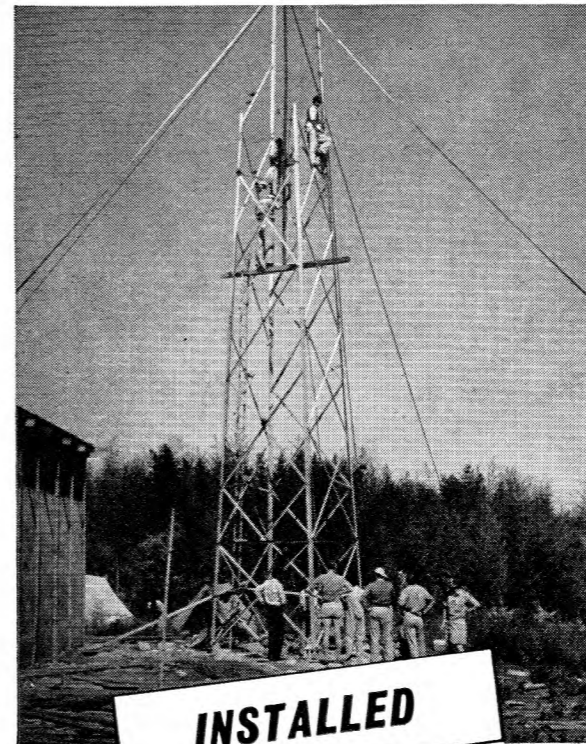

**INSTALLED**



**MAINTAINED**

**LONG-DISTANCE H.F. TELEGRAPH SYSTEMS** High Frequency systems form a major part of world-wide radio telegraph communication services. Marconi's have recently designed new equipment for such systems incorporating the latest electronic developments to save time and labour, reduce operating costs and eliminate faults. The company is unique in the resourcefulness and skill it can bring to the complete engineering of a system from the surveying stage onwards to the maintenance after it has been installed, and the training of the staff to operate it at maximum efficiency.

**MARCONI'S & A.T.E.** Co-operation between Marconi's and Automatic Telephone and Electric Co. Ltd., now brings together an unrivalled wealth of knowledge and experience for the benefit of all whose work lies in the field of telecommunications.



The Lifeline of Communication is in experienced hands

## MARCONI

*Complete Communication Systems*

MARCONI'S WIRELESS TELEGRAPH COMPANY LIMITED, CHELMSFORD, ESSEX



# CATHODEON

## Miniature Crystal Oven

*New Release!*

This miniature oven has been designed specifically for accurate temperature control of Ministry Style "D" (Cathodeon Type 2M) Crystal Units. It is particularly recommended where the requirement is for a frequency stability better than .0002% over a wide range of ambient temperatures.

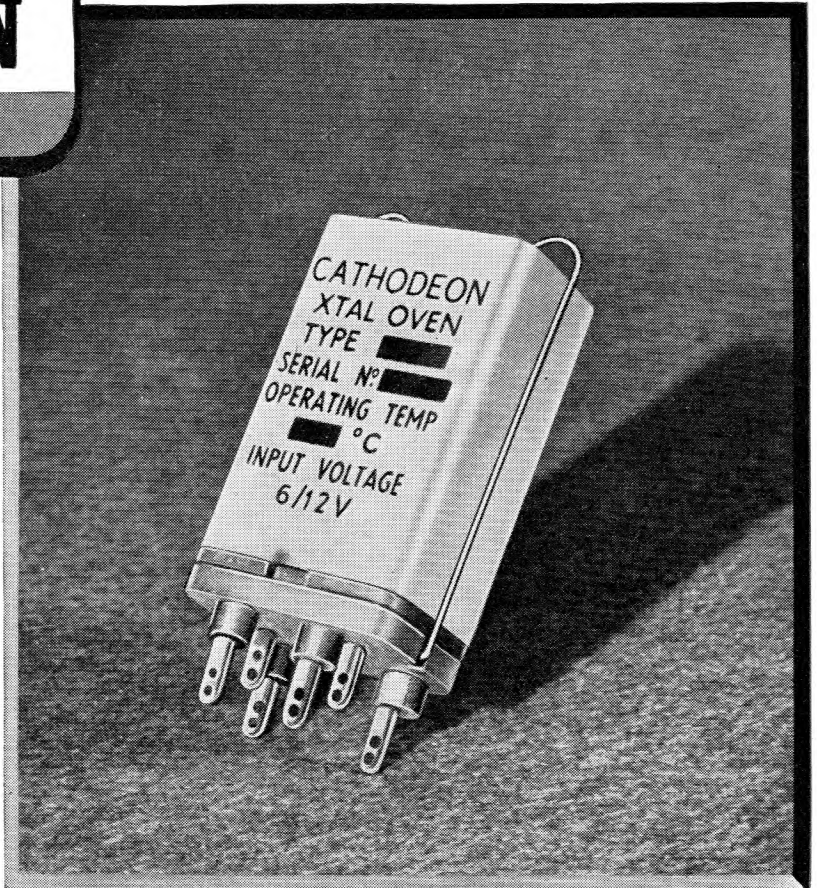

**Centre tapped heater** for 6.3 or 12.6 volt supplies.

**Current consumption** 0.73 amp. at 6.3 volt.

**Temperature differential**  $\pm 2^{\circ}\text{C}$  within a temperature range  $75^{\circ}\text{C}$  to  $85^{\circ}\text{C}$ .

**Temperature control** within the ambient range— $20^{\circ}\text{C}$  to  $+70^{\circ}\text{C}$ .

**Heating time** less than 5 minutes from ambient temperature to  $85^{\circ}\text{C}$ .

**Precision bi-metallic contacts** with provision for On/Off indicating lamp.

**Low loss Mycalon base.**

**Weight**  $1\frac{1}{2}$  oz. (43 grammes).

**Overall Dimensions**  $1\frac{1}{4}'' \times \frac{13}{16}'' \times 2\frac{5}{8}''$  long (3.2 x 2.0 x 6.6 cm.).

**CATHODEON CRYSTALS LIMITED**  
**LINTON CAMBRIDGESHIRE**  
TELEPHONE LINTON 223

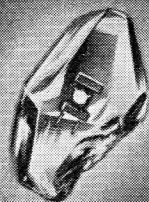



The

## DETECTOR No. 4 Mk. 10

—a TURNER instrument produced for Post Office engineers and combining a high level of sensitivity with accuracy and robust design for work in the field.

**ERNEST TURNER ELECTRICAL INSTRUMENTS LTD.**

**HIGH WYCOMBE      BUCKS      ENGLAND**

Telephone: HIGH WYCOMBE 1301-2-3

Telegrams: GORGEOUS, HIGH WYCOMBE

*Designed for*

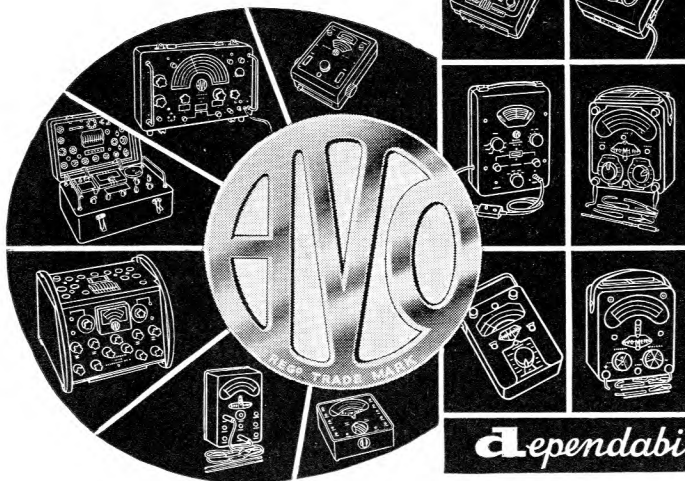

*dependability*

Illustrated Brochure available on request.

Sole Proprietors and Manufacturers:—

*The* **AVOMATIC COIL WINDER & ELECTRICAL EQUIPMENT CO. LTD.**

**AVOCET HOUSE · 92-96 VAUXHALL BRIDGE ROAD · LONDON · S.W.I.**

THE Model 8 is the latest version of the world-famous Universal AvoMeter. In addition to the many well-known AvoMeter features, such as the automatic overload protection cut-out, dual-knob range selection, etc., it has a push-button to obviate the inconvenience of changing over the leads when encountering opposite potentials in respect of a common reference point.

The meter has a sensitivity of 20,000 ohms per volt on all D.C. ranges, and 1,000 ohms per volt on A.C. ranges from 100 volts upwards. Accuracy on D.C. current ranges and A.C. ranges is to B.S. Spec. 89/1954, and on D.C. voltage ranges within 2% of indication from full scale to half scale deflection, and 1% of full scale value below half scale deflection.

VOLTAGE AC/DC: 25mV. to 2,500V.

CURRENT AC/DC: 0.5 microamps to 10 amps.

RESISTANCE:

0-20 megohms with internal batteries,  
0-200 megohms with external D.C. supply.

DECIBELS: -15 Db to +15 Db.

Size: 8½ in. × 7¼ in. × 4½ in.

Weight: 6½ lb (including leads)

List Price **£23 : 10s.**

Phone: VICTORIA 3404 (9 lines)

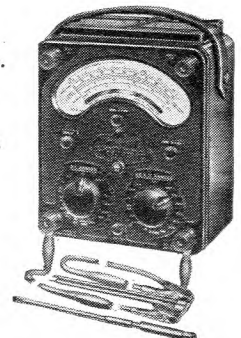



# CONVERTERS

## MODEL 2201

FOR CONVERSION OF MORSE CODE  
OR CABLE CODE PERFORATED TAPE  
TO 5-UNIT SIGNALS OR 5-UNIT PERFO-  
RATED TAPE AT TELEPRINTER SPEED

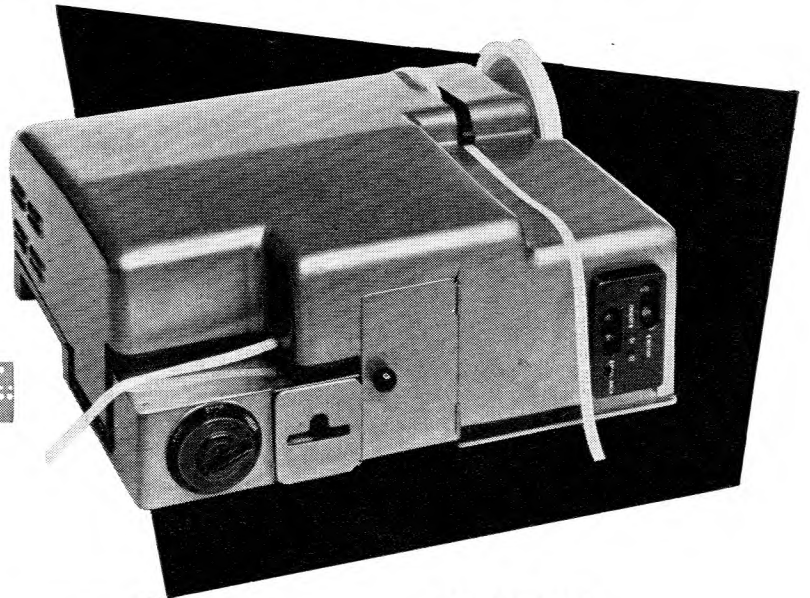
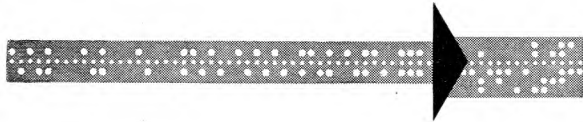

DIMENSIONS: 23" x 21" x 10"

## MODEL 2206

FOR CONVERSION OF 5-UNIT  
PERFORATED TAPE TO MORSE  
CODE OR CABLE CODE PER-  
FORATED TAPE, AT THE RATE OF  
650 CHARACTERS PER MINUTE

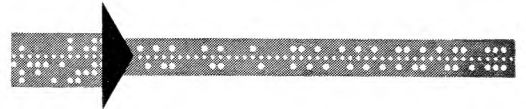
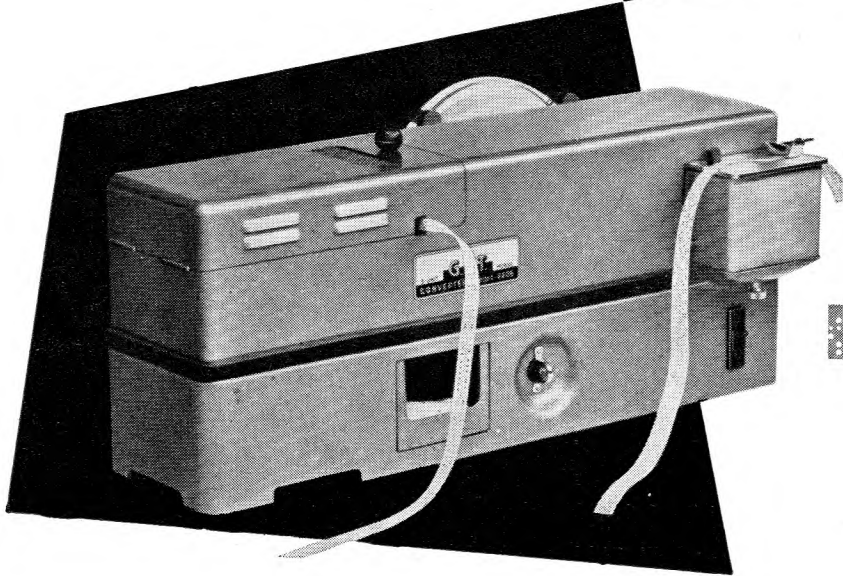

DIMENSIONS: 26" x 12" x 12"

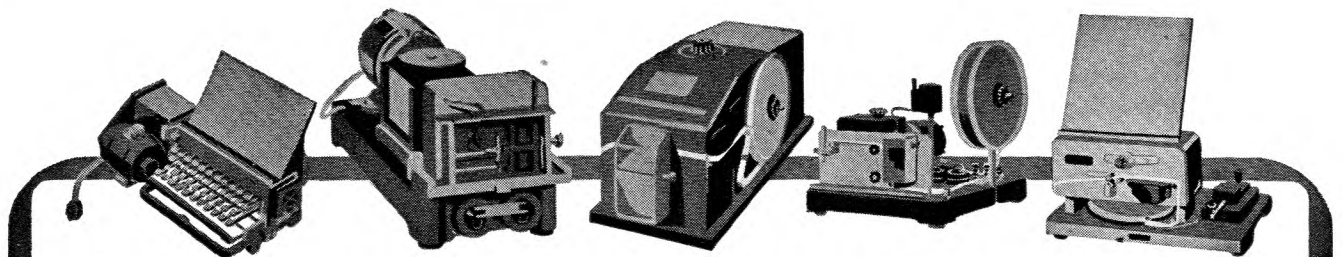

## GREAT NORTHERN TELEGRAPH WORKS

DIVISION OF THE GREAT NORTHERN TELEGRAPH CO. LTD.

4, SYDHAVNS PLADS  
COPENHAGEN SV, DENMARK

LONDON OFFICE: 5, ST. HELEN'S PLACE  
LONDON E. C. 3.



 WESTINGHOUSE 

**Dependable**

*in design and  
performance*

**DC CONSTANT  
VOLTAGE**

*power  
supplies*

WESTINGHOUSE BRAKE & SIGNAL CO., LTD.  
82 York Way, King's Cross, London, N.1

Tel: TERminus 6432

## **Voltage Regulating Transformers and Line Voltage Regulators**

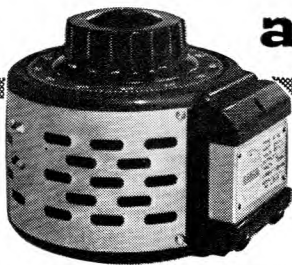

**from 250-580 VA Models 41 and 42**

- \* *Universal fixing centres*
- \* *Choice of ganged or automatic models*

**THE NEW MODELS 71, 72 from 1.5 to 2.5 KVA**

***Self-aligning brush gear***

(PATENT PENDING)

- \* *Universal fixing centres*
- \* *Choice of ganged or automatic models*

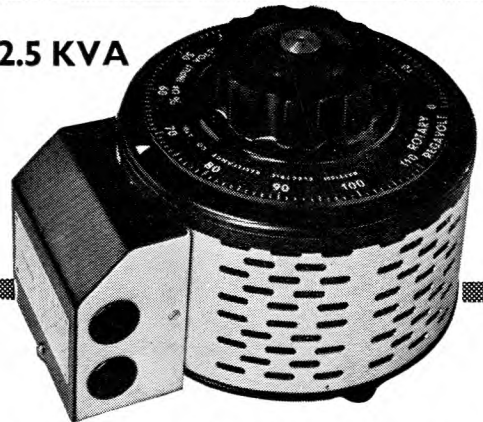

**BERCO**

Details available from:—

**THE BRITISH ELECTRIC RESISTANCE Co. Ltd.**

Queensway · Enfield · Middlesex Telephone: HOWard 2411

Telegrams: Vitrohm, Enfield

# IMPROVEMENT IN THE ACCURACY OF DECADE RESISTANCES

We have pleasure to announce that the well-known and novel

SULLIVAN and GRIFFITHS

## DUAL DIAL DECADE RESISTANCE BOXES

FOR ALL FREQUENCIES

Moreover, the windings are now of **Manganin** in order to reduce the temperature coefficient; more important still, to **improve the long period of stability** and make them as suitable for all **direct-current purposes** as they are for **alternating currents of all frequencies**.

**Screened Resistances** of guaranteed accuracy exactly similar to our well-known Decade Resistances but specially arranged so that one box of a given number of dials gives many different values of maximum resistance. Thus a three-dial box (as illustrated) may be used for instance for

|   |                         |
|---|-------------------------|
| three decades of <b>Thousands, Hundreds and Tens</b>    | a total of 10,000 ohms. |
| or three decades of <b>Hundreds, Tens and Units</b>     | a total of 1,000 ohms.  |
| or three decades of <b>Tens, Units and Tenths</b>       | a total of 100 ohms.    |
| or three decades of <b>Units, Tenths and Hundredths</b> | a total of 10 ohms.     |

have now been improved in accuracy to

**0.05 PER CENT**

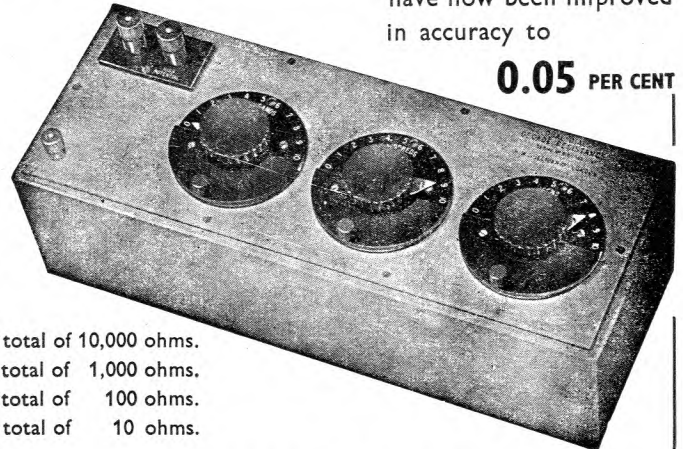

**H. W. SULLIVAN**  
LIMITED

LONDON, S.E.15

Telephone: New Cross 3225 (P.B.X.)

The advantages of such a system will be obvious, for in addition to the economy involved much space is saved and the residual resistance and inductance is much reduced.

The resistances are available in 3-dial, 4-dial and 5-dial types with subdivision of 0.001% down to 0.001 ohm if necessary, depending of course on the number of dials incorporated.

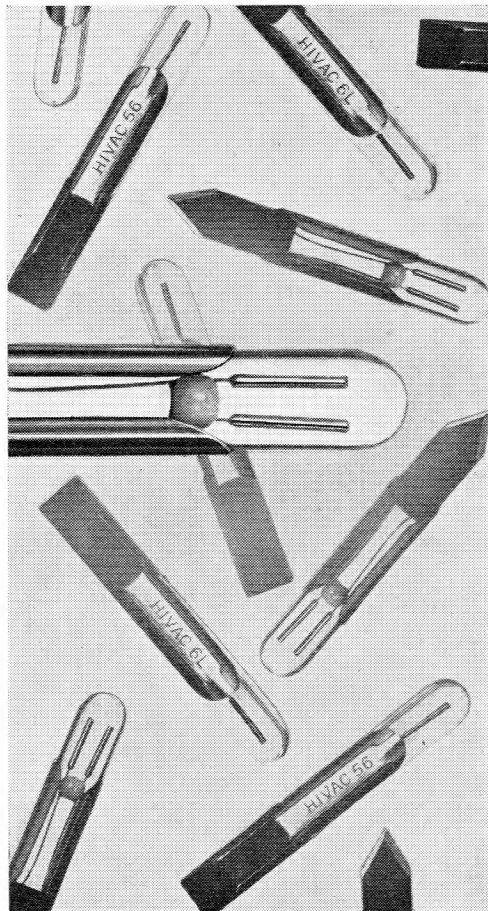

## Neon Indicator Lamp type 6L

Neon Indicator Lamps have the advantage of extremely long life and resistance to vibration.

The Neon Indicator Lamp type 6L conforms mechanically in all respects with the B.P.O. specifications for the No. 2 type telephone switchboard lamp.

|                             |        |
|-----------------------------|--------|
| Nominal striking voltage    | 80V    |
| Nominal maintaining voltage | 60V    |
| Maximum current             | 0.65mA |

*"IT JUST GLOWS TO SHOW"*

**Hivac Limited**

Stonefield Way  
Telephone: Ruislip 3366

South Ruislip

Middlesex



# Legendary! Fabuluary!

“Those pipes!” said Baron Rabbit. “Surely they are vitrified clay conduits?”

“They have been down here even longer than the museum,” said the curator. “They are strong and very smooth. The surface people run electric cables through them.”

“And in that way, the cables can be installed,

serviced and replaced with ease. Vitrified clay conduits save a lot of money. Acids in the soil cannot harm them — they almost last for ever.”

“Salt glazed vitrified clay conduits are legendary,” sighed the curator.

“Salt glazed vitrified clay pipes are fabuluary!” agreed the Baron.

**Put down Salt Glazed Vitrified Clay Pipes and Conduits—they stay down for centuries!**

NATIONAL SALT GLAZED PIPE MANUFACTURERS' ASSOCIATION

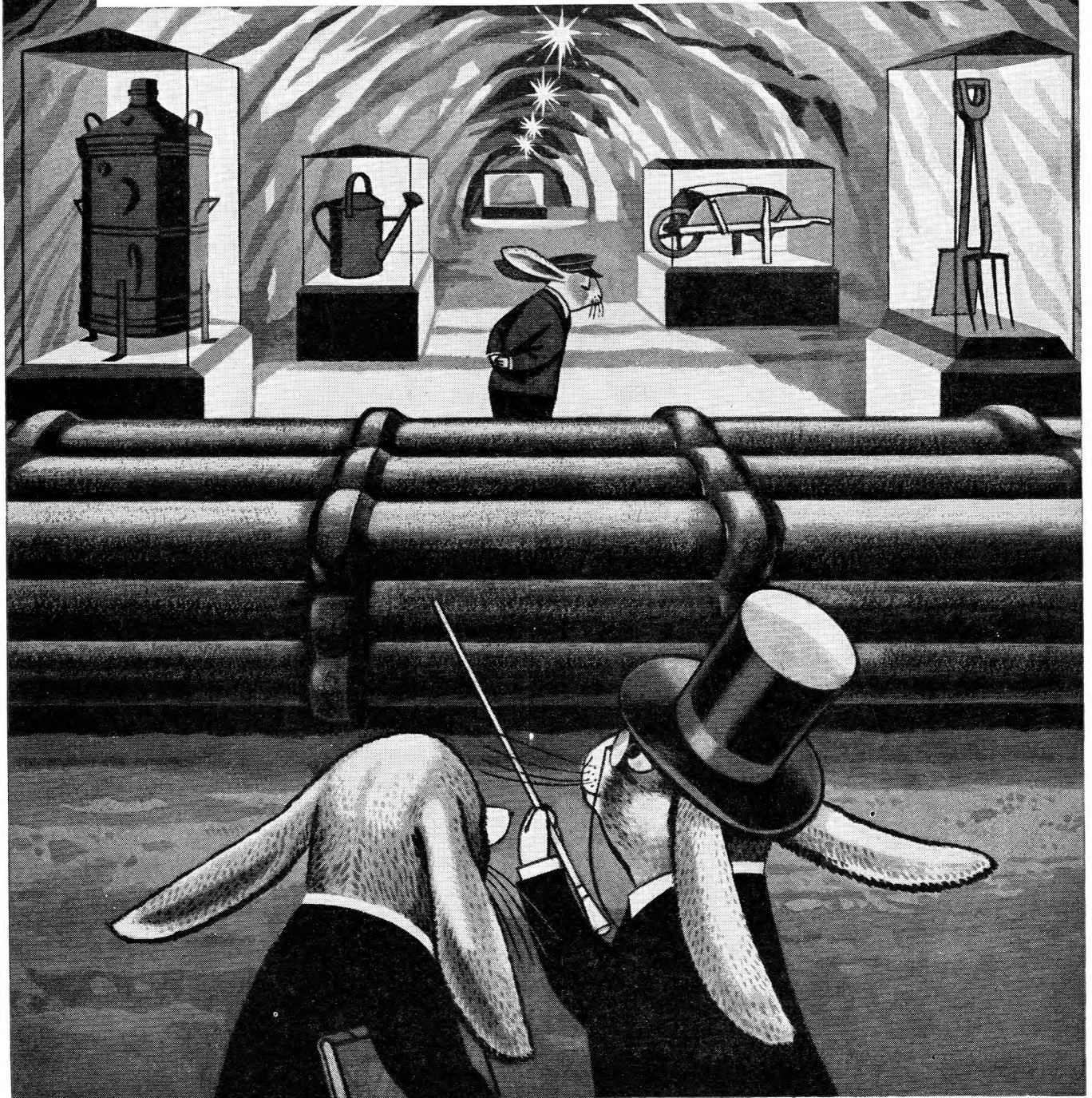



# ADCOLA

PRODUCTS LIMITED  
(Regd. Trade Mark)

## FOR SOLDERING INSTRUMENTS and EQUIPMENT

SUPPLIED FOR ALL VOLTAGES

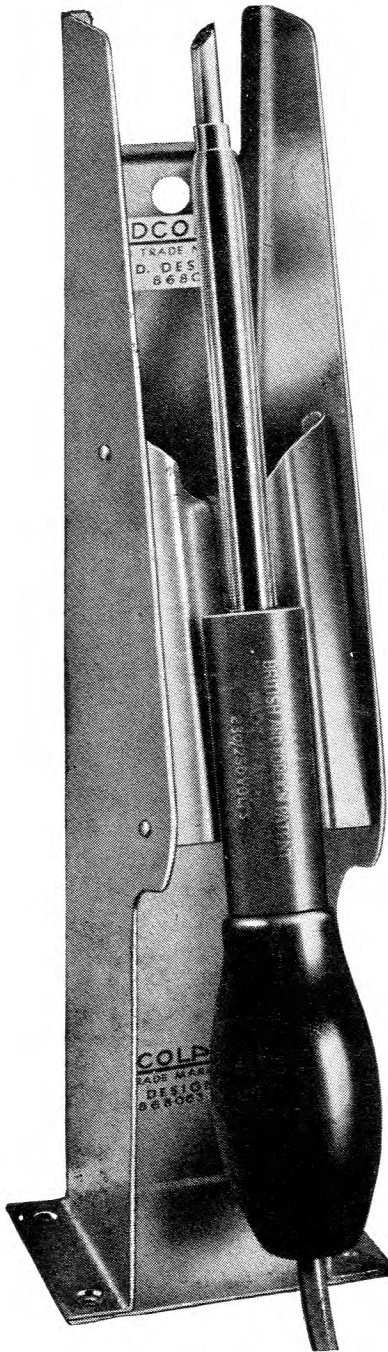

*illustrated*

### DETACHABLE BIT

MODEL  $\frac{3}{16}$ "

List 64

### PROTECTIVE SHIELD

List 68

Write for Catalogues

HEAD OFFICE, SERVICE AND SALES

**ADCOLA PRODUCTS LTD.**

GAUDEN ROAD, CLAPHAM HIGH STREET, LONDON, S.W.4

Phone: MACaulay 3101, 4272

## RADIO AND ELECTRONIC COMPONENTS, Vols. 1-4

By G. W. A. Dummer, M.B.E., M.I.E.E.

A new and unique series of books. The characteristics and specifications of the various components are covered fully. Vol. 1. Fixed Resistors. 28/- net. Vol. 2. Variable Resistors. 30/- net. Vol. 3. Fixed Capacitors. 45/- net. Vol. 4. Variable Capacitors (in preparation).

## TELEPHONY, Vol. 1

A Detailed Exposition of the Telephone Exchange Systems of the British Post Office.

Vol. 1. General Principles and Manual Exchange Systems. By J. Atkinson, A.M.I.E.E., etc. A standard work on the subject. This volume is primarily devoted to the signalling and the switching of the manual exchange systems. 40/- net.

## PITMAN

Parker St., Kingsway, London, W.C.2

for the  
right  
connection

**ANACOS**  
REGD.

telephone  
line  
wire

**FREDERICK SMITH & COMPANY**  
ANACONDA WORKS, SALFORD, 3, LANCS.  
Incorporated in The London Electric Wire Company and Smiths Limited.  
Associated with The Liverpool Electric Cable Co. Ltd. and Vactite Wire Co. Ltd.

## When Space is restricted and high capacity cells required

TUNGSTONE Battery installations can now be supplied by using Faure type (pasted) plates instead of Standard Planté type cells—designed exactly to G.P.O. specification, ensuring maximum efficiency and length of working life.

TUNGSTONE Storage Batteries are being regularly supplied to the British Post Office and Post and Telegraph Departments in many countries overseas.

### OPEN TYPE CELLS

*Available in glass or lead-lined wood boxes in a range of capacities from 100 a.h. to 5,000 a.h.*

### ENCLOSED TYPE CELLS

*In moulded glass containers with sealed-in lid. Capacity range from 10 a.h. to 200 a.h.*



This illustration shows a TUNGSTONE PASTED PLATE Battery of 168 cells—Type THTL6H erected for the G.P.O. for a telegraph installation.

# TUNGSTONE Batteries

TUNGSTONE PRODUCTS LIMITED

10 SALISBURY SQUARE, LONDON, E.C.4 · WORKS: MARKET HARBOROUGH, LEICS

TC 16

# TELEGRAPHY

## and the Carpenter Polarized Relay

The backbone of all telegraph and telex circuits is, of course, the Teleprinter, but it is a polarized relay which makes the teleprinter 'tick' so to speak.

In ever increasing numbers the Type 3 CARPENTER POLARIZED RELAY will be found to be the relay in question, and whether it be for use with teleprinters or teletype equipment, the Type 3 Relay can be relied upon to respond to weak, ill-defined, short-duration pulses of differing polarity, with accuracy, freedom from contact chatter, and a minimum of bias distortion.

Fast becoming recognised as a *standard* in the telegraph field, the Type 3 Carpenter Polarized Relay is available mounted on several different bases, to replace many other existing forms of telegraph relay, such as:

BRITISH POST OFFICE TYPE 299AN  
CREED ... .. TYPE 1927  
WESTERN ELECTRIC ... TYPE 209 & 255A, ETC.

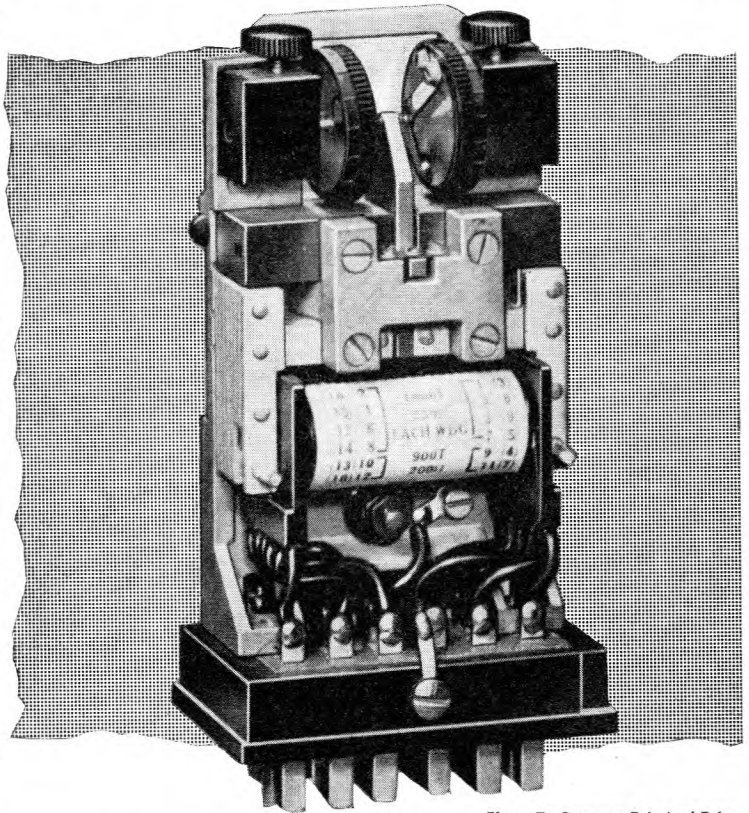

Type 3E1 Carpenter Polarized Relay

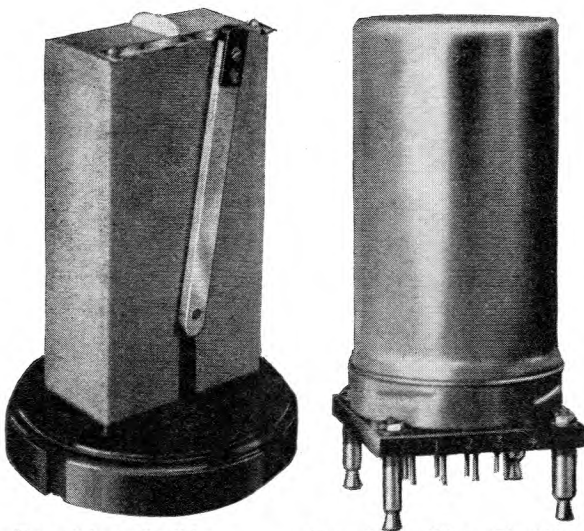

Type 3 Relay on 'Creed' base

Type 3 Relay on 'Western Electric' base

The Type 3 Relay is, of course, supplied for numerous other applications outside the telegraph relay field, where sensitivity, high speed of response, and freedom from contact bounce are essential features. Here are just a few of its typical uses: High speed modulator and demodulator in d.c./a.c. amplifiers. High speed switching relay in electronic stimulators used in biological research.

A sensitive detecting relay, operating from photo-electric cells, used in smoke detecting equipment.

A sensitive detecting relay operating from resistance element heads in fire alarm equipment.

A sensing relay in servo-systems.

A reversing commutator in Maxwell Bridge measuring circuits, etc.

For further details of this and other relays in the range of Carpenter Polarized Relays, write to :



## TELEPHONE MANUFACTURING CO. LTD

Contractors to the Governments of the British Commonwealth and other Nations

HOLLINGSWORTH WORKS · DULWICH · LONDON SE21 TELEPHONE: GIPSY HILL 2211



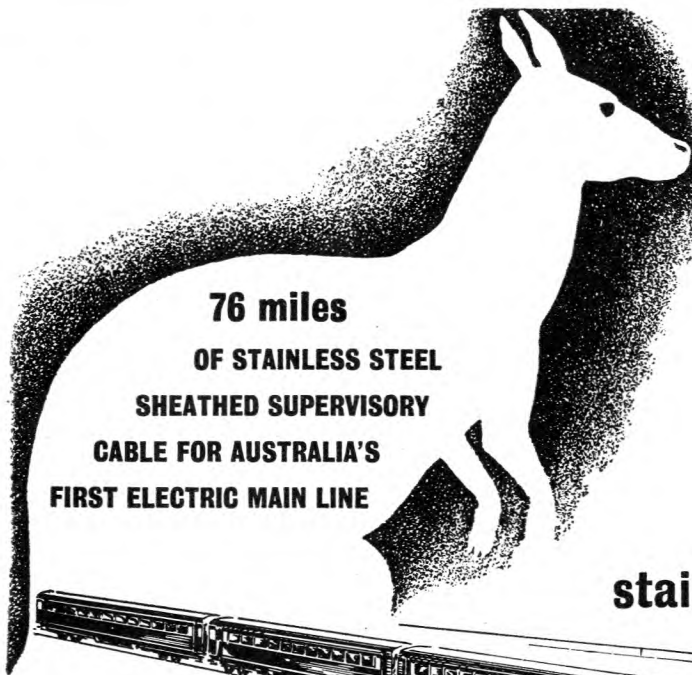

The first main line electric railway in Australia now extends 98 miles from Melbourne to Traralgon, in the Gippsland District of Victoria. Power for the Gippsland line is taken from the State Electricity Commission's 22,000 volt system at four supply points and converted to 1,500 volt direct current at 16 sub-stations, spaced about 5½ miles apart. All sub-stations and tie-stations are unattended and are connected by a 76-mile long, stainless steel sheathed supervisory cable to the electrical depot at Warragul, where the power engineer has, at his finger tips, the control of any sub-station or tie-station and any 22,000 volt, 1,500 volt or 2,200 volt circuit breaker on the system between Narre Warren and Traralgon. The supervisory cable, which is suspended from the R.S.J. pillars supporting the overhead construction, is completely self-supporting by virtue of the austenitic stainless steel sheath which also possesses excellent corrosion resistance. The cable contains fourteen pairs of wires; 3 pairs being used for the control of various groups of sub-stations and tie-stations, the remainder for feeder switch-gear protection.

## PIRELLI-GENERAL stainless steel sheathed cables

An original Pirelli-General development



PIRELLI-GENERAL CABLE WORKS LTD., SOUTHAMPTON. Associated Company of the General Electric Co. Ltd



# OSCILLATOR

## Type 858

### 30 Kc/s—30 Mc/s

THE Oscillator Type 858 is a general purpose CW oscillator with special characteristics of very low harmonic distortion, high frequency stability and constant output level. These features make it particularly suitable for use as a calibrating oscillator.

Three standard output levels are available from separate sockets and the incorporation of a variable control enables any output between 0.5mV and 0.5 volt to be obtained.



**FREQUENCY RANGE**  
30 kc/s—30 Mc/s on 7 ranges.

**FREQUENCY STABILITY**  
Considerably better than 0.05 per cent with mains change from 200–250V.

**HARMONIC DISTORTION**

In general, less than 1 per cent.

**OUTPUT LEVEL**

Remains constant within ± 1 db over complete frequency range.

**OUTPUTS**

500mV, 100mV and 10mV standard. A slidewire attenuator enables a continuous output coverage to be obtained from 500µV to 500mV.

Full details of this or any other Airmec instrument will be forwarded gladly upon request.

**AIRMEC**  
L I M I T E D

HIGH WYCOMBE BUCKINGHAMSHIRE ENGLAND

Telephone: High Wycombe 2060

Cables: Airmec, High Wycombe