

This document was generated by me, Colin Hinson, from a document held at R.A.F. Henlow Signals Museum and is believed to be out of copyright or Crown Copyright . It is presented here (for free) under the Open Government Licence (O.G.L.) if under Crown Copyright and this version of the document is my copyright (along with the Crown Copyright) in much the same way as a photograph would be. If you believe the document to be under copyright, please contact me.

The document should have been downloaded from my website <https://blunham.com/Radar>, if you downloaded it from elsewhere, please let me know (particularly if you were charged for it). You can contact me via my Genuki email page:

<https://www.genuki.org.uk/big/eng/YKS/various?recipient=colin>

**You may not copy the file for onward transmission of the data nor attempt to make monetary gain by the use of these files. If you want someone else to have a copy of the file, point them at the website. It should be noted that most of the pages are identifiable as having been processed by me.**

---

I put a lot of time into producing these files which is why you are met with the above when you open the file.

In order to generate this file, I need to:

1. Scan the pages (Epson 15000 A3 scanner)
2. Split the photographs out from the text only pages
3. Run my own software to split double pages and remove any edge marks such as punch holes
4. Run my own software to clean up the pages
5. Run my own software to set the pages to a given size and align the text correctly.
6. Run Omnipage (Ultimate) on all the pages to OCR them.
7. Generate a searchable Acrobat pdf file.

Hopefully after all that, I end up with a presentable file, though I can't guarantee there aren't errors in the OCR. If you find missing pages, pages in the wrong order, anything else wrong with the file or simply want to make a comment, please drop me a line (see above).

It is my hope that you find the file of use to you personally – I know that I would have liked to have found some of these files years ago – they would have saved me a lot of time !

Colin Hinson

In the village of Blunham, Bedfordshire.

# THE POST OFFICE ELECTRICAL ENGINEERS' JOURNAL



Vol. 54 Part 1

APRIL 1961



## C O N T E N T S

	Page
A LOUDSPEAKING TELEPHONE WITHOUT VOICE SWITCHING—LOUDSPEAKING- TELEPHONE No. 1—W. T. Lowe, A.M.I.E.E., and F. A. Wilson, C.G.I.A., A.M.I.E.E., A.M.Brit.I.R.E. ....	1
CENTRAL SERVICE-OBSERVATION EQUIPMENT USING A TRANSISTOR-CONTROLLED MOTOR-UNISELECTOR—C. D. Vigar, A.M.I.E.E. ....	9
THE UNIT METHOD OF AUTOMATIC TELEPHONE EXCHANGE DESIGN J. P. Lawrence, Graduate I.E.E. ....	14
A NOTE ON THE LAYING EFFECT AND AGING OF SUBMARINE TELEPHONE CABLES R. A. Brockbank, Ph.D., B.Sc.(Eng.), A.M.I.E.E. ....	20
A NEW SMALL CORDLESS P.M.B.X. SWITCHBOARD C. M. Halliday, A.M.I.E.E., and E. J. Lidbetter. ....	22
A SWEEP-FREQUENCY METHOD OF LOCATING FAULTS IN WAVEGUIDE AERIAL FEEDERS J. Hooper, A.M.I.E.E. ....	27
AUTOMATIC LETTER SORTING—THE LUTON EXPERIMENT T. Pilling, B.Sc.(Tech.), A.M.I.E.E., and P. S. Gerard, B.Sc.(Eng.), A.M.I.E.E. ....	31
REFLECTOMETERS D. E. Watt-Carter, A.M.I.E.E. ....	37
COMPONENT RELIABILITY IN POST OFFICE EQUIPMENT A. A. New, M.Sc., F.R.I.C., A.Inst.P. ....	40
THE EQUALIZATION DURING LAYING OF THE ANGLO-SWEDISH SUBMARINE TELEPHONE CABLE—F. Scowen, B.Sc., A.Inst.P., A.M.I.E.E. ....	48
THE COLD ROLLING OF VERY THIN FERROUS TAPES G. W. Lord, B.Sc. ....	51
FLEET (LONDON) AUTOMATIC TELEX EXCHANGE A. Wilcock, A.M.I.E.E., and E. C. Baxter ....	53
NEW DESIGNS OF FURNITURE FOR USE IN ENGINEERING INSTALLATION OFFICES E. H. Seymour, A.M.I.E.E. ....	57
TESTING OF SUBSCRIBERS' DIALS FROM THE TEST-DESK ....	58
NOTES AND COMMENTS ....	60
INSTITUTION OF POST OFFICE ELECTRICAL ENGINEERS ....	61
REGIONAL NOTES ....	62
ASSOCIATE SECTION NOTES ....	64
STAFF CHANGES ....	67
PAPERS AND ARTICLES ON TELECOMMUNICATIONS AND OTHER SCIENTIFIC SUBJECTS	70
BOOK REVIEWS. ....	8, 13, 21, 26, 36, 47, 63, 66, 72

Price 2s. 6d. (Post Paid 3s. 6d.)

Published in April, July, October and January by *The Post Office Electrical Engineers' Journal*,  
G.P.O., 2-12 Gresham Street, London, E.C.2.

Annual Subscription (post paid): Home and Overseas, 14s. (Canada and U.S.A., 2 dollars 25 cents).

# THE POST OFFICE ELECTRICAL ENGINEERS' JOURNAL

Vol. 54 Part 1

APRIL 1961

## A Loudspeaking Telephone without Voice Switching— Loudspeaking-Telephone No. 1

W. T. LOWE, A.M.I.E.E., and F. A. WILSON, C.G.I.A., A.M.I.E.E., A.M.Brit.I.R.E.†

U.D.C. 621.395.623.7:621.395.721.1

Loudspeaking telephones enable subscribers to converse during calls with both hands free, and it is evident that the demand for such an instrument is sufficient to justify development of a Post Office model. This article describes the first of a range of Post Office loudspeaking telephones and discusses its performance and limitations.

### INTRODUCTION

IN 1932, the Post Office developed a loudspeaking-telephone equipment suitable for use with 2-wire lines, and several were installed on privately-rented circuits to provide loudspeaking conference facilities. Others were installed at private branch exchanges for use on extension-to-extension calls, and were barred from use on calls over the public network. Each equipment consisted of a microphone and loudspeaker mounted side by side in a desk cabinet, with their respective sending and receiving amplifiers and power supply housed in a separate box. To prevent unwanted oscillation (howling) due to coupling between the microphone and loudspeaker, either the sending amplifier or receiving amplifier was automatically suppressed, depending on the direction of transmission at a given moment. The suppression was achieved by deriving voltages from the speech signals and using them to control variable attenuation networks; the system was therefore said to be "voice-switched."

Several modified designs were produced experimentally up to 1939, but during 1939-45 most of the loudspeaking telephones were recovered. Until 1955 no loudspeaking telephones were approved for connexion to the public network; this restriction was necessary because of the inferior performance of the loudspeaking telephones at that time compared with the standard telephone.

In 1955 it was decided that the Post Office would develop a "non-switched" loudspeaking telephone (subsequently named Loudspeaking-Telephone No. 1) suitable for use with 2-wire lines of the public network. A non-switched system is one in which the sending-amplifier and receiving-amplifier paths function simultaneously. The advantage of such a system is that,

having no complex switching networks, it is cheaper to produce and easier to maintain than a switched system. Although under certain conditions its performance is inferior to that of a voice-switched instrument, it was considered that there would be sufficient demand to justify development. Ticket agencies, reception desks and information offices, where it is advantageous to have both hands free during calls but where expensive apparatus is not justified, are probably suitable premises for the provision of non-switched loudspeaking telephones.

In a voice-switched equipment the receiving amplifier is suppressed when the sending amplifier is in use, and vice versa. The receiving amplifier may be rendered inoperative, or "suppressed," by using part of the output voltage of the sending amplifier to operate a relay or to control a variable-attenuation network.

The use of voice switching introduces several problems:

(a) The voice-switching circuits can considerably increase the cost of the equipment.

(b) It is desirable that a distant subscriber should be able to break into the conversation by overriding the suppression bias in the near-end loudspeaking equipment. This "break-in" facility and other design features increase the complexity of the switching networks and may cause maintenance difficulties.

(c) First syllables in sentences may be clipped due to slight delay in operation of the switches; under adverse conditions a complete word may be lost.

(d) When a voice-switched loudspeaking telephone is being used in a noisy locality the noise sent to line is suddenly switched off when the user stops talking. This creates the disturbing impression at the distant end that the circuit has been disconnected.

(e) Excessive room noise can hold the voice switch operated and thus prevent break-in by the distant subscriber, or, alternatively, it can cause false break-in.

(f) It is difficult to maintain the correct relationship between the suppression and break-in biases for varying line conditions.

(g) It is difficult to ensure satisfactory operation of the voice-switched networks on circuits with high attenuation where the received speech signals are at a low level.

† Mr. Lowe is in the Subscribers' Apparatus and Miscellaneous Services Branch, E.-in-C.'s Office, and Mr. Wilson is at the Post Office Research Station.

These disadvantages can be reduced to a minimum by careful design, and many commercial equipments now available give good results under average line and room conditions. They are not, however, suitable for use on the public-exchange network where a variety of line conditions are encountered.

The outstanding feature of the voice-switched type of loudspeaking telephone is that it can be used to give loudspeaking reception at both ends of a line. In contrast, the non-voice-switched loudspeaking telephone cannot be used in this way except on very short lines, and will normally be used as a loudspeaking equipment only when a handset is used at the distant end.

At the present time there is no loudspeaking telephone of either type which will work satisfactorily on all calls in the British Post Office network, but with further development this objective may eventually be attained. Present voice-switched instruments are usually capable of working over higher-attenuation connexions than the non-switched type. Thus, the choice of instrument for any particular subscriber depends upon a number of factors. If more than one loudspeaking telephone is required on a single installation, or if calls are to be made over high-attenuation connexions, then a voice-switched loudspeaking telephone must be used. If, however, simple hands-free operation at an economic rental is required then a single non-voice-switched type will be satisfactory.

The Post Office is introducing models of both the non-switched and voice-switched types and these will be known as Loudspeaking-Telephone No. 1 and Loudspeaking-Telephone No. 2, respectively. The remainder of this article is concerned with a description of the Loudspeaking-Telephone No. 1 (Fig. 1).

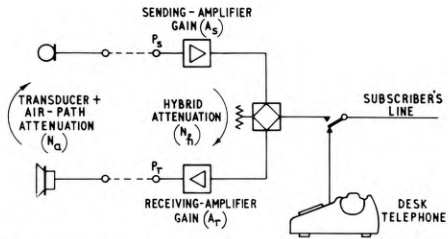

FIG. 2—SCHEMATIC DIAGRAM OF A LOUDSPEAKING TELEPHONE

#### LOUDSPEAKING-TELEPHONE NO. 1

The schematic diagram of a loudspeaking-telephone equipment is shown in Fig. 2. A conventional telephone handset is provided for privacy or for use in the event of failure of the loudspeaking equipment.

There are several ways in which the items comprising a loudspeaking telephone can be grouped without violating the important requirement that the microphone and loudspeaker should be about 2-3 ft apart to reduce sufficiently the acoustic feedback.

After careful consideration it was decided that the best arrangement was to combine in a single control unit all the controls necessary for setting up a call (the ON/OFF key, dial, volume-control key, and indicator lamp), together with the microphone. This unit would then be drawn forward by the user whenever a call was made, and this would ensure that the user would speak close to the microphone (which is desirable in order to reduce to a minimum the effects of room reverberations).



The Loudspeaking-Telephone No. 1 consists of a Telephone No. 708, a Control Unit No. 8A, and an Amplifier Unit No. 138A. The Amplifier Unit No.138A, which is mounted separately, is not shown in this photograph.

FIG. 1—THE NEW LOUDSPEAKING TELEPHONE



The loudspeaker would be fitted in the telephone instrument in place of the dial, and this unit would normally be placed at the back of the desk since on normal calls the handset would not be used. The two amplifiers and hybrid transformer would be fitted in a case, which could be placed in a position remote from the subscriber's desk or table. Thus, in the arrangement chosen for the Loudspeaking-Telephone No. 1, three separate units are provided; these are the control unit, the telephone and the amplifier, the first two of which are shown in Fig. 1.

The loudspeaking telephone is designed to work from 50-volt exchanges, and the transistor amplifier draws its power from the subscriber's line so that it does not need separate power supplies.

### Control Unit

The microphone lies behind the grille at the top of the control unit (Control Unit No. 8A), together with the indicator lamp, which is also mounted in this aperture. The ON/OFF key is on the right-hand side. The left-hand key is a 3-position volume control. The bottom position of this key (position 3) gives maximum receiving-amplifier gain, which can be used advantageously under certain conditions. There is, however, a possibility of howling occurring if the key is left in this position during the setting up of a call. For this reason the bottom position of the key has been made non-locking. All the components, except the microphone and indicator lamp, are mounted on a framework screwed to the base plate, as shown in Fig. 3. The outer case of the unit can be readily removed from the base, and this permits easy access for maintenance.

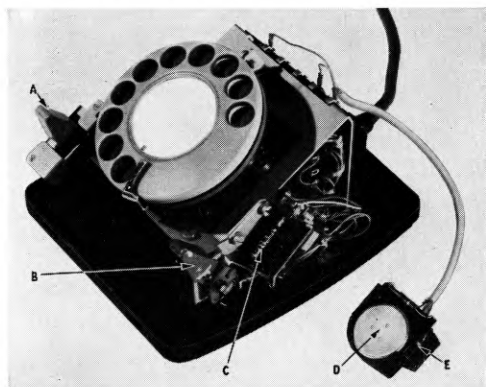

A = Volume control. B = ON/OFF key. C = Relay K. D = Microphone.  
E = Indicator lamp.

FIG. 3—CONTROL UNIT

A special feature of the ON/OFF key is that, although it can be moved manually to the ON or OFF positions as for a normal 2-position locking key, when in the ON position it can be restored electrically to the OFF position. By this means a call can be switched automatically by a relay from the loudspeaking equipment to the conventional telephone by lifting the handset. This is achieved by arranging that when the key is moved to ON, it remains locked by a latch attached to a relay armature. The latch can be disengaged by either elec-

trically operating the relay or manually restoring the key to OFF. Electrical operation of the relay causes the armature to lift the latch out of the locking niche, and a restoring spring then moves the key handle to the OFF position. The relay functions correctly on all subscribers' lines up to the maximum line resistance of 1,000 ohms.

The electrical circuit of the relay is shown in Fig. 4.

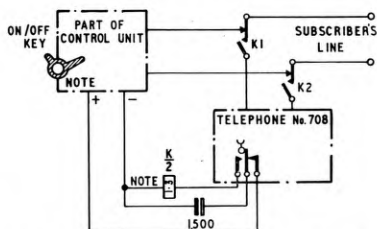

Note: Armature of relay K is mechanically linked to the ON/OFF key

FIG. 4—CIRCUIT OF CONTROL-UNIT CHANGE-OVER RELAY

While the loudspeaking telephone is in use, i.e. the control key is in the ON position, the K relay armature is released and the 1,500  $\mu$ F capacitor is fully charged by the line current. When the handset is lifted the capacitor discharges into the relay coil and relay K operates, releasing the latch, which moves the key to OFF while contacts K1 and K2 switch the line over to the telephone. Relay K remains mechanically locked in its operated position.

It is desirable on such equipment to have an indicator lamp showing when the equipment is switched on, but it is difficult to derive the necessary power entirely from the line. Nevertheless, a 12-volt 20 mA lamp has been specially designed which gives a satisfactory glow down to about 14 mA and, although its light output is only just sufficient on 1,000-ohm subscribers' lines, it is ample on most lines.

### Telephone

The telephone (Telephone No. 708) is a Telephone No. 706<sup>1</sup> modified by mounting a 3 in. loudspeaker in place of the dial and providing an additional switch-hook spring-set. The loudspeaker is of modern design, especially in that the permanent magnet is housed within the cone, resulting in a 3 in. loudspeaker only 0.75 in. deep. This technique has been made possible by the advent of modern magnetic materials from which can be produced small permanent magnets with very high flux-densities. The magnetic path is completed through the frame of the loudspeaker, which is of comparatively heavy gauge material (0.08 in.) to provide a low-reluctance path. The voice coil is multi-layer, and is wound so that it can work between the inner pole-piece of the magnet and the outer pole-piece, which is formed by the 0.08 in. thick housing. The telephone is shown with the case removed in Fig. 5.

### Amplifier

For convenience of production and maintenance, the amplifier (Amplifier No. 138A) is manufactured as three separate units: sending amplifier, receiving amplifier and automatic balance-control (ABC) unit. These are wired to appropriate sockets and line terminals



FIG. 5—TELEPHONE

for interconnexion with the desk telephone and control unit. The complete amplifier and the three separated units are shown in Fig. 6.

#### OPERATION

The equipment is simple to operate. Due to the use of transistors it is unnecessary for the loudspeaking telephone to be switched on some time before it is to be used. To make a call the subscriber operates the ON key and commences dialling on hearing dialling tone from the loudspeaker. The indicator lamp glows when the ON/OFF key is operated. The call is terminated by restoration of the ON/OFF key. During the call the volume-control key is normally left in position 1 (low) or

position 2 (medium). If, during conversation, the handset is required, it is lifted from its cradle and the line is automatically switched to the telephone, and the indicator lamp is extinguished. The call is cleared by replacement of the handset. Occasionally, it may be required to change from the handset to the loudspeaking telephone; to do this the subscriber must operate the key before replacing the handset.

When the loudness of the received speech is inadequate on position 2 of the volume control the subscriber can move the volume control to position 3 for maximum volume, but if the hybrid balance is insufficient the loudspeaking telephone may howl. The subscriber should then revert to the handset.

#### TRANSMISSION FEATURES

There is little difference between the fundamental circuits of the non-voice-switched loudspeaking telephone and a conventional handset telephone. Each consists of a pair of transducers for the transmission and reception of speech, coupled through a hybrid transformer to a 2-wire line. Where the two instruments differ greatly is in their sending and receiving channel sensitivities.

For the loudspeaking telephone, the distance from the mouth to the microphone is at least 18 in., and the reproducer is not directly against the ear as with the telephone receiver but may be 3 ft or more away. Electrical amplification is therefore required in both the sending and receiving paths of the loudspeaking telephone in order to give results comparable with the standard handset.

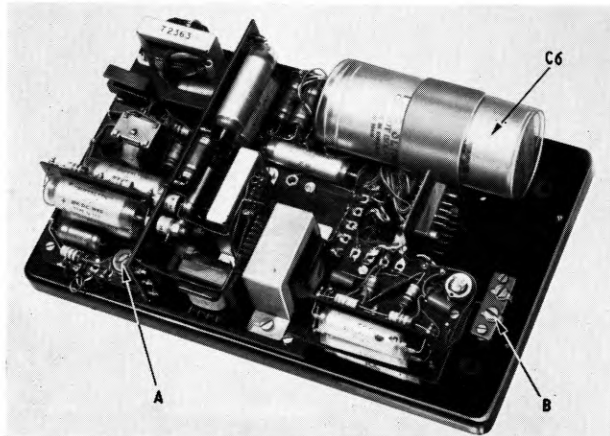

(a) Complete Amplifier

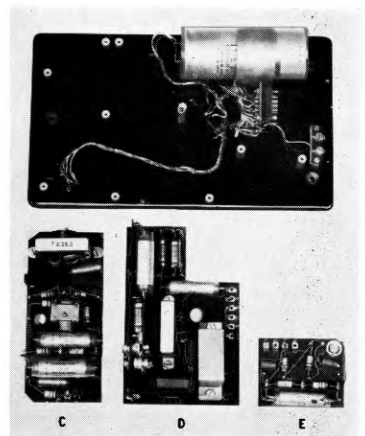

(b) Amplifier Units

A = Receiving-gain pre-set control, B = Line terminals, C = Receiving amplifier, D = ABC unit, E = Sending amplifier.

FIG. 6—AMPLIFIER

An electromagnetic microphone is used because of its superior frequency response compared with the carbon-granule transmitter, and also because of its smaller size. Its low sensitivity is no handicap as the sending-amplifier gain can compensate for this.

Given perfection in the hybrid transformer and balancing, then during sending all power would be dissipated in the line and balance, and none in the receive path.<sup>2</sup> Under these conditions the telephone would work perfectly, assuming that sufficient gain were available from the receiving amplifier for the lowest levels of incoming signal. Balance perfection at all frequencies is unobtainable in practice, and this is the main limitation of the instrument. If the loss from  $P_r$  to  $P_s$  via the air-path be denoted by  $N_a$  (see Fig. 2), and the loss introduced between the sending and receiving paths via the hybrid is denoted by  $N_h$ , then the total gain at any frequency which can be used in the amplifiers,  $A_s + A_r$ , is limited because for stability  $A_s + A_r \leq N_a + N_h$ . In practice, even for a given installation,  $N_a$  is a variable quantity because movements of the user change the acoustic reflections; thus, the total gain allowable is somewhat less than  $N_a + N_h$ . Usually  $A_s$  is pre-set to provide a chosen sending level and  $A_r$  is under the control of the subscriber, and then  $A_{r(max)} \approx N_a + N_h - A_s$ . On some telephone connexions, because of the limitation of  $N_h$ ,  $A_{r(max)}$  may be too low to provide a sufficient loudspeaker signal, especially if the incoming signal is weak. The loudspeaking-telephone is then unusable, but calls can be made by using the associated handset.

With these considerations in mind, it is obvious that the design should be such that  $N_h$  is as high as possible over the frequency range in use and on all connexions, and that the sending-frequency and receiving-frequency characteristics produce maximum articulation efficiency with maximum stability.  $N_a$  should also be as high as possible but, as its value is governed to a large extent by the disposition of the items on the subscriber's desk, little control can be exercised by the designer.

In addition, the frequency characteristics must be so arranged that when instability does occur the frequency of the resulting "howl" does not interfere with voice-frequency signalling systems, which may be associated with the particular telephone connexion in use. At present it appears that howling frequencies between approximately 1,000 c/s and 2,000 c/s meet this requirement.<sup>1</sup>

#### D.C. SUPPLY FOR AMPLIFIERS AND INDICATOR LAMP

The resistance of subscribers' lines connected to a 50-volt exchange can lie between zero and 1,000 ohms, and the voltage at the telephone terminals can vary, correspondingly, from 21 volts to 8 volts.

To limit variations in the d.c. supply to the amplifiers and indicator lamp, regulation is necessary. The circuit arrangement is shown in Fig. 7. On 1,000-ohm lines the p.d. across rectifier MR1-5 is 8 volts, and at this voltage the rectifier is designed to draw a negligible shunting current of under 5 mA. On zero-resistance lines the voltage across rectifiers MR1-5 rises, and the rectifier then draws a shunting current of about 30 mA, causing an additional voltage drop in the exchange transmission bridge so that the d.c. supply-line voltage does not exceed 14 volts. The d.c. supply line is decoupled from the subscriber's line by inductor L1 and capacitor C6. The supply is connected in parallel with

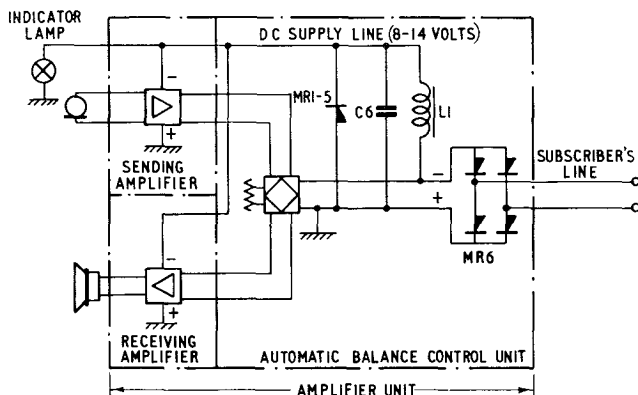

FIG. 7.—D.C. SUPPLY FOR AMPLIFIERS AND INDICATOR LAMP

the line as this simplifies the difficulty of meeting the signalling requirement that the maximum telephone resistance on 1,000-ohm lines shall not exceed 330 ohms. Rectifier MR6 is necessary to maintain correct polarity for the amplifiers, irrespective of the line polarity.

#### AMPLIFIER

The amplifier is subdivided into three units: the sending amplifier, the receiving amplifier, and the automatic balance control unit, as shown in Fig. 6.

##### *Sending Amplifier*

The sending amplifier is a conventional 3-stage transistor amplifier. When the talker is 2 ft from the microphone the amplifier is capable of transmitting a speech signal to line at a slightly lower level than that which would be obtained from a handset. It has a nominal maximum gain of 76 db between 300 c/s and 3,500 c/s, and can be used with ambient temperatures not exceeding 45°C.

When the amplifier is received from the manufacturer the gain is set for use with lines of less than 500 ohms resistance. An L-type attenuator in the output circuit can be switched by a link to increase by 4 db the level transmitted to line for use with lines of greater than 500 ohms resistance.

##### *Receiving Amplifier*

This amplifier, using four transistors, provides a maximum output of 200 mW, with less than 5 per cent total distortion, to the 3-ohm loudspeaker when the d.c. supply is 9 volts. The output stage operates in Class B push-pull and requires a low-impedance d.c. supply, which is provided by capacitor C6 (1,500  $\mu$ F). During peak signals, the amplifier power is drawn from this capacitor rather than from the higher-resistance supply of the line, capacitor C6 being recharged when the signal voltage falls.

It is probable that the output transformer used will be dispensed with in future designs of the receiving amplifier because miniature loudspeakers are becoming available with voice-coils wound to the higher impedances (e.g. 40-70 ohms) required by transformerless output stages.

##### *Automatic Balance-Control Unit*

The principal purpose of this unit, apart from linking the sending and receiving channels with the line, is to keep the hybrid attenuation  $N_h$  (Fig. 2) as high as possible.



A basic hybrid circuit is shown in Fig. 8 (a). The transformer consists of three windings; windings 2 and 3 have equal turns and are connected in series-aiding. When a generator is applied to winding 1, currents  $i_1$  and  $i_2$  flow in the networks and, clearly, when  $Z_L = Z_B$ ,  $i_1 = i_2$  and, because the two currents in  $Z_R$  are equal and opposite, the net current in  $Z_R$  is zero. This is the balanced condition, i.e. the generator has delivered power into both  $Z_L$  and  $Z_B$ , but none into  $Z_R$ .

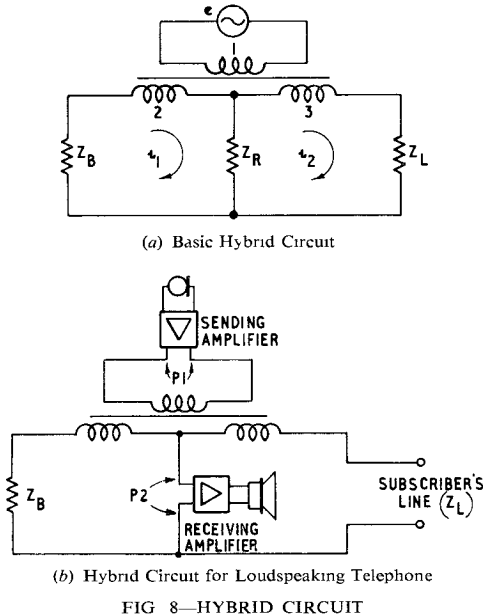

FIG. 8—HYBRID CIRCUIT

The practical arrangement in a loudspeaking telephone is shown in Fig. 8 (b). The attenuation  $N_h$  (the attenuation between P1 and P2) is very high when  $Z_L = Z_B$ . The amplifier gains can, therefore, be made high without instability occurring, and the telephone can provide adequately-high-level signals in both directions.

Unfortunately, the impedance  $Z_L$  presented by the subscriber's line varies over a very wide range in both modulus and phase, and it changes considerably with frequency. Furthermore, on any single call it changes at least once because the impedance of the circuit when the connexion is established is different from that while the call is being set up. This condition can be illustrated by considering a call being set up for a subscriber with a very short line to a manual exchange or private branch exchange. While waiting for the operator to answer, and also under certain other conditions, the value of  $Z_L$  is extremely high, amounting, in fact, almost to a disconnection;  $N_h$  is then very low.

Thus, the subscriber must reduce the receiving-amplifier gain to avoid instability while the call is being set up but will have to readjust it to provide sufficient loudspeaker output once the call is established. This detracts from the "hands-free" facility which the telephone should provide. However, such violent impedance variations do not occur for the subscriber on a long line because the impedance of the local line is always present between his telephone and the exchange.

Considering Fig. 8 (a) again, it may at first be thought advantageous to add a shunt or series network to  $Z_L$  to reduce the effect of its variations. Balancing is then

improved, but the gain due to the improved balance is usually offset by the power loss in the added network and necessitates an increased gain in both the sending and receiving amplifiers.<sup>4</sup> In general, therefore, increased stability is not achieved. One exception is the example mentioned, where a subscriber on a very short line is setting up a call and the impedance across the telephone terminals approaches an open circuit. On such a call a fairly-high-impedance shunt (2,200 ohms in series with  $0.1 \mu\text{F}$ ) across the line terminals improves stability by some 5 db on a disconnection, yet results in a total sending loss plus receiving loss of less than 2 db. The increased stability of some 3 db may seem small, but it is of great value in an instrument of this type because it avoids the inconvenience to the subscriber of repeated volume-control changes. The shunt network is designated R1, C1 in Fig. 9, which shows the com-

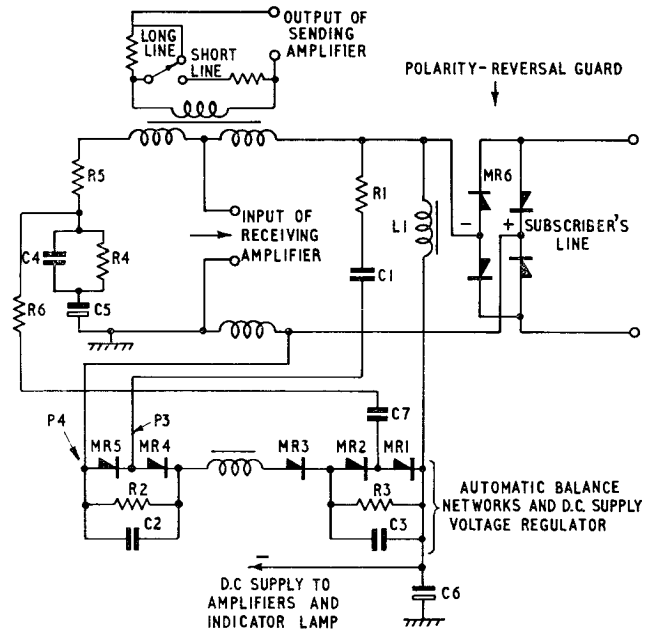

FIG. 9—AUTOMATIC BALANCE-CONTROL UNIT

plete circuit of the ABC unit. This has a basic hybrid network similar to that shown in Fig. 8 except that the line winding is split into two equal parts for cancellation of hum, which may be induced from external sources. On long lines the shunt loss of R1, C1 is not required and is automatically removed. This is achieved by the network MR4, MR5, R2, C2 in a manner similar to that used in the automatic regulator of the Telephone No. 706, as described elsewhere.<sup>1, 5</sup> When connected via a zero-resistance line to a 50-volt exchange, the network impedance between points P3 and P4 is about 12 ohms, while on 1,000-ohm lines it rises to over 5,000 ohms. Thus, the network R1, C1 is effectively in shunt with the line when the latter is short, disconnected when the line is long, and pro rata on intermediate lines. Rectifiers MR4 and MR5 also form part of the d.c. voltage regulator.

A similar automatic network is used to control the impedance of the balance. The network MR1, MR2, R3, C3 exercises this control and effectively shunts part of the balance network R4, R5, C4 via the resistor R6 (in series with the capacitors C5, C6 and C7)

when on short lines. The balancing arrangement is designed for the range of impedances found in the Post Office network and takes into account the network R1, C1. The change of balance impedance with subscriber's line length for a 50-volt exchange is shown in Fig. 10. Even this arrangement leaves much to be desired in the aim to achieve perfect balancing, but the improvement over a fixed 4-element balance is fully justified in view of the low cost.

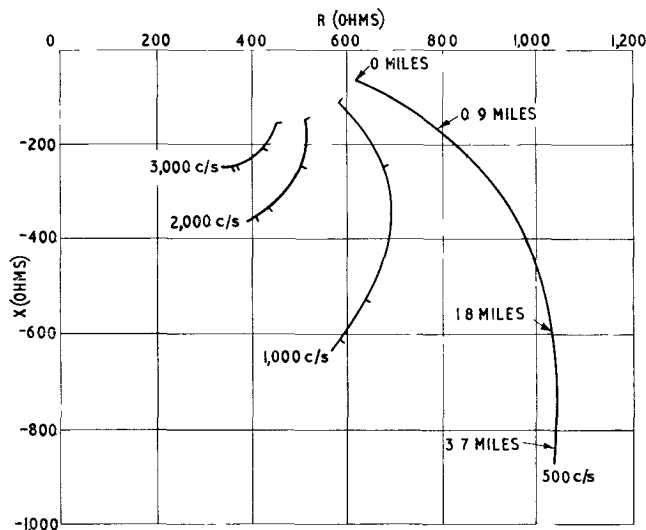

FIG. 10.—CHANGE OF BALANCE IMPEDANCE WITH LENGTH OF SUBSCRIBER'S LINE AND WITH FREQUENCY  
For 50-volt exchange and  $6\frac{1}{2}$  lb/mile conductors

Circuit details of an automatic balancing unit, which also includes transmission equalization, are given in the Appendix. This type of unit is still in the experimental stage but obviously has many advantages for future designs of non-switched or partially-switched instruments.

#### PERFORMANCE AND LIMITATIONS IN USE

Little can be said at this stage about the operation of loudspeaking telephones in the Post Office network because the number tested has been small. Similar equipments have been used in other countries, and, for instance, in the U.S.A. the Bell Telephone Co. has introduced the Speakerphone<sup>6</sup> (a non-voice-switched instrument).

There is little doubt that a major field of usefulness is on private branch exchanges where extension-to-extension calls are most frequently made. Under these conditions the incoming signal strength is sufficient for ample loudness from the loudspeaker when the volume control is set to the low or medium position. However, when two Loudspeaking-Telephones No. 1 work together, satisfactory loudspeaking operation at both ends may not be obtained unless the rooms are quiet and a loud signal is not required.

When using the loudspeaking telephone on junction calls, about 10–15 db junction attenuation is probably the highest which most subscribers would tolerate before preferring to use the handset. This assumes that room noise is not excessive.

The received speech at the distant end is at a somewhat lower level than when generated from a handset, but this is partially compensated for by the improved quality obtained from an electromagnetic microphone

compared with the carbon-granule transmitter. Because the subscriber will be compelled to use a handset on the higher-attenuation calls, there is little risk of the distant-end reception being below standard.

#### INSTALLATION

The loudspeaking telephone can be used on direct exchange lines, on extensions, on private branch exchanges, and on certain extension plans.

The 2-wire line is connected to the amplifier unit by terminals, and the control unit and telephone unit are connected to the amplifier unit by plugs and sockets and then placed in their working positions. If the subscriber's line has a resistance exceeding 500 ohms the gain of the sending amplifier is increased by adjustment of the 2-position link in the ABC unit.

Receiving loudness can be adjusted by two controls in series, one available to the subscriber, i.e. the volume-control key on the control unit, and the other a pre-set gain control within the amplifier unit. With the volume-control key in the middle position, the ON key is operated and, on automatic systems, dialling tone should be heard. The pre-set gain control is then carefully adjusted so that the loudspeaking telephone just does not howl. On manual systems a similar adjustment is made with only an answering cord connected. This adjusts the loudspeaking telephone so that it will not howl on any connexion when the volume control is in the low or medium positions.

#### MAINTENANCE

A component which has caused maintenance engineers misgivings is the electrolytic capacitor. The transistor circuits, because of their low impedances, need quite a large number of electrolytic capacitors, but fortunately of low-voltage working; however, to increase reliability, high-grade electrolytic capacitors have been used.

At the subscriber's installation the maintenance engineer will renew any of the three units which becomes faulty, the testing and changing being simplified by the provision of plugs and sockets within the amplifier unit. It is undesirable that further maintenance should be done at the subscriber's premises.

#### CONCLUSIONS

There is a considerable demand by subscribers for loudspeaking telephones, mainly from those who are conversant with the facilities obtainable and know that such items are available. It is expected that the provision of the Loudspeaking-Telephone No. 1 will satisfy much of this demand by providing an instrument which, although having certain limitations, can be offered at a reasonable rental, and will provide the valuable "hands-free" facility.

The loudspeaking telephone requires no mains power-supply connexion, and, for a non-voice-switched loudspeaking telephone, has a high level of transmission performance. Its cost and estimated maintenance requirements are low.

#### ACKNOWLEDGEMENTS

The design and production of an item such as this is only accomplished through the combined efforts and knowledge of many people both in industry and in the Post Office. The authors wish to thank their colleagues for help in the design of the instrument, and in the preparation of this article.

## References

- <sup>1</sup> SPENCER, H. J. C., and WILSON, F. A. The New 700-Type Table Telephone—Telephone No. 706. *P.O.E.E.J.*, Vol. 52, p. 1, Apr. 1959.
- <sup>2</sup> SPENCER, H. J. C. Some Principles of Anti-Side-Tone Telephone Circuits. *P.O.E.E.J.*, Vol. 48, p. 208, Jan. 1956.
- <sup>3</sup> HORSFIELD, B. R., and SMITH, D. C. A.C. Signalling—A Review of Current Problems. *I.P.O.E.E. Printed Paper No. 204*, 1952.
- <sup>4</sup> RODDAM, T. Return Loss. *Wireless World*, Vol. 63, p. 521, Nov. 1957.
- <sup>5</sup> WILLIAMS, F. E., and WILSON, F. A. Design of an Automatic Sensitivity Control for a New Subscriber's Telephone Set—The British Post Office 700-Type Telephone. *Proceedings I.E.E.*, Paper No. 2867E, Mar. 1959 (Vol. 106, Part B, p. 361).
- <sup>6</sup> CLEMENCY, W. F., ROMANOW, F. E., and ROSE, A. F. The Bell System Speakerphone. *American I.E.E. Transactions*, Vol. 76, Part 1, p. 148, May 1957.

## APPENDIX

### An Automatic Balance-Control Unit Incorporating Transmission Equalization

This unit may be considered as a replacement for the unit described in the above article. Its principle of operation is somewhat different in that it employs a fixed balance and an automatically controlled network, in the form of an L-type attenuator, in tandem with the line to reduce the range of line impedances which the hybrid circuit is required to balance.

If the maximum permissible length of subscriber's line is  $l$  miles and in any particular case the length of line is  $x$  miles, then the automatic circuit inserts, between the hybrid transformer and the line, a network (series resistance and shunt capacitance) approximately equivalent to a line of length  $(l-x)$  miles. The hybrid transformer circuit is, therefore, connected to a similar, very much reduced, range of line impedances whatever the length of the subscriber's line, and receiving levels in both directions are automatically compensated.

As in the case of the ABC unit already described, the p.d. between points a and b ( $V_{a-b}$ ) in Figure 11 varies according to the resistance of the subscriber's line (e.g. 14 volts on zero-resistance lines to 8 volts on 1,000-ohm lines). Direct current will therefore flow through the two parallel paths R1, MR3, etc., and R2, R5, and a p.d. will be developed between points c and d. This potential biases the rectifiers MR1 and MR2, and resistors R1, R2 and R5 are chosen so that on zero-resistance lines the bias is either reverse or very low in the forward direction. However, resistor R5 must be of fairly high resistance as it is connected directly across the line.

To speech signals, points c and d are at the same potential because they are linked by the low-reactance capacitor C2; thus, the impedance between points e and d ( $Z_{e-d}$ ) is that of the two equal combinations MR1, R3 and MR2, R4 in parallel. On zero-resistance lines, because MR1 and MR2 are biased to very high impedances,  $Z_{e-d}$ , which is, in effect, a series element in the subscriber's line, is approximately equal to  $R_3/2$  or  $R_4/2$ . Thus, the maximum resistance of the series arm of the L-type

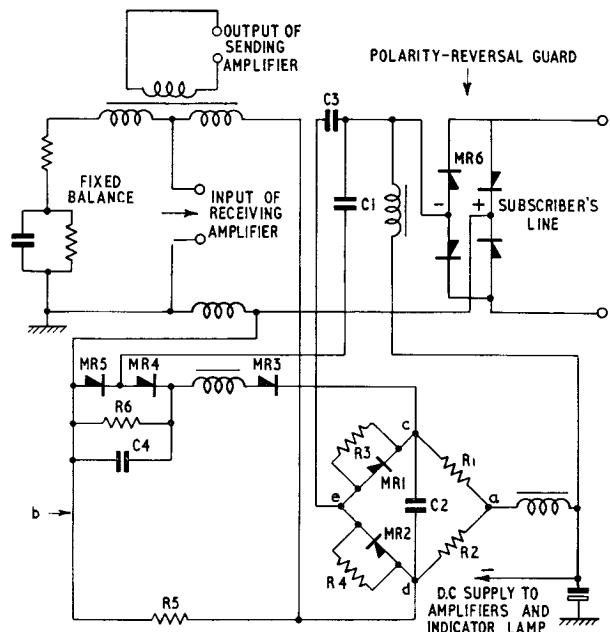

FIG. 11—AUTOMATIC BALANCE CONTROL UNIT INCORPORATING TRANSMISSION EQUALIZATION

attenuator can be made any practical value by the choice of suitable values for the resistors R3 and R4.

The shunt-capacitance arm of the attenuator is controlled by the network MR4, MR5, R6, C4 in a similar manner to that adopted for the present ABC unit.

Comparing the electrical conditions on 1,000-ohm lines with those given above for zero-resistance lines:

- (a)  $V_{a-b}$  falls from 14 volts to 8 volts.
- (b) The voltage across R2 decreases in a similar ratio.
- (c) The voltage across R1 decreases in a lower ratio owing to the rise in resistance of the rectifier chain MR3–MR5 at lower currents.

The voltage across points c and d therefore rises, causing rectifiers MR1 and MR2 to conduct; thus, their impedances fall to values very much smaller than R3 or R4 (e.g. 10–20 ohms is easily obtained using junction diodes for MR1 and MR2). The series arm of the attenuator is then effectively short-circuited. The shunt arm is similarly rendered inoperative by the considerable rise in impedance of MR4 and MR5.

Although only the extremes of line resistance have been considered, it can also be shown that an automatically controlled network may be obtained which closely simulates the difference between a line of a given maximum resistance and the line in use.

## Book Review

“Proceedings of the Symposium on Microminiaturization of Electronic Assemblies.” Edited by Eleanor F. Horsey. Hayden Book Co., Inc., New York, and Chapman & Hall, Ltd., London. viii + 278 pp. 185 ill. 88s.

This book comprises 21 papers presented at an “instructional-type” symposium at the Diamond Ordnance Fuze Laboratories in the autumn of 1958, under the headings of Techniques (5 papers), Semiconductors (3 papers), Components (7 papers), Circuits (4 papers), Missile Systems (2 papers), and Microelectronics in Industry (2 papers).

Microminiaturization has not been clearly defined, but generally refers to the design of electronic equipment in which reductions in the size and weight of components has enabled component packing densities to be achieved in the range of 100,000 to several million components per cubic foot. “Solid circuits” and “molecular electronics” extend

this range up to about 30,000,000/ft<sup>3</sup>. (To set the scale it may be said that pre-1940 conventional circuits had component packing densities up to about 1,000/ft<sup>3</sup>, and that the new transistorized Medresco hearing-aid unit has a figure of about 8,000–14,000/ft<sup>3</sup>, depending on whether the dimensions considered take into account the protective case, or not.)

This book has a great deal of information packed into it, particularly with respect to constructional techniques, and will undoubtedly be a great help to those who have to develop very small equipments. One paper is devoted to “The Design of a Transistor NOR Circuit for Minimum Power Dissipation,” but otherwise there is not very much reference to the problems raised by the concentration of many heat-producing components into a small space. The 50 pages on circuits do, however, indicate many points by which the circuits can be adapted so as to favour micro-miniaturization.

A. A. N.



# Central Service-Observation Equipment Using a Transistor-Controlled Motor-Uniselector

C. D. VIGAR, A.M.I.E.E.†

U.D.C. 621.395.31:621.395.342.24:621.382.3

Recent developments in electronic techniques have enabled the central service-observation equipment to be redesigned to give improved facilities. This article describes the way in which electronic techniques are used to give an improved method of access to the equipment carrying the traffic selected for observation. The problems arising in circuits which combine solid-state and electro-mechanical devices and the savings which result from this combination are also discussed.

## INTRODUCTION

THE existing central service-observation (C.S.O.) equipment<sup>1</sup> uses four uniselectors to gain access to the selectors or relay-sets it is observing. The observed selectors are wired to the banks of the four uniselectors so that at any time each uniselector is connected to one selector. When a call is made on one of the four observed selectors it is connected to the observing operator at the distant observation centre via the junction equipment and C.S.O. junction. The operator can then observe the pulses dialled and the progress of the call. On the termination of the observation all four uniselectors step forward, each one stopping on the next outlet connected to a free selector. Thus, the next observation will be made on one of four different selectors. As only four selectors are monitored at a time, the traffic offered to the operator is often inadequate to keep her fully occupied.

The introduction of subscriber trunk dialling has made it necessary to observe metering which is taking place over junctions.<sup>2</sup> This necessitated a change to the equipment and the opportunity was taken to carry out the following modifications:

(a) Replace the four access uniselectors by a motor-uniselector which starts to find a selector immediately it is seized and monitors it before dialling commences.

(b) Replace the valve amplifier by a transistor amplifier.

† Telephone Exchange Systems Development Branch, E.-in-C.'s Office.

(c) Replace the valve dial-pulse detector by a transistor monitor unit.<sup>3</sup>

(d) Provide a transistor monitor unit to detect metering which is taking place over junctions.<sup>2</sup>

(e) Replace the valve meter-pulse detection circuit by a transistor circuit.

The arrangement of the modified equipment is shown in Fig. 1. Its operation is similar to that of the existing equipment with the exception of the operation of the motor-uniselector finder. When the operator's headset is plugged into the observation position and the junction key is thrown, the outgoing signalling circuit switches on the amplifier and detector circuits. The finder will be standing on a home position, and will await the arrival of a call on any one of 24 selectors in a group being observed. When a selector is seized the wipers of the finder uniselector rotate to it and connect its positive, negative, private and meter wires to the C.S.O. junction circuit.

A monitoring unit detects the dial pulses and repeats them to the observation position. The reversal and meter-pulse detectors repeat the called-subscriber-answer condition and the meter pulses. If the selected relay-set is relaying meter pulses by reversals over a junction, the outgoing signalling circuit transmits a called-subscriber-answer condition on the first reversal and meter pulses on subsequent signals from the reversal detector. Speech signals from the high-impedance monitoring circuit are amplified by the transistor amplifier before transmission over the C.S.O. junction. When either the observed selector releases, or the observation operator operates the release key, the finder moves to the next home position.

## FINDER CIRCUIT OPERATION

The finder is a 100-outlet motor-uniselector with four home positions. Each outlet is connected to one of the

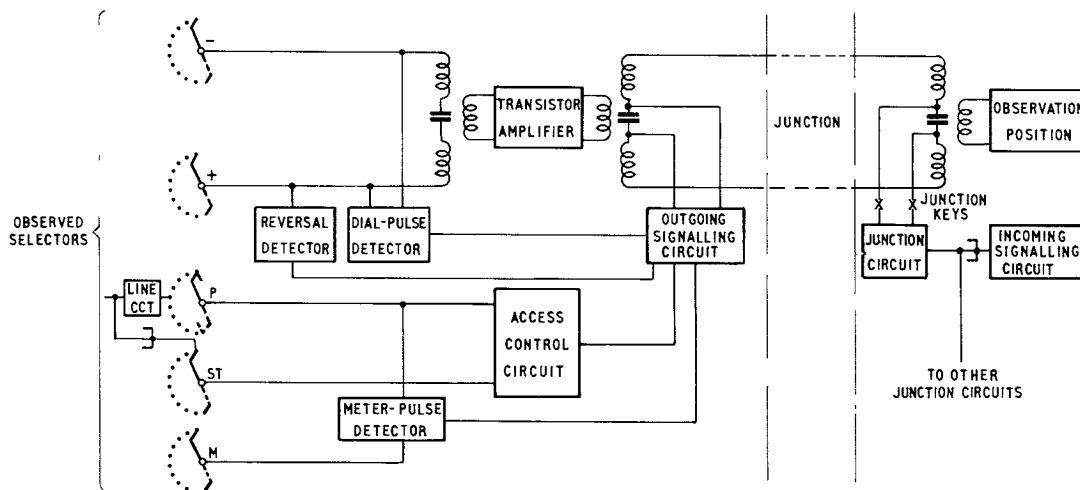

FIG. 1—BLOCK SCHEMATIC DIAGRAM OF THE TRANSISTOR-CONTROLLED C.S.O. EQUIPMENT

selectors or relay-sets that are to be observed and each home position can receive a start signal from any one of the P-wires of the 24 circuits in the group. A signal is given by a line circuit when the selector to which it is connected is seized, and this starts the wipers of the finder uniselector rotating if they are at a home position when the signal is given. The wipers pass over free circuits and also over circuits in use when the hunting commenced, but stop on the circuit which gave the start signal. The time between the start signal and the wipers reaching the 24th contact is about 170 ms.

A block schematic diagram of the finder is shown in Fig. 2. The P-wire of each line circuit is connected to

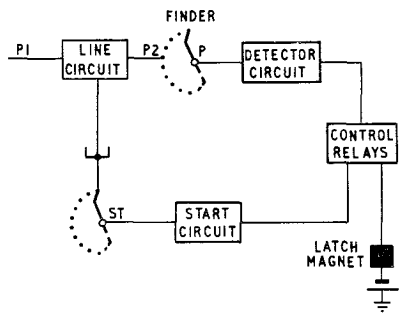

FIG. 2—BLOCK SCHEMATIC DIAGRAM OF THE CONTROLLING ELEMENTS OF THE MOTOR UNISELECTOR

the P-wire of a selector on which observations are to be made. When the selector is taken into use an earth is connected to point P1 of the line circuit. At the initial connexion of this earth the line circuit generates a positive voltage which rises sharply to +50 volts and falls exponentially to earth potential in about 200 ms. This voltage causes the start circuit to operate the latch magnet and the finder uniselector wipers rotate. When the detector circuit observes that the P wiper of the finder has made contact with a P2 wire on which this positive voltage also appears, it will stop the wipers rotating.

#### Marking the Calling Circuit

The basic elements of the line circuit are shown in Fig. 3. In the idle condition capacitor C1 is charged to a potential of 50 volts, being connected on one side to -50 volts through resistors R1 and RX, and on the other side to earth via resistors R2, R5 and R3. When the observed selector is taken into use its P-wire will be earthed,

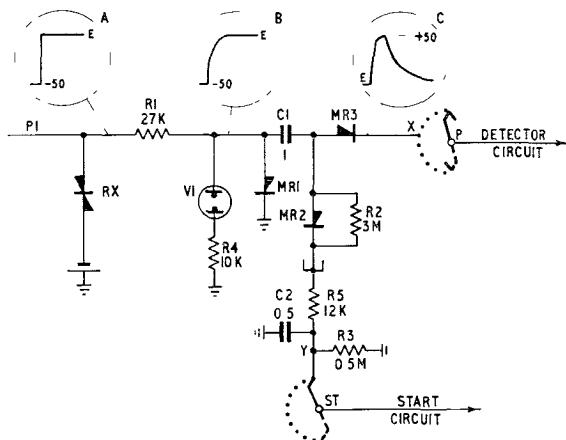

FIG. 3—THE LINE CIRCUIT, SHOWING THE PROTECTIVE DEVICES

and this produces a voltage "step," as shown in the circle A. Current will flow through resistor R1 changing the potential on one plate of the capacitor C1, as shown in circle B. The potential of the other plate of the capacitor will follow this change, but as it is normally at earth potential it will rise exponentially to +50 volts. After the initial change it will slowly discharge, exponentially, through MR2 and resistors R5 and R3. The resultant voltage change at points X and Y is shown in circle C. The voltage at point Y is used to start the uniselector hunting. The voltage at point X is used to mark the calling circuit and thus enable the detection circuit to find the circuit which caused the hunting. The P-bank contacts of all other line circuits will be at earth potential as the capacitor C1 of a circuit that is free will be charged (-50 volts at point P1 and earth at point Y). The bank contact of a previously engaged circuit will be at earth potential because capacitor C1 will have discharged, and both plates will be at earth potential.

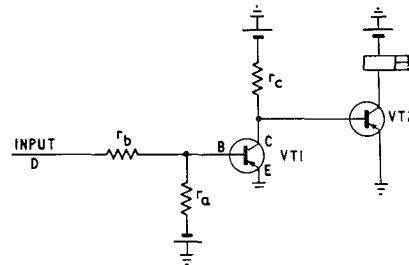

FIG. 4—THE SWITCHING CIRCUIT

#### Switching Circuit

A transistor switching circuit of the type shown in Fig. 4 is used to detect the potential at points X and Y. Transistor VT1 is normally conducting and its collector maintains an earth potential on the base of VT2 so that VT2 does not conduct. A positive voltage at the input will switch off VT1, the current through  $r_c$  will then flow through the base-emitter junction of VT2 causing it to conduct and operate the relay. A high-speed relay is used because the inductance of this relay is low and the induced voltage generated in its coil when it releases is so small that damage to the transistor is prevented. The design principles for the switching circuit are given in the appendix.

#### Start Circuit

The start circuit (Fig. 5) consists of a switching circuit which has positive feedback connected to it by means of capacitor C2 and resistor R4. The P-wires of the observed circuits are connected through rectifiers to a

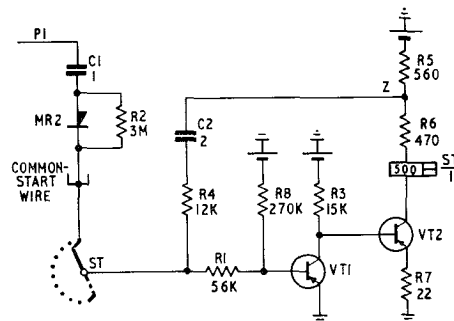

FIG. 5—THE START CIRCUIT

common point which is connected to the input of the start circuit via the home contact of the finder uniselector. A positive pulse from one of the P-wires will cause the switching circuit to operate relay ST. Contact ST1 operates the latch magnet and the wipers of the finder uniselector rotate. The collector current of VT2 will pass through resistor R5, causing the potential of point Z to rise from -50 volts to about -30 volts. This will raise the potential of capacitor C2 by 20 volts, causing it to discharge through resistors R4, R1 and R8. This discharge prevents VT1 from conducting for about 200 ms, and thus relay ST remains operated long enough for the uniselector to find the calling circuit.

The potential across VT1 when it is conducting is a few millivolts and this may allow the base of VT2 to become sufficiently negative to allow a small current to flow to the collector of VT2. Should this happen the emitter-collector current will cause a voltage drop across R7, which will make the emitter negative, reduce the leakage current and safeguard VT2 when it is not conducting.

#### Detector Circuit

The wipers of the motor uniselector are stopped by the operation of relay HS, which is also in a switching circuit of the type shown in Fig. 4. The input to the circuit is connected to the P wiper and the relay operates when the wipers of the finder encounter the positive voltage at point X (Fig. 3).

#### CONNEXION OF THE MONITORING UNITS

When the marked circuit has been found, monitoring units are connected to the negative and positive wires to detect and relay to the C.S.O. operator's position information about the numbers dialled, and any metering that takes place on the observed connexion.

The monitoring unit used to detect dial pulses is connected to the positive line, and when the dial springs open the positive line assumes a negative potential, the blocking oscillator of the monitoring unit will oscillate and cause the relay connected to the output of the monitoring unit to operate and repeat the dial pulses over the C.S.O. junction.

A monitoring unit is also used to detect metering-over-junction (M.O.J.) signals. Its connexion to this type of junction circuit is shown in Fig. 6. As the junction circuit is symmetrical, reversing the wires will cause the potential of each point in the line to swing above and below -25 volts. The point A, Fig. 6, which is the terminating point of the incoming junction, will change from -6 volts to -44 volts when the wires of a junction

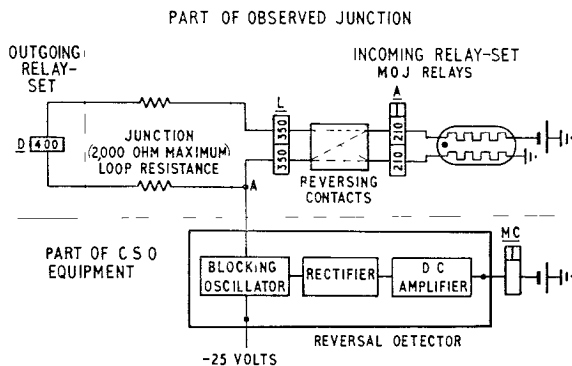

FIG. 6—DETECTION OF METERING-OVER-JUNCTION SIGNALS

of maximum resistance (2,000 ohms) are reversed, and from -22 volts to -28 volts when a junction of zero resistance is reversed. The base of the transistor of the blocking oscillator in the monitoring unit is connected to -25 volts, obtained from a potential divider, and oscillation will thus take place only when the junction is reversed. This signal causes relay MC to operate and repeat the information over the C.S.O. junction.

#### METER-PULSE DETECTION

A C.S.O. equipment, which may be fitted in any type of exchange, must be able to accept any type of meter pulse and operate a relay when it is received. There are three types of meter pulse:

(a) Positive-battery or booster-battery metering systems. A meter pulse consists of a change in potential of the P-wire from earth to +50 volts.

(b) Fourth-wire earth metering system. A meter pulse consists of a change in potential of a separate fourth wire, to which the meter is connected, from -50 volts to earth potential.

(c) Fourth-wire battery metering systems. A meter pulse consists of a change in potential of a separate fourth wire, to which the meter is connected, from earth to -25 volts.

The meter-pulse detection circuit is shown in Fig. 7.

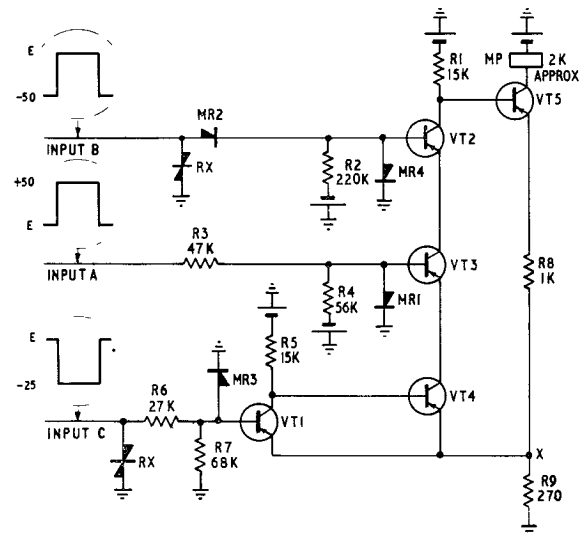

FIG. 7—THE METER-PULSE DETECTION UNIT

When no meter pulse is being received transistors VT2, VT3 and VT4 conduct, current flows through resistors R1 and R9, and the base-emitter junction of VT5 is short-circuited because its base is approximately at the potential of point X. Transistor VT5 is therefore cut off. When a meter pulse is received, one of the transistors VT2, 3 or 4 is switched off and current will flow through resistor R1 to the base of VT5 causing it to conduct. Its collector current flows through resistors R8 and R9 and operates the relay. The resistor R8 serves the same purpose as R7 in the start circuit (Fig. 5).

The three separate inputs to the meter-pulse detector circuit are designed to cater for the three different types of meter pulse which may be encountered. Their operation is as follows:

(a) The input lead A will accept a positive-battery meter pulse. When a meter pulse is received the



potential of the base of VT3 is raised until it reaches earth potential. The diode MR1 then conducts and prevents the voltage rising high enough to damage the transistor. With an earth connected to its base, VT3 ceases to conduct and current through VT5 operates relay MP.

(b) The input lead B will accept meter pulses from the fourth-wire earth metering system. The negative potential connected to resistor R2 keeps VT5 conducting in the normal condition. The series rectifier MR2 prevents the -50 volts potential on the P-wire from passing a large current through the base of VT2. When a meter pulse raises the input lead to earth potential, VT2 is switched off and VT5 again conducts and operates relay MP.

(c) The input lead C will accept meter pulses from the fourth-wire battery metering system. In the normal state VT1 is prevented from conducting by the earth potential at the rectifier MR3. The current through resistor R5 causes VT4 to conduct. When the potential of the input lead falls to -25 volts during a meter pulse, resistors R6 and R7 act as a potential divider and the base potential of VT1 is reduced, causing it to conduct. The base-emitter junction of VT4 is then short-circuited, VT4 no longer conducts and VT5 operates relay MP.

#### PROTECTION OF SEMICONDUCTOR COMPONENTS

On the release of the relays which are normally connected to the P-wire very-high-voltage surges (about 300 volts) are produced and would destroy the rectifiers and transistors unless some protection were provided. The protection devices are shown in Fig. 3. The main protector is the cold-cathode tube V1, which strikes at 85 volts and shunts the induced voltage to earth through resistor R4. Resistor R4 prevents an excessive current flowing through V1. However, the tube may take nearly a millisecond to strike during which time a damaging voltage may have passed through the capacitor C1. To prevent this, the initial voltage is reduced by the non-linear resistor RX, which also serves to feed -50 volts to the capacitor C1 for the normal operation of the circuit.

A simpler means of protection could have been provided by a capacitor connected in place of RX (Fig. 3) but this would have affected the operate and release times of relays connected to the P-wire and consequently the operation of associated electromechanical equipment.

#### PREVENTION OF FALSE OPERATION

The line circuit (Fig. 2) is designed to generate a positive voltage when the P-wire of the observed selector is raised in potential. When a free selector is seized the potential on its P-wire is raised from -50 volts to earth and the resultant positive voltages at points X and Y (Fig. 3) cause the finder to find the seized selector; but when a meter pulse is sent from a selector in a positive-battery or a booster-battery metering system the potential of the P-wire is raised from earth to +50 volts for a period of 250 ms. This rise in potential of the P-wire will also cause the line circuit to generate a positive voltage and would result in the operation of the finder unless preventive measures are taken. The rectifier MR1 in the line circuit (Fig. 3) conducts when a meter pulse attempts to raise the potential of the capacitor above that of earth. The resistor R1 allows the potential of the P-wire to rise to +50 volts, thus permitting the subscriber's meter to operate while the P1 side of

capacitor C1 is maintained near earth potential. However, because of the forward resistance of rectifier MR1, a small positive voltage is actually generated by the line circuit; it is not enough to operate the start circuit, but if the finder were searching as a result of a genuine start signal this voltage would be enough to cause false operation of the detector circuit. False operation is prevented by providing a circuit which will inhibit the operation of relay HS, which would stop the finder wipers if it detects a positive voltage on the P-wire.

The circuit to perform this function is shown in Fig. 8.

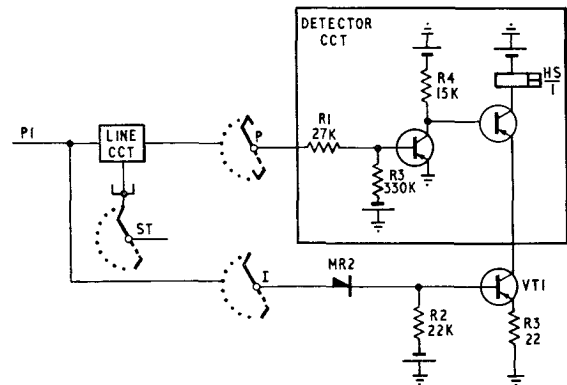

FIG 8—THE INHIBIT CIRCUIT TO PREVENT SWITCHING TO A POSITIVE-BATTERY METER PULSE

Transistor VT1 is normally kept conducting by the current passing through resistor R2. Relay HS can be operated by the detector circuit when a positive voltage resulting from a genuine start signal is detected on arc P. The base of VT1 is connected to the wipers of arc I which sweep over the P-wires of the selectors; a positive voltage detected on this arc can only come from a meter pulse. This positive voltage passes through MR2 to the base of VT1, switches it off and prevents the operation of relay HS.

In practice it has been found that the start circuit may also be falsely operated by induced voltages in the cabling. These voltages, which are of about 50 volts and 10 ms duration, occur when a selector sharing the same cable as the observed selector releases. Resistor R5 and capacitor C2 (Fig. 3) form a filter circuit which prevents these voltages from reaching the start circuit.

#### CONCLUSIONS

The design of this equipment shows that transistor circuits can be used to receive signals of a transient nature and interpret them to control electromechanical equipment. By designing circuits using both transistors and relays, facilities can be obtained which could not be provided by these components when used by themselves.

Transistors offer advantages over valves in this respect because they do not require ancillary circuits such as power-supply units, anode-current check circuits, and timing circuits to prevent the connexion of H.T. while the valves are cold. Also, ventilation is not required to keep down the ambient temperature of the equipment.

However, transistors are electrically delicate and must not be exposed to the high voltages generated by electromagnets. If special protection is required it must be designed so that the performance of the electromechanical circuits is not affected.

## References

- <sup>1</sup> BARNARD, A. J. and BECK, E. H. A. The New Centralized Service-Observation System. *P.O.E.E.J.*, Vol. 49, p. 81, July 1956.
- <sup>2</sup> HEPTINSTALL, D. L. and RYAN, W. A. Metering Over Junctions. *P.O.E.E.J.*, Vol. 51, p. 126, Jan. 1959.
- <sup>3</sup> PRICE, C. K. A Line-Signal Monitoring Unit using Transistors. *P.O.E.E.J.*, Vol. 53, p. 121, July 1960.

## APPENDIX

### Design of the Switching Circuit

Because the voltage of the exchange battery is 50 volts considerable advantage is gained by using a transistor which will operate with 50 volts on its collector. A suitable transistor which will stand such a high collector voltage is the CV 7007, and this transistor is used throughout the equipment. Its limiting parameters are:

Maximum collector voltage	$V_c = 60$ volts
Maximum collector current	$I_c = 125$ mA
Maximum reverse base-emitter voltage	$V_b = + 6$ volts
Maximum collector leakage current in the off condition	$I_{co} = 100$ $\mu$ A
Maximum base current	

The basic circuit for a transistor connected as a switch in common-emitter configuration is shown in Fig. 4. The limiting parameters of the transistor determine the maximum and minimum permissible values of  $r_a$ ,  $r_b$  and  $r_c$ .

As the transistor is being used as a switch very little power is dissipated in the transistor and the maximum power rating is not the limiting parameter restricting the collector current.

$$\text{Power, } P_c = V_c I_c$$

where  $V_c$  = collector voltage  
 $I_c$  = collector current.

As, when the transistor is in the off condition,  $I_c$  is almost zero, and when it is in the on condition  $V_c$  is almost zero, the power to

be dissipated is very small. Only during the time of switching from one condition to the other is there any danger of power in the transistor raising its temperature to a dangerous level. The power dissipated during switching will be small provided that the switching times are not long. Thus, the minimum value of  $r_c$  is limited only by the maximum value of  $I_c$ . The maximum value of  $r_c$  is determined only by the current required to operate the succeeding stage when the transistor is switched off.

The value of  $r_a$  is limited by three requirements:

(i) The current through  $r_a$  must be large enough to "bottom" the transistor in the on condition.

(ii) When the 50 volts is applied at the point D, resistors  $r_a$  and  $r_b$  acting as a potential divider must not allow the potential of point B to rise above +6 volts.

(iii) Resistor  $r_a$  must restrict the base current to less than 20 mA.

The base-emitter impedance of a transistor is small and the resistor  $r_b$  is inserted to increase the input impedance of the circuit. The maximum value of resistor  $r_b$  is limited, however, by the leakage current which flows in the reverse direction from the collector to the base when the transistor is in the off condition. This current is usually referred to as  $I_{co}$  (or sometimes  $I_{bo}$ ), it is temperature dependent and may be as large as 100  $\mu$ A at the upper working temperature. If resistor  $r_b$  is large,  $I_{co}$  can cause a voltage drop across  $r_b$  so that in the off condition the base, B, is less positive than the point D and the condition may be reached in which the base potential falls low enough to allow the transistor to conduct. The current which flows increases the transistor temperature and therefore the value of  $I_{co}$ . The potential drop across  $r_b$  further lowers the base potential. There is then both current flowing through the transistor and a voltage drop from collector to emitter. The circuit now ceases to function as a switch and, if resistor  $r_c$  is small, the transistor will probably be destroyed by thermal runaway. In practice this means that resistor  $r_b$  must be low, i.e. less than about 50,000 ohms.

## Book Review

"Aluminium Busbar." A. G. Thomas, B.Sc.(Eng.), A.M.I.E.E., A.M.Amer.I.E.E., and P. J. H. Rata, B.Sc.(Eng.), A.C.G.I. Published for Northern Aluminium Co., Ltd., by Hutchinson & Co. (Publishers), Ltd. 105 pp. 54 ill. 21s.

This book, although well written and covering the subject very fully, is a "company book." It deals specifically with grades of aluminium alloys and products marketed by the Northern Aluminium Co., Ltd. Chapter 1, "B.S. 2898," says "2 busbar materials are available. The first is . . ." and proceeds to quote two NORAL grades completely ignoring other sources of supply. This attitude is continued all through the book. Another example occurs on pages 67 and 68 where the only jointing compound mentioned is a proprietary brand, whereas B.S. 159 and E.R.A. Technical Report Z/T 118 have quite a good word for the humble petroleum jelly.

There are points in the book which are somewhat puzzling; for instance, considering Fig. 6 and 9, one is left in some doubt as to which way channel sections should be used to obtain the maximum efficiency. This is possibly the result of using material collected from different sources. Another point which could have been made a little clearer is on page 67, where the author, in stating that two methods of cleaning are available, refers to a method of chemical cleaning using jointing compounds; his only succeeding reference to jointing compounds refers to a particular compound which is not of the "cleaning" type. The method of jointing described and illustrated on page 68 is, however, the accepted standard method and produces satisfactory jointing with a large range of jointing compounds.

The paper jacket carries a short synopsis on the front flap in which a statement is made that the current-carrying capacity of aluminium is about 75 per cent of that of copper. This may be so in some particular case but the normal method of comparison is the conductivity per unit cross-section and this is accepted as being approximately 60 per cent of the conductivity of copper for equal cross-section. The statement referred to does not appear in Chapter 1 where the specific resistance given confirms the usual value of about 60 per cent of the specific resistance of copper.

A very useful point of practical application is that "rating factors" for structural and engineering sections are given in Table 6. These classes of aluminium alloys can often be obtained at short notice from local sources for an urgent job, and they are useful where greater than normal strength or rigidity is required.

Apart from these criticisms the book contains a large amount of collected information and the bibliography is good. It brings together under one cover all the major information required for the design of busbar systems using aluminium, the worked examples in Chapter 6 being extremely helpful. Chapter 2 is devoted to design considerations and covers losses due to temperature rises, voltage drop and corona effects. Chapters 3 and 4 cover busbars for d.c. and a.c. applications, respectively, and Chapter 4 coupled with Chapter 5 (Reactance of Busbars) gives excellent coverage to the problems to be dealt with in a.c. applications. Chapter 7 covers mechanical factors to be considered in designing a system.

On the whole, apart from the "company book" aspect, the treatment of the subject is excellent and the book is a "must" for anybody concerned with the design of busbar systems.

L. H. C.

# The Unit Method of Automatic Telephone Exchange Design

J. P. LAWRENCE, Graduate I.E.E.†

U.D.C. 621.395.722

One of the problems of exchange planning in recent years has been the replacement of obsolete or worn-out equipment without affecting the service life of other equipment in the exchange. The unit method of automatic telephone exchange design has been developed to ensure that the need for ultimate replacement is taken into account in the preliminary planning and design of new exchanges. Both the method and its application are considered in this article.

## INTRODUCTION

THE planning of a telephone system involves a long-term survey of future requirements and developments since, in common with all public utilities, it must be capable of easy extension to meet increasing demands for service, while at the same time permitting the incorporation of new facilities made possible by technical progress. From an economic aspect it is essential that all telephone plant should remain in service as long as possible consistent with satisfactory performance, and individual items or groups of equipment be replaced at the end of their life without prejudice to the working life of equipment with which they may be associated.

The success with which these requirements can be fulfilled will obviously depend on the methods of plant provision. This article describes the principles underlying the unit method of automatic telephone exchange design, and discusses alternative ways in which it may be applied to achieve the desired equipment flexibility and ease of replacement.

## TRADITIONAL PLANNING METHODS

### *Building*

Traditionally, a telephone exchange building has been provided to meet the requirements of the exchange unit for a 20-year period, and for the purposes of site and accommodation calculations a forecast of the increase in subscribers' connexions and their telephone-traffic characteristics, together with an estimate of trunks and junctions required by the end of that period, is supplied to the design engineer. By applying standard design principles to these limited traffic data, the 20-year requirements for the equipment racks, power equipment and distribution frames can be obtained, which, after careful scrutiny, enable floor plans to be prepared and floor-space requirements to be assessed. The addition of switchroom and ancillary accommodation requirements completes the basic information required for the design of the building.

### *Site*

Having decided the initial building requirements, it is necessary to specify the required exchange-site capacity and define an area within which the search for a suitable site should be confined. The capacity of an exchange site is normally defined as that which will accommodate the 20-year building requirements with an allowance for a 100 per cent extension of the essential floor space. In practice, some deviation from this standard may be necessary due to local conditions such as exceptional

requirements for ancillary accommodation, building restrictions, etc. The actual exchange-site area will, of course, be affected by the method which will be used to extend the building to meet the post-20-year requirements.

### *Apparatus-Room Floor Layout*

Apparatus racks and distribution frames are arranged on the exchange apparatus-room floor with the object of obtaining a compact self-contained unit at the end of the 20-year period when, ideally, the apparatus-room floor space will be fully utilized. Each instalment of equipment is provided to meet the requirements of an approximate 5-year period. Thus, if the ideal is achieved, the apparatus room will eventually accommodate equipment in four main age-groups corresponding to the initial installation, extension 1, extension 2 and extension 3, provided at the opening date, and the 5-year, 10-year and 15-year dates, respectively.

With the traditional layout, racks are grouped according to type, e.g. 1st selector racks, and space is left within each group for expansion to the 20-year requirements. Fig. 1 shows the disposition of racks and space for the initial installation and the final layout of equipment for a medium-sized non-director exchange. It should be noted that space is normally left for expansion of the main distribution frame (M.D.F.) to the capacity demanded by full utilization of the site.

The relative disposition of groups of racks and frames is governed by the need to: (a) keep cabling costs to a minimum, and (b) facilitate maintenance functions such as call tracing, testing, replacement of equipment, etc. It follows that the subscribers' equipment, i.e. the calling equipments, final selectors, meters and the subscribers' intermediate distribution frame (I.D.F.), are located in close proximity to one another, and the selector and relay-set racks and the equipment I.D.F. to which they are cabled are similarly associated.

In large exchanges with automanual switchboards the subscribers' meters are located in a separate meter room. This arrangement can, however, involve the provision of a long cable run to the subscribers' I.D.F. with an appreciable increase in the cost of cabling.

## DISADVANTAGES OF TRADITIONAL PLANNING METHODS

It is some 35 years since it became standard practice in the British Post Office to provide new automatic exchanges to replace those manual exchanges which had become worn out or obsolete, but it is only recently that the problem of automatic-exchange replacement has arisen. The study of this problem has led to a review of the traditional methods by which exchanges have been planned, particularly with regard to such long-term considerations as accommodation planning, numbering-scheme requirements and the replacement of equipment. It is now possible to see how these methods must be modified to meet the demands of a network which, it is intended, will be fully automatic by 1970, and in which the expansion of subscriber trunk dialling (S.T.D.) is rapidly taking place.

Any review of automatic telephone exchange development must be made against the background of the econ-

† Exchange Equipment and Accommodation Branch, E.-in-C.'s Office.

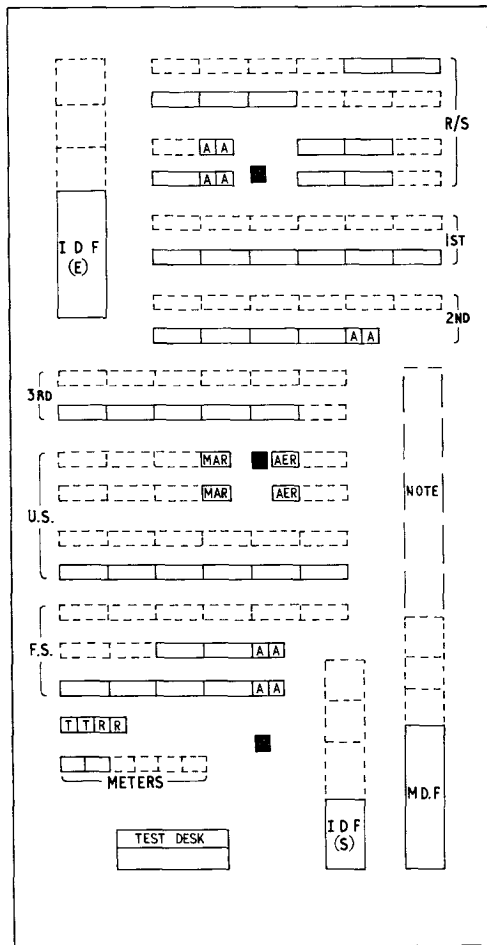

— Equipment provided initially  
 - - - - - Additional equipment

Note. This extension to the M.D.F. will enable it to serve all equipment ultimately provided on the exchange site.

- I.D.F. (E) = Equipment I.D.F.
- I.D.F. (S) = Subscribers' I.D.F.
- A = Routiner or traffic-recorder access equipment
- T = Traffic-recorder control rack
- R = Routiner rack
- AER = Alarm equipment rack
- MAR = Miscellaneous apparatus rack

FIG. 1—TRADITIONAL EQUIPMENT LAYOUT FOR A MEDIUM-SIZED NON-DIRECTOR EXCHANGE

omic conditions and fluctuations in demand that have existed. The lack of necessary capital during the war and post-war years inevitably led to the adoption of expedients, which are contrary to any course of planned engineering development. At the same time, many pre-war forecasts of the increases in subscribers' connexions have proved to be inadequate, resulting in premature exhaustion of exchange sites, buildings and numbering schemes.

The original planning method can be criticized on the grounds that it made no provision for the planned replacement of exchange equipment as it became worn out or obsolete. Furthermore, it should be noted that, whilst sufficient floor space was provided to meet the forecast development, the traditional method of arranging equipment on the apparatus floor is not without disadvantages. These disadvantages can be summarized as follows:

(a) Both exchange development and traffic distribution can vary widely in individual cases from the original forecast. Accurate assessment of floor-space require-

ments for the individual groups of equipment at the 20-year date, which the present method requires, is extremely difficult to realize in practice.

(b) The equipment installed initially is scattered over the apparatus-room floor so that, as illustrated in Fig. 1, the 20-year floor space is, in effect, fully used at the opening date. Space surplus to immediate requirements cannot, therefore, be readily used for other purposes since it is broken up into a number of small areas between groups of apparatus racks.

(c) The equipment racks in different age-groups, i.e. initial installation, extension 1, etc., are intermingled on the apparatus floor so that independent replacement of the initial installation is difficult and expensive. In some cases independent replacement has been impossible, leading to uneconomic premature recovery of plant.

The unit method of exchange design promises to overcome these disadvantages and is discussed in detail in the following paragraphs.

#### DESIGN OF EXCHANGES IN UNITS

The design of exchanges in units represents a departure from traditional standards inasmuch as the equipment is laid out in self-contained units on the apparatus-room floor. The units are arranged in order of provision, as shown schematically in Fig. 2. If all the units are of the

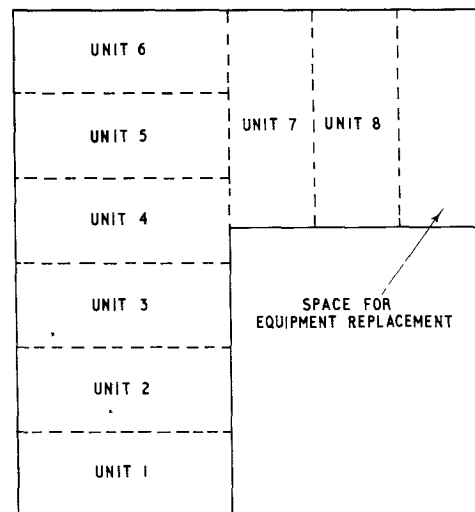

FIG. 2—LAYOUT FOR EXCHANGE BASED ON UNIT-METHOD DESIGN

same size it is theoretically possible to replace unit 1 independently at the end of its life by reserving floor space in the extended portion of the building and providing a replacement unit for unit 1 in this space. Unit 2 can then be replaced in the space vacated by unit 1, and so on. Thus, with such a method of equipment replacement, the maximum life for all equipment would be obtained.

In addition to keeping equipment in service as long as possible, unit design offers the prospect of maintaining the exchange in the original building indefinitely—provided, of course, that growth beyond the date at which the site capacity is fully utilized is taken over by an adjacent exchange or exchanges. Moreover, it will be seen that spare floor space is no longer divided into small portions distributed over the apparatus floor but is available as a single block, which diminishes with each exchange extension. This presents some advantage in

that it should facilitate the introduction of a new type of equipment, e.g. electronic, at some future date.

From the replacement point of view, the ideal unit layout is one in which (a) the whole of the exchange equipment is divided into units, (b) the units are as small as possible, to keep the space for equipment replacement to a minimum, and (c) the number of cables running from each unit is a minimum.

It is necessary to define each unit in terms of the capacity of the subscribers' line multiple and the equipment contained within the unit; this can be done in a number of ways.

The units can be designed on an installation basis, i.e. the first unit comprises the whole of the equipment installed initially whilst the remaining units correspond to extensions 1, 2, 3, etc. This method has a serious disadvantage, however, in regard to the disparity in size of the units, since in most cases the initial installation of equipment is appreciably larger than subsequent extensions. The amount of floor space required for equipment renewal would, therefore, be large, and the advantage of independent replacement of the units could only be realized at the expense of inefficient use of available accommodation.

A more practical method of unit design becomes possible if the exchange equipment is considered as: (a) subscribers' equipment, the quantities of which are determined by the number of the exchange subscribers and their traffic characteristics, and (b) tandem equipment, provided for the switching of junction and trunk calls controlled at other exchanges, and miscellaneous equipment, not necessarily related to the capacity of the subscribers' line multiple of the exchange and to some extent capable of independent growth. It is then possible to either provide subscribers' equipment in units each of a specific multiple capacity and having a proportion of tandem and miscellaneous equipment, or arrange subscribers' equipment in units whilst the remaining equipment is provided as a single tandem and miscellaneous equipment section laid out in the traditional manner.

Initial investigations into the application of these methods of design to non-director and director exchanges favoured the adoption of the latter method, using a 2,000-line multiple unit as the basic unit.

#### THE 2,000-LINE MULTIPLE UNIT SCHEME

In this scheme, an example of which is illustrated in Fig. 3, the following equipment is located in the units: (a) 1st selectors serving ordinary and coin-box subscribers' groups, (b) final selectors, (c) subscribers' uniselectors, (d) penultimate selectors, (e) meter racks, and (f) subscribers' I.D.F.

The tandem and miscellaneous section comprises: (a) 1st selectors serving incoming junctions and trunks, (b) 2nd and 3rd selectors other than penultimate ones, (c) S.T.D. equipment, (d) relay-sets, (e) equipment I.D.F., and (f) miscellaneous equipment.

The subscribers' equipment is arranged in units of 1,800 subscribers' uniselectors and 2,000-line multiple capacity. In spite of the similarity in multiple capacities for different units there is some variation in the number of penultimate and final-selector racks in these units due to the variations in the proportion of ordinary and 2-10 P.B.X. final selectors and to the inclusion in some units of 11-and-over P.B.X. final selectors. In addition, unit 1 accommodates the whole of the coin-box sub-

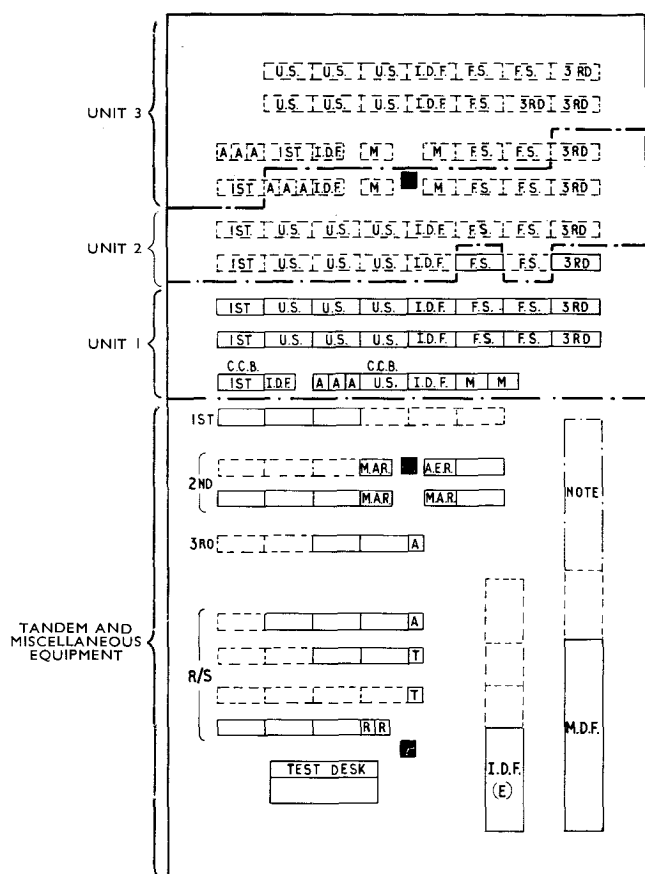

Legend:  
 — Equipment provided initially  
 - - - Additional equipment

Note: This extension of the M.D.F. will enable it to serve all equipment ultimately provided on the exchange site.

I.D.F. (E) = Equipment I.D.F.  
 A = Router or traffic-recorder access equipment  
 T = Traffic-recorder control rack  
 R = Router rack  
 M = Meter rack  
 AER = Alarm equipment rack  
 MAR = Miscellaneous apparatus rack  
 C.C.B. = Coin-box equipment

FIG. 3—NON-DIRECTOR EXCHANGE EQUIPMENT LAYOUT BASED ON THE 2,000-LINE MULTIPLE UNIT

scribers' calling equipments that will be required during the life of the exchange.

The size of the unit adopted was favoured for a number of reasons. The 2,000-line multiple unit gives a convenient apparatus-room floor layout and occupies a comparatively small area so that floor-space requirements for equipment replacement are correspondingly small. Moreover, the multiple size is a convenient one in regard to the size of an initial installation and subsequent extensions of equipment generally. The choice of a whole number of 1,000-line multiple groups enables the penultimate-selector to final-selector cabling to be kept within the unit, thereby facilitating its design as a self-contained group of equipment capable of being easily replaced. The provision of 1,800 subscribers' uniselectors on six racks (300 uniselectors per rack) gives a uniselector to 1st selector grading of convenient size when 90 per cent of the subscribers' lines in the multiple are in use.

The main features of design include:

(a) The provision of separate subscribers' I.D.F. facilities in each unit, which may be met either by the provision of two 4 ft 6 in. rack-type I.D.F.s with inter-jumpering, as shown in Fig. 3, or by a single

double-sided frame, 4 ft 7½ in. long, located in line with the apparatus racks. In either event tie-cables must be provided between units to provide the required flexibility between calling equipments and the final-selector multiple numbers; cables for tie-circuits to the equipment I.D.F. are also necessary.

Compared with the 4 ft 6 in. frame, the double-sided I.D.F. requires more floor space, but it does provide greater capacity. Since it is desirable to keep cables for external connexions to a minimum, this capacity may be used to provide interconnexion between subscribers' uniselectors and their associated 1st selectors. With rack-type I.D.F.s, however, an additional 2 ft 9 in. frame per unit is required for this purpose.

(b) The location of subscribers' meters with the other apparatus racks in the appropriate subscribers' units.

(c) The grading of the outlets of the ordinary 1st selectors by extending the multiple between units either by direct tie-cables or by using tie-pairs via the equipment I.D.F.

(d) Direct cabling of the outlets of penultimate selectors to the final-selector racks.

(e) The provision of a composite rack to accommodate both 1st and penultimate selectors where economy in rack provision can be achieved thereby. This does, of course, complicate the cabling of both 1st selector and penultimate-selector outlets, and makes it necessary to augment the outgoing tie-circuits from the rack concerned to both the equipment I.D.F. and the final selectors.

The tandem and miscellaneous equipment section is located at the opposite end of the exchange to that into which the subscribers' units will be extended, and is laid out in accordance with traditional methods. The relay-set racks and miscellaneous racks will be replaced on a rack-by-rack basis. Group-selector racks, which are linked by rack-to-rack tie-cables, present a more difficult problem, and space is reserved for the ultimate provision of a suite of racks to facilitate equipment replacement.

#### *Advantages and Disadvantages of the Method*

A trial, using the 2,000-line multiple units, was planned at a number of exchanges and in the course of carrying out the trial it was possible to assess the advantages and disadvantages of the method.

The weakness of the method from the aspect of replacing the equipment at some future date is the retention of the standard layout for the tandem-equipment section. Thus, with a large exchange having an appreciable quantity of tandem equipment the principal advantage of unit design would appear to be only partially realized.

The problem of flexibility of connexion between subscribers' calling equipments and final selectors in different units is one which is fundamental to all unit methods, and is one which increases as the capacity of the subscribers' line multiple of individual units is reduced. Whilst the rack-type I.D.F. in the 2,000-line multiple unit offered a reasonable prospect of sufficient flexibility when the method was originally developed, the introduction of S.T.D. has shown that this flexibility will, in some cases, be inadequate. This is brought about by the need to provide certain auxiliary equipment, e.g. subscribers' private-meter control equipments between calling equipments and 1st selectors, and since, in view of the uncertainty of demand, such equipment cannot

at this stage be split economically into individual units it must be provided in the tandem-equipment section. A complex network of tie-cables between individual subscribers' I.D.F.s and the equipment I.D.F. might, therefore, become necessary and this would result in a reduction of the capacity available on the individual subscribers' I.D.F.s for normal flexibility purposes.

To effect economies in equipment provision a 50-point linefinder calling equipment, to work in conjunction with ordinary subscribers' uniselectors, has recently been introduced for low-calling-rate subscribers.<sup>1</sup> A single 4 ft 6 in. rack of 50-point linefinder equipment associated with 50 subscribers' uniselectors can cater for some 750 subscribers. This compares very favourably with the 2½ racks required by an individual unselector system. Efficient use of this linefinder system, however, normally demands the provision ultimately, if not immediately, of large blocks of calling equipments and, except where the ratio of low-calling-rate to high-calling-rate subscribers is within certain narrow limits, the division of calling equipments into 2,000-line multiple units is liable to introduce an appreciable number of partially equipped linefinder racks.

However, the small 2,000-line multiple unit is one which can be replaced easily and which requires a comparatively small area of floor space to be reserved for ultimate equipment replacement. For a small exchange, where the tandem-equipment section is small and where the subscribers' requirements are such that S.T.D. and 50-point linefinder equipment can be provided economically and efficiently, its adoption may well be justified. To meet other circumstances a modified scheme has been suggested.

#### MODIFIED UNIT METHOD

The modified unit method has been developed for the planning of new exchanges and has been introduced in conjunction with changes in the fundamental planning of exchange buildings.

It is intended that, in the future, each exchange will be planned, and the initial building will be provided, to cater for a specific multiple capacity in that building. Buildings will no longer be provided to meet the requirements of a fixed 20-year period, but, in effect, will be planned for an initial building-design period of 10-20 years, the actual period depending upon such factors as the rate of increase in subscribers' connexions, development of the numbering scheme, possible changes in exchange-area layout, and site limitations. In this way it will be possible to plan using a forecast which is likely to be more realistic than that for the previous fixed 20-year period, and provision for the longer period can be deferred until development can more easily be foreseen.

Equipment will be provided as a combination of units of 2,000-line, 3,000-line, 4,000-line, or 5,000-line multiple capacity per unit, each unit being served by a separate subscribers' I.D.F. located parallel to the suites of apparatus racks. Where the 2,000-line multiple unit is required it may be provided either separately or as the first instalment of a 4,000-line multiple unit. In the latter case, space will be left for the subscribers' I.D.F. to grow to the ultimate capacity of a 4,000-line multiple.

The choice of units to be provided in the initial building must be decided by a consideration of the individual factors operating in each project. Normally, a single unit of appropriate size (up to a 5,000-line multiple





## ECONOMIC CONSIDERATIONS

The unit method offers appreciably greater prospects for the independent replacement of exchange equipment than have hitherto been realized, and the resultant increase in effective equipment life, with the possibility of planned development of the exchange site and building, represents a considerable long-term economic advantage.

Studies carried out prior to the adoption of unit design have indicated that in the short term the change in equipment capital costs is likely to be a marginal one in favour of the new standard. This arises because the equipment installed at any particular time is confined to a smaller floor area than with the traditional method, thereby reducing cabling costs, but the number of partially equipped racks is liable to increase. The increase in apparatus costs tends, therefore, to offset cabling economies.

The space required for equipment at the initial building design date will, in general, be similar for both traditional and unit design methods. The unit method does, however, permit the initial building to be designed for a shorter term than the 20-year period previously used. The resultant economy will depend of course upon the individual characteristics, e.g. rate of growth, of the exchange concerned.

## CONCLUSION

The modified unit method is now being used for the design of new automatic telephone exchanges. Recent experience, together with present trends in exchange planning, favours separate treatment of tandem equipment. It is expected, therefore, that in the majority of cases, the retention of a separate tandem and miscellaneous equipment section will provide the best solution.

Exchange design must take into account not only the demands of ultimate equipment replacement, but the need for economic plant provision and for flexibility to meet increasing demands for service and new facilities. Full consideration must, therefore, be taken of local conditions and in some cases a compromise will be justified. The final course must be decided from a study of the exchange concerned, when account must be taken of such factors as the type and status of the exchange, tandem-equipment requirements, subscribers' development and traffic characteristics, etc. In this way, it will be possible to ensure that the experience and skill of the design engineer are fully employed in achieving maximum economy and efficiency in automatic telephone exchange design.

## References

- <sup>1</sup> FOX, W. H., ASHWELL, J. L. K., and WEAVER, A. L. Subscribers' 50-point Linefinder System. *P.O.E.E.J.*, Vol. 51, p. 81, July 1958.
- <sup>2</sup> FRANCIS, H. E. Post War Exchange Design. *I.P.O.E.E. Printed Paper No. 181*, 1943.
- <sup>3</sup> HIX, K. W. The Telephone Exchange Main Distribution Frame. *P.O.E.E.J.*, Vol. 53, p. 226, Jan. 1961.

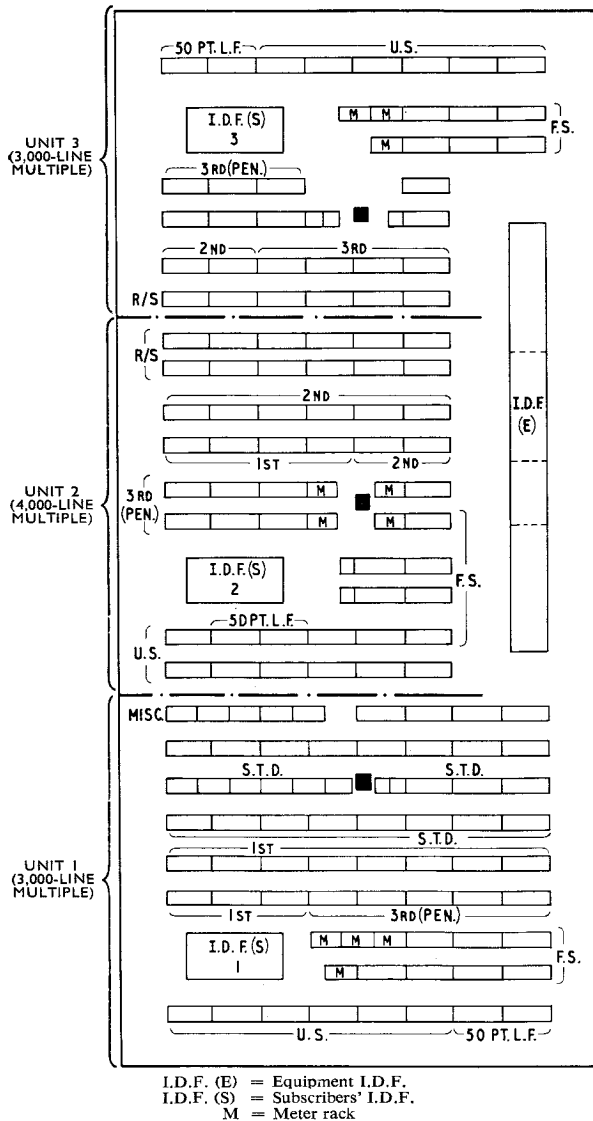

FIG. 5—NON-DIRECTOR EXCHANGE EQUIPMENT LAYOUT BASED ON MODIFIED UNIT-METHOD DESIGN WITHOUT SEPARATE TANDEM EQUIPMENT

exchanges can now be served by a single frame located across the apparatus room. Irrespective of the arrangements adopted for the tandem section, a separate equipment I.D.F. will be necessary to provide flexibility of the interconnexions between selectors, relay-sets, manual-board terminations and miscellaneous equipment generally. Sufficient vertical sections of the frame will be provided for all the exchange equipment that will occupy the original building, with an allowance for the termination of tie-cables to the equipment I.D.F. which will eventually be provided in the extended portion of the building.

# A Note on the Laying Effect and Aging of Submarine Telephone Cables

R. A. BROCKBANK, Ph.D., B.Sc.(Eng.), A.M.I.E.E.†

U.D.C. 621.315.28:621.317.341

Measurements on the first transatlantic telephone cable (TAT-1) showed that an appreciable decrease in attenuation was taking place during aging, in addition to the initial decrease in attenuation measured during the laying operation. After considerable study and experimenting a length of special cable was manufactured and laid. Measurements on this cable showed that no laying effect had occurred and that the aging effect over 7 months was negligible, and it is believed that the location of, and the cure for, these phenomena have now been definitely established.

THE change-over from submarine telegraph cables to carrier telephone cables, which began about 1930, necessitated the addition of a metallic return conductor to the cable structure. At telegraph frequencies the return path of a submarine cable is adequately and efficiently obtained through the medium of the sea, but with signals of increasing frequencies the return current concentrates closer to the cable so that a low and stable cable attenuation is only possible by providing a low-resistance return path directly over the core insulation. The construction which has been generally adopted for this conductor consists of a layer of long-lay copper tapes laid up over the core insulation, followed by an overlapping short-lay copper binding tape. Among useful functions that have been ascribed to this binding tape are (a) retaining the outer coaxial conductor, (b) acting as an anti-teredo barrier, and (c) reducing the possibility of environmental cracking of the polythene insulation by the lighter constituents of the compound used to impregnate the jute bedding for the armour.

For many years coaxial cables with this type of construction were used, in general, on short shallow-water schemes and they gave every satisfaction from the point of view of electrical performance. In 1955, however, in preparation for the laying of the first transatlantic telephone cable (TAT-1), a sea trial was carried out by Bell Telephone Laboratories' engineers on board H.M.T.S. *Monarch* to check the electrical characteristics of this cable on the ocean bed. This was the first occasion on which precision measurements had been conducted during a laying operation and it came as an unwelcome shock to find that immediately the cable was laid its attenuation was appreciably lower than could be explained by theory, which allowed for pressure and temperature changes. This "laying effect," as it came to be known, was found to be of the order of 1.5 per cent in 3,000 fathoms at 160 kc/s, and appeared to increase with frequency and depth. Later tests by the Post Office showed that this effect was still considerable in depths of only 50 fathoms.

TAT-1 was, however, duly laid, correction for this unexpected effect being carried out by submerged equalizers inserted during the laying operation. Since that project a considerable number of systems have been laid, and with each one the sea-bottom attenuation characteristic has had to be arrived at by subtracting an empirical loss curve, which was often rather indefinite, from the expected theoretical curve.

The TAT-1 cable system had not been laid very long

before it was evident that, after allowing for the annual temperature variation, the cable was aging in such a manner that there would be a still further decrease in attenuation. After four years the overall change is 13 db at 150 kc/s, which represents nearly 0.5 per cent of the total cable attenuation. The annual change has, however, been steadily decreasing. The effect of this aging is serious, and companders have had to be inserted in the higher-frequency channels to restore the signal/noise ratio.

The question naturally arose as to whether the aging was a continuation of the laying effect or whether another mechanism was at work. The latter appeared unlikely as there was difficulty in producing even one satisfactory explanation for the decrease in attenuation. In this connexion some tests carried out by the Post Office Research Branch are of interest. In 1955, lengths of TAT-1 type cable had been laid in about 120 fathoms and had been measured over a period of two years, by which time the aging change had become appreciable. After this period one of the cables was recovered, stored in the ship's tank and re-measured; its attenuation appeared to be equal to the original value measured on the cable in the ship's tank, decreased by the aging change. The cable was then relaid and re-measured, and it was found that the loss curve was a repetition of the curve obtained just before the cable was picked up. These results were considered to be significant in showing that the laying effect was reversible even after the cable had been laid for a long time, whereas the aging effect appeared to persist unchanged, at least during the few days of testing. This conclusion tended to give more weight to the contention that two separate mechanisms, or perhaps two manifestations of the same mechanism, were involved.

In the last few years many theories have been evolved and experiments performed in an attempt to explain these changes. Perhaps the most puzzling feature has been that the change has been a decrease in attenuation, since reasonable explanations for an increase in attenuation would have been much more readily forthcoming. One theory, i.e. that all the changes were due to consolidation of the centre composite conductor, has since been eliminated by results obtained on a cable with a solid-wire centre conductor, which indicated no significant change in the laying effect.

The problem was still unresolved in 1959 when it was proposed by the author that a length of special cable be made to check what was considered to be the most likely cause of cable variations; namely, the presence of the short-lay copper binding tape. A length of 6 nautical miles of armoured cable, which was conventional in all respects except for the omission of the copper binding tape, was therefore manufactured; the rubber-wax-bitumen impregnated tape normally applied over the binding tape was lapped directly over the long-lay tapes. The cable was laid in April 1960 in the English Channel in 40 fathoms and tests showed that there was no laying effect within the accuracy of measurement, i.e. 0.1 per

† Post Office Research Station.

cent. In similar conditions a conventional cable would be expected to show a decrease in attenuation of about 0.7 per cent. The cable was left on the sea bottom and a further test made 7 months later. From the Post Office tests on TAT-1 cable a decrease of attenuation due to aging of around 0.5 per cent would be expected after this period but, in fact, tests indicated a slight rise in attenuation of the order of 0.15 per cent, though this was barely significant in view of the inaccuracies in the measurement and the temperature determination.

It is concluded from these tests that the laying and aging effects which have been experienced with submarine telephone cables are entirely due to the presence of the short-lay copper binding tape, which is lapped directly over and in contact with the return-conductor tapes. The omission of this tape eliminated both anomalous effects. Although the location of, and the cure for, these phenomena now seem to have been definitely established, the precise mechanism causing these variations has not been pursued, but it is presumably bound up in some way with varying contact impedances between the copper layers involved.

As a result of this experiment the 60-nautical-mile Colwyn Bay-Douglas (Isle of Man) system, which is to be laid in 1961 with four 120-circuit repeaters, will employ this modified type of cable. Results, particularly in respect of long term aging, will be awaited with interest.

In the light-weight cable being manufactured for the U.K.-Canada (CANTAT) system to be laid this year, a screening tape has been wound over the return tapes to increase the crosstalk attenuation between the spiral layers of the cable in the ship's tanks. Special care has, however, been taken to ensure that each turn of the screen is insulated both from adjacent turns and from the return tapes.

#### ACKNOWLEDGEMENT

The author is particularly grateful to Mr. K. J. Chapman and his colleagues at the Post Office Research Station who have been directly responsible for the precision measurements made on board ship during the various sea trials.

---

## Book Reviews

"A Source Book in Mathematics" (Two Volumes). David E. Smith. Dover Publications, Inc., N.Y., and Constable & Co., London. Vol. I: xiv + 324 pp. 32 ill. Vol. II: xiv + 418 pp. 83 ill. 28s. per set.

The purpose of this source book is to supply students with a selection of excerpts from the original works of the makers of mathematics. It is believed that by knowing the beginnings of his subject a student will be encouraged to follow its growth. This will enable him to see how it has developed and to appreciate more clearly its present status.

This work, which is in two volumes, presents the great discoveries in mathematics from the Renaissance to the end of the 19th century. It contains significant selections from the original writings of Newton, Leibniz, Riemann, Bernoulli, and many others. These selections have been taken from 125 different treatises and articles; many of them had to be translated into English.

In the first volume the field of numbers is covered in 24 articles which trace developments from the first steps in printed arithmetic, through selected number systems, to the early phases of the modern theory of numbers. Here is Dedekind on imaginary numbers, Euler on the use of  $\epsilon$  to represent  $2\cdot 718 \dots$ , Gauss on number congruence, Delamain on the slide rule, Pascal on calculating machines, etc. The 18 articles on algebra include writings by Fermat, Wallis, Abel, Galois, etc.

In the second volume the field of geometry is covered by 36 articles that span 500 years. Here are extracts from the works of early writers such as Fermat, Desargues and Descartes. This is followed by selections from the works of later writers like Lobachevsky, Bolyai and DeMoivre, who revived the study in the 19th century and developed non-Euclidean geometry. Also included are Chebyshev and Laplace writings on probability. The development of the calculus, function theory, and quaternions is covered from early sources to important advances resulting from Hamilton's non-commutative law of quaternions and Grassmann's Ausdehnungslehre. This section also contains works of Bessel, Mobius, Cauchy and other pioneering mathematicians.

Together, these two volumes will enable the student to read about the great discoveries in mathematics exactly as the world saw them for the first time.

H. J. J.

"Annual Review in Automatic Programming." Vol. I. Edited by R. Goodman, M.A., B.Sc. Pergamon Press, Ltd. xi + 300 pp. 63s.

This book consists mainly of the papers read at the Working Conference on Automatic Programming of Digital Computers, held at the Brighton Technical College in April, 1959. If the intention is to provide a record of the conference it would have been preferable to give a full report of the discussions which presumably took place; a report is only given in summary form for one paper, although it is claimed that "whenever possible the papers have been modified to deal with points made in the discussion." On the other hand, if the intention is to provide a review or text book on automatic programming techniques, the present form seems hardly adequate. This is for two main reasons. Firstly, of the 18 papers, 13 deal with more or less detailed descriptions of particular programming schemes or the application of one of these schemes to a specific problem. Little has been said as to how these schemes are implemented, nor is any detailed picture given of the problems which beset the designer of translation programs. Secondly (and this is a common fault of books in the field of automatic computers), the subject matter is now more of historic interest than any other; thus, no mention is made of COBOL, i.e. common business orientated language, which is already over a year old in this country. However, some interest or even entertainment may be gained by comparing (or contrasting) predictions and other statements in the book with subsequent developments. Nevertheless, it is felt that the aim of providing "a convenient, comparative and easily available record of the position to date" has been partly achieved.

The book contains, as an appendix, reprints of Turing's papers "On Computable Numbers." The reason given is that these provide "the fundamental theorem upon which all automatic programming is based." While this is, in a sense, true, and the reappearance of this work in print is welcomed, it does seem somewhat out of place and rather like, for instance, including Shannon on information theory in a handbook for telegraphists.

The book is well produced, the printing being clear and accurate; this reviewer detected only one misprint. Future volumes in the series will be awaited with interest.

J. B. S.

# A New Small Cordless P.M.B.X. Switchboard

C. M. HALLIDAY, A.M.I.E.E., and E. J. LIDBETTER†

U.D.C. 621.395.23

The first of a new range of private manual branch exchange switchboards of the cordless type has a capacity for two exchange lines and six extensions. It is a lamp-signalling switchboard of compact design incorporating new features, and the power supply is derived from a separate mains-driven unit supplying 50 volts d.c. and 25 c/s a.c.

## INTRODUCTION

THE requirements for small manually-operated telephone switchboards for use in subscribers' premises have, for many years, been met by a range of cordless switchboards, all of which are of a similar basic design. Private manual branch exchanges (P.M.B.X.s) of this type have a maximum capacity of three exchange lines and nine extensions; lever keys are used to interconnect the circuits, and the signalling facilities are provided by indicators.

A new range of cordless switchboards is now being designed to supersede the existing series, and the first of these new designs, the P.M.B.X. No. 2/2A, has a maximum capacity of two exchange lines and six extensions. The type of switchboard that it supersedes has a maximum capacity of two exchange lines and four extensions. The new switchboard has been given a modern appearance, approved by the Council of Industrial Design, so that it will harmonize with other new designs of subscribers' apparatus. Lamp signalling is used and the connecting keys are of a new miniature type.

The number of extensions that can be connected to the new switchboard has been increased to six compared with four on the existing design, as it has been found more economical to have a higher extension to exchange line ratio for a switchboard of this size. It has been confirmed nevertheless that the traffic-carrying capacity of three connecting circuits will suffice even with the increased number of extensions, and therefore no change has been made in the number of such circuits.

The adoption of the 4-wire extension principle\* has enabled all the requisite facilities to be provided in the most economical manner. Briefly, this principle consists of running an extra wire plus an earth lead to each extension telephone for supervisory purposes. A

4-wire/2-wire conversion relay-set has been designed for use on external extensions that need to be connected via the public-exchange local-line network. All the extension line circuits on the switchboard can be used for 4-wire extensions, while extension circuits No. 4-6 can, by simple rearrangement of cords and straps within the switchboard, be used for 2-wire extensions, private circuits, or inter-switchboard extensions. In addition to the conversion relay-sets necessary for 2-wire extensions, auxiliary units are also required for private circuits and inter-switchboard extensions.

The power supply for the switchboard is derived from an external a.c. mains-driven power unit supplying 50 volts d.c. and 25 c/s a.c. for ringing purposes.

## FACILITIES PROVIDED

The main facilities provided by the new switchboard are as follows:

- (a) Lamp signalling for exchange lines and extensions.
- (b) A transmission and signalling limit of 500 ohms for an extension circuit and 1,000 ohms for an exchange-to-extension connexion when connected to an exchange with equipment for 1,000-ohm lines.
- (c) Press-button recall on extension-to-extension and extension-to-exchange calls under all conditions.
- (d) Individual clearing on extension-to-extension calls.
- (e) Holding of an exchange call by the P.M.B.X. operator while speaking to an extension on the same connecting circuit, the conversation being inaudible on the exchange line.
- (f) Connexion of private wires and inter-switchboard circuits without modification to the permanent wiring of the switchboard.

## PHYSICAL DESIGN

The new switchboard, which is shown in Fig. 1, will

† Subscribers' Apparatus and Miscellaneous Services Branch, E.-in-C.'s Office.

\* LIDBETTER, E. J. The 4-Wire Extension Principle for Small Cordless P.M.B.X. Switchboards. *P.O.E.E.J.*, Vol. 53, p. 167, Oct. 1960.

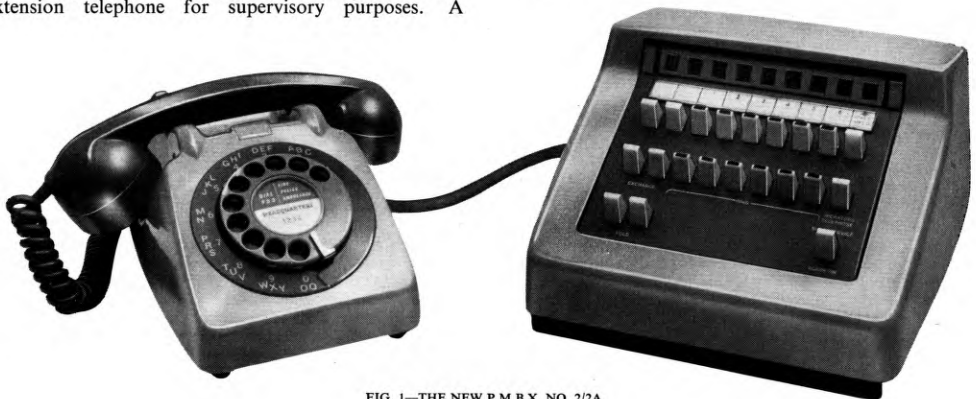

FIG. 1—THE NEW P.M.B.X. NO. 2/2A

normally be provided in two-tone grey with a matching Telephone No. 706 as the operator's instrument. The switchboard has a metal chassis and a plastic cover, and its dimensions are approximately 8 in. wide by 5 in. high by 10 in. deep. The design of a compact item has been made easier by the adoption of the 4-wire extension principle and by the introduction of lamp signalling to replace the indicators used on the present type of switchboard. In addition, a new miniature key (the 1,000-type key) has been used instead of the standard lever key. The springs of this new key, which are comb-operated, are similar to relay springs and have twin contacts. The key handles are small and wedge-shaped (see Fig. 2).

The keys, lamp jack and the circuit-designation label-strip are mounted on the panel in such a manner that all screw heads are concealed. When the lamp-jack lens-strip is removed by releasing the phosphor-bronze clips at each end of the cover, the lamp-jack screw-heads are exposed. By releasing these screws the lamp-jack may be drawn forward to permit lamps to be changed without the use of a lamp extractor or the removal of the switchboard cover.

The thermoplastic cover of the switchboard is vacuum-formed by deep drawing p.v.c.† sheet and is polished after forming. The leading edge of the cover slots under the front of the face panel and adjustable plates on the sides of the panel form dust seals. The cover is removed by releasing the captive screws at the rear on the base.

The chassis consists of three sections; the front and rear panels, hinging on the base plate, form a triangle when the chassis is closed, as shown in Fig. 2. By releasing the screws at the apex the hinged panels can be opened outwards to permit inspection of the wiring and components, as shown in Fig. 3. To conserve space in the switchboard, small wire-wound resistors and tubular

† p.v.c.—polyvinyl-chloride.

capacitors have been used and are mounted on insulated tags fixed direct into the rear panel of the chassis. Plastic dust covers are provided to shield the 600-type and 3,000-type relays.

A connexion block with 70 terminals is mounted on the base. Some of the terminals are used for the connexion of the operator's telephone, subscriber's private meter and a 38-conductor flexible cord for the exchange lines, extensions and miscellaneous terminations. The remainder of the terminals are provided to permit rearrangements of straps and cords when 2-wire extensions, private circuits or inter-switchboard extensions are required, thus avoiding the modifications to the permanent wiring that are necessary in some applications on the present type of switchboard. The free end of the 38-way cord is terminated on a multi-way plug which fits into a wall-mounted jack cabled to the connexion box. If subscribers' private metering is required, a Meter No. 19, as used on direct exchange lines, is associated with the switchboard.

#### ELECTRICAL DESIGN

A new parallel-feed transmission bridge has been adopted for economic reasons. For 50-volt working the transmission bridge consists of a  $300 + 300$ -ohm coil with an  $0.1 \mu\text{F}$  capacitor across the output to give improved side-tone balance. This combination is suitable for all extension-to-extension calls up to a signalling limit of 500 ohms, with either 300-type or 700-type telephones. Non-removable relay shields fitted to the transmission-bridge relays increase the crosstalk attenuation between circuits to at least 75 db.

A new lamp (Lamp No. 2, 45 volts) has been developed for use on the switchboard. It has a reasonably flat lumens/resistance response over the range 0–500 ohms line-plus-telephone loop resistance, and the use of this lamp has obviated the need for a line-signalling relay.

No hand generator is fitted in the switchboard; the ringing supply is derived from a frequency-division mains-operated unit producing a 25 c/s a.c. output.

The switchboard circuits have been designed to operate from a nominal 50-volt d.c. supply but are capable of operating from a supply in the range 45–55 volts, and this has permitted economies to be made in the design of the power unit. Arrangements have been made to ensure that exchange calls already in progress are maintained if a mains failure occurs. It is recognized and accepted, however, that extension-to-extension and inter-switchboard calls will fail under such conditions, but it is considered that little inconvenience will be caused thereby, since failures of the mains supply in this country are generally few and of short duration. Under mains-failure conditions night-service arrangements are adopted. At installations where a break in service cannot be tolerated, however, the switchboard will be operated from a floated-battery system.

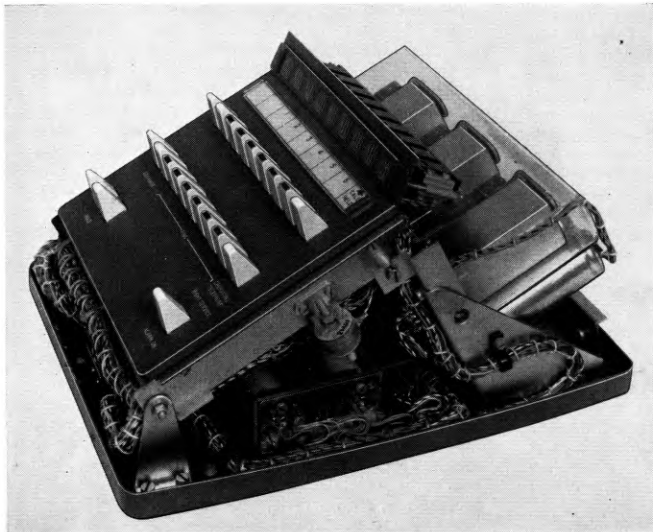

FIG. 2.—CHASSIS OF SWITCHBOARD CLOSED



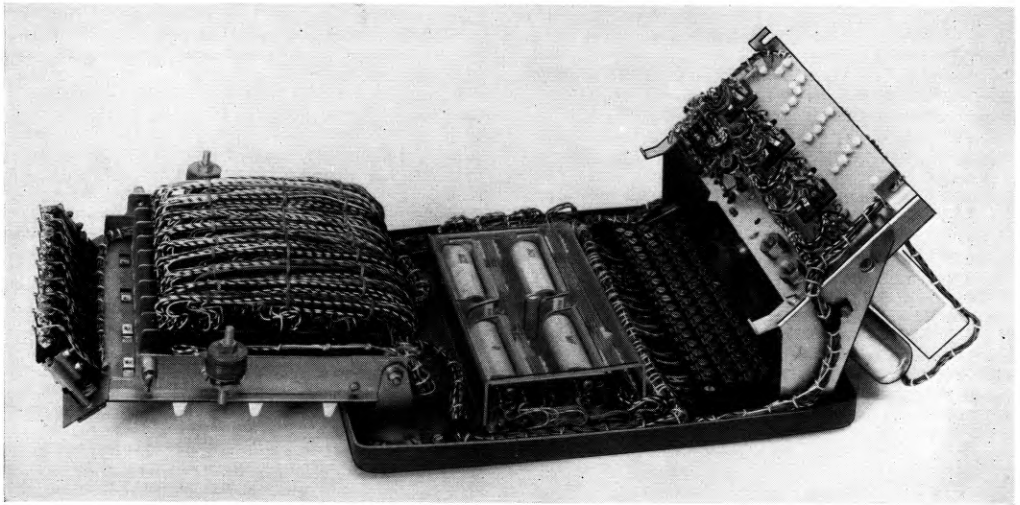

FIG. 3—CHASSIS OF SWITCHBOARD OPENED

#### CIRCUIT DESCRIPTION AND OPERATION

The 4-wire extension principle is used on all internal extensions and can be applied to external extensions within the curtilage of the subscriber's premises. Where external extensions are connected via the local-line network it will generally be desirable and more economical to use a 4-wire/2-wire conversion relay-set. For all extensions without a conversion unit the exchange-to-extension transmission and signalling limit is the same as that of a direct exchange line, since a relay is not required for supervisory purposes. On external extensions for which conversion units are required this limit is reduced to 900 ohms. The difference is due to the resistance of the supervisory relays in the conversion unit.

If the switchboard is used to replace an existing installation, the internal extensions will have to be wired for 4-wire-working and it will be necessary to change the extension telephones to include the additional auxiliary switch-hook spring-set.

A simplified circuit diagram of the new switchboard is shown in Fig. 4.

#### *Extension-to-Extension Calls*

When a call is originated at an extension by lifting the telephone handset, earth via KX1, the telephone loop, KX2 and the calling lamp operates the pilot relay, P, connected to -50 volts, and the extension calling lamp glows when contact P2 operates and short-circuits the high-resistance coil of the P relay. Contact P1 causes an audible alarm to be given if the ALARM ON key, KA, is operated. If more than one extension is calling the switchboard, overhearing between the extensions is suppressed by capacitor CI. The call is answered by operating the OPERATOR'S TELEPHONE key, KO, associated with the chosen connecting circuit and the appropriate connect-extension key, KX, and by lifting the handset of the operator's telephone. The transmission-bridge

relay, L, feeds transmitter current to both telephones.

If connexion to another extension is required, the operator checks that the extension is disengaged by observation of the keys, and calls the extension by the operation of the appropriate ringing key, which connects 25 c/s ringing current to the extension. When the called extension answers, the calling lamp glows and the KX key associated with that extension is operated to complete the connexion. The operator then restores key KO and replaces the operating telephone handset. Either extension can recall the switchboard by depressing the recall button on the extension telephone. An earth (on the fourth wire from the connexion box) is then extended to the C wire (the third wire) and the calling lamp glows while the recall button is pressed. When the call is completed and the extension handset is replaced, an earth is extended via the auxiliary switch-hook spring-set, SWA, to the C wire to give a clearing signal on the calling lamp via key contact KX4. Individual clearing signals are given when either extension replaces the handset.

#### *Extension-to-Exchange Calls*

If the calling extension requests connexion to an exchange line, the connect-exchange key, KE, of a free exchange line is operated. This disconnects the local 50-volt supply from the connecting circuit at KE1 and KE2 and extends the extension to the exchange line. As there are no supervisory relays in the connecting circuit (the third wire being used for supervisory purposes) no additional relays are required to prevent the calling lamp flashing to pulsing if the exchange line is connected to an automatic exchange. The exchange-line connecting-keys are, however, arranged as on the previous type of switchboard, to prevent two exchange lines being connected together. When the exchange call is completed the clearing signal is given on the extension calling lamp only, when the extension telephone handset is replaced.



conversation being audible on the exchange line. This facility is normally used on incoming exchange-line calls. A single CALL HELD lamp common to both exchange lines is provided to give a visual indication to the operator when a hold condition is applied.

#### *Mains Failure*

As the switchboard has been designed to work from a mains-operated 50-volt d.c. supply unit, the circuits have been arranged so that exchange-line service is maintained under mains-failure conditions. A mains-failure relay, MF, has been included and is operated by the 50-volt supply. When a mains failure occurs relay MF releases and contacts MF1, 2 and 3 connect the bell of the operator's telephone to the first exchange line so as to give an audible indication of an incoming call. The operator can answer the exchange call under mains-failure conditions by operation of the appropriate KE and KO connecting keys and by removing the handset from the operator's telephone. Outgoing exchange calls can also be originated by the operator in the normal manner. The operating instructions for this type of switchboard will advise subscribers to connect the remaining exchange line to a selected extension, as for night-service working, should a mains failure occur, and the selected extension will then have direct access to the second exchange line.

#### *Press-Button Recall*

By fitting a press-button key with a make contact in parallel with the auxiliary switch-hook spring-set of each extension telephone, press-button recall is effected by extending the earth on the fourth wire to the C wire (the third wire), and recall can be provided on all extension and exchange calls.

#### *Night Service*

Night-service arrangements are provided by the NIGHT SERVICE key, KNS, which disconnects the pilot relay, the extension calling lamps and also the AC relay

locking circuit. Selected extensions can then be connected to the exchange lines by operating the KE and KX keys to a specific connecting circuit.

#### *Private Circuits, Inter-switchboard and External Extensions*

Using the additional terminals which have been provided for extensions No. 4-6, private circuits, inter-switchboard and external extensions can be connected without modification to the permanent wiring of the P.M.B.X. When an exchange-line key and an extension-connecting key are operated together in the same connecting circuit, earth is applied to the extension P terminal from KO4 via KE5 and KX5. This earth can be used to operate a relay in an auxiliary unit. The contacts of this relay disconnect the line, thus providing a prohibition facility to prevent the interconnexion of exchange lines and private circuits.

An auxiliary switch-hook spring-set, SWB, controls relays in the 4-wire/2-wire conversion relay-set when this is provided. The circuit of the relay-set is such that, when the operator intervenes on an established exchange call, the exchange line is held by a loop and current for the extension is provided from the local transmission feed in the relay-set. The SWB spring-set ensures that calls are not inadvertently released by the operator entering the circuit by operating key KO before lifting the handset of the operator's telephone.

#### CONCLUSION

It is confidently expected that the new cordless P.M.B.X., with its use of modern materials, compact design and an increased range of facilities, will be more attractive to the subscriber and to the Post Office than the existing type of cordless switchboard which it supersedes.

#### ACKNOWLEDGEMENT

The authors wish to thank Ericsson Telephones, Ltd. who, as the liaison manufacturers, worked in close co-operation with the Post Office on this development.

---

## Book Review

"Beam and Wave Electronics in Microwave Tubes." R. G. E. Hutter. D. Van Nostrand Co., Inc., New York and London, xii + 378 pp. 158 ill. 73s. 6d.

This is a specialist work written by an expert in microwave valve theory. The author is chief engineer of the Special Tube Operations Division at Sylvania Electronic Products, Inc., and he says in his preface that his aim was to write a textbook for schools and an introductory reading for engineers who were transferring their activities to microwave valves from other non-microwave fields. It is not a book for valve designers; its purpose is somewhat too general for such practical people. Principles and theories are set out in a manner that suggests that one of the author's aims was to provide mental exercises for his students. One feels strongly that he is trying to stimulate interest in electron-beam theories, and devices based on them, in order to counteract the bias towards research in solid-state equivalents of thermionic valves. Mr. Hutter feels that many worthwhile developments can still be made in small-signal microwave thermionic valves which will make them successful competitors with

transistors in a number of fields, and he is anxious in his book to revive interest for research in electron-beam valves. For this reason, perhaps, he avoids the most recent developments such as masers and parametric devices and concentrates on thermionic valves for frequencies in the range 300-30,000Mc/s.

The mathematical treatment is fairly thorough. Many readers will disagree with the author's fundamental belief that "physical pictures cannot be formed or appreciated without the mental effort required to understand the mathematical details of the analyses of these tubes." Vision often plays a more important part in engineering development than analysis, but this does not seem to be Mr. Hutter's view. In this book he has made a collection of mathematical analyses of the behaviour of electron beams under most of the conditions that could be experienced in microwave valves such as klystrons, magnetrons and travelling wave valves, and concludes with a chapter on noise generation in microwave devices.

This book is definitely for the specialist, as it is too analytical for the general telecommunications engineer. It is beautifully produced and is very well illustrated.

C. F. F.

# A Swept-Frequency Method of Locating Faults in Waveguide Aerial Feeders

J. HOOPER, A.M.I.E.E.†

U.D.C. 621.317.333.4:621.372.8:621.396.679.4

The general principles of a close-range, high-resolution, frequency-modulation echo-sounding equipment are explained and their application to a practical method of locating faulty waveguide-feeder junctions in a 4,000 Mc/s radio-relay system is described. It is possible to measure, at the input to a waveguide feeder, those reflections having voltage reflection coefficients greater than 0.005 and caused by waveguide junctions up to 300 ft from the input. These junctions can be located within 2 per cent of their actual distance from the waveguide input, even in the presence of other reflections from junctions spaced 10 ft or more apart.

## INTRODUCTION

AN important development in this country since the war has been the introduction of broadband microwave radio-relay systems for the point-to-point transmission of television and multi-channel telephony. An example of such a system for the transmission of telephony has been described in this Journal.<sup>1</sup> The system uses frequency modulation to avoid an unacceptable amount of signal distortion and noise; amplitude modulation requires a degree of linearity in the amplifiers that is difficult to obtain. Frequency modulation also demands linearity but, in general, it is the linearity of the phase/frequency characteristic that is important if the quality of transmission is to be acceptable. The linearity requirements of the phase/frequency characteristic become more severe as the modulation band-width increases and it is likely that these linearity requirements will set a limit to the number of telephone channels that can be carried by a single carrier using frequency modulation.

An important source of non-linearity of the phase/frequency characteristic is the aerial feeder where impedance mismatches give rise to multiple reflections and, hence, to echoes. Each echo causes a ripple on the phase/frequency characteristic and the effect on performance is more noticeable in telephony than in television. For the latter a relatively strong echo of sufficient delay will cause a ghost image, but for telephony each echo of a group of very small echoes will introduce some intermodulation noise.<sup>2</sup> The total intermodulation noise of a system will be the summation of the intermodulation noise contributions from each echo, not only for a single feeder but for all the feeders of the complete system of several radio links in tandem. For telephony, therefore, exceptionally high-quality aerial feeders are required.

The aerial feeders of a microwave radio installation are generally of rectangular copper waveguide along the inside of which the radio energy travels. To achieve the desired high quality of impedance matching the inside dimensions of the waveguide are maintained to within small tolerances. The tolerance is  $\pm 0.003$  in. for a  $2\frac{1}{2}$  in.  $\times$   $1\frac{1}{4}$  in. waveguide such as that used for 4,000 Mc/s radio-relay systems.

The waveguide feeder, which may be up to 300 ft in length, is assembled in lengths of about 10 ft, each length

being butt-jointed to its neighbour by a pair of bolted brass flanges. During assembly it is difficult to achieve a smooth transition at each point, and impedance mismatch may be found at all the joints of the waveguide feeder. If the magnitude of an impedance mismatch, in terms of its voltage reflection coefficient,\*  $r$ , exceeds a given value then the joint at which it originates is classed as faulty. The value of  $r$  which can be accepted is to some extent arbitrary since it depends on the amount of non-linearity allowed in the radio equipment and the propagation path (along which echoes may also originate), but experience shows that  $r = 0.01$  is a reasonable limit for circuits carrying up to about 1,000 telephone channels.

It follows that there is a need for a method of measuring  $r$  separately for each joint of a complete waveguide in order that faulty ones may be located. The alternative is a trial and error method of testing each joint during assembly using a slotted-line instrument; this can be time consuming and even misleading since the reflections from two or more joints may cancel at a particular frequency, although each will produce its own quota of intermodulation noise. Testing a waveguide feeder after it has been in service is of even more practical importance, for if the reflection coefficient of each joint cannot be measured separately to locate a faulty joint then the waveguide feeder must be broken down section by section. Apart from the time taken to do this, there is the possibility that damage will be done during the process, resulting in additional faults.

The method described here is one whereby the reflection coefficient of each joint in a waveguide feeder may be measured separately. Although the equipment described is particular to microwave waveguide feeders the method is quite general and may be applied to all long transmission lines and, indeed, to reflections originating along a radio path. The principle is that of a radar system which can measure separately the time delays and amplitudes of echoes. The type of radar system chosen is known as frequency-modulation radar and, for reasons to be given, is preferred to the better-known pulse-modulation radar. The equipment described can measure a minimum reflection coefficient of 0.005 and locate the position of the joint concerned to within  $\pm 2$  per cent of its distance from the waveguide input.

## PRINCIPLE OF THE METHOD

If a detector is coupled to a zero-loss waveguide feeder close to the input terminal, where a r.f. signal source is connected, the detector will sample the wave as it passes along the waveguide toward the output. Let there be a reflection of coefficient  $r$  at a distance  $L$  from the detector, and let the group velocity of the wave be  $V_g$ : then, after a time  $\Delta t = 2L/V_g$ , the detector will once again be sampling the same wave, but it will be travelling in the opposite direction and reduced in amplitude by a factor  $r$ . Now let the frequency of the source be varied at a uniform rate. Because of the time interval between the direct and reflected waves at the detector two-frequencies will be present simultaneously. Fig. 1 shows, as the

† Mr. Hooper was formerly at the Post Office Research Station.  
\* Voltage reflection coefficient is the vector ratio of the return voltage to the voltage that would exist at the point if the transmitting lines were extended under reflectionless conditions.

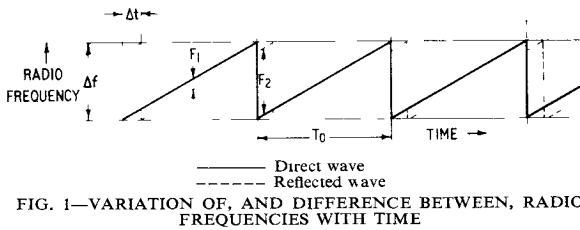

FIG. 1—VARIATION OF, AND DIFFERENCE BETWEEN, RADIO FREQUENCIES WITH TIME

full-line curve, the variation of frequency of the direct wave with time. The frequency is varied in a saw-tooth manner over a total range of frequency  $\Delta f$ . The cycle of events is repeated at a rate  $1/T_0$ . The broken line shows the frequency of a reflected wave, delayed by time  $\Delta t$  with respect to the direct wave. It will be seen that most of the time there is a constant frequency difference,  $F_1$ , between the two waves; for a time  $\Delta t$  out of every period  $T_0$  another frequency difference,  $F_2$ , occurs. Provided that  $\Delta t$  is very much smaller than  $T_0$  the effect of  $F_2$  can be ignored (it is in any case much greater than  $F_1$ ), and to a good approximation  $F_1$  may be treated as constant over the whole of the period  $T_0$ . The frequency difference  $F_1$  is related to the rate of change of frequency  $\Delta f/T_0$  and the delay time  $\Delta t$  by the equation

$$F_1 = \Delta t \Delta f / T_0 \dots \dots \dots (1)$$

and to the distance to the reflection by

$$F_1 = (2L/V_g)(\Delta f/T_0) \dots \dots \dots (2)$$

$F_1$  is, therefore, proportional to the distance of the reflection from the detector, so that if  $F_1$  can be measured the distance  $L$  can be determined.

*Measurement of Frequency Difference  $F_1$*

The two waves at the detector, because of their frequency difference, will apparently reinforce and oppose one another, and produce an amplitude variation. The detector will, therefore, observe a time-varying field. The frequency of variation of the field is known as the beat frequency and, provided  $r$  is small, the beat frequency is equal to  $F_1$  and will appear at the detector output. In principle, all that is now necessary is to connect a calibrated, tunable amplifier to the detector to measure the beat frequency, and  $F_1$  and  $L$  can be determined. In practice, matters are somewhat more complicated, as discussed later.

*Measurement of Reflection Coefficient  $r$*

When the two waves beat together they will produce a resultant field whose relative amplitude is  $(1 + r)$  at the maximum and  $(1 - r)$  at the minimum. The beat-frequency wave at the detector output will, therefore, have a peak-to-peak amplitude proportional to  $2r$ , and the value of  $r$  may be determined by comparing the output of the tunable amplifier to that obtained when a known reflection is deliberately obtained from the waveguide feeder. The value of  $r$  so determined is not the true reflection coefficient but will be slightly smaller than the reflection coefficient originating at the distant point because of the loss of the practical waveguide. If  $R$  is the true reflection coefficient at the point of reflection and  $A$  the ratio of the output voltage to the input voltage for a waveguide  $2L$  long, then a correction can be applied, as given by  $R = r/A$ .

*Output of the Detector*

The detector output will not in general consist of a single frequency equal to  $F_1$  even when, as is assumed

here, the detector is linear and the duration of  $F_2$  is negligible. Fig. 2 shows the form of a typical output from the detector. The general expression for the output

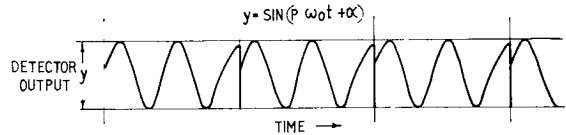

FIG. 2—OUTPUT WAVEFORM FROM DETECTOR

wave is given by  $\sin(P\omega_0 t + \alpha)$ , where  $\omega_0 = 2\pi F_0$ ;  $F_0$  is the frequency of the modulation,  $\alpha$  is a constant-phase term which merely describes the point at which the waveform starts, and  $P$  is the number of beats during one cycle of modulation. In Fig. 2,  $P$  has a value almost equal to  $2\frac{1}{2}$ . When  $P$  is other than a whole number there is a phase discontinuity at the start of each modulation cycle, as illustrated in the figure. Such a waveform, when analysed, resolves into a line spectrum, each component of which is an harmonic of the modulation frequency.

The general expression for the line spectrum is complicated and not very helpful for cursory inspection. Fig. 3 shows in a simplified and approximate manner the components of the line spectrum, provided that the

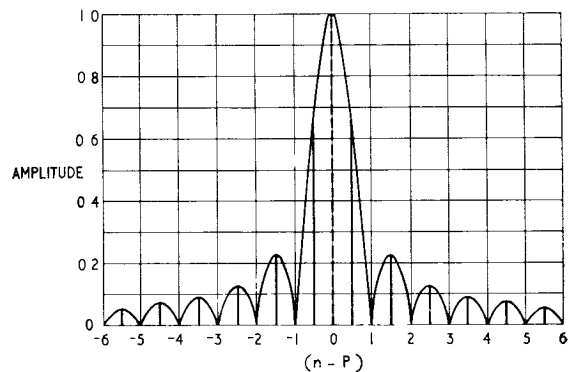

FIG. 3—ENVELOPE OF BEAT-FREQUENCY SPECTRA

number of beats per modulation cycle is ten or more. The curve represents the envelope of all possible spectra. The units of the abscissa of the envelope curve are given in terms of  $(n - P)$ , where  $n$  is the number of the harmonic whose amplitude is required. For example, if  $P$  is equal to  $10.7$  and it is required to find the amplitude of the seventh harmonic of the line spectrum, then  $(n - P) = -3.7$  and the amplitude is the height of the curve above the point  $-3.7$  on the horizontal axis. The other harmonics may be found in the same way for this particular value of  $P$ . The equation of the envelope curve is  $|\sin \{\pi(n - P)\} / \pi(n - P)|$ . Two extreme examples of harmonic spectra are shown. The full lines within the envelope show the spectrum for the maximum phase discontinuity, i.e. when  $P$  is equal to a whole number plus one-half, and the broken line the spectrum when  $P$  is equal to a whole number. In the latter case only one frequency is present and  $F_1$  is exactly equal to the harmonic  $n = P$ . In the former case the spectrum has the maximum spread and  $F_1$  is midway between the two largest harmonics  $n = P + \frac{1}{2}$  and  $n = P - \frac{1}{2}$ . In all cases the frequency  $F_1$  is at or near the largest harmonics of the spectrum and may, therefore, be determined from

the frequencies of maximum response of the tunable amplifier.

#### Measurement of a Number of Reflections

It has been assumed in the foregoing analysis that there is only one reflection in the waveguide feeder. With several reflections present there will be a corresponding number of beat-frequencies at the detector output. Provided that the detector is linear, no inter-modulation frequencies will be present. The beat-frequency waves may then be resolved and measured separately if they are far enough apart in frequency and the selectivity of the tunable amplifier is adequate. The resolving power of the equipment is a very important property which is dealt with in more detail later.

The effect of multiple reflections can be ignored. For example, with two reflections of  $r = 0.1$ , located at distances  $L_1$  and  $L_2$  from the detector, the first multiple reflection between them would be measured as a reflection at a distance  $4L_2 - 2L_1$ , but its amplitude would be 0.001 and, therefore, undetectable in comparison with the primary reflections.

#### RESOLVING POWER

The resolving power of an equipment is its ability to discriminate between two adjacent reflections. In this equipment there must be discrimination between reflections from mismatches with a spacing of about 10 ft of waveguide. However, it is instructive to consider what is the maximum inherent resolving power of the method using perfect equipment.

Since the detector output consists of a spectrum of harmonics it is apparent that two beat-frequencies may be resolved only if they are at least one harmonic interval apart. This interval is equal to  $1/T_0$ . Expressing two beat-frequencies differing by  $1/T_0$  in terms of Equation (1) and taking their difference, the minimum resolvable time interval between reflections is,  $T = 1/\Delta f$

From this it can be seen that as the frequency sweep  $\Delta f$  increases, the resolving power increases since the equipment becomes capable of separating more closely-spaced reflections. It should be noted that this is independent of the modulation frequency,  $1/T_0$ .

Considerations of resolving power show that f.m. radar is preferable to pulse radar. Briefly, a frequency-sweep of 100 Mc/s is required to resolve reflections of 10 milli-microseconds time spacing. A frequency-sweep of 100 Mc/s or more is now readily obtained using a backward-wave oscillator<sup>3</sup> (B.W.O.). For pulse radar a pulse of 10 milli-microseconds is required for the same resolving power. Apart from the difficulty of generating such narrow pulses, a post-detector amplifier with a wide video band-width and a high quality oscilloscope to display the pulses would be required. The f.m. radar requires audio amplification only, the amplifier having a band-width no greater than the modulation frequency. Furthermore, because of the wide noise band-width in the pulse system, very high peak-power pulses are essential if the pulse radar is to be as sensitive as f.m. radar.

There are four main limitations to the resolving power of the equipment:

(a) Non-linearity of the frequency/voltage characteristic of the B.W.O.

(b) The variation of group-velocity ( $V_g$ ) with frequency of the waves in the waveguide.

(c) Noise due to the B.W.O. supply.

(d) Amplitude modulation of the B.W.O. output.

The first three of these limitations cause the resolving power of the equipment to decrease as the distance to the reflections increases. The fourth limitation mainly affects the resolving power for close reflections. The effects of these limitations have been mitigated as follows:

(a) The frequency of the B.W.O. is approximately proportional to the square root of the line-electrode voltage. To obtain a constant rate of change of radio frequency over the modulation cycle it is convenient to apply a saw-tooth voltage with an exponential shape which modulates from high to low frequency. The modulating voltage is described by the function  $e^{-bt}$  between the limits  $t = 0$  and  $t = T_0$ , and for any given range of frequencies there will be a particular value of  $b$  that gives the closest approximation to a linear frequency sweep. In the equipment,  $b$  can be adjusted so that the maximum response is obtained from a given reflection.

(b) The group-velocity ( $V_g$ ) of the waves depends upon frequency thus,

$$V_g = c \sqrt{1 - \frac{f_c^2}{f^2}},$$

where  $c$  is the velocity of light, and  $f_c$  and  $f$  are, respectively, the cut-off frequency of the waveguide and the radio-frequency. Equation (2) shows that  $F_1$  depends upon  $V_g$ , and analysis shows that the effect of its variation is the same as that described under (a). The variation of  $V_g$  can, therefore, be compensated by increasing the value of the exponential factor  $b$ .

(c) Noise due to the B.W.O. supply introduces spurious radio-frequency modulation which has the same effect as (a) and (b). The noise level is kept within the required limits for the equipment by normal smoothing techniques reinforced by substantial negative feedback.

(d) Amplitude modulation of the B.W.O. output produces two effects. The first is a small reduction of resolving power for all reflections, since some of the energy of  $F_1$  is dispersed into amplitude-modulation sidebands. The second and more noticeable effect is the introduction of relatively high-power harmonics into the detector output due to demodulation of the large direct wave. These harmonics are of low frequencies and interfere with the low beat-frequencies originating from close-range reflections. Fortunately, the unwanted harmonics can be cancelled in the output of a double-balanced detector whilst the beat-frequency output is doubled. In the equipment, two balanced detectors sample the r.f. energy at a quarter of a wavelength spacing, with their outputs connected to a balance-to-unbalance transformer.

#### PRACTICAL APPLICATION

The heart of the equipment developed to locate faults on waveguide feeders is the backward-wave oscillator valve.<sup>3</sup> This valve is capable of a frequency-sweep of 2,300–4,500 Mc/s by application of a varying voltage to its line electrode. The valve, together with its 1,500-volt power unit and modulation circuits, is housed in a single cabinet. The remaining items of equipment are a double-beam oscilloscope and an audio amplifier, tunable over the range 300–6,000 c/s and fitted with an output-level meter. The waveguide output from the cabinet is connected, in turn, to a 90° bend, a 90° twist, a wavemeter, a padding section, a double detector (connected to the tuned amplifier) and, finally, a waveguide switch. The switch enables the equipment to be



connected either to the waveguide under test or to a comparison reflection of known amplitude and delay. Using the tunable amplifier as a wide-band amplifier the detector output is displayed on the oscilloscope, which also displays the wavemeter response, thus enabling the frequency sweep to be set up between known radio-frequency limits.

#### PERFORMANCE OF THE EQUIPMENT

The sweep-amplitude,  $\Delta f$ , of the B.W.O. is continuously variable from 0–400 Mc/s over any part of the range 2,500–4,500 Mc/s. The modulation frequency is 50 c/s and the tunable amplifier can analyse a spectrum from the sixth to the hundred-and-twentieth harmonic. A maximum potential resolving power, capable of distinguishing between reflections 1 ft apart, is obtainable when  $\Delta f = 400$  Mc/s. The tunable amplifier then allows 6–120 ft of waveguide to be scanned at maximum resolution. Longer lengths may be scanned by reducing  $\Delta f$ , but this reduces resolution. In practice, due to the imperfections discussed and the finite selectivity of the tunable amplifier, the potential resolving power is not obtained for the distant reflections, but it is adequate to discriminate between reflections 10 ft apart at a distance of up to 300 ft away.

To carry out a measurement, after adjustments have been made to calibrate the response in amplitude and time delay from the comparison reflection, the output is switched to the waveguide under test. Generally it is found convenient, in the absence of large responses, to plot the output spectrum of the detectors in the form shown in Fig. 4. This figure shows the output of the

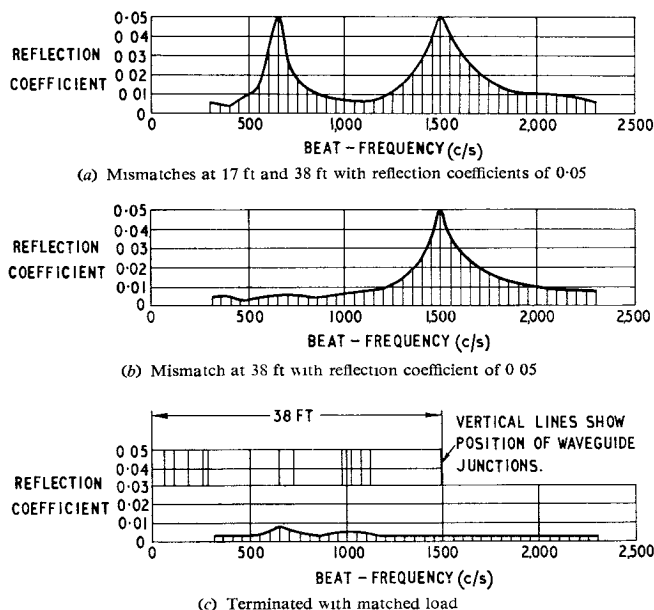
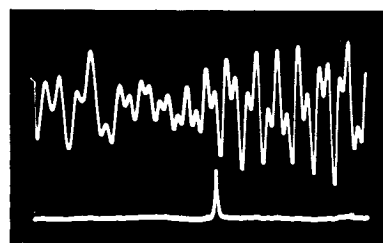
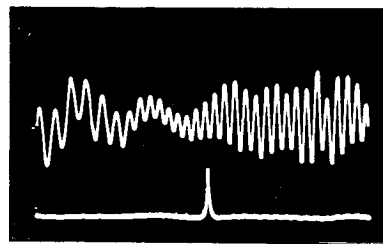

FIG. 4—SPECTRUM FOR WAVEGUIDE OF 38 FEET, USING FREQUENCY SWEEP OF 3,756–4,059 MC/S

tunable amplifier when connected to a 38 ft length of waveguide with joints at intervals as marked on Fig 4(c). Fig. 4(a) shows the output with reflections of coefficient  $r = 0.05$  at 17 ft and 38 ft, Fig. 4(b) with  $r = 0.05$  at 38 ft only, and Fig. 4(c) with no reflection present. Fig. 5 shows the detector output displayed on the oscilloscope for the same three conditions; these displayed waveforms have to be analysed to obtain the spectra shown in Fig. 4. The lower trace in each oscillogram shows the



(a) Mismatches at 17 ft and 38 ft with reflection coefficients of 0.05



(b) Mismatch at 38 ft with reflection coefficient of 0.05

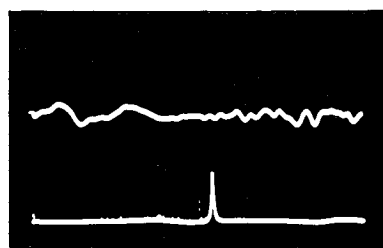

(c) Terminated with matched load

FIG. 5—OSCILLOSCOPE DISPLAY FOR WAVEGUIDE OF 38 FEET, USING FREQUENCY SWEEP OF 3,756–4,059 MC/S

frequency-marker response of the wavemeter. The equipment, as may be seen, is capable of detecting reflections with coefficients of the order of 0.005 and, at the distance shown, of resolving them when about 3 ft apart.

#### CONCLUSIONS

The equipment has been used in the field to check the waveguide feeders of the Braewynner-Thrumster radio link.<sup>1</sup> These feeders range from 50 to 250 ft in length, with from 15 to 35 junctions per feeder. Only one junction was found to have a reflection coefficient of more than 0.01. A reflection coefficient of 0.02 was indicated at a junction about 6 ft from the aerial termination of the shortest feeder; visual inspection showed a “pulled” flange as the cause of the mismatch and, incidentally, accounted for a gas leak from the pressurized waveguide. Checking the waveguide feeders took less than half a day for each site, and the location of the fault but a few minutes. Without the frequency-sweep equipment, checking the feeders would have taken several days at each site and the faulty junction might well have remained undetected.

#### References

- <sup>1</sup> CORKE, R. L., EPHGRAVE, E. V., HOOPER, J., and WRAY, D. A 4,000 Mc/s Radio System for the Transmission of Four Telephony Supergroups (240 circuits). *P.O.E.E.J.*, Vol. 50, p. 106, July 1957.
- <sup>2</sup> MEDHURST, R. G., and SMALL, G. F. An Extended Analysis of Echo Distortion in the F.M. Transmission of Frequency-Division Multiplex. *Proceedings I.E.E.*, Paper No. 2006R, Mar. 1956 (Vol. 103, Part B, p. 190).
- <sup>3</sup> Compagnie Générale de T.S.F. Carcinotron. *Telonde*, No. 1, p. 3, 1955.

# Automatic Letter Sorting—The Luton Experiment

T. PILLING, B.Sc.(Tech.), A.M.I.E.E., and P. S. GERARD, B.Sc.(Eng.), A.M.I.E.E.†

U.D.C. 681.178

Machines have been successfully developed for performing many of the separate processes involved in handling mail. The stage has now been reached where devices that have already proved satisfactory for carrying out individual processes can be combined to form a mail-handling system suited to the needs of a large sorting office.

## INTRODUCTION

FOR over 20 years experiments have been carried out and ingenious machines have been constructed to perform various postal processes mechanically instead of manually. Over the last five years much of this work has come to fruition, and in various sorting offices in the United Kingdom full-scale field trials have been conducted using prototypes of such machines. The first of these was the single-operator letter-sorting machine<sup>1</sup> that was installed initially at Bath sorting office and then at Southampton sorting office. Such was the success of this machine that a first batch of 20 production models was ordered, and these have now been distributed to a number of sorting offices for further trials.

To work in co-operation with the letter-sorting machine a code translator was designed<sup>2</sup> and installed in the Southampton sorting office. This translator reduced the mental effort required of the sorter and proved completely satisfactory in all its functions.

At the same time as these equipments were undergoing field trials, letter-facing and segregating equipment<sup>3</sup> was being designed, built and finally installed at Southampton sorting office. This equipment has also proved successful and production models have been ordered for more extensive trials.

One outcome of these experimental installations is that a number of well-trying mechanical and electronic units or "building bricks" have emerged which permit, without further experiment or trial, the planning of complex mail-handling systems. Such was the state of affairs when the Luton experiment was first considered.

To understand fully the need for the Luton experiment it is first necessary to say a little about the operation of the single-operator letter-sorting machine and the code translator mentioned above.

## SINGLE-OPERATOR LETTER-SORTING MACHINE

Each postman on a manual sorting duty is provided with a sorting frame with 48 pigeon-holes into which he can sort the mail. Successive stages of sorting and the sum total of the outputs from all sorters finally produce bundles of mail ready for dispatch either to other towns when outward mail is being sorted or for local delivery when inward mail is dealt with.

With the adoption of the single-operator letter-sorting machine the sorting process was speeded up and made less arduous. The sorter now had 144 boxes into which he could sort the mail (at a maximum rate of 110 items/minute), so that the number of sequential stages of sorting was reduced. He was also able to sit comfortably at the machine, thereby eliminating the need to stand and

stretch in order to reach the top-corner boxes of a manual sorting-frame. It was also found that the average machine sorting rate was higher than the average manual sorting rate by about 20 per cent.

For manual outward sorting the sorter has to remember the appropriate compartment of the sorting frame for each group of towns out of a total of 1,700 post-towns, and because of this is a skilled man, while inward sorting requires a great knowledge of the locality. Skill is also required of the operator of the sorting-machine. For each destination he has to remember which two keys (one left-hand and one right-hand) he has to depress on his keyboard, which has 12 keys for each hand, thus giving 144 combinations. It takes time for a sorter to become quick at this operation, but once having acquired the art his output rate is higher than that of a manual sorter.

Nevertheless, in spite of the improved sorting rate and a reduction in the number of secondary sorting stages required, it is undesirable to have to rely on the acquired skill and memory of an operator. By putting the routing of the letters in the sorting machine under the control of an electronic "brain," a less skilled sorter can be employed. To accomplish this improvement a translator was designed to carry out the function of converting the address as it appears on a letter into a code which could be acted upon by the sorting machine.

## CODE TRANSLATOR

Prior to designing the translator an investigation was made into the possibility of using an alphabetical keyboard (similar to that on an ordinary typewriter) to replace the keyboard with 12 + 12 keys on the letter-sorting machine. The idea was to instruct the operator to extract characters from the post-town name according to a set rule, and to key these characters sequentially, leaving the translator to route the letter through the machine. The result of this investigation, carried out jointly with the Mechanization and Buildings Department, showed that, consistent with a sufficiently high sorting rate and minimum ambiguities, a 5-character code extraction could be accepted and that, for outward sorting, these characters should be the first three and the last two of the post-town name, e.g. Southampton would become SOUON and Rye RYEYE. For inward sorting, the extraction should be the first two and last two letters of the thoroughfare name plus the first letter of the type of thoroughfare, e.g. Neasden Lane would become NEENL.

Thus, with the alphabetical keyboard and a translator working in conjunction with the letter-sorting machine, the operator would now only have to be able to read the address (not always an easy matter) and to type in order to feed all the necessary information to the machine; the mental effort would thus be considerably reduced.

A translator<sup>2</sup> was constructed for the above purpose, employing square-loop magnetic cores driven by transistors. The apparatus was completely satisfactory

† Post Office Research Station.

and, because of the speed at which translations could be performed, the possibilities that are being exploited in the Luton experiment became apparent.

#### CODE MARKING OF LETTERS

A single-operator letter-sorting machine is an expensive piece of equipment and is not employed economically if an operator uses it at an average of only half its possible operating rate. The average output rate of an operator is about 50 items/minute, although he can reach peaks of nearly 100 items/minute, while the machine has a maximum output rate of 110 items/minute. It would be economical therefore for two operators to work one machine and for the machine to be run synchronously at full rate, instead of on demand. It is essential, however, that each operator should be allowed to work at his own speed and not be tied to a particular machine speed. Two operators cannot therefore work one machine directly without complicated synchronizing equipment.

The information relating to the routing through the machine between the code-extraction point (i.e. the keyboard) and the point of entry into the distribution section of the sorting machine can best be carried by the letters themselves, in the form of code markings. Furthermore, the keyboard can then be detached from the sorting machine to form a separate unit, a coding desk, and an automatic code-reader can be added to the sorting machine. With this scheme a number of sorters can operate coding desks remote from the sorting machines, passing their outputs to the inputs of the sorting machines, in which the codes carried on the letters can be scanned by the code-readers and the letters routed to the correct boxes in the sorting machines.

A further advantage which would accrue from code-marking letters is that, once a letter had been marked with a code at the office of posting, it need never be inspected again except by machine until it arrived at its office of delivery. For example, a letter posted at Penzance and destined for Crieff in Perthshire would be sorted a number of times on its journey. If, at Penzance, it could be marked with the unique code for Crieff, the first sorting machine would group it with London letters. In London it would be grouped probably with Glasgow letters and in this fashion it would be guided to its destination.

Had the inward (street) sorting information also been marked in code on the letter at the office of posting, it would have been possible to arrange that at Crieff this inward code could be read by a local sorting-machine code-reader and be directed to a sorting box appropriate to the postman's walk that included the requisite street. Unfortunately, this would have involved the original coding-machine operator in making two extractions, resulting in a considerably reduced sorting rate. However, another experiment is in progress at Norwich in which the public are being asked to co-operate. Houses and business premises are allotted codes of six digits, e.g. ABC/12D, the first three digits referring to the post-town and the second three to the street. Persons corresponding with Norwich are asked to include this public code in addition to the normal address, and statistics are being obtained of the scale of public co-operation. The idea is that, if the percentage usage of this code is sufficiently high, the scheme will eventually be introduced on a national scale, so that coding-machine operators would no longer have to read and extract the correct codes for the post-town and the street but would

merely copy-type the public code. The two halves of the code will produce on the letter two distinct sets of code marks, one of which will determine the route of the letter from the office of posting to office of delivery whilst the other set will determine to which postman the letter should be directed when it reaches its destination office.

#### A SORTING SCHEME FOR A LARGE MECHANIZED SORTING OFFICE

It has been explained in the preceding sections how, by separating the keyboard from the sorting machines, several benefits accrue. If the sorting office of a large town is completely mechanized, the number of sorting machines is determined by the number of boxes required for the final stage of sorting the mail. The number of coding desks is determined by the size of the largest mail collection, the average operator rate and the schedule of train connexions, etc. An early investigation of a large sorting office indicated that the requirements for outward sorting would be approximately 16 operators working into six sorting machines and 14 stacking units. A statistical analysis of the mail showed that 50 per cent of it would be sorted into 14 selections and each selection would warrant a separate stacker (termed a main-selection stacker when used in this way). The remaining 50 per cent of the mail would require six sorting machines to sort it adequately for dispatch.

A photograph and a plan of a model of such an office are shown in Fig. 1. Each coding desk has letter conveyors to each of the six sorting machines and 14 main-selection stackers. The equipment is shown mounted on a false floor (or plinth) which houses the conveyors.

Each coding-desk operator has a separate conveyor from which the letters he has coded can be diverted either to the sorting machines or the main-selection stackers. Thus he has a primary conveyor with, in this instance, 20 (14 + 6) outlets. The diverted letters from all operators are carried by wide flat belts (called aggregating-conveyors) to the sorting machines or to the main-selection stackers. In each sorting machine the random stream of letters is stacked and then fed synchronously into the code-reader, which in turn directs the letters to the appropriate box.

If at any time a coding desk, primary conveyor, aggregating conveyor, sorting machine or main-selection stacker ceases to function correctly, the whole system is not brought to a standstill. This is a most important feature of the scheme. Alternatively, at slack periods of the day, only a limited portion of the equipment need be utilized. The scheme is equally applicable to inward as well as outward sorting, the main-selection stackers becoming the destinations for letters to large firms, etc., when used for inward sorting.

Two translators are shown in Fig. 1. They deal with (a) the translation from the operator's code extracted from the post-town name to the code required to be marked on the letter by the printer in the coding desk, and (b) the translation from the printed code-marks on the letter to the sorting-machine instruction required by the code-reader in the sorting-machine input. Each translator searches the two sets of equipment continuously, seeking a translation to perform. The rate of search is fast enough to leave the operator unaware that he is connected to shared equipment and also to leave unaffected the synchronous operation of the sorting machines.



## LUTON EXPERIMENT

The Luton experiment was designed to test all the elements of a scheme such as that outlined above. Fig. 2 shows the Luton scheme diagrammatically. Two coding desks are provided, each with its separate primary conveyor. Each of these conveyors has four diversion points that necessitate four aggregating conveyors and four main-selection stackers, one of these stackers (not shown in Fig. 2) being allocated to letters bound for the code-reading sorting machine. In addition, at the end of each primary conveyor another stacker is provided. A single sorting machine with a code-reader is provided, together with the necessary translators.

### Coding Desks

The coding desks and code-reading letter-sorting machines at Luton cannot be described fully here, but a brief explanation of their function is necessary. Each coding desk is in fact the separated keyboard-end of a single-operator letter-sorting machine modified to house two printing units and a code-reading unit. In this form the coding desks become a "building brick" of the whole structure. Fig. 2 includes a block schematic diagram of the coding desk. It shows the four principal parts, namely the keyboard, the printer, the code-reader and the comparator. The translators also interwork with this unit.

The letters to be coded appear on demand in the operator's viewing position. He reads the address, makes the requisite mental extraction of the 5-character code and types it. This code is passed on to the first translator, which in turn directs the printer to mark the letter with the necessary bits of a 12-digit binary code plus a start mark and, if necessary, a parity digit. The bits are dots of a phosphorescent material that are virtually invisible except when irradiated by an ultra-violet-light source.

The letter meanwhile has passed into one of two identical printing units. The operator then proceeds to code the next letter and this will in turn pass into the

other printing unit. The use of two printing units allows sufficient time for the letter to be aligned accurately and marked with the appropriate code, before it passes through the reader unit. The information from the translator that is used to set up the printer is also passed into a comparator unit in synchronism with the passage of the letter through the code-reader. If the printer has operated correctly the two sets of signals will agree, bit by bit, throughout the binary code. If, however, due to omission or addition of binary marks the codes do not agree, the comparator causes a reject divertor to operate, and the letter is extracted from the system.

The reader unit also performs the separate function of scanning the codes on items which have been coded at other offices and are ready for inward sorting. The desk is switched to automatic operation for this purpose.

In all instances binary signals detected by any code-reader are passed to the second translator. This second translator selects the appropriate aggregating conveyor for each letter and sets the divertor control-unit accordingly. This control unit is a memory device which arranges that the letters passing along the primary conveyor are diverted on to the appropriate aggregating conveyors or, in the absence of a signal, are allowed to pass into the end stacker. Letters that fall on to the four aggregating conveyors from the two primary conveyors shown in Fig. 2 are stacked in random order.

### Code-Reading Letter-Sorting Machine

The first aggregating conveyor collects letters that require further sorting in the code-reading sorting machine. At the time of writing, the link between the output of this aggregating conveyor and the input to the code-reading letter-sorting machine is manual, the aggregating conveyor feeding a main-selection stacker, as do all the other aggregating conveyors. The letters required to be sorted in the sorting machine are placed on its feed conveyor and are fed separately at synchronous speed into the machine, passing the code-reader almost immediately after separation. The binary-code signals

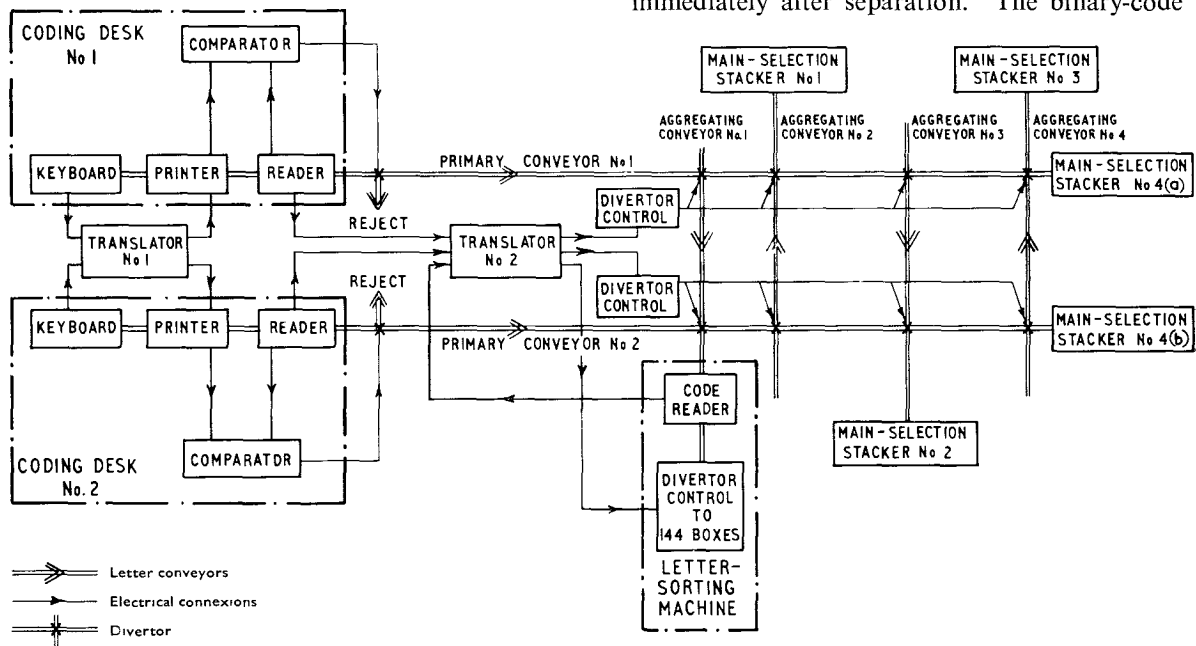

Note: At present Aggregating Conveyor No. 1 feeds a main-selection stacker and not the letter-sorting machine. The eventual arrangement will, however, be as shown.

FIG. 2—DIAGRAM OF LUTON SCHEME

from this code-reader are passed to the second translator and this in turn sets the divertor-control memory-system in the sorting machine to direct and divert each letter into its appropriate box.

The letter-sorting machine, modified to read code marks, forms another of the "building bricks" with which the whole scheme is constructed.

#### Stackers, Conveyors, Divertors and Memory Units

The remainder of the component "bricks" with which the Luton scheme is constructed consist of stackers, conveyors, divertors and memory units, most of which are essentially copies of well-tried machines. The stackers, for example, are identical with those used at the output of the letter and packet segregator installation<sup>3</sup> at Southampton sorting office.

The primary conveyors shown in Fig. 3 and 4 are constructed along the same lines as the 3-inch-wide belt system employed in the letter-facing machine<sup>3</sup> also installed in the Southampton sorting office. The system is built up with one continuous belt driven at one point only at approximately 100 ft/minute. The belt provides both transport for the letter and drive for the free-running rollers and, because it is continuous, the whole system moves at the same speed. It is necessary to have a twist section in the run in order to complete

the belt circuit without using two belts. This section gives the letters a rotation of 180° about their longitudinal axis, but this is of no consequence.

Diverted letters, with a long edge leading, are slid across skid plates by the belt and fall on to aggregating conveyors at right-angles to the motion of these conveyors, so that the letters then travel short-edge leading, as required by the stackers.

The 8-inch-wide aggregating belt is folded back on itself in such a manner as to form four separate letter paths with only one length of continuous belt, the whole moving at approximately 100 ft/minute. Once the letters have been diverted out of the straight-through path of the primary conveyor their position on the belt in relation to other letters is no longer of consequence. The coding operators can work at their own speeds and, because the coding desks are not synchronized one with the other, it is likely that one letter will fall on top of another on the aggregating belt. The stackers can easily cope with this situation.

However, the timing of the letters from the moment of release from the printing unit in the coding desk up to the point of diversion is important. For this reason the continuous belt of the primary conveyor has been carried back into the coding desk to form the means of conveying the letter there, so that timing can be accurate as far as the divertors. This is indicated in Fig. 4.

The equipment at Luton has in one distribution unit a memory made up of parts of the pin-wheel memory designed for the production-model letter-sorting machine.<sup>1</sup> The other control unit employs a magnetic drum for its memory. The pin-wheel memory has the advantage that the setting of the pins provides both memory and the means of operating the divertor linkage. With a magnetic-drum memory it is necessary to convert the signal received at the pick-up point to a mechanical operation. This can be done in many ways, and at Luton a pneumatic system is being used by way of experiment and for experience of this type of equipment.

#### CONCLUSIONS

The Luton experiment is another step in the chain of trials designed to render automatic the handling and sorting of letter mail. The first step was the design and manufacture of an operator-controlled sorting machine, followed closely by the second step of providing a code translator to reduce the mental effort required of the operator. The third step, being carried out at Luton, is the marking of letters with code marks. This step enables many operators to work simultaneously with a few sorting machines, thereby improving the economics of the process. At the same time, the code marking of letters opens up the possibility of automatic sorting at the delivery

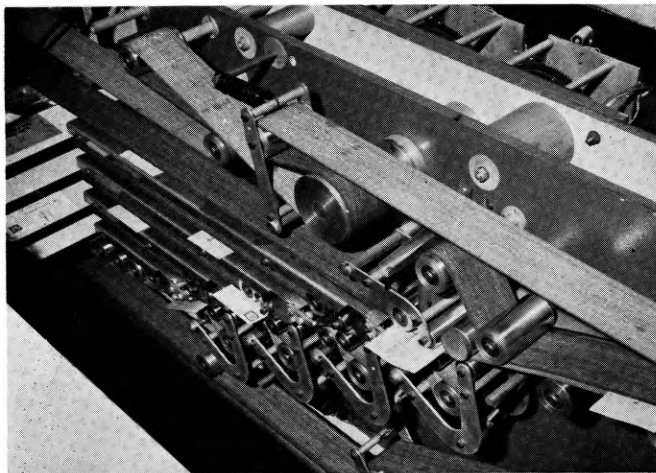

FIG. 3—PRIMARY CONVEYOR

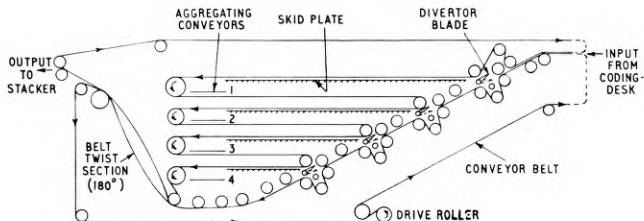

FIG. 4—EXPLANATORY DIAGRAM OF PRIMARY CONVEYOR



office, using codes printed at the collection office. To cover this portion of the scheme, a small unit is being manufactured for installation at the Mount Pleasant sorting office in London. This unit will consist of one coding desk and one code-reading letter-sorting machine together with the necessary 5-digit binary-code translator and binary-code-to-machine-code translator. The Mount Pleasant unit will send coded mail to Luton for inward sorting and will receive coded mail from Luton for outward sorting, thereby testing the complete scheme.

The equipment at Luton employs, in the main, well-tested principles which have been given field trials in various sorting offices. It also assumes the role of a

test bed for economic and life-test studies of various other parts such as memory systems, divertors, letter-jam alarms, etc. The experiment will also yield valuable statistical data for the Postal Services Department.

#### References

<sup>1</sup> COPPING, G. P., BEAK, K. L., and LANGTON, H. J. A Single-Operator Letter-Sorting Machine. *P.O.E.E.J.*, Vol. 51, pp. 104 and 188, July and Oct. 1958.

<sup>2</sup> ANDREWS, J. D. A Code Translator for Letter-Sorting Machines. *P.O.E.E.J.*, Vol. 52, p. 199, Oct. 1959.

<sup>3</sup> COPPING, G. P., MYERS, T. R., GERARD, P. S., and ANDREWS, J. D. Mechanization of the Initial Stages of Processing Mail. *P.O.E.E.J.*, Vol. 52, p. 286, Jan. 1960, and Vol. 53, p. 12, Apr. 1960.

## Book Reviews

"Numerical Methods for High Speed Computers." G. N. Lance, M.Sc., Ph.D., M.I.A.S., A.F.R.Ae.S. Iliffe & Sons, Ltd. x + 166 pp. 4 ill. 42s.

Numerical analysis is a subject which, while it offers many opportunities for advanced theory, is at the same time intensely practical; in particular, in the adapting of computational procedures to the computational aids available. Thus, pencil-and-paper, graphs, slide-rules, desk machines, and so on, all have their features which must be considered in choosing a procedure; a given type of problem may be handled in quite different ways according to the aid used.

Electronic digital computers have features which often make new procedures desirable. These features are: the preference for many repetitions of a simple process, rather than few repetitions of a complicated process; the difficulty of storing tables of functions; the difficulty of arranging for any intelligent being to keep an eye on the progress of a calculation. A great deal of work has been done, and a great deal of work is still going on, in devising suitable computational procedures. Dr. Lance's book gives a fairly comprehensive review of the situation up to 1959.

An introductory chapter reviews calculating by hand machines and leads up to automatic computers. There is a chapter on evaluation of functions—square roots, exponentials, logarithms, trigonometric functions, and so on, where the requirements of automatic computers have led to entirely new methods; in many of these methods the properties of Chebyshev polynomials have been exploited. The solution of ordinary and partial differential equations is dealt with, and so also are matrix manipulations, solutions of algebraic and transcendental equations, evaluation of continued fractions, interpolation, and numerical evaluation of integrals. An appendix deals with floating-point working. There is a bibliography of about one hundred items, an author index, and a short (two-page) subject index.

Although the user of a computer may rely almost entirely on sub-routines and library programs supplied with his computer, the need for extension and adaption of these is likely to arise and this book will help in giving him an understanding of principles. He will, however, have to be familiar with numerical methods.

One could have wished for more on the subject of floating-point working. This is a fundamental operation used in many calculations and especially in autodes, which are now almost a standard feature of any computer. Most autodes use the method described by Lance, in which rounding-off errors may mean that the printed result is not to be trusted; the user has still to decide for himself how accurate are his answers. Several workers are looking into improved methods which give some indication of the number of trustworthy figures in results.

W. E. T.

"National Certificate Mathematics," Vol. I (First year course). P. Abbott, B.A., and C. E. Kerridge, B.Sc. Completely revised by W. E. Fisher, O.B.E., D.Sc., A.M.I.Mech.E. The English Universities Press, Ltd. 410 pp. 135 ill. 9s. 6d.

This book is a revised version of the original work by P. Abbott and C. E. Kerridge, which was first published in 1938. Fifteen impressions have been taken since that date, giving an indication of the popularity of this book.

The part-time nature of the National Certificate curriculum means that students must devote most of their leisure time to study if they are to complete the course successfully. Most students do not appreciate this, or prefer to ignore it, during the early stages of the course, and the consequent lack of familiarity with fundamentals is the most common cause of failure in later years. Presumably with this in mind, this book treats the rather elementary subject matter briefly and simply, the various points being illustrated with some 140 worked examples. The main feature, however, is the number and variety of unworked examples for practice, and in his revision Dr. Fisher has modernized these problems, where possible, and has increased the total number to over 900.

Some of these examples anticipate the work of later chapters; for example, a quadratic equation is included as one of the exercises at the end of the chapter on simple linear equations. In his preface, Dr. Fisher claims that "this is not altogether accidental" and tests the alertness of the student. It is felt that students are more likely to think that they have missed some point in the text, and will waste time in attempting what is to them an impossible question. This will be aggravated by the brevity of the text, which also gives rise to incomplete treatment of some items. An example of this occurs in Chapter 1, the section on Approximations referring only to significant figure accuracy and making no mention of the specification of a given number of decimal places; inexperienced students are frequently confused on this point. The handling of logarithms with a negative characteristic receives very scanty treatment, particularly the calculation of roots of numbers between 0 and 1.

This book will normally be used in support of class instruction, however, and these faults will undoubtedly be remedied during tutorial periods. Any student who finds the time to complete all the practical exercises in this book cannot fail to become thoroughly familiar with the elementary principles of mathematics, and in so doing will provide himself with an invaluable background for his work in all subjects in later years of the National Certificate course.

G. H. K.

# Reflectometers

D. E. WATT-CARTER, A.M.I.E.E.†

U.D.C. 621.317.742

At high-frequency radio-transmitting stations where open-wire transmission lines are in general use it has been the practice to use travelling meters, loosely-coupled inductively to the line, to measure the standing waves. The introduction of coaxial feeders for distribution at transmitting stations has led to the use of devices which can continuously monitor the standing-wave condition on a feeder and the power output from the transmitter. The devices are known collectively as reflectometers, and the operation of the directional-coupler type and wattmeter type is described in this article.

## INTRODUCTION

IT is well known that if energy is transmitted along a transmission line terminated by an impedance differing in value from its characteristic impedance, some of the energy will be reflected from the termination giving rise to a standing wave of both voltage and current along the transmission line. At high-frequency radio-transmitting stations, where open-wire transmission lines are in general use between the transmitters and aerials, it has been the practice to measure this standing wave using travelling meters, loosely-coupled inductively to the line, as a means of determining and adjusting the impedance characteristics of the aerials.

The effect of mis-termination of the feeders on a high-power radio-transmitting system is, in the first place, to cause a reduction in the amount of power delivered to the aerial. In practice, the output circuit of the transmitter is designed to be capable of adjustment to match normally-occurring impedance variations, but even though the output power of the transmitter be restored to normal by such an adjustment, the standing wave will still be present and will give rise to an increase in attenuation along the line as well as to undesirably high peak voltages in the transmitter and line. If in an extreme case a transmission line happened to become disconnected or earthed the voltages set up might be sufficient to cause serious damage to the installation.

The introduction in recent years of transmitters arranged for coaxial-line outputs, and the use of coaxial feeders for distribution to a point some distance from the transmitter building, has made the feeders less accessible for standing-wave-ratio measurements of the travelling-meter type; on the other hand it has opened the way to the use of more elegant measuring techniques which can be exploited in various ways. A modern transmitter can be fitted with a device which continuously monitors the standing-wave condition on the feeder and the power output from the transmitter and, should conditions deteriorate below a predetermined amount, will cause the transmitter to shut down. These devices may take several forms, known collectively as reflectometers, and a description of two of these is given in the following sections. Before doing so, however, it may be helpful in explaining the simple theory of their operation if the conditions existing on a mismatched transmission line are briefly stated.

## THE MISMATCHED TRANSMISSION LINE

Suppose a transmission line supports two oppositely-travelling electromagnetic-wave systems, as shown in Fig. 1. In both systems the ratio  $V_1/I_1 = V_2/I_2 = Z_0$ , the characteristic impedance of the line, and the voltage

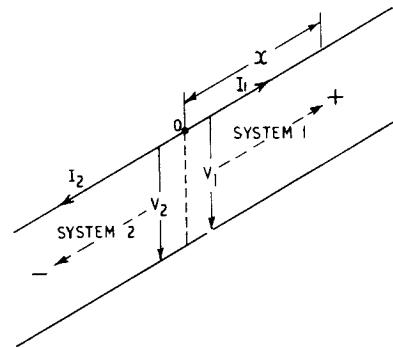

FIG. 1.—TRANSMISSION LINE CARRYING TWO OPPOSITELY-TRAVELLING ELECTROMAGNETIC-WAVE SYSTEMS

and current of either system are, therefore, in phase at all points. If, further, the ratio  $V_2/V_1 = I_2/I_1 = r$ , this ratio is the reflection coefficient of the combined wave-system. Without loss of generality, the origin O may be selected at a point in the line where  $V_1$  and  $V_2$  are in phase. It will be noted that at this point  $I_1$  and  $I_2$  are in opposition and, therefore, that a current-minimum point is also a voltage-maximum point on the line. At any point on the line a distance  $x$  metres from O, legitimately assuming negligible attenuation and ignoring the common pulsantance term,

$$\begin{aligned} V_1 &= V_{10}e^{j\beta x} \\ I_1 &= \frac{V_{10}}{Z_0} e^{j\beta x} \\ V_2 &= V_{20}e^{-j\beta x} = rV_{10}e^{-j\beta x} \\ I_2 &= \frac{V_{20}}{Z_0} e^{-j\beta x} = \frac{rV_{10}}{Z_0} e^{-j\beta x} \end{aligned}$$

where  $\beta$  is the phase constant of the line in radians/metre.

The resultant line voltage at a distance  $x$  from O is therefore:

$$\begin{aligned} V_x &= V_{10} \cdot (e^{j\beta x} + re^{-j\beta x}) \\ &= V_{10} [(1+r)\cos\beta x + j(1-r)\sin\beta x] \end{aligned} \quad (1)$$

Similarly, the resultant line current is:

$$I_x = \frac{V_{10}}{Z_0} [(1-r)\cos\beta x + j(1+r)\sin\beta x] \quad (2)$$

If the line is cut at this point and terminated by an impedance preserving the two electromagnetic wave systems its value will be given by:

$$Z_x = V_x/I_x = Z_0 \left\{ \frac{1-r^2 + 2jr \sin 2\beta x}{1+r^2 - 2r \cos 2\beta x} \right\} \dots \quad (3)$$

It will be noticed that the phase angle between line voltage and current is, in general, not zero and equals

$$\tan^{-1} \left[ \frac{2r}{1-r^2} \sin 2\beta x \right]$$

The power associated with the forward-travelling wave is  $V_1I_1$  and with the backward-travelling wave is  $V_2I_2$ , so that the resultant power flowing in the line is:

$$P = \frac{V_1^2 - V_2^2}{Z_0} = \frac{V_1^2(1-r^2)}{Z_0} \dots \quad (4)$$

† Overseas Radio Planning and Provision Branch, E.-in-C.'s Office.

The power flow may also be derived from the scalar product  $V_{\lambda}I_x$ , which, from equations (1) and (2), will be found to give the same result as equation (4). It is clear, therefore, that power flow in a transmission line may be determined either by measuring separately the power in the forward and backward waves and subtracting one from the other, or by measuring the line voltage and current at a single point and finding their scalar product. The first method requires a directional-coupler and the second method a form of wattmeter.

TRANSMITTER REFLECTOMETERS

The Directional-Coupler Type

In order to measure separately the two oppositely-travelling waves on the transmission line it is necessary to couple with one field system to the exclusion of the other. Suppose a small metallic loop is inserted into a coaxial line which carries an electromagnetic wave in one direction only (Fig. 2). The loop is loaded with a

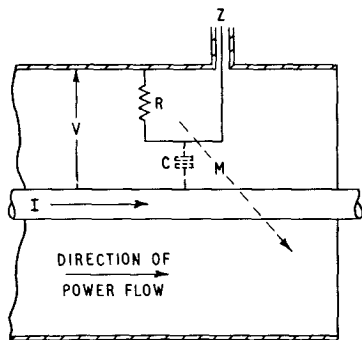

FIG. 2—DIRECTIONAL COUPLER IN A COAXIAL CABLE

resistance  $R$  and the output is delivered into the impedance  $Z$ . This loop will couple both into the magnetic field via its mutual inductance  $M$  and into the electric field via its capacitance  $C$ . If it is not to upset the line conditions appreciably its self-inductance and capacitance must both be small and then, with a good degree of accuracy, the following expressions may be written for the currents flowing into the impedance  $Z$ :

That due to electric coupling,

$$i_1 = \frac{j\omega CR}{R + Z} \cdot V \dots\dots\dots (5)$$

That due to magnetic coupling,

$$i_2 = \frac{j\omega M}{R + Z} \cdot I \dots\dots\dots (6)$$

The two currents are in phase quadrature with  $V$  and  $I$ , respectively, and are, therefore, in phase with each other.

Suppose now the direction of the wave is reversed, by changing the direction of either  $V$  or  $I$ . Then,  $i_2$  opposes  $i_1$  and, by correct choice of the loop parameters, they may be made to cancel. The condition for this is found, by equating equations (5) and (6), to be  $M/CR = Z_0$ .

Thus, a correctly proportioned loop will respond to a wave travelling in one direction only, and it will be noticed that this unidirectional property is insensitive to frequency, so that it is suitable for wideband operation. The actual loop dimensions are chosen by using approximate methods to calculate  $C$  and  $M$ , and the precise balance is achieved by determining  $R$  experimentally.

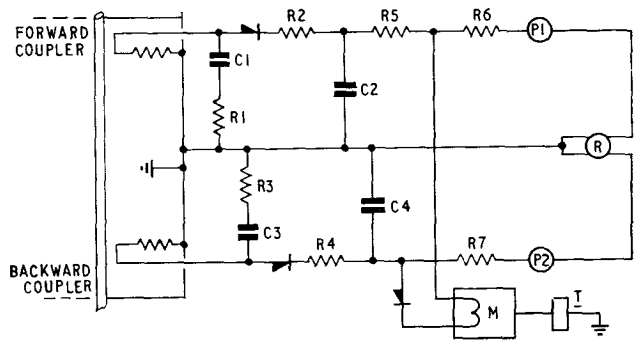

FIG. 3—REFLECTOMETER USING DIRECTIONAL COUPLERS

In the directional-coupler type of reflectometer a combination of two opposed directional couplers is used to form a reflectometer, as shown schematically in Fig. 3. Outputs from the forward and backward couplers are applied, respectively, via simple networks  $C1, R1$  and  $C3, R3$  to compensate for rising output with frequency, to rectifiers and smoothing circuits  $C2, R2$  and  $C4, R4$ . The rectified signals are then applied to a ratiometer,  $R$ , calibrated to read their ratio, which is the reflection coefficient of the wave in the transmission line. The meters  $P1$  and  $P2$  are calibrated in terms of the forward and backward power, respectively, and the difference between their readings indicates the power being conveyed to the load along the transmission line. It will be noted from equation (4) that if the reflection coefficient does not exceed 0.3, which is so in all normal circumstances, then the error in taking the reading of the forward-power meter  $P1$  as the true power is less than +10 per cent, so that for most practical purposes the backward-power meter  $P2$  is omitted.

The transmitter is prevented from operating under badly mismatched conditions by the incorporation of an auxiliary circuit, in which a signal from the backward-coupler circuit and a proportion of the signal from the forward-coupler circuit, derived from the dividing network  $R5, R6$ , are applied to a magnetic amplifier,  $M$ . Under normal line conditions no current flows, but should the reflected component increase the backward-coupler signal takes over and the magnetic-amplifier output is made to decrease and release relay  $T$ , which disconnects the h.t. power supplies from the transmitter.

The Wattmeter Type

Another type of reflectometer is illustrated schematically in Fig. 4. In this arrangement signals proportional

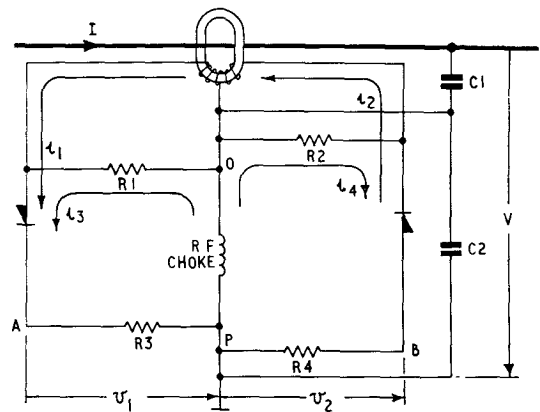

FIG. 4—REFLECTOMETER USING LINE CURRENT AND VOLTAGE COUPLING

to the line current and line voltage are applied to a rectifier-resistor network, containing resistors R1, R2, R3 and R4, via a toroidal transformer, having a centre-tapped secondary winding, and a potential divider consisting of two capacitors C1 and C2 ( $C_2 \gg C_1$ ).

It is shown in the Appendix that if the network components are correctly chosen and the network is balanced ( $R_1 = R_2$  and  $R_3 = R_4$ ), the ratio of the direct currents flowing through the resistors R3 and R4 (or of the voltages appearing across them) is numerically equal to the reflection coefficient of the line.

An alternative method of using this circuit is to place a trip relay in series with the r.f. choke and to make the resistor R3 variable. The value of  $r$  at which the current through the relay falls to zero and releases the relay may then be determined by the setting of resistor R3.

It will be noticed that the voltage appearing across the points AB of the bridge will be proportional to  $V_1(1 + r)$ . If a second bridge is provided identical with the first, except that one of the rectifiers is reversed relative to the other, then the voltage appearing across AB will be proportional to  $V_1(1 - r)$ . If these two voltages are applied to a conventional type of d.c. wattmeter the reading will be proportional to their product, i.e.  $V_1^2(1 - r^2)$ , which, as seen from equation (4), is proportional to the power flowing in the line.

#### CONCLUSION

Reflectometers of both the types described in this article are in service as transmitter-monitoring devices at Post Office high-frequency transmitting stations, the first type in transmitters installed at the Rugby B and Criggon stations, and the second in transmitters installed at the Ongar, Dorchester and Rugby A stations. Both types are applicable to other frequencies, both higher and lower; the first type of instrument, being dependent on defined electromagnetic field patterns, is more suited to higher frequencies, and the second method could readily be extended to lower frequencies where lumped-circuit techniques are more applicable.

#### APPENDIX

##### Derivation of the Current and Voltage Relationships in the Reflectometer of Figure 4

In considering the currents flowing in the network illustrated by Fig. 4 it is convenient to deal separately with those due to inductive and capacitive coupling to the line. For the moment the effect of the rectifiers will be disregarded.

The elements of the network which are relevant to the currents  $i_1$  and  $i_2$ , derived from the inductive coupling, are shown in Fig. 5(a). The mesh equations for the left-hand half of the network are

$$(i_1 + i_1')j\omega L + i_1(R_3 + 1/j\omega C_2) = j\omega MI$$

$$\text{and} \quad -i_1' R_1 + i_1(R_3 + 1/j\omega C_2) = 0,$$

from which it is deduced that

$$i_1 = \frac{j\omega MIR_1}{j\omega L(R_1 + R_3) + \omega L/\omega C_2 + R_1 R_3 + R_1/j\omega C_2}$$

If  $\omega L \gg R_1 \gg 1/\omega C_2$ , this expression simplifies to:

$$i_1 = \frac{MIR_1}{L(R_1 + R_3)}$$

A similar expression may be found for  $i_2$  by considering the right-hand half of the network.

Referring to Fig. 5(b), the capacitive divider  $C_1, C_2$

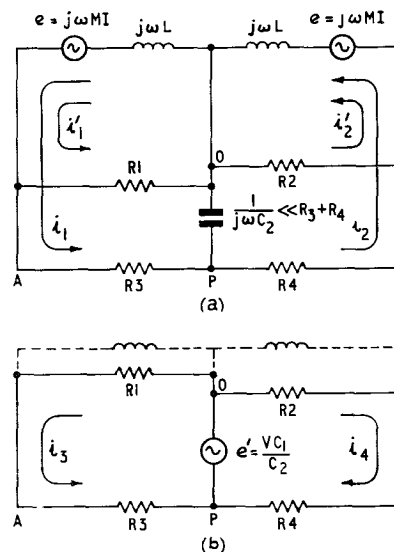

(a) For inductive coupling  
(b) For capacitive coupling

FIG. 5—EQUIVALENT CIRCUITS FOR NETWORK OF WATTMETER-TYPE REFLECTOMETER

introduces into the network a voltage  $e'$  across OP which is approximately equal to  $VC_1/C_2$  (since  $C_1 \ll C_2$ ). The reactance of  $C_2$  is so much smaller in value than the resistances that its effect may be ignored, and the currents  $i_3$  and  $i_4$  are then given by:

$$i_3 = \frac{VC_1}{C_2(R_1 + R_3)}$$

$$\text{and} \quad i_4 = \frac{VC_1}{C_2(R_2 + R_4)}$$

It will be noticed that  $i_1$  and  $i_2$  are in phase with the line current  $I$ , and  $i_3$  and  $i_4$  with the line voltage  $V$ . Also, the relative senses of the currents  $i_1$  and  $i_3$  are the same, whereas those of currents  $i_2$  and  $i_4$  are opposite.

Suppose the parameters of the network are chosen such that  $C_1/C_2 = MR_1/LZ_0 = MR_2/LZ_0 = K$ , and making  $R_1 = R_3$ , then the resultant currents flowing in the resistors R3 and R4 are, respectively,

$$i_1 + i_3 = K(Z_0 I + V)/(R_1 + R_3)$$

$$\text{and} \quad i_2 - i_4 = K(Z_0 I - V)/(R_2 + R_4)$$

The expressions for  $V$  and  $I$  given by equations (1) and (2) may be inserted in the right-hand side of these equations to transform them to:

$$i_1 + i_3 = 2KV_1(\cos\beta x + j\sin\beta x)/(R_1 + R_3)$$

$$= [2KV_1/(R_1 + R_3)] \angle \beta x$$

$$i_2 - i_4 = 2KV_1 r(\cos\beta x + j\sin\beta x)/(R_2 + R_4)$$

$$= [2KV_1 r/(R_2 + R_4)] \angle \beta x$$

That is to say, for a given reflection coefficient,  $r$ , the currents in R3 and R4 are of constant magnitude, independent of the position of the standing wave relative to the coupling point.

The effect of placing rectifiers in series with R3 and R4 will be to cause direct currents to flow through them substantially proportional to the magnitudes of the resultant alternating currents, and it follows that

$$\frac{|i_2 - i_4|}{|i_1 + i_3|} = \frac{r(R_1 + R_3)}{(R_2 + R_4)}$$

If the bridge is made symmetrical ( $R_3 = R_4$ ) then the ratio of these currents, or of the voltages  $v_1$  and  $v_2$  appearing across the resistors R3 and R4, is numerically equal to the reflection coefficient  $r$ .

# Component Reliability in Post Office Equipment\*

A. A. NEW, M.Sc., F.R.I.C., A.Inst.P.†

U.D.C. 621.3.03.004.15

The growing use of electronic equipment and the need for apparatus capable of functioning for very long periods without any maintenance attention have increased the importance of component reliability. The necessity of determining the exact reasons for failures is stressed and the effects of working conditions on the lives and performance of components are reviewed. The analysis of statistical data relating to component reliability is discussed and some statistics of failures of components in Post Office equipment are given.

## REASONS FOR INCREASED INTEREST IN RELIABILITY

THE Post Office, with its very large investment in telecommunications plant, has always required its equipment to have a long life and be very reliable.

The developments that have taken place during the last decade have, however, greatly increased the importance of reliability. The growing use of electronic equipment and particularly the tendency for it to be used to carry out functions previously performed by electromechanical equipment have offered the prospect of reducing maintenance attention almost to vanishing point. If, as a consequence, equipment can be left unattended for many years without failure, extremely important developments become possible. The introduction of electronic computers into everyday Post Office work also lends added importance to achieving reliability in electronic apparatus.

Some organizations have found it desirable to employ engineers whose sole concern is reliability, but the production of reliable equipment depends on the application of certain principles from the earliest stages of design. To be fully effective, therefore, a reliability engineer must also be a design engineer in every relevant sense. A more reasonable alternative is that every design engineer should have a knowledge of the principles governing reliability.

In operating electronic equipment reliably for a very long period, one of the major factors is the reliability of the individual components when working under the conditions of temperature, humidity, voltage, mechanical wear and operational hazard to which the equipment is normally subjected.

The probability of failure of an equipment due to random failures of its components when such failures are very rare is the sum of the probabilities of failure of each kind of component multiplied by the number of components of that kind. However, if the incidence of failures is high enough for the possibility of the simultaneous occurrence of more than one fault in an equipment to become appreciable, the above probability is often reduced by such simultaneous faults or by multiple failures.

Hence, if all kinds of components had the same probability of failure, the equipment with the least components would be the most reliable. In fact, different kinds of components have widely different failure rates.

## RELIABILITY AND STABILITY

Reliability implies the absence of failures, and stability the absence of change in the characteristics of components. Nevertheless, reliability and stability may be assessed in terms of failures and drift, and it is by

studies of these phenomena that the way to avoid them can be discovered and components improved.

Superficially there are two broad classes of failures: those due to an abrupt change of some important parameter to zero or infinity, called catastrophic failures, and those which occur more gradually due to a drift of some parameter outside a value corresponding to some limit of performance of the equipment. Short-circuits and disconnexions are failures in all circumstances, but failure by drift depends on the requirements of the design of the equipment in which the component is used. In addition, if regular maintenance is carried out, some drifting components can be replaced before the equipment-failure limit is reached. Such factors are liable to introduce a lack of precision into statements on the reliability of components and should be defined clearly if there is any possibility of ambiguity.

## MECHANISMS OF FAILURE

Statistical studies on components give a measure of the reliability of a component or the effect of a condition, and may be used to improve the reliability of an equipment by allowing the best choice to be made from many alternatives, but such studies cannot directly indicate how the reliability of the component can be improved. The only way this can be done is by determining the mechanisms of failure of faulty components by the appropriate chemical and physical methods and deducing from these investigations how such mechanisms may be slowed down or eliminated without introducing other failure mechanisms. An alternative is to design a completely new component, making use of the best physical and chemical information available, but such a component needs thorough life-testing before its reliability is known.

There is a reason for every failure. This may seem an unnecessary truism, but it is worth stating because mere lack of information and the desire for simple statistics lead to the lumping together of many different kinds of faults, and sometimes inferences are subsequently made as though (a) the faults were all the same kind, or (b) they were purely random events, when neither of these assumptions is justified. The use of statistics and the assumption of randomness are much better than subjective judgments based on a few samples under unknown conditions, but the result should be regarded as a rough approximation adopted because of incomplete information. A grouping in accordance with the individual mechanisms of failure can often indicate useful inferences and generalizations.

In general one may say that, when components are working as intended, only electrons are being permanently displaced. If matter, in the form of atoms, ions, molecules or aggregations of them, is being permanently displaced such a displacement may constitute a mechanism by which the component may fail. Component failure mechanisms may arise from misuse, bad

\* This is an expanded version of a paper contributed to the I.E.E. Symposium on Electronic Equipment Reliability on 18 May 1960.

† Post Office Research Station.

design, failure of other components, mechanical causes, or chemical and physical processes.

As the writer has dealt with the detailed mechanisms of failure of components in general<sup>1</sup> and of mica capacitors in particular<sup>2</sup> at some length elsewhere, readers requiring further details are referred to those papers. Many mechanisms of failure of valves and drift of their characteristics have been described by G. H. Metson<sup>3, 4, 5</sup> and others, including considerations affecting valves for the transatlantic telephone cable system;<sup>6</sup> transistors have been dealt with by F. F. Roberts.<sup>7</sup> The use of component reliability data in circuit design has been described by A. C. Lynch.<sup>8</sup>

#### ACCELERATING AND DE-RATING FACTORS

When estimating the effect of altering the working conditions or of de-rating components, or when considering the use of accelerated life-tests, a knowledge of the magnitude of the accelerating or de-rating factor<sup>†</sup> involved is essential. It is much to be preferred that this information should relate to the individual mechanisms of failure of components rather than to the components themselves, although the need for generalizations sometimes makes the latter association unavoidable.

#### *Change of Parameters with Time*

During shelf life and working life the parameters of a component are continually changing even though the rate of change may be very small and detectable only with very sensitive measuring equipment. Some of these variations are cyclic and associated with some cyclic change in temperature, humidity, voltage or other condition. Such variations are predictable from a knowledge of the relationship between the condition and the parameter concerned. Other types of change are continuous and are usually termed drift.

If such drifts are plotted against time for various types of component and parameter many different types of curve may be found, including some, such as those relating to the conductance of valves,<sup>9</sup> which are nearly straight lines. Some drifts may be negligibly small at first, but increase with time, as does the resistance of a conductor a part of whose surface is being corroded away at a constant rate. Other drifts may be fairly rapid initially, but may asymptotically approach some fixed value, as sometimes happens when the relaxation of a frozen-in strain in a plastic takes place and governs the capacitance drift of a capacitor. Any of these types of drift may terminate abruptly with the value suddenly increasing or dropping to zero on account of some secondary effect, but the main reason that abrupt catastrophic failures of an unpredictable nature occur is that the change at the spot where the failure will take place, which may be an exceedingly small area, is masked by some large unchanging quantity which has always to be measured along with it, e.g. the current at the minute faulty portion of the dielectric of a 1  $\mu$ F paper capacitor may have to increase 10,000 times before it is noticeable in comparison with the normal leakage current of the vastly greater area of sound dielectric.

<sup>†</sup> An accelerating factor is a measure of the rate of increase of deterioration caused by a given change in conditions and hence of the shortening of life. A de-rating factor is a measure of the extent to which one operational condition must be reduced in intensity (*a*) to balance the intensified action of some other condition, or (*b*) to produce a given increase in length of life.

#### *Environments*

The environment in which a component is required to work has a profound effect on the length of its life. It cannot be too strongly stressed that this statement refers to the environment immediately adjacent to the component, and includes *all* the conditions relating to that environment.

The exact quantitative effect of ambient conditions on the life of a component is a complex function which can only be stated for a given component after a considerable study of the processes underlying its mechanisms of failure. The accelerating effect of a change in conditions is often different for various mechanisms of failure, and hence, when endeavouring to predict the life of a component by extrapolating from data obtained in accelerated life-tests, a separate extrapolation should be made for each mechanism of failure. The expected life should then be taken as the lowest of the individual values so obtained. A great deal of research is being done on this subject, but in the meantime use is often made of the following generalizations.

*Temperature.* Many failure mechanisms act more rapidly when the temperature is raised, and for some of them the rate of increase is roughly doubled for every 10°C rise in temperature.<sup>10</sup> For example, some types of impregnated capacitor described by Brotherton<sup>11</sup> had rates of failure at temperatures of 65°C and 85°C related by a factor of 2.2 per 10°C.

Many component-failure processes are chemical reactions. The speed of many chemical reactions varies with temperature by a factor<sup>12</sup> of 2-3 per 10°C. The speed in most instances is governed by either the reaction rate (in many processes involving gases or liquids) or the diffusion rate (mainly processes involving, in addition, one or more solids<sup>13</sup>). These rates may be represented in simplified form by  $A \exp(-E_c/RT)$  and  $A_d \exp(-E_e/kT)$  typically, where *A* and *A<sub>d</sub>* are frequency factors representing frequency of collisions, *E<sub>c</sub>* and *E<sub>e</sub>* are the activation energy in calories/mole and in electron volts respectively, *R* is the gas-constant/mole, *k* is Boltzmann's constant (*R*/*N<sub>a</sub>*, where *N<sub>a</sub>* = Avogadro's number) and *T* is the absolute temperature. The logarithms of the above expressions plotted against the reciprocal of absolute temperature give straight lines, and hence the temperature coefficient is not a constant but decreases with increasing temperature.<sup>14</sup>

If the activation energy *E<sub>c</sub>* is of the order of 20,000 and the *A* values are such as commonly occur, the reaction rate is perceptible at ordinary temperatures, and the temperature coefficient (per 10°C) is about 2-3 (3.1 for 20-30°C, falling to 2.6 for 50-60°C). If the activation energy is as high as 40,000, the reaction rate is imperceptible at ordinary temperatures<sup>13</sup> (the temperature needs to be raised several hundred degrees before the rate is appreciable), but its rate temperature coefficient (per 10°C) is now much higher (about 9.3 for 20-30°C falling to 6.5 for 50-60°C).

It can thus be seen that rate temperature coefficients of 2-3 times (per 10°C) are often met because they occur where the rate is appreciable and hence the process is both noticeable and readily measurable.

The above is a simplified picture assuming that the reaction consists of a single process, but in practice this is rarely so. Most reactions consist of a number of processes with different activation energies (and rates). One process usually predominates as an overall speed or



rate-determining factor in a particular range of temperature while another is more important in a different temperature range. Hence, curves derived as above sometimes consist not of one straight line but of two or more, with a slightly curved portion where they meet, depending on the extent of the temperature range over which they have been made. If there is a change of state of one of the materials involved there will also be a marked change in the reaction rate at the temperature at which the change occurs.

It is useful to analyse data in this way because the straight-line relationship permits a certain amount of interpolation and extrapolation and because many activation energies are known or can be calculated theoretically. The possibility of a particular reaction being concerned in some failure mechanism may thus be considered quantitatively.

In such analyses the data should be derived from one mechanism of failure only and it should be clear whether, in the range of conditions used in any extrapolation, one or more than one process is operative. If more than one process is present the plot may consist of more than one straight line and this must be taken into account in any estimates of expected life.

The above refers mainly to the mechanisms of failure arising from chemical reactions, but other failure mechanisms such as those due to relaxation of long chain molecules are also accelerated by rise of temperature. Because the movement of such molecules takes place through a very large number of separate jumps of the atoms or groups constituting them, their rate temperature coefficients are subject to similar considerations but with the difference that there are two (or more) processes approaching equilibrium.

*Humidity.* Many deterioration mechanisms of components are accelerated by a rise in ambient humidity if some electrically functional part is capable of absorbing moisture or of having moisture condensed on it. The effect may become evident as chemical corrosion, or as increased capacitance, power factor, or leakage current. If the leakage current is high it may lead to electrochemical corrosion, perhaps followed by a short-circuit or disconnection.

If there is some severe restriction on the rate of entry of the moisture vapour, either because it can only enter through a fine crack or pinhole, or because it has to diffuse through some plastic seal or casing, this restriction may be the overall controlling factor of the rate of deterioration.

The rate at which such mechanisms act is usually a function of the rate of diffusion of moisture. This is governed by Fick's law,<sup>15</sup> which states that the rate of diffusion of a vapour through a permeable membrane is proportional to the difference in vapour pressure between the two sides of the membrane. In practice the "membrane" is formed by the casing, coating, or filling intended to prevent moisture entering the component.

Most electrolytic capacitors (excluding recent completely dry types containing manganese-dioxide coatings) call for a modification of part of the above in that their capacitance and power-factor values often drift at a rate which is a function of the difference in moisture-vapour pressure between their interiors and the external ambient atmosphere. If it is drier outside than inside they dry out; if the moisture-vapour pressure is greater outside than inside, moisture will diffuse in until the available

space is full and the internal pressure may then cause leaks of liquid or force open the case, resulting in a catastrophic fall of insulation resistance.

Where moisture is condensed as liquid water on a surface, deterioration is a function of the amount and distribution of the water film deposited, but often the conditions of such films change so frequently and so rapidly that precise investigations are difficult.

*Voltage.* Based mainly on empirical work, it has been shown that in many instances the rate of deterioration of components, such as impregnated-paper capacitors, whose failure mechanism consists of a slow deterioration of a dielectric under d.c. stress of the order of 1-100 volts/micron, is proportional to a power  $n$  between 4 and 8 of the applied potential.<sup>16, 17</sup> Brotherton<sup>11</sup> showed that for capacitor impregnants in general use  $n$  varies from 4-6. For convenience it is usually taken that the life of such capacitors is inversely proportional to the fifth power of  $V$ .

*Current or Loading.* The life of resistors and wires is related to their loading. Over the full range of current or loading from zero up to that causing rapid breakdown there are usually several different mechanisms of failure, each one predominating over a part of the range. At the higher end the temperature of the working element of the component (a function of heat evolved less heat lost) may be the most important factor and be a cause of resistance drift. For low-current values at which the heat evolved is negligible, the predominant factor may be electrolytic attack, and the length of life may be related to the current by processes based on Faraday's laws. If the current is variable the main factor is the total quantity of electricity passed. This applies to the leakage current in some types of capacitor and to leakage currents between poorly-insulated conductors.

With small resistors most of the heat dissipated is conducted along the leads, but with larger resistors a greater part of the heat is dissipated by convection. Radiation only becomes important at surface temperatures of the order of 300°C or more. De-rating graphs for the various types of resistor are given in the Inter-Service Standards RCL111 and 112.<sup>18</sup>

*Frequency.* If a deterioration process occurs once per cycle of an applied alternating potential, e.g. the ionization of gas in an enclosed space in a dielectric with impact of the ions on the inner surface of the dielectric, then, other things being equal, the rate of deterioration may be proportional to the frequency of the alternating potential.

#### STATISTICAL DISTRIBUTIONS

##### *Considerations Arising when Dealing with Large Batches*

When large batches of components have to be studied it is of interest to consider the main distributions occurring. Such information gives various measures of the quality of the populations of components concerned but does not indicate directly how the components may be improved. It is useful in assessing statistical data on component reliability such as those given in Tables 1-4. If a rigorous estimate of significance or comparison with some hypothesis or mathematical curve is desired this can be done simply by the use of the chi-squared test and tables.<sup>19</sup>

##### *Distribution of Parameter Values in a Population*

The distribution of capacitance values of an actual

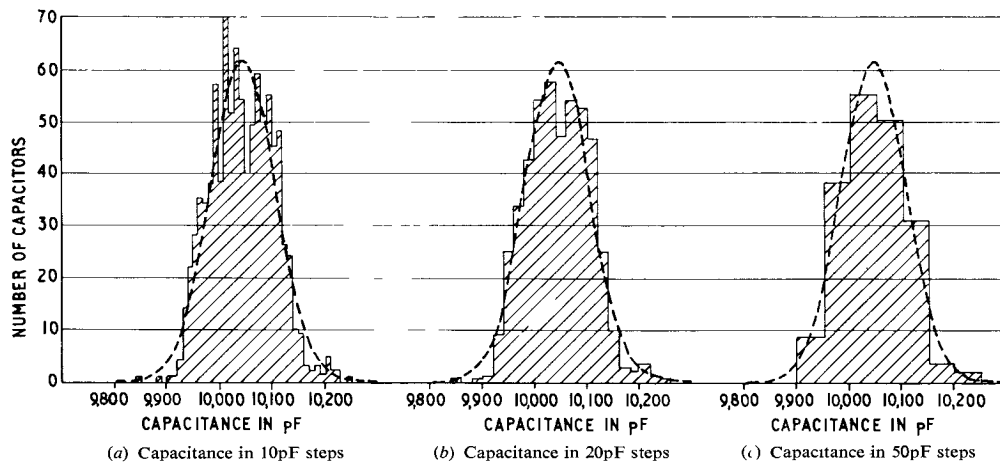

The plots were made with different width steps to emphasize different features. The superimposed dotted line gives the curve of the normal distribution.

FIG 1—THE DISTRIBUTION OF CAPACITANCE VALUES IN A BATCH OF 1,000 CAPACITORS

consignment of 1,000 capacitors of nominally 10,000 pF capacitance and  $\pm 1$  per cent tolerance is shown in Fig. 1. The three histograms show analyses of the same set of data in steps of 10 pF, 20 pF and 50 pF, while superimposed on each is the theoretical curve obtained by assuming a normal distribution of the same number of samples with the same mean and standard deviation. They illustrate the following features of interest:

(a) They resemble the theoretical normal distribution fairly closely, so that mathematics that has been worked out for such a distribution can be applied if desired. Fortunately, the departure from it has to be severe before tests of significance on averages become inaccurate.<sup>19</sup>

(b) The mean of the batch is a little higher than the nominal value.

(c) Only two of the 1,000 are outside the lower tolerance, but 136 are outside the upper tolerance. This arises partly from the difference between real and nominal means and partly because

- (i) the distribution is slightly skew, and
- (ii) there is a slight double hump in the distribution, the minimum of the hump coinciding with the mean value of the whole batch.

Some or all of these features are found in measurements on all batches of components, often with greater divergencies from the normal curve. The increasing use of automatic selection machines in resistor production can, for example, result in batches having a very strongly double-humped distribution if a 5 per cent tolerance batch contains only individuals which are between + 2 per cent and + 5 per cent or - 2 per cent and - 5 per cent of the mean value. Distributions with a greater degree of skewness than the above are common.

#### Distribution of Failures with Time

The distribution of failures in the time domain is very important in expressing and estimating the reliability of components and equipments during service.

The ideal distribution economically, if life were proportional to cost, would be that in which all the components of an equipment were due to wear out simultaneously on the day after it had been discarded, but this is impracticable.

If the distribution of failures with time of large

numbers of components in an equipment is plotted, a curve with a shape rather like one of the dotted curves in Fig. 2 and 3 may be obtained. Such curves consist of three main parts, an initial rapidly-falling portion usually consisting of small numbers of failures of each of several different mechanisms of failure of several kinds of components (usually termed "early failures" or "rogues"), an intermediate fairly flat portion related to a low failure rate, and a humped portion which corresponds to the main-failure mechanism of one type of component.

If several different main-failure mechanisms are present, the individual humps tend to be smoothed out when all failures are lumped together. If the failures from many types of component in an equipment are taken together, a further smoothing of the distribution curve occurs, and if the failures in equipments of various ages are also treated together, still further flattening takes place. Two further causes of flattening of this curve are that failures due to maltreatment are often

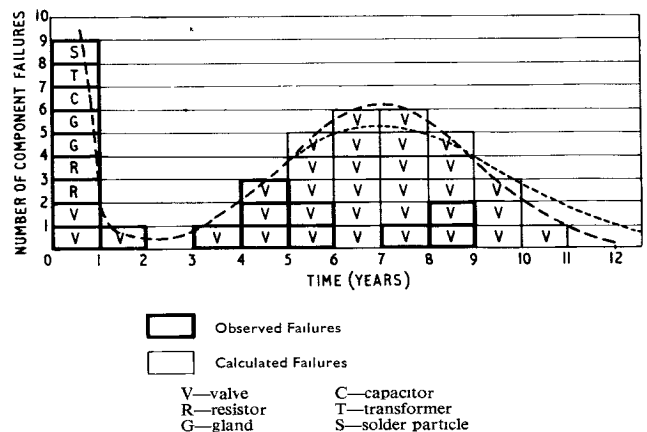

Many examples are known of normal (--- curve) or skewed-normal (--- curve) distributions in time of failures of a single type of component during accelerated life-tests, but little information is available relating to the whole working life of complete batches of a single type of component.

The thick lines indicate observed failures and the thin lines show the additional failures which could be expected if at any time a failure occurred only the faulty valve were replaced instead of all three in the repeater. The estimate assumes that the observed failures indicate the earlier side of the hump and a half-life of 7 years. It agrees with the total number of valves of the type and the usual shape for one failure mechanism.

FIG. 2—DISTRIBUTION OF COMPONENT FAILURES WITH TIME FOR SUBMERGED REPEATERS LAID 1951-1954

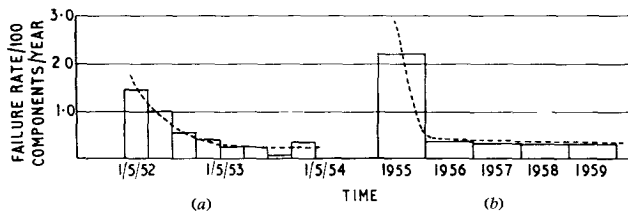

(a) 20 db video amplifiers  
(b) Experimental electronic director, Richmond exchange  
FIG. 3—FAILURES PER 100 COMPONENTS PER YEAR

randomly distributed and that the higher incidence of early failures is often hidden by a deliberate pre-aging of the components or the equipment or both. Such a procedure removes many of the failures, which are not included in the failure distribution curve.

Hence, in equipments containing large numbers of components of different kinds and ages, it is usual to find that the failure rate shows only moderate changes from year to year, and that fault rates can therefore be expressed, with a useful degree of accuracy, as  $x$  per cent per unit of time.

When referring to a single mechanism of failure of a single component this method of expression is less valid, because the distribution is often more or less normal or log-normal, and the half-life, together with some expression of the spread, such as standard deviation, variability, or the time to 0.1 per cent, 1 per cent or 10 per cent failures, defines the situation more closely.

However, when there are several failure mechanisms present, including early ones, the  $x$  per cent per unit of time method (which really assumes that failures have a purely random distribution) has some value provided that designers are clear about its limitations and the actual time of test is not too short, say not less than a year.

#### *Distribution of Rare Failures in the Number Domain (Number of Incidents per Interval)*

The distributions when the numbers of failures per unit of time or equipment are low and often zero are of interest in at least three connexions: firstly, with regard to the principle of redundancy where a component is in parallel with  $n$  others of the same kind and value, so that complete failure will only happen when there is a coincidence of  $n$  failures at the same part of the circuit; and, secondly, when a situation exists that there are, say, four components of the same type in each of 20 equipments and failures of such components in the individual equipments have been 0, 0, 1, 0, 3, 0, 1, 2, 0, 0, 1, 4, 1, 0, 2, 0, 0, 2, 0, 0. Does this mean that there were special local circumstances affecting the equipments with three and four failures which could only be determined by studying those equipments closely, or would a mere random distribution of 17 failures have a high probability of producing an instance of three and of four failures in a single equipment? Thirdly, there is a similar situation concerning time intervals, e.g. if the above failures occurred in say successive weekly periods, is there a high probability that the weeks with three and four failures had special conditions (e.g. high humidity, high line voltage) causing the high failure rate, or is there a high probability that a random distribution would produce these results?

The distribution of scarce events like the above takes place in accordance with the Poisson series:

$$e^{-m}, \frac{me^{-m}}{1!}, \frac{m^2e^{-m}}{2!}, \frac{m^3e^{-m}}{3!} \text{ et seq.},$$

if the events are occurring randomly, where  $m$  is the average frequency and  $e^{-m}$  corresponds to zero occurrences.

If random, the failures may well be grouped together for study, but if not it is wise to examine with more than usual thoroughness the conditions affecting the minority of outstanding failures. These may contain the most extreme (and hence the most readily recognizable) condition of a general cause of failure, or some condition which is specific to them and not to the majority.

#### *Other Statistical Distributions and Calculation of Equipment Reliability.*

Other distributions applicable in certain circumstances in the calculation of equipment reliability are the Binomial, Exponential,<sup>20, 21, 23</sup> Gamma,<sup>22</sup> and Weibull.<sup>22</sup>

Methods of calculating reliability of service equipments from component data have been published in this country<sup>20</sup> and the U.S.A.<sup>23</sup>

#### DEGREES OF RELIABILITY AND LENGTH OF LIFE REQUIRED BY THE POST OFFICE

The desire for the maximum reliability of equipment at an economic cost leads to several different degrees of reliability when applied to specific types of equipment. These degrees of reliability may for convenience be arbitrarily listed as follows, where the standard of reliability for (a) is a little better than that of the ordinary commercial radio set:

(a) Hearing aids for Ministry of Health (developed and partly designed by the Post Office: 3-year life with a small percentage of failures (i.e. about 0.1 per cent–0.2 per cent component failures per year).

(b) Computers for other Government Departments: 10-year life and serviceable for at least 90 per cent of the time.

(c) General telecommunications equipment: 20-year life with minimum interruptions of service (for electronic exchanges about 0.05 per cent component failures per year has been suggested).

(d) Shallow-water submerged repeaters: 10-year life with not more than a few days out-of-service time per system per year.

(e) Deep-water submerged repeaters: 20-year life with no failures (one failure in 20 years allows only 0.0004 per cent component failures per year).

These standards are liable to be raised and greater reliability may be required. They are equipment requirements, but a knowledge of them is essential as a background to the statistics of component performance that follow.

#### SOME STATISTICS OF RELIABILITY OF COMPONENTS USED BY THE POST OFFICE

It is only possible here to deal with the simpler statistics of field performance of components, and Tables 1–4 give some rates of relative failure occurrence and percentage failure rates per annum of components in certain Post Office equipments. In each example wiring is counted as one unit, but in a few instances further information is given concerning the number of terminations or soldered joints.

TABLE 1  
Relative Incidence of Failures of Components in General  
Telecommunications Equipment

Type of Equipment	Type of Component	Percentage of Total Failures of all Components
Carrier-generating equipment and supergroup translating equipment (1951-52)	Valves	39.6
	Jacks ( <i>see note</i> )	11.2
	Wiring	10.1
	Capacitors	6.6
	Relays	6.3
	Resistors	6.1
	Fuses	5.1
	Filters	4.1
	Valveholders	3.7
	Transformers	2.4
	Potentiometers	1.9
	Rectifiers	1.0
	Attenuators	1.0
	Fuse panels	0.2
	Connexion strips	0.2
	Coils	0.2
	Keys	0.2
Modulators	0.1	
Magnetic-drum register-translator <sup>24</sup> (1959)	Cold-cathode tubes	43
	Valves	13
	Wiring	13
	Rectifiers, germanium point-contact selenium	13
	Resistors	3
	Plugs and sockets (including multi-contact plugs and coaxial plugs)	13
	Capacitors	0
		0
		0
		0
Video amplifier panels (1956-57)	Valves	58.2
	Resistors (fixed-value)	16.4
	Wiring	9.1
	Capacitors, foil-and-paper ceramic trimmer	5.5
	Potentiometers	1.8
	Fuses	3.6
	Relays	3.6

Note: Nearly all failures were on input and output jacks of amplifiers and were due to too-short lengths of cord associated with jacks.

In addition to the data contained in Tables 1 and 2, information relating to the relative incidence of failures in hearing aids shows that relatively few failures of active or passive electronic components occurred but that most failures were due to broken cases and receivers. In the first year of operation of the "Mosaic" computer,<sup>25</sup> however, the most serious cause of faults was drift in high-stability resistors. The average rate of valve replacements was 10 per month. There were also some failures due to open-circuits in resistors and bifilar coils.

The crudities of these simple forms of statistics are well known and have been commented on already (e.g. the combination of failures caused both by manufacturing faults and by wearing out, a type of failure occurring mainly with valves, together with random and systematic failures), and, where arbitrary choices of data have had to be made, the more conservative course has been followed. The data on repeaters, for example, include some repeaters which have had several years of shelf life before starting their operational life and this has been counted in the calculations. In most instances there were a few more repeaters than there were repeater

positions in the cable systems, leading, where failures and replacements have occurred, to an increased probability of finding early (manufacturing) failures, though of course also a decreased probability of finding late (wearing out) failures. Also, the number of passive-component failures is increased by items like glands or loose solder, which are extremely important in this context but may not be so in other circumstances.

The large number of figures for groups of components among which no failures have taken place are quoted because it is felt that this information is often as valuable in indicating the low failure rates that can be achieved (even though the exact level is not known) as figures for the actual failure rate of less reliable types.

Tables 1-4 show that components in electronic equipment used by the Post Office have much the same relative reliabilities as those quoted in the literature<sup>20</sup> for many other equipments. Valves usually have the highest failure rate, followed by resistors, capacitors and wiring at a considerably lower level, while inductors and transformers of normal types rarely have failures. The rates for resistors, capacitors and wiring would be lower still were it not for the relatively large numbers of such components and of wiring joints in equipment. Occasionally, by reason of a bad batch or unfair rating or design, any one of the other components may temporarily show a high failure rate until the matter has been diagnosed and dealt with.

Tables 3 and 4, which give failure rates per 100 components per annum, show lower rates for land telecommunications equipment than have been published for comparable equipment elsewhere.<sup>20</sup>

The figures for failure rates for components in underwater repeaters show that the comparatively simple ideas on component reliability applied to submerged

TABLE 2  
Incidence of Failures of Components in Submerged Repeaters

Type of Repeater	Type of Component	Number of Failures (Note)
Shallow-water, early experimental types 1943-1951 and 1946 (still working)	Capacitors, silvered mica	3
	clamped mica	1
	Resistors (fixed-value)	1
	Switches	1
Shallow-water, laid 1951 and still working	Valves	10
	Resistors (wire-wound)	2
	Capacitors	1
	Transformer screen	1
	Glands	1
Shallow-water, laid 1953 and 1954, still working	Valves	2
	Glands	1
	Not yet identified	1 due to loose solder 1 noisy amplifier
Shallow-water, laid 1954 and still working	Not yet identified	1
Transatlantic telephone cable laid 1956	—	0 (cable severed three times by trawlers)
Deep-water, systems laid 1958 and 1959	—	0

Note: The figures quoted are the totals at 1 January 1960

TABLE 3  
Failure Rate per 100 Components per Year—General Telecommunications Equipment

Type of Equipment	Type of Component	Failure Rate		
		1st Year	2nd Year	
Experimental electronic director at Richmond Exchange <sup>36</sup> (1952-53)	Valves	3.9	2.8	
	Cold-cathode diodes	4.4	2.7	
	Resistors	1.2	0.11	
	Capacitors	0.04	0.02	
	Rectifiers (mainly copper-oxide)	0.26	0.04	
	Valveholders	1.7	0.9	
	Tags (individually)	0.3	0.1	
	Soldered joints	<0.007	<0.007	
	All passive components (note)	0.02	0.01	
	All types (note)	0.25 0.52		
	Video amplifiers (20 db) (1956-59)	Valves	1.7	2.1
		Wiring	5.4	0.7
Fuses		0.5	0.2	
Potentiometers		0.5	not available	
Metal rectifiers		0.3	" "	
Relays		0.3	" "	
Resistors		0.2	" "	
Capacitors		0.09	" "	
Switches		<0.5	" "	
Inductors		<0.3	" "	
Plugs and sockets		<0.1	" "	
All passive components		0.16	0.11	
All types		0.36	0.32	
Magnetic-drum register-translator equipment at Lee Green <sup>34</sup> Exchange (1959)		Valves	0.8	
	Cold-cathode tubes	6.2		
	Resistors	0.1		
	Rectifiers	0.09		
	Wiring (taken as one component) (as separate terminations)	490		
	Plugs and sockets	0.005		
	coaxial	<2.8		
	multi-pin	<0.3		
	Capacitors	<0.1		
	All passive components	0.12 (average)		
All types	0.17 ( " )			
Subscriber trunk-dialling equipment at Bristol <sup>37</sup> (Dec. 1958-Apr. 1960)	Valves	11.2 (improvements made in Nov. 1959 reduced failure rate considerably)		
	Cold-cathode tubes	0.15		
	Resistors	0.001		
	Capacitors paper polystyrene	0.007		
	Chokes	0.11 (two out of three failures due to maltreatment)		
	Selenium diodes (miniature)	0.07		
	Rectifiers copper-oxide	0.008		
	All passive components	4.9		
	All types	0.011 (average)		
		0.022 ( " )		

Note: Counting tags and associated wiring and joints as one component.

repeaters in the 1940s gave results about as good as those given by ordinary telecommunications equipment in the 1950s. Progressive refinements have achieved a level of reliability of the order of 10-100 times better than that of the first submerged repeaters. This improvement has been the result of a great deal of co-operative research between the scientific, engineering and manufacturing bodies concerned, and has inevitably been accompanied by higher cost of components. However, where the effect of single failures of equipments is very costly, the increased cost of the more reliable components is worth while.

#### TYPES OF COMPONENTS WHOSE RELIABILITY PARTICULARLY NEEDS IMPROVING

There is a need for a range of highly reliable components at an economic price to enable developments which are now possible to become practicable.

The components causing most failures in the equipment which have been discussed are valves and cold-

cathode tubes. With the expected increased use of transistors, there will be a need for many capacitors of large values of capacitance. This requirement can, at present, only be met reasonably (on grounds of physical size) by electrolytic capacitors. The electrolytic capacitor has had a poor reputation for reliability in the past, but much more is known now about its mechanisms of failure, and somewhat more reliable items are becoming available. Before they can be used in under-water repeaters, however, they will need to be even more reliable than the best types widely available at present, and studies are being made with this end in view.

#### FUTURE DEVELOPMENTS AND PROBLEMS

The cost of achieving the improved degree of reliability shown in submerged-repeater components is considerable, and some of the increased reliability due to the human element may not be obtained when future equipments are made. For both these reasons intensive studies will have to continue to ascertain more precisely which refinements and precautions are most important and to perfect components and constructions which allow the least possibility of causing faults or mistakes.

New components and materials have become available in recent years which offer design advantages but which have no long history of proved performance. These call for an increased use of scientific knowledge and testing methods, particularly along the lines of accelerated life

TABLE 4  
Failure Rate per 100 Components per Year—Submerged Repeaters

Type of Component	Failure Rate (Note 1)					
	Shallow-Water Repeaters				Deep-Water Repeaters, Transatlantic Telephone Cable, laid 1956	
	Early Experimental Types (1943-1951 and 1946, still working)	Laid 1951 and still working	Laid 1953-54 and still working	Laid 1954 and still working	All Components	British Components
Valves	<0.8 (note 2)	4.6	0.6	<0.4	<0.06	<0.3
Inductors						
all types	<0.1	<0.02	<0.015	<0.04	<0.01	<0.02
air core	—	<0.13	<0.08	<0.08	—	<0.07
dust core	—	<0.06	<0.02	<0.08	—	<0.05
coaxial	—	<0.46	<0.3	<0.7	—	<0.4
Capacitors						
all types	0.3	0.015	<0.010	<0.02	<0.006	<0.014
paper and foil	<0.3	0.06	<0.04	<0.08	—	<0.05
mica	0.3	<0.02	<0.013	<0.03	—	<0.02
electrolytic	>6.4	—	—	—	—	—
Resistors						
all types	0.08	0.03	<0.011	<0.02	<0.006	<0.02
wire wound	—	0.05	0.017	<0.07	—	<0.07
vitreous enamel	—	—	—	<0.2	—	<0.12
carbon composition	—	<0.05	<0.03	<0.05	—	<0.03
carbon film	—	<0.7	<0.4	<1.3	—	<0.2
Transformers	0.9	<0.7	<0.4	<0.7	<0.10	<0.6
Switches	6.4	—	—	—	—	—
Relays	—	<0.2	<0.14	—	—	—
Metal rectifiers	—	<1.4	<0.9	<0.7	—	<0.4
Varistors	—	<0.7	<0.4	—	—	—
Thermistors	—	—	—	<0.3	—	—
Crystals	—	—	—	<0.7	<0.17	<0.4
Fuses	—	—	—	<2.6	—	<0.6
Glands	<1.2	0.7	0.4	<1.3	<0.10	<0.8
Wiring	<2.4	<1.4	0.4	<2.6	<0.20	<1.6
All passive components	0.2	0.03	0.01	0.008	<0.002	<0.005
All components	0.2	0.08	0.02	0.008	<0.002	<0.005

Note 1: The sign < means that no failures occurred and that the failure rate is therefore lower than the figure quoted, which is based on one failure. The different rates shown in such instances arise merely from the different quantities of components involved and the length of time they have been in service. Similarly, the differences between the rates for British and all components in the transatlantic telephone cable arise from the fact that about half the total components were British.

Note 2: There is some doubt whether in fact a valve failure did occur.

Note 3: The failure rates shown are those appropriate to Jan. 1960. Most of the rates prefixed by the sign < for repeaters laid from 1951-1956 will now be lower, e.g. for the 1956 transatlantic telephone cable, about 25 per cent lower.

testing, which in turn can only be developed from an improved knowledge of the mechanisms of failure of the components concerned.

More use should be made of knowledge of component reliability and stability in circuit design, e.g. A. C. Lynch<sup>8</sup> has shown that it is an over-simplification to consider the least complicated circuits as the most reliable, and has pointed out that it is the number of components used in a way which will cause failure that is the true criterion.

The application of these ideas will obviously be necessary to the much smaller passive components of all types which are becoming available, to transistors, diodes, diode variable capacitors and to printed circuits.

#### ACKNOWLEDGEMENT

The author is indebted to his colleagues at the Post Office Research Station and in other branches of the Post Office for the help they have given.

#### References

- <sup>1</sup> NEW, A. A. Some Mechanisms of Failure of Components. Proceedings of the Conference on Reliability of Electronic Equipments, Stockholm, 21 and 22 Apr. 1958 (also reprinted in *Teknisk-Vetenskaplig Forskning*, Vol. 29, p. 276, Aug. 1958 and, in slightly revised form, in *Radio and Electronic Components*, Vol. 1, p. 193, Feb. 1960).
- <sup>2</sup> NEW, A. A. Some Mechanisms of Failure of Capacitors with Mica Dielectrics. *Proceedings I.E.E.*, Paper No. 3261M, July 1960 (Vol. 107, Part B, p. 357).
- <sup>3</sup> METSON, G. H. A study of the Long-Term Emission Behaviour of an Oxide-Coated Valve. *Proceedings I.E.E.*, Paper No. 1790R, Sept. 1955 (Vol. 102, Part B, p. 657).
- <sup>4</sup> METSON, G. H., WAGENER, S., HOLMES, M. F., and CHILD, M. R. The Life of Oxide Cathodes in Modern Receiving Valves. *Proceedings I.E.E.*, Paper No. 1137R, Mar. 1951 (Vol. 99, Part III, p. 69).
- <sup>5</sup> METSON, G. H., RICKARD, E. F., and HEWLETT, F. M. Some Experiments on the Breakdown of Heater-Cathode Insulation in Oxide-Cathode Receiving Valves. *Proceedings I.E.E.*, Paper No. 1857R, Sept. 1955 (Vol. 102, Part B, p. 678).
- <sup>6</sup> METSON, G. H., MCNALLY, J. O., VEAZIE, E. A., and HOLMES, M. F. Electron Tubes for the Transatlantic Cable System. *Proceedings I.E.E.*, Paper No. 2279R, 1957 (Vol. 104, Part B, Supplement No. 4, p. 60).
- <sup>7</sup> ROBERTS, F. F., HENDERSON, J. C., and HASTIE, R. A. An

Accelerated Aging Experiment on Germanium p-n-p Alloy Type Transistors. *Proceedings I.E.E.*, Paper No. 3008E, 1959 (Vol. 106, Part B, Supplement No. 17, p. 958).

<sup>8</sup> LYNCH, A. C. The Reliability of Small Electrical Apparatus. *Transactions of the Society of Instrument Technology*, Vol. 1, p. 32, Dec. 1947.

<sup>9</sup> HOLMES, M. F., and REYNOLDS, F. H. New Valves for Deep-Water Submerged Telephone Repeaters. *P.O.E.E.J.*, Vol. 53, p. 98, July 1960.

<sup>10</sup> BROTHERTON, M. Capacitors (D. Van Nostrand, 1946), p. 48.

<sup>11</sup> BROTHERTON, M. Paper Capacitors under Direct Voltage. *Proceedings I.R.E.*, Mar. 1944, p. 139.

<sup>12</sup> GLASSTONE, S. Textbook of Physical Chemistry, Second Edition (Macmillan, 1948), p. 1087.

<sup>13</sup> GOODEVE, C. F. Physico-Chemical Principles in Process Metallurgy. *Discussions of the Faraday Society*, Vol. 4, 1948.

<sup>14</sup> HINSHELWOOD, C. N. The Kinetics of Chemical Change (Oxford University Press, 1940).

<sup>15</sup> BARRER, R. M. Diffusion in and through Solids (Cambridge University Press, 1941).

<sup>16</sup> WHITEHEAD, J. B. Impregnated Paper Insulation (John Wiley and Sons, New York, 1935).

<sup>17</sup> WHITEHEAD, J. B. Lectures on Dielectric Theory and Insulation (McGraw-Hill Book Co. Inc., New York, 1927).

<sup>18</sup> Inter-Service Standards for Radio Components, RC Series (Radio Components Standardization Committee, Ministry of Supply, London).

<sup>19</sup> BROWNLEE, K. A. Industrial Experimentation, Fourth Edition (H.M. Stationery Office, 1949).

<sup>20</sup> DUMMER, G. W. A., and GRIFFIN, N. Electronic Equipment Reliability (Pitman, 1960).

<sup>21</sup> SALZ, M. H. Methods for Evaluating Reliability. Fifth I.R.E. Symposium on Reliability and Quality Control, 1959, p. 89.

<sup>22</sup> HERD, G. R. Some Statistical Concepts and Techniques for Reliability Analysis and Prediction. Fifth I.R.E. Symposium on Reliability and Quality Control, 1959, p. 126.

<sup>23</sup> HENNEY, K. Reliability Factors for Ground Electronic Equipment (McGraw-Hill Book Co. Inc., 1956).

<sup>24</sup> MARWING, K. G. Design Features of the Lee Green Magnetic-Drum Register-Translator. *P.O.E.E.J.*, Vol. 51, p. 137, July 1958.

<sup>25</sup> COOMBS, A. W. M. "Mosaic"—an Electronic Digital Computer. *P.O.E.E.J.*, Vol. 48, pp. 114, 137 and 212, July, Oct. 1955 and Jan. 1956, and Vol. 49, pp. 18 and 126, Apr. and July 1956.

<sup>26</sup> BAKER, H., and GEE, J. A. Experimental Electronic Director—Field Trial Results. *P.O.E.E.J.*, Vol. 47, p. 197, Jan. 1954.

<sup>27</sup> FRANCIS, H. E. The General Plan for Subscriber Trunk Dialling. *P.O.E.E.J.*, Vol. 51, p. 258, Jan. 1959.

## Book Review

"Alternating Current Machines." Second edition. Prof. H. Cotton, M.B.E., D.Sc., M.I.E.E. Cleaver-Hume Press, Ltd. 328 pp. 175 ill. 21s.

This book is one of ten volumes in the Cleaver-Hume Electrical Series. It explains, in a non-mathematical way, the theory of operation of all types of alternating-current machines in common use, and should be easily understood by any reader with a knowledge of basic electrical theory. The text is amply illustrated and particular emphasis has been placed on the constructional details of the equipment described.

The first chapter describes how a rotating field is produced in an a.c. machine. Subsequent chapters first describe the constructional features of each class of machine, and then explain their operating characteristics and show how each type is suited to the particular duties for which it is employed. The relative merits of the many types of small single-phase induction motors are particularly well explained. Formulae

are given for the calculation of characteristics such as synchronous speed, generated e.m.f., motor torque and slip, and the practical application of these formulae is well illustrated by numerical examples.

A comparison of the relative merits of d.c. motors would have been valuable in the chapter on polyphase commutator motors, and the chapter dealing with the conversion of a.c. to d.c. is thought incomplete without a reference to germanium and silicon rectifiers.

The disadvantage of textbook references to British Standards is illustrated by the references to B.S. 169 and B.S. 266, both of which were superseded in 1955 by B.S. 2613. Also, the definition of "Synchronous Impedance" does not correspond with that in the "Glossary of Terms used in Electrical Engineering" (B.S. 205, 1943).

This book will be of great value to the student and engineer concerned with the general applications of a.c. machinery in industry, or with its maintenance and repair.

*I.P.O.E.E. Library No 2027.*

R. G. M.



# The Equalization During Laying of the Anglo-Swedish Submarine Telephone Cable

F. SCOWEN, B.Sc., A.Inst.P., A.M.I.E.E.†

U.D.C. 621.372.552 : 621.315.285 (410 : 485)

During the laying of the Anglo-Swedish cable in mid-1960 a submerged equalizer was designed and manufactured on H.M.T.S. "Monarch", and was inserted into the cable without holding up the cable-laying. This was the first occasion on which such an operation had been performed.

## INTRODUCTION

IN May 1960 a technique was employed which, it is believed, had not been used before during the actual laying of a repeatered submarine telephone cable. This new technique involved the carrying out on board the cable ship of the design, construction, and insertion in the cable of an equalizer network, to such a timetable that it did not interfere with the normal cable-laying program.

The first transatlantic telephone cable (TAT-1),<sup>1</sup> which was laid during 1955 and 1956, used a stock of pre-constructed equalizers of five different attenuation frequency characteristics, so that a suitable one could be inserted into the cable at predetermined positions during laying to compensate for any unexpected effects that appeared during the laying. However, the success of this remedial action depended on the advance knowledge that the design engineers had of the probable changes of cable and repeater characteristics when the cable and repeaters were transferred from the cable ship to the ocean bottom. The system employed two cables each provided with simple unidirectional repeaters, and such a system does not have the equalization difficulties arising from the directional filters that form an essential part of the two-way repeaters of the type used in the Anglo-Swedish cable.<sup>2</sup>

In 1957 a repeatered two-way single cable was laid between Marseilles and Algiers,<sup>3</sup> and this cable was laid in two sections. Measurements were made on the first half when it had been completely laid and from these measurements an equalizer was designed and constructed on shore. This equalizer was inserted in the cable when the ship returned to pick up the end of the first half of the cable to connect it to the second half before that was laid.

The Anglo-Swedish cable has a transmission loss at the highest channel frequency of some 1,650 db, and this loss is neutralized by the gain of the 29 submerged repeaters and the terminal receive line amplifiers. The loss of the cable is approximately proportional to the square-root of frequency and, for perfect operation of the system, the cable loss must be matched at all frequencies by the gain of the repeaters; moreover, there should be as close a match as possible between the loss of a length of cable between adjacent repeaters and the gain of a repeater.

## GENERAL PROBLEMS OF SYSTEM DESIGN

When developing a submerged repeatered system the cable and repeaters have to be designed concurrently, and at an early stage a target gain/frequency characteristic

has to be set for the repeater designer. As the project progresses, this target is changed in the light of cable-characteristic information obtained by the cable engineers, and the design of the repeater is modified accordingly. A stage is reached, however, after which the design of the cable and repeater must not be changed if they are to be made in time for the laying program. In order to keep to a minimum the number of components in a repeater (and thus to keep down the fault liability, which is proportional to the number of components) the actual repeater gain cannot exactly match the target gain. The components used in a repeater cannot be made to have their precise design values and there will thus be slight differences between the gain/frequency characteristics of the various repeaters.

The first lengths of cable from which the original repeater target gain is determined will have been made from a small batch of material and the cable for the route will have been made from a larger but different batch of material. The cable transmission characteristics are susceptible to very small changes in the mechanical and electrical characteristics of the materials used during manufacture of the cable; the different armouring applied to the various lengths of cable also has slightly different effects on the cable characteristics. As the time approaches for the cable and repeaters to be loaded into the cable ship, the production characteristics of cable and repeaters are carefully inspected to discover by how much the cable attenuation and repeater gain deviate from the design characteristics.

Furthermore, the cable attenuation changes as the cable leaves the ship's tanks and sinks to the sea bottom, because of what is known as the laying effect; this effect is made up of several parts which depend mainly on the temperature change and the depth of water. The laying effect will have been determined from cable-laying trials made using the first trial length of cable but, like the cable attenuation, it is dependent on the characteristics of the materials used in making the cable.

## EQUALIZING THE ANGLO-SWEDISH CABLE

For the Anglo-Swedish cable, information about the production characteristics of the cable and repeaters was used to design an equalizer which, installed at the mid-point of the system, would compensate for one half of the expected difference between the cable loss and the repeater gain for the whole route; this equalizer was made by the contractor making the repeaters, and was inserted into a demountable pressure-resistant housing. The equalizer for the other half of this difference was to be fitted at a terminal station. At this stage the system was as accurately equalized as allowed by the information about the cable (including the laying effect) and repeaters then available to the system engineers.

The gain of the repeaters at the top channel frequency of 608 kc/s is 55 db, and for the optimum performance of the link the repeaters had to be separated by lengths of cable which, when laid and at the mean yearly temperature of the sea bottom, would have a loss of 55 db at the same

† Post Office Research Station.

frequency. The lengths of cable required for the various repeater sections were cut in the factory, using the latest available information about the laying effect, so that they should have had this loss when on the sea bottom; they were then loaded into the tanks of H.M.T.S. *Monarch*.

In order to provide for flexibility during laying, the whole cable was divided into four roughly equal lengths or blocks. Block 1 started with a length of cable which, together with the length of cable between Middlesbrough repeater station and the buoyed-off shore end, would have a loss of 55 db at 608 kc/s; then followed eight repeaters and seven and a half lengths of cable. Thus, Block 1 ended with a half repeater-section length of cable after repeater number 8. Block 2 started with a half-section length of cable plus an extra length of cable for adjustment, and this was followed by seven repeaters, six and a half lengths of cable, and the equalizer; Block 2 thus ended with a half-section length of cable and the equalizer. Block 3 had seven repeaters and over seven lengths of cable; the cable between the start of the section and repeater number 16 was half a section in length plus an adjustment length, and the block ended in a half-section length of cable. Block 4 had six repeaters, and Block 4A was loaded into H.M.T.S. *Ariel* with repeater number 29 for laying at the Swedish shore-end of the route, where the water was too shallow for H.M.T.S. *Monarch*.

When H.M.T.S. *Monarch* reached Middlesbrough and connected the United Kingdom end of Block 1 to the buoyed end, the system, from *Monarch* through Block 1 to Middlesbrough, was energized and cable laying commenced. During the laying of this block, transmission measurements were made between the ship and the shore end at roughly hourly intervals, using 12 frequencies spread over the range 60–608 kc/s. At the start of the laying all of Block 1 was in the ship's tanks at a temperature approximately that of the sea surface. As the cable was laid, its temperature dropped by about 12°C as it approached the sea bottom, and as a result the cable loss fell continuously.

As the laying proceeded, graphs were constructed showing the transmission loss between the ship and the shore end against the length of cable laid, at each of the 12 frequencies (Fig. 1). On the graph there is a vertical line at the end of Block 1, and about 12 hours before reaching the end of the block the transmission-loss/cable-length-laid characteristics were extrapolated to obtain an estimate of the loss at each of the measurement frequencies when the whole of Block 1 had been laid; this extrapolation is shown in Fig. 1. Meanwhile, the loss of Block 1 that would have been expected if the cable and repeaters had been accurately matched at all frequencies was calculated for each of the measurement frequencies and the results were plotted along the end-of-block line in the figure; the extrapolated end-of-block losses were compared with the "accurately-matched" losses and the end-of-block expected misalignment was determined. This misalignment is shown in Fig. 2. It will be seen from the curve in Fig. 2(a) that the expected end-of-block misalignment at 608 kc/s is 0.6 db, and this is equivalent to the loss of 0.2 nautical miles (n.m.) of cable. Power was removed from the system, and Block 2 was adjusted by making the cable length between its beginning and the first repeater in Block 2 equal to a half-section plus 0.2 nautical miles. The adjusted Block 2 was then spliced to the end of Block 1, Blocks 1 and 2 were energized, and regular

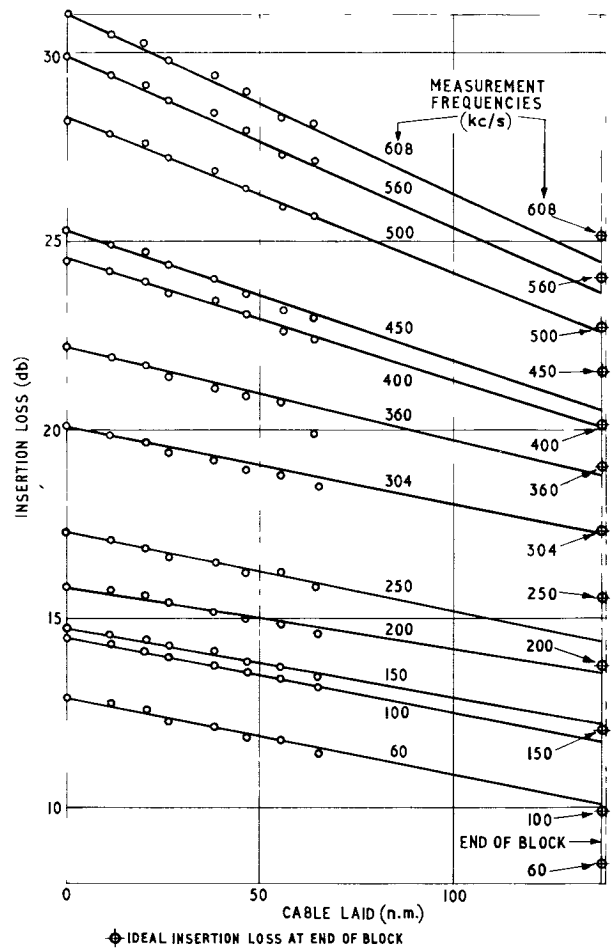

FIG 1—INSERTION-LOSS CHANGES OF BLOCK 1 DURING LAYING

hourly measurements were again commenced between ship and shore.

Once again the transmission-loss/cable-length-laid characteristics were plotted, and 12 hours from the expected time of laying the end of Block 2 an expected end-of-block misalignment characteristic was plotted and power was cut off. This time a length adjustment

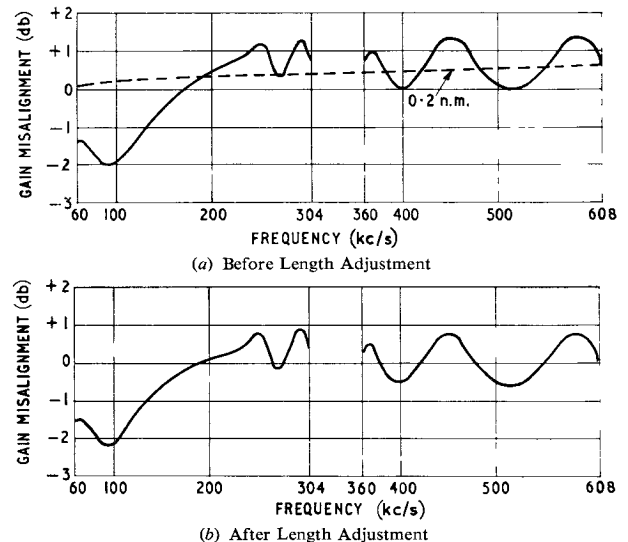

FIG. 2—ESTIMATED INSERTION-LOSS/FREQUENCY CHARACTERISTIC OF BLOCK 1 WHEN COMPLETELY LAID

was chosen and an equalizer network was designed to correct this misalignment as completely as possible. At this stage of the cable laying it became apparent that the 29th repeater (in Block 4A) would be laid too close inshore and, therefore, an artificial cable loss equivalent to 2 n.m. of cable was put in the equalizer and a corresponding length of cable was cut off from the beginning of Block 3; this had the effect of bringing the repeaters of the second half of the system 2 n.m. nearer the United Kingdom and the 29th repeater 2 n.m. further off the Swedish shore.

The equalizer and artificial line were constructed from components of submerged-repeater quality, made by the manufacturers of the submerged repeaters in their special clean-area submerged-repeater shop and delivered to H.M.T.S. *Monarch* in a hermetically sealed box. The components comprised resistors, inductors and capacitors of such values that networks giving peaks of 2 db or 4 db loss, or flat losses of 2 db or 4 db with troughs of zero loss, could be formed with the peak or trough frequencies adjustable in 5 per cent steps over the frequency range from below 60 kc/s to well above 600 kc/s, and with the half-loss width of the peaks or troughs divided by the peak or trough frequency being adjustable in steps over the range 0.04 to 4. A cabin on the ship had been converted by a thorough cleaning and painting, and by the installation of air cleaning and conditioning equipment, to match the conditions of cleanliness that exist in the contractor's submerged-repeater clean-area shop. Two Research Branch officers had been trained in the handling and assembly of submerged-repeater components and units, and they constructed the equalizer and artificial line networks (Fig. 3).

The completed network was inspected visually to the standards applied in the contractor's submerged-repeater clean-area shop and checked electrically. Afterwards, it was inserted into a box in the pressure housing, which already contained the half-section equalizer described earlier in this article. The box was then hermetically sealed and the pressure housing was closed. The length adjustment was made, Block 3 was spliced on to Block 2, Blocks 1, 2 and 3 were energized, and regular hourly tests were recommenced.

Block 3 was treated in much the same way as Block 1, and a length adjustment was made at the beginning of Block 4 to correct the expected end-of-Block 3 misalignment at 608 kc/s. Similar measurements were made during the laying of Block 4, but no length adjustment was made when it was spliced to the beginning of Block 4A; the misalignment at the end of Block 4 was corrected at the terminal station at Goteborg.



FIG. 3—ASSEMBLY OF VARIABLE EQUALIZER ON H.M.T.S. *MONARCH*

#### CONCLUSION

During the whole of the operations described the laying proceeded at the normal speed, and the length adjustment and equalization did not delay the laying program. The final results of the operation were considered to be most satisfactory.

During 1961 the CANTAT<sup>4</sup> cable will be laid between Scotland and Newfoundland. It will be a single-cable scheme using repeaters similar to those used on the Anglo-Swedish cable and six to eight equalizers will be inserted in the cable; the program to be followed will be very similar to that described in this article.

#### ACKNOWLEDGEMENTS

The design of the system and the equalizer unit, the precision transmission measurements, and the construction on board the cable ship of the equalizer network were all performed by the author's colleagues in the Submarine Transmission Systems Division of Research Branch.

#### References

- <sup>1</sup> The Transatlantic Telephone Cable. *P.O.E.E.J.*, Vol. 49, Part 4, Jan. 1957.
- <sup>2</sup> The Anglo-Swedish Submarine Telephone Cable. *P.O.E.E.J.*, Vol. 53, p. 165, Oct. 1960.
- <sup>3</sup> Liaison Marseille-Alger. *L'Onde Electrique*, No. 372, p. 166, Mar. 1958.
- <sup>4</sup> A Proposed New Telephone Cable between the United Kingdom and Canada. *P.O.E.E.J.*, Vol. 50, p. 104, July 1957.

# The Cold Rolling of Very Thin Ferrous Tapes

G. W. LORD, B.Sc.†

U.D.C. 621.771.2: 621.3.042.143.2

To enable a rolling mill at the Post Office Research Station to be used for rolling magnetic-alloy tapes of less thickness than its designed limit, several adaptors and special tensioning equipment have been made. With these easily changed adaptors the mill can now do work normally requiring several different mills, and can produce material as thin as any which has been produced elsewhere in the world by rolling.

## INTRODUCTION

A ROLLING mill for magnetic alloys was installed at the Post Office Research Station, but in its original form it could not roll them to the thicknesses (0.001 in. or less) that are sometimes needed. Various alternative types of mills were considered but eventually an adaptor for the existing mill was designed. This adaptor, together with auxiliary tensioning equipment, enabled the mill to produce material as thin as that produced anywhere by rolling.

In the adaptor, the original rolls drive two additional small work rolls by friction. With adaptors of various sizes the one mill can then do the work of several. This is particularly valuable in the laboratory where versatility is more important than production capacity. With the one rolling mill, and its easily interchanged adaptors, nickel-iron alloys can be prepared from the raw materials by the powder metallurgy method and rolled to a fraction of one-thousandth of an inch in less than three days.

## UNIFORMITY OF SECTION OF STRIP

When considering what happens to a material during rolling, it is a useful conception to think of rolling putty with rubber rolls in a rubber housing. In practice, the rolls have a Young's Modulus similar to that of the material being rolled, but the significant difference is that the rolls have a much higher elastic limit. Thinking in terms of the flexible mill, it will be appreciated that whilst the material being rolled yields plastically, at the same time the rolls and mill housing are yielding elastically. Hence, even if the unstressed rolls are truly cylindrical, they are distorted somewhat during rolling, and, therefore, the rolled strip cannot be perfectly uniform in cross-section.

An attempt to minimize this effect is often made by cambering the roll surface during grinding so that the roll is slightly barrel-shaped. This enables the centre portion of the strip to be finished at uniform thickness but the extreme edges still taper, and different amounts of camber are required for different finishing thicknesses.

Another way of reducing the lenticularity of cross-section to a minimum is to keep the loads on the rolls always small. This means that rolls of a given diameter must never be used to roll material which is near the limit of thickness that could be achieved with those rolls. Practically, 8 in. diameter rolls will roll nickel-iron alloys to 0.008 in. fairly easily, or to 0.002 in. with extreme difficulty but, to avoid excessive lenticularity, should not be used beyond 0.016 in. At this stage it is better to use smaller work rolls; then further large reductions can be made with relatively light loads. Rolls of 1 in. diameter may be used to roll down to 0.002 in. or 0.0015 in.

However, if the width of tape is to be maintained, the

ratio of the length to diameter of the 1 in. rolls will be greater than that of the 8 in. rolls with a consequent loss of rigidity. Thus, for effective rolling, it is essential that the smaller rolls be supported to improve their rigidity.

One way of doing this is shown in Fig. 1, where the small-diameter work rolls are enclosed between four bearing pads and between the large backing rolls, which provide

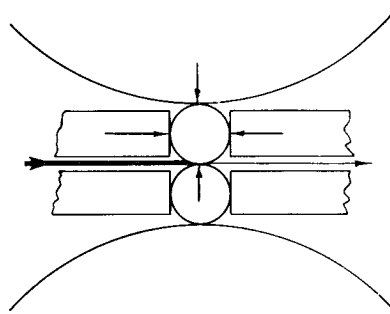

FIG. 1—WORK ROLLS SUPPORTED BETWEEN FOUR BEARING PADS

the desired support and also drive the work rolls by friction. If sufficient load is applied to the bearing pads to maintain them in contact with the rolls during all conditions of rolling, then the friction is such that the rolls will either overheat or fail to be driven. Slackening of bearing loads will permit roll movement in the direction of rolling and, consequently, instability. Thus, the position of the rolls is indeterminate and the quality of tape rolled in this mill is inferior in flatness, lenticularity and appearance, and is also inconsistent. The mill is also difficult to load with strip.

To overcome this, the roll conformation shown in Fig. 2 was devised. Here the position of the rolls is unambiguous for all significant roll loads; it therefore produces consistent strip. The angle between the plane

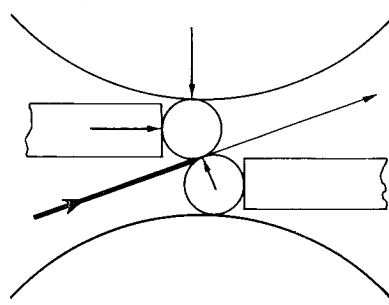

FIG. 2—INCLINED-ROLL METHOD OF SUPPORTING WORK ROLLS

containing the axes of the small rolls and the plane containing the axes of the large rolls is not critical and is designed to be about 20 degrees. The two planes intersect in the line of contact between the small rolls, though this is not essential. Criteria in choosing the angle are: it should be large enough to prevent one work roll from being drawn past the other, and small enough to avoid excessive frictional losses at the bearing pads.

Changing to a smaller diameter of work roll tends to

† Post Office Research Station.

reduce the lenticularity of the strip, due to the smaller roll loading and distortion; with these conditions the outgoing strip necessarily has its centre rolled more than the edges. Unfortunately, sideways flow in thin materials is negligible, so any improvement in uniformity of thickness achieved in this way causes the strip to distort with its centre longer than its edges. Flatness can only be restored by applying sufficient tension to the outgoing strip to stretch the edges, thus restoring the degree of lenticularity present in the ingoing strip.

Where flatness and uniform thickness are simultaneously required in the finished thin strip, it is essential that lenticularity be reduced to a minimum not only during the later stages but during all stages of rolling.

#### STRIP TENSION

The need for tension to flatten the strip and maintain its flatness has already been mentioned. The equipment providing this tension must be capable of being preset to any desired value, which it must maintain while the mill is at a standstill, accelerating, rolling at full speed and decelerating back to a standstill. The actual value of tension required varies with the size of material being rolled. Most of the magnetic alloys have an ultimate tensile strength of between 65,000 and 70,000 lb/in<sup>2</sup>, and up to 80 per cent of this may be required for tension: thus, for a 2 in. wide strip starting at 0.016 in. and being rolled to 0.008 in., 800–900 lb may be required. Towards the other limit, the tension required for a  $\frac{1}{8}$  in. wide tape being rolled to 0.0001 in. may be as low as 6 oz.

The range of tensions so far available with the mill at the Post Office Research Station is incomplete, the maximum tension being about 240 lb, with a gap between 70 lb and 20 lb. None of the equipment can compensate for mill acceleration. Thus it has been impossible to roll tape much wider than 1 in., and rather poor quality has been achieved with thicknesses of 0.008 in. and 0.004 in. All thicknesses of strip tend to be inferior over the part of the strip rolled during the acceleration period of the mill, except where the required tension is large compared with the temporary tension changes due to acceleration.

Back tension, to restrain the strip as it enters the mill, is also needed; it allows the strip to be fed into the mill straight and fairly flat, and prevents sideways wandering during rolling. In general, back tension is kept equal to the front tension, although it has been suggested that larger back tensions may be advantageous. The adjustment can easily be carried out before the rolls are closed on to the strip.

New equipment is being built to provide front tensions from 2 oz to 800 lb in three ranges of 2 oz–2 lb, 2 lb–50 lb, and 50 lb–800 lb. Tension will be provided by a slipping magnetic-particle clutch, and it is hoped to provide compensation for acceleration on the two lower ranges. This should make it possible to finish good quality tape in any size from 2 in.  $\times$  0.008 in. down to  $\frac{1}{16}$  in.  $\times$  0.0001 in.

#### LUBRICATION AND MAINTENANCE

There are two main aspects of lubrication of a mill: firstly, that of the rolls and their bearings considered as a piece of machinery, and secondly, lubrication to reduce the friction between the rolls and the strip.

It will be realized that where there is, for example, a 50 per cent reduction in thickness during one passage of

the strip through the mill, then the strip will emerge from the rolls about twice as fast as it enters them. Since there is little sideways spread it emerges at about the peripheral speed of the rolls, and there will be considerable slip between the surfaces of the rolls and the strip surfaces. Some authorities assert that there is only one line of non-slipping contact between roll and strip. Thus, there are great frictional forces in the roll pinch.

The practical results of reducing these forces by lubrication are to improve the reduction in thickness for each passage of the strip through the mill, work formerly lost as heat being now usefully employed, and also to improve the finish of the strip as a more burnished appearance is obtained.

There is little difficulty in lubricating the backing rolls as oil in adequate quantities can be pumped to their journals at high pressures. On the work rolls, however, there are the two different requirements for lubrication, that of the strip and that of the work-roll bearings, and care must be taken that neither interferes with the other. The work-roll lubricants must not contaminate the strip, and those containing graphite or molybdenum disulphide cannot be used. With the adaptors, standard rolling oils have been satisfactory for both purposes, but care must be taken to avoid contamination from the oil pumped to the journals of the backing rolls.

The work rolls are simple cylinders and the bearings are flat plates of hard-rolled bronze, so they are relatively cheap and large stocks can be held. As the rolls are peripherally driven their diameters are not critical, nor need the diameters be precisely the same. Hence, selection is not needed and the rolls may be reground several times before they at last become too small for further use. End-thrust pads, mounted in the adaptor frame to limit sideways movements of the work rolls, are flat plates of hardened silver steel and, though spares are held, none has been used yet. Rolls and bearings can be changed in a few minutes. An equally important but more subtle form of maintenance is the need for cleanliness, particularly the removal of flakes of metal that tend to congregate where the rolls touch their bearing pads, and cause dented or broken strip, or even scored rolls and bearings.

#### DEVELOPMENT

The mill-and-adaptor system described was so successful that it was patented in several countries, exploitation of the patents being the responsibility of the National Research Development Corporation. The latter financed the building of a mill designed around the inclined-roll principle. The mill has tensioning gear capable of maintaining front and back tensions at any selected values in the range 1–400 lb with an accuracy of  $\pm 1$  per cent. Pressure is applied hydraulically to the roll system and is automatically maintained at any pre-set value. If required, different loads can be applied to each end of the rolls. After passing initial trials, the mill was installed for field trial in the Birmingham works of a manufacturer of nickel alloys. After minor modifications to hydraulic valves and tensioning equipment, the mill was set to work, rolling a wide range of magnetic and other tough alloys. The field trial was so successful that the mill was then purchased by the firm, who now produce magnetic alloys in thinner gauges than any other British manufacturer. The mill has been demonstrated to metal manufacturers from Britain and overseas.

# Fleet (London) Automatic Telex Exchange

A. WILCOCK, A.M.I.E.E., and E. C. BAXTER†

U.D.C. 621.394.34: 621.394.722

The opening of Fleet automatic telex exchange in London has recently completed the conversion to automatic working of the inland telex network. This article describes the exchange and gives an account of some of the problems associated with its construction and opening.

## INTRODUCTION

THE conversion of the United Kingdom telex network to automatic working<sup>1, 2</sup> has been completed recently by the opening of Fleet exchange in London. The exchange was brought into use in three stages during November and December 1960, being completed on 10 December.

The name "Fleet" was chosen for the London automatic telex exchange because this name has been given to the building in which the exchange is installed. This building, in Farringdon Street, E.C.2, is close to the course of the old Fleet River, now covered over, and to Fleet Street.

The provincial exchanges, apart from those at Hull and Cambridge, were all converted to automatic working in advance of Fleet exchange. Manual switchboards were, however, retained at the zone centres to route the traffic from the zones and dependent areas to the London switchboards serving the majority of subscribers in London and the international telex network. Coincident with the opening of Fleet exchange, the Hull and Cambridge exchanges were converted to automatic working, and the provincial manual switchboards and the London inland switchboard were closed down.

## INSTALLATION

Because the London exchange (Fleet) is the focal point of the United Kingdom telex network, it would have been an advantage, in converting the network to automatic working, if the exchange could have been installed early in the conversion program. Unfortunately, this was precluded by the lack of a suitable building. It was of considerable importance, therefore, that the installation of the exchange should be completed as soon as possible after accommodation became available, both to obtain the economies of a fully automatic network and to avoid uneconomic extension of the manual switchboards in the Central Telegraph Office (C.T.O.).

It was against this background that installation commenced in the new Fleet Building on 25 May 1959, the earliest allowed by the building contractor. At this time the basement and sub-basement, which were to accommodate the telex exchange, were barely ready for occupation. The building above was a skeleton of about four floors, and a temporary waterproof seal

was placed over the second floor to enable installation work to proceed. At the completion of the call-through test in October 1960 the rest of the 11-storey building (Fig. 1) was then only nearing completion. It will be realized that during the installation period continuous efforts were necessary by both the exchange-equipment contractor's staff and the Post Office staff to reduce the dust and dirt in the basement sufficiently to allow work to carry on. Great credit is due to both parties for their determination to complete the job on time in spite of the difficulties.

Approximately 250 4 ft 6 in. wide racks and 77 other types of rack were installed before the exchange was opened. Fig. 2 shows a general view of the sub-basement, with routing-translator racks in the foreground and trunk relay-set and group-selector racks beyond. Installation of a further 50 racks for outgoing inter-

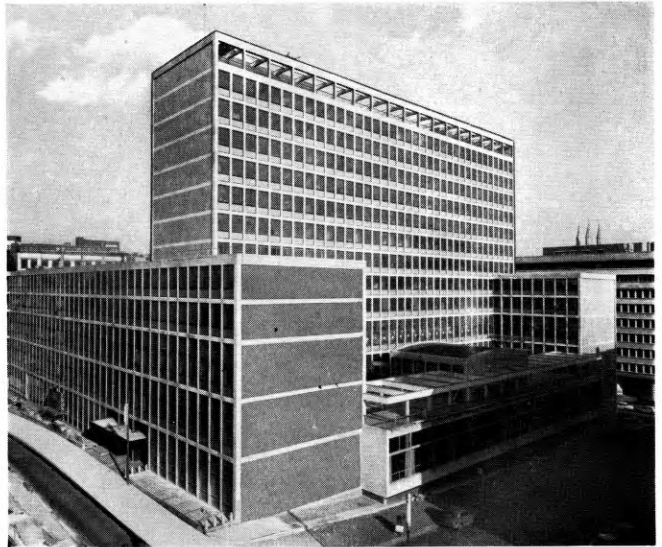

FIG. 1.—FLEET BUILDING SHORTLY AFTER THE AUTOMATIC TELEX EXCHANGE WAS OPENED (10 DECEMBER 1960)

national telex subscriber dialling is now proceeding, and these should be brought into service in the spring of this year.

The installation period was considerably reduced by

† Mr. Wilcock is in the Telegraph Branch, E.-in-C.'s Office. Mr. Baxter is now in the External Telecommunications Executive; at the time this article was written he was in the London Telecommunications Region.

<sup>1</sup> FORSTER, A. E. T., BARTON, R. W., and ELLIS, W. A. The Automatic Telex Service. *I.P.O.E.E. Printed Paper No. 215, 1959.*

<sup>2</sup> FORSTER, A. E. T. Automatic Switching for the Telex Service. *P.O.E.E.J.*, Vol. 51, p. 193, Oct. 1958.



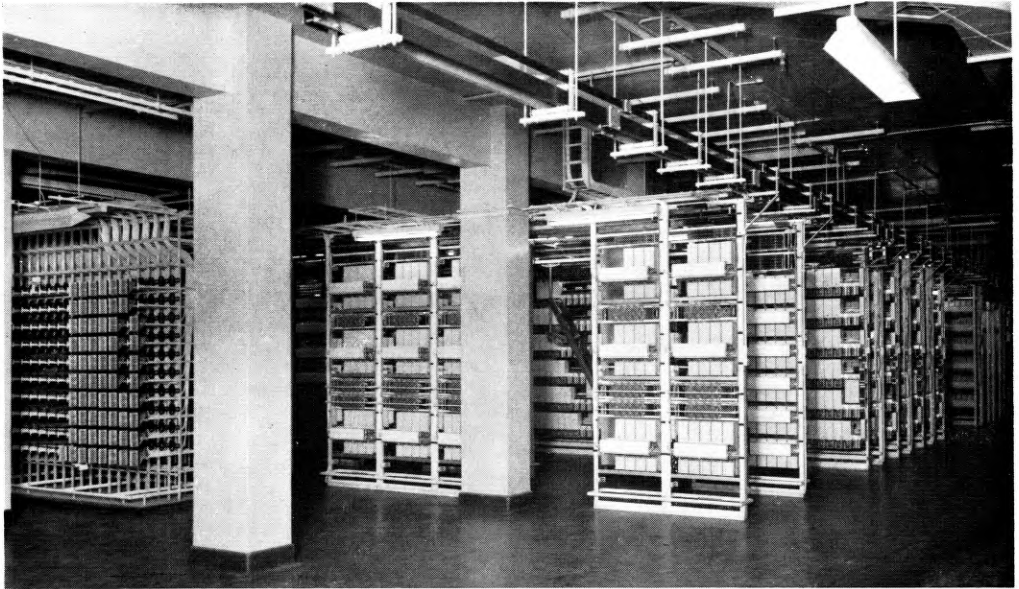

FIG. 2—SUB-BASEMENT APPARATUS ROOM

the use of cable clips instead of stitching to secure the cables to the cable racking. Fig. 3 illustrates these clips and shows that stitching is only required at bends (vertical or horizontal) and on vertical runs between floors.

#### DESCRIPTION AND FACILITIES

Fleet telex exchange is both a zone exchange in the national network and an international switching centre. As an international switching centre it will eventually deal with all the United Kingdom subscribers' incoming and outgoing international traffic as well as some through traffic between Europe and North America.

The design of the exchange differs from that of a telephone exchange of comparable size largely because of the quite different characteristics of telex traffic. International telex traffic is almost 50% of the total, while local traffic wholly within an exchange area is as low as 25–30%, the remaining traffic being trunk calls within the United Kingdom. The requirements of telegraph signalling and the need to have printed service-signals also contribute to the differences in design compared with telephone-exchange practice.

Fleet exchange serves all the telex subscribers in the London charging area and subscribers in the Home Counties, who are connected to the following hypothetical exchanges within Fleet: Brighton, Canterbury, Colchester, Guildford, Luton, Norwich, Oxford, Portsmouth, Reading, Southend-on-Sea and Tunbridge Wells. Exceptionally, subscribers in the Cambridge charging area are connected to an exchange at Cambridge. The total number of subscribers connected to Fleet exchange on completion of the conversion was 3,450, the national total at that time being approximately 6,700.

The trunk circuits connected to the exchange included some 87 outgoing, 68 incoming and 239 bothway trunk circuits to the provincial exchanges, 254 incoming international trunk circuits and some 350 circuits between the international switchboards in the C.T.O. and Fleet exchange.

Access to the International switchboard is via level 29 at Fleet exchange. In addition, the following services are available to all United Kingdom subscribers via level 20.

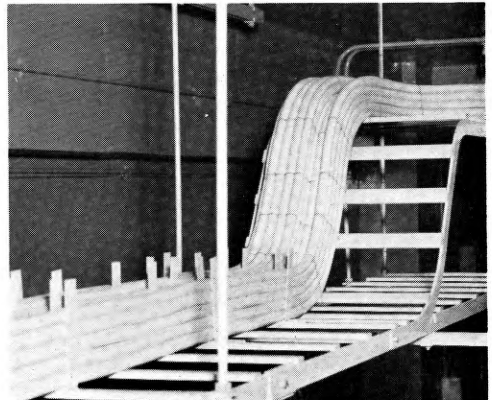
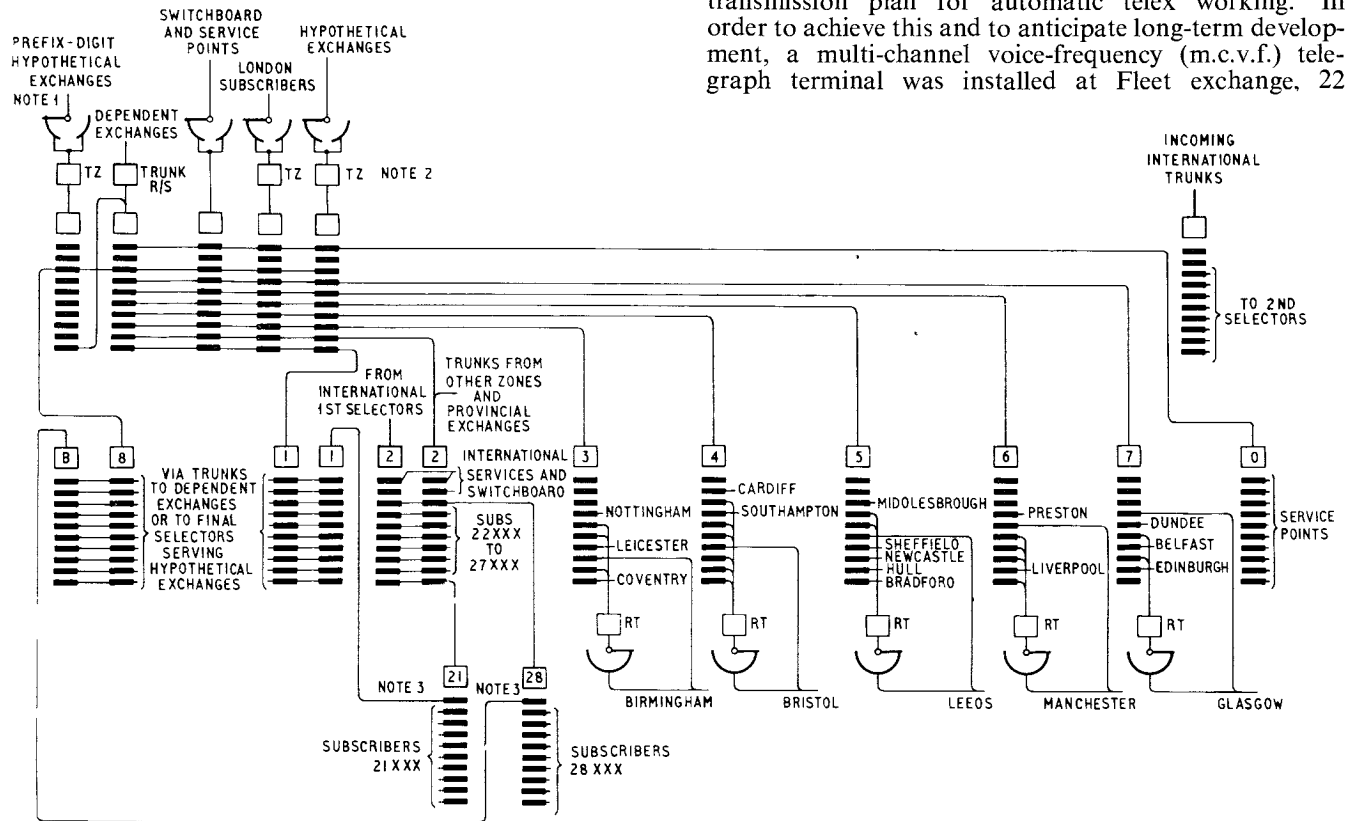

FIG. 3—EXAMPLE OF CABLE CLIPS AND STITCHING

Dial Code	Service Point
201	International switchboard (radio calls)
2002	Printergrams (international inquiry)
2003	Telex inquiries (inland)
2004	Printergrams (overseas)
2005	Printergrams (Europe)
2006	Telex inquiries (international)
2009	Multitelex
2000	Assistance

All incoming international dialling circuits enter the United Kingdom telex network at Fleet and are terminated on a separate group of 1st selectors, which, while having the normal 1st selector outlets, additionally provide access to an "overseas operator assistance" level and to an international through-tandem level. The operators of 18 European countries were able to dial into the United Kingdom network from the opening date.

All final selectors in Fleet have facilities for switching to the first free circuit in a group not exceeding 10 lines. There is a small requirement for groups of lines slightly in excess of 10 and to meet this need an expedient is adopted, using the regular "2-10 line" final selectors. This facility is obtained by rearranging the trunking from level 229 3rd selectors so that approximately half the traffic is offered to each of two inputs to the 229 final-selector group. In this way it is possible to grade the outlets to subscribers having more than 10 lines.



TZ—Time-Zone Metering Equipment, RT—Routing Translator

Notes:

1 This routing applies to hypothetical exchanges which will shortly become physical exchanges. It is adopted to avoid a change in dialling procedure when the physical exchange is opened.

A simplified trunking diagram of the exchange is shown in Fig. 4.

#### OPENING ARRANGEMENTS

Prior to the opening of Fleet there were five telex exchanges in London, i.e. Inland A, B, and C, and international manual exchanges in the C.T.O. and the automatic telex exchange at Shoreditch. The inland exchanges had 82 positions and a total operating staff of 150, whilst the International exchange had 190 positions, which with auxiliary services required a staff of 700 operators and supervisors.

Each of these exchanges, except Inland C, had separate trunk routes to all provincial zone and the larger area automatic telex exchanges. There were also the routes from the provincial zone manual boards, and those to Cambridge and Hull manual exchanges, which were converted to automatic working at the same time as the opening of Fleet. In all, there were 40 separate routes to 13 towns.

The requirement for a number of routes between London and any particular provincial town, though necessary during the conversion period, was uneconomic since it led to the provision of more circuits than were really necessary to carry the telex traffic. The opportunity was therefore taken to provide an integrated inland trunk network for both inland and international traffic. At the same time, the routing of the trunk circuits was arranged to provide a satisfactory degree of diversity and the circuits were made to conform to the overall transmission plan for automatic telex working. In order to achieve this and to anticipate long-term development, a multi-channel voice-frequency (m.c.v.f.) telegraph terminal was installed at Fleet exchange, 22

FIG. 4—SIMPLIFIED TRUNKING DIAGRAM OF FLEET TELEX EXCHANGE

systems being provided initially. In addition, many rearrangements affecting other m.c.v.f. terminals in London were necessary.

Since there is as yet no telephone exchange in the Fleet Building, the external cable network serving the telex exchange consists entirely of junction cables to nearby exchanges and repeater stations. This added to the volume of work in the transfer arrangements as it necessitated the preparation of a circuit advice, equivalent to that of a long junction, for every circuit affected by the transfer. In all 5,600 such advices were prepared.

The Fleet automatic exchange was to serve the subscribers from the five London exchanges mentioned above and from four automatic sub-centres (A.S.C.s) and one manual exchange in the Home Counties. There were 874 automatic subscribers and 2,574 manual subscribers; of these 370 were in the Home Counties and presented the greatest problem in the transfer of the subscribers' lines. To have attempted to transfer them all together would have necessitated simultaneous co-operation from over 50 points in the Home Counties in work of considerable complexity.

It was decided therefore to cut out the four A.S.C.s and the manual exchange (at Reading) before the transfer to automatic working and to serve these subscribers temporarily by direct lines to the London manual boards. Although this did not appreciably increase the amount of traffic to be handled by the switchboards, the use of a direct line for each subscriber necessitated the provision of more calling equipments. These calling equipments were provided on a new exchange, Inland C, which, owing to accommodation and supply difficulties, had to be obtained by splitting-off a suite of the existing Inland B exchange in the C.T.O., and by installing the necessary calling equipments to provide individual instead of ancillary appearances.

Coincident with the opening of Fleet was the bringing into service of the Hull and Cambridge automatic telex exchanges. This, together with the complicated transfer arrangements for the London and Home Counties subscribers, inland and international trunks, and the increase in incoming dialling routes from 10 to 18, led to the decision to bring Fleet exchange into use in three stages. These were:

*(a) Stage 1*

*(i) 12 November.* All 874 automatic telex subscribers on Shoreditch exchange, together with its inland and international trunks, transferred to Fleet exchange, all service levels transferred to Fleet and additional trunk circuits provided wherever possible.

*(ii) 17-25 November.* Additional trunk circuits provided to meet opening-date requirements, making use where necessary of existing manual routes.

*(b) Stage 2 (3 December).* Home Counties subscribers transferred to Fleet. Hull and Cambridge exchanges opened.

*(c) Stage 3 (10 December).* All remaining London manual sub-

scribers transferred to Fleet, together with incoming trunk circuits from all countries availing themselves of international dialling-in facilities.

TEST ROOM

For staff economy reasons, and to have only one telex testing point in London, all the testing functions of the C.T.O. were transferred to Fleet test room on 10 December. All circuits to C.T.O. were accordingly routed via Fleet before the transfer.

Fifteen test-desks have been installed in the test room (Fig. 5) and are arranged in two groups, one of six positions for testing inland, international and radio trunks, and the other group for testing subscribers' lines and equipment.

THE NEAR FUTURE

As is clear from the foregoing, the opening of Fleet exchange completes the conversion of the United Kingdom telex network to automatic working. It also provides for calls from the continent over cable circuits to be set up automatically by a continental operator, and in a few cases by a continental subscriber, to any subscriber in the U.K. Facilities enabling continental subscribers to set up calls to any subscriber in the United Kingdom will be extended rapidly, but this is dependent on suitable arrangements being made in the continental exchanges.

Equipment is now being installed which will enable subscribers in the United Kingdom to dial subscribers on many continental automatic telex networks, the calls being routed via submarine cable circuits. In addition, equipment is being provided to enable overseas operators to complete calls automatically to subscribers in the United Kingdom over radio telegraph circuits.

A cordless switchboard is to be installed in the Fleet building in 1962 and will replace those at present remaining in the C.T.O., which is to be demolished. It will be required to handle (a) assistance traffic for the whole of the United Kingdom, (b) outgoing calls on cable routes to manual networks, and (c) outgoing calls on radio circuits.



In the foreground are maintenance-control positions.  
FIG. 5—GENERAL VIEW OF TEST ROOM

# New Designs of Furniture for Use in Engineering Installation Offices

E. H. SEYMOUR, A.M.I.E.E.†

U.D.C. 645.4

The work of installing, shifting and recovering Post Office apparatus at subscribers' and renters' premises is controlled from engineering Installation Offices. The types of furniture and fittings provided for such offices have recently been reviewed and, as a result, some new items are to be introduced.

THE function of an Installation Office is to control and co-ordinate the engineering work involved in installing, shifting or recovering apparatus at subscribers' or renters' premises. In addition to planning and controlling the execution of the work and recording its progress, the staff of an Installation Office is responsible for the allocation and efficient utilization of local line plant. These duties necessarily require the maintenance of extensive files and records to which frequent reference has to be made. To facilitate this work the Installation Office has special furniture and fittings, and, as a result of a recent review by a Post Office Headquarters Study Group, some new items are to be introduced.

Installation Offices have two main groups of staff: Control Officers, who deal with the Advice Notes (A.N.s)\* and control the installation work necessary to provide the services ordered on the A.N.s; and Routing and Records Officers, who are responsible for maintaining the local line-plant records and for allocating cable pairs for the circuits required. The staff on each of these duties is constantly engaged in handling large

† Subscribers' Apparatus and Miscellaneous Services Branch, E.-in-C.'s Office.

\* A.N.s—documents issued by the Sales Division of a Telephone Manager's office and which constitute the authority for carrying out installation or other work at subscribers' or renters' premises.



FIG. 1.—NEW TABLE FOR CONTROL OFFICERS

numbers of forms or cards, and the principal objective when designing the new furniture was to place all such documents in an orderly filing system within easy reach of the staff. A new type of table for Control Officers and a new filing system for Routing and Records Officers are the main changes to the office equipment. These and other subsidiary features are described briefly below. Field trials of prototype tables were held at six Installation Offices in various parts of the country to ensure that the items finally introduced meet operational needs.

## TABLE FOR CONTROL OFFICERS

The new table for Control Officers is shown in Fig. 1. The radical change from the present arrangement is the elimination of the vertical filing rack and the associated facia board used for sorting and holding A.N.s. Instead, the A.N.s are held in two wells, one at each end of the new table. Each well contains a "Flexifold" holder consisting of a set of linen folders suspended from rails so that they can easily be moved backwards and forwards. The A.N.s and associated papers are filed in sets of strong manilla folders each having a stout identification tab riveted to the top, and these manilla folders are carried in the linen folders of the Flexifold. The two wells can between them contain a maximum of about 1,500 A.N.s and, where the average holdings are less than this, the whole Flexifold can be pulled forward to the front of the table to reduce the distance the user has to reach. Each complete Flexifold is housed in a box which can be removed from the well as occasion demands for cleaning, finger grips being provided to enable the box to be taken out easily.

The top two drawers, left and right, each provide accommodation for about 150 dialling-code lists. The divisions within the drawers are square so that the code lists may be stacked facing either forwards or sideways, whichever is more convenient to the user. The two shallow drawers, left and right, are each provided with fitments having 40 compartments for holding dial-centre labels. A Perspex cover, whilst allowing the printing on them to be seen easily, prevents the labels from jumping when the drawer is closed. In addition, provision is made (not shown in Fig. 1) for stacking several hundred labels used on extension-plan installations.

The third drawer, left, is for general-purpose stationery, and the bottom drawer, left, serves as a personal drawer and is fitted with a lock. The bottom drawer, right, holds paper, plans, etc., of foolscap size and is divided into sections.

#### TABLES FOR ROUTING AND RECORDS OFFICERS

Each routing and records duty normally consists of a two-man team, and access is required by both men to the more frequently used records—the distribution point (D.P.) and main and branch cable cards. The field trials showed that some form of rotary drum was the best and most compact means of housing the D.P. cards, and Fig. 2 shows the arrangement finally adopted. The rotary drum illustrated is a free-standing item mounted on rollers, but it will normally be placed between the two tables, as shown, to provide joint access to the cards. The drum can accommodate a maximum of 6,000 D.P. cards, a quantity which is ample for one routing and records duty in an average Installation Office. In exceptional circumstances two drums may be needed and they may then be placed centrally between the two tables or one may be put alongside each table, whichever arrangement is better suited to the local requirements.

The main and branch cable cards will be kept in stout cardboard covers provided with split rings to allow the covers to be opened flat at any position and also to permit any card or cards to be easily withdrawn and re-inserted irrespective of the position in the cover. It was the intention to house these covers in a small open-fronted bookcase standing on top of the back portion of the rotary drum (the position can easily be visualized from Fig. 2). However, a system is at present under



FIG. 2—ROUTING AND RECORDS POSITIONS, SHOWING NEW ROTARY DRUM CARD FILE

consideration which may dispense with the need to hold these cards at Installation Offices, and, until this question is resolved, the covers will be filed in any convenient position.

The tables used are standard types already available.

#### CHAIRS

Because of the constant bodily movement associated with these two duties, a swivel chair of the Middlebrough type (Fig. 1), adjustable in height from 16½–19 in., will be made available. Standard steel spring chairs may, however, be used by those officers who prefer them.

## Testing of Subscribers' Dials from the Test-Desk

U.D.C. 621.317 : 621.395.636.1

**T**HE only measurement which can at present be made from the test-desk on the dial at a subscriber's premises is that of speed, using an indicator actuated by a clockwork mechanism which is inherently inaccurate and does not lend itself to precise calibration. The make/break ratio of the dial pulses also influences the performance of the exchange equipment, and tests have shown that failures due to ratio faults are more prevalent than those attributable to speed. One result of the inadequacy of the present testing method is that dials are often changed unnecessarily.

These considerations, and the advent of subscriber trunk dialling, which has made dial maintenance of even greater importance than hitherto, have led to the development of a new test circuit.

#### NEW TEST CIRCUIT

The new circuit is primarily for the measurement from the test-desk of the speed and ratio of dials at subscribers' premises. It can, however, be used to measure

the speed and ratio of other pulse sources and, with suitable conversion equipment, can be used for measuring the pulses transmitted by some types of signalling system. The speed and ratio ranges covered are 7.5–15 p.p.s. and 10–90 per cent break, respectively. The new circuit will be incorporated in the "56 Type" test-desk<sup>1</sup> and may be fitted on existing desks.

Elements of the circuit are shown in Fig. 1. Dial pulses operate and release relay AA (Fig. 1(a)), which is a polarized relay of the Carpenter type.<sup>2</sup>

The principle of operation is to charge a capacitor for a period dependent on the speed or ratio of the pulses being measured and then to compare the resulting voltage with that existing on a reference capacitor. The charging rate is adjusted by means of a variable resistor, calibrated for speed and ratio so that the two voltages are equal and a null reading is obtained. Because of the acceleration and deceleration occurring during rotation of a dial, the first and last pulses of a train are not measured but are used for setting the equipment; the



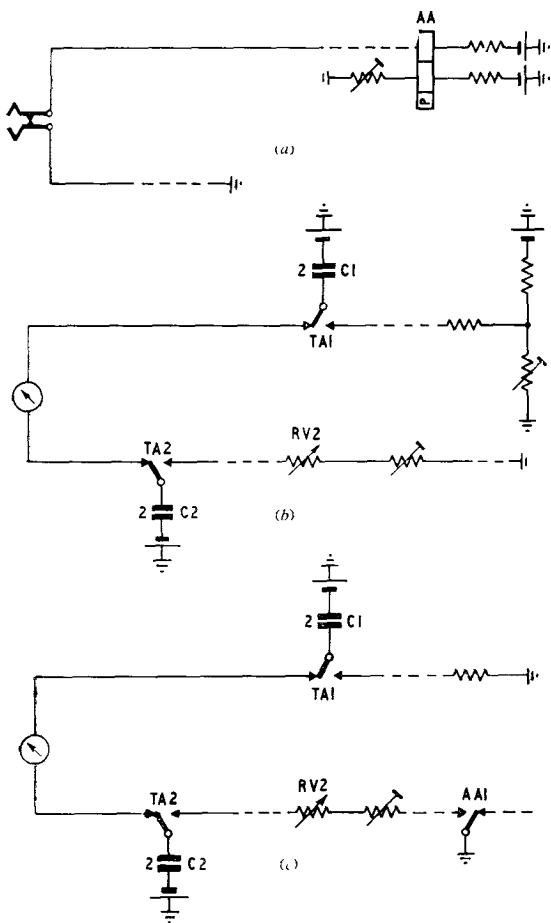

FIG 1—ELEMENTS OF NEW DIAL-TEST CIRCUIT

measurements are made on the eight pulses remaining when digit 0 is dialled. The total number of pulses received can be displayed if required.

Fig. 1(b) shows the circuit arranged to measure speed. Relay TA operates at the beginning of the second break period and remains held during the subsequent pulses. During this period, capacitor C1 is charged to a predetermined voltage but capacitor C2 is charged to a value dependent on the setting of the calibrated control, RV2, and the time required for eight pulses. If, for example, pulses are received at 10 p.p.s. and RV2 is set to this value, then when relay TA releases and the capacitor voltages are compared via the meter, which has a centre-zero scale, C2 will have been charged to the same voltage as C1 and no deflexion of the meter needle will be observed. When making a test, several trains of pulses are dialled to check that there is no variation in speed from one train to another and to enable successive adjustments of RV2 to be made to obtain a satisfactory null reading. It will be appreciated that both speed and

ratio tests are the average of measurements of eight pulses out of a train of ten.

For ratio measurements (Fig. 1(c)), relay TA operates and releases as before, but in this test the charge on capacitor C2 depends on the length of the make periods of contact AA1 as well as on the setting of RV2. At the end of the pulse train, therefore, capacitor C1 will have been charged to a value dependent on the total time for eight pulses while capacitor C2 will have been charged to a value dependent on the integrated make periods of the dial springs. This may be expressed in terms of percentage break and, when RV2 has been adjusted to give a null deflexion, the value is read from the appropriate scale.

#### OPERATION

When testing over subscribers' lines, factors other than dial characteristics influence the received pulses. As far as the line constants are concerned it is found in practice that the line capacitance can be ignored in the face of the much larger spark-quench capacitance in the subscriber's instrument, the effect of which is allowed for during calibration. The inductance of a subscriber's line can also be neglected. If leakance is large enough to affect pulse measurements, it constitutes a fault condition in itself; normally it has no appreciable effect. The line resistance varies from line to line and means are provided for adjusting the current in the receiving relay to the value at which the circuit was calibrated.

The circuit is calibrated for speed and ratio by using an external source of pulses of known parameters; a suitable instrument is the pulse generator and measuring set designated Tester AT 5300.<sup>3</sup> Provision is made for checking that the circuit remains accurate. A field-trial model was examined after six months' use and the calibration was found to be unchanged. The self-check arrangements incorporated in the tester did not reveal any need for re-calibration after a further six months' period.

Each suite of test-desks will be provided with one of the new test circuits, with a meter and control keys mounted on each testing position.

#### ACKNOWLEDGEMENT

The authors gratefully acknowledge the assistance of officers of the Southampton Telephone Area who co-operated in building and setting up the field-trial model.

L.W.P.  
H.C.A.

#### References

- <sup>1</sup> ADAMS, H. C., and PRATTEN, L. W. Testing Facilities on Test-Desks in Automatic Telephone Exchanges. *P.O.E.E.J.*, Vol. 53, p. 275, Jan. 1961.
- <sup>2</sup> TURNER, H. A., and SCOTT, B. A Polarized Relay of Improved Performance. *P.O.E.E.J.*, Vol. 43, p. 85, July 1950.
- <sup>3</sup> ILES, S. H. A Tester for the Measurement of Pulse Distortion in Automatic Telephone Systems. *P.O.E.E.J.*, Vol. 47, p. 203, Jan. 1955.



## Notes and Comments

### New Year Honours

The Board of Editors offers congratulations to the following engineers honoured by Her Majesty the Queen in the New Year Honours List:

Bristol Telephone Area	.. .. .	P. G. Hallett, T.D.	Assistant Engineer	..	Officer of the Most Excellent Order of the British Empire (for service in the Territorial Army)
Cambridge Telephone Area	.. .. .	E. J. Easter	Lately Technical Officer	..	British Empire Medal
Centre Telephone Area, London	.. .. .	A. Wooldridge	Technician, Class IIA..	..	British Empire Medal
Telecommunications Region					
Engineering Department	.. .. .	C. W. Sowton	Assistant Staff Engineer	..	Officer of the Most Excellent Order of the British Empire
Engineering Department	.. .. .	R. B. Dickinson	Executive Engineer	..	Member of the Most Excellent Order of the British Empire
Gloucester Telephone Area	.. .. .	F. E. Huckfield	Assistant Engineer	..	Member of the Most Excellent Order of the British Empire
Newcastle-upon-Tyne Telephone Area	.. .. .	C. Maddison	Technical Officer	..	British Empire Medal
Research Station	.. .. .	L. R. Sparks	Technical Officer	..	British Empire Medal

### Retirement of Captain W. H. Leech, O.B.E., D.S.C.

Captain Leech, Submarine Superintendent, who retired on 31 January after 40 years' service, started his seagoing career in 1912 as an apprentice with Houlder Bros., joining the R.N.R. on the outbreak of the First World War. On demobilization in 1920 he entered the Post Office as a junior officer in H.M.T.S. *Alert* at Dover, serving in various capacities until promoted to Chief Officer of H.M.T.S. *Monarch* at Woolwich in 1936.

In 1938 Capt. Leech came ashore as Assistant Submarine Superintendent. He returned to sea in December 1939 on promotion to the command of H.M.T.S. *Ariel* when she was first commissioned. In May 1940 he took command of H.M.T.S. *Iris* when she was first commissioned, serving in her throughout the remainder of the Second World War and taking part in the expedition to the Azores and in laying cables in support of the allied landings in Normandy and the Cherbourg peninsula.

In 1946 Capt. Leech "swallowed the anchor" when he finally came ashore as Submarine Superintendent. During his "trick at the helm" he gradually built up an organization which developed from one concerned only with cable work in home waters into one engaged in the laying and repairing of submarine cables in many parts

of the world. In this work he was in close and cordial contact with the principal international cable companies. When long-distance submarine-telephone-cable systems became practicable he was concerned with new developments in submarine-cable operational procedures which have since become models for the future.

He was awarded the D.S.C. in 1945, an honour which gave much pleasure to his colleagues at sea, as it was a recognition of the difficult nature of some of the work they were called upon to do whilst going about their lawful business. In 1951 he was honoured with the O.B.E.

Capt. Leech leaves Submarine Branch at a time when the new *Alert* is almost ready for service, and when the preparations for laying CANTAT are almost completed—the ground-work well and truly laid. His many friends in the Post Office and overseas, ashore and afloat, remember him with pleasure, are grateful for the help and advice he gave and wish him well in his retirement.

I. R. F.

### Captain I. R. Finlayson

Capt. Finlayson, recently appointed Submarine Superintendent, Submarine Branch, received his early training at the Royal College of Science and Technology,



Glasgow, and served his apprenticeship with the Blue Funnel Line.

After service as a junior officer with various shipping companies, and a short spell of service as a Sub-Lieutenant in the R.N.R. during the Munich crisis, Capt. Finlayson entered the Post Office in September 1939 when he joined the cable ship H.M.T.S. *Monarch* as Fourth Officer. Transferred to H.M.T.S. *Ariel* when she was first commissioned, he served in all ranks up to Chief Officer, and in 1944 moved to Headquarters to take up the post of Assistant Submarine Superintendent.

In May 1946 he took command of H.M.T.S. *Iris*, a post which he held until his appointment as Deputy Submarine Superintendent in August 1960. Under his

command, *Iris*, operating from her base at Dalmuir, Glasgow, steamed many thousands of miles on submarine-cable operations, chiefly on repairs to cables in waters around the British Isles, particularly in the Irish Sea and off the coast of Scotland.

Capt. Finlayson has taken over command of Submarine Branch at a time when a heavy cable-laying program for the Commonwealth Cable Network, commencing with the laying of the CANTAT cable, is about to start. His wide experience of submarine-cable work, combined with a characteristic thoroughness and perseverance, and a ready sense of humour, equip him well for his new post, and he carries with him the best wishes of his colleagues in the cable-ship service.

A. I.

## Institution of Post Office Electrical Engineers

### Retired Members

The following members, who retired during 1960, have retained their membership of the Institution under Rule 11 (a):

W. J. Marshall, 10 South Hill Grove, Harrow, Middlesex.  
G. J. Channon, 80 Chiswick Lane, Chiswick, London, W.4.  
G. Daly, 3 Belgrave Road, Wanstead, London, E.11.  
T. E. Walker, 25 Wynford Terrace, Leeds, 16.  
H. S. Waters, 53 Spring Lane, Woodside, London, S.E.25.  
A. G. Southgate, 285 Osborne Road, Hornchurch, Essex.

S. WELCH,  
General Secretary.

### Additions to the Library

Library requisition forms are available from Honorary Local Secretaries, from Associate Section Centre Secretaries and representatives, and from the Librarian, I.P.O.E.E., G.P.O., 2-12 Gresham Street, London, E.C.2.

2603 *A Course of Applied Mathematics*. D. F. Lawden (Brit. 1960).

Devised mainly to assist students reading for science degrees at a level lower than honours. Assumes intermediate degree standard, or "A" level of the G.C.E. Covers dynamics, statics, field theory and hydro-mechanics.

2604 *Magic of Numbers*. R. Toquet (Brit. 1960).

Lightning calculators and their secrets; how to do mental arithmetic; animal calculators.

2605 *Domestic Water Heating*. R. Grierson (Brit. 1950).

A critical analysis of current practice in the supply of hot water for domestic purposes.

2606 *Hi-Fi Amplifier Circuits*. E. Rodenhuis (Dutch 1960).

Intended for those people interested in building and experimenting with high-quality amplifiers.

2607 *Junction Transistors in Pulse Circuits*. P. A. Neeteson (Dutch 1959).

Designed to give an adequate knowledge of the fundamental principles of pulse circuit design and the application of junction transistors in such circuits.

2608 *Heat Engines*. R. Joel (Brit. 1960).

Covers the work necessary for the subject of Heat Engines set in the O.N.C. and O.N. Dip. examinations.

2609 *Basic Concepts of Elementary Mathematics*. W. L. Schaaf (Amer. 1960).

Attempts to capture the spirit of contemporary mathematics and to integrate it with those aspects of "classical" mathematics which are pertinent to the elementary school.

2610 *Close-up Colour Photography*. C. H. S. Tupholme (Brit. 1960).

Describes the fascination of, and the techniques used in, making photographic studies of small objects.

2611 *Principles of Illumination*. H. Cotton (Brit. 1960).

A comprehensive book on fundamental principles of lighting which goes beyond the examination-syllabus requirements to meet the needs of the practising illumination engineer.

2612 *Direct Conversion of Heat to Electricity*. J. Kaye and J. L. Welsh (Amer. 1960).

This book is an edited collection of papers on the fundamentals and practical applications and problems of each type of conversion scheme.

2613 *Applied Mechanics for Engineers*. J. C. Grassie (Brit. 1960).

A textbook for students designed to show how the three branches of applied mechanics—statics, dynamics and strength of materials—are co-related.

2614 *Engineering Mathematics*. J. Blakey and M. Hutton (Brit. 1960).

A revision of J. Blakey's "University Mathematics" to make it more suitable for engineering students of degree standard.

2615 *Photographing Colour*. W. Benser (Brit. 1959).

A book for the amateur photographer.

2616 *Relativity for Engineers and Science Teachers*. L. H. A. Carr (Brit. 1960).

A simple textbook explaining the meaning of the special theory of relativity in a form suitable for the average engineer or engineering student.

2617 *Low Frequency Amplifiers*. A. Schure (Amer. 1959).

Presents the major specifications for low-frequency amplifiers covering the range from zero to 100,000 c/s.

2618 *Magnetism and Electromagnetism*. A. Schure. (Amer. 1959).

Discusses the major theoretical considerations of magnetism, magnetic circuits, and electromagnetism.

2619 *Mathematics for Telecommunications, Vol. 2*. D. F. Spooner and W. H. Grinstead (Brit. 1960).

Covers the mathematics required for the third and fourth year of the City and Guilds' Telecommunications Technician's Course, contains rather more than is required for the O.N.C. in engineering, and should have particular appeal to electrical and telecommunication O.N.C. candidates.

2620 *Principles of A.C.* W. Sluckin and J. R. Greener (Brit. 1959).

Assumes only some familiarity with electricity and magnetism. Uses the M.K.S. system of units.

W. D. FLORENCE,  
Librarian.

# Regional Notes

## North-Eastern Region DONCASTER MOTORWAY

The Doncaster motorway will, when completed, bypass Doncaster on the west side and do much to alleviate the traffic congestion in the town. Starting at the Humber Head bridge, north of Doncaster on route A1 where the road crosses the King's Cross-Leeds main railway line, the motorway will extend  $12\frac{1}{2}$  miles southwards to finish at Blyth. In between these two points, 32 bridges will have been built and Post Office plant is affected at 14 of them.

Access to the motorway at intermediate points will be obtainable only at two places. At both places a 4-way duct track has been laid across the west-side slip roads. Along all motorway bridges a nest of four steel pipes has also been laid. In case it is necessary to provide emergency telephones, ducts have been laid across the motorway at 1-mile intervals.

One of the major projects has been the construction of a roundabout and the four associated slip roads on the Doncaster-Sheffield route, A630, at Warmsworth. The motorway passes beneath the roundabout and this has resulted in the roundabout being built as two separate bridges, one for each direction of traffic. The old road ran between these two bridges and the telephone plant along it consisted of one 4-way and two 2-way ducts containing the four Doncaster-Sheffield trunk cables and five local cables.

Before the old road could be dug out, the southern bridge of the roundabout had to be built and traffic diverted to it. During the building of this bridge the existing duct-track was excavated and a narrow suspension bridge built so that its cat-walk floor was beneath the track. Thus, when the motorway contractor continued to excavate, the old road was completely removed, and the bridge and its cables were left some 30 ft above the surface of the motorway. To lighten the load on the suspension bridge the 4-way duct and one of the 2-way ducts were removed.

The second bridge was then built and during construction twelve 4 in. steel pipes were laid across it. A duct-track of two 6-way ducts was provided from each side of this bridge to join up with the existing track. The work also involved the construction of five R2A manholes. On completion of the new track, cables were laid and circuits diverted into them. Finally, the old cables and the suspension bridge were removed.

## Northern Ireland

### APPLICATION OF S.S. D.C. No. 2 EQUIPMENT TO THE BELFAST-ENNISKILLEN TRUNK ROUTE

From the experience gained on the Belfast-Dublin trunk route with Signalling System D.C. No. 2 equipment, it was considered that the provision of dialling facilities on the Belfast-Enniskillen trunk route would be possible, and indeed desirable, prior to the introduction of subscriber trunk dialling at Belfast. The use of D.C. No. 2 equipment would permit direct dialling to Enniskillen non-director automatic exchange, and tandem dialling to the 21 U.A.X.s of which it forms the parent.

The cable route Belfast-Enniskillen consists of 108 miles of 20 lb/mile conductor having a signalling-path resistance of 5,050 ohms and a calculated pulsing limit of 96,000 microfarad-ohms. The present pulsing and signalling limits for D.C. No. 2 equipment at 50-volt exchanges are 76,000 microfarad-ohms and 8,200 ohms. From the foregoing it will be seen that, although the route has a time constant of 96,000 microfarad-ohms compared with the limit of 76,000 microfarad-ohms, the signalling-path resistance is well within the specified limit, and from a purely theoretical study it would appear that the performance of the route should be satisfactory.

To test the practicability of the theoretical study, one circuit in the Belfast-Enniskillen direction was put into service on an experimental basis during February 1957, and one circuit in the Enniskillen-Belfast direction during March 1957. The performance of both circuits carrying telephone traffic was entirely satisfactory. It was particularly noticeable that under cable-fault conditions these two circuits were the last to become unworkable, as the remainder of the route, employing differential signalling, was more susceptible to the unbalanced conditions, which prevented satisfactory signalling. Consideration was given by the Engineering Department in August 1957 to the conversion of the complete route to D.C. No. 2 signalling, the installation to be regarded initially as a field trial. Due to equipment and accommodation shortages it was not possible to proceed until April 1960, when the complete route was converted to D.C. No. 2 working.

Although the results of the field trial have shown that in these particular circumstances it is possible to dial over a D.C. No. 2 link of 96,000 microfarad-ohms, the introduction of trunk mechanization at Belfast will preclude the use of over-limit D.C. No. 2 signalling as a permanent method, since with tandem dialling the pulsing limits would be exceeded. It is understood that as soon as practicable after the introduction of trunk mechanization, A.C. No. 9 equipment will be installed on the Belfast-Enniskillen route.

H. C. P.

## Midland Region

### NEW TELEPHONE EXCHANGE AT LEICESTER

With the opening of the new non-director automatic exchange at Wharf Street on the 10 December 1960, the conversion of the Leicester multi-exchange area from Siemens No. 16 type equipment was virtually completed, only one small satellite exchange remaining on the old system.

The new exchange, comprising a 10,000-line unit and a 5,000-line unit, is housed in a modern building which also accommodates the trunk non-director automatic exchange and junction tandem switching and subscriber trunk dialling (S.T.D.) equipment.

S.T.D., which was introduced on the opening day, uses 68 electronic registers and associated translators, and serves not only Leicester but also the remaining satellite and non-director exchanges in the home charging group.

Installation of equipment has been in progress over the past  $2\frac{1}{2}$  years, commencing with the trunk non-director exchange, and at the time the installation of this equipment commenced in the basement the upper floors had not been erected. Similarly, when the main automatic-apparatus installation commenced, only the apparatus floors were completed. It was difficult to ensure that while this building work was progressing the installed apparatus remained free from dust, but adequate screening of the apparatus rooms enabled the difficulties to be overcome.

It was fortunately possible to open part of the exchange in advance of the main exchange transfer and, by opening the junction tandem section of the equipment in July and subsequently transferring additional routes to the new equipment, the main exchange transfer was effected with only a minimum number of junctions being concerned. Similarly, the S.T.D. equipment and the 5,000-line unit was available well in advance, and by transferring official telephones to the 5,000-line unit they were provided with full S.T.D. access and adequate pre-opening testing of the S.T.D. facilities was possible. This enabled various initial difficulties to be overcome and gave good time for the maintenance staff to become familiar with the system.

The extensive underground-cable work was completed six

months before the opening, leaving time for the transfer of external extensions, etc., and pre-transfer testing of subscriber apparatus.

The exchange was opened for service at 7.30 a.m. on 10 December 1960, with the transfer of subscribers from the Siemens No. 16 type exchange and also those which were served by the CB1 relief manual exchange "Granby," which was closed down concurrently. S.T.D. was introduced at 3 p.m. during a ceremony at which the Assistant Postmaster-General declared the building open and an inaugural call to Flamborough Head Lighthouse was made by the Lord Mayor of Leicester.

With the opening of the new exchange, S.T.D. became available to 15,000 subscribers connected to the Leicester and three remote non-director exchanges, and extension of the service to the remaining satellite and remote non-director exchanges during 1961 will make S.T.D. available to a further 20,000 subscribers.

Installation of the exchange was carried out by Associated Electrical Industries, Ltd., with The General Electric Co., Ltd., as contractors for the electronic equipment, and it is due in no small measure to their co-operation that the whole scheme has progressed satisfactorily.

W. L. S.

### London Telecommunications Region EXPLOSION RISKS

Work on overhauling Post Office plant in an oil-storage depot to bring it into line with flameproof requirements had hardly been completed when another installation, at a printing works, was reported as needing attention. Both these installations presented unusual difficulties, and the second one involved considerable risks.

When an oil tanker is in port the risks of fire and explosion are mainly confined to those days when bulk cargoes are transferred to storage. Large volumes of vapour, often equivalent to hundreds of gallons of liquid, are displaced from the tanks and linger in the compound until dispersed by winds. The depot referred to here has another special hazard, for alongside it runs a railway siding on an embankment, now served by electric trains using an overhead contact wire.

The telephone requirements for a tanker in port are met by providing a flameproof (and weatherproof) telephone on the dolphin against which the tanker is moored. Where telephones are needed in close proximity to pumping machinery the wiring is best done in mineral-insulated cable. This is much easier to install than solid drawn galvanized conduit and flameproof fittings. A section

of earlier conduit work at this installation was condemned as unsatisfactory, but, even if it had been well done, there would have remained the possibility of transmission along the conduit of an inflammable mixture and an explosion, as the sealing of conduit is difficult to carry out satisfactorily. With copper-sheathed cable there is no enclosed space which can possibly transmit an explosive mixture, and at this installation jointless cable runs were achieved from the No. 16 lead-in insulator to the flameproof telephone, using appropriate flameproof sealing glands on the latter. The power relay and mains-operated bell were wired similarly. Particular care must be taken when working in such locations; an electric drill is forbidden, and an ordinary hand lamp is unsafe. Even for working in dark corners a normal pocket torch is not allowed; in this instance the subscriber lent a husky Buxton-certified torch.

The place where the considerable risk was found is the machine room of a firm specializing in the printing of illustrated photogravure magazines. This is a large room, filled with machines and much too noisy to be considered for a telephone. There is, however, a telephone extension bell and its wiring. The bell was an ordinary 6 in. magneto type (No. 67A) and had associated with it an ordinary tumbler switch. The wiring was of "flameproof" type, but was not suitable for a situation where a spark might set off an explosion. By contrast, all the other electrical services were flameproof or had been made specially safe. The case only came to light when a chance telephone call rang the extension bell at a time when the machine room was being examined by the Factory Inspector for compliance with flameproof and other safety requirements.

At these premises the driving motors for the machines are commutator types and are made safe by fresh air pumped via ventilating ducts. The lighting in the room is all in flameproof fittings with the lamps, filament and fluorescent, in special, sealed, glass fittings. Even small signal lamps on the control panels have to be fitted inside their individual metal boxes, with coloured glass windows held down by screws, which only a special key will remove. Casings of switchgear have wide flanges on all joints. The installation is classed as Group 2 (Pentane) under the Ministry of Fuel and Power regulations, and any equipment used must be up to that standard.

The installation has now been made safe by fitting a flameproof mains-operated bell controlled by a power relay near the telephone, which is in a quiet vestibule outside the room and the danger area. Once more a run of mineral-insulated cable was used, nearly 50 yd being needed. This is by far the most suitable cable for a difficult run such as was encountered.

A. F. T.

---

## Book Review

"Magnetic Materials in the Electrical Industry." P. R. Bardell, B.Sc., M.I.E.E., F.Inst.P. Macdonald & Co. (Publishers), Ltd. 320 pp. 166 ill. 32s. 6d.

This new edition differs from the old mainly in the addition of chapters on ferrites and on the testing of materials by magnetic methods. Both these new chapters might well have been longer; they are satisfactory as far as they go—some errors about the physics of ferrites do not affect the practical considerations which are the main feature of the book. Changes elsewhere include a fuller and better account of the commercially available nickel-iron alloys, and some additional material on magnetic recording, including the recording of television signals. The development of cube-textured silicon-iron and of Supermendur is not mentioned, perhaps because they have not yet come into industrial use. The changes, then, are minor, and one suspects that if the

book were being written afresh some of the material would now be differently chosen.

The emphasis remains, as in the first edition, strongly on the practical applications of magnetic materials. Even so, the scope is so wide that a book of this size can provide only an introduction, and it fulfils this purpose very well. The only criticism which might be made of the use of the available space is that many of the photographs show only the outside of a box and convey little more than the assurance that the apparatus really has existed. The author is not afraid to mention manufacturers' names; he seems to have succeeded in doing this impartially, and for most readers the presence of trade names will make the book more useful.

A reviewer of the first edition referred to this book as making a common-sense approach, and the present reviewer agrees. As before, the book is well indexed, well produced, and seems to be good value for money.

*I.P.O.E.E. Library No. 2303.*

A. C. L.

# Associate Section Notes

## Ipswich Centre

Since our last report we have held our first dinner at the Regal Café, Felixstowe. The dinner was attended by the Associate Section President, Mr. A. H. C. Knox, the Telephone Manager, Mr. L. H. Brown, and Mrs. Brown, the Area Engineer, Mr. F. K. Radcliffe, and Mrs. Radcliffe, the Regional Liaison Officer, Mr. Harrison, and Chairman of the Ipswich Centre, Mr. P. E. Buck, and Mrs. Buck. These guests, together with members and their wives and friends, enjoyed what proved to be a highly successful evening. So successful was this venture that already consideration is being given to making this an annual event. Mention should be made of the entertaining diversions provided during the evening by two of our members, Messrs. Raffie and Shelton, among which was their version of "ERNIE," which, although it would have made the staff at Lytham St. Annes turn grey with fright, provided our guests with a good laugh.

The photograph shows some of our members at the cable works of Standard Telephones and Cables, Ltd., during a visit in September. This was one of the many



MEMBERS OF THE IPSWICH CENTRE AT THE CABLE WORKS OF S. T. & C., LTD

enjoyable and instructive visits included in our summer program. The winter program started in October with a film show, which was much appreciated by members, and we are grateful to the Shell B.P. Library for the loan of these films.

Our December meeting was of particular interest, since it included a paper given by one of our local supervising officers, Mr. H. W. Lewington, entitled "Problems in the Provision of Service on New Estates." This paper, which had already been read before many senior sections, including one in Scotland and another in Northern Ireland, was much appreciated by members.

Our future program will include such subjects as "Water Supplies," "Railway Electrification" and "S.T.D.," and should prove most enjoyable to members.

E. W. C.

## Guildford Centre

During the summer of 1960 members paid a visit to the Bowater Paper Mill, Sittingbourne, Kent. This was most interesting, and covered the manufacture of paper from logs to the end product.

The winter session commenced with a lecture by Mr.

H. J. C. Spencer, Subscribers' Apparatus and Miscellaneous Services Branch, Engineering Department, on the 700-type telephones. This proved a very popular talk and was well illustrated with colour slides. For our next meeting we had an excellent film show, with an attendance of 76 members and friends. The program for the remainder of the session was as follows:

10 January: Film show.

1 February: Talk on the Museum switching terminal by Mr. W. L. Newman, of the London Telecommunications Region.

16 February: Film show at Aldershot Civil Service Club.

28 February: "Colour in the Home," by Mr. Panther.  
J. F. T. W.

## Shepton Mallet Centre

This Centre has once again enjoyed some most interesting lectures, several because of kind invitations from the Bath Centre, with whom we maintain cordial relations.

Mr. L. Vranich's prize-winning paper on "Radio Direction Finding" was most engrossing, and he communicated his intense interest in the subject very effectively.

We would like to emphasize again how worthwhile it is to organize even such a small Centre as this—about 20 members. The interest aroused and the spontaneous co-operation in the running of the Centre have proved most valuable assets to the members, and have fostered the communal spirit.

## Bath Centre

It is very pleasing to be able to report an active, stimulated and enthusiastic membership. Since the annual general meeting visits have been organized to the control room of the South-Western Regional Electricity Generating Board at Keynsham (June), the police driving school at Devizes, Wiltshire (July), and Kilmersdon colliery in the Somerset coalfields (September).

All these visits were well supported and much enjoyed, even if the excursion along a coal face proved a little difficult to the larger members of the party. The demonstration of safety-first road manners and commentary driving by the police instructors was most instructive and impressive; an outing on the skid-pan proved an exciting conclusion to a wonderful afternoon.

Lectures have been given to the Centre on "Transistor manufacture and design" (October), and "More M.P.G." (December).

The lecture on transistor development was given by Mr. Charman, of Semiconductors, Ltd., Swindon. His technical lecture was illustrated by a film showing details of the firm's premises, plant and processes. Many questions showed the interest of a full-capacity audience.

The motoring lecture was presented by Mr. R. J. Root, Automotive Engineer of the Mobiloil Petroleum Co., Ltd. Attendance was below normal, since Bath was in the grip of the worst floods for 200 years. Mr. Root gave an excellent lecture on all aspects of motoring economy from basic mechanics to highly expert driving techniques. A film of the Mobilgas Economy Rally was followed by a lively question time.

Also included in the varied program were the now established annual motor treasure hunt, held in August, and a most successful quiz against the visiting Gloucester Centre, held in November. Through the offices of the Journal, I wish to thank the Gloucester Centre for a very good evening.

The officers and committee of the Centre wish to thank all members for their encouragement and support, and hope that the good work will be maintained, not forgetting suggestions for future visits, lectures or events.

D. G. R.

### Dundee Centre

Twenty of our members attended a demonstration of the River Tay model, which surprised most of us by its size (about 125 ft long, 75 ft wide at one end and tapering to 3 ft at the other) and by the great amount of detail shown, including the projected new road bridge.

About 20 members visited the offices of John Leng & Co., Ltd., and witnessed one of the newspapers being compiled and the associated work, which culminated with the paper being printed.

Our first talk, given to about 40 members, was on "Microwaves for the Layman," by Mr. J. S. R. Lawson. Also at this extremely interesting meeting we had the pleasure of the company of Mr. Blackburn, our Regional Engineer (Maintenance), who presented Mr. A. W. Brighton with an Institution Certificate of Merit for his essay on "Fault Statistics—Their Aid to Production and Efficiency."

We are looking forward to a talk on "TV Link Testing," by Messrs. R. B. Duncan and G. Duff.

J. S. B.

### Glasgow and Scotland West Centre

The winds of change have been blowing up here in Glasgow. First, we made a determined effort to increase our membership, which had dropped to just over 100, and have now brought it up to close on 200. The purpose of this drive was twofold: (a) to increase our income, and (b) with the increased income, to hold our meetings in a more congenial atmosphere. This we have done. Our annual general meeting last year was held outside official premises and was highly successful, as was also the first meeting of this session. Another change was the opening of the Telephone Manager's new offices in Marland House; we took advantage of this and held some of our meetings there. This again was very successful, the comfort and surroundings being ideal. Our program up to date has been as follows:

"700-Type Telephone," by Mr. W. Sheldon, of Glasgow.  
"Why Educational Problems To-day?" by Mr. William Phillips, M.A., Deputy Rector, Marr College, Troon.

"S.T.D. and the Director Exchange," by Messrs. B. B. Gould and S. H. Sheppard, of the Telephone Exchange Systems Development Branch, Engineering Department.

We are looking forward now to the second half of our program, which includes films on transistors and magnetic materials by Mullard, Ltd., a visit to John Brown's Shipyard, Clydebank, a visit to Hunterston nuclear power station, and a conducted tour of the new Post Office cable ship before she leaves the Clyde.

J. F.

### Middlesbrough Centre

The newly formed Middlesbrough Centre was inaugurated on 4 August 1960, when a meeting was held and the following officers were appointed: *Chairman*: Mr. R. Costello; *Secretary*: Mr. N. Williams; *Committee*: Messrs. A. Williams, K. Ashworth, A. Bird and K. W. Roe.

The session opened in October 1960 with a lecture on "Repeated Submarine Cables," by Mr. F. Scowen, of the Post Office Research Station. The talk proved to be both interesting and instructive and was well attended; a lively discussion followed.

For our November meeting a talk on "Subscriber Trunk Dialling," recently introduced in Middlesbrough, was given by Mr. S. Hinson and Mr. W. Smith, both Technical Officers in Middlesbrough automatic telephone exchange. The use of numerous large-scale diagrams produced by the lecturers enabled them to hold the interest of the audience during the explanation of a complex subject. The meeting was an outstanding success with an audience of about 60.

The December meeting took the form of a visit to the Middlesbrough fire station. The visit was made more interesting by the fact that an alarm occurred during the

visit, giving an excellent opportunity to see the service in action.

The program for the remainder of the 1960-61 session was arranged as follows:

January: Film show.

February: A talk on automatic telex.

March: Visit to Cameron's brewery.

April: A talk on refrigeration and ventilation plant.

May: Annual general meeting.

The committee are very pleased with the progress of the Centre and welcome all members to future meetings.

N. W.

### Leeds Centre

The current program is now well under way and meetings are well attended.

On 14 October 30 of our members travelled to Cambridge to spend an interesting day at Pye Telecommunications, Ltd.

Memories of many warm and happy days spent in the Lake District were brought back to us in a talk entitled "Lakeland Days," given by Mr. P. Broadbent, a member of the Leeds Centre. This was an open meeting and 40 of our members and friends had a most enjoyable evening.

On Thursday, 15 December 1960, we held our annual dinner and dance at the Ringsways Restaurant, Whitehall Road, Leeds; 100 of our members and guests attended. During an excellent meal the resident quartet played light music; later the Chairman, Mr. T. M. Smith, proposed a toast to the Queen, and afterwards briefly referred to the future of the Centre and thanked all members for their support. Mr. E. Hopkinson replied and then, on behalf of the Centre, made a presentation to our past Chairman, Mr. C. Baker. During the remainder of the evening there was dancing, songs by Mr. Frain, and magical entertainment by Mr. G. Blake.

E. B. B.

### Shrewsbury Centre

At the annual general meeting, held on 7 October, the following officers were elected: *Chairman*: Mr. J. F. A. Callear; *Vice-Chairman*: Mr. E. Dodd; *Secretary*: Mr. H. Christmas; *Treasurer*: Mr. R. Poulson; *Committee*: Messrs. W. Dodd, P. K. Nicholson, J. Swannick, J. Fleming, G. Ridgway and R. Jervis.

H. C.

### London Centre

The November talk, "The Nature of Annoying Sound," given to the Centre at Waterloo Bridge House, was by Mr. E. A. Newman, Deputy Superintendent of the Applied Physics Division of the National Physical Laboratory. Mr. Newman explained how the annoyance of certain sounds was caused not by loudness but by the make-up of the sound, and showed how the National Physical Laboratory were tackling the problems of aircraft and traffic noise.

For some years now the December meeting has been the occasion of a technical film show. The films shown last December were "This is the B.B.C.," "Hazard," and "The History of the Cinema."

In January, Messrs. I. J. Shelley and S. Edwardson of the B.B.C. gave their talk, "Cablefilm," and explained how B.B.C. newsfilm is transmitted over the TAT cable. Film sequences showed how the technique had developed from early tests made in 1957, and these were followed by films of important events that had been shown on television since the visit of the Queen to Canada in 1958. Demonstration equipment included the receiving film camera for the slow-speed telerecording apparatus and the transmission equipment.

With the advent of S.T.D. in the London Telecommunications Region many of our Areas have asked for follow-up talks on the subject after Mr. H. E. Francis's introductory lecture last year. Messrs. B. B. Gould and S. H. Sheppard,



of the Telephone Exchange Systems Development Branch, Engineering Department, covered the director aspect with their talk, "S.T.D. as it affects Director Exchanges," given before the Centre, the Circuit Laboratory of the Telephone Exchange Standards and Maintenance Branch, Engineering Department, and the North and West Areas, while Mr. B. G. Woods of the Circuit Laboratory has kindly covered the non-director aspect by talking about the non-director register-translator (electromechanical) for S.T.D. before the Circuit Laboratory Branch, and the North and North-West Areas.

The Centre was proud to learn that Mr. L. J. Garland, of Long Distance Area, had won the first prize in the 1959-60 Associate Section Papers Awards for his paper, "Continental Semi-Automatic Switching Exchange."

On 18 November a team from the Centre met a team from Brighton Centre at the Telephone Manager's Office at Brighton for a technical quiz. Our party, some 25 in all, contained a composite team of three members from each of last session's London Telecommunications Region finalists, West and City Areas. After an enjoyable meal provided by our Brighton hosts, the match began with our President, Mr. A. H. C. Knox, acting as Question Master, while Mr. Greening, our Regional Liaison Officer, and Mr. S. J. Edwards, the Telephone Manager of Brighton, adjudicated. After mounting excitement the two teams drew and the London team just lost on the first of the supplementary questions, thus bringing to a close one of our most entertaining quiz evenings. The opening rounds of a further inter-area technical quiz were played in the London Telecommunications Region before Christmas, with East, South-West and West Areas beating their contestants Centre Area, Circuit Laboratory and Test Section, respectively, while City Area received a bye against South-East Area.

Orders for about 800 Associate Section ties have now been received. Of this number some 250 have been ordered from the Home Counties Region and five other Centres throughout the country, while the remaining 550 have been ordered by the Areas comprising the London Centre. Completion of orders takes about two months.

In addition to the visits organized by each Area, the Centre has arranged two visits so far this session. The first of these was to New Scotland Yard, while the other was a whole-day visit to the Central Electricity Generating Board, Grid Control Centre, at East Grinstead, Sussex. This latter visit gave us the opportunity to see the control and telemetering systems used by the C.E.G.B. to control that part of the national grid in South-East England.

D. W. W.

#### Colwyn Bay Centre

The opening of the new repeater station at Colwyn Bay has enabled the meetings of the Centre to be held in the spacious welfare accommodation available; this has resulted in an increased attendance.

Meetings during 1960 included a lecture on "Postal Mechanization," by Mr. C. J. Lamping, of the Engineering Branch, Post Office Headquarters, Wales and Border Counties, at which the postal staff were our guests; "This is the B.B.C.," a film of the work of the Corporation, introduced by their North Wales representative, Mr. S. Jones; a film show and lecture by a representative of Mullard, Ltd.; and a repeat visit to the works of John Summers, Ltd.

A lecture, "S.T.D., Part II," a film show, and a talk by a representative of the police force are scheduled for the beginning of 1961.

E. W. W.

---

## Book Review

"Electronic Circuits, Signals and Systems." S. J. Mason and H. J. Zimmermann. John Wiley & Sons, Inc., New York, and Chapman & Hall, Ltd., London. xviii + 616 pp. 355 ill. 100s.

This book is one of a series being prepared by members of the electrical-engineering department of the Massachusetts Institute of Technology to document "the hard core of essential information given to all students in electrical engineering." The emphasis in all the books of the series is on basic principles and methods of analysis; discussions of industrial practice, which contribute little to the student's ability and which nowadays are liable to be out of date by the time the book appears, are severely limited. An earlier book in this series by the same authors, "Electronic Circuit Theory," applied elementary linear-circuit theory to electronic circuits and described the behaviour of such devices as amplifiers, modulators, oscillators, waveform generators, etc. The emphasis was on circuit theory.

Here, the subject is taken one major step forward to consider complete systems composed of these devices. In a system one is concerned with the transmission of a signal, and the component devices are to be regarded as units for processing this signal. The detailed distribution of voltages and currents within the device and the precise manner by which the specific processing is achieved are, from this viewpoint, of little concern; the important thing is the functional relation between input and output signal. The bulk of the book is concerned with describing methods of analysing such systems.

It opens with two chapters which deal with matrix methods and topological methods in circuit analysis. They

are in the nature of groundwork for the rest of the book, are rather loosely connected with the main topic, and are not very inspiring. The next two chapters discuss the first main approach to the subject, namely, signal flow graphs and their applications. Signal flow graphs were developed some years ago by Professor Mason as a method of presenting in geometrical form the relations implied by a set of simultaneous equations such as one may use to describe the progress of a signal through a system. Simple rules for manipulating a flow graph allow one to "solve" the system it represents without explicitly concerning oneself with the simultaneous equations.

The other main part of the book is contained in the two chapters which follow and is devoted to signal analysis. Here the basic tool is the Fourier transform. One chapter is concerned with the dual representation of a signal as a function of time and a function of frequency, and the other chapter with the way these two representations are modified when the signal is sent through a linear system. Both chapters are a delight to read.

A further chapter deals with the elements of nonlinear systems and of linear systems with time-varying elements and describes the connexion between them; this leads to a discussion of various modulation processes. The last chapter is a short one about feedback systems.

The general standard of treatment in the whole book is excellent; there are copious diagrams, well conceived and clearly drawn, and there is just about the right amount of mathematics. Altogether it is a book which can be highly recommended.

H. J. O.

# Staff Changes

## Promotions

Name	Region, etc.	Date	Name	Region, etc.	Date
<i>Deputy Submarine Superintendent to Submarine Superintendent</i>			<i>Inspector to Assistant Engineer—continued</i>		
Finlayson, I. R.	E.-in-C.O.	1.2.61	Marshall, P. S. H.	L.T. Reg.	4.11.60
<i>Senior Executive Engineer to Assistant Staff Engineer</i>			Allmond, J.	L.T. Reg.	4.11.60
Rees, T. J.	E.-in-C.O.	24.10.60	Weller, S.	L.T. Reg.	4.11.60
Macdiarmid, I. F.	E.-in-C.O.	24.10.60	Janes, C. K.	L.T. Reg.	4.11.60
Gordon, S. C.	E.-in-C.O.	24.10.60	Burch, L. J.	L.T. Reg.	21.11.60
Bennett, R. O.	T.S.U.	24.10.60	Spiers, B. N.	N.W. Reg.	11.11.60
Mitchell, M.	War Office	16.12.60	Middleton, T.	Mid. Reg.	12.12.60
(In absentia)			Lenton, A. L.	N.E. Reg.	12.12.60
Walker, N.	E.-in-C.O.	16.12.60	Wellington, P. F.	L.T. Reg.	29.12.60
<i>Senior Executive Engineer to Principal</i>			<i>Technical Officer to Assistant Engineer</i>		
Hawkins, A. P.	E.T.E. to Personnel Dept.	12.12.60	Rogers, J. O.	E.T.E.	1.10.60
<i>Efficiency Engineer to Regional Engineer</i>			Holdsworth, H.	N.E. Reg.	12.10.60
Greenwood, G. C.	H.C. Reg.	30.9.60	Hemming, L. H.	Mid. Reg.	3.10.60
<i>Efficiency Engineer to Deputy Telephone Manager</i>			Weate, S. J.	Mid. Reg.	3.10.60
Brett, G. E.	L.T. Reg.	8.12.60	Clarke, W. H.	H.C. Reg.	13.10.60
<i>Executive Engineer to Area Engineer</i>			Carter, S. W.	H.C. Reg.	13.10.60
Donovon, J. G.	L.T. Reg.	5.10.60	Adams, K. G. S.	Mid. Reg.	26.10.60
Johnson, E. S.	Mid. Reg.	15.11.60	Charles, R. G.	Mid. Reg.	31.10.60
Moore, B. H.	L.T. Reg.	12.12.60	Knapp, J. G.	Mid. Reg.	31.10.60
<i>Executive Engineer to Power Engineer</i>			Ford, J. R.	Mid. Reg.	26.10.60
Greenall, J.	L.P. Reg. to Mid. Reg.	7.11.60	Brooks, G. D.	Mid. Reg.	26.10.60
Alexander, G. E.	L.T. Reg.	12.12.60	Hudson, D. A.	Mid. Reg.	26.10.60
<i>Executive Engineer to Senior Executive Engineer</i>			Barratt, F. C.	Mid. Reg.	26.10.60
Ridout, P. N.	E.-in-C.O.	3.10.60	Hume, H. G.	E.-in-C.O.	17.10.60
Barton, R. W.	E.-in-C.O.	15.11.60	Jones, D. H.	N.W. Reg.	19.10.60
Hawkins, A. P.	E.T.E.	22.11.60	Prestwich, J. D.	N.W. Reg.	31.10.60
Chilver, L. W. J.	E.-in-C.O.	22.11.60	Jenkins, E. G. E.	W.B.C.	23.11.60
Mead, A. C.	H.C. Reg. to E.-in-C.O.	22.11.60	Ankers, W. L.	W.B.C.	5.9.60
McGrath, H. T.	E.-in-C.O.	22.11.60	Henderson, G. C.	Scot.	14.11.60
McLusky, R. F.	E.-in-C.O.	13.12.60	Dixon, R. J.	N.W. Reg. to E.-in-C.O.	14.11.60
Stephenson, M.	E.-in-C.O. to T.S.U.	13.12.60	Tanner, R. K. R.	L.T. Reg. to E.-in-C.O.	14.11.60
Harding, D. J.	E.-in-C.O.	13.12.60	Powell, D. J.	L.T. Reg. to E.-in-C.O.	14.11.60
Masters, D. C.	E.T.E. to E.-in-C.O.	13.12.60	Phillips, A. B.	N.W. Reg. to E.-in-C.O.	14.11.60
Taylor, S. A.	E.-in-C.O.	14.12.60	Rothwell, F.	N.W. Reg. to E.-in-C.O.	14.11.60
Banham, H.	E.-in-C.O.	14.12.60	Whitcombe, S. J.	E.-in-C.O.	14.11.60
Arnott, H.	E.-in-C.O.	14.12.60	Aust, K. E.	L.T. Reg. to E.-in-C.O.	14.11.60
Ravenscroft, I. A.	E.-in-C.O.	2.1.61	Young, G. W. J.	L.T. Reg. to E.-in-C.O.	14.11.60
<i>Assistant Engineer to Executive Engineer</i>			Livermore, R. W. D.	L.T. Reg. to E.-in-C.O.	14.11.60
Beaumont, C. L. G.	Mid. Reg.	6.10.60	Castle, W. C.	L.T. Reg. to E.-in-C.O.	14.11.60
Webb, J. A. G.	L.T. Reg.	23.9.60	Ansell, D.	E.-in-C.O.	14.11.60
Sparkes, G. T.	H.C. Reg. to E.-in-C.O.	24.10.60	Philby, C. J.	E.-in-C.O.	14.11.60
Brewin, R. C.	E.-in-C.O.	23.9.60	Gipp, J. A. L.	L.T. Reg. to E.-in-C.O.	14.11.60
Baxter, B. W.	E.-in-C.O.	23.9.60	Ireland, W. A.	L.T. Reg. to E.-in-C.O.	14.11.60
Sander, D. H.	E.-in-C.O.	29.9.60	Garland, J. L.	L.T. Reg. to E.-in-C.O.	14.11.60
Fletcher, N. E.	E.-in-C.O.	31.10.60	Trumper, J. W.	L.T. Reg. to E.-in-C.O.	14.11.60
Kirk, L. W.	L.P. Reg.	24.11.60	Coleman, E. R.	S.W. Reg. to E.-in-C.O.	14.11.60
Taylor, G. E.	L.T. Reg.	28.10.60	Lack, W. T.	H.C. Reg.	29.11.60
Crutchett, S. H.	L.T. Reg. to E.-in-C.O.	7.11.60	Rooke, S. A.	L.T. Reg.	4.11.60
Brookes, G. F.	L.T. Reg. to E.-in-C.O.	18.11.60	Morath, H. E.	L.T. Reg.	4.11.60
Jackson, F. G.	E.-in-C.O.	28.11.60	Hildersley, S. E. G.	L.T. Reg.	4.11.60
Russell, A. C.	L.T. Reg.	23.11.60	Matthews, E. G. I.	L.T. Reg.	4.11.60
Kennedy, D. J. W.	L.T. Reg.	23.11.60	Yates, J. F.	L.T. Reg.	4.11.60
Moncrieff, A. W.	E.-in-C.O. to Factories Dept.	12.12.60	Cowley, C. W. H.	L.T. Reg.	4.11.60
Wood, J. W.	E.-in-C.O.	21.12.60	Barber, T. H.	L.T. Reg.	4.11.60
Prout, A. G.	E.-in-C.O.	7.12.60	Hewitt, A. R.	L.T. Reg.	14.11.60
Endersby, J. C.	E.-in-C.O.	7.12.60	Lane, J.	L.T. Reg.	4.11.60
<i>Inspector to Assistant Engineer</i>			Bryan, W. R.	L.T. Reg.	4.11.60
Lee, J. A.	N.E. Reg.	12.10.60	Roach, W. G.	L.T. Reg.	4.11.60
Forster, H.	N.E. Reg.	12.10.60	Wood, W. S.	W.B.C.	8.11.60
Elms, D. B. H.	S.W. Reg.	8.11.60	Gould, D.	L.T. Reg.	21.11.60
Darby, E. L.	S.W. Reg.	8.11.60	Peckham, D. A.	L.T. Reg.	21.11.60
Cox, J. W.	S.W. Reg.	8.11.60	Hourie, J.	N.W. Reg.	18.11.60
			Briggs, W.	N.W. Reg.	28.11.60
			Topping, J. H.	N.W. Reg.	30.11.60
			Biggs, R.	N.W. Reg.	30.11.60
			Bryant, P.	L.P. Reg.	18.3.60
			Brown, G. R.	N.E. Reg.	13.10.60
			Crombie, A. M.	Scot.	23.11.60
			Riley, G. A.	Mid. Reg.	5.12.60
			Hughes, O. H. D.	Mid. Reg.	5.12.60
			Borrett, J. L.	N.E. Reg.	12.12.60
			Newton, F.	N.E. Reg.	12.12.60

Promotions—continued

Name	Region, etc.	Date	Name	Region, etc.	Date
<i>Technical Officer to Assistant Engineer—continued</i>			<i>Technician I to Inspector—continued</i>		
Belk, K. J. . . . .	N.E. Reg. . . . .	12.12.60	Aldred, H. . . . .	Mid. Reg. . . . .	5.12.60
Poynter, W. A. . . . .	S.W. Reg. . . . .	13.12.60	Bradley, R. G. . . . .	Mid. Reg. . . . .	5.12.60
Dymond, J. . . . .	N.I. . . . .	29.12.60	Vernon, V. R. . . . .	Mid. Reg. . . . .	5.12.60
Taylor, G. A. . . . .	Mid. Reg. . . . .	9.12.60	Lynch, P. A. . . . .	Scot. . . . .	12.12.60
Picard, P. B. . . . .	L.T. Reg. . . . .	29.12.60	Milligan, G. W. F. . . . .	Scot. . . . .	12.12.60
Popple, L. H. . . . .	L.T. Reg. . . . .	29.12.60	Alderson, J. . . . .	N.E. Reg. . . . .	12.12.60
Parker, E. A. . . . .	L.T. Reg. . . . .	29.12.60	Musgrave, S. . . . .	W.B.C. . . . .	9.12.60
Clegg, R. . . . .	L.T. Reg. . . . .	29.12.60	Davies, D. . . . .	W.B.C. . . . .	12.12.60
Wild, C. P. W. . . . .	L.T. Reg. . . . .	29.12.60	Sandercock, R. . . . .	S.W. Reg. . . . .	6.12.60
Smith, J. D. . . . .	L.T. Reg. . . . .	29.12.60	Lamb, D. W. A. . . . .	S.W. Reg. . . . .	21.12.60
Macre, J. . . . .	L.T. Reg. . . . .	29.12.60	Stacey, N. S. T. . . . .	S.W. Reg. . . . .	16.12.60
Doubleday, W. H. . . . .	L.T. Reg. . . . .	29.12.60	Thorne, M. . . . .	S.W. Reg. . . . .	21.12.60
Gray, C. L. . . . .	L.T. Reg. . . . .	29.12.60	Sparks, S. . . . .	S.W. Reg. . . . .	21.12.60
Dauncey, L. A. . . . .	L.T. Reg. . . . .	29.12.60	Francis, E. G. E. . . . .	L.T. Reg. . . . .	29.12.60
Sayers, P. . . . .	L.T. Reg. . . . .	29.12.60	Leeds, P. E. A. . . . .	L.T. Reg. . . . .	29.12.60
Lucy, J. H. . . . .	E.T.E. . . . .	22.12.60	Hall, G. A. . . . .	L.T. Reg. . . . .	29.12.60
<i>Technical Officer to Inspector</i>			<i>Senior Scientific Officer to Principal Scientific Officer</i>		
Falconer, A. D. . . . .	Scot. . . . .	26.9.60	Reynolds, F. H. . . . .	E.-in-C.O. . . . .	5.10.60
Walton, R. W. . . . .	L.T. Reg. . . . .	4.11.60	<i>Assistant (Scientific) to Senior Assistant (Scientific)</i>		
Dwyer, C. W. . . . .	L.T. Reg. . . . .	4.11.60	Marriott, M. . . . .	E.-in-C.O. . . . .	14.11.60
Page, P. F. E. . . . .	L.T. Reg. . . . .	4.11.60	Schroder, P. M. (Mrs.) . . . . .	E.-in-C.O. . . . .	7.11.60
Furse, A. E. . . . .	S.W. Reg. . . . .	16.12.60	<i>Assistant Experimental Officer (Open Competition)</i>		
Bryant, S. B. R. . . . .	S.W. Reg. . . . .	16.12.60	Kershaw, B. L. . . . .	E.-in-C.O. . . . .	7.10.60
Stockman, H. W. . . . .	S.W. Reg. . . . .	16.12.60	Fishwick, B. J. . . . .	E.-in-C.O. . . . .	11.10.60
Hollingsworth, W. F. . . . .	L.T. Reg. . . . .	29.12.60	Booth, A. J. . . . .	E.-in-C.O. . . . .	19.10.60
Woods, W. H. . . . .	L.T. Reg. . . . .	29.12.60	Dack, R. N. . . . .	E.-in-C.O. . . . .	25.10.60
Maltby, W. G. F. . . . .	L.T. Reg. . . . .	29.12.60	<i>Technical Assistant I to Assistant Regional Motor Transport Officer</i>		
Smith, C. W. . . . .	L.T. Reg. . . . .	29.12.60	Thompson, J. . . . .	Scot. to N.E. Reg. . . . .	2.1.61
Brookes, R. F. A. . . . .	L.T. Reg. . . . .	29.12.60	<i>Senior Executive Officer to Chief Executive Officer</i>		
Watson, C. H. . . . .	L.T. Reg. . . . .	29.12.60	Norris, S. A. . . . .	E.-in-C.O. . . . .	1.11.60
Turvey, G. J. H. . . . .	L.T. Reg. . . . .	29.12.60	<i>Higher Executive Officer to Senior Executive Officer</i>		
Miall, P. G. . . . .	L.T. Reg. . . . .	29.12.60	Attrill, R. A. . . . .	E.-in-C.O. . . . .	1.11.60
Brooks, A. E. . . . .	L.T. Reg. . . . .	29.12.60	<i>Executive Officer to Higher Executive Officer</i>		
Burgess, B. R. . . . .	L.T. Reg. . . . .	29.12.60	Rainbird, F. C. . . . .	E.-in-C.O. . . . .	29.8.60
Denby, A. G. . . . .	L.T. Reg. . . . .	29.12.60	Anderson, C. . . . .	E.-in-C.O. . . . .	24.10.60
<i>Technician I to Inspector</i>			Florence, W. D. . . . .	E.-in-C.O. . . . .	7.11.60
Wellings, W. H. . . . .	W.B.C. . . . .	3.10.60	<i>Clerical Officer to Executive Officer</i>		
Sedgewick, W. A. . . . .	N.E. Reg. . . . .	2.10.60	Machin, C. W. . . . .	E.-in-C.O. . . . .	29.8.60
Wigley, A. J. . . . .	H.C. Reg. . . . .	31.10.60	Coyne, A. K. (Mrs.) . . . . .	E.-in-C.O. . . . .	24.10.60
Hurst, G. S. . . . .	W.B.C. . . . .	13.10.60	Allington, L. C. . . . .	E.-in-C.O. . . . .	31.10.60
Cox, A. M. . . . .	W.B.C. . . . .	19.10.60	Dee-Crowne, L. A. . . . .	E.-in-C.O. . . . .	5.12.60
Kennedy, W. . . . .	N.E. Reg. . . . .	12.10.60	<i>Retirements and Resignations</i>		
Barber, R. . . . .	N.E. Reg. . . . .	12.10.60	<i>Submarine Superintendent</i>		
Massey, H. J. . . . .	N.W. Reg. . . . .	31.10.60	Leech, W. H. . . . .	E.-in-C.O. . . . .	31.1.61
Sutherland, J. S. . . . .	N.W. Reg. . . . .	31.10.60	<i>Area Engineer</i>		
Haskell, J. H. . . . .	H.C. Reg. . . . .	29.11.60	Rimes, R. E. . . . .	N.E. Reg. . . . .	30.11.60
Burborough, W. G. . . . .	E.T.E. . . . .	1.11.60	Holliday, R. F. . . . .	L.T. Reg. . . . .	9.12.60
Woodworth, J. F. . . . .	W.B.C. . . . .	8.11.60	<i>Senior Executive Engineer</i>		
Ratcliffe, T. . . . .	H.C. Reg. . . . .	29.11.60	Waters, H. S. . . . .	E.-in-C.O. . . . .	8.10.60
Budgen, B. J. . . . .	S.W. Reg. . . . .	24.10.60	McKie, A. N. . . . .	War Office . . . . .	27.12.60
Bland, E. . . . .	L.T. Reg. . . . .	4.11.60	<i>Executive Engineer</i>		
Oakes, L. A. . . . .	L.T. Reg. . . . .	4.11.60	Widdicks, J. A. . . . .	E.-in-C.O. . . . .	31.8.60
Duke, E. . . . .	N.W. Reg. . . . .	18.11.60	(Resigned)		
Parker, W. . . . .	N.W. Reg. . . . .	28.11.60	May, E. J. P. . . . .	E.-in-C.O. . . . .	31.8.60
Scurr, S. . . . .	N.W. Reg. . . . .	28.11.60	(Resigned)		
Woods, G. W. . . . .	H.C. Reg. . . . .	22.9.60	Hasnip, A. G. . . . .	Mid. Reg. . . . .	31.8.60
			Dunkley, L. W. . . . .	Mid. Reg. . . . .	5.10.60
			Waterhouse, L. R. . . . .	N.W. Reg. . . . .	14.10.60
			Oldacre, A. G. . . . .	L.T. Reg. . . . .	27.10.60
			Myers, B. L. (Resigned)	E.-in-C.O. . . . .	31.12.60
			Marks, T. A. . . . .	H.C. Reg. . . . .	31.12.60
			Easterwood, D. . . . .	N.W. Reg. . . . .	21.12.60

**Retirements and Resignations—continued**

Name	Region, etc.	Date	Name	Region, etc.	Date
<i>Assistant Engineer</i>			<i>Assistant Engineer—continued</i>		
Laver, J. ..	S.W. Reg. ..	1.9.60	Beardmore, A. R. ..	E.-in-C.O. ..	31.12.60
Juden, T. D. ..	L.T. Reg. ..	4.10.60	(Resigned)		
Bartholomew, R. F. ..	H.C. Reg. ..	7.10.60	Saunders, W. A. F. ..	E.-in-C.O. ..	31.12.60
Andrews, R. ..	N.E. Reg. ..	12.10.60	(Resigned)		
Sweeney, L. ..	W.B.C. ..	14.10.60	<i>Inspector</i>		
McFarlane, H. C. ..	Scot. ..	14.10.60	Robinson, A. ..	N.E. Reg. ..	2.10.60
Simpson, E. S. ..	L.T. Reg. ..	16.10.60	Wiseman, J. B. ..	L.T. Reg. ..	15.10.60
English, H. J. ..	L.T. Reg. ..	18.10.60	Berry, F. L. ..	L.T. Reg. ..	20.10.60
McHugh, G. P. ..	N.E. Reg. ..	28.10.60	Gregson, J. L. ..	N.W. Reg. ..	21.10.60
Topham, L. C. ..	Mid. Reg. ..	29.10.60	Harriman F. ..	N.E. Reg. ..	29.10.60
Howorth, E. (Resigned)	E.-in-C.O. ..	28.10.60	Weatherley, H. S. ..	E.T.E. ..	31.10.60
Kallaway, H. N. ..	S.W. Reg. ..	23.10.60	Taylor, B. B. ..	E.-in-C.O. ..	2.11.60
Pullee, G. C. ..	L.T. Reg. ..	8.11.60	Griffiths, J. ..	W.B.C. ..	8.11.60
Duncan, G. L. ..	N.I. ..	15.11.60	Middleton, L. V. S. ..	S.W. Reg. ..	14.11.60
Meadows, A. ..	N.E. Reg. ..	23.11.60	Thompson, T. W. ..	H.C. Reg. ..	3.10.60
Latham, J. ..	L.P. Reg. ..	30.11.58	Lancaster, G. ..	Mid. Reg. ..	11.11.60
Physick, R. A. S. ..	L.P. Reg. ..	14.12.59	Hargreaves, T. ..	N.W. Reg. ..	1.12.60
Ketteringham, A. ..	L.P. Reg. ..	22.9.60	Beevours, J. H. ..	N.E. Reg. ..	7.12.60
Jones, C. J. ..	S.W. Reg. ..	30.11.60	Hamilton, N. K. ..	N.W. Reg. ..	10.12.60
Porter, R. E. ..	N.W. Reg. ..	5.12.60	Kemp, W. H. ..	L.T. Reg. ..	29.12.60
Seabridge, G. E. ..	E.-in-C.O. ..	9.12.60	Crawford, A. J. ..	W.B.C. ..	31.12.60
Waite, W. C. H. ..	S.W. Reg. ..	14.12.60	<i>Principal Scientific Officer</i>		
Stephenson, S. ..	N.E. Reg. ..	16.12.60	Glover, D. W.* ..	E.-in-C.O. ..	16.11.60
Griffiths, H. ..	W.B.C. ..	18.12.60	<i>Chief Executive Officer</i>		
Moss, J. F. ..	Mid. Reg. ..	19.12.60	Southgate, A. G. ..	E.-in-C.O. ..	31.10.60
Boon, J. W. H. ..	N.E. Reg. ..	23.12.60	<i>Executive Officer</i>		
Evet, F. T. ..	L.T. Reg. ..	29.12.60	Lambert, F. S. T. ..	E.-in-C.O. ..	30.11.60
McBain, A. ..	E.-in-C.O. ..	30.12.60	Harris, E. A. J. ..	E.-in-C.O. ..	31.12.60
Howard, A. ..	L.T. Reg. ..	30.12.60			
Loudwell, A. J. ..	L.T. Reg. ..	31.12.60			
Osman, J. F. ..	L.T. Reg. ..	31.12.60			
Goodwin, G. F. ..	L.T. Reg. ..	31.12.60			
Baines, G. W. ..	N.W. Reg. ..	31.12.60			

\* Mr. D. W. Glover is continuing as a disestablished officer with E.-in-C.O.

**Transfers**

Name	Region, etc.	Date	Name	Region, etc.	Date
<i>Chief Regional Engineer to Chief Motor Transport Officer</i>			<i>Assistant Engineer</i>		
Hough, F. A. ..	L.P. Reg. to E.-in-C.O. ..	24.10.60	Morgan, E. P. ..	Foreign Office to W.B.C.	1.12.59
<i>Power Engineer</i>			Steel, J. R. ..	E.-in-C.O. to Ministry of Transport	17.10.60
Hills, E. G. ..	L.T. Reg. to E.-in-C.O. ..	7.11.60	Marshall, N. E. ..	E.-in-C.O. to Scot. ..	5.12.60
<i>Senior Executive Engineer</i>			Godwin, B.M. ..	E.-in-C.O. to Sierra Leone	22.12.60
Carden, R. W. G. ..	E.-in-C.O. to Pakistan ..	8.12.60	<i>Inspector</i>		
<i>Executive Engineer</i>			George, R. W. ..	L.P. Reg. to L.T. Reg. ..	10.11.58
Eburah, J. W. ..	L.T. Reg. to Ministry of Transport	15.8.60	<i>Senior Scientific Officer</i>		
Williams, L. F. ..	Factories Department to Mid. Reg.	12.9.60	Hastie, R. A. ..	E.-in-C.O. to Ministry of Transport	1.11.60
Heywood, A. W. ..	E.-in-C.O. to Foreign Office	24.10.60	<i>Assistant Experimental Officer</i>		
Hughes, C. J. ..	E.-in-C.O. to Sudan ..	12.12.60	Harrington, D. ..	E.-in-C.O. to Ministry of Transport	1.11.60
Foster, H. A. L. ..	E.-in-C.O. to Jordan ..	31.12.60	<i>Executive Officer</i>		
Harris, T. ..	E.-in-C.O. to L.T. Reg. ..	2.1.61	Henrick, E. W. F. ..	E.-in-C.O. to A.G.D. ..	5.12.60
Beak, K. L. ..	E.-in-C.O. to H.M.S.O. ..	2.1.61			

**Deaths**

Name	Region, etc.	Date	Name	Region, etc.	Date
<i>Executive Engineer</i>			<i>Inspector</i>		
Morgan, L. O. ..	L.T. Reg. ..	2.12.60	Dew, W. S. ..	E.-in-C.O. ..	14.11.60
Painter, C. H. ..	Mid. Reg. ..	5.12.60	Ross, W. ..	Scot. ..	22.11.60
<i>Assistant Engineer</i>			Brennan, W. E. ..	N.W. Reg. ..	5.12.60
Harvey, C. ..	L.T. Reg. ..	10.12.60	Sampson, A. B. ..	L.T. Reg. ..	19.12.60
			Stapleton, E. C. ..	L.P. Reg. ..	23.12.60

# Papers and Articles on Telecommunications and Other Scientific Subjects

The following is a list of the authors, titles and places of publication of papers and articles written by Post Office staff (sometimes in association with members of other organizations) and published during 1960.

- AYERS, S. A New Type of Piezo-electric Flexural Vibrator in the Form of Balanced Cantilevers. I.E.E. Monograph No. 391E, July 1960. (*Proceedings I.E.E.*, Vol. 108, Part C, p. 35, Mar. 1961).
- BAMPTON, J. F. The British Contribution to TAT 2. *Post Office Telecommunications Journal*, Vol. 12, p. 162, Autumn 1960.
- BILLEN, J. C. Producing More Circuits from the Transatlantic Cable. *Post Office Telecommunications Journal*, Vol. 13, p. 23, Winter 1960.
- BISHOP, D. K., CAPLIN, J. S.,\* and GRUNDY, S.\* Channel Selection in Highgate Wood Electronic Telephone Exchange. *Proceedings I.E.E.*, Paper No. 3569E, Nov. 1960 (Vol. 108, Part B, Supplement 20).
- BOURDEAUX, N. The New Post Office Coast Radio Station. *The Consulting Engineer*, Vol. 18, p. 203, Aug. 1960.
- BRAY, W. J. The Future of Microwaves for Telecommunications. *The New Scientist*, Vol. 7, p. 649, 17 Mar. 1960.
- BRAY, W. J. The Standardization of International Microwave Radio-Relay Systems. *Proceedings I.E.E.*, Paper No. 3412E, Mar. 1960 (Vol. 108, Part B, p. 180).
- BREWER, R., LAWRENCE, J. A., and LAVER, F. J. M. The Appraisal of Operational Reliability in Electronic Systems. *Symposium on Electronic Equipment Reliability*, p. 6 (I.E.E., May 1960).
- BROADHURST, S. W. An Experimental Electronic Telephone Exchange. *Post Office Telecommunications Journal*, Vol. 12, p. 59, Spring 1960.
- BUCK, G. A., see RICHARDS, D. L.
- CAPLIN, J. S., see BISHOP D. K.
- CARASSO, J. I. Environmental Effects on the Growth of Excess Reverse Current in Germanium *p-n* Junctions. *Proceedings I.E.E.*, Paper No. 3080E, Mar. 1960 (Vol. 106, Part B, Supplement 17, p. 964).
- CARASSO, J. I., and STELZER, I. The Surface Chemistry of Germanium: Part 3.—Erosion by Chlorine. *Journal of the Chemical Society*, Vol. 357, p. 1797, 1960.
- CATT, L. H. Secondary Cells for Post Office Telecommunications. *I.P.O.E.E. Printed Paper No.* 218, 1960.
- CATT, L. H. Stationary Batteries in the British Post Office. *Proceedings of the Second International Symposium on Batteries*, Paper No. 31/1, Oct. 1960. (Published on behalf of the Inter-Departmental Committee on Batteries by the Signals Research and Development Establishment, Christchurch, Hants.)
- CHEETHAM, H. Televising the Grand National. *Post Office Telecommunications Journal*, Vol. 12, p. 136, Summer 1960.
- CROISDALE, A. C. Automatic Error-Correction for Long Distance Radio Telegraphy. *Post Office Telecommunications Journal*, Vol. 12, p. 78, Spring 1960.
- CROISDALE, A. C. Error Rates and Error Detection on Telegraph Circuits. (Presented at Data Symposium, Delft, Sept. 1960). *I.R.E. Transactions on Communication Systems*, Mar. 1961.
- CROSSLEY, C. G.,\* DUERDOTH, W. T., FRENCH, J. A. T., and ROUS, R. F.\* Speech and Signalling Switching Equipment in the Highgate Wood Electronic Telephone Exchange. *Proceedings I.E.E.*, Paper No. 3393E, Nov. 1960 (Vol. 108, Part B, Supplement 20).
- DUERDOTH, W. T., see CROSSLEY, C. G.
- DUERDOTH, W. T., and LAWRENCE, J. A. Reliability and Maintenance of Electronic Exchanges. *Proceedings I.E.E.*, Paper No. 3375E, Nov. 1960 (Vol. 108, Part B, Supplement 20).
- EVANS, G. O., see JOWETT, J. K. S.
- EVEREST, D. A.,† and HARRISON, J. C. The Chemistry of Quadrivalent Germanium:  
Part 7.—Further Studies of the Complexes formed between Germanium and Polyhydric Alcohols.  
Part 8.—Complexes of Germanium with Tartaric, Lactic and Mucic Acid. *Journal of the Chemical Society*, pp. 1745 and 3752, Apr. and Oct. 1960.
- FLOWERS, T. H. A Review of Electronic Exchange Developments. *British Communications and Electronics*, Vol. 7, p. 894, Dec. 1960.
- FLOWERS, T. H. Transmission Network Planning with Electronic Exchanges. *Proceedings I.E.E.*, Paper No. 3373E, Nov. 1960 (Vol. 108, Part B, Supplement 20).
- FLOWERS, T. H. Users Requirements and Problems—Electronic Telephone Exchanges. *Symposium on Electronic Equipment Reliability*, p. 11 (I.E.E., May 1960).
- FREEBODY, J. W. H., and HERON, K. M. Some Engineering Factors of Importance in Relation to Reliability of Government Automatic Data Processing Systems. Discussion Meetings on “The Reliability and Maintenance of Digital Computer Systems,” Jan. 1960 (I.E.E. and British Computer Society, Ltd.).
- FREEBODY, J. W. H., and LAVER, F. J. M. Reliability and the User of Automatic Data Processing Systems. *Symposium on Electronic Equipment Reliability*, p. 12 (I.E.E., May 1960).
- FRENCH, J. A. T., see CROSSLEY, C. G.
- GILL, LT.-COL. W. E. Some Modern Developments in Telecommunications (Chairman's Address to I.E.E. Local Centre). *Electrical Times*, Vol. 138, p. 595, Oct. 1960, and *Proceedings I.E.E.*, Vol. 108, Part B, p. 137, Mar. 1961.

- GRUNDY, S., see BISHOP, D. K.
- HARRIS, L. R. F. Highgate Wood Experimental Electronic Telephone Exchange—General System Description. *British Communications and Electronics*, Vol. 7, p. 897, Dec. 1960.
- HARRIS, L. R. F., MANN, V. E.,† and WARD, P. W.\* The Highgate Wood Experimental Electronic Telephone Exchange System: General Introduction. *Proceedings I.E.E.*, Paper No. 3376E, Nov. 1960 (Vol. 108, Part B, Supplement 20).
- HARRIS, L. R. F., see WARD, P. W.
- HARRISON, J. C., see EVEREST, D. A.
- HASTIE, R. A., see WRAY, D.
- HERON, K. M., see FREEBODY, J. W. H.
- HOWARD, Miss J., see WALKER, E. V.
- HUGHES, A. V. The Manufacture of Transmission Equipment. *Post Office Telecommunications Journal*, Vol. 12, p. 90, Spring 1960.
- JOWETT, J. K. S. V.H.F. Field-Strength Measurements over Paths in the Irish Sea involving Mountain Obstacles. *Proceedings I.E.E.*, Paper No. 3169E, Mar. 1960 (Vol. 107, Part B, p. 141).
- JOWETT, J. K. S., and EVANS, G. O. Radio Forecasting. *Post Office Telecommunications Journal*, Vol. 12, p. 122, Summer 1960.
- KILVINGTON, T. The Technical Consideration of Television in the International Field. *Journal of the British Institution of Radio Engineers*, Vol. 20, p. 293, Apr. 1960.
- LAVER, F. J. M. A Computer in the Office. *Civil Service Opinion*, Vol. 37, p. 8, Jan. 1960.
- LAVER, F. J. M., see BREWER, R.
- LAVER, F. J. M., see FREEBODY, J. W. H.
- LAWRENCE, J. A., see BREWER, R.
- LAWRENCE, J. A., see DUERDOTH, W. T.
- LAWSON, R. W. The Influence of Residual Gas on the Performance of the British Post Office Submarine Telephone Repeater Valve Type 6P12. *Vacuum*, Vol. 10, p. 100, Feb./Apr. 1960.
- LYNCH, A. C. The Temperature Coefficient of Metallized-Mica Capacitors. *Radio and Electronic Components*, Vol. 1, p. 243, Mar. 1960.
- LYNCH, A. C. New Magnetic Materials. *Science Survey*, Vol. 1, p. 48 (Hulton Press, 1960).
- MACDIARMID, I. F. Waveform Distortion in Television Links. *Journal of the British Institution of Radio Engineers*, Vol. 20, p. 201, Mar. 1960.
- MANN, V. E., see HARRIS, L. R. F.
- MASON, H. J. S. Graphical Symbols for Telecommunications. *Post Office Telecommunications Journal*, Vol. 13, p. 14, Winter 1960.
- MAY, C. A. Highgate Wood Electronic Telephone Exchange: Facilities and Problems of Compatibility. *Proceedings I.E.E.*, Paper No. 3374E, Nov. 1960 (Vol. 108, Part B, Supplement 20).
- MOORE, B. H. Post Office Work for Outside Broadcasts. *Post Office Telecommunications Journal*, Vol. 13, p. 17, Winter 1960.
- NEW, A. A. An Analysis of Failure of Components. *Radio and Electronic Components*, Vol. 1, p. 193, Feb. 1960.
- NEW, A. A. Some Mechanisms of Failure of Capacitors with Mica Dielectrics. *Proceedings I.E.E.*, Paper No. 3261M, July 1960 (Vol. 107, Part B, p. 357).
- ORCHARD, H. J. The Phase and Envelope Delay of Butterworth and Tchebycheff Filters. *I.R.E. Transactions on Circuit Theory*, Vol. CT-7, p. 180, June 1960.
- ORCHARD, H. J. Predistortion of Singly-Loaded Reactance Networks. *I.R.E. Transactions on Circuit Theory*, Vol. CT-7, p. 181, June 1960.
- POPE, G. J. A Transistor Constant-Volume Amplifier. *Wireless World*, Vol. 66, p. 80, Feb. 1960.
- RAVENSCROFT, Miss M. J., see THOMPSON, J. H.
- RICHARDS, D. L., and BUCK, G. A. Telephone Echo Tests. *Proceedings I.E.E.*, Paper No. 3338E, Nov. 1960 (Vol. 107, Part B, p. 553).
- ROUS, R. F., see CROSSLEY, C. G.
- SCOWEN, F. The Design of Reliable Systems for Submarine Cables. *Symposium on Electronic Equipment Reliability*, p. 32 (I.E.E., May 1960).
- SHOTTON, D. C., see WALKER, E. V.
- STELZER, I., see CARASSO, J. I.
- THOMPSON, J. H., and RAVENSCROFT, Miss M. J. The Determination of Copper in Lead and Lead Cable-Sheathing Alloys. *The Analyst*, Vol. 85, p. 735, Oct. 1960.
- TILLMAN, J. R. Microminiaturization. *Post Office Telecommunications Journal*, Vol. 13, p. 45, Winter 1960.
- TOBIN, W. J. E. Keysending from Subscribers' Telephones. *Post Office Telecommunications Journal*, Vol. 12, p. 118, Summer 1960.
- WALKER, E. V., HOWARD, Miss J., and SHOTTON, D. C. The Production of Silicon-Iron Magnetic Strip with (110) (001) Texture by Cold Rolling from Sintered Compacts. *Journal of the Iron and Steel Institute*, Vol. 194, Part 1, p. 96, Jan. 1960.
- WARD, P. W.,\* and HARRIS, L. R. F. The Trunking of 100-Channel T.D.M. Exchanges. *Proceedings, I.E.E.*, Paper No. 3455E, Nov. 1960 (Vol. 108, Part B, Supplement 20).
- WARD, P. W., see HARRIS, L. R. F. and others.
- WHITE, R. W. Long-Distance Waveguides. *Post Office Telecommunications Journal*, Vol. 12, p. 178, Autumn 1960.
- WRAY, D. Television Network Switching. *Electrical Industries Export*, Vol. 60, p. 37, Jan. 1960.
- WRAY, D., and HASTIE, R. A. Waveguide Bend with Continuously-Changing Radius of Curvature. *Electronic Technology*, Vol. 37, p. 76, Feb. 1960.
- WYLIE, T. S. The Provision of Post Office Broadband Links for Commercial Television and Other Services in Northern Ireland. *Proceedings I.E.E.*, Abstract No. 3188, Jan. 1960 (Vol. 107, Part B, p. 14).
- YOUNG, J. E. Other People's Jobs: Senior Communications Officer, Home Office. *Post Office Telecommunications Journal*, Vol. 12, p. 63, Spring 1960.

\*Messrs. Caplin, Crossley, Grundy, Rous and Ward are with the General Electric Company, Ltd.

†Mr. Mann is with British Telecommunications Research, Ltd.

‡Mr. Everest is at the National Chemical Laboratory.



## BOARD OF EDITORS

D. A. BARRON, M.Sc., M.I.E.E., Chairman.  
L. F. SCANTLEBURY, Whit.Sch., A.C.G.I., D.I.C., M.I.E.E.  
T. H. FLOWERS, M.B.E., B.Sc.(Eng.), M.I.E.E.  
W. J. E. TOBIN, B.Sc.(Eng.), A.C.G.I., D.I.C., M.I.E.E.  
A. J. LECKENBY, M.B.E.  
G. J. MILLEN, A.M.I.E.E.  
R. F. WALDEGRAVE.  
E. DAVIES, A.M.I.E.E., Managing Editor.  
A. G. LEIGHTON, B.Sc.(Eng.), A.M.I.E.E., Deputy Managing Editor.  
J. MARTIN, B.Sc.(Eng.), A.M.I.E.E. } Assistant Editors.  
R. A. SUDELL }  
B. FARR, A.B.I., Secretary-Treasurer.  
B. CROSS, Advertisement Manager.

### Copyright

The entire contents of this Journal are covered by general copyright, and special permission is necessary for reprinting long extracts, but editors are welcome to use not more than one-third of any article, provided credit is given at the beginning or end thus: "From *The Post Office Electrical Engineers' Journal*."

The Board of Editors is not responsible for the statements made or the opinions expressed in any of the articles in this Journal, unless such statement is made specifically by the Board.

### Subscriptions and Back Numbers

The Journal is published quarterly, in April, July, October and January, price 2s. 6d. (3s. 6d. post paid) per copy or 14s. per year post paid (2 dollars 25 cents, Canada and U.S.A.). Back numbers will be supplied, if available, price 2s. 6d. (3s. 6d. post paid) per copy. Orders should be sent to *The Post Office Electrical*

*Engineers' Journal*, G.P.O., 2-12 Gresham Street, London, E.C.2. Employees of the British Post Office can obtain the Journal through local agents.

### Binding

Readers can have their copies of volumes bound at a cost of 15s. by sending the complete set of parts to the local Post Office distribution agent or to *The Post Office Electrical Engineers' Journal*, G.P.O., 2-12 Gresham Street, London, E.C.2.

### Remittances

Remittances should be made payable to "*The P.O.E.E. Journal*" and should be crossed "& Co."

### Advertisements

All correspondence relating to advertisement space reservations, copy, proofs, etc., should be addressed to the Advertisement Manager, *The Post Office Electrical Engineers' Journal*, G.P.O., 2-12 Gresham Street, London, E.C.2.

### Communications

With the exceptions indicated above, all communications should be addressed to the Managing Editor, *The Post Office Electrical Engineers' Journal*, G.P.O., 2-12 Gresham Street, London, E.C.2. Telephone: HEAdquarters 1234.

### Model Answer Books

Books of model answers to certain of the City and Guilds of London Institute examinations in telecommunications are published by the Board of Editors. Details of the books available are given at the end of the Supplement to the Journal.

## Book Reviews

"Progress in Dielectrics." Vol. II. Edited by J. B. Birks, B.A., Ph.D., D.Sc., F.Inst.P., A.M.I.E.E., and J. H. Schulman, Ph.D. Heywood & Co., Ltd. vii + 225 pp. 76 ill. 55s.

In reviewing Volume I of this series, the present writer doubted whether there would be enough suitable material to keep the series alive. Volume II is better than he feared, but of less general interest than a reader might reasonably hope.

A review of polymers brings some order into the seeming chaos of materials. The abbreviations used for them are, however, unfamiliar, and the few trade names quoted are American. The reader is assumed to know that irradiation of polymers has so far achieved little that cannot be carried out by alternative means—the one, admittedly important, exception being the raising of the softening temperature of polythene. The article on irradiated polymers will not tell him this, but it will tell him everything else he is likely to want to know.

A survey of the theory of dielectrics is a masterpiece of condensation, but much of its material is already accessible elsewhere. An article on "artificial dielectrics"—that is, structures used to refract microwaves—is in odd company, although the subject is of some general interest because of the parallels to be drawn with ordinary dielectrics on the one hand and with optical components on the other. A review of high-permittivity ceramics is extraordinary for the amount of manufacturing detail it includes, and one on glasses is also a diligent survey, but neither unites the many crumbs of information into a memorable whole.

The book, then, includes much that is of interest to the specialist, who may well use it for reference on points of detail, but it contains less than it should of the type of survey which interests the general reader.

A. C. L.

"Foundations of Electrodynamics." P. Moon and D. E. Spencer. D. Van Nostrand Co., Ltd. vii + 314 pp. 155 ill. 73s.

Of the many textbooks available to the student of electromagnetic theory few can be more suited to his needs than the book under review. This statement is illustrated by the opening chapter, which gives a very concise treatment of vector analysis. The chapter commences with a description of co-ordinate systems and concludes with retarded vector potential theory—no mean achievement in a space of 23 pages considering that, in the opinion of the writer of this review, adequate explanation is given. Chapters on the basic concepts of electromagnetism, Maxwell's equations and Laplace's equation follow. The theory developed is then applied to a variety of subjects such as the mutual inductance between loops, skin effect, waveguides and aerials. The last two chapters are perhaps of little interest to the communications engineer since they deal with moving systems and relativistic electrodynamics. Where necessary the authors discuss briefly, as they arise, mathematical topics such as improper integrals and Bessel functions, thus making the book as self-contained as possible.

Each chapter concludes with a summary, references and a set of problems. The summary would be more useful at the beginning of the chapter; the reader would then know, in general terms, what was about to be considered. The book concludes with some useful appendices which include vector-analysis formulae in the three main co-ordinate systems and the solutions of the differential equations which occur in the text.

Conscientious study of the book will give the student a thorough grounding in electromagnetic theory and will provide a firm foundation for the more advanced aspects of the subject. Because of the range of practical problems dealt with, many communications engineers will find the book useful for reference purposes.

The M.K.S. system of units is used throughout.

C. F. D.

# DENSO MASTIC H.D. is essential for...

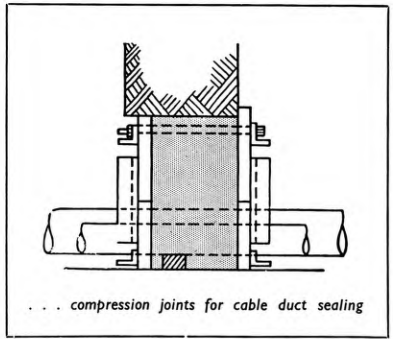
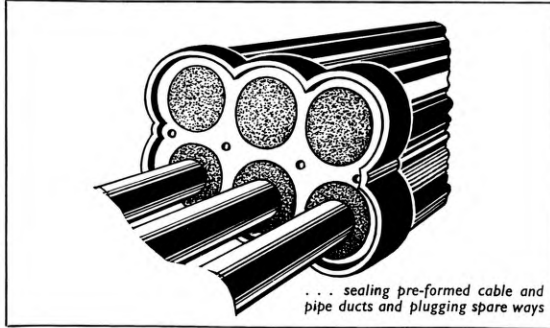

... plugging and sealing against air, gas and water. It meets the requirements of the several B.S. Codes of Practice and is adopted generally by Public Authority and Industry ...

... and saves time, labour, money

## WINN & COALES LTD

**LONDON**  
Tel.: GIPsy Hill 7511

**MANCHESTER**  
(also Contracting Dept.) Tel.: Sale 8271

**BELFAST**  
Tel.: 56623

**DUBLIN**  
Tel.: 61768

Agents throughout the Commonwealth

*More* for less...

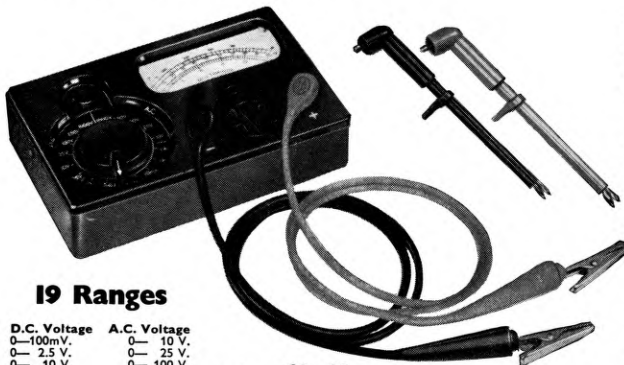

### 19 Ranges

<b>D.C. Voltage</b>	<b>A.C. Voltage</b>
0—100mV.	0—10 V.
0—2.5 V.	0—25 V.
0—10 V.	0—100 V.
0—25 V.	0—250 V.
0—100 V.	0—1000 V.
0—250 V.	
0—1000 V.	
<b>D.C. Current</b>	
0—100mA	
0—1mA	
0—10mA	
0—100mA	
0—1 A	
<b>Resistance</b>	
0—20,000Ω	
0—2MΩ	

List Price: **£9 : 10s.**

complete with test Leads and Crocodile Clips.

Leather case if required 39/-

Size 5½ × 3½ × 1½ in.  
Weight: 1 lb. approx.

Write now for illustrated literature to:

**AVO LTD** AVOCET HOUSE · 92-96 VAUXHALL BRIDGE ROAD  
LONDON S.W.1  
Victoria 3404 (12 lines)

...with the

# MULTIMINOR

**ANOTHER JLT FIRST!**

**TRANSISTORISED A.C. VOLTAGE REGULATOR**  
 MODEL T200

Exceptional reliability coupled with precision performance. Combination of semi-conductor and magnetic design techniques gives fast response time. Suitable for incorporation in larger equipments where reliability and long service are of prime importance.

**Mains input voltage:** 200-250v.  $\pm 10\%$ .

**Regulation  $\pm 0.25\%$  for:** (a)  $\pm 10\%$  input voltage change, (b) no load to full load.

**Output power:** 200VA.

**Power factor range:** 0.9 leading to 0.7 lagging.

**Frequency range:** 45 c.p.s.-55 c.p.s.

**J. LANGHAM THOMPSON LTD.**

BUSHEY HEATH · HERTFORDSHIRE · ENGLAND

Telephone: Bushey Heath 2411 (6 lines) Grams &amp; Cables: "Tommy Watford"



## The Chinese had a use for it

Quartz was valued by craftsmen of the Ming Dynasty as a medium for creating religious symbols, ornaments and jewelry of great beauty. Today, at STC, quartz has a vital 20th Century function. Modern electronics and telecommunications call for quartz crystals made to extremely high standards, and STC's precision manufacturing techniques produce crystals to meet these requirements.

STC quartz crystals maintain a high degree of stability under conditions of severe vibration, shock and climatic change.

*Write for detailed literature . . .*



# *Standard Telephones and Cables Limited*

Registered Office : Connaught House, Aldwych, London W.C.2

QUARTZ CRYSTAL DIVISION · HARLOW · ESSEX

# ADCOLA

(Patented) LIMITED  
(Legal Trade Mark)

## SOLDERING INSTRUMENTS and EQUIPMENT

Illustrated

L64  $\frac{3}{16}$ " DETACHABLE  
BIT MODEL IN  
PROTECTIVE  
SHIELD L700  
FITTED WITH  
ACCESSORIES FOR  
BIT CLEANING, ETC.

ALL VOLT RANGES  
6/7 to 230/250 VOLTS

British and Foreign  
Patents and Registered  
designs

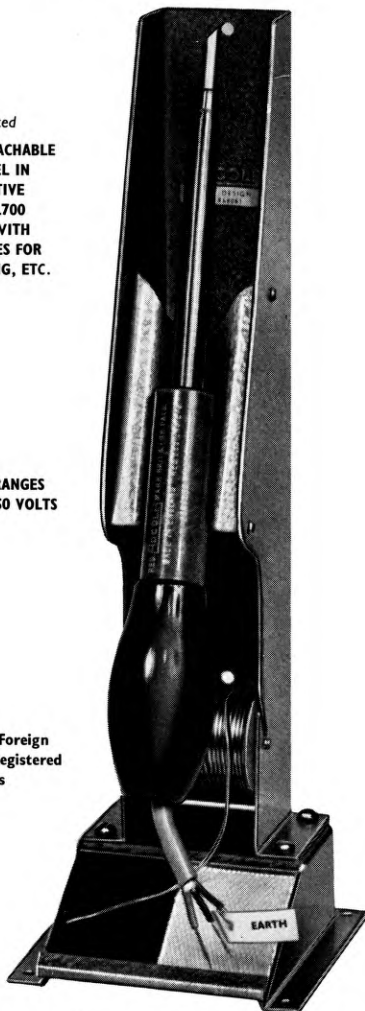

For further information and full illustrated catalogue apply head office

**ADCOLA PRODUCTS LIMITED**  
GAUDEN ROAD, CLAPHAM HIGH STREET,  
LONDON, S.W.4

Telephones: MACaulay 3101 and 4272

Telegrams: SOLJOINT

## VALUABLE FREE BOOK

Tells You How to Pass Your C. & G. or  
Promotion Exam. at **First Attempt!**

All Post Office personnel who are anxious to obtain early promotion should at once send for a copy of our handbook "**ENGINEERING OPPORTUNITIES**" which, among other intensely interesting matter, describes our unique methods of preparation for the G.P.O., **LIMITED COMPETITIONS** for appointment as Assistant Engineer, Executive Engineer, Traffic Officer, Telecommunications Traffic Superintendent; **CITY AND GUILDS EXAMINATIONS** for the Telecommunication Technicians' Certificate and for individual subjects—Mathematics, Engineering Science, Engineering Drawing, Elementary Telecommunication Practice, Telecommunication Principles, Radio and Line Transmission, Telegraphy and Telephony, Line Plant Practice. It also contains details of our courses covering the City and Guilds Examinations in Electrical Engineering Practice, the Grad. Brit.I.R.E. and A.M.S.E. Examinations, in addition to a wide range of non-examination courses in all branches of engineering—Radio and Electronics, Electrical, Mechanical, etc.

We also provide tuition for the Radio Amateurs' Examination and the P.M.G. Certificates for Radio Operators, with or without Morse training. Details are given in the handbook.

We definitely guarantee  
**"NO PASS—NO FEE"**

If you intend to make the most of today's opportunities, you cannot afford to miss reading "**ENGINEERING OPPORTUNITIES**." It tells you everything you want to know to secure advancement, and describes many opportunities you may now be missing through lack of information—Send for your copy today—**FREE** and without obligation.

**BRITISH INSTITUTE  
OF ENGINEERING TECHNOLOGY**  
369 COLLEGE HOUSE,  
29-31 WRIGHT'S LANE, LONDON, W.8

# BIET

## from Pitman's List

### INDUCTION-TYPE INTEGRATING METERS

By G. F. Shottor, M.I.E.E., and G. F. Tagg, B.Sc., Ph.D., etc.

A theoretical and practical investigation into induction-type meters and instruments used universally for measuring the consumption of electricity. It introduces a new explanation of their action based on experiments and also a mathematical analysis. A book for research workers, engineers, teachers, the maintenance divisions of electricity undertakings and for instrument manufacturers. 63s. net

### ELECTRONIC FUNDAMENTALS AND APPLICATIONS

By John D. Ryder

The author has consolidated the fundamental phenomena underlying both the transistor and semi-conductor devices into one treatment. In addition, he has brought together electronics and basic network theory and has emphasized the standard methods that prevail once an electronic device is reduced to a linear active circuit; the treatment generally is qualitative and emphasis is given to the basic properties of an analytic method or process. 60s. net

★ ★ ★

From all booksellers

**PITMAN** PARKER STREET,  
KINGSWAY, LONDON, W.C.2

You are invited to send for this new Indexed Summary of

# STC valves

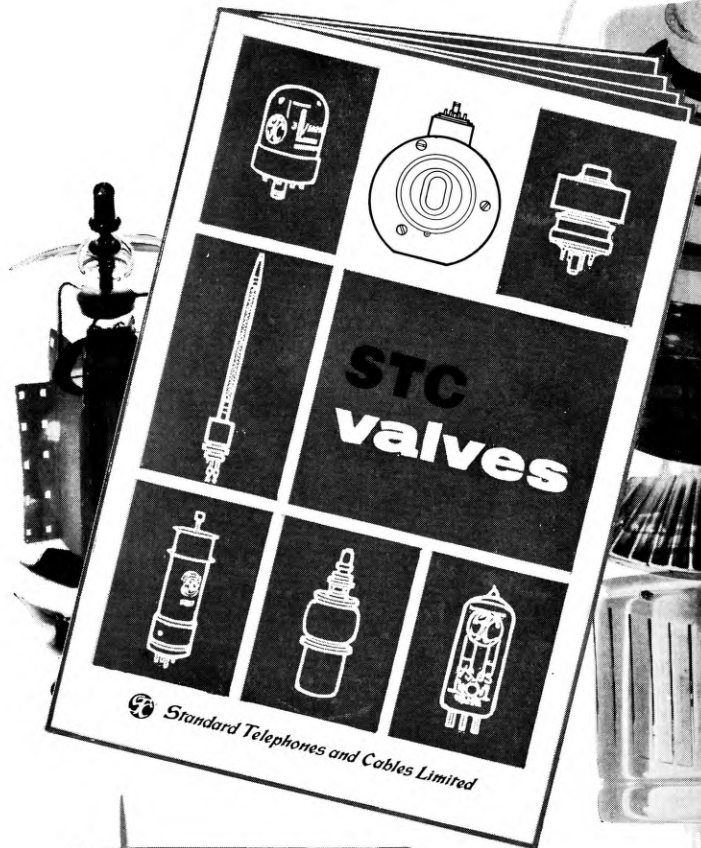

**Standard Telephones and Cables Limited**

Registered Office: Connaught House, Aldwych, London W.G.2

VALVE DIVISION: FOOTSCRAY • SIDCUP • KENT





# Radio Sonde and electronic equipment

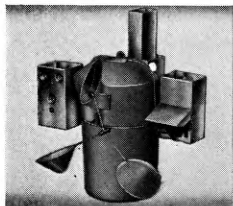

Radio Sonde Transmitter, supplied to British meteorological Office and foreign governments.

The items shown here are representative of the extensive variety of products manufactured by the Whiteley organisation. Our technical resources are available for the development and production of specialised components for the electronic industry.

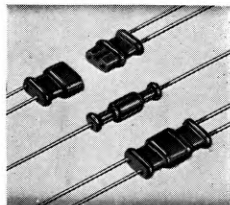

Waterproof plugs and sockets moulded in Polythene for under-water or outdoor installation.

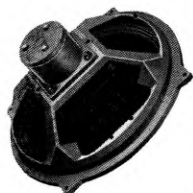

Stentorian Cambric Cone Units, recognised throughout the world as the greatest value in High Fidelity.



The Post Office Tester is a multi-range meter used for making tests on subscribers' apparatus and lines.

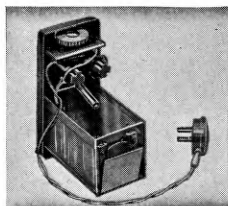

Potted components and assemblies in epoxy, Polyester resins and Polythene.



This fixed frequency oscillator is constructed on a standard octal base and encapsulated in epoxy resin.

**WHITELEY ELECTRICAL RADIO CO. LTD · Mansfield · Notts**

WA/15



*Economy begins  
at the design stage*

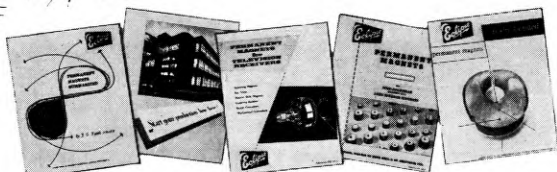

*Free  
technical  
literature*



## permanent magnets

Permanent magnets, like many other aspects of technology, are making spectacular progress day by day. Remarkable economies in production can be effected if experts are consulted at the design stage. Eclipse have a highly developed research programme that makes them leaders in this field. Bring Eclipse Permanent Magnets into your preliminary design discussions—and be thankful.

Made by the designers and manufacturers of Eclipse Permanent Magnet Chucks

JAMES NEILL & CO. (SHEFFIELD) LTD · SHEFFIELD · ENGLAND



# STC

medium and  
high power  
ISB and  
general purpose  
transmitters

## TYPE QT.3A

Type	Frequency Range	Output Power
QT.3A	2.5—28 Mc/s	8 kW for single frequency operation or 8 kW p.e.p. for multichannel working.
QT.4A	4—27.5 Mc/s	20 kW for single frequency operation or 30 kW p.e.p. for multichannel working.
QT.5A	4—27.5 Mc/s	85 kW for single frequency operation or 80 kW p.e.p. for multichannel working. Instantaneous change to high efficiency low power working.

- Suitable for Radio Telephone and Telegraph Links
- Automatic Tuning and Loading
- v.s.w.r. Monitor
- Synthesizer or Crystal Control
- Rapid Fault Location by Metering and Lamps
- Tuning and Loading automatically corrected for varying v.s.w.r.
- Full Remote Control
- Suitable for unattended operation

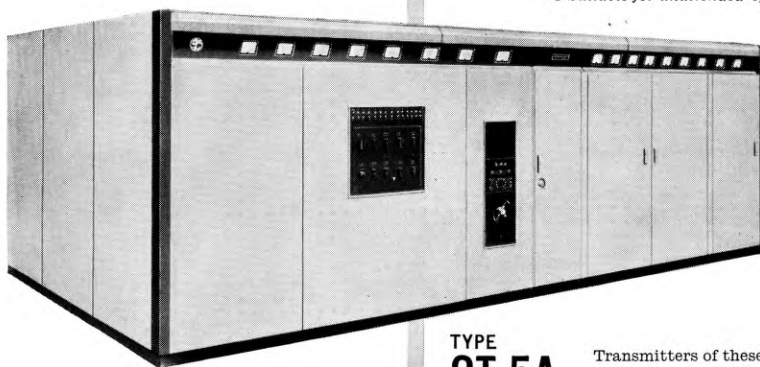

## TYPE QT.5A

Transmitters of these types have been ordered by the British Post Office.



## Standard Telephones and Cables Limited

Registered Office: Connaught House, Aldwych, London W.C.2.

RADIO SYSTEMS DIVISION : OAKLEIGH ROAD · NEW SOUTHGATE · LONDON N.11



# 5-unit tape transmitter

model 20

Sequential type for single wire transmission.  
For single or double current operation.  
7½ unit transmission at 45.5, 50, or 75 bauds

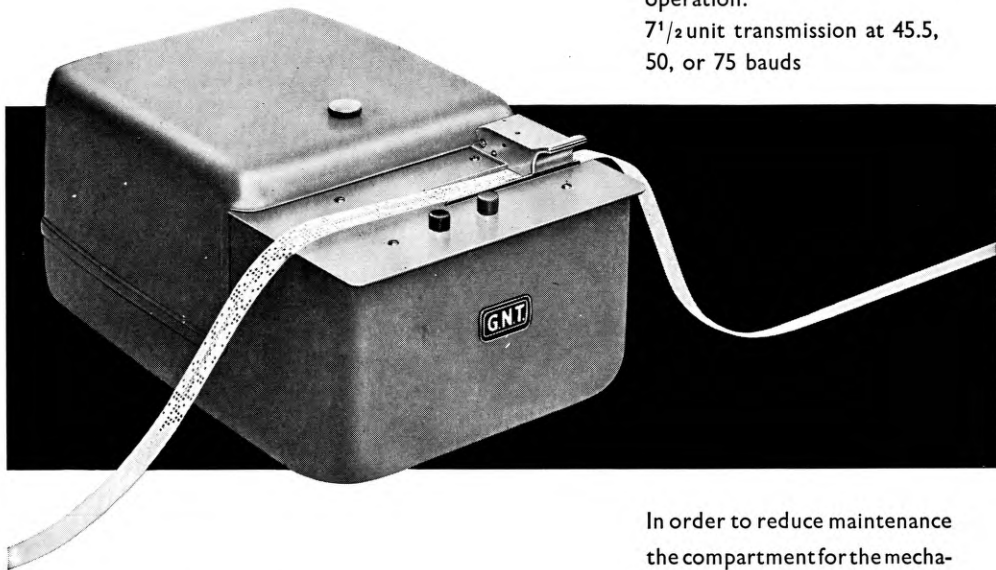

*Meets all the requirements  
of a modern 5-unit tape transmitter.*

In order to reduce maintenance the compartment for the mechanism is pressurised so that dust and paper fluff cannot enter the operating parts.

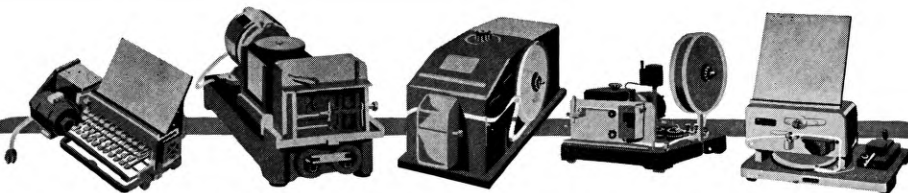

## GREAT NORTHERN TELEGRAPH WORKS

DIVISION OF THE GREAT NORTHERN TELEGRAPH CO. LTD.

4, SYDHAVNS PLADS  
COPENHAGEN SV, DENMARK

LONDON OFFICE: 5, ST. HELEN'S PLACE  
LONDON E. C. 3.

testing  
communications systems

which serve  
the world.....

To install and maintain all telecommunications systems— Audio, Broadcast, Telegraph, Multi-channel, Coaxial, Submarine Cable and Microwave, etc.—STC provides a wide range of transmission testing apparatus.

As actual manufacturers of a great variety of telecommunications equipment, including the constituent components, STC have an unrivalled knowledge of data, performance, life and factors to be tested to keep the equipment in peak condition.

That knowledge is embodied in all STC testing apparatus together with all the precision and reliability for which STC equipment is world-famous.

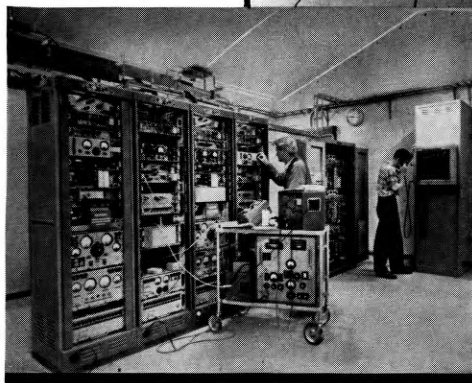

OSCILLATORS · LEVEL MEASURING SETS · MICROWAVE TEST SETS  
BRIDGES · FILTERS · PSOPHOMETERS · WHITE NOISE TEST SETS, ETC.

*Send for leaflets covering your systems.*



61/21C

**Standard Telephones and Cables Limited**

Registered Office: Connaught House, Aldwych, London W.C.2

**TRANSMISSION SYSTEMS DIVISION : NORTH WOOLWICH · LONDON · E.16**

# FOR ECONOMICAL EFFICIENCY

**SPECIFY  
TAYLOR  
JUMBO**



. . . the World's most versatile crane! It lifts, carries, tows, loads, dumps—all with equal efficiency and exceptional economy.

Whatever the task—installing kiosks, erecting poles, handling cable drums or assisting with depot maintenance—a fast-travelling Taylor Jumbo can supply the low-cost answer.

Have you seen our latest literature? It's yours for the asking!

**F. TAYLOR & SONS (Manchester) LTD.**  
WARRINGTON ROAD, GLAZEBURY, LANCS.



# STC

## P.V.C. insulated and sheathed interphone cables

suitable for the wiring of all  
telephone installations

STC manufacture and stock a range of P.V.C. insulated and P.V.C. sheathed interphone cables which conform generally to current B.P.O. and B.S. standards for this type of cable. Some of these cables are protected with an armouring of galvanised steel wire and an overall sheath of P.V.C. The range of cables extends from 1 pair to 100 pairs, usually in 5 pair steps. Other sizes very much larger than these can be manufactured at short notice to order. These cables are used for telecommunications, telemetering and electronics applications. The unarmoured cables are suitable for internal use and the armoured range is for short runs of buried cable, for runs to be cleated to the outside of buildings or for short spans of self-supporting cable.

Top: Unarmoured Type — Bottom: Armoured Type

Ask for publication H/102

### Standard Telephones and Cables Limited

Registered Office: Connaught House, Aldwych, London W.C.2

RUBBER & PLASTIC CABLE DIVISION: CORPORATION ROAD · NEWPORT · MON.





# STC

## WORLD WIDE EXPERIENCE

### ★ South Africa

#### ONE OF 18 COUNTRIES HAVING STC MICROWAVE SYSTEMS

STC have supplied and installed the first 600 circuit, 4000 Mc/s microwave telephone system for the South African Post Office. Duplicated radio channels with automatic baseband switching are provided over the route between Johannesburg and Klerksdorp, approximately 110 miles (177 km).

#### ★ STC also supplied

- Aerial equipment
- Frequency division multiplex equipment
- Transmission Test equipment
- High quality music programme equipment
- YHF radio links and yagi aerials
- Remote indication and supervisory equipment

JOHANNESBURG

DOORNKLOOF

POTCHEFSTROOM

BRITZKOP

KLERKSDORP

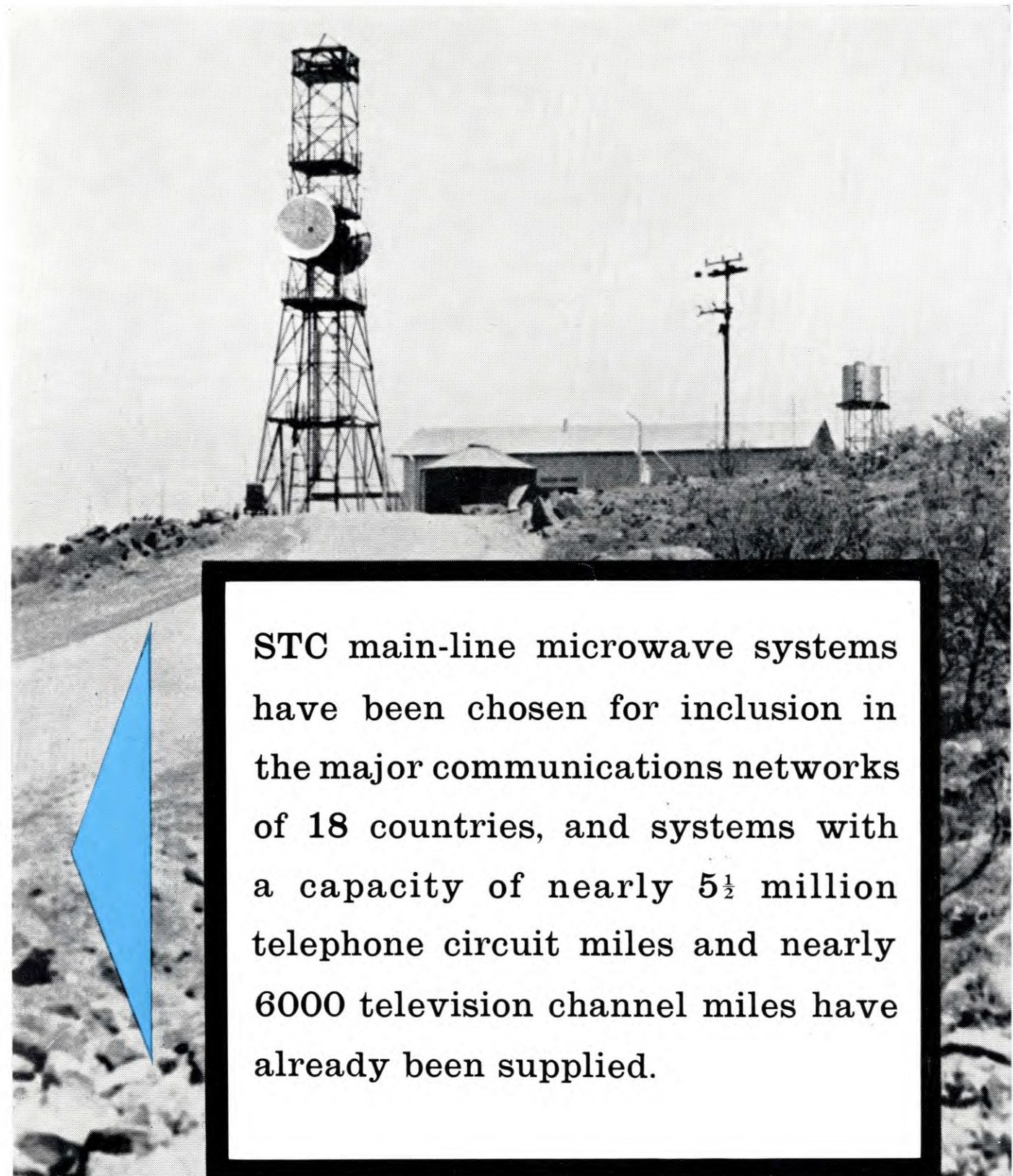
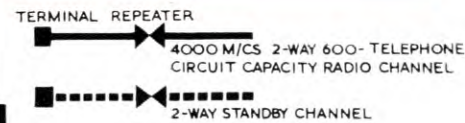

STC main-line microwave systems have been chosen for inclusion in the major communications networks of 18 countries, and systems with a capacity of nearly 5½ million telephone circuit miles and nearly 6000 television channel miles have already been supplied.

*Britzkop Repeater Station*



61/3C

## Standard Telephones and Cables Limited

Registered Office: Connaught House, Aldwych, London, W.C.2

TRANSMISSION SYSTEMS DIVISION: NORTH WOOLWICH · LONDON · E.16



# TO HOUSE YOUR VALUABLE ELECTRONIC EQUIPMENT



**RACKS**

*Contact*



**CONSOLES**



**Datum**



**CASES**

A member of



INSTRUMENT RACKS • CABINETS • CASES  
CONSOLES • PANELS • CHASSIS UNITS

**DATUM METAL PRODUCTS LTD.**

COLNE WAY TRADING ESTATE • WATFORD-BY-PASS • WATFORD • HERTS  
Telephone: Watford 22351      Telegrams: Datum, Watford

DP/1

*Ernest Turner*

## Electrical Measuring Instruments

Ideally matching contemporary panel design, the Ernest Turner Model 703, illustrated here, is enhanced by the flush-fitting surround. A high degree of accuracy is adequately supported by the easy-to-read scale and clean dial layout. Full details of the range of rectangular electrical measuring instruments and flush mountings are contained in Leaflets 85/G and 85/AF, available on request.

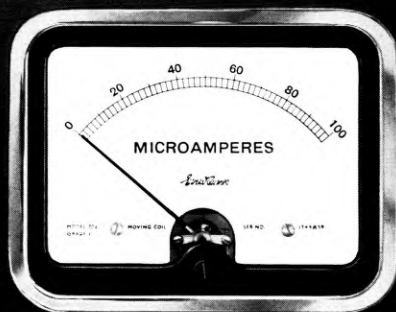

**Ernest Turner Electrical Instruments Ltd**

HIGH WYCOMBE • BUCKINGHAMSHIRE • ENGLAND

# FIRST 8 TUBE COAXIAL CABLE IN SOUTH AFRICA

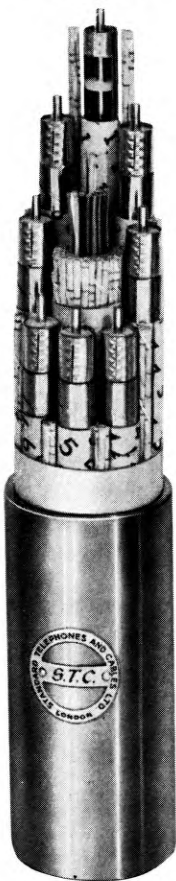

STC is manufacturing, to supply to the South African Post Office, communication cables containing 4 and 8 coaxial tubes type 375 PDWI incorporating paper and polythene insulated control and supervisory circuits. The cables, to be installed on the Durban—Shepstone 7 400 Mc/s microwave route, will provide entrance facilities at the terminal and repeater station sites.



*STC are also supplying terminal and repeater equipment for the 7 400 Mc/s microwave system.*

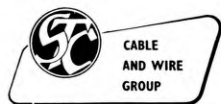

***Standard Telephones and Cables Limited***

Registered Office: Connaught House, Aldwych, London W.C.2

TELEPHONE CABLE DIVISION: NORTH WOOLWICH · LONDON E.16

**For the largest  
capacity systems**

consult

**G.E.C.**

**SHF the system for the 60's**

**UHF**

**VHF**

**G.E.C.**

**EVERYTHING FOR TELECOMMUNICATIONS**

Great difficulty has been experienced by Administrations in planning nation-wide radio networks employing one frequency band. By using broad-band radio equipment in two different frequency bands the problem of frequency allocation is greatly simplified. G.E.C. are now supplying two types of long haul radio system, one operating in the SHF frequency band and the other in the UHF frequency band, in addition to small capacity systems operating in the VHF frequency bands. The complete range is given below:

System	SPO. 5555	SPO. 5502	SPO. 5060	SPO. 5052	SPO. 5051
Frequency bands	5925—6425 Mc/s	1700—2300 Mc/s	132—156 Mc/s 156—184 Mc/s 235—270 Mc/s	445—475 Mc/s	71.5—100 Mc/s 132—156 Mc/s 156—184 Mc/s 235—270 Mc/s
Capacity	(a) 960 speech circuits arranged in 16 supergroups or (b) 900 speech circuits arranged in 3 master-groups or (c) monochrome or colour television (405, 525 or 625 line) or (d) monochrome television plus sound channel	(a) 300 speech circuits or (b) monochrome or colour television (405, 525 or 625 line)	9 speech circuits	5 speech circuits	5 speech circuits

*G.E.C. offers a complete service  
from original survey to final commissioning*

*For further information please write to:*

**THE GENERAL ELECTRIC COMPANY LIMITED OF ENGLAND**  
TELEPHONE WORKS · COVENTRY · ENGLAND  
Works at Coventry, Middlesbrough, London, Portsmouth

*Smee's G.E.C. 77*



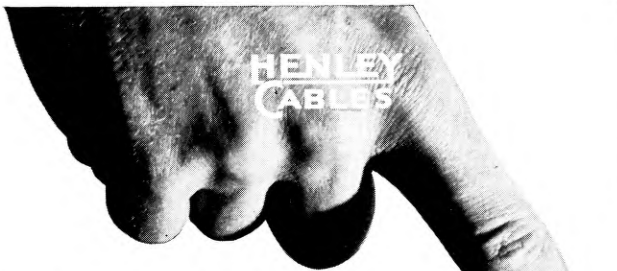

**A NEW SYMBOL  
FOR  
COMMUNICATION  
CABLES**

In the communication cables field the new drum symbolises the combined resources of Henley, Liverpool Cables and Siemens Ediswan.

For communication cables of all types—paper, plastic or textile insulated—small switchboard wires, local distribution and trunk type cables or composite co-axial cables—including loading coil accessories—A.E.I. leadership is unsurpassed.

YOU CAN RELY ON A.E.I.



**CABLE DIVISION**

TELEPHONE CABLE DEPARTMENT

Associated Electrical Industries Ltd.,

Woolwich, London, S.E.18 Telephone: Woolwich 2020



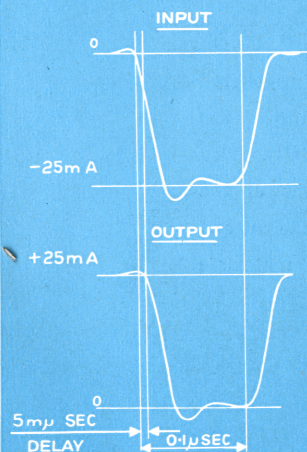
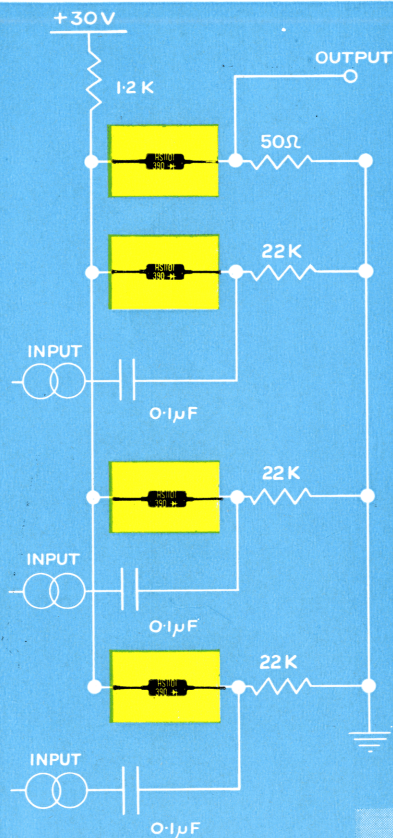

## FOR HIGH PERFORMANCE COMPUTER CIRCUITS specify

# H diodes

fast recovery  
silicon junction  
low hole storage



Hughes HS11 series are alloyed junction silicon *computer* diodes, operative over wide temperature ranges and characterized by *fast recovery time*.

Made in Glenrothes, Scotland, the Hughes range of silicon and germanium diodes are subminiature devices with extremely stable electrical and mechanical characteristics. These diodes are specially designed and constructed to meet the most exacting requirements of military or commercial applications. They are double wire ended and fusion-sealed in a subminiature one-piece glass envelope to ensure complete isolation of the active elements from damage or contamination. The small size, combined with rigidity of construction and small mass of the elements, enable them to withstand successfully physical shock and vibration.

Type No.	Continuous Ratings 25°C		Characteristics 25°C	
	Max. Rated P.I.V. (Volts)	Max. Forward Current	Min. Forward Current at 1.5V	Max. Reverse Current at P.I.V.
HS1101	150	80 mA	30 mA	1 µA
HS1102	100	80 mA	30 mA	1 µA
HS1103	50	80 mA	30 mA	1 µA
HS1104	150	60 mA	15 mA	1 µA
HS1105	100	60 mA	15 mA	1 µA
HS1106	50	60 mA	15 mA	1 µA
HS1107	150	40 mA	5 mA	1 µA
HS1108	100	40 mA	5 mA	1 µA
HS1109	50	40 mA	5 mA	1 µA

TEMPERATURE RANGE -65°C TO 150°C

Typical Stored Charge Measurement, 700 pico-coulombs.

Typical recovery time:

0.3 µsec measured in JAN256 circuit, to 80 K ohms when switched from I: 5 mA to V: -35 volts  
1.0 µsec measured in IBM "Y" circuit to 400 K ohms when switched from I: 30 mA to V: -35 volts  
Special Diodes from this range are available, featuring higher conductivity or faster recovery.

Qualified engineers in our Research and Development laboratories at Glenrothes are available to help with your application problems.

Home and Overseas enquiries to:

## HUGHES INTERNATIONAL (U.K.) LTD

KERSHAW HOUSE, GREAT WEST ROAD, HOUNSLOW, MIDDLESEX · HOUNSLOW 5222





*Photograph by courtesy of  
H.M. Postmaster-General*

**'DIAKON'**

*'Diakon' is the registered trade mark for the  
acrylic polymer manufactured by I.C.I.*

This new telephone handset, introduced by the G.P.O. in 1959 and now being offered to subscribers all over the United Kingdom, is moulded from 'Diakon', one of the many extremely efficient and colourful plastics materials made by I.C.I.

DK6

IMPERIAL CHEMICAL INDUSTRIES LIMITED · LONDON · S.W.1





# PROPAGAS

PROPANE

carries weight  
in the  
building industry

Propane and Butane are now available to industry from the great British refineries of the Shell and BP Groups. They are petroleum gases delivered and stored as liquids under moderate pressure. These versatile products assist the Building industry for temporary or permanent space heating and floodlighting of buildings, the ideal mobile equipment for Builders, Plumbers and Decorators.

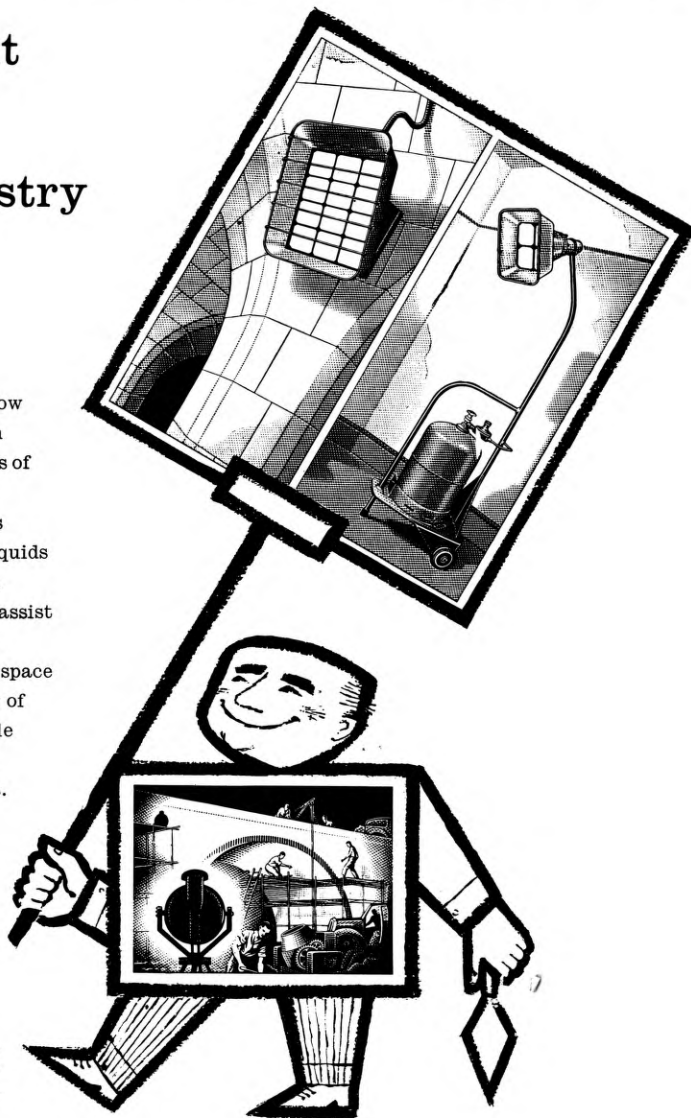

*For full details of these and other products including Floodlighting and Space Heating Equipment, apply now to:*



**Shell-Mex and B.P. Gases Limited**

(Regd users of trade marks)

Cecil Chambers 76-86 Strand London WC2 Telephone: TEMple Bar 1234

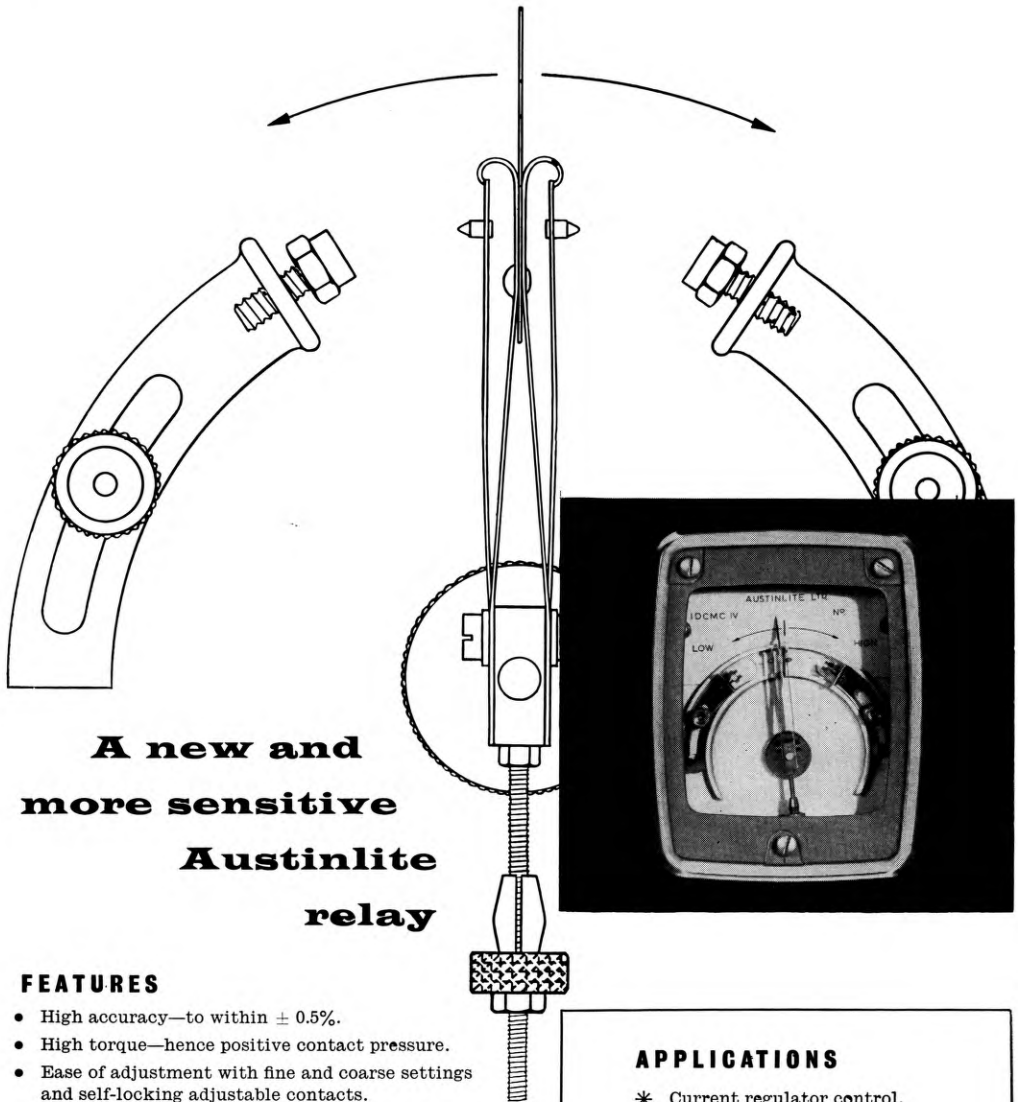

**A new and  
more sensitive  
Austinlite  
relay**

**FEATURES**

- High accuracy—to within  $\pm 0.5\%$ .
- High torque—hence positive contact pressure.
- Ease of adjustment with fine and coarse settings and self-locking adjustable contacts.
- Choice of either two or four adjustable contacts.
- Contemporary case design—projection or flush mounting.
- Dustproof and suitable for use in the tropics.
- Conforms to Post Office Specification P.T. 1025B.
- Suitable for current or voltage sensing on either D.C. or A.C.

**APPLICATIONS**

- \* Current regulator control.
- \* Voltage regulator control.
- \* Monitoring duties.
- \* Limiting duties.
- \* Equipment protection.

*Austinlite* **ELECTRICAL EQUIPMENT**  
(Custom-built by Stone-Chance Ltd.)  
**Makers of Sumo Pumps and Stone-Chance Lighthouses)**

AUSTINLITE LTD · PICKERSLEIGH ROAD  
MALVERN · WORCS · PHONE: MALVERN 2686  
London Office: Schomberg House  
82 Pall Mall, SW1 · Phone: TRA 1964

# A.T.E. TRANSMISSION EQUIPMENT TYPE CM FOR RADIO, LINE AND CABLE CARRIER SYSTEMS

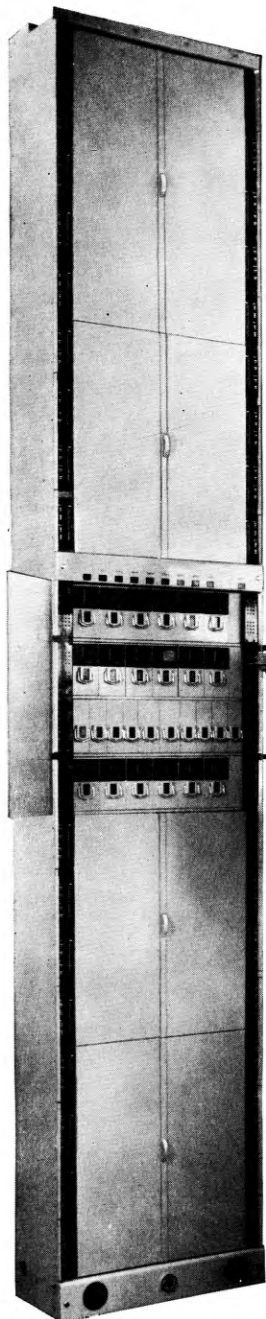

TYPICAL TYPE CM TERMINAL RACKSIDE

- \* Fully transistorised, mains or station battery operation
- \* Optional inbuilt out-band 3825c/s signalling, ring down or dialling
- \* New racksides of high equipment capacity within conventional rack dimensions
- \* Readily installed and extended with minimum station cabling
- \* Compact, reliable, versatile

*Write for further information to:—*

**AUTOMATIC TELEPHONE  
& ELECTRIC CO. LTD.**

Strowger House, Arundel Street, London, W.C.2.

*'Phone: Temple Bar 9262*





## The Painton **FLATPOT** SUBMINIATURE ADJUSTABLE POTENTIOMETER

- ★ Wirewound
- ★ Stable settings
- ★ Fine screwdriver adjustment
- ★ Space saving
- ★ Rapid delivery

*Write for leaflet  
FP1/2*

**Painton & Co. Ltd.**  
KINGSTHORPE NORTHAMPTON  
Tel: 34251 (10 lines) Grams: 'Ceil Northampton'  
Telex: 31576

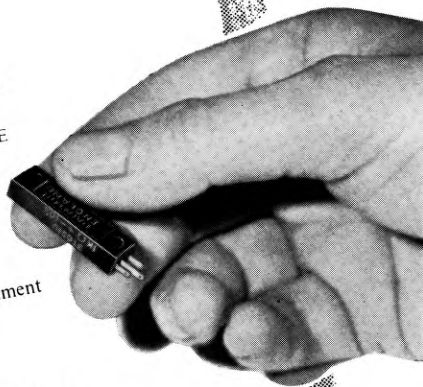

# ERICSSON

## AMPLIFIED TELEPHONE HANDSETS

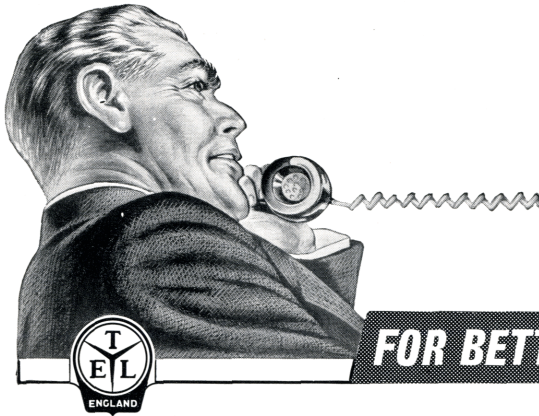

**FOR BETTER HEARING** →

**AMPLIFIED TELEPHONE HANDSETS**, of reliable and high quality performance, have been designed to improve reception for subscribers with impaired hearing. In addition, they may be used with advantage in certain noisy locations where reception is inadequate.

These handsets — illustrated is the new ETELFONE version — are available in a variety of forms to provide direct replacement for all existing types associated with telephones manufactured by this Company, including Local-battery instruments.

Power is taken from the instrument batteries in L.B. installations but for C.B. systems the amplifier is powered by the telephone line current.

- ▶ **PRINTED CIRCUIT, SINGLE-TRANSISTOR AMPLIFIER**
- ▶ **NO LOCAL POWER SUPPLY REQUIRED SINCE THE AMPLIFIER IS POWERED BY TELEPHONE LINE CURRENT**
- ▶ **ADJUSTABLE GAIN, CONTROLLED BY SUBSCRIBER**
- ▶ **OVERLOAD CHARACTERISTICS OF AMPLIFIER SAFEGUARDS THE SUBSCRIBERS HEARING**
- ▶ **MAXIMUM GAIN IN EXCESS OF 20 DECIBELS**



**BLACK**  
**LACQUER RED**  
**CONCORD BLUE**  
**ELEPHANT GREY**  
**FOREST GREEN**  
**TOPAZ YELLOW**  
**IVORY**

FOR FURTHER INFORMATION PLEASE WRITE TO:—

**ERICSSON TELEPHONES LIMITED — ETELCO LIMITED**

HEAD OFFICE:— 22 LINCOLNS INN FIELDS, LONDON, W.C.2. TEL. HOL. 6936.

WORKS:— BEESTON, NOTTINGHAM AND SUNDERLAND.

# SILVER STAR CAPACITORS

square  section

## for transistorised circuits

Something new in silvered mica capacitors — new in the Silver Star range!

Designed specially for transistor circuitry, these miniature square-section capacitors are particularly useful when the component density is high.

And they are ideal for printed circuits, for they can be cemented to the circuit board — a big advantage when acceleration forces are high.

*Two sizes (A15E and A25E) together cover the capacitance range from 33 to 20,000  $\mu\text{F}$ . For values above 6,000  $\mu\text{F}$  the capacitance tolerance can be as close as  $\pm 1$  per cent.*

- Square section
- Miniature size
- Ideal for printed circuitry
- 50 volt rating
- Fired construction for maximum long-term stability
- Synthetic resin encapsulated
- Ideal for "high g" applications
- Silver Star<sup>®</sup> quality

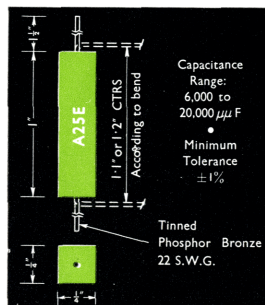
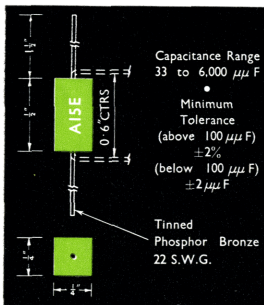

Full technical information available on request.

One of the specialised products of

**Johnson  Matthey**

JOHNSON, MATTHEY & CO., LIMITED  
73-83 HATTON GARDEN, LONDON, E.C.1  
Telephone: Holborn 6989  
Victoria Street, Birmingham, 1.  
75-79 Eyre Street, Sheffield, 1

Telephone: Central 8004  
Telephone: 29212



*“Twitcherton!*  
*Is this really*  
**FORMICA\* ?”**



Yes, this is an interesting example of the use of Formica industrial laminates. Here we have a uniselector (one of possibly thousands used in an automatic telephone exchange) made by The General Electric Company Limited. Paper-base laminates were provided for the uniselector by Formica Limited – they possess very high di-electric strength (that is, they are excellent insulators) and conform to the exacting specifications laid down by the G.P.O.

This is just one more of the many unexpected uses of Formica products. Out of the kitchen and into the wide world of telecommunications . . . what *will* Formica Limited be doing next ?

**FORMICA**  
 make

DECORATIVE LAMINATES  
 EXTRUDED LAMINATES  
**INDUSTRIAL LAMINATES**  
 CHAIR SETS



For full information on any FORMICA product please write to :

**Formica Limited, De La Rue House, 84-86 Regent Street, London, W.1. Tel: REGent 8020**

\*FORMICA is a registered trade mark



Channel rack mounting  
6 groups without signalling  
or 4 groups with in-built  
out-of-band signalling.

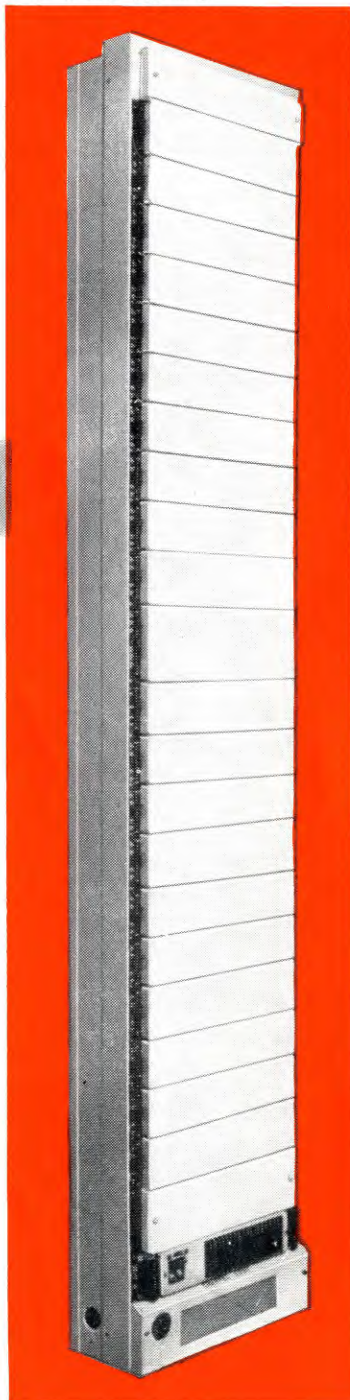

Group translating rack  
mounting 20 groups  
(less covers).

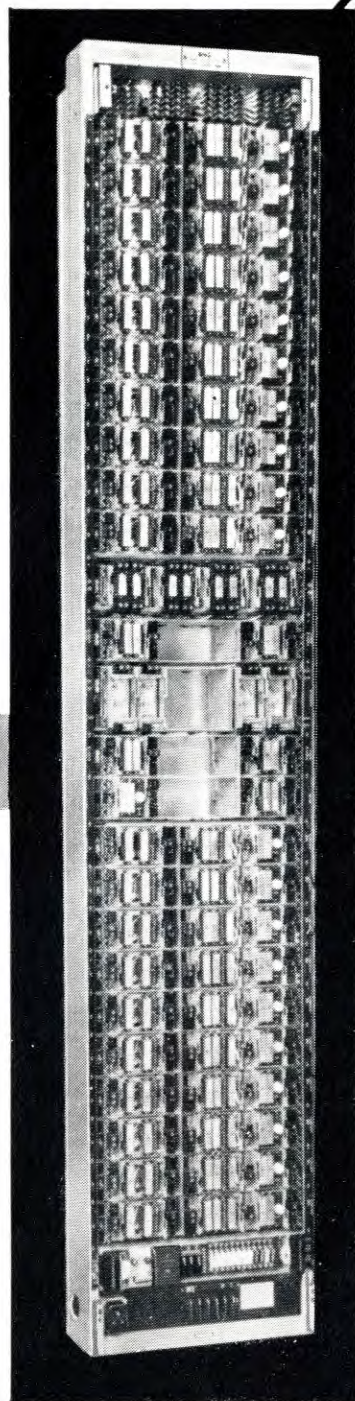

**Transistorised Transmission Equipment  
includes**

- |                                   |                                     |
|-----------------------------------|-------------------------------------|
| Channel Equipment                 | Rural Carrier Equipment             |
| Group Translating Equipment       | Voice Frequency Telegraph Equipment |
| Super Group Translating Equipment | 3-Circuit open wire line Equipment  |

**G.E.C.**

**FULLY TRANSISTORISED  
Multiplex  
Equipment**

Completely transistorised channel, group and supergroup equipments are in full production at the Telephone Works of The General Electric Company Ltd.

Orders have been received from the British Post Office for over 500 groups (6000 circuit ends) of channel equipment as well as a substantial quantity of group translating equipment.

The first of these equipments is already in service. In addition equipments have also been ordered by several Overseas Administrations.

The development of these new equipments is the result of six years experience in the design and operation of transistorised transmission equipments.

Since the introduction of their transistorised voice frequency telegraph equipment in 1954, the G.E.C. has supplied high-grade transmission equipment incorporating more than 250,000 transistors.

*For further information on the transistorised channel and translating equipment please write for standard specification SPO 1371*



**Everything for Telecommunications**

THE GENERAL ELECTRIC COMPANY LIMITED OF ENGLAND

TELEPHONE WORKS · COVENTRY · ENGLAND

WORKS AT COVENTRY · MIDDLESBROUGH · LONDON · PORTSMOUTH



# NEW STYLE CORDLESS

# SWITCHBOARD

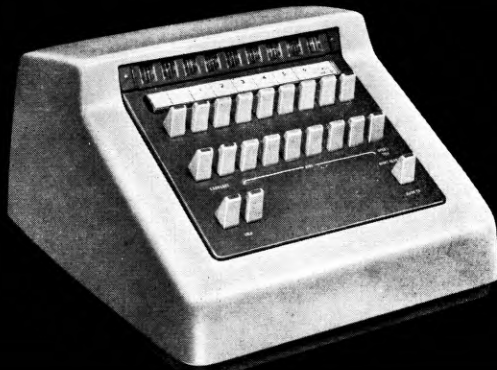

Attractive appearance is an essential consideration when designing subscribers' apparatus, but important, too, is small size. Both these objectives have been achieved in this *lamp signalling* switchboard, designed in conjunction with the B.P.O. to supersede the existing indicator signalling 2 + 4 switchboard housed in a bulky, outmoded wooden cabinet.

Although considerably smaller than its predecessor, it provides two more extensions and has a total capacity for two exchange lines and six extensions.

Much of the reduction in size has been obtained by the adoption of a new 4-wire principle for local extension lines. This has enabled certain additional facilities to be provided with fewer components, as for example, operator re-call and secretarial 'hold'.

A grey plastic drop-on cover, with a simple release action, provides easy access to all components conveniently arranged on a 3-section, hinged chassis of drawn steel. The key and lamp panel is tastefully finished in a durable coating of grey P.V.C. and the ivory coloured key handles are shaped and marked to facilitate operation.

Power for transmission and signalling is normally derived from a mains driven unit.

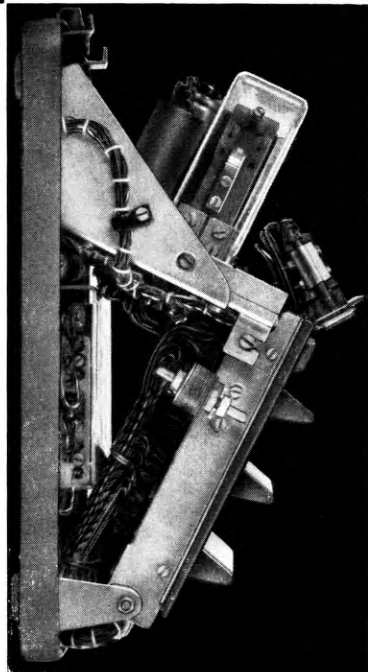

**ERICSSON TELEPHONES LTD**  
**E TELCO LTD**

# Glazed Vitrified Clay Conduits

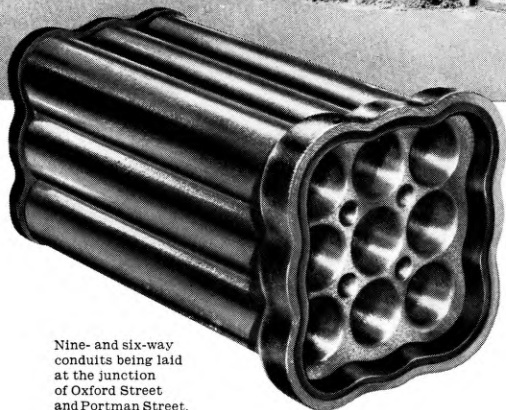

Nine- and six-way conduits being laid at the junction of Oxford Street and Portman Street, London W.1.

## serve . . . the West End well

Only **glazed vitrified clay conduits** can guarantee the degree of protection demanded by the authorities for the permanent security of our tele-communications. The importance of using **glazed vitrified clay conduits** is widely accepted to-day, especially in our cities where the flow of traffic must be disturbed to the minimum and where the heavy cost of re-excitation must be avoided.

Experience has proved that there is no adequate substitute for **glazed vitrified clay conduits**.

*For information write to The Secretary*

NATIONAL SALT GLAZED PIPE MANUFACTURERS' ASSOCIATION  
Hanover Court, Hanover Square, LONDON, W.1.

Telephone MAYfair 0364.







*A complete 600 channel  
four tube repeater*

**BRIGHTON**  
**-CHICHESTER**  
**LINK BY**  
**A.T.E.**

The latest type of small core coaxial system is now being installed to provide a new 35-mile telecommunication link between Brighton and Chichester. It will provide the G.P.O. with an economic, high quality system for circuits between the two towns.

The buried type transistorised repeater is of a completely new design developed by A.T.E. It is power-fed along the cable and contained in a hermetically sealed, pressurised nickel iron box, suitable for installation in footway boxes or underground chambers. For full details write for publication T.E.B 3202.

- *Fully transistorised system of proved reliability*
- *Meets latest C.C.I.T.T. recommendations*
- *Up to 300 channels per pair of tubes*
- *Compact power-fed repeaters*
- *In-built supervisory and maintenance facilities*

**A.T.E. Coaxial system type C300A**

*for use on small core coaxial cables*



**AUTOMATIC TELEPHONE  
& ELECTRIC CO. LTD.,**

Strowger House, Arundel Street, London, W.C.2

Tele: TEMple Bar 9262.

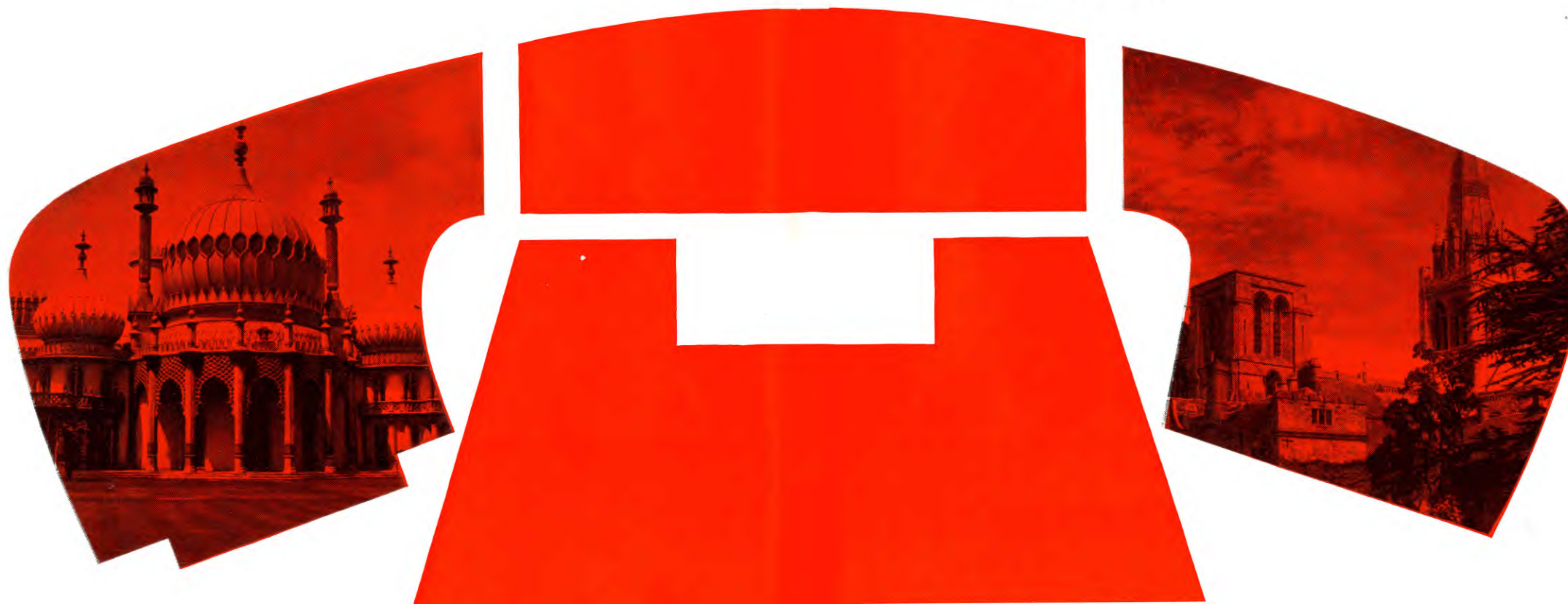

## TUNGSTONE BATTERIES

are playing their part in the latest development in the Telephone System of this country, viz :-

## TRUNK DIALLING SYSTEM

Tungstone Products Ltd. are privileged to have installed their Batteries in the majority of "Satellite" Exchanges in the first area selected by H.M. Postmaster General for this great step forward in the history of the Telephone Service.

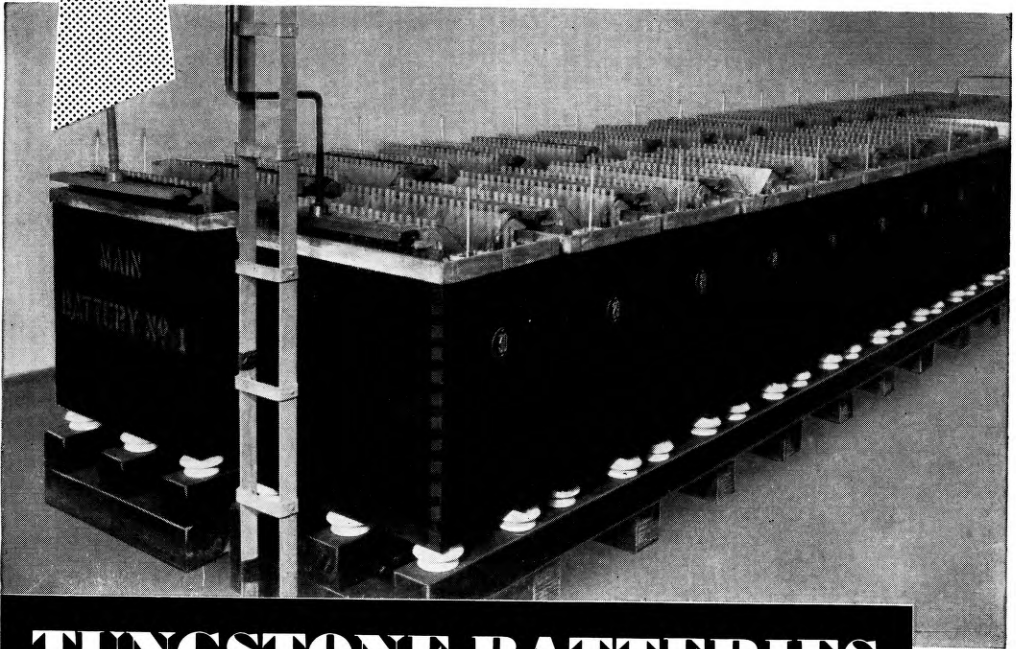

## TUNGSTONE BATTERIES

TUNGSTONE PRODUCTS LIMITED, 10 SALISBURY SQUARE, LONDON, E.C.4.

Works: MARKET HARBOROUGH, LEICS.



# SPECIALISTS

## IN REPEATERED SUBMARINE TELEPHONE CABLE SYSTEMS



*Assembly of a supervisory unit for a Submerged Repeater*

Submarine Cables Ltd., specialise in complete submarine telephone cable systems—cable, submerged repeaters, cable laying and terminal equipment.

Submarine Cables Ltd. developed the new unarmoured (lightweight) cable designed by the British Post Office and the Company's factory at Greenwich is producing this type of cable for the first Commonwealth link (called CANTAT) between Scotland and Canada, to the order of the Canadian Overseas Telecommunication Corporation and Cable and Wireless Ltd. Their Repeater Division at Erith, Kent, is making the submerged repeaters for the CANTAT extension from Newfoundland up the St. Lawrence River, to the order of the Canadian Overseas Telecommunication Corporation.

Submarine Cables Ltd., backed by over a hundred years of experience, are in a position to give expert technical advice on any submarine-cable telecommunications problem.

## **SUBMARINE CABLES LIMITED**

*Owned jointly by Associated Electrical Industries Ltd. and British Insulated Callender's Cables Ltd.*

HEAD OFFICE: Mercury House, Theobald's Road, London WC1 • Telephone: HOLborn 8711 • Telegrams: Telsiem, London  
WORKS: Telcon Works, Greenwich: Ocean Works, Erith, Kent

# CANADA



*This map indicates the positions of TMC installations.*

## GENERAL

- \* Can be energized from suitable batteries or a.c. mains.
- \* Plug-in units and panels make transport, installation and maintenance easier.
- \* Great care has been taken to simplify the problem of installation. Racksides may be mounted side-by-side back-to-back or back to a wall. Cable entries are arranged for both overhead and floor-duct distribution.

## TECHNICAL

- \* Channel spacings of 120, 170 or 240 c/s.
- \* Speeds of 50-66 to 100-120 bauds.
- \* 24, 18 or 12 channels on one self-contained rackside.
- \* Bothway and unidirectional versions.
- \* Local loops for polar or neutral full and half duplex.
- \* Compact plug-in sub-units, units and panels give maximum flexibility.
- \* Fully transistorized.

# CHOOSSES

# TMC

## V.F. telegraph equipment

TMC transistorized frequency modulated V.F. Telegraph Equipment is an acknowledged contribution to the recent advances made by the electronics industry in the field of telecommunications. In comparison with earlier designs, it effects considerable economies by using less space, reducing the power consumed and being simple to install as well as easy to maintain.

In Canada, and elsewhere, TMC V.F. Telegraph Equipment is widely used. You'll find its general and technical features worthy of your attention.

# TMC

*Further information from:*

**Telephone Manufacturing Company Limited**

**Transmission Division:**

**Cray Works, Sevenoaks Way, Orpington, Kent**

**Telephone: Orpington 26611**

## SELLING AGENTS

**Australia and New Zealand:**

Telephone Manufacturing Co. (A'sia) Pty. Ltd., Sydney, New South Wales

**Canada and U.S.A.:**

Telephone Manufacturing Co. Ltd., Toronto, Ontario



# NEW VINKOR SERIES

Covers frequencies from 100 Kc/s to **2** Mc/s

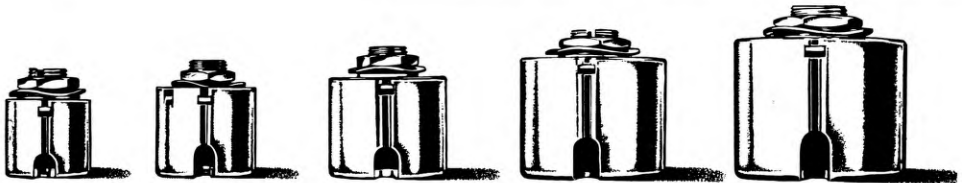

A new series of Vinkor adjustable pot cores has been developed by Mullard for use in the frequency range 100 kc/s to 2Mc/s. This series is in addition to the highly successful group already widely used for frequencies between 1 kc/s and 200 kc/s.

The world's most efficient pot core assembly, the Mullard Vinkor gives a choice of 3 permeabilities and has exceptionally high performance and stability. Write today for full details of the wide range of Vinkors now available.

**Mullard** **VINKOR**

ADJUSTABLE POT CORE ASSEMBLIES



MULLARD LTD., COMPONENT DIVISION, MULLARD HOUSE, TORRINGTON PLACE, W.C.1.

MCI

**WESTINGHOUSE**

# Rectifiers

FOR

## ANGLO-SWEDISH SUBMERGED COAXIAL CABLE

GÖTEBORG

MIDDLESBROUGH

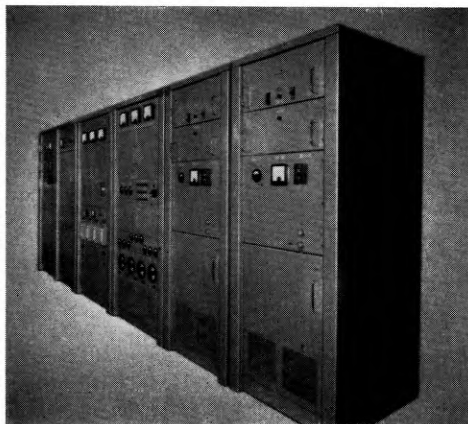

To meet the requirements of d.c. power supplies for submerged repeaters Westinghouse have developed a range of equipments which employ a transductor regulator, controlled by means of a magnetic discriminator.

The complete equipment illustrated above, which was supplied for the Anglo-Swedish cable system, consists of a suite of six cubicles comprising three constant current units, two control cubicles, power separation filter and cable terminating cubicle. Complete indication, alarm, interlock and test facilities are built into the equipment.

Other equipments are at present in the course of being supplied for the Transatlantic Cable System, H.M.T.S. Monarch, and the Bermuda Manahawkin Link.

For full details of Westinghouse rectifiers for telecommunications please write to Dept. P.O. 4/61, Rectifier Division (Special Products)

**WESTINGHOUSE BRAKE AND SIGNAL CO. LTD** · 82 YORK WAY, KING'S CROSS · **LONDON, N1.**

Terminus 6432

	PAGE		PAGE
Avo Ltd. . . . .	1	Neill, James, & Co. (Sheffield), Ltd. . . . .	6
Adcola Products, Ltd. . . . .	4	Painton & Co., Ltd. . . . .	24
Associated Electrical Industries, Ltd. . . . .	18	Pitman, Sir Isaac, & Sons, Ltd. . . . .	4
Automatic Telephone & Electric Co., Ltd. . . . .	23, 32-33	Shell-Mex & B.P. Gases, Ltd. . . . .	21
British Institute of Engineering Technology . . . . .	4	Standard Telephones & Cables, Ltd. 3, 5, 7, 9, 11, 12-13, 15, 42	
Datum Metal Products, Ltd. . . . .	14	Stone-Chance, Ltd. (Austinlite) . . . . .	22
Ericsson Telephones, Ltd. . . . .	25, 30	Stonebridge Electrical Co., Ltd., The . . . . .	40
Formica, Ltd. . . . .	27	Submarine Cables, Ltd. . . . .	35
General Electric Co., Ltd., The . . . . .	16-17, 28-29	Taylor, F., & Sons (Manchester), Ltd. . . . .	10
Great Northern Telegraph Co., Ltd. . . . .	8	Telephone Manufacturing Co., Ltd. . . . .	36-37
Hughes International (U.K.), Ltd. . . . .	19	Thompson, J. Langham, Ltd. . . . .	2
Imperial Chemical Industries, Ltd. . . . .	20	Tungstone Products, Ltd. . . . .	34
Johnson, Matthey & Co., Ltd. . . . .	26	Turner, Ernest, Electrical Instruments, Ltd. . . . .	14
Marconi's Wireless Telegraph Co., Ltd. . . . .	41	Westinghouse Brake & Signal Co., Ltd. . . . .	39
Mullard, Ltd. . . . .	38	Whiteley Electrical Radio Co., Ltd. . . . .	6
National Salt Glazed Pipe Manufacturers' Association . . . . .	31	Winn & Coales, Ltd. . . . .	1

# SUBSCRIBER TRUNK DIALLING METERS

Adopted for the new scheme for the United Kingdom and commencing at **BRISTOL**, these counters are part of a British-made range available for telephone and other systems. The designs are based on extensive Continental experience.



THE STONEBRIDGE ELECTRICAL CO. LTD.

6 QUEEN ANNE'S GATE • LONDON, S.W.1 Telephone: TRAFalgar 1444

CONTROLS & INSTRUMENTS

**STONEBRIDGE**

Agents and Licensees in U.K. for 'SODECO' Geneva



# MARCONI

## microwave communication systems

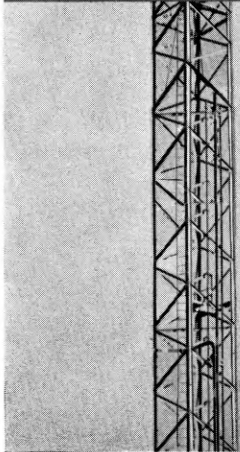
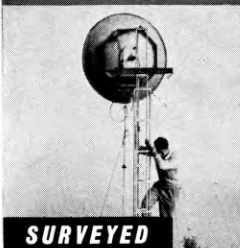

**HIGH PERFORMANCE** Marconi microwave systems, with capacities from 60 to 960 channels and capable of carrying high quality television, are designed to meet exacting international standards of performance with margins in hand.

**EXTREME SIMPLICITY** Travelling wave tube techniques ensure extremely simple circuitry and make full use of high gain and great band width available. A unidirectional repeater consists of only three travelling wave tube amplifiers and one frequency change oscillator with their power supplies.

**GREAT RELIABILITY** The use of travelling wave tubes in the repeaters has allowed considerable reduction in the number of valves and components used. Thus the likelihood of unexpected failure has been considerably reduced.

**EASY MAINTENANCE** The design of the units ensures easy access to all parts of the equipment and the extensive use of printed circuitry allows speedy and accurate replacement of precision circuits by technician staff, without realignment of the equipment.

**EXTREME SAFETY** All high voltages are fully interlocked.

World leaders in all travelling wave tube microwave systems

*The Post and Telegraph Authorities in more than 80 countries rely on*

# MARCONI

## COMMUNICATIONS SYSTEMS



# STC coaxial cable for STD

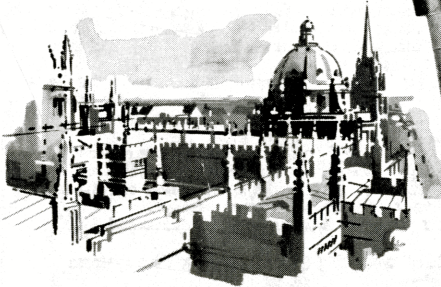
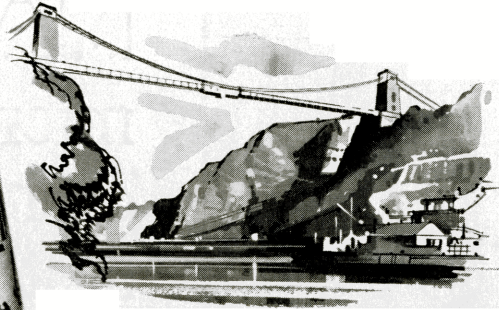
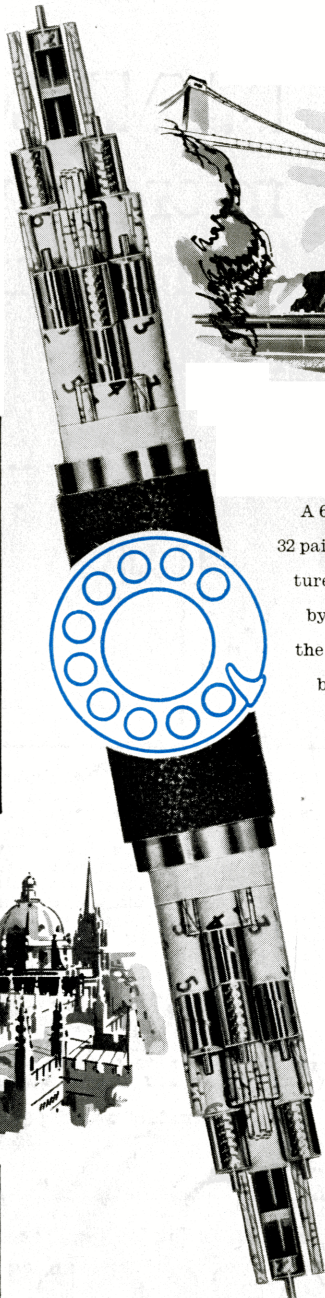

A 6-tube, type 375 Coaxial Cable incorporating 32 pairs 20 lb/mile conductors has been manufactured and installed between Bristol and Oxford by Standard Telephones & Cables Limited for the British Post Office. The cable, necessitated by the introduction of the Subscriber Trunk Dialling (STD) system in Bristol, provides additional trunk circuits between Bristol, Oxford, Birmingham, London and other principal cities. STC pioneered the introduction of the first coaxial cable and have been responsible for all subsequent major developments. Already the company has manufactured and installed in the U.K. alone over 3000 route miles of cable incorporating over 10,000 miles of coaxial tube.

*The new STC Telephone Cable Catalogue B/102 describes these and other cables and is available from:*

**Standard Telephones and Cables Limited**

Registered Office: Connaught House, Aldwych, London W.C.2

TELEPHONE CABLE DIVISION: NORTH WOOLWICH · LONDON E.16

