

This document was generated by me, Colin Hinson, from a document held at R.A.F. Henlow Signals Museum and is believed to be out of copyright or Crown Copyright . It is presented here (for free) under the Open Government Licence (O.G.L.) if under Crown Copyright and this version of the document is my copyright (along with the Crown Copyright) in much the same way as a photograph would be. If you believe the document to be under copyright, please contact me.

The document should have been downloaded from my website <https://blunham.com/Radar>, if you downloaded it from elsewhere, please let me know (particularly if you were charged for it). You can contact me via my Genuki email page:

<https://www.genuki.org.uk/big/eng/YKS/various?recipient=colin>

You may not copy the file for onward transmission of the data nor attempt to make monetary gain by the use of these files. If you want someone else to have a copy of the file, point them at the website. It should be noted that most of the pages are identifiable as having been processed by me.

I put a lot of time into producing these files which is why you are met with the above when you open the file.

In order to generate this file, I need to:

1. Scan the pages (Epson 15000 A3 scanner)
2. Split the photographs out from the text only pages
3. Run my own software to split double pages and remove any edge marks such as punch holes
4. Run my own software to clean up the pages
5. Run my own software to set the pages to a given size and align the text correctly.
6. Run Omnipage (Ultimate) on all the pages to OCR them.
7. Generate a searchable Acrobat pdf file.

Hopefully after all that, I end up with a presentable file, though I can't guarantee there aren't errors in the OCR. If you find missing pages, pages in the wrong order, anything else wrong with the file or simply want to make a comment, please drop me a line (see above).

It is my hope that you find the file of use to you personally – I know that I would have liked to have found some of these files years ago – they would have saved me a lot of time !

Colin Hinson

In the village of Blunham, Bedfordshire.

THE POST OFFICE ELECTRICAL ENGINEERS' JOURNAL



Vol. 59 Part 1

APRIL 1966

C O N T E N T S

	Page
AN INTRODUCTION TO THE POST OFFICE DATEL SERVICES—N. G. Smith	1
THE REPAIR OF FAULTY LOADING POTS—R. E. King and F. Woolley	5
DEVELOPMENT OF PULSE-CODE-MODULATION SYSTEMS	10
THE NEW POST OFFICE RAILWAY STATION AT THE NEW WESTERN DISTRICT OFFICE— A. C. Mackay, A.M.I.E.E., A.M.I.Loco.E.	12
MATERIALS AND FIRE HAZARDS—P. Taylor, Ph.D., B.Sc., A.R.I.C.	16
THE NEW STATUS OF THE TECHNICAL SUPPORT UNIT	18
THE INTRODUCTION OF SUBSCRIBER TRUNK DIALLING AT UNIT AUTOMATIC EX- CHANGES—J. H. Hoyle	20
ENGINEERING ASPECTS OF STAFF COMFORT—R. W. Hopwood, B.Sc.	26
DEVELOPMENTS IN EXCHANGE EQUIPMENT: POST OFFICE INTRODUCES ELECTRONIC AND CROSSBAR EXCHANGES	33
A CLEAN ROOM FOR THE PRODUCTION OF SILICON PLANAR TRANSISTORS—R. L. Corke, A.M.I.E.E., and A. W. Searls, A.M.I.E.E.	34
ALL-FIGURE TELEPHONE NUMBERS	40
OPERATION AND MAINTENANCE OF SECONDARY-CELL BATTERIES—A. E. Mahoney.	43
NEW JOINTERS' TENTS—TENTS, JOINTERS', No. 3 and 4—F. Hayton	52
STAY ANCHORAGES—A. E. Lund	53
A PRECISION MAGNETIC TAPE-RECORDER—R. W. Bigg	55
NOTES AND COMMENTS	60
INSTITUTION OF POST OFFICE ELECTRICAL ENGINEERS	60
REGIONAL NOTES	61
ASSOCIATE SECTION NOTES	64
STAFF CHANGES	66
PAPERS AND ARTICLES ON TELECOMMUNICATIONS AND OTHER SCIENTIFIC SUBJECTS	71
BOOK REVIEW	4, 9, 15, 19, 42, 59, 65

Price 3s. (Post Paid 4s.)

Published in April, July, October and January by *The Post Office Electrical Engineers' Journal*,
G.P.O., 2-12 Gresham Street, London, E.C.2.

Annual Subscription (post paid): Home, 16s.: Overseas, 17s. (Canada and U.S.A., 2 dollars 75 cents.)

THE POST OFFICE ELECTRICAL ENGINEERS' JOURNAL

Vol. 59 Part 1

APRIL 1966

An Introduction to the Post Office Datel Services

N. G. SMITH†

U.D.C. 621.394.4:681.142

The increasing use of computers has created a demand for data-transmission facilities over telegraph and telephone circuits. To meet this demand the Post Office has introduced the Datel Services. These new services, together with brief details of the equipment involved, are described.

INTRODUCTION

THE use of computer systems in the United Kingdom for business, governmental, and scientific (including university) purposes has been increasing steadily during the last 10 years. The rate of growth is quickening, while the scope of use is widening, and many users are beginning to find that the ability to transmit computer data quickly between geographically-separate locations is an integral part of the development of data-processing and control systems. This need for data-transmission facilities is certain to increase substantially in the future as the exploitation of computer systems is enlarged to embrace more activities and as the use of real-time systems* develops. The British Post Office, realizing the importance of this new field of communications, has introduced a new class of service under the title of "The Datel Services."

Initially, four services were announced: Datel 100 Service, Datel 200 Service, Datel 300 Service and Datel 600 Service. Since then, two further services have been introduced, namely, Datel 2000 Service and International Datel 600 Service. These services, to which reference was made in an earlier issue of this Journal,¹ are described in this article.

DATEL 100 SERVICE

The first service to be made available was the Datel 100 Service, which caters for the transmission of binary data at rates up to 100 binary digits (bits)/second.

The transmission of binary data at rates up to 50 bits/second can be readily achieved via the normal telex facilities. Higher rates, up to 100 bits/second, are available on private telegraph circuits which, if necessary, make use of 100-baud multi-circuit voice-frequency (v.f.) telegraph equipment.

During the transmission of binary data, element errors may be caused by line disturbances. If data are to be processed automatically it is obviously necessary to try and detect any errors that do occur, so that they may be corrected before the data are used. Equipment to carry out this function has been developed by the Post Office, and was described in detail in an earlier issue of this Journal.²

†Telegraph and Data Systems Branch, E.-in-C.'s Office.

*Real-time systems—data-processing systems which operate at sufficient speed to analyse or control external events happening concurrently.

The standard Post Office tape-readers (automatic transmitters) and tape punches (reperforators) can only handle paper tape in which the character code does not exceed five information elements. Such a code can only provide 2^5 , i.e. 32, different code combinations, of which five are allocated in the International Alphabet No. 2 to machine functions, namely letter shift, figure shift, carriage return, line feed and space. It is thus only possible with the 5-unit code to cater for capital letters, numerals 0 to 9, and a limited range of punctuation marks and other signs and functions. Data-processing equipments sometimes need a more extensive alphabet than the 5-unit code provides, and then a higher-level code, e.g. having 6, 7 or 8 elements/character, is required. Privately-owned equipment to handle these higher-level codes may be used on private circuits, subject to the normal Post Office approval arrangements.

In order to allow higher-level codes to be used on telex connexions, privately-owned equipment may be connected to the telex line via a switching unit provided by the Post Office. This switching unit, known as the Unit, Telex, No. 7, switches the private equipment into circuit in response to the operation of a push-button key, mounted on the unit, after the telex connexion has been established in the normal way. A second push-button enables the connexion to be restored to normal teleprinter working. If the connexion is cleared before the private equipment is switched out of circuit the Unit, Telex, No. 7 will automatically carry out this function, thus ensuring that, in the idle condition, the telex line is connected to a standard telex-station termination. In order to avoid false clear-signals being given on telex connexions when higher-level codes are used it is essential that the code signals should not cause a period of continuous start signal that exceeds 160 ms, i.e. equivalent to 8 signal elements at 50 bits/second. It may be necessary on international calls for this maximum period of continuous start signals to be further restricted. Arrangements can also be made to allow the use of non-standard 5-unit character codes on telex lines.

DATEL 600 SERVICE

While transmission at rates up to 50 bits/second on telex connexions, and up to 100 bits/second on private circuits, is adequate for some users, customers with the more powerful computer systems find this speed much too slow both for the volumes of data involved and for the work capacity of their data-processing systems. There is, thus, a need for systems to provide higher rates of data

transmission, and the Datel 600 Service is designed to meet this need. It enables customers to transmit binary d.c. signals at rates up to 600 bits/second, and, under favourable conditions, up to 1,200 bits/second, i.e. up to 24 times faster than is possible using telex.

In order to achieve the higher transmission rate the Datel 600 Service makes use of telephone-type circuits. Transmission is achieved by the conversion of the d.c. binary signals to voice frequencies which may then be transmitted over telephone-type circuits. The C.C.I.T.T.,* at its Plenary meeting in June 1964, approved a draft recommendation³ for a 600/1,200 bits/second modem[†] for use in the switched public telephone network. A unit, developed by the Post Office in conjunction with a manufacturer, which complies with this recommendation, became available in December 1964, and is known as the Datel Modem No. 1A (Fig. 1). This equipment is capable of accepting data from customers' data sources (tape readers, card readers, etc.), converting the data to signals in the telephone speech band by frequency modulation of a v.f. carrier, and, at the receiving end, of demodulating

Reference is also made in the recommendation to frequency accuracy, level of power of the transmitted v.f. signal, and the response time of carrier-fail circuits.

The Datel Modem No. 1A is capable of operation at 600 bits/second on connexions established over the public switched telephone network in the United Kingdom and also over telephone-type leased circuits. On many connexions, however, it is possible to transmit at 1,200 bits/second. The transmission rate possible is determined by the incidence of heavily-loaded cables, which restricts the bandwidth available, and the group-delay/frequency distortion, which, though normally unimportant so far as speech is concerned, has a profound effect on the transmission of data. The design of the Datel Modem No. 1A is such that it will operate at 1,200 bits/second over connexions with group-delay/frequency characteristics equivalent to those of three telephone carrier channels in tandem, or 100 miles of standard loaded cable, i.e. a 20 lb/mile cable loaded with 88 mH at intervals of 1.136 miles. At 600 bits/second the effect of the circuit group-delay/frequency characteristics just



FIG. 1.—DATEL MODEM No. 1A WITH 700-TYPE TELEPHONE

and restoring this v.f. signal to d.c. binary signals to control customers' data sinks, i.e. equipment that accepts data signals after transmission. A low-speed, 75 bits/second backward channel is available, if required.

Briefly, the principal characteristics laid down in the C.C.I.T.T. recommendations are as follows:

(a) The use of frequency modulation with either a synchronous or asynchronous mode of transmission.

(b) Two modes of operation, using the characteristic frequencies shown in Table 1 for the forward data-transmission channel.

TABLE 1

Characteristic Frequencies Recommended by C.C.I.T.T. for 600/1,200 bits/second Modem

Mode	Nominal Mean Frequency (F_0 c/s)	Binary Symbol 1 (F_1 c/s)	Binary Symbol 0 (F_0 c/s)
A1 (up to 600 bits/second)	1,500	1,300	1,700
A2 (up to 1,200 bits/second)	1,700	1,300	2,100

(c) Optional provision of a backward channel for use at modulation rates up to 75 bits/second using the characteristic frequencies $F_z = 390$ c/s and $F_A = 450$ c/s.

quoted may be more than doubled. A further factor which seriously affects performance, but is difficult to measure, is signal echo. As would be expected, the effect is more critical when operating at 1,200 bits/second than at 600 bits/second. However, since the transmission characteristics of private circuits can be controlled, it is generally possible for the Datel Modem No. 1A to operate at 1,200 bits/second on this type of connexion.

INTERNATIONAL DATEL 600 SERVICE

Initially, when the Datel 600 Service was introduced in January, 1965, it was confined to the inland telephone network, but is now being extended to other countries. In this form it is known as the International Datel 600 Service.

The International Datel 600 Service was opened on 1 July 1965, when data transmission at rates up to 600 or 1,200 bits/second was made available to the United States. As agreements are concluded with foreign administrations, the facility to transmit and receive data to and from other countries will grow. The International Datel 600 Service is now available from the United

*C.C.I.T.T.—International Telegraph and Telephone Consultative Committee.

†Modem—combined modulator and demodulator.

Kingdom to the United States, Denmark, Austria, and France. The Post Office Datel Modem No. 1A will be the standard termination in this country, and will operate satisfactorily to any distant equipment provided it complies with the C.C.I.T.T. recommended standard.³

DATEL 2000 SERVICE

The Datel 600 Service is able to meet the needs of many customers at the present time. However, there is a growing demand for transmission rates exceeding 1,200 bits/second. To cater for this requirement the Datel 2000 Service was introduced.

No terminal equipment (modem) is provided by the Post Office for the Datel 2000 Service at present, although it may well be later on. As data-transmission rates increase, the characteristics of the telephone lines used become more critical. The Datel 2000 Service is intended to meet the needs of customers who require private telephone circuits, of a higher-quality than is normally available, for use with privately-owned modems designed to operate at higher transmission rates. The characteristics of a typical Tariff S private circuit are given in an earlier issue of this Journal.⁴ The types of improvement offered cover attenuation/frequency characteristic, overall loss, and group-delay/frequency characteristic.

For customers who wish to transmit data at rates greater than 1,200 bits/second the improvement under Datel 2000 Service will enable transmission rates of 2,000 or 2,400 bits/second to be achieved with suitable modulation and demodulation equipment. No particular rate can be guaranteed, as much depends on the design of the modem used.

DATEL 200 SERVICE

The customers' equipment (data sources and sinks), for use at transmission rates of about 150 characters/second (equivalent to 750 to 1,200 bits/second depending on the number of code elements forming a character) and above, tends to be expensive. Also, the systems described under the Datel 600 Service can only provide the higher rates of transmission in one direction at a time on connexions via the public switched telephone network, although, as indicated earlier, a duplex service is available if the transmission rate of the backward channel is restricted to 75 bits/second.

To enable customers to exploit lower-cost data terminal equipment operating at lower speeds, together with the ability to transmit in both directions simultaneously, a modem capable of duplex operation at any modulation rate up to 200 bits/second is being developed. The facilities offered by this modem will be marketed as the Datel 200 Service.

The Post Office equipment will be known as the Datel

Modem No. 2A, and is illustrated in Fig. 2. The modem will comply with C.C.I.T.T. Recommendation V21.⁵ Briefly, the main points in this recommendation are as follows.

(a) Data transmission should be possible in both directions simultaneously on 2-wire circuits at any rate up to 200 bits/second; frequency-shift modulation should be used.

(b) The characteristic frequencies should be as shown in Table 2.

(c) Data may be transmitted synchronously or asynchronously.

(d) Channel No. 1 (Table 2) should be used for the transmission of callers' data (i.e. the person making the telephone call) towards the called station, while Channel No. 2 should be used for transmission in the other direction.

TABLE 2

Characteristic Frequencies Recommended by C.C.I.T.T. for 200 bits/second Modem

Channel No.	Nominal Mean Frequency (F_0 c/s)	Binary Symbol 1 (F_1 c/s)	Binary Symbol 0 (F_0 c/s)
1	1,080	980	1,180
2	1,750	1,650	1,850

As indicated in the C.C.I.T.T. recommendation, duplex operation of this equipment on 2-wire circuits, such as found on the public switched telephone network, is obtained by frequency division. Since Channel No. 1 is always to be used to transmit the callers' data it is necessary to be able to switch the frequency band used for transmission or reception to enable any one 200 bits/second modem to work to any other 200 bits/second modem. The design of the Post Office modem will be such that normally it is in the calling-station mode. When it is connected to a telephone exchange line to which an incoming calling signal is applied automatically, the modem will detect the calling signal (ringing current) and will automatically switch to the called-station mode. It will remain in this mode so long as the calling signal persists or the handset of the telephone used to answer the call is off its rest. If the modem is used on a line terminating on a manual telephone exchange, a channel-selection key, to be operated on incoming calls, will be fitted to the telephone. It is expected that the modem for the Datel 200 Service will become available during 1966.

DATEL 300 SERVICE

Although the Datel 200 Service is intended to provide



FIG. 2.—DATEL MODEM No. 2A WITH 700-TYPE TELEPHONE

facilities for lower-cost data transmission, a demand can be foreseen for an even cheaper unidirectional system to meet the needs of customers who wish to collect at one central point small quantities of data from a number of out-stations. To meet this demand the Datel 300 Service is being developed.

Two systems are being considered each of which will be designed for use primarily with one data-input medium. One system will be for use where the data at the out-station are recorded on punched cards or are to be transmitted manually from a simple numeric keyboard, and the second system will be for use with data recorded on punched tape. The number of out-stations connected to each in-station will probably be in the range 10-20, and, thus, the accent in these systems is on low-cost out-station equipment to give lowest overall cost. To achieve this, it is envisaged that the out-station will be an integrated unit, i.e. data reader and modem combined. At the present time there is no C.C.I.T.T. recommendation for equipment of this type, and it is proposed to use a multi-frequency code, as described below, for signalling from the out-station. For the punched-card or keyboard system the multi-frequency code will be derived from 12 frequencies divided into three groups of four: a character will be represented by one frequency out of each group. With this arrangement of three times one-out-of-four code, the maximum number of characters is $4 \times 4 \times 4$, i.e. 64. One of these combinations is reserved as a character separator, so that 63 combinations are available for the system alphabet. The standard punched-card code set out in British Standard 3174⁶ comprises 39 characters; thus, 63 code combinations are more than adequate and margin is left for additional control combinations that may be required.

The second system, which is intended primarily for transmission from punched-paper tape at the out-station, is capable of handling tapes of up to 8 tracks. The number of code combinations required is thus 2⁸, i.e. 256. In order to achieve this number using a multi-frequency code of the type described above, either 16 frequencies are required, i.e. four times one-out-of-four, or the character must be transmitted in two sequential parts as two 4-element characters. This latter arrangement requires two

groups of four frequencies for the 4-element character, and a separate group of two frequencies to identify the character halves as they are transmitted. Thus, 10 frequencies in all are required, and this arrangement is preferred for the paper-tape system because of the restricted frequency bandwidth generally available on the public switched telephone network.

CONCLUSIONS

The information given in this article is of necessity only brief. It does, however, show how the Post Office is meeting the demands for data transmission which the growing use of electronic computers creates. The data transmission rates are restricted mainly by the limitations imposed by the use of telephone circuits, particularly those comprising connexions via the public switched telephone network. The information transfer-rates at computer inputs and outputs greatly exceed those possible over normal speech circuits, but new transmission techniques, such as pulse-code modulation, will, no doubt, influence the method of providing higher data-signalling rates. Furthermore, as the use of electronic computers advances, the demands on the Post Office for new Datel Services offer interesting, and exciting prospects for the future, and may lead to the establishment of a separate switched network of circuits.

ACKNOWLEDGEMENTS

The Datel Modem No. 1A was developed by the Plessey Company, Ltd., to a Post Office specification, and the Datel Modem No.2A was similarly developed by the Telephone Manufacturing Co., Ltd.

References

- ¹ALLERY, G. D. Some Aspects of Data Transmission. *P.O.E.E.J.*, Vol. 57, p. 264, Jan. 1965.
- ²WHEELER, D. W. E., and SALLIS, R. T. G. Detection of Errors in Data Transmission on 50-Baud Telegraph Circuits. *P.O.E.E.J.*, Vol. 58, p. 194, Oct. 1965.
- ³C.C.I.T.T. Blue Book, Vol. VIII, Recommendation V23.
- ⁴TUCKER, A. A. Long-Distance Private Telephone Circuits for Commercial Renters. *P.O.E.E.J.*, Vol. 55, p. 187, Oct. 1962.
- ⁵C.C.I.T.T. Blue Book, Vol. VIII, Recommendation V21.
- ⁶British Standard 3174: 1959. Alpha-Numeric Punching Codes for Data Processing Cards. British Standards Institution.

Book Review

"Precision Electrical Measurements in Industry." Edited by J. R. Thompson. Butterworth & Co., Ltd. xiv + 123 pp. 123 ill. 37s. 6d.

This book is an edited version of the seven papers presented at the Symposium on Procedures and Practices in Precision Electrical Measurements in Industry, which was held in November 1963 at Hatfield College of Technology. The topics were chosen to be of current importance in the field.

The first paper is by A. C. Lynch (Post Office Research Station); it deals with general principles and contains stimulating ideas on errors and on factors underlying the choice of methods of measurement. The second paper, by G. H. Rayner (N.P.L.), deals with the principles involved in the construction of stable standards. A paper by J. J.

Hill (N.P.L.) deals with audio-frequency measurements; it is followed by a contribution from P. M. Clifford (Hawker-Siddeley Dynamics, Ltd.) on the systematic checking of precision decade bridges. Paper No. 5, by R. L. Corke (Post Office Research Station) describes precision frequency measurements, and is followed by a paper from J. A. Lane (Radio Research Station) on radio-frequency measurements, particularly at u.h.f. and microwave frequencies. The final paper, by J. T. Briggs (Ferranti) describes how adequate electrical standardization is carried out in a large manufacturing organization. The book contains accounts of the discussions at the symposium, and concludes with a comprehensive bibliography of nearly 400 references.

The book forms a useful survey of selected topics in electrical measurements, and is a compact collection of much useful information.

H.G.B.

The Repair of Faulty Loading Pots

R. E. KING and F. WOOLLEY†

U.D.C. 621.318.4.004.67: 621.372.221

It is still necessary to use large numbers of loading pots in the trunk network, and the repair of existing items at relatively low cost is an attractive proposition. The methods used to effect such repairs are described.

INTRODUCTION

WHILE the expanding use of coaxial cables and microwave-radio techniques has affected the demand for loading coils in the provision of trunk circuits, there is, nevertheless, on account of the considerable growth of the trunk network as a whole, a continuing and very substantial need for loading coils for use in the main-cable trunk system. These loading coils, more generally referred to as loading pots and consisting of a coil assembly of from 14 to more than 500 coils contained in a single case, continue, therefore, to represent a significant proportion of the capital cost of an underground-cable trunk route. In consequence, the repair of these loading pots by the Post Office Factories Department, at a fraction of their cost as new, has proved to be a most attractive proposition, particularly as replacements for many of the types still in service are no longer readily obtainable.

If only a few coils in a loading pot have become faulty they can be replaced either by un coils placed in the cable joint or by a unit-type loading pot consisting of up to four coils in a lead case, with a single tail or stub; these unit-type loading pots are generally made by the Factories Department. However, the more usual cause of a loading pot becoming faulty is the ingress of moisture, either through the stub cables, as a result of a fault in the cable sheath at some point along the route, or through a hole in the case, resulting in the insulation resistance of all the coils in the loading pot becoming low. If the moisture has entered as the result of a fault in the cable sheath the insulation resistance of the cable can be raised by desiccation, but this will not remove moisture which has penetrated the coils. It was failures of this type which led to the investigation, several years ago, of the possibility of repairing loading pots. The repair procedure which is described here has been developed jointly by the Post Office Engineering Department and the Post Office Factories Department.

All types of loading pots at present in use consist basically of toroidal coils assembled in columns or on dowels supported in a metal framework similar to that shown in Fig. 1, the whole assembly being enclosed in a metal case. The connexions to the coils are made by stub cables which enter the case through metal glands in the lid, the joint between the cable sheath and the gland being sealed by a plumber's wipe. The lid is secured to the case by a water-tight joint, the case being filled with an insulating wax which serves to maintain the insulation of the coils and, in some designs, also assists in retaining the coils in their correct position.

The foregoing description does no more than outline the basic details of the construction of a loading pot.

†Mr. King is in the Test and Inspection Branch, E.-in-C.'s Office, and Mr. Woolley is in the Post Office Factories Department.

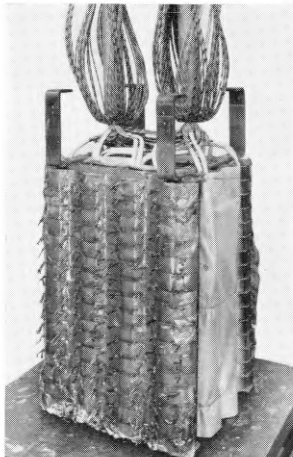

FIG. 1—LOADING-COIL ASSEMBLY WITH STUB CABLES CONNECTED DIRECTLY TO LEAD-OUT WIRES

Each manufacturer has produced cases of several different designs, with a variety of methods of supporting the coils. In general, successive designs have been smaller, with smaller coils and lighter conductors than their predecessors, and have, therefore, proved more intricate to repair. The Factories Department has developed special equipment and methods to enable any type of loading pot in use to be repaired.

METHOD OF REPAIR

The earliest types of loading pot have a large cast-iron case with a cast-iron lid bolted to a flange on the case, the joint being sealed by a corrugated-copper washer. A typical loading pot of this type, in the condition in which such pots are usually received for repair, is shown in Fig. 2. The coils in these pots are as much as 9 in. in diameter, with cores of soft-iron wire. Many of the older loading pots have phantom-circuit loading as well as side-circuit loading; this further complicates their repair.

Loading pots with cast-iron cases are more susceptible to faults than modern types. The cast-iron cases are frequently porous, allowing a steady ingress of moisture, although this fact was not discovered until comparatively recently when the introduction of electronic leak-detectors, with the use of a tracer gas, revealed this porosity. Later types of loading coils have cases fabricated from steel sheets with welded seams, the lids being either of steel, welded to the case, or cast from an alloy of brass and sealed to the case with a wiped joint. These steel cases frequently rust through, as do the steel glands where the cable enters the lid. All defective cases are replaced by new ones fabricated from $\frac{1}{4}$ in. steel plate, and all steel glands are replaced by brass ones during repair.



FIG. 2—TYPICAL CAST-IRON LOADING POT AS RECEIVED FOR REPAIR

Opening the Loading-Pot Case

Before opening the case to start the repair of a loading coil, the filling plug in the lid of the pot is unscrewed and replaced by a swan-necked tube. The upper part of the case is then heated, melting the wax, which expands and overflows through the tube. The case is then allowed to cool, the resultant shrinkage of the wax leaving the top few inches of the case empty and enabling the lid to be removed. On a cast-iron case the lid is removed by undoing the fixing bolts, whilst for a case with a wiped joint the wipe is melted off and the screws securing the lid to the sides of the case removed: the lid is then raised with a hoist. Most cases, however, are of all-welded construction and are cut open with an oxy-acetylene torch. A typical welded case, as received for repair, is shown in Fig. 3, with the line of the proposed cut marked round the top of the case. A modern single-stub case of welded con-



The white line round the top of the case indicates the proposed line of the cut.
FIG. 3—TYPICAL WELDED CASE AS RECEIVED FOR REPAIR

struction is shown in Fig. 4, after having been cut open. The opening of these cases calls for considerable skill and experience to avoid damaging the coils or their support-



FIG. 4—MODERN SINGLE-STUB CASE OF WELDED CONSTRUCTION CUT OPEN

ing structure. Other methods of opening cases, such as the use of circular saws, have been tried but discarded because of the risk of damage.

Removing Coil Assembly from Case

With the exception of the early cast-iron loading pots, where the coil assembly is bolted to the case and not to the lid, the next step is to remove the coil assembly from the case. In order to do this the wax is melted by heating the loading pot in an air-heated Mitchell oven at a temperature of 140°C for a period of 24 hours or more, according to the size of the case.

Care is required when melting the wax to ensure that it is heated slowly and evenly; if it is overheated its insulating properties are destroyed and its subsequent replacement adds considerably to the cost of repairing a loading coil. Fig. 5 shows a typical case with the coil assembly being removed after the wax has been melted.

After the coil assembly has been removed it is immersed in a specially-designed wax bath, which is at a temperature of 140°C, to remove all surplus wax, thus enabling the insulating covers to be removed, leaving the coils clean and accessible for repair. Fig. 6 shows a typical coil assembly at this stage.

Initial Tests

The insulation of the coils is then tested to determine which require replacement. Experience has made it possible to limit this initial testing to those loading pots which show evidence of a significant quantity of moisture having penetrated the case, a fact which can often be determined by the appearance of the wax which overflows when the case is first heated. This wax has a distinctive frothy appearance when moisture is present.

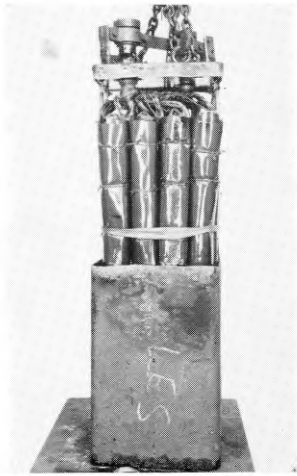

FIG. 5—TYPICAL CASE WITH COIL ASSEMBLY BEING REMOVED



FIG. 6—COIL ASSEMBLY AFTER SURPLUS WAX HAS BEEN REMOVED

Removing Old Stub-Cables

Having cleaned the coils, the lid and the remains of the cable stubs are removed. There are two methods of connecting the stub cables to the coils; one method is shown in Fig. 6, the cables being connected in the top of the case—to tails leading to the coils, a method which is

also used with pots having cast-iron cases; the other method is shown in Fig. 1, where the cables are connected directly to the lead-out wires of the coils.

When the old stub-cables are being removed, the tails leading to the coils are colleted with numbered sleeves to ensure that the new stub-cables are connected in the same order, whilst if connexion is direct to the coils a record is made of which coil is connected to each pair, thus ensuring that the pairs are loaded in the same manner as they were before repair. This is particularly important, as any variation in the connexions can lead to an undesirably high level of crosstalk. After the removal of the old cable-ends, suitable lengths of new cable are cut; non-standard lengths may be provided if it is desired to replace the loading pot in the manhole from which it was removed, without additional cable having to be jointed in. The cable used for the stubs has a sheath of an alloy of lead, antimony and tin; this alloy combines adequate ductility with resistance to fatigue cracking.

Fitting New Stub-Cables

The ends of the cables that are to be jointed to the coils have the sheath removed and are then immersed in hot wax for a period; this enables the paper-covered conductors to be manipulated between the columns of coils without suffering damage. The prepared cables are then passed through the sealing glands, and the lid and cables are supported above the coil assembly in a suitable position for jointing the cables to the coils. The coils are connected to the cable, commencing with the centre layer, each joint being soldered and insulated with a paper sleeve. Fig. 1 shows one type of assembly with the centre layers already connected; it will be seen that the insulation of the cable pairs is protected by a wrapping of linen tape where the wires pass through the supporting framework of the coils. With the type of assembly shown in Fig. 7, on which the jointing is almost complete, the cable pairs pass through insulating bushes in the framework

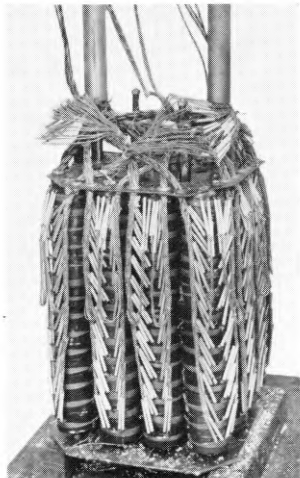

FIG. 7—COIL ASSEMBLY ON WHICH JOINTING IS ALMOST COMPLETE

and no further protection is necessary. When the cables have been jointed to the coils the lid is lowered and secured to the framework, and the space between the cable sheath and the inside of the sealing glands is caulked with lead strip. The joint between the cable and the gland is then plumbed: because of the heat absorption of the case, the wiping of this joint requires considerable experience, as melting of the cable sheath must be avoided. The coil assembly is then wrapped with empire cloth, secured by linen tape, and carefully lowered into the case. The loading pot is now in the stage shown in Fig. 8, this particular pot having been fitted with a new steel-plate case.



FIG. 8—LOADING POT FITTED IN NEW STEEL-PLATE CASE

Intermediate Testing

The intermediate stage of testing now commences. The d.c. resistance of each wire from stub to stub through the coil is measured, using a sensitive Wheatstone bridge. The pairs are then loop-connected with the coils series-aiding, and the inductance and effective resistance of each pair is measured at a frequency of 1,800 c/s for speech circuits and 7,000 c/s for music circuits, the results of both d.c. and a.c. tests being recorded for comparison with the figures obtained during final testing. The type of bridge used for the measurement of inductance and effective resistance depends on the inductance of the coils being measured and the frequency at which the measurement is made. For most coils a modified form of Maxwell bridge, designed for rapid comparison of the coils with standard inductors and variable resistors, is used, whilst for music-circuit coils an Owen bridge, calibrated directly in terms of resistance and inductance, is used. The standard inductors are selected loading coils mounted in wooden cases in which the coils float in granulated cork. These coils are carefully calibrated using a resonant

bridge; all the other components of the bridges are also subjected to regular calibration.

The measurements just described are followed by tests for insulation resistance and high-voltage breakdown. For these tests the wires of one stub cable are separated whilst those of each layer of the other cable are formed into eight groups consisting of the four individual wires of alternate quads connected together. Thus, all red A-wires of a layer are connected together, likewise the B-wires, C-wires and D-wires; the blue quads are similarly treated. In this way each wire is in a separate group from any other wire with which a fault could cause it to be in contact. All the groups are then connected together and to the case of the loading pot. Each group is subsequently disconnected in turn, and the insulation resistance between this group and the remainder measured, at 500 volts, with an electronic megohm-meter. After testing, each group is reconnected to the remainder.

High-voltage testing is carried out with an ionization tester which limits the current, hence obviating any damage that might occur in the event of a fault. First, the groups of wires are disconnected from the case, whilst still being connected to each other, and a d.c. voltage of 1,500 volts or 3,000 volts, according to the grade of coil, is applied between the case and the coils. The wires are reconnected to the case, the groups being successively disconnected, and a d.c. voltage of 750 volts is applied between each group and the remainder. Should any coil prove to be faulty during this intermediate stage of testing, the whole assembly is carefully lifted out of the case, the faulty coils replaced, the assembly returned to the case and the tests repeated.

When the intermediate tests have been satisfactorily completed the lid is secured to the case by bolting, plumbing or welding, according to the type of case. With welded cases the lid is secured by arc welding, as there is less risk of damage to the coils than there would be with gas welding. The loading pot is then heated at a temperature of 140°C for 24 hours in the air-heated Mitchell oven. Meanwhile, the wax that was originally removed from the case, and which is re-used whenever possible, is melted in electrically-heated containers at a temperature high enough to boil off any moisture but below that at which the insulating properties of the wax would be impaired. The melted wax is then drawn off and poured into the heated loading pot through the filling orifice; to eliminate any voids in the wax, further wax is added as that in the case cools and shrinks, until the level is within 1 in. of the top.

Final Testing

When the case has cooled after being filled with wax, the final electrical tests are carried out; these are the same as the intermediate tests except that the d.c. resistance is not measured. The results obtained for inductance and effective resistance are compared with those obtained during the intermediate tests, because any variation could indicate the possibility of a defective joint within an individual coil. The ends of the stub cables are then sealed, and the case is pressure-tested at 20 lb/in² to prove that all sealing joints are sound.

A schematic diagram of the pressure-testing apparatus is shown in Fig. 9. A mixture of 0.1 per cent Arcton with dry air is injected into the case through an adaptor fitted in place of the filling plug. This adaptor consists of two concentric tubes, the outlet from the

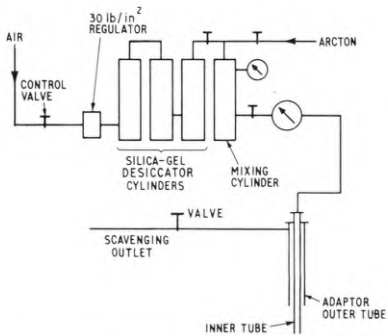

FIG. 9—SCHEMATIC DIAGRAM OF PRESSURE-TESTING ARRANGEMENTS

outer tube being closed whilst the Arcton-air mixture is injected through the centre tube at a pressure of 20 lb/in². All joints in the case and cable are then searched with a probe unit consisting of a tube up which the gas from any leak is drawn by a small fan to pass over a heated platinum cathode. When gases of the Halogen-containing group, of which Arcton is one, are drawn over this cathode the positive-ion emission is increased, this increase being indicated, both visually and audibly, by a suitable detector to give evidence of a leak. When the pressure test has been satisfactorily completed the outlet from the outer tube of the adaptor is opened and dry air is injected under pressure through the centre tube until the case is thoroughly scavenged and all traces of Arcton removed.

The sensitivity of this method of pressure-testing was demonstrated by the finding of a previously inexplicable cause of moisture entering bolted-type cast-iron cases; this phenomenon was traced to edge-to-edge porosity of the asbestos-compound sheet gaskets used to replace the original corrugated copper ones during repair. Copper-asbestos gaskets are now used as replacements and are both more efficient and economic.

Completion of Repair

When all tests have been satisfactorily completed the

case is filled to the top with wax and the filling plug screwed in. The case is then cleaned and coated with a rust-inhibiting paint, and supporting brackets for the stub cables are fitted to enable the loading pot to be safely transported. A typical completed loading pot is shown in Fig. 10.

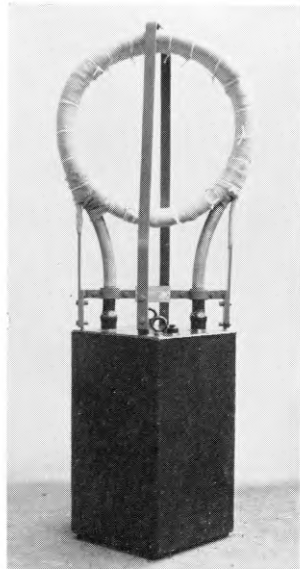

FIG. 10—COMPLETED LOADING POT WITH SUPPORTING BRACKETS FOR STUB CABLES TO ENABLE POT TO BE TRANSPORTED SAFELY

ACKNOWLEDGEMENT

The authors wish to express their thanks to their colleagues in the Engineering Department and Factories Department who have assisted in the compilation of this article.

Book Review

"Theory of Sampled-Data Control Systems." David P. Lindorff. John Wiley & Sons, Ltd. xiv + 305 pp. 172 ill. 81s.

The author's stated aim is "to establish continuity in an approach to the sampled-data control problem" and the book requires familiarity with continuous systems control theory. The book is suitable, mainly, for graduates in electrical engineering with theoretical interests in this field.

It falls into two main parts. Chapters 1-6 deal with linear sampled-data control systems and their treatment, mainly by z-transform techniques. Here the author assumes his readers to possess a quite extensive knowledge of the mathematics of functions of a complex variable and a more

than elementary acquaintance with signal flow graph techniques. Chapters 7-9 deal primarily with non-linear systems by the use of the "state variable" concept and Lyapunov's stability theorems, and one chapter is devoted to an explanation of the concept itself. Matrix methods are used extensively, and a reader without knowledge of matrix manipulation will find these chapters difficult. The sequence of presentation itself very usefully reminds the reader that the system function technique is by no means the only or even necessarily the most powerful analytic tool for control-system analysis.

The author achieves his aims for readers possessing adequate mathematical skill. Each chapter contains a good set of references and a useful collection of problems.

L.W.H.

Development of Pulse-Code-Modulation Systems

U.D.C. 621.395.45:621.376.56

Recent technical advances have made the use of pulse-code-modulation (p.c.m.) systems a possible economic alternative to audio or frequency-division-multiplex systems over short distances. An outline is given of p.c.m. junction systems and of some field-trial projects. The possible use of p.c.m. transmission systems interconnected by time-division-multiplex methods is also discussed.

INTRODUCTION

THE possibilities of pulse-code-modulation (p.c.m.) systems¹ for the transmission of speech have been known for some 30 years. Only recently, with the introduction of transistors and digital-type circuits, have practical designs been possible which show signs of being economic relative to present types of audio and frequency-division-multiplex (f.d.m.) systems for distances of 15–30 miles.

In 1964 arrangements were made for trials of three experimental systems, developed by contractors, each providing 23 or 24 telephone circuits on two pairs in different quads of deloaded audio cables. Experience gathered from this work and from various studies by the Post Office Research Station led to plans for the wide use of p.c.m. for junction circuits. A stimulus to this approach has arisen from the possibility of overall savings and improved transmission by using an integrated design of p.c.m. line system and associated digital-type tandem-switching exchange. Apart from this factor, which may take some time to resolve, there is considerable interest in a system which may enable the effective circuit capacity of existing audio-type junction cables to be increased several-fold.

GENERAL OUTLINE OF P.C.M. JUNCTION SYSTEMS

The speech signals from a channel of a p.c.m. system are sampled at a rate not less than twice the highest audio frequency it is intended to transmit. It is convenient to use a sampling rate of 8,000 time/second to obtain an output of amplitude-modulated pulses (pulse-amplitude-modulation (p.a.m.) signals) containing full information as regards the speech signal. The samples from a number of channels are collected sequentially on to a common highway, so building up a multi-channel time-divided signal. There are certain disadvantages if p.a.m. signals are to be transmitted satisfactorily over long distances, e.g. closely-spaced wide-bandwidth linear amplifiers are required to preserve a high signal-to-noise ratio, and phase equalization may also be necessary. To simplify the transmission problem the pulse amplitudes are interpreted by a multi-digit binary code, typically, 7 bits, identifying 128 amplitude levels. The p.a.m. signals are thus converted to p.c.m. signals using the nearest of the 128 levels. An extra digit is generally added to provide signalling information, and in some systems this digit is also shared with distributed synchronizing signals between the two terminals. In other systems, one speech channel is given-up and used exclusively for the synchronizing signals.

The p.c.m. line signals have the great advantage that they can be allowed to approach the level of noise and crosstalk, the requirement being merely to recognize

whether a pulse is present or not; the repeater then takes the form of a pulse regenerator which restores the received pulse train to an undistorted pulse train for transmission over the next section. The timing of the regenerative repeater is derived from the repetition rate of the received pulses. The usual spacing of repeaters is 2,000 yards on 20 lb/mile cable, coinciding with loading-coil positions.

As a result of converting the p.a.m. signals to p.c.m. signals only a limited number of amplitude levels can be transmitted, and it is necessary to make each of these output levels correspond to a small step in the range of input levels. This step, or quantum, in the assessment of signal level introduces fluctuating errors which have the effect of noise, usually referred to as quantization noise, in the presence of speech. For a constant signal-to-quantization-noise ratio over the dynamic signal range, it is necessary to maintain a fixed relation between step size and input-signal level at the step. In practice, departures from this condition are permitted for the highest and lowest signals. To achieve the required distribution of sampling levels a non-linear encoder, or a compandor plus linear encoder, is employed so that the lower input levels have more sampling steps than the higher input levels.

In the absence of speech, small noise signals at the audio input will cause line signals corresponding to the full level of the first step and, effectively, the noise is increased to a constant level. The higher the compression ratio of the compandor the lower is this idle-circuit noise.

At the receiving terminal the processes are reversed, and the derived p.a.m. signals are applied to a 4 kc/s low-pass filter to obtain the equivalent audio signals.

FIELD TRIALS ON EXPERIMENTAL P.C.M. SYSTEMS

As already mentioned, three systems developed by contractors have been tried in the field. Details of these systems are given in the table.

Details of Field Trial P.C.M. Systems

System	Channels	Code	Bit Rate (megabits/second)	Route
1	23 speech + 1 synchronizing.	8-digit speech and 1-digit signalling. Unit disparity binary.	1.728	Guildford-Haslemere
2	24 speech with distributed synchronizing signals.	7-digit speech and 1-digit signalling and synchronization. Alternating binary.	1.536	Coventry-Rugby
3	24 speech + 1 synchronizing.	7-digit speech and 1-digit signalling. Alternating binary.	1.6	Reading-Marlow

The code used in System 1 was arranged to have unit disparity between the number of marks and spaces ('1's or '0's) in a given signal. This limits the d.c. component

¹WHYTE, J. S. Pulse Code Modulation, Part 1—An Introduction to Pulse Code Modulation. *P.O.E.E.J.*, Vol. 54, p. 86, July 1961.

of the line signal, and, since the straight binary code (1, 0) can be transmitted at a higher level than the +1, 0, -1 of alternating binary, the margin against interference is increased. System 3 employed a non-linear encoder and Systems 1 and 2 used companders, all with different laws. The line repeaters were fitted in cast-iron boxes (Repeater Equipment Case No. 1)² accommodated in manholes, generally at 2,000-yard spacings but with shorter spacings adjacent to the terminal equipments. Power for the repeaters was fed, at a constant 50 mA d.c., from the terminal equipments over the phantoms of the two transmission pairs.

Two of the trial systems have been used for public-traffic purposes and the performance has been satisfactory.

In the preliminary field work it was shown that very few systems could be worked in the same or adjacent cable layers because of digital errors arising from near-end crosstalk and general cable noise. It appeared that large scale p.c.m. exploitation of audio cables could only be achieved by separating the pairs for the two directions of transmission by one or more layers, or by using two cables. An extensive program for measuring the distribution of crosstalk and noise at frequencies up to 3 Mc/s in audio cables has been set in train, and preliminary results support the above views.

FUTURE USE OF P.C.M. SYSTEMS

It is likely that considerable use will be made of p.c.m. junction systems in association with deloaded audio cables. Much depends on cost, since, as this falls, the potential field of use expands very rapidly.

Initial orders for some 70 systems in the London Telecommunications Region and nine in other Regions are about to be placed. The system specification calls for 24 channels each using a code of seven digits for speech and one digit for signalling and synchronizing, the line signal being in the form of alternating binary at a rate of 1.536 megabits/second. The general standard of performance has been based on trunk-junction* applications in the national network.

The p.c.m. terminals include signalling termination sets which contain the 2-wire/4-wire hybrids and means for converting d.c. signalling conditions to the digital line signals. The interfaces between the multiplex equipment and the 2-wire outlets are specified. An alternative design has 4-wire connexions and extends them, with appropriate d.c. signalling conditions, to conventional relay-sets.

The Post Office will deload and extend selected cable pairs to the repeater boxes (Repeater Equipment Cases

²CLINCH, C. E. E., and STENSON, D. W. Housing of Repeater Equipment Underground. *P.O.E.E.J.*, Vol. 56, p. 158, Oct. 1963.

*Trunk-junction—a junction used for completing trunk calls.

No. 1), each of which is capable of housing 48 repeaters with common supervisory units.

P.C.M. SWITCHING

There are particularly attractive possibilities for exploiting p.c.m. junction systems in the London tandem network, at present comprising some 40,000 audio junctions. Many of the routes are of such a length that p.c.m. transmission is likely to be attractive economically as a straightforward audio-to-audio alternative to physical pairs for each junction. If, however, p.c.m. junctions are to be interconnected at a tandem exchange, there are advantages in using a time-division-multiplex (t.d.m.) exchange compatible with the p.c.m. line systems and capable of switching the signals in digital form without conversion to audio. In such an integrated p.c.m. switching and transmission system there would be no need for p.c.m. terminals at the tandem end of the p.c.m. junctions, so that the minimum junction length for which p.c.m. systems would be economic would be effectively halved. The transmission loss between any two local exchanges so connected could be maintained at 3 db.

Close control of the coding and decoding characteristics is necessary in an integrated system, for any terminal may have to work with any other. The p.c.m. exchange involves some special requirements, which have been studied at the Post Office Research Station. For example, an outgoing route required by a certain incoming channel may not be free in the time slot occupied by the incoming channel; the exchange then has to introduce a small amount of delay to shift the signals to a free outgoing time slot. Suitable "slot-changing" techniques have been developed, as have "slot aligners" to absorb delay variations due to cable-temperature changes on p.c.m. junctions. These variations would otherwise disturb the timing of signals within the exchange, where an accuracy better than 0.1 μ s is required. There are also network-synchronizing problems which would be important in a widespread application of integrated systems.

A field experiment is being planned to facilitate the study of practical problems in associating a p.c.m. tandem exchange with the existing Strowger network, and to assess the feasibility of the integrated system. A model exchange will be built, small in itself but using techniques appropriate to a 10,000-junction exchange. Being essentially a fast (1.5 megabits/second) data-handling machine, the model exchange, which is planned for installation in 1967, will provide an opportunity to exploit silicon integrated circuits. The use of these in place of discrete components is expected to give a great improvement in the reliability of complex logical systems.

H.B.L. and A.W.P.

The New Post Office Railway Station at the New Western District Office

A. C. MACKAY, A.M.I.E.E., A.M.I.Loco.E.†

U.D.C. 625.42:725.16

Many of the postal-sorting offices in London are due for rebuilding, particularly as they are unsuitable for housing the equipment required for the modernization of the postal service. A description is given of some of the problems faced when seeking a site for the New Western District Office, and the complications surmounted in blending the Post Office Railway to the new building.

HISTORY OF THE POST OFFICE RAILWAY

THE Post Office (London) Railway Bill was put before Parliament in 1913, "to enable the Postmaster-General to construct for the purposes of the Post Office, certain underground railways and other works in London, and for purposes in connexion with such railways and works."

In presenting this Bill, it was stated that as long ago as 1853 Sir Rowland Hill had suggested that mails might be transmitted underground, and during the years 1873 and 1874 the Pneumatic Tube Company of London built a pneumatic tube to convey mails from the General Post Office to Euston Station. This scheme was in operation for only a short time, as it proved impossible to keep the tube air-tight. A Post Office Committee was appointed in 1909 to determine whether to recommend an improved type of pneumatic tube such as that being developed in New York, Chicago and Boston, or whether an underground railway should be favoured. It was decided that the mail-carrying capacity of the pneumatic system would be inadequate, even with the optimum size of tube. The only system which seemed to offer an improvement over the conveyance of mails by road van was an underground electric railway, and proposals were made for $6\frac{1}{2}$ miles of tunnelling to run through the centre of London, from Eastern District Office to Liverpool Street Station, King Edward Building, Mount Pleasant, Western Central District Office, Western District Office, the Western Parcels Office and Paddington District Office and the main-line station.

The declared advantages expected of the railway were as follows:

- (a) The conveyance of letters and parcels between the sorting offices on the route would be accelerated.
- (b) The reduction of the large expenditure on road vans.
- (c) Relief from congestion of the streets by the removal of a very large number of Post Office vans, both horse-drawn and motor.

In these respects the Post Office Railway, eventually completed in 1927,¹ has been successful, and if it were not for today's high cost of tunnelling the case for carrying out a number of the extensions envisaged by the 1909 Committee would be indisputable.

SELECTION OF A SITE FOR THE NEW WESTERN DISTRICT OFFICE

Many of the main sorting offices in London are housed

¹Post Office Railway, London Postal Region.

²The Post Office (London) Railway, *P.O.E.E.J.*, Vol. 21, p. 147, July 1928.

in very old buildings, which are no longer suitable or adequate. Due to their importance in the postal structure, the old Western District Office, in Wimpole Street, and the Western Parcels Office, in Bird Street, were given some priority in the rebuilding program. Apart from the difficulties of out-housing such busy offices during rebuilding, the areas of the sites were considered to be far too small. The alternative was to develop a fresh site, and, naturally, one stipulation was that access to the Post Office Railway should be feasible.

The site acquired at Rathbone Place, London, W.1, in 1952 proved to meet all major requirements. It was well situated in the W.1 Postal District, and was large enough to accommodate both letter-sorting and parcel-sorting offices, and have space for further developments. Also, it was actually above the route of the Post Office Railway.

METHOD OF EXCAVATION

The problems associated with the formation of a station were delegated to consultant civil engineers, and Parliamentary powers for carrying out their proposals were obtained in 1956.

It was decided that the route of the railway should be diverted to provide a station with its axis running east-west, i.e. at right angles to Rathbone Place and Newman St. All other stations along the route are in the form of twin segmented cast-iron tunnels, of either 21 or 25 ft diameter, and this form of construction was the first considered. To avoid overloading the cast-iron segments, the columns supporting the building above would have been taken to footings below the tunnel level, but the tops of the tunnels would have been only 10 ft below the lowest basement level, and, therefore, the danger of distortion or overstressing was apparent. This scheme was, therefore, abandoned in favour of making a reinforced-concrete box excavation, 180 ft by 90 ft by 70 ft deep.

The box-excitation method provided for a much-improved station layout and for an additional floor immediately above the station for housing railway equipment. The walls and base could be designed to support the superimposed loads from the building above. One added complication was, of course, that it is not a simple matter to make such an excavation, with vertical sides, without the risk of movement of the adjacent ground and danger to the buildings thereon.

The main contract was awarded in April 1956, and the following description of the procedure adopted will be assisted by reference to Fig. 1 and 2.

First a shallow excavation with sloping sides was made over the area, and then the upper part of the area intended for deep excavation was enclosed in a coffer-dam of interlocking sheet-steel, driven far enough into the clay to effect a cut-off and prevent the intrusion of any surface water. At the corners of the enclosure, where interlocking sheets would not be effective, the gravel subsoil was chemically consolidated.

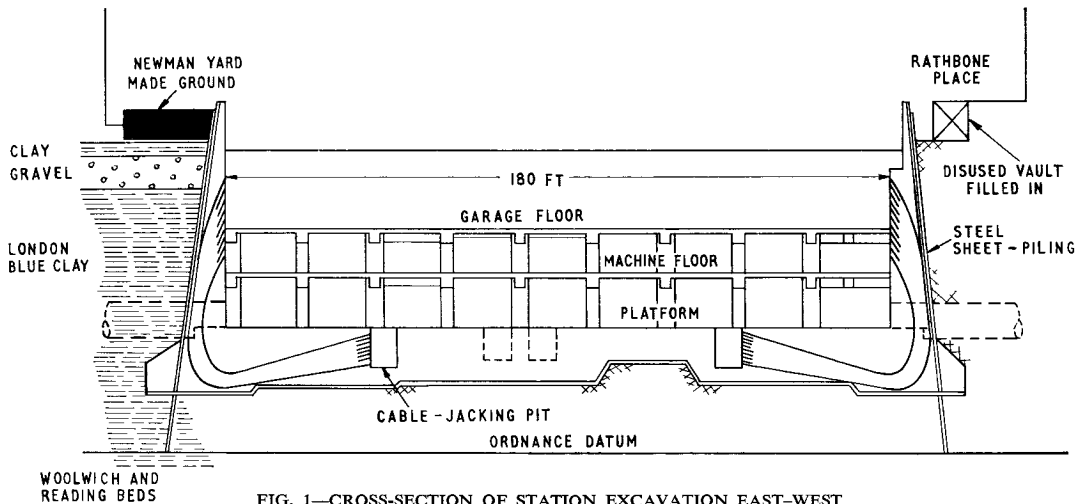

FIG. 1—CROSS-SECTION OF STATION EXCAVATION EAST-WEST

Steel "soldier" piles, 80 ft long, were driven at intervals of 5 ft around the periphery, penetrating to a depth below that of the intended excavation. Steel frames were assembled at between 10 and 11 ft vertical centres (determined by the intended floor spacing in the permanent structure) as the excavation developed, and needle joists were positioned between the steel soldier piles and the frames. Hydraulic jacks were used to apply pre-determined stresses, calculated to prevent ground movement.

The frames were supported on steel "king" piles. Reinforced-concrete curtain walls, 9 in. thick, were cast in situ against the trimmed sides of the excavation and between the flanges of the steel soldier piles to ensure uniform distribution of pressures imposed by the jacks.

The presence of the existing 9 ft diameter segmented cast-iron tube, running across the south-west corner of the site and carrying the tracks of the Post Office Railway, added to the difficulties in carrying out the pile work, and made careful planning even more essential. Several of the piles were designed to pass within 12 in. of the tube, and this after being driven through 70 ft of London blue clay.

One of the largest excavations ever attempted in central London having been completed, work commenced on the construction of the railway station and the necessary diversion of the tunnels, together with the foundation work of the building that was later to be erected above. It had been decided that the east and west end walls should be built as cantilevers, with monolithic connexions to the side walls, and to post-tension them in order to minimize deflexions (see Fig. 3). One thousand two hundred cables, averaging 100 ft long, were incorporated in the walls and bases, each cable consisting of 12 steel wires of 0.276 in. diameter. A light rigid sheathing

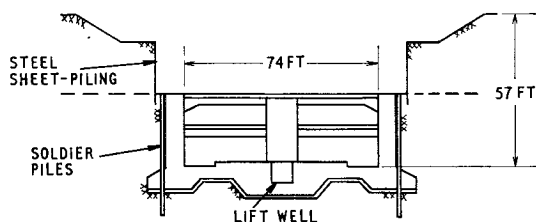

FIG. 2—CROSS-SECTION OF STATION EXCAVATION NORTH-SOUTH

was used to protect the cables, except at the 6 ft radius at the heel of the wall where steel tubing was required. The cable terminations were made in precast concrete blocks set in the walls and jacking pits, and, at the appropriate stages, tension was applied. As the structure progressed, and the needle joists were removed, the effect was observed by the use of 162 vibrating-wire strain gauges which had been embedded in the concrete.

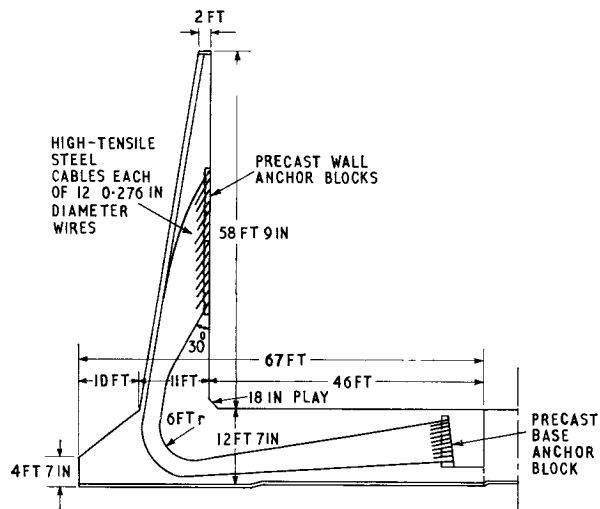

FIG. 3—ELEVATION OF END WALL, SHOWING METHOD OF POST-TENSIONING

DRIVING THE TUNNELS

With the excavation completed, headings were made on the east and west walls to commence the tunnel drives (see Fig. 4). Changes of tunnel section and the sharp curves limited the number of long drives and precluded the use of a tunnelling shield. Therefore, all the digging was carried out by compressed-air-driven hand tools. The clay was removed from the working face by a battery locomotive pulling tipper skips over a 2 ft gauge light track. Flat-top bogies were used to carry the cast-iron tunnel segments with which the tunnels were lined, and also the cement for grouting behind the newly erected segments.

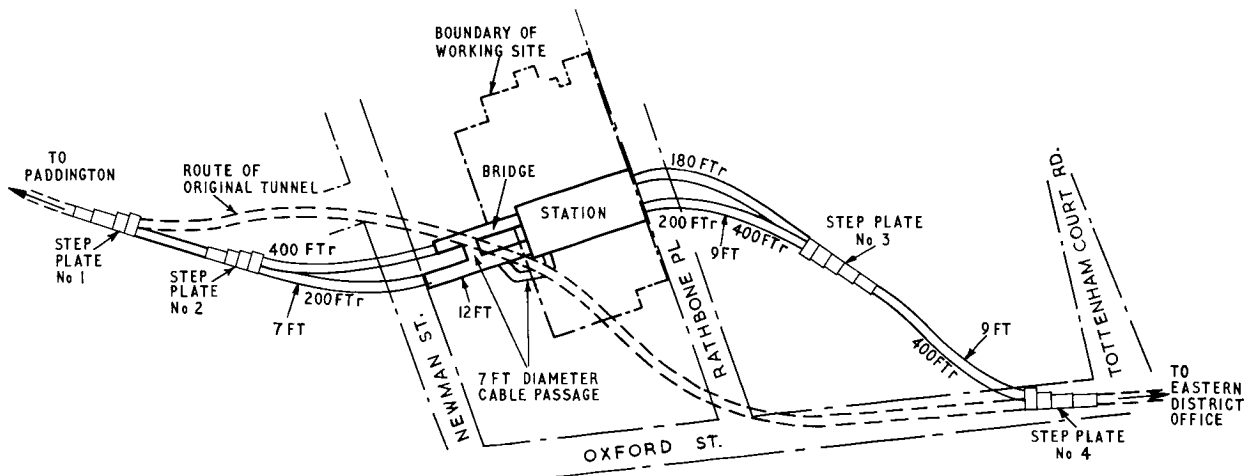

FIG. 4—NEW WESTERN DISTRICT OFFICE POST OFFICE RAILWAY TUNNEL LAYOUT

Step-plate junctions No. 2 and 3 were formed to provide the diversions from a single tunnel, containing east and west bound tracks, to separate tracks on either side of the station island-platform, as is the usual practice. Junctions No. 1 and 4 were required for the wedding of the old and new tunnels and subsequent diversion of tracks. It was considered vital that there should be no interruption of the normal Post Office Railway services, as there is now no alternative method of transport available. Junctions No. 1 and 4 were made large enough to encompass the old 9 ft diameter tunnel, which was temporarily supported by timber struts. The speed of the trains was considerably reduced from their normal 35 miles/hour during the whole of this operation.

When all the new tunnel and concrete work had progressed as far as possible, two tracks were laid via the northerly route, from step plate No. 1, through the station, and out to step plate No. 4. One track was intended as permanent, the sleepers being set in finished concrete, though provision was made for the insertion of rail switches (points) at a later date. Parts of the second track, between step plate No. 2 and the station, and between the station and step plate No. 3, were temporary and for use only until the other route through the station could be completed; they occupied space in the tunnel which would later be required for a "safe-walking" path, and the bed was, therefore, made of weak concrete set on a layer of paper to prevent bonding.

DIVERSION OF ROUTES

The vital point in the construction had now been reached when the trains would be diverted from the old tunnel, but, as the work could be carried out only during week-ends, the operation was spread over a period of six weeks.

During the first two week-ends the segments of the tunnel were removed down to track level. The concrete bed and segments below the track were demolished during the next two week-ends, the tracks being left supported on timber rafts. The fifth week-end was used for further preparation work: new tracks beds were formed, and prefabricated sections of track were suspended above their intended final positions.

Everything possible was done to reduce the amount of work to be carried out during the sixth and last week-end,

as it was obvious that the 35 hours available would be barely sufficient to complete the program. As soon as the last train had passed through the old tunnel at 11.0 o'clock on the Saturday evening, the tracks at step plate junctions No. 1 and 4 were removed and concrete was laid to form the final levels and elevations for the new tracks, which were then lowered into position. Prepared shuttering was fixed between the sleepers and the inverts, and concrete was poured to secure the tracks in the bed. The final work of bonding and cabling and clearing all equipment from the tunnel was completed, and a battery locomotive was used to tow a train over the new sections to check clearances. At 10.0 o'clock on the Monday morning, the first train passed safely through the new station under its own power.

COMPLETION OF STATION

While the tunnel work was being carried out progress was being made on the formation of the station. A massive concrete base below the platform was designed to carry three rows of columns at 40 ft centres to support the building above. Tunnel portals had to be provided in the end walls, and openings were required to the upper floors for three lifts, two twin-band riser conveyors, and a twin spiral chute, in addition to stairways. Not until much of this work had been completed could the way be cleared for the diversion of the new tracks to their final positions on either side of the platform.

Completion of the station and machinery floors left the north and south walls retained by the internal permanent structure up to the level of the machinery-floor ceiling, while the east and west end walls were adequately stressed by virtue of the post-tensioning system, and they retained the surrounding earth up to ground level. The two upper stress frames, with their needle struts holding the sheet piling in position, were still in situ.

The area of the excavation was now extended both east and west to the limits of the foundations for the new building, and to the depth of the proposed sub-basement. The stressing frames were removed as the pressures were released. Extensive underpinning of the adjacent property was necessary, and the concrete beds formed for this purpose were also used as part of the foundations for the new District Office. Reinforced-concrete pillars were erected upon foundation blocks set in the blue clay, and from this point the building progressed in a more

orthodox fashion. The project was completed in November 1958.

In all, 58,000 yd³ of earth were removed from the excavations, requiring 11,600 journeys by 5 yd³ lorries. 13,500 yd³ of concrete, 1,150 tons of mild-steel re-inforcement, and 146 tons of high-tensile steel wire were used in the construction work below ground level.

While the new sorting office was being erected above the station, Post Office staff were engaged in installing equipment to make the station ready for operation. At no time, other than the normal maintenance periods, was interruption of the service permitted. Cabling was transferred from the old tunnel to the new route through the station, and the tracks were divided into sections with their separate feeders to give control over the movement of trains. A room on the machinery floor was equipped with all the necessary control apparatus to reduce the speed of trains as they approach the station and stop them at the appropriate loading berth.

TRAIN CONTROL AT THE NEW STATION

The process of train control at the new station is described briefly as follows. As a train passes from the normal automatic section it enters a dead section of track, de-energizing the motor and the brake solenoid to slow the train. The bridging by the train of the running rails of this section operates a 440-volt contactor via a time-delay device; thus, after an interval of slowing time, power at 440 volts is applied to the conductor rail and the train continues to move forward to a point where the voltage is dropped to 150 volts to give a reasonable speed of approach to the loading berth. The short duration of application of the 440-volt supply is necessary to guard against the consequences of a train actually coming to a standstill in the braking section, when the 150-volt supply might not provide sufficient torque to restart the train. As a further safeguard against the remote possibility of a train stalling and causing delay to service, a switch is provided in the head-wall of the station platform, to override the track circuit at the station approach and apply

the full voltage to the conductor rail. The normal track circuit, which leaves a "dead" section of track behind each train, is used to prevent one train from running into the rear of another.

The operation of the train-despatch push-switch by the platform staff energizes the conductor rail via a 440-volt contactor, and, after a set time, there is a change-over to 150 volts, giving a low speed until the train reaches the first automatic section out of the station. Two stabling berths, with automatic shunting from the first to the second, are provided on each road.

The whole station area is controlled from a console equipped with two main switches, four sectional switches, receive and send switches for loading and stabling berths, and an illuminated route diagram. Occupation of sections is shown by a change of colour of the illuminating lamps.

LOCAL RAILWAY POWER SUPPLIES

Electric power supplies for the Post Office Railway, and for the building, are provided by the London Electricity Board: a 440-volt 3-phase supply for the building, and an 11 kV supply for the railway. The 11 kV supply is taken to transformer and mercury-arc rectifier units² on the machinery floor to produce the two voltages required for traction purposes. In the event of a failure of the 11 kV supply, facilities are available for a rapid change-over to the 6.6 kV supply from the sub-station at King Edward Building.

CONCLUSIONS

Several other sorting offices on the route of the Post Office Railway are scheduled for rebuilding in the near future, and it might prove desirable to lengthen some stations when circumstances are opportune. No deviation of the route can be envisaged, and the cost of such work as carried out at the New Western District Office would be prohibitive for the sole purpose of carrying out station improvements.

²Post Office Railway—Change to Mercury-Arc Rectifiers. *P.O.E.E.J.*, Vol. 52, p. 300, Jan. 1960.

Book Review

"The Transistor." Joachim Dosse. D. Van Nostrand Co., Inc. 283 pp. 131 ill. 55s.

This book is a translation, by Michael and Renate Prandervand, from the fourth edition of "Der Transistor." New editions of the book have appeared every two years since it was first published, keeping pace with the rapid development in the subject.

The book opens with a brief history of the transistor, and then chapter 2 goes on to introduce the basic electrical properties of semiconductors. The very useful account of the p-n diode includes an explanation of the action at the contacts between the leads and the semiconductor material, and the reader is then introduced to transistor action. Here, careful consideration is given to the parasitic currents. The chapter then deals with the electrical properties of various circuit configurations. A description of the transient behaviour leads to a section dealing with switching properties.

Chapter 3 gives a survey of the chief methods of manufacture, extending from the alloy structure to the silicon planar technique, and includes a brief account of epitaxy. There are several photographs of sectioned transistors. A short section on field-effect devices and four-layer controlled rectifiers follows.

Chapter 4 deals with the electrical properties, and considers temperature effects, noise, and life; a very thorough treatment of equivalent circuits is also given.

The next chapter surveys amplifier circuits, switching applications, negative-resistance circuits and oscillators, and it is followed by a brief chapter describing symbols and parameters. Finally, there is a very comprehensive bibliography of over 300 references.

Despite the translators' occasional lapses into a rather unusual style of English, this book must be classed among the best introductions to the subject.

H.G.B.

Materials and Fire Hazards

P. E. TAYLOR, Ph.D., B.Sc., A.R.I.C.†

U.D.C. 620.1:614.841

The risk of fire in telecommunication equipment must be kept to a minimum, but there are difficulties in designing equipment that is completely free of fire hazard. The flammabilities of various materials used in telecommunication equipment are discussed, and a typical method of test is described.

INTRODUCTION

IN telecommunication equipment the highest standards of reliability are required, and a great deal of thought has been given to means of reducing, to the smallest possible level, the risk of failure due to fire.

All forms of electrical equipment are potentially self-igniting, whether through the heating of a conductor which is accidentally overloaded, by arcing at contact surfaces, from current leakage through a deteriorated insulator, or by power loss in a dielectric, and, therefore, such equipment presents peculiar fire hazards.

An ideal solution would be to use only incombustible materials in the manufacture of electrical equipment, but for various reasons, such as difficulty of fabrication, poor performance in other respects, or the high cost of the incombustible materials that are available at present, this cannot be regarded as a practical possibility. Efforts are therefore directed, in the first place, to reducing the probability of an ignition to the lowest possible level, and, in the second, to ensuring that the resultant fire is self-extinguishing or, if this is not possible, that the rate of spread of the fire is so slow that there is a good chance of extinguishing it with simple fire-fighting equipment before much damage has been done.

Many metals will burn under suitable conditions, but even the most combustible, magnesium, does not present any fire hazard, because the conditions for ignition do not occur in normal use. Other inorganic materials, such as glass, asbestos and porcelain, are incombustible. For all practical purposes, fire hazards arise from the use of the various organic materials which find a wide use as insulators, as dielectrics, and in the supporting and housing of all forms of telecommunication equipment.

Organic materials vary in combustibility from PTFE (polytetrafluorethylene) at one extreme, which cannot be made to burn in any circumstances, to cellulose nitrate at the other, which will burn fiercely even in the absence of air. Most of the commonly used materials occupy an intermediate position in that, although they may be ignited, whether or not they produce a self-propagating fire depends very much on external circumstances such as the rate at which heat is lost from the fire by conduction or radiation, the air supply, or a number of other factors that are difficult to predict for a particular situation.

There are accepted methods of test which are designed to enable the property of flammability of a material to be controlled, but these tests are useful chiefly for ensuring that the least flammable of a range of materials is used for a particular purpose; it is not safe to assume, because a material passes the standard flammability test, that there are no fire hazards associated with its use. Indeed, it seems that in many instances the acceptance level is fixed at a certain point, not because the designer is

satisfied with it, but merely because it is recognized that there is no hope of getting anything better.

WIRES AND CABLES

It is interesting to consider the flammability test applied to Post Office jumper wire. The test is done on the complete wire because it is recognized that the make-up is equally as important as the nature of the materials in determining flammability. For example, the diameter of the conductor is important, as it determines how rapidly heat is conveyed away from the seat of the fire and whether the fire will be self-propagating.

At one time jumper wire was insulated with rubber, braided with wool and finally treated with a rather malodorous size, the wool and the size reducing the considerable flammability of the rubber. The test consisted of the application of a standard flame to the middle of a length of wire supported horizontally in a draught-free enclosure. After a few seconds the flame was removed, and the burning coverings of the wire were required to be self-extinguishing within a short time.

Jumper wire is now covered with polyvinylchloride (PVC), plus a cotton braid and a cellulose lacquer, and it is possible to impose a more severe test, as shown in



FLAMMABILITY TEST ON JUMPER WIRE

†Test and Inspection Branch, E.-in-C.'s Office.

the illustration, in which the wire is supported vertically and flame propagation is greatly favoured—conditions under which the original rubber-covered wire would undoubtedly have failed. There has been a similar reduction of the flammability of switchboard cable, which originally relied on the overall application of a lead foil (to conduct away heat) covered by a cotton braiding treated with a lead paint to reduce the flammability of wires which were insulated with fabric. This class of cable is now sheathed with PVC.

There can be little doubt that exchange equipment now being manufactured and installed represents a vast improvement from the point of view of reduction of fire hazards compared with older equipment, with its bundles of fabric-covered wires impregnated with beeswax and its capacitors embedded in petroleum jelly and sealed with bitumen. A large part of the improvement has been due to the introduction of PVC as a wire covering and sheathing material. It is of interest that the use of waxed textile persists in the lacing twine that is still used for cable forms. However, in the presence of large amounts of PVC this does not add to the fire hazard.

It is not always realized that the flammability of PVC is a very variable property. The rigid form of PVC, which contains only minor amounts of filler and mould lubricant, is quite incombustible. To obtain the flexible grades used for wire covering it is necessary to add large amounts of plasticizers which themselves are flammable liquids, and the resultant compound will burn. Other plasticizers such as tricresyl phosphate or one of the chlorinated hydrocarbons which are incombustible may replace all or part of the flammable type, but in general these do not produce the desired physical and electrical properties for a good wire-covering. A well compounded PVC represents a compromise between conflicting requirements, and the need for a test method which will hold the flammability at an agreed level is obvious.

The only serious rival to PVC as a wire covering at present is polythene, which has superior electrical properties and in other respects, such as ease of fabrication, physical robustness and cost, is generally comparable. From the point of view of flammability, however, polythene presents serious hazards. A piece of polythene is not easy to ignite, because it melts before it produces flammable vapours, and in this respect it behaves similarly to paraffin wax, which it chemically resembles. If, however, there is anything like the wick of a candle to hold the molten material in the combustion zone, polythene burns very readily. A bundle of wires can act as such a wick, as can also a fabric braid, paper lappings and so on, and for this reason polythene-covered wires are not used where there is a serious fire hazard.

There are various ways in which the flammability of polythene may be reduced: one method is to incorporate a proportion of antimony oxide, which has flame-quenching properties (as illustrated by the current advertisements for a decorators' paint which contains antimony oxide as a pigment); another is to modify the molecule chemically. Such modified polythenes have disadvantages in other respects; in particular, they are more expensive, and there seems little chance of their being used as a wire-covering even where fire hazards are important.

PTFE has already been mentioned as being quite incombustible, and this makes it an interesting possibility for a wire-covering for the future. Its electrical properties are equal to those of polythene, it withstands

high temperatures without decomposition or melting, which PVC and polythene do not, and it does not deteriorate with age. Although it is somewhat less flexible, this does not present any insuperable difficulty, and it is probably only its high price that restricts its use at present to a few special applications for which there is no alternative.

SURFACE FINISHES AND MOULDINGS

PVC is an example of a material in which an initially low flammability is raised by the addition of plasticizers that are necessary to improve its physical properties. The opposite state of affairs is seen in cellulose nitrate lacquers (so-called cellulose) in which the very high flammability of the base material is reduced to an acceptable level by the addition of plasticizers. Cellulose lacquers were the first serious rivals to the traditional finishes for wood, which, in effect, consisted of coating the wood with shellac (french polishing). From the industrial point of view the new lacquers had the merit that less skill was required in their application and the finish produced was generally more resistant to marring.

Cellulose finishes for wood came under suspicion at one time, after a fire in which it was found that flame propagated rapidly over the surface of wood panels with this type of finish. The problem has been studied by paint manufacturers; there are now accepted methods of test, and cellulose lacquers for wood are available which are no more flammable than the wood to which they are applied. Other modern wood finishes such as the polyesters or the polyurethanes do not as a rule present any great fire hazard, because of their high decomposition temperatures.

Specifications for instrument housings made of wood sometimes contain the requirement that the inner surface shall be flameproofed, and this is a difficult requirement to enforce. A great number of substances have been proposed for this purpose and are intended to work either by evolving an inert vapour when heated or by fusing and thus preventing the access of oxygen to the heated area, but reductions in flammability produced in this way are not very great. One commonly used treatment consists in the application of a solution of ammonium phosphate. At high temperatures this substance decomposes to ammonia and fusible oxides of phosphorus.

The thermoplastic materials used for the manufacture of telephone cases, until recently acrylic resins but now ABS (acrylonitrile-butadiene-styrene polymers), are combustible materials which burn readily once ignited. This does not seem to be a matter of any practical concern, partly because in a large mass it is necessary to apply a flame for some time before ignition occurs but also because a telephone is usually sited in surroundings which are much more combustible than its plastic case.

The earliest telephones made from thermosetting resins, such as urea formaldehyde or phenol formaldehyde resins, were also combustible, but, in general, thermosetting resins are more difficult to ignite because of their high decomposition temperatures.

Expanded polystyrene, which is now widely used as a cushioning material in packaging and for heat and sound insulation, was at one time considered not to present any great fire hazard because it passed the accepted test for flammability, which consists of the application of a flame to the lower edge of a sheet supported at an angle of

45°. It has been pointed out* that for this material such a test does not give a fair assessment of the flammability because the material shrinks away from the flame before it has a chance to ignite. If the conditions are altered to prevent this, expanded polystyrene burns readily. It is understood that special grades of expanded polystyrene of reduced flammability are now being developed, but, clearly, also the methods of testing for flammability will need to be modified for materials of this type.

Another commonly used material whose flammability has recently been called in question is the so-called "fibre glass," actually polyester resin reinforced with glass fibre. Polyester resins are combustible, but like many similar materials are not readily ignited in the mass. The presence of the glass fibre has a wick effect which increases the overall flammability, and work is in hand to reduce this by chemically modifying the resin.

SOLVENTS

It may be of interest to consider the flammability of solvents used in the cleaning of telecommunication equipment and of mixtures containing them, such as paints used for maintenance. Interest in the flammability of petroleum spirit began when this was supplied as a burning oil for lamps, and at that time the paraffin often contained volatile fractions which nowadays would be classified as petrol or gasoline. The Abel Flash-Point Apparatus was defined by Act of Parliament and determines the temperature at which, under minutely specified conditions, a liquid will produce a flammable vapour in a closed space. There are restrictions on the use and storage of liquids which have a flash point of less than 100°F. In practice, this has had the effect of severely

*CARPENTER, D. A. Flammability Test for Expanded Polystyrene. *British Plastics*, Vol. 38, p. 284, May 1965.

limiting the volatility of hydrocarbon solvents which could be used for cleaning purposes or as thinners in paints. The aliphatic or aromatic hydrocarbons which are supplied for these purposes are carefully adjusted mixtures that have the highest possible volatility without falling below the legal minimum flash point.

Another approach is to add a proportion of a chlorinated solvent to reduce the flammability of more volatile solvents, and mixtures of this sort are widely used for cleaning telecommunication equipment during manufacture and during factory repair. As might be expected the introduction of chlorinated solvents raises other problems such as toxicity and corrosiveness, and cleaning mixtures may contain as many as four different ingredients in an effort to get the best combination of properties. It will be clear, however, that the Government regulations do no more than reduce the risk in using flammable solvents and do not absolve the user from the need to exercise reasonable care.

CONCLUSIONS

Enough has been said to show the difficulties in designing equipment that will be free from fire hazards, and to point out the dangers implicit in relying only on laboratory tests which, in many instances, are more concerned in holding the level of flammability of a restricted range of materials at an acceptable level than in predicting performance in use. A great deal has been learnt from past experience, and much can be done by comparing the flammability of a new and unproven material with that of a material which has given good service in the past. For a new material in a novel application, however, there does not appear to be any adequate alternative to a test on a complete mock-up in which all the conditions are matched as closely as possible to those of actual service.

The New Status of the Technical Support Unit

U.D.C. 681.142

The Technical Support Unit, formed in 1958 to give technical support to the Treasury in relation to automatic-data-processing equipment, is now under the administrative control of the Ministry of Technology. The effect of this transfer on the scope of operation of the Unit is explained.

ON 1 March 1965 the Minister of Technology made a statement in the House of Commons of which the following is an extract:

"The Government consider that it is essential that there should be a rapid increase in the use of computers and computer techniques in industry and commerce and that there should be a flourishing British Computer Industry. Plans have been prepared to serve these ends.

First, I am forming a Computer Advisory Unit within the Ministry of Technology to advise on computer requirements over the whole Public Sector. All proposals for computer requirements for civil purpose will be referred to this Unit for objective technical appraisal before procurement is authorized. A similar procedure will apply to computers purchased with public moneys by

Universities, Colleges of Advanced Technology, and Research Councils. The advice of the Unit will also be available to local authorities, nationalized industries and other users in the Public Sector. With its accumulating knowledge of the needs of users it will work closely with the computer industry in planning new developments. The Unit will be based on the Technical Support Unit of the Treasury which will be transferred to the Ministry of Technology and built up to roughly double its present size as rapidly as possible."

The purpose of this note is to explain in greater detail the effect of the transfer upon the scope of operations of the Technical Support Unit (T.S.U.).

The Unit was formed as a Branch of the Post Office Engineering Department in 1958 to give technical support to the Treasury's Organization and Methods Division in relation to the rapidly expanding requirements of Government Departments for automatic data-processing (a.d.p.) equipment. Except in the case of the Post Office (which makes its own arrangements) contracts for such computers are placed by Her Majesty's

Stationery Office (H.M.S.O.), at the request of the Treasury, and so several parties—the user Department, the Treasury, H.M.S.O., and the manufacturers—are involved in the discussions which precede seeking of tenders and the ultimate placing of a contract. The T.S.U. has been called upon to give technical advice in these discussions, particularly when novel items are involved in the systems under consideration. To fulfil this obligation the Unit has made technical appraisals of the computer systems available, and has collected information through contacts with industry about current and future developments. When a contract has been placed the Unit has conducted trials at the factory before delivery and again at the site after installation. In the course of this work it has established well-defined standards of technical performance and has encouraged the computer industry to improve the reliability of its products.

The T.S.U. has also given advice—in association with the Ministry of Public Building and Works—on the accommodation required for computers and on the attendant problems of air conditioning, power supplies and special building features. After installation, the performance of computers in service has been monitored and a check has been made upon the quality of maintenance. All technical factors affecting computers, either current or proposed, for a.d.p. installations have, therefore, come within the purview of the T.S.U.

The transfer of the administrative control of the T.S.U. from the Treasury to the Ministry of Technology, forecast by the Minister on 1 March 1965, took place a month later, but subsequent reorganization has modified the structure then proposed. The T.S.U. and two other Units—a Computer Advisory Unit (C.A.U.) and an Operational Analysis Unit (O.A.U.)—together form a section known as the Computer Advisory Service (C.A.S.) which, in turn, is part of the Computer Division of the Ministry. The C.A.S. gives advice and technical assistance on the application of computers for users in the Public Sector other than Government Departments. It is concerned more generally with the formulation of a broad view of users' requirements and the translation of this experience into technical equipment specifications and system-design policy, and it provides representation

on national and international bodies for hardware and software specifications and standards. Broadly speaking, the C.A.U. deals with computer-application proposals and external queries, and maintains liaison with the users and their associations; the T.S.U. provides consulting-engineer services in relation to the evaluation, specification, selection, installation, acceptance and maintenance of the computer systems.

Despite this change of status the T.S.U. remains a Branch of the Post Office Engineering Department, and it continues as hitherto to give a service to the Treasury, for a.d.p. projects in Government Departments. In addition, however, through the C.A.S. it is now concerned with computer installations required for educational, scientific, industrial and local-government applications. This increased loading of the Unit has coincided with a considerable upsurge in the rapidly changing computer technology. New techniques such as microminiaturization, new methods of storage, and new systems organization have to be evaluated, and, whereas in the early days the Unit was primarily concerned with ensuring that hardware met the required standards, there is now a growing need for the study in depth of software of ever increasing complexity.

To cope with the greater volume of work, it has been necessary to double the size of the T.S.U. to a strength of about 50 engineers. The Unit now has eight groups, of which four are concerned with systems appraisal (both hardware and software), two with peripheral equipment and circuit techniques, and two with trials, accommodation and maintenance questions. Such a large influx of staff in itself poses a considerable problem in the need for training, a requirement which the Unit is meeting largely from its own resources.

Despite efforts to recruit from other Government Departments, the staff of the T.S.U. has been provided almost entirely from the Post Office Engineering Department. It should, however, be to the benefit of the Engineering Department to have a pool of engineers, highly trained in computer techniques, from which it can draw in the future when telecommunications will be increasingly concerned with this type of approach.

A.J.F.

Book Review

“The Measurement and Suppression of Noise.” A. J. King, M.Sc.Tech., D.Sc., F.Inst.P., M.I.E.E. Chapman and Hall. xi + 180 pp. 91 ill. 40s.

The whole of this book is written in almost a conversational style and is very easy to read. This attraction unfortunately has, in Part I, been allowed to debase the material one expects under the heading of “Basic Theory,” which leaves unanswered the many queries which will arise in the reader's mind. The author has attempted to fill the book from his very great experience and has almost completely succeeded, for only in a few places has the desire to include extra material led to a poor treatment. The first chapter is one such, giving the feeling also that the author has not got into his stride. The attempt to cover too much within 180 pages returns in Chapter 3, where the broad

principles of making an objective measurement of a subjective effect are suddenly forsaken for a superficial treatment of the absolute calibration of microphones. Such determinations are of prime importance, and if they cannot be given a proper treatment then mere comment with adequate reference is preferable.

The author's essentially practical approach is welcomed, but a little more care should have gone into translating his personal techniques into textbook terminology, i.e.: approximations written as equalities and the mixing of m.k.s., c.g.s., and f.p.s. units are to be deprecated, whilst one or two diagrams are difficult to follow without the original papers from which they were taken. Over 100 references are quoted yet this is still less than justice.

This is indeed an admirable and welcome introduction to a subject which, in general, is poorly understood.

A.H.I.

The Introduction of Subscriber Trunk Dialling at Unit Automatic Exchanges

J. H. HOYLE†

U.D.C. 621.395.374:621.395.722

The conversion of unit automatic exchanges to subscriber trunk dialling working involves a considerable number of existing exchanges, and to minimize capital expenditure it was imperative that maximum use be made of existing exchange equipment and accommodation. In general, this has been achieved by minor modifications of the line circuits, line finders, group selectors, final selectors and parent automatic exchange relay-sets. Some new signalling and switching equipment has been necessary, and this is, in the main, accommodated in new units.

INTRODUCTION

THERE are some of the older types of unit automatic exchange (U.A.X.) which are now obsolescent, namely U.A.X.s No. 5, 6 and 7, and there are others which are due for replacement by small automatic exchanges (S.A.X.s) within the next 5 years. It would be uneconomical for subscriber trunk dialling (S.T.D.) facilities to be provided at such exchanges, and for these reasons the introduction of S.T.D. will be confined to U.A.X.s No. 12, 13 and 14.

The general scheme adopted^{1,2} is based on the provision of direct access from the U.A.X. 1st selectors at a group switching centre (G.S.C.). This necessitates regenerating the first digit by a pulse sender and provision for storing the subscriber-dialled digits. It may be necessary to re-parent some U.A.X.s, and, where long junction routes are involved, provision has been made for the application of Signalling System, D.C., No. 2 or Signalling System, A.C., No. 8.

A single group of junctions carries the mixed traffic from the U.A.X., i.e. trunk, assistance or local calls, to or via the parent automatic exchange, and certain barring arrangements are, therefore, required on the level-9 access. Where required, translation of the first digit is also used for discriminating purposes.

If warranted by the amount of outgoing traffic, three separate groups of junctions may be employed at the larger U.A.X.s, as shown below.

- (i) Traffic routed via the register and assistance relay-sets (levels 1 and 0).
- (ii) Traffic routed via level-9 relay-sets.
- (iii) Traffic routed via levels 9, 1 and 0.

Pay-on-answer coin-boxes³ will not be available for the initial S.T.D. installations. The prepayment coin-boxes will be retained, and users will complete local automatic calls as before. For other types of call the code 100 will be dialled, this being translated at the U.A.X. into a code that will route the call via the G.S.C. to the auto-manual board. At a later stage, pay-on-answer coin-boxes with full S.T.D. facilities will be provided.

Metering of S.T.D. calls follows the established technique of metering over junctions⁴ whereby periodic meter pulses are returned to the U.A.X. equipment from the register-access relay-set⁵ at the G.S.C. Periodic

metering⁶ of local calls is controlled by local-call timers⁷ at the U.A.X.

MODIFICATION OF EXISTING EXCHANGE EQUIPMENT

Although in principle the modifications are similar for each of the three types of U.A.X. there are some points of difference in detail, arising from differences of basic design. It is, therefore, convenient to outline them separately. In doing so only installations with prepayment coin-boxes will be considered; the arrangements for pay-on-answer coin-boxes are described in detail under another heading.

U.A.X. No. 12

A simplified trunking diagram of the S.T.D. arrangements at a U.A.X. No. 12 is shown in Fig. 1. Prior to

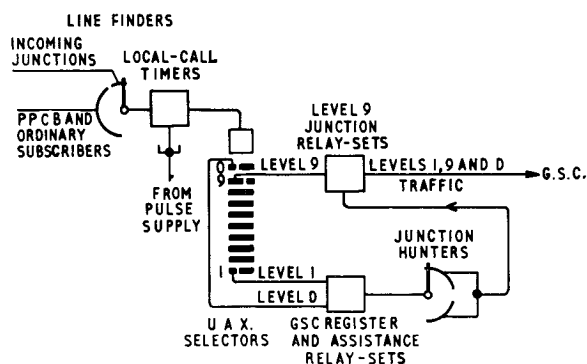

P.P.C.B.—Prepayment coin-box

FIG. 1—SIMPLIFIED DIAGRAM OF U.A.X. No. 12 S.T.D. TRUNKING ARRANGEMENTS

S.T.D. working, all traffic to and via the parent exchange was routed from selector level 9 at the U.A.X. For S.T.D. working it will be seen from Fig. 1 that, in addition to level 9, the first few outlets on levels 1 and 0 are cabled to S.T.D. junction relay-sets which, in association with junction hunters, permit calls to be routed to the G.S.C. via a common junction group. This involves re-numbering subscribers' lines having numbers 211, 212, et sqq., and 201, 202, et sqq., and in addition, if the U.A.X. has an extended multiple, lines with numbers 611, 612, et sqq., and 601, 602, et sqq. These changes to the selector-bank wiring involve a slight reduction in the maximum capacity of the subscribers' multiple.

The original level-9 and associated route-discriminating relay-sets have been retained, with suitable modification, and continue to be used for gaining access to exchanges within the local-call area, and for emergency and other services.

Modification of the existing junction relay-sets is required for the following reasons.

- (a) To dispense with the discriminating signals that were previously transmitted over the junction, on

†Telephone Exchange Systems Development Branch, E.-in-C.'s Office.

connexions via the manual board, to switch and identify calls from ordinary subscribers or from prepayment coin-boxes.

(b) To bar the dialling codes 1 and 0 to incoming junction calls.

(c) To disconnect local-call timing on incoming junction calls.

(d) To ensure the correct clear-down sequence to prevent possible fraudulent S.T.D. calls.

In addition to the circuit modifications outlined above, the following changes to the selector circuits are required.

(a) The wiring is modified to permit the insertion of local-call timers between the line-finder wipers and the selector circuit.

(b) The NP springs are recovered from level 9, as it is no longer a requirement that assistance calls be routed via level 9.

(c) NP springs are provided on level 0 to disconnect local-call timing on S.T.D. calls.

U.A.X. No. 13

The modifications required at U.A.X.s No. 13 are, in principle, similar to those already described for the U.A.X. No. 12. A significant difference, however, is that without disturbing the existing subscribers' multiple range, group-selector levels 1 and 0 are already available for trunking out to the G.S.C. register and assistance relay-sets.

Also, it will be seen from Fig. 2 that the local-call timers are connected after the group selectors instead of

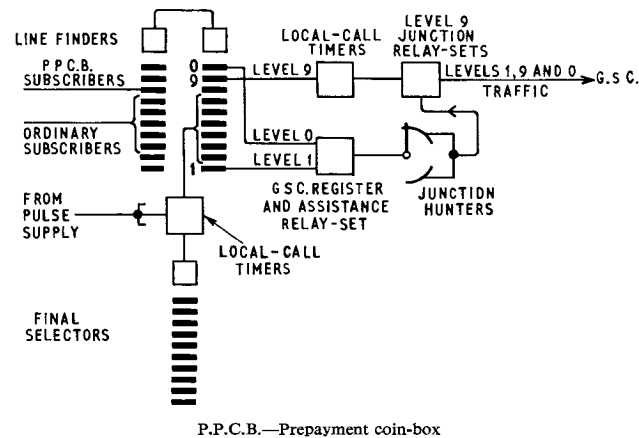

FIG. 2—SIMPLIFIED DIAGRAM OF U.A.X. No. 13 S.T.D. TRUNKING ARRANGEMENTS

in the usual and more economical arrangement used for the other two types of U.A.X. This method of trunking has been adopted to avoid the switching complications involved in disconnecting the local-call timers for calls routed via levels 1 or 0 of the group selector.

U.A.X. No. 14

All the modifications enumerated previously for the U.A.X. No. 12 are applicable to the U.A.X. No. 14, with the exception of modification (a) of the selector circuit.

For the U.A.X. No. 14, alternative schemes may be used to facilitate cabling of the 1st selector levels 1 and 0 to the S.T.D. junction relay-sets. The first scheme is shown in Fig. 3, and is used at U.A.X.s where the estimated number of exchange lines will not exceed

1,200 after a minimum period of 10 years from the introduction of S.T.D.

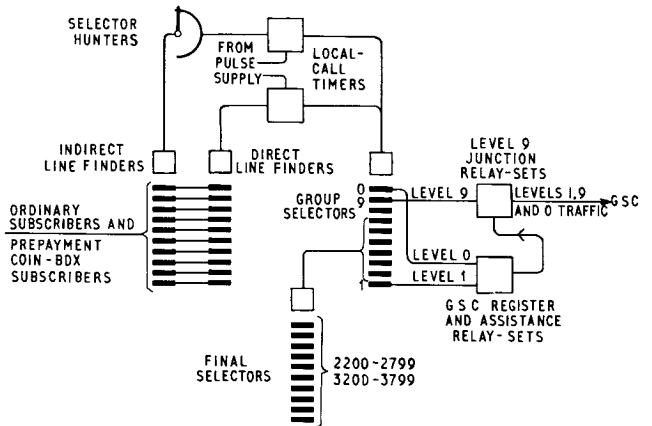

FIG. 3—SIMPLIFIED DIAGRAM OF U.A.X. No. 14 (1,200-LINE MULTIPLE S.T.D. TRUNKING ARRANGEMENTS WITH DIGIT-ABSORPTION ON 1st GROUP SELECTORS)

By making 1st selector levels 1 and 0 available for traffic to the G.S.C. it is necessary to re-number those subscribers' lines within the numbering ranges 2,000–2,199 and 3,000–3,199. Where provision is made for 1,200 exchange lines, only four 1st selector levels—levels 1, 8, 9 and 0—remain available for junction traffic. Of these, the associated codes 1, 9 and 0 are required for traffic to and via the G.S.C.; however, the code 8 may be expanded if required by the use of 2nd selectors at the U.A.X.

Fig. 4 shows the second scheme, in which the 1st selectors have been modified to dispense with absorption

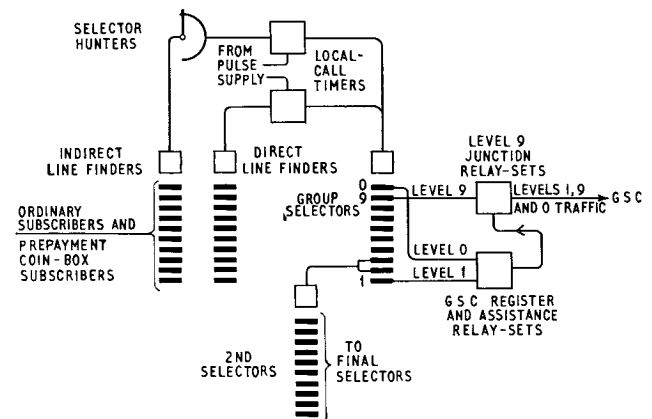

FIG. 4—SIMPLIFIED DIAGRAM OF S.T.D. ARRANGEMENTS AT U.A.X. No. 14 (2,000-LINE MULTIPLE) WITHOUT DIGIT ABSORPTION

of the first digit if it is a 2 or a 3, trunking to the final selectors being completed via a group of 2nd selectors. The rearrangement permits the subscribers' multiple to be extended to an ultimate capacity of 2,000 lines, with the further advantage that eight of the 1st selector levels are available for junction traffic.

ADDITIONAL S.T.D. EQUIPMENT

One of the problems at U.A.X.s is that of accommodating additional equipment. Where possible, space has been used in existing units, but certain major items have

required the provision of additional units for S.T.D. equipment. Although the units are different for each of the three types of U.A.X., all have jacked-in equipment to facilitate maintenance.

The various items of additional equipment are described below under individual headings.

G.S.C. REGISTER AND ASSISTANCE RELAY-SET

Access to the G.S.C. register and assistance relay-set is gained by either of two separate paths of entry, namely, via levels 0 or 1 of the U.A.X. 1st selector, the operation of relay WS in the relay-set circuit providing discrimination for level-1 calls.

The relay-set performs the combined functions of local register, metering-over-junction relay-set and assistance relay-set, the latter function being determined from the operation of relay WS. Because the first digit dialled by the subscriber is used for selecting the path of entry, it is necessary, after seizing a junction, to reproduce this digit to step the 1st selector at the G.S.C. This is done by a pulse-sending element, and a facility is also incorporated for sending a limited number of additional digits to provide for charging-group discrimination. On assistance calls this latter feature permits discrimination between prepayment and pay-on-answer coin-box calls. The pulse sender and positioning of the G.S.C. selectors require that the subsequent information dialled by the subscriber should be received and held in a temporary store, and for this purpose use is made of a mechanical pulse-regenerator, a storage and sending device that, in addition to its advantages in cost, is economical in space requirements.

Table 1 shows the register and assistance relay-set translations that will usually be required.

Level-0 Calls

The G.S.C. register and assistance relay-set is seized via level 0 for trunk calls, operating relay A (Fig. 5)

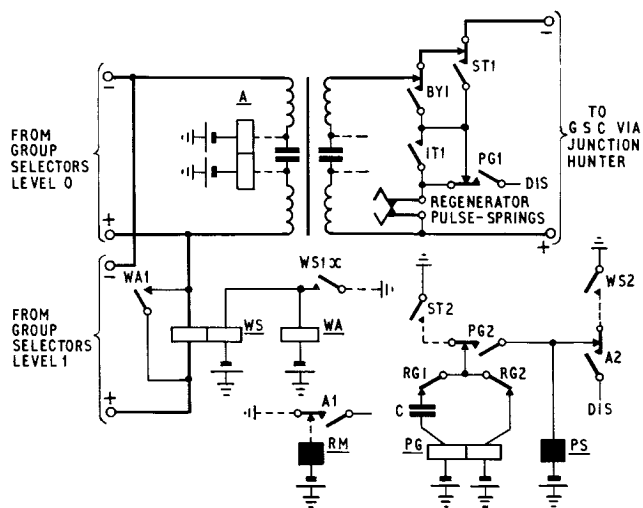

FIG. 5—SIMPLIFIED DIAGRAM OF LEVEL-1 STEERING RELAYS AND PULSE GENERATOR (G.S.C. REGISTER AND ASSISTANCE RELAY-SET)

without operating relay WS, and pulses dialled subsequently are applied to magnet RM and stored in the regenerator.

After the first train of dialled pulses has been stored in the regenerator, a seizure loop is prepared at contact BY1 and the search for and the seizure of an outgoing junction is initiated via the junction hunter. Use is made of the inter-digital-pause timing relays to provide a

TABLE 1
Translations Provided by Register and Assistance Relay-Set

Digits Dialled	Calling Subscriber	Digits Received by Register and Assistance Relay-Set	Digits Transmitted by Register and Assistance Relay-Set	Remarks
100	Ordinary, or pay-on-answer coin-box	00	100	Coin-box discrimination by tone
0	Prepayment coin-box	Nil	11	Level 11 reserved at G.S.C. for manual-board calls from prepayment coin-boxes
100		00		
19X 18X 17X	Ordinary, or pay-on-answer coin-box	9X 8X 7X	19X 18X 17X	These codes are barred to prepayment coin-boxes
National number	Ordinary	National number less initial digit 0	02, 04 or 06, plus remaining digits of national number	*Digits 2, 4 or 6 received by register-access relay-set for charging-group discrimination
National number	Pay-on-answer coin-box	National number less initial digit 0	01, 03 or 05, plus remaining digits of national number	*Digits 1, 3 or 5 received by register-access relay-set for charging-group discrimination
11-16	Ordinary, or prepayment or pay-on-answer coin-boxes	1-6	Nil	These codes are barred to all subscribers

*The purpose of the discriminating codes 01 (pay-on-answer coin-box) and 02 (ordinary subscriber) is two-fold: first, to indicate to the register-translator that the call is from a U.A.X. situated within the same charging group as the G.S.C., and, secondly, to provide coin-box discrimination. Should the call originate from a U.A.X. in a dependent charging group the pairs of codes 03 and 04, or 05 and 06, are used for charging-group and coin-box discrimination.

delay before the operation of relay ST; this delay allows for the seizure time of the G.S.C. equipment. The operation of relay ST permits pulse sending by contact PGI, whilst contact PG2 steps the pulse-sender magnet. The pulse-generator relay, relay PG, in association with capacitor C, provides trains of pulses at the rate of 10 pulses/second.

Referring now to Fig. 6, the pulse sender, it will be seen that uniselector PS controls relay IT, which at contact IT1 (Fig. 5) provides a masking circuit for the inter-digital pauses required during pulse sending. The pulse-sender bank connexions are arranged for the routing digits indicated, relay IT being connected to the appropriate bank contacts to give inter-digital-pause masking of the pulse-generator relay contact PG1 (Fig. 5). Relay RG (Fig. 6) provides the end-of-sending

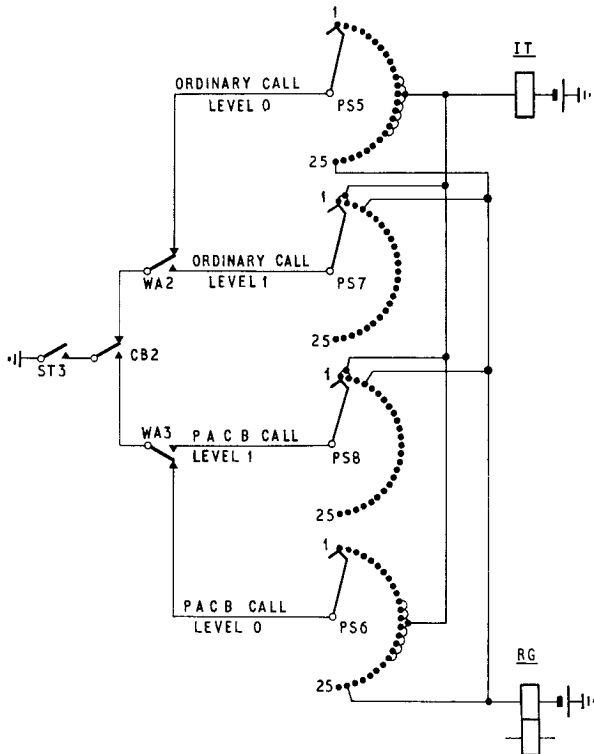

Note: The pulse-sender arcs are strapped to send as follows:
arc PS5—06, arc PS6—05, arc PS7—1 and arc PS8—1.
P A.C.B.—Pay-on-answer coin-box.

FIG. 6—SIMPLIFIED DIAGRAM OF PULSE SENDER (G.S.C. REGISTER AND ASSISTANCE RELAY-SET)

signal to release and isolate relay PG at contacts RG1 and RG2 (Fig. 5). The bank contacts of four arcs of uniselector PS are terminated on a connexion strip to allow translations to be arranged by appropriate cross-connexions, the appropriate uniselector-arc wiper being selected by contacts of relay WA for level-1 calls, and, in addition, a contact of relay CB for coin-box originated calls. Relay CB (not shown in Fig. 5 or 6) is operated from a -50-volt potential on the meter wire, as in normal U.A.X. practice.

It should be mentioned that, because the pulse sender is used to originate the pulses which position the G.S.C. selectors, the normal 800 ms inter-digital pause is provided. With completion of pulse sending, indicated by the operation of relay RG, a circuit is completed for

the regenerator to start sending its stored digits to the G.S.C. register. To ensure that the regenerator has the storage capacity for the longer national or international numbers the inter-digital pause (obtained from timing relays) is reduced to 400 ms.

Level-1 Calls

For level-1 calls a different sequence of operation occurs from that on level-0 calls. Referring to Fig. 5 and 7 it will be seen that, with the operation of relay WS, the

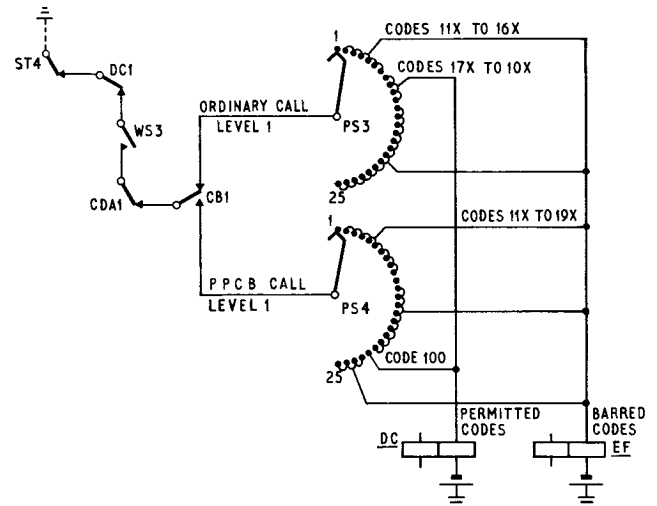

P.P.C.B.—Prepayment coin-box.

FIG. 7—SIMPLIFIED DIAGRAM OF DIGIT-COUNTING AND DISCRIMINATION ELEMENT (G.S.C. REGISTER AND ASSISTANCE RELAY-SET)

pulses dialled subsequently are repeated to the PS magnet via contacts A2 and WS2; this is in addition to normal storage in the regenerator. The stepping of uniselector PS provides pulse counting and, in conjunction with relay EF (Fig. 7), gives a facility for barring calls: the operation of relay EF results in the return of number-unobtainable tone to the caller, and a junction is not seized. If the call is one that is permitted, operation of relay DC (Fig. 7) starts the junction hunter searching for a free junction and also homes uniselector PS in readiness for its pulse-sending function. When a free junction has been found, the operation of relay ST completes a seizure loop at contact ST1, and applies a start signal to the pulse-generating relay via contact ST2 (Fig. 5). The pulse-sending uniselector arcs PS7 and PS8 (Fig. 6) are prepared by contact ST3; the first two contacts of these arcs are used to mask pulse sending by the operation of relay IT, to allow for the seizure time of the G.S.C. equipment. After sending the routing digit the operation of relay RG (Fig. 6) allows the sender uniselector to home, and, after a relay-timed inter-digital pause, transmits the regenerator-stored digits, the pause between pulse trains being 800 ms.

Level-1 Prepayment Coin-Box Calls

The circuit is required to cater for either pay-on-answer or prepayment coin-box calls. Although the assistance code for prepayment coin-boxes will be 100, it is necessary to provide a discrimination signal to enable the operator to identify a prepayment coin-box. Such calls are routed from level 11 at the G.S.C., and it is arranged that the pulse sender transmits these digits.

The CB relay will be operated with seizure of the relay-set, and this allows the counting function of uniselector PS to check both subsequent digits 00. This is shown in Fig. 7, where contact 21 of uniselector arc PS4 gives a permitted code. The circuit also arranges for coin-box relay CB to suppress the input to the regenerator, so that the digits 00 are used for counting only and are absorbed.

Pay-On-Answer Coin-Box Calls

Fig. 8 shows the trunking arrangements for pay-on-answer coin-boxes at U.A.X.s No. 13; the trunking

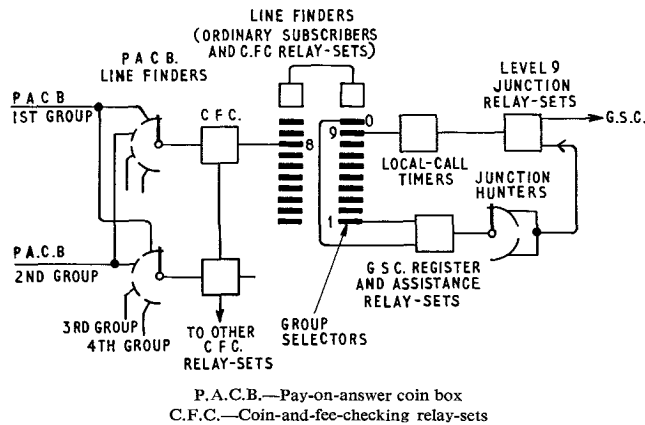

FIG. 8—TRUNKING ARRANGEMENTS AT A U.A.X. No. 13 FOR PAY-ON-ANSWER COIN-BOX CALLS

arrangements at the other U.A.X.s are similar in principle. The special feature adopted with the introduction of pay-on-answer coin-box calls is the use of uniselector line finders serving a maximum of either 25 or 50 coin-box lines. Coin-box traffic is then connected to the normal line finder level 8, via coin-and-fee-checking relay-sets. A large coin-box group can thus be accommodated, using a minimum of coin-and-fee-checking relay-sets.

Each coin-and-fee-checking equipment and its associated uniselector line finder serve a small number of line equipments. Arrangements are made for a line-equipment "start" signal to be diverted to a succeeding coin-and-fee-checking relay-set in the event of the line equipment's normally-associated relay-set being busy or faulty.

The coin-and-fee-checking relay-set is the standard equipment for dealing with pay-on-answer coin-box calls; the principles of this equipment have been described elsewhere.³ The relay-set provides a signal for coin-slot control by the operator, and, therefore, the register and assistance relay-set receives this signal and repeats it to the coin-fee-checking relay-set.

LEVEL-9 JUNCTION RELAY-SETS

Reference has previously been made to the modifications required for existing junction relay-sets for S.T.D. working. These modifications have resulted in some redundant relays, etc., in these equipments, the retention of which can, however, be justified on economic grounds. For new work, for instance to cater for an increase of junction-group size, or where it is essential to gain additional mounting space, new circuits have been designed: one for pay-on-answer, and one for prepayment coin-box working. Both have the access-barring facility built into the relay-set. Typical barring arrangements are shown in Table 2.

TABLE 2
Typical Access-Barring Arrangements

Dialling Code	Classification
90	Barred to all subscribers
910-916	Barred to all subscribers
917	Barred to all subscribers, but may be unbarred if access to engineering services is required
918-919	Barred to all subscribers
92-97	Permitted codes
980	Barred to prepayment coin-boxes
981-989	Permitted codes
99	Permitted code

LOCAL-CALL TIMING

The local-call timers for the three types of U.A.X. differ somewhat in detail, but all are similar in principle to those in general use at non-director exchanges.⁷ Fig. 1, 2, 3 and 4 indicate at which points this equipment is inserted in the trunking for the different types of U.A.X. Fig. 9 shows a simplified circuit for the U.A.X.

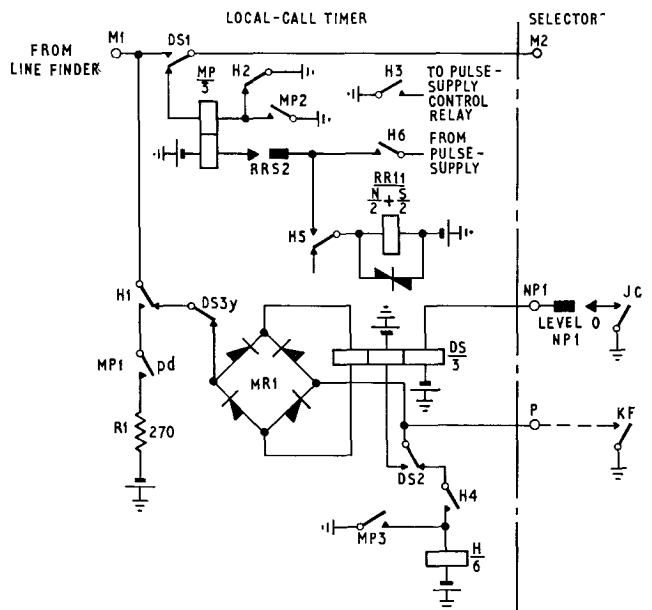

FIG. 9—SIMPLIFIED CIRCUIT DIAGRAM OF LOCAL-CALL TIMER CIRCUIT AT U.A.X. No. 12

No. 12, giving the essential metering arrangement and the method of inhibiting periodic metering on certain classes of call.

Ordinary Subscribers' Local and Junction Calls

When the called subscriber answers, a -50-volt pulse is applied over the M2 wire from the selector or junction relay-set. This pulse operates relays MP and H, extending a -50-volt pulse on the M1 wire to the subscriber's meter. Relay H remains held to the P-wire earth, and relay MP releases when the negative pulse on the M2 wire ceases.

The pulse supply is connected by relay H, and ratchet relay RR steps to these pulses. At the end of the 10th pulse, springs RRS2 close, and relay MP operates in parallel with relay RR to the 11th pulse, applying a further pulse to the subscriber's meter at contact MP1. This cycle continues for the duration of the call.

Coin-Box Calls

It will be evident that for calls from prepayment coin-boxes timing of local calls cannot be applied, and, therefore, the local-call-timing circuit is made ineffective.

When pay-on-answer coin-box working applies, local-call timing is embodied in the coin-and-fee-checking relay-set, and, again, the local-call-timing circuit is made ineffective. This feature is catered for by operating relay DS from the -50-volt signal applied to the M1 wire. The rectifier MR1 is necessary only to ensure correct current energization of relay DS to either a negative potential (coin-box calls) or to positive potential (incoming-junction calls). Relay DS is locked to the P-wire earth for the duration of the call, and the M1 wire is extended forward to receive the single meter pulse on answer.

0-Level Calls

0-level calls are subject to periodic metering from the metering-over-junction facility of the junction relay-set. For such calls the local-call timer is made ineffective by the direct operation of relay DS, via the selector NP springs and contact JC, after junction discrimination has been made by the selector.

Meter-Pulse Supplies

The provision of standard pulse-generating and tariff-control equipment⁸ at U.A.X.s would clearly be uneconomic; one solution is to extend the pulses over a junction line from the G.S.C. The need for a special junction for this purpose has been avoided by taking advantage of an existing type of wire broadcast system. The continuous 72 kc/s carrier of this equipment is modulated by signals of 44 c/s and 26 c/s, which at the U.A.X., after demodulation and amplification, provide earth pulses for both ordinary and coin-box tariff rates that are then used to pulse the distribution relays. This arrangement has the added merit of using the carrier system in its idle condition, thereby facilitating monitoring of the carrier signal. Provision has been made for remote aural checking of the tariff rate by dialling final-selector test numbers.

ADDITIONAL FEATURES

Subscribers' Private Meters

The application of standard S.T.D. facilities has required provision of equipment for those subscribers who may require private meters; this equipment has been described elsewhere.⁹ If a private meter is fitted, meter signals are repeated as 45-volt 50 c/s pulses and extended to the subscriber's equipment using the line pair as an earthed-phantom circuit.

Trunk Barring

Trunk barring is also available for subscribers who may wish to prevent unauthorized use of their exchange lines for trunk or assistance calls. At the telephone instrument a rectifier shunt-circuit may be connected across the dial springs by the operation of a Yale-type

key. At the exchange, a trunk-barring relay-set is fitted; this uses a miniature uniselector for pulse counting, and should the first digit be 0 or the first two digits 1 and 0 the line potential is reversed, allowing the telephone-instrument rectifier circuit to shunt the dial springs and prevent further pulsing.

Routine Junction Testing

Levels 1 and 0 at the U.A.X. are barred to incoming junction calls to prevent possible fraudulent routing of calls. It is, however, required that an operator should be able to carry out junction routine testing by dialling out over a junction to the U.A.X. and back to the G.S.C. via U.A.X. levels 1 or 0. To achieve this the operator first removes the barring facility in the following manner.

A test number at the U.A.X. is dialled; the operator then applies a trunk-offering signal and controlling relays at the U.A.X. then remove the barring facility from the G.S.C. register and assistance relay-sets. The operator holds the connexion during this period of routine testing. On the completion of testing, the connexion is released to restore the barring facility.

Remotely Controlled Junction Busying

On unidirectional outgoing junctions from the U.A.X. to the G.S.C. a facility has been provided to enable the junctions to be busied to U.A.X. traffic, by remote control from the G.S.C.

The system adopted is the same as that used at main exchanges whereby a high-resistance guard relay associated with the outgoing relay-set is connected across the line and, in the idle state, is permanently operated by the -50-volt and earth potentials from the G.S.C. If the line is disconnected, or the polarity reversed due to a fault condition, the guard relay releases to busy the junction at the U.A.X.

When the circuit is seized for an outgoing call the guard relay is disconnected from the line to avoid impairing transmission and signalling performance.

CONCLUSIONS

The introduction of S.T.D. at U.A.X.s will mean that many subscribers in small communities will benefit from the modernization of the telephone service. In addition, the useful life of these small exchanges will be considerably extended, with a consequent saving in capital expenditure.

References

¹FRANCIS, H. E. The General Plan for Subscriber Trunk Dialling. *P.O.E.E.J.*, Vol. 51, p. 258, Jan. 1959.

²JACKSON, F. G. Subscriber Trunk Dialling for U.A.X. Subscribers. *P.O.E.E.J.*, Vol. 56, p. 21, Apr. 1963.

³BASTOW, F. J., COLLINGWOOD, J. D., NEWELL, E., and PRICE, C. K. The Pay-on-Answer Coin-Box System. *P.O.E.E.J.*, Vol. 51, p. 343, Jan. 1959.

⁴HEPTINSTALL, D. L., and RYAN, W. A. Metering Over Junctions. *P.O.E.E.J.*, Vol. 51, p. 335, Jan. 1959.

⁵BARNARD, A. J., BENSON, D. L., and WOOD, R. A. Controlling Register-Translators. *P.O.E.E.J.*, Vol. 51, p. 272, Jan. 1959.

⁶WALKER, N. Periodic Metering. *P.O.E.E.J.*, Vol. 51, p. 320, Jan. 1959.

⁷ELLIS, D. R. B., and GORTON, B. D. Local-Call Timers. *P.O.E.E.J.*, Vol. 51, p. 333, Jan. 1959.

⁸RUSSELL, P. S., GORTON, B. D., LUMBER, A. L., and CUMMING, W. S. Pulse-Generating and Tariff-Control Equipment for Periodic Metering. *P.O.E.E.J.*, Vol. 51, p. 324, Jan. 1959.

⁹GRESSWELL, F., BELK, J. L., and ALDERSON, G. A. Subscribers' Private Meter Equipment. *P.O.E.E.J.*, Vol. 51, p. 338, Jan. 1959.

Engineering Aspects of Staff Comfort

R. W. HOPWOOD, B.Sc.†

U.D.C. 331.827

Standards of comfort at work are continually under review and generally improving. This article shows where the achievement of comfortable working conditions impinges on the work of engineers in the Post Office, and describes some of the problems met.

INTRODUCTION

HISTORY shows a steadily rising standard of comfort in organized employment. The British Post Office, through its Building and Welfare Department and through the normal staff-consultation channels, is constantly reviewing many aspects of staff comfort. This article deals with those aspects which commonly pose problems for engineers, namely, temperature control, ventilation, lighting and noise, which together largely determine the environment conditions.

The definition, used here, of comfortable conditions will be those indoor environmental conditions which enable most people to work efficiently and without undue fatigue. The qualification "most" is necessary because of the variability of human beings, as will be shown later.

Of the four factors mentioned above, temperature control is usually the most important, and comfort zones of temperature alone have been quoted by some workers, while closely allied to it is the question of ventilation; these two problems will be dealt with first.

Although equipment designers sometimes call for close temperature or humidity control, or both, to improve performance, it is a fact that in the majority of Post Office premises the environment is controlled with the object of promoting staff comfort, and the environment thus obtained is found to be well suited to most of the apparatus that has to be dealt with.

GENERAL ASPECTS OF TEMPERATURE CONTROL AND VENTILATION

Comfort Zone

Comfort is a matter of individual conviction, and so experimental work takes the form of questioning the subjects as to their feelings after a certain time in a controlled laboratory environment or in a carefully measured field environment. The most important factor involved is temperature. Fig. 1, produced by Chrenko,¹ shows the comfort zone based on data obtained by Bedford in 1936 for persons engaged on very light industrial work. The upper curve represents the incidence of uncomfortable warmth, while the lower curve represents the percentage of uncomfortable cooling. The shaded area represents Bedford's comfort zone, defined as that in which not less than 70 per cent of the subjects were comfortable. In fact, he found that within this zone (60°F to 68°F dry bulb) at least 86 per cent of assessments ranged from "comfortably cool" to "comfortably warm."

Bedford's results show conclusively that there is no one ideal air temperature for all people in one situation. Similarly, comfort zones are not the same in different countries, the range in America, for example, being some 4°F higher than for Britain and still rising. This difference seems to be due to long custom and to different clothing

habits. A shift of comfort zone between winter and summer is apparent in Britain and America simply due to the lighter clothing worn by most people in warm weather.

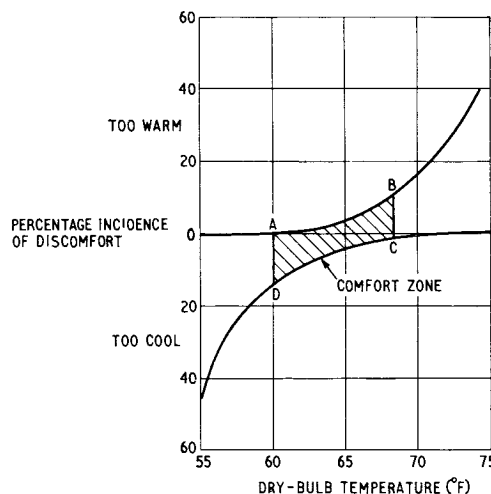

FIG. 1.—COMFORT ZONE RELATED TO DRY-BULB TEMPERATURE OF AIR FROM RESULTS OF AN INVESTIGATION INTO THERMAL COMFORT OF FACTORY OPERATIVES

Physiological Aspects

The human body can receive or lose heat by:

- (a) radiation,
- (b) convection,
- (c) evaporation or condensation, and
- (d) conduction.

A person doing sedentary work generates heat at about 400 B.t.u./h. (110 watts) and must lose this amount of heat to the environment. Failure to do so will result in a steadily rising body temperature, leading to exhaustion and collapse. Thus, the problem is not to heat the body but to control the loss of heat from it.

If the average temperature of walls, floor and ceiling (i.e. the mean radiant temperature or m.r.t.) is high, and the air temperature is also high so that little heat can be lost from the body by radiation, convection or conduction, then equilibrium can only be restored by evaporation loss, i.e. through sweating. This could not be considered comfortable.

The rate of heat generated by the body is not uniform over the body but is greater at the head than the feet. Research carried out by Chrenko² indicates that for maximum comfort the air temperature at head level should be several degrees lower than that at ankle level. For sedentary subjects, optimum air temperatures suggested by Dr. Chrenko are 70°F for the feet, 66°F for the hands, and 60°F for the head. This is a most important observation for two reasons: firstly, because most heating systems give a rising temperature from floor to ceiling, i.e. the wrong way for comfort, and, secondly, because relief from over-heating at head level is not easy to arrange on an individual basis. Over-heating generally can be compensated for by reduced weight of clothing, but clearly this does not apply to the head. Thus, the age-old

†Power Branch, E.-in-C.'s Office.

problem of keeping the feet warm is not solved merely by cutting down floor draughts, although this is very important, but requires more heat to be directed towards the feet. This cannot be done merely by increased room heating unless considerable air movement is also ensured to increase the heat loss from the head. The best approach possible with normal types of central heating is to increase the radiant-heat content in such a way that the radiation can reach the feet.

The balance between heat lost by radiation and convection will depend on the relation between air temperature and m.r.t., but it is found that for sedentary work in normally-heated accommodation the difference between the two is very small. A high radiant temperature can arise, however, from sun shining through windows, and acute discomfort can be caused. Radiant temperatures exceeding 100°F have been measured in certain positions in rooms having normal air temperatures.

Humidity

It is now considered that in Great Britain, at normal room temperature, atmospheric humidity has little effect on assessment of warmth but has some effect on the impression of stuffiness or freshness. The higher the humidity the more likely the impression of stuffiness. Both the ventilation rate (fresh air) and total air movement also have an effect on the feeling of freshness—the more, the fresher.

Comfort Measurement

Many attempts have been made to combine the effects of air temperature, radiant temperature, relative humidity and air speed into one index and, preferably, one measurement, but the latest work in this field suggests that these attempts have not succeeded. The single index approach would allow quite wide variations of air temperature to be compensated by other factors, but modern work suggests that the dry-bulb temperature must be within the comfort zone and other factors must be separately kept within bounds—this at least restores faith in the ordinary thermometer as the starting point for assessing comfort conditions.

BUILDING AND ENGINEERING ASPECTS OF TEMPERATURE CONTROL AND VENTILATION

The ideal conditions to be met for sedentary work are fairly well established, their ranges being as follows.

Mean dry-bulb temperature (T°): 62–68°F winter, 65–72°F summer, with a minimum gradient, or small negative gradient, from floor to ceiling.

Mean radiant temperature (m.r.t.): between $T^\circ - 2$ and $T^\circ + 4$ at head level.

Relative humidity (r.h.): 30–70 per cent.

Air movement: 15–50 ft/min.

In addition, a ventilation rate of 1,000 ft³ of fresh air per hour per person is required to maintain air purity.

The problem in the past has been almost entirely a winter heating one, and this is still the major concern. However, over-heating in summer-time is becoming serious in apparatus rooms with high internal heat gains.

Heating

Central heating in some form is essential in large buildings, but the balance between the radiation and convective components is influenced by the method of heat distribution, as indicated in the following table for a

variety of hot-water systems. Warm-air systems give virtually no radiation at all.

Relative Percentages of Heat Distributed by Radiation and Convection by Different Types of Hot-Water Heaters

Type of Heater	Percentage of Heat Distributed by Radiation	Percentage of Heat Distributed by Convection
Column-type radiator	20	80
Panel-type radiator	40	60
Heated wall-panels	50–65	35–50
Heated floors and ceilings	50–65	35–50

Systems based wholly on warm air from central plenum ducts are not generally favoured because the walls and floors must necessarily be at a lower temperature than the air, giving a low m.r.t. and down draughts which are unchecked because of the lack of any warm-air upsurges from heaters under windows. Insufficient heating at foot level might, therefore, be expected on theoretical grounds.

The “cold-wall” effect is greatest in buildings with large windows and poorly-insulated walls, and vice versa. In modern Post Office buildings with only moderate window area and very good wall insulation the effect may be small enough to ignore. Experiments are being conducted with combined warm-air heating and ventilation systems in a number of automatic telephone exchanges where, because of the need for a forced-ventilation system, a particularly good economic case can be made. Systems introducing warm air at low level are more expensive and tend to raise dust.

Electrical Underfloor Heating

The use of electrical underfloor heating has been described fully in a previous issue of this Journal.³ Its main interest here is that it is one of the few systems that can produce an air temperature at ankle level greater than at head level. It has no tendency to raise dust, and present evidence is that it should have a very high comfort rating.

Ventilation

A gentle stream of cool air, say, 40 ft/min, directed against the face in an over-warm room is very pleasant; the same air-stream directed against the back of the head is a likely cause for complaint. In a room with a large number of people not all facing the same way, “ideal” ventilation for everyone is almost impossible to achieve. It is usual, therefore, in mechanical ventilating schemes to ensure that the air currents reaching the occupants are not much below room temperature and are of a speed between 15 and 50 ft/min. The aim is to mix the incoming air with the room air, by creating turbulence, before it reaches the occupants.

Higher air-speeds can be safely used in over-heated rooms, and ordinary ceiling fans can be very effective in making such rooms more tolerable by increasing the heat loss of the occupants by convection. A limit is reached, however, for office work when the air currents begin to move papers about on the desks, i.e. around 200 ft/min.

Relative humidity normally requires no correction in Britain in simple ventilating systems since it rarely varies

beyond the quite wide tolerances acceptable for comfort. Occasionally, discomfort may arise from low r.h. in very cold weather: thus, air at 32°F, 50 per cent r.h. has an r.h. of 16 per cent at 65°F. Internal r.h. percentages will be about 10 per cent higher, however, due to moisture gains from occupants, and, in addition, the hygroscopic nature of the surfaces in a room have an equalizing effect on r.h. over long periods.

Cooling

Generally speaking, cooling for staff comfort should only be necessary in Britain in apparatus rooms containing concentrations of high heat-dissipation equipment. The need for cooling can arise due to abnormal solar gains through large windows, and, whilst the heat can be removed by refrigerating plant, the process is always expensive—the right course is to prevent the heat entering the building and this is the responsibility of the architect. Inside blinds can only reduce the heat gain by about 50 per cent; outside ones are more effective.

The heat entering and trapped in a building due to a single window 10 ft × 10 ft facing south in latitude 52°N could reach 20,000 B.t.u./h. To remove this heat by cooling plant would involve plant costing perhaps £800, occupying a floor space of about 20 ft², and having high maintenance costs. Even the most elaborate cooling plant will fail to produce comfortable conditions for any person forced to sit in the direct rays of powerful sunlight.

Where heat from apparatus exceeds about 10 watts/ft² of floor area over the major portion of a large room, special cooling arrangements must be considered. In the past this has generally meant high rates of ventilation without cooling, and up to 60 room air-changes per hour have been achieved without undue draught or noise. Large fresh-air quantities, however, produce problems of filtration in dirty areas, and the tendency is to rely more and more on cooling plant. This, preferably, takes the form of a central cooling-plant and fan installation with high-quality air filters. Recirculation of a high proportion of the air for recooling is, of course, essential. Fig. 2 and 3 show parts of a typical plant of 70 tons* refrigeration capacity, i.e. 246 kW of heat extraction, and Fig. 4 shows schematically the component parts. Such a plant may cost about £60,000 and require a total plant-room area of about 2,000 ft². Again, it is emphasized that mechanical heat removal is not cheap.

Where a plant room of adequate size cannot be found, one of the air-cooling systems shown in Fig. 5–7 may be possible. With the systems illustrated in Fig. 5(a) and 5(b) no plant space is required outside the apparatus room. For those illustrated in Fig. 6(a) and 6(b) the cooling arrangements are out-housed, while for those in Fig. 7(a) and 7(b) the compressor is also out-housed. Other arrangements along similar lines are

*The cooling capacity of a refrigeration plant is usually expressed in "tons of refrigeration." 1 ton of refrigeration being a heat-extraction rate of 12,000 B.t.u./h.

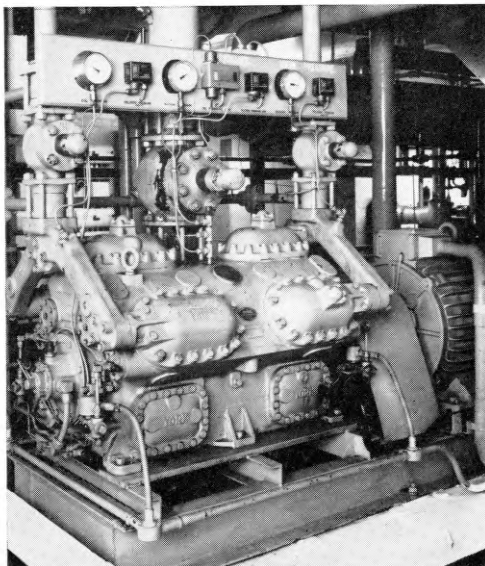

FIG. 2.—TWELVE-CYLINDER SINGLE-STAGE COMPRESSOR

sometimes used. Systems, using local units, are, however, open to serious criticism for apparatus-room cooling because of:

- (a) the poor filtering of air in the apparatus room,
- (b) their high noise level,
- (c) the necessity for water or refrigerant lines in the apparatus room, and
- (d) their high maintenance liability, which is likely to

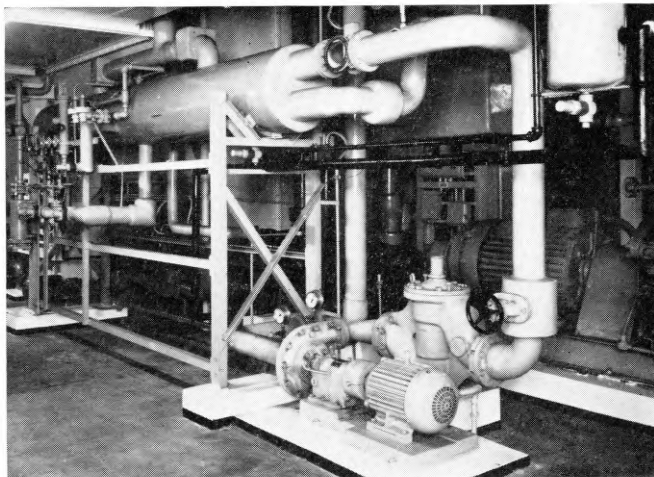

FIG. 3.—SHELL-AND-TUBE WATER CHILLER (EVAPORATER) AND CIRCULATING PUMP

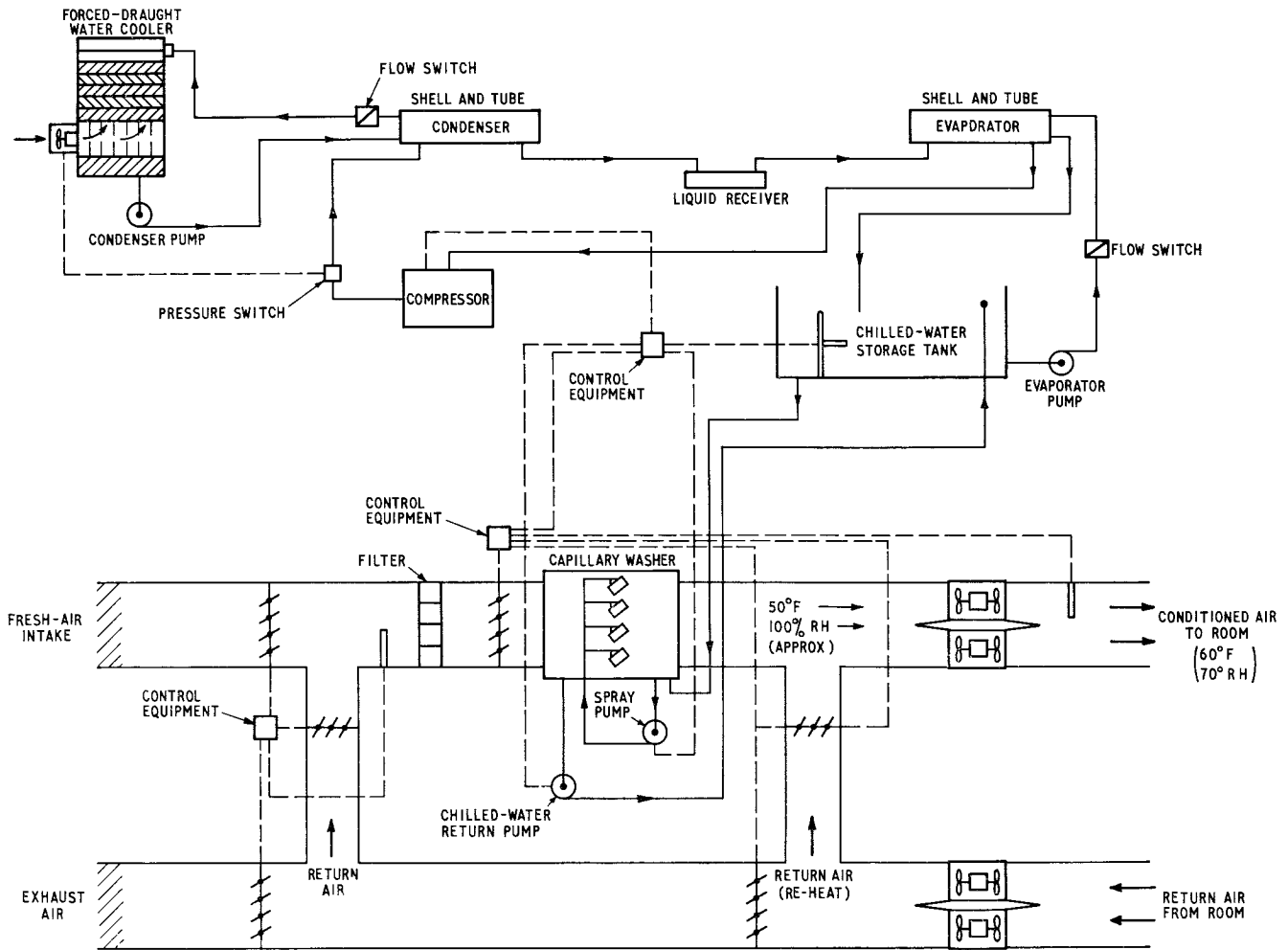

FIG. 4—SIMPLIFIED DIAGRAM OF 70-TON AIR-CONDITIONING SYSTEM

interfere with apparatus operation and maintenance.

The moral is obvious: for all new apparatus rooms, calculations of heat dissipation must be made well in advance, so that the need for cooling plant can be assessed, and proper provision made for it.

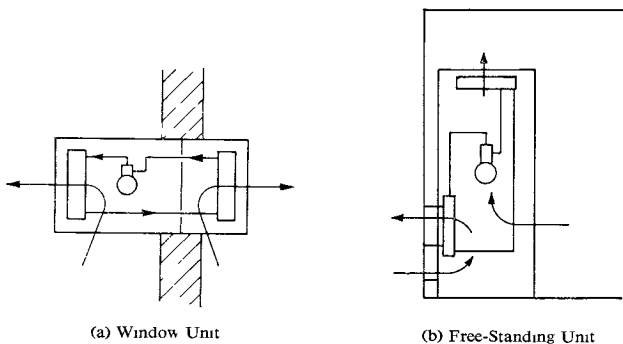

FIG. 5—UNIT AIR-CONDITIONING SYSTEMS WITH LOCAL AIR-HANDLING UNIT

LIGHTING

Lighting is not, perhaps, usually thought of in terms of comfort, but wrongly used it can certainly cause discomfort in the form of glare. Unlike heating, there is no

obvious upper limit to the amount of light human beings can enjoy. With the higher levels of illumination now being generally introduced, discomfort from glare has become much more important, and the Illumination Engineering Society's (I.E.S.) lighting code⁴ not only specifies means of establishing a glare index* for any general lighting design, but also lists permissible limiting glare indexes along with the recommended illumination level for many different types of work.

The above remarks apply only to direct glare and not to glare reflected from shiny surfaces. Particularly difficult is the reflection from the high-gloss paper much used in technical literature—including that dealing with lighting design! There seems as yet no satisfactory solution to this problem.

Whereas a few years ago 4-6 lumens/ft² was common in offices and other work places, the minimum is now about 15 lumens/ft². The official figure for Government offices was, until recently, 15 lumens/ft². It has now been decided that, for new and certain existing office buildings, the level of artificial lighting should be increased to 30 lumens/ft². This is the average illumination on the working plane under average conditions.

*The glare index, based on the Building Research Station's glare formula, takes account of number, size and type of fittings, room dimensions, and reflection factors of floor, walls and ceiling.

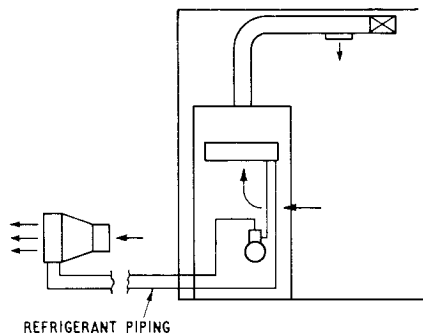

(a) Free-Standing Unit with Remote Air-Cooled Condenser

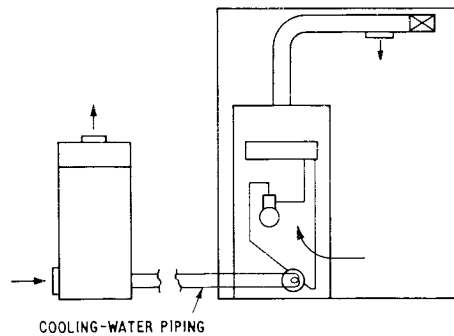

(b) Free-Standing Unit with Water-Cooled Condenser and Remote Cooling Tower

Note: Fans, filters, fresh-air make-up, drain connexions, etc., not shown.

FIG. 6—SPLIT AIR-CONDITIONING SYSTEMS WITH LOCAL AIR-HANDLING UNIT AND OUT-HOUSED COOLING PLANT

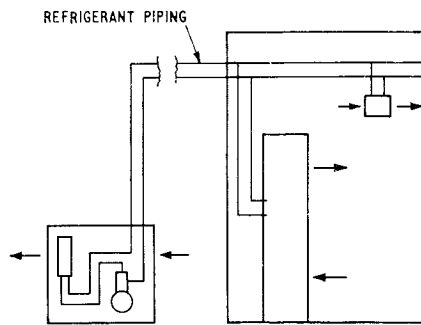

(a) Remote Air-Cooled Condensing Unit serving Direct-Expansion Coolers

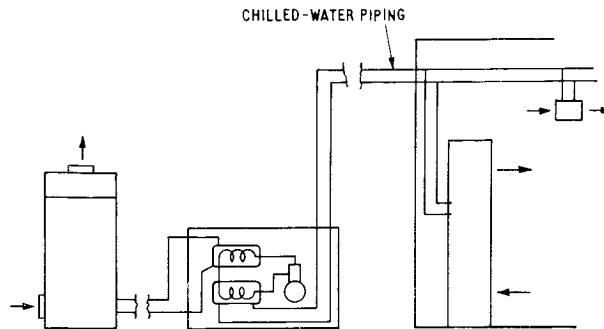

(b) Remote Water-Chiller with Cooling Tower serving Fan-Coil Units

Note: Fans, filters, fresh-air make-up, drain connexions, etc., not shown.

FIG. 7—SPLIT AIR-CONDITIONING SYSTEMS IN WHICH COOLING AND COMPRESSOR PLANTS ARE OUT-HOUSED

At these levels of illumination the heat from lamps begins to become a problem in mild weather, and fluorescent lighting is the most practical, and usually the cheapest, way of achieving good office lighting; the efficiencies of the most commonly used fluorescent tubes average about 60 lumens/watts, against about 12 for filament lamps, making the former much cheaper and cooler to run. However, the cost of fluorescent fittings is high, and the "break-even" point is around 500 burning hours per annum, depending on choice of fitting: most offices exceed 500 hours burning per annum.

Every rise in the authorized level of artificial lighting automatically increases the number of burning hours, and the stage is soon reached when some rooms or parts of rooms with poor day lighting are consistently below the agreed standard so that the lights are on more or less throughout the working day. Even in new buildings it is not necessarily desirable to enlarge the windows to give adequate day lighting everywhere, because of the attendant problems of heating in winter and cooling in summer.

In deep side-lit offices day lighting falls off severely away from the windows, and permanent supplementary artificial lighting (p.s.a.l.) is recommended in the I.E.S. code for rooms where the daylight factor* is less than 2 per cent. P.S.A.L. is intended to be arranged on a 2-level circuit so that the illumination level, and perhaps colour, can be changed when daylight fades into night. There are obvious difficulties here because the sudden switching from a high level of artificial lighting to a lower one is

*Daylight factor at a point indoors is expressed as a percentage of the total light available under the unobstructed sky, assumed of uniform brightness.

sure to cause adverse comment from people working in the room.

General and Local Lighting

General lighting means lighting which produces a nearly even illumination over the whole room, or would do so if it were not for obstructions, and this form of lighting is used almost universally for general office work.

For other types of sedentary work, and notably in drawing offices, a mixture of general and local lighting is often used. A comprehensive study of drawing offices by the Building Research Station in 1958,⁵ which included two Post Office drawing offices, resulted in a recommendation for the mixed system, although a number of large modern drawing offices are successfully operating with high-level general lighting only.

To see detail easily and quickly there must be not only sufficient light on the work but a suitable balance of the brightness of the work itself, the immediate surroundings and the general surroundings. Since the brightness (luminance) of a matt surface is approximately the product of illumination and reflection factor, the colours and materials of the surfaces enter into the question. Now, the eyes will always be attracted to the brightest part of the field of view, and it follows that, for easy working, the work area should be brighter than the surroundings. It has been suggested by a number of workers in the lighting field that for work requiring high illumination the brightness of the work, the near surround and the far surround should be in the ratio 10 : 3 : 1 for comfortable working.

Illuminated Ceilings

It follows from the previous paragraph that an illumin-

ated ceiling, if used as the sole illumination for an office is likely to have a poor performance: if such a ceiling is of high luminance it is distracting and produces glare, and if it is of low luminance it has a depressing uniformity giving low contrasts and producing feelings of drowsiness.

Lighting and Decorative Treatment

There is a tendency in any general lighting scheme to produce a rather monotonous uniformity if the decorations and furniture are such as to produce a lack of variety of brightness patterns. The use of mixed colours and pictures in modern offices is the obvious remedy. Special lighting effects, e.g. the use of recessed "down-lighters" to produce sparkle, can be employed where cost is not a prime consideration and provided reflective glare is avoided.

It is recognized that good lighting plus good decorative treatment in offices can create a cheerful working environment with beneficial results generally. For this reason a good level of illumination, 15 lumens/ft² or more, is usually provided even for jobs which on a strict size-of-detail basis would qualify for a lower standard.

NOISE

Considerations of comfort at work would not be complete without mention of noise. There is ample evidence that a critical attitude to the noise levels of working environments, though of recent origin, is developing rapidly. Whereas most environmental conditions are steadily improving, noise is steadily getting worse in our modern civilization.

Noise Measurement

The subject of noise measurement is a complex one. There is very little information available on the effects of moderate noise levels on the comfort and efficiency of sedentary workers, and no agreed method of assessing the relative nuisance value of different types of noise.

The response of the human ear to pure tones of different frequency and intensity is well understood. The latest results, due to Robinson and Dadson,⁶ are shown in Fig. 8. Sound-level meters for measuring complex sounds are based on this pure-tone response information by measuring the r.m.s. sound pressure on a decibel scale

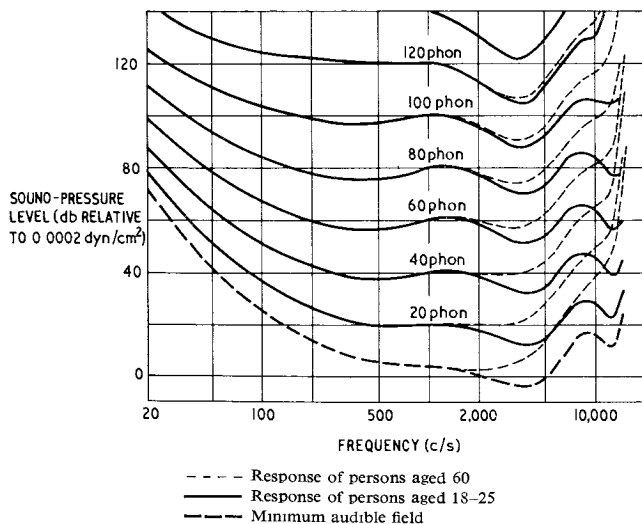
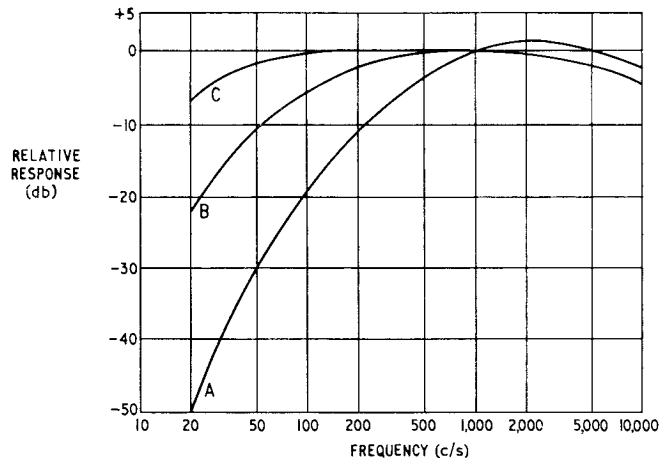

FIG. 8—EQUAL-LOUDNESS CONTOURS

based on 0.0002 dyn/cm², using weighting networks in accordance with B.S. 3489⁷ to allow for the varying sensitivity of the ear with frequency and level. The three weighting networks are shown in Fig. 9, and were originally intended to be used as follows.

- (i) A weighting: up to a level of 55 db.
- (ii) B weighting: levels of 55–85 db.
- (iii) C weighting: levels above 85 db.



The curves A, B and C are plotted from figures given in B.S.3489 : 1962.
FIG. 9—WEIGHTING CURVES FOR SOUND-LEVEL METERS

Unfortunately, subjective tests suggest that readings taken on this simple sound-level meter are not always valid for assessing the nuisance value of a sound. As an example of this, studies of traffic noise in cities have shown that the A-weighting network gave the best correlation with subjective assessments of noisiness for high levels of noise as well as low. Nevertheless, the weighted db—as the reading is called—can be a very useful guide for many types of noise, particularly if supported by experimental information.

Many attempts are being made at the present time to develop an objective method of assessing the nuisance value of any complex sound. These attempts are based on analysis of the sound by octave bands, $\frac{1}{3}$ octave bands, or variable-width bands. Until these researches produce a proven and easily-handled method, engineers must, in the main, rely on the simple noise-level meter and experience in interpreting readings taken with it. Octave-band analyses are useful, however, for investigating the typical noise spectra of particular types of machinery, and these measurements can be made using the same noise-level meter plus a set of filters. The results of such a test can be plotted and compared with a series of noise-criterion curves, such as those due to Beranek⁸ shown in Fig. 10. Limiting noise-criterion curves are then suggested, from experiment, for various situations and occupations. Thus, for a general office with typewriters, noise-criterion curve 50 is quoted: such a curve might give a single reading on a noise meter of around 65 db. The noise-rating curve quoted for a private office is 40, but these recommendations are, of course, quite arbitrary.

Discussing the assessment of annoyance from moderate levels of noise, the report of the Government Committee on the problem of noise⁹ (The "Wilson Report") says "It seems inconceivable that an annoyance meter should ever be designed which would be of practical use to the

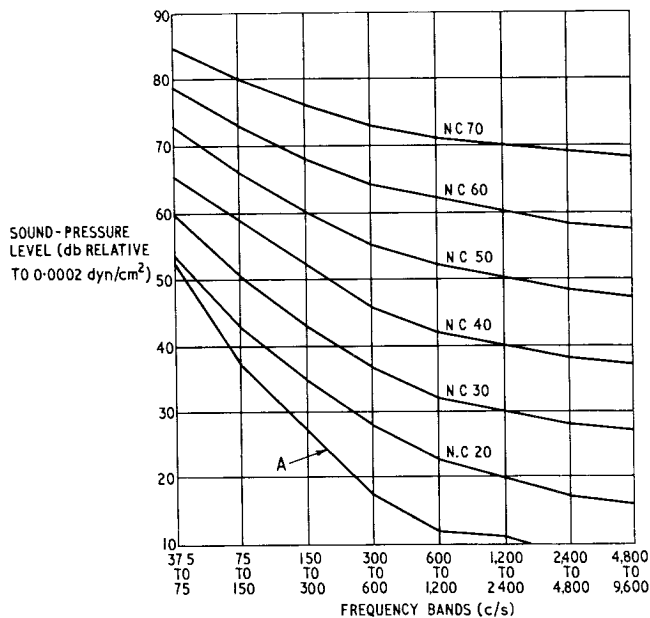

N.C.—Noise criterion
 A—Approximate threshold of hearing for continuous noise
 FIG. 10—NOISE-CRITERION LEVELS

legislator . . .” Both this report, and the report of the Post Office Working Party on Accommodation for Clerical Mechanization, refer to the lack of information on the effects on health and efficiency of moderate noise. The latter body considered that “more information should be obtained about the effects of noise on efficiency and human behaviour, with particular reference to office machines.” Nevertheless, the committee felt justified in recommending a provisional standard of 78 weighted db at machine operator’s positions, and 74 weighted db at adjacent clerical positions. This is the only officially recognized noise standard for Post Office accommodation, although it is customary for the Engineering Department’s specifications for ventilation and similar equipment to specify a limit for noise levels.

Noise from Ventilating Plant

Generally, it is possible to suppress noise from ventilating plant and air-conditioning plant so that in the occupied rooms it is completely unobtrusive. This is achieved primarily by lining air ducts with absorbent material, e.g. 1 in. thick, bonded glass fibre, or by specially-constructed silencers. Very large reductions of noise are possible with modern silencers consisting of a number of straight passages with perforated walls lined with absorbent material. In a recent application¹⁰ over 50 db attenuation at the main-fan frequency of about 500 c/s was obtained with such a silencer 7 ft 6 in. long, with negligible pressure drop.

Structure-borne ventilating-plant noise must, of course,

be catered for in the usual way by resilient mountings, and partitions between plant rooms and occupied rooms must have appropriate sound-insulation properties. A 9 in. brick wall without windows or openings will give a noise reduction of about 50 db.

Noise from Office Machines

In offices containing office machines the noise source is in the occupied accommodation, and noise reduction is more difficult. Ceilings and walls can be treated acoustically, but silencing of the machine itself is often necessary. Reductions of about 4 db of directly radiated noise have been achieved in a number of cases by lining the machine casings with noise-damping material such as polyurethane foam combined, when necessary, with anti-drumming material having a high stiffness and damping factor.

Complete enclosure of the machines in sound-proof covers is usually impossible for operational reasons.

Noise from the Street

The main defence against traffic noise and other outside noises is a solid building, but openable windows amounting to 10 per cent of a wall area will reduce the attenuation of that wall from a high figure of, say, 50 db to about 10 db or less. If the windows are tightly closed the attenuation would be of the order of 25 db, and double glazing can improve the figure to 40 db.

This means that in very noisy situations a forced-ventilation system may be desirable so that all windows can be sealed. Centralized ventilation plants would be used in new buildings, but where the problem arises in existing buildings it would sometimes be more practical to use local ventilation units with fan and fresh-air inlet, the interior being acoustically treated to give an attenuation of about 30 db.

References

- ¹CHRENKO, F. A. The Assessment of Subjective Reactions in Heating and Ventilating Research. *Journal of the Institution of Heating and Ventilating Engineers*, Vol. 23, p. 281, Nov. 1955.
- ²CHRENKO, F. A. Human Factors in Heating. *Design*, Vol. 165, p. 62, Sept. 1962, and Vol. 166, p. 50, Oct. 1962.
- ³WILLIAMS, J. Electric Underfloor Heating. *P.O.E.E.J.*, Vol. 56, p. 181, Oct. 1963.
- ⁴Recommendations for Good Interior Lighting. The Illumination Engineering Society, 1961.
- ⁵COLLINS, J. B., and LANGDON, F. J. A Survey of Drawing Office Lighting Requirements. *Transactions of the Illumination Engineering Society*, Vol. 25, No. 3, p. 87, 1960.
- ⁶ROBINSON, D. W. and DADSON, R. S. A Re-determination of the Equal Loudness Relations for Pure Tones. *British Journal of Applied Physics*, Vol. 7, p. 166, 1956.
- ⁷British Standard 3489: 1962. A Specification for Sound-Level Meters, Industrial Grade. British Standards Institution, 1962.
- ⁸BERANEK, L. L. Revised Criteria for Noise in Buildings. *Noise Control*, Vol. 3, p. 19, Jan. 1957.
- ⁹Noise—Final Report. Cmd. 2056. Her Majesty’s Stationery Office, 1963.
- ¹⁰HUNTER, R. S. Ventilation Plant for the Post Office Engineering Department’s Main Conference Room. *P.O.E.E.J.*, Vol. 56, p. 194, Oct. 1963.

Developments in Exchange Equipment: Post Office Introduces Electronic and Crossbar Exchanges

U.D.C. 621.395.722:621.395.344,5

Successful trials in public service have led to the decision to order all future telephone exchanges of small and medium size in electronic form, while the design of electronic equipment for larger exchanges and also for extending existing Strowger exchanges is well advanced. Some crossbar equipment is also being used to meet the present heavy demand for exchange equipment.

THE Post Office and the British telephone-exchange equipment industry have recently achieved a major break through in the design and production of a commercially viable electronic exchange. After successful trials in public service of designs developed under the auspices of the Joint Electronic Research Committee (J.E.R.C.), comprising the Post Office and the five principal telephone-exchange equipment manufacturers in the United Kingdom, the Post Office has decided to order all exchanges in the smaller and medium-size ranges in the electronic form from now on. This is the first stage of the plan to modernize the telephone system by installing electronic equipment. Britain is thereby one of the leading telephone administrations in the world in the development and manufacture of electronic exchanges. The advantages of using electronic techniques in telephone exchanges include greater reliability, faster connexions, additional subscriber services, lower maintenance costs and smaller space requirements.

Two other major joint electronic developments (also under the auspices of J.E.R.C.) are well advanced. These are a design for new large electronic exchanges, and electronic equipment for extending existing Strowger exchanges and eventually replacing the Strowger-type electromechanical equipment used at present. The tests on these equipments, which have already commenced, should be completed in time for the Post Office to decide to order these types of equipment where it best meets its requirements.

This first decisive step towards electronic switching comes at a time when the Post Office is planning its largest-ever program of expansion. Over the next 4 years it needs more than £350m of exchange equipment—three times what was bought in the previous 4 years. The Post Office will take as much electronic equipment as it can obtain to meet its expanded needs, and so minimize its requirements for equipment of the electromechanical type; this will, however, continue to be required at or above the existing level for some years to come.

*HILLEN, C. F. J., LONG, R. C., and PORRITT, W. R. A. The Field Trial of Two Small Electronic Exchanges at Leamington and Peterborough. *P.O.E.E.J.*, Vol. 58, p.1, Apr. 1965.

Most of this electromechanical equipment will be of the well-tried Strowger type which has been in use here and throughout the world for many years. But the Post Office has also decided to meet part of its rapidly-increasing requirements by taking some exchanges in the British designed 5005 crossbar system—successfully developed for the export market by the Automatic Telephone and Electric Co., Ltd., of the Plessey Telecommunications Group. A trial 5005 crossbar exchange of about 1,500 lines has been operating with satisfactory results at Broughton (North Western Region) for well over a year. The scope for 5005 crossbar equipment is small in relation to total needs, but it is needed to provide new exchanges in areas that would otherwise have to wait longer for service. Orders for additional crossbar exchanges are already in preparation, and will be placed in the near future. The equipment will be used in both director and non-director areas where new exchanges are required.

Field-trial models of the small electronic exchange, which is designed to provide for up to a 2,000-line multiple and to cater for up to about 240 erlangs of traffic, have been on trial at the Peterborough and Leamington exchanges since the middle of 1965.* In both installations the total calls handled is approaching the million mark and service has been exceptionally good. Orders have already been placed for five small exchanges with multiples of between 800 and 1,000 lines. These will be installed at Ambergate (Midland Region), Odiham (Home Counties Region), Brampton (North Western Region), Llanwern (Wales and Border Counties) and Bishopton (Scotland). Installation has already begun at Ambergate, and the others will follow during 1967.

The initial orders have been shared between Ericsson Telephones, Ltd., Nottingham, and the General Electric Co. (Telecommunications), Ltd., Coventry. Orders for about 50 more exchanges of the same type are also in preparation and are expected to be placed within the next 12 months or so. The exchange type will be known as the TXE 2.

The large electronic exchange system for a 2,000-line multiple upwards has also been developed jointly by the J.E.R.C., and is expected to become available during 1968. A full-scale model is already under test in the Post Office Circuit Laboratory. Electronic equipment, firstly to extend and then replace Strowger exchanges, has also been developed by the J.E.R.C., and is also expected to become available during 1968.

All three systems use dry-reed relays for the speech-path crosspoints, with electronic controls.

A Clean Room for the Production of Silicon Planar Transistors

R. L. CORKE, A.M.I.E.E., and A. W. SEARLS, A.M.I.E.E.†

U.D.C. 621.382.3.002.2

The production of specially-reliable transistors requires controlled conditions, including a substantially dust-free environment for certain stages of manufacture. A clean room at the Post Office Research Station has been constructed for the production of silicon n-p-n planar transistors for application to submarine-cable systems. A general description is given of the clean room and its operation, together with possible future developments.

INTRODUCTION

THE successful use of transistors in the amplifiers and supervisory circuits of repeaters for submarine-cable systems requires transistors that are highly reliable for long periods of time. Given adequate reliability, the wide-band characteristics and the modest power needs of transistors combine to make their application to both long and short systems attractive.

The first applications will be to several shallow-water systems under the English Channel and the North Sea to provide 4 Mc/s links to the Channel Islands, the Continent and to Norway. For these a silicon planar n-p-n diffused junction-type of transistor has been developed with a frequency cut-off of 400 Mc/s; this type is known as Transistor 4A2. A description has been given in a previous issue of this Journal¹ of the prototype transistor from which the 4A2 has been developed. Other silicon planar transistors with a cut-off of 1,000 Mc/s will follow, and these, coded 10A, will possibly find applications in long cable systems with 10 Mc/s bandwidth.

One of the prime objectives of 4A-transistor production at the Post Office Research Station is to demonstrate the reliability and long-life potentials of these transistors. To do this it is necessary to make them under carefully controlled and reproducible conditions, to subject batches to quality and reliability testing, and, with the minimum possible changes in procedures, to build up stocks for service use. Briefly, the reliability and suitability for the application are demonstrated by measuring small changes of electrical parameters when the transistors are carrying a normal current and are maintained at elevated temperatures for moderate lengths of time. By employing statistical methods and by assuming a single failure mode the behaviour of transistors of the same origin can be predicted with known confidence for operation over much longer lengths of time at the temperature they will experience in service.

For valid life and reliability predictions it is essential to control the production processes with exactness as well as to verify that materials and components are of uniformly high quality. The transistor, by its nature, is highly sensitive to impurities, both within the silicon and on its surface. The presence of unwanted contaminants in and near the junctions of a transistor will modify the gain and other important characteristics. The contaminating molecules may, in some instances, be innocuous in themselves. If, however, they can be broken down by heat or ionic dissociation then the resultant products may drift or diffuse and cause leakage or other unacceptable changes in electrical characteristics. The extreme sensitivity of the transistor to contamination,

and the rapid onset of detectable changes at elevated temperatures (300°C), make it possible to test randomly-selected specimens from a batch and so obtain an estimate of the quality of the batch within a few hours.

The small size of the emitter (75-micron* diameter) and of the bonded-wire connexions (25-micron diameter, approximately), as well as the sensitivity of the device to contamination, make it necessary to protect the transistor from dust and particulate matter that could accidentally fall upon it before it is safely encapsulated. General room dust, lint from clothing, debris such as hair, skin, dandruff and spray, as well as finger grease, are typical contaminants from which the transistor must be protected by rigorous cleansing, by avoiding handling, and by minimizing exposure to the atmosphere of the room. Because some exposure to the room atmosphere is unavoidable for mechanical reasons during fabrication, it is essential to carry out most of the latter processes of manufacture in an atmosphere which is substantially free from dust.

There are several ways in which work may be done in a clean environment. The operator can remain outside and, by inserting his hands and arms through sealed gloves and observing through a transparent side to the clean space, he can carry out operations in a relatively clean environment. The disadvantages of this so-called glove-box method is that the operator is not able to move freely, gloves are clumsy for some operations, the material of the gloves may contain contaminants and the problems of transferring work from one glove box to the next one are far from simple and often result in an inflexible layout of equipment. Another way is to have an open-sided box with an air flow outwards, into which the operator inserts his hands and forearms. This is less clumsy than the glove box, but it is technically unsound unless the hands and arms of the operator can be relied upon not to transport dust into the clean space; such a requirement is not easy to satisfy.

The method used for the present transistor production is to provide a room sealed against the ingress of dust and into which filtered air is continuously pumped. In an annexe, for entry and changing, operators remove their outer clothing and dress in special clothes, which are lint-free, and a hat that covers most of the head. By following a set procedure for entering, a minimum of dust is transported into the clean room. The operators can then move with freedom within the room and work in reasonably comfortable conditions. Throughout this article the term "clean room" is used when referring to a room of this type and operated in the manner prescribed.

CLEAN ROOM

The clean-room installation consists of the following main parts.

- (a) Entry and changing areas.
- (b) Air lock.
- (c) Working space in clean room.
- (d) Working space outside clean room.
- (e) Air-conditioning plant.

†Post Office Research Station.

*1 micron (μm) = 10^{-6}m , i.e. $25\ \mu\text{m} \approx 0.001\ \text{in}$.

A simplified plan of the parts (a) to (d) is shown in Fig. 1. The air-conditioning plant is fitted partly over the entry and changing areas and partly on the roof of the building containing the clean room.

load-bearing characteristics, and for those parts of the clean room that are load bearing a higher-density flax board is used. The two exhaust pillars in the centre of the clean room contain light steel columns which support

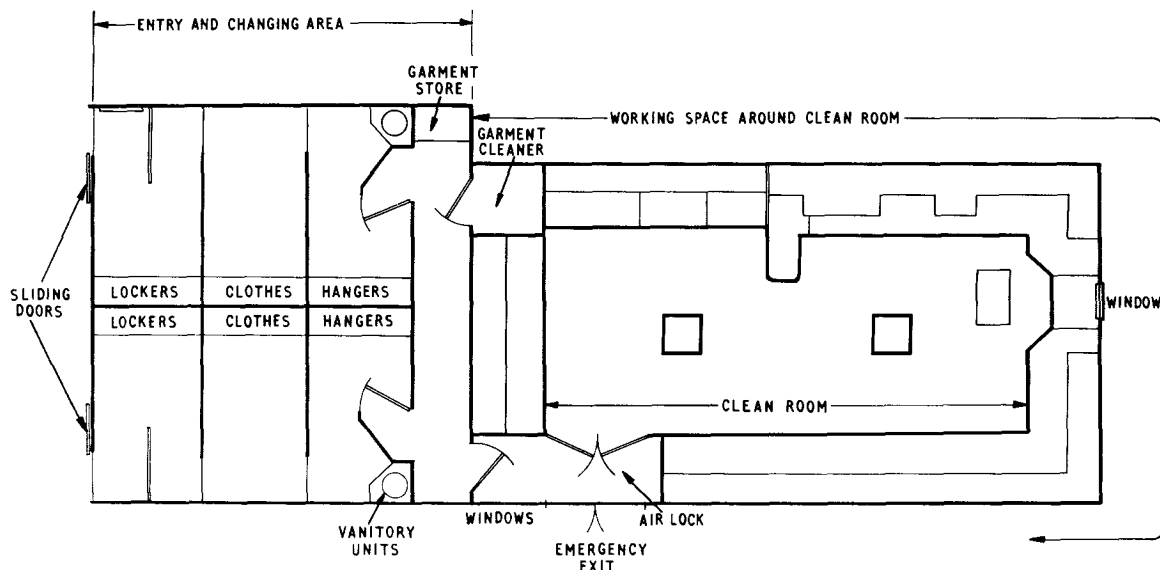

FIG. 1—PLAN OF CHANGING AREA AND CLEAN AREA

Persons enter the changing area through a self-closing sliding door, and, after leaving all outer clothing in the outer cubicle, they move to the centre cubicle where cotton undergarments and socks are put on. Staff then enter the third compartment, where they may wash and where the outer garment and hat are put on; these are made of continuous-filament nylon, the outer garment, in the general form of a flying suit, fitting the wearer closely at neck, wrists and ankles. Plastic sandals are also provided and are worn in the clean room. When leaving the clean room the procedure is reversed, the clothing being left behind in the appropriate cubicles. The clothing bears a code, so that the operators wear the clothes issued to them individually. The two changing suites operate in parallel for male operators, but if women were required to enter the clean room one changing area would be reserved for their use.

The air lock between the changing area and the clean room occupies, in effect, part of a corridor and has a door at each end to separate the air system of the clean room, which is at a higher pressure, from that of the changing area. The air lock prevents excessive loss of air when operators go in and out. Opposite walls of the air lock are formed of two double doors, fitted with "panic" bolts: these doors could be used, in an emergency, to get directly out of the clean room. The normal doors of the air lock are not interlocked in any way, since this would be a safety hazard. Instead, if both doors are accidentally opened together for too long, and air pressure is lost from the clean room, a warning alarm is sounded.

GENERAL CONSTRUCTION

The fabric of the structure is made of flax board, which consists of fibres of flax compressed in boards and bonded with resin glue. The board has an acceptable fire resistance. The density of the board determines the

the centre of the roofspan. The flax board is covered on the inside with melamine-formaldehyde sheets coloured pale blue and white. On the outside of the board are sheets of similar material in a lower grade and coloured brown. Each side of the board is thus of equal structural strength. The ceiling is translucent Perspex supported from alloy frames. The floor is covered with polyvinylchloride (PVC) sheeting with welded joints, and PVC coving is used to seal the flooring to the walls.

Facilities Provided within Working Space

The working space of the clean room is shown in more detail in the plan of Fig. 2. In an area of 16 ft by 32 ft the working positions are placed round the periphery. Most of the positions are at benches built against the walls of the room, where the operators are seated. Some of the work is done at standing positions if seating is not practicable. There is one exception to this peripheral layout: the main inspection point is an island position.

Cleaning, etching and photographic bays, from left to right, respectively, in Fig. 3, are opposite the entry doors and provide both facilities for cleaning silicon slices* and for cleaning during intermediate stages of manufacture. The fluids used are methyl alcohol, trichloroethylene and dibutylphthalate in apparatus (Soxhlets) for continuous distillation. The Soxhlets are mounted within the right-hand fume cupboard with a separate full-loss ventilation system arranged so that there is always a small negative air pressure with respect to the clean room and no fuming can take place into the room. The centre, similar, fume cupboard shown in Fig. 3 is used for etching, and for cleaning processes involving hydrofluoric acid,

*A silicon slice, n-type, doped with phosphorus, is about 25 mm in diameter and about 0.2 mm thick. On it will be formed some 250 transistor devices before it is divided up into 1 mm squares, each with one transistor.¹

sulphuric acid, and other active reagents. The third fume cupboard is for a photographic type of operation which is a rather elaborate ultra-violet light contact-printing system using a mask-alignment apparatus located near to the photographic bay and shown on the right of Fig. 3.

boron vapour, and for phosphorous diffusion by a somewhat similar method.

The next operating position has a high-vacuum coating equipment for evaporating aluminium on the surface of the slice to provide the base and emitter electrodes. This is operated partly from inside and partly from out-

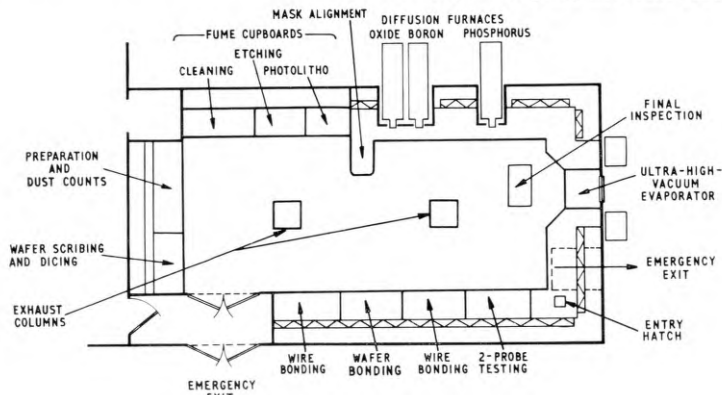

FIG. 2—DETAILED PLAN OF CLEAN AREA



FIG. 3—CLEANING, ETCHING AND PHOTOGRAPHIC POSITIONS

Continuing clockwise round the room, there are three furnace tubes (Fig. 4) which just protrude into the room at sealed portholes. These 5 ft long tubes are of silica, and each extends out of the clean room through its furnace, which stands in an alcove outside. The tubes are charged and unloaded from within the clean room, but the rest of the furnace operation is performed outside. The three furnaces are, respectively, for oxidizing silicon slices by providing a thin continuous film of silicon dioxide over the slice by a process of baking at a temperature near to $1,000^{\circ}\text{C}$ in steam, for boron diffusion by baking slices at about $1,100^{\circ}\text{C}$ in the presence of a

side the clean room. To facilitate co-operation here and elsewhere, loud-speaking telephones are fitted in the room. These are of a waterproof pattern, as used in hospital operating theatres.³

The remainder of the periphery of the room is mainly occupied by a work-bench (Fig. 5) on which are placed equipments for 2-probe testing (measurement of certain d.c. parameters), dicing (cutting up slices into individual transistors), heading (brazing individual transistors to a header) and wire bonding (attaching 0.001 in. diameter wires from emitter and base to terminal posts). The operators require to be comfortably seated before the

apparatus so that they have proper vision with the microscopes and can operate the micro-manipulators with accuracy.

the floor, the bench walls and tops, and the ceiling. The space under the benches is not included in the clean area and is used for housing all services and ancillary equip-



FIG. 4—CHARGING THE BORON DIFFUSION FURNACE



FIG. 5—TWO-PROBE TESTING, DICING, HEADING AND WIRE-BONDING POSITIONS

At one point on the bench, not shown in the photographs, is a section of wall, coloured red, for use as an emergency exit. This section can be kicked down, taking with it a portion of the outer wall. Both sections fold down and form a smooth floor over which the occupants can slide out.

Air Flow, Humidity and Lighting

The cross-section of the clean room shown in Fig. 6 is taken through the right-hand air-exhaust column of the two shown in Fig. 2. This shows the box defining the limits of the so-called "white" area, which is bounded by

ment: it is accessible from outside by removing covers.

Pre-filtered air at 21°C, with a relative humidity not exceeding 40 per cent, enters from manifold A (Fig. 6) through a restriction to an absolute filter, B, of which a number are fitted behind grilles over the available wall area above the bench tops. These filters remove particles exceeding 0.5 micron diameter from the air, which then drifts across the room towards one of the exhaust columns, C, at a speed of about 0.25 m/s. The flow is encouraged to be laminar by the shape of the roof and by suitably arranging the entry holes along the length of each exhaust column. The air is returned by manifold D

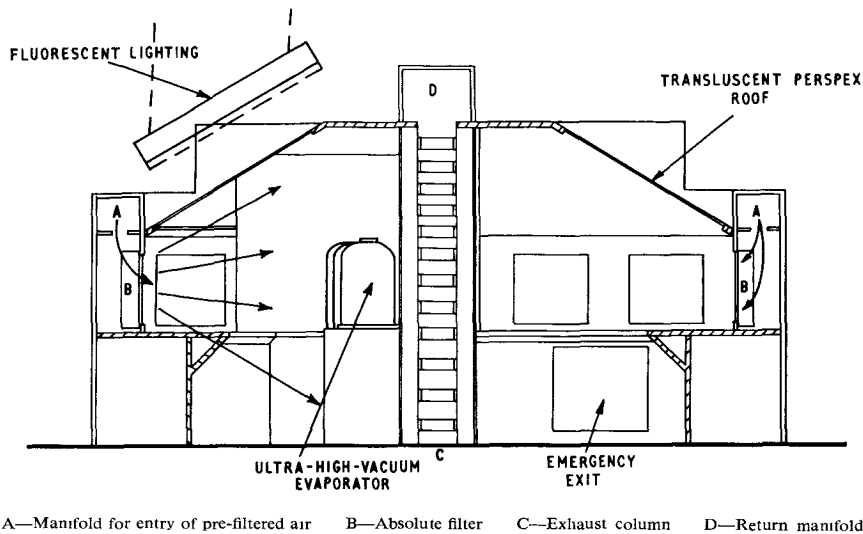

FIG. 6—CROSS-SECTION OF CLEAN ROOM

to the circulatory fans on the roof of the changing area, where it is mixed with 10 per cent of fresh air and then recirculated. A certain quantity of air is allowed to leak from the clean room, which has an over-pressure of about 1 cm of water gauge with respect to the atmosphere, so that dust cannot enter when hermetic sealing is not possible. The leak rate, the fresh air intake, and the over-pressure are inter-related. The rate of circulation is such that the air content of the room is circulated 60 times per hour and the fresh-air input replaces the air 10 times per hour.

The humidity of the air is kept below 40 per cent relative humidity because some processing cannot be done above 45 per cent relative humidity. Air is chilled by passing it over the expansion coils of refrigerating equipment, and the water so condensed is run off. The air is next warmed to 21°C. The temperature and humidity sensing heads in the main air duct are arranged to control the heaters and the refrigerators so that the temperature is always within 1°C of 21°C and the relative humidity is not greater than 40 per cent. The ventilation equipment is fully automatic, and is protected by interlocks and against fire hazards.

The lighting is provided by a battery of fluorescent lamps mounted above the translucent roof. The total power is some 6 kW and the lighting on the work bench is at a level of 70 lumens/ft². This general high-level of lighting is desirable for the nature of the work, and to have attained this with lamps within the room would have introduced more local heating than was desirable and would have stimulated convection air currents which can cause agglomeration of dust particles. Furthermore, maintenance of the lighting equipment is facilitated by this mounting arrangement.

CLEAN-ROOM SURROUND

It has been mentioned that the services are run around the clean room in an under-bench space and that some equipment, e.g. furnaces, project into the surround.

There are also control cubicles for the furnaces and the high-vacuum coating unit, as well as a number of points where bottled and liquid gases are brought into position and connected to supply lines entering the

furnaces and the clean room. When operators inside and outside the room are working together they are aided by the loud-speaking telephones, already mentioned, and by windows that give a limited view. The work pieces, such as slices, headers and materials, enter and leave through a hatch designed to carry a minimum of contamination into the room.

The absolute filters fitted round the walls of the clean room can be changed when necessary from outside by releasing a sealing panel and withdrawing the filter; this could be done while normal work is being performed if one panel at a time were removed. A change is necessary when the filters become partially choked and the pressure difference, as measured by a manometer, rises appreciably across a filter.

Normally, however, changing of the absolute filters should only be required after several years' running. On the other hand, the primary filters in the air-conditioning equipment are changed every few weeks when their resistance to air flow rises producing more than a predetermined pressure drop.

To keep dirt down in the vicinity the approaches and surround of the clean room are maintained at a higher-than-average state of cleanliness and decoration, and this also has the advantage of continually reminding all who use the room of the need for extreme cleanliness.

CLEANLINESS OF CLEAN ROOM

Measurement of Air-Borne Dust

Regular measurements are made of the dust content by taking small samples of air at a number of points in the clean room. The dust content of the air sample is examined for sizes and quantity with an instrument known as a Konimeter.* This instrument has a spring-loaded piston which, when released with a trigger, sucks in 5 cm³ of air in such a way that the incoming air impinges on a glass plate that has been treated with an adhesive. Dust adheres to the plate, which is then examined with a microscope forming part of the instrument. A graticule in the microscope field, with calibrated black dots, enables the operator to estimate the sizes of the dust particles. A dark-ground illuminator is used to enable particles down to 0.5 μm to be seen. The Konimeter can take up to 30 samples on the glass plate by turning it after each exposure to bring a fresh area into position for the next exposure.

Typical results obtained with the Konimeter are tabulated below.

This method of measuring dust is reasonably satisfactory on a comparative basis, for it enables the trend in dust distribution to be monitored at places in the room where cleanliness is specially important—for example, at the photographic processing point. It is not, however, suitable for measurement of the average dust in the whole room because of the small size of the air sample.

Other instruments have been tried. The Thermal

*The Konimeter is made by Messrs. W. Watson and Sons, Ltd., and was designed in collaboration with the Ministry of Fuel and Power.

Typical Dust Measurements Obtained with Konimeter

Sample Number	Number of Particles Present of the Following Particle Sizes (in μm)					
	$\frac{1}{2}$	1	2	4	6	>6
1	0	0	1	0	0	0
2	0	0	0	0	0	1
3	8	2	0	0	0	0
4	13	5	5	2	2	7*

*Plant vibration caused this excessive condition.

Precipitator^{3†} uses a hot filament to deflect an air stream containing the dust to be measured on to a plate for subsequent microscopic examination. This instrument requires to be run for some time before measurements are made, and it proved unsatisfactory for the purpose of quick sampling.

Dust measuring-apparatus based on particle-counter techniques are available commercially. Apparatus of this type continuously samples a metered air stream which carries the dust past a sharply-focussed illuminator and a photo-electric cell which generates signals corresponding in amplitude and number to the size and number of the illuminated dust particles. These signals pass to a counter and amplitude sorter to record the number and sizes of the dust particles passing the light cell. The apparatus is complex and expensive and it could not be justified for the present application.

Dust Control

The preservation of cleanliness in the clean room and in the changing areas is based, first, on preventive procedures carried out by the staff as already described. In addition, the following further precautions and cleaning are carried out.

Handkerchiefs are not taken by the staff into the clean room because their use would be a prolific source of dust. A dispenser and disposal unit for paper handkerchiefs is contained in one of the central pillars. Clothing arriving from the laundry is taken through the changing rooms in polythene bags, which can be lightly swabbed to remove dust adhering to their outer surface. The nylon clothing itself cannot be guaranteed to be free from lint, which it may collect at the laundry. To remove the lint and dust from the nylon clothing it is treated in a garment-cleaning cubicle (see Fig. 1), where it is attached at the neck, wrist and ankle openings to ducts carrying clean turbulent air which inflates the suit. Dust and lint adhering to the inside and, more specifically, to the outside of the suit is shaken off, withdrawn by vigorous airflow, and trapped in filters, the cleaned air being recirculated.

An industrial vacuum-type cleaner can be attached to ducts on the outside of the clean room and a flexible hose with brush attachments is connected to the other end of the ducts inside the clean room for floor cleaning. This is a means of removing particulate matter accidentally brought into the room on sandals, as well as debris generated in the room by abrasion. Vacuum cleaning, even with brush assistance, cannot remove effectively very

[†]Made by Messrs. Casella, Ltd., in collaboration with the National Coal Board, Mining Research Establishment.

small particles, which adhere with a tenacity increasing with smallness.

To prevent a build-up of small-sized particles it is recommended that all surfaces should be regularly swabbed with polyurethane sponges just moistened with water containing $\frac{1}{2}$ fl oz/gal of a non-ionic detergent, e.g. Lissapol D. When modifications of equipment are in progress it is usual to clean continuously in the vicinity of the work with vacuum cleaner and swabs.

EXPERIENCE IN OPERATING THE CLEAN ROOM

Experience has been gained in operating the room over a period of about 2 years, during the latter few months of which the Transistor 4A2 has been in production. The cleanliness of the room itself is of a high order, and in normal operation it is unusual to find a particle in the Konimeter sample exceeding 1 micron in diameter, except in the vicinity of the door and the intake hatch.

The operational aspects of the clean room have proved excellent, and the only serious problem encountered has been that of reducing to a tolerable level the vibration reaching the equipment in the clean room from the ventilation plant. Occasionally vibration has reached the room from nearby sources in the building, such as heavy weights being dropped and masonry alterations. It is desirable when possible to build a clean room on a solid floor and to isolate it from sources of vibration, including its own ventilating plant. The temperature, humidity, and lighting conditions make a pleasant environment for work. The outstanding disadvantage of this type of clean room is the large proportion of ineffective time: for the room described here 10 minutes is allowed for changing clothes, and, with four shifts a day, this amounts daily to 80 minutes.

A clean room for a given standard of cleanliness and a given function is virtually a fixed design, and it would not be easy to up-rate a room once built. It is, therefore, prudent at the outset to use a design that will give the required cleanliness with a small, but not too great, margin, otherwise the cost will be unduly high. It is also prudent to have space for expansion and changes of practice, for it is not possible to modify extensively the technical functions within the room without a shut-down of all operations.

Mention has already been made of some alternative designs that were considered before placing the contract for the room described here. In 1962 there was no reasonable intermediate design as an alternative to the glove box or the present type of clean room. There are now indications that the disadvantages of the open-sided box at that time have now been largely overcome. If new techniques result in reducing the volume of clean space to that immediately surrounding the work then, not only should the capital cost be less, but the operating costs also would be reduced.

CONCLUSIONS

There is, in industry generally, an increasing application of clean rooms of various types to suit work which has to be protected from accidental contamination brought to it by the atmosphere or by the worker. In electronics, the trend towards smallness in designs such as microcircuits, as well as the increasing demand for improved reliability of components, is generating an extended interest in clean rooms. It is to be hoped that

in due course a British Standard will be established for the specification of clean rooms.

ACKNOWLEDGEMENTS

The authors thank the staff of the New-Works Division of the Ministry of Public Buildings and Works and the contractor, Messrs. Air Movement, Ltd. The basic ideas of the contractor were developed into a final design in mutual consultation with the Ministry and the Post Office Research Station. The authors also thank

the staff of the Coal Board Mining Research Establishment for advice on methods of measurement of dust particles.

References

- ¹HENDERSON, J. C., and WILSON, SYLVIA J. Design and Technology of Silicon Planar Transistors. *P.O.E.E.J.*, Vol. 56, p. 239, Jan. 1964.
²LOWE, W. T. A Waterproof Loudspeaking Telephone. *P.O.E.E.J.*, Vol. 55, p. 6, Apr. 1962.
³HAMILTON, R. J. Respirable Dust Sampling Instrument. *Colliery Engineering*, p. 342, Aug. 1957.

All-Figure Telephone Numbers

U.D.C. 621.395.636.1

The reasons for the adoption of all-figure telephone numbers in the United Kingdom are briefly reviewed, and the way in which the change from mixed letter-and-figure numbers will be implemented is outlined.

INTRODUCTION

THE announcement by the Postmaster-General on 26 July 1965, that in future all telephone numbers in the United Kingdom would need to be in all-figure form, heralded the end of the mixed letter-and-figure telephone number, which has been used in director areas for nearly 40 years.

The change-over to all-figure numbers, which will also involve the replacement by figures of the letters in a number of subscriber-trunk-dialling (S.T.D.) dialling codes, will commence this year and will be completed by 1970.

REASONS FOR THE CHANGE

There are three compelling reasons which combine to make a change to all-figure numbers essential in the next few years.

International Subscriber Dialling

With the development and automation of the world's telephone systems and the lines linking them, much effort is being directed to providing and extending facilities for subscribers to dial their own international calls. The retention of letters in our telephone numbers would be a serious impediment to international dialling, since most other administrations use only figures on their telephone dials. Of the few countries which still use letters the three most important ones, the U.S.A., Canada and France, are already converting their systems to all-figure numbering.

Future Growth in the Large Cities

The 7-digit numbering scheme used in the six director areas (London, Birmingham, Edinburgh, Glasgow, Liverpool and Manchester) has a theoretical capacity for 1,000 exchange units of 10,000 lines each. If this whole capacity were available for subscriber's numbers the numbering scheme could cater for growth until well into the next century in London and for longer in the other director areas. The practical number capacity is, however, only a fraction of the theoretical capacity due to several limiting factors, the chief of which is the letter-code requirement, e.g. WHI 1212 for Whitehall 1212.

Letters appear in only nine holes of the dial, and O, which coincides with the digit 0 that is used for S.T.D. access, is impermissible as the first letter of any exchange code. There are, therefore, $8 \times 9 \times 9$, i.e. 648, possible letter-code combinations. Each exchange code must, however, be digitally unique and must be capable of forming the first three letters of a pronounceable word suitable for an exchange name. With these restrictions, the number of useful codes is less than half the possible combinations. At the present rate of growth in London all suitable letter codes will be taken into use by 1970. A change to the numbering scheme before this date is therefore essential to cater for future growth.

By dropping the letter-code requirement the numbering-scheme capacity can, without any equipment changes, be more than doubled and will then provide for growth in London until the end of the century. The number of 3-figure codes available will be $8 \times 10 \times 10$, i.e. 800, 0 and 1 being impermissible as first digits as they are used for S.T.D. and service access.

Some consideration was given to an alternative possibility for increasing the numbering capacity. This involves retaining the present exchange codes and expanding from four to five digits the numerical portion following some codes. The resultant 8-digit numbers would have necessitated modification of existing directors and incoming register-translators, which were designed only for 7-digit storage. The departure from uniformity in the numbering scheme would also have required the incorporation in the directors of a means for detecting the end of dialling. Since this scheme was very costly, and in no way assisted in solving the international dialling problem, it was not pursued.

Decentralization of Trunk Switching in the Large Cities

Trunk traffic into the six director areas is at present switched at central exchanges which are linked by junction networks to all the exchanges in the area. A recent comprehensive study of the routing and switching of trunk and junction traffic in London has shown that there would be an economic advantage if switching could be decentralized to exchanges which each served only a sector of the area.

With the present non-systematic allocation of exchange codes in the director areas, routing on a sector basis could only be achieved if S.T.D. controlling register-translators

could separately identify each exchange in every director area. This would require a large 4-digit and 5-digit translation capability far beyond the present register-translator capacity. Alternatively, it would be necessary to re-allocate exchange codes so that the first one or two digits identified the sector in which the exchange was situated.

replaced by three figures and the exchange names will disappear. In some instances the figures equivalent to the letter code will be used, but in others different figures will be used in preparation for sectorization. For S.T.D. and local codes the figure equivalent will be used. Typical examples are shown in the following table.

Typical Dialling-Code Changes

Type of Number or Code	Old Form	New Form	Type of Number or Code	Old Form	New Form
Subscriber numbers	ABBey 2870 ACORn 4321	222 2870 992 4321	S.T.D. codes		
Speaking clock, etc.	TIM DIR ASK 8011	123 192 246 8011	Abbeytown Abbots Bromley Aberdeen	OWN 56 OBU 374 OAB 4	0965 6 0283 74 0224
Local codes	MX AX 8	69 298	National numbers		
			London ABBey 2870 Manchester BLAckfriars 9898 Abbeytown 299 Abbots Bromley 299 Aberdeen 34344	01 ABB 2870 061 BLA 9898 OWN 56 299 OBU 374 299 OAB 4 34344	01-222 2870 061-252 9898 0965 6-299 0283 74-299 0224-34344

Note: The hyphen in the all-figure national number separates the local number from the S.T.D. code.

This would be extremely confusing to subscribers, and, in London, would be impracticable owing to the lack of the spare exchange codes which would be necessary to implement a change.

By changing to all-figure codes the opportunity arises for allocating such codes on a sector basis. In London the first two digits, and in provincial director areas the first digit, of an exchange code will indicate the sector the exchange is in. Sector routing then becomes practicable, since a controlling register-translator can identify the appropriate sector from an examination of the first three digits of the national number (excluding the prefix 0), e.g. for a London exchange (0)1 23X XXXX and for a Birmingham exchange (0)21 2XX XXXX.

THE NEW TELEPHONE NUMBERS AND CODES

In the director areas the 3-letter exchange codes will be

IMPLEMENTING THE CHANGE

A change of this magnitude, affecting most subscribers in the country, must of necessity be made gradually so as to cause minimum inconvenience to telephone users. From the starting date all new numbers on director exchanges will be allocated in all-figure form. Natural change due to new subscribers, removals and transfers will result in about 1.5 million all-figure numbers coming into use in the next 3 years. At this point in time the remaining letter-and-figure numbers will be changed to all-figure form. During the transition period, and for some time after the final change, access to an exchange will be provided by both the letter code and the new figure code. The use of letters in S.T.D. codes will disappear during this period as new dialling-code booklets are issued in all-figure style.

Although the main problems of the change are service

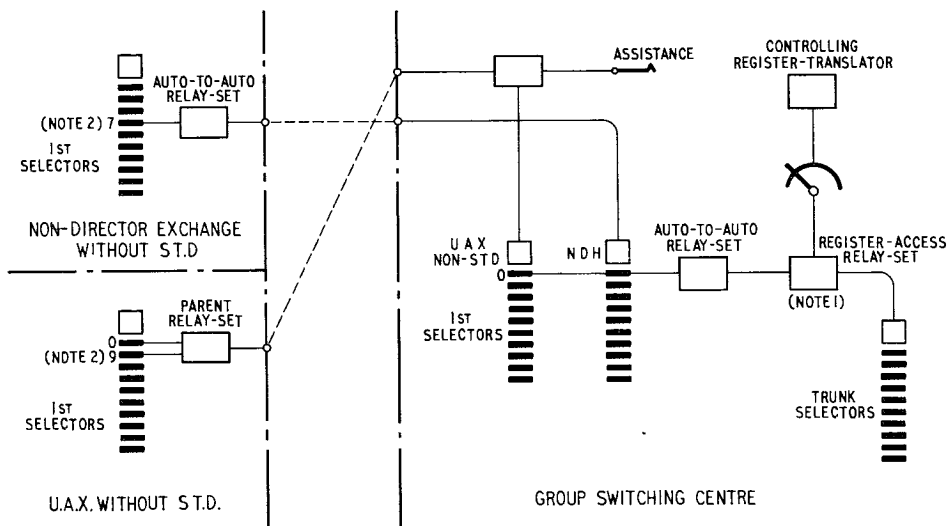

N.D.H.—Non-director exchanges in home charging group

- Notes:
1. This relay-set is strapped to bar all calls other than to the local-fee area.
 2. If, for example, the published all-figure number is 021 223 XXXX, the dialling instructions are:
 - (a) from non-director exchanges in fringe areas dial 7 021 223 XXXX,
 - (b) from U.A.X.s in fringe areas dial 9 021 223 XXXX.

TRUNKING DIAGRAM FOR ACCESS TO DIRECTOR AREA VIA REGISTER-TRANSLATORS AT GROUP SWITCHING CENTRE

ones, some engineering work has had to be done to prepare for the change.

Provision of Duplicate Translations

Where, for sectorization reasons, the figure codes are not the numerical equivalent of the letter codes it has been necessary to make arrangements so that these exchanges are accessible by either the existing letter codes or the new all-figure codes. The provision of this alternative-code access has involved duplication of a number of translations on directors, incoming trunk register-translators and incoming international register-translators at exchanges in the director areas. Also, at exchanges in the director-area fringe which route calls by national number directly to some director exchanges, it has been necessary to provide duplicate translations, and, in some circumstances, to supplement the controlling register-translator fourth-digit and fifth-digit translation relays which are used on this class of call.

Access from Non-S.T.D. Exchanges in the Director Area Fringes

Subscribers connected to exchanges which have not yet

got S.T.D. and are in charging groups adjacent to a director area, dial figure codes for direct access to some director exchanges. The codes are shown in dialling-code lists against the exchange names, which appear in alphabetical order. With the introduction of all-figure codes for these director exchanges a second entry in numerical order would be necessary, and this would, in effect, instruct the subscriber to substitute one figure code for another.

This was considered undesirable from a service viewpoint, and arrangements have been made, using existing designs of equipment, whereby access from a given exchange to all exchanges in the director area is obtained by dialling a common code. To do this it has been necessary to make arrangements for routing the traffic either via controlling register-translators at a nearby group switching centre (G.S.C.) or via incoming register-translators at the director-area trunk exchange. The trunking for the former arrangement is shown in the accompanying figure.

A.J.B.

Book Reviews

“Rectifier Circuits (Theory and Design.)” Johannes Schaefer. John Wiley & Sons, Ltd. xix + 347 pp. 218 ill. 102s.

This book, which was written primarily for the practising rectifier engineer is separated into three sections dealing, respectively, with rectifier connexions, d.c. characteristics and a.c. characteristics.

The first section of 72 pages discusses most of the single-phase and three-phase transformer connexions found in rectifier equipments. A whole chapter is devoted to the application of 12-pulse rectifier systems derived from 3-phase supplies by means of transformers connected in fork, zig-zag, and star-delta with inter-phase reactor, now commonplace in the larger telephone exchanges. Formulae relating to the equivalent power rating of the transformer for each connexion are derived from first principles in a most lucid manner enabling the most economic transformer connexion to be chosen.

The second and largest section of the book, of some 200 pages, deals with regulation, the operation of line-controlled inverters and the calculation of short-circuit currents. This section also examines the use of phase control of output voltage, now being obtained by the use of thyristors in some rectifier sets supplying transistorized line amplifiers. The section concludes with a chapter on voltage and current ripple and derives expressions for the harmonic frequencies developed by rectifier systems. Only two pages are devoted to the reduction of ripple by inductive-capacitive smoothing circuits which are, consequently, dealt with in a rather cursory manner.

The third, rather shorter, section of the book considers a.c. characteristics by treating the rectifier set itself merely as a “black box” having only pulse number and phase angle. Current waveforms and the effects of load and commutating characteristics on power factor are examined.

The book concludes with an appendix of useful mathematical formulae, a bibliography of related works of reference and a comprehensive index.

All the formulae derived is summarized in Table 1, which is in the form of a separate booklet, so that all of the relationships for a particular connexion can be readily consulted without searching through the text. This is an

extremely useful feature of the book but it could easily be mislaid. It would be more satisfactory if Table 1 were to be made an integral part of the book, possibly in the form of concertina-type folding sheets.

The book treats the subject matter in a clear logical manner, largely non-mathematically. In common with other books published in the U.S.A. it uses the decimal method of numbering formulae and diagrams, favoured by many students but rarely used by British publishers.

The book does not, amongst other things, consider the characteristics of the various types of rectifying element or the use of transductor and variable auto-transformer voltage-control methods. Because of these omissions and the lack of detailed information on smoothing circuits, telecommunications engineers will find the book wanting. Students preparing for the I.E.E. Part III examinations may find the work sufficiently useful to justify purchasing a personal copy.

D.A.S.

“Dictionary of Electrical Engineering, Telecommunications and Electronics. Vol. 1: German-English-French.” W. Goedecke. Sir Isaac Pitman & Sons, Ltd. 826 pp. 63s.

This first volume of a trilingual (German-English-French) dictionary contains more than 26,000 terms used in electrical engineering, telecommunications and electronics, together with their related fields. The key language is German: the words are arranged in alphabetical order in columns, and opposite each appears the English and French equivalents. This arrangement makes for easy searching for the term required.

It is claimed by the compiler that the terms listed were collected in the course of many years' activity as a technical translator, the main source of the collection being journals and modern text-books published in English, French or German. The book does in fact contain many new terms which are not to be found in earlier dictionaries covering the same field.

The arrangement of the dictionary in three volumes is to facilitate translating into and out of any of the three languages. Volume 2 (French-German-English) and Volume 3 (English-German-French) are to be published in the near future.

Volume 1 is well produced on good quality paper and at 3 guineas seems very good value for money.

D.C.G.

Operation and Maintenance of Secondary-Cell Batteries

A. E. MAHONEY†

U.D.C. 621.355.2

The useful life obtained from a battery of secondary cells and the maintenance attention it will require, depend on the form of operation, the correct performance of routine maintenance and the type of cell construction. The forms of operation and the most common routine maintenance functions are described and some insight given into the problems encountered with the various types of cell in service.

INTRODUCTION

BATTERIES of lead-acid secondary cells are associated with most Post Office telecommunication power plants and ensure both continuity of supply to equipment during power-plant switching operations and a reserve of power for a specified period in the event of mains-supply failure. The maintenance specified for these batteries is that necessary to keep them in the best electrical and mechanical condition and to ensure that a reasonable life is obtained.

The suitability of the various types of cell available for the different forms of working is largely decided by their design and performance, features which also influence the day-to-day maintenance attention needed. This article describes the various forms of battery operation and explains the purpose of common routine maintenance action. The construction and maintenance of each type of cell is also discussed.

OPERATION

The maintenance required by a battery and the life obtained from it are, to a large extent, dependent on the form of working. Each form of working is briefly reviewed here, but floating-trickle-charge working is described in rather more detail.

Charge-Discharge

Charge-discharge is an obsolete form of working for large batteries but is still used for some small power plants. Two batteries are provided: one is discharged to the load whilst the other is charged and then stands idle until the batteries are changed-over. The cell plates are thus kept in a lively state, with the positive plates of formed-plate cells tending to increase in capacity. Cell life is normally terminated due to mechanical weakness of the positive plates or due to internal short-circuits resulting from distortion of grown and over-formed positive plates. The battery life is influenced by the period taken for each charge-discharge cycle, but is not normally expected to exceed 1,000 cycles.

Partial Charge-Discharge

Partial charge-discharge is an obsolescent form of working although perhaps about two thirds of the telephone exchange power plants in the United Kingdom still operate on this principle. Whilst some of these power plants use the battery voltage as the reference for switching operations, the majority place the extent of charging under the ultimate control of an ampere-hour meter, with the battery input being directly related to the

output. Ideally, the charging equipment should be such that the battery reaches a full-charge state once or twice a day, but, as this type of plant was produced in various sizes to cater for set ranges of day load, it can happen that best operating conditions are not always realized. Investigations have revealed the occurrence of up to nine charges per day with over-frequent end-of-charge gassing conditions.

Over-formation of the positive plates, with vertical and lateral expansion of the plates, which become mechanically weak in the process, is the main reason for the relatively-short battery life of about 9 years obtained with partial charge-discharge working under ampere-hour meter control. Additionally, towards the end of battery life, repeated maintenance attention becomes necessary to prevent or remove short-circuits resulting from preferential working between parts of plates, due to the buckling of "grown" positives. Wood laths are often inserted between plates of large open-type cells to hold distorted positive plates away from adjacent negative plates.

Partial-charge-discharge U.A.X. power plant operating under the control of an ampere-hour meter was superseded by a type (Power Plant No. 214*) using the battery voltage as a reference and incorporating end-cell switching. Unfortunately, the improved battery life expected when this plant was introduced has not been achieved, the average life obtained being no more than 6 years; the plant is now to be superseded by a new type of power plant operating on the floating-trickle-charge principle.

Assisted Discharge

The assisted-discharge system as used at some telephone exchanges is a crude form of float working using a motor-generator and two batteries worked on an alternate weekly basis. The plant operation is such that the charge current is adjusted in steps under the control of a contact voltmeter monitoring the battery voltage. Between automatic adjustments of the generator output current the battery experiences small charges and discharges as the load varies. The battery voltage at a 50-volt exchange, for example, fluctuates at an equivalent of from 2.03 to 2.07 volts per cell. This form of working is not conducive to good battery life.

Floating

Floating is the most common form of battery operation at the larger telephone exchanges. Motor-generators or rectifiers are used as the charging source, and the outputs are varied continuously according to the load so that the battery is neither charged nor discharged in normal operation.

The batteries are maintained within close limits of a nominal 51.5 volts (equivalent to 2.06 volts per cell), which is somewhat below the voltage necessary to maintain them in a full-charge condition unless regular

†Power Branch, E.-in-C.'s Office.

*Sander, D. H. A New Power Plant for U.A.X.s No. 12 and 13—Power Plant No. 214. *P.O.E.E.J.*, Vol. 52, p. 265, Jan. 1960.

refreshing charges are given at 2-weekly intervals, equalizing charges at 13-weekly intervals and conditioning cycles annually.

The battery life achieved is about 15 years, by which time the positive plates have lost sufficient capacity or otherwise so deteriorated that replacement becomes necessary. At this time the residual useful life of the negative plates may be about 10 years and a decision must be made whether or not to re-use them. With the general provision of stand-by engine-driven alternators giving alternative a.c. supplies to power plants the combined battery reserve for an installation can be reduced from 24 hours to the busy-hour load only. The installed battery capacity is, therefore, substantially reduced and the saving effected by re-using old negative plates is consequently not so marked; the practice is thus gradually dying.

Floating Partial Trickle-Charge

With the form of working known as floating partial trickle-charge the battery is operated in parallel with the load and with the charging source at such a voltage that whilst the battery receives a slight charge this is not sufficient to maintain the battery in a full-charge condition indefinitely. For batteries of formed-plate cells with a maximum electrolyte density of 1.210 this voltage is equivalent to about 2.2 volts per cell. The battery will, however, lose capacity at a slower rate than when floating at the open-circuit voltage, and, whilst refreshing charges should not be necessary, equalizing charges will be required either as an infrequent routine or as and when required. This form of working is employed for intermediate repeater-station power plant, in which the batteries are maintained at 2.2 volts per cell.

Floating Trickle-Charge

The present trend in British telecommunication power-plant design is to produce power plants which, whilst supplying the load within prescribed equipment voltage limits, also trickle-charge the battery so that it is always in a fully-charged condition ready for immediate service. It is important that the trickle-charge rate should not be such that the cells are permitted to gas, and it is usual for the battery to be controlled at a voltage equivalent to 2.3 volts per cell. End-cell switching arrangements may be incorporated in the power plant to prevent the voltage on discharge falling below the minimum required for satisfactory operation of the equipment. Floating trickle-charge working is thought to be the best system for maintaining a battery in good condition, and a battery life of 20 years is expected.

Automatic recharge from a constant-potential source, following an emergency discharge, is a normal feature of the power plant. Such charging is an economic proposition, since wastage of energy due to decomposition of water in the electrolyte and the production of heat, features which are normally encountered with other forms of recharging, is virtually eliminated. At the beginning of such a recharge the battery would accept a maximum current limited only by the total resistance of the charge circuit, and it is usual, therefore, to include an over-riding current-limiting feature in the rectifier design. The maximum charge-current thus permitted will flow through the battery until the voltage rises to an equivalent of 2.3 volts per cell; the voltage-control

circuit will then function and cause the charge current to be gradually reduced to a very small value so that the voltage of the battery cannot exceed the control value. At this point the battery has been found to be about 95 per cent recharged. The tail end of the charge will be at a trickle rate, and the battery may not be restored to a full-charge condition for several days.

Fig. 1 is a typical recharge curve obtained during a test of a 200 Ah battery (Cells, Secondary, No. 22), and

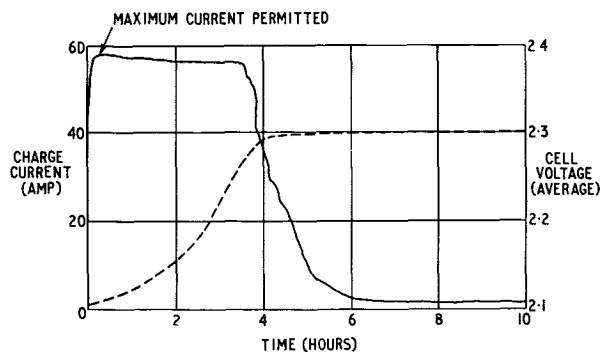

FIG. 1.—RECHARGE OF 200 Ah CELL, SECONDARY, No 22 FROM CONSTANT-POTENTIAL SOURCE

illustrates the automatic recharge of a fully-discharged battery from a constant-potential rectifier with over-riding current control.

If cells having a compact form of assembly are charged under these conditions the specific-gravity readings may cease to be a reliable reference of the cell state during the charge and for a considerable time afterwards. The close proximity of plates and separators inhibits the free circulation of electrolyte, and diffusion of electrolyte is not assisted by any gassing at the plate surfaces. During one test, specific-gravity readings indicated a recharge of only 70 per cent whereas the actual recharge at the time was of the order of 95 per cent. This difficulty is not experienced with cells having adequate spacing between plates, and the discrepancy not so marked if the battery is charged from only a partially-discharged condition. However, the majority of constant-potential power plants will be provided with close-assembly-type cells and some alternative to the normal specific-gravity routine records as a means of determining the condition of cells may be desirable. A revised maintenance procedure is now on trial at some installations: in this procedure routine specific-gravity readings are abandoned in favour of cell-voltage readings, which are entered in the log book.

It must be appreciated that voltage readings alone will not give an indication of the state of charge of a cell, but any change in that state caused by, say, a partial short-circuit will be indicated by some fall in the voltage of that cell whilst the voltages of other cells in the same battery remain substantially unchanged. A normal fluctuation of cell voltage within certain limits can be expected: for example, a rectifier forming part of the power plant supplying transistor-type transmission equipment is required to maintain a 12-cell battery within 2 per cent of a nominal 27.6 volts, giving a cell-voltage variation of up to about 0.05 volts in normal working. In these circumstances a variation of say 0.15 volts could be considered as abnormal and demanding investigation.

Due to the individuality of cells the potential across a battery may not be evenly distributed between each cell,

but this should not noticeably affect the acceptable voltage variation, which should be the same for all the cells in a battery. To demonstrate the voltage variations that could be expected, a 24-cell 60 Ah battery was placed on trickle-charge at a controlled voltage of 55.2 volts, a 150 mA load being connected across one cell and a 125 mA load across another. The results obtained are given in the table and indicate that a partial short-circuit will be immediately reflected by an excessive voltage variation, the subsequent voltage drop being at a much reduced rate.

Effect of Partial Short-Circuit Cell on Voltage

Time (days)	Cell with 150 mA Load (volts)	Cell with 125 mA Load (volts)	Average Volts of Remaining Cells
Start	2.13	2.17	2.32
1	2.03	2.04	2.35
7	2.01	2.02	2.35
12	2.01	2.02	2.30

It can be fairly concluded that voltage indication may be used as an aid to maintenance, and in lieu of specific-gravity readings, of batteries normally trickle-charged or otherwise kept in a steady state of charge but not of batteries worked in any other way.

If one or more cells in a battery become short-circuited the additional voltage distributed over the remaining cells might be such that they would commence to gas, thereby giving a further visual indication of a fault condition. If at any check the voltage variation of all the cells is found to be excessive, this indicates that the charging source is suspect and the rectifier setting-up procedure should be checked.

It is probable that a routine voltage-check on a 4-weekly basis would be sufficient, but for an old battery it may be advisable to increase the frequency somewhat. Suitable single-cell voltmeters would be made available if voltage tests were introduced as a standard procedure. Any variation in electrolyte density affects the cell voltage; thus, if cell voltages are recorded, the electrolyte losses due to evaporation must be kept to a minimum.

Trickle Charging

For trickle charging, the battery is connected across a charging source but not normally across a load. The charge rate applied is not greater than that required to just maintain the battery in a fully-charged condition without undue gassing. Generally, a charge rate between the 500-hour and the 1,000-hour rates is adequate, with cell voltages not exceeding 2.3 volts.

All types of formed-plate cells may be trickle charged to keep them in good condition when not in service. Trickle charging of pasted-plate cells is limited to certain types, as indicated later.

ROUTINE MAINTENANCE

If a battery is to be kept in good condition regular maintenance is essential. Included in the routine attention required is the regular recording of battery data to provide a history of performance throughout the battery life. This is useful in the investigation of any troubles or unusual phenomena. The routine, tests and inspections appropriate to the type of cell comprising the battery, and to the form of working, are included in a main-

tenance schedule applicable to the associated power plant. Descriptions of the common routine tests and inspections and their objects are given in the following paragraphs.

Adjustment of Electrolyte Level

The volume of electrolyte in a cell gradually decreases due to loss by spraying when the cell is receiving a gassing charge and through evaporation; an increase in the average density of the electrolyte may then be noticed. The frequency and extent of routine topping-up depends on the cell type and the system worked. Open-type cells have a higher evaporation rate than enclosed-type cells, and the loss due to spraying will be greater; batteries worked on a charge-discharge system require more frequent topping-up than those operated on a float system.

It is important that the level of electrolyte should not be allowed to fall below the top of the plates, otherwise the exposed portion of the plates will be damaged due to abnormal sulphation.

Specific Gravity of Pilot-Cell Electrolyte

For general record purposes an end cell of a battery may be considered as typical of all the cells in the battery, and as such is designated as the pilot cell and labelled accordingly. The state of charge of this cell as indicated by the density of its electrolyte is regarded as an indication of the degree of charge of the battery as a whole. Routine logging of the specific gravity of the pilot cell provides an essential record, sometimes in conjunction with other plant records such as ampere-hour-meter readings, especially where the battery is not subjected to any cycles of discharge and recharge. Any progressive loss in capacity due to battery deterioration or faulty power-plant working is apparent from the chart or table compiled in the log book.

The specific gravity of the pilot cell only is recorded when a refreshing charge is given, and it is considered that a sufficient indication of when the charge should be terminated can be obtained from this reading.

Specific Gravities of Electrolytes of All Cells

The specific gravities of the electrolytes of all the cells in a battery are regularly checked to ensure that no cell is losing capacity at an abnormal rate due to a fault condition such as an internal short-circuit.

Refreshing Charge

Where cell voltages are maintained under normal working conditions at the open-circuit value, i.e. the voltage of a fully-charged cell when neither charging nor discharging, there is a gradual decrease in its capacity due to self-discharge. This decrease may be in the order of 1 per cent per day for new cells, but may be much greater in old cells. The object of refreshing charges is to restore this loss of capacity, and charges are continued until the specific gravity of the pilot cell is restored to within a "point" (0.001) or two of that obtained at the last previous full charge.

Equalizing Charge

The objects of periodic equalizing charges are three-fold. First, to ensure that any cell which may not have been fully charged during a previous refreshing charge is

restored to a fully-charged condition. On formed-plate cells the charge is, therefore, not terminated until the density of the electrolyte in all the cells of a battery has been stabilized, i.e. it has remained reasonably constant for three half-hourly readings. With pasted-plate-type cells the charge is only given if the density of the electrolyte in any cell has fallen more than a specified amount since the last full charge. For cells of this type the equalizing charge is given at the finishing rate (a charge current equivalent to 9 per cent or 6 per cent of the assigned capacity, according to cell size) and is continued until the specific gravity of the low cell remains constant for 4 hours. Such an extensive overcharge may not be necessary with modern pasted-plate cells, and a trial to see if the charge can be safely reduced is proposed.

Secondly, the effect of regular, but not over-frequent, gassing charges on a battery not normally receiving such charges is beneficial to its general electrical condition. The effect of impurities is lessened, and the formation of obdurate sulphation due to incomplete cycling is retarded.

Thirdly, new reference data are provided for subsequent refreshing charges.

Conditioning Cycles

Conditioning cycles are intended to maintain plate material in an active state, thus preventing the battery from becoming sluggish in operation and unable to deliver full capacity at the required discharge rate. The discharge part of the cycle is to the equipment load and, as the cycle is normally only performed on telephone-exchange batteries, will not therefore be at a steady rate. No true comparison can thus be made between the capacity obtained during the test and the assigned capacity of the battery. If, however, the discharge seems to terminate prematurely the matter must be investigated and, perhaps, a controlled test-discharge performed. The recharge part of the cycle is normally performed using the installed power plant, but, if necessary, this is supplemented with temporary charging plant to complete the charge in a reasonable time.

The application of annual conditioning cycles, confined initially to batteries on float working, was extended to include batteries on partial charge-discharge working following actual experience with nominally fully-charged batteries that were not able to furnish full capacity at the rate required. In view of the difficulties encountered in performing conditioning cycles at U.A.X.s, and the high cost of such a cycle, it was subsequently decided to extend the periodicity to 3 years for all batteries on partial charge-discharge working.

Other maintenance difficulties associated with small-capacity cells could make their replacement on a routine basis a desirable proposition; conditioning cycles for batteries of these cells would then be abandoned.

Special Charge

Special charges are sometimes necessary if a battery is operated under the control of an ampere-hour meter. The instrument used is geared to permit the battery input to be 120 per cent of the output, thus making allowance for the inefficiency of the charge and for unrecorded discharge currents smaller than the minimum operate current of the instrument. It may be, however, that the maximum discharge normally recorded on the instrument at a particular installation does not represent a very large proportion of the battery capacity. In such conditions

the excess of charge over discharge is not a very significant value, and additional special charges may be required. The special charge is achieved by advancing the ampere-hour meter pointer to show an additional discharge equal to 20 per cent of the battery capacity, the charge being allowed to continue until it is automatically switched off when the meter pointer reaches zero. Special charges are not given at specified intervals but only as and when required and are not therefore included in schedules of routine maintenance.

Checks for Plate-to-Lining Contacts

Batteries of cells contained in lead-lined wood boxes are subjected to a voltage test to ensure that no inadvertent contacts exist between the positive and negative plates and the cell lining. Confusing results can, however, be obtained with these tests, which are further discussed in the section on testing.

Examination and Cleaning

Particles of active material may be dislodged from positive plates, and, whilst the majority of particles will settle in the bottom of the cell as sediment or sludge, some will be deposited on negative plates or be carried by electrolyte spray on to plate lugs. Where an open form of assembly exists, particles deposited on negative plates may build up and form bridges between negative and positive plates, causing the cell to discharge itself. Regular scaling of the plates of open-type cells removes these growths and prevents the resultant internal short-circuits. Electrolyte spray, given off during the gassing stage of a charge, will settle on plate lugs, and subsequent evaporation leaves high concentrations of electrolyte in any depressions or irregularities on the lug edges. Wiping plate-lug edges limits the extent to which the lugs are attacked by concentrated acid containing particles of active material.

The containers of some enclosed-type cells are not self-supporting, and it is necessary to clamp these cells together on a battery rack. In these circumstances there is a danger of tracking between cells having a high potential difference between them. Instances have occurred where the heat developed in a leakage path has so damaged the cell containers that they have had to be replaced. The insertion of spacers between cell rows lengthens the leakage path, but it is important that the cell lids be kept clean and dry. Where conditions are such that condensation occurs that could lead to tracking, cell lids can be treated with a silicone polish to prevent the build-up of a continuous path of water.

Battery Records

The regular compilation of records in a log book produces a ready reference to past specific-gravity readings, etc., which are required for the satisfactory control of further maintenance charges. Where routine battery charges are not performed, this record provides the only evidence that the power plant continues to maintain the battery in a satisfactory state. For example, the various sections of the battery associated with the U.A.X. Power Plant No. 214 might not receive the same amount of charge, and this is readily indicated by the extent of topping-up required by the various cell groups.

The "History" section of the log book includes all details of major defects, repairs, special tests and

abnormal behaviour: this information is most helpful in the investigation of faults or short battery life.

CELL TYPES AND THEIR MAINTENANCE

The fault conditions, and hence the maintenance attention that might be expected for a battery, depend to some extent on the cell construction. In the following paragraphs the effects on maintenance of certain design features are described, and the most common faults met in service are discussed, under the various British Post Office coded titles of the cells.

Cells, Secondary, Enclosed, No. 1-5

Cells, Secondary, Enclosed, No. 1-5 are small enclosed-type cells of up to 125 Ah capacity and have generally given satisfactory life with all types of power plant. Maintenance attention is normally limited to external cleaning and the prevention of pillar corrosion, which at one time was particularly troublesome and was eventually traced back to faulty casting during manufacture.

Antimonial poisoning, which affects many types of formed-plate cell, has been the cause of plant misoperation, especially on the partial charge-discharge power plant used at U.A.X.s. Antimony released during normal cell working is deposited on the negative plates, and one effect is the reduction of the negative-to-electrolyte potential so that the end-of-charge cell voltage is reduced from above 2.6 volts to about 2.45 volts.

Remedial action to limit the effect of this poisoning is to charge the battery at a high rate to dispel antimony as stibine (SbH_3) or otherwise render it inactive. This action has been found to give sufficient improvement in some cases, but no remedial measure having a lasting effect seems available.

Cells, Secondary, Enclosed, No. 1-5 have largely been superseded by cells from the Cells, Secondary, No. 21 or No. 22 ranges, which have similar characteristics at the nominal discharge rate but which, generally, occupy a smaller space.

Cells, Secondary, Stationary, No. 9-11

Cells, Secondary, Stationary, No. 9-11 are open-type formed-plate cells of from 200-300 Ah capacity, contained in glass boxes. The robust construction of these cells enables a reasonable life to be obtained even under the most arduous conditions. The cell construction is such that major maintenance attention, i.e. renewal of plate sections or cleaning out of sediment, can be easily performed by the maintenance staff.

Corrosion of plate lugs and at bolted connexions can be troublesome, and tests have been made with proprietary preparations to ascertain if better protection could be obtained. Results indicate that, where dissimilar metals are in contact, some of these preparations may be a better inhibitor than petroleum jelly once corrosion has started, but connexions carefully treated initially with petroleum jelly are as adequately protected and not more prone to corrosion than those otherwise treated. On the basis of this result the use of proprietary preparations, which are usually much dearer than petroleum jelly, is not recommended.

Cells, Secondary, Stationary, No. 9-11 have been superseded by cells from the Cells, Secondary, No. 22 range, which, as enclosed-type cells, have the advantage that they can be installed in apparatus rooms and do not require a separate battery room.

Cells, Secondary, No. 12-16

Cells, Secondary, No. 12-16 are formed-positive-plate cells, from 400-15,050 Ah capacity, contained in lead-lined wooden boxes. As the only formed-plate cells over 2,200 Ah currently available they are used with all forms of working.

If frequent charging or cycling occurs, internal short-circuits can be a common maintenance problem. Short-circuits may be caused by "treeing," which occurs during over-charging. Treeing consists of a growth of spongy-lead pips on the negative plates; the pips eventually make contact with adjacent positive plates. Buckling of over-formed or sulphated positive plates, caused by over-charging or under-charging, respectively, also leads to short-circuits.

Glass-tube separators are used, and, as no other physical barrier exists between plates to obstruct the growth of "trees," scaling of plates is called for on a routine basis.

Over-charging is indicated by the excessive build-up of deposit shed from positive plates and by the appearance of plates that look too rich in colour. Under-charging is indicated by the poor colour of positive plates and early gassing at negative plates when the cell is being charged. A fall in specific-gravity readings may be an indication of under-charging but, due to sulphation of sediment, it may also be evidence of over-charging.

If over-charging has occurred the battery is given an equalizing charge, after which the electrolytes are adjusted to the correct density. The over-charging may also expell expander from the negative plates; they may then harden and lose capacity. To check this the battery may be test-discharged, and if the cadmium readings indicate the battery capacity is limited by the negative plates these plates can be replaced.

If under-charging has occurred the battery can be given a series of pulse charges at a slow rate, i.e. at the 20-30 hour rate, until gassing starts immediately the charge is connected. If this action does not produce a satisfactory increase in cell capacity the positive or negative plates may be replaced, as indicated by the test results.

If otherwise suitable, buckled plates may be re-used after straightening. The growth can be such that, after straightening, the plates are too wide to be reinserted in the box, and on occasion the corners of plates have been trimmed to permit their re-use on a short-term basis.

Cell Boxes. Teak alone used to be specified in the manufacture of cell boxes, but subsequent relaxation permitted the use of various soft and hard woods. These alternatives have generally been satisfactory, and if teak were now required for a medium-capacity battery installation the cost would be increased by about £200.

The drying rate of wood under natural conditions is in the order of one year per inch thickness; thus, the development of cracks due to drying out might, with the thickness of wood used for cell boxes, be expected to occur in the first year in use whilst the box is still under maker's guarantee. This drying time will vary somewhat depending upon the relative humidity of the battery room. Splitting of boxes can also be caused by wood movement due to seasonal changes in room humidity, and the existing approved box-design includes skew dovetail jointing at the corners to keep splitting to a minimum. A modified box design utilizes separate corner-pieces glued to the planks, using single-tongue or double-tongue

joints with the grain running at right angles to the side planks. Several installations using such boxes are now on trial, but these have not been in service long enough to prove their long-term effectiveness.

Of the alternative box materials considered that might require less maintenance attention, glass, ebonite and reinforced plastic are the most successful. Moulded-glass boxes are eminently suitable but become too expensive in the larger sizes, whereas ebonite compares favourably with wood in all sizes. Illustrations of ebonite and glass-fibre-reinforced PVC trial boxes are given in Fig.2 and 3, respectively.

One attraction of these boxes is that cells initially plated to a much-reduced capacity can easily be extended

to full capacity by the removal of an auxiliary box, whereas the present standard arrangement requires the removal of a welded-lead partition. The problems of leakage and box saturation are obviated, and routine plate-to-lining and lining-to-lining tests become unnecessary.

Cells, Secondary, No. 18 and No. 19

Cells, Secondary, No. 18 and No. 19 are pasted-plate cells with capacities of up to 840 Ah at the 5-hour rate of discharge to an end voltage of 1.7 volts at 60°F. A separate hydrometer pocket distinguishes these cells from similar pasted-plate traction cells commercially available. The hydrometer pocket enables a float-type hydrometer to be provided in each cell, but this arrangement is not entirely satisfactory for maintenance purposes as, owing to diffusion difficulties, reliable specific-gravity readings are not immediately obtainable. The wrapped ebonite box is not self-supporting, and batteries of these cells must be so arranged that all cells are adequately supported from all sides to limit box distortion.

Pasted-positive plates cannot increase or maintain capacity by conversion of grid material as do formed plates, thus no initial excess capacity is provided in the associated negative plates, as in formed-plate cells, to maintain cell capacity as the negative plates deteriorate. Both plate sections of pasted-plate cells thus lose capacity together, resulting in a rapid fall-off in cell capacity towards the end of the cell life. In fact, and probably due to the difficulty in manufacturing plates to a precise capacity, it is usually found that new cells reach a maximum capacity of about 10 per cent in excess of the nominal capacity after a short period in service; thereafter, the cell slowly loses capacity until, towards the end of its useful life, the capacity starts to fall rapidly. Cells are normally renewed when the cell capacity is reduced to 90 per cent of the nominal.

Cells, Secondary, No. 18 and No. 19 have grids hardened with antimony and are not, therefore, suitable for trickle-charge working. Cells of this type with antimony-free or antimony-reduced grids are now available, and field trials to determine their performance and life on floating trickle-charge working are in progress.

As indicated in the previous section on routine maintenance, the charge finishing rate depends on the size of the cell. A smaller current is not desirable as a moderate amount of gassing is necessary to maintain the paste in an open condition and remove impurities from the plates. A lower charge-rate might therefore result in a reduction of capacity at high rates of discharge and also in increased self-discharge. Experience shows that the determination of actual losses during a period of float working may not be reliably indicated by hydrometer readings, and it is normal to float these cells at 2.15 volts and to intentionally over-charge batteries when routine conditioning charges are performed.

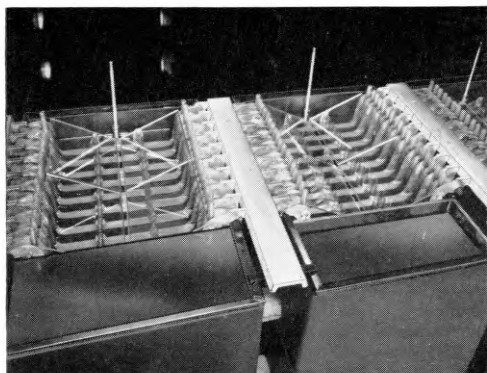

FIG. 2—EBONITE BOX (CAPACITY 2,600 Ah PLATED TO 1,800 Ah)

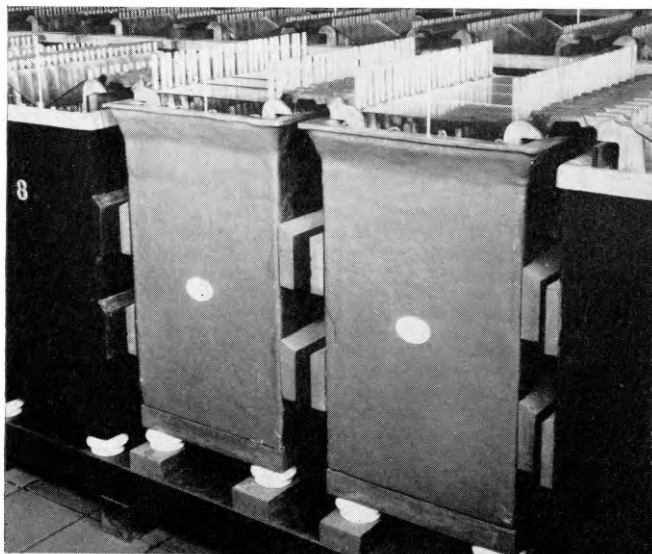

FIG. 3—PVC BOX REINFORCED WITH GLASS-FIBRE (CAPACITY 2,600 Ah)

It is quite common for cell lids to be forced upwards by the plate-grid corrosion, with resultant cracking of the pitch used to seal the lids. This fault generally occurs towards the end of cell life, and no remedial action is normally necessary. Leakage from ebonite boxes is rare, and day-to-day maintenance, apart from routine charging and topping-up, is limited to keeping all lids clean and dry.

In restricted accommodation, pasted-plate cells have sometimes been used instead of formed-plate cells, and at such installations it has usually been necessary to reduce the number of cells in the battery to obtain operation at the optimum float voltage. Where this is done, an increase in capacity is necessary to retain the correct stand-by requirement. Correct operation of the power plant must also be considered.

Cells, Secondary, No. 21 and No. 22

Cells, Secondary, No. 21 and 22 are enclosed-type formed-plate cells using thin positive plates. A close form of assembly with microporous PVC separators enables a low internal resistance to be obtained, giving good performance at high rates of discharge; this makes them particularly suitable for engine-starting duty.

The performance of these cells at the 10-hour rate of discharge is very similar to that of Cells, Secondary, Enclosed, No. 1-5 and Cells, Secondary, Stationary, No. 9-11, with the advantage that generally they occupy a smaller space for a given capacity. These two ranges of cells were, therefore, superseded for new work by the thin-plate types of cell, which are available in various sizes up to 400 Ah capacity. The cell design is "type approved," and individual cells or batteries are not subjected to test on installation unless the data thus obtained are required for subsequent maintenance purposes.

The cells became generally available in 1961, and experience to date reveals that whilst they give satisfactory service on trickle-charge or floating-trickle-charge working, some features of the design make them unsuitable for working where cycling of any sort is entailed or where shedding of positive-plate material can be expected. The positive plates are suspended from the top, but the negative plates and the separators rest on a plastic support located in the bottom of the cell. Active material from positive plates, formed and shed during cycling, and which in other formed-plate cells is permitted to fall freely away from the plate sections, builds up against this plate support and is liable to make contact with the negative-plate section. Once this contact is made the sediment will form part of the negative section and be rapidly converted to a bulky coral-like mass of chemical lead filling the available space. Under these conditions any sediment adhering to the surface of the separator may complete a path between plates of opposite polarity and thus short-circuit the cell. Fig. 4 shows deposit built up against the negative-plate supports, and Fig. 5 demonstrates conversion of the sediment when in contact with negative plates.

Cells associated with partial charge-discharge power plants have reached the stage described above after only 1 year in service, although the average time seems to be from 18 months to 2 years. Remedial action, consisting of the removal of the cell lid, transferring the cell body to a clean box, and resealing the lid is, except perhaps for the smallest sizes, an economical proposition compared

with renewal of the cells and should be considered where suitable facilities exist. Visual inspection of plates at this stage shows them to be in good mechanical condition,

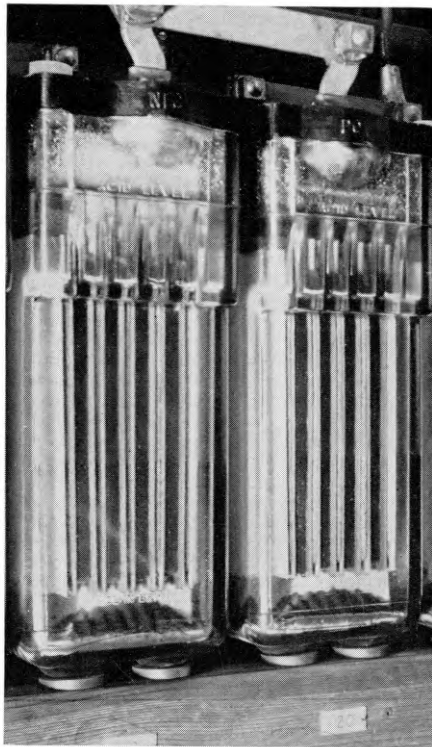

FIG. 4—CELLS, SECONDARY, No. 22, SHOWING BUILD-UP OF SEDIMENT AGAINST NEGATIVE-PLATE SUPPORT

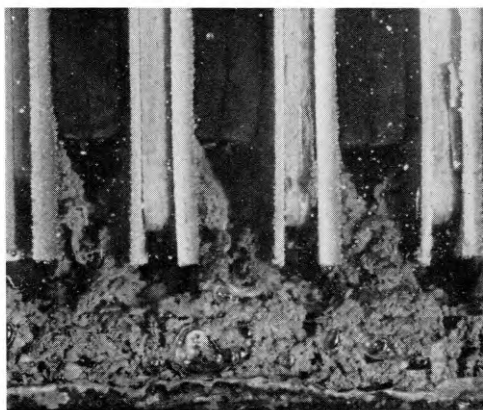

FIG. 5—CELLS, SECONDARY, No. 22, SHOWING CONVERSION OF SEDIMENT IN CONTACT WITH NEGATIVE PLATES

and electrical tests confirm that 95 per cent nominal capacity is still available.

Where modification of the power plant can easily be effected to eliminate battery cycling, this may in the long term be preferable to repeated extensive battery attention. For example, if the existing rectifier output is such as to supply the day load the rectifier size may be increased to meet the peak-load current at a voltage not less than the battery open-circuit value.

Modification of cell design either to inhibit shedding of positive-plate material, or to provide an alternative form of negative plate and separator support to preclude obstruction to the free-fall of deposit or to protect plates against internal short-circuits, is obviously necessary if the thin-plate-type cells are to continue to be used for all forms of power-plant working. Actions currently being considered include the replacement of the plate support with plastic tuning-fork-shape rods and the protection of the bottom and sides of negative plates with polystyrene insulating-paint.

Corrosion in the form of characteristically greenish "worms" of copper sulphate at the point where the copper insert emerges from the lead pillar has been commonly experienced. This was found to be due to acid penetration at the junction, and has been eliminated by greasing prior to the initial charge at the maker's works.

Reports are received, infrequently, of an offensive smell emitted from individual batteries. This phenomenon, not confined to Cells, Secondary, No. 21 and No. 22, is due to the emission of sulphuretted hydrogen from the electrolyte, and is an indication of an electrolyte containing an excessive amount of sulphurous acid or sulphur dioxide. Some of the sulphur dioxide may be deposited as sulphur in the cell, and if the smell can be tolerated its emission finally ceases.

Deposits of fine white material sometimes appear in new cells in even rows immediately below plate separators. This material is wood-flour used to improve the low-temperature permeability of some separators and has no deleterious effect on cell operations.

Because the quantity of acid is not directly related to the cell capacity in all cell sizes, the specific-gravity range will vary with the cell size. With one make the Cell Secondary, No. 21/15 has a range of 45 divisions whereas the Cell, Secondary, No. 22/400 has a range of 130 divisions. The importance of the variations in range must be appreciated if the significance of routine hydrometer readings is to be understood. For example, a fall of 15 divisions on the No. 21/15 cell represents a 33 per cent loss in capacity, but a similar fall on the No. 22/400 represents only an 11 per cent loss in capacity.

Traction Cells

A new type of traction cell with tubular-positive-plate construction has lately become widely available. The antimonial lead spines of the positive-plate grid are embedded in active material contained in sleeves of fabric, Terylene or braided glass-fibre, according to the cell make. Each positive plate thus consists of a row of tubes connected together at the top by a lead commoning bar and sealed at the bottom with a common plug moulded in polythene or lead. The attraction of this construction is that the spines are completely surrounded by active material, and the tendency for antimony to be released and interfere with cell operation is claimed to be minimized, thus making the cells suitable for use with trickle-charge working.

Traction-cell batteries have been installed under various forms of working to assess their operation. Fig. 6 shows a trial battery of tubular-positive cells used to replace an old battery of open-type cells. The



Wooden laths, inserted to prevent contact between distorted positive plates and the negative plates can be seen in the old battery on the left-hand side

FIG. 6—TRIAL BATTERY OF 800 Ah TUBULAR-POSITIVE-PLATE CELLS TO REPLACE OLD BATTERY OF OPEN-TYPE CELLS

wrapped-ebonite containers of these cells are not self-supporting and they must be contained, individually or in groups according to size and weight, in supporting crates.

Although car-type batteries have been used at small telephone exchanges when normal stationary cells have been in short supply, it is difficult to foretell when they are approaching the end of life. If, therefore, the possibility of battery collapse in service is to be minimized, testing or routine replacement of car-type batteries must be frequent, and their use for telecommunication purposes is not, therefore, normally recommended.

TESTING

Apart from acceptance testing, which is not detailed here but which provides essential data for subsequent maintenance, test-discharges are performed only as and when required to check the electrical capability of the battery. It may be expected, therefore, that a battery will generally only be test-discharged towards the end of its useful life. Such discharges should not be confused with conditioning cycles performed on a routine basis and which may be unregulated discharges to a varying load, to reduce wastage of energy. The only other electrical test, performed as a routine, is the plate-to-lining contact check.

Maintenance test-discharges on batteries of formed-plate cells are performed at the nominal 10-hour rate and continued until the voltage falls to an equivalent of 1.83 volts per cell, the capacity so obtained being adjusted for any variation in temperature from the nominal 60°F. All voltages, specific-gravity readings and the discharge current are recorded periodically throughout the test. The negative-to-cadmium* potential is recorded towards the end of the discharge.

The object of cadmium readings is to enable a check to be made on the respective capacities of the positive and negative plates so that a decision can be made on the possibility of re-using some plates. The general principles and procedure details associated with cadmium testing are given in standard instructions, but there has always been some controversy on the reliability and usefulness of these measurements. It is generally accepted that cadmium readings are influenced by variable factors such as plate size, non-uniformity of current distribution between plates, and the influence of adjacent positive plates, and, consequently, that approximate rather than absolute values are obtained. The shape of the curve obtained by plotting these values against discharge time

*A cadmium test-electrode is inserted in the electrolyte to form a separate cell for testing purposes.

is, however, a significant indication of the state of the negative plates.

If the curve shows a slow steady rise with an overall increase of say 0.1 volt, it is at least reasonable to assume that the negative-plate capacity is not less than that of the positive plates (an extension of the negative-plate discharge using other positive plates would be necessary to determine the actual capacity of the negative plate). If, however, the curve shows a sudden rapid rise towards the end of discharge it is probable that the negative plate is reaching the limit of its capacity, even if the actual increase is not much greater than 0.15 volts.

If during a maintenance test-discharge a favourable cadmium voltage curve is obtained it may be that a further period of life could be given by the negative plates when assembled with a new set of positive plates. However, no decision is made to re-use negative plates without expert examination of a sample plate to determine the amount of sulphate present, the porosity, and the general condition of the paste.

Cadmium readings cannot easily be obtained on enclosed-type cells, and the procedure adopted for new cells is to type-approve samples which are then taken as typical of similar cells subsequently purchased. Cadmium testing of these cells is not required for maintenance purposes, as partial replating of small-capacity enclosed-type cells is not an economic proposition.

The routine maintenance instruction detailing the procedure for plate-to-lining contact checks indicates the approximate voltages that apply if no contacts exist. A variety of unusual voltage conditions can arise due to short-circuits between plates and linings, between linings, or a combination of both types of defect. For example, if a lining-to-lining contact exists the voltage between the linings will be reduced to zero, and to permit this condition the positive-to-lining voltage in one cell and the lining-to-negative voltage in the other will also be reduced to zero. It is essential, therefore, that where a plate-to-lining contact is indicated during a routine test that an inspection be made to ensure that linings are not in contact before any action is taken to discharge the linings.

CONCLUSIONS

Whereas previous changes in methods of battery operation have not lead to changes in the basic battery-maintenance procedure, some alternative procedure will be required where the latest types of formed-plate cells are worked on a floating-trickle-charge basis. It is expected that, as modified maintenance procedures are introduced and as operational difficulties related to cell design are overcome, battery maintenance time and cost will be reduced.

New Jointers' Tents—Tents, Jointers', No. 3 and 4

F. HAYTON†

U.D.C. 625.748:621.315.68

The traditional type of wood-framed canvas-covered jointers' shelter has been in use for very many years. Tents constructed of more modern materials have now been developed, giving better working conditions and greater safety as well as being more weatherproof and durable.

INTRODUCTION

JOINTERS' shelters (Tents, Jointers', No. 1) have been used by the British Post Office since the beginning of this century. Their traditional construction—canvas stretched on an ash frame—remained unchanged until

CHANGES IN DESIGN

The metal-framed tents referred to above were heavier than the equivalent wood-framed types and were difficult to repair. Some trouble was also experienced in obtaining a satisfactory attachment between the metal frame and the canvas, so, as soon as suitable timber was freely available, the previous type of construction was resumed.

During 1959 experiments were carried out with various plastic and fibre-glass (including rigid fibre-glass) coverings in an attempt to reduce the weight, make the tents



(a) Jointers' Tent No. 1

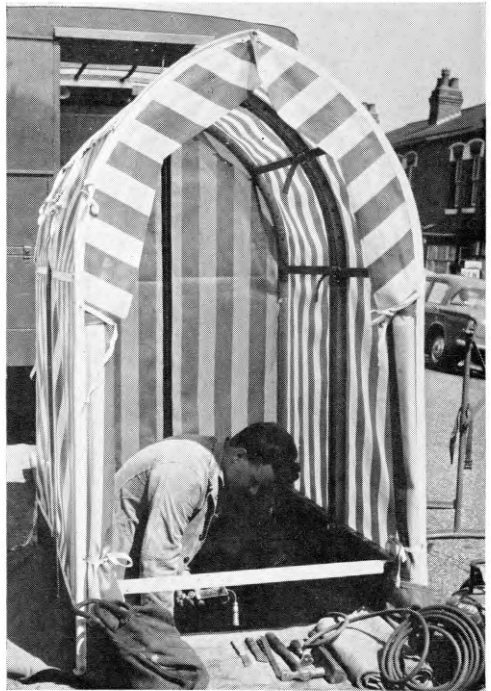

(b) Jointers' Tent No. 3

COMPARISON OF WORKING CONDITIONS IN THE NO. 1 AND NO. 3 TYPES OF JOINTERS' TENT

1959, except for a short period immediately after the end of the second world war when steel tubing was used for the framework as satisfactory timber was not available. Recently, attempts have been made to produce a tent made from modern materials which is easier to erect and transport, more weatherproof and more durable than the earlier ones.

flame-proof, and permit the entry of natural light.

In 1961 and 1962 400 tents of the conventional type, but with a covering of a p.v.c.-fibre-glass laminate patterned with red and white stripes, were sent out on a nation-wide field trial. Reports were encouraging, so in 1963 a further trial was made using a laminate of p.v.c. and nylon net (Plastolene). These tents had slide (zip) fasteners on the door flaps in place of the eyelets and tying tapes used on the previous issues. In addition,

†External Plant and Protection Branch, E.-in-C.'s Office.

Harley buckles and hooks replaced the conventional brass buckles on the fastening straps; these buckles could be attached and tightened with one hand, thus simplifying the erection of the tent. The roof ventilating flaps, previously held in place with tying tapes, were fastened down with Velcro tape; this is a patented fabric fastener consisting of a strip of minute hooks which engage on a corresponding strip of felt fabric. The top sections of the entrance flaps were also held in place by this method. Tents of this construction are now the standard and are coded "Tents, Jointers", No. 3."

The illustration shows the difference in visibility inside the earlier standard tent compared with that in a Tent, Jointers', No. 3.

A smaller version of the new tent, similar in size to the present Tent, Jointers', Small (No. 2), will soon be available and be known as Tent, Jointers', No. 4.

TENT REPAIR

The Post Office Factories Department have arranged to repair the new tents when necessary, and the arrangements also include the repair of canvas tents and their conversion to Tents, Jointers', No. 3 or 4. Thus, canvas tents, when maintenance exchanged, will be re-covered with Plastolene and re-issued as Tents, Jointers', No. 3 or 4. In this way, Post Office canvas tents will soon disappear from the street scene.

Small punctures and tears in the new tents can be repaired *in situ* by using a repair outfit (Kit, Repair, No. 1), which contains Plastolene patches and a suitable adhesive.

CURRENT DEVELOPMENTS

Some experiments have been carried out with laminated marine-type plywood in order to overcome difficulties encountered in obtaining satisfactory ash bends for the tent framework. As the plywood bends are stable in shape it has been possible to reduce the amount of iron-work needed for stiffening, and this has resulted in a saving in weight of 28 lb per tent.

Four types of "fold flat" tents are on trial, three of which are variations of the standard tent but with straight roof members instead of the existing arch. The roof is designed to fold down, so that the complete tent can be dismantled and folded into a flat rectangular parcel.

The fourth type—developed by the staff of the Dundee Telephone Area—consists of a tubular-steel frame with two separate plastic sheets: one sheet forms the walls of the tent, the other forms the roof.

CONCLUSIONS

The Tent, Jointers', No. 3 is easier to erect, more weatherproof and probably more durable than the superseded item. It also gives better working conditions and greater safety, but it is only slightly lighter and no easier to transport than the earlier tent. Work on these aspects of the problem is continuing.

ACKNOWLEDGEMENT

The photographs were provided by Brunskill, Little and Partners, Ltd.

Stay Anchorages

A. E. LUND†

U.D.C. 621.315.66

A method of providing stay anchorages, by utilizing the mechanical pole-erection units to instal screw anchors, is described.

MUCH effort has been expended in the past in an endeavour to improve upon the standard method of providing a stay anchorage, but to date no system has proved to be an economic alternative to the use of stay rods and stay-blocks.

With the introduction of pole-erection units* (formerly known as line-construction units) aimed at mechanizing poling work, it was felt that a reappraisal of methods previously tried, together with any new ideas, might well be worthwhile.

The three following methods seemed worth considering.

(i) Using the pole-erection unit, three holes are drilled side by side and the stayblock is installed. This is basically the same as the standard method, except that it saves digging time.

†External Plant and Protection Branch, E.-in-C.'s Office.

*WARD, W. C. A Line-Construction Vehicle. *P.O.E.E.J.*, Vol. 55, p. 226, Jan. 1963.

(ii) As a development of (i), a single hole is drilled and the stay-block is dropped in end-on. By varying both the angle of drilling the hole and the position of the stay rod in the block, load holding can be improved, but this method has limited use.

(iii) The use of screw anchors. This method was first considered in 1923, and objections then ranged from excessive soil disturbance to the need to screw the anchors in manually.

Of the three methods the screw anchor seemed most promising, and the only problem was one of adapting it for use with the pole-erection unit.

At first, a method that did not require any dismantling of the pole-erection unit was obviously the most desirable, and, therefore, an adaptor was tried which fixed securely to the end of the screw anchor but just slotted on to the tip of the auger of the pole-erection unit. This arrangement proved to be unstable in use, the adaptor acting as a universal joint and "knuckling" every time pressure was applied.

A second adaptor was designed to overcome this shortcoming. It consists of a hollow tube with a square socket at one end and a hexagonal socket at the other

(Fig. 1). The auger of the pole-erection unit is removed and the hexagonal socket of the adaptor is fitted directly

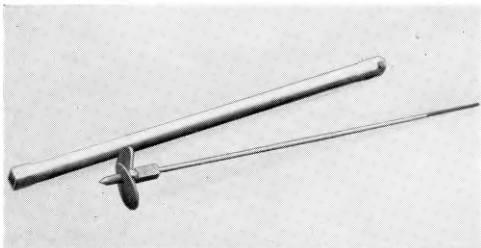

FIG. 1—ADAPTOR AND SCREW ANCHOR

on to the main drive-shaft (Fig. 2). Once fitted, this provides a rigid extension of the drive-shaft and, consequently, a positive drive. The shaft of the screw anchor fits up inside the adaptor tube, and the square socket of the adaptor engages the square back-nut of the anchor plate.

The advantages of this system are that:

(i) since the shaft of the anchor takes no torque when being driven in, its diameter can be reduced, and

(ii) since the whole system is rigid, it is possible to drill at any angle, i.e. insert the anchor in the line of the stay.

With this method, and using screw anchors of various sizes, tests of installing anchors and measuring their load holding were carried out. As a result of these tests, field trials are now being held.

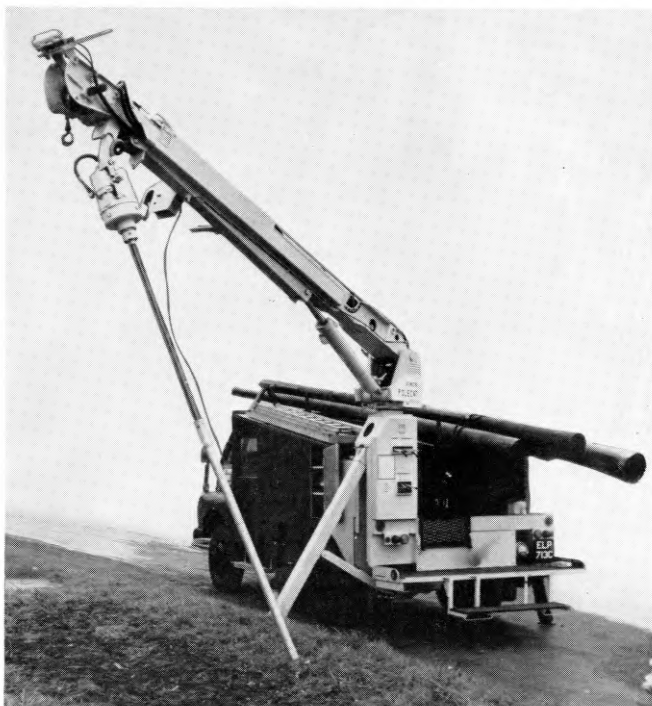

FIG. 2—ADAPTOR FITTED TO DRIVE-SHAFT OF POLE-ERECTION UNIT

A Precision Magnetic Tape-Recorder

R. W. BIGG†

U.D.C. 621.395.625.3

A precision tape-recorder that was provided to facilitate telegraph transmission tests via communication satellites is described. The tape-recorder incorporates a speed-control system which ensures that the signal obtained on replay is virtually free from errors due to tape-speed variation.

INTRODUCTION

WHEN international telegraph transmission tests were planned as part of the testing program for the first communication satellite TELSTAR it was realized that differences in technical characteristics between multi-channel voice-frequency (m.c.v.f.) telegraph and facsimile equipments operating to United States standards and European equipment designed to C.C.I.T.T.* standards would make direct evaluation of the quality of received signals difficult.

It was, therefore, agreed with the National Aeronautics and Space Administration (N.A.S.A.) of the U.S.A. that each participant in the tests should record test signals, to the appropriate standard and to an agreed specification, on magnetic tapes and send the tapes to the other participants for transmission via the satellite. In this way the acquisition and installation of m.c.v.f. telegraph terminal equipment and facsimile equipment to the standards used by other operating agencies could be avoided. An added advantage of providing magnetic recording equipment at the testing terminals is that a recording can be made of signals received during a satellite transmission, and this enables analysis of the signals to be made subsequent to the actual time of transmission: the recorded signals can be replayed for analysis as often as required.

If telegraph signals replayed from magnetic tape are to be of value in assessing the performance of a telegraph transmission system the recording equipment itself must have standards of performance and reliability high enough to ensure that it does not add any significant distortion to the received signals. Also, since tapes recorded on one machine are required to be replayed on another, the tape machines themselves must conform to similar standards and be capable of controlling tape speed to within very close limits.

It was specified that the machines used should be precision instruments to Inter-Range Instrumentation Group (I.R.I.G.) standards, using $\frac{1}{2}$ in. tape and I.R.I.G. tracks No. 1, 3, 5 and 7. The tape speed to be used was 30 in./s, with a recording system employing frequency modulation of a 27 kc/s carrier. The tape speed on replay was to be controlled by a 50 c/s signal recorded on one of the tracks. It was further specified that the four tracks should be utilized as follows.

Track 1: To be used for tape-speed control purposes, by recording a 50 c/s (± 0.01 per cent) sine wave frequency-modulating a 27 kc/s carrier.

Track 3: To be the information channel, on which a carrier frequency of 27 kc/s, frequency modulated by the information signal, was to be recorded.

Track 5: To be used for wow and flutter control, by recording an unmodulated 27 kc/s carrier frequency.

Track 7: As for track 3.

A precision tape-recorder, complying with the foregoing requirements and compatible with the type of machine to be used in the U.S.A. for the satellite tests, was purchased by the British Post Office from a British manufacturer. A brief description of this machine, which incorporates some novel features, is given in the following paragraphs.

DESCRIPTION OF TAPE-RECORDER

The tape-recorder is housed in a two-section cabinet approximately 5 ft 6 in. high, 4 ft wide and 2 ft 3 in. deep (Fig. 1). The cabinet is fitted with castors to facilitate movement of the equipment within the test area.

Facilities

The machine is designed so that any one of three methods of recording can be used with the basic tape-transport. The three systems are (i) direct recording, (ii) frequency-modulation (f.m.) recording, and (iii) digital-pulse recording. Each track has separate "record" and "replay" plug-in units, connexions being made via multi-way plugs and sockets. To change from one recording system to another it is necessary only to insert units of the appropriate type.

Six tape speeds are available with the basic tape-transport, allowing the possibility of six bandwidths with each method of recording. With the f.m. system the possible bandwidths are as shown in the table.

Bandwidths Available with Frequency-Modulation Recording

Tape Speed (in./s)	Carrier Frequency (kc/s)	Bandwidth (kc/s)
$1\frac{7}{8}$	1.6875	0-0.300
$3\frac{3}{4}$	3.375	0-0.625
$7\frac{1}{2}$	6.75	0-1.25
15	13.5	0-2.5
30	27	0-5
60	54	0-10

Facilities are provided to record and replay at either 15 in./s or 30 in./s in the f.m. mode on all four tracks.

Frequency-Modulation Recording System

In the absence of an input signal a multivibrator in the channel record unit oscillates at the carrier frequency. The carrier frequency, which, as mentioned above, is different for each tape speed, is selected by a 6-position switch on the front of the record unit.

The input impedance is high in order to produce a low tapping loss when the recorder is connected to a 600-ohm circuit, and the input signal is fed, via a variable attenuator calibrated in decibels, to an amplifying stage consisting of a double-triode, the two halves of which are connected in series between the h.t. line and

†Telegraph Branch, E.-in-C.'s Office.

*C.C.I.T.T.—International Telegraph and Telephone Consultative Committee.

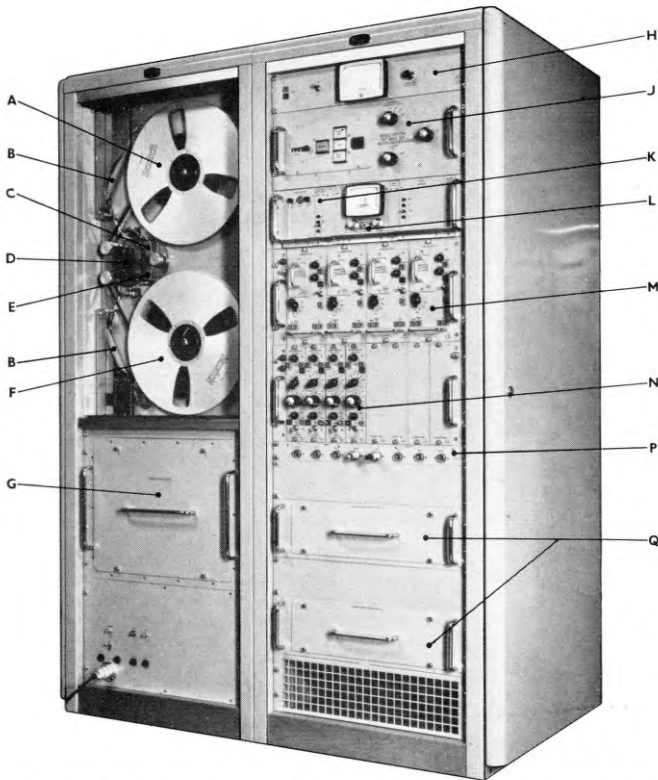

A—Feed spool B—Tape sensing arms C—Recording heads D—Capstan E—Replaying heads
 F—Take-up spool G—Speed-lock power amplifier H—A.C./D.C. testmeter J—Tape-deck control unit
 K—Speed-lock replay unit L—Speed-lock control unit M—Four f.m. replay units
 N—Four f.m. record units P—Input and output sockets Q—Power-supply units

FIG. 1—FRONT VIEW OF THE TAPE-RECORDER

earth; this type of amplifier is used to reduce frequency drift due to heater-voltage variations. The output voltage from the amplifier controls the frequency of the multivibrator. Thus, the output train from the multivibrator is frequency-modulated by the input signal. After amplification this frequency-modulated carrier signal is fed, via an output transformer and a relay contact, to the recording head and recorded on the tape. The relay is energized only when the RECORD button is pressed, ensuring that the recording head is disconnected except when recording, and the possibility of accidental erasure is minimized. Fig. 2 is a block schematic diagram of the recording circuit.

When the tape is replayed, the recorded f.m. signal is picked up by the replay head on the appropriate track and fed to the corresponding replay unit, a block schematic circuit of which is shown in Fig. 3. The signal is amplified and limited in the first three stages of the replay unit. Since the amplitude of the signal from the replay head is dependent upon tape speed, a gain-correction circuit has been included in the first stage to

keep the output reasonably constant at all speeds. In the second stage a bandwidth-limitation circuit is incorporated to reduce the effects of out-of-band noise. The amplitude of the signal is limited at the third stage.

During the process of recording the signal on the tape, and recovering and amplifying it, the pulses become rounded, and to restore the square wave-shape the limiter stage is followed by a Schmitt-trigger circuit. The output from the Schmitt circuit is differentiated, and the positive-going pulses are used to trigger a pulse generator that consists of a monostable multivibrator, which, when triggered, produces an output pulse of predetermined width. The resulting output from the pulse generator is a frequency-modulated train of constant-width pulses. This signal is fed into an *m*-derived, 3-section, low-pass filter, the cut-off frequency of which is different for each tape speed; the filter is a plug-in unit, and the appropriate unit is selected for the tape speed being used. The d.c. and low-frequency components of the f.m. pulse-train appear at the output of the filter, the carrier being attenuated by some 60 db.

The demodulated signal is amplified by a d.c. amplifier, and a cathode-follower stage provides an output of 600 ohms impedance.

The overall gain of the system is designed to be unity. Thus, if a recording is made of a signal at a point on a circuit of 600 ohms impedance, the output signal level on replay will be the same as that of the original signal.

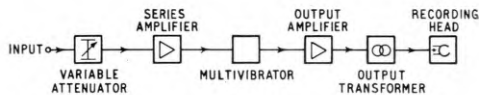

FIG. 2—BLOCK SCHEMATIC DIAGRAM OF THE RECORD UNIT

Speed-Lock System

The speed-lock system is designed to ensure that the effective speed of the tape on replaying is equivalent to that at which the recording was made. This is achieved by means of a signal of precise frequency recorded on another track of the tape. A block schematic diagram of the system is shown in Fig. 4.

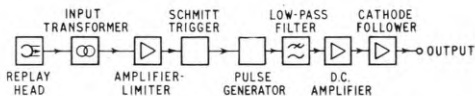

FIG. 3—BLOCK SCHEMATIC DIAGRAM OF THE REPLAY UNIT

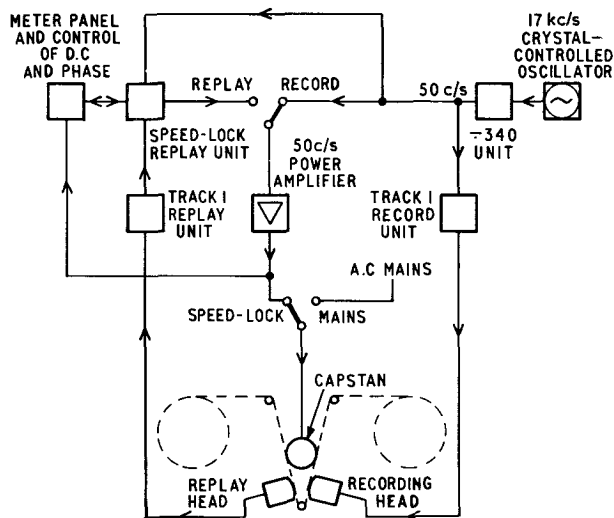

FIG. 4—BLOCK SCHEMATIC DIAGRAM OF THE SPEED-LOCK SYSTEM

When it is required to use the speed-lock system a switch at the rear of the deck control unit is operated. This transfers the drive of the synchronous capstan-motor from the normal mains supply to the output from a 50 c/s power amplifier.

During recording, an accurate 50 c/s signal, derived from a crystal-controlled oscillator, is recorded on track 1 of the tape. A 50 c/s signal from the same source is applied to the input of the power amplifier and drives the capstan-motor. A meter is provided which enables the operator to monitor the output voltage from the power amplifier.

On replaying, a phase comparison is made between the 50 c/s signal obtained from the tape and the 50 c/s signal derived from the crystal-controlled oscillator. When the two signals are 90° out of phase the output voltage produced by the phase-comparator circuit is zero with respect to a reference point. As the phase of the signal coming from the tape changes, due to a change in tape speed (either during recording or replaying) or to stretching of the tape, the output voltage from the phase-comparator circuit becomes positive or negative, depending upon the direction of the phase change.

The phase comparison is accomplished in the speed-lock replay unit. In the same unit a third 50 c/s signal, derived from a multivibrator, is fed to the input of the power amplifier to drive the capstan-motor. The precise frequency of the multivibrator, and therefore the capstan speed, is controlled by the output voltage from the phase-comparator circuit.

The speed-lock system will remain locked over a range of 180° ($\pm 90^\circ$) relative phase change between the two signals. For all normal circumstances this is quite adequate, as any speed variations occur relatively slowly and the system is able to compensate before the phase difference exceeds the limit. In order to bring the system to the centre of its locking range, a manual control is provided which injects d.c. in addition to the output voltage from the phase-comparator circuit. By means of this control the tape speed is adjusted at the commencement of replay until the speed-control system begins to function in a stable manner. This is indicated on a centre-zero meter provided for the purpose, by a

stable reading of output voltage from the phase-comparator circuit. When a stable reading has been obtained the manual control is further adjusted until a zero reading on the meter is obtained; this indicates the centre of the locking range of the system.

Wow and Flutter Compensation

On track 5 of the tape is recorded an unmodulated carrier signal, which is used to compensate for wow and flutter voltages appearing on the two information tracks. The compensation system is of the subtractive type. In the absence of wow or flutter the output from the replay unit on the compensation track will be zero volts. Any wow or flutter which occurs gives rise to an output voltage from the replay unit on the compensation track; this voltage is fed to the replay units on the two information tracks in anti-phase to the wow or flutter voltages appearing there.

Compensation is optional, and is applied by operating a switch on the replay unit of the track it is required to compensate. If compensation is not required, track 5 can be used as an additional information channel.

Tape-Position Indicating Meter

An accurate means of quickly finding a particular section of tape is essential. The tape-position indicating meter, driven electronically by the centre tape-guide, enables this to be achieved, being accurate to within 1 ft.

Behind the deck plate, the spindle of the centre tape-guide carries a shutter which, when rotated by the passage of tape, interrupts a beam of light falling on a photo-transistor. The transistor circuit produces output pulses corresponding to light-on and light-off conditions. The pulse-repetition frequency is directly proportional to the shutter speed and, therefore, to the tape speed. The pulse train is divided by six, and the output from the last divider circuit operates a high-speed relay, the single contact of which operates the indicating meter. The overall circuit is so designed that the meter indicates, in feet, the length of tape passing round the guide. Whenever the tape direction is reversed, it is arranged that the meter drive is also reversed. Thus, if the meter is set to read zero at the commencement of a spool it will always indicate the tape position, in feet, from the commencement of the spool.

Tape Deck

The capstan-motor, which is a 3-speed synchronous type, drives a flywheel via a rubber rim, the capstan itself forming part of the flywheel. The motor is pivoted and, at rest, is held in such a position that it is disengaged from the flywheel. This avoids the formation of a flat spot on the rubber rim, which could cause a speed variation. When the capstan-control switch is turned to the ON position, the capstan-motor is pulled into contact with the flywheel by one of two solenoids. To obtain the three lower tape-speeds the motor is pulled in one direction against an outer rim on the flywheel, and for the three upper tape-speeds it is pulled the opposite way against an inner rim. The tape is gripped against the capstan by a pair of pinch rollers, actuated by another solenoid when the RUN button is pushed. The motor is reversible, thus enabling the tape to be driven in either direction.

At the higher tape-speeds it takes several seconds for

the spooling motors to accelerate the tape up to the capstan speed, and the operation of the pinch rollers must be delayed until this speed has been reached, otherwise the tape would be subjected to a severe stress. At the three higher tape-speeds, therefore, the pinch rollers are controlled by a separate circuit which assesses the tape speed, and, when this matches the capstan speed,

energizes the pinch-roller solenoid. To assess the tape speed a similar circuit is used to that which drives the tape-position indicating meter; the centre tape-guide carries a second shutter which interrupts the light beam falling on a second photo-transistor, and the transistor circuit produces an output pulse train. As the tape accelerates the pulse-repetition frequency increases, and

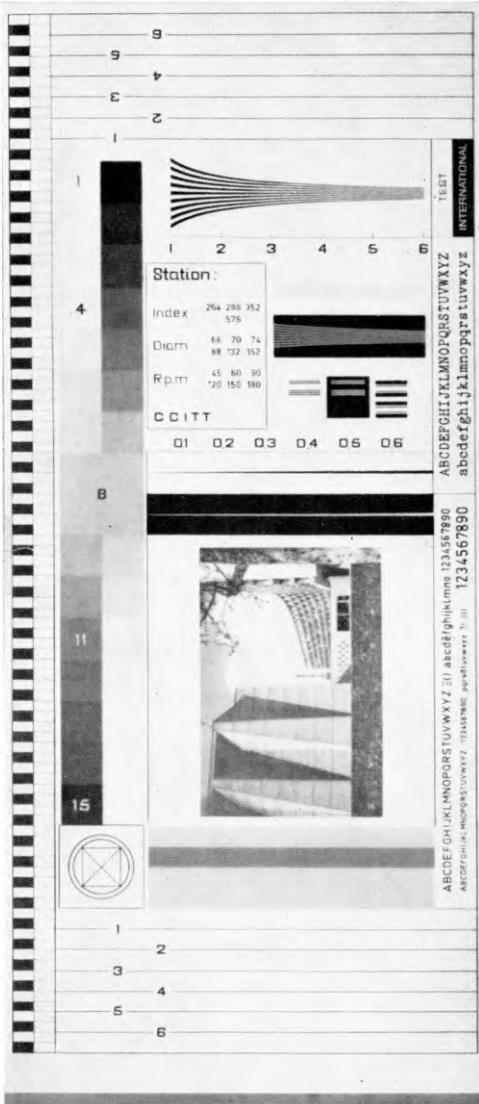

(a) Recorded and Replayed Using the Speed-Lock System

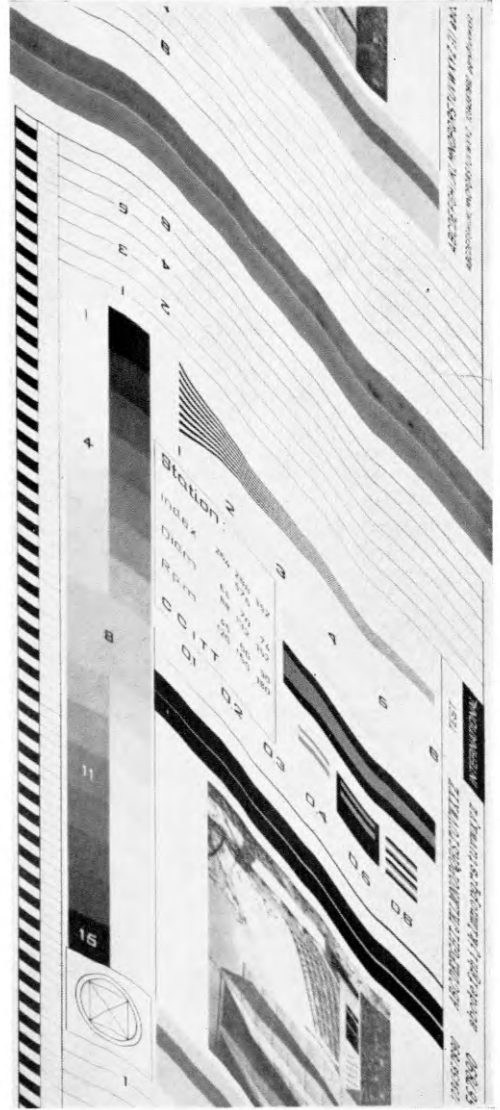

(b) Recorded and Replayed Using A.C. Mains Drive

FIG. 5—FACSIMILE TEST-CARD REPRODUCED FROM A TAPE RECORDING

when it reaches a pre-determined value, selected in conjunction with the tape speed being used, the pinch-roller solenoid is energized.

The spooling motors act on a back plate to each spool mounting, via a rubber-rimmed roller. The motor and roller are mounted on a swinging carriage, to which is also attached an arm carrying tape-sensing rollers. A spring tensions the carriage and sensing rollers against the tape remaining on the spool, and an air dashpot prevents rapid movement of the carriage. Thus, the radius of the point of drive on the spool back-plates is determined by the amount of tape on the spool. The application of a low reverse voltage to the motor on the feed spool gives a slight braking effect. In this way a uniform driving torque and consistent tape tension is achieved throughout. The stopping brakes take the form of pressure pads applied to the rims of the spool back-plates by the release of a solenoid.

The recording and replay heads are mounted on separate accurately-machined plates attached to the deck plate by four screws. Connexions to the heads are made by miniature plugs and sockets, the head assemblies thus being easily removed for cleaning.

The tape deck is able to accommodate 14 in. spools holding 7,200 ft of 0.5 in. instrumentation tape, giving approximately 40 min playing time at a tape speed of 30 in./s.

Power Supplies and Ventilation

The recorder requires a power supply of nominally 240 volts a.c. and draws a maximum current of 4 amperes. An automatic voltage-regulating unit supplies the individual power units within the machine with 240 volts \pm 2.5 per cent when the mains-supply voltage lies within the range 212–266 volts.

The electronic equipment is kept at a suitable temperature by a blower unit mounted at the bottom of the cabinet. Air is drawn in through a filter from the front,

and is blown upwards over the equipment and out of louvres in the top of the cabinet.

CONCLUSIONS

Frequency-modulated voice-frequency telegraph signals and frequency-modulated and amplitude-modulated facsimile signals, have been recorded and replayed successfully, the additional impairment introduced being small. The accuracy of the speed-lock system is apparent when photo-telegraph signals are recorded and replayed. This form of telegraphy requires precise synchronization of the transmitter and receiver, otherwise horizontal lines on the original are reproduced with a slant. The control of tape speed is so good in this respect that it is impossible to distinguish between the directly received picture and the recorded picture when subsequently replayed. Two recorded reproductions of the C.C.I.T.T. facsimile test-card are shown in Fig. 5. One, Fig. 5(a), was recorded and replayed using the speed-lock system, the other, Fig. 5(b), was recorded and replayed within 15 minutes using a.c. mains drive. The slant imparted to horizontal lines in the second picture represents a mean speed difference, between recording and replaying, of approximately 1 part in 10^3 , and variation of the mains frequency, either during recording or replaying, is indicated by variation of the angle of the slant throughout the picture.

Spurious noise pulses can be troublesome, more so when recording v.f. telegraph signals than facsimile signals. Noise on a received picture shows up as small specks or streaks, but it can cause an individual telegraph-signal element to be highly distorted, possibly producing an error. It has been found that meticulous attention to the cleanliness of the heads, and of the tape itself, minimizes this form of interference.

ACKNOWLEDGEMENTS

The author wishes to thank Epsilon Industries, Ltd., for assistance and information used in writing this article.

Books Received

"Principles of Microwave Circuits." Edited by C. G. Montgomery, R. H. Dicke and E. M. Purcell. Constable and Company, Ltd. xvi+486 pp. 294 ill. 18s.

"Microwave Transmission Circuits." Edited by G. J. Rugar. Constable and Company, Ltd. xvii+725pp. 624 ill. 24s.

"Waveguide Handbook." Edited by N. Marcuvitz. Constable and Company, Ltd. xiv+428 pp. 288 ill. 18s.

"Microwave Antenna Theory and Design." Edited by S. Silver. Constable and Company, Ltd. ix+623 pp. 338 ill. 24s.

The above four books were originally published by McGraw-Hill Book Co., Inc., in the Massachusetts Institute of Technology Radiation Laboratory Series as Volume 8 (1948), Volume 9 (1948), Volume 10 (1951) and Volume 12 (1949), respectively. By the co-operation of McGraw-Hill with Dover Publications, Inc., the books, unabridged and unaltered, have now been reproduced in Dover paperback editions on a paper which, the publishers claim, gives minimum show-through and will not discolour or become brittle with age; the pages are sewn in signatures, and the books may be opened flat without fear of pages dropping out.

The impedance concept and the equivalent circuits of microwave devices form the basic subject matter for "Principles of Microwave Circuits." Treating only linear circuit

elements, the authors stress the underlying principles and theoretical results, with specific devices discussed only as illustrations of the general methods described.

"Microwave Transmission Circuits" contains a wealth of theoretical and practical information on problems of microwave transmission along coaxial lines or waveguides. Limiting their coverage of circuits to those designed to operate within a wavelength range of 12 cm to 1.2 cm, i.e. a frequency range of 2,500–25,000 Mc/s, the authors give primarily an exposition of principles and techniques, although a number of designs with performance data are also presented.

The "Waveguide Handbook" deals with the reformation of microwave field problems as microwave network problems, treating specifically the class of electromagnetic "boundary value" or "diffraction" problems descriptive of the scattering properties of discontinuities in waveguides. It contains a very comprehensive collection of equivalent-circuit data for waveguide junctions and discontinuities.

"Microwave Antenna Theory and Design" presents the basic theory that underlies the design and operation of various types of dipole and reflector antennas. The treatment is technical and mathematical, and includes a full discussion of the electromagnetic theory and physical optics that are needed for microwave antenna design, the material falling into four divisions: basic theory, theory and design of feeds, theory and design of complete antenna systems, and antenna-measuring techniques and equipment.

Notes and Comments

New Year Honours

The Board of Editors offers congratulations to the following engineers honoured by Her Majesty the Queen in the New Year Honours List:

Cable Depot, London	E. Rickwood	Technician I with Allowance	British Empire Medal
Centre Telephone Area,	J. Prescott	Area Engineer	Member of the Most Excellent Order of the British Empire
London Telecommunications Region			
Engineering Department	L. F. Scantlebury	Staff Engineer	Officer of the Most Excellent Order of the British Empire
Engineering Department	S. Pitham	Senior Executive	Member of the Most Excellent Order of the British Empire
Engineering Department	L. M. Pusey	Chief Draughtsman	Member of the Most Excellent Order of the British Empire
Glasgow Telephone Area	A. C. Patrick	Inspector	British Empire Medal
Manchester Telephone Area	L. Brennan	Inspector	British Empire Medal
North Telephone Area,	A. C. Welling	Technical Officer with Allowance	British Empire Medal
London Telecommunications Region			

Circulation of The Post Office Electrical Engineers' Journal

The Board of Editors is pleased to note the continuing increase in the circulation of the Journal, as shown by the following statistics.

Journal Issue	Number of Copies Printed
Vol. 58, Part 1, Apr. 1965	29,630
Vol. 58, Part 2, July 1965	30,300
Vol. 58, Part 3, Oct. 1965	30,490
Vol. 58, Part 4, Jan. 1966	31,600

Approximately 10 per cent of the Journals are sold to overseas readers in more than 50 countries.

Syllabi and Copies of Question Papers for the Telecommunication Technicians' Course

The syllabi and copies of question papers set for examinations of the Telecommunication Technicians' Course of the City and Guilds of London Institute are not sold by *The Post Office Electrical Engineers' Journal*. They should be purchased from the Department of Technology, City and Guilds of London Institute, 76 Portland Place, London, W.1.

Readers are reminded, however, that books of model answers to certain of the City and Guilds of London Institute examinations in telecommunications are published by the Board of Editors. Details of the books available are always given at the end of the Supplement to the Journal.

Institution of Post Office Electrical Engineers

Mr. H. E. Wilcockson, A.M.I.E.E.

The Institution mourns the loss of a good friend and a staunch colleague in the death of Mr. H. E. Wilcockson, the previous General Secretary, on 22 January 1966, aged 59 years.

His active association with the Institution was a long and meritorious one over almost 30 years. At various times during this period he served in many capacities on Council, on various committees of Council, and on the London Centre Committee. He was appointed General Secretary of the Institution in 1951, relinquishing this office in 1957 due to ill health. As General Secretary he conducted the affairs of the Institution with considerable distinction. He will long be remembered for his part in the arrangements for the Jubilee of the Institution in 1956. He applied himself wholeheartedly to this task and the success of the Jubilee celebration was in large part due to him.

Mr. Wilcockson was elected an Honorary Member of the Institution in 1958 in recognition of his considerable services.

Members of the Institution will remember him for his kindness and gentility. In particular, Council and Local

Centre officers will remember him for his integrity, his ready help on all problems, and his untiring work for the success of the Institution. He earned the enduring respect of us all.

Retired Members

The following members, who retired during 1965, have retained their membership of the Institution under Rule 11 (a):

- L. C. W. Corke, 84 Claremont St., Gt. Moor, Stockport, Cheshire.
- G. S. Berkeley, 79 Cassiobury Drive, Watford, Herts.
- F. Summers, "Hillboro," Grange Fell Road, Grange-over-Sands, Lancashire.
- C. H. Sayers, 6 Cherry Tree Road, East Finchley, London, N.2.
- J. G. Hobbs, Casa Rosetas, La Cabaneta, Marratxi, Majorca, Spain.

S. WELCH,
General Secretary

Regional Notes

South Western Region A NO-TONE DETECTOR

As an alternative to sensing the quality of service by the number of reported complaints, it is becoming increasingly necessary to employ engineering plant monitoring equipment to sample exchange traffic.

The use of artificial-traffic equipment provides this service, but it can be argued that however extensive the set up program, under certain circumstances, a limited sample only can be obtained, and, in exchanges already near the point of traffic overload, additional and unwanted traffic is originated.

The alternative is to sample live traffic. The advantages are as follows.

(a) The examination of the choice of paths through a network by subscriber-originated traffic is more comprehensive than any other form of examination.

(b) The live-traffic examination is self-programming in that the sample make-up will tend to be self-adjusting to the variation in traffic interest, i.e. high-usage routings will yield more observations than low-usage routings.

(c) The call failures detected should, in the main, lead to the identification of first degree faults.

(d) The exchange maintenance officer has a day-to-day record of the service given to subscribers on his exchange.

(e) The call sample each day will be appreciably higher than the centralized service observation sample each month.

(f) The monitoring equipment does not of itself introduce the possibility of a call failure due to incorrectly generated digits, as can happen with call senders.

Calls which result in no tone being received account for the main percentage of call failures which could be caused by failure of Post Office plant. In the Bournemouth Telephone Area these amount to 65-70 per cent of the total failures. If such failures were identified a significant improvement in the quality of service should result.

To gain experience with the use of live-traffic monitors a no-tone detector and digit-display equipment was introduced in Boscombe exchange, which is a non-director discriminator satellite exchange. To reduce costs and time, use was made of the existing observation access equipment to gain access to a large selection of selectors. An override device has been incorporated to give precedence to the use of the normal observation equipment for normal traffic service observation.

Although it is understood that the Engineering Department are developing a standard detector which will be available for general use in the non-detector areas the results obtained at Boscombe have been sufficiently rewarding to justify extended use of the locally-designed equipment.

The information gained from our colleagues in the Birmingham Telephone Area, who demonstrated the use of no-tone detectors, is freely acknowledged.

B.H.

Midland Region PORTABLE RELIEF TRUNK SWITCHBOARDS

It frequently occurs that temporary relief to an auto-manual centre is required, e.g. just prior to the introduction of S.T.D. or pending completion of an extension contract, and there have been available for some years a number of types of portable relief unit. The facilities offered by these units consist of the control of two manual-signalling trunk circuits on a delay-working basis and their connexion into the local network. No timing equipment is fitted.

As the trunk network is now almost completely automatic these facilities leave something to be desired, and it was decided to produce experimentally a local re-design of the equipment, with full dialling facilities on both sides of the connecting circuits. It became apparent that certainly four,

and if possible five, connecting circuits would be appropriate, and that full value could not be obtained from the units unless standard timing clocks were provided on each circuit.

It was found possible to accommodate five circuits, each with dial, speak, monitor and release keys, supervisory lamps and Clock No. 44. The common position-equipment includes a SPLITTING key (for speaking on one side of the connexion only), a CALL SUPERVISOR key with lamp and buzzer, a ROUTINE TEST key for applying a fast pulse to the timing clocks, and a RING key for trunk-offering to U.A.X.s. In addition, there are four outgoing speaker circuits with dialling facilities, which can be arranged, to suit local requirements, as either individual or multiplied lines to such services as directory enquiries or trunk-offer selectors.

The equipment is fitted in a wooden case, on a framework which can be drawn out, complete with the key panel, through the front of the case for maintenance access. All connexions are taken via two multi-way plugs and jacks on the rear end of the unit. Each unit generates its own 3-minute time signal from a transistor oscillator and an interrupter circuit using a Type-4 uniselector. Apart from the case and some of the oscillator components only rate-book items have been used in the design. The illustration shows two units installed at Kettering exchange.

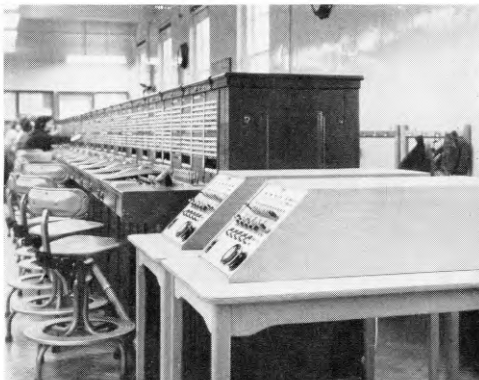

PORTABLE RELIEF TRUNK SWITCHBOARDS AT KETTERING

The installation of a unit in an exchange consists of placing it on a suitable table and running two 31-wire cables from the plugs at the rear to the intermediate distribution frame. From here, connexion is required to five trunk 1st selectors, five local 1st selectors, seven fuses and a 6-second pulse supply. Units can only be used where these selectors are available, although, if the necessary junctions can be provided, connexion can be made to trunk 1st selectors in a remote exchange.

Although the units have had only a few weeks trial at the time of writing they are proving extremely successful, and, in fact, due to the ease of circuit seizure and release, they can carry slightly more traffic than a standard sleeve-control position used for suspended calls.

T.G.E.B.

Scotland A NOVEL SOLUTION TO A MAINTENANCE PROBLEM

During the fairly heavy snow in December 1965, numerous Post Office lines in the Aberdeen Telephone Area were, as

usual, affected by breakage of the overhead wires. This damage was tackled energetically, but the prompt restoration of service was threatened in the more isolated parts because roads were rendered impassable by snow for long periods. The main damage occurred south of Inverness, in the region of the Cairngorms which are famous for their ski slopes. Members of the local external working party are proficient skiers and arrangements were made to hire skis for them so that they could travel over the affected roads.

By this means, it was possible to restore service on isolated lines in a matter of hours rather than days; so far as is known, this is the first instance in Britain of the use of skis to maintain telephone service.

W.S.

Home Counties Region

LAYING PLASTIC DUCT BY MOLEPLOUGH

Recently, trials have been made in the Colchester Telephone Area, drawing plastic duct behind a moleplough, using a standard Post Office (No. 2) Tractor-Winch. The plastic duct is of two sizes in grey rigid PVC: Duct No. 56 has a 2 in. bore and is provided in 10 ft lengths, and Duct No. 54 has a 3½ in. bore and is provided in 20 ft lengths.

The wall thickness of Duct No. 56 is 0.062 in. and of Duct No. 54 is 0.15 in. These ducts have one end expanded to form a socket, giving a push-fit joint with the next length, which can be made air-tight if a plastic adhesive is applied before assembly. Convenient lengths of 160 ft to 240 ft are assembled at the roadside with a 7/14 steel wire through the centre and fastened to a steel-cap at the leading end, while a tightening device is pushed into the last socket. The wire is tightened until the line of ducts bows slightly, and the steel-cap is attached by a link to the back of the blade of the moleplough which is standing in a slit trench. When the moleplough is pulled by the winch, the line of ducts enters the trench behind the blade, and is drawn in by the steel-cap attached to the 7/14 steel wire pushing the last duct, as shown in the illustration.

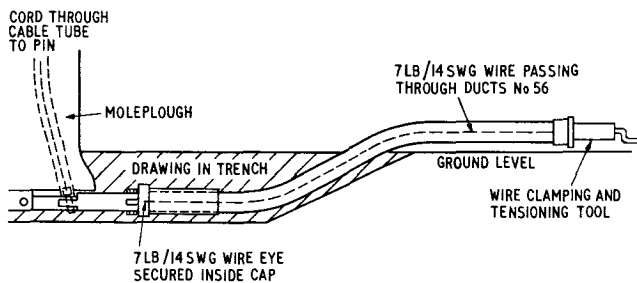

LAYING PLASTIC DUCT BY MOLEPLOUGH

A prototype Post Office Moleplough No. 2 was used for the trials. The blade is designed to lift the soil, the upheaval being pressed down behind the blade by a roller with a seat for a man to ride on. When the blade meets an obstruction the front end of the plough may be released and pulled clear, but future models will have a quick-release pin, lever operated to free the duct cap from the blade, and allow easier excavation. The duct slides smoothly through suitable soil, but on bends or in gravelly soils the length of duct should be reduced to avoid overstressing the rear socket, a condition indicated by white stress lines in the grey plastic. Finally, the tightening device is removed, and a plastic draw-rope or a polythene cable-end swivel connector is attached to the 7/14 steel wire, which is drawn out. Successive lengths may be joined together by entering the spigot into the socket after it has been raised in the trench, and then pressing the duct down. The 3½ in. duct can be more easily jointed by sliding a plastic collar over the butt ends, and taping with PVC adhesive tape. Jointing chambers are built afterwards, where required, by sawing through the duct; long lengths are

practicable if a plastic draw-rope is left in the duct for subsequent cabling.

The duct can be laid at a depth of 24 in. in carriageway crossings by first digging a 4 in. trench with an excavator and pushing the jointed ducts down to the trench bottom, using a crumber attachment to level off loose soil which falls back into the trench.

In two weeks 1,580 yards of plastic duct was laid and cabled from Weeley to Tendring in a grass verge, using a 4-men gang, a tractor and driver, with a stores lorry and driver laying out duct and cable drums.

To link two Colchester estates as soon as the kerbs were haunched, 160 yards of 3½ in. duct were laid in a day in conditions which were too hazardous for laying earthenware ducts, and before the other services were laid. Early service was made available at the far end of another estate by laying plastic duct from the entrance to the flexibility points as soon as the kerbs were placed. This was done in appalling weather, and where a mechanical trench excavator could not dig.

Advantages of the ducts are lightness, ease of handling, freedom from breakages, good resistance to impact, few and simple joints, and flexibility which gives a clean, smooth bore around bends. The speed of provision is outstanding, even in adverse conditions, e.g. 700 yards in 230 man-hours.

Disadvantages are the frequent stoppages due to tree roots and solid obstructions, and breakage of mechanical fuses. The time lost can be reduced if the moleplough is designed to slip the cap so that the blade can be pulled out by the winch, if the shear links are replaceable and if an improved cutter blade is used. Guiding the plough around bends is difficult due to the design of the land sprags on the HD/F2 Boughton winch, which tear up the road surface. A Marshall tractor-winch was superior in this respect, being anchored by a flat angle-iron with the weight of the tractor above it.

There are no cabling difficulties as the collars do not break, and broken ducts can easily be replaced. A new socket can be formed with a hot brass mandrel.

The help and co-operation of colleagues in the External Plant and Protection Branch, Engineering Department, is gratefully acknowledged.

K.R.J.

HIGH WYCOMBE AUTOMATIC TELEPHONE EXCHANGE

High Wycombe automatic telephone exchange was cut into service at 8.0 a.m. on 11 December 1965. The multiple provides for 12,000 subscribers. Initially, approximately 8,000 subscribers on the C.B.1 exchange, 420 subscribers from adjacent exchanges at Penn and Holmer Green, and 500 new subscribers were connected. 1,330 trunks and junctions were provided to meet the needs of the new G.S.C. which will ultimately serve Beaconsfield, Gt. Missenden, Amersham, Chalfont St. Giles, and Chesham.

The plant consists of three standard 5,000-line units and a tandem unit in a multi-floor building. It was advantageous to use one intermediate distribution frame for the three 5,000-line units. The power plant is a standard Power Plant 222H with the exception that the batteries are high-capacity submarine types.

The S.T.D. equipment is served by 6 translators and 75 registers with associated equipment, with the retained C.B.1 manual board providing the auto-manual centre.

The trunks and junctions were transferred on a piece-meal basis to enable the operators to be thoroughly conversant with the method of operation before the transfer of the subscribers.

The building also houses v.f. telegraph and transmission equipment.

The transfer had the normal difficulties associated with such an operation and was further bedevilled by a shortage of time to do the work. However, the loyal co-operation of all concerned enabled a successful transfer to be achieved.

A.E.D., J.E.W., and J.S.C.

London Telecommunications Region

FIELD TRIAL OF PUSH-BUTTON TELEPHONES

Trials to test public reaction to the use of push-button telephones have commenced, and 280 subscribers on the Langham Exchange, Centre Telephone Area, London, are to participate. Two systems are being tried, although the push-button telephones used in both have a similar outward appearance with the dial replaced by 10 push-buttons. Outgoing calls are initiated by the pressing of the relative buttons in sequence for the required number. In one system (200 subscribers), a signalling code consisting of two v.f. tones for each digit, from a choice of seven tones, is transmitted to the exchange. The v.f. tones are produced from a transistorized oscillator fitted inside the Telephone 728L. The signals received at the exchange are converted to normal loop-disconnect pulses. In the other system (80 subscribers), the push-button d.c. signals from the Telephone 730L are converted to loop-disconnect pulses at the subscriber's installation by a Sender 6A.

The first of the push-button telephones operating on the former system was installed on the afternoon of the 10 January. The installation of the remaining telephones continued from the following day at a rate of approximately 10 per day. The majority of subscribers selected for the trial of this system have direct exchange lines, some with plan sets, but two of the subscribers are having their complete switchboard installation converted to push-button telephones, i.e. operator's telephone and all extensions. As only existing subscribers are participating, the installation procedure is relatively simple: the line is tested on the subscriber's apparatus and line tester, the existing telephone equipment is recovered, the push-button telephone is installed, and tests are made to one position of the exchange test desk equipped with new test equipment. These tests include frequency and transmission measurements. An essential item of the test equipment is a test register and receiver.

The exchange equipment comprises 10 subscribers' registers and multi-frequency receivers which translate the v.f. signals to Strowger pulses. These are then fed to one of 32 1st-code selectors in Langham Exchange. The receiver will also accept Strowger pulses and, after repeating the first train, divert the remainder directly to the 1st-code selectors. The multi-frequency receiver is transistorized, uses printed-circuit plug-in cards, and the output is registered on reed-relays.

E.B.M. and D.B.

PROGRAMMED LEARNING AND ITS USE FOR THE TRIMPHONE

The introduction of a new luxury telephone, the Trimphone, provided the Regional Engineering Training School with an opportunity to employ the advantages of programmed learning, to fulfil an urgent need in training. The North-West Telephone Area was chosen for the field trial of 600 Trimphones, and subscribers' apparatus installation staff in a variety of locations were required to install the instruments. Several months would have passed before existing Regional Training Courses could be revised to include such new apparatus, and even then only a proportion of the staff would receive instruction. However, a programmed learning project provided every installation technician with the information he needed to know before, rather than long after, his first installation, and at a cost to the Telephone Area of only 1½-2 hours working time per technician. Every stage of the program, from its conception right through to the

final production, was the work of the programmed-learning group at the Paul Street Regional Engineering Training School.

Programmed learning provides a teaching situation in which a program acts as an instructor for the trainee, and leads him through a set of specified behaviours. The program is a carefully-designed sequence of small instructional steps, presented to the trainee at his own learning pace. The final draft of the program consisted of 77 frames (short sections of instruction) and was presented on the "Canterbury" teaching machine, as shown in the photograph.



A TEACHING MACHINE IN USE

Four such machines were located at Installation Controls a few weeks before the scheduled date for commencement of installations, thus providing a suitable situation for technicians to work through the program. The program required an average time of 57 minutes for instruction to be received on the facilities and technical and installation details of the Trimphone, and on official policy when answering subscribers' queries. This required the technician to acquire both a theoretical understanding and practical knowledge of the Trimphone. Approximately 300 technicians received the instruction, and comments from both supervising staff and technicians showed acceptance of the program in principle and content.

Validation of the final draft by means of a written test resulted in over 80 per cent of the subjects achieving more than the 80 per cent mark. A retention test given three weeks after the program, to the same sample, showed marks reduced by only 5 per cent, to 75 per cent. Evidence is thus available to show that the program will teach effectively. Resulting from this experimental project other programs have been written, and work is now in hand to convert a complete initial-installation course entirely to programmed-learning form.

K.R.C.

Associate Section Notes

Sheffield Centre

To initiate the 1965-66 session a party of members visited the Westhorpe Colliery near Sheffield. The visit was a sequel to a lecture given in 1964 by an officer of the East Midlands division of the N.C.B.

After descending the shaft a "paddy train" took the party down the air-outlet shaft for a mile, and a further mile was covered on foot to the coal face, a seam some 5 ft thick. There the party were shown the coal being cut by a mechanized cutter, and were able to appreciate at first hand the working conditions of the miners. After returning to the shaft on foot a very welcome shower awaited the party at the pit head.

The summer social outing was on Sunday, 11 July, and a party of members and their families visited Flamingo Park Zoo and the City of York.

Through the courtesy of Messrs. Firth Brown, Ltd., the Centre enjoyed a film show on the subject of special steels, their manufacture and their use in the aircraft industry. Also included was "Highlights of The Farnborough Air Shows." Later in September Messrs. H. P. Brookes and A. M. Light gave a paper entitled "The Location of Faults in Cables." A short history of fault-location techniques was followed by a demonstration of some of the latest localizing equipment, including the pulse-echo tester.

B.A.S.

Bath Centre

During the summer months members had the opportunity of making visits to local industries, and to manufacturers further afield.

On the evening of 14 July a party visited the Avon Rubber Company's main factory at Melksham, Wilts. There all the processes entailed in the manufacture of car and motorcycle tyres were seen. Sunday, 25 July, was chosen as the date for the car treasure hunt, which has become an annual social event. The weather was not exceptionally good but this did not deter members from enjoying this well-organized event.

In August a visit was arranged to what must be one of the few private family breweries in the country, and at Wadworth Brewery, Devizes, members had the opportunity of seeing all aspects of the brewing and bottling of beer. Not many members attended, but those who did were taken to the sampling room at the close of the tour and asked to help themselves.

During the latter part of the year visits were made to: Richard Thomas & Baldwin's Spencer Works at Llanwern, Newport, Monmouthshire, to see the manufacture of steel plate in one of the most modern plants in the country, where production is controlled by computer; to Southampton to board the R.M.S. *Queen Mary* and view the docks; and to the British Motor Corporation car factory at Cowley.

The winter program commenced with the second annual dinner-dance, held this time in the banqueting room of the Assembly Rooms, Bath. Close on 100 members, wives and friends attended, to dine and dance until midnight to Alan Cole and his band.

The first talk of the session was given by Mr. Robert Walker, the well-known racing motorist. His first-hand knowledge of international racing and world-renowned drivers, coupled with the showing of films of actual races, made it an interesting meeting.

In early December we were extremely fortunate to have as a lecturer Mr. P. J. Edwards, whose lecture, "Microwave Radio-Relay Systems," had been requested to give members a knowledge of the rapidly growing Post Office microwave radio network commencing with the historical background and development of microwave links. Mr. Edwards gave a very comprehensive talk on the equipment of microwave systems and its function, the growing network

and possible future trends, all points being well-illustrated by both pictorial and diagrammatic slides.

For the future, lectures on "Business Consultancy" and "S.T.D. for U.A.X.s" have been arranged.

R.R.D.

Ipswich Centre

The summer program for 1965 got off to a good start on 12 May with a visit to the instrument factory of Sangamo Weston, Ltd., at Felixstowe, where we saw the manufacture of electricity consumers' energy meters in the most modern factory of its type in the country.

In June we visited the factory of Colchester Lathes, Ltd., and saw the production of machines destined for use in engineering workshops all over the world.

On 22 July we were guests of the Commanding Officer at the local R.A.F. station, Wattisham—the former home of the famous "111" aerobatic squadron—and spent an interesting afternoon investigating the mysteries of airborne radar and talking to pilots of the station's Lightning fighters.

A car rally was organized in August, which provided an entertaining Sunday outing for many members and their families.

In September we visited the S.T. & C. cable factory at Woolwich where we saw the manufacture of conventional telephone and coaxial cables. Later in the same month we spent an interesting evening at the Cambridge Observatories, where we were able to view the stars through some of the most powerful optical telescopes in the country.

The summer program concluded with a visit to the Mullard valve factory at Mitcham, Surrey, where the latest techniques in the manufacture of valves, semiconductor devices, and micro-printed circuits were explained to us.

R.L.B.

Bletchley Centre

The winter session got off to a very good start with two very successful ventures.

The first of these was a visit to the British Aircraft Corporation factory at Weybridge on 30 November. Twenty-five members attended and were given an extensive tour of the complete factory. Interesting things were seen, including VC 10s in various stages of completion.

On Wednesday, 1 December, a very interesting talk was given by Mr. A. H. Knox, the subject of his talk being, "Problems of the Region." The Chairman for this occasion was Mr. Hoare, President of the Association Section, and we are pleased to report an attendance of 130 at this meeting. Members would like to thank Mr. Knox for this enlightening talk.

Visits were made to Vauxhall Motors (Luton) on 12 January and to Triumph-Standards (Coventry) on 10 February.

W.J.A.

Reading Centre

After the instructive and entertaining visit to the Crowthorne track of the Road Research Laboratory, the winter session of the centre opened in October with a talk on "Medical Electrical Equipment" by Dr. E. F. Mason of the Radcliffe Infirmary, Oxford. In November, Mr. H. P. Brooks gave us a talk on "Fault Locating in Cables" and brought along an interesting display of working exhibits. The December talk was appropriate for the season, being on the "Production of 'High Speed' Gas" by Mr. Fairman of the Southern Gas Board. All these talks were illustrated by slides.

The rest of the program has included, "Modern Maintenance" by Mr. T. F. A. Urben, Telephone Exchange Maintenance and Standards Branch, Engineering Department, on 18 January, "Future Developments of Telephone Instru-

ments" by Mr. T. C. Harding, Subscribers' Apparatus and Miscellaneous Services Branch, Engineering Department, on 22 February, and a talk on the Wankel Engine in March.

Our annual general meeting will be held on 26 April.

P.L.C.

Inverness Centre

In October a talk on "Gardening" by Mr. Dawson of the North of Scotland College of Agriculture attracted a good turn-out of members. Judging by the many questions, the gardeners present spent a profitable and enjoyable evening.

On 25 November Mr. A. Campbell of the Senior Section gave an interesting talk on "Old Silver", and showed by picture and exhibit the differing types of silverware used throughout the ages.

This was followed by a talk by Mr. J. S. Wilson on "Taking up Cine." This talk gave practical advice to the beginner on the choice of equipment, and on filming techniques, demonstrating the points made by showing 8 mm. films.

W.C.

Exeter Centre

The 1965-66 session opened with a particularly well-attended paper by Mr. M. W. Bayley, Wales and Border Counties, entitled "Subscriber Trunk Dialling at U.A.X.s." Because the speaker was unable to attend all three Centres this was a joint session, members from both Barnstaple and Plymouth travelling to Exeter to hear the paper. The speaker illustrated his paper with slides of the circuits at the U.A.X. and trunking at both the U.A.X. and G.S.C. The facilities of relay-sets at the U.A.X. were explained in detail. Question time followed a break for tea, and there were still questions outstanding when the meeting was halted to allow the speaker to catch his train. The attendance exceeded 110 and enthusiastic applause followed a vote of thanks by Mr. G. S. Steer.

The second meeting of the session was a talk given by Mr. C. A. Clod, headmaster of a local school. Mr. Clod has spent many years studying Devon and Cornwall and his talk, which was given on 16 December, on "Aspects of Tin Mining in Cornwall" was about one of his many interests in the history of the two counties. The speaker opened his talk by explaining how he first became interested in mining, and in particular the miners, when he realized that the early Cornish tin miner would normally walk anything in the region of 12 miles, work a 13-hour day, and then walk the same journey home on legs, weary with working under what today would be considered inhuman conditions. During the evening, the lives

of the early Cornish miners were pleasantly unfolded, although the revelation itself was not so pleasant. Like our speaker one found oneself wondering what made these people "tick," but for most members it was inconceivable that they should have "ticked" at all.

It is interesting to note that the speaker involved himself in a solid hour's talking to answer four questions, and in answer to one question, on the early uses of copper, the meeting learned something about ancient wars, and distribution of wealth in the West Country. It is hoped that this very able speaker will come back during the next session and talk to us again. A vote of thanks by Mr. L. J. Squires heralded warm applause from the meeting.

The Centre is now looking forward to a visit to the laboratories of the Marine Biological Association of the United Kingdom at Plymouth, special arrangements for which have been made to accommodate the large number who wish to attend.

T.F.K.

Aberdeen Centre

In September 1965 the Aberdeen Centre was privileged to have Mr. E. Hoare, President of the Associate Section, as the opening speaker of our 1965-66 session. His subject "The Next Forty Years" was enjoyed by all present.

The B.B.C. played hosts to our Centre in October. On 4 October a party of 20 was shown the Aberdeen sound and television studios. A fortnight later a party of 15 travelled by bus to the v.h.f. and television transmitter station at Meldrum. On both occasions the B.B.C. engineers gave enlightening explanations of the equipment shown.

In November one of our members, Mr. T. J. Pike, gave a very interesting talk on "Tape Recording and the Equipment Answering No. 1," the operation of which he explained in detail.

G.D.A.

Taunton Centre

The 1965-66 session started with a visit to Exeter at the invitation of the Exeter Centre to hear Mr. M. W. Bayley give his paper "S.T.D. at U.A.X.s." The winter's program included the following papers: "Location of Faults in Cables" (a survey of present-day methods), "The P.O. Traffic Division," and "Local Lines, Past, Present and Future."

It is hoped to visit a place of interest this summer.

F.D.C.

Books Received

"Electromagnetic Theory: A Critical Examination of Fundamentals" (Two volumes). Alfred O'Rahilly. Constable and Co., Ltd. xvii + 884 pp. 73 ill. 36s (18s per volume).

In 1938 a book entitled "Electromagnetics" was published by Longmans, Green and Co., Inc., and Cork University Press. The present book, "Electromagnetic Theory," is an unabridged and corrected republication of the earlier work, and now appears as a two-volume paperback. Professor O'Rahilly's book was written as an essay in constructive criticism, in which existing expositions were freely criticized without regard for authority, the arguments not being put forward dogmatically but rather for the purpose of awakening teachers from their "dogmatic slumber."

The foreword written by Professor A. W. Conway makes it clear that he considers "the appearance of this book, which shows what the classical theory is and what it rests on, is opportune. But it is more than a review of existing knowledge, it is a courageous attempt at reconstruction; and if we do not always agree with the writer, he certainly

makes us reflect. I recommend this book to every serious student of electromagnetics."

"Radio and Electronic Components, Volume 6: Connectors, Relays and Switches." G. W. A. Dummer, M.B.E., M.I.E.E., M.I.E.E.E., M.I.E.R.E., and N. E. Hyde, M.I.E.E., F.B.I.S. x+229 pp. 95 ill. 50s.

Connectors, relays and switches all depend on the establishment of good electrical contact for their efficient operation, and, therefore, a book covering such a range of devices would be incomplete without a discussion of the physics of contacts and contact phenomena: in this book something like 15 per cent is given over to a chapter dealing with this matter.

The book is not confined just to the three items covered by its title: it includes general information on connexion methods, such as the variety of soldering, welding and pressure methods, and on the requirements of microelectronics, where connexions are made to semiconductor integrated circuits and to thin-film circuits. At the back end of the book there is a bibliography of some 270 entries, subdivided for ease of reference into eight sub-titled sections.

Staff Changes

Promotions

Name	Region, etc.	Date	Name	Region, etc.	Date
<i>Staff Engineer to Deputy Director</i>			<i>Assistant Executive Engineer (Open Competition)—continued</i>		
Francis, H. E.	L.T. Reg.	25.11.65	Rumsey, D. C.	E.-in-C.O.	23.11.65
<i>Senior Executive Engineer to Assistant Staff Engineer</i>			Adams, M. J.	E.-in-C.O.	23.11.65
Aspinall, E.	E.-in-C.O.	20.12.65	Hercus, P. T.	E.-in-C.O.	6.12.65
Edwards, P. J.	E.-in-C.O.	13.12.65	<i>Inspector to Assistant Executive Engineer</i>		
Adams, R. H.	E.-in-C.O.	13.12.65	Phillips, W. J.	L.P. Reg.	16.8.65
Withers, D. J.	E.-in-C.O.	13.12.65	McKiernan, H.	N.W. Reg.	11.10.65
Simpson, W. G.	E.-in-C.O.	13.12.65	Fisher, A. C. G.	L.T. Reg.	4.10.65
Back, R. E. G.	E.-in-C.O.	13.12.65	Johnson, R. A.	Mid. Reg.	25.10.65
Fleetwood, C. H. J.	E.-in-C.O.	3.1.66	Fellows, S. E.	Mid. Reg.	25.10.65
Bailey, N. G.	C.E.S.D.	24.1.66	Alexander, F. E.	Mid. Reg.	25.10.65
<i>Area Engineer to Regional Engineer</i>			Falconer, A. D.	Scot.	15.11.65
Gould-Bacon, F. C.	L.T. Reg.	23.11.65	Pen, E. E.	L.P. Reg.	4.11.65
Spratley, E. W. F.	H.C. Reg. to Joint P.O./ M.P.B.W., R.D.G.	24.11.65	Bury, P. S.	L.T. Reg.	10.11.65
<i>Senior Executive Engineer to Regional Engineer</i>			Guy, E. W.	L.T. Reg.	10.11.65
Griffiths, R. J.	L.T. Reg.	23.11.65	Purrott, H. E.	L.T. Reg.	10.11.65
Stevens, A. J.	N.W. Reg.	23.11.65	Radden, J. C.	L.T. Reg.	10.11.65
<i>Executive Engineer to Area Engineer</i>			Saggers, G. E.	L.T. Reg.	10.11.65
Scott, J.	L.T. Reg. to H.C. Reg.	8.11.65	Evans, F. R.	L.T. Reg.	10.11.65
Buck, G. A.	H.C. Reg.	12.10.65	Hollingsworth, W. F.	L.T. Reg.	10.11.65
Isherwood, J. E.	L.T. Reg.	11.6.65	Brooks, A. E.	L.T. Reg.	10.11.65
<i>Executive Engineer to Senior Executive Engineer</i>			Smith, P. M.	L.T. Reg.	10.11.65
Kennard, D. E.	E.-in-C.O.	25.10.65	Burgess, B. R.	L.T. Reg.	10.11.65
Baker, A. E.	E.-in-C.O.	21.10.65	Sampson, J. D.	L.T. Reg.	10.11.65
Adams, A. V. G.	N.I. to N.E. Reg.	8.11.65	Francis, R. J.	L.T. Reg.	10.11.65
Muckett, R. G.	E.-in-C.O.	15.11.65	Smoker, B. W.	L.T. Reg.	10.11.65
Mather, A. L.	E.-in-C.O.	17.11.65	Cotton, W. T.	L.T. Reg.	10.11.65
Wheeler, D. W. E.	E.-in-C.O.	13.5.65	Percy, V. D.	L.T. Reg.	10.11.65
(In absentia)			Cormack, G.	Scot.	4.11.65
Cummings, F. G.	E.-in-C.O.	23.8.65	Curtis, E. H.	L.T. Reg.	10.11.65
<i>Executive Engineer (Open Competition)</i>			Jones, L. C.	W.B.C.	22.11.65
Clarke, P. G.	E.-in-C.O.	11.10.65	Clark, A. F.	N.W. Reg.	16.11.65
Aitken, J. F.	E.-in-C.O.	18.10.65	Goodship, D.	N.W. Reg.	16.11.65
Dhanjal, A. S.	E.-in-C.O.	8.11.65	Worth, D. G.	N.W. Reg.	16.11.65
Grenfell, F.	E.-in-C.O.	8.11.65	Czunyi, A.	Mid. Reg.	25.11.65
Booth, A. J.	E.-in-C.O.	1.11.65	Jones, H. T.	L.T. Reg.	30.11.65
Tonks, D.	E.-in-C.O.	29.11.65	Johnson, W.	N.W. Reg.	6.12.65
Harris, J. P.	N.E. Reg.	29.11.65	Leech, R.	N.W. Reg.	6.12.65
Walton, W. A.	E.-in-C.O.	10.1.66	Ryan, G.	N.E. Reg.	23.12.65
<i>Assistant Executive Engineer to Executive Engineer</i>			Cox, F.	L.T. Reg.	15.12.65
Selwood, R. S.	L.T. Reg.	7.10.65	Cooper, F. E.	S.W. Reg.	6.12.65
Collett, P. E. G.	H.C. Reg.	7.10.65	Milan, J. H.	S.W. Reg.	6.12.65
Cree, J. M.	E.-in-C.O.	11.10.65	Grant, F.	Mid. Reg.	17.12.65
Peters, D. F. M.	Scot.	1.11.65	Robson, R. A.	L.T. Reg.	15.12.65
Marshall, A. G.	Scot.	18.10.65	Brewer, E.	L.T. Reg.	15.12.65
Wright, J. M.	Scot.	25.10.65	Davis, G. H.	L.T. Reg.	15.12.65
Ashley, A. R.	S.W. Reg.	15.11.65	Warne, F. W.	L.T. Reg.	15.12.65
Prichard, O. E.	S.W. Reg.	15.11.65	Hart, A. A.	L.T. Reg.	15.12.65
<i>Assistant Executive Engineer (Open Competition)</i>			Terry, R. F.	L.T. Reg.	15.12.65
Vick, P.	E.-in-C.O.	23.11.65	Maltby, W. G. F.	L.T. Reg.	15.12.65
Gibbons, C.	E.-in-C.O.	23.11.65	Miall, P. G.	L.T. Reg.	15.12.65
Rattansi, A. A.	E.-in-C.O.	23.11.65	Lacey, D. H.	L.T. Reg.	15.12.65
Mills, P. G.	E.-in-C.O.	23.11.65	<i>Technical Officer to Assistant Executive Engineer</i>		
Mehta, K.	E.-in-C.O.	23.11.65	Taylor, H. W. H. F.	H.C. Reg.	1.10.65
Way, J. C.	E.-in-C.O.	23.11.65	Hart, F.	N.E. Reg.	27.8.65
Green, N. J.	E.-in-C.O.	23.11.65	Thorpe, R. E.	N.E. Reg.	13.9.65
Clarke, P. N.	E.-in-C.O.	23.11.65	Gatenby, J.	N.E. Reg.	6.9.65
Allen, F. O.	E.-in-C.O.	23.11.65	McLaren, F.	N.E. Reg.	16.9.65
Hawes, M. J.	E.-in-C.O.	23.11.65	Vidler, S. J.	H.C. Reg.	8.10.65
Gossage, V. J.	E.-in-C.O.	23.11.65	Woods, J. R.	H.C. Reg.	8.10.65
Brennan, R.	E.-in-C.O.	23.11.65	Rust, E. F.	H.C. Reg.	8.10.65
			Gooden, R. E.	H.C. Reg.	8.10.65
			Mountstephen, I. J.	H.C. Reg.	8.10.65
			Mitchell, R. L.	H.C. Reg.	8.10.65
			Willis, D. S. J.	H.C. Reg.	8.10.65
			Harden, P. J.	H.C. Reg.	8.10.65
			Augur, L. G.	H.C. Reg.	25.10.65
			Rolfe, T. A.	H.C. Reg.	8.10.65
			Thomas, L. F. F.	W.B.C.	1.10.65
			Davies, K. C.	W.B.C.	11.10.65
			Kiddie, W.	Scot.	24.9.65
			McCaffrey, J. B.	Scot.	24.9.65

Promotions—continued

Name	Region, etc.	Date	Name	Region, etc.	Date
<i>Technical Officer to Assistant Executive Engineer—continued</i>			<i>Technical Officer to Assistant Executive Engineer—continued</i>		
Johnson, T. A.	Mid. Reg.	25.10.65	Burt, D. R.	L.T. Reg.	10.11.65
Weynberg, G. W.	S.W. Reg.	7.10.65	Lawrence, J. H.	Scot.	4.11.65
Ayers, S. D.	S.W. Reg.	18.10.65	White, D.	Scot.	4.11.65
Davies, P. A. N.	Mid. Reg.	25.10.65	Jackson, T.	N.W. Reg.	23.11.65
Perrett, H. G.	S.W. Reg.	19.10.65	Leech, B. W.	N.W. Reg.	22.11.65
Cottell, A. F. J.	S.W. Reg.	19.10.65	Garner, H. S.	N.W. Reg.	22.11.65
Moseley, B. C.	Mid. Reg.	25.10.65	Taylor, J.	N.W. Reg.	16.11.65
Kelly, B. D.	W.B.C.	18.10.65	Overend, D.	N.W. Reg.	16.11.65
Bruford, J.	S.W. Reg.	25.10.65	Morris, R.	N.W. Reg.	16.11.65
Moule, H. R.	S.W. Reg.	20.10.65	Harding, A. W.	N.W. Reg.	22.11.65
Tonkin, K.	S.W. Reg.	20.10.65	Wood, R.	N.W. Reg.	16.11.65
Price, E. A.	Mid. Reg.	25.10.65	Dugard, F.	S.W. Reg.	18.11.65
Saunders, C. R.	Mid. Reg.	25.10.65	Dams, P. G.	Mid. Reg.	25.11.65
Gillon, J.	N.I.	4.10.65	Smith, B. W.	Mid. Reg.	25.11.65
Funston, N. H.	N.I.	2.8.65	Bradbury, R.	L.T. Reg.	30.11.65
Graham, G.	Scot.	22.6.64	Rider, R. D.	L.T. Reg.	30.11.65
Shaddock, A. R.	S.W. Reg.	1.11.65	Woodward, R. H.	L.T. Reg.	15.12.65
Hookway, P. G.	S.W. Reg.	19.10.65	Lamb, A.	N.W. Reg.	6.12.65
Crowther, D.	N.E. Reg.	5.11.65	Boothroyd, C. R.	N.W. Reg.	6.12.65
Andrews, D. J.	S.W. Reg.	15.11.65	Hodson, G.	N.W. Reg.	15.12.65
Tyers, K. I.	Mid. Reg.	16.11.65	Schofield, T.	N.W. Reg.	15.12.65
Charles, W. J.	Scot.	1.11.65	Eaton, R.	N.E. Reg.	23.12.65
Picot, A. V.	N.E. Reg.	1.11.65	Hitchman, V.	Mid. Reg.	8.12.65
Woolgar, B. K.	E-in-C.O.	5.11.65	Powis, G. T.	Mid. Reg.	8.12.65
Bray, M. T. G.	L.T. Reg. to E-in-C.O.	5.11.65	Wright, N. F.	Mid. Reg.	8.12.65
Tapper, T. K.	L.T. Reg. to E-in-C.O.	5.11.65	James, J. F.	E-in-C.O.	10.12.65
Lindsay, I. D.	L.T. Reg. to E-in-C.O.	5.11.65	Sweetland, L. G.	E-in-C.O.	10.12.65
Dore, C. E.	L.T. Reg. to E-in-C.O.	5.11.65	Taylor, L. J.	S.W. Reg.	6.12.65
Bloxham, G.	E-in-C.O.	5.11.65	Osborne, G. H. G.	S.W. Reg.	6.12.65
Allan, J.	Mid. Reg.	25.11.65	Cordingley, J.	S.W. Reg.	6.12.65
Abbott, D. F.	H.C. Reg.	9.11.65	Pringle, E. R.	W.B.C.	14.12.65
Mann, P. H.	H.C. Reg.	9.11.65	Drury, R.	N.E. Reg.	23.12.65
Callaghan, K. R. A.	H.C. Reg.	9.11.65	Davies, P. G.	L.T. Reg.	15.12.65
Smyllie, W. M.	L.T. Reg.	10.11.65	Batt, E. J. W.	L.T. Reg.	15.12.65
Chiddy, N. F.	L.T. Reg.	10.11.65	Jordan, W. T.	L.T. Reg.	15.12.65
Davis, H. J.	L.T. Reg.	10.11.65	Condon, S. W.	S.W. Reg.	8.12.65
Osborne, A. S.	L.T. Reg.	10.11.65	Johnson, J. C. F.	L.T. Reg.	15.12.65
Ansell, E. T.	L.T. Reg.	10.11.65	Hall, D. F.	L.T. Reg.	15.12.65
Dobbs, K. O.	L.T. Reg.	10.11.65	Palmer, R. P.	L.T. Reg.	15.12.65
Smith, R. N.	L.T. Reg.	10.11.65	Axe, F. G.	S.W. Reg.	8.12.65
Seward, E.	L.T. Reg.	10.11.65	Chivers, P. R.	S.W. Reg.	21.12.65
Conchie, J. L.	L.T. Reg.	10.11.65	Joy, S. C.	L.T. Reg.	15.12.65
Hunt, L. L. V.	L.T. Reg.	10.11.65	Groves, P. A.	L.T. Reg.	15.12.65
Silwood, A.	L.T. Reg.	10.11.65	Boon, F.	L.T. Reg.	15.12.65
Benning, A. E.	L.T. Reg.	10.11.65	Bean, P. T.	L.T. Reg.	15.12.65
Trumper, E. D.	L.T. Reg.	10.11.65	Bright, T. G.	L.T. Reg.	15.12.65
Leonard, J. L.	L.T. Reg.	10.11.65	Nicholson, R. A.	L.T. Reg.	15.12.65
Wright, J. S.	L.T. Reg.	10.11.65	Moyse, B. J.	L.T. Reg.	15.12.65
Peters, J. B.	L.T. Reg.	10.11.65	Anderson, D. R.	L.T. Reg.	15.12.65
Way, S. J. F.	L.T. Reg.	10.11.65	Elson, C. B.	L.T. Reg.	15.12.65
Neaster, J. M. H.	L.T. Reg.	10.11.65	Benjafield, P.	L.T. Reg.	15.12.65
Lewis, R. G.	L.T. Reg.	10.11.65			
Burch, S. S.	L.T. Reg.	10.11.65			
Carr, G. A.	L.T. Reg.	10.11.65			
Harcus, R.	L.T. Reg.	10.11.65			
Murfett, S. L.	L.T. Reg.	10.11.65			
Butler, P. B.	L.T. Reg.	10.11.65			
Nicholson, F. A.	L.T. Reg.	10.11.65			
Robins, A. G.	L.T. Reg.	10.11.65			
Carter, K. K.	L.T. Reg.	10.11.65			
Thompson, R. D.	L.T. Reg.	10.11.65			
Parker, D. R.	L.T. Reg.	10.11.65			
Sutton, M. L.	L.T. Reg.	10.11.65			
Oliver, G. E.	L.T. Reg.	10.11.65			
Keller, D. G.	L.T. Reg.	10.11.65			
Brasher, W. D.	L.T. Reg.	10.11.65			
McKay, R. P.	L.T. Reg.	10.11.65			
Denyer, P. H.	L.T. Reg.	10.11.65			
Glascock, A. E.	L.T. Reg.	10.11.65			
Fryatt, L. W.	L.T. Reg.	10.11.65			
Bowery, A. A.	L.T. Reg.	10.11.65			
Pitt, J. J.	L.T. Reg.	10.11.65			
Houghton, C. A.	L.T. Reg.	10.11.65			
Penman, A.	L.T. Reg.	10.11.65			
Morris, M. P.	L.T. Reg.	10.11.65			
Read, P. L.	L.T. Reg.	30.11.65			
			<i>Draughtsman to Assistant Executive Engineer</i>		
			Jeremiah, J. D.	S.W. Reg.	18.10.65
			Bartram, E. R.	Mid. Reg.	8.12.65
			Brown, N.	Mid. Reg.	8.12.65
			Barnes, J. A.	Mid. Reg.	8.12.65
			Boyle, G. P.	Mid. Reg.	8.12.65
			Plant, K. T.	Mid. Reg.	8.12.65
			Sudron, B.	Mid. Reg.	8.12.65
			Eüson, D. J.	Mid. Reg.	17.12.65
			Warner, K.	Mid. Reg.	17.12.65
			Harborne, D. B.	Mid. Reg.	17.12.65
			Woodhouse, J. H.	Mid. Reg.	17.12.65
			<i>Technical Officer to Inspector</i>		
			Axford, T. C.	L.T. Reg.	10.11.65
			Peck, W. C.	L.T. Reg.	10.11.65
			Bloomfield, R. W.	L.T. Reg.	10.11.65
			Cheney, F. T.	L.T. Reg.	10.11.65
			Smallpiece, V. F.	L.T. Reg.	10.11.65
			Frame, W. R.	L.T. Reg.	10.11.65
			Deery, B. S.	L.T. Reg.	10.11.65
			Byrne, G.	N.W. Reg.	15.12.65
			Burke, J. P.	N.W. Reg.	15.12.65

Promotions—continued

Name	Region, etc.	Date	Name	Region, etc.	Date
<i>Technical Officer to Inspector—continued</i>			<i>Scientific Officer (Open Competition)</i>		
Morris, W. D.	N.W. Reg.	15.12.65	Carter, J. W.	E.-in-C.O.	5.10.65
Thompson, A. G.	N.W. Reg.	15.12.65	<i>Assistant Experimental Officer (Open Competition)</i>		
Knight, J. H.	N.W. Reg.	15.12.65	Leigh, P. A.	E.-in-C.O.	1.10.65
Robertson, D. G.	L.T. Reg.	29.12.65	Howell, M. E. (Miss)	C.E.S.D.	2.11.65
<i>Senior Technician to Inspector</i>			Watts, P. A.	C.E.S.D.	2.12.65
Mason, A.	N.W. Reg.	20.10.65	Adamson, B.	E.-in-C.O.	7.12.65
Kelly, B.	N.W. Reg.	20.10.65	Winterborn, A. R. (Miss)	E.-in-C.O.	17.12.65
Donaldson, A.	N.W. Reg.	20.10.65	Parker, A. (Mrs.)	E.-in-C.O.	29.12.65
Delaney, E.	N.W. Reg.	20.10.65	Crawford, J. G.	E.-in-C.O.	19.1.66
Williamson, E.	N.W. Reg.	20.10.65	<i>Assistant (Scientific) (Open Competition)</i>		
Roberts, E.	W.B.C.	29.11.65	Hunt, R. C.	E.-in-C.O.	6.12.65
Warburton, F. B.	N.W. Reg.	15.12.65	Plackett, K. D.	E.-in-C.O.	6.12.65
Wales, A. G. E.	N.E. Reg.	23.12.65	<i>Motor Transport Officer III to Motor Transport Officer II</i>		
<i>Technician I to Inspector</i>			Smith, P. F.	E.-in-C.O.	12.1.66
McKinnon, J.	Scot.	9.8.65	<i>Technical Assistant to Assistant Regional Motor Transport Officer</i>		
O'Neill, J. B.	Scot.	18.10.65	Wood, B. V. S. H.	N.E. Reg.	5.10.65
Vernon, J. M.	Scot.	24.9.65	Birks, J.	Scot.	12.10.65
McLean, D. C.	Scot.	24.9.65	<i>Workshop Supervisor III to Technical Assistant</i>		
Kelday, C.	Scot.	25.10.65	Hull, F.	London Reg. to E.-in-C.O.	30.9.65
White, R. L.	N.W. Reg.	25.10.65	Dillon, J. B.	London Reg. to E.-in-C.O.	24.11.65
Pettett, C. S. W.	L.T. Reg.	4.10.65	<i>Mechanic-in-Charge to Technical Assistant</i>		
Jessop, J. P.	L.T. Reg.	4.10.65	Leask, W. H.	Scot.	24.11.65
Golding, H. G.	L.T. Reg.	4.10.65	<i>Senior Mechanic to Technical Assistant</i>		
White, D. W.	L.T. Reg.	4.10.65	Doe, D. D.	London Reg. to E.-in-C.O.	30.9.65
Winterton, J. R.	L.T. Reg.	12.10.65	Lane, D. A.	London Reg. to E.-in-C.O.	24.11.65
Rayner, J. A. B.	L.T. Reg.	4.10.65	<i>Mechanic A to Technical Assistant</i>		
Batson, T. A.	L.T. Reg.	4.10.65	Thirwall, C.	E.-in-C.O.	30.9.65
Hanner, T. C.	L.T. Reg.	4.10.65	Griffiths, G. T.	Mid. Reg.	30.9.65
Rudd, D. J.	L.T. Reg.	4.10.65	Duncan, W. D.	Scot. to E.-in-C.O.	30.9.65
Hatley, A. S.	L.T. Reg.	4.10.65	Stephens, P. J.	Scot. to N.I.	24.11.65
Tupper, A. F.	L.T. Reg.	4.10.65	<i>Draughtsman to Technical Assistant</i>		
Easterbrook, S. G.	L.T. Reg.	4.10.65	Doran, P.	N.W. Reg. to Mid. Reg.	24.11.65
Brown, E.	N.E. Reg.	16.11.65	<i>Senior Draughtsman to Chief Draughtsman</i>		
Caulfield, H. G. C.	L.P. Reg.	21.9.65	Tompkins, L. J.	E.-in-C.O.	1.11.65
Gray, L. A.	L.P. Reg.	21.9.65	<i>Leading Draughtsman to Senior Draughtsman</i>		
Stratford, E. H.	L.T. Reg.	10.11.65	Bradley, A. G.	N.E. Reg.	15.1.66
Cowan, D. E.	L.T. Reg.	10.11.65	<i>Draughtsman to Leading Draughtsman</i>		
Kember, R. I. M.	L.T. Reg.	10.11.65	Godden, E. H.	E.-in-C.O.	11.10.65
McDonald, A.	Scot.	4.11.65	Laidlow, A. D. L.	Scot. to E.-in-C.O.	12.10.65
Drummond, G.	Scot.	15.11.65	Wheeler, B. F. E.	L.T. Reg. to E.-in-C.O.	25.10.65
Hodgson, N.	N.W. Reg.	22.11.65	Murr, B. C.	E.-in-C.O. to Ministry of Health	22.11.65
Williams, D.	N.W. Reg.	16.11.65	Hewison, W. E.	N.E. Reg.	2.12.65
Handley, K.	N.W. Reg.	16.11.65	Best, A. E.	S.W. Reg.	2.12.65
Roberts, A. H.	N.W. Reg.	22.11.65	Johnson, G. M.	L.T. Reg. to Scot.	2.12.65
Ladyman, F.	N.W. Reg.	22.11.65	Bridge, F. D.	N.E. Reg.	2.12.65
Hawkins, J.	N.W. Reg.	15.12.65	Mount, R.	N.W. Reg.	2.12.65
Farren, D.	N.E. Reg.	23.12.65	Benson, F.	Scot.	2.12.65
Underwood, A. T.	Mid. Reg.	30.12.65	Chambers, J. H.	Mid. Reg.	2.12.65
Pearce, F. E.	Mid. Reg.	30.12.65	Millington, E. W.	W.B.C. to N.W. Reg.	2.12.65
Barrow, R. W.	Mid. Reg.	30.12.65	<i>Illustrator to Leading Draughtsman</i>		
Whittaker, R. F. J.	Mid. Reg.	30.12.65	Moss, P. E.	E.-in-C.O.	1.10.65
Hawkins, W. B.	Mid. Reg.	30.12.65	<i>Draughtsman (Open Competition)</i>		
Coley, W. C.	Mid. Reg.	30.12.65	Pease, C. W.	C.E.S.D.	4.11.65
Smith, D. H.	Mid. Reg.	30.12.65	Carter, D. L.	E.-in-C.O.	10.1.66
Conner, H. E.	Mid. Reg.	30.12.65	Kent, E.	E.-in-C.O.	13.1.66
Grant, G. R.	Mid. Reg.	30.12.65	Smith, M. F.	E.-in-C.O.	21.1.66
Bruton, R. E.	Mid. Reg.	30.12.65	Aikens, J. E. F.	E.-in-C.O.	28.1.66
Owen, D. M.	Mid. Reg.	30.12.65	<i>Experimental Officer to Senior Experimental Officer</i>		
Winfield, A. W. D.	Mid. Reg.	30.12.65	Laidlow, J. O.	E.-in-C.O.	8.10.65
Hamblett, W. O.	Mid. Reg.	30.12.65	Greenaway, P. E.	E.-in-C.O.	21.10.65
Mutton, F. A.	Mid. Reg.	30.12.65	Hauser, T. V.	E.-in-C.O.	2.11.65
Root, G. A.	Mid. Reg.	30.12.65	Wilderspin, K. R.	E.-in-C.O.	17.11.65
Woonton, F. D.	Mid. Reg.	30.12.65	<i>Senior Scientific Officer (Open Competition)</i>		
Wadsley, K.	Mid. Reg.	30.12.65	Dobson, R. M.	E.-in-C.O.	1.10.65

Promotions—continued

Name	Region, etc.	Date	Name	Region, etc.	Date
<i>Higher Executive Officer to Senior Executive Officer</i>			<i>Executive Officer (Open Competition)—continued</i>		
Pearce, J. R.	E.O.D.	15.11.65	Wilson, W.	E.-in-C.O.	9.12.65
<i>Executive Officer to Higher Executive Officer</i>			Stern, J. (Miss)	E.-in-C.O.	13.12.65
Crook, J.	E.-in-C.O.	12.11.65	Brown, J. M. (Miss)	E.-in-C.O.	3.1.66
Mariner, E. M. (Miss)	E.-in-C.O.	16.11.65	<i>Clerical Officer to Executive Officer</i>		
Lucas, L. G.	E.-in-C.O.	7.12.65	Temple, Y. (Miss)	E.-in-C.O.	12.11.65
Foster, A. F.	E.-in-C.O.	9.12.65	Allee, F. E. P. (Mrs.)	E.-in-C.O.	12.11.65
<i>Executive Officer (Open Competition)</i>			Reynolds, D. F.	E.-in-C.O.	22.11.65
O'Brien, M. T. (Miss)	E.-in-C.O.	6.11.65	Wilkinson, R.	E.-in-C.O.	22.11.65
Dickson, K.	E.-in-C.O.	13.12.65	Lyford, B. T.	E.-in-C.O.	29.11.65
			Collis, J.	E.-in-C.O.	9.12.65
			Worth, R. H.	E.-in-C.O.	3.1.66

Retirements and Resignations

Name	Region, etc.	Date	Name	Region, etc.	Date
<i>Regional Engineer</i>			<i>Assistant Executive Engineer—continued</i>		
Brett, S. I.	L.T. Reg.	30.1.66	Whillans, A.	Scot.	13.12.65
<i>Area Engineer</i>			Sisseam, W. E.	L.P. Reg.	14.12.65
Hughes, J. A.	E.T.E.	6.1.66	Weller, G. A.	E.-in-C.O.	15.12.65
<i>Senior Executive Engineer</i>			Falconer, D.	Scot.	25.12.65
Broadhurst, J. H.	E.-in-C.O.	26.12.65	Gunn, D. H.	E.-in-C.O.	30.12.65
<i>Executive Engineer</i>			Marsh, L. E. H.	L.T. Reg.	31.12.65
Reade, N. I.	E.-in-C.O.	12.10.65	Howard, F.	E.-in-C.O.	31.12.65
Solomon, A. J.	E.T.E.	17.10.65	Godden, W. E. W.	L.T. Reg.	31.12.65
Evans, T.	N.W. Reg.	29.8.65	Mayes, C. F.	E.T.E.	31.12.65
Hobden, H. A.	L.T. Reg.	29.10.65	Barrett, D.	L.T. Reg.	31.12.65
Richards, H. B.	E.-in-C.O.	31.8.65	Stephen, J.	E.-in-C.O.	3.12.65
Henk, A. J. C.	N.E. Reg.	10.11.65	(Resigned)		
Clark, E. A.	N.E. Reg.	25.11.65	Ancliff, B. T.	Mid. Reg.	28.12.65
Walters, E. W.	E.-in-C.O.	30.11.65	(Resigned)		
Fagg, S. L. F.	E.-in-C.O.	31.12.65	Dixon, A.	E.-in-C.O.	28.12.65
Stocker, J. F.	E.-in-C.O.	28.12.65	(Resigned)		
Lines, P. D.	E.-in-C.O.	29.12.65	Cripton, E. W.	E.-in-C.O.	31.12.65
(Resigned)			(Resigned)		
Radford, W. E.	Mid. Reg.	2.1.66	<i>Inspectors</i>		
Capon, S. J.	L.T. Reg.	25.1.66	King, B.	N.E. Reg.	23.9.65
<i>Assistant Executive Engineer</i>			Babidge, M. W.	S.W. Reg.	5.10.65
Addis, J. H.	L.P. Reg.	21.9.65	Knight, E. G.	H.C. Reg.	15.10.65
Pople, K.	S.W. Reg.	1.10.65	Sykes, D. H.	Mid. Reg.	26.10.65
Conolly, E. J.	N.W. Reg.	8.10.65	McAlindon, D.	N.W. Reg.	2.11.65
Phillips, J. A.	S.W. Reg.	18.10.65	Williams, J. W. C.	L.T. Reg.	4.11.65
Burgess, R. W.	L.T. Reg.	19.10.65	Leslie, C. M.	Scot.	15.11.65
Scott, W.	N.E. Reg.	19.10.65	Driver, S. H.	L.T. Reg.	17.11.65
Ward, M. A.	L.T. Reg.	26.10.65	Law, F. T.	L.T. Reg.	31.12.65
Naylor, C.	N.W. Reg.	31.10.65	<i>Principal Scientific Officer</i>		
Collins, J.	S.W. Reg.	2.11.65	Bull, R. L.	E.-in-C.O.	30.11.65
Huckstep, G. W.	L.T. Reg.	3.11.65	<i>Assistant (Scientific)</i>		
Squire, F. A.	S.W. Reg.	5.11.65	Chidley, N. F. G.	E.-in-C.O.	15.10.65
Gairns, A.	E.-in-C.O.	5.11.65	(Resigned)		
Figg, M. H.	E.T.E.	6.11.65	<i>Regional Motor Transport Officer</i>		
Hipkin, E. S.	E.T.E.	6.11.65	Huxley, R. T.	London Reg.	10.12.65
McCloud, J. H.	N.I.	16.11.65	<i>Technical Assistant</i>		
Cowan, R. H.	Scot.	17.11.65	Trimmer, G. J. P.	London Reg.	1.10.65
Banyard, P. W.	H.C. Reg.	19.11.65	Webber, A. L. D.	H.C. Reg.	31.12.65
Burch, L. J.	L.T. Reg.	19.11.65	<i>Draughtsman</i>		
Baird, S. G. C.	N.I.	24.11.65	Ashley, W. R.	E.-in-C.O.	26.11.65
Woolford, A. L.	E.T.E.	30.11.65	<i>Higher Executive Officer</i>		
Hudson, H.	L.T. Reg.	30.11.65	Coe, G. M. M. (Miss)	E.-in-C.O.	14.11.65
Coulson, R. S.	E.-in-C.O.	26.11.65			
(Resigned)					
Canfield, W.	L.T. Reg.	12.12.65			

Transfers

Name	Region, etc.	Date	Name	Region, etc.	Date
<i>Assistant Staff Engineer</i>			<i>Senior Scientific Officer</i>		
Carden, R. W. G.	E.-in-C.O. to Scot.	1.10.65	Eastwood, G. W.	E.-in-C.O. to Science Research Council	1.12.65
Rymer, N. B.	C.E.S.D. to E.-in-C.O.	3.1.66	Jasinski, K. M.	E.-in-C.O. to S.B.R.D.	24.1.66
Harris, D. J.	Joint P.O./M.P.B.W., R.D.G., to L.T. Reg.	31.1.66	<i>Experimental Officer</i>		
<i>Area Engineer</i>			Johnson, C. B. C.	E.-in-C.O. to C.A.S./T.S.U.	10.1.66
Sturdy F. H.	H.C. Reg. to N.E. Reg.	1.11.65	Addley, J. A.	C.E.S.D. to C.A.S./T.S.U.	31.1.66
<i>Senior Executive Engineer</i>			<i>Scientific Officer</i>		
Irwin, A.	E.-in-C.O. to Libya	8.11.65	Morgan, P. M. (Miss)	E.-in-C.O. to Ministry of Transport	9.8.65
Howard, R. F.	E.-in-C.O. to S.H.A.P.E.	2.11.65	<i>Assistant Experimental Officer</i>		
Whittaker, J. W.	E.-in-C.O. to L.T. Reg.	3.1.66	Warwick, J. B. (Mrs.)	E.-in-C.O. to Ministry of Defence	31.8.65
<i>Executive Engineers</i>			<i>Assistant (Scientific)</i>		
Perry, E. T.	Ghana to L.T. Reg.	13.10.65	Moore, P. D. (Miss)	E.-in-C.O. to C.E.S.D.	24.1.66
Luetchford, J. C.	E.-in-C.O. to Fiji	25.10.65	<i>Motor Transport Officer II</i>		
Pattemore, T. E.	E.-in-C.O. to Ministry of Defence	28.6.65	Lord, A. C.	E.-in-C.O. to H.C. Reg.	22.12.65
Hoskyns, R. F.	E.-in-C.O. to S.H.A.P.E.	1.11.65	<i>Regional Motor Transport Officer</i>		
Barry, D. W.	E.-in-C.O. to S.H.A.P.E.	1.11.65	Humphrey, M. C.	H.C. Reg. to London Reg.	13.12.65
Jelliffe, C. A.	S.W. Reg. to H.C. Reg.	8.11.65	<i>Assistant Regional Motor Transport Officer</i>		
Connell, D. R. W.	H.C. Reg. to S.W. Reg.	8.11.65	James, H. S.	E.-in-C.O. to H.C. Reg.	2.8.65
Trumper, J. W.	E.-in-C.O. to L.T. Reg.	6.12.65	<i>Technical Assistant</i>		
Galloway, J.	E.-in-C.O. to Ministry of Transport	13.12.65	Charles, A. W.	London Reg. to S.W. Reg.	19.7.65
Belcher, P. L.	E.-in-C.O. to Ministry of Transport	29.12.65	Hennis, F.	N.I. to E.-in-C.O.	28.10.65
Friday, F. F.	E.-in-C.O. to Mid. Reg.	1.1.66	<i>Draughtsman</i>		
Busby, K. D.	E.-in-C.O. to L.T. Reg.	31.1.66	Hill, A. B.	E.-in-C.O. to L.T. Reg.	1.7.65
Turner, P. A.	E.-in-C.O. to Ministry of Aviation	31.1.66	Hutchins, C. D.	L.T. Reg. to E.-in-C.O.	6.9.65
<i>Assistant Executive Engineer</i>			Bush, J. F.	C.E.S.D. to E.-in-C.O.	27.9.65
Jackson, D. W.	Nigeria to L.T. Reg.	4.10.65	Shnibsole, R. C.	Ministry of Defence to E.-in-C.O.	20.9.65
Bennett, W. L. G.	E.-in-C.O. to Scot.	4.10.65	<i>Executive Officer</i>		
Myers, H. B.	E.-in-C.O. to Mid. Reg.	1.11.65	Lovett, F. H.	E.-in-C.O. to T.S.U.	6.7.65
Gerrard, H.	E.-in-C.O. to L.T. Reg.	15.11.65	Walker, M. T. (Mrs.)	E.-in-C.O. to L.T. Reg.	1.12.65
Portway, A. E.	E.-in-C.O. to N.E. Reg.	22.11.65	Hobbs, H. R.	L.T. Reg. to E.-in-C.O.	24.1.66
Cartwright, F. A.	E.-in-C.O. to Ministry of Aviation	30.11.65	Rawlings, C. G. E.	E.-in-C.O. to L.T. Reg.	24.1.66
Bullimore, A. A.	E.-in-C.O. to Fiji	4.12.65	<i>Principal Scientific Officer</i>		
Barnes, S. L. S.	E.-in-C.O. to Ministry of Transport	20.12.65	Thomson, W. E.	L.T. Reg. to E.-in-C.O.	3.1.66
Slater, T. G. W.	Nigeria to L.T. Reg.	29.11.65	<i>Deputy Chief Regional Engineer</i>		

Deaths

Name	Region, etc.	Date	Name	Region, etc.	Date
<i>Deputy Chief Regional Engineer</i>			<i>Assistant Executive Engineer—continued</i>		
Straw, J. G.	L.T. Reg.	13.1.66	Lockett, A. E.	S.W. Reg.	24.10.65
<i>Assistant Staff Engineer</i>			McKay, C. S.	Scot.	5.11.65
Wilcockson, H. E.	E.-in-C.O.	22.1.66	Gregory, E. O.	E.-in-C.O.	7.12.65
<i>Executive Engineer</i>			Newton, C. B.	L.T. Reg.	11.12.65
Stevens, P. F.	E.-in-C.O.	9.9.65	<i>Inspector</i>		
Hothan, J. W.	H.C. Reg.	27.9.65	Williams, I. G.	L.T. Reg.	30.3.65
<i>Assistant Executive Engineer</i>			Parker, O. B.	S.W. Reg.	30.4.65
Stevens, P. B.	L.T. Reg.	5.4.65	Savage, G. H. R.	Mid. Reg.	13.6.65
Price, G. W. G.	E.-in-C.O.	27.4.65	Woodhead, D. E.	N.W. Reg.	26.6.65
Gothorp, J. W.	E.T.E.	20.6.65	Bower, G. E.	Mid. Reg.	7.9.65
Rowlinson, S. C.	H.C. Reg.	20.7.65	Osborn, J.	L.T. Reg.	7.12.65
Poole, S. R.	E.-in-C.O.	22.7.65	<i>Assistant Experimental Officer</i>		
Morris, I. C.	E.-in-C.O.	23.7.65	Taylor, C. B.	E.-in-C.O.	9.6.65
Whiting, R.	W.B.C.	6.10.65	<i>Draughtsman</i>		
Spurgeon, H. J.	H.C. Reg.	21.10.65	Wood, E.	E.-in-C.O.	16.5.65

Papers and Articles on Telecommunications and Other Scientific Subjects

The following is a list of the authors, titles and places of publication of papers and articles written by Post Office staff (sometimes in association with members of other organizations) and published during 1965.

- ALLAN, A. F. G. A New Device for Finding Cable Leaks. *Post Office Telecommunications Journal*, Vol. 17, No. 4, p. 14, Winter 1965.
- ALLAN, A. F. G. Maintaining the Trunk Cable Network. *Post Office Telecommunications Journal*, Vol. 17, No. 3, p. 24, Autumn 1965.
- ALLERY, G. D., and SMITH, N. G. A Standard Modem for Data Transmission over the Telephone Network at 600/1,200 Bits/Sec. *I.E.E. Colloquium on Data and Telegraph Transmission*, Oct. 1965.
- ALLNATT, J. W., and PROSSER, R. D. Subjective Quality of Television Pictures Impaired by Long Delayed Echoes. *Proceedings I.E.E.*, Vol. 112, p. 487, Mar. 1965.
- ALLNATT, J. W., see LEWIS, N. W.
- ALLNATT, J. W. Subjective Quality of Colour-Television Pictures Impaired by Gain and Delay Inequalities Between Luminance and Chrominance Channels. *Proceedings I.E.E.* Vol. 112, p. 1,819, Oct. 1965.
- BAKER, D., and BRYAN, I. E. An Improved Form of Thermo-Compression Bond. *British Journal of Applied Physics*, Vol. 16, p. 865, June 1965.
- BRAY, W. J. Satellite Communication Systems. *The Institute Of Physics and The Physical Society Bulletin*, Vol. 16, No. 12, Dec. 1965.
- BRICE, P. S. Radio-Wave Propagation. *I.T.U. Telecommunication Journal*, Vol. 32, No. 6, p. 214, June 1965.
- BRYNN, I. E., see BAKER, D.
- CARASSO, J. I., and FAKTOR, M. M. Tetragonal Germanium Dioxide and Equilibria in the Ge-O-H system. *Journal of the Electrochemical Society*, Vol. 112, No. 8, p. 817, Aug. 1965.
- CARDEN, R. W. G. Getting at the Facts. *Post Office Telecommunications Journal*, Vol. 17, No. 1, p. 16, Spring 1965.
- CARTER, J. W., see DAGLISH, H. N.
- CARTER, R. O., and WHEELER, L. K. LINCOMPLEX—A System for Improving High-frequency Radio-Telephone Circuits. *British Communications and Electronics*, Vol. 12, No. 8, p. 494, Aug. 1965.
- CHAKRABORTY, D., and MILLWARD, G. F. D. A Nitrogen-Cooled Degenerate Parametric Amplifier for a Radiometric Application. *Electronic Engineering*, Vol. 37, p. 532, Aug. 1965.
- CHAKRABORTY, D., see DAGLISH, H. N.
- CRANK, G. J. Monarch Tries a New Idea. *Post Office Telecommunications Journal*, Vol. 17, No. 4, p. 38, Winter 1965.
- CROFT, E. How Work Study Works. *Post Office Telecommunications Journal*, Vol. 17, No. 2, p. 32, Summer 1965.
- DAGLEISH, D. I., and JEFFERIS, A. K. Evolutionary Medium Altitude Communication Satellite Systems. *I.E.E. Electronic Letters*, Vol. 1, No. 2, p. 37, Apr. 1965.
- DAGLEISH, D. I., and JEFFERIS, A. K. Some Orbits for Communication Satellite Systems Affording Multiple Access. *Proceedings I.E.E.*, Vol. 112, No. 1, p. 21, Jan. 1965.
- DAGLISH, H. N., and CARTER, J. W. Coded Terminations for Use as 4 Gc/s Microwave Standard Noise Sources. *Proceedings I.E.E.*, Vol. 112, p. 705, Apr. 1965.
- DAGLISH, H. N., and CHAKRABORTY, D. Applications of Parametric Amplifiers in Satellite Communications. *Proceedings of Joint I.E.E./I.E.R.E. Symposia on Microwave Applications of Semiconductors*, June/July 1965.
- ENOCH, R. D. The Induced Magnetic Anisotropy in a Cold Rolled Ni-Mo Alloy. *British Journal of Applied Physics*, Vol. 16, p. 1,519, Oct. 1965.
- ENOCH, R. D., and WILDERSPIN, K. R. Directed Ni-Ni and Fe-Fe Pair Contributions to the Induced Anisotropy in Some Cold-Rolled Polycrystalline Ni-Fe Alloys. *Proceedings International Conference on Magnetism, Nottingham*, p. 748, Jan. 1965.
- EVANS, C. R., see ULLMANN, J. R.
- FAKTOR, M. M., see CARASSO, J. I.
- FINN, F. G. The Engineers Found the Answer (Wire Wrapping Tool). *Post Office Telecommunications Journal*, Vol. 17, No. 3, p. 23, Autumn 1965.
- FRANKLIN, R. H. Cutting the Costs of the Trunk and Junction Networks. *Post Office Telecommunications Journal*, Vol. 17, p. 31, Winter 1965.
- HARRIS, L. R. F., and LAWRENCE, J. A. A Review of Electronic Switching Developments in the United Kingdom. *Proceedings National Electronics Conference, Chicago*, p. 396, 1965.
- HARRIS, L. R. F., and LAWRENCE, J. A. A Survey of Electronic Switching Problems in the United Kingdom. *Proceedings National Electronics Conference, Chicago*, p. 391, 1965.
- HEARNDEN, A. H. This P.A.B.X. Needs No Operator (Refers to P.A.B.X. 6). *Post Office Telecommunications Journal*, Vol. 17, No. 4, p. 36, Winter 1965.
- HENDERSON, J. C. A General Discussion on "Dislocations in Solids" held at University of Goettingen, 15-17 Sept., 1964. *Discussions of the Faraday Society*, No. 38—1964, p. 317, 1965.
- HENLEY, H. R. Economic Logic. *Wireless World*, Vol. 71, p. 518, Oct. 1965.
- HENLEY, H. R. Logic Without Tears. *Wireless World*, Vol. 71, p. 44, Jan. 1965.
- HENLEY, H. R. Logik Utan Tarar. *Elektronik (Stockholm)*, Vol. 71, No. 5, p. 78, Oct. 1965.
- HOWARD, J. Factors Which Influence the Growth and Size of Secondary Crystals in Nickel and Some Nickel Alloys Rolled From Sintered Compacts. *Metallurgia*, Vol. 72, p. 103, Sept. 1965.

- HOWARD, J. Secondary Recrystallisation in Silicon-Iron and Some Other Iron Alloys Rolled From Sintered Compacts. *Transactions of Metallurgical Society*, Vol. 233, p. 1,791. Sept. 1965.
- HYATT, S. L. Telephones on Wheels. *Post Office Telecommunications Journal*, Vol. 17, No. 3, p. 36, Autumn 1965
- ITHELL, A. H., JOHNSON, E. G. T., and YATES, R. F. The Acoustical Impedance of Human Ears and a New Artificial Ear. *Acustica*, Vol. 15, No. 2, p. 109, 1965.
- JEFFERIS, A. K. Communications by Satellite Systems. *I.E.E. Students Quarterly Journal*, Vol. 35, No. 140, p. 191, June 1965.
- JEFFERIS, A. K., see DALGLEISH, D. I.
- JOHNSON, E. G. T., see ITHELL, A. H.
- KENNARD, D. E. Two-Way Radio Cuts Cabling Costs. *Post Office Telecommunications Journal*, Vol. 17, No. 2, p. 18, Summer 1965.
- KILVINGTON, T. Post Office Tower and the New Microwave Relay Network. *Systems and Communications*, Vol. 1, No. 2, p. 18, Oct. 1965.
- LAWRENCE, J. A., see HARRIS, L. R. H.
- LEWIS, N. W., and ALLNATT, J. W. Subjective Quality of Television Pictures with Multiple Impairments. *I.E.E. Electronics Letters*, Vol. 1, p. 187, Sept. 1965.
- LOYD, H. F. A New Equipment Design. *Post Office Telecommunications Journal*, Vol. 17, No. 2, p. 42, Summer 1965.
- LORD, T. K. The Public Address Call Service. *Post Office Telecommunications Journal*, Vol. 17, No. 3, p. 33, Autumn 1965.
- LUCAS, D. R. H. Recorded Information Services—2, How the Equipment Works. *Post Office Telecommunications Journal*, Vol. 17, No. 1, p. 40, Spring 1965.
- LYNCH, A. C. Measurement of the Dielectric Properties of Low-Loss Materials. *Proceedings I.E.E.*, Vol. 112, p. 426, Feb. 1965.
- MACDIARMID, I. F., and SHELLEY, I. J. Correcting Colour Signal Distortion. *Wireless World*, Vol. 71, p. 113, Mar. 1965.
- MACHEN, G. F. Equipment Surveys—Uniselectors. *Instruments Electronic Automation Year Book and Buyers Guide*, p. 492, Mar. 1965.
- MERLO, D. Development of Group-Delay Equalizers for 4 Gc/s. *Proceedings I.E.E.*, Vol. 112, No. 2, p. 289, Feb. 1965.
- MERLO, D., *et al.* Effect of Some Component Tolerances and Measuring Errors on Noise Measurements. *I.E.E. Electronics Letters*, Vol. 1, No. 4, p. 250, Nov. 1965.
- MILLWARD, G. F. D., see CHAKRABORTY, D.
- MORGAN, T. J. Long-Term Assessment of Future Telecommunications Requirements. *A.T.E. Journal*, Vol. 21, No. 3, p. 123, July 1965.
- MYERSON, R. J. W. And Now Transistors on the Sea Bed. *Post Office Telecommunications Journal*, Vol. 17, No. 1, p. 32, Spring 1965.
- NEILL, T. B. M. A New Potential Function for a Planar Triode. *British Journal of Applied Physics*, Vol. 16, p. 137, Feb. 1965.
- NEILL, T. B. M. The Effect of Statistical Variations in Grid Winding Pitch upon the Performance of a Planar Triode. *British Journal of Applied Physics*, Vol. 16, p. 1,161, Aug. 1965.
- PANICHELLI, P. A., and REID, H. A. Putting Telephones into New Houses. *Post Office Telecommunications Journal*, Vol. 17, No. 3, p. 12, Autumn 1965.
- PEARSON, H. E. Measuring Technique used to Establish the Profile Accuracy of a 85 ft Diameter Aerial. *I.E.E. Electronics Letters*, Vol. 1, No. 4, p. 91, June 1965.
- PROSSER, R. D., and ALLNATT, J. W. Subjective Quality of Television Pictures Impaired by Random Noise. *Proceedings I.E.E.*, Vol. 112, p. 1,099, June 1965.
- REID, H. A., see PANICHELLI, P. A.
- RHODES, J. Data Transmission. *I.T.U. Telecommunication Journal*, Vol. 32, No. 11, p. 472, Nov. 1965.
- RIDOUT, P. N., see WHEELER, L. K.
- ROBINSON, H. E. Better and Cheaper Air Blocks. *Post Office Telecommunications Journal*, Vol. 17, No. 2, p. 36, Summer 1965.
- SHELLEY, I. J.,* see MACDIARMID, I. F.
- SHEPPARD, J. A., and TOWEY, H. O. A Pair of Statistical Twins. *Post Office Telecommunications Journal*, Vol. 17, No. 4, p. 20, Winter 1965.
- SMITH, N. G., see ALLERY, G. D.
- TOWEY, H. O., see SHEPPARD, J. A.
- ULLMANN, J. R. A Basic Approach to Pattern Recognition. *The Computer Journal*, Vol. 7, No. 4, p. 282, Jan. 1965.
- ULLMANN, J. R., and EVANS, C. R. A Proposed Behavioural Test for Distinguishing Between the Perceptual Judgement Mechanisms of Humans and Those of a Machine. *Transactions of the Institute of Electrical and Electronics Engineers on Human Factors in Electronics*, Vol. HFE-6, No. 1, p. 86, Sept. 1965.
- ULLMANN, J. R. Parallel Recognition of Idealized Line Characters. *Kybernetik*, Vol. 2, Part 5, p. 221, June 1965.
- ULLMANN, J. R. Some Problems in Artificial Intelligence. *Progress in Brain Research*, Vol. 17, p. 102, 1965.
- WHEELER, L. K. A Brief Review of Telegraph Multiplexing Methods. *I.E.E. Colloquium on Data and Telegraph Transmission*, Oct. 1965.
- WHEELER, L. K. Taking the Noise out of Radio Circuits. *Post Office Telecommunications Journal*, Vol. 17, No. 2, p. 26, Summer 1965.
- WHEELER, L. K., see CARTER, R. O.
- WHEELER, L. K., and RIDOUT, P. N. A Comparison of Factor Binary Signalling Methods. *I.E.E. Colloquium on Data and Telegraph Transmission*, Oct. 1965.
- WILDERSPIN, K. R., see ENOCH, R. D.
- YATES, R. F., see ITHELL, A. H.

*Mr. Shelley is with the British Broadcasting Corporation.

BOARD OF EDITORS

J. H. H. MERRIMAN, O.B.E., M.Sc., A.Inst.P., M.I.E.E., Chairman.
L. F. SCANTLEBURY, O.B.E., Whit.Sch., A.C.G.I., D.I.C., M.I.E.E.
W. J. E. TOBIN, O.B.E., B.Sc.(Eng.), A.C.G.I., D.I.C., M.I.E.E.
E. W. AYERS, B.Sc.(Eng.), A.M.I.E.E.
E. J. MARKBY, A.M.I.E.E.
E. HOARE, B.Sc., M.I.E.E.
A. G. LEIGHTON, B.Sc.(Eng.), A.M.I.E.E., Managing Editor.
J. MARTIN, B.Sc.(Eng.), A.M.I.E.E., Deputy Managing Editor.
N. J. H. NINNIM, B.Eng. } Assistant Editors.
R. A. SUDELL. }
B. FARR, A.B.I., Secretary-Treasurer.
R. P. MYHILL, Advertisement Manager.

Copyright

The entire contents of this Journal are covered by general copyright, and special permission is necessary for reprinting long extracts, but editors are welcome to use not more than one-third of any article, provided that credit is given at the beginning or end thus: "From *The Post Office Electrical Engineers' Journal*."

The Board of Editors is not responsible for the statements made or the opinions expressed in any of the articles in this Journal, unless such statement is made specifically by the Board.

Subscriptions and Back Numbers

The Journal is published quarterly, in April, July, October and January, at 3s. per copy; the post-paid price is 4s. per copy (16s. per year) via inland mail, and 4s. 3d. (17s., or 2 dollars 75 cents Canada and U.S.A., per year) via overseas mail. Back numbers will be supplied, if available, price 3s. (4s. inland mail, 4s. 3d. overseas mail) per copy. With the exception of April, July

and October 1964 Journals, copies of the April 1965 and all earlier Journals are no longer available. Orders should be sent to *The Post Office Electrical Engineers' Journal*, G.P.O., 2-12 Gresham Street, London, E.C.2.

Employees of the British Post Office can obtain the Journal through local agents.

Binding

Readers can have their copies of volumes bound at a cost of 15s. by sending the complete set of parts to the local Post Office distribution agent or to *The Post Office Electrical Engineers' Journal*, G.P.O., 2-12 Gresham Street, London, E.C.2.

Remittances

Remittances should be made payable to "*The P.O.E.E. Journal*" and should be crossed "& Co."

Advertisements

All correspondence relating to advertisement space reservations, copy, proofs, etc., should be addressed to the Advertisement Manager, *The Post Office Electrical Engineers' Journal*, G.P.O., 2-12 Gresham Street, London, E.C.2.

Communications

With the exceptions indicated above, all communications should be addressed to the Managing Editor, *The Post Office Electrical Engineers' Journal*, G.P.O., 2-12 Gresham Street, London, E.C.2. Telephone: HEAdquarters 1234.

Model Answer Books

Books of model answers to certain of the City and Guilds of London Institute examinations in telecommunications are published by the Board of Editors. Details of the books available are given at the end of the Supplement to the Journal.

MODEL ANSWER BOOKS

CITY AND GUILDS OF LONDON INSTITUTE EXAMINATIONS FOR THE TELECOMMUNICATION TECHNICIANS' COURSE

These model answer books are available each covering one of the following subjects.

TELECOMMUNICATION PRINCIPLES A TELECOMMUNICATION PRINCIPLES B ELEMENTARY TELECOMMUNICATION PRACTICE

PRICE 7/6 each (Post Paid 8/-)

A model answer book for one of the subjects under the old Telecommunications Engineering Course is still available and is offered at a considerably reduced price.

TELEPHONE EXCHANGE SYSTEMS I

Model answers published in this book come within the syllabuses for Telephony and Telegraphy A, and for Telephony B.

PRICE 2/- (Post Paid 2/6)

Orders may be sent to the *Journal* Local Agents or to
The Post Office Electrical Engineers' Journal, G.P.O., 2-12 Gresham Street, London, E.C.2.

THE
PYE **Linesman**
FULLY
TRANSISTORISED
PORTABLE TWO WAY
RADIOTELEPHONE



Based on the now famous Pye Bantam solid-state Walkie/Talkie, the Pye Linesman with many additional features, makes it suitable for use in all types of weather, the Pye Linesman is proving invaluable in cable laying, road construction, building sites etc.

Important features are that it is free-standing, incorporates large capacity batteries, is weatherproof and has a voltage indicator to show the state of the battery.

The 'Linesman' is designed never to let you down in the field. It is available for AM and FM in frequency bands from 25-174 Mc/s. It is used by the British Post Office.

PYE TELECOMMUNICATIONS LIMITED

CAMBRIDGE · ENGLAND · TELEPHONE: TEVERSHAM (CAMBRIDGE) 61222 · TELEX No. 81166

STC TELECOMMUNICATIONS REVIEW

APRIL, 1966



rrrrringg, rrrringg...
rrrrringg, rrrrin

It doesn't

You'd scarcely expect a very out-of-the-ordinary phone to ring like an ordinary one.

And consider how entirely new and supremely functional the STC *Deltaphone* is.

It's so compact, the body of the set is only slightly wider than the dial—4.3 ins. (111 mm.) in all! Lightweight, too. At 4 ozs. (113.4 gms.), the handset, which rests along the body, is less than half the weight of a conventional handset, so that the whole instrument can easily be picked up in one hand.

Add now high technical specifications to match this crisp, up-to-the-minute appearance, a choice of restrained and attractive colours, optional dial illumination . . . and you'd scarcely expect the STC *Deltaphone* just to ring.

And it doesn't. It warbles discreetly, at any volume level you choose.

Standard Telephones and Cables Limited, Telephone Switching Division, Oakleigh Road, New Southgate, London, N.11. Telephone: ENTERprise 1234. Telex: 21612.

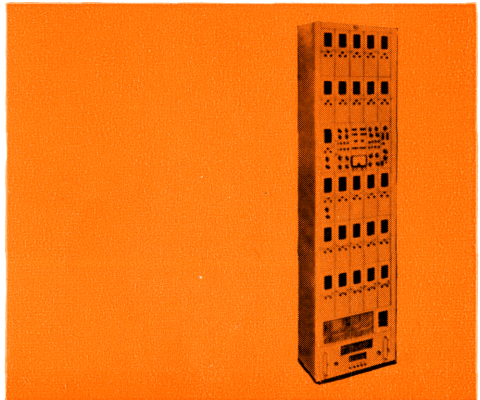

ARQ

Automatic error correction equipment type TEC.1

TEC.1 is for use in conjunction with the terminal equipment of long distance international telegraph circuits over radio paths for such services as public telegrams, telex and leased channel operation in accordance with CCIR requirements. It automatically detects and corrects telegraph code errors which may be introduced into the message by interference from static, multi-path propagation or other sources.

- Fully transistorized
- Four-channel or two-channel operation by switching or two-channel in separate cabinet
- Channel subdivision of all channels included on the main equipment
- CCITT and American speeds
- Tested repetition cycle
- Automatic and manual character-phasing
- Compatible with other equipments
- Book techniques used throughout for easy routine servicing or replacement
- Adequate test and monitoring points provided
- Small number of types of basic units reduces spares holdings to a minimum.

Standard Telephones and Cables Limited, Radio Division, Oakleigh Road, New Southgate, London, N.11. Telephone: ENTERprise 1234. Telex: 21612.



STEPMASTER PABX

Two models of efficiency

The STC Stepmaster PABX gives you the fast, foolproof communications you need, while leaving the operator beautifully unruffled.

It meets the most up-to-date requirements for a Cordless Private Automatic Branch Exchange of advanced design and compact proportions.

And the use of keysender marking techniques, plus the very simple working procedure, so ease the operator's task that a secretary or receptionist can comfortably work the switchboard in addition to her other duties.

- 20, 50 and 100 line units • Smart, modern switchboard • New lightweight high performance handset
- B.P.O. type 'long-life' components • Transistorized ringing and tone circuits • All 'plug-in' type equipment • Quick and easy extension to full capacity • Simple installation and maintenance.

Standard Telephones and Cables Limited, Telephone Switching Division, Oakleigh Road, New Southgate, London, N.11. Telephone: ENTerprise 1234. Telex: 21612.



Complete submarine cable telephone systems

STC are fully equipped to cover every phase of submarine cabling for telephonic and telegraphic transmission. Plan, design, supply and install—a complete service from drawing-board to operation. Systems providing up to 640 high quality telephone circuits can be supplied.

STC systems include shallow or deep water submerged repeaters, land based terminal equipment and repeater power feeding equipment for long and short systems. One of the few commercial organizations in the world qualified to provide fully integrated systems tailored to any location and specification, STC have supplied equipment now in operation over a total route length of twenty thousand nautical miles.

The illustrations show STC submarine repeaters on the deck of the cable ship "Monarch" ready for laying, and a suite of terminal equipment.

Standard Telephones and Cables Limited, Transmission Systems Group, Basildon, Essex. Telephone: Basildon 3040. Telex: 99101.

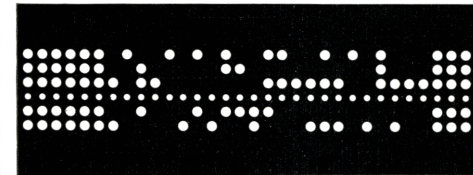
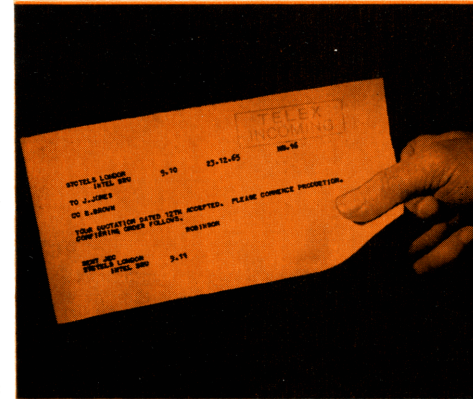

The message is your business ... speeding it through is ours

STC know telegraphy inside out and outside in, provide a complete range of equipment—and equally complete skill and experience—for direct and indirect systems, large, medium and small.

Telex switching, international and local, is an STC speciality no less than the provision of private networks for the police, railways and similar bodies.

And, throughout the world, STC message switching systems—from the simplest manual transfer right through semi- and fully-automatic systems—speed the vital messages of corporations, civil airlines and commercial networks of every kind.

The moment *you* have any telegraphic problem it's just good business to phone, write or telex STC.

Standard Telephones and Cables Limited, Telephone Switching Division, Oakleigh Road, New Southgate, London, N.11. Telephone: ENTerprise 1234. Telex: 21612.

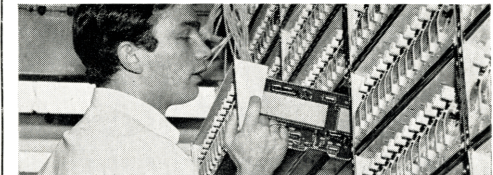

Unique world-wide capability in integrated communication systems

- System planning
- Survey
- Project Management
- Installation
- Maintenance
- Overhaul

for all types of telecommunication transmission systems.

The Installation Division of the STC Transmission Systems Group is the only organization of its type in the world. Self-contained and independent, and backed by the international resources of STC, the Division offers world-wide capability in the provision of Integrated Communication Systems, including consultancy services, and advisory and training services for the user's staff.

Standard Telephones and Cables Limited, Transmission Systems Group, Basildon, Essex. Telephone: Basildon 3040. Telex: 99101.

PLESSEY PVT 150 series

1-kW linear transmitters

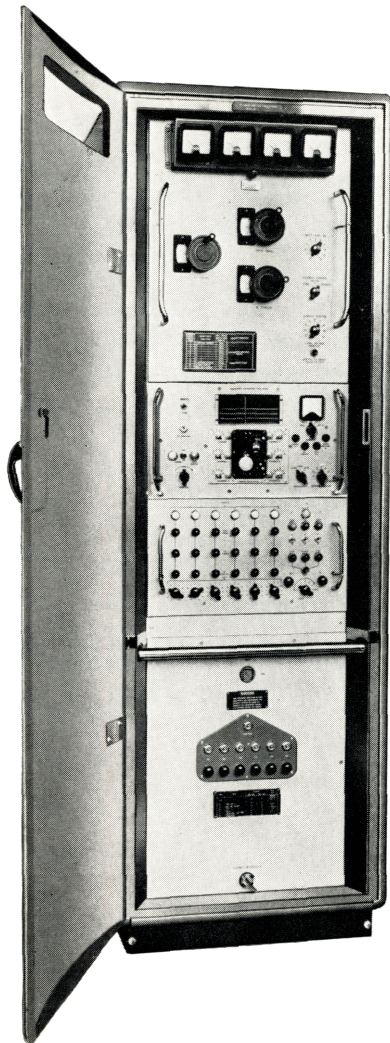

As a result of an intensive study of modern long-distance communications problems, Plessey Engineers have developed and produced the PVT 150 series of H.F. transmission systems. Essential design features which distinguish these transmitters include:—

1. Low spurious radiation
2. Wideband preamplifier
3. VSWR and radiated-power indications
4. No band switching
5. Ability to operate unattended
6. Local, extended and remote control available

Multi-Purpose

These versatile transmitters are suitable for ground-to-air, ship-to-shore and military communications networks as well as point-to-point long-range transmissions. Installation is made simple by reduction of external connections to a minimum. A1, A3H, A3A, A3J, A3BA, A3B and F1 signals can be accommodated. Alternatively, with an external drive unit the transmitters are suitable for any emissions within a 12-kc/s bandwidth.

Proven Reliability

Because the highest engineering standards are used throughout the equipment, it has proved reliable under the most adverse conditions. Operating temperature range is from -15°C to $+55^{\circ}\text{C}$ at 95% humidity. Operating altitudes up to 8,000 ft (2,400 metres).

Wide Range — Many Extras Available

The PVT 150 series of transmitters can be supplied for use with external drive unit (PVT 150A) or as a complete transmitter (PVT 150B). Both versions can be provided with manual or servo tuning, and can be used with local, extended or remote control. Extras available include ISB Drive Unit (PF 215/223), Frequency Synthesizer (PG 331) and Monitor (PV 218).

Used throughout the World

These outstanding advantages have attracted attention throughout the world; PVT 150 transmitters are currently in use both in Britain and overseas.

Brief Specification

Frequency Range: 1.6–27.5 Mc/s
 Output: 1 kW p.e.p.
 Power Consumption: 5 kVA
 Channel Changing Period: Servo tuned approx. 12 sec.
 Manually tuned approx. 1 min.
 Facilities Provided: Any type of emission within a 12-kc/s bandwidth.

For full technical details please write to:

The Plessey Company Limited
 Radio Systems Division
 Ilford, Essex, England.
 Telephone: ILFord 3040. Telex: 23166.

PLESSEY
Electronics



PE(5)

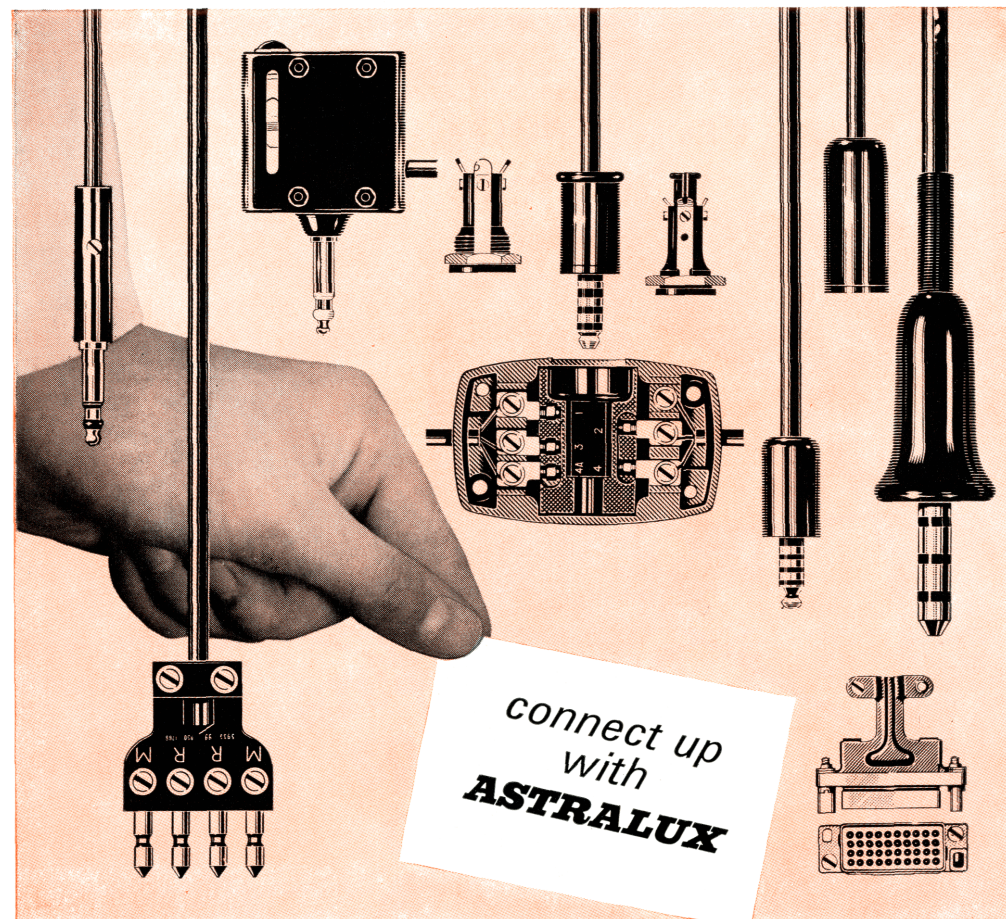

PLUGS, SOCKETS, JACKS—in all sizes and for every purpose—are made by the Special Products Division of Astralux Dynamics Ltd. They're chosen by the British Government and approved by the Post Office and Aircraft Industry. The special Astralux design service for prototype models is used by these organisations and by private industry. You can rely on Astralux efficiency and technical accuracy to produce equipment strictly to specification—and quickly. Plugs, Sockets and Jacks are just some of the products of a company streamlined to serve world-wide industry today. Learn more about what Astralux can offer you. Write to us for descriptive literature.

Illustrated from left to right

- 1 Plug 316
- 2 Plug 406
- 3 Plug 235
- 4 Jack 84A
- 5 Plug 420
- 6 Jack 95A
- 7 Socket 626 with Hex. Nut
- 8 Plug 671
- 9 Socket 626
- 10 Plug Electrical 119
- 11 40-way Connector male and female

ASTRALUX dynamics limited

SPECIAL PRODUCTS DIVISION · NEW STREET · BRIGHTLINGSEA · COLCHESTER · ESSEX

Let Preformed dead ends take the load...

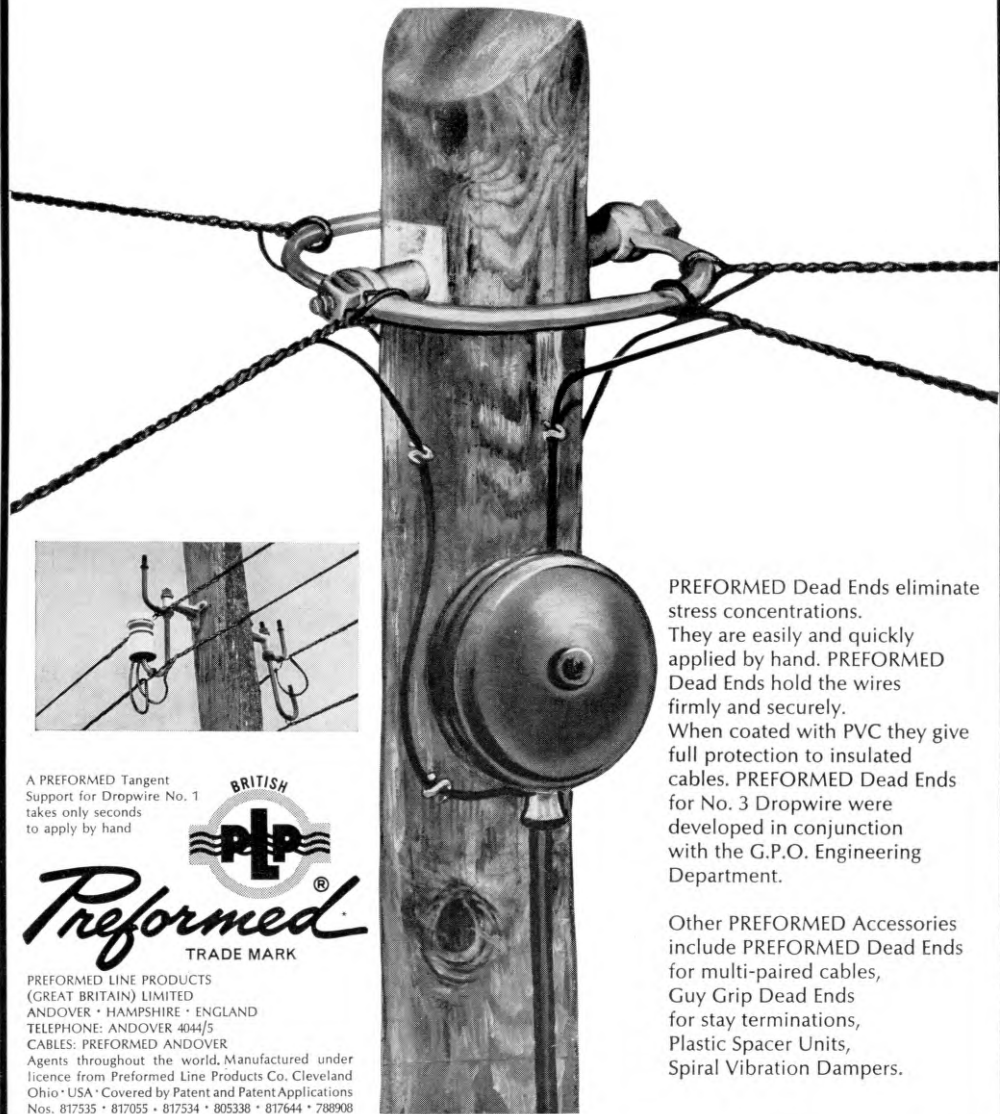

PREFORMED Dead Ends eliminate stress concentrations. They are easily and quickly applied by hand. PREFORMED Dead Ends hold the wires firmly and securely. When coated with PVC they give full protection to insulated cables. PREFORMED Dead Ends for No. 3 Dropwire were developed in conjunction with the G.P.O. Engineering Department.

Other PREFORMED Accessories include PREFORMED Dead Ends for multi-paired cables, Guy Grip Dead Ends for stay terminations, Plastic Spacer Units, Spiral Vibration Dampers.

A PREFORMED Tangent Support for Dropwire No. 1 takes only seconds to apply by hand



Preformed[®]
TRADE MARK

PREFORMED LINE PRODUCTS
(GREAT BRITAIN) LIMITED
ANDOVER • HAMPSHIRE • ENGLAND
TELEPHONE: ANDOVER 4044/5
CABLES: PREFORMED ANDOVER

Agents throughout the world. Manufactured under licence from Preformed Line Products Co. Cleveland Ohio • USA • Covered by Patent and Patent Applications Nos. 817535 • 817055 • 817534 • 805338 • 817644 • 788908

REX[®]

THE REED ELECTRONIC EXCHANGE
NO. 18 SYSTEM



**serves a
much greater
area in far less
space than a
conventional
exchange**

DESIGNED FOR UNRESTRICTED EXPANSION

By providing electronic common control of reed relay spatial switching, the REX system offers an extremely compact and reliable solution to both the switching and control problems of modern exchange design. The REX exchange has been developed by AEI to integrate smoothly with existing automatic networks its exceptional flexibility ensures full growth capacity

AEI

combines sophisticated electronics with building-block simplicity

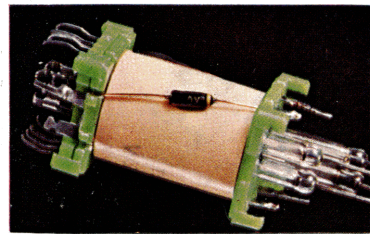

THE REX SWITCHING ELEMENT

The basis of the REX system is this reed relay crosspoint switching element. It contains only nine components, compared with 200 in a bimotional selector, and its very simplicity makes it uniquely reliable. It gives highest quality transmission paths with gold at the point of connection, requires no routine maintenance, generates no vibration and therefore no microphonic noise. There's nothing to wear out and it is sealed completely to be immune to interference by dust or atmospheric pollution.

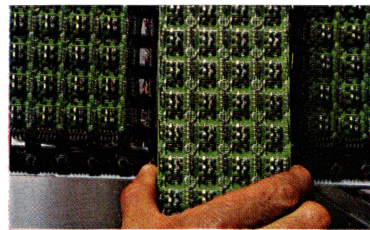

THE REX SWITCHING MATRIX

Since multiple wiring across the end-caps is inherent in the reed relay crosspoint design, switching matrices can be built up in any form simply by clipping reed relay crosspoints together. Matrices may be enlarged in any ordinate simply by the addition of rows and columns of reed relay crosspoints to cater for any switching requirements. This means that unlimited provision for the growth of lines and links is built into the REX system.

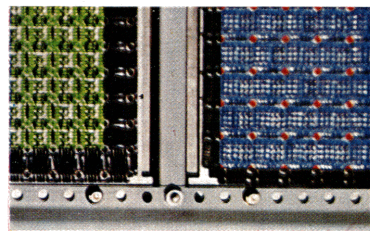

THE REX SWITCHING UNIT

Basic switching arrays (normally called sections) are built up out of matrices and assembled in parallel to form a REX switching unit. The number of sections supplied depends on the anticipated originating traffic per line. Typically, a 1000-line four-section unit would serve a community with an average calling rate of 150 call seconds per line in the busy hour; other calling rates can be accommodated by varying the number of sections.

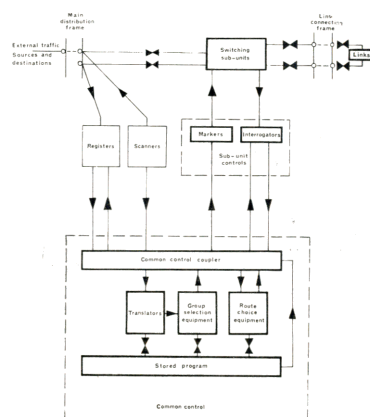

THE MULTI-UNIT REX EXCHANGE

Switching and linking arrangements are provided for all sections of each unit so that complete crosspoint path interconnection is made between all lines of the REX exchange. For purposes of service and simplicity of electronic control the units are divided into self-contained basic switching blocks termed 'sub-units'. Each sub-unit is linked only to adjacent sub-units, a linking pattern which provides for every traffic pattern and retains simplicity of control.

THE REX ELECTRONIC CONTROL

Closely related in its simplicity to the 'building block' structure of REX switching equipment, the REX electronic control system has three main areas of activity:

SCANNERS AND REGISTERS

These determine the source and final destination of a call.

MARKERS AND INTERROGATORS

Provided on a per-sub-unit basis, these controls are concerned with interrogating the state of crosspoint paths and marking these paths through the switching sub-units.

COMMON CONTROL

The control processes the necessary call setting data in accordance with instructions from the stored programme control in such a way that the calls are routed with maximum utilisation of the switching network.

serves a much greater area in far less space than a conventional exchange: every part accessible – every part replaceable!

The REX subscriber's line circuit tolerates substantially wider line conditions enabling a REX exchange to serve an area much larger than that of a conventional exchange, permitting big reductions in line plant investment.

AEI engineers have devised the entirely new Reed & Electronic Modular Apparatus practice (REMA) for the REX exchange providing completely compatible mounting of reed relays and electronic circuit components. Combined with a new sliding frame installation system, the REMA practice allows more than 20,000 lines of REX equipment to be accommodated in the space normally required by a 10,000 line electromechanical exchange. In existing buildings this means more space for future expansion: in new exchanges it makes possible great savings in construction and installation costs.

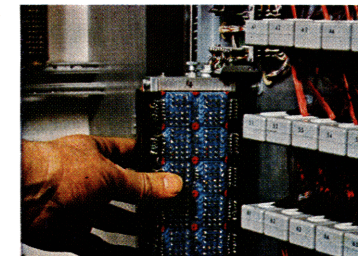
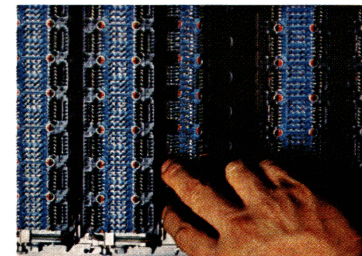
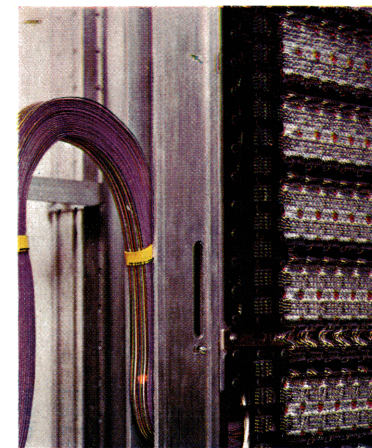
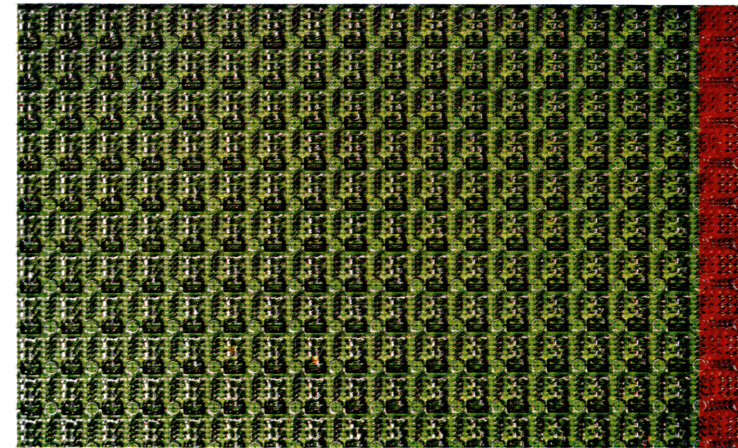

(TOP LEFT) Part of a cross-point switching frame also showing associated electronic modules.

(TOP RIGHT) A sub frame withdrawn for inspection showing the method of tape wiring.

(AT LEFT) Electronic modules can be arranged to revolve horizontally or swing down for inspection and maintenance.

(BOTTOM LEFT) Terminal wafers may be easily withdrawn from the main block to reveal circuit components mounted within the wafer.

(BOTTOM RIGHT) Frame assembly illustrating the wiring gutters used to accommodate the tape wiring.

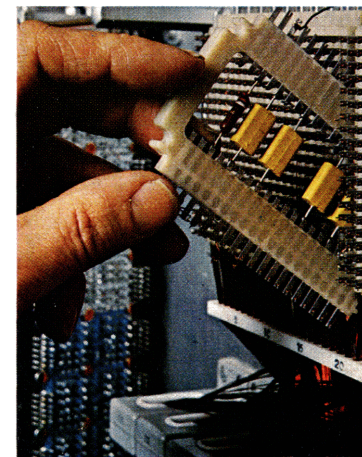

checks and reports on its own performance **automatically!**

The high-speed electronic control system is programmed to provide complete self-checking and reporting facilities for maintenance purposes. A prototype reed electronic exchange supplied to the BPO at Leighton Buzzard has been designed for completely unattended operation and can report all servicing requirements to a remote maintenance control centre.

Exhaustive circuit design and testing during the development period, and replication of important items of equipment, enables a high degree of security of service to be offered.

FUTURE FACILITIES

The basic design permits the provision of all future switching facilities likely to be required by a modern telecommunications network, including abbreviated dialling and subscribers' automatic transfer, together with all current standard features such as data for automatic message accounting. A stored programme control is provided to expedite inclusion of these facilities.

REX — A SUMMARY

The exchange employs electronic common control of reed relay spatial switching arrays providing sealed precious metal contacts in the speech-path. The electronic control is simple in design and provides economic high-speed operation readily adaptable to provide expanded service and facilities.

Full security of service has been achieved in the system by exhaustive testing in the design stage, coupled with the multiple provision (with automatic changeover) of the vital control functions. At the same time REX offers dramatic savings in floor space with consequent reduction in the building capacity required for present switching systems in multi-exchange urban areas. The system is completely flexible to allow for the extension of lines and traffic growth. It requires minimal maintenance which is simple and largely automatic.

INFORMATION SERVICE FOR ADMINISTRATIONS

AEI Telecommunications Group can supply technical information on detailed aspects of REX which will be of interest to experts in the field of automatic telephony. In addition, courses of technical lectures have been prepared, together with detailed lecture notes, and AEI would welcome invitations for a team of lecturers to be sent to provide, for the engineering staff of interested Administrations, a short introductory course on the principles of the REX system. Later, more detailed courses could be arranged for an Administration's key personnel in our UK factories, and detailed on-site instruction would be provided during the actual installation of REX exchanges. AEI are also prepared to consider setting up and staffing training schools in those territories where it is proposed to standardise on reed-electronic exchange switching equipment. Please write for fully illustrated REX brochure.



Vital links in the international telecommunity

At the Goonhilly satellite station in Cornwall, international take-off point for communication via satellite, G.E.C. (Telecommunications) Ltd. has supplied the 6 000 Mc/s transmitter units which provide the drive for the 8kW amplifier unit, also supplied by G.E.C. From Goonhilly, the TV and telephony signals received via satellite are transmitted through an extensive national network of microwave radio routes in which equipment supplied by the company provides vital links. Looking ahead in space-age research, G.E.C. (Telecommunications) Ltd. is supplying equipment for the power supplies for U.K. III, the first all-British satellite. On earth and in space, G.E.C. (Telecommunications) Ltd. supplies the vital links that shape the international telecommunity in more than 60 countries in the world.



G.E.C.

Takes telecommunications into tomorrow

G.E.C. (Telecommunications) Ltd.
Telephone Works, Coventry, England

Serving a growing telecommunity

A £1½ million contract for automatic telephone exchange equipment for the Hong Kong Telephone Company Limited is the latest stage in the long and close association of G.E.C. with the planned development of the Hong Kong telephone network. G.E.C. is supplying equipment for six new exchanges and for a substantial expansion to a seventh. The largest, at rapidly developing Wong Tai Sin will be equipped initially to serve 30,000 subscribers, but with the provision for expansion to 100,000 which will make it one of the largest automatic telephone exchanges in the world. The other exchanges vary in size from 200 to 10,000 lines, and in all cases provide for substantial expansion to meet the anticipated growth of this expanding telecommunity. The total number of lines now installed or on order is over 400,000. More than half of these have been installed in the past five years. Nearly threequarters of the exchange equipment has been supplied by G.E.C. Further outlook: over a million lines by 1980.

MEETING ADEN'S NEEDS—FOR TODAY AND TOMORROW

G.E.C. equipment has been supplied for all the five exchanges which make up Aden's comprehensive telephone network. They include the new Crater automatic exchange, equipped initially with 2000 lines with provision for expansion to 5000 lines, put into service last April. In addition, G.E.C. equipment will be used in an expansion to Little Aden exchange, and in the new exchange at Al Mansoura (which replaces an automatic exchange supplied by G.E.C. a quarter of a century ago).

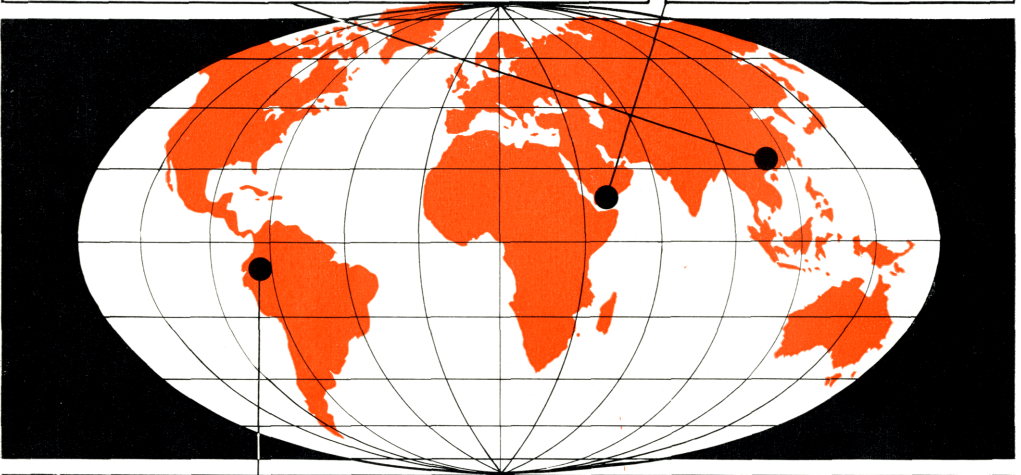

EXCHANGE EXPANSION IN COLOMBIA

Latest stage in the close association of G.E.C. with the growth of the Cali telephone network in Colombia is an order for the supply of 6000 lines of telephone exchange equipment to extend existing G.E.C. exchanges in the city. This follows orders for 14,500 lines received since 1963. Altogether G.E.C. has supplied or has orders for 47,000 lines of equipment for Cali. In addition, G.E.C. are supplying 7000 "G.E.C. 706" type telephones.

G.E.C.

**Takes telecommunications
into tomorrow**



Three-way co-operation behind cordless P.A.B.X. for Nigerian Railways H.Q.

The latest PB4200 "cordless" P.A.B.X. has been installed at the headquarters of the Nigerian Railway Corporation at Ebute-Metta, Lagos. Initial capacity is 60 exchange lines and 600 extension lines. Half the extension line circuits have full P.A.B.X. facilities, while the others are barred all access to the operator or public exchange. The operators connect circuits have full availability access to the exchange lines. The use of the keysenders on the three cordless manual consoles greatly speeds the extension of incoming traffic. Paging assistance circuits and conference equipment are among the special facilities provided. Expansion to 800 extension lines, with provision for selective route restriction equipment to limit access to the subscriber trunk dialling network, is already being studied. This equipment, planned to meet present and future needs, was supplied by G.E.C. in conjunction with G.E.C. (Telecommunications) Nigeria Ltd. and installed and maintained by the Nigerian Railway Corporation technicians—a three-way co-operative exercise in international telecommunity.

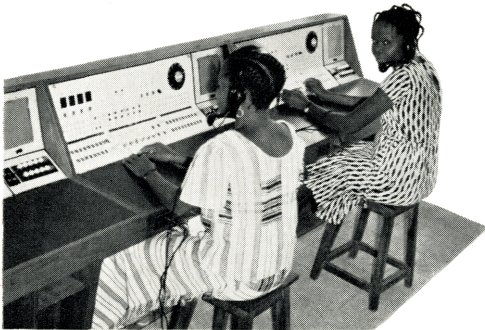

Making the most of existing junction cable routes



Increasing the capacity of existing junction routes is now an economic proposition thanks to the new G.E.C. 24-circuit Pulse Code Modulation Equipment type SPO1800. 24 high-quality 300c/s—3400c/s speech circuits with signalling facilities can be provided over two pairs of an audio cable.



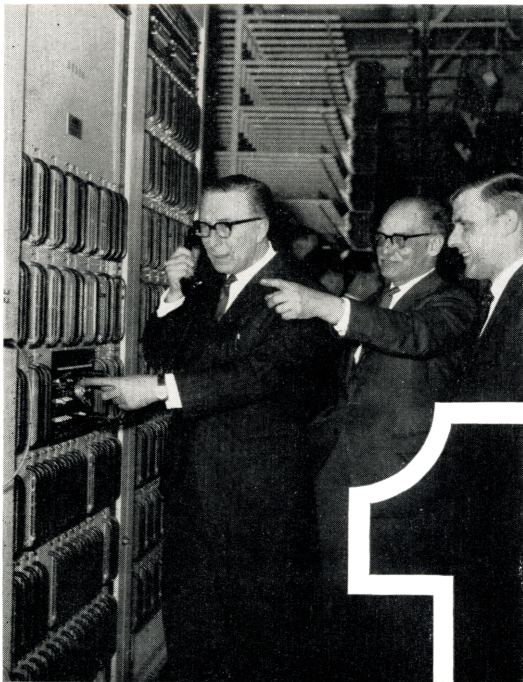

Mr. J. A. Lawrence, Senior Staff Engineer T.P.E. Branch of the G.P.O. tries out the electronic exchange equipment at Leamington Spa following its switch into public service.

1 2-3

Treble first in electronic exchanges

The first fully-operational electronic telephone exchange in the United Kingdom was supplied to the British Post Office by G.E.C. (Telecommunications) Limited. It has recently completed 12-months public service at Leamington Spa in the heart of England. During this time, nearly one million successful calls have been made. There have been only two significant faults in the electronic equipment; both were automatically detected and neither caused any degradation of service to the subscribers. This exchange has been developed by G.E.C. (Telecommunications) Limited under the auspices of the Joint Electronic Research Committee (J.E.R.C.) which comprises the G.P.O. and the British Telephone Industry.

The first electronic exchanges to go into public service in Scotland and Wales are to be supplied by G.E.C. for installation at Bishopton near Glasgow and at Llanwern near Newport. It is expected that installation will begin in 1967.

This treble first in the practical application of electronic exchanges will enable G.E.C. to set the pace in making them available to Telephone Administrations in many different parts of the world.

G.E.C.

Takes telecommunications into tomorrow



Smart simplicity is the keynote for the new G.E.C. Sonic 70 telephone

Smart modern lines make the new G.E.C. SONIC 70 telephone part of tomorrow's telecommunications. The simplicity of circuit design enables a considerable reduction in unit cost to be achieved, yet there is no loss of performance, with the result that this handsome new instrument fulfils the promise of its smart appearance. It is available in black, white, two-tone green and two-tone grey.



Pushbutton Progress

G.E.C. pushbutton telephones and associated exchange equipment have been chosen for Britain's first public field trial of pushbutton dialling using high-speed multi-frequency signalling. The G.E.C. pushbutton telephones enable even the longest S.T.D. code to be transmitted in much less time than it would take to dial. The subscriber can transmit the number as fast as he can think, therefore the possibility of 'dialling' errors is reduced to a minimum.



Long, long link

It's more than a thousand miles from Arica, in the northern zone of Chile, to Santiago, the capital. In terms of the 2876 route miles involved, the new \$3½ million microwave radio network being supplied by G.E.C. (Telecommunications) Ltd. will traverse more than double the direct distance, including difficult and remote terrain where access to unattended repeater stations will be a problem.

Here, the improved reliability and reduced power consumption of the G.E.C. family of completely semi-conducted systems will be particularly important.

In the planning of the nation-wide microwave network, a whole range of newly developed systems, in none of which is a single tube used, has been applied.

- * A broadband 2000 Mc/s system conveying either 960 speech circuits or TV.
- * A narrow band 2000 Mc/s system conveying up to 60 speech circuits.
- * A broadband 7500 Mc/s system conveying 300 speech circuits.
- * 5 and 12 circuit systems in the V.H.F. and lower U.H.F. frequency bands.

G.E.C. transmission equipment, including the new G.E.C. range of completely semi-conducted microwave radio equipment, is in use in many other parts of the world. In Europe, Africa, the Middle East, the Far East, Australasia, and the Americas, G.E.C. transmission equipment, of high and low capacity, is meeting the growing needs of the international telecommunity.



G.E.C.

**Takes telecommunications
into tomorrow**

G.E.C. (Telecommunications) Ltd.
Telephone Works, Coventry, England

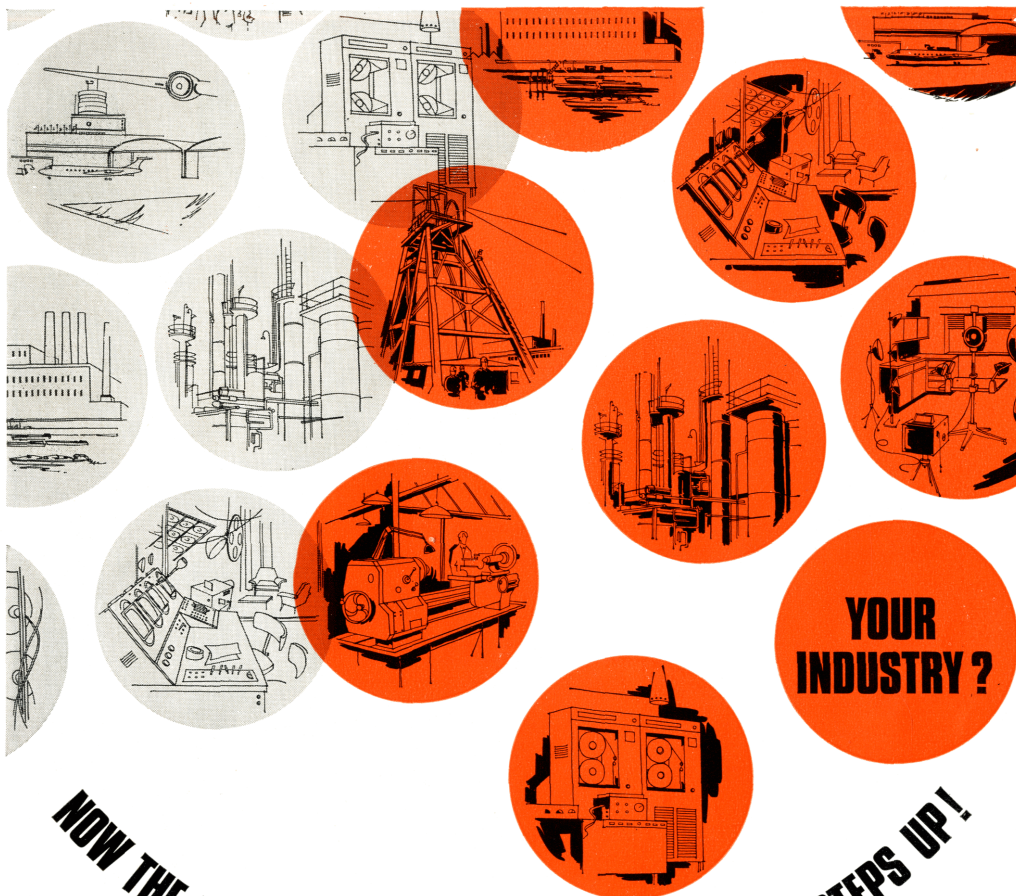

**YOUR
INDUSTRY ?**

NOW THE BIG SWING TO ASTRALUX V.S.T. REALLY STEPS UP!

Everywhere Astralux Voltage Stabilising Transformers outperform and outdate conventional C.V.T. systems

HERE'S WHY ASTRALUX V.S.T. IS REPLACING C.V.T. IN INDUSTRY AFTER INDUSTRY:

Better Performance. That means improved Output Voltage Stability—output voltage maintained within $\pm 0.5\%$ for input voltage changes of $+10\%$ — 20% . Even when the voltage fluctuation is as great as $+10\%$ to -30% the V.S.T. will maintain the output voltage to within $\pm 1\%$. ● **Latest Materials.** High temperature (Class F) materials give optimum reliability and increased safety margins on operating temperatures. ● **Low external field** The latest techniques in magnetic core design give improved performance, coupled with high efficiency, while still offering low external fields. ● **Stable Voltage—Stable Prices.**

ASTRALUX prices remain stable over long periods, so costing a job ahead is facilitated with this advanced system.

● **Over 10,000 models!** The ASTRALUX V.S.T. Standard Range consists of ten basic models with over a thousand variations on each. *No other manufacturer* offers such a choice, or can offer such economical prices. ● **Low Cost Specials.** You can order V.S.T. 'specials' at little more than the cost of standard units. Our design department will be happy to prepare prototypes to your specification, for incorporation into equipment under development. Free illustrated booklet giving full details of ASTRALUX V.S.T. from

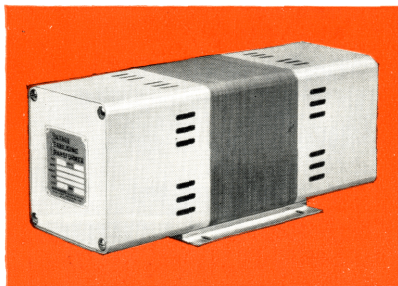

ASTRALUX dynamics limited

TRANSFORMER DIVISION • BRIGHTLINGSEA • COLCHESTER • ESSEX • TELEPHONE: BRIGHTLINGSEA 417.

FIXED CAPACITORS

A wide range, to suit practically every application, is listed in our Catalogue. Types included are:-

- Silvered Mica
- Ceramic (including Disc, Tubular and lead-through patterns)
- Foil and Paper
- Metallised Paper and Polyester
- Electrolytic (a great variety)

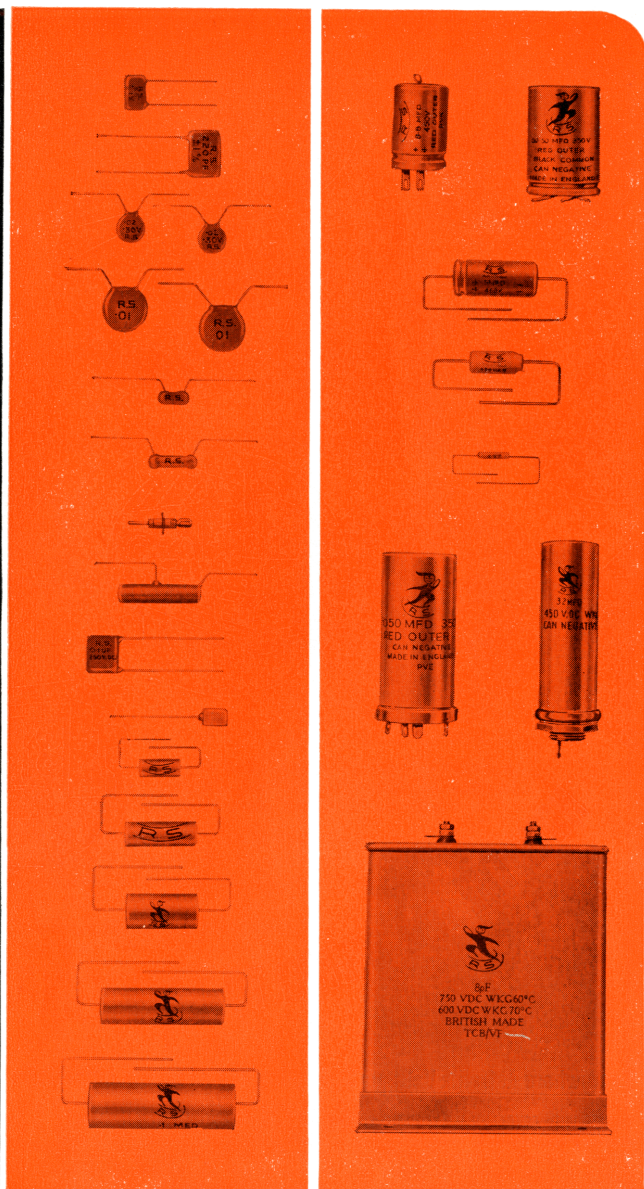

Radiospares Ltd

4/8 Maple Street, London, W.1.

'Phone: EUSton 7232 (8 lines) Telegrams & Cables: Radosperes, London, W.1.



ONE CABLE... BUT A THOUSAND VOICES!

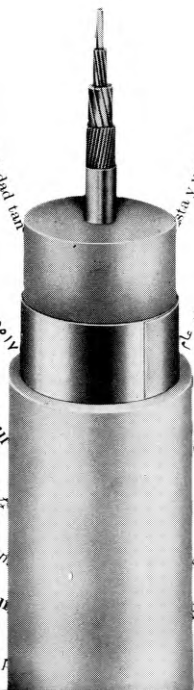

The first submarine cable, laid between England and France in 1891, provided one or two speech circuits. The Atlantic telephone cable system of 1956 provided thirty-six circuits.

Submarine Cables Ltd. can now supply a submarine telephone cable system with transistorised submerged repeaters capable of handling up to 640 simultaneous conversations. Five systems of this type equipped for 480 circuits and with AEI terminal equipment, also fully transistorised, are

on order for installation in the North Sea, Baltic and English Channel in 1966-7. Such systems are suitable for ocean, coastal and inter-island routes—wherever, in fact, trade demands reliable communications.

Submarine Cables Ltd
owned jointly by AEI and BICC
Greenwich London S.E.10 England

AEI equipment at Hong Kong's SEACOM terminal

'TRANSLATES' UP TO EIGHTY CONVERSATIONS AT A TIME!



AEI terminal equipment enables up to eighty conversations to be transmitted along the SEACOM cable simultaneously. This is done by 'translating' each speech channel to a different frequency and placing them side by side to form a band of frequencies suitable for transmission along the cable. To maintain signal strength this band is amplified by repeaters placed at points along the underwater cable. At the receiving end the band is separated into individual speech channels which are then switched to their receiving telephones. This merging and diverging process is carried on automatically in both directions at the same time! Special test signals are sent

through the equipment and cable from each end and are constantly monitored at the receiving end. If a fault is detected, an alarm is given and the standby equipment is automatically switched in. This equipment is then monitored in the same way.

AEI have supplied equipment for all stages of the SEACOM project - installing over three hundred racksides of operating, test and monitoring plant.

Submarine Cables Limited (jointly owned by AEI and BICC) supplied a number of the repeaters and most of the lightweight cable for the SEACOM project.

AEI
TELECOMMUNICATIONS

TRANSMISSION & CONTROL SYSTEMS DEPARTMENT
Woolwich, London SE18.

WHITELEY

Epoxy Resin Mouldings

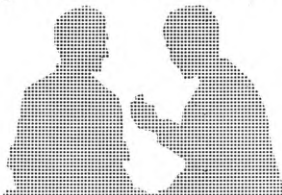

Great mechanical strength, excellent electrical insulation and complete climatic protection are ensured in Whiteley Epoxy Resin mouldings. Low shrinkage and strong adhesion to components and leads renders these Resins particularly suitable for encapsulation. Full details will be gladly sent on request.



Line Isolating Transformer

Transformer 395A—1 is a low loss audio frequency transformer, for use as an isolating transformer on circuits employing 17 c/s signalling, i.e. Post Office telephones. The insulation of the 'line' winding provides isolation against voltage surges of up to 25 KV rms. and continuously applied voltages of 14 KV rms. Please write for full details.

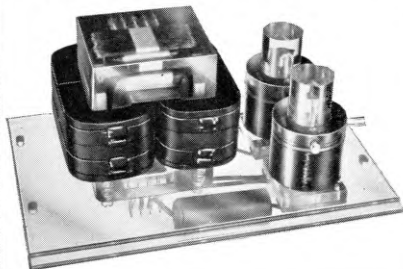

WHITELEY ELECTRICAL RADIO CO LTD

MANSFIELD · NOTTS Tel: Mansfield 1762/5

ADCOLA SOLDERING
EQUIPMENT
PRODUCTS LIMITED
(Regd Trade Mark)

FOR
TOTAL EFFICIENCY

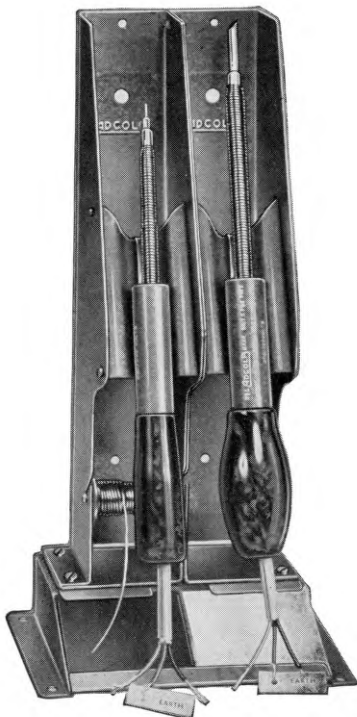

FOR CATALOGUES APPLY DIRECT TO SALES DEPT

ADCOLA PRODUCTS LTD.

ADCOLA HOUSE

GAUDEN ROAD

LONDON, S.W.4

Telephone: MACAULAY 0291/3

Telegrams: SOLJOINT, LONDON S.W.4

Marconi Self-Tuning H.F System
—the first in the world to be station
planned from input to output



breakthrough

MST 7½ kW transmitter H1100 series

An h.f linear amplifier transmitter for high-grade telecommunications.

Frequency range: H1100 and H1101, 4—27.5 Mc/s

H1102 and H1103, 2—27.5 Mc/s

Output power: 7—8 kW p.e.p, 5—6 kW c.w.

The H1100 series meets all CCIR Recommendations.

saves 85% floor space

Transmitters can be mounted side by side and back to back or against a wall; built-in cooling fan; no external air-ducts. These features lead to smaller, simpler, cheaper buildings or more services in existing buildings.

simplicity

R.F circuits have only three tuning controls and two range switches. Final valve can be replaced in 30 seconds. Miniature circuit breakers (used instead of fuses throughout) can be reset instantly. All sub-assemblies are easily tested because they are electrically complete units.

rugged reliability

Stainless steel shafts in ball-bearings in rigid machined castings; stainless steel spur gears meshing with silicon bronze; heavy r.f coil contacts with high contact pressure—some examples of design features giving long term endurance and operational reliability. Specified performance achieved with ample margins.

self-tuning

Types H1101 and H1103, used with MST drive equipment, give *one-man* control of an entire transmitting station and continuous automatic aerial loading.

MANUAL TUNING

Manually tuned versions, types H1100 and H1102, are available which, when fitted with built-in drive units, become entirely self-contained transmitters for four spot frequencies and all types of modulation.

Manual tuning takes less than 60 seconds.

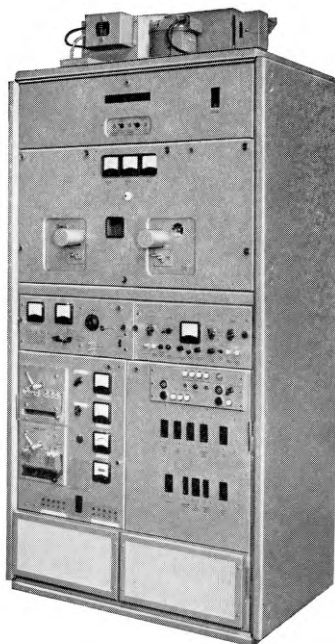

Marconi telecommunications systems

DENSO Mastic isn't much to look at, BUT!!



—it's not meant to be pretty. It's the PRACTICAL aspects—ease of application, durability, mouldability, gas-proofing and water-proofing properties—that ensure its constant use by Gas, Water and Electrical Authorities, Civil and Structural Engineers the world over.

The picture shows DENSO Mastic being applied to a large pipe coupling to provide a regular contour for overwrapping with DENSO Anti-Corrosion Tape but it is equally useful for sealing service entries, plugging spare ducts, filling joint boxes etc.

Complete the coupon below and send to us to see how DENSO Mastic can ease your particular problems.

Please send me without obligation the following literature: (tick where required)

Denso Mastics and Compounds <input type="checkbox"/>	Denso for the Electrical Industry <input type="checkbox"/>
Denso for the Building Trade <input type="checkbox"/>	Denso protection for Structural Steelwork <input type="checkbox"/>
Denso for the Plumber, Builder, Electrician & Maintenance Engineer <input type="checkbox"/>	

NAME

ADDRESS

P.O.1.

WINN & COALES LTD.

Denso House, Chapel Road, London, S.E.27. Tel: GIPsy Hill 7511
Also at Manchester, Belfast and Dublin. Denso Agents throughout the world.

Filters/ Networks Service

Offers deliveries as short as 2 months for design and supply of small quantities.

Offers extensive design facilities, including computer programmes, for frequency filters, attenuation equalizers, delay equalizers.

Fields of application include carrier telephony, telegraphy, and data transmission.

Please write, giving full technical specifications or for pamphlet 1232/PJ to:
Barr and Stroud Ltd.,
Annesland,
Glasgow, W.3.
Tel: Jordanhill 9601
Telex: 778114

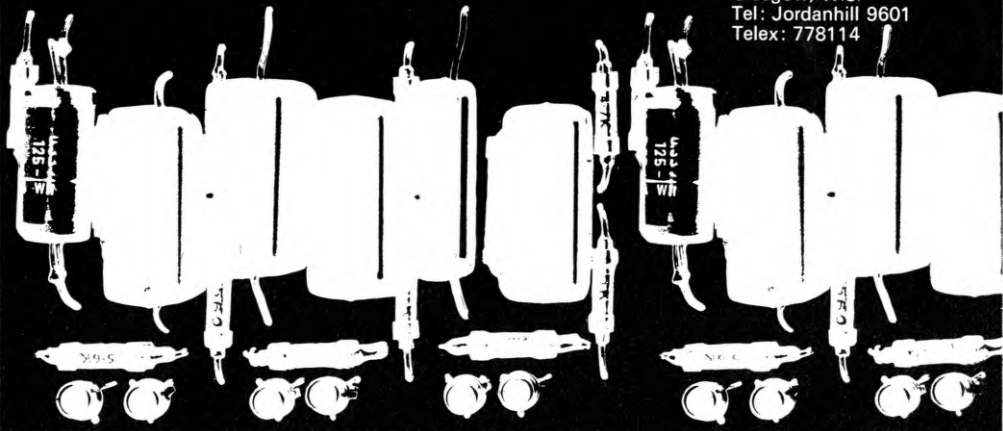

London Office: 1 Pall Mall East, S.W.1. Tel: Whitehall 1541. Telex: 261977

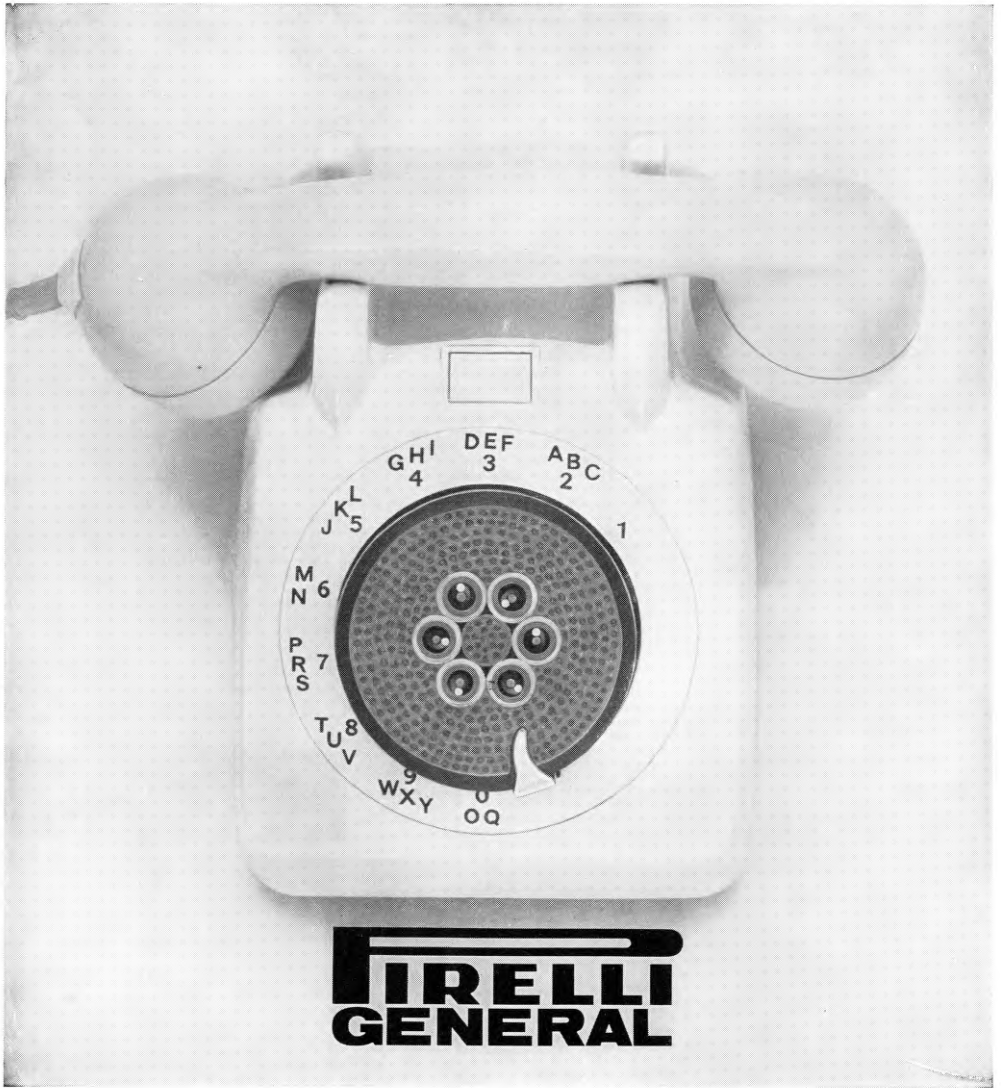

TELECOMMUNICATIONS CABLES

Pirelli General are in a position to advise on complete Telecommunications schemes and are organised to manufacture and install cables for distribution and trunk services; also carrier and all types of coaxial cables.

Pirelli General also manufacture cables to meet special requirements of Public Utilities or of industry.

Barbs

Oxley P.T.F.E. 'Barb' Insulators, Plugs and sockets are unequalled for their electrical and mechanical performance and their sheer ease of assembly into plain holes. The Terminal sizes range from the Sub-Miniature 062—to the larger 250 range.

Write for technical details of Oxley products

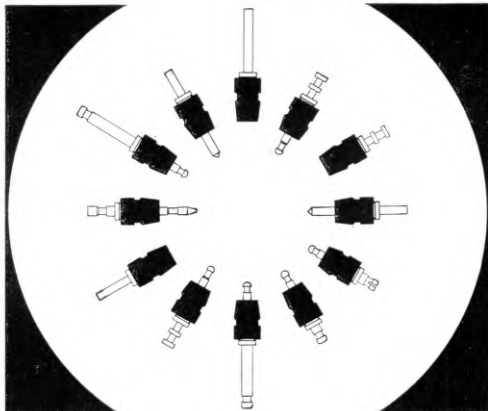

OXLEY
DEVELOPMENTS
COMPANY LTD.

ULVERSTON,
LANCASHIRE,
ENGLAND

Tel: ULVERSTON 2567
Cables:
OXLEY ULVERSTON

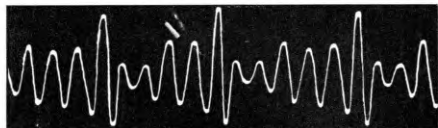

Telecommunication Principles

R. N. Renton

This book contains all the basic essential details of electricity and magnetism required by every student of telephony, telegraphy or radio (including television). The emphasis of the book is always on fundamental principles—a useful feature being the worked examples that appear throughout to demonstrate the application of these principles to the calculations needed in practice. Now in its third edition, the book fully covers the revised City and Guilds Syllabus.

50s net *new third edition*

available from all bookshops

Pitman Parker Street London WC2

Insuloid

Insulok System

THE SIMPLEST, MOST ECONOMICAL,
MOST EFFECTIVE CABLE BINDING
SYSTEM.

New
LK2A Tie
in 10" lengths
for greater
cable
capacity

The Insulok Cable Tie utilises one component. Moulded from tough, flexible nylon it is immensely strong and virtually indestructible. Taking only seconds to fix, the Insulok Tie features a unique, non-return cam-action locking device which ensures that once fixed the tie will never come off or slacken.

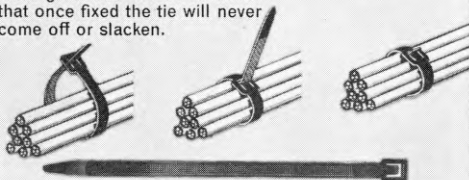

INSULOK LK CRADLE

for use with LK1, LK2, LK2A & LK3 Cable Ties

The Insulok Cradle—LKC—provides an anchorage for use with the Insulok Cable Ties. It provides a $\frac{3}{8}$ " clearance between the panel and cables, therefore being suitable for tropical or high humidity conditions. Moulded in tough nylon to withstand temperatures varying from -80°C to $+150^{\circ}\text{C}$, INSULOK LK Cradles provide maximum security in all climatic conditions. Colour Black.

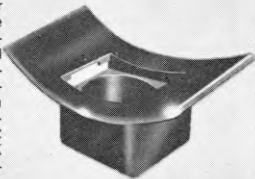

INSULOK TIE GUIDE



Made from extremely strong P.V.C., this very handy accessory is designed to slip smoothly between and under cable runs, permitting the easy insertion of the Insulok Cable Ties even in the most confined positions. The recessed channel guides the Cable Ties quickly and easily around any size of cable run.

Insuloid

WIRING SYSTEM SPECIALISTS

Full details of the Insulok Cable Tie system and many other cable fixing devices are contained in the Insuloid Catalogue available on request to:

INSULOID MANUFACTURING CO. LIMITED.

Sharston Works, Leeston Road, Wythenshawe, Manchester, England.
Tel: WYThenshawe 5415-7-7 Grams: Insuloid Manchester Telex: 66657

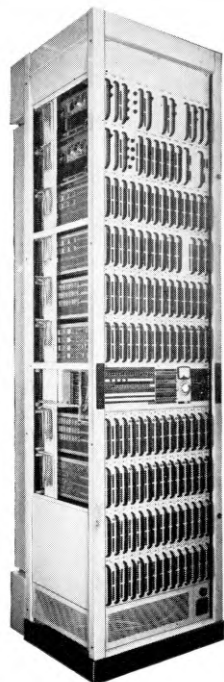
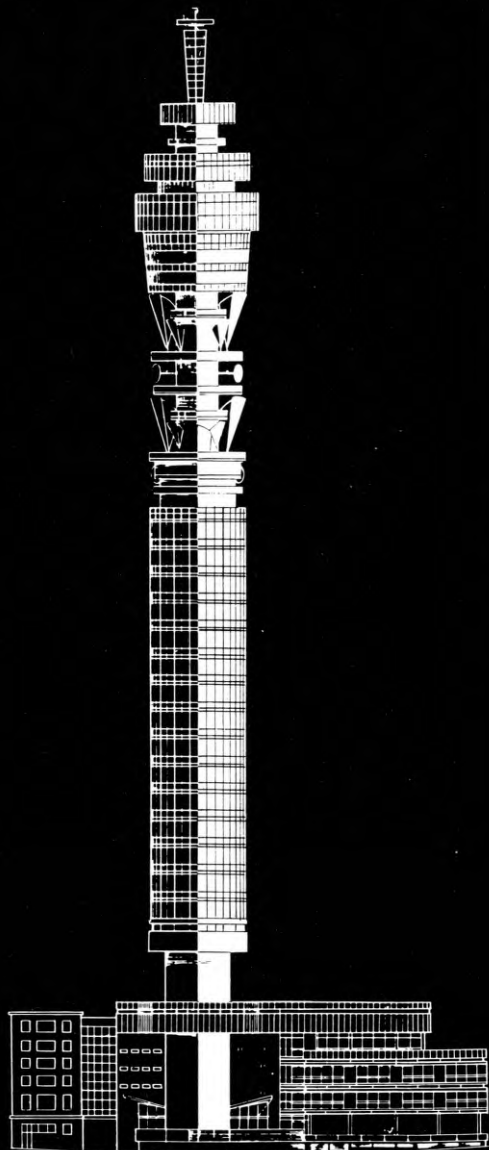

Incoming Register Translator

The Trunk Switching Equipment is controlled electronically by the Ferrite-Core and Transistor Register Translator developed by E.T.L. for this and similar applications. Housed in units based on an equipment practice of the company's design, it occupies approximately one sixth of the floor area of an electromechanical equivalent. In addition it offers potentially much greater reliability and flexibility in use.

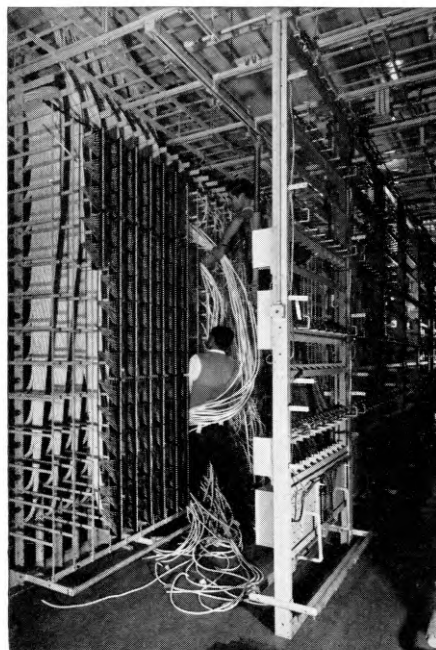

Cabling in progress

Mercury exchange utilises nearly 1,000 racks which provide accommodation for 11,000 relay sets and more than 10,500 selectors together with ancillary equipment and covers a floor area of nearly one acre. Over 15,000 incoming trunks and outgoing junctions are terminated at the Main Distribution Frames. From here calls go out to the exchanges in the London Director Network. Also part of this mammoth enterprise is a local tandem exchange which replaces one installed by the company well over twenty years ago.

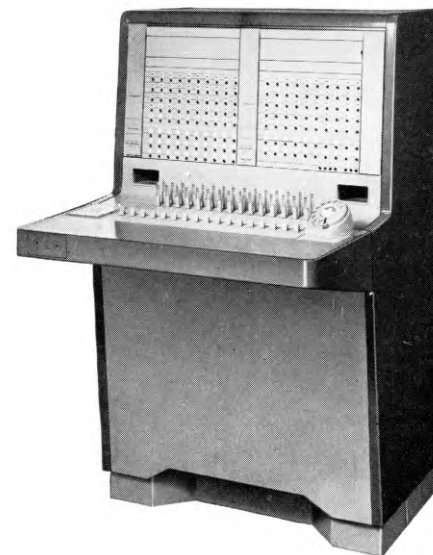

Floor Pattern Lamp Signalling PMBX

The first of its type to go into service, this compact switchboard now being installed in the Howland Street building incorporates many new features among which are automatic ringing and automatic holding of exchange calls, 'jack-in' relay sets and individually removable jacks. This design will form the basis of the new standard B.P.O. PMBX.

MERCURY

the largest exchange order of its type ever awarded by the B.P.O. to a single manufacturer

A further E.T.L. contribution to Britain's S.T.D. network is the recent installation of Mercury Trunk Exchange in the Tower Building, Howland Street, London. Developed in conjunction with the B.P.O. and now operational, this exchange will serve as a master switching centre for the increasing volume of trunk telephone traffic entering London via the massive micro-wave tower. As the largest installation of its kind in the world, this undertaking represents further evidence of E.T.L.'s leading position in the field of telecommunications.

Plessey Telecommunications Group

ERICSSON TELEPHONES LIMITED • ETELCO LIMITED

Head Office & Main Works: Beeston · Nottingham · Tel: Nottm. 254831 · Telex 37666
Registered Office: 22 Lincoln's Inn Fields · London · WC2 · Tel: HOLborn 6936





for quick, easy faultless soldering

Leading telephone and equipment manufacturers in Great Britain use Ersin Multicore Solder for reliability.

Ersin Multicore Solder is made in Europe's largest cored solder factory and contains only the purest tin and lead plus five cores of extra active non-corrosive Ersin flux.

You will find there is an Ersin Multicore Solder exactly suited to your purpose, whether it is the rapid soldering of miniature components by a production soldering process, or the individual production of large units of equipment such as fully transistorised submersible repeaters. Alloy, diameter of the solder, type and percentage of flux in the solder are all points to be considered.

The best is the most economical

The life and reputation of any piece of electronic equipment can rest entirely on the solder used in the assembly, a minute fraction of its cost. That is why the finest, most dependable cored solder is always the most economical and the best. Ersin Multicore is the most widely used cored solder in Britain and is exported to over 50 countries.

Savbit Alloy

Ersin Multicore Savbit Alloy is specially made to overcome the rapid pitting and wear of soldering iron bits. A precise amount of copper is added to prevent the copper of the soldering iron bit being absorbed into the solder alloy: this eliminates the need for frequent resurfacing of the bit, whose life is prolonged up to ten times. Because the soldering iron bit is kept in good condition soldering speed and efficiency are increased.

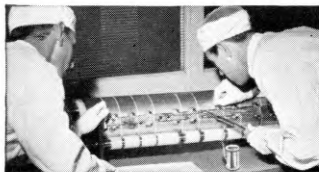

Ersin Multicore Solder is shown being used at the Erith factory of Submarine Cables Ltd., in the production of a submersible repeater designed to last for a minimum of 20 years under the sea without attention.

THERE IS AN ERSIN MULTICORE SOLDER FOR EVERY PURPOSE WHERE PRECISION SOLDERING IS REQUIRED

Engineers and technicians are invited to write on their Company's letter heading for the completely revised 6th Edition of the 24-page booklet "MODERN SOLDERS" containing data on melting points, gauges, alloys, etc.

MULTICORE SOLDERS LTD.

Maylands Ave., Hemel Hempstead, Herts. (Hemel Hempstead 3636)

MI1

LUSTRAPHONE

Equipment

wherever better standards are required
for **SOUND COMMUNICATION**
MICROPHONES and all their accessories
"RADIOMIC" SYSTEMS
PORTABLE P/A SYSTEMS with or without
"Radiomic"
NOISE CANCELLING INTERCOM-
SYSTEMS
AUDIO EQUIPMENT
ACCESSORIES-COMPONENTS-FITMENTS

LUSTRAPHONE

OUTSTANDING IN QUALITY AND PERFORMANCE
BRITISH IN DESIGN AND MATERIALS

LUSTRAPHONE LTD.

St. George's Works, Regent's Park Road,
London, N.W.1 Telephone: PR1mrose 8844

VALUABLE FREE BOOK

**Tells You How to Pass Your C. & C.
Examination at First Attempt!**

All Post Office personnel who are anxious to obtain early promotion should at once send for a copy of our handbook "ENGINEERING OPPORTUNITIES" which, among other intensely interesting matter, describes our unique methods of preparation for the **CITY AND GUILDS EXAMINATIONS** for the **Telecommunication Technicians' Certificate** and for individual subjects—**Mathematics, Engineering Science, Engineering Drawing, Elementary Telecommunication Practice, Telecommunication Principles, Radio and Line Transmission, Telegraphy and Telephony, Line Plant Practice**. It also contains details of our courses covering the G.C.E. subjects required for promotion to Assistant Engineer, Telecommunication Traffic Superintendent and other grades; and the City and Guilds examinations in **Electrical Engineering Practice, the A.M.I.E.R.E. and A.M.S.E. Examinations**, in addition to a wide range of non-examination courses in all branches of engineering—**Radio and Electronics, Electrical, Mechanical, etc.**

We also provide tuition for the Radio Amateurs' Examination and the P.M.G. Certificates for Radio Operators, with or without Morse training. Details are given in the handbook.

**On "SATISFACTION OR
REFUND OF FEE" terms**

If you intend to make the most of today's opportunities, you cannot afford to miss reading "ENGINEERING OPPORTUNITIES." It tells you everything you want to know to secure advancement, and describes many opportunities you may now be missing through lack of information. Send for your copy today—**FREE** and without obligation.



**BRITISH INSTITUTE
OF ENGINEERING TECHNOLOGY
727 COLLEGE HOUSE,
29-31 WRIGHT'S LANE, LONDON, W.8**

BIET

CATT/ANI a completely automatic account-recording system at a highly competitive cost!



CUSTOM BUILT BY AEI FOR DDD

The CATT/ANI system provides a punched tape record of all the information needed for DDD recording and accounting.

The CATT equipment has been specially designed by AEI for the North American long distance calling system and, together with the ANI system, fulfills all DDD specifications. This high grade AEI package takes up minimum space, is extremely flexible and fully compatible with existing telephone exchange and machine accounting equipment.

CATT/ANI systems can be supplied as a complete package or in individual units. Prices are highly competitive—in fact ANI costs less than any other comparable equipment.

CATT Centralised Automatic Toll Ticketing

Suitable for all types of national, regional and local Toll Switching centres, CATT handles all DDD routing functions and works with any Register/Translator equipment where operator or toll dialling facilities already exist.

Supplied with DC or MF outpulsing to suit local conditions and to provide remote operation by CSP routing machine where

required. Person-to-person, collect calls etc., can be checked by routing to a manual operator with automatic sending under the operator's control if required. A full Sender/Tabulator/Translator common control gives maximum equipment economy and security.

ANI Automatic Number Identification

ANI is an inexpensive high speed system using DC to avoid interference with telephone exchange operation. Self-checking and fault printout facilities are included and the system is fully protected against misoperation by outside agencies. No special power or tone sources are required and MF or DC loop outpulsing can be arranged to suit all destination signalling conditions. (Individual sets of transistor oscillators are supplied in each ANI Register.)

For full technical details, please contact

AEI
TELECOMMUNICATIONS

Woolwich, London S.E.18.

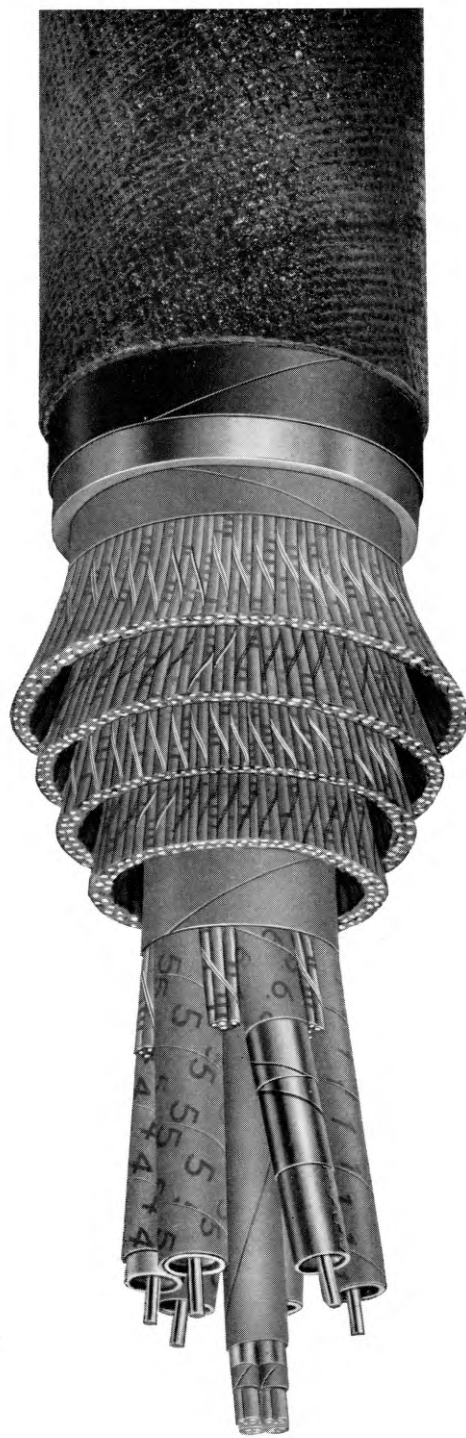

◀ TYPE 174 AND TYPE 375 COAXIAL CABLE

For television circuits and multichannel telephony, BICC manufacture cables containing coaxial pairs meeting the C.C.I.T.T. recommendations. These can be combined with symmetrical pairs for audio frequency or short-haul carrier circuits.

BICC

BRITISH INSULATED CALLENDER'S CABLES LIMITED

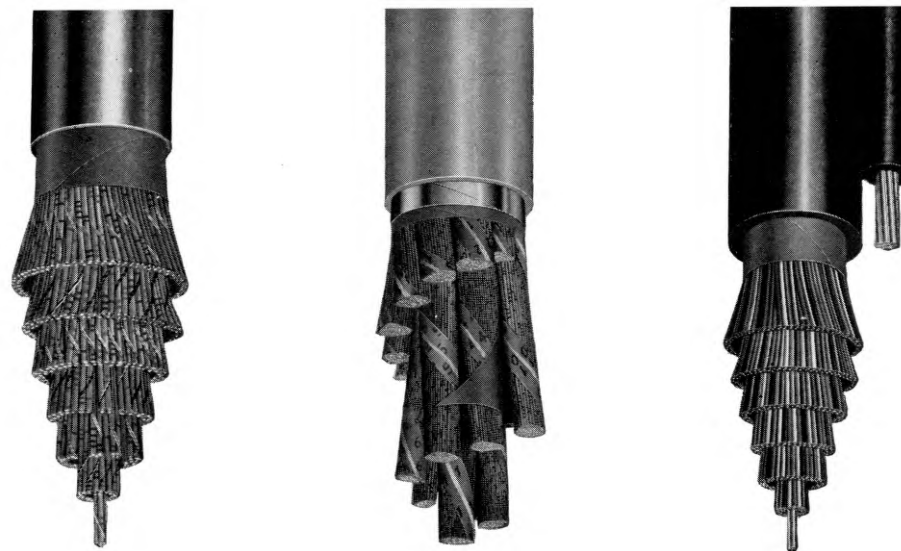

QUAD TRUNK CABLE

This cable, manufactured to a British Post Office specification, is produced in large quantities for audio frequency junction circuits. In common with other types of cable, they can be made to comply with any national or private specification.

UNIT TWIN CABLES

Large cables of unit construction are specially suited to the systematic arrangement of a dense telephone subscriber network. Units of 25, 50 or 100 pairs are first assembled, then the required number of units are combined and sheathed to form the complete cable. Paper insulated, lead or polythene sheathed cables or all-polythene types are available.

POLYTHENE INSULATED DISTRIBUTION CABLE

Because of their ease of installation, reliability and low cost, polythene insulated distribution cables are widely used, particularly in sizes up to 100 pairs. They may be installed underground or, as in the case of the type illustrated, used with an integral suspension strand wherever aerial installation is preferred.

TELEPHONE CABLES

are designed and manufactured to meet C.C.I.T.T. recommendations or any other specific requirements. They are the products of modern plant, specialist engineers and over sixty years of experience—backed by extensive research and development facilities. BICC undertake the manufacture and installation of cables for every type of telecommunication system anywhere in the World.

Technical information on BICC Telephone Cables is contained in our publications—freely available to Telephone Administrations.

Group Head Office: 21 BLOOMSBURY STREET LONDON WC1 ENGLAND Branches and Agents throughout the World

Any type or make of
ENAMELLED WIRE
 copper or resistance alloy
 can be incorporated in our
TEXTILE COVERED
WINDING WIRES



STANDARD-BS 156

(oleo-resinous)

VINYL-ACETAL-BS 1844

(Synthetic)

Bicalex
 Conymel
 Polyanite
 Lewmex
 Simvar

POLYURETHANE-BS 3188

(Easy solder 'F' or 'M')

Bicelflux
 Conysol
 Polysol
 Lewcosol
 Sims Quick Solder

Also **POLYFLUX**

(Epoxy-resin, easy solder)

DIAMEL

(Epoxy-resin on resistance wire only)

A complete and comprehensive range from one single source plus a service which it is our constant aim to maintain.

Textile covered wires in enamelled copper, plain copper, tinned copper or resistance alloys.

Single, twisted pair, bifilar.

T.N.A. Wires for easy soldering and bonding.

Tinsellated conductors.

Bunched conductors, textile covered or waxed.

Wave-winding Wires a speciality

If you have any development problem which involves winding wires, remember that textiles are versatile and if a suitable wire does not exist we are always ready to elaborate new types.

A complete range from one source
FINE WIRES LIMITED

P.O. BOX 78, NOTTINGHAM

TELEPHONE: 44301

TELEGRAMS: STRENGTH, NOTTINGHAM

LONDON SALES OFFICE: 6/10 GT. PORTLAND STREET, W.1.

PHONE: LANGHAM 1071

LITESOLD SOLDERING INSTRUMENTS

- SEVEN SIZES, FROM 10 WATTS TO 55 WATTS
- REPLACEABLE BITS, COPPER & PERMATIP
- EXCELLENT TEMPERATURE REGULATION
- COOL, UNBREAKABLE HANDLE
- RAPID HEATING
- SIMPLE SERVICING
- ALL VOLTAGES
- LOW COST



LITESOLD instruments are compact and nicely balanced. Bits are spring-collet mounted for firmness and easy removal. Copper bits are standard, in sizes from $\frac{3}{32}$ " to $\frac{13}{32}$ " dia. PERMATIP bits are slightly slower, but eliminate bit face wear. LITESOLD elements are encased in specially pre-oxidised wire for constant temperature regulation from new — less glamour but honest design, also apparent in the simple, unbreakable handle, with the element unit secured by two self-tapping screws (servicing couldn't be easier) and firm, spring-on clip. LITESOLD hollow-spindle construction prevents heat loss into the handle (which DOES stay cool) and improves performance. Useful LITESOLD accessories include HEAT GUARDS for elements, and BENCH STANDS.

Free details of the whole wide range of LITESOLD and ADAMIN soldering equipment in brochure PO.34.

LIGHT SOLDERING DEVELOPMENTS LTD., 28 Sydenham Road, Croydon, Surrey. Tel: CRO 8589

TELEPHONE CABLES

the makers with... **experience** 1837-1965

techniques paper-polythene-moisture barrier-water block-coaxial

capacity audio-1,500,000 pair miles a year
coaxial-5000 tube miles a year

current export orders exceed £7,000,000

CABLE • PLANNING • INSTALLATION

TELEPHONE CABLES LIMITED • DAGENHAM • ENGLAND

INDEX TO ADVERTISERS

	PAGE		PAGE
Adcola Products, Ltd.	21	Lustraphone, Ltd.	28
Associated Electrical Industries, Ltd.	7-10, 20, 29	Marconi Co., Ltd., The	22
Astralux Dynamics, Ltd.	5, 17	Multicore Solders, Ltd.	28
Avo, Ltd.	34	Oxley Developments Co., Ltd.	25
Barr and Stroud, Ltd.	23	Pirelli General Cable Works, Ltd.	24
British Institute of Engineering Technology	28	Pitman, Sir Isaac, & Sons, Ltd.	25
British Insulated Callender's Cables, Ltd.	30-31	Plessey Co., Ltd., The	4
Electro Dynamic Construction Co., Ltd.	35	Preformed Line Products (Great Britain), Ltd.	6
Ericsson Telephones, Ltd.	26-27	Radiospares, Ltd.	18
Fine Wires, Ltd.	32	Standard Telephones & Cables, Ltd.	1-3
Ferranti, Ltd.	36	Submarine Cables, Ltd.	19
G.E.C. (Telecommunications), Ltd.	11-16	Telephone Cables, Ltd.	33
Insuloid, Ltd.	25	Whiteley Electrical Radio Co., Ltd.	21
Light Soldering Developments, Ltd.	32	Winn & Coales, Ltd.	23

40 ranges of direct readings with a single instrument...



The Model 40 AVOMETER

A self-contained multi-range a.c./d.c. instrument providing 40 ranges of direct readings of current, voltage and resistance on a 5-inch hand calibrated scale fitted with an anti-parallax mirror. Range selection is accomplished by two rotary switches, for a.c. and d.c. respectively, and a press button provides additional ranges by halving the current and voltage ranges shown on the switch knobs. Full scale deflection on voltage ranges is obtained with a consumption of 3mA. or 6mA. according to whether the press button is used or not. The total resistance of the meter is 200,000 ohms.

The instrument meets the accuracy requirements of B.S.S. 89/1954 for 5" scale length portable industrial instruments. It also complies with the requirements of U.K. Air Registration Board and Merchant Shipping (Radio) Rules 1952.

It is a robust, compact and portable instrument, protected by an automatic cut-out against damage through inadvertent overload.

Size: $8 \times 7\frac{1}{2} \times 4\frac{1}{2}$ in. Weight: $6\frac{1}{2}$ lb.

A leather carrying case is available, if required.

Power Factor and reactive kV.A. can be measured in a.c. circuits by means of an external accessory, the Universal Avometer Power Factor & Wattage Unit.

Write for descriptive brochure, or for complete Catalogue of Avo Instruments.

CURRENT: a.c. and d.c. 0 to 12 amps.
VOLTAGE: a.c. and d.c. 0 to 1,200 volts.
RESISTANCE: Up to 1 megohm.



AVO LTD

AVOCET HOUSE, 92-96 VAUXHALL BRIDGE ROAD, LONDON, S.W.1. Telephone: VICtoria 3404.





Our governors are saluted all over the world

Wherever they are used our centrifugal governors earn respect. It's a matter of integrity—and we put a lot of that into our products. Of course we make many more things than governors. There are alternators and control gear,

converters, motors and generators—and more besides. There is electrical equipment designed for marine use, and for railways, for road vehicles and industrial trucks. We make many things ... just that much better.



Electro-Dynamic Construction Co. Ltd., St. Mary Cray, Orpington, Kent · Tel: Orpington 27551-5

Glasgow Office: 40 Houldsworth Street, C.3. Central 2629

FERRANTI

First into the Future

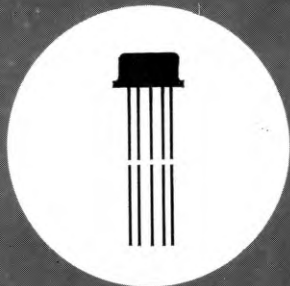

ACTUAL SIZE

OUTLINE BS 3934: SO-44B
IEC: PC6
JEDEC: TO-77A
BASE BS 3934: SB8-1A
IEC: B7A

A NEW RANGE OF SILICON n-p-n PLANAR DOUBLE TRANSISTORS ZDT40 SERIES

■ High transition frequency ■ Low output capacitance ■ Designed for use in D.C. Amplifiers

RATINGS AND CHARACTERISTICS

RATING OR CHARACTERISTIC	SYMBOL	ZDT40*	ZDT41†	ZDT42	ZDT44	ZDT45	TEST CONDITIONS
MAX. COLLECTOR EMITTER SUSTAINING VOLTAGE	$V_{CEO(sus)}$	35	45	60	60	70 VOLTS	
MAX. COLLECTOR BASE VOLTAGE	V_{CBO}	45	60	60	60	100 VOLTS	
MAX. DISSIPATION @ 25°C AMB. TEMP. (COMBINED DISSIPATION)		500	500	500	500	500mW	
MAX. COLLECTOR BASE REVERSE CURRENT	I_{CBO}	0.5	0.05	0.05	0.05	0.05 μ A	$V_{CB} = V_{CBO}$ (MAX)
MAX. EMITTER BASE REVERSE CURRENT	I_{EBO}	0.1	0.05	0.05	0.05	0.05 μ A	$V_{EB} = 5V$ (ZDT40:4V)
D.C. CURRENT GAIN	h_{FE}	75-200	75-170	60-200	60-200	60-200	$I_C = 10mA$ (pulsed) $V_{CE} = 6V$
D.C. CURRENT GAIN RATIO ($h_{FE1} \leq h_{FE2}$)	h_{FE1}/h_{FE2}			0.9-1.0	0.8-1.0	0.8-1.0	$I_C = 0.1 mA$ $V_{CE} = 6V$
GAIN/BANDWIDTH PRODUCT	f _T	MINIMUM	250	250	250	250 Mc/s	$I_C = 10 mA$ $V_{CE} = 6V$
		TYPICAL	290	290	290	290 Mc/s	
MAX. BASE/EMITTER VOLTAGE DIFFERENTIAL	$V_{1BE} - V_{2BE}$			5	10	10mV	$I_C = 0.1 mA$
				5	10	10 mV	$I_C = 1.0 mA$
MAX. OUTPUT CAPACITANCE	c_{ob}	8	8	8	8	8pF	$V_{CB} = 6V$

* ZDT40 contains two ZT82 transistors † ZDT41 contains two ZT84 transistors

Write now for full details

FERRANTI LTD · GEM MILL · CHADDERTON · OLDHAM · LANCs Tel: (061) MAIn 6661