

This document was generated by me, Colin Hinson, from a document held at R.A.F. Henlow Signals Museum and is believed to be out of copyright or Crown Copyright . It is presented here (for free) under the Open Government Licence (O.G.L.) if under Crown Copyright and this version of the document is my copyright (along with the Crown Copyright) in much the same way as a photograph would be. If you believe the document to be under copyright, please contact me.

The document should have been downloaded from my website <https://blunham.com/Radar>, if you downloaded it from elsewhere, please let me know (particularly if you were charged for it). You can contact me via my Genuki email page:

<https://www.genuki.org.uk/big/eng/YKS/various?recipient=colin>

**You may not copy the file for onward transmission of the data nor attempt to make monetary gain by the use of these files. If you want someone else to have a copy of the file, point them at the website. It should be noted that most of the pages are identifiable as having been processed by me.**

---

I put a lot of time into producing these files which is why you are met with the above when you open the file.

In order to generate this file, I need to:

1. Scan the pages (Epson 15000 A3 scanner)
2. Split the photographs out from the text only pages
3. Run my own software to split double pages and remove any edge marks such as punch holes
4. Run my own software to clean up the pages
5. Run my own software to set the pages to a given size and align the text correctly.
6. Run Omnipage (Ultimate) on all the pages to OCR them.
7. Generate a searchable Acrobat pdf file.

Hopefully after all that, I end up with a presentable file, though I can't guarantee there aren't errors in the OCR. If you find missing pages, pages in the wrong order, anything else wrong with the file or simply want to make a comment, please drop me a line (see above).

It is my hope that you find the file of use to you personally – I know that I would have liked to have found some of these files years ago – they would have saved me a lot of time !

Colin Hinson

In the village of Blunham, Bedfordshire.

# THE POST OFFICE ELECTRICAL ENGINEERS' JOURNAL



Vol. 59 Part 3

OCTOBER 1966



## CONTENTS

	Page
THE CHARACTERISTICS OF TELEPHONE CIRCUITS IN RELATION TO DATA TRANSMISSION—M. B. Williams, B.Sc.(Eng.), A.M.I.E.E. ....	151
THE LINCOMPLEX SYSTEM FOR THE IMPROVEMENT OF H.F. RADIO-TELEPHONE CIRCUITS—D. E. Watt-Carter, B.Sc.(Eng.), M.I.E.E. and L. K. Wheeler, B.Sc.(Eng.), A.M.I.E.E. ....	163
PLANNING LONDON'S FUTURE TELEPHONE NETWORK BY COMPUTER—W. E. Thomson, M.A. and D. Breary, M.I.E.E. ....	167
THE 5005-CROSSBAR TELEPHONE-EXCHANGE SWITCHING SYSTEM, Part 1—Trunking and Facilities—A. C. Corner, M.B.E. ....	170
THE NEW LEAFIELD RADIO STATION, Part 2—The Control System—J. A. Chambers, A.M.I.E.E.	178
A DEVICE TO REPLACE CONVENTIONAL POLARIZED RELAYS—R. T. G. Sallis. ....	181
INCOMING CORE-TYPE REGISTER-TRANSLATOR FOR DIRECTOR AREAS, Part 2—The Functional Design—C. K. Price and W. A. Ireland. ....	183
THE NEW LEAFIELD RADIO STATION, Part 3—Carrier Generation—P. R. Hutton-Penman and F. M. Billingham, B.Sc.(Eng.), A.M.I.E.E. ....	196
A 12 Mc/s SUBMERGED-REPEATER SYSTEM. ....	199
SUBSCRIBER PUSH-BUTTON TELEPHONES MARKET-RESEARCH TRIAL—A. H. Elkins. ....	200
SEMICONDUCTOR DEVICE DEVELOPMENTS: GENERAL INTRODUCTION—M. F. Holmes, B.Sc., A.M.I.E.E. ....	202
SHEATH JOINTING OF PLASTIC-SHEATHED CABLES—E. D. Latimer, A.M.I.E.E. and H. E. Robinson. ....	206
ELECTRONIC TELEPHONE EXCHANGES: AN INTRODUCTORY REVIEW OF DEVELOPMENTS—L. R. F. Harris, M.A., A.M.I.E.E. ....	211
NOTES AND COMMENTS. ....	220
INSTITUTION OF POST OFFICE ELECTRICAL ENGINEERS. ....	222
REGIONAL NOTES. ....	225
ASSOCIATE SECTION NOTES. ....	226
STAFF CHANGES. ....	228
BOOK REVIEWS. ....	162, 169, 227

Price 3s. (Post Paid 4s.)

Published in April, July, October and January by *The Post Office Electrical Engineers' Journal*, G.P.O., 2-12 Gresham Street, London, E.C.2.

Annual Subscription (post paid): Home, 16s.; Overseas, 17s. (Canada and U.S.A., 2 dollars 75 cents).

# THE POST OFFICE ELECTRICAL ENGINEERS' JOURNAL

Vol. 59 Part 3

OCTOBER 1966

## The Characteristics of Telephone Circuits in Relation to Data Transmission

M. B. WILLIAMS, B.Sc.(Eng.), A.M.I.E.E.†

U.D.C. 621.395.45:621.394

The effects of the transmission characteristics of telephone circuits on data transmission using the present techniques, are reviewed. As well as discussing the relevant basic properties of telephone transmission channels, the particular limitations imposed by conditions encountered in practice on point-to-point circuits and on switched connexions are also considered.

### INTRODUCTION

THE public telephone service came into being to enable its subscribers to talk, one to another, at first locally and then over increasing distances as junction and trunk communications expanded, gradually extending across international frontiers until world-wide telephony became possible. Throughout this period of development the guiding principle and the criterion of success has always been satisfactory transmission and reproduction of telephone speech; as a means to this end, the electrical transmission path provided between the subscribers' line terminals has been carefully designed for the economical transmission of speech. For this purpose, the specification of attenuation/frequency response, intelligible crosstalk and psophometric noise is substantially all that is necessary; phase distortion and short-term effects such as clicks or impulsive noise are relatively unimportant.

For many years the availability of the telephone network has inspired its use for the transmission of non-speech signals; machine-to-machine communication, in the forms of telegraphy, telemetry and picture transmission, for example, is rapidly increasing. Such transmission is much less tolerant than speech of certain transmission impairments, particularly short-term effects such as impulsive noise or short breaks. Data transmission is an application of telegraphy which is likely to penetrate deeply and extensively into the telephone system, and although the telephone system cannot now be re-designed to meet special data-transmission requirements, it can be expected, as far as economic factors permit, that data transmission will be borne in mind in future developments of telephone systems and apparatus.

At present, therefore, the introduction and expansion of data-transmission facilities have to be based on the characteristics of the telephone network as it is found. This article reviews the knowledge of those transmission

characteristics of telephone circuits and connexions which are of interest for data transmission using the types of system currently envisaged, with particular reference to serial modems such as the Datal Modem No. 1.<sup>1</sup>

### BASIC PROPERTIES OF TRANSMISSION CHANNELS

#### Loss and Group Delay

Fig. 1 and 2 show the loss/frequency and group-delay/frequency characteristics of typical carrier channels and

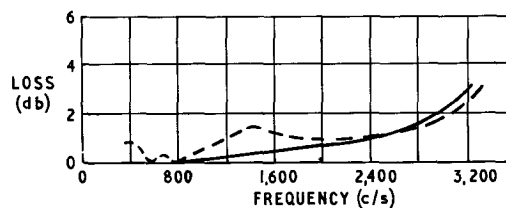

--- Carrier channel  
— 20 miles of 20 lb/mile cable with standard loading  
FIG. 1—LOSS/FREQUENCY CHARACTERISTICS OF A TYPICAL CARRIER CHANNEL AND OF 20 MILES OF AUDIO CABLE PAIR WITH STANDARD LOADING

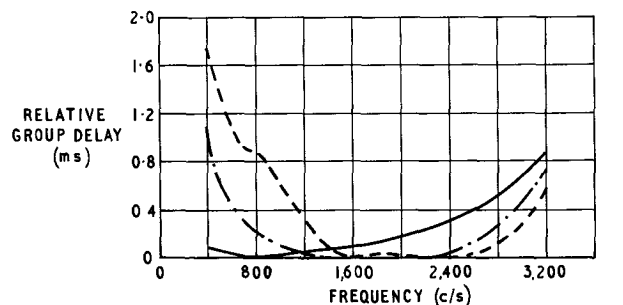

— 20 miles of 20 lb/mile cable with standard loading  
--- Carrier channel (Frequency-Translating Equipment No. 1A or No. 11A)  
- - - Carrier channel (Frequency-Translating Equipment No. 80A)  
FIG. 2—GROUP-DELAY/FREQUENCY CHARACTERISTICS OF TYPICAL CARRIER CHANNELS AND OF 20 MILES OF AUDIO CABLE PAIR WITH STANDARD LOADING

of a properly terminated, uniform, loaded audio cable pair (20 miles of standard loaded cable, i.e. having 20 lb/mile conductors loaded with 88 mH at intervals of 1.136 miles). For a particular class of plant these characteristics have similar shapes, so that, without special equalization, the characteristics of several carrier channels in tandem or of a number of properly terminated loaded audio cable pairs add systematically. The quality

†Mr. Williams is in the Long-Range Systems Planning Unit, E.-in-C.'s Office, but was formerly in the Main Lines Development and Maintenance Branch, E.-in-C.'s Office.

of a carrier channel is determined almost entirely by the filters in the channel translating equipment, but there is a small effect on the edge channels of a group from through-group filters, as can be seen from Fig. 3; this

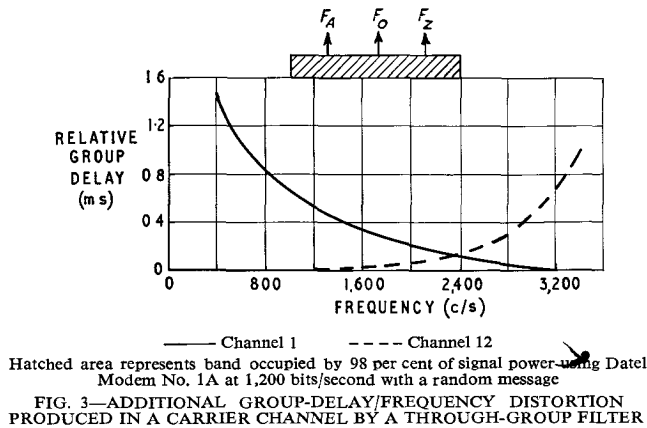

would be significant if there were many such filters involved in a through group or if it were desired to exploit an edge channel towards the limits of the transmitted band. Fig. 4 and 5 show, respectively, the measured

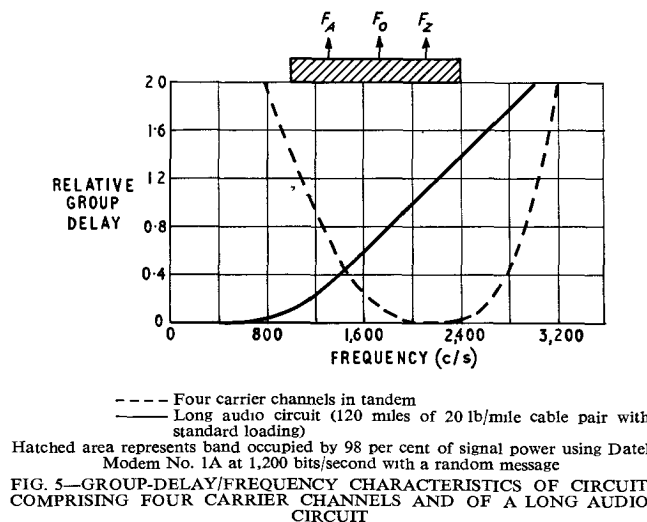
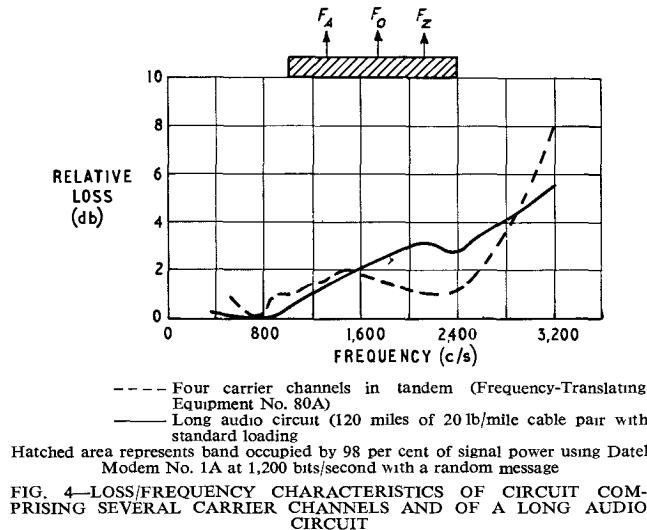

values of the loss/frequency and group-delay/frequency characteristics of both a long circuit made up from several carrier channels and of a long audio circuit of uniform construction and correct termination.

Experimental performance results on unidirectional low-loss circuits indicate that the Datal Modem No. 1 will operate with low distortion at 1,200 bits/second, in the absence of line noise, over a circuit equivalent to about 100 miles of cable with standard loading or four standard carrier channels in tandem. Typical characteristics for such circuits are shown in Fig. 4 and 5. The Datal Modem No. 1 uses frequency modulation and, at 1,200 bits/second, the mean carrier frequency is 1,700 c/s and the modulation index is 0.67. Approximately 98 per cent of the signal power (long-term average assuming random messages) is transmitted within the band 1,000–2,400 c/s, over which the variation in group delay is 1.4 ms. At 600 bits/second, the working range, i.e. the length of audio cable or the number of carrier channels in tandem, for the same distortion would be about three times as great as at 1,200 bits/second.

Only limited experience has been obtained with data modems operating at higher speeds; in general, increasingly severe requirements for uniformity of the transmission characteristics are necessary as the signalling rate is increased, although the bandwidth requirements may be minimized by the use of multi-level modulation techniques. Some considerations in providing private circuits suitable for higher-speed modems are described in the section entitled "Point-to-Point Circuits."

Loaded cables which are not properly terminated or have discontinuities along their length give very undesirable transmission characteristics. Fig. 6 compares the measured loss/frequency and group-delay/frequency characteristics for two junctions between the same two exchanges, each about 15 miles long. One junction is routed on a direct loaded cable, the other is routed via two intermediate exchanges and has two loaded sections separated by 1.7 miles of non-loaded cable; the non-loaded cable, in conjunction with the end-sections of the loaded cable, acts as an abnormal, low-cut-off, section and severely attenuates signals in the upper part of the normal telephone frequency band. It has to be recognized that junction circuits giving this degraded transmission exist in the network, possibly mis-routed as a result of plant shortages on the direct route or as a consequence of cable diversions, incorrect use of tie cables or as a result of exchange transfers. A similar condition can occur on a switched connexion in a metropolitan network involving a tandem exchange where two loaded junctions with incorrect end-sections are connected together. A similar undesirable effect is produced by a missing loading coil, so that it is important that faulty loading coils should be located and replaced as soon as possible.

Reference so far has been made only to standard loading; account has, however, to be taken of the existence of medium and heavy loading in the network, a relic of the early days of audio cables. Cables with such loading introduce very severe delay distortion, as can be seen from Fig. 7. In time, all non-standard loading can be expected to disappear from the network; with the present rapid increase in the rate of providing new plant, such loading should soon become an insignificant proportion of the total.

Negative-impedance repeaters have recently been introduced into the telephone system to extend the



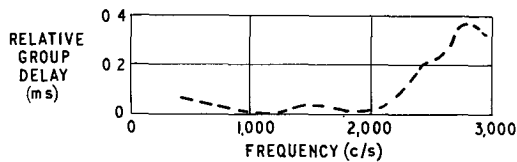

a) Relative Group-Delay/Frequency Characteristic of 15-Mile Junction with Two Loaded Sections Separated by Non-Loaded Section

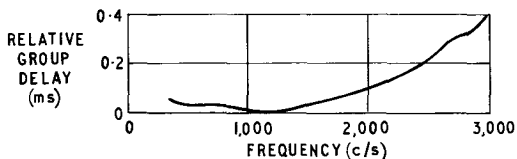

b) Relative Group-Delay/Frequency Characteristic of 15-Mile Junction Consisting Wholly of Loaded Cable

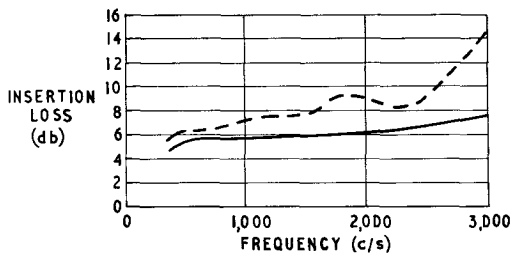

----- Junction circuit with intermediate non-loaded section  
 ——— Junction circuit with loaded cable throughout

(c) Relative Loss/Frequency Characteristics of Junctions Referred to in (a) and (b)

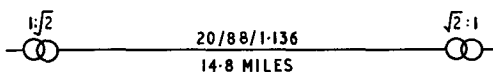

20/88/1-136—20 lb/mile cable pair loaded with 88 mH at 1-136-mile intervals (standard loading)

UL—non-loaded cable pair

(d) Cable Plan of Junctions Referred to in (a), (b) and (c)

FIG. 6—COMPARISON OF MEASURED GROUP-DELAY/FREQUENCY AND LOSS/FREQUENCY CHARACTERISTICS OF TWO JUNCTION CIRCUITS BETWEEN THE SAME TWO EXCHANGES

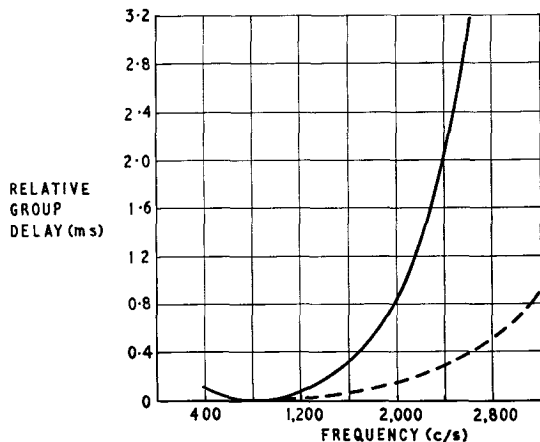

----- 20 miles of 20 lb/mile cable with standard loading  
 ——— 20 miles of 20 lb/mile cable loaded with 176 mH at 1-125-mile intervals

FIG. 7—GROUP-DELAY/FREQUENCY CHARACTERISTICS OF CIRCUITS HAVING STANDARD AND HEAVY LOADING

distance over which 2-wire circuits can be operated on loaded cables. The influence of this type of repeater on data transmission has not been investigated, but it

seems likely that echo effects (especially if the margin of stability is small) and the slope of the loss/frequency characteristic may be significant. Fig. 8 indicates the

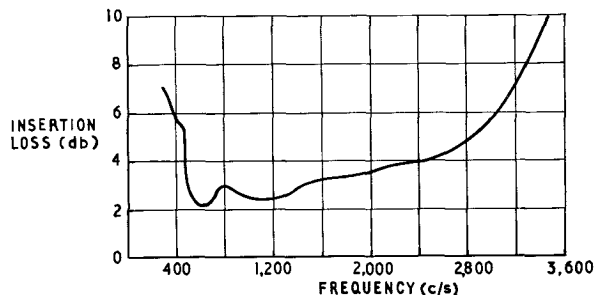

(a) Insertion Loss/Frequency Characteristic

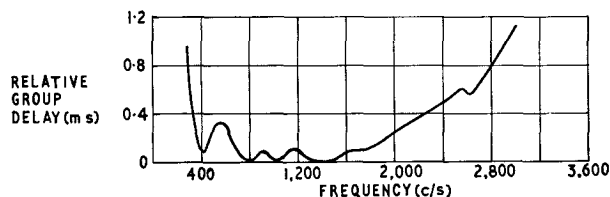

(b) Relative Group-Delay/Frequency Characteristic

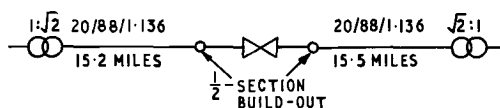

20/88/1 136—20 lb/mile cable loaded with 88 mH at 1-136-mile intervals (standard loading)

(c) Cable Plan of Junction Circuit Referred to in (a) and (b)

FIG. 8—MEASURED TRANSMISSION CHARACTERISTICS OF TYPICAL LOADED JUNCTION CIRCUIT HAVING NEGATIVE-IMPEDANCE REPEATER AT ABOUT THE MID-POINT

measured transmission characteristics of a typical 30-mile circuit with standard loading and having a negative-impedance repeater at about the mid-point.

### Echo

In unfavourable conditions a data-transmission signal can be accompanied by a delayed replica of itself—an echo—which, if of large relative amplitude, may interfere with the correct operation of the data receiver. Steady-state measurements of loss or group delay will show large fluctuations over the frequency band. A low-amplitude echo may only slightly reduce the margin against other transmission impairments. In contrast to the importance of talker-echo in long-distance telephony, where time delays of tens of milliseconds at least are significant, data transmission is concerned with listener echo and with time delays down to fractions of a millisecond. Thus, multiple reflections within a 2-wire circuit, as well as echoes formed by the loop path of a 4-wire circuit, may be important. From some tests on practical circuits with a Datel Modem No. 1 at 1,200 bits/second it has been estimated that it is desirable, for this mode of operation of this particular modem, that the amplitude of long-delayed echoes (e.g. around a 4-wire loop) be limited to ensure that a signal-to-echo ratio of at least 15 db is achieved. At a particular frequency, if the overall loss, 2-wire to 2-wire, of a 4-wire type trunk circuit in the two directions of transmission is  $L_1$  and  $L_2$  db and the balance return-loss under the

working conditions at the two hybrid terminations is  $B_1$  and  $B_2$  db, then the signal-to-echo ratio and the loop loss around the 4-wire loop are each equal to  $B_1 + B_2 + L_1 + L_2$  db. If, for example,  $L_1 = L_2 = 3$  db, then balance return-losses each equal to 4.5 db over the frequency band of interest for data transmission would allow a signal-to-echo ratio of 15 db to be obtained.

On the public switched telephone network, data-transmission systems must be expected to encounter somewhat less than 15 db signal-to-echo ratio in adverse circumstances, e.g. over "best-possible" trunk circuits connected at each end to loaded-cable junctions having incorrect end-sections.

It may be necessary to introduce an appropriate test procedure (for example, measurement of the loop loss around the 4-wire path under specified terminating conditions) on private circuits intended for data transmission, especially where higher-speed systems are to be used. Multi-condition modulation, used in such systems, may well be more sensitive to echo signals.

### Crosstalk

Intelligible crosstalk between one circuit and another in a telephone-cable network is normally kept to a very low value to avoid overhearing and, consequently, no significant interference between telephone and data communications or between two data communications need to be expected. However, go-to-return crosstalk, i.e. between the two directions of transmission of a single circuit, does not have to be kept to such strict standards for telephony and, on the older types of multi-channel carrier systems, quite poor values of go-to-return crosstalk attenuation, e.g. down to 40 db, can be met. Values of 60 db or more are typical of modern plant, and such plant would have to be used for duplex working on a 4-wire private circuit using similar frequency bands for the two directions of transmission.

### Noise

Noise on telephone circuits is normally assessed with the aid of a psophometer with a weighting network, the characteristics of the instrument—square-law detector, 250 ms time-constant of the meter, and the shape of the weighting network—having been chosen with speech transmission in mind. The psophometer is thus adapted to measuring sustained noise or noise which varies only very slowly with time, such as thermal noise, crosstalk babble, power induction, etc., which are important in relation to data transmission only where circuits are very long or where the data-signal level is very low as, for example, at the receiving end of a connexion of high loss. The shape of the weighting-network characteristic is not very relevant to data transmission except in so far as it provides useful suppression of certain frequency components (power-supply hum and carrier leaks) which do not affect data receivers; where the energy spectrum of the noise is known, psophometric measurements can be used as a relative guide to data-transmission performance.

Theoretical studies indicate that, in the absence of other impairments, a 1,200-baud frequency-modulation system should give a satisfactory performance with a signal-to-noise ratio of 10 db, assuming uniform-spectrum random noise, psophometrically weighted, over the telephone band of 300–3,400 c/s. Some 10 db additional margin may be assumed to be necessary in

the presence of transmission impairments such as those given by the circuit characteristics of Fig. 4 and 5.

A characteristic of carrier systems on cables or radio-relay links which are used for providing long-distance circuits is that thermal and intermodulation noise is a design parameter, the circuit noise usually having the characteristics of random noise with the power approximately proportional to length. A long telephone circuit, therefore, is characterized by a steady background noise, the subjective effect of which is determined by the reading of a psophometer. At a point of zero relative level on a transmission system the noise level measured in practice would be expected to be somewhere between  $-60$  dbm0p\* on a good national circuit and  $-40$  dbm0p on a long, unfavourable, inter-continental circuit. If the data-signal level on the transmission system is close to the target value of  $-10$  dbm0, a signal-to-noise ratio of at least 30 db should be obtained, and this performance is adequate in the presence of other impairments which may be expected on a telephone circuit. An important factor, therefore, in the success of a data-transmission service over private circuits or, more particularly, over the switched network, will be achieving the target value of signal level at all carrier systems in the circuit or connexion. Table 1 gives an estimate of signal-to-noise values which might be obtained on switched connexions used for data transmission over the inland trunk network assuming the signal level to be correctly set at  $-10$  dbm0 at the group switching centre (G.S.C.); these values were deduced from a survey of loss and noise measurements made several years ago and are psophometric values. A general reduction in the losses achieved on trunk connexions is expected now and in the future as a result of the improvements referred to in more detail in the section entitled "Switched Connexions," and can be expected to lead to more favourable signal-to-noise ratios on the majority of calls.

TABLE 1  
Estimated Signal-to-Noise Ratios at Data Receivers on Inland Trunk Calls Involving Two Zones

Type of Connexion	90 Per Cent of Possible Connexions Have Signal-to-Noise Ratio Better Than
Between group centre towns	31 db
Between minor exchanges	29 db
Between dependent exchanges	28 db

For data transmission over telephone circuits of moderate length (e.g. wholly within the United Kingdom) impulsive noise is the only significant form of noise interference which has to be considered. Unfortunately, this form of noise is the least predictable, since it generally arises from plant deficiencies. Various sources of impulsive noise may be identified, as follows.

(i) In audio cables, crosstalk couplings (usually pure reactances) between pairs carrying high-energy pulses, such as dialling or unfiltered teleprinter signals, can introduce severe interference into a pair carrying a low-level data-transmission signal. This interference

\*dbm0p—the ratio, expressed in decibels, of the noise power, measured psophometrically, at a point in a transmission path, to the test level at that point.

takes the form of spikes, the disturbing signal waveform being differentiated by the crosstalk path, and, except where band limited by filters or loading coils, having energy components extending over a wide frequency band. Interference of this kind may be minimized by ensuring that apparatus connected to the cable pairs is well balanced about earth. If this condition could be maintained throughout an audio-cable circuit, the standard of crosstalk attenuation in a properly maintained audio cable in the local or junction network would be adequate to prevent significant interference with data transmission except under abnormal or fault conditions, such as a wet cable or a jointing error.

(ii) Impulsive noise can be generated within multi-channel carrier systems by clipping of the multiplex signal as a result of insufficient load capacity of some common amplifier. Well-maintained practical systems have adequate margin for this source to be normally unimportant except under fault conditions, e.g. severe misalignment or valve failure. Intermodulation can also produce impulsive-noise components which could be of high amplitude without disturbing speech transmission. Fortunately, most wideband carrier systems are conservatively designed, so that intermodulation noise is not dominant; Fig. 9 shows the total noise relative to load

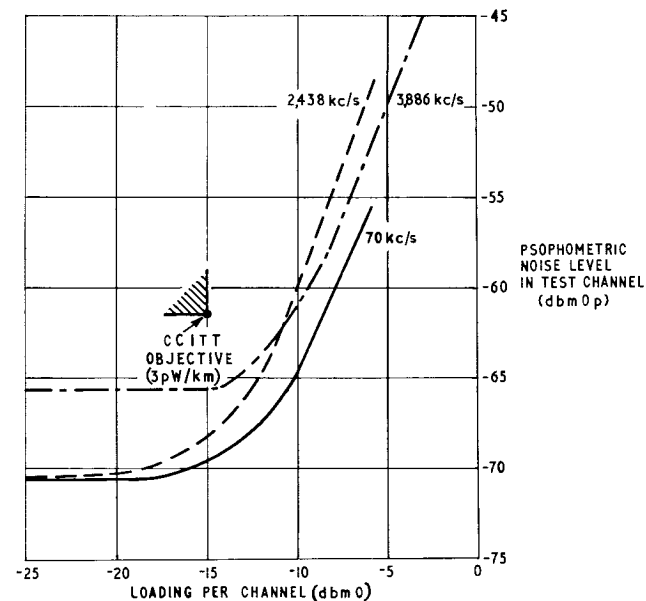

Notes:  
 1. Conventional loading/channel for design purposes is  $-15 \text{ dbm} 0$   
 2. C.C.I.T.T. noise objective is  $3 \text{ pW/km}$

FIG. 9—VARIATION IN NOISE PERFORMANCE WITH TRAFFIC LOADING OF CHANNELS ON COAXIAL-CABLE SYSTEM 150 MILES LONG

performance of a typical coaxial-line system<sup>2</sup> as commissioned, showing the considerable margin for load increase before intermodulation predominates. Of course, correct alignment and good maintenance are necessary for this margin to be maintained during normal operation. Insufficient experience of wideband radio-relay systems is available for analogous conclusions to be drawn at present, although the C.C.I.R.\* design objectives allow high-level short-duration noise peaks ( $-30 \text{ dbm} 0$  measured with  $5 \text{ ms}$  integrating time) to exist for a very small percentage of the time (equivalent to

\*C.C.I.R.—International Radio Consultative Committee.

260 seconds per month for a 2,500 km reference circuit).

External causes have been found to produce impulsive noise on carrier-cable and radio-relay systems, many of the sources being unsuspected until disclosed by investigations into impulsive noise. One important source of external disturbance is by electromagnetic couplings of switching transients from a power circuit into an imperfectly screened h.f. transmission path. The older type of h.f. transmission equipment is particularly liable to this influence. Table 2 shows the results of a recent survey of typical channels using a prototype pulse counter (see the section entitled "Testing Methods"). The threshold setting of this counter to uniform-spectrum random noise is about 13 db above the mean power of the random noise, so that any indications which are considerably more than 13 db above the mean noise power are likely to represent noise disturbances that have a different source from the background noise.

(iii) The most serious source of impulsive noise occurs on switched connexions through automatic telephone exchanges. The predominant noise in the frequency range of interest for data transmission ( $900\text{--}2,400 \text{ c/s}$ ) is due to small movements of contacting surfaces in the speech paths of selector circuits. These movements are due to mechanical vibration caused mainly by the stepping of adjacent mechanisms and occur at wiper-to-bank contacts, at shelf jacks, and at relay spring-sets. Fig. 10 and 11 show the frequency of occurrence of such pulses

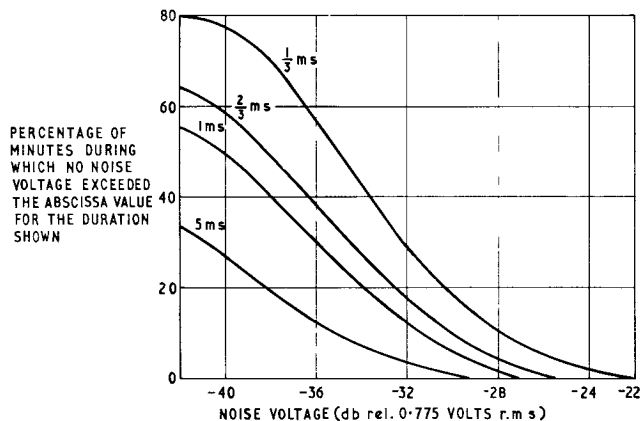

The noise voltages are expressed as sinusoidal signals of equivalent peak-to-peak values

FIG. 10—MEASURED NOISE VOLTAGES ON AUTOMATIC-EXCHANGE CONNEXIONS (2,000-TYPE AND PRE-2,000-TYPE DIRECTOR EXCHANGES)

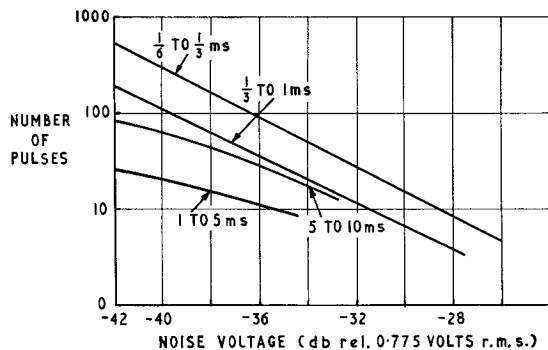

The test period was approximately 3 hours

FIG. 11—TOTAL NUMBER OF SHORT PULSES DURING WHICH GIVEN VALUE OF NOISE VOLTAGE WAS EXCEEDED FOR THE DURATION GIVEN



TABLE 2  
Noise Measurements Made on a Sample of Trunk Telephone Circuits

Type of Line Plant	Approximate Length (miles) (Note 1)	Psophometric Noise Power (dbm0p) (Note 2)	Measurements with Pulse-Counter at Zero Relative Level Point (Note 3)			Remarks
			Level Setting Giving Continuous Counting (db) (Note 4)	Number of Pulses Recorded in Typical 10-Minute Period at Arbitrary Level Setting		
				No.	Level Setting (db) (Note 4)	
4 Mc/s coaxial-cable systems	220 A	Varying, - 64 to - 60	- 48	190	- 45	H.F. line out of adjustment. Interference from group-reference pilot, and occasional interference from change-over relays.
	220 B	Varying, - 63 to - 58	- 44	200	- 35	
	220 A	- 55	- 41	150	- 38	
	220 B	Varying, - 56 to - 53	- 43	170	- 38	
	500	- 55	- 41	250	- 38	
24-circuit symmetrical pair carrier systems	75	- 65	- 49	100	- 40	
	200	- 64	- 48	20	- 40	
	75 A	- 73	- 60	14	- 41	
	75 B	- 73	- 62	75	- 44	
	185 A	- 65	- 49	30	- 40	
	185 B	- 64	- 49	180	- 40	
	55 A	- 72	- 59	5	- 44	
55 B	- 72	- 59	4	- 44		
12 Mc/s coaxial-cable systems	200 A	- 57	- 44	580	- 38	
	200 B	- 60	- 46	30	- 40	
	200 A	- 58	- 43	260	- 40	
	200 B	- 58	- 47	430	- 37	
2.6 Mc/s coaxial-cable systems	280	- 57	- 43	250	- 37	
	110	- 56	- 43	200	- 37	
	200 A	- 55	- 42	180	- 40	
	200 B	- 59	- 42	80	- 39	
	200 A	- 57	- 44	30	- 40	
	200 B	- 59	- 45	200	- 39	
Audio cable	200 A	- 63	- 50	10	- 40	Audible crosstalk from v.f. telegraph system.
	200 B	- 60	- 43	270	- 40	

Notes:

1. Letters A or B indicate different directions of transmission of the same circuit.
2. All circuits measured between terminal repeater stations, excluding all exchange equipment.
3. Data weighting in circuit.
4. Level shown in decibels with reference to calibration with 0 dbm (0.775 volt r.m.s.) 1,000 c/s signal.

on an established connexion. Peak-to-peak values of 100 mV are typical. Other, less serious, sources of impulsive noise in exchanges have been identified as relay operation and selector-magnet operation, noise voltages from these sources being developed across the bus-bar impedance and transmitted into the connexion via the transmission bridge.

Permissible Signal Power

The power of the data signal emitted from a subscriber's apparatus has to be kept as high as possible to minimize noise interference encountered on the circuit or connexion and to permit satisfactory operation of the data receiver. On the other hand, the data signal must not cause crosstalk problems in the local-cable network nor contribute excessively to the loading of multi-channel carrier systems. With these requirements in mind, the C.C.I.T.T.\* has recommended that the signal power emitted from subscribers' apparatus should not exceed 1 mW, and, in addition, to control the loading of

multi-channel carrier equipment by continuous-tone signals such as those produced by frequency-modulation or phase-modulation data modulators, the mean power of data circuits should not differ much from the conventional value of channel loading (-15 dbm0 for each direction of transmission) which is used in the design of multi-channel carrier systems. On the assumption that only a small proportion of circuits will be carrying data signals at any time, a value of -10 dbm0 is recommended for continuous-tone systems on private circuits. On an international switched connexion used for simplex data transmission the signal-power level emitted by subscribers' equipment should be chosen according to the loss between the equipment and the point of entry to an international circuit so that, on the average, the value of -10 dbm0 is achieved at the input to the international circuit. Similarly, for duplex data transmission on international connexions, the recommended value for each direction of transmission is -13 dbm0.

In the British Post Office Datel service over the switched telephone network the signal-power level emitted by the subscriber's modem is adjusted to give a nominal value

\*C.C.I.T.T.—International Telegraph and Telephone Consultative Committee.

at the G.S.C. to which he will normally have access for setting up calls over the trunk network. At the time of installing the modem, pads are adjusted so that the level of the frequency corresponding to binary 1 is  $-10 \text{ dbm} \pm 1 \text{ db}$  at the G.S.C. This level was chosen after consideration of the national transmission plan as it now is, and it will be reviewed in the light of experience with the Datel service.

The send level permitted on private circuits has been established for some time at a value of 1 volt peak-to-peak across a 600-ohm resistor connected in place of the line. This limit is applicable to any non-speech operation and is not confined to data-transmission systems. Where a data-transmission system is used with a continuous-tone type of signal, e.g. a frequency-modulated signal, the 1 volt peak-to-peak limit corresponds to about  $-7 \text{ dbm}$  at the renter's terminals and, if allowance is made for the loss of the local line, complies with the  $-10 \text{ dbm}$  figure recommended by the C.C.I.T.T. for the power level of a data signal on a channel of a carrier system.

### Frequency Shift

Signals transmitted through carrier circuits are subject to frequency shift, because the oscillators used for generating the carrier supplies for modulation and demodulation are not precisely locked in frequency. The design of the carrier-generation equipment and the maintenance practices for carrier supplies are intended to ensure that the end-to-end frequency error due to any possible connexion of channels should not exceed 2 c/s. Under fault conditions this value may be exceeded for very short periods, but a frequency error somewhat in excess of 2 c/s would not seriously affect the data channel of a Datel Modem No. 1 although it might interfere with the operation of a low-speed supervisory channel of narrow bandwidth.

### Power-Supply Interference

**Modulation.** The use of a.c. power supplies for carrier systems introduces the possibility of unwanted hum-modulation products being generated as a result of obscure non-linear processes in circuits carrying both power-frequency and carrier-frequency signals. Some trouble has been experienced with picture transmission and with frequency-modulation multi-circuit voice-frequency telegraph systems from this cause; some data-transmission systems using narrow-band frequency modulation or multi-level phase modulation may be susceptible also. Two main mechanisms are known to exist in British Post Office carrier systems; they are, briefly, as follows.

(i) Direct modulation with a.c. power. The early-type coaxial-line systems may generate 50 c/s modulation products on signals within supergroup 1 (60–300 kc/s on the line) by intermodulation within an inductor in the power-separating filters.

(ii) Impure carrier supplies. Certain types of harmonic generator which “square off” a basic carrier through a valve limiter-stage must be supplied with smoothed h.t. current to avoid the generation of impure carrier frequencies. Floating-battery h.t. supplies may deteriorate (e.g. a bridge rectifier may become unbalanced) and introduce large ripple-components. Special maintenance attention is necessary to avoid this condition, which is not easily detected.

**Power-Supply Hum.** Discrete hum components (power supplies and low-order harmonics) ought not to affect data-transmission receivers because such components are outside the band necessary for the reception of the modulated carrier. Design of telephone systems on the basis of psophometric weighting of noise permits large absolute values of power-supply hum to exist on audio circuits. The hum usually arises from power induction into external plant or from incomplete smoothing of exchange power supplies if batteries are float-charged. Designers of data modems have been advised to allow for the existence of power-frequency voltages of up to 2 volts peak-to-peak at the telephone-line terminals.

### POINT-TO-POINT CIRCUITS

Private circuits on telephone-type plant (Tariff S circuits<sup>1</sup>) are normally set up between terminal repeater stations to the technical standards appropriate to junction or trunk telephone circuits. Local ends from the terminal repeater stations to the renter's premises may, however, limit the transmission performance in respect of the loss and loss/frequency response that can be achieved overall. In particular, low-loss circuits or circuits which require to be loss-equalized over a specified frequency band cannot generally be obtained unless the 4-wire part of the circuit is extended down to the local exchange, or even into the renter's premises, and extra amplification provided to offset equalizer loss. Fig. 12, showing the overall loss/frequency characteristic,

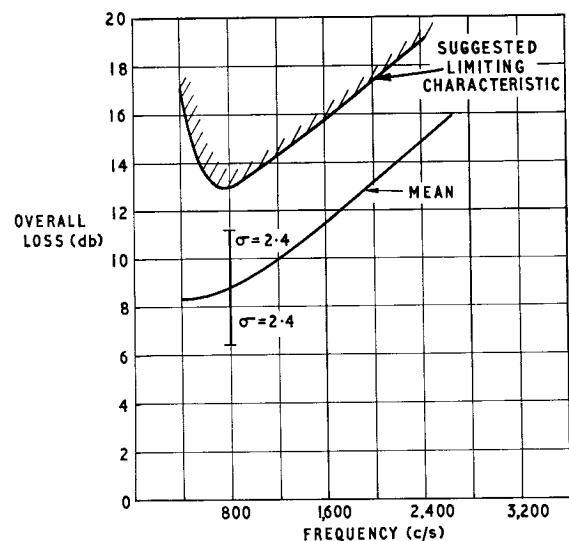

Loss measured between 2-wire terminations  
 FIG. 12—LOSS/FREQUENCY CHARACTERISTICS OF PRIVATE CIRCUITS  
 OVER 25 MILES IN LENGTH

2-wire to 2-wire, of private speech circuits, was obtained from a survey among commercial renter's circuits a few years ago.

The characteristic shown in Fig. 12 is typical for the general Tariff S category of private circuit used for speech transmission, and, though satisfactory for data transmission at signalling speeds up to 1,200 bits/second, is generally too restrictive. For data transmissions at higher speeds with adequate operating margin, more precise control of the loss/frequency characteristic and also of the group-delay/frequency characteristic is necessary. Limits have, therefore, been set for these two

parameters for private circuits, provided at the standard Tariff S, to be used for data transmission and other non-speech applications; these limits are shown graphically on Fig. 13 and 14, respectively. Similar objectives have been recommended by the C.C.I.T.T. for special-quality leased (private) international circuits.

Some users will undoubtedly require telephone-type circuits of improved quality capable of data transmission at much higher signalling rates. This requirement is covered by the new Datel 2000 service which offers,

when suitable plant is available, circuits having a performance as specified by the renter for the interconnexion of his data modems. Since the circuit specification and the type of modem will vary for different renters it is not possible to relate the Datel 2000 service to a particular data-signalling rate.

Achieving the requisite loss/frequency characteristic depends on well-established equalization techniques, but the provision of private circuits to a specification for group-delay/frequency response is a new departure for

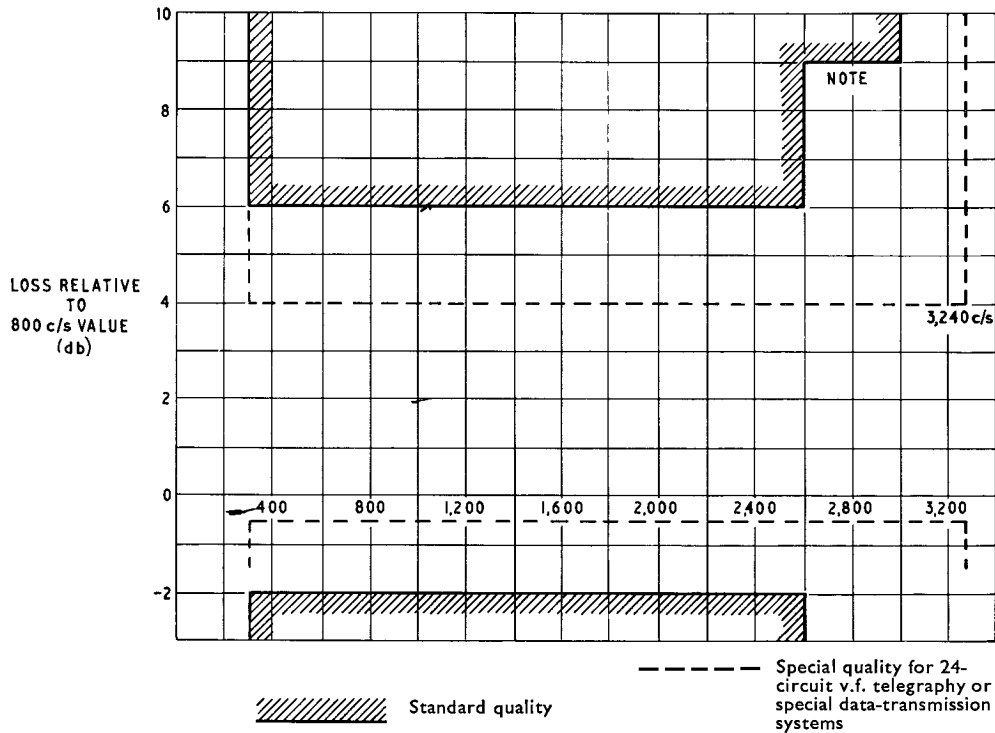
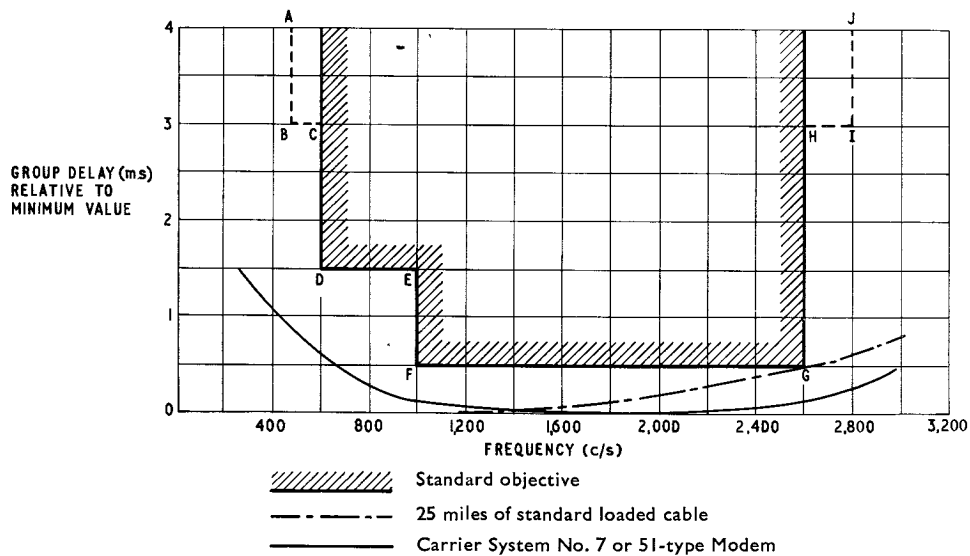

FIG. 13—LIMITS FOR LOSS/FREQUENCY CHARACTERISTICS OF PRIVATE CIRCUITS USED FOR NON-SPEECH APPLICATIONS



Notes:

1. The outline ABCDEFGHIJ is the C.C.I.T.T. objective given in Recommendation M 89 for special-quality leased international circuits
2. Characteristics of typical British Post Office plant shown for comparison

FIG. 14—BRITISH POST OFFICE OBJECTIVE FOR GROUP-DELAY/FREQUENCY CHARACTERISTICS OF PRIVATE CIRCUITS FOR NON-SPEECH APPLICATIONS



the British Post Office. It is not generally practicable under field conditions to set up a circuit, measure its group-delay/frequency characteristic and then compute and construct a group-delay equalizer, although this has been done for a few special circuits where equipment and effort were available.

A straightforward procedure for providing private circuits to a specified group-delay/frequency objective must begin with the selection of plant to give the minimum group-delay distortion, i.e. minimizing the number of carrier terminals and minimizing the length and loading of loaded-cable sections. The limits of Fig. 14 correspond to values which could be achieved, without special equalization, on a circuit comprising two (or up to three, depending upon the type) carrier channels in tandem or 25 miles of audio cable with standard loading. Careful attention must be paid to correct termination of any audio cables, and to maintaining good values of balance return-loss at 2-wire/4-wire hybrid terminations to avoid echoes. The aim is to ensure that the delay distortion of the complete circuit will be the simple sum of the smooth curves appropriate to the individual sections of plant and which can then be corrected without measurements, by fitting a predetermined type of delay equalizer chosen from a limited range of standard units. Table 3 indicates some typical standard units of delay equalizer for correcting circuits to the standard Tariff S or C.C.I.T.T. special-quality limits for which stock provision is being considered.

TABLE 3  
Typical Standard Delay-Equalizer Units

Type of Unit	Compensation For
1	12 + 25 miles of audio cable with standard loading
2	50 miles of audio cable with standard loading
3	100 miles of audio cable with standard loading
4 or 5	One 4 kc/s-spaced carrier channel (two types of channel equipment)
6	One 3 kc/s-spaced carrier channel

For some circuits required for a Datal 2000 service further means of controlling the group-delay/frequency characteristic will be necessary. The provision of a wider range of standard equalizer units is one possible solution; alternatively, variable mop-up equalizers or variable waveform-correctors could be adjusted to give optimum results with a particular type of data modem, perhaps associated with the renter's equipment.

To obtain the best performance for data transmission the following precautions are desirable when planning and setting up circuits on loaded cables.

(i) End-sections should be built out correctly and the appropriate type of line-transformer fitted.

(ii) Sections of non-loaded cable connected directly to loaded cables should be built out with suitable compensating networks or, where unidirectional transmission only is needed, such sections, or a change of loading, should be masked with amplifiers.

(iii) Cables with abnormal or missing loading sections should be avoided.

(iv) Loading no heavier than standard loading should be used.

(v) The use of negative-impedance repeaters should be avoided.

No specification for noise performance on special-quality private circuits has yet been formulated, but the following target values are under consideration:

(a) psophometric noise:  $-48$  dbm0, and,

(b) impulsive noise: not more than 30 counts per  $\frac{1}{2}$  hour at a setting of  $-30$  dbm0, using the C.C.I.T.T. pulse counter (see the section entitled "Testing Methods").

Reliability is likely to be a dominant requirement for private circuits used for data transmission. Where a commercial or industrial enterprise is organized around a data-processing installation it may in time come to depend heavily upon its data-transmission facilities. In extreme cases, provision of duplicate circuits may be seen to be justified, but in most instances, where a single circuit only is rented, the renter will rely upon the Post Office to do its best to maintain continuity of service. One of the major difficulties at the present time in the use of multi-channel carrier cable or radio-relay systems for the provision of private circuits is that such circuits lose their identity and cannot be given special consideration. Thus, interruptions or disturbances are frequently caused by unco-ordinated transmission or power maintenance routines, as well as by plant renewals or rearrangements, and by the operation of automatic changeover of power supplies and carrier-generating equipment. Many studies have been made of the problem of short breaks on h.f. transmission systems:<sup>4</sup> as an example, Table 4 shows the analysis of an investigation

TABLE 4  
Distribution of Durations of Interruptions Recorded on a 200-mile Channel During Two Weeks

Duration of Interruption	Total Number of Interruptions	Number of Interruptions whose Cause Could Not Be Identified
< 10 ms	4	4
10-20 ms	16	7
20-50 ms	21	3
50-100 ms	7	0
100-300 ms	20	1
300 ms to 1 minute	25	1
> 1 minute	7	2
Totals	100	18

during two weeks in January 1966 on a channel with a total length of 200 miles, set-up on a through supergroup routed over three old-type coaxial systems. It will be seen that unidentifiable causes are in the minority, giving confidence that where modern design features and maintenance practices can be introduced, the incidence of short breaks can be kept under control. Use of a nominated reserve or make-good circuit to maintain service during foreseen interruptions is not without hazard, unless such a circuit is carefully selected to have characteristics closely similar to the normal circuit, and unless the patching facilities are reliable. It is to be hoped that developments in circuit provision and maintenance techniques will keep pace with the needs of renters.

Where a private circuit has to provide for alternative

speech or data transmission, signalling facilities will generally be necessary: if carrier channels are involved some type of in-band voice-frequency (v.f.) signalling, e.g. 500/20 c/s or 1v.f. (2,280 c/s), may have to be used. On such circuits, signal imitation by the data transmission must be prevented, at the cost of restricting the available bandwidth, according to principles similar to those adopted for the switched telephone network (see the next section). Fig. 15 indicates the power-level restrictions

terms. From a survey made several years ago, estimates were made of the probability of encountering an overall loss between local exchanges on inland trunk calls of more than 30 db at 1,600 c/s. These conclusions are shown in Table 5, classified according to the types of terminal local exchange involved.

The frequency of 1,600 c/s, although chosen for the survey as giving a good indication of the articulation efficiency of a connexion, is sufficiently close to the mean

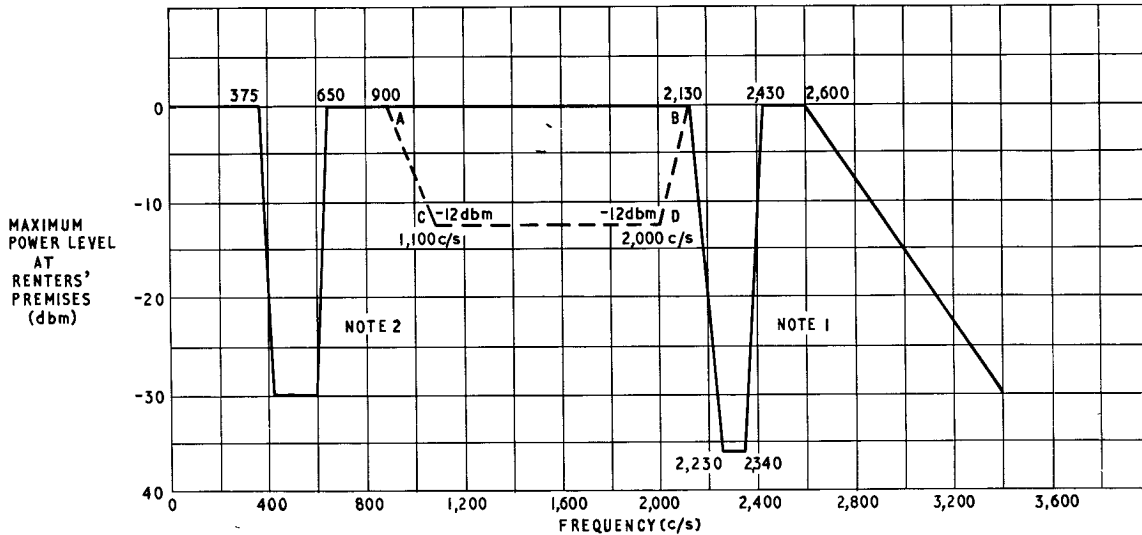

Notes:

1. Area of sensitivity of Signalling System A.C. No. 13. Signal components up to 0 dbm may be permitted within this area if always accompanied by signals in area ABCD
2. Area of sensitivity of 500/20 c/s signalling receivers. Signal components within this range may be permitted if characteristics preclude false operation of 500/20 c/s signalling equipment

FIG. 15—POWER-LEVEL RESTRICTIONS ON PRIVATE CIRCUITS

which apply to data-transmission signals on private circuits with voice-frequency signalling.

#### SWITCHED CONNEXIONS

Although the transmission characteristics of junction and trunk plant are well-defined, the overall characteristics of switched connexions involve random selections from available plant and can only be expressed in statistical

TABLE 5

Estimated Percentage of Calls Having More Than 30 db Loss Between Local Exchanges

Originating Subscriber's Exchange	Called Subscriber's Exchange	Estimated Percentage of Calls Having More Than 30 db Loss Between Local Exchanges at 1,600 c/s
In a group-centre town	In a group-centre town	0.1
	Minor Dependent	0.1
Minor	In a group-centre town	0.1
	Minor Dependent	3.6
Dependent	In a group-centre town	0.1
	Minor	14.5
	Dependent	16.8

carrier frequency of a typical serial modem (e.g. Datal Modem No. 1 on its 600 or 1,200 bits/second modes) to serve as a guide to the possibility of correct operation of a data receiver. Designers of data-transmission systems have been advised to assume an overall loss/frequency characteristic similar to that given in Fig. 16; this curve

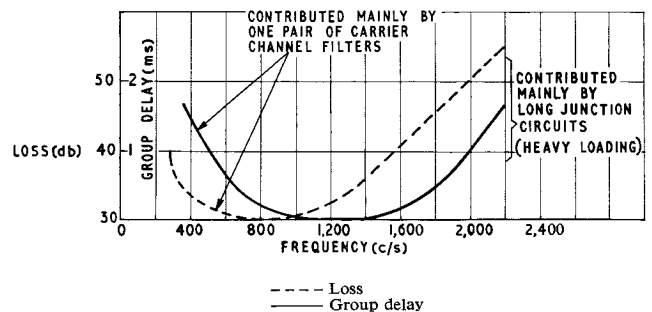

FIG. 16—NOMINAL LOSS/FREQUENCY AND GROUP-DELAY/FREQUENCY CHARACTERISTICS OF AN EXTREME CONNEXION INVOLVING LONG JUNCTION AND TRUNK CIRCUITS

was deduced by combining the results of the above survey with estimates of the systematic summations of the distortions of the loss/frequency characteristics caused by carrier channel filters, non-uniform audio cables and transmission bridges. A conventional group-delay/frequency characteristic is also shown in Fig. 16.

Since the surveys referred to above were made, there have been significant changes in the junction and trunk networks, notably in the progressive reduction in

the incidence of heavily loaded circuits and in the extension of carrier working, including the introduction of group automatic gain-control. The new routing and switching plan,<sup>5</sup> with S.T.D., eliminates dependent exchanges and has, as a transmission objective, a maximum nominal loss between local exchanges of 20 db at 1,600 c/s. When the new plan is effective, and other improvements have been absorbed, a new survey would be expected to show substantial reduction in the probability of obtaining connexions of excessive loss.

An important factor limiting the use of switched trunk connexions for data transmission is the presence of v.f. signalling receivers which may split or clear down an established connexion if falsely operated by data signals. To avoid such failures, modems for use on the switched network have to limit the signal-energy spectrum either by avoiding prohibited frequency bands or by ensuring that an adequate guarding signal is transmitted. Fig. 17

transmission. Echo suppressors, which prevent transmission simultaneously in the two directions of transmission, obviously prevent duplex data transmission, e.g. data in one direction and supervisory signals in the reverse direction, and also interfere with 2-way simplex operation by introducing time delays, due to hang-over, into the sequence of reversing the direction of working.

To obviate both of the foregoing difficulties due to echo suppressors, the C.C.I.T.T. is studying the standardization of a disabling device which would recognize the presence of a standard disabling signal and open up both directions of transmission through any echo suppressor in a connexion. A new British Post Office design of echo suppressor (coded No. 7A) is now under development and will incorporate a disabler. In the absence of a definitive recommendation of the C.C.I.T.T. for the characteristics of the disabling

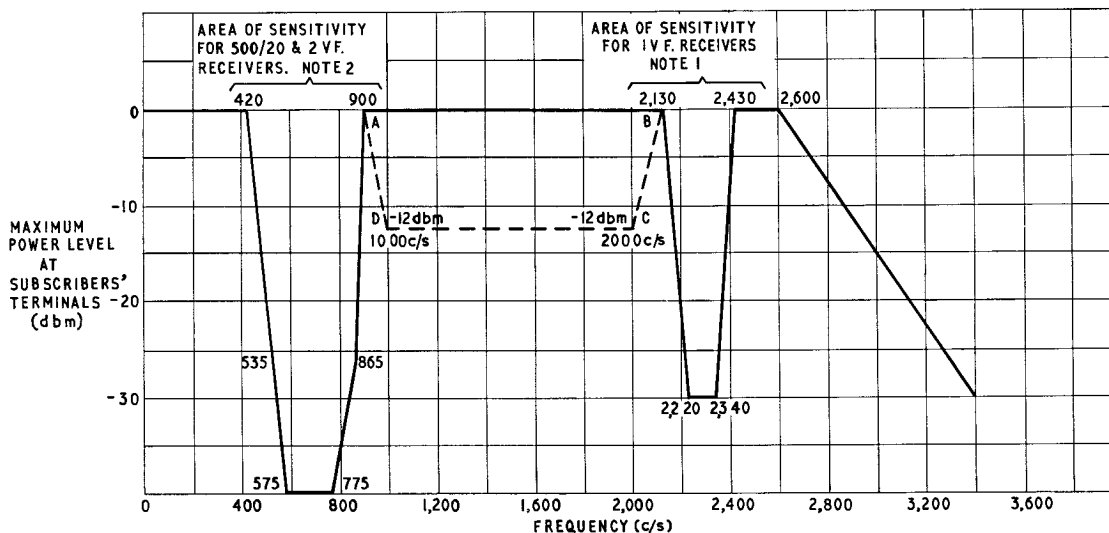

Notes:

1. Signal components up to 0 dbm may be permitted within this area if always accompanied by signals in area ABCD
2. Signals having components within this area may be permitted if characteristics preclude false operation of trunk-signalling equipment

FIG. 17—POWER-LEVEL RESTRICTIONS FOR DATA TRANSMISSION OVER SWITCHED CONNEXIONS

indicates the signal limitations imposed by signalling receivers. In addition, care has to be taken to avoid the generation in signalling receivers of intermodulation products falling within the prohibited bands. This consideration, dictated by the 2 v.f. signalling system, is an important constraint upon the development of parallel data-transmission systems such as those involving the transmission of combinations of two tones selected from separate groups of frequencies (sometimes referred to as *m*-out-of-*n* systems).

If international connexions are set up on the international switched telephone network, all the problems encountered on inland calls are likely to be present, possibly in enhanced degree. In addition, special features peculiar to international circuits may be encountered: such items as companders, time-sharing devices (T.A.S.I.)<sup>6</sup> and echo suppressors have to be considered. The first two of these do not directly hinder serial data transmission, although the compander advantage which enables a high level of circuit noise to be tolerated for telephony would not be obtained, and a compandered circuit might therefore not permit satisfactory data

circuits, the disabler in this new echo suppressor is being arranged to be compatible with North American practice, where a disabling tone of 2,125 c/s is widely used, as well as with the C.C.I.T.T. Recommendations V21 and V23 which provisionally allow the use of  $2,100 \pm 15$  c/s by agreement.

Echo suppressors exist in the inland trunk network on a few routes having special characteristics, mainly involving long audio or 1 + 1 carrier circuits. It is not practicable to modify such suppressors, and the risk, rapidly diminishing with the expansion of the telephone network, of a data call meeting an echo suppressor has to be accepted for the time being.

TESTING METHODS

Some of the transmission characteristics which are significant for data transmission can be measured with normally available testing equipment; other characteristics require special measuring equipment. Reference has already been made to the pulse counter provisionally standardized by the C.C.I.T.T.; arrangements are being made for a British Post Office version of this instrument



(coded Tester No. 158A) to become available as a field instrument. The essential features recommended by the C.C.I.T.T. are as follows.

(a) The counter should register a pulse whenever the applied voltage (irrespective of sign) exceeds a pre-set threshold.

(b) The threshold should be adjustable over the range 0 to -50 db relative to the peak value of a sinusoidal signal of 1 mW in 600 ohms.

(c) The speed at which repeated pulses are counted may be limited by the mechanical register to about eight pulses/second; thus, the number of registrations in a given period is not necessarily the number of noise pulses received, but must be interpreted as an indication of the number of 125 ms intervals containing one or more disturbances.

(d) The instrument should have two alternative bandwidth settings:

(i) "flat response"—within  $\pm 1$  db over the band 275-3,250 c/s and capable of measuring pulses of duration down to 50  $\mu$ s without loss of sensitivity, or

(ii) "data weighting"—derived from the flat response by the insertion of a weighting network having a response within  $\pm 1$ db over the band 750-2,300 c/s and falling off outside this band at a rate of about 18 db per octave.

(e) A timer should be incorporated so that the instrument may be left unattended to record pulses for a pre-determined period, up to 30 minutes.

Although a group-delay/frequency specification for Tariff S circuits for data transmission exists, it is not practicable to introduce group-delay measuring sets as a standard feature. Such equipment is very complex and costly, and test results have to be interpreted with care, especially when echo paths are present giving rise to ripples or undulations in the characteristic. It seems probable that careful assessment of loss/frequency measurements in conjunction with simple means of observing waveform distortion would be sufficient to show whether or not a gross fault affecting data transmission was likely to exist on a circuit. Consideration is being given to providing simple means for observing waveform distortion using special test signals and measuring equipment designed to explore the distortion

over that part of the frequency band used for data transmission, e.g. 1,000-2,400 c/s.

#### CONCLUSIONS

This article has given a general review of the transmission aspects involved in making use of the public telephone system for data transmission either via switched calls or over private circuits. Many of the problems are common to other non-speech applications, and for the best use to be made of available facilities much more detailed knowledge is required of the characteristics of the network under present rapidly changing conditions. Plans are being made to obtain, by field survey, statistical information that will be of value to designers of higher-speed modems. Where particular plant characteristics have been quoted in this article they should be regarded as illustrative only.

Wideband channels, such as group or supergroup links, and purely digital-transmission systems, such as those using pulse-code modulation, clearly have considerable application for non-speech communication, but their use is outside the scope of this article.

#### ACKNOWLEDGEMENTS

Acknowledgements are due to colleagues in the Main Lines Development and Maintenance Branch, the Main Lines Planning and Provision Branch and in the Telegraph and Data Systems Branch for the use of information obtained over a long period, and for assistance in preparing this article.

#### References

- <sup>1</sup>SMITH, N. G. and ROBERTS, L. W. A Modem for the Datel 600 Service—Datel Modem No. 1A. *P.O.E.E.J.*, Vol. 59, p. 108, July 1965.
- <sup>2</sup>SIMPSON, W. G. and COLLIER, M. E. A New 4-Mc/s Coaxial Line Equipment—C.E.L. No. 6A. *P.O.E.E.J.*, Vol. 50, p. 24, Apr. 1957.
- <sup>3</sup>TUCKER, A. A. Long-Distance Private Telephone Circuits for Commercial Renters. *P.O.E.E.J.*, Vol. 55, p. 187, Oct. 1962.
- <sup>4</sup>MORRELL, F. O. Maintenance of Multi-Channel Carrier Systems. *I.P.O.E.E.* Printed Paper No. 194, 1948.
- <sup>5</sup>TOBIN, W. J. E., and STRATTON, J. A New Switching and Transmission Plan for the Inland Trunk Network. *P.O.E.E.J.*, Vol. 55, p. 75, July 1960.
- <sup>6</sup>CLINCH, C. E. E. Time Assignment Speech Interpolation (T.A.S.I.). *P.O.E.E.J.*, Vol. 53, p. 197, Oct. 1960.

## Book Review

"A Laboratory Manual of Electronics." K. J. Dean, B.Sc., A.M.I.E.E., A.Inst.P., A.M.I.E.R.E. Blackie and Son, Ltd. xi + 143 pp. 105 ill. 12s.

This small book is a compilation of 66 experiments which are designed to give an understanding of basic electronics to candidates who are preparing for Higher National Certificate or the examinations of the institutions. The topics range from the determination of the characteristics of valves and transistors, through amplifiers and oscillators, to waveform generators and logic circuits. Magnetic devices are a notable omission, and in later editions some of the thermionic valve experiments will no doubt be replaced by transistor equivalents.

Any student who completes the sequence, especially if he

adopts the enquiring frame of mind the author recommends, will acquire an excellent appreciation of the foundations of instrumentation and control-systems technology. Whether in fact a student would find the time to complete all the experiments is a moot point. It may be that in the author's own establishment, where the exercises were developed, the specified supplies and active components are readily available, but at most other colleges time-consuming modifications are likely to be dictated by the accessible facilities and equipment.

In spite of this limitation, few practising teachers in the field would fail to derive some benefit from the book. The art of designing experiments which are both informative and thought-provoking is not an easy one, and it is always profitable to examine the work of successful practitioners.

C.W.

# The Lincompex System for the Protection of H.F. Radio-Telephone Circuits

D. E. WATT-CARTER, B.Sc.(Eng.), M.I.E.E.,<sup>†</sup> and L. K. WHEELER, B.Sc.(Eng.), A.M.I.E.E.\*

U.D.C. 621.395.665.1:621.391.82:621.396.4

The effects of radio noise and interference on the performance of h.f. radio-telephone circuits are reduced by the introduction of true compandor action, which is effected by controlling the expanders through a separate channel. The transmission equivalent of the speech circuit is maintained at a small constant loss, making singing suppressors unnecessary and, consequently, increasing the ease and confidence with which users can converse.

## INTRODUCTION

ALTHOUGH the development of alternative means of long-distance communication in the form of the repeated submarine telephone cable and the earth satellite has tended to overshadow the high-frequency (h.f.) radio link in recent years, there continues a need (which will probably persist for a long time) for h.f. radio communication over many routes where other means are not available and might not prove economic. However, there is no doubt concerning the need to improve the performance of such circuits, by reducing the effects of noise and increasing their stability in the presence of fading, so that increased utilization may result.

The Lincompex system has proved capable of providing a very considerable improvement in h.f. radio telephony, but before discussing its principles and development it will be as well to review, in outline, the existing composition of radio-telephone circuit equipment.

## PRESENT PRACTICE AT THE RADIO-TELEPHONY TERMINAL

The overall control of radio-telephone calls is exercised in the United Kingdom at the London Radio-Telephony Terminal.<sup>1</sup> Each speech channel (250–3,000 c/s) is equipped, as follows, with apparatus aimed at the efficient use of the radio circuit.

(a) A transmit constant-volume amplifier (c.v.a.) to maintain a sensibly-constant level of speech signal at the input to the radio transmitter despite variations of speech volume between different talkers and differences in telephone-line losses. This ensures that the full capability of the transmitter is utilized by the peaks of speech on all calls.

(b) A receive c.v.a. which reduces the effects of short-term fading. This is not eliminated by the automatic gain control of the radio receiver, which is effective in dealing with only long-term variations.

(c) A singing suppressor, which is necessitated largely by the presence of the transmit c.v.a. Since the gains of the c.v.a.s are related inversely to speech level, there is the distinct likelihood under normal operating conditions of the total gain of the two channels forming the bi-directional radio circuit exceeding the return losses of the 2-wire/4-wire terminations at the ends of the circuit and producing instability (singing). The singing suppressor is a voice-operated device which inserts loss in the send path when the receive path is in use, and vice versa.

The present equipment still leaves much to be desired.

<sup>†</sup>Overseas Radio Planning and Provision Branch, E.-in-C.'s Office.

\*Post Office Research Station.

The transmit c.v.a. performs the assigned function of maintaining a sensibly-constant mean speech level at the transmitter input, regardless of talker level, but the action is such that the amplitude relationship of the speech waveform components during phrases is preserved. Hence, the peak-to-mean-power ratio is maintained high, and the transmitter inevitably works well below its rated mean power for a large proportion of the time. The receive c.v.a. reduces the speech-level variations resulting from fading, but it cannot discriminate against atmospheric noise and interference and will, in fact, accentuate them during pauses in speech if their level exceeds the threshold at which c.v.a. action is invoked. Singing suppressors are susceptible to misoperation by high levels of received noise, so that clipping or suppression of speech in the transmit channel can result. Even under good radio conditions the action of the singing suppressor tends to inhibit the free flow of conversation.

It is evident that the difficulties of long-distance h.f. radio propagation have led to a variable-gain radio system that contrasts sharply with line practice on international circuits, where the normal objective is to maintain a constant loss of 7 db between the 2-wire points at the international switchboards. There is thus an important distinction between a radio and a line connexion. In the former, the received speech volume is independent both of the distant-end talker level and of the line losses between the talker and the radio-telephone terminal, whereas, in the latter, received speech volume is directly related to both of these quantities.

## AN IMPROVED SYSTEM

The improved system described here has, as its main objective, the conversion of existing radio-telephone channels so that they become, both operationally and technically, as closely equivalent to line circuits as available bandwidth, radio-propagation difficulties and economic considerations will permit.

In line transmission, the effects of noise can be reduced by the use of a compandor (commonly with a 2:1 compression ratio), but such a system will function correctly only if the loss remains constant between the output of the compressor at the sending end and the input of the expander at the receiving end. This requirement has hitherto precluded the application of compandor techniques to h.f. radio circuits; but if information concerning the degree of compression introduced at the sending end is accurately conveyed to the expander at the receiving end by a separate, robust, information channel the difficulty can be overcome. With proper compandor action, the loss of the circuit overall is maintained constant, so stability can be attained without the aid of singing suppressors. Moreover, because the gain of the expander will no longer depend directly upon the signal which it receives for transmission, there is no need to restrict the degree of compression.

The Lincompex (LINKed COMPRESSor and EXpander) system has been developed from this concept, which was first put forward in this country by R. O. Carter and H. B. Law;<sup>2</sup> it was subsequently found that a similar scheme had been evolved in France,<sup>3</sup> but there is no further record of this being developed for general application. An outline of the Lincompex system used in a 4-month trial on a United Kingdom-India h.f. radio circuit has been given elsewhere.<sup>4,5</sup> The system has now been further developed to produce a design for equipment, differing in a number of respects from its predecessor, which will be given a more extensive trial on a number of routes.

The principles may be summarized as follows. The speech is compressed to a sensibly-constant amplitude, the compressors acting at almost the syllabic rate of speech, and the compressor control-current modulating the frequency of an oscillator in a separate control channel. The compressed speech and the f.m. control-signal are combined for transmission over a nominal 3 kc/s-bandwidth radio channel. On reception, the speech and control signals are separated and amplified to constant level: the demodulated control signal is used to set the expander gain, thus restoring the original variations of speech-signal amplitude. Because the output level at the receiving end depends solely on the frequency of the control signal, which is itself directly related to the input level at the transmitting end, the overall system loss or gain can be maintained at a constant value. Operation with a slight loss (2-wire to 2-wire) permits singing suppressors to be discarded, although echo suppressors will be needed, as on long line circuits.

#### DESCRIPTION OF SYSTEM IN OUTLINE

The Lincompex equipment is essentially 4-wire apparatus; the send and receive halves are not interconnected in any way, so they may be separately located if this should be convenient for other considerations. The 2-wire/4-wire terminations, echo-suppressors and signalling apparatus need not be installed at the same point. A simplified block schematic diagram of an equipment which can be readily incorporated in an existing radio-telephone system is shown in Fig. 1.

#### Send Side

At the input to the system, the speech signals take two paths. One is to the amplitude assessor, which is basically a 2 : 1 compressor, its gain being controlled in the usual way by rectifying and smoothing a portion of the output to produce a current to control a variable-loss circuit at its input. The main output is similarly rectified and smoothed to provide a d.c. signal, which will be referred to as the control signal. The other path of the speech signal is through a 4 ms delay to two 2 : 1 compressors in tandem. The variable-loss circuits of these compressors are actuated, not by their individual outputs, but by the control signal derived in the first path. The amplitude of the speech output from the second compressor is sensibly constant, for the time-constant of the control-current circuit of about 19 ms permits the gain to be varied at practically syllabic rate. The separately-derived control signal and the 4 ms delay reduce the peaks in the speech amplitude which tend to occur at the onset of a high-level signal, i.e. the gain of the compressor is partially reduced in anticipation of the arrival of the signal.

The control signal also modulates the frequency of an oscillator so that its output changes by 2 c/s for a change of 1 db in the level of the speech input to the amplitude assessor. This relationship is achieved by the use of a logarithmic amplifier before the frequency modulator. The range of frequency is nominally 2,840-2,960 c/s but, under dynamic conditions, the spectrum of the control channel extends from 2,810 c/s to 2,990 c/s.

A low-pass filter is connected in the speech path to restrict its spectrum to below 2,700 c/s to prevent interference with the control channel. The design of the frequency-modulated oscillator is such that its spectrum is restricted sensibly to the band 2,810-2,990 c/s. The control channel, because of its relatively narrower bandwidth, suffers delay relative to the speech signal, and, to ensure that the two signals are synchronized to a sufficient degree of accuracy, compensation is effected by the insertion of a delay of up to 10 ms in the speech path. The two paths are combined to produce a composite signal contained within the normal 250-3,000 c/s range of a speech channel.

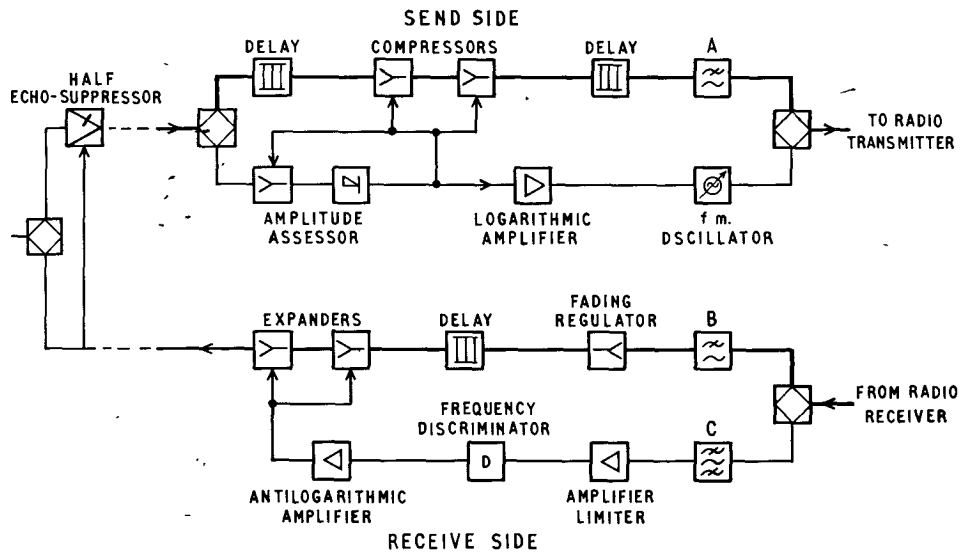

FIG. 1—BLOCK SCHEMATIC DIAGRAM OF LINCOMPEX EQUIPMENT

### Receive Side

The demodulated signal from the radio channel is divided between two paths, the speech signal being selected by a 2,700 c/s low-pass filter and the control signal by a band-pass filter (2,800–3,000 c/s). Residual fading of the speech signal which has not been suppressed by the radio-receiver automatic gain control, is removed by a fast-acting c.v.a. (or fading regulator) with a limited range of compression (this is discussed later), so that a signal of appropriate level is presented to the expanders. The control tone is limited and demodulated by a frequency discriminator. The demodulated signal is passed through an antilogarithmic amplifier which feeds the variable-loss circuits of the expanders through *CR* networks to reproduce the control currents of the compressors. As in the send side, the control-path propagation time is longer than that of the speech path, so compensating delay (up to 12 ms) is inserted between the c.v.a. and the expanders; this may be varied to accommodate various circuit arrangements, e.g. the insertion of privacy apparatus.

## DESIGN CONSIDERATIONS

### Compressors

The compressors used in this Lincompex equipment are based upon those described in an earlier article.<sup>6</sup> These have a 2 : 1 compression law, i.e. the gain is reduced by  $x/2$  db when the input is increased by  $x$  db. The amplitude assessor is essentially a single compressor but also determines the gains of the two compressors in the speech path so that each varies similarly, i.e. the total gain is reduced by  $2(x/2)$  db when the input signal changes by  $x$  db, resulting in a constant-level output or infinite compression.

Certain modifications have been made to the original compressors: the variable-loss circuits are fed from an external source instead of from the individual output circuit, and the gain of the amplifier has been reduced so that, even under the most severe transient conditions, the output stage is not overloaded; with compressors in tandem this would produce intolerable distortion. All the variable-loss circuits are fed from separate full-wave rectified outputs from an additional amplifier following the compressor in the assessor path. The rectifier circuits, which form current sources, feed the various circuits via capacitor-resistor circuits which control the speed of gain variation. Whilst a short time-constant produces rapid control of the gain and would permit a small value for the delay preceding the speech-path compressors, it would also necessitate a wider bandwidth for the control channel and, hence, require a reduction in the frequency range allocated to speech if the total bandwidth to be used should remain constant. Some subjective tests on a noisy circuit with various values of *CR* showed that, if the time-constant exceeds about 25 ms, each speech syllable is followed by a noticeable small burst of noise because the expander gain does not decrease sufficiently rapidly on the cessation of the signal. A time-constant of 18–20 ms was found to be about optimum and has been adopted in the latest design.

The range of input over which the amplitude assessor is effective and produces a control current according to a 2 : 1 compression law is about 60 db, but the speech-path compressors are restricted in their range by clamping their control circuits so that the maximum gain is limited.

This is done for two reasons: to prevent the radio transmitter from being fully loaded by line noise when speech is absent, and to ensure overall stability of the circuit, as discussed later.

### Expanders

The expanders are basically the companions to the compressors,<sup>6</sup> but are modified to operate with a control current supplied externally and not derived from the signal to be transmitted. The time-constant of the variable-loss control circuits is about 8 ms. This, in conjunction with the frequency-range restrictions of the control channel, produces an adequate approximation to the time-response of the compressors.

### Control Channel

The design of the control channel presents a number of problems which necessitate compromise between the various requirements. It is desirable to have a logarithmic relationship between frequency shift and speech amplitude so that any slight discrepancy in alignment of sending and receiving equipment results in a uniform level change at all amplitudes. The relationship frequency-change/db should be large enough to keep level changes within reasonable limits consistent with the attainable accuracy of frequency translation in other equipment in the path, but small enough, in view of the level range to be transmitted and the required speed of response, to leave adequate frequency range for the speech path within the 3 kc/s combined channel. It is very desirable to use the lowest bandwidth after the frequency discriminator at the receiving end to achieve the best signal-to-noise improvement, but filtration must be of a simple form and not introduce undesirable overshoot in the transient condition. From this aspect, the ideal would be to use a circuit with the same time-constant as at the sending end, but this would require the equivalent of the unrestricted control current, after logarithmic conversion, to be transmitted; this would need more bandwidth than can be afforded. The compromise solution adopted was to feed the logarithmic amplifier via a *CR* circuit of 4–5 ms and restrict the frequency of the output which modulates the frequency-shift oscillator to about 50 c/s. This, in combination with a control-circuit time-constant of 8 ms for the expanders (i.e. a nominal bandwidth of 20 c/s), produces a completely acceptable degree of matching between compressor and expander control-current waveforms and yet permits a maximum shift of 120 c/s in a bandwidth of about 180 c/s. This in turn permits, after allowing for a suitable filter cross-over region, a speech band up to about 2,700 c/s to be transmitted (compared with the minimal value of 2,600 c/s recommended by the C.C.I.R.\*). The frequency of the oscillator decreases with increase of the control current, and the midband frequency of 2,900 c/s corresponds to a level of –25 dbm<sub>0</sub> in the speech path.

### Fading Regulator

The range of the input signal for which a constant output is produced is –15 db to +10 db with respect to the nominal received level. This is sufficient to cater for expected level variations during a large proportion of the time. It must be restricted, because, in conjunction with the range of compression at the sending end, it influences

\*C.C.I.R.—International Radio Consultative Committee.

the margin of stability of the whole circuit. The fading regulator is based on the common compressor circuit but is provided with a supplementary amplifier and rectifier to produce a forward-acting control of the variable-loss circuit.

### Comanding Range and Stability

To prevent the compressors from operating at so large a gain during intersyllable pauses, or in the absence of speech, that the line noise would be amplified to the reference level and radiated over the radio circuit, it is desirable to limit the maximum input level at which full compression is effective. This is done by "clamping" the control circuits of the compressors so that the control current cannot fall below a chosen minimum value even though the output from the amplitude assessor may fall below this. Therefore, small signals which lie below the compression range will be transmitted at a lower level than the normal compressed output. In the absence of fading, the fading regulator will treat such a signal as though it had faded and will try to raise its level to normal, so the signal presented to the expanders will be as if it had been compressed. Hence, to preserve the overall constant loss, the expanders must insert a loss equivalent to the sum of the gains of the clamped compressors and of the fading regulator. To obtain this result, the signal received in the control channel, which originates from the amplitude assessor, must be as though the compressors were not clamped. Therefore, the amplitude assessor must be effective over at least the combined downward ranges of the compressors and fading regulator. In this equipment, the compressors are effective with inputs down to 40 db below the reference level, which, in conjunction with a downward range of 15 db of the fading regulator, necessitates a minimum level at which the amplitude assessor is fully effective of at least 55 db below the reference level. Allowing for signals exceeding the reference level by 5 db, a full range of control over 60 db is required, and the variable-frequency oscillator must be capable of working with a shift of 120 c/s, at 2 c/s per db change in level.

### Equalization of Propagation Time

It was mentioned earlier that delay should be inserted in the compressed-speech path so that the speech signal and corresponding control signal arrive at the expander together. The accuracy of equalization does not require to be very high to satisfy the average listener, but it has considerable influence upon the distortion of tone pulses such as those used for signalling, and where 500/20 or 1,000/20 c/s ringing is used it is desirable that the difference between overall propagation time in the two paths should not exceed 4 ms. In the present equipment, the mean difference to be compensated is 19 ms, the compensation being divided between the two ends. Where other apparatus which might produce delay is inserted in the speech path, due allowance must be made by varying the compensating delay. One example is where privacy apparatus is used.

### Separation of Speech and Control Signals

To prevent mutual interference between the control-signal and speech bands, each must be suitably restricted. The design of the frequency-shift oscillator is such that the spectrum of the signal is restricted internally to within

the range 2,800–3,000 c/s. The frequency range of the compressed speech is limited by a low-pass filter, A (see Fig. 1). At the receiving end, the composite signal is divided by a low-pass filter, B, and a band-pass filter, C, for the control signal. Filters A and C must, in combination, prevent speech-path signals from affecting the control signal. For signals close to the control channel, the discrimination should be about 45 db, and for signals more remote from the control channel an allowance for selective fading must be made, increasing the discrimination to at least 60 db. Filter B must reject the control signal, the attenuation being at least 55 db to ensure, for a large proportion of time, 40 db under selective-fading conditions. For convenience, filters A and B have been made similar, and their characteristics together with that of filter C are shown in Fig. 2.

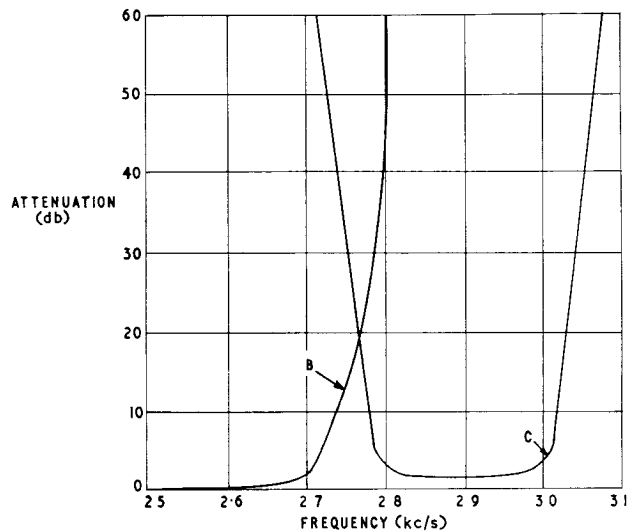

B—Compressed-speech path low-pass filter characteristic.  
C—Control-channel band-pass filter characteristic.  
The characteristics B and C relate to the filters designated B and C in Fig. 1.

FIG. 2—CHARACTERISTICS OF FILTERS

### RADIO-TRANSMITTER LOADING

The relative levels of the speech and control channels have been decided on the following basis. The bandwidths occupied by the two signals are in the ratio of approximately  $12\frac{1}{2} : 1$  so that, assuming uniform spectrum noise, equal signal-to-noise ratios would be achieved, when test level is transmitted in the compressed speech path, if the control signal were 11 db lower. However, as the control signal is all-important, it was decided to make its level only —5 db with reference to the speech test level.

Under these conditions, comparative tests of transmitter loading have been carried out, and it was found that for the same peak envelope power, where four speech channels are carried, the actual mean compressed speech power with Lincompex was about 1 db higher than the mean speech power in conventional systems, despite the fact that the control channels, which are continuously present, are accommodated as well. This is apparently a small increase, but it must be remembered that the fast action of the compressors will enhance the weaker syllables of speech, so that the usable transmitter power is more effectively distributed and a better signal-to-noise ratio will result.

So far, the new equipment has not been subjected to trials on an actual radio circuit, but objective measurements of characteristics indicate that there should be an appreciable improvement in performance over that of the earlier equipment which underwent a successful field trial on the London–New Delhi route. The speech-frequency band extends up to 2,700 c/s (compared with 2,450 c/s on the earlier equipment), the performance of the control channel has been improved by better limiting and low-frequency filtration so that it is more resistant to noise, and transmitted speech quality has been improved by revising the conditions of operation of the compressors.

Tests through an artificial-fading machine with injected noise indicate that circuits should not become uncommercial until the signal-to-noise ratio deteriorates to within the range 15–20 db. The main point of weakness in this type of system is, of course, the control channel, because a high level of interference in this can cause failure. However, tests in which high-speed frequency-shift telegraph signals are located so that one of the frequencies falls in the middle of the control band have been made, and the signal-to-interference ratio can be reduced to 15 db before really significant effects on the speech transmission occur, producing sharp clicks and some mutilation of the speech.

These facts should assure an enhanced performance relative to that previously attained.

This further development of the Lincompex system should ensure successful results in the extended field trial envisaged. Based upon this recent work, proposals have been made to the C.C.I.R. for provisional standardization of the parameters of such systems.

## ACKNOWLEDGEMENTS

A number of people have been concerned with the development of this system from the time of its conception but the authors are particularly indebted to Messrs. E. R. Broad, B. H. Redington and A. R. Amery, who have been responsible for the earlier field-trial equipment and the subsequent revisions leading to the present design.

## References

- <sup>1</sup>SOWTON, C. W., and BALCHIN, D. B. The New London Radio-Telephony Terminal. *P.O.E.E.J.*, Vol. 44, p. 25, Apr. 1951.
- <sup>2</sup>LAW, H. B., and THOMSON, D. Some Experiments with Syllabic Constant-Volume Amplifiers. Proceedings of I.E.E. Convention on H.F. Communication, p. 283, Mar. 1963.
- <sup>3</sup>DEMAN, P. Circuits Téléphoniques sur Liaisons de Faible Qualité. *L'Onde Electrique*, Vol. 41, p. 656, July-Aug. 1961.
- <sup>4</sup>CARTER, R. O., and WHEELER, L. K. Lincompex—A System for Improving High-Frequency Radio-Telephone Circuits. *British Communications and Electronics*, Vol. 12, p. 494, Aug. 1965.
- <sup>5</sup>WHEELER, L. K. Taking the Noise out of Radio Circuits. *Post Office Telecommunications Journal*, Vol. 17, p. 26, Summer 1965.
- <sup>6</sup>THOMSON, D. A Speech Compandor Using Junction Transistors. *P.O.E.E.J.*, Vol. 55, p. 14, Apr. 1962.

## Planning London's Future Telephone Network by Computer

W. E. THOMSON, M.A., and D. BREARY, M.I.E.E.†

U.D.C. 621.395.74: 681.142

The London Trunk and Junction Network Task Force made extensive use of computers in deciding on its plan for the future extension of London's telephone network. The particular parts of the work for which computers were used are indicated, with an outline description of the principles behind the computer programs, and the organization required.

part of a year was spent in preliminary work of various kinds before real results began to emerge. But once the necessary data and computer programs were available, many variations of plans could be tested easily and quickly.

## INTRODUCTION

THE London Trunk and Junction Network Task Force, a specially set-up team of engineering, scientific and traffic staff, spent about 2 years in planning the development of London's telephone system; its recommendations are described elsewhere.<sup>1</sup> The Task Force broke new ground in several directions, in particular, in the use of electronic digital computers; this article describes the main applications of computers in the Task Force and says something about the organization of the work.

By using computers, the Task Force was able to undertake studies that limits on time and manpower would have put out of the question without them, and its recommendations are, consequently, more surely based. The task was still a formidable one, and the best

†Formerly in the London Trunk and Junction Network Task Force; Mr. Thomson is now at the Post Office Research Station and Mr. Breary is with the International Telecommunications Union in Addis Ababa.

## TRAFFIC FORECASTING

An essential prerequisite to any planning was an estimate of traffic in erlangs from each exchange building in the London director area to (i) all exchange buildings in that area, (ii) exchanges in adjacent charging groups, and (iii) provincial group switching centres, the number of traffic quantities required being approximately 30,000, 15,000, and 60,000, respectively. Such an estimate was required for each of the dates 1970, 1985, 2000.

The forecasting followed conventional lines in starting off with a grand-total traffic, deduced from very broad considerations, subdividing this total into three subtotals for the three groups of terminating points, again using fairly broad considerations, and, finally, distributing these subtotals into the required number of traffic quantities, using proportions derived, in general, from the current traffic quantities, and current and forecast calling rates and numbers of connexions at the originating and terminating points.

Some preliminary work was needed to produce the

current traffic quantities, partly because in some instances the traffic records were in terms of calls rather than erlangs, and partly because the exchange buildings used for planning served some new exchange areas not in being when the records were taken.

The production of these forecasts was covered by several computer programs, typical of data-processing programs in that only elementary calculations were needed, but needing careful planning to handle efficiently the large quantities of input and output.

#### TRAFFIC ROUTING

The most important decision to be made was the number and location of intermediate switching points in London; the final choice was seven sector switching centres in the suburbs, handling within-director-area, adjacent-charging-group and trunk traffic, supplemented by the existing five sub-tandems for within-director-area traffic, and several units in the centre each handling one class of traffic.<sup>1</sup>

The approach to this decision considered the three classes of traffic separately, in the first place. For each class, a number of likely schemes were formulated, a scheme being characterized by the number and locations of intermediate switching points, and by the permitted routings between any two terminal points. The traffic to be handled was then allocated to the available routes so as to make best use of the scheme, i.e. to minimize the scheme cost. In most cases, the results suggested further schemes or variations of previously tried schemes. Eventually, a short list of schemes for each class resulted, to be considered as a whole, taking other factors besides cost into account.

In this work, computers were used for the optimum allocation of traffic, but the formulation of schemes and exploratory modification of promising schemes were more suited to human judgement. Two methods were used: one for within-director-area (and also for adjacent-charging-group) traffic, the other for trunk traffic.

##### *Within-Director-Area Traffic*

Intermediate switching points, i.e. tandem exchanges in this section, are of value in that they allow the use of common routes for several parcels of traffic, thereby making more efficient use of circuits, since the number of circuits per erlang falls as the number of erlangs increases. Unfortunately, this very fact makes the design process more difficult, since any one parcel of traffic cannot be routed independently of others.

This difficulty was overcome in the computer program by a rather elaborate trial-and-error process, in which certain auxiliary routes between tandem and local exchanges are assumed to be provided at the beginning of the process but may be discarded if the process reveals them not to be economically justified. The local exchanges are systematically considered in pairs, the various permissible routings for the traffic between them costed, and the cheapest chosen; for routings involving an auxiliary tandem route an approximate cost is used and, if this turns out to be cheapest, the choice of this routing is regarded as tentative, and a record kept of the cost of the next cheapest alternative. At appropriate stages in the program, when all the parcels of traffic that might be carried on any one auxiliary tandem route have been considered, the situation is re-examined:

the number of circuits required to carry the total traffic tentatively allocated to the route in question can be calculated, and the true cost determined and compared with the total of next-cheapest costs. If the true cost is not greater, the tentative decisions are accepted. Otherwise the auxiliary tandem route is discarded, and the appropriate part of the process repeated, with the permissible routings changed to exclude the discarded auxiliary tandem route.

It cannot be asserted that this process is perfect, i.e. producing the absolute minimum cost, but the resultant cost should be negligibly greater than the minimum. In the course of developing the program, a further stage of refinement was used which pilot trials with artificial data had shown to be capable of reducing the cost still further, but when this was used with real data, the resultant reduction was only a few pounds in a total of several million pounds, so the refinement was omitted.

The main result of the program was, of course, the total cost. In addition, costs and information about routings in parts of the network, and a general summary of routings and traffic were output. A further tape was output, not normally for printing, that recorded the routing chosen for each pair of exchanges involved (approximately 30,000 pairs); the intention was that this tape could be one of the inputs for separate programs making particular analyses of the effects of any one scheme.

The running time for this program, on the Elliott 503 Computer,<sup>2</sup> varied with the number of tandems in the scheme concerned, but was generally in the range 20–40 minutes.

##### *Trunk Traffic*

The computer programs for allocating trunk traffic were quite different from those for within-director-area traffic. One reason was that, with trunk traffic, automatic alternative routing must be allowed for. The other was that efficient use of programming and other staff in the Task Force led to a decision to choose a method that was suitable for manual as well as computer processing. Thus, costing of schemes went ahead by manual processing while programs were being written that gradually took over successive stages in processing each scheme.

The method used was an approximate one that allowed a decision to be taken about the routing of each parcel of traffic independently of others. The precise application of the method varied from scheme to scheme, and at different stages within a scheme, but its essence can be seen in considering the routing of the traffic from a sector switching centre to a provincial group switching centre. This traffic, if large enough, would all be carried on a direct route, or, if small enough, would all overflow to switching units in central London; if in between, some would go on a direct route and some would overflow.

The mixture of manual and computer processing led to special arrangements that would not have been needed if a computer alone had been used. For example, computer results for intermediate stages were arranged so that when printed they could be used as a work sheet for subsequent manual processing.

#### MISCELLANEOUS PROGRAMS

Many other programs were written, for various purposes. Some were incidental to the writing of other



programs: for example, programs to evaluate certain constants. The formulation of within-director-area schemes was helped by analyses of the traffic concerned: for example, the director area was divided into a central area surrounded by three annular areas and an analysis made of the traffic between all pairs of areas, grouped in 1-mile straight-line distance ranges. As previously mentioned, the within-director-area traffic-allocation program produced an output tape recording the routing for each parcel of traffic; one use made of this was in a program that gave a statistical analysis of traffic against transmission loss, with overall average loss, and average loss in several sub-divisions. Finally, a considerable use was made of data-checking programs; this point is discussed more fully in the next section.

#### ORGANIZATION

The method of working followed conventional lines in starting off with preliminary discussions between technical and computer personnel to decide if and how computers could be used and to produce program specifications to be turned over to a programmer; the development of the program usually involved further discussions with the technical side. The Task Force suffered from the universal complaint of not having enough programmers, and some were trained within the Task Force; eventually, the programmers included scientific, engineering and traffic staff. The programming language was almost exclusively Elliott Autocode,<sup>3</sup> primarily because that language was most familiar to the programmers available initially, but a few programs were written in ALGOL.<sup>3</sup>

It was found necessary to set up a processing section responsible for keeping records of program and data tapes, and also for looking after master and working copies of the tapes; about 150 program and 2,000 data tapes were accumulated. This section was also responsible for production runs of most programs.

Two types of computer were used by the Task Force: the Elliott 803, mostly the Post Office Engineering Department's Elliott 803,<sup>4</sup> and the Elliott 503.<sup>2</sup> These two computers are largely compatible (but the Elliott 503 is some 60 times faster), so that in many cases preliminary processing of program and data tapes took place on the Elliott 803, to be followed by productions runs on the Elliott 503. This arrangement developed almost naturally from the fact that the Engineering Department's Elliott 803 is run "open-shop" and time

is available at short notice, whereas the Elliott 503 installations used were "closed-shop," so that, as a rule, production runs had to take their place among other work in a queue. To avoid delay from abortive Elliott 503 runs, great use was made of data-checking programs. For example, a data tape might specify the grouping of London's 170 or so exchange buildings into 20 or so tandem areas, the buildings being specified by serial numbers, other numbers specifying the number of tandem areas and the total numbers of buildings in each area: a checking program tests that each serial number occurs once and only once.

#### CONCLUSIONS

The application of electronic digital computers to the technical work of the Post Office is being extensively studied and some results have been achieved.<sup>5</sup> The work of the Task Force, although directed towards specific problems in London, may be of some use in wider fields, and to this end the following few comments are made.

(a) The Task Force programs could not be used as they stand for similar planning problems in other cities, but would need comparatively minor changes.

(b) The programs are intended for use in planning, not for plant provision. The principles might well be of use for this, but considerable further work would be needed to take account of various practical restrictions.

(c) It would have been better, on the whole, if ALGOL had been used as the programming language. The assembling of variations of a main program, and the adaptation and extension to other fields, would have been easier.

(d) The Task Force's experience confirms (although it hardly needs confirming) that regular use of computers will require the automatic collection of data in a form suitable for computer processing.

#### References

<sup>1</sup>FRANCIS, H. E., and DAVIS, E. Decentralization of London's Trunk and Tandem Telephone Exchanges. *P.O.E.E.J.*, Vol. 59, p. 75, July 1966.

<sup>2</sup>MCGRATH, H. T. New Computing Facilities for the Post Office Engineering Department. *P.O.E.E.J.*, Vol. 58, p. 38, Apr. 1965.

<sup>3</sup>LAVER, F. J. M. On Programming Computers. *P.O.E.E.J.*, Vol. 55, p. 125, July 1962.

<sup>4</sup>ALLERY, G. D. The Post Office Engineering Department's Computer. *P.O.E.E.J.*, Vol. 55, p. 199, Oct. 1962.

<sup>5</sup>CROSS, B. Using a Computer for Main-Line Planning and Provision. *P.O.E.E.J.*, Vol. 58, p. 272, Jan. 1966.

---

## Book Review

"Third Year Electrical Installation Practice." H. A. Miller, A.M.I.E.E. Edward Arnold, Ltd. x + 177 pp. 139 ill. 14s.

This book covers lighting, heating, machines and instruments, and consists of explanatory notes and practical exercises for students taking courses in Electrical Installation leading to the relative examinations of the City and Guilds of London Institute and other examining bodies. The author has not used a mathematical approach or given detailed descriptions but has tended to present information simply. The book is amply illustrated but some of the diagrams might well be simplified to match the lack of detail in the text. Lamp characteristics are, however, given in detail

which is quite out of keeping with the rest of the book.

The information on motors is patchy, and such basic information as the essential difference in the characteristics of series-wound and shunt-wound d.c. motors is not mentioned. A number of inaccuracies have crept into the sections on lighting and heating, probably through an attempt to oversimplify. This has marred the descriptions of electrical water heaters, electrical storage heating, the quartz iodine lamp, and the heat pump. Tables provided to assist in fault-finding in fluorescent-lighting circuits and electrical machines are, however, excellent.

It is unfortunate that the author has not maintained a uniform high standard throughout this book, which might otherwise have been a useful addition to many students' libraries.

T.J.B.

# The 5005-Crossbar Telephone-Exchange Switching System

## Part 1—Trunking and Facilities

A. C. CORNER, M.B.E.†

U.D.C. 621.395.344; 621.395.722

Part 1 of this article briefly describes the principle of operation of the crossbar switch and explains how it is used as a basic unit in the 5005-crossbar exchange. The main features of this type of exchange are reviewed, and the description includes trunking arrangements, facilities and the method of operation for various classes of call. Part 2 will deal with operational experience of 5005-crossbar equipment and will also discuss maintenance techniques.

### INTRODUCTION

THE use of fixed precious-metal contact assemblies for the switching of telephone connexions has always been considered an attractive alternative to the use of base-metal sliding contacts actuated by electromagnets or rotating machines. A system using only relays was installed by the British Post Office in Fleetwood, Lancashire, in 1923, and gave good service for about 30 years. From 1922 onwards, various forms of crossbar switch were developed, all derived from the original U.S.A. patent of Reynolds in 1916. In Sweden a crossbar switch with 100 outlets was used in exchanges constructed on a Strowger trunking scheme so that each switch carried only one call; this system was outstandingly fault-free but did not compete in first cost with any of the established sliding-contact systems.

About 1940 a crossbar system was developed in the U.S.A. using crossbar switches of 10 (sometimes 20) inlets and 10 outlets; each such switch could carry up to 10 calls simultaneously. This system used a method of register and marker control similar in basic principle to that used in the all-relay exchange installed by the

†Automatic Telephone & Electric Co., Ltd.

British Post Office and already mentioned. Between 1940 and 1950 several other crossbar systems, all using variants of the same switch and trunking principle, were developed.

The 5005 system described in this article differs from the earlier crossbar systems in its trunking arrangements, in the employment of the self-steering principle to ensure satisfactory routing of calls around busy or faulty paths, and in the use of a new equipment practice in which each shelf carries a switch, or a group of relays, that is an autonomous switching unit.

Fig. 1 shows part of the 5005-crossbar Intercontinental Exchange installed in Sydney, Australia, for the termination of the COMPAC cable.

### PRINCIPLE OF THE CROSSBAR SWITCH

The crossbar switch used in the 5005 system is an assembly of 10 large relays called "bridges," each having 12 spring-sets of, usually, nine make contacts each. The bridge differs from an ordinary relay, however, in its ability to select which of its 12 spring-sets shall be actuated when its armature operates. This selection is performed by 12 "select magnets" which are common to all the bridges of the switch. In Fig. 2 the 10 bridges can be seen mounted vertically with six horizontal bars running across the switch in front of them. Each bar has an armature controlled by two select magnets, so that the bar will rotate through a small angle, either clockwise or anticlockwise, when either of the magnets is energized. Each bar carries 10 "select fingers," made of springy steel wire, which project into the bridge in the space between the armature and the spring-sets.

Fig. 3 is an explanatory sketch of the basic parts of a switch, and the operations required to actuate the spring-set at one cross-point in a switch are as follows.

(a) The operation of a select magnet brings all the select fingers on that bar into their upper or lower actuating positions on all 10 bridges: the switch is now said to be "alerted."

(b) The operation of the bridge magnet traps the particular select finger that is in the actuating position on that bridge, and thus operates the selected spring-set.

(c) The release of the select magnet returns the other nine select fingers to their normal positions, but leaves the tenth trapped by the armature of the bridge magnet. The select magnets can now be used for setting up other calls from other bridges to other outlets.



FIG. 1—5005-CROSSBAR INTERCONTINENTAL EXCHANGE INSTALLED IN SYDNEY, AUSTRALIA, FOR TERMINATION OF COMPAC CABLE

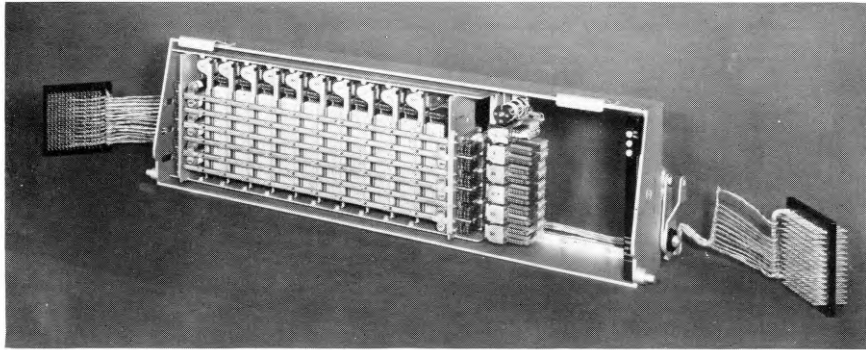
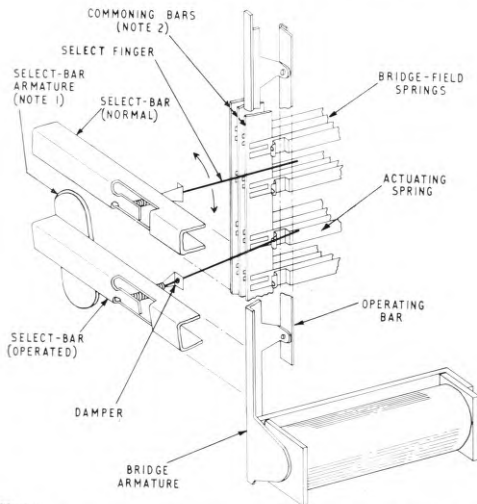

FIG. 2—CROSSBAR SWITCH WITH CONTROL RELAYS, MOUNTED ON SHELF AND WIRED TO TERMINAL BLOCKS



Notes:  
 1. The armatures of alternate select bars are mounted at opposite ends of the bars, as can be seen in Fig. 2.  
 2. One surface of each commoning bar is a conductor; the other surface is an insulator.

FIG. 3—EXPLANATORY SKETCH TO SHOW PRINCIPLE OF OPERATION

The spring-set at the chosen cross-point remains operated so long as the bridge magnet remains operated. When the bridge magnet releases, the trapped finger springs back into its normal position.

In the 5005 system the select magnets are used in combinations of two at a time, and, by suitable interconnection of the spring-sets, this enables each bridge to select one out of 28 outlets. As the most economic size for most trunking patterns is 25 outlets this leaves up to three outlets available for test access or additional availability, when required.

#### THE CROSSBAR SWITCH AS A TRUNKING UNIT

The standard "building brick" of the 5005 system is a crossbar switch with its own controlling relays, mounted

on a shelf and wired out to terminal blocks as shown in Fig. 2. One terminal block serves the 10 inlets and the other serves the 28 outlets. Any inlet can be connected to any outlet by the operation of the bridge serving that inlet, after the correct combination of two select magnets has been operated to select the required cross-points. The switch can carry 10 simultaneous calls, with the limitation that they must be set up one after another and not simultaneously. The delay caused by this limitation is not significant.

The bridges are always referred to as inlets, regardless of the direction in which the call is being set up. This is necessary because some switches carry both originating and terminating calls.

To use this building brick economically it is necessary to employ a method of interconnecting successive ranks of switches called "link trunking," the basic principle of which is illustrated in Fig. 4(a). This shows four switches (usually designated B-switches) connected by 12 links to three other switches (usually referred to as A-switches) so that any of the 16 subscribers served by the B-switches can be connected to any of the nine trunks belonging to the A-switches. To make the diagram simple, each switch is shown with only three inlets and four outlets. Thus, each B-switch serves four subscribers, and each subscriber has access via three links to three A-switches, through each of which he can reach three trunks.

Fig. 4(b) is the conventional, and more convenient, way of representing the arrangement shown in Fig. 4(a).

#### 5005-Crossbar Exchange Trunking Scheme

Fig. 5 shows the basic principle of the distributor stage of a 5005-crossbar exchange: it comprises 20 B-distributor-switches and eight A-distributor-switches. It distributes the originating calls from 500 subscribers to 40 originating trunks. The 40 originating trunks can be increased to 50, 60, 70, or 80 by increasing the number of A-distributor-switches to suit different calling rates.

A 5005-crossbar exchange is built up of one or more 500-line distributors according to the number of subscribers, with a maximum of 200 distributors for a 100,000-line exchange.

In addition to the distributors, an exchange has one or more routers (see Fig. 6), so called because they contain the route switches. Each router contains 160 transmis-

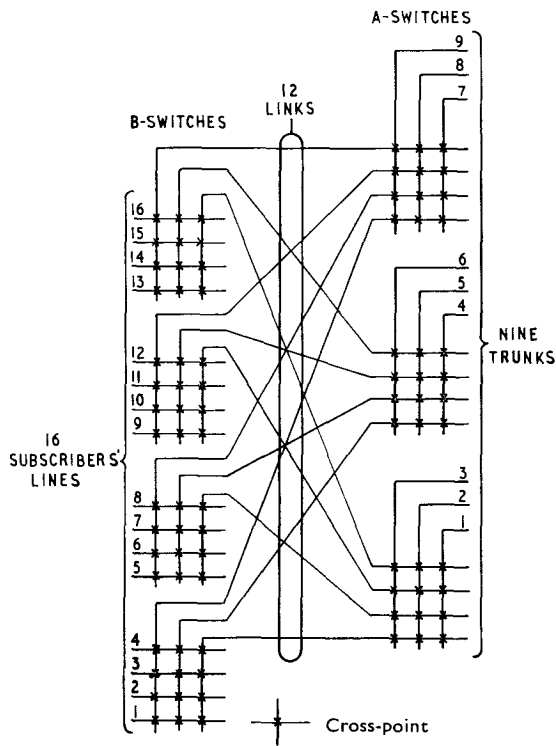

(a) Principle of Link Trunking.

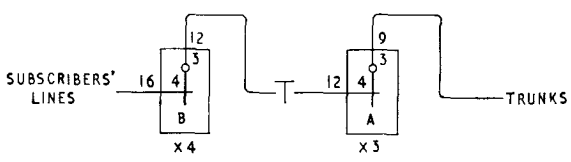

(b) Conventional Method of Showing Link-Trunking Principle.  
 FIG. 4—LINK TRUNKING

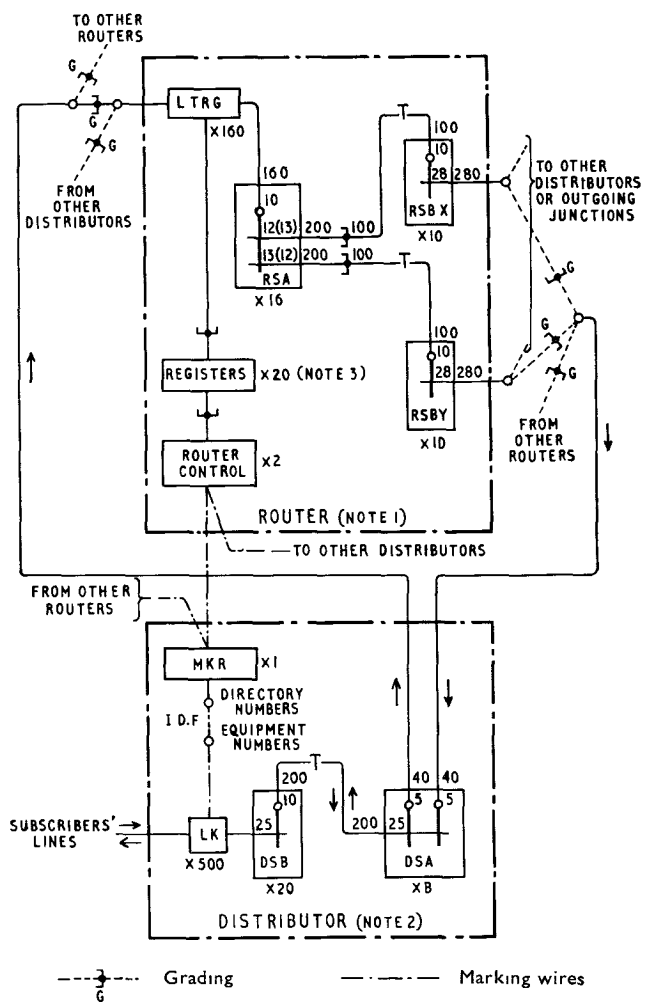

FIG. 6—TRUNKING SCHEME FOR 5005 EXCHANGE OF 500-10,000 LINES SHOWING ROUTERS AND DISTRIBUTORS

- Notes:
1. One router is provided for 100 erlangs.
  2. One distributor is provided for each 500 lines.
  3. The number of registers actually provided depends on the traffic requirements.

FIG. 6—TRUNKING SCHEME FOR 5005 EXCHANGE OF 500-10,000 LINES SHOWING ROUTERS AND DISTRIBUTORS

any number of intermediate switching stages, by the application of marking signals to the two terminal points. A call is set up between the two marked points without the aid of any external controlling connexions at the intermediate switching stages.

When a subscriber makes a call, the B-distributor-switch in which his line appears is alerted, by the operation of his line relay, via a one-at-a-time circuit that prevents conflict with other calls attempted in the same B-distributor-switch at the same instant. The alerted B-distributor-switch applies a marking signal to each of its idle links to alert the A-distributor-switches in that distributor. Each alerted A-distributor-switch now applies a marking signal to each of its idle originating trunks. It should be noted that an originating trunk, although itself idle, can test busy due to the busy condition of another originating trunk coming from another distributor, with which it shares the same transmission relay-group, in the grading.

sion relay-groups for d.c. line feed, ringing, metering, etc., about 20 registers and two router controls (designated, respectively, X and Y).

Each router carries about 100 erlangs of mixed locally originated and incoming-junction traffic. A typical 10,000-line exchange with an originating busy-hour calling rate of 0.04 erlangs per line and 50 per cent outgoing-junction traffic would have six routers and 20 distributors.

**Self-Steering Principle**

The self-steering principle is a method of setting-up calls from a point of origin to a point of destination, via

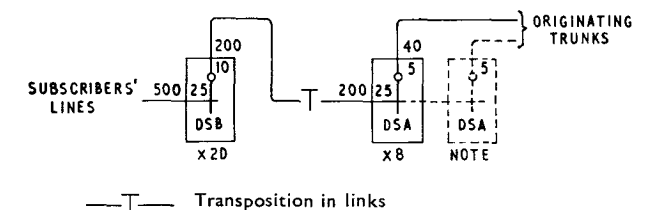

FIG. 5—500-LINE DISTRIBUTOR STAGE OF 5005 SYSTEM

The selection of the first free originating trunk out of the 40 connected to the distributor is controlled by an "endless-chain" circuit which is arranged so that the starting point of the search is advanced by five originating trunks after each call. The traffic is thus distributed smoothly over all the A-distributor-switches and, therefore, over all the routers.

When an originating trunk is chosen, its bridge magnet is operated by an earth on the P-wire. This closes the cross-points already selected by the select magnets when the A-distributor-switch was alerted. The P-wire and the speech wires are thus extended from the originating trunk via the link to the B-distributor-switch inlet, where the earth on the P-wire operates the bridge magnet and closes the cross-point that was selected when the select magnets were operated by the caller's line relay.

The caller's line is thus connected to the transmission relay-group and the caller's K relay operates. The alerted condition is now removed from the B-distributor-switch, and then from the A-distributor-switches.

During these operations, the transmission relay-group has seized a register; a transmission relay-group which does not have access to a free register causes the originating trunks which it serves to test busy. The time required to connect a caller to a register is 600 ms.

#### *Use of Registers and Senders*

The incoming digital information is received by, and stored in, a register that may be arranged to receive 10 pulses/second, d.c. keying or m.f. keying from subscribers, or 10 pulses/second, 20 pulses/second or m.f. signalling over junctions.

When sufficient digits have been received in the register, the call is set up in one marking operation via the precious-metal relay-type contacts of the crossbar switches. On a call terminating within the same exchange, setting-up takes place when the caller has dialled the last digit. On an outgoing call, setting-up takes place when sufficient digits have been received to determine the outgoing route. The remaining digits are then received by, and stored in, the register for subsequent pulsing-out by a sender of the appropriate type to provide the kind of pulsing required by the distant exchange.

The registers and senders are of all-relay design. Experimental investigation of the use of electronic registers and senders in the 5005 system has not shown any advantage in maintenance effort or first cost.

### OPERATION OF 5005-CROSSBAR EXCHANGE

#### *Local Call*

When a subscriber makes a call his line is connected via a transmission relay-group to a register, as explained above. A one-out-of-five class-of-service signal is put into the register and stored for future use. The caller dials the complete number into the register and, when all digits have been stored, the register applies to either router control to mark the call. In an exchange of up to 10,000 lines the router control connects itself, via marking wires, to the marker of the 500-line distributor that is indicated by the "thousands" and "hundreds" digits stored in the register. The marker is basically a relay "tree" having five "hundreds" relays and 50 "tens" relays. A signal applied by the router control to the appropriate "units" wire, when the appropriate "tens"

relay is operated, appears on the required one of the 500 output terminals of the marker.

There is an intermediate distribution frame (I.D.F.) between these 500 terminals (which are in directory-number order) and the marker-wire (M-wire) terminals of the 500-line circuits (which are in equipment-number order) so that, within the same 500-line distributor, any line circuit can have any directory number out of a block of 500, any line equipments can be grouped together for P.B.X. hunting, and any directory numbers can be allocated for night service within the same 500-line distributor.

In an exchange of more than 10,000 lines, the distributors are grouped into 5,000-line "offices." The router control seizes one out of 20 office-markers, through which it gains access to the required one out of 10 markers. The marker has an entry relay for each router control, i.e. in an exchange with six routers, each marker would have 12 entry relays.

The condition of the marking wire of the subscriber's line circuit informs the router control what to do next, as follows.

(a) If the marking condition is a negative potential, then the called subscriber's line is free and the router control is to set up the call.

(b) If the marking condition is earth potential the called subscriber's line is busy and the router control is to return busy tone from the transmission relay-group.

(c) If the marking condition is a positive potential, the number called is a spare number and the router control is to return number-unobtainable (N.U.) tone from the transmission relay group.

(d) A disconnexion on the marking wire indicates a fault in the marking system, and a second attempt is made to set up the call via another router control while the details of the failure are printed on the equipment monitor. If this second attempt fails, N.U. tone is returned from the transmission relay-group.

Assuming a negative marking potential is encountered, the B-distributor-switch is alerted, and the marking signal is applied over all idle links to the A-distributor-switches of the distributor. A route relay (which is unique to this combination of one router control and one marker) is operated by the entry relay in the marker and allows the marking signals to return from the alerted A-distributor-switches over half the terminating trunks to the outlets of half the B-route-switches in the router from which the call is being set up.

In the same manner, the marking signals are passed back by the B-route-switches over the idle links in one half of the router to that A-route-switch which serves the transmission relay-group on which the call is waiting to be set up. The A-route-switch accepts the marking that arrives on the first idle link, and rejects the others.

The arrival of the marking signal in the A-route-switch causes the router control to be advised that at least one free path exists through the A-route-switch, B-route-switch, A-distributor-switch and B-distributor-switch to the called line.

The router control now applies earth to the P-wire via the register and the transmission relay-group. The four bridges in the A-route-switch, B-route-switch, A-distributor-switch and B-distributor-switch operate in succession to close the cross-points and establish the call, the connexion from caller to called subscriber being

as shown in Fig. 7. After the continuity of the positive and negative wires has been checked from the router control via the register and transmission relay-group and the four switches to the called subscriber's line

### Incoming-Junction Call

Each incoming junction is terminated on its own incoming transmission relay-group, of which there are several types to provide for different junction facilities,

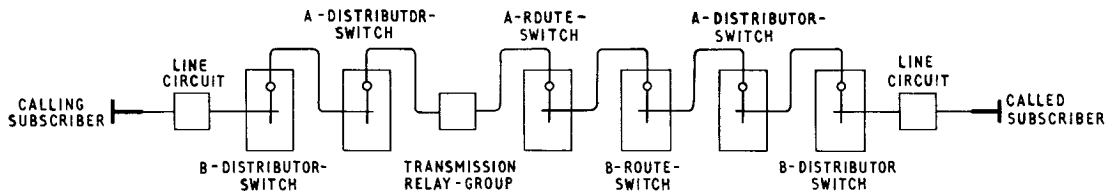

FIG. 7.—SWITCHING STAGES FOR A LOCAL CALL IN A 5005-CROSSBAR EXCHANGE

circuit, the router control releases and all marking circuits are cleared: the register also releases.

If, after a timed period, the marking had failed to return across the exchange from the called subscriber's line circuit to the A-route-switch, or if the continuity check had failed, the router control would have instructed the register to make a second attempt, using the other router control. Non-arrival of the marking signal is registered on a meter as first (or second) attempt congestion. Continuity failure is also registered on a meter, and causes a print-out on the equipment monitor as well. The other router control has a different path of entry to the marker, so that, at the second attempt, a different route relay is operated, and therefore, the B-route-switches in the other half of the router are used. For first attempts, calls use either of the two router controls, X or Y, at random, and always use the other router control for a second attempt. Failure of the second attempt causes the return of busy or N.U. tone from the transmission relay-group.

Since each router has two router controls, each of which independently controls half the B-route-switches in that router, it follows that every router control in the exchange can set up a call independently of, and simultaneously with, every other router control, provided no two router controls attempt to gain entry into the same 500-line distributor (where the marker will accept entry from only one router control at a time), and provided also that no two calls both originate in the same block of 10 transmission relay-groups served by one A-route-switch. In either of the latter events, conflicting markings are avoided by causing one call to wait while the previous call is being set up. The setting-up time is just over 1 second.

After the release of the register, router control, etc., the transmission relay-group applies a 1-second burst of continuous ringing, followed by interrupted ringing, to the called line. When a reply is received, the transmission relay-group operates the caller's meter once, and then applies local-call timing at the rate appropriate to the time of day.

Under called-subscriber-held conditions, the transmission relay-group releases after a timed period, and the caller's line remains "parked" on his line circuit until he clears. The same parking scheme is used after a timed period for lines having a permanent calling condition due to a fault or misoperation, for callers who fail to dial at all, and for incompletely dialled calls, in order to avoid unnecessary holding of transmission relay-groups and registers.

e.g. incoming from automatic exchanges, with or without metering-over-junctions, incoming from manual exchanges, and so on.

The incoming transmission relay-group seizes an incoming register, of which there are several types to provide for the different junction facilities referred to above, and also to provide for m.f. pulsing, if this is used by the distant exchange. The incoming transmission relay-group passes a class-of-service signal into the register immediately on seizure: this indicates to the register the digits, used in transit, that are to be reconstituted. Other class-of-service signals can be used to indicate to the register the charging area from which the call has come, whether certain codes should be barred, and, at a group switching centre (G.S.C.), whether the call has come from a remote non-director exchange, from a unit automatic exchange (U.A.X.), or from another G.S.C., and so on.

The incoming register receives the digital information from the previous exchange, and applies to the router control to set up the call in a similar way to a local call, as already described. When a reply is received the appropriate conditions, i.e. reverse-potential supervision or metering-over-junction signals, are returned over the junction, according to the type of incoming transmission relay-group used.

If the first digit to arrive over the junction reaches the incoming transmission relay-group before a register has been seized, the search for a free register is abandoned, and busy tone is returned over the junction to the preceding exchange.

The above description refers to a 5005-crossbar exchange in a Strowger network of the type now in use in Britain. The boundary conditions of the 5005-crossbar equipment are, therefore, identical with those of a Strowger exchange. If the 5005 system is used in networks where other types of switching system are in use, the incoming transmission relay-group and the incoming register are arranged to provide the boundary conditions required by the other exchanges.

### Outgoing-Junction Call (Non-Director Area)

Fig. 8 is a trunking diagram showing the routing of an outgoing-junction call using a second stage of route switches.

The local register, having received the code digits, recognizes the code as not being that of its own exchange. It therefore applies immediately to the router control to set up the call to an outgoing junction. Further digits arriving from the caller are stored in the register. The

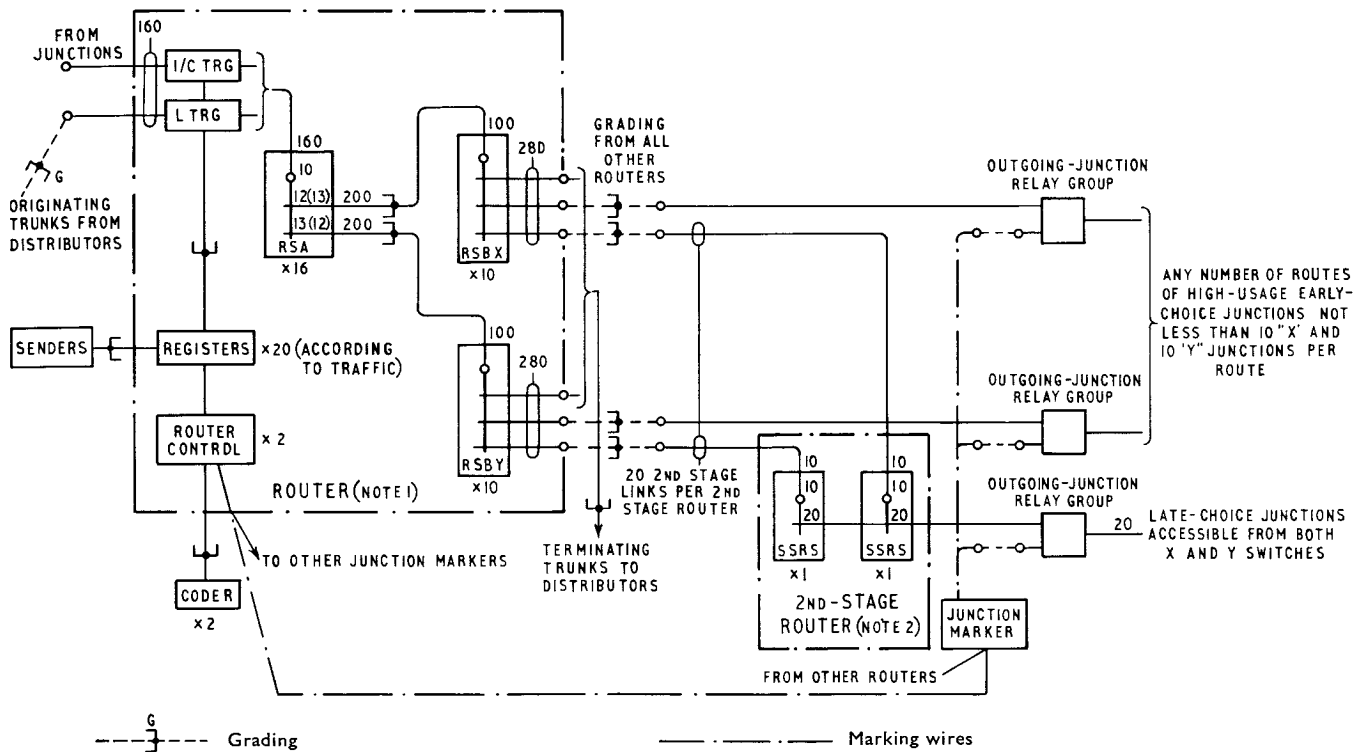

LTRG—Local transmission relay-group. I/C TRG—Incoming transmission relay-group. RSA—A-route-switch. RSB—B-route-switch. SSRS—Second-stage route switch.

Notes. 1. One router per 100 erlangs.

2. One pair of second-stage route switches per 20 junctions.

FIG. 8—OUTGOING-JUNCTION TRUNKING IN 5005-CROSSBAR EXCHANGE USING SECOND-STAGE ROUTE SWITCHES

router control, on receiving a demand to set up an outgoing-junction call, applies to the coder for instructions; there are at least two coders, and these are accessible to all the router controls. The coder examines the class-of-service information and the code digits stored in the register, and returns instructions to the router control, of which the following is a typical selection.

(a) No code: return N.U. tone from the transmission relay-group.

(b) Barred code: return N.U. tone from the transmission relay-group, or re-route to the manual board.

(c) Incomplete code: examine the information again after the next digit has been received.

(d) Valid code:

(i) apply to one of the junction markers No.1–10,

(ii) apply to one of the routes No. 1–10 in this junction marker,

(iii) the number of digits in the objective-exchange numbering scheme is either 4, 5, 6 or 7 and is invariable,

(iv) the number of digits in the objective exchange numbering scheme is variable, but is not less than either 4, 5, 6 or 7, as the case may be, and

(v) meter rate for the call is one selected from a range of 16 rates.

The coder can give alternative routing instructions if the primary route is busy, and is equipped to examine as many digits and to provide as many output terminals after each digit as necessary. The coder is held for 125 ms on each outgoing-junction call.

The router control, having received instructions from the coder, applies to the required junction marker in the same way that it applies to the line marker in the distributor on a local call.

Large groups of outgoing junctions are usually connected to the B-route-switch outlets. The B-route-switch outlets in all the routers are arranged in a form of grading with an availability of 20, 30, 40 . . . 100, according to junction traffic and the number of B-route-switch outlets which can be allotted to each route.

The junction marker applies a marking signal to every idle junction in the required route, and this marking signal travels back via B-route-switches and A-route-switches to the originating router in the same manner as described for the marking of a local call. The call is then set up as already described.

For small groups of junctions, a second-stage route switch is used. Second-stage route switches can also be used for large groups of junctions if the number of junctions is too great to be served by the available B-route-switch outlets. This removes all practical limitations from the number of outgoing junctions which can be connected to an exchange.

When a second-stage route switch is used, the first idle junction in the required route can be marked individually because the second-stage route switch having been alerted, it applies marking via half the idle second-stage links back to half the B-route-switches in the router of origin; the other half would be marked at the second attempt, as already described.

For large junction routes, it is economical to provide



access to a large number of high-usage early-choice junctions via mass-marked B-route-switch outlets, and, at the same time, access to individually marked late-choice junctions through a second-stage route switch. The call will always take a B-route-switch outlet, if one is free and accessible, in preference to a second-stage route-switch outlet.

The outgoing junctions in the required route having been marked, and the marking having returned across the exchange to the A-route-switch, the bridges in the A-route-switches and B-route-switches (and possibly the second-stage route switch) are operated, and the continuity is checked over the positive and negative speech wires. The speech wires, augmented by a third wire, the CA wire, via the junction marker provide three 4-way classes of service for the outgoing junction, to tell the register how to proceed. The following is a typical allocation of these three classes of service.

- (a) Class one:
  - (i) pulse out at 10 pulses/second, or
  - (ii) pulse out at 20 pulses/second, or
  - (iii) send in m.f. code, or
  - (iv) no pulsing out required.
- (b) Class two: Omit one to three code digits or omit none before sending numerical digits.
- (c) Class three:
  - (i) remove feeding bridge from transmission relay-group, or
  - (ii) collision call on bothway junction: release and set-up again,
  - (iii) spare, and
  - (iv) spare.

Faults in the marking system, congestion, and continuity failures are dealt with as already described for a local call.

The router control and junction marker now release and the register seizes a sender of the type instructed by the outgoing-junction class-of-service.

As senders are not used on incoming or terminating calls, and, as their holding time is about half that of a register, the number of senders required is usually less than half the number of registers.

The sender sends out the digits stored in the register. Typically, on a call to a Strowger exchange, transmission of the penultimate digit is restrained until end of dialling has been established and the last digit has been received in the register. The sender and register then release.

If the distant exchange is of the Strowger type, the sender pulses out at 10 pulses/second with 850 ms interdigital pauses. If the distant exchange is of the 5005-crossbar type, the sender pulses out at 20 pulses/second with 300 ms inter-digital pauses. In this case, the out-pulsing of the sender tends to catch up with the arrival of incoming digits from the subscriber, and, once the sender has caught up, each digit is re-transmitted immediately on arrival. Provision for restraining transmission of the penultimate digit until the last digit has arrived from the caller is unnecessary on calls to other 5005-crossbar exchanges.

Senders arranged for m.f. sending can be provided for use on calls to other 5005-crossbar exchanges, if required. This reduces post-dialling delay on calls over indirect junction routes; such a reduction is not of much value on calls that use direct routes. However, m.f. sending has the advantage that it is self-checking.

On outgoing-junction calls, the transmission relay-group normally provides a D-and-I loop forward. However, on calls to manual-board operators for which manual hold is required, and on calls to outgoing junctions on which metering-over-junction signals are received from the distant exchange, the feeding bridge is removed from the transmission relay-group, and the caller receives d.c. line feed from the outgoing-junction relay group. The operation of the caller's meter is then controlled by pulses returned over the P-wire from the outgoing-junction relay-group.

In those exchanges in which the meter-rate determination is provided locally (item  $d(v)$  in the list of coder instructions given above), the meter rate obtained from the coder is stored in the outgoing-junction relay group immediately after the continuity check has been made.

#### *Outgoing-Junction Call (Director Area)*

The alternative routing facility provided in the coder enables small groups of high-usage direct junctions to be provided to a large number of exchanges in the area, and quite possibly to all of them, so that only a comparatively small proportion of the total traffic need be routed via the tandem exchange.

Calls which are routed over direct junctions require no director facilities at all, and are dealt with exactly as described for outgoing-junction calls in non-director areas. The second class-of-service in the outgoing-junction relay group is strapped to instruct the register and sender to omit the code digits and to pulse out the numerical digits only.

Calls that are routed via a tandem exchange leave the 5005-crossbar exchange via outgoing junctions equipped with relay groups which have access to transenders, i.e. translating senders. The numbers of these outgoing-junction relay groups can be made comparatively small, by arranging for the bulk of the outgoing traffic to be handled by high-usage direct junctions. The number of transenders will, therefore, be very much smaller than the number of registers—typically, half a dozen transenders could serve a 5,000-line exchange.

A transender, having been seized by an outgoing-junction relay group, receives the digits across the exchange from the register and sender at 20 pulses/second. The arrival of digits in the transender from the register at 20 pulses/second tends to catch up with the arrival of digits in the register at 10 pulses/second from the subscriber. As soon as the transender has caught up, its operations are performed one digit behind the subscriber's dialling. When the transender has received enough digits, it applies to the outgoing coder successively for the first, second, et. seq., routing digits and transmits these to the junction. On its last application to the outgoing coder, say the sixth, it is instructed to pulse out the numerical digits, and is informed how many code digits to omit (in case the area does not have a completely uniform numbering scheme). The transender releases after pulsing out the last numerical digit.

#### *Outgoing S.T.D. or I.S.D. Call*

For an outgoing subscriber-dialled trunk call or an international subscriber-dialled (I.S.D.) call, the caller seizes the transmission relay-group and register as already described, and dials a number beginning with the access digit 0. The register can be strapped to apply immediately

to the router control to set up the call to the outgoing subscriber trunk dialling (S.T.D.) junction group, if there is only one such group, or it can await further digits if a choice of route has to be made.

The first seven digits dialled by the caller are stored in the register, as already described. By the time the seventh digit has arrived the call will have been set up to an outgoing junction, and the register will have seized a sender. The sender has storage for three additional digits (allowing for 10 digits altogether), and also has access to a small pool of auxiliary digit stores for use on I.S.D. calls.

The meter rate for the call is controlled from the outgoing-junction relay group, either by meter pulses received over the junction, if the 5005-crossbar exchange is a remote non-director exchange, or by meter-rate determination from the coder if it is a G.S.C.

The sender which is seized by the register on an S.T.D. or I.S.D. call can be one of the common pool of 10 pulses/second senders used on all outgoing-junction calls or it can be one of a special pool of S.T.D./I.S.D. senders arranged for m.f. pulsing out, according to the method of signalling digital information required by the distant exchange.

#### *Transit Call*

A transit call arrives on an incoming transmission relay-group, as already described. On applying to the router control and coder, the class of service of the incoming transmission relay-group causes the coder to modify the instructions that it returns to the router control to allow for barred codes, or for S.T.D. procedure used in error by a caller, or for the determination of the meter rate with respect to the charging areas of origin and destination.

The transit call is then set up as already described for an outgoing call. If 10 pulses/second or 20 pulses/second signalling is used on the incoming or the outgoing side, all the digits are received in the register, and as many as are required by the distant exchange are sent out by the sender. If, however, the previous exchange sends digital information by m.f. pulsing, and if the next exchange expects to receive digital information by m.f. pulsing, then the m.f. register at the transit exchange retires after the call has been set up, leaving the register at the next exchange to receive m.f. pulses direct from the sender at the originating exchange.

#### MISCELLANEOUS SERVICE FACILITIES

Coin-box lines, shared-service lines, transfer of incoming calls, subscribers' 2-stage preference, and subscribers' private meters are provided as in Strowger exchanges.

Trunk-offering and test-access facilities are provided via the normal switch train by means of a class-of-service strap on the incoming transmission relay-group from the manual board or test desk. The strap instructs the

router control to override the busy condition of the called subscriber's line and set up the call. The transmission relay-group then returns busy tone until instructed by an earth signal to switch through. Centralized service observation is provided by access circuits attached to a percentage of transmission relay-groups.

#### CONCLUSIONS

The 5005-crossbar system uses 3,000-type relays for general purposes and large-capacity long-life relays (A.T.E. Type 501) for control circuits. Wrapped joints are used extensively for making connexions to terminal blocks and to the large-capacity relays. The equipment practice avoids the use of jack-in equipment almost entirely. "Circuit links" in all control wires are provided on terminal blocks, enabling any equipment unit to be isolated from traffic if maintenance attention is necessary.

The performance of the whole exchange is under continuous surveillance by an electronically-controlled monitor, which provides a local or remote print-out of the history of any call that fails to be successfully established on completion of dialling.

#### ACKNOWLEDGEMENT

The author wishes to thank the management of the Plessey Telecommunications Group for permission to publish this information, and his colleagues in the Crossbar Division of Automatic Telephone & Electric Company, Ltd., by whom the 5005-crossbar system was developed.

*(To be continued)*

#### *Bibliography*

- <sup>1</sup>ISTERLING, J. The Type 5005 Crossbar System—A New Concept in Crossbar Exchanges. *A.T.E. Journal*, Vol. 18, p. 149, Oct. 1962.
- <sup>2</sup>LEA, H. H. The Type 5005 Crossbar System—Some Aspects of Equipment Design. *A.T.E. Journal*, Vol. 19, p. 16, Jan. 1963.
- <sup>3</sup>LINCOLN, N. A., SMITH, J. R. W., and SMITH, J. L. The Type 5005 Crossbar System—Trunking Design, Traffic Theory. *A.T.E. Journal*, Vol. 19, p. 64, Apr. 1963.
- <sup>4</sup>CORNER, A. C. The Trunking Principles of the 5005T 4-Wire Crossbar Exchange for National and Intercontinental Service. *A.T.E. Journal*, Vol. 20, p. 41, Jan. 1964.
- <sup>5</sup>BRADLEY, A. The Type 5005D Small Crossbar Exchange. *A.T.E. Journal*, Vol. 20, p. 83, Apr. 1964.
- <sup>6</sup>CORSER, A., and SANDS, A. J. Maintenance and Operation of the 5005 Crossbar Exchange. *A.T.E. Journal*, Vol. 20, p. 127, July 1964.
- <sup>7</sup>REEVES, L. N., BECKETT, G. J., and LITTLE, R. F. The 5005T Intercontinental Exchange, Sydney, Australia. *A.T.E. Journal*, Vol. 20, p. 138, Oct. 1964.
- <sup>8</sup>CURTIS, G., and LUNT, R. J. Broughton Crossbar Telephone Exchange—A.T.E. Type 5005A. *A.T.E. Journal*, Vol. 21, p. 38, Jan. 1965.
- <sup>9</sup>CORSER, A. Performance of the 5005 Crossbar Exchange on the Company's Premises. *A.T.E. Journal*, Vol. 21, p. 90, Apr. 1965.
- <sup>10</sup>SANDS, A. J. The Installation and Testing of an Overseas 5005 Crossbar Telephone Exchange. *A.T.E. Journal*, Vol. 21, p. 120, July 1965.

# The New Leaffield Radio Station

## Part 2—The Control System

J. A. Chambers, A.M.I.E.E.†

U.D.C. 621.396.71:621.316.726:621.396.61

The factors governing the design of the new Leaffield transmitting station were described in Part 1. Part 2 describes in greater detail the control system which, in principle, probably approaches the ultimate design for the remote operation of high-frequency point-to-point transmitting stations. Some information on the transmission-checking devices employed at the station is also given.

### INTRODUCTION

**B**ETWEEN 1954 and 1960 over 50 high-power high-frequency transmitters, capable of remote control, were installed at Post Office radio stations to cater for the post-war expansion in long-distance telephone and telegraph traffic. A typical installation is the Rugby B Station<sup>1</sup> containing 28 identical 30 kW transmitters.

Transmitters of this era can be switched on or off, tuned to any one of six predetermined frequencies, and connected to an appropriate aerial in response to control signals from a central control position (C.C.P.) located within the station. With this arrangement, the day-to-day functions of between 20 and 30 transmitters, as necessitated by traffic requirements and changing propagation conditions, can be dealt with by one or two men at the C.C.P. Similar operations for an equivalent number of manually-adjusted transmitters would require many more men.

Although a considerable step forward, the above system does not contain sufficient inherent reliability to prevent some service interruptions, and changing to a

†Overseas Radio Planning and Provision Branch, E.-in-C.'s Office.

<sup>1</sup>COOK, A., and HALL, L. L. The Rugby "B" High Frequency Transmitting Station. *P.O.E.E.J.*, Vol. 50, p. 15, Apr. 1957.

<sup>2</sup>BOOTH, C. F., and MACLARTY, B. N. The New High-Frequency Transmitting Station at Rugby. *Proceedings I.E.E.*, Vol. 103, Part B.

spare transmitter, which is necessarily manually-tuned, involves some time in restoring service. For this and other reasons the plant utilization efficiency is not appreciably higher than before.

The advent of the frequency-following type of transmitter, which, in association with a frequency-synthesizer that will automatically tune itself, on instruction, to any frequency within its range, has enabled a higher degree of flexibility and service reliability to be achieved, and this, in conjunction with a newly-developed control system, enables control of transmitting stations from traffic terminals to be contemplated.

Eighteen frequency-following transmitters have been provided at Leaffield, divided into three groups of six (one group with transmitters each of 85 kW output and two groups with transmitters each of 30 kW output), and the control system not only provides complete flexibility within a group but also allows a degree of interconnexion between the groups.

The arrangement and working of the 30 kW system is described below.

### CONTROL SYSTEM FOR POINT-TO-POINT SERVICE

Fig. 1 shows a simplified diagram of connexions between the lines incoming to the radio station and the directional aeriels for a particular service. The example chosen, which is typical of a high proportion of current point-to-point services, represents an arrangement of frequency-division multiplex (f.d.m.) telegraph systems in the upper side-band (u.s.b.) and the lower sideband (l.s.b.) of an independent-sideband (i.s.b.) transmission. The necessary control functions at the daily commencement of service, or when changing the frequency of transmissions, are

(a) to connect the output of the drive equipment, which

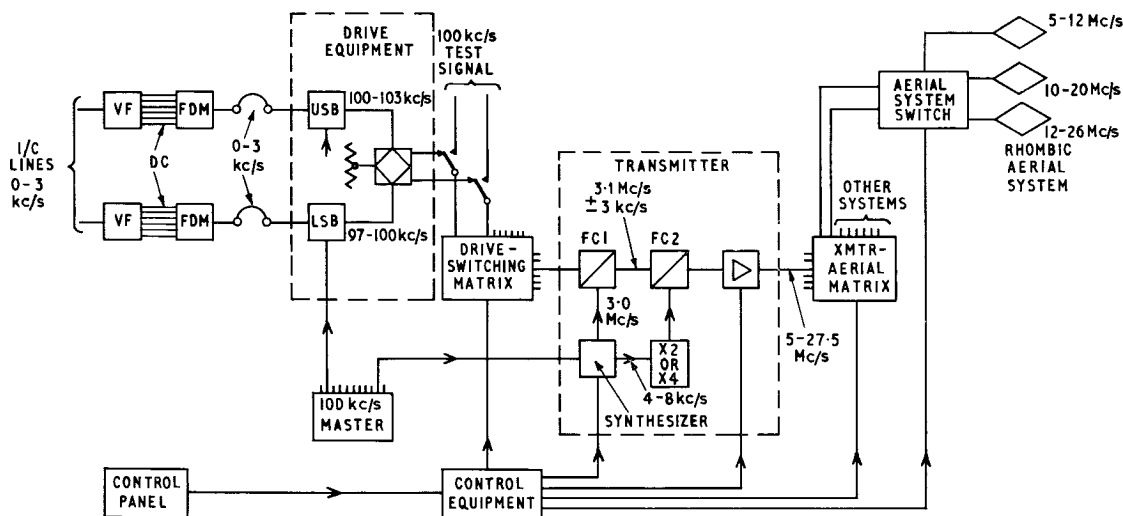

FIG 1 SIMPLIFIED ARRANGEMENT OF CONNEXIONS BETWEEN LINES AND AERIALS

is normally associated with a particular service, to a selected free transmitter via the drive-switching matrix, and to switch on the transmitter,

(b) to set the frequency-synthesizer so that the transmitter will tune itself to the frequency required for the service,

(c) to connect the radio-frequency (r.f.) output from the transmitter, via the transmitter-aerial matrix, to the correct aerial-system switch, and

(d) to operate the aerial-system switch to select the aerial best suited to the frequency of transmission.

All these functions are accomplished automatically following the operation, at the C.C.P., of a single 6-position selector which provides for a choice of one of five frequency allocations for the service and an "off" condition.

The essentials of the control circuit are shown diagrammatically in Fig. 2. Functions (a) and (c) are

switching relays TA–TF operate the appropriate switches in the drive-switching matrix and in the transmitter-aerial matrix.

The transmitter tunes itself to the required transmission frequency following the application of, firstly, a d.c. signal which indicates in which one of nine frequency bands the required output-frequency will fall and, secondly, a r.f. signal from the synthesizer, in the 4–8 Mc/s range, which is a submultiple of the required conversion frequency. This signal is multiplied in the transmitter by two or four, according to information derived from the band-indicating signal, and is then applied to frequency changer FC2 of Fig. 1. This is accomplished in the following manner.

Only one of the relays AM–EM, shown in Fig. 2, can be operated at any one time. Assuming that, say, relay DM is operated, the circuit through only one of the contacts DM 1–6 can be completed, depending upon which of the relays TA–TF is operated. The completed circuit

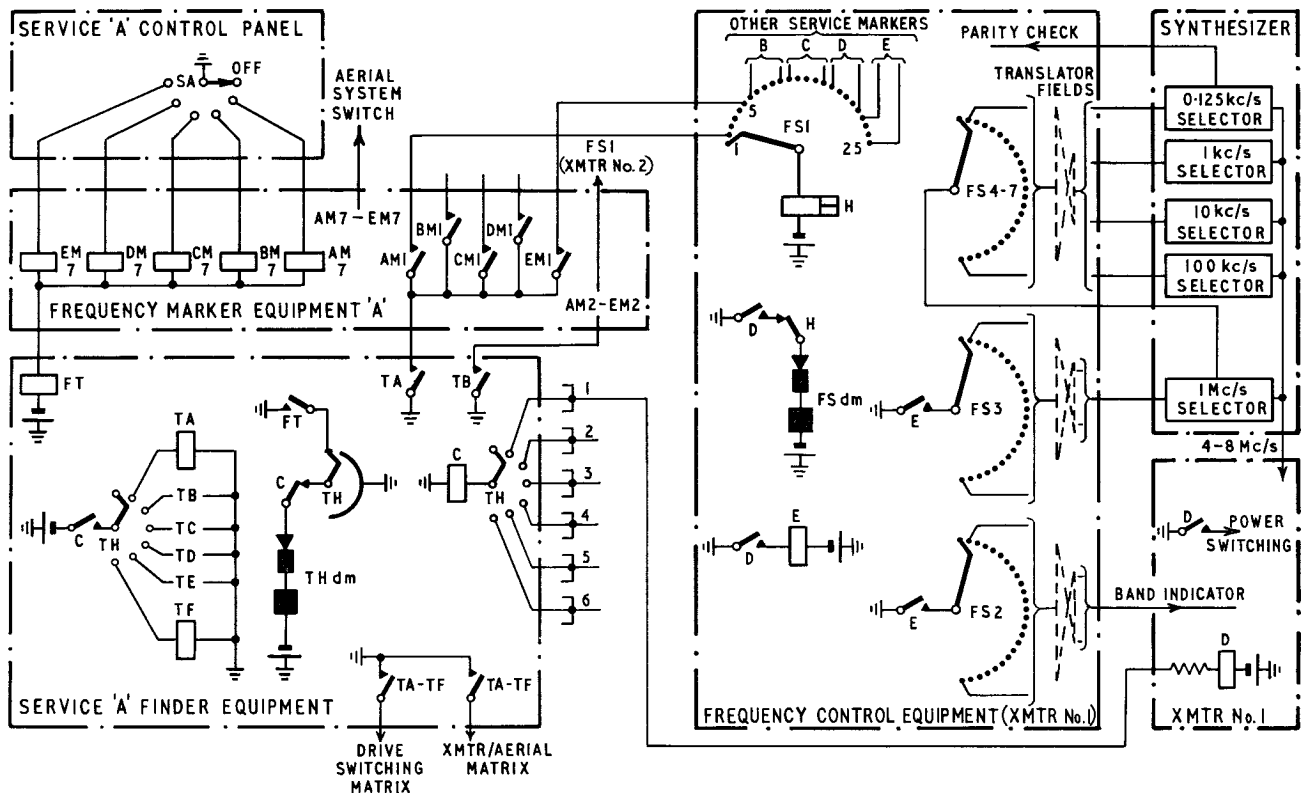

FIG. 2—CONTROL CIRCUIT

performed by means of a line-finder. When the frequency selector, SA, is moved from the OFF position one of the relays AM–EM and relay FT operate. An FT contact causes the associated finder, TH, to hunt for a free transmitter. A free transmitter extends, through its relay D, a negative potential which is multiplied to all finders in the group-control system, and finder TH stops when such a condition is encountered. The multiple is then "busied" through the low-resistance coil of relay C and, at the same time, relay D operates. Contacts of relay D initiate the switching-on process for the transmitter seized and complete the drive circuit for the uniselector, FS, in the associated frequency-control equipment. Contacts of one of the auxiliary-service

is extended to mark uniselector FS, which finds the marked position and extends, via uniselector arc FS2, a d.c. band-switching signal to the transmitter and, via uniselector arcs FS 3–7, a signal to the selector-switches in the associated frequency-synthesizer. The connexions from uniselector FS are made through translation fields, which are programmed in accordance with the 25 frequency allocations required for the complete transmitter group. A 50-point selector is used to enable the allocations for both 30 kW groups to be programmed. Thus, if need be, a transmitter can readily be switched from its normal group to form a seventh transmitter in the other group. The selector-switches in the synthesizer operate sequentially, i.e. when the 1 Mc/s is

correctly positioned via uniselector arc FS3 the marking signal is transferred from arc FS3 to uniselector arc FS4, which then extends it to mark the 100 kc/s selector, and so on until all the selectors in the synthesizer are correctly positioned. The marking signal finally operates a parity-check relay to indicate completion of the frequency-selection function. Contact DM7 provides information for the aerial-system switch, to ensure that the aerial appropriate to the frequency is selected.

To ensure continuity of service during frequency changes the signal is radiated for a short time on two frequencies, a procedure known as dualling. For each dualled service there are two identical frequency selectors at the control panel, each having its associated finder equipment. There are also two outputs from each drive equipment into the drive-switching matrix and two outputs from the transmitter-aerial matrix into the aerial-system switch for each dualled service.

Because Leaffield has been designed to permit eventual control from the London traffic terminals, it has been necessary to build a high degree of reliability into the control system and to provide evidence at the control point that commands have been correctly obeyed. This has been achieved, as exemplified in the description of the synthesizer control, by arranging that correct completion of each function results in the operation of a parity-check relay. Contacts of all such relays are arranged to give a single "ready" signal when all functions have been performed correctly. As part of this parity-check system the transmitters have level detectors at their inputs and outputs which include auxiliary circuits to give an alarm indication if the levels become subnormal during traffic and, in conjunction with a standard input test-signal, to prevent a transmitter from being connected to traffic unless the output power is normal. Low output from a transmitter, or failure in any equipment associated with it, will cause this transmitter to be discarded from the system and a search for another transmitter to commence.

In general, conventional electromagnetic telephone-switching components have been employed in the d.c. control circuits. These are expected to have adequate reliability since the switching actions will be infrequent (several times per day for each service, generally) and mechanical wear will be insignificant during the life of the associated radio equipment. Also, little if any deterioration of contacts is expected in these components because of the rural situation of the station.

Special precautions have been taken in the drive-switching matrix because of the low signal level at this point. Unprotected electrically-dry metallic contacts in low-level signal paths have quite often been a cause of trouble in the past, and for this reason the matrix has been designed around the sealed reed-contact switch which is expected to give a long and trouble-free life. Fig. 3 shows a complete  $11 \times 7$  coaxial matrix with one "transmitter level" partly withdrawn. The reed contacts form the inner conductor of a removable insert, and the operating coil is wound over the insert. The connexions to the coil are made through the printed-wiring board mounted on the withdrawable frame.

#### ASSESSMENT OF QUALITY OF TRANSMISSIONS

If a report of a faulty transmission is made by the distant receiving terminal it is essential to be able to

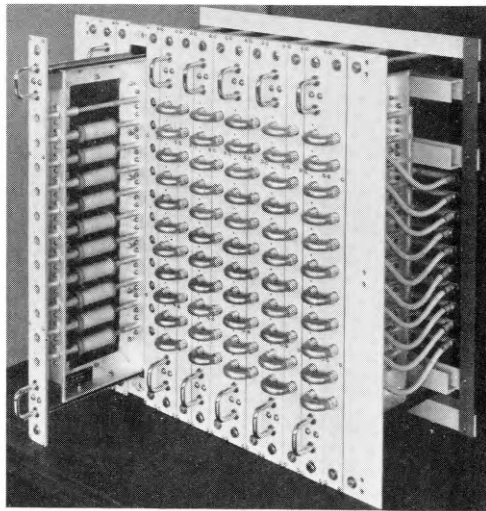

FIG. 3—THE  $11 \times 7$  COAXIAL MATRIX

check whether or not this is due to the radio transmitting equipment, and if the transmission is of the f.d.m. type it must be first broken down into its channel components. In general, the channel signals cannot be intelligibly printed at the radio station without highly specialized and expensive equipment, but by comparing any f.d.m. channel input-signal from the traffic terminal with the corresponding output signal from the transmitter it is possible to determine if there is a fault in the radio equipment.

Fig. 4 shows, in outline, the arrangement for making these comparisons. A small portion of the r.f. output from each transmitter is demodulated to 3.1 Mc/s, and thence to 100 kc/s. The 100 kc/s signals are connected to a reed-switch matrix, similar to that used for drive switching, and it is arranged that any particular output of this matrix is always associated with the same service regardless of the transmitter in use. Selection of any one service output can be made at the C.C.P. for connexion to a simplified i.s.b. receiver which demodulates the side-band signals to baseband frequencies. The baseband may be displaced in discrete steps, by means of a frequency-changer, to permit each f.d.m. channel in turn to be centred within a single filter and thence demodulated to d.c. The d.c. signal is then compared, on an oscilloscope or a double-pen undulator, with the corresponding input to the f.d.m. equipment. Comparison will disclose any abnormalities in the radiated signals, such as (a) incorrect amplitude, (b) polarity inversion, or (c) excessive distortion.

This arrangement is primarily intended for use by attendant staff at Leaffield, but it could form the basis for extending inspection facilities to the traffic terminals in due course.

#### CONCLUSIONS

The development of the Leaffield control system has

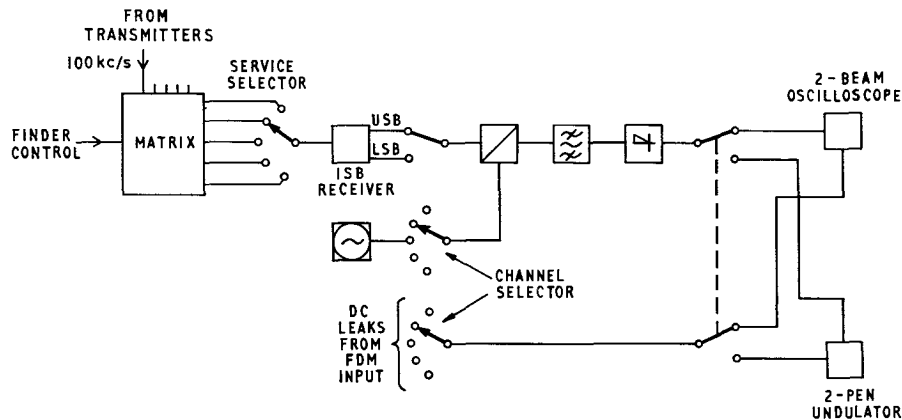

FIG. 4—TELEGRAPH CHANNEL INSPECTION

brought nearer the time when it will be possible to operate large high-power transmitting stations by remote control from the traffic terminal with a minimum of local staffing. When this finally comes about, the

operating costs, already substantially reduced by centralized local control as at Rugby B, will be still further reduced. The principles of design evolved at Leaffield are being essentially followed in other similar projects.

(Part 3 appears on page 196)

## A Device to Replace Conventional Polarized Relays

R. T. G. SALLIS†

U.D.C. 621.318.562.3:621.318.57

Some electromagnetic polarized relays used for signal repetition in telegraph circuits are subjected to heavy use and require servicing at frequent intervals. Some worth-while advantages in maintenance costs and circuit efficiency could be obtained by the replacement of such relays by an inherently more reliable item. Such a device, using semiconductors as the active components, has been developed and has proved very satisfactory in service.

### INTRODUCTION

ON heavily-worked telegraph circuits the contacts of conventional polarized relays are subjected to heavy wear, particularly when the signalling voltage is the usual  $\pm 80$  volts and is operating highly inductive loads such as teleprinters. In many instances the relays require changing every day, and particular difficulty has been experienced on certain telegraph equipment such as automatic-repetition systems (ARQ) used on radio circuits<sup>1</sup> and time-division multiplexing equipment used on circuits over submarine cables.<sup>2</sup> These types of equipment use many polarized relays, and, because of the synchronous method of working, the relays are operating continuously at modulation rates as high as 192 bauds, resulting in about  $7 \times 10^6$  operations per day.

A large saving in maintenance manhours and an im-

provement in technical efficiency and annual charges could be achieved if these relays could be replaced by devices which would require no routine maintenance and were not significantly expensive.

Various types of semiconductor component are potentially suitable for use in a semiconductor-type relay, but one difficulty is the relatively high voltages and currents which have to be controlled; peak-to-peak voltages of 300 volts are often experienced when working into highly-reactive loads. However, the recent production of reasonably-priced high-voltage transistors has allowed the design of an economical switching circuit using only diodes and transistors as the active elements. For the device described below it was necessary to convert the  $\pm 6$ -volt signals produced by the multiplexing equipments into  $\pm 80$ -volt signals for distribution to terminating teleprinters or for transmission over cable pairs between the London telex exchange (Fleet) and the overseas telegraph terminal at Electra House, London, in circumstances where low-level signalling voltages would not be satisfactory.

### DESCRIPTION OF SEMICONDUCTOR-TYPE RELAY

The diagram shows the basic circuit used for the semiconductor-type relay. With no bias connected and the potential of the input wire negative relative to earth, transistor VT1 is cut off and transistor VT2 conducts. As a result, current flows into the base of transistor VT5, and the transistor conducts. The emitter current of transistor VT5 is the base current of transistor VT7;

†Telegraph and Data Systems Branch, E.-in-C.'s Office.

<sup>1</sup>CROISDALE, A. C. Teleprinting Over Long-Distance Radio Links. *P.O.E.E.J.*, Vol. 51, p. 88, July 1958, and p. 219, Oct. 1958.

<sup>2</sup>CROISDALE, A. C. Time-Division Multiplex Telegraphy on the Transatlantic Telephone Cable. *P.O.E.E.J.*, Vol. 54, p. 113, July 1961.

transistor VT7 is bottomed, and, in this condition, provides a low-resistance connexion between the output wire and the  $-80$ -volt supply. A negative potential is fed

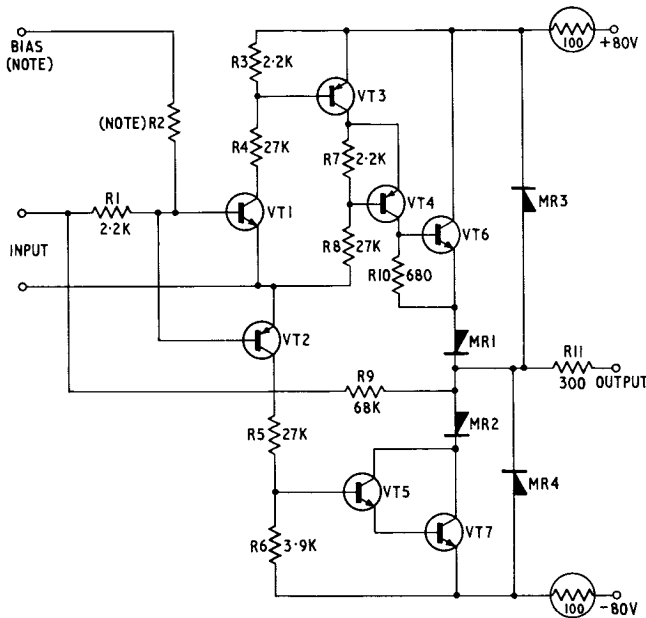

Note: The potential applied at this point may be either  $+80$  volts or  $-80$  volts, and the value of resistor R2 is selected to give the desired operating conditions

CIRCUIT DIAGRAM OF SEMICONDUCTOR-TYPE RELAY

back via resistor R9 to the input circuit to maintain the device firmly in the  $-80$ -volt switched condition until the input wire becomes positive.

The feedback circuit also serves to trigger the relay into the required state. For example, upon a transition from positive to negative potential at the input, as soon as the potential has become negative by only a small amount, changes occur in the conducting states of transistors VT2, VT5 and VT7, causing a negative potential to be fed back from the output. Regenerative action round the loop then quickly puts the device fully into the  $-80$ -volt conducting state. Because of this very rapid change-over it is possible to use transistors that are rated for only low-power dissipations.

The reason for including transistor VT5 in the circuit is to obtain the gain needed to hold transistor VT7 in the bottomed condition, even under fault conditions. If transistor VT7 departed from the bottomed state the voltage across it would rise, and the power dissipated in it would exceed the safe limit. Transistors VT5 and VT7 are both n-p-n types capable of withstanding a backward voltage of 200 volts, a value in excess of the voltage they are required to withstand in the present circuit.

When a positive potential is applied to the input, transistor VT1 conducts and transistor VT2 is cut off. With transistor VT2 in a state of non-conduction, conduction in transistors VT5 and VT7 also ceases. The collector current of transistor VT1 produces a voltage across resistor R3, so causing base current to flow in transistor VT3. The voltage across resistor R7 due to the

collector current of transistor VT3 causes base current to flow in transistor VT4. The collector current of transistor VT4 is also the base current of transistor VT6; transistor VT6 now conducts and connects the output wire to the  $+80$ -volt supply. A positive potential is fed back via resistor R9 to the input circuit to maintain the device firmly in the  $+80$ -volt switched condition.

Transistors VT3 and VT4 are necessary to obtain the current gain needed to hold transistor VT6 in the bottomed condition, even under fault conditions. Fundamentally, one transistor could effect this, but inexpensive p-n-p transistors that can withstand backward voltages of 160 volts are not at present obtainable. The transistors used will withstand a 125-volt backward voltage, and the circuit design ensures that this value is not exceeded. When the output is switched from  $+80$  volts to  $-80$  volts, a potential of 160 volts exists between the emitter of transistor VT3 and the collector of transistor VT4. However, the collector of transistor VT3 and the emitter of transistor VT4 are each at earth potential and the desired voltage limitation is achieved.

Diodes MR1, MR2, MR3 and MR4 are included in the circuit to prevent damage to the output circuit if the device is connected to its load via a low-pass filter, e.g. a Filter, Frequency, No. 4B. The input voltage to such a filter is likely to assume instantaneous values exceeding 80 volts, and diodes MR1 and MR2 prevent reverse potentials being applied to the output transistors. Diodes MR3 and MR4 act as voltage clamps and provide a low-impedance path for the reverse current, the energy being dissipated in the 300-ohm resistor.

A biasing arrangement, consisting of resistor R2, may be connected to the input circuit if required. Suitable values may be chosen for resistor R2 so that, by applying the appropriate potential, the output may be switched as desired to either the positive or negative condition if the input circuit is left open-circuit, and so provide a simulated double-current effect if the applied signal is single current. By varying the value of resistor R1, which limits the current into the base of transistor VT1, it is possible to operate satisfactorily over a wide range of nominal input voltages.

#### PERFORMANCE

Prototypes to this design have been manufactured and have performed efficiently. There would appear to be no practical limit to their life if the comparatively-wide tolerances of the components used in the device are not too closely encroached upon.

#### CONCLUSIONS

The semiconductor relay has offered a satisfactory solution to a telegraph transmission difficulty. It has been convenient in the present application to assemble the components on a printed-wiring board associated with the appropriate relay base and cover to allow easy replacement of the existing electromagnetic relay. In new equipment, however, a device such as this would lose its individual identity and the components would be assembled integrally with the associated electronic circuits.



# Incoming Core-Type Register-Translator For Director Areas

## Part 2—The Functional Design

C. K. PRICE and W. A. IRELAND†

U.D.C. 621.395.341.72:621.395.345

This article, which is in two parts, describes an electronic, time-shared, register-translator system which incorporates magnetic-core information stores, and magnetic-core and semiconductor circuit elements. The register-translator is used in director areas to distribute incoming traffic to each exchange in the area. Part 1 dealt with the principles of design; Part 2 describes the logic design of the incoming register-translator, the design being based on the use of elements described in Part 1.

### INTRODUCTION

THE common processing equipment, which this part of the article describes, comprises four sections: the "in" computer, which, broadly, is concerned with those processes involved in the detection of incoming digits and their distribution to the relevant digit stores, the "incoming digit stores" in which incoming digital information is retained, the "translator" which is concerned with the interpretation of combinations of incoming code digits, and the "out" computer which is concerned with those processes involved in the transmission of digits and release of registers.

It will be recalled that the common processing equipment is allocated, during discrete time slots each of approximately 80  $\mu$ s duration, to each of 200 registers in turn, one complete scan period occupying 16 $\frac{2}{3}$  ms. Each time slot is divided into three phases, namely, read, decide and write, known as R<sub>0</sub>, R<sub>2</sub> and R<sub>w</sub> times, respectively. For any register, therefore, information is read out of the corresponding register column in the central data store at R<sub>0</sub> time, acted upon at R<sub>2</sub> time, and the store updated at R<sub>w</sub> time. Access by each input to the common processing equipment is via individual register signal-conversion circuits (s.c.c.).

The sequence in which the different functional parts of the equipment are described below can be seen by reference to the block schematic diagram of Fig. 10 (Part 1): first, the in computer is broken down into the four functions shown, the logical operation of the circuit for each function being described in some detail; this is followed by a description of the incoming-digit stores; thirdly, there is a description of the translator; finally, the out computer is broken down into the six functions shown, again, the logical operations being described in some detail.

### Symbols and Signal Designations Used

It must be emphasized, as in Part 1 of this article, that in describing the operation of ferrite cores used as two-state devices the terms "set" and "reset" refer to the two states, but such two-state devices produce only transient outputs corresponding with and occurring at one or other of the two possible changes of state. In all the functional diagrams in this article the general symbol for a toggle has been used with the letters S and R inserted to indicate the set and reset states, respectively.

Each function is given a letter code, and this code is

†Telephone Exchange Systems Development Branch, E.-in-C.'s Office.

used in the designation of components appearing in the functional diagram associated with each function. The code is also used in the designation of signals, be they derived from amplifiers reading out information held in the central-data-store cores or from cores within the logic circuit for the function; designation of signals from the latter cores always refer to the set outputs of the cores, i.e. at time R<sub>0</sub>, unless otherwise stated.

The following are examples of the method of coding the functions and signals. The digit distributor is designated "distributor DD," and the function control element used in the logic circuit for distributor DD is designated "element DD-FC1." The fifth core in the 10-stage function unit used in the time-slot-free/time-slot-seized control (FS) logic circuit is designated "core FS-5," and the output signal from the set state of that core is "signal FS-5."

The reading and writing amplifiers associated with the central-data-store cores are identified by a letter code. Those operating in the two-out-of-five mode are identified by the letter series A to E, e.g. those associated with the pulsing-in counter, counter PIC, are designated "amplifier PIC-A" to "amplifier PIC-E," and signals originating from these amplifiers are coded "signal PIC-A" to "signal PIC-E." Auxiliary amplifiers (1-stage function units) associated with central-data-store cores and operating in conjunction with a 10-stage function unit commence their coding at letter F, e.g. the amplifier FS-F in the time-slot-free/time-slot-seized control circuit.

In the functional circuit diagrams used to describe the various sections of the equipment an abbreviated form of diagram has been used: the only connexions shown are those which join standard units together to perform the required logical functions; the internal connexions of the complete function units are not included. For the circuit of the 10-stage function unit, for example, refer to Fig. 12 (Part 1). The following table shows the code relationship used for coded signals in the two-out-of-five mode and the one-out-of-ten mode.

Code-Conversion Table

One-out-of-ten	Two-out-of-five
1	A.B
2	A.C
3	B.C
4	A.D
5	B.D
6	C.D
7	A.E
8	B.E
9	C.E
10	D.E

### TIME-SLOT-FREE/TIME-SLOT-SEIZED CONTROL AND LOOP-DISCONNECTED DETECTOR

The time-slot-free/time-slot-seized control (FS) is used (a) to generate time-slot-free or time-slot-seized signals

used in all function units, and (b) to measure the duration of line-break signals to distinguish between a break during dialling and a clear-down. The functional circuit for control FS is shown in Fig. 18.

### Time-Slot Free

The time-slot-free signal is required in all function units, being used to establish the home positions for all functions for idle registers. This signal is generated by

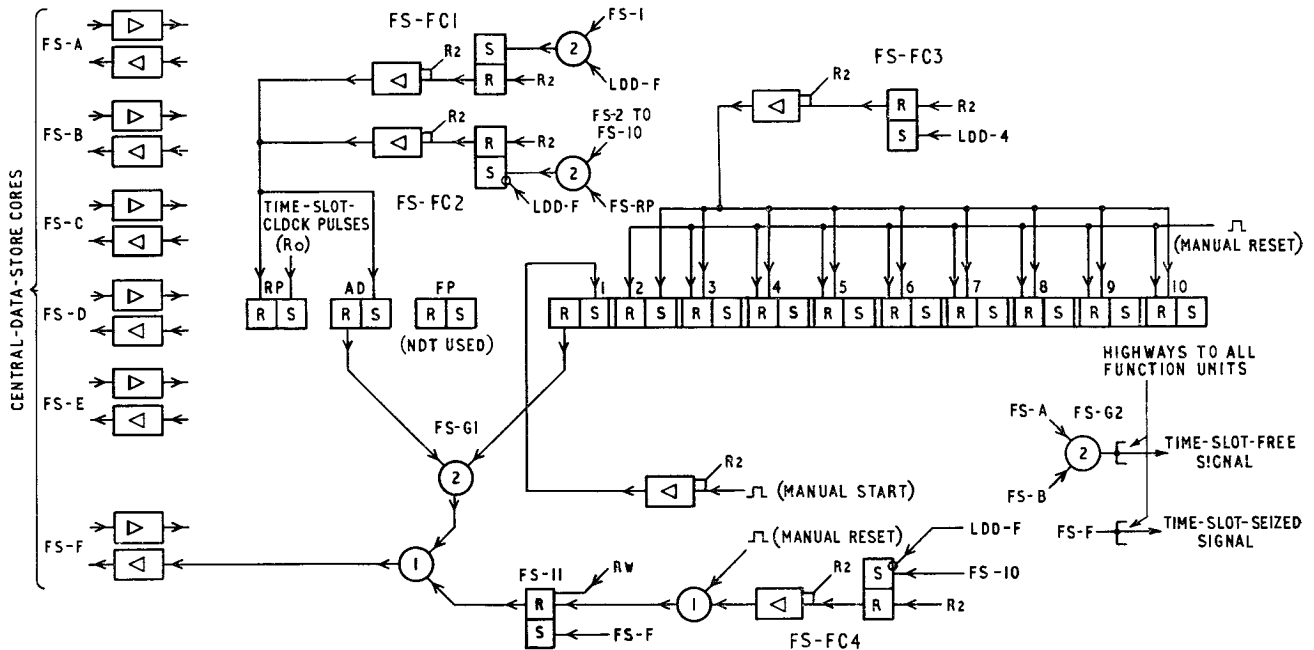

FIG. 18—FUNCTIONAL CIRCUIT OF TIME-SLOT-FREE/TIME-SLOT-SEIZED CONTROL

The loop-disconnected detector (LDD) is used (a) to generate the "dial-pulse" signals, which drive the pulsing-in counter (PIC), (b) to generate the "end-of-dial-break" signal, which resets control FS, and (c) to measure the duration of the "line-make" signal produced by the register s.c.c. to determine the incoming interdigital pause. The functional circuit for detector LDD is shown in Fig. 19.

control FS, and therefore the free-pattern circuit in the standard 10-stage function unit used for this function and normally activated by the common time-slot-free-highway signal cannot be used. Some other means must be used to insert the free-pattern condition (value 1) into the control FS, and it is arranged that core FS-1 shall be set, all other cores having been reset, when the equipment is first switched on. Alternatively, as shown

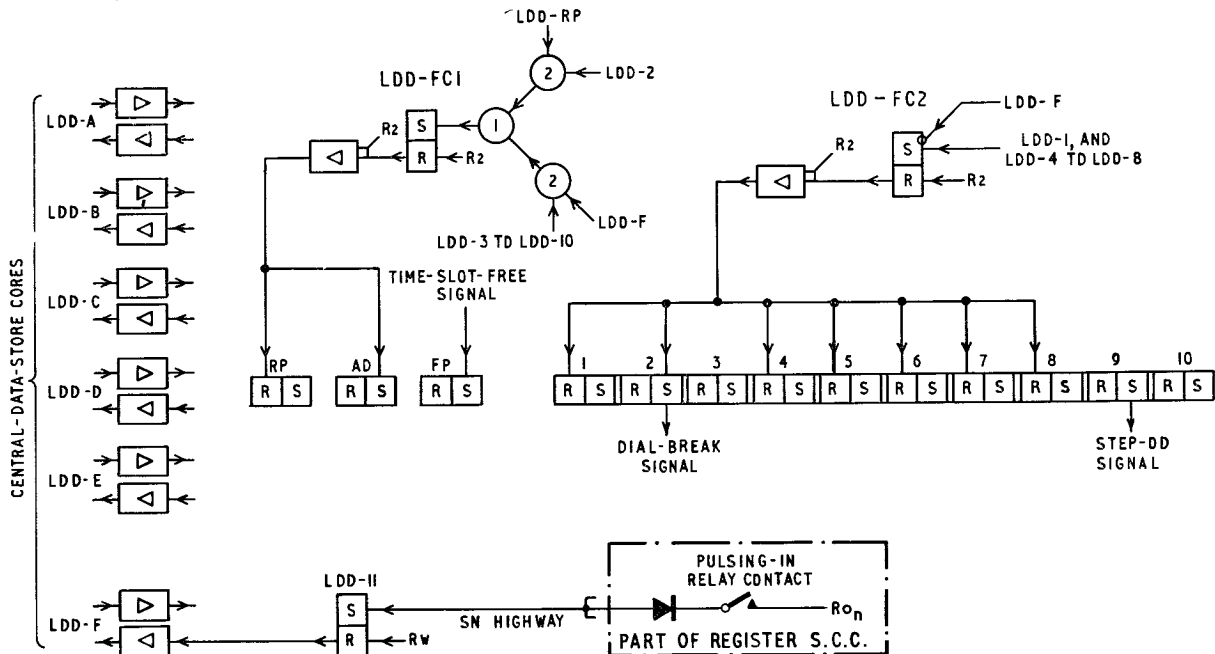

FIG. 19—FUNCTIONAL CIRCUIT OF LOOP-DISCONNECTED DETECTOR

in Fig. 18, provision is made for manual reset-start.

When the reset pulse is applied, cores FS-2 to FS-10 and core FS-11 are reset. The ensuing start pulse sets core FS-1 at each time-slot R<sub>2</sub> time. By the repeating action of the 10-stage function unit, re-cycling of the value 1 continues after removal of the start condition until register seizure. However, because this control also generates the time-slot-seized signal, an all-time-slot clock signal (R<sub>o</sub>) instead of the common time-slot-seized-highway signal sets core FS-RP.

Thus, at each time-slot R<sub>o</sub> time, read amplifiers FS-A and FS-B produce outputs which are gated together (gate FS-G<sub>2</sub>) and distributed as time-slot-free signals to all other function units in the system. When any time slot is seized, the corresponding time-slot-free pulse is replaced by a time-slot-seized signal.

#### *Time-Slot Seized*

When a register s.c.c. is seized, the corresponding register R<sub>o</sub> pulse is passed via the SN highway to set core LDD-11 (see Fig. 19). At the ensuing R<sub>w</sub> time, core LDD-11 is reset, and the output signal, amplified by write amplifier LDD-F, is stored in the corresponding core in the register column concerned in the central data store. At the following R<sub>o</sub> time, 16 $\frac{3}{8}$  ms later, and at every R<sub>o</sub> time while the seize condition obtains, read amplifier LDD-F produces an output signal used to control the time-slot-free/time-slot-seized control, FS, and the loop-disconnected detector, LDD.

In function control element FS-FC1, signal FS-1 with signal LDD-F set a core, the output of which at R<sub>2</sub> time resets core FS-RP (previously set during R<sub>o</sub> time) and sets the "advance" core, core FS-AD. At the ensuing R<sub>w</sub> time, cores FS-AD and FS-1 are reset. The control FS, which can be considered as in position 1, is thus advanced to position 2, write amplifiers FS-A and FS-C being stimulated. At the next R<sub>o</sub> time, 16 $\frac{3}{8}$  ms later, read amplifiers FS-A and FS-C outputs appear and set core FS-2. Function control element FS-FC1 is now inoperative, because it requires the signal FS-1 which is not now present, and element FS-FC2 is inhibited by signal LDD-F; hence, there is no advance instruction and the repeat core FS-RP, set during time R<sub>o</sub>, remains set until time R<sub>w</sub>, when it and core FS-2 are reset, re-writing the value 2 into the register-column core concerned. At successive R<sub>o</sub> times, amplifiers FS-A and FS-C read out, maintaining position 2 in the 10-stage function unit core store while, at corresponding R<sub>w</sub> times, the write amplifiers FS-A and FS-C are stimulated to pass the value 2 into the register-column cores concerned.

In gate FS-G<sub>1</sub>, signal FS-AD plus signal FS-1 produce a combined signal which marks time-slot seizure and which is passed to the register-column core concerned via write amplifier FS-F at R<sub>w</sub> time. At R<sub>o</sub> time, 16 $\frac{3}{8}$  ms later, read amplifier FS-F produces an output which is distributed as a time-slot-seized signal to all other function units. This amplifier also produces an output which sets core FS-11 so that the time-slot-seized condition is returned to the register-column core concerned each R<sub>w</sub> time, and is thus maintained even though control FS has advanced to position 2.

Detector LDD resides on position LDD-1 while the seized condition persists, because the "free" pattern (value 1), retained by the register-column cores when the time slot is first seized, is read out and sets core LDD-1.

Function control element LDD-FC2 is inhibited by signal LDD-F, thus ensuring the regeneration of position LDD-1. At this stage, therefore, control FS re-cycles on position 2 and detector LDD on position 1 until a break condition is detected on the highway SN.

#### *Break Condition*

Read amplifier LDD-F reads out while the make condition is signalled via highway SN; thus, element FS-FC2 is inhibited during the make period. When a break condition occurs, signal LDD-F does not appear 16 $\frac{3}{8}$  ms later at time R<sub>o</sub>; hence, signals FS-RP plus FS-2 to FS-10 set core FS-AD and reset core FS-RP at R<sub>2</sub> time so that, at the following R<sub>w</sub> time, the two-out-of-five code representing position 3 is passed to the register-column cores concerned.

At the next R<sub>o</sub> time, 16 $\frac{3}{8}$  ms later, core FS-3 is set. At R<sub>2</sub> time, core FS-RP is reset, and core FS-AD is set by signals FS-RP and FS-2 to FS-10 as before. At the ensuing R<sub>w</sub> time, the two-out-of-five code representing position 4 is passed to the register-column cores concerned. The count continues to advance in this manner one position every 16 $\frac{3}{8}$  ms scan period as long as the break condition persists.

The absence of signal LDD-F in element LDD-FC2 causes the generation of a signal at R<sub>2</sub> time which forces the detector LDD to position 2, core LDD-2 output being ineffective at this stage because, in those gates in which this signal is used, e.g. element LDD-FC1, it is accompanied by signal LDD-RP, which only occurs during time R<sub>o</sub>. The value 2 is passed to the register-column cores concerned, and is read out at the next R<sub>o</sub> time to set core LDD-2 and to produce the "dial-break" signal at R<sub>w</sub> time—the use of this signal is described later.

In element LDD-FC1, signal LDD-2 with signal LDD-RP produce an advance instruction so that detector LDD advances to position 3 at R<sub>w</sub> time. Detector LDD then re-cycles at position 3 awaiting termination of the break period. Thus, during the break period control FS advances one position per scan time and detector LDD re-cycles on position 3. One of two conditions is now possible: dial break or clear.

#### *Dial Break*

The dial-break condition persists for nominally 66 $\frac{3}{8}$  ms; hence, control FS could have advanced to position 6 or possibly further, depending upon the actual dial speed and synchronization with the scan periods. When the dial-break condition ends and signal LDD-F reappears, the advance instruction is not provided because element FS-FC2 is inhibited by signal LDD-F, and control FS repeats the position reached.

In element LDD-FC1, however, the reappearance of signal LDD-F with signals LLD-3 to LLD-10 produces an advance instruction, and detector LDD position 3 is advanced to position 4 at R<sub>w</sub> time. Thus, at the following R<sub>o</sub> time 16 $\frac{3}{8}$  ms later, core LDD-4 is set and, in element FS-FC3, produces a signal which, at R<sub>2</sub> time, returns detector FS to position 2. It should be noted that in element FS-FC2, signal FS-RP, occurring as it does during the R<sub>o</sub> period, ensures that signals FS-2 to FS-10 are made ineffective when occurring at R<sub>2</sub> time.

Meanwhile, for the duration of the make period, detector LDD continues to advance one position per scan time by virtue of the advance instruction initiated

in element LDD-FC1 by signals LDD-F and LDD-3 to LDD-10.

*Clear*

Control FS advances to position 10, and thence to position 1 by virtue of the advance instruction initiated in element FS-FC2 by signals FS-RP and FS-2 to FS-10. In the absence of signal LDD-F, control FS re-cycles on position 1 awaiting a fresh make condition representing another seizure.

At element FS-FC4, signal FS-10 initiates a signal which, at time R<sub>2</sub> of that scan period, resets core FS-11 so that the ensuing R<sub>w</sub> pulse is ineffective and no FS-F signal is returned to the register. The time-slot-seized signal is, therefore, not produced at the next R<sub>o</sub> time.

When read amplifiers FS-A and FS-B produce their output at the next R<sub>o</sub> time, the time-slot-free pulse is generated by signals FS-A plus FS-B in gate FS-G2 and continue to do so until the register is seized again as already described.

*Make Period*

It will be recalled that, at the end of the dial-break period, control FS re-cycles on position 2 while detector LDD advances one step per scan time from position 4. One of two conditions is possible: dial make or incoming inter-digital pause (i.d.p.).

*Dial-Make Period Ends*

A dial-make period is nominally 33½ ms; hence, detector LDD will have advanced to position 6 or possibly as far as position 8, depending upon the actual dial speed and synchronization with the scan periods. It will be seen that the action of core LDD-11 masks any bouncing of the s.c.c. pulsing-in contact.

The non-appearance of signal LDD-F in element LDD-FC2 allows a resetting condition to be applied to the 10-stage function unit cores at time R<sub>2</sub> such that detector LDD takes up position 2, and this value is returned to the register-column cores concerned at time R<sub>w</sub>. At the following R<sub>o</sub> time, core LDD-2 is set, thus

producing the dial-break signal, but, as already described, detector LDD advances to position 3 by virtue of the advance instruction produced in element LDD-FC1. Control FS, re-cycling on position 2 during the make period, now advances one step per scan time while the break period continues.

*Incoming Inter-Digital Pause*

The make period may persist longer than the nominal 33½ ms period, in which case, after due regard for tolerances, an incoming i.d.p. can be assumed. It will be recalled that detector LDD advances one step per scan period while make conditions obtain, i.e. in the presence of signal LDD-F; at core LDD-9 (at time R<sub>o</sub>) a "step-DD" pulse is generated, and at core LDD-10 the output signal resets the pulsing-in counter, described below, to position 1 (see element PIC-FC3, Fig. 20). Detector LDD returns to position 1 at the next scan time, and then recycles on this position awaiting the next break period—signified by the absence of signal LDD-F at element LDD-FC2.

PULSING-IN COUNTER

The pulsing-in counter (PIC) is used (a) to count the number of dial-pulse signals in the loop-disconnect pulse train of any digit, and (b) to retain the digit counted-in pending its transfer to the appropriate incoming-digit store as determined by the incoming-digits distributor. The functional circuit for counter PIC is shown in Fig. 20.

In the time-slot-seized condition, before dialling-in takes place, counter PIC re-cycles on position 1—this is because of the carry-over from the free-pattern condition. With a digit of any one of 10 values to be stored in a 10-position unit, it is necessary to absorb one dial pulse in each instance, so that, for example, when digit 6 is received it will result in counter PIC taking up position 6 and not position 7. Element PIC-F is used for this purpose and the first dial pulse is absorbed, as described below.

When read amplifiers LDD-A and LDD-C (position 2) read out, a signal signifying the first dial-break is passed

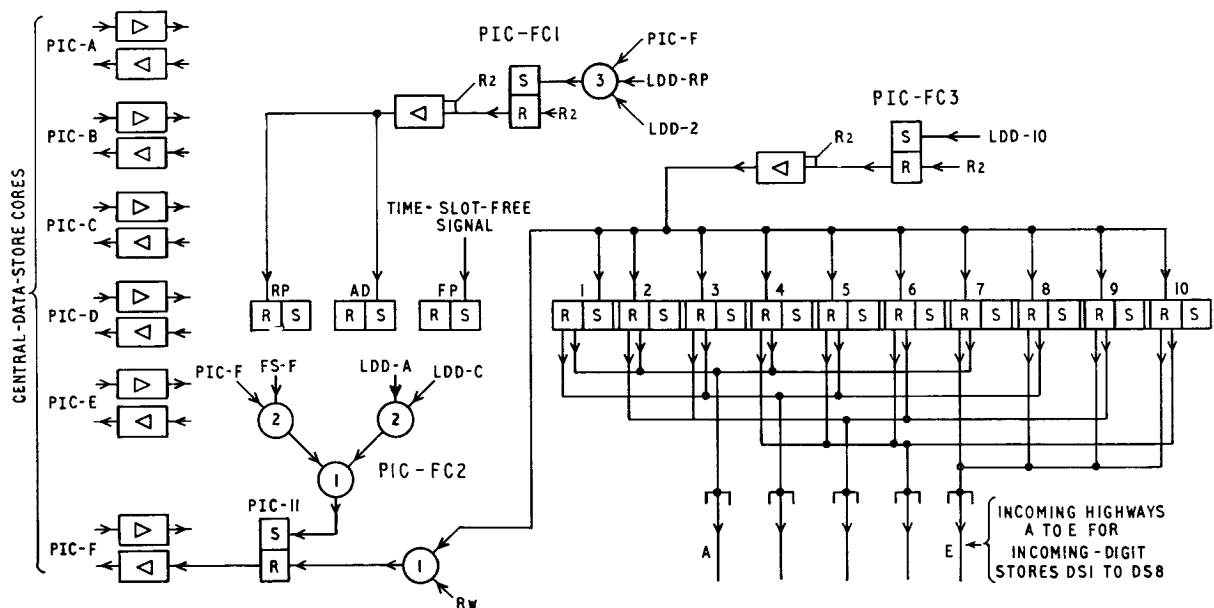

FIG. 20—FUNCTIONAL CIRCUIT OF PULSING-IN COUNTER

to the register-column core associated with write amplifier PIC-F (function control element PIC-FC2). This information is re-cycled by virtue of signals PIC-F and FS-F (time-slot-seized) in element PIC-FC2. The repeat and advance control element PIC-FC1 is ineffective at this stage because, when amplifier PIC-F reads out, detector LDD has advanced to position 3 under the control of the advance instruction from signals LDD-2 plus LDD-RP in element LDD-FC1, produced one scan time previously. Thus, the first dial break does not cause counter PIC to advance.

It will be recalled that detector LDD advances one step per scan time during the make period, being reset to position 2 when the next dial break occurs. Thus,  $16\frac{2}{3}$  ms after the second dial-break signal, signals LDD-2, LDD-RP and PIC-F, at  $R_0$  time, cause element PIC-FC1 to give an advance instruction to counter PIC and value 2 is passed to the register-column cores concerned at the ensuing  $R_w$  time. At time  $R_0$ ,  $16\frac{2}{3}$  ms later, counter PIC takes up position 2 and detector LDD, position 3. Detector LDD re-cycles on position 3 during the break period, advances during the next make period, is reset to position 2 at the conclusion of the make period, and, then, one scan time later, gives an advance instruction, as described above, to counter PIC which itself, one further scan time later, reads out information from the register-column cores that sets counter PIC to position 3.

Counter PIC therefore records a position corresponding with the total dial breaks per pulse train, i.e. the dialled digit. After transfer of the digit to an incoming-digit store at position LDD-9 as described below, counter PIC is forced to position 1 by the i.d.p. detected signal, signal LDD-10 in element PIC-FC3.

#### Transfer of Digit to Incoming-Digit Store

The transfer of the digit stored in counter PIC is controlled by signal LDD-9. When signal LDD-9 appears in element DD-FC1 (Fig. 21), an advance instruction is given to the incoming-digits distributor at time  $R_2$ . At the ensuing  $R_w$  time, therefore, when the position of counter PIC is read out and applied to the appropriate two-out-of-five write amplifiers, the same position value is also applied to the incoming-digit stores input highways, the particular store in which the digit value is inserted being determined by the position of the incoming-digits distributor.

### INCOMING-DIGITS DISTRIBUTOR

The incoming-digits distributor (DD) is used to distribute the received digits to the appropriate incoming-digit stores under the control of the incoming interdigital pause signal produced by detector LDD. The functional circuit for distributor DD is shown in Fig. 21.

Distributor DD resides upon position 1 when the time slot is seized, as a result of the carry-over from the free pattern. When a digit is to be transferred from counter PIC to an incoming-digit store, signal LDD-9 initiates an advance instruction, core DD-AD being set and core DD-RP being reset at time  $R_2$ . At the ensuing  $R_w$  time, core DD-1 and core DD-AD are reset, producing a discrete output at gate DD-G1 and writing position 2 in the register-column cores. Between digit-transfer events, distributor DD re-cycles on its new position, i.e. position 2 in this instance, and gate DD-G2 is ineffective because of the absence of signal DD-AD (reset output). This sequence is followed for each of the succeeding incoming digits, gates DD-G1 to DD-G8 being activated in succession.

The outputs from gates DD-G1 to DD-G8 steer the two-out-of-five digit signal from counter PIC into the appropriate incoming-digit store, where the information is retained until the time slot becomes free.

When the correct number of digits has been stored, the distributor is prevented from further advance by a condition signifying that all expected digits have been received; this is the "number-complete" signal applied to element DD-FC1.

### INCOMING-DIGIT STORES

The incoming-digit stores (DS1 to DS8) are used to store the incoming digits transferred from counter PIC under the control of distributor DD. The functional circuit for store DS1 is shown in Fig. 22, and this store is considered below.

#### Time-Slot-Free Pattern

The FP core is set by a pulse from the time-slot-free highway at time  $R_0$  and is reset at time  $R_w$ . Value 1 in two-out-of-five code is passed to the register-column cores concerned.

#### Time-Slot-Seized Pattern

The time-slot-free highway pulse is replaced by the

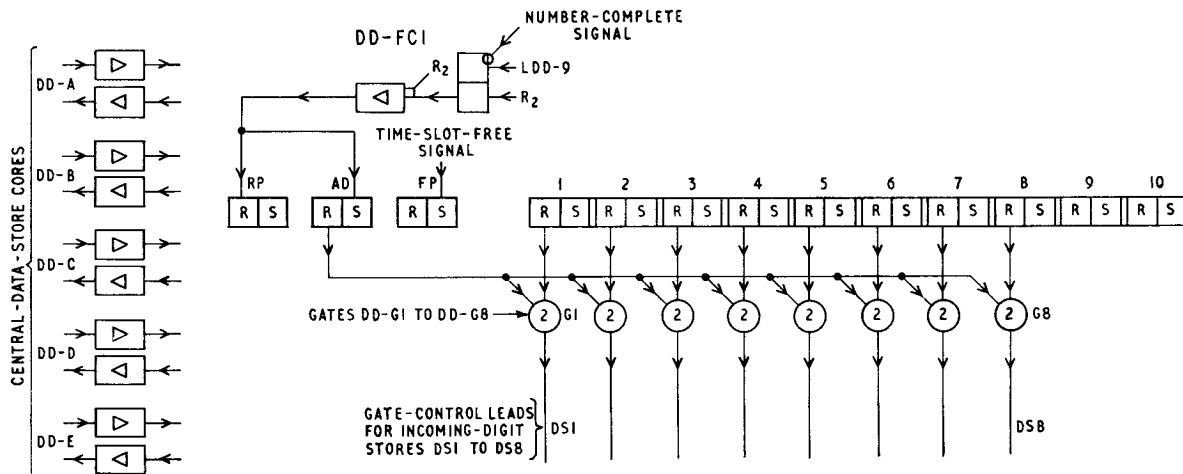
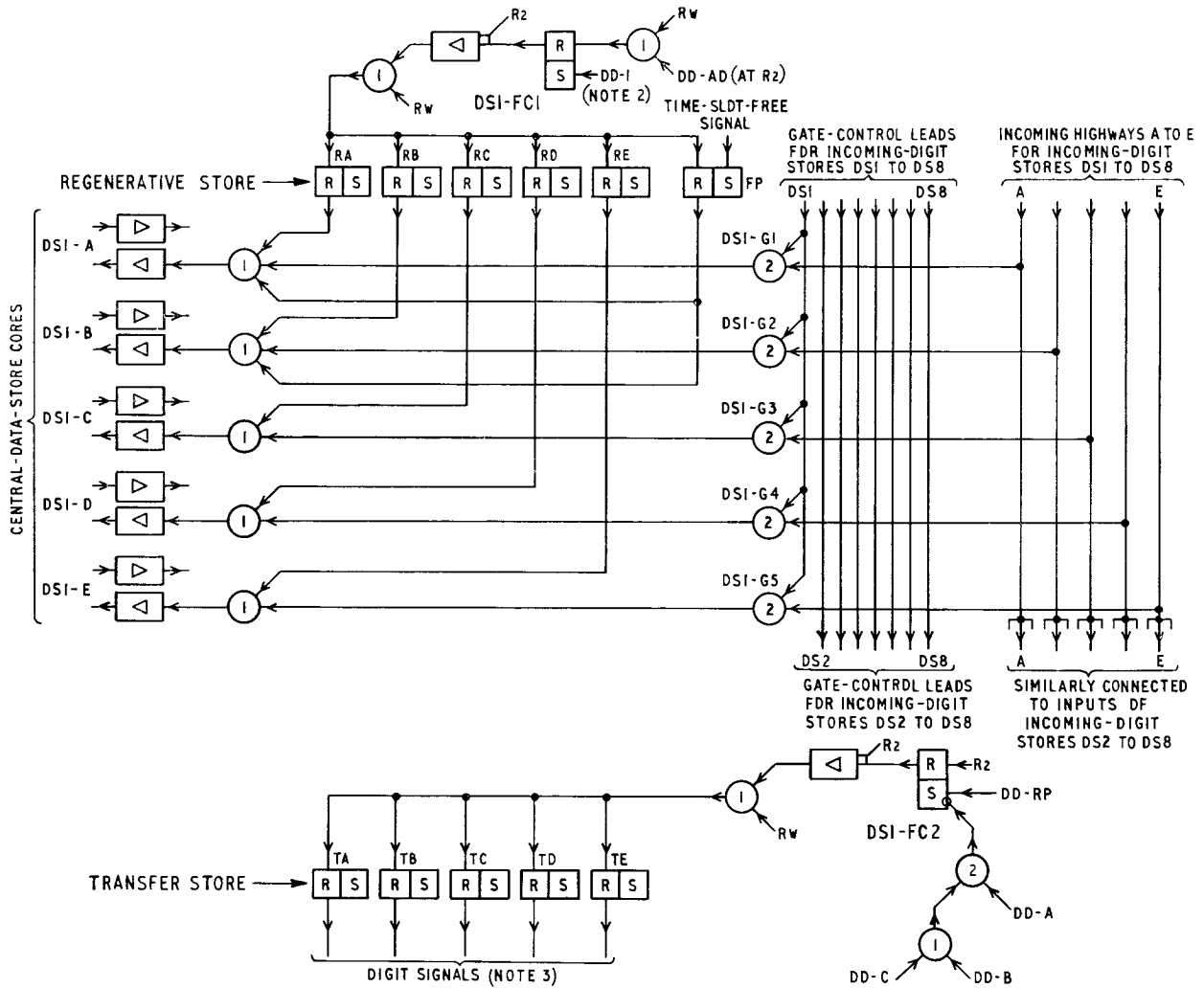

FIG 21—FUNCTIONAL CIRCUIT OF INCOMING-DIGITS DISTRIBUTOR



Notes: 1. Seven other similar incoming-digit stores, DS2 to DS8, are also provided.  
 2. For incoming-digit stores DS2 to DS8 this signal is DD-2 to DD-8, respectively.  
 3. Incoming-digit stores DS1 to DS3 hold the code digits; stores DS4 to DS8 hold the numerical digits. The code-digit signals are applied to the translation field via two-out-of-five/one-out-of-ten decoders. The numerical-digit signals are transferred to the send counter via a two-out-of-five/one-out-of-ten decoder.

FIG. 22—FUNCTIONAL CIRCUIT OF INCOMING-DIGIT STORE NO. 1

time-slot-seized highway pulse; hence, cores DS1-RA and DS1-RB, and cores DS1-TA and DS1-TB are set. At time  $R_w$  the set cores are reset, the regenerative-store outputs stimulating the appropriate write amplifiers and the transfer-store outputs being ineffective.

#### Digit-Value Insertion in Store DS1

Two operations within the time slot concerned must occur: first, the incoming-digit store regenerative-store cores, set by the residual free-pattern condition, must be reset, and, second, the regenerative-store cores corresponding with the digit value to be stored must be set. Consider store DS1 and element DSI-FC1: the core in element DSI-FC1 is set at  $R_0$  time by signal DD1 and, when a digit is received, reset at  $R_2$  time by core DD-AD, otherwise, it is reset ineffectively, at time  $R_w$ . The reset at time  $R_2$  results in a resetting signal being applied to all cores in the regenerative store and, thus, the erasure of the free pattern.

The digit value to be stored appears in two-out-of-five form on the incoming-digit stores input highways at  $R_w$

time, and the two-out-of-five signals concerned are gated into the write amplifiers via gates DSI-G1 to DSI-G5. Thus, the digit signals are passed directly to the register-column cores concerned. For all successive scan times, the digit value is regenerated via the regenerative store in the usual way except that the information is retained in the two-out-of-five form.

The operation of stores DS2 to DS8 is similar for the succeeding digits. It should be noted that in each incoming-digit store, free-pattern clearance is effected by a corresponding distributor DD position signal in element DSI-FC1 to DS8-FC1, respectively.

#### Reading the Stored-Digit Value

Each scan time the stored digit is read out of the register-column cores, and a corresponding pair of cores is set in the transfer store as well as in the regenerative store. Normally these are reset, ineffectively, at time  $R_w$  but, when they are reset at time  $R_2$ , their outputs become available for use in external circuits.

It will be seen from Fig. 22 that the digit held in store

DS1 can be read only after distributor DD has reached position 3, for in element DS1-FC2 signal DD-RP, which initiates the action, is inhibited while distributor DD is in position 1 (signals DD-A and DD-B) and in position 2 (signals DD-A and DD-C).

In the incoming-register-translator equipment, the outputs from stores DS1, DS2 and DS3, representing the A-code, B-code and C-code digits, respectively, are applied to the translator. Some 2-digit codes are catered for, so that every A-code plus B-code combination is applied to the translation field whether it is part of a 3-digit code or not.

With the numerical incoming-digit stores, the digits are read out as required on demands initiated by program switch B in the out computer, as described later.

#### TRANSLATOR

A photograph of a suite of cabinets showing some of the translation fields is shown in Fig. 23. The translator

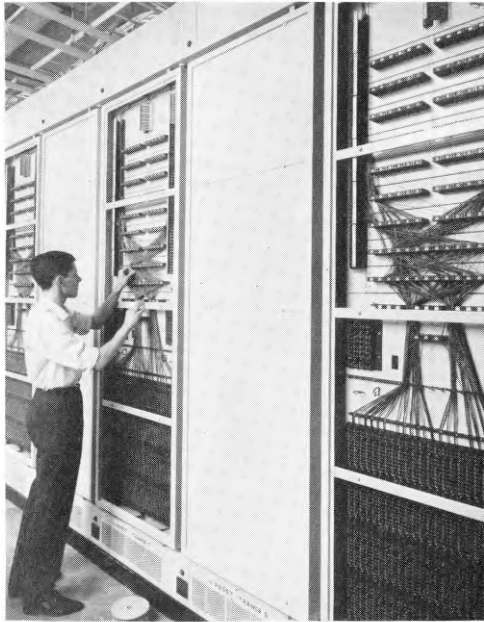

FIG. 23—REAR VIEW OF E.C.E. CABINETS SHOWING SOME OF THE TRANSLATION FIELDS

operates in substantially the same manner as that provided in the field-trial 3-digit director model at Balham telephone exchange,\* although the decoder arrangements have been simplified. Only an A-code plus B-code digits decoder is provided, each translation threading being connected to one of 100 points, representing the A-code plus B-code combinations, and one of 10 points representing the C-code digit value.

\*LOUGHHEAD, W. A. E., and MATTHEWS, G. A. An Experimental 3-digit Electronic Director Using Magnetic-Core Circuits, *P.O.E.E.J.*, Vol. 56, p. 255, Jan. 1964.

The translation field consists essentially of a matrix of specially designed transformers; each transformer can accommodate up to about 250 loosely-threaded wires. The translation field accommodates one row of 10 transformers assigned the values 1-0, respectively, per routing digit. The incoming-register-translator translation field has eight such rows. The outputs of corresponding transformers in each row are commoned so that a signal representing a value in the range 1-0, and produced in any row, will appear at a common point.

Translation is achieved by joining the appropriate A.B point to the C point by an electrically decoupled, flexible wire threading the required transformer in each row. Thus, for example, routing digits 3147, which are required for code 606, are achieved by connecting point A.B60 to point C6 via transformer 3 in row 1, transformer 1 in row 2, transformer 4 in row 3, transformer 7 in row 4, and transformer LRD (see below) in row 5.

A current pulse in the wire produces an output voltage at each transformer, but one of eight "row-demand" signals, representing the routing-digit order and generated by the out computer coincidentally with the current pulse in the wire, activates one row, and only one row. The out computer receives the digit value, in the range 1-0, in response to the combined A, B, C and row-demand signals.

#### Control Transformers

In addition to the routing-digit transformers, certain other control transformers, each giving a signal to the out computer when stimulated, are provided as follows.

**LRD Transformer.** Each threading wire, except those embracing eight routing digits, is passed through a last-routing-digit (LRD) transformer on the row following the last routing digit.

**CO Transformer.** Each threading wire corresponding with a code for which subsequent numerical digits are not required is passed through one of the several code-only (CO) transformers with which the field is equipped.

**SC Transformer.** All code points, including those of spare codes, must be connected to ensure operation of the outgoing-digits check circuit. Adjacent to each A.B.C terminal on each of the 100 A.B connexion strips is a spare-code terminal, 100 corresponding terminals per C-code digit value being commoned and connected to the respective C1-0 terminals, the 10 commons concerned passing through a spare code (SC) transformer connected to the out computer. All spare codes are marked by the insertion of a strap between the relevant A.B and SC terminals, and the stimulation of such a code results in the return of a spare-code signal to the out computer and the consequent forced-release of the call concerned.

**DMF Transformer.** The demand-m.f. (DMF) transformer facilitates selection of the point in the routing-digits sequence at which multifrequency (m.f.) sending is to commence.

**IND (1-0) Transformers.** The interrogate numerical-digit (IND) transformers, of which there are 10, labelled 1-0, respectively, cater for the possibility of subscribers' numbers in London ultimately consisting of five numerical digits and avoid the necessity for an incoming i.d.p. time-out on all calls once mixed 4-digit and 5-digit numbers are introduced. Thus, for example, if level 2 at MAYfair were allocated to 5-digit numbers, the MAY threading wire would embrace the IND 2 transformer. If the common processing equipment, in examining the



first numerical digit value, finds that this value is the same as signified by an IND transformer output (in the instance mentioned, 2) then the in computer awaits the receipt of five numerical digits; otherwise a number with four numerical digits is assumed.

**TDC Transformer.** All 2-digit-code threading wires are passed through the 2-digit-code (TDC) transformer and are connected to a special terminal in lieu of the C termination. When the A.B code point is marked, any 2-digit code threading wire stimulated at this time causes the return of a TDC signal to the out computer. A code-only 2-digit-code threading wire also passes through a CO transformer, otherwise the out computer will seek subsequent numerical digits. Alternative routing on 2-digit codes is catered for by a second threading-wire termination equivalent to the C (alternative) terminals.

**DCM (1-20) Transformers.** Access to these transformers is via terminals mounted on the translation-field front panel. When the traffic quantity utilizing any code is to be measured, the corresponding threading wire is connected to one of the pairs of terminals giving access to the 20 dialled-code meters (DCM). The DCM transformers are connected to gates stimulated by row-demand 1, and the output pulses are lengthened to actuate associated traffic meters. By this arrangement, at any time, the traffic appropriate to each of any 20 codes may be metered simultaneously.

**AR (1-40) Transformers.** Access to these transformers is via groups of three terminals mounted on the translation-field front panel. When the alternative-routing facility is to be applied to any code, the corresponding

the secondary routing will be demanded subsequently.

The secondary-routing threading wire embraces transformers in the translation field corresponding with the required alternative routing and terminates at one end on the third terminal of the group of AR terminals already mentioned and, at the other end, on the appropriate C-digit terminal, to complete the code identity, in an additional row of C terminals, C (alternative) 1-0, provided for the purpose.

### Check Circuit

Translations can be checked by means of a system of controlled processing. A call can be inserted by means of a dial on the equipment control panel and the resulting outgoing digits (routing plus numerical digits) observed on a lamp display at a "slow-motion" rate, either automatically at approximately 2-second intervals or under manual control.

An automatically-operating check circuit verifies the correct performance of signals returned to the out computer by the translation field. Any detected malfunction results in an alarm being given to the cabinet fault-analyser circuit.

### 100 ms COUNTER

The 100 ms counter (C) produces, for each time slot, the basic timing pulses for the out computer. It is driven one step every  $16\frac{2}{3}$  ms while a time slot is seized, and is arranged to cycle over six positions every 100 ms. The functional circuit for counter C is shown in Fig. 24.

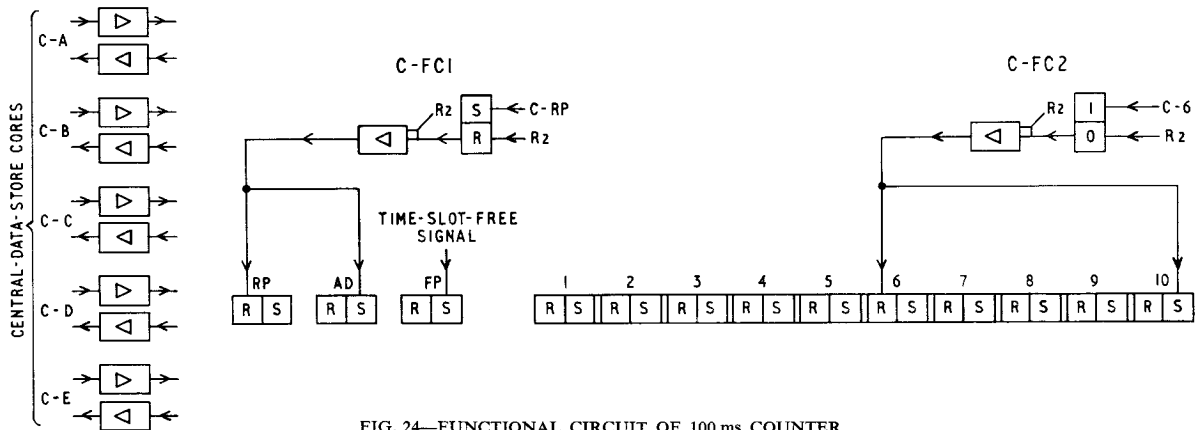

FIG. 24—FUNCTIONAL CIRCUIT OF 100 ms COUNTER

threading wire is connected to a pair of terminals in one of the groups of terminals giving access to the 40 alternative-routing (AR) transformers. These transformers are connected to gates stimulated by a signal preceding the row-demand signals, hence any code subject to alternative routing will produce an output signal signifying this fact prior to the demand for any routing digits. The selection of a routing, primary or secondary, is decided by the position of a relay associated with the primary route and known as the route-busy relay. This relay is operated, typically, while all circuits in the primary route are busy. Thus, if the route-busy relay is normal when the alternative-routing output signal mentioned above is produced, those digits comprising the primary routing will be demanded subsequently; if the relay is operated at this time, those digits comprising

While the time slot is free, signals representing value 1 are passed to the register-column cores concerned by the action of core C-FP. When the time slot is seized, therefore, core C-1 is set by the value 1 read out of the register column. In element C-FC1, signal C-RP initiates an advance instruction, and value 2 is written into the register column concerned at ensuing  $R_w$  time. This process occurs at every scan time; hence, the counter takes one step every  $16\frac{2}{3}$  ms and advances to position 6. When core C-6 is set, element C-FC2 produces a signal at time  $R_2$ , which resets core C-6 and sets core C-10. At the ensuing  $R_w$  time, with cores C-AD and C-10 resetting coincidentally, the value 1 is passed to the register-column cores concerned. The process continues, outputs from any core in counter C appearing at 100 ms intervals while the time slot remains seized.

### SEND SWITCH

The send switch (SND) determines the number of pulses to be transmitted and is the equivalent of the send switch in a conventional electromechanical register. The functional circuit for switch SND is shown in Fig. 25.

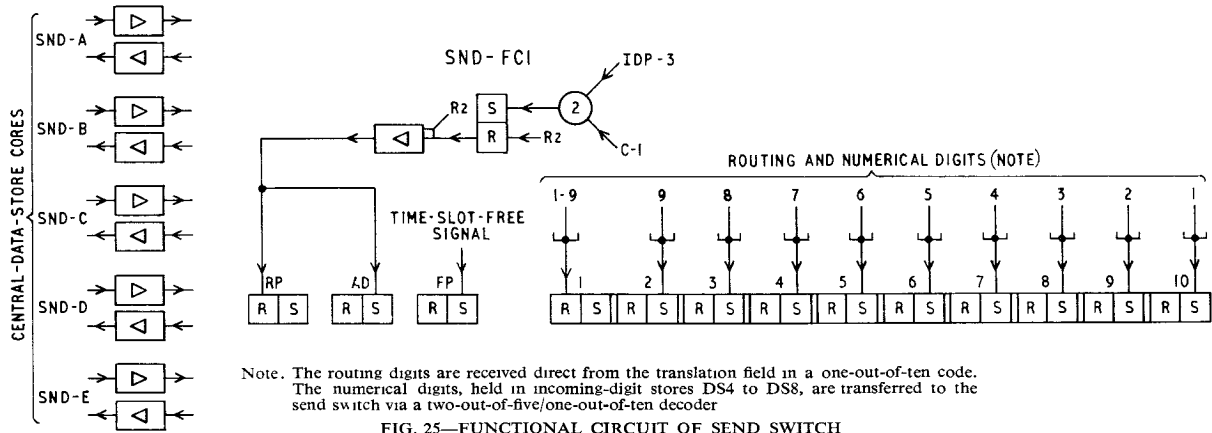

While the time slot is free, value 1 is passed to the register column concerned by the action of core FP. When the time slot is seized, therefore, core SND-1 is set by the value 1 read out of the register column, and this information is re-cycled in the usual way pending the receipt of a routing-digit signal from the translator.

The translator operates at time  $R_2$ ; hence, at time  $R_2$  of the time slot concerned, a routing-digit signal received from the translator sets one of the SND 10-stage function unit cores, e.g. the digit 4 signal sets core 7, the digit 8 sets core 3, and so on. Similarly, a numerical digit extracted from an incoming-digit store appears at time  $R_2$ . Any digit-signal value in the range 1-9 is accompanied by an additional signal which resets core SND-1. Thus, the receipt of the digit 0 leaves SND-1 set.

Successive C-1 signals at element SND-FC1, and occurring at 100 ms intervals, cause switch SND to advance one position every 100 ms, eventually causing the switch to reach position 1 after the appropriate number of steps (it must be assumed that the inter-digital-pause counter is on position 3 at this stage). Thus, for example, a digit 4, setting core 7, results in the switch SND advancing four steps to position 1. At position SND-1 an advance instruction is given to the inter-digital-pause counter when counter C reaches position C-6 (see element IDP-FC3, Fig. 27), so that signal IDP-3 will be absent from element SND-FC1 at the next C-1 signal, thus causing switch SND to remain at position 1. Activation of the switch SND as described above and pulsing-out,

as follows, depends upon the operation of the inter-digital-pause counter.

### PULSING-OUT CONTROL

The pulsing-out control (POC) is used to control the

register s.c.c. pulsing-out relays via the open-loop and close-loop highways as determined by switch SND. The functional circuit for control POC is shown in Fig. 26.

Each time switch SND takes one step, control POC makes the pulsing-out relay in the register s.c.c. concerned operate and release once.

While the time slot is free, value 1 is passed to the register column concerned by the action of core FP. When the time slot is seized, therefore, core POC-1 is set, and this information re-cycles in the usual manner pending the receipt of a signal from the inter-digital-pause counter. When the inter-digital-pause counter moves to position 3, signals IDP-3 and C-1 in element POC-FC1 produce an advance instruction; hence, value 2 is passed to the register column concerned. When amplifier POC-B reads out, a pulse is sent via the open-loop highway to operate relay PO, and, hence, open the outgoing-line loop in the register s.c.c. concerned.

Another output from read amplifier POC-B sets core POC-2, and this position is retained for three scan periods (a total of 50 ms) because of the absence of an advance instruction from gate POC-FC1, counter C being at intermediate positions. However, at the end of the 50 ms period, counter C is in position 5, and control POC is forced to position 1 by the output from element POC-FC2 at time  $R_2$ .  $16\frac{2}{3}$  ms later amplifier POC-A reads out and a pulse is sent over the close-loop highway to release relay PO, thus closing the outgoing-line loop in the

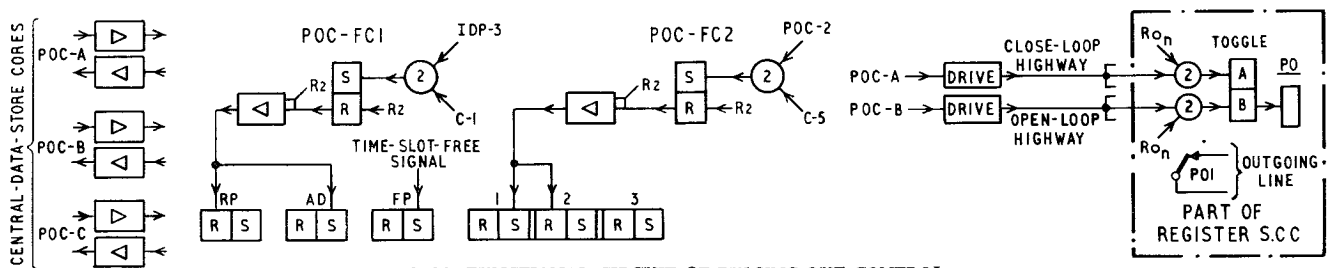

register s.c.c. concerned, the outgoing line having been open for a total of  $66\frac{2}{3}$  ms.

Counter C is in position 6 at this stage, but one scan period, i.e.  $16\frac{2}{3}$  ms, later when counter C reaches position 1 an advance instruction is generated in element POC-FC1. With the elapse of one further scan time (a total of  $33\frac{1}{3}$  ms) amplifier POC-B reads out, setting core POC-2 and transmitting a pulse over the open-loop highway to operate relay PO, thus opening the outgoing-line loop in the register s.c.c. concerned. The outgoing line is, therefore, looped for  $33\frac{1}{3}$  ms and, at this stage, counter C is at position 2.

The process continues as described, the relevant register s.c.c. relay PO being energized and de-energized for  $66\frac{2}{3}$  ms and  $33\frac{1}{3}$  ms, respectively, every 100 ms as long as element POC-FC1 is stimulated by signal IDP-3. The number of break pulses transmitted will be as many as the number of positions switch SND must traverse to advance to position 1, at which signal IDP-3 is removed.

#### INTER-DIGITAL-PAUSE COUNTER

The inter-digital-pause counter (IDP) is used to determine the length of the outgoing pulse-train inter-digital pauses. The normal inter-digital pause persists for 800 ms but may be curtailed by the detection of distant-selector switching. A 500 ms pause is given between the penultimate and last digits and, although this is not fully illustrated here, a 500 ms interval elapses between the end of the last digit and the transmission of the normal-release signal to the s.c.c. The functional circuit for counter IDP is shown in Fig. 27.

SND is accompanied by a "digit returned" signal (TDR) which, at R<sub>2</sub> time, forces counter IDP to position 3. Thus value 3 replaces value 1 in the register column and is read out one scan period later to produce signal IDP-3. This appears coincidentally with signal C-1 to initiate the switch SND and control POC operations described earlier and thus allow pulsing-out to start. Element IDP-FC3 is not activated until the last pulse module of the train being transmitted is complete, i.e. when signal C-6 appears; an advance instruction is given to counter IDP, and one scan period later counter IDP produces signal IDP-4. Elements SND-FC1 and POC-FC1 are rendered ineffective and pulsing-out ceases, the outgoing line remaining looped while counter IDP, being driven by signal C-6 in element IDP-FC3, advances one position per 100 ms to time-off the duration of the inter-digital pause.

#### Normal I.D.P.

Counter IDP advances to position 1 in 700 ms, arriving at this position coincidentally with counter C at position 1. It should be noted that this is actually  $683\frac{1}{3}$  ms after the conclusion of the last  $33\frac{1}{3}$  ms make period, which expires at the time of signal C-2. Element IDP-FC1, which uses signal IDP-1, does not become effective for another four scan periods, when signal C-5 appears, thus stimulating write amplifier IDP-G so that signal IDP-G appears after one more scan period and, thus, coincidentally with signal C-6 (see section entitled "Program Switches A and B").

When counter C is at position 6, the demand for the

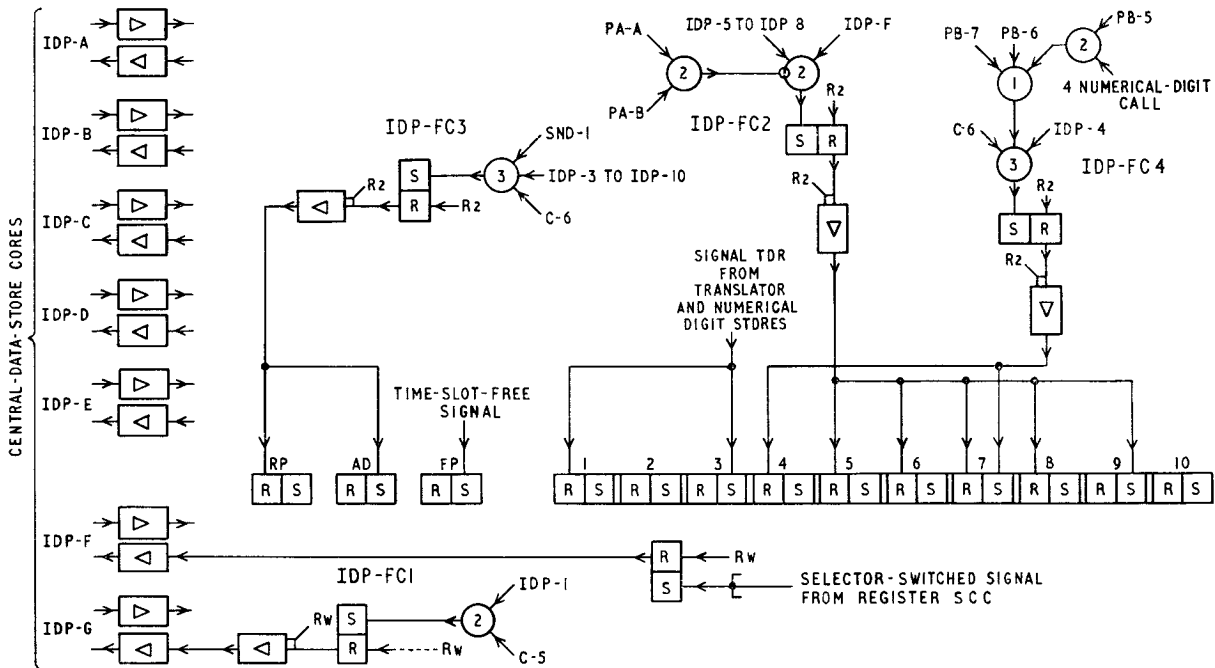

FIG. 27—FUNCTIONAL CIRCUIT OF INTER-DIGITAL-PAUSE COUNTER

While the time slot is free, value 1 is passed to the register column concerned by the action of core FP. When the time slot is seized, therefore, core IDP-1 is set and the value 1 regenerated each scan period until a digit is transferred from the translator to switch SND.

The transfer of a digit from the translator to switch

next digit is made (at time R<sub>2</sub>). The demanded digit may be extended from the translator or be extracted from a digit store. The accompanying signal TDR in either case forces counter IDP to position 3, as previously described, thus preventing any further advance of counter IDP and preparing for the commencement of pulsing-out. In

elements SND-FC1 and POC-FC1 one scan later, at the time of signal C-1, advance instructions are given to switch SND and control POC. At the time of signal C-2  $16\frac{2}{3}$  ms later still, the outgoing-line loop is opened to commence the first break period of the next digit train. The total period between the expiry of the preceding make period and the commencement of the first break period of the following digit is thus 800 ms.

### Curtailed I.D.P.

Receipt of a signal from the register s.c.c. indicating that a distant selector has switched the line through to the next stage, the selector-switched signal, stimulates write amplifier IDP-F, and signal IDP-F appearing  $16\frac{2}{3}$  ms later, forces the counter IDP to position 9. This action is controlled by element IDP-FC2 and is subject to the following conditions: signals stimulating the

normal release signal to the s.c.c. or the last i.d.p. on a 5-numerical-digit call. As above, the pause of 500 ms is initiated.

If signal PB-7 appears, this is because the call has 5 numerical digits and element IDP-FC4 must now be stimulated to initiate the 500 ms pause prior to transmission of the normal release signal to the s.c.c.

### PROGRAM SWITCHES A AND B

The program switches A and B (PA and PB, respectively) operate in sequence and are the equivalent of the control switch in a conventional electromechanical register: switch PA controls the sending of the routing digits and switch PB controls the sending of the numerical digits and release signals. The functional circuits for switches PA and PB are shown in Fig. 28 and 29, respectively. Fig. 29 also includes elements IDP-FC5 to

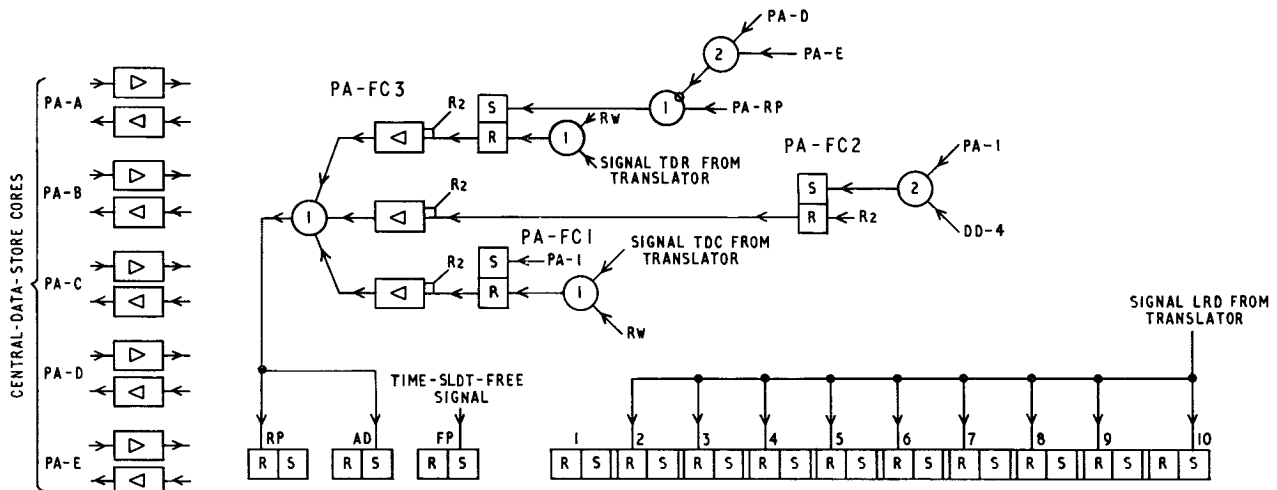

FIG. 28—FUNCTIONAL CIRCUIT OF PROGRAM SWITCH A

selector-switched signal and appearing within the first 100 ms of the inter-digital-pause period are ignored, to cover s.c.c. operations, and the first selector-switched event is also ignored, to cover register-access relay-set operations. The former condition is catered for by signals IDP-5 to IDP-8 and the latter condition by signals PA-A and PA-B in element IDP-FC2.

After counter IDP has been forced to position 9, as described above, the residual i.d.p. is between 300 and 400 ms, the actual period being dependent upon the point within the 100 ms counter IDP drive period at which the selector-switched signal occurs.

### Short I.D.P.

A 500 ms i.d.p. can be given between the penultimate and ultimate digits, and this is governed by element IDP-FC4. This element, when stimulated, forces counter IDP to position 7, whence the shortened i.d.p. follows.

Signal PB-5 occurs when program switch PB steps to position 5 signifying that the third numerical digit has been extracted from the incoming-digit store. Hence, for 4-numerical-digit calls, element IDP-FC4 is stimulated by signal PB-5 with signal IDP-4, at time C6, to force counter IDP to position 7 and shorten the i.d.p. to 500 ms.

Signal PB-6 occurs when program switch PB steps to position 6 signifying that the fourth numerical digit has been extracted from the incoming-digit store, and, hence, that this is either the pause prior to transmission of the

IDP-FC17 which are nominally associated with the IDP counter (Fig. 27); they are included here for convenience of explanation.

While the time slot is free, value 1 is passed to the register column concerned by the action of core FP. When the time slot is seized, therefore, the cores PA-1 and PB-1 are set.

### Routing Digits Demanded

The sending program starts when either a 2-digit-code signal (TDC) is received from the translation field or, on a 3-digit-code call, the third digit has been pulsed in. In either event, switch PA is advanced from position 1 to position 2, element PA-FC1 governing the 2-digit-code case and element PA-FC2 the 3-digit-code case. Subsequent advance of the counter is controlled by element PA-FC3.

In element PA-FC1 the translator signal TDC, occurring at time R<sub>2</sub>, resets the element core, previously set by signal PA-1, to advance switch PA to position 2. In the absence of the signal TDC, the core is reset, ineffectively, at time R<sub>w</sub>. In element PA-FC2 the incoming-digits distributor signal DD-4, signifying that the third digit has been received, combines with signal PA-1 to produce an advance signal for switch PA. In either instance, signal PA-2 combines with signal IDP-G in element IDP-FC5 to demand the first routing digit from the translator.

The transmission of the routing digit from the trans-

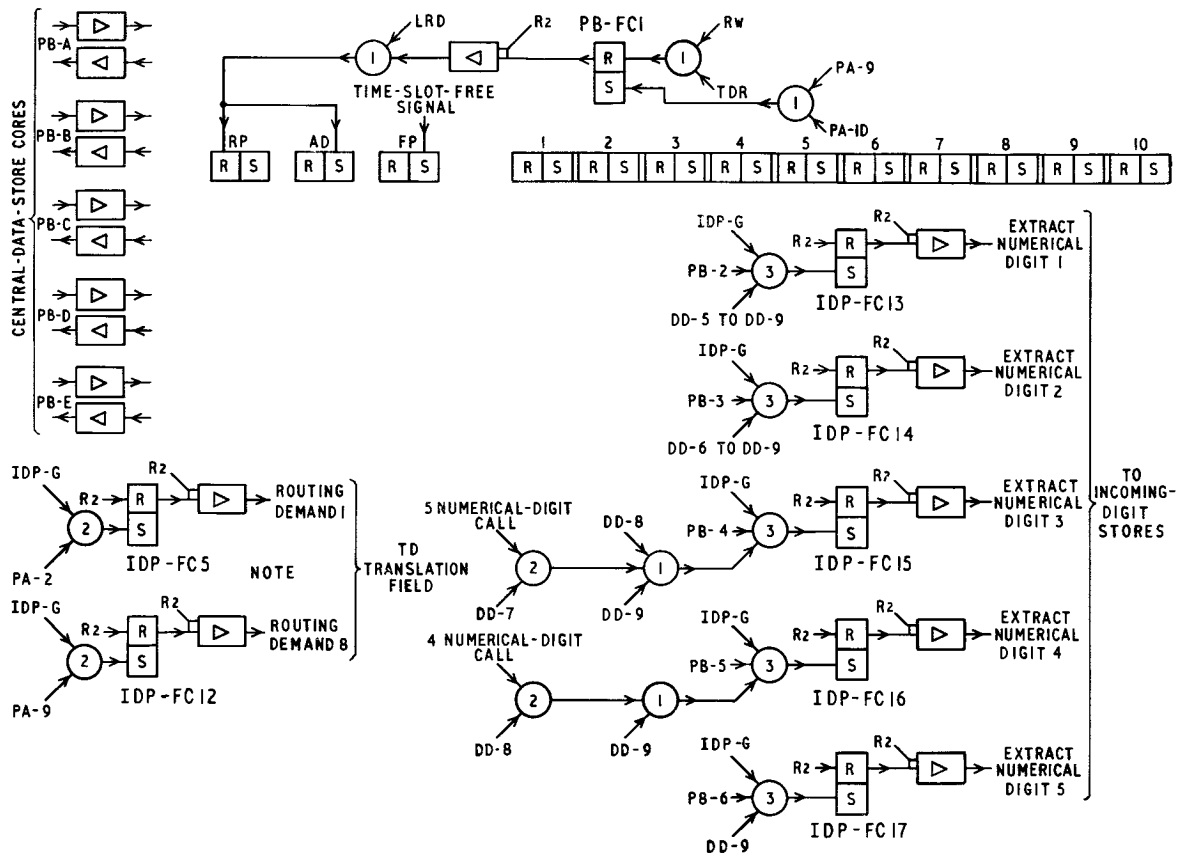

Note: Function control elements IDP-FC6 to IDP-FC11 are similarly connected, using signals PA-3 to PA-8, to produce routing demands 2 to 7, respectively.

FIG. 29—FUNCTIONAL CIRCUIT OF PROGRAM SWITCH B

lator by switch SND is accompanied by signal TDR. This signal, occurring at time R<sub>2</sub>, resets element PA-FC3 core, previously set by signal PA-RP, to advance switch PA to position 3.

Successive routing-digit demands on the translator are made by signal IDP-G in conjunction with corresponding switch PA position signals PA-3 to PA-9 in elements IDP-FC6 to IDP-FC12, respectively. Switch PA responds to the consequential TDR signals by advancing one step each time until element PA-FC3 is inhibited by the combination of signals PA-D and PA-E, representing the completion of the eighth demand—the maximum possible.

The last-routing-digit signal, LRD, occurs at time R<sub>2</sub>, and when received from the translator it causes switch PA to take up position 10. It should be noted that in the case of eight-routing-digit calls, no LRD signal is required because completion of the eighth demand results in switch PA advancing from position 9 to position 10.

#### Numerical Digits Demanded

Successive numerical-digit demands on the incoming-digit stores are made by signal IDP-G in conjunction with corresponding switch PB positions, and are controlled by the incoming-digits distributor DD signals in elements IDP-FC13 to IDP-FC17, respectively. Thus, for example, the first numerical digit can be transmitted after receipt of signal LRD, which advances switch PB from position 1 to position 2, provided that the digit has been completely received, this fact being established by reference

to distributor DD position; for the first numerical digit (digit N<sub>1</sub>) to be completely received, distributor DD must be further advanced than position 4, so that signals DD-5 to DD-9 are used. Similarly, for digit N<sub>2</sub>, signals DD-6 to DD-9 are used.

For 8-routing-digit calls, switch PB is advanced from position 1 to position 2 by signals PA-9 and TDR in element PB-FC1. Subsequently, switch PB advances one position on each occasion that signal TDR, confirming transfer of a numerical digit from digit store to switch SND, appears in element PB-FC1, switch PA recycling on position 10 at this stage.

A further requirement is that the last two digits shall be transmitted with only a 500 ms i.d.p., this facility being complicated by the need to cater for 4-digit and 5-digit numbering schemes. Elements IDP-FC15 to IDP-FC17 provide the required facilities. For a 4-numerical-digit call, digit N<sub>3</sub> must not be transmitted until digit N<sub>4</sub> has been received, namely, until distributor DD is further advanced than position 7, so that signals DD-8 and DD-9 are included in element IDP-FC15. However, for a 5-numerical-digit call, digit N<sub>3</sub> is transmitted when distributor DD has reached position 7 or beyond so that the signal DD-7, gated with a signal signifying a 5-numerical-digit call, is also included in IDP-FC15. In a 5-numerical-digit call, digit N<sub>4</sub> must not be transmitted until digit N<sub>5</sub> has been received, namely, until distributor DD is further advanced than position 8 so that the signal DD-9 is included in IDP-FC16. However, in a 4-numerical-digit call, distributor DD does not advance beyond position 8 so that signal DD-8, gated with a signal

signifying 4-numerical-digit call, is also included in element IDP-FC16. Element IDP-FC17 controls the extraction of the fifth numerical digit from the relevant incoming-digit store.

#### ADDITIONAL FACILITIES

##### *Normal Release*

The operation of the normal-release facility results in the switching of the line through the register-access relay-set, and the dissociation of register-access relay-set and s.c.c. Normal release is initiated by the completion of the sending of routing and numerical digits on a normal call but of routing digits only when the translator indicates a code-only call.

The normal-release signal to the s.c.c. is the application of a pulse to highway Z. The normal-release circuits also contribute to the forced-release condition, which, with other signals, requires the Z signal as well.

The dissociation of the register-access and signal-conversion circuits results in the removal of the seize condition from highway SN, and control FS times this removal to verify release and, thence, mark the time slot as free. This timing period is covered in the s.c.c. by a delay element which guards the conversion circuit against fresh seizure during the timing.

Failure to receive confirmation of release results in the application of a freeze condition to the s.c.c., as described below.

##### *Forced Release*

The operation of the forced-release facility results in the return of number-unobtainable tone (N.U.T.) to the caller from the register-access relay-set, and the dissociation of register-access relay-set and s.c.c. The pulsing-out relay is first operated to open the outgoing-line loop, and thus release distant selectors, and then, after a delay of 1 second, a pulse on highway Z initiates the return of N.U.T. and the dissociation process.

The interval of 1 second between the opening of the pulsing-out loop and signal Z guards the outgoing junction during release of the distant selectors. Control FS verifies release, and the s.c.c. clear-down guard operates as for a normal release.

##### *Freeze*

The freeze condition, which can arise as the result of certain circuit misoperation, for example failure to confirm release of an s.c.c., is signalled to the s.c.c. concerned via a highway, and is similar to forced release in that N.U.T. is returned to the caller and dissociation of register-access relay-set and s.c.c. takes place. Additionally, the register is busied and the state of the register is "frozen," i.e. the register does not revert to time-slot-free conditions, as an aid to maintenance diagnosis of the fault condition. Cancellation is by manual actuation of a key on the equipment control panel.

##### *Comparator Access*

Association of comparator and register s.c.c. is by means of a "connect" signal via an E.C.E.-S.C.C. highway, resulting in the connexion to the comparator of certain of the more important elements of the s.c.c. concerned.

Provision is made for association of the comparator with one or more selected s.c.c. when required, instead of by the normal process of random association. Provision is also made for association display: it is possible

to see which s.c.c. is currently connected to the comparator, and it is also possible to display the identity of all those s.c.c. that have been associated with the comparator during a given period. The facilities provided by the comparator are described in Part I; a detailed description of this equipment is outside the scope of this article.

##### *Test Registers*

There are four test registers: three are concerned with the inbuilt routiner (the logic-check system), and the other is used to gain access to the equipment manually from the control panel for maintenance test purposes, primarily in connexion with the check of translation-field translations. When translations are to be checked, the controlled-processing facility is used as described below.

##### *Controlled Processing*

It will be recalled that signal IDP-G defines the end of the i.d.p. and is used to demand the next digit for pulsing out. By making the generation of this signal dependent upon a key, manual control of processing can be provided and the digits may then be demanded as required. This facility is provided, but is restricted to the test registers. Additionally, under controlled-processing conditions, the manually-demanded digit values are displayed on control-panel lamps. A refinement of the facility is the inclusion of a timing element which can substitute the key and give automatically controlled processing, digit demands being made at approximately 2-second intervals.

When checking translations, the manual test register will generally be used so that the cabinet-pair need not be taken out of service. The control-panel dial enables appropriate calls to be dialled in, and the automatic display gives a means of easily verifying translations.

Additionally, the manual test register in each of a number of cabinet-pairs can be coupled together by means of keys so that, when checking translations, the call need only be dialled once for the group of cabinets concerned. In this instance, processing and display may be carried out at each control panel, although facilities are given for the use of a remote test box which can be used to enable staff to originate the test call and observe the results simultaneously for all cabinet-pairs concerned.

#### TESTERS

In addition to the many inbuilt check circuits and maintenance aids, two testers per installation are provided. One is trolley mounted and is used primarily to test signal-conversion circuits, although it can of course be used to test the response of a register-translator to dialled-in digits. The second tester is a floor-mounted rack which, with the set of test specifications provided, enables comprehensive tests to be carried out on any plug-in unit of equipment used in the whole register-translator system.

An oscilloscope is also provided, and each plug-in unit is equipped with an adequate number of oscilloscope test points to facilitate location of faults to the plug-in unit concerned *in situ*.

#### ACKNOWLEDGEMENT

The development of the equipment described in this article was carried out on behalf of the British Telephone Technical Development Committee by Ericsson Telephones, Ltd., of the Plessey Telecommunications Group.

# The New Leaffield Radio Station

## Part 3—Carrier Generation

P. R. HUTTON-PENMAN and F. M. BILLINGHURST, B.Sc.(Eng.), A.M.I.E.E.†

U.D.C. 621.396.71:621.373.42:621.396.61

Carrier generation at the new Leaffield transmitting station is performed by frequency synthesizers controlled from highly-stable master oscillators buried below ground. The novel features of the installation and the performance achieved are described.

### INTRODUCTION

THE greater flexibility and utilization efficiency offered by the introduction of self-tuning transmitters at the new Leaffield station could be fully exploited only if the full range of carrier supplies were made available to every transmitter in a group. In addition, to enable h.f. radio circuits to operate without receiver automatic frequency-control in the future, it is necessary that each frequency shall always be within  $\pm 3$  c/s (1 part in  $10^7$  at 30 Mc/s) of its allocated value. These considerations led to the adoption of frequency-synthesizers controlled from one master-oscillator source, and so requiring infrequent checking and adjusting, in place of a group of crystal-controlled oscillators on discrete frequencies.

This article describes the master-oscillator source and the method of distribution, and indicates briefly the method of frequency synthesis used to generate the carrier supplies.

### MASTER OSCILLATORS AND DISTRIBUTION

As all the emissions from the station are dependent upon the master-oscillator source it is essential to ensure that it is not interrupted. Three oscillators have been provided, therefore, together with automatic change-over, to feed a low-impedance distribution bus-bar. Continuous monitoring is provided on all three oscillators so that an indication of failure is given even though the unit may not be in use. Fig. 1 is a simplified schematic diagram of the arrangement used.

#### The Master Oscillators

There are economic and other advantages in operating each master oscillator directly at the conveniently low frequency of 100 kc/s, which led to the use of oscillators controlled by GT-cut crystals. This type of oscillator usually employs an oven to maintain the crystal at a temperature between 50° and 60° C. In the Leaffield installation, however, each crystal with its drive oscillator is inserted in a bore hole at a depth of 30 ft. By this means a reliable and stable environment is secured at a much lower temperature ( $13^\circ \pm 0.25^\circ$  C) than in an oven, with no short-term variations or risk of mechanical shock. The result is a much reduced aging rate and no "cycling" errors.

Each bore-hole used at Leaffield consists of a 6 in. diameter welded steel tube, pressure-tested to ensure that it is waterproof, vertically aligned to within 1 in. and grouted-in with a minimum of 2 in. of concrete.

The crystal, drive amplifier, frequency-adjusting

mechanism and a resistance-thermometer element are assembled in a sealed copper canister which is filled with dry nitrogen. The canister has three nylon wheels at each

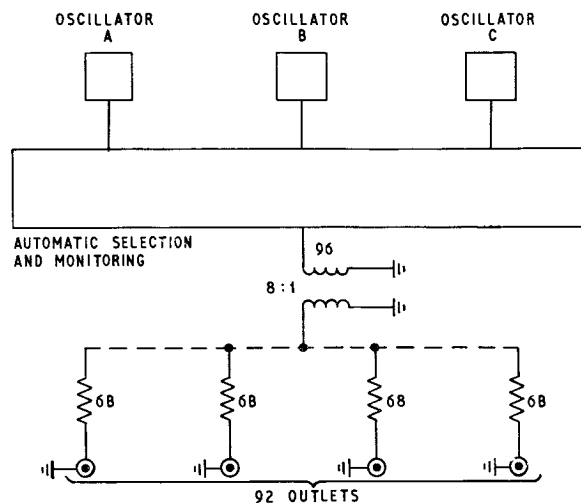

FIG. 1.—SIMPLIFIED FREQUENCY-DISTRIBUTION ARRANGEMENTS

end to guide it and to prevent contact with the tube. Supply leads, a coaxial output lead, and wires from the resistance-thermometer element are brought out from the canister in a single cable which passes through a gland at the top. This cable is used for raising and lowering the canister and has on it five polystyrene plugs which pass into the tube to limit air convection currents. A canister being lowered into a hole is shown in Fig. 2.

In the interests of maximum stability, the oscillator is designed to ensure that the forward gain is just sufficient to maintain the crystal in oscillation. This is achieved by providing two feedback paths in the oscillatory circuit, one being regenerative and the other degenerative. The degenerative path incorporates a thermistor element arranged so that it compensates for variations in oscillation amplitude and ensures the correct condition to just maintain oscillation.

#### Automatic Selection and Monitoring

Although only one oscillator is connected to the distribution network at a time, it is necessary to keep all three operating continuously, not only to secure maximum protection but to maintain the required stability. Their output levels are monitored continuously, and alarms draw attention to variations beyond a prescribed amount. Immediate change-over to a spare oscillator (in 5 ms, half the length of a 100-baud telegraph element) takes place if the variation exceeds 3 db.

#### Distribution

The selected oscillator output, which will be approxi-

†Overseas Radio Planning and Provision Branch, E.-in-C.'s Office.



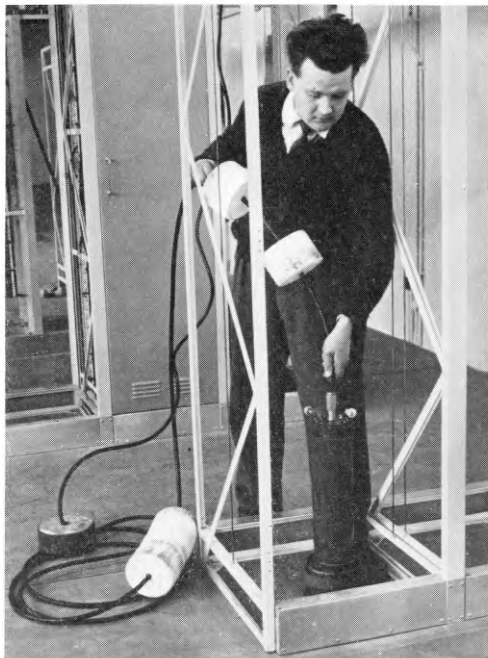

FIG. 2—LOWERING A FREQUENCY-GENERATOR CANISTER INTO ITS 30 FT TUBE

mately 3 watts at an impedance of 96 ohms, is first transformed to an impedance of 1.5 ohms and then connected to a resistive distribution network to provide a total of 92 outlets, each of which will deliver 10 mW into a 72-ohm load with an isolation between outlets better than 30 db.

### Performance

The canisters were inserted into the bore holes at the beginning of January 1963. At that time no power supply was available and the mean temperature inside the three canisters was  $10.0^{\circ}\text{C}$ . There was a steady rise in temperature as the building was completed and occupied. When power was applied to the oscillators at the end of September, the temperature rose sharply and was  $11.2^{\circ}\text{C}$  by mid-October. It then settled down to a gradual rise of about  $0.07^{\circ}\text{C}$  per month during 1964 and less during 1965. Superimposed upon this rise was an annual cyclic variation of less than  $\pm 0.15^{\circ}\text{C}$ . A plot of the mean temperature of the three canisters from January 1963 is shown in Fig. 3(a).

A regular check has been kept on the frequency stability, and the variations of the three oscillators over a typical 6-month period are given in Fig. 3(b). These show that to be within  $\pm 1$  part in  $10^9$  it will not be necessary to make adjustments more frequently than once per year. The canister temperature is not significantly affected by the small quantity of heat dissipated in the capacitor-drive motor.

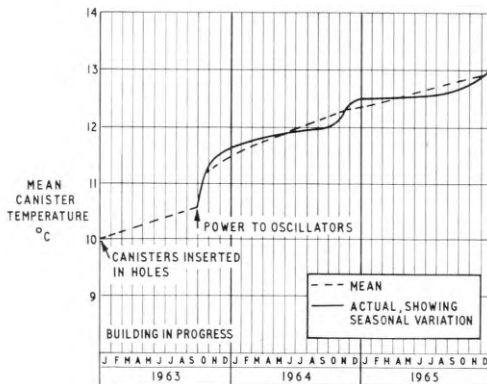

(a) Mean Temperature inside the Canisters

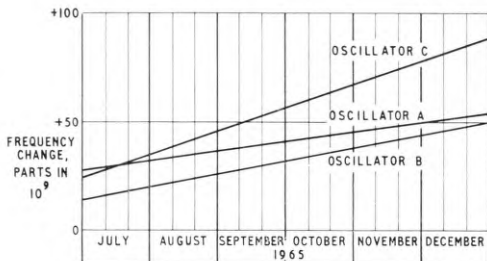

(b) Typical Frequency-Drift Curves

FIG. 3—PERFORMANCE OF OSCILLATORS AT A DEPTH OF 30 FT

### THE FREQUENCY SYNTHESIZER

The frequency synthesizer used at Leaffield was designed and manufactured to a Post Office specification to produce a signal, at any multiple of 125 c/s, between 4.0 Mc/s and 7.999875 Mc/s when connected to a 100 kc/s source. The specification also required that the frequency stability of the output should reflect the frequency stability of the 100 kc/s source. In addition to the stepped-frequency output, up to five fixed-frequency carriers can be produced by the insertion of suitable sub-units.

The equipment, which is entirely of transistor-type circuits, occupies only  $5\frac{1}{4}$  in. of rack space and operates from a 20-volt d.c. supply. In addition, a 50-volt supply is required to operate the electromagnetic frequency-selector switches.

### Method of Synthesis

A detailed description of the method of synthesis used has been given elsewhere\* and only a brief account is included here.

Carrier synthesis at any selected frequency between 4 and 8 Mc/s is achieved by generating five component

\*LAWSON, A. N. A Transistorized Frequency Synthesizer. I.E.E. Convention on H.F. Communication, Mar. 1963.

frequencies, one in each decade frequency range commencing at 100–1,000 c/s, and combining them by mixing and filtering. Each range uses a scale of 10 except the lowest, which uses a scale of 8, yielding 125 c/s steps. Fig. 4 shows in block schematic form the arrangement used.

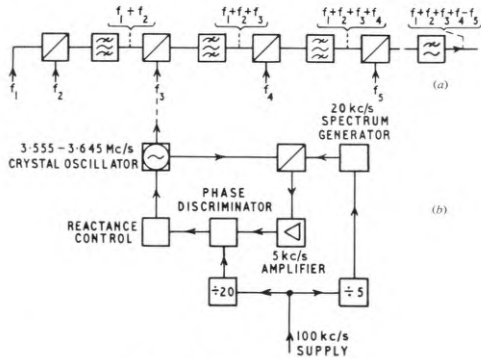

(a) Basic Arrangement  
(b) 10 kc/s Component Generator  
FIG. 4—THE FREQUENCY SYNTHESIZER

The same technique is used to produce all the component frequencies ( $f_1$  to  $f_5$ ); Fig. 4(b) shows the arrangement for the 10–100 kc/s decade ( $f_5$  series). A crystal-controlled oscillator, working in the range 3.555 Mc/s to 3.645 Mc/s, is fitted with 10 crystals having “natural” resonant frequencies spaced approximately 10 kc/s apart, one of which is selected to produce oscillation at the required value  $f_5$ . This oscillator is then “phase-locked” to the 100 kc/s source in the following manner.

The oscillator output is mixed with a 20 kc/s harmonic series generated from the 100 kc/s supply. One of the harmonics combines with the oscillator output to produce a signal at approximately 5 kc/s which is compared in a phase discriminator with a 5 kc/s signal, again derived from the 100 kc/s supply. The discriminator d.c. output is supplied either to a variable-capacitance diode or to a variable inductor to adjust the oscillator so as to maintain a zero difference-frequency.

A checking system is included which ensures that an alarm is given and the output disconnected should any oscillator chain lose its phase-lock or any other fault occur.

#### Performance

Non-harmonic spurious components are at least 65 db below the operating output level of 40 mW, and short-term random phase modulation is less than 0.1°. An assembly of synthesizers is shown in Fig. 5.

The power consumption is approximately 12 watts, and the equipment operates satisfactorily with the supply voltage in the range 17 to 21 volts, with temperature

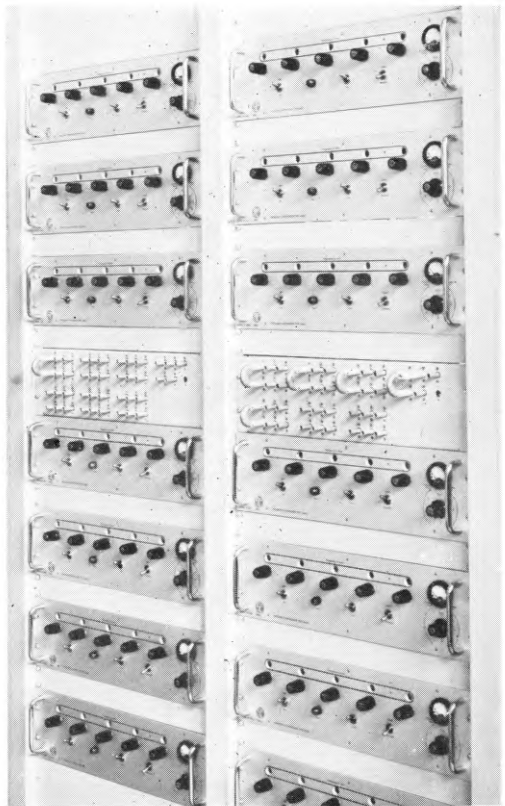

FIG. 5—AN ASSEMBLY OF SYNTHESIZERS

variations between 10°C and 35°C, and with the 100 kc/s signal input level within the limits of –16 dbm to +10 dbm.

#### CONCLUSIONS

Carrier-generation techniques not previously used in the Post Office have been adopted at the new Leafeld transmitting station. Experience so far indicates that, apart from some initial problems, the synthesizers work satisfactorily and reliably. The stability of the 100 kc/s master oscillators is proving to be approximately one order better than expected, and, in consequence, it should be necessary to make a frequency correction only once per year to maintain an accuracy of  $\pm 3$  c/s at an emitted frequency of 30.0 Mc/s.

(To be continued)

# A 12 Mc/s Submerged-Repeater System

U.D.C. 621.395.45:621.375.2:621.315.28

A submerged-repeater system with a circuit capacity of 18 super-groups and a maximum range of 4,000 nautical miles is now being developed. The wide bandwidth necessitates a very large number of closely spaced repeaters, and the design problems involved are briefly reviewed.

IN 1961 the CANTAT system, working up to about 0.6 Mc/s, provided 80 3 kc/s circuits. Demands for greater traffic capacity have since led to systems being developed working up to the following frequencies: 1 Mc/s (160 circuits, Guam–Madang–Cairns), 3 Mc/s (360 circuits, Lisbon–Capetown) and 5 Mc/s (640 circuits, United Kingdom–Lisbon).

The British Post Office Research Branch is now engaged on the design of submarine cable and repeaters having a highest working frequency of 12 Mc/s. Such a system will provide for the both-way transmission of 18 super-groups of telephone circuits, equivalent to 1,440 3 kc/s speech circuits, and the system is being designed to span a distance of 4,000 nautical miles (n.m.). Since it is well known that the capital cost per circuit decreases rapidly as the bandwidth increases, the cost of providing a channel in this system may be only about one eighth that of a channel in the CANTAT system.

At 12 Mc/s the loss of a 1.5 in. diameter Lightweight cable would be about 25,000 db for a 4,000 n.m. link, and, if a variation of  $\pm 3$  db were to be allowed during a 20-year system life, the cable loss and repeater gain would have to remain constant to about 0.01 per cent over that period. Since the repeater spacing with this cable will be only about 7 n.m., nearly 600 repeaters will be required for the maximum route length. This system, therefore, will demand much higher standards of long-term stability than have previously been required. It is possible that a still larger cable, e.g. 1.85 in. diameter, may be more economic, and the use of such a cable, by reducing the number of repeaters required, would slightly ease the stability problem. Fortunately, it has now been demonstrated that the Lightweight cable suffers no measurable aging after laying.

A further difficulty arises in respect of the initial equalization of the system during the laying operation since, in terms of decibels of loss and gain involved, it will proceed at three times the speed of that of the CANTAT system, but the time taken to make a shipboard-designed equalizer cannot be substantially reduced. Cable characteristics are, however, now much better known and, fortunately, the lowest transmitted frequency will be well above the region where major cable deviations can occur due to variations in the thicknesses of the conductors. Against this, however, the dielectric loss (which is proportional to frequency) will become a larger proportion of the total loss than it was when the top frequency was 0.6 Mc/s; it will, therefore, be necessary to control the loss angle of the polythene to a much tighter degree than was necessary when the top frequency was lower. It is concluded from a preliminary survey that, through improvements in a number of techniques, it will be quite satisfactory to retain the present general principle of shipboard equalization.

The 12 Mc/s repeater will use a new type of transistor (Post Office type 10A) now being developed in the Research Branch and by a contractor, and, as a feedback

amplifier will be used, the performance of these transistors and their associated circuits will be important at frequencies of the order of 500 Mc/s. Unfortunately, a transistor is a non-minimum phase network, and its phase change sets a limit to the amount of negative feedback that can be applied.

It is, however, very evident that there will be serious difficulties in providing sufficient feedback to meet the two following requirements of the amplifiers.

*Linearity.* Because of the much greater number of circuits and the much larger number of repeaters in tandem the linearity requirements are much more formidable than in previous amplifiers. Reducing the repeater gain can overcome this, but only at the expense of inefficient design and by incurring other penalties.

*Stability.* The stringent requirements for stability have been mentioned earlier. The problem is further complicated by the fact that there has not yet been time to evaluate accurately the long-term stability of the new transistors. Inadequate feedback performance could, however, be countered by less elegant solutions involving the inclusion of shore-controlled equalizers in the system or by inserting appropriately designed equalizers into the system if and when aging becomes serious.

Several methods of amplifier arrangements are being explored. One interesting proposal is a form of amplifier investigated by H. S. Black of the Bell Telephone Laboratories some 41 years ago before he formulated the negative-feedback principle.

The design of a 12 Mc/s amplifier would be simple if the components used were pure resistors, capacitors and inductors. At the frequencies important to the feedback requirements, each of the nominally pure components will have associated with itself the series effect of the leads and the impedances representing the shunting capacitance and capacitances to earth. Thus, the design of an amplifier will have to be much more dependent on the performance of the components than was the case when a much lower top frequency was employed.

In a long-distance submarine-cable system it is possible that the cable will be cut near the shore by trawlers. At such a cut a surge current, equal to the line voltage divided by the characteristic impedance of the cable, will be propagated in each direction away from the cut. This very large surge current will have a steep wavefront, and its energy will be distributed between the frequency bands used by the line signals and the repeater power-feed. Protection is, therefore, required to prevent this surge from causing damage to the repeaters; a solution to this problem has been reached in the 0.6 and 3.0 Mc/s valve repeaters, but further work will be necessary before the 12 Mc/s transistor repeater is adequately protected.

The lower power-feed voltage of a transistor amplifier is welcome after the comparatively high voltage of a valve amplifier, but the larger number of repeaters involved offsets this to some extent.

A supervisory circuit somewhat different from that used in the 0.6 Mc/s submerged repeater will probably be employed in this system. The earlier supervisory circuit enabled one terminal station to measure the loop gain from that station to every repeater and the noise level at

each repeater output. A pulse supervisory equipment is fitted at each terminal station, and this would enable the station staff to locate any repeater that had become markedly more non-linear than normal. The supervisory equipment fitted in the new 12 Mc/s repeaters will enable one terminal station to measure the noise at the output of each repeater amplifier and will enable the other station to measure or monitor continuously the level at any repeater. The first station will also be able to determine

the gain between each repeater and itself, since it is unlikely that the noise output of each repeater will vary rapidly with time.

Clearly, the whole approach to this greater bandwidth system must be much more sophisticated than with earlier designs, but there appears to be no fundamental reason why a wholly satisfactory 12 Mc/s system should not be fully developed by 1968.

R.A.B. and F.S.

---

## Subscriber Push-Button Telephones Market-Research Trial

A. H. ELKINS†

U.D.C. 621.395.636:621.395.652:621.395.721.1

The push-button sending of the call information from the telephone to the exchange has advantages over the dial technique. At a later time, it is proposed to offer push-button telephone facilities to the United Kingdom subscribers, but, prior to this, subscriber reaction was required. The general features of a market-research trial equipment are described.

---

### INTRODUCTION

**P**USH-BUTTON sending of the call information from the telephone set is a simpler and faster operation than dialling, as the depression of a button transmits the relevant digit to the exchange. The faster sending will enable advantage to be realized of the new, fast, switching and signalling systems in terms of a faster call set-up. The simpler operation has merit when sending a large number of digits, as may occur with national and international subscriber dialling.

To assess subscribers' reaction to the push-button technique, and to test the basic design features, a market-research trial was conducted at Langham Strowger-type director exchange, London, January–April 1966. Some 200 subscribers were equipped with push-button telephone sets.

### GENERAL FEATURES OF THE TRIAL EQUIPMENT

The system uses a basic  $2 \times (1\text{-out-of-4})$  code multi-frequency (m.f.) signalling technique, the frequencies being in two groups, as follows:

- |                  |       |       |       |           |
|------------------|-------|-------|-------|-----------|
| (i) Low group:   | 697   | 770   | 852   | 941 c/s   |
| (ii) High group: | 1,209 | 1,336 | 1,477 | 1,633 c/s |

As a signal consists of two frequencies compounded, one from each group, the basic concept permits 16 combinations. The 1,633 c/s signalling frequency was omitted for the Langham trial, the resulting one-out-of-four plus one-out-of-three code allowing 12 combinations, 10 of which were used for the digital signalling. The basic one-out-of-four concept has considerable merit in minimizing signal imitation and signal interference, and was adopted for this reason. The signal-imitation problem arises as the microphone is not inoperative for the whole time the m.f. receiver at the exchange is associated with the subscriber's line.

---

† Telephone Exchange Systems Development Branch, E.-in-C.'s Office.

In the basic system (Fig. 1) a 2-frequency signal is generated at the telephone set when a button is depressed, transistor oscillators, powered from the exchange, being provided in the telephone sets for this purpose.

The receiver consists of (i) a low-gain common-input amplifier, which also effects line-to-equipment impedance matching, (ii) filters for separating the two groups, (iii) a limiter for each group, which is also the receiver "guard," (iv) selective circuits for separating the frequencies within each group, and (v) detectors and output circuits for operating the storage equipment.

The limiter action, besides providing a signal with a substantially specific output-level to the selection stage, provides the guarding action in each group. Instantaneous limiting accentuates differences in level between components of a m.f. input, and reduces all component levels at the output of the limiter. With a m.f. input, the highest-level frequency dominates at the limiter output, but at a level below that which would result from a single-frequency input. Thus, depending upon the level response of the detection circuit, the limiter action guards against signal interference and signal imitation: firstly, the attenuated interfering frequencies tend to be below detection level, the signal frequency being the dominant output, and, secondly, the usual result of a m.f. speech (or other interference) input is that all output frequencies from the limiter are below detection level.

In the detail of the Langham equipment, the receiver checks for a one-and-one-only frequency signal in each of the two groups. The frequencies so checked must persist and be coincident as two-and-two-only for 25 ms, after which time a 50 ms pulse is generated which removes an inhibition from the two appropriate relay-drive circuits to permit pulse operation of the relays.

### TRUNKING ARRANGEMENTS

Fig. 2 shows the arrangements adopted to trunk the trial equipment in with the existing equipment, the additional equipment for the signal conversion (m.f. to loop-disconnect pulses) being inserted between the subscribers' calling equipments and the 1st code selectors.

On call origination, the caller is extended to a register and to the normal director equipment. Dial tone is returned via the register, being ceased when the first push-button signal is received. The register receives and

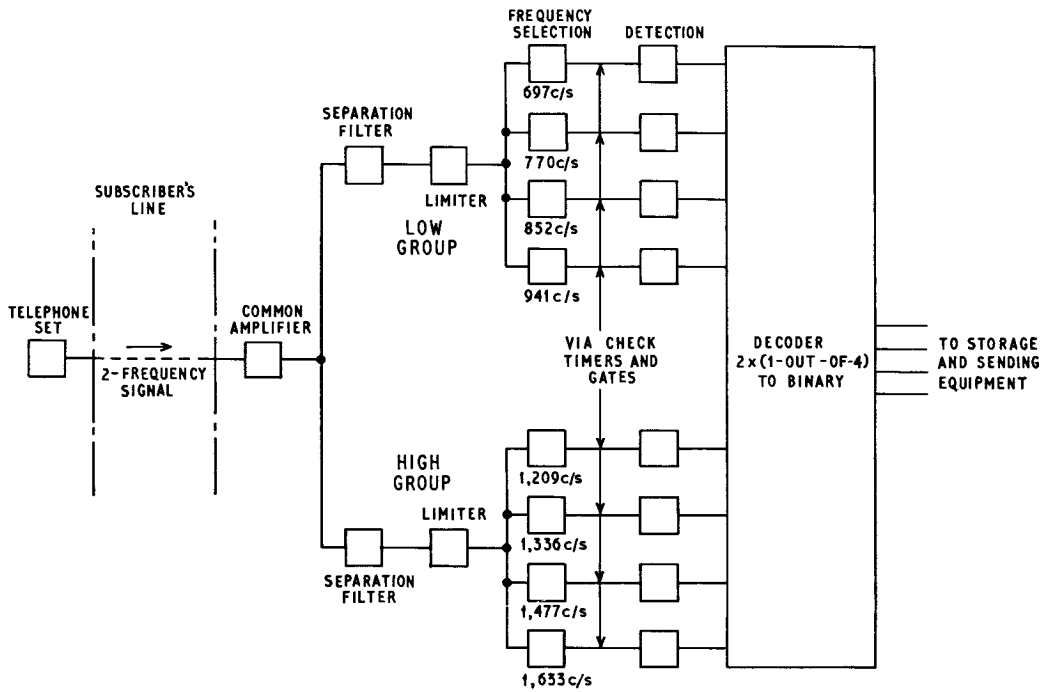

FIG. 1—BASIC SIGNALLING ARRANGEMENT

stores all the push-button signals, converts them to the equivalent loop-disconnect pulses, which are transmitted to the normal director equipment. On completion of the loop-disconnect pulse-out, the register is released, and

completely satisfactory. By means of a questionnaire, subscribers' views were obtained on such points as push-button layout, button shape, button "feel," post-dialling delay, etc.: this information will be assessed for the standard system. All the subscribers preferred the push-buttons to the dial.

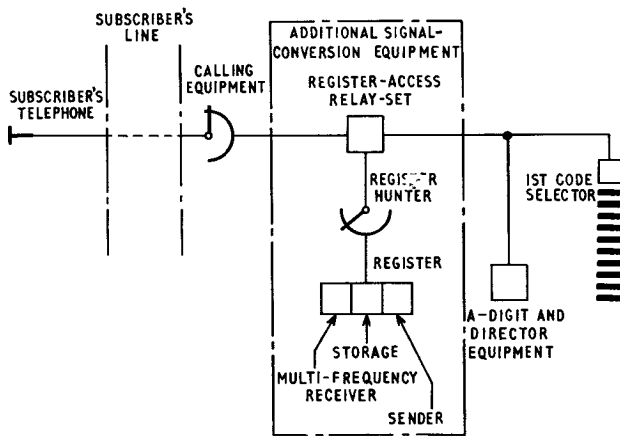

FIG. 2—BASIC TRUNKING

the transmission path is switched through at the register-access relay-set.

The equipment also caters for any dial telephone which may be in the group. When a call is originated from one of these telephones the first dialled loop-disconnect digit is received in the register and repeated to the director equipment. The register releases during the first interdigital pause, and the subsequent loop-disconnect dialled digits are received by the director equipment in the normal manner.

#### RESULTS

No faults attributable to the push-button equipment arose during the trial and in this respect the trial was

#### FUTURE DEVELOPMENT

A standard push-button system is now being developed. In basic concept this will be much the same as the Langham exchange system except that the frequencies will be raised to the range 900 c/s to some 2,000 c/s. This is not due to any weakness inherent in the use of the Langham frequencies, but to a requirement to admit, as a possibility to the extent technically practicable, the facility of push-button data signalling over switched connexions, and, thus, to the requirement to avoid difficulties with 600/750 c/s v.f. signalling which is employed on many trunk circuits.

For the convenience of using readily available telephone sets, a 2 × 5 push-button layout was used for the Langham trial, thus:

1	2	3	4	5
6	7	8	9	0

The standard system will use a 3 × 3 × 3 × 1 push-button layout in accordance with international recommendation, thus:

1	2	3
4	5	6
7	8	9
		0

#### ACKNOWLEDGEMENT

Appreciation is expressed to the General Electric Co. (Telecommunications), Ltd., who supplied the Langham trial equipment.

# Semiconductor Device Developments: General Introduction

M. F. HOLMES, B.Sc., A.M.I.E.E.†

U.D.C. 621.382

This article, which is intended as an introduction to a series of related articles, gives a brief historical outline of the developments between 1954 and 1961 that led to the special types of semiconductor device that are of particular interest at present. The advantages of silicon planar devices are described, and the effects on development of the need for greater reliability are discussed. Some new lines of development are suggested.

## INTRODUCTION

IN 1954 a series of articles on the transistor appeared in this Journal.<sup>1</sup> The development which had occurred between 1948, the date of the original discovery, and 1954 was already substantial. Between 1954 and the present time development has continued at an ever-increasing pace. In 1954 the thermionic valve was still in a dominant position in communications engineering. In 1966 the transistor occupies this position and is the active element adopted for most new work. Under these conditions of growth it is appropriate that a second series of articles should be started.

The original series of articles was intended for readers who had not studied transistors. In 1966 it is doubtful if any readers could be found who had not made some study of the subject. For this reason the approach of the new articles will differ somewhat from that of the earlier series. The accent is less on a general review of transistor principles and production for, in an expanding field of activity such as this, excellent reviews can now be found in the literature and in many textbooks. Emphasis will rather be placed on specific devices in which the British Post Office is particularly interested, or on research in techniques which parallels the development of such devices.

Since 1961 the Post Office, in common with most other organizations where advanced semiconductor development is studied, has concentrated its activities on the most successful technique so far discovered: silicon planar technology. Several special devices have been designed and produced to meet the particular Post Office need for great reliability coupled with the necessary performance at very high frequencies. These devices will be described in subsequent articles.

In this article, which is intended as an introduction to those that follow, a brief outline is given of the historical developments bridging the gap between 1954 and 1961. This is followed by an explanation of the technical development which has led to concentration on silicon planar devices, and by a survey of the problems that have had to be faced in attempting to provide the special devices that are needed by the Post Office; an attempt is made to forecast future lines of advance. The accuracy of this forecast will be reviewed in the last article of the series.

## HISTORICAL REVIEW 1954-1961

Up to 1964, point-contact transistors and junction transistors of the grown or alloy form were of primary interest, and germanium was the material used in most instances. The energy gap between the valence and conduction bands in germanium is, however, 0.72 eV, and

this limits the use of this material in transistors to junction temperatures of not more than about 85°C. Above this temperature, leakage currents would be excessive. In order to overcome this disadvantage, and obtain a higher maximum safe junction temperature, there was pressure to develop silicon (energy gap 1.12 eV) as a transistor material. Single-crystal silicon was, in fact, produced in the U.S.A. in the mid-fifties, and there was some preference at that time for silicon alloy transistors.

The technological situation, however, continued to advance rapidly, and diffusion techniques coupled with thermo-compression bonding led to germanium and silicon mesa devices in the late fifties. These devices were the first to achieve, through diffusion, the narrow base widths now commonplace in the art, and this resulted in a greatly improved frequency performance. A cross-section of a typical mesa device is shown in Fig. 1. The

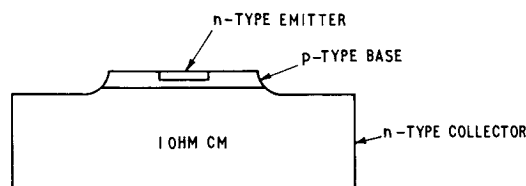
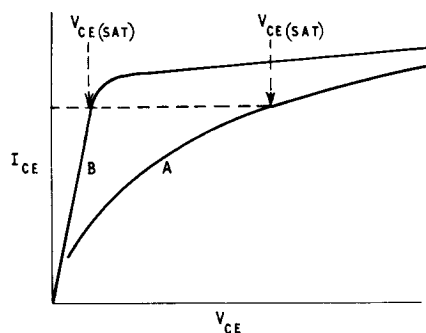

FIG. 1—CROSS-SECTION OF A MESA TRANSISTOR

name "mesa" is used because the resulting structure looks like a mesa or mountain plateau. A useful criterion of frequency performance is the parameter  $f_{\alpha b}$ , the cut-off frequency at which the value of  $\alpha$ , the current gain  $\left( = \left| \frac{\delta I_c}{\delta I_b} \right|_{V_c \text{ const}} \right)$ , is 0.707 of its low-frequency value, i.e. 3 db down. For silicon a base width of the order of  $4 \times 10^{-4}$  cm is a practical possibility using the mesa technique, and this can give values of  $f_{\alpha b}$  of 100 Mc/s or more.

In spite of the improvement in frequency response achieved by the mesa devices there still remained several parameters where an improvement in transistor technology was required. One of these was the collector-emitter saturation voltage,  $V_{CE(SAT)}$ , where a high value means a reduced power output. This is illustrated in Fig. 2 where,



Curve A—Characteristic for a typical mesa transistor with large value of  $V_{CE(SAT)}$   
Curve B—Characteristic for a typical epitaxial mesa transistor with a smaller value of  $V_{CE(SAT)}$

FIG. 2— $I_{CE}/V_{CE}$  CHARACTERISTICS FOR TWO TYPES OF TRANSISTOR

† Post Office Research Station.

for a given operating point, curve A with a higher value of  $V_{CE(SAT)}$  does not allow the power output that can be obtained from curve B. High values of  $V_{CE(SAT)}$  are due to a large series collector resistance, and this occurs in the mesa devices for the following reasons. First, on mechanical grounds, the thickness of the silicon slice from which the transistors are made cannot be reduced much below 80 microns and is usually of the order of 120 microns. Second, the collector region comprises by far the greater part of this thickness (of the order of 95 per cent), and the collector must have high resistivity for a high collector breakdown voltage and a low output capacitance. The thickness of the collector region and its high resistivity combine to give a large series collector resistance and a high value of  $V_{CE(SAT)}$ . This difficulty was resolved through the introduction of epitaxial techniques, as illustrated in Fig. 3. Here a thin (of the order of 10

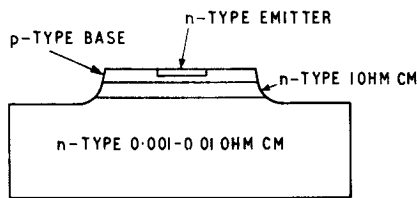

FIG. 3—CROSS-SECTION OF AN EPITAXIAL MESA TRANSISTOR

microns), relatively high resistivity (1–6 ohm cm), layer is deposited epitaxially on a thick (of the order of 120 microns), low resistivity (0.001–0.01 ohm cm), substrate.

The word epitaxial means that the crystal structure of the thin layer is an exact match and continuation of the crystal lattice of the thick substrate, so making the complete structure the monocrystal necessary for high electron and hole mobility and for long carrier lifetimes. The emitter–base and base–collector junctions are both constructed inside the thin high-resistivity layer, and, therefore, satisfactory breakdown and capacitance characteristics are achieved. In spite of the high resistivity of the collector adjacent to the base–collector junction, the resistance of this part of the transistor is relatively low because the epitaxial layer is so thin. This resistance is not much increased by the low-resistivity substrate, and, consequently, the whole series collector resistance is reduced and, with it, the value of  $V_{CE(SAT)}$  (Fig. 2, curve B). This epitaxial technique improved the performance of the mesa devices, and has also been applied with equal success to the silicon planar devices which have now largely superseded the mesas. One of the later articles in this series will give a more detailed explanation of the technique.

Other, and perhaps more serious, defects in the performance of the mesa transistors should be mentioned. These arose from the unprotected surface of the devices, especially in the region of the p–n junctions. The discontinuity in the crystal lattice at the surface of a semiconductor, the crystal dislocations at the surface, and the adsorption of chemical impurities all produce surface states which degrade the operation of a semiconductor device. The mesa transistor is given a chemical etch at the end of the production process in an attempt to clean the surface. This action, however, is only a palliative and, because it cannot always be perfectly controlled itself, gives rise to excessive spread of characteristics. Because of the surface states the noise figure of the mesa transistors

could be improved and the current gain at low current levels is rather low, e.g. less than 5 at  $1 \mu A$ . The leakage current  $I_{CBO}$  for silicon mesa transistors is between 10 and 100 nA,\* and this relatively high level is also due to the unprotected surface. The attempt to improve these defects in the mesa devices led to the planar devices which have become so important since 1961.

#### SILICON PLANAR TECHNOLOGY

The silicon planar devices are different in structure from the mesa devices. There is no plateau appearance, the surface is planar, as the name suggests, and the base and emitter regions are countersunk into the bulk of the collector, as shown in Fig. 4. The most important

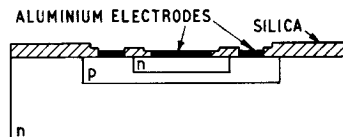

FIG. 4—CROSS-SECTION OF A SILICON PLANAR TRANSISTOR

difference is, however, the protection given to the surface of the device where the p–n junctions intersect this surface. A protective layer is formed by the oxidation of the silicon and is, in fact, a thin layer (of the order of 1 micron) of silica ( $SiO_2$ ). The silicon planar production techniques have been described in an earlier article<sup>2</sup> in this Journal and these will not, therefore, be considered in detail here. One point is, however, worth mentioning: the base and emitter regions are diffused into the collector and base regions, respectively, through windows cut in the protective layer of silica. The impurity atoms, boron and phosphorus, forming the base and emitter regions, respectively, diffuse laterally as well as vertically down into the slice. In this way the p–n junction is formed a few microns underneath the silica layer, giving much better control of surface states.

Due to the protection given to the surface, the leakage is reduced by an order of magnitude compared with the mesa device, and a noise figure as low as 3–4 db is attainable. The current gain at  $1 \mu A$  can be as high as 100, and the absence of the final etch gives a tighter control of characteristics. In the early stages of development of the technology it was also hoped that the protective layer would give great stability of characteristics over a long period, and in British Post Office experience, as far as a limited period of assessment can show, this hope is being justified.

Reliability and stability of characteristics is a vital necessity for the components in any electrical equipment in an isolated environment. The submarine repeater is an obvious example, and these needs led to the development by the Post Office of several thermionic valves in the 1950s which had substantially improved long-term stability. It was, however, possible to build redundancy into the submarine amplifier, and this was of assistance in supporting the basic reliability of the active device, the thermionic valve.

The promise of silicon-planar-transistor reliability, coupled with the prospect of improved bandwidth, suggested in 1962 that the time had come when the

\* nA—nanoampere, i.e.  $10^{-9}$  ampere.



thermionic valve in submarine amplifiers could, with advantage, be replaced by the transistor for new systems. Two factors combined to emphasize the need for even greater reliability and stability in the case of the transistor than was needed for the valve. First, it was not possible to build redundancy into the transistor-type amplifier. Second, the increased bandwidth possible with transistors, giving an increased number of circuits in the cable, requires closer repeater spacing and an even greater need for stability of characteristics, particularly current gain, with life. In addition, with five or more times the number of circuits than could be provided with the earlier valve-type repeaters, the loss of revenue caused by a breakdown due to transistor failure becomes proportionately more serious.

The target of designing, developing and producing transistors for submarine repeaters led the Post Office to concentrate a substantial research effort on to the two problems of increased bandwidth capability and greater reliability. The result has been a series of silicon planar transistors known as the types 4A, 10A and 20A, of progressively increasing frequency cut-off. The figure in the type description denotes the value of  $f_T/100$  for each, where  $f_T$  is measured in megacycles/second and is the value of the product of the high-frequency common-emitter current gain and the frequency at which it is measured (in the region where the gain/frequency characteristics is falling at 6 db/octave). At the present time the type 4A is in production for use in both shallow-water and deep-water systems, the type 10A is at the pilot production stage, and the type 20A is at the design stage. The problems and characteristics associated with these transistors will be considered in greater detail in subsequent articles.

#### RELIABILITY

The emphasis on reliability has been explained in the previous section, and a substantial research effort has been directed towards improvements in this field. Thermo-compression bonding has been used for connexions to the base and emitter regions of transistors for many years, but there has always existed a danger that gold wires bonded to aluminium films on the transistor surface—the standard practice—might not be entirely satisfactory when reliability standards such as those needed for submarine repeaters were the target. This attitude arose from the knowledge that gold, aluminium and silicon can form binary and ternary compounds whose mechanical and electrical properties are not as satisfactory as those of the pure elements. The alternative of aluminium wire bonded to aluminium films, although a theoretically very satisfactory solution, posed several technological problems. These have been solved at the Post Office Research Station, using an improved form of thermo-compression bond,<sup>3</sup> and the new bond is being used for both the type 4A and the type 10A transistors intended for submarine use.

In addition to this major contribution towards reliability, it should be realized that the production of very reliable transistors needs careful control of environment during production. In particular, it is important that dust-free conditions should be provided for important processes. The precautions that have been taken in this connexion have been described recently in this Journal,<sup>4</sup> where the philosophy behind the Post Office Research Station clean-room techniques is also explained.

The general planar-production techniques have been modified in ways which lead to greater stability of characteristics and, consequently, greater long-term reliability. These modifications will be discussed in the articles dealing with particular transistor types. Finally, a system of testing has been devised which has as one of its objectives the elimination of devices which can be regarded as electrically or mechanically suspect. This system, together with the one aimed at the statistical prediction of the failure rate, will be considered later in the series. The basic statistical methods have already been described.<sup>5</sup>

#### FUTURE DEVELOPMENTS

For the future there are many lines of research and development that can be followed in a field which shows no sign of contracting. The difficulty is to know which lines will prove of most value to the Post Office and, at the same time, make the maximum and best use of the experience gained over the past years. Reliability is one field where a firm foundation for new work has already been laid, and a research project has been started which makes use of techniques established during the work on epitaxy. This is the development of silicon nitride as a protective layer for new devices. Silicon nitride promises to be less porous and a better barrier to diffusion than the silica now being used. These properties could be particularly valuable in the development of insulated-gate field-effect devices. In one of these devices, of which a diagram is shown in Fig. 5, the flow of electrons between

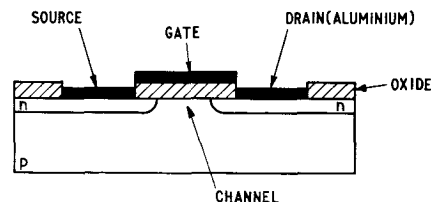

FIG. 5—CROSS-SECTION OF AN INSULATED-GATE FIELD-EFFECT TRANSISTOR (A M.O.S.T.)

source and drain is controlled by a signal applied to the gate. The gate is insulated from the channel in present devices by a layer of silica. Another name for the device is a m.o.s.t. where the letters derive from the sequence of materials between gate and channel: metal film (m), oxide insulating film (o), semiconductor channel (s), transistor (t). The stability of the m.o.s.t. is very sensitive to the movement of impurities in the insulating film, and the substitution of the nitride for the oxide here could be especially useful.

One other point of difference between the m.o.s.t. and the conventional transistor should be mentioned. In the former, the current flow is formed by one carrier, either electrons or holes; in the latter, the action depends on the simultaneous movement of both electrons and holes. The m.o.s.t. is, therefore, known as a unipolar device, the transistor as a bipolar. This difference has implications when considering the structure of the material from which these devices are made. The conventional transistor, the bipolar device, is sensitive to imperfections in structure which could lead to recombination of holes and electrons and so to shorter lifetimes. Single-crystal silicon, relatively free from imperfections, is therefore used for bipolar-device production. For unipolar devices using only one

carrier type recombination is not a problem and the use of poly-crystalline material is possible.

Another line of research and development stems from this point. Components made from semiconductor materials include not only transistors but also resistors and capacitors. These can be formed using planar techniques in single-crystal silicon. An alternative is, however, to use the thin-film approach and to construct resistors, capacitors and transistors by vacuum evaporation and deposition on an insulating substrate. This has some advantage for resistors and capacitors, since the tolerances can be improved by using thin-film techniques in place of planar methods. For transistors, on the other hand, the vacuum-deposition process leads usually to polycrystalline silicon and so excludes the bipolar version. If the problem of obtaining single-crystal silicon from an evaporation process were solved it would be very advantageous to thin-film technology, for resistors, capacitors and transistors could then be made using compatible process techniques.

The preceding paragraph leads directly to consideration of the problems of microcircuits, the natural development from single devices to monolithic integrated circuits where all the circuit components are included in a single tiny block of silicon not much larger than the 1 mm square block used for a single transistor. Here also the Post Office is vitally interested, particularly in the application of such integrated circuits to telephone-exchange development. Problems of reliability and stability are again very important, and it is probable that some of the techniques learnt on single components can be applied to the more complex integrated-circuit development. New problems will be presented, however, due to the fact that the standard method of accelerating aging processes, raising the ambient temperature, will be complicated by different rates of heat dissipation in different parts of the circuit. A solution will be assisted by the determination of the thermal contours of the circuit, and a promising technique is now being studied. It is also possible that the silicon-nitride protective layer mentioned earlier could be used for integrated circuits. The encapsulation of devices with many leads brings new technological difficulties, and some of these derive from the effect on the integrated circuit of impurity products of the encapsulation process.

Finally, it is necessary to attempt to look beyond the present generation of semiconductor devices to a new generation. One direction is towards devices of improved high-frequency performance, and this can perhaps be assessed on the basis of  $f_{ab}$ ,  $f_T$  or  $f_{max}$ . The first two have already been defined and, for completeness and use in the present context, the last is defined as that frequency at which the gain drops to unity. It is also the maximum frequency of oscillation of the transistor and is given by

$$f_{max} = \frac{a}{\sqrt{r'_b C_c t_{ec}}}$$

where  $a$  = constant,  $r'_b$  = base resistance,  $C_c$  = collector capacitance, and  $t_{ec}$  = emitter-collector transit time.

In order to improve the high-frequency performance,  $f_{max}$  must be increased. The base resistance  $r'_b$  and the transit time  $t_{ec}$  must both, therefore, be decreased. To

reduce  $t_{ec}$  needs a thin base region. This, however, increases  $r'_b$ , for the base resistance is not the resistance across the base region but the resistance along it to the base-electrode contact. These opposing needs suggest that a different base material, which can be thin and yet have a low resistance, could be used with advantage, and a metal film is an obvious choice. The new structure takes its name from the new method of forming the base and is known as a metal-base transistor (m.b.t.).

A metal film between 100 and 200 Å thick, sandwiched between two identical n-type semiconductor films as emitter and collector, is a construction which could increase  $f_{max}$  by a factor of 10 or more. The electrons do not move through the m.b.t. as they do through the bipolar transistor, where their flow is diffusion limited and their mean kinetic energy is low. In the m.b.t. the electrons are injected from the emitter with relatively high kinetic energies by a thermionic-emission-like process over a potential barrier into the metal base. Because of this, the m.b.t. is known as a "hot electron device." An assessment of the possible value of the metal-base transistor and the technical problems of development and production is now being made.

#### CONCLUSIONS

A review has been attempted in this article of the research and development effort that has led to special devices of particular interest here and now. New lines of development have been suggested which may lead to the devices needed for the future. These are supplemented by basic work on solid-state conduction processes, on the problems of dislocations in crystal structures and on the use of the electron microscope X-ray diffraction<sup>6</sup> and low-energy electron diffraction in the examination of crystals.

Much of the material which has only been briefly discussed here will be described in greater detail in following articles, which will be published in subsequent issues of the Journal under the same generic title as this article, i.e. "Semiconductor Device Developments." It is hoped that the whole series will give as accurate a picture as possible of a situation which, of its own nature, is bound to remain fluid.

#### References

- <sup>1</sup>TILLMAN, J. R., ROBERTS, F. F., SPEIGHT, E. E., CARASSO, J. I., YEMM, H., and BASSETT, H. G. The Transistor, Parts 1-6, *P.O.E.E.J.*, Vol. 47, pp. 92, 94, 166, 217, July and Oct. 1954, Jan. 1955, Vol. 48, pp. 43, 47, Apr. 1955.
- <sup>2</sup>HENDERSON, J. C., and WILSON, Sylvia J. Design and Technology of Silicon Planar Transistors. *P.O.E.E.J.*, Vol. 56, p. 239, Jan. 1964.
- <sup>3</sup>BAKER, D., and BRYAN, I. E. An Improved Form of Thermo-compression Bond. *British Journal of Applied Physics*, Vol. 16, p. 865, June 1965.
- <sup>4</sup>CORKE, R. L., and SEARLS, A. W. A Clean Room for the Production of Silicon Planar Transistors. *P.O.E.E.J.*, Vol. 59, p. 34, Apr. 1966.
- <sup>5</sup>ROBERTS, F. F., SANVOISIN, R., and MORGAN, Patricia M. Some Reliability Studies on Silicon Planar Transistors. *P.O.E.E.J.*, Vol. 57, p. 122, July 1964.
- <sup>6</sup>HENDERSON, J. C., and HALLIWELL, Mary A. The Use of X-Ray Diffraction to Study Defects Occurring During Silicon-Device Manufacture. *P.O.E.E.J.*, Vol. 59, p. 94, July 1966.

# Sheath Jointing of Plastic-Sheathed Cables

E. D. LATIMER, A.M.I.E.E., and H. E. ROBINSON†

U.D.C. 621.315.687.1:621.315.616.96

Polythene, as a cable-sheathing material, is rapidly taking the place of lead in the British Post Office cable network, and this has required the solution of a difficult jointing problem. At jointing points in cables the sheathing has to be cut back to expose the conductors, and, when these have been jointed, the jointing gap has to be enclosed within a water-tight sleeve that must also be air-tight if the cable is pressurized. Methods, some experimental, of enclosing the jointing gap are described and illustrated for polythene-sheathed cables.

## INTRODUCTION

**P**OLYTHENE, as a cable-sheathing material, is now being used extensively instead of lead, for telephone cables in the United Kingdom. Its lightness, resistance to corrosion, and other advantages make it very attractive as a sheathing material. For new work in the local-cable networks polythene-sheathed cable is used exclusively, and its use will soon extend into the trunk and junction audio-cable network, not on an experimental basis, as at present, but as standard practice.

Polythene with all its advantages as a sheathing material has, however, presented telephone-cable engineers with a difficult jointing problem to solve: when two lengths of cable have to be jointed together it is necessary to cut back the sheath at the jointing point to expose the conductors, and, when these have been jointed, the jointing gap has to be enclosed within a water-tight sleeve that must also be air-tight if the cable is pressurized. This sleeve is usually considerably greater in diameter than the cable. With lead-sheathed cables the procedure is comparatively simple, use being made of a lead sleeve dressed down and plumbed on to the sheath at each of its ends. Such a procedure is, of course, not possible for polythene-sheathed cables, but many methods of enclosing the jointing gap have been devised and used for these cables, some of the more recent being of an experimental nature and requiring further development, primarily for the simplification of the jointing apparatus required.

Some of the techniques used necessitate the stocking and carrying of a large number of piece-parts to cater for all sizes of cable, and, furthermore, are not well adapted to the making of spur joints. Nevertheless, all the methods are described and illustrated in this article, the methods being divided into four categories: mechanical, injection welding, electric welding, and adhesive. Some of the methods have been developed by the British Post Office and some by the cable manufacturers; one method, the polythene screw-joint, has been developed jointly by the Post Office and a plastics firm.

## MECHANICAL METHODS

### Expanding-Plug Joint

The expanding plug provides a means of filling the space between the joint sleeve (usually polythene and therefore not dressed down at its ends) and the cable sheath. It comprises a cylindrical rubber plug or ring held between two circular metal plates by means of bolts which pass through the plates and the rubber plug. The

rubber plug and plates are of similar diameter, slightly less than the inner diameter of the sleeve. Expanding plugs are made in a variety of types and sizes; some have a single hole through the plates and rubber plug to accommodate one cable (Fig. 1(a)), but others have two or more holes (Fig. 1(b)), the unused holes being filled with short

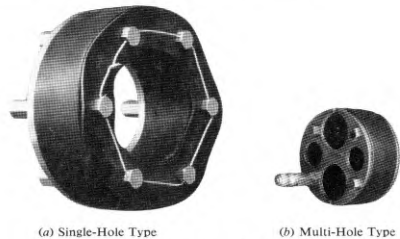

FIG. 1—TWO TYPES OF EXPANDING PLUG

ebonite rods. The bolts of small expanding plugs are not provided with nuts because they screw into threaded holes in the back plates, but the bolts of large plugs pass through non-threaded holes, do not rotate within the rubber plug, and are provided with cap-nuts.

As shown in Fig. 2, an expanding plug is inserted into each end of a sleeve open at both ends, or into the open end of a sleeve closed at one end, while a brass reinforcing collar is fitted over the end of the polythene sleeve where it has to withstand the outward pressure of the expanding plug. The metal plates of the expanding plug are drawn together to compress the rubber by tightening the nuts or heads of the bolts; this compression causes the rubber to expand radially inwards and outwards, and to bear upon the cable sheath and upon the inner surface of the sleeve. To ensure that the rubber plug is compressed to the requisite degree, the nuts or heads of the bolts are tightened by means of a torque spanner, i.e. a spanner fitted with a mechanism which disengages immediately the correct torque is exceeded.

Until recently all expanding plugs had rigid brass plates, but large plugs now have a flexible, steel, wavy plate on the side of the plug which is located inside a cable joint and will, therefore, be in a dry and non-corrosive atmosphere; the other plate is rigid and is made of brass. The rubber plug is made to follow the contours of the wavy plate by tightening the nuts of the plug, and when these are tightened to the required degree the plate flexes slightly between the bolts. The compressive force exerted by the front and back plates on the rubber plug gradually lessens as progressive "waisting" of the cable occurs over the area where it is subjected to pressure from the plug; several days may elapse before the waisting effect upon the cable sheath stabilizes. The compressive force is also lessened by a fall in ambient temperature, because the thermal coefficient of volume contraction, or expansion, of rubber is very high. The reduction in compressive force arising from both these causes results in a reduced

†External Plant and Protection Branch, E.-in-C.'s Office.

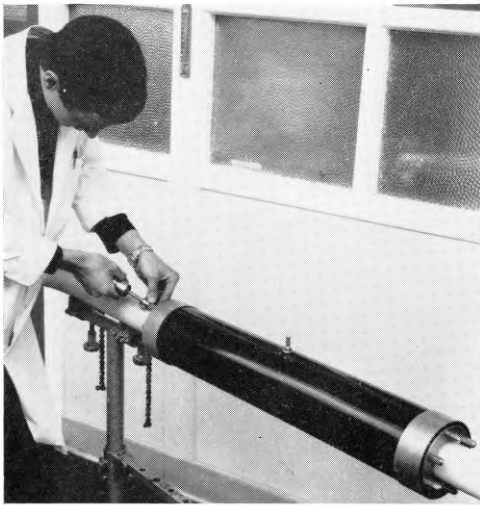

(a) Double-Ended Sleeve with Single-Hole Expanding Plugs



(b) Single-Ended Sleeve with Multi-Hole Expanding Plug  
FIG. 2—EXAMPLES OF EXPANDING-PLUG JOINTS

amount of flexing of the back plate, but, nevertheless, the potential energy stored in the flexed plate, though reduced, is still sufficient to prevent the compressive force on the rubber plug from falling to a level which would render the expanding plug ineffective as an air-tight and water-

tight seal. Flexible back plates have not been found necessary for the smaller expanding plugs.

Expanding plugs have been used for jointing purposes on polythene-sheathed cables in the local network for some 15 years, and when, in April 1964, paper-core polythene-sheathed cables were introduced as standard for all new local cables over 100 pairs the decision was taken to use this well-tried sheath-jointing method.

#### *Polythene Screw-Joint*

The polythene screw-joint (Fig. 3) utilizes a moulded polythene sleeve (divided at its centre in the larger sizes)

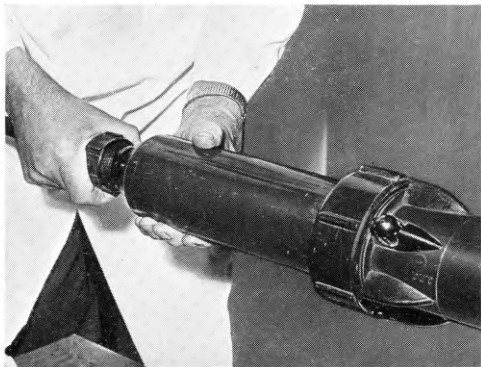

FIG. 3—POLYTHENE SCREW-JOINT

over each end of which is threaded a cup-shaped polythene nut through which the cable passes; the nut, with a special buttress thread to prevent the "overriding" which would occur under stress if an ordinary thread were used in a material such as polythene, encloses a tapering rubber sealing ring and a polythene compression ring. Hand tightening of the nut makes an air-tight seal between the cable and sleeve. Each size of polythene sleeve can be made suitable for a range of cable sizes by fitting a rubber sealing ring having a hole of a diameter to suit the cable to be jointed. An air valve is mounted in the body of the sleeve to facilitate (local) air pressure-testing of the completed joint.

The larger sizes of moulded polythene sleeve are divided at their centres. A divided sleeve has a clamping nut to unite the half sleeves on accurately-moulded male and female tapered ends; a special C-spanner, made of polythene, is provided for tightening this nut. No rubber sealing ring is required to make an effective air-tight seal at the division of a divided sleeve.

#### INJECTION-WELDING METHOD

Sheath closure by the injection-welding method (Fig. 4) is effected, for small cables up to about 1 in. in diameter, by passing molten polythene around each end of the polythene sleeve and the adjacent cable sheath, so welding them together. For larger cables, the polythene sleeve, at each of its ends, fits over another shorter, polythene sleeve, called an adaptor, which tapers down to the cable sheath; for sheath closure by welding it is, therefore, necessary to pass molten polythene around each end of the polythene



FIG. 4—INJECTION-WELDED JOINT

sleeve and the adjacent portion of the adaptor, and around the small end of each adaptor and the adjacent cable sheath. When the polythene sleeve is divided at or near its centre, molten polythene is passed around the junction of the two sections of sleeve, which are supported internally by a short length of brass or aluminium tubing.

Each area to be welded is enclosed within a mould constructed as follows. The side walls of the mould are built up by wrapping aluminium tape, turn over turn, around the cable sheath, sleeve, or adaptor until the required wall dimension has been reached. The circumferential outer wall is formed from two flexible metal strips, each equipped with a tubular stem to act as inlet and outlet for the molten polythene, bent around the outer surface of the formed side walls to encompass them; the amount by which these metal strips overlap is dependent upon the size of the mould being formed. The whole assembly is clamped in position with worm-drive clips.

An injection gun is loaded with a polythene charge and is heated, using a propane-gas torch, to a temperature high enough for welding purposes. The injector is then attached to one of the two tubular stems of the mould (see Fig. 4), and, by means of a plunger contained within the gun and operated by turning a screw, molten polythene is injected quickly into the mould until it flows from the opposite tubular stem. Injection is then continued slowly until the gun is discharged, when it is removed and replaced by a ram. A second ram, already in position in the outlet stem, is screwed in until it closes the spew hole. At

intervals of approximately 2 minutes, both rams are tightened a little to maintain pressure on the injected polythene while it is cooling, preventing the formation of contraction voids. The weld is ready for release from the mould after cooling for approximately 10 minutes.

#### ELECTRIC-WELDING METHOD

The electric-welding method (Fig. 5) makes use of polythene adaptors at the ends of the polythene sleeve for



FIG. 5—ELECTRIC-WELDED JOINT

all sizes of cable; welds are, therefore, made between cable sheath and adaptor, and between adaptor and sleeve. When the polythene sleeve has an expanded end so that it can overlap the other section of sleeve in preparation for welding.

To make a sheath-to-adaptor weld, a circular wire-mesh electric heater, the weld heater, is inserted between cable and adaptor, and over the adaptor at the heater position is wound, turn over turn, a neoprene tape, applied with a 10 per cent stretch. The tape, which is "tailor-made" for each cable size, is nine turns long and has a one-turn long wire-mesh electric heater attached to its seventh turn so that, when the tape is applied, this heater is under the two outside layers. The functions of the neoprene heating-and-compression tape are to soften the polythene of the adaptor in that area of the heater located between the cable and adaptor, to apply pressure between the surfaces to be welded and the heater, and to maintain a steady pressure on the welded surfaces during the time taken for the polythene to cool, thus inhibiting contraction failures of the weld. The adaptor-to-sleeve and divided-sleeve welds are made in a similar manner.

Both the heaters are energized from a 110-volt a.c. supply via a step-down transformer and a control unit



which houses timing and current-regulating devices. Initially, the tape heater is switched on, and after a few minutes it is automatically switched off by the tape heater timing-device. The weld heater, which is attached to a carrier frame, is then switched on, and after a few seconds the polythene in the vicinity of this heater melts sufficiently to enable the carrier frame, and therefore the heater, to be oscillated by hand through about 90° in order to agitate the molten polythene. Towards the end of the welding period the heater is prepared for withdrawal by a combined oscillatory and axial motion, the completion of withdrawal coinciding with the disconnection of the current by the weld-heater timing device. The weld is allowed to cool naturally, and then the neoprene tape and associated heater are removed.

#### ADHESIVE METHODS

##### *Resinwrap Joint*

The Resinwrap method makes use of either a divided polythene sleeve tapering down to the cable sheath or an ordinary polythene sleeve fitted over epoxy-resin plugs cast on the cable sheath to fill the space between the ends of the sleeve and the cable. The plugs project beyond the ends of the sleeve for 3-4 in. A polythene mesh tape, Resinwrap, which is impregnated with a thixotropic liquid epoxy resin, is wrapped, at each end of the sleeve, around the cable and thence over the tapered portion of the sleeve (Fig. 6), or, if an ordinary sleeve is being used, around the

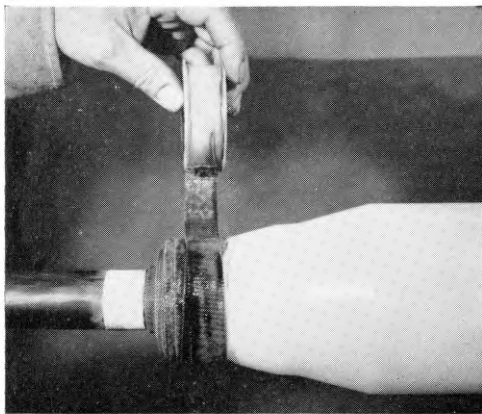

FIG. 6—RESINWRAP JOINT

projecting portion of the epoxy-resin plug and thence over a short length of the sleeve. When the sleeve is divided at or near its centre, the epoxy-resin-impregnated tape is wrapped around the junction of the two sections of sleeve, which are supported internally by a short length of polythene tubing. The bindings of tape are applied in such a manner that, when completed, their shape resembles that of a conventional plumber's wiper; they are, therefore, known as "wipes."

Polythene is chemically inert, and, in order to obtain satisfactory adhesion between the epoxy resin and the polythene cable sheath and sleeve, the polythene surfaces concerned are, before taping or casting the epoxy-resin

plugs, thoroughly degreased and then oxidized by flame-treating them, using a propane torch. The polythene-mesh tape is contained in a dispenser into which thixotropic liquid epoxy resin is forced from a squeeze tube, thereby impregnating the tape. With care, contact between the epoxy resin and the hands can be avoided. The taping, when completed, is wrapped with two turns of polythene-coated aluminium foil, the polythene being on the outside; over this foil is wrapped an adhesive PVC tape.

Resinwrap joints can be opened and closed any number of times. To open a joint, the wipes are heated gently without disturbing the oxidized polythene surfaces. As much of the wipes as possible is cut away with a knife, finishing with a coarse file. To close a joint which has been opened, new wipes are built up with Resinwrap. The cast-plug technique, described above, is well adapted to the construction of spur joints, since any number of cables can be included within the cast plug when a spur joint is constructed.

The Resinwrap method of jointing, using a polythene sleeve, is suitable for lead-sheathed cables, a satisfactory bond to the lead being obtainable by cleaning and abrading its surface before applying the Resinwrap.

##### *Taped Joint*

The jointing gap in the taped joint (Fig. 7) is enclosed

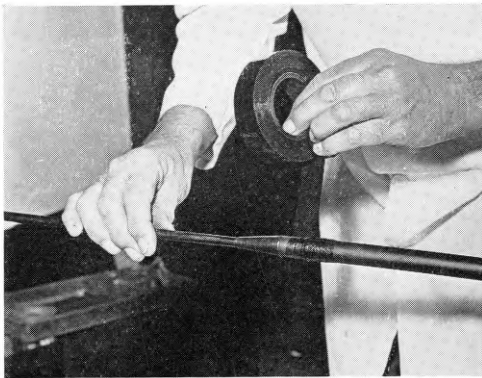

FIG. 7—TAPED JOINT

within a polythene sleeve into each end of which is inserted a tapered end-piece of polythene. Each end-piece is cut at a point on the tapered section to make it fit the cable, and polythene-based self-amalgamating tape is wrapped around the cable near the end-piece and continued until it covers the end-piece and a short length of the sleeve; two lappings of tape are applied. This tape is then compressed by tightly wrapping it with an adhesive PVC tape.

##### *Resin-Putty Joint*

To close the gap between each end of the polythene sleeve used with the resin-putty joint (Fig. 8) and the cable or cables entering it, an epoxy-resin putty is used. Since this putty does not adhere effectively to polythene, the expedient is adopted of first bonding aluminium foil to the



FIG. 8—RESIN-PUTTY JOINT

polythene surface and then bonding resin-putty to the aluminium with a synthetic rubber-based adhesive. The aluminium-foil bonding is effected by wrapping around each end of the polythene sleeve, and around the cable adjacent to the sleeve, a polythene-coated aluminium foil, the polythene being innermost; the foil is then bound to the sleeve or cable by a close binding of copper wire, which, after being heated gently by a flame from a propane-gas torch and then allowed to cool, is removed, leaving the aluminium firmly bonded in position. The resin-putty is prepared by thoroughly kneading together a base synthetic resin and a hardener, both in putty form. As soon as the two components are mixed, hardening commences, but the mixture retains its plasticity long enough for the making of a wiped joint at each end of the polythene sleeve similar in form to a plumber's wipe. After coating the surfaces of the aluminium foil with the adhesive, the putty is applied, roughly formed to a bulbous shape, and finally wiped with a moleskin cloth, lubricated with water, to give a neat appearance. The putty is hard after 1-3 hours, depending upon the size of the cable being jointed.

The time taken for the putty to harden or cure is dependent upon the temperature to which it is raised by chemical change within its mass (the generation of heat

in this way is called the exotherm), and when the bulk of the putty wipe is large this temperature is higher, and the curing time less, than when it is small. The amount of heat generated in a wipe is directly proportional to its mass, and the amount of heat lost, since this is largely by radiation, is directly proportional to the area of its outer surface; this area increases at a relatively slow rate with increase of size, and therefore of mass, of the wipe, with the result that the temperature of the exotherm is higher for a large wipe than for a small one.

When the polythene sleeve is divided, the two sections of sleeve are supported internally by a short length of polythene tube, and are joined together by means of a polythene-coated aluminium foil bonded over their junction, the foil being reinforced with resin-putty applied as previously described.

This method of jointing, slightly modified, is suitable for lead-sheathed cables using a polythene sleeve. Before applying the putty, the lead sheath adjacent to the sleeve should be prepared by tinning its surface with a tin-zinc solder and then coating the surface of the solder with the adhesive.

#### CONCLUSIONS

Sheath-jointing methods which require a large number of piece-parts to be stocked and carried, need complicated apparatus, or are not well adapted for the making of spur joints, leave much to be desired when considered for long-term use by Post Office personnel.

The Post Office resin-putty joint, proved by extensive field trials, uses no piece-parts or apparatus, caters for any combination of spur cables, and can be applied, with only slight modification of technique, to sheaths of PVC, lead, aluminium, or steel. Furthermore, the technique is easily learned, and still allows scope for the skilled jointer to exercise his traditional skill in wiping a joint. It is possible that this method will soon supersede the expanding-plug method of sheath jointing used in the Post Office local-cable network for all cables over 100 pairs, and will become standard for polythene-sheathed cables of all sizes when they are introduced to the trunk and junction network in the near future. For cables, up to and including 100 pairs, in the local-cable network it is probable that the simple Post Office taped joint will be adopted, particularly as a new type of end-piece, having two tapered cable entries, is being developed to cater for spur cables. The taped joint cannot be guaranteed to withstand the air pressure of a pressurized cable system, but it is reliable for small local cables not exceeding 100 pairs since these are used in parts of the network where the cables are not normally pressurized.

#### ACKNOWLEDGEMENTS

The polythene screw-joint was developed jointly by the British Post Office and Kautex, Ltd., the injection-welded joint by British Insulated Callender's Cables, Ltd., the electric-welded joint by Telephone Cables, Ltd., and the Resinwrap joint by Pirelli General Cable Works, Ltd.



# Electronic Telephone Exchanges: An Introductory Review of Developments

L. R. F. HARRIS, M.A., A.M.I.E.E.†

U.D.C. 621.395.345:621.395.722

This article, the first of a series dealing with electronic telephone exchanges, reviews the main research and development projects carried out in this field during the last 20 years in the United Kingdom. The steps leading to the prototype development of the three most promising systems are described, and the factors that influenced the choice of the reed-relay systems for large-scale introduction into the British Post Office network are discussed.

## INTRODUCTION

THE development of electronic telephone exchanges has now reached the point where their large-scale introduction into the British network can be seriously considered. Three systems are in an advanced state of development, and between them they are expected to meet virtually all the Post Office requirements for various kinds of switching equipment. Each system uses reed relays as speech-path switches, with electronic controls appropriate to its expected role in the network. One system, TXE2, has been designed for new small exchanges having an initial capacity of up to 2,000 lines. The second system, TXE3, has been developed primarily for larger new exchanges of various types, and the third, the reed-selector system, is intended specifically for the extension and replacement of Strowger exchanges with modern equipment.

In view of the rapid expansion of the telephone network the availability of these three systems is particularly timely. On current forecasts the network is expected to double in size over the next 10 years, and to treble in fifteen. In addition, much of the existing equipment is nearing the end of its useful life and continues to give good service only at the cost of increased maintenance. In the early years of rapid expansion, Strowger equipment, supplemented by some crossbar exchanges, will continue to meet the greater proportion of the Post Office requirement for new switching equipment, but the production of electronic equipment is expected to build up steadily from now on, and in 10 years' time perhaps 90 per cent of the demand will be met in this way. Already it has been announced that all new exchanges of up to 2,000 lines will be ordered in electronic form, and orders for some 50 TXE2 exchanges are being placed in the current ordering year. Orders for a number of the larger TXE3 exchanges are also planned, and orders for the reed-selector system for extension purposes are expected to follow a field trial in London later this year.

The three systems are the outcome of nearly 20 years of continuous research and development in the electronic-switching field in this country. Numerous difficulties have been encountered and overcome during this period, and their gradual resolution has led to a growing understanding of the many basic problems to be solved in the development of an entirely new switching system. Some five phases of development—and learning—can be discerned in the progress of electronic switching in this country so far:

† Mr. Harris is in the Long-Range Systems Planning Unit, E.-in-C.'s Office, but was formerly in the Telephone Electronic Exchange Systems Development Branch, E.-in-C.'s Office.

early research, the Highgate Wood experiment, prototype development projects, development for production, and development for the future. While these phases naturally overlap, they provide a convenient framework in which to review progress to date; they also serve to introduce the many aspects of the subject to be considered in more detail in later articles.

## EARLY RESEARCH

Following the rapid progress made with the development of electronic devices and techniques during the second world war, it became apparent that they offered many advantages in telephone switching. The absence of mechanical wear due to moving parts suggested that they would be intrinsically more reliable than their electromechanical counterparts, and the adaptability and high operating speeds of electronic components suggested that capital costs could be reduced by the extensive use of common equipment. Electronic techniques also offered the possibilities of reducing building costs by savings in space, weight and power, and of improving overall transmission performance.

With these potential advantages in view, the Post Office and the principal British manufacturers embarked on research programs to find ways and means of exploiting them. With the knowledge available today, it may seem that these programs were premature, but they did represent a very fundamental reappraisal of basic telephone-switching principles in this country. Most of the pre-war research and development activity in the telephone-switching field had been concentrated on the change-over from manual to automatic working, using the Strowger system operating on step-by-step principles, and the war itself had precluded the detailed study of alternative systems for some years. The substantial post-war demand for telephones was, therefore, met with step-by-step equipment, and the reappraisal of switching fundamentals was largely carried out in the context of electronic-switching research.

In the early research days much of the work was empirical, and some time elapsed before certain fundamental technical concepts were formulated. Thus, it took time to recognize that all systems—be they step-by-step, manual, rotary, crossbar or electronic—perform the same basic sequence of operations involving a limited number of basic types of function:

(a) speech-path switching, involving the operation of switches and, therefore, an inherent "memory" of the connexions established through the exchange,

(b) signal reception, e.g. the calling condition, the identity of the wanted subscriber, the answer and clear conditions,

(c) signal transmission, e.g. the calling or ring signal,

(d) testing and selection, e.g. finding a free transmission path through the exchange between a calling subscriber and a free wanted subscriber,

(e) permanent information storage, e.g. a record of the

action to be taken in response to all possible demands for service and all signals which may be received,

(f) temporary information storage, e.g. recording the busy or free condition of each speech path in the exchange, the stage reached in the call, the digits received, etc., and

(g) semi-permanent information storage, e.g. the subscriber's meter record.

It became clear that there was a very wide variety of techniques which could be used to perform each of these basic functions, and that the characteristics of any telephone-exchange system would depend overwhelmingly on the choice made and on the way in which the techniques were co-ordinated. The choice of speech-path technique was seen to be of particular importance, and early consideration was given to all three classical transmission techniques as a basis for electronic switching; these are as follows.

(a) Space division—in which each connexion is physically separated from the others. In space-division switches, each inlet is provided with a number of "cross-points," any of which can be operated to give access to required outlets.

(b) Frequency division—in which a common transmission path is shared by a number of connexions, each allocated a different part of the frequency spectrum. Speech and signals are switched from one frequency band to another using selected carrier frequencies and filters.

(c) Time division—in which a common transmission path is again shared, each connexion being allocated different time positions, generally cyclically recurring. In time-division-multiplex (t.d.m.) systems, speech and other signals are transmitted over common "highways" in the form of pulses from which the modulating waveform can be recovered, e.g. for transmission to line.

Much of the early work was pioneered at the Post Office Research Station at Dollis Hill, where it was soon concluded that, with the electronic devices available at the time, spatial arrays of cross-points would be prohibitively expensive, particularly in large exchanges, and that t.d.m., using pulse-amplitude modulation whereby information is transmitted as pulse samples, offered a more promising basis.<sup>1</sup> The technique had a considerable advantage over frequency division in that it was entirely compatible with the performance of logical operations required to detect calling lines, to select free paths and to set up and release connexions. Indeed, subsequent research showed that t.d.m. transmission was compatible with virtually all of the logical operations required in a telephone exchange.

The analytical work during these early years led to a number of general conclusions which have continued to play an important part in subsequent developments in this country. For example, it was clear that electronic exchanges would not be economic if they continued to employ the step-by-step path-selection principles of the Strowger system without the use of registers. The use of registers, in which the information designating the wanted subscriber or junction could be received and stored, can save considerable quantities of switching equipment because a connexion through the exchange may be set up from end to end, e.g. from calling line to called line, in one selection process which takes into account all the busy paths that may be encountered at each stage of switching. Using exchange-code translation, the use of registers can also provide routing flexibility of the kind

given by the director system, leading to further switching and junction economies.

The design of electronic register-translators featured prominently in the early research work, and laid the foundation for the subsequent experimental trial of electronic directors at Richmond (London) telephone exchange.<sup>2</sup> This in turn led to the development of subscriber-trunk-dialling (S.T.D.) register-translators for use in the larger group switching centres (G.S.C.) in non-director areas, such as Bristol, where the S.T.D. service was inaugurated in 1958. Early research by the Automatic Telephone & Electric Co., Ltd., on magnetic-drum techniques similarly laid the foundation for the experimental trial of directors at Lee Green (London) telephone exchange, and for the subsequent use of the magnetic-drum equipments which have provided S.T.D. register-translation facilities in director areas since 1961.<sup>3</sup>

Other features of the early research systems that have continued to be exploited during the developments which followed include the use of subscribers' switches which carry both directions of traffic and which are used for all kinds of connexions to registers, junctions, etc. The efficiency of electronic systems has further been enhanced by providing complete flexibility between the equipment position on which a subscriber's line terminates and the directory number of the subscriber. Such flexibility implies that spare directory numbers do not involve spare equipment positions, that both parties on a shared-service line can share the same equipment position—for both directions of traffic—and that a group of private-branch-exchange (P.B.X.) lines can be distributed over the subscriber's equipment positions, enabling P.B.X. line groups to grow without wasting equipment or changing directory numbers. The efficiency of electronic switching networks has similarly been enhanced by enabling any junction of any route to occupy any junction-equipment number position, and by enabling lines to be terminated anywhere virtually without regard to their class of service. Such flexibility has been obtained using a "line library" which stores the directory numbers, junction routes, classes-of-service, and type-of-line information for every line terminated on the exchange.

A general pattern of system organization (Fig. 1) emerged from the early studies, and most of the subse-

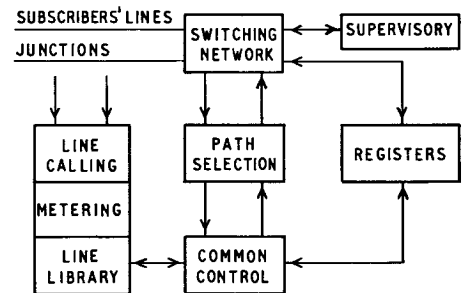

FIG. 1—GENERAL SYSTEM ORGANIZATION

quent exchange projects have contained the following broad functional equipments:

(a) switching networks, which give access between subscriber's lines, junctions, registers, and miscellaneous equipments as required,

(b) path-selection equipment, which selects suitable paths through the network,

(c) common-control equipment, which determines the exchange terminals between which a connexion is required,

(d) register equipment, which receives and stores information identifying the wanted subscriber or junction route, and passes it to the common-control equipment,

(e) line-calling equipment, which detects line-calling conditions and indicates them to the common-control equipment,

(f) line-library equipment, which makes available to the common-control equipment the directory number or junction route number, class-of-service and type-of-line information for every exchange terminal,

(g) supervisory equipment, which progresses each established connexion through the network, and controls ringing, metering and the release of connexions, and

(h) metering equipment, which records the cumulative call charge to the subscriber.

This pattern was followed in the evolution of t.d.m. switching systems, and by 1955 it seemed that the t.d.m. approach provided the basis of an attractive and potentially-economic telephone system. Inter-highway switching of pulse channels enabled calls to be routed through an exchange with one modulation-demodulation stage only, irrespective of the exchange size, and logical operations of the type required in the path-selection, common-control, register, line-calling and supervisory equipments could all be performed using techniques which were entirely compatible with the t.d.m. transmission path. The approach fully exploited the high operating speeds possible with electronic techniques, and the use of t.d.m. could be seen as an extension of the time-sharing principles which had already played such an important part in the provision of an economic telephone service.<sup>4</sup>

Time sharing occurs when apparatus is used for different subscribers, connexions or functions at different times. The following three basic methods of time sharing were recognized during this phase of development.

(a) Time sharing by switching: a free item of equipment is seized when required, held continuously while it performs the required operation, and released when the operation is complete. Cord circuits, junctions, registers, switches, path-selection equipment—and many staff—are shared by this method. A study of the problems posed when a number of sources originate demands for association with a smaller number of items of equipment leads to congestion, or traffic, theory.

(b) Time sharing by coding: information is transmitted, stored or indicated in coded form. The significance or function of any one element of the code will then be dependent upon the state of the remaining elements. For example, using binary coding, 16 conditions or functions can be indicated by four elements. Relays, switches in stages, signalling elements, and register-storage elements are frequently time-shared by coding. The exploitation of the technique depends upon the number of different independent states which a system can assume, and Boolean algebra and selective communication theory are relevant theories.<sup>5</sup>

(c) Time sharing by sampling: common circuits are used to operate on or transmit information in the form of pulse samples. Time-division-multiplex systems, delay-line stores, and the reading and writing heads of magnetic drums are examples using this kind of sharing. It is usual

to take samples at a fixed repetition frequency determined by the rate at which the information is changing. This in turn is limited by the bandwidth and signal-to-noise ratio of the communication channel used, and analysis of this problem leads to structural communication theory.

Time sharing is a common theme in all telephone-exchange systems, and congestion theory and communication theory, collectively, give a unity to systems using widely different techniques. From the foregoing it will be seen that the early research phase in the development of electronic telephone exchanges did much to establish a number of fundamental principles which were new to telephony in this country. A growing awareness of the information concepts, and of the basic sequences of operations required, did much to clarify requirements, and a number of experimental projects gave laboratory experience of a variety of electronic switching circuits. Most of the circuits were based on thermionic valves and cold-cathode tubes, but semiconductor diodes were increasingly used as switching elements and for logic purposes.

#### THE HIGHGATE WOOD EXPERIMENT

The growing understanding of telephone-switching fundamentals was accompanied by the increasing availability of transistors in quantities. Transistors were expected to revolutionize the electronics industry, and greatly to improve the prospects for electronic switching. However, it was appreciated that there would be a great many problems to be solved in developing an entirely new system. It was apparent that if the object was to be achieved within a reasonable period, a very considerable effort would be needed—an effort unlikely to be available to any single organization then existing in the country. It was realized that the effort would have to cover all aspects of telephone-switching research, development, planning and production, and range over components, devices, equipment practice, circuits and systems. After due consideration it was agreed that this could be achieved by pooling, in a co-operative program, the research efforts of the Post Office and those manufacturers having experience of both electronics and telephone switching.

The Joint Electronic Research Committee (J.E.R.C.) was thus formed in 1956, and since that time close co-operation has existed between the research and development teams of all parties. These comprise the British Post Office and the five principal British manufacturers of telephone-switching equipment: Associated Electrical Industries, Ltd. (A.E.I.), then Siemens Edison Swan, Ltd., Automatic Telephone & Electric Co., Ltd. (A.T.E.), Ericsson Telephones, Ltd. (E.T.L.), The General Electric Co., Ltd. (G.E.C.), and Standard Telephones and Cables, Ltd. (S.T.C.).

The formation of J.E.R.C. immediately led to an invaluable interchange of information and views between the parties, and with the experience gained from the earlier independent research studies, the Committee was soon able to agree that, in the first instance, the combined efforts should be concentrated on the development and field trial of a t.d.m. system.<sup>6,7</sup>

In determining the general requirements and features of the system it was recognized that most of the electronic techniques available at the time were more suited to large exchanges than to small, and it was, therefore, decided that the system should be capable of serving from about 2,000 to 20,000 lines. In view of the experimental nature

of the trial exchange, it was also decided that it should be backed up by a conventional Strowger exchange to which subscribers could be transferred during periods of modification, and at the end of the trial. This decision was important in that it forced the design to work with existing instruments and signalling methods, even though it was believed that electronic exchanges would be more advantageous when working with subscribers', and other, apparatus specifically designed for use with electronic exchanges. Full director facilities were required, and it was agreed that electronic solutions should be found wherever possible. It was also agreed that the experimental exchange should provide design, manufacturing and field experience of a variety of techniques, and that each part would be designed by separate teams provided by the J.E.R.C. parties, and would use the system, circuit and equipment techniques with which its designers were most familiar.

The system itself used a 4-wire transmission path with 2-wire to 4-wire conversion in each line terminal equipment. Each line could be switched, when required, to any of 100 amplitude-modulated pulse channels on highways common to up to 800 subscribers' lines and junctions. Each channel had a repetition frequency of 10 kc/s, and each connexion was set up through line and inter-highway switches by storing channel pulses in 100  $\mu$ s magnetostriction delay lines. Magnetostriction delay lines also formed the central feature of the common register and supervisory equipments, which controlled the setting-up and progressing of all calls. Common apparatus selected the channels to be used on all connexions, using information stored on magnetic drums. This information included a library of exchange code-translations together with the directory number, class-of-service, class-of-line and state-of-line information for each line terminal. The magnetic drum also provided a meter record for each subscriber.

Following a laboratory trial of the system at Dollis Hill in 1959, a 600-line field trial of the system was installed, tested and commissioned at Highgate Wood in North London, and put into service in December 1962. Fig. 2 shows register racks installed at Highgate Wood Exchange. The growth in the local demand for service overtook the capacity of the trial exchange after a few months, and service experience with the equipment was limited. However, the trial was continued on a care and maintenance basis, and the equipment was kept in operating condition with artificial traffic until the summer of 1965. The trial exchange provided encouraging data on reliability, and showed that complex equipment could be maintained by local staff in the field.

The Highgate Wood project provided design, manufacturing and field experience of a wide variety of circuit and equipment techniques, and there is no doubt that many detailed lessons were learned which were to the benefit of subsequent projects. As a viable switching system, the Highgate Wood system suffered from the very diversity of techniques which it was designed to test. Circuit diversity coupled with the overall power (and ventilation) requirements, due to the extensive use of thermionic valves, were clearly features which could not be carried forward into a practical system.

Furthermore, the system was unnecessarily complex in that the various areas of the system used different methods of signalling and of manipulating information. Difficult boundary problems were posed as a result, and

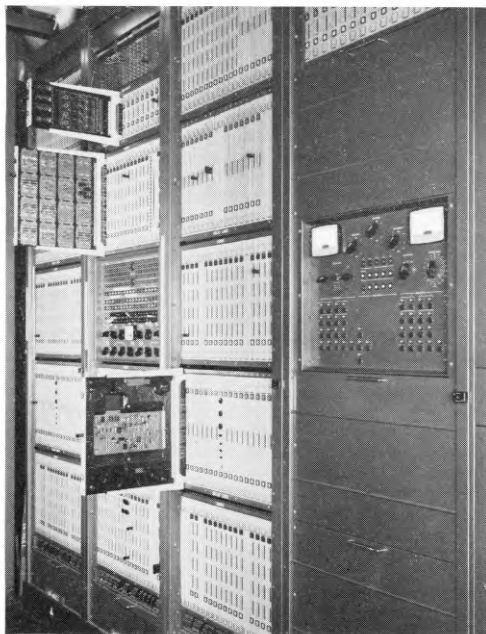

FIG.2—REGISTER RACKS INSTALLED AT HIGHGATE WOOD ELECTRONIC EXCHANGE

their successful solution required careful and close liaison between the six parties involved in the design. In fact, some 12 teams at different addresses participated in the design, and not the least of the important lessons learned from the project concerned the difficulties of co-ordinating the activities of such a dispersed design group. While boundary conditions were agreed jointly, some formidable liaison problems were posed.

However, the main value of the Highgate Wood project was that it stressed to the designers the importance of those essential features and characteristics of switching systems which can readily be taken for granted in established systems. Such features as maintainability, reliability, continuity of service, simplicity of power and ventilation requirements, adequacy of transmission performance, ease of extension, and suitability to a wide range of applications were seen in a new light following the practical design experience gained with the Highgate Wood project.

In particular, the project caused the designers to face more realistically the formidable problems of providing 24-hour service throughout the life of the exchange. The Highgate Wood system included a number of common equipments on which the success of all calls depended, and which, therefore, had to be secured against the effects of faults. The approach made to this problem was to duplicate the common equipments, and to provide automatic routing, fault diagnosis and change-over facilities. While the approach seemed reasonably successful, detailed analysis during the design showed the extreme difficulty of providing routing and change-over equip-

ment to meet every kind of failure. An important lesson was that any practicable system should require, and use, less-demanding methods of achieving fault-tolerance.

#### PROTOTYPE DEVELOPMENT PROJECTS

While the Highgate Wood system was the main project undertaken in the early years following the formation of J.E.R.C., it was by no means the only one, and by 1957 a wide variety of research studies were under way as part of the co-operative program. Naturally, the main emphasis was on the development of an electronic-exchange switching system, and the particular problems of both large and small exchanges were studied in relation to the available techniques. A whole range of time-division and space-division systems was considered, together with a wide diversity of cross-points, trunking configurations and control principles.

A number of more general studies were also put in hand with the objective of fully exploiting the characteristics of electronic switching. For example, considerable attention was paid to the design of new subscribers' instruments. Push-button signalling was proposed in order to take advantage of the fast switching possible with electronic techniques. In addition, tone-calling was expected to be a more pleasant alternative to ringing as a means of attracting the attention of the wanted subscriber, as well as greatly reducing the signalling power to be sent from the electronic exchange. Low-current microphones were also envisaged.

Redesign of the subscribers' instrument also featured in basic transmission studies, and it was expected that considerable advantage would be taken of the inherent gain provided with some forms of electronic switching (notably 4-wire t.d.m.) in order to improve transmission performance of the network and to reduce line-plant costs. Many of the expected advantages of 4-wire t.d.m. exchanges stemmed from the necessary provision of individual line units which acted as an interface between the t.d.m. equipment and the line plant. Each line unit could, therefore, incorporate current-feeding, signalling and transmission features appropriate to the line. In particular, impedance matching and gain adjustment could be provided individually for each line.<sup>8</sup>

The impact of electronic switching on junction signalling was also considered, and various line and inter-register signalling systems were studied with the objective of improving the overall effectiveness of the telephone network. Remote line-concentrators, automatic accounting, centralized maintenance centres, automatic traffic recording, and the provision of new facilities and services were other general aspects which received attention during this phase.

These general studies were accompanied by a growing expertise in circuit design, and in the design and evaluation of systems. Costing techniques and techniques for estimating the traffic-carrying capacity, reliability and fault tolerance of various systems were evolved, and in 1960 a comprehensive schedule of desiderata was drawn up against which each of a number of proposed systems was evaluated. Cost, reliability, maintainability, accommodation savings and the need for reasonable power requirements naturally figured highly in this list, but importance was also given to improved transmission performance, potential line-plant savings, new facilities, interworking with new designs of instruments and signalling system, and to such general features as simplicity of

design, coherence of technique and universality of application.

By 1960 some seven promising electronic switching systems had been studied by the various J.E.R.C. parties:

(a) a 100-channel t.d.m. system using magnetic-drum control,

(b) a 100-channel t.d.m. system using magnetostriction delay-line temporary memories,

(c) a 30-channel t.d.m. system using ferrite-core temporary storage,

(d) a space-division system using semiconductor cross-points and ferrite-core storage,

(e) a space-division system using cold-cathode tube cross-points,

(f) a space-division system using reed-relay cross-points, and

(g) a 100-channel t.d.m. system with space-division line concentrators.

The systems were evaluated, and it was established that a number of them could provide the basis of a development for production. It was recognized that it would be difficult to choose between the more promising approaches, and after due consideration three systems were selected for prototype development, with the objective of establishing sufficiently accurate data for a choice to be made.

The main features of the three systems were as follows,

*Low-Speed T.D.M. System.* The low-speed t.d.m. system was a 4-wire t.d.m. system in which each of 30 subscribers in a group was permanently allocated one of 30 pulse channels. Ferrite-core storage was used for connexion, supervisory and register memories, and to provide a meter record. A threaded-core translation field stored the semi-permanent information relating to each subscriber. The system aimed to reproduce the advantages of multi-path security used in electromechanical systems. Pending the choice of a system for production, the program provided for a laboratory model and a pre-production field trial. The development was undertaken by S.T.C. and E.T.L. in co-operation with the Post Office.<sup>9</sup>

*High-Speed T.D.M. System.* The high-speed t.d.m. system was a 4-wire t.d.m. system in which each subscriber could be allocated, on demand, any one of 72 pulse channels on either of two highways. Magnetostriction delay lines were used for connexion, supervisory and register memories. The system was an evolution of the Highgate Wood design, in which particular attention was paid to the security of the speech-path and control apparatus. The development was undertaken by G.E.C. and A.T.E. in co-operation with the Post Office, and a pre-production trial was planned, the equipment for which was installed in the manufacturer's laboratories at Coventry.<sup>10</sup>

*Reed-Relay System.* The reed-relay system is a space-division system with reed-relay cross-points. The speech-path trunking comprises 3-stage cross-point arrays via which calls are established under the control of duplicated electronic control equipment. A capacitively-coupled store provides translation information. The system is based upon the principles of sectionalization and trunking pioneered by A.E.I., who undertook the development in co-operation with A.T.E., S.T.C. and the Post Office. A laboratory model of the system was installed in the manufacturer's laboratories at Blackheath, and the equipment for a complete 3,000-line pre-production trial exchange is currently being commissioned at Leighton Buzzard.<sup>11</sup>

The three projects were tackled vigorously, and by mid-1963 it could be concluded that there was little prospect of producing an economically-viable t.d.m. system for production in the near future. T.D.M. systems were, therefore, referred back to research, and the t.d.m. field trials were abandoned.

Several factors contributed to this decision. For example, power requirements proved to be excessive despite the elimination of thermionic valves, and there were reservations as to the ease with which t.d.m. equipment could be maintained without the aid of elaborate and costly test equipment. Furthermore, it was proving difficult to meet noise and crosstalk requirements. While there was some confidence that these difficulties could be overcome with continuing development, it was recognized that a very considerable effort would be needed to solve all the technical problems, and a firm conclusion was that development for production should be based on proven techniques and that its scope should be closely related to the effort and experience available.

The main lesson from this phase, however, was that the problems of introducing a new switching system into a well-established network are very formidable, particularly if their transmission and signalling characteristics are markedly different from that of the established system with which it must interwork for many years. Some of the features of t.d.m. exchanges which might, in the long run, confer benefits on the rest of the network, can actually degrade performance in the short term. For example, the inherent gain, referred to earlier, could in the long term improve overall transmission performance and save line-plant costs, but in the short term it is very difficult to match even the present transmission performance without using a wide range of accurate line balances and gain settings. Furthermore, the cost of providing, selecting and adjusting individual line balances and gains appropriately for the present diversity of plant could offset any long-term savings in line plant. Similarly, although t.d.m. exchanges would readily permit the introduction of new and improved subscribers' instruments, the power-handling capacity of the t.d.m. speech path is limited and totally incompatible with the power needed to ring a conventional telephone bell. Expensive interface equipment is, therefore, required when working with existing instruments and, indeed, with any conventional signalling system.

It is clearly impracticable and uneconomic to change the surrounding line plant and telephone apparatus when an isolated electronic exchange is introduced into the network, and these problems of incompatibility have formed an economic barrier to which no acceptable solution has been found. The t.d.m. developments, therefore, led to the conclusion that any new telephone-switching system for use in a well-established system must be compatible with the existing equipment, and that for many years at least, electronic switching developments should be based on metallic cross-points.

#### DEVELOPMENT FOR PRODUCTION

When these conclusions were reached in 1963, considerable experience had already been gained with reed relays. Not only was the laboratory model of the Leighton Buzzard large-exchange system under test, but models of two small exchanges were showing satisfactory results. With this experience, there was no difficulty in agreeing that the development of electronic switching

systems for production should be based upon reed relays. Such cross-points have the following advantages:

(a) they lend themselves to automatic production techniques, i.e. for assembly, wiring and testing,

(b) they offer extremely high reliability in that their contacts are sealed against the atmosphere, adjustment and cleaning are unnecessary, and they produce little contact noise,

(c) they have a high operating speed, e.g. 1.5 ms to operate and less than 0.5 ms to release,

(d) they require little space, e.g. a 4-contact relay occupies less than 2 in<sup>3</sup>,

(e) they can be used in a variety of switching configurations, as well as for logic purposes, and

(f) they pose no new transmission problems, and have no restrictive limitations on bandwidth or power-handling capacity.

These advantages, had of course, contributed to the 1960 decision to include a reed-relay system in the three systems chosen for prototype development. They had also been taken into account when in 1961 the Post Office initiated studies of reed-relay systems for application in the small-exchange field. These studies were undertaken when it became clear that none of the prototype systems would meet the requirements of small exchanges economically, and they led on to two development projects undertaken by E.T.L. and G.E.C., respectively; during 1963, laboratory models of two experimental systems were constructed and tested, and were followed by field trials of 200-line units (Fig. 3) at Leamington and Peterborough. These were put into public service during the first half of 1965: both have given excellent service, and have demonstrated the reliability which can be achieved with electronic switching equipment.<sup>13</sup>

These two systems, together with the Leighton Buzzard project, provided a firm basis for the development of reed-relay systems for production, which started in earnest early in 1964. Production development began with the formation of a new control organization set up under the general terms of the Joint Electronic Research Agreement, and current developments for new exchanges are controlled by the Reed Electronic Project Executive Board, supported by a Project Operating Panel responsible for implementing the Board's decisions.

Two systems, TXE2 for small exchanges and TXE3 for large exchanges, have so far been developed under the direct auspices of the Board.<sup>13,14</sup> E.T.L. have been the sole company responsible for the design of the TXE2 system, but the large-exchange development was considered to be too large for one company alone and the system was divided into two areas: switching and control. A.E.I. have been the company responsible for the former and S.T.C. for the latter, although A.T.E., G.E.C. and the Post Office have also contributed to the design. The Post Office have played a major liaison and progressing role in both developments, and the general techniques of critical path analysis have been used on both projects. Each project has involved the design, documentation and testing of some 100 major units in about 2 years.

The two systems are primarily aimed at meeting the Post Office requirements for new exchanges, but under certain circumstances each will also be suitable for the extension and piecemeal replacement of Strowger exchanges. However, there has been a growing appreciation



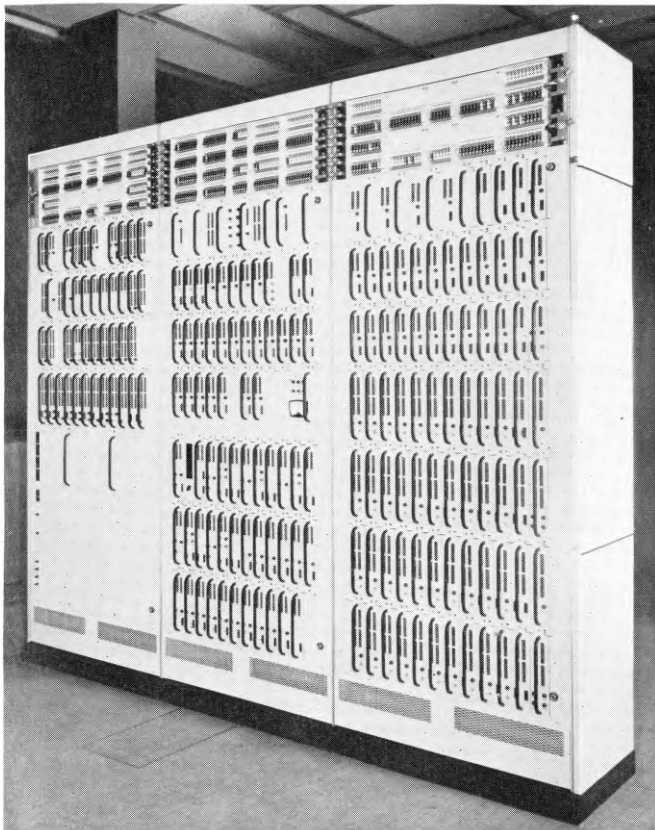

FIG. 3—FIELD-TRIAL INSTALLATION OF SMALL ELECTRONIC EXCHANGE

of the special problems of extending and replacing existing exchanges, and, during 1964, Post Office studies led to a further development, the reed selector system, aimed specifically at these extension problems. This has been carried out primarily by A.T.E., E.T.L. and G.E.C. in co-operation with the Post Office.<sup>15</sup>

The details of the three systems will be given in later articles in the series. Here it must suffice to say that each system uses reed-relay switches with electronic controls appropriate to its role in the network. The systems have been developed to the same standards, which aim to provide a quality and grade of service at least as good as those given by the best conventional systems. In order to achieve a long and reliable service life, particular attention has been paid to the quality of the components and devices used, and to the design parameters and operating conditions to be met. Care has also been taken to minimize the number of types of transistors and diodes used in order to simplify replacement problems and to ensure continuity of supply. Carefully specified reed contact units will be used as cross-points and for logic purposes under specified conditions.

New equipment practices have been developed for the production systems, and these have aimed particularly at saving space, and reducing production, installation and maintenance costs. Equipment will be mounted in depth on racks which are compatible with existing accommodation standards, and plugs and sockets will be used to simplify testing and to reduce installation and extension costs. In all aspects of the developments particular emphasis has been on low initial costs, maintainability, simplicity, reduced accommodation requirements, compatibility with existing equipment, suitability for automatic production and standard packaging, and easy installation. These objectives are primarily directed towards reducing the overall costs of the telephone service, and, in particular, at enabling the network to expand without proportionate increases in manpower. Other features which might be expected to have long-term advantages have been included in the current design only if they seem consistent with these objectives.

In the short term this country is faced with a very large capital-investment program in order to meet the immediate expansion of the telephone network. There is, therefore, considerable pressure to add new subscribers at the cheapest possible cost, and under these circumstances it is very difficult to justify features, no matter how attractive, which may add significantly to the cost of providing telephone service. It is particularly difficult to justify features which only lead to benefits in the long term. A typical example is the

problem of reducing the time to effect a connexion. Push-button telephones are currently on field trial, but, even when these are in widespread use, the overall connexion time will be determined primarily by the slow-speed Strowger signalling used in most of the network. On long-distance calls the problem will be much reduced by the use of high-speed inter-register signalling, and each of the electronic systems under development will be register controlled and will give rapid switching through the exchange. However, the provision of high-speed signalling between exchanges adds substantially to the cost of register equipment, and cannot be justified at this stage. Similar arguments apply to the provision of exchange-code translation facilities, and, in the early years at least, it is not proposed to equip all new local electronic exchanges with registers having full translation or high-speed signalling capabilities. Easy addition of these capabilities at a later stage is, however, an objective.<sup>16</sup>

The speed-of-connexion problem is but one of many where there is an apparent conflict between short-term and long-term requirements; a major lesson during this



phase of development has been the recognition of the fundamental nature of this problem and of possible solutions to it.

#### DEVELOPMENT FOR THE FUTURE

The nature of the problems to be solved is concerned more with certain fundamental characteristics of telephone networks than with specific techniques or systems. Some understanding of these characteristics can be gained by considering the progress made since the introduction of the telephone less than 90 years ago. In attaining its present size, the network has had a considerable growth rate which could not have been maintained without the continuing introduction of new techniques and devices leading to cost and, more particularly, manpower savings. Furthermore, the growth rate could not have been maintained as economically unless the equipment used had had a long working life of 30 years or more. The network thus contains many vintages of equipment and designs, which have become more numerous as continuing developments have led to the provision of an ever-increasing range of services and facilities.

Growth, change and diversity of technique, and change of capability, are all key characteristics of telephone networks, and all are to some extent unpredictable. Telephone administrations all over the world find it difficult to predict the growth requirements of a telephone network in terms of numbers of telephones, or traffic, or in terms of the demands for new services and facilities. Similarly, few telephone engineers would wish to be specific as to the devices and techniques which will be introduced into the network, even in the next decade. These new techniques will not only lead to economies in the provision of a telephone service, but will, in the long run, greatly extend the communication services which can be provided economically by the telephone network, but it is difficult, indeed, to predict the date or rate at which they will become available.

Telephone networks have very considerable inherent transmission, signalling and data-manipulating capability whose full exploitation is only at a beginning. Already the possibilities of switched television between subscribers, of remote reading of gas and electricity meters, of automatic "shopping" by telephone and similar facilities are being discussed, and there are no doubt many other powerful and attractive facilities which could be provided using the inherent features of telephone systems. Service facilities such as automatic accounting, the provision and manipulation of traffic data, and the automatic location and indication of exchange and line-plant faults, can also be envisaged which will lead to greater service efficiency and economy.

However, the problems of introducing new services and facilities, or, indeed, of improving the overall performance of the network are formidable. Much of the automatic switching equipment, in particular, is highly specialized in function and its modification is both technically difficult and expensive. Furthermore, economics dictate that it cannot be scrapped prematurely, particularly in a period of rapid growth when resources are limited. In such circumstances, new facilities, e.g. subscriber trunk dialling, are largely accommodated by adding further specialized equipments in existing exchanges, and even this involves major rearrangements of equipment and numerous wiring changes.

The cost of such modifications represents an inertia

which makes it difficult to introduce widespread changes quickly, and, as already described, the performance of new and improved equipment will be to some extent masked by that of the old with which it must interwork. No criticism of existing designs of equipment is intended; without them today's networks could not have attained their present size and capability. However, the problems of introducing changes is a real and continuing one, for there is generally a short-term economic advantage to be gained by designing new equipment merely to match the performance of the old. Clearly, unless its function can later be changed or extended economically and readily, the new equipment will, in its turn, continue the constraints of the old.

Fortunately, some of the electronic switching techniques offer the possibility of greatly easing this problem, and designs can be envisaged which, while being entirely compatible with existing equipment, can be more readily modified and extended to provide new services when required. Using computer-like techniques, the facilities provided by an exchange can be determined very largely by a program of instructions stored in electronic form. This program virtually dictates the action to be taken by the exchange upon the receipt of signals, and, by modifying the stored program, the action of the exchange can be changed. New facilities, particularly those involving the mere manipulation of data, can generally be introduced without modifying the equipment installed in exchanges or changing the factory product. Some major changes in facilities may require the incorporation of additional units to detect or send signals, or the extension of the program store. Nevertheless, the general principles are extremely powerful, and in the long run they should greatly simplify the problems of providing new services and facilities.

This approach has already been exploited to some extent in TXE3, the production system for large exchanges, where it is used to control the setting-up of all connexions through a general-purpose switching network. The full exploitation of stored-program control requires a massive development effort, however, and in this country it is expected that its application will build up gradually as experience accumulates and economics dictate.<sup>17</sup>

Another major problem concerns the introduction of new techniques. It is clear that with the increasing pace of modern developments there will be increasing economic pressure to change designs more frequently than has been the case with Strowger equipments, and it can be expected that several different vintages of equipment, perhaps employing widely different techniques, may be required to interwork in the same exchange. Fortunately, again, the general system organization of the production systems developed in this country will permit the ready introduction of new designs. The systems tend to be made up of a comparatively small number of racks with clearly-defined functions and clearly-defined boundary conditions for interworking with other racks. This implies that new designs of equipment can be introduced provided that they meet the specified boundary conditions. This aspect of system design is already permitting evolutionary development in that some of the units of TXE3 are being redesigned using silicon integrated circuits.

The principles of evolutionary development are being extended in a revised design of a large-exchange system, TXE4, currently being designed. In this system it is

expected that the use of stored-program control will be increased to cover register operation, and the general design of the system will aim specifically at permitting the ready introduction of new vintages of equipment.

This evolutionary concept is by no means restricted to the control and data-manipulating areas of the exchange systems, and the problems of introducing different kinds of switching unit into an exchange are being specifically examined. This may be particularly relevant when considering the introduction of integrated switching and transmission systems using pulse-code modulation (p.c.m.).<sup>18</sup> An experimental p.c.m. switching unit to be used as a tandem exchange in London to switch between p.c.m. junctions is currently being planned, and it seems possible that the extent to which integrated p.c.m. is used in the network of the future will depend very much on the ease with which p.c.m. switching units can be incorporated into existing exchanges.<sup>19</sup> If they cannot, it may well be that the problems of incompatibility will more than offset the apparent advantages of directly switching p.c.m. circuits.

#### CONCLUSIONS

This introductory article has reviewed the main research and development projects carried out in the electronic-switching field in this country over the past 20 years. It will be seen from the many aspects of the subject which have been touched on in this article that a major effort has been needed to disentangle the problems of introducing a new switching system into the network, and to develop viable switching systems meeting the needs of the country. A great many people in the Post Office and in industry have contributed to the ideas, conclusions and achievements recorded here, and it is quite clear that a continuing effort will be required in the future if the advantages of electronic switching are to be fully exploited. The rate at which the full benefits of electronic switching will mature will depend very much on the way in which the available research, development and production effort is co-ordinated.

Virtually nothing has been said in this article about overseas developments in the electronic-switching field. Here it must suffice to say that most of the leading manufacturing countries have also carried out prolonged and intensive research and development programs, and field-trial exchanges of various kinds have been in service in many parts of the world. So far, only in the United States have plans been published for introducing electronic exchanges into the network on a larger scale. In the Bell System some 20 stored-program controlled electronic exchanges have already been installed, and their policy is to achieve a 100 per cent penetration of electronic switching equipment by the year 2000.<sup>20</sup> It can be expected that other countries will adopt similar policies in due course, and the overseas interest in electronic switching is reflected by the scope of the recent International Conference in Paris, at which some 150 papers were presented and some 1,000 delegates from 25 countries took part.

In view of the overseas interest and, more particularly, in view of the British plans for introducing electronic-

switching systems into the network, the series of articles, of which this is the introduction, seems timely. The subject has many facets which have not so far been discussed in this Journal, and a quite lengthy series of articles has been planned for subsequent issues. These articles, which will be published under the same generic title as this article, i.e. "Electronic Telephone Exchanges," will provide a comprehensive coverage of the many aspects of the subject, including principles, circuit techniques and operation of the systems developed under the auspices of the Joint Electronic Research Committee and the British Telephone Technical Development Committee.

#### References

- <sup>1</sup>FLOWERS, T. H. Electronic Telephone Exchanges. *Proceedings I.E.E.*, Paper No. 1,266, Mar. 1952 (Vol.99, Part 1, p. 181).
- <sup>2</sup>HERON, K. M., BAKER, H., and BENSON, D. L. An Experimental Electronic Director. *P.O.E.E.J.*, Vol. 44, p. 97, Oct. 1951.
- <sup>3</sup>BENSON, D. L., and VOGAN, D. H. Controlling Register-Translators, Part 4—Magnetic-Drum Register-Translators. *P.O.E.E.J.*, Vol. 51, p. 291, Jan. 1959.
- <sup>4</sup>HARRIS, L. R. F. Time Sharing as a Basis for Electronic Telephone Switching. *Proceedings I.E.E.*, Paper No. 1,993R, Mar. 1956 (Vol. 103B, Part B, p. 722).
- <sup>5</sup>SHANNON, C. E. A Mathematical Theory of Communication. *Bell System Technical Journal*, Vol. 27, p.379, July 1948.
- <sup>6</sup>HARRIS, L. R. F., MANN, V. E., and WARD, P. W. The Highgate Wood Experimental Electronic Telephone Exchange System: General Introduction. *Proceedings I.E.E.*, Paper No. 3,376E, Nov. 1960 (Vol. 107, Part B, Supplement No. 20, p.70).
- <sup>7</sup>BROADHURST, S. W. The Highgate Wood Electronic Telephone Exchange. *P.O.E.E.J.*, Vol. 55, p. 265, Jan. 1963.
- <sup>8</sup>FLOWERS, T. H. Transmission Network Planning with Electronic Exchanges. *Proceedings I.E.E.*, Paper No.3,373E, Nov. 1960 (Vol. 107, Part B, Supplement No. 20, p. 364).
- <sup>9</sup>FLOWERS, T. H. Trunking of a T.D.M. Electronic Exchange with Subscribers' Lines having Permanently-Allocated Multiplex Channels. *Proceedings I.E.E.*, Paper No. 4,831E, Oct. 1962 (Vol. 112, p.1,878).
- <sup>10</sup>CAPLIN, J. S., and REGER, H. P. A Time-Division-Multiplex Exchange with Alternative Routing. *Transactions I.E.E.E.*, Vol. COM 14, p. 221, June 1966.
- <sup>11</sup>WARMAN, J. B. REX—A Sectionalized Space-Division Switching System. *Transactions I.E.E.E.*, Vol. COM 14, p. 226, June 1966.
- <sup>12</sup>HILLEN, C. F. J., LONG, R. C., and PORRITT, W. R. A. The Field Trial of Two Small Electronic Exchanges at Leamington and Peterborough. *P.O.E.E.J.*, Vol. 58, p. 1, Apr. 1965.
- <sup>13</sup>MATTHEWS, G. A., and HILLEN, C. F. J. A Small Electronic Exchange (PENTEX) for the British Post Office. *Proceedings of the International Conference on Electronic Switching, Paris, 1966.*
- <sup>14</sup>WARMAN, J. B., and MARTIN, J. Large Electronic Exchanges (REX): General Introduction. *Proceedings of the International Conference on Electronic Switching, Paris, 1966.*
- <sup>15</sup>LAWRENCE, J. A. The Reed Selector System. *Proceedings of the International Conference on Electronic Switching, Paris, 1966.*
- <sup>16</sup>HORSFIELD, B. R. Inter-Exchange Signalling. *Proceedings of the International Conference on Electronic Switching, Paris, 1966.*
- <sup>17</sup>BRYAN, D. G., and BENSON, D. L. Electronic Control Systems for Large Exchanges. *Proceedings of the International Conference on Electronic Switching, Paris, 1966.*
- <sup>18</sup>DUERDOTH, W. The Possibility of an Integrated P.C.M. Switching and Transmission Network. *Proceedings of the International Conference on Electronic Switching, Paris, 1966.*
- <sup>19</sup>WARMAN, J. B., SIMMONS, B. D., and WARREN, K. G. The Introduction of P.C.M. Junction Links and Switching into a Dispersed Generalized REX System. *Proceedings of the International Conference on Electronic Switching, Paris, 1966.*
- <sup>20</sup>No. 1 Electronic Switching System. *Bell System Technical Journal*. Vol. 43, No. 5, Parts 1 and 2, Sept. 1964.

## Notes and Comments

### E. C. Swain, B.Sc.(Eng.), M.I.E.E.

The promotion of Edwin Swain to Staff Engineer of the Local Lines and Wired Broadcasting Branch is an event which has given pleasure to his many friends and associates, not only at Headquarters, but also in the Regions and Telephone Areas.

Mr. Swain hails from Derbyshire, and started his Post Office career as a Youth-in-Training in the circuit laboratory in 1932, where he became a skilled workman after a few months.

In 1934 he was successful in the competitive examination for Probationary Inspectors, and was posted to Scotland, where he received training in the Edinburgh and Aberdeen Sections. In 1935 he became Probationary Assistant Engineer (old style), and was appointed to the Technical Section of the Superintending Engineer's Office, where he was involved in the initial work for providing telephone service to the Highlands and the Islands. Whilst there he saw the setting up of the Scottish Directorate. He transferred to the Telephone Manager's Office at Edinburgh in 1938, and was responsible for



major-works planning and construction (internal and external).

In 1943 he joined the External Plant and Protection Branch, which was then at Harrogate, and became responsible for corrosion problems. He was promoted to Executive Engineer (old style) in December of the same year. Later, whilst in this Branch, he represented the Post Office at C.C.I.T.T. and C.M.I. conferences on the protection of Post Office plant from corrosion and the adverse effects of high-voltage power systems.

For five years, from 1952 to 1957, he was Area Engineer in charge of external planning and construction in the North Telephone Area, London Telecommunications Region.

At the end of this period he was promoted Assistant Staff Engineer in the Local Lines and Wired Broadcasting Branch, and has served there up to the present time, in which period the number of applications for service

awaiting line plant has been reduced from approximately 130,000 to negligible size. He is a member of the C.C.I.T.T. Special Autonomous Working Party (GAS 2) on Local Telephone Networks.

Mr. Swain is of great good humour and is seldom seen to be ruffled, even when working under heavy pressure. The successful application of the science of local-line planning and provision calls for a careful blend of economic theory and practical experience. "LLB" is fortunate to have a head in whom these attributes are so well proportioned.

W.C.W.

### A. J. Leckenby, M.B.E.

Mr. A. J. Leckenby, who has been appointed Chief Regional Engineer on the reorganization of the Home Counties Region, entered the service as a Probationary Inspector in 1926. He was successful in the Limited Competition for Assistant Engineers (old style) in 1932, and, after a short time in the Test Section, was employed in the Coventry Area until 1939 when he was promoted to Executive Engineer (old style) and joined the Lines Branch War Group. He joined the Royal Corps of Signals for a short time in 1942 and, after returning to the War Group, was recalled as a Major and headquartered in Grenoble and Paris, where he controlled the routing and allocation of circuits for the Supreme Headquarters Allied Expeditionary Force. His experience in the War Group enabled him to make a major contribution in the composite control of British and U.S.A. signals, working in conjunction with the French P.T.T. He was awarded the M.B.E., Croix de Guerre, and Legion of Merit. He was later transferred to the Control Commission and undertook the long-lines control in the British



Zone of Germany, using a German labour force to restore communications. He was demobilized with the rank of Colonel.

On returning to civilian life he became Area Engineer, South East Area, London Telecommunications Region,

until 1948, when he was promoted Assistant Staff Engineer in the Organization and Efficiency Branch, where, in addition to important O and M assignments, he was engaged on problems of engineering organization, complementing and grading, and in important negotiations with Staff Associations. He brought to this work a ready understanding of the problems in the field, and his wide experience enabled him to negotiate from personal knowledge of the work.

In 1957 he went to the Home Counties Region on transmission and lines work, and faced the problem of rapidly expanding the line network. He was promoted Deputy Chief Regional Engineer in 1962, and took charge of staff work generally and Regional promotion boards in particular. He served as President of the Associate Section of the Institution from 1962 to 1964.

Jack Leckenby has an equable and generous temperament, and an ability to mix well with all people. He inspires confidence in all who work for him, and brings to all problems, be they technical or human, a wealth of experience and understanding. Over the course of his varied career he has made many friends in all Branches of the Post Office. They were delighted to see him promoted and wish him well in his new job.

A.K.

#### **M. B. Williams, B.Sc.(Eng.), A.M.I.E.E.**

Mr. Williams, who has been appointed Staff Engineer in the recently formed Long-Range Systems Planning Unit, entered the Post Office in 1933 as a Youth-in-Training in the Test Section, London. He transferred to Cable Test in 1937, and in the following year he was successful in the Limited Competition for Probationary Inspectors, being appointed to the Cable-Balancing Section of the London Telecommunications Region Engineering Branch.

In 1940 he joined the Lines Branch of the Engineer-in-Chief's Office, and was engaged on circuit-provision work and emergency schemes until 1943, when he was seconded to the Signals Research and Development Establishment of the Ministry of Supply, for work on military carrier systems.

He returned to Lines Branch in 1945, and until 1948



he was engaged on cable maintenance and field investigations. After a period in the Branch Laboratory, during which time he was promoted to Senior Executive Engineer, he took charge of the h.f. systems maintenance group. This appointment coincided with the beginning of a period of rapid expansion of the television service, and he was soon actively engaged on the setting up of the Regional television outside-broadcast teams, and the development and the provision of the necessary test and repeater equipment.

In 1955 he took charge of the wideband line-systems development group in the Main Lines Development and Maintenance (LMD) Branch, and, at the same time, he began a period of participation in C.C.I.F./C.C.I.T.T. activities, which continued until his present appointment. He will be greatly missed both here and abroad by the members of the various Study Groups and Working Parties on which he has served. Some of the groups in which he has played a notable part have been the transmission-systems study group (Study Group XV) and the specialized working party on coaxial-cable systems; a strong advocate of international standardization, he took an active part in the joint Study Groups and Working Parties dealing with the setting up of common standards to facilitate the inter-working of cable and radio-relay systems.

Appointed to Assistant Staff Engineer in LMD Branch in 1960, he took up responsibility for transmission standards of the inland trunk network and United Kingdom international circuits, as well as maintenance of the trunk network. Thus, he became increasingly engaged on the problems concerning the use of telephone circuits for data transmission, and was a member of the United Kingdom delegation to the specialized C.C.I.T.T. Study Group dealing with these problems.

Mr. Williams has been a tower of strength throughout his entire stay in LMD Branch, and his logical and detached approach to problems, coupled with his far-sighted views on a wide variety of transmission matters, will undoubtedly be considerable assets in his new appointment.

Mr. Williams is also known for his fund of information on a wide variety of subjects, including many far removed from his day-to-day work, where again his enquiring outlook finds full play. His very many friends and colleagues wish him every success in his new sphere.

R.H.F.

#### **Retirement of R. F. J. Jarvis, Ph.D., A.M.I.E.E.**

Dr. R. F. J. Jarvis has recently retired from the Post Office (Research Branch), at his own request at the age of 58.

He joined the Engineering Department as an Assistant Engineer (old style) in 1928, coming directly to the Post Office from a postgraduate research course at City and Guilds Engineering College. He was initially assigned to the Radio Branch at Dollis Hill, and subsequently joined the Research Branch in which he remained until his retirement. He made valuable contributions, particularly in theoretical studies, to the early coaxial-cable investigations. His flair for electrical measurement work and his meticulous experimental techniques were invaluable when he was in charge of the Radio-Frequency Measurements Group at the Radio Branch Wembley Laboratory. In this capacity he initiated work on microwave techniques

many years in advance of the applications of this type of transmission system to the trunk network. He was associated with much of the early work in the Engineering



Department on broadband multi-channel telephony and television transmission, and was a member of the United Kingdom delegation to C.C.I.F. Conferences in Paris and Montreux on broadband line transmission in 1946 and 1947. He also represented the Post Office on the Inter-Services Radio Measurements Committee and the Inter-Services Technical Valve Committee for many years.

In 1948 Dr. Jarvis was promoted to Senior Principal Scientific Officer in the Research Branch as Head of a Division consisting of the Patents Group, the Mathematics Group and the Library. He was for a time Chairman of the Joint Electronic Research Committee's Patents Sub-Committee, and in recent years was mainly occupied by the study of patent cases of interest to the Post Office.

Dr. Jarvis's chief hobby is the history of science. He

has the rare ability to appear to transport himself to the past, in which he has a great sentimental interest, and to re-live the thoughts and ideas of the early scientists. Old scientific books and manuscripts are a source of delight and inspiration to him, and he spends many hours hunting around old bookstalls for items of interest.

He is capable of intense concentration, enjoys serious conversation and could be a good listener, but the unwary conversationalist could discover that he has no awareness of the passage of time.

He is an unassuming and modest man respected by all who know him. However, to the younger members of the staff he was a shadowy don-like figure, a link with the past, even to his 1934 Austin 10 car from which he could not bear to be parted.

The few who had the privilege of working with him were aware of his intensely analytical mind, his great ability to get down to fundamentals, and his firm sense of values. They also found in him a loyal, friendly colleague who usually had a twinkle in his eye.

All his colleagues at Dollis Hill and in the City wish Dr. Jarvis a long and happy retirement, and look forward to the publication of his first book on the history of science.

W.J.B.

### Supplement and Model Answer Books

Students studying for City and Guilds of London Institute examinations in telecommunications are reminded that the Supplement to the Journal includes model answers to examination questions set in all the subjects of the Telecommunication Technicians' Course. Back numbers of the Journal are available in limited quantities only, and students are urged to place a regular order for the Journal to ensure that they keep informed of current developments in telecommunications and receive all copies of the Supplement.

Books of model answers are available for some telecommunication subjects, and details of these books are given at the end of each Supplement. These books include a new model answer book for Radio and Line Transmission A.

---

## Institution of Post Office Electrical Engineers

### Essay Competition 1966-67

To further interest in the performance of engineering duties and to encourage the expression of thought given to day-to-day departmental activities, the Council of the Institution of Post Office Electrical Engineers offers five prizes, a first prize of six guineas and four prizes of three guineas, for the five most meritorious essays submitted by members of the Post Office Engineering Department below the rank of Inspector. In addition to the five prizes, the Council awards five certificates of merit. Awards of prizes and certificates made by the Institution are recorded on the staff docketts of the recipients.

An essay submitted for consideration of an award in the essay competition and also submitted in connexion with the Associate Section I.P.O.E.E. prizes will not be eligible to receive both awards.

In judging the merits of an essay, consideration will be given to clearness of expression, correct use of words, neatness and arrangement, and, although technical accuracy is essential, a high technical standard is not absolutely necessary to qualify for an award. The Council hopes that this assurance will encourage a larger number to enter. Marks will be awarded for originality of essays submitted.

Copies of previous prize-winning essays have been bound and placed in the Institution Central Library. Members of the Associate Section can borrow these copies from the Librarian, I.P.O.E.E., G.P.O., 2-12 Gresham Street, London, E.C.2.

Competitors may choose any subject relevant to current telephone, telegraph or radio practice, or allied sciences. Foolscap or quarto paper should be used, and the essay should be between 2,000 and 5,000 words. An inch margin



is to be left on each page. A certificate is required to be given by each competitor, at the end of the essay, in the following terms:

*"In forwarding the foregoing essay of ..... words, I certify that the work is my own unaided effort in regard to both composition and drawing."*

*Name (in block capitals)*

*Signature*

*Rank . . .*

*Departmental Address*

*Date*

The essays must reach

The Secretary,

The Institution of Post Office Electrical Engineers,

G.P.O.,

2-12 Gresham Street,

London, E.C.2,

by 15 January, 1967.

The Council reserves the right to refrain from awarding the full number of prizes and certificates if in its opinion the essays submitted do not attain a sufficiently high standard.

#### **Institution Field Medal Awards, 1964-65 Session**

The list of Field Medal Award winners was published in the July 1966 issue of the Journal. The Council of the Institution is indebted to Mr. J. W. Freebody, Chairman of the Papers Selection Committee of Council, for the following precis of the medal-winning papers:

*"The Training of Youths."* By E. H. Piper.

This paper, which is designed to stimulate interest in the training of youths for engineering work in the Post Office, achieves its object admirably.

The author argues that with the recent increase in engineering youth recruitment and the extension of the training period from two to three years, during a period of tremendous expansion of the telephone service, it is now opportune to make a critical assessment of our present policy and methods, especially as many new ideas are being developed for the training of young people for industry generally.

Quoting Galileo, "You cannot teach a man anything; you can help him to find it within himself," the author proceeds to define training as "being the development, under proper guidance and leadership, of latent abilities into useful skills coupled with the application of technical knowledge."

The increasing interest by Governments in the training of the nation's youths and apprentices is shown to be a general trend in European countries, including the United Kingdom. The author, whilst stating that the Post Office has a good record for training and that it compares favourably in most respects with other United Kingdom industries, argues that the Post Office has failed to match the large increase in trainees by a sufficient increase in training officers, and that much is being lost from this failure.

The usual educational standard required for youths is three G.C.E. passes, preferably in English, mathematics and a science subject, and in the author's experience the Secondary Modern Schools provide the best recruits for training and development into good technicians and technical officers. He considers that Grammar School boys are best suited for student apprenticeships where they can receive a suitable training for the higher engineering grades. Contrary to the adverse public image of modern youths, the author claims that in his experience those entering technical training today are ambitious, more mature and less inhibited than earlier generations and, under respected leadership,

quite determined to succeed and make a worth-while contribution to their work.

Much stress is laid in the paper on the need for the Area Training Officer to be given freedom of action to develop contacts with school headmasters, careers masters, parents and with Youth Employment officers, in order to stimulate recruitment of the right young men. The training officers need for close co-operation from the Post Office Public Relations officers in recruitment is also stressed.

Based on the local educational standards, it is proposed in the paper that recruits should sit a preliminary written test (a typical question paper is presented), to be followed by an interview with the Area Training Officer alone so that the candidate can be more relaxed than when facing an interview board of three or four men.

A strong case is made for training officers to be specially trained for their duties, even by outside bodies, and for them to be given wider responsibilities and more time for follow-up visits in the field. The case for the introduction of training supervisors to oversee the field training of youths and to augment the minimal amount of time available by first-line supervisors is well presented, as is also the simplification of the reporting and recording procedures.

The author's views on technical education and the relative merits of City & Guilds courses and National Certificate courses show a preference for the former for the majority of youths. Some novel proposals for a National Certificate of Telecommunication and for full-time City & Guilds courses organized by the Regional Training Schools are put forward in the belief that a more uniform standard of instruction and closer integration of vocational and field training with technical education would ensure the development of better technicians in the future.

*"The Birmingham Television Network Switching Centre."* By R. C. Mansell, F. C. Salter and L. Turner.

This paper opens with a brief review of the development of the television network at Birmingham and is significant inasmuch as it points a way to the future where the timed switching of wide transmission bands could well be needed at other centres in the country for the expansion of television, facsimile, high-speed data and the more exotic communication facilities of the future.

The authors describe the new switching centre in some detail and refer to the arrangements for the external cable lead-in and termination, the general layout of the network switching centre and the reasons why this layout was adopted. Installation practices, the provision of trunking and superstructure, and power distribution, are treated fully. A very brief description of each type of equipment for the apparatus room is also given.

The system of video transmission direct on coaxial cables is more fully described, together with its various applications on short internal ties, with remote control and supervision for the equipment at remote unattended premises. The transmission of sound signals, an essential part of the television service, is not overlooked, though it seems remarkable that the equipment provided was developed over 25 years ago.

An interesting description of the control room is given, including the video distribution frame, the video distribution rack and the network switching equipment, which is a 10 × 10 crossbar system with switching effected by push-button Yaxley switches. The authors also outline the video-frequency test console and the picture-monitoring switching equipment.

The arrangements for changing-over the links from the old to the new network switching centre without interference with the transmission service are reviewed, and the paper concludes with a glance into the future—the B.B.C.2 625-line network, the introduction of 62-type equipment and a colour-television service.

"Post Office Engineering Drivers and Road Safety." By J. Logan.

This paper examines some of the factors which affect safe driving, and suggests ways and means of making our driving safer.

In referring to the appalling slaughter on the roads of Great Britain, in which each month about 500 persons are killed, 6,000 seriously injured, and 20,000 slightly injured, the author says that the Post Office, as a major road user, has a constant duty to do everything possible to foster safe driving. Whilst acknowledging the many road safety schemes and procedures which the Post Office operates, he considers that more can still be done to make driving safer and easier. To the customary group of road-safety measures, namely, "engineering," "enforcement" and "education," the author adds two more: "emolument" and "example."

He suggests that improvements in the design of our commercial vans would reduce accident rates, and among these the following are discussed: improved shark-nosed bonnets, generous windscreens with very slim front pillars, larger windows in the side doors, and estate-car bodies or vans with side windows in the bodies to improve all-round visibility. A change from the dull dark-green colour to a conspicuous ivory or primrose colour is also suggested.

Parking facilities at U.A.X.s, exchanges and engineering centres need, in his view, to be developed to get parked vehicles off the road wherever possible.

The author suggests that enforcement by the Police or other organizations is not effective and would be better replaced, within the Post Office, by requiring any driver who was shown to be at fault to pay a proportion of the costs of repair as a penalty.

Great emphasis is placed on constantly alerting drivers to the needs for safe driving by a continuous stream of propaganda, including film shows and discussion groups. The present practice of initial training followed by a driving test and then no further training is deprecated, and the author suggests the setting up of a central driving school with the thought that attendance at such a school, away from home, would add force to the need for safe driving.

The Safe Driving Awards made by the Royal Society for the Prevention of Accidents do not appear to make much impact on engineering drivers. Various bonus schemes for safe driving administered by other large-fleet operators are described, but these are not favoured by the author because they are difficult to operate fairly.

To set an example in safe driving is considered of considerable value, and all supervising officers are urged to become advanced motorists. The Institute of Advanced Motorists and the Silver Wheel organizations are described; the former teaches skill and the latter concentrates on good behaviour. It is suggested that if Post Office driving instructors could be entered for membership of these organizations a great stimulus for good driving might accrue.

S. WELCH,  
General Secretary.

#### Additions to the Library

Library requisition forms are available from Honorary Local Secretaries, from Associate Section Centre Secretaries and representatives, and from the Librarian, I.P.O.E.E., G.P.O., 2-12 Gt. Gt. Street, London, E.C.2.

2875 *Electrons and Waves*. J. R. Pierce (Brit. 1965).

An introduction to the science of electronics and communication.

2876 *The Pleasure of Mathematics*. A. W. Goodman (Amer. 1965).

Aimed at all who wish to widen their horizons to include mathematics.

2877 *Relativity and Common Sense*. H. Bondi (Brit. 1965).

A new approach, picturing relativity as an organic growth inevitable when man began to deal with velocities approaching the speed of light.

2878 *Guide to Radio Technique, Vol. 1: Fundamentals, Valves, Semiconductors*. E. Julander (Dutch 1965).

A source of basic information for all who wish to improve their knowledge by self-tuition and as a textbook for commercial and technical colleges, etc.

2879 *Information and Communication Theory*. A. M. Rosie (Brit. 1966).

For the general reader as well as the more serious student.

2880 *Elementary Circuit Properties of Transistors*. C. L. Searle, etc. (Amer. 1966).

One of the books issued by the American Semiconductor Electronics Education Committee. Imparts a thorough familiarity with the elementary circuit properties of single-stage transistor circuits.

2881 *Tape Recorder Servicing Manual*. H. W. Hellyer (Brit. 1965).

Includes the manufacturers' published data on the various recorders.

2882 *Trunk Waveguide Telecommunications*. A. E. Karbowski (Brit. 1965).

An introduction for all concerned with microwaves and telecommunications.

2883 *The Mystery of the Expanding Universe*. W. Bonnor (Brit. 1964).

Assumes no previous knowledge and no mathematics.

2884 *Technical Mathematics, General Course, Part 1*. A. Geary, H. V. Lowry, and H. A. Hayden (Brit. 1963).

2885 *The Computer Age*. G. Burck (Amer. 1965).

A thorough examination of the growing importance of the computer in our way of life.

2886 *The Physical Basis of Electronics*. J. G. R. van Kijck (Dutch 1964).

A systematic survey of the most important groups of physical phenomena on which electronic applications are based.

2887 *Colour Television Explained*. W. A. Holm (German 1965).

Describes in detail the theoretical bases of colour television and also makes the problems arising out of its practical realization more familiar and intelligible to a larger public. Readers should know the fundamentals of monochrome television.

2888 *Transistor Radio Servicing Made Easy*. W. Lemons (Amer. 1965).

Covers the practical aspect of servicing, only incidental theory being presented.

2889 *Vibrations, Waves and Diffraction*. H. J. J. Braddick (Amer. 1965).

Phenomena which repeat periodically and waves of many kinds make up a good deal of physics, and this textbook emphasizes the strong common line of thought running through such topics as sound, optics, or electronic circuits, touching also on electromagnetism and quantum mechanics.

2890 *High-Fidelity Systems*. R. F. Allison (Amer. 1965).

A layman's guide to the installation and care of sound systems in the home.

2891 *Cooke and Wheatstone and the Invention of the Electric Telegraph*. G. Hubbard (Brit. 1965).

Covers the earlier work on which the invention was founded and how it came to England, the way in which the two men collaborated, and the history of the earlier telegraph lines.

2892 *Semiconductor Circuits*. J. R. Abrahams and G. J. Pridham (Brit. 1966).

Written specifically for the student; aims to give him confidence in his ability to design and modify circuits involving transistors and related semiconductor devices.

W. D. FLORENCE,  
Librarian.



# Regional Notes

## Wales and Border Counties DAWLEY NEW TOWN

Planning for a large new town in Shropshire was started in 1963 by the Dawley Development Corporation and culminated in the publication of the draft Master Plan in 1965. Delays and changes to plans which characterize this sort of development, and the short notice generally given of localized upsurges in the demand for telephones, lead to the need for a flexible interim scheme for giving service.

Dawley village was served by a U.A.X. 13, and it was likely that the demand for telephones would be between one and two thousand before the correct site for a large non-director exchange could be determined and the exchange built and brought into service. To meet the demands of the new town without delay it was decided to augment the U.A.X. 13 by two S.A.X.s located in areas where a demand for service was springing up and to link all three numerically under the name "Dawley." This required a 4-digit group-selector satellite scheme to be devised. The trunking adopted gives scope for increasing the multiple beyond  $3 \times 600$  subscribers' lines by increasing the number of linked U.A.X.s and S.A.X.s to five, and also, should the need arise, by increasing individual multiples beyond 600 subscribers' lines. Incoming and outgoing S.T.D. will be available.

This interim scheme, at present comprising the original U.A.X. 13 and one of the S.A.X.s, is working well and will be augmented by another S.A.X. in 1968. There are no immediate plans for providing further S.A.X.s. A life of at least 8 years is expected from the first S.A.X.; the others will naturally have shorter lives. In due course the S.A.X. equipment and their timber buildings will be re-used within the Directorate.

The method avoids the retention of mobile S.T.D. exchanges for a protracted period, and the linked-numbering scheme enables telephone subscribers to be associated with the name of the new town from the outset—a point considered important by the Dawley Development Corporation. Bearing in mind the flexibility of design to cater for the expected high calling rates of the initial lines, the facilities offered, the convenience from the line-plant and economics points of view of splitting the developing area into small units and providing equipment only when and where required, by comparison with alternative methods of giving service this is an economical method which may have application elsewhere.

J.I.C.

## North-Eastern Region

### ERECTION OF CRANE TOWER AT TINSHILL RADIO STATION (LEEDS)

Thursday, 14 April, was the day planned for the erection of the crane tower on the top of the concrete radio tower at Tinshill Radio Station, subject to weather conditions being satisfactory. The concrete tower stands 116 ft above ground level, and the crane tower is a cylindrical structure 40 ft high, comprising a retractable lifting jib and associated luffing, rotating and lifting gear.

The previous day what is believed to be one of the largest mobile cranes in the country had arrived on the site and had been assembled with its 200 ft jib, in readiness to lift the 8-ton crane tower up to the top platform of the concrete tower.

The whole operation, from off-loading the crane tower to placing it in position on the top platform, where it was secured by 30  $1\frac{1}{4}$  in. bolts, took just less than 4 hours.

J.T.

## Northern Ireland BRASS TACKS

Arising out of the road and street re-arrangements in the dock area of the City of Belfast, connected with the recently

opened Queen Elizabeth Bridge works, a carrier pole was encountered which had steps and fittings made of solid brass. This was found to be alongside the former site of a chemical works which employed sulphuric-acid reactions. It is difficult to assess the age of the line plant but the pole was a pre-Post Office type and was still in good order.

The condition of the fittings is noticeably good, and a conservative estimate is that the plant has been in use for at least 40 years. One is compelled to look back and admire the expertise of the National Telephone Company supervisors, many of whom were known to have been in office in the old Sectional Engineer days. It must be noted, too, how they correctly placed equipment with safety standards to meet the circumstances.

H.G.

## FIRST SMALL AUTOMATIC EXCHANGE IN NORTHERN IRELAND IN SERVICE AT GREY- ABBEY, CO. DOWN

The first small automatic exchange (S.A.X.) in Northern Ireland was opened at Greyabbey (Co. Down) on 18 November 1965. This replaced the existing U.A.X. 12 which had served the community for almost 20 years.

The new building is a standard B1 timber type with a thermoplastic tiled floor and a fluorescent-lighting scheme designed to suit the rack layout.

Due to the apparatus racks being some  $3\frac{1}{2}$  in. higher than the wall-fixing angle-iron used in B1-type timber buildings, specially cranked twin tie-bars were used for securing the racks, wall-fixing angle-iron being provided on both sides of the building and the twin tie-bars made to extend from wall to wall. The tie-bars, which also accommodated the cable runway, were manufactured in the Regional workshop.

To accommodate a gas-pressure panel and terminating units, a suitably modified Rack, Apparatus, No. 42B was installed adjacent to the miscellaneous apparatus rack. This necessitated a change of position for the positive battery. Power for the new exchange is provided by a Power Plant No. 227 (the first to be installed in Northern Ireland).

The U.A.X. 12 worked as a dependent exchange on Newtownards U.A.X. 14, assistance traffic being routed via the U.A.X. 14 to Belfast manual board. These arrangements were, of course, unsuitable for a small automatic exchange, and special steps were taken to meet the necessary requirements until such times as planned re-parenting on Bangor G.S.C. is practical. Assistance traffic is routed direct to Belfast manual board while level 9, and incoming traffic continues to be routed via the U.A.X. 14. The unusual practice of connecting the alarm extension to the trunk-offering circuit was adopted since this is the only direct outgoing circuit from Belfast to the S.A.X.

During installation the thermoplastic tiled floor was protected by the use of hardboard sheets. Toilet and washing facilities were provided in the vacated A-type brick building.

For future cases the "gridded mesh" system for cabling will be used and, consequently, at least some of the apparatus racks will be supplied complete with cable tails. This should also tend to reduce installation costs.

F.J.R. and T.H.L.

## Scotland

### KIRKCALDY NON-DIRECTOR AUTO-MANUAL CENTRE

Kirkcaldy non-director auto-manual group switching centre and its group-selector satellite exchange were switched into service at 5.30 p.m. on 14 July 1966. The transfer was accompanied by an opening ceremony in the Town House where the Lord Provost of the Burgh was invited to make the inaugural call to the Under-Secretary of State for Scotland at the Houses of Parliament.

The automatic exchanges, having standard 4,000-type equipment, are based on the unit system and use a mixed 4-digit and 5-digit numbering scheme, contained within a total multiple capacity of 5,500 lines. The S.T.D. equipment is served by 17 registers and 2 translators, while the trunks and junctions use a mixture of S.S.A.C. No. 9, S.S.D.C. No. 2 and loop-disconnect signalling equipment backed up where necessary by transistor-type amplifiers. The auto-manual centre is equipped with 24 A-positions and eight monitor positions serving as a combined inquiry and directory inquiry suite. The main exchange and the auto-manual centre are contained within a modern building built behind Wemyssfield House, a rather solid, sedate, red sandstone, 19th century mansion house which now serves as an administrative block.

Approximately 4,400 subscribers' lines and nearly 1,000 junctions were involved in this transfer from Kirkcaldy S16 exchange and its satellite, Dysart, to the new plant. S.T.D. was introduced to the Burgh as well as to the adjacent new town of Glenrothes.

Call boxes, during the transfer period, were maintained on a pre-payment basis on a specially prepared grading group. After the transfer, they were converted singly to the pay-on-answer equipment. The appropriate equipments have been provided at the following U.A.X. 13 exchanges: Kinghorn, Markinch, Leslie, Lochgelly, Ballingay, Lundin Links, Thornton and Cardenden, which at the time of transfer necessitated the subscribers terminated thereon to dial 100 for the first time. The S.T.D. facility was then made available to them during the ensuing fortnight. At the same time Anstruther and Elie were converted from C.B.S.2 working to 4,000-type S.A.X.s with S.T.D., of 500-line and 400-line multiple capacities, respectively.

The transfer as a whole was not beset with any untoward difficulty except that of manning so many stations simultaneously.

It is interesting to note that the original Siemens 16 automatic exchange and its auto-manual switchboard were brought into service on the 27 June 1925 with 612 subscribers, 9 call offices, 1 rural party line of 8 subscribers, and 80 junction circuits. At that transfer there were 13 junction faults and 5 subscriber's line faults. The District Manager of the day remarked in his report that the large number of "no replies" at the time of testing was "due to the fact that a war memorial was being unveiled at the same time."

W.S.

#### North-Western Region

##### TWO-LEVEL MANHOLES IN SALFORD

Due to redevelopment of the area surrounding Pendleton Exchange, sweeping changes are taking place in road levels, etc. Ultimately the exchange, which will be practically rebuilt, is to be left on an island site considerably above the level of neighbouring buildings and roads.

The main A6 road, carrying through traffic, is to be lowered by about 26 ft and will run under a roundabout which is to be built to connect several local roads to each other. Because of the two levels involved, some manholes and duct routes have had to be constructed at depths considerably deeper than is normal. In order to do this, two pairs of manholes, each consisting of one manhole above another

connected by a vertical shaft, are being built. In the case of the pair on the same side of the A6 as the exchange, excavation to a depth of approximately 32 ft was necessary, and, due to the nature of the ground (clay and running sand), close sheet-steel piling had to be used. The vertical shaft was originally planned to be about 20 ft, thus making a gap of about 13 ft between the top of the lower and the bottom of the higher manhole. However, subsequent changes in the development plans have resulted in most of the shaft being unnecessary, so that the top manhole will now rest on the bottom one and at right angles to it.

The other pair of manholes will be smaller, and the duct route connecting the two lower manholes will be done by pipe jacking, a comparatively new technique in this Telephone Area.

Other innovations include 50-volt lighting fed from a transformer in the exchange cable chamber, and the use of Unistrut cable holders built into the structure of the shaft. The shaft itself is split into three vertical sections for ease of cabling in from different directions. The bottom manhole of the pair is to be connected by a trap valve to a public sewer.

As already mentioned, the nature of the ground has necessitated close piling not only in the construction of the manholes but also in some parts of the duct track. Dewatering plant has also been used with considerable success in some sections. The duct track so far completed or under construction is a 20-way PVC duct in concrete.

L.H. and S.J.

#### Home Counties Region

##### REMOVAL OF A BATTERY HUT

North Marston U.A.X. 12X, in the Oxford Telephone Area, is shortly to be replaced by a small automatic exchange (S.A.X.).

Because of the restricted site, it was necessary to remove a standard battery hut from the rear of the existing U.A.X. before the S.A.X. could be built. It was decided to attempt the removal by the use of a mobile crane.

The hut, containing a set of "Cells, Secondary, No. 4" and a "Panel, Charging, No. 31," weighs approximately 1 ton. The cells were secured to the battery rack using timber battens, and the battery rack and charging panel were firmly bolted to the floor of the hut. The battery and mains leads were extended from the U.A.X. building on flexible tails and the original leads and conduits recovered. The holding-down bolts were then cut. Lateral support was provided by bolting two timber and angle-iron frameworks to the hut, 1 ft 6 in. from each end.

A 6-ton crane was hired and positioned in the field adjacent to the exchange. Two double 3 in. rope slings were passed under the hut about 1 ft from each end and attached to the crane's jib. The hut was lifted clear of the holding-down bolts, rotated through 180°, shifted 6 yards and lowered on to a prepared foundation of concrete blocks. The power supply was maintained to the exchange without interruption.

The operation was completed by four men in 1½ hours, and showed considerable saving over the conventional method, which would have entailed erecting a new hut and providing a new battery before recovery of the existing hut and battery.

C.E.E. and H.J.R.

---

## Associate Section Notes

#### Chichester Centre

The session opened with a lecture in October on the "G.P.O. Tower" by Mr. Newman, illustrated by colour slides and photographs. In November we had a members' meeting which brought back memories of the summer holidays and events.

A visit to the B.B.C Television Centre studios in December, to attend a production, was fully supported.

In January and February two lectures on S.T.D. were given in anticipation of the opening of the G.S.C. later in the year.

The annual general meeting was held in March when the

following officers were elected: *Chairman*: Mr. R. D. Barrett; *Secretary*: Mr. H. S. Pennicott; *Treasurer*: Mr. M. J. Holford.

The meeting concluded with a film show by courtesy of I.C.I. and the Irish Tourist Agency.

H.S.P.

#### Middlesbrough Centre

The annual general meeting was held on 5 April 1966, followed by a film show. The following officers were elected: *Chairman*: Mr. E. E. Sparkes; *Secretary*: Mr. K. Whalley; *Treasurer*: Mr. R. G. Inns; *Assistant Secretary*: Mr. R. C. Purvis; *Librarian*: Mr. D. A. Pratt; *Committee*: Messrs. K. Roe, R. Oliver, R. Vipond and D. Campbell.

During the past session members of the Centre enjoyed an active program of talks and films, and a highlight of the session was a tour, by boat, of the River Tees estuary when members had an opportunity of seeing the docks and wharves of that northern port from a fresh angle.

There was discussion at the annual general meeting on the provisional program for the new session, when it is hoped to present a varied and interesting selection of papers.

K.W.

#### Aberdeen Centre

At the April meeting one of our own members, Mr. G. T. Donaldson, gave a demonstration on the operation of an amateur radio station. Mr. Donaldson, who had set up his equipment in Telephone House, was perhaps unfortunate in that the waveband was quiet during the early part of the evening. This meeting was a continuation of our policy of introducing members' hobbies to the Centre, and those present enjoyed an interesting and informative evening.

The closing meeting of our 1965-66 session, the annual general meeting, was held on 3 June. The following office bearers were elected: *President*: Mr. J. H. Sharp; *Vice-President*: Mr. H. A. McFarlane; *Liaison Officer*: Mr. A.

Birss; *Chairman*: Mr. R. T. Ross; *Vice-Chairman*: Mr. A. Forster; *Secretary and Treasurer*: Mr. G. D. Adam; *Assistant Secretary*: Mr. R. Mathewson; *Librarian*: Mr. W. Williamson; *Auditors*: Mr. E. Petrie and Mr. D. Duncan; *Committee*: Messrs. G. Black, R. M. Hill, I. Hogg, R. Kemp, T. Laing, K. Marr, J. Michie, J. S. M. Morrison, J. T. Pike, J. H. Robertson, R. Sandison, A. S. Steel, J. A. Stephen, A. Webster and A. E. Yule; *Out-station Representatives*: Messrs. G. C. McKee, W. L. Duncan (Elgin); D. Sutherland (Fraserburgh); A. Wilkie (Huntly); J. W. H. Leask (Lerwick); and J. D. Elder (Peterhead).

An enjoyable dinner and an entertaining social evening followed the meeting.

We would like to take this opportunity of wishing our retiring President, Mr. J. B. Duff, E.R.D., who was present at the dinner and social evening, a very long and happy retirement.

G.D.A.

#### Dundee Centre

The annual general meeting of the Dundee Centre was held on 2 May, at which the following appointments were made: *Chairman*: Mr. R. L. Topping; *Vice-Chairman*: Mr. R. C. Smith; *Treasurer*: Mr. D. L. Miller; *Secretary*: Mr. R. T. Lumsden; *Committee*: Messrs. R. A. Bunt, A. Bannerman, J. Patrick, W. Hennesey, J. H. Marshall and R. M. Burns.

The 1965-66 session proved to be a most successful one, both from attendance at the meetings and the quality and variety of them.

Although it seems to become more difficult each year to think of ideas for a program, suggestions like "Postal Mechanization," "Computers," a "Forth Road Bridge" film with a supporting film about "Bees" by one of our members, and several other suggestions make the 1966-67 session one to look forward to.

R.T.L.

---

## Books Received

"Instruments, Electronics, Automation—Year Book and Buyers Guide, 1966." 2nd Edition. Edited by T. G. Williams, A.M.I.Mech.E., M.Inst.F. Morgan Brothers (Publishers), Ltd. 688 pp. 60s.

This book, compiled in co-operation with *Instrument Review*, *Electronic Engineering* and *Control*, contains five major sections: Manufacturers' Addresses, Buyers' Guide, Trade Names, Illustrated Products, and Equipment Surveys. The section on equipment surveys provides technical background information and data relating to equipment commercially available in the instrument, electronics and automation industries, the information being presented as short papers under 22 headings, each paper having associated tables giving data for specific products.

The remaining portion of the guide, about 75 pages, covers a miscellany of useful information under five headings: Association Addresses lists Associations, Institutions, Societies and other bodies connected with the instrument, electronics and automation industries, with details of their main objects and principal officers; Who's Who gives career details of prominent people engaged in the same and allied industries; Who Buys is a guide to the people responsible for the procurement of supplies for Public Services in

the United Kingdom; Export Information is an introduction to services provided by the Board of Trade to assist firms in building up their export markets; Standard Specifications lists alphabetically the British Standards and Defence specifications relating to instruments, controls and electronic components.

"Electrical Who's Who, 1966-67." Published for *Electrical Review* by Iliffe Books, Ltd. 549 pp. 65s. (67s. 1d. by post).

The 1966-67 edition of "Electrical Who's Who" contains about 8,250 entries, covering prominent people in the electrical and allied professions and industries; each entry gives brief particulars of education and career. This biographical section takes up the major part of the book, occupying 474 pages of the total 549 pages. The remainder contains a list of abbreviations, short obituaries of persons whose names appeared in the last edition but have died since its publication, a guide to firms and organizations, and an addenda containing additions and amendments to the biographical section which were notified to the publishers after the main body of the book went to press.

Companies and organizations were invited to submit their own lists for inclusion in the section "Guide to Firms and Organizations." It is, therefore, easy to ascertain the names of the principals of a particular firm or organization and, from there, to refer to the biographical entries.

# Staff Changes

## Promotions

Name	Region, etc.	Date	Name	Region, etc.	Date
<i>Deputy Chief Regional Engineer to Chief Regional Engineer</i>			<i>Executive Engineer (Open Competition)</i>		
Leckenby, A. J.	H.C. Reg.	23.5.66	Thompson, A. A.	E.-in-C.O.	28.4.66
<i>Assistant Staff Engineer to Staff Engineer</i>			Coackley, R.	E.-in-C.O.	20.6.66
Williams, M. B.	E.-in-C.O.	16.5.66	Crompton, D. M.	E.-in-C.O.	13.6.66
Swain, E. C.	E.-in-C.O.	6.6.66	Rayner, R. C.	E.-in-C.O.	13.6.66
<i>Senior Executive Engineer to Assistant Staff Engineer</i>			<i>Executive Engineer (Limited Competition)</i>		
Granger, S. H.	E.-in-C.O.	19.5.66	Wilson, R. S.	E.-in-C.O.	31.5.66
Stephenson, M.	T.S.U. to E.-in-C.O.	16.5.66	Small, D. J.	E.-in-C.O.	27.6.66
White, I. G.	E.-in-C.O.	16.5.66	Dingle, B. D.	E.-in-C.O.	23.6.66
Baker, D.	E.-in-C.O.	23.6.66	Harris, J. G.	E.-in-C.O.	16.5.66
Spencer, H. J. C.	E.-in-C.O.	30.6.66	Spanton, J. G.	E.-in-C.O.	20.6.66
Welsh, A. W.	E.-in-C.O.	30.6.66	Stoddard, A. G.	E.-in-C.O.	13.5.66
<i>Senior Executive Engineer to Regional Engineer</i>			Laurance, J. L. A.	E.-in-C.O.	21.4.66
Gibson, R. W.	E.-in-C.O. to L.T. Reg.	6.5.66	Bohannan, T. D.	T.S.U.	11.5.66
<i>Executive Engineer to Area Engineer</i>			Bryant, R. I.	E.-in-C.O.	20.4.66
Murray, A. J.	L.T. Reg.	5.5.66	Coles, R. W.	E.T.E.	13.6.66
Aldrich, G. A.	L.T. Reg.	5.5.66	Brennan, J.	E.-in-C.O.	13.6.66
Luther, S. F.	S.W. Reg. to W.B.C.	31.5.66	Orchard, G.	E.-in-C.O.	22.4.66
Hitchcock, J. D.	H.C. Reg. to L.T. Reg.	1.6.66	Vickery, A.	E.-in-C.O.	13.6.66
Stollard, A. G.	N.W. Reg.	27.5.66	Bennett, H. A. J.	E.-in-C.O.	20.6.66
Lawson, R.	N.E. Reg.	27.5.66	Williams, H.	W.B.C. to E.-in-C.O.	31.5.66
Rouse, G. H.	N.E. Reg.	27.5.66	Bissell, D. R.	E.-in-C.O.	13.5.66
Roberts, A. W.	L.T. Reg.	24.6.66	Knox, D. M.	E.-in-C.O.	20.6.66
Warburton, D.	L.T. Reg.	27.5.66	Turner, D. C.	Mid. Reg.	13.6.66
Long, W. J.	Mid. Reg.	2.6.66	Hutt, B. J.	E.-in-C.O. to E.T.E.	13.6.66
Kennedy, B.	Mid. Reg.	2.6.66	Ashe, J. G.	L.T. Reg.	27.6.66
Soutar, D.	Scot.	13.6.66	Loy, A. F.	T.S.U.	20.4.66
White, P. S.	L.T. Reg. to H.C. Reg.	3.6.66	Myers, E. A.	E.-in-C.O.	13.6.66
Jennings, P. H.	N.I. to Mid. Reg.	20.6.66	Drinkwater, T. J.	E.-in-C.O.	20.6.66
<i>Executive Engineer to Senior Executive Engineer</i>			Hill, R. A.	E.-in-C.O.	31.5.66
Warwick, H. A.	H.C. Reg. to E.-in-C.O.	1.4.66	Cole, H.	E.-in-C.O.	13.6.66
Ogden, R. S. I.	E.-in-C.O.	18.4.66	Leavitt, F. C.	E.-in-C.O.	31.5.66
Lifford, S.	E.-in-C.O.	25.4.66	Coles, D. C.	H.C. Reg.	20.6.66
Moxon, R. L.	E.-in-C.O.	22.4.66	Clark, T.	E.-in-C.O.	13.6.66
Woolley, C. E.	E.-in-C.O.	22.4.66	Philpott, M. J.	E.-in-C.O.	13.6.66
Mills, L. R. N.	E.-in-C.O.	22.4.66	Morris, R.	L.T. Reg.	27.6.66
Marsden, S.	E.-in-C.O.	22.4.66	Adam, T. W.	T.S.U.	27.4.66
Dickie, W.	N.W. Reg.	22.4.66	Hall, G. C.	E.-in-C.O. to E.T.E.	20.6.66
Spurgin, D. A.	E.-in-C.O.	22.4.66	Clay, J. P.	E.-in-C.O.	13.6.66
Aries, S. J.	E.-in-C.O.	26.4.66	Barton, D. S.	E.-in-C.O.	13.6.66
Gresswell, F.	H.C. Reg.	26.4.66	Miller, J. R.	E.-in-C.O.	23.6.66
Berry, R. W.	E.-in-C.O.	9.5.66	McLean, J. M.	E.-in-C.O.	20.6.66
Groves, H. J.	E.-in-C.O.	9.5.66	Richardson, J. E.	E.-in-C.O.	31.5.66
Wheatley, M. A. J.	L.T. Reg.	5.5.66	Williams, J. F.	N.W. Reg.	13.6.66
Dudman, E. C.	L.T. Reg.	5.5.66	Smith, R. A.	E.-in-C.O.	27.6.66
Gates, J. F.	E.-in-C.O.	27.5.66	Fry, R. A.	S.W. Reg. to E.-in-C.O.	31.5.66
Sandy, R. H. J.	E.-in-C.O.	27.5.66	<i>Assistant Executive Engineer to Executive Engineer</i>		
Holmes, T. E.	E.-in-C.O.	27.5.66	Hubbard, E. W. C.	E.-in-C.O.	1.4.66
Brewin, R. C.	E.-in-C.O.	27.5.66	Chatfield, R. A.	Mid. Reg. to E.-in-C.O.	1.4.66
Halliday, C. M.	E.-in-C.O.	27.5.66	Kershaw, R. J.	E.-in-C.O.	1.4.66
Searls, A. W.	E.-in-C.O.	27.5.66	Smith, H. O. J.	E.-in-C.O.	1.4.66
Lumber, A. L.	E.-in-C.O.	27.5.66	Sheppard, H. G.	E.-in-C.O.	7.4.66
Vigar, C. D.	E.-in-C.O.	27.5.66	Miles, B. T. W.	E.T.E.	1.4.66
Beckley, D. J.	E.-in-C.O.	2.6.66	Jarvis, E. G.	E.-in-C.O.	12.4.66
Williamson, J. B.	Mid. Reg.	27.5.66	Stokes, J. W.	N.W. Reg.	1.4.66
McLeod, J.	N.W. Reg.	27.5.66	Roberts, S.	N.W. Reg.	1.4.66
Wardman, D.	N.W. Reg. to N.E. Reg.	27.6.66	Felton, N. R.	N.W. Reg.	1.4.66
Harrison, P.	N.E. Reg.	27.5.66	Kinston, F.	Mid. Reg.	1.4.66
Tavener, A. L.	L.T. Reg. to E.T.E.	27.5.66	Bearon, J. W.	Mid. Reg.	1.4.66
Holmes, A. C.	L.T. Reg.	27.5.66	Thompson, C. H.	Mid. Reg.	1.4.66
Rangecroft, W.	S.W. Reg.	27.5.66	Hunt, H.	Mid. Reg.	1.4.66
Roberts, A. W.	C.E.S.D.	24.6.66	Hunt, C. H.	Mid. Reg.	1.4.66
Spurlock, K. E.	W.B.C.	2.6.66	Anderson, W. R.	Mid. Reg.	1.4.66
			Beeston, B.	L.T. Reg.	1.4.66
			Kennett, P.	L.T. Reg.	1.4.66
			Walters, R. C.	L.T. Reg.	1.4.66
			Watling, A. G.	H.C. Reg.	1.4.66
			Simmons, H. H.	H.C. Reg.	1.4.66
			Freeman, S. L. V.	H.C. Reg.	1.4.66
			Oxley, R.	N.E. Reg.	18.4.66

Promotions—continued

Name	Region, etc.	Date	Name	Region, etc.	Date
<i>Assistant Executive Engineer to Executive Engineer—continued</i>			<i>Technical Officer to Assistant Executive Engineer—continued</i>		
Gannon, J. ..	N.E. Reg. ..	18.4.66	Baughan, F. R. H. ..	E.T.E. ..	19.4.66
Albutt, L. A. ..	E.-in-C.O. ..	21.4.66	Rawson, R. P. ..	E.T.E. ..	19.4.66
Patrick, H. C. ..	N.I. ..	21.4.66	Sangster, I. S. ..	E.T.E. ..	19.4.66
Franklin, L. E. ..	Mid. Reg. ..	1.4.66	Fife, D. R. J. ..	E.T.E. ..	19.4.66
Macbride, J. M. R. ..	Scot. ..	18.4.66	Heron, A. R. M. ..	E.T.E. ..	19.4.66
Scantlebury, W. G. ..	W.B.C. ..	12.4.66	Wood, R. R. ..	E.T.E. ..	19.4.66
Bladon, E. R. ..	Mid. Reg. to H.C. Reg. ..	9.5.66	Sagoe, R. K. J. ..	E.T.E. ..	19.4.66
Slough, H. R. ..	H.C. Reg. ..	2.5.66	Cameron, J. ..	E.T.E. ..	19.4.66
Ritchie, J. E. ..	E.-in-C.O. ..	9.5.66	Vincent, C. A. F. ..	W.B.C. ..	26.4.66
Smith, A. R. ..	L.T. Reg. to E.-in-C.O. ..	9.5.66	Stevenson, A. W. W. ..	Scot. ..	14.3.66
Brown, H. W. ..	E.-in-C.O. ..	9.5.66	Crampton, D. A. ..	H.C. Reg. ..	13.5.66
Sheldrake, R. P. G. ..	E.T.E. to T.S.U. ..	9.5.66	Bradbury, W. J. F. ..	Mid. Reg. ..	2.5.66
Brien, J. ..	Scot. ..	19.5.66	Butler, E. A. ..	N.W. Reg. ..	19.5.66
Smith, J. ..	Scot. ..	19.5.66	Holrovd, A. ..	N.W. Reg. ..	19.5.66
Wright, K. R. ..	H.C. Reg. ..	29.6.66	Parker, N. ..	N.W. Reg. ..	23.5.66
Masdin, R. M. ..	H.C. Reg. ..	29.6.66	Shipperbottom, J. W. ..	N.W. Reg. ..	19.5.66
Stamps, R. G. ..	H.C. Reg. ..	29.6.66	Pearce, G. D. ..	E.-in-C.O. ..	16.5.66
Gibbons, A. G. ..	H.C. Reg. ..	29.6.66	Babidge, D. M. ..	S.W. Reg. ..	9.5.66
Mallett, F. H. ..	H.C. Reg. ..	29.6.66	Blanchard, P. L. ..	S.W. Reg. ..	9.5.66
Carron, L. F. ..	L.T. Reg. ..	29.6.66	Humby, A. J. ..	H.C. Reg. ..	13.5.66
Croner, F. B. ..	L.T. Reg. ..	29.6.66	Porter, D. J. ..	W.B.C. ..	16.5.66
Hodgeson, A. S. ..	L.T. Reg. ..	29.6.66	Pilgrim, C. G. ..	H.C. Reg. ..	13.5.66
Lowson, W. C. ..	E.T.E. ..	29.6.66	West, P. ..	Mid. Reg. ..	19.5.66
<i>Inspector to Assistant Executive Engineer</i>			Woodhead, H. ..	Mid. Reg. ..	23.5.66
Strath, H. ..	Scot. ..	4.4.66	Stewart, D. M. ..	Mid. Reg. ..	19.5.66
Roberts, H. C. ..	H.C. Reg. ..	4.4.66	Gundy, J. ..	Mid. Reg. ..	19.5.66
Simpson, R. ..	Scot. ..	4.4.66	Abbott, D. J. ..	Mid. Reg. ..	19.5.66
Downie, W. ..	Scot. ..	14.3.66	Minns, D. J. ..	Mid. Reg. ..	27.5.66
Ogg, J. F. ..	Scot. ..	4.4.66	Creed, S. J. ..	Mid. Reg. ..	19.5.66
Giltinan, F. T. I. ..	W.B.C. ..	29.4.66	Lilley, J. Y. ..	Scot. ..	27.4.66
Smith, H. M. ..	W.B.C. ..	5.4.66	Whiteside, D. C. E. ..	W.B.C. ..	20.5.66
Howell, F. L. ..	W.B.C. ..	26.4.66	Miles, J. K. ..	S.W. Reg. ..	19.5.66
Riddick, S. ..	Scot. ..	12.5.66	Collins, R. A. ..	E.T.E. ..	16.5.66
Davies, D. ..	W.B.C. ..	23.5.66	Forde-Johnson, T. ..	N.W. Reg. ..	19.5.66
Hurst, E. J. ..	N.E. Reg. ..	18.5.66	Lilley, D. B. ..	N.W. Reg. ..	19.5.66
Brown, A. ..	Mid. Reg. ..	27.5.66	Wainwright, T. ..	N.W. Reg. ..	19.5.66
Durant, D. L. ..	Mid. Reg. ..	27.5.66	<i>Technical Officer to Inspector</i>		
Tombs, F. A. ..	Mid. Reg. ..	27.5.66	McNeill, J. D. ..	Scot. ..	5.4.66
Arrowsmith, R. J. ..	Mid. Reg. ..	27.5.66	Hill, P. A. ..	L.T. Reg. ..	1.4.66
Perry, J. F. ..	Mid. Reg. ..	27.5.66	O'Dowd, E. ..	Scot. ..	11.4.66
Ledsham, K. ..	S.W. Reg. ..	19.5.66	Lyle, R. P. P. ..	Scot. ..	16.5.66
<i>Technical Officer to Assistant Executive Engineer</i>			<i>Senior Technician to Inspector</i>		
Moir, W. I. ..	Scot. ..	30.8.66	Bell, J. P. ..	Scot. ..	15.3.66
Heaton, P. M. ..	N.W. Reg. ..	1.4.66	Bennett, E. A. ..	N.E. Reg. ..	18.5.66
McAnulty, P. ..	Scot. ..	14.3.66	Riddoch, J. M. ..	Scot. ..	27.4.66
Mutch, A. C. T. ..	Scot. ..	4.4.66	Allison, J. W. ..	Scot. ..	9.5.66
Jeary, E. R. ..	H.C. Reg. ..	18.4.66	<i>Technician I to Inspector</i>		
Monkhouse, D. G. ..	H.C. Reg. ..	4.4.66	Brown, J. A. ..	Scot. ..	23.6.65
Saunders, B. S. ..	H.C. Reg. ..	18.4.66	Deas, C. ..	Scot. ..	10.1.66
Carter, R. J. ..	H.C. Reg. ..	4.4.66	Aplin, S. A. ..	S.W. Reg. ..	6.4.66
Greenwood, R. G. ..	H.C. Reg. ..	12.4.66	Blann, J. N. ..	W.B.C. ..	9.5.66
Appleyard, R. ..	H.C. Reg. ..	12.4.66	Sanders, H. F. ..	H.C. Reg. ..	13.5.66
Brittain, E. J. ..	H.C. Reg. ..	18.4.66	Johnson, P. R. ..	Mid. Reg. ..	19.5.66
Ginnis, A. J. ..	H.C. Reg. ..	18.4.66	Tomkinson, T. ..	Mid. Reg. ..	19.5.66
Osborne, I. G. ..	H.C. Reg. ..	4.4.66	Hauxwell, J. G. ..	Mid. Reg. ..	19.5.66
Ransey, F. ..	H.C. Reg. ..	19.4.66	<i>Senior Scientific Officer to Principal Scientific Officer</i>		
Jones, R. C. ..	L.T. Reg. ..	13.4.66	Cleaver, A. J. ..	E.-in-C.O. ..	17.5.66
Binks, T. J. ..	L.T. Reg. ..	1.4.66	Neill, T. B. M. ..	E.-in-C.O. ..	25.5.66
Hampton, G. ..	Scot. ..	28.3.66	<i>Scientific Officer to Senior Scientific Officer</i>		
Brown, J. P. ..	Scot. ..	9.3.66	Brownlie, J. D. ..	E.-in-C.O. ..	16.5.66
Jarrett, J. E. ..	H.C. Reg. ..	6.4.66	Melia, A. J. ..	E.-in-C.O. ..	16.5.66
Robertson, D. C. ..	H.C. Reg. ..	25.4.66	<i>Experimental Officer (Open Competition)</i>		
Tye, J. C. ..	W.B.C. ..	4.4.66	Woolley, F. M. ..	E.-in-C.O. ..	4.7.66
Lloyd, T. W. ..	W.B.C. ..	30.3.66	<i>Senior Assistant (Scientific) to Experimental Officer</i>		
Davies, T. J. ..	W.B.C. ..	30.3.66	Hemming, L. H. ..	E.-in-C.O. ..	31.5.66
Rushworth, D. ..	W.B.C. ..	30.3.66			
Nyhan, P. ..	W.B.C. ..	30.3.66			
Dale, W. H. ..	Mid. Reg. ..	20.4.66			
Arrowsmith, G. H. ..	W.B.C. ..	5.4.66			
Shillitto, H. ..	Mid. Reg. ..	20.4.66			
Lang, J. J. ..	Scot. ..	4.4.66			
Houghton, L. ..	N.W. Reg. ..	12.4.66			
Carroll, D. ..	N.W. Reg. ..	19.4.66			

Promotions—continued

Name	Region, etc.	Date	Name	Region, etc.	Date
<i>Assistant Experimental Officer to Experimental Officer</i>			<i>Leading Draughtsman to Senior Draughtsman</i>		
Fishwick, B. J.	E.-in-C.O.	4.5.66	Bissell, D. R.	E.-in-C.O.	1.4.66
Balscom, P. M.	E.-in-C.O.	3.5.66	<i>Draughtsman to Leading Draughtsman</i>		
Viveash, J. P. (Miss)	E.-in-C.O.	3.5.66	Dutton, A. C.	L.T. Reg.	1.6.66
Hutchings, M. J.	E.-in-C.O.	3.5.66	Gill, D. J.	H.C. Reg.	1.6.66
Blyth, W.	E.-in-C.O.	3.5.66	Graham, J. E.	H.C. Reg.	1.6.66
<i>Scientific Officer (Open Competition)</i>			Dielhenn, G. A.	H.C. Reg.	1.6.66
Jefkins, D. M. (Mrs.)	E.-in-C.O.	22.4.66	Ford, J.	E.-in-C.O.	1.6.66
<i>Assistant Experimental Officer (Open Competition)</i>			McClelland, R. J.	N.E. Reg.	1.6.66
Panday, R. N.	E.-in-C.O.	1.4.66	Westmoreland, G.	N.E. Reg.	1.6.66
Khot, E. V. V.	E.-in-C.O.	13.6.66	Malcolm, D. F.	L.P. Reg.	1.6.66
<i>Assistant (Scientific) (Open Competition)</i>			O'Connell, H. E.	L.P. Reg.	1.6.66
Ho, K. M.	E.-in-C.O.	27.6.66	<i>Draughtsman (Open Competition)</i>		
<i>Assistant (Scientific) to Assistant Experimental Officer</i>			Hutchinson, K. J.	E.-in-C.O.	1.4.66
Espeut, K. W.	E.-in-C.O.	1.6.66	Bailey, B. P.	E.-in-C.O.	6.6.66
<i>Motor Transport Officer II to Motor Transport Officer I</i>			<i>Clerical Officer to Executive Officer</i>		
Humphrey, M. C.	E.-in-C.O.	24.6.66	Turner, J. E.	E.-in-C.O.	25.4.66
			Tanner, E.	E.-in-C.O.	25.4.66
			Lockwood, F. L. (Miss)	E.-in-C.O.	7.6.66
			Everett, H. J.	E.-in-C.O.	20.6.66

Retirements and Resignations

Name	Region, etc.	Date	Name	Region, etc.	Date
<i>Assistant Staff Engineer</i>			<i>Assistant Executive Engineer—continued</i>		
Hollinghurst, F.	E.-in-C.O.	18.5.66	Sutton, S. E.	L.T. Reg.	31.5.66
<i>Area Engineer</i>			Walters, F.	L.T. Reg.	31.5.66
Roy, D. W.	L.T. Reg.	25.3.66	Hooker, E. E.	L.T. Reg.	31.5.66
Barrat, J. W.	N.E. Reg.	13.3.66	Newbury, A. H.	L.T. Reg.	31.5.66
McLeod, J.	Scot.	5.2.66	Proffitt, C.	N.W. Reg.	31.5.66
Pocock, D. G.	L.T. Reg.	7.2.66	Patience, A.	E.-in-C.O.	31.5.66
Pride, C. A.	L.T. Reg.	26.4.66	(Resigned)		
<i>Senior Executive Engineer</i>			Roberts, D. W.	E.-in-C.O.	31.5.66
Antwhistle, A. W.	Mid. Reg.	27.3.66	(Resigned)		
<i>Executive Engineer</i>			<i>Inspector</i>		
Giles, F. R.	E.-in-C.O.	21.4.66	Walker, J. N. H.	S.W. Reg.	12.4.66
Young, A. C.	H.C. Reg.	15.4.66	Kent, J. C.	L.T. Reg.	21.4.66
Roberts, A.	Mid. Reg.	30.4.66	Burrough, C. F.	L.T. Reg.	21.5.66
Ashwell, J. W. G.	L.P. Reg.	31.5.66	Cowdrey, A. N.	H.C. Reg.	26.5.66
Garnett, J. A.	L.T. Reg.	7.6.66	Patrick, E.	Scot.	31.5.66
Devey, G. B.	S.W. Reg.	10.6.66	<i>Senior Principal Scientific Officer</i>		
Allsup, E. F. W.	W.B.C.	30.6.66	Jarvis, R. F. J.	E.-in-C.O.	30.4.66
Black, N.E.	Mid. Reg.	29.6.66	<i>Assistant (Scientific)</i>		
<i>Assistant Executive Engineer</i>			Geary, J. F.	E.-in-C.O.	27.5.66
Colledge, T. A. P.	S.W. Reg.	6.4.66	<i>Motor Transport Officer I</i>		
Giles, S.	H.C. Reg.	8.4.66	Collman, E. L.	E.-in-C.O.	31.5.66
Wright, N. F.	W.B.C.	12.4.66	<i>Motor Transport Officer III</i>		
Thatcher, F. J.	L.T. Reg.	19.4.66	Sturrock, E. S.	E.-in-C.O.	31.5.66
Thomas, M. T.	N.W. Reg.	21.4.66	<i>Senior Draughtsman</i>		
James, E.	H.C. Reg.	22.4.66	Aris, F. C.	E.-in-C.O.	30.6.66
Thomas, E. B.	W.B.C.	28.4.66	<i>Leading Draughtsman</i>		
Berry, G. (Resigned)	E.-in-C.O.	29.4.66	Ranger, A. C.	E.-in-C.O.	27.6.66
Cook, S. V.	N.W. Reg.	17.4.66	<i>Draughtsman</i>		
Platts, T. I.	S.W. Reg.	3.5.66	Hutchins, D. C.	E.-in-C.O.	20.5.66
Grant, J.	E.-in-C.O.	9.5.66	(Resigned)		
Gale, R. W.	S.W. Reg.	16.5.66			
Philipson, W.	N.W. Reg.	19.5.66			
Jones, H. G.	L.T. Reg.	20.5.66			
Wood, A. G. W.	L.T. Reg.	20.5.66			
Griffin, W. J.	E.-in-C.O.	21.5.66			
McGaw, J. M.	Scot.	23.5.66			

### Transfers

Name	Region, etc.	Date	Name	Region, etc.	Date
<i>Assistant Staff Engineer</i>			<i>Assistant Executive Engineer—continued</i>		
Cobbe, D. W. R.	E.-in-C.O. to L.T. Reg.	13.4.66	Doubleday, W. H.	L.T. Reg. to E.-in-C.O.	4.4.66
<i>Senior Executive Engineer</i>			Grimsdale, A. W.	L.T. Reg. to H.C. Reg.	12.4.66
Goddard, F. A. L.	E.-in-C.O. to E.T.E.	23.5.66	Hunt, R. J.	E.-in-C.O. to M.P.B.W.	2.5.66
<i>Executive Engineer</i>			<i>Motor Transport Officer III to Assistant Regional Motor Transport Officer</i>		
Jennings, P. H.	N.I. to East Africa	4.4.66	North, H. E.	E.-in-C.O. to L.T. Reg.	22.6.66
Beckley, D. J.	N.A.T.O. to E.-in-C.O.	1.4.66	<i>Draughtsman</i>		
Peace, L.	E.-in-C.O. to N.E. Reg.	4.4.66	Joice, F.	E.-in-C.O. to N.W. Reg.	4.4.66
Murray, J. I.	E.-in-C.O. to Scot.	2.5.66	Lucas, D. G.	E.-in-C.O. to H.C. Reg.	1.6.66
Crook, S.	E.-in-C.O. to G.C.H.Q.	23.5.66	<i>Executive Officer</i>		
<i>Assistant Executive Engineer</i>			Bruce, D. M. (Miss)	E.-in-C.O. to P.R.D.	20.8.66
Hearsey, R. R. L.	E.-in-C.O. to H.C. Reg.	1.4.66			

### Deaths

Name	Region, etc.	Date	Name	Region, etc.	Date
<i>Executive Engineer</i>			<i>Assistant Executive Engineer—continued</i>		
Lock, J. H.	N.W. Reg.	14.3.66	Pollard, J.	N.W. Reg.	2.4.66
Pariser, F. A. A.	Mid. Reg.	13.3.66	Boylett, A.	N.W. Reg.	6.4.66
Smith, N. D.	E.-in-C.O.	8.6.66	Stewart, H. C.	E.-in-C.O.	4.5.66
<i>Assistant Executive Engineer</i>			<i>Assistant Regional Motor Transport Officer</i>		
Pearce, M. A.	S.W. Reg.	2.4.66	Pickles, A.	L.T. Reg.	10.5.66

#### BOARD OF EDITORS

J. H. H. MERRIMAN, O.B.E., M.Sc., A.Inst.P., M.I.E.E., Chairman.  
 L. F. SCANTLEBURY, O.B.E., Whit.Sch., A.C.G.I., D.I.C., M.I.E.E.  
 W. J. E. TOBIN, O.B.E., B.Sc.(Eng.), A.C.G.I., D.I.C., M.I.E.E.  
 E. W. AYERS, B.Sc.(Eng.), A.M.I.E.E.  
 E. J. MARKBY, A.M.I.E.E.  
 E. HOARE, B.Sc., M.I.E.E.  
 A. G. LEIGHTON, B.Sc.(Eng.), A.M.I.E.E., Managing Editor.  
 J. MARTIN, B.Sc.(Eng.), A.M.I.E.E., Deputy Managing Editor.  
 N. J. H. NINNIM, B.Eng., } Assistant Editors.  
 R. A. SUDELL, }  
 B. FARR, A.B.I., Secretary-Treasurer.  
 R. P. MYHILL, Advertisement Manager.

#### Copyright

The entire contents of this Journal are covered by general copyright, and special permission is necessary for reprinting long extracts, but editors are welcome to use not more than one-third of any article, provided that credit is given at the beginning or end thus: "From *The Post Office Electrical Engineers' Journal*."

The Board of Editors is not responsible for the statements made or the opinions expressed in any of the articles in this Journal, unless such statement is made specifically by the Board.

#### Subscriptions and Back Numbers

The Journal is published quarterly, in April, July, October and January, at 3s. per copy; the post-paid price is 4s. per copy (16s. per year) via inland mail, and 4s. 3d. (17s., or 2 dollars 75 cents Canada and U.S.A., per year) via overseas mail. Back numbers will be supplied, if available, price 3s. (4s. inland mail, 4s. 3d. overseas mail) per copy. With the exception of April, July

and October 1964 and July 1965 Journals, copies of the October 1965 and all earlier Journals are no longer available. Orders should be sent to *The Post Office Electrical Engineers' Journal*, G.P.O., 2-12 Gresham Street, London, E.C.2.

Employees of the British Post Office can obtain the Journal through local agents.

#### Binding

Readers can have their copies of volumes bound at a cost of 15s. by sending the complete set of parts to the local Post Office distribution agent or to *The Post Office Electrical Engineers' Journal*, G.P.O., 2-12 Gresham Street, London, E.C.2.

#### Remittances

Remittances should be made payable to "The P.O.E.E. Journal" and should be crossed "& Co."

#### Advertisements

All correspondence relating to advertisement space reservations, copy, proofs, etc., should be addressed to the Advertisement Manager, *The Post Office Electrical Engineers' Journal*, G.P.O., 2-12 Gresham Street, London, E.C.2.

#### Communications

With the exceptions indicated above, all communications should be addressed to the Managing Editor, *The Post Office Electrical Engineers' Journal*, G.P.O., 2-12 Gresham Street, London, E.C.2. Telephone: HEADquarters 1234.

#### Model Answer Books

Books of model answers to certain of the City and Guilds of London Institute examinations in telecommunications are published by the Board of Editors. Details of the books available are given at the end of the Supplement to the Journal.



# THE Pye Linesman

**FULLY  
TRANSISTORISED  
PORTABLE TWO WAY  
RADIOTELEPHONE**



Based on the now famous Pye Bantam solid-state Walkie/Talkie, the Pye Linesman with many additional features, makes it suitable for use in all types of weather, the Pye Linesman is proving invaluable in cable laying, road construction, building sites etc.

Important features are that it is free-standing, incorporates large capacity batteries, is weatherproof and has a voltage indicator to show the state of the battery.

The 'Linesman' is designed never to let you down in the field. It is available for FM in frequency bands from 25—174 Mc/s. It is used by the British Post Office.

**PYE TELECOMMUNICATIONS LIMITED**

CAMBRIDGE · ENGLAND · TELEPHONE: CAMBRIDGE 61222 · TELEX No. 81166





## TELECOMMUNICATIONS CABLES

Pirelli General are in a position to advise on complete Telecommunications schemes and are organised to manufacture and install cables for distribution and trunk services; also carrier and all types of coaxial cables.

Pirelli General also manufacture cables to meet special requirements of Public Utilities or of industry.

# REX<sup>®</sup>

THE REED ELECTRONIC EXCHANGE

NO. 18 SYSTEM

serves a  
much greater  
area in far less  
space than a  
conventional  
exchange

## DESIGNED FOR UNRESTRICTED EXPANSION

By providing electronic common control of reed relay spatial switching, the REX system offers an extremely compact and reliable solution to both the switching and control problems of modern exchange design. The REX exchange has been developed by AEI to integrate smoothly with existing automatic networks its exceptional flexibility ensures full growth capacity

**AEI**  
TELECOMMUNICATIONS



# combines sophisticated electronics with building-block simplicity

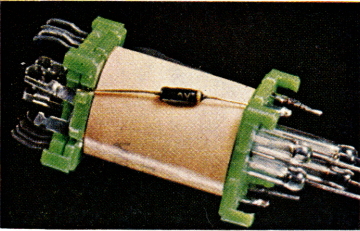

## THE REX SWITCHING ELEMENT

The basis of the REX system is this reed relay crosspoint switching element. It contains only nine components, compared with 200 in a bimotional selector, and its very simplicity makes it uniquely reliable. It gives highest quality transmission paths with gold at the point of connection, requires no routine maintenance, generates no vibration and therefore no microphonic noise. There's nothing to wear out and it is sealed completely to be immune to interference by dust or atmospheric pollution.

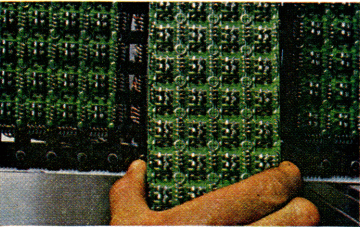

## THE REX SWITCHING MATRIX

Since multiple wiring across the end-caps is inherent in the reed relay crosspoint design, switching matrices can be built up in any form simply by clipping reed relay crosspoints together. Matrices may be enlarged in any ordinate simply by the addition of rows and columns of reed relay crosspoints to cater for any switching requirements. This means that unlimited provision for the growth of lines and links is built into the REX system.

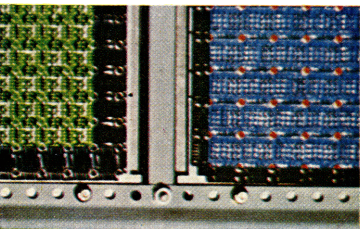

## THE REX SWITCHING UNIT

Basic switching arrays (normally called sections) are built up out of matrices and assembled in parallel to form a REX switching unit. The number of sections supplied depends on the anticipated originating traffic per line. Typically, a 1000-line four-section unit would serve a community with an average calling rate of 150 call seconds per line in the busy hour; other calling rates can be accommodated by varying the number of sections.

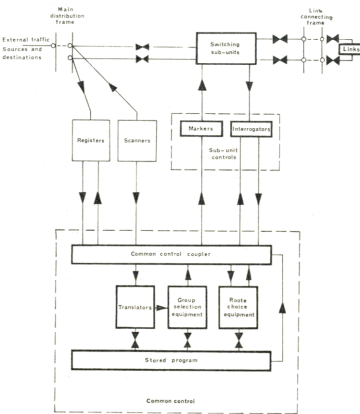

## THE MULTI-UNIT REX EXCHANGE

Switching and linking arrangements are provided for all sections of each unit so that complete crosspoint path interconnection is made between all lines of the REX exchange. For purposes of security of service and simplicity of electronic control the units are divided into self-contained basic switching blocks termed 'sub-units'. Each sub-unit is linked only to adjacent sub-units, a linking pattern which provides for every traffic pattern and retains simplicity of control.

## THE REX ELECTRONIC CONTROL

Closely related in its simplicity to the 'building block' structure of REX switching equipment, the REX electronic control system has three main areas of activity:

### SCANNERS AND REGISTERS

These determine the source and final destination of a call.

### MARKERS AND INTERROGATORS

Provided on a per-sub-unit basis, these controls are concerned with interrogating the state of crosspoint paths and marking these paths through the switching sub-units.

### COMMON CONTROL

The control processes the necessary call setting data in accordance with instructions from the stored programme control in such a way that the calls are routed with maximum utilisation of the switching network.

# serves a much greater area in far less space than a conventional exchange: every part accessible – every part replaceable!

The REX subscriber's line circuit tolerates substantially wider line conditions enabling a REX exchange to serve an area much larger than that of a conventional exchange, permitting big reductions in line plant investment.

AEI engineers have devised the entirely new Reed & Electronic Modular Apparatus practice (REMA) for the REX exchange providing completely compatible mounting of reed relays and electronic circuit components. Combined with a new sliding frame installation system, the REMA practice allows more than 20,000 lines of REX equipment to be accommodated in the space normally required by a 10,000 line electromechanical exchange. In existing buildings this means more space for future expansion; in new exchanges it makes possible great savings in construction and installation costs.

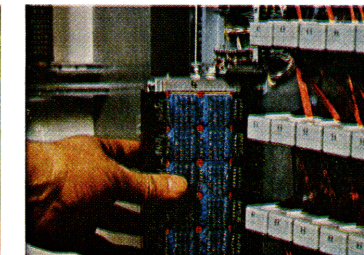
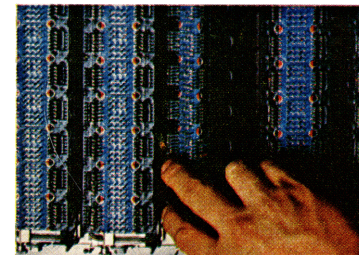
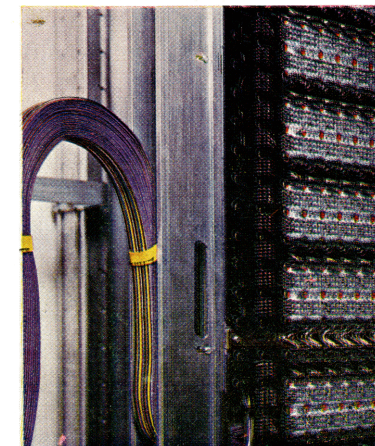
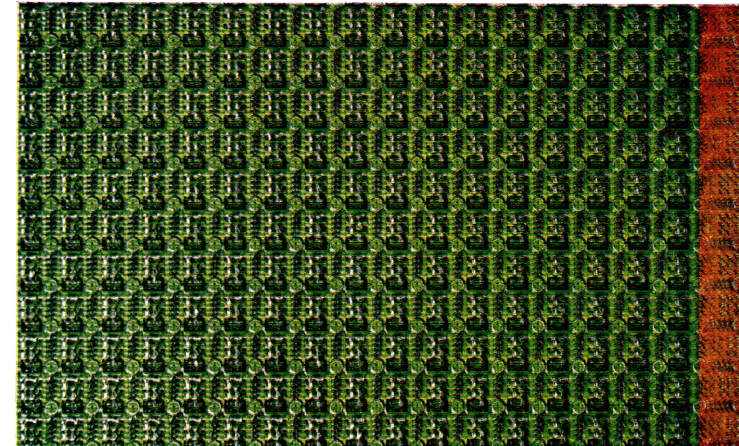

(TOP LEFT) Part of a cross-point switching frame also showing associated electronic modules.

(TOP RIGHT) A sub frame withdrawn for inspection showing the method of tape wiring.

(AT LEFT) Electronic modules can be arranged to revolve horizontally or swing down for inspection and maintenance.

(BOTTOM LEFT) Terminal wafers may be easily withdrawn from the main block to reveal circuit components mounted within the wafer.

(BOTTOM RIGHT) Frame assembly illustrating the wiring gutters used to accommodate the tape wiring.

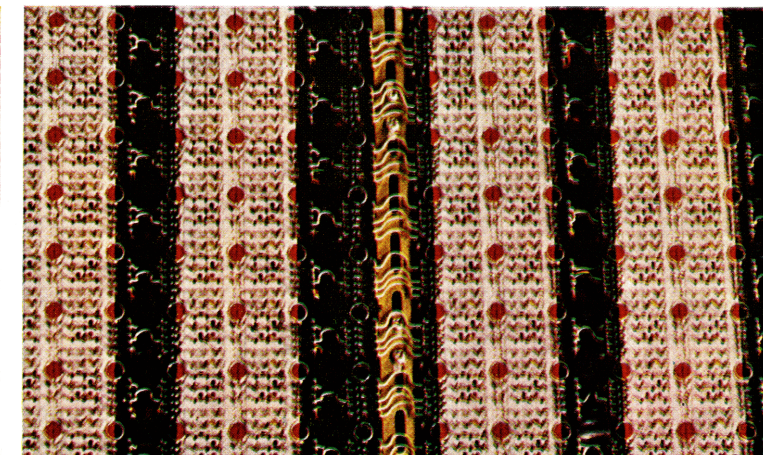
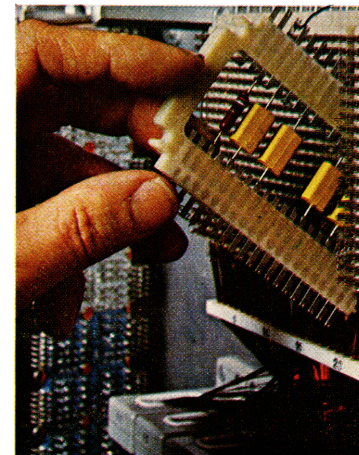



## checks and reports on its own performance automatically!

---

The high-speed electronic control system is programmed to provide complete self-checking and reporting facilities for maintenance purposes. A prototype reed electronic exchange supplied to the BPO at Leighton Buzzard has been designed for completely unattended operation and can report all servicing requirements to a remote maintenance control centre.

Exhaustive circuit design and testing during the development period, and replication of important items of equipment, enables a high degree of security of service to be offered.

### FUTURE FACILITIES

The basic design permits the provision of all future switching facilities likely to be required by a modern telecommunications network, including abbreviated dialling and subscribers' automatic transfer, together with all current standard features such as data for automatic message accounting. A stored programme control is provided to expedite inclusion of these facilities.

---

### REX — A SUMMARY

The exchange employs electronic common control of reed relay spatial switching arrays providing sealed precious metal contacts in the speech-path. The electronic control is simple in design and provides economic high-speed operation readily adaptable to provide expanded service and facilities.

Full security of service has been achieved in the system by exhaustive testing in the design stage, coupled with the multiple provision (with automatic changeover) of the vital control functions. At the same time REX offers dramatic savings in floor space with consequent reduction in the building capacity required for present switching systems in multi-exchange urban areas. The system is completely flexible to allow for the extension of lines and traffic growth. It requires minimal maintenance which is simple and largely automatic.

### INFORMATION SERVICE FOR ADMINISTRATIONS

AEI Telecommunications Group can supply technical information on detailed aspects of REX which will be of interest to experts in the field of automatic telephony. In addition, courses of technical lectures have been prepared, together with detailed lecture notes, and AEI would welcome invitations for a team of lecturers to be sent to provide, for the engineering staff of interested Administrations, a short introductory course on the principles of the REX system. Later, more detailed courses could be arranged for an Administration's key personnel in our UK factories, and detailed on-site instruction would be provided during the actual installation of REX exchanges. AEI are also prepared to consider setting up and staffing training schools in those territories where it is proposed to standardise on reed-electronic exchange switching equipment. Please write for fully illustrated REX brochure.

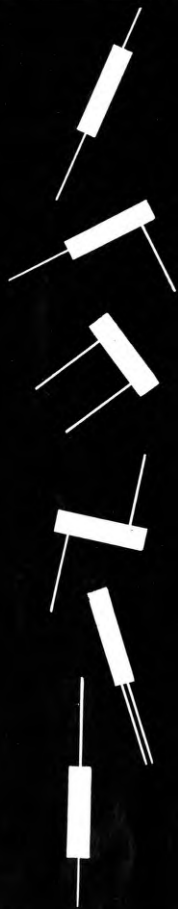

# FERRANTI SILICON STRAIN GAUGE TRANSDUCERS

GAUGES MOUNTED FOR YOU  
 MINIATURE GAUGES 0.1" x 0.010"  
 ENCAPSULATED GAUGES.—  
 TRIMMED TO CUSTOMER'S DIMENSIONS  
 SUPPLIED WITH ANY LEAD-OUT ORIENTATION

ZPG SERIES	
Sizes	.625 x .125 to .10 x .010 ins
Gauge Factor	80 to 140 positive 70 to 100 negative
Resistance	140 to 750 ohms
Operating Temp.	-40 to +160 °C

## UNDER ADVANCED DEVELOPMENT

Diffused passivated piezoresistive devices. Encapsulated n and p half bridges, designed to give constant bridge impedance and compensated for temperature and apparent strain.

**FERRANTI**  
*First into the Future*

FERRANTI LTD · GEM MILL · CHADDERTON · LANCS · Telephone (061) MAIn 6661



# Marconi

## SELF-TUNING

### h.f. receivers

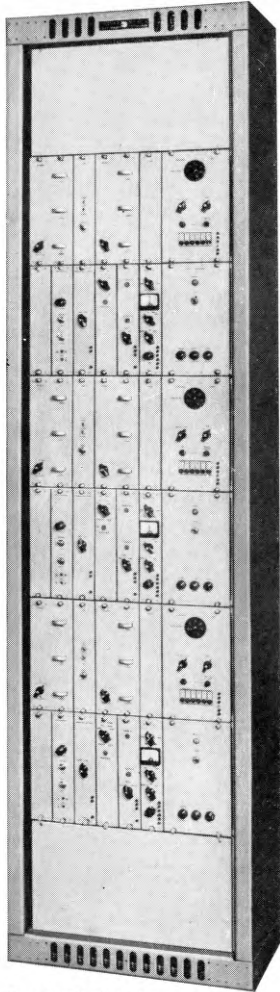

*Three double diversity  
H2002 receivers*

The H2002 Series of MST receivers for high grade point-to-point h.f. communication services.

H2002 double diversity f.s.k.

H2102 double diversity i.s.b. or s.s.b.

H2112 single path i.s.b. or s.s.b.

**NO OSCILLATORS**  
**NO VARIABLE CAPACITORS**  
**NO MECHANICAL TELEGRAPH RELAYS**  
**NO TUNING SCALES**

The new range of MST transistorized receivers uses synthesizers to provide accurate selection of 250,000 frequencies.

Elimination of manual tuning by a unique self-tuning system (using servo controlled varactor diodes) allows centralized extended control.

Exceptionally good frequency stability renders a.f.c. unnecessary on stable transmissions.

One man control of an entire receiving station.

60% space saved by much smaller equipment and back to back and side by side installation.

**RECEIVER**



**BREAKTHROUGH**

## Marconi telecommunications systems

# When a subscriber is more than 3 miles from a line—it's cheaper to install a PLESSEY '700' radio telephone

The cost of a good quality copper wire circuit using poles is equal to the cost of a radio link at 3 miles (4.8 km). And it's much easier to install a radio.

Terrain, distance and duration of service often make a line telephone system impossible or too costly to install. In these situations Plessey can provide fully line integrated automatic radio telephone systems with these benefits—*low installation costs, minimum maintenance, greater reliability.*

All-transistor Plessey '700' radio telephones enable subscribers to dial anywhere within existing line networks. They're available in pole or 19" rack mounted versions. Power requirements are at a minimum and can be derived from batteries, a.c.-d.c. converters, thermo-electric or solar sources. The sets operate up to 470 Mc/s in ambient temperatures from  $-20^{\circ}\text{C}$  to  $+55^{\circ}\text{C}$ . Optional power amplifiers, coin boxes and party line operation are available.

The Plessey range of radio telephone systems also includes single and multi-channel UHF/VHF equipments. A comprehensive systems planning, surveying and installation service is available. Write for a copy of the Plessey Radio Telephone Catalogue.

**PLESSEY Electronics** 

AT&E (Bridgnorth) Limited, Bridgnorth, Shropshire, England. Telex: 33373

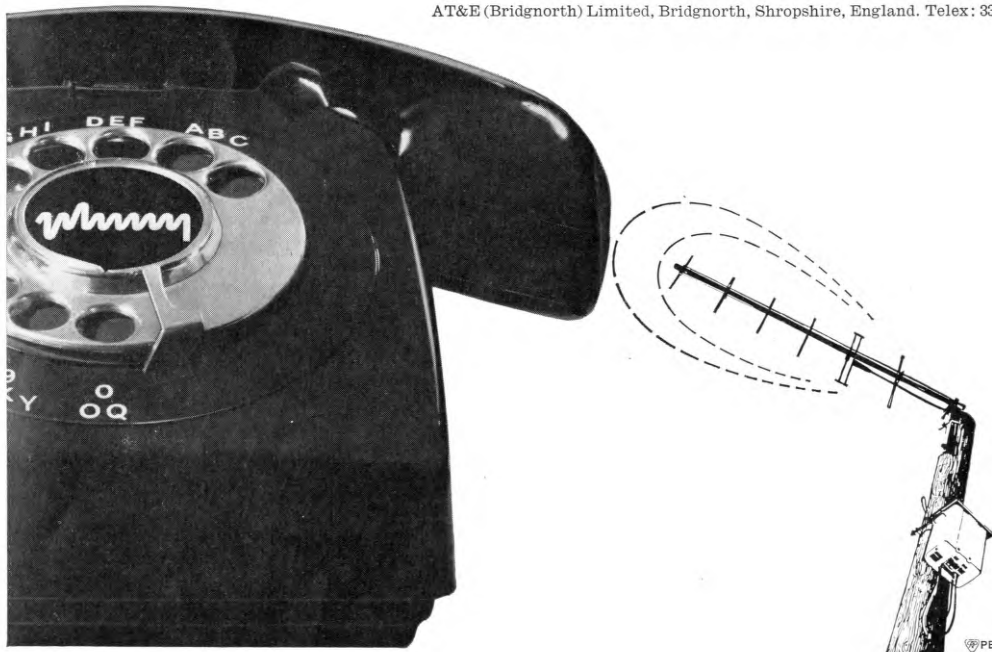

# Let Preformed dead ends take the load...

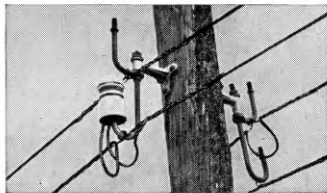
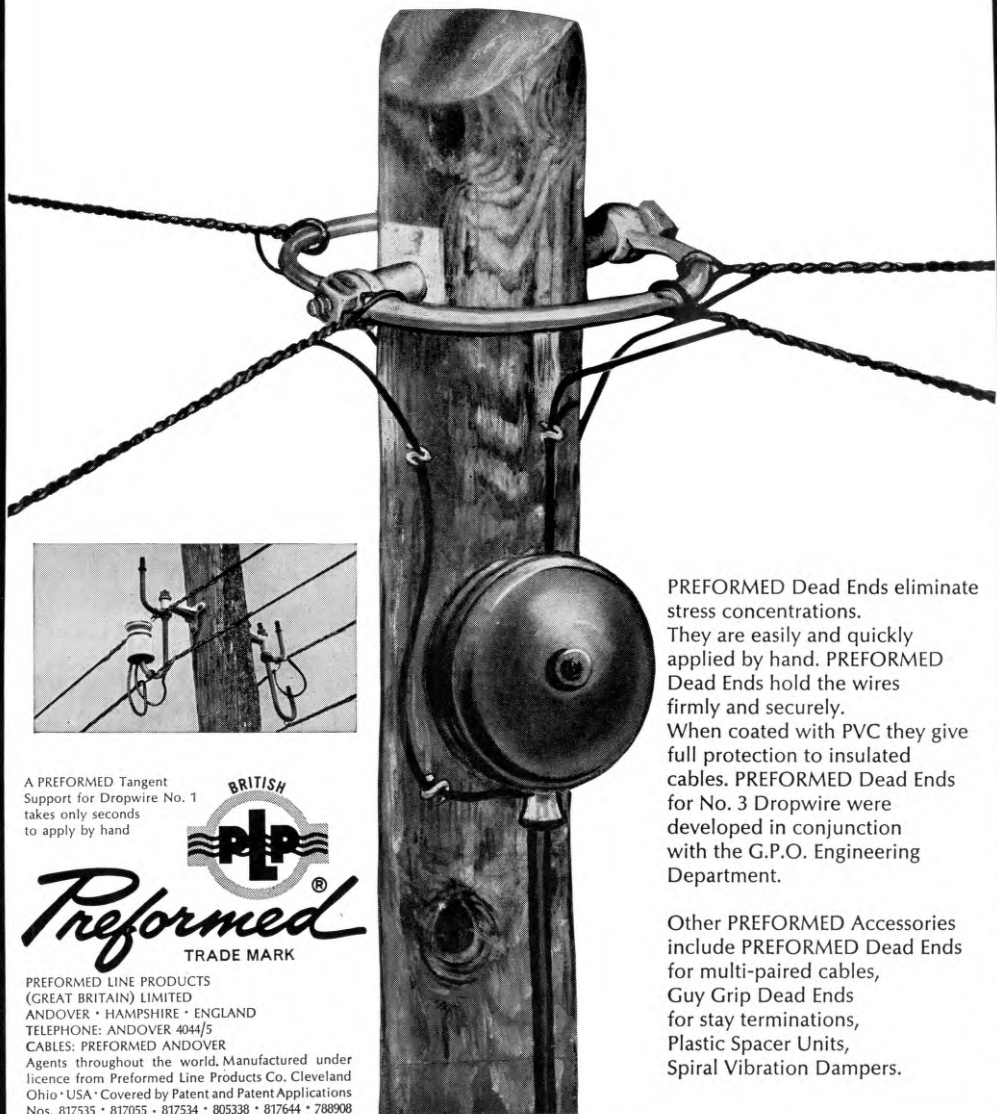

A PREFORMED Tangent  
Support for Dropwire No. 1  
takes only seconds  
to apply by hand



**Preformed**  
TRADE MARK

PREFORMED LINE PRODUCTS  
(GREAT BRITAIN) LIMITED  
ANDOVER • HAMPSHIRE • ENGLAND  
TELEPHONE: ANDOVER 4044/5  
CABLES: PREFORMED ANDOVER

Agents throughout the world. Manufactured under  
licence from Preformed Line Products Co. Cleveland  
Ohio • USA • Covered by Patent and Patent Applications  
Nos. 817535 • 817055 • 817534 • 805338 • 817644 • 788908

PREFORMED Dead Ends eliminate stress concentrations. They are easily and quickly applied by hand. PREFORMED Dead Ends hold the wires firmly and securely. When coated with PVC they give full protection to insulated cables. PREFORMED Dead Ends for No. 3 Dropwire were developed in conjunction with the G.P.O. Engineering Department.

Other PREFORMED Accessories include PREFORMED Dead Ends for multi-paired cables, Guy Grip Dead Ends for stay terminations, Plastic Spacer Units, Spiral Vibration Dampers.

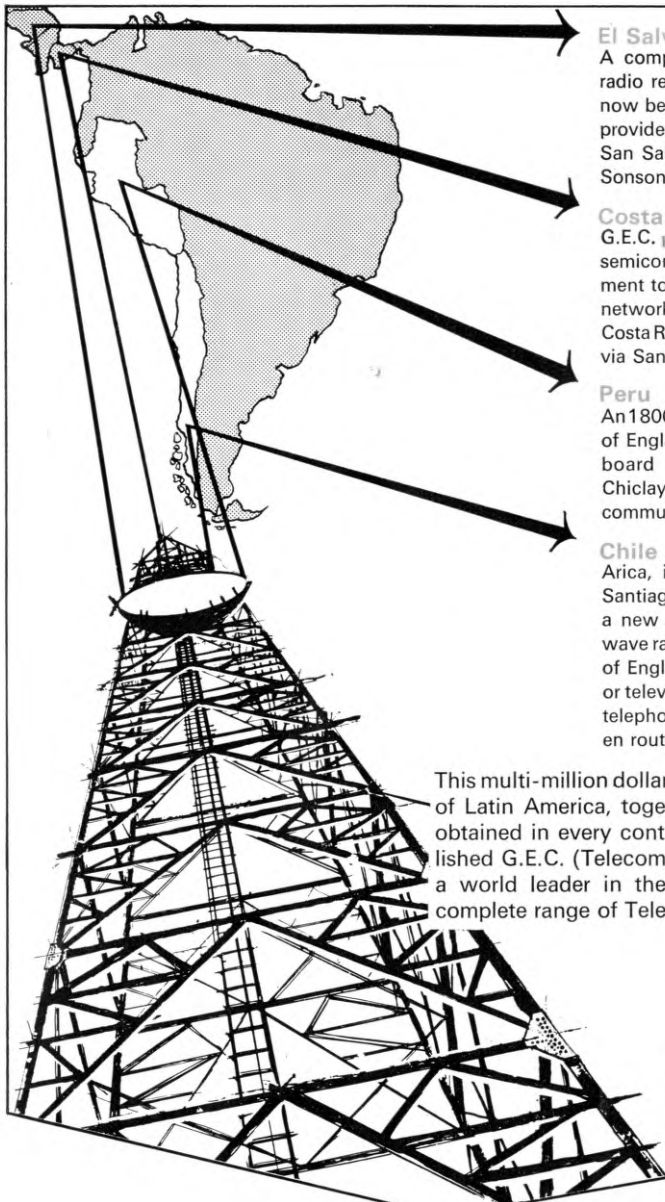

#### **El Salvador**

A completely semiconductored microwave radio relay system by G.E.C. of England is now being installed to span the country and provide telephone communication between San Salvador and San Miguel, Santa Ana, Sonsonate and Usulután.

#### **Costa Rica**

G.E.C. of England is supplying completely semiconductored microwave radio equipment to provide a telephone communication network linking all the principle towns of Costa Rica. The network extends from Liberia, via San Jose, down to Panama.

#### **Peru**

An 1800km microwave radio system by G.E.C. of England, stretches along the Pacific seaboard linking Arequipa, Lima, Trujillo, Chiclayo and Piura in a nationwide telephone communication network.

#### **Chile**

Arica, in the northern zone of Chile, and Santiago, the capital, will soon be linked by a new completely semiconductored microwave radio network being supplied by G.E.C. of England. The network conveys telephone or television signals and in addition provides telephone communication for 21 other towns en route.

This multi-million dollar contribution to the development of Latin America, together with many other contracts obtained in every continent of the world, have established G.E.C. (Telecommunications) Ltd., of England as a world leader in the design and manufacture of a complete range of Telecommunications equipment.

**G.E.C. of England  
serves the  
progress of  
Central and  
South America**



**G.E.C. (Telecommunications) Ltd**  
of Coventry, England

## VALUABLE FREE BOOK

Tells You How to Pass Your C. & C. Examination at *First Attempt!*

All Post Office personnel who are anxious to obtain early promotion should at once send for a copy of our handbook "ENGINEERING OPPORTUNITIES" which, among other intensely interesting matter, describes our unique methods of preparation for the CITY AND GUILDS EXAMINATIONS for the Telecommunication Technicians' Certificate and for individual subjects—Mathematics, Engineering Science, Engineering Drawing, Elementary Telecommunication Practice, Telecommunication Principles, Radio and Line Transmission, Telegraphy and Telephony, Line Plant Practice. It also contains details of our courses covering the C.C.E. subjects required for promotion to Assistant Engineer, Telecommunication Traffic Superintendent and other grades; and the City and Guilds examinations in Electrical Engineering Practice, the A.M.I.E.R.E. and A.M.S.E. Examinations, in addition to a wide range of non-examination courses in all branches of engineering—Radio and Electronics, Electrical, Mechanical, etc.

We also provide tuition for the Radio Amateurs' Examination and the P.M.G. Certificates for Radio Operators, with or without Morse training. Details are given in the handbook.

On "SATISFACTION OR REFUND OF FEE" terms

If you intend to make the most of today's opportunities, you cannot afford to miss reading "ENGINEERING OPPORTUNITIES." It tells you everything you want to know to secure advancement, and describes many opportunities you may now be missing through lack of information. Send for your copy today—FREE and without obligation.

BRITISH INSTITUTE  
OF ENGINEERING TECHNOLOGY  
727D ALDERMASTON COURT,  
ALDERMASTON, BERKSHIRE

# BIET

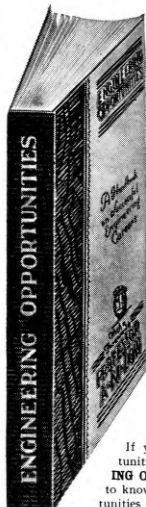

MAKE A RELIABLE CONTACT WITH OXLEY

4 mm PLUG & SOCKET

The Oxley P.T.F.E. insulated 4 mm sockets are quickly and firmly anchored into plain drilled or punched holes made possible by the well-proven patented "barb" principle. The complementary plug is of unique patented design and presents four integral independently sprung segments which together with a palladium finish provides consistently low contact resistance after repeated insertions.

Holes in chassis — .312=5/16"=7.94 mm dia.  
Plug extraction force — greater than 2 lb.  
Chassis thickness — 10/16 SWG=064"/.128=2,4/3, 2 mm.  
Working voltage — 2,000v. D.C.  
Max. current — 7 amps.  
Contact resistance — less than .002 ohms.  
British Patent Nos. 786862, 885876 ET AL.

# OXLEY

DEVELOPMENTS  
COMPANY  
LIMITED  
ULVERSTON,  
LANCASHIRE, ENGLAND.  
Telephone: Ulverston 2507  
Cables: Oxley Ulverston



## Reliability

A dependable telephone system is essential to modern society. Connollys cables, with built-in reliability, have played an important part in maintaining the efficient operation of the public telephone service in this country since 1890: and Connollys reliability has been further proved in telecommunication installation in the many countries overseas.

# CONNOLLYS

Connollys (Blackley) Limited  
Cable Division  
Blackley, Manchester 9  
Telephone: Cheetham Hill 1801

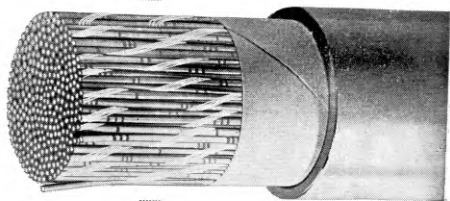



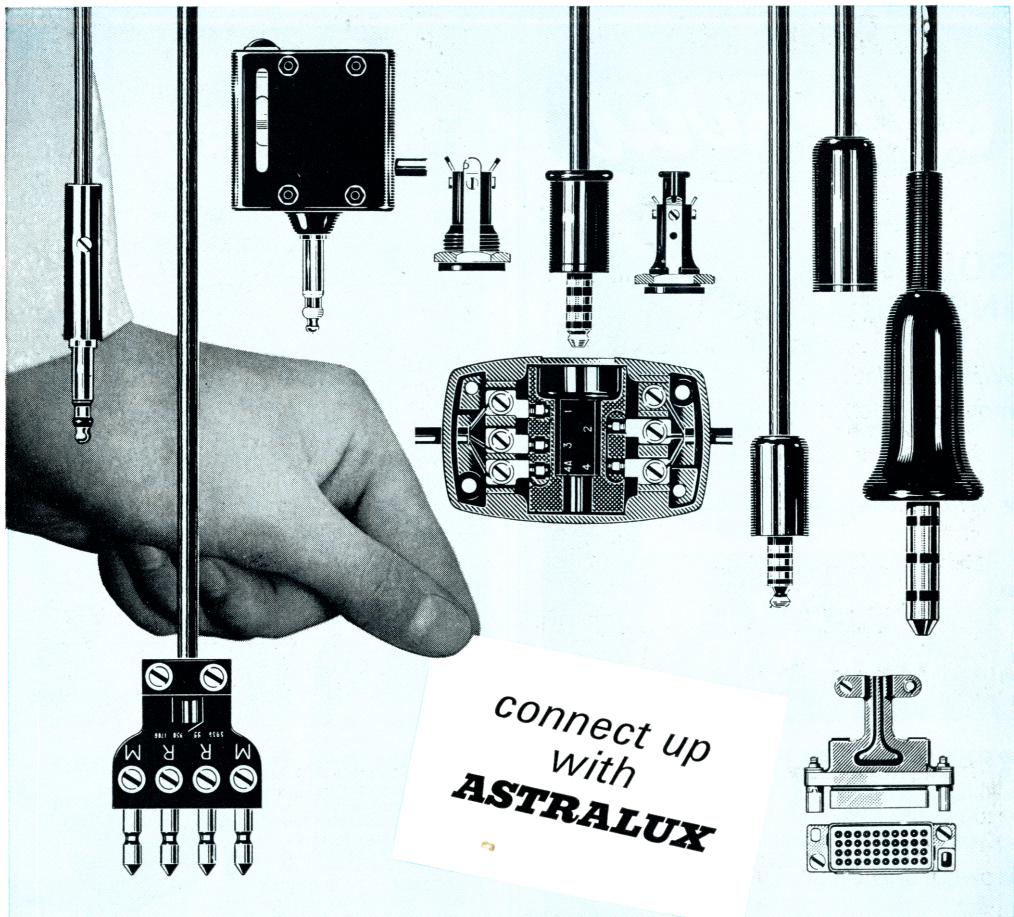

PLUGS, SOCKETS, JACKS—in all sizes and for every purpose—are made by the Special Products Division of Astralux Dynamics Ltd. They're chosen by the British Government and approved by the Post Office and Aircraft Industry. The special Astralux design service for prototype models is used by these organisations and by private industry. You can rely on Astralux efficiency and technical accuracy to produce equipment strictly to specification—and quickly. Plugs, Sockets and Jacks are just some of the products of a company streamlined to serve world-wide industry today. Learn more about what Astralux can offer *you*. Write to us for descriptive literature.

Illustrated from left to right

- 1 Plug 316    2 Plug 406
- 3 Plug 235    4 Jack 84A
- 5 Plug 420    6 Jack 95A
- 7 Socket 626 with Hex. Nut
- 8 Plug 671    9 Socket 626
- 10 Plug Electrical 119
- 11 40-way Connector  
male and female

**ASTRALUX** *dynamics limited*





## STEPMASTER PABX

### Two models of efficiency

The STC Stepmaster PABX gives you the fast, foolproof communications you need, while leaving the operator beautifully unruffled.

It meets the most up-to-date requirements for a Cordless Private Automatic Branch Exchange of advanced design and compact proportions.

And the use of keysender marking techniques, plus the very simple working procedure, so ease the operator's task that a secretary or receptionist can comfortably work the switchboard in addition to her other duties.

□ 20, 50 and 100 line units □ Smart, modern switchboard □ New lightweight high performance handset □ B.P.O. type 'long-life' components □ Transistorized ringing and tone circuits □ All 'plug-in' type equipment □ Quick and easy extension to full capacity □ Simple installation and maintenance.

Standard Telephones and Cables Limited, Telephone Switching Group, Oakleigh Road, New Southgate, London, N.11. Telephone: ENTerprise 1234. Telex: 261912.

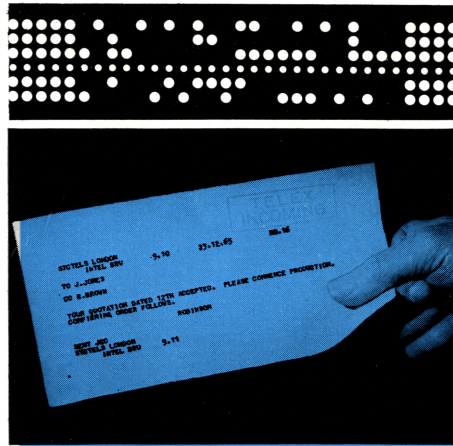

### The message is your business ... speeding it through is ours

STC know teleggraphy inside out and outside in, provide a complete range of equipment—and equally complete skill and experience—for direct and indirect systems, large, medium and small.

Telex switching, international and local, is an STC speciality no less than the provision of private networks for the police, railways and similar bodies.

And, throughout the world, STC message switching systems—from the simplest manual transfer right through semi- and fully-automatic systems—speed the vital messages of corporations, civil airlines and commercial networks of every kind.

The moment *you* have any telegraphic problem it's just good business to phone, write or telex STC.

Standard Telephones and Cables Limited, Telephone Switching Group, Oakleigh Road, New Southgate, London, N.11. Telephone: ENTerprise 1234. Telex: 261912.

**TOP.20-B**                      **TPP.20**

### Privacy in radio telephony

Whether it's a matter of discussing an important business deal or just saying hello to Mother, most international administrations operating into radio links consider privacy to be essential. STC provides this facility through the TPP.20 four-wire fully transistorized five-band speech scrambler equipment. This advanced equipment is designed to operate with h.f. radio link control terminals such as the STC TOP.20-B.

Both the TPP.20 and the TOP.20-B handle four speech channels: both are extremely compact and embody modern techniques of transistorization and module construction.

**Five Band Speech Scrambler Type TPP.20**

- Four speech channels.
- Fully transistorized.
- 4-wire system (separate send and receive paths).
- Remote selection of combinations.
- Compact yet extremely accessible.
- Cabinet 36 in. (91.4cm.) high x 20½ in. (52cm.) wide x 8½ in. (22cm.) deep.

**Radio Link Control Terminal Type TOP.20-B**

- Four speech channels.
- Fully automatic.
- Relay type VODAS switching.
- Built-in shifter and inverter for each circuit.
- Automatic station identification for each circuit.
- Console 75 in. (190.5cm.) high x 33 in. (83.8cm.) wide x 19 in. (48.3cm.) deep.

For further information please write, phone, or telex Standard Telephones and Cables Limited, Radio Division, Oakleigh Road, New Southgate, London N.11. Telephone: ENTerprise 1234. Telex: 261912.

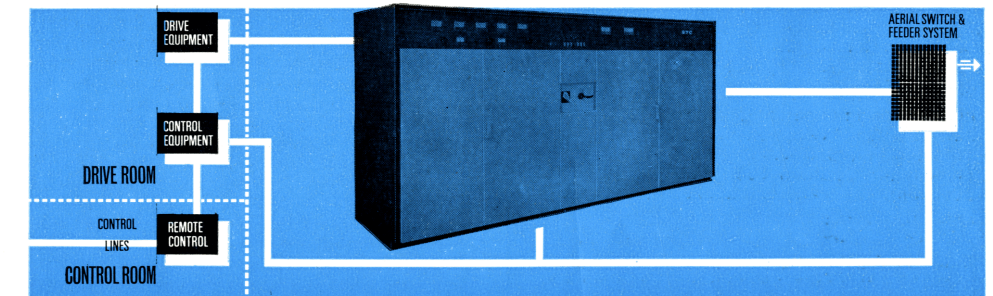

### The QT.8-A STANFAST transmitter amplifier

The QT.8-A is the latest of the STC QT Series of automatic transmitter amplifiers for use in the STANFAST HF communication system. It operates in the frequency range 4—28Mc/s with a power output of 20kW for single frequency working or 30kW p.e.p. Being of the linear amplitude response type it is suitable for i.s.b. and d.s.b. telephony or for single or multichannel telephony. Its built-in automatic control and tuning facilities enable the frequency to be set up locally or from a remote position making the amplifier suitable for unattended operation.

■ Automatic tuning ■ High reliability ■ Automatic load correction ■ Rapid fault location ■ Solid state logic control circuits ■ SWR monitoring ■ Manual tuning facility provided ■ ISB techniques effect bandwidth saving and power economy ■ Negative feedback improves linearity and gain stability ■ Requires front access only ■ Meets CCIR requirements

For further details write, phone or telex Standard Telephones and Cables Limited, Radio Division, Oakleigh Road, New Southgate, London N.11. Telephone: ENTerprise 1234. Telex: 261912.



## INTEGRATED COMMUNICATION SERVICES

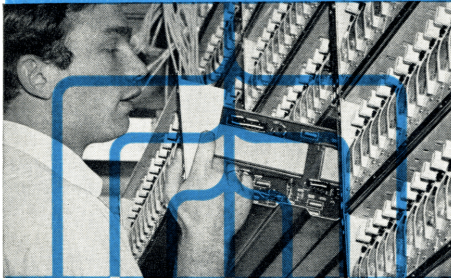

system  
planning

project  
management

commissioning

overhaul

survey

installation

maintenance

## World-wide capability in integrated communication services

□ System planning □ Survey □ Project Management □ Installation □ Maintenance □ Overhaul of all types of telecommunication transmission systems. The Installation Division of the STC Transmission Systems Group is one of the few organisations of its type in the world. Self-contained and independent, and backed by the international resources of STC, the Division offers world-wide capability in the provision of integrated communications systems, including consultancy services, and advisory and training services for the user's staff.

For further information please write, phone or telex Standard Telephones and Cables Limited, Transmission Systems Group, Basildon, Essex. Telephone: Basildon 3040. Telex: 99101. (STC Basildon).

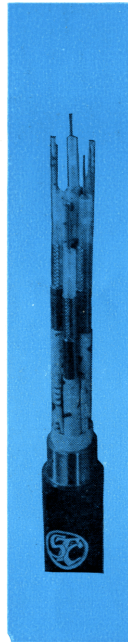

## Big success with small-core systems

In 1961 STC supplied the first small-core coaxial cable telephone system to enter service anywhere in the world. STC has maintained the lead, and are currently offering two types of all-transistor system working over 0.174 in. (4.4 mm.) coaxial cores.

The LF1A 300 circuit system has a line frequency band of 60-1 300 kc/s and employs repeaters spaced at nominal intervals of 2.5 miles (5.8 km.). The LF4B 960 circuit system has a line frequency band of 60 kc/s to 4.028 Mc/s and has repeaters spaced at nominal intervals of 2.6 miles (4 km.).

Features of both systems are:

Repeaters installed underground and power-fed over the cables

Automatic gain control at alternate repeaters

Special circuits give maximum protection against lightning

Terminal equipment engineered in the STC Mark 6 Construction

To date STC has supplied or has on order small-core systems for a total of 2,800 system miles, including 184 terminal repeaters and 926 dependent repeaters.

Standard Telephones and Cables Limited, Transmission Systems Group, Basildon, Essex. Telephone: Basildon 3040. Telex: 99101 (STC. Basildon)

# STC

world-wide telecommunications and electronics

# FIXED RESISTORS AND THERMISTORS

## GENERAL PURPOSE FIXED RESISTORS (actual size)

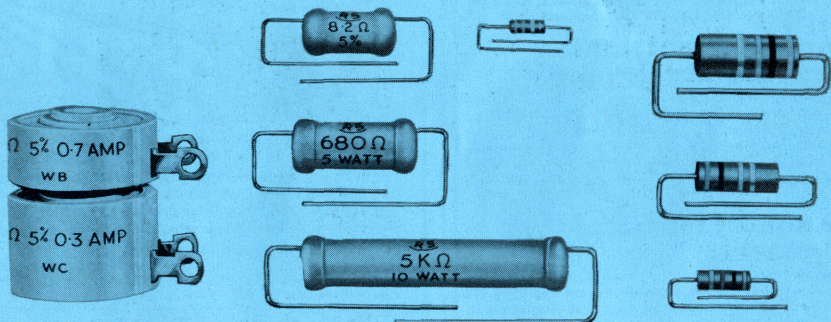

## THERMISTORS (actual size)

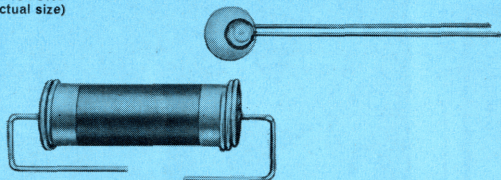

## HIGH STABILITY RESISTORS (actual size)

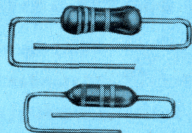

A wide range for delivery "by-return" of:

**WIRE-WOUND RESISTORS**—ratings 3W. (0.5-10 $\Omega$ ), 5W. (15 $\Omega$ -8.2K $\Omega$ ), 10W. (15 $\Omega$ -25K $\Omega$ ) and 30W. (33 $\Omega$ -1.5K $\Omega$ ), all at 5% tolerance.

**POWER SECTIONS**—for "build up" wire-wound resistors in units from 10 $\Omega$  (-7A) to 2.2K $\Omega$  (-065A), all at 5% tolerance.

**CARBON COMPOSITION RESISTORS**— $\frac{1}{10}$ W. (10 $\Omega$ -1M $\Omega$ )  $\frac{1}{2}$ W. and 1W. (4.7 $\Omega$ -22M $\Omega$ ) or 2W. (10 $\Omega$ -22M $\Omega$ ), all at 10% tolerance.

**HIGH STABILITY RESISTORS**—Carbon Film rated at  $\frac{1}{2}$ W. (10 $\Omega$ -22M $\Omega$ ) at 5% tolerance and Oxide Film rated at 1W. (10 $\Omega$ -1M $\Omega$ ) at 2% tolerance.

**THERMISTORS** for current surge limiting and temperature compensation.



## **Radiospares Ltd.**

4-8 MAPLE STREET · LONDON W.1 · ENGLAND

Telephone: EUSon 7232 (8 lines). Telegrams and Cables: RADOSPERES, LONDON, W.1



## PITMAN

### Connectors, Relays and Switches

G. W. A. Dummer and N. E. Hyde 50s net  
This is the latest volume, the sixth, in the **Radio and Electronic Components** series by Mr. Dummer. This series has been designed to meet the needs of the rapidly expanding electronics industry for information about specific components. **Connectors, Relays and Switches** is the first book in the world covering electronic connections, a subject of extreme importance due to the improvement in reliability of components and integrated circuits, requiring similar improvements in connection methods. This work will be welcomed by the electronic industry.

### Advanced Electrical Power and Machines

G. S. Brosnan and J. T. Hayden £5 net  
Based on the paper of the same name in the B.Sc.(Eng.) Part III examination of the London University, this book assumes only an elementary knowledge of magnetism, electrical machines and networks. From this it develops the theory in a way which emphasises the physical concepts involved.

### Advanced Electrical Engineering

A. H. Morton 65s net  
Intended as a textbook for students taking the Part III examination of the Institution of Electrical Engineers in Advanced Electrical Engineering. It will also be found useful by students of both Light and Heavy Current Engineering who are preparing for first degrees at universities and colleges throughout the country.

from all booksellers Pitman Parker St, London WC2

## LUSTRAPHONE

Equipment

wherever better standards are required

for **SOUND COMMUNICATION**

**MICROPHONES** and all their accessories

"**RADIOMIC**" SYSTEMS

**PORTABLE P/A SYSTEMS** with or without

"Radiomic"

**NOISE CANCELLING INTERCOM-  
SYSTEMS**

**AUDIO EQUIPMENT**

**ACCESSORIES-COMPONENTS-FITMENTS**

LUSTRAPHONE

OUTSTANDING IN QUALITY AND PERFORMANCE  
BRITISH IN DESIGN AND MATERIALS

## LUSTRAPHONE LTD.

St. George's Works, Regent's Park Road,  
London, N.W.1 Telephone: PR1mrose 8844

## Why do leading electronic manufacturers use

ERSIN

**Multicore**

5 CORE

SOLDER

Because they realise that their reputation can rest upon the quality of the solder they use. For utmost reliability they use Ersin Multicore, the only solder containing the purest tin and lead, plus 5 cores of extra-active, non-corrosive Ersin flux. Whatever the application, there is an Ersin Multicore Solder which is exactly right for the job.

### Standard Telephones and Cables Ltd.

The manufacture of Automatic Telephone Exchange Equipment involves many million soldered joints. The accessibility of many of the wires is restricted after they have been terminated, and it is therefore essential that only solder of proved reliability be used. Consequently Ersin Multicore Solder, 60/40 alloy, has for many years been preferred by Telephone Manufacturers in Britain and overseas. It is approved by the British G.P.O. and many foreign Telephone Authorities, and is shown here being used by Standard Telephones and Cables Limited in the manufacture of a G.P.O. Line Finer Rack.

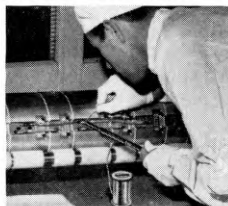
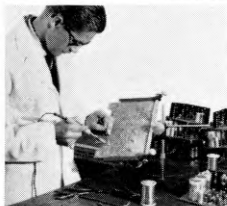
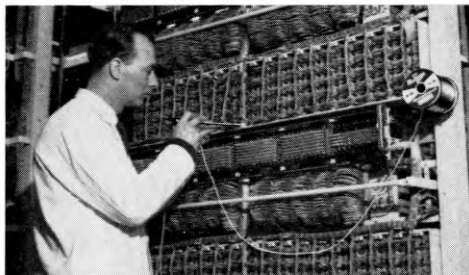

### H. J. Leak & Co. Ltd.

Ersin Multicore Sa/bit alloy is shown in use in the wiring construction of the Leak Integrated Stereo 30 Transistor Amplifier. In order to ensure the utmost reliability, the Leak High Fidelity equipment has been made with Ersin Multicore Solder for more than 20 years.

### Submarine Cables Ltd.

Ersin Multicore Solder is shown being used at the Erith factory of Submarine Cables Ltd., in the production of a submersible repeater designed to last for a minimum of 20 years under the sea without attention.

Engineers and technicians are invited to write on their Company's letterheading for the booklet "MODERN SOLDERS" containing data on melting points, alloys, etc.

### MULTICORE SOLDERS LTD.

Hemel Hempstead, Herts. Telephone:  
Hemel Hempstead 3636 Telex: 82363

M 33



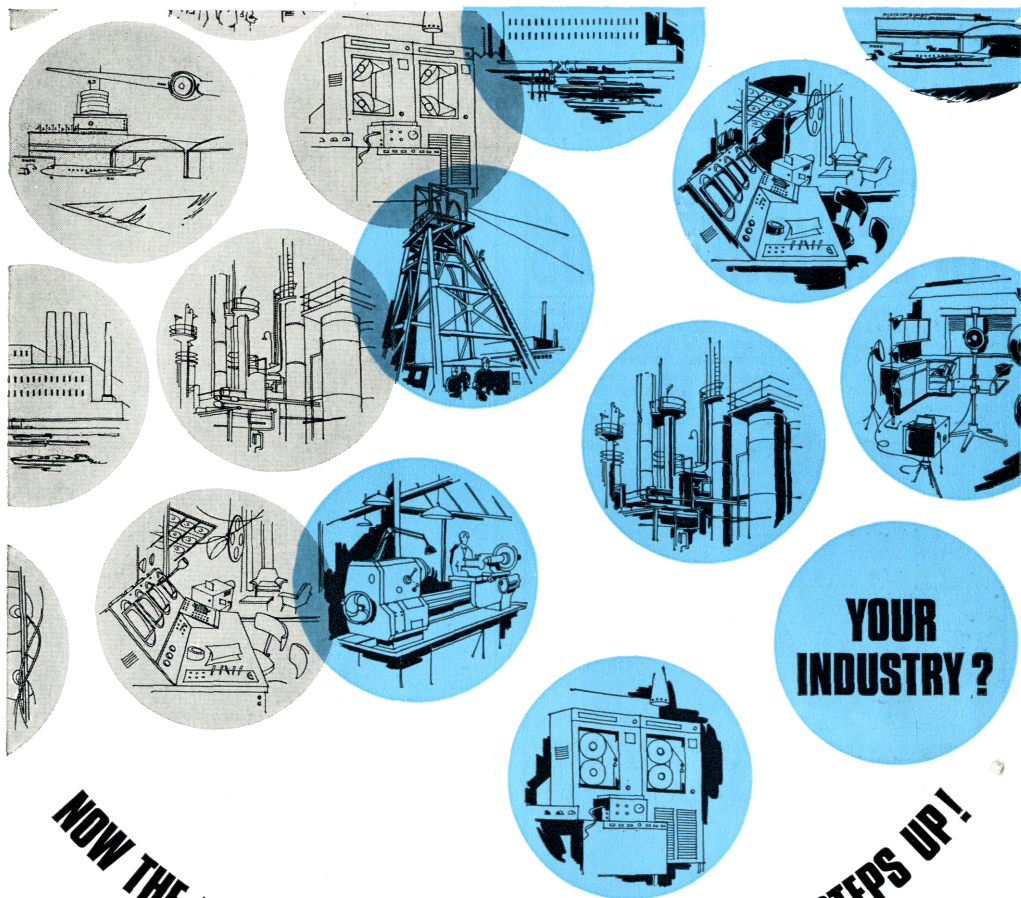

**NOW THE BIG SWING TO ASTRALUX V.S.T. REALLY STEPS UP!**

**Everywhere Astralux Voltage Stabilising Transformers outperform and outdate conventional C.V.T. systems**

**HERE'S WHY ASTRALUX V.S.T. IS REPLACING C.V.T. IN INDUSTRY AFTER INDUSTRY:**

**Better Performance.** That means improved Output Voltage Stability—output voltage maintained within  $\pm 0.5\%$  for input voltage changes of  $+10\%$ — $20\%$ . Even when the voltage fluctuation is as great as  $+10\%$  to  $-30\%$  the V.S.T. will maintain the output voltage to within  $\pm 1\%$ . ● **Latest Materials.** High temperature (Class F) materials give optimum reliability and increased safety margins on operating temperatures. ● **Low external field** The latest techniques in magnetic core design give improved performance, coupled with high efficiency, while still offering low external fields. ● **Stable Voltage—Stable Prices.**

ASTRALUX prices remain stable over long periods, so costing a job ahead is facilitated with this advanced system. ● **Over 10,000 models!** The ASTRALUX V.S.T. Standard Range consists of ten basic models with over a thousand variations on each. *No other manufacturer* offers such a choice, or can offer such economical prices. ● **Low Cost Specials.** You can order V.S.T. 'specials' at little more than the cost of standard units. Our design department will be happy to prepare prototypes to your specification, for incorporation into equipment under development. Free illustrated booklet giving full details of ASTRALUX V.S.T. from

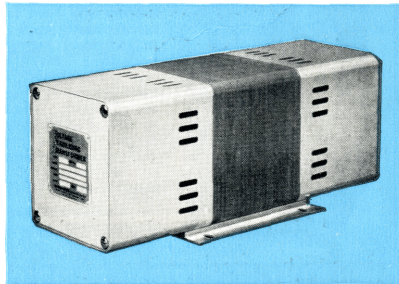

**ASTRALUX** dynamics limited

TRANSFORMER DIVISION • BRIGHTLINGSEA • COLCHESTER • ESSEX • TELEPHONE: BRIGHTLINGSEA 417.

# WHITELEY

ELECTRICAL RADIO CO. LTD.

## for acoustic hoods

All noisy environments such as factories, workshops, department stores and hotels require the facility of an acoustic hood which permits telephone conversations to be held without the interference of annoying background noises. Whiteley acoustic hoods are strongly made from resin bonded ply and finished in a cellulose enamel which makes these suitable for indoor or outdoor use.

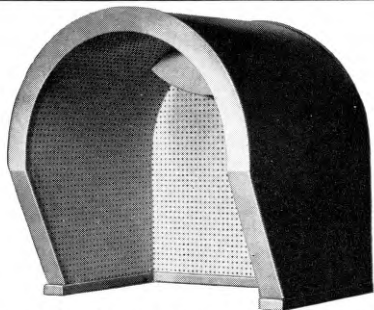

Standard Hood Dimensions 25" high x 20½" deep x 24½" wide

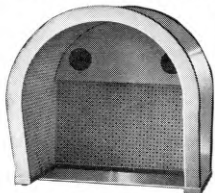

Fitted with loudspeakers

Also available with internal light and/or a storage shelf below hood

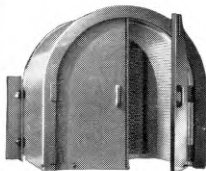

Fitted with doors for outdoor use

## & directory holders

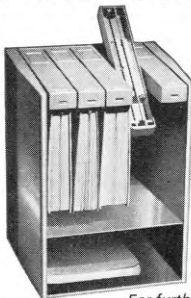

These attractive, and extremely functional, directory holders will hold five directories neatly and securely, in individual swivel holders permitting easy identification and reference. The lower shelf provides additional storage space. The units are of cast alloy and are finished in an attractive grey epoxy resin enamel and constructed to strict G.P.O. design specifications.

Directory Holder Dimensions  
17½" high x 13½" wide x 13½" deep

For further details please write or telephone.

**WHITELEY ELECTRICAL RADIO CO. LTD**

MANSFIELD · NOTTS · ENGLAND Tel: Mansfield 1762 5  
London Office: 109 KINGSWAY, W.C.2 Tel: HOLborn 3074

**ADCOLA** SOLDERING  
EQUIPMENT  
PRODUCTS LIMITED  
(Regd Trade Mark)

FOR  
TOTAL EFFICIENCY

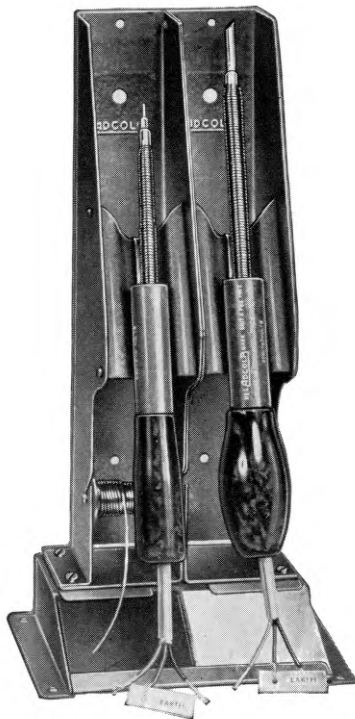

FOR CATALOGUES APPLY DIRECT TO SALES DEPT

**ADCOLA PRODUCTS LTD.**

**ADCOLA HOUSE**

**GAUDEN ROAD**

**LONDON, S.W.4**

Telephone: MACAULAY 0291/3

Telegrams: SOLJOINT, LONDON S.W.4



# SPLIT-SECOND AUTOMATIC TUNING TO ANY ONE OF MILLIONS OF FREQUENCIES

## THAT'S WHAT THE SYNTHESIZER CONTROL ON THE PLESSEY PVR 800 HF RECEIVING SYSTEM CAN DO

Exceptional ease of operation and versatility, combined with maximum reliability, has been achieved in the PVR 800 series, which tunes to any one of 2.5 million frequencies or any one of 6 preselected synthesized frequencies in .25 of a second. The unique engineering concept—using wide band techniques, a frequency synthesizer and semi-conductor components—gives the following advantages:

### RELIABILITY

Fully transistorised—low power consumption.  
Constant performance over complete band—no variable capacitors or varactor diodes used.  
Solid state reliability—tuning by vacuum reed relays.  
Increased accuracy and frequency stability.  
Incremental synthesizer tuning in 10 CPS steps.  
Electronic telegraph relays reduce distortion and eliminate adjustment.

### VERSATILITY

Range of receivers cover CW, FSK, FAX, SSB, ISB speech and telegraphy, single-path, twin-path or dual diversity reception. Provides 2.5 million channels between 3 and 27.5 Mc/s.

### SIMPLICITY

Local, extended or remote control for one-man operation of complete station. Modular construction and plug-in printed circuit cards facilitate simple servicing.

*The PVR 800 conforms to CCIR recommendations and is in production for the British Post Office.*

We will be happy to send you the Plessey PVR 800 booklet giving full details; please write to the address below:

The Plessey Company Limited  
Radio Systems Division  
Ilford, Essex, England  
Telephone: Ilford 3040 Telex: 23166

# PLESSEY Electronics



## Designed for Dependability!

### Model **8** Avometer

The Model 8 Universal Avometer is a high sensitivity multi-range ac/dc electrical testing instrument providing 31 ranges of readings on a 5-inch hand calibrated scale. Quick range selection is effected by two interlocking rotary switches for a.c. and d.c. respectively.

This latest model, Mk3, incorporates increased sensitivity in the lower a.c. ranges and wide frequency characteristics. A fused ohms circuit provides increased protection against inadvertent overload, and there is an improved temperature coefficient over the whole range.

With the aid of a range of d.c. shunts measurements can be made up to 400 amps d.c.

*Write for Brochure or for complete Catalogue of AVO Instruments.*

**AVO LIMITED** AVOGET HOUSE · DOVER · KENT



Dimensions:  
8½ × 7½ × 4½ inches.  
Weight 6½ lb.

Telephone- Dover 2626



A8/11

## MODEL ANSWER BOOKS

CITY AND GUILDS OF LONDON INSTITUTE EXAMINATIONS FOR THE  
TELECOMMUNICATION TECHNICIANS' COURSE

Four model answer books are available, each covering one of the following subjects.

**TELECOMMUNICATION  
PRINCIPLES A**

**TELECOMMUNICATION  
PRINCIPLES B**

**ELEMENTARY TELECOMMUNICATION PRACTICE**

**RADIO AND LINE TRANSMISSION A**

PRICE 7/6 each (Post Paid 8/-)

Orders may be sent to the *Journal* Local Agents or to  
*The Post Office Electrical Engineers' Journal*, G.P.O., 2-12 Gresham Street, London, E.C.2.





## E.D.C. make the motors and generators **you can't buy from stock**

Specials only! As small or as large an order as you like, but we carry no stocks of complete units because everything is made to order. A.C. motors for example. Mechanically, we can make to fit any combination of fixing arrangement. They can be watertight or flame-proof. They can be super-silent. We can make them with

more than one winding giving multi-speeds, or shock-proof up to 240 G—and that's a lot of G.

There's virtually no limit to the variations we can achieve in A.C. generators. They are widely used in industrial, marine and the telecommunications fields. As we said—specials!

TELL ME MORE ABOUT YOUR PURPOSE-MADE  
A.C. GENERATORS AND MOTORS.

NAME \_\_\_\_\_

COMPANY \_\_\_\_\_

ADDRESS \_\_\_\_\_  
\_\_\_\_\_



**ELECTRO-DYNAMIC CONSTRUCTION CO. LTD**

ST. MARY CRAY, ORPINGTON, KENT. TELEPHONE: ORPINGTON 27551.  
GRAMS: ELEDAMIC ST. MARY CRAY, Also at GLASGOW-MANCHESTER

## INDEX TO ADVERTISERS

	PAGE		PAGE
Adcola Products, Ltd. . . . .	24	Multicore Solders, Ltd. . . . .	22
Associated Electrical Industries, Ltd. . . . .	5-8, 29	Oxley Developments Co., Ltd. . . . .	14
Astralux Dynamics, Ltd. . . . .	15, 23	Pirelli General Cable Works, Ltd. . . . .	4
Avo, Ltd. . . . .	26	Pitman, Sir Isaac, & Sons, Ltd. . . . .	22
British Institute of Engineering Technology . . . . .	14	Plessey Co., Ltd., The . . . . .	11, 25
Connollys (Blackley), Ltd. . . . .	14	Preformed Line Products (Great Britain), Ltd. . . . .	12
Electro-Dynamic Construction Co., Ltd. . . . .	27	Pye Telecommunications, Ltd. . . . .	2
Ferranti, Ltd. . . . .	9	Radiospares, Ltd. . . . .	21
G.E.C. (Telecommunications), Ltd. . . . .	13	Standard Telephones & Cables, Ltd. . . . .	17-20
Insuloid, Ltd. . . . .	16	Submarine Cables, Ltd. . . . .	3
Light Soldering Developments, Ltd. . . . .	16	Telephone Cables, Ltd. . . . .	30
Lustraphone, Ltd. . . . .	22	Whiteley Electrical Radio Co., Ltd. . . . .	24
Marconi Co., Ltd., The . . . . .	10	Winn & Coales, Ltd. . . . .	28

# LITERATURE

to help  
in your  
fight against  
corrosion

Building, Steelwork,  
Electrical, Maintenance  
and Plumbing.

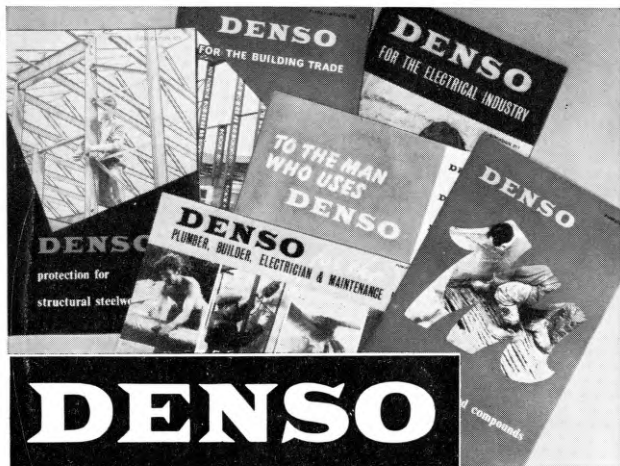

The DENSO Anti-Corrosion Service offers a wide range of materials—tapes, cords and compounds—to cope with most anti-corrosion, waterproofing and sealing problems.

To illustrate how DENSO can help in *your* particular industry, we offer a number of booklets each dealing with specific subjects.

Complete and mail the coupon below for any that you require.

#### WINN & COALES LTD.

Denso House, Chapel Rd., London, S.E.27. Tel: GIP 7511  
Also at Manchester, Belfast and Dublin.  
Denso Agents throughout the World.

Please send me without obligation the following literature:

- Denso Mastics and Compounds  Denso for the Electrical Industry   
 Denso for the Building Trade  Denso protection for structural steelwork   
 Denso for the Plumber, Builder, Electrician & Maintenance Engineer

*(tick where required)*

NAME \_\_\_\_\_

ADDRESS \_\_\_\_\_

P.O.S.

# CATT/ANI a completely automatic account-recording system at a highly competitive cost!



## CUSTOM BUILT BY AEI FOR DDD

The CATT/ANI system provides a punched tape record of all the information needed for DDD recording and accounting.

The CATT equipment has been specially designed by AEI for the North American long distance calling system and, together with the ANI system, fulfills all DDD specifications. This high grade AEI package takes up minimum space, is extremely flexible and fully compatible with existing telephone exchange and machine accounting equipment.

CATT/ANI systems can be supplied as a complete package or in individual units. Prices are highly competitive—in fact ANI costs less than any other comparable equipment.

## CATT Centralised Automatic Toll Ticketing

Suitable for all types of national, regional and local Toll Switching centres, CATT handles all DDD routing functions and works with any Register/Translator equipment where operator or toll dialling facilities already exist.

Supplied with DC or MF outpulsing to suit local conditions and to provide remote operation by CSP routing machine where

required. Person-to-person, collect calls etc., can be checked by routing to a manual operator with automatic sending under the operator's control if required. A full Sender/Tabulator/Translator common control gives maximum equipment economy and security.

## ANI Automatic Number Identification

ANI is an inexpensive high speed system using DC to avoid interference with telephone exchange operation. Self-checking and fault printout facilities are included and the system is fully protected against misoperation by outside agencies. No special power or tone sources are required and MF or DC loop outpulsing can be arranged to suit all destination signalling conditions. (Individual sets of transistor oscillators are supplied in each ANI Register.)

*For full technical details, please contact*

**AEI**  
TELECOMMUNICATIONS

Woolwich, London S.E.18.

# TCL *cables speak all languages...*



*TCL cables being laid in the main business centre of Hong-Kong*

TCL is very much in the export business. TCL serves the British Post Office and organisations throughout the world. Current overseas orders exceed £7 million. TCL produces all types of dry core and plastic cables, supplies Coaxial cables capable of handling some 2 million high frequency channels and over 3 million conductor miles annually. TCL has, in fact, the largest telephone cable plant in Europe. Why are TCL cables in such demand? Because they are reliable and always meet specification. A complete technical advisory service is readily available.

# TCL

Telephone Cables Limited, Dagenham, England  
Telephone: DOMinion 6611 Cables: Drycore Dagenham  
THE ORGANISATION WITH 130 YEARS' EXPERIENCE