

Please do not upload this copyright pdf document to any other website. Breach of copyright may result in a criminal conviction.

This pdf document was generated by me Colin Hinson from a Crown copyright document held at R.A.F. Henlow Signals Museum. It is presented here (for free) under the Open Government Licence (O.G.L.) and this pdf version of the document is my copyright (along with the Crown Copyright) in much the same way as a photograph would be.

The document should have been downloaded from my website <https://blunham.com/Radar>, or any mirror site named on that site. If you downloaded it from elsewhere, please let me know (particularly if you were charged for it). You can contact me via my Genuki email page: <https://www.genuki.org.uk/big/eng/YKS/various?recipient=colin>

You may not copy the file for onward transmission of the data nor attempt to make monetary gain by the use of these files. If you want someone else to have a copy of the file, point them at the website. (<https://blunham.com/Radar>). Please do not point them at the file itself as it may move or the site may be updated.

It should be noted that most of the pages are identifiable as having been processed by me.

I put a lot of time into producing these files which is why you are met with this page when you open the file.

In order to generate this file, I need to scan the pages, split the double pages and remove any edge marks such as punch holes, clean up the pages, set the relevant pages to be all the same size and alignment. I then run Omnipage (OCR) to generate the searchable text and then generate the pdf file.

Hopefully after all that, I end up with a presentable file. If you find missing pages, pages in the wrong order, anything else wrong with the file or simply want to make a comment, please drop me a line (see above).

It is my hope that you find the file of use to you personally – I know that I would have liked to have found some of these files years ago – they would have saved me a lot of time !

Colin Hinson

In the village of Blunham, Bedfordshire.

AIR PUBLICATION

2883 G

VOLUME I

2nd Edition

**RECEIVING EQUIPMENT
TYPE R. 1475
AND
VARIANTS**

GENERAL AND TECHNICAL INFORMATION

Prepared by direction of
the Minister of Supply

A. I. Rowlands.

Promulgated by Order
of the Air Council

J. H. Barnes.

A I R M I N I S T R Y

LAYOUT OF A.P.2883G
RECEIVING EQUIPMENT TYPE R.1475
AND VARIANTS

*Heavy type denotes the books being issued under this
A.P. number; when issued they will be listed in A.P.113*

Volume 1 (2nd Edition)	Leading particulars. General and technical information
Volume 2	General orders and modifications
Volume 3, Part 1	Schedule of spare parts
Volume 3, Part 2	<i>Inapplicable</i>
Volume 3, Part 3	<i>Scales of unit equipment (application to be decided later)</i>
Volume 3, Part 4	<i>Scales of servicing spares (application to be decided later)</i>
Volume 4	<i>Planned servicing schedules (application to be decided later)</i>
Volume 5	<i>Basic servicing schedules (application to be decided later)</i>
Volume 6	<i>Repair and reconditioning schedule (application to be decided later)</i>

LIST OF PARTS

Note.—*A list of chapters appears at the beginning of each part*

1 **Leading particulars and general information**

2 **Technical information**

PART I

LEADING PARTICULARS AND GENERAL INFORMATION

LIST OF CHAPTERS

Note.—A list of contents appears at the beginning of each chapter

1 General description, R.1475

2 Installation and operation, R.1475
(to be issued later)

Chapter I

GENERAL DESCRIPTION, R.1475

LIST OF CONTENTS

	Para.		Para.
Introduction	1	System switch	30
General characteristics	3	Sensitivity and volume controls	34
Sensitivity	9	Scale trimmer	36
Selectivity	10	AVC switch	37
Power supply and consumption	12	Range switch	38
Power output	13	Noise limiter switch	39
Dimensions and weights	14	Guard units (tuning units Type 131 and 132)	40
Receiver layout	15		
Controls	17	Guard channel controls	
Main channel controls	18	Tuning controls	43
Guard channel controls	19	Guard RF gain control	44
Main tuning control	21	Guard switch	45
Scale lock	29	Aerial matching	46

LIST OF ILLUSTRATIONS

	Fig.		Fig.
Receiver unit Type 88 and power unit Type 360, on bench mountings... ..	1	Overall response curves	4
Relation between signal input, signal output and noise output	2	AF input-output characteristics	5
IF selectivity, variation in different positions of system switch	3	Receiver unit Type 88, block schematic	6
		Receiver unit Type 88, front view showing controls	7
		Method of reading frequency scale	8

LEADING PARTICULARS OF RECEIVER UNIT TYPE 88

(Main component of receiving equipment Type R.1475)

Stores Ref.	10D/1541
Purpose of equipment	General-purpose ground receiver
Type of wave	CW, MCW, or R/T
Frequency range	Main channel, 2-20 Mc/s Guard channel, 2-7.5 Mc/s
Frequency stability	Thermally-controlled local oscillator gives re-setting accuracy better than 4 kc/s, between 11.3 and 20 Mc/s, and within 2 kc/s between 2 and 11.3 Mc/s
Crystal... ..	BFO crystal controlled, 600 kc/s. Also gives calibration check facility at 600 kc/s intervals
Maximum sensitivity	1 μ V for 50mW at high-level output, for a S/N ratio of 20dB 1 μ V for 1mW at low-level output, for a S/N ratio of 20dB
Selectivity	On R/T and wide-band CW positions, IF cut off is 8dB per kc/s; AF output is level to 2dB from 270 to 2,750 c/s On other CW positions, IF cut-off is 1 dB per kc/s Listening-out bandwidth is 3 kc/s 1.2 kc/s and 300 c/s AF filters can be inserted by switching

LEADING PARTICULARS—Continued

Output impedance	...	Provision for 20,000, 600 or 150 ohms output load
Valves	...	VI, V5, V7—CV1053 V2, V12—CV1932 V3, V4—CV1347 V6—CV216 V8, V9, V11—CV587 V10—CV1054 V13—CV1103
Power input	...	HT feed, approx. 65mA at 250V LT feed, approx. 1.8A at 12V
Power output	...	Max. undistorted output at low-level, 3.75mW Max. undistorted output at high-level, 150mW
Approximate overall dimensions	...	Length 16½ in., width 8½ in., height 8¾ in.
Weight	...	31 lb.
Associated equipment...	Power unit	Type 360 (Stores Ref. 10K/1260) for 190–240 volts, 50 c/s AC supply
Connector set	...	Connectors are made up on site from material supplied in transit case Type 77

Introduction

1. The receiving equipment Type R.1475 consists basically of the receiver unit Type 88 and the power unit Type 360. Variants may be introduced, necessitating modifications to the receiver unit, the power unit, or both. The receiver unit Type 88 is a general-purpose ground station receiver covering a nominal frequency band from 2 to 20 Mc/s in four ranges, namely 2 to 3.62, 3.58 to 6.44, 6.38 to 11.38, and 11.24 to 20.14 Mc/s. For descriptive purposes these bands may be taken as 2 to 3.6, 3.6 to 6.4, 6.4 to 11.3, and 11.3 to 20 Mc/s. The general appearance of

the receiver and power unit, as arranged for bench mounting, is shown in fig. 1. The protective grille shown in this figure is not used when the receiver is rack mounted.

2. The equipment is tropicalized to the standard current in 1945. It should be capable of withstanding highly humid conditions at temperatures up to + 40 deg. celsius, or arctic conditions down to - 40 deg. celsius. It is designed for operation under conditions of severe vibration, and is therefore suitable for use as part of a mobile installation.

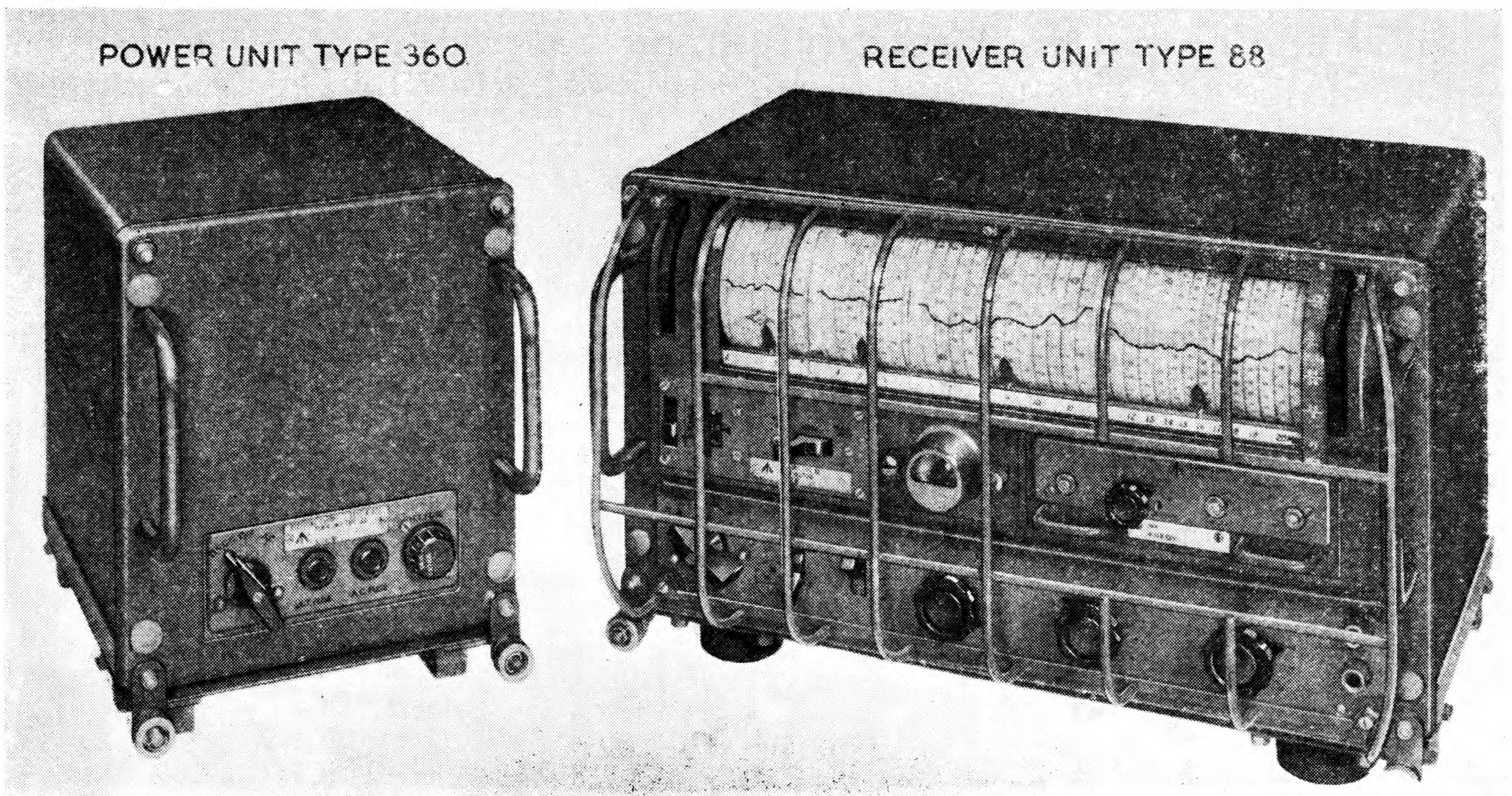

Fig. 1. Receiver unit Type 88 and power unit Type 360, on bench mountings

General characteristics

3. The receiver employs a super-heterodyne circuit, with a pre-selector RF stage and a power output stage, provision being made for CW, MCW or RT reception. While the circuits generally follow conventional practice, certain improvements in mechanical design and electrical circuit development have been incorporated. As a result, the receiver possesses the characteristic features described in the following paragraphs (*para. 4 to 13*).

4. The tuning scale can be set to any frequency within the band 2—11.3 Mc/s with an accuracy of 2 kc/s, i.e., within the side-bands of an R/T transmission or within beat-note range of a CW transmission. On the 11.3–20 Mc/s band the scale can be set to within 4 kc/s of a specified frequency.

5. The receiver incorporates a self-monitoring system by which the calibration can be checked at 600 kc/s intervals over the whole frequency range by means of an internal crystal standard. Means are provided for adjusting the calibration to compensate for any permanent or semi-permanent changes due to a gradual temperature drift. Normal changes in temperatures are however automatically compensated by special thermally-controlled capacitors and inductors in the local oscillator circuit.

6. A noise-limiting circuit is incorporated, by which sharp impulsive noises (caused for example by the ignition circuits of internal combustion engines) are greatly reduced in amplitude. Since the duration of each individual noise pulse of this type is generally quite small, and the limiting circuit provides for rapid recovery of the receiver, the noise suppression only slightly reduces the intelligibility of R/T traffic. A higher degree of suppression is available where appreciable distortion can be accepted, i.e., for CW reception.

7. Independent RF and AF gain controls are provided, any condition from full AVC to full manual control being obtainable. An improved system of amplified AVC is employed; this is combined with the manual RF gain control in such a manner that the sensitivity can be set manually, but the AVC over-rides the manual setting when the in-

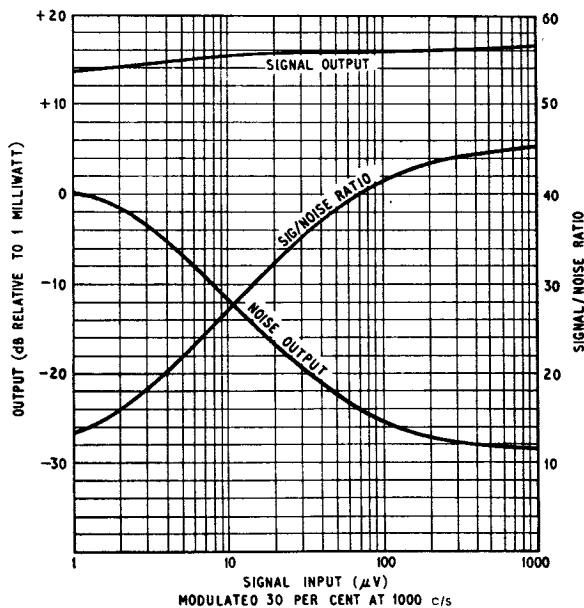

Fig. 2. Relation between signal input, signal output and noise output

coming signal strength is sufficient to overload the receiver. The AVC characteristics are such that an 80dB change in input causes less than 6dB change in output. The AVC time-constant is adjustable in two steps. One position is suitable for hand-speed CW reception, and the other gives optimum conditions for R/T, high-speed CW, or listening through during CW traffic.

8. In addition to the main signal frequency channel, an additional receiving channel is provided on a single pre-selected frequency in the 2 to 7.5 Mc/s band; this is referred to as the 'guard' channel. When it is in use, signals on the 'guard' frequency break through, irrespective of the frequency setting of the main channel. Difficulty may, however, be experienced if the main and guard channel frequencies are in harmonic relationship. The guard channel can be switched off when not required.

Sensitivity

9. The sensitivity characteristics of the receiver are as follows:—

(1) On CW. Throughout the whole frequency range, the sensitivity is better than 1 microvolt for 50 milliwatts at the high-

level output terminals, or 1 milliwatt at the low-level output terminals, for a signal/noise ratio of not less than 20dB.

(2) On MCW and R/T. Fig. 2 shows the relation between signal and noise outputs for various signal levels, the signal being modulated to a depth of 30 per cent at 1,000 c/s. These measurements were actually made at 7.4 Mc/s; the signal-noise ratio does not differ by more than 2dB from that shown, over the whole frequency range.

Selectivity

10. The selectivity of the IF amplifier is shown graphically in fig. 3. In the R/T, S/C, and wide-band CW positions, the rate of cut-off is 8dB per kc/s, and on the medium and narrow-band CW positions, is 11dB per kc/s. The protection against IF interference is better than 100dB throughout the tuning range.

11. Overall response curves are given in fig. 4. On R/T, the overall response is level to within 2dB between 270 and 2,750 c/s. The nominal bandwidth on CW may be either 3 kc/s, 1.2 kc/s, or 300 c/s, the two latter bandwidths being obtained by suitable AF filters.

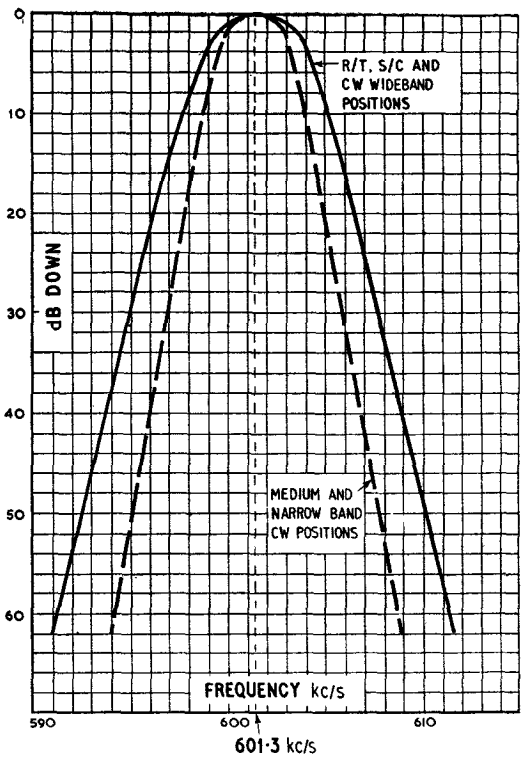

Fig. 3. IF selectivity, variation in different positions of system switch

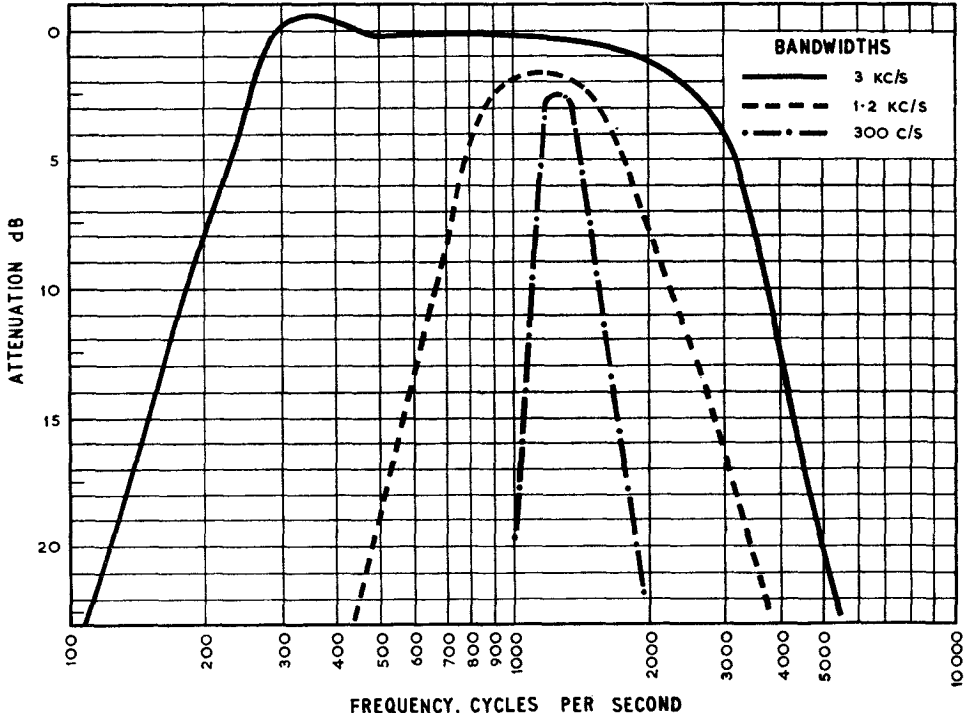

Fig. 4. Overall response curves

Power supply and consumption

12. Power supply is normally provided by a power unit Type 360 which may be operated from either a 12-volt battery or from 190-240-volt AC mains. The power consumption of the receiver is of the order of 50 watts, the HT feed being approximately 65 mA at 250 volts, and the LT feed approximately 1.8 amperes at 12 volts.

Power output

13. The maximum undistorted output at the low-level balanced output terminals is 3.75 milliwatts, and at the high-level output terminals, 150 milliwatts. The input-output characteristics of the AF amplifier are shown in fig. 5.

Dimensions and weights

14. The dimensions of the receiver unit Type 88 are—length 16½ in., height 8¾ in., depth 8½ in. Its weight is approximately 31 lb. The dimensions of the power unit Type 360 are, length 4½ in., height 8¾ in., depth 8½ in. Its weight is approximately 20 lb. The receiver unit and power unit are supplied in separate transit cases. A third case, known as transit case Type 77, contains mountings and accessories. The three cases are enclosed in

one large transit case, the weight of the complete outfit being approximately 2 cwt. The dimensions of this outer case are—length 5 ft., width 1 ft. 4 in., height 1 ft. 7 in.

Receiver layout

15. The receiver unit Type 88 includes thirteen valves. The Type number, function, and circuit notation of each is shown in the block schematic diagram, fig. 6. All valves have international octal bases; the connections, looking on the base of the valve, are shown in the following table. All the valves (except V6 the voltage stabilizer, which has no heater) have 6.3-volt heaters, and to accommodate these to a 12-volt supply, they are arranged as follows. The heaters of V5, V7, V8, V12, and V13 are connected in parallel. These may be referred to as group 1. The heaters of V1, V2, V9, V10, and V11 are also connected in parallel (V9 and V10 having a common RF choke in series); these may be called group 2. Groups 1 and 2 are connected in series across the 12-volt supply, the total current consumption of each group being approximately the same. Valves V3 and V4, being of the same type, are separately connected in series across the 12-volt supply. The arrangement is shown diagrammatically in fig. 6.

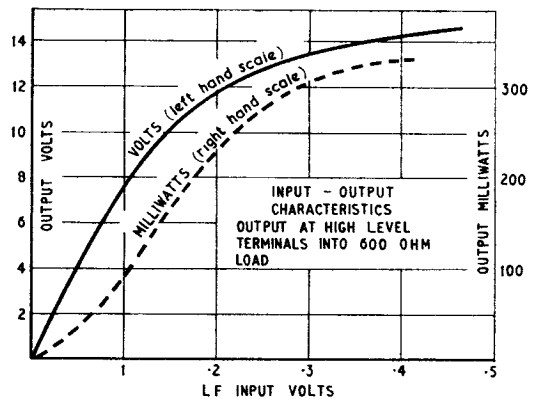
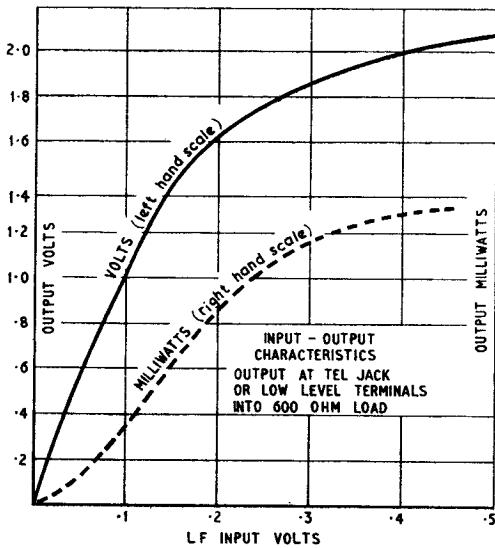

Fig. 5. AF input-output characteristics

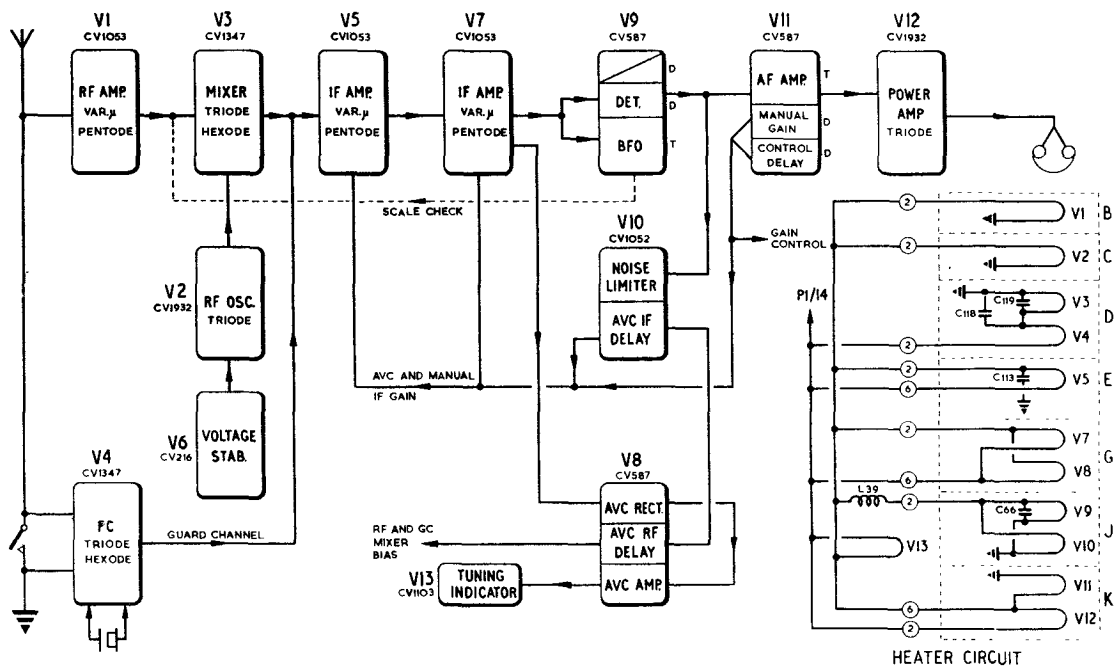

Fig. 6. Receiver unit Type 88, block schematic

Pin	CV1053	CV1932	CV1347	CV216	CV587	CV1054	CV1103
1	M	-	M	-	-	M.S	-
2	H	H	H	C (cold)	H	H	H
3	A	A	A	x	A	D2	A
4	G2	x	G4	x	D2	C2	Target
5	G3	G	G2	A	D1	D1	G
6	x	x	Ao	x	-	x	x
7	H	H	H	x	H	H	H
8	C	C	C	x	C	C1	C
TC	G1		G1		G		

- denotes that a pin is fitted, but no internal connection
 x denotes that no pin is fitted
 M = metallizing
 H = heater

C = cathode. Double cathodes C1, C2
 S = internal shield
 G = grid (numbered from cathode outwards)
 A = anode. Ao oscillator anode
 D = diode anode. Double diode anodes D1, D2

16. Referring to fig. 6, the main receiving channel includes the RF amplifier V1, the local oscillator V2, and the main mixer valve V3, feeding into the common IF and AF stages. The guard channel includes the valve V4 which acts as a crystal-controlled local oscillator and mixer, and also feeds into the common IF and AF stages. The oscillator HT voltage is stabilized by the valve V6.

Two stages of IF amplification, V5 and V7, follow the mixer stage. V8 is a double-diode triode, which acts as the AVC rectifier and AVC delay controls, while another double-diode triode V9 acts as second or signal detector. During CW reception, the triode section of V9 acts as the beat-frequency oscillator. The triode section of the double-diode triode V11 is an AF amplifier, while

the diode sections take part in the AVC delay control. V10 is a double-diode, one section being used in the noise limiting circuit, and the other as part of the manual gain control delay system. The valve V12 is an AF power amplifier and feeds the output transformer, either high or low-level outputs being available. The magic-eye tuning indicator V13 is fed from the cathode of the AVC amplifier V8. A detailed description of the circuit action is given in Part 2, Chapter 1.

Controls (fig. 7)

17. The operating controls may be divided into two groups, namely, the main and guard channel controls.

Main channel controls

18. The main channel controls are as follows:—

- (1) Tuning control
- (2) Scale lock
- (3) System switch
- (4) RF gain control
- (5) AF gain control
- (6) Scale trimmer
- (7) AVC time-constant switch
- (8) Range switch
- (9) Noise limiter switch

Guard channel controls

19. The guard channel controls are:—

- (1) Frequency trimmer
 - (2) Guard RF gain control
 - (3) Guard channel switch
 - (4) Oscillator trimmer
 - (5) First RF trimmer
 - (6) Second RF trimmer
- } Pre-set

20. It will be observed that, contrary to the usual practice, no BFO (beat-frequency oscillator) control is fitted for CW reception. This is because the scale setting is inherently within audible beat-note range of the nominal frequency. This high degree of discrimination is achieved, in the main channel, by the use of a thermally-compensated local oscillator, and in the guard channel by the use of a crystal-controlled local oscillator fitted with a manually-controlled trimmer giving a small range of frequency variation, together with the use of a crystal-controlled beat-frequency oscillator for CW reception. The frequency of the latter is 600 kc/s, and the local oscillators for the main and guard channels respectively are both set up in such a manner that an intermediate frequency of 601.3 kc/s is always maintained. Thus the nominal note frequency in CW reception is 1,300 c/s.

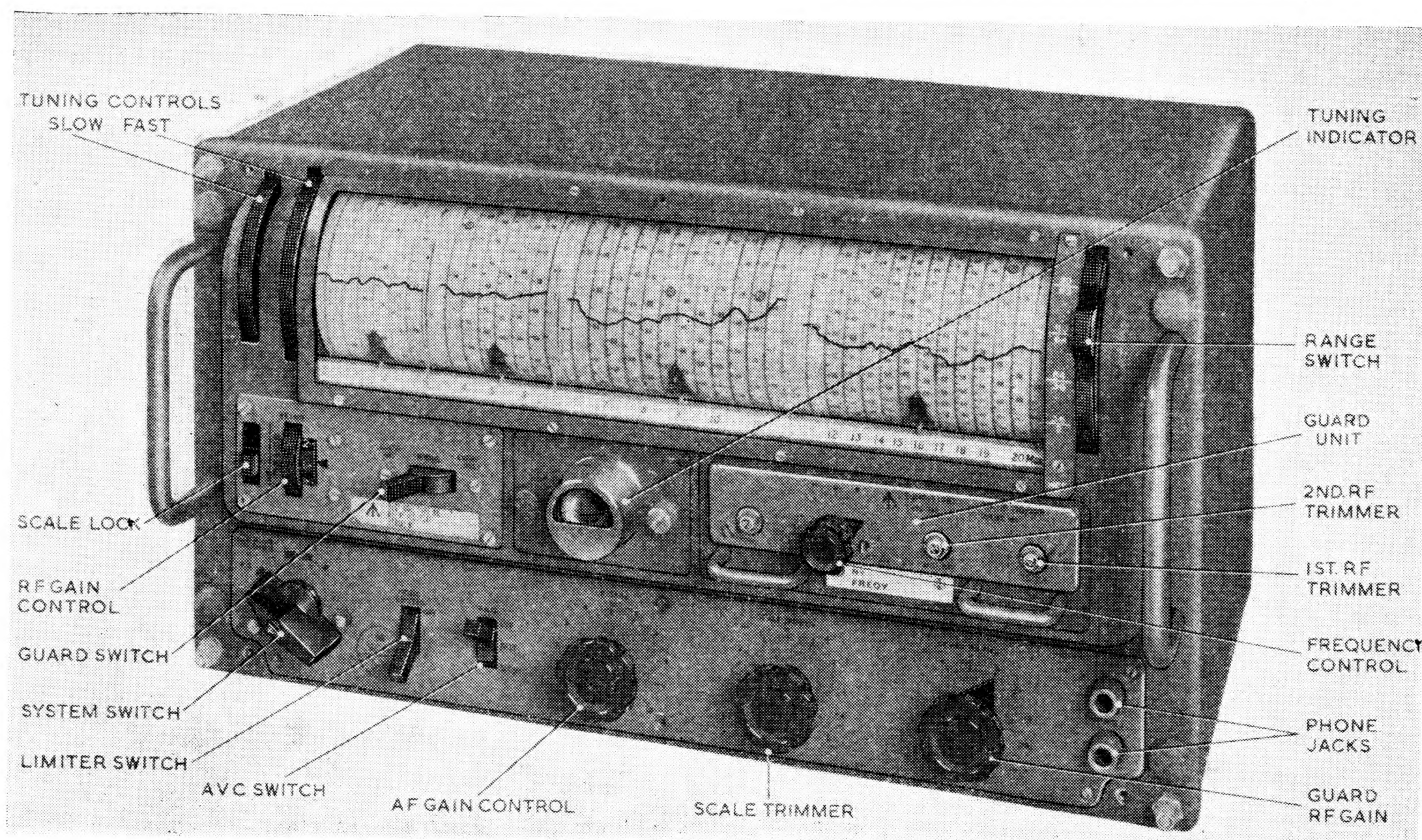

Fig. 7. Receiver unit Type 88, front view showing controls

Main tuning control

21. In the main channel, the frequency band 2 to 20 Mc/s is covered in four bands, namely 2 to 3.62, 3.58 to 6.44, 6.38 to 11.38, and 11.24 to 20.14 Mc/s. As already stated, at the highest frequency the scale can be set to within 4 kc/s of the nominal frequency, and at lower frequencies even closer.

22. The whole frequency range is covered by a scale thirty feet long, of which each of the two lower ranges occupies five feet, and the two higher ranges each occupy ten feet. The discrimination is thus reasonably uniform over the whole range, 10 kc/s steps being represented by about one-eighth of an inch at the higher frequencies, and somewhat more at the lower end of the scale. The scale is marked at 10 kc/s intervals throughout the frequency range.

23. The scale itself is a spiral line drawn upon a cylindrical surface divided into four ranges, the axis of the cylinder being horizontal (*fig. 1*). The scale lighting is controlled by the range switch so that only the portion of the scale corresponding with the selected range is illuminated.

24. A transparent window carrying a cursor line is fitted close to the curved surface of the scale. The frequency setting is indicated by the intersection of the frequency scale and the cursor line. Four metal pointers (one for each range) are fitted near the bottom of the scale. As the latter is rotated, these pointers move horizontally along a fixed horizontal scale showing whole numbers of megacycles.

25. *Fig. 8* shows, diagrammatically, one range of the scale. As already stated, the black pointer indicates the whole number of megacycles per second (reading the number immediately to the left of the pointer). At the intersection of the cursor line and the frequency scale is shown the fraction of a megacycle to be added to the whole number. Thus in *fig. 8*, the pointer reads '8' on the bottom scale, and the reading at the intersection is 53 (3), the digit in brackets being estimated by eye. The scale is therefore set to 8.53 (3) Mc/s.

26. The frequency calibration can readily be checked at 600 kc/s intervals over the whole frequency range by putting the SYSTEM switch to the position marked S/C (which is an abbreviation for SCALE CHECK). In this position the harmonics of the 600 kc/s crystal-controlled beat-frequency oscillator are fed into the input circuit of the main

mixer valve, the RF amplifier and guard mixer valves being switched off. On rotating the scale throughout its whole range, heterodyne beat notes are heard at 600 kc/s intervals along the scale, the frequencies at which they occur being, of course, multiples of 600 kc/s.

27. The points at which these beat-notes are heard are known as the checking points. They are clearly marked on the scale by being printed in white figures on a black circle. On the range 6.4 to 11.3 Mc/s, the checking frequencies are 6.6, 7.2, 7.8, etc., Mc/s. Two of these, 6.6 and 9.6 Mc/s, are indicated in *fig. 8*.

28. Tuning is performed by knurled thumb-operated controls at the left-hand end of the scale. Two such controls are provided, one giving a one-to-one ratio drive, and the other driving through a five-to-one reduction gearing for fine tuning. The controls are located just above the carrying handle, and the latter forms a convenient support for the hand during the operation.

Scale lock

29. The SCALE LOCK control is provided in order to prevent accidental displacement of the scale, after setting the latter to the desired frequency. It is intended primarily for use when the receiver is installed in a vehicle. In the design of this lock, care has been taken to ensure that the operation of the lock does not displace the scale from the desired setting.

System switch

30. The SYSTEM switch controls three distinct operations, namely,

- (1) Variation of selectivity
- (2) Beat-frequency oscillation on-off switching
- (3) Circuit changes for scale checking.

The switch has five positions. The first three are marked only by rectangles of varying width, representing CW reception on varying bandwidths. The first is the 'narrow' position, the IF bandwidth being 3 kc/s and the AF bandwidth 300 c/s; the second is the 'medium' position, having an IF bandwidth of 3 kc/s and an AF bandwidth of 1.2 kc/s, and the third is the 'wide' position, with an IF bandwidth of 5 kc/s and an AF bandwidth of 3 kc/s.

31. The fourth position, marked S/C (SCALE CHECK) is used when checking the calibration, as described in the following chapter. In all

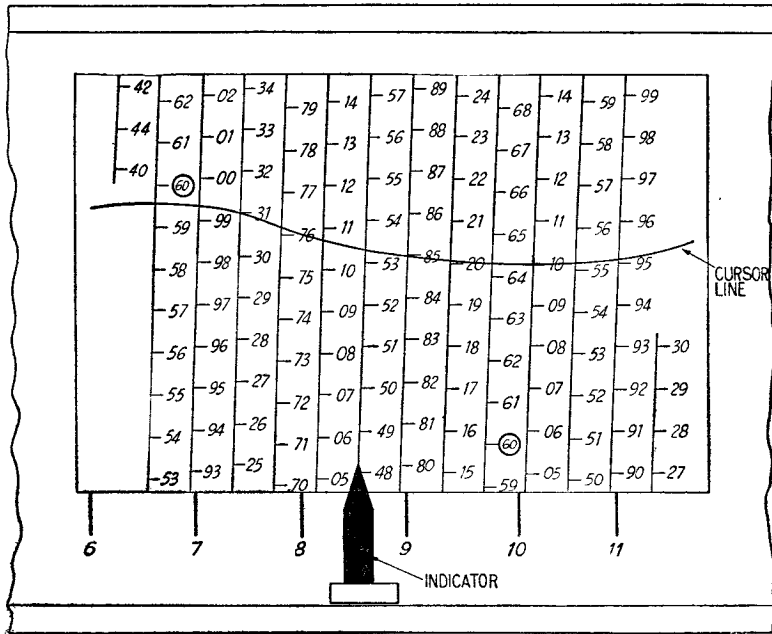

Fig. 8. Method of reading frequency scale

the above positions the beat-frequency oscillator is switched on.

32. The fifth position is marked R/T, and provides for either R/T or MCW reception, the beat-frequency oscillator being switched off. The IF bandwidth is 5 kc/s and the AF bandwidth 3 kc/s. The overall response of the amplifier is practically level between 270 and 2,750 c/s.

33. The circuit changes made by the SYSTEM switch are dealt with in Part 2, Chap. 1 of this volume.

Sensitivity and volume controls

34. Independent sensitivity and volume controls are provided, the former being marked HF GAIN and the latter LF GAIN. In this publication, however, they will be referred to as the RF GAIN and AF GAIN controls respectively, in accordance with the approved current nomenclature.

35. The RF GAIN control is a potentiometer which supplies variable standing bias to the RF amplifier valve along the RF AVC line. Full manual control of sensitivity is thus obtained, but the AVC can over-ride the manual control if required. Even if the controls are mis-adjusted, grid blocking

cannot be produced by strong signals. The AF GAIN control is conventional, operating in the control-grid circuit of the AF amplifying valve preceding the output stage.

Scale trimmer

36. The scale trimmer is fitted to compensate for any change in the calibration due to temperature drift, or any other cause which affects the whole of the local oscillator circuits equally. It cannot, however, compensate for a change affecting one tuned circuit only, e.g., a defective condenser. If, therefore, any component of an oscillator 'range' circuit becomes defective, and a replacement component is fitted, the range affected will require re-trimming by adjustment of the appropriate trimming capacitance.

AVC switch

37. The AVC switch has three positions; in the first, the AVC system is switched off. The other positions provide a slow and a fast AVC response respectively. For listening through during CW reception, for reception of high-speed CW, and for R/T reception, a fast response (short time-constant) is required. For hand-speed CW reception, however, a slow response (long time-constant)

generally gives superior results. This demarcation is not absolutely rigid, however, and the AVC switch should be adjusted to give the best results under the particular conditions prevailing at the time.

Range switch

38. The range switch selects the desired frequency range, and in addition switches the scale lighting, so that only the required band on the frequency scale is illuminated.

Noise limiter switch

39. The noise limiter switch gives two degrees of noise limiting, and an OFF position. Position 1 gives a degree of noise limiting suitable for R/T reception, where too drastic reduction may cause excessive distortion. Position 2 gives greater noise reduction, and may be used for R/T reception if the increased distortion can be accepted. Provided the limiter switch is not OFF, the higher degree of limiting is automatically applied when the system switch is in any one of the three CW positions.

Guard units (tuning units Type 131 and 132)

40. The guard unit allows a constant watch to be kept on any single frequency in the band 2 to 7.5 Mc/s while using the main channel on another frequency. Two guard units are provided; unit P (tuning unit Type 131) covers the range 2 to 4.2 Mc/s, and unit Q (tuning unit Type 132) the range 4.1 to 7.5 Mc/s. Each guard unit should theoretically be fitted with a quartz crystal differing by 601.3 kc/s from the frequency allotted to the guard channel, but in practice a crystal differing by 600 kc/s is used, the frequency being 'pulled' as requisite to give the correct intermediate frequency by adjusting the FREQUENCY control on the guard unit.

41. After plugging in a crystal unit of the correct frequency, the guard unit is fitted into the guard channel housing through a rectangular orifice in the front panel. Connection to the unit is made automatically by spring contacts.

42. The guard unit works in conjunction with the guard mixer valve V4. It includes a two-stage band-pass tuner which couples the aerial circuit to the control-grid of the mixer section of the guard mixer valve, and also a crystal-controlled local oscillator, which works in conjunction with the triode section of the guard mixer valve. The output of the latter feeds into the common IF amplifier stages.

Guard channel controls

Tuning controls

43. Each guard unit has four tuning controls, all of which are simple condenser trimmers. Three of these are pre-set, and are fitted with the conventional type of slotted-head control. The fourth, which is the guard frequency trimmer control referred to in para. 40, is fitted with a small knob and scale, marked in arbitrary divisions up to ± 5 . This control serves to 'pull' the frequency over a short range, and so allows the correct intermediate frequency to be obtained. The pre-set controls are set up during the initial alignment procedure at the maker's works, and should not require subsequent adjustment in the field. The method of doing so is, however, described in Part 2, Chap. 3 of this Volume.

Guard RF gain control

44. The guard RF gain control is mounted on the front panel. It controls the sensitivity of the guard channel and is so designed that the sensitivity can be reduced to zero. The primary object of this control is to limit the amount of noise introduced by the guard mixer valve. When this has been adjusted, the control may remain set for all normal conditions, the sensitivity of both channels being controlled simultaneously by the main channel sensitivity (RF gain) control. The operation of the guard RF gain control does not, however, affect the sensitivity of the main channel. When main and guard channels are adjusted to give equal gain, the noise level is only 3dB higher than with the guard channel switched off.

Guard switch

45. The guard switch has three positions, namely, GUARD ONLY, NORMAL (guard and main channels both ON) and GUARD OFF. When either channel is switched off, a compensating load is thrown into the 80-volt line feeding the screening-grids of the main mixer, guard mixer, and first IF valves, in order that the sensitivity of the channel in use shall not require readjustment.

Aerial matching

46. Arrangements are made to connect an unbalanced co-axial feeder to a tapping point on the first coil of the input circuit on each range, by means of a co-axial socket fitted on the rear of the chassis. The input impedance of the receiver is then approximately 45 ohms. Alternatively, open aerial and earth terminals are provided, the aerial being then connected to the top end of the selected range coil. The input impedance is then approximately 600 ohms.

Chapter 2

INSTALLATION AND OPERATION

LIST OF CONTENTS

	Para.		Para.
<i>Installation</i>	1	<i>Operation</i>	15
<i>Rack mounting</i>	4	<i>Main channel adjustments</i>	17
<i>Bench mounting</i>	6	<i>Guard channel adjustments</i>	21
<i>Connectors</i>	7	<i>Harmonic interference</i>	24
<i>Aerial input</i>	12	<i>Overall calibration check</i>	26

LIST OF ILLUSTRATIONS

	Fig.		Fig.
<i>Contents of transit case Type 77</i>	1	<i>Typical installation diagram</i>	2

INSTALLATION

1. The installation of the receiving equipment Type 1475 is very straightforward. Provision is made for either rack or bench mounting, according to the type of station in which it is installed.

2. The equipment is supplied in a large transit case (Stores Ref. 10D/32196), which encloses three smaller cases, namely, case transit for receiver unit Type 88 (Stores Ref. 10D/2530), case transit for power unit Type 360 (Stores Ref. 10D/1958) and case transit Type 77 (Stores Ref. 10Y/77) which contains the following accessories:—

(1) Mounting Type 656 (10A/17535) for bench mounting of receiver unit

(2) Mounting Type 657 (10A/17536) for bench mounting of power unit

(3) Panel Type 384 (10D/2039) 19 in., for rack mounting of power unit

(4) Plug Type 195 (10H/324) three in number (4-pole Jones type)

(5) Socket Type 138 (10H/327) three in number (4-pole Jones type)

(6) Plug Type 161 (10H/184) one in number (co-axial)

(7) Cover Type 241 (10A/314846) six in number (with 12 screws, for plugs and sockets)

(8) Insulator Type 400 (10B/1234) six in number (for plugs and sockets)

(9) Cable electric LT Dumet 19, 12 ft. (5E/1349).

(10) Cable electric LT Dumet 4, 12 ft. (5E/1328)

(11) Cable electric LT Duvin 4, 12 ft. (5E/2108)

(12) Brackets fixing Type 13 (10B/2042) two in number

These accessories are shown in fig. 1.

3. If at any time it is necessary to re-pack the equipment in its transit cases, it should be noted that the visor Type 28 (Stores Ref. 10A/317537), which is a protective grille over the front panel, is fitted to the receiver before placing the latter in its transit case, even if it has not been fitted during its Service use.

Rack mounting

4. Before mounting the receiver unit, the dust cover should be removed, and the output transformer set for the appropriate impedance and level desired (*para.* 15). After replacing the dust cover, the two fixing brackets should be attached by means of the four conical nuts on the front panel in such a manner that the turned-over portions of the brackets support the sides of the receiver.

5. If an AC power supply is to be used, the front panel and dust cover of the power unit must be removed, and the mains transformer set for the correct mains voltage; a range of 190 to 240 volts is available. The power unit

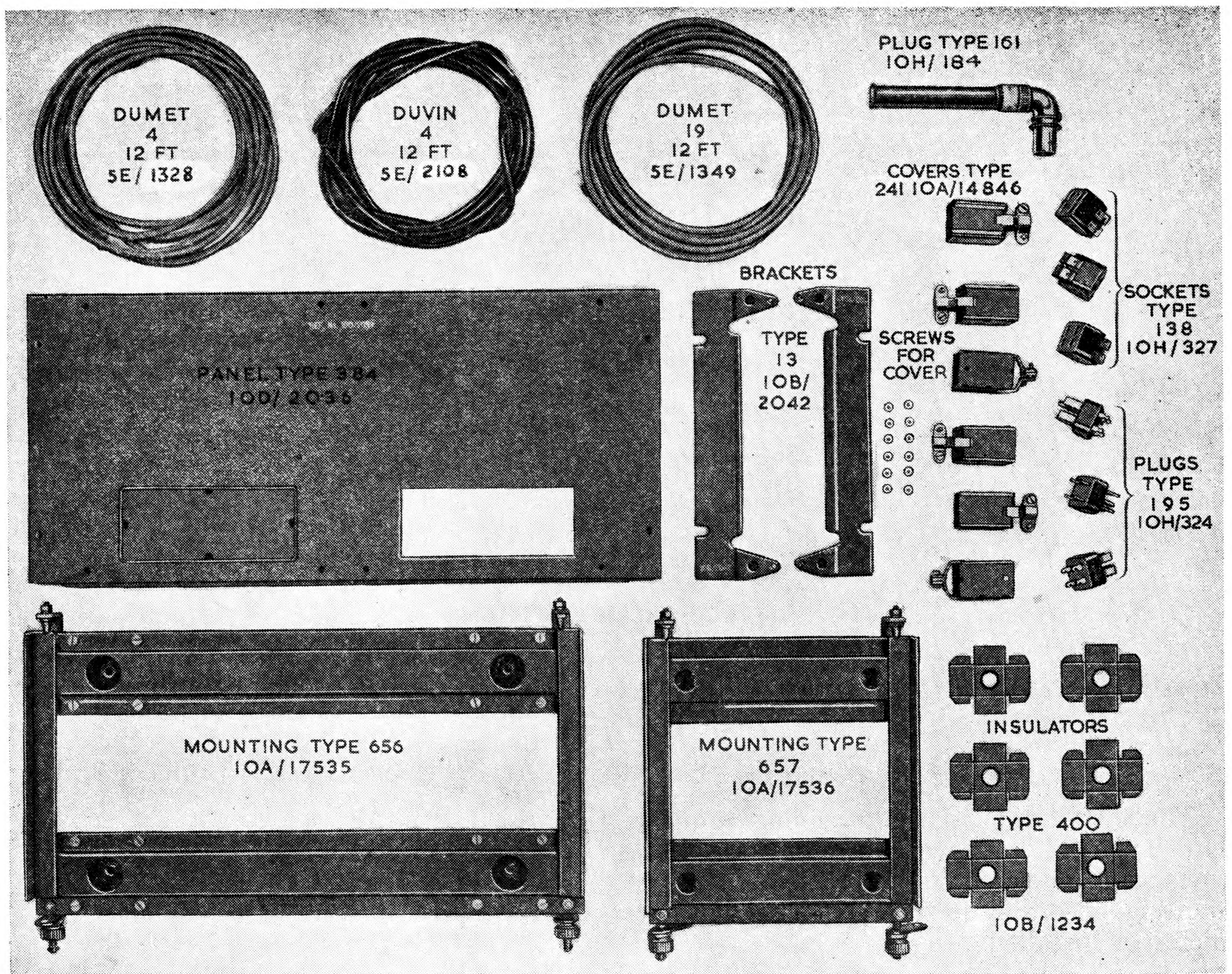

Fig. 1. Contents of transit case Type 77

must then be fitted to the panel Type 384 by means of the studs and conical nuts which originally secured the front panel, and the dust cover replaced. The front panel of the power unit should be stowed in the power unit transit case, and should be replaced on the power unit if the latter is returned to store at any future time.

Bench mounting

6. Where bench mounting is to be adopted, the protective grille (visor Type 28) should be left in position when the receiver is unpacked. The dust cover of the receiver should be removed, and the output tapping set, as described above. After replacing the dust cover, the receiver is mounted on the mounting Type 656, which should previously be fitted in the desired position. The mounting Type 657 for the power unit should be placed in position at the same time. After removing the dust cover of the power unit and setting the mains voltage tapping, the dust cover should be replaced and the power unit fitted on its mounting.

Connectors

7. A typical installation diagram is given in fig. 2. The cables, plugs and sockets supplied in the transit case Type 77 are used to make up the connectors between the units, and for the power supply. These are as follows:—

- (1) Dumet LT 19, between the 12-volt battery and the power unit
- (2) Dumet LT 19, between the power unit and the receiver unit
- (3) Dumet LT 4, between the power unit and the receiver unit

The combined lengths of the connectors (1) and (2) above must not exceed 12 ft; this total length may be divided as requisite between the two connectors.

8. The connectors (2) and (3) above are actually combined into a single connector terminated at one end (power unit) by a Jones plug Type 195, and at the other (receiver) by a Jones socket Type 138. At the plug end, the *Red* core of the Dumet 4 is connected to pin 16 and the *Blue* core to pin

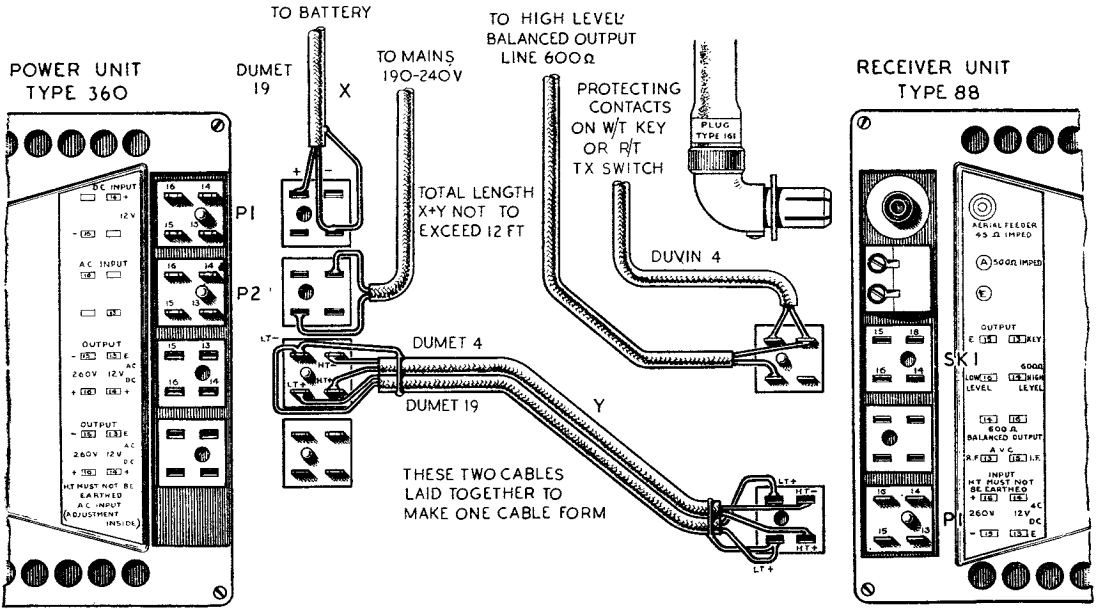

Fig. 2. Typical installation diagram

15. The *Red* core of the Dumet 19 is connected to pin 14, and the *Blue* core to pin 13. The metal braiding of both cables must be perfectly bonded to pin 13. Similar connections are made at the socket end.

9. The plug of this dual connector engages with socket SK1 on the power unit, and the socket end with plug P1 on the receiver.

WARNING

On no account must pin 15 or any point on the negative HT line be connected to earth, since this line is at -55 volts to earth.

10. One end of the connector (1) above is fitted with a Jones socket Type 138. The *Red* core should be connected to pin 14, and the *Blue* core to pin 15. The metal braiding of the cable must also be perfectly bonded to pin 15. The other end of this cable should be fitted with suitable battery lugs, *Red* core to positive and *Blue* core to negative.

11. A connector is also required between the relay circuit terminations on SK1 of the receiver and the protecting contacts of the morse key (in the case of W/T transmission) or send-receive switch (in the case of R/T transmission). A length of Duvin 4 is suitable for this purpose; this should be

terminated by a plug Type 195, to mate with socket SK1 on the receiver. The cores should be connected, *Red* to pin 13, *Blue* to pin 15.

Aerial input

12. No hard and fast rules can be laid down regarding the connection of the aerial feeder to the receiver, since this depends upon the type of aerial and feeder used. Where the aerial is of low impedance, e.g., approximating to a quarter-wave aerial with a total (radiation plus loss) resistance of the order of 40 ohms, a Uniradio 4 feeder may be used. This should be terminated by the plug Type 161 supplied. When clipping up, care must be taken to avoid sharp bends or twists in the cable; the minimum radius for a bend is $4\frac{1}{2}$ in., and the maximum permissible amount of twist is 45 deg.

13. Aerials of appreciably higher impedance should be connected through a single-wire feeder to the A terminal of the receiver, the E terminal on the same block being earthed. Such an aerial is most likely to be used at the high-frequency end of the receiver range, and might, for example, consist of an inverted V aerial several wavelengths long at the middle of the band to be covered.

14. In certain stations, it may be found convenient or necessary to operate several receivers on different channels from a common

receiving aerial, an aperiodic amplifier such as the amplifier Type A.1416A being used to couple the aerial to the respective receivers. Where this system is adopted, the individual receivers are fed from the amplifier by connecting an output point on the latter to the co-axial (low impedance) aerial plug on the receiver. The amplifier Type A.1414A is fitted with output points for seven receivers, a variable attenuator being provided for each.

OPERATION

15. Before installing the receiver, the tapping on the output transformer should be set according to the impedance of the headphones in use, tapping 1 being used for 20,000-ohm phones, tapping 2 for 600-ohm phones, and tapping 3 for 150-ohm phones. The maximum undistorted output to the phones is 3.75 milliwatts. This tapping should be set for local testing and monitoring, even when the normal output is to be delivered to a 600-ohm line for transmission to a remote operating station. The output in the latter case should be taken from the high-level output terminals, i.e., pins 14 and 15 on the socket SK1. This will deliver 150 milliwatts into a 600-ohm line, irrespective of the setting of the output transformer tapping.

16. For local testing at remotely-controlled stations, and for normal operation where space is restricted, e.g., in vehicles, the low-level telephones may be plugged directly into the telephone jacks on the front panel. Where the operator is not seated close to the receiver, an independent telephone jack circuit may be provided. This may be connected by a suitable plug to points 16 and 15 (earthy) on SK1. Alternatively, a low-level balanced output circuit may be wired to points 14 and 16 on SK2.

Main channel adjustments

17. Before attempting to tune to the desired frequency, the gain controls should be set in the following manner. Set the noise limiter switch to OFF, the AVC switch to FAST, and the guard switch to GUARD OFF. Then set the SYSTEM switch to the 'wide band' CW position, and tune the receiver to any loud signal which may be available. This may be either a CW or a R/T signal; in the latter case, since the BFO is switched on when the SYSTEM switch is at CW, the switch may be moved to the R/T position. Bring the volume down to a comfortable level by the AF GAIN control, then retune the receiver to a frequency upon

which there is no carrier (*refer NOTE*) and adjust the RF GAIN control for maximum tolerable noise. The receiver is then correctly adjusted for maximum useful sensitivity.

Note . . .

If the system switch is moved to the R/T position as suggested above, it should be moved back to the CW 'wide band' position at this point, to ensure that there is no carrier upon the frequency to which the receiver is tuned, bearing in mind that a CW signal or temporarily unmodulated carrier may be present, although inaudible with the system switch in the R/T position. If no carrier is present, switch back to the R/T position.

18. Set the RANGE switch to the desired range and check the calibration as follows. Set the SYSTEM switch to SCALE CHECK, and the tuning scale to the check point nearest to the desired frequency. The scale trimmer control should then be adjusted until the calibration is correct. If the desired frequency is near the middle of the particular range, a scale check should also be made at the nearest check point on the other side of the desired frequency.

19. Return the SYSTEM switch to the required position (CW or R/T). While listening out for CW signals, the wide-band position should, if possible, be used, but the medium or narrow band CW positions may be used while actually receiving signals, if this is necessitated by the prevailing interference level.

20. During operation the AVC switch should be set in accordance with the receiving conditions at the time, the SLOW position being generally preferable for receiving hand-speed CW, and the FAST for other purposes. The noise limiter should be switched on if impulsive noise interference is present.

Guard channel adjustments

21. If the guard channel facility is to be used, it is necessary to select a crystal unit differing by 600 kc/s from the specified guard frequency, and plug it into the appropriate guard unit, according to the frequency range. Unit P (tuning unit Type 131) covers the range 2 to 4.2 Mc/s, and unit Q (tuning unit Type 132) covers 4.1 to 7.5 Mc/s. After plugging in the crystal, insert the unit into the guard unit housing.

22. The guard frequency tuning controls may be set up either by the use of signals of the desired frequency radiated by a distant station, or by reference to a suitable signal generator or radiating wavemeter. First put the guard switch to GUARD ONLY and adjust the guard unit FREQUENCY control for maximum signal. Then adjust the pre-set controls (1ST RF and 2ND RF) in turn for maximum signal.

23. Then put the guard switch to NORMAL, and adjust the GUARD RF GAIN control so that a decrease in noise level which is just perceptible occurs on switching from NORMAL to GUARD OFF. Return the switch to NORMAL; the receiver is then adjusted for reception on both channels.

Harmonic interference

24. When using the receiver in the NORMAL condition, if the guard channel and main channel frequencies are in harmonic relationship, interference may be experienced from the fundamental oscillation or harmonics of the guard frequency oscillator. For example, suppose the guard crystal frequency is 2.2 Mc/s, and the main channel frequency is 6.6 Mc/s. If the crystal oscillation has a third harmonic of sufficiently large amplitude, a continuous whistle may be set up when the SYSTEM switch is in the CW position. If the switch is in the R/T position, speech may be seriously distorted. Slight trimming of the guard FREQUENCY control may possibly overcome this.

25. If continuous interference is experienced, and the above phenomenon is suspected, the

source of the whistle (on CW) may be confirmed by switching off the guard channel, when the interference should cease. In certain conditions, however, it may be impossible to operate on main and guard channels which are in harmonic relationship.

Overall calibration check

26. The overall calibration of the receiver may be checked as follows. Set the RANGE switch to the 2-3.6 Mc/s range, and the SYSTEM switch to SCALE CHECK. Commencing at the lowest reading on the scale, rotate the tuning control slowly while listening for the harmonic beat-notes. These should occur at 2.4, 3.0, and 3.6 Mc/s, these frequencies (check points) being specially identified on the scale. If exact coincidence is not obtained, adjust the scale trimmer control slightly until the calibration is correct.

27. A similar procedure should be followed on all four ranges, the calibration being checked at each check point. If it is found impossible to adjust the calibration on a certain range or ranges, but possible on others, it is probable that a defect has occurred in the range/s for which the scale trimmer will not compensate. The most likely source of the trouble is a defect in the oscillator unit C, which should be removed, and a serviceable one fitted in its place. If this is not practicable, the complete receiver unit should be replaced by a new one. On the other hand, if it is found impossible to adjust the calibration on all four ranges, it is probable that a defect has occurred in the scale trimmer L30, or in its shunt inductance L30A, or in the associated components and wiring.

PART 2
TECHNICAL INFORMATION

LIST OF CHAPTERS

Note.—A list of contents appears at the beginning of each chapter

- 1 Mechanical and circuit details, R.1475**
(to be issued later)
- 2 Power supply, R.1475** (to be issued later)
- 3 Servicing information** (to be issued later)

Chapter I

MECHANICAL AND CIRCUIT DETAILS, R.1475

LIST OF CONTENTS

	Para.		Para.
Mechanical assembly		RF bias line	40
Chassis	1	Local oscillator (main channel)	41
Plug-in units	6	Range switch	45
Components mounted on chassis	12	Aerial circuit	46
Details of Units	18	Main channel input circuit	47
Aerial unit A (tuning unit Type 145)	19	RF amplifier and band-pass coupling to mixer ...	48
RF amplifier unit B (tuning unit Type 146)	21	Local oscillator switching	50
Local oscillator unit C (oscillator unit Type 171)	23	Mixer stages	55
Mixer unit D (mixer unit Type 11)	26	Intermediate-frequency amplifier	59
First IF unit E (IF unit Type 37)	27	System switch	61
Unit F (inductance-condenser unit Type 88)	28	IF selectivity	62
Second IF unit G (IF unit Type 38)	29	AF selectivity	65
BFO unit J (oscillator unit Type 170)	30	Scale check position	66
Output unit K (output unit Type 45)	32	Beat-frequency oscillator	69
Guard units P and Q (tuning units Type 131 and 132)	33	Second detector	71
Circuit details		AVC system	73
Side tone and listening through	34	Manual gain delay	78
Simplified circuit diagram	37	Noise limiter	82
Guard channel input circuit	38	AF amplifier and output stage	86
RF amplifier	39	Output transformer	90
		Tuning indicator	94

LIST OF ILLUSTRATIONS

	Fig.		Fig.
Receiver unit Type 88, plan view with dust cover and valves removed	1	Oscillator unit Type 171 (unit C) circuit and component mounting	12
Receiver unit Type 88, underside view (dust cover removed)	2	Mixer unit Type 11 (unit D) component location and circuit with connections to inductance-condenser unit Type 88 (unit F)	13
Receiver unit Type 88, right-hand end (dust cover removed)	3	IF unit Type 37 (unit E) circuit and component mounting	14
Receiver unit Type 88, left-hand end (dust cover removed)	4	IF unit Type 38 (unit G) circuit and component mounting	15
Receiver unit Type 88, rear view (dust cover removed)	5	Oscillator unit Type 170 (unit J) circuit and component mounting	16
Block Schematic showing functions of units	6	Output unit Type 45 (unit K) circuit and component mounting	17
Receiver unit Type 88, rear view with unit K removed	7	Tuning unit Type 131 (unit P) and Type 132 (unit Q) circuit and component mounting	18
Components mounted on tag boards	8	Relay and guard units, with covers	19
Chassis circuits, schematic... ..	9	Connections of attenuator relay	20
Tuning unit Type 145 (unit A) circuit and component mounting	10	Simplified circuit diagram, receiving unit Type 88	21
Tuning unit Type 146 (unit B) circuit and component mounting	11		

RESTRICTED

MECHANICAL ASSEMBLY

Chassis

1. The chassis of the receiver unit Type 88 is of specially rigid construction, being of **H** section when viewed in plan (*fig. 1* and *2*) and **I** section when viewed in end elevation (*fig. 3* and *4*). Vertical stiffeners are fitted across the rear horizontal extensions while the front panel acts as a stiffener for the four front horizontal extensions. This rigidity is essential if the accuracy of the calibration is to be maintained. A dust cover, perforated along the upper edge for ventilation, encloses the chassis.

2. The panel assembly consists of a metal panel arranged to fit in front of the vertical chassis. The panel carries the system switch, the noise limiter and AVC switches, the AF gain and guard RF gain potentiometers, and the scale trimmer inductance with its control. In addition, two telephone jacks are mounted. The panel is cut away where necessary to allow certain components fixed on the chassis to protrude through the panel. These are the range scale window, the tuning and range controls, the scale lock, the RF gain (sensitivity) control, the guard switch, and the cathode-ray tuning indicator V13. The housing for the guard unit also forms part of the panel, spring contacts being fitted in such a manner that the guard unit is auto-

matically connected into circuit as soon as it is placed in position.

3. The cylindrical scale is mounted before the vertical chassis, supported by ball bearings mounted in plates attached to the upper horizontal extensions of the chassis (*fig. 3* and *4*). The scale drum has a solid metal spindle with a shallow female-threaded hole at each end; this spindle is of such a length that it fits snugly between the ball-bearing housings. A male-threaded bolt with a knurled head ($\frac{9}{32}$ in. in diameter and $\frac{11}{16}$ in. long) passes through the ball bearing at each end and mates with the female thread in the end of the spindle.

4. Scale lamps with shades are fitted on the chassis behind the scale (*fig. 1*). The scale lock consists of a pair of brake blocks which are fitted with springs, and bear upon each side of the knurled tuning control. These blocks are held off the latter when the scale lock is OFF.

5. The four-gang tuning condenser is mounted on the upper right-hand corner of the chassis, and is driven from the tuning controls through a counter-shaft (*fig. 1*.) A pinion on the counter-shaft meshes with a large pinion mounted upon the tapered shaft of the condenser drive. This final pinion consists of

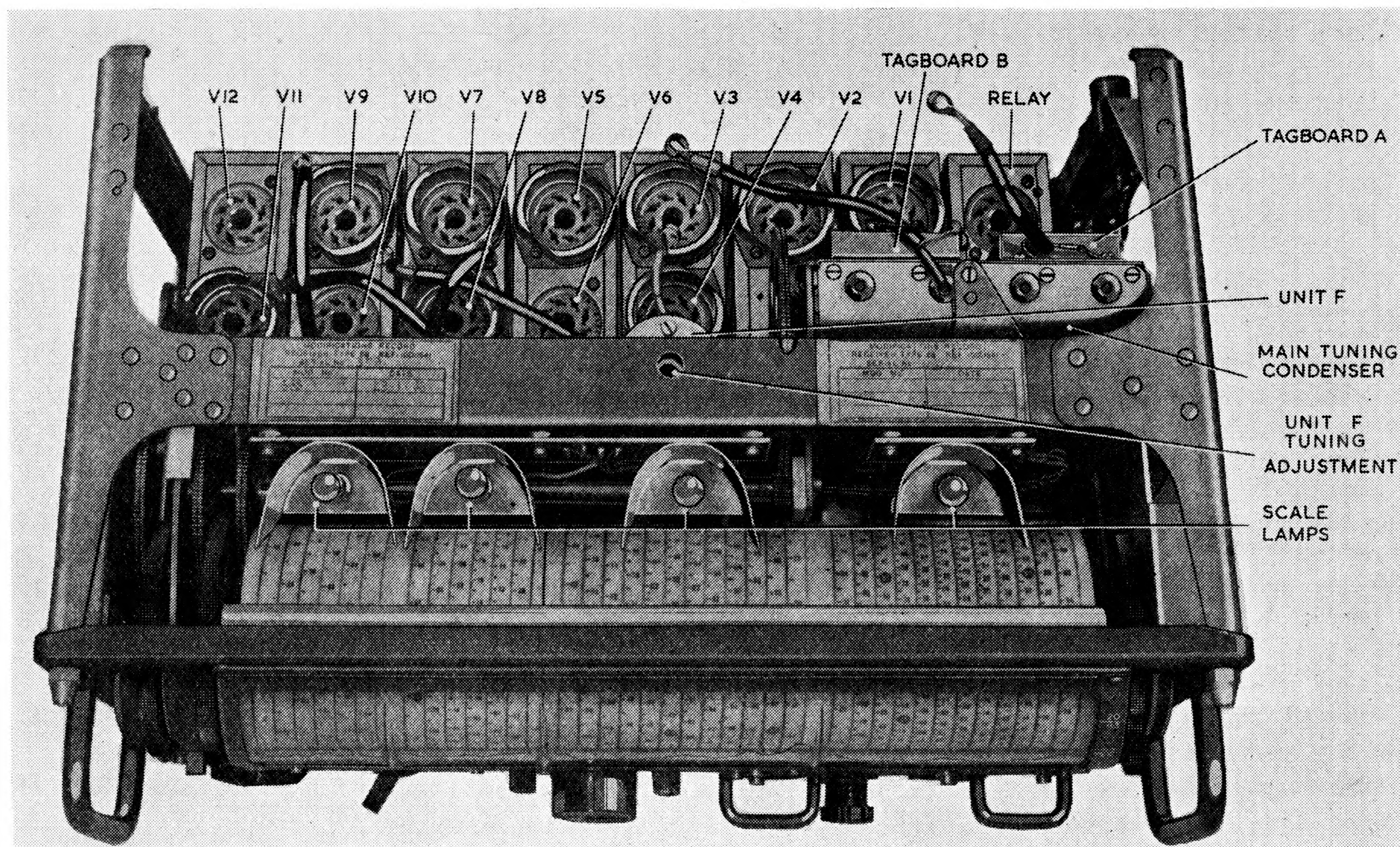

Fig. 1. Receiver unit Type 88, plan view with dust cover and valves removed

two circular toothed plates held together by springs, forming a well-known type of anti-backlash gearing. Considerable force is necessary to remove the pinion from the condenser spindle, and unless great care is exercised, both the condenser gang and the anti-backlash pinion may be damaged.

Plug-in units

6. Most of the resistors, fixed condensers, inductances and switch units are mounted in eight plug-in units, fitted upon the rear side of the vertical chassis, as shown in fig. 2 and 5. The block schematic diagram (fig. 6) is given to assist in visualizing the electrical relationship between these units. Viewed from the rear, and taken in order from left to right, they are :—

<i>Unit</i>	<i>Function</i>
A	Aerial unit
B	RF amplifier unit
C	Local oscillator unit
D	Mixer unit
E	First IF unit
G	Second IF unit
J	Beat-frequency oscillator unit
K	Output unit

7. The plug-in units A to K are of uniform size and very similar in external appearance, the only difference being in the type and number of valves fitted on the top of each unit, and the arrangement of perforations for access to the trimming adjustments. These trimmers are annotated with the appropriate circuit reference (fig. 2 and 5).

8. Inside the screening box of each unit is fitted a rectangular plate known as a wafer, upon which all the components are mounted. One or more rotary switch units are mounted approximately in the middle of each wafer. The rotating portion of each switch unit is self-centring, in order to allow for manufacturing tolerances in the relative disposition of the units with reference to the axis of the switch bar by which they are actuated. One switch unit, shown in fig. 3 and in circuit diagrams as S1F, is mounted directly upon the chassis. This unit controls the scale lighting.

9. Unit A has three switch units, S2F, S2R, S3R; unit B has three switch units S4R, S4F, S5R, and unit C has four switch units S6R, S6F, S7R, S7F. The eleven switch units just mentioned, which together form the

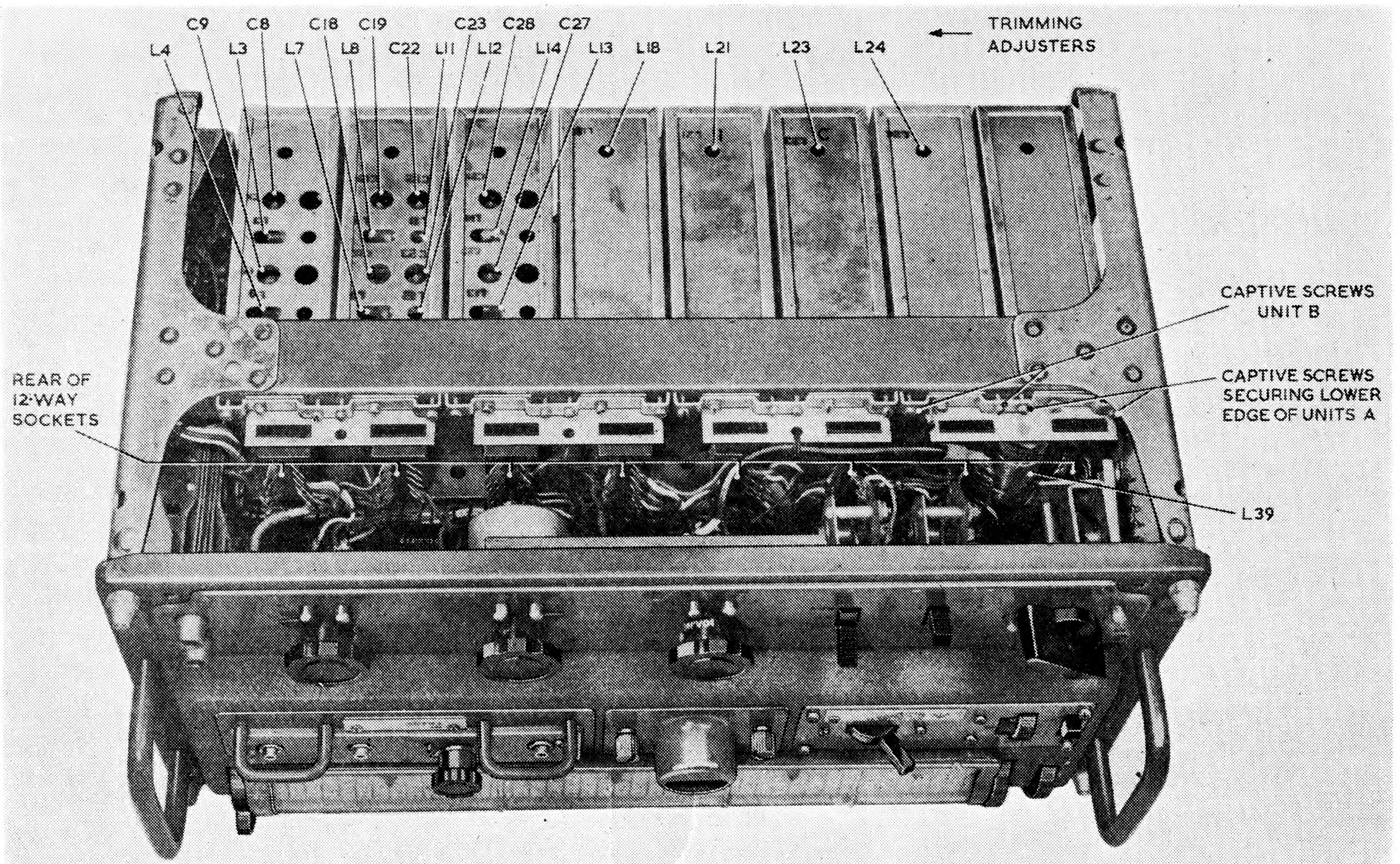

Fig. 2. Receiver unit Type 88, underside view (dust cover removed)

RANGE switch, are actuated by a common switch bar; the latter is a floating fit in the moving member of each switch unit. The bar is inserted from the right-hand end of the chassis, viewed from the front, and is actuated by the thumb-operated range-change switch through a link action with a toggle device, which locks the switch in the selected position (fig. 3). The switch bar can be removed, after removing the dust cover, by unscrewing a 'keep-screw' and then withdrawing the bar horizontally with a pair of pliers.

Warning

On no account must any attempt be made to remove the plug-in unit for examination or renewal, without first withdrawing the common switch bar as directed above. A warning to this effect is stencilled on the rear of the receiver.

10. Unit D has two switch units S8R and S8F, but S8R is not used. Unit E has two switch units S9F, S9R; unit G has two switch units S10R, S10F; unit J has two switch units S11R, S11F, and unit K has two switch units S12R, S12F. These ten units are also actuated by a common switch bar, similar to that already described, but inserted from the left-hand end of the chassis, viewed from the front. Fig. 4 shows the switch bar partly withdrawn. The switch bar is operated through a link action similar to that operating the RANGE switch, but in this case the link is driven from the SYSTEM switch through bevel gearing. The warning in the previous paragraph applies equally to the units operated by the system switch.

11. A small unit, referred to as unit F, is mounted directly upon the chassis near the

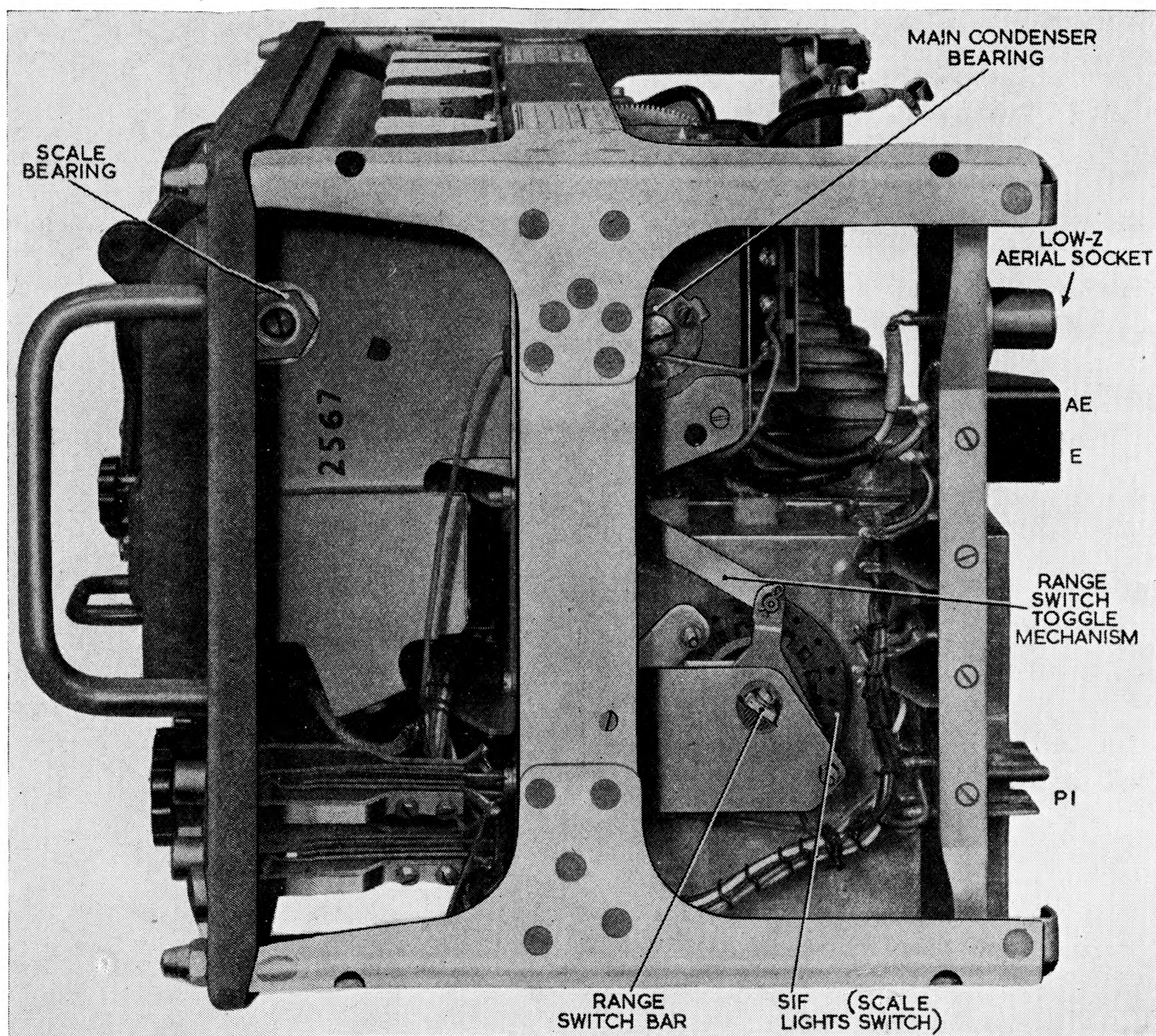

Fig. 3. Receiver unit Type 88, right-hand end (dust cover removed)

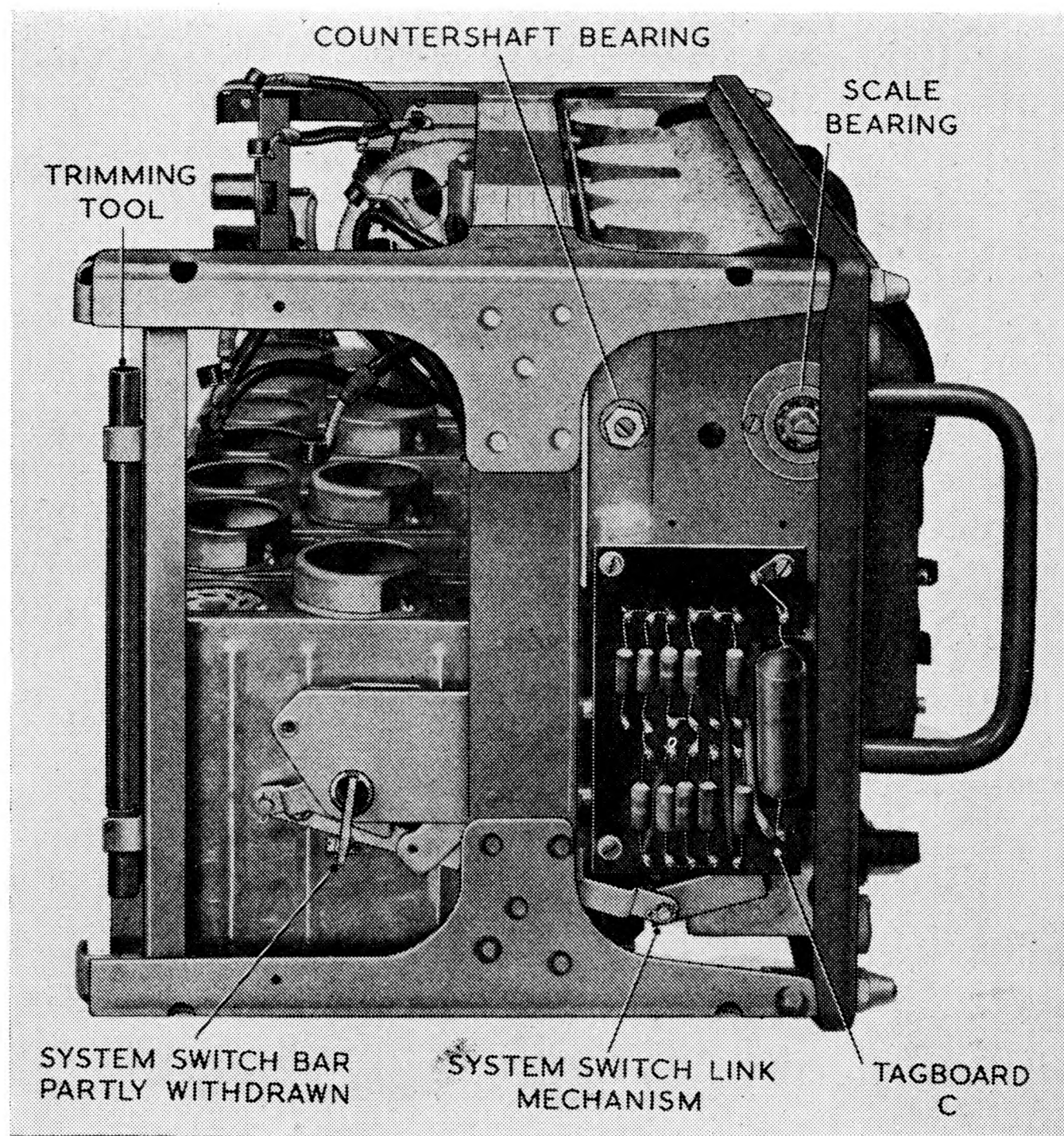

Fig. 4. Receiver unit Type 88, left-hand end (dust cover removed)

first IF valve V5. This contains an element of the first IF band-pass filter. The two guard units are known as units P and Q respectively; either of these may be plugged into position from the front of the receiver.

Components mounted on chassis

12. Three groups of components are mounted on the casing of the tuning condenser. These are :—

(1) Tagboard B, carrying the negative-temperature-coefficient condensers C107, C108, C109, C110 (fig. 7).

(2) Tagboard A, carrying R5, R6 and C4. This tagboard is enclosed by a light sheet metal cover (fig. 7).

(3) Thermally-controlled condenser C116.

On the left-hand end of the chassis, viewed from the front, is a small tagboard C (fig. 4), carrying R59, R62, R61, R75, R56, R51, R52, R60, R58, R57 and C100.

13. The output transformer (together with a small tagboard carrying R50) and a small tagboard D (carrying resistors R64, R65, R25, and R54) are mounted on the rear of the chassis (fig. 7). The scale lamp switch unit S1F is also fitted on the chassis, at the right-hand end (fig. 3).

14. The lower portion of the chassis is occupied by the eight 10-way sockets into which the plugs on units A, B, C, D, E, J and K are mated. In fig. 7, unit K has been removed to show the 12-point plug mounted thereon. Each plug-in unit is secured (after plugging in) by four screws, two of which are 'captive' on the upper edge of the unit itself (refer to unit K in fig. 7) and two are 'captive' on a bar on the underside of the chassis (fig. 2 refers).

15. The location of components on the tagboards mentioned in para. 12 and 13 is shown in fig. 8.

16. On the vertical stiffener at the left-hand end of the chassis, as viewed from the rear (fig. 5), are mounted the inlets and outlets for all external connections other than the telephone jacks. From top to bottom, these are :—

(1) Co-axial inlet SK3 for low impedance aerial.

(2) Aerial and earth terminal block for high impedance aerial.

(3) Jones socket SK1, numbered :—
13,—relay keying.

14, output, high level, for 600-ohm phones.

15, earth.

16, output, low level, for 20,000, 600 or 150-ohm phones.

(4) Jones socket SK2, numbered :—
13, RF AVC.

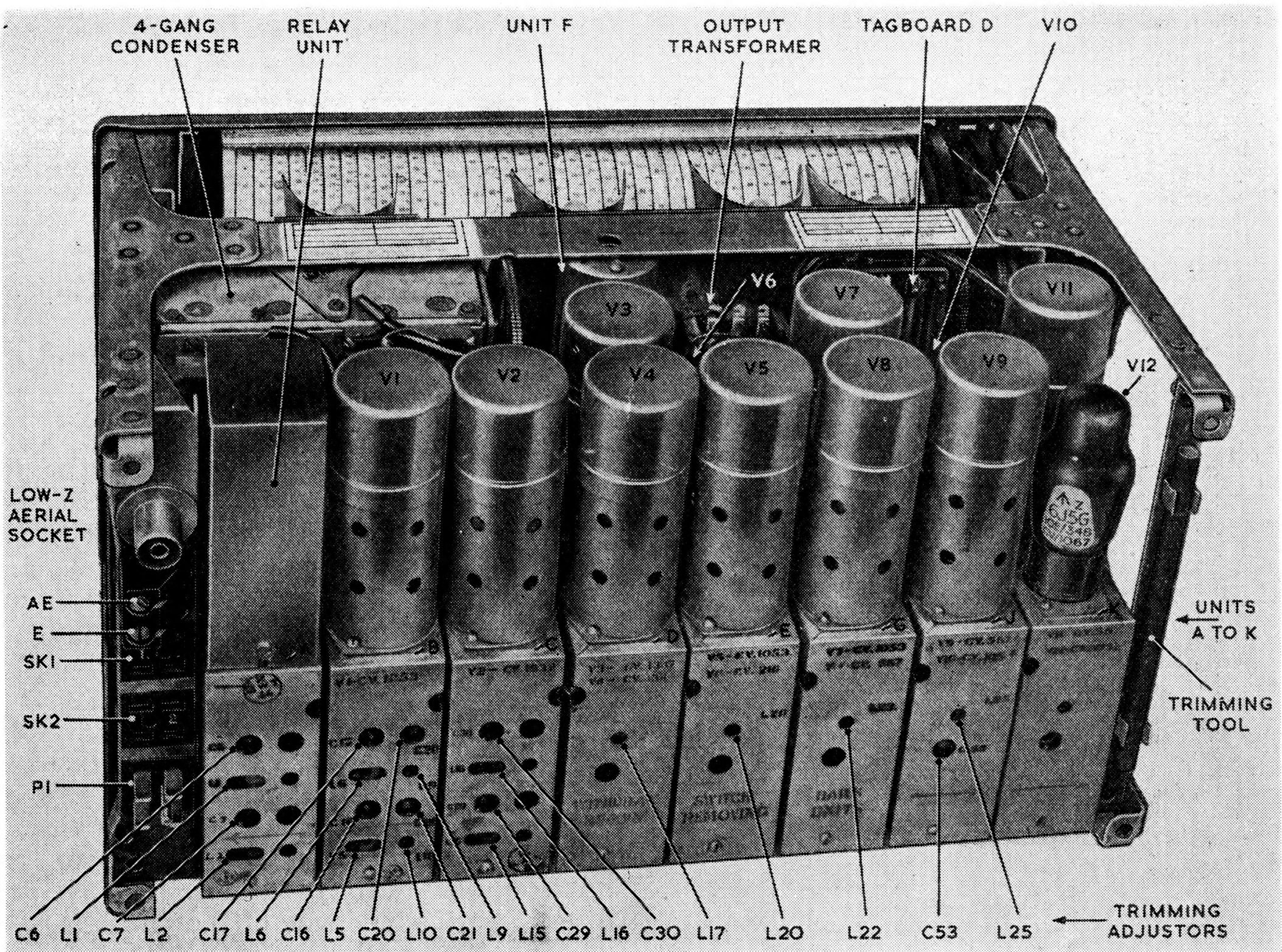

Fig. 5. Receiver unit Type 88, rear view (dust cover removed)

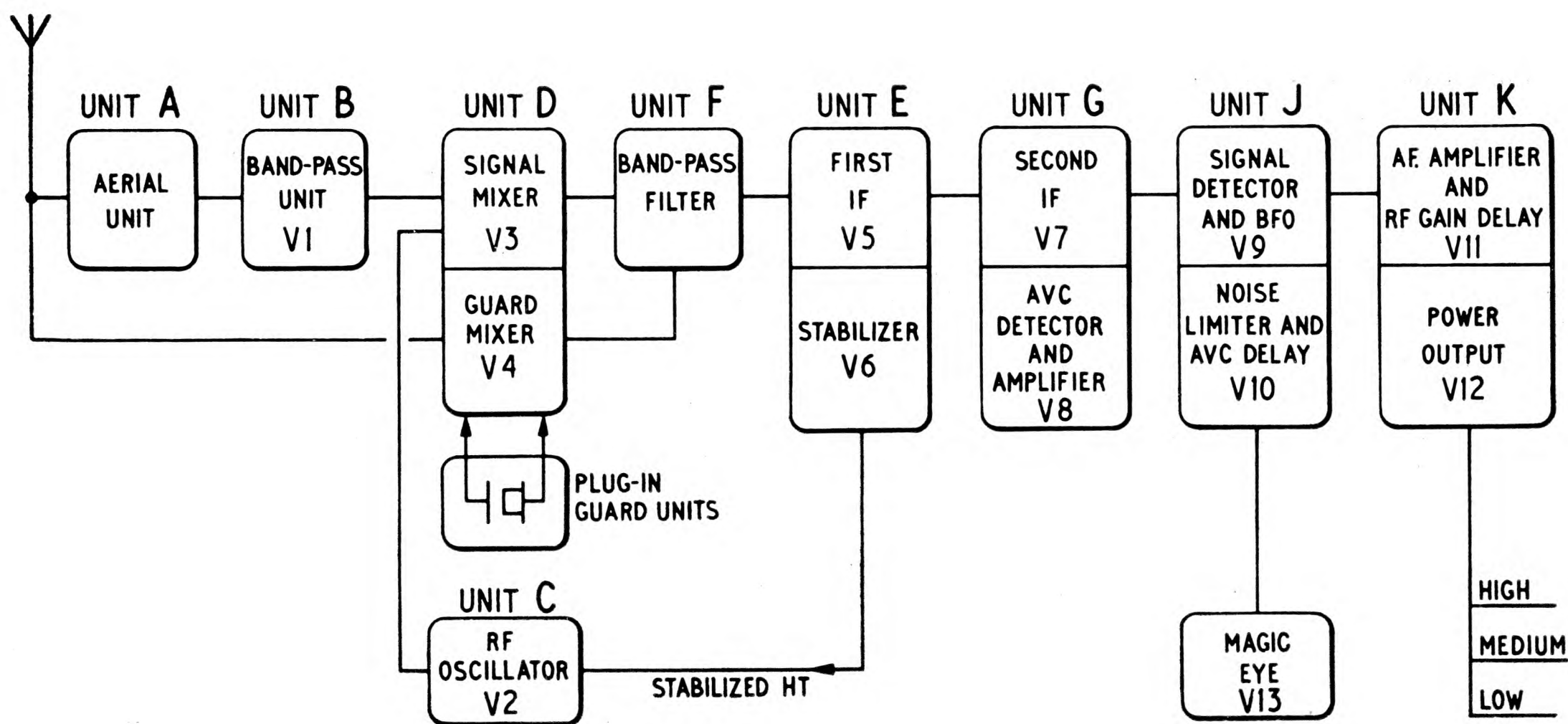

Fig. 6. Block schematic showing functions of units

- | | |
|------------------------------------|---------------------------|
| 14, balanced output,
low level, | } into 600-ohm
phones. |
| 16, balanced output,
low level, | |
| 15, IF, AVC. | |

- (5) Jones plug P1, numbered :—
- 13, earth.
 - 14, positive 12-volt supply to heaters.
 - 15, negative HT.
 - 16, positive HT.

17. When the dust cover is removed and the receiver is viewed from the rear, practically the only components which can be seen are the inlets and outlets referred to in the previous paragraph and the eight plug-in units with their valve cans on top. It should be noted that there is only one direct connection between any of these units, namely, a short length of copper wire from C26 in unit C which is soldered to a pin on unit D, the screening cans being cut away sufficiently to allow this to be done.

Warning

The connection referred to above must be removed before attempting to withdraw either unit C or unit D, after removing the switch bar as explained in para. 9.

Details of units

18. In the following description, the four ranges are referred to by their nominal end-values, e.g., 2 to 3.6 Mc/s. Actually, the bands extend slightly beyond the nominal end-values as explained in Part 1, Chap. 1. The electrical relationship between the units is given in schematic form in fig. 6, and the interconnections between the unit sockets are given in fig. 9.

Aerial unit A (tuning unit Type 145)

19. Details of the aerial tuning unit are shown in fig. 10. The valve holder on top houses the aerial attenuator relay. The principal components on the wafer are the three switch units S2F, S2R, S3R, the aerial-to-RF band-pass coupling coils L1, L2, L3, L4, and the corresponding trimmer condensers C6, C7, C8, C9. On each coil alternative input impedances are provided, the top end of each winding being taken to a contact on

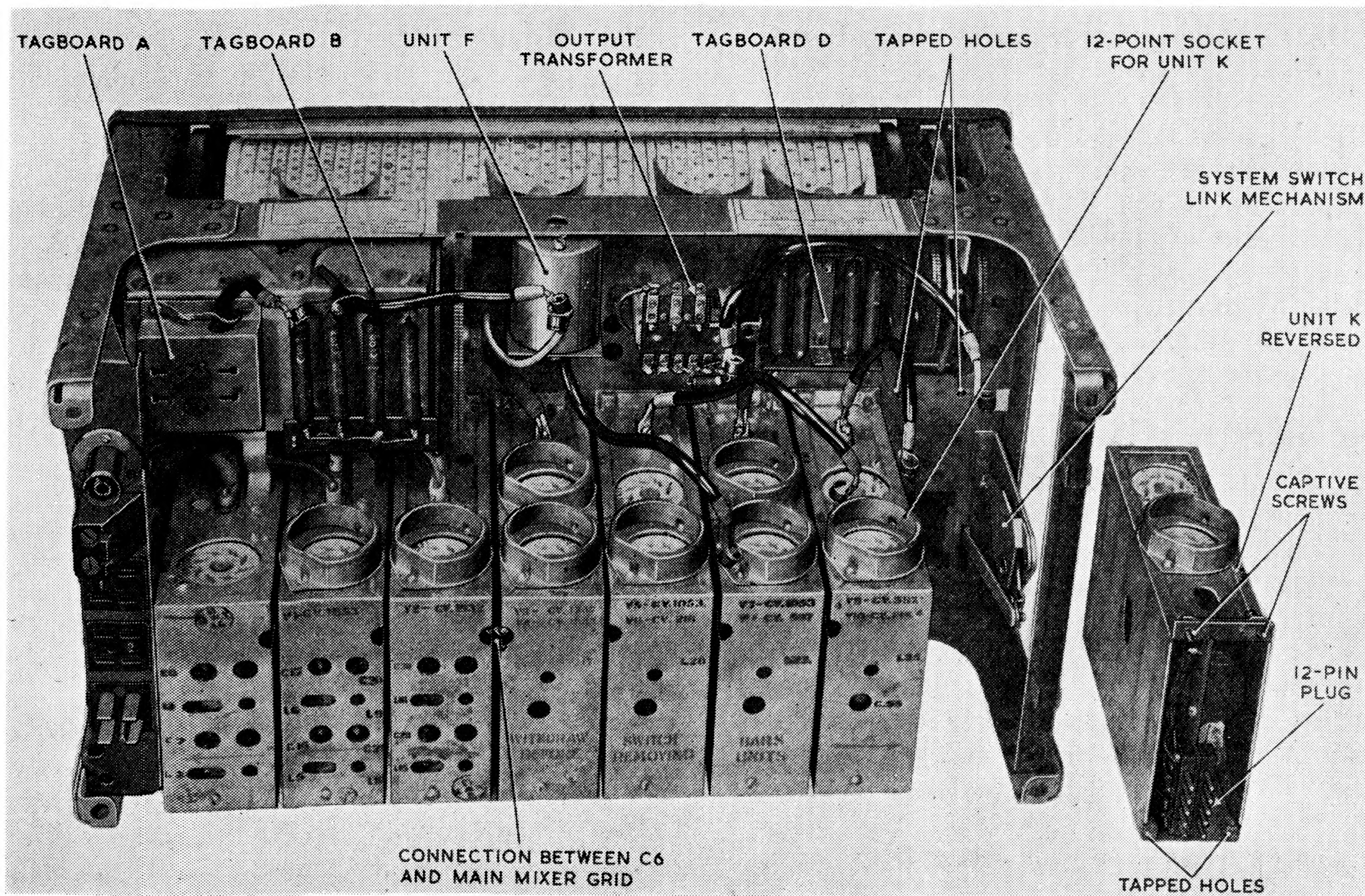

Fig. 7. Receiver unit Type 88, rear view with unit K removed

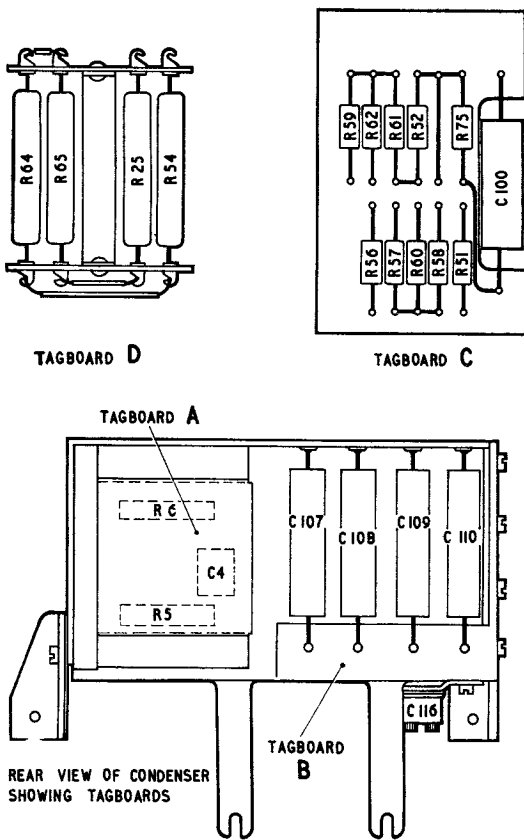

Fig. 8. Components mounted on tag boards

S2F. The selected range coil is connected, by this switch unit (via contacts on the attenuator relay) to the high-impedance aerial terminal on the rear of the chassis. Low-impedance tapping points on the same coils are connected by the switch unit S2R to the low-impedance aerial plug, via another set of contacts on the attenuator relay.

20. The corresponding output tappings on the secondary windings of these coils are connected by the switch unit S3R to the first section (C95) of the four-gang tuning condenser. The high-potential plates of the latter are also connected to R5, R6 and C4, a screened lead from R6 being taken to the top cap (control-grid) of the valve V1. As stated in para. 12 the components R5, R6 and C4 are mounted in a small enclosed tag-board on the rear of the condenser screen.

RF amplifier unit B (tuning unit Type 146)

21. Details of the band-pass unit are given in fig 11. The valve can on top houses the

RF amplifier valve V1. Three switch units are fitted, namely, S4F, S4R and S5R. The principal components on the wafer are the coils and trimming condensers comprising the four ranges of "RF to mixer" coupling band-pass units. The 11.3 to 20 Mc/s range is slightly different from the other three, in that an RF choke L40 and condenser C128 are used to couple the coil L5 to the RF amplifying valve, whereas in the other three ranges, mutual inductance coupling is employed. The coils comprising the first stages of the four ranges are coupled to the coils comprising the second stages of the filter by mutual inductance. For example, the 2 to 3.6 Mc/s range consists of L8 and L12, each coil having its own trimmer. The coil L8 is mounted on the front of the wafer, and L12 on the rear. The two coils are not immediately adjacent to each other on opposite sides of the wafer, but are separated by a distance just sufficient to give the required degree of very loose coupling. Similar considerations apply to other pairs of coils.

22. Two flexible screened connections are taken from sockets on top of the unit. One of these is taken to C96, which is a section of the four-gang condenser, and the other to the top cap (control-grid) of the valve V3.

Local oscillator unit C (oscillator unit Type 171)

23. Details of the oscillator unit are given in fig. 12. The valve can on top houses the main channel oscillator valve V2. The principal components on the wafer are the four ranges of local oscillator coils (L13 to L16) with their trimmer condensers C27, C28, C29, C30, four switch units (S6F, S6R, S7F, S7R) and a thermal compensator, represented in the circuit diagrams by the coil L30A and condenser C115. The coil and condenser are mounted as a single unit, as shown in fig. 12. The action of the compensator is explained in para. 42-43.

24. The coupling between the local oscillator circuit and the mixer valve is made via C26, in unit C, to a terminal pin on the mixer unit D, the latter point being connected to the mixer grid of V3. This lead is the only direct connection between plug-in units.

25. The switch unit S6R connects into circuit the desired anode winding of the four oscillator range coils; S7F connects the thermal compensator L30A (and also the external scale trimmer inductance L30 in parallel therewith) across the correct fraction of the

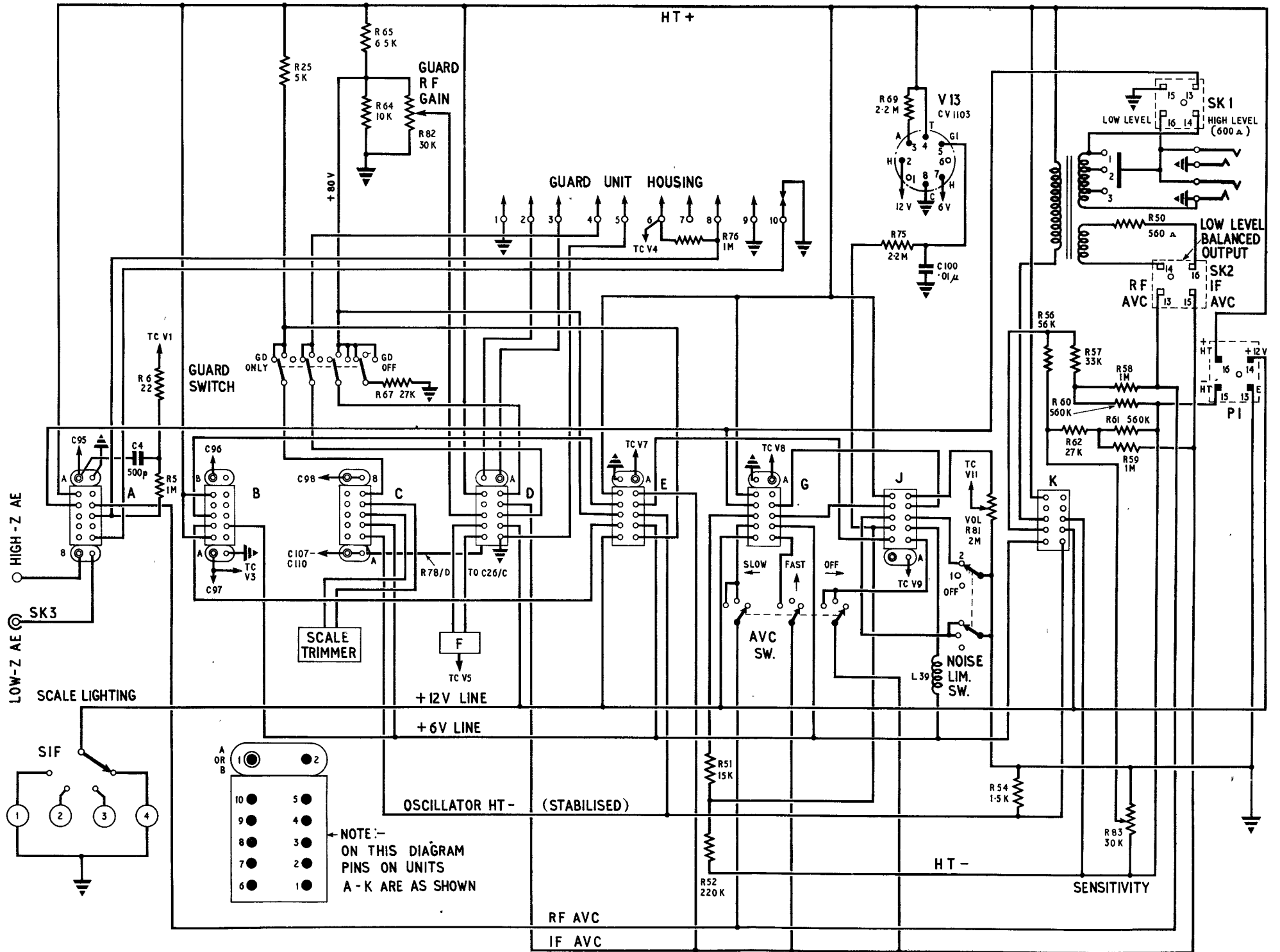
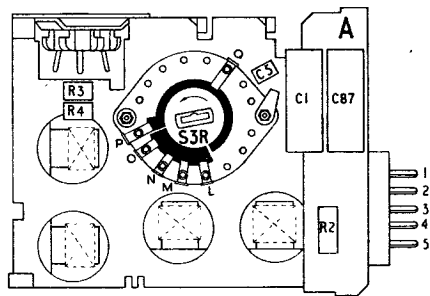
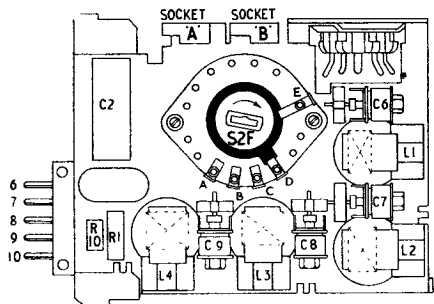
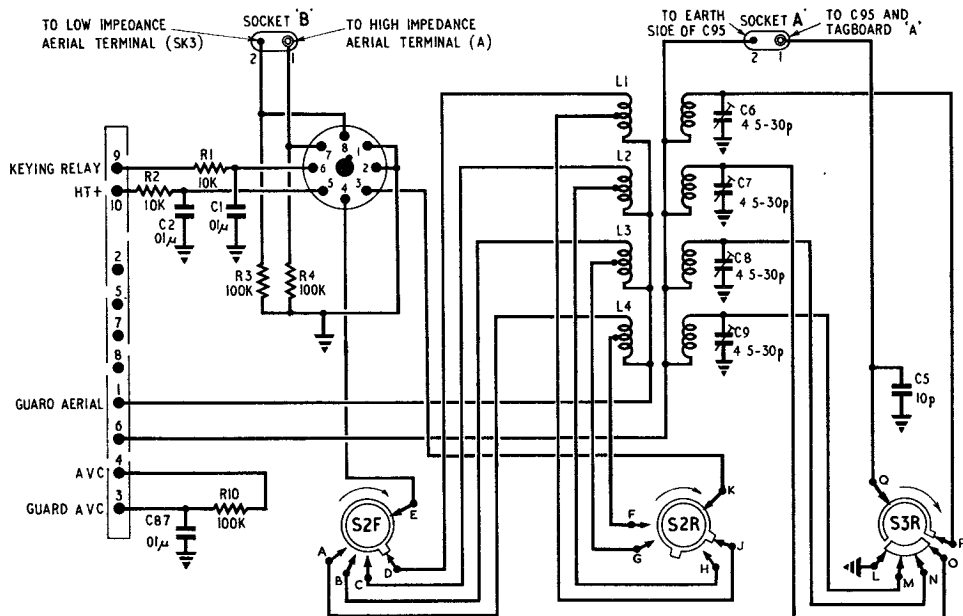

FIG. 9

CHASSIS CIRCUITS, SCHEMATIC

FIG. 9



S2R ON REAR OF S2F

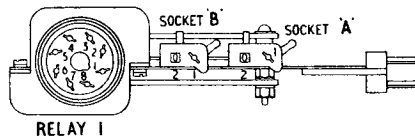
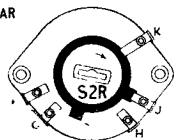

SEE PARA 46-47 FOR ACTION OF SWITCHES S2F S2R S3R WHICH ARE SHOWN ON 11-3-20 M/CS RANGE

Fig. 10. Tuning unit Type I45 (unit A) circuit and component mounting

grid winding. The switch unit S7R connects the required padding condenser of the group C31, C32, C33 in series with the band of negative-temperature-coefficient condensers C107-C110.

Mixer unit D (mixer unit Type 11)

26. Details of the mixer unit are given in fig. 13. The valve cans on top house the main mixer valve V3 and the guard mixer valve V4. The principal components on the wafer

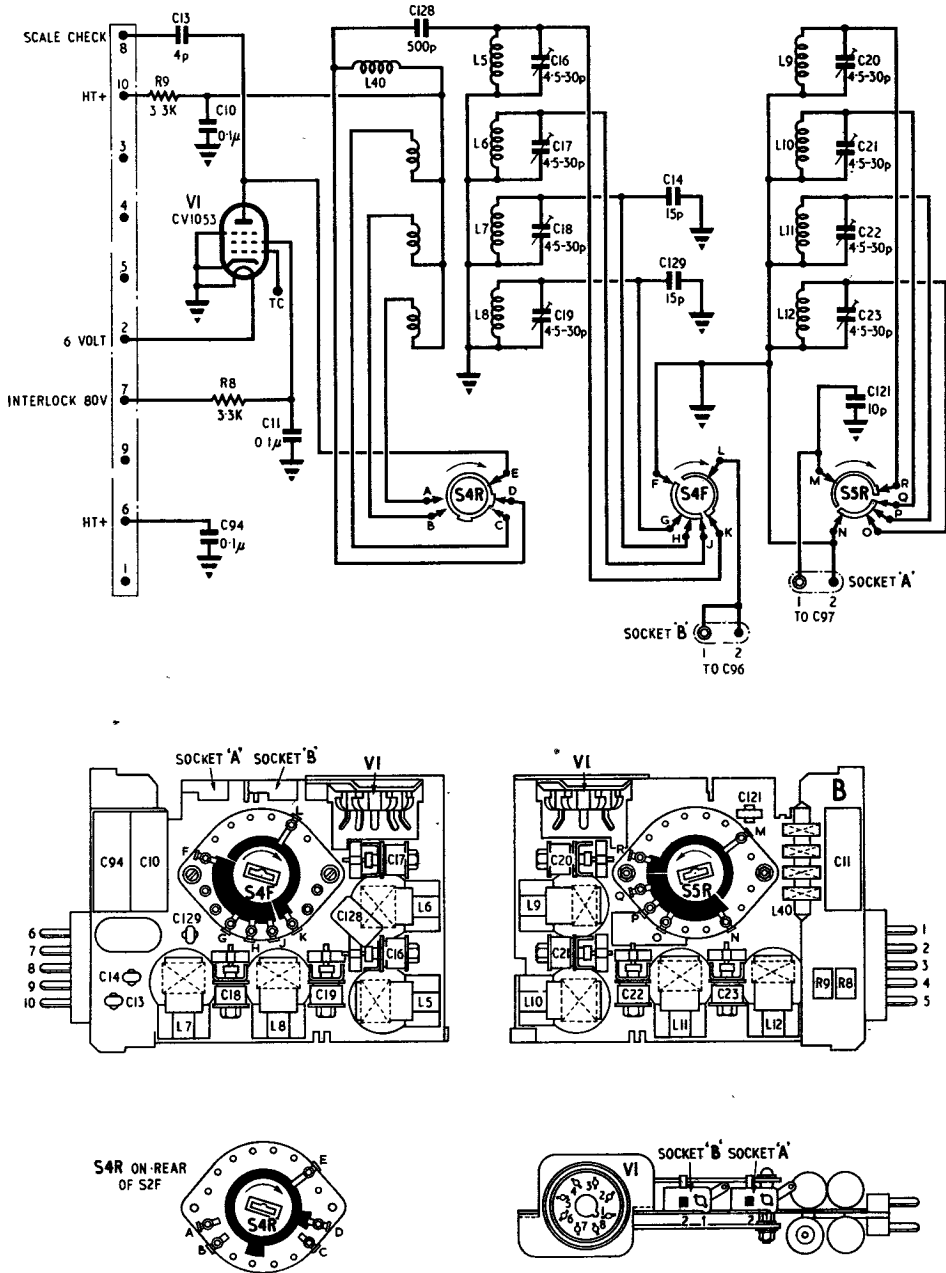

SEE PARA 48-49 FOR ACTION OF SWITCHES S4F, S4R, S5R WHICH ARE SHOWN ON 11.3-20 M/cs RANGE

Fig. 11. Tuning unit Type 146 (unit B) circuit and component mounting

are the switch unit S8F and the first two tuned circuits of the first IF band-pass filter. Switch unit S8F is the first of the units comprising the SYSTEM switch; its function

is to vary the IF selectivity as explained in para. 61. It also switches off the guard mixer valve V4 when in the SCALE CHECK position (para. 66).

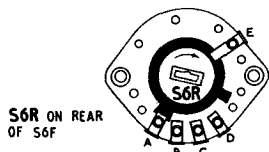
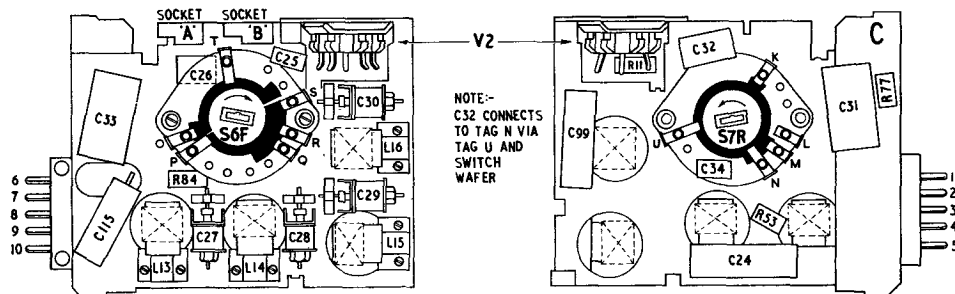
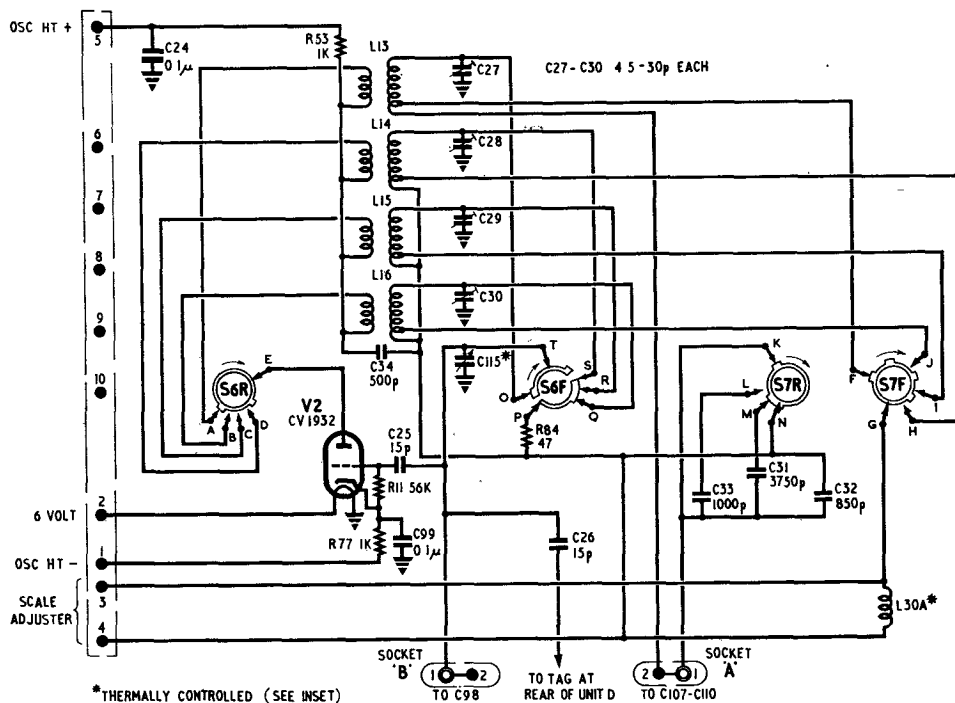

SEE PARA 48 - 52 FOR ACTION OF SWITCHES S6R, S6F, S7R, S7F WHICH ARE SHOWN ON 11-5-20 M/CS RANGE

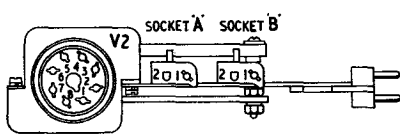
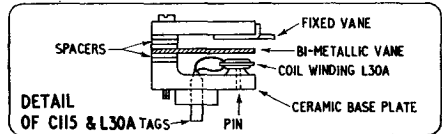
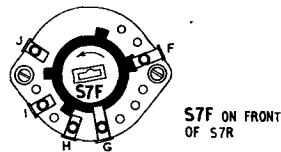
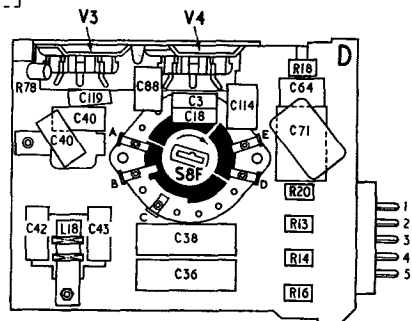
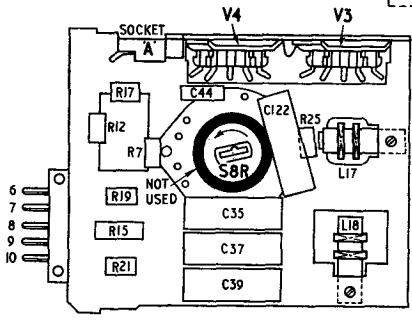
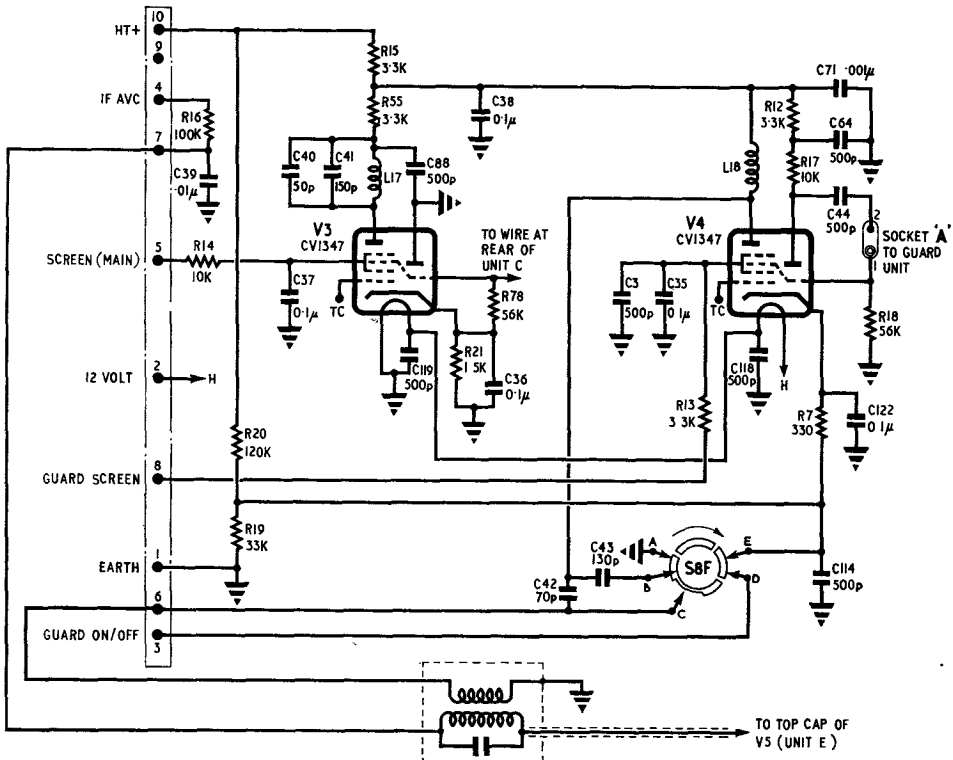

Fig. 12. Oscillator unit Type 171 (unit C) circuit and component mounting

27. Details of the first IF unit are given in fig. 14. The valve cans on top house the first IF valve V5 and the local oscillator voltage stabilizer valve V6. The principal components on the wafer are the switch units

S9F, S9R, and the second IF band-pass filter. Switch unit S9F varies the IF selectivity, and also performs a special function in the SCALE CHECK position (*para.* 66). Switch unit S9R switches off the amplifying valve V1 in this position, as explained in the same paragraph.



SEE PARA 55 - 60 FOR ACTION OF SWITCH S8F WHICH IS SHOWN IN POSITION I

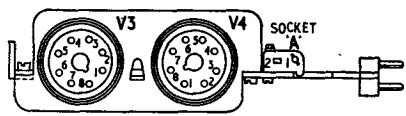
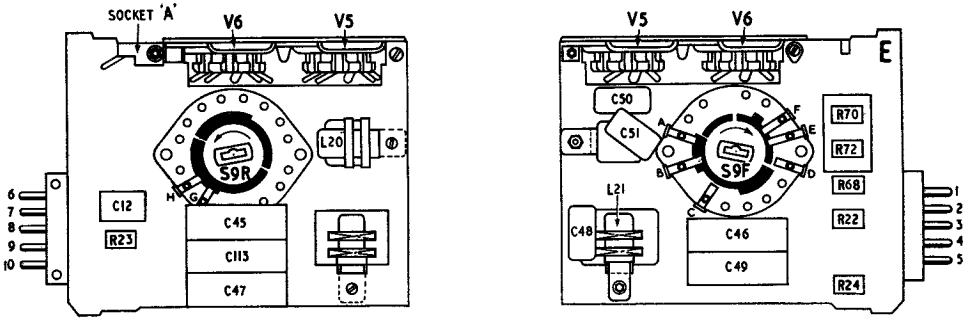
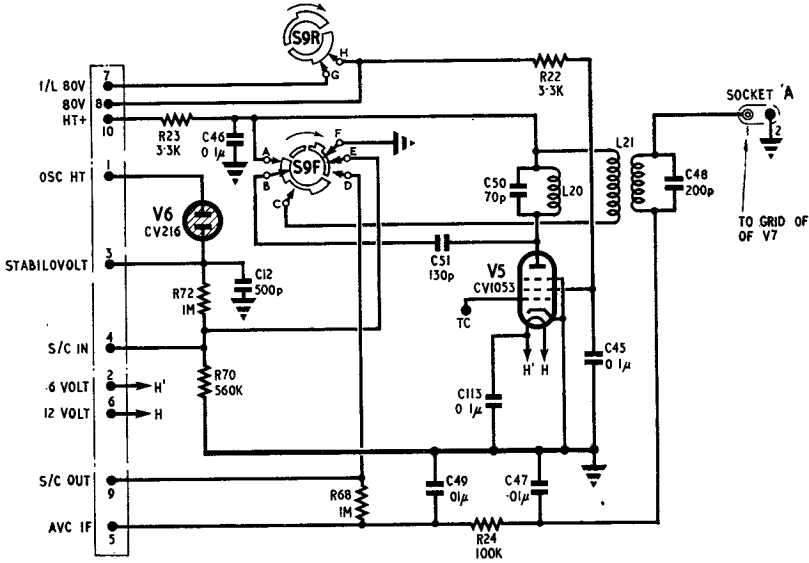

Fig. 13. Mixer unit Type II (unit D) component location and circuit with connections to inductance-condenser unit Type 88 (unit F)

Unit F (inductance-condenser unit Type 88)

28. Unit F is a small cylindrical can mounted directly on the rear of the chassis. It contains the third coupled circuit L19, C52 of the first IF band-pass filter. The inductance L19 is actually a pair of honeycomb coils, one of which is a small coupling coil by which

the main coil is coupled to the previous circuit of the filter. The main coil and C52 together form a closed circuit, one end of which is connected to the top cap (i.e., control-grid) of V5. The other end is connected to pin 7 of unit D and thence, through R16, to the IF AVC line.



SEE PARA 63,66 FOR ACTION OF SWITCHES S9F, S9R RESPECTIVELY. THESE SWITCHES ARE SHOWN IN POSITION 1

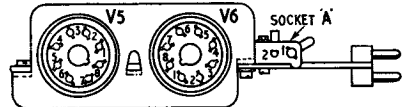

Fig. 14. IF unit Type 37 (unit E) circuit and component mounting

Second IF unit G (IF unit Type 38)

29. Details of the second IF unit are given in fig. 15. The principal components on the wafer are the switch units S10R and S10F, and the third IF band-pass filter. Switch unit S10R switches on the attenuator relay when in the scale check position, while S10F varies the selectivity of the third IF band-pass filter.

BFO unit J (oscillator unit Type 170)

30. Details of the BFO unit are given in fig. 16. The valves on top are V9 and V10, the former being the BFO and second (signal) detector, and the latter the noise limiter and AVC delay. The principal components on the wafer are the switch units S11R, S11F, the BFO oscillator circuit L25, C75, the associated harmonic filter L26, C73, R38, and

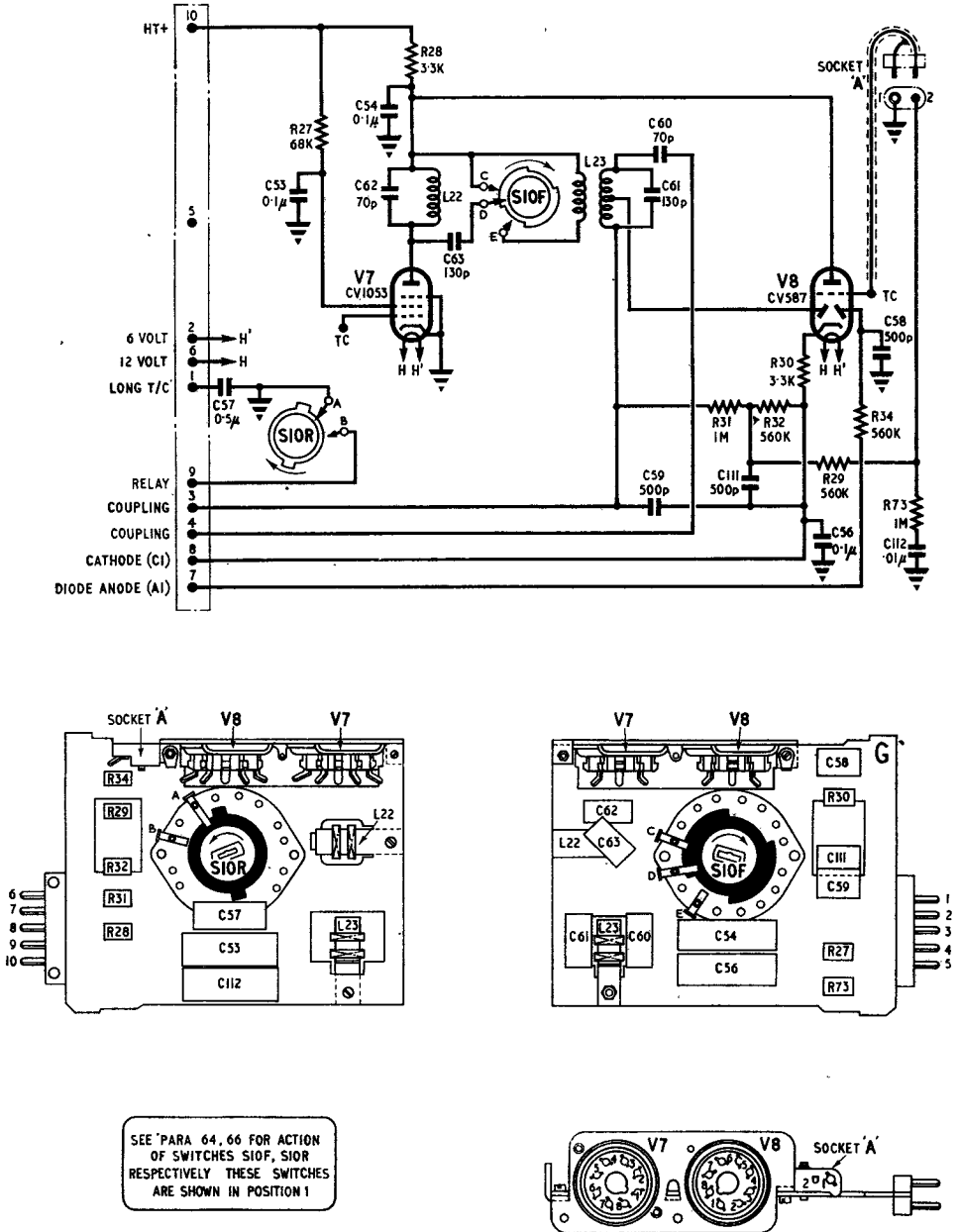
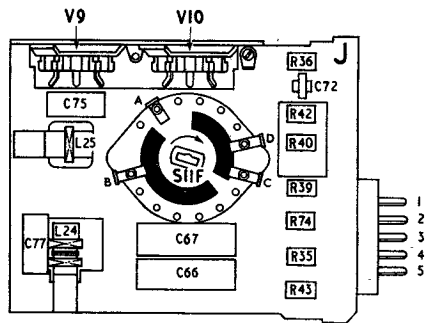
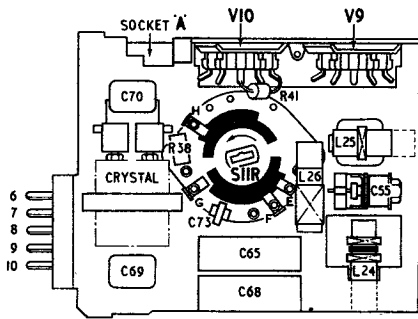
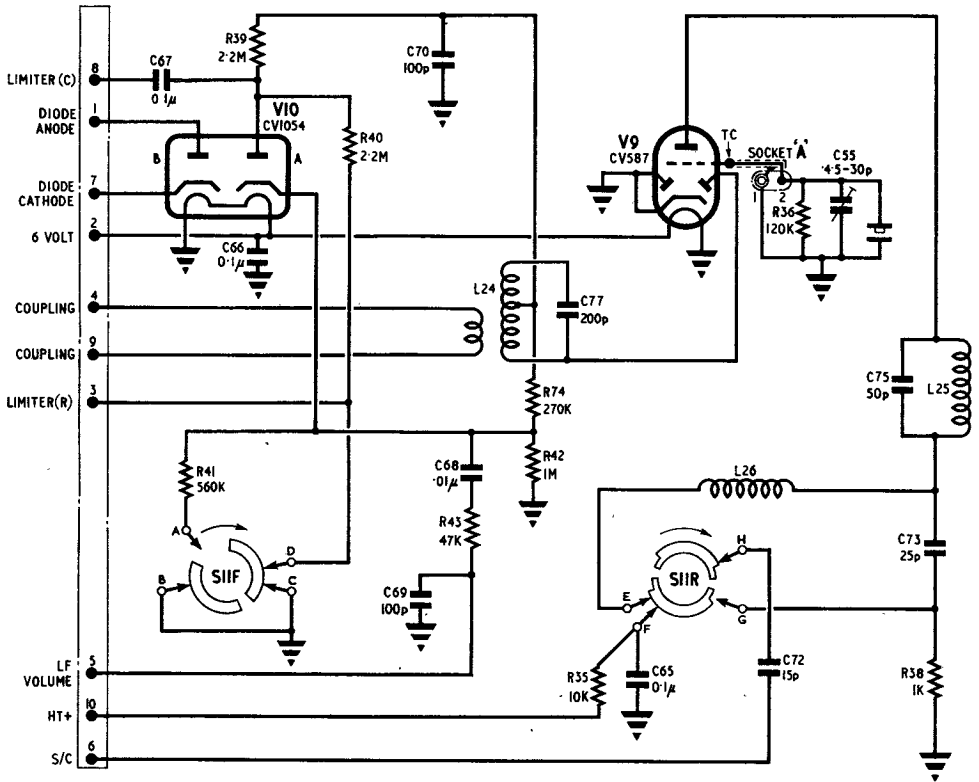

Fig. 15. IF unit Type 38 (unit G) circuit and component mounting



SEE PARA 67, 70, 85 FOR ACTION OF SWITCHES SIIF, SIIR WHICH ARE SHOWN IN POSITION 1 OF SYSTEM SWITCH

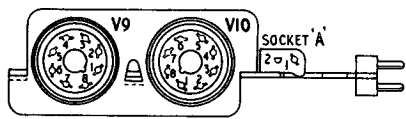
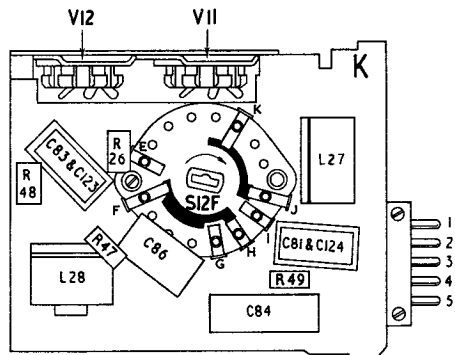
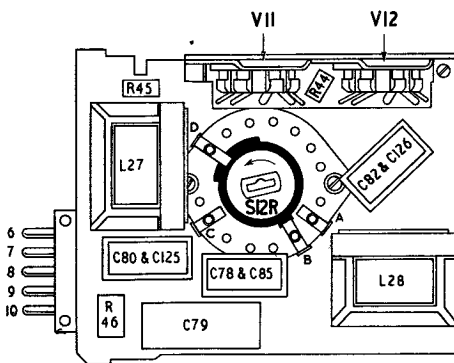
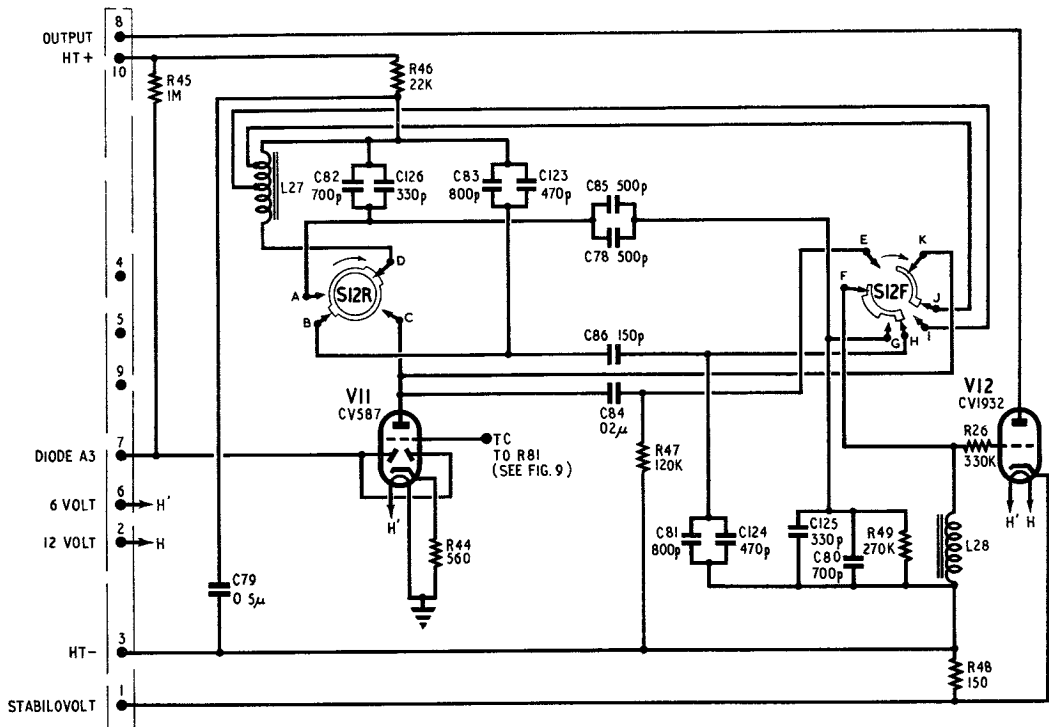

Fig. 16. Oscillator unit Type 170 (unit J) circuit and component mounting



SEE PARA 87-89 FOR ACTION OF SWITCHES S12R, S12F WHICH ARE SHOWN IN POSITION 1 OF SYSTEM SWITCH

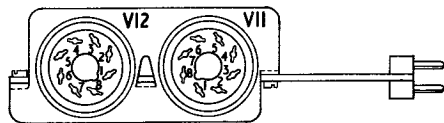

Fig. 17. Output unit Type 45 (unit K) circuit and component mounting

the quartz crystal, which is of standard Air Ministry plug-in type for 600 kc/s. The condenser C55 is a trimmer which is capable of 'pulling' the crystal frequency by about ± 50 c/s, to compensate for manufacturing tolerance.

31. The switch unit S11R completes the HT circuit to the BFO in all positions except R/T, where the BFO is inoperative. In the SCALE CHECK position it also connects the harmonic output from C73 to the input winding of the RF band-pass unit, via C72, S9F (in the second IF unit) and C13 (in the RF band-pass unit). The switch unit S11F operates in the AVC and noise limiting circuits as explained in para. 85.

Output unit K (output unit Type 45)

32. Details of the output unit are given in fig. 17. The valves fitted on the top are the AF amplifier V11 and the power amplifier V12. The principal components on the wafer are the switch units S12R and S12F and the AF filter components L27, L28, with associated resistors and condensers. The switch units control the AF selectivity as explained in para. 87-89. The output from the power

amplifier valve is fed into the output transformer, which is mounted on the chassis.

Guard units P and Q (tuning units Type 131 and 132)

33. Details of the circuit and component arrangements of the two guard units are shown in fig. 18, (a) showing unit P and (b), unit Q. The general arrangement may be seen from fig. 19. All connections between the external circuits and the internal circuits of the guard unit in use are made through ten contacts on the underside; these engage with spring finger contacts in the guard unit housing on the chassis. Each unit is supplied complete, except for the crystal. If the guard frequency facility is to be used, a crystal of the desired frequency must be inserted before the receiver is put into service. To do this the top cover of the unit must be removed as shown in fig. 19, and the crystal inserted in the holder on the left-hand side of the screen.

CIRCUIT DETAILS

Side tone and listening through

34. Fig. 20 is a schematic diagram of the connections of the aerial attenuator relay.

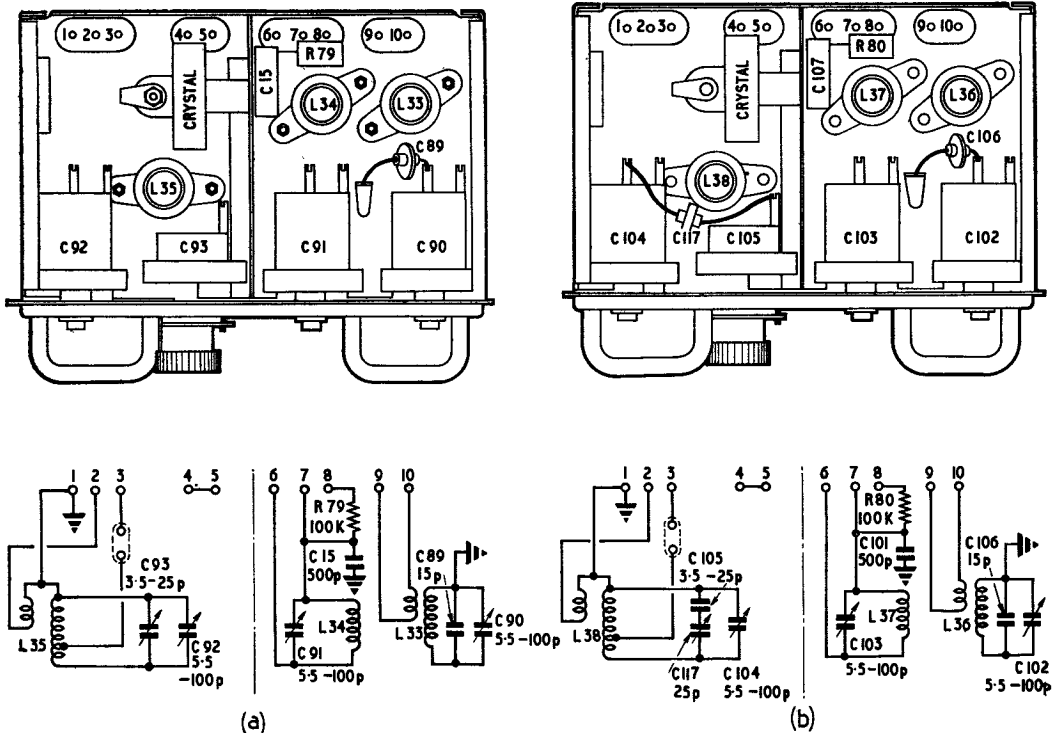

Fig. 18. Tuning unit Type 131 (unit P) and Type 132 (unit Q) circuit and component mounting

The connection from the aerial input socket or terminal to the selected aerial circuit range is made through contacts on the attenuator relay, the latter being mounted on an octal valve base upon the aerial plug-in unit A. The operating coil of the relay is fed from the HT line through suitable current-limiting resistances, provision being made for keying the relay via contacts 13 and 15 on the uppermost Jones socket SK1 at the rear of the receiver. The relay and its mounting are shown in fig. 19.

35. Fig. 20 shows the theoretical connections of the aerial relay during transmission and reception. When keyed, the aerial circuit is interrupted at the relay contacts, but the aerial is not completely isolated from the input circuit of the receiver, owing to the capacitance between the relay springs. The latter are however arranged so that the capacitance coupling is very small, and when the relay is energized, the attenuation introduced into the aerial circuit is sufficient to give comfortable 'side tone' from an adjacent transmitter. For W/T traffic, arrange-

ments must be made for the use of a suitable morse key (either hand operating or relay) with additional contacts by which the attenuator relay can be keyed in unison with the transmitter, to give the normal 'listening through' requirements.

36. For R/T traffic arrangements must be made to energise the relay when the carrier wave is switched on. The relay is energized by the action of the SYSTEM switch when the latter is put to SCALE CHECK. This prevents incoming signals from breaking through and being confused with the scale-checking harmonics.

Simplified circuit diagram

37. Fig. 21 is a simplified circuit diagram of the receiver unit and should be referred to when reading the following circuit description.

Guard channel input circuit

38. The low potential ends of the primary windings of the aerial range coils are all common, and are connected to contact 10 of

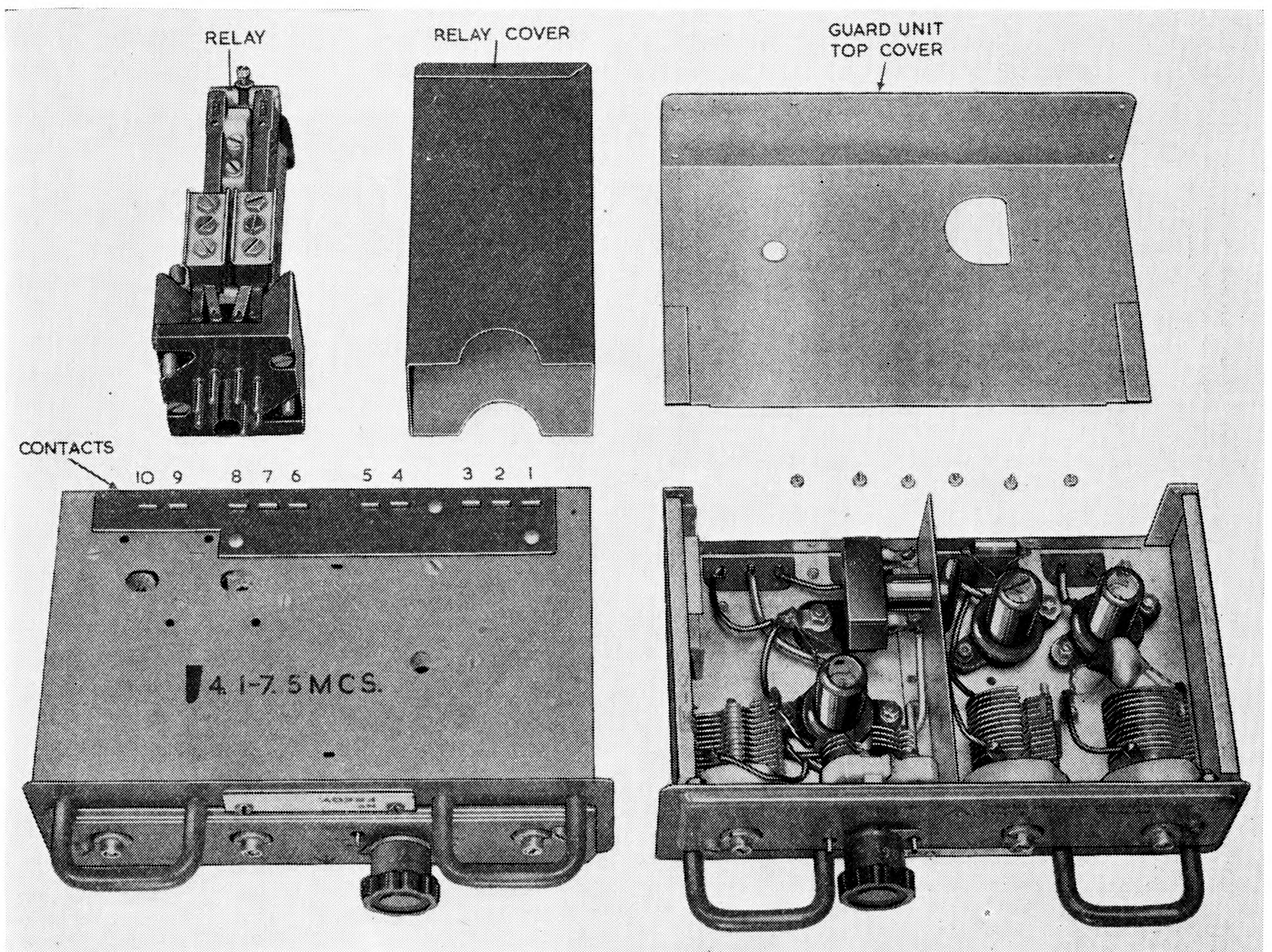

Fig. 19. Relay and guard units, with covers

the guard unit housing. If no guard unit is in place, this point is earthed through a spring contact. When a guard unit is inserted into the housing, however, the primary winding of the guard unit input circuit is connected in series with the selected main channel primary circuit, so that the guard frequency input is eventually applied to the guard channel mixer valve V4.

RF amplifier

39. The RF amplifier is designed to provide sufficient selectivity to eliminate cross-modulation and blocking effects, and to give a high degree of image signal protection. This selectivity is achieved by using a band-pass filter as the coupling between the RF amplifying valve V1 and the main mixer valve V3. Pairs of mutual inductance coupled coils are used on each range, the precise degree of coupling for each range being obtained by the spacing and positioning of the coils. The amplification is sufficient to make the noise contribution of the circuits following V1 negligible in comparison with the thermal agitation noise from the aerial circuit.

RF bias line

40. A variable bias is supplied to the control grid of V1 through R5 and R10 from the manual RF gain control R83. Automatic gain control is also applied via the RF AVC line from the resistance network R58, R57, R56 and R83. This network receives the AVC output voltage from the valve V8 and a delay

voltage from the valve V11, as explained in para. 73-81.

Local oscillator (main channel)

41. In order to make full use of the advantages of the high discrimination scale, special care has been taken in the design of the local oscillator stage to ensure maximum stability under conditions of varying ambient temperature. Losses in stray capacitances have been reduced to a minimum by the use of ceramic insulation at all important points. The oscillator and mixer valves are very loosely coupled to the oscillatory circuit, so that variations in valve parameters have no appreciable effect on the frequency.

42. The remaining thermal drift arises from two main sources, the tuning coils and the tuning condenser. These components are compensated in the following manner. The tuning condenser is compensated on the low-frequency (maximum capacitance) end of each band by a negative-temperature-coefficient condenser. This consists of C107-C110 in parallel, mounted upon the screening cover of the tuning condenser. To compensate at the high-frequency (minimum capacitance) end of each band, a small bi-metallic strip compensator is used; this is also mounted on the cover of the tuning condenser. In conjunction with a fixed metal plate, the bi-metallic strip forms a capacitance which varies in value with temperature changes in such a manner as to keep the oscillator

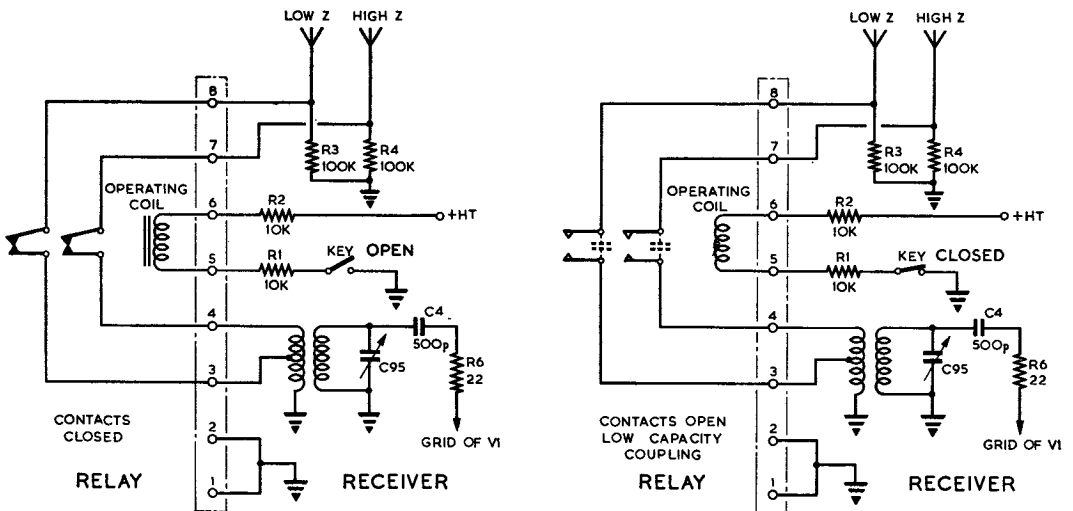

Fig. 20. Connections of attenuator relay

frequency sensibly constant. This compensator is shown in the circuit diagrams etc. as C116.

43. A somewhat similar compensator C115 is mounted on the local oscillator unit in order to compensate for the temperature variation of the stray capacitances and inductances. The action of this compensator may be explained as follows. Referring to fig. 12, the capacitive portion is similar to that of the compensator C116, but the bi-metallic strip is silver-plated. A small coil, shown as L30A, is mounted near the underside of the strip. When the temperature changes, the strip moves with reference to the fixed plate and also with reference to the coil. This causes the capacitance between the plates to change, while at the same time the inductance of the coil L30A also changes. The coil is connected to the range coil at the same point as the scale trimmer inductance with which it is virtually in parallel. This compensator is mounted inside the oscillator plug-in unit in order that it will follow the temperature variations of the tuning coils as closely as possible.

44. The HT supply to the local oscillator is stabilized by a valve Type CV216 (V6). Thus the oscillator is kept as free as possible from frequency instability due to voltage variations.

Range switch

45. The range switch operates the scale lighting switch unit S1F, mounted directly upon the chassis, and the switch units S2F, S2R, S3R, S4R, S4F, S5R, S6R, S7F, S7R and S5F which are mounted inside the various plug-in units on the rear of the chassis. The functions of these switch units are explained in the following paragraphs. The angular rotation between each consecutive switch contact is twenty degrees (approx.).

Aerial circuit

46. The switch unit S2F receives the RF signal input from the "open aerial" terminal A, via the contacts on the attenuator relay, and switches this input to the high-potential end of the primary winding of the selected range coil (L1-L4). The switch unit S2R takes the RF signal input from the co-axial socket SK3, via contacts on the attenuator relay, to a low-impedance tapping on the selected primary winding. Thus, according to which type of aerial is in use, the input impedance is appropriately matched.

Main channel input circuit

47. The switch unit S3R connects the first section (C95) of the main tuning condenser to the selected main channel secondary winding. The signal developed across C95 is applied to the control grid of the RF amplifying valve V1, through C4 and R6. The windings belonging to ranges of lower frequency than the selected range are short-circuited and earthed by other contacts on the switch unit S3R.

RF amplifier and band-pass coupling to mixer

48. The RF amplifying valve V1 is coupled to the main channel mixer valve V3 by a band-pass filter, a separate filter being provided for each range. The first coil is selected by the switch unit S4R and connected to the anode of V1, the other ends of the four coils being connected together and to the HT line via R9. The required secondary winding is selected by the switch unit S4F, and connected to the second section (C96) of the tuning condenser, the ranges of lower frequency than that selected being short-circuited and earthed on the same switch unit.

49. A further section of this filter is provided for each range by the coils L9-L12, each with its own trimmer condenser. The low-potential ends of these coils are earthed, and the high-potential ends are taken to the switch unit S5R, which connects the selected range to the third section (C97) of the tuning condenser. Coils not in use are short circuited and earthed as in previous stages. The selected coil is also connected to the control grid of the hexode section in the main channel mixer valve V3.

Local oscillator switching

50. The coils L13-L16 are the tuned transformers for the four ranges. The appropriate primary winding is selected by the switch unit S6R and connected in the anode circuit of the local oscillator valve V2. The common ends are connected to the HT line through R53, S15R (which is one unit of the guard switch) and R25. The switch unit S15R breaks this HT supply when in the GUARD ONLY position, and completes it in the NORMAL and GUARD OFF positions.

51. The switch unit S7F controls the scale trimmer inductance L30 (with the thermally controlled coil L30A in parallel). Switch unit S7R controls the series padding condensers of the oscillator grid circuit, and the switch unit S6F connects the fourth section (C98) of

the tuning condenser to the selected winding L13-L16. The high-potential ends of these secondaries are connected to contacts on the switch units, and the selector contact connects the selected secondary to the control-grid of the valve V2, through the condenser C25, and also to the high potential side of C98. A second selector contact short-circuits lower frequency secondaries not in use, and connects their earthy ends to a selector contact on switch unit S7R. The latter contact connects the padding condensers C31, C32, C33 and the negative-temperature-coefficient condensers C107-C110 (four in parallel) between the earthy ends of the secondaries and earth.

52. The padding condensers are introduced into the circuit as follows. On the range 11·3-20 Mc/s none is in circuit, the negative-temperature-coefficient condensers being connected directly between the low-potential ends of the secondaries and earth. On the range 6·4-11·3 Mc/s, C31, C32 and C33, in parallel, are in series with the bank C107-C110. On the range 3·6 to 6·4 Mc/s, C32 and C33 are in series with the bank C107-C110, and on the range 2 to 3·6 Mc/s, C32 alone is in series.

53. The scale trimmer inductance L30 is connected between a selector contact on the switch unit S7F and the common low-potential ends of the secondaries, so that it is shunted across a portion only of the selected secondary range coil. The number of turns so shunted differs on different ranges, and is so chosen that the scale trimmer can be made to restore the calibration on all four ranges if it is disturbed by any cause which affects the whole oscillator circuits uniformly.

54. The local oscillations generated by V2 are fed through C26 into the control grid of the triode section in the main mixer valve V3. The anode of this section is earthed, and the triode section does not function as such, being used merely to obtain a connection to the mixer grid of the hexode section.

Mixer stages

55. The main channel signal from the RF band-pass filter is fed into the control grid of V3, and the local oscillator output to the mixer grid. The output of the mixer valve is fed directly into the first of the tuned circuits comprising the first IF band-pass filter. The main channel can be switched off when

desired by putting the guard switch S15 to GUARD ONLY. This breaks the 80-volt screening-grid voltage supply to V3.

56. The guard channel input is fed into the control grid of the guard mixer valve V4. AVC voltages are also fed into this grid from the RF AVC line, via R10 and R76. The triode section of the valve acts as the guard channel local oscillator and is crystal-controlled. The output of the guard mixer is fed into the second of the three tuned circuits comprising the first IF band-pass filter.

57. Referring to fig. 21, the cathode of the guard mixer valve is connected to a tapping on the fixed potentiometer R20, R19. When a guard unit is placed in the housing, the contacts 4 and 5 are closed. Provided that the guard channel is switched on at S15, and that S8F of the SYSTEM switch is in any position other than SCALE CHECK, R19 is short circuited, and the cathode of V4 is only a volt or so above earth potential. The valve V4 therefore passes anode current and functions in the normal manner.

58. If however the guard unit is removed (thus breaking the circuit at contacts 4 and 5) or if the guard channel is switched off at S15, or if the SYSTEM switch is put to SCALE CHECK, R19 is no longer short circuited. The cathode of V4 is then about 40 volts above the potential of the control grid, and the anode current is cut off, so in effect switching off the guard channel.

Intermediate-frequency amplifier

59. Two stages of intermediate-frequency amplification are provided, with a total of eight tuned circuits. Three of these form the first IF band-pass filter, between the mixer stage and the first IF amplifying valve V5. The third tuned circuit is located in unit F, a small cylindrical can mounted on the chassis. The second IF filter, between V5 and the second IF amplifying valve V7, has only two tuned circuits. The third IF band-pass filter, between V7 and the second detector stage (part of V9) also has three tuned circuits.

60. Two degrees of IF selectivity are provided, namely, a band-width of 5 kc/s for R/T, MCW and wide-band CW reception, and a narrower band-width (nominally about 3 kc/s) for use with the AF filters. The band-width is varied by the SYSTEM switch.

System Switch

61. The SYSTEM switch controls the group of switch units S8F, S9F, S10R, S10F, S11R, S12R and S12F. This switch gives three degrees of CW selectivity, with the BFO switched on automatically. It also provides the scale check facility, and the wide-band R/T selectivity, the BFO in the two latter positions being automatically switched off. For brevity, the switch positions will be referred to by numbers, 1 being the 300 c/s CW position, 2 the 1.2 kc/s CW position, 3 the 3 kc/s CW position, 4 the S/C (SCALE CHECK) position, and 5 the R/T position. The angular rotation between switch contacts is approximately 20 deg.

IF selectivity

62. The method of varying the IF band width in the three filters is the same, and may be explained with reference to the first filter. When the system switch is in position 1 or 2, the winding of L18 (which is located in mixer unit D) is in effect shunted by C43 via contacts on the switch unit S8F. The closed circuit L18, C43 is coupled to the following tuned circuit L19, C52 (unit F) by the condenser C42. In positions 3, 4 and 5, C43 is disconnected from the earthy end of L18 and is connected in parallel with C42, increasing the degree of coupling between the first and second tuned circuits and so broadening the response curve.

63. Similar considerations apply to the second and third IF band-pass filters, the selectivity switching being performed by switch units S9F and S10F, in the following manner. Taking the circuits in the first IF unit E, when the system switch is in position 1 or 2, the operative contacts on the switch unit S9F cause the winding of L20 (permanently shunted by C50) to be also shunted by the condenser C51. The coupling coil on L21 is not in circuit, and the only coupling between L20 and the main coil of L21 is a very loose magnetic one, designed to give the narrow bandwidth of 3 kc/s. When the switch is in position 3, 4, and 5, however, the coupling coil on L21 (a few turns only) is connected in series with C51. This gives a tighter magnetic coupling between the two circuits, so designed that the wide bandwidth (5 kc/s) is obtained.

64. In the second IF unit G, when the system switch is in position 1 or 2, contacts on switch unit S10F causes the winding of L22 to be shunted by condenser C63 (in addition to the permanent shunt C62), and the loose

magnetic coupling between L22 and the main winding of L23 is designed to give the narrow bandwidth of 3 kc/s. With the switch in position 3, 4 or 5, however, the condenser C63 is connected across L22 in series with the coupling coil (a few turns only) on L23. The tighter magnetic coupling so obtained is designed to give the wider bandwidth of 5 kc/s.

AF selectivity

65. The switch units S12R and S12F, which are also controlled by the SYSTEM switch, vary the AF selectivity as explained in para. 86-89.

Scale check position

66. The circuit changes made by the SYSTEM switch when in the SCALE CHECK position are as follows. The guard mixer valve is rendered inoperative by the switch unit S8F, as described in para. 57. The RF amplifying valve is also rendered inoperative by cutting off its screening-grid potential, the switch unit S9R interrupting the circuit between R8 and the 80-volt line from the junction of R64 and R65. The attenuator relay is energized from the HT line via the switch S10R. The effect of these changes is to isolate from the aerial the RF band-pass filter following V1, so that signals will not be received during scale checking, and also, by shutting down the guard frequency local oscillator, to prevent spurious harmonics of the latter being mistaken for 'scale checking' harmonics of the BFO.

67. Referring to fig. 21, the source of the scale checking harmonics may be considered to be the choke L26 in the anode circuit of the BFO valve V9. The harmonics are fed through the condenser C73 to the switch unit S11R, thence, via C72, to the junction of R70 and R72. From this point they are fed, via S9F and the condenser C13, to the anode circuit winding of the RF band-pass filter following V1, the latter valve being cut off by the absence of screening-grid potential as explained in the preceding paragraph. From the 'earthy' end of the band-pass winding the harmonic currents return to the source via the condenser C10, earth, and C65.

68. When the SYSTEM switch is in the SCALE CHECK position, the resistor R68 is connected between the IF AVC line and the junction of R70 and R72 by the action of switch unit S9F. This reduces the standing bias on the IF valves so that the IF stages operate in

their most sensitive condition during scale checking.

Beat-frequency oscillator

69. The beat-frequency oscillator consists of the triode section of the double-diode triode V9, together with the oscillatory circuit L25, C75. The frequency is determined by the low-temperature-coefficient crystal in the control grid circuit, which operates in conjunction with the grid leak resistor R36 and the capacitance trimmer C55. The latter is provided in order that the beat frequency oscillation may be adjusted to exactly 600 kc/s, since the accuracy of the scale-checking system depends upon the accuracy with which this frequency is maintained.

70. The BFO is switched off by interrupting the anode HT supply between R35 and L26 at the switch unit S11R. This occurs only when the SYSTEM switch is in the R/T position.

Second detector

71. One of the diode sections of the valve V9 is used as the second detector; the other diode section is not used. When the BFO is switched on, the heterodyne oscillation also is fed into the detector input circuit L24, C77, via the anode-grid capacitance of V9.

72. The load circuit of the detector consists of R74 and R42 in series, shunted by C70 which acts as the 'reservoir' capacitance of the detector system. The AF voltage across R42 is applied (through C68 and R43) to the potentiometer R81, which is the AF gain control. The AF signal is fed from the tapping of the latter directly into the control grid of the valve V11, the triode portion of which functions as an AF amplifier. The noise limiter circuit is connected across the diode load; its operation is explained in para. 82-85.

AVC system

73. The more common forms of AVC suffer from the defect that when the signal strength increases, the signal/noise ratio does not increase so rapidly as is desirable. This is because the same AVC voltage is usually applied to both RF and IF stages. In this receiver, the defect is overcome by delaying the AVC voltage applied to the RF amplifier until an appreciable AVC voltage has been applied to the IF amplifier.

74. In order that efficient AVC may be obtained without controlling the mixer valve, a DC amplified system is employed. This eliminates frequency variation with change of signal amplitude in the local oscillator, and also prevents overloading at high input levels.

75. The main AVC detector is the diode D1 in V8, the input voltage being derived from the tap on the secondary L23 of the IF transformer. The resulting rectified current flows through R30, R31 and R32. In the absence of any signal input there is, of course, no rectified output and the cathode of V8 is maintained at approximately 30 volts positive to earth by the space current through R30, R51 and R52. During the reception of a signal the rectified bias voltage developed across R30 and R32 is applied to the control grid of V8 through R29, and the anode current falls.

76. When the AVC switch is 'on' (S14F closed) there is a chain of components connected between the junction of R51 and R52, and the tapping on the RF GAIN potentiometer R83, namely, the diode D3 (part of V10) S14F, R59 and R62. Suppose the RF GAIN control to be set to the mid-point of its voltage range (this is not the mid-point of its travel). Then the tapping on R83, and consequently the anode of D3, will be at -28 volts to earth. When the junction of R51 and R52 (and consequently the cathode of D3) falls below -28 volts, therefore, the diode D3 becomes conductive, and a bias voltage is developed across R59, R62 and part of R83. This voltage is applied to the IF valves via the IF AVC line. Any further increase in the input signal will cause a further fall of potential at the junction R51, R52 and a consequent increase in the voltage across R59, R62, i.e., in the IF AVC voltage.

77. The anode of the diode D2 (part of V8) is normally at about 1.5 volts below earth potential (the switch unit S14F being closed). As the signal strength increases, the potential of the cathode of V8 falls, and may eventually become lower than the potential of the anode of D2. If this occurs, D2 also becomes conductive and a negative bias voltage is developed across R58 in addition to the -1.5 volts at the junction R57, R60. This bias is supplied to the RF amplifier valve V1 via the RF AVC line, and also to the control grid of the guard mixer valve V4.

As previously stated, the main channel mixer valve V3 is not subject to AVC.

Manual gain delay

78. The standing bias for the IF valves is provided by the potentiometer network R83, R62 and R61 between earth and the HT negative. Standing bias for the RF valve V1 and guard mixer valve V4 are provided by the network R45, R57, R58, R60.

79. It is desirable to maintain the above delay action (by which the bias applied to the RF valve is delayed until about 5 volts bias has been applied to the IF valves) when the AVC is switched off and manual gain control only is in use. This is achieved by the diode D4 (part of V11) in conjunction with the network R57, R56. The junction R57, R56, is maintained at 5 volts above earth potential by a positive feed from the HT line via R45 in conjunction with the diode D4 and the resistor R44. The resistors forming the fixed potentiometer R57, R60, are so chosen that $6\frac{1}{2}$ volts are developed across R57, and the junction between R57 and R60 is then $1\frac{1}{2}$ volts negative with respect to earth. This is the standing bias fed into the RF AVC line.

80. As the sensitivity is reduced by the manual RF GAIN control R83, bias is applied to the IF valves via R62 and R59, but the potential (+ 5 volts) at the junction R57, R56, is held constant by the diode D4 until the RF GAIN control has been moved far enough to annul this potential. The diode D4 then ceases to conduct and the bias developed across the operative portion of the RF GAIN control is then applied to the RF AVC line via R57 and R58.

81. From the foregoing it will be seen that the bias applied to the RF valve is delayed until 5 volts bias has been applied to the IF valves, whether the AVC is switched "on" or "off". This ensures that the highest possible signal/noise ratio is maintained at all signal levels.

Noise limiter

82. The noise limiter operates on any voltage pulse of short duration, provided that its amplitude is greater than that of the signal level at the instant it occurs. Referring to fig. 21, the cathode of the limiter diode D5, (part of V10) is connected to the junction R74, R42, the latter being part of the second detector diode anode load (*para.* 72). The anode of the limiting diode is connected via a 2.2 megohm resistor R39 to the negative

end of the resistor R74. The condenser C67 ($0.1\mu\text{F}$) is connected between the diode anode and earth by the switch S13 when the limiter is switched on (i.e., in positions 1 and 2).

83. When a signal of normal level is received, the limiter diode does not conduct because the condenser C67 becomes negatively charged from the detector diode load via R39. When a pulse of appreciably greater amplitude than the signal level is received, however, the cathode of the limiter diode is impulsed negatively. The limiting diode anode is also connected to a point receiving a negative pulse, but it cannot follow this change of potential instantaneously because of the large time-constant of R39 and C67 (about 0.3 second). The cathode thus becomes momentarily more negative than the anode and the diode becomes conductive. The diode and C67, in series, now form a low-impedance path shunting C68, R43 and R81. In effect, therefore, the input circuit to the AF amplifying valve V11 is short circuited during the pulse.

84. When the resistor R40 is also connected between the anode of D5 and earth by placing the switch S13 in position 2, the standing potentials of the anode and cathode of the limiting diode are made more nearly equal. Consequently, upon the receipt of a pulse, limiting commences even more rapidly than when the switch is in position 1. Position 2 is intended chiefly for MCW reception, where distortion of the audio waveform of the signals is not important, but may also be used for R/T reception if the additional distortion can be accepted.

85. It is important to appreciate the action of the switch unit S11F, in connection with the limiting circuit. The switch unit connects R40 between the anode of D5 and earth in all positions of the SYSTEM switch other than R/T. It follows therefore that, provided the limiter switch S13 is not in the OFF position, the higher degree of limiting action is always applied for CW reception. Another pair of contacts on switch unit S11F connects R41 in parallel with R42 in all except the "300 c/s bandwidth CW" position of the SYSTEM switch. This gives greater AF gain on the 300 c/s position to compensate for the additional attenuation introduced by the narrow-width filter.

AF amplifier and output stage

86. The AF amplifying valve V11 is coupled to the output valve V12 by an AF filter

consisting of L27, L28 and several associated condensers. The filter is of the type commonly known as 'top-end capacitance coupling.' The circuit is shown in detail in the diagram of the output unit K (*fig. 17*), and in simplified form in *fig. 21*. Three degrees of AF selectivity are provided by the switch units S12R and S12F; the action of the switches is as follows.

87. In position 1 of the SYSTEM switch, S12R and S12F perform the following operations.

(1) S12F :—

(a) Connects the tapping on L27 nearest to the HT positive end of the coil to the anode of V11, i.e., the lowest value of inductance is in circuit.

(b) Shunts C124 and C81 (in parallel) across L28.

(c) Connects the inter-valve coupling condenser C86 to the grid of the valve V12 (through R26).

(2) S12R :—

(a) Shunts C83 and C123 (in parallel) across the whole of L27.

(b) Connects inter-valve coupling condenser C86 to the end of L27 joined to contact D on S12R.

88. On rotating the SYSTEM switch into position 2, the following actions occur.

(1) S12F :—

(a) Disconnects the previous tapping on L27 from the anode of V11 and connects the other tapping on L27 to this anode. This increases the amount of inductance in circuit.

(b) Disconnects the inter-valve coupling condenser C86 from the junction of R26 and L28, and connects in its place the parallel combination C85, C78.

(c) Disconnects the shunt condensers C81 and C124 across L28 and substitutes a shunt combination of C80, C125, R49 (all in parallel).

(2) S12R :—

(a) Disconnects the shunt condensers

C83, C123 (in parallel) across the whole of L27 and substitutes C82 and C126 in parallel.

(b) At the same time it disconnects C86 from the end of L27 joined to contact D on S12R and substitutes the parallel combination C85, C78.

89. On rotating the SYSTEM switch into positions 3, 4 or 5, the circuits are changed as follows :—

(1) S12F :—

(a) Disconnects previous tapping on L27 from anode of V11.

(b) Disconnects the shunt C80, C125, R49 across L28.

(c) Disconnects coupling condensers C85, C78 from R26.

(d) Connects C84 from anode of V11 to R26.

(e) Connects R47 across L28.

(2) S12R :—

(a) Disconnects the shunt C82, C126, across L27.

(b) Connects whole of L27 between R46 and anode of V11.

Output transformer

90. The output transformer has two secondary windings. One of these, giving a low level balanced output, is taken to points 14 and 16 on the Jones socket SK2 at the rear of the receiver. The other secondary is tapped, the tapplings being taken to a small panel mounted on the transformer. This carries terminal points marked 1, 2 and 3, the desired output being selected by a screw-in connector. This secondary gives either high-level or a low-level unbalanced output, the arrangements being as follows.

91. The point 14 on the socket SK1 (at the rear of the receiver) is permanently connected to the high-potential end of the unbalanced secondary winding, the other end of which is connected to earth. Point 15 on SK1 is also earthed. From points 14 and 15 on SK1, therefore, a high-level output can be obtained into a load of 600 ohms impedance. It should be noted that this facility is

available irrespective of the tapping selected on the transformer.

92. A low-level output can be obtained by plugging telephones into the jacks provided on the front panel. The transformer must be set according to the impedance of the telephones, tapping 1 being used for 20,000-ohm phones, tapping 2 for 600-ohm phones, and tapping 3 for 150-ohm phones.

93. The maximum undistorted output at

the low-level terminals is 3.75 milliwatts, and at the high-level terminals, 150 milliwatts.

Tuning indicator

94. The tuning indicator V13 is operated from the cathode of the AVC DC amplifier (part of V8). If two or more receivers are used together for diversity reception with their AVC lines linked this method of tuning allows each receiver to be tuned independently by means of its own tuning indicator.

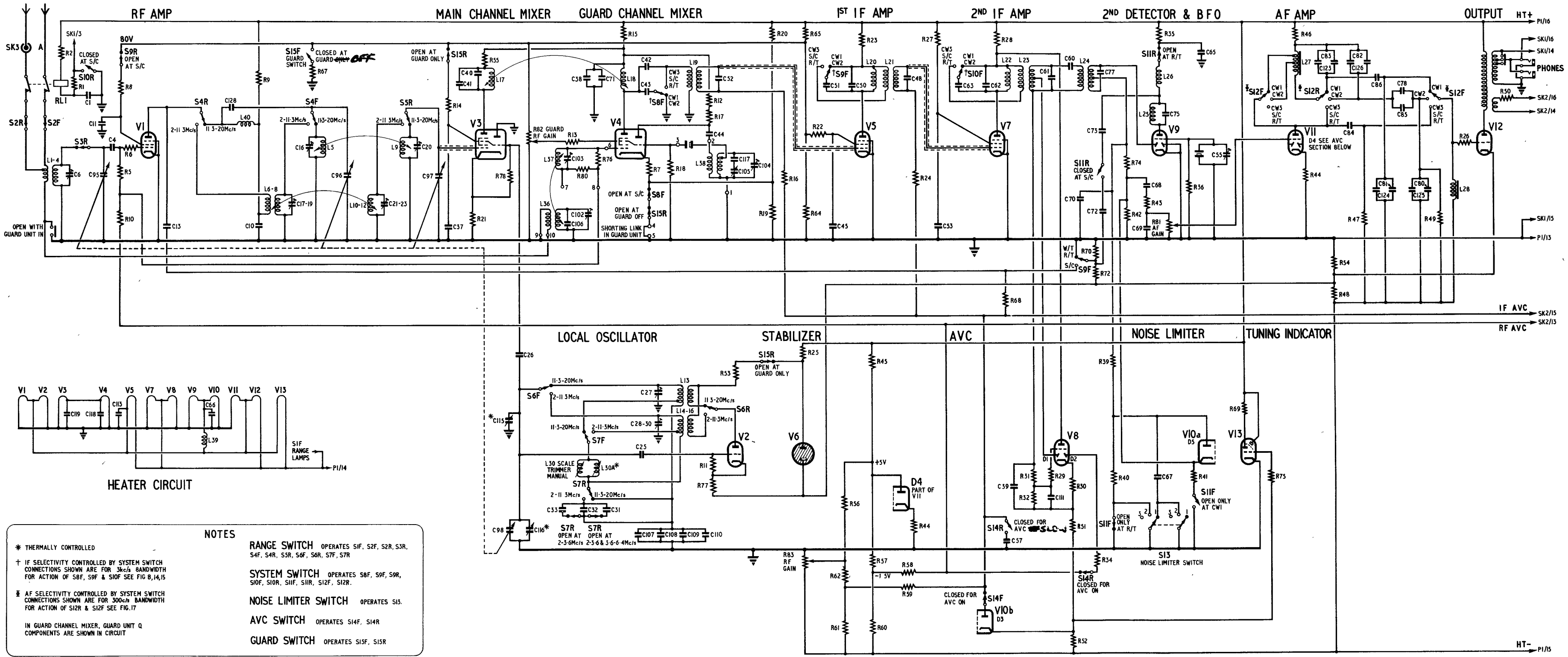

NOTES

* THERMALLY CONTROLLED

† IF SELECTIVITY CONTROLLED BY SYSTEM SWITCH CONNECTIONS SHOWN ARE FOR 3kc/s BANDWIDTH FOR ACTION OF S8F, S9F & S10F SEE FIG. 8, 14, 15

‡ AF SELECTIVITY CONTROLLED BY SYSTEM SWITCH CONNECTIONS SHOWN ARE FOR 300-c/s BANDWIDTH FOR ACTION OF S12R & S12F SEE FIG. 17

IN GUARD CHANNEL MIXER, GUARD UNIT Q COMPONENTS ARE SHOWN IN CIRCUIT

RANGE SWITCH OPERATES S1F, S2F, S2R, S3R, S4F, S4R, S5R, S6F, S6R, S7F, S7R

SYSTEM SWITCH OPERATES S8F, S9F, S9R, S10F, S10R, S11F, S11R, S12F, S12R.

NOISE LIMITER SWITCH OPERATES S13.

AVC SWITCH OPERATES S14F, S14R

GUARD SWITCH OPERATES S15F, S15R

FIG. 21
4464 M.32639 G.928 6/51 1800 T.B.L. 55

SIMPLIFIED CIRCUIT DIAGRAM, RECEIVING UNIT TYPE 88

FIG. 21

Chapter 2

POWER SUPPLY, R.1475

LIST OF CONTENTS

	Para.		Para.
Requirements	1	Circuit details	9
Power unit Type 360	2	Circuit with AC input	11
General arrangement	4	Circuit with DC input	18

LIST OF ILLUSTRATIONS

	Fig.		Fig.
Power unit Type 360, front view with dust cover removed	1	Power unit Type 360, underside of 3-position switch	4
Power unit Type 360, rear view	2	Location of components in filter unit Type 141	5
Power unit Type 360, right-hand side view	3	Power unit Type 360, circuit	6
		Power unit Type 360, simplified circuit	7

Requirements

1. The power unit used with the receiving unit Type 88 must be capable of supplying 250 volts HT, 12 volts LT and 55 volts negative grid bias when operated either from 190/240 volt AC mains, or from a 12-volt battery. The present standard power unit fulfilling this requirement is the power unit Type 360.

Power unit Type 360

2. When used on an AC mains supply the power unit Type 360 operates in the conventional manner, the input voltage being applied to the primary winding of a transformer. The HT secondary output of the latter is rectified by a bridge-type metal rectifier, the total output DC voltage being of the order of 300 volts. This is split (in the receiving unit Type 88) to provide 250 volts HT (approx) and 55 volts (approx) grid bias. The LT secondary provides a 12-volt AC supply to the valve

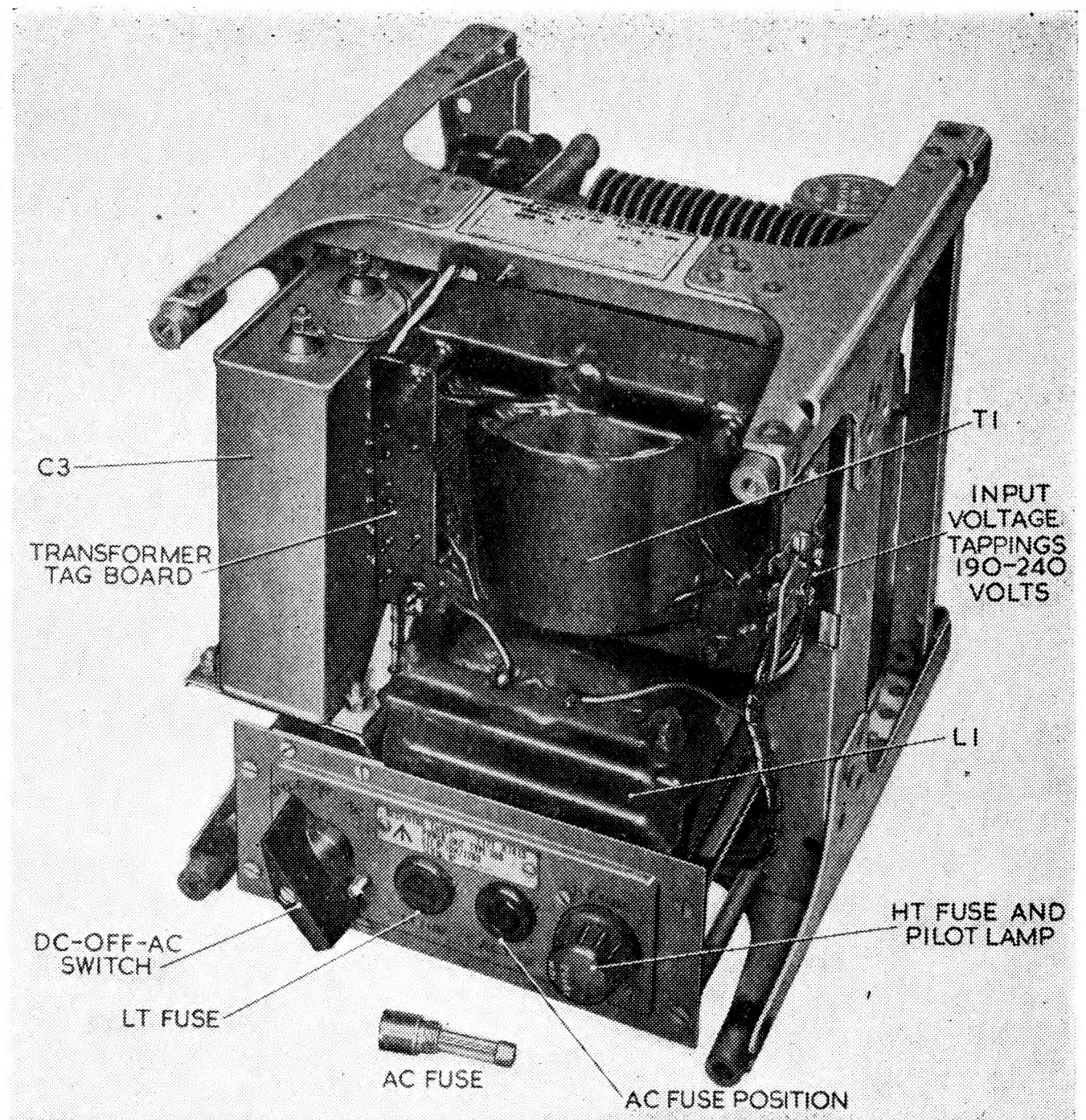

Fig. 1. Power unit Type 360, front view with dust cover removed.

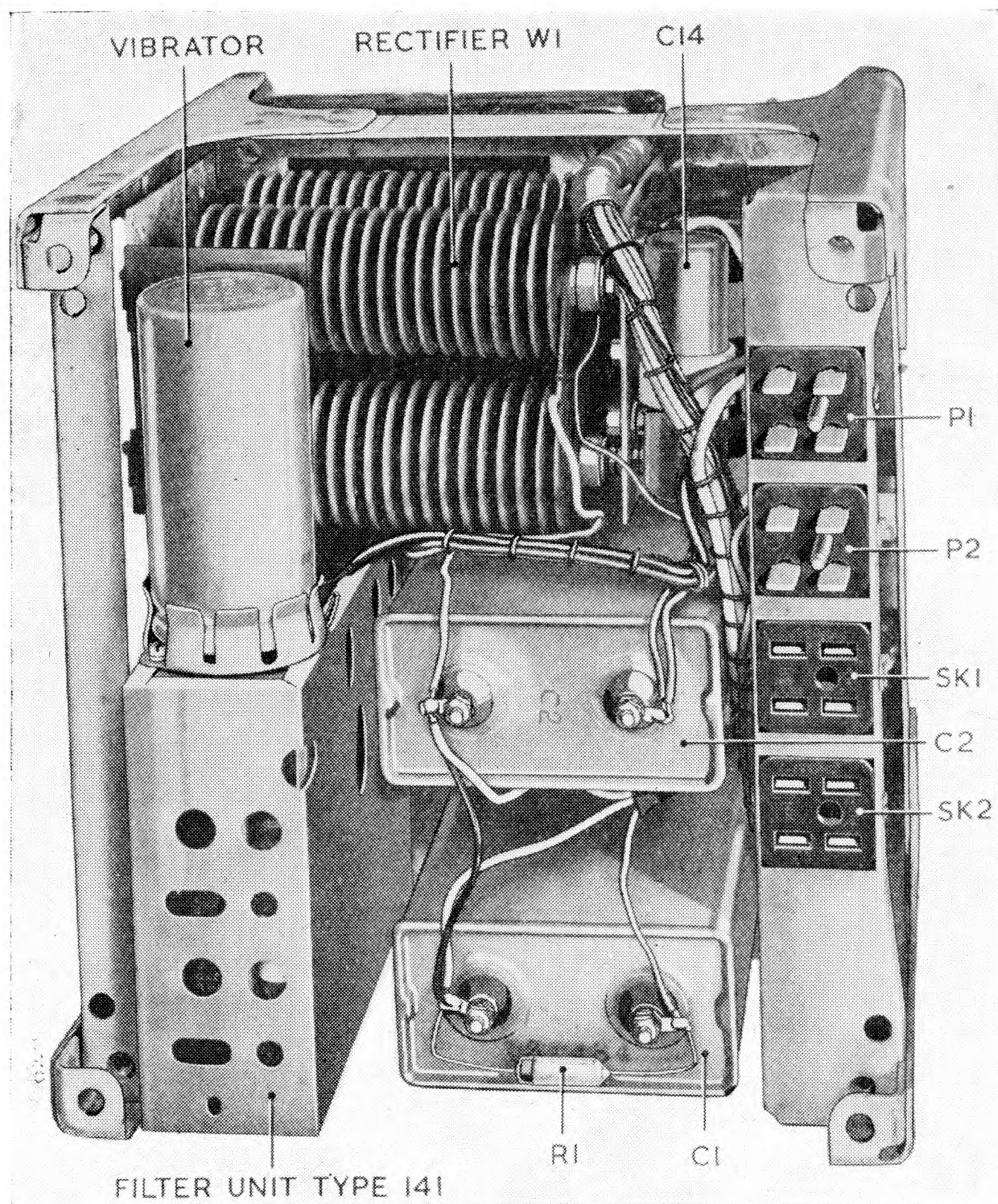

Fig. 2. Power unit Type 360, rear view

heaters ; the latter are of the 6.3-volt type and are run in groups, connected two in series across the LT supply, as shown in fig. 1, Chap. 3, of this Part.

3. When used on a 12-volt battery supply the same transformer is used, the DC output of the battery being converted into an alternating current by a vibrator unit before being applied to the primary winding of the transformer. In this connection, it must be understood that when using a DC input, the winding used, on AC, as the 12-volt secondary for valve heater supply becomes part of the primary winding, while the winding used as the primary on AC becomes part of the secondary winding. The circuit changes are made by the main 3-position switch as described in para. 6 *et. seq.*

General arrangement

4. The general arrangement of the main components is seen in fig. 1, 2, 3, and 4. The principal ones are the mains transformer T1, the filter unit Type 141, the rectifier unit Type 4, and the main switch. Fuses are provided in the 12-volt DC supply, the AC supply and the positive HT output lead.

5. Filter unit Type 141 consists of a metal screening box somewhat similar in size and shape to the plug-in units of the receiving unit Type 88. A vibrator unit is mounted on top of this unit in a cylindrical metal can with an American four-pin base. It is thus easily replaced by a spare, after removing the dust cover of the power unit. The main body of the filter unit houses the chokes and condensers of the filter system. The location of most of these components is shown in fig. 5.

6. The main switch has three positions, namely, 12-V DC, OFF,

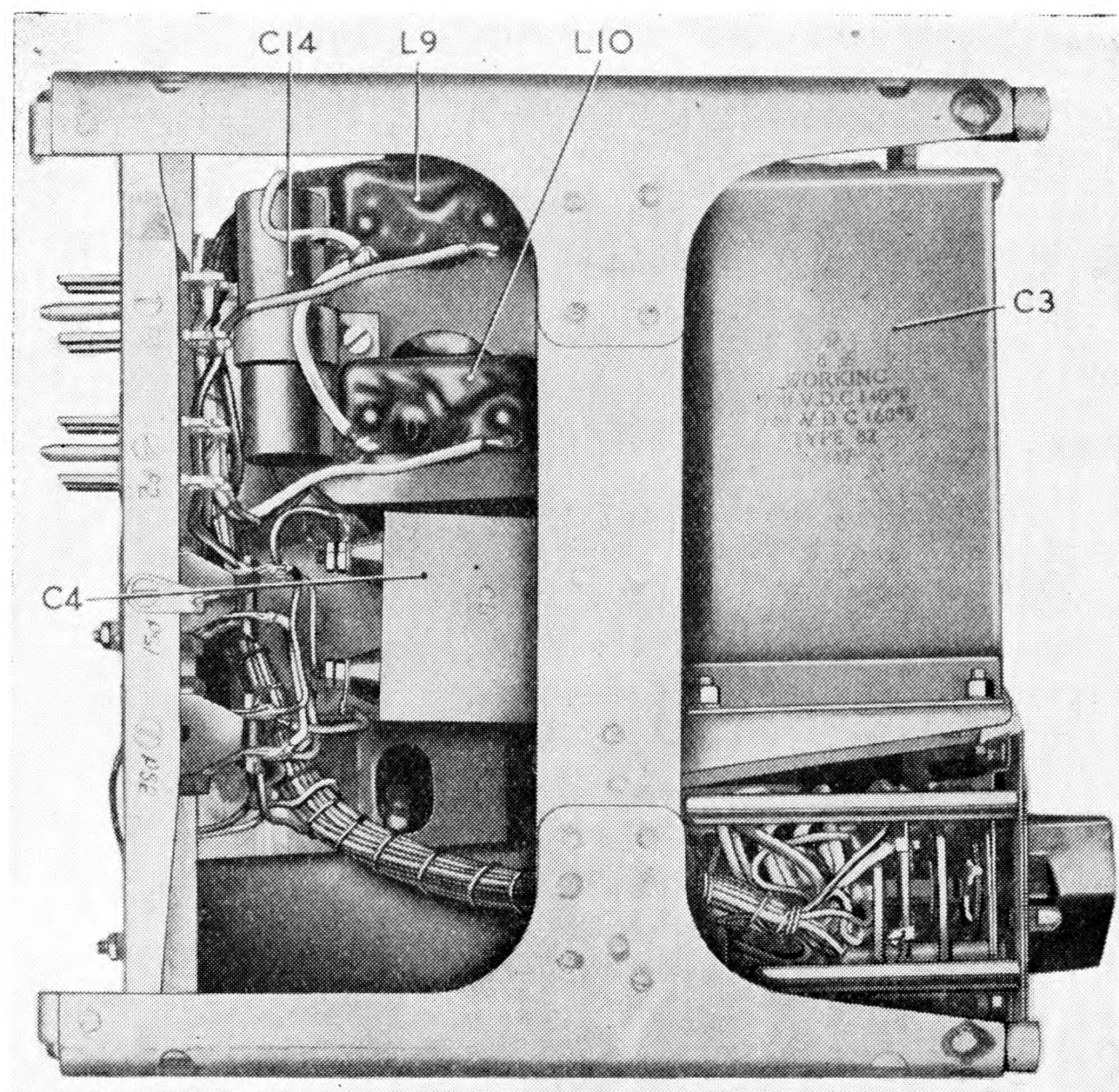

Fig. 3. Power unit Type 360, right-hand side view

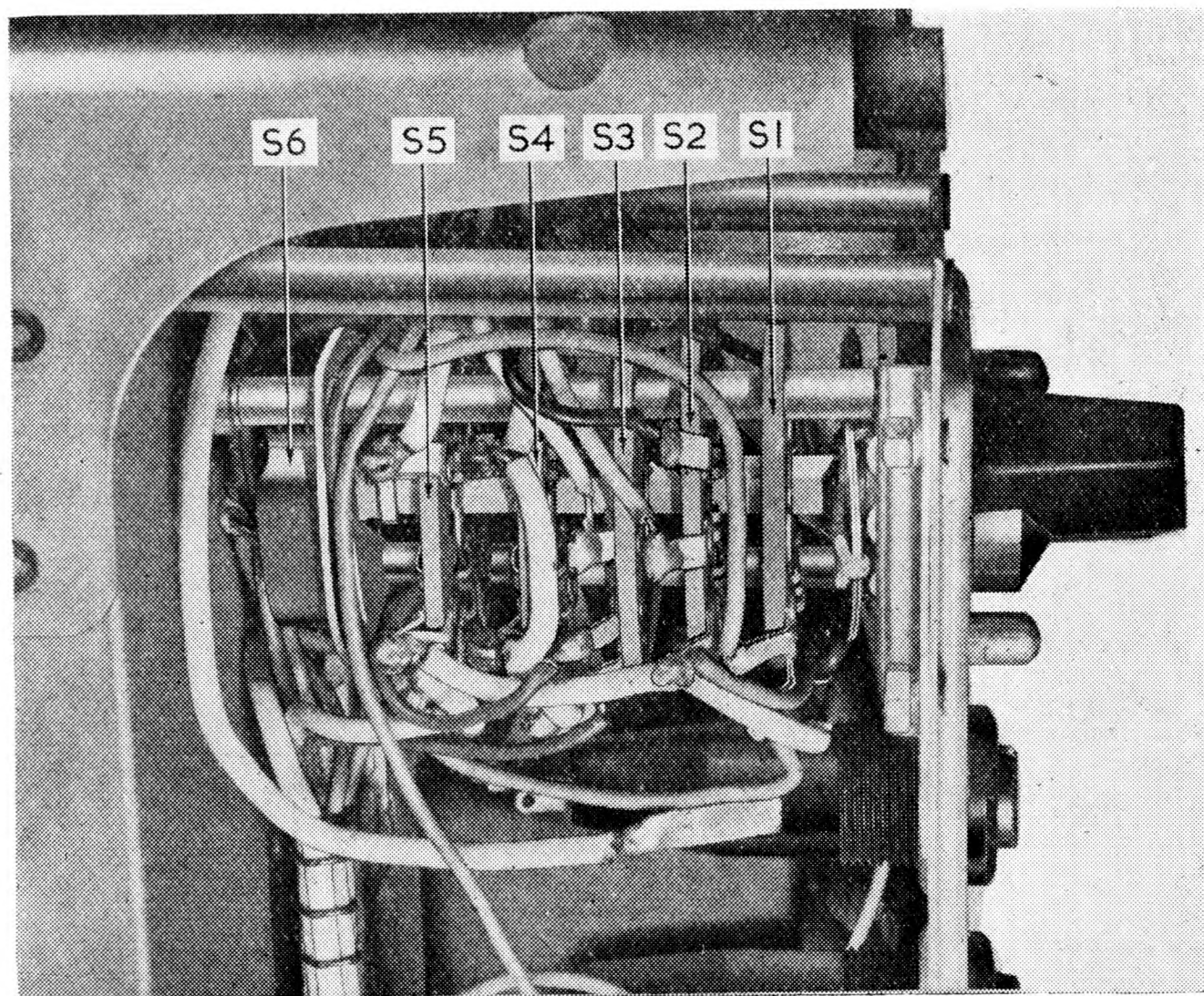

Fig. 4. Power unit Type 360, underside of 3-position switch

and AC. It consists of five wafer switches comprising seven switch units, referred to as S1F, S2F, S3R, S4F, S4R, S5F and S5R. The five switches are mounted on a common spindle, the end of which is arranged to operate, when switching from the OFF position to the AC position or vice versa, a toggle-actuated quick make-and-break switch S6, in the main AC supply circuit. This switch, S6, is not actuated when switching from the OFF position to the 12-v DC position and vice versa.

7. The seven switch units perform the circuit changes required for the two kinds of power output. Referring to fig. 6, it will be seen that corresponding contacts of S4F and S4R are "commoned," as are also the corresponding contacts of S5F and S5R. On each of these switch units, also, certain contacts are "commoned," for example, on S4F contacts 7 and 10 are commoned, contacts 3 and 12 are commoned and contacts 1, 4, and 6 are commoned. This has been done in order to provide ample current-carrying capacity in the switching system.

8. The rear of the power unit carries two Jones plugs P1, P2, and two Jones sockets SK1, SK2. The plug P1 is the battery connection and is marked DC INPUT. Plug P2 is marked AC INPUT. The Jones sockets are alternative outputs, all similarly-numbered points being commoned. Points 13 and 14

are the LT output, 13 being earthed and 14 being the LT positive. Points 15 and 16 are the HT output, 16 being positive. This marking corresponds with that on the power input plug of the receiving unit Type 88.

Note . . .

The two alternative output Jones sockets must never be used to supply two receiving units Type 88 at the same time. This is because the power rating of the mains transformer is insufficient to cope with the LT and HT requirements of two receiving units simultaneously.

Circuit details

9. A complete circuit diagram of the power unit is given in fig. 6 and a simplified diagram in fig. 7. In tracing circuits, it is necessary to remember that, as stated in para. 2 and 3, the transformer functions in the normal manner when using an AC supply, the winding connected

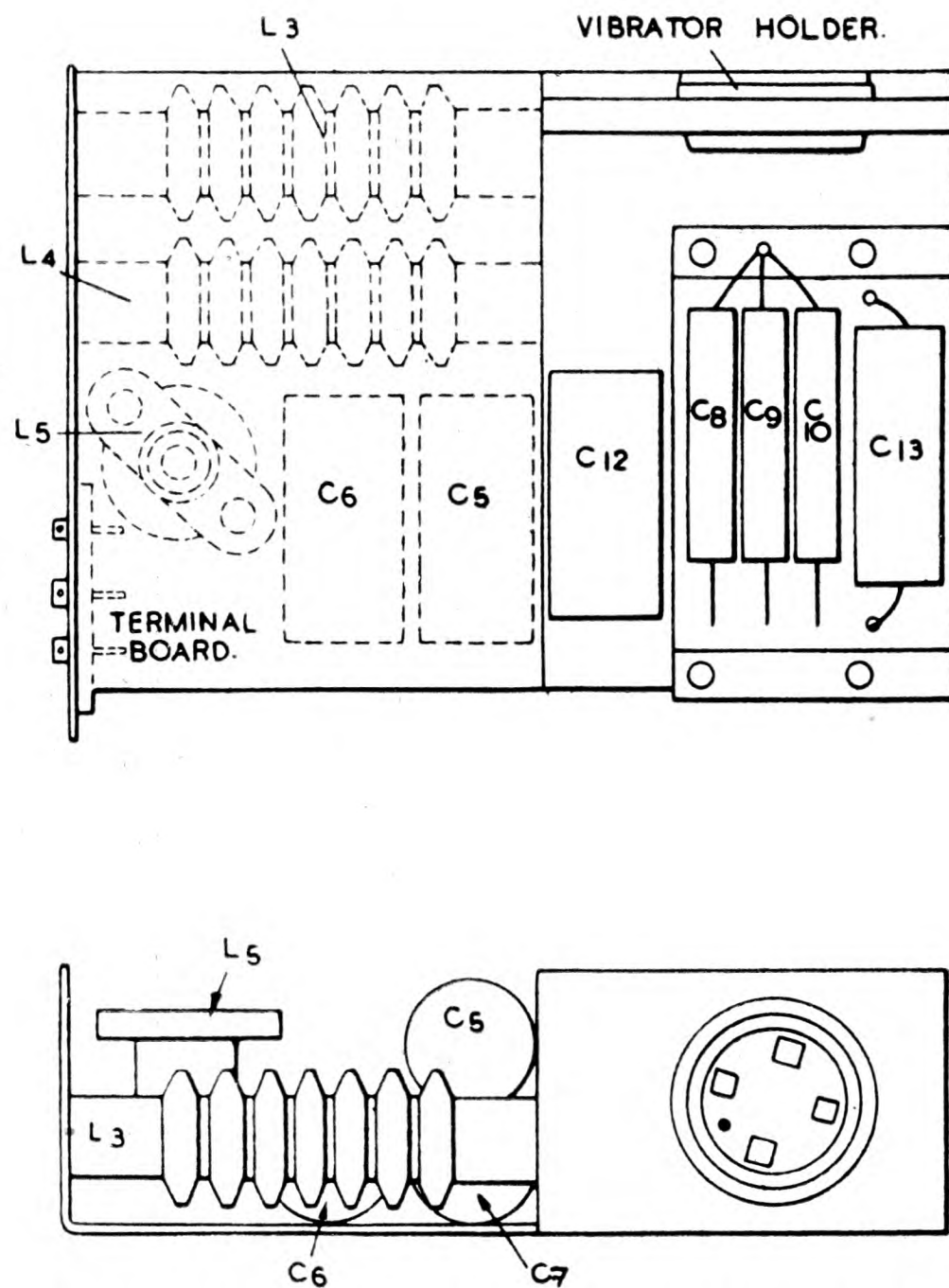
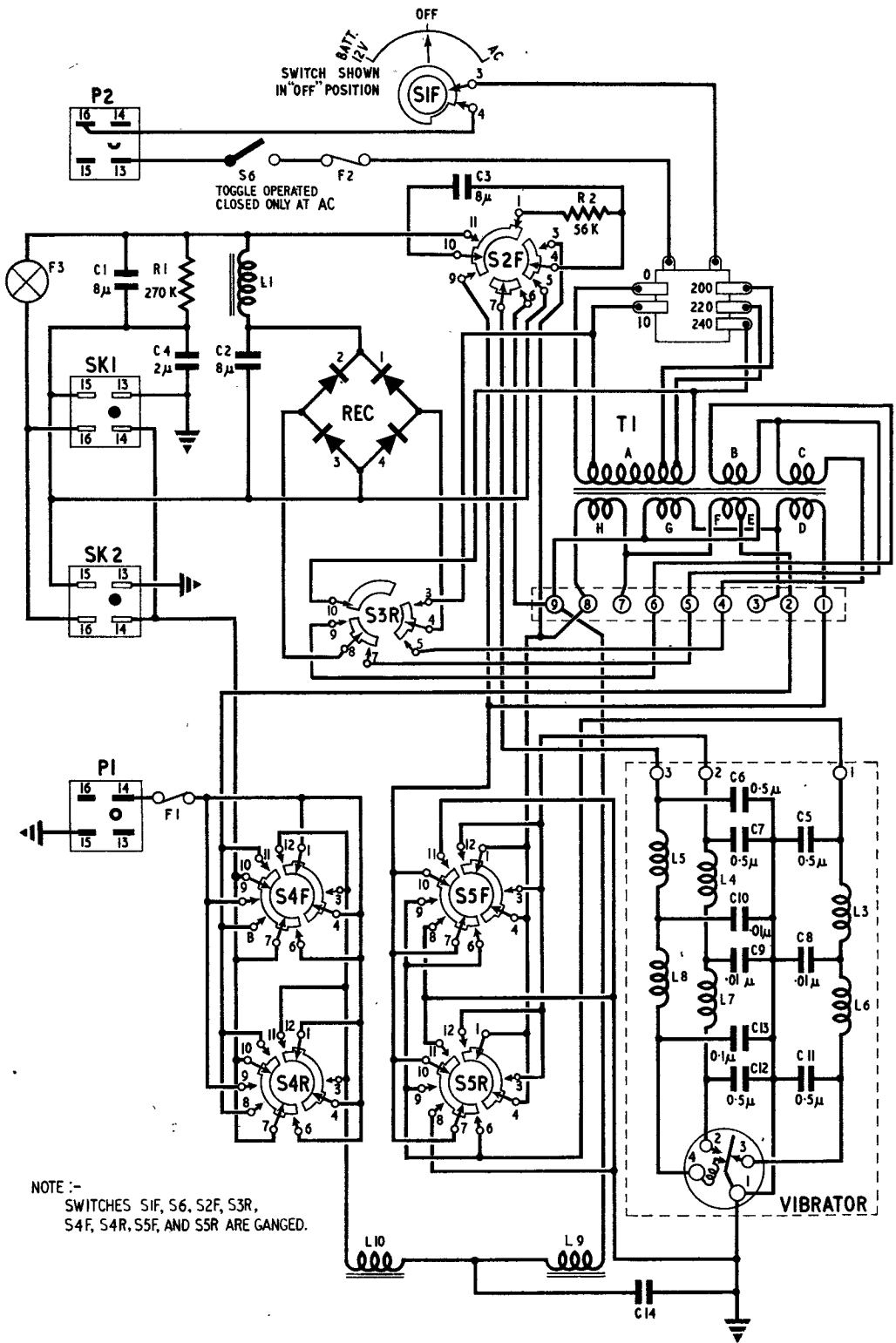

Fig. 5. Location of components in filter unit Type 141



NOTE :-
 SWITCHES S1F, S6, S2F, S3R,
 S4F, S4R, S5F, AND S5R ARE GANGED.

Fig. 6. Power unit Type 360, circuit

to the 240-220-200-10-0 volt tappings being used as the primary. When using a battery supply, however, this winding becomes part of the secondary, i.e., output, winding. For this reason, instead of being marked "primary" and "secondary," the windings have been lettered A, B, C, etc. in the circuit diagrams.

10. In the following description, where switches or contacts are "commoned," only one of the possible paths through the commoned points is mentioned. The circuits are most easily traced by reference to fig. 7, but fig. 6 should be consulted with regard to the physical connections of the switch unit contacts.

Circuit with AC input

11. Starting from point 13 on the input plug P2, the circuit may be traced through the quick make-and-break switch S6 and the fuse F2 to one tapping on the voltage tapping board, and thence through the selected tapping (0 or 10) to one end of winding A. From the other end of the winding one of three tappings may be selected, viz., 200, 220, or 240 volts. From this point the circuit is taken through the switch unit S1F, and then back to plug P2, point 16. It should be noted that switch unit S1F does not break this circuit when in the OFF position because its break is not sufficiently rapid to extinguish arcing. Hence the necessity for the switch S6.

12. The windings B and C function as the HT secondary, and are connected in series. One end of B is connected to tag 6, and one end of C to tag 4, the junction of B and C being connected to tag 5. Tags 4 and 6 are connected to the two input terminals of a bridge-type metal rectifier via contacts 5, 4 and 9, 8 respectively on wafer S3R of the main switch.

13. The first filter condenser C2 is connected directly across the output terminals of the rectifier. From its positive side the HT DC circuit continues through the smoothing choke L1 and the HT fuse F3, which is a 6·2-volt lamp, to a point 16 on the output sockets SK1, SK2. The negative end of the rectifier is directly connected to the points 15 on the output sockets.

14. From the output side of the choke L1, the condenser C1 is connected to the

negative HT output line, a bleeder resistor R1 being shunted across it to ensure that it does not retain a charge when the power unit is switched off. The condenser C4 is connected between the negative HT line and earth.

15. On no account must the negative HT line be directly earthed, as it is used to provide the required -55 volts grid bias, i.e., it is 55 volts below earth potential. A condenser C4 is connected between the negative HT line and earth.

16. The LT supply is derived from the windings D, G and E, which are connected between tags 1 and 2 of the transformer tagboard. From tag 2, the circuit may be traced through contacts 8 and 7 on switch unit S4R to the point 14 on the output sockets, which are accordingly marked 12-v DC/AC. As the LT negative of the receiver is earthed, the current returns from earth, through contact 8 on the switch unit S5F, thence via contact 7 to tag 1 on the tagboard, and so back to the transformer.

17. The condenser C3 is an additional smoothing capacitance. When using AC supply it is connected in parallel with C1 by the action of switch unit S2F. When this switch is in the OFF position, the resistor R2 is connected directly across this condenser, and thus discharges it.

Circuit with DC input

18. When used with a DC input the windings D, E, F, G, H become the primary winding, and the windings A and B become the HT and the windings A and B become the H secondary. The battery is connected to terminal 14 (positive) and 15 (negative) on the plug P1. From 14 the circuit may be traced through the battery fuse F1 to contact 1 on the switch unit S4R, thence via contact 12 to the smoothing chokes L10 and L9, and so on to tag 9 on the tagboard.

19. At tag 9 the circuit divides into two branches, one of which is the driving circuit of the vibrator unit, and the other the feed to the centre-tapped primary winding of the transformer. The driving circuit proceeds via contacts 6, 7, on switch unit S2F to the terminal 3 on the filter unit Type 141, thence via chokes L5, L8 to the driving coil of the vibrator unit. From the latter, when the vibrator contact is closed, there is a direct path through the vibrator reed to earth;

when the vibrator contact is open, there is no circuit and the driving coil is not energized. Thus the driving coil and reed function as a self-driving interrupter. The battery is earthed at point 15 on plug P1.

20. One-half of the centre-tapped primary winding may be traced from tag 9, through winding G and D in series to tag 1, and the other half through windings E, F, and H in series to tag 8. From tag 1 the circuit continues through contacts 7, 6 on switch unit S5F to terminal 1 on the filter unit Type 141. Similarly, from tag 8 a circuit may be traced through contacts 1, 12 to terminal 2 on the filter unit. Terminal 1 is connected through chokes L3 and L6 to one of the converter contacts of the vibrator, while terminal 2 is connected through chokes L4, L7, to the other.

21. When the reed is in vibration, therefore, the two halves of the centre-tapped primary winding are connected to earth alternately. The windings are so arranged that they cause fluxes of opposite polarity to be set up in the core. The windings G, D in series, or E, F, H in series, thus act alternately as the primary of a step-up transformer, of which the secondary is constituted by the windings A and B in series.

22. The HT DC supply is obtained from the transformer as follows. From the 240-volt end of the winding A the circuit is taken via contacts 9 and 10 on switch unit S3R to winding B on the transformer, and thence to tag 5. From the latter point the circuit continues through contacts 7 and 8 on switch unit S3R to one input terminal of the rectifier unit (i.e., the junction of rectifier elements 2 and 3, *fig. 7*). The opposite input terminal of the rectifier unit (i.e., the junction of rectifier

elements 1 and 4) is connected to the tapping at the "0-volts" end of winding A through contacts 4 and 3 on switch unit S3R.

23. The above arrangements provide an HT AC supply to the rectifier which, therefore, functions in the same manner as when the switch is in the AC position.

Note . . .

Since the main switch is at 12-V DC, the switch S6 and the switch unit S1F are open, and there is no circuit to the plug P2. Thus, where a mains supply is normally used, and the battery supply is used merely as a stand-by, the latter may be switched on, when required, without disconnecting the mains supply at P2.

24. The condenser C3, which as already stated is switched by the switch unit S2F, is connected directly across the outer ends of the centre-tapped primary (tags 1 and 8) when the main switch is in the 12-v DC position.

25. When using the 12-volt battery supply the receiver unit Type 88 obtains its LT supply directly from the battery as follows. From point 14 on P1, which is connected to the positive pole of the battery, the circuit continues to contact 6 on switch unit S4R, thence to contact 7, and from the latter directly to point 14 on the output sockets SK1 and SK2. The negative pole of the battery is earthed at point 15 on P1 in the power unit, while the negative side of the heater circuit in the receiving unit is also earthed. The two earthed points are connected by one core of the twin connector and are also bonded to the braiding of the connector at each end.

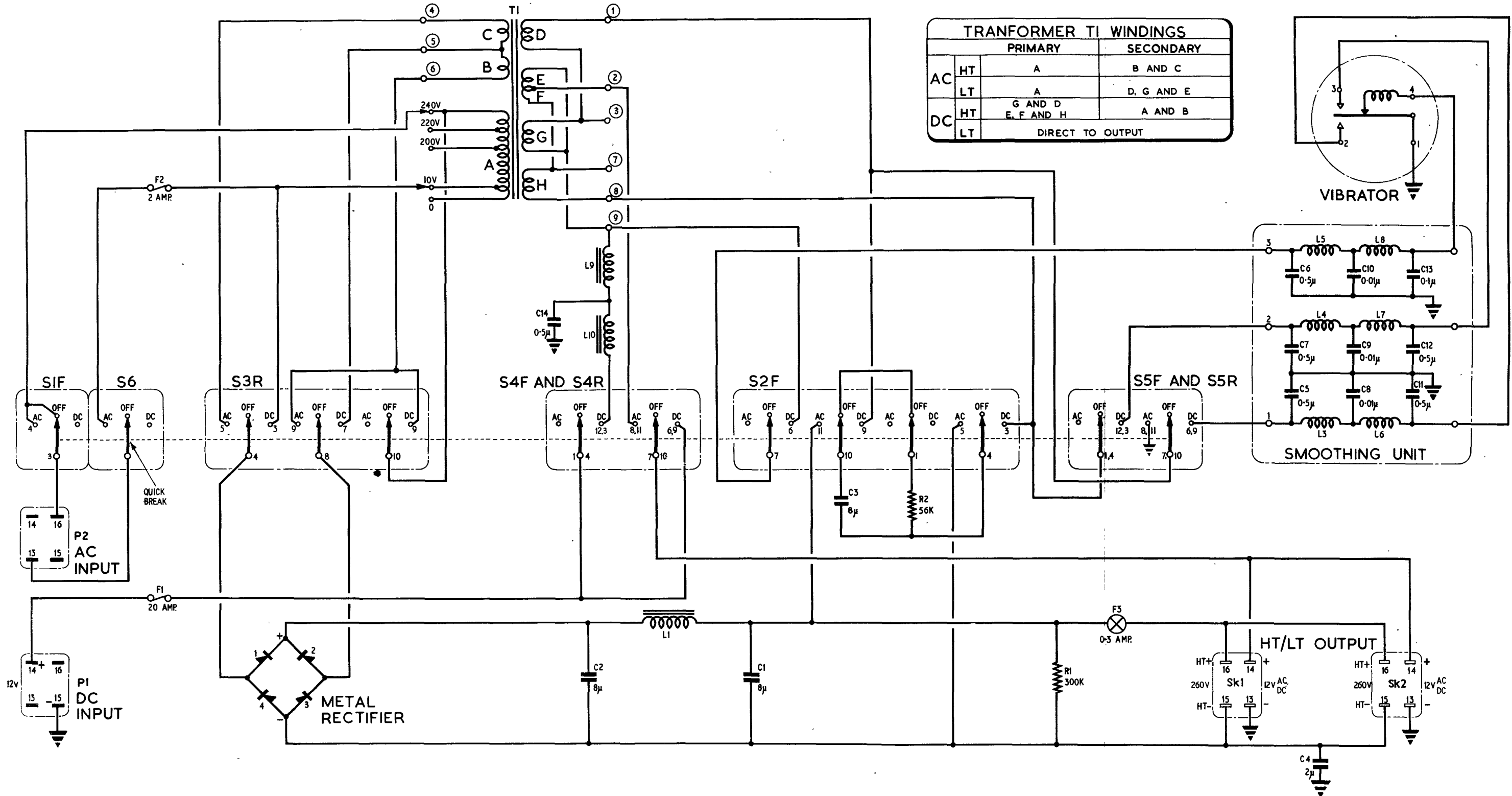

FIG. 7

POWER UNIT TYPE 360, SIMPLIFIED CIRCUIT

FIG. 7

Chapter 3

SERVICING INFORMATION, R.1475

LIST OF CONTENTS

	Para.		Para.
Removal of plug-in units	1	Signal frequency amplifier performance	42
Removal of filter unit Type 141	3	Sensitivity in R/T condition	44
Re-alignment of receiver	4	Sensitivity using open wire aerial	47
Alignment of IF amplifier	6	Sensitivity in 1.2 kc/s CW condition	48
Adjustment of the second heterodyne	11	Image rejection	50
Calibration of receiver		Intermediate frequency rejection	51
Approximate alignment of heterodyne oscillator	16	Keying relay attenuation	54
Final alignment of heterodyne oscillator	21	Scale trimmer test	55
Alignment of RF circuits	25	Automatic gain control	58
Guard unit alignment	30	AGC noise characteristic	61
Acceptance tests	35	Overall fidelity	62
General tests	36	Calibration (tuning scale)	65
Heat run	37	Frequency changer oscillator stability	67
High/low voltage tests	38	Guard unit sensitivity	69
Audio-frequency tests	39	Selectivity, image rejection	71
IF amplifier performance	40		

ILLUSTRATION

Receiving unit Type 88—circuit Fig. 1

Removal of plug-in units

1. Before removing any one or more of units D, E, G, J and K, it is necessary to remove the SYSTEM switch bar. Similarly, before removing one or more of the units A, B and C, it is necessary to remove the RANGE switch bar.

WARNING

If this is not done before trying to unplug the unit or units, the switch bar may be bent and the switches in the plug-in units damaged.

2. To remove one of the plug-in units, therefore, the following procedure should be followed, after removing the dust cover.

- (1) Remove the appropriate switch bar. To do this, first remove the small securing screw with its spring washer, and then withdraw the bar with a pair of pliers. Replace the securing screw and washer to prevent loss.

- (2) If the plug-in unit to be removed is either C or D (or both) unsolder the short lead connecting unit C to unit D.
- (3) Remove the valve or valves, or, on unit A, the relay unit.
- (4) Remove any leads which may be plugged into sockets A and B on the top of the unit.
- (5) Slacken off two captive screws at the top of the plug-in unit. These are accessible from the rear.
- (6) Invert the receiver and slacken off two captive screws at the bottom of the plug-in unit. These are accessible from the front.
- (7) The plug-in unit may then be withdrawn.

Removal of filter unit Type 141

3. This is fitted in power unit Type 360. To remove it, proceed as follows:—

- (1) Remove the dust cover, and invert the power unit.
- (2) Unsolder the following leads, viz., Blue, Orange, and Yellow; these are the upper, middle, and lower connections as viewed in the inverted position, and are accessible from the front.
- (3) Remove two small screws just above the soldered connections.
- (4) Turn the power unit right side up, and remove the plug-in vibrator unit from its holder. Working at the rear of the unit, slacken off two captive screws holding the upper edge of the plug-in unit.
- (5) Remove the earth lead (if fitted) from the vibrator mounting.
- (6) The filter unit can then be removed.

Re-alignment of receiver

4. The receiving equipment Type R.1475 is issued to the Service in a properly lined-up and calibrated condition and should not require further adjustment (other than scale trimming as described in *Part 1, Chap. 2*) unless a major repair or replacement (such as a complete ganged condenser) has been made. Such repairs and replacements are normally made only in properly equipped Servicing or Maintenance Units.

5. The following paragraphs (*para. 6-34*) explain the manner in which the receiving unit Type 88 is initially aligned and calibrated at the maker's works. This information is issued as a guide to those concerned in drawing up repair schemes, servicing schedules, etc. After the alignment and calibration has been performed, a series of performance tests are carried out as detailed in *para. 36-68*. Reference should be made as necessary to the complete circuit diagram *fig. 1* which is placed at the end of the chapter.

Alignment of IF amplifier

6. As the second heterodyne oscillator is crystal-controlled, it is necessary to offset the intermediate frequency in order to obtain the highest performance from the note filter. For this reason, the intermediate frequency must be 601.3 kc/s. There are two methods of ensuring that the IF amplifiers are aligned to the correct frequency.

- (1) By the use of a crystal-controlled signal generator on 601.3 kc/s.
- (2) By adjusting the signal generator to give maximum output on the higher

side-band of the heterodyne note when the 300 c/s note filter is in operation.

7. To ensure a symmetrical response by either of these methods it is essential that the alignment be performed with the intermediate frequency circuits switched to the narrow band selectivity. However, in order that 400 c/s modulation of the signal generator may be employed, without drastic cut-off by the second heterodyne or AF note filter, it is necessary to perform the alignment with the output and heterodyne wafer switches in the 5 kc/s R/T position. The adoption of the procedure detailed below enables these conditions to be fulfilled.

8. As the required combination of IF and AF selectivity is not normally provided by the SYSTEM switch, it is necessary to replace the switch bar (which operates the wafer switch units comprising the SYSTEM switch) by a special short switch bar operating only upon the heterodyne and output units. *This bar is not supplied to user Units.* Care must be taken to remove this special bar and replace the normal one when the alignment has been completed.

Method 1—Crystal-controlled generator

9. The procedure is as follows:—

- (1) Connect a crystal-controlled signal generator to the grid of V3, using a frequency of 601.3 kc/s.
- (2) Set controls as follows:—

(a) RANGE switch	2.0-3.6 Mc/s
(b) Sensitivity control	Maximum
(c) GUARD switch	OFF
(d) NOISE LIMITER switch	OFF
(e) AVC switch	OFF
(f) AF volume control	To a convenient level of about 10 mW
(g) SYSTEM switch	As stated below.
- (3) Set SYSTEM switch to 300 c/s filter position.
- (4) Remove SYSTEM switch bar and insert special short bar.
- (5) Return SYSTEM switch to R/T position (5 kc/s bandwidth).
- (6) Tune IF circuits for maximum output, using 400 c/s modulation. Commence at L24 and work back to the mixer unit L17. It may be necessary to reduce the input at intervals to prevent overloading.

- (7) When maximum output has been obtained, return the SYSTEM switch to the CW 300 c/s filter position.
- (8) Remove the special switch bar and replace by the normal one.

- | | |
|--------------------------|-----------|
| (a) SYSTEM switch | 5 kc/s CW |
| (b) GUARD switch | OFF |
| (c) NOISE LIMITER switch | OFF |
| (d) AVC switch | OFF |

Method 2—Maximum high-band output

10. To use this method, connect the signal generator to the grid of V3 and set the controls as in steps (1) and (2) above. Then proceed as follows:—

- (3) Set SYSTEM switch to 300 c/s filter position.
- (4) Inject a CW signal of about 595 kc/s, and tune the signal generator slowly to a higher frequency. As the signal generator frequency approaches that of the second heterodyne a beat note will be heard which will rise to a maximum at 598.7 kc/s, fall to zero at 600 kc/s, and rise to a second maximum at 601.3 kc/s. **This second maximum is the correct frequency, and the signal generator should remain at this tuning point throughout the alignment.**
- (5) Remove SYSTEM switch bar and replace by the special short one.
- (6) Continue as for method 1, steps (5), (6), (7) and (8).

Adjustment of the second heterodyne

11. During initial alignment, and subsequently if the B.F.O. unit is renewed, two adjustments are necessary to the second heterodyne circuit.

- (1) The voltage at the control grid of V9 must be adjusted to an amplitude of about 8 volts (peak) by means of the screw core in L25. The voltage should fall as the core is unscrewed.
- (2) The frequency must be adjusted to 600 kc/s by means of the trimmer capacitance C55.

12. These adjustments are to a certain degree interdependent and it is therefore important that the frequency adjustment is always the last to be performed. During initial manufacture it is done immediately after the heat run so that the temperature of the crystal will be as near as possible to the middle of its operating range. The controls should be set as follows:—

13. The output of a 600 kc/s crystal-controlled signal generator should be injected into the control-grid of the mixer valve V3 and the sensitivity and volume controls adjusted until a low beat note is heard. Adjust the core in L25 until about 8 volts peak is obtained at the grid of V9.

14. The trimmer C55 should then be adjusted to give zero beat. The total range of adjustment available is about 50 c/s. Final adjustments may most conveniently be performed visually by watching the tuning indicator. If the sensitivity control is suitably adjusted, the tuning indicator will open and shut with the beat note.

15. Re-check the output voltage at the control grid of V9 and if necessary repeat the above adjustments, always finishing with the frequency adjustment.

Calibration of receiver

Approximate alignment of heterodyne oscillator

16. Before commencing the detailed calibration of the receiver scale, it is necessary to align the first heterodyne oscillator at two points in each range with sufficient accuracy to prevent any confusion with image signals. To do this, it is convenient first to draw a straight line, in removable ink, along the middle of the escutcheon window on the outside. This line must be erased after the actual calibration has been performed.

17. Set the controls as follows:—

- | | |
|--------------------------|-----------------------|
| (a) Sensitivity control | Maximum |
| (b) GUARD switch | OFF |
| (c) NOISE LIMITER switch | OFF |
| (d) AVC switch | FAST |
| (e) SYSTEM switch | CW 5 kc/s |
| (f) AF volume control | to a convenient level |
| (g) Scale trimmer | zero |

18. The procedure will be explained with reference to the 11.3-20 Mc/s range. Turn the receiver scale until 11.73 Mc/s appears at

the centre line of the escutcheon window. Inject a signal of 11.73 Mc/s from a signal generator to the control-grid of V3. Adjust the core of L13 until a beat note is heard. Ensure that this is not the image frequency by tuning the signal generator to 12.93 Mc/s where a signal should be heard.

19. If this is correct, turn the receiver scale until 19.1 Mc/s appears at the centre line of the escutcheon window. Adjust the capacitive trimmer C27 until a beat note is heard. Ensure that this is not an image frequency by tuning the signal generator to 20.3 Mc/s, where a signal should be heard. If this is correct retune the scale to 11.73 Mc/s and repeat the process.

20. A similar procedure is adopted for the other ranges, the appropriate frequencies and trimming adjusters being as shown in Table 1.

TABLE I

Range	Frequency	Trimmer	Image check
11.3- 20	11.73 19.1	L13 C27	12.93 20.3
6.4- 11.3	6.65 10.8	L14 C28	7.85 12.0
3.6- 6.4	3.74 6.12	L15 C29	4.94 7.32
2- 3.6	2.08 3.47	L16 C30	3.28 4.67

Final alignment of heterodyne oscillator

21. The actual calibration requires the use of a suitable calibrator unit and is performed as follows. Set the controls as shown below.

- (a) Sensitivity control Maximum
- (b) SYSTEM switch 5 kc/s CW
- (c) GUARD switch OFF
- (d) NOISE LIMITER OFF
- (e) AVC switch FAST
- (f) AF volume control To a
convenient
level
- (g) Scale trimmer Zero

The calibrator output is connected to the control grid of V3.

Range 11.3 to 20 Mc/s

22. Switch the calibrator to 0.5 Mc/s harmonic sequence. Set the receiver to 11.5 Mc/s (using the temporary straight line, para. 16), and adjust L13 until a low beat

note is heard. Only a small adjustment should be necessary as this point has already been aligned to signal generator accuracy.

23. Set the receiver to 19.5 Mc/s and adjust C27 until the same low beat note is heard. Repeat these adjustments if necessary. Then tune the receiver until the zero beat at 20 Mc/s is heard, and mark the window opposite the 20 Mc/s calibration on the scale. Having located this point, turn the scale towards the low frequency end, and mark the window at 0.5 Mc/s intervals each time zero beat is heard.

24. A similar procedure is adopted on other ranges, the frequencies for alignment, and calibration intervals, being as follows:—

Range 6.4 to 11.3 Mc/s

- (1) Switch calibrator to 0.5 Mc/s sequence.
- (2) Align L14 at 6.5 Mc/s.
- (3) Align C28 at 11.0 Mc/s.
- (4) Calibrate at 0.5 Mc/s intervals commencing at 11.0 Mc/s and finishing at 6.5 Mc/s.

Range 3.6 to 6.4 Mc/s

- (1) Switch calibrator to 0.5 Mc/s sequence.
- (2) Align L15 at 4.0 Mc/s.
- (3) Align C29 at 6.0 Mc/s.
- (4) Switch calibrator to 200 kc/s sequence and calibrate at 200 kc/s intervals commencing at 6.4 Mc/s and finishing at 3.6 Mc/s.

Range 2 to 3.6 Mc/s

- (1) Switch calibrator to 0.5 Mc/s sequence.
- (2) Align L16 at 2.0 Mc/s.
- (3) Align C30 at 3.5 Mc/s.
- (4) Switch calibrator to 100 kc/s sequence and calibrate at 100 kc/s intervals, commencing at 3.6 Mc/s and finishing at 2 Mc/s.

The window may now be removed and a smooth curve drawn on the inside of the window through the marked points, taking care to avoid parallax. The straight line on the outside of the window should then be erased.

Alignment of RF circuits

25. The alignment of the RF section of the receiver follows normal practice. The signal generator used for this purpose should represent a source of 45 ohms resistance; if the signal generator impedance is 80 ohms, a series resistor of 35 ohms is fitted in series

between the signal generator output plug and the receiver input plug.

26. This is done by making up a co-axial connector consisting of a 3 ft. length of Uni-radio No. 4 cable, terminated at the receiver end by a plug Type 160. At the signal generator end, a 35-ohm non-inductive resistor is fitted, the outer end of this being connected to a plug or socket appropriate to the type of signal generator being used. The resistor must be screened by a short length of copper tube bonded to the signal generator plug or socket at one end and to the outer conductor of the co-axial cable at the other. The resistor should be as small as possible ($\frac{1}{4}$ watt) and every precaution must be taken with the screening so that there is no leakage from the signal generator directly into the receiver.

27. The controls should be set as follows:—

- | | |
|--------------------------|-----------------------|
| (a) Sensitivity control | Maximum |
| (b) AF volume control | To a convenient level |
| (c) NOISE LIMITER switch | OFF |
| (d) AVC switch | OFF |
| (e) GUARD switch | OFF |
| (f) SYSTEM switch | R/T |
| (g) Scale trimmer | Zero |

The signal generator should be set to give an output at 400 c/s, modulated to a depth of 30 per cent.

28. The capacitance adjustments should be made first by setting the signal generator to the high-frequency gang point and tuning the receiver for maximum output. The trimmer adjustments should be made in the following order:—first, mixer control grid; second, R/F anode tuning condenser; third, aerial tuning condenser. The receiver and signal generator should then be tuned to the low-frequency ganging point and the inductance trimmers adjusted in the same order. This procedure should be repeated until optimum ganging is obtained. Particular care should be exercised at the high-frequency end of the 11.3 to 20 Mc/s range as the adjustment of the trimmer tends to pull the oscillator frequency. Successive adjustments should be made, rocking the main tuning control for maximum output during each adjustment.

29. Table 2 shows the ganging frequency and necessary adjustments for each band.

TABLE 2

Range	Frequency Mc/s	Adjust		
		Grid	Anode	Aerial
11.3-20	19.13	C20	C16	C6
	11.73	L9	L5	L1
6.4-11.3	10.81	C21	C17	C7
	6.65	L10	L6	L2
3.6-6.4	6.12	C22	C18	C8
	3.74	L11	L7	L3
2-3.6	3.47	C23	C19	C9
	2.08	L12	L8	L4

Guard unit alignment

30. Very little trimming should be necessary in the guard units if the coils are adjusted accurately to the standard value before assembly, as there is no ganging involved. Set the controls as follows:—

- | | |
|--------------------------|-----------------------|
| (a) Sensitivity control | Maximum |
| (b) AF volume control | To a convenient level |
| (c) SYSTEM switch | 5 kc/s CW |
| (d) GUARD switch | GUARD ONLY |
| (e) AVC switch | OFF |
| (f) NOISE LIMITER switch | OFF |
| (g) Guard sensitivity | Maximum |

Edition A (2 to 4.2 Mc/s)

31. The method of procedure is as follows:—

- (1) Insert crystal of 3.6 Mc/s in the guard unit.
- (2) Insert guard unit into the receiver.
- (3) Set frequency trimmer to +5 (fully clockwise).
- (4) Inject a signal of 4.2 Mc/s (unmodulated).
- (5) Rotate oscillator trimmer until oscillations just commence.
- (6) Return frequency trimmer to zero (this should vary the beat note).

(7) Trim first and second RF trimmers for maximum output.

The unit should then be lined up for this frequency. If oscillations do not commence as the oscillator trimmer is tuned, the inductance of oscillator coil L33 is probably too large and the core should be unscrewed slightly.

32. Some confusion may arise in trimming the RF circuits as a false maximum appears as the second RF is tuned through the oscillator frequency. The real maximum is very much larger and identification presents no difficulty when this point is appreciated.

33. The above sequence should be repeated at 2.0 Mc/s using a crystal of 2.6 Mc/s.

Edition B (4.1 to 7.5 Mc/s)

34. The procedure for Edition B (4.1 to 7.5 Mc/s) is identical with the above, the crystal frequencies being 4.7 and 6.9 Mc/s respectively.

Acceptance tests

35. The following paragraphs (*para.* 36-68) give the tests to which each receiver is subjected before acceptance. This information is included only as a guide to those interested in drawing up repair schemes, servicing schedules, etc. The test procedure requires the use of test equipment not normally available in User Units. Reference may be made as necessary to fig. 1.

General tests

36. Each instrument is checked to ascertain the continuity and correctness of wiring. This test consists of a point to point check, or such other electrical method as will ensure the accuracy of the wiring. The insulation resistance between parts not intended to be electrically connected is measured and must be not less than 100 megohms with 500 volts DC applied. All components and sub-assemblies are tested according to their relevant drawings and/or specification before incorporation in the equipment. Com-

ponents and sub-assemblies for which specifications do not exist are subjected to, and must withstand, the tests specified in W.T. Board Specn. No. K.110, Issue 1942, and any additional tests that may be called for by the Design Authority.

Heat run

37. Before the final acceptance test is carried out, each equipment is subjected to a heat run lasting 2 hours. For the period of this test the supply voltage is maintained at 6 per cent above the nominal value for which the equipment is adjusted.

High/low voltage tests

38. The equipment is tested for satisfactory operation at plus and minus 6 per cent of the nominal value of supply voltage for which the equipment is adjusted. With the supply at these upper and lower limits, all other dependent electrical measurements specified must lie within the tolerances stated.

Audio-frequency tests

39. With the conditions of test as outlined below, the frequency response of the filter circuits must be as given in Table 3.

- (a) SYSTEM switch 1,200 c/s or 300 c/s as required
- (b) AF volume control Maximum
- (c) GUARD switch OFF
- (d) NOISE LIMITER switch OFF

The nominal mid-band frequency is defined as the mean of the two frequencies at which the response is 6dB below the optimum point on the transmission frequency response when using the appropriate filter. The top of the response curve must be sensibly flat (within 3dB) over a frequency bandwidth not less than 150 c/s when using the 300 c/s filter, and not less than 600 c/s when using the 1,200 c/s filter.

TABLE 3

System switch position	Mid-band frequency limits in c/s	Total band-width in c/s at 6dB	Total band-width in c/s at 20dB
300 c/s	1,200-1,400	⋈ 200 ⋈ 250	⋈ 600
1,200 c/s	1,200-1,400	⋈ 1,100 ⋈ 1,500	⋈ 4,400

⋈ Not less than

⋈ Not greater than

IF amplifier performance

40. The IF amplifier selectivity is checked using the following conditions of test:—

- | | |
|--------------------------|-----------|
| (a) AVC switch | OFF |
| (b) Sensitivity control | Maximum |
| (c) GUARD switch | OFF |
| (d) NOISE LIMITER switch | OFF |
| (e) Tuning controls | 3.6 Mc/s |
| (f) SYSTEM switch | See below |

41. The test is performed by connecting a signal generator between V3 control grid and chassis. Its output is adjusted to 25 microvolts at 600 kc/s, the signal generator output being modulated to a depth of 30 per cent at 400 c/s or 1,000 c/s. The nominal 5 kc/s IF response is measured with the SYSTEM switch in the R/T position. In order to measure the nominal 3 kc/s IF response it is necessary to first turn the SYSTEM switch to 1.2 kc/s CW position, and then replace the switch selector bar by one of a short type which will engage only the second heterodyne and audio filter switches. When the SYSTEM switch is returned to the 5 kc/s RT position, the second heterodyne and audio filter circuits will be switched out, leaving the IF couplings in the nominal 3 kc/s position. The signal generator frequency is adjusted to provide peak output on the receiver, and the mid-band frequency of the amplifier is determined by taking the mean of two frequencies giving an output 6dB below that obtained at peak. All subsequent frequency readings should be quoted with reference to this frequency. The bandwidth relative to mid-band frequency is taken at 6 and 60dB below the peak value obtained with receiver at maximum sensitivity, and at 6 and 40dB with receiver gain reduced by 20dB. The transmission/frequency response at full and reduced gain should be substantially constant and the results should conform to Table 4. *Care must be taken to replace the long switch bar when the test is completed, placing the SYSTEM switch in the 1.2 kc/s CW position do so.*

TABLE 4

System switch	Attenuation dB	Total bandwidth limit in kc/s	Mid-band frequency kc/s
5 kc/s	6	≤ 5.0	601.2—
	60	≥ 20.0	601.4
1.2 kc/s	6	≤ 2.4	601.2—
	60	≥ 16.0	601.4
5 kc/s	6	≤ 5.0	601.2—
Gain reduced	40	≥ 16.0	601.4

Signal frequency amplifier performance

42. The circuit stability of the amplifier is checked under the following test conditions:—

- | | |
|--------------------------|---------|
| (a) SYSTEM switch | R/T |
| (b) Sensitivity control | Maximum |
| (c) GUARD switch | NORMAL |
| (d) NOISE LIMITER switch | OFF |
| (e) AVC switch | OFF |

43. The gain of the receiver is increased above the maximum normal working condition by shunting resistance R62 by a resistor having a value of 33,000 ohms. In this condition the bias to all valves in the RF and IF amplifiers is reduced. Tests are made as follows:—

- (1) With receiver input on open circuit.
- (2) With receiver input terminated in its characteristic impedance 45 ohms.
- (3) With an input signal of 1 microvolt to the 45-ohm input.

Tests for instability are made at the highest frequency in each band.

Sensitivity in R/T condition

44. The sensitivity of the receiver is checked under the following test conditions:—

- | | |
|--------------------------|---------|
| (a) SYSTEM switch | R/T |
| (b) AF volume control | Maximum |
| (c) AGC switch | OFF |
| (d) NOISE LIMITER switch | OFF |
| (e) GUARD switch | OFF |
| (f) Scale trimmer | Zero |

45. The signal generator employed for these tests must be arranged to represent a resistive source of 45 ohms. If a series resistor is employed it should be located within the screening of the generator lead. The lead termination must be efficiently screened and the earth shield bonded to the chassis. Every precaution must be taken to guard against generator leakage. A signal modulated 30 per cent at 400 c/s or 1,000 c/s at the frequencies and levels specified in Table 5 is injected into the receiver. The latter is operated at full audio gain, and the radio frequency gain adjusted to give an output of 50 milliwatts into 600 ohms measured at the high level output of the receiver. Having obtained a measurement at given frequency, modulation is switched off and a reading of noise level taken.

46. The noise level obtained must not exceed the following values:—

Using 1,000 c/s modulation, noise level 0.5 mW.

Using 400 c/s modulation, noise level 0.9 mW.

TABLE 5

Range	Frequency Mc/s	Max. input in microvolts sensitivity tests	Min. image attenuation in dB	Max. input in microvolts to 500 ohms aerial	Scale trimmer min, freq. change kc/s
1	20.0	4.0	30	20	115
	15.0	5.0	50		
	11.3	7.0	60		
2	11.3	4.5	50	20	45
	6.4	4.5	75		
3	6.4	4.0	65	20	25
	3.6	5.0	85		
4	3.6	4.0	80	20	15
	2.0	4.0	94		

Sensitivity using open wire aerial

47. Signals modulated 30 per cent at 400 or 1,000 c/s are injected into the receiver from a signal generator representing a resistive source of 500 ohms at the levels and frequencies specified in Table 5. In all other respects the conditions and requirements are as detailed in para. 44.

Sensitivity in 1.2 kc/s CW condition

48. The conditions for this test are:—

- (a) SYSTEM switch 1.2 kc/s CW
- (b) AF volume control Maximum
- (c) AVC switch OFF
- (d) NOISE LIMITER switch OFF
- (e) GUARD switch OFF

49. From a signal generator arranged to represent a resistive source of 45 ohms as in para. 44, a signal of 1 microvolt (unmodulated) is injected into the receiver at frequencies of 11.3 Mc/s (11.3-20 Mc/s band), 6.4 Mc/s (6.4-11.3 Mc/s band), 3.6 Mc/s (3.6-6.4 Mc/s), and 2.0 Mc/s (2.0-3.6 Mc/s band). The tuning and RF gain control are adjusted to provide a maximum output of 50 milliwatts. The input signal is switched off and a check made to ensure that the noise level does not exceed 0.5 milliwatt.

Image rejection

50. With conditions as defined in para. 44, a signal of 2 microvolts modulated to a

depth of 30 per cent at the selected frequency is injected into the receiver. The RF gain control is adjusted to produce an output of 50 milliwatts. The frequency of the injected signal is increased to the image frequency and the input signal level is increased by the ratio specified in Table 4. The new output level must not exceed 50 milliwatts.

Intermediate frequency rejection

51. The controls are set as follows:—

- (a) SYSTEM switch R/T
- (b) AF volume control Maximum
- (c) Frequency Tuned to 2 Mc/s
- (d) GUARD switch OFF
- (e) AVC switch OFF
- (f) NOISE LIMITER switch OFF

52. A signal is injected at a frequency of 2 Mc/s, the level being 2 microvolt modulated to a depth of 30 per cent at either 400 or 1,000 c/s. The RF gain control is adjusted to provide an output of 50 milliwatts.

53. The frequency of the signal generator is changed to 601.3 kc/s modulated as before, and the input signal level is increased to 100 millivolts. The output level in this condition must not exceed 50 milliwatts.

Keying relay attenuation

54. The test conditions are as in para. 44; with an input signal of 2 microvolts, at any frequency within the band, the output level is adjusted to 50 milliwatts. The relay is operated to attenuate the input signal and the input level is increased to 200 microvolts. In this condition the output must not exceed 50 milliwatts.

Scale trimmer test

55. The controls are set as follows:—

- | | |
|--------------------------|-----------|
| (a) SYSTEM switch | 5 kc/s CW |
| (b) Sensitivity control | Maximum |
| (c) AVC switch | SLOW |
| (d) NOISE LIMITER switch | OFF |

56. The scale trimmer is set to the position marked negative 5 and the receiver tuned to produce zero beat with a signal at the specified frequency injected from a signal generator.

57. The scale trimmer is then reset to the position marked positive 5 and the signal generator returned to again produce zero beat. The change in signal frequency is noted. This must not be less than the values given in Table 4.

Automatic gain control

58. The test conditions are as follows:—

- | | |
|--------------------------|-------------------------------------|
| (a) SYSTEM switch | R/T |
| (b) Frequency | 11.3 Mc/s
(11.3-20
Mc/s band) |
| (c) Sensitivity control | Maximum |
| (d) NOISE LIMITER switch | OFF |
| (e) AVC switch | FAST |
| (f) Signal modulation | 30 per cent at
400 c/s |

59. A signal of 100 millivolts is injected into the 45-ohm aerial socket and the AF gain control adjusted until the receiver does not overload. The output is noted, and the input signal then reduced to 3 microvolts. The output level must not fall by more than 8dB. A signal of 50 microvolts is then injected into the 45-ohm aerial socket and the maximum undistorted output is measured. From the unbalanced 600-ohm high level output, it must be at least 25 milliwatts.

60. In a similar manner, the maximum undistorted output at the 600-ohm low level balanced and unbalanced terminals is checked and must be at least 3 milliwatts.

AGC noise characteristic

61. With conditions of test as in para. 44, a signal of 3 microvolts unmodulated is injected and the volume control adjusted to produce a convenient output noise level. The signal input is then increased to 100 microvolts and the noise level must fall by not less than 25dB.

Overall fidelity

62. The controls are set as follows:—

- | | |
|--------------------------|---------|
| (a) SYSTEM switch | R/T |
| (b) Frequency | 2 Mc/s |
| (c) AF volume control | Maximum |
| (d) AVC switch | OFF |
| (e) NOISE LIMITER switch | OFF |
| (f) GUARD switch | OFF |

63. A signal generator is connected to the 45-ohm input circuit and the signal modulated to a depth of 30 per cent by an external source covering a frequency range of 100 c/s to 5,000 c/s. The level of the signal is adjusted to 1 millivolt. The signal is modulated at a frequency of 250 c/s and the gain controlled entirely by the RF gain control. After tuning for maximum output, the modulating frequency is changed to 1,000 c/s and the RF gain control adjusted to provide an output level of 50 milliwatts.

64. The output level for the various modulating frequencies given below is then measured while keeping the modulation depth constant at 30 per cent. The AF output attenuation should be as follows:—

<i>Modulation frequency in c/s</i>	<i>AF output attenuation with reference to output at 1,000 c/s</i>
100	≤ 18 dB
250	≥ 6 dB
1,000	reference level
2,500	≥ 6dB
5,000	≤ 18dB

Calibration (tuning scale)

65. The frequency of the crystal of the beat frequency oscillator must be adjusted to 600 kc/s at 40 deg. celsius. The receiver calibration is then checked at not less than three frequencies in each of the four ranges, using an external source to provide standard frequency signals.

66. The setting accuracy of the receiver must be such that the tuning error shall be not more than 2 kc/s from 2.0-11.3 Mc/s and 4 kc/s from 11.3-20.0 Mc/s. These tests are made at normal ambient temperatures.

Frequency changer oscillator stability

67. The oscillator stability must be such that at normal room temperature and after a warming period of not more than 30 minutes, the frequency does not drift at a greater rate than 3 kc/s per hour (for the next two hours). Drift readings are taken every 15 minutes, and one in every twenty receivers is given a similar test lasting 8 hours.

68. Tests are made at 19.8 Mc/s, but other frequencies are also checked if necessary. The drift may be checked against the scale check signal.

Guard unit sensitivity

69. The conditions of test are:—
(a) SYSTEM switch R/T
(b) AF volume control Maximum
(c) GUARD switch GUARD ONLY

- (d) AVC switch OFF
- (e) NOISE LIMITER switch OFF

70. The appropriate crystal is inserted in the unit to be tested and a signal of 30 microvolts modulated 30 per cent is injected. The guard unit RF gain control is adjusted until the AF output from the unbalanced 600-ohm output terminals is 5 milliwatts. The modulation is then switched off and the noise level is measured. The signal-to-noise ratio must be not less than 20dB.

Selectivity, image rejection

71. With the equipment set up as stated in para. 69, a signal of 5 microvolts modulated 30 per cent is injected and the RF gain adjusted to provide an output level of 50 milliwatts from the high level output. The signal generator is retuned to the image frequency in each case and the increase in input signal necessary to restore the output level to 50 milliwatts is measured. It must be not less than the ratio specified in the following Table 6.

TABLE 6

Edition	Crystal freq. in Mc/s	Sig. freq. in Mc/s	Min. image ratio in dB
A	2.6	2.0	60
A	3.5	4.1	45
B	4.7	4.1	56
B	6.9	7.5	36

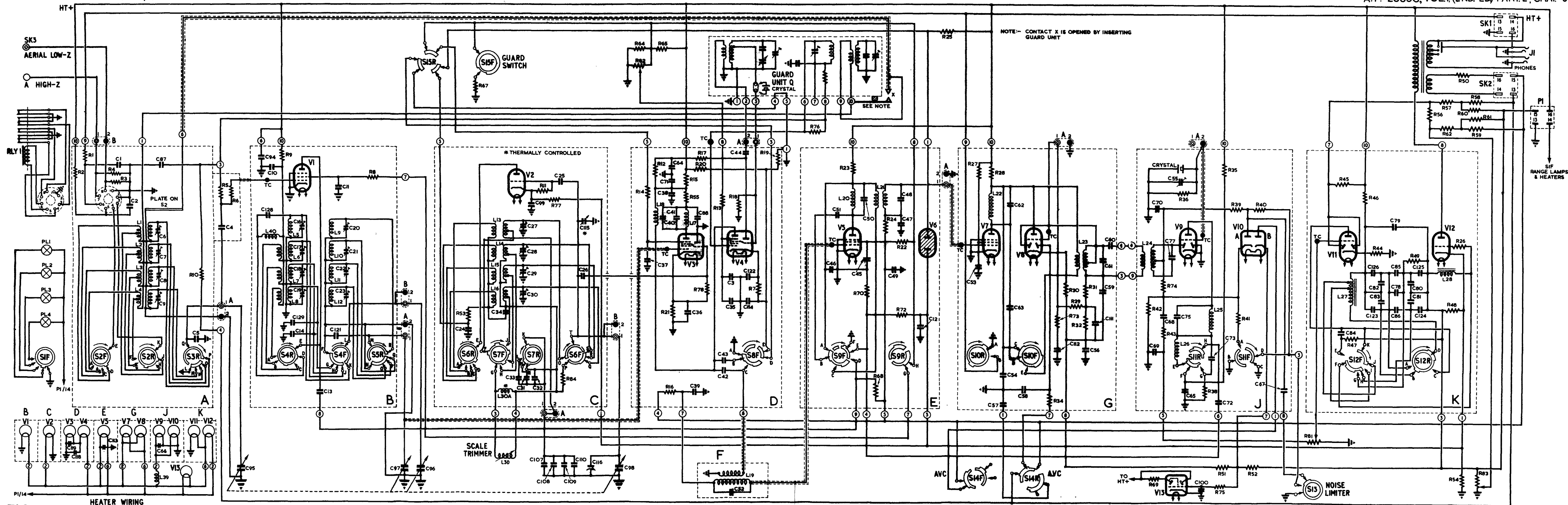

FIG. 1

RECEIVING UNIT TYPE 88-CIRCUIT

FIG. 1