

Please do not upload this copyright pdf document to any other website. Breach of copyright may result in a criminal conviction.

This document was generated by me Colin Hinson from a document held at Henlow Signals Museum. It is presented here (for free) and this version of the document is my copyright (along with the Signals Museum) in much the same way as a photograph would be. Be aware that breach of copyright can result in a criminal record.

The document should have been downloaded from my website <https://blunham.com/Radar>, if you downloaded it from elsewhere, please let me know (particularly if you were charged for it). You can contact me via my Genuki email page:

<https://www.genuki.org.uk/big/eng/YKS/various?recipient=colin>

You may not copy the file for onward transmission of the data nor attempt to make monetary gain by the use of these files. If you want someone else to have a copy of the file, please point them at the website (<https://blunham.com/Radar>).

Please do not point them at the file itself as the file may move or be updated.

I put a lot of time into producing these files which is why you are met with this page when you open the file.

In order to generate this file, I need to scan the pages, split the double pages and remove any edge marks such as punch holes, clean up the pages, set the relevant pages to be all the same size and alignment. I then run Omnipage (OCR) to generate the searchable text and then generate the pdf file.

Hopefully after all that, I end up with a presentable file. If you find missing pages, pages in the wrong order, anything else wrong with the file or simply want to make a comment, please drop me a line (see above).

It is my hope that you find the file of use to you personally – I know that I would have liked to have found some of these files years ago – they would have saved me a lot of time !

Colin Hinson

In the village of Blunham, Bedfordshire.

ADJUSTMENTS

BULLETIN 309B
VOL 2

TECHNICAL MANUAL
32 TELETYPEWRITER SETS
KEYBOARD SEND-RECEIVE (KSR)
RECEIVE-ONLY (RO)
AUTOMATIC SEND-RECEIVE (ASR)

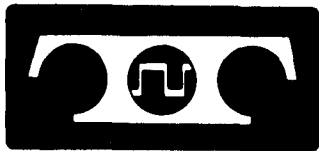

TELETYPE[®]
CORPORATION

5555 TOUHY AVENUE, SKOKIE, ILLINOIS

309B
VOLUME 2

INTRODUCTION

Bulletin 309B is a technical manual that provides general and specific information about the 32 Receive-Only (RO), Keyboard Send-Receive (KSR), and Automatic Send-Receive (ASR) Teletypewriter Sets and their component units.

Volume 1 provides general descriptions and principles of operation, circuit descriptions, installation instructions, and removal and replacement of components for Model 32 Teletypewriter Sets. It also provides lubrication and disassembly and reassembly information for the keyboard, typing unit, tape reader, and tape punch as well as lubrication information for the cover. Volume 2 provides adjustment information for all components except the call control unit.

Each volume is made up of a group of appropriate, independent sections. They are separately identified by title and section number, and the pages of each section are numbered consecutively, independent of other sections. The identifying number of a section, a 9-digit number, appears on each page of the section, in the upper left corner of left-hand pages and the upper right corner of right-hand pages.

To locate specific information, refer to table of contents. Find the name of the involved component in column one and the title of the section in column two. The correct 9-digit section will then be found in column three. The sections are arranged in the order shown in the table of contents. Turn to page one of the section indicated where the contents of that section will be found (except where a section is small and does not require a listing of contents).

The sections comprising this bulletin are now stocked separately and may be individually ordered if the entire bulletin is not required.

TABLE OF CONTENTS

FILING INSTRUCTIONS

1. The following filing instructions apply to changes sent to the field.
2. Asterisk (*) in the table of contents indicates changes.
3. When the issue of a section changes, replace the old issue with the attached new one.
4. In the case of addendums, turn to the affected section and follow the instructions on the first page of the attached addendum.
5. Replace the old table of contents with this new one.

<u>Equipment</u>	<u>Title</u>	<u>Section</u>	<u>Issue</u>
Keyboard	Adjustments	574-171-700TC	3*
Typing Unit	Adjustments	574-172-700TC	4*
Tape Reader	Adjustments	574-174-700TC	3*
Tape Punch	Adjustments	574-175-700TC	3*
Cover	Adjustments	574-176-700TC	1

32 KEYBOARD

ADJUSTMENTS

CONTENTS	PAGE
1. GENERAL	1
2. BASIC UNIT	4
BREAK keylever spring	8
Contact block spring	6
Contact wires — marking (KBA-2)	5
Contact wires — spacing (KBA-3)	5
Contact wire spring	6
Distributor trip linkage (KBA-7)	11, 12
HERE IS keylever spring	8
Keylever spring	7
Latchlever spring	13
LTRS-FIGS detent spring	9
Nonrepeat lever spring	10
REPT keylever spring	8
Reset bail spring	8
Spacebar spring	7
Universal lever spring	10
Universal link (KBA-1)	4
Universal link spring	9

1. GENERAL

1.01 This section provides adjustment information for mechanically reset Model 32 keyboards (Figures 1 and 2). It is reissued to include engineering changes, make corrections, and to add alphanumeric codes to the adjustment titles. Since it is a general revision, marginal arrows to indicate changes and additions are omitted. The alphanumeric codes provide a universal method for adjustment identification.

Note: Adjustment information for solenoid-reset keyboards is found in Section 574-121-703TC.

1.02 In the adjustments covered in this section, location of clearances, position of parts, and point and angle of scale applications are illustrated by line drawings. Requirements and procedures accompany the line drawings. Tools necessary to make adjustments are shown in Section 570-005-800TC.

1.03 The adjustments appear in a sequence that should be followed when a complete readjustment of the keyboard is made. No adjustment should be made without completely understanding the procedure. Therefore, read the entire procedure before making an adjustment.

Note: Disconnect power from keyboard before making any adjustment.

1.04 References to left, right, and front (Figure 3) are made viewing the keyboard from its normal operating position.

1.05 When a procedure calls for using pry points to make an adjustment, place a screwdriver between the points and pry as directed.

1.06 When the keyboard is removed from the subbase to facilitate the making of an adjustment and subsequently replaced, recheck any adjustments that may have been affected. Also, if parts are removed from the keyboard to facilitate the making of an adjustment, be sure that they are subsequently replaced. Recheck any adjustment that may have been affected by the removal of parts.

1.07 Related adjustments are listed with some of the adjustment texts and are primarily intended to aid in troubleshooting the equipment. Note that some adjustments affect other adjustments. For example, see the DISTRIBUTOR TRIP LINKAGE (KBA-7) adjustment. Note that this adjustment affects the TRIP LEVER ENGAGEMENT (KBA-8) adjustment in Section 574-172-700TC. If the former adjustment is changed, check the latter adjustment.

1.08 The spring tensions specified are indications, not exact values. Therefore, to obtain reliable readings, measure spring tensions with spring scales placed in the positions shown on line drawings. Springs that do not meet their requirements should be replaced by new ones. Only those springs that directly affect the operation of the keyboard are measured; however, others may be measured indirectly. Any springs that are indirectly measured should be replaced

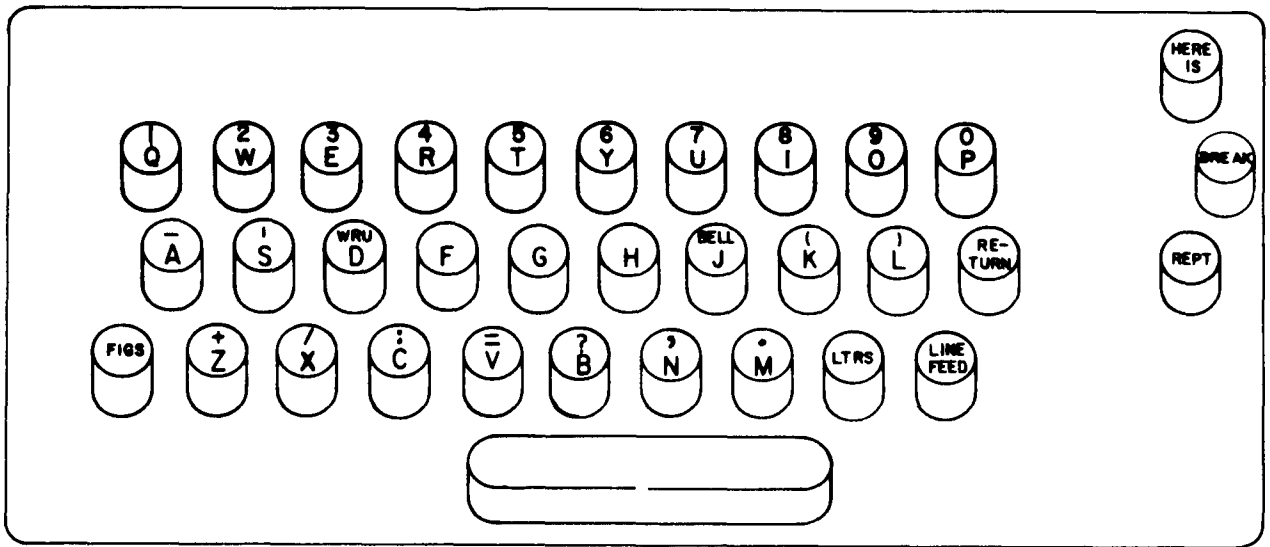

Figure 1 - Model 32 (3 Row 5 Level) Keyboard

one at a time, with the requirement checked each time a spring is replaced.

Note 1: The alphanumeric coding system is not used for spring adjustments.

Note 2: The spring tensions may be checked in any sequence.

1.09 With the keyboard and typing unit assembled on the subbase, adjustment procedures may specify that the typing unit be placed into the stop position. It is in the stop position when the selector armature is attracted (forward) and all clutches are disengaged. Furthermore, the keyboard will be latched (universal lever down and blocked from moving upward).

Note: The keyboard is tripped when the universal lever is up (unlatched).

1.10 To place the typing unit in the stop position hold the selector armature attracted (forward). Manually rotate the main shaft clockwise (as viewed from the left) until all clutches are in a stop position. Fully disengage all

clutches by positioning a screwdriver to the associated stop-lug. Push the clutch disc in the normal direction of main shaft rotation until the corresponding latchlever seats in its clutch disc notch. This permits the clutch shoes to release their tensions on the clutch drum. With all clutches disengaged, the main shaft will turn freely without any dragging of the clutch shoes.

Note 1: A stop position is where a shoe release lever contacts a trip lever.

Note 2: The distributor clutch will not disengage unless the keyboard is latched and the answer-back drum is in its home position. The answer-back home position is where the control lever is fully detented into the answer-back drum.

1.11 A clutch becomes engaged when a trip lever moves away from its shoe release lever. When moved up, a trip lever no longer holds a shoe release lever in its stop position. When the shoe release lever and stop-lug on the clutch disc move apart, the clutch shoes wedge against the drum to permit the shaft and the clutch assembly to turn together.



Figure 2 - Model 32 (4 Row 5 Level) Keyboard

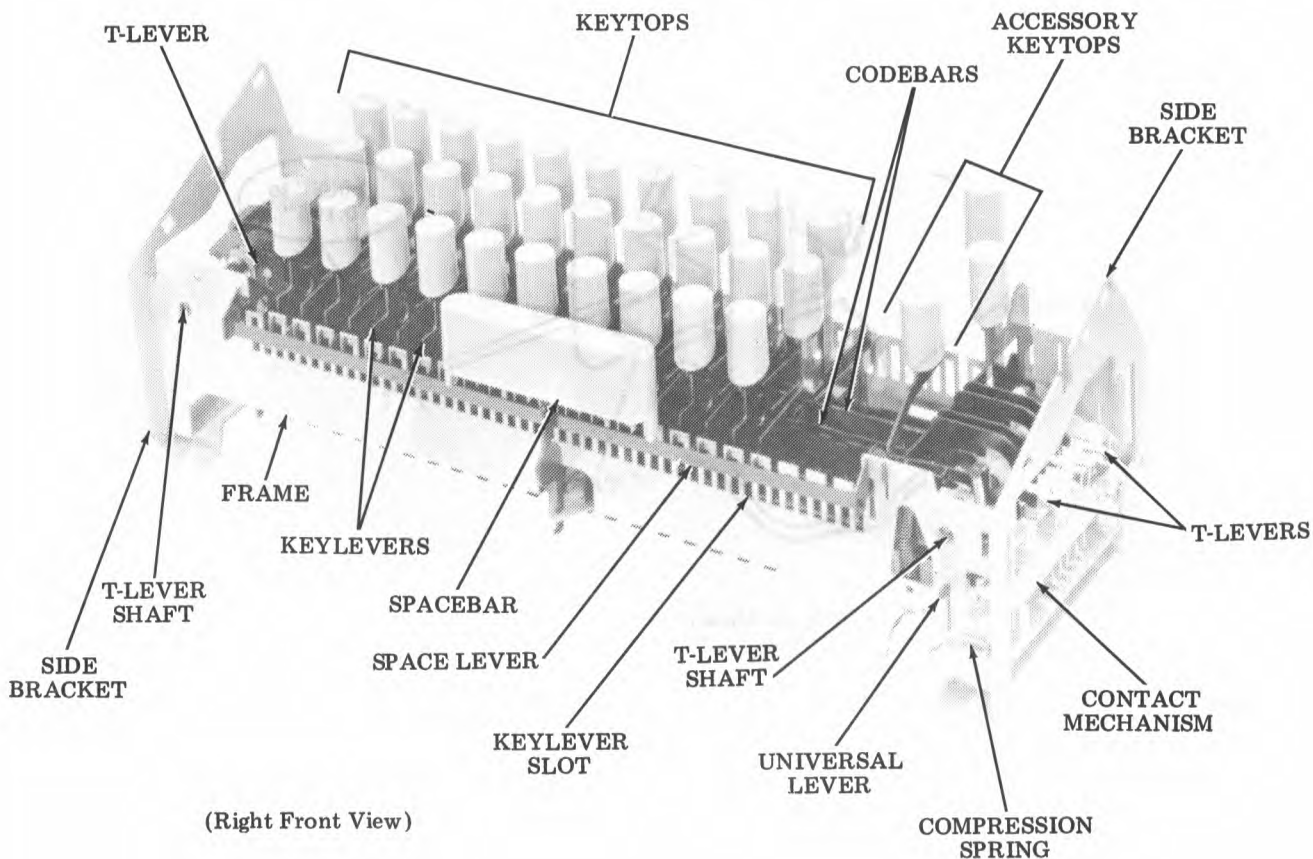

Figure 3 - Keyboard (Cover Removed)

SECTION 574-171-700TC

2. BASIC UNIT

2.01 Universal Link

Note: Remove keyboard and call control unit from subbase. For removal instructions, refer to Section 574-160-702TC.

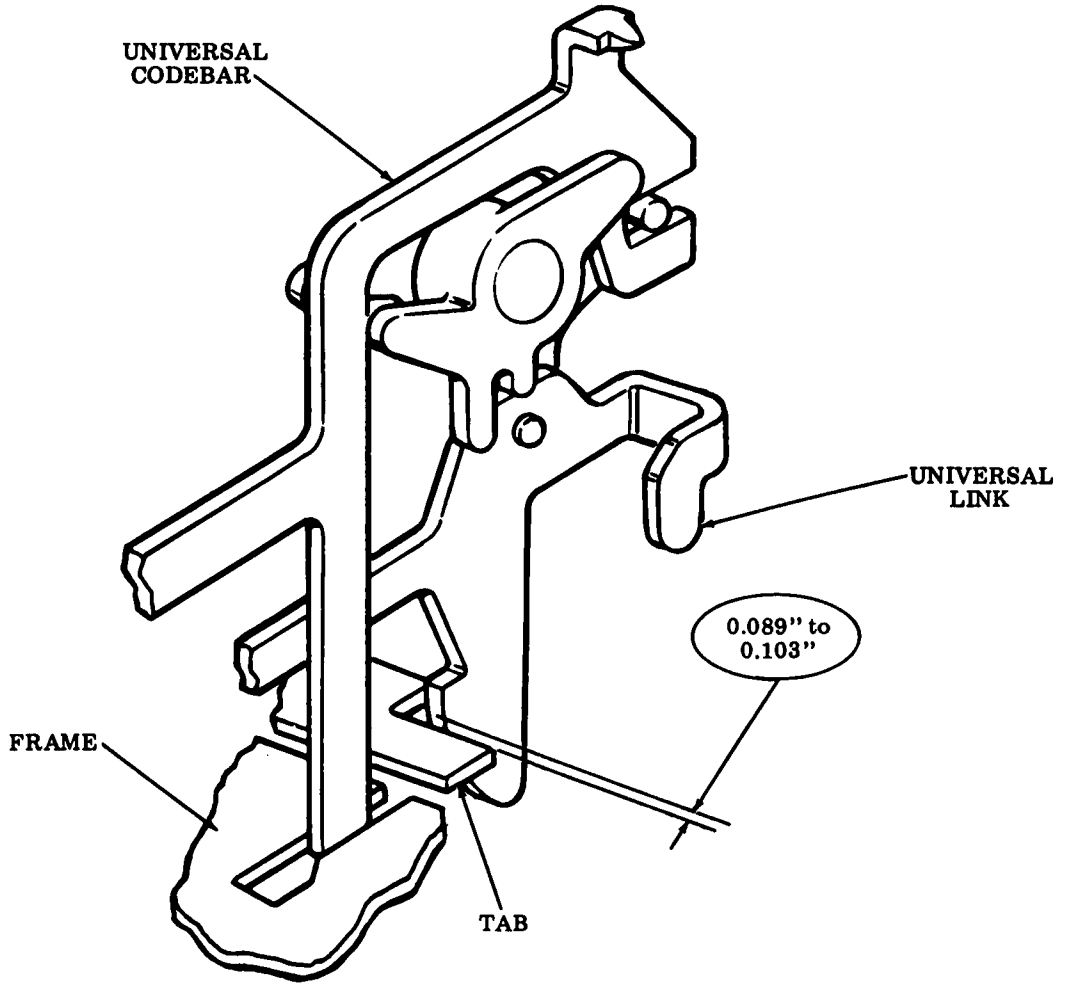

(Left Front View)

UNIVERSAL LINK (KBA-1)

Requirement

Min 0.089 inch -- Max 0.103 inch
between universal link and frame when universal lever is latched.

To Adjust

Place screwdriver through opening in front of frame and bend tab.

2.02 Contact Wires

CONTACT WIRES — MARKING (KBA-2)

To Check

Push universal lever down until latched by latchlever. Place T-levers down in marking position. Take up play of contact block in downward direction and release. Take up play of each contact wire in upward direction and release.

Requirement

Min 0.012 inch -- Max 0.027 inch between the no. 1 contact wire (first reset-bail actuated contact wire from front of keyboard) and its associated terminal.

Min 0.018 inch -- Max 0.032 inch between remaining marking contact wires and their associated terminals.

To Adjust

Bend contact wire with TP185829 bending tool at position shown.

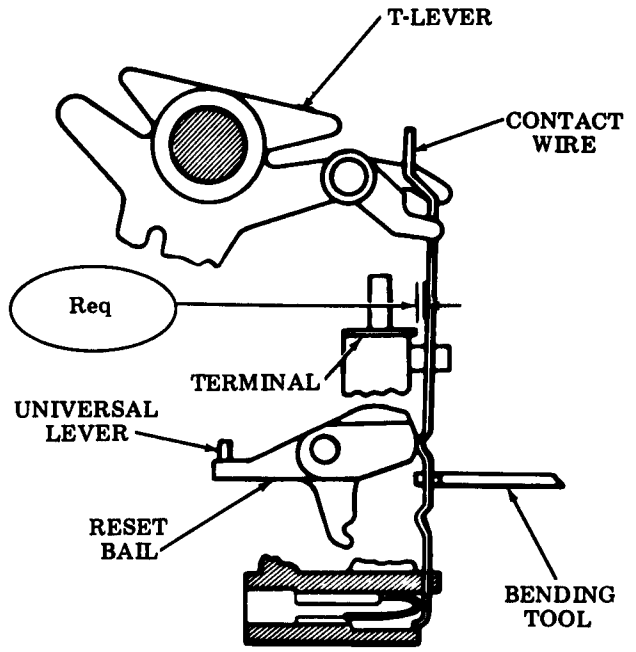

(Front View)

CONTACT WIRES — SPACING (KBA-3)

To Check

Push universal lever down until latched by latchlever. Place T-levers up in spacing position. Trip keyboard by depressing universal codebar. Take up play of T-levers against universal lever and release. Take up play of contact block in downward direction and release. Take up play of each contact wire in upward direction and release.

Requirement

Min 0.020 inch -- Max 0.040 inch between terminal and each contact wire previously adjusted in KBA-2.

To Adjust

Bend contact wire with TP185829 bending tool at position shown.

Note: Adjustment KBA-2 affects adjustment KBA-3.

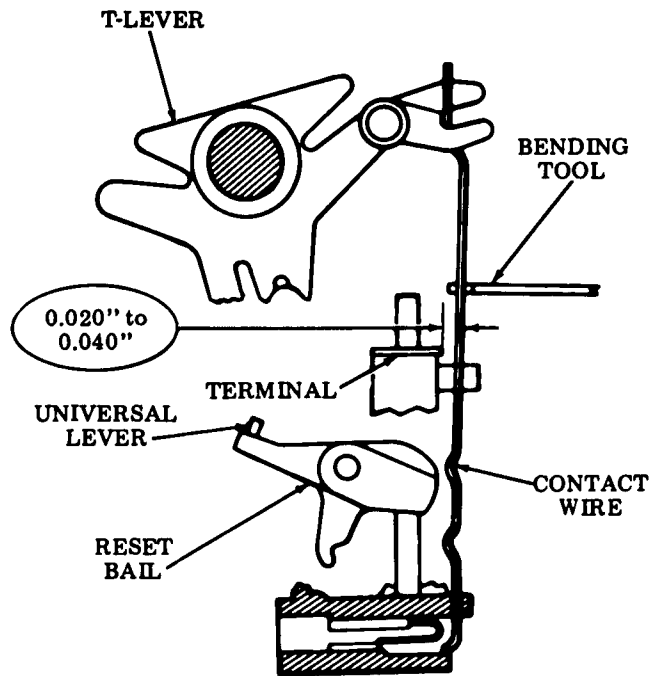

(Front View)

2.03 Contact Block Spring and Contact Wire Spring

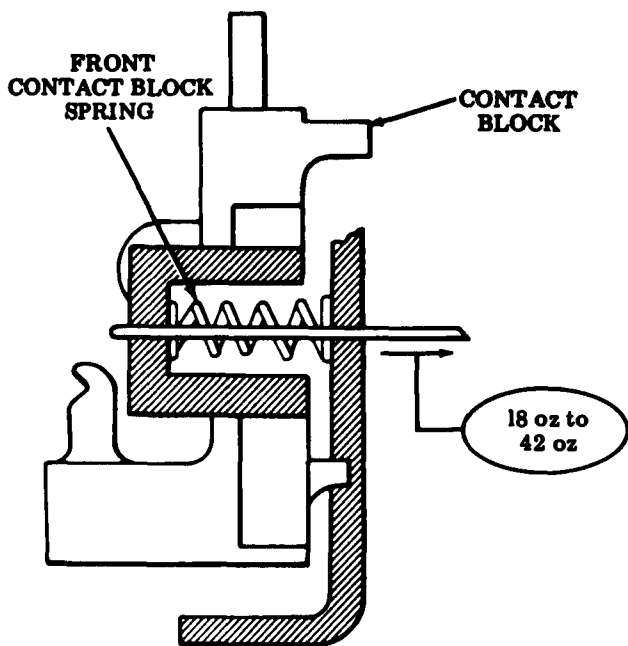

(Front View)

CONTACT BLOCK SPRING

Requirement

Min 18 oz -- Max 42 oz
to start contact block moving.

Note: Check both front and rear contact
block springs.

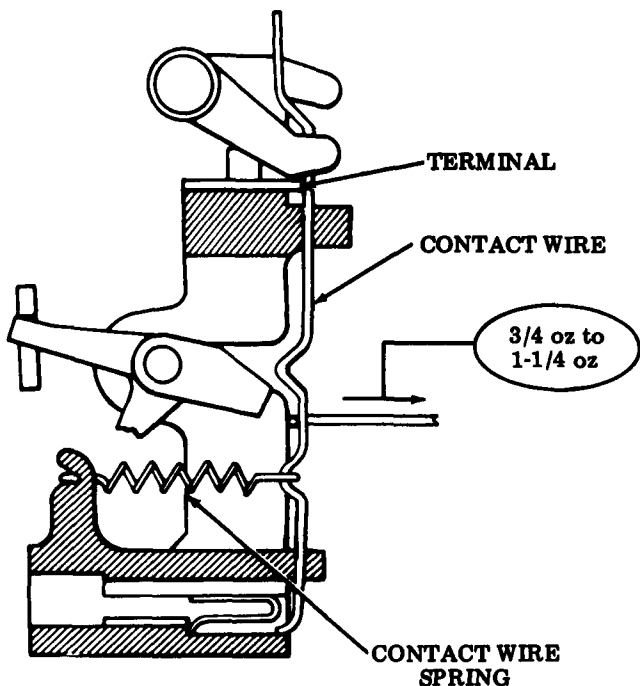

(Front View)

CONTACT WIRE SPRING

To Check

Latch universal lever. Place T-levers down
to marking position. Depress universal code-
bar.

Requirement

Min 3/4 oz -- Max 1-1/4 oz
to start each contact wire moving away
from terminal.

2.04 Spacebar Spring and Keylever Spring

SPACEBAR SPRING

To Check

Latch universal lever. Depress spacebar and then release.

Requirement

Min 5 grams -- Max 25 grams to start spacebar moving.

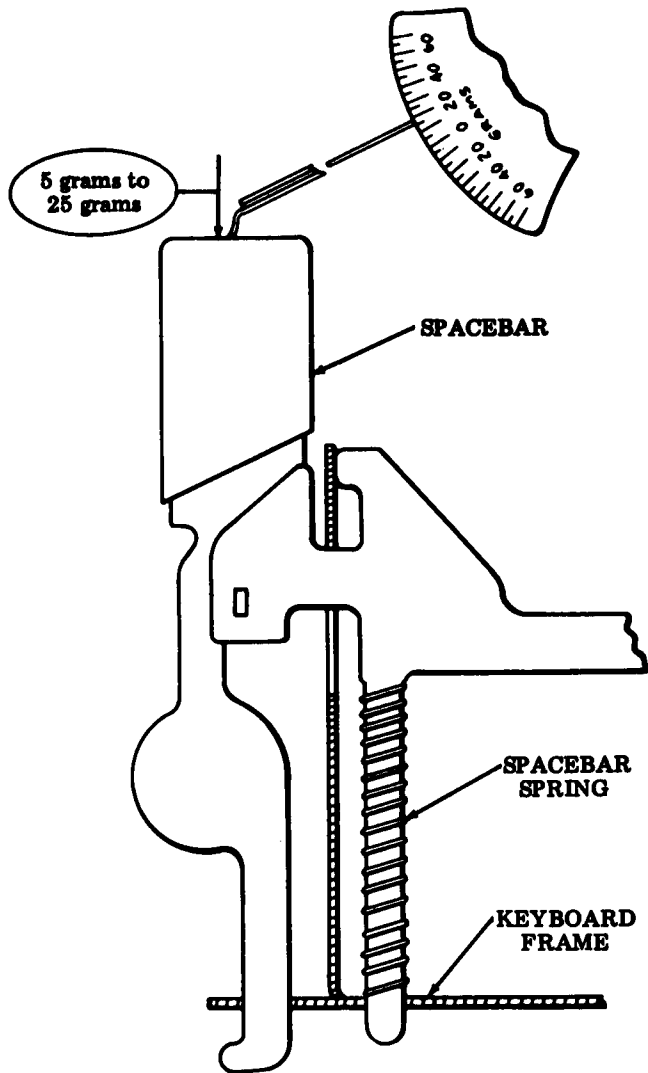

(Right Side View)

KEYLEVER SPRING

To Check

Latch universal lever. Depress any keytop and release.

Requirement

Min 5 grams -- Max 30 grams to start selected keytop moving.

Note: Check each keylever spring.

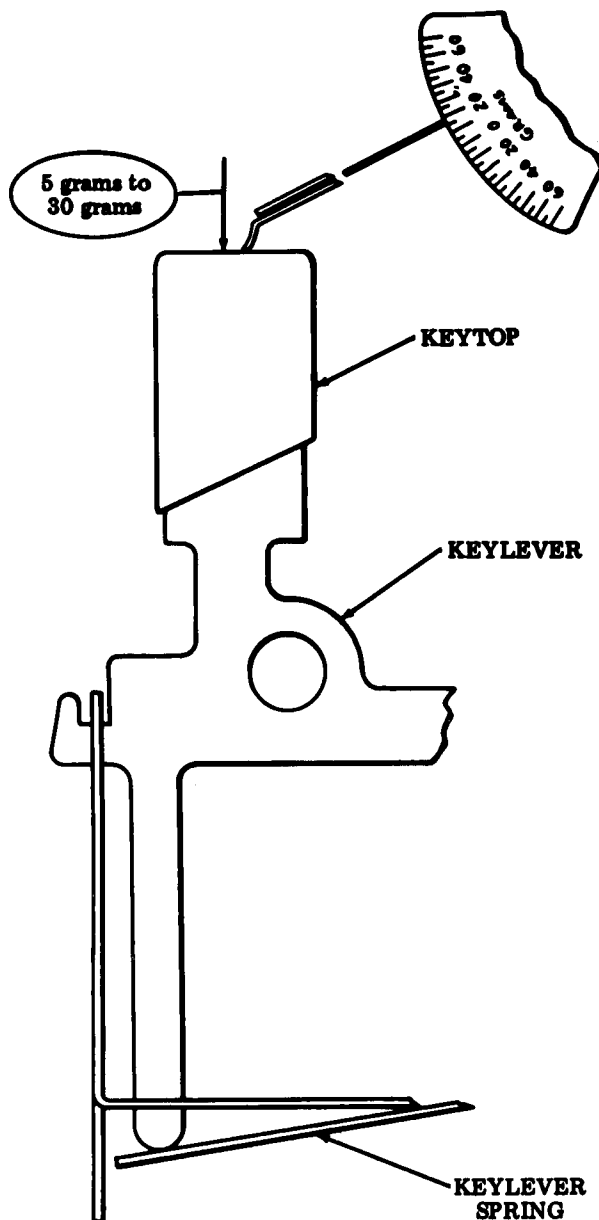

(Right Side View)

SECTION 574-171-700TC

2.05 HERE IS, BREAK, and REPT Keylever Springs

"BREAK" KEYLEVER SPRING

Requirement

Min 12 oz -- Max 18 oz
to start keytop moving.

"HERE IS" KEYLEVER SPRING

Requirement

Min 18 grams -- Max 35 grams
to start keytop moving.

"REPT" KEYLEVER SPRING

Requirement

Min 15 grams -- Max 30 grams
to start keytop moving.

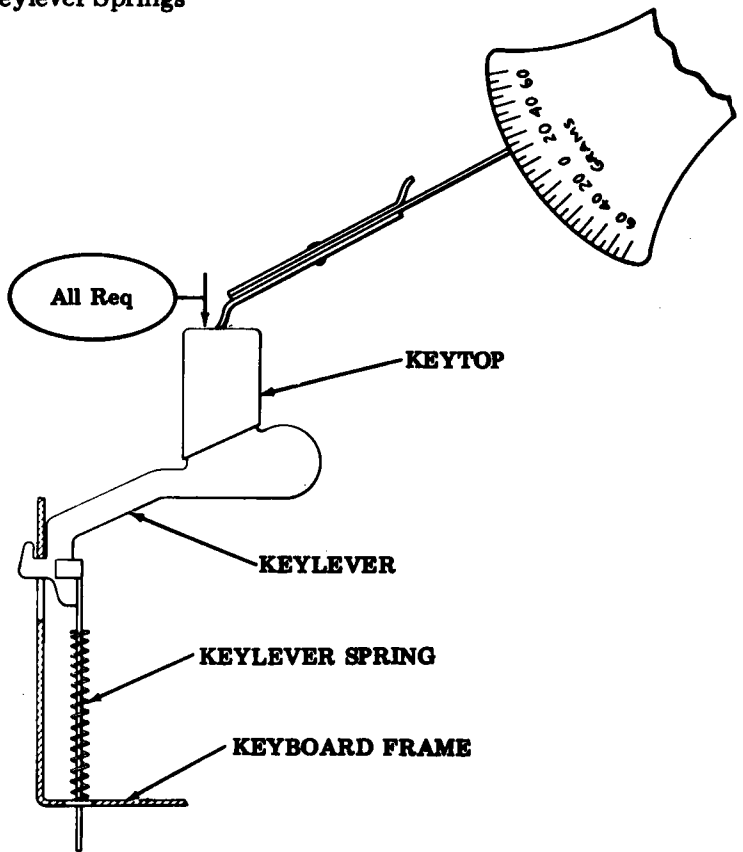

(Right Side View)

2.06 Reset Bail Spring

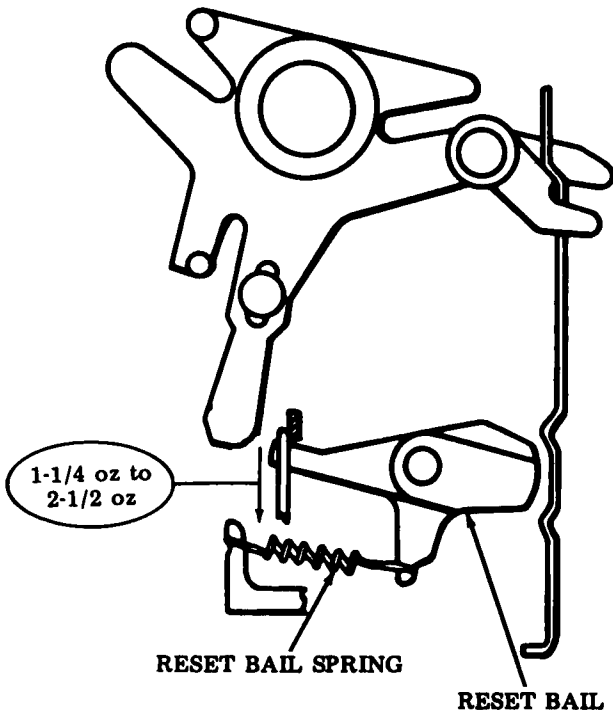

(Front View)

RESET BAIL SPRING

To Check

Latch universal lever. Depress LTRS keytop.

Requirement

Min 1-1/4 oz -- Max 2-1/2 oz
to start reset bail moving.

2.07 LTRS-FIGS Detent Spring and Universal Link Spring

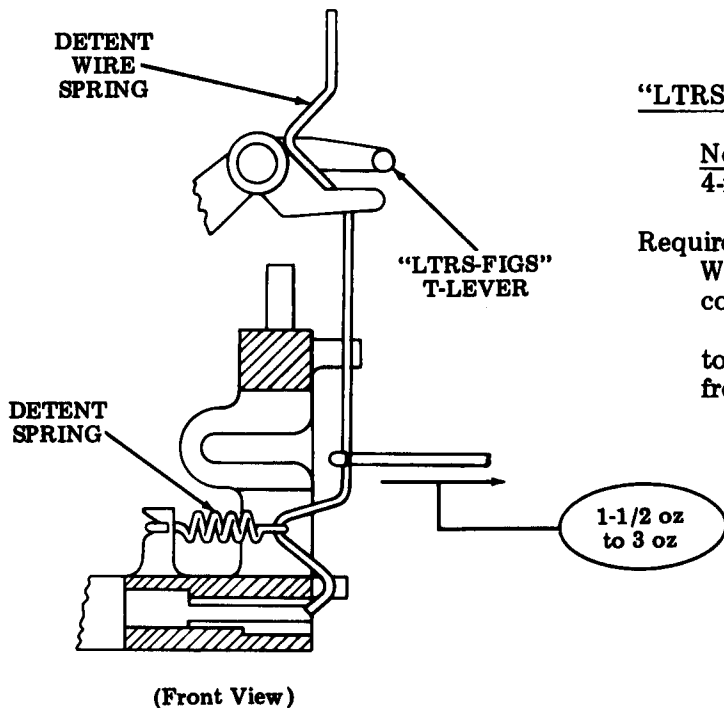

"LTRS-FIGS" DETENT SPRING

Note: This adjustment applies only to 4-row 5-level keyboards.

Requirement
 With LTRS-FIGS T-lever either up in LTRS condition or down in FIGS condition
 Min 1-1/2 oz -- Max 3 oz
 to start detent wire spring moving away from LTRS-FIGS T-lever.

UNIVERSAL LINK SPRING

To Check

Latch universal lever. Trip keyboard by depressing universal codebar.

Requirement

Min 1/2 oz -- Max 1-1/4 oz
 to start universal link moving.

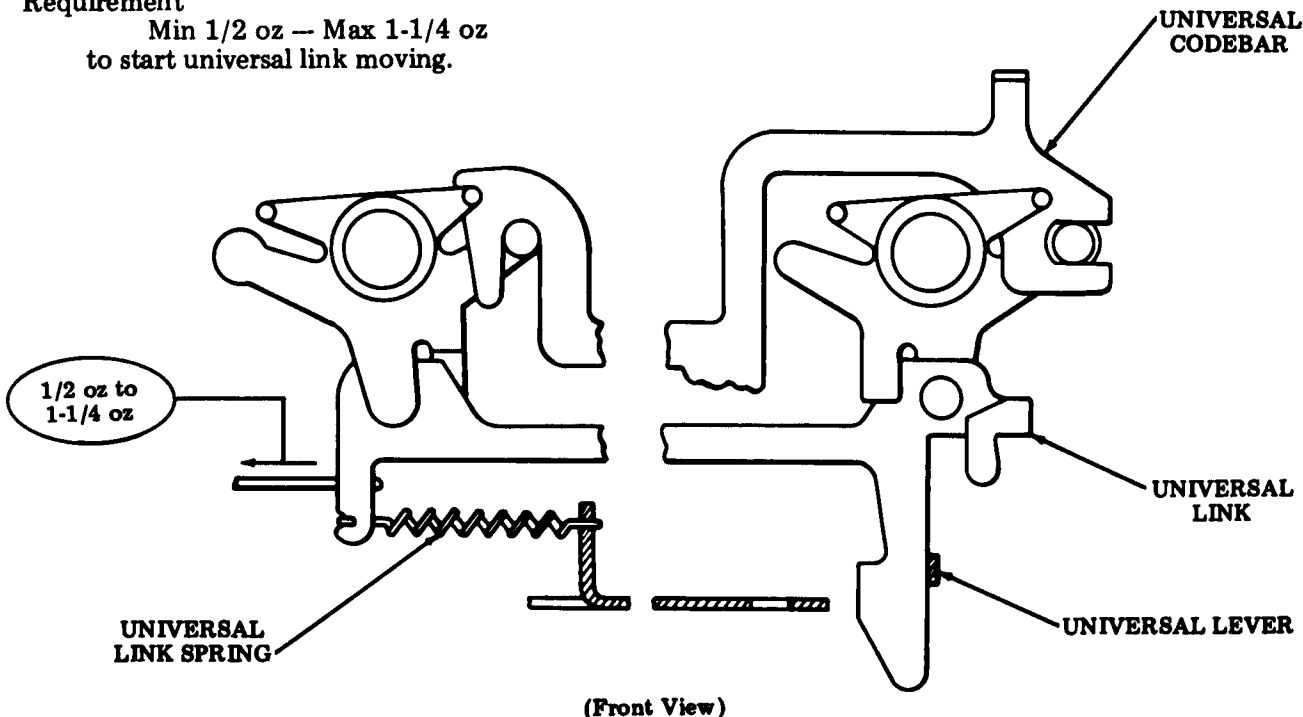

SECTION 574-171-700TC

2.08 Nonrepeat Lever Spring

Note: Remove keyboard cover. For disassembly instructions, refer to Section 574-171-702TC.

NONREPEAT LEVER SPRING

Requirement

Min 1/4 oz -- Max 3/4 oz
to start nonrepeat lever moving with universal lever latched.

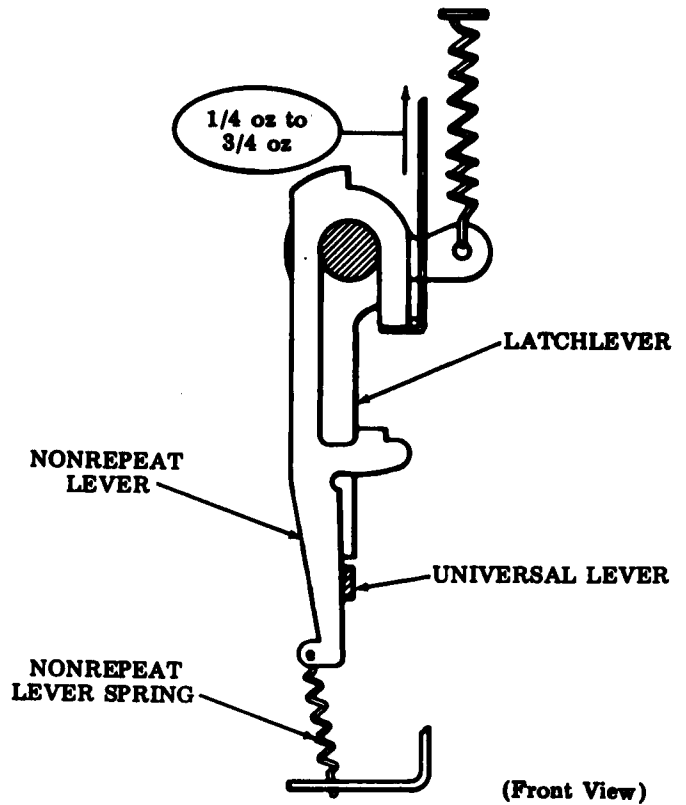

2.09 Universal Lever Spring

UNIVERSAL LEVER SPRING

To Check

Remove H-plate. Latch universal lever.

Requirement

Min 1/2 oz -- Max 1-1/2 oz
to start universal lever moving while holding reset bail away from universal lever.

Note: Replace keyboard cover. For reassembly instructions, refer to Section 574-171-702TC.

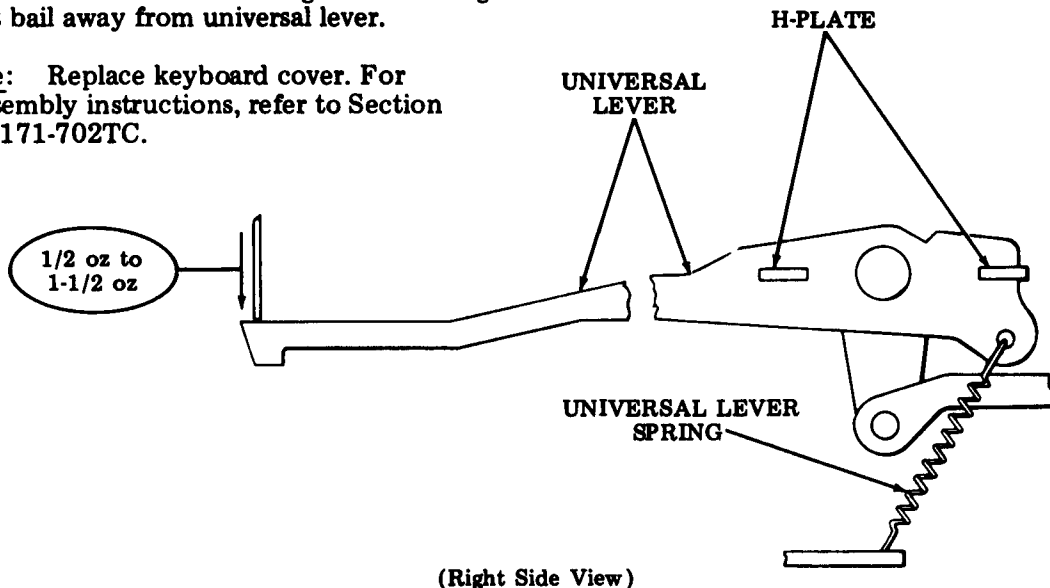

2.10 Distributor Trip Linkage

DISTRIBUTOR TRIP LINKAGE – Method 1 (KBA-7)

Note 1: Use only Method 1 (2.10), or Method 2 (2.11). Do not intermix. Method 1 is preferred.

Note 2: Replace keyboard, H-plate, and call control unit onto subbase. For replacement instructions, refer to Section 574-160-702TC.

To Check

Place typing unit in stop position. Engage distributor clutch. From front of keyboard, latch universal lever. Attach gauge TP186308 to front of keyboard frame. Rotate distributor shaft until its cam post (late design) or cam roller (early design) is on high part of keyboard trip lever camming surface.

Requirement

Top edge of universal lever (now in lowest position) should be within thickness of lower tab of gauge as seen by eye.

To Adjust

Loosen clamp screw. Using pry points, position adjusting bracket until requirement is met. Tighten clamp screw.

Related Adjustment

Affects

TRIP LEVER ENGAGEMENT (KBA-8) in Section 574-172-700TC.

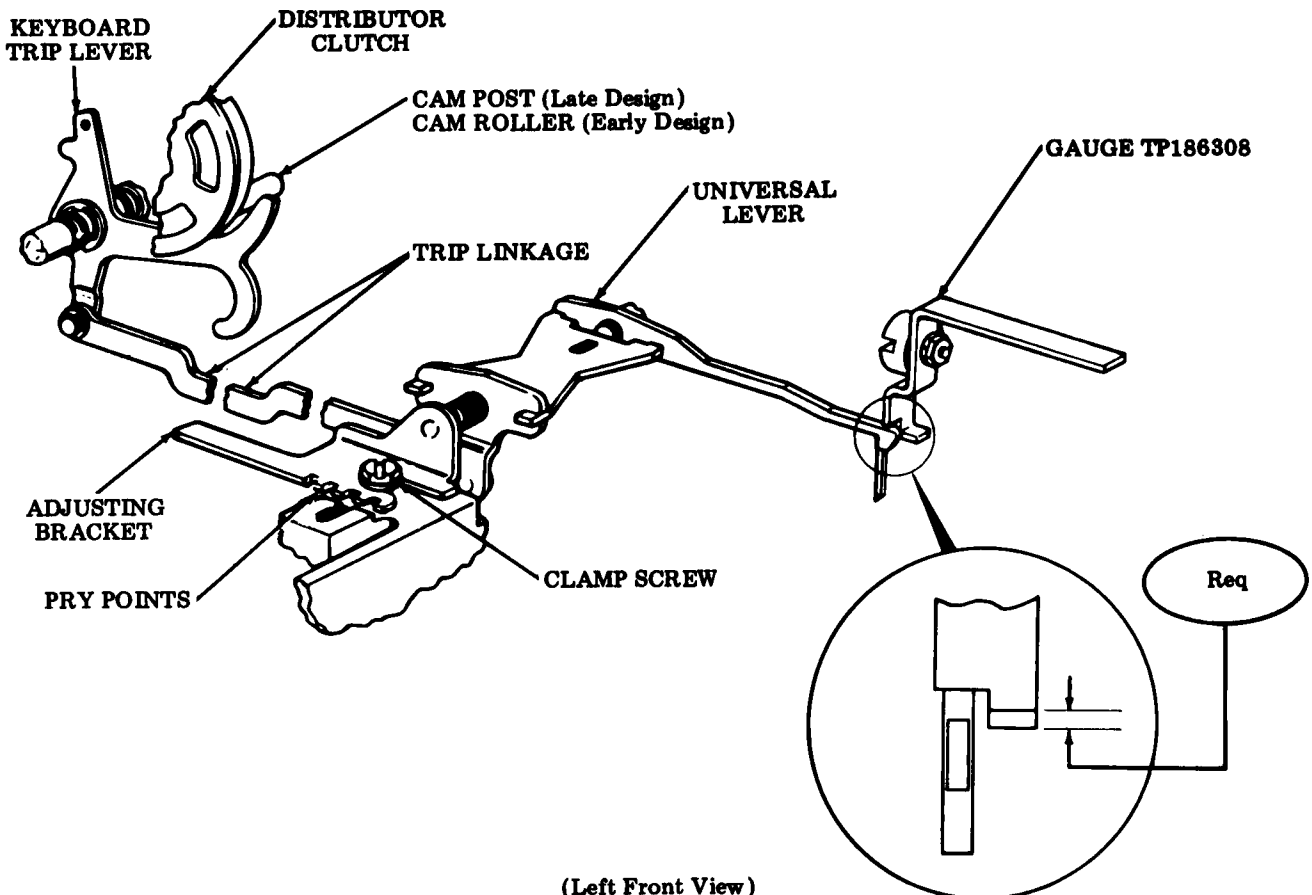

SECTION 574-171-700TC

2.11 Distributor Trip Linkage (continued)

DISTRIBUTOR TRIP LINKAGE — Method 2 (KBA-7)

Note: The requirement applies to early and late design keyboards having the TP180086, TP182240, or TP185766 universal lever.

To Check

Place typing unit in stop position. Engage distributor clutch. Rotate distributor shaft until keyboard trip lever is on high part of its cam. Push against reset bail spring anchor with just enough force to slightly move the reset bail, then release.

Requirement

Min 0.014 — Max 0.058 inch
between latchlever and universal lever.

To Adjust

Loosen clamp screw. Using pry points, position adjusting bracket until requirement is met. Tighten clamp screw.

Related Adjustment

Affects

TRIP LEVER ENGAGEMENT (KBA-8) in Section 574-172-700TC.

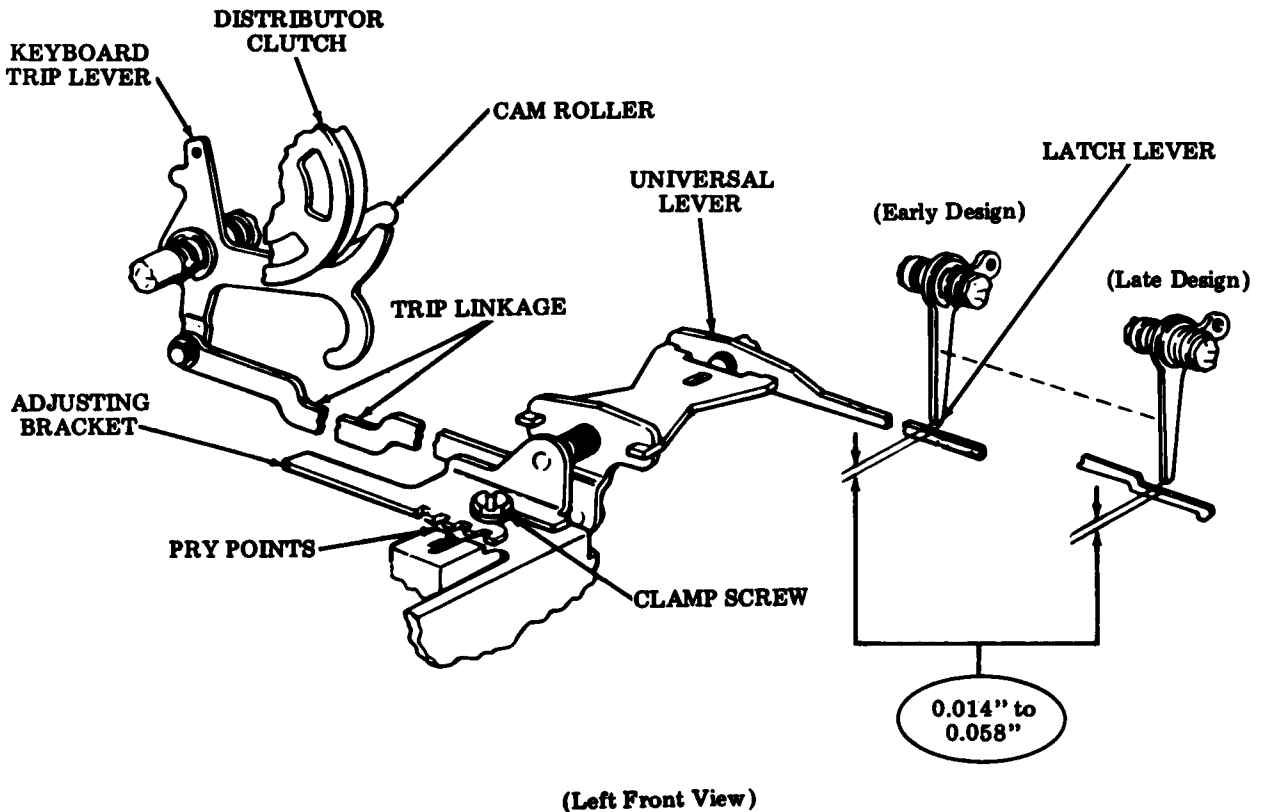

2.12 Latchlever Spring

LATCHLEVER SPRING

To Check

Place typing unit in stop position. Engage distributor clutch. Rotate main shaft until keyboard trip lever reaches its lowest point.

Requirement

Min 1/2 oz -- Max 1 oz
to start latchlever moving.

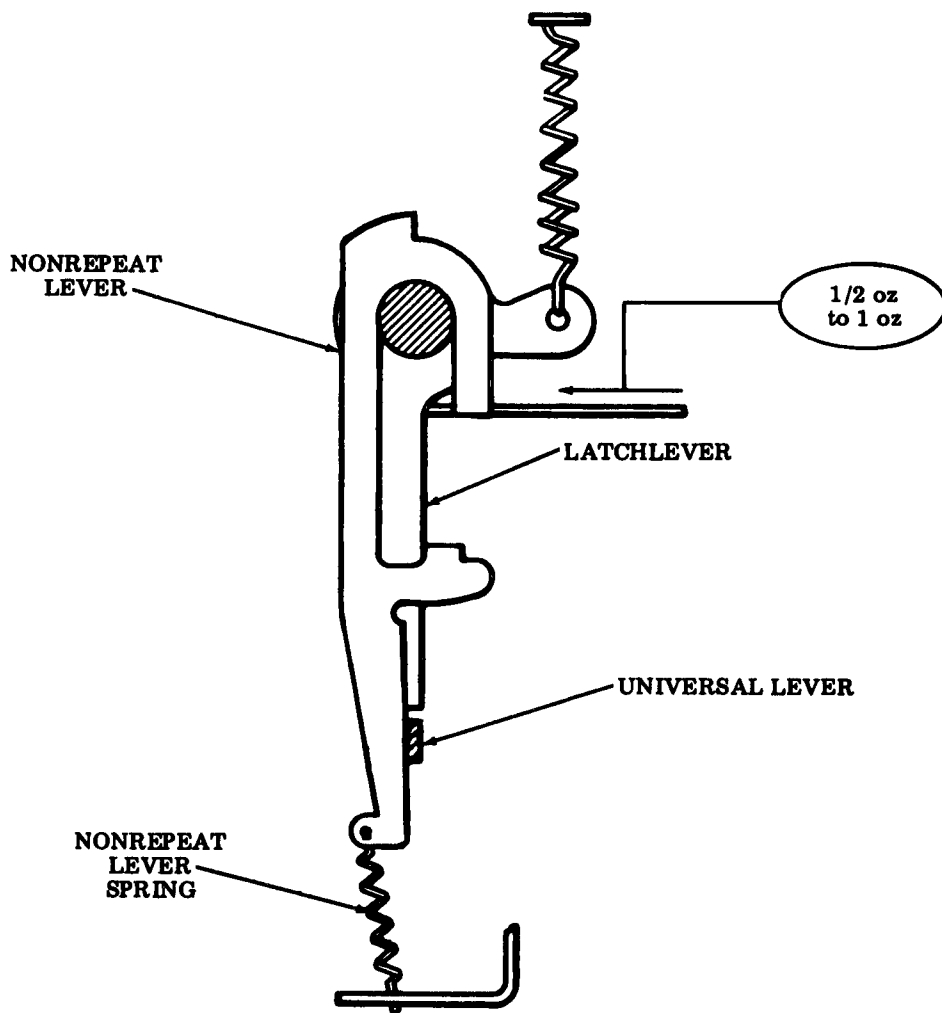

(Front View)

32 TYPING UNIT

ADJUSTMENTS

CONTENTS	PAGE	CONTENTS	PAGE
1. GENERAL	4	Stop bail spring	17
2. BASIC UNIT	9	Trip lever engagement	14
Carriage Area (CRA)		Trip shaft position	12
Final printing alignment	130	Form Feed Area (FOA)	
Front rollers clearance	49	Cam lobe position - S	105
Left slide guideplate reset	59	Clutch shoe lever gap - S	101
Power bail roller clearance	50	Form feed belt tension - S	100
Print drive lever positioning	54	Form-out bail spring - S	119
Print hammer bail spring	65	Form-out contact operating bail	
Print hammer trip lever release	60	clearance - S	119
Print hammer trip lever reset	61	Form-out contact pressure and gap - S	119
Print hammer trip lever spring	65	Form-out lever overtravel - S	104
Print suppression latchlever		Form-out lever — reset clearance	
endplay	56	(early design) - S	107
Print suppression latchlever		Form-out lever — reset clearance	
release	63	(late design) - S	108
Rack and pinion backlash	50	Form-out lever spring - S	104
Rear rail position	51	Latchlever assembly spring - S	104
Rear roller clearance	52	Latchlever spring - S	101
Reset lever positioning	55	Line feed bail spring - S	114
Ribbon drive lever spring	69	Line feed lever line-up and	
Ribbon feed pawl spring	69	endplay - S	103
Ribbon guide spring	65	Line feed lever spring - S	114
Ribbon positioning	62	Line feed pawl stripping - S	113
Ribbon power lever drive	68	Line feed selection - S	114
Ribbon ratchet spring	69	Reset follower lever spring - S	105
Ribbon reverse arm spring	69	Trip lever engagement —	
Right slide guideplate reset	58	(final) - S	111
Rotary drive bail spring	66	Trip lever engagement —	
Slide guideplate springs	57	form-out - S	109
Slide springs	67	Trip lever engagement —	
Third pulse linkage positioning	53	line feed - S	110
Typewheel "home" position		Trip lever engagement —	
(preliminary)	64	preliminary - S	102
Typewheel positioning (preliminary)	57	Trip lever spring - S	101
Typewheel return spring	152	Trip lever upstop position - S	112
Vertical drive bail spring	66	Trip shaft endplay - S	103
Distributor Area (DBA)		Function Area (FNA)	
Brush holder gap	11	Automatic codebar spring	39
Brush holder position	15	Bearing alignment	32
Brush holder spring	16	Bell clapper gap	48
Clutch latchlever spring	16	Blocking lever springs	38
Clutch shoe lever gap	13	Carriage return lever —	
Keyboard follower lever spring	17	latch clearance	47
Shaft left bearing gap	11		

SECTION 574-172-700TC

CONTENTS	PAGE
Carriage return spring	48
Codebar reset ball spring	35
Codebar reset guide position	37
Codebar reset lever line-up	34
Codebar reset lever position	35
Codebar springs	39
End-of-line bell signal - S	129
End-of-line latch spring	79
Function bail spring	43
Function lever retainer	43
Function lever springs	41
Function pawl spring	40
Function shaft and casting position	46
Left rocker drive	40
Line feed function strip lever spring - S	41
Line length selection	127
Main shaft rotation	32
Margin bell bellcrank clearance	128
Print suppression and no. 3 codebar spring	39
Print suppression cam follower spring	45
Print suppression latch — horizontal clearance	36
Print suppression latch — vertical clearance	45
Right rocker drive	42
Rocker shaft position and endplay	33
Selector blocking levers positioning	38
Stripper bail clearance	44
 Main Shaft Area (MSA)	
Clutch shoe lever spring	25
Clutch shoe spring	25
Codebar and function clutch shoe lever gaps	24
Codebar and function clutch latchlever springs	24
Codebar clutch endplay	20
Codebar clutch trip lever engagement	22
Codebar clutch trip lever line-up	21
Driven gear line-up	20
Form feed clutch endplay - S	99
Function clutch endplay	19
Function clutch position (preliminary).	19
Function clutch trip lever engagement	23
Latchlever endplay - S	99
Left bearing position	18

CONTENTS	PAGE
Selector cam endplay	18
Trip lever springs	23
Trip shaft latchlever endplay	21
 Motor Area (MRA)	
Belt tension	10
Gear backlash	9
 Paper Alarm Control Area (Paper Controls)	
Paper alarm contact lever clearance - S	125
Paper alarm contact pressure and gap - S	125
Paper lever spring - S	125
 Platen Area (PLA)	
Cam zero position - S	116, 117
Copyholder wire position - F	92
Detent position - F	84
Detent position - S	115
Detent ratchet pawl spring - S	115
Form length selection - S	118
Idler position - S	106
Left margin position - F	79
Left margin position - S	124
Line feed blocking lever spring - F	83
Line feed drive arm clearance - F	86
Line feed drive link position - F	88
Line feed drive link spring — horizontal - F	85
Line feed drive link spring — upstop - F	85
Line feed link yield spring - F	85
Line feed pawl downstop position - F	89
Line feed pawl spring - F	89
Line feed selection - F	83
Line feed stripper plate clearance - F	91
Line feed upstop bracket position - F	87
Paper guide springs - F	80
Paper guide spring - S	93
Paper guideplate clearance - S	98
Paper guideplate springs - F	80
Paper guideplate spring - S	93
Paper straightener bail spring - F	80
Platen detent pawl spring - F	90
Platen endplay - F	94
Platen — horizontal position - F	77
Platen — horizontal position - S	95, 96

CONTENTS	PAGE	CONTENTS	PAGE
Platen knob position - S	93	Blocking follower lever spring.	132
Platen knob spring - S	93	Blocking latch spring.	142
Pressure roller clearance - F.	90	Blocking link clearance	131
Printing line position — final - S.	121	Character suppression contact wire gap	141
Printing line position — preliminary - S.	120	Code contact wire gap	145
Reset follower lever — reset position - S	116	Contact wire spring.	144
Right margin position - S	124	Control lever spring — horizontal.	132
Right paper guide position - S	122	Control lever spring — vertical (early design).	142
Vertical type alignment - F.	78	Control lever spring — vertical (late design).	143
Vertical type alignment - S.	96, 97	Detent spring	144
Wire guide position - S	123	Drum position.	133
Zeroizing button - S.	106	Feed lever position	135
Selector Area (SLA)		Feed lever spring	145
Armature bracket position (preliminary)	26	Feed pawl position.	136
Armature spring.	28	Feed pawl spring.	144
Latchlever spring	29	HERE IS bellcrank positioning	137
Pushlever springs.	31	Instructions for coding the answer- back drum	156, 157
Receiving margins.	129	Tripbail positioning.	138
Selector lever springs	30	Trip lever adjusting tab clearance.	140
Shoe lever gap and trip lever engagement	27	Trip lever clearance	134
Spacing locklever spring.	30	Trip lever overtravel and armature gap	139
Start lever spring	29	Trip lever spring	143
Stripper bail spring.	31	Auxiliary Contact Assembly — TP183594	
Trip lever spring	27	Front contact spring	148
Spacing Area (SPA)		Time delay contact bracket position.	148
Carriage bounce	82	Function Box Switches	
Carriage return arm springs.	82	Contact assembly position.	146
Carriage return latch spring.	82	Receive-Only Sets	
Carriage return lever spring.	72	Keyboard adjusting bracket position.	147
Carriage return lever — unlatch clearance.	81	Two-Color Printing	
Check pawl spring.	74	Blocking link clearance	150
Feed pawl spring.	73	Color selection latch overtravel	153
Feed pawl stop position	70	Latch bellcrank spring.	151
Feed pawl travel.	74	Platen — horizontal position - F.	149
Left margin printing	126	Ribbon guide positioning.	154
Space bellcrank spring.	70	Ribbon guide spring.	151
Space suppression lever clearance — printing.	71	Typewheel return spring	152
Space suppression lever clearance — spacing	72	Function Area	
Space suppression lever spring	73	Coding and installation of TP180801 universal function lever	155
Spacing belt tension.	75		
3. VARIATIONS TO BASIC UNIT.	131		
Answer-Back Area (ABA)			
Armature spring.	142		

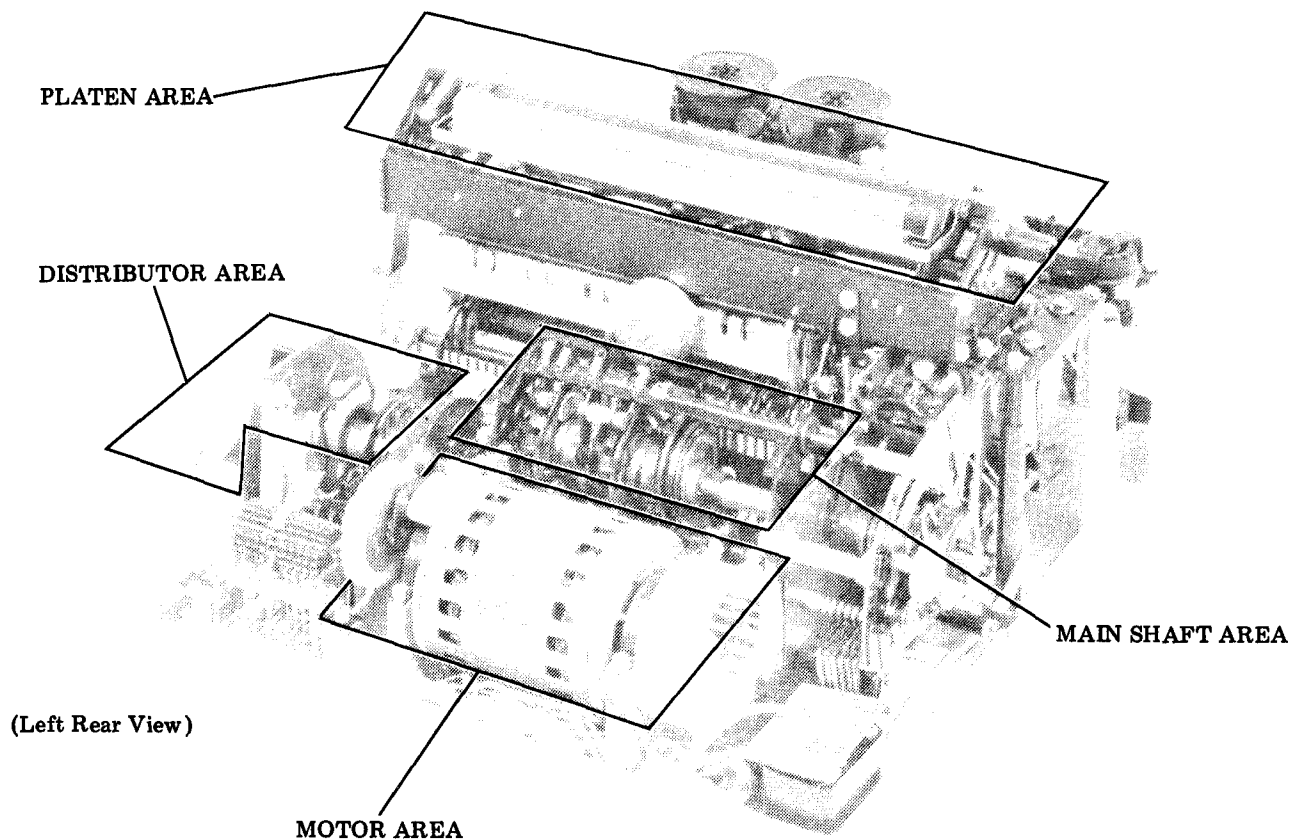

Figure 1 - Distributor, Main Shaft, Motor, and Platen Areas

1. GENERAL

1.01 This section provides adjustment information for the Model 32 typing unit. It is reissued to include engineering changes and to make corrections. Because this is a general revision, arrows normally used in the margin to indicate changes are omitted.

1.02 Alpha-numeric codes are used to supplement the adjustment titles. The codes contain key characters to designate specific areas (Carriage, Distributor, etc), and numerals to identify the adjustments in that area. All location of clearances, position of parts, and angles of scale measurement are illustrated by line drawings. Tools required to perform the adjustments are listed in Section 570-005-800TC. A DXD800 Test Set was used to establish the selector receiving margins.

1.03 Adjustments are divided into two categories — basic and variations. Basic adjustments apply to all friction feed and/or sprocket feed typing units. Adjustments found under variations apply only to typing units which have the particular feature(s) under considera-

tion. The F and S following an adjustment title mean that the adjustment applies only to friction feed (F) or sprocket feed (S) typing units. No letter designation indicates that the adjustment applies to both types of equipment.

1.04 Adjustments are presented in a definite order which is considered the best to follow when completely readjusting the equipment. Certain interrelated adjustments, which appear on the same page, should be checked and adjusted in a definite sequence. The sequence is indicated by the letters (A), (B), etc. No single adjustment should be undertaken without first completely understanding the procedure and knowing the requirements. Therefore, read a procedure all the way through before making an adjustment or checking a spring tension.

Note: Disconnect the typing unit from any ac or dc potential prior to inspection, minor repair, extensive maintenance, or a complete readjustment.

1.05 References to left, right, front, rear, etc consider the typing unit to be viewed from a position where the carriage area faces

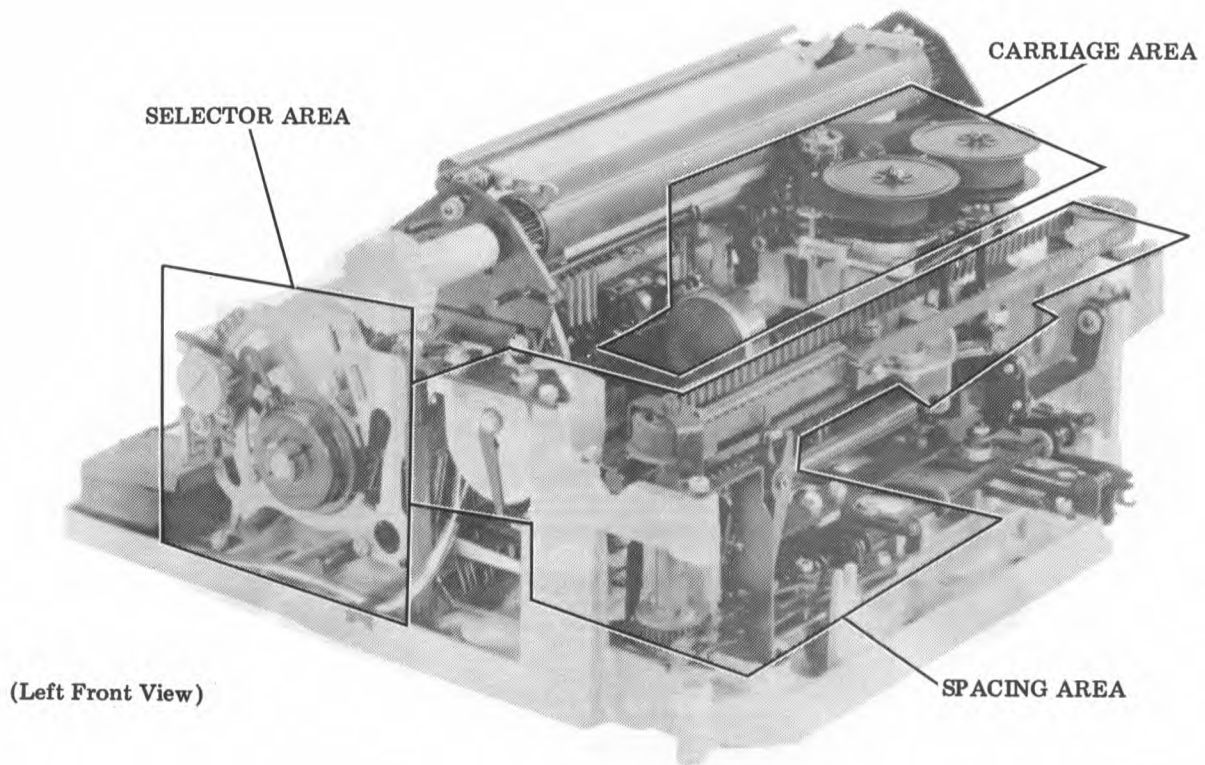

Figure 2 - Carriage, Selector, and Spacing Areas

up and the selector area is located to the viewer's left.

1.06 Unless specifically stated otherwise, make screws or nuts friction tight to make an adjustment and tighten them securely once the adjustment has been made.

1.07 When a procedure calls for using pry points or slots to make an adjustment, place a screwdriver between the points or in the slots and pry parts in the proper direction.

1.08 When a requirement calls for a range which includes the word "some", this limit of the range should be considered as any finite amount greater than contact but not exceeding the other limit of the requirement.

1.09 Due to a high degree of congestion within certain areas of some typing units, some disassembly will be required prior to making certain adjustments. If parts or subassemblies

are removed from the typing unit to facilitate the making of an adjustment, be sure that they are subsequently replaced. Recheck any adjustments that may have been affected by the removal of parts or subassemblies.

Note 1: Do not remove parts and/or subassemblies unless it is considered absolutely necessary to perform an adjustment.

Note 2: Instructions for the disassembly and reassembly of parts and/or subassemblies are given in Section 574-172-800TC.

Note 3: Do not lift typing unit while holding any part of the selector mechanism. Refer to Section 574-160-702TC for proper method of lifting typing unit from its subbase.

1.10 Related adjustments are listed with some of the adjustment texts and are primarily intended to aid in troubleshooting the equipment. As an example, suppose that in searching for a

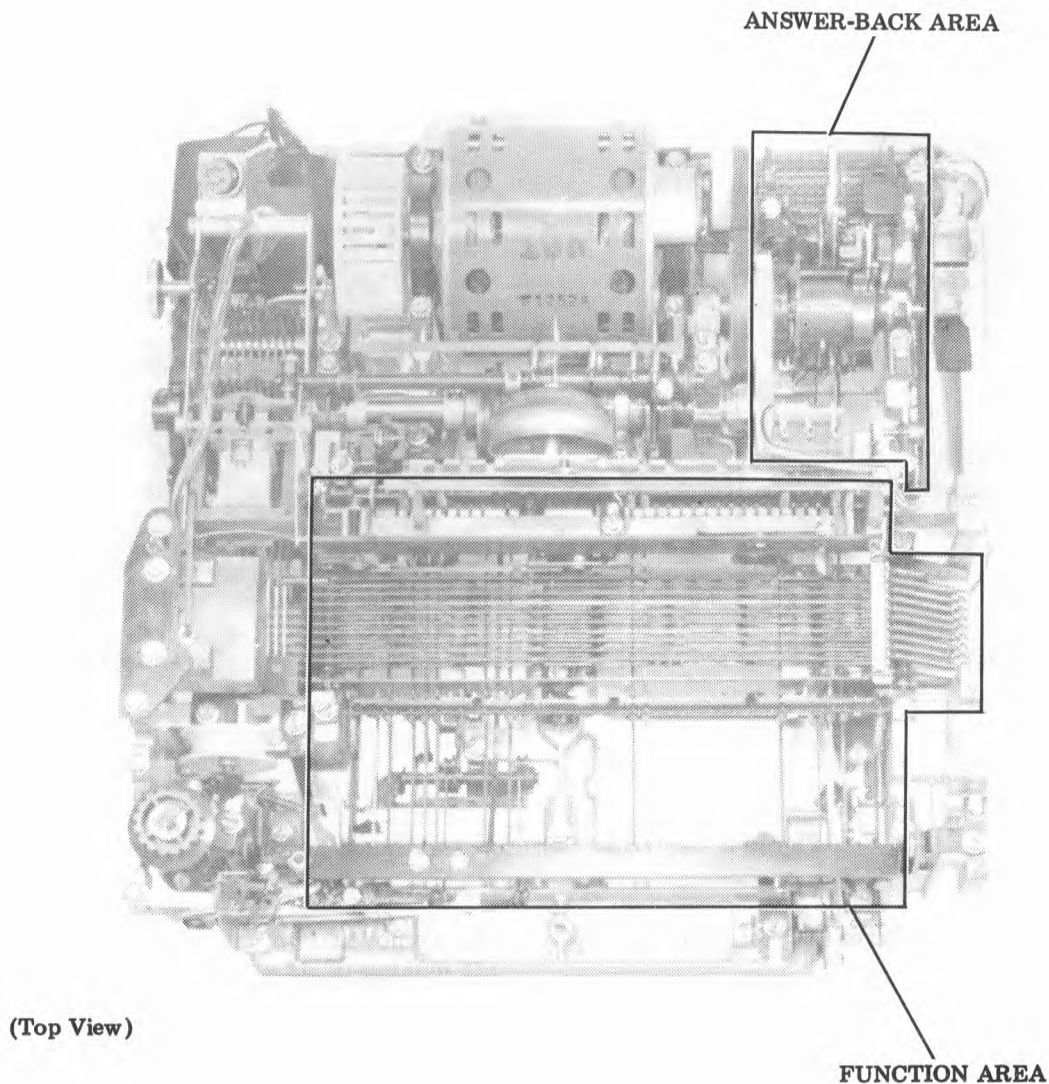

Figure 3 - Answer-Back and Function Areas

trouble it is discovered that the FUNCTION CLUTCH POSITION adjustment does not meet its requirement. Under Related Adjustments it is indicated that this adjustment is affected by the LEFT BEARING POSITION adjustment. First, check it to see if it is the cause of the trouble. Also, it is indicated that the FUNCTION CLUTCH POSITION adjustment affects FUNCTION CLUTCH ENDPLAY, CODEBAR CLUTCH ENDPLAY, and CODEBAR CLUTCH TRIP LEVER LINE-UP adjustments. If the former adjustment is changed, check the latter adjustments.

Note: Information in parentheses () following any related adjustment gives the associated paragraph number and area, if different from the paragraph number at the top of the page.

1.11 The spring tensions specified in this section are indications, not exact values. Therefore, to obtain reliable readings, it is important that spring tensions be measured by spring scales placed in the positions shown on pertinent line drawings. Springs that do not meet their requirements should be replaced by

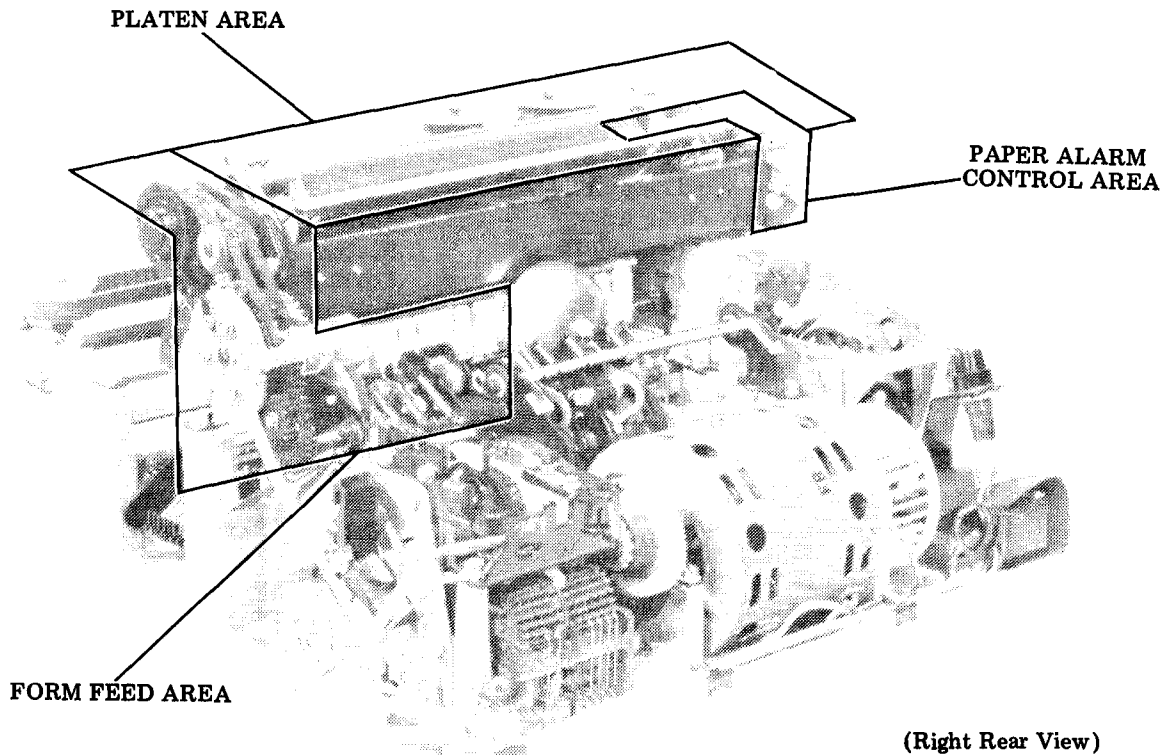

Figure 4 - Paper Alarm Control Form Feed, and Platen Areas

new ones. Only those springs that directly affect the operation of the typing unit are measured, however, others may be measured indirectly in the process. If, at first, the spring tension requirement cannot be met, replace the indicated spring being directly measured. Then if the requirement is not met, any springs that are indirectly measured in the procedure should be replaced, one at a time, with the performance of requirement checks each time a spring is replaced.

Note 1: Use only spring scales which are recommended by the manufacturer and found in Maintenance Tools Section 570-005-800TC.

Note 2: The spring tensions may be checked in any sequence.

Note 3: The alpha-numeric coding system is not used for spring tensions.

1.12 All adjustment procedures should be started with the typing unit in the stop condition. In the stop condition, the selector armature is in its attracted (frontward) position and all clutches are disengaged and latched. To place the typing unit in the stop condition, use

TP185832 armature clip to hold the selector armature in its attracted (frontward) position. Rotate the main shaft clockwise (as viewed from the left) until all clutches are in a stop position. Fully disengage all of the clutches as instructed in 1.13 following.

Note 1: A stop position is that position where a shoe lever contacts a trip lever.

Note 2: The distributor clutch will not disengage if the typing unit is removed from a set unless the keyboard adjusting bracket is adjusted per 3.17. Adjustment must be remade to set requirements when the typing unit is replaced in an ASR or KSR set.

Note 3: The distributor clutch will not disengage unless the answer-back drum is in its home position, which is the position where the control lever is fully detented into the indent on the answer-back drum.

1.13 When disengaged, a clutch is latched so that a shoe lever is held in its stop position by a trip lever while a corresponding

latchlever is seated in a notch of the clutch disc. This allows the clutch shoes to release their tension on the clutch drum. With all clutches disengaged, the main shaft will turn freely without any clutch shoes dragging.

Note: If the shaft is turned by hand, a clutch will not fully disengage upon reaching a stop position. Where an adjustment procedure calls for disengagement, rotate the clutch to a stop position, apply a screwdriver to the associated stop-lug, and push the clutch disc in the normal direction of main shaft rotation until the corresponding latchlever seats in its clutch disc notch. As a reminder, the word "latched" follows instructions to disengage the clutches.

1.14 A clutch is engaged when a trip lever is moved up so that it no longer holds a shoe lever in its stop position. When this action occurs, the shoe lever and a stop-lug on the clutch disc move apart, and the clutch shoes wedge against the drum, so that when the shaft is turned, the clutch will turn in unison with it.

1.15 Manual Operation: To manually operate the typing unit, place it in the stop condition as instructed in 1.12 and 1.13. Momentarily permit the armature to move to its unattracted (rearward) position to trip the selector clutch. Slowly rotate the main shaft clockwise (as viewed from the left) until all push levers have moved under their respective selector levers. Using a spring hook, strip the push levers from under the selector levers corresponding to the spacing elements of the code combination to be set up. Then continue to rotate the main shaft until the proper condition is set up or the character is cleared through the typing unit.

1.16 The selector levers are numbered 1, 2, 3, 4, and 5 from left to right. To set up the character Y, for example, whose 5-level code combination is 1-3-5, strip the pushlevers from the 2 and 4 selector levers.

1.17 To aid in physically locating the adjustments and spring tensions, the typing unit is divided into eleven areas. These areas are indicated in Figures 1 through 4 as follows:

<u>Area</u>	<u>Figure</u>
Carriage	2
Distributor	1
Function	3
Main Shaft	1
Motor	1
Selector	2
Spacing	2
Platen	1, 4
Form Feed	4
Answer-Back	3
Paper Alarm Control	4

1.18 These areas, and various adjustment categories, are identified by the following adjustment codes:

- ABA — Answer-Back Area
- CRA — Carriage Area
- DBA — Distributor Area
- FNA — Function Area
- FOA — Form-Out Adjustments
- FPA — Final Printer Adjustments
- KBA — Keyboard Area
- MDA — Margins and Dashpot Area
- MIA — Miscellaneous Adjustments
- MRA — Motor Area
- MSA — Main Shaft Area
- PLA — Platen and Line Feed Area
- SLA — Selector Area
- SPA — Spacing Area
- VFA — Variable Feature Adjustments

1.19 To facilitate making the adjustments, remove the typing unit from the sub-base. For instructions, refer to Section 574-160-702TC.

1.20 In some of the adjustment routines, the requirements must be checked at specific points in the operating cycle. With the codebar clutch tripped, the main shaft is rotated to the desired position. Three positions are designated as follows:

Note: Late design units have indicator marks on the function cam and carriage drive link to help locate these positions. For units so equipped, the indicator positions are given in parentheses.

Position 1 — The main shaft is rotated until the function bail is in its uppermost position. (In late design printers, the indicator mark on the carriage drive link is centered within the first notch on the function cam, and the hole on the cam is down.)

Position 2 — The main shaft is rotated until the carriage drive ball is in its rearmost position. (In late design printers, the indicator mark on the carriage drive link is centered within the second notch on the function cam, and the hole on the cam is toward the rear.)

Position 3 — The main shaft is rotated until the function bail is in its lowermost position. (The indicator mark on the carriage drive link is centered within the third notch on the function cam, and the hole on the cam is up.)

2. BASIC UNIT

2.01 Motor Area

GEAR BACKLASH (MRA-1)

To Check

Find position of tightest pinion and intermediate gear engagement.
Hold intermediate gear stationary.
Observe fan rim radial motion.

Requirement

For 2-1/2 inch diameter fan:
Min 0.010 inch---Max 0.032 inch play at fan rim.
For 3 inch diameter fan:
Min some---Max 0.050 inch play at fan rim.

To Adjust

Loosen mounting screws and position motor gear bracket. Tighten screws.

Related Adjustment

Affects
BELT TENSION (2.02)

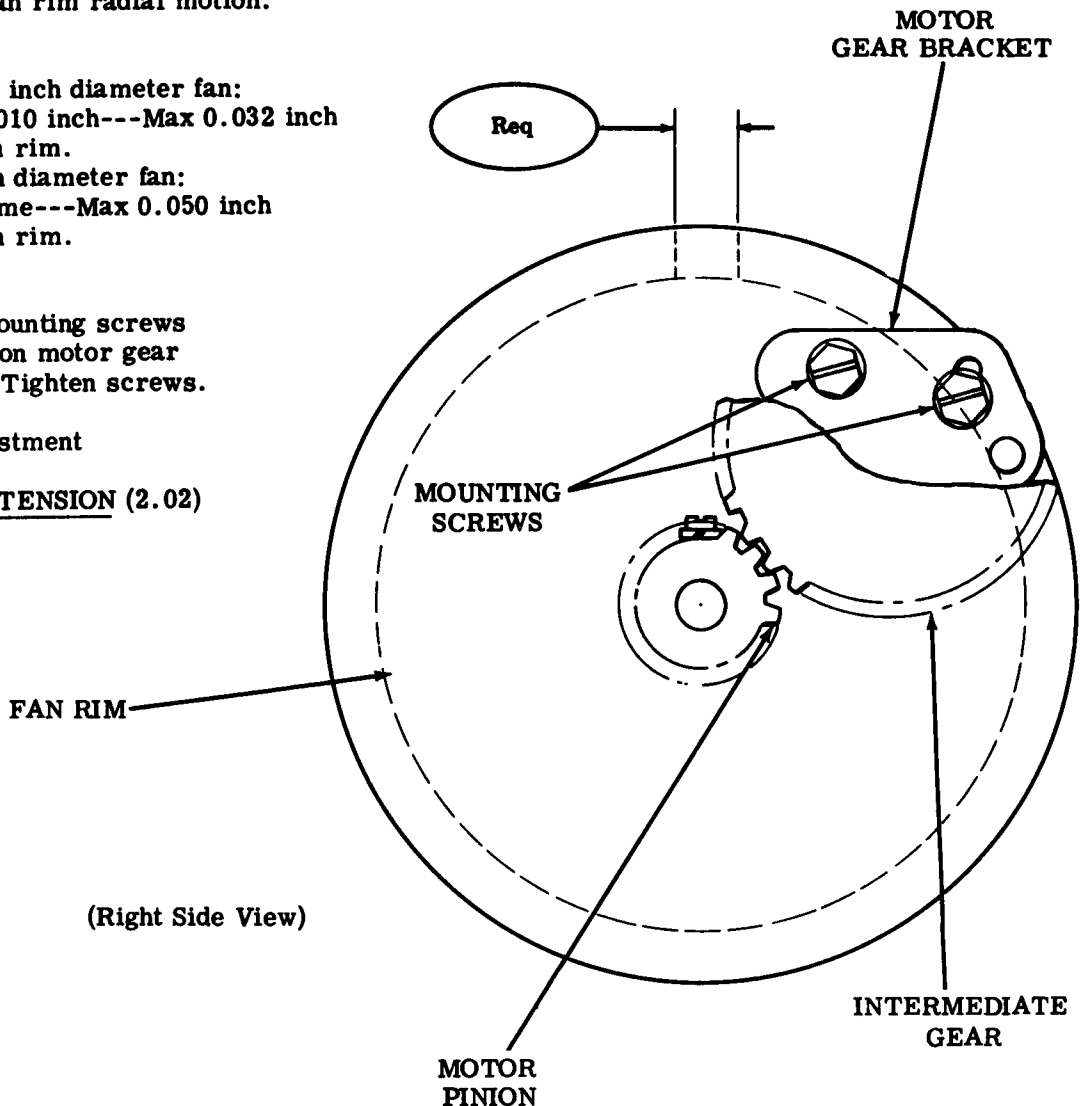

SECTION 574-172-700TC

2.02 Motor Area (continued)

BELT TENSION (MRA-2)

To Check

Rotate fan clockwise (viewed from left) until upper level of motor belt becomes taut. Using a spring scale, apply 16 oz force at center of belt.

Requirement

Min 0.100 inch---Max 0.135 inch deflection at center of motor belt.

To Adjust

Loosen four clampscrews and rotate motor in cradle. Tighten clampscrews.

Related Adjustments

Affected By

GEAR BACKLASH (2.01)

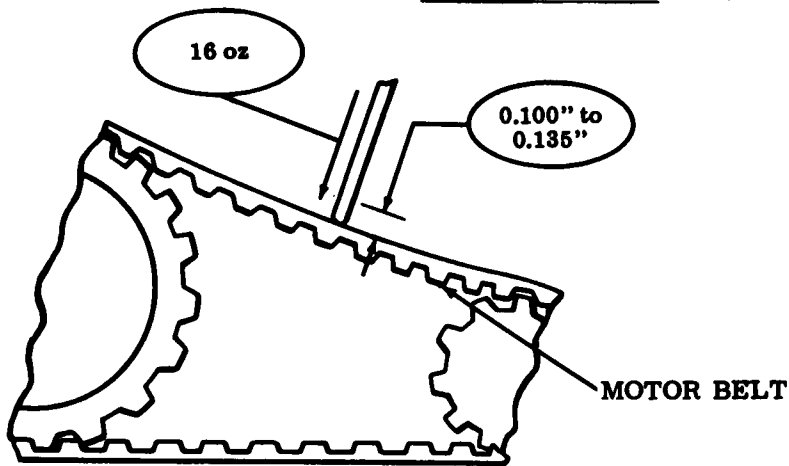

(Right Side View)

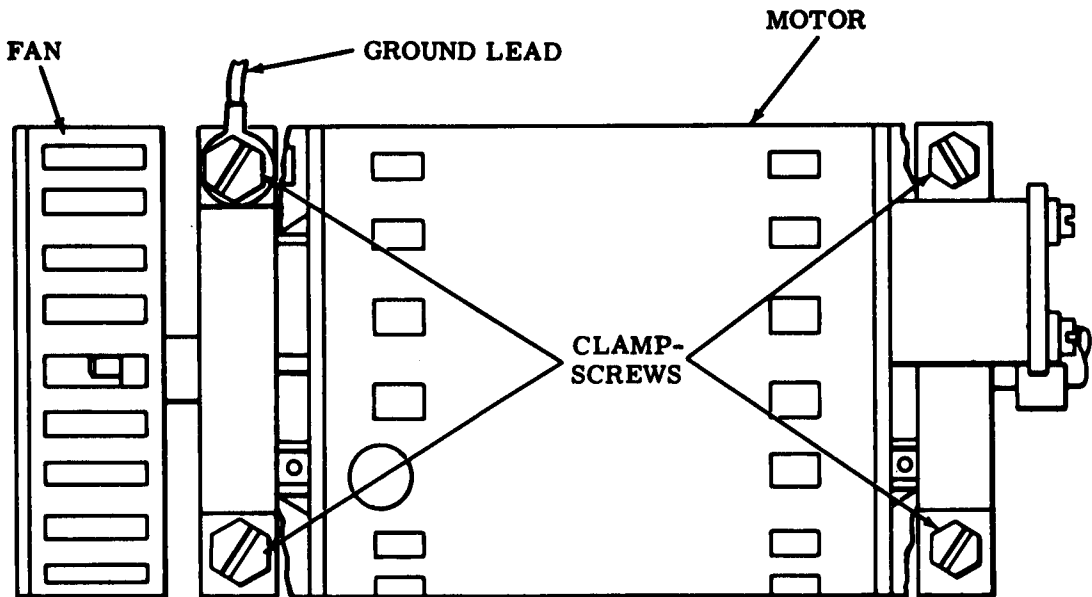

(Top View)

2.03 Distributor Area

(B) SHAFT LEFT BEARING GAP (DBA-2)

Requirement

With distributor clutch disengaged and latched, and clutch gear assembly held to the right,

Min some---Max 0.012 inch between left bearing and clutch gear assembly as gauged by eye.

To Adjust

Disengage (latch) distributor clutch. Hold clutch gear assembly firmly to right. Position left bearing to meet requirement with clamp screws loosened. Tighten left bearing clamp screws.

Related Adjustments

Affected By

BRUSH HOLDER GAP (2.03)

(A) BRUSH HOLDER GAP (DBA-1)

(1) Requirement

With brush holder pointer aligned with the locating mark on the disc

Min 0.010 inch---Max 0.060 inch between brush holder pointer and disc.

(2) Requirement

During entire brush holder rotation

Min 0.002 inch

between any brush holder and disc.

To Adjust

With three bearing clamp screws loosened, position distributor shaft assembly and right bearing right or left to meet requirement. Tighten right, but not left, bearing clamp screw.

Related Adjustments

Affects

SHAFT LEFT BEARING GAP (2.03)

TRIP SHAFT POSITION (2.04)

DRIVEN GEAR LINE-UP (2.12)

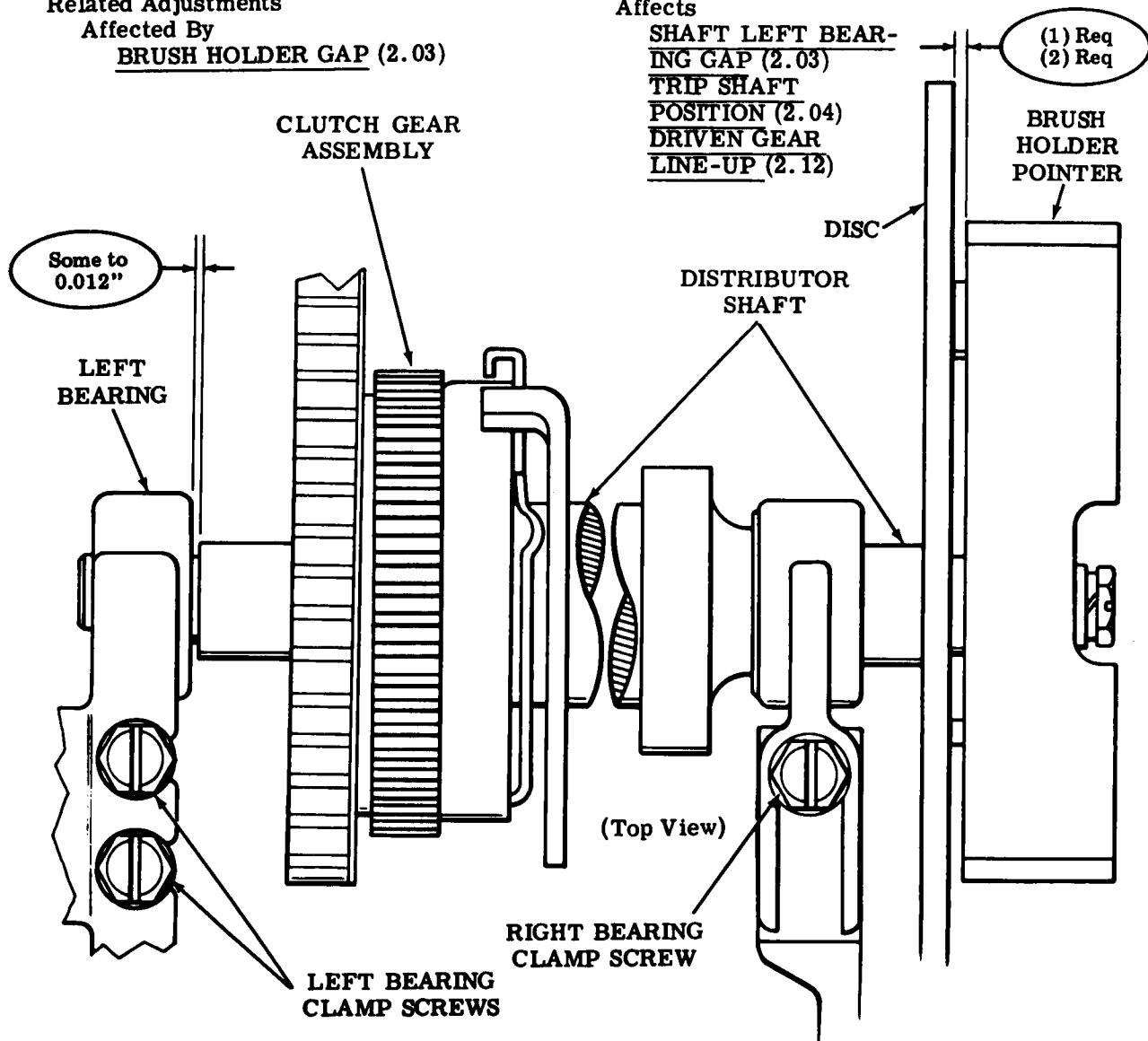

2.04 Distributor Area (continued)

TRIP SHAFT POSITION (DBA-3)

To Check

Place distributor clutch in the stop position.

(1) Requirement

With play taken up to minimize all clearances, the trip lever should engage
Min two-thirds width
of formed end of shoe lever.

(2) Requirement

Rear extension of control lever should not bind in its slot in answer-back block.

To Adjust

Loosen clamp screw and post friction tight. Move trip shaft right or left to meet requirements and bias trip shaft towards the front. Tighten clamp screw and post.

Related Adjustments

Affects

FEED PAWL POSITION (3.06)

Affected By

BRUSH HOLDER GAP (2.03)

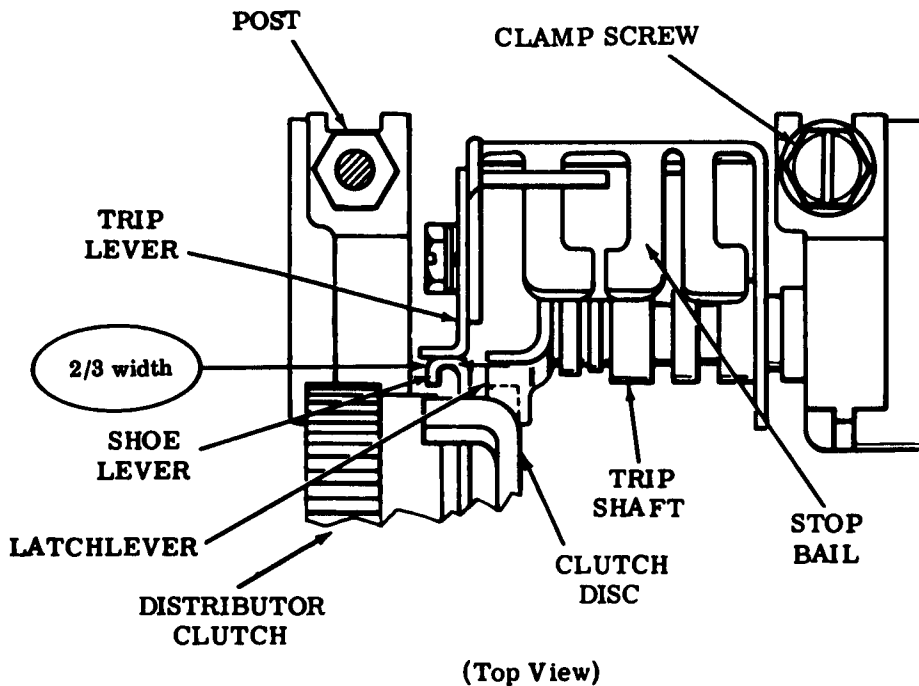
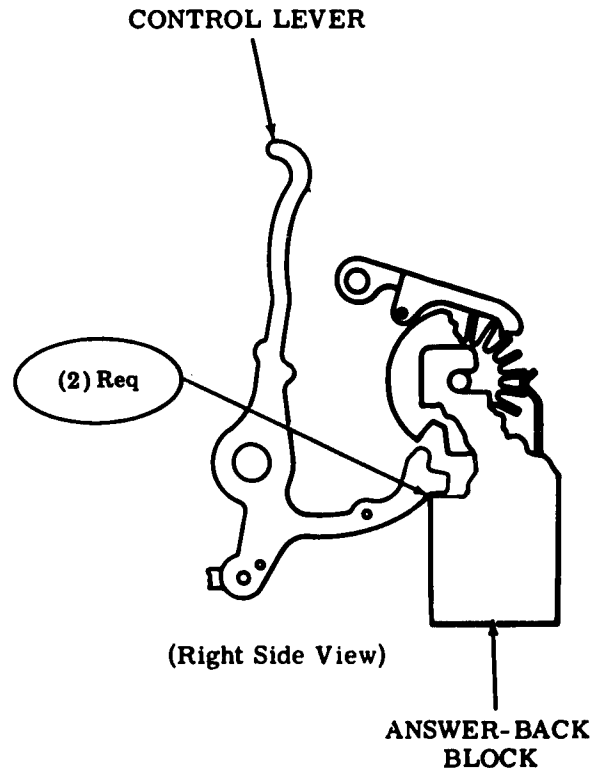

2.05 Distributor Area (continued)

CLUTCH SHOE LEVER GAP (DBA-4)**To Check**

Place distributor clutch in stop position (in late design units, position reference mark on sprocket insert on top and vertically in line with distributor shaft). With distributor clutch disengaged and latched, measure and record clearance between shoe lever and stop-lug. Trip distributor clutch by moving trip lever rearward. Fully seat the clutch shoes by applying 32 +1/2 ounces of pressure against the shoe lever along its normal path of forward travel. Measure and record same clearance as above.

- (1) Requirement
With distributor clutch disengaged (latched)
Min 0.015 inch
between stop-lug and shoe lever.
- (2) Requirement
Clearance between stop-lug and shoe lever
Min 0.050 inch---Max 0.080 inch
greater when distributor clutch is engaged than when disengaged.

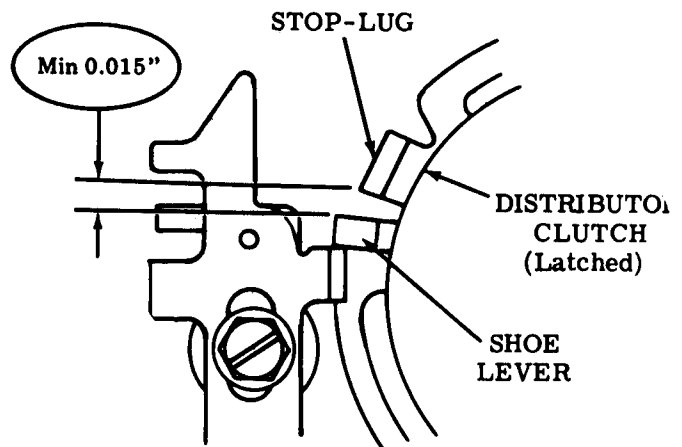
**To Adjust**

Remove answer-back drum. With clamp screw friction tight, position trip lever using pry point. Tighten clamp screw. Replace answer-back drum.

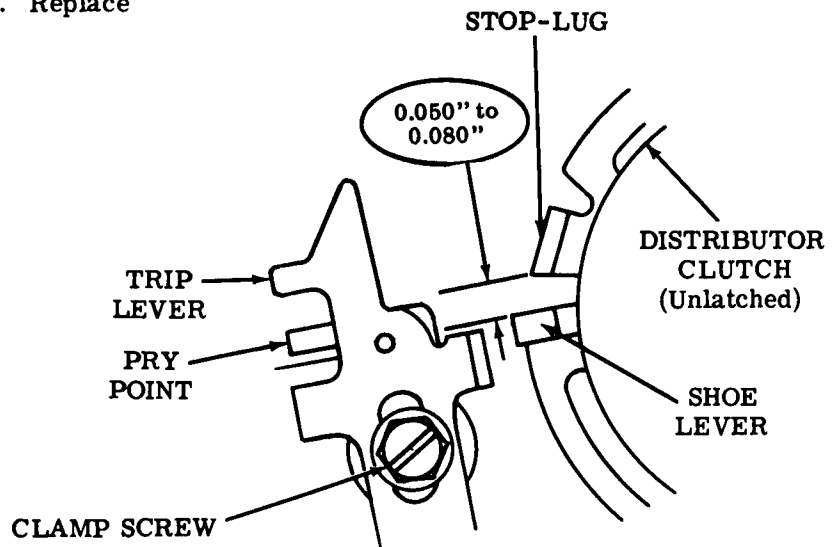

(Left Side View)

2.06 Distributor Area (continued)

Note: Before proceeding, replace typing unit onto subbase. For instructions, refer to Section 574-160-702TC.

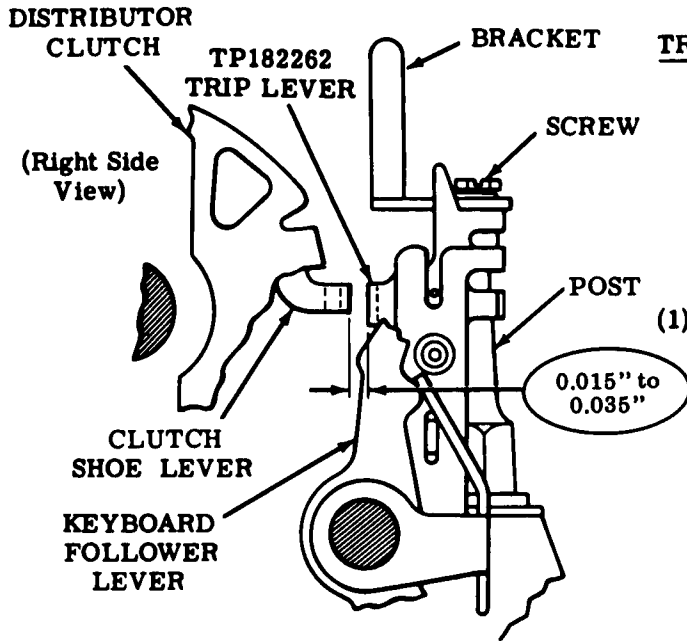

TRIP LEVER ENGAGEMENT (KBA-8)

Note 1: The answer-back control lever and reader trip lever should not be touching their respective stop bail adjusting tabs when checking this adjustment.

Note 2: Perform (1) To Check only on late design units containing the TP182262 trip lever.

(1) To Check

Disengage (latch) distributor clutch. Depress any nonfunction keytop to unlatch distributor clutch. If necessary, loosen screw and position bracket to obtain clearance between bracket and trip lever. Tighten screw. Rotate clutch to align upper edges of shoe lever and trip lever.

Requirement

Min 0.015 inch---Max 0.035 inch between shoe lever and trip lever.

To Adjust

Remove answer-back drum. Use TP180993 bending tool to bend center adjusting tab. Replace answer-back drum.

(2) To Check

Place keyboard universal lever in latched position and rotate distributor clutch to position the shoe lever up to, but not touching, the trip lever.

Requirement

Shoe lever should be Min flush---Max 0.015 inch beyond rearmost surface of trip lever.

To Adjust

Early Design (without TP182262)

Remove answer-back drum. Use TP180993 bending tool to bend center adjusting tab. Replace answer-back drum.

Late Design (with TP182262)

Loosen screw friction tight and position bracket. Tighten screw.

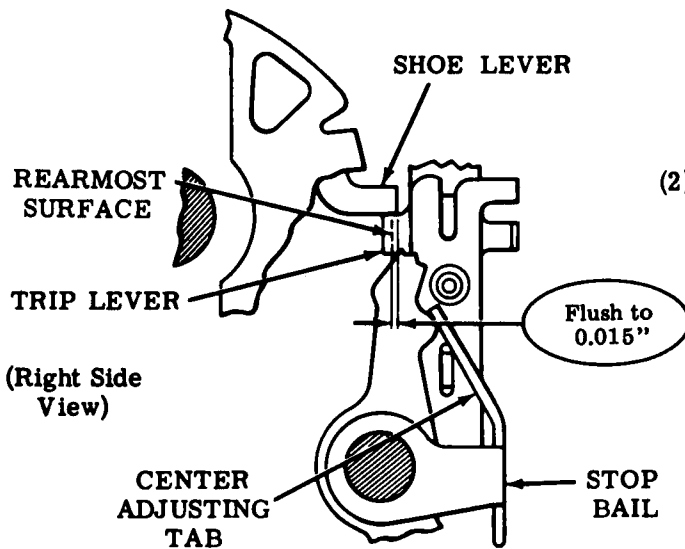

2.07 Distributor Area (continued)

BRUSH HOLDER POSITION (DBA-5)

Requirement

With distributor clutch disengaged (latched) pointer should be within locating mark.

To Adjust

Loosen mounting screw and position distributor brush holder. Tighten mounting screw.

Note: Rotate the brush holder in a clockwise direction only.

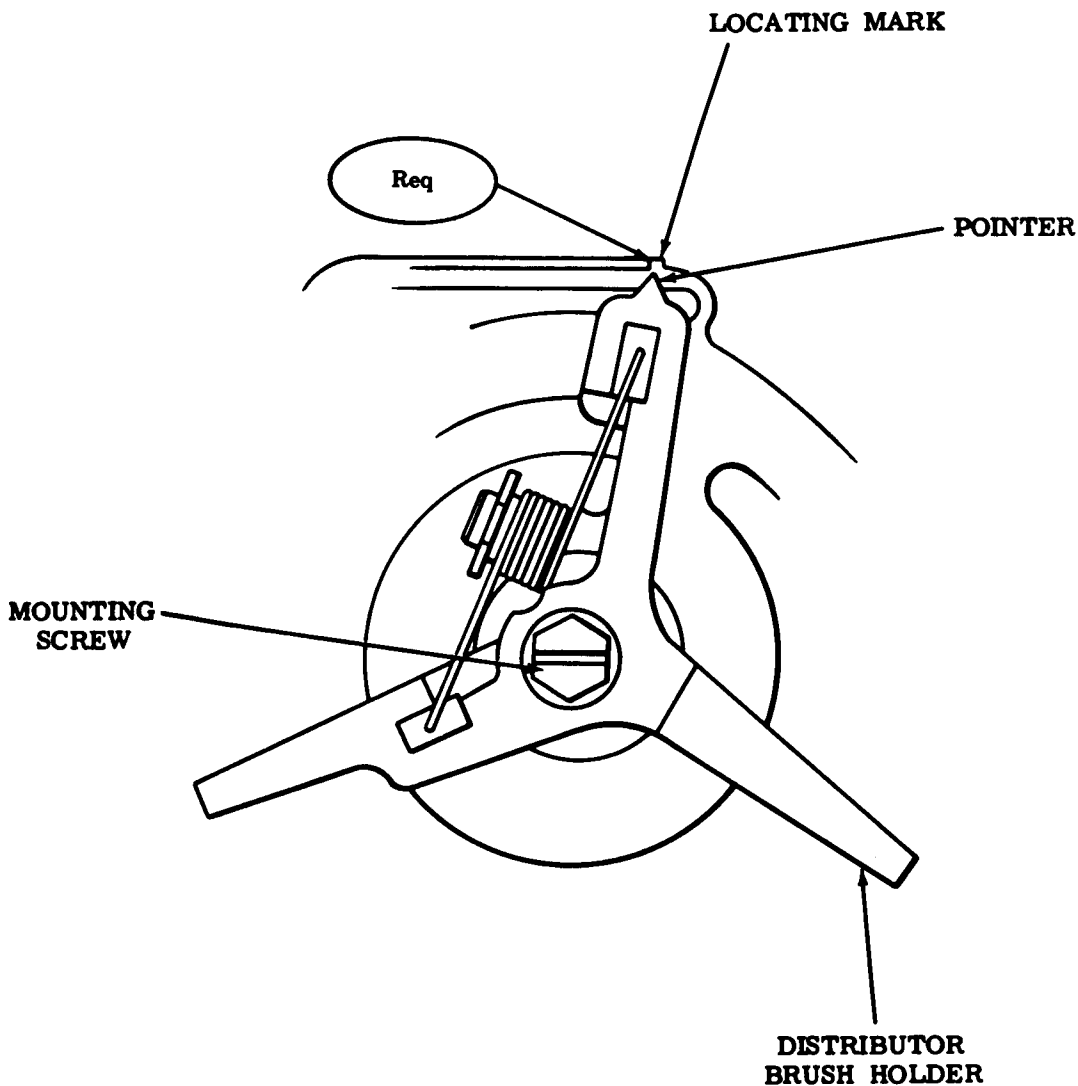

(Right Side View)

2.08 Distributor Area (continued)

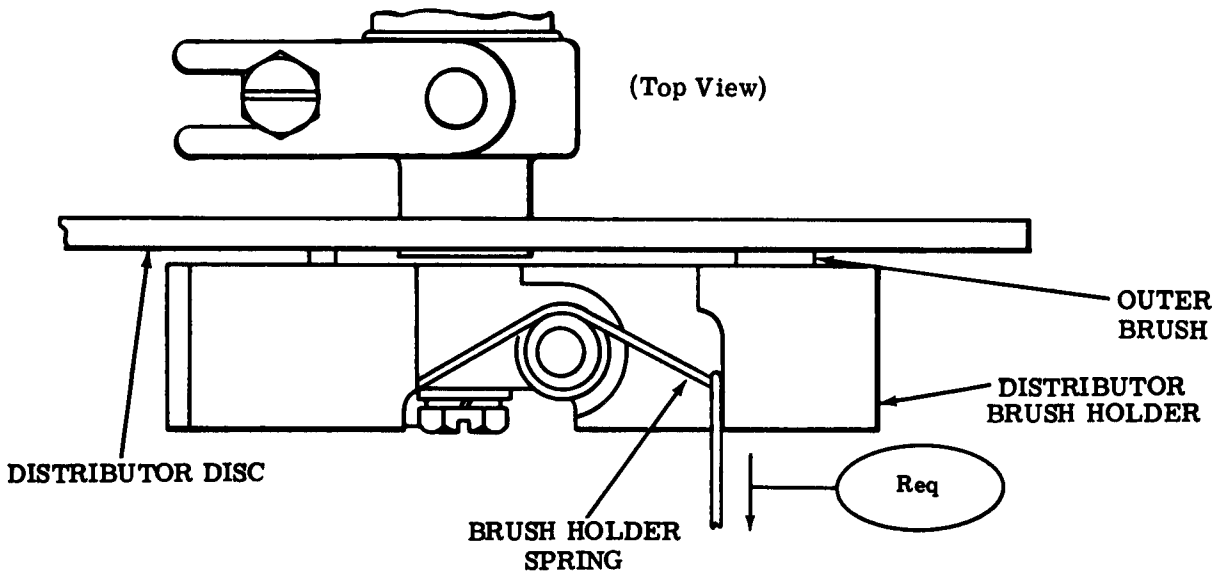

BRUSH HOLDER SPRING

Requirement

New brush

Min 10-1/2 oz---Max 13-1/2 oz

Brush worn to 1/4 inch length

Min 7-1/2 oz---Max 10-1/2 oz
to start outer brush moving.

CLUTCH LATCHLEVER SPRING

Requirement

With clutch tripped and latchlever resting on clutch disc as shown

Min 1-1/4 oz---Max 2-1/4 oz
to start clutch latchlever moving.

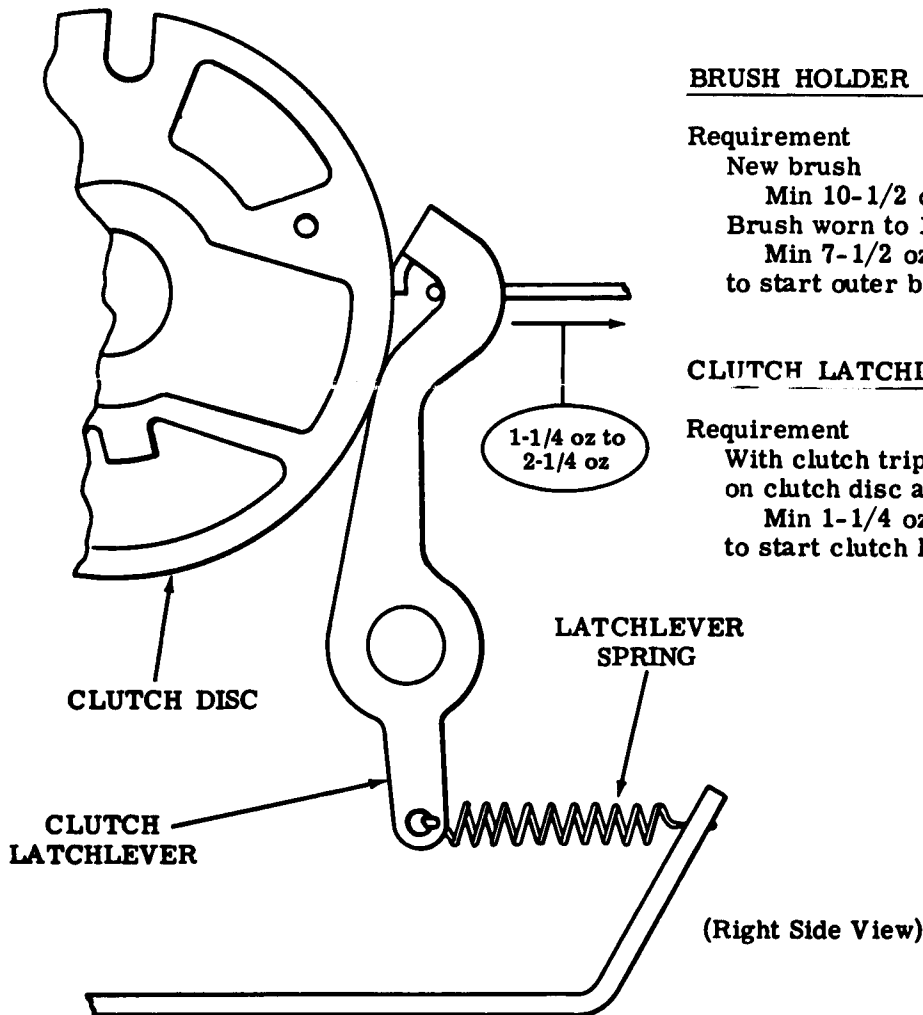

2.09 Distributor Area (continued)

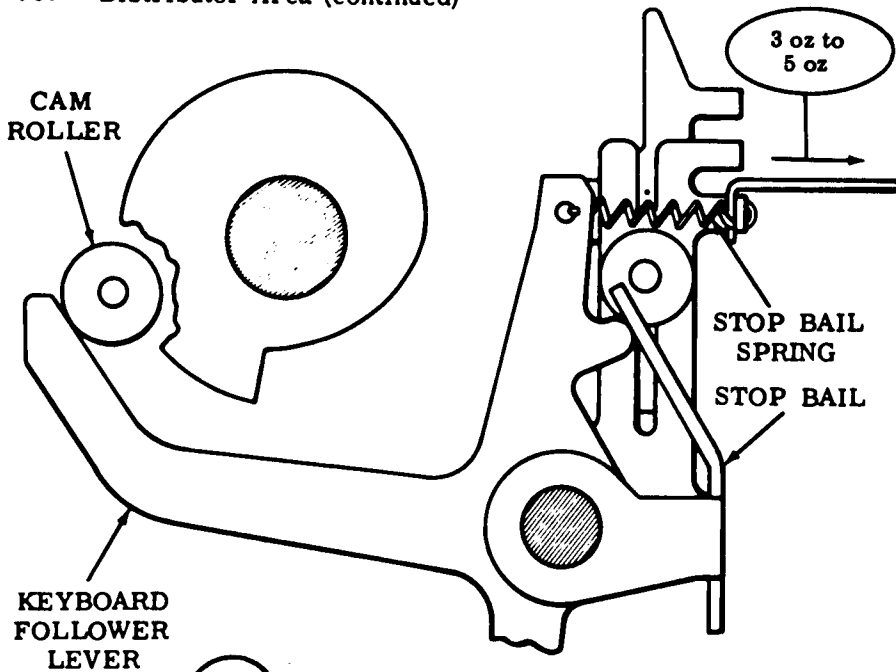

STOP BAIL SPRING

To Check
Place answer-back drum in home position. Trip distributor clutch and rotate main shaft until keyboard follower lever is moved by cam roller to its lowest point.

Requirement
Min 3 oz---Max 5 oz to start stop bail moving.

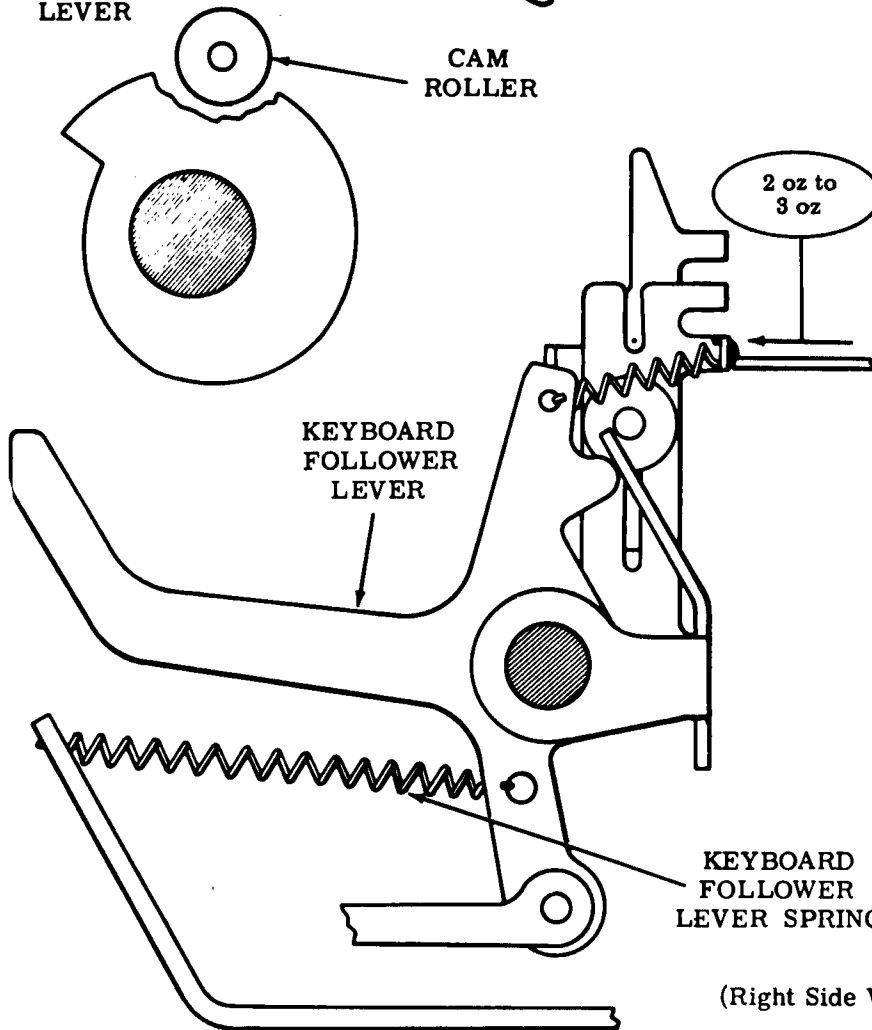

KEYBOARD FOLLOWER LEVER SPRING

Requirement
With H-plate removed and keyboard follower lever not in contact with cam roller
Min 2 oz---Max 3 oz to start keyboard follower lever moving.

2.10 Main Shaft Area

Note: If a complete readjustment of the typing unit is to be performed, loosen all screws on main shaft except collar screw immediately to the right of the left main shaft bearing.

(A) LEFT BEARING POSITION (MSA-1)

Requirement

The start cam follower, selector levers, and spacing locklever should fully engage their cams when cam sleeve is in contact with the left bearing, and the left side of the left bearing should protrude beyond selector side plate.

To Adjust

Loosen left bearing clamp screws and position left bearing. Tighten clamp screws.

Related Adjustments Affects

- FUNCTION SHAFT AND CASTING POSITION (2.38)
- DRIVEN GEAR LINE-UP (2.12)
- CODEBAR CLUTCH TRIP LEVER LINE-UP (2.13)

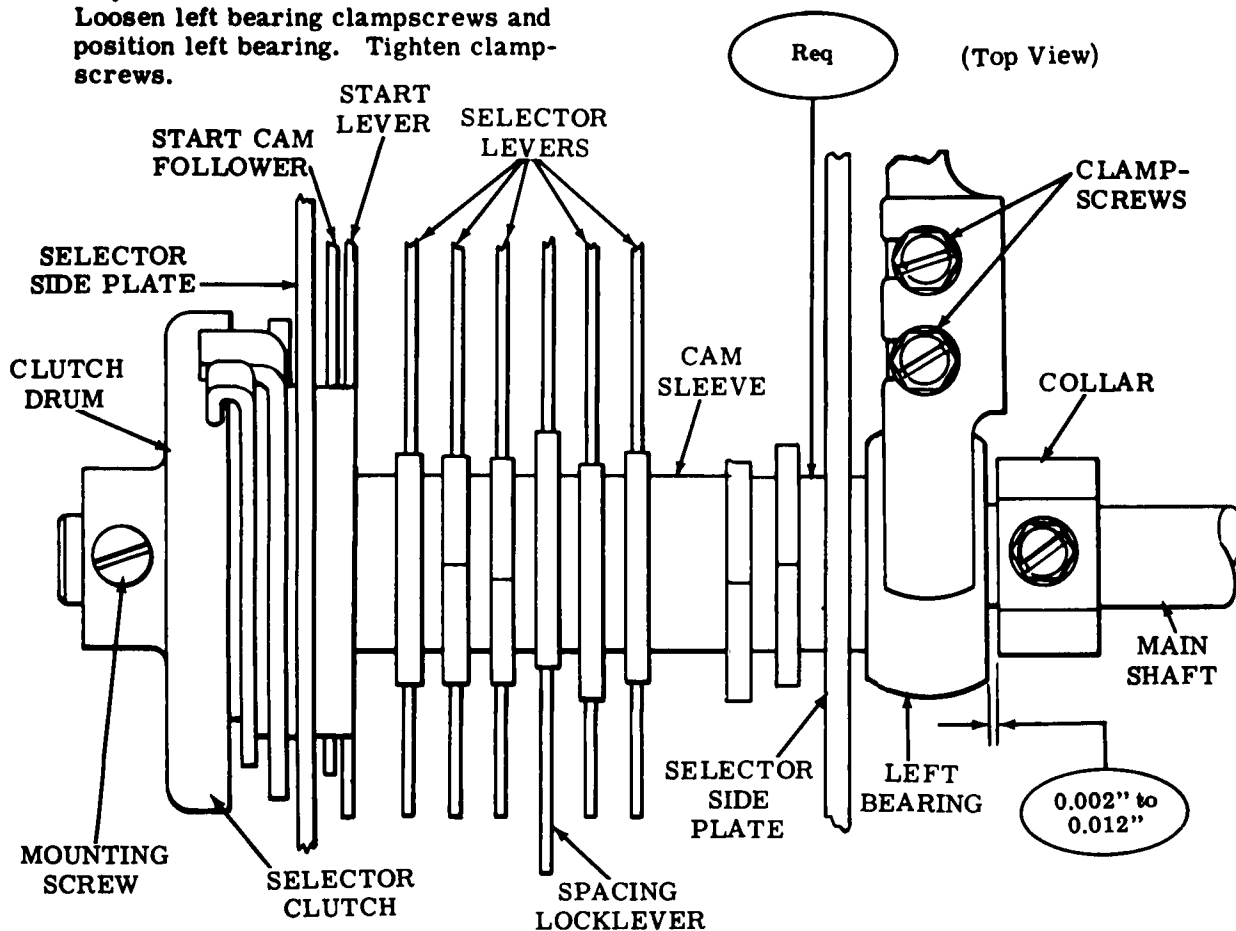

(B) SELECTOR CAM ENDPLAY (MSA-2)

To Check

Disengage (latch) selector clutch. Take up play in main shaft toward right.

Requirement

Min 0.002 inch---Max 0.012 inch endplay between left bearing and collar.

To Adjust

With the selector clutch drum mounting screw friction tight, position the clutch drum. Tighten mounting screw.

Related Adjustments Affects

- DRIVEN GEAR LINE-UP (2.12)
- CODEBAR CLUTCH TRIP LEVER LINE-UP (2.13)

2.11 Main Shaft Area (continued)

Note: Adjustment MSA-3 is to be done only when completely readjusting the typing unit.

(B) FUNCTION CLUTCH ENDPLAY (MSA-4)

To Check

Disengage (latch) function clutch. Take up clearances to make function clutch endplay a maximum.

Requirement

Min 0.005 inch---Max 0.015 inch endplay in function clutch.

To Adjust

Loosen collar clamp screw and position function clutch to meet requirement. Tighten clamp screw.

Related Adjustment

Affected By

FUNCTION CLUTCH POSITION (2.11)

(A) FUNCTION CLUTCH POSITION (Preliminary) (MSA-3)

To Check

Disengage (latch) function clutch. Take up play to minimize clearance between carriage drive eccentric and end of roller shaft.

Requirement

Min 0.020 inch---Max 0.040 inch clearance between carriage drive eccentric and end of roller shaft as gauged by eye.

To Adjust

Loosen the left and right function casting clamp screws (do not loosen the center clamp screw) friction tight and align the left side of lower portion of function casting with left side of lower projection of codebar basket rear tie bar by moving function casting. Loosen drum mounting screw and position function clutch to meet requirement. Tighten drum mounting screw.*

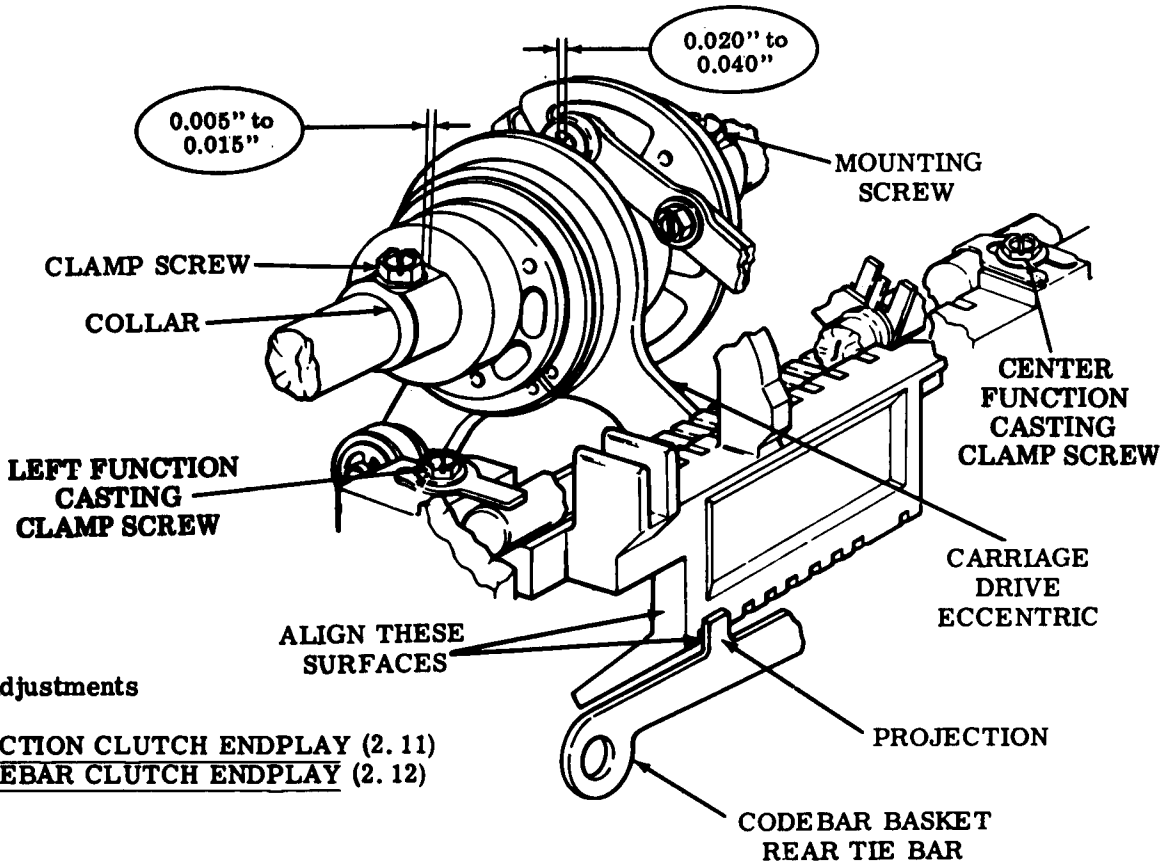

*Related Adjustments Affects

FUNCTION CLUTCH ENDPLAY (2.11)
CODEBAR CLUTCH ENDPLAY (2.12)

2.12 Main Shaft Area (continued)

CODEBAR CLUTCH ENDPLAY (MSA-5)

To Check

Disengage (latch) codebar clutch. Take up clearances to make codebar clutch endplay a maximum.

Requirement

Min 0.005 inch---Max 0.015 inch endplay in codebar clutch.

To Adjust

Loosen codebar clutch mounting screw and position codebar clutch to meet requirement. Tighten codebar clutch mounting screw.

Related Adjustments

Affects

CODEBAR CLUTCH TRIP LEVER LINE-UP (2.13)

CODEBAR RESET LEVER LINE-UP (2.26)

Affected By

FUNCTION CLUTCH POSITION (2.11)

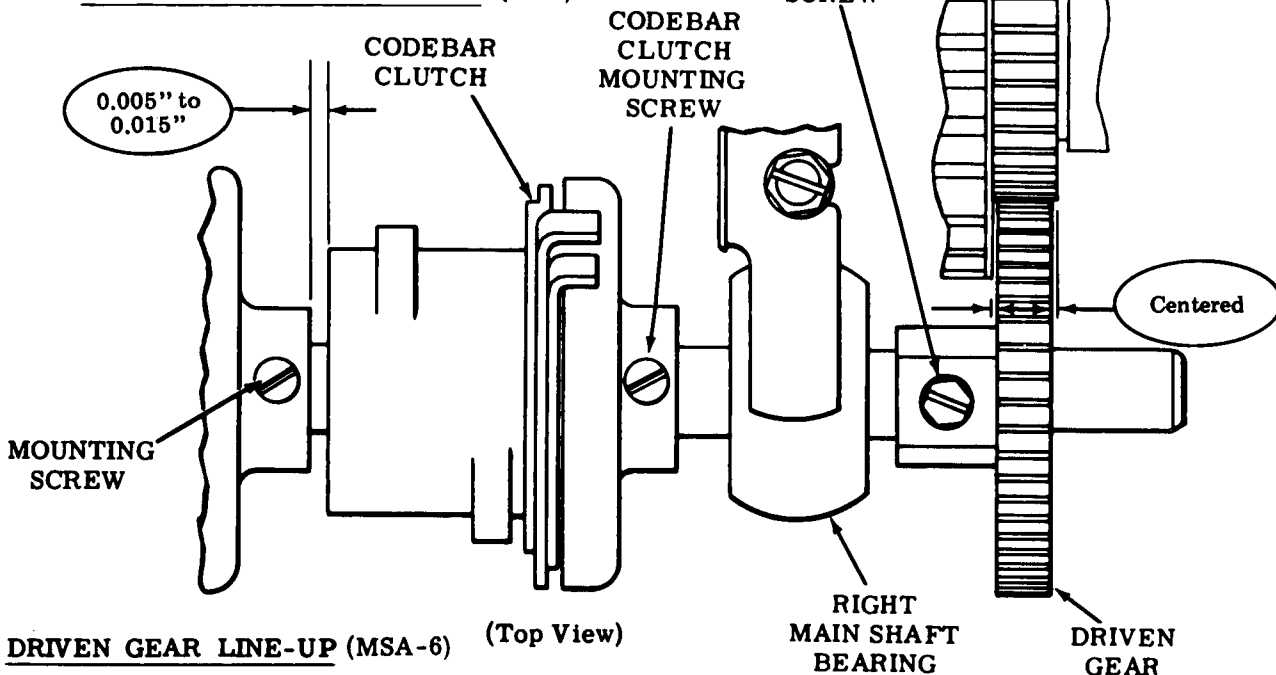

DRIVEN GEAR LINE-UP (MSA-6) (Top View)

Requirement

Driven gear centered on drive gear as gauged by eye.

To Adjust

Loosen driven gear mounting screw, and position driven gear to meet requirement. Tighten driven gear mounting screw.

Related Adjustments

Affected By

LEFT BEARING POSITION (2.10)

BRUSH HOLDER GAP (2.03)

SELECTOR CAM ENDPLAY (2.10)

2.13 Main Shaft Area (continued)

CODEBAR CLUTCH TRIP LEVER LINE-UP (MSA-7)

To Check

Disengage (latch) codebar and function clutches. Take up play of main shaft codebar and function clutches to left (as viewed from front) and play of trip shaft assembly to right.

(1) Requirement

As gauged by eye, right edge of codebar clutch trip lever approximately aligned with right edge of shoe lever within 0.020 inch.

(2) Requirement

Min 0.005 inch between function clutch trip roller's shaft and codebar reset cam when all play is taken up to make clearance minimum.

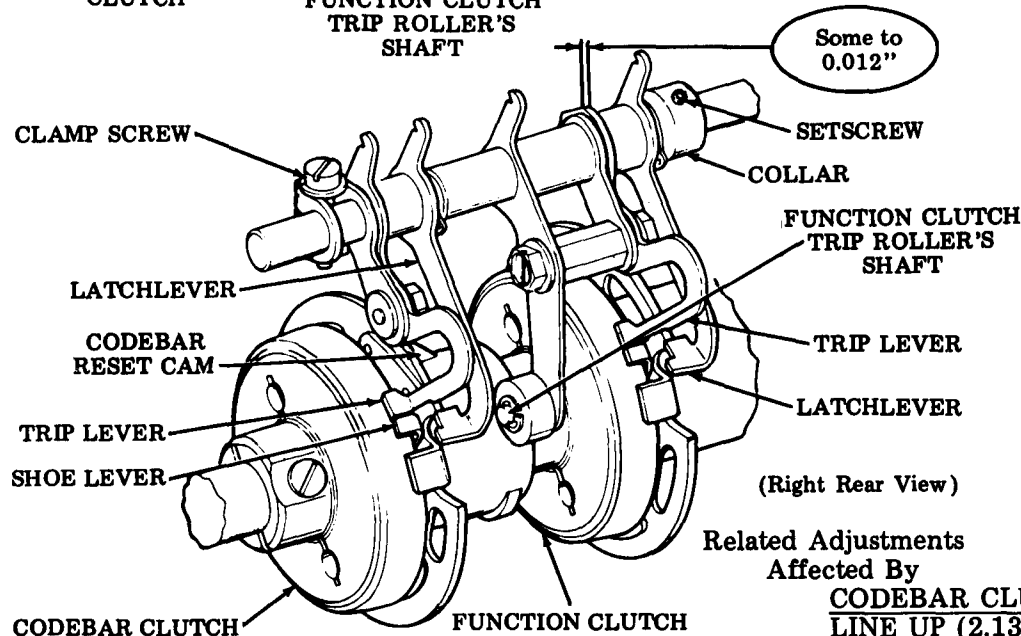
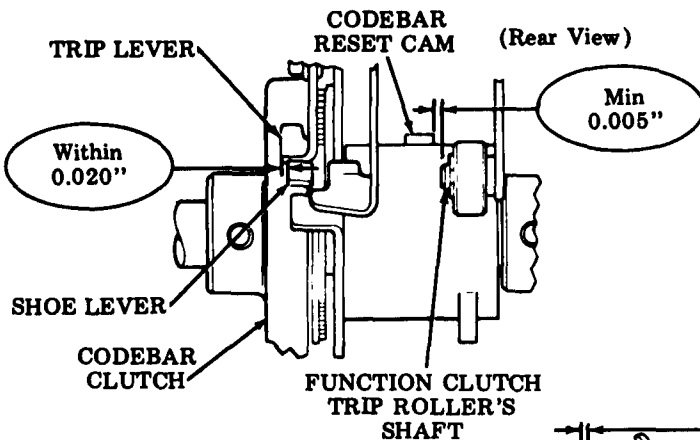

To Adjust

Loosen clamp screw and position trip lever.

Note: It may also be necessary to loosen setscrew in collar.

Related Adjustments

Affects

TRIP SHAFT LATCHLEVER ENDPLAY (2.13)

CODEBAR CLUTCH TRIP LEVER ENGAGEMENT (2.14)

Affected By

LEFT BEARING POSITION (2.10)

SELECTOR CAM ENDPLAY (2.10)

CODEBAR CLUTCH ENDPLAY (2.12)

TRIP SHAFT LATCHLEVER ENDPLAY (MSA-8)

Requirement

Min some -- Max 0.012 inch endplay in function clutch latchlever, as gauged by eye.

To Adjust

Loosen setscrew and position collar. Tighten setscrew. On units with TP186731 compression ring, compress ring tabs and position ring. Clearance to be measured between function clutch latchlever and trip lever.

Related Adjustments

Affected By

CODEBAR CLUTCH TRIP LEVER LINE UP (2.13)

2.14 Main Shaft Area (continued)

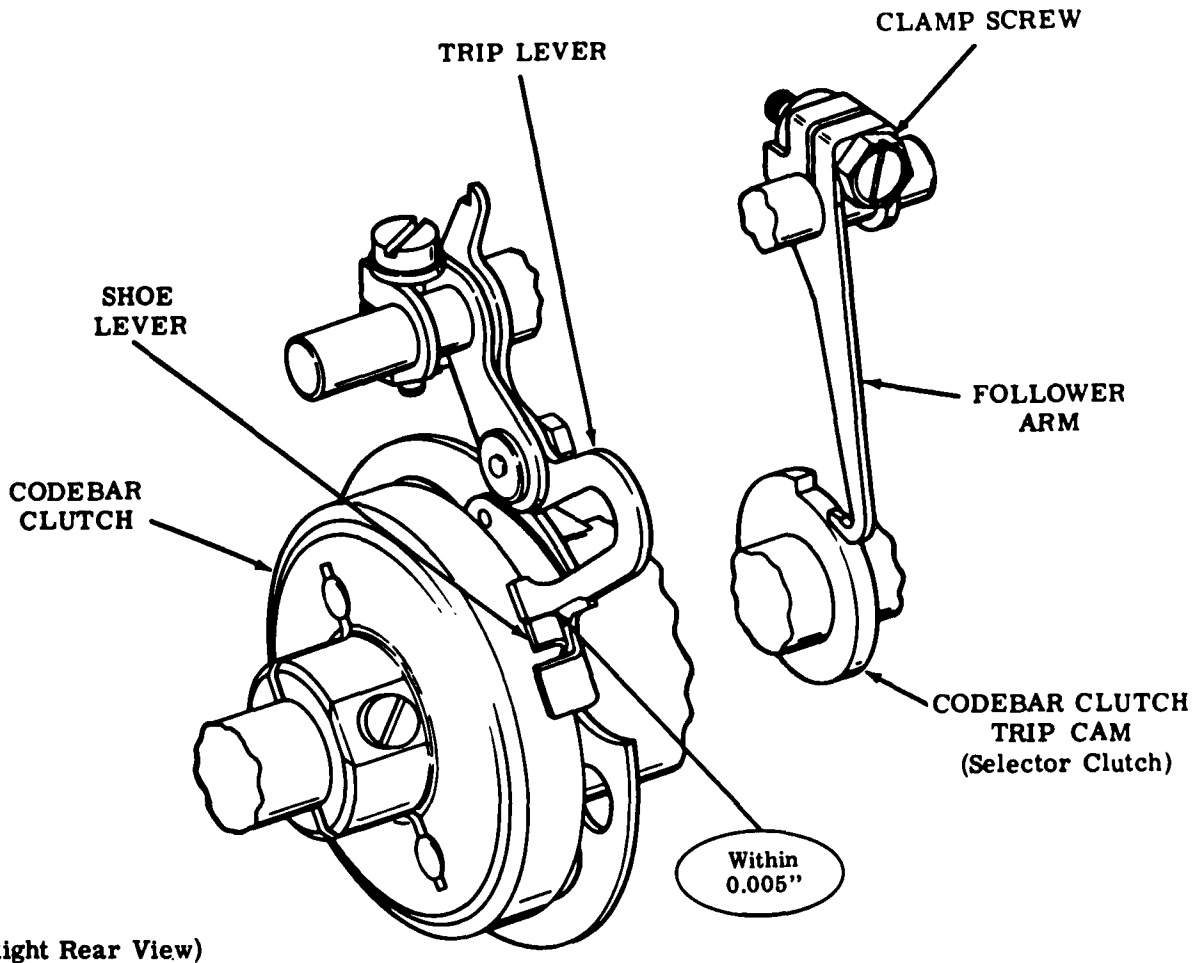

CODEBAR CLUTCH TRIP LEVER ENGAGEMENT (MSA-9)

Requirement

With typing unit in stop condition, the upper surfaces of the trip lever and shoe lever should be flush within 0.005 inch.

To Adjust

Loosen clamp screw and position codebar clutch trip cam follower arm. Tighten clamp screw.

Note: Make sure follower arm is at center of codebar clutch trip cam.

Related Adjustments

Affected By

CODEBAR CLUTCH TRIP LEVER LINE-UP (2.13)

2.15 Main Shaft Area (continued)

TRIP LEVER SPRINGS

Note: Check for both codebar and function clutches.

Requirement

With clutch engaged, codebar clutch
 Min 6 oz---Max 12 oz
 function clutch
 Min 2 oz---Max 4 oz
 to start trip lever moving.

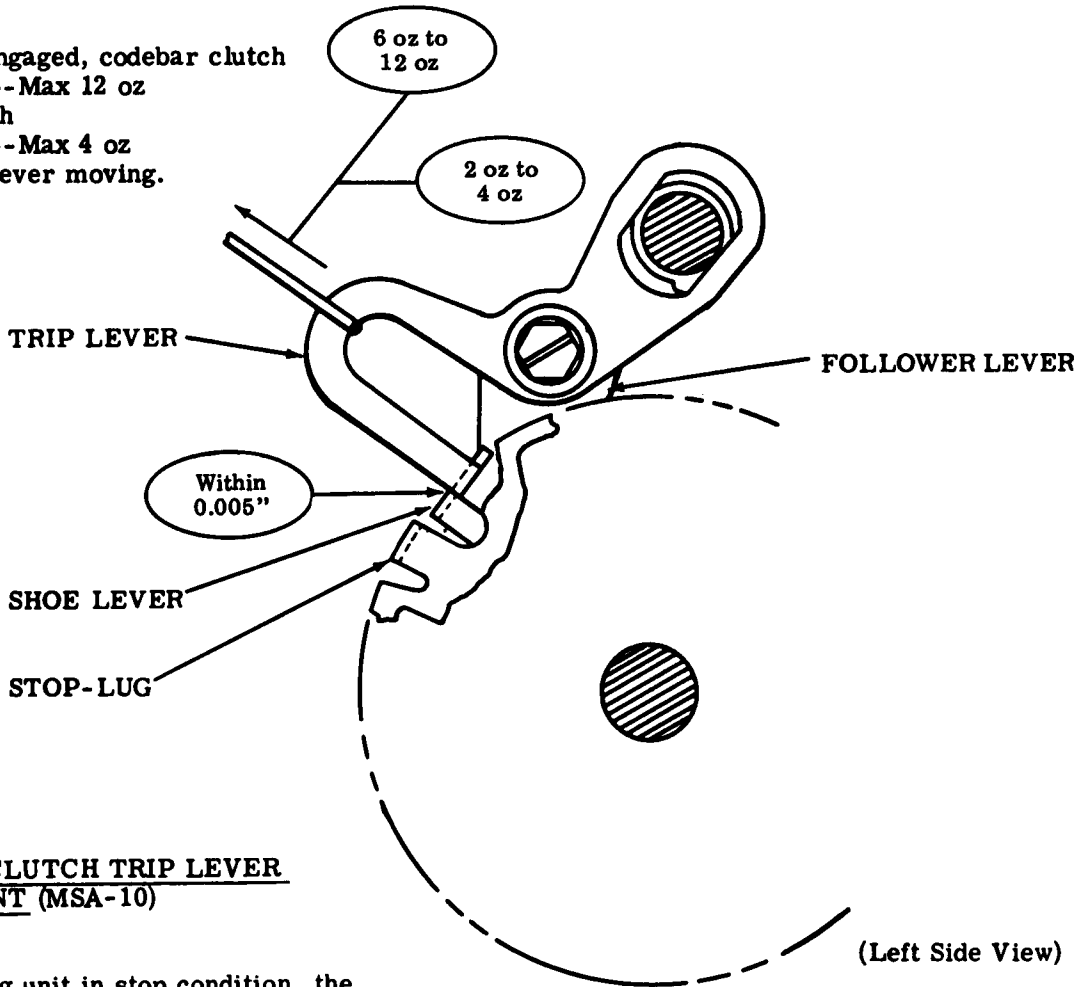

FUNCTION CLUTCH TRIP LEVER ENGAGEMENT (MSA-10)

Requirement

With typing unit in stop condition, the upper surfaces of the trip lever and shoe lever should be flush within 0.005 inch.

To Adjust

Loosen clamp screw and position follower lever. Tighten clamp screw.

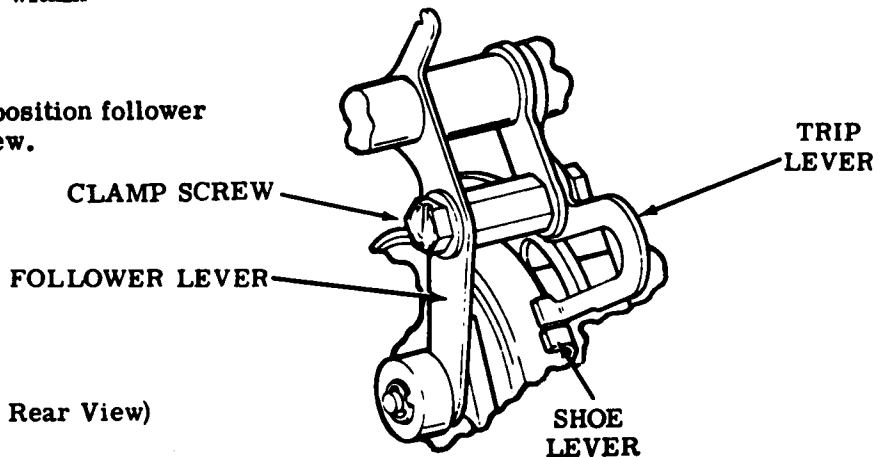

(Right Rear View)

2.16 Main Shaft Area (continued)

CODEBAR AND FUNCTION CLUTCH SHOE
LEVER GAPS (MSA-11 and MSA-12)

(1) To Check

Rotate main shaft to disengage (latch) clutches and continue to rotate main shaft so screw heads are up. Push up on stop-lugs so latchlevers seat in notches of clutch discs, then release. Push down on shoe levers until they touch stop-lugs, then release.

Requirement

Clearance between shoe lever and stop-lug should be
Min 0.015 inch
with clutch disengaged and latchlever firmly seated against edge of notch in clutch disc.

(2) To Check

Trip clutch by lifting trip lever. Permit trip lever to come to rest on shoe lever. Fully seat clutch shoes by applying 32 \pm 1/2 ounce force against shoe lever in normal path of forward travel.

Requirement

If there is a scribed line on the trip lever, the line should line up with the leading edge of the shoe lever (gauge by eye). If there is a notch in the trip lever, the leading edge of the shoe lever should be within the notch when viewed perpendicular to the notch. If there is no scribed line or notch on the trip lever, there should be

Min 0.055 inch — Max 0.085 inch
greater clearance between stop-lug and shoe lever when clutch is engaged than when disengaged and latched.

To Adjust

Loosen clamp screw friction tight. Position trip lever to meet requirements. Tighten clamp screws.

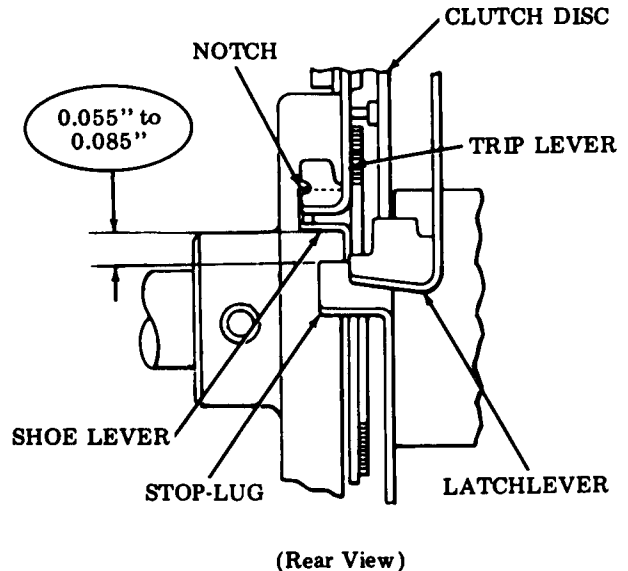
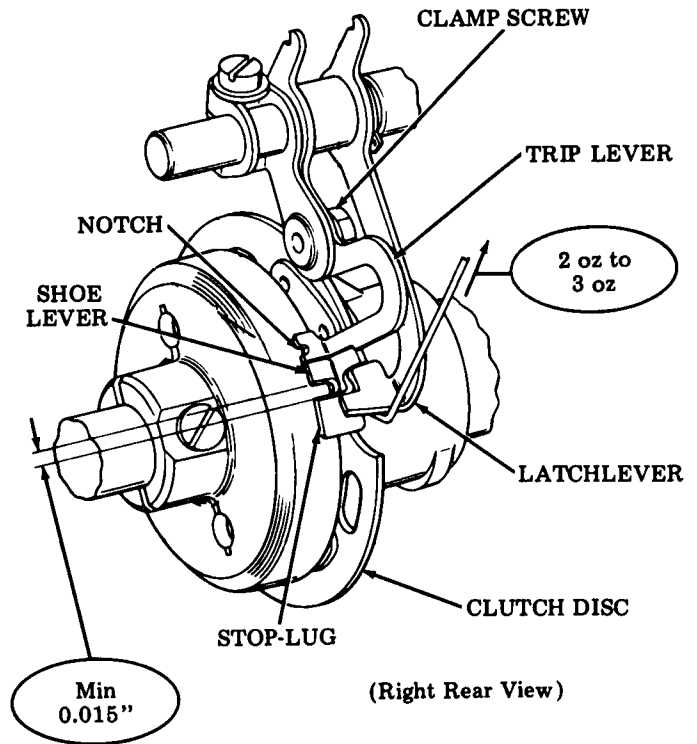

CODEBAR AND FUNCTION CLUTCH LATCH-
LEVER SPRINGS

Requirement

With latchlever resting on high portion of clutch disc

Min 2 oz -- Max 3 oz
to start latchlever moving.

2.17 Main Shaft Area (continued)

Note 1: These tensions apply to all clutches.

CLUTCH SHOE LEVER SPRING

Requirement

With clutch engaged and clutch disc held to prevent its turning

Min 15 oz---Max 20 oz
to pull clutch shoe lever into contact with stop-lug.

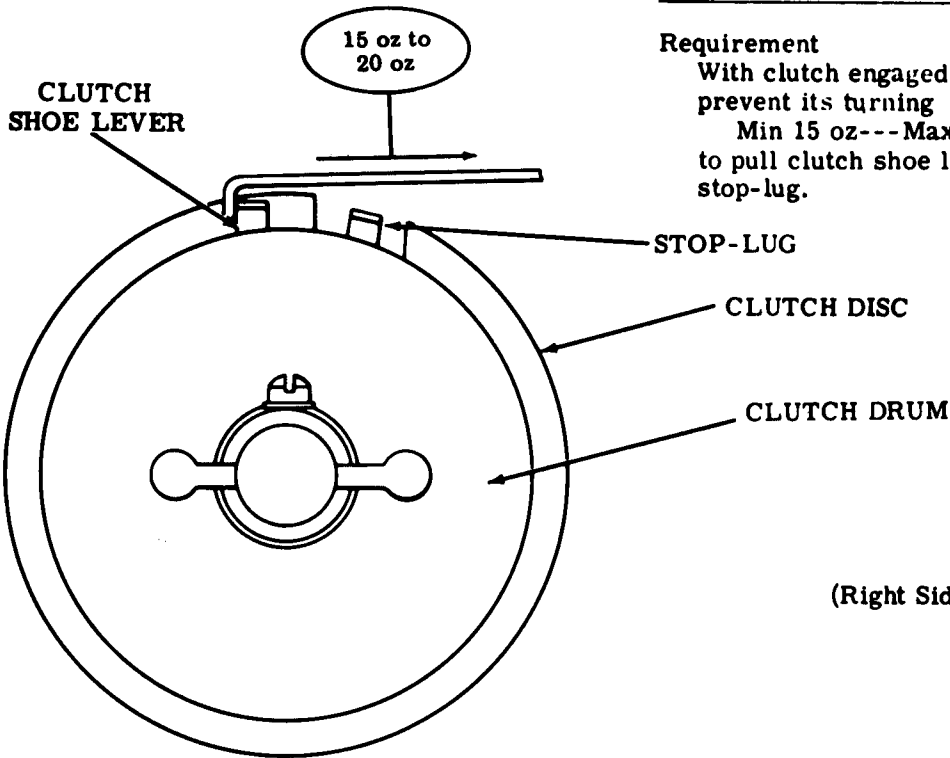

(Right Side View)

CLUTCH SHOE SPRING

Note 2: In order to check this spring tension, it is necessary to remove the clutch from the main shaft. Therefore, it should not be checked unless there is reason to believe it will not meet its requirement.

To Check
Remove clutch drum.

Requirement

Min 3 oz---Max 5 oz
to start primary clutch shoe moving.

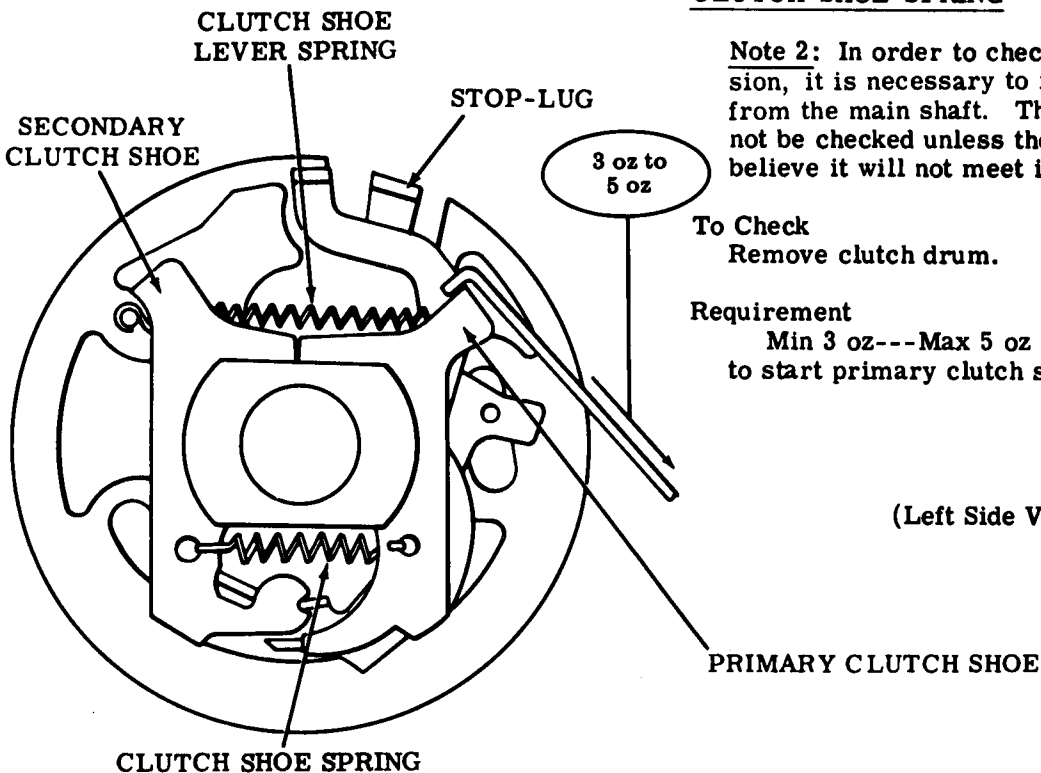

(Left Side View)

2.18 Selector Area

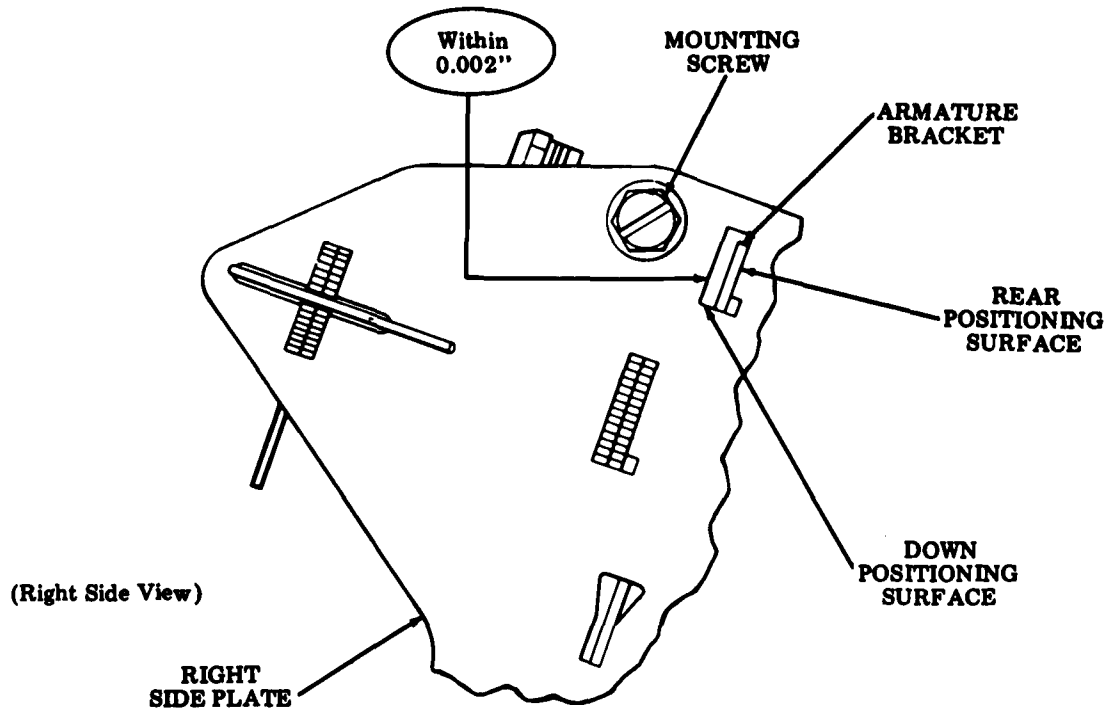

ARMATURE BRACKET POSITION
(Preliminary) (SLA-1)

Requirement

Armature bracket should be positioned against its down and rear positioning surfaces on right and left side plates so that it is parallel within 0.002 inch with rear surfaces measured at ends.

To Adjust

Loosen two mounting screws and position bracket. Tighten mounting screws.

Related Adjustments

Affects

- ARMATURE SPRING (2.20)**
- RECEIVING MARGINS (2.123)**
- SHOE LEVER GAP AND TRIP**
- LEVER ENGAGEMENT (2.19)**

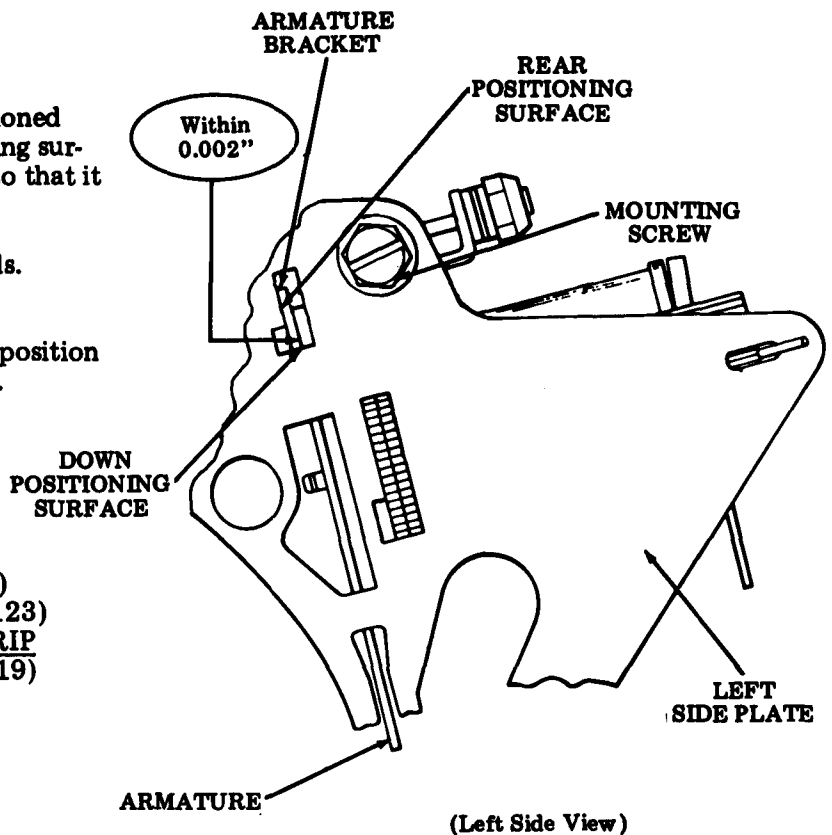

2.19 Selector Area (continued).

SHOE LEVER GAP AND TRIP LEVER ENGAGEMENT (SLA-2)

(1) To Check

Set up an all spacing code combination in selector. Rotate main shaft to disengage clutch and continue to rotate shaft until clutch mounting screw head is up. Push up on stop-lug so latchlever seats in notch of clutch disc, then release.

(1) Requirement

Clearance between shoe lever and stop-lug should be
Min 0.015 inch
with clutch disengaged and latched.

(2) Requirement

Trip lever should engage shoe lever a minimum of the upper 2/3 thickness of the shoe lever and a maximum of the upper surfaces of the levers flush.

(2) To Check

Trip clutch by depressing selector armature. Hold clutch disc against latchlever and fully seat clutch shoes by applying $32 \pm 1/2$ ounce force against shoe lever in normal path of forward travel. Release tension slowly.

(3) Requirement

Clearance between shoe lever and stop-lug should be
Min 0.055 inch -- Max 0.085 inch
greater when selector clutch is engaged than when disengaged.

Note: The forward edge of the shoe lever should be approximately in line with the forward edge of the scribed line on the trip lever (gauge by eye) units so equipped.

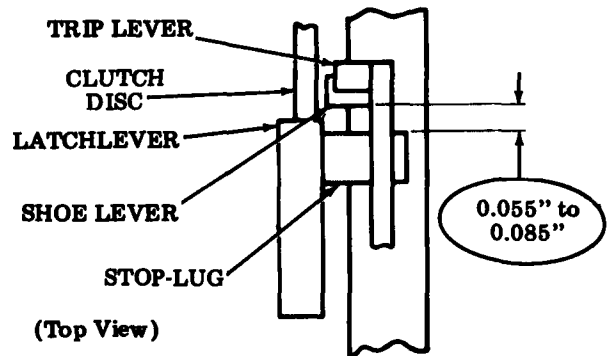
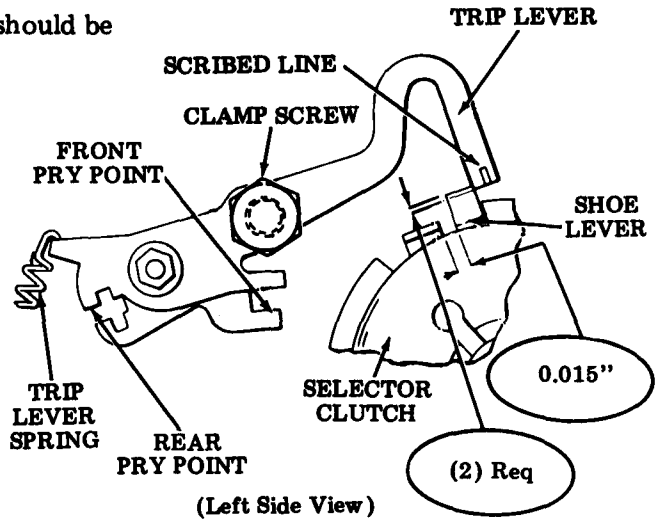

To Adjust

Loosen clamp screw friction tight. Position trip lever to meet requirements using rear pry points, or to meet requirement (2) using front pry points. Tighten clamp screw.

Related Adjustments

Affects

RECEIVING MARGINS (2.123)

Affected By

ARMATURE BRACKET POSITION (2.18)

TRIP LEVER SPRING

Requirement

With typing unit in stop condition and shoe lever held away from trip lever

Min 6 oz--Max $7-3/4$ oz
to start trip lever moving.

Note: Start lever and latchlever springs also influence this spring tension. Check them individually if above requirement is not met. If they meet requirements, replace trip lever spring.

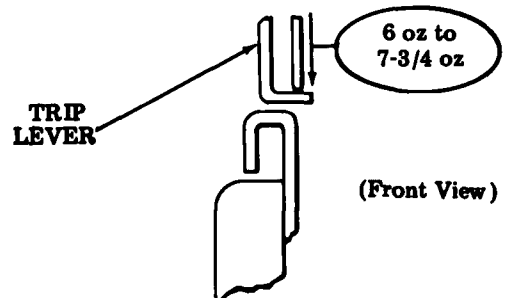

2.20 Selector Area (continued)

ARMATURE SPRING

Note: This is a preliminary adjustment. It should not be considered final until RECEIVING MARGINS (2.123) adjustment is completed, and, as finally adjusted, it could fall outside limits specified below.

To Check

Place typing unit in stop condition and move carriage near right margin. Remove armature clip. Rotate selector clutch until start lever, selector levers, and spacing locklever do not contact armature.

Requirement

Min 2-1/4 oz---Max 4-3/4 oz
to pull armature to midpoint of travel.

To Adjust

Rotate adjusting nut clockwise to increase armature spring tension and counter-clockwise to decrease it.

Related Adjustments

Affects

RECEIVING MARGINS (2.123)

Affected By

ARMATURE BRACKET POSITION (2.18)

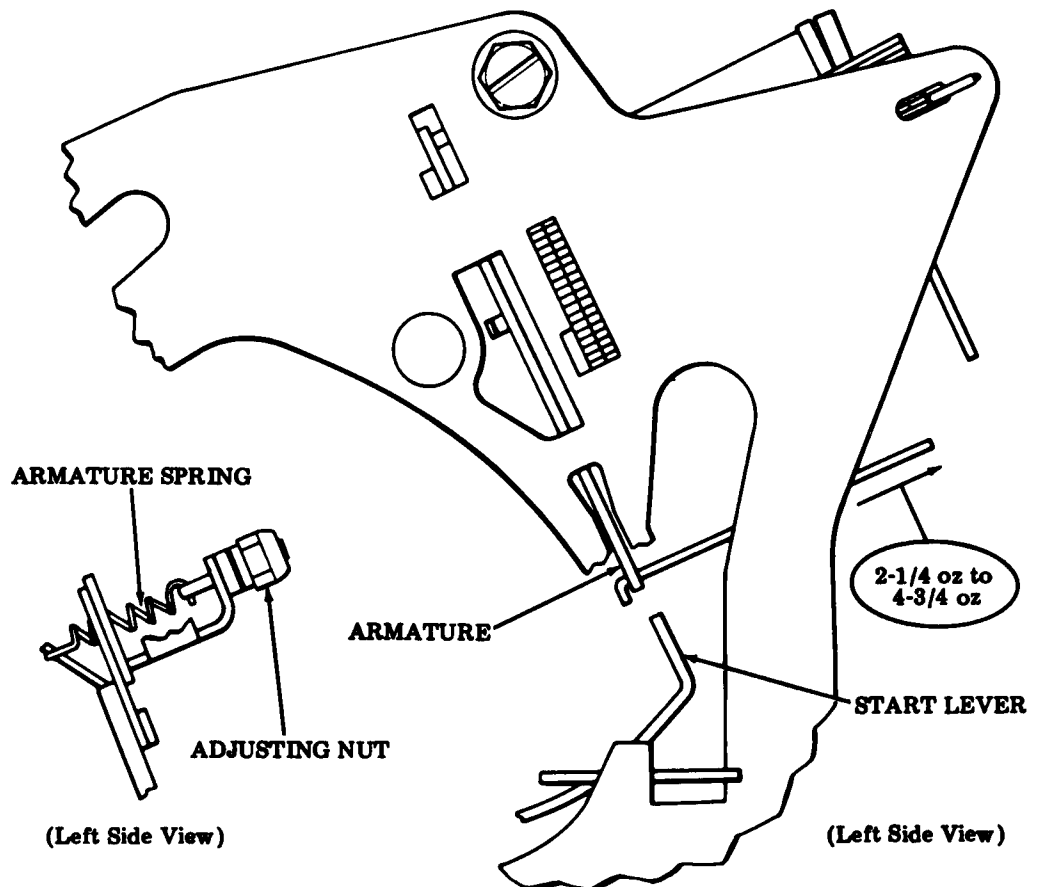

2.21 Selector Area (continued)

START LEVER SPRING

Requirement

With typing unit in stop condition

Min 19 oz---Max 23 oz

to pull start lever spring to installed length.

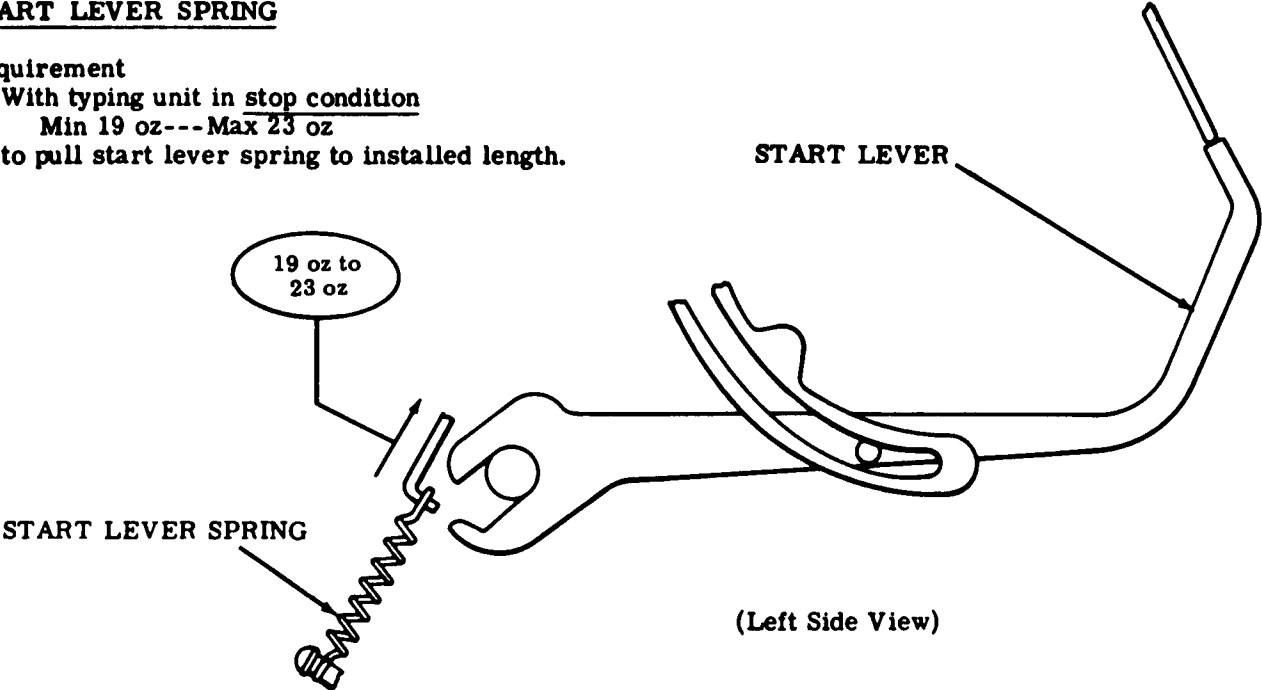

LATCHLEVER SPRING

Requirement

With selector latchlever resting on high part of clutch disc

Min 2 oz---Max 3 oz

to start selector latchlever moving.

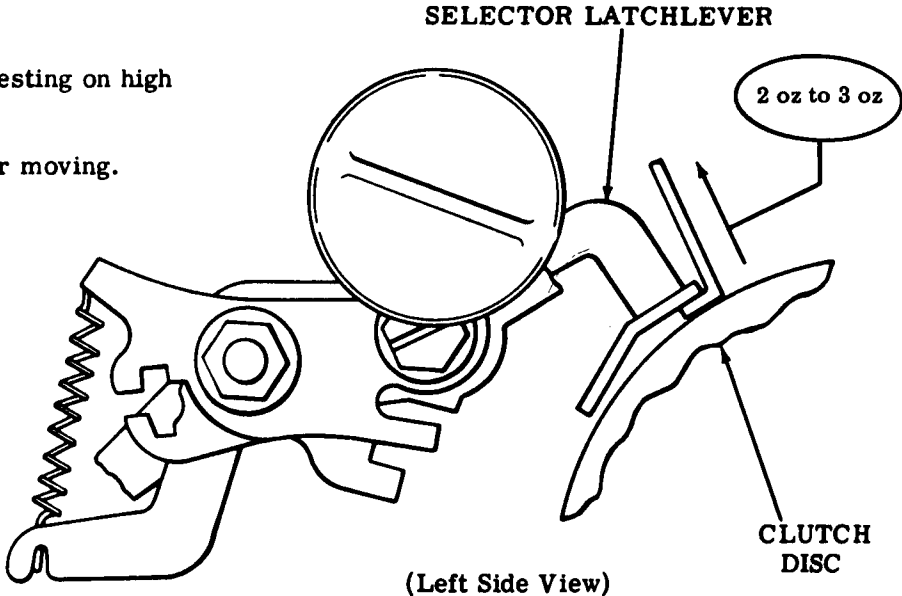

2.22 Selector Area (continued)

SELECTOR LEVER SPRINGS

To Check

Set up BLANK, an all spacing code combination, in selector. Rotate main shaft until typing unit is in stop condition.

Requirement

Min 1-1/2 oz---Max 3-1/4 oz to start selector lever moving.

Note: Check each selector lever spring.

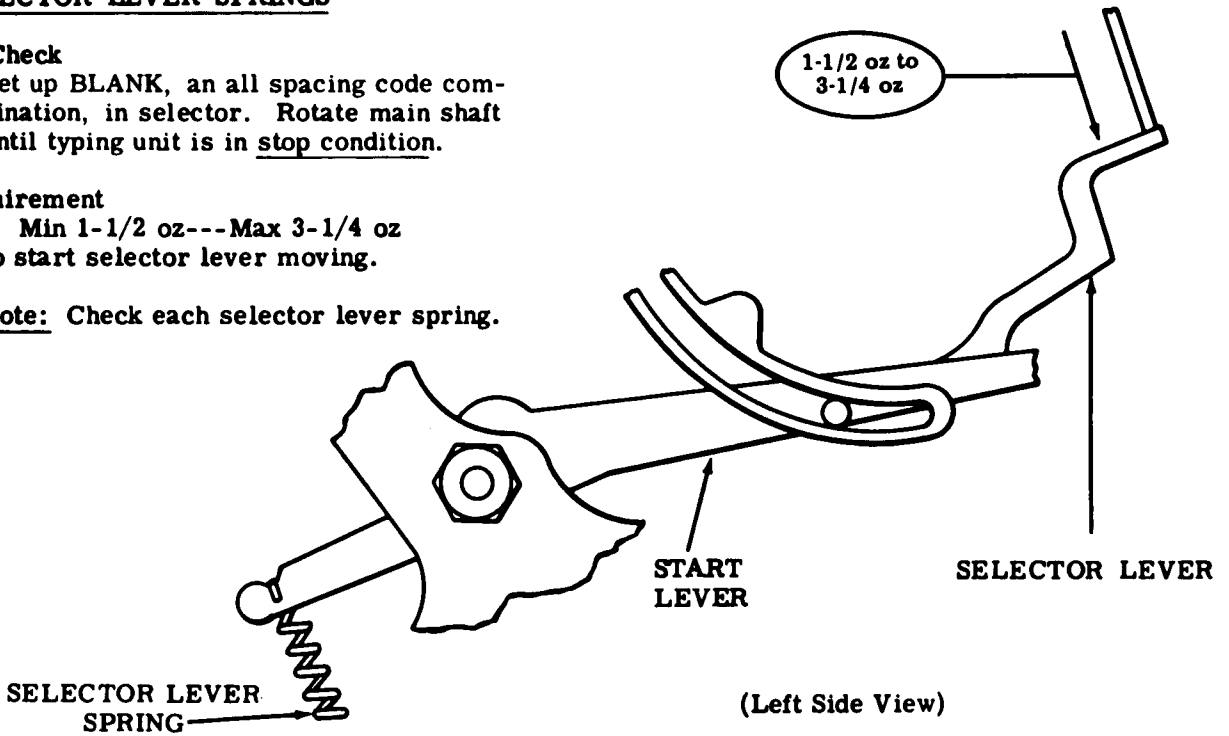

SPACING LOCKLEVER SPRING

To Check

Set up BLANK, and all spacing code combination, in selector. Rotate main shaft until typing unit is in stop condition.

Requirement

Min 1-1/2 oz---Max 3 oz to start locklever moving.

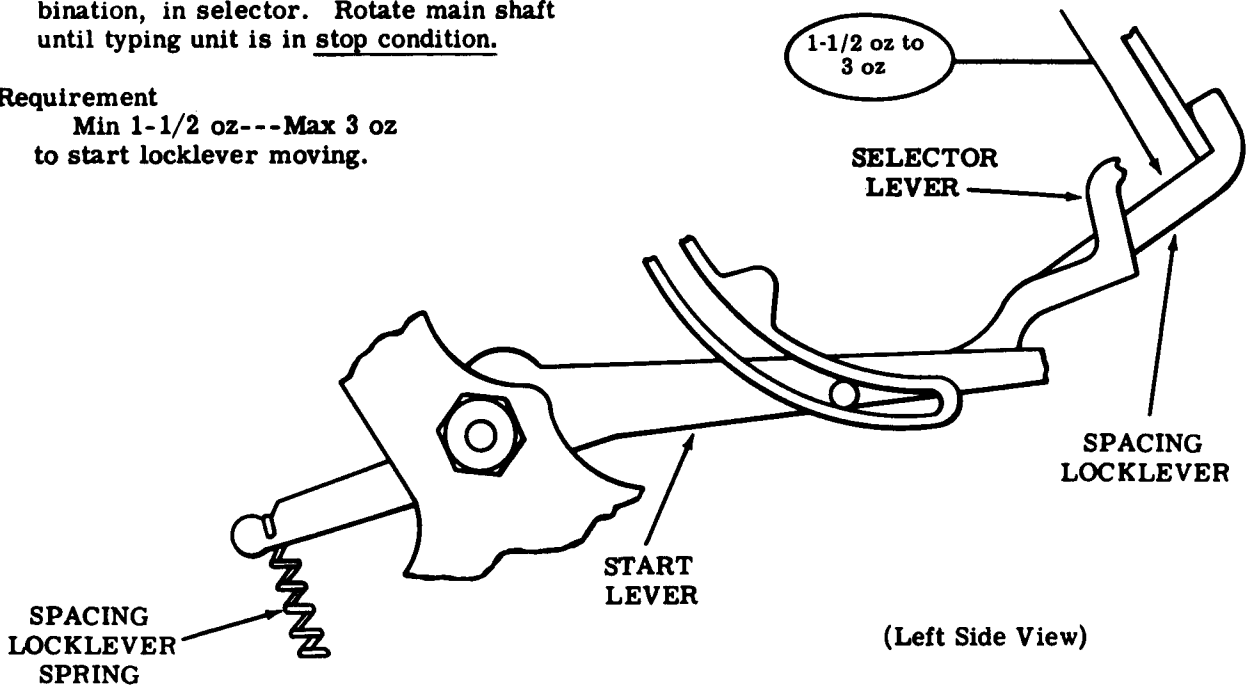

2.23 Selector Area (continued)

STRIPPER BAIL SPRING

To Check

Set range finder at 60. Set up an all spacing code combination, in selector. Rotate main shaft until typing unit is in stop condition.

Requirement

Min 1/4 oz---Max 1 oz
to start stripper bail moving.

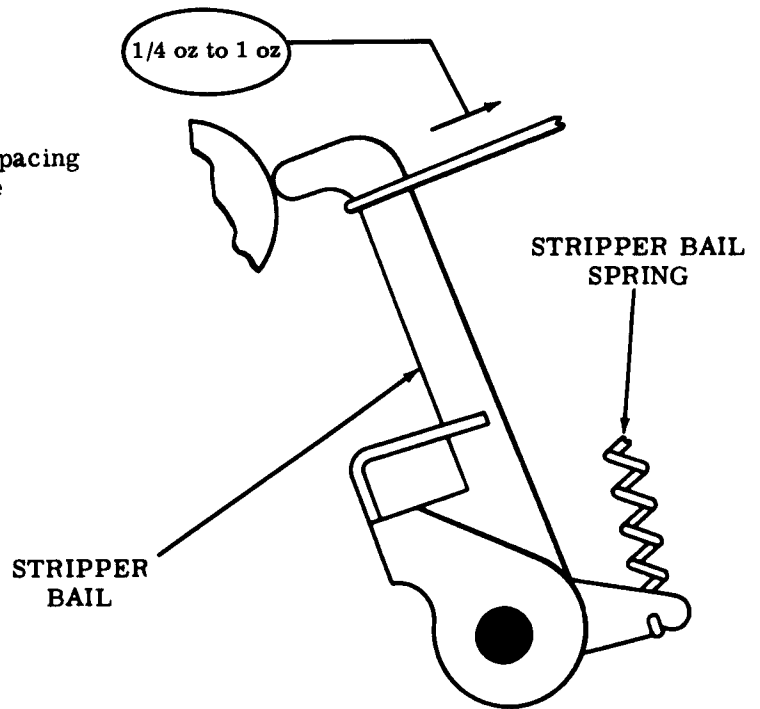

(Left Side View)

PUSHLEVER SPRINGS

Note 1: To measure this tension, selector mechanism must be removed from typing unit. Therefore, do not check it unless there is cause to suspect it will not meet requirement.

CAUTION: BEFORE REMOVING SELECTOR CLUTCH, MAKE SURE ARMATURE IS IN THE SPACING POSITION. HOLD SELECTOR LEVERS IN PLACE AWAY FROM SELECTOR CLUTCH WITH TP184098 TOOL.

Requirement

With blocking lever held away from push lever
Min 1-1/2 oz---Max 3 oz
to start pushlever moving.

Note 2: Check each pushlever spring.

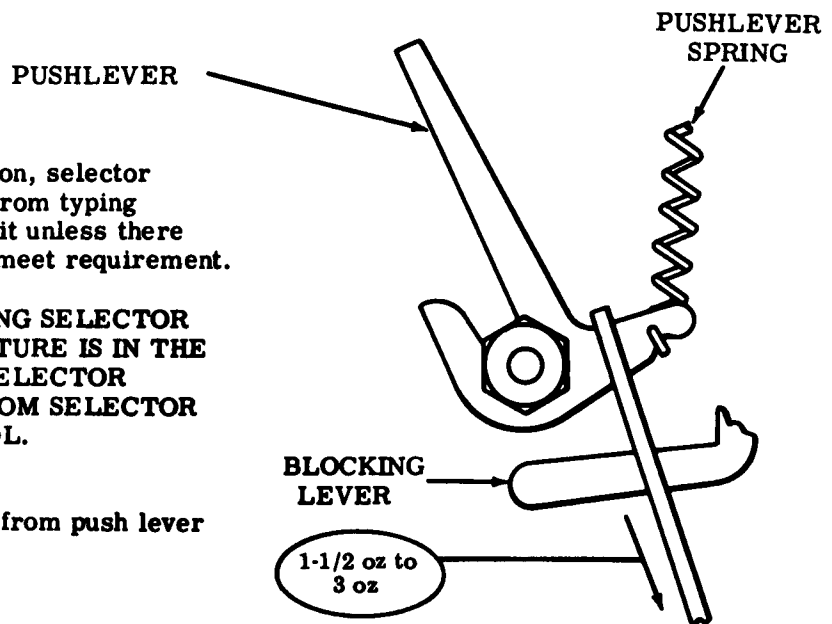

(Left Side View)

2.24 Function Area

(A) MAIN SHAFT ROTATION (FNA-3)

Note 1: After making any adjustments which affect the typing unit drive system, the main shaft should be checked for binds or excessive drag. Excessive drag or binding when the main shaft is rotated will cause inadequate receiving margins.

To Check

With all clutches disengaged (latched), manually rotate main shaft.

Requirement

No excessive drag or binding should be detected.

Note 2: If binds or excessive drag occur, remove motor belt at intermediate gear and recheck requirement.

To Adjust

If excessive drag or binding occurs with motor belt installed, but does not occur when belt is removed, check following adjustments:

GEAR BACKLASH (Motor Area) (2.01)

BELT TENSION (Motor Area) (2.02)

If drag or binding occurs with motor belt removed, check the following adjustments:

LEFT BEARING POSITION (Main Shaft Area) (2.10)

SELECTOR CAM ENDPLAY (Main Shaft Area) (2.10)

SHOE LEVER GAP AND TRIP LEVER ENGAGEMENT (Selector Area) (2.19)

FUNCTION CLUTCH ENDPLAY (Main Shaft Area) (2.11)

CODEBAR CLUTCH ENDPLAY (Main Shaft Area) (2.12)

CODEBAR AND FUNCTION CLUTCH SHOE LEVER GAPS (Main Shaft Area) (2.16)

DRIVEN GEAR LINEUP (Main Shaft Area) (2.12)

SHAFT LEFT BEARING GAP (Distributor Area) (2.03)

CLUTCH SHOE LEVER GAP (Distributor Area) (2.05)

FORM FEED CLUTCH ENDPLAY - S (Main Shaft Area) (2.92)

BEARING ALIGNMENT (Function Area) (2.24)

Replace motor belt and recheck requirement.

(B) BEARING ALIGNMENT (FNA-2)

Note: This adjustment applies to main shaft bearings, distributor shaft bearings, function rocker shaft bearings, and codebar reset bail bearings. It should only be made if a bind is detected in associated shafts. Upon completion of this adjustment, the bearing(s) adjustment and any related adjustments should be rechecked.

Requirement

Bearings should be aligned with their respective shaft.

To Adjust

(a) With bearing clamps loosened, position bearing using finger pressure while rotating associated shaft. Tighten clamp screws.

(b) If bind still exists, keep bearing clamp tightened and apply a light tap vertically to top of bearing clamp.

2.25 Function Area (continued)

ROCKER SHAFT POSITION AND ENDPLAY (FNA-1)

(1) Requirement

Left and right bearings should be centered on base casting (gauge by eye).

To Adjust

Loosen collar setscrews and bearing clamp screws and position bearings.
Tighten bearing clamp screws.

(2) Requirement

The left end of function rocker shaft should line up with inside top edge of base casting lip, however:

0.030 inch misalignment is permissible to the left

0.060 inch misalignment is permissible to the right.

(3) Requirement

Min some---Max 0.010 inch
endplay in function rocker shaft.

To Adjust

Loosen setscrews and position function rocker shaft and both collars.
Tighten both setscrews.

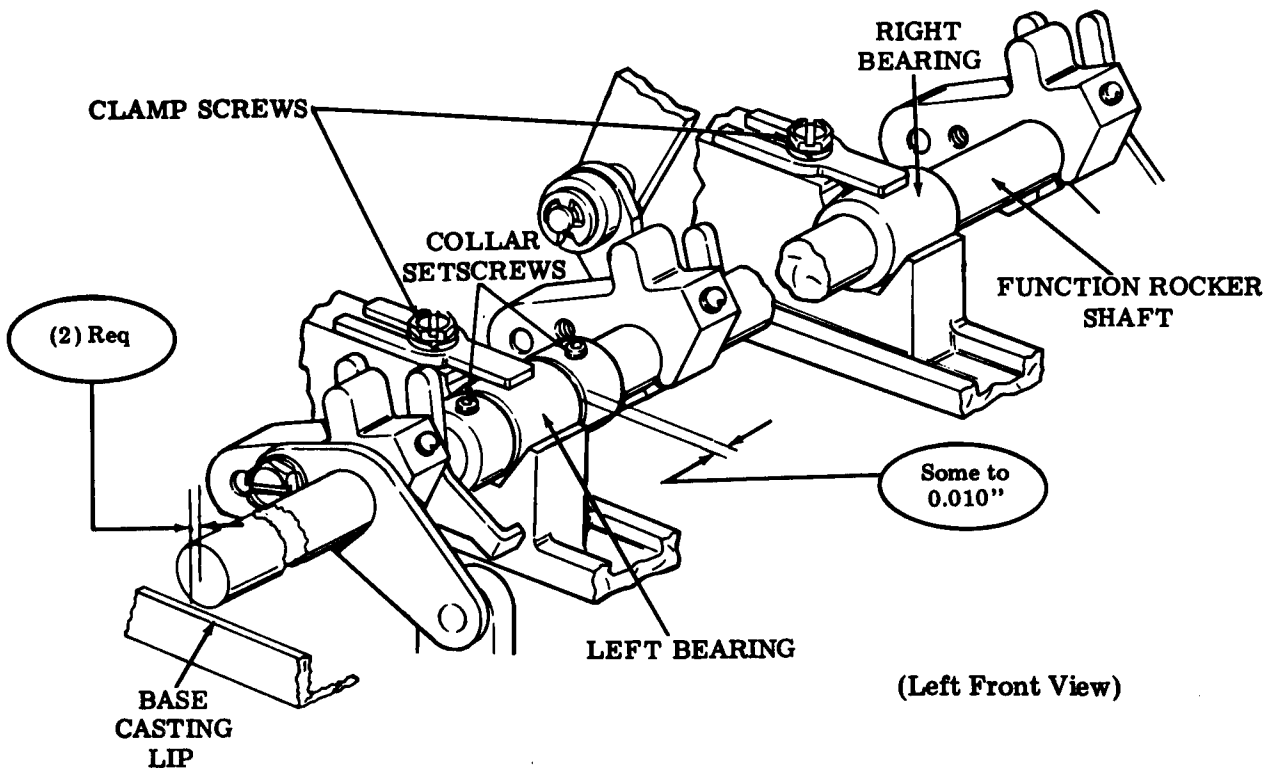

Related Adjustments

Affects

CODEBAR RESET LEVER LINE-UP (2.26)

CODEBAR RESET LEVER POSITION (2.27)

PRINT SUPPRESSION LATCH — HORIZONTAL CLEARANCE (2.28)

2.26 Function Area (continued)

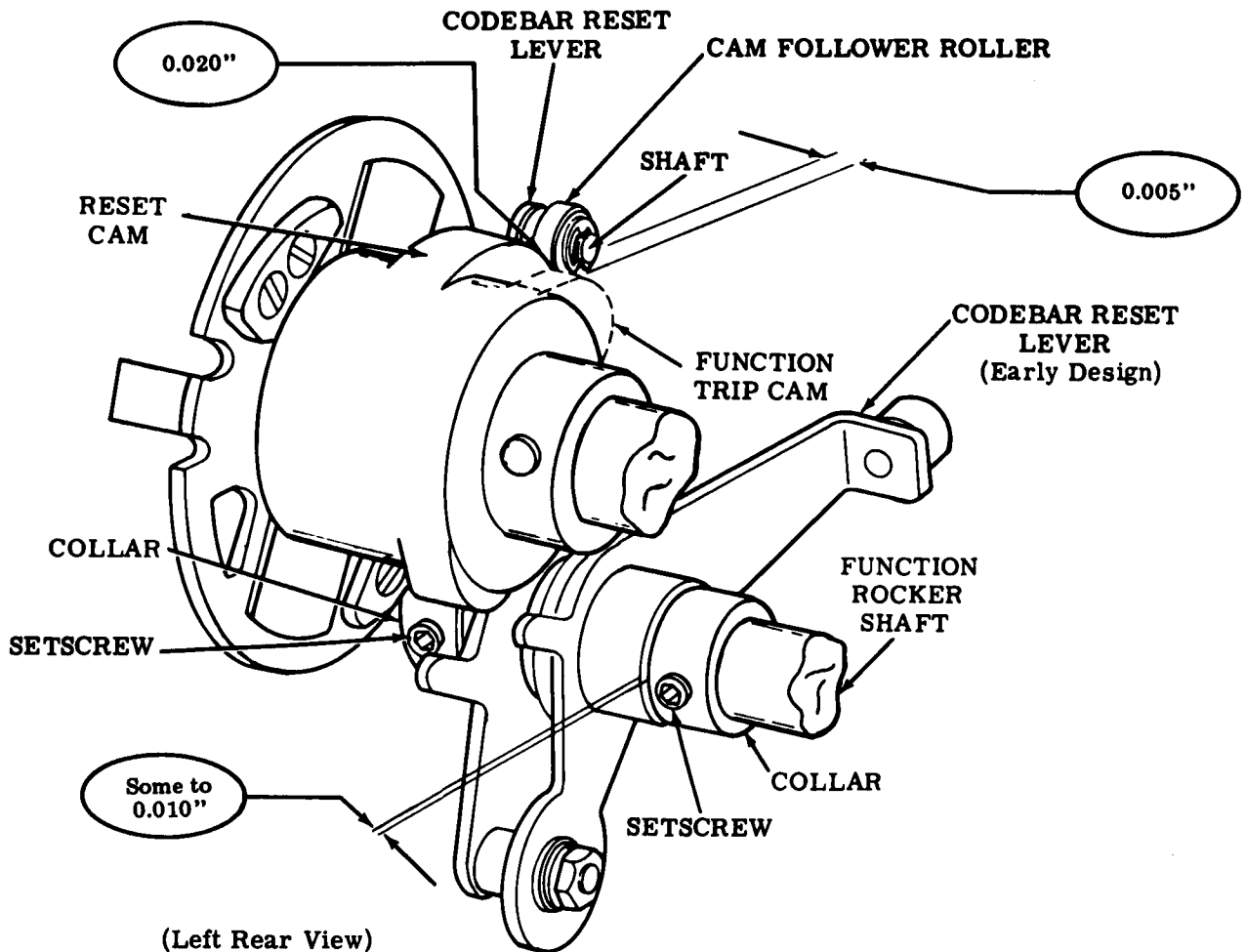

CODEBAR RESET LEVER LINE-UP (FNA-4)

Requirement

With typing unit in stop condition

- (1) Cam follower roller approximately centered on reset cam, as gauged by eye,
Max 0.020 inch
overhang permitted on right side only.
- (2) Min some---Max 0.010 inch
endplay in codebar reset lever.
- (3) Min 0.005 inch
between cam follower roller's shaft and function trip cam.

To Adjust

Loosen setscrews and position two collars.

Related Adjustments

Affects

CODEBAR RESET LEVER POSITION (2.27)

Affected By

ROCKER SHAFT POSITION AND ENDPLAY (2.25)

CODEBAR CLUTCH ENDPLAY (2.12)

2.27 Function Area (continued)

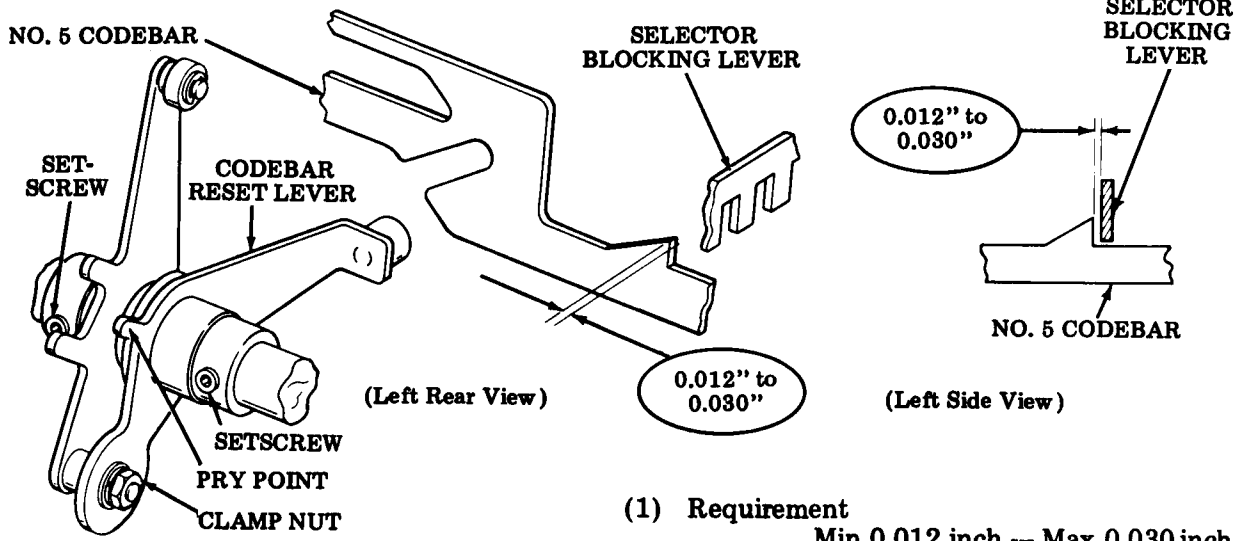

(Late design units have adjusting screw.)

(1) Requirement

Min 0.012 inch -- Max 0.030 inch between the codebar closest to front of typing unit and its selector blocking lever.

(2) Requirement (For two-color printing units only)

Some clearance between projection of "R" codebar and blocking link when play in blocking link is taken up for minimum gap.

To Adjust

Early Design: Loosen clamp nut. Use pry point to adjust codebar reset lever.

Late Design (With adjusting screw): Loosen two setscrews. Turn adjusting screw.

Related Adjustments

Affects

PRINT SUPPRESSION LATCH - HORIZONTAL CLEARANCE (2.28)
PRINT SUPPRESSION LATCH - VERTICAL CLEARANCE (2.37)
FUNCTION SHAFT AND CASTING POSITION (2.38); REAR RAIL POSITION (Carriage Area) (2.43); THIRD PULSE LINKAGE POSITIONING (Carriage Area) (2.45); PRINT SUPPRESSION LATCHLEVER RELEASE (Carriage Area) (2.55); SPACE SUPPRESSION LEVER CLEARANCE - PRINTING (Spacing Area) (2.63)

Affected By

ROCKER SHAFT POSITION AND ENDPLAY (2.25); CODEBAR RESET LEVER LINE-UP (2.26)

CODEBAR RESET BAIL SPRING

To Check

Set up an all spacing code combination, in the selector and rotate main shaft until codebar reset bail is in highest position.

Requirement

Min 5-3/4 oz -- Max 8-3/4 oz to start codebar reset bail moving.

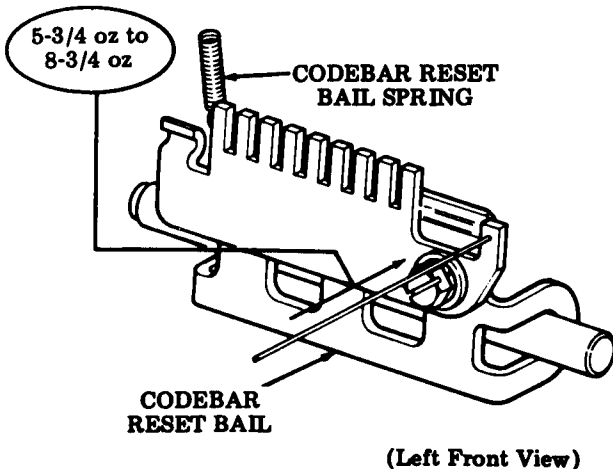

CODEBAR RESET LEVER POSITION (FNA-5)

To Check

Place typing unit in stop condition. Push selector stripper bail towards front. Take up play between no. 5 codebar and its associated blocking lever.

2.28 Function Area (continued)

PRINT SUPPRESSION LATCH — HORIZONTAL CLEARANCE (FNA-6)

- (1) Requirement
 With typing unit in the stop condition
 Min 0.010 inch---Max 0.025 inch
 between print suppression latch and
 print suppression codebar.

Note 1: Disregard Requirement (2)
 for typing units which are not equipped
 with TP180744 collars.

- (2) Requirement
 Print suppression cam follower and
 latch should move freely.

Note 2: Some typing units have one
 clamp nut to loosen, others two,
 depending upon the configuration of
 the latch bracket used.

To Adjust

Loosen clamp nut(s) and setscrews in
 collars (see Note 1 and Note 2). Position
 latch bracket using pry point to meet
 Requirement (1). Tighten clamp nuts.
 Position collars to meet Requirement
 (2). Tighten setscrews.

Related Adjustments

Affects

FUNCTION SHAFT AND CASTING POSITION (2.38)

Affected By

ROCKER SHAFT POSITION AND ENDPLAY (2.25)
CODEBAR RESET LEVER POSITION (2.27)

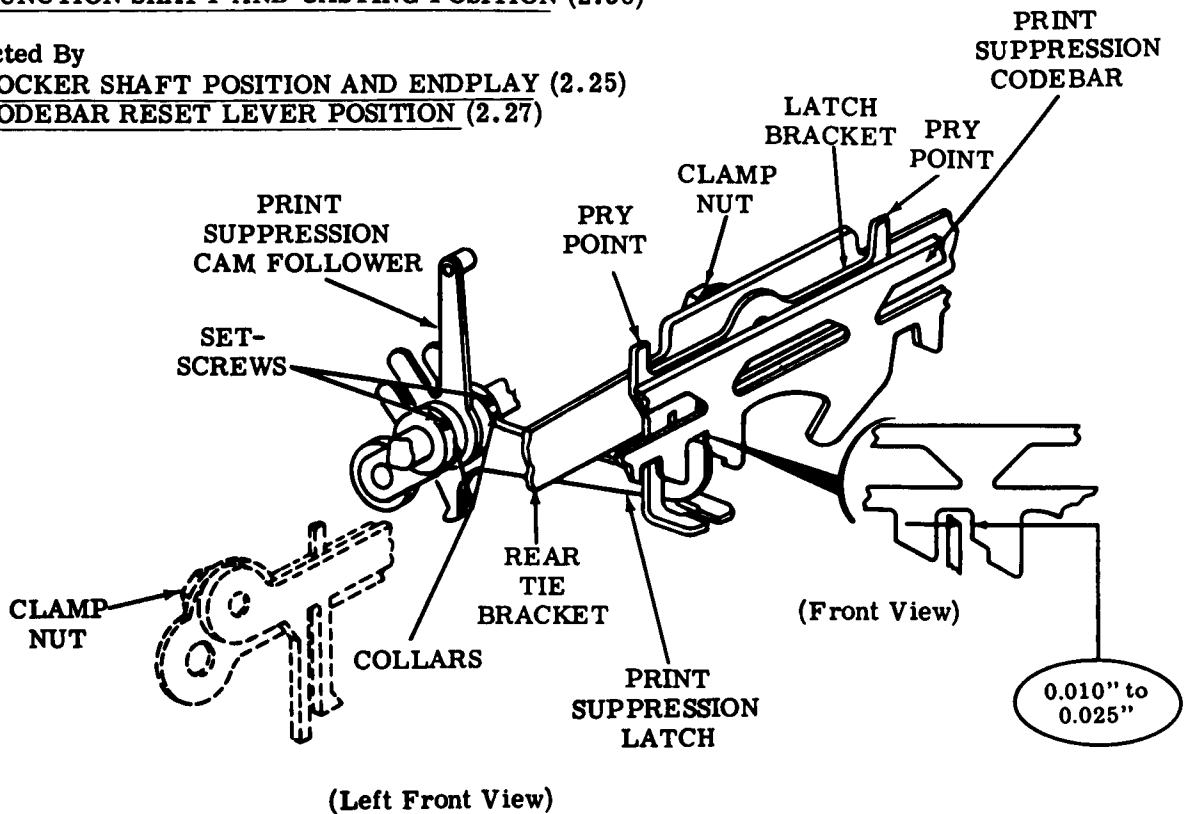

2.29 Function Area (continued)

CODEBAR RESET GUIDE POSITION (FNA-7)

(1) Requirement

Codebars should have no noticeable curvature when viewed from their ends.

Note: The following To Check is for units equipped with TP180801 universal function lever, or its equivalent.

To Check

Set up an all marking code in the selector. Rotate main shaft until universal function lever reaches its highest point of travel (position no. 1). Lightly take up play between universal function lever and codebars.

(2) Requirement

The codebars should engage the universal function lever tines.

To Adjust

Loosen clamp screw and position codebar guide using pry point. Tighten clamp screw.

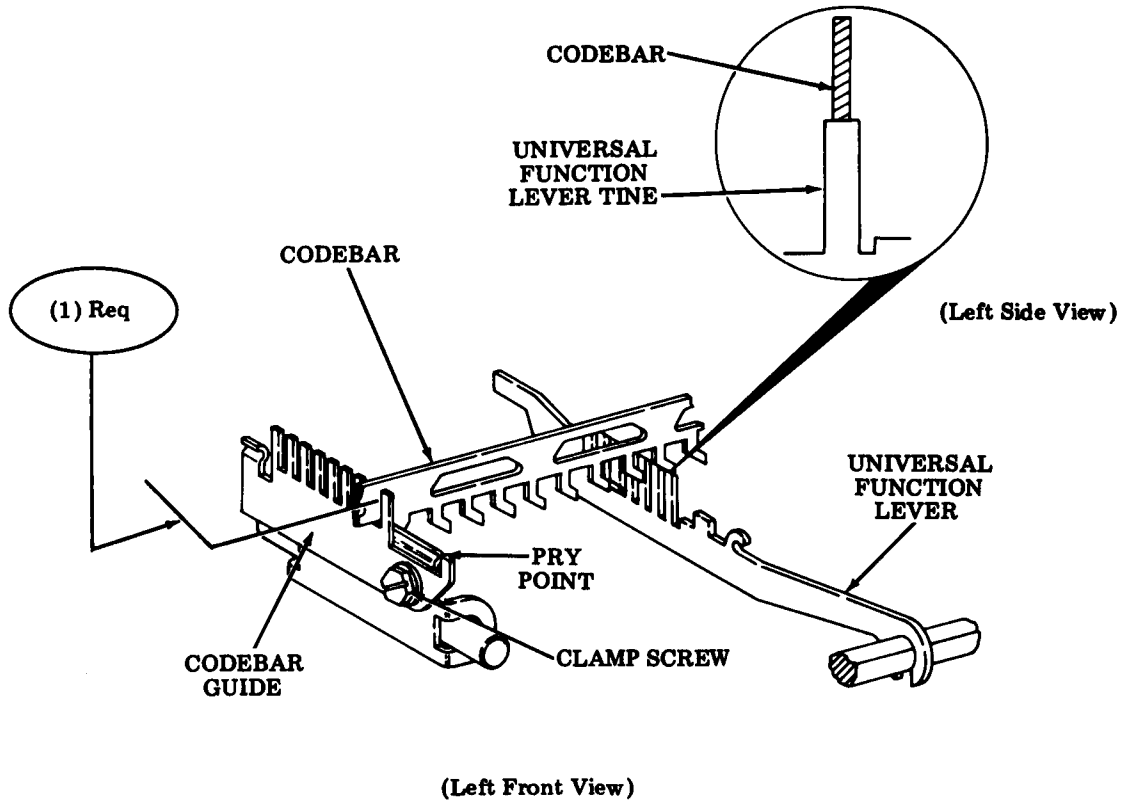

2.30 Function Area (continued)

SELECTOR BLOCKING LEVERS POSITIONING (FNA-8)

Note: Set range finder to 80.

To Check

Place typing unit in stop position. Set up an all marking code in selector. Engage codebar clutch. Rotate main shaft until left end of no. 1 codebar is flush with left (outer) edge of no. 1 blocking lever.

(1) Requirement

Min 0.006 inch---Max 0.050 inch
between the no. 1 blocking lever and its associated codebar.

(2) Requirement

Min 0.003 inch
between all remaining blocking levers and their associated codebars.

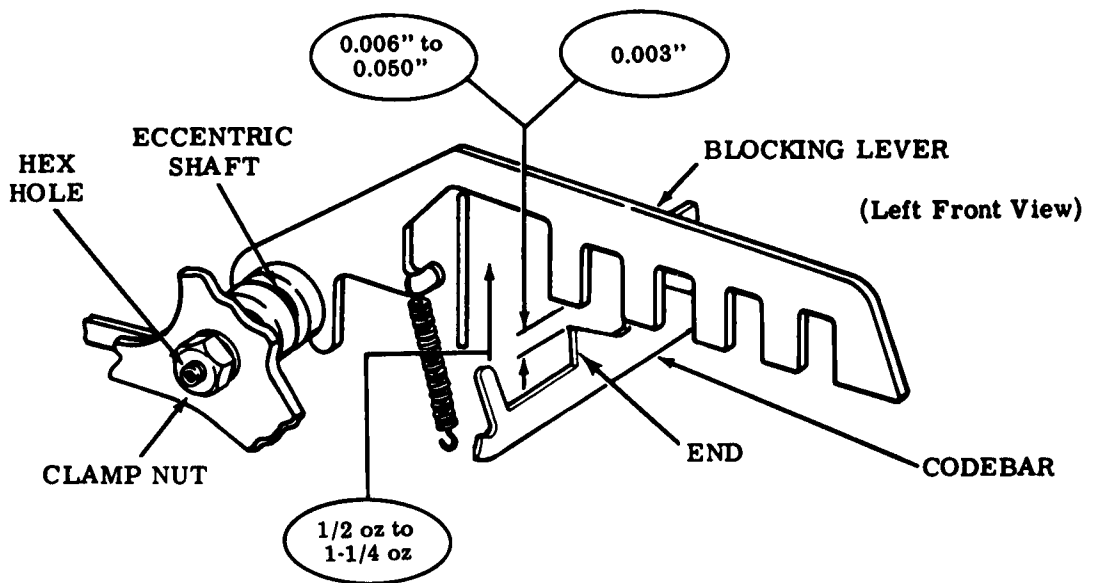

To Adjust

Loosen clamp nut and position eccentric with hex key wrench. Keep high part of eccentric toward rear of typing unit. Tighten clamp nut.

BLOCKING LEVER SPRINGS

To Check

Set up an all spacing code combination, in the selector. Rotate main shaft until typing unit is in stop condition.

Requirement

Min 1/2 oz---Max 1-1/4 oz
to start blocking lever moving.

Note: Check each blocking lever spring.

2.31 Function Area (continued)

AUTOMATIC CODEBAR SPRING

Requirement

With carriage at left margin TP180948 automatic codebar with TP84575 spring

Min 1/2 oz---Max 1-3/4 oz

TP183495, TP183496, TP183497, or TP183498 automatic codebar with early design spring TP22746

Min 2 oz---Max 3 oz

TP183495, TP183496, TP183497, or TP183498 automatic codebar with late design spring TP36351

Min 2-3/4 oz---Max 3-3/4 oz

to start automatic codebar moving.

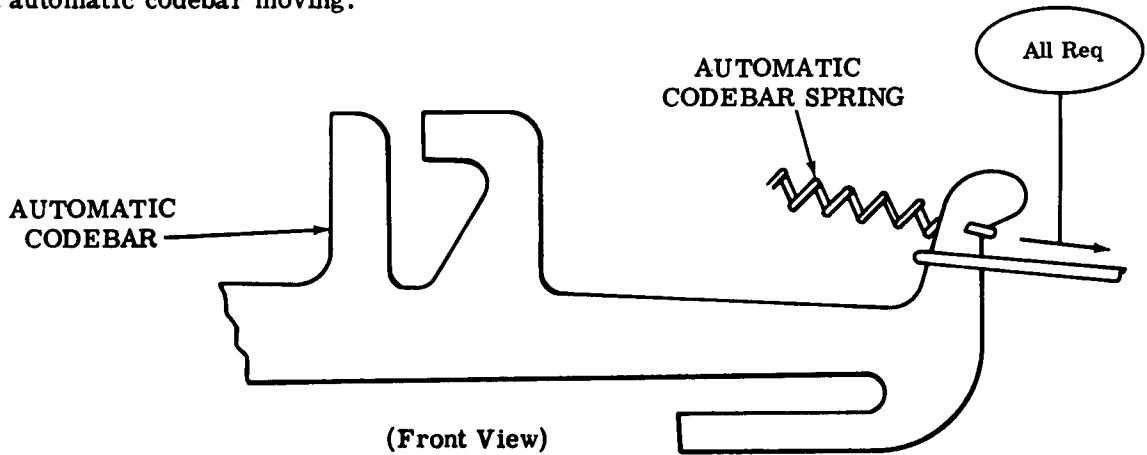

PRINT SUPPRESSION AND NO. 3 CODEBAR SPRING

CODEBAR SPRINGS

Requirement

With typing unit in stop condition and no. 3 codebar follower on carriage lifted

Min 12 oz---Max 14 oz

to start codebar moving.

Note: Check the print suppression and no. 3 codebar spring.

Note: Check each codebar spring other than automatic, print suppression, and no. 3.

Requirement

With typing unit in stop condition and codebar follower lifted

Min 5-1/2 oz---Max 7-1/2 oz
to start codebar moving.

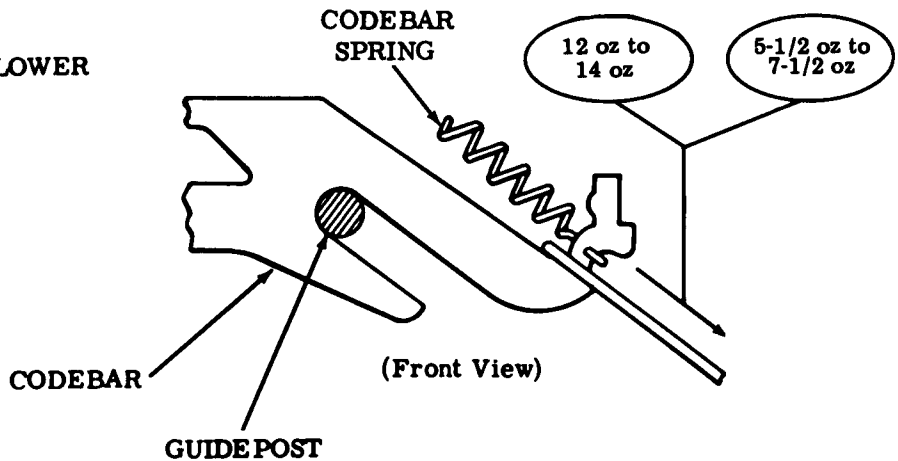
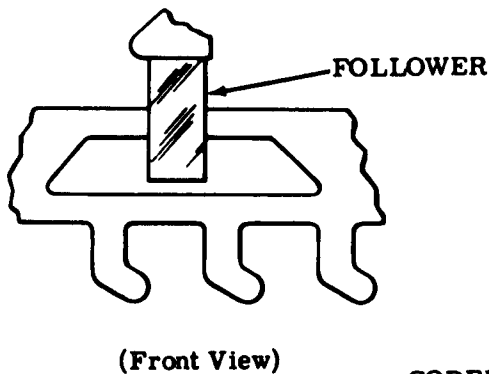

2.32 Function Area (continued)

FUNCTION PAWL SPRING

Requirement

With typing unit in stop condition and all external loads which would influence the requirement removed

Pawl Spring	TP49420 (26 Turns)	TP86283 (38 Turns)	TP180863 (33 Turns)
-------------	-----------------------	-----------------------	------------------------

Min	9 oz	1-1/4 oz	3 oz
Max	13 oz	2-1/2 oz	5-1/2 oz

to start each function pawl moving.

Note: Check each pawl spring. TP180863 pawl spring is used with the carriage return function pawl. TP86283 pawl spring is used with the answer-back blocking function pawl. TP49420 pawl spring is used with BELL function pawl. All others may be either the TP49420 or TP86283 pawl springs.

LEFT ROCKER DRIVE (FNA 10)

To Check

Set up carriage return code combination (---4-) in selector. Rotate main shaft until function bail is at highest point of travel (position no. 1). Take up carriage return function lever play in an upward direction at the pivot to minimum clearance.

Requirement

Min 0.015 inch---Max 0.050 inch between carriage return function lever and its function pawl.

To Adjust

Loosen clamp screw. Use pry point to adjust rocker drive arm. Tighten clampscrew.

Note: On early design units pry point is on the center drive arm. On late design units pry point is on left side of left drive arm.

Related Adjustments

Affects

- RIGHT ROCKER DRIVE (2.34)
- CARRIAGE RETURN LEVER — LATCH CLEARANCE (2.39)
- FUNCTION LEVER RETAINER (2.35)
- SPACE SUPPRESSION LEVER CLEARANCE - SPACING (2.64)
- LINE FEED DRIVE ARM CLEARANCE - F (Platen Area) (2.79)
- Related Tape Punch Adjustments (Refer to Section 574-175-700TC)

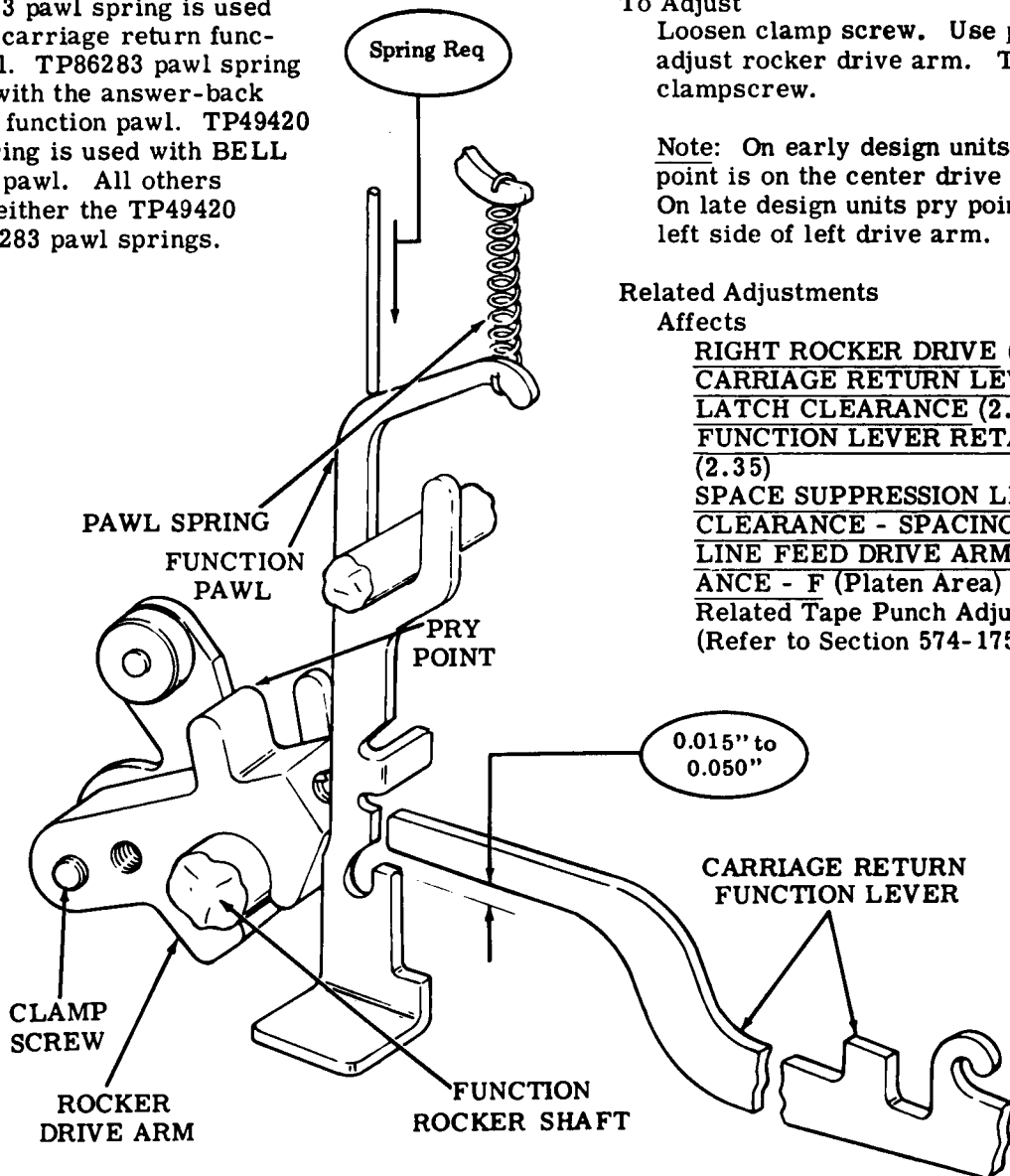

(Left Front View)

2.33 Function Area (continued)

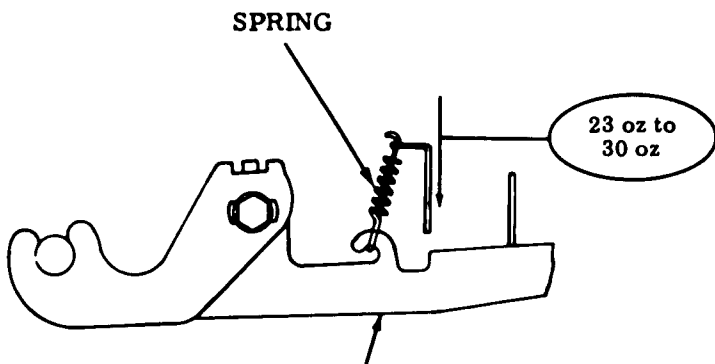

LINE FEED FUNCTION STRIP LEVER

(Right Side View)

LINE FEED FUNCTION STRIP LEVER SPRING - S

Requirement

With a spring scale positioned on the line feed function strip lever

Min 23 oz---Max 30 oz
to start the line feed function strip lever moving.

FUNCTION LEVER SPRINGS

Requirement

With typing unit in stop condition, the spring scale requirements to start each function lever moving are

- (1) Min 19 oz---Max 24 oz to start LF and AUTO LF function levers moving.

Note 1: Hold the blocking pawl up when checking this requirement.

- (2) Min 3-1/2 oz---Max 5-1/2 oz to start carriage return function lever moving.

Note 2: Hold carriage return lever in frontward position.

- (3) Min 3-1/2 oz---Max 5-1/2 oz to start remaining function levers moving.

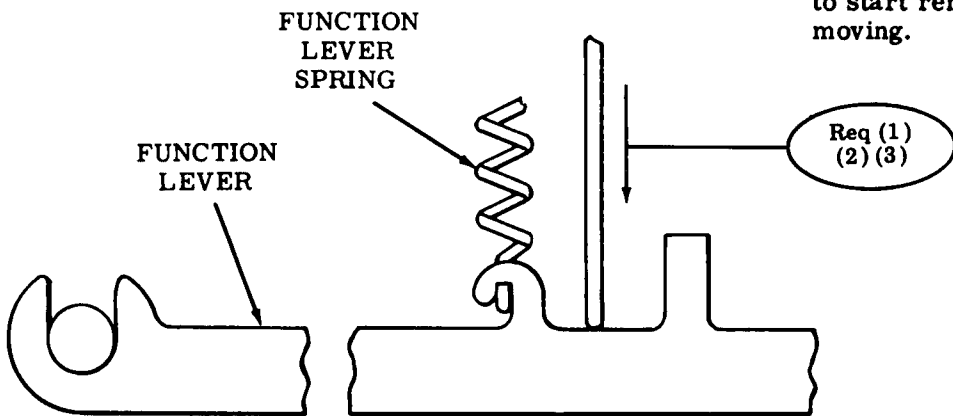

(Right Side View)

2.34 Function Area (continued)

RIGHT ROCKER DRIVE (FNA-11)

To Check

Disengage (latch) distributor clutch. Make sure the answer-back blocking lever is fully latched by the answer-back blocking pawl. Set up answer-back character WRU code combination (1--4-) in selector. Trip the codebar clutch and rotate main shaft until function bail is at its highest point (position no. 1). Make sure that distributor clutch has not been tripped. Take up answer-back function lever play in an upward direction at the pivot to minimize clearance.

Requirement

Min 0.015 inch---Max 0.050 inch between answer-back function lever and its function pawl.

To Adjust

Loosen clamp screw. Use pry point to adjust right rocker arm. Tighten clamp screw.

Related Adjustments

Affects

- FORM-OUT LEVER OVERTRAVEL - S
(Form Feed Area) (2.97)
- LINE FEED PAWL STRIPPING - S
(Form Feed Area) (2.106)
- TRIPBAIL POSITIONING (3.08)

Affected By

LEFT ROCKER DRIVE (2.32)

Note: If typing unit is not equipped with the answer-back feature, select a code combination which will permit the right-most function lever to be selected.

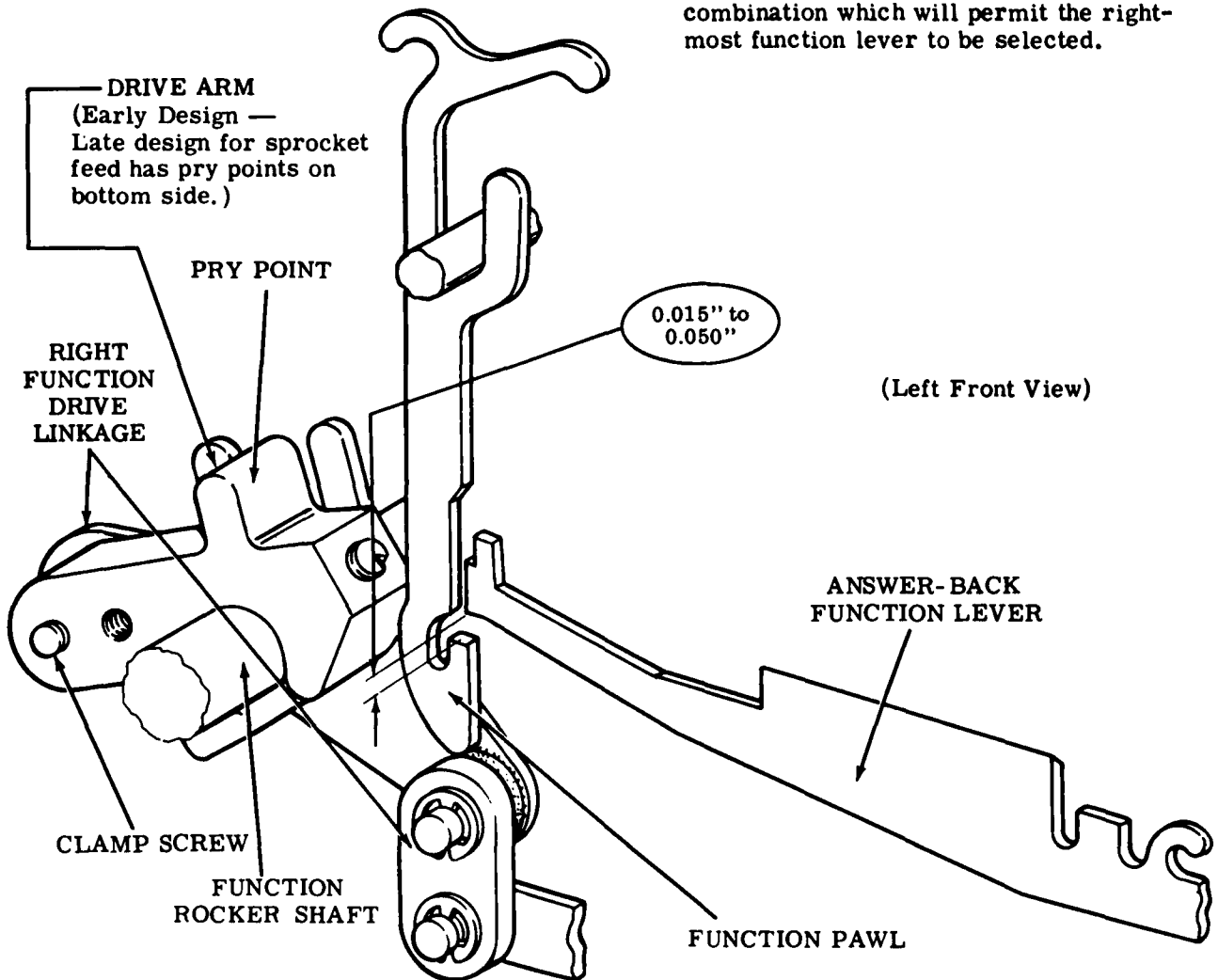

(Left Front View)

2.35 Function Area (continued)

FUNCTION LEVER RETAINER (FNA-12)

For units equipped with TP183851 (left) and TP183853 (right) function lever retainers.

To Check

With an all spacing code combination in the selector, manually operate the typing unit until the blade is at its highest point of travel (position no. 1).

Requirement

Min some --- Max 0.040 inch
between the function lever retainers and function levers at the closest point.

Note: The lower edges at the mounting portion of the retainer should not extend below the lower edge of the blade.

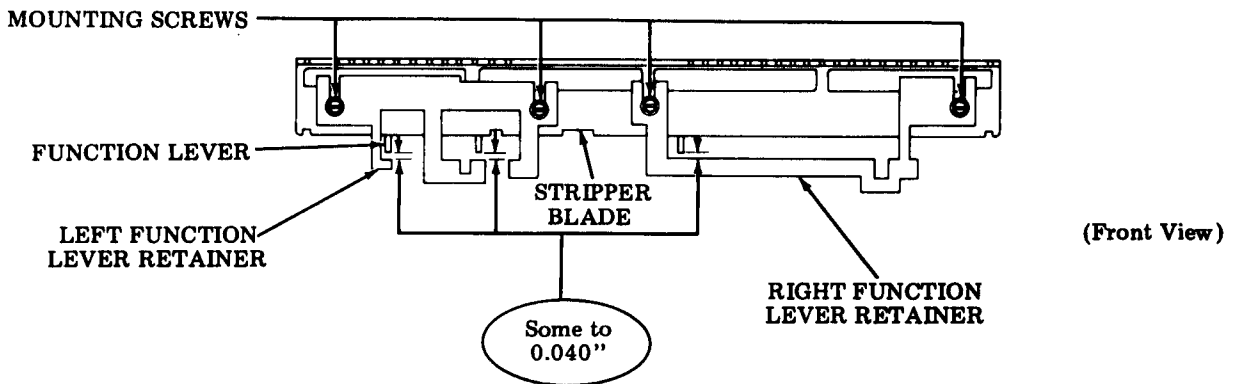

To Adjust

Loosen mounting screws and position retainers. Tighten screws.

FUNCTION BAIL SPRING

Requirement

With typing unit in stop condition

Min 72 oz -- Max 104 oz

to pull both function bail springs to installed length.

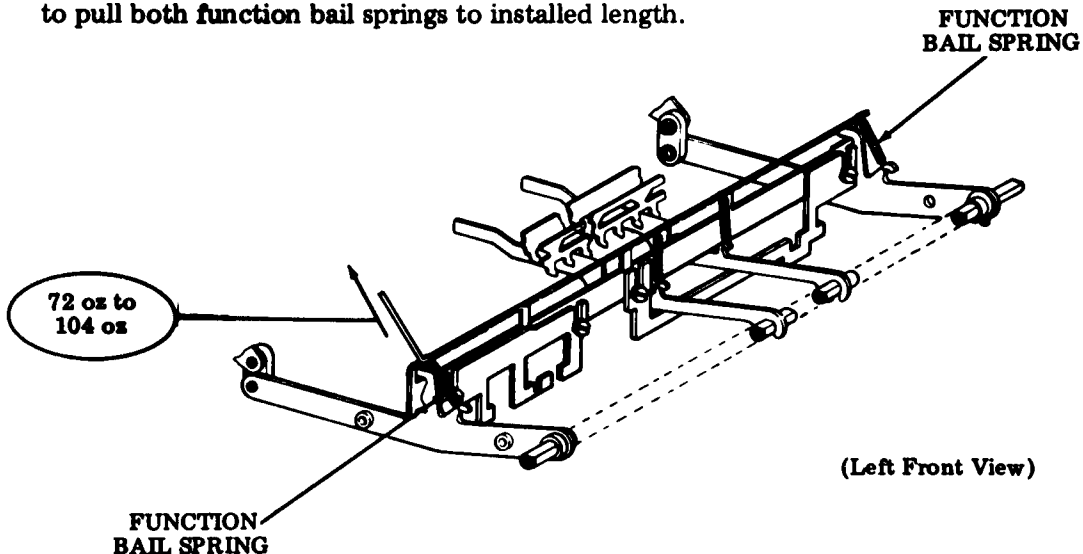

2.36 Function Area (continued)

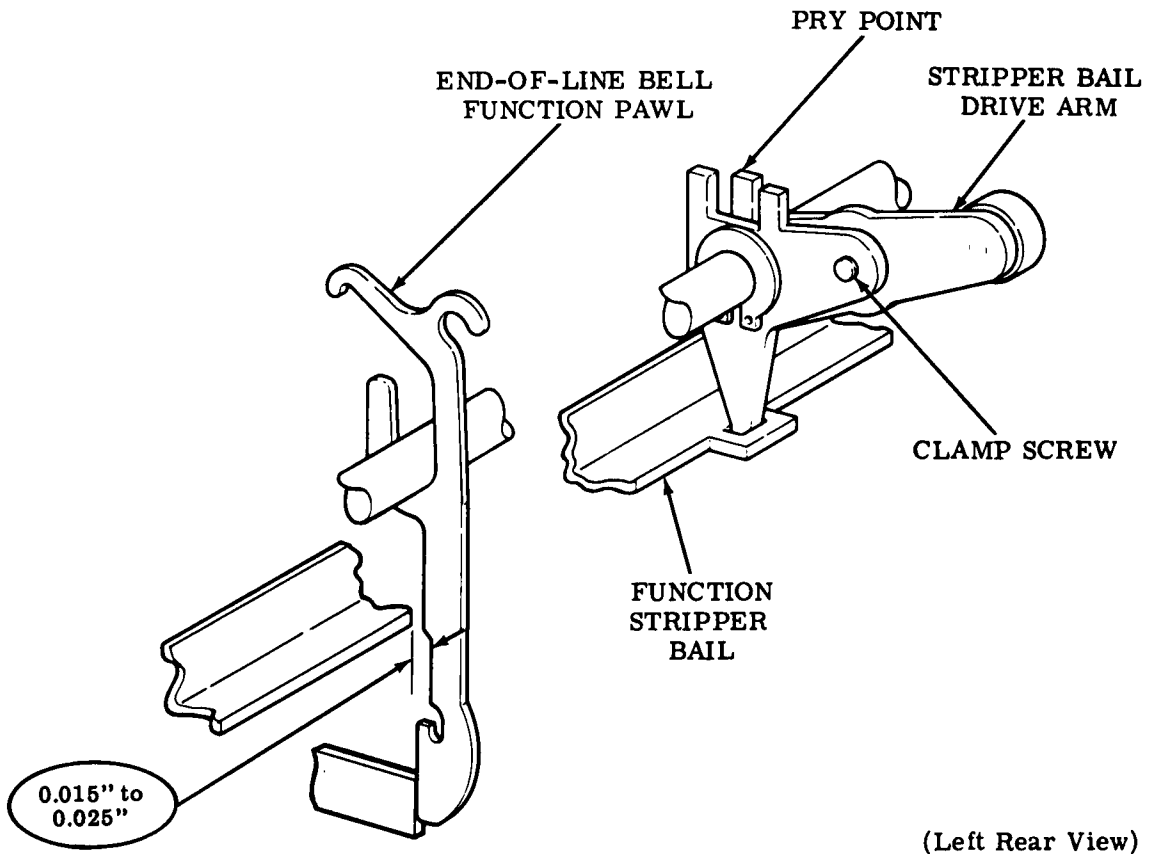

STRIPPER BAIL CLEARANCE (FNA-14)

Requirement

With typing unit in stop condition

Min 0.015 inch---Max 0.025 inch
between function stripper bail and edge of stripped
end-of-line bell function.

Note: For typing units which are not equipped with the
end-of-line bell function pawl, check requirement at the TP180792
function pawl closest to slot F in function casting.

To Adjust

Loosen clamp screw. Use pry point to position stripper bail drive
arm. Tighten clamp screw.

Related Adjustment

Affects

LINE FEED STRIPPER PLATE CLEARANCE - F (Platen Area) (2.84)

2.37 Function Area (continued)

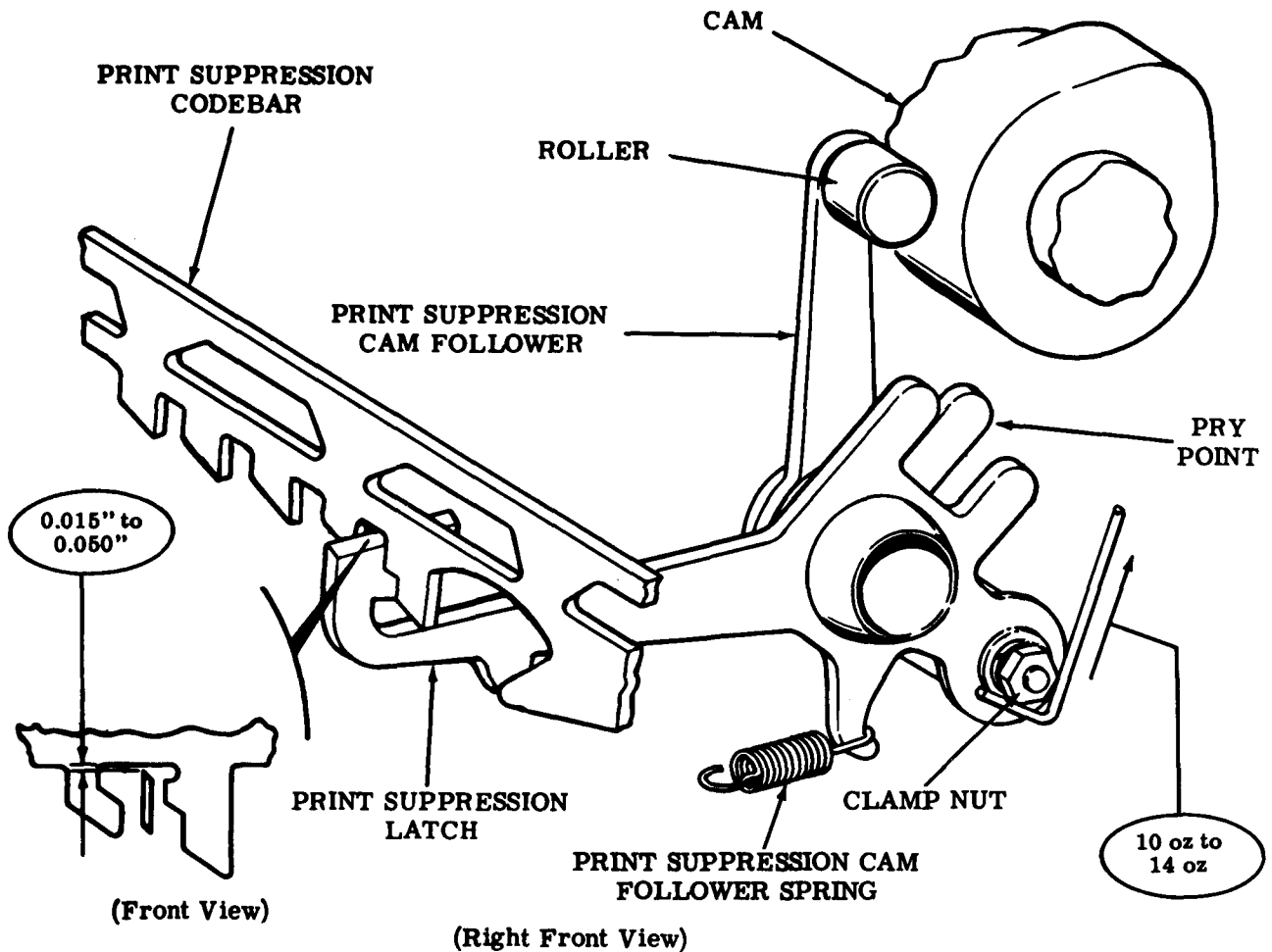

PRINT SUPPRESSION LATCH — VERTICAL CLEARANCE (FNA-15)

Requirement

With typing unit in stop condition and print suppression cam follower roller resting on its cam

Min 0.015 inch---Max 0.050 inch between print suppression latch and print suppression codebar.

To Adjust

Loosen clamp nut. Using pry point, position print suppression cam follower. Tighten clamp nut.

Related Adjustments

Affected By

CODEBAR RESET LEVER POSITION (2.27)

PRINT SUPPRESSION CAM FOLLOWER SPRING

Requirement

With typing unit in stop condition

Min 10 oz---Max 14 oz to start print suppression cam follower moving.

2.38 Function Area (continued)

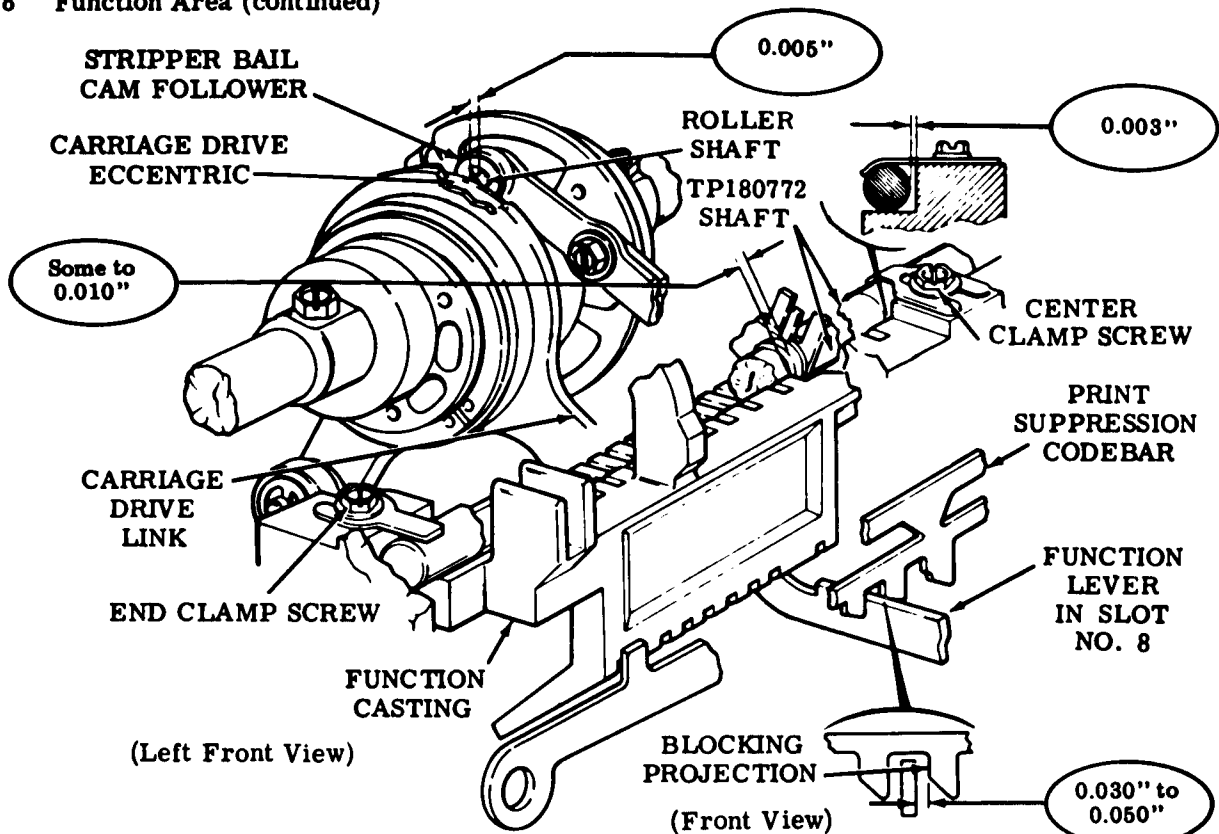

FUNCTION SHAFT AND CASTING POSITION
(FNA-16)

Note: The Requirement (1) applies only to TP180772 shafts which have raised rings which serve to locate the stripper bail cam follower.

- (1) Requirement
Min some---Max 0.010 inch between stripper bail cam follower and left side of slot in function casting.

To Adjust
Loosen clamp screws and position TP180772 shaft.

- (2) Requirement
The shaft should be in contact with, or not more than Max 0.003 inch away from the vertical surface at the center of the function casting.

To Adjust
With the center and two end clamp screws loosened, position to meet Requirements (1) and (2).

To Check
Manually set up an all spacing code combination in selector. Rotate main shaft until suppression cam follower just begins to rise on its cam.

- (3) Requirement
Min 0.030 inch---Max 0.050 inch between blocking projection on print suppression codebar and the function lever in slot no. 8.

- (4) Requirement
Min 0.005 inch between carriage drive eccentric and roller shaft on stripper bail cam follower with play taken up to make clearance a minimum.

To Adjust
Loosen two end clamp screws and left rear codebar basket clamp screw if bracket TP187103 is present. Position function casting to meet requirements (3) and (4). Tighten screws.

Related Adjustments

Affected By

- CODEBAR RESET LEVER POSITION (2.27)
- PRINT SUPPRESSION LATCH — HORIZONTAL CLEARANCE (2.28)
- LEFT BEARING POSITION (2.10)

2.39 Function Area (continued)

CARRIAGE RETURN LEVER - LATCH CLEARANCE (FNA-17)

(Left Front View)

To Check

Position carriage to center of typing unit and carefully remove carriage return spring. Set up carriage return code combination (---4-) in selector. Rotate main shaft until function bail reaches lowest point of travel. Position left end of carriage return lever rearward to eliminate its play.

(1) Requirement

Early design
carriage return lever flush with
carriage return latch
Within 0.005 inch

(2) Requirement

Late design
Min some---Max 0.030 inch
between carriage return lever and
carriage return latch.

To Adjust

Loosen clamp screw. Use pry points to position carriage return lever. Tighten clamp screw. Replace carriage return spring.

Related Adjustment

Affected By

LEFT ROCKER DRIVE (2.32)

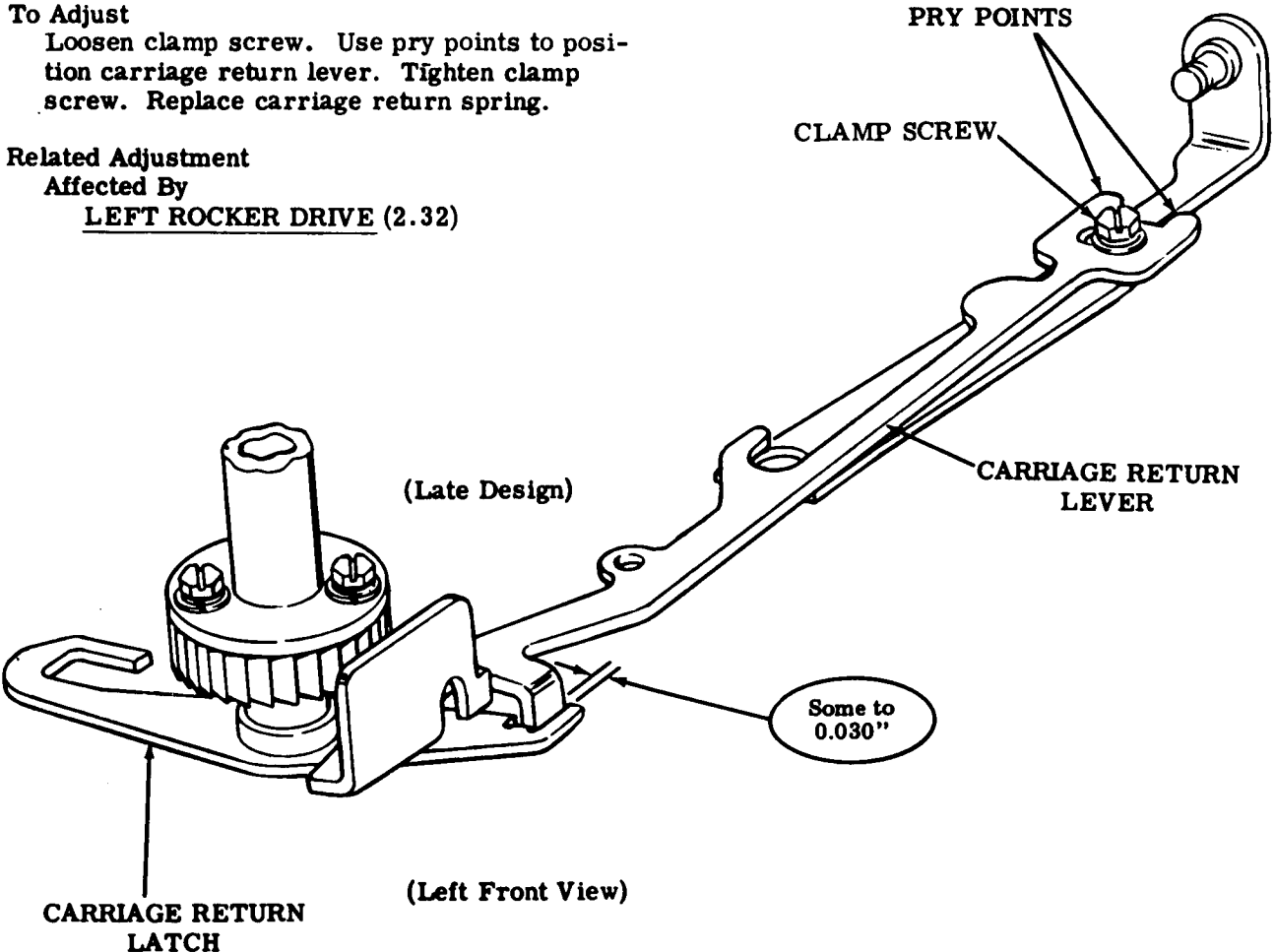
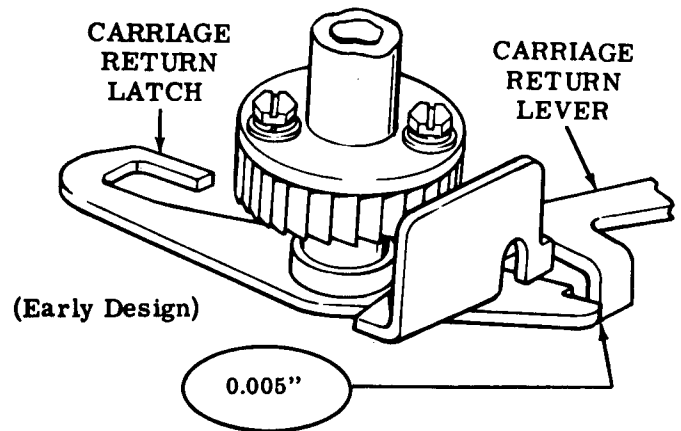

2.40 Function Area (continued)

CARRIAGE RETURN SPRING

Requirement

With typing unit in stop condition and carriage at right margin

Min 56 oz---Max 64 oz

to pull carriage return spring to installed length.

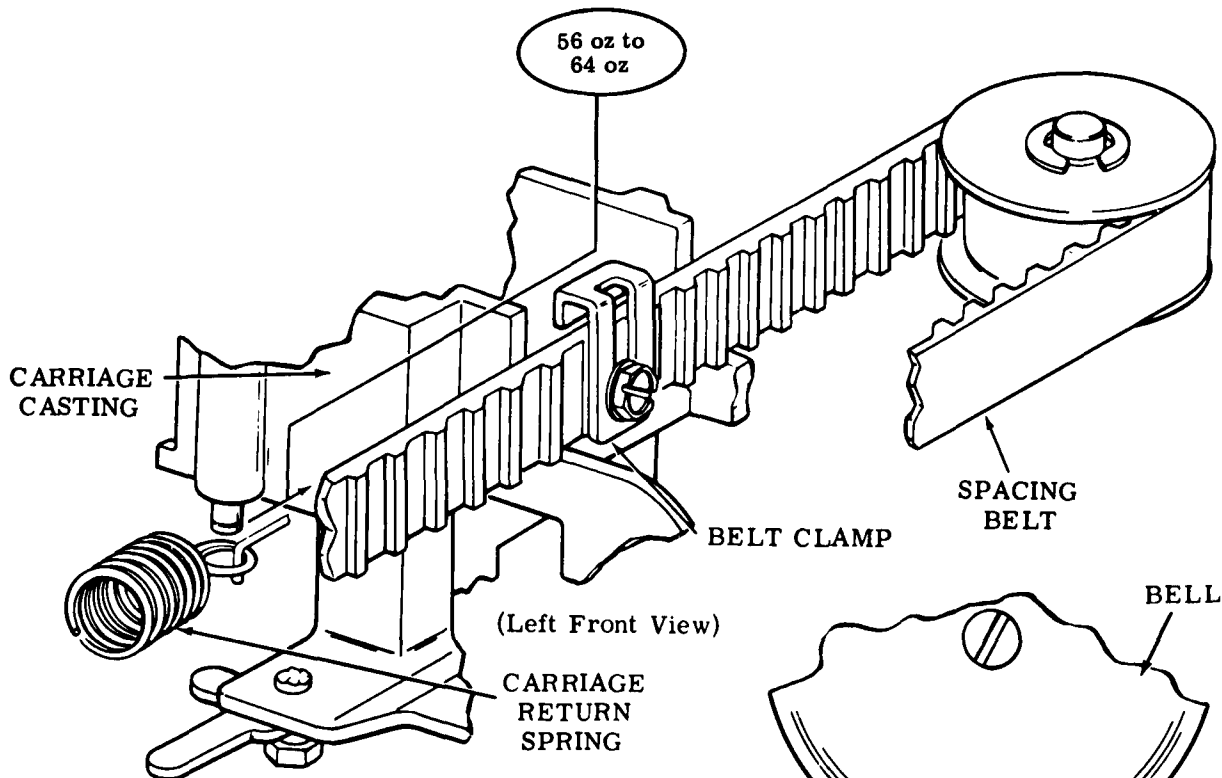

BELL CLAPPER GAP (FNA-18)

(1) Requirement (Preliminary)

With typing unit in stop condition

Min 0.030 inch---Max 0.070 inch

between clapper and bell.

To Adjust

Using pliers, bend clapper spring.

(2) Requirement (Final)

The bell must be audible when operated.

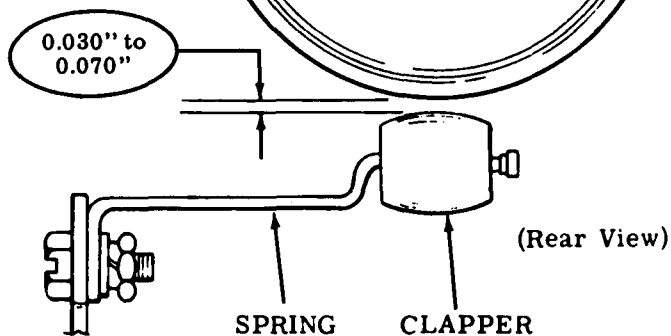

2.41 Carriage Area

FRONT ROLLERS CLEARANCE (CRA-1)

Note 1: This adjustment does not apply to typing units equipped with nonadjustable parts such as TP183503 bearing housing and TP183504 bearing retainer.

To Check

Place typing unit in stop condition.
Remove the carriage return spring.
Take up roller play toward the front of the typing unit.

Requirement

Min some---Max 0.005 inch
between carriage front roller and
carriage front rail.

To Adjust

Loosen mounting nut and position each roller against rail by means of eccentric shaft. Slowly back off eccentric shaft to meet requirement. Tighten mounting nut.

Note 2: Some positions of carriage front roller may show a slight drag condition. This is acceptable providing there is no perceptible increase in carriage friction due to condition.

Related Adjustments**Affects**

PRINT DRIVE LEVER POSITIONING (2.46)
PRINT SUPPRESSION LATCHLEVER RELEASE (2.55)
RIBBON POWER LEVER DRIVE (2.60)
PLATEN HORIZONTAL POSITION - F (2.69)
PLATEN HORIZONTAL POSITION - S (2.88)

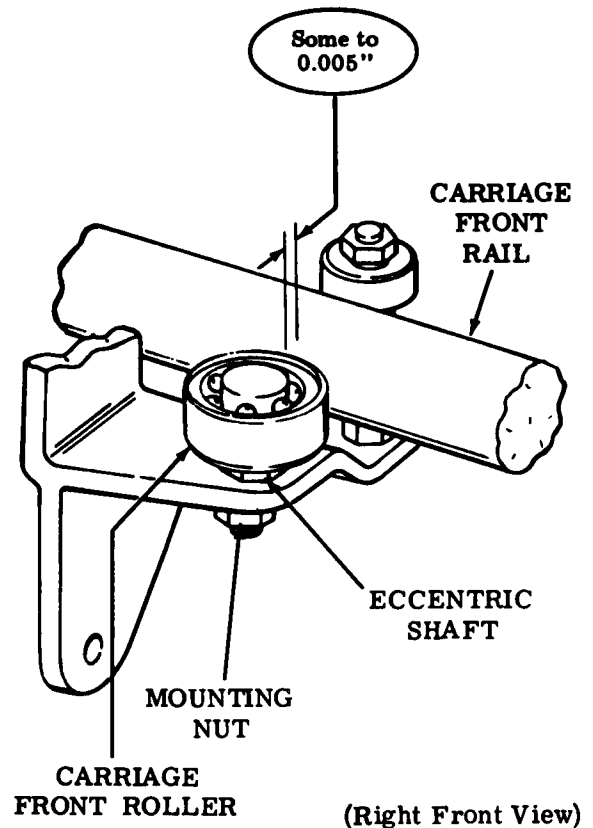

SECTION 574-172-700TC

2.42 Carriage Area (continued)

POWER BAIL ROLLER CLEARANCE (CRA-2)

To Check

Position front roller over carriage drive bail arm. Typing unit in stop condition. Trip function clutch and rotate main shaft until carriage drive bail reaches rearmost position (position no. 2). Do not reverse rotation of main shaft.

Requirement

Min some---Max 0.005 inch between front roller and carriage drive bail.

To Adjust

Loosen mounting nut. Position front roller by means of eccentric shaft. Tighten mounting nut.

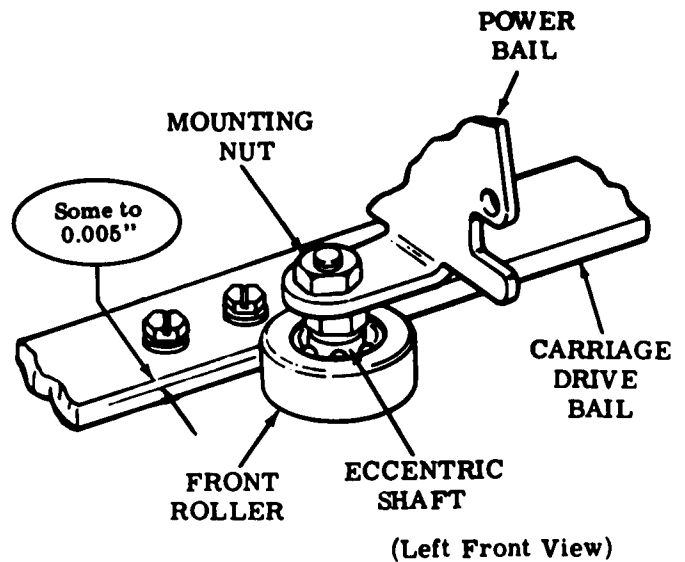

RACK AND PINION BACKLASH (CRA-3)

Note 1: This adjustment is to be performed only on early design carriages having the TP180548 adjusting plate and TP180549 bracket. Late design carriages do not require this adjustment.

To Check

Place typing unit in stop condition.

Requirement

Each rack should have Min some---Max 0.010 inch backlash.

To Adjust

Loosen lock plate clamp screws and move lock plate towards the rear. Loosen one adjusting plate clamp screw friction tight and place a 0.010-inch feeler gauge between the rack and adjusting plate. Position adjusting plate for no play between the rack and pinion using pry point. Tighten adjusting plate clamp screw and remove feeler gauge. Repeat procedure for adjusting plate on other side. Position lock plate against adjusting plates. Tighten lock plate clamp screws.

Note 2: Do not loosen both adjusting plate clamp screws at the same time.

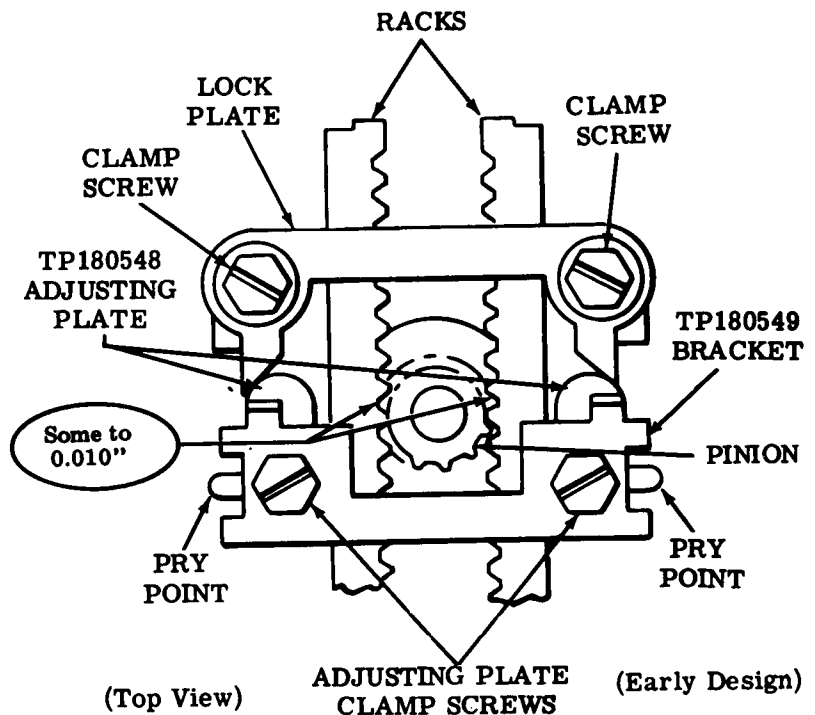
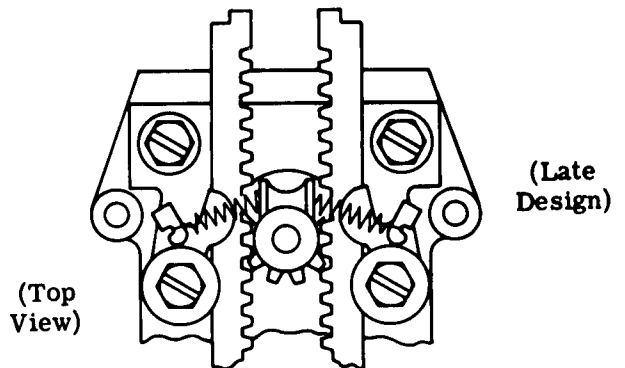

2.43 Carriage Area (continued)

REAR RAIL POSITION (CRA-4)

(1) To Check

Position the dashpot plunger just outside the dashpot cylinder. With the FIGS code (12-45) set up in selector, rotate the main shaft until the shift slide is in its uppermost position and contacts the stop plate. Take up all play to minimize the required clearance.

Requirement

Min 0.025 inch---Max 0.040 inch between bottom edge of shift slide and top edge of stop plate.

(2) To Check

Condition the typing unit as in (1) To Check above except place carriage to the right with center of the typewheel 1/2 inch from the right hand margin.

Requirement

Min 0.025 inch---Max 0.040 inch between bottom edge of shift slide and top edge of stop plate.

(3) To Check

Calculate the difference between the recorded measurements in To Check (1) and To Check (2) above.

Requirement

Max 0.010 inch difference between recorded measurements.

To Adjust

Loosen two carriage rear rail mounting screws friction tight, and position carriage rear rail using pry point. Tighten mounting screws.

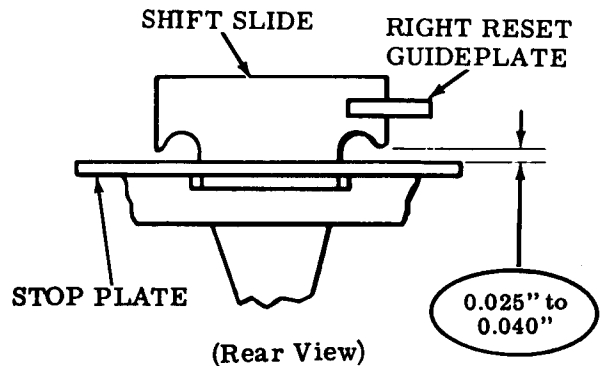

Related Adjustments

Affects

- PRINT DRIVE LEVER POSITIONING (2.46)
- THIRD PULSE LINKAGE POSITIONING (2.45)
- RESET LEVER POSITIONING (2.47)
- PRINT SUPPRESSION LATCHLEVER RELEASE (2.55)
- PRESSURE ROLLER CLEARANCE (Platen Area) (2.83)
- REAR ROLLER CLEARANCE (2.44)
- RIGHT SLIDE GUIDEPLATE RESET (2.50)
- LEFT SLIDE GUIDEPLATE RESET (2.51)
- PRINT HAMMER TRIP LEVER RELEASE (2.52)
- PRINT HAMMER TRIP LEVER RESET (2.53)
- REBON POWER LEVER DRIVE (2.60)
- VERTICAL TYPE ALIGNMENT - F (2.70)
- VERTICAL TYPE ALIGNMENT - S (2.89, 2.90)

Affected by

- CODEBAR RESET LEVER POSITION (Function Area) (2.27)

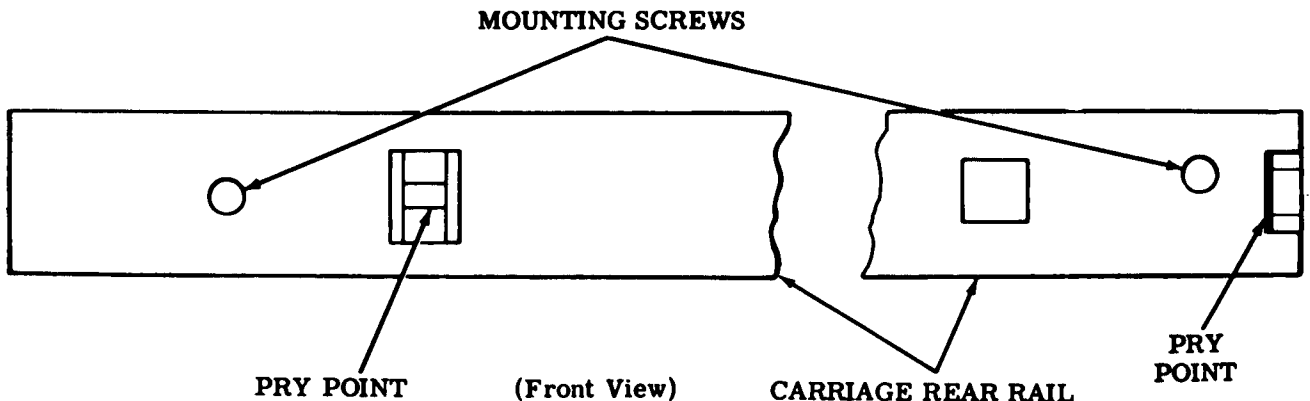

2.44 Carriage Area (continued)

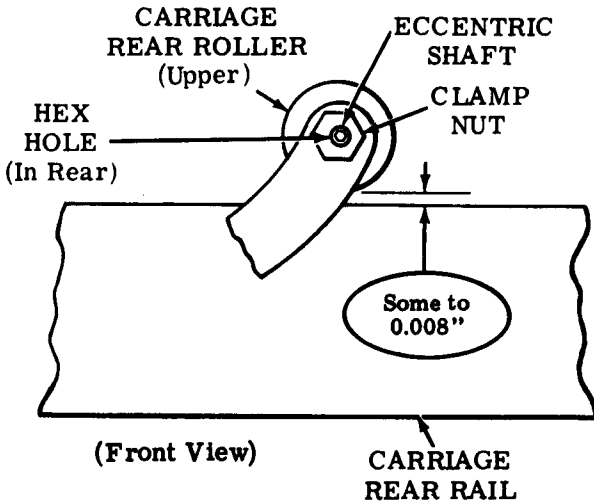

REAR ROLLER CLEARANCE (CRA-5)

To Check

Rotate main shaft until carriage drive bail is in rearmost position. Position carriage so dashpot plunger is just clear of dashpot cylinder and check requirement. Also check requirement with carriage within 1/2 inch of right margin.

Requirement

Min some--- Max 0.008 inch between carriage rear rail and carriage rear roller (upper).

To Adjust

Loosen clamp nut and position eccentric shaft with hex wrench in hex hole. Tighten clamp nut.

Related Adjustments

Affects

- THIRD PULSE LINKAGE POSITIONING (2.45)
- PRINT DRIVE LEVER POSITIONING (2.46)
- RESET LEVER POSITIONING (2.47)
- RIGHT SLIDE GUIDEPLATE RESET (2.50)
- PRINT HAMMER TRIP LEVER RELEASE (2.52)
- PRINT HAMMER TRIP LEVER RESET (2.53)

Affected By

- REAR RAIL POSITION (2.43)

2.45 Carriage Area (continued)

THIRD PULSE LINKAGE POSITIONING (CRA-10)**To Check**

Place carriage at center of platen. With an all marking code combination set up in selector, manually operate the typing unit until the function clutch just trips. Take up play in left rack in a downward direction.

Requirement

Min 0.010 inch---Max 0.050 inch
between rotary drive arm and left rack.

To Adjust

Bend pulse lever using pry points.

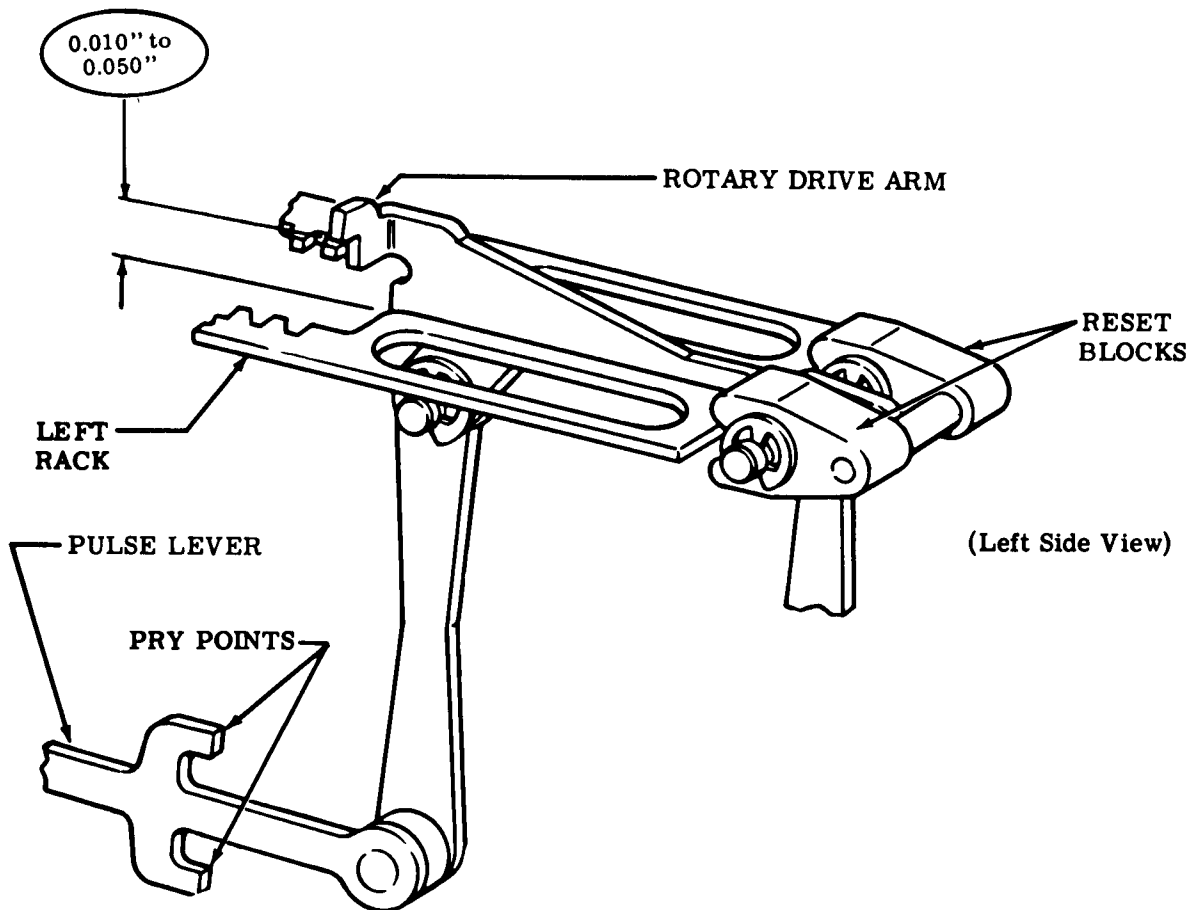
**Related Adjustments****Affected By**

CODEBAR RESET LEVER POSITION (Function Area) (2.27)

REAR RAIL POSITION (2.43)

REAR ROLLER CLEARANCE (2.44)

2.46 Carriage Area (continued)

PRINT DRIVE LEVER POSITIONING (CRA-6)

To Check

Place typing unit in stop condition and move carriage until its power bail rollers are positioned directly above the carriage drive link. Take up play in vertical drive bail in a downward direction, and take up play in common stop arm toward the left. Loosen rotary drive bail clamp screw.

Requirement

Late design typing units equipped with TP183993 function clutch cam sleeve
 Min 0.065 inch---Max 0.090 inch
 between vertical drive bail and common stop arm.

Early design typing units equipped with TP180806 function clutch cam sleeve
 Min 0.229 inch---Max 0.239 inch

between vertical drive bail and common stop arm as gauged with a TP180588 adjusting tool.

Note: The TP180588 adjusting tool has a nominal dimension of 0.234 inch.

To Adjust

Loosen print drive lever clamp screw and position print drive lever using pry points. Tighten clamp screw.

Related Adjustments

Affects

- RIGHT SLIDE GUIDEPLATE RESET (2.50)
- PRINT HAMMER TRIP LEVER RESET (2.53)
- LEFT SLIDE GUIDEPLATE RESET (2.51)
- RIBBON POSITIONING (2.54)
- VERTICAL TYPE ALIGNMENT - F (2.70)
- VERTICAL TYPE ALIGNMENT - S (2.89)
- PRINT SUPPRESSION LATCH-LEVER ENDPLAY (2.48)

Affected By

- REAR RAIL POSITION (2.43)
- FRONT ROLLERS CLEARANCE (2.41)
- REAR ROLLER CLEARANCE (2.44)

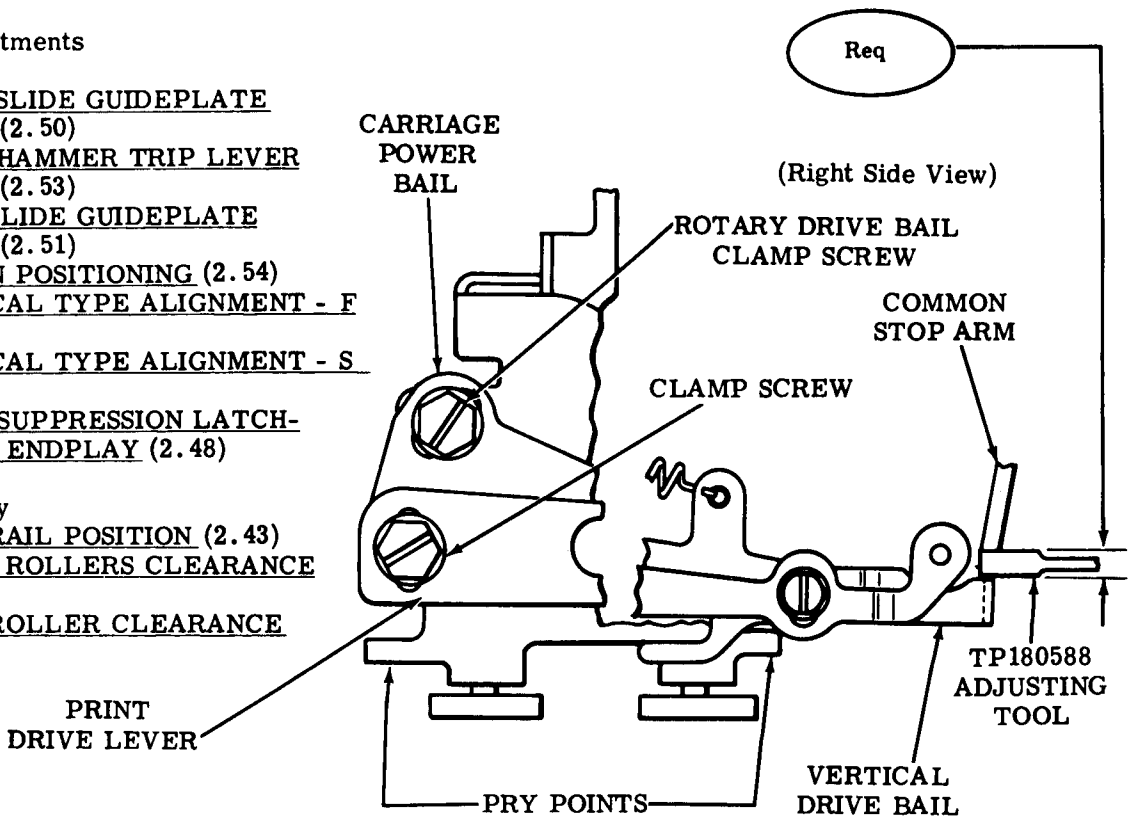

2.47 Carriage Area (continued)

RESET LEVER POSITIONING (CRA-11)

Requirement

When typing unit returns to stop condition, racks should be completely reset.

To Adjust

Place carriage in center of typing unit. Loosen clamp screw and allow positioning spring to fully reset racks. Tighten clamp screw.

Related Adjustments

Affects

RIBBON POWER LEVER DRIVE (2.60)

Affected By

REAR RAIL POSITION (2.43)

REAR ROLLER CLEARANCE (2.44)

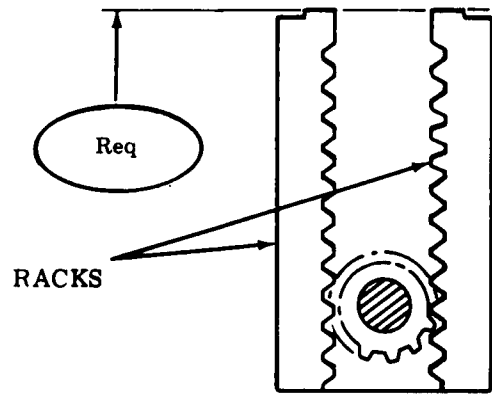

(Top View)

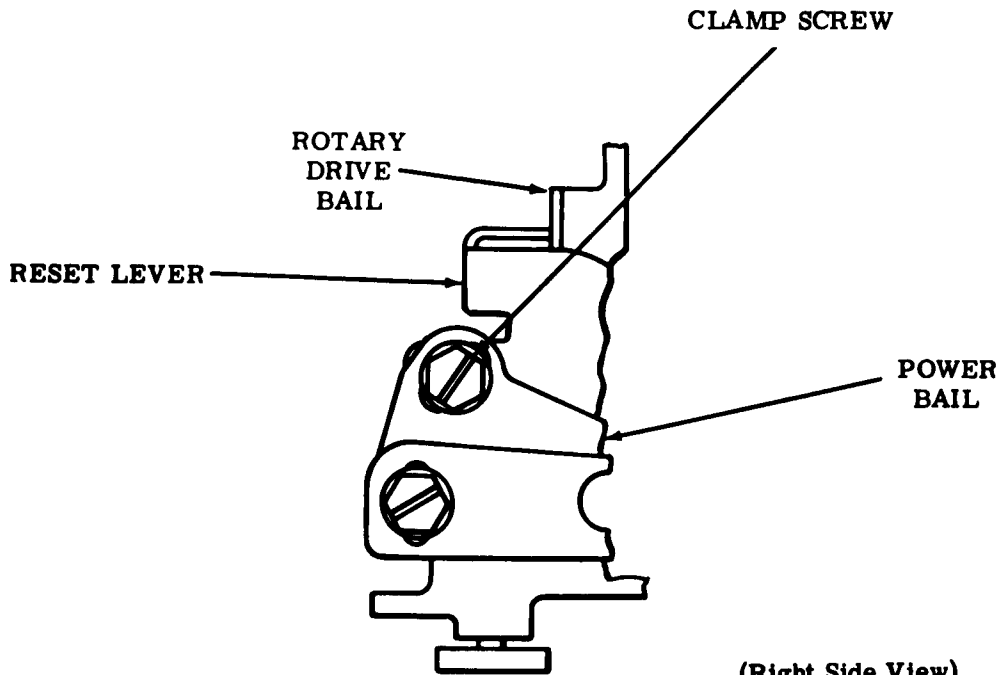

(Right Side View)

2.48 Carriage Area (continued)

PRINT SUPPRESSION LATCHLEVER ENDPLAY (CRA-12)

To Check

Take up play in print suppression latchlever towards carriage casting.

Requirement

Print suppression latchlever should fully engage print hammer bail with no binds.

To Adjust

Loosen setscrew with hex key wrench and position collar. Tighten setscrew.

Related Adjustments

Affected By

PRINT DRIVE LEVER POSITIONING (2.46)

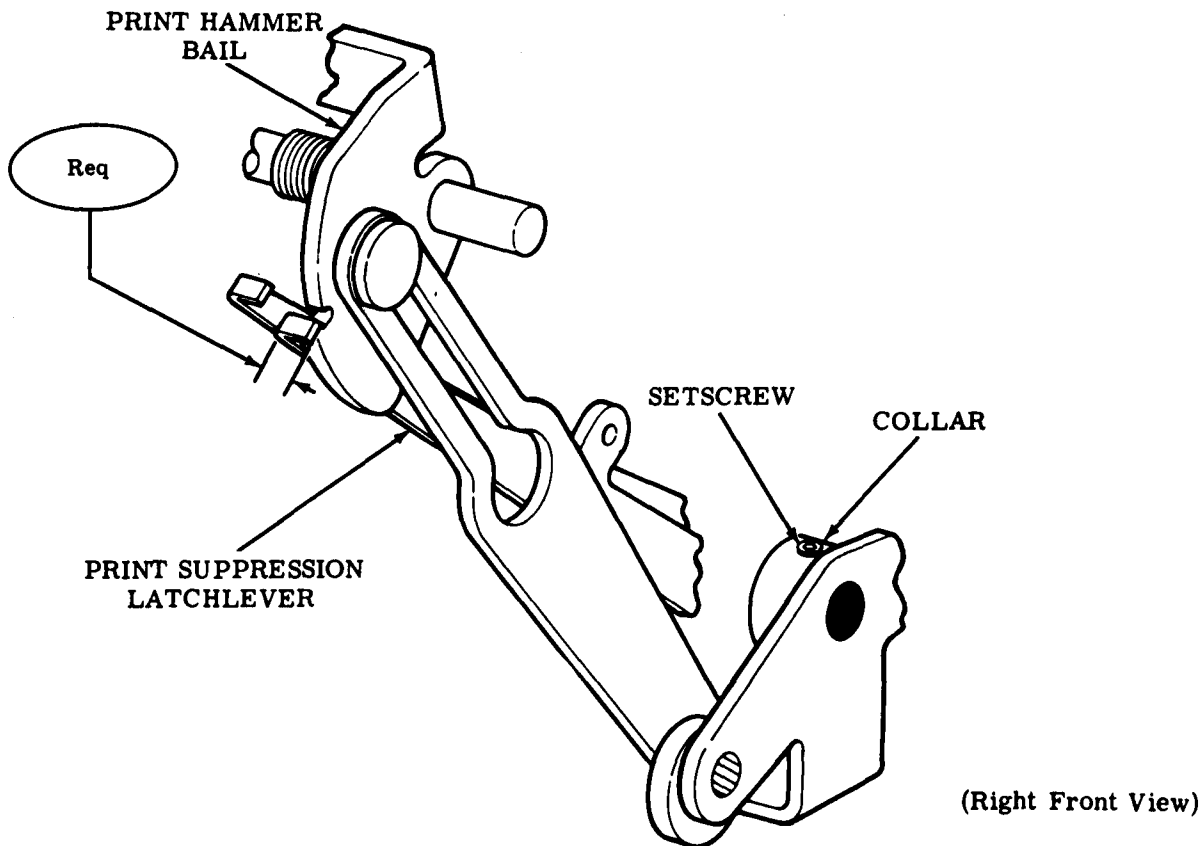

2.49 Carriage Area (continued)

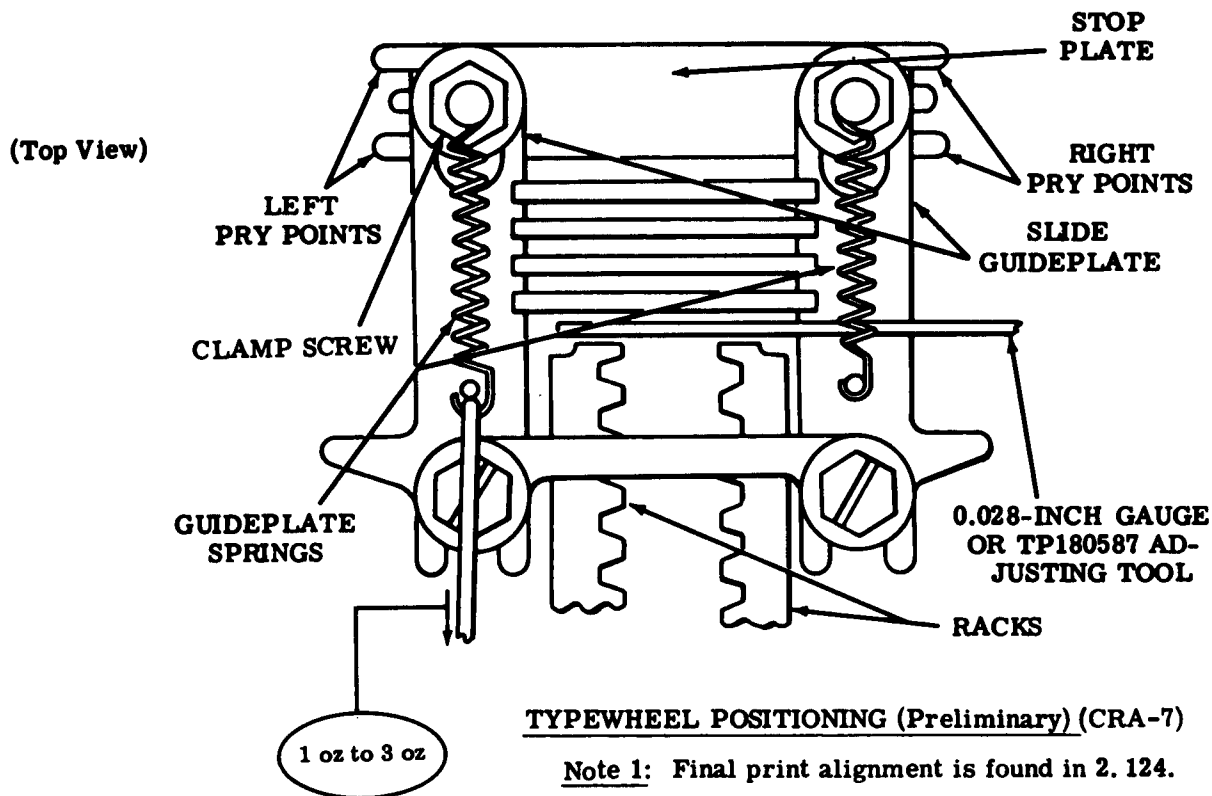

TYPEWHEEL POSITIONING (Preliminary) (CRA-7)

Note 1: Final print alignment is found in 2.124.

To Check

Set up code combination in selector of a character in counterclockwise field of typewheel. Rotate main shaft until carriage drive bail is in rearmost position. Check to see if vertical row containing character is properly selected. Repeat for a character in clockwise field.

Requirement

Typewheel positioning correct in both clockwise and counterclockwise directions.

To Adjust

Place typing unit in stop condition. Open up **LEFT SLIDE GUIDEPLATE RESET (2.51)** and **RIGHT SLIDE GUIDEPLATE RESET (2.50)** adjustments. Loosen two clamp screws friction tight. Place either 0.028-inch gauge or TP180587 adjusting tool across end of racks. Hold reset lever in place and position stop plate so that entire slide assembly is tight against racks and tool.

Related Adjustments

Affects

- LEFT SLIDE GUIDEPLATE RESET (2.51)**
- RIGHT SLIDE GUIDEPLATE RESET (2.50)**

SLIDE GUIDEPLATE SPRINGS

Note 1: To check slide guideplate springs, it is necessary to remove the carriage mechanism from the typing unit. See appropriate disassembly and reassembly section. Do not check unless there is reason to believe that the slide guideplate springs will not meet their requirement.

Requirement

Min 1 oz---Max 3 oz
to pull each spring to installed length.

Note 2: Check right and left springs.

2.50 Carriage Area (continued)

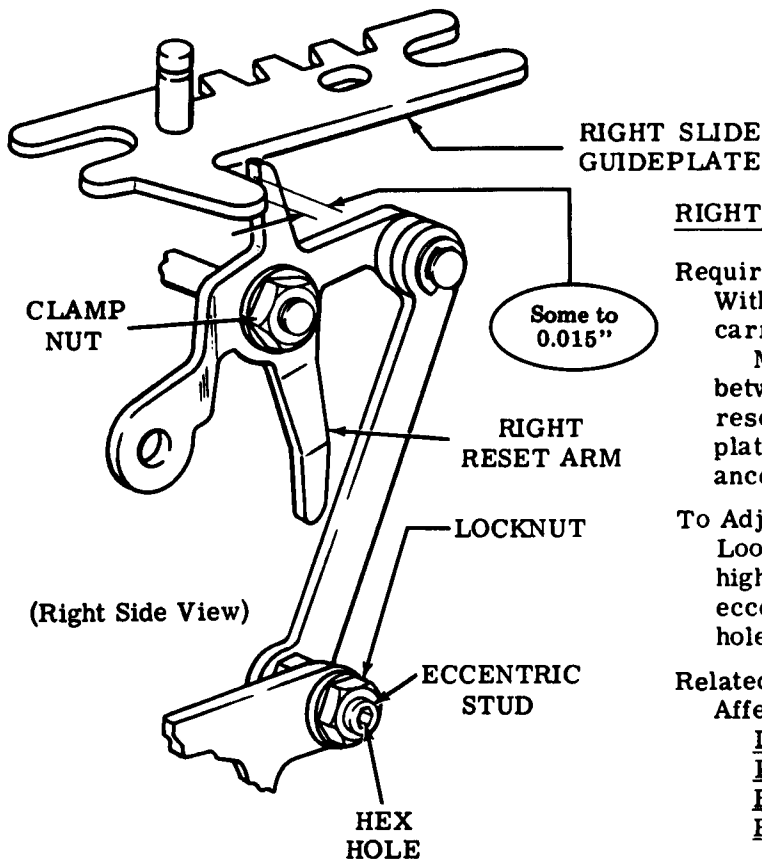

RIGHT SLIDE GUIDEPLATE RESET (CRA-8)

Requirement

With typing unit in stop condition and carriage over the carriage drive link
 Min some---Max 0.015 inch
 between right slide guideplate and the right reset arm when right and left slide guideplates are held toward front to make clearance a maximum.

To Adjust

Loosen eccentric stud locknut. With high point of eccentric to rear, rotate eccentric stud with hex wrench in hex hole. Tighten locknut.

Related Adjustments

Affects

- LEFT SLIDE GUIDEPLATE RESET (2.51)
- PRINT HAMMER TRIP LEVER RELEASE (2.52)
- RIBBON POSITIONING (2.54)

Affected By

- REAR RAIL POSITION (2.43)
- REAR ROLLER CLEARANCE (2.44)
- PRINT DRIVE LEVER POSITIONING (2.46)
- TYPEWHEEL POSITIONING (2.49)

2.51 Carriage Area (continued)

LEFT SLIDE GUIDEPLATE RESET (CRA-8)**Requirement**

With typing unit in stop condition and the carriage positioned over the carriage drive link

Min some---Max 0.015 inch
between left slide guideplate and left reset arm when the right and left slide guideplates are held toward the front to make clearance a maximum.

To Adjust

Loosen left reset arm clamp nut. Position left reset arm using pry point. Tighten clamp nut.

Related Adjustments**Affects**

RIBBON POSITIONING (2.54)

Affected By

REAR RAIL POSITION (2.43)

PRINT DRIVE LEVER POSITIONING (2.46)

TYPEWHEEL POSITIONING (Preliminary) (2.49)

RIGHT SLIDE GUIDEPLATE RESET (2.50)

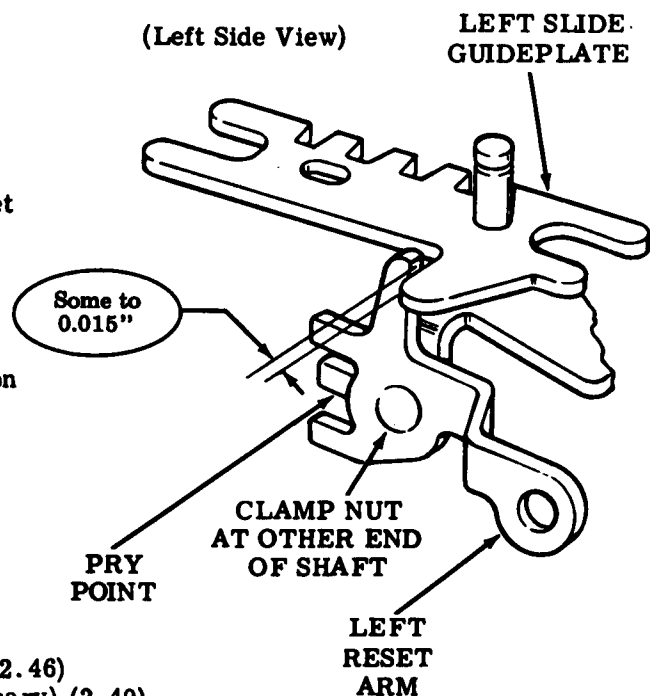

2.52 Carriage Area (continued)

PRINT HAMMER TRIP LEVER RELEASE
(CRA-9)

(1) To Check

Place carriage with lower front roller centered between drive bracket mounting screws. With unit in stop condition, trip selector clutch and set up an all marking code combination. Rotate main shaft until carriage drive bail reaches its rearmost position (position no. 2). Take up print hammer trip lever play lightly toward bail and release.

(1) Requirement

Min 0.040 inch --- Max 0.110 inch between print hammer bail and print hammer trip lever.

To Adjust

Loosen print hammer trip lever clamp screw and position print hammer trip lever using pry point. Tighten clamp screw.

(2) To Check

Move the carriage to the right until the front roller is over the retaining screw of the spring bracket.

(2) Requirement

The clearance between print hammer bail and print hammer trip lever to be Within 0.020 inch of Requirement (1) above.

To Adjust

With carriage drive bail right pivot clamp screw friction tight, position right pivot. Tighten clamp screw.

(3) Requirement

Vertical endplay of carriage drive bail should be
Min some --- Max 0.015 inch

To Adjust

Loosen clamp screw at left end pivot and position pivot to meet requirement. Tighten clamp screw.

(Right Side View)

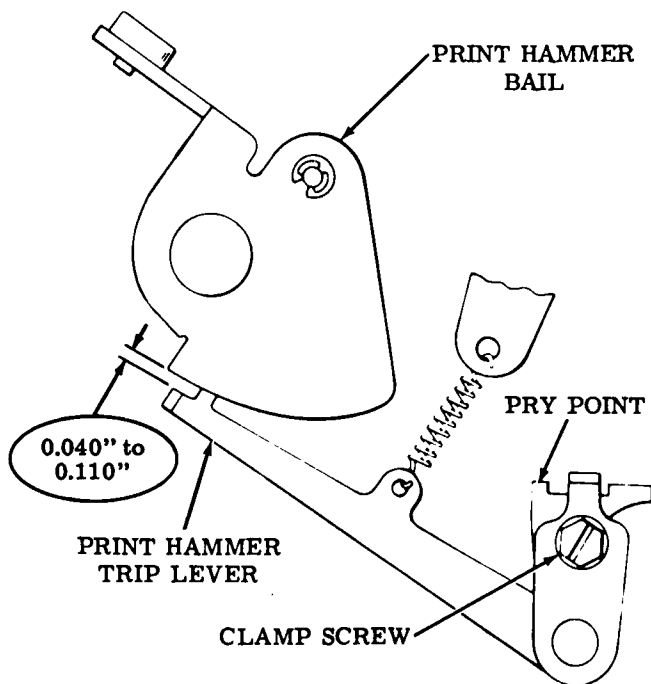

CARRIAGE DRIVE BAIL CARRIAGE DRIVE LINK CLAMP SCREW

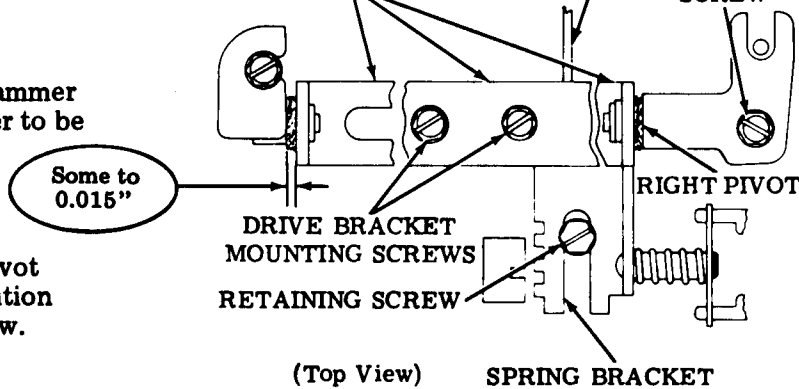

(Top View) SPRING BRACKET

Related Adjustments

Affects

- FEED PAWL STOP POSITION
(Spacing Area) (2.62)
- PRINT HAMMER TRIP LEVER RESET (2.53)
- RIGHT SLIDE GUIDEPLATE RESET
(2.50)
- REAR RAIL POSITION (2.43)
- REAR ROLLER CLEARANCE (2.44)

2.53 Carriage Area (continued)

PRINT HAMMER TRIP LEVER RESET (CRA-13)

Requirement

With typing unit in stop condition
 Min 0.010 inch---Max 0.050 inch
 between print hammer bail and print
 hammer trip lever.

To Adjust

Loosen clamp nut and position print
 hammer reset arm eccentric pivot
 with hex key wrench in hex hole.
 Tighten clamp nut.

Note: Keep high part of eccentric
 pivot toward front of typing unit.

Related Adjustment

Affected By

- REAR RAIL POSITION (2.43)
- REAR ROLLER CLEARANCE (2.44)
- PRINT DRIVE LEVER POSITIONING (2.46)
- PRINT HAMMER TRIP LEVER RELEASE (2.52)

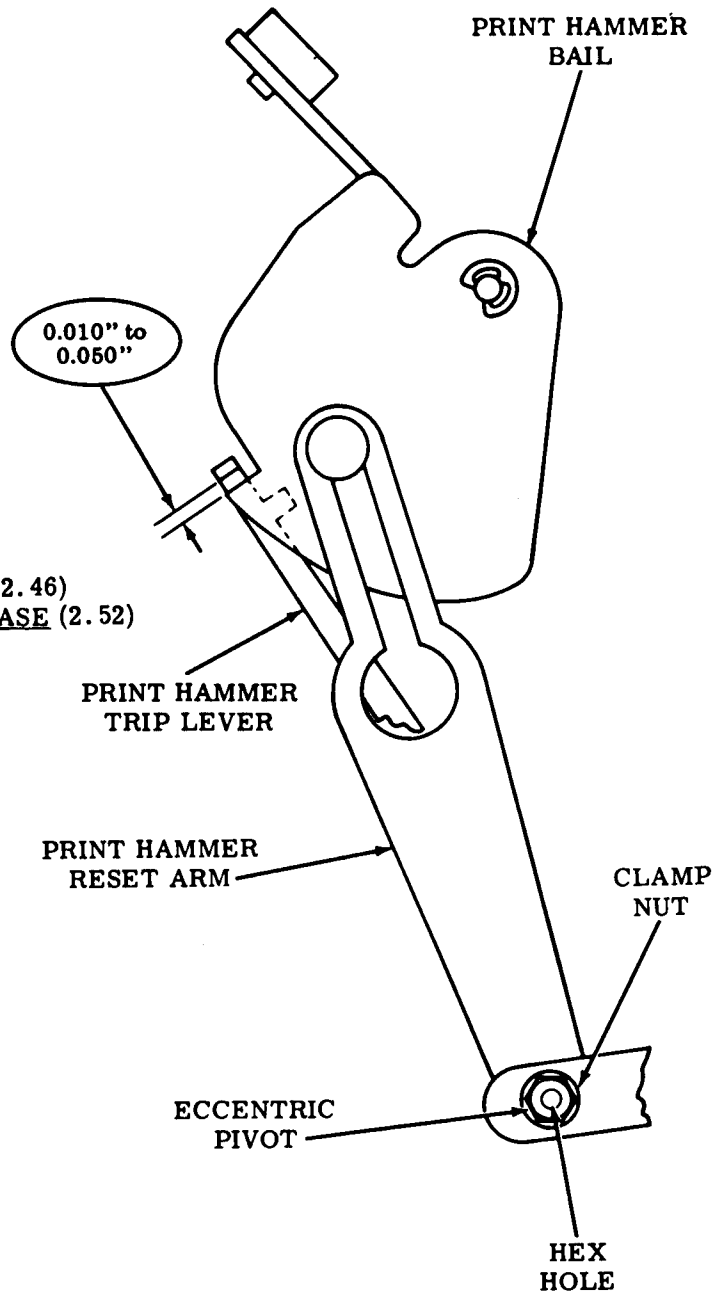

(Right Side View)

2.54 Carriage Area (continued)

Note: Do not make this adjustment on units with two-color printing. Instead, make COLOR SELECTION LATCH OVERTRAVEL (3.23) and RIBBON GUIDE POSITIONING (3.24).

RIBBON POSITIONING (CRA-14)

To Check

Trip function clutch and rotate main shaft until carriage drive bail is in its rearmost position (position no. 2). Continue rotating main shaft until the right ribbon link, during its downward travel, just contacts the top surface of the ribbon guide.

Requirement

Min some---Max 0.010 inch
between the left ribbon link and the ribbon guide as gauged by eye.

To Adjust

Loosen left reset arm clamp nut. Position eccentric stud using hex key wrench in hex hole. Tighten clamp nut.

Related Adjustments

Affected By

- LEFT SLIDE GUIDEPLATE RESET (2.51)
- PRINT DRIVE LEVER POSITIONING (2.46)
- RIGHT SLIDE GUIDEPLATE RESET (2.50)

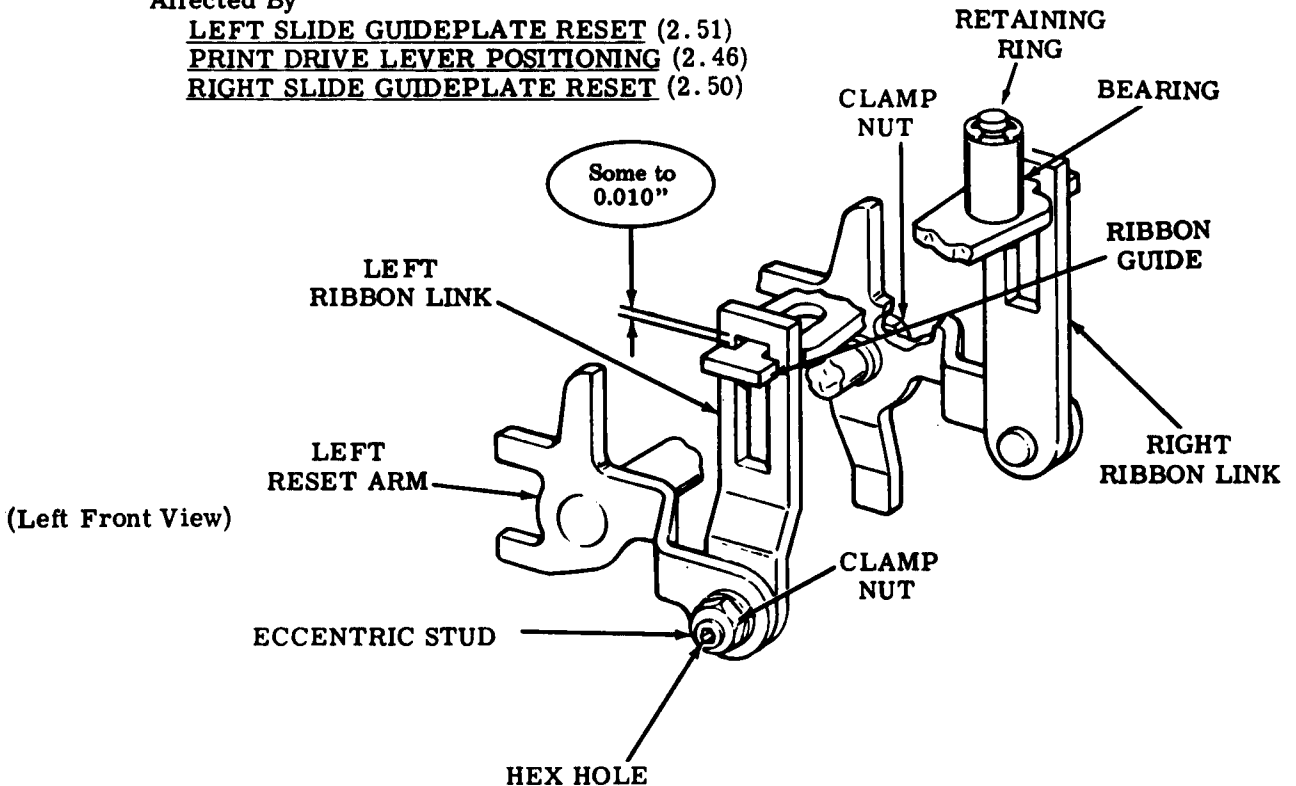

2.55 Carriage Area (continued)

PRINT SUPPRESSION LATCHLEVER RELEASE (CRA-15)**To Check**

Move carriage until its power bail roller is positioned directly over carriage drive link. Set up the "T" code (----5) combination in the selector. Rotate main shaft until the carriage drive bail reaches its rearmost position (position no. 2). The print suppression codebar must be all the way (fully) up.

Requirement

Min 0.015 inch---Max 0.055 inch
between print suppression latchlever and print hammer bail when play in print suppression latchlever is taken up and held to make gap a minimum.

To Adjust

With print suppression latchlever held against print hammer bail, bend print suppression latchlever using pry points.

Note: Use top pry point to make gap larger. Use bottom pry point to make gap smaller.

Related Adjustments**Affected By**

CODEBAR RESET LEVER POSITION (Function Area) (2.27)

FRONT ROLLERS CLEARANCE (2.41)

REAR RAIL POSITION (2.43)

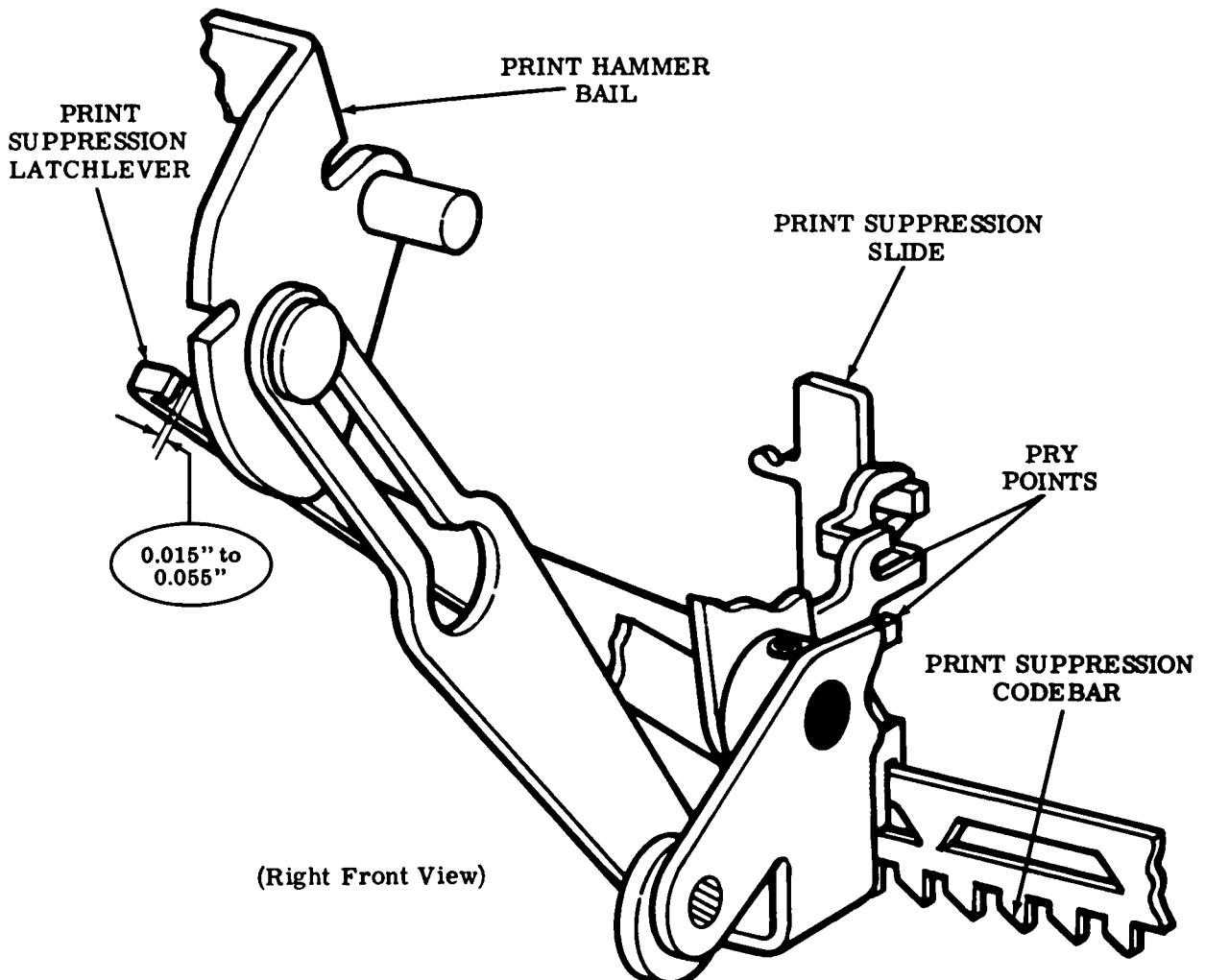

(Right Front View)

2.56 Carriage Area (continued)

TYPEWHEEL "HOME" POSITION (Preliminary) (CRA-16)

To Check

Place typing unit in the stop condition.

(1) Requirement

The typewheel home position indicator (projection or hole, depending on the style of typewheel) should be at its closest position to the platen.

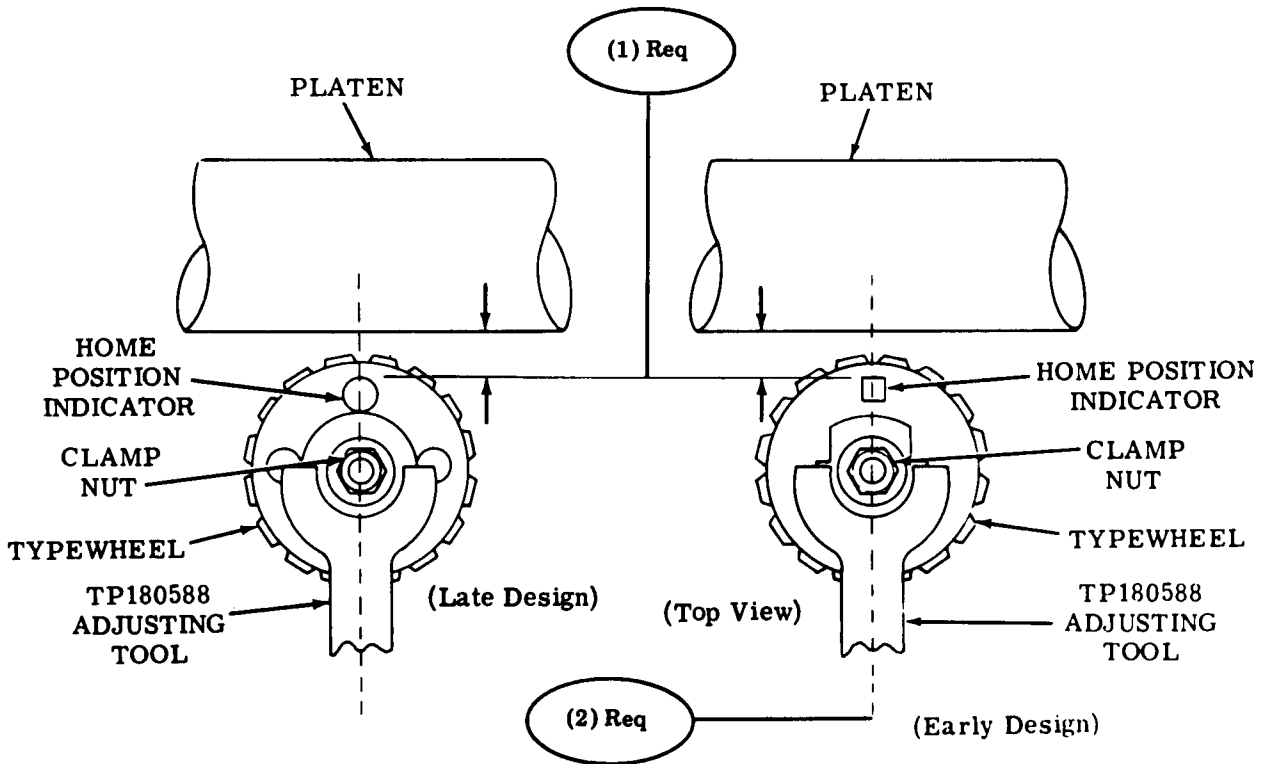

(2) Requirement

The typewheel home position indicator (projection or hole, depending on the style of typewheel) and the clamp nut should be aligned perpendicular to the platen, as gauged by eye.

To Adjust

Loosen clamp nut and position typewheel using TP180588 adjusting tool. Tighten clamp nut.

Related Adjustments

Affects

FINAL PRINTING ALIGNMENT (2.124)

2.57 Carriage Area (continued)

PRINT HAMMER BAIL SPRING

Requirement

With typing unit in stop condition
 Min 3 oz---Max 4-1/2 oz
 to start print hammer moving.

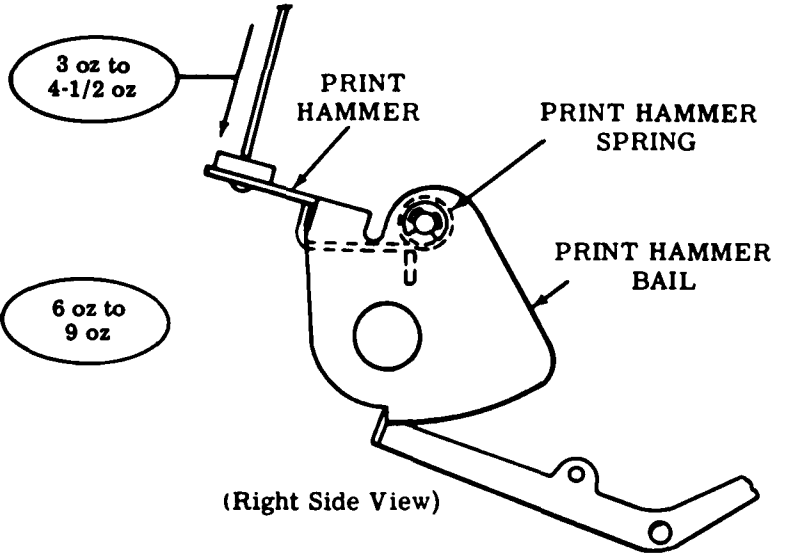
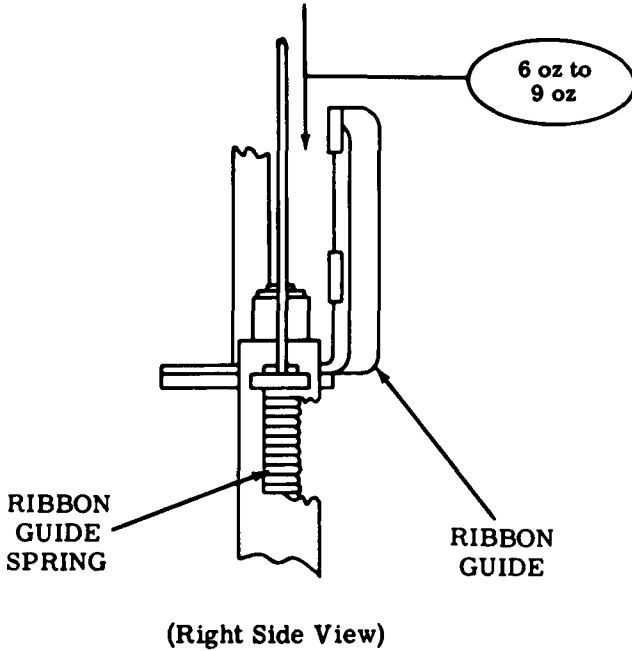

RIBBON GUIDE SPRING

To Check

Remove ribbon from ribbon guide. Trip selector clutch and rotate main shaft until carriage drive bail is in rearmost position.

Requirement

Min 6 oz---Max 9 oz
 to start ribbon guide moving.

PRINT HAMMER TRIP LEVER SPRING

Requirement

With typing unit in stop condition
 Min 1 oz---Max 2-1/2 oz
 to start print hammer trip lever moving.

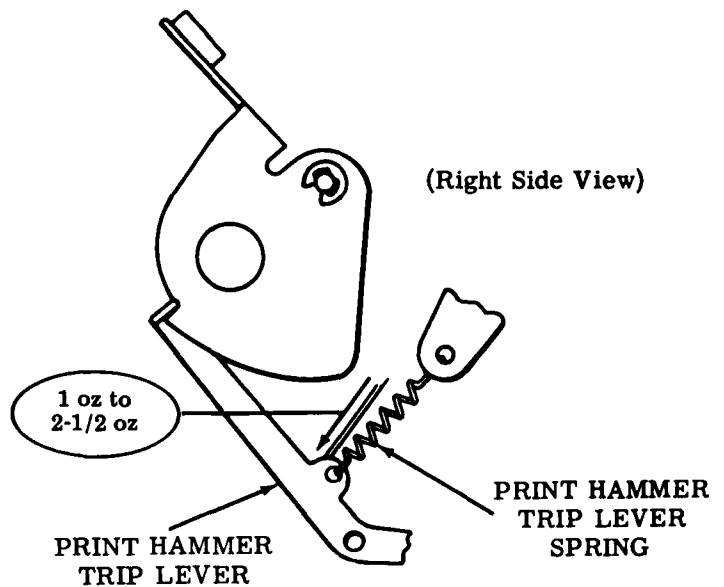

2.58 Carriage Area (continued)

ROTARY DRIVE BAIL SPRING

To Check

Set up an all marking code combination in selector and rotate main shaft until the carriage drive bail is in its rear-most position.

Requirement

Min 17 oz---Max 21-1/2 oz to start rotary drive bail moving.

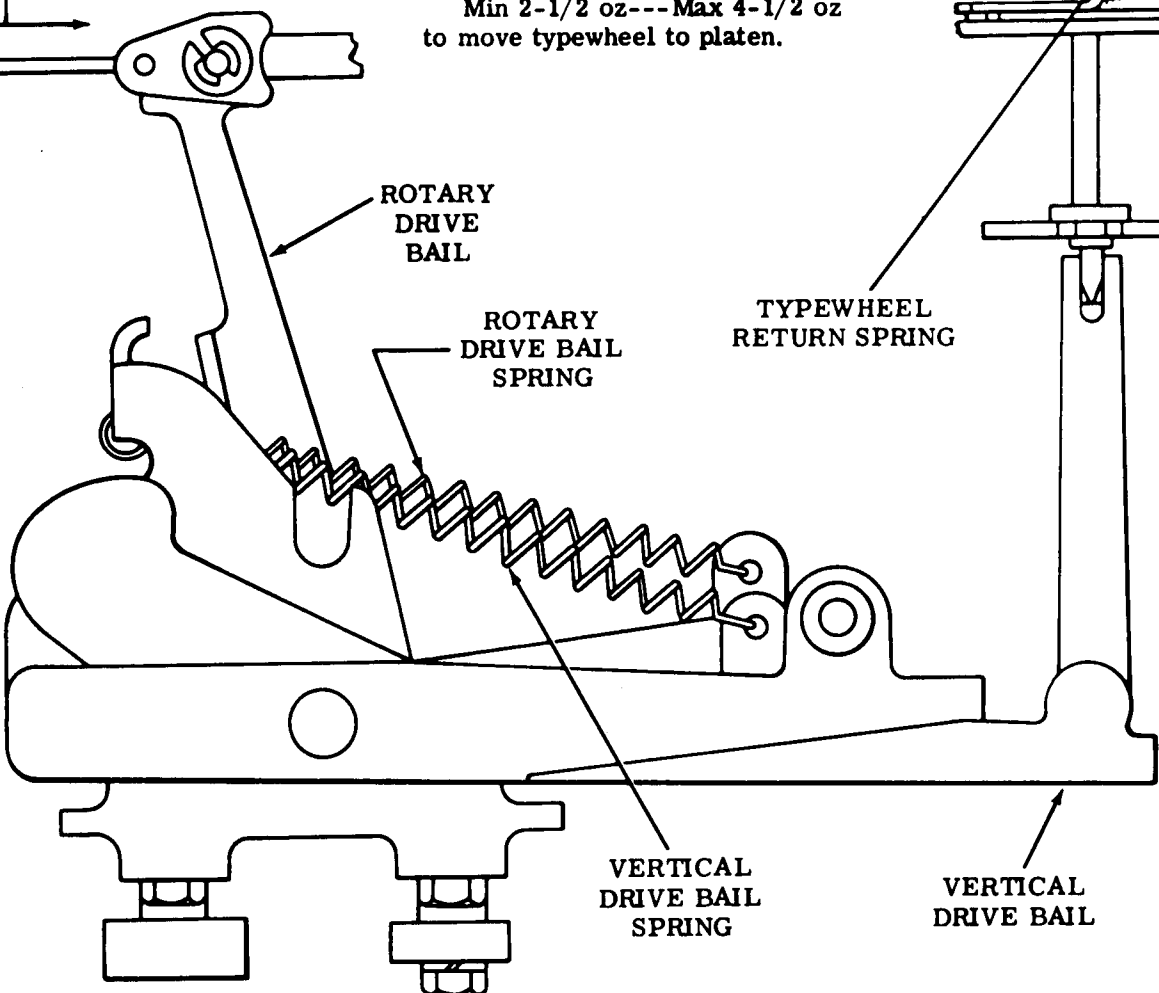
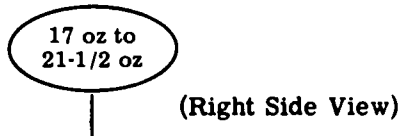

VERTICAL DRIVE BAIL SPRING

Requirement

With typing unit in stop condition
Min 13 oz---Max 18 oz to start typewheel moving.

Note: The following requirement does not apply to typing units with two-color printing. See TYPEWHEEL RETURN SPRING adjustment. (3.22)

Requirement

With typing unit in stop condition
Min 2-1/2 oz---Max 4-1/2 oz to move typewheel to platen.

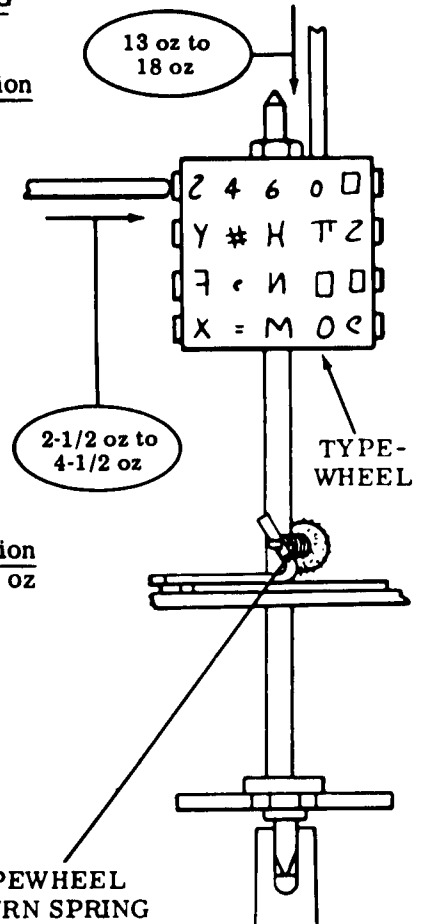

2.59 Carriage Area (continued)

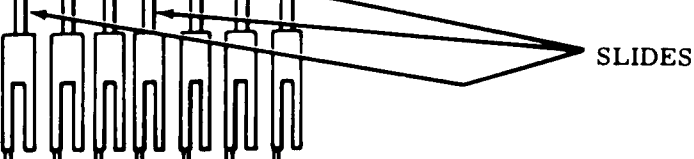
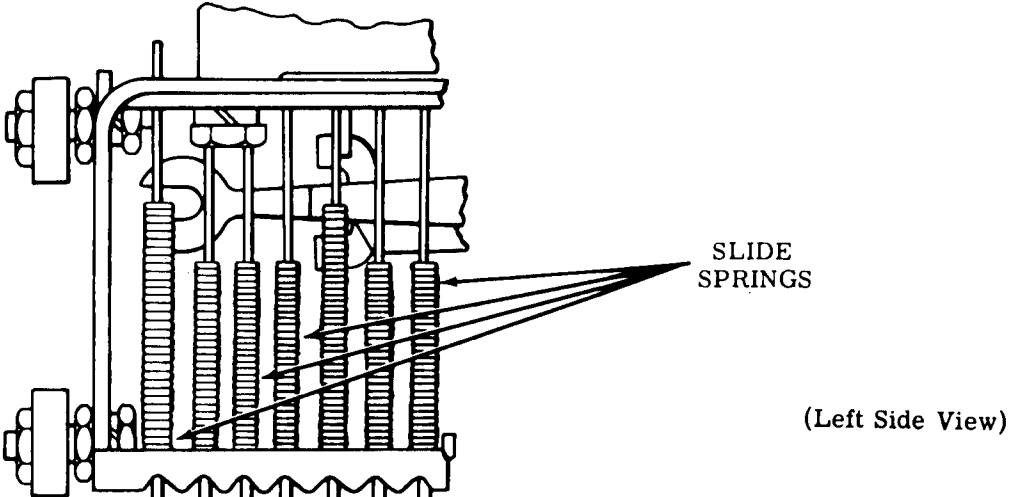

SLIDE SPRINGS

Note: To check tensions of the slide springs, it is necessary to remove the carriage mechanism from typing unit. For instructions see Section 574-172-702TC. Do not check unless there is reason to believe that the slide springs do not meet their requirements.

Requirement
 With carriage power bail in its stop position, towards the front, it should require values as shown in chart, to start slides moving.

* Print Suppression

SLIDE NO.	4 AND 5	3	1 AND 2	0	PS*
Min	1/4 oz	3-3/4 oz	2 oz	1/4 oz	3-3/4 oz
Max	1-1/4 oz	4-1/2 oz	3 oz	1 oz	4-1/2 oz

2.60 Carriage Area (continued)

RIBBON POWER LEVER DRIVE (CRA-17)

(1) To Check

Manually operate the typing unit until the carriage drive bail is in the rearmost position. Rotate left ribbon ratchet until the ribbon spool shaft and ribbon spool pin are approximately aligned with the tip of the feed pawl. Seat feed pawl against left ribbon ratchet.

Requirement

Min 0.010 inch---Max 0.045 inch
between face of left ribbon ratchet tooth and the corner tip of check pawl.

(2) To Check

Repeat (1) To Check above, except apply all instructions to right ribbon ratchet.

Requirement

Min 0.010 inch---Max 0.045 inch
between face of right ribbon ratchet tooth and corner tip of check pawl.

To Adjust

Loosen locknut and position the eccentric stud with hex key wrench in hex hole. Tighten locknut.

Note: Position eccentric stud to the bottom of its mounting slot when tightening locknut.

Related Adjustments

Affected By

- FRONT ROLLERS CLEARANCE (2.41)
- REAR RAIL POSITION (2.43)
- RESET LEVER POSITIONING (2.47)

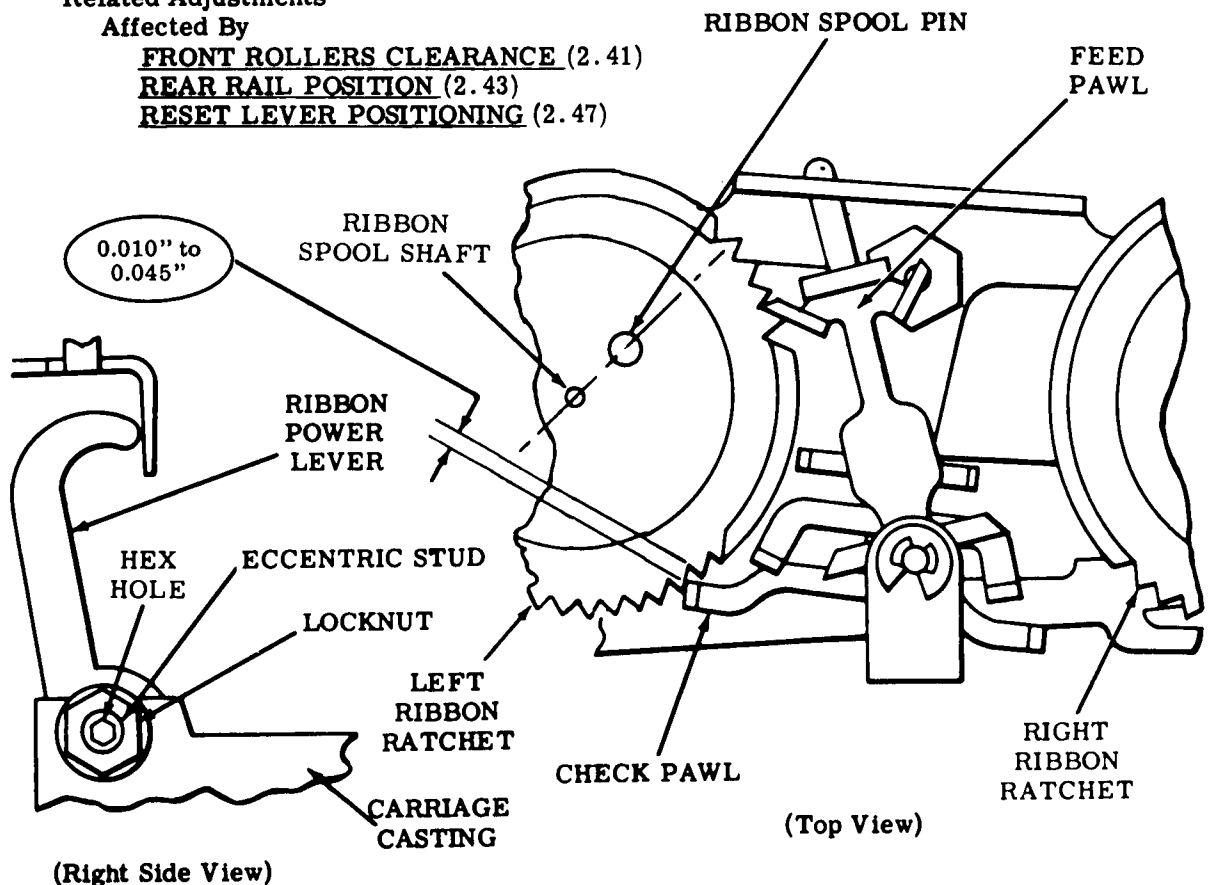

2.61 Carriage Area (continued)

RIBBON RATCHET SPRING

Requirement

With feed and check pawls disengaged from ratchet wheel.

Min 1-1/2 oz---Max 3-1/2 oz
to start ratchet wheel moving.

RIBBON REVERSE ARM SPRING

Requirement

With typing unit in stop condition and ribbon removed

Min 1-1/2 oz---Max 3 oz
to start reverse arm moving.

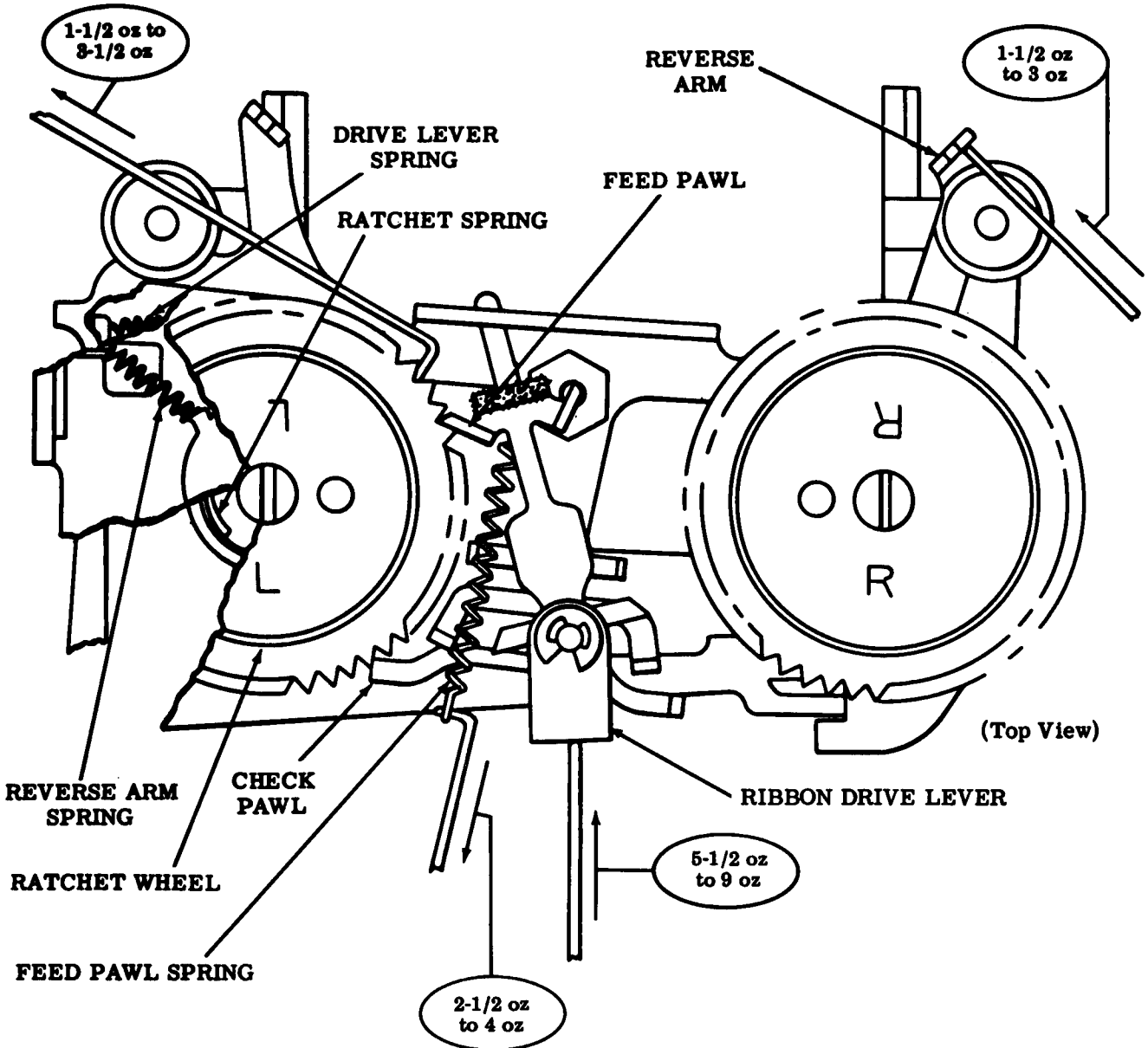

RIBBON FEED PAWL SPRING

Requirement

With typing unit in stop condition

Min 2-1/2 oz---Max 4 oz
to pull feed pawl spring to installed length.

RIBBON DRIVE LEVER SPRING

Requirement

With typing unit in stop condition

Min 5-1/2 oz---Max 9 oz
to start ribbon drive lever moving.

2.62 Spacing Area

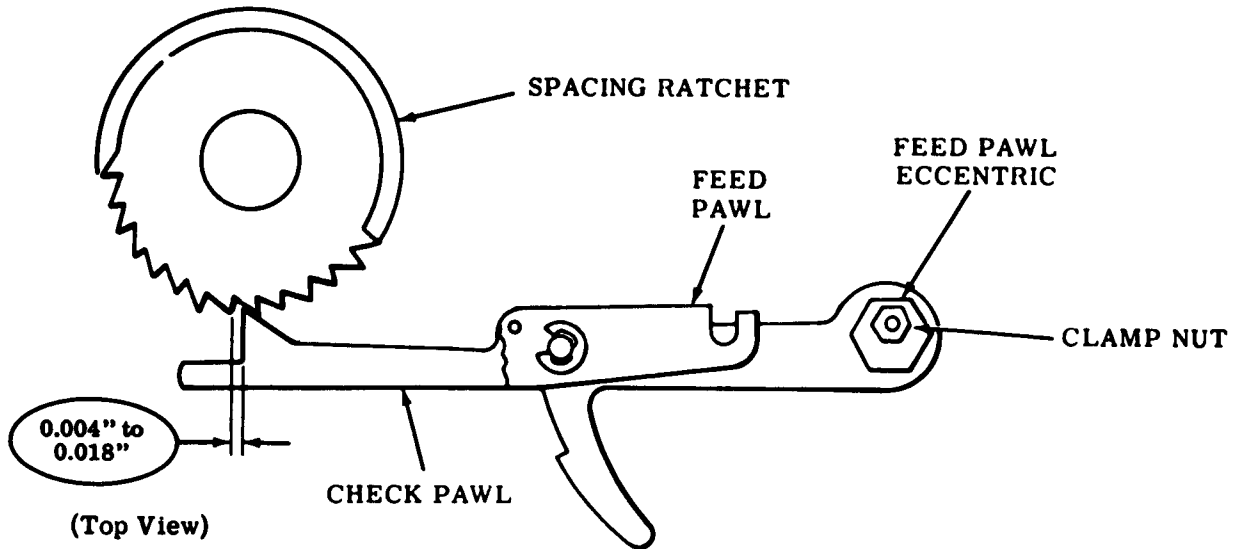

FEED PAWL STOP POSITION (SPA-1)

To Check

Place carriage at center of platen. Place typing unit in stop condition.

Requirement

With feed pawl in full engagement with spacing ratchet

Min 0.004 inch---Max 0.018 inch between check pawl and spacing ratchet tooth.

To Adjust

Loosen clamp nut. Rotate feed pawl eccentric. Keep high part of eccentric toward front. Tighten clamp nut.

Related Adjustment

Affected By

PRINT HAMMER TRIP LEVER RELEASE
(Carriage Area) (2.52)

SPACE BELLCRANK SPRING

- (1) Requirement (Units with pry point adjustment of space suppression lever)
With typing unit in stop condition
Min 3 oz---Max 5 oz
to start bellcrank moving.
- (2) Requirement (Units with eccentric adjustment of space suppression lever)
With typing unit in stop condition
Min 5 oz---Max 7 oz
to start bellcrank moving.

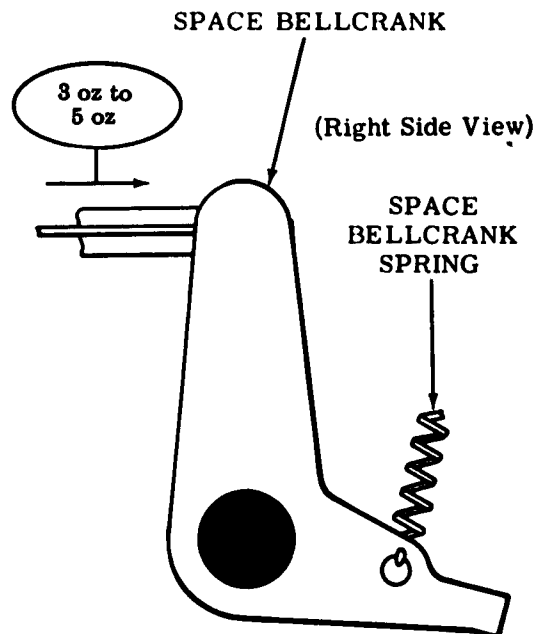

2.63 Spacing Area (continued)

SPACE SUPPRESSION LEVER CLEARANCE — PRINTING (SPA-2)**To Check**

Move carriage to the center of platen. Set up the T code combination (----5) in the selector. Rotate the main shaft until the front vertical surface of the right end of feed pawl is aligned with notch on space suppression lever.

(1) Requirement

With all play taken up to minimize gap
Min 0.005 inch---Max 0.040 inch
between right end of feed pawl and tip
of notch on the space suppression lever.

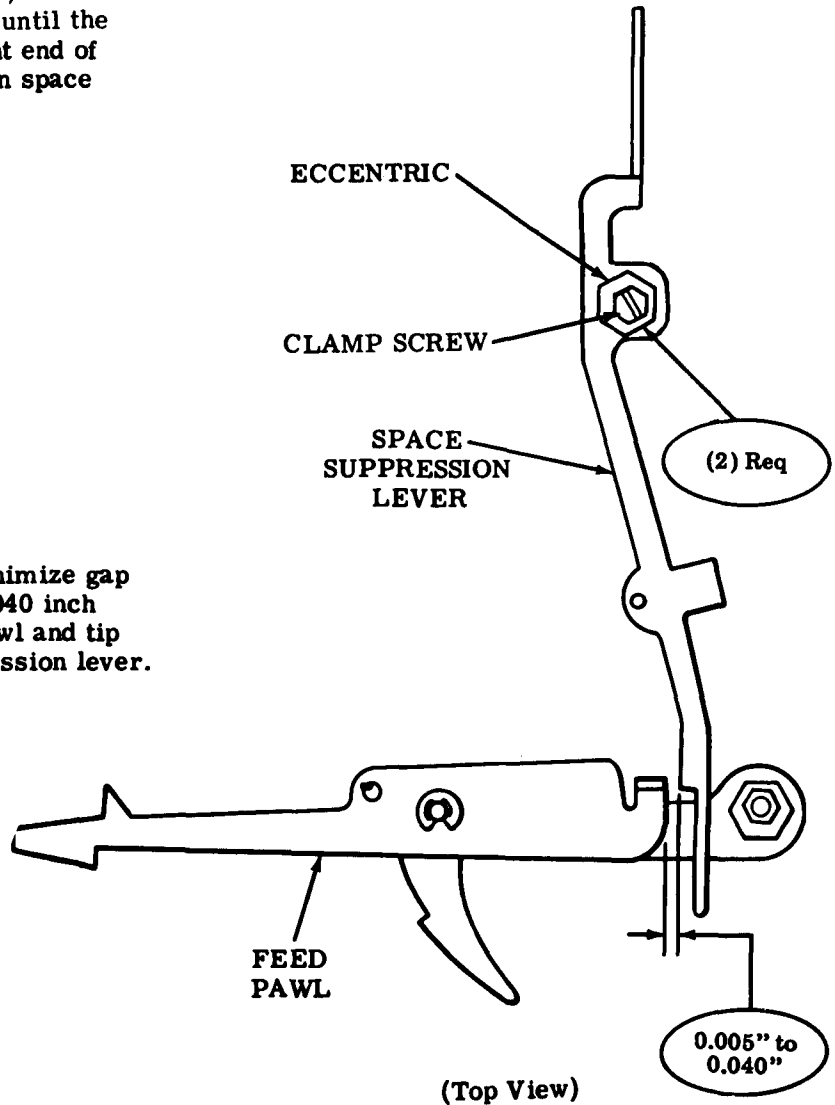

(Top View)

(2) Requirement

The position of high part of eccentric should be toward the rear of the typing unit.

To Adjust

Loosen eccentric clamp screw friction tight.
Position eccentric. Tighten eccentric
clamp screw.

Related Adjustment

Affected By

CODEBAR RESET LEVER POSITION
(Function Area) (2.27)

2.64 Spacing Area (continued)

CARRIAGE RETURN LEVER SPRING

To Check

Place typing unit in stop condition and manually return carriage. Hold feed pawl and check pawl away from carriage return lever.

Requirement

Min 1 oz---Max 3 oz
to start carriage return lever moving.

(Top View)

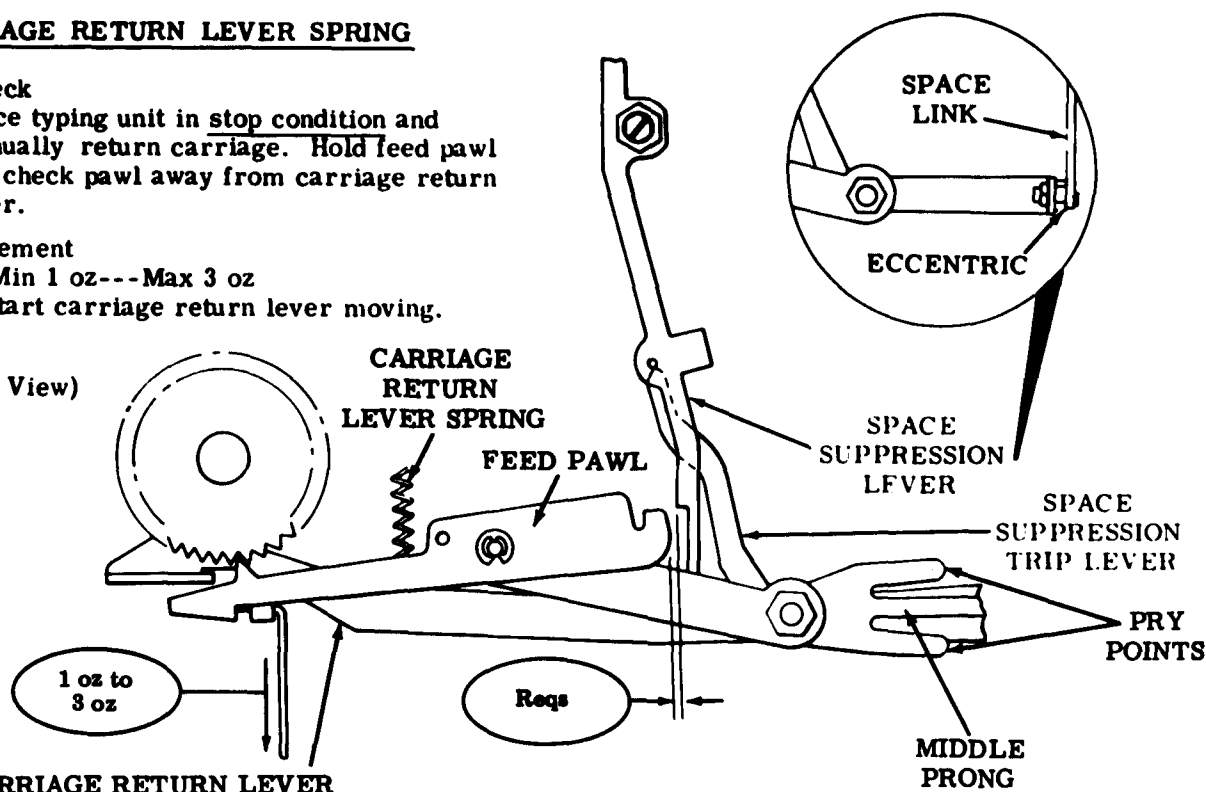

SPACE SUPPRESSION LEVER CLEARANCE — SPACING (SPA-3)

- (1) To Check (Typing units with pry points)
Move carriage to the center of platen. Set up space code combination (--3--) in the selector. Rotate main shaft until front vertical surface of right end of feed pawl is aligned with notch on space suppression lever.

Requirement

With all play taken up to minimize gap
Min some---Max 0.040 inch
between right end of feed pawl and tip of notch on space suppression lever. With an all marking code combination set up in the selector, rotate main shaft through one complete revolution and check for horizontal motion of the space suppression lever. If motion occurs, refine requirement to min side and recheck.

To Adjust

Position space suppression trip lever by bending middle prong. Use front pry point to increase clearance. Use rear pry point to decrease clearance.

- (2) To Check (Typing units with eccentric — see inset)

Move carriage to center of platen. Set up space code combination (--3--) in selector. Rotate main shaft until front vertical surface of right end of feed pawl is aligned with notch on space suppression lever.

Requirement

Min 0.005 inch---Max 0.040 inch
between right end of feed pawl and tip of notch of space suppression lever.
Take up all play to minimize clearance.

To Adjust

Loosen clamp nut and position eccentric keeping high part of eccentric toward bottom of unit. Rotate high part of eccentric to rear to increase gap and forward to decrease gap.

Related Adjustments

Affected By
LEFT ROCKER DRIVE (2.32)

2.65 Spacing Area

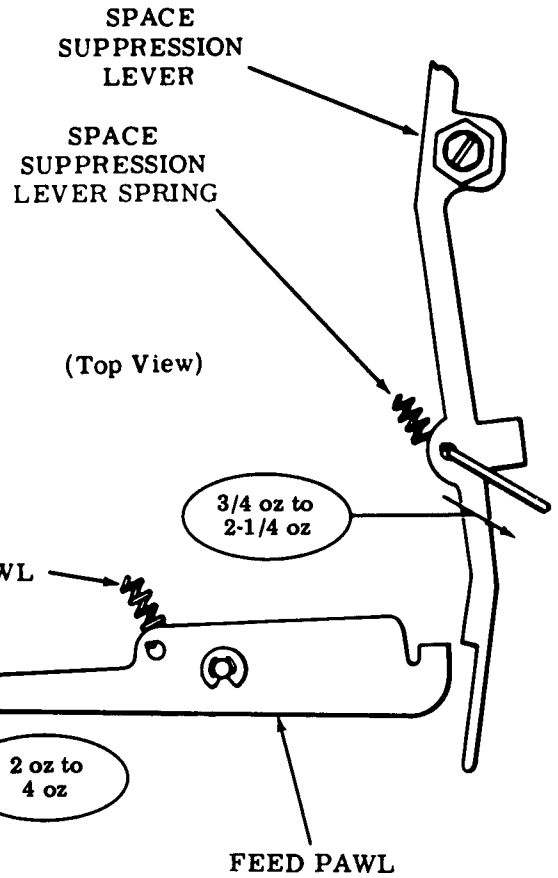

SPACE SUPPRESSION LEVER SPRING

Requirement

With typing unit in stop condition

Min 3/4 oz---Max 2-1/4 oz
to start space suppression lever moving.

FEED PAWL SPRING

Requirement

With typing unit in stop condition
and feed pawl disengaged from
spacing ratchet

Min 2 oz---Max 4 oz
to start feed pawl moving.

2.66 Spacing Area (continued)

FEED PAWL TRAVEL (SPA-4)

To Check

Place carriage to left margin and set up any printing input character code in the selector. Rotate main shaft until carriage bail reaches its rearmost position (position no. 2). Hold check pawl away from ratchet.

Requirement

Min 0.010 inch---Max 0.030 inch between the feeding surface of the feed pawl and the face of ratchet.

To Adjust

Loosen clamp nut. Position spacing drive roller. Tighten clamp nut.

Related Adjustment

Affected By

LEFT MARGIN POSITION - F (2.71)

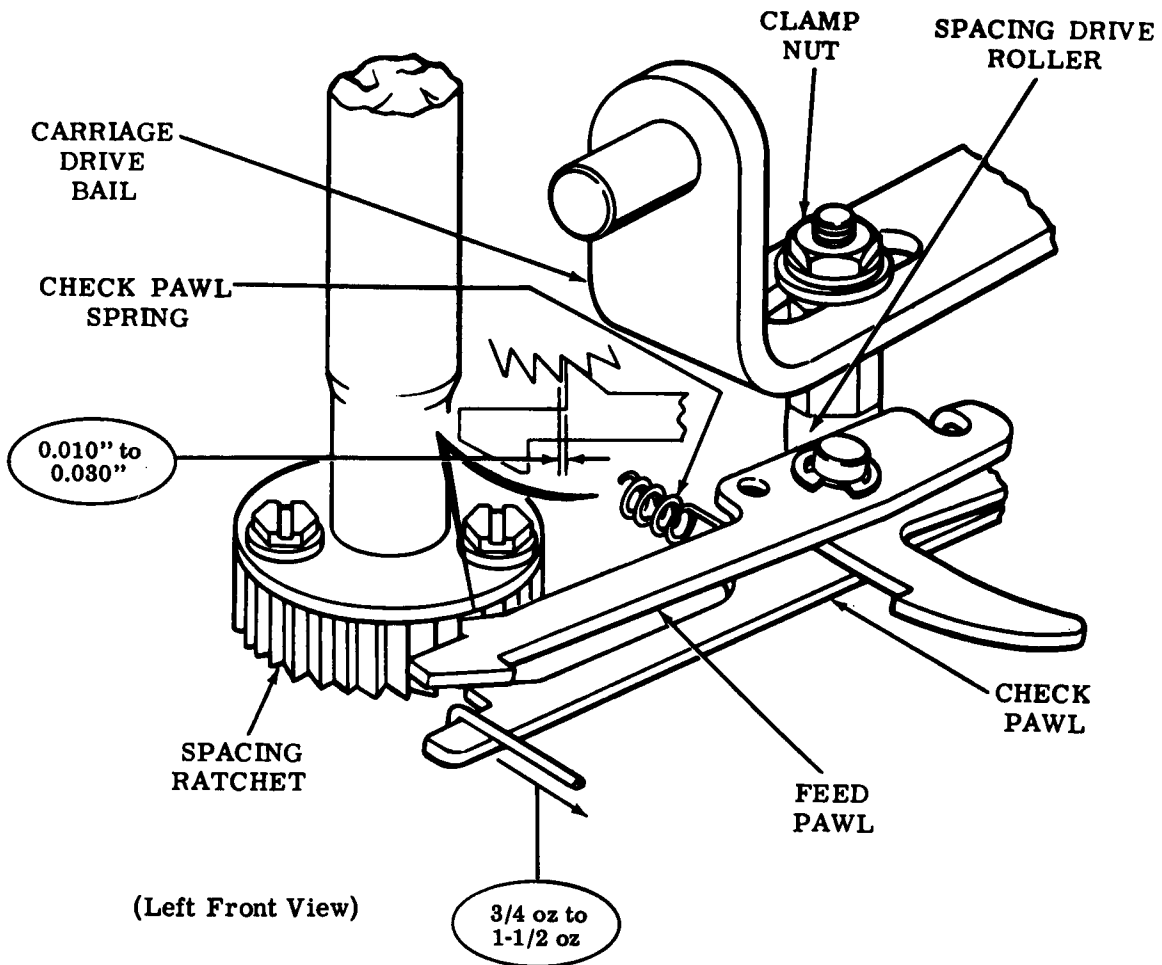

CHECK PAWL SPRING

Requirement

With typing unit in stop condition
Min 3/4 oz---Max 1-1/2 oz
to start check pawl moving.

2.67 Spacing Area (continued)

SPACING BELT TENSION (MDA-1)**Requirement**

With the carriage piston in the dashpot cylinder, and 10 ounces of pressure applied near center of belt

Min 9/16 inch---Max 11/16 inch
between outer surfaces of belt.

To Adjust

Loosen mounting screws and
position right pulley bracket.
Tighten screws.

Related Adjustment

Affects

LEFT MARGIN PRINTING (2.119)

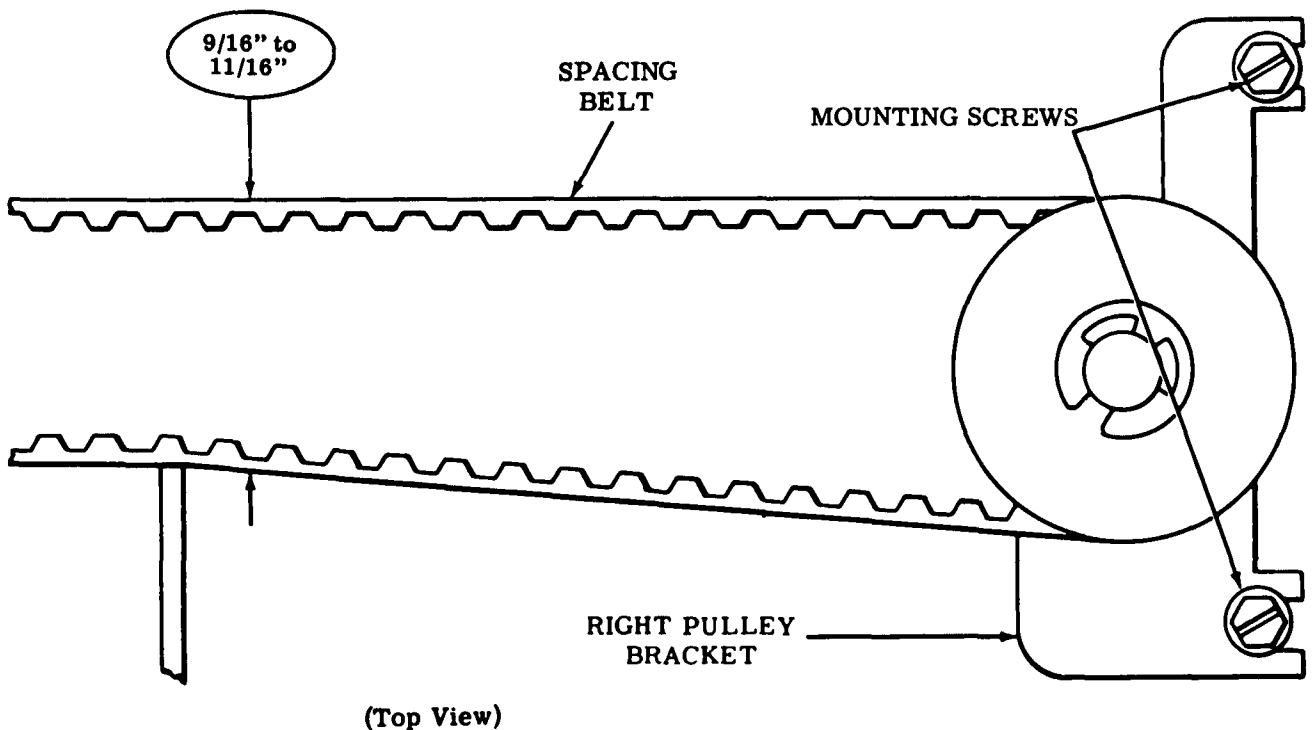

SECTION 574-172-700TC

2.68 Platen Area

Note: There are three types of line feed drive links in the platen area (shown below). The normal sequence of adjustments applies to the 'pry' and 'yield w/pry' types. The sequence of adjustment for the 'yield' only type is as follows: PLA-1, -2, -3, -5, -6, -4, -8, -9, -10, -11, and -12.

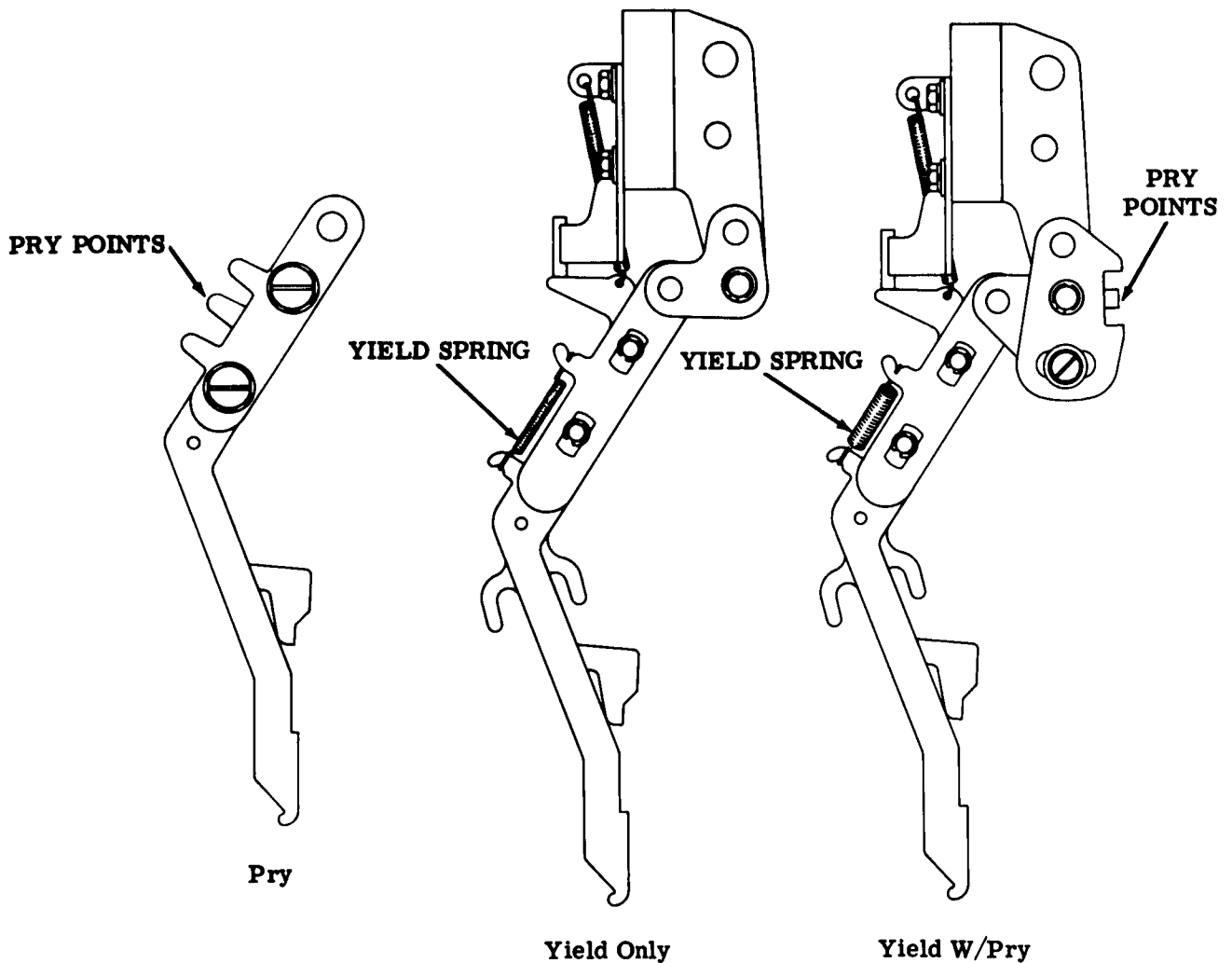

(Left Side View)

2.69 Platen Area

PLATEN — HORIZONTAL POSITION - F (PLA-1)

Note 1: This adjustment does not apply to units with two-color printing.
See PLATEN — HORIZONTAL POSITION adjustment (3.19).

(1) To Check

Place the flat surface on the left side of the platen up so that it is horizontal to the base casting. Place the carriage at the left margin and check requirement. Move the carriage to the right margin and again check requirement.

Requirement

Min 0.050 inch---Max 0.065 inch
between ribbon guide and platen at both left and right margins.

(2) To Check

Place carriage to center of platen and rotate platen until maximum clearance is obtained between platen and ribbon guide. Set up the E code combination (1---) in the selector. Rotate main shaft until carriage drive bail is in its rearmost position. Push typewheel to the rear until it just touches the platen.

Note 2: The typing unit should not have paper or ribbon installed.

Requirement

Typewheel should not touch inside of either ribbon guide.

To Adjust

Loosen four horizontal positioning screws. Position platen horizontally. Tighten positioning screws.

Related Adjustments

Affects

LINE FEED STRIPPER PLATE CLEARANCE - F (2.84)

Affected By

FRONT ROLLERS CLEARANCE (2.41)

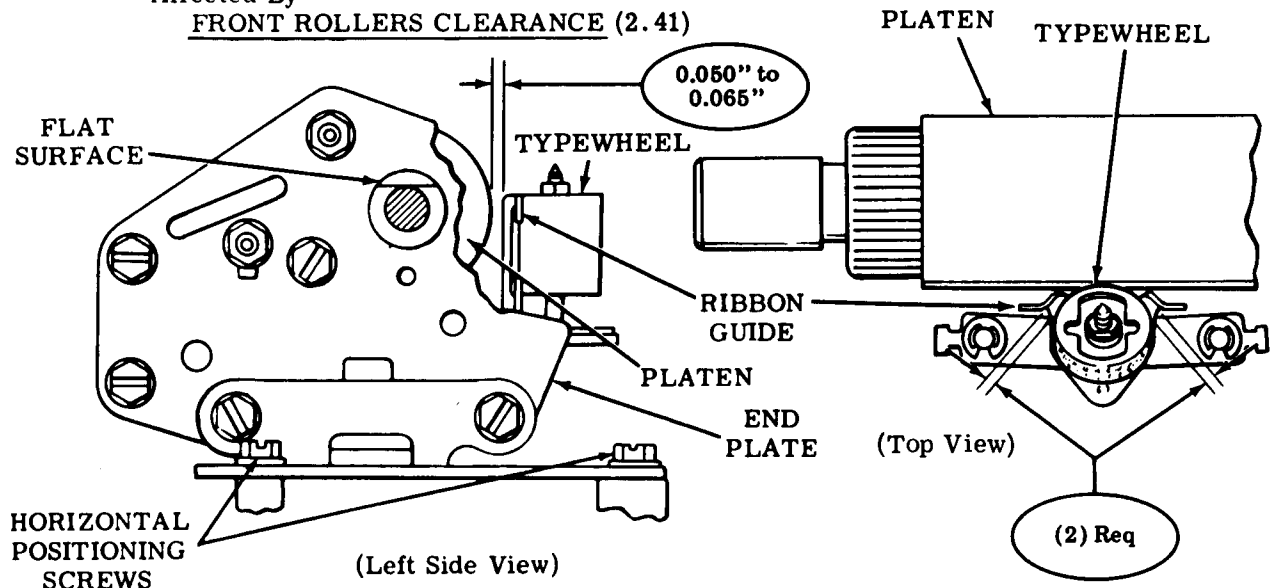

2.70 Platen Area (continued)

VERTICAL TYPE ALIGNMENT - F (PLA-2)

For typing units equipped with adjustable vertical drive bail such as TP180606:

(1) To Check

Place paper and ribbon in unit. Place carriage to left margin. Set up the E code combination (1----) in the selector and rotate the main shaft until the character is printed.

Requirement

When the printed character is examined by eye from top to bottom, the shading should be approximately the same with no overscoring or underscoring.

To Adjust

Loosen adjusting screw on vertical drive bail and position the typewheel using pry point. Tighten adjusting screw.

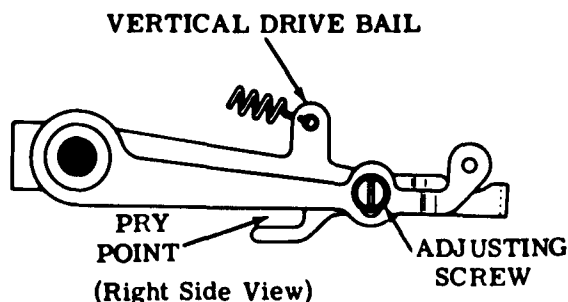

(2) To Check

Place carriage to right margin. Set up the E code combination (1----) in the selector and rotate main shaft until the character is printed.

Requirement

When the printed character is examined by eye from top to bottom, the shading should be approximately the same with no overscoring or underscoring.

To Adjust

Loosen vertical positioning screws on right side. Position the right end of the platen using pry point. Do not twist the platen. Tighten positioning screws.

For typing units equipped with nonadjustable vertical drive bail such as TP180526:

To Check

Place paper in typing unit. Set up the E code combination (1----) in the selector and rotate the main shaft until the character is printed. Repeat several times along the length of the platen.

Requirement

When each printed character is examined by eye from top to bottom, the shading should be approximately the same with no overscoring or underscoring.

To Adjust

Loosen four vertical positioning screws. Position the platen using pry points. Do not twist the platen. Tighten positioning screws.

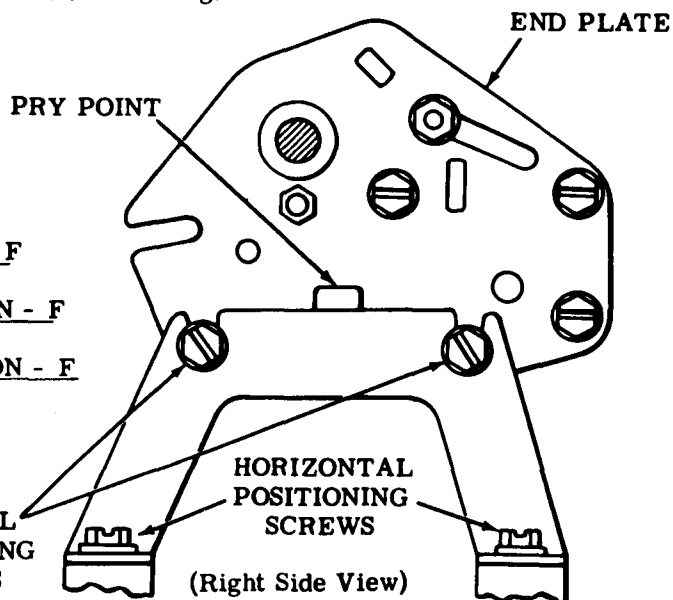

Related Adjustments

Affects

- LINE FEED DRIVE ARM CLEARANCE - F (2.79)
- LINE FEED PAWL DOWNSTOP POSITION - F (2.82)
- LINE FEED UPSTOP BRACKET POSITION - F (2.80)
- PRESSURE ROLLER CLEARANCE (2.83)
- LINE FEED DRIVE LINK POSITION - F (2.81)

Affected By

- REAR RAIL POSITION (2.43)
- PRINT DRIVE LEVER POSITIONING (2.46)

2.71 Platen Area (continued)

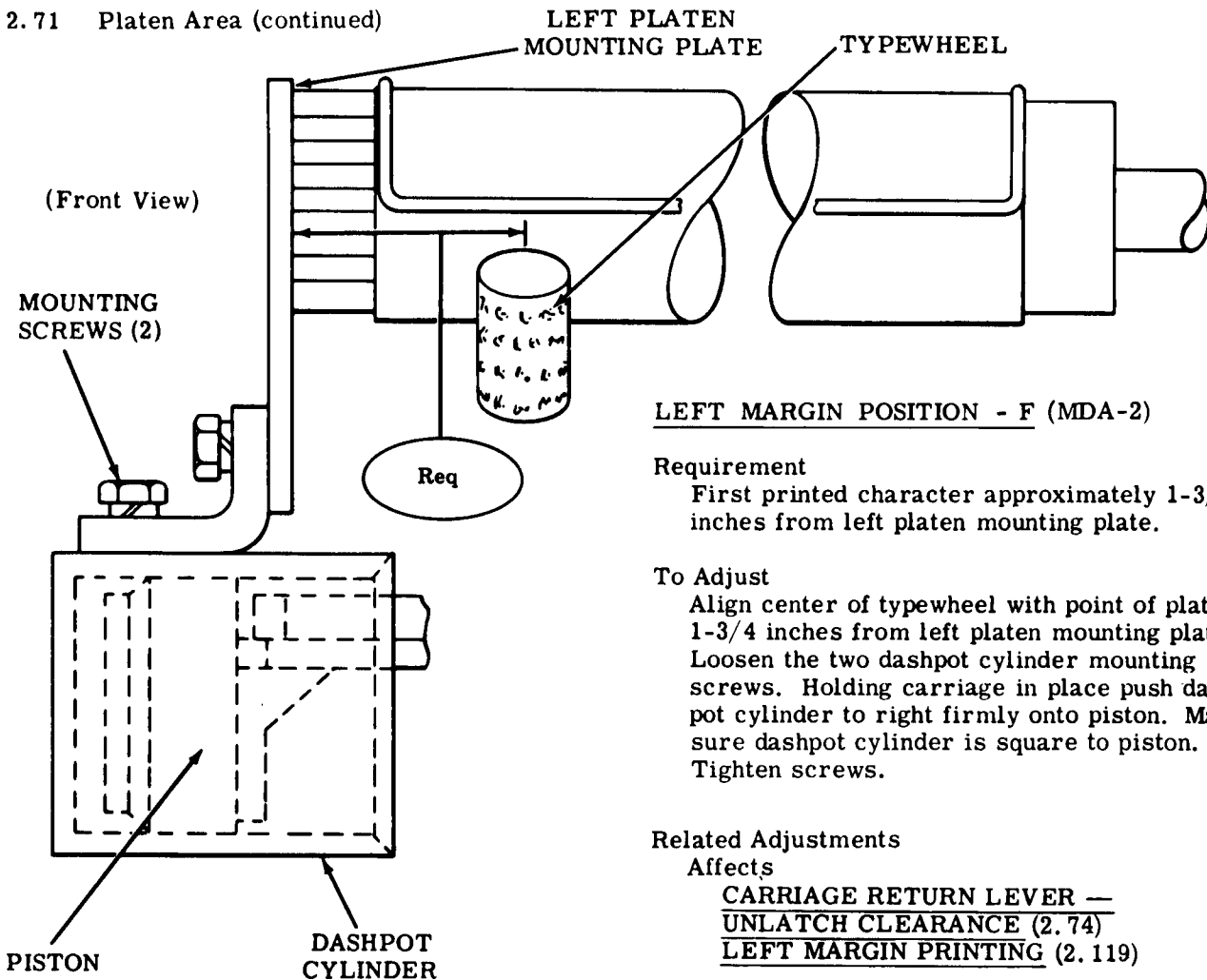

2.72 Function Area (continued)

END-OF-LINE LATCH SPRING

Requirement
With typing unit in stop condition, carriage return lever unlatched
Min 1-1/2 oz---Max 3 oz
to start end-of-line latch moving.

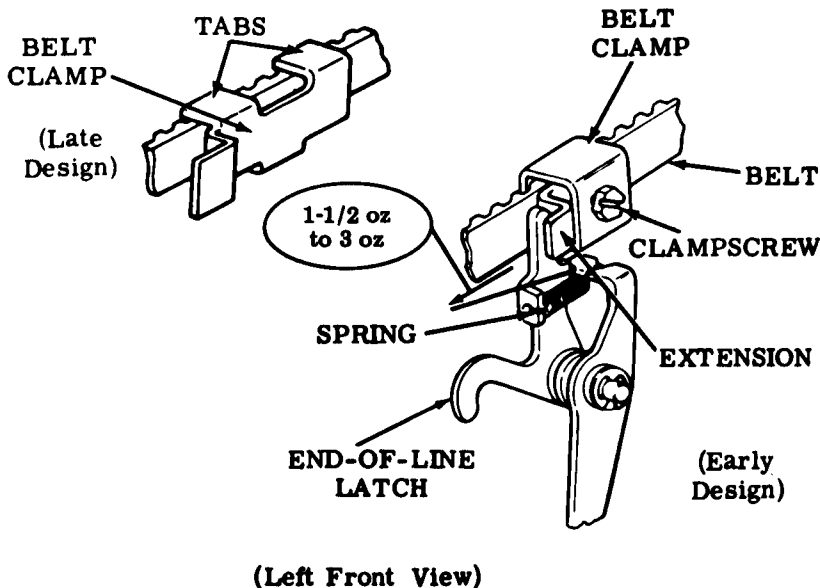

2.73 Platen Area (continued)

PAPER GUIDE SPRINGS - F

Requirement

With scale at either the left or right end of paper guide

Min 1-1/2 oz---Max 3-1/2 oz to start paper guide moving.

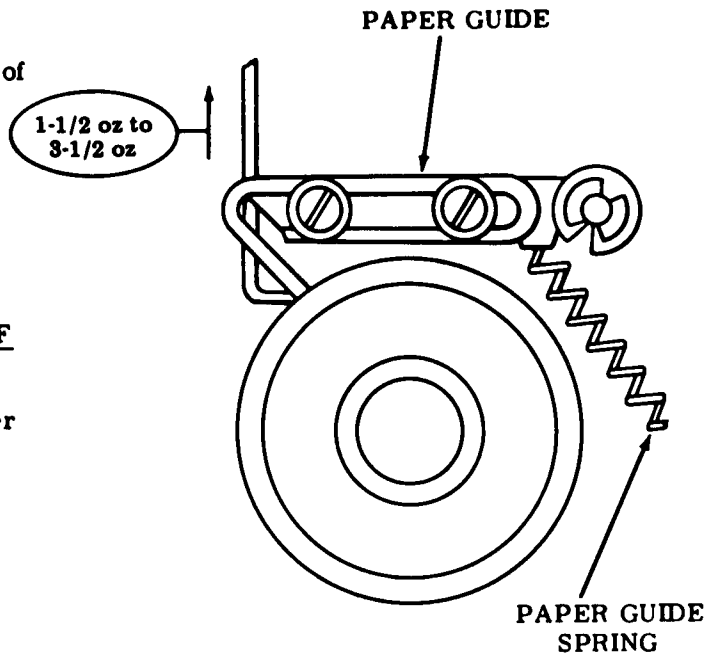

(Right Side View)

PAPER STRAIGHTENER BAIL SPRING - F

Requirement

With scale at center of paper straightener bail

Min 1 oz---Max 3 oz to start paper straightener bail moving.

PAPER GUIDEPLATE SPRINGS - F

Requirement

With pressure lever released

Min 3/4 oz---Max 1-3/4 oz to start paper guideplate moving.

Note: Check each of two springs.

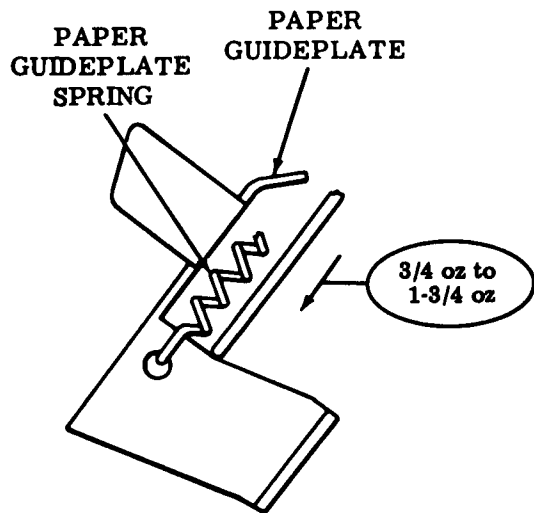

(Right Side View)

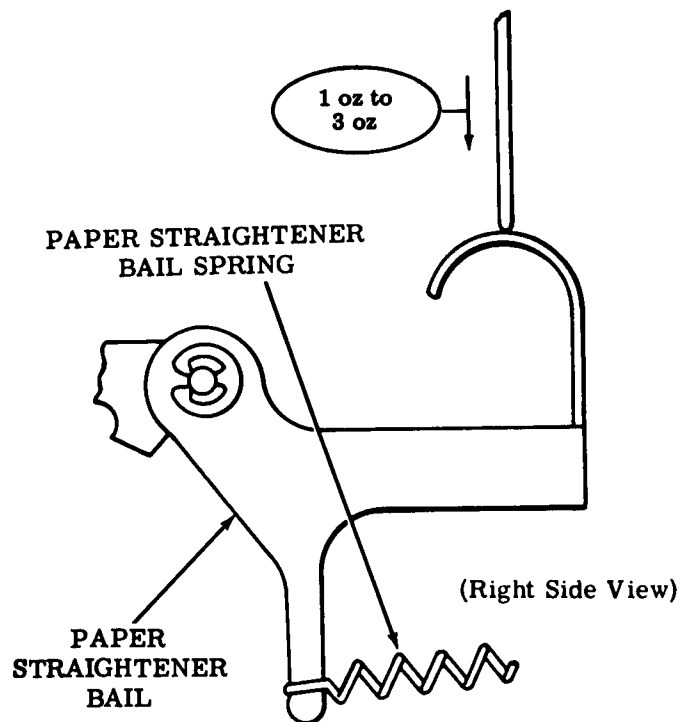

(Right Side View)

2.74 Spacing Area (continued)

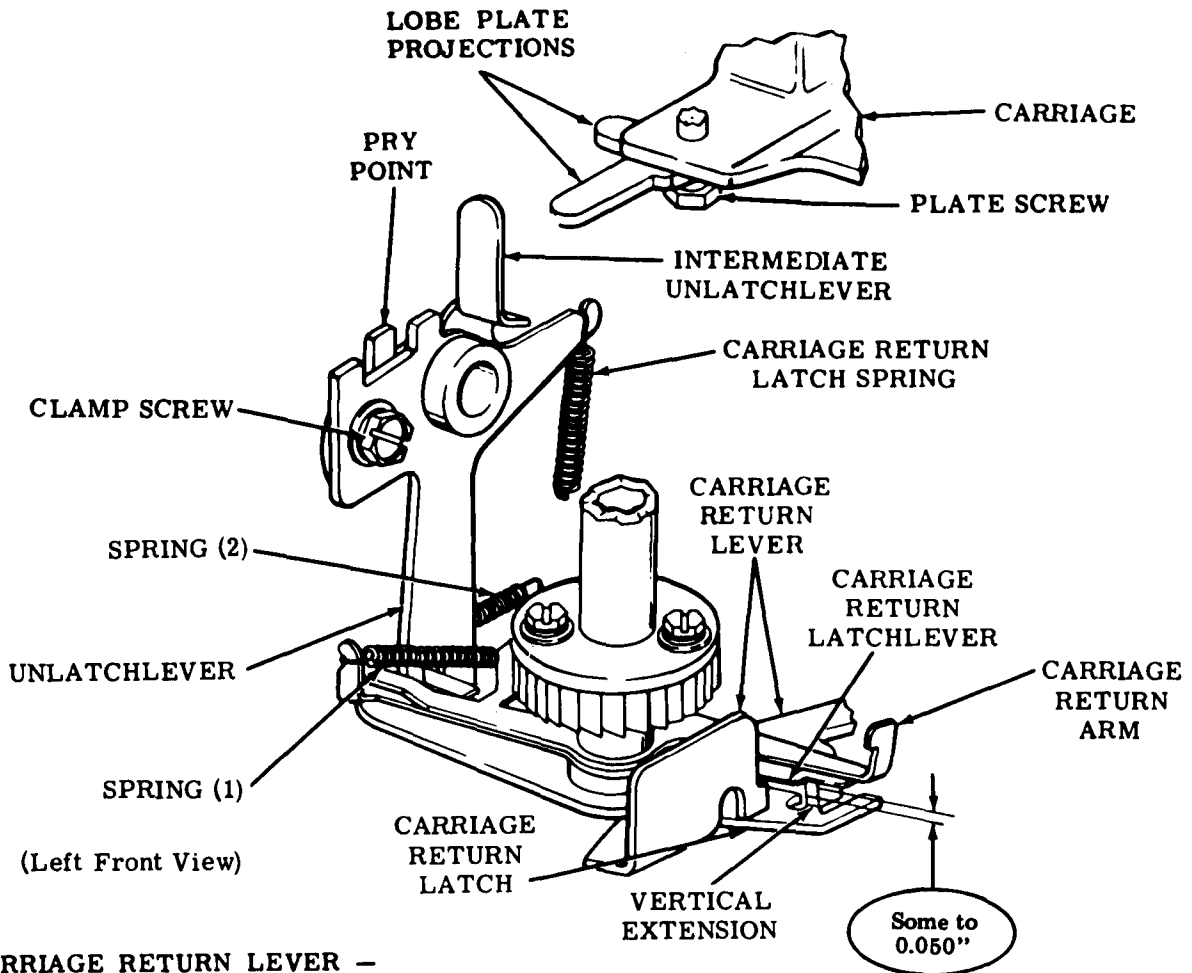

CARRIAGE RETURN LEVER - UNLATCH CLEARANCE (MDA-5)

(1) To Check

Move carriage to left margin by placing carriage return lever in its forward latched position. Take up all play to minimize the required clearances.

Requirement

Min some---Max 0.050 inch between the carriage return latch and the vertical extension of the carriage return lever.

To Adjust

Loosen clamp screw. Use pry points to position carriage return latch. Tighten clamp screw.

Note: Perform the following check only if the typing unit is being completely readjusted.

(2) To Check

Repeat To Check (1) above.

Requirement

The intermediate unlatch lever should be aligned with the lobe plate projection which most nearly touches it.

To Adjust

Loosen plate screw. Position lobe projection plate. Tighten plate screw. Check FRONT ROLLERS CLEARANCE (2.41).

Related Adjustments

Affected By

LEFT MARGIN POSITION - S (2.117)
LEFT MARGIN POSITION - F (2.71)

2.75 Spacing Area (continued)

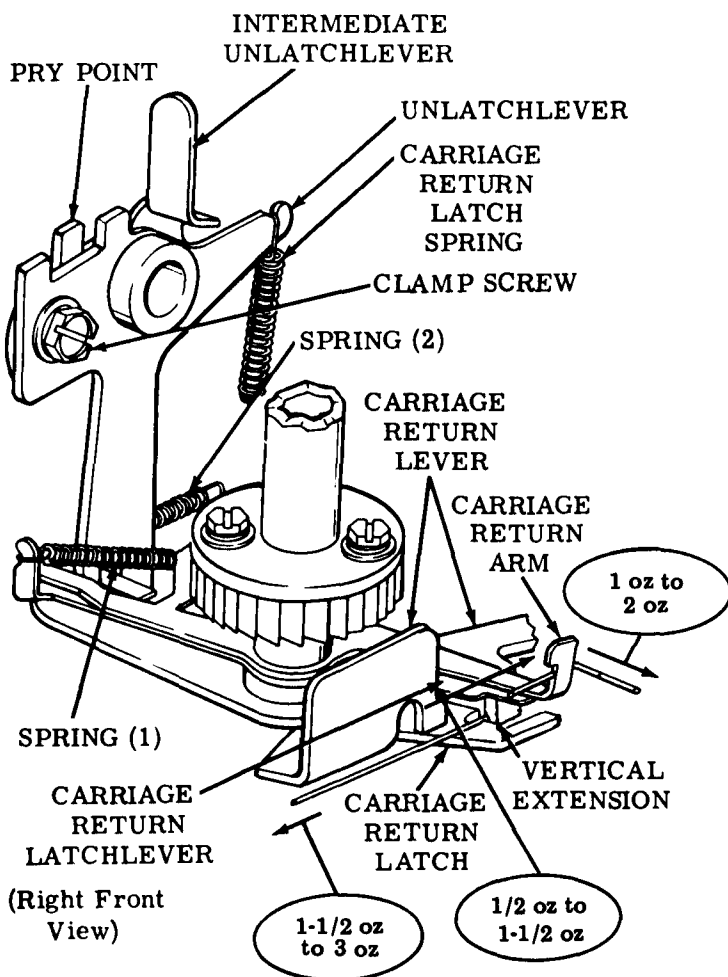

CARRIAGE BOUNCE (MDA-4)

To Check

Place carriage at right margin, manually disengage the check pawl and feed pawl of the spacing mechanism.

Requirement

No pneumatic or mechanical bounce of carriage upon its return.

To Adjust

Loosen orifice adjusting plate clamp screw and close the orifice completely. Then gradually open until pneumatic bounce is eliminated while operating unit. Tighten clamp screw.

Note: The orifice should never become fully uncovered. If it does become fully uncovered, it is possible that the lobe plate projection may be broken.

CARRIAGE RETURN ARM SPRINGS

To Check

Place typing unit in stop condition and engage feed pawl and check pawl with spacing ratchet.

(1) Requirement

Min 1 oz---Max 2 oz to start arm moving.

(2) Requirement

Min 1/2 oz---Max 1-1/2 oz to start arm moving.

CARRIAGE RETURN LATCH SPRING

To Check

With typing unit in stop condition and carriage return lever unlatched, place carriage away from left margin.

Requirement

Min 1-1/2 oz---Max 3 oz to start carriage return latch moving.

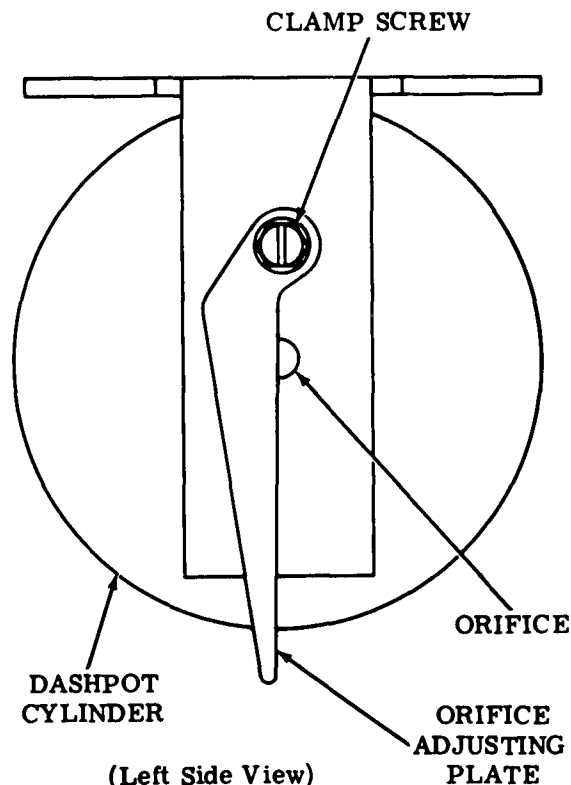

2.76 Platen Area (continued)

LINE FEED SELECTION - F (PLA-3)

Requirement

Upstop stud should be at bottom of slot for single line feed or at top for double line feed.

To Adjust

Loosen clamp nut. Position upstop stud. Tighten clamp nut.

Related Adjustments

Affects

DETENT POSITION - F (2.77)

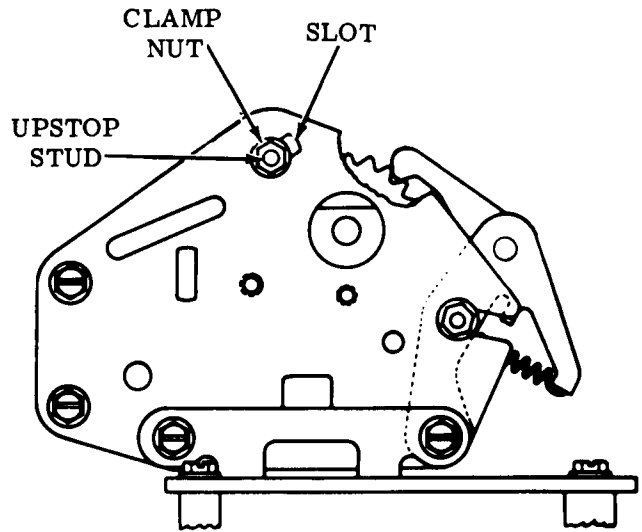

(Left Side View)

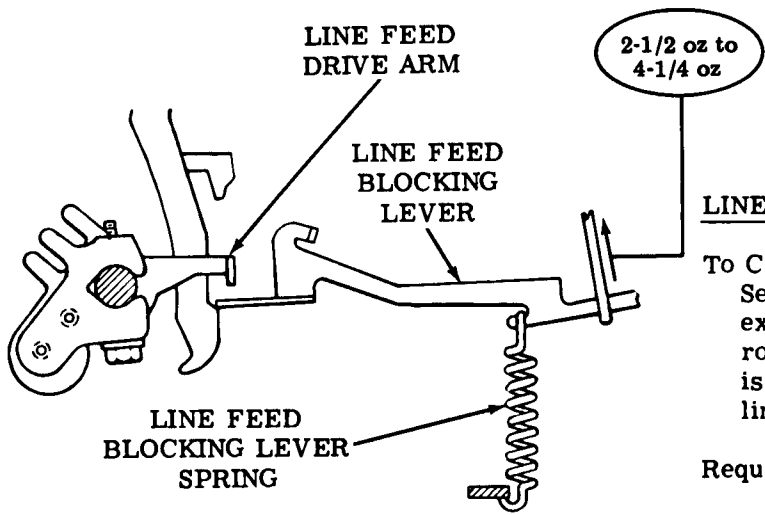

(Left Side View)

LINE FEED BLOCKING LEVER SPRING - F

To Check

Set up any code combination in the selector except the line feed code combination and rotate the main shaft until the function bail is at highest point. Hold line feed drive link away from line feed blocking lever.

Requirement

Min 2-1/2 oz --- Max 4-1/4 oz to start line feed blocking lever moving.

SECTION 574-172-700TC

2.77 Platen Area (continued)

DETENT POSITION - F (PLA-4)

For units with "pry" and "yield w/pry".

(1) To Check

Place typing unit in single line feed condition.

Requirement

When operated by finger pressure, line feed pawl should fully seat in platen ratchet without interference from teeth.

For units with "yield" only.

(2) To Check

Place typing unit in double line feed condition.

Requirement

When operated by finger pressure, line feed pawl should enter into highest tooth possible on platen ratchet.

To Adjust (All units)

Loosen clamp nut(s)* and position detent at top end of adjusting slot. With detent fully seated in ratchet, rotate platen by backing off detent until pawl just enters ratchet along its path of travel. Tighten nut(s).

***Note 1:** Units with TP181030 bracket have one clamp nut and those with the TP185796 bracket have two clamp nuts.

Related Adjustments

Affects

LINE FEED DRIVE LINK POSITION - F (2.81)

Affected By

VERTICAL TYPE ALIGNMENT - F (2.70)

LINE FEED SELECTION - F (2.76)

Note 2: This adjustment is affected by VERTICAL TYPE ALIGNMENT - F (2.70) only when equipped with TP180526 nonadjustable vertical drive bail.

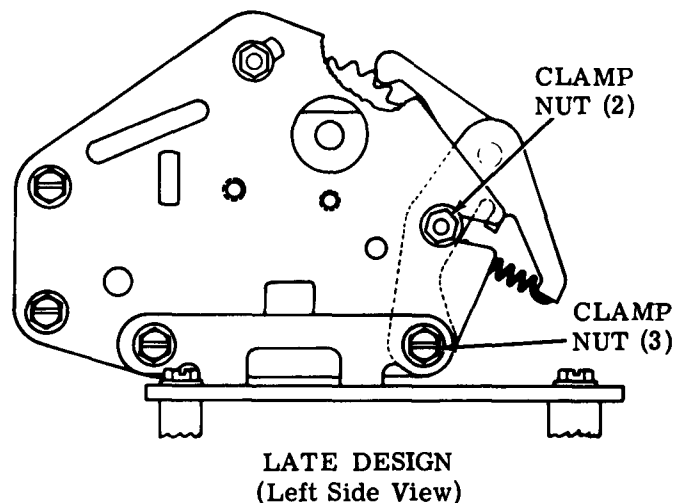
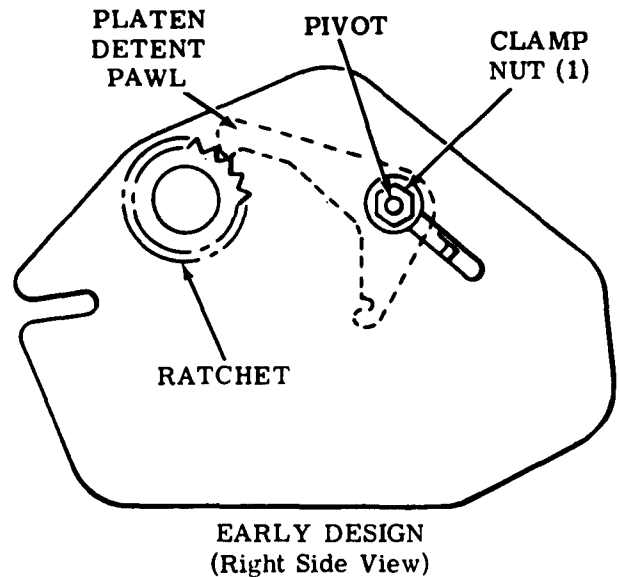

2.78 Platen Area (continued)

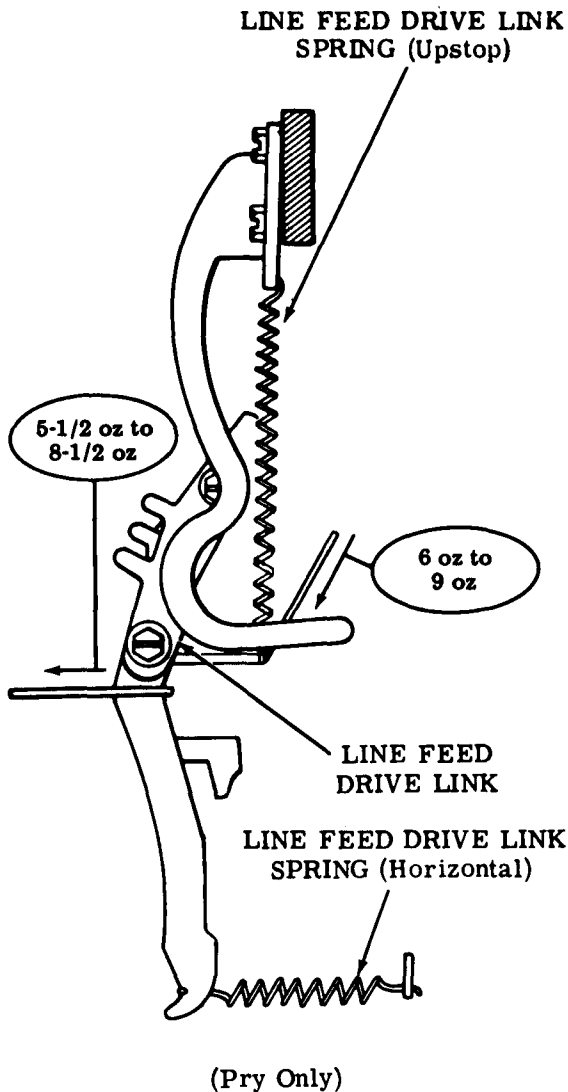

(Left Side View)

LINE FEED DRIVE LINK SPRING — HORIZONTAL - F

Requirement

With typing unit in stop condition
 Min 5-1/2 oz---Max 8-1/2 oz
 to start line feed drive link moving.

LINE FEED DRIVE LINK SPRING — UPSTOP - F

Requirement

Early Design: With typing unit in stop condition
 Min 6 oz---Max 9 oz
 to start line feed drive link moving.

Late Design: With typing unit in stop condition
 Min 4 oz---Max 7 oz
 to start line feed drive link moving.

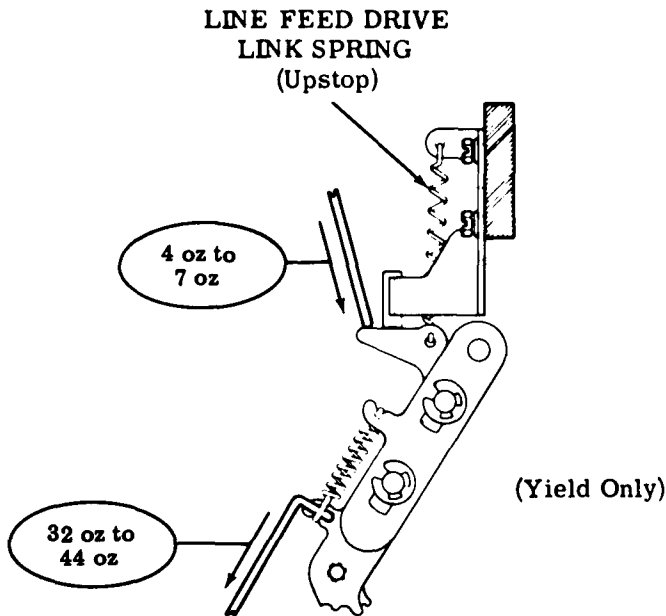

(Left Side View)

LINE FEED LINK YIELD SPRING - F
 ("Yield" Only Shown)

(1) Requirement

Min 32 oz---Max 44 oz
 to pull yield spring to installed length
 on units with "yield" only line feed link.

(2) Requirement

Min 6 lb---Max 7 lb
 to pull yield spring to installed length
 on units with "yield w/pry" line feed link.

2.79 Platen Area (continued)

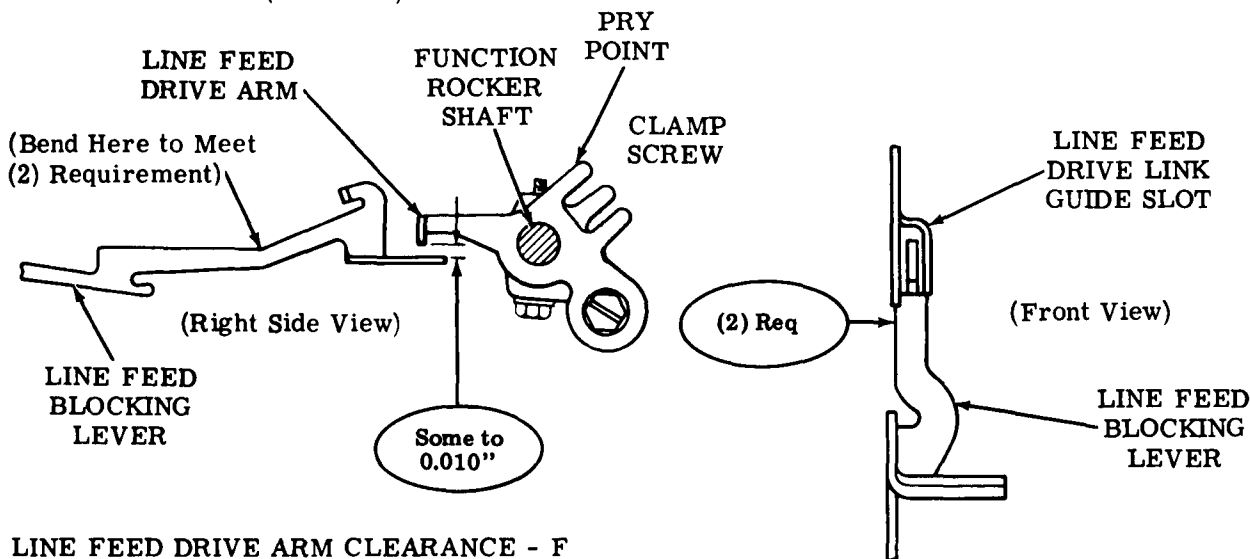

LINE FEED DRIVE ARM CLEARANCE - F (PLA-5)

To Check

Place carriage to center of platen. Manually operate typing unit and set up line feed code combination (-2---) in selector. Rotate main shaft until function bail is at highest point (position no. 1). Hold print suppression codebar to right, and take up upward play of line feed function lever. Release print suppression codebar and take up downward play of blocking lever. Release all levers.

(2) Requirement

The line feed blocking lever centrally located with the line feed drive link guide slot opening.

To Adjust

Bend the line feed blocking lever between its rear guide and formed tab where shown.

(1) Requirement

Min some---Max 0.010 inch between line feed drive arm and line feed blocking lever.

Note: The minimum requirement (some) will be considered met if there is no clearance between the line feed function lever and the function drive bail.

To Adjust

Loosen clamp screw. Position line feed drive arm using pry point. Tighten clamp screw.

Related Adjustments

Affects

- LINE FEED UPSTOP BRACKET POSITION - F (2.80)
- LINE FEED PAWL DOWNSTOP POSITION - F (2.82)

Affected By

- LEFT ROCKER DRIVE (Function Area) (2.32)

2.80 Platen Area (continued)

LINE FEED UPSTOP BRACKET POSITION - F (PLA-6)

Units with "pry" and "yield w/pry."

To Check

Place typing unit in stop condition. Trip function clutch by lifting its trip lever. Rotate main shaft until function bail is at highest point (position no. 1). Push down on line feed drive link to engage and latch line feed blocking lever.

Requirement

Min 0.020 inch---Max 0.040 inch between line feed drive arm and line feed blocking lever.

To Adjust

Loosen mounting screws and position line feed upstop bracket. If downstop (PLA-8) interferes with feed pawl spring bracket, loosen downstop clamp nut and move downstop for clearance. Tighten mounting screws.

Units with "yield" only (no "pry" adjustment).

To Check

Place typing unit in stop condition. With carriage in center of unit and line feed code (-2---) in selector, turn main shaft until function bail is in uppermost position (position no. 1). Hold print suppression codebar to right, and take up upward play of line feed function lever. Release print suppression codebar and take up downward play of blocking lever. Release all levers.

Requirement

Min some---Max 0.015 inch between line feed blocking lever and line feed drive link latching surface.

To Adjust

Loosen mounting screws and position line feed upstop bracket. If downstop (PLA-8) interferes with feed pawl spring bracket, loosen downstop clamp nut and move downstop for clearance. Tighten mounting screws.

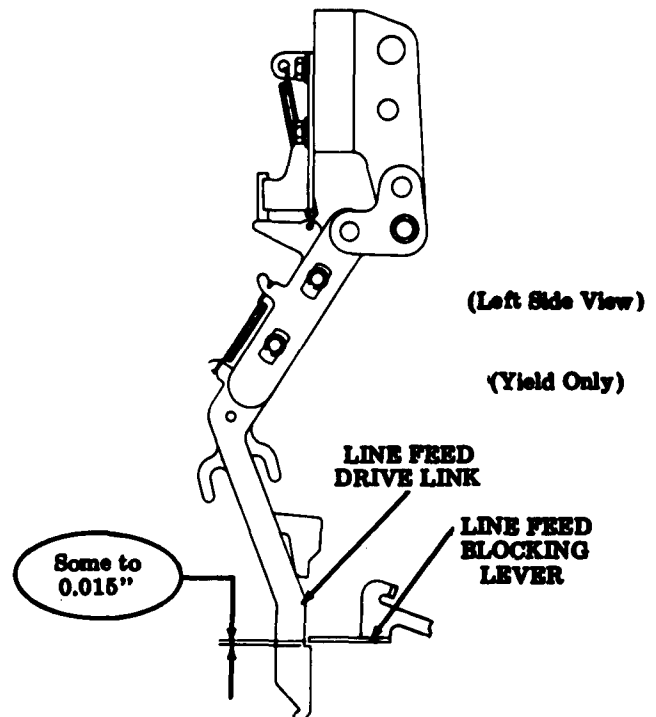
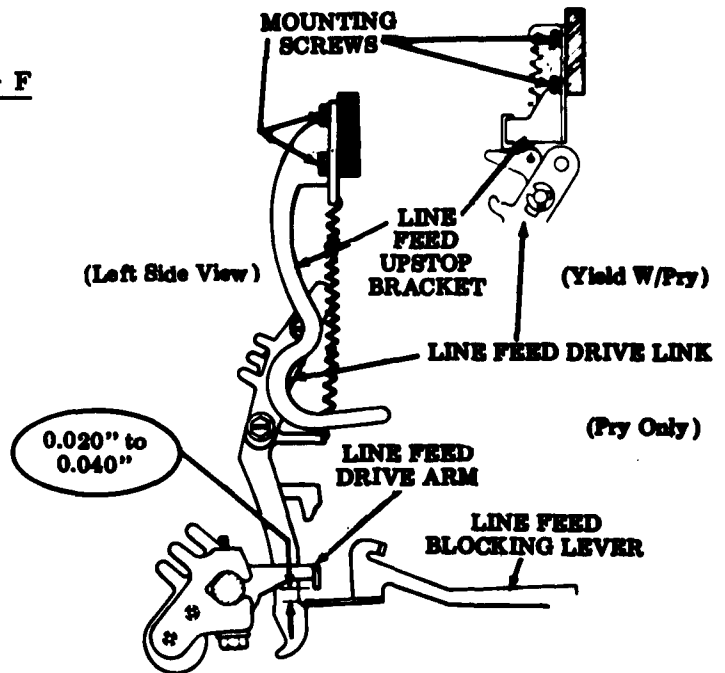

Related Adjustments

Affected By

- VERTICAL TYPE ALIGNMENT - F (2.70)
- LINE FEED DRIVE ARM CLEARANCE - F (2.79)

Note: This adjustment is affected by VERTICAL TYPE ALIGNMENT - F (2.70) only when equipped with TPI80528 non-adjustable vertical drive bail.

SECTION 574-172-700TC

2.81 Platen Area (continued)

LINE FEED DRIVE LINK POSITION - F (PLA-7)

Note 1: This adjustment does not apply to "yield" only.

Units with "pry" only.

To Check

Place the carriage to the center of the platen. Place the flat surface on left side of platen up and horizontally to base casting, and set up the line feed code combination (-2---) in the selector. Rotate main shaft until function bail reaches its lowest point (position no. 3). Lower the detent into its notch. The platen should barely move.

(1) Requirement

The motion supplied by the drive arm of the function rocker shaft to the line feed pawl should be adequate to rotate the platen the required amount.

(2) Requirement

Hold platen detent pawl away from ratchet and rotate main shaft until function bail is in its lowest position (position no. 3). Lower platen detent pawl into its seat between two ratchet teeth. The platen should barely move.

To Adjust

Loosen line feed stripper plate clamp screw and back off line feed stripper plate (see LINE FEED STRIPPER PLATE CLEARANCE (2.84)). Loosen downstop nut friction tight (2.82) and position downstop stud in lowermost position. Loosen two clamp screws and use pry points to position line feed drive link so that line feed pawl indexes platen one tooth and platen detent pawl seats fully in ratchet. Tighten clamp screws. Readjust downstop stud as required.

Units with "yield w/pry" only.

To Check

Place typing unit in double line feed condition and function clutch in the stop condition.

Requirement

Min some---Max 0.030 inch between tip of ratchet teeth and closest tooth of feed pawl.

To Adjust

Loosen clamp screw on line feed bellcrank and position feed pawl using pry point. Use upper pry point to reduce gap. Use lower pry point to enlarge gap. Tighten clamp screw.

Note 2: Do the following to insure proper line feed linkage operation:

- (a) With unit set for double line feed and feed pawl in its highest position, there should be no contact of platen ratchet with feed pawl for one full rotation of platen.
- (b) With line feed selected and function drive ball in its lowest position, there should be contact between feed pawl and downstop post.

Related Adjustments

Affects

LINE FEED PAWL DOWNSTOP POSITION - F (2.82)

Affected By

DETENT POSITION - F (2.77)

VERTICAL TYPE ALIGNMENT - F (2.70)

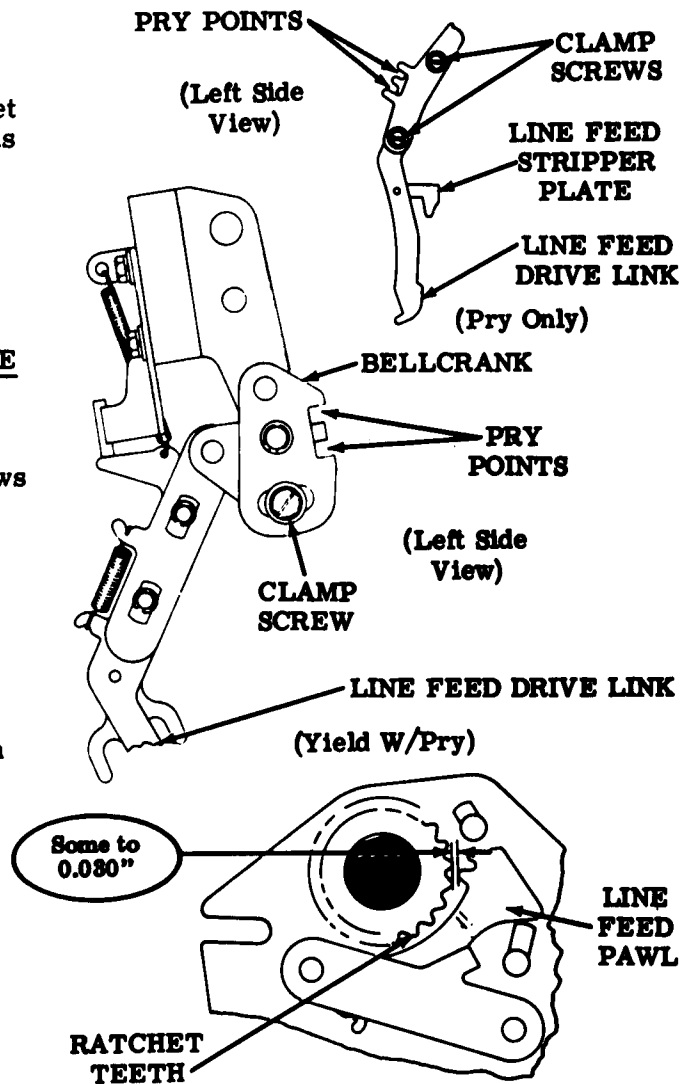

2.82 Platen Area (continued)

LINE FEED PAWL DOWNSTOP POSITION - F
(PLA-8)

Units with "pry" only.

To Check

Place the flat surface on the left side of platen up and horizontal to base casting. Set up the line feed code combination (-2---) in the selector. Rotate main shaft until function bail reaches its lowest position (position no. 3). Take up play of platen in left end plate toward the rear and hold.

Requirement

With platen detent pawl fully seated in ratchet
Min 0.005 inch---Max 0.015 inch
between back of line feed pawl and its downstop.

To Adjust

Loosen downstop clamp nut. Position downstop. Tighten clamp nut.

Units with "yield" only.

To Check

Place the flat surface or the left side of the platen up and horizontal to base casting. Manually engage ratchet with line feed pawl and advance platen on tooth if set is in single line feed, and two teeth if set is in double line feed.

Requirement

With platen detent pawl fully seated in ratchet
Min 0.005 inch---Max 0.015 inch
between back of line feed pawl and its downstop.

To Adjust

Loosen downstop clamp nut friction tight and position downstop post to the bottom of its slot. Unhook spring from upstop bracket. Position downstop post to meet requirement. Tighten clamp nut. Rehook spring on upstop bracket.

LINE FEED PAWL SPRING - F

Requirement

With typing unit in stop condition
Min 3/4 oz---Max 1-3/4 oz
to start line feed pawl moving.

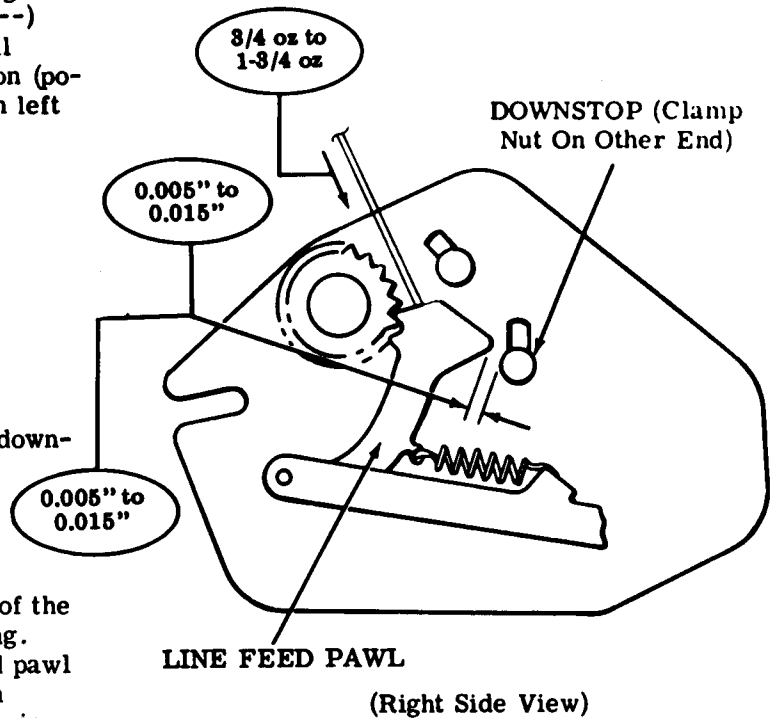

Note: Yield spring of line feed drive link should not extend while marking or checking this requirement.

Related Adjustments

Affected By

- LINE FEED DRIVE ARM CLEARANCE - F (2.79)
- LINE FEED DRIVE LINK POSITION - F (2.81)
- VERTICAL TYPE ALIGNMENT - F (2.70)

SECTION 574-172-700TC

2.83 Platen Area (continued)

PRESSURE ROLLER CLEARANCE (PLA-10)

To Check

Position carriage with lock bracket left mounting screw directly under pressure roller.
Release pressure roller (pressure lever placed in forward position).

Requirement

Min 0.010 inch
between pressure roller and left mounting screw.

Note: Clearance should not be so large that roller is not detented in released position.

To Adjust

Loosen clamp screw. Position pressure roller adjusting bracket. Tighten clamp screw.

Related Adjustment

Affected By

REAR RAIL POSITION (Carriage Area) (2.43)

VERTICAL TYPE ALIGNMENT - F (2.70)

Note: This adjustment is affected by VERTICAL TYPE ALIGNMENT - F (2.70)
only when equipped with TP180526 nonadjustable vertical drive ball.

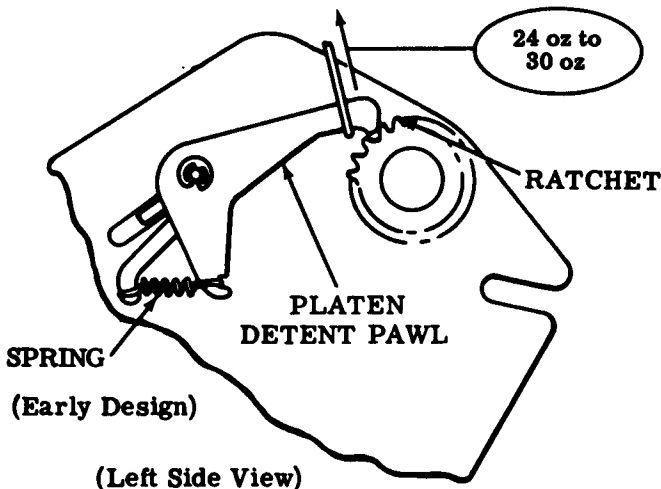
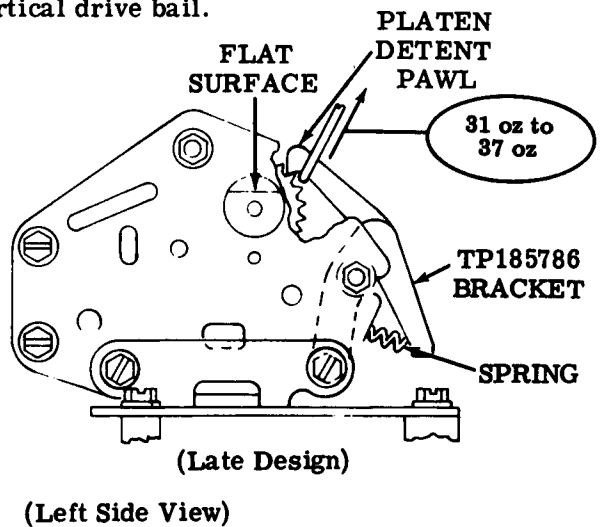
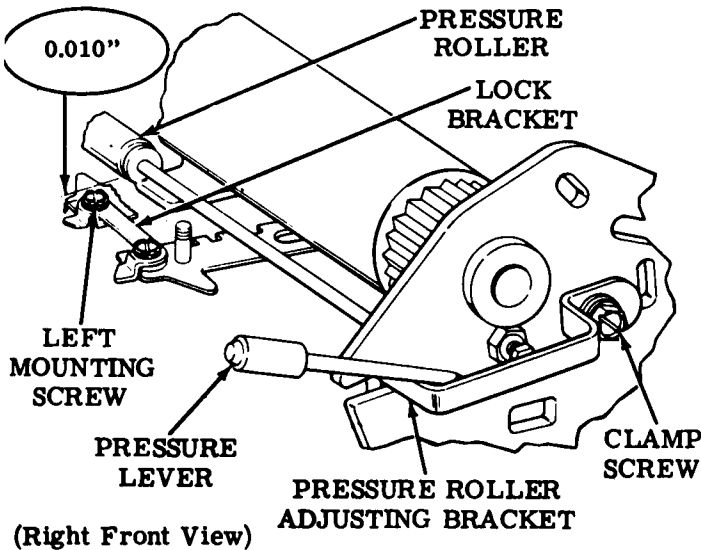

PLATEN DETENT PAWL SPRING - F

Requirement

Early Design

Min 24 oz---Max 30 oz

Late Design

Min 31 oz---Max 37 oz

to start platen detent pawl moving.

2.84 Platen Area (continued)

Note: "Yield w/pry." design line feed drive link shown. "Yield" only design unit (yield spring on drive link) adjusted in same way

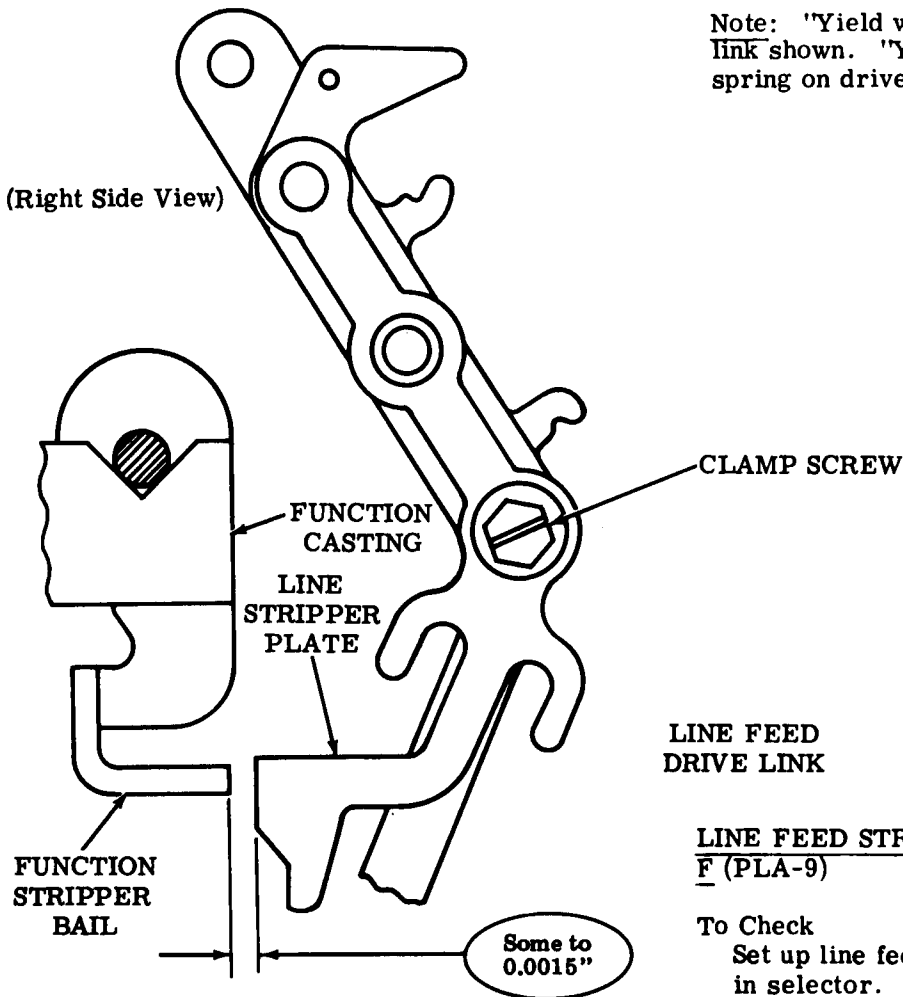

LINE FEED DRIVE LINK

LINE FEED STRIPPER PLATE CLEARANCE - F (PLA-9)

To Check

Set up line feed code combination (-2---) in selector. Rotate main shaft until carriage drive bail is in the rearmost position (position no. 2).

(1) Requirement

The line feed stripper plate should be Min some---Max 0.0015 inch away from function stripper bail.

(2) Requirement

The line feed blocking lever and line feed drive link should fully engage.

To Adjust

Loosen clamp screw. Position line feed stripper plate by means of pry points. Tighten clamp screw.

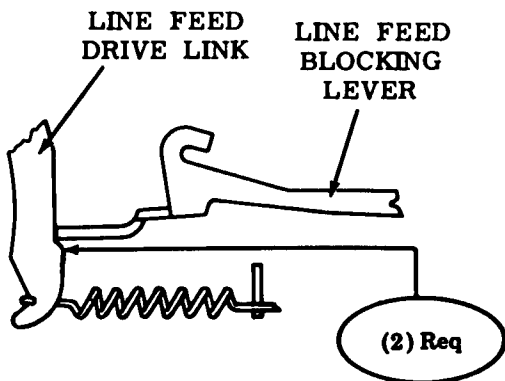

(Left Side View)

Related Adjustments

Affected By

- STRIPPER BAIL CLEARANCE (2.36)
- PLATEN — HORIZONTAL POSITION - F (2.69)

2.85 Platen Area (continued)

COPYHOLDER WIRE POSITION - F (PLA-11)

(1) Requirement

The copyholder wire should fall somewhere between two lines of printed copy, not obscuring more than 1/2 the height of either line.

To Adjust

Loosen four mounting screws. Position copyholder wire. Tighten screws.

(2) Requirement

After raising and releasing, the copyholder wire should return and rest against the platen at its center with a maximum of 0.020 inch between platen and copyholder wire at both the left and right ends.

To Adjust

Bend copyholder wire.

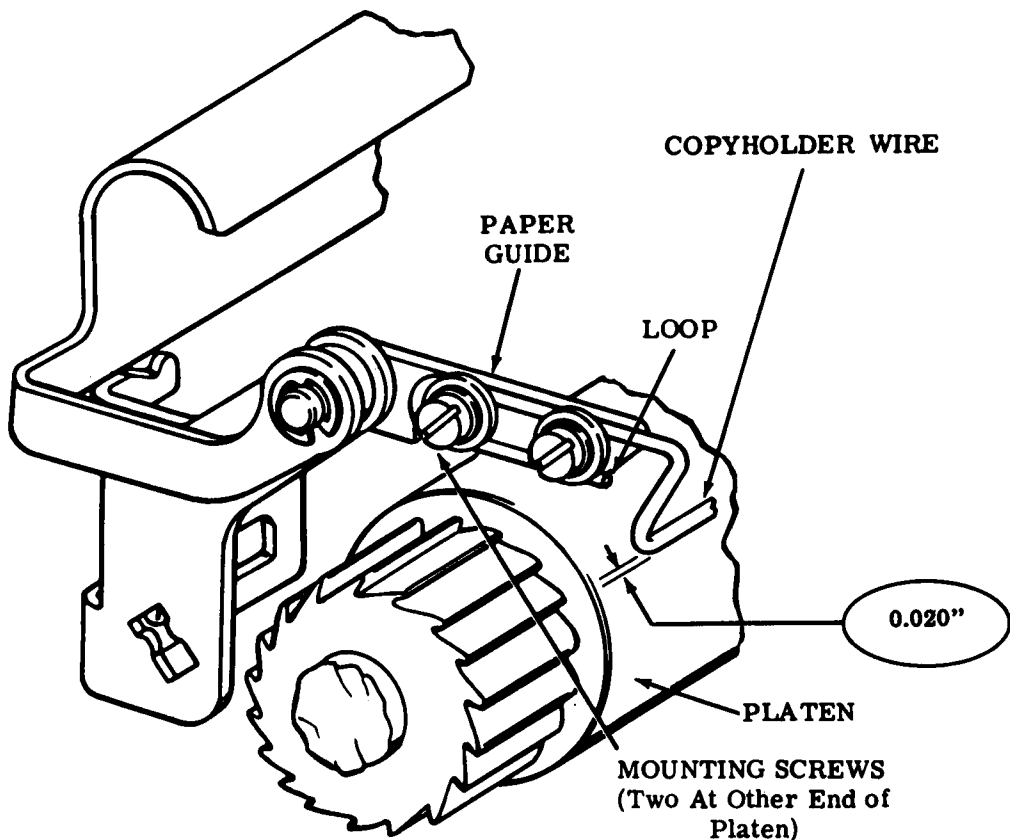

(Left Side View)

2.86 Platen Area (continued)

PAPER GUIDE SPRING - S

Requirement

With paper guides resting on platen
 Min 16 oz---Max 18 oz
 to pull each paper guide spring to installed length.

PAPER GUIDEPLATE SPRING - S

Requirement

With a spring scale positioned at middle of paper guideplate
 Min 3-1/2 oz---Max 7-1/2 oz
 to start paper guideplate moving.

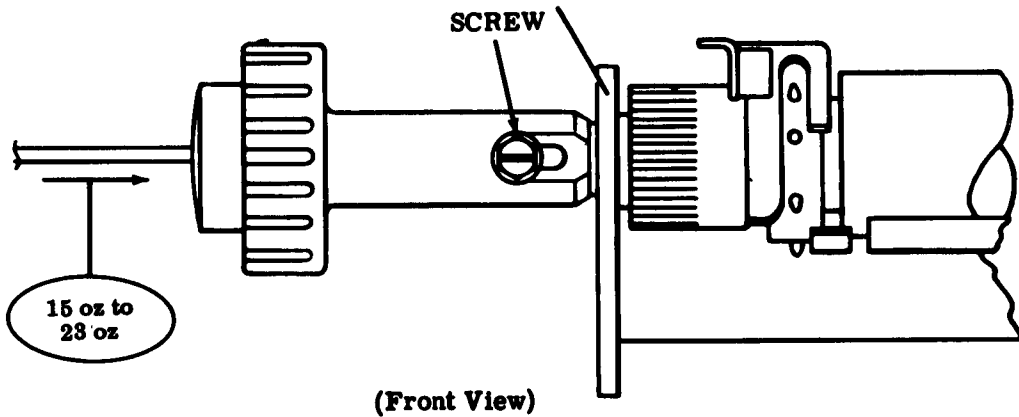
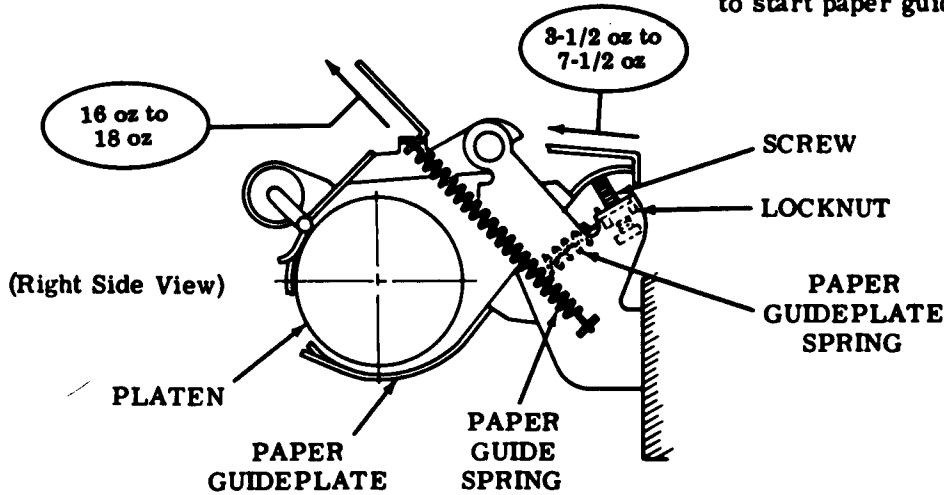

PLATEN KNOB SPRING - S

Requirement

With a spring scale positioned on platen knob
 Min 15 oz---Max 23 oz
 to start platen knob moving.

PLATEN KNOB POSITION - S (FOA-22)

Requirement

The platen knob should be fully seated toward the right.

To Adjust

When typing unit is on its subbase and cover is installed, loosen screw and position platen knob. Tighten screw.

2.87 Platen Area (continued)

PLATEN ENDPLAY - F (PLA-12)

Note: This adjustment applies only to typing units equipped with TP185816 adjusting screw.

To Check

Position platen against the left end plate.

Requirement

Min 0.002 inch---Max 0.015 inch
between the TP185816 adjusting screw and the right end of the platen.

To Adjust

Loosen the locknut. Position platen against the left end plate. Position the TP185816 adjusting screw. Tighten locknut.

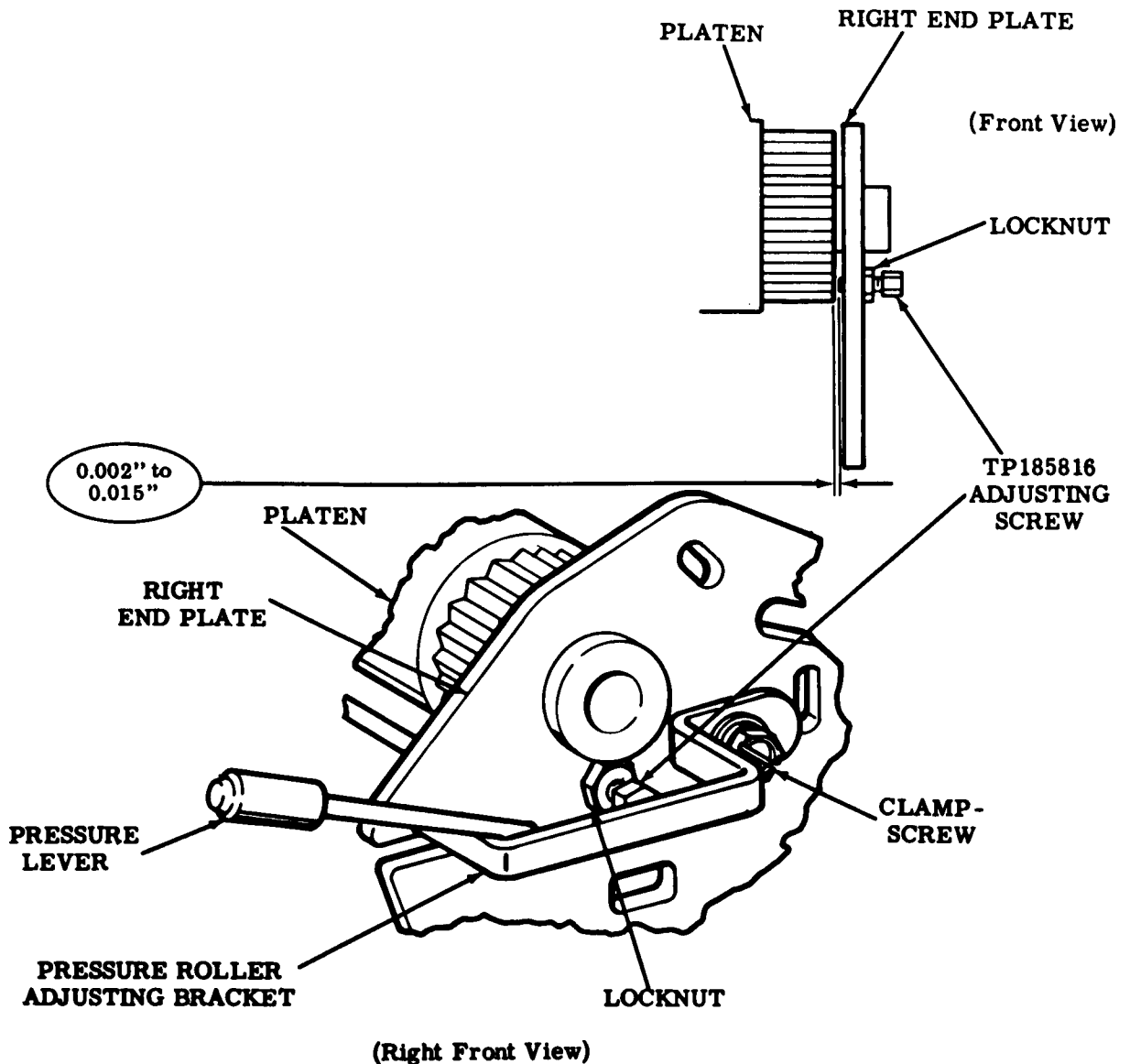

2.88 Platen Area (continued)

Note 1: If idler has not previously been backed off, loosen nut securing idler post to end plate and position idler to low point in slot before making the following adjustment.

PLATEN – HORIZONTAL POSITION - S (FOA-23)

(1) To Check

Place the platen knob screw up and permit the detent ratchet pawl to seat in a groove of the detent ratchet. Place the carriage at the left margin and check requirement. Move the carriage to the right margin and again check requirement.

Requirement

Min 0.050 inch---Max 0.065 inch between ribbon guide and platen at both left and right ends.

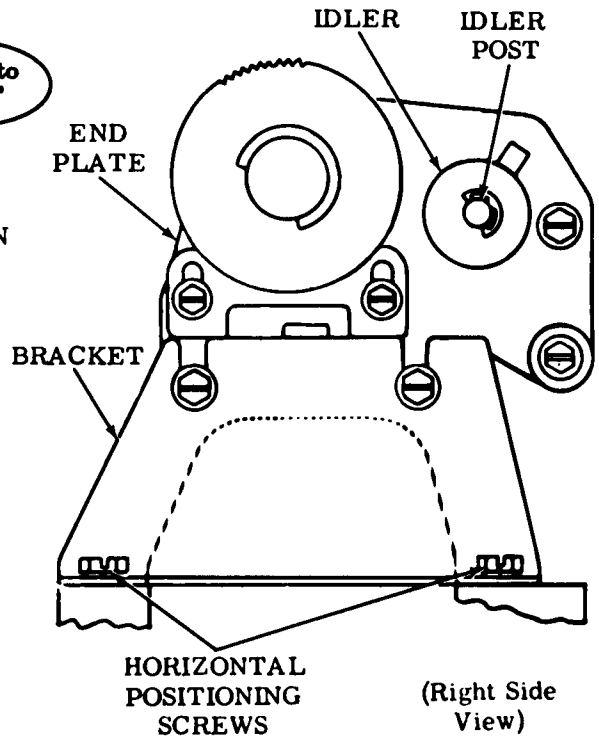
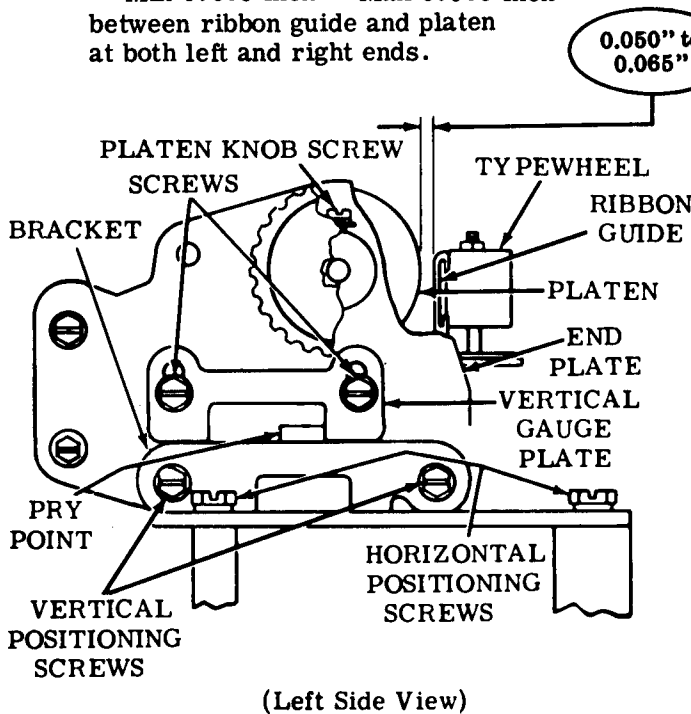

Note 3: Outline of early design bracket shown by broken line.

(2) To Check

Place carriage to center of platen and rotate platen until maximum clearance is obtained between platen and ribbon guide. Set up E code combination (1----) in the selector. Rotate main shaft until carriage drive bail is in its rearmost position. Push typewheel to the rear until it just touches the platen.

Note 2: The typing unit should not have sprocket forms or ribbon installed.

Requirement

Typewheel should not touch side of either ribbon guide.

Related Adjustments

Affected By

FRONT ROLLERS CLEARANCE (2.41)

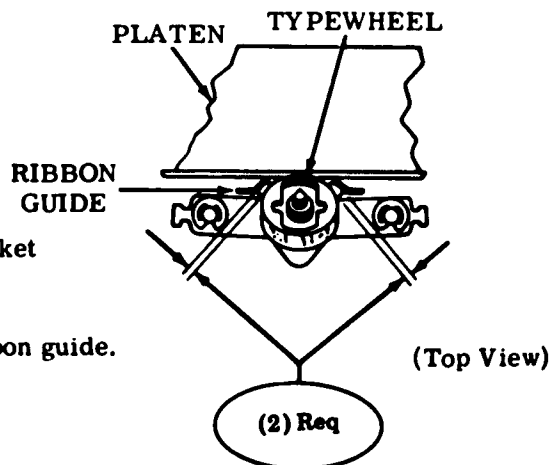

SECTION 574-172-700TC

2.89 Platen Area (continued)

PLATEN — HORIZONTAL POSITION - S (FOA-23) (continued)

To Adjust

Loosen four horizontal positioning screws. Position platen horizontally. Tighten the four horizontal positioning screws.

Related Adjustments

Affects

VERTICAL TYPE ALIGNMENT - S (2.89, 2.90)

IDLER POSITION - S (2.99)

DETENT POSITION - S (2.108)

FORM FEED BELT TENSION - S (2.93)

CAM ZERO POSITION - S (2.109, 2.110)

WIRE GUIDE POSITION - S (2.116)

Note: If the idler has not previously been backed off, loosen the nut securing the idler post and back off the idler before making the VERTICAL TYPE ALIGNMENT - S (2.89, 2.90) adjustment.

VERTICAL TYPE ALIGNMENT - S (FOA-24)

Typing units equipped with adjustable vertical drive bail such as TP180606:

(1) To Check

Place carriage to left margin. Set up the E code combination (1----) in the selector and rotate the main shaft until the character is printed.

Requirement

When the printed character is examined by eye from top to bottom, the shading should be approximately the same with no overscoring or underscoring.

To Adjust

Loosen adjusting screw on vertical drive bail and position the typewheel using pry point.

(2) To Check

Place carriage to right margin. Set up the E code combination (1----) in the selector and rotate main shaft until the character is printed.

Requirement

When the printed character is examined by eye from top to bottom, the shading should be approximately the same with no overscoring or underscoring.

To Adjust

Loosen the vertical gauge plate screws on the right side of the platen mechanism and back off the vertical gauge plate. Loosen vertical positioning screws on right side. Position the right end of the platen using pry point. Do not twist the platen. After adjusting, position the vertical gauge plate on the right side so that it is resting on its associated bracket. Tighten all screws.

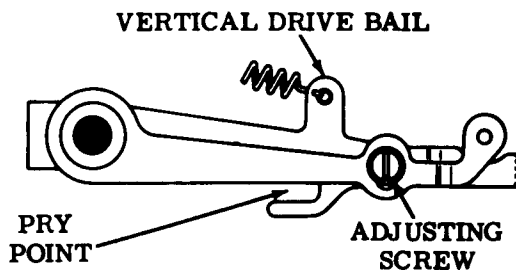

(Right Side View)

2.90 Platen Area (continued)

VERTICAL TYPE ALIGNMENT - S (FOA-24) (continued)

Typing units equipped with nonadjustable vertical drive bail such as TP180526:

To Check

Place paper in typing unit. Set up the E code combination (1----) in the selector and rotate the main shaft until the character is printed. Repeat several times along the length of the platen.

Requirement

When each printed character is examined by eye from top to bottom, the shading should be approximately the same with no overscoring or underscoring.

To Adjust

Loosen the vertical gauge plate screws and back off the vertical gauge plate on each side of the platen mechanism. Loosen four vertical positioning screws and position the platen using pry points. Do not twist the platen. After adjusting, position each vertical gauge plate so that it is resting on the top of its associated bracket. Tighten all screws.

Related Adjustments**Affects**

IDLER POSITION - S (2.99)
DETENT POSITION - S (2.108)
CAM ZERO POSITION - S (2.109, 2.110)
WIRE GUIDE POSITION (2.116)

Affected By

PLATEN — HORIZONTAL POSITION - S (2.88)
REAR RAIL POSITION (2.43)
PRINT DRIVE LEVER POSITIONING (2.46)

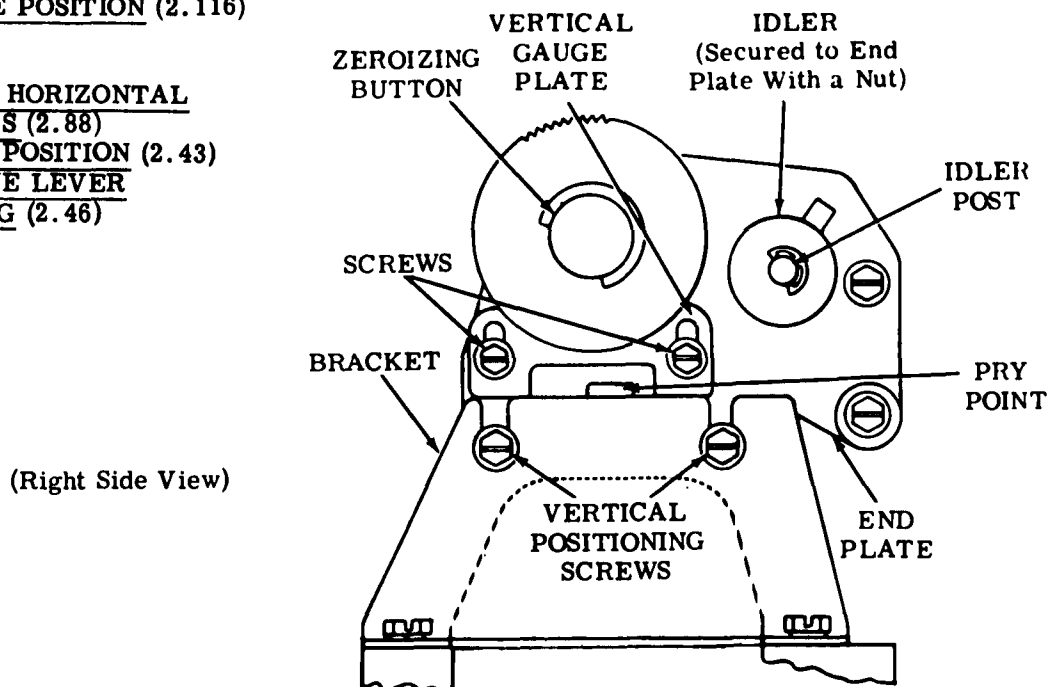

Note: Outline of early design bracket shown by broken line..

2.91 Platen Area (continued)

PAPER GUIDEPLATE CLEARANCE - S (FOA-21)

Requirement

With no sprocket forms in the platen mechanism

Min 0.008 inch---Max 0.025 inch between the platen and the left and right ends of the paper guideplate adjacent to the fingers. Record the two clearances (see Note 2).

To Adjust

Loosen locknut and adjust screw.
Tighten locknut.

Note 1: If the adjustment cannot be made as indicated above, remove the platen mechanism from the typing unit. For instructions, see appropriate disassembly and reassembly section. Then, preliminary adjust as follows:

Preliminary Requirement

With the screw backed off and no sprocket forms in the platen mechanism

Min zero---Max 0.012 inch between the platen and the left and right ends of the paper guideplate — adjacent to the fingers. Record the two clearances (see Note 2).

Preliminary Adjust

Loosen end plate screws friction tight and position end plates. Tighten screws.

Note 2: The fingers at both the left and right ends of the platen should be Min some---Max 0.015 inch beyond the recorded gap between the platen and the left and right ends of the paper guideplate. Bend fingers to meet the requirement.

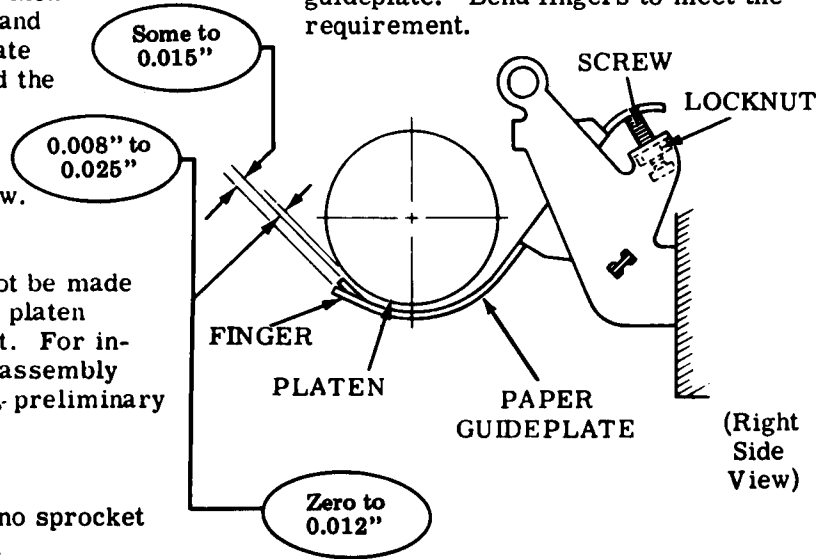

Note 3: Replace platen mechanism onto the typing unit. For instructions see appropriate disassembly and reassembly section. Check requirement.

Related Adjustments

Affects

PAPER ALARM CONTACT LEVER CLEARANCE - S (2.118)

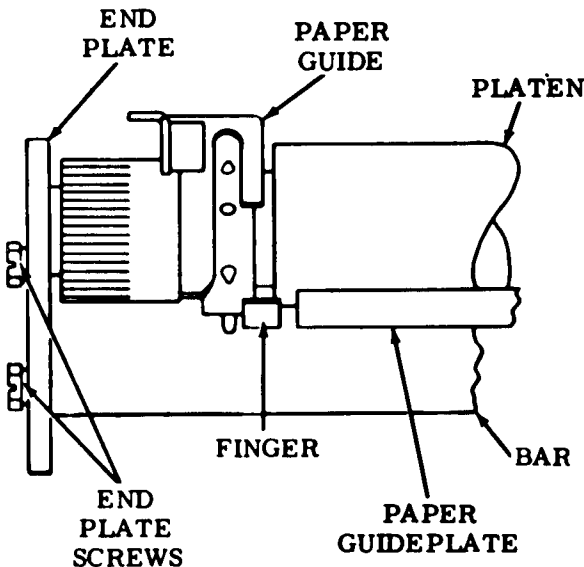

(Front View)

2.92 Main Shaft Area (continued)

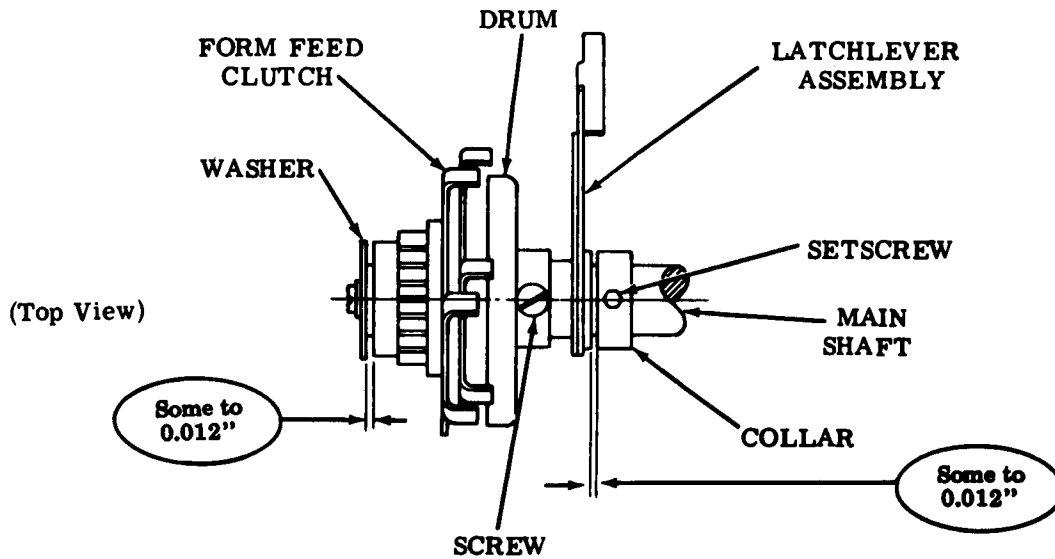
**(A) FORM FEED CLUTCH ENDPLAY - S (FOA-1)****Requirement**

Min some---Max 0.012 inch
endplay between washer and form
feed clutch.

To Adjust

Loosen drum screw and position drum.

(B) LATCHLEVER ENDPLAY (FOA-2)**Requirement**

Min some---Max 0.012 inch
endplay between latchlever assembly and collar.

To Adjust

Loosen setscrew and position collar.
Tighten screw.

SECTION 574-172-700TC

2.93 Form Feed Area

FORM FEED BELT TENSION - S (FOA-3)

Note 1: Check tension only if the form feed belt is suspected of not meeting its requirement.

Requirement

The form feed belt tension should not be too tight or too loose.

To Adjust

Loosen three form feed assembly bracket mounting screws and hook a spring scale under the trip shaft at the latchlever. Position and pull up with a force of 7 pounds and hold. Tighten the three form feed assembly bracket mounting screws in the following order: first, the right front mounting screw; then, the right rear mounting screw, and finally, the left mounting screw.

Related Adjustments

Affects

FORM-OUT LEVER OVERTRAVEL - S (2.97)

FORM-OUT LEVER — RESET CLEARANCE - S (Late Design) (2.101) and (Early Design) (2.100)

TRIP LEVER ENGAGEMENT — LINE FEED - S (2.103)

TRIP LEVER UPSTOP POSITION - S (2.105)

LINE FEED SELECTION - S (2.107)

IDLER POSITION - S (2.99)

DETENT POSITION - S (2.108)

RESET FOLLOWER LEVER — RESET POSITION - S (2.109)

CAM ZERO POSITION - S (2.109, 2.110)

CLUTCH SHOE LEVER GAP - S (2.94)

TRIP SHAFT ENDPLAY - S (2.96)

TRIP LEVER ENGAGEMENT — FORM-OUT - S (2.102)

FORM-OUT CONTACT PRESSURE AND GAP - S (2.112)

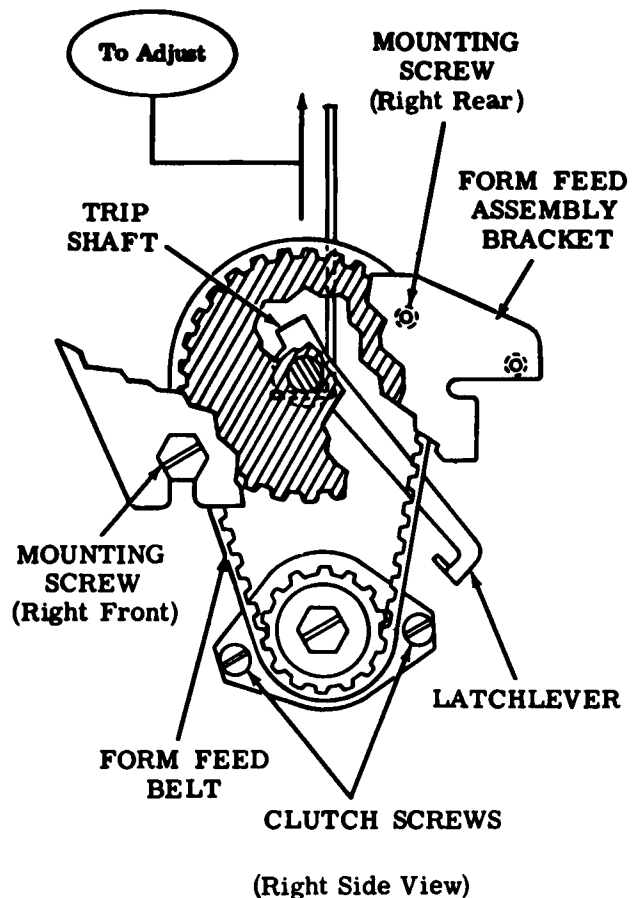

Note 2: Make certain that the shaft is free by rotating reset follower lever. If necessary, free trip shaft by repositioning the left mounting bracket of the form feed assembly bracket against the form feed assembly bracket.

Note 3: The left mounting screw is located on the left side of the form feed bracket.

2.94 Form Feed Area (continued)

CAUTION: DO NOT DISTURB THE CLUTCH SCREWS UNLESS ABSOLUTELY NECESSARY. CLUTCH SCREWS ARE SECURED BY AN ADHESIVE AT THE FACTORY.

CLUTCH SHOE LEVER GAP - S (FOA-4)**(1) To Check**

Rotate the main shaft until the form feed clutch is in that stop position which brings the flat surface of the adjusting disc to the position illustrated. The head of the clutch drum mounting screw should be up. Disengage (latch) the form feed clutch. Pull shoe lever against stop-lug and release.

Requirement

Min 0.015 inch -- Max 0.040 inch
between the stop-lug and the shoe lever.

To Adjust

Loosen clamp screw and position trip lever. Tighten clamp screw.

(2) To Check

Raise trip lever to trip (engage) form feed clutch. Fully seat clutch shoes by applying 32 ±1/2 ounces of pressure against shoe lever along its normal path of forward travel. Again measure and record shoe lever, stop-lug clearance.

Requirement

Clearance between stop-lug and shoe lever.
Min 0.055 inch -- Max 0.085 inch
greater when form feed clutch is engaged than when disengaged.

Note: Do not make the following adjustment unless requirements cannot be met. If the clutch screws are disturbed, they must be resealed with an application of TP186171 Glyptal adhesive.

To Adjust

Loosen the two clutch screws friction tight and position adjusting disc. Apply appropriate adhesive (Glyptal) to clutch screw threads. Tighten both screws before adhesive dries.

LATCHLEVER SPRING - S**Requirement**

With latchlever resting on the high part of the cam
Min 3 oz -- Max 7 oz
to start latchlever moving.

TRIP LEVER SPRING - S**Requirement**

With trip lever tab resting on top of a stop-lug
Early Design
Min 3 oz -- Max 4-1/2 oz
to start lever moving.
Late Design
Min 14 oz -- Max 18 oz
to pull trip lever spring to installed length.

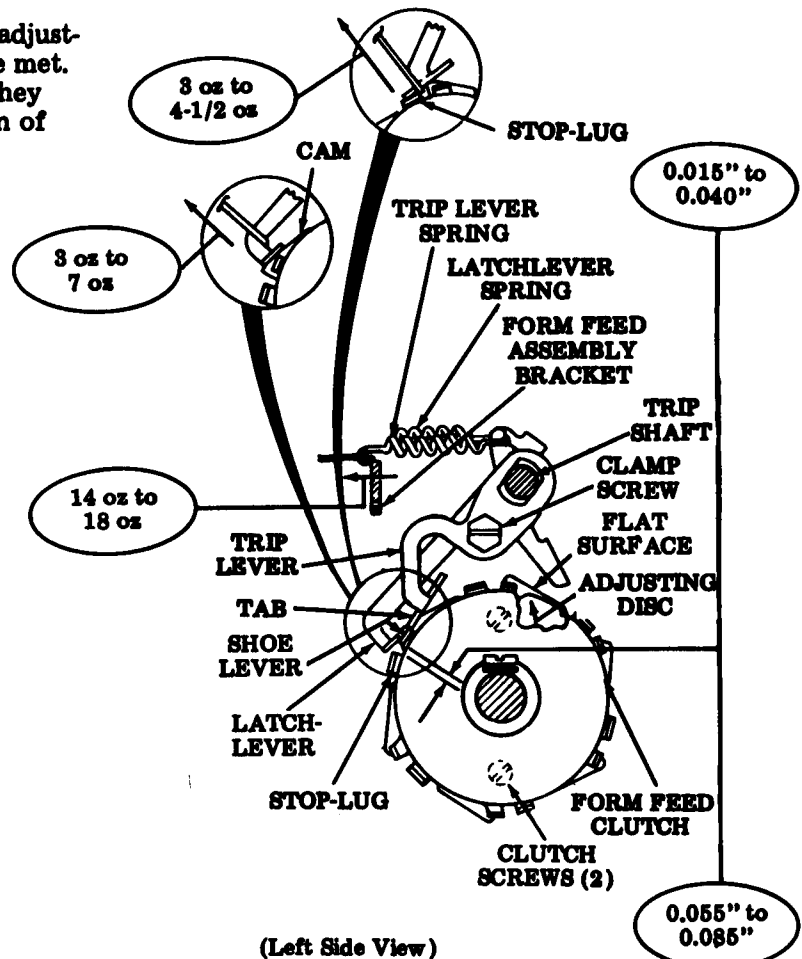

2.95 Form Feed Area (continued)

TRIP LEVER ENGAGEMENT (Preliminary) - S (FOA-14)

Note 1: This adjustment applies to late design typing units containing the TP185998 nickel plated plate.

Note 2: Before making this adjustment the following conditions must be met:

- (a) There should be some clearance between the line feed lever and function pawl.
- (b) The form-out trip lever pry points should be positioned as shown (pry points centered) and the trip lever latched.

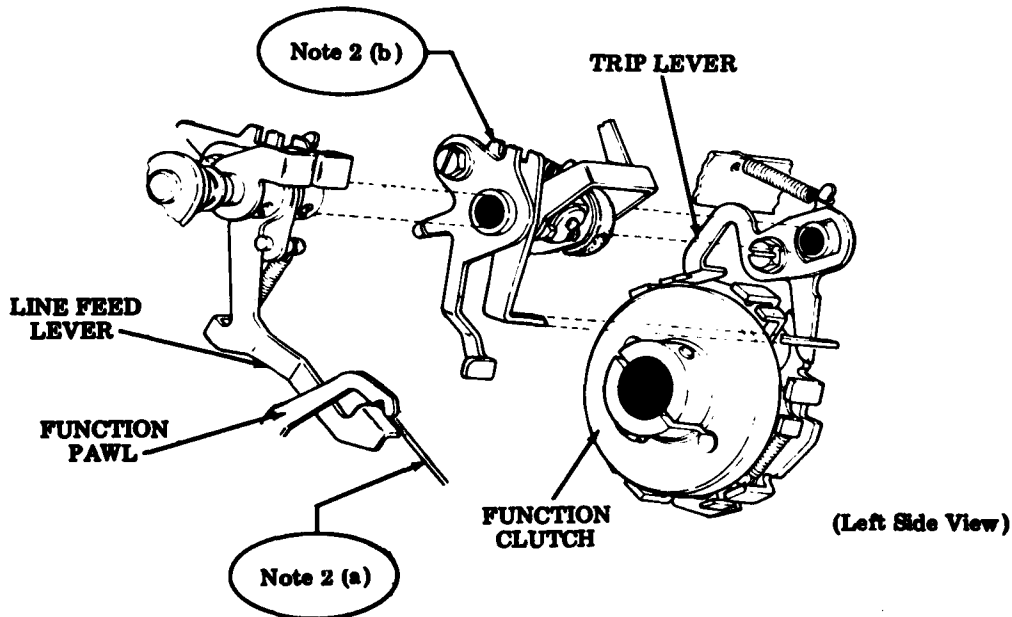

To Check

Rotate form feed clutch until a shoe lever is just about to contact the trip lever.

Requirement

Top surface of trip lever should be flush to 0.010 inch below top surface of shoe lever.

To Adjust

Loosen the two adjusting plate screws and position adjusting plate by first lowering as far as possible and then raising to meet this requirement. This assures contact between the bottom surface of the trip lever and the stop plate.

Related Adjustments

Affects

TRIP LEVER ENGAGEMENT - LINE FEED (Final) - S (Late Design) (2.104)

Affected By

CLUTCH SHOE LEVER GAP - S (2.94)

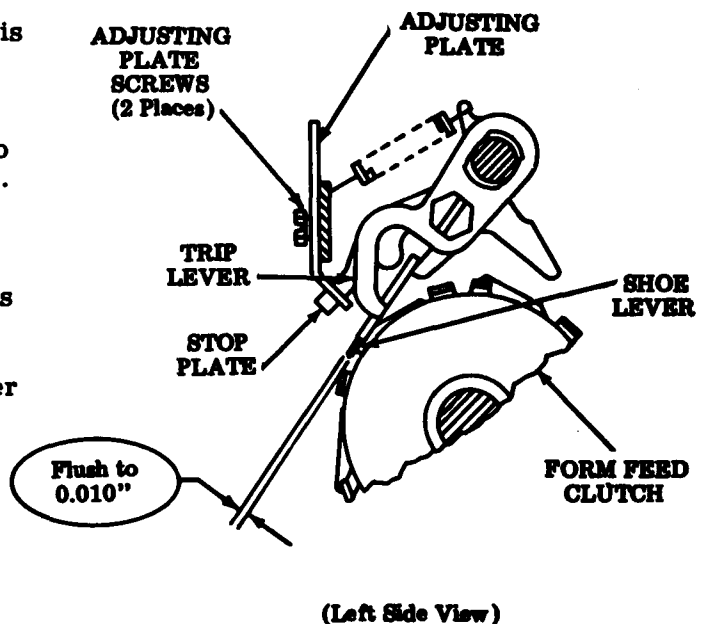

(Left Side View)

2.96 Form Feed Area (continued)

TRIP SHAFT ENDPLAY - S (FOA-5)

Requirement

Min some---Max 0.012 inch endplay of the trip shaft.

To Adjust

Loosen clamp screw and position reset follower lever on trip shaft. Tighten clamp screw.

Related Adjustments

Affected By

FORM FEED BELT TENSION - S (2.93)

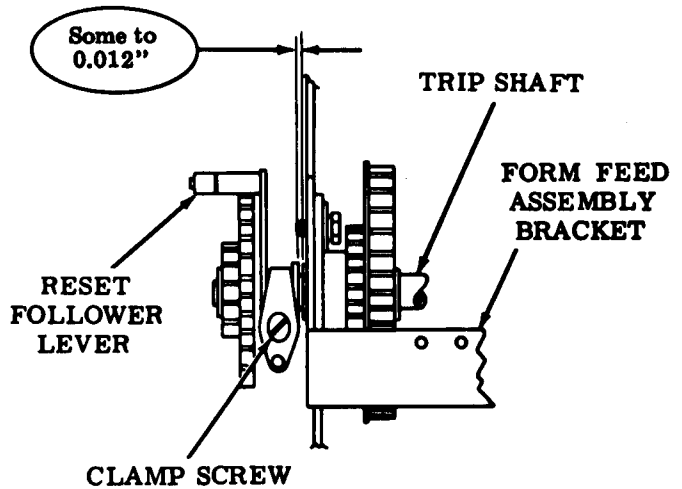

(Rear View)

LINE FEED LEVER LINE-UP AND ENDPLAY - S (FOA-6)

(1) **Requirement**

The line feed pawl should engage the flat on the tab of the line feed lever.

(2) **Requirement**

With all endplay taken up toward the right
Min some---Max 0.012 inch
between line feed lever and collar.

(3) **Requirement**

There must be some clearance between the line feed lever and the main shaft gear.

To Adjust

Loosen collar setscrews and position collars to meet Requirements (1) and (2). Loosen main shaft gear screw and position main shaft gear to meet Requirement (3). Tighten all screws.

Related Adjustment

Affected By

FORM FEED BELT TENSION - S (2.93)

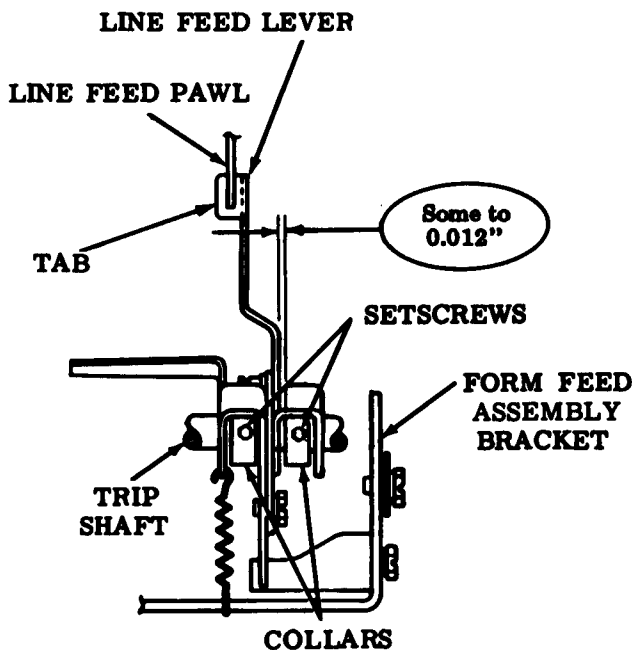

(Front View)

2.97 Form Feed Area (continued)

FORM-OUT LEVER OVERTRAVEL - S
(FOA-7)

To Check

With the reset lever on the low part of the cam, and with the form-out code combination (1---5) set up in selector, rotate the main shaft until the form-out function lever is in its lowermost position.

Requirement

Min 0.010 inch---Max 0.020 inch clearance between form-out lever and notch of arm.

To Adjust

Loosen screw, hold form-out function lever against its pawl, and position arm using pry points. Tighten screw.

Related Adjustment

Affected By
RIGHT ROCKER DRIVE (Function Area)
(2.34)
FORM FEED BELT TENSION - S
(2.93)

FORM-OUT LEVER SPRING - S

Requirement

With the form-out lever latched
Min 34 oz---Max 44 oz
to pull form-out lever spring to installed length.

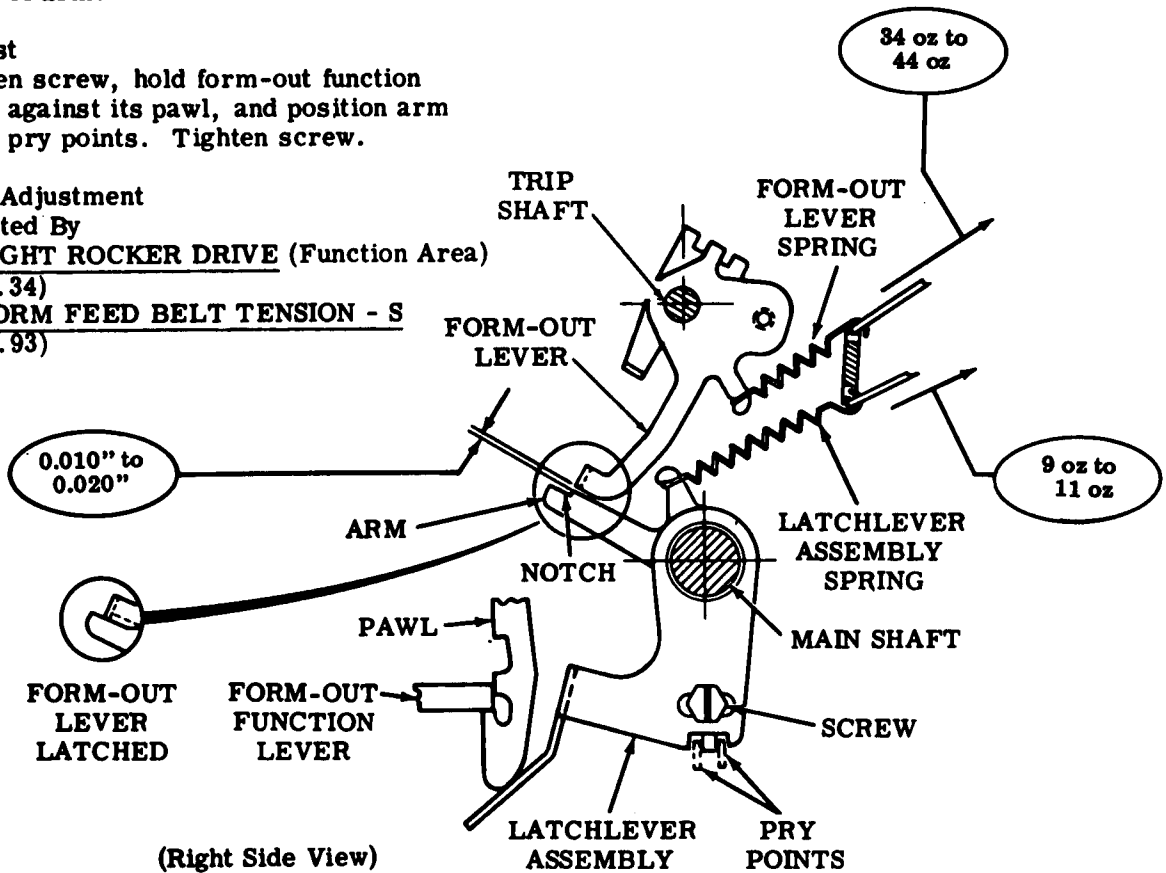

LATCHLEVER ASSEMBLY SPRING - S

Requirement

With the form-out lever latched
Min 9 oz---Max 11 oz
to pull latchlever assembly spring
to installed length.

2.98 Form Feed Area (continued)

RESET FOLLOWER LEVER SPRING - S**Requirement**

With reset follower lever on low part of cam

Min 12 oz---Max 16 oz
to pull reset follower lever
spring to installed length.

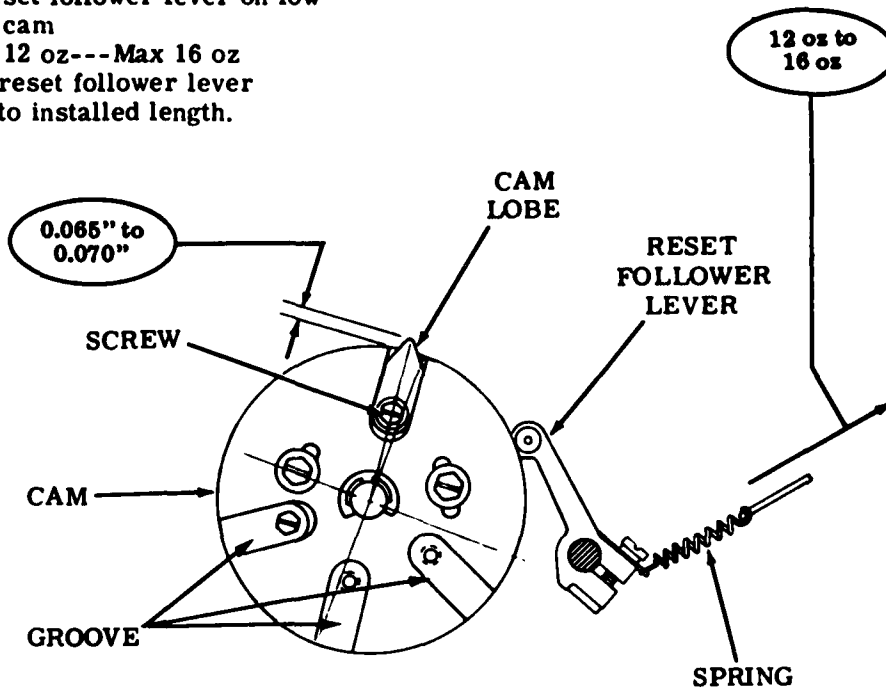

(Right Side View)

CAM LOBE POSITION - S (FOA-8)

Note: Cam lobes, in addition to the one opposite the three closely spaced grooves, should be adjusted according to the FORM-OUT LEVER — RESET CLEARANCE - S (2.100 or 2.101) adjustment.

Requirement

The top of the cam lobe should be
Min 0.065 inch---Max 0.070 inch
above the low point of the cam.

To Adjust

Loosen screw and position the cam lobe.
Tighten screw.

Related Adjustment

Affects

FORM-OUT LEVER — RESET CLEARANCE - S (2.100 or 2.101)

2.99 Platen Area (continued)

ZEROIZING BUTTON - S

Requirement

With a spring scale positioned on zeroizing button
 Min 15 oz---Max 23 oz
 to start zeroizing button moving.

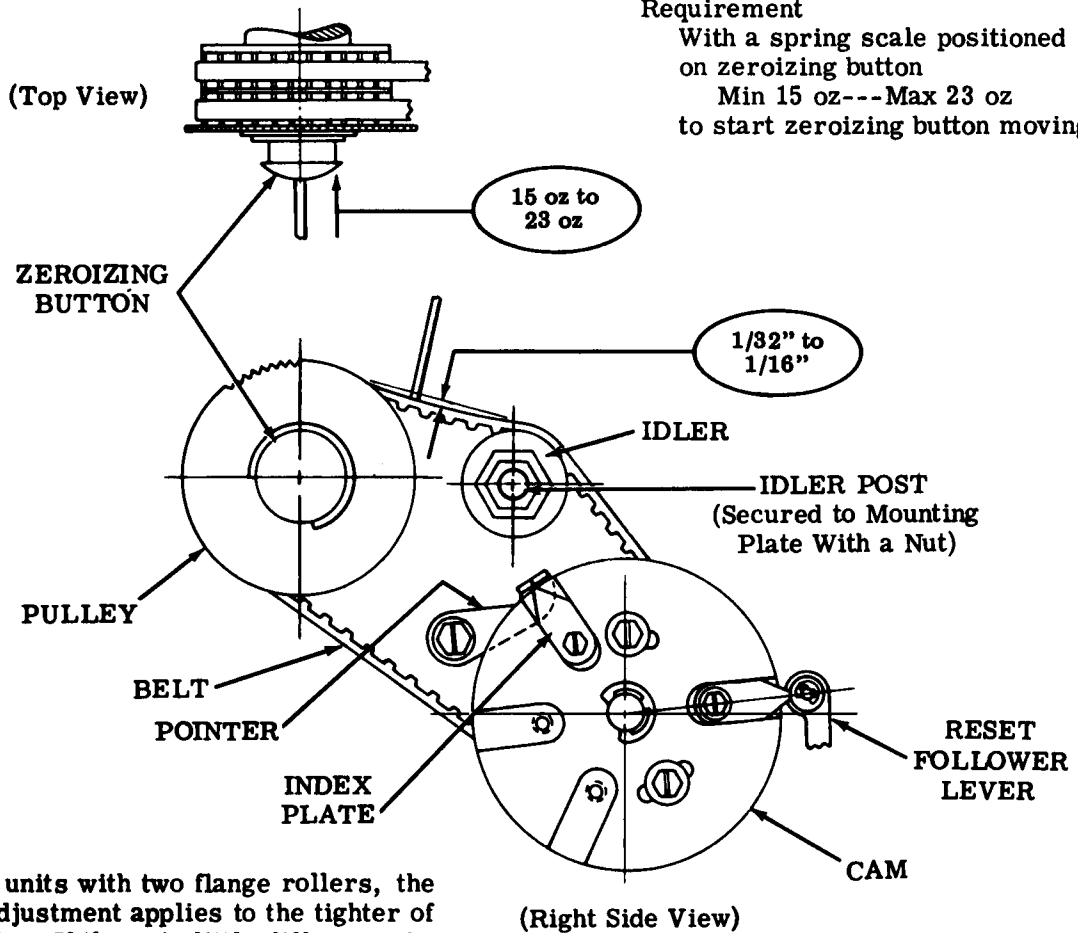

Note: For units with two flange rollers, the following adjustment applies to the tighter of the two belts. If there is little difference in tightness, the adjustment applies to the outer belt. On units with single flange rollers, the requirement applies to both belts.

IDLER POSITION - S (FOA-25)

To Check

Place a 16 oz spring load to the belt between the idler and the pulley and note the amount of deflection.

Requirement

Min 1/32 inch---Max 1/16 inch deflection of belt.

To Adjust

On units with two flange rollers, loosen idler post and position. Tighten idler post. On units with single flange rollers, loosen idler post and position inner belt; for outer belt loosen eccentric nut and position outer belt. Tighten nut.

Related Adjustments

Affects

- DETENT POSITION - S (2.108)
- RESET FOLLOWER LEVER —
- RESET POSITION - S (2.109)
- CAM ZERO POSITION (2.109)
- PRINTING LINE POSITION FINAL - S (2.114)

Affected By

- PLATEN — HORIZONTAL POSITION - S (2.88)
- VERTICAL TYPE ALIGNMENT - S (2.89)

2.100 Form Feed Area (continued)

FORM-OUT LEVER - RESET CLEARANCE - S (Early Design) (FOA-10)

To Check

With the typing unit in stop condition, rotate the main shaft until all clutch mounting screw-heads are in the vertical position. Place the reset follower lever on the high point of the cam lobe by pushing in on the zeroizing button and rotating the pulley.

(1) Requirement

Min 0.005 inch---Max 0.020 inch
between the latching surface of the arm and the form-out lever.

(2) Requirement

The trip lever and latchlever should have
Min some---Max 0.012 inch
endplay.

To Adjust

Place reset follower lever on high point of cam lobe. Loosen clamp screw friction tight and, using pry point, position the reset lever. Tighten clamp screw.

Related Adjustments

Affects

TRIP LEVER ENGAGEMENT - LINE FEED - S (2.103)

FORM-OUT CONTACT OPERATING BAIL CLEARANCE - S (2.112)

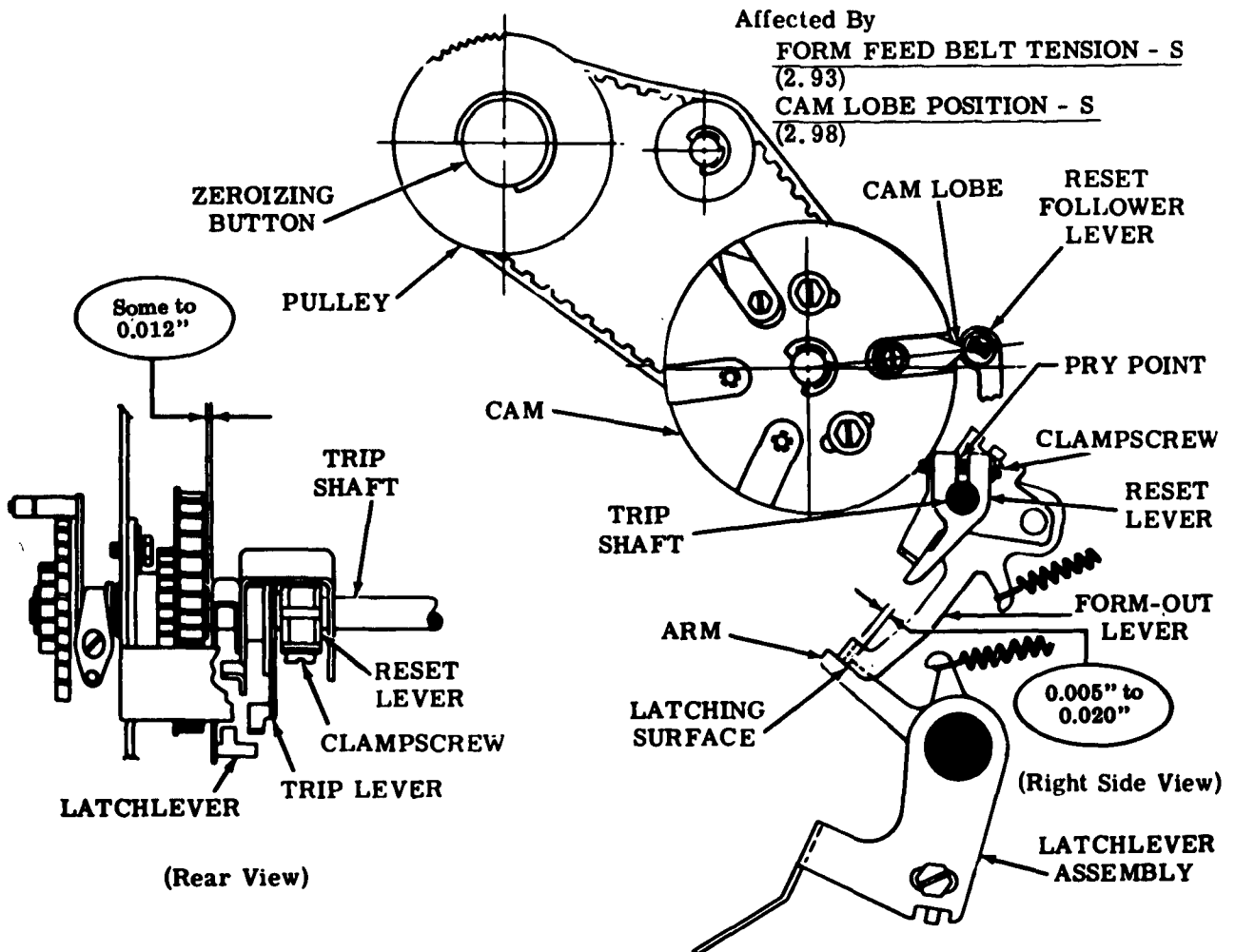

2. 101 Form Feed Area (continued)

FORM-OUT LEVER — RESET CLEARANCE - S (Late Design) (FOA-15)

Note: Check To Check (1) only when making a complete readjustment of typing unit.

(1) To Check

With typing unit in stop condition rotate main shaft until all clutch mounting screwheads are in vertical position. Place reset follower lever on low part of cam by pushing in on zeroizing button and rotating pulley. Push down on arm of latchlever assembly to unlatch form-out lever.

Requirement

- (a) Reset lever should just touch underside of form-out lever extension.
- (b) The trip lever and latchlever should have
Min some---Max 0.012 inch
endplay.

To Adjust

Loosen reset lever clamp screw and position reset lever using pry point. Tighten clamp screw.

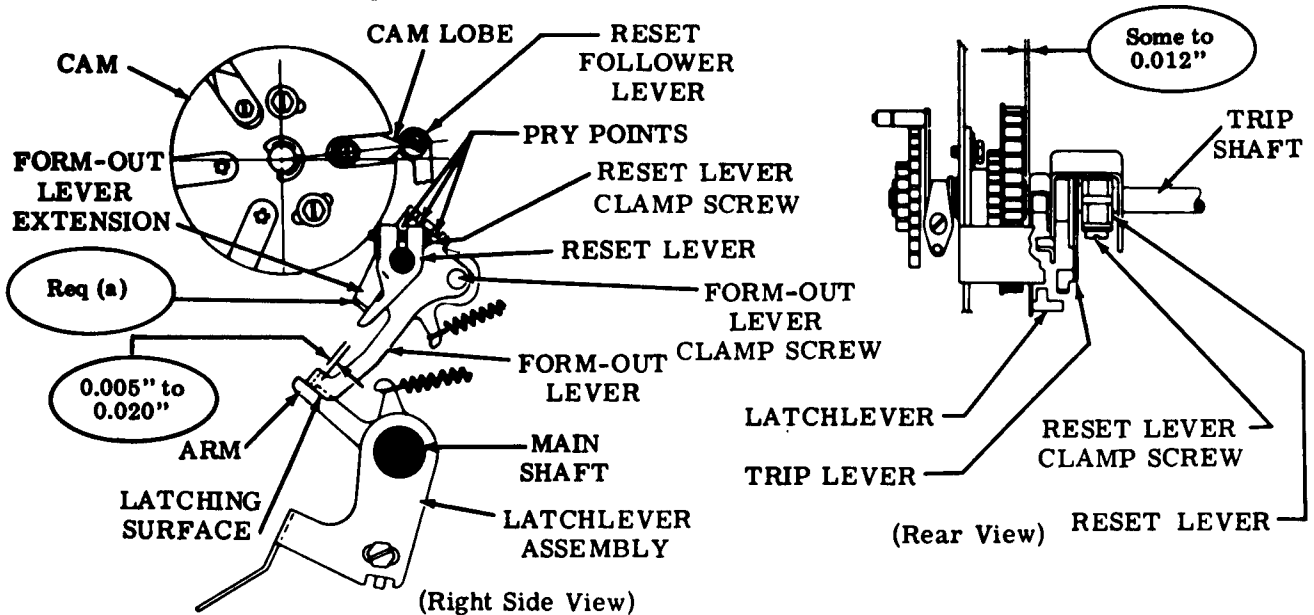

(2) To Check

With typing unit in stop condition rotate main shaft until all clutch mounting screwheads are in vertical position. Place reset follower lever on high point of cam lobe by pushing in on zeroizing button and rotating pulley.

Requirement

Min 0.005 inch---Max 0.020 inch
between latching surface of arm and form-out lever.

To Adjust

With form-out lever clamp screw friction tight, position form-out lever using pry points. Tighten clamp screw.

Related Adjustments

Affected By

- FORM FEED BELT TENSION - S (2. 93)
- CAM LOBE POSITION - S (2. 98)

2.102 Form Feed Area (continued)

TRIP LEVER ENGAGEMENT — FORM-OUT - S (FOA-9)

Note 1: The following adjustment applies only to early design typing units.

To Check

Rotate form feed clutch until a shoe lever just about contacts the trip lever. Hold form-out lever against latching surface of latchlever assembly.

Note 2: If the reset lever and/or line feed bail interfere when checking this adjustment,

- (a) Loosen reset lever clamp screw and position reset lever so that it does not interfere.
- (b) Loosen line feed downstop screw and position downstop to lowermost position. Position line feed lever so that line feed bail does not interfere.

- (1) Requirement
Top surface of shoe lever should not be above top surface of trip lever.
- (2) Requirement
Shoe lever should engage trip lever
Min 2/3 thickness
of trip lever.

Note 3: Check requirements at each of the six shoe levers.

To Adjust

Loosen form-out lever screw. Hold form-out lever against latching surface of latchlever assembly and position trip lever using form-out lever pry points. Tighten all screws.

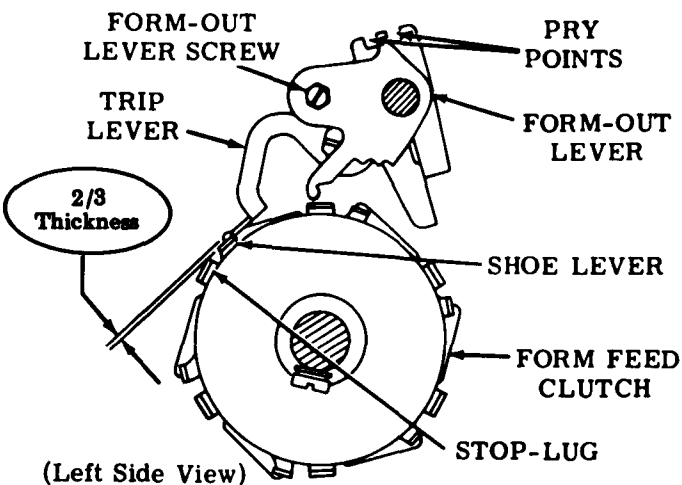

(Left Side View)

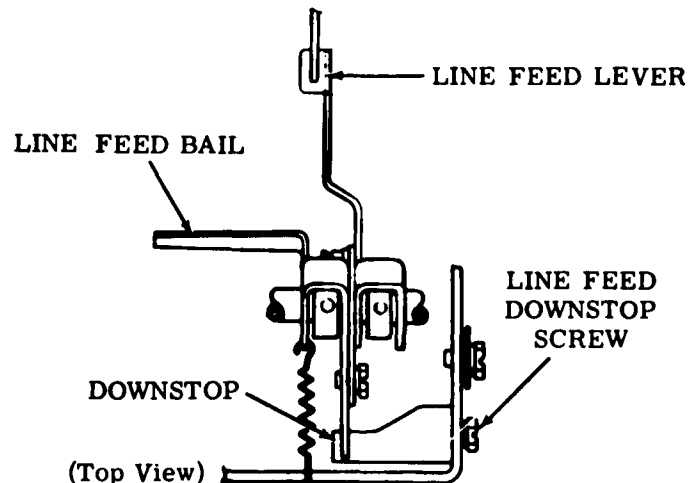

(Top View)

Related Adjustments

Affects
TRIP LEVER ENGAGEMENT —
LINE FEED - S (2.103)
LINE FEED SELECTION - S (2.107)

Affected By
FORM FEED BELT TENSION - S (2.93)
CLUTCH SHOE LEVER GAP - S
(2.94)

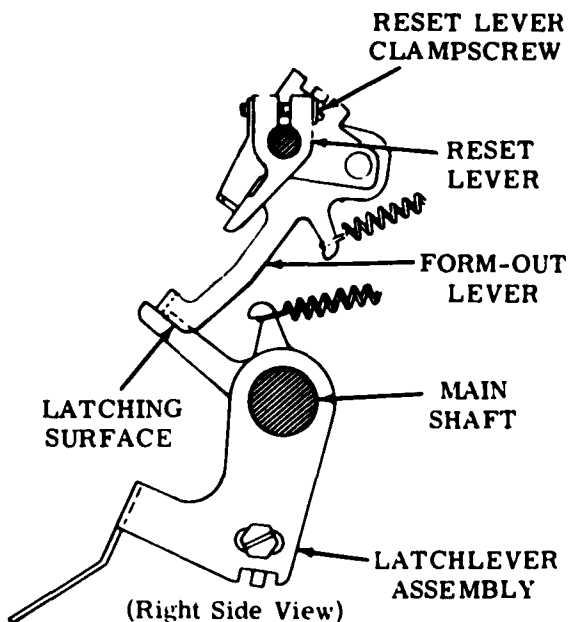

(Right Side View)

2.103 Form Feed Area (continued)

Note 1: The following adjustment applies only to early design typing units.

TRIP LEVER ENGAGEMENT — LINE FEED - S (FOA-11)

To Check

Rotate form feed clutch until a shoe lever just about contacts the trip lever. Place the reset follower lever on the high point of the cam lobe by pushing in on the zeroizing button and rotating the pulley.

(1) Requirement

Top surface of shoe lever should never be above top surface of trip lever.

(2) Requirement

Shoe lever should engage trip lever
Min 2/3 thickness of trip lever.

Note 2: Check Requirement (1) and (2) at each of six shoe levers.

To Adjust

Loosen downstop screw and position downstop so that line feed bail positions trip lever to meet Requirements (1) and (2). Tighten screw.

Related Adjustments

Affects

LINE FEED SELECTION - S (2.107)

Affected By

CLUTCH SHOE LEVER GAP - S (2.94)

TRIP LEVER ENGAGEMENT — FORM-OUT - S (2.102)

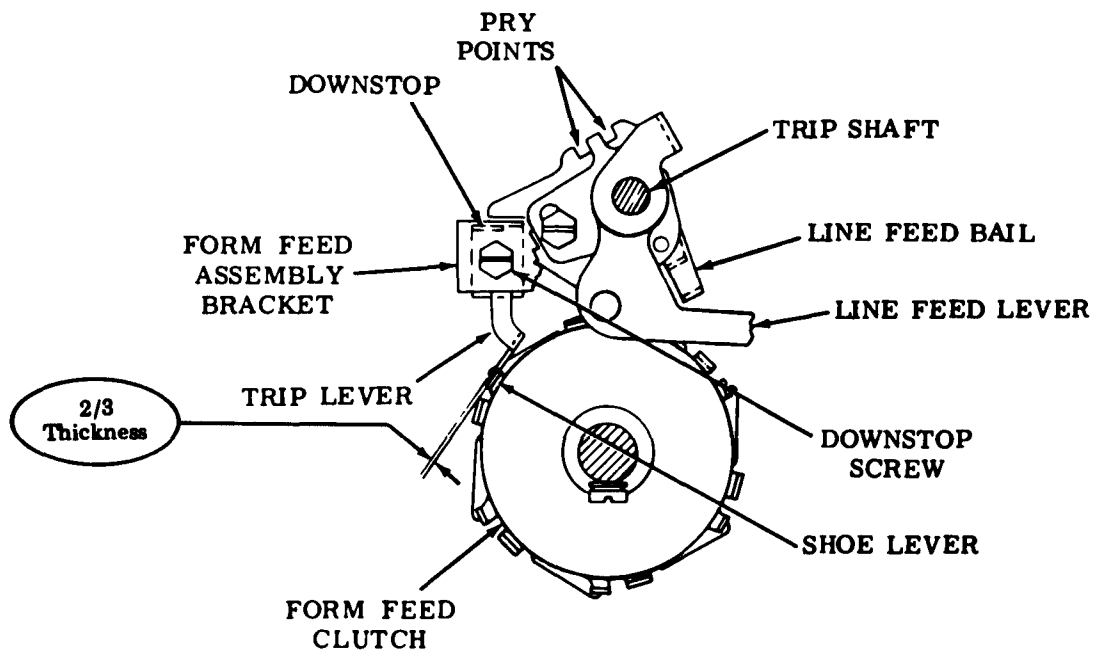

(Left Side View)

2.104 Form Feed Area (continued)

TRIP LEVER ENGAGEMENT (Final) - S (Late Design) (FOA-16)

Note: This adjustment applies to late design typing units containing the TP185998 nickel-plated plate.

To Check

Rotate main shaft until the flat surface of the form feed clutch adjusting disc is positioned as illustrated. Disengage (latch) form feed clutch. Continue rotating main shaft until all clutch mounting screwheads are in a vertical position. Trip form feed clutch and rotate main shaft until the advancing shoe lever is just about to contact the trip lever.

Requirement

With shoe lever not touching but almost in contact with trip lever, the shoe lever thickness should be approximately centered with the trip lever thickness.

To Adjust

Loosen two adjusting plate screws and position adjusting plate by first lowering as far as possible and then raising to meet requirement. This is to insure contact between bottom surface of the trip lever and the stop plate. Tighten both screws.

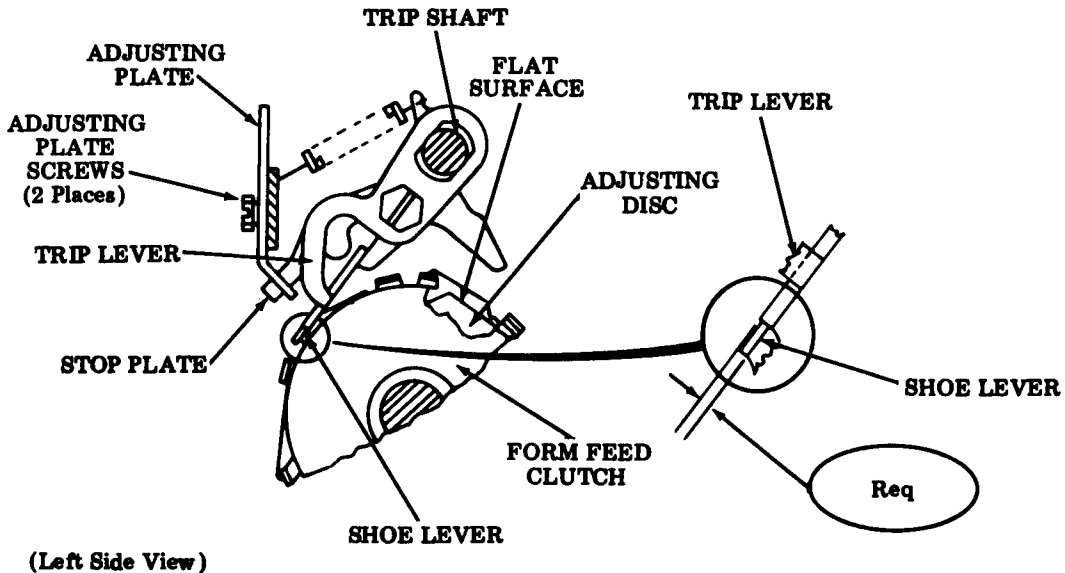
**Related Adjustments****Affects**

FORM-OUT CONTACT OPERATING BAIL CLEARANCE - S (2.112)

Affected By

TRIP LEVER ENGAGEMENT (Preliminary) - S (2.95)

SECTION 574-172-700TC

2.105 Form Feed Area (continued)

TRIP LEVER UPSTOP POSITION - S (FOA-12)

Note: The following adjustment applies only to early design typing units.

To Check

Rotate main shaft until the flat surface of the form feed clutch adjusting disc is positioned as illustrated. Disengage (latch) the form feed clutch. Resume rotating the main shaft until all the clutch mounting screwheads are in a vertical position. Press down the line feed bail to trip clutch and rotate main shaft until stop-lug is directly under the trip lever.

Requirement

Min 0.020 inch — Max 0.035 inch
between trip lever and stop-lug.

To Adjust

Loosen upstop screws and position upstop. Tighten screws.

Related Adjustments

Affects

FORM-OUT CONTACT PRESSURE AND GAP - S (2.112)

Affected By

FORM FEED BELT TENSION - S (2.93)

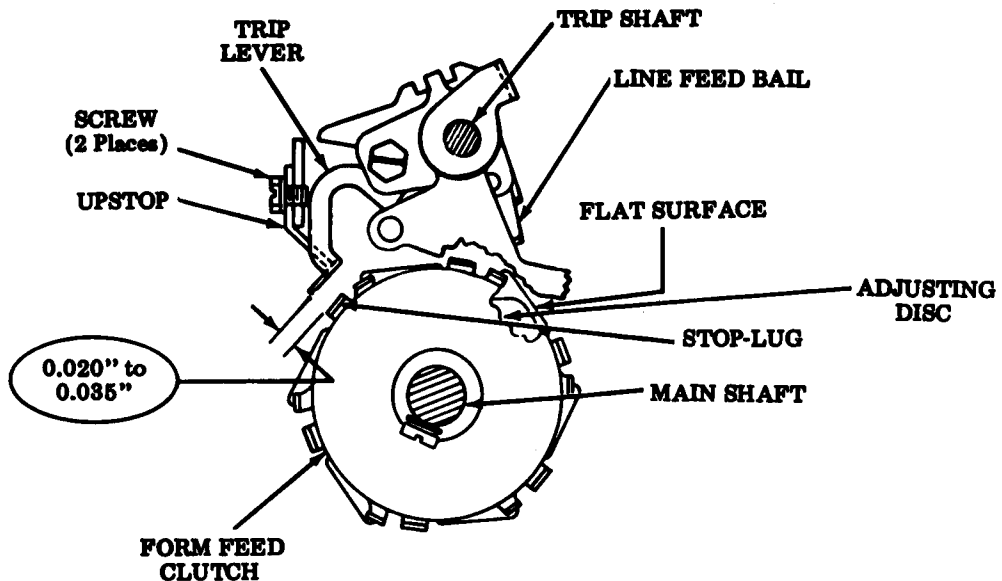

(Left Side View)

2.106 Form Feed Area (continued)

LINE FEED PAWL STRIPPING - S (FOA-18)**To Check**

Set up the typing unit for single line feed (LINE FEED SELECTION - S (2.107) adjustment). Push the line feed strip lever down and allow the line feed upstop pawl to assume its normal position against the line feed pawl. Manually set up the line feed code combination (-2---) in the selector and rotate the main shaft until the line feed pawl just strips off the line feed function lever.

Requirement

The trip lever should fall
Min on---Max 0.035 inch
before stop-lug.

To Adjust

- Loosen screw friction tight. Using pry points position line feed strip lever rearward three-fourths of its full adjusting range.
- Check LINE FEED SELECTION - S (2.107) adjustment for single line feed.
- Set up line feed code combination (-2---) in selector and rotate main shaft until line feed pawl just strips off line feed function lever.
- Check requirement and tighten screw if requirement is met.
- If requirement is not met, move line feed strip lever slightly toward front of typing unit. Repeat steps (b), (c), and (d). Continue this procedure until requirement is met.

Related Adjustments**Affected By**

RIGHT ROCKER DRIVE (Function Area)
(2.34)

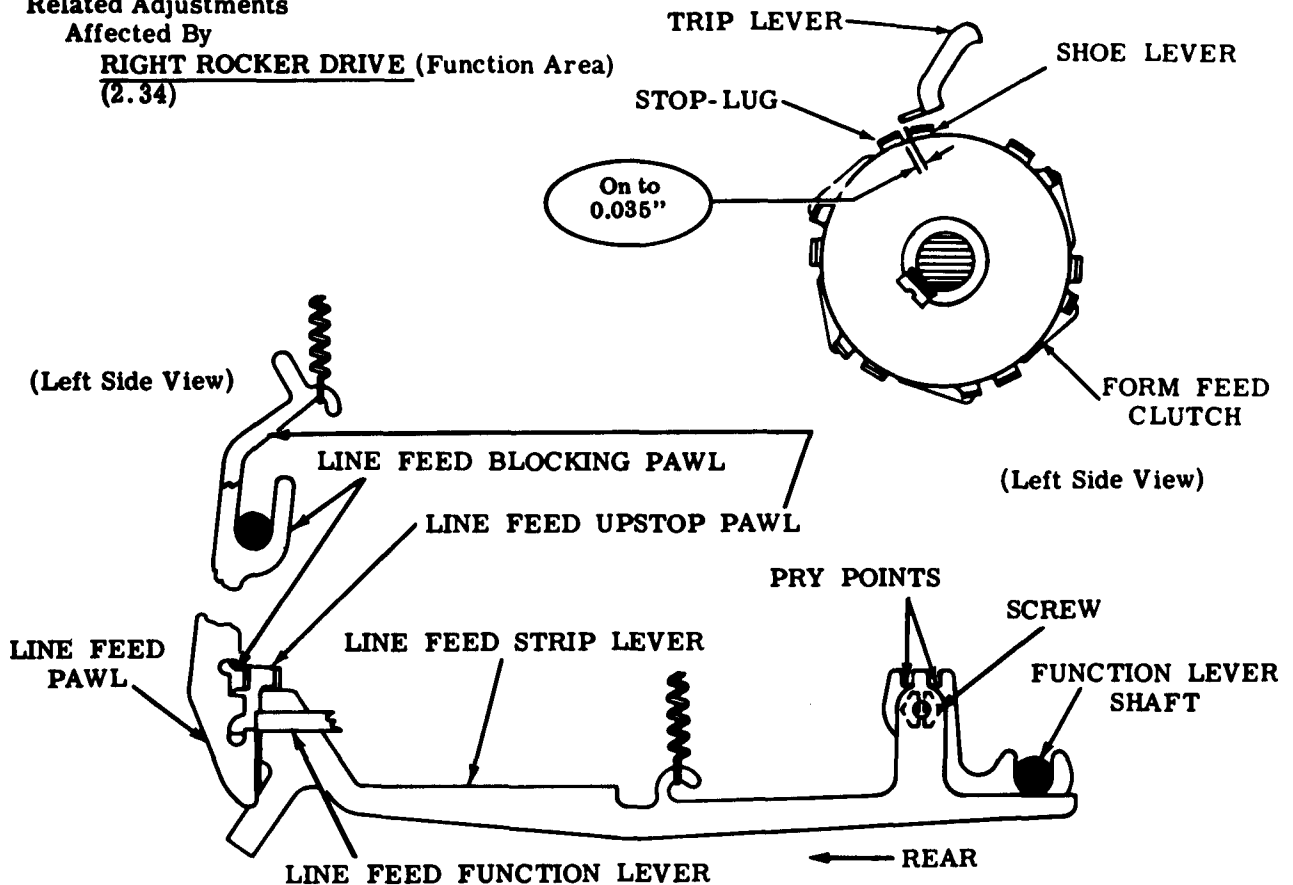

2.107 Form Feed Area (continued)

LINE FEED BAIL SPRING - S

Requirement

Early Design

Min 4 oz---Max 8 oz

Late Design

Min 2 oz---Max 4 oz
to pull line feed bail spring to installed length.

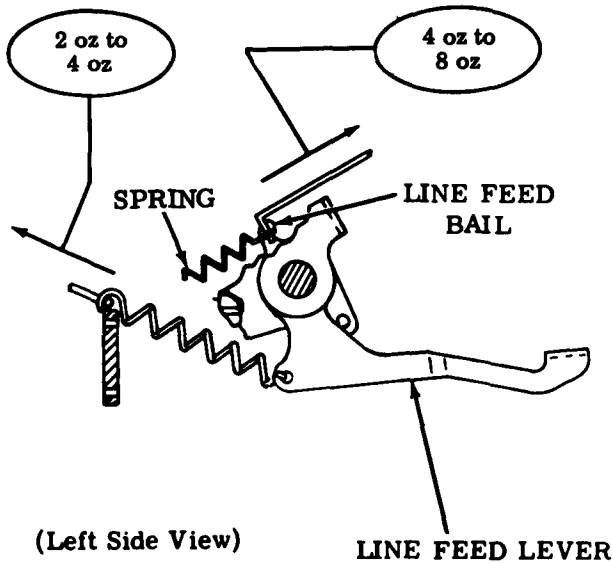

(Left Side View)

LINE FEED SELECTION - S (FOA-13 or FOA-17)

To Check

Place typing unit in stop condition.

Requirement

Single line feed

Min 0.110---Max 0.130 inch
between pawl and line feed lever.

Double line feed

Min zero---Max 0.010 inch
between pawl and line feed lever.

To Adjust

Early Design (FOA-13)

While holding rear part of line feed lever against downstop, loosen screw friction tight. Position line feed lever using pry points. Tighten screw.

Late Design (FOA-17)

With screw friction tight, position line feed lever using pry points. Tighten screw.

Related Adjustments

Affected By

- FORM FEED BELT TENSION - S (2.93)
- TRIP LEVER ENGAGEMENT -
- LINE FEED - S (2.103)
- TRIP LEVER ENGAGEMENT -
- FORM-OUT - S (2.102)

LINE FEED LEVER SPRING - S

Requirement

Early Design

With arm held against downstop
Min 21 oz---Max 35 oz
to start line feed lever moving.

Late Design

Min 27 oz---Max 40 oz
to push arm down until line feed lever contacts pawl.

Note: Late design typing units are not equipped with a downstop.

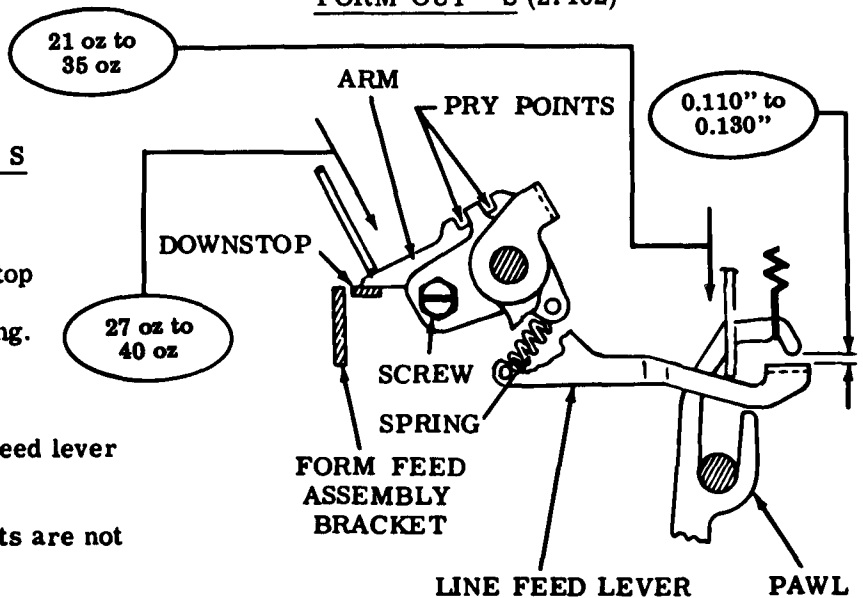

(Left Side View)

2.108 Platen Area (continued)

DETENT POSITION - S (FOA-26)

CAUTION: TO PREVENT ELECTRICAL SHOCK EXERCISE CARE WHEN WORKING WITH TYPING UNIT UNDER POWER.

To Check

Set up line feed code combination (-2---) in selector. Place TP185832 armature clip so as to hold armature attracted. Plug in typing unit plugs into proper call control receptacles and apply power to typing unit. Engage code-bar clutch to permit a line feed cycle to complete itself under power. Check requirement. Remove all power connections.

(1) Requirement

The pawl should be fully seated with a Max 0.007 inch between pawl and detent ratchet tooth.

(2) Requirement

Min some---Max 0.030 inch between the plate and detent ratchet.

To Adjust

Loosen both setscrews. Use finger pressure to engage and hold pawl firmly in detent ratchet. Depress line feed keytop. Tighten setscrews.

Related Adjustments

Affected By

- FORM FEED BELT TENSION - S
(Form Feed Area) (2.93)
- PLATEN — HORIZONTAL POSITION - S
(2.88, 2.89)
- VERTICAL TYPE ALIGNMENT - S
(2.89, 2.90)
- IDLER POSITION - S (2.99)

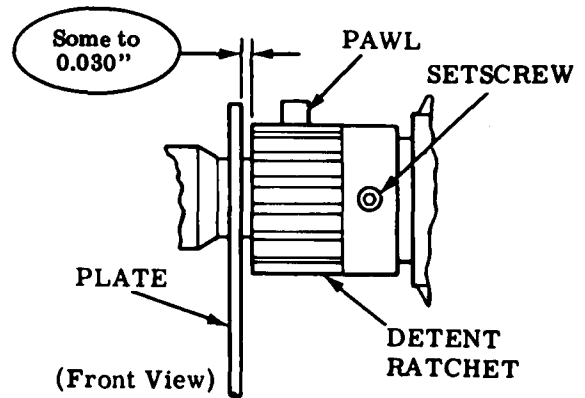

DETENT RATCHET PAWL SPRING - S

Requirement

With a spring scale positioned under detent ratchet pawl
Min 24 oz---Max 30 oz
to start pawl moving.

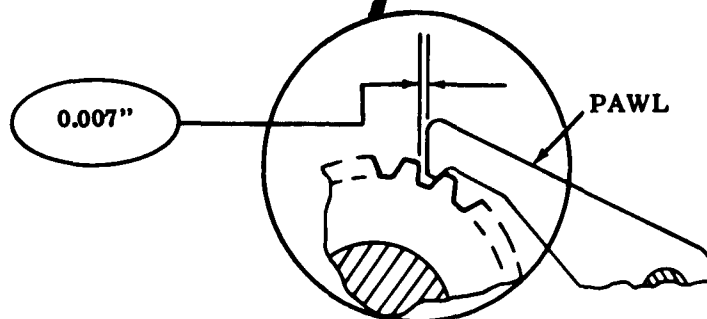
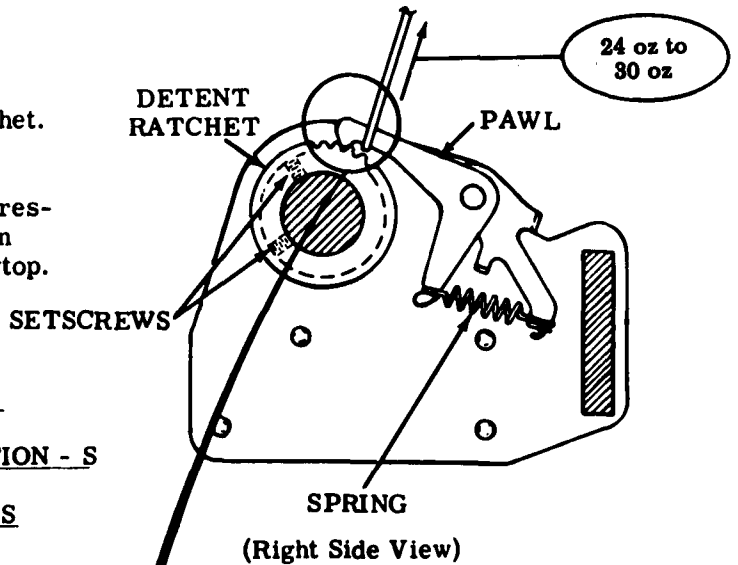

2. 109 Platen Area (continued)

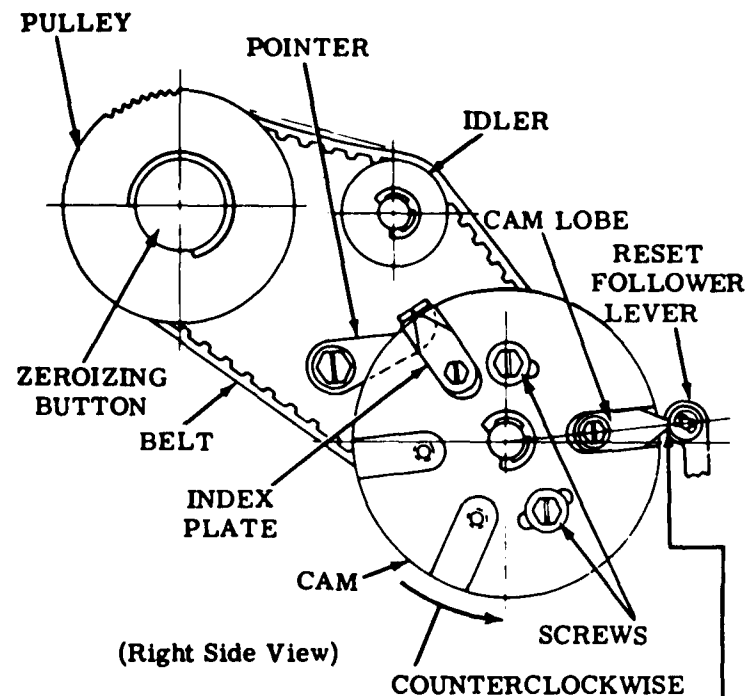

(A) RESET FOLLOWER LEVER — RESET POSITION - S (FOA-30)

CAUTION: TO PREVENT ELECTRICAL SHOCK EXERCISE CARE WHEN WORKING WITH TYPING UNIT UNDER POWER.

To Check

Set up form-out code combination (1---5) in selector. Place TP185832 armature clip so as to hold armature attracted. Plug typing unit plugs into proper call control unit receptacles and apply power to typing unit. Engage codebar clutch to permit a form-out cycle to complete itself under power. Check requirement. Remove all power connections.

Requirement

At the end of form-out cycle, reset follower lever should come to rest on flat surface of cam lobe.

To Adjust

Loosen screws and adjust cam. Tighten screws.

Related Adjustments

Affects

CAM ZERO POSITION - S (2.109, 2.110)

Affected By

FORM FEED BELT TENSION - S (2.93)

IDLER POSITION - S (2.99)

PLATEN — HORIZONTAL POSITION - S (2.88, 2.89)

VERTICAL TYPE ALIGNMENT - S (2.89, 2.90)

(B) CAM ZERO POSITION - S (FOA-31)

To Check

With cam lobes and index plates located on cam as shown on associated line drawings, place typing unit in stop condition.

Note: Reset follower lever must rest on proper cam lobe to zero a sprocket form. Place it in such position by depressing zeroizing button and rotating pulley until reset follower lever rests on cam lobe opposite three closely spaced grooves (on cam) facing toward the front of typing unit.

One cam lobe (FOA-32):

(1) **Requirement**

With reset follower lever on flat surface of cam lobe and zeroizing button in its right most position
Min some---Max 0.035 inch between bottom surface of pointer and low part of cam.

(2) **Requirement**

When viewed along line-of-sight shown, tip of pointer should be aligned with index plate aluminized surface, as gauged by eye.

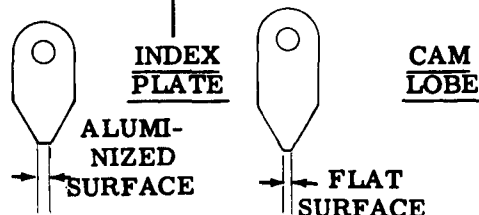
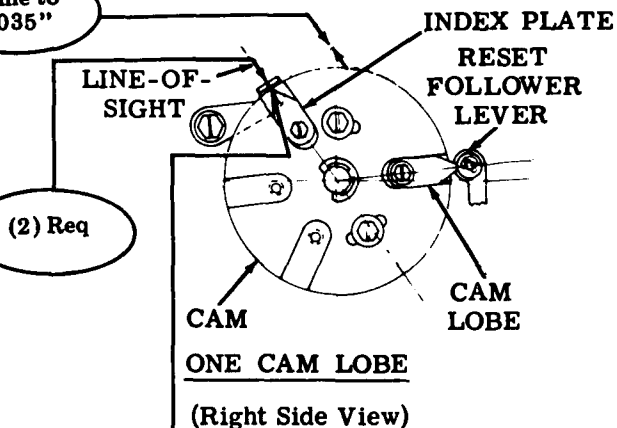
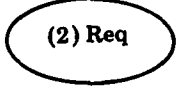
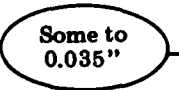
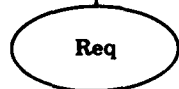

2.110 Platen Area (continued)

CAM ZERO POSITION - S (continued)

Two cam lobes (FOA-33):

- (1) Requirement
With reset follower lever on flat surface of cam lobe and zeroizing button in its rightmost position
Min some---Max 0.035 inch between bottom surface of pointer and low part of cam.
- (2) Requirement
When viewed along line-of-sight shown, tip of pointer should be aligned with index plate aluminized surface, as gauged by eye.

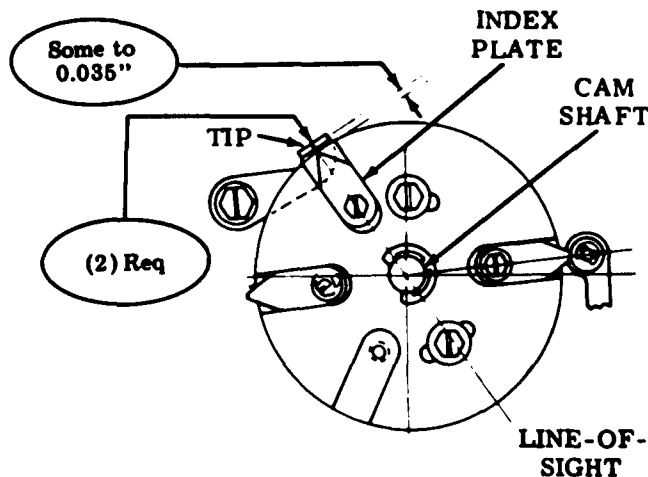

TWO CAM LOBES

Three cam lobes (FOA-34):

- (1) Requirement
With reset follower lever on flat surface of cam lobe A and zeroizing button in its rightmost position
Min some---Max 0.035 inch between bottom surface of pointer and low part of cam.
- (2) Requirement
When viewed along line-of-sight shown, tip of pointer should be aligned with flat surface of lobe B, as gauged by eye.

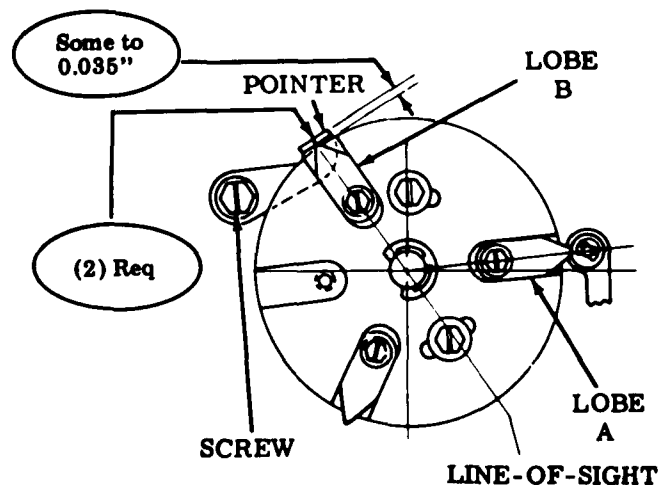

THREE CAM LOBES

(Right Side Views)

To Adjust
Loosen screw and position pointer. Tighten screw.

Related Adjustments

Affected By

- FORM FEED BELT TENSION - S (2.93)
- IDLER POSITION - S (2.99)
- RESET FOLLOWER LEVER —
- RESET POSITION - S (2.109)

2.111 Platen Area (continued)

FORM LENGTH SELECTION - S (FOA-39)

To Check

The control cam of the platen drive mechanism normally will come with two cam lobes. This causes sprocket forms to feed out one-half the basic form length.

Requirement

A longer form length.

To Adjust

Line up the pointer with the aluminized surface of the index plate. Remove and discard the cam lobe which is located in the other side of the control cam opposite the reset follower lever.

Note: A listing of gears which provide various form feed lengths can be found in the appropriate parts section.

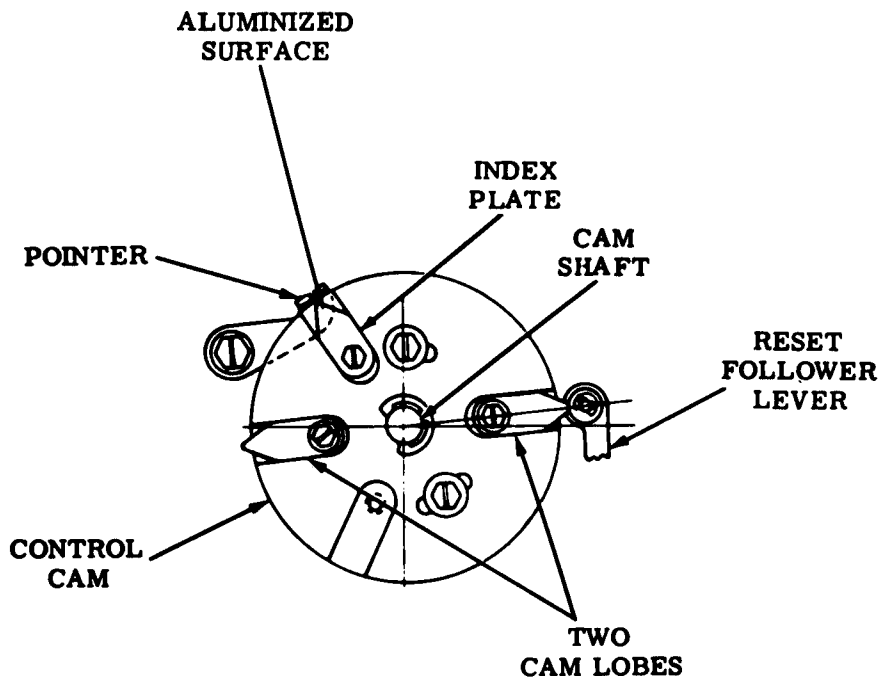

(Right Side View)

2.112 Form Feed Area (continued)

FORM-OUT CONTACT OPERATING BAIL CLEARANCE - S (FOA-20)

To Check

With the typing unit in stop condition, place the reset follower lever on the low part of the cam by pushing in on the zeroizing button and rotating the pulley until the required situation is obtained.

Requirement

Min 0.005 inch---Max 0.015 inch between form-out bail and insulator.

To Adjust

Loosen clamp screw and position contact bracket. Tighten clamp screw.

Related Adjustments

Affected By

TRIP LEVER ENGAGEMENT -- FORM-OUT - S (2.102)

FORM-OUT BAIL SPRING - S

Requirement

With the form-out lever latched

Min 4 oz---Max 8 oz to start form-out bail spring moving.

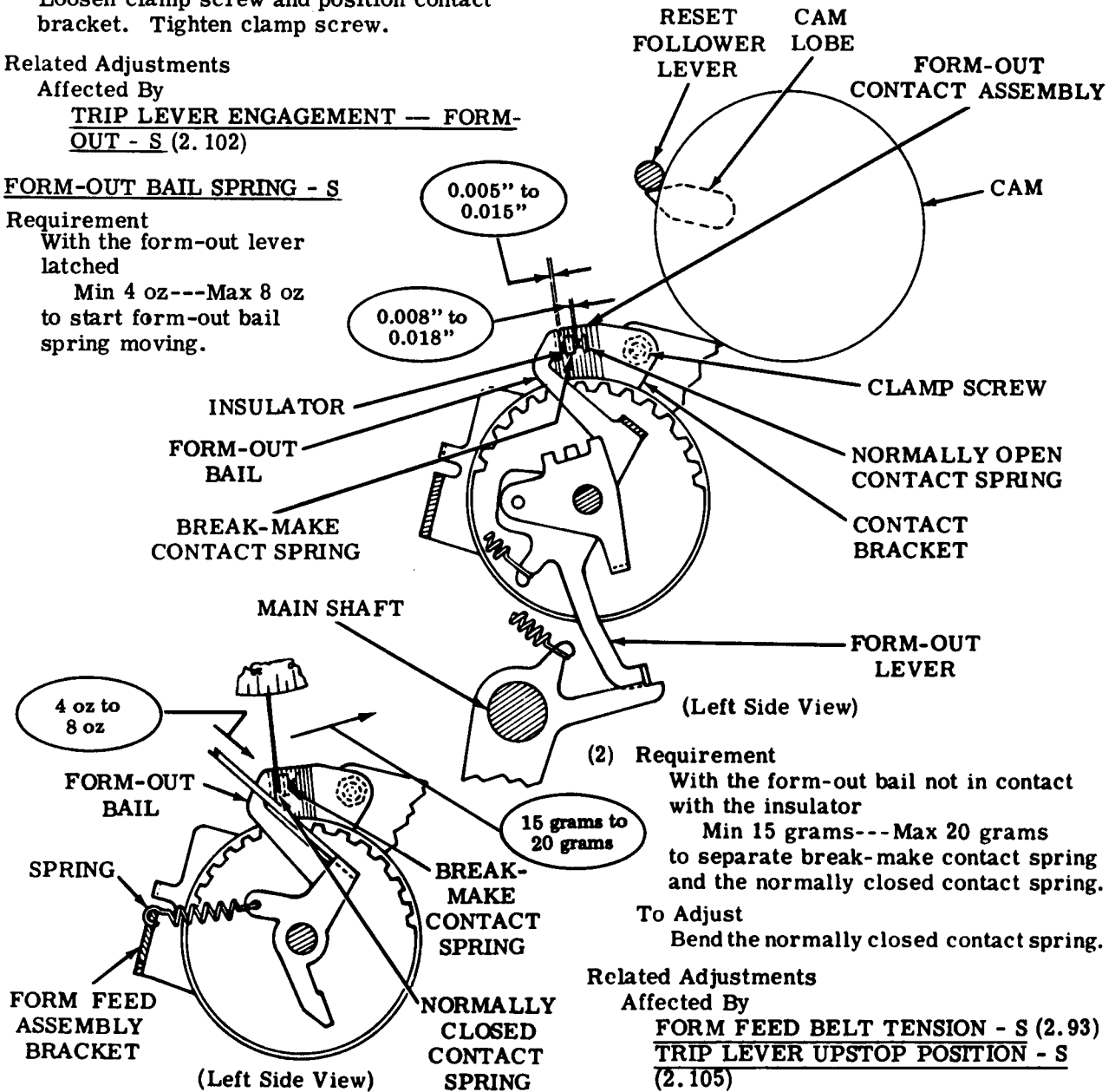

FORM-OUT CONTACT PRESSURE AND GAP - S (FOA-19)

(1) Requirement

With the form-out bail not in contact with the insulator

Min 0.008 inch---Max 0.018 inch between a contact of the break-make contact spring and the contact of the normally open contact spring.

To Adjust

Bend the normally open contact spring.

(2) Requirement

With the form-out bail not in contact with the insulator

Min 15 grams---Max 20 grams to separate break-make contact spring and the normally closed contact spring.

To Adjust

Bend the normally closed contact spring.

Related Adjustments

Affected By

FORM FEED BELT TENSION - S (2.93)
TRIP LEVER UPSTOP POSITION - S (2.105)

2.113 Platen Area (continued)

PRINTING LINE POSITION (Preliminary) - S
(FOA-27)

(1) Requirement

The left sprocket ring pins should be centrally located within the paper guide slot.

To Adjust

Loosen setscrews and position the left sprocket ring.

Note: Do not tighten setscrews until adjustment has been completed.

(2) Requirement

With the setscrews of the left and right sprocket rings in line, place a single sprocket form on the platen with the sprocket form feed holes over the left and right sprocket ring pins. The left and right sprocket ring pins should be in line and centrally located in the sprocket form feed holes.

To Adjust

Loosen setscrews and position the left and/or right sprocket rings as required. Tighten all setscrews.

Related Adjustments

Affects

RIGHT PAPER GUIDE POSITION - S
(2.115)

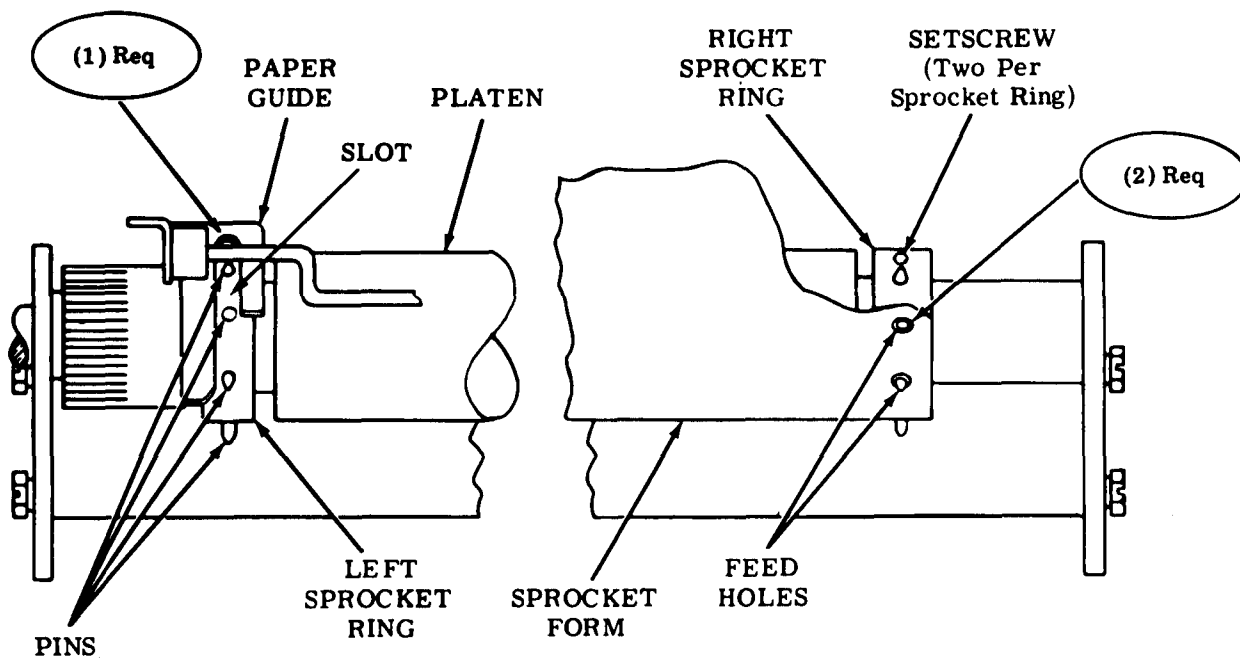

(Front View)

2.114 Platen Area (continued)

PRINTING LINE POSITION (Final) - S (FOA-27)

To Check

Place a single sheet of sprocket form in platen mechanism. Print the character M several times to establish a printed line.

Note: On nonprinted forms, draw a horizontal line across form connecting bottom of sprocket feed holes.

Requirement

Printed Form

Printed line should be aligned with sprocket form lines.

Nonprinted Form

- (a) Printed line should be aligned with drawn line.
- (b) Printed line should not touch drawn line.
- (c) Printed line should not be more than 1/32 inch above drawn line with no more than 1/64 inch variation along its entire length.

To Adjust

Early Design

Modify Requirement (2) of PRINTING LINE POSITION (Preliminary) - S (2.113)

Late Design (containing adjusting clamp screw)

Loosen clamp screw and position platen. Tighten clamp screw.

Related Adjustments

Affects

RIGHT PAPER GUIDE POSITION - S (2.115)

Affected By

PRINTING LINE POSITION (Preliminary) - S (2.113)

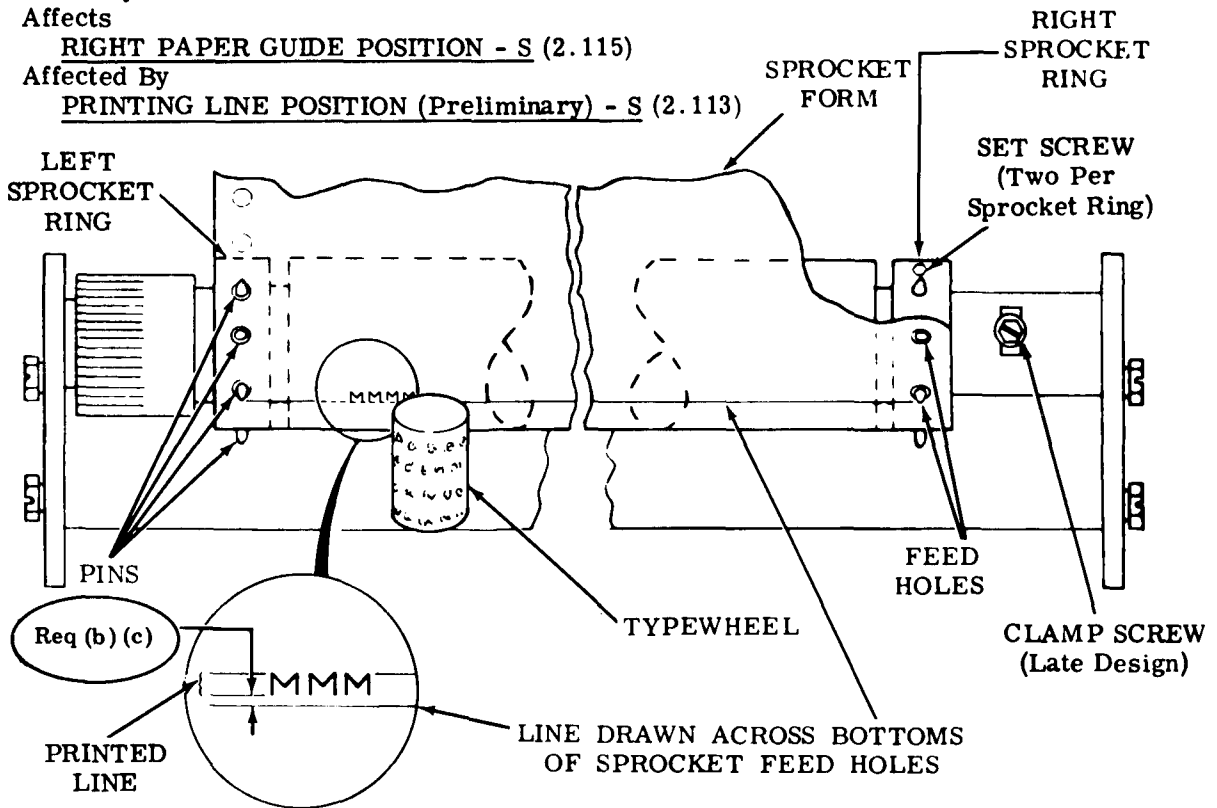

(Front View)

2.115 Platen Area (continued)

RIGHT PAPER GUIDE POSITION - S (FOA-28)

Requirement

The right sprocket ring pins should be centrally located within the paper guide slot.

To Adjust

Loosen screws and position right paper guide.
Tighten screws.

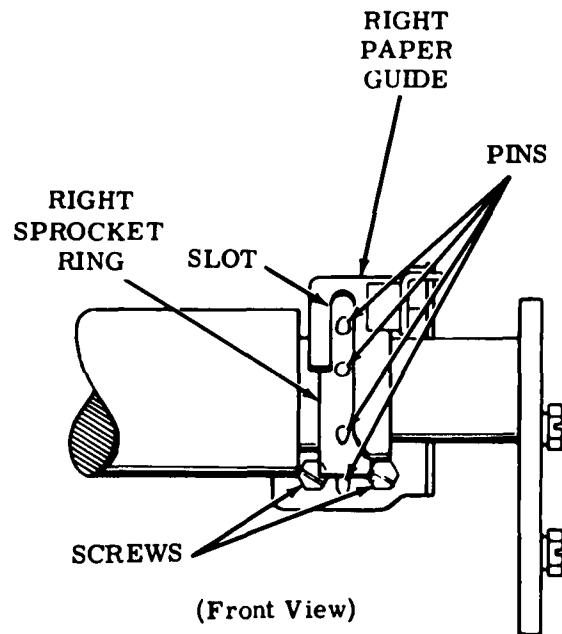

Related Adjustments

Affected By

PRINTING LINE POSITION (Final) - S (2.114)

2.116 Platen Area (continued)

WIRE GUIDE POSITION - S (FOA-29)**To Check**

Put a sprocket form containing several lines of printed copy in the unit. Place platen in its detented position with top edge of form feed holes engaging top edge of sprocket ring pins. Place left and right paper guides in contact with their associated sprocket rings in contact with their associated sprocket rings.

Requirement

The wire guide should fully contact the sprocket form and should be centrally located between the lines of printed copy with a maximum of 1/2 line overlap.

To Adjust

Loosen setscrew at each end of wire guide. Hold paper guides against their sprocket rings and position wire guide. Tighten both setscrews.

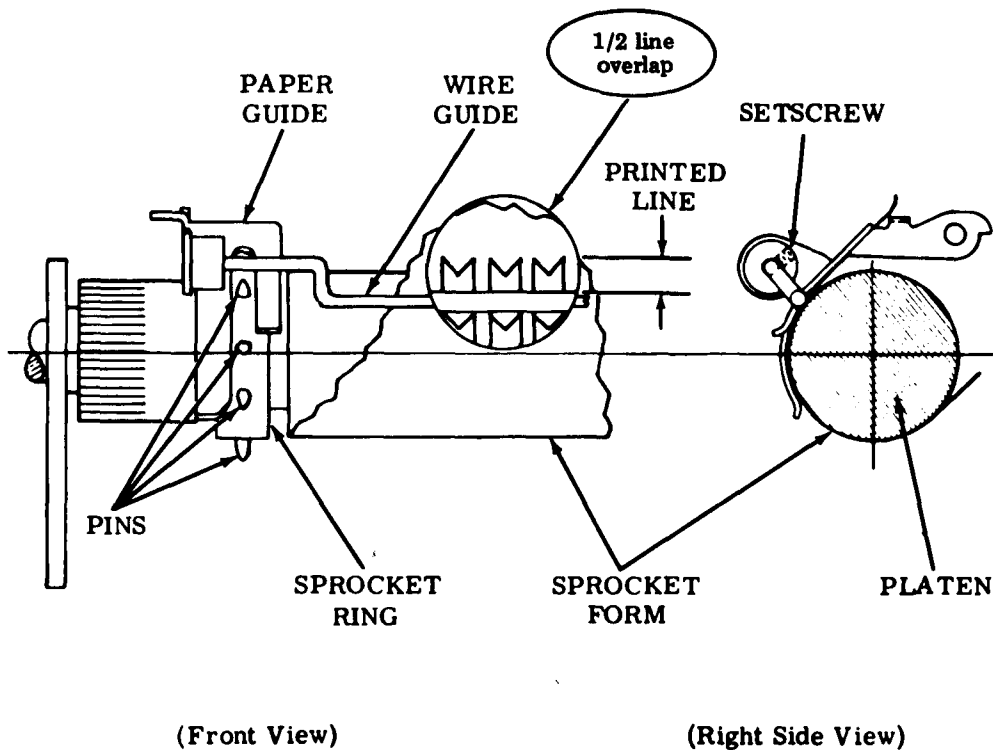
**Related Adjustments****Affected By**

PLATEN — HORIZONTAL POSITION - S (2.88)

VERTICAL TYPE ALIGNMENT - S (2.89, 2.90)

2.117 Platen Area (continued)

LEFT MARGIN POSITION - S (FOA-35)

To Check

Place platen knob screw in a vertical position and carriage to the left hand margin. Fully seat piston in dashpot cylinder.

(1) Requirement

Approximately 3/8 inch between edge of sprocket ring pin and V-projection.

(2) Requirement

Min 0.030 inch between the closest sprocket ring pin and ribbon guide.

To Adjust

Loosen two dashpot cylinder mounting screws and position dashpot cylinder. Tighten screws.

Related Adjustments

Affects

- RIGHT MARGIN POSITION - S (2.117)
- CARRIAGE RETURN LEVER —
- UNLATCH CLEARANCE (2.74)
- LEFT MARGIN PRINTING (2.119)

RIGHT MARGIN POSITION - S (FOA-36)

To Check

Place carriage to the right to the 72nd character position. Hold feed pawl out of engagement with spacing ratchet, so that only check pawl is engaged.

Requirement

Min 0.030 inch between right sprocket ring pin and ribbon guide.

To Adjust

Refine LEFT MARGIN POSITION - S (2.117) adjustment.

Related Adjustments

Affected By

LEFT MARGIN POSITION - S (2.117)

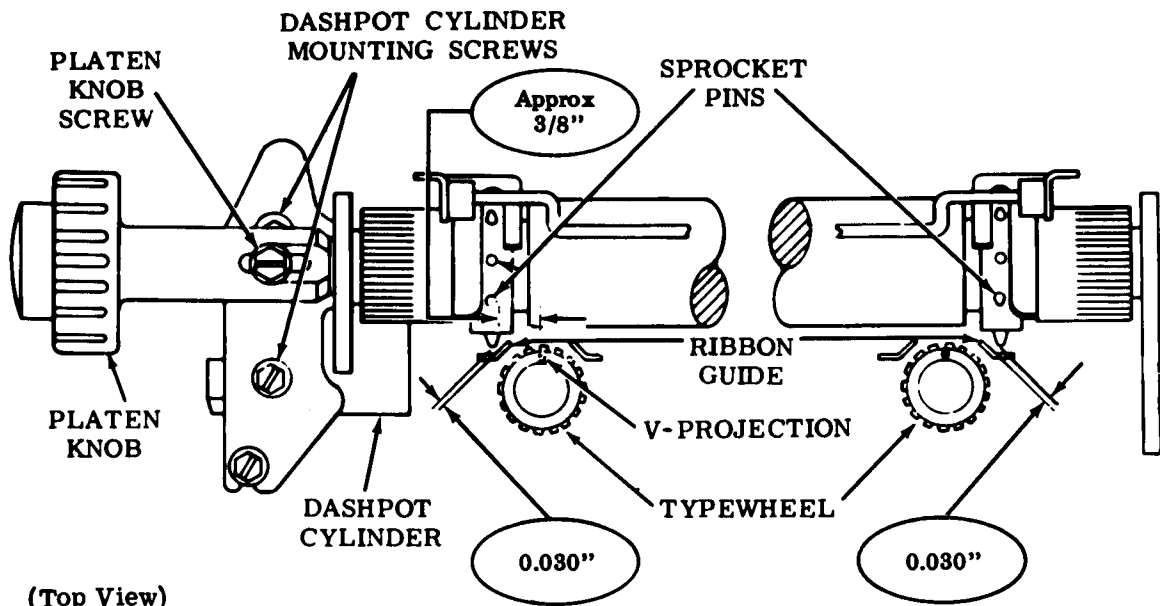

(Top View)

2.118 Paper Controls (Paper Alarm Control Area)

(A) PAPER ALARM CONTACT PRESSURE AND GAP - S (FOA-40)

(1) Requirement

With the paper alarm lever not in contact with insulator
 Min 15 grams---Max 20 grams to separate the contacts of the break-make contact spring and normally closed contact spring.

(C) PAPER LEVER SPRING - S

Note: This spring tension is to be checked after the PAPER ALARM CONTACT PRESSURE AND GAP - S (FOA-40) and PAPER ALARM CONTACT LEVER CLEARANCE - S (FOA-41) requirements are satisfied.

To Check

Place a single sheet of a sprocket form between the paper alarm lever and paper guideplate. Hold the sprocket form taut over the cutout in the paper guideplate and allow the paper alarm lever to rest on the sprocket form. Position a spring scale over the paper alarm lever at the rectangular opening in the paper guideplate.

Requirement

Min 1 oz---Max 1-1/2 oz to move paper alarm lever from sprocket form.

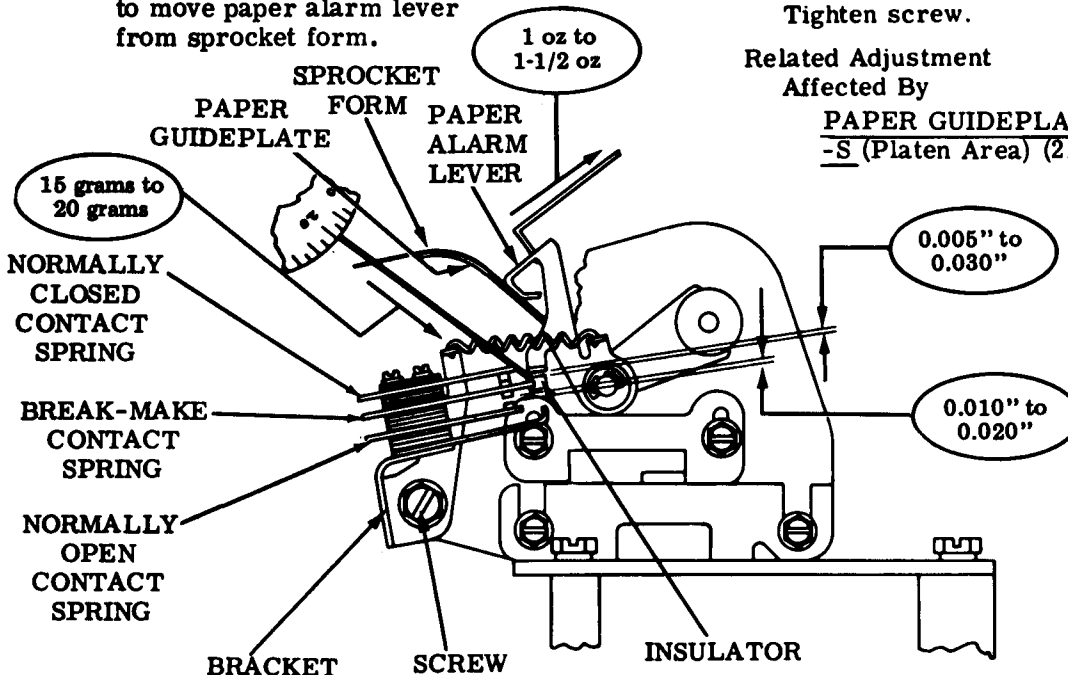

(Left Side View)

(2) Requirement

With the paper alarm lever not in contact with insulator
 Min 0.010 inch---Max 0.020 inch between the contacts of the break-make contact spring and the normally open contact spring.

To Adjust

Bend normally closed contact spring.

Related Adjustment

Affected By

PAPER GUIDEPLATE CLEARANCE -S (Platen Area) (2.91)

(B) PAPER ALARM CONTACT LEVER CLEARANCE - S (FOA-41)

To Check

Place a single sheet of a sprocket form between the paper alarm lever and paper guideplate. Hold the sprocket form taut over the cutout in the paper guideplate.

Requirement

Min 0.005 inch---Max 0.030 inch between insulator and paper alarm lever.

To Adjust

Loosen screw and position bracket. Tighten screw.

Related Adjustment

Affected By

PAPER GUIDEPLATE CLEARANCE -S (Platen Area) (2.91)

2.119 Spacing Area (continued)

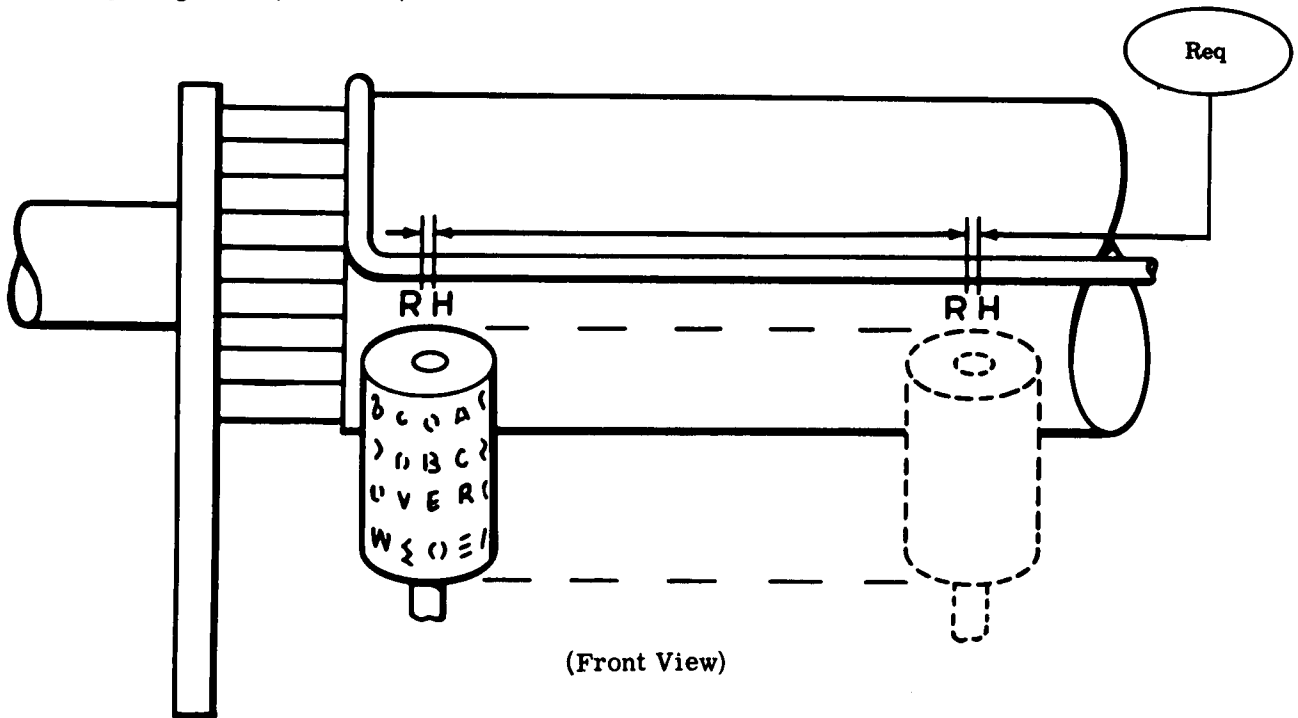

Note: FEED PAWL TRAVEL (2.67) adjustment **MUST** be rechecked in conjunction with this adjustment.

LEFT MARGIN PRINTING (MDA-6)

To Check

Print two or more characters such as RH at left margin and at center of line.

Requirement

Character to character spacing approximately same as center of line as at left margin.

To Adjust

With spacing ratchet clamp screws friction tight, seat piston firmly in the dashpot. Rotate the carriage return arm counter-clockwise to permit the feed pawl and check pawl to move toward the spacing ratchet. Position the spacing ratchet so that the check pawl rests on top of a spacing ratchet tooth. Tighten spacing ratchet clamp screws. Recheck requirement and refine adjustment if necessary.

Related Adjustments

Affects

- FEED PAWL TRAVEL (2.67)
- RIGHT MARGIN POSITION - S (2.117)

Affected By

- SPACING BELT TENSION (2.68)
- LEFT MARGIN POSITION - S (Platen Area) (2.117)
- LEFT MARGIN POSITION - F (Platen Area) (2.71)

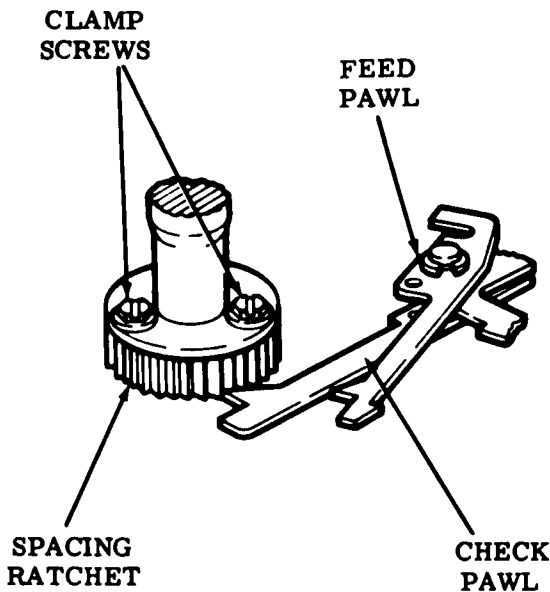

(Left Front View)

2.120 Function Area (continued)
LINE LENGTH SELECTION (MDA-3)

(1) Requirement (Units with end-of-line space suppression)

Select the proper line length as follows:
 With the carriage located one character before the end of a line (for example: character 71 on a 72 character line), rotate the main shaft until the carriage drive bail reaches its rearmost position

Min 0.025 inch---Max 0.100 inch
 between end-of-line lever and spacing toggle link.

To Adjust

Early Design: Loosen clampscrew and position belt clamp and extension. Tighten clampscrew.

Late Design: Bend tabs away from belt and position belt clamp. Crimp belt clamp and tabs securely on belt.

Note: Use either TP180948 or TP183498 automatic codebar and no other on typing units equipped with end-of-line space suppression.

(2) Requirement (Units with automatic carriage return-line feed)

Select either a 69, 72, or 74 character line length. The left edge of the last printed character (69, 72, or 74) at the end of a complete line may touch the right edge of the next to last character. Also, the last printed character may be displaced vertically below the next to last character by as much as 1/4 character for single line feed or 1 character for double line feed.

To Adjust

TP180948 Automatic Codebar: On sprocket feed units using TP180948 codebar, do not break off any projections. On friction feed units, break off projections on TP180948 codebar as follows:

Line Length (Characters)	End-of-Line Bell (Characters)	Projection Removed
69	65	None
72	68	1
74	70	1 and 2

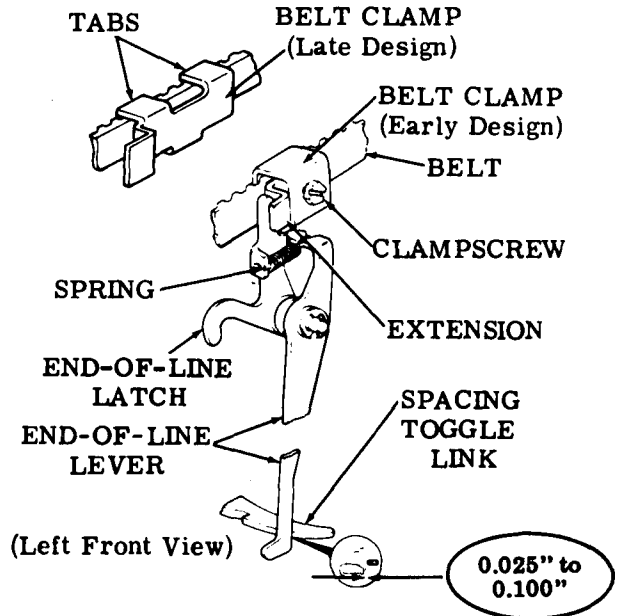

TP183495, TP183496, TP183497 automatic codebars: Use the proper automatic codebar as follows:

Line Length (Characters)	End-of-Line Bell (Characters)	Automatic Codebar
69	68	TP183495
72	71	TP183496
74	73	TP183497

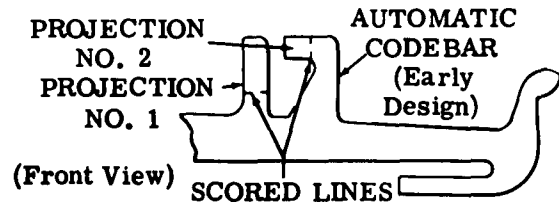

Note 1: Use either TP180948 or TP183498 automatic codebar and no other on typing units equipped with end-of-line space suppression.

Note 2: The late design TP183495-96-97 or 98 codebar must be used with the TP185971 set of parts providing the end-of-line bell to ring on the 61st character.

Related Adjustments

Affected By

LEFT MARGIN PRINTING (2.119)

LEFT MARGIN POSITION - S (2.117)

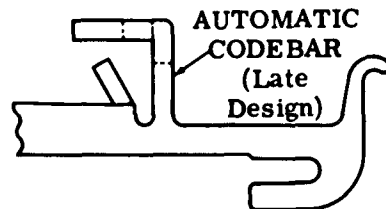

2.121 Function Area (continued)

MARGIN BELL BELLCRANK CLEARANCE
(MDA-7)

(A) To Check

Place carriage at left margin. Place typing unit in stop position.

(1) Requirement

Min 0.005 inch---Max 0.020 inch between the bellcrank extension and the "A" codebar when the bellcrank upstop is held against the upper surface of the cutout in the rear rail.

(2) Requirement

The bell function lever extension and the "A" codebar should fully engage.

To Adjust

Using the TP180993 bending tool, bend vertical leg of bellcrank to meet Requirement (1) and bend the bell function lever extension to meet Requirement (2).

Note: This adjustment applies only to typing units equipped with the margin bell feature to ring on approximately the 61st character for friction feed units and approximately the 63rd character for sprocket feed units. (It is permissible for bell to ring twice as carriage is spaced along the line.)

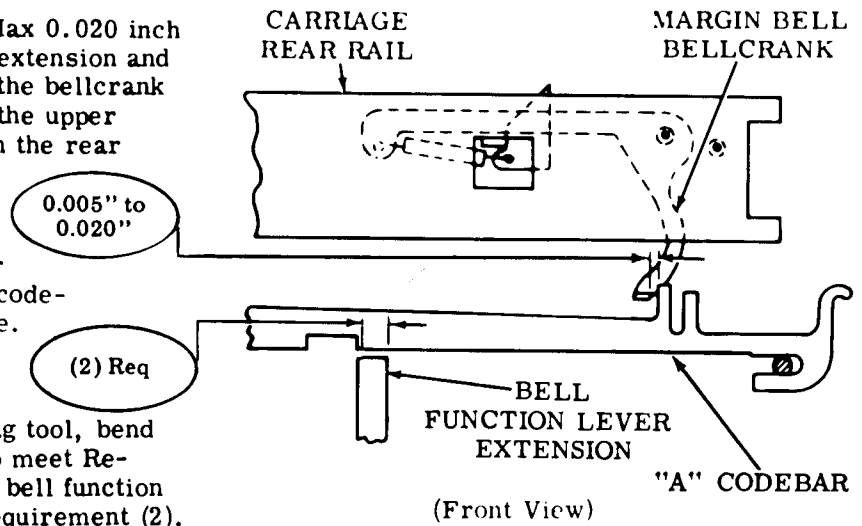

Note: This adjustment applies only to typing units equipped with combination of automatic carriage return and margin bell features.

(B) To Check

By positioning carriage to approximately the 61st character, upper rear carriage roller will fully depress latch on margin bell bellcrank.

Requirement

Automatic carriage return function lever extension and "A" codebar should fully engage.

To Adjust

Using TP180993 bending tool, bend automatic carriage return function lever extension to meet requirement.

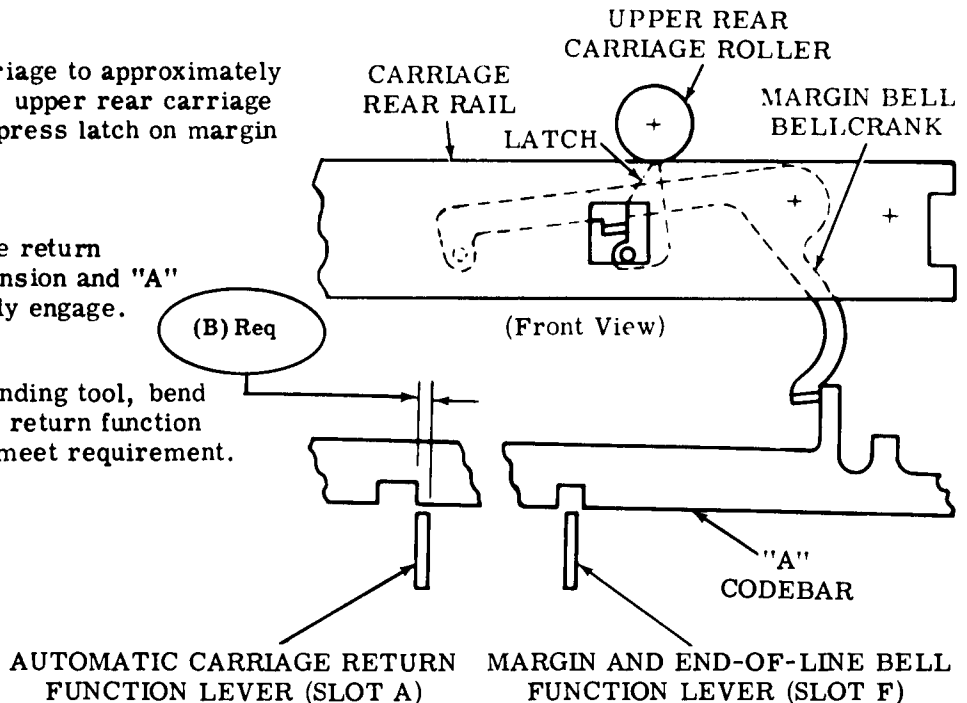

2.122 Function Area (continued)

END-OF-LINE BELL SIGNAL - S (FOA-37)

Note: This requirement applies only to sprocket feed typing units equipped with TP180948 automatic codebar.

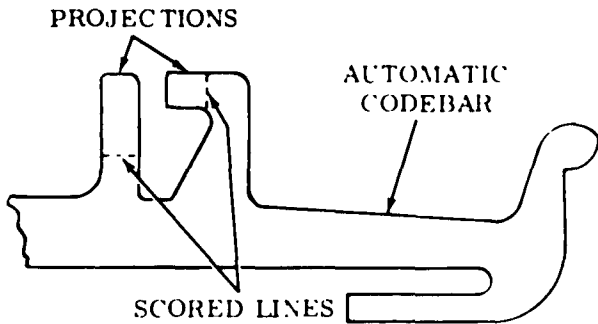

(Front View)

Requirement

The bell should ring at approximately the 68th character.

To Adjust

The automatic codebar projections must not be removed. Replace codebar.

2.123 Selector Area (continued)

RECEIVING MARGINS (FPA-1)

To Check

Set up test situation using typing unit and Signal Distortion Test Set to check selector receiving margins.

Requirement

Obtain minimum selector receiving margins as follows:

<u>SPEED</u>	<u>RANGE ZERO DISTORTION</u>	<u>OVERALL BIAS</u>	<u>END DISTORTION</u>
All Speeds	Set at 72	38 Percent*	35 Percent*

*At same range scale setting.

To Adjust

Refine ARMATURE SPRING (2.20) and, if necessary, refine ARMATURE BRACKET POSITION (Preliminary) (2.18) and/or BELT TENSION (Motor Area) (2.02) adjustments.

Note: The refinement of the ARMATURE BRACKET POSITION (2.18) or BELT TENSION (Motor Area) (2.02) adjustment need not be performed unless the refinement of the ARMATURE SPRING (2.20) adjustment fails to bring about the minimum selector receiving margins.

Related Adjustments

Affected By

- ARMATURE BRACKET POSITION (2.18)
- ARMATURE SPRING (2.20)
- SHOE LEVER GAP AND TRIP LEVER ENGAGEMENT (2.19)

2.124 Carriage Area (continued)

FINAL PRINTING ALIGNMENT (FPA-2)

Note 1: When typing unit is adjusted as instructed on previous pages, quality of printed copy should be good. However, minor readjustments may be necessary.

To Check

Print TH at various points along length of printing line.

Requirement

Quality of printed characters should be good.

To Adjust

Use the following guide in making readjustments.

Shading of top and bottom of characters not equal and/or underscoring or overscoring of characters ---

---refine VERTICAL TYPE ALIGNMENT - F (Platen Area) (2.70) or -S (2.89, 2.90) adjustment by either moving typewheel vertically (late design) or moving platen toward portion of light shading (early design).

Note 2: The following punctuation marks comma (,), apostrophe ('), dash (-), underline (_), and period (.), may exhibit underscoring or overscoring. The overscoring or underscoring is acceptable on these characters provided the nature of another character is not changed and the mark is not interpreted as a character.

Left character T or poor quality ---

---using left pry points. refine TYPEWHEEL POSITIONING (2.49) adjustment.

Right character H of poor quality ---

---using right pry points. refine TYPEWHEEL POSITIONING (2.49) adjustment.

Characters spread out ---

---refine TYPEWHEEL POSITIONING (2.49) adjustment by moving plate frontward.

Characters run together ---

---refine TYPEWHEEL POSITIONING (2.49) adjustment by moving plate rearward.

Both characters of light shading on left side ---

---refine TYPEWHEEL "HOME" POSITION (2.56) adjustment by rotating wheel clockwise as viewed from top.

Both characters of light shading on right side ---

---refine TYPEWHEEL "HOME" POSITION (2.56) adjustment by rotating wheel counterclockwise as viewed from top.

Related Adjustments

Affected By

TYPEWHEEL "HOME" POSITION (2.56)

3. VARIATIONS TO BASIC UNIT

3.01 Answer-Back Area

Note 1: Do not make this adjustment on units with two-color printing. Instead, make the BLOCKING LINK CLEARANCE adjustment (3.20).

Note 2: The answer-back trip lever adjusting tab should clear the control lever before proceeding with the following adjustments.

BLOCKING LINK CLEARANCE (ABA-1)

To Check

Disengage (latch) distributor and function clutches, engage the answer-back blocking lever fully in indent of answer-back blocking pawl. Take up play in the answer-back blocking pawl toward the front of the typing unit.

Requirement

Min some---Max 0.020 inch between the blocking link and tab on answer-back blocking pawl.

To Adjust

Bend adjusting tab on blocking follower lever with TP180993 bending tool.

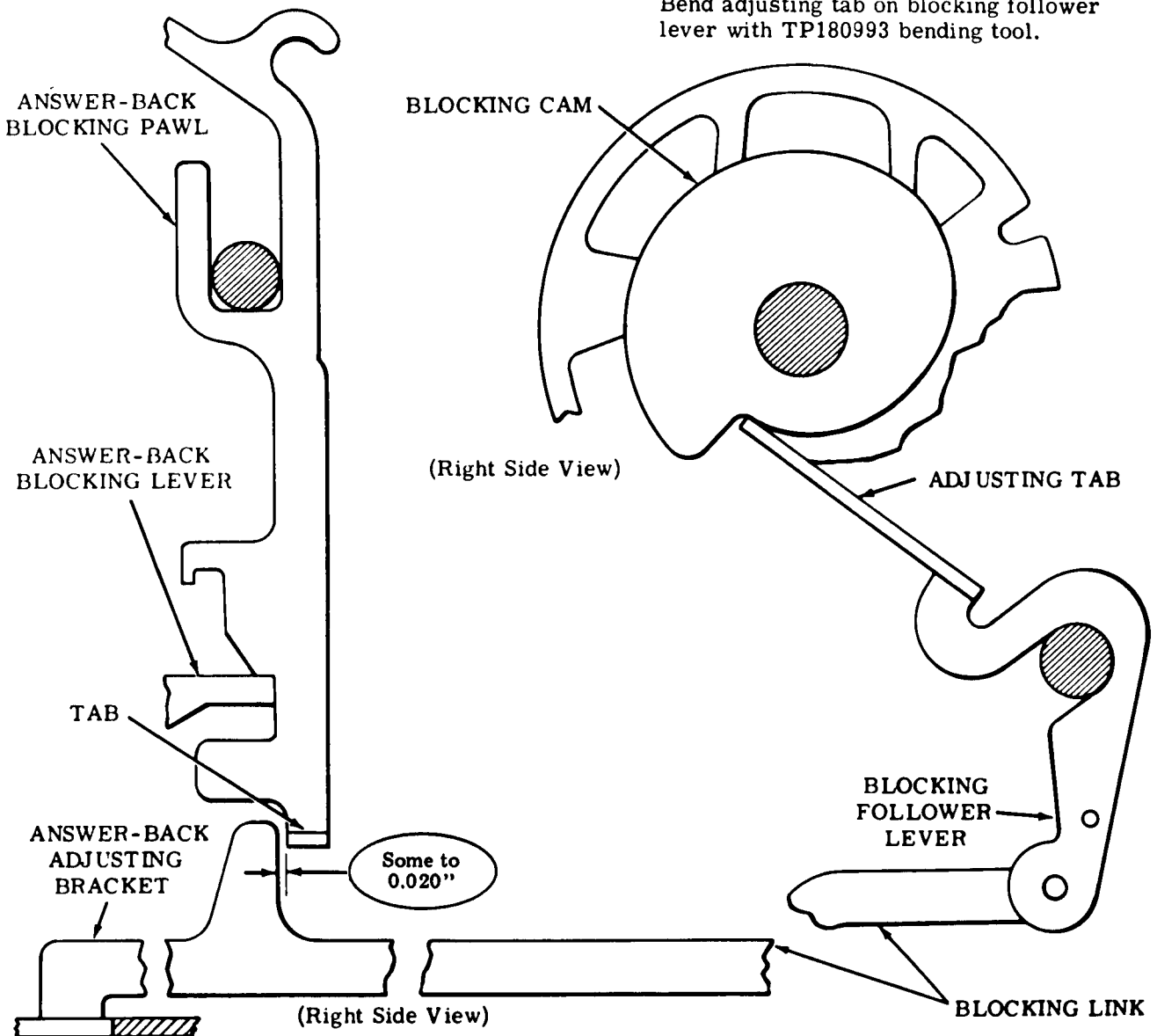

3.02 Answer-Back Area (continued)

CONTROL LEVER SPRING — HORIZONTAL

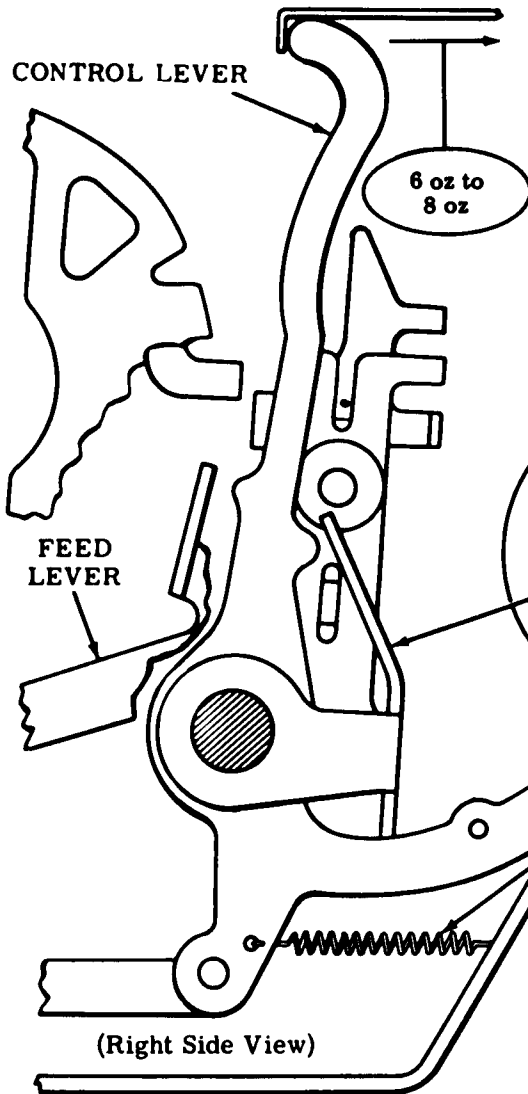

To Check

Place control lever out of indent and on high part of answer-back drum. Rotate main shaft until feed lever is moved by cam roller to its lowest point. Hold stop bail away from control lever.

Requirement

Min 6 oz---Max 8 oz
to start control lever moving.

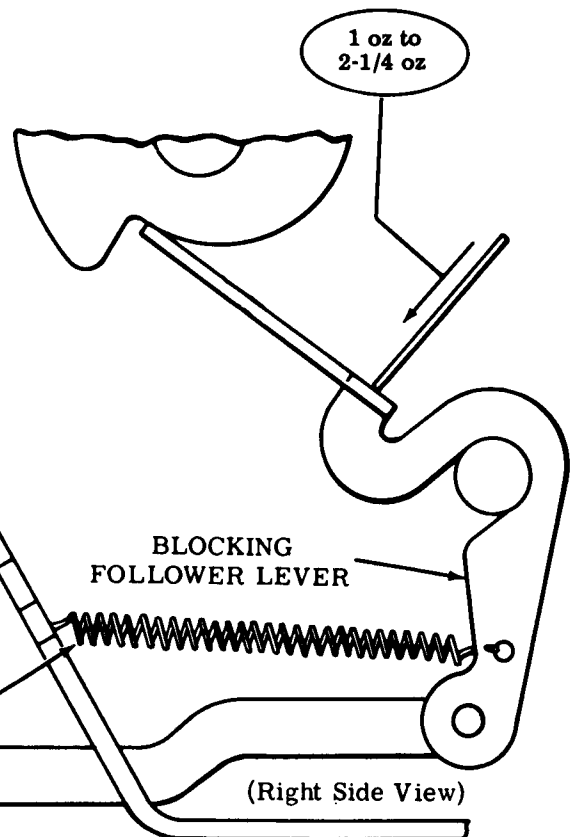

BLOCKING FOLLOWER LEVER SPRING

Requirement

With distributor clutch disengaged (latched)
Min 1 oz---Max 2-1/4 oz
to start blocking follower lever moving.

3.03 Answer-Back Area (continued)

DRUM POSITION (ABA-2)

To Check

With distributor clutch disengaged (latched), rotate answer-back drum until lower extension of control lever engages indent of answer-back drum and detent lever is between ST and 20 rows on answer-back drum. Make sure there is clearance between the feed lever adjusting tab and the control lever. If not, bend the feed lever adjusting tab toward the front of the typing unit.

(1) Requirement

Hold the feed pawl out of engagement with the answer-back drum and manually move the upper extension of the control lever toward the rear of the typing unit while checking to see that the answer-back drum is fully detented.

(2) Requirement

With finger pressure, push lightly on drum in a counterclockwise direction. While maintaining this light pressure, pull drum detent lever out of engagement with drum. There should be no or barely perceptible counterclockwise movement of answer-back drum.

(3) Requirement

The axis of the answer-back drum should be parallel to the trip pivot shaft as gauged by eye.

To Adjust

Loosen HERE IS adjusting bracket clamp screw and answer-back bracket clamp screw. With answer-back block mounting screws friction tight, position block to meet requirements.

Note: If complete readjustment of answer-back is to be performed, leave HERE IS and answer-back bracket screws loosened until the brackets are adjusted in their normal sequence. If not, tighten screws.

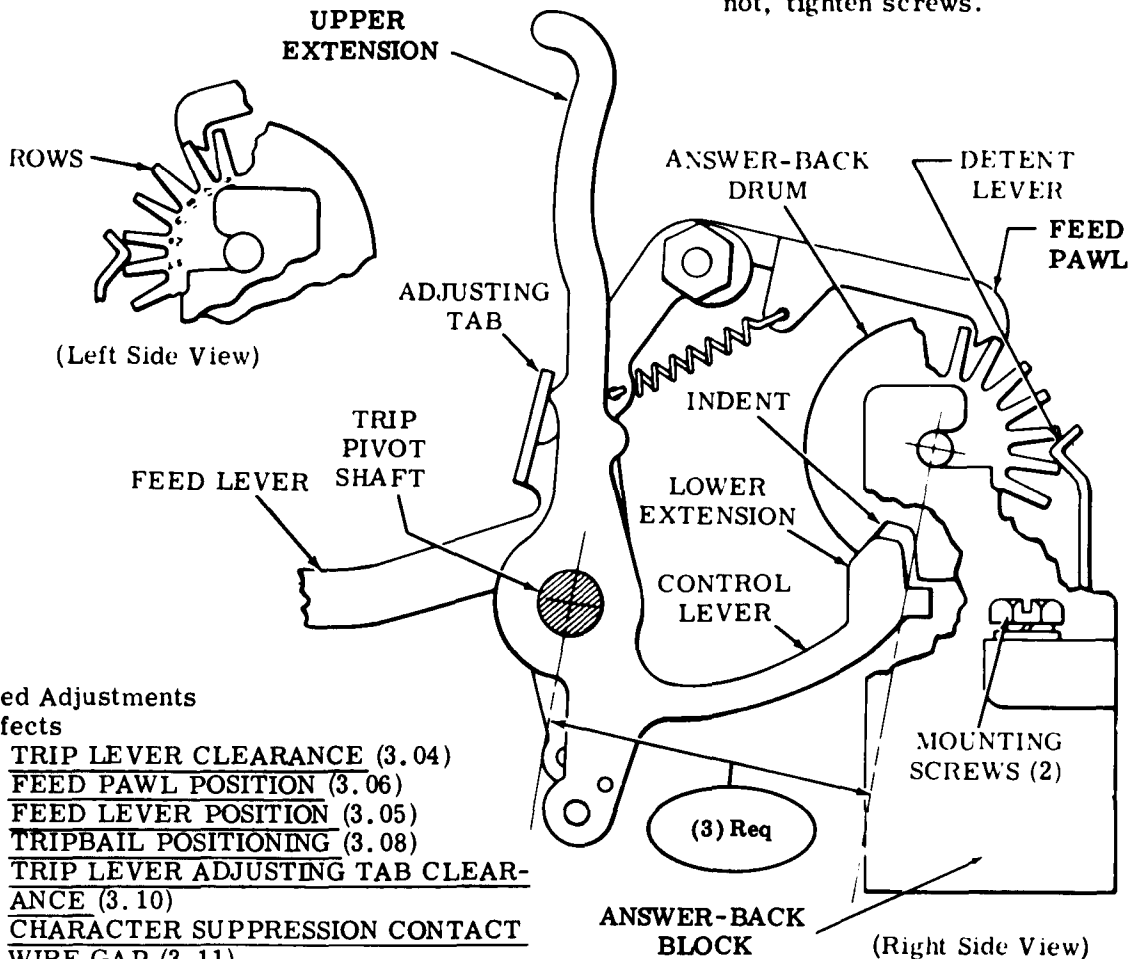

Related Adjustments
Affects

- TRIP LEVER CLEARANCE (3.04)
- FEED PAWL POSITION (3.06)
- FEED LEVER POSITION (3.05)
- TRIPBAIL POSITIONING (3.08)
- TRIP LEVER ADJUSTING TAB CLEARANCE (3.10)
- CHARACTER SUPPRESSION CONTACT WIRE GAP (3.11)

3.03 Answer-Back Area (continued)

DRUM POSITION (ABA-2)

To Check

With distributor clutch disengaged (latched), rotate answer-back drum until lower extension of control lever engages indent of answer-back drum and detent lever is between ST and 20 rows on answer-back drum. Make sure there is clearance between the feed lever adjusting tab and the control lever. If not, bend the feed lever adjusting tab toward the front of the typing unit.

(1) Requirement

Hold the feed pawl out of engagement with the answer-back drum and manually move the upper extension of the control lever toward the rear of the typing unit while checking to see that the answer-back drum is fully detented.

(2) Requirement

With finger pressure, push lightly on drum in a counterclockwise direction. While maintaining this light pressure, pull drum detent lever out of engagement with drum. There should be no or barely perceptible counterclockwise movement of answer-back drum.

(3) Requirement

The axis of the answer-back drum should be parallel to the trip pivot shaft as gauged by eye.

To Adjust

Loosen HERE IS adjusting bracket clamp screw and answer-back bracket clamp screw. With answer-back block mounting screws friction tight, position block to meet requirements.

Note: If complete readjustment of answer-back is to be performed, leave HERE IS and answer-back bracket screws loosened until the brackets are adjusted in their normal sequence. If not, tighten screws.

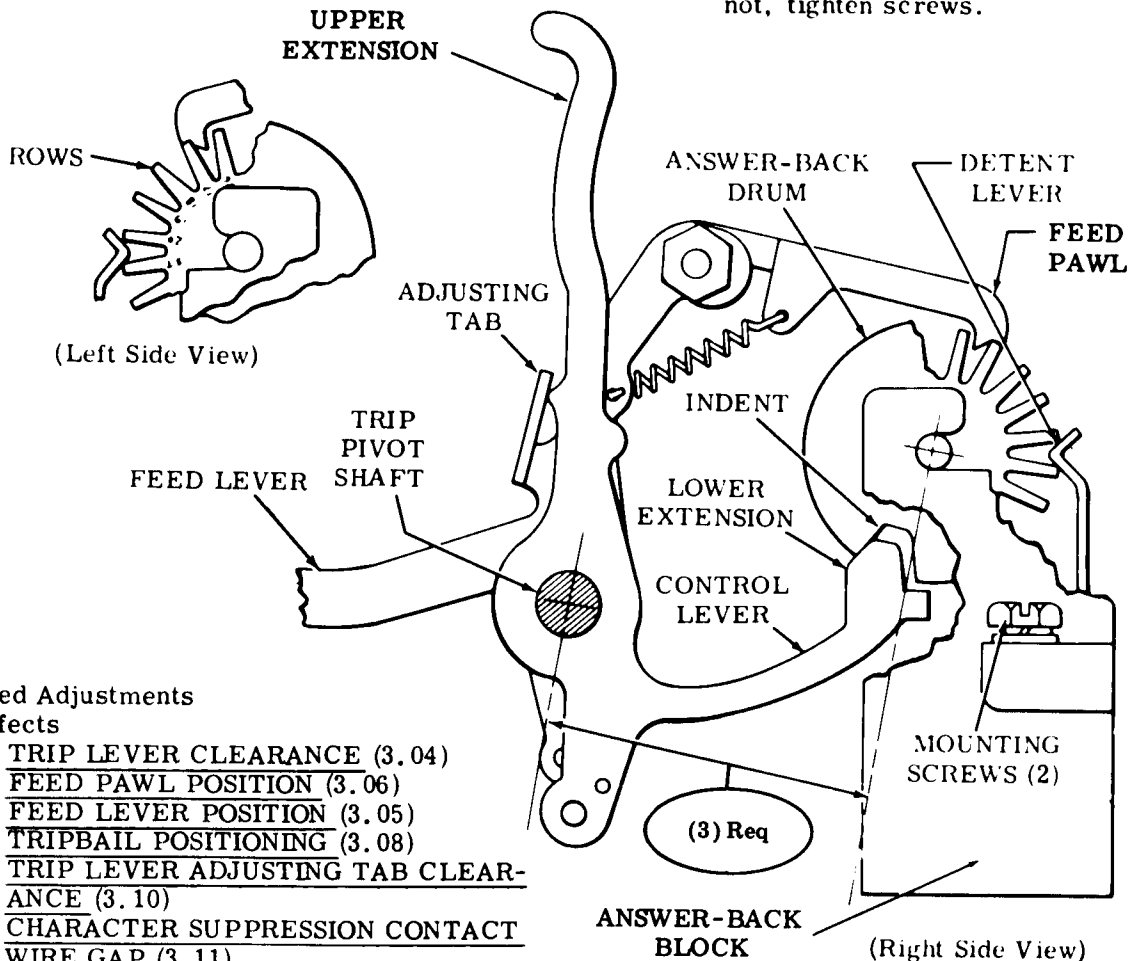

Related Adjustments
Affects

- TRIP LEVER CLEARANCE (3.04)
- FEED PAWL POSITION (3.06)
- FEED LEVER POSITION (3.05)
- TRIPBAIL POSITIONING (3.08)
- TRIP LEVER ADJUSTING TAB CLEARANCE (3.10)
- CHARACTER SUPPRESSION CONTACT WIRE GAP (3.11)

3.04 Answer-Back Area (continued)

TRIP LEVER CLEARANCE (ABA-3)

To Check

Trip distributor clutch and manually rotate main shaft to place upper edge of clutch shoe lever in line with upper edge of trip lever. Lift feed pawl and manually rotate answer-back drum counterclockwise until detent lever is located between row 1 and 2 on answer-back drum.

Requirement

Min 0.015 inch---Max 0.035 inch
between clutch shoe lever and trip lever.

To Adjust

Bend right adjusting tab using TP180993 bending tool.

Note: The plane of right adjusting tab should be parallel to the axis of trip pivot shaft, as gauged by eye.

Related Adjustments

Affected By
DRUM POSITION (3.03)

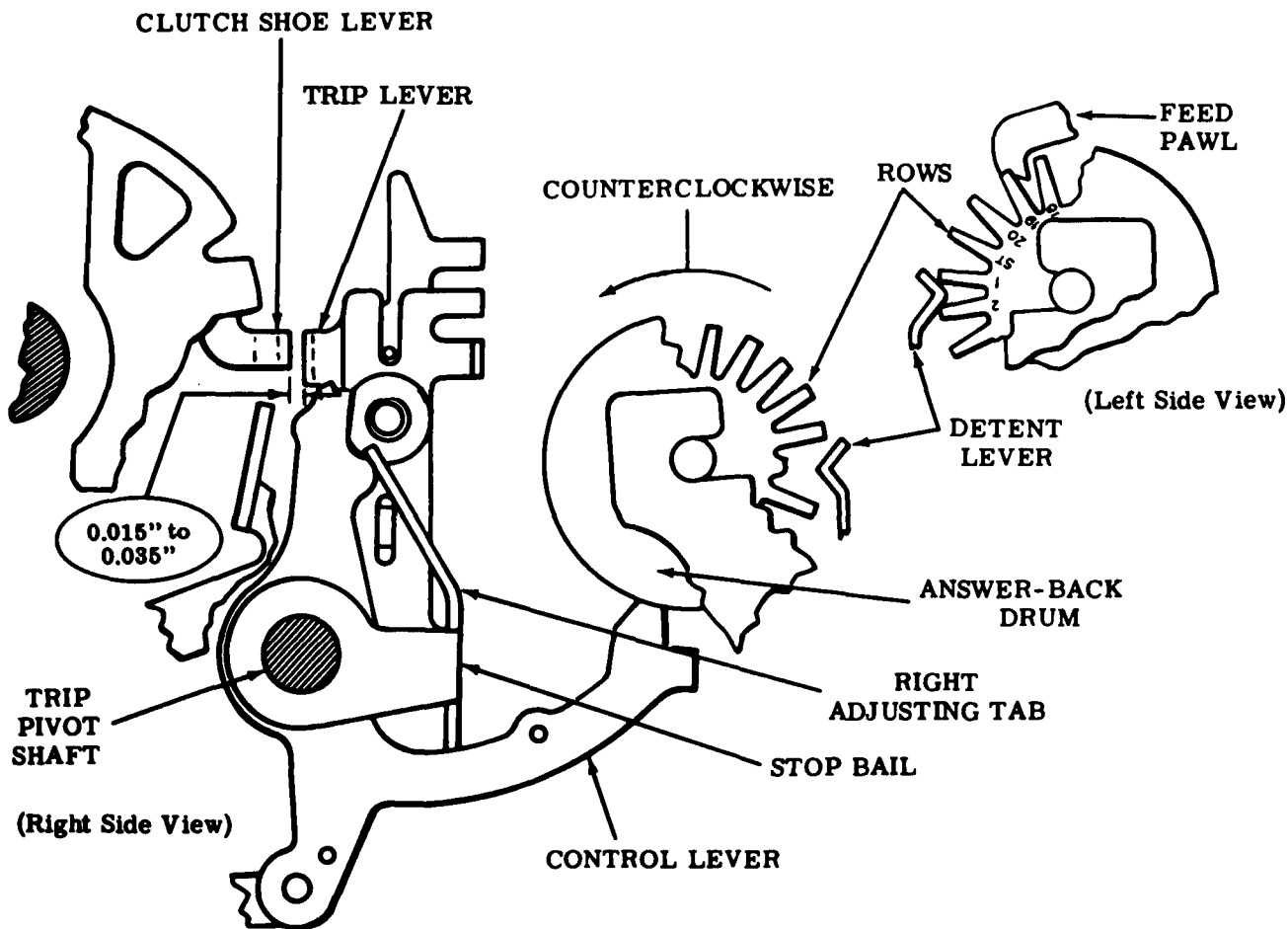

3.05 Answer-Back Area (continued)

FEED LEVER POSITION (ABA-4)

To Check

With answer-back drum fully detented in its home position, trip distributor clutch and manually rotate main shaft until cam roller is adjacent to high part of feed lever. Rotate cam roller to minimize clearance. Hold feed pawl clear of answer-back drum.

Requirement

Min some---Max 0.010 inch
between feed lever and cam roller.

To Adjust

Bend feed lever adjusting tab with TP180993 bending tool.

Related Adjustments

Affects

TRIPBAIL POSITIONING (3.08)

FEED PAWL POSITION (3.06)

Affected By

DRUM POSITION (3.03)

Note 1: Rollers with identifying groove near clutch disc do not require rotation to determine minimum clearance. The minimum requirement is met if there is no perceptible movement of the answer-back feed pawl when rotating the distributor shaft to its stop position.

Note 2: For increased feed margin, particularly when changing drums, hold requirement to minimum side.

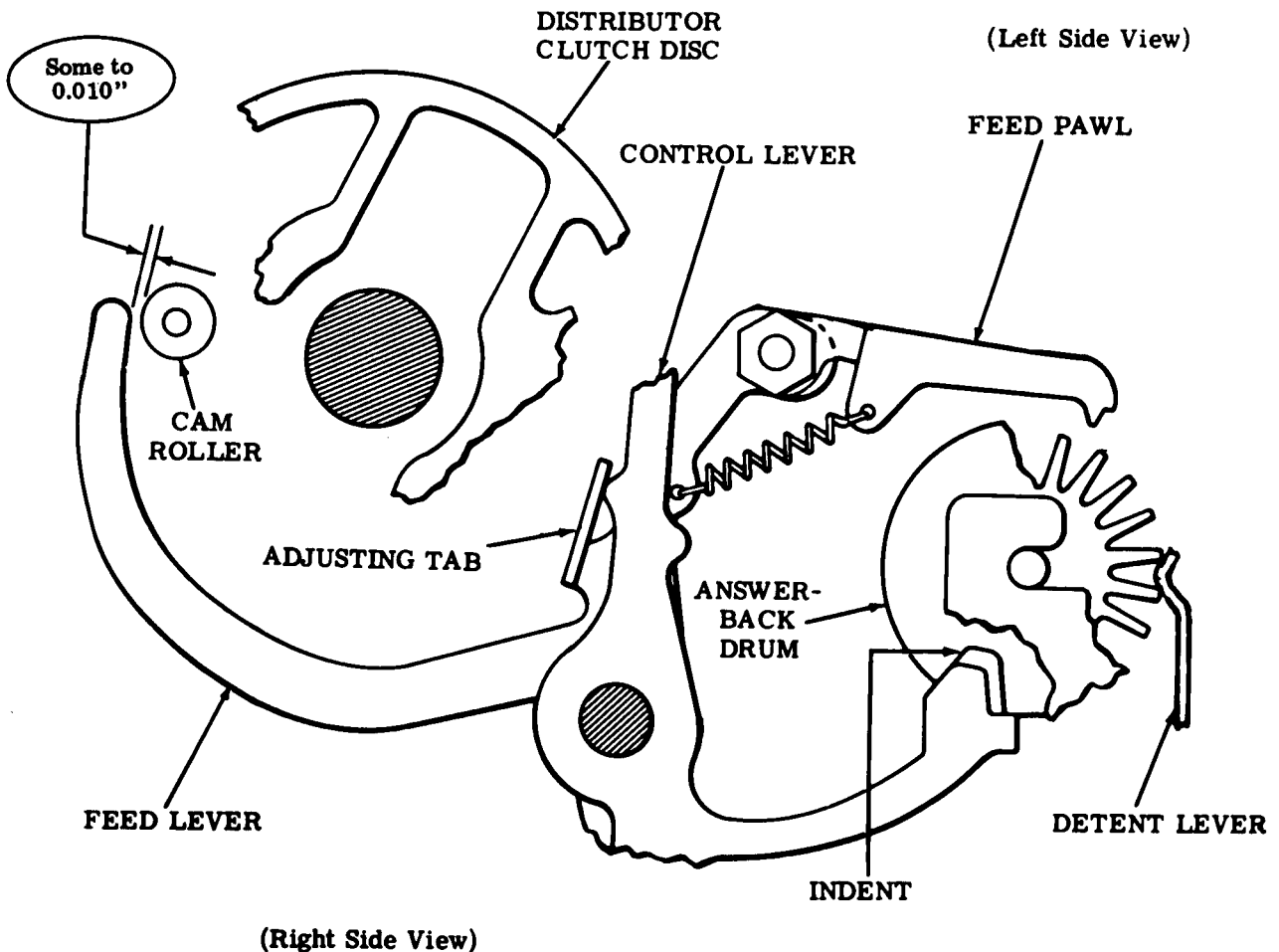

3.06 Answer-Back Area (continued)

FEED PAWL POSITION (ABA-5)

(1) To Check

With answer-back drum fully detented in its home position, disengage (latch) distributor clutch. Manually trip distributor clutch and rotate main shaft until the cam roller is adjacent to high part of feed lever. Position feed pawl fully within answer-back ratchet. Take up all play to maximize clearance.

Requirement

Min some---Max 0.005 inch between feed pawl and rear face of no. 16 drum tooth.

Note: The "some" requirement is met if when feed pawl is raised just above no. 16 tooth it returns behind it under its own spring force when released.

To Adjust

With adjusting nut and screw friction tight, position feed pawl against rear surface of no. 16 tooth. Tighten nut and screw.

(2) To Check

Push the top of the control lever toward the rear of typing unit and simultaneously rotate the main shaft. Observe the operation of the feed pawl.

Requirement

While operating, the feed pawl should be centrally located on feed ratchet teeth.

To Adjust

Bend feed lever just below feed pawl.

Related Adjustments

Affects

TRIPBAIL POSITIONING (3.08)

Affected By

TRIP SHAFT POSITION (2.04)

DRUM POSITION (3.03)

FEED LEVER POSITION (3.05)

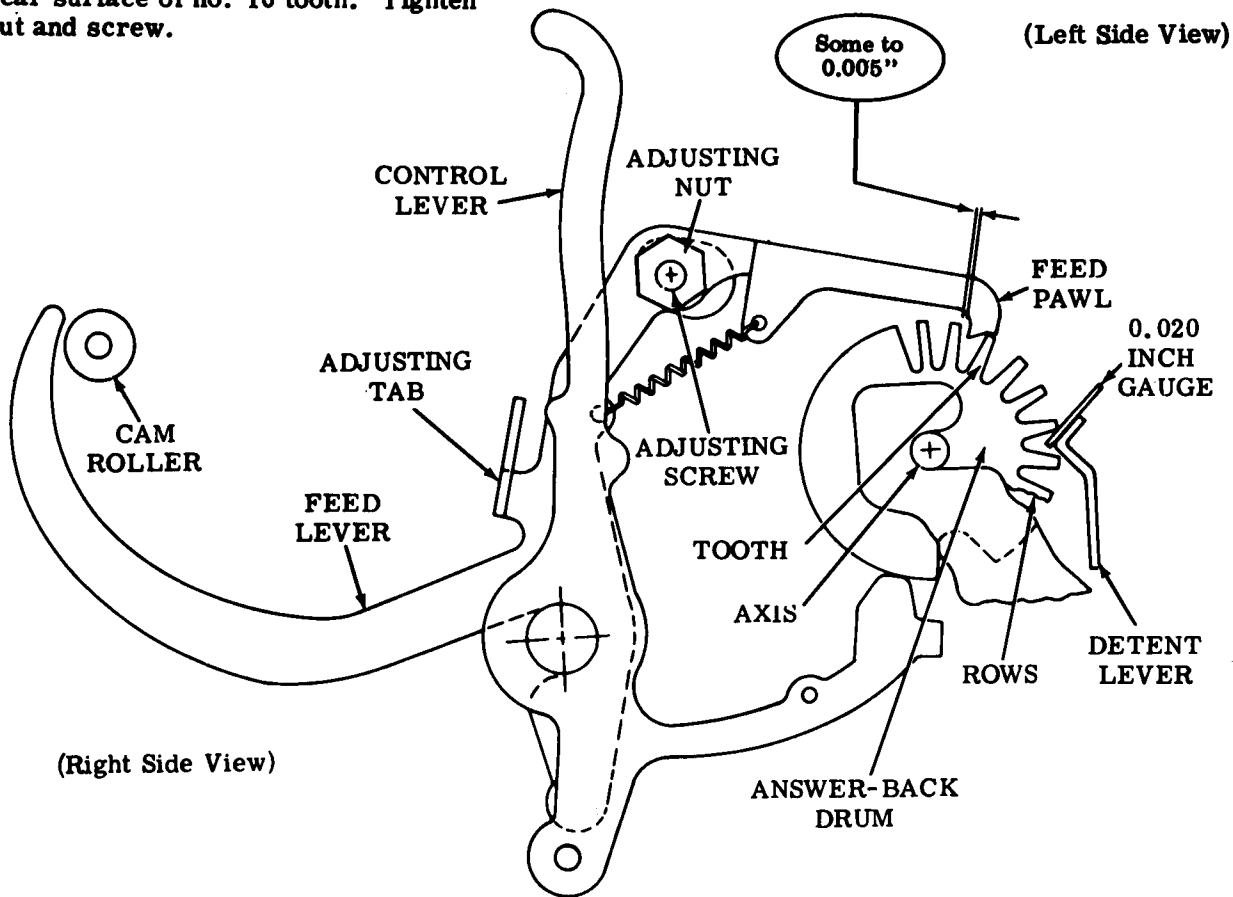

3.07 Answer-Back Area (continued)

"HERE IS" BELLCRANK POSITIONING (ABA-6)

Note: Make this adjustment with both printer and keyboard installed on subbase.

(1) To Check

Apply power to set and disengage all clutches. Depress HERE IS keytop for about one character cycle.

Requirement

The distributor clutch and answer-back drum should operate within the same character cycle. With a force of 10 to 20 ounces applied to the HERE IS keytop, there should be

Min 0.020 inch---Max 0.040 inch overtravel between the answer-back feed pawl and no. 17 drum tooth.

(2) To Check

Fully detent answer-back drum in its home position. Disengage distributor clutch.

Requirement

With the HERE IS keytop unoperated, there should be some clearance between tip of HERE IS keytop and bellcrank.

To Adjust

Position keyboard fully forward. (Keyboard end brackets will be touching the bosses at the front of the subbase when the keyboard is fully forward.) Fully detent answer-back drum in its home position. Trip distributor clutch by depressing HERE IS keytop. Rotate distributor shaft until the answer-back feed lever is no longer contacting the clutch disc cam roller. Loosen answer-back clamp screw friction tight. Insert screwdriver in pry points and position HERE IS adjusting bracket to meet requirement. Tighten clamp screw.

Related Adjustments

Affects

TRIPBAIL POSITIONING (3.08)
CHARACTER SUPPRESSION CONTACT WIRE GAP (3.11)

Affected By

DRUM POSITION (3.03)
FEED PAWL POSITION (3.06)
FEED LEVER POSITION (3.05)

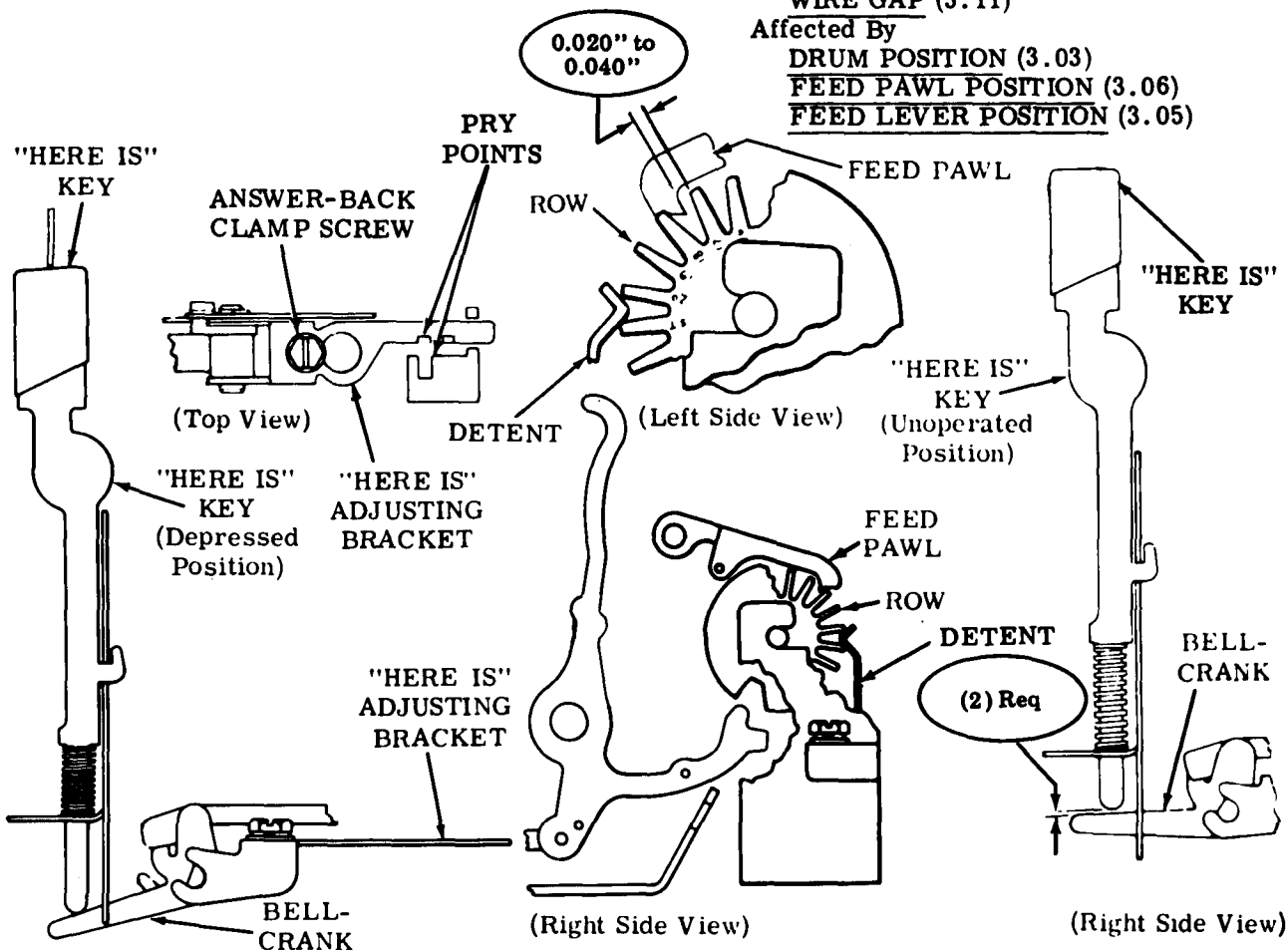

3.08 Answer-Back Area (continued)

TRIPBAIL POSITIONING (ABA-7)

(1) To Check

Place the typing unit in stop condition. Trip function clutch and rotate main shaft until the function bail is in its highest position. Push the answer-back function pawl down until its notch is engaged by its function lever. Trip the distributor clutch and continue to rotate the main shaft until the answer-back function pawl reaches its lowest point of travel (position No. 3).

Note: The feed pawl will move back to pick up the next tooth on the answer-back drum feed ratchet.

With the feed pawl centered on the answer-back drum feed ratchet, take up play in feed pawl toward the rear.

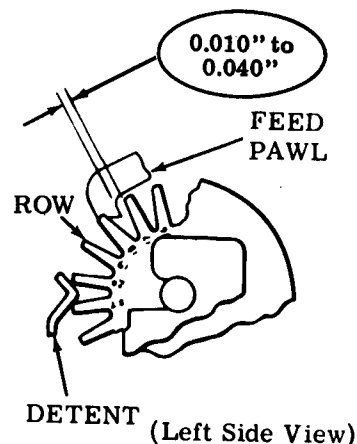

Requirement

Min 0.010 inch---Max 0.040 inch overtravel between feed pawl and face of answer-back drum feed ratchet of row 17.

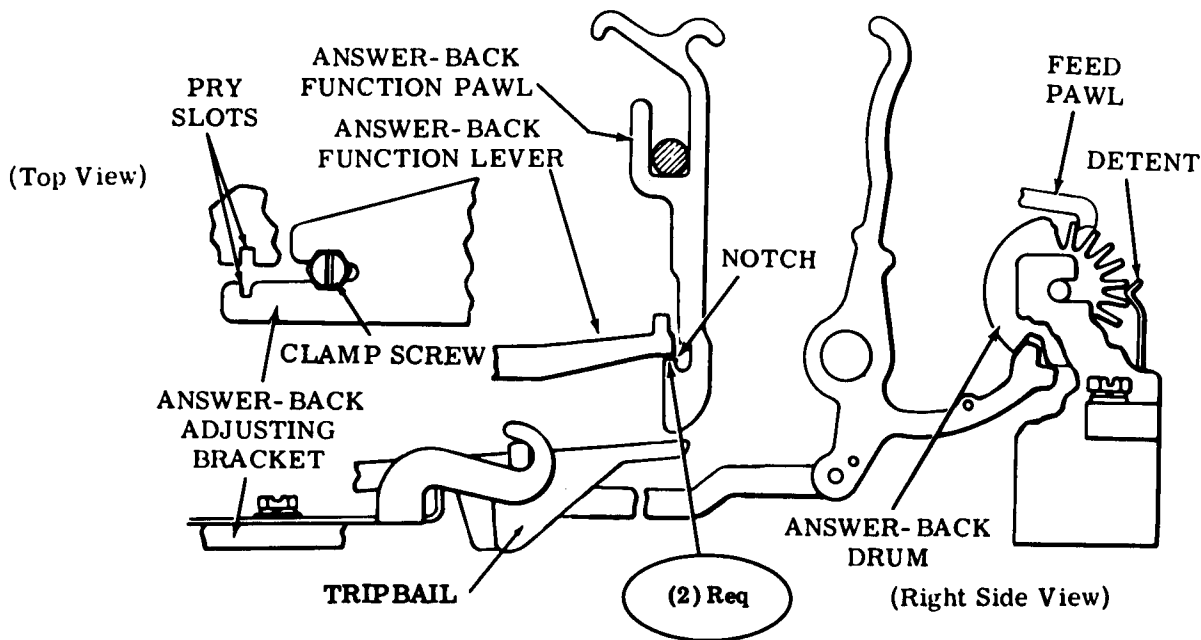

(2) To Check

With typing unit in stop condition, set up the code combination for the answer-back call character in the selector. Rotate the main shaft until the answer-back function pawl moves forward to its selected position. Observe the forward movement of the answer-back function pawl.

Requirement

As function bail approaches its highest point of travel, answer-back function pawl must move forward freely to its selected position without hesitation.

To Adjust

Loosen clamp screw friction tight. Position answer-back adjusting bracket using pry slots. Tighten clamp screw.

Related Adjustments

- Affected By
- DRUM POSITION (3.03)
- FEED PAWL POSITION (3.06)
- RIGHT ROCKER DRIVE (2.36)

3.09 Answer-Back Area (continued)

Note: The adjustment on this page applies only to typing units equipped with an answer-back trip magnet mechanism. Before proceeding with adjustment, make sure magnet bracket is positioned as far forward and to the left on base casting post as mounting screws will permit.

TRIP LEVER OVERTRAVEL AND ARMATURE GAP (VFA-1)

To Check

With the answer-back drum fully detented in its home position, trip distributor clutch and rotate main shaft until the pointer of the distributor brush holder is in line with the intersection of the conductor path and the stop segment. Control lever must be clear of answer-back to trip lever adjusting tab — if necessary, bend tab forward to provide clearance. Place armature in its attracted position, and take up play toward rear of typing unit.

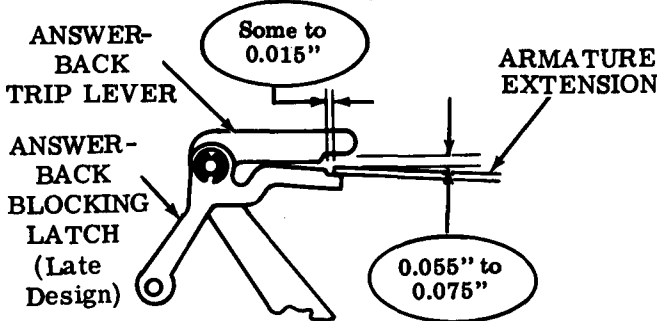

(1) Requirement

Min some---Max 0.015 inch between the end of armature extension and the blocking surface of the answer-back blocking latch when the latch is aligned with the trip lever.

To Adjust

Loosen armature extension mounting screw friction tight. Position the armature extension using pry points. Tighten screw.

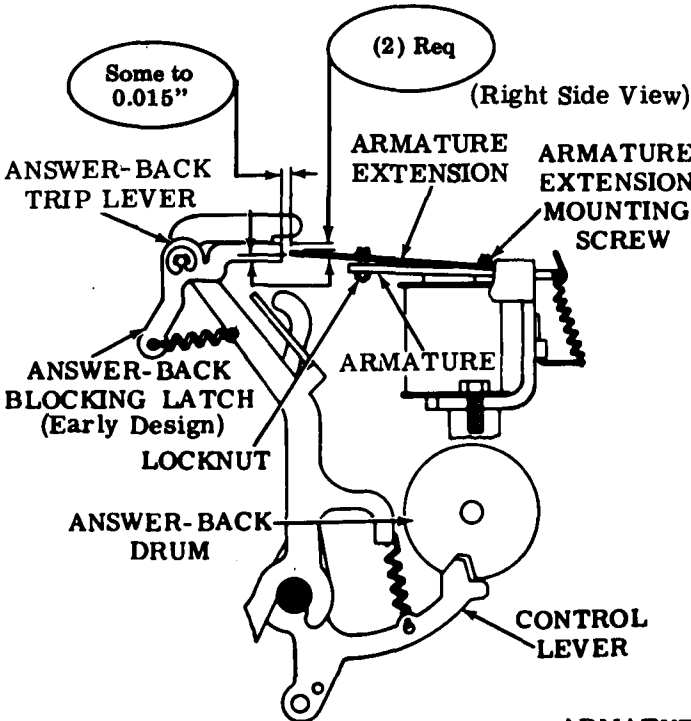

(2) Requirement

Units with early design blocking latch. Front end of armature extension should be vertically centered between the top and bottom surfaces of the answer-back blocking latch as gauged by eye.

Units with late design blocking latch

Min 0.055 inch---Max 0.075 inch between armature extension and lower surface of answer-back trip lever.

To Adjust

Loosen armature extension adjusting screw locknut friction tight. Position armature extension using armature extension adjusting screw. Tighten locknut.

Related Adjustments

Affects

- TRIP LEVER ADJUSTING TAB CLEARANCE (3.10)
- CHARACTER SUPPRESSION CONTACT WIRE GAP (3.11)

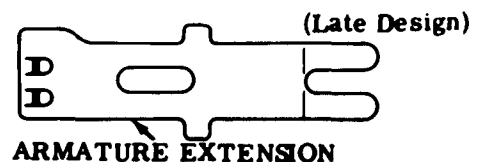
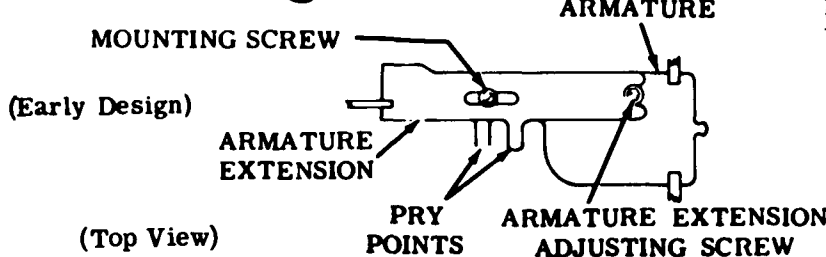

3.10 Answer-Back Area (continued)

Note: The following adjustment applies only to typing units equipped with an answer-back trip magnet mechanism.

TRIP LEVER ADJUSTING TAB CLEARANCE
(VFA-2)

To Check

With the answer-back drum fully detented in its home position, place the typing unit in its stop position. With the armature in its unattracted position, and biased toward the rear, center the trip lever between the armature extension guide ears. Center the control lever on the adjusting tab of the trip lever.

Requirement

Min some---Max 0.020 inch
between adjusting tab and tip of control lever.

To Adjust

Bend adjusting tab at its inner edge to front or rear with TP180993 bending tool.

Related Adjustments

Affects

CHARACTER SUPPRESSION CONTACT
WIRE GAP (3.11)

Affected By

TRIP LEVER OVERTRAVEL AND
ARMATURE GAP (3.09)
DRUM POSITION (3.03)

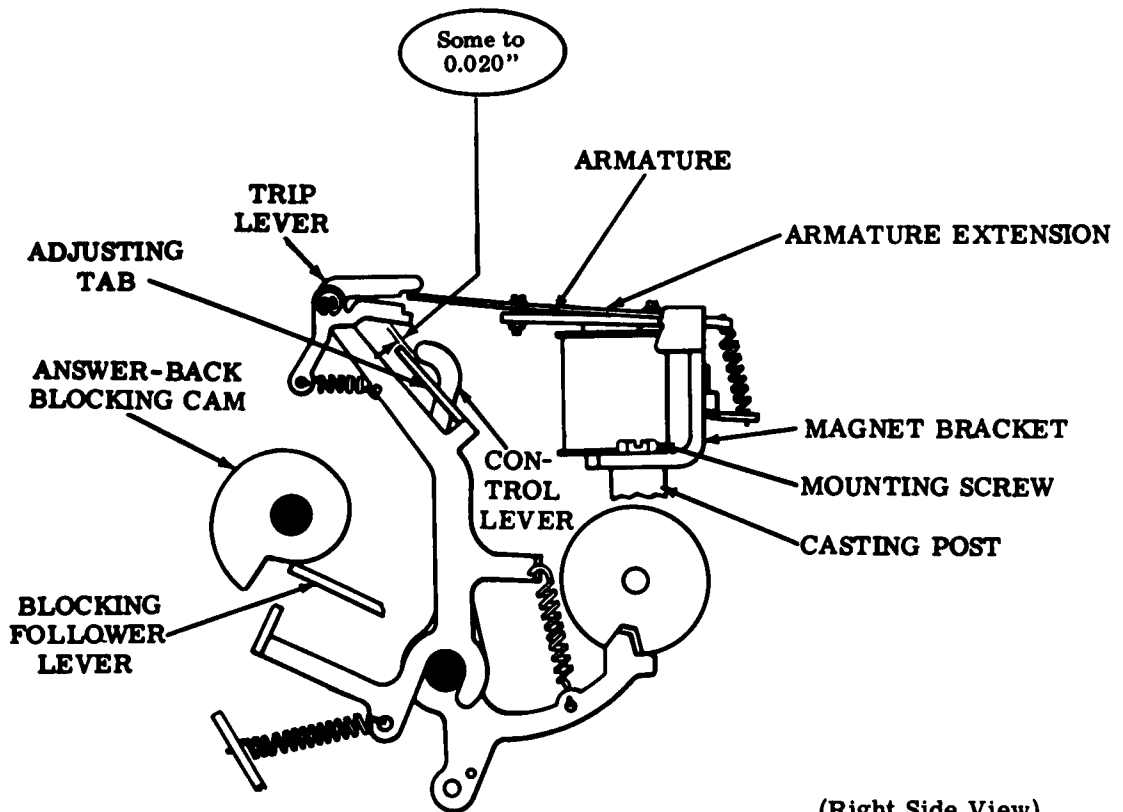

3.11 Answer-Back Area (continued)

CHARACTER SUPPRESSION CONTACT WIRE GAP (ABA-8)**To Check**

With answer-back drum fully detented in its home position, disengage (latch) distributor clutch.

Requirement

Min 0.030 inch--- Max 0.055 inch
between suppression contact wire and
common contact.

To Adjust

Position adjusting spring on the tie link.

Related Adjustments**Affected By**

TRIP LEVER OVERTRAVEL AND ARMATURE GAP (3.09)

DRUM POSITION (3.03)

TRIP LEVER ADJUSTING TAB CLEARANCE (3.10)

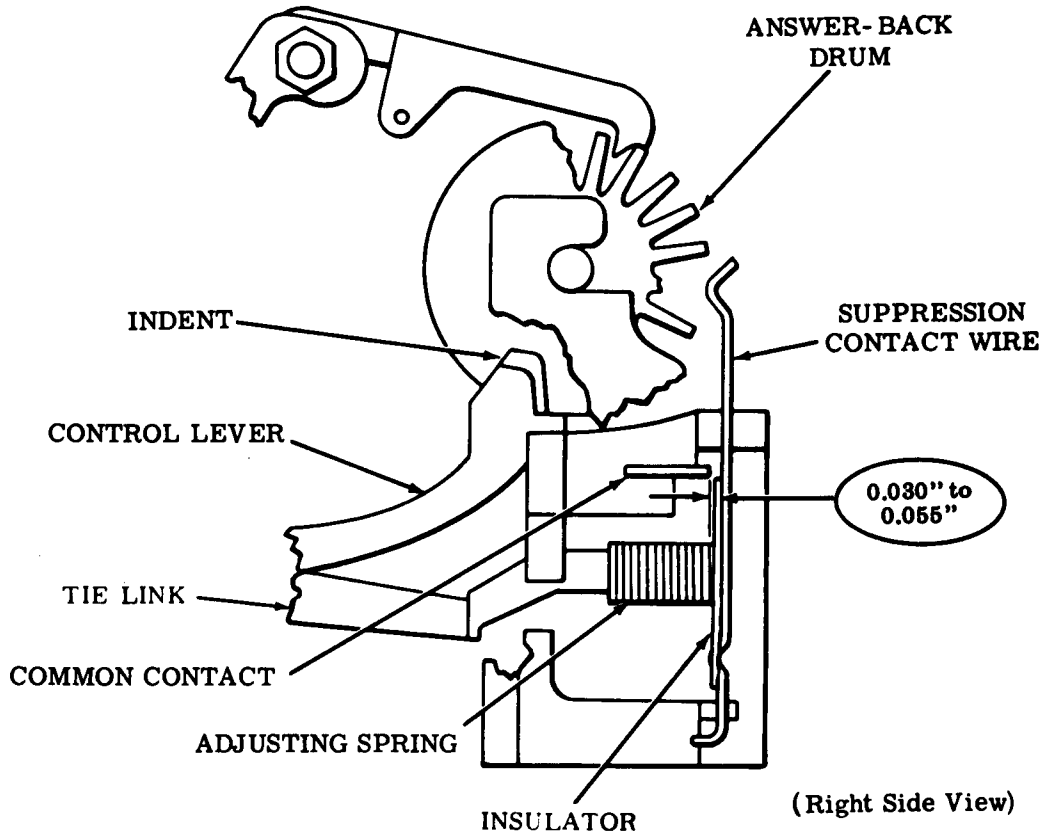

3.12 Answer-Back Area (continued)

CONTROL LEVER SPRING — VERTICAL (Early Design)

Requirement

With distributor clutch tripped and blocking follower lever on high part of blocking cam
 Min 7-1/2 oz---Max 10-1/2 oz
 to start control lever moving.

ARMATURE SPRING

To Check

Trip distributor clutch. Rotate main shaft until blocking follower lever is on high part of blocking cam and armature is in its un-attracted position.

BLOCKING LATCH SPRING

Requirement

With distributor clutch disengaged (latched)
 Min some*---Max 3/4 oz
 to start blocking latch moving.

Requirement

Min 2-1/2 oz---Max 3-1/2 oz
 to start armature moving.

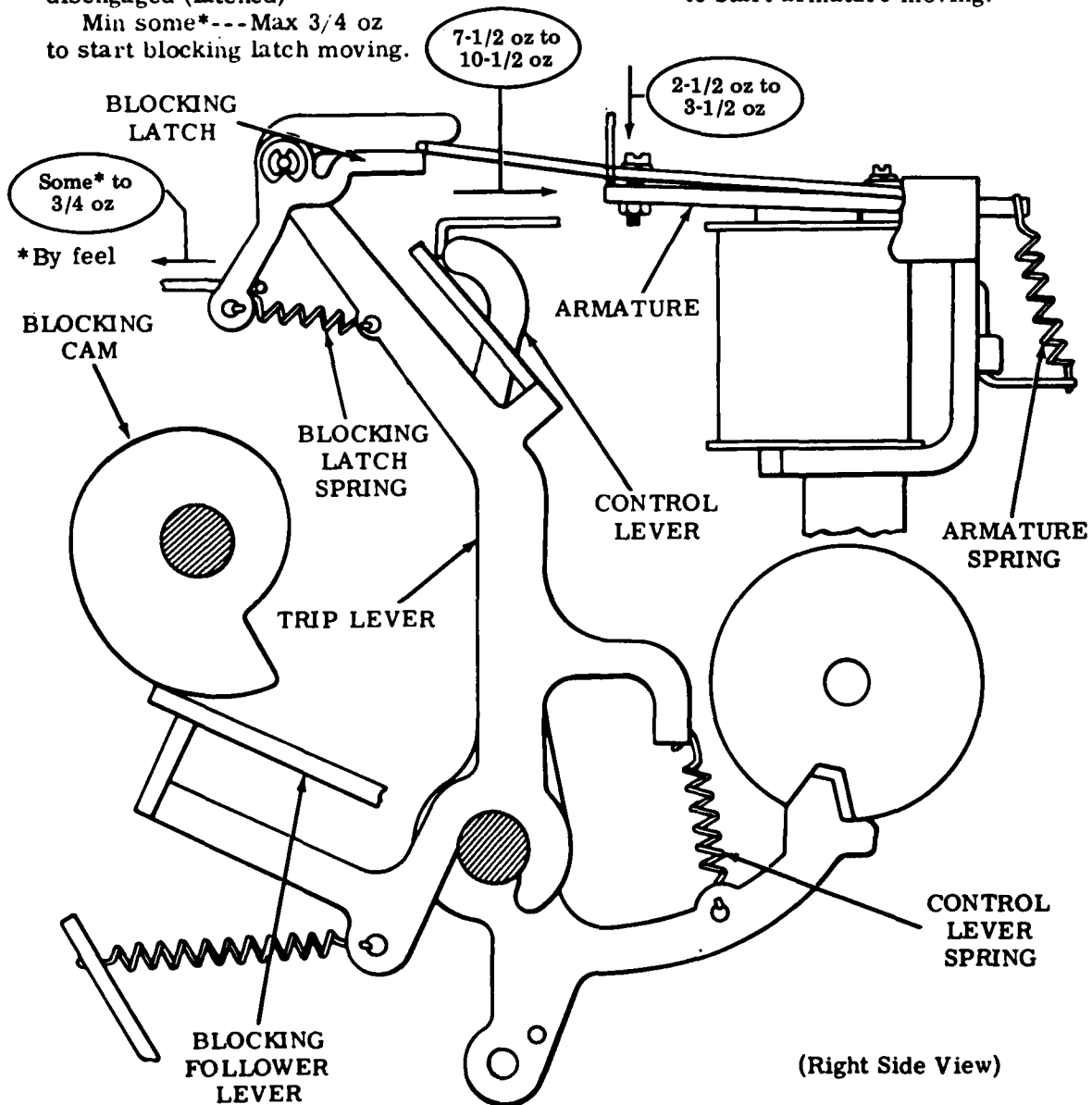

3.13 Answer-Back Area (continued)

TRIP LEVER SPRING

To Check

Disengage (latch) distributor clutch. Manually trip armature. Position stop bail so that its adjusting tab does not interfere with control lever. Hold armature in its attracted position.

Requirement

Min 3 oz---Max 4-1/2 oz
to start trip lever moving.

CONTROL LEVER SPRING — VERTICAL
(Late Design)

To Check

Disengage (latch) distributor clutch. Manually rotate the answer-back drum until control lever is on high part of answer-back drum. Position stop bail so that its adjusting tab does not interfere with control lever.

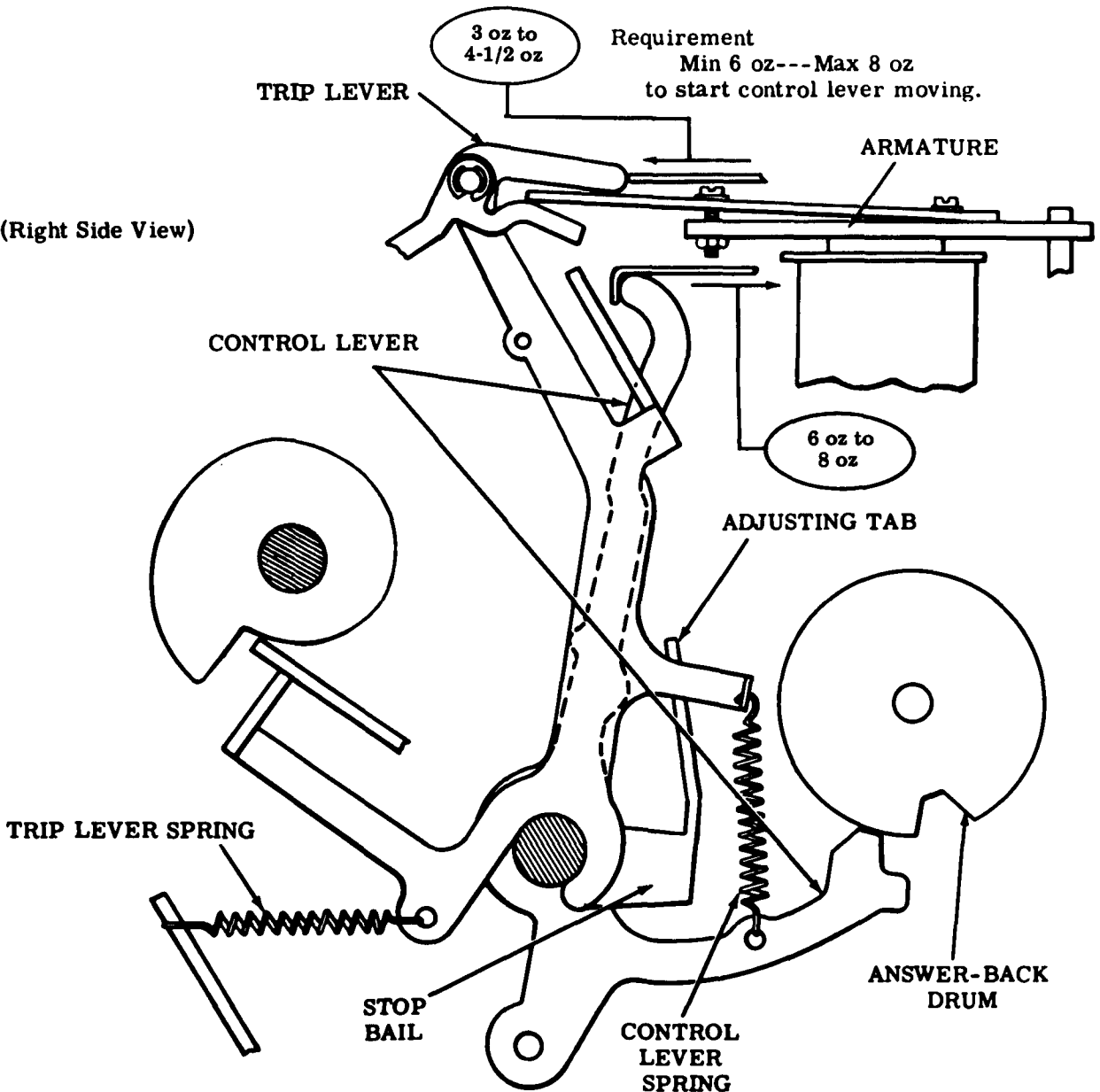

3.14 Answer-Back Area (continued)

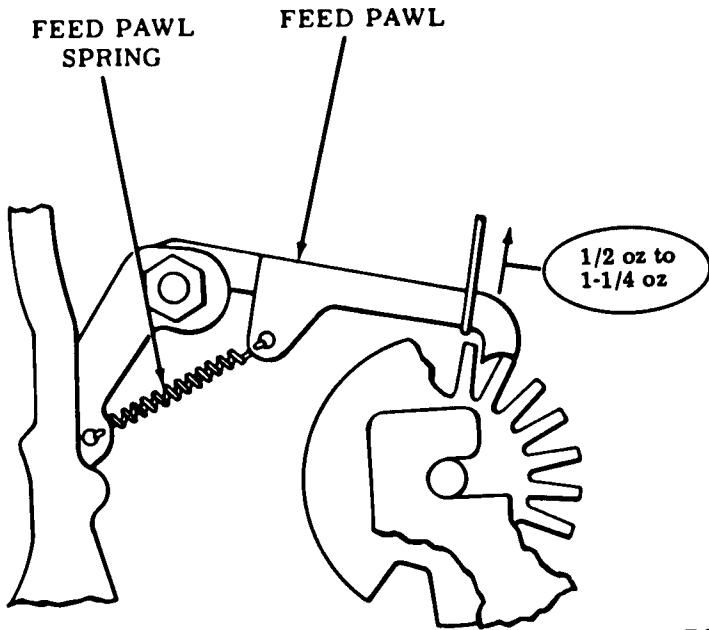

(Right Side View)

FEED PAWL SPRING

Requirement

With distributor clutch disengaged (latched)

Min 1/2 oz---Max 1-1/4 oz to start feed pawl moving.

DETENT SPRING

Requirement

Min 8 oz---Max 12 oz to start detent moving.

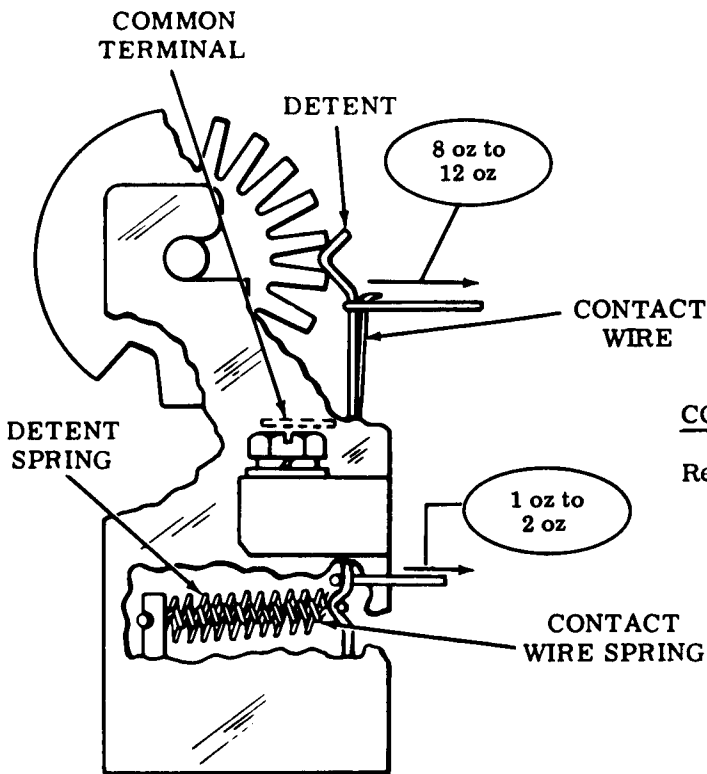

(Right Side View)

CONTACT WIRE SPRING

Requirement

Min 1 oz---Max 2 oz to start contact wire moving away from common terminal.

3.15 Answer-Back Area (continued)

FEED LEVER SPRING

Requirement

With distributor clutch disengaged (latched) and feed pawl held out of engagement with answer-back drum

Min 4-1/4 oz---Max 5-1/4 oz to start feed lever moving.

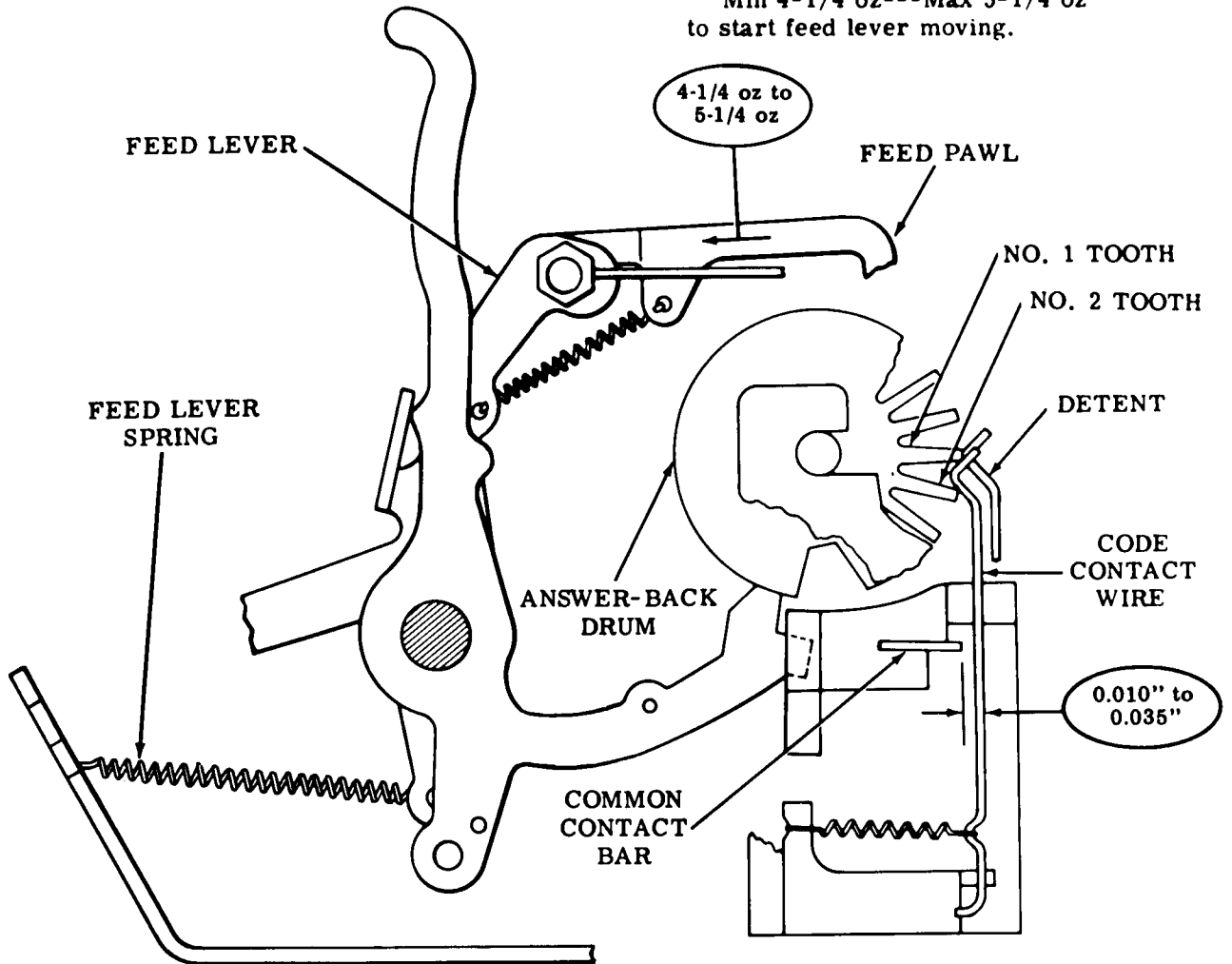

(Right Side View)

CODE CONTACT WIRE GAP (ABA-9)

To Check

Manually rotate drum until contact wires are riding between no. 1 and no. 2 tooth (detent riding on top of no. 1 tooth).

Requirement

Min 0.010 inch---Max 0.035 inch between code contact wires and common contact bar.

To Adjust

Bend contact wires.

3.16 Function Box Switches (Function Area)

CONTACT ASSEMBLY POSITION (MIA-1)

(1) To Check

Set up code combination in selector that is to operate the function pawl associated with a contact arm and rotate the main shaft until the function bail is in its highest position (position No. 1).

Requirement

Min 0.010 inch---Max 0.020 inch
between the contact arm and the contact at the closest point as illustrated.

(2) To Check

Place typing unit in stop condition.

Requirement

Min some
clearance between the function pawl and the tip of the contact arm.

To Adjust

With two clamp screws friction tight, position the contact assembly on the function casting. If necessary, bend the upper contact. Tighten clamp screws.

Note: For (1) To Check, be sure that the contact arm lines up with and is in contact with the function pawl.

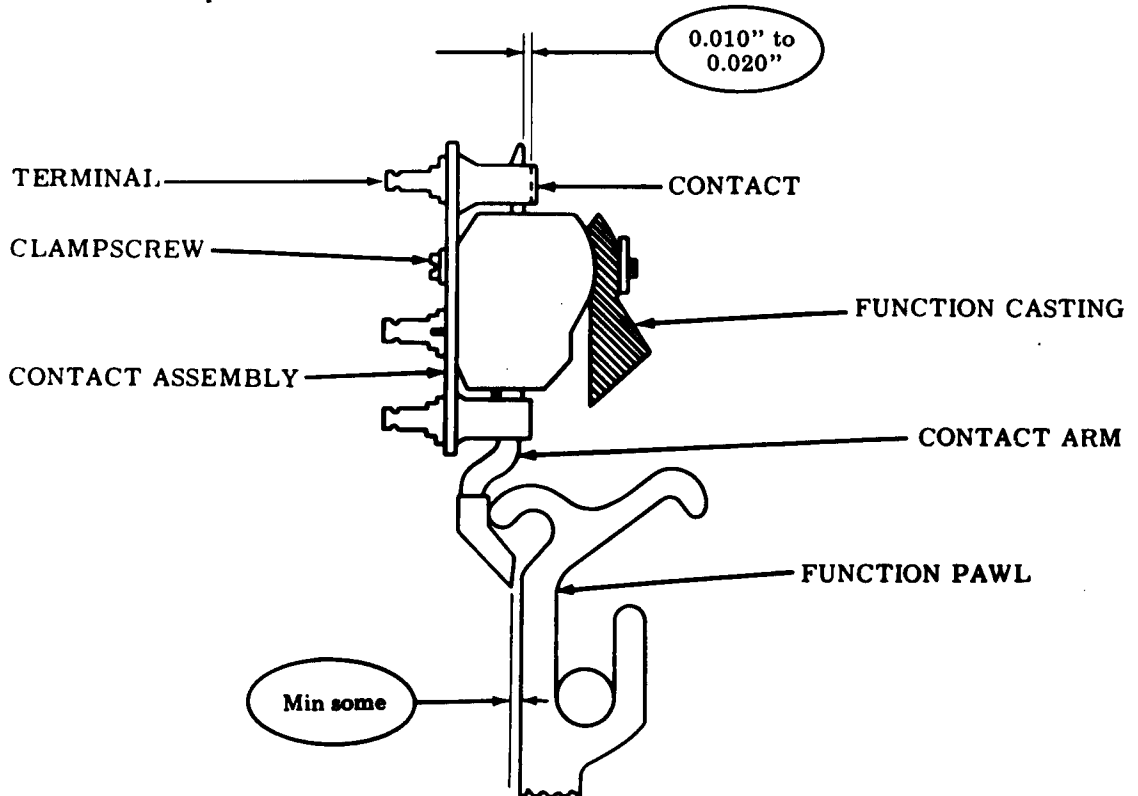

(Left Side View)

3.17 Receive-Only Sets (Distributor Area)

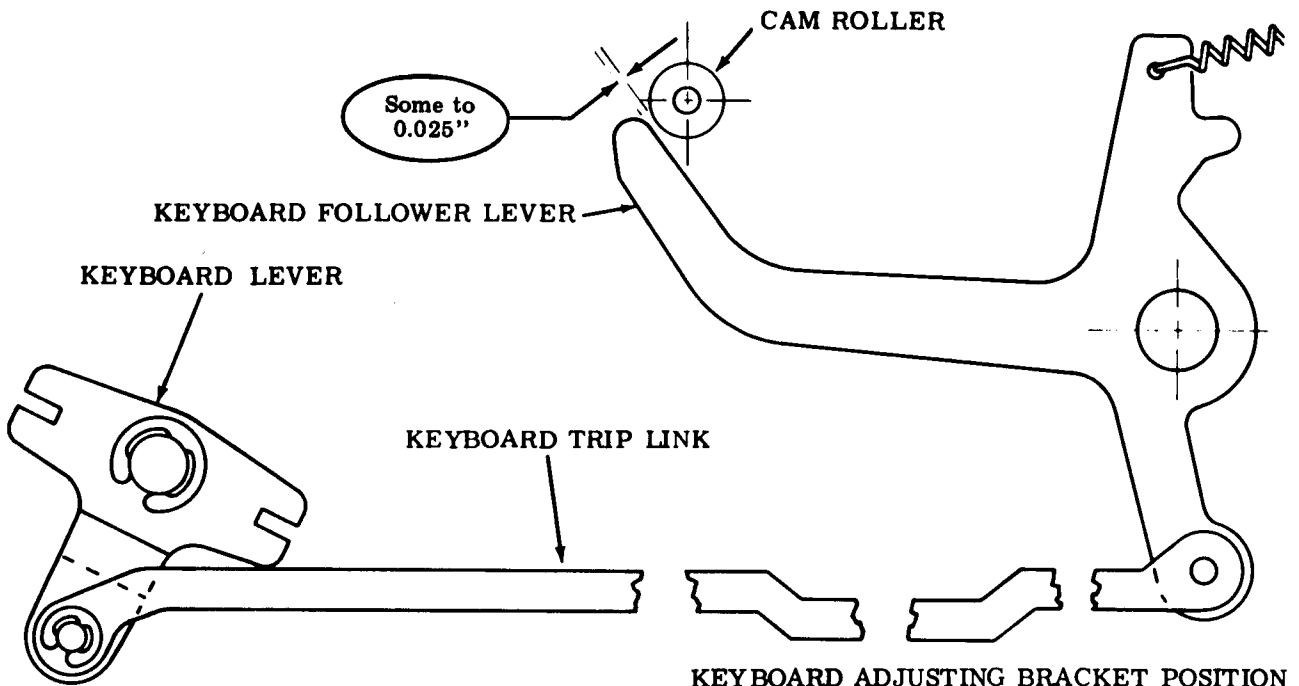

(Right Side View)

KEYBOARD ADJUSTING BRACKET POSITION (MIA-2)

To Check

Trip distributor clutch and rotate main shaft until cam roller is on high part of keyboard follower lever. Place keyboard lever in its lowest position.

Requirement

Min some---Max 0.025 inch between keyboard follower lever and cam roller as gauged by eye.

To Adjust

Loosen clamp screw friction tight. Move adjusting bracket using pry points. Tighten clamp screw.

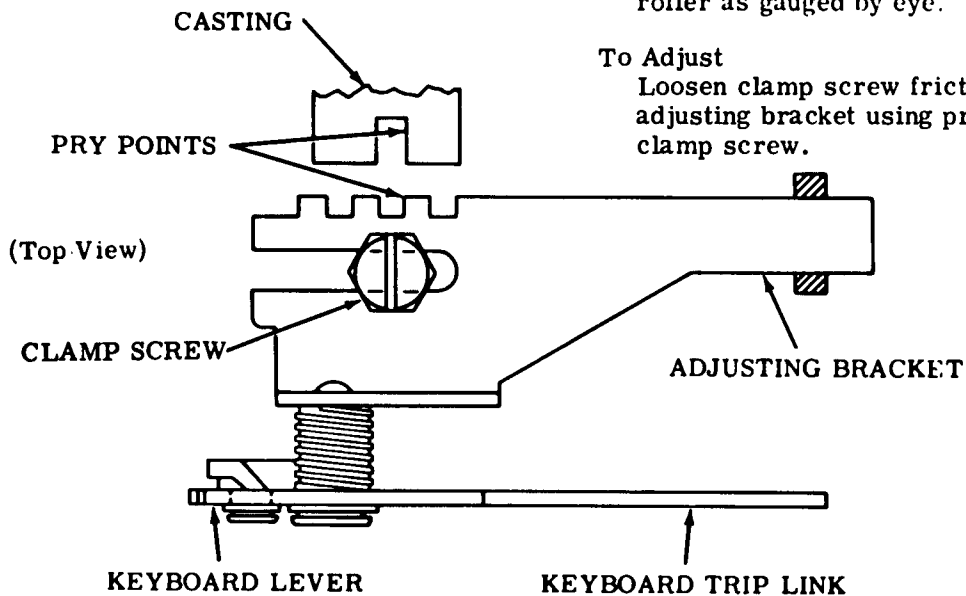

(Top View)

3.18 Auxiliary Contact Assembly (TP183594) (Main Shaft Area)

TIME DELAY CONTACT BRACKET POSITION (VFA-5)

To Check

Place the typing unit in the stop condition. Engage the function clutch and rotate the main shaft until the cam follower is on high part of its cam.

Requirement

Max 0.010 inch separation of front contact spring from stiffener.

To Adjust

Loosen mounting screw and position bracket. Tighten screw.

FRONT CONTACT SPRING

Requirement

With typing unit in stop condition
Min 4-1/2 oz --- Max 6 oz
to just separate the front contact spring from the stiffener.

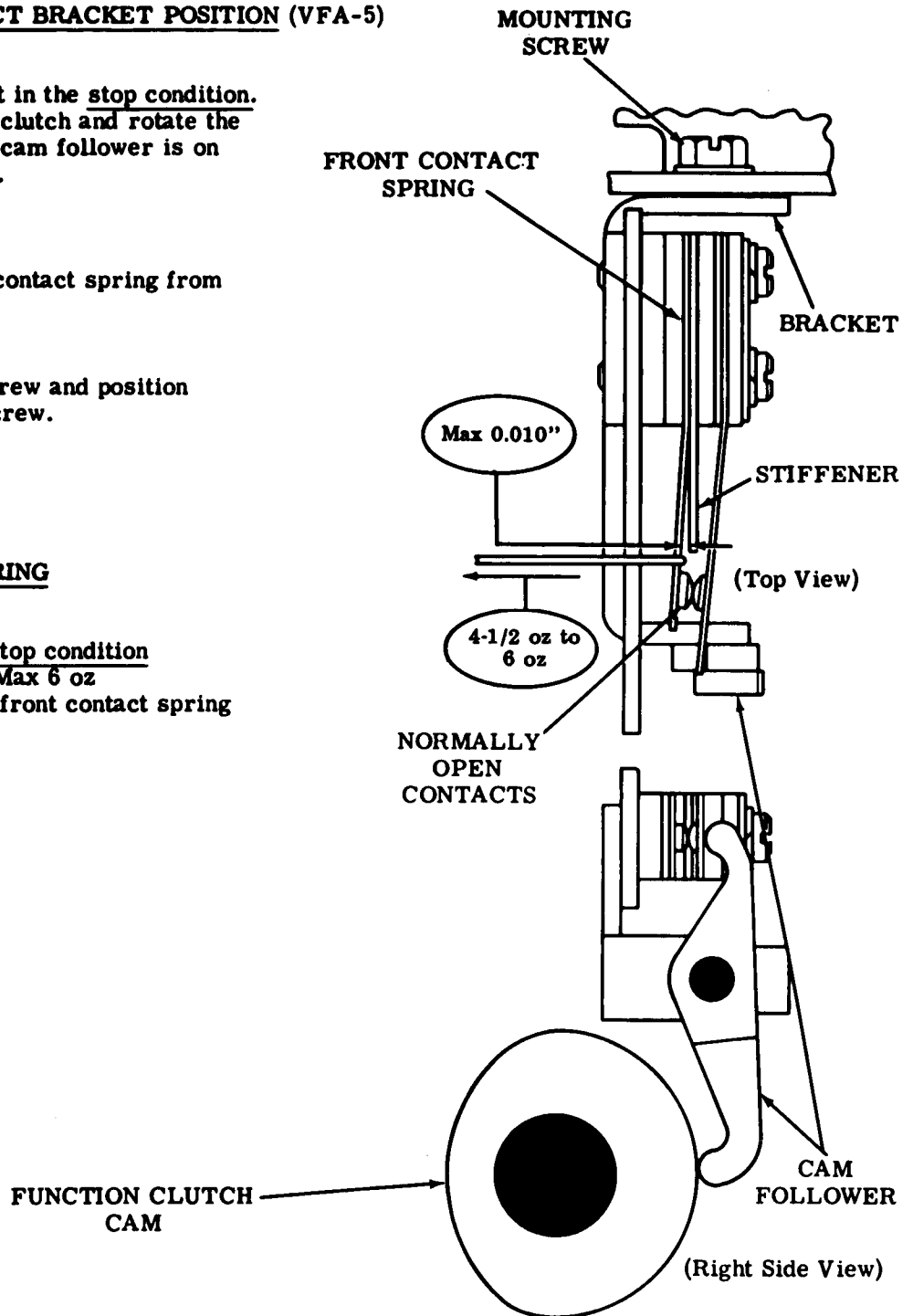

3.19 Two-Color Printing (Platen Area)

PLATEN – HORIZONTAL POSITION - F (PLA-1)

(1) To Check

Place the flat surface on the left side of the platen up so that it is horizontal to the base casting. Place the carriage at the left margin and check requirement. Move the carriage to the right margin and again check requirement.

Requirement

Min 0.050 inch---Max 0.065 inch (Early design units with TP183885 Plate)

Min 0.070 inch---Max 0.085 inch (Late design units with TP180610 Shield)
between ribbon guide and platen at both left and right margins.

(2) To Check

Place carriage to center of platen and rotate platen until maximum clearance is obtained between platen and ribbon guide. Set up the E code combination (1----) in the selector. Rotate main shaft until carriage drive bail is in its rearmost position (position no. 2). Push typewheel to the rear until it just touches the platen.

Note: The typing unit should not have paper or ribbon installed.

Requirement

Typewheel should not touch inside of either ribbon guide.

To Adjust

Loosen four horizontal positioning screws. Position platen horizontally. Tighten positioning screws.

Related Adjustments

Affects

LINE FEED STRIPPER PLATE CLEARANCE - F (2.84)

Affected By

FRONT ROLLERS CLEARANCE (2.41)

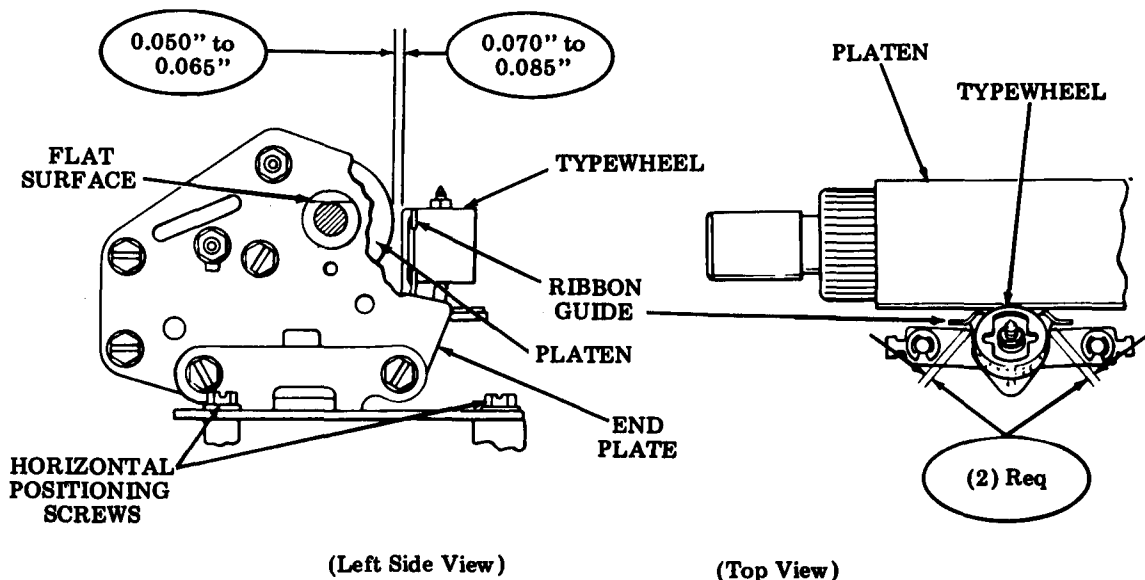

3.20 Two-Color Printing (Answer-Back Area)

BLOCKING LINK CLEARANCE

To Check

Place typing unit in stop condition, engage the distributor and codebar clutches. Rotate the main shaft until the adjusting tab is on the high part of the blocking cam and codebar reset bail is in its highest position. Take up all clearances to make gap between R codebar and blocking link a minimum.

Requirement

Min 0.050 inch---Max 0.070 inch
between R codebar blocking extension and tine on blocking link.

To Adjust

Bend adjusting tab with TP180993 bending tool.

Related Adjustment

Affects

COLOR SELECTION LATCH OVERTRAVEL (3.23)

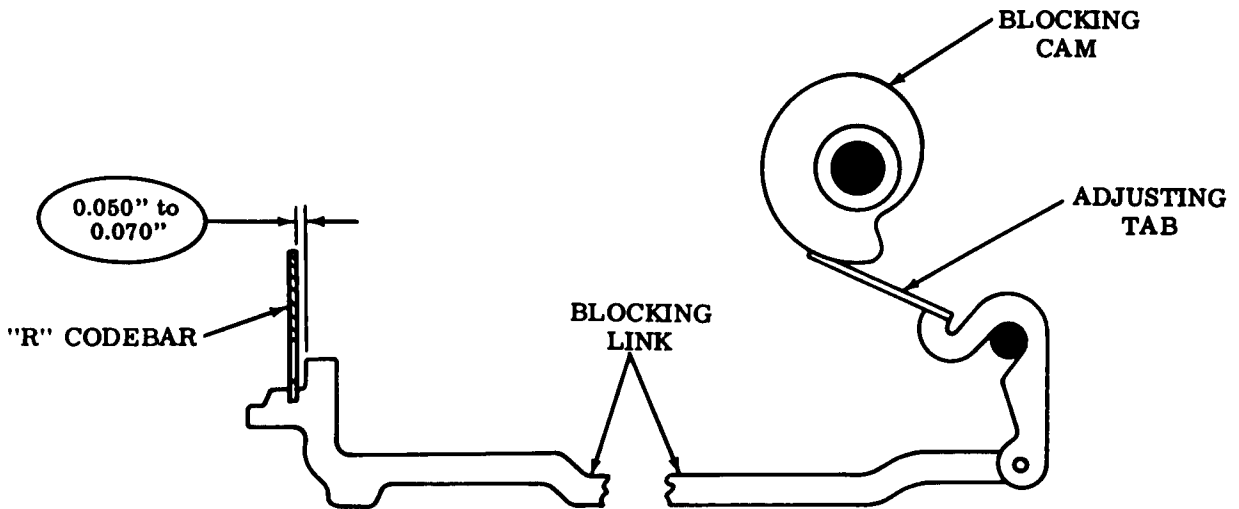

(Right Side View)

Note: If the typing unit is equipped with the answer-back trip magnet mechanism (TP182045), the TRIP LEVER OVERTRAVEL AND ARMATURE GAP (Answer-Back Area) (3.09) adjustment should be made at this time. If necessary, the answer-back trip lever adjusting tab should be bent forward to clear the control lever before proceeding with the remaining answer-back adjustments.

3.21 Two-Color Printing (Carriage Area)

RIBBON GUIDE SPRING

To Check
Place typing unit in the stop condition, engage the function clutch. Rotate main shaft until ribbon guide rises to its highest position.

Requirement
Min 5 oz---Max 6 oz
to start ribbon guide moving downward.

LATCH BELLCRANK SPRING

Requirement
With typing unit in stop condition
Min 1/2 oz---Max 1 oz
to start latch bellcrank moving.

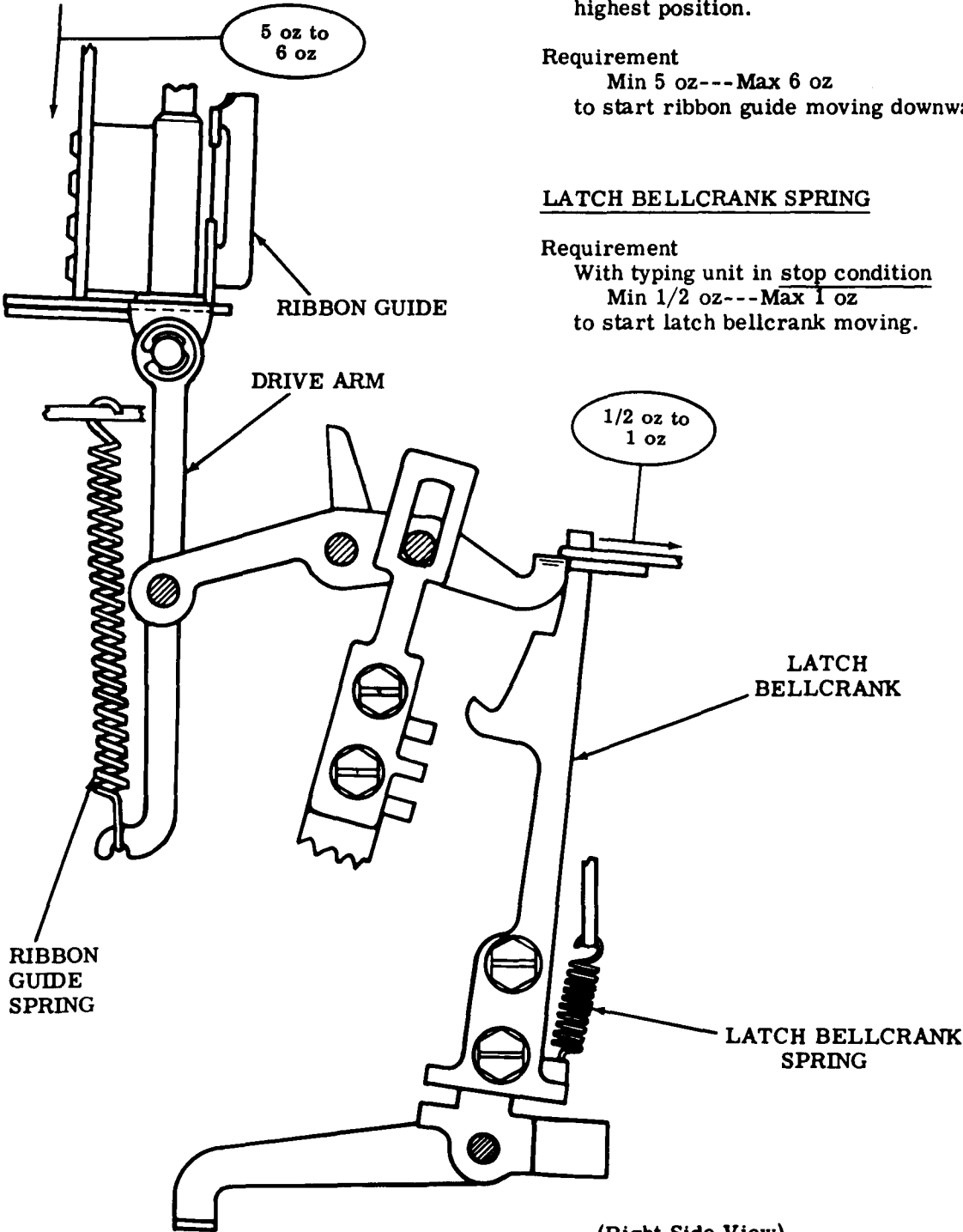

(Right Side View)

3.22 Two-Color Printing (Carriage Area) (continued)

TYPEWHEEL RETURN SPRING

Requirement

With typing unit in stop condition

Min 5 oz --- Max 6 oz
to move typewheel to platen.

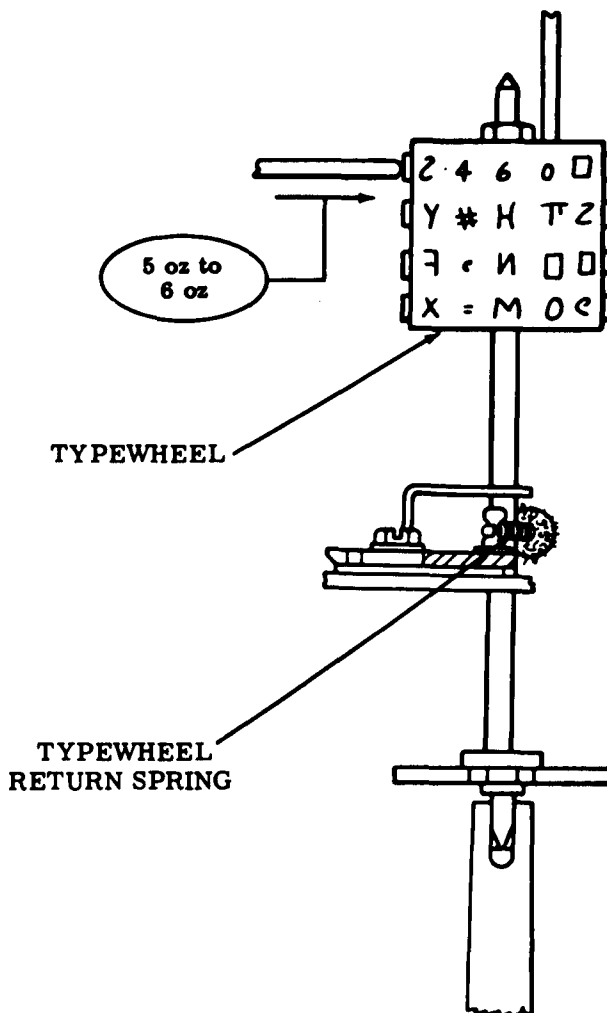

(Right Side View)

3.23 Two-Color Printing (Carriage Area) (continued)

COLOR SELECTION LATCH OVERTRAVEL (VFA-4)**To Check**

Place typing unit in the stop position. Engage distributor clutch. Rotate main shaft until carriage drive bail is at its rearmost position. Select "R" codebar.

Requirement

Early Design units with TP183538 or TP188628 stop lever

Min 0.020 inch — Max 0.040 inch

Late Design units with TP188829 stop lever

Min 0.010 inch — Max 0.030 inch

To Adjust

Loosen screws and position latch bellcrank. Tighten screws.

Related Adjustment

Affected By

BLOCKING LINK CLEARANCE (3.20)

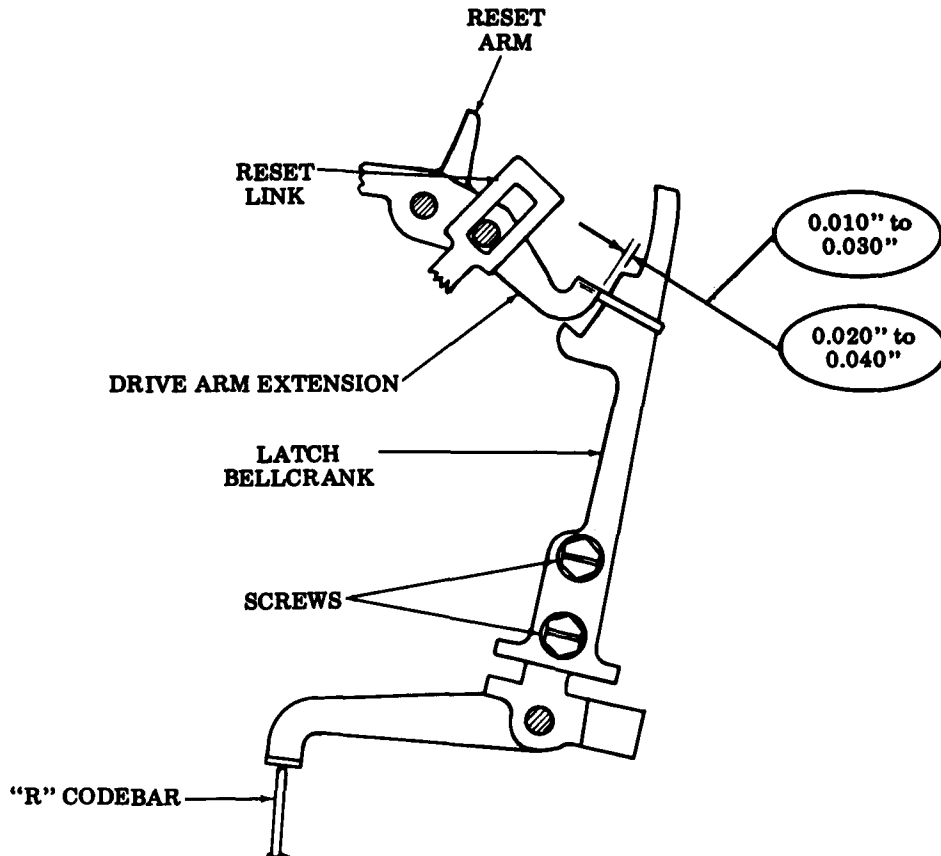

(Right Side View)

3.24 Two-Color Printing (Carriage Area) (continued)

RIBBON GUIDE POSITIONING

To Check

Print any four characters such as illustrated. Place the typing unit in stop condition.

Requirement

Min 0.010 inch---Max 0.020 inch

between the top horizontal edge of the ribbon and lower edge of the printed characters as gauged by eye.

To Adjust

Loosen screws and position reset link using pry points. Tighten screws.

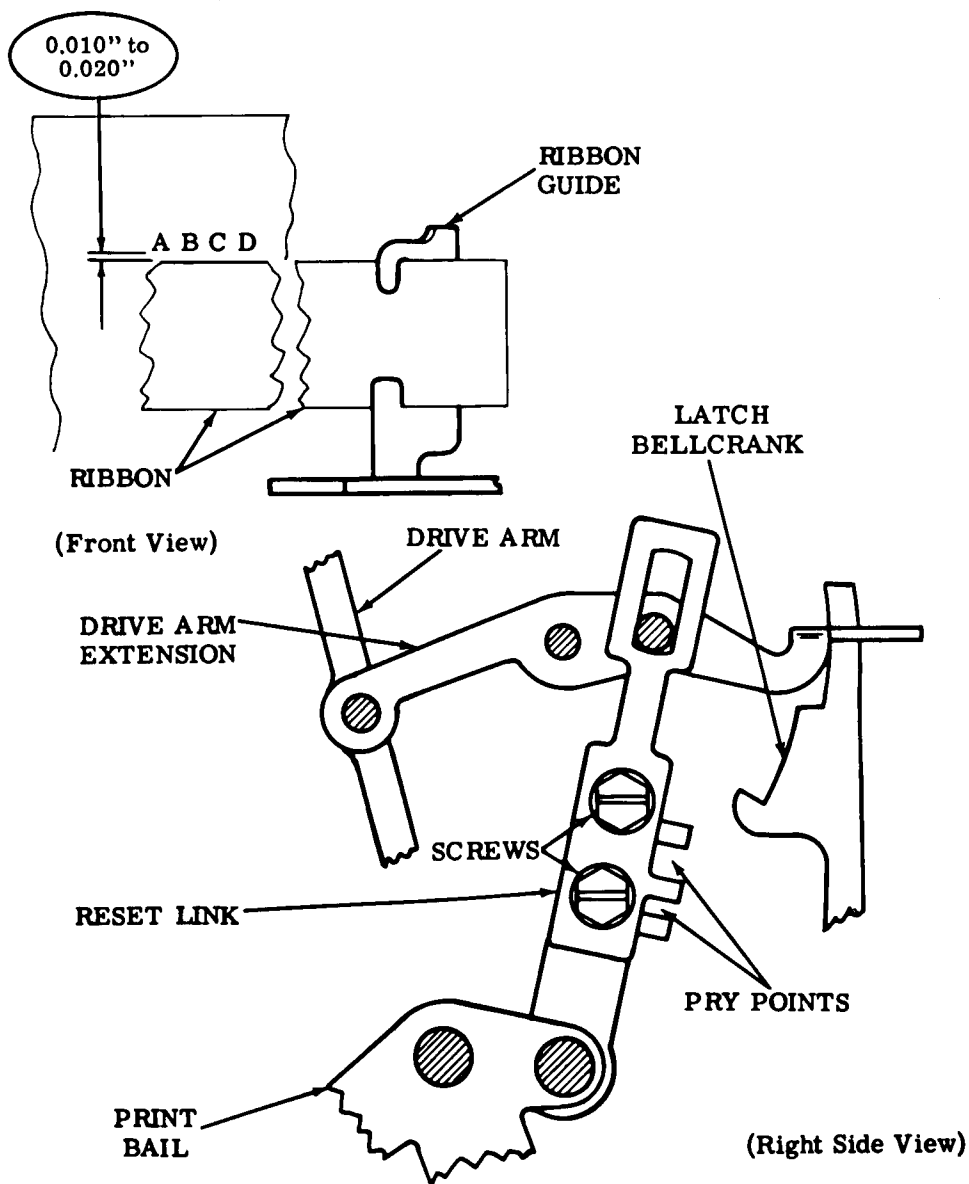

3.25 Function Area

CODING AND INSTALLATION OF TP180801 UNIVERSAL FUNCTION LEVER

Note: The following instructions do not apply to the answer-back function lever and the carriage return drive function lever.

- (a) The tines on the universal function lever are numbered from right to left in the illustration as follows: PS, 0, 1, 2, 3, 4, 5, (6), (7). Since model 32 is 5 level equipment, the (6) and (7) levels are not used.
- (b) There are two rows of tines on the universal function lever. The straight row of tines corresponds to the marking pulses of a given code combination. The bent row of tines corresponds to the spacing pulses of a given code combination.
- (c) The "0" tine represents the shift level. If the code combination falls in the "Figures" category, break the straight tine at 0. If it falls to the "Letters" category break the bent tine at 0.
- (d) The tines on the universal function lever are easily broken off with long nose pliers.
- (e) The TP180801 universal function lever is to be installed only in the numbered slots of the function casting.
- (f) If the typing unit is equipped with a function lever retainer, lower the retainer sufficiently to allow the universal function lever to be installed under the codebar basket. Readjust the function lever retainer.
- (g) Place the universal function lever under the codebar basket with the open end of the pivot slot on the pivot shaft.
- (h) Holding the lever vertically, squeeze it onto the pivot shaft with a pair of pliers. This is a "snap" fit and sufficient pressure should be applied with the pliers to get the lever fully on the shaft. The lever should pivot freely once on the shaft.
- (i) Locate the proper numerical slot on the function casting, place the lever in the slot, and install a TP91120 spring.

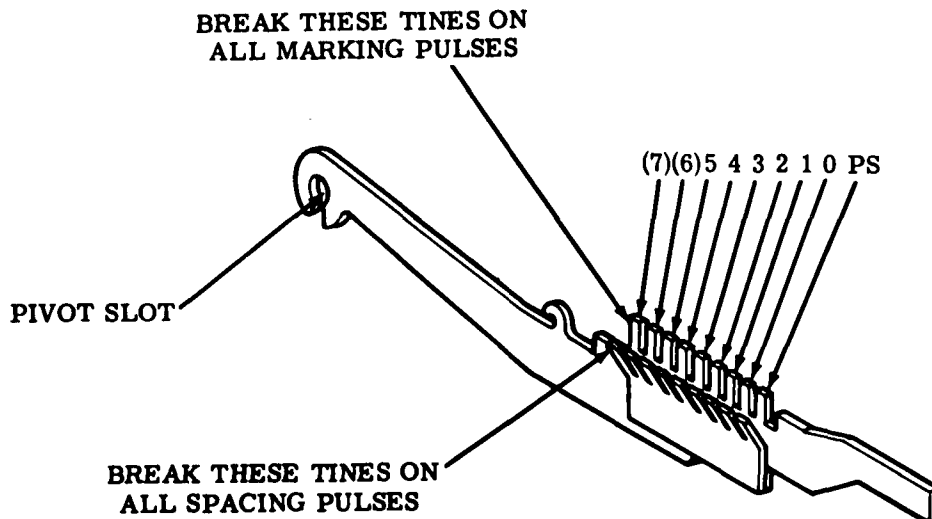

3.26 Answer-Back Area (continued)

INSTRUCTIONS FOR CODING THE ANSWER-BACK DRUM

- (a) To remove the answer-back drum for coding, press back and down on the tab portion of the TP180854 brace until it becomes detented in its open position. Lift feed pawl slightly (do not overextend its spring) and remove drum.
- (b) Code the answer-back drum in a counterclockwise direction starting with row no. 1 (Figure 5).

Note 1: The ST row is the first row sensed at the beginning of an answer-back cycle. It is coded at the factory for character suppression and must not be recoded.

Note 2: The TP184149 answer-back drum (in which the suppression tine is not factory removed, as in other drums) requires a coding pattern. When a tine is removed, at least one tine (same level, adjacent row) must also be removed. The coding pattern thus established results in a minimum of two successive removed tines in each area of required tine removal.

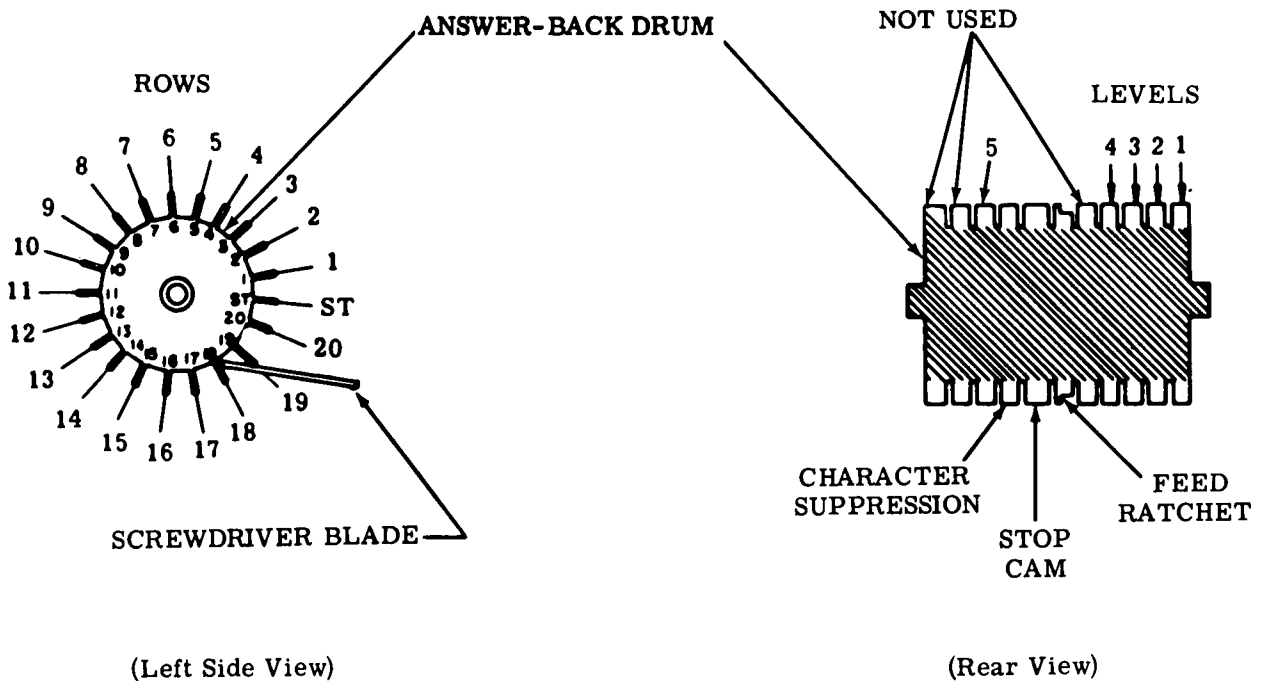

Figure 5 - Answer-Back Drum

3.27 Answer-Back Area (continued)

INSTRUCTIONS FOR CODING THE ANSWER-BACK DRUM (continued)

The tines of the three unused levels may be left intact since no contact wires sense these positions.

- (c) A particular character is coded by either retaining or removing tines within a row, as illustrated in Figure 5. A tine may be removed by either of the two following methods:

Method 1: Place the end of a screwdriver blade at the base of a tine in the row previously coded. Press the side of the blade against the top of the unwanted tine until the tine breaks off. Figure 5 illustrates this method — pressure applied to base of row no. 18 and against top of adjacent tine being removed from row no. 19.

Method 2: Place the unwanted tine in the slot of a TP161686 tine tool, or grasp the tine firmly with long-nose pliers. With the tool or pliers held stationary, rotate the answer-back drum back and forth until the tine breaks off near its base. Do not damage adjacent tines.

Note: If a coding error is made, or for some other reason it is necessary to suppress (erase) characters from the answer-back drum, remove the character suppression tine from the row(s) affected.

- (d) The length of an answer-back sequence can be varied either by removing the stop cam tine(s) and/or the character suppression tine(s).
- (e) For short sequences, code the drum for either 2- or 3-cycle operation by removing the appropriate tine(s) as indicated in Figure 5.
- (f) Removal of the character suppression tine from any row prevents transmission from the answer-back mechanism. To shorten the answer-back sequence, remove the suppression tine from any unused row(s) after the end of a message.

Note: On sets used in systems where a response to each answer-back activation signal must be obtained, do not remove the character suppression tine from the last row of each segment of the answer-back drum. For answer-back drums coded for 1-cycle operation this is row no. 20. The last row can be coded with any other character that is compatible with the particular system.

- (g) The number of rows available for message coding is shown below for 1-, 2-, or 3-cycle operation.

CYCLE OPERATION	TOTAL ROWS	AVAILABLE ROWS
1	21	20
2	10(11)*	9(10)*
3	7	6

*Alternately one, then the other.

- (h) The number of rows available for actual station identification is less than shown above because each coded message should begin and end with CARRIAGE RETURN and LINE FEED (this may be altered in specific applications). This assures that the transmitted message will appear at the beginning of a line of the receiving teletypewriter set and eliminates overprinting.

- (i) To replace the answer-back drum, place the TP180854 brace in its detented open position, and lift feed pawl (do not overextend its spring). Replace drum with its shaft firmly seated in the contact block slots. Release feed pawl and TP180854 brace. Rotate answer-back drum to assure proper seating of its associated parts. Check that the contact wires are located in their proper slots.

LETTERS		FIGURES	MARKING PULSES REMOVE TINES
A		-	1-2
B		?	1-4-5
C		:	2-3-4
D		WRU	1-4
E		3	1
F		\$	1-3-4
G		&	2-4-5
H		#	3-5
I		8	2-3
J		BELL	1-2-4
K		(1-2-3-4
L)	2-5
M		.	3-4-5
N		,	3-4
O		9	4-5
P		0	2-3-5
Q		1	1-2-3-5
R		4	2-4
S		'	1-3
T		5	5
U		7	1-2-3
V		;	2-3-4-5
W		2	1-2-5
X		/	1-3-4-5
Y		6	1-3-5
Z		"	1-5
CARRIAGE RETURN			4
LINE FEED			2
LETTERS SHIFT			1-2-3-4-5
FIGURES SHIFT			1-2-4-5
SPACE			3
BLANK			NONE

REMOVE TINES IN THE FOLLOWING ROWS TO GET THE PROPER CYCLE		
CYCLES	CHARACTER SUPPRESSION	STOP CAM
1 Cycle	Row ST	Row 6
2 Cycle	Row ST Row 11	Row 6 Row 17
3 Cycle	Row ST Row 7 Row 14	Row 6 Row 13 Row 20

Note 1: Tines present on the drum represent spacing pulses. Tines removed from the drum represent marking pulses.

Note 2: Be sure to allow for any variation from the codes above that are unique to the system in which the answer-back drum will be used.

Figure 6 - Answer-Back Drum Code Arrangement

**32 TAPE READER
 ADJUSTMENTS**

CONTENTS	PAGE
1. GENERAL	1
2. BASIC UNIT	5
Clutch Trip Area	
Armature extension (RRA-2)	7
Contact gap (RRA-4)	8
Feed magnet contact spring	9
Magnet core	5
Reader trip lever spring	9
Reader — clutch trip lever (RRA-3)	7
Trip magnet	5
Trip lever overtravel (RRA-1)	6
Trip magnet armature spring	6
Tape Reader Area	
Armature spring	20
Blocking pawl (RRA-7)	14
Blocking pawl spring	13
Contact wires* spring	16
Control (or tape-out) contact wires* (RRA-9/RRA-13)	16
Control detent spring	19
Detent lever (RRA-5)	10
Detent lever spring	10
Feed pawl (RRA-6)	11,12
Latch spring	21
Reader mounting bracket (RRA-11)	22,23
Sensing contact wire spring	19
Sensing pin (RRA-8)	15
Sensing pin spring	15
Start contact wires (RRA-12)	17
Tape lid latch handle (RRA-10)	18
Tape lid spring	18
Tape-out pin spring	20
Tight-tape lever spring	19
Upstop spring	13
3. VARIATIONS TO THE BASIC UNIT	24
Reset and busy switch timing (RRA-14)	24

1. GENERAL

1.01 This section provides adjustment and maintenance information for the Model 32 Tape Reader. It is reissued to include engineering changes. Because this is a general revision, marginal arrows normally used to indicate changes are omitted.

1.02 Location of clearances, position of parts, and point and angle of scale applications are illustrated by line drawings. Tools required to perform adjustments are listed in Section 570-005-800TC.

1.03 The sequence in which the adjustments appear should be followed when a complete readjustment of the tape reader is undertaken. No adjustment should be made without completely understanding the procedure. Read a procedure all the way through before making an adjustment.

Note 1: Check all related adjustments (1.07).

Note 2: Disconnect all power.

1.04 References to left, right, front, rear, etc consider the tape reader to be viewed where the feed wheel faces up and the lid latch is to the viewer's right. References to the clutch trip area consider the armature extension to be facing up with the contact bracket pry points located to the viewer's right.

1.05 When a procedure calls for using pry points or slots to make an adjustment, place a screwdriver between the points or in the slots and pry parts in the proper direction.

1.06 If parts are removed from the tape reader to facilitate making an adjustment, be sure that they are replaced.

Note: Recheck any adjustment that may have been affected by the removal of parts.

1.07 Related adjustments are listed with some of the adjustment text and are primarily intended to aid in troubleshooting the

equipment. As an example, suppose that in searching for a trouble it is discovered that the BLOCKING PAWL (RRA-7) adjustment does not meet its requirement. Under "Related Adjustment," it is indicated that this adjustment is affected by the DETENT LEVER (RRA-5) and FEED PAWL (RRA-6) adjustments. Check these to see if either is the cause of the trouble. Also, note that certain adjustments affect other adjustments. For example, see the DETENT LEVER (RRA-5) adjustment. Note that this adjustment affects the FEED PAWL (RRA-6) and BLOCKING PAWL (RRA-7) adjustments. If the former adjustment is changed, check the latter adjustments.

1.08 The spring tensions specified are indications, not exact values. Therefore, to obtain reliable readings, measure spring tensions with scales placed in the positions shown on line drawings. Springs that do not meet their requirements should be replaced by new ones. Only those springs that directly affect the operation of the tape reader are measured, however, others may be measured indirectly in the process. If this is the case and the requirement is not met, replace the springs one at a time, starting with the indicated spring, until the requirement is satisfied.

Note: Spring tensions may be checked in any sequence.

1.09 Certain adjustments specify that an armature is to be in its attracted position prior to checking a requirement. This refers to an armature's position when it is magnetically attracted to its magnet core. If a separate power supply is not available, the armature can be held attracted by utilizing power normally supplied by the ASR set. This is accomplished with the motor power turned off and the reader trip magnet armature manually energized.

CAUTION: THE TAPE READER FEED MAGNET OPERATES UNDER HIGH VOLTAGE. THIS HIGH VOLTAGE REMAINS FOR ABOUT 10 SECONDS AFTER POWER IS DISCONNECTED.

1.10 When inserting a tape that has originated from the tape punch, into a tape reader, allow some slack in the tape between the punch and the reader. This is done to close the reader tape lid.

Note: Do not place the control lever directly into the FREE position while the tape reader is operating under power. Place the control lever into the STOP position and wait until after the tape reader has stopped before moving it beyond the STOP position and into the FREE position. The FREE

TAPE READER AREA

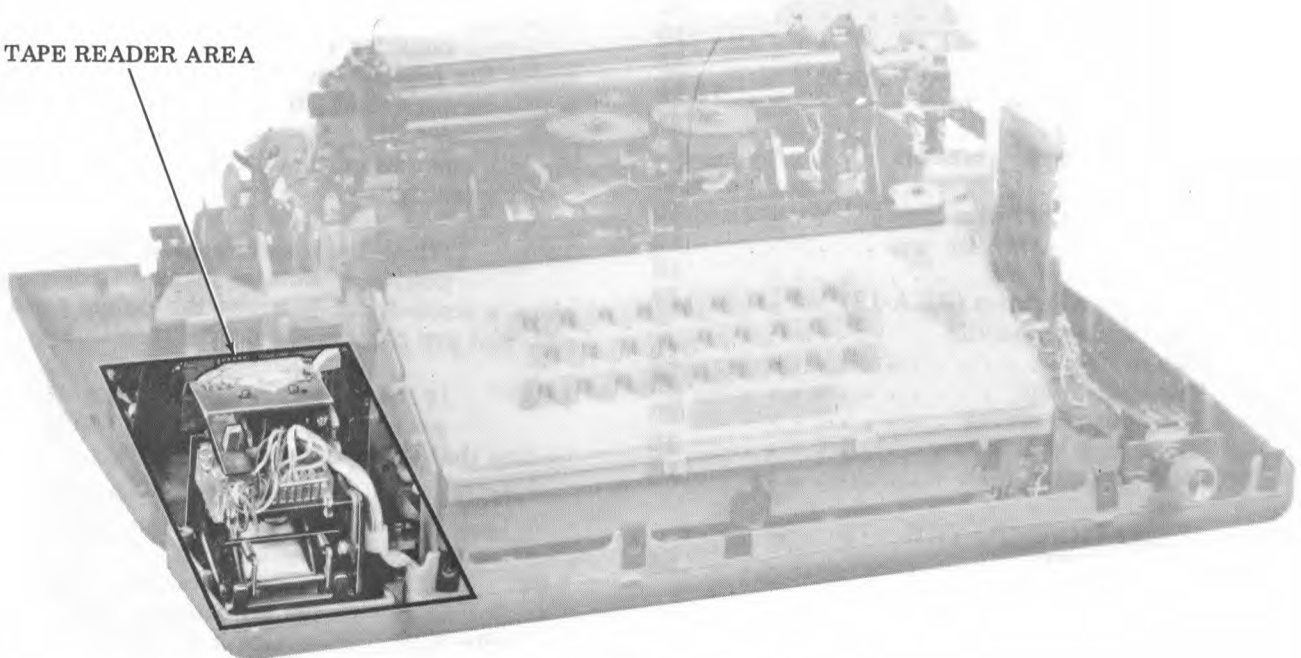

Figure 1 - Tape Reader Area

position of the control lever is used to facilitate the insertion and/or removal of paper tape from the tape reader.

1.11 All adjustments in the "Clutch Trip Area" should be started with the typing unit in the stop condition. It is in the stop condition when the selector armature is in its attracted (frontward) position and all clutches are disengaged.

1.12 To place the typing unit in the stop condition, hold the selector armature in its attracted (frontward) position. Rotate the main shaft clockwise (as viewed from the left) until all clutches are fully disengaged as instructed in 1.13 below.

1.13 When disengaged, a clutch is latched so that a shoe lever is held in its stop position by a trip lever while a corresponding latchlever is seated in a notch of the clutch disc. This allows the clutch shoes to release their tensions on the clutch drum. With all clutches disengaged, the main shaft will turn freely without any clutch shoes dragging.

Note 1: The clutch stop position is that position where a shoe lever contacts a trip lever.

Note 2: If the shaft is turned by hand, a clutch will not fully disengage upon reaching

a stop position. Where an adjustment procedure requires disengagement, rotate the clutch to a stop position, apply a screwdriver to the associated stop-lug, and push the clutch disc in the normal direction of main shaft rotation until the corresponding latch-lever seats in its clutch disc notch.

Note 3: The distributor clutch will not disengage unless the answer-back drum is in its home position, which is the position where the control lever is fully detented into the indent on the answer-back drum.

1.14 There are two areas in which tape reader adjustments and spring tensions are found. As aids in locating the areas, Figures 1 and 2 are provided. They indicate the areas as follows:

<u>Area</u>	<u>Figure</u>
Clutch trip	2
Tape reader	1

1.15 To provide a universal method of adjustment identification, alpha-numeric code combinations (RRA-no.) are used to supplement the adjustment titles.

Note: The alpha-numeric codes are not used for spring adjustments.

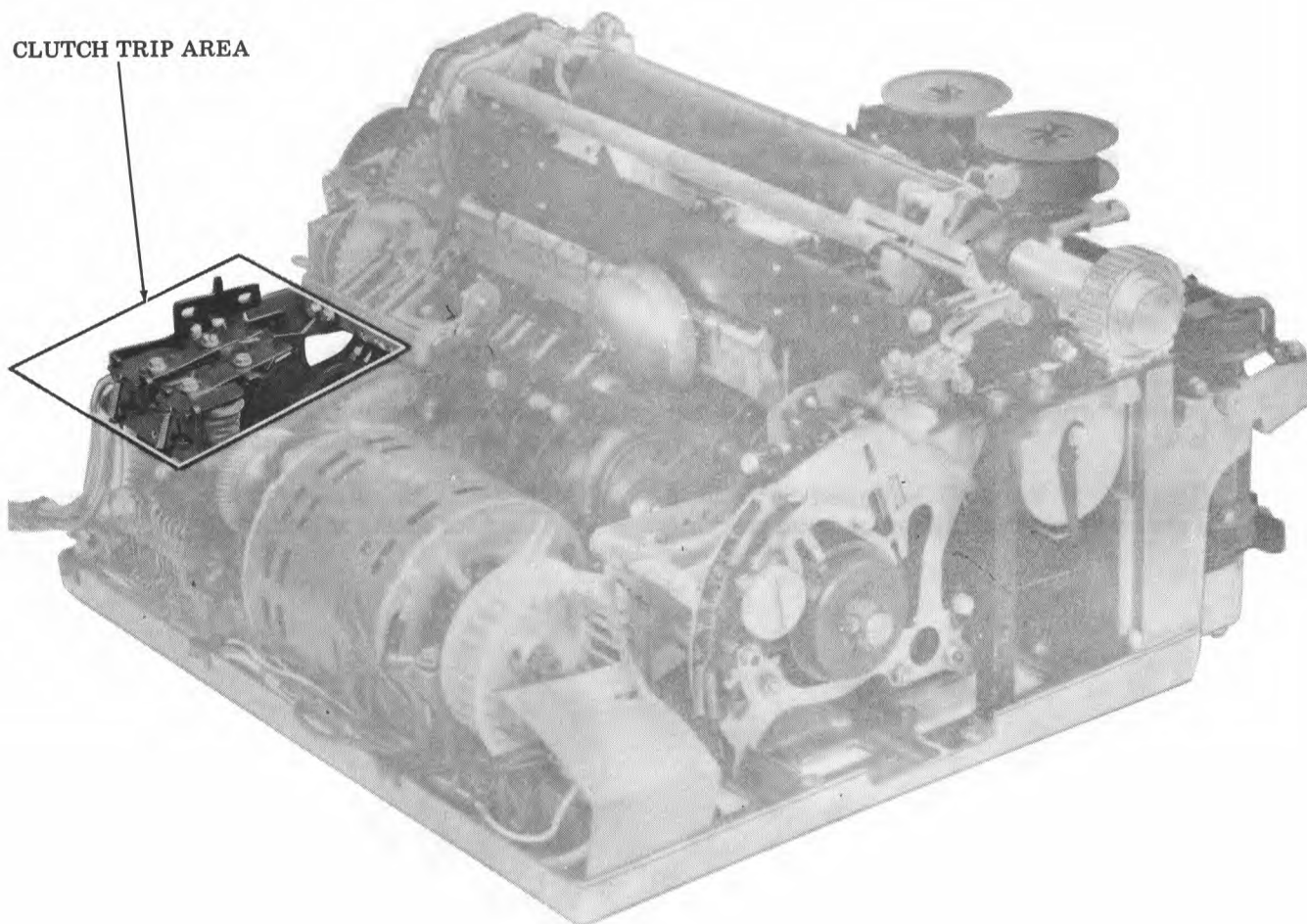

Figure 2 - Clutch Trip Area (Without Reader Feed Magnet Contact Assembly)

2. BASIC UNIT

2.01 Clutch Trip Area

Note: The following positioning of the trip magnet must be correct before proceeding with the adjustments in the reader.

MAGNET CORE

Requirement

Magnet core slot to be perpendicular to magnet bracket pivot surface as gauged by eye.

To Adjust

With clutch trip coil mounting screw loosened, position clutch trip coil. Tighten screw.

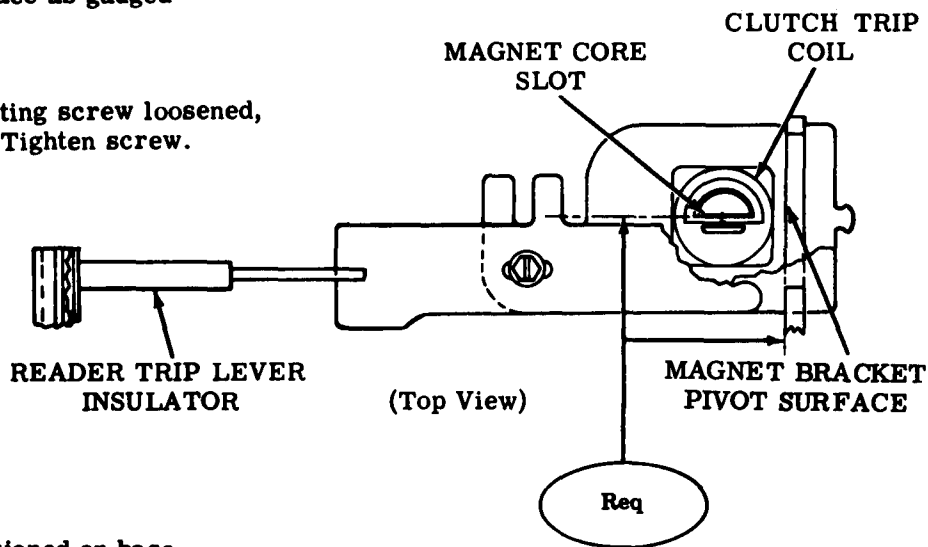

TRIP MAGNET

Requirement

Magnet bracket to be positioned on base casting post as far forward and to the left as possible.

To Adjust

Position magnet bracket with three mounting screws loosened. Tighten screws.

Related Adjustments

Affects

TRIP LEVER OVERTRAVEL (RRA-1)

CONTACT GAP (RRA-4)

ARMATURE EXTENSION (RRA-2)

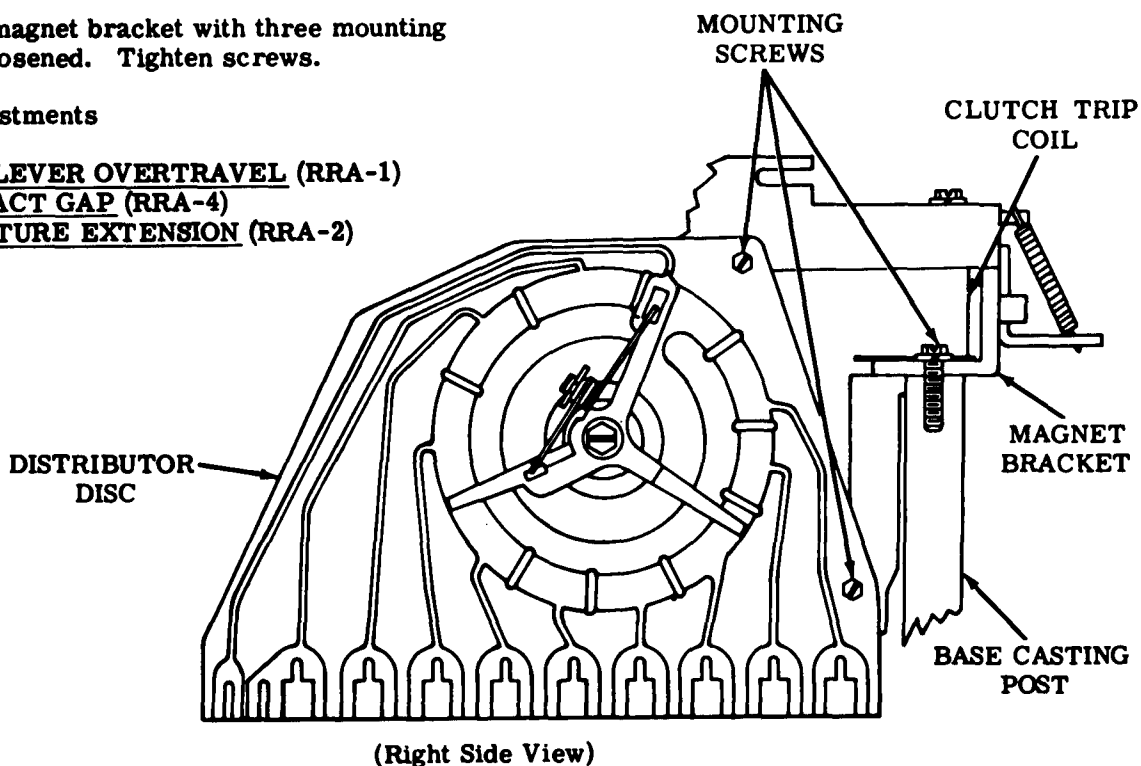

SECTION 574-174-700TC

2.02 Clutch Trip Area (continued)

TRIP LEVER OVERTRAVEL (RRA-1)

To Check

Trip distributor clutch by momentarily holding armature in its attracted position. Rotate main shaft until cam roller is on high part of reader trip lever cam. Take up play in the armature toward the rear and release. If armature does not have guide ears to center the trip lever, position the reader trip lever to the center of the armature extension.

Requirement

Min 0.010 inch --- Max 0.030 inch
between the end of armature extension and
latching surface of reader trip lever.

To Adjust

With armature extension mounting screw
loosened friction tight, position armature
extension using pry point. Tighten screw.

Related Adjustment

Affects

CONTACT GAP (RRA-4)

TRIP MAGNET ARMATURE SPRING

Requirement

With armature in its unattracted position
and cam roller on high part of
reader trip lever cam
Min 2 oz --- Max 4 oz
to start armature moving.

Note: The requirement for readers
containing busy and reset switches is
Min 2 oz --- Max 3 oz

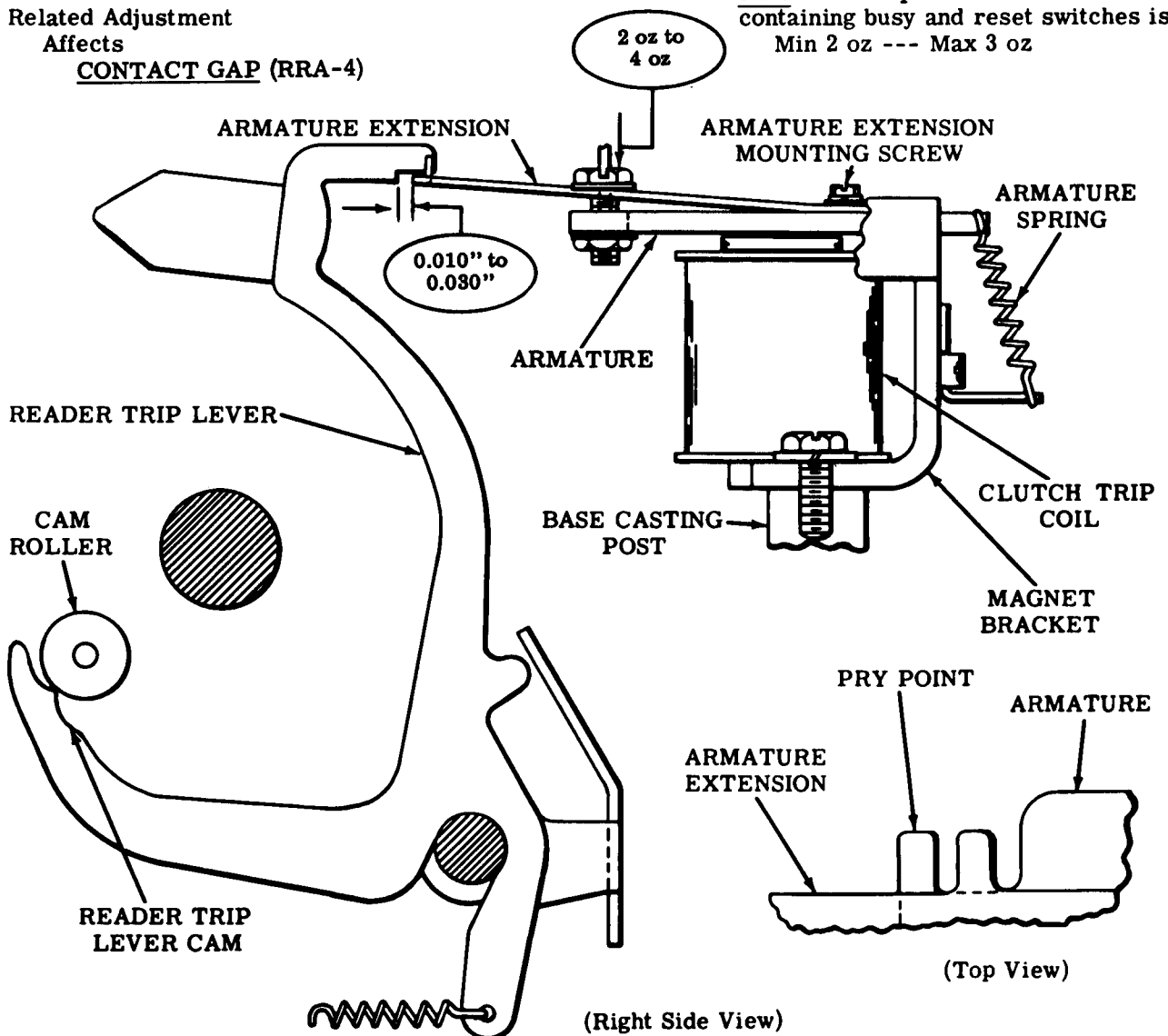

2.03 Clutch Trip Area (continued)

ARMATURE EXTENSION (RRA-2)**To Check**

Place typing unit in stop condition. Hold armature in attracted position and rotate main shaft until a clearance of

Min Some — Max 0.040 inch
exists between end of armature extension and reader trip lever.

Requirement

Min Some — Max 0.030 inch
between the armature extension and reader trip lever at its closest point.

To Adjust

Loosen adjusting screw and locknut. Position armature extension. Tighten adjusting screw and locknut.

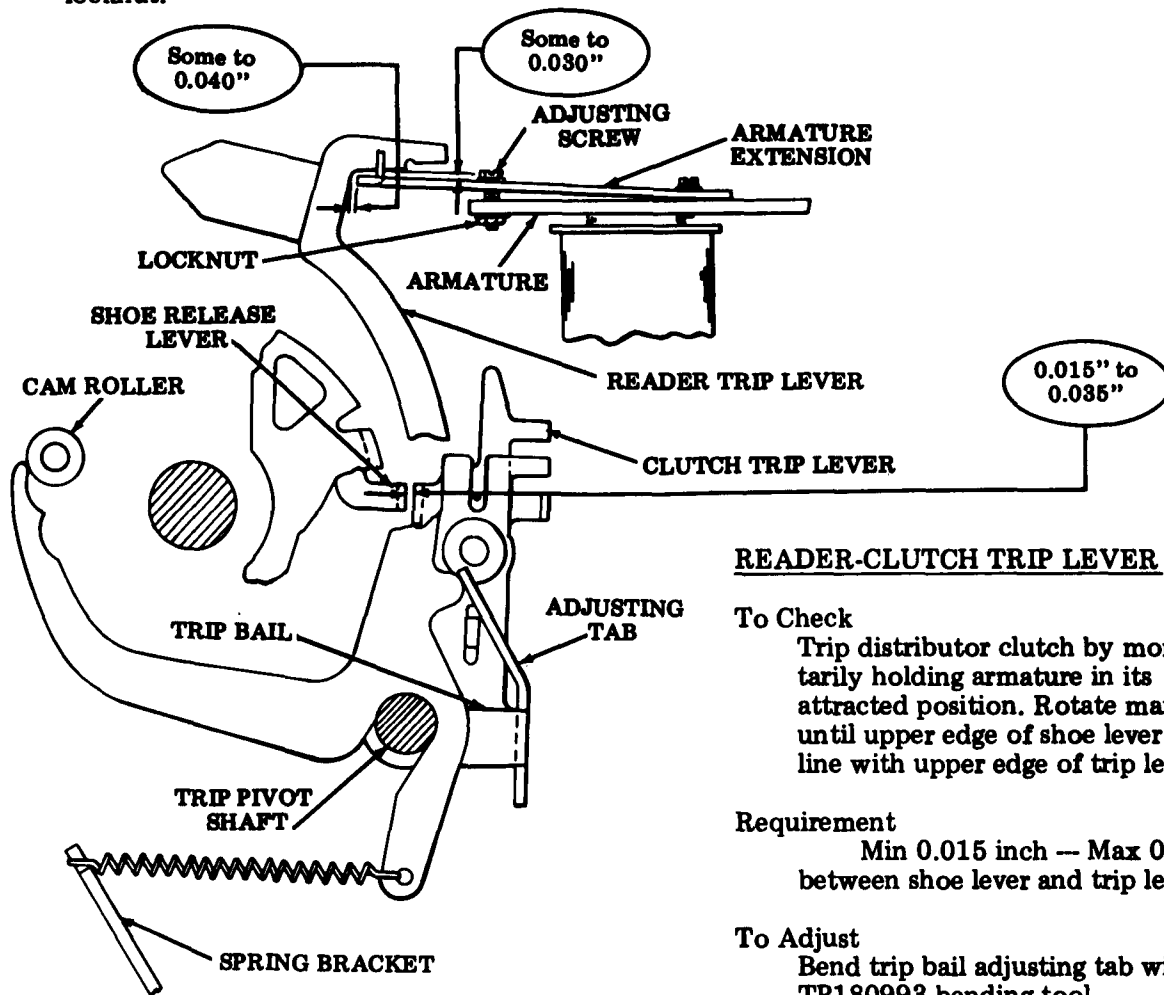

(Right Side View)

READER-CLUTCH TRIP LEVER (RRA-3)**To Check**

Trip distributor clutch by momentarily holding armature in its attracted position. Rotate main shaft until upper edge of shoe lever is in line with upper edge of trip lever.

Requirement

Min 0.015 inch — Max 0.035 inch
between shoe lever and trip lever.

To Adjust

Bend trip bail adjusting tab with TP180993 bending tool.

Note: Keep plane of adjusting tab parallel to axis of trip pivot shaft.

Related Adjustment

Affects

TRIP LEVER ENGAGEMENT
(KBA-8) in Section 574-172-700TC.

SECTION 574-174-700TC

2.04 Clutch Trip Area (continued)

CONTACT GAP (RRA-4)

To Check

Place distributor clutch in stop condition with armature in its unattracted position. If armature does not have guide ears to center the trip lever, position the reader trip lever to the center of the armature extension.

(1) Requirement

There should be some clearance between the contact leaf springs and the contact assembly cover, and between the trip lever insulator and the cover. The contacts should be in line as gauged by eye.

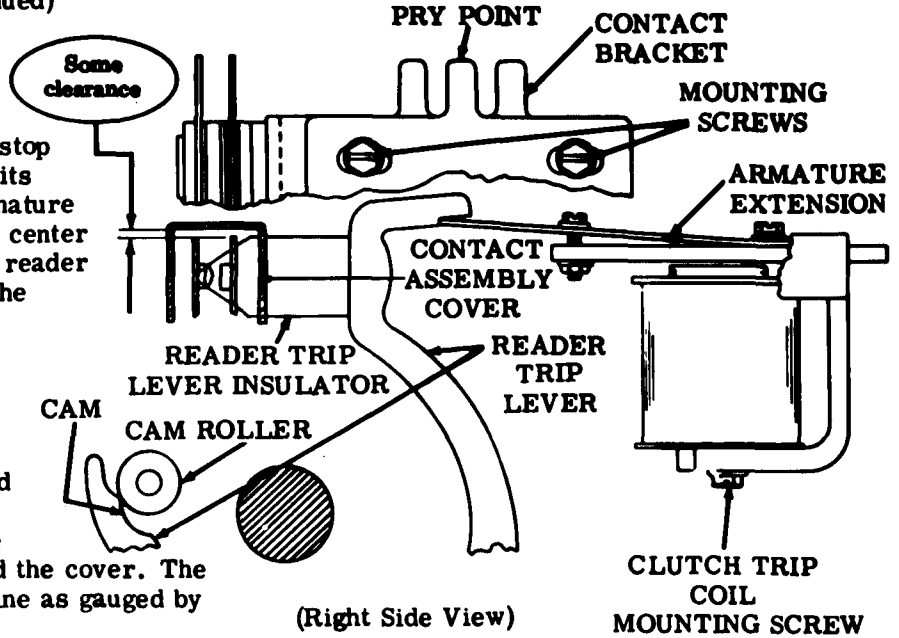

(Right Side View)

To Adjust

Loosen cover mounting screw. Position cover to meet requirement. Tighten mounting screw.

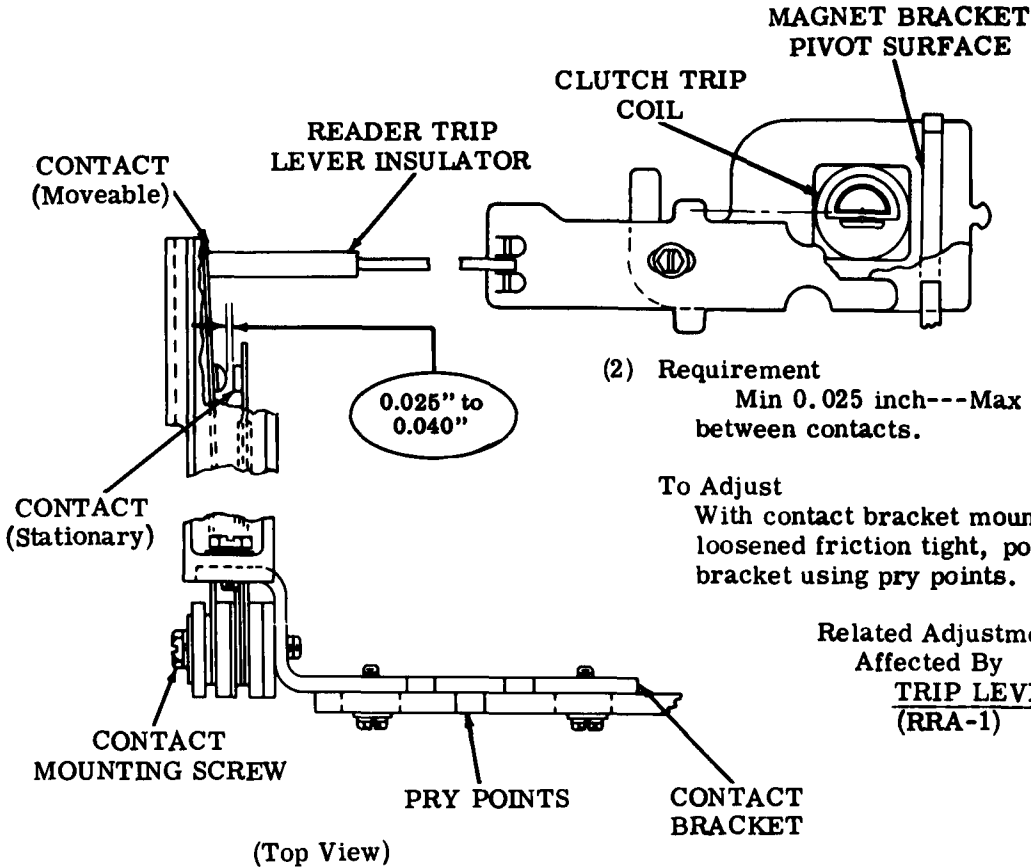

(Top View)

(2) Requirement

Min 0.025 inch---Max 0.040 inch between contacts.

To Adjust

With contact bracket mounting screws loosened friction tight, position contact bracket using pry points. Tighten screws.

Related Adjustment

Affected By

TRIP LEVER OVERTRAVEL
(RRA-1)

2.05 Clutch Trip Area (continued)

FEED MAGNET CONTACT SPRING

Requirement

With reader trip lever insulator out of contact with swinger spring
 Min 2 oz -- Max 3 oz
 to open contacts.

To Adjust

Bend swinger spring near the contact insulators with spring bender TP110445.

(Top View)

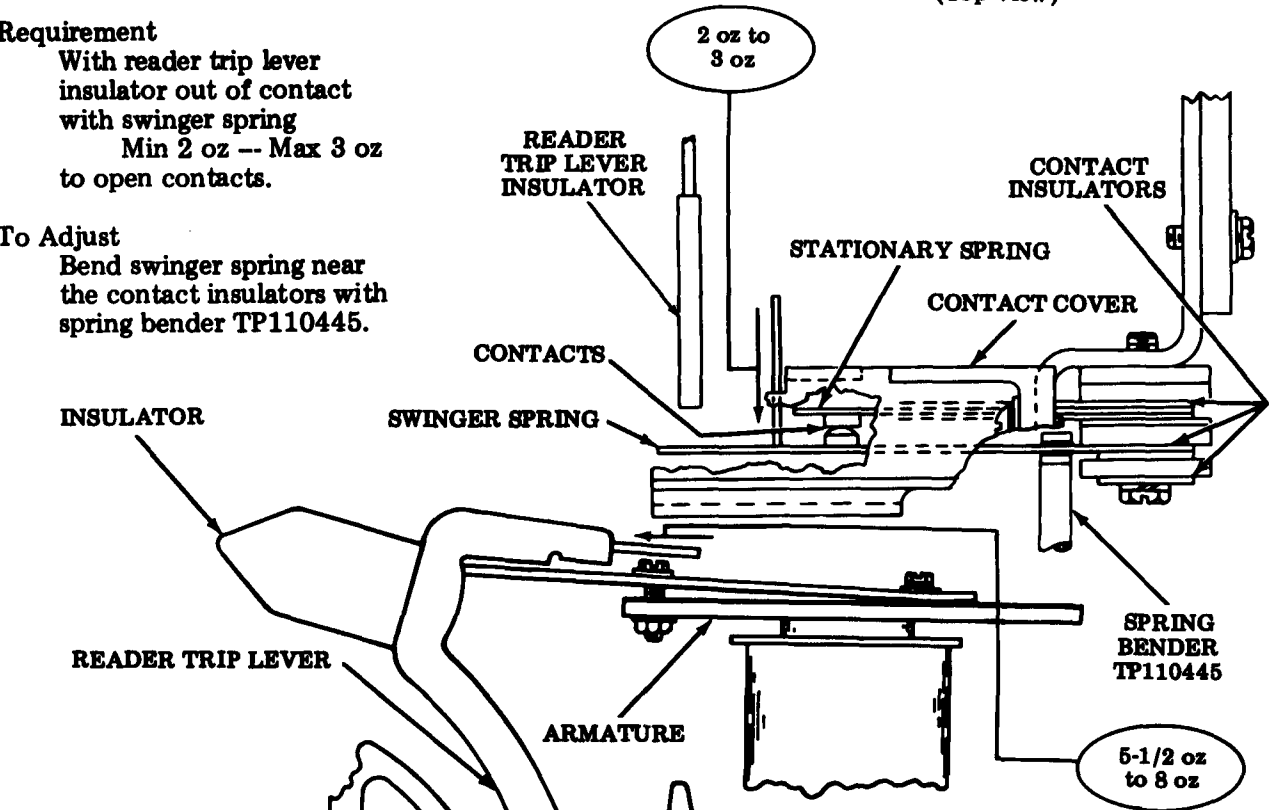

READER TRIP LEVER SPRING

To Check

Place typing unit in stop condition. Place armature in its attracted position and adjusting tab out of contact with reader trip lever.

Requirement

Min 5-1/2 oz -- Max 8 oz
 to start reader trip lever moving.

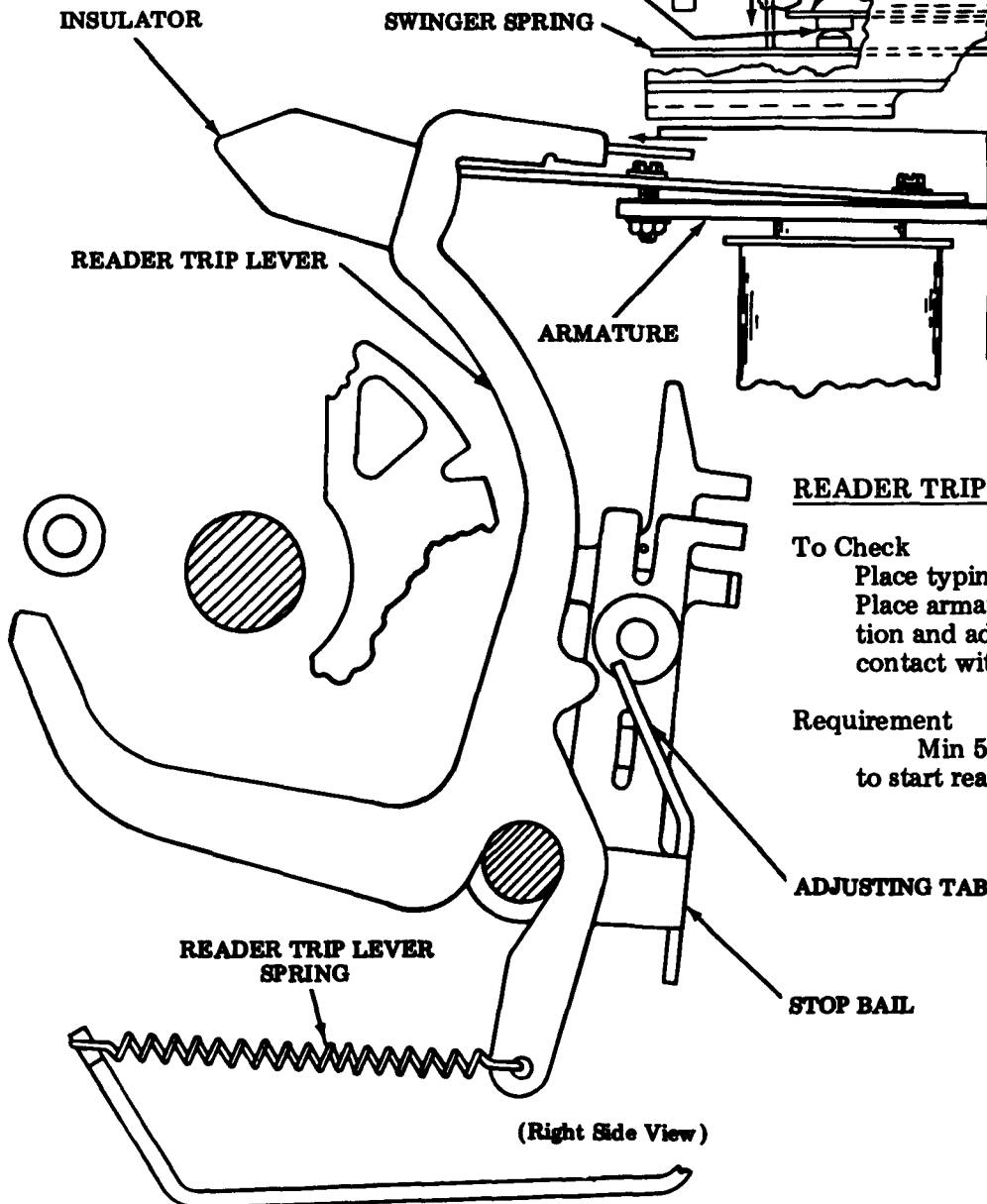

(Right Side View)

2.06 Tape Reader Area

DETENT LEVER (RRA-5)

Requirement

Place control lever in FREE position. Rotate feed wheel in direction of tape travel to a point where the feed wheel pins are at their maximum advance position with respect to the sensing pins. Tips of sensing pins must be centrally located in the code holes of an all marking code.

Note: If the tape reader is operating under power, do not push the control lever beyond the STOP position until the tape reader has stopped.

To Adjust

With detent bracket mounting screw friction tight, position detent bracket by means of pry points. Tighten screw.

Related Adjustments

Affects

- FEED PAWL (RRA-6)
- BLOCKING PAWL (RRA-7)

DETENT LEVER SPRING

Requirement

Min 3-1/2 oz
 Max 5-1/2 oz
 to start detent lever moving.

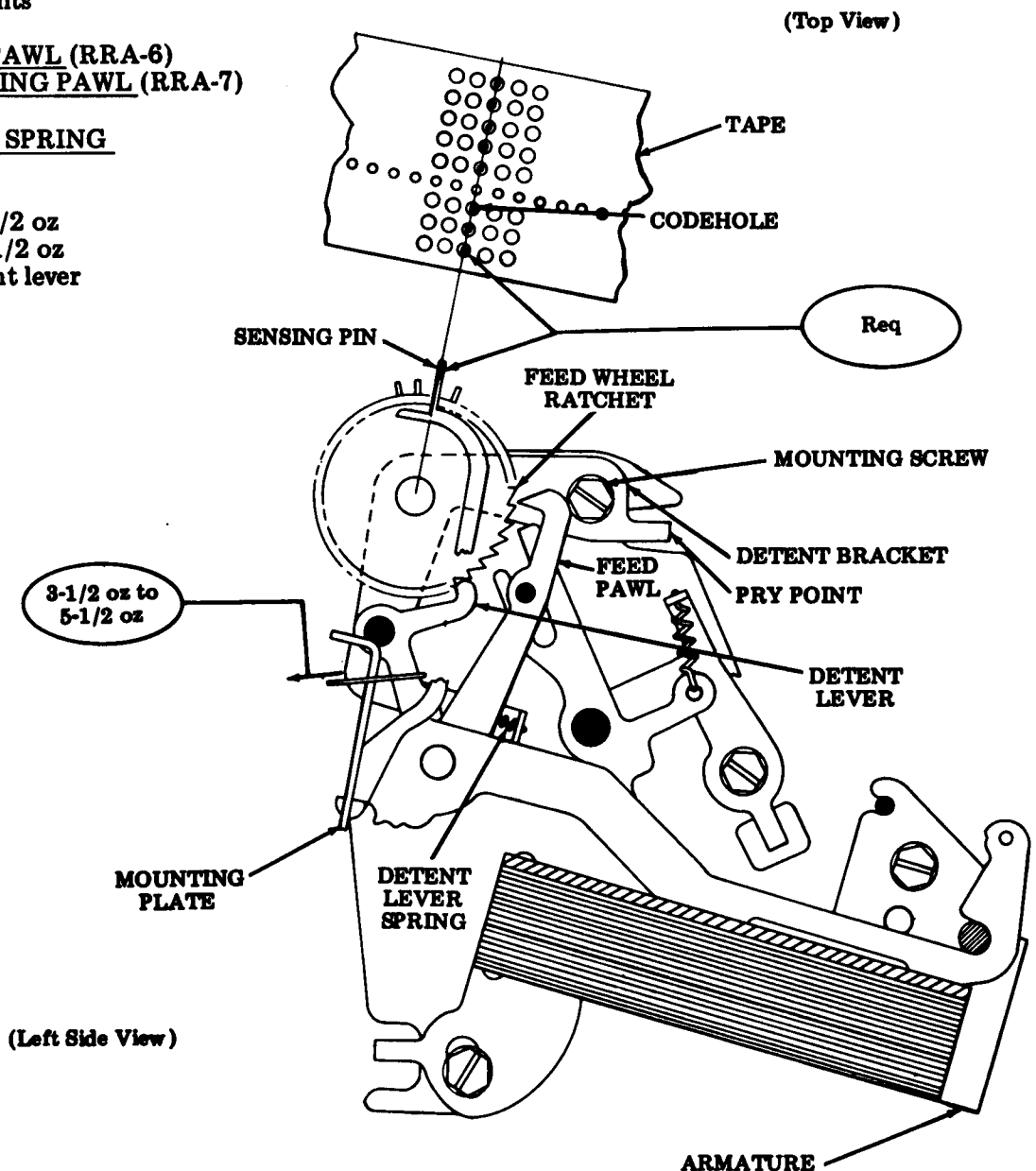

2.07 Tape Reader Area (continued)

FEED PAWL (RRA-6)

(1) To Check
Place armature in attracted position.

(1) Requirement
Min 0.020 inch --- Max 0.045 inch between feed pawl and ratchet tooth and a total of 5 ratchet teeth between detent and feed pawl.

To Adjust
Place armature in attracted position magnet bracket centered within adjusting slot.
Loosen 2 bracket mounting screws so that upstop bracket is free to move.

Loosen sensing pin guide so it is free to move.

Insert 183103 tool (or a 0.045 inch feeler gauge) between upstop bracket and shoulder of upstop shoulder screw. Position upstop bracket flat on tool (within 0.003 inch). Tighten mounting screws. Remove tool.

Note: Tighten magnet bracket mounting screws A and B first. Then rotate vibration dampner until the upper finger presses firmly on contact block extension. Tighten magnet bracket mounting screw C.

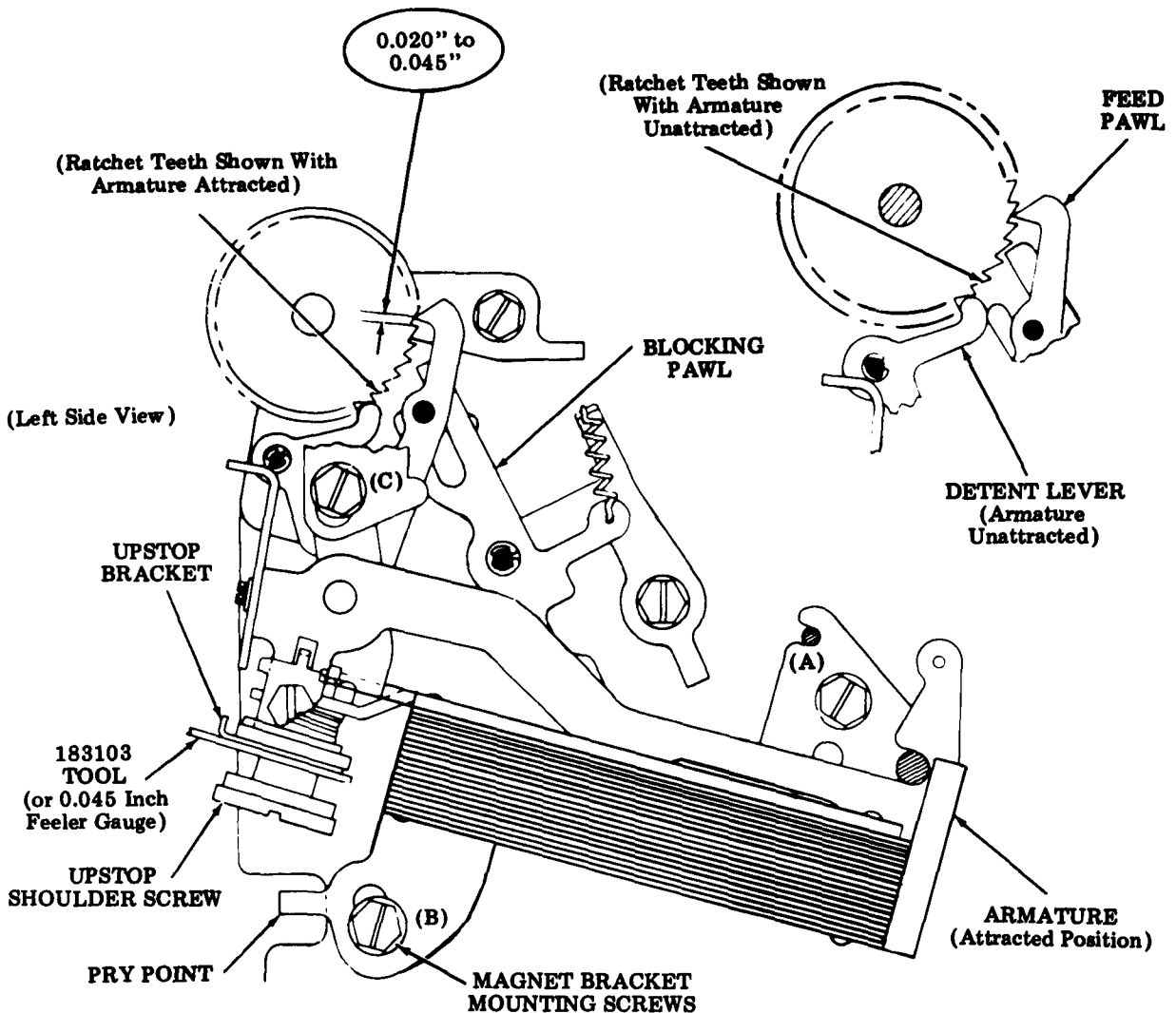

SECTION 574-174-700TC

2.08 Tape Reader Area (continued)

FEED PAWL (RRA-6) (continued)

(2) To Check

Place armature in unattracted position. Check for some clearance between the blocking pawl and ratchet tooth. If some clearance is not present, provide some clearance with the **BLOCKING PAWL (RRA-7)** adjustment. Rotate ratchet to a position that provides least clearance between feed pawl and ratchet tooth.

(2) Requirement

Min some --- Max 0.008 inch between feed pawl and ratchet tooth at closest tooth and a total of 5 ratchet teeth between detent and feed pawl.

To Adjust

Place armature in unattracted position. Loosen three bracket mounting screws. Insert screwdriver between pry points and position the magnet bracket to meet requirement. Tighten mounting screw.

Related Adjustments

Affects

BLOCKING PAWL (RRA-7)
SENSING PIN (RRA-8)

Affected By

TRIPLEVER OVERTRAVEL (RRA-1)

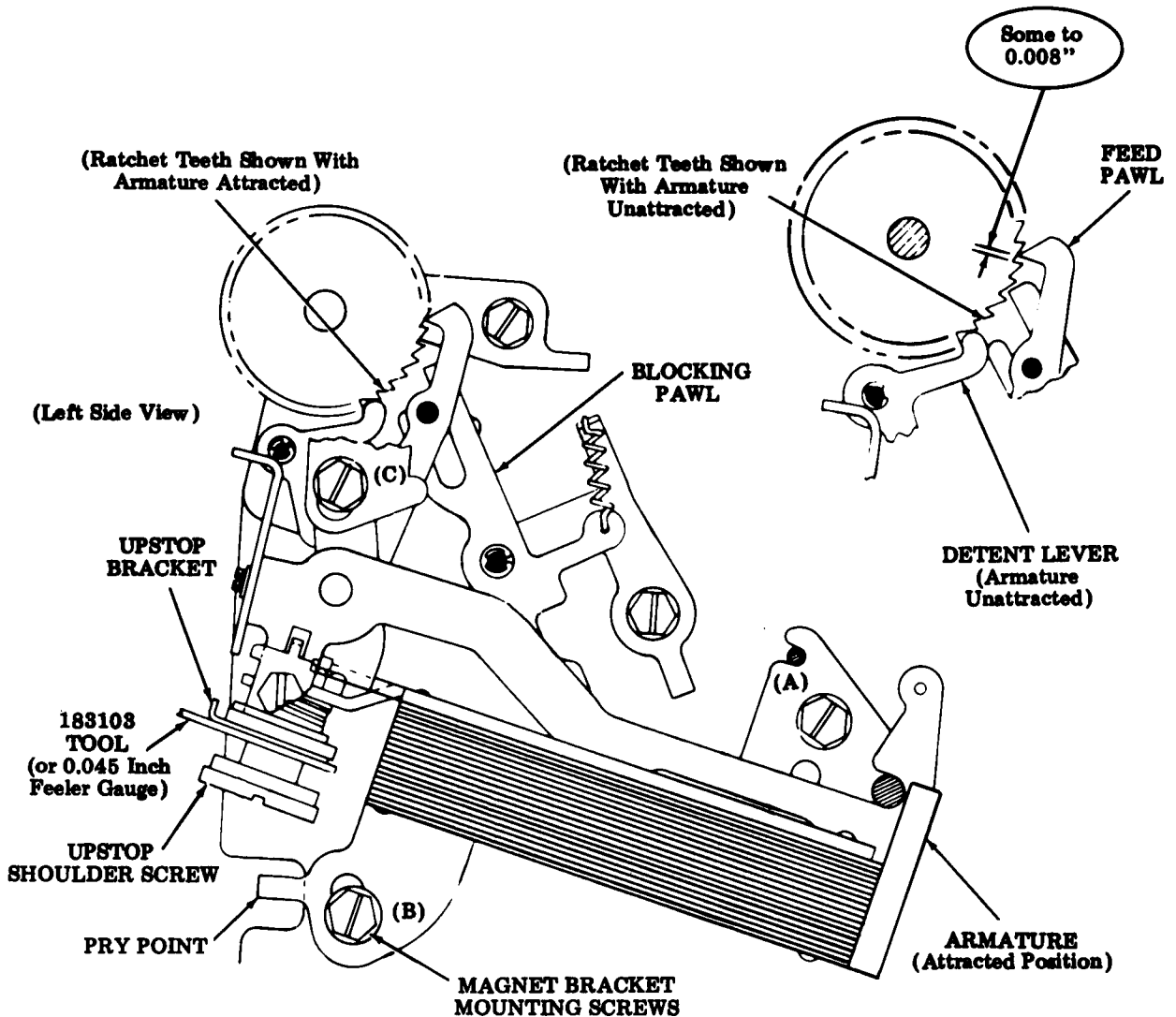

2.09 Tape Reader Area (continued)

UPSTOP SPRING

Requirement

With armature spring post removed from its slot in magnet bracket
Min 14 oz --- Max 20 oz
to start upstop bushing moving.

BLOCKING PAWL SPRING

Requirement

With the armature in its unattracted position and control lever in START position
Min 2 oz --- Max 3-1/2 oz
to start blocking pawl moving.

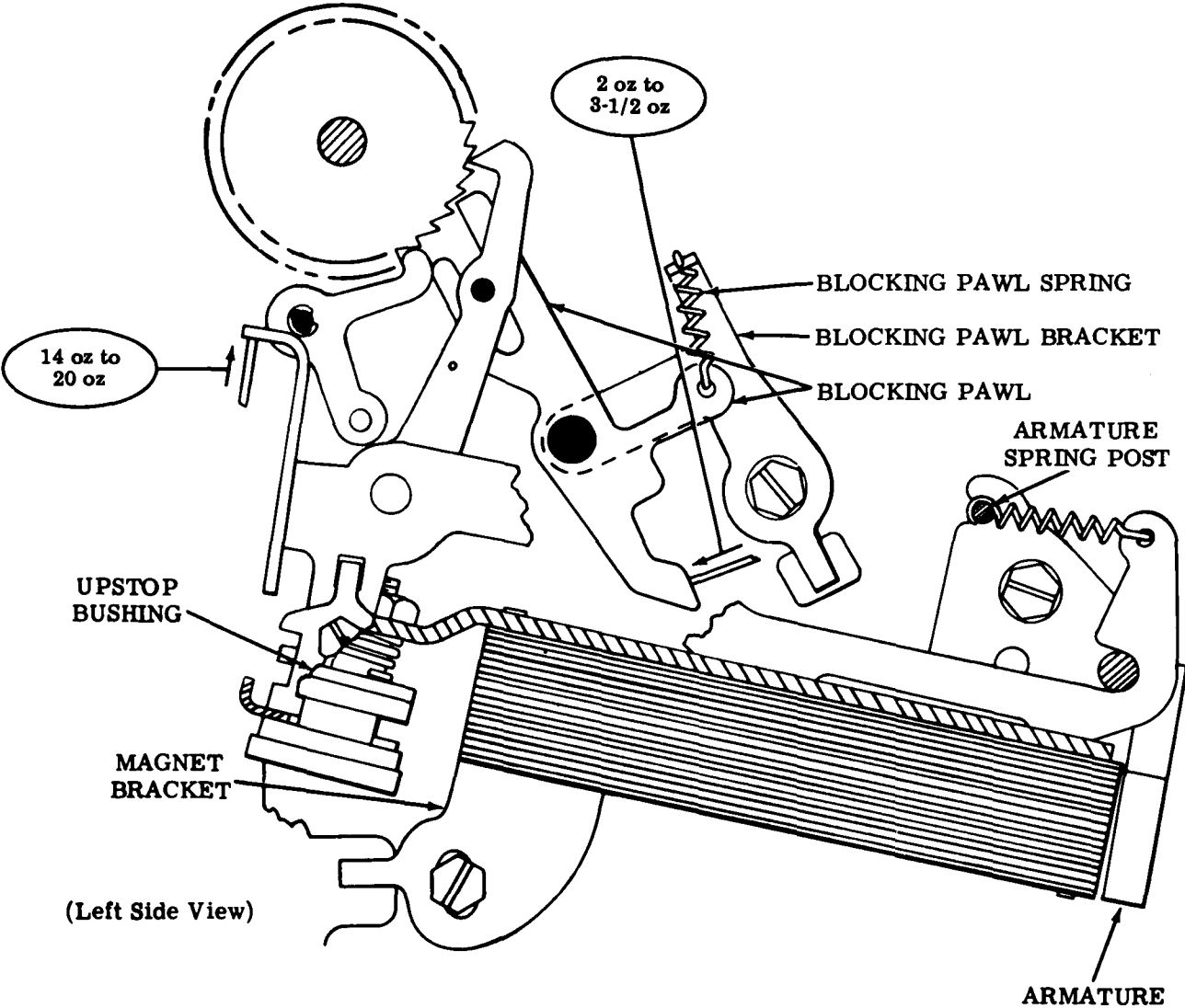

2.10 Tape Reader Area (continued)

BLOCKING PAWL (RRA-7)

To Check

Place armature in unattracted position. Check to see that there is some clearance between feed pawl and ratchet tooth. If not, provide clearance. See FEED PAWL (RRA-6).

Requirement

Rotate ratchet for least clearance between end of blocking pawl and a ratchet tooth
Min Some---Max 0.003 inch
at closest point between end of blocking pawl and the ratchet tooth.

To Adjust

With blocking pawl bracket mounting screw loosened friction tight, position blocking pawl bracket using pry point. Tighten mounting screw.

Related Adjustments

Affected By

DETENT LEVER (RRA-5)
FEED PAWL (RRA-6)

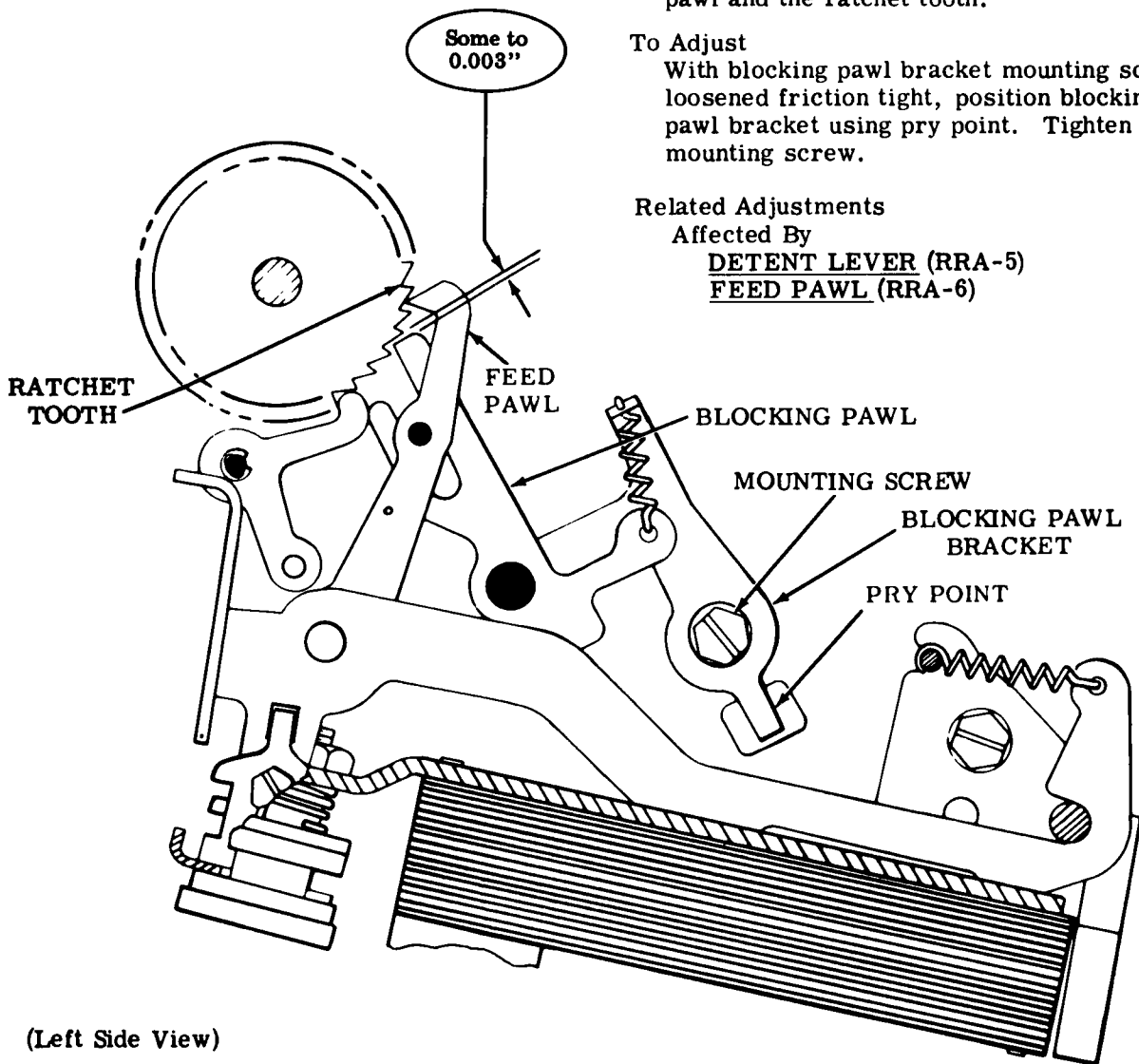

(Left Side View)

2.11 Tape Reader Area (continued)

SENSING PIN SPRING

Requirement

With armature in its attracted position
 Min 1-1/2 oz --- Max 2-3/4 oz
 to position sensing pin flush with top plate.

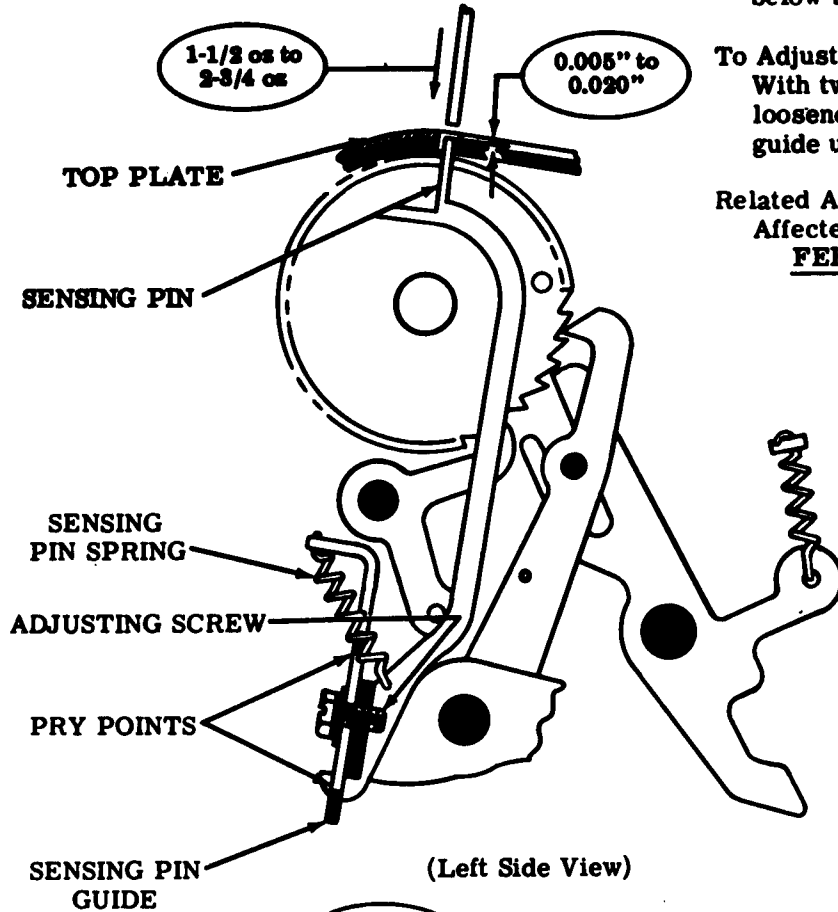

SENSING PIN (RRA-8)

Requirement

With armature in unattracted position, the tip of all sensing pins shall be
 Min 0.005 --- Max 0.020 inch
 below top surface of top plate.

To Adjust

With two sensing pin guide adjusting screws loosened friction tight, position sensing pin guide using pry points. Tighten screws.

Related Adjustment

Affected By
FEED PAWL (RRA-6)

Note: This adjustment may be made by using the thin-slotted end of tool TP183103. To check the above requirement (0.015 inch), hold the tool directly above the sensing pins and measure the clearance. Adjust, if necessary, as indicated above.

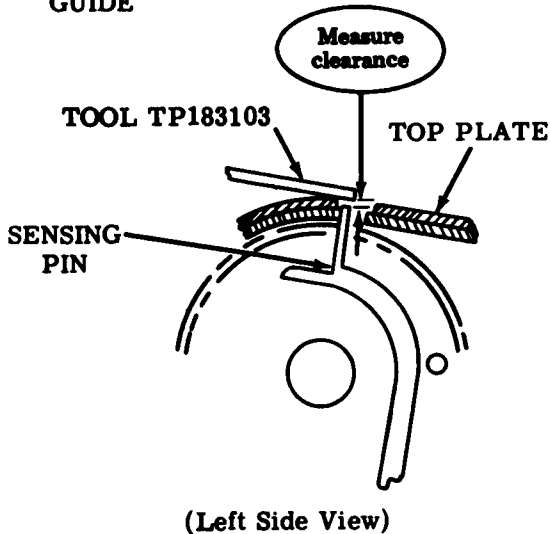

SECTION 574-174-700TC

2.12 Tape Reader Area (continued)

CONTACT WIRES* SPRING

To Check

Place control lever in **START** position and fully depress tape-out pin.

Requirement

Min 1-1/4 oz — Max 2-1/4 oz
to start each contact wire* moving.

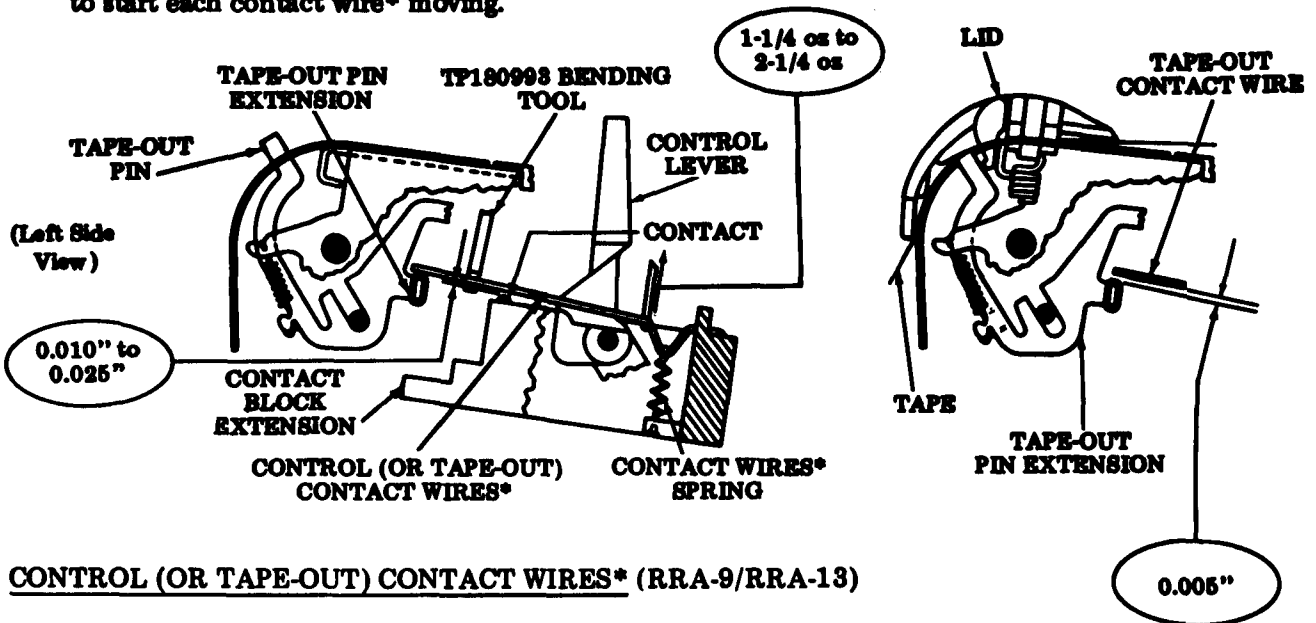

CONTROL (OR TAPE-OUT) CONTACT WIRES* (RRA-9/RRA-13)

Note 1: Readers without automatic reader control, place control lever in **START** position; with automatic control, **NEUTRAL** position.

(1) Requirement

With tape-out pin in its fully up position,
Min 0.010 inch — Max 0.025 inch
between control (or tape-out) contact wires* and contact.

(2) Requirement

With tape in reader and reader lid closed,
Min 0.005 inch
clearance between the tape-out pin extension and tape-out contact wire.

To Adjust

Bend control (or tape-out) contact wires* between the contact and the tape-out pin extension with bending tool TP180993.

***Note 2:** The location of the contact wires is shown below:

TAPE READERS WITH AUTOMATIC READER CONTROL

TAPE READERS WITHOUT AUTOMATIC READER CONTROL

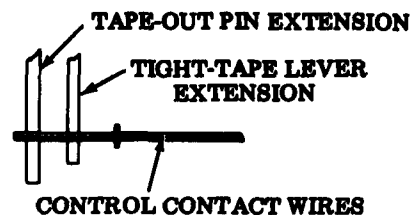
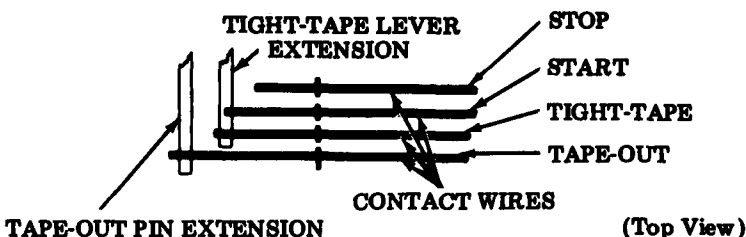

2.13 Tape Reader Area (continued)

Note: The following adjustment applies only to tape readers with automatic reader control.

START CONTACT WIRES (RRA-12)

Requirement

With the control lever in the neutral position (resting in a position midway between START and STOP positions)

Min 0.035 inch --- Max 0.055 inch
between the start contact wires and their contact.

To Adjust

With the control lever in the FREE position, bend start contact wires between contact block and control lever cam surface with bending tool TP180993.

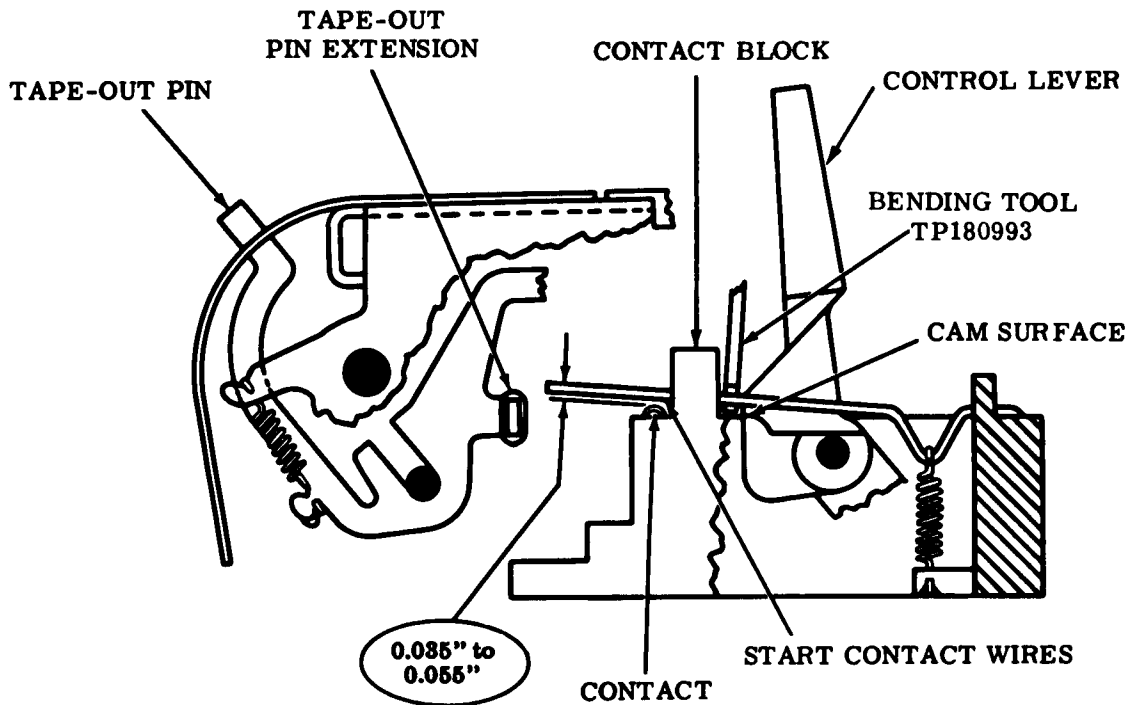

(Left Side View)

SECTION 574-174-700TC

2.14 Tape Reader Area (continued)

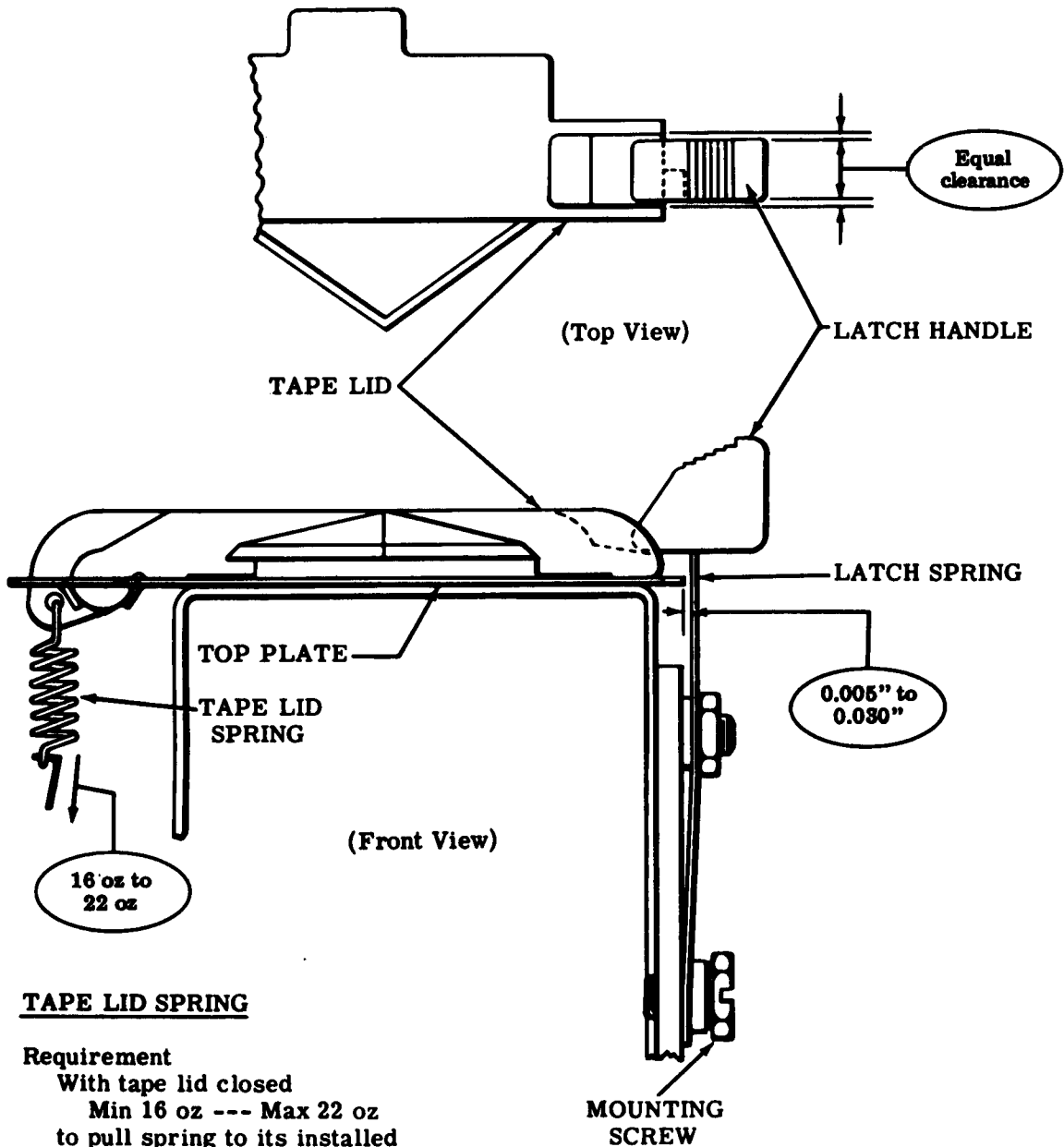

TAPE LID SPRING

Requirement

With tape lid closed
Min 16 oz --- Max 22 oz
to pull spring to its installed
length.

TAPE LID LATCH HANDLE (RRA-10)

Requirement

- (1) With tape lid closed
Min 0.005 inch --- Max 0.030 inch
between top plate and latch spring.
- (2) Equal clearance between latch and tape lid.

To Adjust

With mounting screw friction tight, position
latch handle vertically. Tighten screw.

2.15 Tape Reader Area (continued)

TIGHT-TAPE LEVER SPRING

Requirement

With the tape lid closed
 Min 1 oz --- Max 2-1/4 oz
 to start tight-tape lever moving.

CONTROL DETENT SPRING

Requirement

Place control lever in STOP position,

Note: For tape readers with automatic reader control, place the control lever in the neutral position.

Without* Min 5 oz --- Max 9 oz
 With* Min 12 oz --- Max 16 oz
 to start control detent lever moving.

*Automatic reader control.

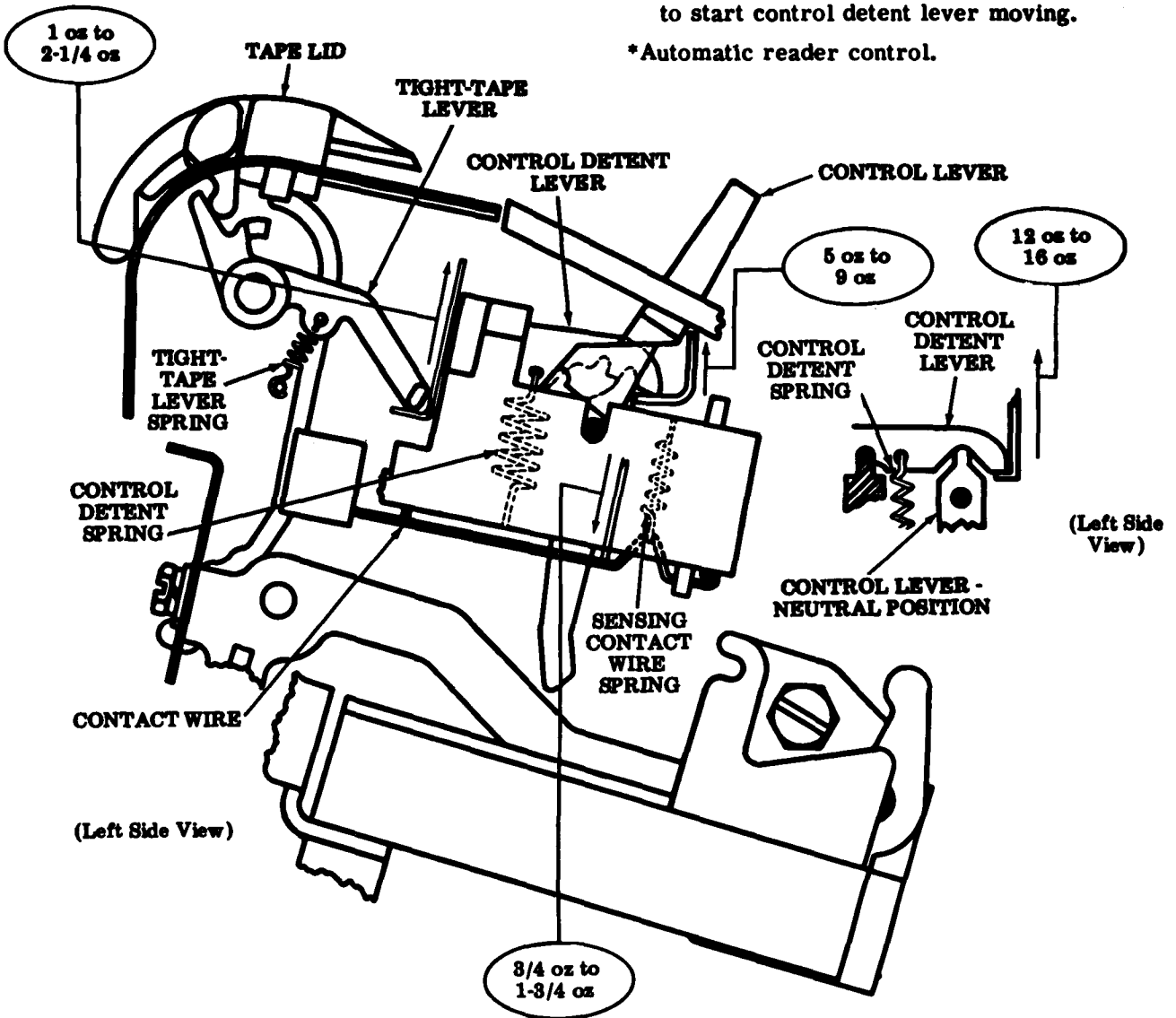

SENSING CONTACT WIRE SPRING

Requirement

With armature in its attracted position
 Min 3/4 oz --- Max 1-3/4 oz
 to start contact wire moving.

2.16 Tape Reader Area (continued)

TAPE-OUT PIN SPRING

Requirement

With tape lid open and control contact wires held away from the tape-out pin extension

Min 1-3/4 oz --- Max 3-3/4 oz to start tape-out pin moving.

Note: On tape readers equipped with automatic reader control, hold the control tape-out contact wires away from the tape-out pin extension.

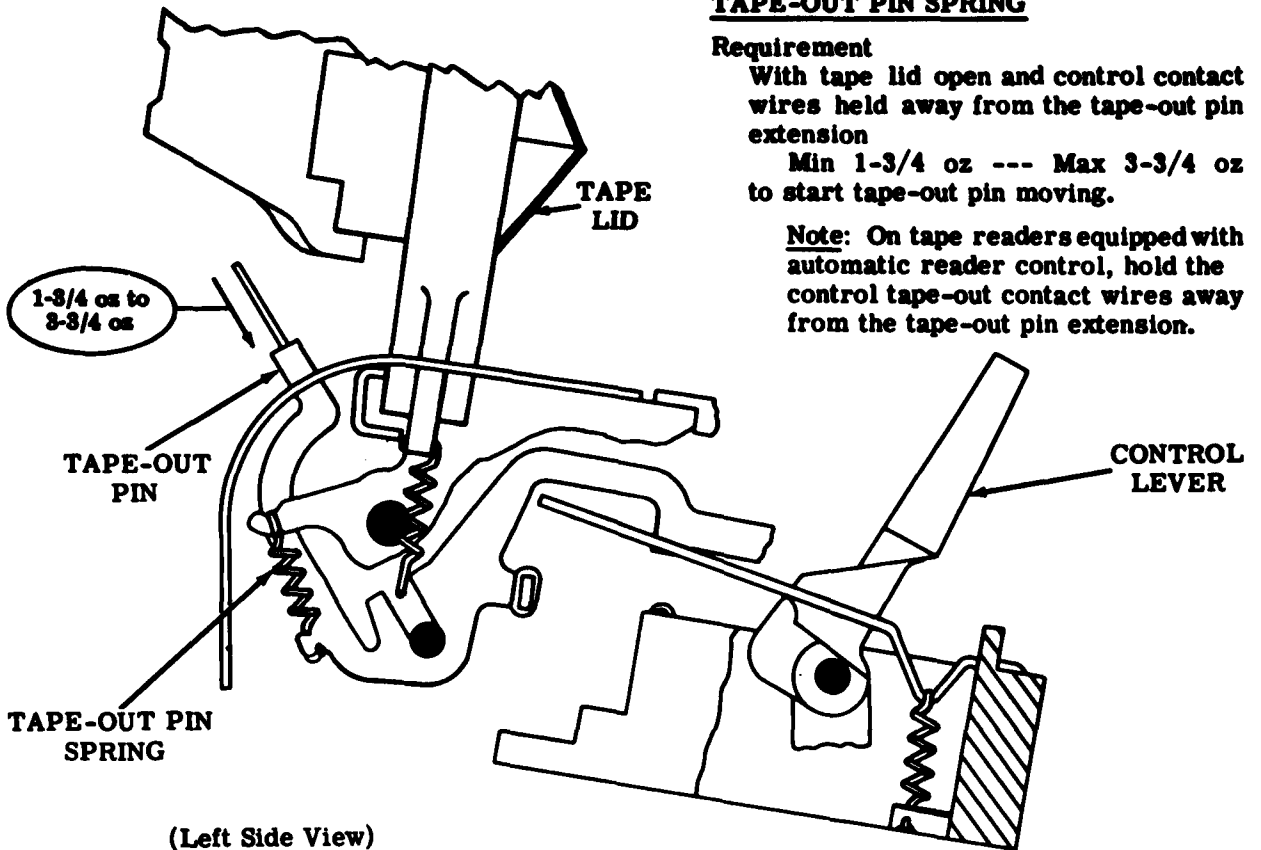

(Left Side View)

ARMATURE SPRING

Requirement

With armature in its unattracted position

Min 24 oz --- Max 37 oz to start spring post moving. Measure each end individually.

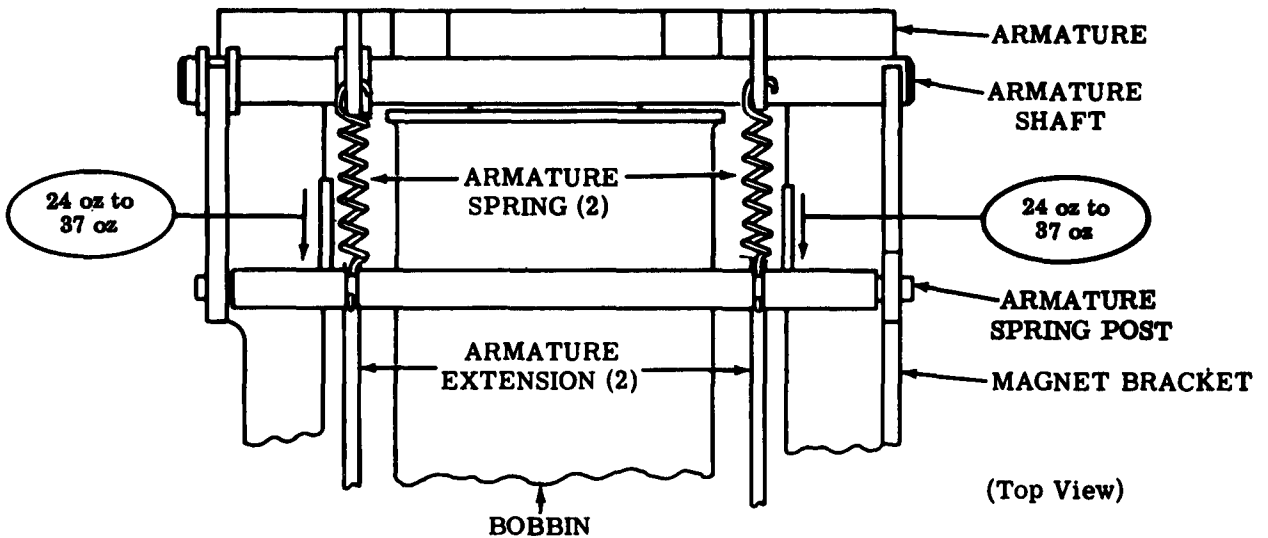

(Top View)

2.17 Tape Reader Area (continued)

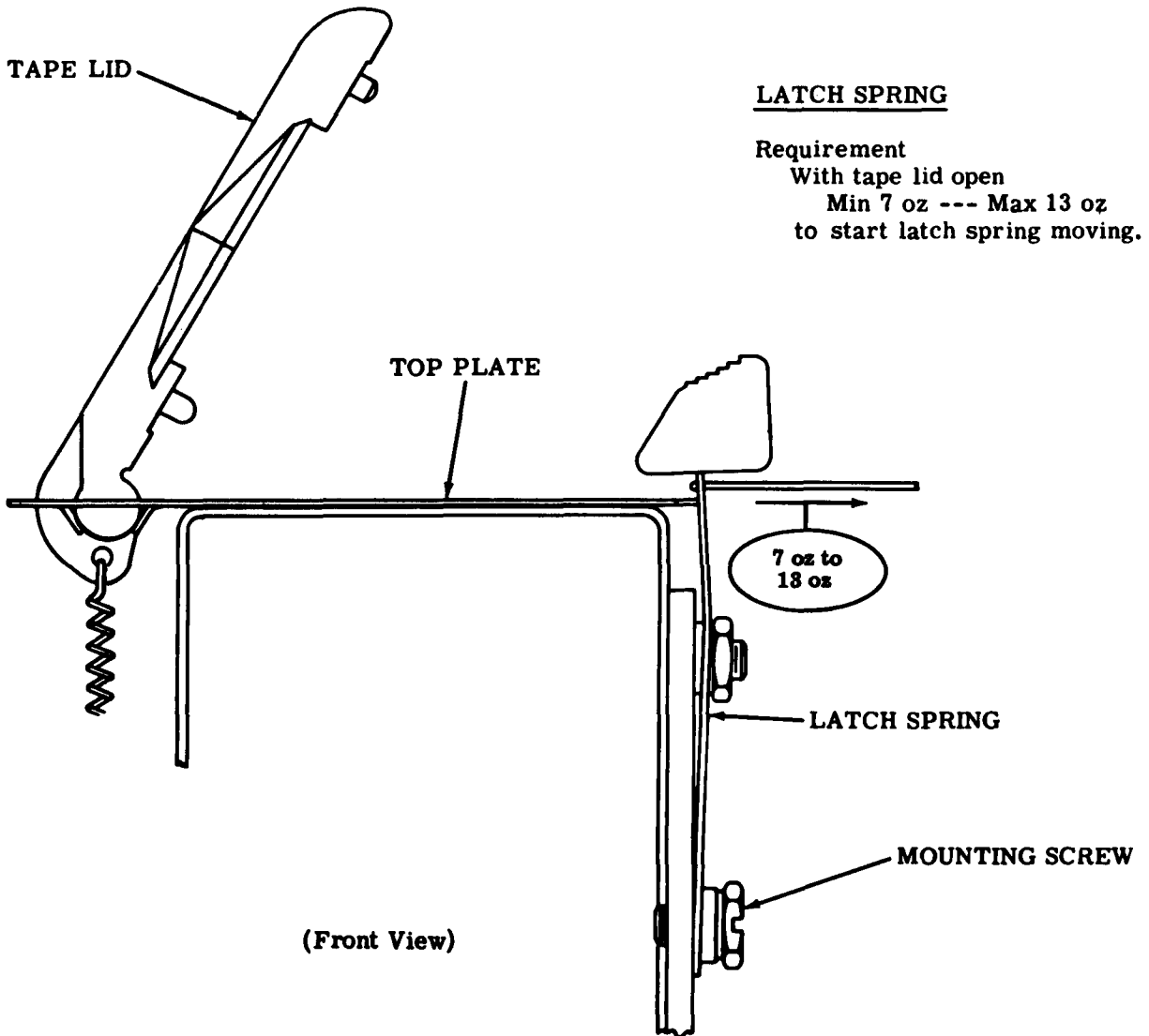

2.18 Tape Reader Area (continued)

Note: The following adjustment applies to tape readers with early design bases.

READER MOUNTING BRACKET (RRA-11)

Requirement

There should be equal clearance on three sides between top plate and tape reader cover.

To Adjust

With three mounting screws friction tight, position tape reader base. Tighten screws.

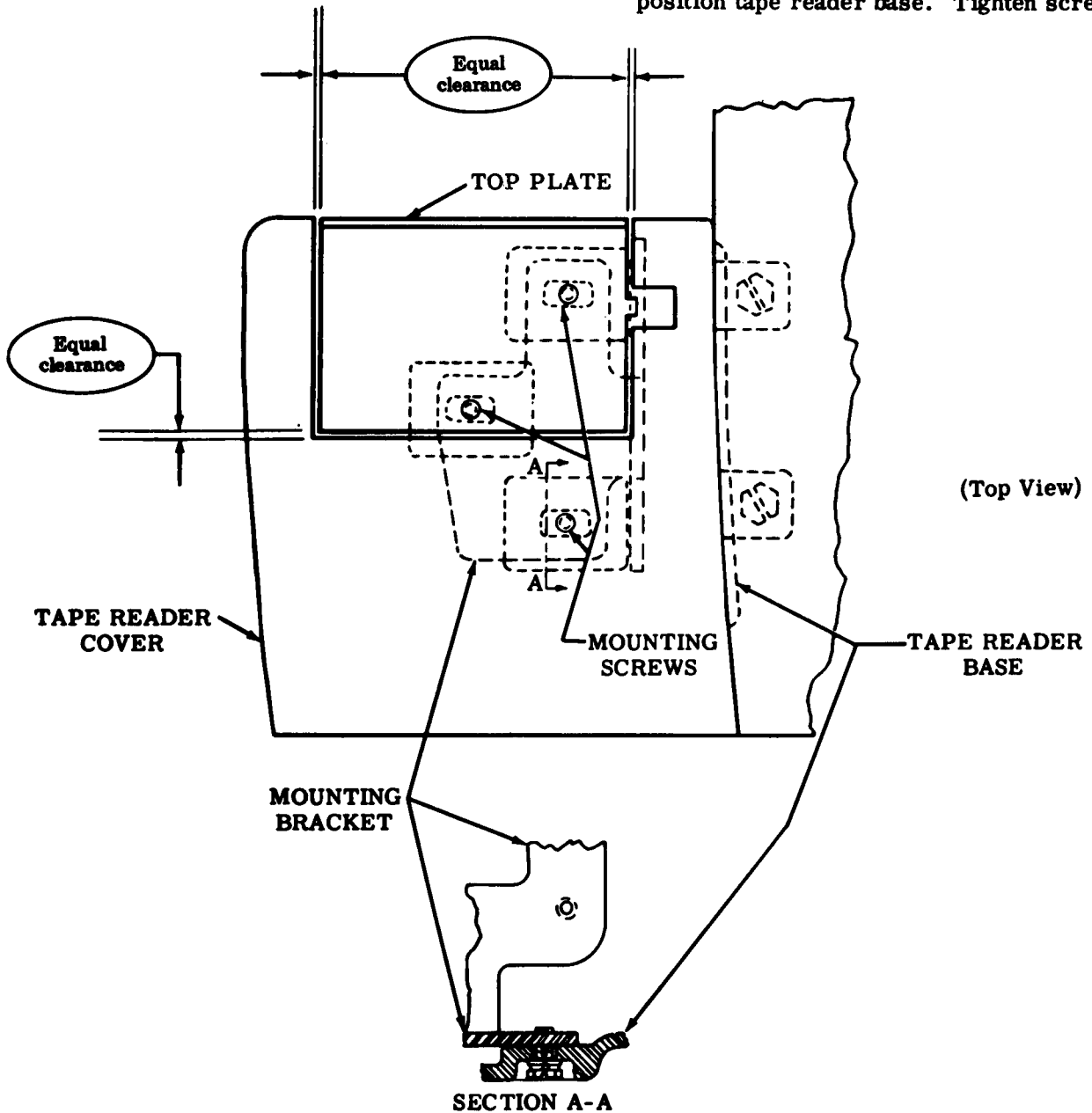

2.19 Tape Reader Area (continued)

Note: The following adjustment applies to tape readers with late design bases.

READER MOUNTING BRACKET (RRA-11) (Continued)

- (1) Requirement
 Top plate to be
 Min Flush --- Max 0.030 inch
 below cover.
- (2) Requirement
 Equal clearance between top plate and tape reader cover on three sides.

To Adjust

With four adjusting screws and locking screw (L) loosened and mounting bracket lying flat on tape reader base, position tape reader. Run two adjusting screws (X) up until requirement is approximately met. Tighten locking screw friction tight. Run two adjusting screws (Y) up until requirement is approximately met. Refine all four adjusting screws. Tighten locking screw (L).

CAUTION: (1) TO PREVENT STRIPPING OF THREADS IN READER BASE WHEN ADJUSTING OR REFINING (X) OR (Y) SCREWS, BACK OFF SLIGHTLY ON CENTER LOCKING SCREW WHEN RESISTANCE IS FELT. (2) AFTER COMPLETING THE ADJUSTMENT PROCEDURE, CHECK THAT ALL FOUR ADJUSTING SCREWS ARE AT LEAST FRICTION TIGHT. IF NOT, TIGHTEN LOOSE SCREW(S) FRICTION TIGHT.

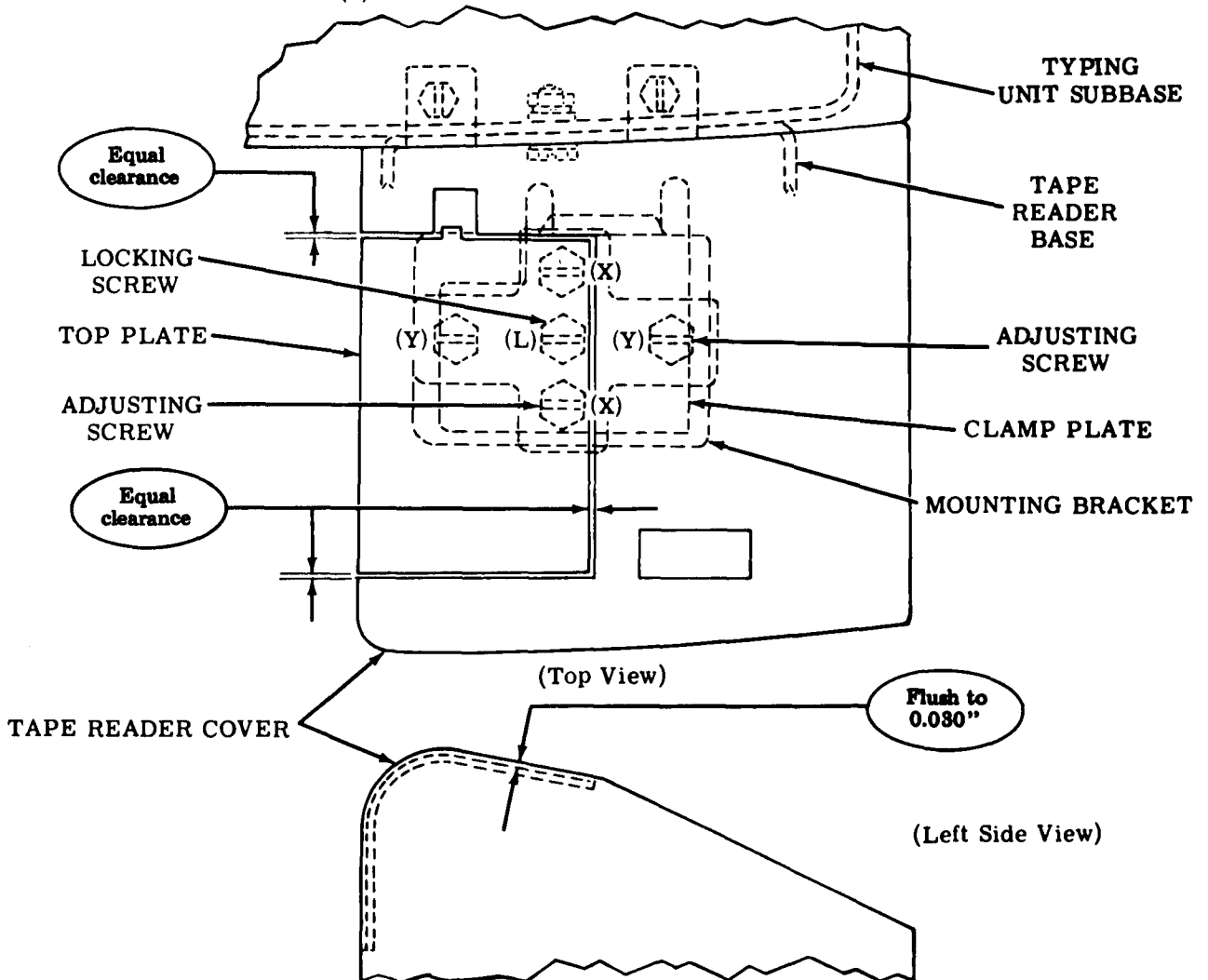

SECTION 574-174-700TC

3. VARIATIONS TO THE BASIC UNIT

3.01 Tape Reader Area

Note: The following adjustment applies to readers equipped with timing contacts.

RESET AND BUSY SWITCH TIMING (RRA-14)

(1) Requirement (Preliminary)

The busy and reset switches should be centered in their bracket slots.

(2) Requirement (Final)

With the sensing pins fully down, the reset switch should be closed and the busy switch should be open. With the sensing pins fully up (energized position), the reset switch should be open and the busy switch should be closed.

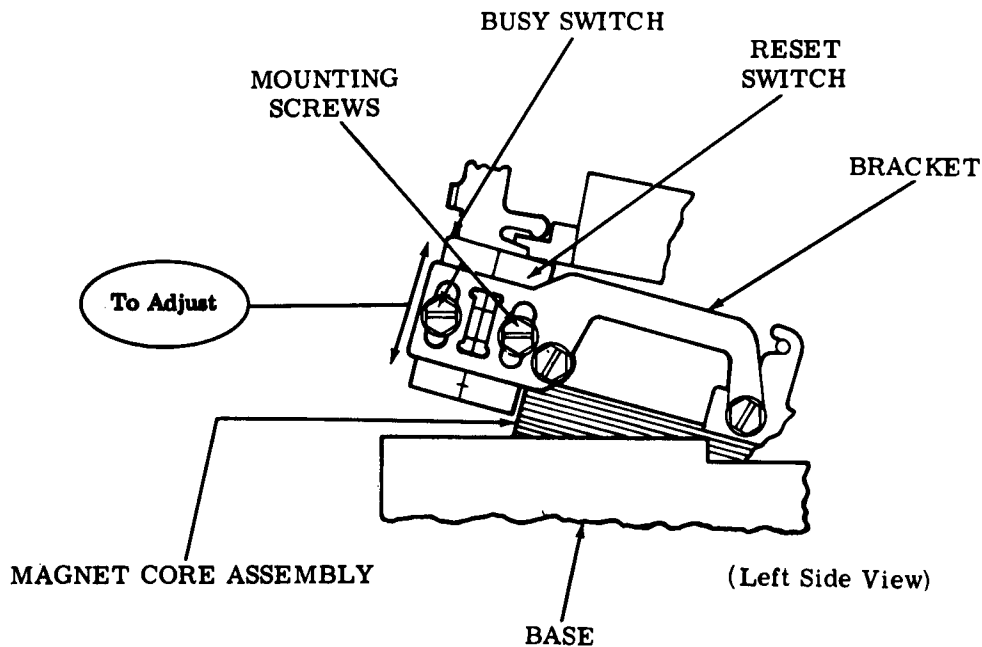

To Adjust

With switch mounting screws friction tight, position switches up or down. Tighten screws.

32 TAPE PUNCH

ADJUSTMENTS

CONTENTS	PAGE
1. GENERAL	1
2. BASIC UNIT	4
Backspace lever spring	16
Chad chute extension (PFA-11)	12
Codebar extension springs	13
Control detent lever spring	17
Control pushbuttons	17
Detent lever spring	15
Drive link spring	18
Feed pawl spring	15
Feed wheel ratchet and pawl — final (PFA-8)	10
Feed wheel ratchet and pawl — preliminary (PFA-3)	5
Pawl and lever springs	14
Pawl upstop assembly — final (PFA-7)	9
Pawl upstop assembly — preliminary (PFA-1)	4
Punch block assembly	18
Punch penetration (PFA-6)	8
Sensing lever springs	13
Stripper bail spring	14
Stripper bail upstop (PFA-4)	6
Tape bias spring (PFA-10)	12
Tape guide compression spring	17
Tape guide tension spring	16
Tape nudger (PFA-2)	4
Tape punch drive (PFA-5)	7
Ten characters per inch (PFA-9)	11
3. VARIATION TO BASIC UNIT	19
Folded tape guide	19

1. GENERAL

1.01 This section contains adjustment information for the 32 tape punch. It is reissued to include engineering changes and add alpha-numeric codes to the adjustment titles. These codes are not used for the spring adjustments. Because this is a general revision,

arrows normally used to indicate changes are omitted.

1.02 Figure 1 shows the tape punch area where the adjustments are made.

1.03 In the adjustment procedures, location of clearances, position of parts, and angle of scale applications are illustrated by line drawings. Requirements and procedures accompany the line drawings. Tools, to make adjustments, are listed in Section 570-005-800TC.

1.04 The sequence in which the adjustments appear should be followed when a complete readjustment of the tape punch is undertaken. No adjustment should be made without completely understanding the procedure and the requirements.

Note: Disconnect power from unit.

1.05 References to left, right, front, or rear, etc consider the tape punch to be viewed from its normal operating position (Figure 1).

1.06 When a procedure calls for using pry points or slots to make an adjustment, place a screwdriver between the points or in the slots and pry parts in the proper direction.

1.07 If the tape punch or any of its parts are removed from the typing unit and then replaced, check any adjustment that may have been affected.

1.08 The spring tensions specified in this section are indications, not exact values. Therefore, to obtain reliable readings, it is important that spring tensions be measured by spring scales placed in the positions shown on pertinent line drawings. Springs that do not meet their requirements should be replaced by new ones. Only springs that directly affect the operation of the tape punch are measured, however, others may be measured indirectly in the process. If this is the case and the requirement is not met, replace the springs one at a time starting with the indicated spring until the requirement is satisfied.

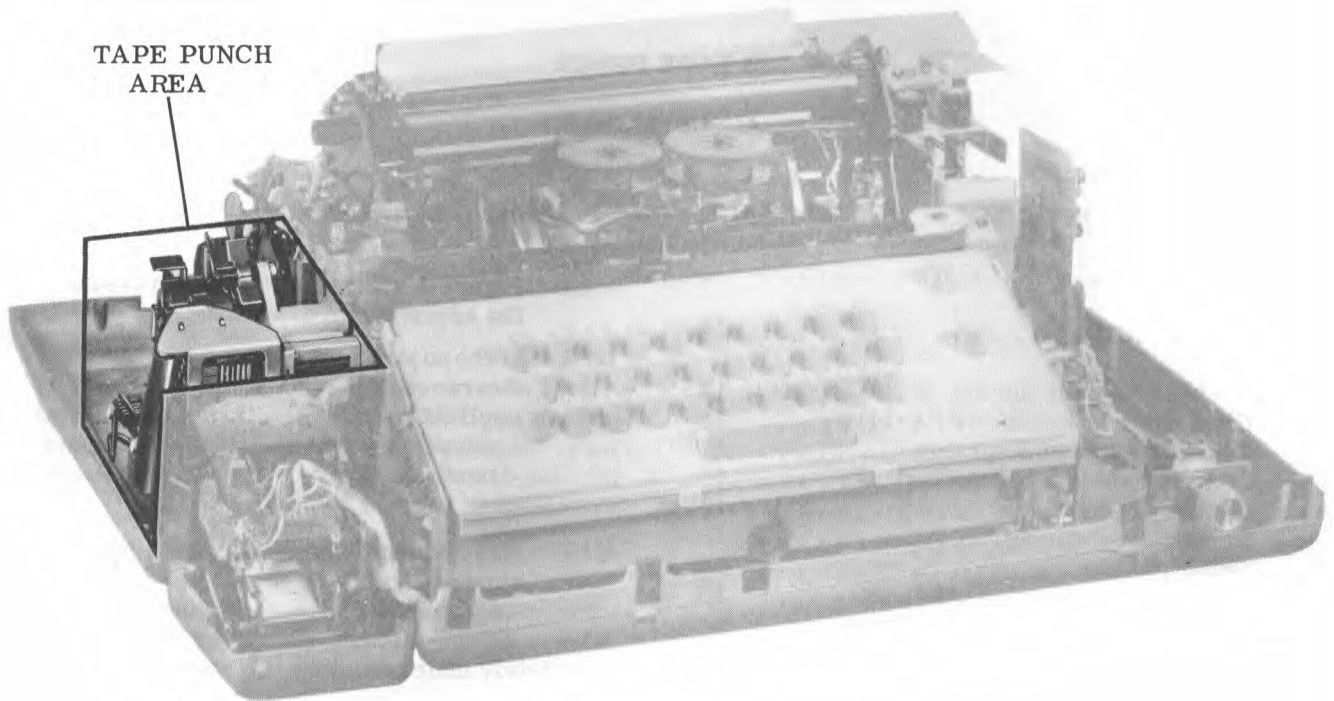

(Right Front View)

Figure 1 - Tape Punch Area

Note: Spring tensions may be checked in any sequence.

1.09 Certain adjustments require that the tape punch be either "on" or "off." These conditions can be identified as follows:

(a) "Off" condition: A tape punch is "off" when the control lever is in its clockwise detented position, and fully engages the drive post.

(b) "On" condition: A tape punch is "on" when the control lever is detented in its counterclockwise position and the drive post is fully engaged by the drive link.

1.10 With the tape punch and typing unit assembly together, all adjusting procedures should be started with the typing unit in the stop condition. It is in the stop condition when the selector armature is in its attracted (forward) position and all clutches are disengaged.

Note: When the typing unit is in the stop condition and the punch is "on", the tape punch is said to be in the off position.

1.11 To place the typing unit in the stop condition, hold the selector armature in its attracted (forward) position. Rotate the main shaft clockwise (as viewed from the left) until all clutches are disengaged.

1.12 When disengaged, a clutch is latched so that the shoe lever is held in its stop position by the trip lever while the corresponding latchlever is seated in a notch of the clutch disc. This allows the clutch shoes to release their tension on the clutch drum. With all clutches disengaged, the main shaft will turn freely without any clutch shoes dragging.

Note 1: The clutch stop position is that position where a shoe lever contacts a trip lever.

Note 2: If the shaft is turned by hand, a clutch will not fully disengage upon reaching a stop position. To fully disengage a clutch, rotate the clutch to a stop position, apply a screwdriver to the associated stop-lug, and push

the clutch disc in the normal direction of main shaft rotation until the corresponding latch-lever seats in its clutch disc notch.

Note 3: The distributor clutch will not disengage unless the answer-back drum is in its home position, which is the position where the control lever is fully detented into the indent on the answer-back drum.

1.13 Manual Operation: To manually operate the typing unit, place it in the stop condition as instructed in 1.11. Momentarily permit the armature to move to its unattracted (rearward) position to trip the selector clutch. Slowly rotate the main shaft clockwise (as viewed from the left) until all push levers have moved under their respective selector levers. Using a spring hook, strip the push lever from under the selector levers corresponding to the spacing elements of the code combination to be set up. Then continue to rotate the main shaft until the proper

condition is set up or the character is cleared through the typing unit.

1.14 The selector levers are arranged from 1 through 4 left to right. To set up the character "Y" for example, whose combination is 1-3-5, strip the push levers from the 2 and 4 selector levers.

1.15 The relationship between code levels, sensing levers, and codebar extensions is illustrated in Figure 2.

1.16 Some adjustments must be made at specific points in the operating cycle. These points are specified as follows:
 Position 1 - The main shaft is rotated until the function bail is in its uppermost position.
 Position 3 - The main shaft is rotated until the function bail is in its lowermost position.

Note: Position 2 is not required for any tape punch adjustments.

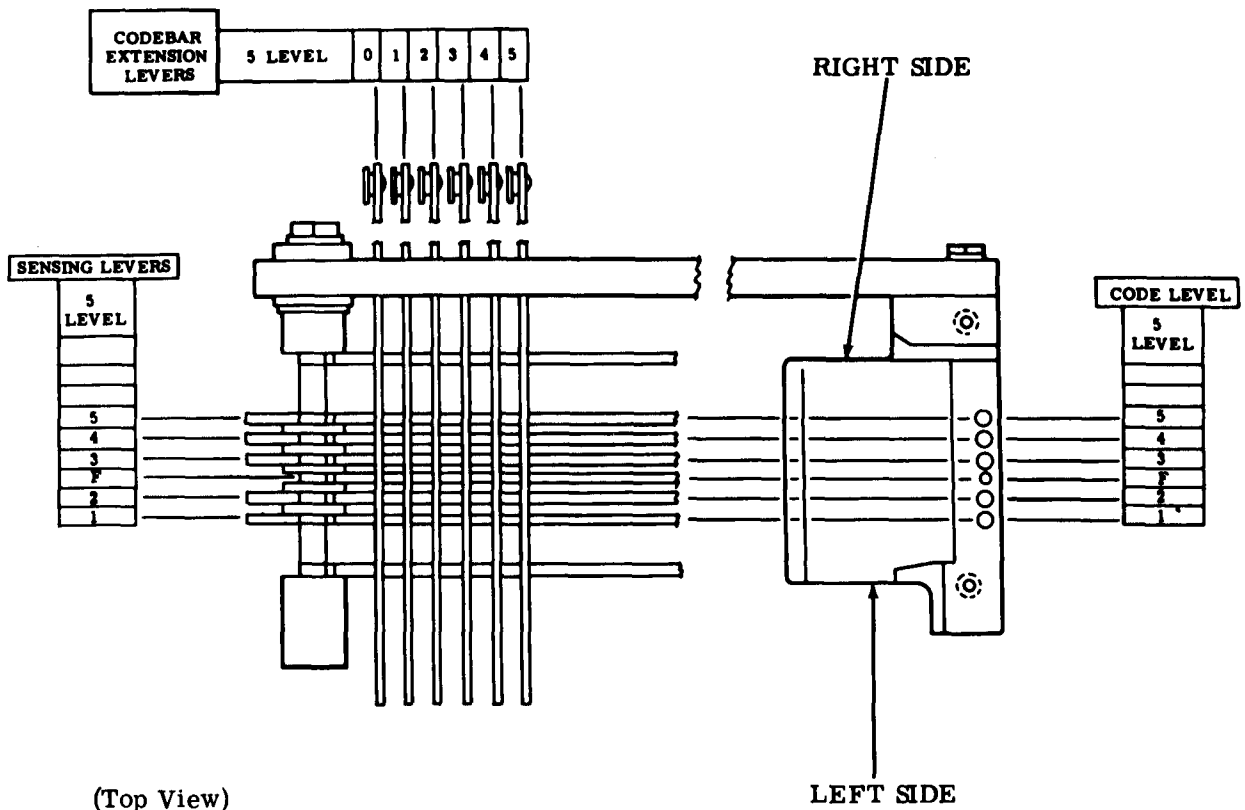

Figure 2 - Tape Punch Code Level Cross Reference Chart

2. BASIC UNIT

2.01 Tape Punch Area

Note 1: These adjustments are to be made only if the areas have been disturbed during disassembly.

Note 2: Prior to making adjustments, remove the chad extension. Reassemble when the adjustments are completed.

PAWL UPSTOP ASSEMBLY — PRELIMINARY (PFA-1)

Requirement

The pawl upstop assembly should be positioned so that it is vertical or within 2 degrees clockwise from vertical, as gauged by eye.

To Adjust

Loosen the screw which secures the pawl upstop assembly post to the tape punch casting and position pawl upstop assembly. Tighten screw.

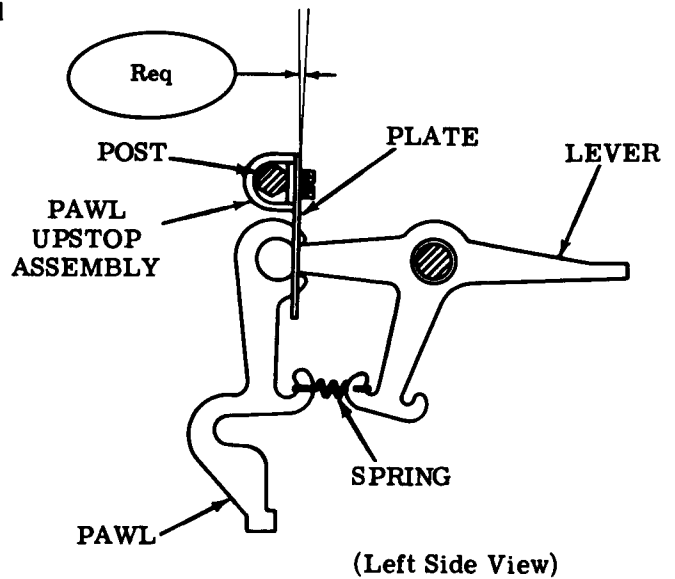

TAPE NUDGER (PFA-2)

Note: This adjustment applies only to tape punch castings which have an elongated tape nudger post mounting hole.

Requirement

The post should be in its rearmost position.

To Adjust

Loosen the screw which secures the post to the tape punch casting and position the post. Tighten screw.

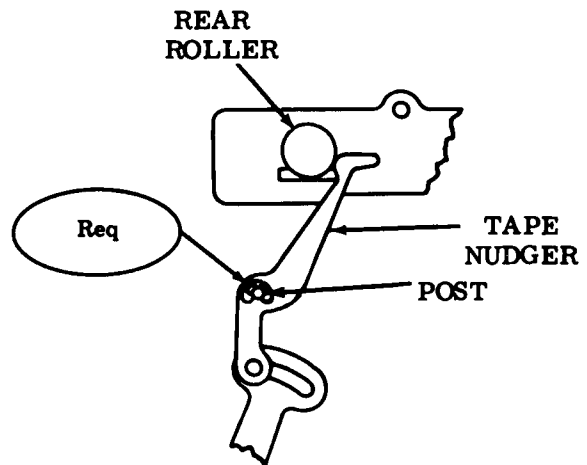

2.02 Tape Punch Area (continued)

FEED WHEEL RATCHET AND PAWL — PRELIMINARY (PFA-3)

Requirement

The plate should be in middle of slot located in feed pawl arm, as gauged by eye.

To Adjust

Loosen nut and adjust plate using pry points. Tighten nut.

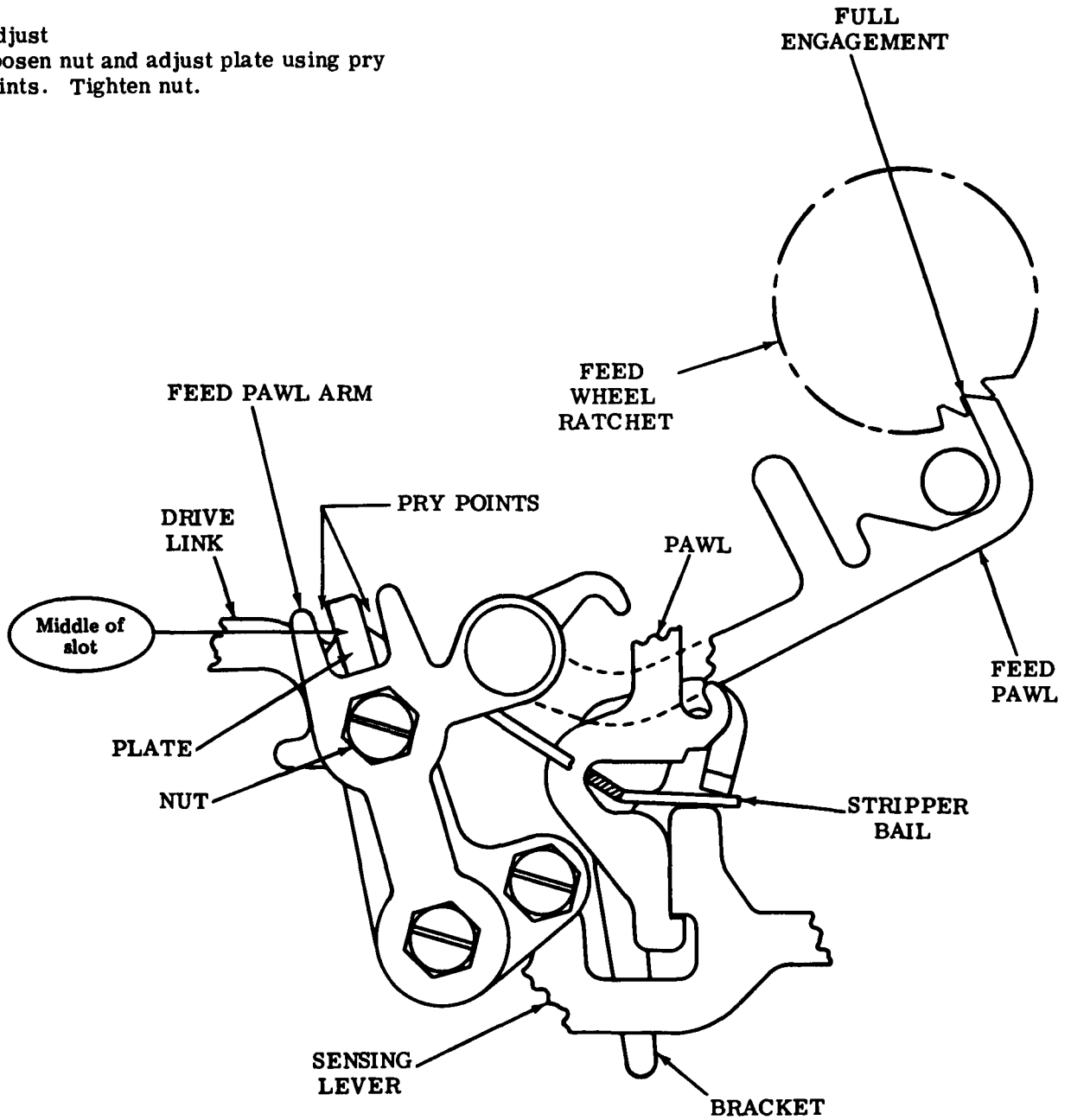

(Left Side View)

2.03 Tape Punch Area (continued)

STRIPPER BAIL UPSTOP (PFA-4)

Requirement

With main shaft in stop position, and tape punch in "off" (manual control), "unlock" (auto control), or "on" (remote control), the stripper bail should clear bottom corner of stripping surface of lowermost pawl by

Min some---Max 0.012 inch

To Adjust

With all pawls in their uppermost position, loosen screw and rotate bracket to meet requirement. Tighten screw.

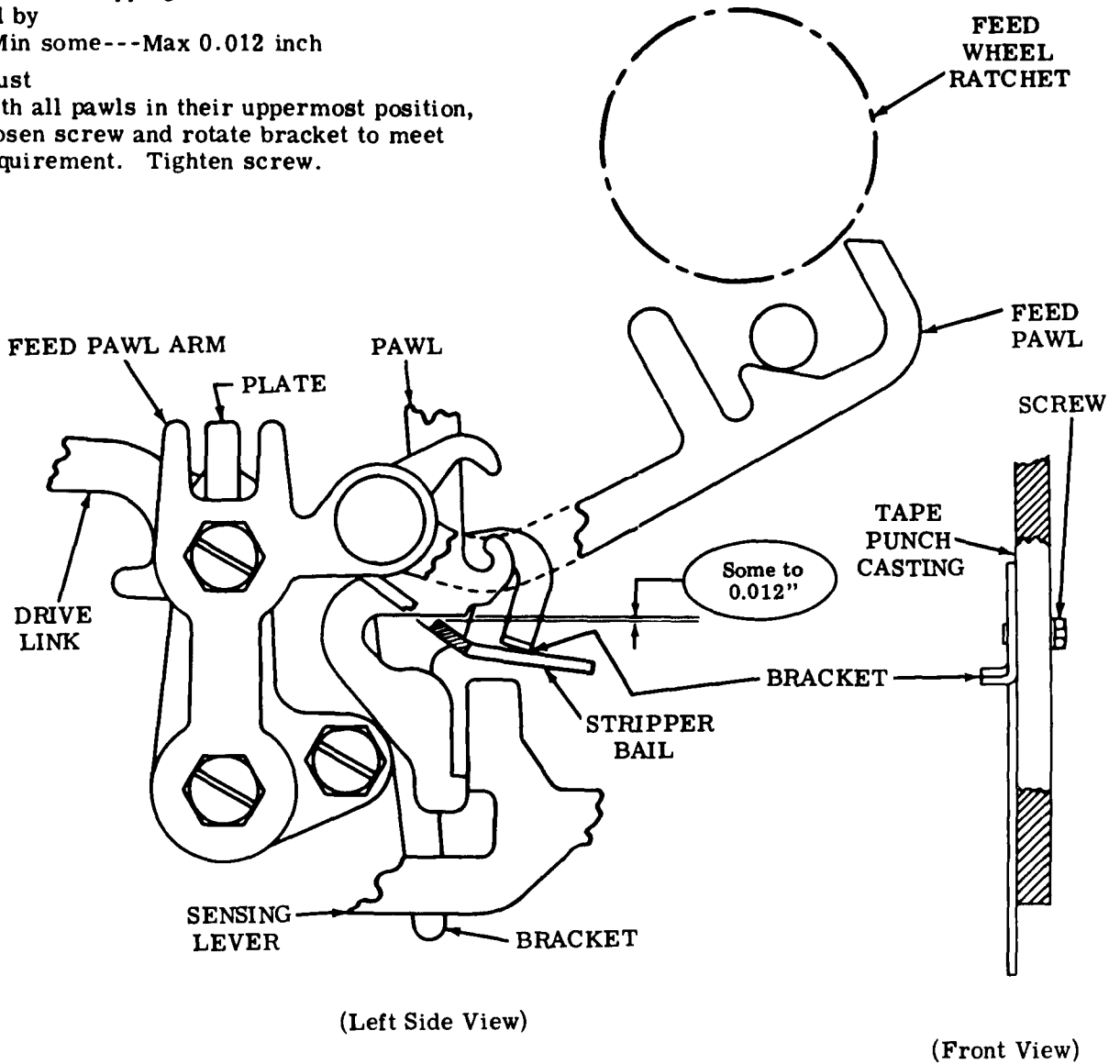

2.04 Tape Punch Area (continued)

Note 1: For the adjustments which follow, the tape punch should be mounted to the typing unit. For instructions, see section titled "32 Tape Punch, Disassembly and Reassembly."

Note 2: The following Tape Punch Area adjustments must be made in sequence: TAPE PUNCH DRIVE, PUNCH PENETRATION, PAWL UPSTOP ASSEMBLY -- FINAL, and FEED WHEEL RATCHET AND PAWL -- FINAL. Prior to making the above adjustments, check or make the following Tape Punch Area adjustments: PAWL UPSTOP ASSEMBLY -- PRELIMINARY, TAPE NUDGER, FEED WHEEL RATCHET AND PAWL -- PRELIMINARY, and STRIPPER BAIL UPSTOP.

TAPE PUNCH DRIVE (PFA-5)

To Check
With no tape in the tape punch and with the tape punch "on," manually rotate the main shaft until the stripper bail is in its most forward position (position 3). Take up rear roller play toward rear and tape nudger play in a clockwise direction.

Requirement
Min 0.030 inch---Max 0.080 inch
at point of least clearance between rear roller and tape nudger.

To Adjust
Loosen adjusting screw and use pry points to position plate. Tighten screw.

Related Adjustment
Affected by
LEFT ROCKER DRIVE (FNA-10) in
Section 574-172-700TC.

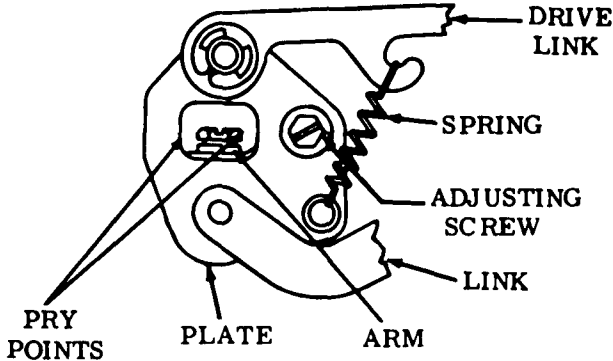

EARLY DESIGN
(Left Side View)

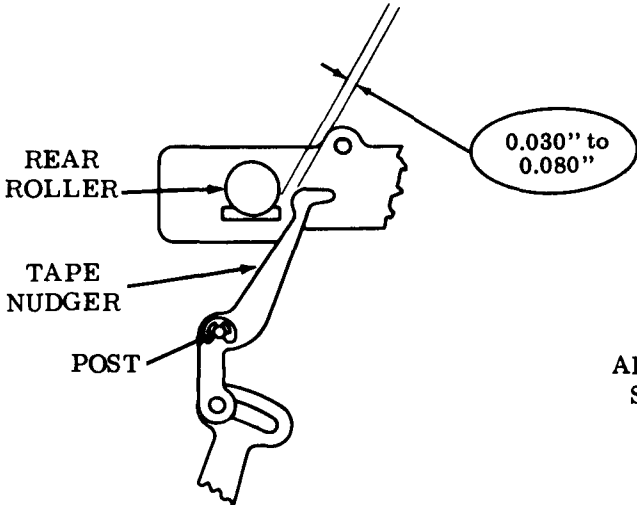

EARLY OR
LATE DESIGN
(Left Side View)

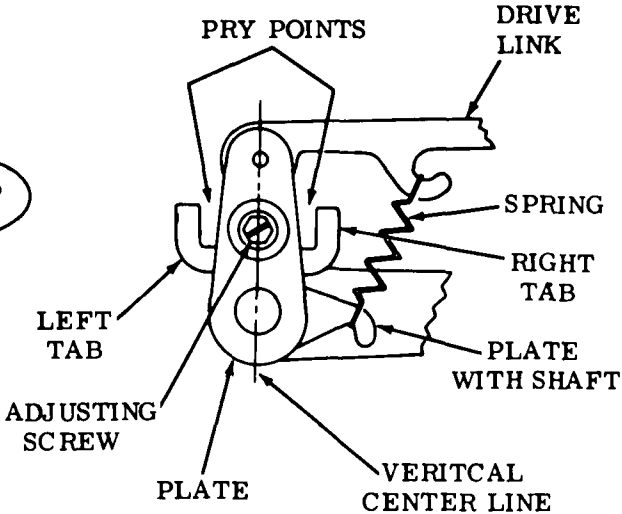

LATE DESIGN
(Left Side View)

2.05 Tape Punch Area (continued)

PUNCH PENETRATION (PFA-6)

To Check

With the tape punch "on," set up an all-marking code combination in the selector. Manually rotate the main shaft until the stripper bail is in its most forward position.

Requirement

Min 0.017 inch---Max 0.037 inch between bottom surface of holder and top surface of any lever.

To Adjust

With code lever post mounting screw (and support plate nut on late design units) friction tight, position post within the elongated base hole (and support plate hole - late design units). Tighten screw and nut.

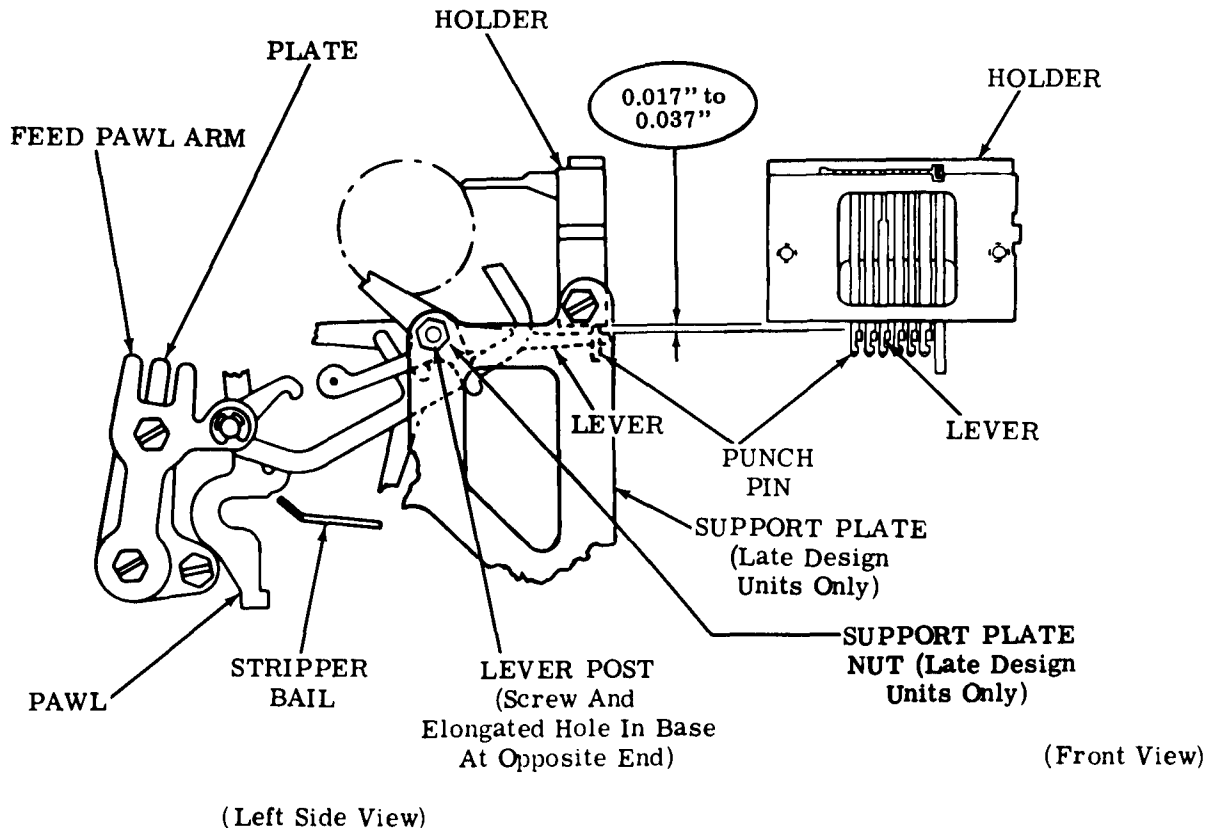

Note: For those 5-level tape punches equipped with an auxiliary TP182186 drive bail, repeat the above procedure with a FIGS D code combination set up in the selector. Omit checking the lever in the no. 3 code level position (Figure 2), since it is not operated.

2.06 Tape Punch Area (continued)

PAWL UPSTOP ASSEMBLY — FINAL (PFA-7)**To Check**

With the tape punch "on," set up an all-marking code combination in the selector. Manually rotate the main shaft until the stripper bail is in its rearmost position (position 1).

Note 1: For tape punches equipped with a FIGS D control, use the following "To Check" procedure:

To Check

With the tape punch "on," set up the code combination in the selector that will cause the FIGS D control to operate. Manually rotate the main shaft until the stripper bail is in its rearmost position (position 1). Check requirement (1). Then, set up an all-marking code combination in selector. Manually rotate the main shaft until the stripper bail is in its rearmost position (position 1). Check requirement (2).

(1) Requirement

Min 0.005 inch---Max 0.020 inch
between the leftmost sensing lever
(Figure 2) and its associated pawl.

Note 2: For tape punches equipped with the FIGS D control, the requirement will be checked between the second from the left sensing lever (Figure 2) and its associated pawl.

Note 3: There should also be some clearance between the rightmost sensing lever (Figure 2) and its associated pawl.

Note 4: "Some clearance" can be determined if a sensing lever is pressed down slightly without moving its associated pawl.

(2) Requirement

Some clearance between the feed lever and its associated pawl and each sensing lever and its associated pawl.

To Adjust

Loosen the screw which secures the pawl upstop assembly post to the tape punch casting. Provide proper clearance by rotating the pawl upstop assembly. Tighten screw. Recheck requirement (1) above and refine if necessary. Remake STRIPPER BAIL UPSTOP (PFA-4) adjustment.

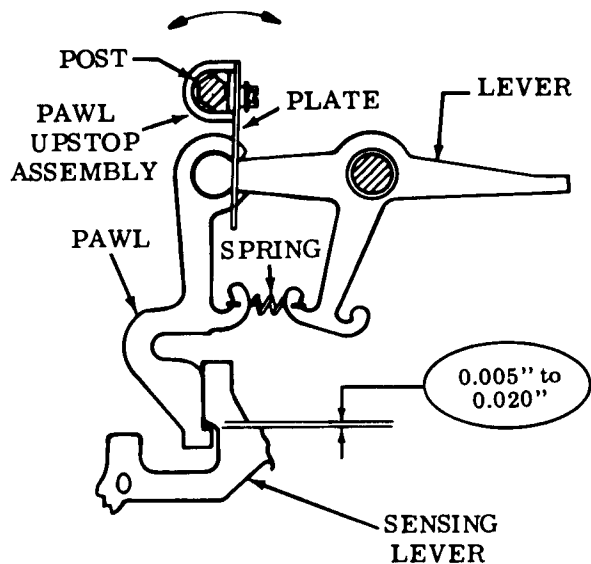

(Left Side View)

CAUTION: EXERCISE CARE AND SEE THAT THE PLATE OF THE PAWL UPSTOP ASSEMBLY ALWAYS GUIDES THE PAWL AND LEVER SIMULTANEOUSLY. AVOID ROTATING PLATE IN A COUNTERCLOCKWISE DIRECTION FROM ITS VERTICAL POSITION IF POSSIBLE.

2.07 Tape Punch Area (continued)

FEED WHEEL RATCHET AND PAWL — FINAL (PFA-8)

To Check

With no tape in the tape punch and with the tape punch "on," set up an all-marking code combination in the selector. Manually rotate the main shaft until the stripper bail is in its rearmost position (position 1). Take up all play in stripper bail toward the front.

Requirement

With feed wheel ratchet in its fully detented position
Min some---Max 0.010 inch
between the feed pawl and feed wheel ratchet tooth.

To Adjust

Loosen screw* and position plate w/bushing using pry points. Tighten screw. Backspace feed wheel ratchet one full revolution, one tooth at a time, using backspace lever. Check each tooth to see if the requirement is met. Gauge by eye. Readjust where necessary.

*Note: In late design units equipped with a support plate, remove two mounting screws and nut. Then move support plate out of the way to facilitate checking this adjustment. Replace after adjustment.

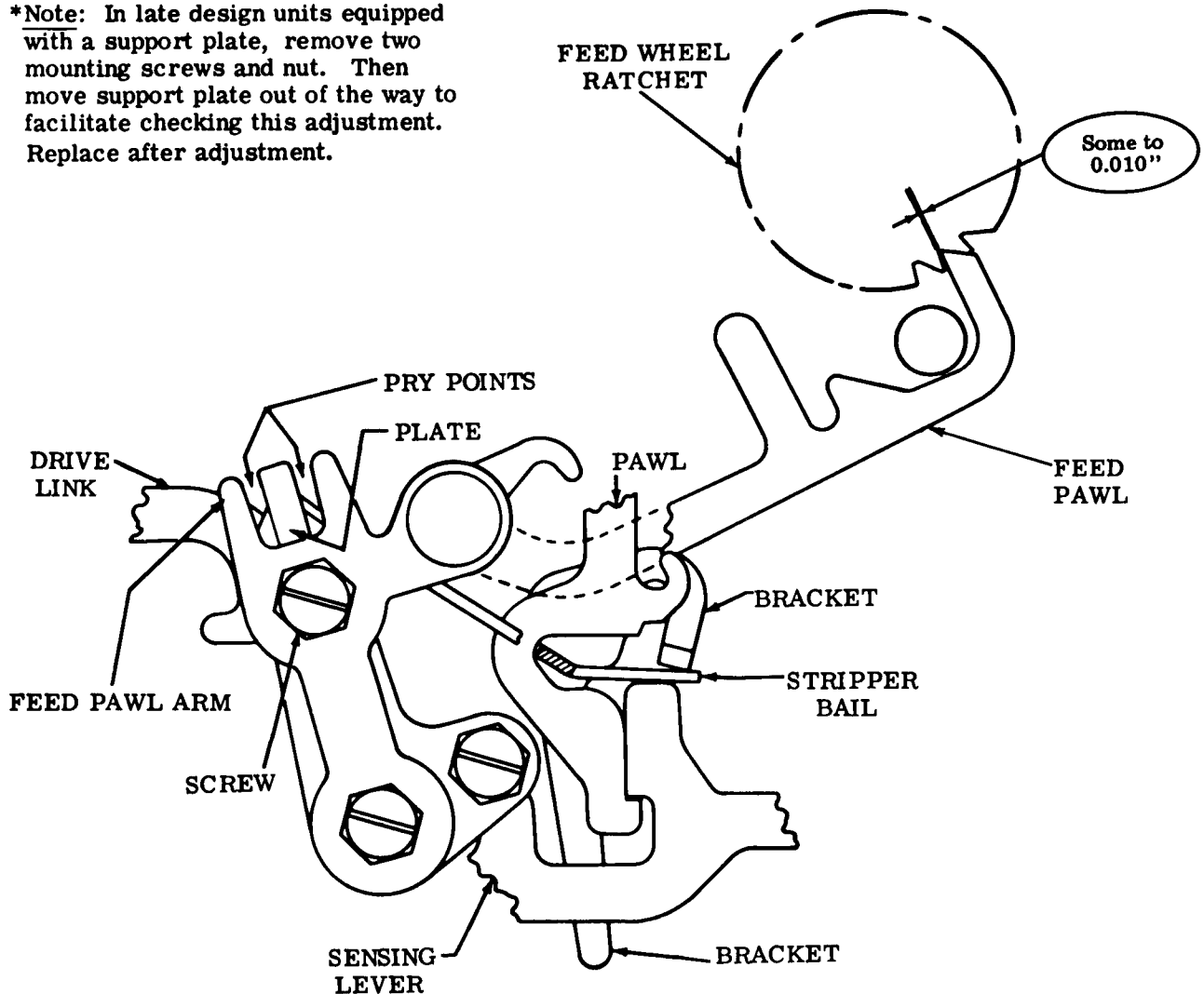

(Left Side View)

2.08 Tape Punch Area (continued)

TEN CHARACTERS PER INCH (PFA-9)

Note: From left to right, with the smooth side of TP156011 gauge up, there are six holes in line — five holes with 0.072-inch diameters and one hole with a 0.086-inch diameter.

To Check

Position one end of spring to lower notch of arm w/bushing. Operate the typing unit under power and perforate an alternate R and Y code combination in approximately 8 inches of tape. Tear the 8-inch length of punched tape from the tape punch and place it to the smooth side of TP156011 gauge. Concentrically align a no. 2 code hole of the punched tape with the first 0.072-inch diameter hole of TP156011 gauge.

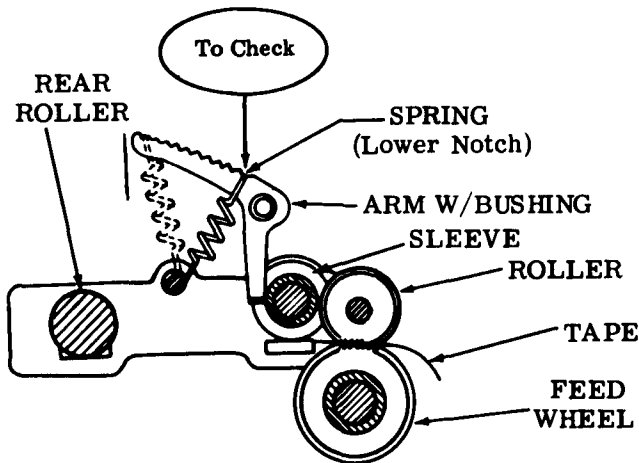

(Left Side View)

(1) Requirement

The four remaining 0.072-inch diameter gauge holes should be visible through corresponding no. 2 code holes in the punched tape.

(2) Requirement

The no. 2 code hole which corresponds with the 0.086-inch diameter gauge hole should lie entirely within the perimeter of that gauge hole.

To Adjust

If the no. 2 code hole is beyond the edge of the hole in the gauge, position spring upward, notch by notch, until requirement is met. If the no. 2 code hole is short of the edge of the hole in the gauge, position spring toward lower notch of arm.

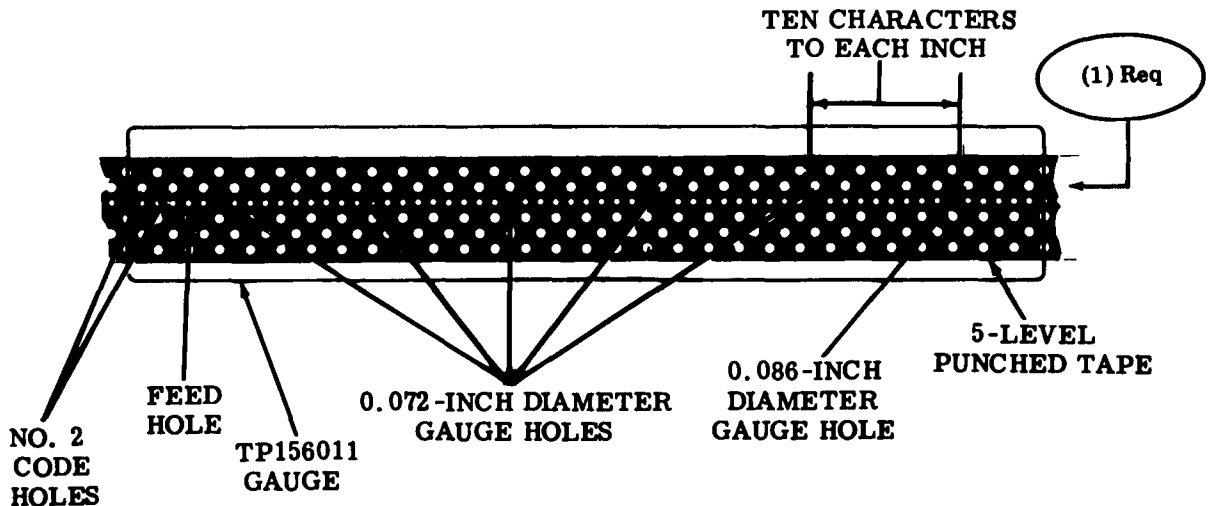

(Top View)

2.09 Tape Punch Area (continued)

TAPE BIAS SPRING (PFA-10)

Requirement

With tape removed from the tape punch, tape bias spring should rest against side of die plate and should be symmetrical about the tape opening, as gauged by eye.

To Adjust

Loosen tape bias spring screw and position tape bias spring so that it just rests against the left side of clearance slot and is symmetrical about the tape opening. Tighten screw.

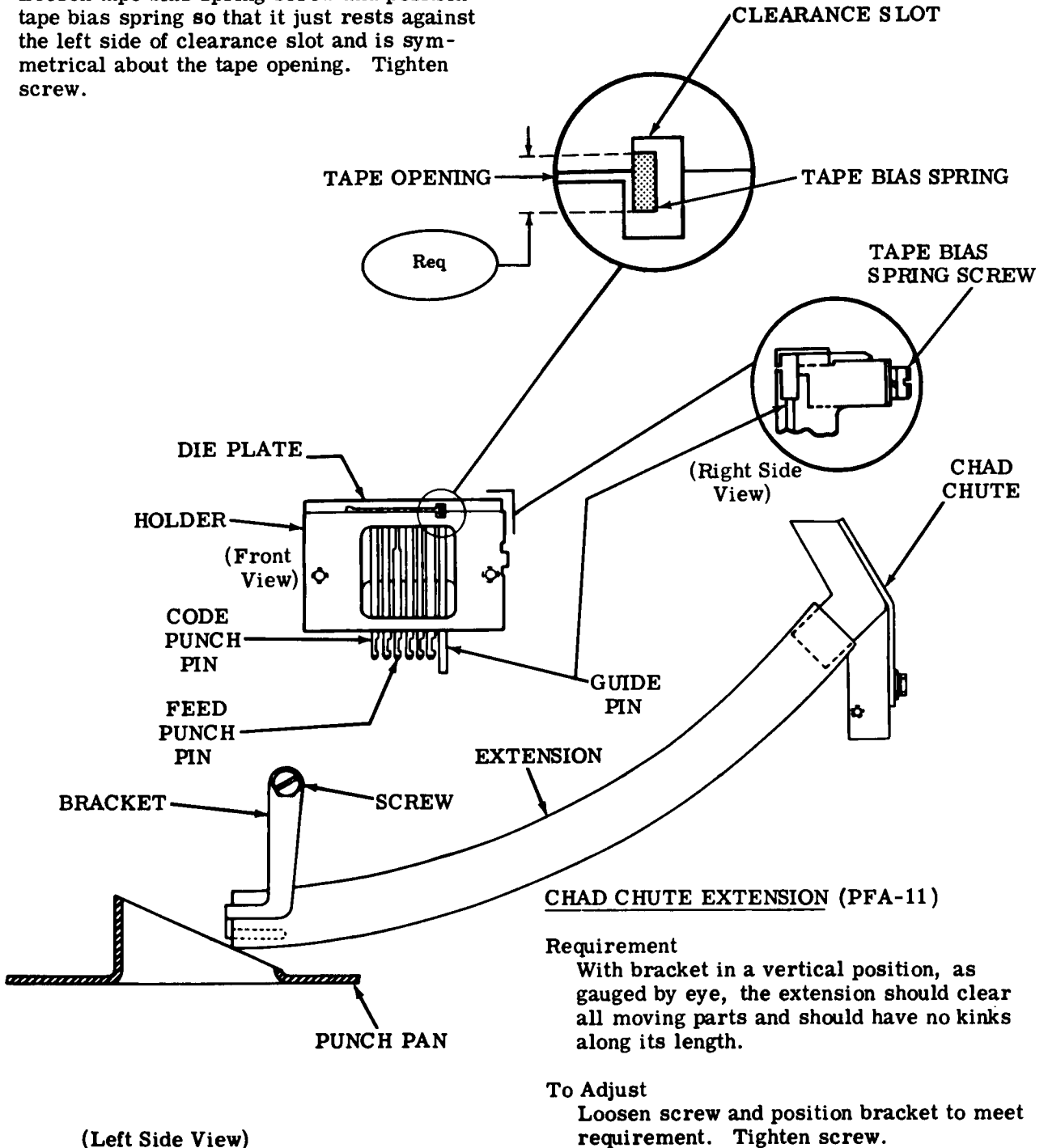

Requirement

With bracket in a vertical position, as gauged by eye, the extension should clear all moving parts and should have no kinks along its length.

To Adjust

Loosen screw and position bracket to meet requirement. Tighten screw.

(Left Side View)

2.10 Tape Punch Area (continued)

CODEBAR EXTENSION SPRINGS

Requirement

With the typing unit in stop condition
 Min 3/4 oz ---Max 1-1/4 oz
 to pull spring to its installed length.

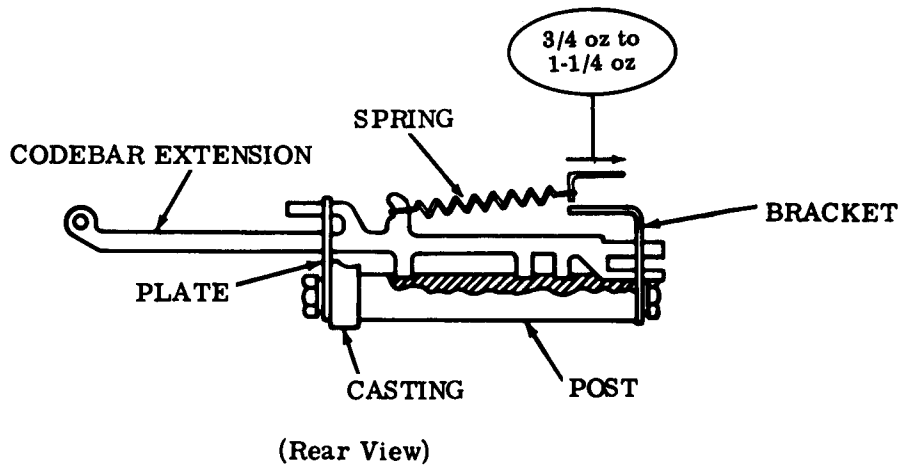

SENSING LEVER SPRINGS

Requirement

With the tape punch in off position
 Min 15 grams ---Max 32 grams
 to start sensing lever moving.

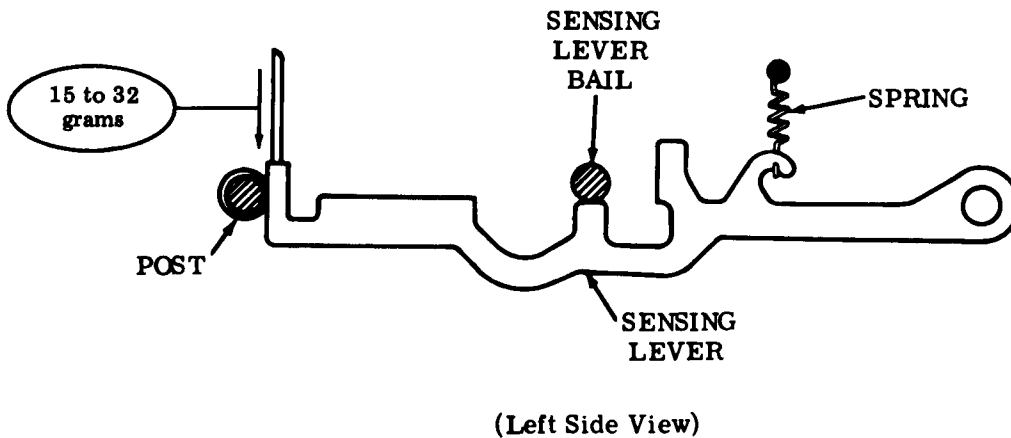

2.11 Tape Punch Area (continued)

PAWL AND LEVER SPRINGS

Requirement

With the tape punch "off"

Upper spring:

Min 1 oz---Max 2 oz

Lower spring:

Min 1-1/2 oz---Max 2-1/2 oz
to start pawl moving.

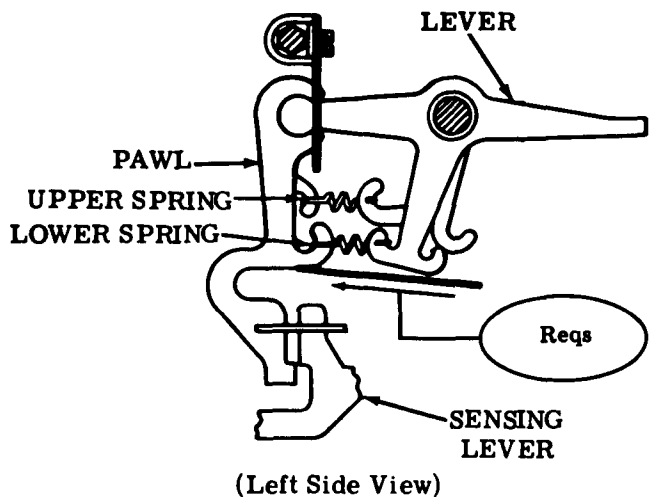

STRIPPER BAIL SPRING

Requirement

With tape punch in off position

Min 12 oz---Max 15 oz

to pull spring to its installed length.

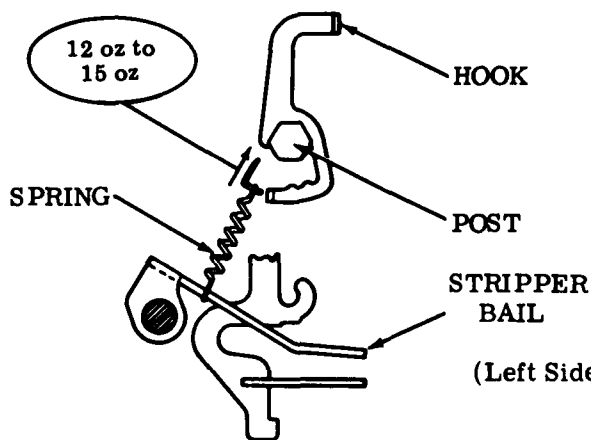

EARLY DESIGN

STRIPPER BAIL SPRING

Requirement

With tape punch in off position

Min 7 oz---Max 13 oz

to start the stripper bail moving.

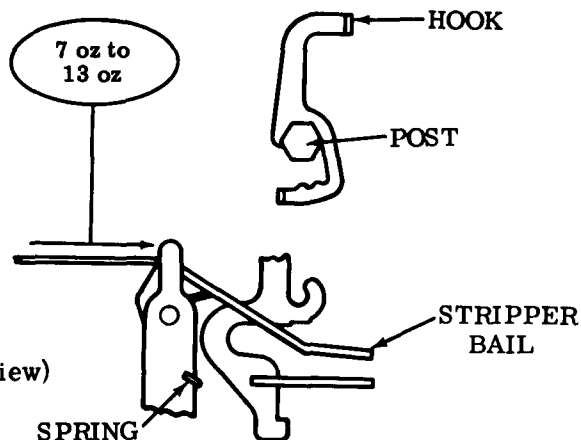

LATE DESIGN

2.12 Tape Punch Area (continued)

FEED PAWL SPRING

Requirement

With tape punch in off position
 Min 1/2 oz --- Max 1 oz
 to start feed pawl moving.

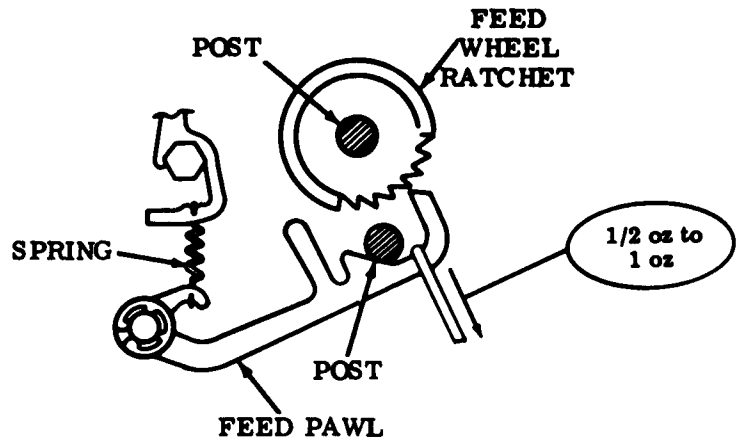

(Left Side View)

DETENT LEVER SPRING

Requirement

With the tape punch "off"
 Min 13 oz --- Max 17 oz
 to start detent lever moving.

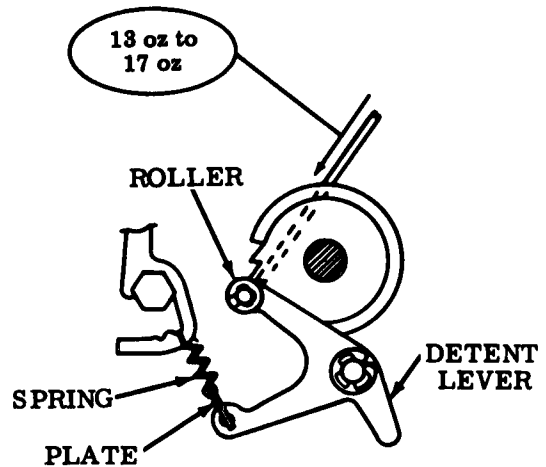

(Left Side View)

2.13 Tape Punch Area (continued)

BACKSPACE LEVER SPRING

Requirement

With the tape punch in off position

Min 3-1/2 oz --- Max 5-1/2 oz
to pull spring to its installed length.

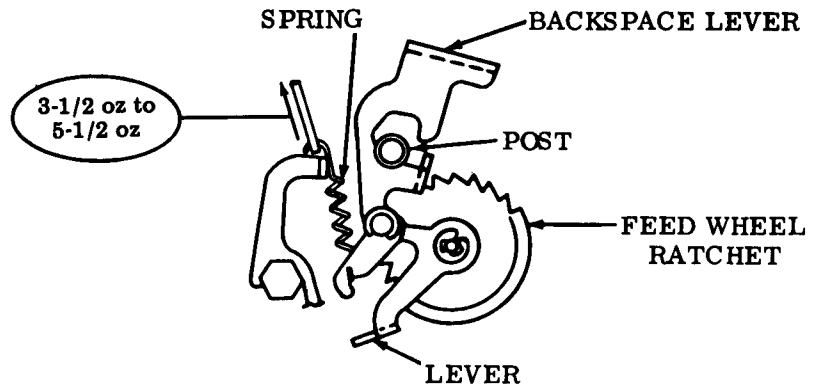

(Left Side View)

TAPE GUIDE TENSION SPRING

Requirement

Min 34 oz --- Max 38 oz
to pull spring to upper notch
installed length.

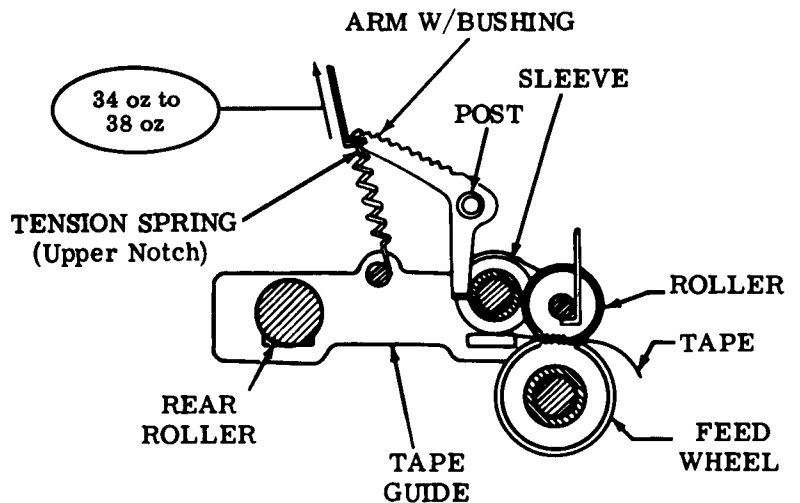

(Left Side View)

2.14 Tape Punch Area (continued)

TAPE GUIDE COMPRESSION SPRING

Requirement

Remove the tape guide tension spring.
Place roller slightly above the feed wheel

Min 24 oz---Max 48 oz
to start tape guide moving.

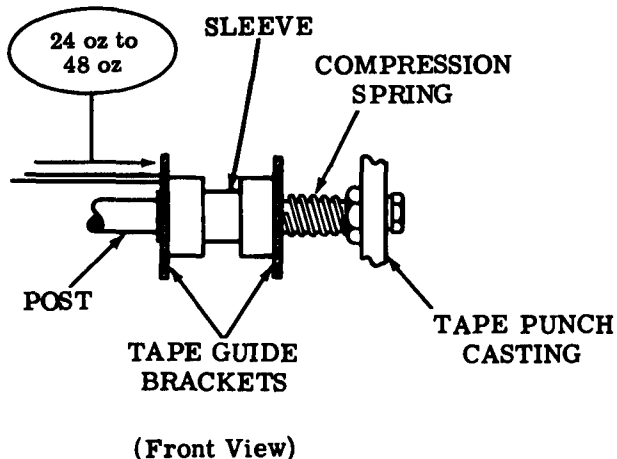

CONTROL PUSHBUTTONS

Requirement

Min 1/2 oz---Max 1-1/2 oz
to push each control pushbutton
down 1/8 inch
as gauged by eye, while
remaining control pushbuttons
remain in their normal upward
positions.

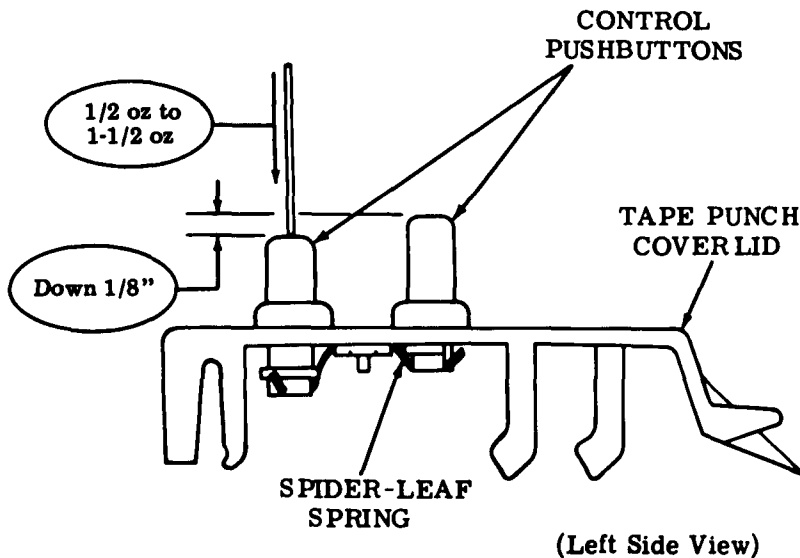

CONTROL DETENT LEVER SPRING

Note: This adjustment applies only to
tape punches equipped with TP182843
detent lever.

Requirement

With tape punch "off"
Min 10-1/2 oz--Max 14-1/2 oz
to start detent lever moving.

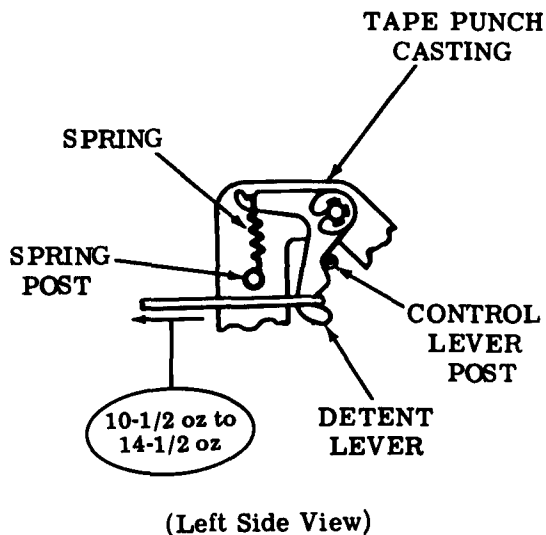

2.15 Tape Punch Area (continued)

DRIVE LINK SPRING

Requirement

With tape punch "off"

Min 7 oz---Max 9 oz
to start drive link moving.

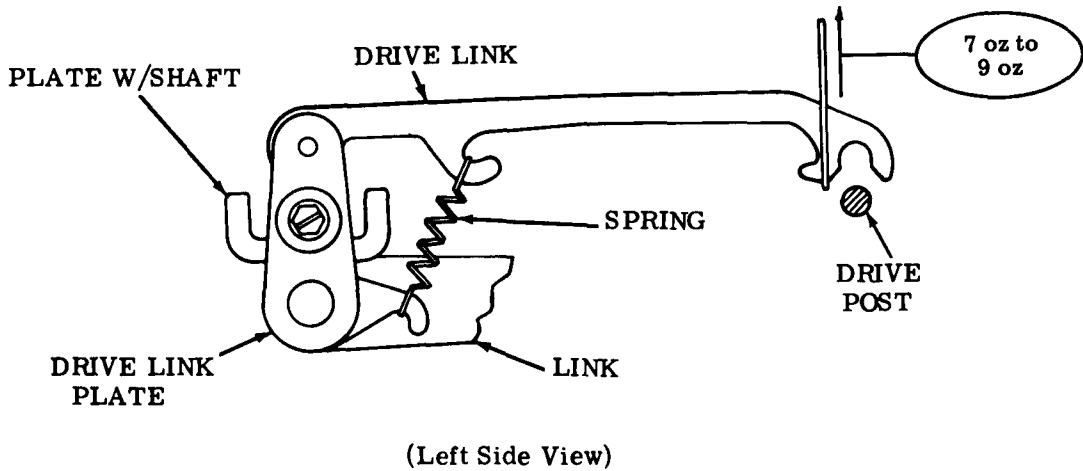

PUNCH BLOCK ASSEMBLY

To Check

Remove the punch block assembly from the tape punch. Replace after performing this adjustment. (For instructions, refer to Section 574-175-702TC.)

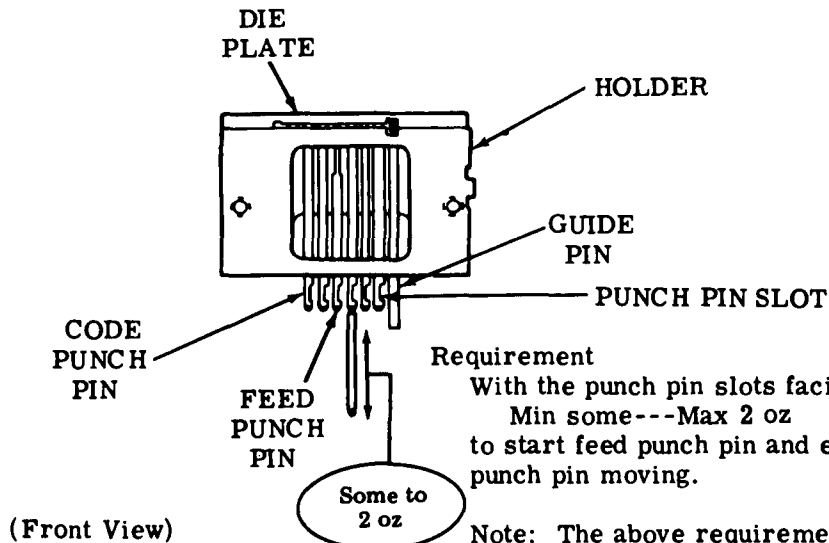

Requirement

With the punch pin slots facing the guide pin
Min some---Max 2 oz
to start feed punch pin and each code
punch pin moving.

Note: The above requirement must be met
anywhere along each punch pin's upward and
downward travel in holder.

3. VARIATION TO BASIC UNIT

3.01 Tape Punch Area

FOLDED TAPE GUIDE

(1) Requirement

With no tape in punch, bracket should be flush with top surface of punch block casting.

To Adjust

Loosen screw and position bracket.
Tighten screw.

Note 1: This adjustment applies only to tape punches equipped with TP185705 folded tape guide modification kit.

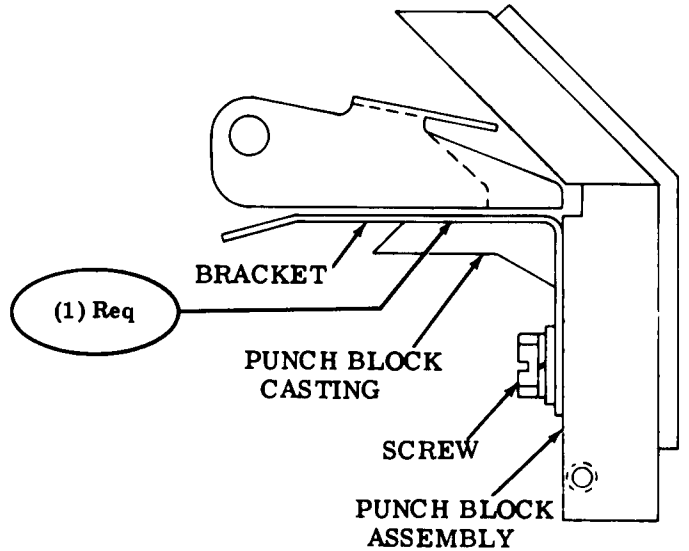

(Left Side View)

(2) Requirement

With tape in punch
Min some---Max 0.015 inch
between tape depressor tab and
underside of chad chute.

To Adjust

Bend tape depressor tab.

Note 2: Check TEN CHARACTERS PER INCH (PFA-9).

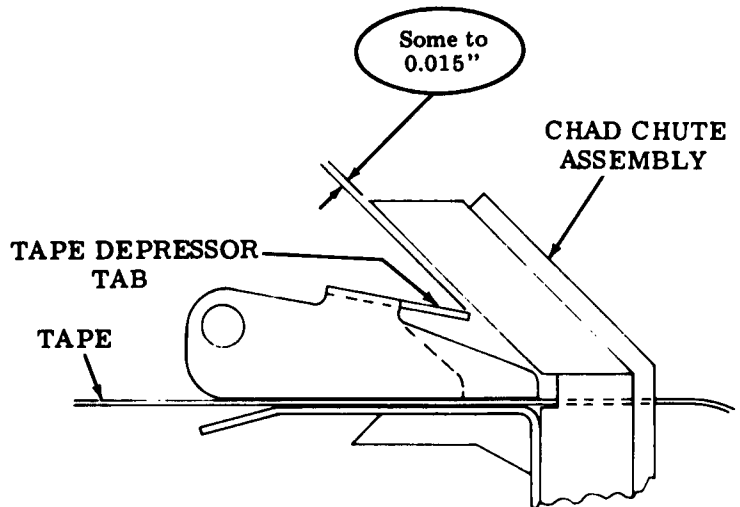

(Left Side View)

32 COVERS
 ADJUSTMENTS

CONTENTS	PAGE	
1. GENERAL.	1	Receive (KSR) and Automatic Send-Receive (ASR) Sets (Figures 1 and 2).
2. BASIC UNIT	3	1.02 After completing an adjustment, replace cover and/or any parts that were removed. Check any adjustments affected by the removal of the cover and/or parts.
Call Control Area		
Dial to cover	3	CAUTION: ELECTRICAL POWER MUST BE REMOVED FROM UNIT BEFORE ANY ADJUSTMENTS ARE MADE.
Knob to bezel.	3	
Paper Area		1.03 In the adjustments covered in this section, location of clearances and position of parts are illustrated by line drawings. Requirements and procedures are set forth in the texts that accompany the line drawings.
Low paper contact operating arm . . .	4	
Tape Punch Area		1.04 Reference to left, right, front, or rear, etc, consider the cover to be viewed from a position where the lid is up and the nameplate position is facing the viewer.
Control pushbuttons	7	
Tape Reader Area		1.05 Unless specifically stated otherwise, position screws or nuts friction tight to make an adjustment, and tighten them securely once the adjustment has been made.
Reader mounting bracket (early design).	5	1.06 Tools needed to perform adjustments are included in TP185830 maintenance tool kit and are listed in Section 570-005-800.
Reader mounting bracket (late design).	6	1.07 Check appropriate disassembly and re-assembly section for approved procedure of cover and parts removal.
1. GENERAL		
1.01 This section is issued to provide adjustment information for the 32 typing unit, tape punch, and reader covers. The requirements apply to covers for both Keyboard Send-		

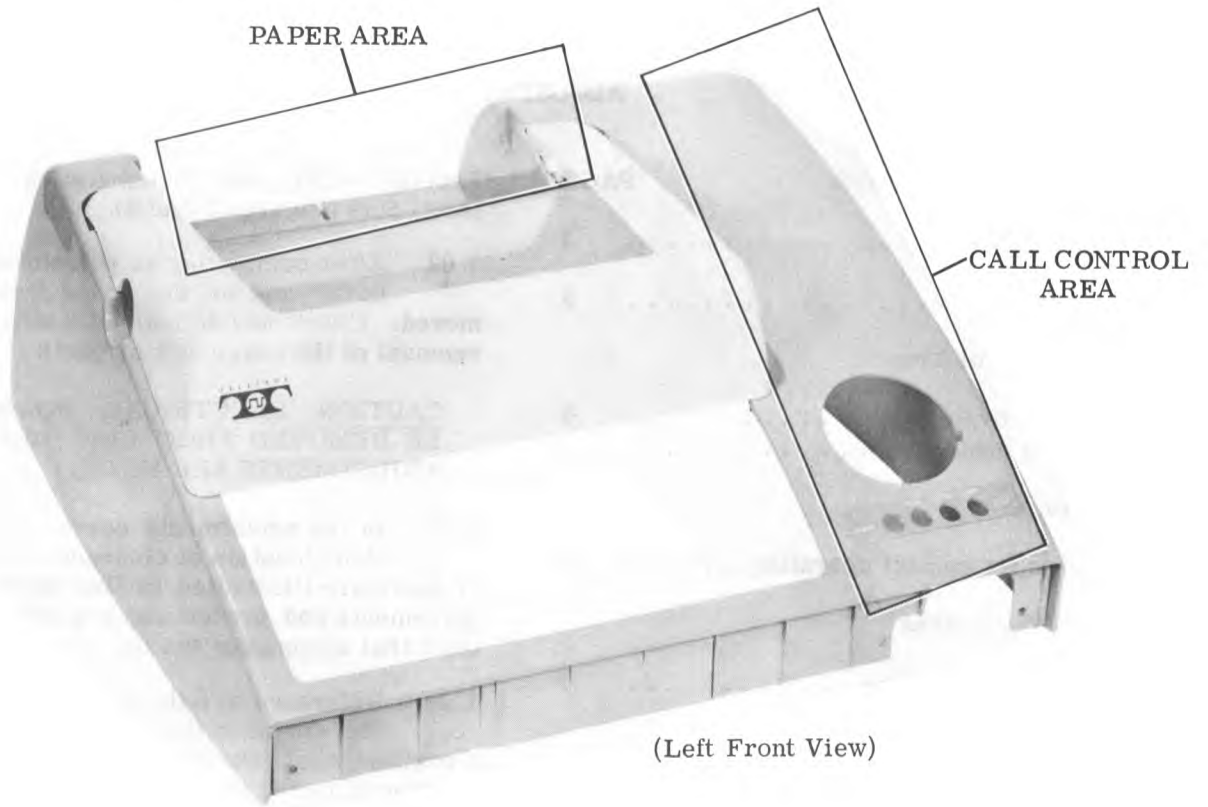

Figure 1 - Cover (Keyboard Send-Receive Set)

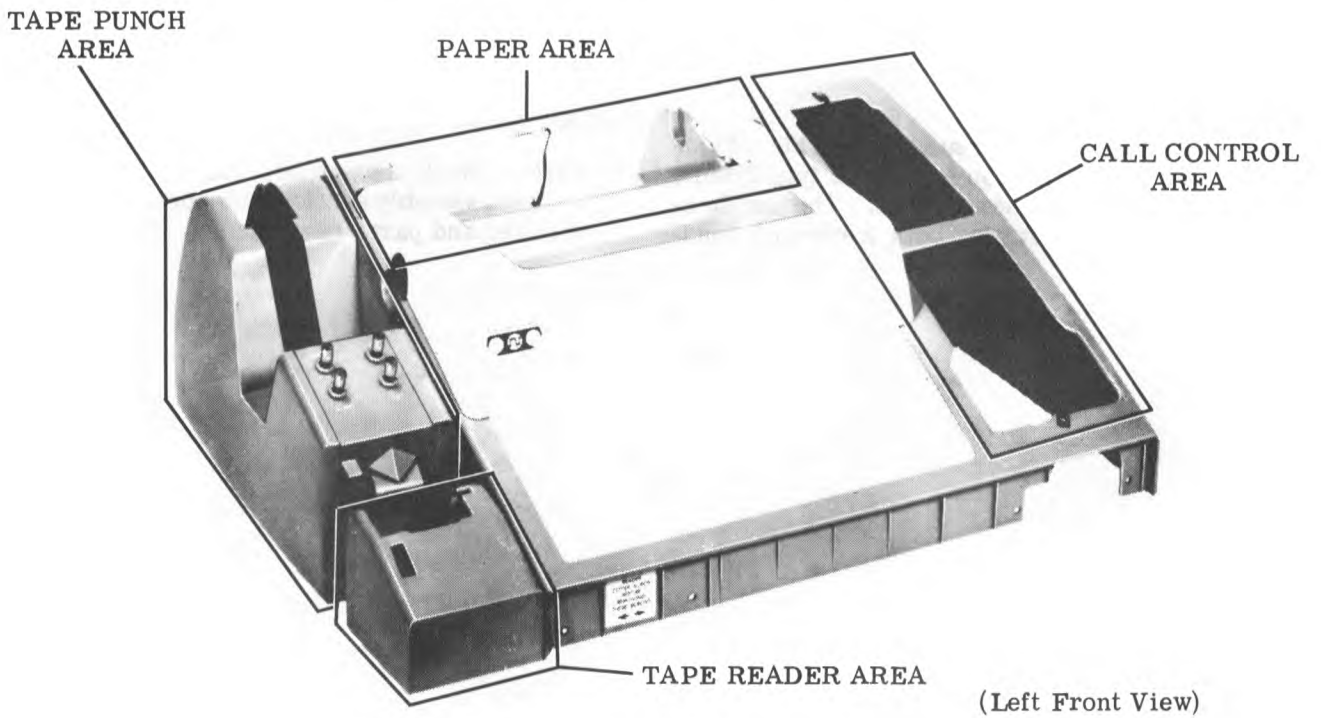
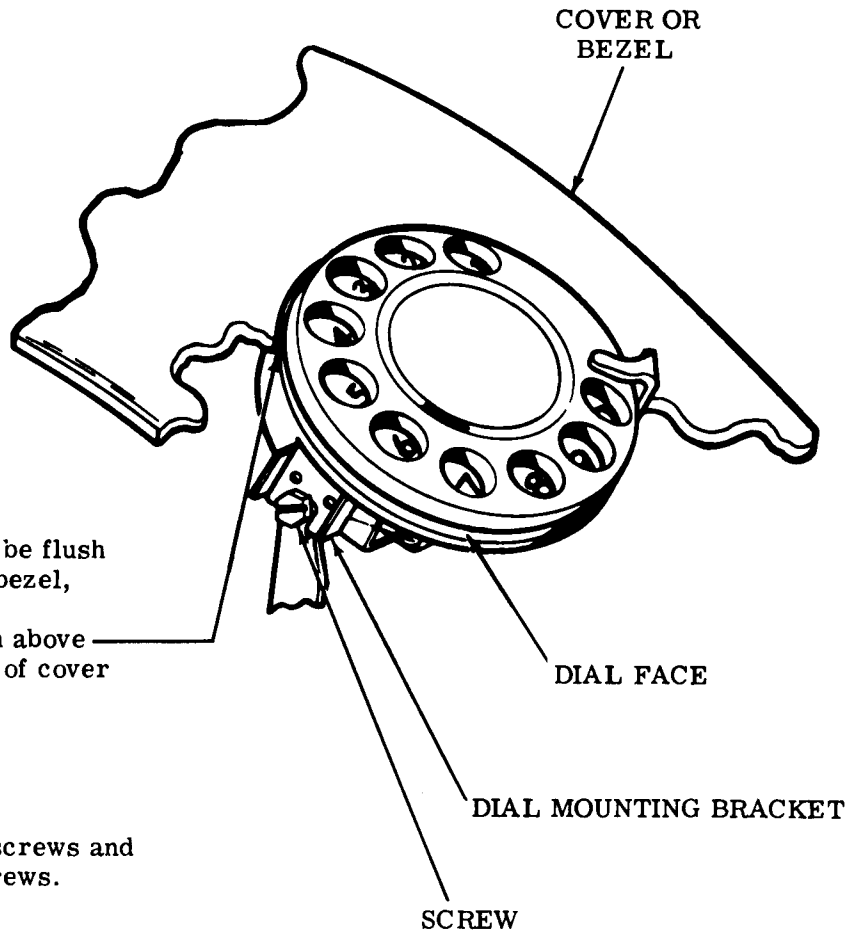

Figure 2 - Cover (Automatic Keyboard Send-Receive Set)

2. BASIC UNIT

2.01 Call Control Area

(Left Front View)



DIAL TO COVER

Requirement

The numbered dial face should be flush to outside surface of cover or bezel, within

1/16 inch below---3/32 inch above and parallel to outside surface of cover or bezel, within

1/16 inch as gauged by eye.

To Adjust

Loosen dial mounting bracket screws and position dial face. Tighten screws.

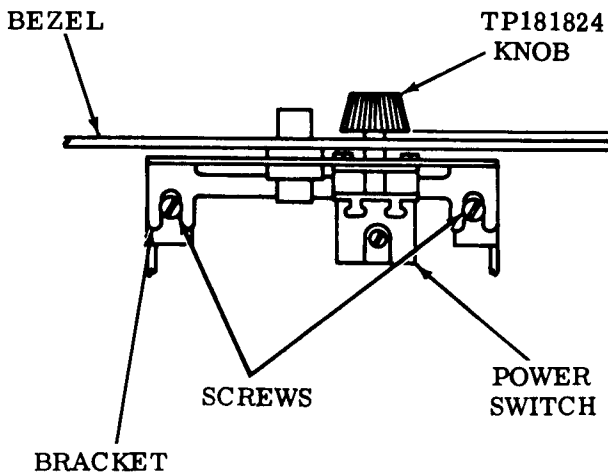

(Rear View)

KNOB TO BEZEL

To Check

Fully seat the TP181824 knob on the power switch.

Requirement

Min some---Max 1/8 inch between the bottom of the knob and the face of the bezel.

To Adjust

Remove the TP181824 knob and the cover (refer to appropriate disassembly and reassembly section). Loosen screws and position bracket. Tighten screws and replace cover and knob. Recheck Requirement.

2.02 Paper Area

Note 1: The following adjustment applies only to typing units with TP181441 switch mounted on the base casting next to the left function shaft clamp.

LOW-PAPER CONTACT OPERATING ARM

- (1) Requirement (Preliminary)
With paper spindle in place
Min 1/16 inch---Max 3/16 inch
between operating arm and spindle.

To Adjust
Bend the wire operating arm.

- (2) Requirement (Final)
Switch will operate when predetermined
low paper supply is reached.

To Adjust
If switch operates when diameter of
paper supply roll is too large, bend
arm closer to roll. If switch operates
when paper supply is too low, bend arm
away from roll.

Note 2: The operating arm should pass through the cover slot, free from any contact with the cover.

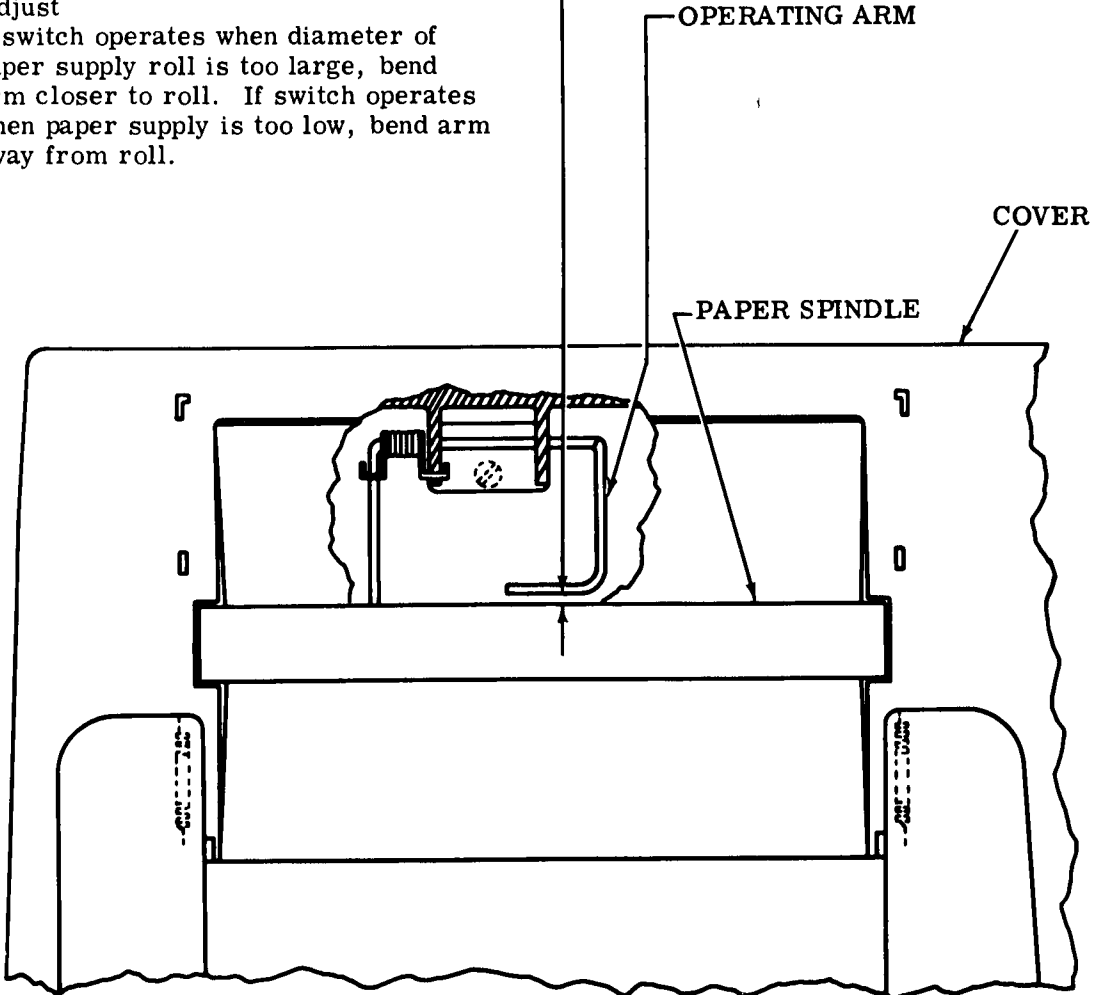

(Top View)

2.03 Tape Reader Area

Note: The following adjustment applies to tape readers with early design bases.

READER MOUNTING BRACKET (Early Design)

Requirement

There should be equal clearance on three sides between top plate and tape reader cover.

To Adjust

With three mounting screws friction tight, position tape reader base. Tighten screws.

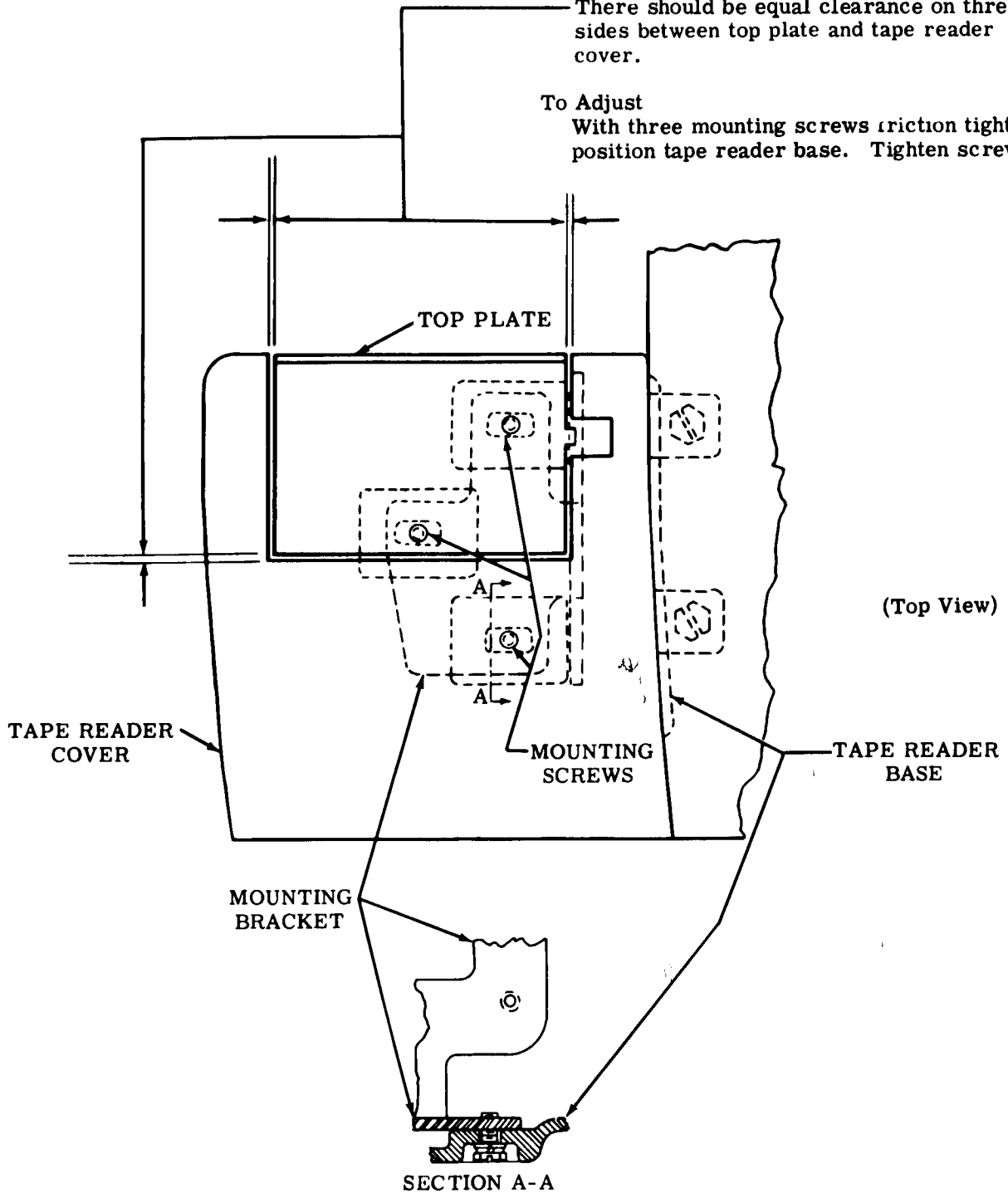

2.04 Tape Reader Area (continued)

Note: The following adjustment applies to tape readers with late design bases.

READER MOUNTING BRACKET (Late Design)

(1) Requirement

Top plate to be
Min flush---Max 0.030 inch
below cover.

(2) Requirement

Equal clearance between top plate and tape reader cover on three sides.

To Adjust

With four adjusting screws and locking screw (L) loosened and mounting bracket lying flat on tape reader base, position tape reader. Run two adjusting screws (X) up until requirement is approximately met. Tighten locking screw friction tight. Run two adjusting screws (Y) up until requirement is approximately met. Refine all four adjusting screws, loosen locking screw if necessary. Tighten locking screw.

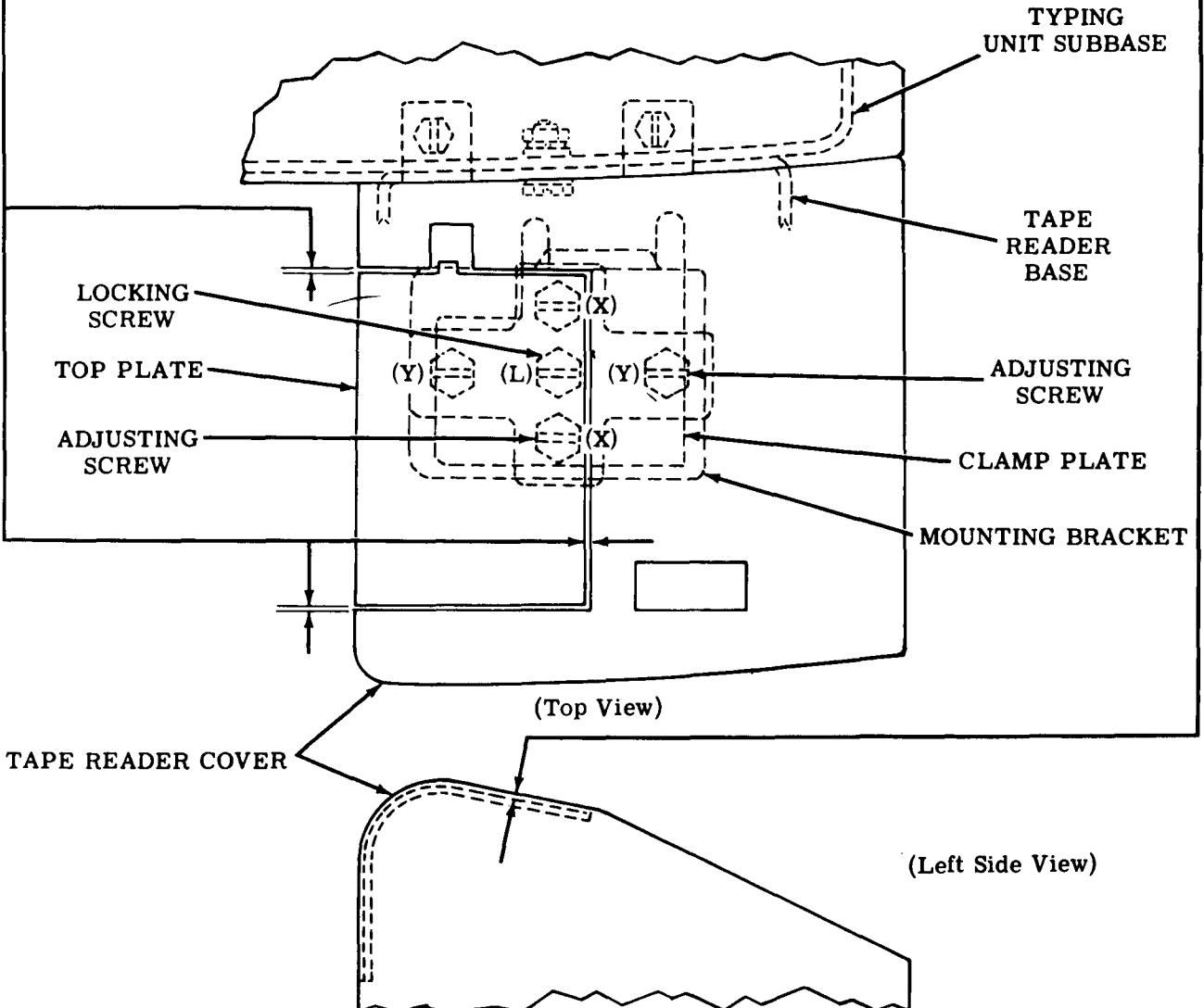

2.05 Tape Punch Area

CONTROL PUSHBUTTONS

Requirement

Min 1/2 oz---Max 1-1/2 oz
 to push each control pushbutton
 down 1/8 inch
 as gauged by eye, while
 remaining control pushbuttons
 remain in their normal upward
 positions.

