

**Please do not upload this copyright pdf document to any other website. Breach of copyright may result in a criminal conviction.**

This pdf document was generated by me Colin Hinson from a Crown copyright document held at R.A.F. Henlow Signals Museum. It is presented here (for free) under the Open Government Licence (O.G.L.) and this pdf version of the document is my copyright (along with the Crown Copyright) in much the same way as a photograph would be.

The document should have been downloaded from my website <https://blunham.com/Radar>, or any mirror site named on that site. If you downloaded it from elsewhere, please let me know (particularly if you were charged for it). You can contact me via my Genuki email page: <https://www.genuki.org.uk/big/eng/YKS/various?recipient=colin>

**You may not copy the file for onward transmission of the data nor attempt to make monetary gain by the use of these files. If you want someone else to have a copy of the file, point them at the website. (<https://blunham.com/Radar>). Please do not point them at the file itself as it may move or the site may be updated.**

It should be noted that most of the pages are identifiable as having been processed by me.

---

I put a lot of time into producing these files which is why you are met with this page when you open the file.

In order to generate this file, I need to scan the pages, split the double pages and remove any edge marks such as punch holes, clean up the pages, set the relevant pages to be all the same size and alignment. I then run Omnipage (OCR) to generate the searchable text and then generate the pdf file.

Hopefully after all that, I end up with a presentable file. If you find missing pages, pages in the wrong order, anything else wrong with the file or simply want to make a comment, please drop me a line (see above).

It is my hope that you find the file of use to you personally – I know that I would have liked to have found some of these files years ago – they would have saved me a lot of time !

Colin Hinson

In the village of Blunham, Bedfordshire.

AIR PUBLICATION

**117G-0604-1**

**VOLTMETER SET ELECTRONIC CT 528**

**GENERAL AND TECHNICAL INFORMATION**

BY COMMAND OF THE DEFENCE COUNCIL



Ministry of Defence

FOR USE IN THE  
ROYAL AIR FORCE

(Prepared by the Ministry of Technology)

## VOLTIMETER SET ELECTRONIC CT 528

### LEADING PARTICULARS

Ref. No.	... ..	10S/6625-99-954-6301
Purpose of equipment	... ..	<i>Precision a.c. milli-voltmeter, 9-range and operating with a bandwidth of 100 kHz. Contains a high-stability power supply sub-unit</i>
Ranges of signal sensitivity	... ..	<i>F.S.D. reads:—1.5mV, 5mV, 15mV, 50mV, 150mV, 500mV, 1.5V, 5V and 15V</i>
Nominal frequency range	... ..	10Hz to 100kHz
Input conditions and impedance	... ..	<i>Normal. Greater than 50 megohms, shunted by 20pF Attenuator: 10:1 1 megohm Transformer (15V max.) Primary inductance is 50H</i>
Accuracy of indication	... ..	<i>Normal input. Within <math>\pm 1\%</math> of f.s.d. at 1kHz. Over frequency band 15Hz to 100kHz the indicated values on all ranges are within <math>\pm 1\%</math> of f.s.d. of indicated values at 1kHz. At 10Hz the indicated values on all ranges are within <math>+0\%</math> <math>-1.5\%</math> of f.s.d. of indicated value at 1kHz. Input attenuator, <math>\pm 0.5\%</math> at 1kHz, capacity compensated Input transformer. Error curves provided between 10Hz to 100kHz</i>
C.R.O. output volts	... ..	<i>When meter indicates f.s.d., voltage at c.r.o. socket is approximately 2.5V</i>
C.R.O. output signal/noise ratio	... ..	<i>The noise voltage is measured at c.r.o. output socket when normal input socket is closed by a 1 megohm resistor At 15V-15mV ranges, noise level is greater than 40dB down on f.s.d. On 5mV range, the noise level is greater than 35dB down on f.s.d. On 1.5mV range the noise level is greater than 30dB down on f.s.d.</i>
Mains requirements	... ..	110V/220V $\pm$ 20V, 50-60Hz, 80VA consumption
Dimensions	... ..	17½ in. $\times$ 11 in. $\times$ 11 in.
Weight	... ..	50 lb
Commercial equivalent	... ..	<i>Solartron Ltd. Feedback voltmeter Type VF252/NS3</i>



**Introduction (fig. 1)**

1. Basically, the a.c. milli-voltmeter (fig. 1) consists of four cascade connected amplifiers, incorporating negative feedback to obtain good gain stability, feeding a meter circuit. The meter circuit employs a feedback technique which, to all practical purposes, eliminates the effects of variations and non-linearities in the meter rectifying system. The sensitivity ranges of the instrument are 1.5mV, 5mV, 15mV, 50mV, 150mV, 500mV, 1.5V, 5V and 15V for full-scale deflection, and the voltage across the meter circuit for full-scale deflection is the same for all ranges.

2. The sensitivity ranges are obtained, partly by switching the negative feedback operative on the input amplifier, and partly by means of an attenuator after the input amplifier. The usefulness of the instrument is further increased by the input conditions switch, by which it is possible to select an isolated input through a 1:1 wide band transformer or an attenuated input through a 10:1 attenuator. Fig. 2 illustrates, in block diagram form, the various component circuits which, together, constitute the a.c. milli-voltmeter.

**VOLTMETER—  
CIRCUIT DESCRIPTION (fig. 6)**

**Input circuit**

3. By means of the input condition switch, the signal may be applied to the input amplifier by any one of the following circuits:—

(1) Normal input. In this condition, the signal is fed via the input condition switch

directly to the input amplifier; the input impedance is greater than 50 megohms shunted by approximately 20pF.

(2) Attenuator input. The input impedance of the attenuator is nominally 1 megohm, and the attenuation ratio is 10:1. The input attenuator consists of R89, R90, R91, RV1, C1, C2 and C29. C1 is the d.c. isolating capacitor. The resistors R89, R90, R91 and RV1 form a simple voltage divider. RV1 is a variable resistor used to pre-set the voltage division at low frequencies, and C2 and C29 are used to compensate for the effect of stray capacitance at high frequencies. C29 is a variable capacitor and is used to pre-set the attenuation at the high frequencies.

(3) Transformer input. The input transformer T1 is a wide-band isolating transformer. It has primary inductance of 50H, the primary being isolated from the chassis. One side of the secondary is taken to the input amplifier grid circuit via the input condition switch. This transformer has an earthed screen between the primary and secondary windings. The useful frequency range of the transformer is from 10Hz to 100kHz.

**Input amplifier**

4. This consists of two pentode amplifiers and a triode cathode-follower, overall negative feedback being returned from the cathode-follower output to the first amplifier cathode. The input circuit of this amplifier is required to operate at high im-

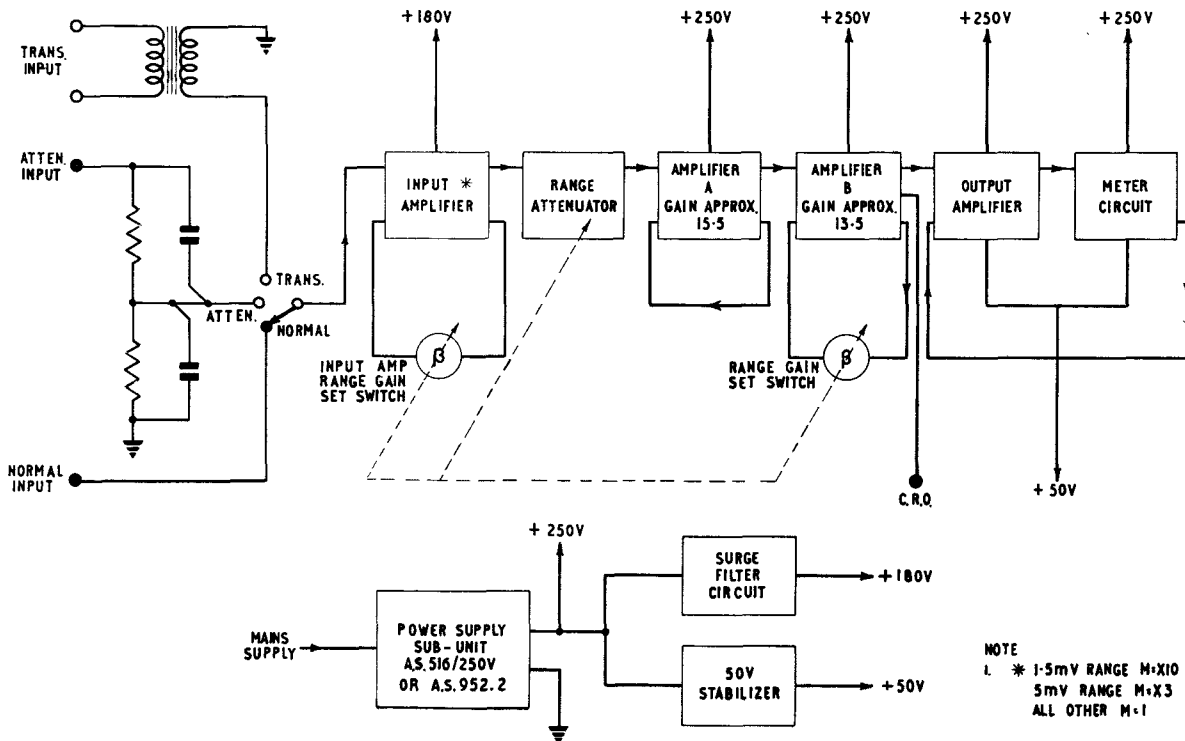

**Fig. 2. CT 528—block diagram**

pedance, and consequently, to minimize hum and microphony effects, a low microphony valve (CV2901) is employed as V1. V2 (CV2135) is a valve of a similar type. V3B (CV455) is one section of a double-triode and is employed as a cathode-follower.

5. The input amplifier serves two functions:

(1) To act as a buffer stage with a high input impedance and a low output impedance.

(2) To provide the following voltage gains by the setting of S2:—

- X 10 on the 1.5mV range
- X 3 on the 5mV range
- X 1 on all other ranges.

The input resistance on the 1.5mV range is approximately 50 megohms, indicating a gain of 20dB operative around the feedback loop. On other ranges, loop gain is correspondingly higher.

6. To provide the gain required on each range, the range attenuator also acts as a feedback attenuator for the input amplifier. This feedback attenuator is compensated for by a pre-set capacitor C30. Additional compensation is provided in the 5mV range by the capacitor C33. C4 across R3 and C25 in series with R9 between V2 anode and h.t. negative, combine to prevent parasitic oscillations, by reducing the rate of phase lag with frequency. To reduce hum and noise a resistor R98 is connected in series with V1 heater.

#### Range attenuator

7. The range attenuator comprises R15, R16, R17, R18, R19, R20, R21, R22 and R23. It is a simple ladder attenuator and its input resistance is nominally 21.444 ohms. It has nine positions. On the first three positions, corresponding to the 1.5mV, 5mV and 15mV ranges, no attenuation takes place. The attenuation per step for the remaining positions is approximately 10dB.

8. On the first three positions, the range attenuator acts as the feedback attenuator for the input amplifier, the necessary connections are made by a separate switch bank which is ganged to the range attenuator switch. Capacitor C31 compensates the attenuator against "break across" when a high level, high frequency input signal is applied to the amplifier.

#### Amplifier (A)

9. Amplifier (A) consists of a double-triode valve V4 and a pentode valve V5, together with their associated components. The amplifier is a feedback type, employing two stages of amplification, and a cathode-follower with overall negative feedback returned from the cathode-follower output via a fixed feedback attenuator to the cathode of the first amplifier. The voltage gain of this amplifier is approximately 15.5. The negative feedback operative round the circuit is approximately 21.5dB.

10. Capacitor C26 in series with R93, connected

from the anode of V4A to the h.t. negative rail and C28 connected across R35 in the cathode circuit of V4B, are to prevent high frequency parasitic oscillations. The capacitor C10 (coupling V5 to V4B) has a resistor R32 connected in parallel. Its action is to reduce the overall phase advance of the circuit at low frequencies, and thus preserve good damping.

#### Amplifier (B)

11. Amplifier (B) consists of a double-triode valve V6 and a pentode valve V7, together with their associated components. This amplifier is constructed along the same lines as amplifier (A), the only difference being in the negative feedback attenuator which, in this case, contains a variable element.

12. In order that all sensitivity ranges of the a.c. milli-voltmeter may be set precisely, each range has been fitted with a separate gain control potentiometer. These potentiometers are numbered RV3 to RV11 inclusive. They are connected in the negative feedback attenuator by means of a switch which is ganged to the range attenuator switch. When a range is selected, the appropriate potentiometer is connected in parallel with R76. The voltage gain of this stage is nominally 13.5 times. The negative feedback operative is approximately 22.5dB.

#### C.R.O. output

13. To facilitate monitoring the measured signal by a cathode-ray oscilloscope, a c.r.o. output socket is provided. The output from amplifier (B) is taken to the grid of V12B, which is one section of a double-triode. This valve is connected as a cathode-follower, and its output is fed via C15 to the c.r.o. socket. For full-scale deflection on the meter, the output voltage at this c.r.o. socket is approximately 2.5V.

#### Output amplifier and meter circuit

14. The output amplifier and meter circuit consists of two pentode valves V8 and V9, a double-triode valve V10, and a double-diode valve V11 and the meter M1, with their associated components. This amplifier has two stages of amplification and a cathode-follower output.

15. The metering circuit is connected between the cathode of the cathode-follower and the +50V rail. Direct coupling is used for this connection and, consequently, the quiescent potential of the cathode is arranged to be at +50V. The output from the cathode-follower is fed to the double-diode V11, which is connected as a full-wave rectifier for the meter M1. When the output voltage overcomes the diode standing bias (which is approximately 2V), current flows through the diode.

16. The current flows through the conducting half of the double-diode and then divides through a parallel network. One branch of this network consists of the meter M1 in series with a 1.5 kilohm resistor; the other branch of the network consists of a 1.5 kilohm resistor. Since the resistance of the meter is negligible by comparison

to 1.5 kilohms, the currents flowing through the two branches are considered equal.

17. After passing through this parallel network, the two currents combine to flow through R53 and R54 and then to the 50V rail. The voltage produced across R54 is fed back to the cathode of V8 and provides overall negative feedback for the output amplifier and metering circuit. The voltage produced by the current through R53 and R54 is fed back to the screen grid of V8, its action being to provide decoupling for this screen grid. To maintain good damping at very low frequencies, the capacitor C17 coupling V9 and V10 has R64 connected in parallel. This resistor, in conjunction with the grid leak R63, transfers a portion of the quiescent anode potential of V9 to the control grid of V10.

18. In order that the d.c. cathode potential of V10 shall be held at approximately +50V d.c., feedback is employed round V9 and V10. This negative feedback is obtained by connecting the cathode of V10 back to the grid of V9, via its grid leak R68. The capacitor C16, connected from the cathode of V10, gives a measure of phase advance at very high frequencies and thus damping the amplifier at such frequencies and reducing the susceptibility to parasitic oscillations.

19. Before the signal voltage applied to the meter diodes reaches the amplitude (2V peak) necessary to overcome the standing bias, no overall negative feedback is operative, and the open gain of the amplifier is realized. This gain can be assessed by measuring the input to the amplifier necessary to bring about the inception of diode current. It is found to be 11.2mV (peak).

20. Now the diode bias is 2V; therefore, the open gain of the output amplifier is approximately 45dB. When feedback is operative, the gain of the output amplifier is approximately 7dB; therefore, the negative feedback around the output amplifier when the diodes are conducting, is approximately 38dB. Due to the standing bias on V11 when there is no input to the millivoltmeter, there is a very small residual indication on M1 of between  $\frac{1}{2}$  and 1% of f.s.d. The effect of this error decreases with increasing meter reading.

21. Earlier models of CT528 have power supply unit sub-type AS.516/250 fitted, whilst later versions have power supply sub-unit type AS.952.2/250 incorporated. The two sub-units are interchangeable and para. 22 to 25 refer to both units. Principles of operation and circuit description however are different, and are referred to separately.

### Power supplies

22. The main h.t. rail of the a.c. millivoltmeter is supplied from a power supply sub-unit 250V/50mA. This provides an h.t. line of high stability, low output impedance, and low hum and noise level. The stabilization factor of the power supply sub-unit is approximately 1,000:1; conse-

quently, a mains surge of 5 volts produces an h.t. surge in the order of 5mV. In view of the high sensitivity of the a.c. multi-voltmeter, the h.t. supply to the input amplifier must be devoid of surges even as small as 1mV in amplitude. To ensure that the h.t. supply to this input amplifier meets this stringent requirement, it is fed via a surge filter circuit.

23. This filter circuit consists of two main parts. The first part of the surge filter is an r.c. filter comprised of R13, R14 and C7. This provides a surge-free output of approximately 180V, but at a high output impedance. To ensure good decoupling of the 180V h.t. rail supplying the input amplifier, a low source impedance is required. To obtain this, the second part of the surge filter is used. Basically, it is one section of a double-triode V3a, connected as a cathode-follower, whose input is the surge-free 180V obtained as mentioned above. Therefore, the output from its cathode is the surge-free 180V at a low source impedance. As V3a cannot deal with the entire current required by the input amplifier, some current is fed directly from the 250V rail via R12.

24. The 50V rail is obtained by means of a stabilizer system, operating from the 250V rail. It comprises a double-triode valve V13 and one section of a double-triode valve V12a together with their associated components. The system employed is very similar to a conventional hard valve stabilizer, but it uses two stages of amplification within the control loop, in place of the usual single stage. The 50V rail is obtained from the cathode of the series stabilizing valve V12a. The two sections of V13 form the two-stage amplifier. The overall feedback is obtained by directly coupling the cathode of the series stabilizing valve V12a to the cathode of the first amplifier valve V13a.

25. The reference voltage applied to the grid of V13a is obtained from a voltage divider network connected across the 250V rail. The variable resistor RV12 permits precise adjustment of the rail voltage to the desired value of 50V. The source impedance of the 50V rail rises at high frequencies when the gain of the control loop falls, due to its comparatively narrow bandwidth. A capacitor C14, in series with R39, is connected from the cathode of V12a to the h.t. negative rail. The purpose of this capacitor is to produce a low source impedance at high frequencies. The resistor R39, in series with C14, prevents peaking of the source impedance at the frequency where the capacitor effectively takes over from the stabilizer circuit.

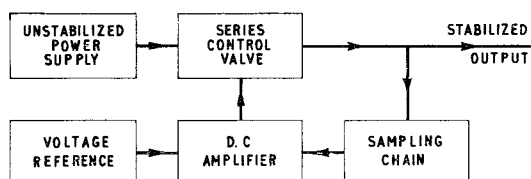

Fig. 3a. Power supply type AS 516 block diagram

## POWER SUB-UNIT TYPE AS 516

### Principles of operation (fig. 3a)

26. The circuit used in each of the power units is composed of:—

- (1) A stable voltage reference
- (2) A sampling chain
- (3) A wide-band d.c. amplifier
- (4) A series control valve
- (5) An unstabilized power supply.

These are connected together as shown in the block diagram (fig. 3a). A proportion of any change which appears on the stabilized output is fed through the sampling chain into the wide-band d.c. amplifier. It is then amplified and fed to the grid of the series control valve. This alters the voltage drop across the series valve in such a sense as to oppose the initial change. The final magnitude of the change is a function of the gain of the wide-band d.c. amplifier.

### Circuit description (fig. 7)

27. The voltage reference is V3 operating at a current between 4 and 6mA according to the output voltage setting. This valve has a striking voltage of 85V. The sampling chain is a series of high-stability carbon resistors connected between the stabilized h.t.+ and h.t.—. It acts as a potential divider supplying various points in the wide-band d.c. amplifier with appropriate potentials.

28. The wide-band d.c. amplifier consists of a pentode for the first amplifier, followed by a double-triode and connected as a cathode-coupled stage. The cathode of V4 is connected through a 100-ohm stopper resistor to V3 so that it is held at a constant potential of approximately 85V. The screen of V4 is fed from a potential divider and the grid is connected to the sampling chain through the diode V6.

29. The purpose of the diode is to give compensation to the d.c. drift introduced by heater-voltage changes. The output of the pentode is applied to a double-triode which is connected as

a cathode-coupled differential amplifier receiving its other input signal from the sampling chain. The output of the cathode-coupled amplifier V5 is directly coupled to the control grid of the series control valve.

30. The series control valve V2 carries most of the current drawn from the stabilized rail, but some current is allowed to by-pass the valve through a resistor. The unstabilized power supply is of conventional form, consisting of a transformer feeding a full-wave rectifier and a capacitor input filter.

## POWER SUB-UNIT TYPE AS.952.2/250

### Principles of operation

31. The circuit used in each of the power units is composed of:—

- (1) Power transformer
- (2) Main full-wave rectifier
- (3) Auxiliary full-wave rectifier
- (4) 75V stabilized supply
- (5) Stable voltage reference
- (6) Feedback network
- (7) D.C. amplifier
- (8) Series control valve

These are connected together as shown in the block diagram (fig. 3b). A proportion of any change which appears on the stabilized output is fed through the feedback network into the wide-band d.c. amplifier. It is then amplified and fed to the grid of the series control valve. This alters the volt drop across the series valve in such a sense as to oppose the initial change. The final magnitude of the change is a function of the gain of the wideband d.c. amplifier. The series valve is pentode connected giving it a high amplification factor. It can thus tolerate large ripple voltages on its anode which eliminates the need for a smoothing choke.

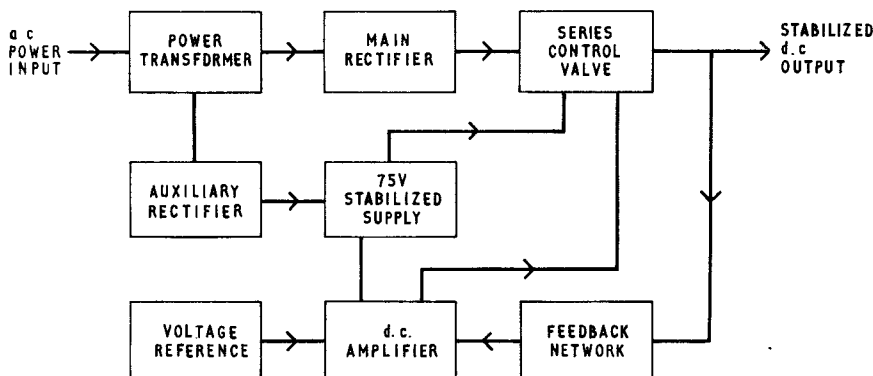

Fig. 3b. Power supply type AS 952.2 block diagram



**Circuit description (fig. 8)**

**32.** The power transformer has two primary windings accurately wound for series or parallel operation and tapped to accept supply voltage of 100-125 volts in 5 volt steps, or 200-250 volts in 10 volt steps. Eight series secondary windings are provided as follows:—

- (1) Main HT: centre tapped, this provides the main 200-300V power
- (2) Auxiliary: centre tapped, this feeds the auxiliary rectifier valve V1 for the 75V stabilized supply
- (3) 5V, 2A: heater supply for main rectifier valve V2
- (4) 6.3V, 2A: heater supply for V1 and series control valve V3
- (5) 6.3V, 1A: heater supply for the d.c. amplifier V5 and V6.
- (6) 6.3V, 1A: a.c. output
- (7) 6.3V, 2A: centre tapped a.c. output
- (8) 6.3V, 4A: centre tapped a.c. output

**33.** The cathode of the main full-wave rectifier (V2) is connected directly to a reservoir capacitor C2, and via R19 to the anode of the series control valve V3. The auxiliary full-wave rectifier V1 has its cathode connected direct to reservoir capacitors C1, C7 and C8, and via R3 to the 75V stabilizer.

**34.** The 75V stabilizer (V4) is a neon stabilizer connected between the positive output of the auxiliary rectifier and the stabilizer HT + ve rail, which is common with the auxiliary negative. This source supplies the anodes of the pentode sections of V5b and V6b, and the triode section of V5. The screen of the series control valve V3 is also supplied via resistor R20 from this source.

**35.** The voltage reference valve V7 operates at a current between 4 and 8mA according to the output voltage setting. V7 has a burning voltage of 85V. The feedback network is a series of high stability resistors connected between the stabilized HT + ve and HT - ve lines. It acts as a potential divider supplying an error signal to the wideband d.c. amplifier.

**36.** The D.C. amplifier consists of two triode-pentode valves (V5 and V6). The pentode sections (V5B and V6B) are connected as a cathode coupled differential amplifier, and the triode sections (V5A and V6A) are similarly connected to form the second stage. The first stage of the amplifier compares the reference voltage with a portion of the H.T. voltage. The reference voltage developed across V7 is filtered by R15 and C5 against noise. The signal is taken from the H.T. line, through the feedback network to the grid of V6B and C4 is added to increase the coupling

for ripple and noise. Under operating conditions the grid of V6B must always be at virtually the same potential as the grid of V5B. Thus as the wiper of RV1 is moved, the H.T. potential must vary to maintain balanced conditions. The push-pull output from this stage is directly coupled to the second stage, where further amplification takes place. The output from one side of the second stage (V5A) is fed via the stopper R4 to the grid of the series control valve. First order correction of d.c. drifts due to heater fluctuations is obtained from the balancing action of the differential amplifiers. The heaters of V5 and V6 valves are returned to a d.c. potential derived from the V5A and V6A cathode resistor network R6 and R7. The series control valve (V3) carries the current drawn from the stabilized h.t. rail. The screen of which valve is fed from the 75V stabilized supply via R20, and a control voltage from the d.c. amplifier is applied to the grid. C6 is connected across the H.T. output and a 0.3 ohm resistor R17 is placed in series with the H.T. + output to obviate unwanted phase shifts when the supply is applied to inductive or capacitive loads.

**Operating instructions**

**37.** Check that the mains-tapping panel is correctly set. Connect the power unit as required, making sure that the chassis is suitably earthed. Switch on, and check that the output voltage is correct. This voltage may be adjusted  $\pm 5\%$  approximately by means of the preset potentiometer RV1.

**38.** To change from 250V output to 300V output. Remove the connections from pin 10 and pin 12 on T1 and replace them on pin 9 and pin 13. Adjust the linking on the voltage panel which is situated under the chassis to 300V. To change from 300V output to 250V output reverse this procedure.

**WARNING . . .**

**When the instrument is switched on, the feedback amplifiers take 15-30 seconds to settle down, and the meter needle swings across the scale. This is quite normal and the overload is less than 100%. The violence of the needle movement is due mainly to the waveforms being applied to the meter. Similar effects may be observed when the instrument is switched from range to range.**

**Connections to the a.c. milli-voltmeter**

**39.** It is recommended that one earth connection only be made from the work on test to the a.c. milli-voltmeter, in order to eliminate the possibility of error voltage arising from loop currents. Further, when either the work, or any auxiliary equipment connected to the work, has a direct earth connection, the a.c. milli-voltmeter should be set to the 47 ohms earth by means of the switch in the front panel. This connects a

47-ohm resistor between the negative earth of the instrument and the mains earth, thus eliminating once again the possibility of a loop current.

40. When the equipment connected to the a.c. milli-voltmeter is fully isolated, the switch should, of course, be set for direct earth. The desired input conditions can be obtained by using the appropriate input connections, i.e. two terminals for transformer input, a coaxial socket for attenuator input, and a coaxial socket for normal input, in conjunction with the input condition switch.

#### **Operating the a.c. milli-voltmeter**

41. The a.c. milli-voltmeter is extremely simple

to use, and to take a voltage reading the procedure is as follows:—

- (1) Set the input condition switch to the required input condition.
- (2) Set the range switch to a suitable range.
- (3) Make connection to the voltage it is required to measure.
- (4) A voltage is then indicated on the a.c. milli-voltmeter.

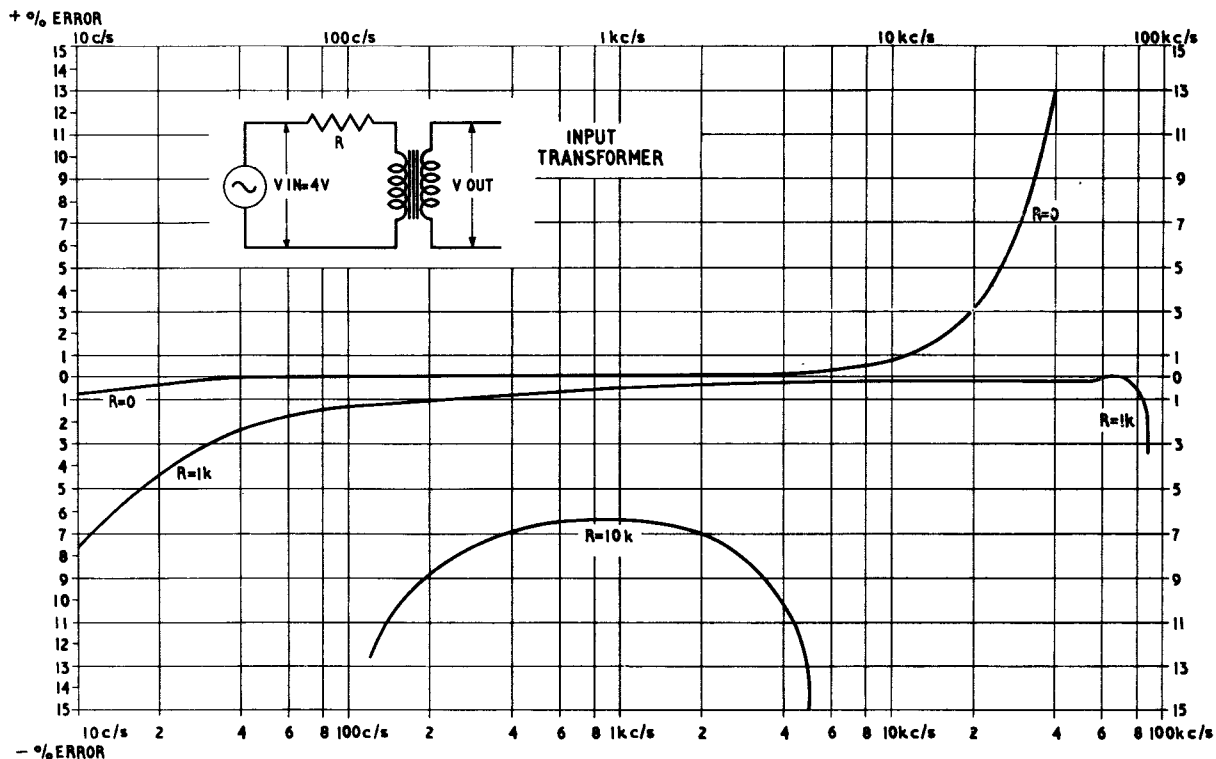

Fig. 4. Input transformer response: frequency—% error

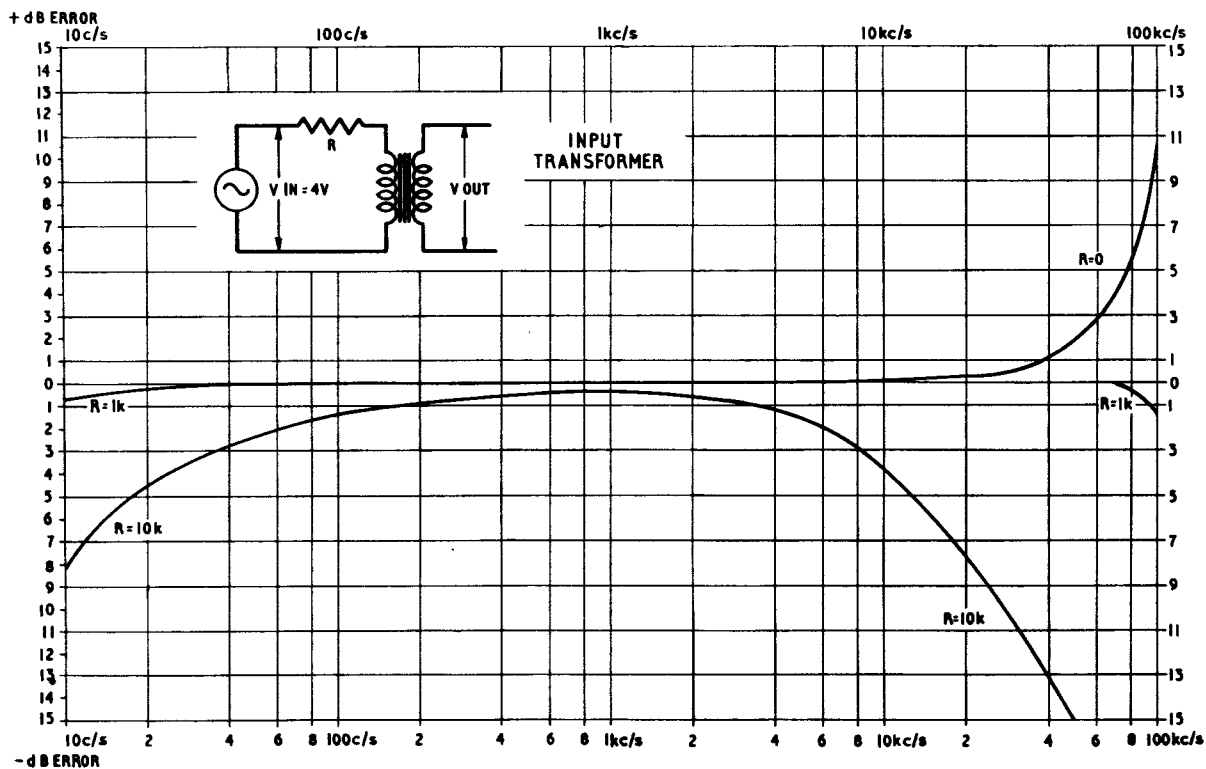

Fig. 5. Input transformer response: frequency—dB error

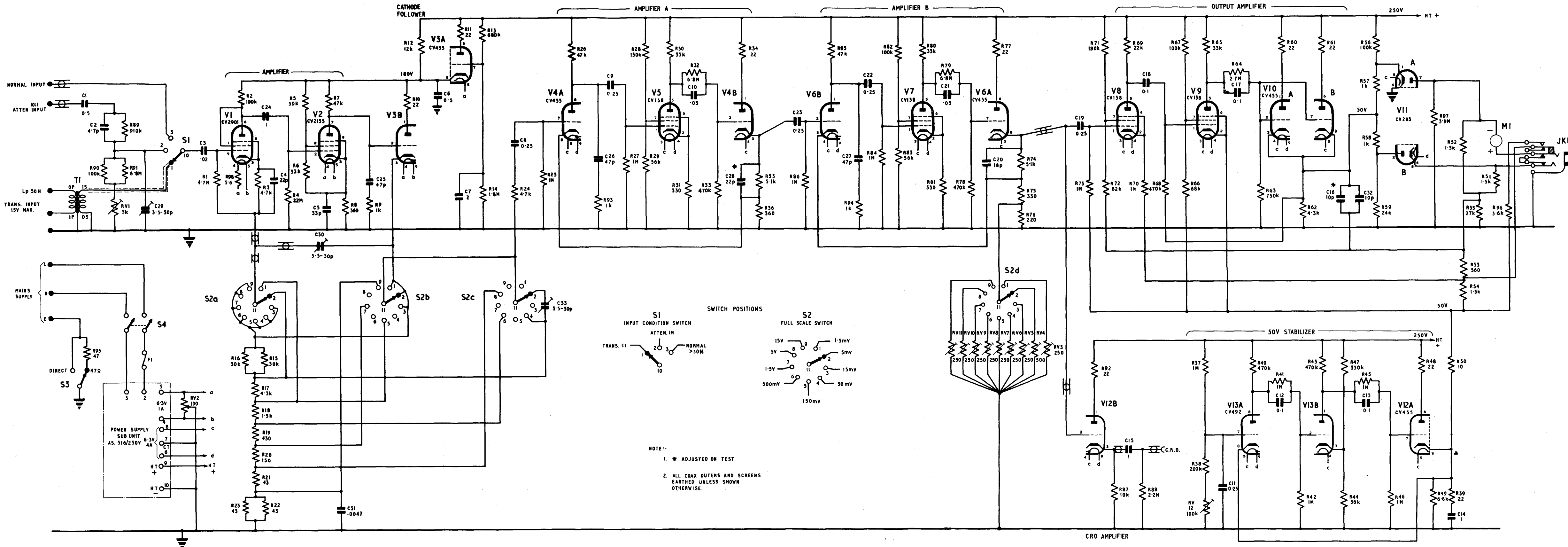

Fig.6  
 Issued Feb. 68

Voltmeter set electronic CT528: circuit

Fig.6