

Please do not upload this copyright pdf document to any other website. Breach of copyright may result in a criminal conviction.

This Acrobat document was generated by me, Colin Hinson, from a document held by the Henlow Signals Museum, believed to be out of copyright. It is presented here (for free) and this pdf version of the document is my copyright in much the same way as a photograph would be. If you believe the document to be under other copyright, please contact me.

The document should have been downloaded from my website <https://blunham.com/Radar>, or any mirror site named on that site. If you downloaded it from elsewhere, please let me know (particularly if you were charged for it). You can contact me via my Genuki email page: <https://www.genuki.org.uk/big/eng/YKS/various?recipient=colin>

You may not copy the file for onward transmission of the data nor attempt to make monetary gain by the use of these files. If you want someone else to have a copy of the file, point them at the website. (<https://blunham.com/Radar>). Please do not point them at the file itself as it may move or the site may be updated.

It should be noted that most of the pages are identifiable as having been processed by me.

I put a lot of time into producing these files which is why you are met with this page when you open the file.

In order to generate this file, I need to scan the pages, split the double pages and remove any edge marks such as punch holes, clean up the pages, set the relevant pages to be all the same size and alignment. I then run Omnipage (OCR) to generate the searchable text and then generate the pdf file.

Hopefully after all that, I end up with a presentable file. If you find missing pages, pages in the wrong order, anything else wrong with the file or simply want to make a comment, please drop me a line (see above).

It is my hope that you find the file of use to you personally – I know that I would have liked to have found some of these files years ago – they would have saved me a lot of time !

Colin Hinson

In the village of Blunham, Bedfordshire.

TF 2331A
DISTORTION FACTOR METER

Instruction Manual

Instruction Manual
No. H52331-910T
for

Distortion Factor Meter
TF 2331 A

Code No. 52331-910 T



1975

MARCONI INSTRUMENTS LIMITED
ST. ALBANS HERTFORDSHIRE ENGLAND

NOTES AND CAUTIONS

ELECTRICAL SAFETY PRECAUTIONS

This equipment is protected in accordance with IEC Safety Class 1. It has been designed and tested according to IEC Publication 348, 'Safety Requirements for Electronic Measuring Apparatus', and has been supplied in a safe condition. The following precautions must be observed by the user to ensure safe operation and to retain the equipment in a safe condition.

Defects and abnormal stresses

Whenever it is likely that protection has been impaired, for example as a result of damage caused by severe conditions of transport or storage, the equipment shall be made inoperative and be secured against any unintended operation.

Removal of covers

Removal of the covers is likely to expose live parts although reasonable precautions have been taken in the design of the equipment to shield such parts. The equipment shall be disconnected from the supply before carrying out any adjustment, replacement or maintenance and repair during which the equipment shall be opened. If any adjustment, maintenance or repair under voltage is inevitable it shall only be carried out by a skilled person who is aware of the hazard involved.

Note that capacitors inside the equipment may still be charged when the equipment has been disconnected from the supply. Before carrying out any work inside the equipment, capacitors connected to high voltage points should be discharged; to discharge mains filter capacitors, if fitted, short together the L (live) and N (neutral) pins of the mains plug.

Mains plug

The mains plug shall only be inserted in a socket outlet provided with a protective earth contact. The protective action shall not be negated by the use of an extension lead without protective conductor. Any interruption of the protective conductor inside or outside the equipment is likely to make the equipment dangerous.

Fuses

Note that the supply fuse is connected in series with the brown (live) wire of the supply lead. If the equipment is connected to the supply via a two-pin plug, it will be possible for the fuse to become connected to the neutral side depending upon the orientation of the plug in its socket. In these circumstances certain parts of the instrument could remain at supply potential even after the fuse has ruptured.

To provide protection against breakdown of the supply lead, its connectors, and filter where fitted, an external supply fuse (e.g. fitted in the connecting plug) should be used in the live lead. The fuse should have a continuous rating not exceeding 6 A.

Make sure that only fuses with the required rated current and of the specified type are used for replacement. The use of mended fuses and the short-circuiting of fuse holders shall be avoided.

RADIO FREQUENCY INTERFERENCE

This equipment conforms with the requirements of EEC Directive 76/889 as to limits of r.f. interference.



Contents

Chapter 1 GENERAL INFORMATION

1.1	Introduction	3
1.2	Data summary	4
1.3	Accessories	6

Chapter 2 OPERATION

2.1	Controls	7
2.2	Preliminaries	8
2.3	Principles of measurement	8
2.4	Measurements on modulation	9
2.5	Noise and distortion measurement	9
2.6	Voltmeter measurements	12
2.7	Sources of error	12
2.8	Use as an amplifier or wavemeter	14
	Decibel conversion tables	15 & 16

Chapter 3 TECHNICAL DESCRIPTION

3.1	General summary	17
3.2	Distortion factor meter section	17
3.3	Voltmeter section	18
3.4	Power supply section	20

Chapter 4 MAINTENANCE

4.1	General	21
4.2	Access to components	21
4.3	AC mains input ranges	22
4.4	Replacement of semiconductors	22
4.5	Circuit voltages	22
4.6	Preset controls	23
4.7	RF detector check	24

Chapter 5 Not assigned

Chapter 6 REPLACEABLE PARTS

	Introduction and ordering	25
--	---------------------------	-----	-----	-----	-----	-----	----

Chapter 7 CIRCUIT DIAGRAMS

	Circuit notes	31
	Fig. 7.1 Power unit	32
	Fig. 7.2 Distortion factor meter section	33
	Fig. 7.3 Voltmeter section	35

1.1 INTRODUCTION

Distortion Factor Meter TF 2331A measures the total distortion and noise of audio signals in the fundamental range from 20 Hz to 20 kHz. A distortion bandwidth of either 100 kHz or 20 kHz can be selected and a low-frequency stop filter enables power supply frequencies to be eliminated from the result. Noise can be measured in the same two bandwidths or via a weighting filter to show the noise level in terms of its interference value in a broadcast system. A telephone weighting filter can be fitted as an alternative.

The instrument consists of a selective amplifier tuned to reject the fundamental component and

a wide band voltmeter to measure the noise and distortion content. Terminals are provided for connecting the voltmeter output to an external meter or oscilloscope.

By switching the voltmeter directly to the input terminals the instrument can be used for direct measurement of voltage in a bandwidth of at least 20 Hz to 100 kHz.

An r.f. detector is incorporated, allowing distortion and noise measurements to be made on the modulating envelope of r.f. signals from 500 kHz to 500 MHz.

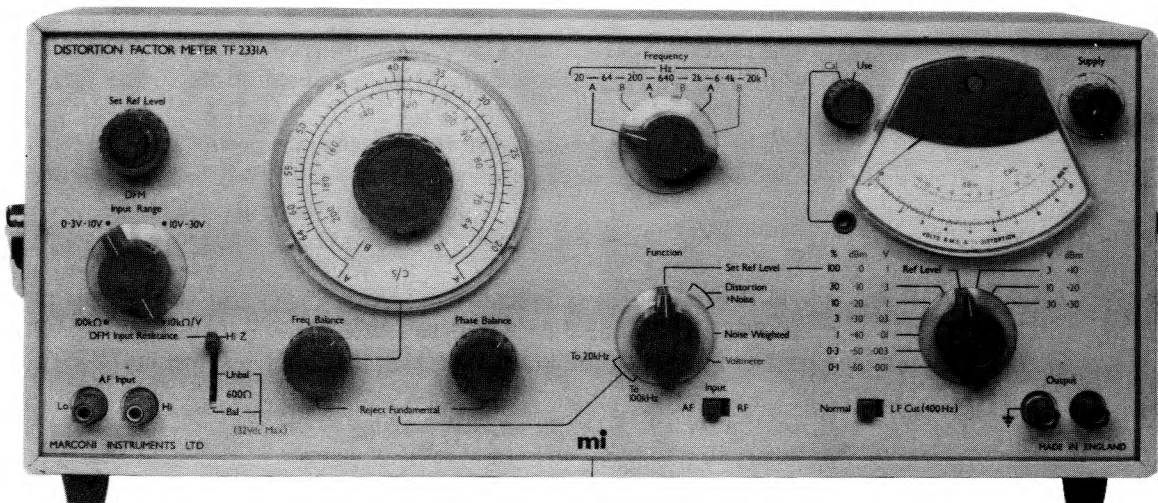

Fig. 1.1 Distortion Factor Meter TF 2331 A

1.2 DATA SUMMARY

FUNDAMENTAL FREQUENCY

Range : 20 Hz to 20 kHz in 6 ranges of 3.16 :1 ratio.
Accuracy : $\pm 3\%$.

DISTORTION MEASUREMENT

RANGE : 7 ranges in 1-3-10 sequence from 0.1% full-scale upwards.

INSTRUMENT DISTORTION

Unbalanced : Less than 0.025% from 200 Hz to 6 kHz.
Less than 0.04% from 20 Hz to 200 Hz and from 6 kHz to 20 kHz.

Balanced : Less than 0.025% from 200 Hz to 6 kHz.
Less than 0.04% from 100 Hz to 200 Hz and from 6 kHz to 20 kHz.
Less than 0.1% from 50 Hz to 100 Hz with up to 10 V input.
Less than 0.15% from 20 Hz to 50 Hz with up to 3 V input.

Fundamental rejection : At least 80 dB.

2nd harmonic attenuation : Less than :-
0.5 dB up to 1 kHz fundamental,
1 dB up to 6 kHz fundamental,
2 dB up to 20 kHz fundamental.

Bandwidth (-3 dB points) : Nominally 100 kHz or 20 kHz, switch selected.

Residual measurement : Within $\pm 2\%$ of full-scale $\pm 1\%$ of reading from 50 Hz to 12 kHz.
Within $\pm 2\%$ of full-scale $\pm 2\%$ of reading from 20 Hz to 100 kHz.

LF cut : Can be introduced below 400 Hz to attenuate power supply frequencies

INPUT RESISTANCE

600 Ω : 600 Ω balanced or unbalanced.
Return loss better than 25 dB at 1 kHz.
Balance better than 50 dB rejection at 1 kHz.

Hi Z : Nominally 10 k Ω /V up to 10 V input.
Nominally 100 k Ω from 10 V to 30 V input.

INPUT REQUIREMENTS

(For 600 Ω and Hi Z)

Minimum : 300 mV (less than -8 dBm into 600 Ω).

Maximum : Approximately 30 V (+32 dBm into 600 Ω).

NOISE MEASUREMENT

(Made with tone off)

INDICATION :	Mean value of noise relative to signal is indicated in 7 ranges in 1-3-10 sequence from 0.1% full-scale upwards.
INSTRUMENT NOISE :	Less than 0.02% (200 μ V); typically 50 μ V. .
BANDWIDTH :	100 kHz or 20 kHz or via a weighting network to the following characteristics :- Broadcast filter to CCIR Recommendation 468 (New Delhi 1970).

VOLTAGE MEASUREMENT

INDICATION :	Mean-level meter calibrated in volts r.m.s./sinusoidal has 10 ranges in 1-3-10 sequence from 1 mV to 30 V full-scale. Also decibel scale calibrated from -12 to +2 dB relative to 1 mW in 600 Ω .
--------------	--

VOLTAGE ACCURACY
(Above 100 μ V)

Unbalanced :	Within $\pm 2\%$ of full-scale $\pm 1\%$ of reading from 50 Hz to 55 kHz. Within $\pm 2\%$ of full-scale $\pm 2\%$ of reading from 20 Hz to 100 kHz.
Balanced :	Within $\pm 2\%$ of full-scale $\pm 1\%$ of reading from 50 Hz to 55 kHz. Within $\pm 8\%$ of full-scale $\pm 2\%$ of reading from 20 Hz to 100 kHz.

INPUT RESISTANCE

Unbalanced :	1 M Ω or 600 Ω .
Balanced :	600 Ω . Return loss better than 30 dB at 1 kHz. Balance better than 50 dB at 1 kHz.

RF INPUT

Frequency range :	500 kHz to 500 MHz.
Input impedance :	50 Ω type N connector.
Amplitude range :	1 V to 4 V at maximum modulation depth.

GENERAL

POWER SUPPLY

Mains :	190 to 260 V or 95 to 130 V, 40 to 500 Hz, 3 VA.
External battery :	18 to 45 V d.c., 25 mA.

General information

DIMENSIONS & WEIGHT

<i>Height</i>	<i>Width</i>	<i>Depth</i>	<i>Weight</i>
205 mm (8 in)	440 mm (17 $\frac{1}{4}$ in)	280 mm (11 in)	8.16 kg (18 lb)

1.3 ACCESSORIES

Supplied :

Mains lead, 43129-071D

Optional :

Rack mounting kit, 41635-041P.

Telephone weighting network to CCITT Recommendation P53A
(Geneva 1972), 44827-522R.

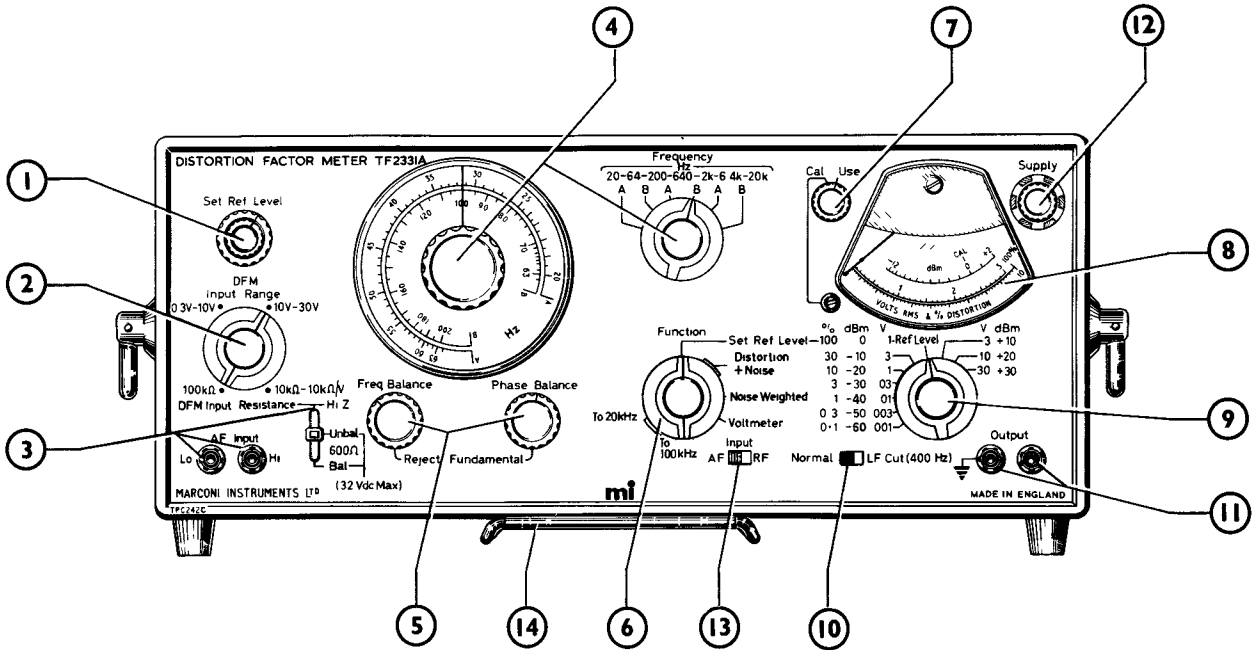

Fig. 2.1 Layout of controls

2.1 CONTROLS

- ① **SET REF LEVEL controls** : Adjust in conjunction with (8) and (9) to bring meter reading to 100% (or to 0 dB for decibel measurements).
- ② **DFM INPUT RANGE selector** : Set to suit level of total signal at AF INPUT terminals. Other end of pointer shows Hi Z input resistance.
- ③ **AF INPUT terminals and switch** : Switch selects input impedances of 600 Ω , balanced or unbalanced, and Hi Z. For DFM measurements the input resistance at Hi Z is shown by the INPUT RANGE setting. For Voltmeter measurements Hi Z equals about 1 M Ω .
- ④ **FREQUENCY controls** : Set to reject fundamental frequency. Use A or B scale according to switch setting. Fig. 2.1 shows controls set to 1 kHz.
- ⑤ **BALANCE controls** : Adjust in turn for maximum rejection of fundamental. PHASE BALANCE is a high discrimination 10-turn potentiometer.
- ⑥ **FUNCTION selector** : Switches in fundamental rejection filter in positions 2 and 3, weighting network in position 4.
- ⑦ **CAL-USE switch** : To standardize meter for Voltmeter measurements, switch to CAL and adjust preset to bring meter to CAL mark.
- ⑧ **METER** : For DFM measurements reads distortion and/or noise relative to total signal in percentage or decibels. For Voltmeter measurements reads input level in volts, or dBm in 600 Ω .
- ⑨ **METER RANGE selector** : The three right-hand settings are for Voltmeter measurements only
- ⑩ **LF CUT switch** : Attenuates frequencies below 400 Hz to eliminate supply hum components.
- ⑪ **OUTPUT terminals** : Provide a signal from the output of the voltmeter amplifier. At meter full-scale the output is 150 mV at a nominal 1 k Ω source impedance.

(12) **SUPPLY switch** : Controls a.c. mains or battery supply. Selection of supply is made by the MAINS-BATTERY switch at rear.

(13) **AF-RF INPUT** : Switches in the r.f. detector enabling measurement of noise and distortion on the modulation envelope of r.f. signals. The RF INPUT socket is located at the rear of the instrument.

(14) **SUPPORT** : Hinges down to raise front of instrument.

2.2 PRELIMINARIES

The instrument may be operated from a.c. mains of a nominal 115 V or 230 V, 40 to 500 Hz; or from a d.c. supply of 18 to 45 V. For a.c. operation the stabilizer allows mains voltages in the ranges 95 to 130 V and 190 to 260 V to be used. The instrument is normally despatched with the 230 V setting unless specified to the contrary. In order to check or change the mains input setting see Sect. 4.3.

For measurements in the field the instrument may also be d.c. powered from an external battery, of from 18 to 45 V, the approximate current drain being 25 mA.

FUSES

Two fuses are fitted, one in the a.c. mains input circuit, the other in the h.t. supply to the stabilizer. The a.c. input fuse should be 100 mA rating for 230 V operation or 250 mA for 115 V. The other fuse is in circuit for both a.c. and d.c. operation and should be 250 mA rating. Both fuses are 20 x 5 mm, the a.c. input fuse a delay type, the h.t. fuse a quick-blow type.

SWITCHING ON

Before switching on :

(1) Check that the mains transformer primary connections are correct for the local supply voltage. If they have to be changed remember that the a.c. input fuse must also be changed.

(2) Set the AC MAINS/BATTERY slider switch on the rear panel to the position appropriate to the type of supply to be used.

(3) Connect to the power supply.

For a.c. mains use the lead supplied, fitting the small 3-pin socket to the AC MAINS plug at the rear of the instrument. Initially it will also be necessary to fit a suitable mains supply plug to the lead, connecting the leads as follows :-

brown to L (live)
blue to N (neutral)
green/yellow to E (earth).

For d.c. connect the battery to the terminals at the rear of the instrument observing the required polarity. It is also advisable to disconnect the a.c. mains lead.

(4) Check and, if necessary, adjust the mechanical zero of the meter.

Switch on by turning the SUPPLY switch clockwise.

2.3 PRINCIPLES OF MEASUREMENT

Distortion factor is defined as :

$$\sqrt{\frac{V_2^2 + V_3^2 + \dots + V_n^2 + N^2}{V_1^2}} \times 100\% \dots (1)$$

where V_1 = amplitude of fundamental

$V_2, V_3 \dots V_n$ = amplitudes of 2nd, 3rd ... nth harmonics

N = amplitudes of noise and hum components.

If the distortion factor is small, say less than 15%, the error involved in measuring it as :

$$\sqrt{\frac{V_2^2 + V_3^2 + \dots + V_n^2 + N^2}{V_1^2 + V_2^2 + V_3^2 + \dots + V_n^2 + N^2}} \times 100\% \dots (2)$$

is also small. It is this latter quantity that is measured by the distortion factor meter.

Measurement is made by first adjusting the gain of the instrument so that a voltage representing the total signal reads 100% or 0 dB on the meter.

The fundamental component is then removed by switching in a tunable rejection filter with the result that the meter indicates the sum of all residual components relative to the level of the total signal.

This residue is made up of harmonics of the fundamental plus supply hum and noise. Assuming that harmonics are the dominant components the instrument indicates the distortion factor, in terms of equation (2), in percentage or in decibels relative to total signal. Hum components at the usual supply frequencies or their harmonics can be eliminated by an l.f. cut filter. The noise level alone can be measured by switching off the wanted signal at source; noise can also be measured in terms of its interference value by introducing a weighting network.

For correct evaluation of distortion a true r.m.s. meter is required but, for reasons of economy, the TF 2331A uses a meter that responds to average value but is calibrated in terms of the r.m.s. value of a sine wave. At low values of distortion the discrepancy is negligible; this is dealt with in more detail in Sect. 2.7 - Sources of Error.

NOTE. When adjusting the SET REF LEVEL control, the meter does NOT indicate the volts across the input terminal.

2.5 NOISE AND DISTORTION MEASUREMENT

- (1) Set the FUNCTION selector to SET REF LEVEL and the meter range selector to REF LEVEL.
- (2) Set DFM INPUT RANGE selector according to the range in which the total signal amplitude lies. If the signal amplitude is unknown it can be checked as described in Sect. 2.6.

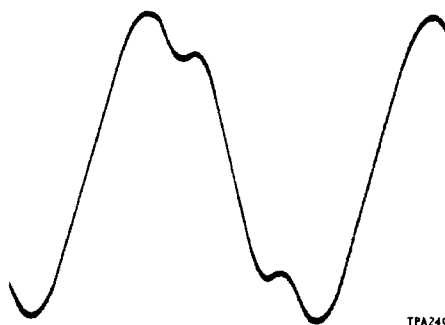

Fig. 2.2 1 kHz waveform with noise and distortion (The equivalent spectrum is shown below)

2.4 MEASUREMENTS ON MODULATION

The built-in r.f. detector stage can accommodate carrier frequencies within the range of 500 kHz to 500 MHz, modulation depths up to 80% and levels between 1 V and 4 V. The input impedance at the r.f. detector socket is 50 Ω. The

- (3) Set the INPUT switch to either AF or RF. Connect the signal leads to the INPUT terminals or, in the case of r.f., to the RF INPUT socket at the rear of the instrument. Set the DFM INPUT RESISTANCE switch to 600 Ω BAL, 600 Ω UNBAL or Hi Z; if set to Hi Z the input impedance, as indicated by the setting of the FUNCTION selector, is 10 kΩ/V up to 10 V input and 100 kΩ above 10 V.

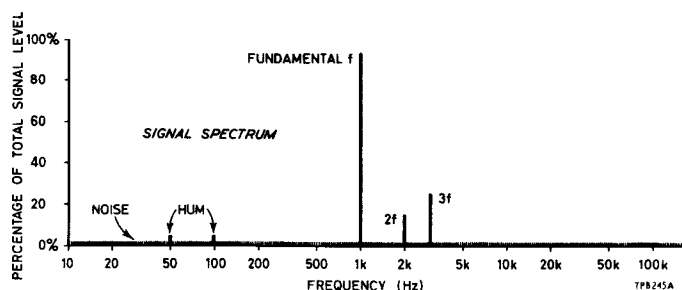
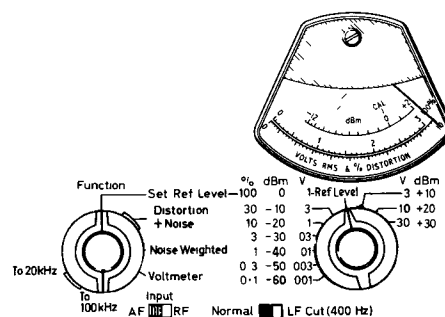

Fig. 2.3 Set reference



Operation

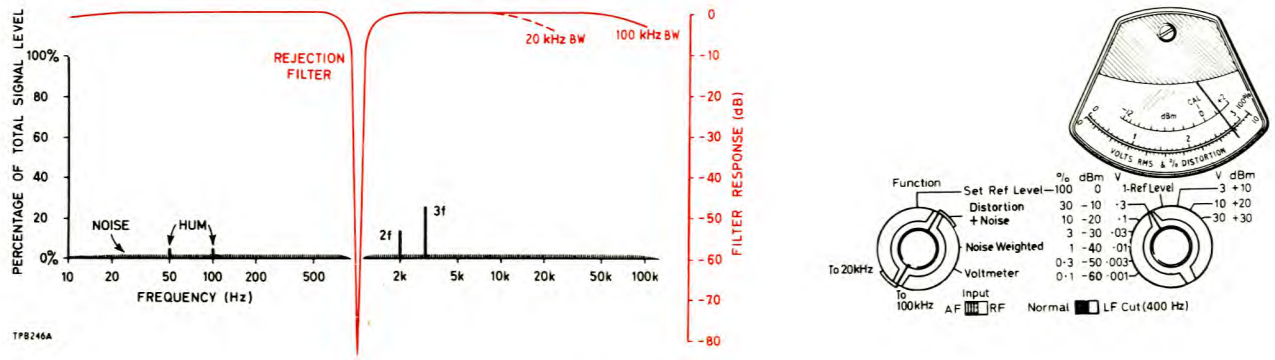

Fig. 2.4 Fundamental rejection

For percentage measurements adjust the SET REF LEVEL control for a meter reading of 100%. This condition is illustrated in Fig. 2.3.

For decibel measurements adjust the SET REF LEVEL control for a meter reading of 0 dB. (In distortion and noise measurements the dBm scale indicates relative levels in decibels, not absolute levels in dBm. The latter calibration is only valid in voltmeter measurements across 600 Ω .)

(4) Move the FUNCTION selector to one of the two REJECT FUNDAMENTAL positions depending on the bandwidth required. In the case of r.f. measurements, the r.f. detector filter bandwidth is 50 kHz. Set the LF CUT switch to NORMAL.

(5) Set the FREQUENCY range selector and dial to the frequency of the fundamental. With the FREQ BALANCE and PHASE BALANCE controls midway adjust the dial for a dip on the meter. Adjust the FREQ BALANCE and PHASE BALANCE controls in turn for maximum dip, switching to

successively lower meter ranges - these controls have no significant effect above 10% distortion, but become very critical below 0.1%.

The meter now shows the level of the total residual components in the selected bandwidth - see Fig. 2.4. Components below 400 Hz can be attenuated by switching to LF CUT - see Fig. 2.5 (a typical LF CUT characteristic is shown in Fig. 4.3). This will show whether power supply hum, for example, is significant; if the reading drops appreciably it is advisable to check that the FREQ BALANCE and PHASE BALANCE controls are still correctly adjusted.

To eliminate harmonics from the residual content, switch off the fundamental tone at the signal source. The meter now indicates noise (including any hum) in the selected bandwidth - see Fig. 2.6. Note that if very low noise levels are to be measured, lower residual noise in the instrument can be obtained by turning the FUNCTION switch back to SET REF LEVEL. In this case the bandwidth will be 100 kHz and LF CUT can still be used if required.

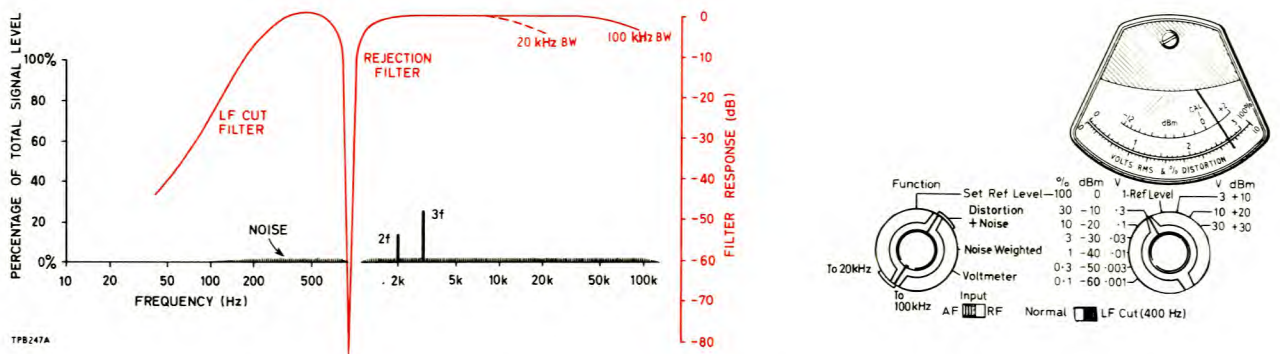

Fig. 2.5 Fundamental rejection with I.f. cut

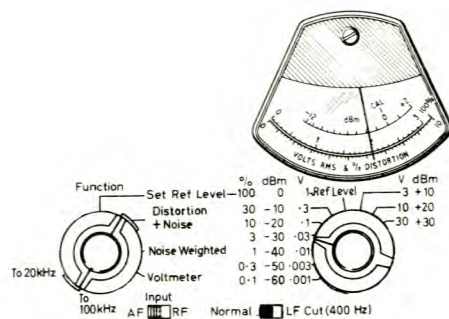
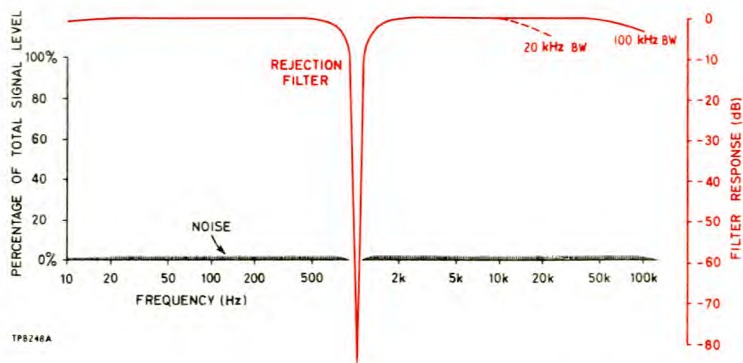

Fig. 2.6 Tone off

(7) To measure the weighted noise set the FUNCTION selector to NOISE VIA FILTER. This introduces a filter - see Fig. 2.7 - with characteristics as defined by the CCIR broadcast weighting network (Recommendation 468). Alternatively the instrument can be fitted with a telephone filter to CCITT Recommendation P53A.

for voltages of 30 V to 100 V, or 1 MΩ for voltages of 100 V to 200 V, or 1.5 MΩ for voltages of 200 V to 300 V.

NOTE. When using the broadcast filter the weighted reading is 8.5 dB lower than would be obtained with a flat 40 Hz to 15 kHz filter. When using the telephone filter the weighted reading is 2.5 dB higher than would be obtained with a flat 300 Hz to 3.4 kHz filter.

Low signal levels

If the signal level, whether a.f. or modulated r.f., is too low it may still be possible to make measurements in decibels by setting the 0 dB reference level with the METER RANGE selector on a different range. For example :-

High signal levels

The maximum signal level that can be measured directly is 32 V a.c. (Note that if there is any superimposed d.c. on the signal this must not exceed 32 V d.c. at either of the 600 Ω impedance settings.)

It is required to measure a distortion factor of about -30 dB in a signal of about 0.3 V amplitude.

Turn the METER RANGE selector to the .3 V range and set the meter pointer to the 0 dB calibration with the SET REF LEVEL control.

Reject the fundamental as described above and turn the METER RANGE selector to the .01 V range. Since three ranges (10 dB steps) have been turned through, the distortion factor is -30 dB plus the meter reading.

Signals of greater than 32 V can be measured by connecting a variable resistor in series with the Hi AF INPUT terminal. Its value should be 500 kΩ

Note that setting the reference level on a lower range reduces the total measuring range.

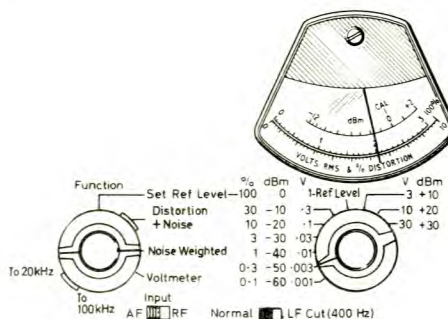
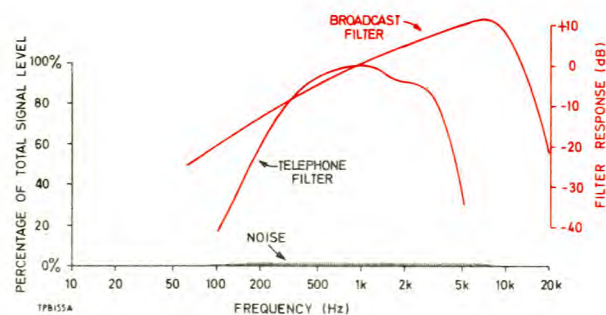

Fig. 2.7 Tone off with weighting filter

2.6 VOLTMETER MEASUREMENTS

The internal voltmeter can be used to indicate the level of a signal up to 100 kHz at the AF INPUT terminals either in volts or in decibels relative to 1 mW in 600 Ω. Before using the instrument in this way the meter should be standardized against the internal calibrating signal. For voltmeter measurements the DFM INPUT RANGE switch, SET REF LEVEL control, FREQUENCY and BALANCE controls are not in circuit and can be left at any setting.

CALIBRATING THE VOLTMETER

Turn the CAL-USE switch to CAL and adjust the calibrating preset control to make the meter read at the CAL mark. This may be done at any setting of the METER RANGE selector.

USING THE VOLTMETER

Turn the CAL-USE switch back to USE.

Turn the FUNCTION selector to VOLTMETER and set the METER RANGE selector to the required full-scale V or dBm value.

Move the INPUT impedance switch to the setting required - the Hi Z position gives an input impedance of about 1 MΩ. The dBm scale on the meter is only valid for measurements across 600 Ω; if the circuit under test is already terminated switch to Hi Z, if not switch to 600 Ω.

Read the voltage from the black scale that corresponds to the full-scale V setting of the METER RANGE selector; or read the signal level in dBm by adding the indication on the red scale to the dBm setting of the METER RANGE selector.

2.7 SOURCES OF ERROR

(1) Average-reading meter

Tends to read low when measuring complex signals, particularly those consisting of two or more nearly equal components; the amount of error depends not only on the degree of distortion but on the order and phase of the harmonics.

If, for example, you are measuring a signal with one predominant large harmonic, an error will be introduced, as shown in Fig. 2.8, when

setting reference level but not when measuring the distortion. The indicated distortion will therefore be high by the amount that the set reference level deflection is low. The error, which lies between the limits shown in the shaded part of Fig. 2.8, is negligible except at high distortion levels and is even lower with combinations of different harmonics.

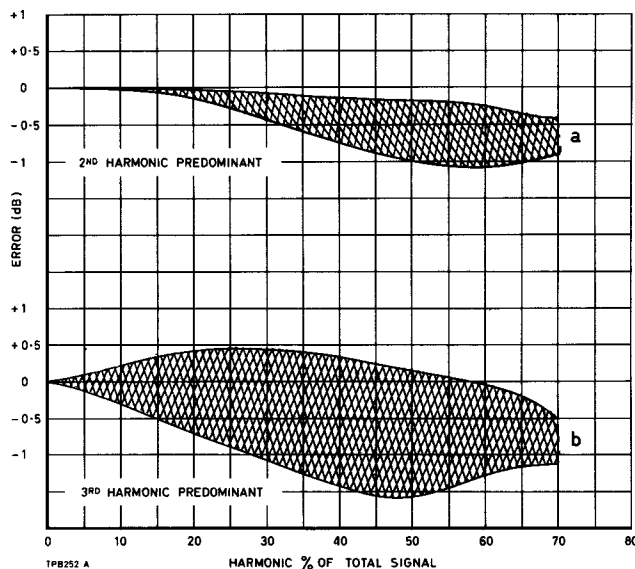

Fig. 2.8 Average r.m.s. error limits

If, on the other hand, the distortion is low but consists of two or more harmonics of comparable level then the set reference level reading will be correct but the distortion reading will be low. For distortion caused by two harmonics the error will have a maximum value of -0.75 dB when the harmonics are equal, regardless of the level of distortion, and will be less at other ratios as shown in Table 2.1.

Table 2.1

Ratio of harmonic levels	Meter error
1 : 1	-0.75 dB
2 : 1	-0.35 dB
5 : 1	-0.2 dB

All errors arising from this cause can be eliminated by using a true r.m.s. voltmeter connected to the output terminals. Ideally the voltmeter should have full-scale deflections of 100 mV, 30 mV, 10 mV, 3 mV, etc.; if so, the set reference level deflection can be made at 100 mV and the other scales will correspond to the % settings of the METER RANGE selector.

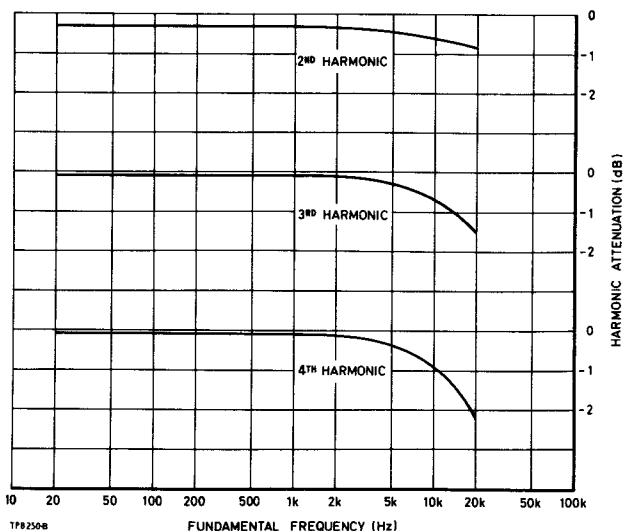

Fig. 2.9 Attenuation of harmonics (100 kHz bandwidth)

(2) Harmonic attenuation

Makes the reading low - see Fig. 2.9. The upper-frequency skirt of the fundamental rejection filter causes a slight attenuation of the lower order harmonics. Harmonics are also attenuated as their frequency approaches the 100 kHz or 20 kHz bandwidth limit; this is naturally more likely to affect the higher order harmonics.

(3) Residual content of instrument

Tends to make the reading high at very low distortion - say less than 0.1%. Residual noise and distortion introduced by the instrument itself gives an error which will be within $\pm 0.025\%$ from 200 Hz to 6 kHz and $\pm 0.04\%$ elsewhere.

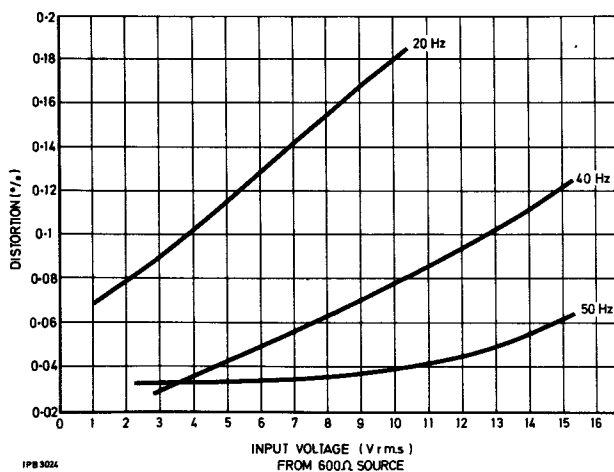

Fig. 2.10 Distortion characteristic with 600 Ω balanced input

(4) 600 Ω balanced input

The transformer used in this input condition introduces a distortion at the lowest frequencies which increases with input voltage but becomes negligible below 16 V and above 50 Hz. The effect is shown in Fig. 2.10.

(5) Distortion on modulated r.f.

Fig. 2.11 shows the working area of the r.f. detector and providing the r.f. input signal falls inside the area shown, the distortion should not be greater than 1%.

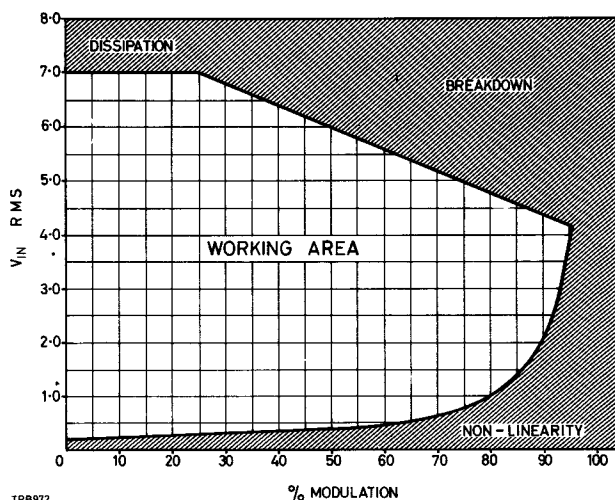

Fig. 2.11 Curve showing the working area of the r.f. detector

(6) Metering errors

The accuracy with which the meter indicates the residual content is within the limits given in Sect. 1.2.

(7) Formula conversion

As mentioned in Sect. 2.2 the distortion factor meter measures distortion relative to total signal rather than relative to fundamental. Below 10% distortion the discrepancy is negligible but it becomes large at high distortion. Conversion from indicated to true distortion factor can be made by means of Fig. 2.12.

Example :

Measurements on a 1 kHz signal with predominantly 2nd harmonic distortion gives a reading of 28% (= -11 dB) distortion.

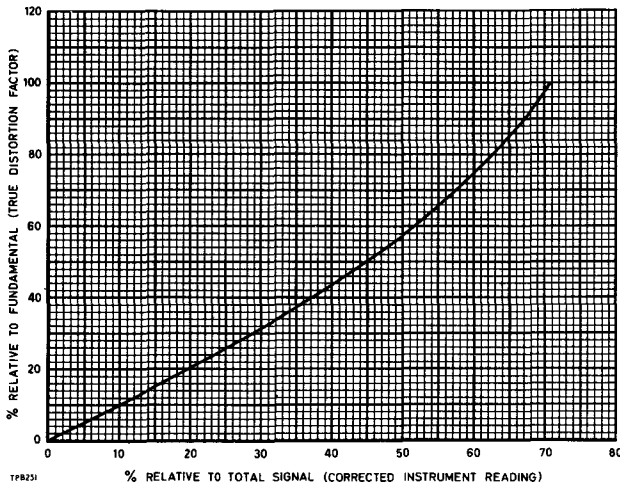

Fig. 2.12 Distortion formula conversion

- (1) Fig. 2.8b shows the set reference level reading is low, and therefore the distortion reading high, by between 0.1 dB and 0.3 dB. Therefore, partially corrected reading is -11.3 to -11.1 dB (= 27.2 to 27.9%).
- (2) Fig. 2.9 shows reading is low by a further 0.3 dB. Therefore, partially corrected reading = -11 to -10.8 dB (= 28 to 28.8%).
- (3) Error due to instrument residual content, i.e., an additional uncertainty of $\pm 0.025\%$ distortion, is negligible.
- (4) Metering error = $\pm 2\%$ of 30% (full-scale) $\pm 1\%$ of 28% = $\pm 0.88\%$, say $\pm 0.9\%$ distortion. Therefore, final corrected reading = 27.1 to 29.7%.

- (5) Formula conversion. The final corrected reading in terms of true distortion factor (relative to fundamental) is given by Fig. 2.12 as 28.5 to 31%.

NOTE. If the signal contains two significant harmonics their approximate ratio should be determined and a further correction obtained from Table 2.1 and carried out after step (1) above.

2.8 USE AS AN AMPLIFIER OR WAVEMETER

The instrument can be used to amplify signals in a range of at least 20 Hz to 100 kHz or to measure frequency between 20 Hz and 20 kHz.

AMPLIFIER

Set up as for voltmeter measurements. The voltmeter amplifier provides a gain of up to $\times 150$ between the INPUT and OUTPUT terminals. Maximum output, which is limited by full-scale deflection, is 150 mV. Output impedance is about 1 k Ω , and input impedance can be switched to either 600 Ω or 1 M Ω . The METER RANGE selector must be set so that the range full-scale value is greater than the input voltage. Therefore, the full amplifier gain of $\times 150$ is only obtained with inputs below 1 mV.

WAVEMETER

Set up as for DFM measurements. The frequency of the input signal is shown by the FREQUENCY controls when adjusted for maximum rejection. If the FREQ BALANCE control is set midway the accuracy of indication is $\pm 3\%$ - the range of this control is about $\pm 0.25\%$ at the h.f. end of the scale to $\pm 0.85\%$ at the l.f. end.

Decibel conversion table

<i>Ratio Down</i>			<i>Ratio Up</i>		
VOLTAGE	POWER	DECIBELS	VOLTAGE	POWER	
1·0	1·0	0	1·0	1·0	
·9886	·9772	·1	1·012	1·023	
·9772	·9550	·2	1·023	1·047	
·9661	·9333	·3	1·035	1·072	
·9550	·9120	·4	1·047	1·096	
·9441	·8913	·5	1·059	1·122	
·9333	·8710	·6	1·072	1·148	
·9226	·8511	·7	1·084	1·175	
·9120	·8318	·8	1·096	1·202	
·9016	·8128	·9	1·109	1·230	
·8913	·7943	1·0	1·122	1·259	
·8710	·7586	1·2	1·148	1·318	
·8511	·7244	1·4	1·175	1·380	
·8318	·6918	1·6	1·202	1·445	
·8128	·6607	1·8	1·230	1·514	
·7943	·6310	2·0	1·259	1·585	
·7762	·6026	2·2	1·288	1·660	
·7586	·5754	2·4	1·318	1·738	
·7413	·5495	2·6	1·349	1·820	
·7244	·5248	2·8	1·380	1·905	
·7079	·5012	3·0	1·413	1·995	
·6683	·4467	3·5	1·496	2·239	
·6310	·3981	4·0	1·585	2·512	
·5957	·3548	4·5	1·679	2·818	
·5623	·3162	5·0	1·778	3·162	
·5309	·2818	5·5	1·884	3·548	
·5012	·2512	6	1·995	3·981	
·4467	·1995	7	2·239	5·012	
·3981	·1585	8	2·512	6·310	
·3548	·1259	9	2·818	7·943	
·3162	·1000	10	3·162	10·000	
·2818	·07943	11	3·548	12·59	
·2512	·06310	12	3·981	15·85	
·2239	·05012	13	4·467	19·95	
·1995	·03981	14	5·012	25·12	
·1778	·03162	15	5·623	31·62	

Decibel conversion table (continued)

Ratio Down		DECIBELS	Ratio Up	
VOLTAGE	POWER		VOLTAGE	POWER
·1585	·02512	16	6·310	39·81
·1413	·01995	17	7·079	50·12
·1259	·01585	18	7·943	63·10
·1122	·01259	19	8·913	79·43
·1000	·01000	20	10·000	100·00
·07943	$6·310 \times 10^{-3}$	22	12·59	158·5
·06310	$3·981 \times 10^{-3}$	24	15·85	251·2
·05012	$2·512 \times 10^{-3}$	26	19·95	398·1
·03981	$1·585 \times 10^{-3}$	28	25·12	631·0
·03162	$1·000 \times 10^{-3}$	30	31·62	1,000
·02512	$6·310 \times 10^{-4}$	32	39·81	$1·585 \times 10^3$
·01995	$3·981 \times 10^{-4}$	34	50·12	$2·512 \times 10^3$
·01585	$2·512 \times 10^{-4}$	36	63·10	$3·981 \times 10^3$
·01259	$1·585 \times 10^{-4}$	38	79·43	$6·310 \times 10^3$
·01000	$1·000 \times 10^{-4}$	40	100·00	$1·000 \times 10^4$
$7·943 \times 10^{-3}$	$6·310 \times 10^{-5}$	42	125·9	$1·585 \times 10^4$
$6·310 \times 10^{-3}$	$3·981 \times 10^{-5}$	44	158·5	$2·512 \times 10^4$
$5·012 \times 10^{-3}$	$2·512 \times 10^{-5}$	46	199·5	$3·981 \times 10^4$
$3·981 \times 10^{-3}$	$1·585 \times 10^{-5}$	48	251·2	$6·310 \times 10^4$
$3·162 \times 10^{-3}$	$1·000 \times 10^{-5}$	50	316·2	$1·000 \times 10^5$
$2·512 \times 10^{-3}$	$6·310 \times 10^{-6}$	52	398·1	$1·585 \times 10^5$
$1·995 \times 10^{-3}$	$3·981 \times 10^{-6}$	54	501·2	$2·512 \times 10^5$
$1·585 \times 10^{-3}$	$2·512 \times 10^{-6}$	56	631·0	$3·981 \times 10^5$
$1·259 \times 10^{-3}$	$1·585 \times 10^{-6}$	58	794·3	$6·310 \times 10^5$
$1·000 \times 10^{-3}$	$1·000 \times 10^{-6}$	60	1,000	$1·000 \times 10^6$
$5·623 \times 10^{-4}$	$3·162 \times 10^{-7}$	65	$1·778 \times 10^3$	$3·162 \times 10^6$
$3·162 \times 10^{-4}$	$1·000 \times 10^{-7}$	70	$3·162 \times 10^3$	$1·000 \times 10^7$
$1·778 \times 10^{-4}$	$3·162 \times 10^{-8}$	75	$5·623 \times 10^3$	$3·162 \times 10^7$
$1·000 \times 10^{-4}$	$1·000 \times 10^{-8}$	80	$1·000 \times 10^4$	$1·000 \times 10^8$
$5·623 \times 10^{-5}$	$3·162 \times 10^{-9}$	85	$1·778 \times 10^4$	$3·162 \times 10^8$
$3·162 \times 10^{-5}$	$1·000 \times 10^{-9}$	90	$3·162 \times 10^4$	$1·000 \times 10^9$
$1·000 \times 10^{-5}$	$1·000 \times 10^{-10}$	100	$1·000 \times 10^5$	$1·000 \times 10^{10}$
$3·162 \times 10^{-6}$	$1·000 \times 10^{-11}$	110	$3·162 \times 10^5$	$1·000 \times 10^{11}$
$1·000 \times 10^{-6}$	$1·000 \times 10^{-12}$	120	$1·000 \times 10^6$	$1·000 \times 10^{12}$
$3·162 \times 10^{-7}$	$1·000 \times 10^{-13}$	130	$3·162 \times 10^6$	$1·000 \times 10^{13}$
$1·000 \times 10^{-7}$	$1·000 \times 10^{-14}$	140	$1·000 \times 10^7$	$1·000 \times 10^{14}$

3.1 GENERAL SUMMARY

There are three main sections in the instrument - DFM, Voltmeter and Power Supply. The DFM section provides for selection of measurement function, adjustment of reference level, and rejection of fundamental. The Voltmeter section measures the output level of the DFM section and has an l.f. cut facility to remove power supply frequency components; it can also be used to measure the voltage applied to the input of the DFM section.

3.2 DISTORTION FACTOR METER SECTION

(Circuit diagram Fig. 7.2)

A choice of three a.f. input impedances is available: 600 Ω balanced, 600 Ω unbalanced and high impedance (Hi Z), determined by the setting of switch SJ. The 600 Ω BAL setting introduces transformer T1 with secondary loading resistors

R1 and R9. For the 600 Ω UNBAL condition the input is terminated directly by R1. At the Hi Z setting the input impedance depends on the amplitude of the input signal. Because of negative feedback the impedance at the base of VT1 is very low (the signal current corresponding to full-scale being approximately 100 μ A). RV1 and R5, in series in the signal path, therefore determine the input impedance on the 1-10 V range. At maximum sensitivity, corresponding to an input of about 0.6 V, the impedance is at its minimum value of 6.2 k Ω .

This rises, as the sensitivity is reduced, to a maximum of about 100 k Ω at an input of 10 V. The input impedance is 50 Ω at the r.f. input socket for signals from 1 V to 4 V.

When the DFM INPUT RANGE selector is switched to the 10-30 V range an attenuator, R2-R3, is introduced. This is sufficient to prevent large variations in input sensitivity affecting the impedance appreciably and so it remains at a nominal 100 k Ω from 10 to 30 V.

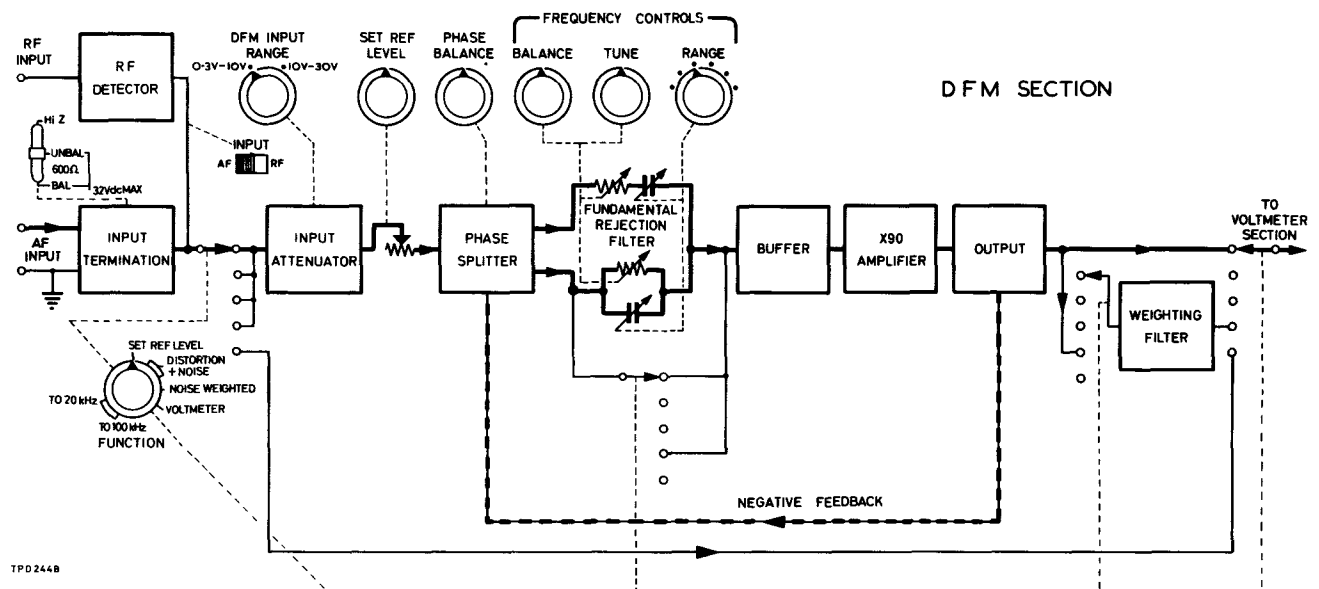

TPD244B

Fig. 3.1 Functional diagram - DFM section

Transistor VT1 is a phase-splitter and provides outputs of opposite phase and appropriate amplitude relationship (2:1) to drive a 'Wien Bridge' type of network. This network is the fundamental rejection filter and the overall negative feedback taken to the base of VT1 (via R17 and C18) serves to flatten the skirts of its response and so presents a sharper curve to the amplifier.

VT1 is a critical stage for noise and distortion and its operating conditions provide a good compromise between the two. It has a fixed emitter load of 750 Ω and a collector load which is adjustable around a nominal 1500 Ω by the PHASE BALANCE control, RV6 - the latter is a 10-turn potentiometer to give the necessary precision of adjustment. The collector load feeds the series CR branch of the fundamental rejection filter and the emitter load the parallel CR branch.

The fundamental rejection filter network provides at least 80 dB rejection using only resistors and capacitors. Variable resistors RV2 and RV5 are ganged together to form the MAIN TUNE control and RV3 and RV4 are ganged together to form the FREQ BALANCE control. The latter is necessary at distortion values below 10% when the MAIN TUNE control becomes too critical. RV2 and RV3 are in the series CR branch of the filter and RV4 and RV5 are in the parallel CR branch.

VT2 is a buffer emitter follower. It is a silicon type to keep the working point of VT3 independent of temperature. VT3 provides the gain in the system (about x90). Its emitter load is bypassed at high frequencies by C20 to maintain the response. VT4 is the output stage and is connected as an emitter follower.

The 100 kHz bandwidth is determined by C30 and the 20 kHz bandwidth by C23 and C30 in parallel. Alternatively the output can be passed through a weighting filter 44827-517M which simulates the response of the ear to a typical broadcast system. This response is shown in Fig. 3.2. The filter includes a 2-stage feedback amplifier VT20 and VT21 with a gain of about 18 dB to compensate for the loss of the filter network.

As an alternative the instrument may be fitted with a telephone weighting network. This response is also shown in Fig. 3.2. The filter board, 44827-522R, is of basically similar design to that of the broadcast filter, except that the amplifier gain is about 8 dB.

3.3 VOLTMETER SECTION

(Circuit diagram Fig. 7.3)

Input transistors VT5, VT6 and VT7 combine to form a high input impedance stage with an overall gain of approximately unity. VT5 operates at a collector current of approximately 10 μA at which it produces current gain to drown the noise of VT6, but produces very little noise itself. It is selected for a fairly high gain at this low collector current, which gives it its low noise characteristic plus a high input impedance.

VT7 is an emitter follower with a 2 k Ω load in its collector circuit to feed the attenuator, controlled by the voltmeter range selector. Since the attenuator itself presents 2 k Ω the resultant a.c. collector load is 1 k Ω .

The fine attenuator, R52 to R61, is a simple potentiometer device with four 10 dB steps giving 10 dB, 20 dB, 30 dB and 40 dB for the 10 V, 3 V, 1 V and .3 V ranges respectively.

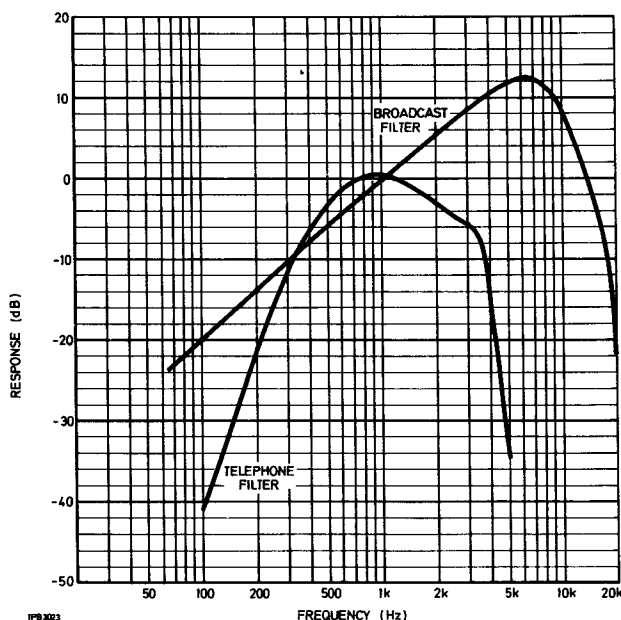

Fig. 3.2 Weighting filter response

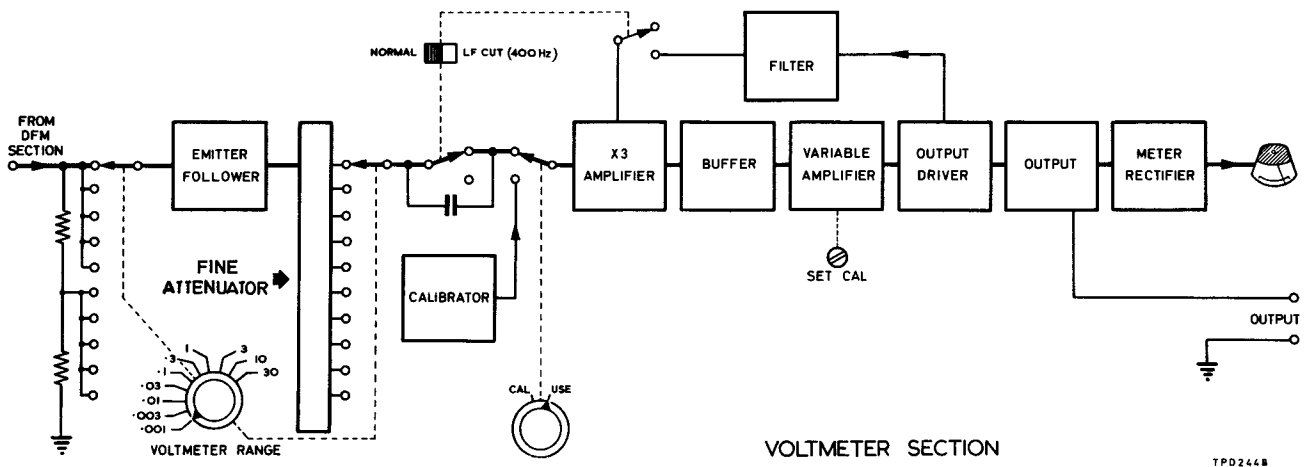

Fig. 3.3 Functional diagram — voltmeter section

When the voltmeter range is set to .1 V the input is attenuated 50 dB by R40, R41 and RV10 (which are capacitance compensated by C40 and C41), and the fine attenuator switched out. As the voltmeter range is lowered further the four 10 dB steps are switched in again.

VT13 is the first transistor in the main voltmeter amplifier. It has a gain of about 3 and always operates at around the 1 mV level. It is, therefore, selected for low noise.

VT14 is a buffer emitter follower and its bias is provided by d.c. feedback from the output stage. R78 provides preliminary bias and so protects VT15 from complete saturation when switching on.

VT15 is an npn transistor connected as an amplifier. Its gain is variable by the a.c. coupled CAL preset potentiometer on the front panel. The collector circuit comprises a 3 k Ω resistor, R84, and a 1 k Ω resistor, R85, in series, the latter being decoupled with a 10 μ F capacitor, C61, giving an l.f. boost to level the frequency response.

VT16 is the driver transistor for the output stage. Its d.c. conditions are set by RV14 so that the output stage transistors have a centralized d.c. output to prevent crushing, limiting or low gain.

VT17 and VT18 are the output pair and are connected in push-pull. Their bases are clamped 6 V apart by MR11 and a collector swing of about ± 2 V is possible before any limiting starts. This is quite adequate to drive the meter diodes. Each emitter circuit has a 220 Ω resistor in series with an 820 Ω resistor bypassed by a 500 μ F capacitor to stabilize the a.c. gain and d.c. working conditions. An output is taken from the emitter of VT18 to the OUTPUT terminals on the front panel. It gives about 150 mV r.m.s. and has a nominal impedance of 1 k Ω . C71 is selected for best accuracy at 100 kHz on all ranges from 1 mV to 100 mV.

A constant standard signal is available at the base of VT13 to set up the gain of the main voltmeter amplifier. It is provided by VT9 and VT12. These transistors form a multivibrator controlled in amplitude of output by MR10. RV11 is set to optimize the full-scale accuracy at medium frequencies on all ranges from 1 mV to 100 mV.

The LF CUT filter removes hum at supply frequencies from the distortion measurement. When it is switched in, low frequencies in the signal path are attenuated by C49 and extra l.f. degeneration is achieved by switching C64 and C65 in series with C59, and C66 in series with C63. Also, a.c. negative feedback at low frequencies is introduced by coupling the emitter circuits of VT16 and VT13 through RV15.

3.4 POWER SUPPLY SECTION

(Circuit diagram Fig. 7.1)

The design of the power supply caters for the use of a.c. supply voltages of 190 to 260 V or 95 to 130 V at 40 to 500 Hz, and d.c. supply voltages of 18 to 45 V. It provides an h.t. of -15 V via a 3-transistor stabilizer network.

If an a.c. supply is used it is rectified by a conventional full-wave rectifier using silicon diodes MR7 and MR8 and smoothed by capacitor C48.

Resistor R56 and capacitor C50 ensure that the collector supply to VT8 is free of ripple.

From the filter, or from a battery, the supply is fed to the stabilizer circuit. This consists of a series stabilizer, VT11, an amplifier, VT8, and an emitter follower, VT10. Part of the output voltage is compared by the amplifier with a reference voltage provided by the Zener diode MR9. The resultant error signal is fed back to the series stabilizer via the emitter follower.

Diode MR6 provides protection against a d.c. supply being connected with reversed polarity.

4.1 GENERAL

This part of the handbook is for guidance where it is most needed in servicing the instrument. In case of difficulties that cannot be resolved with the aid of this book, or for advice on maintaining the instrument, please write or phone our Service Division, or nearest Area Office, or Agent. Always mention the type number and serial number of your instrument (for addresses see rear cover).

This instrument uses semiconductor devices which, although having inherent long-term reliability and mechanical ruggedness, are susceptible to damage by overloading, reversed polarity, and excessive heat or radiation. Avoid hazards such as reversal of batteries, prolonged soldering, strong r.f. fields or other forms of radiation, the use of insulation testers, or accidentally applied short circuits.

4.2 ACCESS TO COMPONENTS

REMOVING CASE

The case can be removed by unplugging the mains lead from the back panel, unscrewing the six coin-slotted screws holding the rear cover and then removing the rear cover and the case.

OPENING THE CHASSIS

To allow easy access to components the chassis is hinged in several places and can be opened out, as shown in Fig. 4.1, by removing the right-angled cross-member from the five pillars and then slackening or removing the appropriate 4BA and 6BA cheese-headed screws, and unsolder wires to tags 26, 27 and 30.

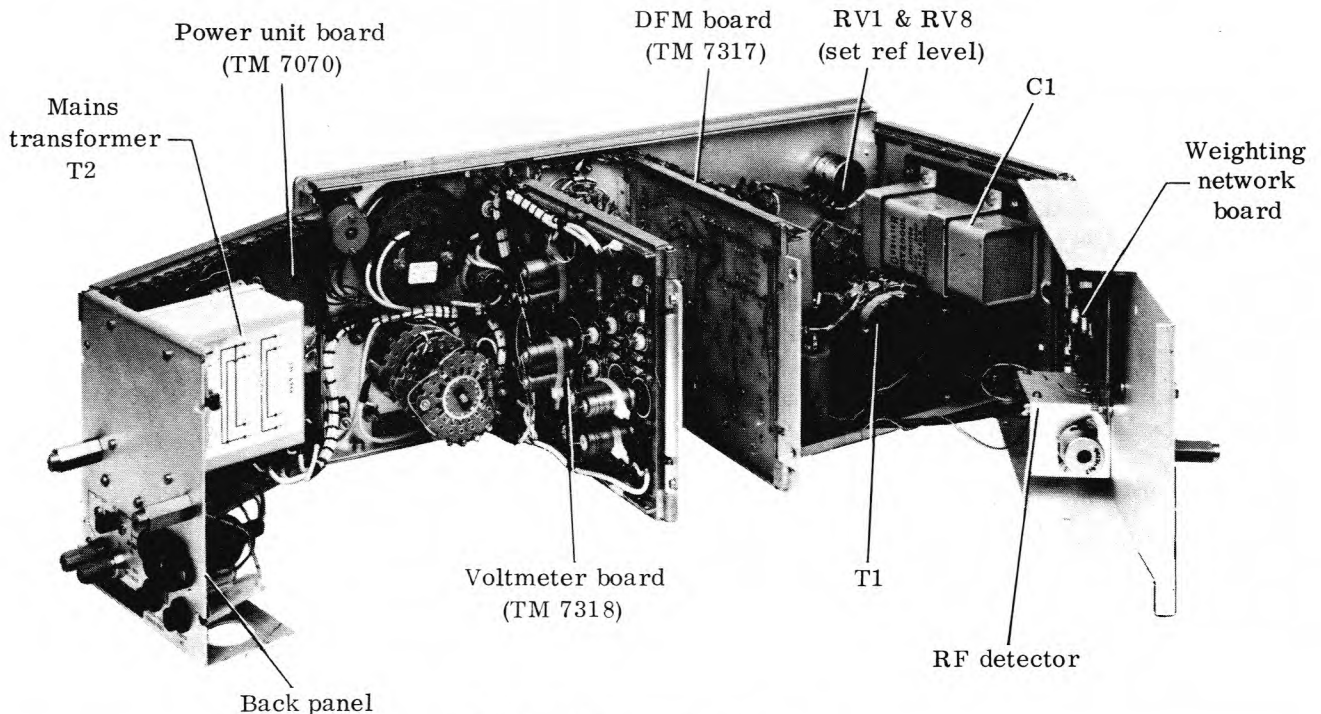

Fig. 4.1 The instrument opened out

PRINTED CIRCUIT BOARD IDENTIFICATION

Starting from the right-hand end of the instrument viewed from front : the first printed circuit board, marked TM 7070, carries the main power supply components; the second, marked TM 7318, carries the main voltmeter components; the third, marked TM 7317, carries the main DFM components; and the small board on the left-hand back-plate, carries the weighting network components.

4.3 A.C. MAINS INPUT RANGES

The mains transformer is mounted in a screening can on the right-hand back-plate of the instrument. The two primary windings should be connected in series for the 190 to 260 V range and in parallel for the 95 to 130 V range, as shown in Fig. 4.2.

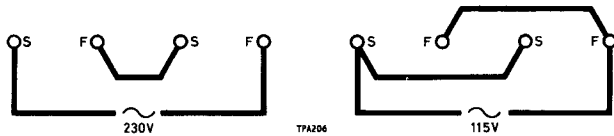

Fig. 4.2 Mains input connections

The reversible label should be adjusted so as to correspond to the transformer setting.

4.4 REPLACEMENT OF SEMICONDUCTORS

Transistors VT1, VT2, VT3 and VT4 are critical for internal noise. To check for noise when replacing them :-

Short-circuit the INPUT terminals; set the FUNCTION selector to SET REF LEVEL and the METER RANGE selector to the .001 V range; select a transistor to give a meter reading under 10% of full-scale (< 100 μV).

As a further guide :-

With VT1 removed the meter should read about 600 μV; with VT3 removed it should read about 200 μV.

If VT3 is replaced ensure that its gain is adequate or attenuation of second harmonics will be greater than that shown in Fig. 2.9.

4.5 CIRCUIT VOLTAGES

Some typical circuit voltages are given below and on the circuit diagram. Those on the circuit diagram are d.c. voltages and those in Tables 4.1 and 4.2 are a.c. signal voltages.

The voltages shown in Tables 4.1 and 4.2 were measured, unless otherwise stated, on a 400 Hz signal with the FUNCTION selector set to SET REF LEVEL, the METER RANGE selector set to the 100% range and the meter set to 100%. To measure them use a valve voltmeter such as Marconi Instruments type TF 2600 (series).

Table 4.1

Transistor Terminals			
Transistor	Base	Emitter	Collector
VT1	10 mV	10 mV	20 mV
VT2	10 mV	10 mV	-
VT3	10 mV	-	1 V
VT4	1 V	1 V	-
VT13	1 mV	-	2 mV
VT14	2 mV	2 mV	-
VT15	2 mV	-	10 mV
VT16	4 mV	-	170 mV
VT17	170 mV	-	900 mV
VT18	170 mV	-	900 mV
*VT20	300 mV	300 mV	-
*VT21	-	-	2.5 V

*Measured with a 1 kHz signal with the FUNCTION selector set to NOISE WEIGHTED and the meter at full-scale on the 30% range.

Table 4.2

Circuit Points	
Point	Voltage
tag 1	0.55 V
tag 35	3.1 mV
tag 40	3.1 mV
tag 45	1 mV

Note that when measuring circuit voltages the test leads should be kept well clear of circuitry.

4.6 PRESET CONTROLS

Apparatus required :

- (a) Multimeter; 20 k Ω /V.
- (b) Standardized valve millivoltmeter; 1 mV - 30 V; e.g., Marconi Instruments type TF 2600 (series).
- (c) Oscillator; 50 Hz to 100 kHz, 1 mV to 30 V; e.g., Marconi Instruments type TF 1101 (series).

SET HT

The h.t. voltage should be checked if VT8, VT10 or VT11 is replaced. Connect to the supply and switch on. Connect the test meter between tag 70 and earth, positive terminal to earth, on the power unit board and adjust RV12 until it indicates 15 V.

DC AT METER INPUT

The d.c. voltage at the collectors of VT17 and VT18 should be checked if any transistors or large value electrolytic capacitors are replaced - if an electrolytic capacitor is replaced the voltage should be rechecked after the instrument has been in use for about one day.

Connect the multimeter between the collector of VT17 or VT18 and earth, positive terminal to earth. Switch the METER RANGE selector to the 30 V range and keep the meter test leads well clear of any circuitry to reduce the possibility of overall oscillation. Adjust RV14 until the meter indicates 7.25 V.

VOLTMETER ACCURACY

The accuracy of the voltmeter and its calibrating voltage should be checked if any of the transistors VT5 to VT18 are replaced. Connect the oscillator to the AF INPUT terminals and set it to 400 Hz. Monitor the signal with the standardized valve millivoltmeter. Set the signal amplitude to 1 mV, 3 mV, 30 mV and 100 mV in turn and optimize the full-scale error between respective voltmeter ranges with the SET CAL control

(RV13). Set the CAL-USE switch to CAL and adjust preset potentiometer RV11 to bring the meter pointer to the CAL calibration. Reset the CAL-USE switch to USE, set the input signal amplitude to 300 mV, 1 V, 3 V, 10 V and 30 V in turn and optimize the full-scale error between the respective voltmeter ranges with preset potentiometer RV10.

LF CUT

The l.f. cut response should be checked if capacitors C59, C63, C64, C65 or C66 are changed. It should conform to the following :-

within ± 0.25 dB above 1 kHz within +0.5 dB, -1.0 dB 400 to 600 Hz at least -30 dB at 60 Hz	}	relative to the response when switched to NORMAL
--	---	---

If it does not, adjust with variable resistor RV15.

A typical curve is shown in Fig. 4.3. To avoid overloading the input circuit when checking this response start at 1 kHz with the METER RANGE selector set to the .1 V range and, leaving the input constant adjust the METER RANGE selector to increase the meter sensitivity as required at other frequencies.

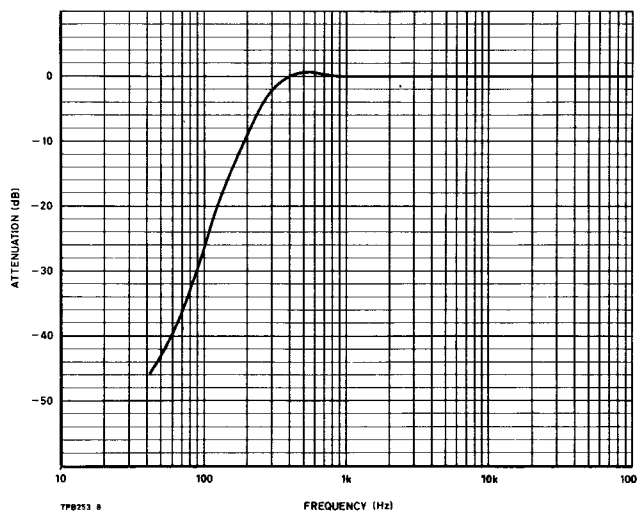

Fig. 4.3 Typical l.f. cut response

LOW RANGES FREQUENCY RESPONSE

Set the instrument controls for use as a voltmeter. Connect the oscillator to the INPUT terminals and set the input signal amplitude to 1 mV, 3 mV, 10 mV and 100 mV in turn at various frequencies between 20 Hz and 100 kHz. Check that the full-scale accuracy of the respective voltmeter ranges is within specification. If it is out at the higher frequencies reselect capacitor C71 (ensure that lifting of the response at 100 kHz is not exaggerated or excessive r.f. gain will result). If it is out at the very low frequencies reselect capacitor C61.

HIGH RANGES FREQUENCY RESPONSE

Set the instrument controls for use as a voltmeter. Connect the oscillator to the INPUT terminals and set the input signal amplitude to 0.3 V, 1 V, 3 V, 10 V and 30 V in turn at various frequencies from 12 kHz to 100 kHz and check that the full-scale error of the respective voltmeter ranges is within specification. If it is not adjust variable capacitor C40.

FILTER GAIN EQUALIZATION

(1) Connect the oscillator to the AF INPUT terminals and adjust it for an output of about 100 mV

at 1 kHz. With the FUNCTION selector at SET REF LEVEL adjust the instrument as in Sect. 2.5 for a convenient reference level on the meter.

(2) Turn the FUNCTION selector to NOISE WEIGHTED. If this results in a different meter reading adjust R115 to restore the reading to the reference level obtained in (1).

4.7 RF DETECTOR CHECK

The following tests may be carried out to check the operation of the r.f. detector. Set the front panel controls as follows :-

AF/RF INPUT to RF
SET REF LEVEL fully clockwise (max.)
FUNCTION switch to SET REF LEVEL

(1) Using a suitable signal generator such as a Marconi Instruments TF 801D, connect an r.f. output of 10 MHz, 1 V e.m.f. and modulated by 1 kHz at 30% to the input socket at the rear of TF 2331A. With the voltmeter range switch at RF LEVEL, the meter reading should not be less than 40 mV.

(2) Repeat the above at 100 MHz and 470 MHz.

Introduction

Replaceable parts are listed in alphabetical order of circuit references, with miscellaneous parts at the end of each list. The following abbreviations are used :

C	: capacitor
Carb	: carbon
Cer	: ceramic
Elec	: electrolytic
FS	: fuse
IC	: integrated circuit
L	: inductor
M	: meter
Met	: metal
MR	: semiconductor diode
Ox	: oxide
PL	: plug
Plas	: plastic
R	: resistor
RV	: variable resistor
S	: switch
SKT	: socket
T	: transformer
Tant	: tantalum
TP	: terminal
VT	: transistor
WW	: wirewound
W	: watts at 70°C

Ordering

When ordering replacements, address the order to our Service Division (address on rear cover) or nearest agent and specify the following for each component required.

- (1) Type* and serial number of instrument
- (2) Complete circuit reference
- (3) Description
- (4) MI code

* as given on the serial number label at the rear of the instrument; if this is superseded by a model number label, quote the model number instead of the type number.

If a part is not listed, state its function, location and description when ordering.

One or more of the parts fitted to the instrument may differ from those listed in this chapter for any of the following reasons :

- (a) Components indicated by † have their value selected during test to achieve particular performance limits.
- (b) Owing to supply difficulties components may be substituted by others of different type or value provided that the overall performance of the instrument is maintained.
- (c) As part of a policy of continuous development, components may be changed in value or type to obtain detail improvements in performance.

Whenever there is such a difference between the component fitted and the one listed, always use as a replacement the same type and value as found in the instrument.

Printed board assemblies

DFM amplifier	TM 7317
RF detector	44823-190S
Weighting filter/amp. (broadcast)	44827-517M
Weighting filter/amp. (telephone)	44827-522R
Voltmeter	TM 7318
Power unit	TM 7070

Replaceable parts

Circuit reference	Description	M.I. code	Circuit reference	Description
C1	Paper 8 μ F 20% 350V	26144-350Y	C36	Plas 250pF 2% 350V
C2	Elec 100 μ F -20+100% 25V	26415-813U		
C3	Elec 22 μ F -20+100% 63V	26415-806A	C40	Var plas 0.25-8pF
C4	Plas 0.432 μ F 1.1% 125V	26518-358T	C41	Plas 0.001 μ F 2% 350V
C5	Plas 0.432 μ F 1.1% 125V	26518-358T	C42	Paper 0.1 μ F 25% 350V
C6	Plas 0.1264 μ F 1.1% 125V	26518-297B	C43	Paper 0.001 μ F 20% 500V
C7	Plas 0.04 μ F 1.1% 125V	26518-244N	C44	Elec 100 μ F -20+100% 25V
C8	Plas 0.01264 μ F 1.1% 125V	26518-222W	C45	Plas 0.1 μ F 10% 250V
C9	Mica 3950pF 0.5% 350V	26257-359S	C46	Elec 470 μ F -20+100% 25V
C10	Plas 0.4 μ F 1.1% 125V	26518-355S	C47	Tant 68 μ F 20% 15V
C11	Plas 0.432 μ F 1.1% 125V	26518-358T	C48	Elec 500 μ F -20+100% 50V
C12	Plas 0.432 μ F 1.1% 125V	26518-358T	C49	Plas 0.033 μ F 10% 160V
C13	Plas 0.1264 μ F 1.1% 125V	26518-297B	C50	Elec 22 μ F -20+50% 100V
C14	Plas 0.04 μ F 1.1% 125V	26518-244N	C51	Plas 0.1 μ F 10% 100V
C15	Plas 0.01264 μ F 1.1% 125V	26518-222W	C52	Paper 0.005 μ F 10% 250V
C16	Mica 3950pF 0.5% 350V	26257-359S	C53	Paper 0.005 μ F 10% 250V
C17	Plas 0.4 μ F 1.1% 125V	26518-355S	C54	Elec 100 μ F -20+100% 25V
C18	Elec 100 μ F -20+100% 25V	26415-813U	C55	Tant 33 μ F 5% 20V
C19	Elec 100 μ F -20+100% 25V	26415-813U	C56	Elec 100 μ F -20+100% 25V
C20	Paper 0.01 μ F 10% 400V	26174-147H	C57	Elec 470 μ F -20+100% 25V
C21	Elec 22 μ F -20+100% 63V	26415-806A	C58	Elec 50 μ F -20+100% 25V
C22	Elec 470 μ F -20+100% 25V	26415-822G	C59	Elec 470 μ F -20+100% 25V
C23	Plas 0.007 μ F 1% 125V	26516-687F	C60	Elec 470 μ F -20+100% 25V
C24	Plas 0.0082 μ F 2% 125V	26516-925Y	C61 †	Elec 47 μ F -20+100% 40V
C25	Plas 0.0027 μ F 1% 125V	26516-918Z	C62	Elec 1000 μ F -20+100% 16V
C26	Plas 0.0082 μ F 2% 125V	26516-925Y	C63	Elec 470 μ F -20+100% 25V
C27	Plas 0.0068 μ F 2% 125V	26516-684N	C64	Plas 1 μ F 10% 160V
C28	Plas 0.0027 μ F 1% 125V	26516-918Z	C65	Plas 1 μ F 10% 160V
			C66	Elec 6.8 μ F 20% 6V
C30	Plas 0.0018 μ F 5% 125V	26516-544E	C67	Elec 22 μ F -20+100% 63V
C31	Elec 1000 μ F -10+50% 63V	26426-081F	C68	Elec 470 μ F -20+100% 25V
C32	Elec 1000 μ F -10+50% 63V	26426-081F	C69	Elec 470 μ F -20+100% 25V
			C70	Tant 100 μ F 20% 10V
C34	Mica 100pF 2% 350V	26272-293V	C71 †	Plas 2200pF 5% 350V
C35	Plas 250pF 2% 350V	26516-342Y	C72	Elec 100 μ F -20+100% 25V

Circuit reference	Description	M.I. code	Circuit reference	Description	M.I. code
C73	Elec 47 μ F -20+100% 40V	26415-810Z	FS1	or 250mA slow-blow (for 115V supply)	23411-055P
C74	Tant 33 μ F 5% 20V	26486-589W	FS2	250mA quick blow	23411-004E
C75	Cer 33pF 5% 750V	26324-822X			
C76	Cer 0.1 μ F -25+50% 30V	26383-031S	L1	(for broadcast filter)	44290-402M
C77	Elec 2 μ F -20+100% 25V	26414-109L	L1	(for telephone filter)	44290-434M
C78	Elec 220 μ F -20+100% 25V	26415-818F	L2	(for broadcast filter)	44290-403C
C79	Elec 470 μ F -20+100% 25V	26415-822G	L2	(for telephone filter)	44290-435C
			L3	(for telephone filter)	44290-436R
C110	Elec 4.7 μ F 20% 25V	26458-004H	L4	(for telephone filter)	44290-437B
C111	Cer 0.001 μ F +80-20% 500V	26383-242P	L4	(for r.f. detector)	44271-417T
C112	Elec 100 μ F +100-20% 25V	26415-813U			
			MR1	1S923	28356-018Y
C124	Plas 220pF 2% 350V	26516-329B	MR2	1S923	28356-018Y
C125	Plas 150pF 2% 350V	26516-289C			
C126	Plas 680pF 2% 350V	26516-446L	MR4	1S923	28356-018Y
C127	Plas 82pF \pm 2pF 350V	26516-225C	MR5	1S923	28356-018Y
C128	Plas 470pF 2% 350V	26516-408U	MR6	MIP92001	28357-048W
			MR7	1N4004	28357-028K
C130	Elec 4.7 μ F 20% 25V	26458-004H	MR8	1N4004	28357-028K
C131	Cer 0.001 μ F +80-20% 500V	26383-242P	MR9	Z5B10	28371-843E
C132	Elec 100 μ F +100-20% 25V	26415-813U	MR10	Z5B6.2	28371-483P
C133	Plas 18pF \pm 2pF 350V	26516-029U	MR11	Z5B6.2	28371-483P
C134	Plas 1200pF 2% 160V	26516-512E	MR12	HP5082-2800	28349-007E
C135	Plas 2640pF 2% 160V	26516-926N	MR13	HP5082-2800	28349-007E
C136	Plas 71700pF 2% 160V	26516-835D	MR14	1N5390	28349-005Z
C137	Plas 1800pF 2% 160V	26516-543H			
C138	Plas 47pF \pm 2pF 350V	26516-167Y	PL1	Mains plug	23423-159P
C139	Plas 41900pF 2% 160V	26516-927L			
C140	Plas 90400pF 2% 160 V	26516-838X	R1	WW 620 Ω 2% 3W	25125-074K
C141	Plas 0.033 μ F 10% 250V	26582-205M	R2	Met film 82k Ω 2% $\frac{1}{4}$ W	24773-319J
C142	Plas 0.22 μ F 2% 63V	26582-571V	R3	Met film 68k Ω 2% $\frac{1}{4}$ W	24773-317N
			R4	Met ox 470k Ω 2% $\frac{1}{2}$ W	24573-137G
FS1	100mA slow-blow (for 230V supply)	23411-052W	R5	Met film 2.7k Ω 2% $\frac{1}{4}$ W	24773-283L
			R6	Met film 3.9k Ω 2% $\frac{1}{4}$ W	24773-287V

Replaceable parts

Circuit reference	Description	M.I. code	Circuit reference	Description	M.I. code
R7	Met film 1.5k Ω 2% $\frac{1}{4}$ W	24773-277U	R46	Met ox 470k Ω 2% $\frac{1}{2}$ W	24573-137G
R8	Met film 5.6k Ω 2% $\frac{1}{4}$ W	24773-291S	R47	Met ox 470k Ω 2% $\frac{1}{2}$ W	24573-137G
R9	Met film 750 Ω 2% $\frac{1}{4}$ W	24773-270R	R48	Met film 6.2k Ω 2% $\frac{1}{4}$ W	24773-292W
R10	Met film 1.8k Ω 2% $\frac{1}{4}$ W	24773-279N	R49	Met film 2k Ω 2% $\frac{1}{4}$ W	24773-280U
R11	Met film 150k Ω 2% $\frac{1}{4}$ W	24773-325V	R50	Met film 1k Ω 2% $\frac{1}{4}$ W	24773-273A
R12	Met film 150k Ω 2% $\frac{1}{4}$ W	24773-325V	R51	Met film 680 Ω 2% $\frac{1}{4}$ W	24773-269K
R13	Met film 1.8k Ω 2% $\frac{1}{4}$ W	24773-279N	R52	Met film 470 Ω 2% $\frac{1}{4}$ W	24773-265M
R14	Met film 1.8k Ω 2% $\frac{1}{4}$ W	24773-279N	R53	Met film 910 Ω 2% $\frac{1}{4}$ W	24773-272K
R15	Carb 330k Ω 5% 1/8W	24311-933C	R54	Met film 820 Ω 2% $\frac{1}{4}$ W	24773-271B
R16	Met film 220k Ω 2% $\frac{1}{4}$ W	24773-329T	R55	Met film 1k Ω 2% $\frac{1}{4}$ W	24773-273A
R17	Met film 13k Ω 2% $\frac{1}{4}$ W	24773-300T	R56	Met film 4.7k Ω 2% $\frac{1}{4}$ W	24773-289W
R18	Met film 4.7k Ω 2% $\frac{1}{4}$ W	24773-289W	R57	Met film 1367 Ω 0.5% 1/8W	24625-101Y
R19	Met film 75k Ω 2% $\frac{1}{4}$ W	24773-318L	R58	Met film 432.4 Ω 0.5% 1/8W	24624-701N
R20	Met film 270 Ω 2% $\frac{1}{4}$ W	24773-259T	R59	Met film 136.7 Ω 0.5% 1/8W	24624-601J
R21	Met film 47k Ω 2% $\frac{1}{4}$ W	24773-313H	R60	Met film 43.24 Ω 0.5% 1/8W	24624-226S
R22	Met film 10k Ω 2% $\frac{1}{4}$ W	24773-297M	R61	Met film 20 Ω 0.5% 1/8W	24624-101M
R23	Met film 100k Ω 2% $\frac{1}{4}$ W	24773-321L	R62	Met film 39k Ω 1% 1/8W	24617-551Y
R24	Met film 100 Ω 2% $\frac{1}{4}$ W	24773-249J	R63	WW 10 Ω 5% $\frac{1}{2}$ W	25123-020F
R25	Met film 820 Ω 2% $\frac{1}{4}$ W	24773-271B	R64	Met film 10k Ω 2% $\frac{1}{4}$ W	24773-297M
R26	Met film 2.2k Ω 2% $\frac{1}{4}$ W	24773-281Y	R65	Met film 4.7k Ω 2% $\frac{1}{4}$ W	24773-289W
			R66	Met film 68k Ω 2% $\frac{1}{4}$ W	24773-317N
R28	Met film 2.2k Ω 2% $\frac{1}{4}$ W	24773-281Y	R67	Met film 1k Ω 2% $\frac{1}{4}$ W	24773-273A
R29	Met film 18 Ω 2% $\frac{1}{4}$ W	24773-231P	R68	Met film 150k Ω 2% $\frac{1}{4}$ W	24773-325V
			R69	Met film 10k Ω 2% $\frac{1}{4}$ W	24773-297M
R32	Met ox 51 Ω 2% $\frac{1}{2}$ W	24573-042D	R70	Met film 4.7k Ω 2% $\frac{1}{4}$ W	24773-289W
R33	Met film 47k Ω 2% $\frac{1}{4}$ W	24773-313H	R71	Met film 3.9k Ω 2% $\frac{1}{4}$ W	24773-287V
R34	Carb 2.2M Ω 5% 1/6W	24312-974S	R72	Met film 33k Ω 2% $\frac{1}{4}$ W	24773-309Z
R35	Met film 10k Ω 2% $\frac{1}{4}$ W	24773-297M	R73	Met film 33k Ω 2% $\frac{1}{4}$ W	24773-309Z
			R74	Met film 1k Ω 2% $\frac{1}{4}$ W	24773-273A
R40	Met film 1M Ω 0.5% $\frac{1}{2}$ W	24655-901T	R75	Met film 3.3k Ω 2% $\frac{1}{4}$ W	24773-285F
R41	Met film 3100 Ω 0.5% $\frac{1}{2}$ W	24655-203A	R76	Met film 1k Ω 2% $\frac{1}{4}$ W	24773-273A
R42	Met film 100 Ω 2% $\frac{1}{4}$ W	24773-249J	R77	Met film 5.6k Ω 2% $\frac{1}{4}$ W	24773-291S
R43	Met ox 1M Ω 2% $\frac{1}{2}$ W	24573-145T	R78	Met film 100k Ω 2% $\frac{1}{4}$ W	24773-321L
R44	Met film 100k Ω 2% $\frac{1}{4}$ W	24773-321L	R79	Met film 10k Ω 2% $\frac{1}{4}$ W	24773-297M
R45	Met ox 470k Ω 2% $\frac{1}{2}$ W	24573-137G	R80	Met film 1.8k Ω 2% $\frac{1}{4}$ W	24773-279N

Circuit reference	Description	M.I. code	Circuit reference	Description
R81	Met film 3.9k Ω 2% $\frac{1}{4}$ W	24773-287V	R121	Met film 62k Ω 2% $\frac{1}{4}$ W
R82	Met film 8.2k Ω 2% $\frac{1}{4}$ W	24773-295P	R122	Met film 4.7k Ω 2% $\frac{1}{4}$ W
R83	Met film 6.2k Ω 2% $\frac{1}{4}$ W	24773-292W	R123	Met film 750 Ω 2% $\frac{1}{4}$ W
R84	Met film 3k Ω 2% $\frac{1}{4}$ W	24773-284J	R124	Var cermet 220 Ω 10% $\frac{1}{2}$ W
R85	Met film 1k Ω 2% $\frac{1}{4}$ W	24773-273A	R125	Met film 390 Ω 2% $\frac{1}{4}$ W
R86	Met film 33 Ω 2% $\frac{1}{4}$ W	24773-237K	R126	Met film 2.2k Ω 2% $\frac{1}{4}$ W
R87	Met film 680 Ω 2% $\frac{1}{4}$ W	24773-269K	R127	Met film 220 Ω 2% $\frac{1}{4}$ W
R88	Met film 15k Ω 2% $\frac{1}{4}$ W	24773-301P	R128	Met film 2.0k Ω 2% $\frac{1}{4}$ W
R89	Met film 20k Ω 2% $\frac{1}{4}$ W	24773-304C		
R90	Met film 2.2k Ω 2% $\frac{1}{4}$ W	24773-281Y	RV1	Var carb 100k Ω +10k Ω 10% 2W
R91	Met film 2.7k Ω 2% $\frac{1}{4}$ W	24773-283L	RV2	Var WW 5.1k Ω +5.1k Ω 2% 4W
R92	Met film 3.9k Ω 2% $\frac{1}{4}$ W	24773-287V	RV3	Var WW 100k Ω +100k Ω 10% $\frac{1}{2}$ W
R93	Met film 820 Ω 2% $\frac{1}{4}$ W	24773-271B	RV4	Var WW 100k Ω +100k Ω 10% 4W
R94	Met film 220 Ω 2% $\frac{1}{4}$ W	24773-257W	RV5	Var WW 5.1k Ω +5.1k Ω 2% 4W
R95	Met film 220 Ω 2% $\frac{1}{4}$ W	24773-257W	RV6	Var WW 1k Ω 5% 2W
R96	Met film 820 Ω 2% $\frac{1}{4}$ W	24773-271B	RV7	Var WW 500 Ω 10% 1W
R97	Met film 1k Ω 2% $\frac{1}{4}$ W	24773-273A	RV8	Var carb 100k Ω +10k Ω 10% 2W
R98	Met film 270 Ω 2% $\frac{1}{4}$ W	24773-259T		
R99	Met film 270 Ω 2% $\frac{1}{4}$ W	24773-259T	RV10	Var cermet 200 Ω 10% 0.3W
R100	Met ox 100k Ω 2% $\frac{1}{2}$ W	24573-121R	RV11	Var carb 22k Ω 20% $\frac{1}{4}$ W
R101	Met ox 100k Ω 2% $\frac{1}{2}$ W	24573-121R	RV12	Var carb 1k Ω 20% $\frac{1}{4}$ W
R102	Met ox 470k Ω 2% $\frac{1}{2}$ W	24573-137G	RV13	Var carb 250 Ω 20% $\frac{1}{4}$ W
R103	Met film 1.5k Ω 2% $\frac{1}{4}$ W	24773-277U	RV14	Var carb 10k Ω 20% $\frac{1}{4}$ W
			RV15	Var carb 10k Ω 20% $\frac{1}{4}$ W
R110	Met film 220k Ω 2% $\frac{1}{4}$ W	24773-329T	SA	DFM INPUT RANGE
R111	Met film 27k Ω 2% $\frac{1}{4}$ W	24773-307K	SB	FUNCTION
R112	Met film 4.7k Ω 2% $\frac{1}{4}$ W	24773-289W	SC	FREQUENCY
R113	Met film 220 Ω 2% $\frac{1}{4}$ W	24773-257W	SD	METER RANGE
R114	Met film 1.8k Ω 2% $\frac{1}{4}$ W	24773-279N	SE	SUPPLY
R115	Var cermet 470 Ω 10% $\frac{1}{2}$ W	25711-541S	SF	BATTERY/AC MAINS
R116	Met film 270 Ω 2% $\frac{1}{4}$ W	24773-259T		
R120	Met film 220k Ω 2% $\frac{1}{4}$ W	24773-329T		

For symbols and abbreviations see introduction to this chapter

Replaceable Parts

Circuit reference	Description	M.I. code	Circuit reference	Description	M.I. code
SG	NORMAL/LF CUT	23467-162D	VT19	BCY71	28435-235L
SH	CAL/USE	44321-406F	VT20	BC308	28433-455R
SJ	INPUT RESISTANCE	44340-080W	VT21	BC238	28452-781A
SK	AF/RF INPUT	23467-160S	VT22	BC308	28433-455R
			VT23	BC238	28452-781A
SKT6	RF INPUT	23443-733F			
				KNOBS	
T1	AF input transformer	43590-024C		Round knob for main FREQUENCY control	41141-204Y
T2	Mains transformer	43490-055V		Round knob for FREQ BALANCE or PHASE BALANCE	41142-704Y
TP1 } TP2 }	AF INPUT terminals	23235-176V		Bar knob with skirt for FUNCTION or DFM INPUT RANGE switch	41145-206Z
TP3 } TP4 }	18 - 45V terminals	23235-176V		Pointer knob with skirt for FREQUENCY or METER RANGE switch	41145-219V
TP5 } TP6 }	OUTPUT terminals	23235-177S		Knob for coarse SET REF LEVEL control	41141-304E
				Knob for fine SET REF LEVEL control	41141-602M
VT1	BCY71	28435-237F		CAL/USE switch	41142-210M
VT2	BCY71	28435-237F		SUPPLY switch	41142-209R
VT3	BCY71	28435-237F		Knob for DFM INPUT RANGE	41141-304E
VT4	BCY71	28435-237F		Knob for FUNCTION switch	41145-219V
VT5	BC108	28452-787N			
VT6	BCY72	28433-487R			
VT7	BCY72	28433-487R			
VT8	MIP95008	44522-004P		MISCELLANEOUS	
VT9	ACY20	28424-747M		Dial for FREQUENCY control	31759-040J
VT10	ACY17	28426-497G		Dial cover moulding	31185-103X
VT11	OC25	28424-807V		Dial boss	33857-106W
VT12	ACY20	28424-747M		Wrap-round case	41651-107A
VT13	BCY71	28435-237F		Case back	41635-034S
VT14	BCY72	28433-487R		Case handle (1 of 2)	22315-504Y
VT15	BSY26	28452-173L		Case foot (1 of 4)	37188-102V
VT16	BCY72	28433-487R		Lifting stand	35121-105V
VT17	BSX20	28452-197H		Front panel surround	41656-019T
VT18	BCY72	28433-487R		Fuse holder for FS1 or FS2	23416-191C

CIRCUIT NOTES

1. COMPONENT VALUES

Resistors : No suffix = ohms, k = kilohms, M = megohms.

Capacitors : No suffix = microfarads, p = picofarads.

Inductors : No suffix = henries, m = millihenries, μ = microhenries.

† value selected during test; nominal value shown.

2. VOLTAGES

Printed in italics. Voltages are d.c. and relative to chassis unless otherwise indicated. Measured with 20 k Ω /V meter (or electronic voltmeter where indicated by ϕ). Power unit voltages relate to 240 V a.c. input.

3. SYMBOLS



preset component



arrow indicates clockwise rotation of knob



panel marking



printed board tag number

4. SWITCHES

Rotary switches are drawn schematically. Numbers or letters indicate control knob setting as shown in key diagrams.

1F = 1st section (front panel), front

1B = 1st section, back

2F = 2nd section, front

etc.

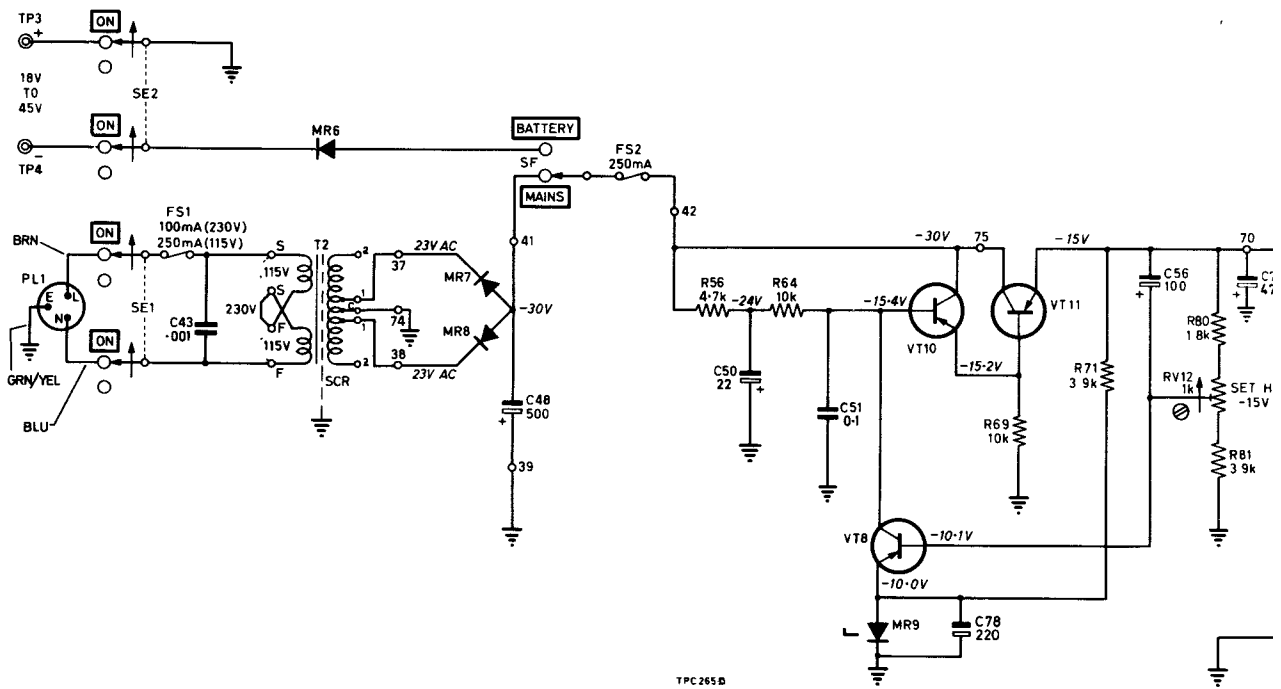

TPC265B

Fig. 7.1 Power unit

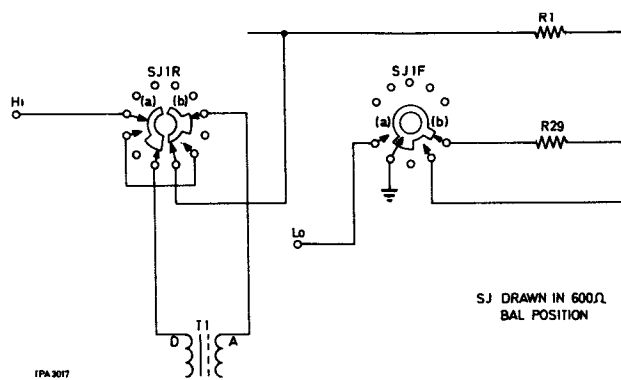

IPA 3017

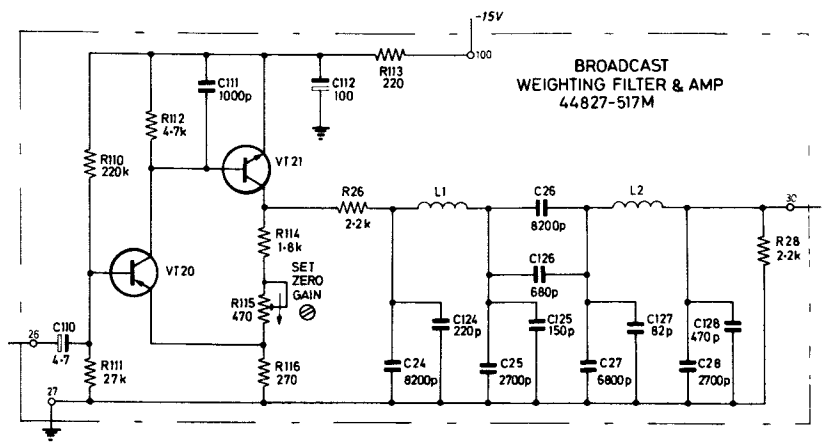
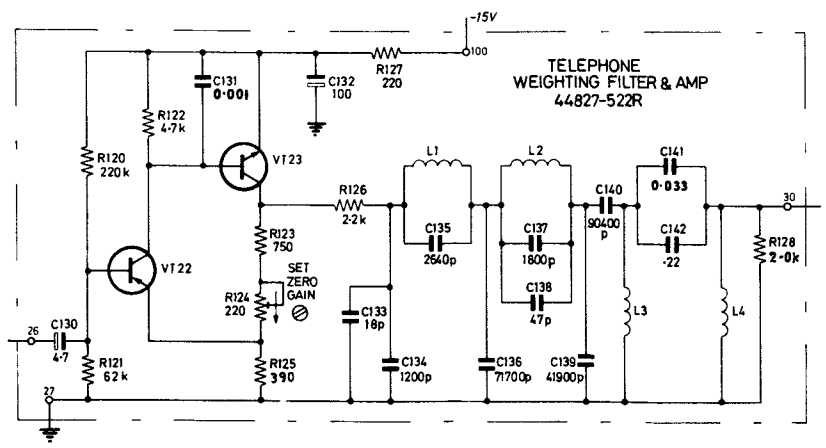
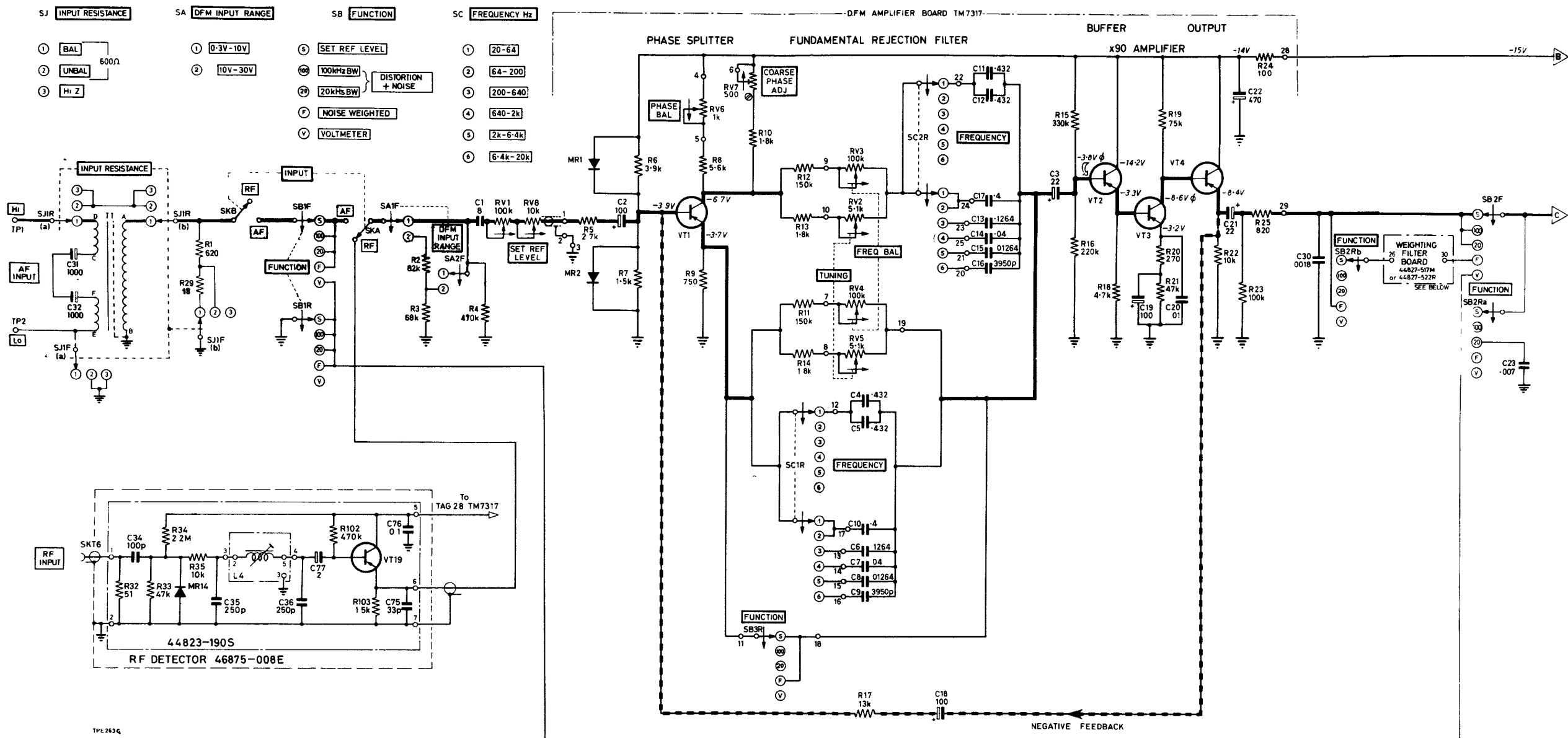
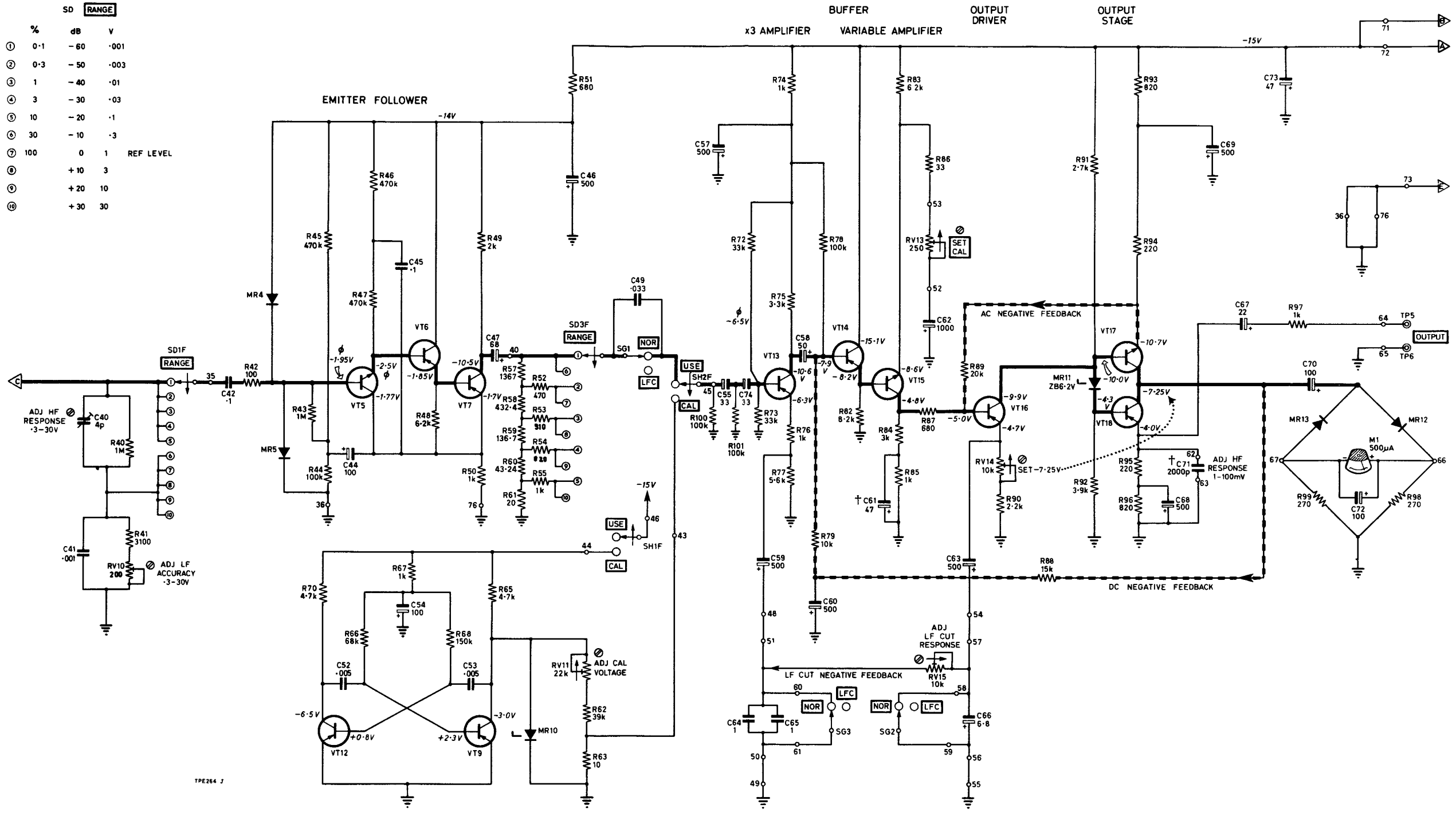

Fig. 7.2 Distortion factor meter section

SD	RANGE	%	dB	V
①	0.1	-60	.001	
②	0.3	-50	.003	
③	1	-40	.01	
④	3	-30	.03	
⑤	10	-20	.1	
⑥	30	-10	.3	
⑦	100	0	1	REF LEVEL
⑧		+10	3	
⑨		+20	10	
⑩		+30	30	



TPE284 J

CAL OSCILLATOR

Fig. 7.3 Voltmeter section