

Please do not upload this copyright pdf document to any other website. Breach of copyright may result in a criminal conviction.

This Acrobat document was generated by me, Colin Hinson, from a document held by the Henlow Signals Museum, believed to be out of copyright. It is presented here (for free) and this pdf version of the document is my copyright in much the same way as a photograph would be. If you believe the document to be under other copyright, please contact me.

The document should have been downloaded from my website <https://blunham.com/Radar>, or any mirror site named on that site. If you downloaded it from elsewhere, please let me know (particularly if you were charged for it). You can contact me via my Genuki email page: <https://www.genuki.org.uk/big/eng/YKS/various?recipient=colin>

You may not copy the file for onward transmission of the data nor attempt to make monetary gain by the use of these files. If you want someone else to have a copy of the file, point them at the website. (<https://blunham.com/Radar>). Please do not point them at the file itself as it may move or the site may be updated.

It should be noted that most of the pages are identifiable as having been processed by me.

I put a lot of time into producing these files which is why you are met with this page when you open the file.

In order to generate this file, I need to scan the pages, split the double pages and remove any edge marks such as punch holes, clean up the pages, set the relevant pages to be all the same size and alignment. I then run Omnipage (OCR) to generate the searchable text and then generate the pdf file.

Hopefully after all that, I end up with a presentable file. If you find missing pages, pages in the wrong order, anything else wrong with the file or simply want to make a comment, please drop me a line (see above).

It is my hope that you find the file of use to you personally – I know that I would have liked to have found some of these files years ago – they would have saved me a lot of time !

Colin Hinson

In the village of Blunham, Bedfordshire.

AN 16-30URM61-3
(Formerly AN 16-35TS403-3)

HANDBOOK

MAINTENANCE INSTRUCTIONS

SIGNAL GENERATOR

TS-403/U

(AN 3URM-61 IS THE OVER-ALL NOMENCLATURE
FOR THE ABOVE GENERATOR AND ACCESSORIES)

PUBLISHED UNDER AUTHORITY OF THE
SECRETARY OF THE AIR FORCE AND THE
CHIEF OF THE BUREAU OF AERONAUTICS



AN 16-3OURM61-3

(Formerly AN 16-35TS403-3)

**HANDBOOK
MAINTENANCE INSTRUCTIONS**

SIGNAL GENERATOR

AN/URM-61

(TS-403/U)

PUBLISHED UNDER AUTHORITY OF THE SECRETARY OF THE AIR FORCE
AND THE CHIEF OF THE BUREAU OF AERONAUTICS



1 SEPTEMBER 1948

REVISED 20 FEBRUARY 1959

Reproduction for non-military use of the information or illustrations contained in this publication is not permitted without specific approval of the issuing service (BuAer or USAF). The policy for use of Classified Publications is established for the Air Force in AFR 205-1 and for the Navy in Navy Regulations, Article 1509.

LIST OF REVISED PAGES ISSUED

INSERT LATEST REVISED PAGES. DESTROY SUPERSEDED PAGES.

NOTE: The portion of the text affected by the current revision is indicated by a vertical line in the outer margins of the page.

Page No.	Date of Latest Revision	Page No.	Date of Latest Revision
*ii	20 February 1959	6-28	5 May 1953
*iv	20 February 1959	6-28A Deleted	5 May 1953
*2-2	20 February 1959	6-29	5 May 1953
*4-5	20 February 1959	6-30	5 May 1953
*4-20	20 February 1959	6-31	5 May 1953
*4-21	20 February 1959	6-32	5 May 1953
*4-22	20 February 1959	6-33	5 May 1953
*4-23	20 February 1959	6-34	5 May 1953
*4-24	20 February 1959	6-35	5 May 1953
*4-25	20 February 1959	6-36	5 May 1953
*4-26	20 February 1959	6-37	5 May 1953
*4-27	20 February 1959	*6-38	20 February 1959
*4-28	20 February 1959	*6-38A	20 February 1959
*4-29	20 February 1959	6-39	5 May 1953
*6-0	20 February 1959	*6-40	20 February 1959
6-1	5 May 1953	6-41	5 May 1953
6-2	5 May 1953	6-42	5 May 1953
6-5	5 May 1953	6-43	5 May 1953
6-6	5 May 1953	*6-44	20 February 1959
6-6A Deleted	5 May 1953	*6-44A	20 February 1959
6-7	5 May 1953	6-45	5 May 1953
6-8	1 May 1954	6-46	5 May 1953
6-9	1 May 1954	6-47	5 May 1953
6-10	1 May 1954	6-48	5 May 1953
6-10A	1 May 1954	6-49	5 May 1953
6-11	5 May 1953	*6-50	20 February 1959
6-12	5 May 1953	*6-51	20 February 1959
6-13	5 May 1953	6-52	5 May 1953
6-14	5 May 1953	6-53	5 May 1953
6-15	5 May 1953	6-54	5 May 1953
6-16	5 May 1953	*6-55	20 February 1959
6-16A Deleted	5 May 1953	*6-56	20 February 1959
6-17	5 May 1953	*7-3/7-4	20 February 1959
6-18	5 May 1953	*7-5/7-6	20 February 1959
6-19	5 May 1953	7-11/7-12	1 August 1949
6-20	5 May 1953	7-13/7-14	1 August 1949
6-20A Deleted	5 May 1953	*1-1	20 February 1959
6-21	5 May 1953	*i-2	20 February 1959
6-22	5 May 1953	*i-3	20 February 1959
6-22A Deleted	5 May 1953	*i-4	20 February 1959
*6-23	20 February 1959	*i-5	20 February 1959
*6-24	20 February 1959		
*6-24A	20 February 1959		
6-25	5 May 1953		
6-26	5 May 1953		
6-27	5 May 1953		

* The asterisk indicates pages revised, added or deleted by the current revision.

ADDITIONAL COPIES OF THIS PUBLICATION MAY BE OBTAINED AS FOLLOWS:

USAF ACTIVITIES.—In accordance with Technical Order No. 00-5-2.

NAVY ACTIVITIES.—Submit request to nearest supply point listed below, using form NavAer-140; NASD, Philadelphia, Pa.; NAS, Alameda, Calif.; NAS, Jacksonville, Fla.; NAS, Norfolk, Va.; NAS, San Diego, Calif.; NAS, Seattle, Wash.; ASD, NSC, Guam.

For listing of available material and details of distribution see Naval Aeronautics Publications Index NavAer 00-500.

LIST OF ILLUSTRATIONS (Continued)

<i>Figure</i>	<i>Title</i>	<i>Page</i>	<i>Figure</i>	<i>Title</i>	<i>Page</i>
4-42.	Positioning of Inner Grid Contact Ring	4-19	7-1.	Signal Generator TS-403/U, Schematic Diagram	7-3
4-43.	Assembly of Grid Contact Clamping Plate	4-19	7-2.	Signal Generator TS-403/U, Practical Wiring Diagram	7-5
4-44.	Complete Drive System Assembled on Panel .	4-20	7-3.	Signal Generator TS-403/U, Front Panel Controls	7-7
4-45.	RF Transmission Line E-142I	4-21	7-4.	Signal Generator TS-403/U, Servicing Block Diagram	7-9
4-46.	Test Set-up for Calibrating Output Attenuator .	4-21	7-5.	Signal Generator TS-403, U, (Voltage 20,000-ohms-per-volt) and Resistance Diagram	7-11
4-47.	Cutaway View of Output RF Probe E-101	4-22	7-6.	Signal Generator TS-403/U, 1000-ohms-per-volt Voltage Diagram	7-13
4-48.	Cutaway View of Impedance-Matching Rod E-124 and Associated Parts	4-23	7-7.	Signal Generator TS-403/U, Overall Dimensions	7-15
4-49.	Cutaway View of Monitor RF Probe E-122	4-24	7-8.	Transit Case CY-669/U, Overall Dimensions	7-19
5-1.	Signal Generator TS-403/U, Back View with Instrument Case Removed.. . . .	5-4	7-9.	RF Cable CG-92B/U (6'), Fabrication Data	7-21
5-2.	Signal Generator TS-403/U, Top View with Instrument Case Removed	5-5	7-10.	Video Cord CG-409/U, (8'2"), Fabrication Data	7-23
5-3.	Signal Generator TS-403/U, Bottom View with Instrument Case Removed..	5-6	7-11.	Attenuator Cable, Fabrication Data	7-25
5-4.	Signal Generator TS-403/U, Left View with Instrument Case Removed.	5-7			

LIST OF TABLES

<i>Table</i>	<i>Title</i>	<i>Page</i>	<i>Table</i>	<i>Title</i>	<i>Page</i>
1-1.	Equipment Supplied	1-1	4-2.	Winding Data	4-28
1-2.	Tubes and Indicator Lamps.	1-3	5-1.	Tube Complement	5-1
2-1.	Operating Controls, Dials nad Terminals	2-3	5-2.	General Characteristics	5-2
4-1.	Trouble Chart	4-2	6-1.	Table of Replaceable Parts	6-5

UNSATISFACTORY REPORT**FOR U. S. ARMY AIR FORCE PERSONNEL**

In the event of malfunctioning, unsatisfactory design or unsatisfactory installation of any of the component units of this equipment, or if the material contained in this book is considered inadequate or erroneous, an Unsatisfactory Report, AAF Form No. 54 or a report in similar form shall be submitted in accordance with the provisions of Army Air Force Regulation No. 15-54, listing:

1. Station and organization.
2. Nameplate data (type number or complete nomenclature if nameplate is not attached to the equipment).
3. Date and nature of failure.
4. Radio model and serial number.
5. Remedy used or proposed to prevent recurrence.
6. Handbook errors or inadequacies, if possible.

FOR U. S. NAVY PERSONNEL

Report of failure of any part of this equipment during its guaranteed life shall be made on Form NAVAER 4112 "Report of Unsatisfactory or Defective Material," or a report in similar form, and forwarded in accordance with the latest instructions of the Bureau of Aeronautics. Such reports of failure shall include:

1. Reporting activity.
2. Nameplate data.
3. Date placed in service.
4. Part which failed.
5. Nature and cause of failure.
6. Remedy used or proposed to prevent recurrence.

CONTRACTUAL GUARANTEE

The Contractor guarantees that at the time of delivery thereof the articles provided for under this contract will be free from any defects in material or workmanship and will conform to the requirements of this contract. Notice of any such defect or nonconformance shall be given by the Government to the Contractor within six (6) months of the delivery of the defective or nonconforming article. If required by the Government within a reasonable time after such notice, the Contractor shall with all possible speed correct or replace the defective or nonconforming article or part thereof. When such correction or replacement requires transportation of the article or part thereof, shipping costs, not exceeding usual

charges, from the delivery point to the Contractor's plant and return, shall be borne by the Contractor; the Government shall bear all other shipping costs. This guaranty shall then continue as to corrected or replacing articles, or, if only parts of such articles are corrected or replaced, to such corrected or replacing parts, until six (6) months after the date of redelivery. If the Government does not require correction or replacement of a defective or nonconforming article, the Contractor, if required by the contracting officer within a reasonable time after the notice of defect or nonconformance, shall repay such portion of the contract price of the article as is equitable in the circumstances.

WARNING

This equipment employs high voltages (600 volts) which are dangerous to life. Operating personnel must at all times observe all safety regulations. Do not change tubes or make adjustments inside the equipment unless the power cord is disconnected. Although bleeder circuits are used to prevent capacitors from retaining charges after the power has been disconnected, always discharge and ground circuits before touching them in order to avoid casualties.

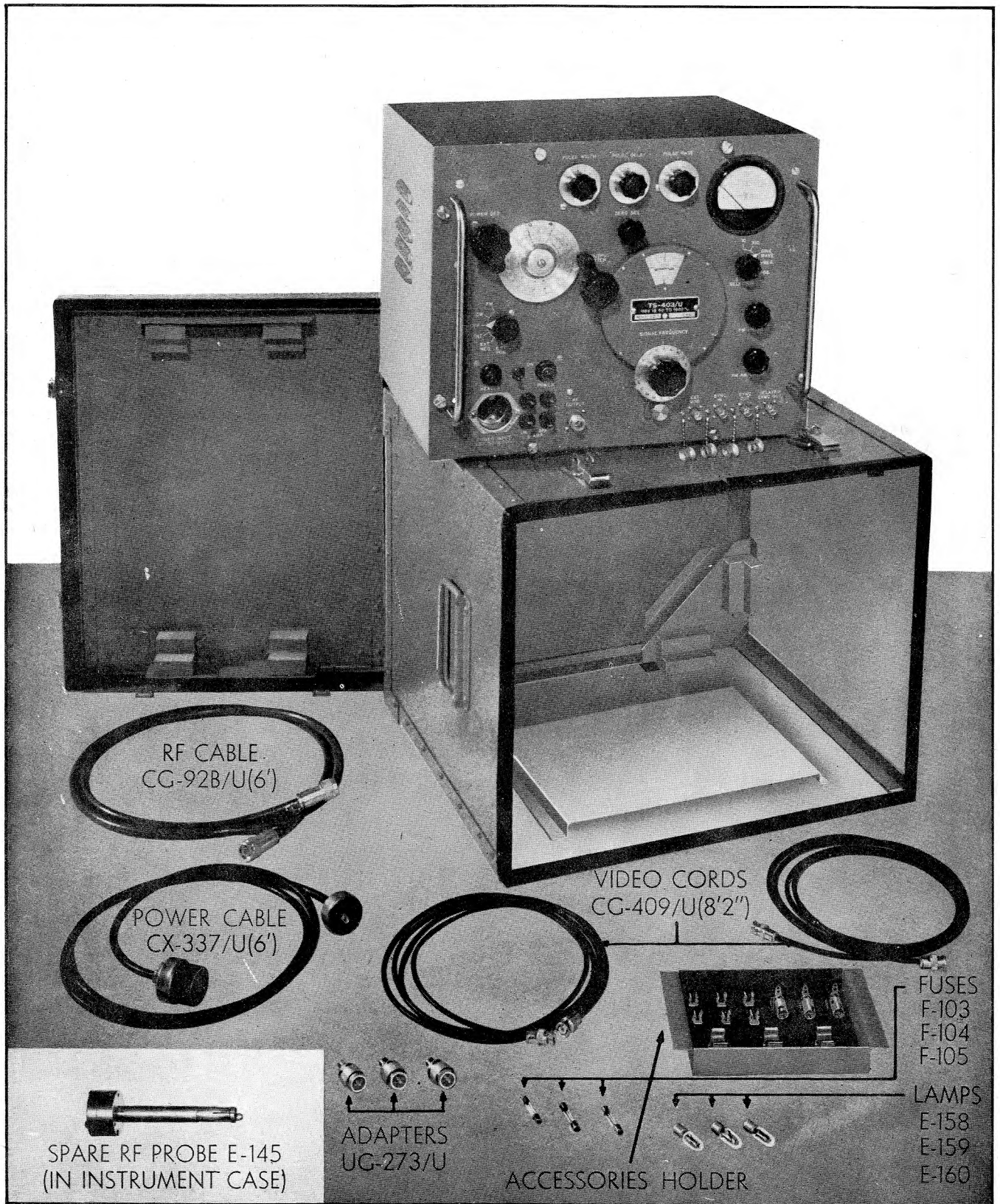

Figure 1-1. Signal Generator TS-403/U, Equipment Supplied

SECTION I

GENERAL DESCRIPTION

1. PURPOSE OF HANDBOOK.

The purpose of this handbook is to describe the operation, adjustment and maintenance of Signal Generator TS-403/U.

2. PURPOSE OF EQUIPMENT.

Signal Generator TS-403/U is a portable, self-contained test equipment designed for use with radio and radar receivers and for other applications requiring small amounts of rf power, such as the measuring of standing wave ratios, antenna characteristics, transmission line characteristics, conversion gain, etc. The instrument generates frequencies from 1800 to 4000 megacycles at amplitudes from 0.1 micro-volt to 0.224 volt when loaded with its rated load of 50 ohms. Both the output frequency and output power from Signal Generator TS-403/U are indicated on direct-reading dials.

3. EQUIPMENT SUPPLIED.

The equipment supplied with Signal Generator TS-403/U is shown in figure 1-1 and listed in table 1-1 below. The weight shown for the equipment itself in the table does not include the weights of the accessories.

Also, two additional spare fuses are located in the spare fuseholders on the front panel of Signal Generator TS-403/U; these two fuses are not included in the table.

4. EQUIPMENT REQUIRED BUT NOT SUPPLIED.

No equipment is required which is not supplied.

5. GENERAL ELECTRICAL CHARACTERISTICS.

Signal Generator TS-403/U generates voltages over a frequency range from 1800 to 4000 megacycles at a maximum power level of one milliwatt or 0.224 volt across 50 ohms. An output attenuator allows the output power to be attenuated over a range from 0 to 127 decibels. Signal Generator TS-403/U is designed to operate from a nominal 115-volt, 50 to 1600 cps, single phase ac power source and draws about 150 watts at a power factor of approximately 0.9.

The instrument is very flexible in operation, producing continuous-wave, pulse-modulated or frequency-modulated output. The instrument can be pulse-modulated either from an internal pulse generator and modulator or from an external source. Circuits and controls are provided for adjusting the width and repetition rate of the

TABLE 1-1. EQUIPMENT SUPPLIED

Quantity per Equipment	Name of Unit	Army-Navy Type Designation	Overall Dimensions (Inches)			Weight (Pounds)	Number Series of Reference Symbol
			Length or Depth	Width	Height		
1	Signal Generator	TS-403, U	17½	14	13½	64	101-199
1	Transit Case	CY-669/U	19½	17	17¾	26	. . .
1	Power Cord	CX-337/U(6')	72			0.62	W-104
1	RF Cable	CG-92B/U(6')	72			1	W-101
2	Video Cord	CG-409/U(8'2")	98			0.25 each	W-102, W-103
3	Adapter	UG-273/U	1-5/16 x ¼ diam			0.06	E-142 to E-144
3	Fuse		1¼ x ¼ diam			0.004 each	F-103 to F-105
3	Pilot Lamp		1⅛ x ⅜ diam			0.004 each	E-158 to E-160
1	RF Probe		2-29/32 x 7/8 OD			0.25	E-145

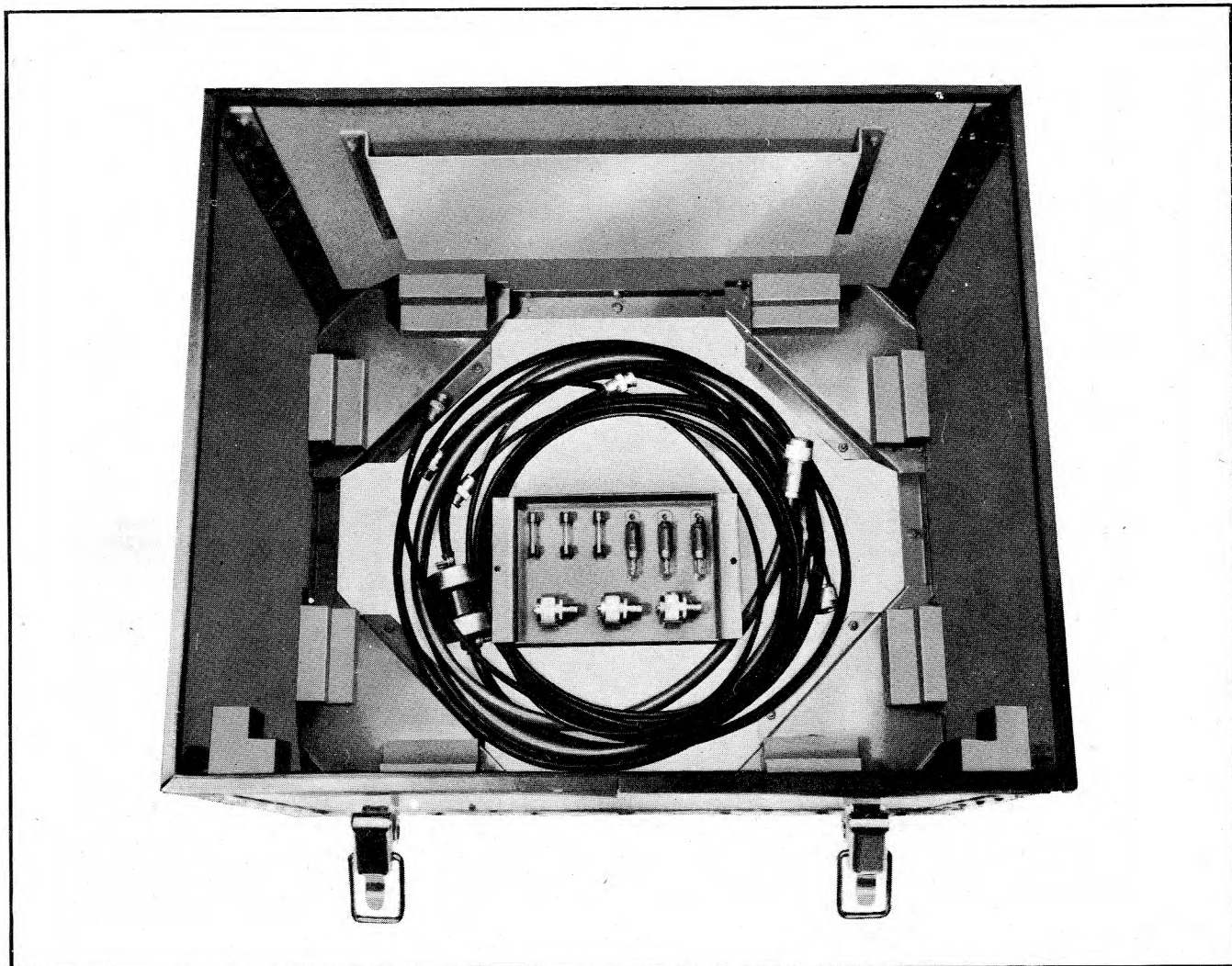

Figure 1-3. Mounting of Accessories in Bottom of Transit Case CY-669/U

plug on each end. Two of these cords are provided with each instrument. The cords are designed to connect to the BNC jacks on Signal Generator TS-403/U.

c. Cord CX-337/U(6') is provided for connecting the power plug on the instrument to the ac supply. The cord consists of approximately six feet of two-conductor cable with a conventional power plug on one end and a motor body on the opposite end.

d. Adapter UG-273/U is provided for adapting the UHF series of connectors to the BNC series. Three such adapters are provided with each instrument.

e. Fuses F-103 to F-105 are provided in the transit case cover for replacing the fuses in the instrument when necessary. Five spare fuses are provided, three being located in the transit case and two in the spare fuse-holders on the front panel of Signal Generator TS-403/U.

f. Pilot lamps E-158 to E-160 are also provided in the transit case cover. Three spare lamps are provided for replacing the lamps in the holders on the panel of the instrument when necessary.

g. RF probe E-145 is located on the back side of the

chassis of the instrument. This assembly is provided as a spare for the monitor RF probe in the instrument. A procedure is included in Section IV of this manual for replacing the RF probe.

9. QUANTITY AND TYPES OF TUBES AND LAMPS.

The vacuum tube and lamps used in Signal Generator TS-403/U are shown in table 1-2 together with the quantities used of each.

TABLE 1-2. TUBES AND INDICATOR LAMPS.

JAN or Navy Type	Quantity	JAN or Navy Type	Quantity
6SL7GT	1	2K28	1
6J6	3	OA2	3
6C4	4	5R4GY	1
6X5GT	2	(lamp)	2
6Y6G	2		

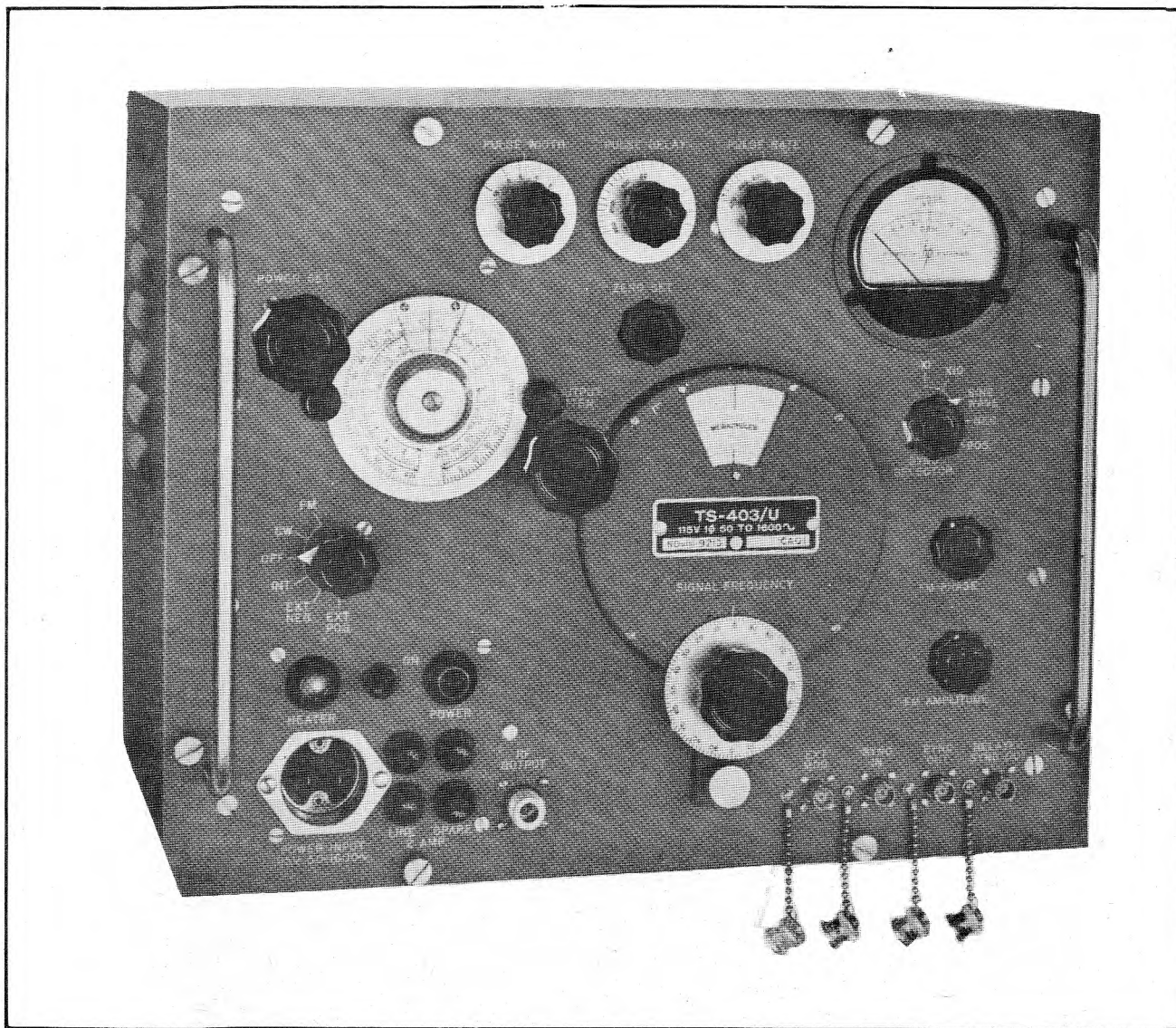

Figure 1-4. Signal Generator TS-403/U, Oblique View

SECTION II OPERATION AND ADJUSTMENT

1. FUNCTION OF EQUIPMENT.

Signal Generator TS-403/U is designed to generate voltages within the frequency range from 1800 to 4000 megacycles. These voltages can be continuous wave, frequency modulated at the power line frequency, or pulse or square wave modulated as desired. The pulsed rf output can be synchronized with external positive or negative pulses or external sine waves—or the output can be modulated directly by external positive or negative pulses or square waves. The pulsed rf output can be delayed over a range from 3 to 300 microseconds. Signal Generator TS-403/U also provides two video pulses, one of which is delayable so that it is coincident with the rf pulse.

2. OPERATING CONTROLS, DIALS AND TERMINALS.

a. CONTROLS.—All controls necessary for the operation of the instrument are located on the front panel. Figure 2-1 shows the front panel of the instrument, while figure 2-2 is an outline drawing of the panel with the controls, dials, and terminals numbered. These numbers are repeated in Table 2-1 which gives the name and function of the corresponding controls. The numbers are also used throughout this section as a reference to the controls.

At least seven different functions can be fulfilled by this signal generator, but since most of them involve the

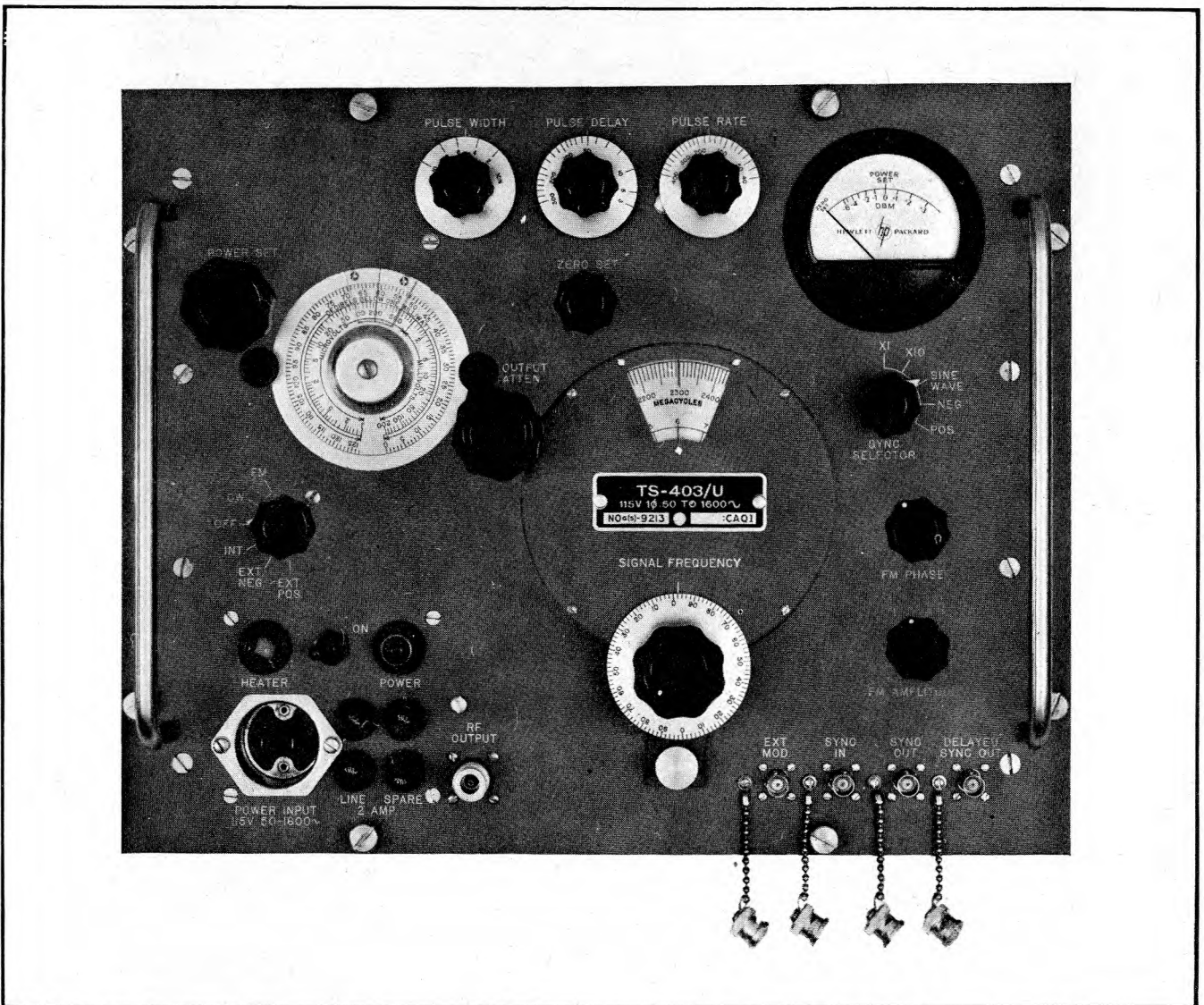

Figure 2-1. Signal Generator TS-403/U, Front Panel Controls

use of the UHF oscillator, consider first the controls and procedure for adjusting this oscillator.

b. OSCILLATOR CONTROLS.

(1) The main tuning dial (number 5 in figure 2-2) is calibrated directly in megacycles from 1800 to 4000 and is the frequency dial for the UHF oscillator. The setting of the main tuning dial is adjusted by control number 6, marked SIGNAL FREQUENCY. In addition to being calibrated directly in frequency, the main tuning dial is calibrated for every half turn of its control knob and the control knob is calibrated from 0 to 100 over each half of its periphery. This feature allows convenient resetting of the main tuning dial and permits interpolation of frequency readings if desired.

(2) Control number 7 is the oscillator modulation selector switch and allows the oscillator to operate in a variety of ways: frequency modulated, continuous wave, internal pulse modulated, external negative pulse or square wave modulated, or external positive pulse or square wave modulated. Before setting the control for any

specific condition of operation, it should be set to the OFF position and the power level meter (number 9) set to the ZERO mark by means of control number 8, the ZERO SET control. This procedure balances the thermistor bridge for zero rf conditions.

The oscillator modulation selector switch (number 7) should then be set to the CW position and the POWER SET control (number 10) adjusted so that the power level meter (number 9) pointer is exactly at the half-scale reference mark. This procedure insures that a standard level of rf is impressed across the output system of the instrument, and even though pulse output may be desired the procedure is useful because it establishes the level of the rf pulses.

(3) The output power level is set with the OUTPUT ATTEN control (number 11). This control adjusts the setting of the output attenuator dial (number 12) which is directly calibrated in decibels from 0 to -127 decibels below one milliwatt and in voltage from 0.224 volt to 0.1 microvolt. The power and voltage calibration is based

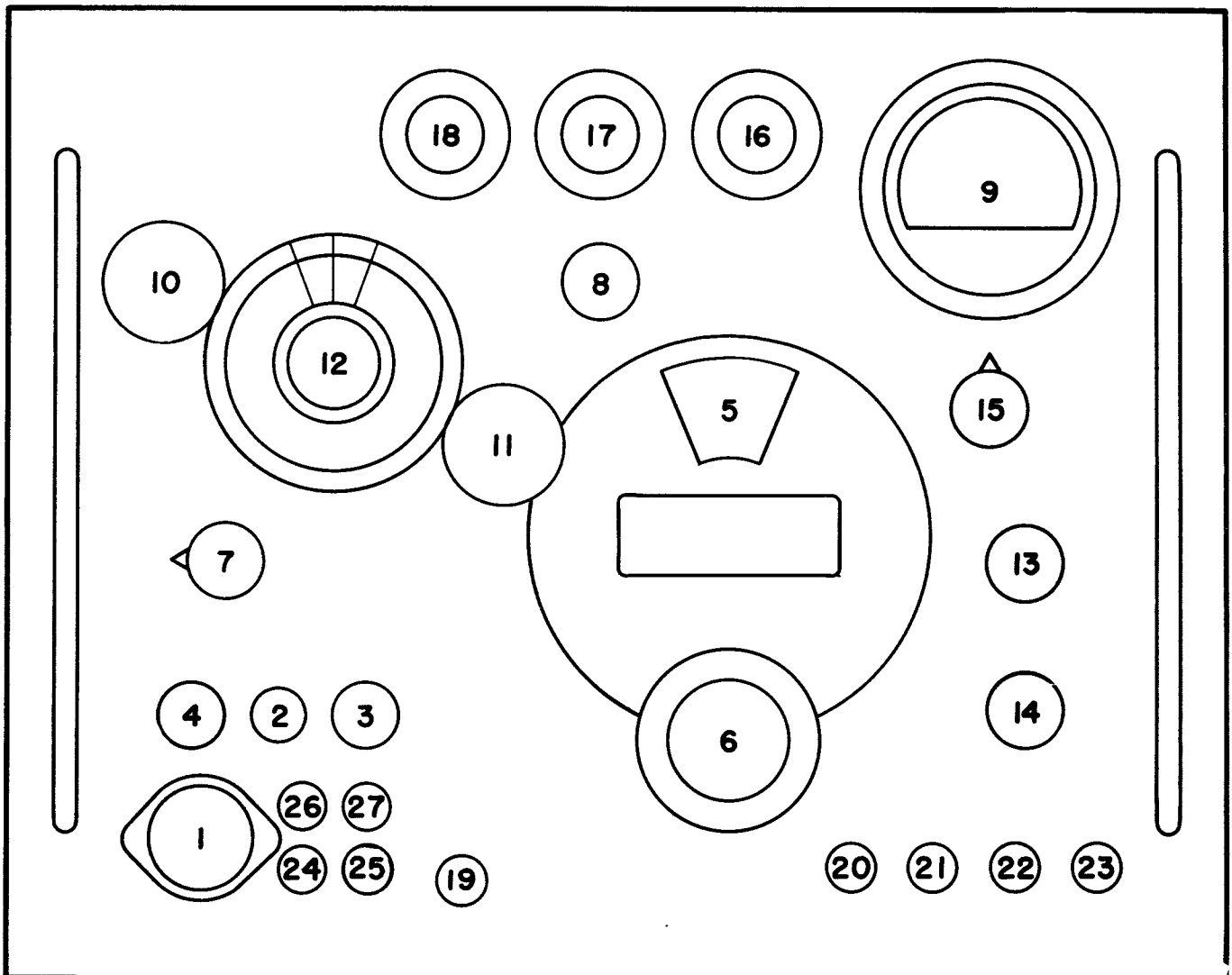

Figure 2-2. Signal Generator TS-403/U, Front Panel With Controls Numbered

upon the assumption that the instrument is working into a 50-ohm resistive load, the load for which the instrument is designed.

(4) The FM PHASE and FM AMPLITUDE controls (numbers 13 and 14 respectively) are provided to allow the phase and deviation of the frequency modulation of the UHF oscillator to be adjusted. The FM PHASE control allows the phase of the ac voltage applied to the repeller of the oscillator to be changed over a range approaching 180° so that the phase may, for example, be made to coincide with the phase of the sweep on an external synchroscope. The FM AMPLITUDE control adjusts the amplitude of the frequency swing of the rf carrier over a maximum range of the order of one-half of one per cent of the carrier frequency. The maximum amount of deviation also is dependent upon the repeller mode in which the oscillator is working; thus at the higher carrier frequencies less deviation is obtainable than at lower carrier frequencies. Neither the FM PHASE nor the FM AMPLITUDE control are calibrated; they should be adjusted to suit the conditions of test.

c. MODULATOR CONTROLS.—There are four controls provided for adjusting the Modulator for the desired type of operation: SYNC SELECTOR switch (number 15), PULSE RATE (number 16), PULSE DELAY (number 17), and PULSE WIDTH (number 18).

(1) The PULSE WIDTH control is calibrated approximately from 0 to 10 microseconds and determines the duration of the rf pulse obtained from the signal generator. It should be noted that the calibrations on the PULSE WIDTH control are accurate within 20% or 2 microseconds, whichever is greater, and that in applications where it is desirable to know the pulse width accurately, the pulse width should be measured on a synchroscope. Also, if the carrier frequency is changed and the PULSE WIDTH control setting kept constant, the width of the output rf pulse may change in the order of one or two microseconds, owing to the characteristics of the oscillator tube.

(2) The PULSE DELAY control is calibrated from 3 to 300 microseconds and determines the time interval between the application of an external synchronizing pulse to the Modulator and the beginning of the output rf pulse from the instrument. Maximum delay of 300 microseconds can not be used when the prf is higher than about 2500 pps because the interval between pulses approaches 300 microseconds and the operation of the pulse delay multivibrator then tends to become unstable. Further, as the prf is increased above 2500, less and less delay can be used until at the highest useable prf of 4000 pps, a delay of about 175 microseconds is the maximum delay that can be used. In any case the delay used should not be more than 75% of the period between pulses.

Inasmuch as the PULSE DELAY control affects the time-phase of the output rf pulse and inasmuch as the start of the output rf pulse is approximately concurrent with the start of the DELAYED SYNC OUT pulse, it should be noted that the PULSE DELAY control affects

the time-phase of the DELAYED SYNC OUT pulse as well as that of the output rf pulse.

The calibration of the PULSE DELAY control is designed to be accurate within plus or minus 20% or 3 microseconds, whichever is greater; therefore, in applications where the interval between the start of the external synchronizing pulse and the start of the rf pulse and or the DELAYED SYNC OUT pulse must be known accurately, this delay interval should be measured on a synchroscope.

(3) The PULSE RATE control is calibrated from 40 to 400 pps and this calibration is multiplied by the first two positions (x1 and x10) of the SYNC SELECTOR switch. Hence, the PULSE RATE control allows direct selection of pulse rates from 40 pps to 400 pps on the x1 range and from 400 to 4000 pps on the x10 range.

The calibration of the PULSE RATE control is designed to be accurate within 25%, and in applications where it is desired to know the pulse repetition rate accurately, the rate should be measured externally.

(4) The SYNC SELECTOR switch allows the Modulator to be synchronized with various types of external voltages and also allows the Modulator to generate pulses having a repetition rate determined by the setting of the PULSE RATE control as described above.

The SINE WAVE position of the switch allows the Modulator to be synchronized with external sine-wave voltages having a peak amplitude between 5 and 50 volts and a frequency between 40 and 4000 cps.

The NEG and POS positions of the switch allow the Modulator to be synchronized with external negative and positive pulses respectively having a peak amplitude between 10 and 50 volts and a repetition rate between 40 and 4000 pulses per second. The external synchronizing pulse must have a duration between 0.5 and 20 microseconds between its half-voltage points and a rise time of less than 0.5 microsecond between 10% and 90% of maximum amplitude. When synchronizing with external positive pulses, it is desirable to turn the PULSE RATE control completely clockwise in order to preclude any possibility of loss of synchronization.

d. OUTPUT TERMINALS.—Three output terminals are provided on Signal Generator TS-403 U, the most important being the RF OUTPUT terminal (number 19 in figure 2-2). At this terminal the rf output is obtained from the instrument.

The SYNC OUT terminal (number 22) provides a positive video pulse for external use. The leading edge of this pulse occurs within 0.5 microsecond of the leading edge of the external synchronizing pulse when the Modulator is synchronized with external pulses. The SYNC OUT pulse has a minimum amplitude of 20 volts and a duration of not more than five microseconds when loaded with rated load. The duration of the pulse is affected by the load that is used. The terminal is designed to be worked into loads ranging from 500 to 100,000 ohms resistive and shunted with not more than 1500 micromicrofarads. Minimum duration of the SYNC OUT pulse is obtained with loads of low capacity and low resistance.

TABLE 2-1. OPERATING CONTROLS, DIALS AND TERMINALS

REFERENCE NO. (Fig. 2-2)	DESIGNATION	FUNCTION
1	POWER INPUT	Power connector
2	ON	Power switch. In the ON position the instrument is on; in the opposite position only the space heater is on.
3	POWER	Pilot lamp (red) that indicates space heater is off and circuits are energized.
4	HEATER	Pilot lamp (white) that indicates space heater is on and circuits are unenergized.
5	MEGACYCLES	Main tuning dial.
6	SIGNAL FREQUENCY	Main tuning dial control knob.
7	FM, CW, OFF, INT, EXT NEG, EXT POS	Oscillator modulation selector switch.
8	ZERO SET	Meter zero set control.
9	POWER SET	Output level reference meter.
10	POWER SET	Adjusts reading of POWER LEVEL meter.
11	OUTPUT ATTEN	Output attenuator control.
12	MICROVOLTS MILLIVOLTS, ETC.	Output level indicating dial.
13	FM PHASE	Adjusts phase of frequency swing of rf carrier when frequency-modulated.
14	FM AMPLITUDE	Adjusts amplitude of frequency swing of rf carrier when frequency-modulated.
15	SYNC SELECTOR	Adjusts Modulator so that it will synchronize with various types of external voltages; also allows Modulator to generate pulses internally.
16	PULSE RATE	Selects pulse repetition rate when Modulator generates internal pulse.
17	PULSE DELAY	Determines delay in microseconds between external synchronizing pulse and start of output rf pulse.
18	PULSE WIDTH	Determines width in microseconds of output rf pulse.
19	RF OUTPUT	Terminal at which rf output is obtained.
20	EXT MOD	Terminal to which external modulating voltage is applied.
21	SYNC IN	Terminal to which external synchronizing voltage is applied.
22	SYNC OUT	Terminal at which undelayable positive video pulse is obtained.
23	DELAYED SYNC OUT	Terminal at which delayable positive video pulse is obtained; this pulse is approximately simultaneous with start of rf pulse.
24	LINE	Holder for 2 ampere line fuse.
25	SPARE	Holder for spare 2 ampere line fuse.
26	LINE	Holder for 2 ampere line fuse.
27	SPARE	Holder for spare 2 ampere line fuse.

The rise time of the SYNC OUT pulse is less than 1.5 microseconds when obtained across the specified load.

The DELAYED SYNC OUT terminal (number 23) also provides a positive video pulse for external use. However, this pulse is primarily different from the pulse available at the SYNC OUT terminal in that it occurs later than the SYNC OUT pulse by the amount indicated by the setting of the PULSE DELAY control. In other words the DELAYED SYNC OUT pulse always occurs from 3 to 300 microseconds later than the SYNC OUT pulse. The characteristics of the DELAYED SYNC OUT pulse are similar to those of the SYNC OUT pulse, having a peak amplitude of at least 20 volts, a duration of not more than 5 microseconds, and a rise time of less than 1.5 microseconds. The DELAYED SYNC OUT terminal also is designed to be worked into loads ranging from 500 to 100,000 ohms resistive shunted by not more than 1500 mmf. The capacitive component of the load affects the duration of the pulse in a manner similar to that of the SYNC OUT pulse.

The distinctions between the three output pulses which are generated by Signal Generator TS-403/U can be summarized as follows: All three have the same repetition rate; however, the RF OUTPUT pulse consists of a pulsed rf carrier whereas the SYNC OUT and DELAYED SYNC OUT pulses are video pulses. In addition the RF OUTPUT and DELAYED SYNC OUT pulses start essentially at the same time, while the SYNC OUT pulse starts from 3 to 300 microseconds earlier. The RF OUTPUT pulse is adjustable in duration over a range from 0.5 to 10 microseconds, while the duration of the SYNC OUT and DELAYED SYNC OUT pulse is not adjustable although it is affected somewhat by the characteristics of the load used.

When Signal Generator TS-403/U is externally modulated, there is essentially no time lag between the application of the external modulating pulse and the time of occurrence of the RF OUTPUT and DELAYED SYNC OUT pulses. Also, when Signal Generator TS-403/U is externally modulated, it is possible to obtain a SYNC OUT pulse when the SYNC SELECTOR switch is in the x1 or x10 positions, but in this case the SYNC OUT pulse does not bear any relation whatsoever to the RF OUTPUT or DELAYED SYNC OUT pulses.

e. INPUT TERMINALS.—Two input terminals are provided on Signal Generator TS-403/U: the EXT MOD terminal (number 20) and the SYNC IN terminal (number 21). The EXT MOD terminal is provided for external modulation of the rf oscillator by external pulses or square waves. The external voltage must have an amplitude between 40 and 70 volts. Pulses of positive polarity can be used to modulate the rf oscillator by setting control number 7 to the EXT POS position, while pulses of negative polarity can be used by setting control number 7 to the EXT NEG position.

It should be noted that the oscillator can only be amplitude-modulated by essentially rectangular pulses or square waves and cannot be amplitude-modulated with sinusoidal waves. This restriction is caused by the characteristics of

the JAN-2K28 rf oscillator tube whose design does not permit sinusoidal amplitude modulation.

The SYNC IN terminal is provided for connecting to the external synchronizing voltage when it is desired to synchronize the Modulator with an external pulse or sine-wave voltage. These external synchronizing voltages should have the characteristics described above in paragraph 2c(4) which explained the operation of the SYNC SELECTOR switch.

f. POWER TERMINAL.—The POWER INPUT terminal (number 1) is provided for connecting to the power line. This terminal should be connected to a nominal 115-volt, 50 to 1600 cps single phase power source by means of power cord CX-337/U(6') which is provided with the signal generator.

3. STEP-BY-STEP OPERATING PROCEDURE.

a. POWER CONNECTION.—Connect the power plug (number 1) of Signal Generator TS-403, U to a nominal 115-volt, 50 to 1600 cps, single phase power source and turn on the power switch (2). Allow the instrument to heat for a minimum of five minutes. If ambient temperature is below about 10° C (50° F), a longer warm-up period of 30 minutes or more is desirable, especially if accuracy of output power is important.

CAUTION

If Signal Generator TS-403/U has been subjected to conditions causing moisture condensation (such as rapid changes in temperature), allow the instrument to heat for as long a time as possible before using. Signal Generator TS-403/U has been designed to withstand extremes in temperature, but it is desirable to dry any condensed moisture.

b. ADJUSTING THE OSCILLATOR.

(1) Set main tuning dial to desired frequency by means of control 6.

(2) Connect external load to RF OUTPUT terminal (19). This load should be 50 ohms resistive. Cable CG-92B/U(6') is provided for convenience in making this connection.

(3) Set Control 7 to OFF position and adjust ZERO SET control so that power level meter reads exactly zero (index line at left end of meter scale arc).

(4) Set control 7 to CW position and adjust POWER SET control so that power level meter pointer is at the 0 DBM mark at half scale on the meter.

(5) Adjust ATTEN control until output attenuator dial indicates desired output power or voltage.

(6) Continuous wave output will now be obtained from the signal generator. If pulse or frequency-modulated output is desired, see the following.

c. TO USE THE MODULATOR AS A FREE-RUNNING PULSE MODULATOR.

(1) Set SYNC SELECTOR switch to x1 or x10 position and adjust PULSE RATE control so that desired repetition rate from 40 to 4000 pps is indicated.

(2) Adjust PULSE WIDTH control for desired pulse width between 0.5 and 10 microseconds.

(3) If the timing of the rf pulse is not suitable for use with the external equipment, such as the range scope of the receiver, adjust the PULSE DELAY control as necessary.

d. TO SYNCHRONIZE THE MODULATOR WITH AN EXTERNAL VOLTAGE.

(1) Connect the external synchronizing voltage to the SYNC IN terminal. Video cable CG-409/U(8'2") is convenient to use in making this connection.

(2) Set the SYNC SELECTOR switch to the SINE WAVE, NEG or POS position, depending upon the type of external synchronizing voltage to be used. If the external synchronizing voltage is a positive pulse, set the PULSE RATE control completely clockwise.

(3) Adjust the PULSE WIDTH control for the desired rf pulse width between 0.5 and 10 microseconds.

(4) If the timing of the RF OUTPUT pulse, in relation to input SYNC pulse, is not suitable for use with the external equipment, adjust the PULSE DELAY control as necessary.

e. TO MODULATE THE OSCILLATOR WITH AN EXTERNAL VOLTAGE.

(1) Connect the external pulse or square wave voltage to the EXT MOD terminal of the signal generator. The modulating voltage should have the characteristics described in paragraph 2*e* above. Video cable CG-409/U(8'2") is convenient to use in making this connection.

(2) Set switch 7 to the EXT NEG or EXT POS position, depending upon the polarity of the modulating voltage.

f. TO OBTAIN FREQUENCY-MODULATED OUTPUT.

(1) Set switch 7 to FM position.

(2) Adjust the FM PHASE and FM AMPLITUDE controls for the desired phase and deviation. The FM PHASE control will vary the phase over a range approaching 180 degrees, while the FM AMPLITUDE control pro-

vides maximum deviations of the order of one-half of one per cent of the carrier frequency. Neither of these controls is calibrated; they should be adjusted to suit the test conditions.

g. TO OBTAIN A TRIGGER FOR EXTERNAL USE.

(1) Two trigger voltages for external use are provided both when the Modulator is free-running and when synchronized with an external voltage.

(2) A positive video pulse is obtainable from the SYNC OUT terminal. This pulse is not capable of being delayed in any way.

(3) A positive video pulse is obtainable from the DELAYED SYNC OUT terminal. This pulse is essentially synchronous with the rf pulse generated by the instrument and is thus delayable over a range from 3 to 300 microseconds.

(4) In cases where the oscillator is modulated by an external pulse or square wave, a positive video pulse also is obtainable from the DELAYED SYNC OUT terminal. In some conditions a pulse is obtainable from the SYNC OUT terminal when the oscillator is externally modulated; however, this pulse bears no relation whatsoever to the output rf pulse or the external modulating pulse.

4. HEATER OPERATION.

The instrument may be shut off while in any operating sequence by turning the power switch (number 2) off. This disconnects the a-c power from the power supply and leaves only the heater connected and in operation. In humid climates such operation is desirable when the instrument is idle to prevent excessive moisture condensation. The power cord must be removed from the POWER INPUT receptacle (number 1) on the front panel in order to remove power from the instrument entirely.

5. MISCELLANEOUS.

A discussion of miscellaneous factors involved in the operation of a UHF Signal Generator is included in Section V under paragraph 3.

SECTION III THEORY OF OPERATION

1. INTRODUCTION.

Signal Generator TS-403/U is a test equipment designed to generate voltages from 1800 to 4000 megacycles at amplitudes from 0.224 volt to 0.1 microvolt. The instrument is designed to work into external loads of 50 ohms.

Signal Generator TS-403/U is capable of generating several types of rf output: pulse, CW, or CW with frequency modulation. Pulsed rf output from the instrument can be synchronized with a variety of external voltages: positive pulses, negative pulses, or sine waves. A delay circuit is provided so that the time of occurrence of the rf output pulse can be delayed from the time of application of the synchronizing voltage. The rf output from the instrument also can be directly modulated by external pulses or square waves.

The instrument generates two separate video pulses which can be used with external equipment. One video pulse is essentially coincident with the application of the external synchronizing voltage; the second video pulse is coincident with the rf pulse generated by the instrument.

2. BLOCK DIAGRAM.

The basic circuit of Signal Generator TS-403/U consists of four sections as shown in figure 3-1: The modu-

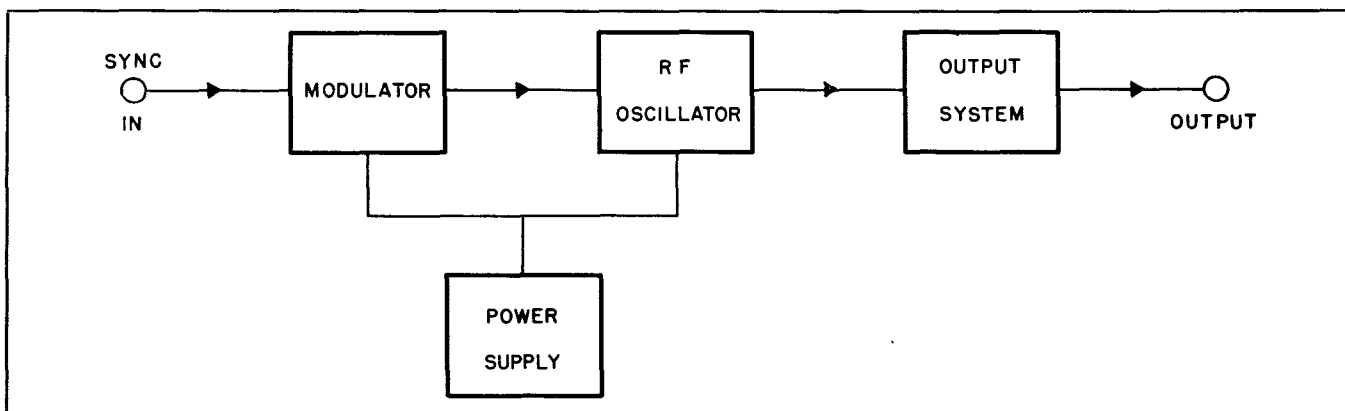

Figure 3-1. Signal Generator TS-403/U, Circuit Block Diagram

lator, rf oscillator, output system, and power supply. The modulator keys the oscillator to produce the desired type of rf output. The output system determines the amount of rf power available to the load and provides a direct-reading power output control. The power supply provides plate and filament power for the modulator and oscillator. A complete schematic diagram of the circuit is given in figure 7-1 at the back of Section VII. Each of the four basic sections of the circuit is described in detail below.

3. RF OSCILLATOR.

The rf oscillator is the heart of Signal Generator TS-403 U, generating the rf power which is delivered to

the external load. The oscillator circuit is that of a velocity-modulation tube operating with an external resonant cavity. The tube used is a type JAN-2K28 reflex klystron, the name "reflex" being derived from the fact that a single set of grids performs the dual function of bunching and then catching the electron stream. An equivalent circuit of the oscillator is shown schematically in figure 3-2.

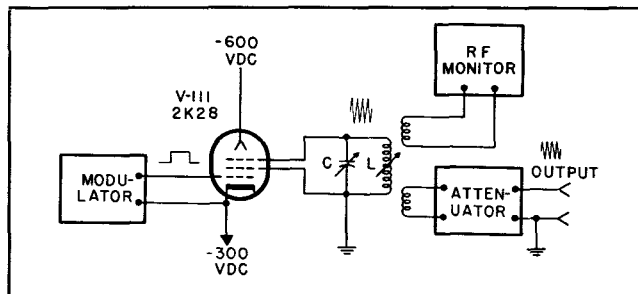

Figure 3-2. Equivalent Oscillator Circuit

The resonant circuit L and C in figure 3-2 connects to two tube electrodes known as resonator grids. Physically, the resonator grids of the tube are separated from the cathode by an accelerator grid which accelerates the electrons drawn from the cathode. The repeller electrode on the

opposite side of the resonator grids from the accelerator grid is at a high negative potential so that it repels electrons. Both the resonator grids and the accelerator grid are of relatively coarse, open construction so that electrons can easily pass through them, electrical conditions permitting.

Assuming that the circuit of figure 3-2 is oscillating, its operation can be considered as follows: the tank circuit and resonator grids are highly positive with respect to the cathode and the accelerator grid has been driven positive with respect to the cathode by the pulse from the Modulator so that electrons are drawn towards the positive resonator grids.

Because the circuit is oscillating, an ac voltage exists across the tank circuit L and C. This same voltage exists between the resonator grids so that the field between the grids is constantly changing, sometimes opposing the passage of electrons and sometimes aiding the passage of electrons. Thus, as the electrons from the cathode pass through the resonator grids, some are decelerated while those passing through an instant later are accelerated. The electrons then travel towards the highly-negative repeller electrode, some with less velocity than others. The high negative potential of the repeller causes the electrons to reverse their direction of travel and proceed back towards the resonator grids. The electrons which were accelerated travel faster than those which were decelerated so that both types arrive back at the resonator grids at the same time or in a bunch. The amplitude of the repeller voltage is such that the bunched electrons arrive back at the resonator grids at a time when the field between the resonator grids opposes the passage of electrons. The electrons thus give up energy to the resonator grids and this energy is "stored" in the tank circuit, sustaining the oscillations.

The tank circuit is coupled to an rf monitor which monitors the amplitude of oscillation. The output power

from the oscillator is coupled to the output terminal through an attenuator system. Both the monitor and attenuator are described below in more detail.

A cut-away view of the actual oscillator circuit used in the signal generator is shown in figure 3-3. The tuned circuit shown in the equivalent oscillator circuit of figure 3-2 is a resonant cavity which is tuned by changing the position of the cavity shorting contact. The output power is coupled to the external load by means of a pick-up loop. An identical loop is provided to supply power to the output monitor so that the amplitude of oscillation and thus the power applied to the output attenuator can be known at all times.

The resonant cavity is built in the form of a coaxial transmission line: one cylinder is within the other cylinder. The cavity contact shorts the line at the opposite end of the cavity from the tube. If the cavity contact is set so that it is an odd multiple of a quarter wave length away from the tube, the cavity appears as a high impedance to the tube and is equivalent to a parallel resonant circuit. By changing the position of the cavity contact, the resonant frequency of the cavity also is changed.

The frequency of oscillation is determined by the resonant frequency of the cavity and by the repeller voltage.

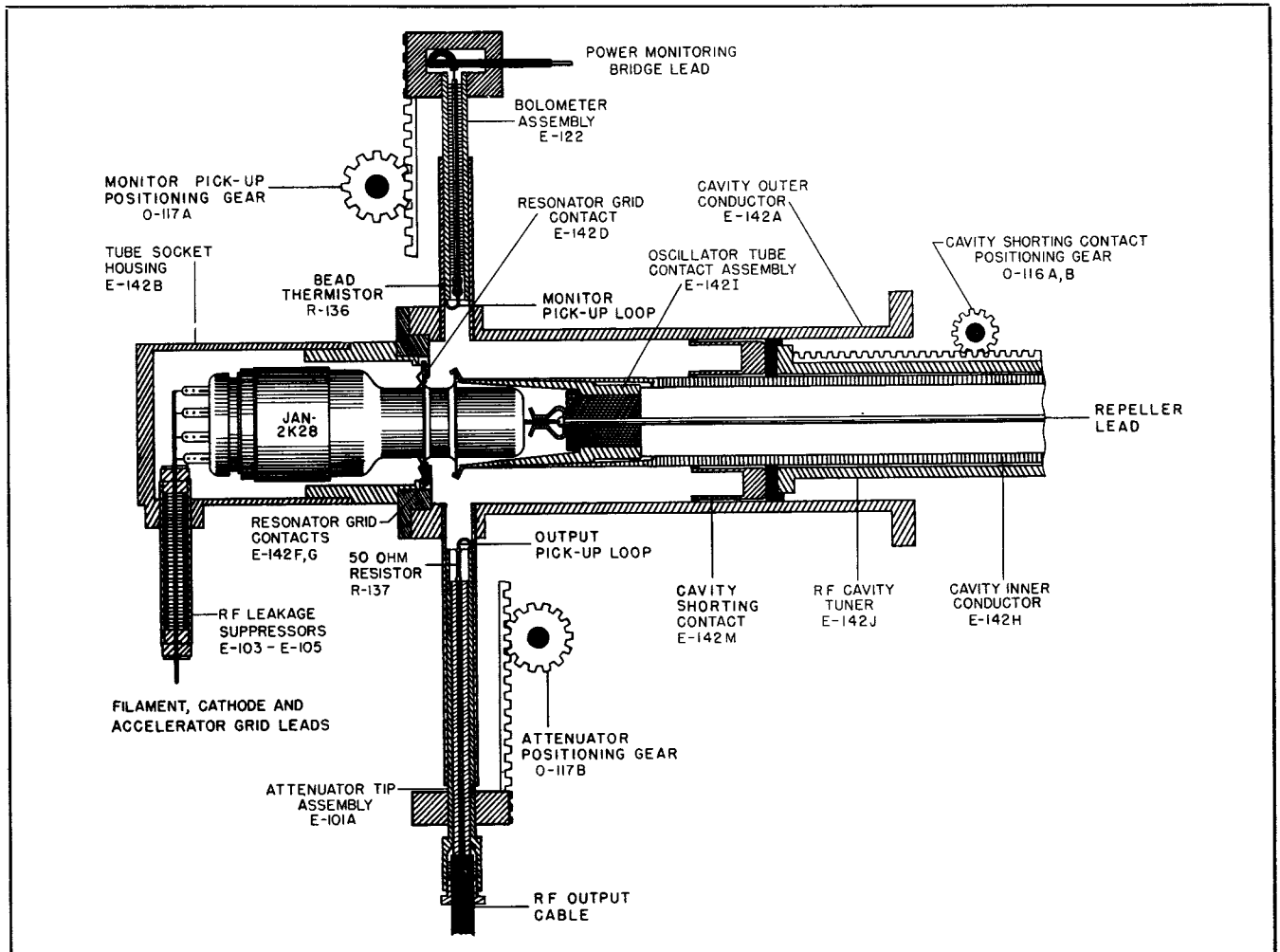

Figure 3-3. Cutaway View of Oscillator

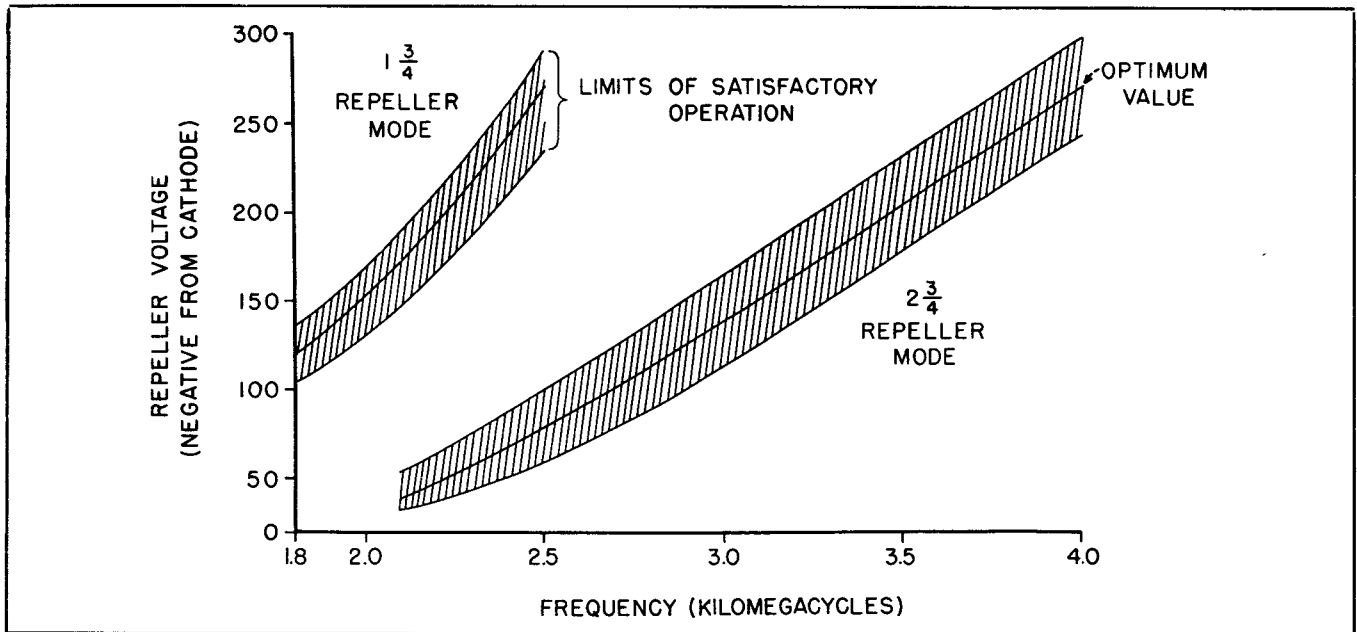

Figure 3-4. Repeller Voltage Characteristics

For a given setting of the cavity there is an optimum value of repeller voltage that causes the bunched electrons to return to the resonator grids at the proper time; hence, the repeller voltage cannot be kept constant over the frequency range of the oscillator. Figure 3-4 shows a plot of the repeller voltage versus frequency characteristic of the circuit. In order to make the oscillator circuit over the wide frequency range from 1800 to 4000 megacycles, an arrangement is used to vary the dc voltage on the repeller so that the repeller voltage is maintained at the optimum point for maximum amplitude of oscillation. However, in the vicinity of 2500 megacycles the repeller voltage becomes excessively high, so that it is convenient to change the repeller voltage to a new value. This can be done without changing the frequency of oscillation at the particular frequency by lowering the repeller voltage so that the tube operates on a higher mode; that is, the bunched electrons require a longer time in cycles to be returned to the resonator grids by the repeller. By adjusting the repeller voltage to the proper value, the bunched electrons still arrive at the resonator at such a time that they give up energy and sustain oscillation. The tube operates on

this higher mode of oscillation from approximately 2400 to 4000 megacycles.

The voltage used to track the repeller is controlled by a wire-wound potentiometer R-173 (figure 3-5). The arm of the potentiometer is mechanically ganged with the cavity shorting contact so that the repeller voltage is maintained at the optimum point for oscillation shown in figure 3-4. The sensitive switch S-102 is operated by a cam on the main tuning drive and changes the voltage applied to the potentiometer so that at about 2400 megacycles the repeller voltage is changed to the lower value. The values of resistors R-174 to R-177 in the voltage divider are selected so that the proper frequency versus voltage characteristic is obtained for the repeller electrode. R-163, R-164, R-166, and R-167 are screwdriver adjusting potentiometers which adjust the voltage applied to the tracking potentiometer R-173.

a. RF OUTPUT.—The rf power output from the oscillator is obtained from the resonant cavity by means of a pick-up loop located in a small section of waveguide which opens into the resonant cavity (figure 3-3). The cross-sectional area of the waveguide is small enough so that energy is usually considered not to be propagated directly down the waveguide; that is, the waveguide is smaller than the cut-off size of waveguide for these frequencies. However, a small amount of energy is propagated down the guide and this energy decreases exponentially as the length of the guide is traversed. Since the output power in decibels is proportional to the square of the voltage obtained, it is possible to move the pick-up in the waveguide by means of a gear system and to calibrate the gear system linearly in decibels of output power. This has been done in the TS-403/U, providing a directly calibrated power output system.

The pick-up loop couples energy from the resonant cavity to the output terminal through a special resistor R-138 which is designed to provide about 6 db of loss in

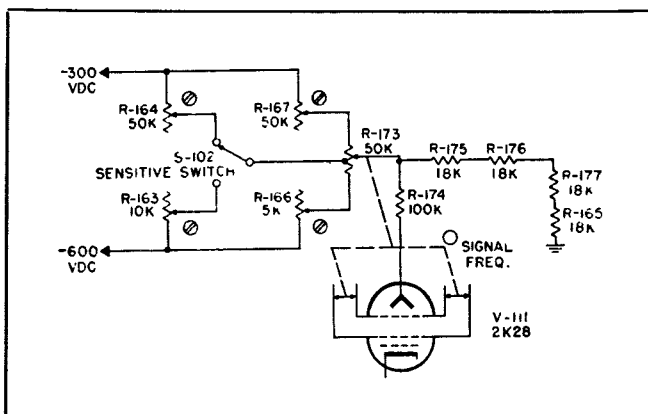

Figure 3-5. Repeller Voltage Tracking Circuit

the circuit. This resistor is additional to the 50-ohm resistor R-137 near the pick-up loop which matches the pick-up to the output line. The function of the special resistor is to make the internal impedance of the generator as near 50 ohms as possible. This the resistor does by isolating to a degree the output terminal from the power source in the same manner as a conventional attenuator at lower frequencies. The effect of the resistor can be seen by considering the generator as the termination on a 50-ohm line. If power is sent down the line toward the generator, some of it will be reflected from a point within the generator if the generator does not appear as 50 ohms. When the special resistor is in the generator, the reflected power is reduced according to the loss in the resistor. Thus,

perature-compensating devices. These two disc thermistors are additional to the bead thermistor which is used as the rf indicator. The complete monitor circuit is shown in figure 3-6.

Basically, the bridge circuit is a Wheatstone type in which the bead thermistor is used as one of the arms. A 200-microampere meter is connected across the bridge to indicate the balance of the circuit, and a disc thermistor R-178 is connected in series with the meter. The latter acts as a sensitivity-regulating device and is necessary because of the inherent characteristic of thermistor bridges to increase in sensitivity as the ambient temperature increases.

The second disc thermistor R-170 is shunted across the entire bridge as a balance-regulating device. Because the

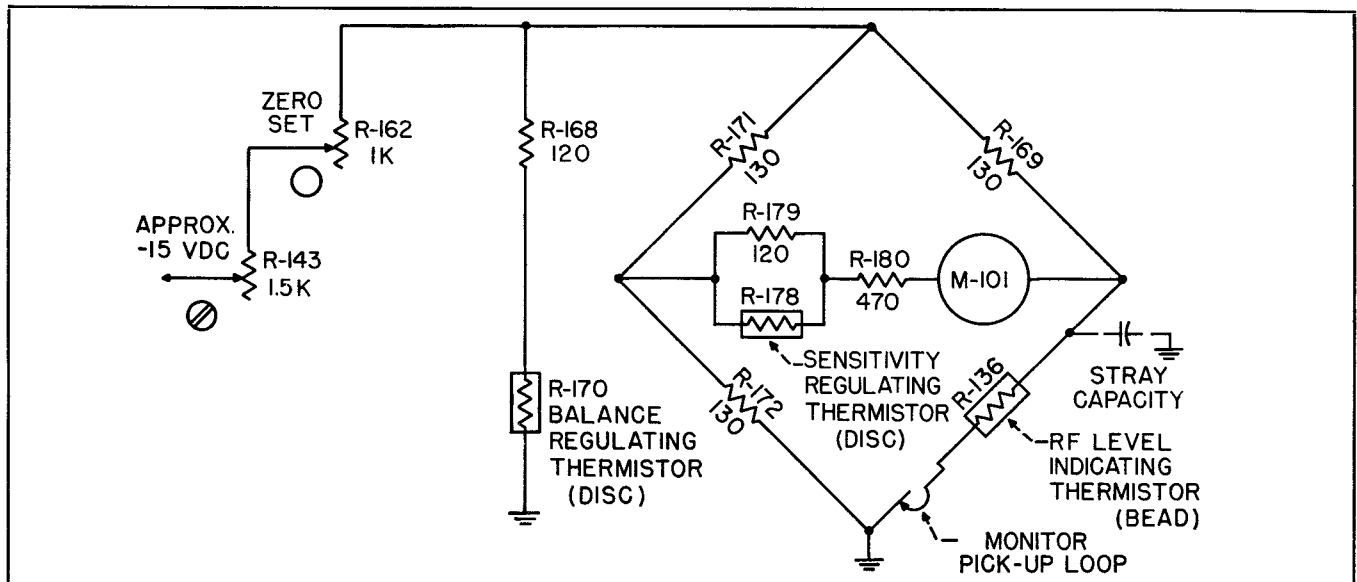

Figure 3-6. Monitor Circuit

standing waves on the line are reduced because the generator is better matched to the line.

The resistor consists of a coating of platinum on a thin glass tube. The rf resistance of the platinum coating is sufficient to cause a 6 db loss in the circuit. The resistor is designed to act as a high-loss center conductor for part of the output transmission line.

b. RF MONITOR.—In order that the power applied to the external load can be known, it is necessary that the current or voltage applied to the load (as well as the load itself) be known. In the TS-403/U, the fields within the cavity are monitored by a thermistor bridge circuit. A pick-up loop and piston type attenuator (figure 3-3) similar to the output system are used to feed a small amount of power from the resonant cavity to a bead thermistor R-136 which is part of the bridge circuit. The bridge is balanced for dc conditions and when the rf power from the resonant cavity is applied to the circuit, the bridge becomes unbalanced, the amount of unbalance being indicated by a dc microammeter connected across the bridge.

The thermistor bridge circuit used in the instrument is known as a "two-disc" bridge circuit, so called because two disc type thermistors are used as sensitivity and tem-

perature-compensating devices. These two disc thermistors are additional to the bead thermistor which is used as the rf indicator. The complete monitor circuit is shown in figure 3-6.

Basically, the bridge circuit is a Wheatstone type in which the bead thermistor is used as one of the arms. A 200-microampere meter is connected across the bridge to indicate the balance of the circuit, and a disc thermistor R-178 is connected in series with the meter. The latter acts as a sensitivity-regulating device and is necessary because of the inherent characteristic of thermistor bridges to increase in sensitivity as the ambient temperature increases.

The second disc thermistor R-170 is shunted across the entire bridge as a balance-regulating device. Because the

bead thermistor R-136 used in the bridge is temperature sensitive, the bridge would tend to drift appreciably from its zero setting as the cavity temperature increased or decreased. The disc thermistor shunted across the bridge compensates for this tendency by changing its dc resistance so that the dc voltage across the bridge is changed in such a manner that the bridge remains in balance even though changes take place in the cavity temperature. This automatic balancing occurs because, by changing the voltage across the bridge, the current through the bead thermistor is changed, thus changing the resistance of the thermistor. By selective design, the dc voltage across the bridge can be varied so as to keep the resistance of the bead thermistor almost constant over a range of ambient temperatures. Thus, the bridge can be zero-set and will remain in balance to a relatively high degree.

The rf power coupled to the bead thermistor by the monitor pick-up loop is not applied to the entire bridge because there is sufficient stray capacity from the wire leading to the bead thermistor to by-pass the power back to the cavity block. This is indicated by the dotted capacity shown in figure 3-6.

Physically, the two disc thermistors are mounted directly upon the oscillator cavity block so that they are main-

tained as close to cavity temperature as possible and so that any changes in the cavity temperature are quickly transferred to the thermistors. Hence, if the cavity temperature changes, the bridge circuit compensates itself so that its sensitivity remains relatively constant and so that the bridge remains in balance for the zero rf condition.

The level of the fields within the oscillator cavity do not remain constant as the frequency of the oscillator is varied, and any changes in the field level are indicated by the monitoring bridge. The rf voltage obtained at the output of the instrument also changes in proportion to the changes within the oscillator cavity. These changes are compensated by moving the bridge pick-up loop closer to or farther from the cavity so that the reading on the

responding to two db more of attenuation. The attenuator dial then shows two db more of attenuation than in the first case. If the original output level is desired, it is necessary to decrease the attenuator reading two db by moving the attenuator pick-up loop closer to the cavity.

4. MODULATOR SECTION.

a. GENERAL.—The Modulator section includes tubes V-101 to V-110. The basic function of the Modulator is to generate a positive video pulse of desired characteristics and to apply that pulse to the accelerator grid of the reflex klystron V-111 so that V-111 will oscillate for the duration of the pulse. The video pulse can, if desired, be synchronized with external pulse or sine-wave voltages.

A block diagram of the Modulator section is shown in

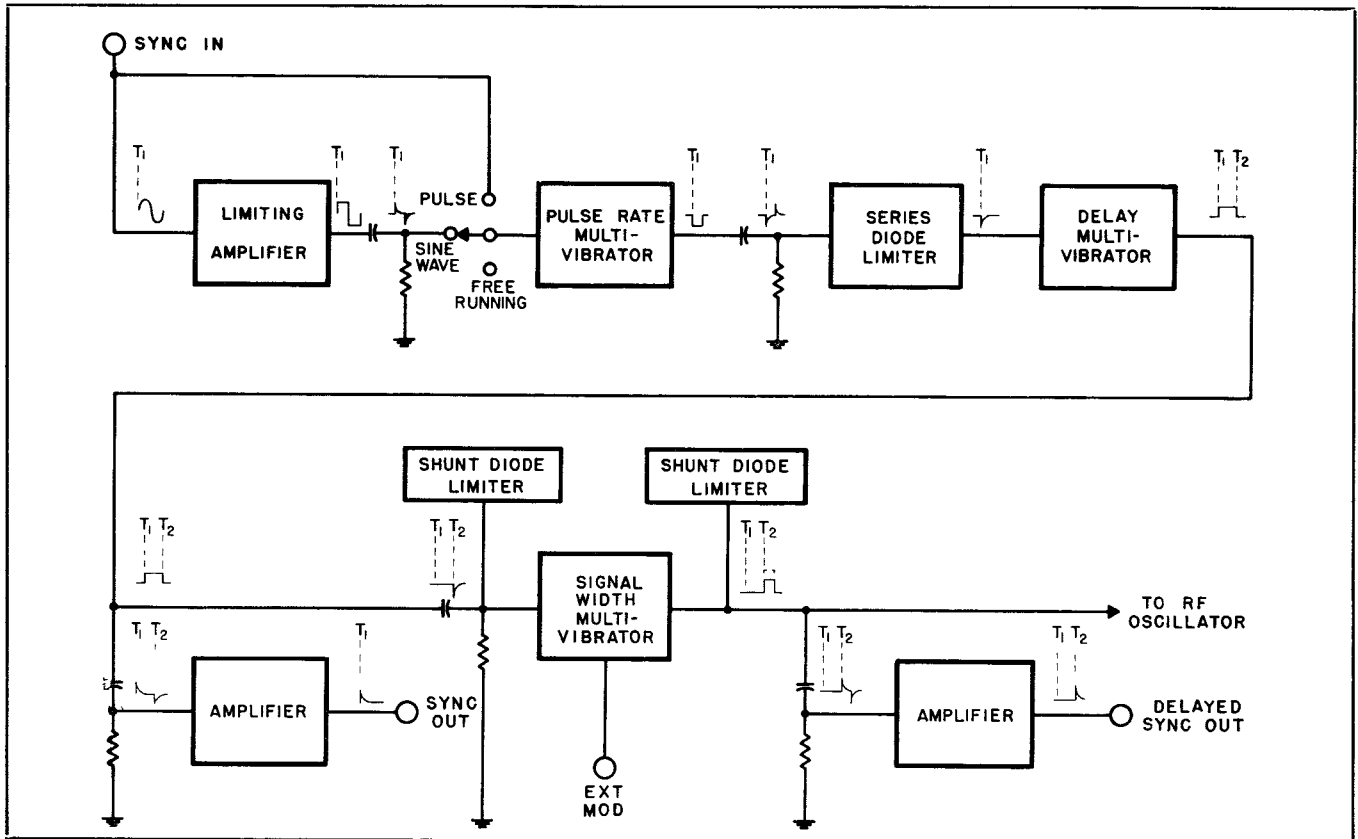

Figure 3-7. Modulator Section Block Diagram

bridge meter is kept constant. The gear system which moves the bridge pick-up loop is mechanically coupled to a ring around the output attenuator dial. The index for the attenuator dial is attached to the ring so that if the position of the monitoring pick-up loop is moved, the index for the attenuator dial is also moved. This system is designed so that any variations in the level of oscillation changes the output attenuator reading a corresponding amount if the reading of the bridge meter is kept constant. For example, if the field level within the cavity drops by two db when the oscillator is set to a new frequency, the reading of the bridge meter falls off two db. Then if the meter reading is advanced two db by moving the monitor pick-up loop closer to the cavity, the index for the attenuator dial automatically moves an amount corre-

figure 3-7. The Pulse Rate Multivibrator (second block in figure 3-7) determines the repetition of the pulses generated by the Modulator. This multivibrator can be synchronized with external pulse or sine-wave voltages—or can generate pulses as a result of its operating in a free-running condition. In order to trigger the multivibrator from sine waves, the sine waves are converted to square waves in the Limiting Amplifier. An RC differentiator at the output of the amplifier converts the square waves to short pulses. The resulting waveforms are shown in the block diagram.

The output of the Pulse Rate Multivibrator is a negative pulse, the leading edge of which is coincident with the leading edge of the trigger voltage as shown by time t_1 . This negative pulse is differentiated by an RC network,

giving a short negative pulse at time t_1 and a short positive pulse at a time coincident with the trailing edge of the multivibrator pulse. These short pulses are applied to the Series Diode Limiter which is designed to pass only the short negative pulse occurring at time t_1 . This short negative pulse is then applied to and triggers the Delay Multivibrator.

The Delay Multivibrator is provided as a means for supplying a time delay between the external synchronizing voltage and the video pulse which is eventually applied to the klystron. The positive pulse generated by the Delay Multivibrator is adjustable in duration over a range from 3 to 300 microseconds and the length of this pulse determines the amount of delay in the circuit. The Delay pulse is differentiated by an RC network, giving a short positive pulse at the leading edge of the pulse (time t_1) and a short negative pulse at the trailing edge of the pulse (time t_2). The positive pulse at time t_1 is shorted out, however, by the first Shunt Diode Limiter, leaving only the negative pip at time t_2 . It should be noted that the time interval between t_1 and t_2 is determined by the duration of the pulse generated by the Delay Multivibrator.

The negative pip occurring at time t_2 is then applied to and triggers the Signal Width Multivibrator, which generates a large positive pulse that is adjustable in duration over a range from 0.5 to 10 microseconds. The amplitude of this pulse is limited at a pre-determined level by the second Shunt Diode Limiter and the pulse is then applied to the accelerator grid of the reflex klystron V-111, allowing oscillation for the duration of the pulse.

The Modulator also provides two separate video pulses for external use. One of these is undelayable and one is delayable. The undelayable pulse is provided at the SYNC OUT terminal and is obtained from the leading edge of the Delay pulse generated by the Delay Multivibrator. The Delay pulse is applied to a differentiating network and the positive pip obtained as a result of the differentiation is brought out to the SYNC OUT terminal through an isolating amplifier. The amplifier is insensitive to negative pulses so that only positive pulses, starting at time t_1 , are obtained.

The external pulse which is delayable is obtained at the DELAYED SYNC OUT terminal. The Signal Width pulse is applied to a differentiating network and the pips resulting from the differentiation are applied to an isolating amplifier which is sensitive only to positive pulses. It should be noted that the start of this delayable pulse occurs at time t_2 and is therefore coincident with the start of the video pulse applied to the accelerator grid of the klystron.

Another function of the Modulator is to allow the klystron to be modulated by external pulses or square waves. The external voltages are applied to one tube of the Signal Width Multivibrator through the EXT MOD terminal. The tube used acts merely as an amplifier in this case.

The waveshapes shown in figure 3-7 are somewhat idealized and do not necessarily illustrate the variations in amplitude which are actually obtained in the circuit. Also,

some of the waveshapes are subject to wide variations, depending upon the repetition rates used and the setting of various controls.

b. PULSE RATE MULTIVIBRATOR.—The initial circuit action of the Modulator can best be considered as beginning with the Pulse Rate Multivibrator V-102. The design of the circuit is such that the Pulse Rate Multivibrator can be synchronized with three types of external voltages: positive pulses, negative pulses, and sine waves. In addition the multivibrator can operate in a free-running condition for applications where it is not desired to synchronize with an external voltage. Since the multivibrator must operate in any of these four conditions, a switching arrangement has been incorporated to allow four different methods of operation for the circuit. Each of these methods is described separately below. It should be noted that each of the four methods produces a negative pulse at the plate of V-102B.

(1) **FREE-RUNNING.**—When switch S-101 is in the x1 or x10 position, the circuit operates as a free-running multivibrator with unbalanced waveform. The multivibrator circuit is shown in figure 3-8 with S-101 drawn in simplified form and unused parts of the circuit removed. Basically, the duration of the pulse generated by the multivibrator at the plate of V-102B is determined by the time constant in the grid of V-102A, while the repetition rate of the multivibrator is determined by the setting of R-109 in the grid circuit of V-102B and by the capacitors C-104 to C-106, also in the grid circuit of V-102B. The multivibrator covers the range from 40 to 4000 pps in two ranges. The higher range from 400 to 4000 pps is obtained by switching C-105 and C-106 out of the circuit. R-109 is the PULSE RATE control and is calibrated directly in pps for the lower range (40 to 400).

It is noteworthy that the grid of V-102A is returned to B plus when the multivibrator is free-running although

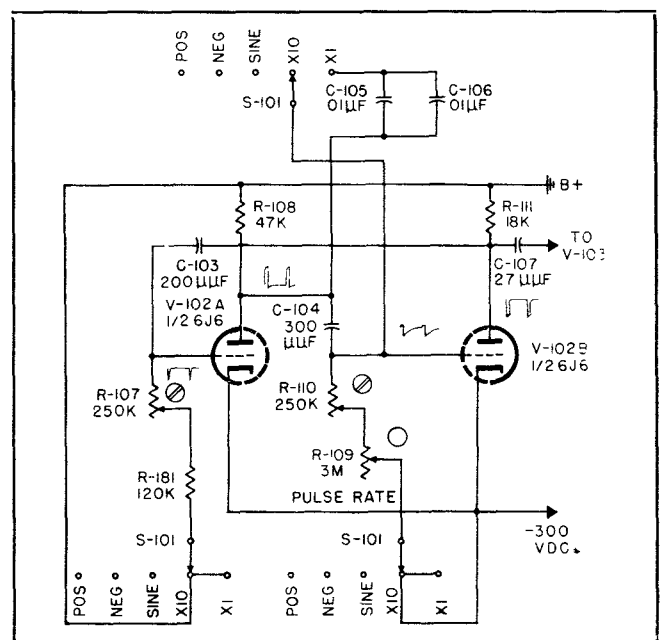

Figure 3-8. Free Running Pulse Rate Multivibrator

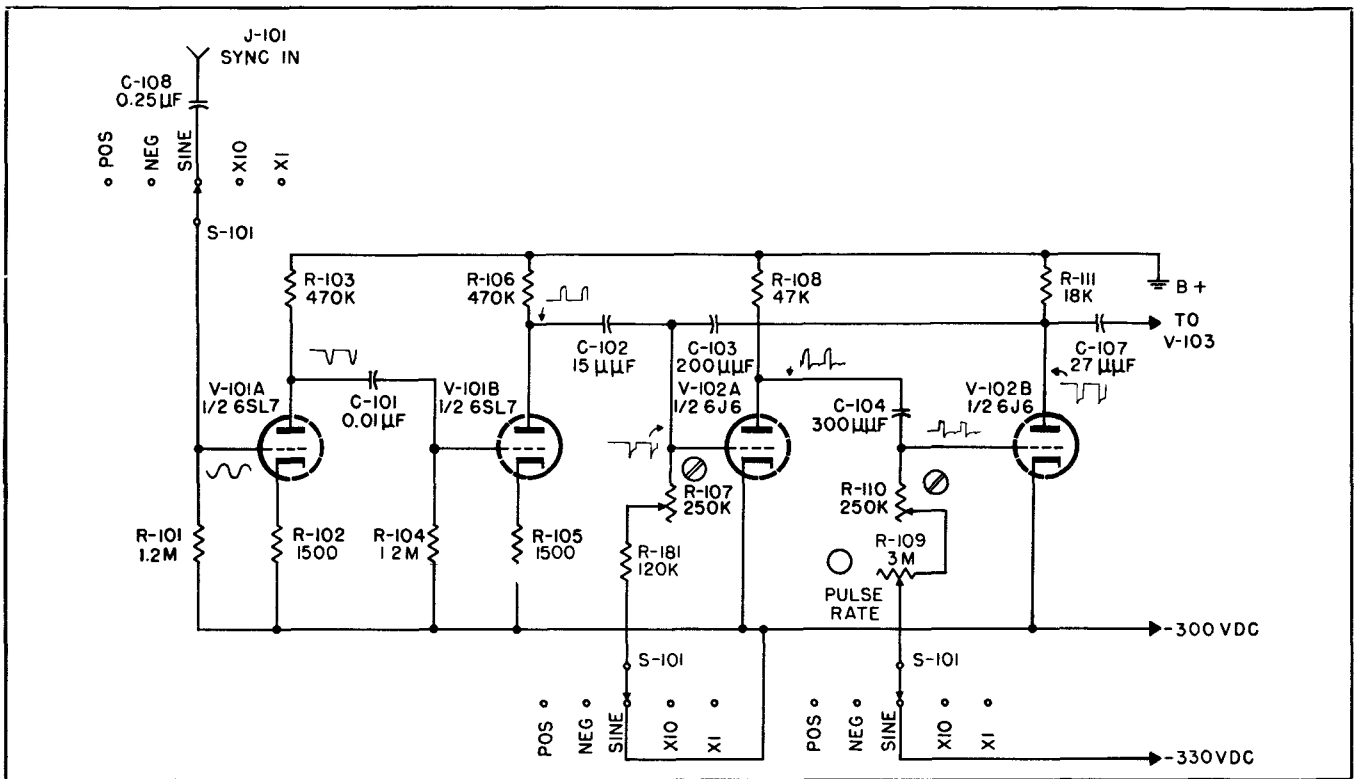

Figure 3-9. External Sine Wave Sync. Circuit

grid current flowing through the grid resistors keeps the grid at cathode potential. The grid is returned to B plus in order to obtain maximum stability from the multivibrator. An increase in stability is obtained because the grid circuit of V-102A, when pulsed, must discharge towards B plus rather than towards the normal grid potential. Thus, the cut-off point of the tube is reached on a high-slope portion of the discharge curve rather than on a low-slope portion of the discharge curve which would approach grid-cut-off in tangential fashion.

(2) EXTERNAL SINE WAVE.—When the Pulse Rate Multivibrator is synchronized with an external sinusoidal voltage (figure 3-9), the grid of V-102A is returned to the cathode through S-101 while the grid of V-102B is returned to a point about 30 volts negative with respect to the cathode. Thus, V-102A is drawing heavy plate current and V-102B is cut off. This is a stable condition and the circuit thus does not act as a multivibrator on external sinusoidal voltages but more as a pulse repeater.

Since the multivibrator is to be synchronized with sinusoidal voltages, it is necessary to convert the sine wave into some sort of trigger pulse in order to obtain positive triggering and hence good stability. This is done by introducing the sinusoidal voltage on the grid of V-101A through S-101. V-101A and V-101B operate with low plate voltage and low grid bias so that they are easily overdriven. A sinusoidal voltage of five volts peak or more is sufficient to overdrive the amplifier and produce a square wave output at the plate of V-101B. This square wave is differentiated by C-102, R-107, and R-181, giving a series of negative pulses. No positive pulses are obtained because V-102A draws grid current and thus shorts positive pulses

to the cathode. The negative pulses reduce the plate current of V-102A, giving a positive voltage pulse in the plate of V-102A. A positive pulse is then impressed on the grid of V-102B, resulting in a negative pulse at the plate of V-102B. The negative pulses in the grid of V-102B are not amplified by V-102B because the grid is returned to a point below cut-off.

(3) EXTERNAL NEGATIVE PULSES.—When the external synchronizing voltage is a negative pulse, the grid of V-102B is returned through S-101 to a point about 30 volts negative with respect to the cathode so that the tube is cut off (figure 3-10). The grid of V-102A is returned to the cathode causing high plate current in the tube. This is a stable condition so that the circuit does not act as a multivibrator on external negative pulses but as a kind of pulse repeater.

External negative pulses are applied to the grid of V-102A, decreasing that tube's plate current and giving a positive voltage pulse. This pulse is differentiated in the next grid circuit. Only the positive pips resulting from the differentiation are useful and these give a negative pulse at the plate of V-102B; negative pulses have no effect on the plate current of V-102B as the grid is normally below cut-off.

The setting of the Pulse Rate control R-109 under these circumstances is not significant because the circuit does not act as a multivibrator.

(4) EXTERNAL POSITIVE PULSES.—When the external synchronizing voltage is a positive pulse (figure 3-11), the pulse is applied to the grid of V-102B through S-101. The grid of V-102B is returned to the cathode, although grid current flowing through the large grid resist-

ance biases the grid somewhat so that the positive pulse does impress a signal on the grid. In order to obtain optimum bias on the grid, it is necessary that the PULSE RATE control be set completely clockwise so that mini-

mum resistance is provided in the grid circuit. In this condition the tube acts as a phase inverter for positive pulses.

V-102B inverts the pulse, giving a negative pulse in its plate circuit.

c. **LIMITER.**—V-103 operates as a series diode limiter and is designed so that it will pass negative voltages but is an open circuit for positive voltages (figure 3-12). The circuit has been designed in this way because the output of V-102B is always a negative pulse and by differentiating this pulse a negative trigger is obtained at the leading edge of the pulse and a positive trigger at the trailing edge of the pulse. The negative trigger is passed by the limiter while the positive trigger is blocked. Therefore, a negative trigger is available which is simultaneous with the leading edge of the pulse obtained from V-102B. In turn the pulse obtained from V-102B is approximately simultaneous with the external pulse applied to the instrument, when an external pulse is applied to the instrument.

The negative pulse passed by the limiter appears much changed at the plate of V-103 owing to the voltage generated at the plate of V-104A by the Delay Multivibrator.

d. **DELAY MULTIVIBRATOR.**—The negative trigger passed by the series diode limiter V-103 is applied to V-104, the Delay Multivibrator (also shown in figure 3-12). This multivibrator provides a time delay between the pulse obtained from the Pulse Rate Multivibrator and the pulse which is applied to the rf oscillator

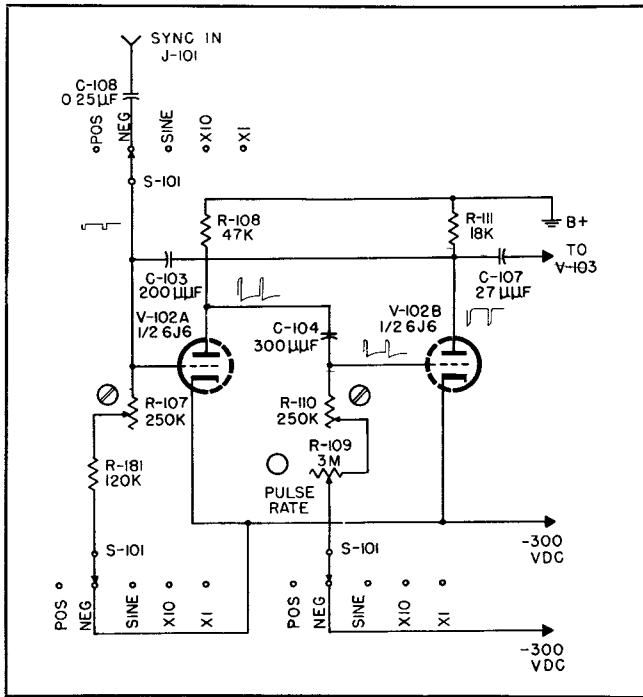

Figure 3-10. External Negative Pulse Sync. Circuit

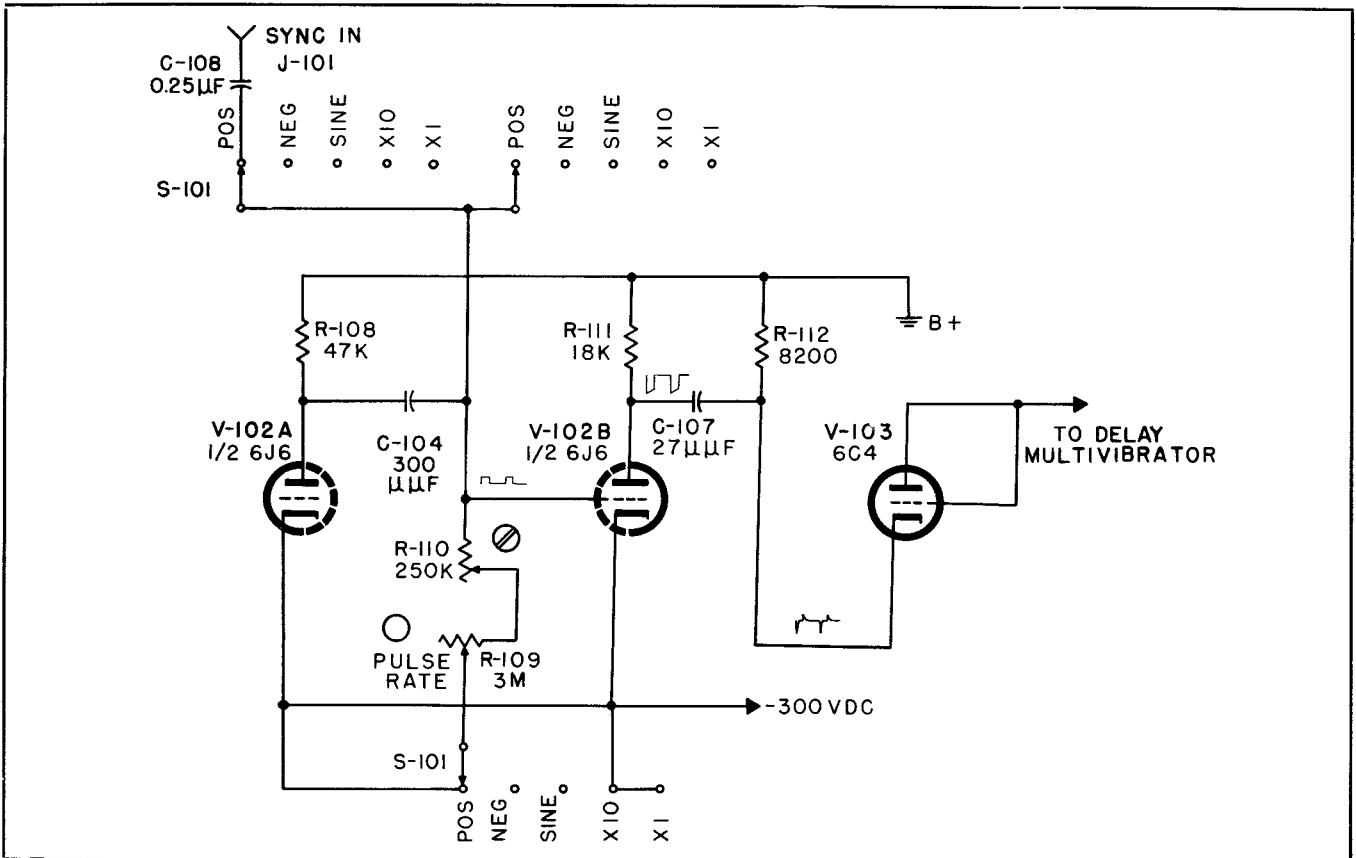

Figure 3-11. External Positive Pulse Sync. Circuit

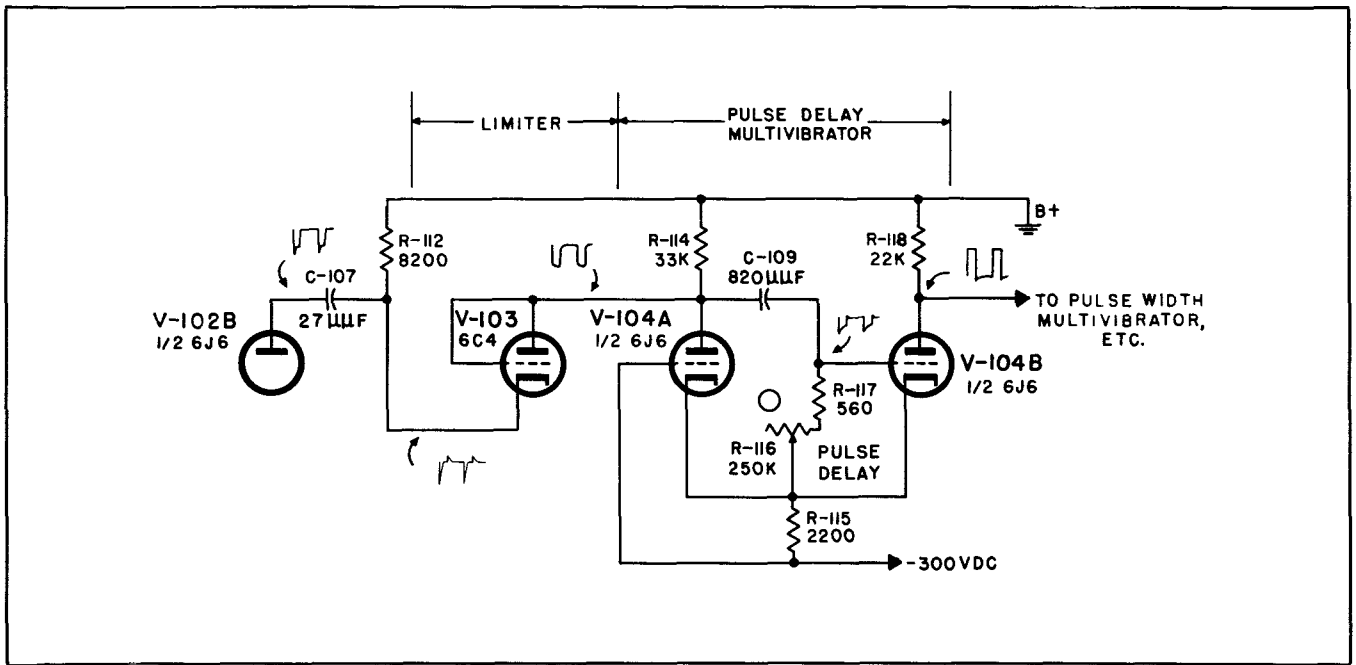

Figure 3-12. Limiter and Delay Multivibrator

The Delay Multivibrator is a one-shot type multivibrator which is triggered from the grid of V-104B. V-104B is normally conducting while V-104A is normally cut off. The negative pulse from V-103 cuts off V-104B and allows V-104A to conduct for a time determined by the time constant in the grid of V-104B. The duration of the pulse generated by the Delay Multivibrator is controlled by R-116, a potentiometer connected as a variable resistor in the grid circuit of V-104B. This control (PULSE DELAY control) adjusts the duration of the pulse generated by the multivibrator over a range from 3 to 300 microseconds. The control is directly calibrated on the front panel in microseconds of delay.

The output from the Delay Multivibrator is a positive pulse at the plate of V-104B. This Delay pulse is applied simultaneously to V-106 and to the first Shunt Diode Limiter V-105A (figure 3-13).

The Delay pulse is differentiated by C-110 and R-119, giving a positive and a negative pip. Only the positive pip is effective because the grid is returned to a point beyond cut-off. The positive pip obtained at the cathode of V-106 is delivered to the SYNC OUT terminal as an undelayable external synchronizing pulse.

The Delay pulse is also applied to V-105A after being differentiated by C-111 and R-123 (not shown in figure 3-13). V-105A shorts out the positive pip at the leading edge of the Delay pulse but is an open circuit for the negative pip at the trailing edge of the Delay pulse. The negative pip is then passed to and triggers the Signal Width Multivibrator. It should be noted that the exact time of occurrence of this negative pip is determined by the duration of the pulse generated by the Delay Multivibrator.

e. SIGNAL WIDTH MULTIVIBRATOR. — V-109 acts with V-107A as the Signal Width Multivibrator (figure 3-14). The function of this multivibrator is to generate

a positive pulse and to apply that pulse to the accelerator grid of the rf oscillator V-111. V-109 also allows external pulses of either positive or negative polarity to modulate the reflex klystron and provides for CW or FM operation of the klystron. The circuit associated with V-109 therefore operates in a number of different ways, depending upon the setting of S-102A, the modulation switch. These different conditions are described below.

On internal modulation the negative pip obtained from the Delay Multivibrator is applied to the grid of V-109 (figure 3-14). V-109 operates with V-107A as a one-shot multivibrator, the duration of its pulse being controlled by C-113 and the resistance in the grid circuit including R-124, the PULSE WIDTH control. R-124 is a 250,000-ohm potentiometer connected as a variable resistor and provides a range of control from approximately 0.5 to 10

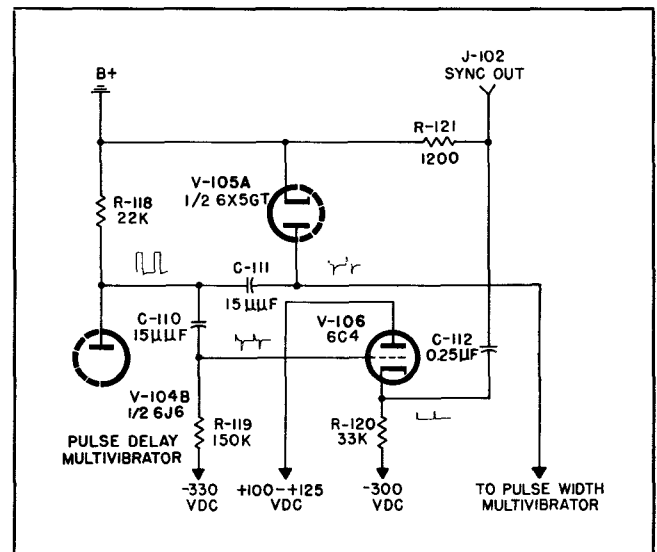

Figure 3-13. Sync. Out Pulse Circuit

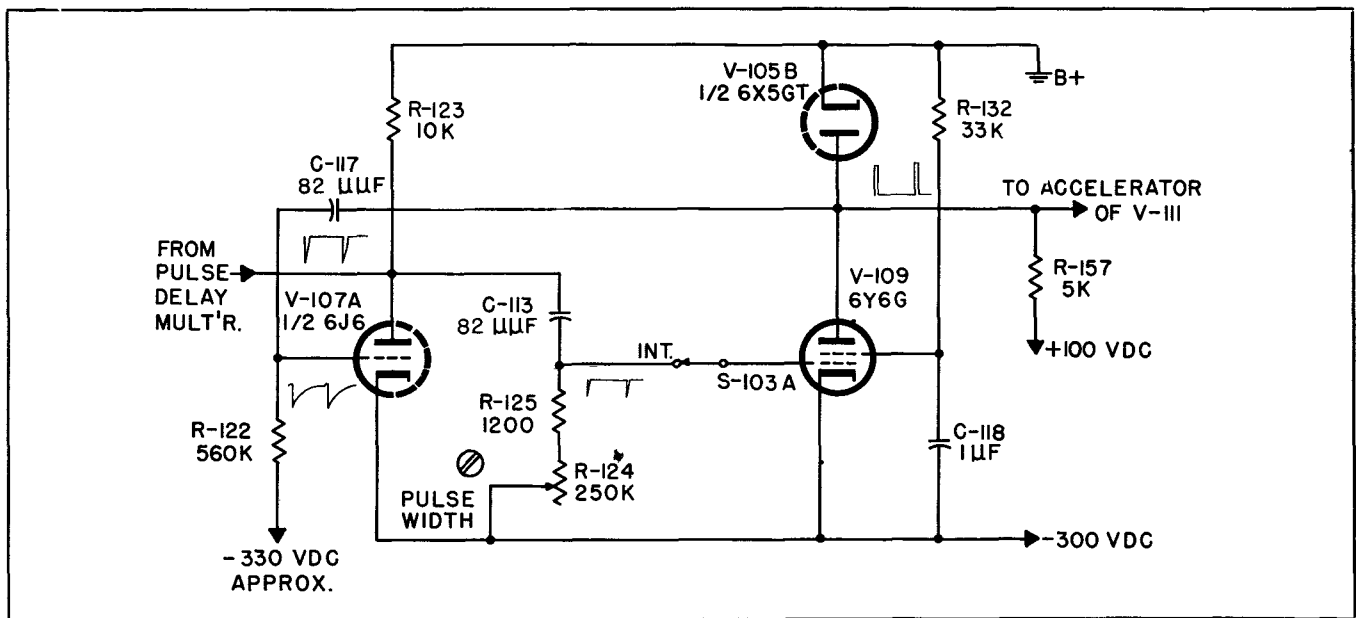

Figure 3-14. Signal Width Multivibrator

microseconds on the width of the pulse generated by the Signal Width Multivibrator.

The positive pulse generated by the Signal Width Multivibrator is applied to the accelerator grid of the reflex klystron V-111, allowing that tube to oscillate for the

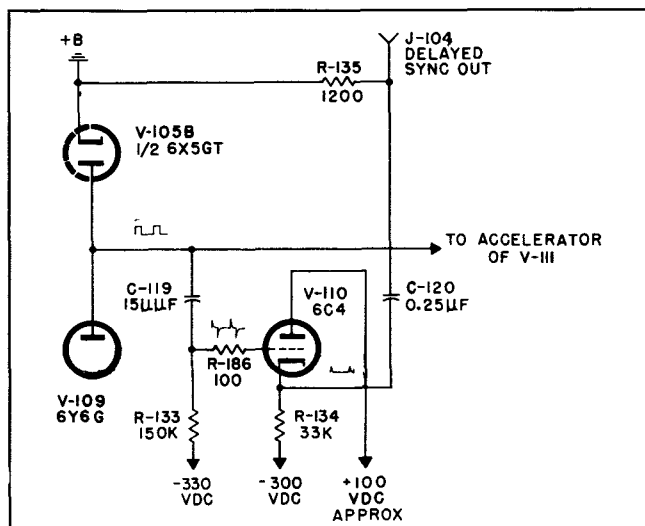

Figure 3-15. Delayed Sync Out Circuit

duration of the pulse. The amplitude of the video pulse generated by the Signal Width Multivibrator is limited by V-105B at a level of about 300 volts.

The pulse generated by the Signal Width Multivibrator is also applied to the grid of V-110 (figure 3-15) after being differentiated by C-119 and R-133 in the grid circuit of V-110. V-110 operates with its grid normally below cut-off and the positive pulse corresponding to the leading edge of the Signal Width Pulse causes a positive video pulse at the cathode of V-110. This positive pulse is applied to Jack J-104 as the DELAYED SYNC OUT pulse and occurs approximately at the beginning of the rf pulse

obtained from the reflex klystron. The negative pip applied to the grid of V-110 at the trailing edge of the Signal Width Pulse has no effect on V-110 because its grid is below cut-off.

f. EXTERNAL MODULATION.—If the oscillator is to be modulated with an external square wave or pulse, the pulse is applied to Jack J-103, the EXT MOD jack (figure 3-16). Positive pulses are applied through S-103A to the grid of V-108 which is normally below cut-off. The positive pulse on the grid results in a negative pulse in the plate of V-108 and this negative pulse is applied to the grid of V-109. A positive pulse is then obtained in the plate of V-109 and is applied to the accelerator grid of the reflex klystron V-111, permitting rf oscillation for the duration of the pulse.

When the external modulating pulse is negative, the pulse is applied directly to the grid of V-109 causing a positive pulse in the plate of V-109. This pulse is then applied to the accelerator grid of the reflex klystron V-111 as before.

g. CW and FM OPERATION.—On both CW and frequency-modulated CW of the reflex klystron oscillator (figure 3-17), the grid of V-109 is tied to a point below cut-off so that the plate of V-109 is at a high dc potential with respect to the cathode of V-111. Since the plate of V-109 is directly connected to the accelerator grid of the reflex klystron, and since the grid of the klystron is at a potential high enough to allow the tube to oscillate, continuous wave oscillation of the klystron occurs.

On frequency-modulated operation of the klystron, some AC voltage from the power supply for the instrument is applied to the repeller of the klystron through C-127 (figure 3-18). This voltage varies the potential of the repeller so that the frequency of oscillation is varied over a maximum range of approximately one-half of one per cent at the frequency of the power line. Two controls are provided in the power supply to allow the phase and

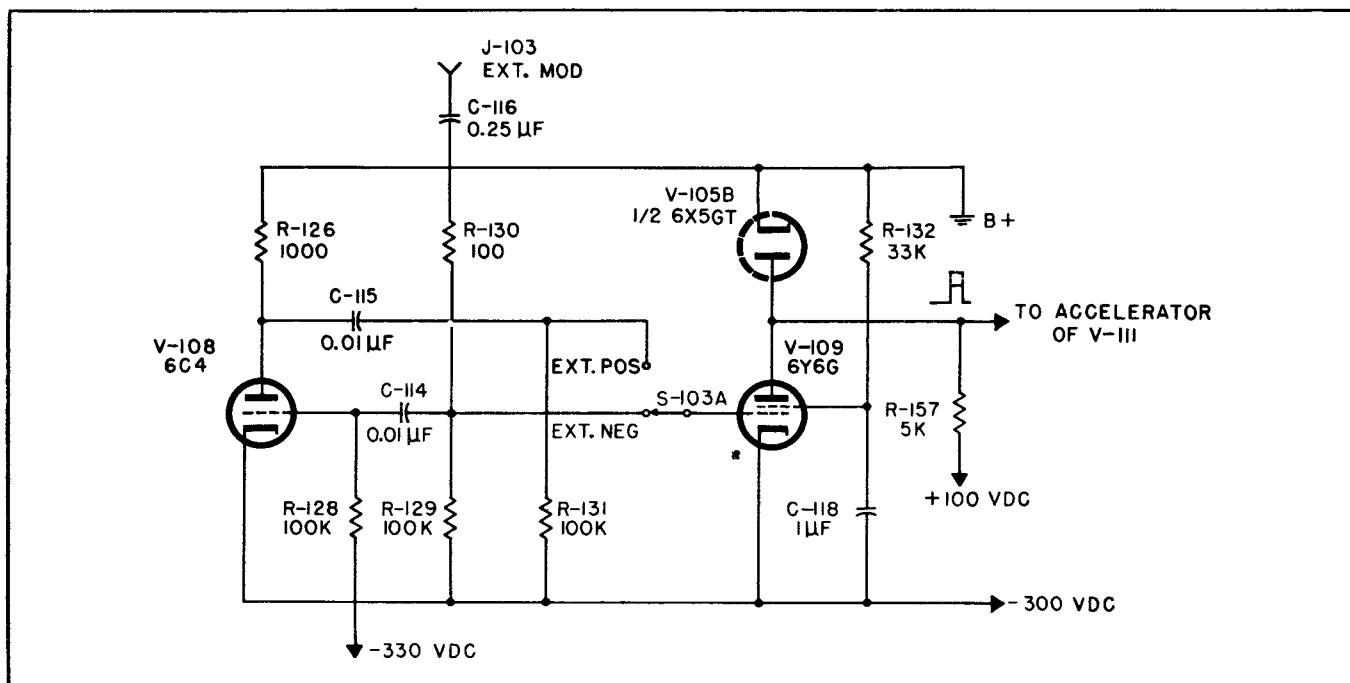

Figure 3-16. External Modulation Circuit

amplitude of the voltage applied to the repeller to be controlled.

In all conditions of operation except frequency-modulated CW, the repeller of the klystron is grounded for ac through C-126.

It should be noted that S-103 is drawn in simplified form in the above figures.

5. MISCELLANEOUS.

The resonant cavity for the rf oscillator must be in direct contact with the resonator grids of the reflex

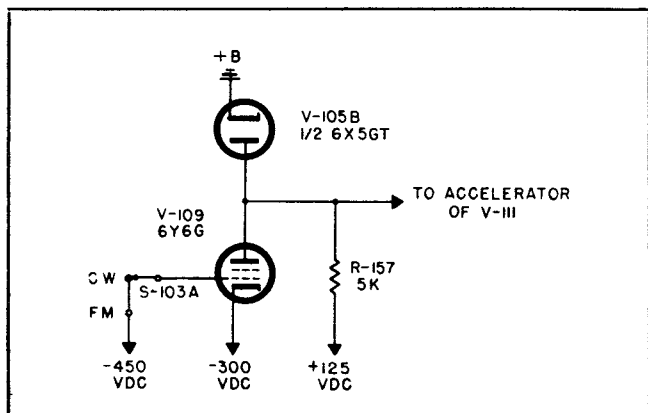

Figure 3-17. Switching Arrangement for CW and FM Operation

klystron V-111, and, since the resonator grids are at a high dc potential relative to the cathode of the tube, the cavity is also at a high dc potential relative to the cathode. However, the cavity is a large metal structure and it is not convenient to insulate the cavity from the chassis of the signal generator. For this reason the Modulator section has been constructed so that B plus is grounded and so that B minus is approximately 300 volts negative with

respect to ground. The grid biasing circuit for the Modulator tubes operates at approximately 330 volts negative with respect to ground.

The four video jacks J-101 to J-104 are fed by shielded leads in order to minimize rf leakage from the signal generator. In addition the leads feeding the video jacks are brought through a cylindrical powdered iron form having a hole coaxially through it. These powdered iron forms offer a high loss (low resistance) of the order of 60 db to any rf voltages on the video leads and thus reduce rf leakage from the video jacks. Certain other leads in the instrument are also provided with these powdered iron forms, including the meter leads, the leads supplying the reflex klystron tube, and the input power leads.

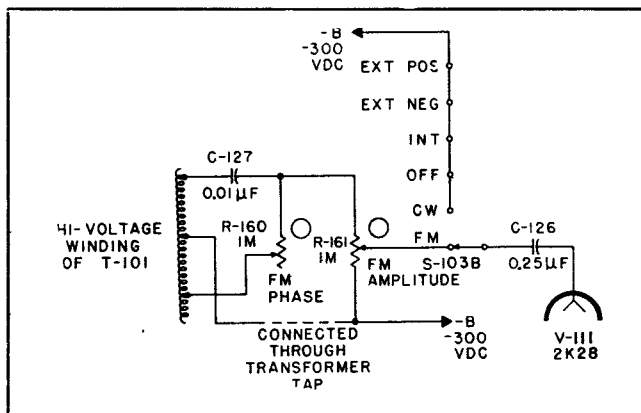

Figure 3-18. Circuit Providing Repeller AC Voltage for FM

Other shielding is used extensively in order to minimize rf leakage. For example, the meter is shielded by an aluminum casting and the louvres of the instrument case are

covered with wire screen in order to prevent leakage through these openings.

6. POWER SUPPLY.

The power supply is designed to supply -300 volts dc for the plate circuits of the Modulator tubes, -330 volts dc for the grid circuits of the Modulator tubes, and -600 volts dc for the repeller circuit of the rf oscillator V-111. These voltages all are given with respect to the chassis voltage (ground). The power supply also provides filament power for all of the tubes as well as an ac voltage, variable in phase in amplitude, for frequency-modulating the rf oscillator, and a positive dc voltage of approximately 125 volts for the accelerator grid circuit of the rf oscillator. The latter voltage drops to about 100 volts dc when the modulator tube V-109 is conducting (that is, in the OFF, INT, and EXT positions of the modulation selector switch).

The full-wave rectifier circuit associated with V-116 provides an output voltage of approximately 425 volts dc. The output of the rectifier is regulated by the electronic regulator circuit associated with V-107B and V-115. This circuit is grounded in such a way that it provides 125 volts dc positive with respect to ground and 300 volts dc negative with respect to ground.

The half-wave rectifier V-117 provides an output of 300 volts dc. This circuit is connected to the full-wave rectifier circuit in such a way that the 300-volt dc output of V-117 is additive to the -300 volt dc output of V-116, providing -600 volts dc overall.

Gaseous voltage regulator tubes are used in the circuit as an aid in maintaining the voltage constant.

Two high-power wirewound resistors R-158 and R-159 are connected across the power input circuit with a switch so that heat can be dissipated within the instrument case during periods of intermittent usage of the instrument.

SECTION IV MAINTENANCE

WARNING

This equipment employs high voltages which are dangerous and may be fatal if contacted by maintenance personnel. Extreme caution should be exercised when working with the equipment. Although bleeder circuits are used, always ground any circuit before touching it.

1. GENERAL.

Signal Generator TS-403/U is an accurate test equipment, and consequently unnecessary repairs and attempts to make the instrument more accurate should not be undertaken, as such attempts almost invariably result in a loss of accuracy. It should be borne in mind that test equipment can be tested satisfactorily only by more accurate test equipment. Such repairs as may become necessary should be undertaken only by authorized maintenance personnel who have sufficient equipment at hand so that such repairs can be made properly.

This precaution is especially true of the complex mechanical drive systems in the instrument. These drives are designed to last far beyond the life of the electrical part of the instrument and should never be tampered with unless some sort of mechanical breakdown occurs. An assembly procedure is included in this section of the instruction book for reference in the event a mechanical failure occurs, but it should be borne in mind that mechanical readjustment should be attempted only as a last resort.

In making repairs on the instrument it is recommended that the test equipment listed in paragraph four of this section be used.

In order to aid in trouble-shooting of the instrument, this section of the instruction book contains voltage diagrams, a trouble chart, and part replacement data, as well as directions for performing electrical tests and recalibrations. In addition Section V contains photographs that show the location of many components.

2. PREVENTIVE MAINTENANCE.

a. ROUTINE CARE.—Reasonable care in transporting, handling, and operating this signal generator will prolong its useful life and minimize the occurrence of trouble. When the instrument is not in use the power should be turned off and the power cord disconnected unless use of the heater is required on account of excessive humidity. In so far as practicable, Signal Generator TS-403/U should be protected from dust, moisture, and extremes of temperature. If it is not to be used for long periods, it should be placed in its transit case.

b. DAILY CARE.—It is desirable to make a daily check of the exterior of the instrument. This check should be carried out as follows: After removing Signal Generator TS-403/U from the transit case, inspect the exterior for dust, dirt, and corrosion. Check the power cable for

rubber deterioration, excessive wear, cuts, and kinks. Replace the cable if necessary. Give special attention to the RF and SYNC connectors. Clean these connectors and the power connector with a cloth or, if necessary, with crocus cloth. Remove grease and oil from the power cable with a soft cloth dampened with dry-cleaning solvent. Clean the meter glass. Remove grease and dust from the exterior of the dust cover and panel with a soft cloth.

c. PERIODIC INSPECTION.—Approximately once a month a more thorough inspection should be made. Remove the dust cover by loosening the eight captive screws on the front panel and slide the unit out of the cover. Inspect all components for blistering or other signs of excessive heating. Make sure all tubes are locked in position. Inspect electrical connections for sign of breaking loose. Tighten all loose mounting nuts and bolts.

CAUTION

Do not tighten nuts and bolts without consideration of the strength of the material and the weight they must support. There are various degrees of pressure needed. Clean the chassis and the RF oscillator exterior using a soft cloth. Do not disassemble the RF oscillator for the periodic inspection.

d. LUBRICATION.—Signal Generator TS-403/U does not require lubrication other than that given it during its manufacture. All bearings used in moving parts are oil-impregnated, sleeve type bearings which will last for the life of the instrument. The gears in the instrument operate at low speeds and transmit negligible power. They are designed to run with only their initial lubrication; additional lubrication will accelerate their wear by collecting dust that acts as an abrasive.

3. TEST EQUIPMENT REQUIRED.

The following test equipment is recommended when performing maintenance work on Signal Generator TS-403/U:

- a.* 1,000 ohms-per-volt readings:
 - TS-297/U Multimeter, or
 - Weston 663 } Alternates
 - Simpson 443 }
- b.* 20,000 ohms-per-volt readings:
 - TS-352/U Multimeter, or
 - Navy "OE" } Alternates
 - Simpson 260 }
 - Weston 790 }
- c.* Vacuum Tube Voltmeter
 - TS-375/U, or
 - RCA-165(D.C.) } Alternates
 - Radio City 662 }

- d. Tube Tester
Signal Corps Type I-177A, or
Hickok 540 or 545 (Alternates)
- e. Frequency Meter TS-186/AP
- f. Oscilloscope
TS-239/UP, or
TS-34/AP (Alternate)
- g. Audio Oscillator
TS-382A/U, or
Model LAJ
Model LAJ-1
Hewlett-Packard 200C
Hewlett-Packard 205AG } Alternates
- b. Pulsed Signal Generator:
Measurements 79B
- i. Wattmeter Bridge:
Hewlett-Packard 760A
- j. Light Beam Galvanometer:
Leeds and Northrup 2420D
- k. Coaxial Line Stretcher:
Hewlett-Packard 430A

- l. Receiver:
Frequency Range 1800 to 4000 megacycles
Maximum Sensitivity 1-10 microvolts
- m. Crystal Detector:
Hewlett-Packard 420A or equivalent

4. LOCALIZING TROUBLE.

The first step in correcting any trouble or failure which may occur in the instrument is to isolate the section of the circuit which is causing the trouble. Such isolation can best be accomplished by considering the circuit as composed of the basic sections shown in figures 3-1 and 3-7. Trouble ordinarily occurs in only one section at a time, so that it is usually necessary to correct only the one trouble. The Servicing Block Diagram (figure 7-4) has been prepared to aid in the isolation of trouble and if the requirements of the chart are fulfilled as regards any one section, that section of the circuit can be assumed to be operating properly. As a further aid in servicing, table 4-1 has been prepared to indicate the causes of certain possible specific troubles. In addition figures 7-5 and 7-6 have been included to indicate the nominal values of dc voltage and resistance to ground encountered at the pins of the tube sockets in the instrument.

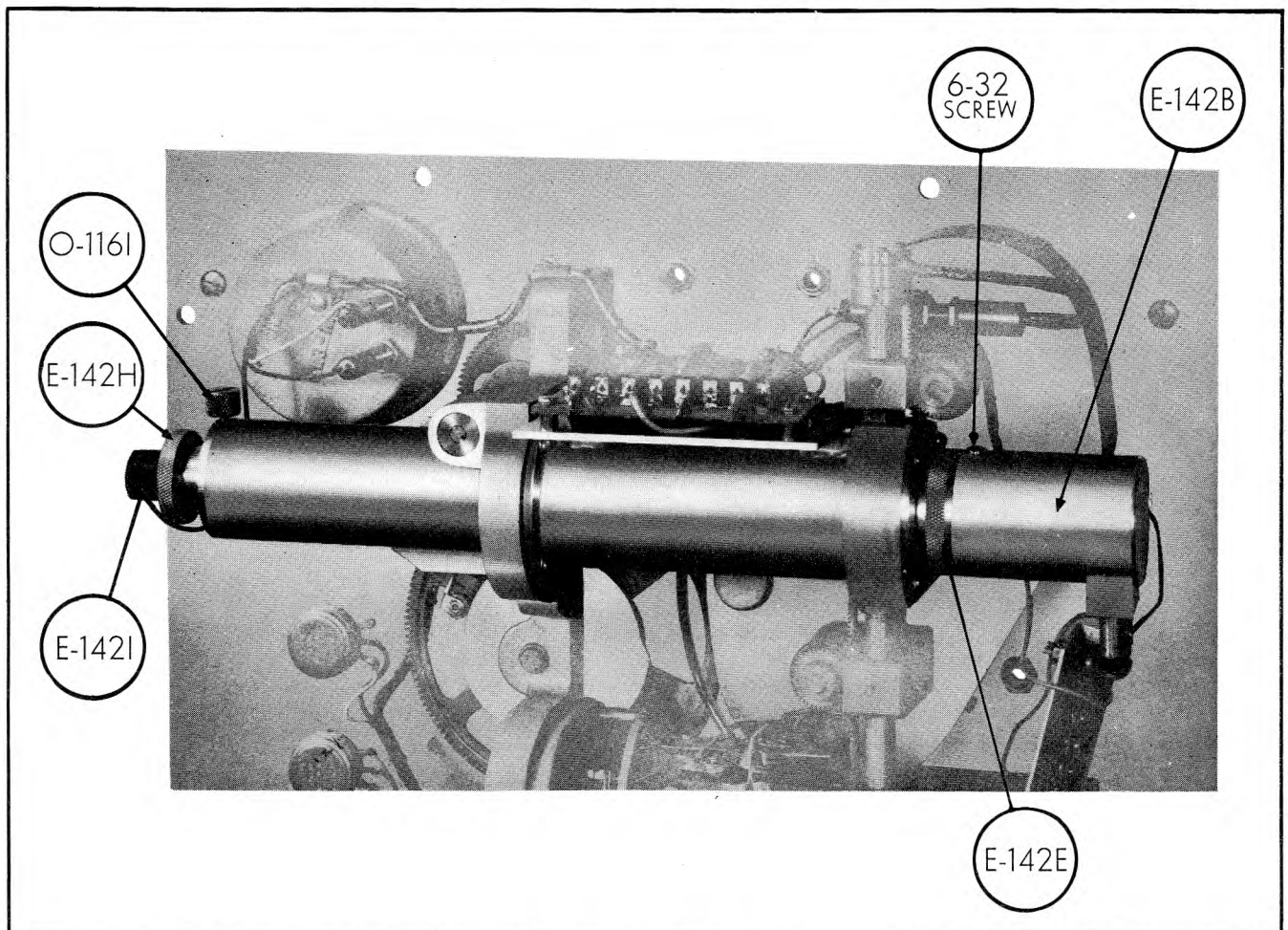

Figure 4-1. Overall View of Oscillator Assembly

TABLE 4-1. TROUBLE CHART

SYMPTOM	TROUBLE	REMEDY
Instrument dead; neither pilot lamp lights; no output.	Blown fuse F-101 and/or F-102.	Replace fuse F-101 and/or F-102 in panel holder.
	Poor connection to AC supply.	Check power connection.
Space heater pilot does not light when power switch set to HEATER position; or light glows only very faintly.	Open pilot lamp I-101 for heater.	Replace pilot lamp I-101.
	Open space heater R-158 and/or R-159.	Replace heater resistor R-158 and/or R-159.
Does not sync with external positive pulses; does sync with other external voltages.	PULSE RATE control not set clockwise.	Set control completely counter-clockwise.
Will not sync with external sine waves; syncs satisfactorily with external pulses.	Defective amplifier V-101.	Replace V-101.
No SYNC OUT video pulse; DELAYED SYNC OUT pulse and RF pulse satisfactory.	Defective amplifier V-106.	Replace V-106.
No DELAYED SYNC OUT pulse; SYNC OUT pulse and RF pulse satisfactory.	Defective amplifier V-110.	Replace V-110.
No DELAYED SYNC OUT pulse nor RF output pulse; SYNC OUT pulse satisfactory.	Defective pulse width tubes V-107A and/or V-109.	Replace V-107 and/or V-109 (Check —300 VDC regulated supply after changing V-107. See paragraph 6b).
Width of RF output pulse unstable especially with near maximum settings on PULSE RATE and PULSE WIDTH controls.		
Unstable SYNC OUT, DELAYED SYNC OUT, and RF output pulses.	Excessive hum from power supply.	Replace regulator tubes V-113, V-114, V-107, and/or V-117. (Readjust —300VDC regulated supply; see paragraph 7e).
No SYNC OUT, DELAYED SYNC OUT, or RF output pulses. Power supply operating properly.	Defective delay tube V-104.	Replace V-104.
	Defective pulse rate tube V-102.	Replace V-102.
Irregular RF output pulse or pulse dies out over part of range.	Incorrect voltage applied to repeller of V-111.	Check setting of potentiometers R-163, R-164, R-166, and/or R-167 (see paragraph 6a, step 13).
	Inoperative rectifier V-117.	Replace V-117; turn instrument off to avoid high voltages.
Low or no RF output; little or no reading on POWER LEVEL meter; video pulse output satisfactory.	Open resistor in repeller circuit.	Check repeller tracking resistors R-163, R-164, R-166, R-167, and/or R-173 to R-177; replace if necessary (see paragraph 6a, step 13).
	Defective oscillator tube V-111.	Replace V-111 (see paragraph 6a).
	Leaky repeller by-pass capacitor C-126.	Replace C-126.
Erratic RF output pulse; video pulse satisfactory, RF output satisfactory on CW.	Defective oscillator tube V-111.	Replace V-111 (see paragraph 6a).
Erratic RF output, "holes" at some RF frequencies or unstable at some frequencies, on both pulse and CW operation.	Cavity wiper making poor connections.	Replace or realign cavity wiper (see paragraph 10a, figures 4-25 to 4-29).
Video pulse and POWER LEVEL meter reading satisfactory. No RF output; Resistance (DC) between center and outer conductors of RF output connector far in excess of approximately 130 ohms.	Open resistor R-137 and/or attenuator pad E-124.	Replace R-137 (see paragraph 11) and/or attenuator pad E-124 (see paragraph 13).
Not possible to zero set meter with ZERO SET control.	Resistor drift.	Readjust R-143 until meter can be zero set (see paragraph 7g).
	Poor regulator tube V-112.	Replace V-112.
Meter requires too frequent adjustment of ZERO SET control.	Poor thermistors R-170 and/or R-178.	Replace R-170 and/or R-178.
Unstable regulation of —300 VDC supply with slight variation in power line voltage or with change in circuit operation.	Poor regulator tubes V-113, V-114, and/or V-107B.	Replace V-113, V-114, and/or V-107 (see paragraph 7e).
	Power line voltage below 103 V RMS.	Increase power line voltage to approximately 115 V RMS.

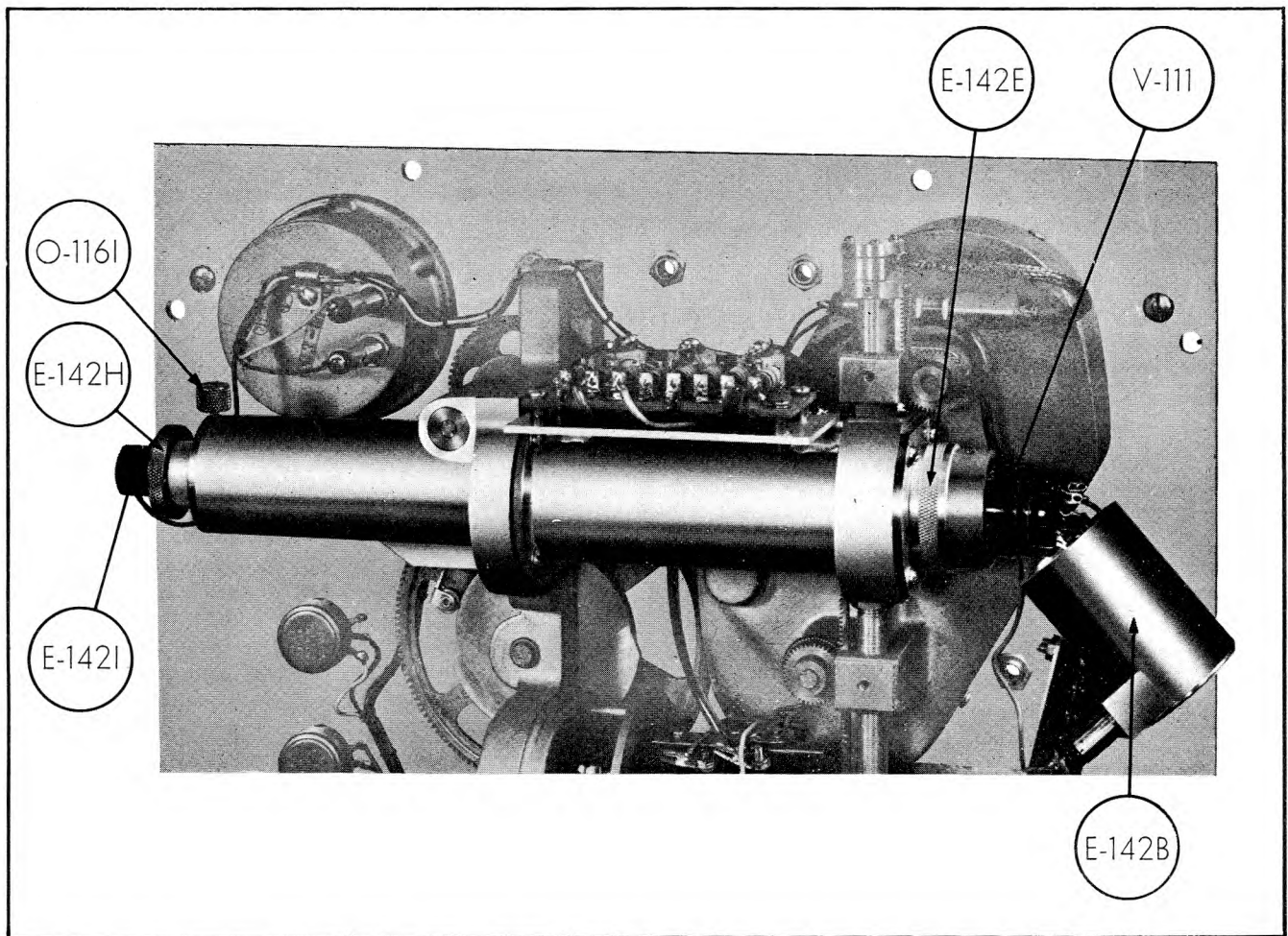

Figure 4-2. Removal of Shield E-142 B

5. REMOVING THE INSTRUMENT CASE.

The front panel and chassis can be removed from the instrument case by loosening the eight captive thumb screws around the edge of the front panel and pulling the panel away from the case.

6. TUBE REPLACEMENT.

In general the tubes in Signal Generator TS-403/U do not require replacement until they cause trouble of some sort. The troubles which can be generally attributed to faulty tubes are insufficient power output, faulty pulsing, etc. All tubes can be replaced quite easily with the exception of the rf oscillator V-111, which requires a special tool and a special procedure.

a. REPLACEMENT OF V-111.—The JAN-2K28 rf oscillator V-111 is completely enclosed within the oscillator cavity and shield. In order to replace this tube, it is necessary to remove the power lead filter cap, although extensive disassembly of the equipment is not necessary. It is not necessary to remove the chassis from the front panel. However the following photographs show the chassis removed for clarity of illustration.

(1) Referring to figure 4-1, remove the #6-32 screw that holds the housing E-142B. Then remove housing E-

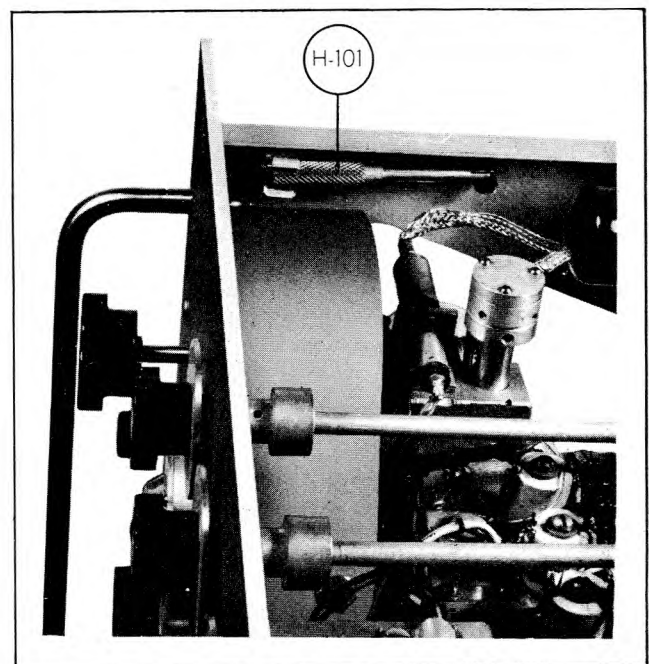

Figure 4-3. Mounting Location of Tool H-101

142B carefully so as not to break the wires running to the tube socket. See figure 4-2. Remove the tube socket from the tube.

(2) Unscrew and remove the housing support E-142E.

(3) Remove special tool H-101 from its mounting on left gusset of chassis (see figure 4-3).

(4) Attach tool to end of the tube contact assembly E-142I as shown in figure 4-4.

(5) Loosen thumbscrew O-116I. Hold tube base with one hand and push the knurled collar on the end of the cavity inner conductor E-142H to the right (as viewed in figure 4-1) as far as it will go. Tighten the thumbscrew.

(6) Still holding the tube so that it will not fall, push the tube contact assembly E-142I slowly until tube is released from contact fingers. See figure 4-5.

(7) Remove the split ring contacts from lower resonator grid of old tube and place on new. Make certain that the solid side of the split ring points towards the tube base.

(8) Insert new tube well into grid contact fingers and pull tool so that E-142I is drawn out of E-142H and so that the tube is locked into the fingers. Be very careful that the tube is securely locked into the contact fingers.

(9) Loosen thumbscrew O-116I and pull inner conductor E-142H gently until tube seats in cavity. Make certain that tube has seated properly.

(10) Replace and tighten housing support E-142E.

(11) Tighten thumbscrew O-116I.

(12) Replace housing E-142B and then the #6-32 screw.

(13) Owing to variations in tube characteristics, it now may be necessary to adjust the repeller voltage on the JAN-2K28 tube. To determine whether or not such adjustment is necessary, connect the RF OUTPUT terminal of Signal Generator TS-403/U to an external synchroscope. It will be necessary also to use a crystal detector in order to demodulate the rf. Set the modulation selector switch (S-103) to the INT position and the SYNC SELECTOR switch (S-101) to either the x1 or x10 positions. The PULSE RATE, PULSE WIDTH, and PULSE DELAY controls can be set as desired.

Check the shape of the rf pulse over the entire frequency range of the signal generator. If the shape of the rf pulse deteriorates (usually in such a way that the top of the pulse has spurious peaks), the repeller voltage tracking should be adjusted by means of potentiometers R-163, R-164, R-166, and R-167 (see paragraph 7a). R-167 should be adjusted for best rf pulse characteristics at the low frequency limit of the dial (1760 megacycles), while R-163 should be adjusted for the same condition at 2400 megacycles (or just below the frequency where the sensitive switch clicks). Recheck the rf pulse shape at frequencies intermediate between 1760 and 2400 megacycles and make any minor adjustments in the settings of R-167 and R-163 that may be necessary for best overall performance.

Next, turn the frequency dial slightly higher than 2400 megacycles until the click of the sensitive switch is heard. At this point adjust R-164 for optimum pulse shape, then adjust R-166 at 4060 megacycles. Check the intermediate frequencies and make any minor readjustments in the settings of R-164 and R-166 which may be necessary for best overall performance.

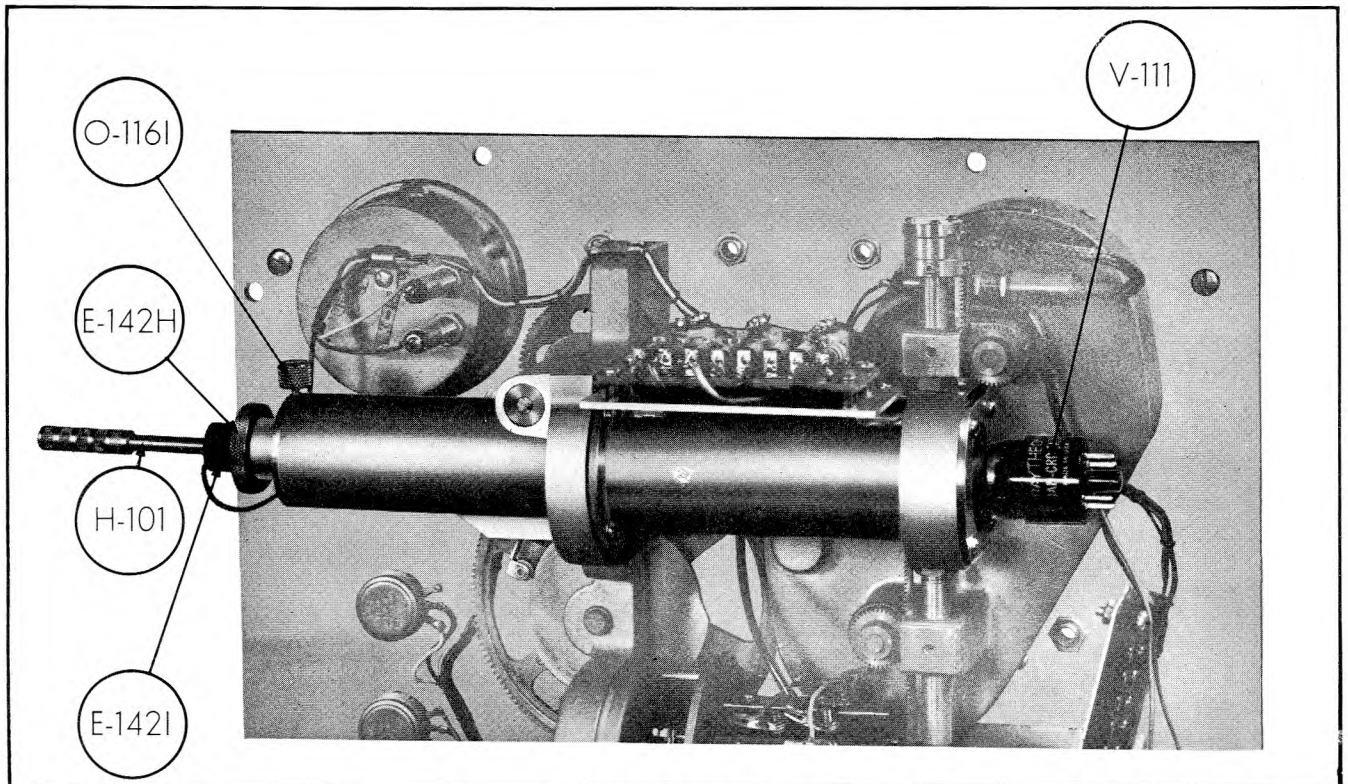

Figure 4-4. Special Tool Attached to End of E-142 I

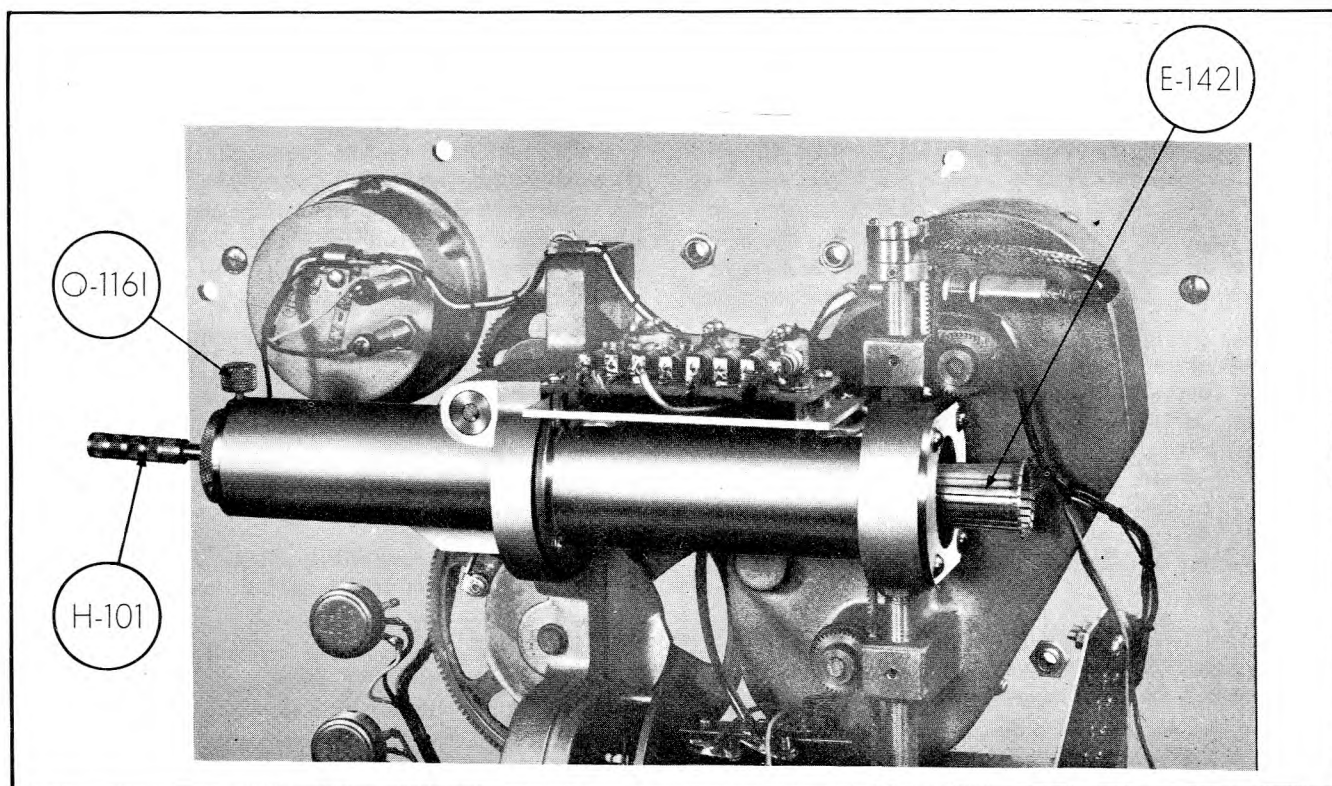

Figure 4-5. Tube Released from Contact Fingers

b. REPLACEMENT OF V-107.—V-107 is a type JAN-6J6 dual triode, half of which operates in the Pulse Width Multivibrator circuit and half in the Voltage Regulator circuit. When replacing this tube, it is necessary to check that the full pulse width of 10 microseconds is available at all output rf frequencies at a pulse rate of 4000 pps (see paragraph 7j) and that the value of the regulated voltage is correct. When the new tube is in the circuit, the dc voltage from pin 7 on V-107 to the chassis should be -300 volts dc. If necessary, adjust R-152 to obtain the required voltage.

7. ELECTRICAL ADJUSTMENTS.

a. GENERAL.—A number of internal adjustments are provided in this instrument in the form of screwdriver-adjusting potentiometers. These potentiometers have locking type bushings and before any adjustment is attempted the lock must be loosened before the shaft can be rotated. After the adjustment is made, the lock should be re-tightened.

b. REPLACEMENT OF POTENTIOMETERS R-107, R-109, AND/OR R-110.—If any of the potentiometers R-107, R-109, and/or R-110 (see figure 5-1) are replaced, it will be necessary to set them so that the calibration of the PULSE RATE control is correct. It is necessary to have an oscilloscope and an accurate audio oscillator in order to make this adjustment (see list of recommended test equipment in paragraph 4).

(1) Set the SYNC SELECTOR switch S-101 on Signal Generator TS-403/U to the x10 position.

(2) Connect the SYNC OUT terminal J-102 on Sig-

nal Generator TS-403/U to the trigger input for the horizontal sweep on the oscilloscope. Adjust the oscilloscope for a fast sweep of 50 microseconds or less.

(3) Connect the output of the oscillator to the vertical amplifier of the oscilloscope. Set the oscillator so that its output is exactly 1000 cps.

(4) Set the Pulse Rate dial exactly at "100."

(5) Now adjust the potentiometer which was replaced so that a single stationary line is obtained on the oscilloscope. (A single straight line also can be obtained when the pulse rate is 500 pps; therefore make certain the proper rate is obtained.) If the PULSE RATE control itself (R-109) was replaced, it is necessary to set the potentiometer shaft by hand, allowing the shaft leading from the dial to remain loose. The shaft can then be tightened after the single stationary line on the oscilloscope has been obtained.

(6) It is now desirable to check the calibration of the PULSE RATE dial at a number of points. The calibration should be accurate within 25%. If the dial is set at "200" so that the pulse rate is 2000 pps, two straight lines will be obtained on the oscilloscope. At 3000 pps, three straight lines will be obtained, while at 4000 pps, four straight lines will be obtained. In some of the figures these lines will cross to form a sort of interwoven pattern.

(7) The same check can be made with the SYNC SELECTOR switch S-101 set to the x1 position. In this case all frequencies should be reduced by 10; that is, the audio oscillator should be set to 100 cps and the calibration checked at 100 pps, 200 pps, etc. The same figures as above will be obtained.

(8) As a result of this check it may be found desirable to make a further minor adjustment of the replaced part in order to obtain best overall accuracy.

c. REPLACEMENT OF R-116.—When replacing potentiometer R-116, the PULSE DELAY control (figure 5-1), it is necessary to tighten the coupler which couples the PULSE DELAY dial to R-116 so that the calibration of the PULSE DELAY dial is within its limits. The calibration of the PULSE DELAY dial is designed to be accurate within 20% or 3 microseconds, whichever is greater.

After the replacement potentiometer has been locked into position and wired into the circuit, the length of the pulse generated at the plate of V-104B should be measured on an oscilloscope having an accurately calibrated sweep speed. If necessary, set potentiometer R-116 by hand so that some convenient pulse length is obtained at the plate of V-104B. Then set the PULSE DELAY dial to the proper reading and tighten the coupler. Check the overall calibration of the dial and make any minor adjustments which may be necessary.

d. REPLACEMENT OF R-124.—If potentiometer R-124, the PULSE WIDTH control, is replaced, the coupler which couples the PULSE WIDTH dial to potentiometer R-124 must be tightened in such a way that the calibration of the dial is within its limits. The calibration of the dial is designed to be within 20% or 2 microseconds, whichever is greater.

In order to set the calibration of the dial, it is necessary to measure the length of the output rf pulse from Signal Generator TS-403/U on a synchroscope or oscilloscope having an accurately calibrated sweep speed. A crystal detector must be connected between Signal Generator TS-403/U and the oscilloscope in order to demodulate the rf pulse. The potentiometer should be set by hand to give a convenient pulse width of, say, five microseconds as measured on the oscilloscope. Then the dial should be set so that it reads five microseconds, and the coupler tightened with the dial and potentiometer in these relative positions. The overall calibration of the dial should then be checked and any minor readjustments made that are necessary.

It may be noticed when checking the length of the rf pulse in this manner that the length of the pulse is dependent upon the frequency at which the rf oscillator is set. For a given setting of the PULSE WIDTH control, the width of the rf pulse at lower frequency settings of the rf oscillator will be greater than at higher frequency settings. This condition is normal and is a function of the JAN-2K28 tube. If desired, the PULSE WIDTH control calibration can be adjusted for best calibration over a certain portion of the frequency range of Signal Generator TS-403/U. This can be done by resetting the dial on its shaft as necessary.

e. REPLACEMENT OF R-152.—Potentiometer R-152 adjusts the value of the regulated voltage in the power supply voltage regulator circuit. If this potentiometer is changed, the procedure given in paragraph 6*b* for replacing the regulator tube should be followed.

f. REPLACEMENT OF R-163, R-164, R-166, and/or R-167.—Directions for resetting these potentiometers are given under paragraph 6*a*, the procedure for replacing V-111.

g. REPLACEMENT OF R-143 AND R-162.—Potentiometers R-143 and R-162 adjust the value of the dc voltage applied to the bolometer bridge circuit. If either of these potentiometers is changed, the following procedure should be followed.

(1) Allow the signal generator to warm up for twenty or thirty minutes after the potentiometer has been replaced.

(2) At the end of this time, set potentiometer R-162, the ZERO SET control, to the center of its arc of rotation. Set the modulation selector switch to the OFF position.

(3) Then adjust R-143 so that the meter reads exactly zero.

(4) Turn the instrument off and allow to cool at room temperature for about one-half hour.

(5) Turn the instrument on and after five minutes of warm-up, make certain that it is possible to zero set the meter with the ZERO SET control. If not, adjust potentiometer R-143 so that this is possible. R-143 should be turned only the minimum amount necessary to allow the meter to be zero set under this condition.

b. REPLACEMENT OF R-160 AND R-161.—Potentiometers R-160 and R-161 are the FM PHASE and FM AMPLITUDE controls. These potentiometers can be replaced when necessary without special precaution.

i. REPLACEMENT OF R-173.—Potentiometer R-173 is a special wire-wound potentiometer which is ganged with the rf oscillator cavity shorting bars. If this potentiometer is replaced, the main tuning dial should be tuned from 2500 megacycles towards approximately 2400 megacycles until the click of the microswitch is heard. The dial should then be reversed until it is just on the high frequency side of the point where the sensitive switch clicks. At this point the defective potentiometer should be removed and the new potentiometer put in with the potentiometer shaft coupler remaining untightened.

Then connect an ohmmeter between the special tap on the potentiometer and the rotor connection. Minimize the ohmmeter reading by adjusting the setting of the potentiometer. The usual minimum resistance obtained is of the order of five or 10 ohms.

With the rotor of the potentiometer in this minimum resistance position, the coupler should be tightened. It is then desirable to check the pulsing of the oscillator as described in paragraph 6*a*.

j. REPLACEMENT OF R-185.—Potentiometer R-185 determines the bias on the grid of V-107A and thus affects the duration of the pulse generated by the Pulse Width Multivibrator V-107A and V-109. If R-185 is replaced, the replacement potentiometer should be adjusted so that the width of the output rf pulse is approximately 11 microseconds when the pulse repetition frequency is 4000 pps. This adjustment should be made with the PULSE WIDTH control set for maximum pulse width. The width

of the output rf pulse should be measured on a synchroscope having an accurately-calibrated sweep (see list of test equipment in paragraph four of this section), and a crystal detector should be used to demodulate the output rf pulse from Signal Generator TS-403/U. After making this adjustment, a check should be made that a 10-microsecond wide pulse is available at all carrier frequencies from 1800 to 4000 megacycles.

8. MONITOR RF PROBE REPLACEMENT.

A spare RF probe, E-145, is provided with Signal Generator TS-403/U and is mounted on the back side of the chassis (see figure 5-1). This spare assembly is pre-calibrated and can only be used with the TS-403/U with which it is supplied. The assembly consists of the monitor pick-up loop, together with the pick-up plunger and bead thermistor R-136 mounted within the plunger. The spare assembly E-145 is mounted in a sheath that is held to the chassis by means of two fuse clips. The clips are welded to the sheath and it is important not to attempt to pry the sheath loose from the clips. In order to remove the assembly, remove the screw that holds the clip nearest X-109 and merely loosen the other screw. Then rotate the sheath one-quarter turn and remove the RF probe. (If no spare RF probe is available, see paragraph 13.)

The defective assembly can be replaced quite easily. Remove the cap by loosening the three #2-56 screws (see figure 4-6) and unsolder the wire from the tie point that is exposed when the cap is removed (figure 4-7). Then in the lower collar loosen the two #8-32 set screws (figure 4-6) that hold the pick-up plunger. After this has been done, the RF probe can be removed from the probe holder as shown in figure 4-8.

Insert the pick-up plunger of the spare assembly in the probe holder very carefully so as not to damage the pick-up loop. Seat the collar of the plunger on the collar of the rack, meshing the keyway with the rack. Tighten the #8-32 set screws in the lower collar. Then the cap of

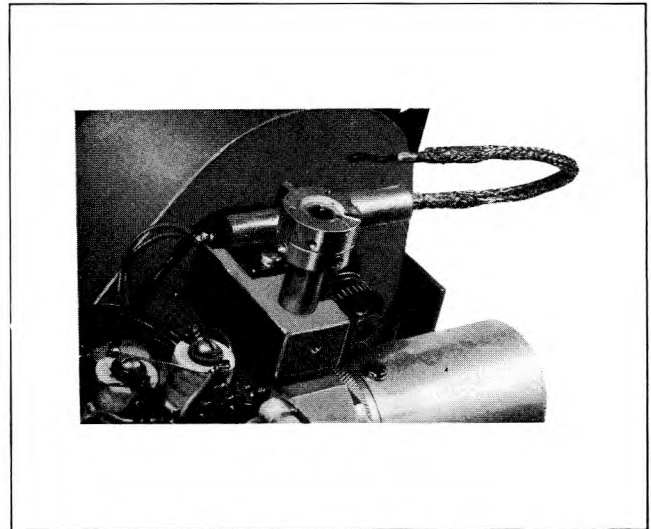

Figure 4-7. Removal of Cap of RF Probe

the assembly should be removed and the shielded wire soldered to the tie-point underneath the cap. Replace the cap.

After the spare RF probe has been installed, it is desirable to turn on the signal generator and allow to heat for twenty minutes or so. At the end of that time, set the modulation selector switch to the OFF position and zero set the meter pointer with the ZERO SET control. If it is not possible to zero set the meter, refer to paragraph 7g.

9. SERVICING BLOCK DIAGRAM.

Figure 7-4, the Servicing Block Diagram is included as an aid in trouble-shooting of the instrument. This diagram shows the pulse shapes and amplitudes obtained throughout the Modulator section of the instrument when the Modulator is synchronized with an external sinusoidal voltage having a frequency of 1000 cps.

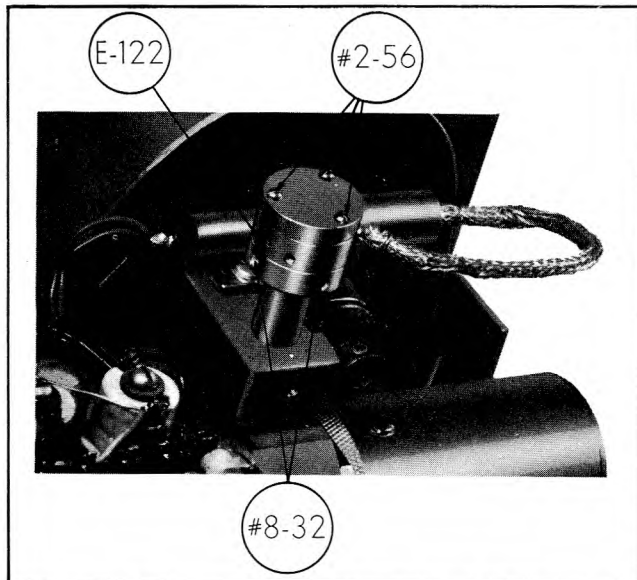

Figure 4-6. Screws Holding RF Probe in Place

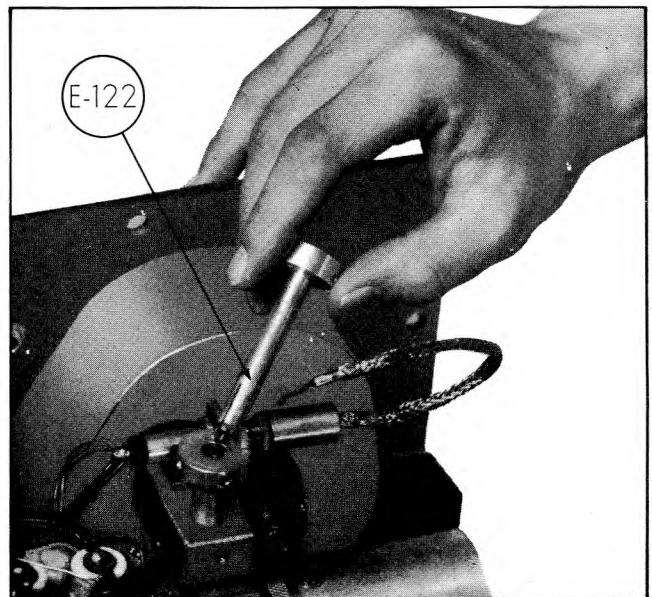

Figure 4-8. Removal of E-122

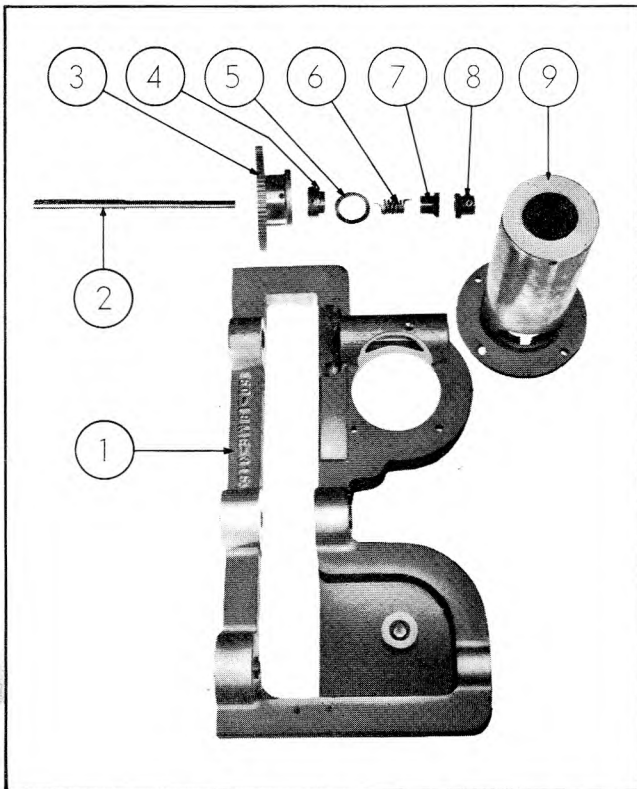

Figure 4-9. Parts Comprising Upper Drive System

It should be noted that the pulse shapes differ widely, especially in the circuits associated with V-102, depending upon whether the Modulator is free-running or synchronized with external voltages and upon the frequency of the external voltage. Therefore, when trouble-shooting in the circuits associated with V-102, remember that a negative pulse is generated at the plate of V-102B in synchronism with the external voltage and that the leading edge of this pulse should be coincident with the leading edge of the external synchronizing voltage.

10. REPAIR OF RF SECTION.

a. MECHANICAL ASSEMBLY.—The series of photographs in Figures 4-9 to 4-45 illustrate the procedures for assembling the various parts which make up the oscillator and attenuator assemblies. This procedure is included here to show the method for assembling parts should the replacement of any part become necessary and should be attempted only by qualified personnel at overhaul bases.

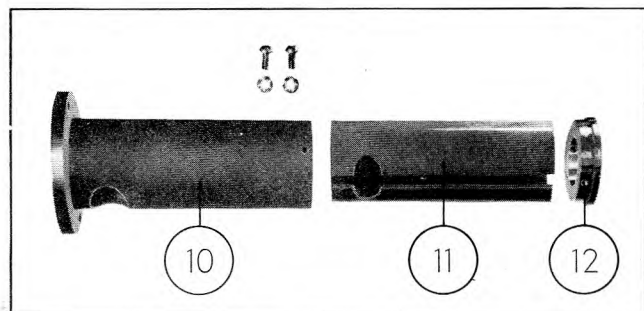

Figure 4-10. Parts Comprising Drive Housing

It should be noted that the mechanical system is complex and that a certain amount of mechanical ingenuity will be necessary in order to repair the system. The complete procedure is included here, although it is intended that only the applicable part of the procedure should be followed when making a repair or replacement.

CAUTION

Many of the parts in the mechanical drives are machined to critical tolerances. Therefore, no attempt should be made to force parts together. Make certain that the parts are being assembled properly and that moving parts run without binds or misalignment.

Figure 4-9 shows the oscillatory support casting (1) and the parts that make up the cavity drive system. The housing (9) can be slipped into position in the circular hole in the casting, orienting the housing so that the elliptical opening mates with the elliptical opening in the casting.

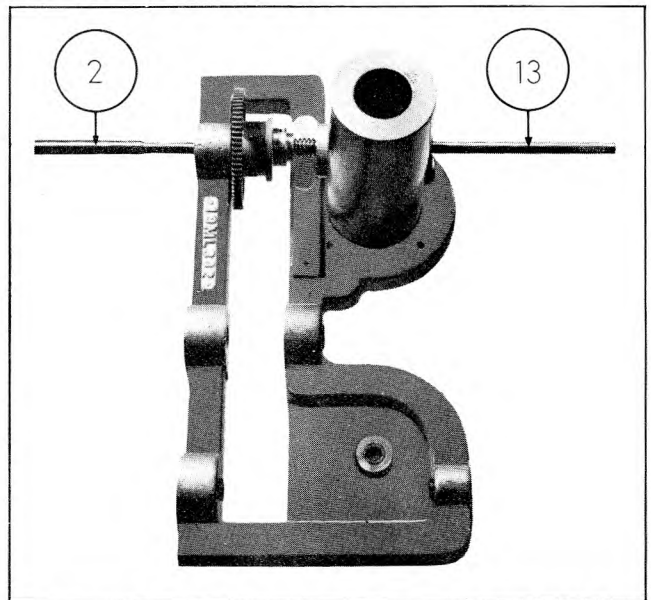

Figure 4-11. Assembly of Upper Drive System

It is not necessary to secure the housing to the casting, although this can be done for convenience in handling until the housing is permanently affixed to the casting at a later point in the assembly procedure.

Inside the housing (9) is a phenolic form filled with aquadag. There is no reason for this form to be removed from the housing, but if necessary the form can be replaced in the order shown in figure 4-10. The phenolic form (11) should be forced into the housing (10) so that the two elliptical openings mate. The form is held in place by friction and by the cap (12). Two #8-32 screws hold the cap in place.

When assembling the parts shown in figure 4-9, it is necessary to mount the parts on a supplementary 1/4" diameter rod and to force the rod out of the casting (1) with the under-cut shaft (2) as shown in figure 4-11. It is convenient to use the shaft (13) shown in figure 4-12 as the supplementary rod. The supplementary rod should be pushed through the casting from left to right until the

left end is in the gap in the casting. Then, the fixed pinion (8), spring-loaded pinion (7), spring (6), washer (5), and pinion stop (4) should be mounted on the rod. The ends of the spring should be fitted into the holes in the pinion stop and spring-loaded pinion. Then slide the undercut shaft, small end first, through the left end of the casting and mount the spur gear (3) on the undercut shaft. This is the condition shown in figure 4-11. Force the supplementary rod out of the casting with the undercut shaft. The undercut shaft should be pressed in as far as it will go (until the left end of the shaft is approximately flush with the left edge of the casting). The two set screws in the hub of the spur gear should be tightened so that there is less than about 0.001-inch end-play in the system. It is not necessary to tighten the set screws in the end pinion or pinion stop at this point in the procedure.

Figure 4-12 shows the parts making up the lower drive system. Assemble the parts in the order shown in figure 4-13. The shaft (13) should be inserted until it protrudes $1\frac{1}{4}$ inch from the left side of the casting. The taper pin (17) for the worm (18) mates with a hole in the shaft and should be pressed into position with pliers, being careful not to distort the shaft. The set screws in the stops (14 and 19) should be tightened so that there is less than 0.003 inch end-play in the system. Turn the shaft clockwise so that the traveling stop (15) runs entirely to the left and the stop pins interfere.

Figure 4-14 shows the parts making up the main drive system. With the lower drive set so that the stop pins interfere, set the upper drive so that the tapped 4-40 hole in the hub of the small spur gear is at three o'clock

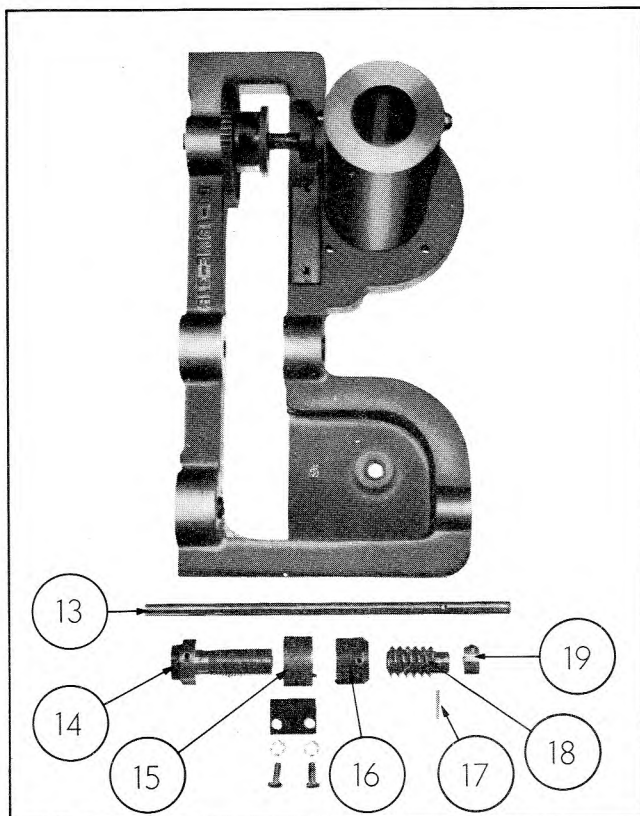

Figure 4-12. Parts Comprising Lower Drive System

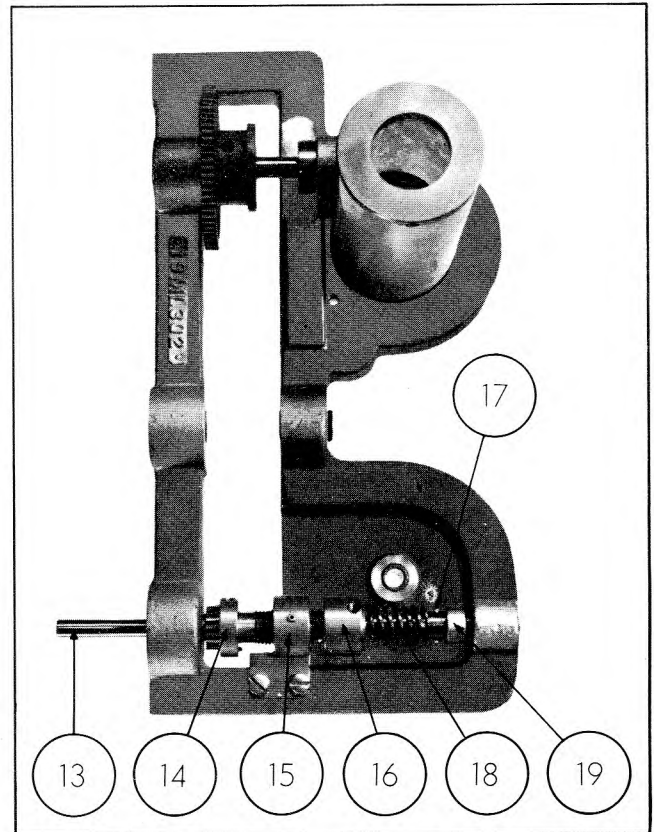

Figure 4-13. Lower Drive System Assembled

when looking at the front edge of the casting. The small spur gear can be seen in figure 4-15 in proper position with a #4-40 screw (23) inserted in the hole. Then mesh the large spur gear (21) with the top and bottom gears in such a way that the 4-40 tapped hole in the hub of the gear will be at 10 o'clock. Put the $5/16$ " diameter shaft (20) through the bearing and gear hub, place cam (22) on shaft and tighten set screws in hub of gear so that the shaft extends $11/16$ " from the face of the casting. It is not necessary to tighten the set screws in the cam at this time.

With the gears still in the same position, that is with the bottom shaft completely clockwise, fasten one end of the 6 inch spring (24) to the 10 o'clock hole in the hub of large spur gear. Start the spring around the hub of the large gear in a clockwise direction, but instead of winding the spring around the drum, push the spring to the back and make one turn around the hub of the cam. Then fasten the loose end of the spring to the 4-40 tapped hole at three o'clock in the hub of the small spur gear. The spring may now be wound on the small drum by turning the lower shaft, and then put in place on the large drum. Figures 4-16 and 4-17 show the spring in place with one end of the spring terminating at three o'clock on the small spur gear hub and with the other end of the spring at 10 o'clock on the large spur gear hub.

Figures 4-18 and 4-19 show the assembly of the sensitive switch S-102 (27) with its auxiliary actuator arm (26) and mounting bracket (25). The tripping of the switch is adjusted at a later point in the assembly pro-

cedure. There are no special precautions to be followed except to make certain that the roller on the auxiliary actuator arm rides properly on the cam (22).

Figures 4-20 and 4-21 show the assembly of the drive worm gear (28), shaft (29), and coupler (30) for potentiometer R-173. It is necessary to mate the worm gear with the worm before inserting the shaft through the gear hub and casting. The hub of the gear should point away from the casting as shown in figure 4-22. The shaft is flattened on one end and the single set screw in the hub of the coupler should be tightened on this flat. The set screws in the worm gear and coupler should be tightened so that there is less than 0.002 inch end play in the system and so that there are no binds. It is important to make certain that the worm gear mates properly with the worm itself.

Figure 4-23 shows the repeller potentiometer mounting bracket (31) with the 6-32 x 1 1/2 inch machine screws (32) and 1-1/16 inch long spacers (33) which mount it to the casting. The parts should be assembled and mounted to the casting as shown in figure 4-24. It is desirable to cement the mounting screws with glyptol or some similar cement.

Figures 4-25 and 4-27 show the assembly of the cavity wiper carriage. The cavity inner conductor (38) should be used to align the parts as shown in figure 4-26 before the 4-40 x 3/8 inch screws (37) are tightened. It is important that the wiper (36) be well centralized and that all of the wiper contacts on the inner circle make good contact with the inner conductor before the screws are tightened. The screws should then be tightened a little at a time without disturbing the alignment of the system. If the wiper is not properly aligned, the oscillator will be inoperative or erratic. Remove the inner conductor from the assembly.

Figures 4-28 and 4-29 show the assembly of the inner conductor (38), wiper carriage and wiper (36), and outer conductor (39). The wiper carriage should be inserted into the housing, aligning the rack on the carriage with the keyway in the housing. It is necessary to tilt the carriage slightly when inserting in order that the rack can clear the pinions inside the housing. The outer conductor (39) can then be slid over the wiper, gently pressing the contact fingers of the wiper in order to allow the outer conductor to slide over the wiper. This should be done while making certain that the rack on the wiper carriage

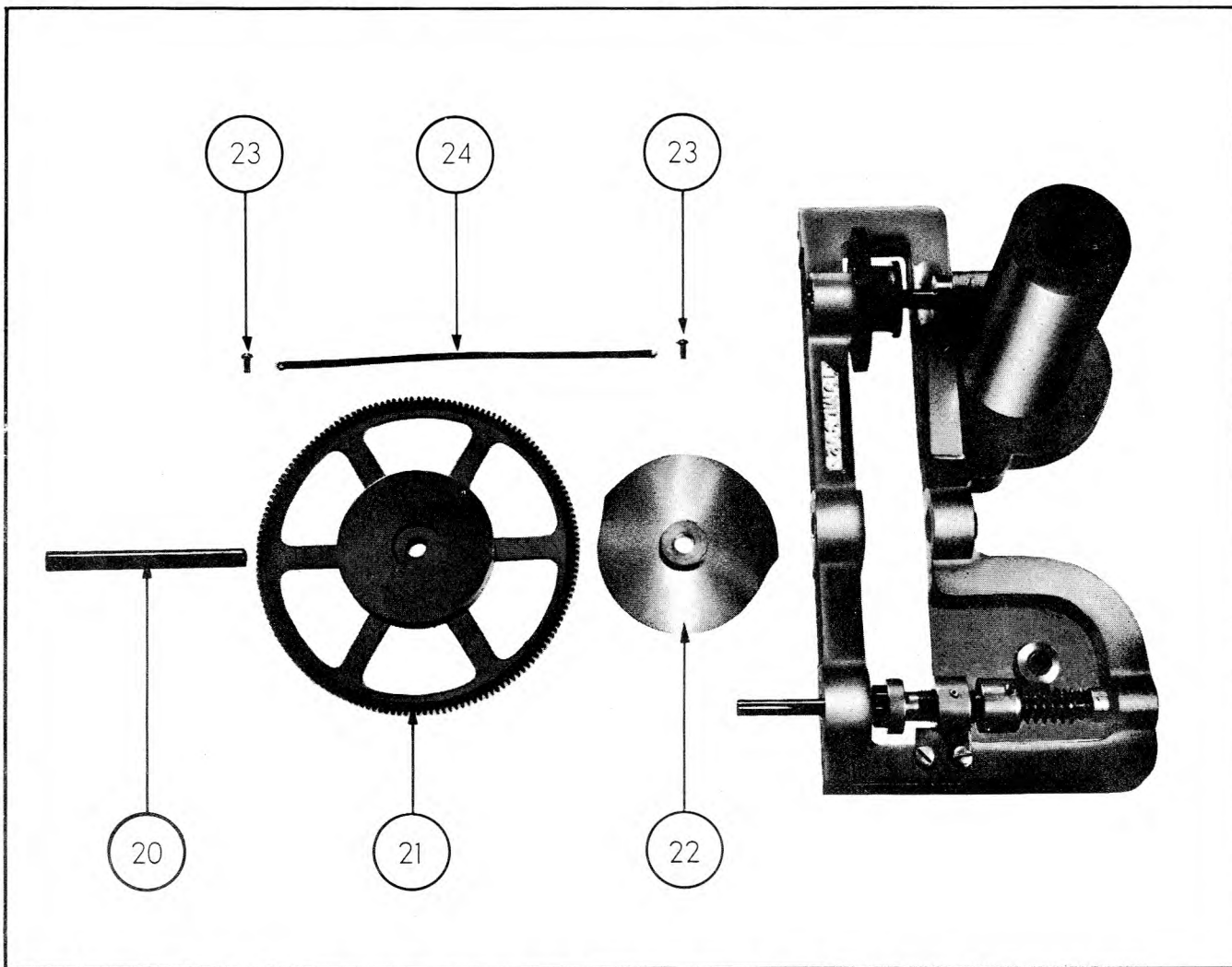

Figure 4-14. Parts Comprising Main Drive System

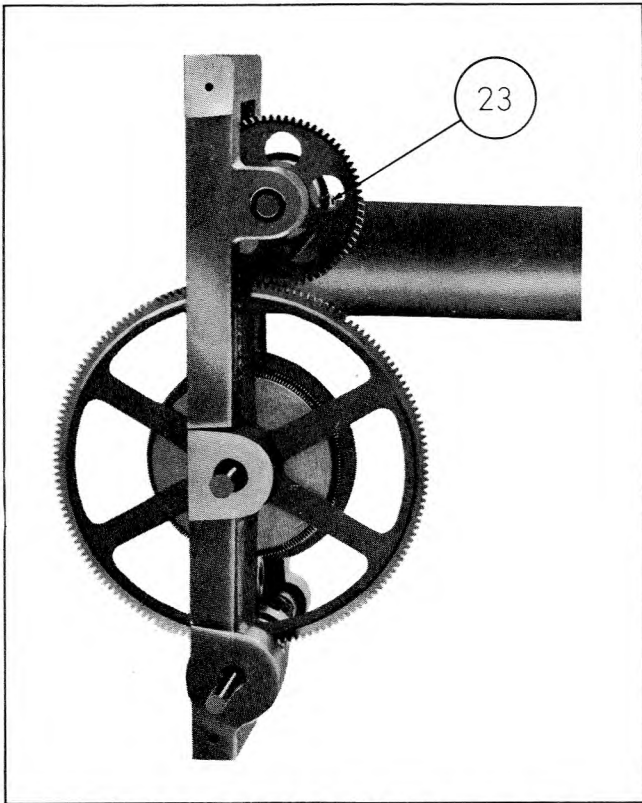

Figure 4-15. Front View of Assembled Drive

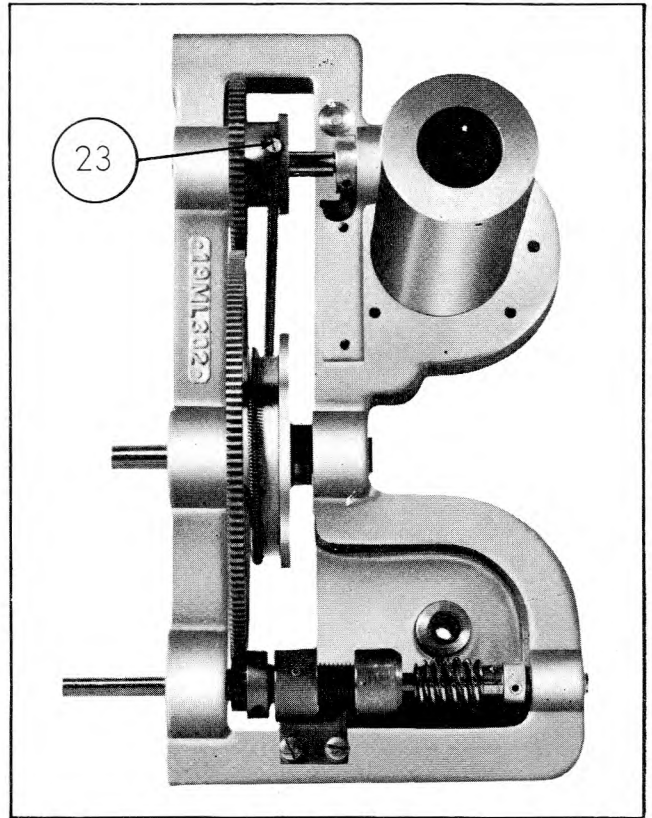

Figure 4-17. Right View of Assembled Drive

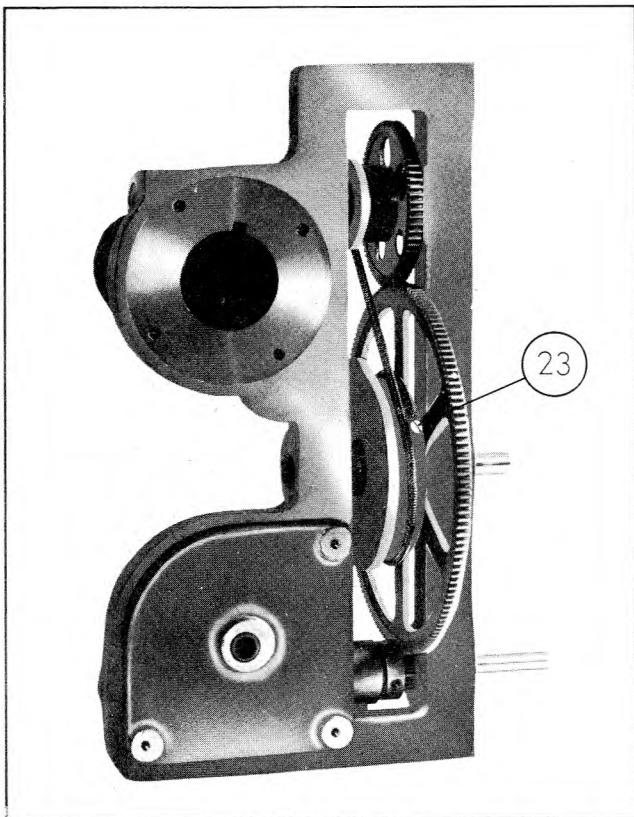

Figure 4-16. Left View of Assembled Drive

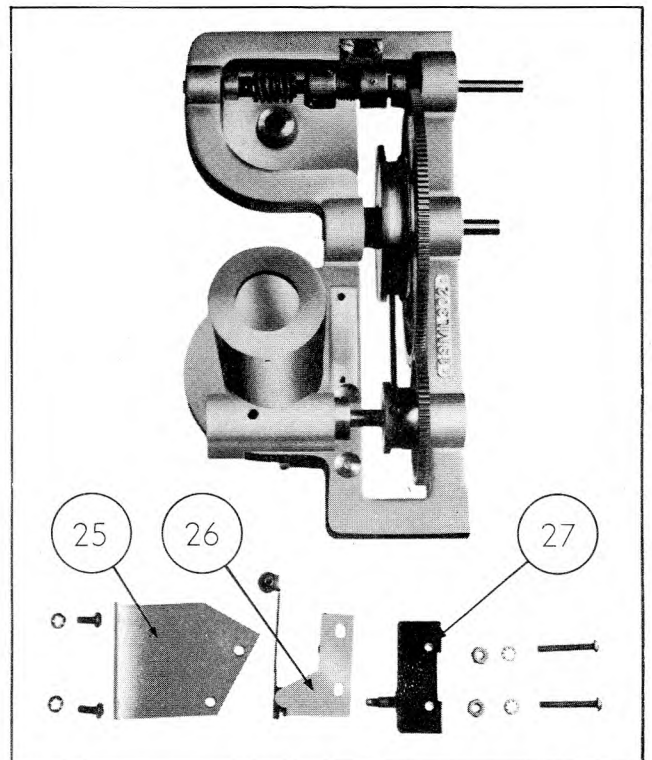

Figure 4-18. Assembly of Sensitive Switch S-102

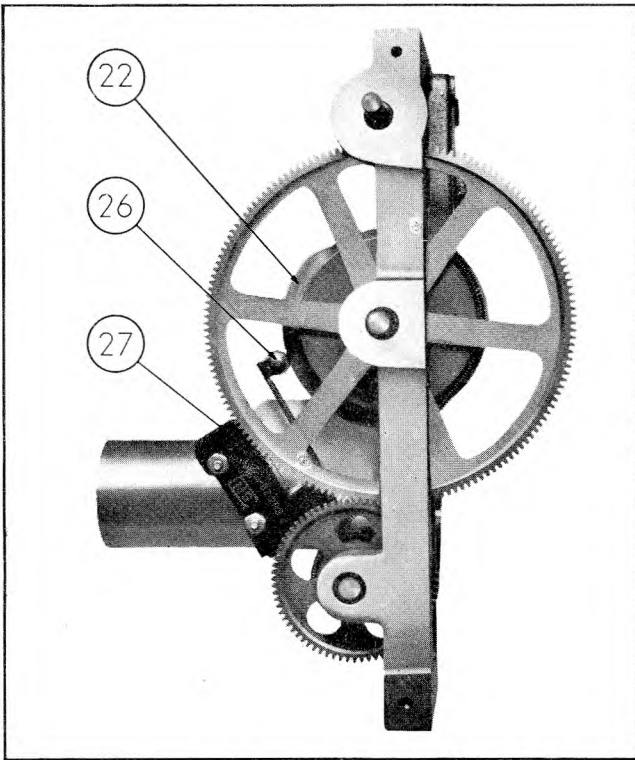

Figure 4-19. Sensitive Switch Mounted on Main Casting

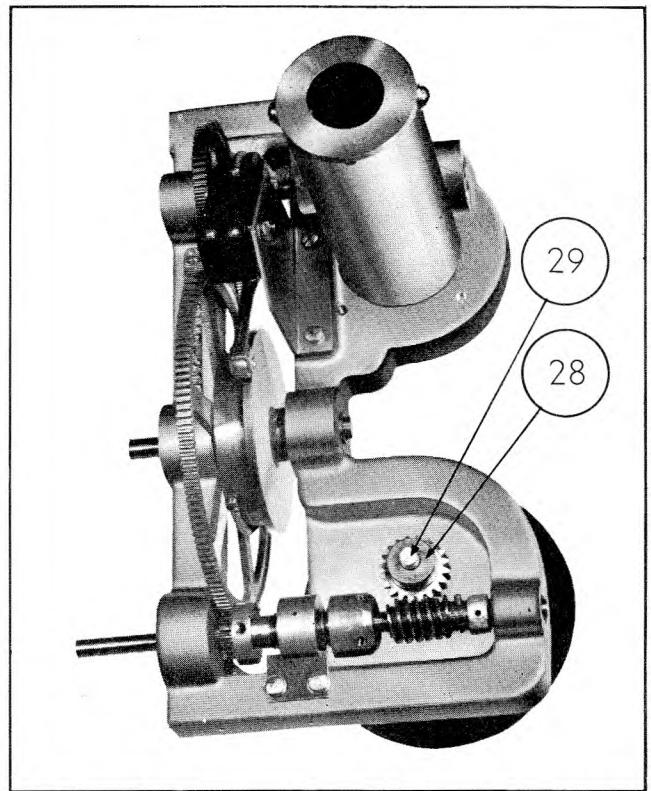

Figure 4-21. Potentiometer Drive Assembled Into Place

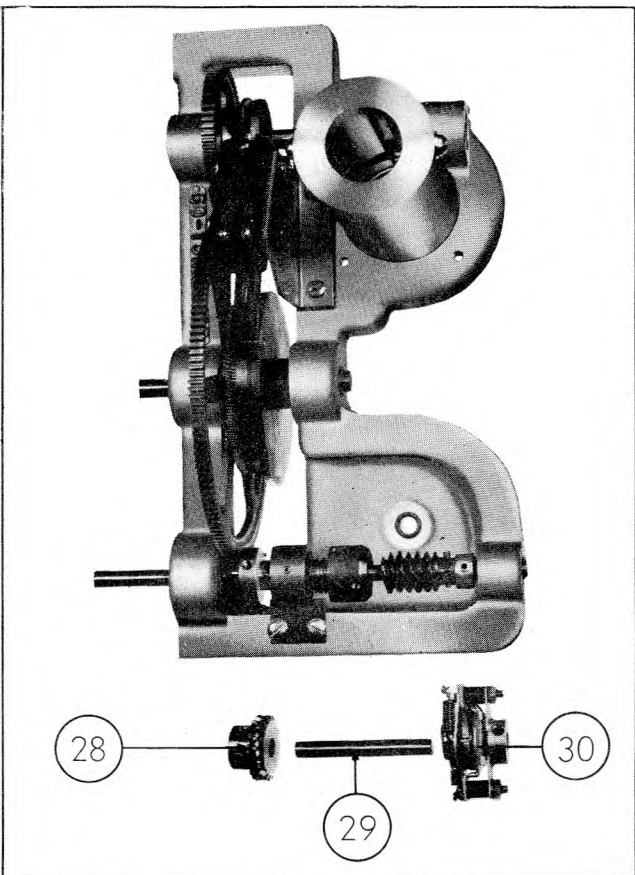

Figure 4-20. Parts Comprising Potentiometer Drive

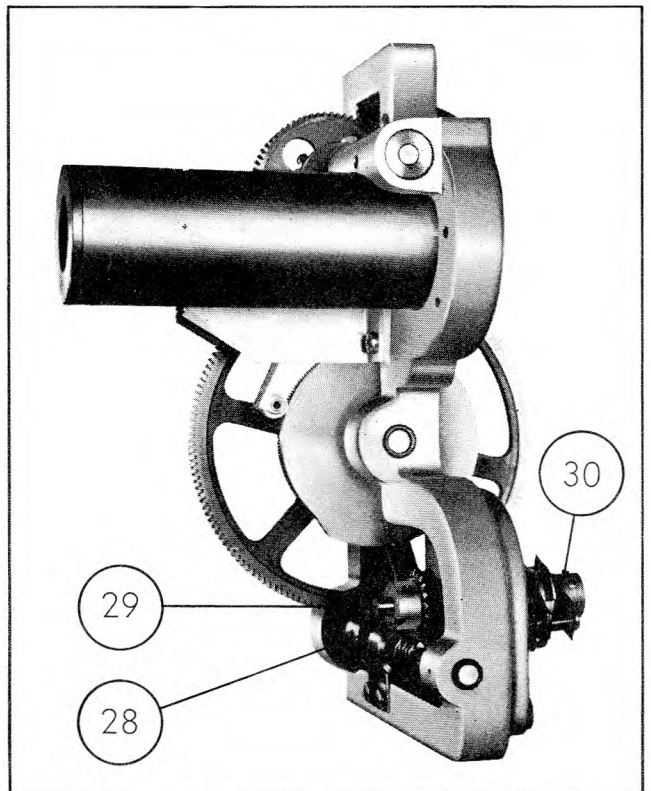

Figure 4-22. Oblique View Showing Potentiometer Drive Assembled

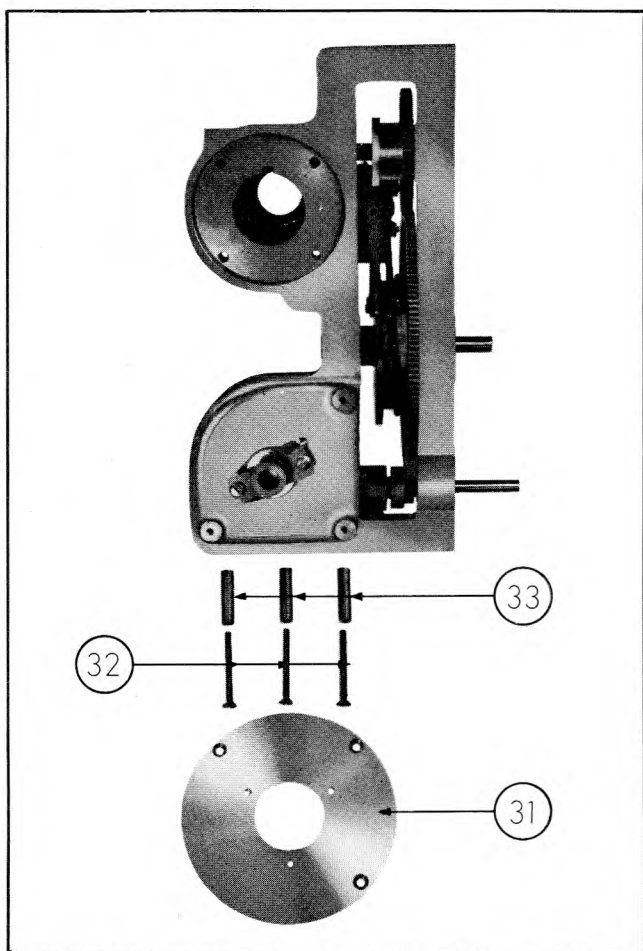

Figure 4-23. Parts Comprising Mounting Bracket for Potentiometer R-173

meshes properly with the pinions inside the carriage housing. The outer conductor should then be fastened to the casting by means of the four 8-32 x 3/4 inch screws (40)

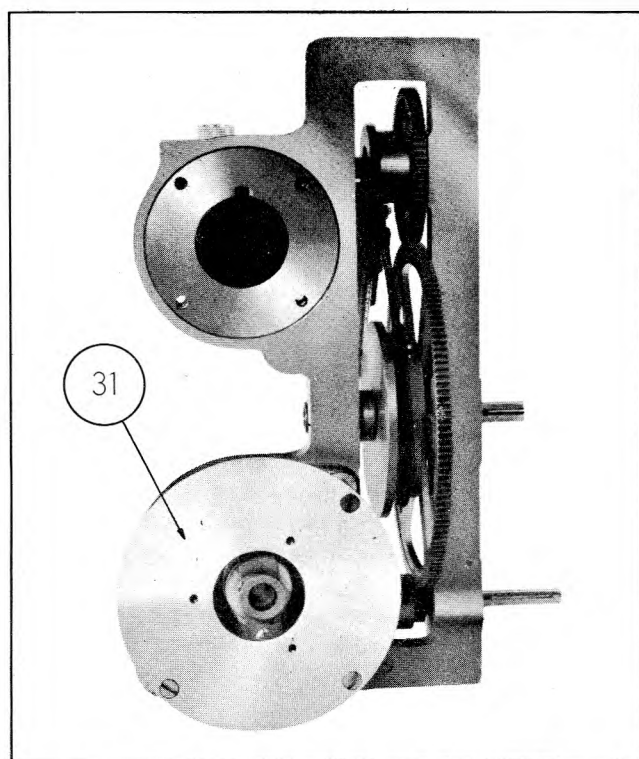

Figure 4-24. Bracket for Potentiometer R-173 in Place

with the flat surfaces of the outer conductor pointing up as shown in figure 4-29. The inner conductor should then be inserted through the back side of the wiper housing (opposite the wiper), thin edge first. This must be done very carefully, passing the thin edge of the conductor through the wiper without damaging the edge of the conductor. The thumb screw (41) can then be inserted as shown in figure 4-29 in order to lock the inner conductor. The exact position of the inner conductor is not important, as it is later positioned by the tube.

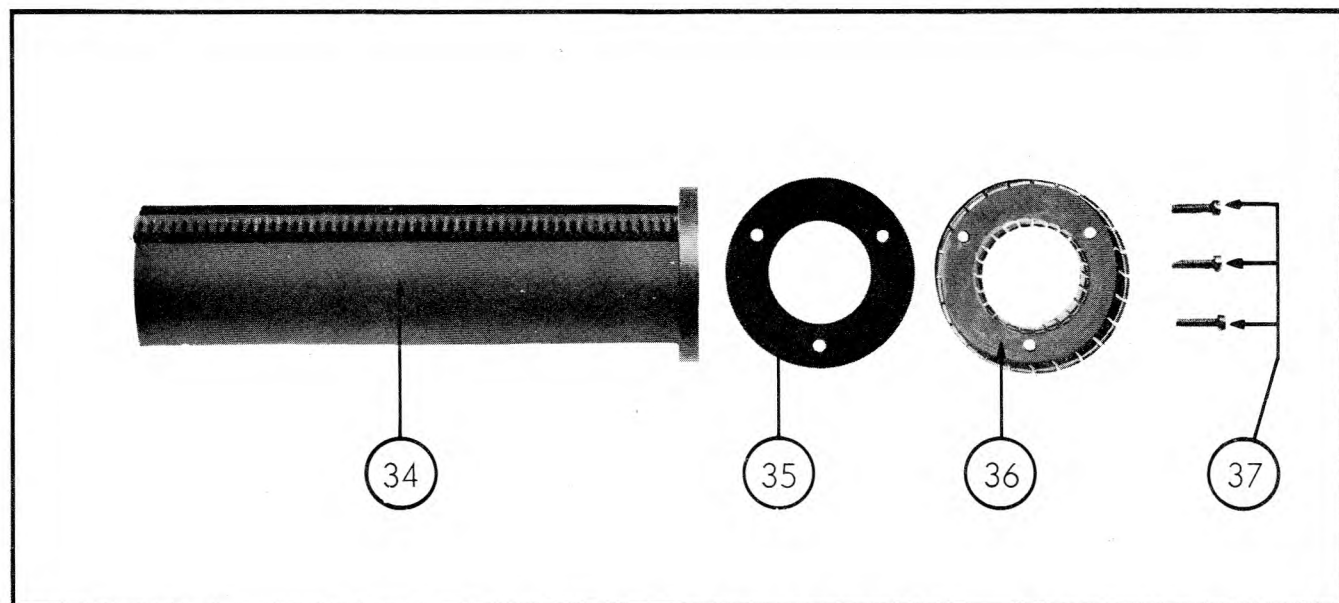

Figure 4-25. Parts Comprising Brush Assembly

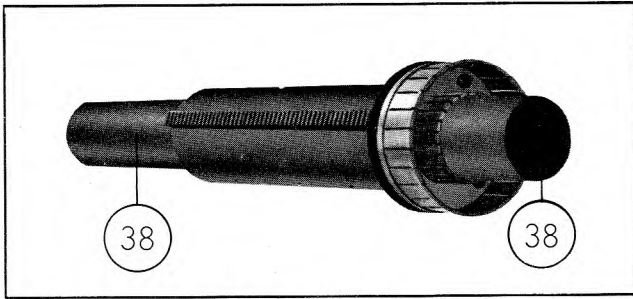

Figure 4-26. Alignment of Brush Assembly

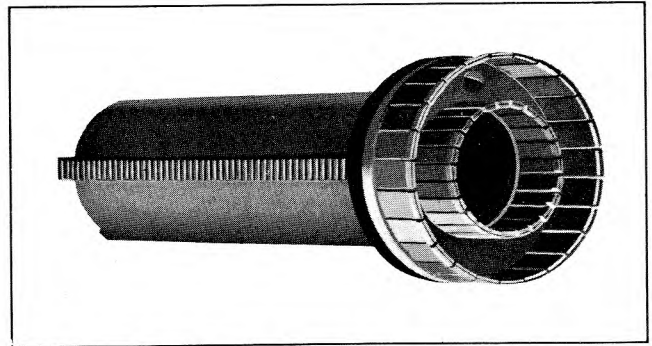

Figure 4-27. Assembled Brush Assembly

Figure 4-30 shows the brush assembly (36) in the cavity. At this point in the assembly it is necessary to adjust the cavity drive pinions. The procedure is to set the lower drive shaft completely clockwise. Then set the brush assembly in the cavity so that the edge of the wiper is about 1-3/16 inches from the end of the cavity but so that one of the #8 set screws in the fixed pinion is visible through the hole in the pinion housing shown in figure 4-9. The set screw should be locked with a set screw wrench and the brush assembly moved so that the second set screw in the fixed pinion can be locked. Now the leading edge of

the brush should be set exactly 1-3/16 inches from the end of the cavity (the surface with the four tapped holes shown in figure 4-30). In order to do this it will be necessary to loosen the set screws in the hub of the upper spur gear. This loosening should be done without changing the position of the spur gear; that is, the spur gear should be set so that the loading spring screw is at three o'clock. At this point retighten the set screws in the hub of the upper spur gear so that there is less than 0.001 inch end play in the upper drive system. Then rotate the pinion

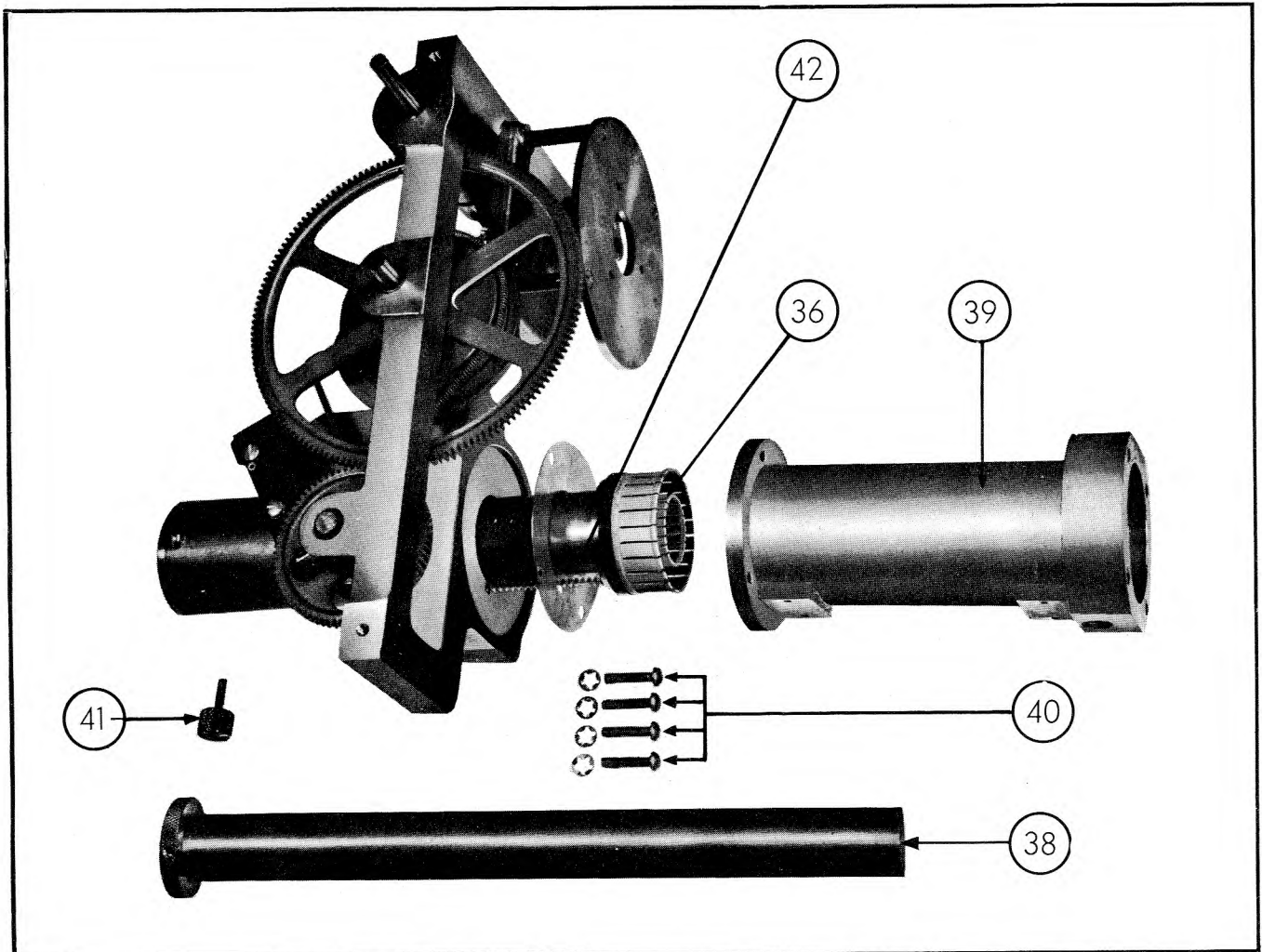

Figure 4-28. Assembly of Brush Assembly, Outer and Inner Conductors

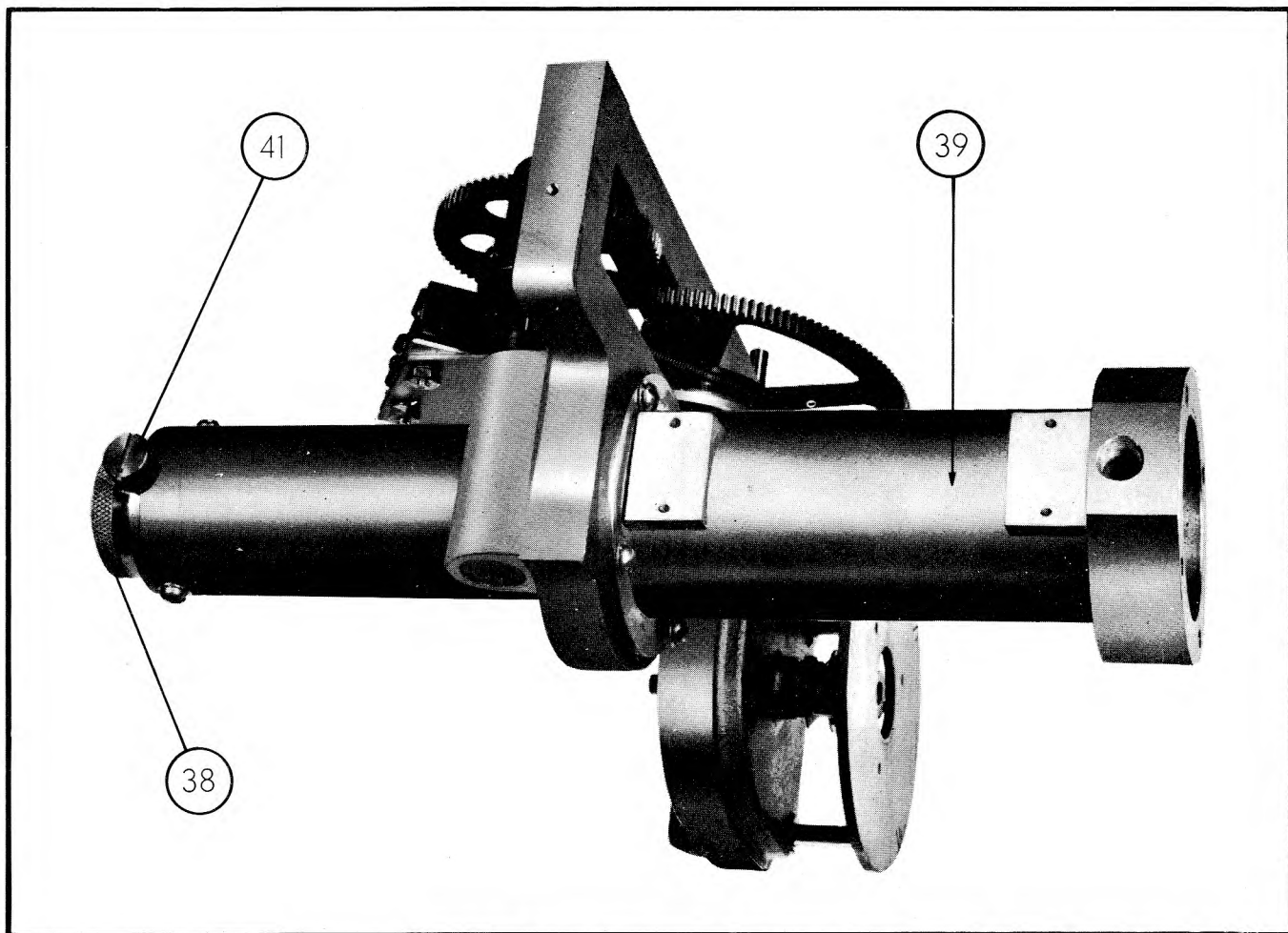

Figure 4-29. Outer Conductor Assembled

stop one-quarter turn clockwise in order to spring-load the spring-loaded pinion and lock the set screws in the stop so that the compression washer is about one-half compressed. Make certain that the drive is smooth and that no binding is present.

Now turn the lower drive shaft 7.5 turns counter-clockwise and in the lower drive system reset the rear stop for the traveling stop so that the stop pins interfere at this point.

The oscillator system is now ready to be mounted on the back of the front panel for the signal generator.

Figures 4-31 to 4-33 show the assembled attenuator drive. Since any part can be replaced without extensive disassembly, no assembly procedure is given. The only precaution necessary is that the upper and lower pinions (43) be properly spring-loaded. This can be seen in figure 4-32 where it is shown that, when spring-loaded, the 2-56 screw (44) which holds the spring is in the center of the hole in the pinion.

The pinions (45 and 46) on the back of the casting shown in figure 4-33 should be secured so that there is as little end play in the system as possible and still have the system operate freely.

Figure 4-34 shows the oscillator and attenuator drive systems mounted on a blank panel. The oscillator mounts

by means of one 8-32 x 1/2 inch binding head screw and one 8-32 x 1/2 inch flat head screw; the attenuator mounts with three 6-32 x 3/8 inch round head screws and one 6-32 x 3/8 inch flat head screw.

Figures 4-35 to 4-37 show the assembly of the attenuator dial and index system. Before tightening the four 6-32 x 1/4 inch flat head screws which hold the index plate (48) and clamping ring (47), place the dial on the hub and fasten the index (49) as shown in figure 4-36. It should now be possible to slip the index plate when the POWER SET control is held fast.

The index plate and POWER SET control should be adjusted so that the POWER SET control swings the index an equal amount on either side of vertical (12 o'clock); thus, in figure 4-36 it is possible to swing the index by use of the POWER SET control from approximately the 28 db mark to approximately the 12 db mark.

The index and dial should then be removed carefully and the four clamping screws shown in figure 4-35 tightened without disturbing the position of the index plate or the POWER SET control. The index and dial should be replaced in such a way that when both POWER SET and OUTPUT ATTEN controls are completely counter-clockwise the index is one db from the zero mark as shown in figure 4-37.

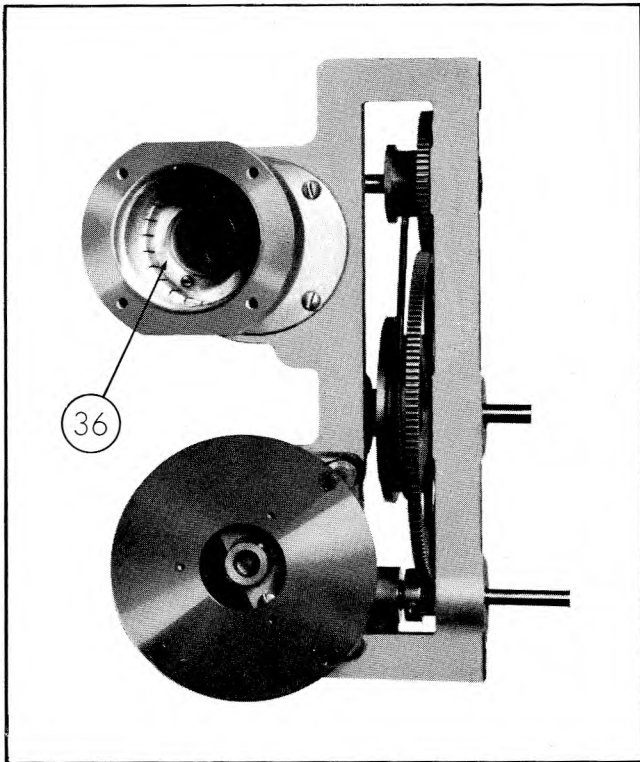

Figure 4-30. Left View of Assembly with Brush in Place

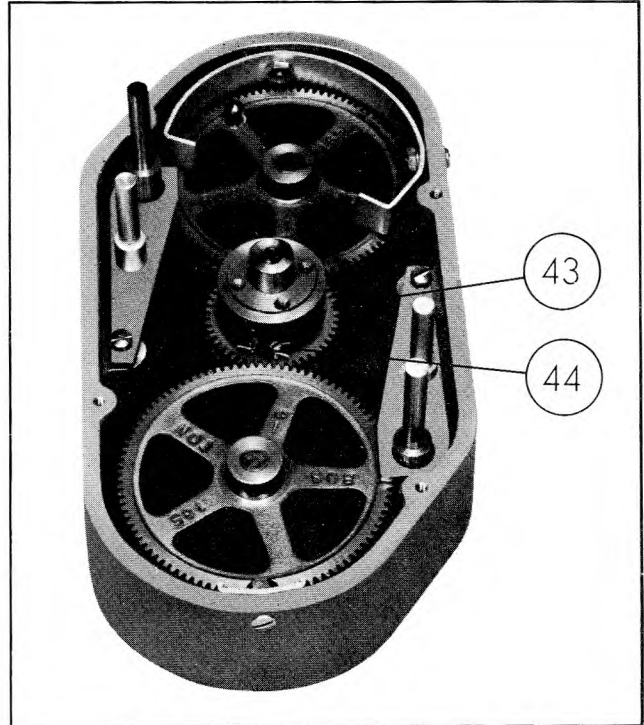

Figure 4-32. Attenuator Gear Case Showing Spring-Loading of Pinion

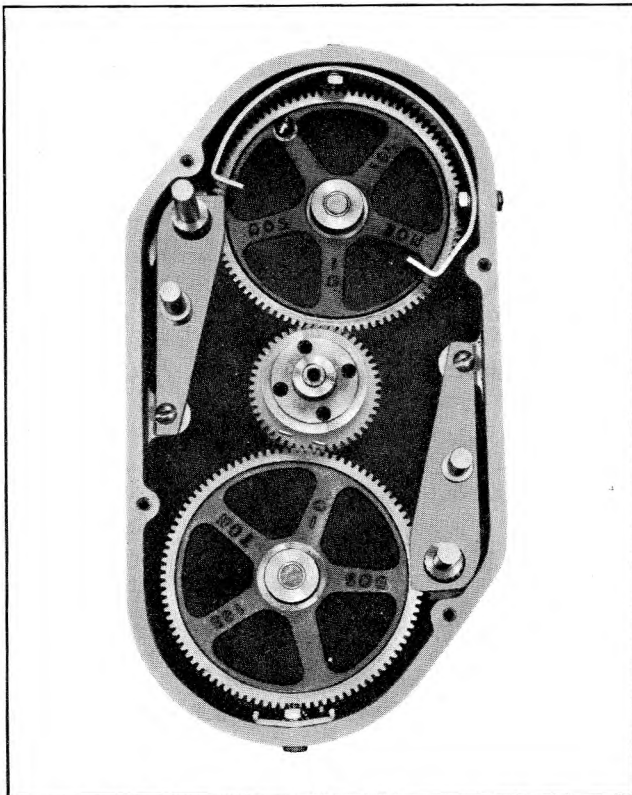

Figure 4-31. Front View of Attenuator Gear Case

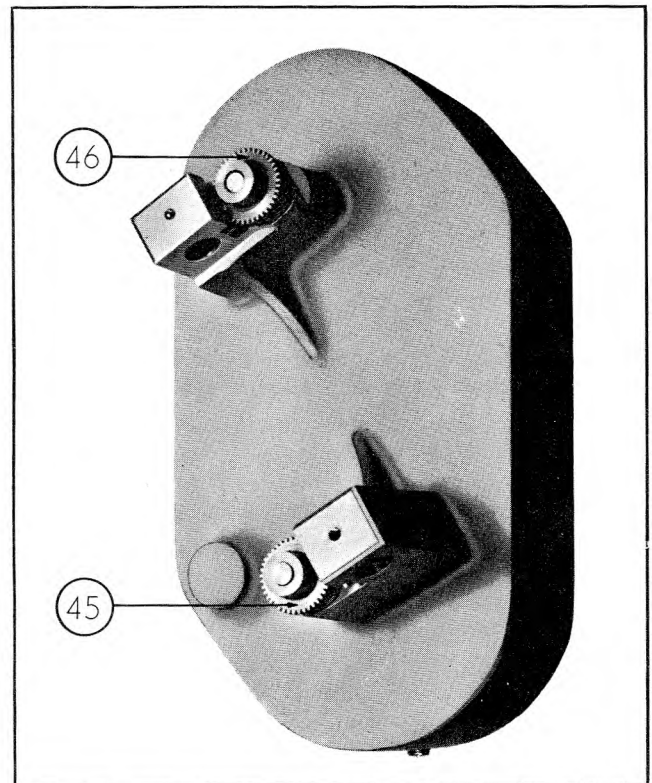

Figure 4-33. Rear View of Attenuator Gear Case

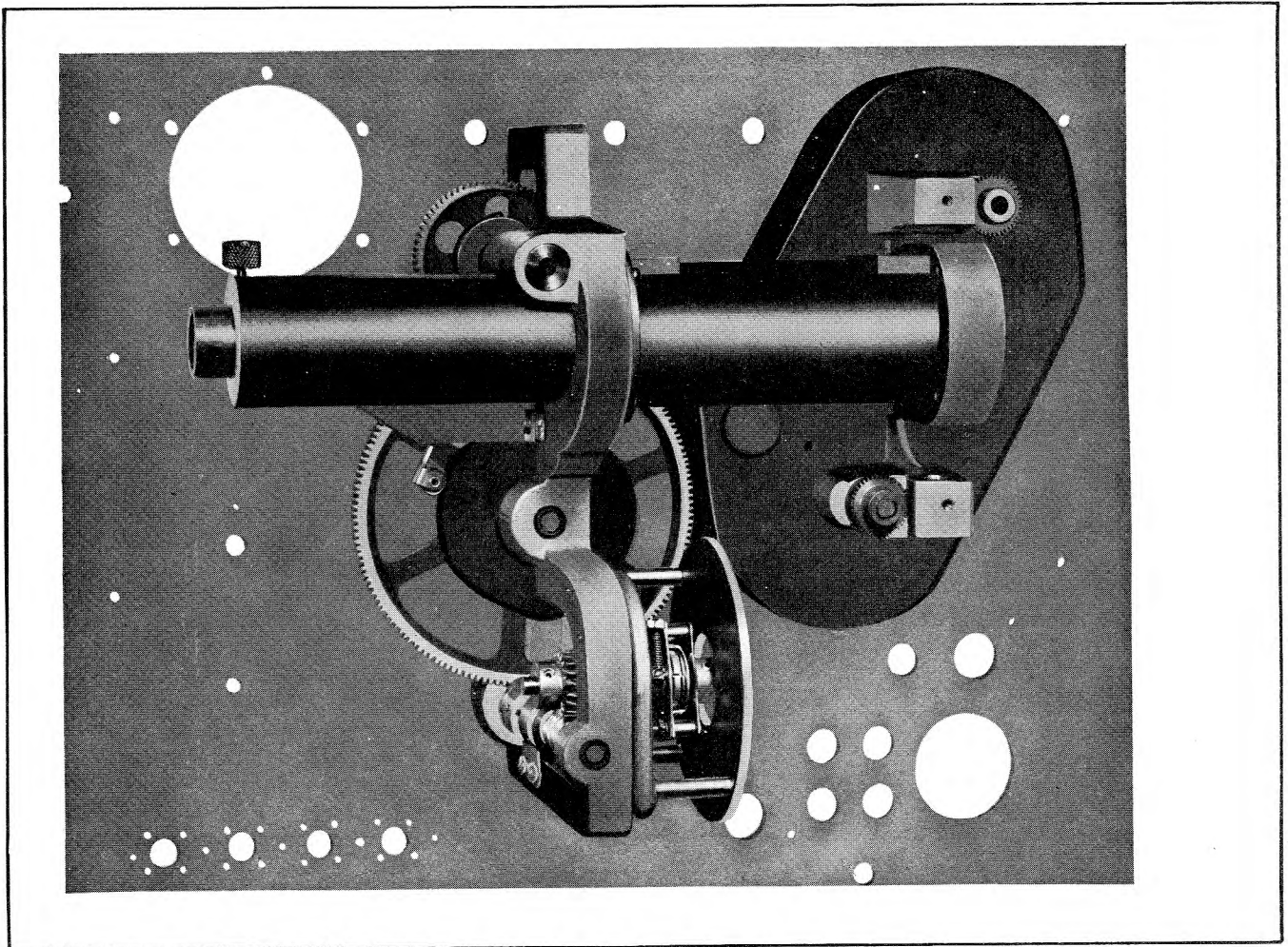

Figure 4-34. Oscillator and Attenuator Assembly Mounted on Panel

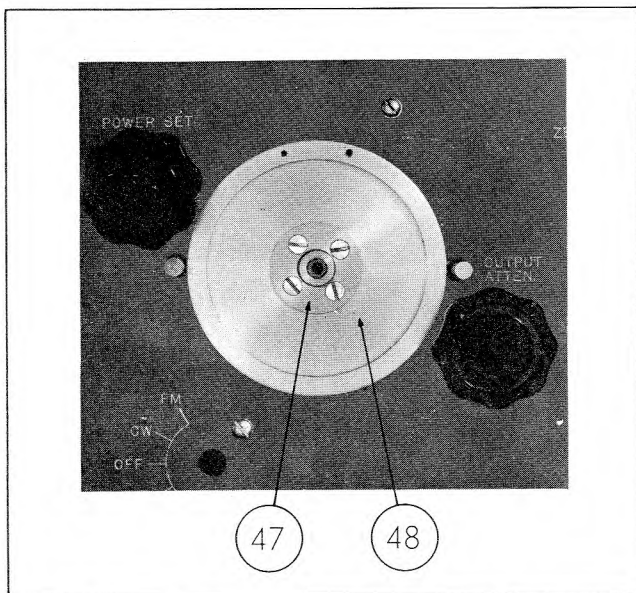

Figure 4-35. Index Plate Assembled

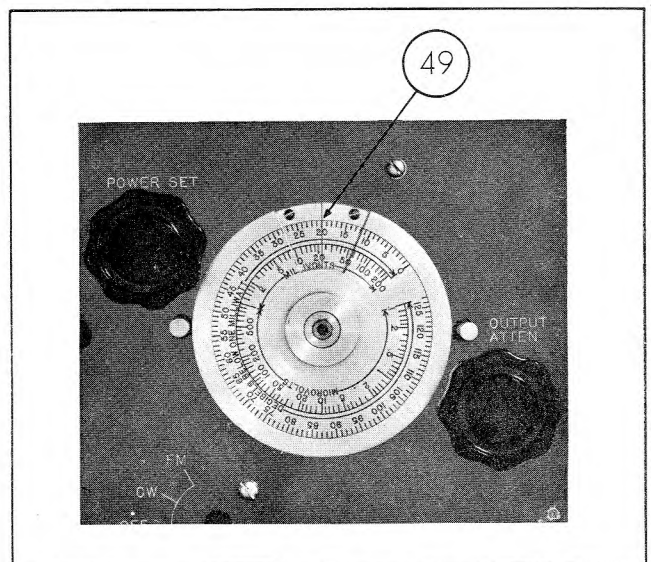

Figure 4-36. Attenuator Dial Assembled for Index Adjustment

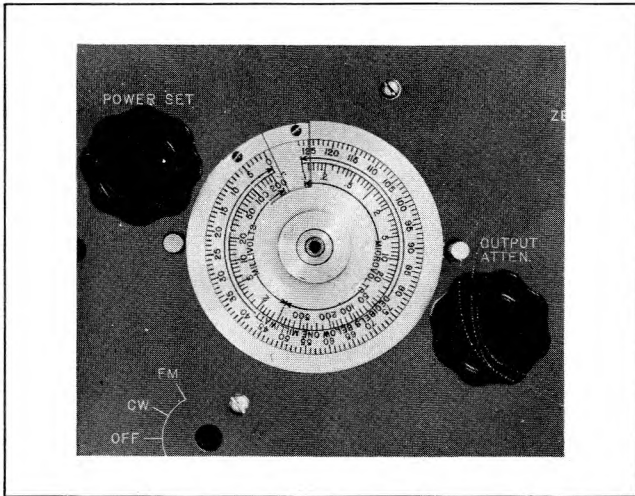

Figure 4-37. Position of Index with Both Controls Set Counter-Clockwise

Figure 4-38 shows assembly of the monitor (50) and attenuator (51) RF probe holders. The holders should be screwed into the cavity block until they are as close to the inside surface of the cavity as possible without any portion of the holder actually extending into the cavity. The locknuts holding the holders should then be secured.

Figure 4-39 shows the assembly of the attenuator rack. If necessary, reset the attenuator pinion so that, when the OUTPUT ATTEN control is completely counter-clockwise, the end of the rack is approximately 1/32" from the cavity block. This adjustment is a matter of trial and error.

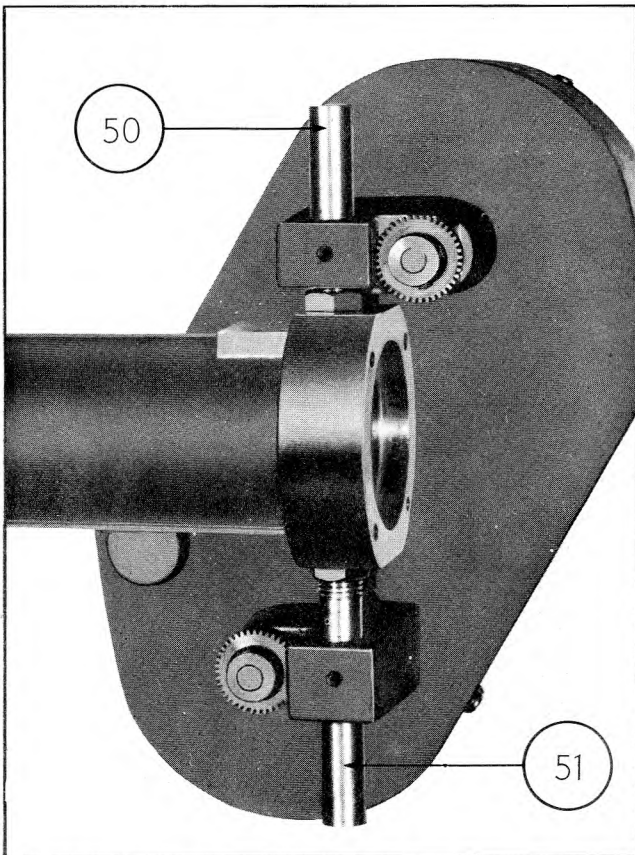

Figure 4-38. Assembly of Monitor and Attenuator RF Probe Holders

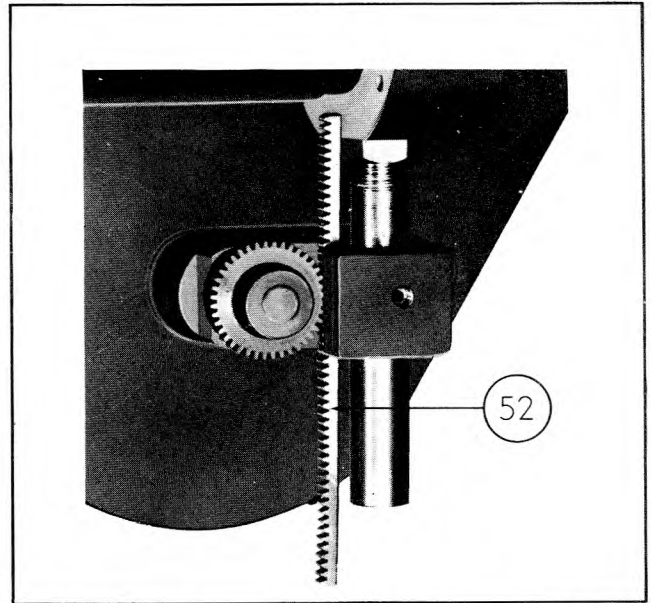

Figure 4-39. Assembly of Attenuator Rack

wise, the screw hole for the loading spring will be at six o'clock as shown by (53) in figure 4-40. The set screws for the pinion should be tightened a little at a time so that the pinion is not tilted on the shaft. Make certain the end play is not excessive. The rack should be meshed with the pinion (using the OUTPUT ATTEN control to turn the pinion) in such a way that when the OUTPUT ATTEN control is turned completely counter-clockwise the end of the rack is approximately 1/32" from the cavity block. This adjustment is a matter of trial and error.

Figure 4-40 shows the spring-loading system for the output attenuator. The output attenuator should be inserted into the probe holder until the hole in the collar mates with the hole in the rack. Secure the collar to the

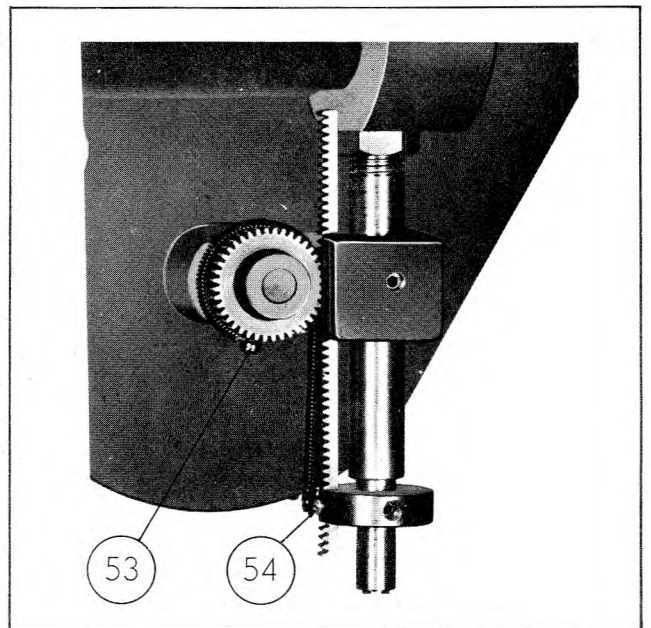

Figure 4-40. Attenuator Drive Loading Spring in Place

rack with the 4-40 round head screw (54). Then turn the OUTPUT ATTEN control completely clockwise. At this point the hole for the screw shown in the pinion should be at six o'clock. The spring can then be strung as shown.

Figure 4-41 shows the spring-loading system for the monitor pick-up. The rack should be meshed with the pinion in such a way that when the POWER SET con-

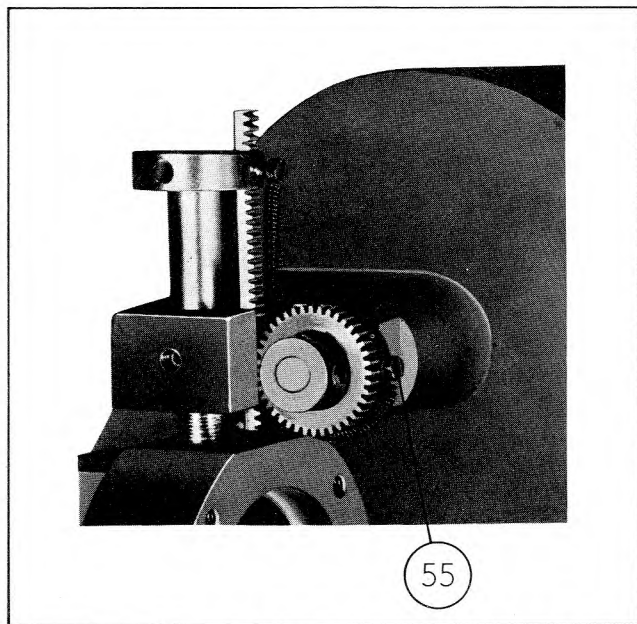

Figure 4-41. Monitor Drive Loading Spring in Place

control is completely counter-clockwise, the end of the rack is $1/16''$ from the cavity. At this point the screw (55) in the pinion should be at three o'clock as shown. If necessary, reset the pinion to obtain this requirement, but retighten the set screws in the pinion a little at a time so that the pinion is not tilted on its shaft and so that there is negligible end play in the pinion drive. The collar should then be secured to the rack as shown in figure 4-41. The collar should not touch the end of the RF probe holder and if necessary the rack can be remeshed with the pinion so that the collar does not travel as far as the end of the RF probe holder. The spring can then be strung as shown.

Figure 4-42 shows the monitor pick-up (56) inserted into the RF probe holder. The pick-up should be inserted until the collar on the pick-up seats against the collar on the rack. The set screws in the latter should then be tightened.

Figure 4-42 also shows the manner in which the inner resonator grid contact ring (57) is inserted. The ends of the fingers on the contact ring should point out of the cavity. The ring should be seated against the flange about $3/8$ inch from the end of the cavity.

Figure 4-43 shows the procedure for assembling the grid contact clamping plate (58). The four 8-32 x $1/2$ inch screws (59) should be tightened until the clamping plate seats against the end of the cavity block.

Figure 4-44 shows the assembly with the repeller tracking potentiometer R-173 in place. The potentiometer

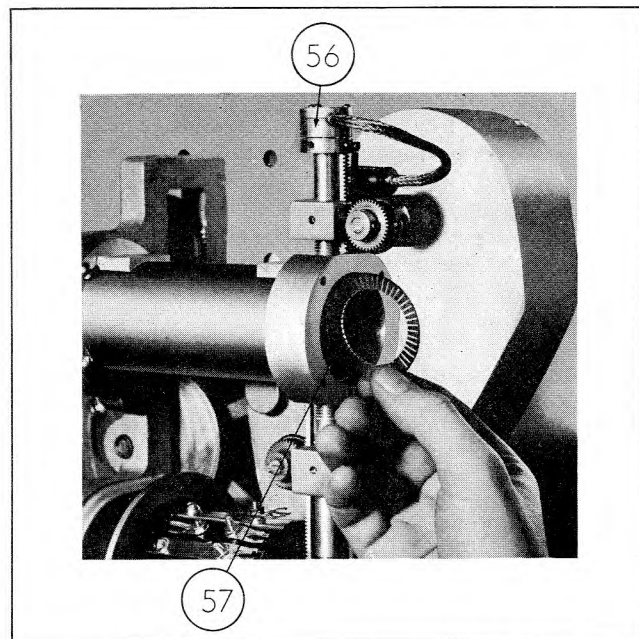

Figure 4-42. Positioning of Inner Grid Contact Ring

mounts to the mounting bracket by means of three 6-32 x $1/2$ inch binding head screws. The terminal side of the potentiometer should point upward as shown. Before tightening the coupler to the shaft of the potentiometer, turn the main tuning shaft completely clockwise. Then adjust the potentiometer so that its contact arm is at the extreme counter-clockwise end of the winding (looking into the open end of the potentiometer). Tighten the coupler to the potentiometer shaft in this position.

Connect an ohmmeter from the special tap on the potentiometer to the arm contact (the middle rear terminal). Turn the main tuning shaft until the ohmmeter reading is minimized (0 to 10 ohms). Then rotate the untightened cam for the sensitive switch so that it is at the point where it causes the sensitive switch to click. Tighten the two set screws in the hub of the cam in this position. Back off the main tuning shaft slightly in a clockwise direction and then reverse its direction again

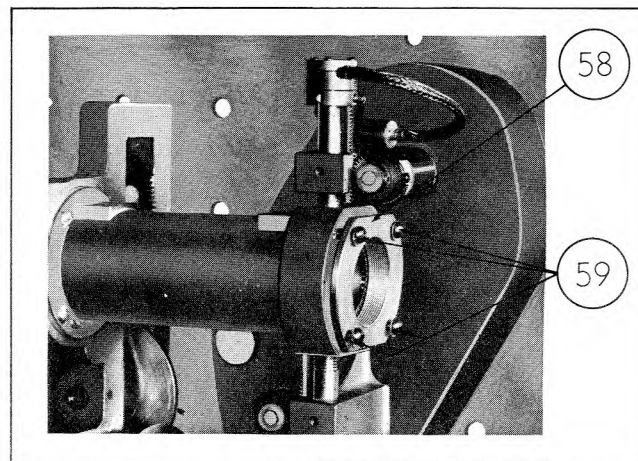

Figure 4-43. Assembly of Grid Contact Clamping Plate

and check that the sensitive switch clicks as the ohmmeter reading goes through its minimum. Also, the roller on the sensitive switch should have gone from the low part of the cam to the high part.

Figure 4-45 shows the repeller and grid contact assembly E-142I. This assembly should be placed inside the inner conductor very carefully, sliding the assembly in from the right side as viewed in figure 4-44. The assembly should be positioned so that the contact fingers protrude about one inch from the end of the cavity.

The JAN-2K28 reflex klystron V-111 and filter cap should now be replaced according to the procedure given in paragraph 6a of Section IV and figures 4-1 to 4-5.

This procedure completes the mechanical assembly and preliminary mechanical adjustment of the oscillator and attenuator drive systems. However, a considerable number of electrical adjustments must yet be made. Before this is done the electrical parts should be mounted and wired in accordance with the schematic diagram (figure 7-1) and practical wiring diagram (figure 7-2). Figures 4-1 to 4-5 also will be found useful for this procedure. The procedures for making the electrical adjustments are described below.

11. REPLACEMENT OF RESISTOR R-137.

Resistor R-137 is a 50-ohm resistor especially designed for high frequency use. The resistor is located next to the output attenuator pick-up loop inside the movable RF probe plunger. In the event that it becomes necessary to replace this resistor, refer to figure 4-47 and to the following procedure.

a. Carefully measure with a ruler the height of the plunger above the collar that is attached to the gear rack so that later it will be possible to replace the plunger in its original position.

b. Loosen the #8 set screws in the collar which holds the plunger to the gear rack. Remove the plunger from the waveguide section.

c. Unsolder the pick-up loop from the end of the attenuator plunger.

d. Remove the locknut which secures the cable to the end of the plunger and slide the plunger off the end of the assembly (away from the cable).

e. Unsolder the inner end of R-137 from the short piece of brass tubing to which it is soldered and remove the resistor.

f. Trim the leads on the replacement resistor so that one lead is approximately one-eighth inch long and the other about one-half inch long.

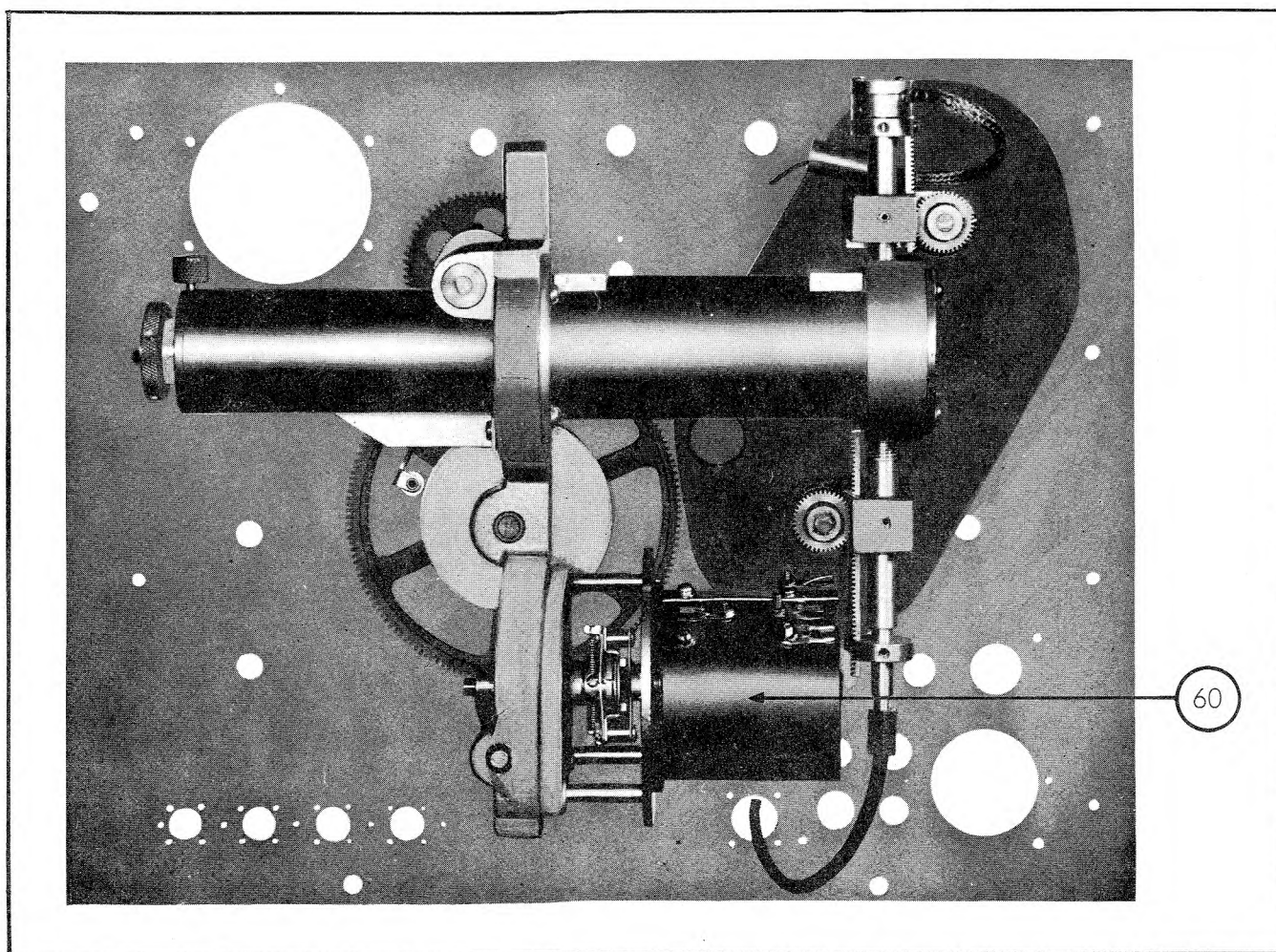
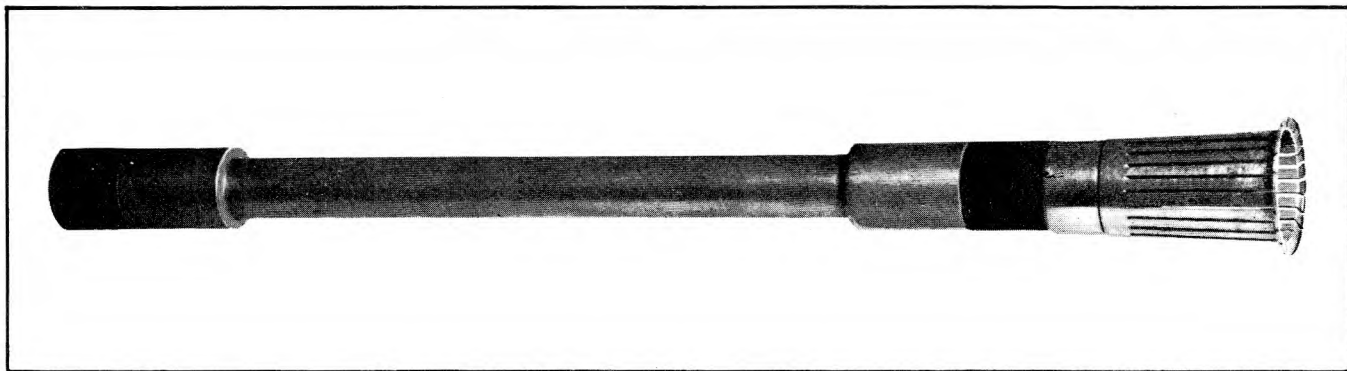

Figure 4-44. Complete Drive System Assembled on Panel

4. 11. 20-6-1



9. 11. 20- 6- 2

Figure 4-45. RF Transmission Line E-142I

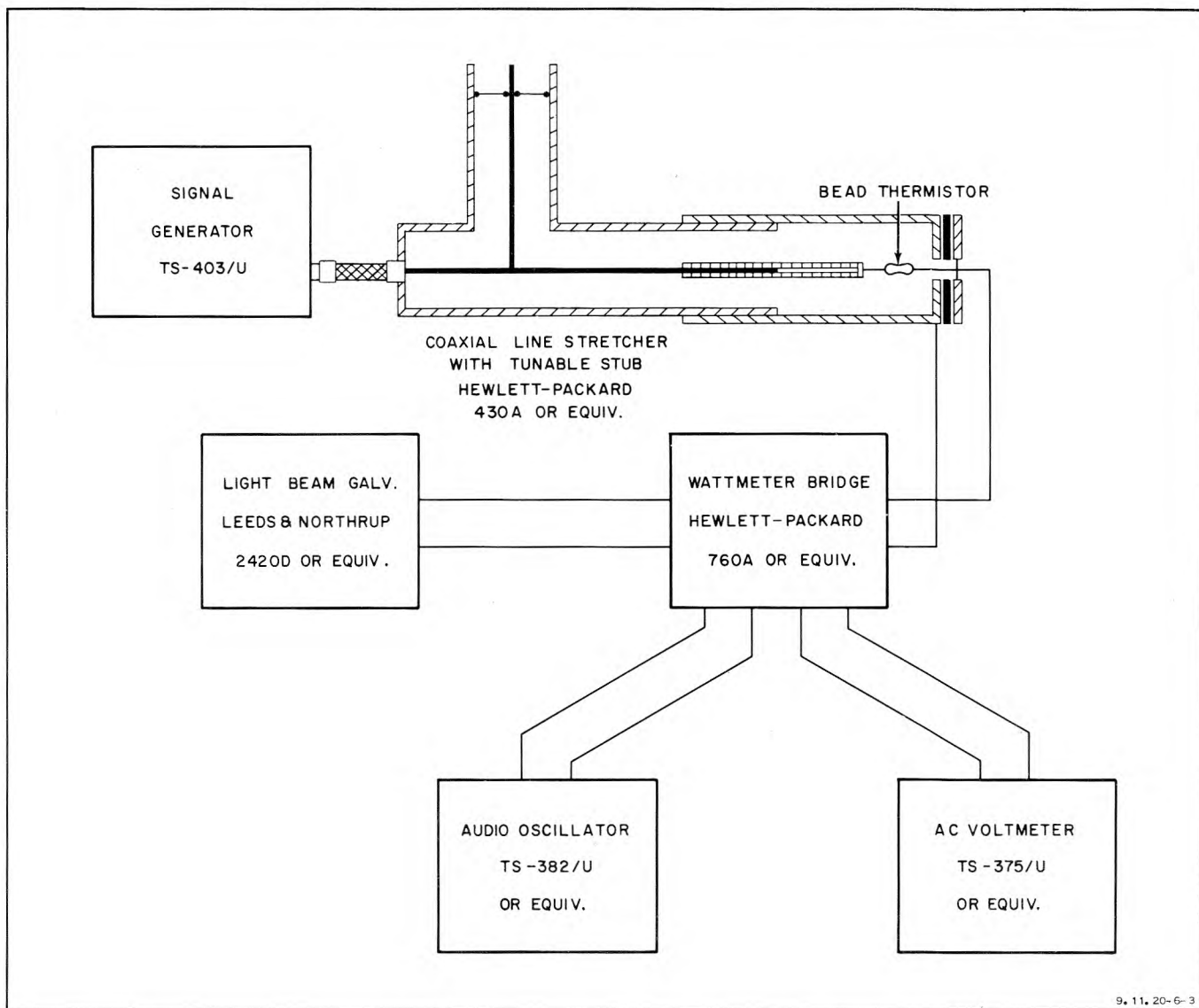

Figure 4-46. Test Set-up for Calibrating Output Attenuator

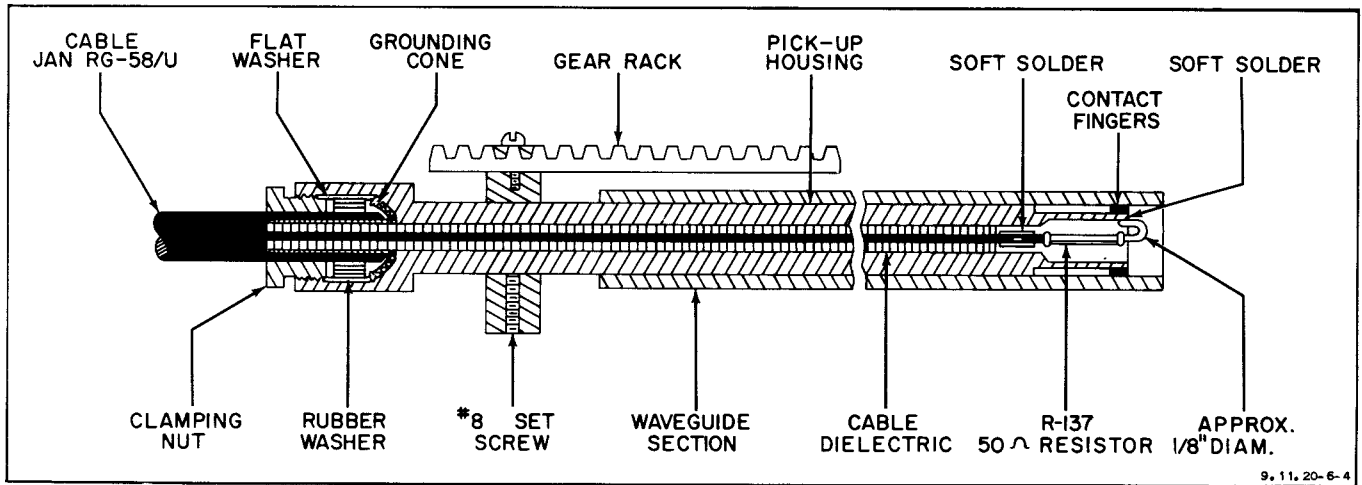

Figure 4-47. Cutaway View of Output RF Probe E-101

g. Insert the short lead on the replacement resistor into the brass tube and solder the lead to the tube.

h. Slide the plunger over the resistor and dielectric and secure the locknut to the top of the plunger.

i. Using a pair of long-nose pliers, form the long lead on the resistor into a pick-up loop having an outside diameter of approximately one-eighth inch. It is important that the loop be neither too large nor too small.

j. Solder the free end of the loop on the resistor to the wall of the plunger just inside the end of the plunger. The loop should not be soldered over any of the slots in the plunger. Use a minimum of solder and make certain that the loop will not short against the sides of the waveguide section.

k. Using an ohmmeter, measure the dc resistance from the pick-up loop to the center contact of the RF OUTPUT connector J-105 in order to make certain that the inner end of R-137 is not shorted to the wall of the plunger. The resistance should be approximately 130 ohms. If a short exists, the resistance will be only about 80 ohms.

l. Replace the plunger and tighten the #8 set screws so that the same length of plunger is exposed as was measured in step a above, and so that the loop is in line with the gear rack as shown in figure 4-46.

m. After the plunger has been replaced, it is necessary to check the accuracy of the output attenuator dial as described in paragraph 14. b, and to readjust the setting of the plunger if required. The measured output power should be accurate within one and one-fourth decibels from that indicated by the output attenuator dial and, oftentimes, the output power will be accurate within about one decibel when the RF probe plunger is carefully adjusted. If the response curve shows a general rise at high frequencies, the usual trouble is that the pick-up loop is too large. A general drop at high frequencies indicates that the pick-up loop is too small.

12. REPLACEMENT OF E-124.

E-124 is a special resistor made up of a platinum film coated on a glass rod. The resistor is located in

the housing back of the RF OUTPUT jack J-105. The resistor is designed to act as a lossy center conductor or fixed attenuator for the cable leading from the output attenuator pick-up loop to the output jack.

Should this special resistor become broken or otherwise open, the dc resistance between the center pin of the RF OUTPUT jack and the connector body will usually become very high. This resistance is ordinarily about 130 ohms, of which 50 ohms is the matching resistor R-137 and 80 ohms is the special resistor E-124. If no rf output is obtained and if the trouble appears to be in the output circuit, it is well to make an examination of this special resistor in order to ascertain that the resistor is not broken. The following procedure should be used in combination with figure 4-48.

a. REMOVAL OF E-124.

(1) Remove Signal Generator TS-403/U from its cover after loosening the eight lock screws on the panel.

(2) With Signal Generator Ts-403/U resting on its back, remove the four #4-40 screws which secure RF OUTPUT connector J-105 to the panel.

(3) Lower the attenuator pad assembly into the hole in the chassis deck until RF OUTPUT connector J-105 is free of panel.

(4) Tilt the output connector end of attenuator pad assembly to the right, away from power input casting, and lift assembly until it and the attached cable are free of the slot in the chassis deck. Do not remove any other parts from the instrument itself in replacing E-124.

(5) To remove E-124 from its housing, first loosen the cable connector nut and carefully remove the cable connector from the attenuator pad housing E-123. The 1/2 inch long teflon insulator can now be seen in the end of the attenuator pad housing. This insulator prevents the pad itself from falling out.

(6) Holding RF panel connector J-105 upward, remove the output connector nut from the RF panel connector and slide the nut off over the housing.

(7) Carefully separate the connector from the housing in a straight line. If the attenuator pad is broken part

of it may remain in the housing and part still hang from the female contact in the panel connector. If pad is in one piece it will usually cling to the panel connector.

(8) In either case the pad should be disengaged from the connector by gently pulling on the pad, grasping it as close to the connector as possible. Complete the removal of attenuator pad E-124 by shaking out housing to insure that no pieces of the pad or foreign material remain within the housing.

b. REPLACEMENT OF E-124.

(1) The following should be checked before attempting to install a new attenuator pad:

(a) Make certain that the $\frac{1}{2}$ inch long teflon insulator is seated flush against the first internal shoulder in the threaded end of attenuator pad housing. If this insulator has fallen out, reseal it with the undercut surface facing away from threaded end of housing.

(b) After forcing the female contact out through the front end of panel connector J-105 by means of #8 Allen key H-102, check that one terminal of new attenuator pad fits properly into the female contact.

(c) Check opposite end of new attenuator pad to see that it fits properly into the pad contact of the cable connector.

(d) Make certain that the $\frac{1}{4}$ inch long panel bead is seated securely against internal shoulder of panel connector J-105. If panel bead has fallen out, reinsert it from rear end of panel connector and seat it securely against internal shoulder of panel connector.

(2) To install new attenuator pad, first gently press one terminal of pad into panel connector female contact as far as possible.

(3) Slide output connector nut, thread first, over threaded end of attenuator housing.

(4) Carefully insert free end of attenuator pad into unthreaded end of housing and seat pad so that its far terminal is inside the hole in the $\frac{1}{2}$ inch long teflon insulator.

(5) Holding the attenuator pad so that it will not drop out, insert pad contact of cable connector into hole in the $\frac{1}{2}$ inch long teflon insulator. Tighten cable connector nut on to attenuator pad housing. If the attenuator pad has been properly inserted, the joint between the pad and the panel connector female contact will be within $\frac{1}{64}$ inch from the end of the attenuator pad housing.

(6) Carefully aligning the female contact on the end of the pad with the hole in the $\frac{1}{4}$ inch long panel bead of the panel connector body, press the attenuator pad housing into the panel connector as far as it will go and tighten the output connector nut.

(7) Insert the cable into the slot in the chassis deck of Signal Generator TS-403/U and rest the cable connector end of the attenuator pad assembly in the hole in the chassis.

(8) Align the panel connector with its hole in the front panel and push the connector through the hole. Secure the panel connector with the four #4-40 screws through the panel.

(9) After completing the replacement of the new pad, the calibration of the output attenuator dial should be checked in accordance with the procedure described in paragraph 14.b.

13. PROCEDURE FOR REPLACING THERMISTOR R-136.

A pre-calibrated monitor RF probe containing thermistor R-136 is supplied with Signal Generator TS-403/U for use if it should become necessary to replace thermistor R-136 (see paragraph 8 of this section). However, if no spare RF probe assembly is available, the following procedure should be followed when replacing R-136.

a. Remove the three #2-56 screws holding the cap on the monitor assembly (figure 4-49) and remove the cap.

b. Unsolder the wire running to the contact which is exposed when the cap is removed.

c. Loosen the two #8-32 set screws in the collar at-

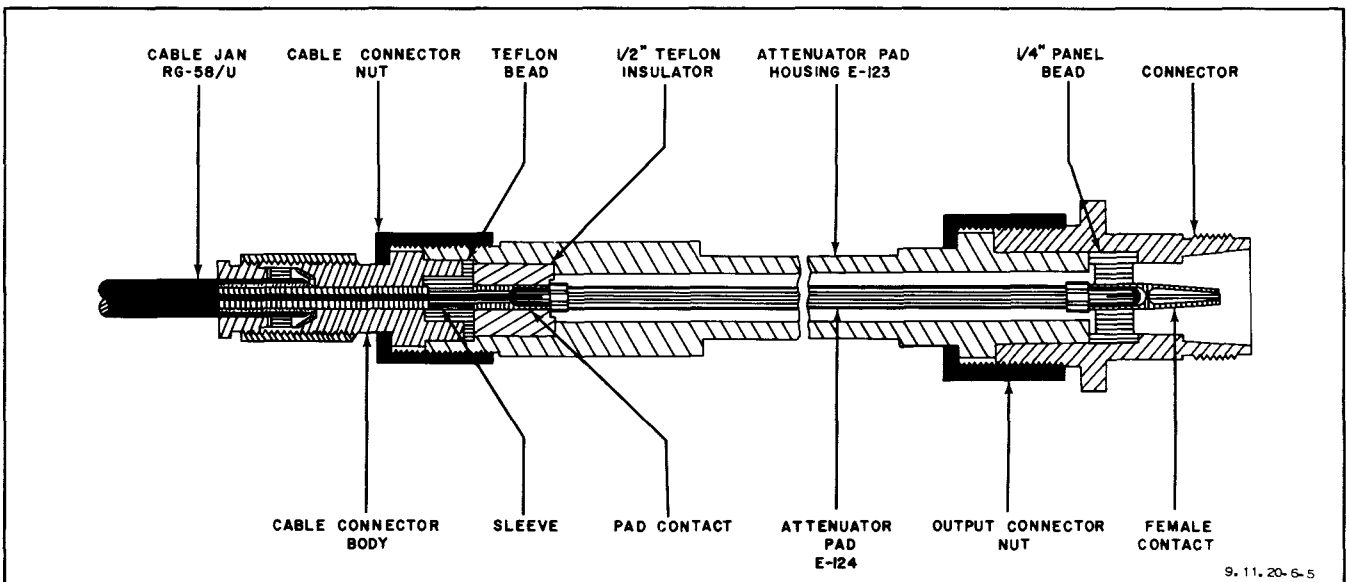

Figure 4-48. Cutaway View of Impedance-Matching Rod E-124 and Associated Parts

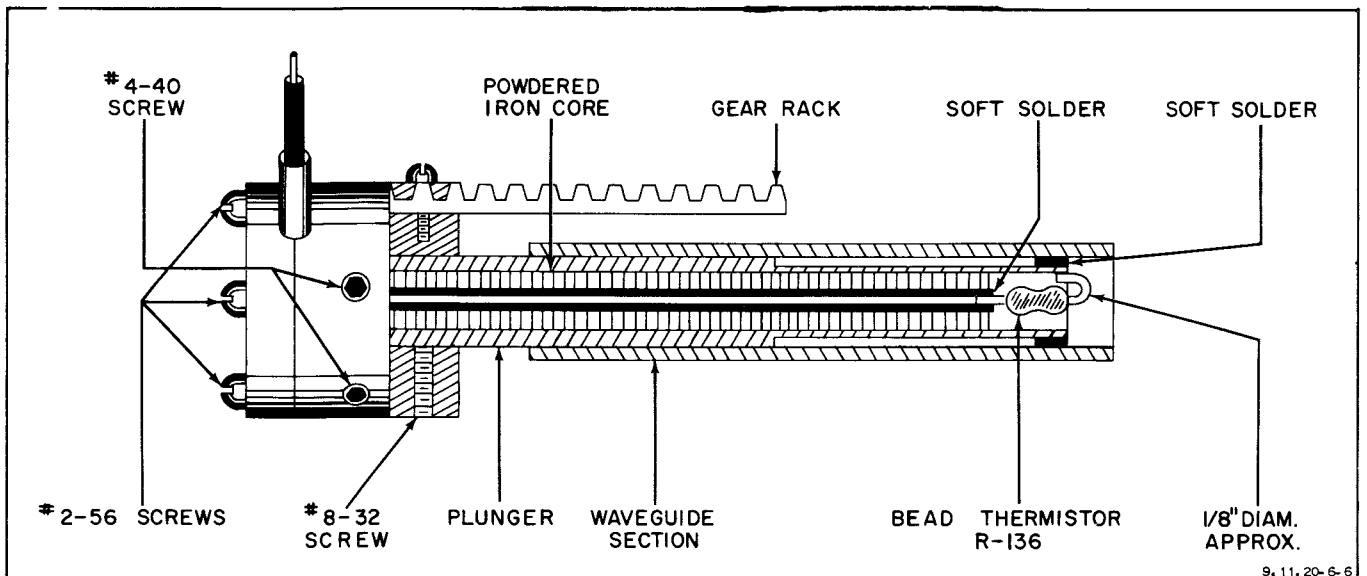

Figure 4-49. Cutaway View of Monitor RF Probe E-122

tached to the gear rack and remove the plunger from the waveguide section.

d. Unsolder the loop on the end of R-136 from the end of the plunger. Then slide the plunger off the powdered iron core so that the thermistor is exposed.

e. Unsolder the lead on the thermistor from the brass tube and remove the thermistor.

f. Trim the leads on the replacement thermistor so that one is approximately one-half inch long and the other about one-fourth inch long.

g. Insert the short lead on the thermistor into the brass tube and solder. Allow enough space between the end of the tube and end of the thermistor so that the soldering iron will not touch the glass bead.

b. Using a pair of long-nose pliers, form the free lead on the thermistor into a loop having an outside diameter of approximately one-eighth inch. The loop should be formed so that it will be in line with the keyway in the collar as shown in figure 4-47.

i. Replace the plunger which was removed in step d above.

j. Solder the end of the loop to the inside of the plunger about 1/32 inch from end of the plunger. Use a minimum of solder and make certain that the loop will not short against the wall of the waveguide section and that the contact fingers have not been bent.

k. Replace the plunger in the waveguide section and tighten the two #8-32 set screws in the collar.

l. It now is necessary to adjust the depth of penetration of the pick-up loop into the waveguide section so that it always will be possible to maintain the meter pointer at the half-scale O DBM mark on the meter over the entire frequency range of the signal generator.

As a first effort in adjusting the depth of penetration of the pick-up loop, it is desirable to set the plunger so that

the collar on the plunger rests on the collar attached to the gear rack. Then turn the instrument on and allow a 20-minute warm-up. After this time turn the modulation selector switch to the OFF position and zero set the meter pointer with the zero set control. (If it is not possible to zero set the meter pointer, refer to paragraph 7g.) Next set the modulation selector switch to the CW position and set the meter pointer to the O DBM mark with the POWER SET control. Then tune the signal generator through its entire frequency range and make certain that it is possible to keep the meter pointer at the O DBM mark at all frequencies.

If the meter pointer will not read as low as the O DBM mark at some or all frequencies, it is necessary to decrease the depth of penetration of the pick-up loop. To do this, loosen the two #8-32 set screws in the collar that is attached to the gear rack, raise the plunger slightly, and re-tighten the set screws. Recheck the operation of the meter at all frequencies and make any further adjustments found necessary.

If the meter pointer will not read as high as the O DBM mark at some or all frequencies, it is necessary to increase the depth of penetration of the pick-up loop. To do this, loosen the two #4-40 set screws in the middle collar of the assembly shown in figure 4-47. Then raise the collar slightly and re-tighten the set screws. Next loosen the two #8-32 set screws in the collar attached to the gear rack, and seat the upper collars against the collar attached to the gear rack. Tighten the two #8-32 set screws. Recheck the operation of the meter at all frequencies and make any further adjustments of the depth of penetration that are found necessary.

m. After the RF probe plunger has been adjusted so that the meter pointer can be maintained at the half-scale O DBM mark and the set screws have been tightened, the calibration of the output attenuator dial should be checked in accordance with the procedure described in paragraph 14.b.

14. CALIBRATION.

a. GENERAL. - This equipment will be inspected at intervals of 90 days to determine the accuracy of the calibration.

b. TEST EQUIPMENT REQUIRED. - The following test equipment, or equivalent, is required to calibrate Signal Generator TS-403/U.

(1) Vacuum Tube Voltmeter, Hewlett-Packard Model 410B.

(2) Frequency Meter TS-186/UP.

(3) Oscilloscope AN/USM-24.

(4) Audio Oscillator TS-382D/U.

(5) Microwave Power Meter, Hewlett-Packard Model 430.

(6) Light Beam Galvanometer, Leeds and Northrup Model 2420D.

(7) Coaxial Line Stretcher, Hewlett-Packard Model 430A.

(8) Crystal Detector, Hewlett-Packard Model 420A.

c. CALIBRATION OF VOLTAGE REGULATOR.

(1) Apply power to Signal Generator TS-403/U and allow to stabilize.

(2) Apply power to vacuum tube voltmeter and allow to stabilize.

(3) Set vacuum tube voltmeter to - d-c volts and 500 volt range.

(4) Connect vacuum tube voltmeter between pin 7 of tube socket X-107 and chassis.

(5) Adjust R-152 for -300 volt indication on vacuum tube voltmeter. (See figure 5-1.)

(6) Disconnect vacuum tube voltmeter.

(7) Set vacuum tube voltmeter to -50 volt scale.

(8) Connect vacuum tube voltmeter between pin 5 of tube socket X-107 and pin 8 of tube socket X-109.

(9) Adjust R-185 for -15 volt indication vacuum tube voltmeter.

(10) Disconnect vacuum tube voltmeter.

(11) Set ZERO SET control to its mechanical center position.

(12) Set modulation selector switch to the OFF position.

(13) Adjust R-143 until meter indicates exactly zero. (Zero set position at left extremity of meter scale.)

(14) Lock R-143, R-152 and R-185.

d. CALIBRATION OF PULSE RATE MULTIVIBRATOR.

(1) Apply power to Oscilloscope AN/USM-24 and allow to stabilize.

(2) Apply power to Audio Oscillator TS-382D/U and allow to stabilize.

(3) Adjust oscilloscope for normal presentation.

(4) Set SWEEP TIME COARSE switch on oscilloscope to 10 position.

(5) Set SWEEP TIME FINE control on oscilloscope to its approximate mechanical center.

(6) Set SYNC. SELECTOR switch on oscilloscope to HI EXT position.

(7) Set MAIN TUNING control on audio oscillator to 100 position.

(8) Set FREQUENCY MULTIPLIER switch on audio oscillator to X10 position.

(9) Connect OUTPUT connector of audio oscillator to SIGNAL INPUT connector of oscilloscope.

(10) Set PULSE RATE control on signal generator to 100 position.

(11) Set SYNC SELECTOR switch on signal generator to X10 position.

(12) Connect SYNC OUT connector of signal generator to EXTERNAL SYNC connector of oscilloscope.

(13) Set R-107 in signal generator to its approximate mechanical center. (See figure 5-1.)

(14) Adjust R-110 in signal generator for a single straight stationary line on oscilloscope.

Note

There will be two positions of R-110 which will give the results desired in step (14); therefore, adjust R-107 as necessary to select desired condition at nearest position to mechanical center of R-110.

(15) Adjust PULSE RATE control clockwise until two straight stationary lines appear on oscilloscope.

(16) PULSE RATE control should be within $\pm 15\%$ of 200 position.

(17) Adjust PULSE RATE control clockwise until four straight stationary lines appear on oscilloscope.

(18) PULSE RATE control should be within \pm 15% of 400 position.

Note

In some of the above indications the lines may cross to form an interwoven pattern. This condition is normal.

(19) Set SYNC SELECTOR switch on signal generator to X1 position.

(20) Set FREQUENCY MUTIPLIER switch on audio oscillator to X1 position.

(21) Adjust PULSE RATE control until four straight stationary lines appear on oscilloscope.

(22) PULSE RATE control should be within \pm 15% of 400 position.

(23) Adjust PULSE RATE control counterclockwise until one straight stationary line appears on oscilloscope.

(24) PULSE RATE control should be within \pm 15% of 100 position.

Note

If results of above checks are not satisfactory over the entire dial spread of PULSE RATE control, it may be necessary to make further minor adjustments of R-107 and R-110 for best overall accuracy.

(25) Disconnect audio oscillator.

(26) Lock R-107 and R-110.

e. CALIBRATION OF DELAY MULTIVIBRATOR.

(1) Connect a test lead from pin 1 of tube socket X-104 to SIGNAL INPUT connector on oscilloscope.

(2) Set SWEEP TIME COARSE switch on oscilloscope to 100 position.

(3) Set MARKER INTERVALS switch on oscilloscope to 10 position.

(4) Adjust SWEEP TIME FINE control on oscilloscope for at least twenty markers on sweep.

(5) Loosen shaft coupling from R-116 to PULSE DELAY control (see figure 5-1). This will allow R-116 to be adjusted independent of dial setting.

(6) Adjust R-116 until delay pulse, as indicated on oscilloscope, is ten markers wide.

(7) Set PULSE DELAY control to 100 position.

(8) Tighten shaft coupling.

(9) Set MARKER INTERVALS switch on oscilloscope to 100 position.

(10) Adjust SWEEP TIME FINE control for at least five markers on sweep.

(11) Adjust PULSE DELAY control clockwise until delay pulse is three markers wide.

(12) PULSE DELAY control should be within \pm 20% of 300 position.

(13) Set MARKER INTERVALS switch on oscilloscope to 1 position.

(14) Set SWEEP TIME COARSE switch on oscilloscope to 10 position.

(15) Adjust SWEEP TIME FINE control on oscilloscope for at least ten markers on sweep.

(16) Adjust PULSE DELAY control counterclockwise until delay pulse is three markers wide.

(17) PULSE DELAY control should be within \pm 20% of 3 position.

Note

If results of above checks are not satisfactory over the entire dial spread of PULSE DELAY control, minor adjustments of R-116 may be made for best overall accuracy.

(18) Disconnect test lead from tube socket X-104.

f. CALIBRATION OF SIGNAL WIDTH MULTIVIBRATOR.

(1) Connect test lead from pin 3 of tube socket X-109 to SIGNAL INPUT connector of oscilloscope.

(2) Set SWEEP TIME COARSE switch on oscilloscope to 10 position.

(3) Set MARKER INTERVALS switch on oscilloscope to 1 position.

(4) Adjust SWEEP TIME FINE control on oscilloscope until there are at least ten markers on sweep.

(5) Set modulation switch S-103A on signal generator to INT position.

(6) Loosen shaft coupling from R-124 to PULSE WIDTH control. (see figure 5-1.)

(7) Adjust R-124 until pulse, as indicated on oscilloscope, is five markers wide.

(8) Set PULSE WIDTH control to 5 position.

(9) Tighten shaft coupling.

(10) Adjust SWEEP TIME FINE control on oscilloscope until there are at least twenty markers on sweep.

(11) Adjust PULSE WIDTH control clockwise until pulse width is ten markers wide.

(12) PULSE WIDTH control should be within \pm 20% of 10 position.

(13) Adjust PULSE WIDTH control counterclockwise until pulse is two markers wide.

(14) PULSE WIDTH control should be within $\pm 20\%$ of 2 position.

Note

If the results of the above checks are not satisfactory over the entire dial spread of PULSE WIDTH control, minor adjustments of R-124 may be made for best overall accuracy.

(15) Disconnect test lead from tube socket X-109 and oscilloscope.

(16) Lock R-124.

g. CALIBRATION OF RF OSCILLATOR.

(1) Apply power to Frequency Meter TS-186/UP and allow to stabilize.

(2) Adjust frequency meter for 3000 megacycle check point.

(3) Connect RF OUTPUT connector from signal generator to RF INPUT connector on frequency meter.

(4) Remove dial cover and loosen main tuning dial on shaft.

(5) Adjust the main tuning shaft for zero beat with the frequency meter signal as noted in frequency meter ear phones.

(6) Set main tuning dial to 3000 position and lock it to the shaft.

(7) Replace dial cover.

(8) Set vacuum tube voltmeter on -d-c volts and 300 volt scale.

(9) Connect vacuum tube voltmeter between center connection on R-173 (brown wire) and pin 8 of tube socket X-109 (red wire).

(10) Adjust SIGNAL FREQUENCY control to 1800 position on main tuning dial of signal generator.

(11) Adjust R-167 (see figure 5-3) for -105 volt indication on vacuum tube voltmeter.

(12) Adjust SIGNAL FREQUENCY control until it is barely on the low frequency side of the point where the sensitive switch clicks (approximately 2400 megacycles).

Note

In step (12) rotate SIGNAL FREQUENCY control counterclockwise until the sensitive switch clicks. Then slowly rotate control clockwise until switch clicks. This should be the proper position.

(13) Adjust R-163 for -240 volt indication on vacuum tube voltmeter.

(14) Adjust SIGNAL FREQUENCY control counterclockwise to high side of point where sensitive switch clicks.

(15) Adjust R-164 for -70 volt indication on vacuum tube voltmeter.

(16) Adjust SIGNAL FREQUENCY control to 4000 position.

(17) Adjust R-166 for -280 volt indication on vacuum tube voltmeter.

(18) Set modulation selector to INT position.

(19) Set SYNC SELECTOR to X10 position.

(20) Connect SYNC OUT connector to EXTERNAL SYNC connector on oscilloscope.

(21) Connect RF OUTPUT connector to Crystal Detector H-P420A input.

(22) Connect crystal detector output to SIGNAL INPUT connector on oscilloscope.

(23) Adjust oscilloscope for standard presentation of signal generator pulse.

(24) Adjust SIGNAL FREQUENCY control throughout its frequency range. The pulse should be clean and without multiple traces or spurious peaks along its top edge. Some jitter may be seen in leading edge of pulse, but this is normal.

Note

If pulse does not conform to conditions expressed in step (24), one or more of the four potentiometers can be readjusted as determined by the frequency or frequencies where the pulse shape is poor.

(25) Lock R-163, R-164, R-166, and R-167.

h. CALIBRATION OF ATTENUATOR.

(1) Set modulation selector switch to CW position.

(2) Adjust POWER SET control for 0 DBM indication on meter.

(3) Adjust SIGNAL FREQUENCY control through its entire range.

(4) It should be possible to maintain meter at 0 DBM at all frequencies by readjusting POWER SET control.

(5) If meter will not read 0 DBM at some or all frequencies, it will be necessary to adjust the depth of penetration of pick-up loop. (Refer to paragraph 13.l.)

(6) Connect equipment for test set-up as shown in figure 4-46.

(7) Adjust SIGNAL FREQUENCY control to 1800 position.

(8) Set modulation selector switch to OFF position.

(9) Adjust ZERO SET control for zero indication on meter.

TABLE 4-2. WINDING DATA

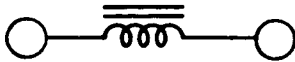
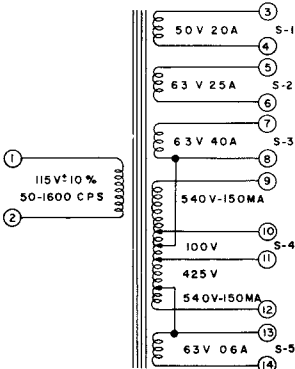
Reference Symbol	Navy Type Designation	Diagram	Winding	Wire Size	Turns	DC Resistance Ohms	Remarks
L-101	-304631		Single	No. 31E	3574	250	Hermetically sealed case; 9.5 henries inductance at 150 ma-dc. Hi volts test; 1750
T-101	-304632		Primary Secondary No. 1 Secondary No. 2 Secondary No. 3 Secondary No. 4 Secondary No. 5	No. 19E No. 18 No. 16 No. 16 No. 30E No. 22	216 10 12.5 12.5 2140 12.5		Hermetically sealed case; Hi volts test; 2500 tapped at 99, 843, 1070 and 1241 turns

(10) Set modulation selector switch to CW position.

(11) Adjust POWER SET control for 0 DBM indication on meter.

(12) Adjust OUTPUT ATTEN control for 200 microwatt level as indicated on external set-up.

(13) Adjust SIGNAL FREQUENCY control to 1900 position.

(14) Set modulation selector switch to OFF position.

(15) Adjust ZERO SET control for zero indication on meter.

(16) Set modulation selector switch to CW position.

(17) Note db reading on meter.

(18) Adjust POWER SET control for 0 DBM indication on meter.

(19) Adjust OUTPUT ATTEN control for 200 microwatt level as indicated on external set-up.

(20) Continue above procedure in 100 megacycle steps for entire frequency range of signal generator.

(21) Using db readings obtained in step (17), plot a response curve for the instrument (dbm versus frequency).

(22) Draw a horizontal line through response curve so that variations are averaged about the line.

(23) Select a frequency where the response curve intersects the horizontal line.

(24) Adjust SIGNAL FREQUENCY control to selected frequency.

(25) Set modulation selector switch to OFF position.

(26) Adjust ZERO SET control for zero indication on meter.

(27) Set modulation selector switch to CW position.

(28) Adjust POWER SET control for 0 DBM indicator on meter.

(29) Adjust OUTPUT ATTEN control for 200 microwatt indication on external set-up.

(30) Loosen the two set screws in the collar holding the attenuator plunger.

(31) Adjust OUTPUT ATTEN control until the 7 DBM mark on the attenuator dial is under the index line.

Note

This adjustment must be made without allowing the attenuator plunger to move.

(32) Tighten set screws.

(33) Secure equipment.

SECTION V SUPPLEMENTARY DATA

1. TUBE AND LAMP COMPLEMENT.

The quantities and functions of the tubes and lamps used in Signal Generator TS-403/U are shown in table 5-1.

TABLE 5-1. TUBE COMPLEMENT

QUANTITY	TYPE	SYMBOL DESIG.	FUNCTION
1	JAN-6SL7GT	V-101	Limiting Amplifier
3	JAN-6J6	V-102	Multivibrator
		V-104	Multivibrator
		V-107	Multivibrator and voltage amplifier
4	JAN-6C4	V-103	Limiter
		V-106	Amplifier
		V-108	Multivibrator
		V-110	Amplifier
2	JAN-6X5GT	V-105	Limiter
		V-117	Half-wave rectifier
2	JAN-6Y6G	V-109	Multivibrator
		V-115	Voltage regulator
1	JAN-2K28	V-111	UHF Oscillator
3	JAN-OA2	V-112	Voltage regulator
		V-113	Voltage regulator
		V-114	Voltage regulator
1	JAN-5R4GY	V-116	Full-wave rectifier
2	Lamp	I-101	Heater on indicator
		I-102	Instrument on indicator

2. GENERAL CHARACTERISTICS.

A summary of the general characteristics of Signal Generator TS-403/U is given in table 5-2.

TABLE 5-2. GENERAL CHARACTERISTICS

FREQUENCY RANGE	1800 to 4000 megacycles
ACCURACY OF FREQUENCY DIAL	Within 1%
MAXIMUM POWER OUTPUT	One milliwatt
RANGE OF OUTPUT ATTENUATOR	0 to -127 dbm (0.224 volt to 0.1 microvolt)
ACCURACY OF ATTENUATOR DIAL	Within 2 db from -7 to -127 dbm
RATED LOAD	50 ohms resistive
TYPE OF OUTPUT POWER	Unmodulated (CW) or modulated (pulse or FM)
PULSE MODULATION	Internal or External
Internal Pulse Modulation:	
Pulse Repetition Rate	Adjustable from 40 to 4000 pps
Pulse Width	Adjustable from 0.5 to 10 microseconds
Pulse Rise Time	Not more than 0.5 microsecond between points that are 10% and 90% of maximum amplitude of initial rise.
Pulse Decay Time	Not more than 0.5 microsecond between points that are 10% and 90% of maximum amplitude on the final decay
Delay	Start of rf pulse delayable over a range from 3 to 300 microseconds
Synchronization	Internal pulse modulation can be synchronized with external pulses or external sine waves
External Synchronizing Pulses:	
Required Peak Amplitude	Between 10 and 50 volts
Polarity	Positive or negative
Required Duration	From 0.5 to 20 microseconds between points that are 50% of maximum amplitude of initial rise
Required Rise Time	0.5 microsecond or less between points that are 10% and 90% of maximum amplitude of initial rise
Required Flatness	Between 90% point of initial rise and 90% point on final decay amplitude must remain between 90% and 100% of maximum amplitude of initial rise
DC Level	Between +10 volts and -10 volts
Repetition Rate	Between 40 and 4000 pps
External Sine Wave Synchronization:	
Required Amplitude	Between 5 and 50 volts peak
Frequency	Between 40 and 4000 cps.
External Modulation	Pulse or square wave of either positive or negative polarity
Required peak amplitude	Between 40 and 70 volts
INTERNAL FM MODULATION	At power line frequency; phase and deviation adjustable
VIDEO OUTPUT	Two different video pulses provided. One is delayable and one is undelayable. Delayable pulse is coincident with start of rf pulse; undelayable pulse is coincident with start of external synchronizing pulse
Amplitude of Video Pulses	At least 20 volts peak across rated load
Rise Time of Video Pulses	0.5 microsecond or less between 10% and 90% of maximum amplitude of initial rise
Polarity of Video Pulses	Positive
DC Level of Video Pulses	Less than 1 volt
POWER SOURCE REQUIRED	115 V, 50-1600 cps, single phase; 150 watts required

3. SIGNAL GENERATOR CONSIDERATIONS.

When using Signal Generator TS-403/U, it must be remembered that the external load on the instrument should be 50 ohms resistive for best accuracy in measurements. The output attenuator dial has been calibrated by using a load which is the conjugate of the internal impedance of the signal generator, that is, a load which draws maximum power from the instrument through the rf cable provided. At the same time the internal impedance of the generator has been maintained sufficiently close to 50 ohms so that in the worst case only a five db VSWR exists when the generator is compared with 50 ohms. These facts combine to give an accuracy of output power level from the instrument of within a fraction of a db, provided a 50-ohm resistive load is used. If the value of the load is not known and if best accuracy in measurements is desired, it is necessary that the standing wave ratio in the line to the load be minimized.

VSWR in Line	Max. Power Loss	Min. Power Loss
1.0	0.4 db	0.4 db
1.5	1.0 db	0.06 db
2.0	1.7 db	0.04 db
2.5	2.3 db	0.15 db
3.0	2.8 db	0.3 db
4.0	3.7 db	0.7 db
5.0	4.5 db	1.2 db

The above data gives the calculated power loss in the worst case, when the load causes a voltage standing wave ratio of the magnitude shown. This loss is the loss from the maximum power available from the generator for a given setting of the output attenuator control. The data does not allow for losses in the transmission line to the load and in most cases such losses are sufficiently small so that they are not of importance.

It will be seen that, when the load is matched to the transmission line, the loss from the maximum power available from the signal generator is approximately 0.4 db in the worst case. Mismatches causing the voltage standing wave ratios given in the left-hand column will give power losses somewhere between the limits shown in the remaining two columns.

Although the losses as shown in db do not consist of large numerical values, it should be noted that they may represent a considerable change in the voltage calibration of the output attenuator dial insofar as the voltage impressed across the external load is concerned.

In most cases when making measurements on receivers designed to work from a 50-ohm line and antenna, the standing wave ratio in the line from the signal generator to the receiver is not significant. The reason for this is that any power reflected from the receiver back towards the generator represents a deficiency in receiver design and the amount of power lost in such cases is considered as a loss subtractive from the gain of the receiver.

A sometimes-overlooked factor which contributes error in high-frequency measurements is the improper assembly of coaxial connectors. A standing wave ratio of several db with attendant error can often be attributed to this cause.

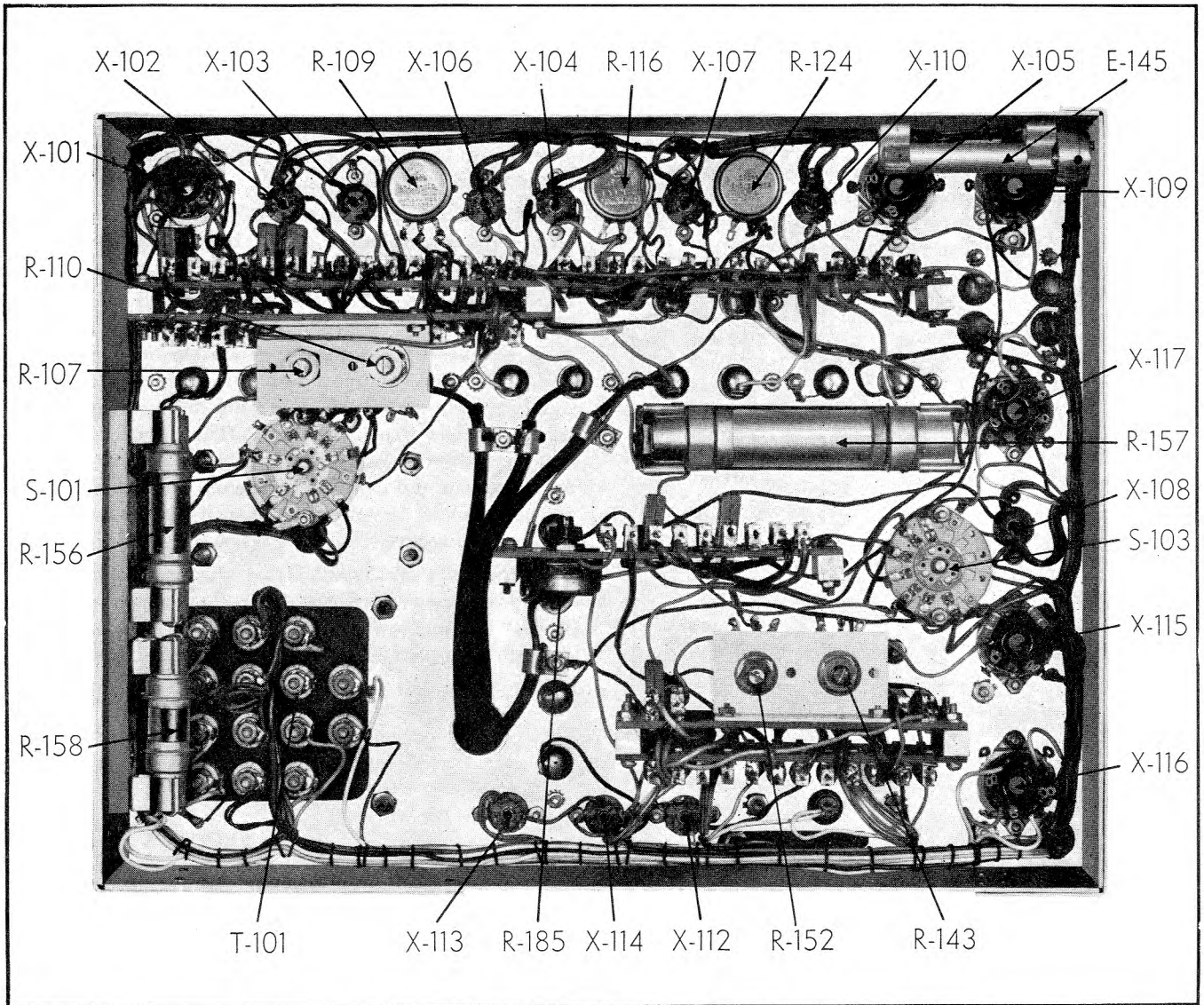

Figure 5-1. Signal Generator TS-403/U, Back View with Instrument Case Removed

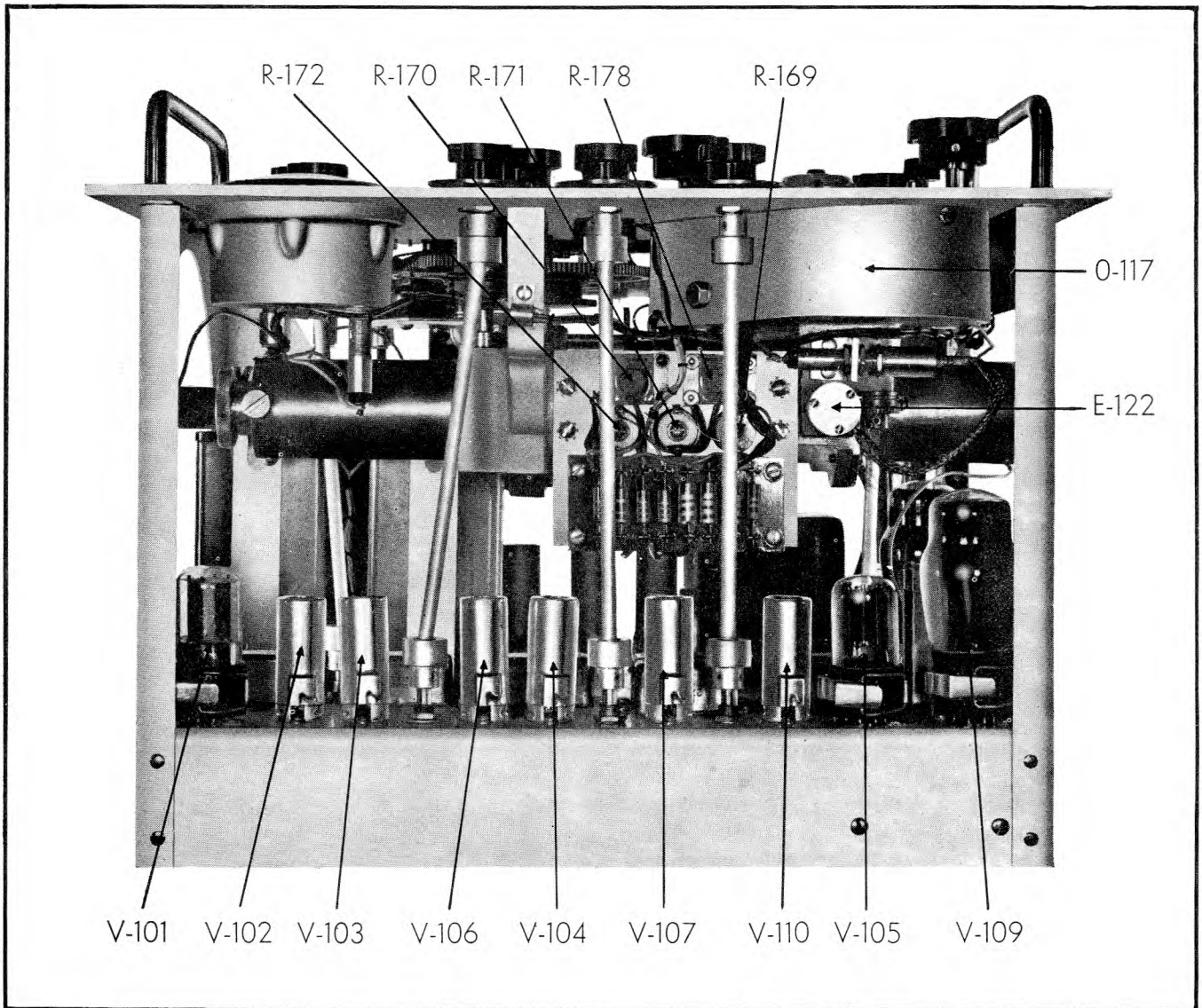

Figure 5-2. Signal Generator TS-403/U, Top View with Instrument Case Removed

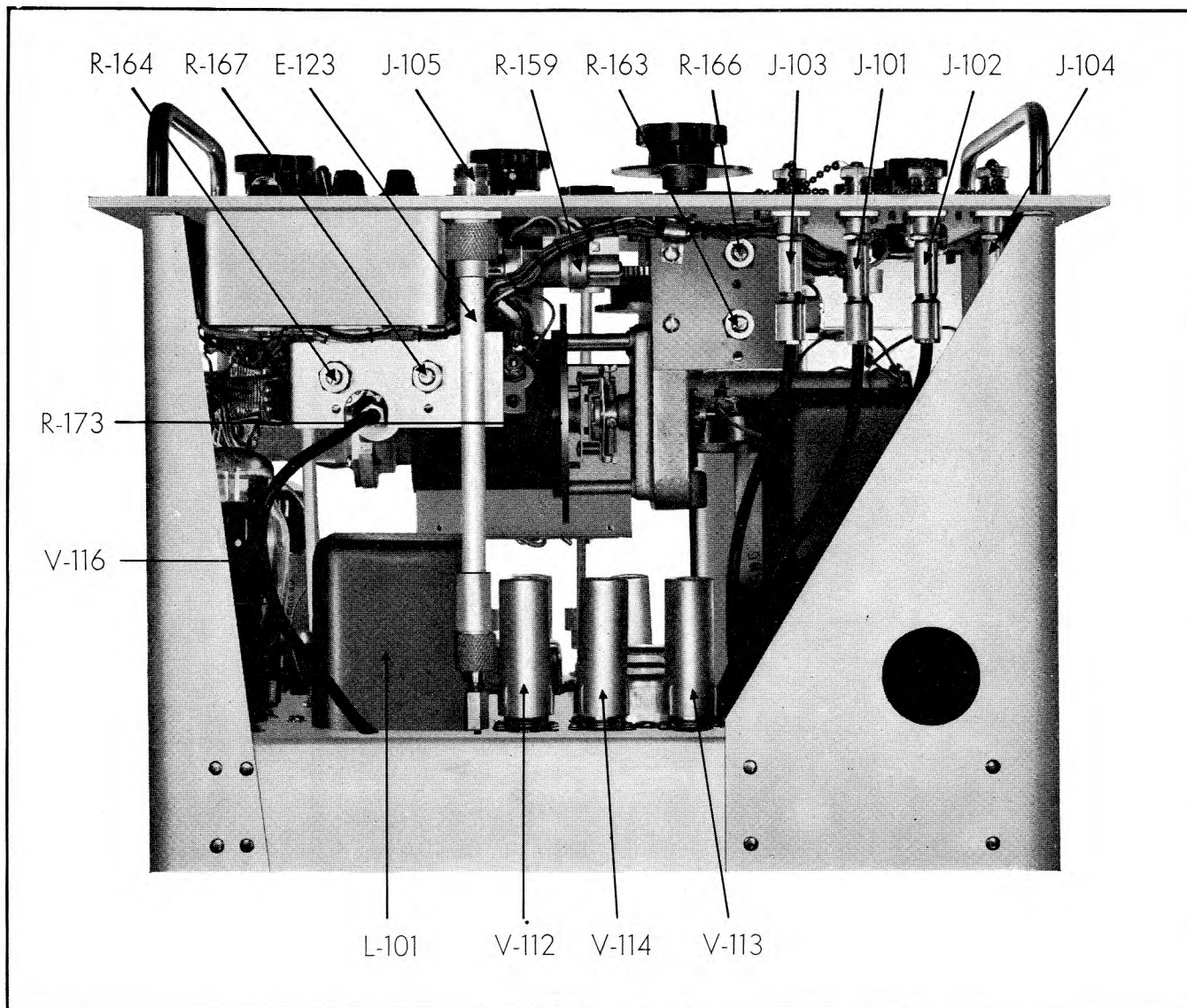

Figure 5-3. Signal Generator TS-403/U, Bottom View with Instrument Case Removed

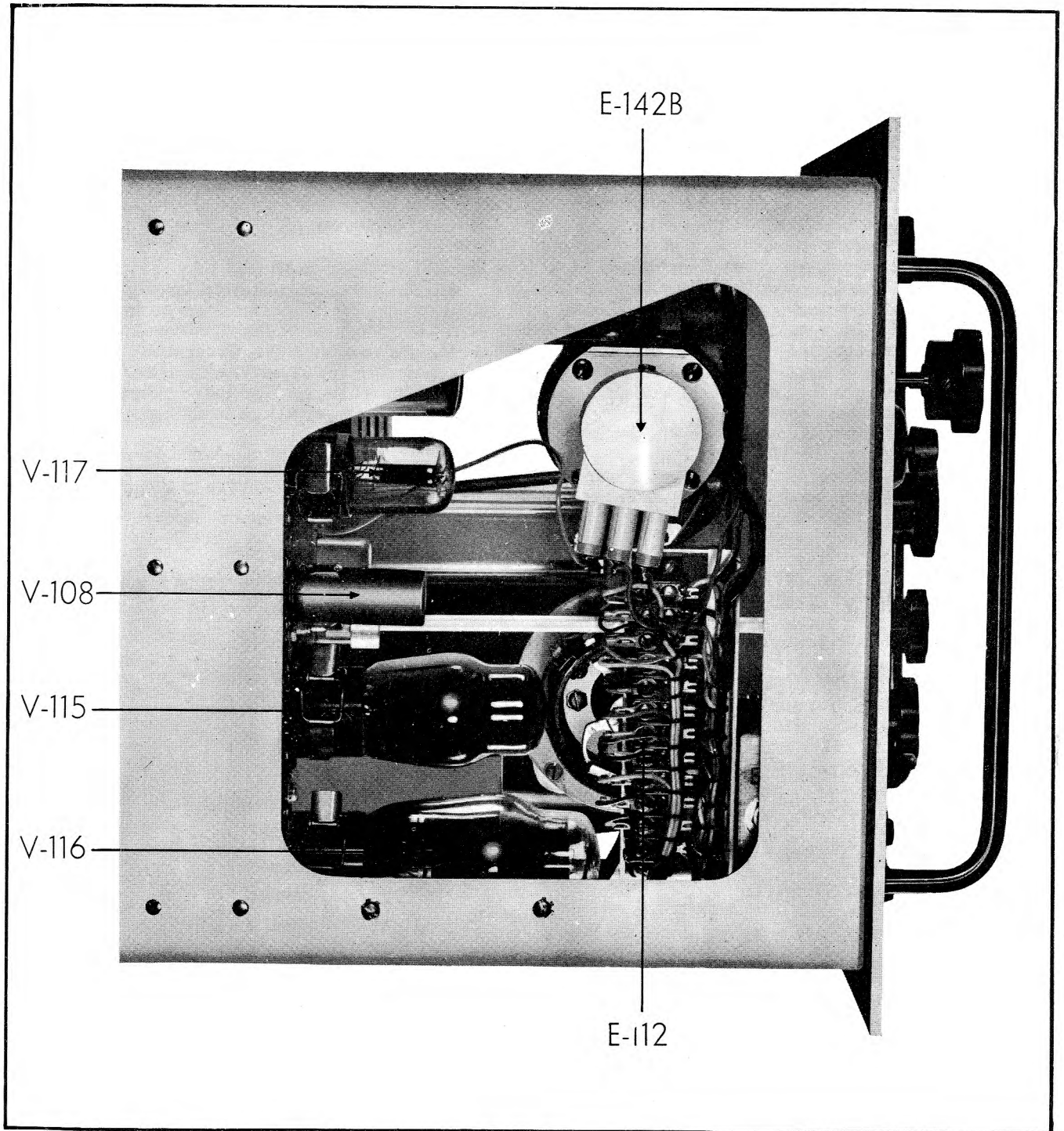

Figure 5-4. Signal Generator TS-403/U, Left View with Instrument Case Removed

SECTION VI
 TABLE OF REPLACEABLE PARTS

1. GENERAL.

The pages of this section of the instruction manual contain a Table of Replaceable Parts for Signal Generator TS-403/U together with additional parts data such as capacitor and resistor color codes.

The Table of Replaceable Parts does not consist of a thorough listing of all parts in the instrument; rather, the Table lists such parts as are reasonably subject to failure and thus eventual replacement. This method will be found to be especially applicable to the parts in the main tuning drive and attenuator drive of the instrument. In general only such parts of these drives as are subject to replacement are listed in the Table.

The Table of Replaceable Parts consists of two sections: the greater portion of the Table consists of a list of parts of the signal generator. This list is followed by a list of the accessories and spares which are provided with the signal generator. In both lists the parts are listed in the alphabetical and numerical order of their reference symbols.

The second column of the table indicates the Air Force, Aviation Supply Office, Signal Corps, and Navy stock numbers when they exist. These stock numbers are listed in the column in the order shown in the column heading. If any of the above-mentioned stock numbers do not exist, a dotted line (....) is shown in the respective position to indicate which of the stock numbers are not included.

Signal Generators TS-403/U, TS-403A/U and TS-403B/U have been supplied under several different contracts. In some cases replaceable parts listed in Table 6-1 are peculiar to the equipments manufactured under certain contracts. Where this is the case, the replaceable part is keyed by a symbol in the fourth or in the fifth and sixth columns. The following keying system has been used:

- No symbol: Contract NOa(s)-9213
- + : Contract NOa(s)-12297 and Contracts
 N383s-54831, N383s-57633, N383s-59709,
 N383s-59710
- ≠ : Contracts N383s-45739, N383s-74507,
 N383s-74917
- o : Contract N383s-18375A

2. ORDERING OF SPARE PARTS.

a. Each Service using this list has established certain depots and service groups for the storage and issue of spare parts to its organizations requiring them. The regulations of each Service should be studied to determine the method and source for requisitioning spare parts. The information in this list, as to manufacturer's or contractor's name, type, model or drawing number, is not to be interpreted as authorization to field agencies to attempt to purchase identical or comparable spare parts direct from the manufacturer or a wholesale or retail store except under emergency conditions as covered by existing regulations of the Service concerned.

b. U. S. ARMY PERSONNEL: This table is for information ONLY and is not to be used as a basis for requisitioning parts. Authorities for obtaining maintenance items are as follows: 1. For using organizations; applicable Service publications of the 00-30

series of AAF Technical Orders. 2. For higher maintenance and supply echelons; the applicable Standard Maintenance List.

c. Where no JAN or Navy standard part number is given to a component, care should be taken in replacing the component with any other part than that listed in Table of Replaceable Parts. This special part probably has been chosen for a special quality not available in standard components, and use of a standard component may result in decreased life or lowered performance.

3. REFERENCE SYMBOLS.

a. The reference symbols shown in the Table of Replaceable Parts are the same as those used in the schematic diagram of the circuit and of the practical wiring diagram for Signal Generator TS-403/U. Each reference symbol consists of a letter followed by a three-digit number. The letter indicates the type of component or apparatus as explained below:

Reference Symbol Letters	
Letter	Type of Component
A	Mounting, Cabinet, Case
C	Capacitor
E	Miscellaneous Electrical Parts
F	Fuse
H	Hardware
I	Indicating Device
J	Jack
L	Reactor
M	Meter
O	Mechanical Parts
P	Plug
R	Resistor
S	Switch
T	Transformer
V	Vacuum Tube
W	Cable
X	Socket

b. The numerical portion of the reference symbol is assigned arbitrarily to components starting with the number 101.

4. ABBREVIATIONS USED IN TABLE.

AM	amplitude modulation
amp	ampere(s)
approx	approximate or approximately
AC	alternating current
AWG	American Wire Gauge

■	B & S	Brown and Sharpe	mtd	mounted	
	°C	degrees Centigrade	mtg	mounting	
	cad	cadmium	mtg, c	mounting center(s)	
■	c, o	consists of	mts	mounts	
	coef	coefficient	mv	millivolt(s)	
	cps	cycles per second	mw	milliwatt(s)	
	CT	center tap or cen tapped	o, a	over-all	■
	c to c	center to center	OD	outside diameter(s)	
	CW	continuous wave	oper	operating	
	d	depth or deep	oz	ounce(s)	
	db	decibel(s)	PD	pitch diameter	
	dbm	decibel(s) with reference to one milliwatt	ph	phase	
	DC	direct current	pl	plated	
	deg	degree(s)	p/o	part of	■
	diam	diameter(s)	pps	pulses per second	
■	dim	dimension(s)	reqd	required	
	DPDT	double pole, double throw	RF	radio frequency	
	dwg	drawing(s)	RHMS	round-head machine screw	
	ea	each	RMS	root mean square	
	ext	external	RT	right	■
	°F	degrees Fahrenheit	sec	second(s)	
	FM	frequency modulation	secd	secondary(ies)	
	freq	frequency(ies)	SPDT	single-pole, double-throw	
	ga	gauge	spec	specification(s)	
	gnd	ground(ed)	temp	temperature	
	h	height or high	term	terminal(s)	
	hex	hexagon or hexagonal	thd	thread(s)	
	hy	henry(s)	thk	thick or thickness	
	ID	inside diameter(s)	UHF	ultra-high-frequency	
	int	internal	u sec	microsecond(s)	
	JAN	Joint Army-Navy	uv	microvolt(s)	
■	lbs	pounds	v	volt(s)	
	lg	length or long	vdcw	volts DC working	
■	LH	left hand	w	watt(s)	
	ma	milliampere(s)	w	with	
	mach	machine	wd	wide or width	
	max	maximum	x	by (as used to express dimensions)	
	mc	megacycle			
	med	medium			
	meg	megohm(s)			
	mf	microfarad(s)			
	min	minimum			
	mmf	micromicrofarad(s)			
	mt	mount			

5. LIST OF MANUFACTURERS.

A list of the manufacturers of replaceable parts appearing in table 6-1 is included in this section. The first column shows the abbreviations used in the table. The second column gives the Navy Type-Number Prefix which is sometimes used as a prefix for Navy Type Designations. The manufacturer's full name and address are listed in the third and fourth columns of the list

ABBREVIATION	NAVY TYPE PREFIX	NAME	ADDRESS
AB	CBZ	Allen-Bradley Co.	Milwaukee 4, Wis.
Allen Mfg	CAYT	Allen Mfg. Co.	Hartford 1, Conn.
Amphenol	CPH	American Phenolic Corp.	Chicago 50, Ill.
Birtcher	CAIS	Birtcher Corp.	Los Angeles, Calif.
	CYB	Birnbach Radio Co., Inc.	New York, N.Y.
Buss	CFA	Bussman Mfg. Co.	St. Louis 7, Mo.
	CAMQ	Cambridge Thermionic Corp.	Cambridge 38, Mass.
Chi Trans	CTR	Chicago Transformer Corp.	Chicago, Ill.
	CDJ	DeJur Amsco Co.	Shelton, Conn.
Dialco	CAYZ	Dial Light Co. of America, Inc.	New York 3, N.Y.
		Dimco-Gray Co.	Dayton, Ohio
	CAYS	Drake Mfg. Co.	Chicago, Ill.
FME	CFD	Federal Mfg. & Engineering Corp.	Brooklyn, N.Y.
		Fahnestock Electric Co.	New York, N.Y.
GE	CG	General Electric Co.	Schenectady 5, N.Y.
Hubbell	CHU	Harvey Hubbell, Inc.	Bridgeport, Conn.
IRC	CIR	International Resistance Co.	Philadelphia, Pa.
Jones HB	CJC	Howard B. Jones Co.	Chicago 18, Ill.
	CAUP	Kurz-Kasch Inc.	Dayton 1, Ohio
Littelfuse	CLF	Littelfuse, Inc.	Chicago 40, Ill.
Micro Switch	CMU	Micro Switch Corp.	Freeport, Ill.
Monadnock Mills		Monadnock Mills, Div. United-Carr Fastener Corp.	San Leandro, Calif.
Oak	COC	Oak Mfg. Co.	Chicago 10, Ill.
		Patton-MacGuyer Co.	Providence 5, R.I.
		Shallcross Mfg. Co.	Collingdale, Pa.
WECo	CW	Western Electric Co.	New York, N.Y.
		Worcester Pressed Aluminum Corp.	Worcester 3, N.Y.
		Zierick Mfg. Corp.	New Rochelle, N.Y.

6. RESISTOR AND CAPACITOR COLOR CODES.

Resistors and capacitors which are manufactured in accordance with Joint Army-Navy standards are identified by a designation consisting of a series of letters and numbers. This designation is known as the JAN designation and identifies the component completely as to electrical and mechanical characteristics. On small parts such as mica capacitors and composition resistors it is impractical to place the JAN designation on the component because of the small physical size of the component. On such components a color code is used to identify the item as to its JAN characteristics. Explanations of the standard color codes and of the type designations for fixed composition resistors per JAN-R-11, power type fixed wirewound resistors per JAN-R-26, fixed mica-dielectric capacitors per JAN-C-5, and fixed paper-

dielectric capacitors per JAN-C-25 are given below as paragraphs 6a, 6b, 6c, and 6d.

a. FIXED COMPOSITION RESISTORS PER JAN-R-11.

(1) Type Designation.—The type designation of fixed composition resistors is formed as follows:

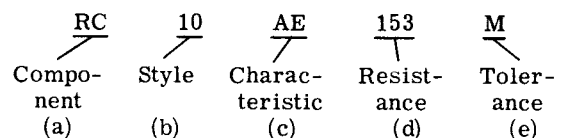

(a) COMPONENT.—The first symbol of the type designation is a two-letter symbol which identifies the part as fixed composition resistor. "R" stands for resistor and "C" distinguishes the subclass of composition resistor.

(b) **STYLE.**—The style is identified by a two-digit symbol which distinguishes the resistor as to power rating, physical shape, and size.

(c) **CHARACTERISTIC.** — The two-letter symbol following the style symbol indicates the type of insulation and resistance characteristic of the resistor in accordance with Specification JAN-R-11.

(d) **RESISTANCE.** — The nominal resistance value of the resistor is identified by a three-digit symbol which follows the characteristic symbol. The first two digits of the resistance symbol are the first two figures of the resistance value in ohms. The final digit specifies the number of zeros which follow the first two figures.

(e) **RESISTANCE TOLERANCE.**—The final letter of the type designation is a single letter which denotes the symmetrical tolerance in percent of the resistor in accordance with the following code:

Letter	Tolerance
J	± 5 percent
K	±10 percent
M	±20 percent

(2) **COLOR CODE.**—The color code used for fixed composition resistors manufactured in accordance with JAN-R-11 is shown below.

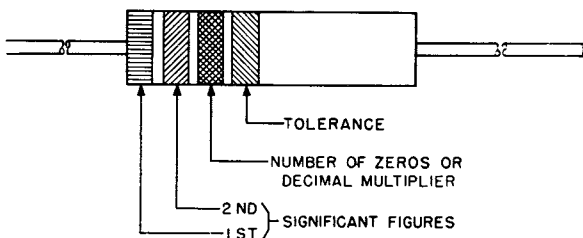

b. POWER TYPE FIXED WIRE-WOUND RESISTORS PER JAN-R-26.

(1) **TYPE DESIGNATION.** — The type designation of power-type fixed wire-wound resistors is formed as follows:

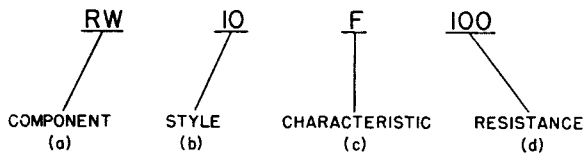

(a) **COMPONENT.**—The first symbol of the type designation consists of a two-letter symbol which identifies the part as a power-type fixed wire-wound resistor. The letter "R" signifies a resistor and the letter "W" denotes the sub-class of power-type fixed wire-wound resistors.

(b) **STYLE.**—The second symbol of the type designation consists of a two-digit symbol which identifies the resistor as to physical shape, size, and power rating, in accordance with the standards of Specification JAN-R-26.

(c) **CHARACTERISTIC.**—The third symbol of the type designation is a single letter which identifies the class, grade, and high ambient temperature derating of the resistor in accordance with the standards of Specification JAN-R-26.

(d) **RESISTANCE.**—The last symbol of the type designation is a three-digit symbol which identifies the resistance value in ohms of the resistor. The first two digits of the symbol are the first two numbers of the resistance, while the third digit indicates the number of zeros which follow the first two numbers. The letter "R" may be substituted for one of the digits to represent the decimal point, but when "R" is used, the last figure of the group becomes significant as in the following example:

$$2R=2.5 \text{ ohms}$$

(2) **COLOR CODE.**—No color is used to identify power-type fixed wire-wound resistors. Instead, the JAN type designation is imprinted on the body of the resistor.

c. FIXED MICA-DIELECTRIC CAPACITORS PER JAN-C-5.

(1) **TYPE DESIGNATION.** — The type designation for fixed mica-dielectric capacitors is formed as follows:

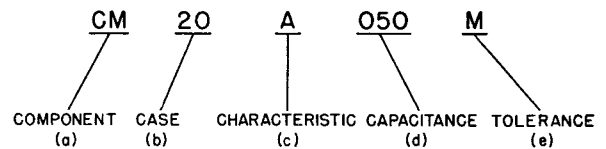

(a) **COMPONENT.** — Fixed mica-dielectric capacitors are identified by the first two letters of the type designation "CM." "C" stands for capacitor and "M" distinguishes the sub-class of mica-dielectric capacitors.

(b) **CASE.**—The second symbol of the type designation is a two-digit symbol which distinguishes the capacitor as to case size and shape in accordance with the standards set out in JAN-C-5.

(c) **CHARACTERISTIC.**—The third symbol of the type designation is a single letter which distinguishes the capacitor as to temperature coefficient, capacity drift, etc., in accordance with the standards of Specification JAN-C-5.

(d) **CAPACITANCE.**—The fourth symbol of the type designation is a three-digit symbol which identifies the capacitance of the capacitor. The first two digits are the first two digits of the capacitance of the capacitor in micromicrofarads. The third digit specifies the number of digits which follow the first two digits. When more than two significant figures are required, additional digits may be used, the last digit always indicating the number of zeros.

(e) **CAPACITANCE.** — The final letter of the type designation identifies the symmetrical capacitance tolerance in percent in accordance with the following code:

Letter	Tolerance
G	± 2 percent
J	± 5 percent
K	±10 percent
M	±20 percent

In no case is the tolerance less than one micromicrofarad.

(2) **COLOR CODE.**—The color code used for fixed

mica-dielectric capacitors manufactured in accordance with Specification JAN-C-5 is shown below.

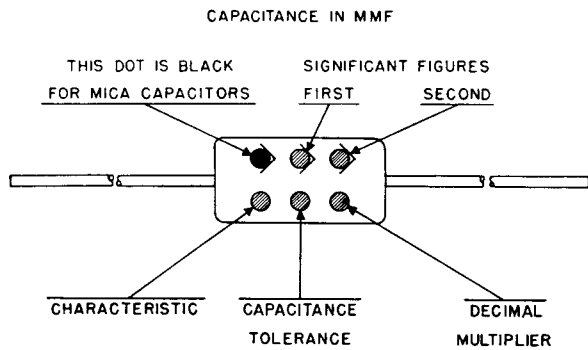

d. FIXED PAPER-DIELECTRIC CAPACITORS PER JAN-C-25.

(1) **TYPE DESIGNATION.**—The type designation of fixed, paper-dielectric, direct-current capacitors which are hermetically sealed in metal cases is formed as follows:

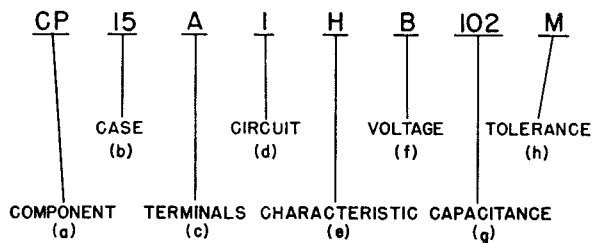

(a) **COMPONENT.**—The first symbol of the type designation consists of a two-letter symbol which identifies the part as a paper-dielectric capacitor. The "C" stands for capacitor and the "P" distinguishes the subclass of paper-dielectric capacitors.

(b) **CASE.**—The second symbol of the type designation is a two-digit symbol which identifies the case

size of the capacitor in accordance with the sizes established by Specification JAN-C-25.

(c) **TERMINALS.**—The third symbol of the type designation is a single letter which identifies the type of terminals on the capacitor in accordance with the definitions set up in JAN-C-25.

(d) **TERMINALS AND CIRCUIT.**—The fourth symbol of the type designation is a single digit which identifies the number of terminals and the circuit diagram of the capacitor in accordance with the definitions of Specification JAN-C-25.

(e) **CHARACTERISTICS.**—The fifth symbol of the type designation is a single letter which identifies the temperature characteristics of the capacitor according to the standards of Specification JAN-C-25.

(f) **VOLTAGE.**—The sixth symbol of the type designation is a single letter which denotes the direct-voltage rating of the capacitor according to the standards of Specification JAN-C-25.

(g) **CAPACITANCE.**—The seventh symbol of the type designation is a three-digit number which identifies the capacitance value of the capacitor. The first two digits represent the first two figures of the capacitance value in micromicrofarads. The third digit indicates the number of zeros which follow.

(h) **CAPACITANCE TOLERANCE.**—The last symbol of the type designation is a single letter which indicates the capacitance tolerance in percent according to the standards of Specification JAN-C-25.

(2) **COLOR CODE.**—No color code is used to identify fixed, paper-dielectric capacitors that are hermetically sealed in metal cases. Instead, the JAN type designation is imprinted on the capacitor.

TABLE 6-1.—TABLE OF REPLACEABLE PARTS

MODEL: SIGNAL GENERATOR TS-403/U

MAJOR ASSEMBLY: SIGNAL GENERATOR TS-403/U (Less Accessories)

REF. SYMBOL	USAF STOCK NO. ASO STOCK NO. SIG C. STOCK NO. NAVY STOCK NO.	NAME OF PART AND DESCRIPTION	FUNCTION	MFR. AND DESIG. OR JAN TYPE	CONT. OR GOV. DWG. OR SPEC. NO.
101-199+ Series	1609-329002175 R16-AN-TS-403/U 3F4325-403	GENERATOR, RF signal: AM, FM, or pulse modulation; 1800 to 4000 mc in one range; metal case w/carrying handles; 17-1/2" lg x 13-1/2" wd x 13-5/8" h overall; accuracy of freq calibration within 1%; one milliwatt max output power; self-contained power adjustment meter calibrated from -6 to +3 dbm; 0-127 db output attenuator; nominal 50 ohm output impedance; CW, pulse, or FM output; pulse output 40 to 4000 pps, can be synchronized with external sine wave or pulse voltages; 3 to 300 u sec delay circuit; can be externally modulated by pulse or square waves; provides delayable or undelayable video pulses for external use; operates from 115 v, 50-1600 cps power source; provided with water-tight transit case 20-9/16" lg x 17-1/4" wd x 17-11/16" h overall; includes output and input coaxial cables, adapters and instruction book	Signal Generator	Signal Generator TS-403/U	Spec. #16G4(Aer)
A-101 N16-M-60911-4456	MOUNTING, bracket: steel, cadmium plated; two #6-32 thread spade lugs, 1-9/16" c to c, 2-15/16" max height	Mounting bracket for C-118	JAN CP06SA5	JAN-C-25
A-102		MOUNTING, bracket: same as A-101	Mounting bracket for C-121		
A-103 N16-M-61127-4446	MOUNTING, bracket: steel, cadmium plated; one #10-32 thread spade lug riveted to mounting; for mounting capacitor	Mounting bracket for C-124	JAN CP07SB6	JAN-C-25
A-104		MOUNTING, bracket: same as A-103	Mounting bracket for C-125		
A-105 2Z3351-566	CABINET: houses components of Signal Generator TS-403/U; aluminum, zinc chromate and gray painted finish; empty; 17-1/2" lg x 11-1/4" wd x 13-5/8" h o/a; bottom of cabinet has one right angle shaped guide on each side for chassis of generator; no handles; front of cabinet is open, all four open edges have castellated strips of beryllium copper attached for grounding to panel	Cabinet for Signal Generator TS-403/U	+Federal Mfg. & Eng. Corp 310-39	+Federal Mfg. & Eng. Corp 310-39

CONTRACT NOa(s)-9213

+CONTRACT NOa(s)-12297 and CONTRACTS N383s-54831, N383s-57633, N383s-59709, N383s-59710

TABLE 6-1.—TABLE OF REPLACEABLE PARTS (Contd)

MODEL: SIGNAL GENERATOR TS-403/U

MAJOR ASSEMBLY: SIGNAL GENERATOR TS-403/U (Less Accessories)

REF. SYMBOL	USAF STOCK NO. ASO STOCK NO. SIG C. STOCK NO. NAVY STOCK NO.	NAME OF PART AND DESCRIPTION	FUNCTION	MFR. AND DESIG. OR JAN TYPE	CONT. OR GOV. DWG. OR SPEC. NO.
C-101	3300-376143950 R16-C-10492-22-100 3K3510312	CAPACITOR, fixed: mica; JAN type #CM35A103J; 10,000 mmf \pm 5%; 300 vdcw; 53/64" lg x 53/64" wd x 11/32" thk; phenolic case; 2 axial wire leads	Couples V-101A to V-101B	JAN CM35A103J	JAN-C-5
C-102	3300-376006800 R16-C-9809-50-100 3K2015011	CAPACITOR, fixed: mica; JAN type #CM20A150K; 15 mmf \pm 10%; 500 vdcw; 51/64" lg x 15/32" wd x 7/32" thk; phenolic case; 2 axial wire leads	Differentiating capacitor between V-101B and V-102A	JAN CM20A150K	JAN-C-5
C-103	3300-376012800 R16-C-9967-20-100 3K2020112 N16-C-29265-3001	CAPACITOR, fixed: mica dielectric; 200 mmf \pm 5%; 500 vdcw; phenolic case; 51/64" lg by 15/32" wide by 7/32" deep; two axial wire leads; lead mounted	Differentiating capacitor	JAN CM20C201J	JAN-C-5
C-104	3300-376022400 R16-C-9994-65 3K2030112 N16-C-29660-9001	CAPACITOR, fixed: mica; 300 mmf \pm 5%; 500 vdcw; phenolic case; 51/64" lg by 15/32" wide by 7/32" deep; two axial wire leads; lead mounted	Differentiating capacitor	JAN CM20C301J	JAN-C-5
C-105		CAPACITOR, fixed: same as C-101	Multivibrator frequency-determining capacitor		
C-106		CAPACITOR, fixed: same as C-101	Multivibrator frequency-determining capacitor		
C-107	3300-376019200 R16-JAN-CM20A270K 3K2027011	CAPACITOR, fixed: mica; JAN type #CM20A270K; 27 mmf \pm 10%; 500 vdcw; 51/64" lg x 15/32" wd x 7/32" thk; phenolic case; 2 axial wire leads	Differentiating capacitor between V-102B and V-103	JAN CM20A270K	JAN-C-5
C-108	3300-318001198 R16-C-11707-190 3DA250-418	CAPACITOR, fixed: paper dielectric; JAN type #CP55B1EG254K; 250,000 mmf \pm 10%; 1000 vdcw; hermetically sealed non-magnetic uninsulated case; 1-13/16" lg x 1" wd x 7/8" h; impregnation not specified; two non-removable solder lug term 3/4" lg located on bottom, spaced 1-1/16" c to c; no internal ground connections; two mtg feet w/ 3/16" diam hole in ea on 2-1/8" centers	DC blocking capacitor for J-101	JAN CP55B1EG254K	JAN-C-25

C-109	3300-376114000 R16-C-10074-400 3K2582111	CAPACITOR, fixed: mica; JAN type #CM25A821K; 820 mmf \pm 10%; 500 vdcw; 1-1/16" lg x 15/32" wd x 7/32" thk; phenolic case; 2 axial wire leads	Differentiating capacitor	JAN CM25A821K	JAN-C-5
C-110		CAPACITOR, fixed: same as C-102	Differentiating capacitor		
C-111		CAPACITOR, fixed: same as C-102	Differentiating capacitor		
C-112		CAPACITOR, fixed: same as C-108	DC blocking capacitor for J-102		
C-113	3300-376043000 R16-JAN-CM20A820K 3K2082011	CAPACITOR, fixed: mica; JAN type #CM20A820K; 82 mmf \pm 10%; 500 vdcw; 51/64" lg x 15/32" wd x 7/32" thk; phenolic case; 2 axial wire leads	Couples V-107A to V-109 when S-102A in "INT" position	JAN CM20A820K	JAN-C-5
C-114	3300-376143900 R16-C-10493-5 3K3510311	CAPACITOR, fixed: mica; JAN type #CM35A103K; 10,000 mmf \pm 10%; 300 vdcw; 53/64" lg x 53/64" wd x 11/32" thk; phenolic case; 2 wire leads on opposite ends	DC blocking capacitor in external modulation circuit	JAN CM35A103K	JAN-C-5
C-115		CAPACITOR, fixed: same as C-114	Couples V-108 to V-109 when S-102A in "EXT POS" position		
C-116		CAPACITOR, fixed: same as C-108	DC blocking capacitor for J-103		
C-117		CAPACITOR, fixed: same as C-113	Feedback capacitor from V-109 to V-107A		
C-118	3300-316958814 R16-C-11419-2 3DB1-192	CAPACITOR, fixed: paper dielectric; JAN type #CP61B1FF105K; 1.0 mf \pm 10%; 600 vdcw; hermetically sealed non-magnetic un-insulated case; 2-1/2" lg x 1-5/16" wd x approx 9/16" h; impregnation not specified; two non-removable solder lug term 3/4" lg located on top, spaced 5/8" c to c; no internal ground connections; mounted by bracket per spec JAN-C-25, bracket type designation #CP06SA5	Screen-by-pass capacitor for V-109	JAN CP61B1FF105K	JAN-C-25
C-119		CAPACITOR, fixed: same as C-102	Couples V-109 to V-110		
C-120		CAPACITOR, fixed: same as C-108	DC blocking capacitor for J-104		
C-121		CAPACITOR, fixed: same as C-118	Voltage ripple by-pass capacitor		
C-122		CAPACITOR, fixed: same as C-108	Bias supply by-pass capacitor		

TABLE 6-1. — TABLE OF REPLACEABLE PARTS (Contd)

MODEL: SIGNAL GENERATOR TS-403/U

MAJOR ASSEMBLY: SIGNAL GENERATOR TS-403/U (Less Accessories)

REF. SYMBOL	USAF STOCK NO. ASO STOCK NO. SIG C. STOCK NO. NAVY STOCK NO.	NAME OF PART AND DESCRIPTION	FUNCTION	MFR. AND DESIG. OR JAN TYPE	CONT. OR GOV. DWG. OR SPEC. NO.
C-123		CAPACITOR, fixed: same as C-108	Voltage ripple coupling capacitor from V-115 to V-107B		
C-124	3300-317642988 R16-C-11612-899 3DB4-251	CAPACITOR, fixed: paper dielectric; JAN type #CP70E1FG405K, 4.0 mf $\pm 10\%$; 1000 vdcw; hermetically sealed steel case, protected for salt spray test per spec JAN-C-25; 2-1/2" lg x 1-3/16" wd x 4-3/4" h; impregnation not specified; two pillar insulator term 1-3/8" h, ea supplied w/two nuts, one lock-washer and one terminal lug, located on top, spaced 2" c to c; no internal ground connections; mounted by bracket per spec JAN-C-25, bracket type designation #CP07SC2	Power supply filter capacitor	JAN CP70E1FG 405K	JAN-C-25
C-125	3300-317276500 R16-C-11665-800 3DB6-41	CAPACITOR, fixed: paper dielectric; JAN type #CP70E1FF605K; 6.0 mf $\pm 10\%$; 600 vdcw; hermetically sealed steel case protected for salt spray test per spec JAN-C-25; 2-1/2" lg x 1-3/16" wd x 4-3/4" h; impregnation not specified; two pillar insulator term 1-3/8" h, ea supplied w/two nuts, one lock-washer and one terminal lug, located on top, spaced 1-1/8" c to c; no internal ground connections; mounted by bracket per spec JAN-C-25, bracket type designation #CP07SB6	Power supply filter capacitor	JAN CP70E1FF 605K	JAN-C-25
C-126		CAPACITOR, fixed: same as C-108	Repeller by-pass capacitor for V-111		
C-127		CAPACITOR, fixed: same as C-114	FM Phase-shifting capacitor		
C-128		CAPACITOR, fixed: same as C-108	By-pass capacitor in voltage regulator		
C-129		CAPACITOR, fixed: same as C-113	\neq R.F. By-pass capacitor		
C-130		CAPACITOR, fixed: same as C-125	\neq Power supply filter capacitor		

E-101	3300-322864900 R16-P-6303-8 3E7350-2.12.1	PROBE, RF: consists of cylindrical co-axial UHF pick-up loop assembly, terminating resistor, and output cable and connector; approximately 11/16" OD by 18-1/2" lg overall; pick-up assembly mts within attenuator wave guide, connector assembly held by special 9/16" - 18 internally thd nut; includes R-137, P-110 and W-105	Provides power absorption and output path from V-111 resonant cavity (attenuator)	+Federal Mfg. & Eng. Corp 310-352 Hewlett-Packard 19M-E-768	+Federal Mfg. & Eng. Corp 310-352 Hewlett-Packard dwg #19M-E-768
E-101 7CHQ-19ME768	PROBE, RF: consists of cylindrical co-axial UHF pick-up loop assembly, co-axial cable, and connector assembly; approx 11/16" OD x 18-1/2" lg overall; pick-up assembly mts within attenuator wave guide, connector assembly held by special 9/16" -18 internally thd nut; this assembly identical to E-101, above, except that RG-55/U cable replaces RG-58/U cable formerly used	Provides power absorption and output path from V-111 resonant cavity	≠Hewlett-Packard 19M-E-768B	≠Hewlett-Packard dwg #19M-E-768B
E-101A	3300-287641461 R16-L-5040-750 2Z3262-22	LINE SECTION, RF transmission: consists of a cylindrical shaped brass tube with special formed silver overlay contact fingers on one end and 3/8" -32 by 9/16" lg thd bore on other end; 7/16" OD by 4-9/32" lg overall; mts within attenuator wave guide E-144, p/o E-101	Provides adjustable power absorbing guide for UHF resonant cavity output (Used in E-101)	+Federal Mfg. & Eng. Corp 310-299 Hewlett-Packard 19M-E-330-4	+Federal Mfg. & Eng. Corp 310-299 Hewlett-Packard dwg #19M-E-330-4
E-101B R16FME310-189	SHELL, connector: brass, silver plated; cylindrical shape; 7/8" lg by 0.480" dia o/a; mounts by 3/8" -32 NF-2 ext thd; 0.125" axial hole drilled through, counterbored 0.206" dia x 0.250" lg on one end and 15° countersink at opposite end 0.090" deep x 0.330" ID; p/o E-101	Coupling shell for attenuator cable	+Federal Mfg. & Eng. Corp 310-189	+Federal Mfg. & Eng. Corp 310-189
E-101C R16FME310-190	INSULATOR, bead: cylindrical shape; Teflon material, grade, type, color and finish not specified; 0.250" lg o/a; 0.404" major OD x 0.206" minor OD x 0.063" ID; fits in connector at end of RF cable; p/o E-101	Dielectric support for center conductor of coaxial line	+Federal Mfg. & Eng. Corp 310-190	+Federal Mfg. & Eng. Corp 310-190
E-102	3300-308417845 R16-F-1988-750 3C1084Z58	FILTER, RF leakage: consists of a silver plated brass cylindrical case 3/8" OD by 2-1/8" lg containing 1 powdered iron core 1/4" OD by 1-1/2" lg; 0.062" dia by 3/16" lg axial leads; case thrd for 3/8" -32 mtg nut	Suppresses RF leakage via monitor lead from resonant cavity	+Federal Mfg. & Eng. Corp 310-58 Hewlett-Packard 19M-E-323-1	+Federal Mfg. & Eng. Corp 310-58 Hewlett-Packard dwg #19M-E-323-1

CONTRACT NOa(s)-9213

+CONTRACT NOa(s)-12297 and CONTRACTS N383s-54831, N383s-57633, N383s-59709, N383s-59710
≠CONTRACTS N383s-45739, N383s-74507, N383s-74917

TABLE 6-1. — TABLE OF REPLACEABLE PARTS (Contd)

MODEL: SIGNAL GENERATOR TS-403/U

MAJOR ASSEMBLY: SIGNAL GENERATOR TS-403/U (Less Accessories)

REF. SYMBOL	USAF STOCK NO. ASO STOCK NO. SIG C. STOCK NO. NAVY STOCK NO.	NAME OF PART AND DESCRIPTION	FUNCTION	MFR. AND DESIG. OR JAN TYPE	CONT. OR GOV. DWG. OR SPEC. NO.
E-103		FILTER, RF leakage: same as E-102	Suppresses RF leakage via accelerator lead to V-111		
E-104		FILTER, RF leakage: same as E-102	Suppresses RF leakage via filament lead to V-111		
E-105		FILTER, RF leakage: same as E-102	Suppresses RF leakage via filament lead to V-111		
E-106		FILTER, RF leakage: same as E-102	Suppresses RF leakage via M-101 meter lead		
E-107		FILTER, RF leakage: same as E-102	Suppresses RF leakage via M-101 meter lead		
E-108		FILTER, RF leakage: same as E-102.	Suppresses RF leakage via a.c. power lead		
E-109		FILTER, RF leakage: same as E-102	Suppresses RF leakage via pilot lamp lead		
E-110		FILTER, RF leakage: same as E-102	Suppresses RF leakage via pilot lamp lead		
E-111		FILTER, RF leakage: same as E-102	Suppresses RF leakage via a.c. power lead		
E-112	3300-387257551 R17-S-17152-50 3Z770-14.1	BOARD, terminal: general purpose; 12 nickel pl brass double screw term; term 3/8" between centers; barriers between term; molded black phenolic; 5-3/16" lg by 11/16" wd by 3/8" thk overall excluding term projection; four 5/32" dia mtg holes on 5/16" by 4-7/8" mtg/c	Terminal strip	Jones H B #12-140-3/4-W	+Federal Mfg. & Eng. Corp TEB-12 Hewlett-Packard dwg #19M-S-709

TABLE 6-1. — TABLE OF REPLACEABLE PARTS (Contd)

MODEL: SIGNAL GENERATOR TS-403/U

MAJOR ASSEMBLY: SIGNAL GENERATOR TS-403/U (Less Accessories)

REF. SYMBOL	USAF STOCK NO. ASO STOCK NO. SIG C. STOCK NO. NAVY STOCK NO.	NAME OF PART AND DESCRIPTION	FUNCTION	MFR. AND DESIG. OR JAN TYPE	CONT. OR GOV. DWG. OR SPEC. NO.
*E-113	3300-387257670 3Z770-30	BOARD, terminal: for mtg small components; 30 pairs silver plated brass turret type terminal posts; term 3/8" between centers; laminated phenolic board; 12-3/8" lg by 1-5/8" wide by 3/32" thk; 6 mtg holes for #6 screw on 1-1/8" by 6" mtg/c	To support circuit components C-101, R-103, R-106, C-102, C-105, C-106, C-104, R-108, R-113, C-103, R-111, C-107, R-112, R-119, C-110, R-118, R-114, C-109, R-117, R-135, C-111, R-123, C-113, R-125, R-122, C-117, C-119, R-133, R-134, R-132	+Federal Mfg. & Eng. Corp 310-324 Hewlett-Packard 19M-M-747	+Federal Mfg. & Eng. Corp 310-324 Hewlett-Packard dwg #19M-M-747
*E-114	3300-387257100 3Z770-16 N17B-78085-8077	BOARD, terminal: for mtg small components; 8 pairs silver plated brass turret type terminal posts; term 3/8" between centers; laminated phenolic board; 6-3/8" lg by 1-5/8" wd by 23/64" thk; 4 mtg holes for #6 screw on 1-1/8" by 6" mtg/c; includes aluminum bracket for mtg two potentiometers	To support circuit components R-101, R-102, R-104, R-105, R-121, R-120, R-181, R-107, R-115, R-110	+Federal Mfg. & Eng. Corp 310-325 Hewlett-Packard 19M-M-748	+Federal Mfg. & Eng. Corp 310-325 Hewlett-Packard dwg #19M-M-748
*E-115	3300-387257550 3Z770-24 N17-B-78178-6674	BOARD, terminal: for mtg small components; 12 pairs silver plated brass turret type terminal posts; term 3/8" between centers; laminated phenolic board; 5-1/4" lg by 1-5/8" wd by 23/64" thk; 4 mtg holes for #6 screw on 1-1/8" by 4-7/8" mtg/c	To support circuit components R-139, R-141, R-144, R-146, R-142, R-145, R-140, R-147, R-155, R-154, R-150, R-151	+Federal Mfg. & Eng. Corp 310-326 Hewlett-Packard 19M-M-749	+Federal Mfg. & Eng. Corp 310-326 Hewlett-Packard dwg #19M-M-749
*E-116	3300-387256510 3Z770-8.9 N17-B-77844-2218	BOARD, terminal: for mtg small components; 4 pairs silver plated brass turret type terminal posts; term 3/8" between centers; laminated phenolic board; 5-1/4" lg by 1-5/8" wd by 23/64" thk; includes aluminum bracket for mtg two potentiometers *Not furnished as a maintenance part for Bureau of Ships activities. If failure occurs, do not request replacement unless the item cannot be repaired or fabricated.	To support circuit components R-148, R-149, R-153, C-127, R-143, R-152	+Federal Mfg. & Eng. Corp 310-327 Hewlett-Packard 19M-M-750	+Federal Mfg. & Eng. Corp 310-327 Hewlett-Packard dwg #19M-M-750

*E-117	3300-387257101 3Z770-16.1 N17-B-78083-8360	BOARD, terminal: for mtg small components; 8 pairs, silver plated brass turret type terminal posts; term 3/8" between centers; laminated phenolic board; 3-3/4" lg by 1-5/8" wd by 23/64" thk; 4 mtg holes for #6 screw on 1-1/8" by 3-3/8" mtg/c	To support circuit components, R-165, R-168, R-179, R-180, R-177, R-176, R-175, R-174	+Federal Mfg. & Eng. Corp 310-329 Hewlett-Packard 19M-M-752	+Federal Mfg. & Eng. Corp 310-329 Hewlett-Packard dwg #19M-M-752
*E-118	3300-387257251 3Z770-18.1 N17-B-78114-9439	BOARD, terminal: for mtg small components; 9 pairs silver plated brass turret type terminal posts; term 3/8" between centers; 3/8" diam mtg hole for single potentiometer; laminated phenolic board; 5-1/8" lg by 1-5/8" wd by 23/64" thk; 4 mtg holes for #6 screw on 4-7/8" by 1-1/8" mtg/c	To support circuit components, R-130, R-127, R-126, C-115, R-131, R-129, C-114, R-128, R-184, R-185	+Federal Mfg. & Eng. Corp 310-328 Hewlett-Packard 19M-M-751	+Federal Mfg. & Eng. Corp 310-328 Hewlett-Packard dwg #19M-M-751
*E-119	3300-298362045 2Z8620.152	BOARD, terminal: resistor holder; 1 pair cad plated phosphor bronze fuse retainer clips and solder lug term mtg on phenolic strip; 5" lg by 1" wide by 1-3/16" h overall; two 5/32" diam mtg holes on 2-5/8" mtg/c; includes E-119A, E-119B	Supports R-157	+Federal Mfg. & Eng. Corp 310-312 Hewlett-Packard 19M-S-714	+Federal Mfg. & Eng. Corp 310-312 Hewlett-Packard dwg #19M-S-714
E-119A R17-S-Q-2372 2Z2712.410 17C-804733-270	CLIP: beryllium copper, silver plated; 1" lg by 3/4" wide by 5/8" high; 60 amp, 250 v a-cw mounts by 1/4" diam hole; 7/8" max diam fuse ferrule, p/o E-119	Used to mount R-157	+Federal Mfg. & Eng. Corp CLP-12	+Federal Mfg. & Eng. Corp CLP-12
E-119B		CLIP: same as E-119A, p/o E-119	Used to mount R-157		
*E-120	3300-298362046 2Z6820.153	BOARD, terminal: resistor holder; 2 pairs cad plated phosphor bronze fuse retainer clips and solder lug term; mtg on bakelite strip; 6" lg by 3/4" wd by 1-1/16" h overall; three 5/32" diam countersunk mtg holes on 1-1/2" and 2-7/8" mtg/c; includes E-120A, E-120B, E-120C, E-120D	Supports R-156 and R-158	+Federal Mfg. & Eng. Corp 310-311 Hewlett-Packard 19M-S-713	+Federal Mfg. & Eng. Corp 310-311 Hewlett-Packard dwg #19M-S-713
E-120A R17-S-Q-2371MOD 2Z2712.409 N17-C-804672-951	CLIP: beryllium copper, silver plated; 25/32" lg by 9/16" wd by 1/2" h; 30 amp, 250 v a-cw; 5/8" max diam fuse ferrule; mounts by 3/16" hole in base; p/o E-120	Used to mount R-156	+Federal Mfg. & Eng. Corp CLP-11	+Federal Mfg. & Eng. Corp CLP-11
E-120B		CLIP: same as E-120A; p/o E-120	Used to mount R-156		
E-120C		CLIP: same as E-120A; p/o E-120	Used to mount R-158		
E-120D		CLIP: same as E-120A; p/o E-120	Used to mount R-158		
		* Not furnished as a maintenance part for Bureau of Ships activities. If failure occurs, do not request replacement unless the item cannot be repaired or fabricated.			

TABLE 6-1.—TABLE OF REPLACEABLE PARTS (Contd)

MODEL: SIGNAL GENERATOR TS-403/U

MAJOR ASSEMBLY: SIGNAL GENERATOR TS-403/U (Less Accessories)

REF. SYMBOL	USAF STOCK NO. ASO STOCK NO. SIG C. STOCK NO. NAVY STOCK NO.	NAME OF PART AND DESCRIPTION	FUNCTION	MFG. AND DESIG. OR JAN TYPE	CONT. OR GOV. DWG. OR SPEC. NO.
*E-121	3300-298362047 2Z6820.154	BOARD, terminal; resistor holder; 1 pair cad plated phosphor-bronze, fuse retainer clips and solder lug term; mtd on bakelite strip; 3-1/2" lg by 5/8" wd by 1" h overall; two 5/32" diam mtg holes on 3" mtg/c; includes E-121A and E-121B	Supports R-159	+Federal Mfg. & Eng. Corp 310-313 Hewlett-Packard 19M-S-746	+Federal Mfg. & Eng. Corp 310-313 Hewlett-Packard dwg #19M-S-746
E-121A		CLIP: same as E-120A; p/o E-121	Used to mount R-159		
E-121B		CLIP: same as E-120A	Used to mount R-159		
E-122	3300-32686270 R16-P-6303-7 3F3707	PROBE, RF: consists of a cylindrical tube 5/16" OD by 2-1/4" lg with a 7/8" OD by 1/2" lg cap on one end; electromagnetic pickup loop mounted on free end of tube; bead thermistor R-136 mounted within tube; two 1/4" OD by 1" lg powdered iron cores also mtd within tube; assembly silver pl; 7/8" OD by 2-29/32" lg overall; mts within special 0.3075" ID guide tube and held by single #8-32 by 1/8" lg set screw on special gear rack assembly; includes thermistor R-136, p/o E-165	Power absorbing assembly for RF power monitoring of V-111 (bolometer)	+Federal Mfg. & Eng. Corp 310-384 Hewlett-Packard 19M-M-740	+Federal Mfg. & Eng. Corp 310-384 Hewlett-Packard dwg #19M-M-740
E-123	3300-291703102 R16-L-5041 2Z5091-38	LINE SECTION, RF transmission: consists of a cylindrical silver pl brass tube with special mtg nut on one end; 7/8" OD by 0.281" ID by 7.255" lg overall; mts on one end by special 3/4"-16 internally thd nut and on other end by 9/16"-18 thd on end of housing tube	Houses and provides outer coaxial conductor for E-124	+Federal Mfg. & Eng. Corp 310-188 tube and 310-194 nut Hewlett-Packard 19M-M-731	+Federal Mfg. & Eng. Corp 310-188 and 310-194 Hewlett-Packard dwg #19M-M-731
E-124	3300-28066104 R16-FME-310-196 2Z394-52	ATTENUATOR, fixed: platinum film on glass rod; 0.125" OD, 6.500" d; 6 db ± 1 db attenuation; DC resistance 70 to 80 ohms; mounts by special .093" diam OD banana pins	Center conductor of UHF standing-wave coaxial pad attenuator for V-111 output	+Federal Mfg. & Eng. Corp 310-196 Hewlett-Packard 19M-E-333	+Federal Mfg. & Eng. Corp 310-196 Hewlett-Packard dwg #19M-E-333
		* Not furnished as a maintenance part for Bureau of Ships activities. If failure occurs, do not request replacement unless the item cannot be repaired or fabricated.			

E-124A R16-FME310-197	ATTENUATOR, fixed: pad type; 80 ohms DC resistance approx; power rating not specified; 0.125" diam x 6.875 lg o/a; ends chamfered to fit connector contacts; conductor is a platinum film on glass rod; p/o E-124 (for identification only - not a replaceable part)	Part of center conductor of coaxial pad	+Federal Mfg. & Eng. Corp 310-197	+Federal Mfg. & Eng. Corp 310-197
E-124B R16-FME310-198	CONTACT, connector: terminal for attenuator pad; brass, silver pl; cylindrical shape; no dimension of this item is greater than one inch; force fitted; two axial slots perpendicular to each other on one end 0.010" wd x 0.1875" deep; p/o E-124 (for identification only - not a replaceable part)	Terminal for attenuator pad coated glass rod E-124A	+Federal Mfg. & Eng. Corp 310-198	+Federal Mfg. & Eng. Corp 310-198
E-124C		CONTACT, connector: same as E-124B	Terminal for attenuator pad		
E-125	3300-295579669 R16-JAN-TS102U02 2Z8308-28 N16-S-34557-8351	SHIELD, tube: brass, nickel pl; cylindrical; open top; twist-lock mounted to tube socket base shield; 0.930" ID by 1-3/4" lg inside; contains internal helical compression spring for holding tube in place	Shields and locks miniature tube V-102 in socket	JAN TS102U02	+JAN-S-28A
E-126		SHIELD, tube: same as E-125	Shields and locks miniature tube V-103 in socket		
E-127		SHIELD, tube: same as E-125	Shields and locks miniature tube V104 in socket		
E-128		SHIELD, tube: same as E-125	Shields and locks miniature tube V-106 in socket		
E-129		SHIELD, tube: same as E-125	Shields and locks miniature tube V-107 in socket		
E-130		SHIELD, tube: same as E-125	Shields and locks miniature tube V-108 in socket		
E-131		SHIELD, tube: same as E-125	Shields and locks miniature tube V-110 in socket		
E-132	3300-295578954 R16-JAN-TS102U03 2Z8304.131 N16-S-34607-6039	SHIELD, tube: brass, nickel pl; cylindrical, open top, twist-lock mounted to tube socket base shield; 2-1/4" lg by 0.930" diam inside; contains internal helical compression spring for holding tube in place	Shields and locks miniature tube V-112 in socket	JAN TS102U03	+JAN-S-28A
E-133		SHIELD, tube: same as E-132	Shields and locks miniature tube V-113 in socket		
E-134		SHIELD, tube: same as E-132	Shields and locks miniature tube V-114 in socket		

TABLE 6-1.—TABLE OF REPLACEABLE PARTS (Contd)

MODEL: SIGNAL GENERATOR TS-403/U

MAJOR ASSEMBLY: SIGNAL GENERATOR TS-403/U (Less Accessories)

REF. SYMBOL	USAF STOCK NO. ASO STOCK NO. SIG C. STOCK NO. NAVY STOCK NO.	NAME OF PART AND DESCRIPTION	FUNCTION	MFR. AND DESIG. OR JAN TYPE	CONT. OR GOV. DWG. OR SPEC. NO.
E-135	8800-444163 G17-L-6297 N17-L-6297	LAMP, incandescent: 6-8 v, 0.15 amp; bulb T-3-1/4 clear; 1-1/8" lg overall; miniature bayonet base; pilot lamp type; burn any position	"HEATER" on pilot lamp held by I-108	GE #47	+Federal Mfg. & Eng. Corp #LAI-1 Hewlett-Packard dwg #19M-S-720
E-136		LAMP, incandescent: same as E-135	"POWER ON" pilot lamp held by I-107		
E-137		This symbol not assigned			
E-138	8800-619703 R17-P-7275-10	HOLDER, fuse: extractor post type; for single 3AG cartridge fuse; molded black phenolic enclosing tube containing one 1/4" fuse contact; other 1/4" fuse contact mtd on molded black phenolic cap with 1/2" OD, #24 thd; cap engraved "FUSE"; 15 amp max; 11/16" OD by 2-5/8" lg overall; 2 solder lug term; includes E-138A cap	Fuseholder for spare fuse	Littelfuse #342001	+Federal Mfg. & Eng. Corp HOF-7 Hewlett-Packard dwg #19M-S-757
E-138A R17-C-2651 3Z930-3.2	CAP: bakelite; 1-1/16" lg by 1/2" diam; mounted by 5/16"-18 thd by 3/16" lg threaded portion of body; p/o E-138, on front panel	Part of fuseholder	+Federal Mfg. & Eng. Corp HOF-7-1	+Federal Mfg. & Eng. Corp HOF-7-1
E-139		HOLDER, fuse: same as E-138	Fuseholder for spare fuse		
E-140		HOLDER, fuse: same as E-138	Fuseholder for F-101		
E-141		HOLDER, fuse: same as E-138	Fuseholder for F-102		
E-142 2Z1926-5	CAVITY ASSEMBLY, tuned: brass enclosure; silver plated; resonant coaxial cavity designed for Klystron oscillator tube V-111; consists of cylindrical outer and inner conductors; includes supporting gear mechanism; contacts for oscillator resonator grids and repeller; frequency range 1800 to 4000 mc; 10-1/4" lg by 5" wd by 9-3/8" high approx; mounts by four #8-32 tapped holes spaced 90° apart on 1-3/16" radius on flange at one end of cavity outer conductor; includes O-116	Tuned cavity and frequency drive assembly	+Federal Mfg. & Eng. Corp 310-183 Hewlett-Packard 19M-E-790	+Federal Mfg. & Eng. Corp 310-183 Hewlett-Packard dwg #19M-E-790

E-142A	3300-291703104 R16-C-16300-950 2Z5091-40	CONDUCTOR, cavity outer: consists of 1-3/4" ID cylindrical shaped silver pl brass tubing with mtg flanges on each end; 2.740" OD by 5.469" lg overall; mts by four #8-32 tapped holes spaced 90° apart on 1-3/16" radius on flange at each end of tube; p/o E-142	Provides housing and outer conductor of UHF resonant cavity	+Federal Mfg. & Eng. Corp 310-137 Hewlett-Packard 19M-E-318-7	+Federal Mfg. & Eng. Corp 310-137 Hewlett-Packard dwg #19M-E-318-7
*E-142B	3300-291703103 R16-S-3924 2Z5091-39	SHIELD, tube: consists of cylindrical shaped brass housing closed at one end and provided with three 3/8"-32 tapped holes for contact to X-111; 2-9/32" lg by 1-3/4" wd by 2" h, overall; mts by single #26 drill hole in circumference of housing 1/4" from open end; p/o E-161	Shields V-111 tube socket	+Federal Mfg. & Eng. Corp 310-122 Hewlett-Packard 19M-E-322-13	+Federal Mfg. & Eng. Corp 310-122 Hewlett-Packard dwg #19M-E-322-13
*E-142C	3300-298334050 R16-F-2393-500 2Z4390-7 N16-F-650431-153	FLANGE, mounting: brass, silver pl; holds item by inside thread; on integral double flatted-flange 1.525" diam, 24 threads per inch; 2.734" wide by 2-1/4" h by .406" d overall; mounts by four 0.1695" holes spaced 90° apart on 1-3/16" radius; p/o E-142	Holds cavity contact E-142D and housing support E-142E in place	+Federal Mfg. & Eng. Corp 310-145 Hewlett-Packard 19M-E-319-13	+Federal Mfg. & Eng. Corp 310-145 Hewlett-Packard dwg #19M-E-319-13
E-142D	3300-287222604 R16-FME-310-153 2Z2712.61	CONTACT, connector: consists of a circular piece of 0.010" beryllium copper with internal, formed contact fingers; silver plated; 48 contact fingers 1/4" lg by 1/16" h, after bending end of taper; overall dim; 1-7/8" OD by 1/16" thk; mounts within V-111 resonant cavity and held in position by above mounting; p/o E-142	Combines with cavity contacts E-142F and E-142G to form contact between resonator grid and outer conductor 142A	+Federal Mfg. & Eng. Corp 310-153 Hewlett-Packard 19M-E-320-4	+Federal Mfg. & Eng. Corp 310-153 Hewlett-Packard dwg #19M-E-320-4
*E-142E	3300-298362049 R16-F-2281-500 2Z6820.156 N16-C-599651-141	FITTING, transmission line: consists of 1-3/8" ID silver plated bronze tubing with 1.551" internal diameter threaded for mounting; 1-3/8" lg, 1-3/4" outside diam; medium knurl band around middle; p/o E-142	Holds cavity contacts E-142F and E-142G and housing E-142B in place	+Federal Mfg. & Eng. Corp 310-149 Hewlett-Packard 19M-E-319-14	+Federal Mfg. & Eng. Corp 310-149 Hewlett-Packard dwg #19M-E-319-14
E-142F	3300-326166260 R16-FME-310-154 5F2682	CLIP, grid contact: consists of a semi-circular piece of 0.008" silver pl. beryllium copper with internal, formed contact fingers mounted within a grooved semicircular brass split ring; three pieces; 1.480" OD by 0.060" thk overall, 1.020" ID; assembly mounts on Klystron grid, consists of E-162, E-163, and E-164	Forms contact between V-111 resonator grid and cavity outer conductor	+Federal Mfg. & Eng. Corp 310-154 Hewlett-Packard 19M-M-730	+Federal Mfg. & Eng. Corp 310-154 Hewlett-Packard dwg #19M-M-730

* Not furnished as a maintenance part for Bureau of Ships activities. If failure occurs, do not request replacement unless the item cannot be repaired or fabricated.

TABLE 6-1.—TABLE OF REPLACEABLE PARTS

MODEL: SIGNAL GENERATOR TS-403/U

MAJOR ASSEMBLY: SIGNAL GENERATOR TS-403/U (Less Accessories)

REF. SYMBOL	USAF STOCK NO. ASO STOCK NO. SIG C. STOCK NO. NAVY STOCK NO.	NAME OF PART AND DESCRIPTION	FUNCTION	MFG. AND DESIG. OR JAN TYPE	CONT. OR GOV. DWG. OR SPEC. NO.
E-142G		CLIP, grid contact: same as E-142F	Combines with cavity contact E-142F to form contact between one resonator grid of V-111 and E-142D contact in cavity outer conductor E-142A (Used in E-142)		
*E-142H	3300-299550402 R16-C-16300-900 2Z1008-121	CONDUCTOR, cavity inner: consists of a cylindrical silver pl brass tube with knurled stop; 1-3/8" OD by 10-3/8" lg overall; mts within above cavity outer conductor; p/o E-142	Inner conductor for coaxial resonant cavity	+Federal Mfg. & Eng. Corp 310-381 Hewlett-Packard 19M-M-739	+Federal Mfg. & Eng. Corp 310-381 Hewlett-Packard dwg #19M-M-739
E-142I	3300-326166262 R16-L-5040-500 3F2682.2	LINE, RF transmission: consists of a silver pl brass cylindrical housing containing six powdered iron cores and a conductor rod running coaxially thru housing; a tube clip and a formed collet with contact fingers for connecting to a circular tube term mtd on one end of assembly; assembly 1.170" OD by 11-1/8" lg overall; friction mtg; includes E-142N, E-142P, E-142Q	Makes contact to V-111 repeller and one resonator grid and filters RF on repeller lead (Used in E-142)	+Federal Mfg. & Eng. Corp 310-340 Hewlett-Packard 19M-E-111	+Federal Mfg. & Eng. Corp 310-340 Hewlett-Packard dwg #19M-E-111
*E-142J	3300-328008480 R16-B-12450 3F5877	CARRIAGE, cavity contact: consists of a cylindrical, nickel plated brass tubing with special double ring of silver overlay contact fingers mounted on one end and with axial gear rack down length of tube surface; approx 5-13/16" lg overall by 1-3/4" OD; includes E-142K and E-142M; (used in E-142)	Provides method for tuning V-111 resonant cavity to desired frequency	+Federal Mfg. & Eng. Corp 310-398 Hewlett-Packard 19M-M-756	+Federal Mfg. & Eng. Corp 310-398 Hewlett-Packard dwg #19M-M-756
E-142K	3300-291620744 R16-FME-310-160 2Z4885-122 N17-I-67033-8861	MOUNTING, tuned cavity: consists of textolite ring with raised rim around circumference; 1.740" OD by 3/16" thk overall; mounts by three 0.120" holes spaced 120° apart on 43/64" radius; p/o E-142J	Supports carriage E-142J in V-111 resonant cavity (Used in E-142)	+Federal Mfg. & Eng. Corp 310-160 Hewlett-Packard 19M-E-321-6	+Federal Mfg. & Eng. Corp 310-160 Hewlett-Packard dwg #19M-E-321-6
* Not furnished as a maintenance part for Bureau of Ships activities. If failure occurs do not request replacement unless the item cannot be repaired or fabricated.					

E-142L	3300-286003190 R16-S-4002-600 2Z141	SLEEVE, insulating: consists of two cylindrical sections of 1/16" thk phenolic tubing mtd one inside the other with special 5/16" wd axial slot down length of combined tube; 1-5/8" diam by 4-1/2" lg overall; special Aquadag coating on inside and between cylindrical sections; friction mtd and held by cavity end piece and flange on tuning drive 0-116; fungus proofed; p/o E-142	Prevents parasitic oscillations behind cavity contact E-142M in coaxial resonant cavity	+Federal Mfg. & Eng. Corp 310-243 Hewlett-Packard 19M-E-334-10	+Federal Mfg. & Eng. Corp 310-243 Hewlett-Packard dwg #19M-E-334-10
E-142M	3300-326166261 R16-FME-310-280 3F2682.1	CONTACT, cavity tuning: consists of two concentric circular rows of beryllium copper formed contact fingers over-layed with silver contact surfaces; 1.750" OD by 11/16" thk overall; mtd by three #4-40 tapped holes spaced 120° apart around contact support ring on 43/64" radius; p/o E-142J	Provides shorting contact between cavity outer and inner conductors for cavity tuning purposes (Used in E-142)	+Federal Mfg. & Eng. Corp 310-280 Hewlett-Packard 19M-E-764	+Federal Mfg. & Eng. Corp 310-280 Hewlett-Packard dwg #19M-E-764
E-142N R16-FME-310-115 3G240-6	INSULATOR, cap: natural grade XXX bake-lite 0.735" OD by 15/16" thk; cylindrical; mounts by 0.128" diam hole at one end; p/o E-142I	Used in transmission line E-142I	+Federal Mfg. & Eng. Corp 310-115	+Federal Mfg. & Eng. Corp 310-115
E-142P R16-FME-310-117 2Z2712.407 N17C-804060-486	CLIP: repeller contact; beryllium copper, silver plated; 25/64" lg by 5/16" wd by 3/8" h; one 0.120" diam hole in base for mounting; p/o E-142I	Used as repeller clip for V-111 Klystron tube	+Federal Mfg. & Eng. Corp 310-117	+Federal Mfg. & Eng. Corp 310-117
E-142Q R16-FME-310-118 2Z2712.408	CLIP: resonator grid; beryllium copper, silver plated; 1.17" max OD, tapered with 0.911" max ID, 2" lg; 24 finger like contacts grip Klystron resonator grid; p/o E-142I	Used as Klystron tube resonator grid contact clip	+Federal Mfg. & Eng. Corp 310-118	+Federal Mfg. & Eng. Corp 310-118
*E-143	3300-291620743 R16-H-6129-10 2Z4885-121	HOLDER, RF probe: consists of a length of 15 ga brass tubing and 0.432" by 3/16" hex lock nut; 0.432" diam by 2" lg overall; mts by lock nut and 7/16"-20 by 5/8" lg thd on one end of tube; p/o bolometer E-122	Wave guide tube for E-122 bolometer probe	+Federal Mfg. & Eng. Corp 310-355 Hewlett-Packard 19M-M-728	+Federal Mfg. & Eng. Corp 310-355 Hewlett-Packard dwg #19M-M-728
*E-144	3300-291620742 R16-H-6129-5 2Z4885-120	HOLDER, RF probe: consists of a length of 16 ga brass tubing and 0.432" diam by 3/16" hex lock nut; 0.432" diam by 3" lg overall; mts by lock nut and 7/16"-20 by 5/8" lg thd on one end of tube; p/o attenuator E-101	Wave guide tube for E-101 attenuator probe	+Federal Mfg. & Eng. Corp 310-357 Hewlett-Packard 19M-M-729	+Federal Mfg. & Eng. Corp 310-357 Hewlett-Packard dwg #19M-M-729
E-145		RF PROBE: See accessories list * Not furnished as a maintenance part for Bureau of Ships activities. If failure occurs, do not request replacement unless the item cannot be repaired or fabricated.	Spare RF monitor probe		

TABLE 6-1.—TABLE OF REPLACEABLE PARTS (Contd)

MODEL: SIGNAL GENERATOR TS-403/U

MAJOR ASSEMBLY: SIGNAL GENERATOR TS-403/U (Less Accessories)

REF. SYMBOL	USAF STOCK NO. ASO STOCK NO. SIG C. STOCK NO. NAVY STOCK NO.	NAME OF PART AND DESCRIPTION	FUNCTION	MFR. AND DESIG. OR JAN TYPE	CONT. OR GOV. DWG. OR SPEC. NO.
E-146	3300-292112098 R16-K-3373-250 2Z5822.33 N16K-700314-485	KNOB: round, fluted; molded black phenolic; for 1/4" diam shaft; mts by two #8-32 set screws spaced 90° apart on hub; white plastic pointer; 1-1/8" OD by 11/16" thk brass insert; shaft hole 1/2" deep	Knob for switch S-101 "SYNC SELECTOR"	+Kurz-Kasch #S-308-64-40282-BB Hewlett-Packard 19M-E-326-1	+Federal Mfg. & Eng. Corp KNB-121 Hewlett-Packard dwg #19M-E-326-1
E-147		KNOB: same as E-146	Knob for switch S-103, "MODULATION SELECTOR"		
E-148	3300-292241255 R16-K-3344-200 2Z5822-94	KNOB: round, fluted; molded black phenolic; for 1/4" diam shaft; mtg by two #8-32 set screws spaced 90° apart on hub; 1-1/8" OD by 5/8" thk; brass insert; shaft hole 1/2" deep	"Zero Set" knob for R-162	+Kurz-Kasch #S-308-64-B-BB Hewlett-Packard 19M-E-326-2	+Federal Mfg. & Eng. Corp KNB-122 Hewlett-Packard dwg #19M-E-326-2
E-149	3300-292181504 R16-K-3373-92 2Z5786.111 N16-K-700314-437	KNOB: round, fluted; molded black phenolic; for 1/4" diam shaft; mts by two #8-32 set screws spaced 90° apart on hub; white index dot on knob face near edge; 1-1/8" OD by 5/8" thk; brass insert; shaft hole 1/2" deep	"FM Phase" knob for R-160	+Kurz-Kasch #S-308-64-B-BB-C1 Hewlett-Packard 19M-E-326-3	+Federal Mfg. & Eng. Corp KNB-123 Hewlett-Packard dwg #19M-E-326-3
E-150		KNOB: same as E-149	"FM Amplitude" knob for R-161		
E-151	3300-292241249 R16-K-3344-250 2Z5822-88	KNOB: round; fluted; molded black phenolic; for 1/4" diam shaft; mts by two #10-32 set screws spaced 90° apart on hub; 1-5/8" OD by 3/4" thk; brass insert; shaft hole 9/16" deep	"Output Atten" knob for RF output attenuator	+Kurz-Kasch #S-309-64-B-BB Hewlett-Packard 19M-E-326-4	+Federal Mfg. & Eng. Corp KNB-124 Hewlett-Packard dwg #19M-E-326-4
E-152		KNOB: same as E-151	"Power Set" knob for con- trol of E-122 bolometer		
E-153	3300-292241402 R16-K-3373-55 2Z5822-230 N16-K-700277-371	KNOB: round, friction grip; molded black phenolic; for 1/4" diam shaft; mts by two #8-32 set screws spaced 90° apart; 5/8" OD by 3/8" thk overall; shaft hole 5/16" deep	Locking knob for RF "Out- put Atten" control	+Kurz-Kasch #S-230-64-BB Hewlett-Packard 19M-E-326-5	+Federal Mfg. & Eng. Corp KNB-127 Hewlett-Packard dwg #19M-E-326-5
E-154		KNOB: same as E-153	Locking knob for "Power Set" control		

<p>E-161 R16-FME-310-84 </p>	<p>..... R16-FME-310-84 </p>	<p>SUB-ASSEMBLY: c/o one tube socket, Amphenol part/dwg #78-S8TM, one socket housing assembly, Federal Mfg & Eng Corp dwg #310-122, three RF filter assemblies, Federal Mfg & Eng Corp dwg #310-58, three pieces of wire, Federal Mfg & Eng Corp dwg numbers, WIR-11, WIR-13, WIR-14, and two lengths of wire, Federal Mfg & Eng Corp dwg #WIR-4; irregular shape; approx o/a dim 2-9/32" lg x 1-3/4" wd x 3" h; RF filters are mounted in socket housing by set screws</p>	<p>Socket and shield for Klystron tube</p>	<p>+Federal Mfg. & Eng. Corp 310-84</p>	<p>+Federal Mfg. & Eng. Corp 310-84</p>
<p>E-162 R16-FME-310-150 </p>	<p>..... R16-FME-310-150 </p>	<p>CONTACT, electron tube: grid contact ring; brass, silver plated; semi-circular ring shape; 1.480" lg x 0.740" wd x 0.060" thk o/a; force fitted int surface has radial grooving 0.023" wd x 0.095" deep; used in pairs, p/o E-142F</p>	<p>Grid contact ring</p>	<p>+Federal Mfg. & Eng. Corp 310-150</p>	<p>+Federal Mfg. & Eng. Corp 310-150</p>
<p>E-163 R16-FME-310-151 </p>	<p>..... R16-FME-310-151 </p>	<p>CONTACT, electron tube: beryllium copper, silver plated; circular ring shape; 1.444" OD x 1.020" ID x 0.039" thk o/a; mechanically held in place; used in pairs, p/o E-142F</p>	<p>Grid contact plate</p>	<p>+Federal Mfg. & Eng. Corp 310-151</p>	<p>+Federal Mfg. & Eng. Corp 310-151</p>
<p>E-164 R16-FME-310-152 </p>	<p>..... R16-FME-310-152 </p>	<p>CONTACT, electron tube: beryllium copper, silver plated; circular ring shape; 1.444" OD x 1.020" ID x 0.031" thk o/a; mechanically held in place; 24 radial slots 1/64" wd x approx 11/32" lg spaced 15 deg apart on inner perimeter; used in pairs, p/o E-142F</p>	<p>Grid contact fingers</p>	<p>+Federal Mfg. & Eng. Corp 310-152</p>	<p>+Federal Mfg. & Eng. Corp 310-152</p>
<p>E-165 R16-FME-310-180 </p>	<p>..... R16-FME-310-180 </p>	<p>PROBE, RF: bolometer type; c/o one bead type resistor, WECo spec #D-166382, two powdered Federal Mfg. & Eng. Corp iron cores, Federal Mfg. & Eng. Corp dwg #CPI-6, one bolometer Federal Mfg. & Eng. Corp contact, Federal Mfg. & Eng. Corp dwg #310-171 one center Federal Mfg. & Eng. Corp tube, Federal Mfg. & Eng. Corp dwg #310-174 one tube, Federal Mfg. & Eng. Corp dwg #310-175 one cap and Federal Mfg. & Eng. Corp shoulder, Federal Mfg. & Eng. Corp dwg #310-179 one wire, Federal Mfg. & Eng. Corp dwg #WIR-11 one shielding, Federal Mfg. & Eng. Corp braid, Federal Mfg. & Eng. Corp dwg #SHB-2 one shielding, Federal Mfg. & Eng. Corp braid, Federal Mfg. & Eng. Corp dwg #SHB-3;</p>	<p>Complete power absorbing assembly for RF power monitoring of V-111</p>	<p>+Federal Mfg. & Eng. Corp 310-180</p>	<p>+Federal Mfg. & Eng. Corp 310-180</p>

TABLE 6-1.—TABLE OF REPLACEABLE PARTS (Contd)

MODEL: SIGNAL GENERATOR TS-403/U

MAJOR ASSEMBLY: SIGNAL GENERATOR TS-403/U (Less Accessories)

REF. SYMBOL	USAF STOCK NO. ASO STOCK NO. SIG C. STOCK NO. NAVY STOCK NO.	NAME OF PART AND DESCRIPTION	FUNCTION	MFR. AND DESIG. OR JAN TYPE	CONT. OR GOV. DWG. OR SPEC. NO.
E-165 (Contd)		frequency range 1800 to 4000 megacycles, bead thermistor detector; irregular shape; approx 8-1/2" lg when extended; held in place by collar one end and flexible terminal wire soldered other end; includes E-122			
E-166 R16-FME-310-191	INSULATOR, bead: cylindrical shape; Teflon material, grade, color, and finish not specified; 0.5" lg o/a; voltage rating not specified; 0.404" OD x 0.125" min ID; one axial hole drilled through 0.125" diam counterbored 0.335" diam to depth of 0.028" on one end	Dielectric support for coaxial attenuator contact connector	+Federal Mfg. & Eng. Corp 310-191	+Federal Mfg. & Eng. Corp 310-191
E-167 R16-FME-310-235	CONTACT, cavity body: beryllium copper, silver flash finish; circular ring shape; 1.696" OD x 0.987" ID x 45/64" lg o/a, brazed to contacts Federal Mfg & Eng Corp dwg #310-236 and #310-237; three axial holes 0.120" diam spaced 120 degrees apart on 0.672" radius, axial groove on one side 37/64" deep x 0.2645" wd; p/o E-142M (for identification only - not a replaceable part)	Part of contact wiper assembly	+Federal Mfg. & Eng. Corp 310-235	+Federal Mfg. & Eng. Corp 310-235
E-168 R16-FME-310-236	CONTACT, cavity inner: silver, finish not specified; circular split ring shape; 0.990" max OD x 5/32" lg o/a; brazed to contact ring Federal Mfg & Eng Corp dwg #310-235, ext surface of ring chamfered 2 deg, split in ring 0.010" max wd; p/o E-142M (for identification only - not a replaceable part)	Part of contact wiper assembly	+Federal Mfg. & Eng. Corp 310-236	+Federal Mfg. & Eng. Corp 310-236
E-169 R16-FME-310-237	CONTACT, cavity outer: silver, finish not specified; circular split ring shape; 1.817" OD x 1.693" ID x 5/32" lg o/a; brazed to contact ring, Federal Mfg & Eng Corp dwg #310-235 int surface of ring chamfered 2 deg, split in ring 0.010 max wd; p/o E-142M (for identification only - not a replaceable part)	Part of contact wiper assembly	+Federal Mfg. & Eng. Corp 310-237	+Federal Mfg. & Eng. Corp 310-237

<p>E-170</p> <p>..... R16-FME-310-425</p>	<p>STRIP, slotted, grounding: grounds panel to cabinet assembly; beryllium copper, silver plated; topview rectangular shape, 8-1/16" lg x approx 31/32" wd, end view 45 deg angle break 1/2" from one edge; mounts by eight holes 3/16" diam irregularly spaced 1/4" from edge; semi-circular cut-out approx 3/8" radius on opposite edge 4-1/4" from one end, slots 0.04" wd x 11/32" lg spaced 3/16" apart along entire length of edge having semi-circular cut-out (for identification only - not a replaceable part)</p>	<p>Grounds cabinet to front panel</p>	<p>+Federal Mfg. & Eng. Corp 310-425</p>	<p>+Federal Mfg. & Eng. Corp 310-425</p>
<p>E-171</p> <p>..... R16-FME-310-426</p>	<p>STRIP, slotted, grounding: grounds panel to cabinet assembly; beryllium copper, silver plated; top view rectangular shape, 8-1/16" lg x approx 31/32" wd, end view 45 deg angle break 1/2" from one edge; mounts by eight holes 3/16" diam irregularly spaced 1/4" from edge; semi-circular cut-out approx 3/8" radius one opposite edge 3-13/16" from one end, slots 0.04" wd x 11/32" lg spaced 3/16" apart along entire length of edge having semi-circular cut-out (for identification only - not a replaceable part)</p>	<p>Grounds cabinet to front panel</p>	<p>+Federal Mfg. & Eng. Corp 310-426</p>	<p>+Federal Mfg. & Eng. Corp 310-426</p>
<p>E-172</p> <p>..... R16-FME-310-427</p>	<p>STRIP, slotted, grounding: grounds panel to cabinet assembly; beryllium copper, silver plated; top view rectangular shape, 11-7/8" lg x approx 31/32" wd, end view 45 deg angle break 1/2" from one edge; mounts by ten holes 3/16" diam irregularly spaced 1/4" from edge; two semi-circular cut-outs approx 3/8" radius each 1-15/16" from each end, slots 0.04" wd x approx 11/32" lg spaced 3/16" apart along entire length of edge having semi-circular cut-outs (for identification only - not a replaceable part)</p>	<p>Grounds cabinet to front panel</p>	<p>+Federal Mfg. & Eng. Corp 310-427</p>	<p>+Federal Mfg. & Eng. Corp 310-427</p>
<p>E-173</p>	<p>STRIP, slotted, grounding: same as E-170</p>	<p>Grounds cabinet to front panel</p>		
<p>E-174</p>	<p>STRIP, slotted, grounding: same as E-171</p>	<p>Grounds cabinet to front panel</p>		
<p>E-175</p>	<p>STRIP, slotted, grounding: same as E-172</p>	<p>Grounds cabinet to front panel</p>		
<p>F-101</p> <p>8800-360982 R17-F-14270-45</p>	<p>FUSE, cartridge: rated 2 amp; slow blowing; opens in 25 sec at 200% overload, 8 sec at 300% and 3 sec at 500%; 25 v max rating; one time; glass body; nickel pl ferrule cap term; 1/4" OD by 1-1/4" lg</p>	<p>Power line fuse</p>	<p>+Buss #MDL2 Type 3AG</p>	<p>+Federal Mfg. & Eng. Corp FUS-19 Hewlett-Packard dwg #19M-S-724</p>

TABLE 6-1.—TABLE OF REPLACEABLE PARTS (Contd)

MODEL: SIGNAL GENERATOR TS-403/U

MAJOR ASSEMBLY: SIGNAL GENERATOR TS-403/U (Less Accessories)

REF. SYMBOL	USAF STOCK NO. ASO STOCK NO. SIG C. STOCK NO. NAVY STOCK NO.	NAME OF PART AND DESCRIPTION	FUNCTION	MFG. AND DESIG. OR JAN TYPE	CONT. OR GOV. DWG. OR SPEC. NO.
F-102		FUSE, cartridge: same as F-101	Power line fuse		
F-106		FUSE, cartridge: same as F-101	Spare on panel		
F-107		FUSE, cartridge: same as F-101	Spare on panel		
H-101	3300-677626812 R16-T-3233 6R7443-8	TOOL, special purpose: rod shaped extractor tool; special purpose; medium knurl on one end, tapped for #4-40 thread on other end; cold rolled steel, nickel pl; 3/8" OD by 3" lg overall; mtd in special holder on chassis when not in use	To remove Klystron tube V-111 from resonant cavity	+Federal Mfg. & Eng. Corp WRE-6 Hewlett-Packard 19M-S-723	+Federal Mfg. & Eng. Corp WRE-6 Hewlett-Packard dwg #19M-S-723
H-102	7900-859490 G41-W-2446	WRENCH: Allen Key set-screw type; 5/64" max distance across flats; 45/64" max lg of short arm, 1-31/32" max length of long arm; alloy steel; cad pl; 90° bend between long and short arms	Wrench for #8 Allen-head set-screw	Allen Mfg. Code #564	+Federal Mfg. & Eng. Corp WRE-4 Hewlett-Packard dwg #19M-S-770
H-103	7900-859480 G41-W-2444	WRENCH: Allen key set-screw type; 0.050" max distance across flats; 21/32" max lg of short arm, 1-27/32" max lg of long arm; alloy steel cad pl; 90° bend between long and short arms	Wrench for #3, #4 Allen-head set-screw	Allen Mfg Code #050	+Federal Mfg. & Eng. Corp WRE-3 Hewlett-Packard dwg #19M-S-771
H-104	7900-859500 G41-W-2449	WRENCH: Allen key set-screw type; 3/32" max distance across flats; 3/4" max lg of short arm, 2-3/32" max lg of long arm; alloy steel cad pl; 90° bend between long and short arms	Wrench for #10, #12 Allen-head set-screw	Allen Mfg. Code #332	+Federal Mfg. & Eng. Corp WRE-5 Hewlett-Packard dwg #19M-S-772
*H-105	3300-298390107 R16-W-3130 2Z8076-107	WINDOW, indicator: transparent lucite; 40° segment between 13/16" and 1-3/4" radius arcs; 1/16" thk; two #44 drill mtg holes on 1-5/8" radius, spaced 7/8" apart; black indicator line scribed down radial center line	Pointer fiducial for attenuator control dial I-104	+Federal Mfg. & Eng. Corp 310-273 Hewlett-Packard 19M-E-324-6	+Federal Mfg. & Eng. Corp 310-273 Hewlett-Packard dwg #19M-E-324-6
		* Not furnished as a maintenance part for Bureau of Ships activities. If failure occurs do not request replacement unless the item cannot be repaired or fabricated.			

*H-106	3300-298390100 R16-W-3140 2Z8076-106	WINDOW, indicator: transparent lucite; 2-1/4" lg by 2" wd by 1/16" thk overall; three tapped mtg holes for #2-56 screws on 1-1/2" by 2" mtg/c indicator line scribed down center line; engraved "MEGACYCLES"	Frontal indicator for signal freq control dial I-105	Federal Mfg. & Eng. Corp 310-275 Hewlett-Packard 19M-E-324-8	Federal Mfg. & Eng. Corp 310-275 Hewlett-Packard dwg #19M-E-324-8
H-107 R16-FME-310-124 6L20924-24, 1S 43-S-4799-9292	SCREW, captive: stainless steel; pas- sivate finish; slot drive; overall dim; 1-1/2" lg by 1/2" dia; knurled heads 3/8" thk by 1/2" dia; 1/4-20 NC-2 thds by 9/16" lg; captive type; used in front panel-dust cover assembly	For holding dust cover (cabinet) to front panel	+ Federal Mfg. & Eng. Corp 310-124	+ Federal Mfg. & Eng. Corp 310-124
H-107	SCREW, captive: stainless steel; pas- sivate finish; slot drive; overall dim; 1-1/2" lg by 1/2" dia; knurled head 3/8" thk by 1/2" dia; shank relieved to 0.1875" dia; 17/32" lg; 1/4-20 NC-2 thds by 9/16" lg; captive type; used in front panel-dust cover assembly	For holding dust cover (cabinet) to front panel	eModel Eng. Part #789-A-6650	eModel Eng. Part #789-A-6650
H-107A		SCREW, captive: same as H-107	For holding dust cover to front panel		
H-107B		SCREW, captive: same as H-107	For holding dust cover to front panel		
H-107C		SCREW, captive: same as H-107	For holding dust cover to front panel		
H-107D		SCREW, captive: same as H-107	For holding dust cover to front panel		
H-107E		SCREW, captive: same as H-107	For holding dust cover to front panel		
H-107F		SCREW, captive: same as H-107	For holding dust cover to front panel		
H-107G		SCREW, captive: same as H-107 * Not furnished as a maintenance part for Bureau of Ships activities. If failure occurs, do not request replacement unless the item cannot be repaired or fabricated.	For holding dust cover to front panel		

TABLE 6-1. -TABLE OF REPLACEABLE PARTS (cont)

MODEL: SIGNAL GENERATOR TS-403/U

MAJOR ASSEMBLY: SIGNAL GENERATOR TS-403/U (Less Accessories)

REF. SYMBOL	USAF STOCK NO. ASO STOCK NO. SIG C. STOCK NO. NAVY STOCK NO.	NAME OF PART AND DESCRIPTION	FUNCTION	MFG. AND DESIG. OR JAN TYPE	CONT. OR GOV. DWG. OR SPEC. NO.
I-101	3300-291396086 R16-D-2262 2Z3723-34	DIAL: consists of 1/16" thk aluminum disc dial rigidly attached to 1-1/8" OD fluted phenolic knob; 1-3/4" OD by 11/16" h overall; single axial mtg hole for 1/4" shaft; held by two #8-32 by 1/8" lg Allen head set screws spaced 90° apart; dial calibrated in pulses per sec from 40 to 400	"PULSE RATE" control dial for R-109	+ Federal Mfg. & Eng. Corp 310-293 Hewlett-Packard 19M-M-743	+ Federal Mfg. & Eng. Corp 310-293 Hewlett-Packard dwg #19M-M-743
I-102	3300-291396085 R16-D-2262-200 2Z3723-33	DIAL: consists of 1/16" thk aluminum disc dial rigidly attached to 1-1/8" OD fluted phenolic knob; 1-3/4" OD by 11/16" h overall; single axial mtg hole for 1/4" shaft, held by two #8-32 by 1/8" lg Allen head set screws spaced 90° apart; dial calibrated in u sec from "MIN" to 10	"PULSE WIDTH" control dial for R-124	+ Federal Mfg. & Eng. Corp 310-294 Hewlett-Packard 19M-M-741	+ Federal Mfg. & Eng. Corp 310-294 Hewlett-Packard dwg #19M-M-741
I-103	3300-291396084 R16-D-2262-300 2Z3723-32	DIAL: consists of 1/16" thk aluminum disc dial rigidly attached to 1-1/8" OD fluted phenolic knob; 1-3/4" OD by 11/16" h overall; single axial mtg hole for 1/4" shaft, held by two #8-32 by 1/8" lg Allen head set screws spaced 90° apart; dial calibrated in u sec from 3 to 300; located on front panel	"PULSE DELAY" control dial for R-116	+ Federal Mfg. & Eng. Corp 310-292 Hewlett-Packard 19M-M-742	+ Federal Mfg. & Eng. Corp 310-292 Hewlett-Packard dwg #19M-M-742
*I-104	3300-291396083 R16-D-2262-400 2Z3723-31	DIAL: consists of a 2.950" OD by 1/16" thk aluminum disc dial and hub mtd within aluminum index disc with raised ring around OD and indicating window H-104; 3-1/2" OD by 17/32" thk overall; dial hub contains single 0.500" diam mtg hole and two #8-32 Allen head set screws spaced 90° apart * Not furnished as a maintenance part for Bureau of Ships activities. If failure occurs, do not request replacement unless the item cannot be repaired or fabricated.	Power level and output attenuator control dial for E-122 and E-101	+ Federal Mfg. & Eng. Corp 310-377 Hewlett-Packard 19M-M-738	+ Federal Mfg. & Eng. Corp 310-377 Hewlett-Packard dwg #19M-M-738

TABLE 6-1. -TABLE OF REPLACEABLE PARTS (cont)

MODEL: SIGNAL GENERATOR TS-403/U

MAJOR ASSEMBLY: SIGNAL GENERATOR TS-403/U (Less Accessories)

REF. SYMBOL	USAF STOCK NO. ASO STOCK NO. SIG C. STOCK NO. NAVY STOCK NO.	NAME OF PART AND DESCRIPTION	FUNCTION	MFG. AND DESIG. OR JAN TYPE	CONT. OR GOV. DWG. OR SPEC. NO.
*I-104 (cont)		around hub, index disc contains single 1.001" diam mtg hole; dial and index disc mtd independently; dial pre-calibrated in two concentric scales with outer marked "DECIBELS BELOW ONE MILLIWATT" in db from 0 to 127, inner scale marked "MICROVOLTS" and "MILLIVOLTS," calibrated from 1 uv to 200 mv; included I-104A, I-104B, H-105			
I-104A R16-FME-310-167 2Z3723-31 N16-S-117101-792	DIAL: 1 microvolt to 200 millivolts clockwise, 0 to 127 decibels counter-clockwise; 2.950" diam by 3/8" thk; 0.629" dia center hole; aluminum, satin finish; shaft mounted by integral hub; p/o I-104	Attenuator dial	+ Federal Mfg. & Eng. Corp 310-167	+ Federal Mfg. & Eng. Corp 310-167
*I-104B 2Z7090-378 N16-P-402001-110	PLATE, dial: rigid plate 3-1/2" OD by 2.280" thk overall; 2.974" diam bore by 0.216" deep aluminum, anodized; mounted by two #2-56 holes and retained by 1.002" diam center hole; p/o I-104 * Not furnished as a maintenance part for Bureau of Ships activities. If failure occurs, do not request replacement unless the item cannot be repaired or fabricated.	For mounting dial I-104A	+ Federal Mfg. & Eng. Corp 310-271	+ Federal Mfg. & Eng. Corp 310-271

AN 16-30URM61-3

Section VI

I-105	3300-291396081 R16-D-2445-250 2Z3723-29	DIAL: aluminum disc dial; 4-15/16" OD by 14 ga thk; friction plate; mtd by single 3/4" diam hole in center; calibrated in two concentric scales, inner scale arbitrary linear from 0 to 15, outer scale calibrated from 1800 to 4000 mc	Signal freq control dial	+Federal Mfg. & Eng. Corp 310-285 Hewlett-Packard 19M-E-328-5	+Federal Mfg. & Eng. Corp 310-285 Hewlett-Packard dwg #19M-E-328-5
I-106	3300-291396082 R16-D-2262-100 2Z3723-30	DIAL: consists of 1/16" thk aluminum disc dial rigidly attached to 1-5/8" OD fluted phenolic knob; 2-1/2" OD by 13/16" thk overall; single axial mtg holes for 1/4" shaft held by two #8-32 by 1/8" lg Allen head set screws spaced 90° apart; dial precalibrated with linear scale from 0 to 100 twice over 360° circumference	Vernier freq control dial	+Federal Mfg. & Eng. Corp 310-279 Hewlett-Packard 19M-M-735	+Federal Mfg. & Eng. Corp 310-279 Hewlett-Packard dwg #19M-M-735
*I-107	8800-529202-77 R17-L-12932-248 2Z5991-190 N17-L-76854-4084	LIGHT, indicator: with lens; approx 1/2" diam red smooth lens sandblasted on back; miniature bay base T-3-1/4 bulb 6-8v, 15 amp; enclosed molded phenolic shell; black nickel pl face; 25/32" diam by 2-1/4" lg overall; 11/16" diam mtg hole required; horizontally mtd socket, lamp replaceable from front of panel; threaded jewel; two solder lug term projecting from base; includes I-107A, I-107B	Holds and provides electrical contact for E-136 "POWER" pilot lamp	Dialco 81410-111	+Federal Mfg. & Eng. Corp LGI-7 Hewlett-Packard dwg #19M-S-708
I-107A R17-C-1955 2Z6125-196 N17L-250627-817	LENS, indicator light: red, smooth glass; non-focusing; 11/16" lg by 5/8" diam overall; mounts by 1/2" diam; 11/16"-27 thd, external, 0.140" lg; p/o I-107	Lens for I-107	+Federal Mfg. & Eng. Corp LGI-7-1	+Federal Mfg. & Eng. Corp LGI-7-1
I-107B 2Z5884-109 N17-L-76656-2486	LAMPHOLDER: molded phenolic; 2-5/16" lg by 13/16" diam; 125 volts, 75 watts; two solder lug type terms; 1/2" diam internal thread for mounting lens holder; p/o I-107	Panel light socket holder p/o I-107	+Federal Mfg. & Eng. Corp LGI-7-2	+Federal Mfg. & Eng. Corp LGI-7-2
*I-108	8800-529143 R17-L-12932-248-10 2Z5991-332 N17-L-76737-2634	LIGHT, indicator with lens; approx 1/2" diam clear smooth lens sandblasted on back; miniature bay base T-3-1/4 bulb; 6-8 v, 15 amp; enclosed molded phenolic shell black nickel pl face; 25/32" diam by 2-1/4" long overall; 11/16" diam mtg hole reqd; horizontally mtd socket, lamp replaceable from front of panel; threaded jewel; two solder lug term projecting from base, includes I-108A and I-108B * Not furnished as a maintenance part for Bureau of Ships activities. If failure occurs, do not request replacement unless the item cannot be repaired or fabricated.	Holds and provides electrical contact for E-135 "HEATER" pilot lamp	Dialco 81410-117	+Federal Mfg. & Eng. Corp LGI-8

TABLE 6-1.—TABLE OF REPLACEABLE PARTS (Contd)

MODEL: SIGNAL GENERATOR TS-403/U

MAJOR ASSEMBLY: SIGNAL GENERATOR TS-403/U (Less Accessories)

REF. SYMBOL	USAF STOCK NO. ASO STOCK NO. SIG C. STOCK NO. NAVY STOCK NO.	NAME OF PART AND DESCRIPTION	FUNCTION	MFR. AND DESIG. OR JAN TYPE	CONT. OR GOV. DWG. OR SPEC. NO.
I-108A R17-L-8532-5 2Z6125-195 N17-L-250843-526	LENS: indicator light; clear smooth glass; non-focusing; 11/16" lg by 5/8" diam; mounted in lensholder by threaded 1/2" diam 11/16-27 external thd, 0.140" lg; p/o I-108	Lens for I-108	+Federal Mfg. & Eng. Corp LGI-8-1	+Federal Mfg. & Eng. Corp LGI-8-1
I-108B 2Z5884-109 N17-L-76656-2486	LAMPHOLDER: molded phenolic; 2-5/16" lg by 13/16" diam; 125 volts, 75 watts; two solder lug type term; 1/2" diam internal thread for mounting lens holder; p/o I-108	Panel light socket holder p/o I-108	+Federal Mfg. & Eng. Corp LGI-8-2	+Federal Mfg. & Eng. Corp LGI-8-2
*J-101	3300-322864945 R16-C-3761-100 3E7350-2.17	CABLE ASSEMBLY, special purpose: JAN type UG-291/U; includes 3/4" OD attached cylindrical case containing one 1/4" OD by 1-1/2" lg powdered iron core for suppressing RF; also includes approximately 17-1/4" of RG-58/U cable attached to cylindrical case; includes J-101A, J-101B, J-101C	"SYNC IN" jack, filter, and cable	+Federal Mfg. & Eng. Corp 310-37 Hewlett-Packard 19M-M-744	+Federal Mfg. & Eng. Corp 310-37 Hewlett-Packard dwg #19M-M-744
J-101A R16-R-2435-1 N17-C-73108-1262	CONNECTOR, receptacle: straight; female; 1-1/32" lg by 11/16" wide by 11/16" high; cylindrical; brass, silver plate; JAN type UG-291/U locking type; Teflon insert; RF impedance 50 ohms; 0.195" diam max cable opening; mounts by 4 holes 0.109" diam, 1/2" c to c; 3/8" hex nut on threaded portion; p/o RF attenuator	"SYNC IN" jack	JAN UG-291/U	+Federal Mfg. & Eng. Corp. CON-19
J-101B N15-C-12201-50	CABLE, RF: shielded, approx 20" lg inner conductor no. 20 AWG with black vinyl jacket; 0.195" diam overall; 52.0 ohms nominal impedance, 28.5 mmf capacitance per ft, 1900 v RMS max voltage rating; JAN type RG-58/U; p/o J-101 (for reference only)	Cable for J-101	JAN RG-58/U	+JAN C-17-A
*J-101C 2Z2935-237 N16-N-88601-1062	COLLAR, locking: brass, silver plated; 5/8" lg by 1/2" diam by 0.076" thk; cylindrical; p/o J-101	Connects filter to cable in J-101	+Federal Mfg. & Eng. Corp 310-62	+Federal Mfg. & Eng. Corp 310-62
J-102		CABLE ASSEMBLY, special purpose: same as J-101 * Not furnished as a maintenance part for Bureau of Ships activities. If failure occurs, do not request replacement unless the item cannot be repaired or fabricated.	"SYNC OUT" jack, filter, and cable		

J-103	CABLE ASSEMBLY, special purpose: JAN type UG-291/U includes 3/4" OD attached cylindrical case containing one 1/4" OD by 1-1/2" lg powdered iron core for suppressing RF; also includes approximately 13-1/4" of RG-58/U cable attached to cylindrical case; includes E-102, J-101A, J-101B, J-101C	"EXT MOD" jack, filter, and cable	+Federal Mfg. & Eng. Corp 310-333	+Federal Mfg. & Eng. Corp 310-333
J-104	CABLE ASSEMBLY, special purpose: JAN type UG-291/U; includes 3/4" OD attached cylindrical case containing one 1/4" OD by 1-1/2" lg powdered iron core for suppressing RF; also includes approximately 19-3/4" of RG-58/U cable attached to cylindrical case; includes E-102, J-101A, J-101B, J-101C	"DELAYED SYNC OUT" jack, filter, and cable	+Federal Mfg. & Eng. Corp 310-334	+Federal Mfg. & Eng. Corp 310-334
J-105	3300-287350478 R16-FME-SUB-9 2Z3062-169	CONNECTOR, receptacle: coaxial; RF; 50 ohms impedance; cylindrical body with square flange; brass, silver plated; 1/2" diam teflon insert 0.250" thk; 1-5/16" lg by 1" wide by 1" high; mounted by four No. 4-40 threaded holes; 0.328" diam max cable opening; contains female contact I.P.C. No. 5703	"RF OUTPUT" connector	+Federal Mfg. & Eng. Corp SUB-9 Hewlett-Packard 19M-M-727	+Federal Mfg. & Eng. Corp SUB-9 Hewlett-Packard dwg #19M-M-727
L-101	3300-308026500 R16-R-1645 3C571	REACTOR: filter choke; 8-10 hy, 150 ma; approx 250 ohms DC resistance; 1750 v RMS test; hermetically sealed metal case; 3-3/16" lg by 3" wd by 3-1/4" h, excluding term; four #8-32 by 3/8" lg mtg screws on 2-3/8" by 2-1/8" mtg/c; two ceramic-insulated solder lug term on bottom	Power supply filter choke	Chi Trans 11156-B	+Federal Mfg. & Eng. Corp 310-69 +JAN-T-27 Grade 1 Class A Hewlett-Packard dwg #19M-M-504
M-101	3300-326451998 R16-M-1920 3F3299-6.1 17M-22753-9477	METER, ammeter: DC; range -6 to +3 dbm; round, metal, flush mtg, hermetically sealed case; 3.500" diam flange by 2.675" diam body by 1.063" d behind flange; accuracy $\pm 2\%$; 0-200 microampere D'Arsonval movement; 75 ohms resistance across term; calibrated for non-magnetic panel; 9 scale divisions, black numerals on white background; self contained; three mtg holes 0.150" diam on radius of 1.58" spaced 120° apart on flange; two solder lug term 1/2" lg, spaced 1" c to c; special "ZERO SET" and "POWER SET" scale markings in red	Power level indicating meter for RF power monitoring bridge	JAN MR36W200DCUA with special scale	+Federal Mfg. & Eng. Corp 310-315 JAN-I-6 Hewlett-Packard dwg #19M-L-507

TABLE 6-1.—TABLE OF REPLACEABLE PARTS (Contd)

MODEL: SIGNAL GENERATOR TS-403/U

MAJOR ASSEMBLY: SIGNAL GENERATOR TS-403/U (Less Accessories)

REF. SYMBOL	USAF STOCK NO. ASO STOCK NO. SIG C. STOCK NO. NAVY STOCK NO.	NAME OF PART AND DESCRIPTION	FUNCTION	MFR. AND DESIG. OR JAN TYPE	CONT. OR GOV. DWG. OR SPEC. NO.
*O-101	3300-696293615 R16-S-3855 6Z3423-2	SHAFT ASSEMBLY: consists of aluminum shaft with coupler heads on ea end; approx 3/4" OD by 7-3/4" lg overall; coupler heads mtg to 1/4" OD shafts by two #8-32 by 1/8" lg Allen set screws spaced 90° apart in each head	Couples R-109 to panel control I-101	+Federal Mfg. & Eng. Corp 310-371 Hewlett-Packard 19M-M-732	+Federal Mfg. & Eng. Corp 310-371 Hewlett-Packard dwg #19M-M-732
O-102		SHAFT ASSEMBLY: same as O-101	Couples R-124 to panel control I-102		
O-103		SHAFT ASSEMBLY: same as O-101	Couples R-116 to panel control I-103		
O-104		SHAFT ASSEMBLY: same as O-101	Couples S-101 to panel control E-146		
O-105		SHAFT ASSEMBLY: same as O-101	Couples S-103 to panel control E-147		
O-106	3300-291697089 R16-C-19628 2Z5042-4	CLAMP, tube: tension lock type; stainless steel; 1-1/4" diam by 3/4" h overall; "L" shaped mtg bracket with single mtg hole for #10 mach screw	Holds tube V-101 in position	Birtcher 926-B	+Federal Mfg. & Eng. Corp CLA-54 Hewlett-Packard dwg #19M-S-753
O-107		CLAMP, tube: same as O-106	Holds tube V-105 in position		
O-108		CLAMP, tube: same as O-106	Holds tube V-117 in position		
O-109	3300-287172845 R16-C-19582 2Z2636-26	CLAMP, tube: tension lock type; stainless steel; 1-3/8" diam by 3/4" h overall; "L" shaped mtg bracket with single mtg hole for #10 mach screw	Holds tube V-109 in position	Birtcher 926-C	+Federal Mfg. & Eng. Corp CLA-53 Hewlett-Packard dwg #19M-S-754
O-110		CLAMP, tube: same as O-109	Holds tube V-115 in position		
O-111		CLAMP, tube: same as O-109	Holds tube V-116 in position		
O-112	3300-298303130 R16-C-4683-300 2Z3350-123	CAP: consists of pin locking type coaxial connector cap and attached chain; JAN type CW-123/U; free end of chain held by #4-40 screw *Not furnished as a maintenance part by Bureau of Ships activities. If failure occurs, do not request replacement unless the item cannot be repaired or fabricated.	Provides protection for J-101 opening	JAN CW-123/U	+Federal Mfg. & Eng. Corp CAC-2

O-113		CAP: same as O-112	Provides protection for J-102 opening		
O-114		CAP: same as O-112	Provides protection for J-103 opening		
O-115		CAP: same as O-112	Provides protection for J-104 opening		
*O-116	3300-298320100 R16-D-4535 2Z3876.104	DRIVE, tuning: consists of an aluminum casting with gear trains and control shaft with sensitive switch S-102 and oscillator drive housing mtd thereon; approx 9-1/2" lg by 7-1/4" wd by 5" d overall; excluding 1/4" OD by 1-1/4" lg steel drive shaft; 1/4" OD by 17/32" lg shaft provided for dial I-105; mts by two #8-32 screws on 8-3/4" mtg/c; p/o E-142	Main freq drive assembly	+Federal Mfg. & Eng. Corp 310-400 Hewlett-Packard 19M-E-755	+Federal Mfg. & Eng. Corp 310-400 Hewlett-Packard dwg #19M-E-755
*O-116A	3300-298345250 R16-FME-310-251 2Z4878-497	GEAR: spur type; nickel pl brass; straight teeth; 16 teeth; 32 pitch, 0.50" PD, 14-1/2° pressure angle; 9/16" OD by 1/8" thk, 0.250" bore, straight face; 7/16" OD hub extends 5/16" from gear face; hub drilled and tapped for two #8-32 set screws spaced 90° apart	Oscillator drive pinion (Used in O-116)	+Federal Mfg. & Eng. Corp 310-251 Hewlett-Packard 19M-E-316-4	+Federal Mfg. & Eng. Corp 310-251 Hewlett-Packard dwg #19M-E-316-4
*O-116B	3300-298345249 R16-FME-310-252 2Z4878-496	GEAR: spur type; nickel pl brass; straight teeth; 16 teeth; 32 pitch 0.50" PD, 14-1/2° pressure angle; 9/16" OD by 1/8" thk, 0.250" bore; straight face; 7/16" OD hub extends 5/16" from gear face; #52 drill hole 3/16" d in hub face on 3/16" radius	Oscillator drive pinion (Used in O-116)	+Federal Mfg. & Eng. Corp 310-252 Hewlett-Packard 19M-E-316-5	+Federal Mfg. & Eng. Corp 310-252 Hewlett-Packard dwg #19M-E-316-5
*O-116C	3300-298345251 R16-FME-310-416 2Z4878-498	GEAR: spur type; nickel pl brass; straight teeth; 18 teeth; 32 pitch, 9/16" PD, 14-1/2° pressure angle; 5/8" OD by 3/16" thk, 3/16" bore; straight face; press fitted and soldered to special hub 13/16" OD extending 1-1/2" beyond gear face, hub undercut and provided with 1/2"-20 by 1-1/8" lg thd, hub has one 1/16" diam stop pin hole on 5/16" radius	Main drive pinion and stop guide (Used in O-116)	+Federal Mfg. & Eng. Corp 310-416 Hewlett-Packard 19M-E-316-3	+Federal Mfg. & Eng. Corp 310-416 Hewlett-Packard dwg #19M-E-316-3
*O-116D	3300-297812011 R42-G-600-200 2Z11180.11 N16-W-900001-155	WORM, gear: hardened steel; 24 pitch double thd; 20° pressure angle; 0.2618" lead; 90° 28 lead angle; 1/2" PD; 13/16" face; 1/2" OD by 1-1/16" lg overall; axial hole for 1/4" shaft, 0.0935" hole in hub for retaining pin, modified for 4/o taper pin * Not furnished as a maintenance part for Bureau of Ships activities. If failure occurs, do not request replacement unless the part cannot be repaired or fabricated.	Drive gear worm, for R-173 (Used in O-116)	+Federal Mfg. & Eng. Corp GRW-2 Hewlett-Packard 19M-E-316-6	+Federal Mfg. & Eng. Corp GRW-2 Hewlett-Packard dwg #19M-E-316-6

TABLE 6-1.—TABLE OF REPLACEABLE PARTS (Contd)

MODEL: SIGNAL GENERATOR TS-403/U

MAJOR ASSEMBLY: SIGNAL GENERATOR TS-403/U (Less Accessories)

REF. SYMBOL	USAF STOCK NO. ASO STOCK NO. SIG C. STOCK NO. NAVY STOCK NO.	NAME OF PART AND DESCRIPTION	FUNCTION	MFR. AND DESIG. OR JAN TYPE	CONT. OR GOV. DWG. OR SPEC. NO.
*O-116E	3300-298245248 R16-FME-310-254 2Z4878-495	GEAR: worm type; nickel pl bronze; straight teeth; 20 teeth, 24 pitch double thd, 0.83" PD, 20° pressure angle; 0.83" OD, 0.250" bore by 1/4" thk; straight face; 5/8" OD by 5/16" lg; hub drilled and tapped for two #8-32 set screws spaced 90° apart	Worm gear for R-173 drive (Used in O-116)	+Federal Mfg. & Eng. Corp 310-254 Hewlett-Packard 19M-E-316-7	+Federal Mfg. & Eng. Corp 310-254 Hewlett-Packard dwg #19M-E-316-7
*O-116F	3300-298345248 R16-FME-310-248 2Z4878-491 N16-G-434048-346	GEAR: spur type; nickel pl brass; straight teeth, 160 teeth, 32 pitch, 5" PD, 14-1/2° pressure angle; 5-1/16" OD by 3/16" thk, 5/16" bore; straight face; hub 3/4" OD by 5/16" thk from gear face; hub press fitted and soldered disk drum 2-7/16" OD by 7/16" thk; drum and hub contain two #8-32 set screw holes spaced 90° apart	Coupling gear between R-173 drive and cavity drive (Used in O-116)	+Federal Mfg. & Eng. Corp 310-248 Hewlett-Packard 19M-E-316-1	+Federal Mfg. & Eng. Corp 310-248 Hewlett-Packard dwg #19M-E-316-1
*O-116G	3300-298345243 R16-FME-310-413 2Z4878-490 N16-G-432330-388	GEAR: spur type; nickel pl brass; straight teeth; 72 teeth; 32 pitch, 2-1/4" PD, 14-1/2° pressure angle; 2-5/16" OD by 3/16" thk, 5/16" bore; straight face; hub 5/8" OD by 5/16" thk from gear face; hub fitted and soldered to special disk drum 1-1/4" OD by 9/16" thk overall; drum and hub contain two #8-32 set screw holes spaced 90° apart	Drive gear for cavity adjustment assembly (Used in O-116)	+Federal Mfg. & Eng. Corp 310-413 Hewlett-Packard 19M-E-316-2	+Federal Mfg. & Eng. Corp 310-413 Hewlett-Packard dwg #19M-E-316-2
O-116H	3300-287696092 R16-C-35992-15 2Z3295-63	COUPLING, flexible: sliding action self-aligning type; coupling yokes, brass hubs, steatite insulating plate, modified rectangular shape; 7/8" lg x 7/8" wd, 11/16" to 7/8" thk depending on adjustment; supplied w/four #6-32 steel socket head set screws, two each side; couples 3/8" diam shaft to 1/4" diam shaft	Adapts to and insures alignment of shaft driving R-173 (Used in O-116)	+Federal Mfg. & Eng. Corp CUP-3 Hewlett-Packard 19M-S-745	+Federal Mfg. & Eng. Corp CUP-3 Hewlett-Packard dwg #19M-S-745
*O-116I	3300-657688770 R16-S-2234 6L18508-6.54	SCREW, thumb: slot drive; non-standard flat fillister type head 1/2" OD by 3/8" thk with med knurl around circumference; brass, nickel pl; #8-32; 1/2" lg thd; flat point	Holds cavity inner conductor in place within outer conductor (Used in O-116)	+Federal Mfg. & Eng. Corp 310-141 Hewlett-Packard 19M-E-319-5	+Federal Mfg. & Eng. Corp 310-141 Hewlett-Packard dwg #19M-E-319-5
		* Not furnished as a maintenance part for Bureau of Ships activities. If failure occurs, do not request replacement unless the part cannot be repaired or fabricated.			

O-116J	3300-295539021 R16-C-30577-250 2Z7855-4	CONTACT, cavity: consists of a circular piece of 0.006" thk beryllium copper with internal, formed contact fingers; silver pl; 2.735" OD by approx 1/4" thk overall; mts by four #18 drill holes spaced 90° apart around circumference on 1-3/16" radius	Grounds RF tuner carriage to oscillator drive housing of O-116	+Federal Mfg. & Eng. Corp 310-240 Hewlett-Packard 19M-E-334-7	+Federal Mfg. & Eng. Corp 310-240 Hewlett-Packard dwg #19M-E-334-7
O-116K	3300-656682770 R16-FME-310-211 6L73483M N16-W-922	WASHER, spring: beryllium copper, silver pl; round, 9/16" ID, 13/16" OD, 0.006" thk; 15° bend across center	Compression washer of gear drive for UHF cavity tuner E-142J (Used in O-116)	+Federal Mfg. & Eng. Corp 310-211 Hewlett-Packard 19M-E-317-14	+Federal Mfg. & Eng. Corp 310-211 Hewlett-Packard dwg #19M-E-317-14
O-117	3300-298342017 R17-G-1815 2Z4875-264	GEARCASE: consists of aluminum casting case with enclosed dual gear trains, two control and locking shafts and dial shaft with bushing to provide independent control by each gear train; 7-7/8" lg by 4-3/8" wd by 3-3/4" thk overall excluding two 1/4" diam by 1-3/8" lg control shafts; mts by four #8-32 tapped holes on 3-11/16" by 4-1/8" mtg/c	Attenuator and power monitoring control drive gear case	+Federal Mfg. & Eng. Corp 310-182 Hewlett-Packard 19M-E-113	+Federal Mfg. & Eng. Corp 310-182 Hewlett-Packard dwg #19M-E-113
*O-117A	3300-298345252 R16-G-2752 2Z4878-499	GEAR: spur type; nickel pl brass; straight teeth, 40 teeth; 48 pitch, 5/6" PD, 14-1/2° pressure angle; 0.781" OD by 1/8" thk, 0.251" bore; straight face; hub 1/2" OD by 15/64" thk 1/4" grooved drum against opposite gear face; 0.781" OD by 5/8" thk overall; hub contains two #8-32 tapped holes spaced 90° apart, drum contains one #4-40 tapped hole	Meshes with gear rack assembly O-123 to drive volometer assembly E-122 (Used in O-117)	+Federal Mfg. & Eng. Corp 310-424 Hewlett-Packard 19M-E-312-7	+Federal Mfg. & Eng. Corp 310-424 Hewlett-Packard dwg #19M-E-312-7
O-117B		GEAR: same as O-117A	Meshes with gear rack assembly O-125 to drive attenuator pick-up loop assembly E-101 (Used in O-117)		
O-118	3300-298298188 R16-FME-BPN-12 2Z1409-124 N16-B-800200-600	BEARING, sleeve; nickel pl brass; approx 1/2" OD by 1/4" ID by 1/2" lg overall, hex shoulder on one end, barrel has 3/8"-32 thd on OD, hex nut on thd barrel for mtg	Bearing for I-101 dial drive shaft	+Federal Mfg. & Eng. Corp BPN-1 19M-S-766	+Federal Mfg. & Eng. Corp dwg #BPN-1 dwg #19M-S-766
O-119		BEARING: same as O-118	Bearing for I-102 dial drive shaft		
O-120		BEARING: same as O-118	Bearing for I-103 dial drive shaft		
O-121		BEARING: same as O-118	Bearing for S-101 switch shaft		
		* Not furnished as a maintenance part for Bureau of Ships activities. If failure occurs, do not request replacement unless the part cannot be repaired or fabricated.			

TABLE 6-1.--TABLE OF REPLACEABLE PARTS (Contd)

MODEL: SIGNAL GENERATOR TS-403/U

MAJOR ASSEMBLY: SIGNAL GENERATOR TS-403/U (Less Accessories)

REF. SYMBOL	USAF STOCK NO. ASO STOCK NO. SIG C. STOCK NO. NAVY STOCK NO.	NAME OF PART AND DESCRIPTION	FUNCTION	MFR. AND DESIG. OR JAN TYPE	CONT. OR GOV. DWG. OR SPEC. NO.
O-122		BEARING: same as O-118	Bearing for S-103 switch shaft		
O-123	3300-298345247 R16-M-4576 2Z4878-494	MONITOR SUB-ASSEMBLY: spur type straight rack; nickel pl brass; straight teeth; 15.29 teeth per inch, 48 pitch; 14-1/2° pressure angle; 2-1/8" lg by 1/8" wd by 1/8" h; straight face; mtd to cylindrical holder by one #2-56 by 1/4" lg RHMS, holder 7/8" diam by 1/4" lg with 0.308" bore, 1-5/8" lg; below coil spring attached to holder; includes O-124	Drives bolometer assembly E-122	+Federal Mfg. & Eng. Corp 310-372 Hewlett-Packard 19M-M-736	+Federal Mfg. & Eng. Corp 310-372 Hewlett-Packard dwg #19M-M-736
*O-124	3300-299450335 R16-S-8450-30 2Z8879-235 N17-S-46761-7276	SPRING: Helical extension type: 0.020" diam tinned music wire; 1/8" OD by 1-5/8" lg overall; approx 70 turns eye term indexed 90°; p/o O-123	Loading spring for bolometer gear rack assembly O-123	+Federal Mfg. & Eng. Corp 310-369 Hewlett-Packard 19M-M-733	+Federal Mfg. & Eng. Corp 310-369 Hewlett-Packard dwg #19M-M-733
O-125	3300-298345246 R16-A-7000 2Z4878-493	ATTENUATOR SUB-ASSEMBLY: spur type straight rack; nickel pl brass; straight teeth; 15.29 teeth per inch; 48 pitch; 14-1/2° pressure angle; 3-7/8" lg by 1/8" wide by 1/8" h; straight face; mtg to cylindrical holder by one #2-56 by 1/4" lg RHMS, holder 7/8" diam by 1/4" lg with 0.308" bore; below 2-1/4" coil spring attached to holder; incl O-126	Drives output attenuator pickup loop assembly E-101	+Federal Mfg. & Eng. Corp 310-375 Hewlett-Packard 19M-M-737	+Federal Mfg. & Eng. Corp 310-375 Hewlett-Packard dwg #19M-M-737
*O-126	3300-299450336 R16-S-8450-35 2Z8874-236 N17-S-46761-9414	SPRING: helical extension type; 0.020" diam tinned music wire; 1/8" OD by 2-1/4" lg overall; approx 100 turns; eye term indexed 90°; p/o O-125	Loading spring for output attenuator pickup loop gear rack assembly O-125	+Federal Mfg. & Eng. Corp 310-370 Hewlett-Packard 19M-M-734	+Federal Mfg. & Eng. Corp 310-370 Hewlett-Packard dwg #19M-M-734
O-127 R17-C-11999-25	CLIP: Fahnestock style; phosphor bronze, nickel pl; 3/4" by 5/16" wide; one terminal hole located on chassis interior, right side	Used to hold Allen wrench H-102	Fahnestock Electric Co. #10	+Federal Mfg. & Eng. Corp CLP-8
O-128		CLIP: same as O-127	Used to hold Allen wrench H-103		
O-129		CLIP: same as O-127	Used to hold Allen wrench H-104		
		* Not furnished as a maintenance part for Bureau of Ships activities. If failure occurs, do not request replacement unless the part cannot be repaired or fabricated.			

*O-130 2Z8878-168 N17-S-46762-4281	SPRING: helical extension type; 0.022" diam tinned music wire; 6" lg by 1/8" OD; eye terminals indexed at 90°; approx 260 turns	For main drive system; around hub of cam	+Federal Mfg. & Eng. Corp 310-207	+Federal Mfg. & Eng. Corp 310-207
O-131		This symbol number not assigned			
*O-132 2Z8878-169 N17-S-46802-2801	SPRING: tinned music wire, 0.035" diam; loop type; 1-1/8" OD, approx 330°; tinned hook term; p/o O-117	Anti-backlash on spring- loaded attenuator pinion in gear case	+Federal Mfg. & Eng. Corp 310-224	+Federal Mfg. & Eng. Corp 310-224
*O-133 2Z8878-171 N17-S-46853-5022	SPRING: helical compression type; tinned music wire, 0.055" diam; 17/64" OD by 1/2" lg; 6 turns, LH; term leads at RT angle to coil; p/o O-116	For gear assembly of upper drive system O-116	+Federal Mfg. & Eng. Corp 310-322	+Federal Mfg. & Eng. Corp 310-322
O-134 R17-C-11110 3Z1013.24 N17-C-804543-151	CLIP: ferrule style; phosphor bronze, nickel plate, 29/64" lg by 11/32" wide by 5/16" high; mts through 0.131" diam hole; p/o chassis	Mounts small end of special tool H-101	Littelfuse #101001	+Federal Mfg. & Eng. Corp CLP-6
O-135 R17-C-10919-282 2Z2712.411 N17-C-804675-101	CLIP: ferrule type; phosphor bronze or spring brass; nickel or steel cad pl; 13/16" lg by 5/8" wd by 1/2" high mts through holes in base; approx 3/4" jaw opening; p/o A-107 holds adapter UG-273/U	Used as spare adapter clip in accessories holder A-107	Worcester Pressed Alum #2003	+Federal Mfg. & Eng. Corp CLP-13
O-136 R16-FME-310-146	GEAR: rack type; brass, nickel plate; straight teeth; 48 pitch; 3-7/16" lg x 1/8" high o/a; one mtg hole 0.089" diam drilled through teeth 3/8" from one end	Linear displacement of attenuator assembly	+Federal Mfg. & Eng. Corp 310-146	+Federal Mfg. & Eng. Corp 310-146
O-137 R16-FME-310-148	GEAR: rack type; brass, nickel plate; straight teeth; 48 pitch; 2-1/8" lg x 1/8" wd x 1/8" high o/a; one mtg hole 0.089" diam drilled through teeth 3/8" from one end	Linear displacement of bolometer assembly	+Federal Mfg. & Eng. Corp 310-148	+Federal Mfg. & Eng. Corp 310-148
O-138 R16-FME-310-158	GEAR: rack type; brass, finish not specified; straight teeth; 32 pitch; 4-13/16" lg x 3/16" wd x 3/16" h o/a; soldered to carriage tube; (for identification only - not a replaceable part)	Linear displacement of cavity tuner	+Federal Mfg. & Eng. Corp 310-158	+Federal Mfg. & Eng. Corp 310-158
		* Not furnished as a maintenance part for Bureau of Ships activities. If failure occurs, do not request replacement unless the item cannot be repaired or fabricated.			

TABLE 6-1.—TABLE OF REPLACEABLE PARTS (Contd)

MODEL: SIGNAL GENERATOR TS-403/U

MAJOR ASSEMBLY: SIGNAL GENERATOR TS-403/U (Less Accessories)

REF. SYMBOL	USAF STOCK NO. ASO STOCK NO. SIG C. STOCK NO. NAVY STOCK NO.	NAME OF PART AND DESCRIPTION	FUNCTION	MFR. AND DESIG. OR JAN TYPE	CONT. OR GOV. DWG. OR SPEC. NO.
O-139 R16-FME-310-213	GEAR: spur type; brass, nickel plated; straight teeth; 96 teeth, 32 pitch, 3" pitch diam; 5/16" diam bore into which bushing Federal Mfg & Eng Corp dwg #310-419, is force fitted reducing bore diam to 0.251", 3/16" face thickness; hub 5/8" diam x 5/16" lg; two radial #6-32 tapped mtg holes in hub for set screws, spaced 90° apart; one axial #6-32 tapped hole on 1-7/32" radius; p/o O-146	Attenuator assembly drive gear	+Federal Mfg. & Eng. Corp 310-213	+Federal Mfg. & Eng. Corp 310-213
O-140 R16-FME-310-214	GEAR: spur type; brass, nickel plated; straight teeth; 96 teeth; 32 pitch, 3" pitch diam; 5/16" diam bore into which bushing, Federal Mfg & Eng Corp dwg #310-419, is force fitted reducing bore diam to 0.251", 3/16" face thickness; hub 5/8" diam x 5/16" lg; two radial #6-32 tapped mtg holes in hub for set screws spaced 90° apart; one radial #4-40 tapped hole 1/4" deep drilled through teeth, two axial #3-48 tapped holes spaced 5/8" c to c on 1-13/32" radius; p/o O-147	Bolometer assembly drive gear	+Federal Mfg. & Eng. Corp 310-214	+Federal Mfg. & Eng. Corp 310-214
O-141 R16-FME-310-215	GEAR: spur type; brass, nickel plated; straight teeth; 48 teeth; 32 pitch, 1-1/2" pitch diam; 0.630" diam bore, 1/16" face thickness; straight face; no hub; soldered to hub; one axial hole 7/32" diam and one #2-56 tapped axial hole spaced 30° apart on 9/16" radius; (for identification only - not a replaceable part in all usages)	Part of bolometer drive and attenuator drive	+Federal Mfg. & Eng. Corp 310-215	+Federal Mfg. & Eng. Corp 310-215
O-142 R16-FME-310-216	HUB: gear hub; brass, finish not specified; cylindrical shape; 0.800" lg x 1-1/4" diam o/a; four axial #6-32 tapped mtg holes 1/4" deep spaced 90° apart on 0.406" radius; (for identification only - not a replaceable part)	Part of bolometer drive and attenuator drive	+Federal Mfg. & Eng. Corp 310-216	+Federal Mfg. & Eng. Corp 310-216
O-143 R16-FME-310-221	GEAR: spur type; brass, nickel plated; straight teeth; 16 teeth; 32 pitch, 0.50" pitch diam 0.252" diam bore, teeth face 3/16" wd; straight face; hub 7/16" diam x 5/8" lg; two radial #8-32 tapped mtg holes in hub spaced 90° apart 5/16" from end of hub	Attenuator knob drive	+Federal Mfg. & Eng. Corp 310-221	+Federal Mfg. & Eng. Corp 310-221

<p>O-144 R16-FME-310-222</p>	<p>..... R16-FME-310-222</p>	<p>GEAR: spur type; brass, nickel plated; straight teeth; 16 teeth; 32 pitch, 0.50" pitch diam; 0.252" bore diam, teeth face 3/16" wd; straight face; hub 7/16" diam x 11/32" lg; two radial #8-32 tapped mtg holes in hub spaced 90° apart 5/32" from end of hub</p>	<p>Bolometer (power set) knob drive</p>	<p>+Federal Mfg. & Eng. Corp 310-222</p>	<p>+Federal Mfg. & Eng. Corp 310-222</p>
<p>O-145 R16-FME-310-234</p>	<p>..... R16-FME-310-234</p>	<p>GEAR: spur type; brass, nickel plated; straight teeth; 48 teeth; 32 pitch, 1-1/2" pitch diam; 0.502" bore diam, 1/16" face thickness; straight face; shaft mounted and held in place by associated parts; one axial hole 7/32" diam and one #2-56 tapped axial hole spaced 30° apart on 9/16" radius</p>	<p>Linkage between bolometer drive and attenuator drive</p>	<p>+Federal Mfg. & Eng. Corp 310-234</p>	<p>+Federal Mfg. & Eng. Corp 310-234</p>
<p>O-146 R16-FME-310-245</p>	<p>..... R16-FME-310-245</p>	<p>GEAR: spur type; brass, nickel plated; straight teeth; 96 teeth; 32 pitch, 3" pitch diam; 5/16" diam bore into which bushing, Federal Mfg & Eng Corp dwg #310-419, is force fitted reducing bore diam to 0.251", 3/16" face thickness; hub 5/8" diam x 5/16" lg; two radial #6-32 tapped mtg holes in hub for set screws spaced 90° apart; one spacer, Federal Mfg & Eng Corp dwg #310-104 mounted on side of gear on 1-7/32" radius by one #6-32 round head machine screw 3/8" lg and one #6 int tooth lockwasher</p>	<p>Attenuator assembly drive component</p>	<p>+Federal Mfg. & Eng. Corp 310-245</p>	<p>+Federal Mfg. & Eng. Corp 310-245</p>
<p>O-147 R16-FME-310-246</p>	<p>..... R16-FME-310-246</p>	<p>GEAR: spur type; brass, nickel plated; straight teeth; 96 teeth; 32 pitch, 3" pitch diam; 5/16" diam bore into which bushing, Federal Mfg & Eng Corp dwg #310-419, is force fitted reducing bore diam to 0.251", 3/16" face thickness; hub 5/8" diam x 5/16" lg; two radial #6-32 tapped mtg holes in hub for set screws spaced 90° apart; one #4-40 fillister head steel machine screw 1/4" lg threaded in 1/4" deep radial hole through teeth, one gear retainer stop, Federal Mfg & Eng Corp dwg #310-330 mounted on side of gear on 1-13/32" radius by two #3-48 round head machine screws 1/4" lg and two #3 int tooth lockwashers</p>	<p>Bolometer assembly drive component</p>	<p>+Federal Mfg. & Eng. Corp 310-246</p>	<p>+Federal Mfg. & Eng. Corp 310-246</p>
<p>O-148 R16-FME-310-249</p>	<p>..... R16-FME-310-249</p>	<p>GEAR: spur type; brass, straight teeth; 160 teeth; 32 pitch, 5" pitch diam; bore diam 5/16", face thickness 3/16"; straight face; hub 0.750" diam x 5/16" lg; hub is force fitted and soldered; (for identification only - not a replaceable part)</p>	<p>Frequency drive component</p>	<p>+Federal Mfg. & Eng. Corp 310-249</p>	<p>+Federal Mfg. & Eng. Corp 310-249</p>

TABLE 6-1.—TABLE OF REPLACEABLE PARTS (Contd)

MODEL: SIGNAL GENERATOR TS-403/U

MAJOR ASSEMBLY: SIGNAL GENERATOR TS-403/U (Less Accessories)

REF. SYMBOL	USAF STOCK NO. ASO STOCK NO. SIG C. STOCK NO. NAVY STOCK NO.	NAME OF PART AND DESCRIPTION	FUNCTION	MFR. AND DESIG. OR JAN TYPE	CONT. OR GOV. DWG. OR SPEC. NO.
O-149 R16-FME-310-414	GEAR: spur type; brass, straight teeth; 72 teeth; 32 pitch, 2-1/4" pitch diam; 5/16" diam bore; 3/16" face thickness; straight face; hub 0.625" diam x 5/16" lg; shaft mounted; (for identification only - not a replaceable part)	Frequency drive component	+Federal Mfg. & Eng. Corp 310-414	+Federal Mfg. & Eng. Corp 310-414
O-150 R16-FME-310-417	GEAR: spur type; brass; straight teeth; 18 teeth; 32 pitch, 9/16" pitch diam; 0.344" bore diam, 3/16" face thickness; no hub; force fitted; 1/32" x 45 deg chamfer on perimeter of bore on one side of gear; (for identification only - not a replaceable part)	Frequency knob drive	+Federal Mfg. & Eng. Corp 310-417	+Federal Mfg. & Eng. Corp 310-417
O-151 R16-FME-310-418	STUD: brass, 1-11/16" lg o/a shoulder 1/4" lg x 13/16" diam o/a; one end threaded 1-1/8" lg w/ 1/2"-20 thd; two radial #8-32 tapped holes in shoulder spaced 90° apart; (for identification only - not a replaceable part)	Stop guide for frequency drive	+Federal Mfg. & Eng. Corp 310-418	+Federal Mfg. & Eng. Corp 310-418
O-152 R16-FME-310-422	GEAR: spur type; brass, straight teeth; 40 teeth; 48 pitch, 0.83" pitch diam; 1/2" bore diam, 1/8" face thickness; no hub; force fitted perimeter of bore chamfered 1/64" x 45 deg on both side of gear; (for identification only - not a replaceable part)	Attenuator and bolometer rack drive	+Federal Mfg. & Eng. Corp 310-422	+Federal Mfg. & Eng. Corp 310-422
O-153		This symbol not assigned			
O-154 R17-C-11183	CLIP: fuse; phosphor bronze, nickel plate; 3/4" h x 7/16" wd o/a; one clip connection; approx 1/8" nominal jaw opening; one 0.196" diam mtg hole in one end of clip; (for identification only - not a replaceable part)	Holder for spare bolometer assembly	Littelfuse, Inc. 2049	+Federal Mfg. & Eng. Corp CLP-15
O-155 R17-C-11184	CLIP: fuse; beryllium copper, silver plated; 3/4" lg x 15/32" wd x 7/16" h o/a; approx 1/4" nominal jaw opening; one 0.196" diam mtg hole in one end of clip (for identification only - not a replaceable part)	Retainer clip for tool H-101	Littelfuse, Inc. 125002	+Federal Mfg. & Eng. Corp CLP-10
O-156 R17-T-4648	TERMINAL, lug: round tongue end type; brass, hot tinned finish; for #14 AWG wire; 11/16" lg x 1/4" wd x 0.020" thk o/a, hole for #4 screw; (for identification only - not a replaceable part)	Ground and connecting lug	Zierick Mfg. Co. #9 series	+Federal Mfg. & Eng. Corp TER-42

O-157 R17-T-4392-50	TERMINAL, lug: round tongue end type; brass, hot tinned finish; for #14 AWG wire; 13/16" lg x 3/8" wd x 0.020" thk o/a; hole for #10 screw; (for identification only - not a replaceable part)	Ground lug	Zierick Mfg. Co. #19 series	+Federal Mfg. & Eng. Corp TER-47
O-158 R17-T-4709	TERMINAL, lug: forked spade type; brass, hot tinned finish; 5/8" lg x 5/16" wd x approx 5/32" h o/a, slot 9/32" lg x 5/32" wd for #6 screw; solder connects to wire; four clamping ears; (for identification only - not a replaceable part)	Spade lug connection to terminal board	Patton-MacGuyver Co. #2009	+Federal Mfg. & Eng. Corp TER-71
O-159 R17-T-4587	TERMINAL, lug: round tongue end type; copper hot tinned finish; 13/16" lg x 11/32" wd x approx 11/64" h o/a; solder connects to wire; four clamping ears; (for identification only - not a replaceable part)	Repeller potentiometer connecting lug	Zierick Mfg. Co. #211 series	+Federal Mfg. & Eng. Corp TER-75
O-160 R16-C-19897-450	CLIP: (Alternate - may replace O-128 and O-129 in combination) fahnestock double type; brass, nickel plated; 1-3/4" lg x 3/8" wd x approx 5/8" h o/a; two fahnestock connections; accommodates up to #10 B&S gauge wire; (for identification only - not a replaceable part)	Clip holder for Allen wrenches	Birnbach Radio Co. Part #33	+Federal Mfg. & Eng. Corp CLP-1
O-161 R17-T-4587-10	TERMINAL, lug: round tongue end type, copper, hot tinned finish; 13/16" lg x 11/32" wd x approx 11/64" h o/a, hole 15/64" diam; solder connects to wire; four clamping ears; (for identification only - not a replaceable part)	Terminal lug connector to C-125	Zierick Mfg. Co. #211 series	+Federal Mfg. & Eng. Corp TER-74
O-162 R17-T-4717	TERMINAL, lug: round tongue end type; brass, hot tinned finish; for 5/64" max diam wire; 11/16" lg x 1/4" wd x 0.020" thk o/a, hole for #8 screws; solder connects to wire; (for identification only - not a replaceable part)	Ground and connecting lug	Zierick Mfg. Co. Part #9 series	+Federal Mfg. & Eng. Corp TER-44
O-163 R17-T-4232	TERMINAL, lug: round tongue end type; brass, hot tinned finish; for 5/64" max diam wire; 11/16" lg x 1/4" wd x 0.020" thk o/a, hole for #6 screw; solder connects to wire; (for identification only - not a replaceable part)	Ground and connecting lug	Zierick Mfg. Co. Part #9 series	+Federal Mfg. & Eng. Corp TER-43
O-164 R17-T-4614-76	TERMINAL, stud: miniature swaged type; brass, silver plated; cylindrical shape; 1/2" lg x 3/16" diam o/a; one axial hole 0.076" diam, 3/32" min depth on bottom of stud; (for identification only - not a replaceable part)	Component mounting	Cambridge Thermionic Corp #300	+Federal Mfg. & Eng. Corp TER-34

TABLE 6-1. -TABLE OF REPLACEABLE PARTS (cont)

MODEL: SIGNAL GENERATOR TS-403/U

MAJOR ASSEMBLY: SIGNAL GENERATOR TS-403/U (Less Accessories)

REF. SYMBOL	USAF STOCK NO. ASO STOCK NO. SIG C. STOCK NO. NAVY STOCK NO.	NAME OF PART AND DESCRIPTION	FUNCTION	MFG. AND DESIG. OR JAN TYPE	CONT. OR GOV. DWG. OR SPEC. NO.
O-165 R16-FME-310-204	CAM SUB-ASSEMBLY: c/o one cam plate, Federal Mfg & Eng Corp dwg #310-208 and one hub, Federal Mfg & Eng Corp dwg #310-209; modified disc shape; 3" diam thk approx o/a dim; two radial mtg holes in hub for set screws	Cam for actuator of microswitch	+ Federal Mfg. & Eng. Corp 310-204	+ Federal Mfg. & Eng. Corp 310-204
P-101	4248-4891 R17-R-2029-20	CONNECTOR, receptacle: 2 flat parallel blade; male contact; straight; approx 2-5/16" OD by 1-1/4" lg o/a with 1-1/2" OD body; 15 amp, 125 v; round metal body; molded black phenolic insert; two screw term on back; mts by two 5/32" diam holes on 2.062" mtg/c; located on front panel	Power line connector	Hubbel #4891	+ Federal Mfg. & Eng. Corp CON-11 Hewlett-Packard dwg #19M-M-763
P-101A	CONNECTOR, receptacle: male; 3 contact cylindrical body with rectangular mtg flange	Power line connector	AN3102-10SL-3P	øMIL-C-5015
P-110 2Z3055-49 N17-C-71109-4867	CONNECTOR, plug: cylindrical shape; brass, silver-plated; locking type; 1-3/16" lg by 11/16" diam, straight; 1 female contact; 50 ohms impedance; constant frequency; 0.280" diam max cable opening, Teflon insert; p/o E-101	Used on RF probe E-101	+ Federal Mfg. & Eng. Corp SUB-6	+ Federal Mfg. & Eng. Corp SUB-6
R-101	3300-381217080 R16-JAN-RC20BF125K 3RC20BF125K	RESISTOR, fixed: composition; 1.2 megohms $\pm 10\%$; 1/2 watt; molded phenolic; 3/8" lg by 0.14" diam; axial leads	Grid resistor for V-101A	JAN RC20BF125K	JAN-R-11
R-102	3300-381167080 R16-JAN-RC20BF152K 3RC20BF152K	RESISTOR, fixed: composition; 1500 ohms $\pm 10\%$; 1/2 watt; molded phenolic; 3/8" lg by 0.14" diam; axial leads	Cathode resistor for V-101A	JAN RC20BF152K	JAN-R-11

TABLE 6-1. - TABLE OF REPLACEABLE PARTS (cont)

MODEL: SIGNAL GENERATOR TS-403/U

MAJOR ASSEMBLY: SIGNAL GENERATOR TS-403/U (Less Accessories)

REF. SYMBOL	USAF STOCK NO. ASO STOCK NO. SIG C. STOCK NO. NAVY STOCK NO.	NAME OF PART AND DESCRIPTION	FUNCTION	MFG. AND DESIG. OR JAN TYPE	CONT. OR GOV. DWG. OR SPEC. NO.
R-103	3300-381169860 R16-JAN-RC20BF474K 3RC20BF474K	RESISTOR, fixed: composition; 470,000 ohms $\pm 10\%$; 1/2 watt; molded phenolic; 3/8" lg by 0.14" diam; axial leads	Plate resistor for V-101A	JAN RC20BF474K	JAN-R-11
R-104		RESISTOR, fixed: same as R-101	Grid resistor for V-101B		
R-105		RESISTOR, fixed: same as R-102	Cathode resistor for V-101B		
R-106		RESISTOR, fixed: same as R-103	Plate resistor for V-101B		

Revised 20 February 1959

6-38A

CONTRACT NOa(s)-9213

+CONTRACT NOa(s)-12297 and CONTRACTS N383s-54831, N383s-57633, N383s-59709, N383s-59710
eCONTRACT N383s-18375A

AN 16-30URM61-3

Section VI

R-107	3300-294454120 R16-P-5593-38-100 2ZK7263-16	RESISTOR, variable (potentiometer): composition; single section, 250,000 ohms \pm 10% 2 watt, 120° C max continuous oper; 3 solder lug term; enclosed metal case 1-1/16" diam by 9/16" d; round screwdriver slotted metal shaft 1/4" diam by 5/8" lg; linear taper; insulated contact arm; normal torque, with shaft-locking device; mtd by bushing 3/8"-32 by 1/2" lg	Pulse rate calibrating adjustment for V-102A	AB #JLU2541 bushing #SD4040L	+Federal Mfg. & Eng. Corp RRV-13 Hewlett-Packard dwg #19M-S-759
∅R-108	3300-381319800 R16-R-17332-8 3RC42BF473K N16-R-50481-457	RESISTOR, fixed: composition; 47,000 ohms \pm 10%; 2 watts; molded phenolic; 11/16" lg by 5/16" diam; axial leads	Plate resistor for V-102A	JAN RC42BF473K	JAN-R-11
R-109	3300-394390027 R16-P-5598-250 3Z7499-3.2	RESISTOR, variable (potentiometer): composition; single section, 3.0 meg \pm 20%; 2 watt, 120° C max continuous oper; 3 solder lug term; enclosed metal case 1/16" diam by 9/16" d; round metal shaft 1/4" diam by 7/8" lg; AB type "B" taper, approx 990,000 ohms at 35%, 270,000 ohms at 50%, and 60,000 ohms at 65% clockwise rotation, insulated contact arm; normal torque mtd by bushing 3/8"-32 by 3/8" lg	Pulse rate control	AB #JB3052 with bushing #P3056	+Federal Mfg. & Eng. Corp RRV-17 Hewlett-Packard dwg #19M-S-758
R-110		RESISTOR, variable (potentiometer): same as R-107	Pulse rate calibrating adjustment for V-102B		
R-111	3300-381317640 R16-JAN-RC30BF183K 3RC30BF183K	RESISTOR, fixed: composition; 18,000 ohms \pm 10%; 1 watt; molded phenolic; 9/16" lg by 0.225" diam; axial leads	Plate resistor for V-102B	JAN RC30BF183K	JAN-R-11
R-112	3300-381171020 R16-JAN-RC20BF822K 3RC20BF822K	RESISTOR, fixed: composition; 8200 ohms \pm 10%; 1/2 watt; molded phenolic; 3/8" lg by 0.14" diam; axial leads	DC return resistor for V-103	JAN RC20BF822K	JAN-R-11
R-113		RESISTOR, fixed: same as R-101	Bleeder resistor for C-108		
R-114	3300-381318960 R16-JAN-RC30BF333K 3RC30BF333K	RESISTOR, fixed: composition; 33,000 ohms \pm 10%; 1 watt; molded phenolic; 9/16" lg by 0.225" diam; axial leads	Plate resistor for V-104A	JAN RC30BF333K	JAN-R-11
		∅ When requesting replacement specify maximum allowable size of 1-1/16" diam by 9/16" deep.			

TABLE 6-1.—TABLE OF REPLACEABLE PARTS (Contd)

MODEL: SIGNAL GENERATOR TS-403/U

MAJOR ASSEMBLY: SIGNAL GENERATOR TS-403/U (Less Accessories)

REF. SYMBOL	USAF STOCK NO. ASO STOCK NO. SIG C. STOCK NO. NAVY STOCK NO.	NAME OF PART AND DESCRIPTION	FUNCTION	MFR. AND DESIG. OR JAN TYPE	CONT. OR GOV. DWG. OR SPEC. NO.
R-115	3300-381318060 R16-JAN-RC30BF222K 3RC30BF222K	RESISTOR, fixed: composition; 2200 ohms \pm 10%; 1 watt, molded phenolic; 9/16" lg by 0.225" diam; axial leads	Cathode resistor for V-104A and V-104B	JAN RC30BF222K	JAN-R-11
R-116	5905-252-6433 R16-P-5593-38-375 3Z7498-25.44	RESISTOR, variable (potentiometer): composition; single section, 250,000 ohms \pm 10%, 2 w, 120° C continuous oper; 3 solder lug term; enclosed metal case 1-1/16" diam by 9/16" d; round metal shaft 1/4" diam by 7/8" lg; AB type "A" taper, approx 7500 ohms at 35%, 27,500 ohms at 50% and 75,000 ohms at 65% clockwise rotation; insulated contact arm; normal torque; mtd by bushing 3/8"-32 by 3/8" lg	Pulse delay control	RV4ATRD254C	+Federal Mfg. & Eng. Corp RRV-15 Hewlett-Packard dwg #19M-S-758
R-117	3300-381320140 R16-JAN-RC30BF561K 3RC30BF561K	RESISTOR, fixed: composition; 560 ohms \pm 10%; 1 watt; molded phenolic 9/16" lg by 0.225" diam; axial leads	Grid resistor for V-104B	JAN RC30BF561K	JAN-R-11
øR-118	3300-381518120 R16-R-17310-178-500 3RC42BF223K N16-R-50373-421	RESISTOR, fixed: composition; 22,000 ohms \pm 10%; 2 watts; molded phenolic; 11/16" lg by 5/16" diam; axial leads	Plate resistor for V-104B	RC42BF223K	JAN-R-11
R-119	3300-381167200 R16-JAN-RC20BF154K 3RC40BF154K	RESISTOR, fixed: composition, 150,000 ohms \pm 10%; 1/2 watt; molded phenolic 3/8" lg by 0.14" diam; axial leads	Grid resistor for V-106	JAN RC20BF154K	JAN-R-11
R-120		RESISTOR, fixed: same as R-114	Cathode resistor for V-106		
R-121	3300-381316620 R16-JAN-RC30BF122K 3RC30BF122K	RESISTOR, fixed: composition; 1200 ohms \pm 10%; 1 watt; molded phenolic; 9/16" lg by 0.225" diam; axial leads	Bleeder resistor for C-112	JAN RC30BF122K	JAN-R-11
		ø When requesting replacement specify maximum allowable size of 11/16" lg by 5/16" diam.			

R-122	3300-381170260 R16-JAN-RC20BF564K 3RC20BF564K	RESISTOR, fixed: composition; 560,000 ohms, $\pm 10\%$; 1/2 w; molded phenolic; 3/8" lg by 0.14" diam; axial leads	Grid resistor for V-107A	JAN RC20BF564K	JAN-R-11
R-123	3300-381316160 R16-JAN-RC30BF103K 3RC30BF103K	RESISTOR, fixed: composition; 10,000 ohms $\pm 10\%$; 1 watt; molded phenolic; 9/16" by 0.225" diam; axial leads	Plate resistor for V-107A	JAN RC30BF103K	JAN-R-11
R-124		RESISTOR, variable (potentiometer): same as R-116	Pulse width control		
R-125	3300-381166620 R16-JAN-RC20BF122K 3RC20BF122K	RESISTOR, fixed: composition; 1200 ohms $\pm 10\%$; 1/2 watt; molded phenolic; 3/8" lg by 0.14" diam; axial leads	Grid resistor for V-109 when S-102A in "INT" position	JAN RC20BF122K	JAN-R-11
R-126	3300-381316100 R16-JAN-RC30BF102K 3RC30BF102K	RESISTOR, fixed: composition; 1000 ohms $\pm 10\%$; 1 watt; molded phenolic; 9/16" lg by 0.225" diam; axial leads	Plate resistor for V-108	JAN RC30BF102K	JAN-R-11
R-127		RESISTOR, fixed: same as R-101	Bleeder resistor for C-116		
R-128	3300-381166220 R16-JAN-RC20BF104K 3RC20BF104K	RESISTOR, fixed: composition; 100,000 ohms $\pm 10\%$; 1/2 watt; molded phenolic; 3/8" lg by 0.14" diam; axial leads	Grid resistor for V-108	JAN RC20BF104K	JAN-R-11
R-129		RESISTOR, fixed: same as R-128	Grid resistor for V-109 when S-102A in "EXT NEG" position		
R-130	3300-381166040 R16-JAN-RC20BF101K 3RC20BF101K	RESISTOR, fixed: composition; 100 ohms $\pm 10\%$; 1/2 watt; molded phenolic; 3/8" lg by 0.14" diam; axial leads	Suppressor resistor in "EXT MOD" input circuit	JAN RC20BF101K	JAN-R-11
R-131		RESISTOR, fixed: same as R-128	Grid resistor for V-109 when S-102A in "EXT POS" position		
øR-132	3300-381518960 N16-R-17327-58 3RC42BF333K N16-R-50418-457	RESISTOR, fixed: composition; 33,000 ohms $\pm 10\%$; 2 watts; molded phenolic; 11/16" lg by 5/16" diam; axial leads ø When requesting replacement specify maximum allowable size of 11/16" lg by 5/16" diam.	Screen voltage dropping resistor for V-109	JAN RC42BF333K	JAN-R-11

TABLE 6-1.—TABLE OF REPLACEABLE PARTS (Contd)

MODEL: SIGNAL GENERATOR TS-403/U

MAJOR ASSEMBLY: SIGNAL GENERATOR TS-403/U (Less Accessories)

REF. SYMBOL	USAF STOCK NO. ASO STOCK NO. SIG C. STOCK NO. NAVY STOCK NO.	NAME OF PART AND DESCRIPTION	FUNCTION	MFR. AND DESIG. OR JAN TYPE	CONT. OR GOV. DWG. OR SPEC. NO.
R-133		RESISTOR, fixed: same as R-119	Grid resistor for V-110		
R-134		RESISTOR, fixed: same as R-114	Cathode resistor for V-110		
R-135		RESISTOR, fixed: same as R-121	Bleeder resistor for C-120		
R-136	3300-399730001 R16-T-2268 3Z6926-12.4	RESISTOR, thermal (thermistor): glass envelope; approx 2000 ohms cold resistance at 25°C; 0.2 v to 1.5 v for 0.1 ma to approx 3 ma range at 25° ambient temp, approx 20 ma max current; power sensitivity range from 0.5 mw to 20 mw for resistance change from 1600 ohms to 54 ohms; cylindrical shaped; semi-conducting bead type, 5/32" max diam by 0.40" max lg; axial lead mtg; p/o E-122	Power monitoring RF indicating thermistor	WECo No. D166382	+Federal Mfg. & Eng. Corp RTB-1 Hewlett-Packard dwg #19M-S-767
R-137	3300-390023746 R16-R-17258-750 3Z6005-169	RESISTOR, fixed: steatite ceramic rod with thin resistance film; 50 ohms ± 20%; 1/4 w; temp coef of resistance approx -0.04% per deg from -55°C to +80°C; body 9/16" lg by 0.100" diam including cup term; phenolic varnish insulation coating; axial leads; special flat freq response at UHF; p/o E-101	Impedance matching resistor	IRC type MPM	+Federal Mfg. & Eng. Corp RES-1015 Hewlett-Packard dwg #19M-S-712
R-138		This symbol not assigned			
∅R-139	3300-381517640 R16-R-17310-97-500 3RC42BF183K N16-R-50355-491	RESISTOR, fixed: composition; 18,000 ohms ± 10%; 2 watts; molded phenolic; 11/16" lg by 5/16" diam; axial leads	Voltage divider resistor in power supply	JAN RC42BF183K	JAN-R-11
∅R-140	3300-381517140 R16-R-17310-63-500 3RC42BF153K N16-R-50337-528	RESISTOR, fixed: composition; 15,000 ohms ± 10%; 2 watts; molded phenolic; 11/16" lg by 5/16" diam; axial leads	Voltage divider resistor in power supply	JAN RC42BF153K	JAN-R-11
R-141		RESISTOR, fixed: same as R-139	Voltage divider resistor in power supply		
R-142		RESISTOR, fixed: same as R-140	Voltage divider resistor in power supply		
		∅ When requesting replacement specify maximum allowable size of 11/16" lg by 5/16" diam			

R-143	3300-294459239 R16-P-5582-50-500 2Z7268-28	RESISTOR, variable (potentiometer): composition; single section, 1500 ohms \pm 10%; 2 watt; 120°C max continuous oper; 3 solder lug term; enclosed metal case 1-1/16" diam by 9/16" d; round screwdriver slotted metal shaft 1/4" diam by 5/8" lg; linear taper; insulated contact arm; normal torque with shaft locking device; mtd by bushing 3/8"-32 by 1/2" lg	Bridge balance adjustment potentiometer	AB #JLU1521 bushing #SD4040L	+Federal Mfg. & Eng. Corp RRV-9 Hewlett-Packard dwg #19M-S-759
R-144		RESISTOR, fixed: same as R-139	Voltage divider resistor in power supply		
R-145		RESISTOR, fixed: same as R-140	Voltage divider resistor in power supply		
R-146		RESISTOR, fixed: same as R-139	Voltage divider resistor in power supply		
R-147	3300-381319800 R16-JAN-RC30BF473K 3RC30BF473K	RESISTOR, fixed: composition; 47,000 ohms \pm 10%; 1 watt; molded phenolic; 9/16" lg by 0.225" diam; axial leads	Voltage divider resistor in power supply	JAN RC30BF473K	JAN-R-11
ØR-148	3300-381517200 R16-R-17349-25 3RC42BF154K N16-R-50679-520	RESISTOR, fixed: composition; 150,000 ohms \pm 10%; 2 watts; molded phenolic; 11/16" lg by 5/16" diam; axial leads	Voltage divider resistor in power supply	JAN RC42BF154K	JAN-R-11
R-149	3300-381317140 R16-JAN-RC30BF153K 3RC30BF153K	RESISTOR, fixed: composition; 15,000 ohms \pm 10%; 1 watt; molded phenolic; 9/16" lg by 0.225" diam, axial leads	Voltage divider resistor in power supply	JAN RC30BF153K	JAN-R-11
R-150	3300-381321060 R16-JAN-RC30BF823K 3RC30BF823K	RESISTOR, fixed: composition; 82,000 ohms \pm 10%; 1 watt; molded phenolic; 9/16" lg by 0.225" diam; axial leads	Voltage divider resistor in power supply	JAN RC30BF823K	JAN-R-11
R-151	3300-381316220 R16-JAN-RC30BF104K 3RC30BF104K	RESISTOR, fixed: composition; 100,000 ohms \pm 10%; 1 watt; molded phenolic; 9/16" lg by 0.225" diam; axial leads	Voltage divider resistor in power supply	JAN RC30BF104K	JAN-R-11
R-152	3300-294454231 R16-P-5588-1 2ZK7263-40	RESISTOR, variable (potentiometer): composition; single section, 50,000 ohms \pm 10%; 2 w, 120°C max continuous oper; 3 solder lug term; enclosed metal case 1-1/16" diam	Voltage regulator adjustment resistor	AB #JLU5031 with bushing #SD4040L	+Federal Mfg. & Eng. Corp RRV-12 Hewlett-Packard dwg #19M-S-759
		Ø When requesting replacement specify maximum allowable size of 11/16" lg by 5/16" diam.			

TABLE 6-1. -TABLE OF REPLACEABLE PARTS (cont)

MODEL: SIGNAL GENERATOR TS-403/U

MAJOR ASSEMBLY: SIGNAL GENERATOR TS-403/U (Less Accessories)

REF. SYMBOL	USAF STOCK NO. ASO STOCK NO. SIG C. STOCK NO. NAVY STOCK NO.	NAME OF PART AND DESCRIPTION	FUNCTION	MFG. AND DESIG. OR JAN TYPE	CONT. OR GOV. DWG. OR SPEC. NO.
R-152 (cont)		by 9/16" d; round screwdriver slotted metal shaft 1/4" diam by 5/8" lg; linear taper; insulated contact arm; normal torque, with shaft locking device mtd by bushing 3/8"-32 by 1/2" lg			
R-153	3300-381318380 R16-JAN-RC30BF224K 3RC30BF224K	RESISTOR, fixed: composition; 220,000 ohms $\pm 10\%$; 1 watt; molded phenolic; 9/16" lg by 0.225" diam; axial leads	Voltage divider resistor in power supply	JAN RC30BF224K	JAN-R-11
R-154	3300-381318580 R16-JAN-RC30BF274K 3RC30BF274K	RESISTOR, fixed: composition; 270,000 ohms $\pm 10\%$; 1 watt; molded phenolic; 9/16" lg by 0.225" diam; axial leads	Couples voltage variations from L-101 output into voltage regulator circuit	JAN RC30BF274K	JAN-R-11
R-155	3300-381319860 R16-JAN-RC30BF474K 3RC30BF474K	RESISTOR, fixed: composition; 470,000 ohms $\pm 10\%$; 1 watt; molded phenolic; 9/16" lg by 0.225" diam; axial leads	Couples voltage variations from L-101 output into voltage regulator circuit	JAN RC30BF474K	JAN-R-11
R-156	3300-385291040 R16-JAN-RW15F632 3RW29104	RESISTOR, fixed: wire wound; 6300 ohms $\pm 5\%$; 20 watts; glass insulation; 2-15/16" lg by 13/16" diam overall; ferrule type term	Voltage dropping resistor for V-117	JAN RW15F632	JAN-R-26A
R-156	RESISTOR, fixed: wire wound; 6300 ohms $\pm 5\%$; 37 watts nominal; ceramic insulation; 3-1/2" lg by 1-1/16" wide; solder lug type terminals; mounts on 4-1/4" centers by two 6-32 screws	Voltage dropping resistor for V-117	RW22G632	øMIL-R-26A
R-157	3300-385285160 R16-JAN-RW14F502 3RW28516	RESISTOR, fixed: wire wound; 5000 ohms $\pm 5\%$; 40 watts; glass insulation; 4-7/16" lg by 1-1/16" diam overall; ferrule type term	Plate load resistor for V-109	JAN RW14F502	JAN-R-26A

TABLE 6-1. -TABLE OF REPLACEABLE PARTS (cont)

MODEL: SIGNAL GENERATOR TS-403/U

MAJOR ASSEMBLY: SIGNAL GENERATOR TS-403/U (Less Accessories)

REF. SYMBOL	USAF STOCK NO. ASO STOCK NO. SIG C.STOCK NO. NAVY STOCK NO.	NAME OF PART AND DESCRIPTION	FUNCTION	MFG. AND DESIG. OR JAN TYPE	CONT. OR GOV. DWG. OR SPEC. NO.
R-157	RESISTOR, fixed: wire wound; 5000 ohms $\pm 5\%$; 37 watts nominal; ceramic insulation; 3-1/2" lg by 1-1/16" wide; solder lug type terminals; mounts on 4-1/4" centers by two 6-32 screws	Plate load resistor for V-109	RW22G502	eMIL-R-26A
R-158	3300-385261060 R16-JAN-RW16F202 3RW26106 N16-R-61836-2475	RESISTOR, fixed: wire wound; 2000 ohms $\pm 5\%$; 14 watts; glass insulation; 2-3/8" lg by 13/16" diam overall; ferrule type term	Heats interior of unit	JAN RW16F202	JAN-R-26A
R-158	RESISTOR, fixed: wire wound; 2000 ohms $\pm 5\%$; 15 watts nominal; ceramic insulation; 1-1/4" lg by 1-1/16" wide; solder lug type terminals; mounts on 2" centers by two 6-32 screws	Heats interior of unit	RW20G202	eMIL-R-26A
R-159		RESISTOR, fixed: same as R-158	Heats interior of unit		
R-160	3300-399812064 R16-P-5595-190-800 3Z7499-1.74	RESISTOR, variable (potentiometer): composition; single section, 1 meg $\pm 20\%$; 2 watt; 120°C max continuous oper; 3 solder lug term; enclosed metal case 1-1/16" diam by 9/16" d; round metal shaft 1/4" diam by 7/8" lg; AB type "A" taper, approx 30,000 ohms at 35%	"FM Phase" control	AB #JA1052 with bushing #P3056	+ Federal Mfg. & Eng. Corp RRV-16 Hewlett-Packard dwg #19M-S-758

AN 16-30URM61-3

Section VI

R-160 (Contd)		100,000 ohms at 50%, and 300,000 ohms at 65% clockwise rotation; insulated contact arm; normal torque; mtd by bushing 3/8"-32 by 3/8" lg			
R-161		RESISTOR, variable (potentiometer): same as R-160	"FM Amplitude" control		
R-162	3300-294459100 R16-P-5581-314-60 2Z7268.6	RESISTOR, variable (potentiometer): composition; single section, 1000 ohms ± 10%; 2w; 120°C max continuous oper; 3 solder lug term; enclosed metal case 1-1/16" diam by 9/16" d; round metal shaft 1/4" diam by 7/8" lg; linear taper; insulated contact arm; normal torque; mtd by bushing 3/8"-32 by 3/8" lg	"Zero Set" control	AB #JU1021 with bushing #P3056	+Federal Mfg. & Eng. Corp RRV-14 Hewlett-Packard dwg #19M-S-758
R-163	3300-294459237 R16-P-5583-21 2Z7268.26	RESISTOR, variable (potentiometer): composition; single section, 10,000 ohms ± 10%; 2 w, 120°C max continuous oper; 3 solder lug term; enclosed metal case 1-1/16" diam by 9/16" d; round screwdriver slotted metal shaft 1/4" diam by 5/8" lg; linear taper; insulated contact arm; normal torque; shaft locking device; mtd by bushing 3/8"-32 by 1/2" lg	Repeller voltage adjustment for V-111	AB #JLU1031 with bushing #SD4040L	+Federal Mfg. & Eng. Corp RRV-11 Hewlett-Packard dwg #19M-S-759
R-164		RESISTOR, variable (potentiometer): same as R-152	Repeller voltage adjustment for V-111		
R-165		RESISTOR, fixed: same as R-139	Voltage divider resistor for power monitoring bridge		
R-166	3300-294445070 R16-P-5583-7-400 2ZK7262-5M.6	RESISTOR, variable (potentiometer): composition; single section, 5000 ohms ± 10%; 2 w, 120°C max continuous oper; 3 solder lug term; enclosed metal case 1-1/16" diam by 9/16" d; round screwdriver slotted metal shaft 1/4" diam by 5/8" lg; linear taper; insulated contact arm; normal torque; shaft locking device; mtg by bushing 3/8"-32 by 1/2" lg	Repeller voltage adjustment for V-111	AB #JLU5021 with bushing #SD4040L	+Federal Mfg. & Eng. Corp RRV-10 Hewlett-Packard dwg #19M-S-759
R-167		RESISTOR, variable (potentiometer): same as R-152	Repeller voltage adjustment for V-111		
R-168	3300-381316580 R16-JAN-RC30BF121K 3RC30BF121K	RESISTOR, fixed: composition; 120 ohms ± 10%; 1 watt; molded phenolic; 9/16" lg by 0.225" diam; axial leads	Voltage dropping resistor for power monitoring bridge balance regulator R-170	JAN RC30BF121K	JAN-R-11

TABLE 6-1.—TABLE OF REPLACEABLE PARTS (Contd)

MODEL: SIGNAL GENERATOR TS-403/U

MAJOR ASSEMBLY: SIGNAL GENERATOR TS-403/U (Less Accessories)

REF. SYMBOL	USAF STOCK NO. ASO STOCK NO. SIG C. STOCK NO. NAVY STOCK NO.	NAME OF PART AND DESCRIPTION	FUNCTION	MFR. AND DESIG. OR JAN TYPE	CONT. OR GOV. DWG. OR SPEC. NO.
R-169	3300-380406000 R16-R-18635-10 3RB4-1300	RESISTOR, fixed: wire wound; 130 ohms \pm 1/2%; rated 212 volts max; ceramic insulation; 11/16" diam by 31/32" lg incl term; solder lug term; mts by 9/64" hole through body (hole for #6 screw)	Power monitoring bridge arm resistor	JAN RB40B130ROD	JAN-R-93
R-170	3300-394186075 R16-T-2270 3Z6926-12	RESISTOR, thermal (thermistor): metal container disc type thermistor; 803 ohms \pm 5% at 75°F; 1-1/4" lg by 7/8" h by 5/16" deep; one pigtail term, metal base is other term; mts by four 0.1285" holes on 1" by 0.625" mtg/c	Balance regulating bridge thermistor	WEC Co No. D-168392	+Federal Mfg. & Eng. Corp RTD-4 Hewlett-Packard dwg #19M-S-715
R-171		RESISTOR, fixed: same as R-169	Power monitoring bridge arm resistor		
R-172		RESISTOR, fixed: same as R-169	Power monitoring bridge arm resistor		
R-173	3300-399809026 R16-P-6958-800 3Z7450-81	RESISTOR, variable (potentiometer): wire wound; 50,000 ohms \pm 10% total with tap at 47% \pm 0.01% of total; 12 w, 100°C max continuous oper; 4 stud screw term; open phenolic case 2-3/4" diam by 2-9/16" d; round phenolic shaft 3/8" diam by 9/32" lg from mtg surface; linear taper; insulated contact arm; normal torque; three #6 mtg holes on face spaced 120° apart 7/8" radius; special tap located at 142° \pm 2° counter-clockwise rotation	Repeller voltage tracking control	DeJur Amsco per Federal #310-321	+Federal Mfg. & Eng. Corp 310-321 Hewlett-Packard dwg #19M-M-769
R-174		RESISTOR, fixed: same as R-151	Voltage divider resistor		
R-175		RESISTOR, fixed: same as R-139	Voltage divider resistor		
R-176		RESISTOR, fixed: same as R-139	Voltage divider resistor		
R-177		RESISTOR, fixed: same as R-139	Voltage divider resistor		
R-178	3300-394186070 R16-T-2265 3Z6926-11	RESISTOR, thermal (thermistor): metal container disc type thermistor; 765 ohms \pm 5% at 75°F; 1-1/4" lg by 7/8" h by 5/16" deep; one pigtail terminal, metal base other terminal; mts by four 0.1285" holes on 1" by 0.625" mtg/c	Sensitivity regulating bridge thermistor	WEC Co No. D-168391	+Federal Mfg. & Eng. Corp RTD-3 Hewlett-Packard dwg #19M-S-715

R-179		RESISTOR, fixed: same as R-168	Sensitivity determining bridge resistor		
R-180	3300-381319680 R16-JAN-RC30BF471K 3RC30BF471K	RESISTOR, fixed: composition; 470 ohms ± 10%; 1 watt; molded phenolic 9/16" lg by 0.225" diam; axial leads	Meter dropping bridge resistor	JAN RC30BF471K	JAN-R-11
R-181	3300-381316700 R16-JAN-RC30BF124K 3RC30BF124K	RESISTOR, fixed: composition; 120,000 ohms ± 10%; 1 watt; molded phenolic; 9/16" lg by 0.225" diam; axial leads	Grid resistor for V-102A	JAN RC30BF124K	JAN-R-11
R-182	3300-381169680 R16-JAN-RC20BF471K 3RC20BF471K	RESISTOR, fixed: composition; 470ohms; ±10%; 1/2 watt; molded phenolic; 3/8" lg by 0.14" diam; axial leads	Parasitic suppressor for screen of V-115	JAN RC20BF471K	JAN-R-11
R-183		RESISTOR, fixed: same as R-182	Parasitic suppressor for grid of V-115		
ØR-184	3300-381518180 R16-R-17352-5-7 3RC42BF224K	RESISTOR, fixed: composition; 220,000 ohms ± 10%; 2 watts; molded phenolic; 5/16" diam by 11/16" lg; axial leads	Voltage divider resistor in power supply voltage regulator	JAN RC42BF224K	JAN-R-11
R-185		RESISTOR, variable (potentiometer): same as R-152	Bias selector resistor		
R-186	3300-381166040 R16-R-17261-19 3RC20BF101K	RESISTOR, fixed: composition; 100 ohms ± 10%; 1/2 watt; molded phenolic; 3/8" lg by 0.14" diam; axial leads	Parasitic suppressor	JAN RC20BF101K	JAN-R-11
R-187	3300-394152286 R16-R-17575 2Z6822-2	RESISTOR, fixed: composition; 22 megohms ± 10%; 1/2 w; molded phenolic; 3/8" lg by 0.14" diam; axial leads	Parasitic suppressor	AB EB-2261	+Federal Mfg. & Eng. Corp RES-1016 Hewlett-Packard dwg #19M-S-793
S-101	3300-395499411 R16-S-11279-647 3Z9825-62.320	SWITCH, rotary: 4 pole 5 position; single section using both sides of wafer; solid silver alloy rotor and contacts; ceramic body 1-7/8" diam by 7/8" d; solder lug term; single hole mtg; bushing 3/8"-32 by 3/8" lg; shaft 1/4" OD by 7/8" lg	"Sync Selector" switch	Oak type #36678-HIC	+Federal Mfg. & Eng. Corp 310-129 Hewlett-Packard dwgs #19M-S-702 #19M-S-402
		Ø When requesting replacement specify maxi- mum allowable size of 5/16" diam by 11/16" lg			

TABLE 6-1.—TABLE OF REPLACEABLE PARTS (Contd)

MODEL: SIGNAL GENERATOR TS-403/U

MAJOR ASSEMBLY: SIGNAL GENERATOR TS-403/U (Less Accessories)

REF. SYMBOL	USAF STOCK NO. ASO STOCK NO. SIG C. STOCK NO. NAVY STOCK NO.	NAME OF PART AND DESCRIPTION	FUNCTION	MFR. AND DESIG. OR JAN TYPE	CONT. OR GOV. DWG. OR SPEC. NO.
S-102	3300-395033059 2Z9558-34.50	SWITCH, sensitive: SPDT; 10 amp, 125 v AC; molded black phenolic case; 1.937" lg by 0.687" wd by 1-23/64" h; plunger type actuator with auxilliary cam driven roller lever actuator mtd on side of case; 9-13 oz. oper pressure; 0.005" movement differential, 0.040" max pre-travel; 0.050" min over-travel one contact normally closed; one contact normally open; solder lug term; two 0.140" diam mtg holes on 1/4" by 1" mtg/c from bottom on side of case	V-111 repeller mode switch and roller actuator	Micro Switch #BZ-2RS with type JR Roller Lever Auxilliary Actuator	JAN-S-63 +Federal Mfg. & Eng. Corp SWI-2 Hewlett-Packard dwg #19M-S-703
S-102A R17-MCS-BZ2RS	SWITCH, sensitive: SPDT JAN #SS02A20; 10 amp, 125 v AC; molded phenolic case per JAN-P-14; 1.937" lg x 0.687" wd x 1-25/32" max h o/a body dim.; spring plunger type actuating mechanism 0.156" diam, 9-13 oz. oper pressure; 0.005" max movement differential, 0.040" max pre-travel; 0.050" min over-travel; momentary action; one contact normally open and one contact normally closed; 3 solder lug term; mounts by two #6-32 RH mach screws, two #6 int tooth lock-washers, and two #6-32 hex nuts supplied with switch in two mtg holes drilled through laterally 1.0" c to c; p/o S-102	Microswitch for repeller mode changing	+Federal Mfg. & Eng. Corp SWI-2-1 JAN SS02A20	JAN-S-63 +Federal Mfg. & Eng. Corp SWI-2-1
S-102B R17-A-75	BAR, switch actuator: hinge roller leaf type; c/o one mtg plate, one actuating bar and one roller wheel; irregular shape; 3" lg x 3/4" wd x 2" h approx o/a dim.; two #6 mtg holes in mtg plate spaced 1" c to c; p/o S-102	Roller-actuator for micro-switch	+Federal Mfg. & Eng. Corp SWI-2-2	+Federal Mfg. & Eng. Corp SWI-2-2
S-103	3300-395499410 R16-S-11279-37 3Z9825-62.319	SWITCH, rotary: 2 pole 6 position; single section using both sides of wafer; solid silver alloy rotor and contacts; ceramic body; 1-7/8" diam by 7/8" d; solder lug term; single hole mtg; bushing 3/8"-32 by 3/8" lg; shaft 1/4" OD by 7/8" lg	Modulation selector switch	OAK type #3627A-HIC	+Federal Mfg. & Eng. Corp 310-128 Hewlett-Packard dwgs #19M-S-701 #19M-S-401
S-104	3300-395739045 R17-S-28225-243 3Z9849.135	SWITCH, toggle: DPDT; JAN ST22N modified in that lever and face are black nickel; 1-1/4" lg by 11/16" wd by 2-1/8" d overall; mts by 7/16"-32 by 1/2" lg bushing	Power line and heater switch	JAN ST22N (modified with black nickel finish)	JAN-S-23 +Federal Mfg. & Eng. Corp SWT-2 Hewlett-Packard dwg #19M-S-765

T-101	3300-299520236 R16-T-6950-425 2Z9613.553	TRANSFORMER, power: filament and plate type; input 115 v \pm 10%; 50-1600 cycles; single ph; 5 output windings; sec'd #1, 5.0 v at 2.0 amp; sec'd #2, 6.3 v at 2.5 amp; sec'd #3, 6.3 v at 4.0 amp; sec'd #4, 540 v at 150 ma CT, also tapped at 50 v point each side of CT; sec'd #5, 6.3 v at 0.6 amp; hermetically sealed metal case; case excluding term 4-9/16" lg by 4-1/4" wd by 5-3/4" h; 14 solder lug term mtd on ceramic feed-through insulators on bottom of case; four #10-32 mtg stud on 3" by 3-3/8" mtg/c	Power transformer	Chi Trans #11931-A	JAN-T-27 Grade 1 Class A +Federal Mig. & Eng. Corp 310-68 Hewlett-Packard dwgs #19M-M-503 #19M-M-506
V-101	3300-234750000 N16-T-56677 2J6SL7GT	TUBE, electron: JAN6SL7GT; dual triode	Limiting amplifier	JAN-6SL7GT	JAN-1-A
V-102	3300-234560000 N16-T-56360 2J6J6	TUBE, electron: JAN 6J6; dual triode	Pulse rate multivibrator tube	JAN-6J6	JAN-1-A
V-103	3300-234475000 N16-T-56214 2J6C4	TUBE, electron: JAN 6C4; triode	Series limiter tube	JAN-6C4	JAN-1-A
V-104		TUBE, electron: same as V-102	Delay multivibrator tube		
V-105	3300-234815200 N16-T-56855 2J6X5GT	TUBE, electron: JAN 6X5GT; dual diode	Limiter tube	JAN-6X5GT	JAN-1-A
V-106		TUBE, electron: same as V-103	Isolating amplifier		
V-107		TUBE, electron: same as V-102	Pulse length multivibrator		
V-108		TUBE, electron: same as V-103	Pulse inverter		
V-109	3300-234820000 N16-T-56915 2J6J6G	TUBE, electron: JAN 6Y6G; tetrode	Pulse length multivibrator	JAN-6Y6G	JAN-1-A
V-110		TUBE, electron: same as V-103	Isolating amplifier		

TABLE 6-1. -TABLE OF REPLACEABLE PARTS (cont)

MODEL: SIGNAL GENERATOR TS-403/U

MAJOR ASSEMBLY: SIGNAL GENERATOR TS-403/U (Less Accessories)

REF. SYMBOL	USAF STOCK NO. ASO STOCK NO. SIG C. STOCK NO. NAVY STOCK NO.	NAME OF PART AND DESCRIPTION	FUNCTION	MFG. AND DESIG. OR JAN TYPE	CONT. OR GOV. DWG. OR SPEC. NO.
† V-111	3300-234199000 N16-T-52628 2J2K28	TUBE, electron: JAN 2K28; Klystron oscillator	UHF oscillator	JAN-2K28	JAN-1-A
V-112	3300-234005100 N16-T-52001 2J0A2	TUBE, electron: JAN 0A2; gas filled regulator	Voltage regulator	JAN-0A2	Jan-1-A
V-113		TUBE, electron: same as V-112	Voltage regulator		
V-114		TUBE, electron: same as V-112	Voltage regulator		
V-115		TUBE, electron: same as V-109	Voltage regulator		
V-116	3300-234355000 N16-T-55444 2J5R4GY	TUBE, electron: JAN 5R4GY; dual diode	Power rectifier	JAN-5R4GY	JAN-1-A
V-117		TUBE, electron: same as V-105	Power rectifier		
W-105 N15-C-12201-50	CABLE, RF: coaxial RF cable; solid copper inner conductor; polyethylene dielectric; tinned copper braid outer conductor; vinyl jacket 0.195" diam overall; AN Type RG-58/U; used in RF probe E-101	Output cable from V-111 resonant cavity	JAN RG-58/U	+ Federal Mfg. & Eng. Corp CAB-6
X-101	3300-295956841 R16-S-6185-525 2Z8678.194	SOCKET, tube: octal; one piece saddle mtg; two 5/32" diam mtg holes on 1-5/16" mtg/c; round phenolic molded body, 1" diam by 1/2" h excluding term; solder coated brass cont	Tube socket for V-101	Monadnock Mills #295501 Cinch #13696	+ Federal Mfg. & Eng. Corp SKT-11 Hewlett-Packard dwg #19M-S-707
		† When ordering replacement, request that this item be "pulse tested."			

X-101	SOCKET, tube: octal; one piece saddle mtg; two 5/32" diam mtg holes on 1-1/2" mtg/c; round mica-filled phenolic molded body, 1-1/8" diam by 5/8" h excluding term; solder coated brass contacts	Tube socket for V-101	TS101P01	ⓄJAN-S-28A
X-102	3300-298420100 R16-S-6183-13 2Z8677.94	SOCKET, tube: 7 contact miniature; one piece saddle mtg; two mtg holes for #4 screws on 7/8" mtg/c; round molded, mica filled phenolic body, 5/8" diam by 5/16" h excluding term; solder coated brass contacts; with metal shield base, 13/16" OD by 3/4" h and center gnd shield 5/32" ID	Tube socket for V-102	JAN S010M	JAN-S-28
X-103		SOCKET, tube: same as X-102	Tube socket for V-103		
X-104		SOCKET, tube: same as X-102	Tube socket for V-104		
X-105		SOCKET, tube: same as X-101	Tube socket for V-105		
X-106		SOCKET, tube: same as X-102	Tube socket for V-106		
X-107		SOCKET, tube: same as X-102	Tube socket for V-107		
X-108		SOCKET, tube: same as X-102	Tube socket for V-108		
X-109		SOCKET, tube: same as X-101	Tube socket for V-109		
X-110		SOCKET, tube: same as X-102	Tube socket for V-110		
X-111	3300-296322500 R16-S-6188-10 2Z8799-137	SOCKET, tube: octal; has retainer ring mtg provision but merely mts on tube in this application; round black, mica-filled bakelite body, 1-3/16" diam by 1/2" h excluding term; phosphor bronze silver pl contacts	Tube socket for V-111	Amphenol #78-S8T	+ Federal Mfg. & Eng. Corp SKT-8 Hewlett-Packard dwg #19M-S-704
X-112		SOCKET, tube: same as X-102	Tube socket for V-112		
X-113		SOCKET, tube: same as X-102	Tube socket for V-113		
X-114		SOCKET, tube: same as X-102	Tube socket for V-114		
X-115		SOCKET, tube: same as X-101	Tube socket for V-115		
X-116		SOCKET, tube: same as X-101	Tube socket for V-116		
X-117		SOCKET, tube: same as X-101	Tube socket for V-117		

TABLE 6-1.—TABLE OF REPLACEABLE PARTS (Contd)

MODEL: SIGNAL GENERATOR TS-403/U

MAJOR ASSEMBLY: SIGNAL GENERATOR TS-403/U (Accessories Only)

REF. SYMBOL	USAF STOCK NO. ASO STOCK NO. SIG C. STOCK NO. NAVY STOCK NO.	NAME OF PART AND DESCRIPTION	FUNCTION	MFR. AND DESIG. OR JAN TYPE	CONT. OR GOV. DWG. OR SPEC. NO.
*A-106	1600-328630940 R16-AN-CY-669U-FME 3F2529-669 N16-C-170001-467	CASE: carrying case; aluminum clad plywood; empty; 20-9/16" lg x 17-1/4" wd x 17-11/16" h o/a; contains mtg provisions for Signal Generator TS-403/U, flat box in bottom for accessories and flat box on one side of interior for instruction book; one folding type handle on each end; eight lid fasteners, approx weight 27 lbs, "TS-403/U" stencilled in black on front, right side and top, includes A-107	Protective transit case for TS-403/U Signal Generator	JAN-CY-669/U	+Federal Mfg. & Eng. Corp 310-2 Hewlett-Packard dwg #19M-E-104
A-107 2Z6820.650 N16-C-170001-473	MOUNTING, panel: aluminum, gray enamel finish; 7-7/16" lg by 4-3/16" wide by 15/16" high; one 0.221" diam mounting hole in each mounting flange with one snapslide fastener H-108 riveted at each hole; 9 clips, O-134 and O-135, 3 lamp holders, J-106, riveted to underside of cover; mounts at bottom of transit case, includes H-108, O-134, O-135, J-106	Mounting for accessories: fuses F-103, F-104, F-105, pilot lamps E-158, E-159, E-160; adapters E-142, E-143, E-144	+Federal Mfg. & Eng. Corp 310-35	+Federal Mfg. & Eng. Corp 310-35
E-145		PROBE, RF: same as E-122 (mounted on instrument chassis)	Spare power absorbing assembly for RF power monitoring of V-111		
E-155	3300-298296948 R16-A-478 2Z308-173	ADAPTER, connector: male one end, female other end; single axial contact on each end; JAN type UG-273/U	Adapter for RF transmission lines W-102 and W-103	JAN UG-273/U	+Federal Mfg. & Eng. Corp CON-48
E-156		ADAPTER, connector: same as E-155	Adapter for RF transmission lines W-102 and W-103		
E-157		ADAPTER, connector: same as E-155	Adapter for RF transmission lines W-102 and W-103		
E-158		LAMP, incandescent: same as E-135	Spare pilot lamp in A-107		
E-159		LAMP, incandescent: same as E-135	Spare pilot lamp in A-107		
E-160		LAMP, incandescent: same as E-135	Spare pilot lamp in A-107		
		* Not furnished as a maintenance part for Bureau of Ships activities. If failure occurs, do not request replacement unless the item cannot be repaired or fabricated.			

F-103		FUSE, cartridge: same as F-101	Spare power fuse in A-107		
F-104		FUSE, cartridge: same as F-101	Spare power fuse in A-107		
F-105		FUSE, cartridge: same as F-101	Spare power fuse in A-107		
H-108	6Z3809G-4	FASTENER: snapslide type; brass, beryllium copper and nickel-silver parts, nickel plated overall 13/16" lg by 1/4" wide by 0.18" high when fully extended; mounts by 0.070" diam hole; p/o accessories mounting A-107 (for identification only - not a replaceable part)	To mount A-107 to transit case	Dimco-Gray Co. Snapslide Fastener Assembly No. 1	+Federal Mfg. & Eng. Corp FAS-7
H-108A	R16-G-6980	GUIDE, latch: guide of snapslide fastener; brass, nickel plated; irregular shape; 0.609" lg x 0.266" wd x 0.109" h o/a; p/o H-108 (for identification only - not a replaceable part)	Part of snapslide fastener	Dimco-Gray Co. Guide #1-G	+Federal Mfg. & Eng. Corp FAS-7-1
H-108B	R16-S-4320	LATCH, fastener: latch of snapslide fastener; brass, nickel plated; irregular shape; approx 1/2" lg x 0.240" wd x 3/16" h o/a; p/o H-108 (for identification only - not a replaceable part)	Part of snapslide fastener	Dimco-Gray Co. Latch #1-L	+Federal Mfg. & Eng. Corp FAS-7-2
H-108C	R16-NE-3889	WASHER, curved: brass, nickel plated; top view round shape, side view arc shaped, 0.219" OD x 0.130" ID x 0.031" material thickness; p/o H-108 (for identification only - not a replaceable part)	Part of snapslide fastener	Dimco-Gray Co. Washer #1-W	+Federal Mfg. & Eng. Corp FAS-7-3
H-108D	R16-B-15698	BUTTON, snapslide fastener: brass, nickel plated; cylindrical shape; 0.326" lg x 0.219" diam o/a; shank of button is 0.250" lg; p/o H-108 (for identification only - not a replaceable part)	Part of snapslide fastener	Dimco-Gray Co. Rivet #1-R	+Federal Mfg. & Eng. Corp FAS-7-4
H-109	R16-FME-310-289	SCREW, thumb: knurled thumb head; steel, passivated finish; #10-24; approx 9/16" lg; threaded portion approx 1/2" lg; modified cup point; head 3/8" major diam x 0.188" minor diam x 3/32" lg	Locks frequency dial	+Federal Mfg. & Eng. Corp 310-289	+Federal Mfg. & Eng. Corp 310-289
H-110	R16-FME-310-304	NUT, knurled: brass, silver plated; 3/8"-32; 9/16" thk; 7/16" OD; ext surface medium knurled	Connector coupling nut	+Federal Mfg. & Eng. Corp 310-304	+Federal Mfg. & Eng. Corp 310-304
H-111		FASTENER: same as H-108	To mount A-107 to transit case		
H-111A		GUIDE, latch: same as H-108A (p/o H-111)	Part of snapslide fastener		

TABLE 6-1.—TABLE OF REPLACEABLE PARTS (Contd)

MODEL: SIGNAL GENERATOR TS-403/U

MAJOR ASSEMBLY: SIGNAL GENERATOR TS-403/U (Accessories Only)

REF. SYMBOL	USAF STOCK NO. ASO STOCK NO. SIG C. STOCK NO. NAVY STOCK NO.	NAME OF PART AND DESCRIPTION	FUNCTION	MFR. AND DESIG. OR JAN TYPE	CONT. OR GOV. DWG. OR SPEC. NO.
H-111B		LATCH, fastener: same as H-108B (p/o H-111)	Part of snapslide fastener		
H-111C		WASHER, curved: same as H-108C (p/o H-111)	Part of snapslide fastener		
H-111D		BUTTON, snapslide fastener: same as H-108D (p/o H-111)	Part of snapslide fastener		
J-106 R17-D-MC209CH	LAMPHOLDER: 1.6" lg by 1.10" wide by 0.90" deep; mts by 5/16" diam; grooved cylinder for attaching lamp; p/o A-107 (for identification only - not a replaceable part)	Mounts spare lamp E-158 in A-107	Drake Mfg. Co. 209CH	+Federal Mfg. & Corp SKL-2
J-107		LAMPHOLDER: same as J-106	Mounts E-159 in A-107		
J-108		LAMPHOLDER: same as J-106	Mounts E-160 in A-107		
P-102	3300-294732192 R16-P-2050 2Z7390-21B	CONNECTOR, plug: straight male cylindrical shape; brass, silver plated; locking type; Teflon insert; 1-3/4" lg by 13/16" diam; 1/2" max cable opening; 52 ohms impedance; p/o W-101	Terminates one end of "RF Output" cable W-101	JAN UG-21B/U	+Federal Mfg. & Eng. Corp CON-47
P-103		CONNECTOR, plug: same as P-102; p/o W-101	Terminates one end of "RF Output" cable W-101		
P-104	3300-294732375 R16-P-3627-375 2Z7390-88	CONNECTOR, plug: JAN type UG-88/U, single round axial male contact; p/o W-102	Terminates one end of RF cable W-102	JAN UG-88/U	+Federal Mfg. & Eng. Corp CON-17
P-105		CONNECTOR, plug: male contact; same as P-104; p/o W-102	Terminates one end of RF cable W-102		
P-106		CONNECTOR, plug: male contact; same as P-104; p/o W-103	Terminates one end of RF cable W-103		
P-107		CONNECTOR, plug: male contact; same as P-104; p/o W-103	Terminates one end of RF cable W-103		
P-108	8800-114005 R17-P-4457	CONNECTOR, plug: two flat parallel blades; 1-17/32" OD by 1-5/32" lg less contacts; 15 amp, 125 v; cylindrical steel covered body; brass inserts molded in body; cable opening adjustable for 0.296" to 0.562" OD cable; p/o W-104	Terminates one end of power cable assembly W-104	Hubbell #7057	+Federal Mfg. & Eng. Corp CON-14 Hewlett-Packard dwg #19M-M-762

P-108A		CONNECTOR, plug: two flat, parallel blades; 1-17/32" thk by 1-1/4" lg less contacts; 15 amp, 125 v; rectangular steel-covered body; blades molded in glass-filled melamine dielectric; cable opening adjustable from 0.125" to 0.450"; provided with grounding blade	Terminates one end of power cable assembly W-104	A. P. M. NO. 920 UP121M	Signal Eng. dwg #789-A-6643 MIL-C-3767
P-109	8800-032007 R17-P-4455	CONNECTOR, plug: two "T" shaped female contacts; straight; 1-17/32" OD by 1-13/16" lg overall; 15 amp, 125 v; cylindrical black composition body partially covered with steel; cable opening adjustable for 0.296" to 0.562" OD cable; p/o W-104	Terminates one end of power cable assembly W-104	Hubbel #7084	+ Federal Mfg. & Eng. Corp CON-13 Hewlett-Packard dwg #19M-M-761
P-109A		CONNECTOR, plug: female; 3 contacts; cylindrical body; w/cable clamp	Terminates one end of power cable assembly W-104	AN3106A-10SL-3S	⊕MIL-C-5015
*W-101	1600-154431048 R16-C-3738-600 1F430-92B.72	CABLE ASSEMBLY, RF: JAN type RG-9A/U coaxial cable; 6' lg, excluding terminations; 6' 3-1/2" overall; JAN type UG-21B/U connectors on each end; includes P-102, P-103	"RF Output" coaxial cable	JAN CG-92A/U(6')	+ Federal Mfg. & Eng. Corp 310-36 Hewlett-Packard dwg #19M-E-412
W-102	1600-154435250 R16-C-3761-50 1F430-409.96	CABLE ASSEMBLY, RF: JAN type RG-58/U coaxial cable; 8' lg excluding terminations; 8' 2" lg overall; JAN type UG-88/U connectors on each end; includes P-104, P-105	Provides connections to J-101, J-102, J-103, or J-104	JANCG-409/U(8' 2")	+ Federal Mfg. & Eng. Corp 310-305 Hewlett-Packard dwg #19M-E-403
W-103		CABLE ASSEMBLY, RF: same as W-102; includes P-106, P-107	Provides connections to J-101, J-102, J-103, or J-104		
*W-104	1600-322852132 R16-AN-CX337/U 3E7350.1-72.5	CABLE ASSEMBLY, power: JAN type CX-337/U; 5' 11-3/4" lg excluding terminations; Hubbel part #7084 connector on one end, Hubbel part #7057 connector on other end; p/o Signal Generator TS-403/U	Provides power connection from unit to power source	JAN CX-337/U(6')	+ Federal Mfg. & Eng. Corp 310-34 Hewlett-Packard dwg #19M-E-404

* Not furnished as a maintenance part for Bureau of Ships activities. If failure occurs, do not request replacement unless the item cannot be repaired or fabricated.

TABLE 6-1. - TABLE OF REPLACEABLE PARTS (cont)

MODEL: SIGNAL GENERATOR TS-403/U

MAJOR ASSEMBLY: SIGNAL GENERATOR TS-403/U (Less Accessories)

REF. SYMBOL	USAF STOCK NO. ASO STOCK NO. SIG C. STOCK NO. NAVY STOCK NO.	NAME OF PART AND DESCRIPTION	FUNCTION	MFG. AND DESIG. OR JAN TYPE	CONT. OR GOV. DWG. OR SPEC. NO.
W-104		CABLE ASSEMBLY, power: JAN type CX-3135/U; 5' 11-3/4" lg excluding terminations; AN3106A-10SL-3S connector on one end; UP121/M connector on other end; p/o Signal Generator TS403/BU	Provides power connection from unit to power source	JAN CX-3135/U(6')	Model Eng. dwg #789-B-6640
W-104A		CABLE, power: two conductor #16 AWG stranded; 0.460" OD by 6' lg; cable used with W-104	Power cord - Part of W-104	MHFF-2	+ Federal Mfg. & Eng. Corp CAB-2 MIL-C-915
W-104B		CABLE, power: three conductor #18 AWG stranded; 0.330" OD by 5' 11-1/4" lg; cable used with W-104	Power cord - Part of W-104	JAN C0-03MGF (3/18) 0.3330	Model Eng. dwg #789-A-6641 MIL-C-3432

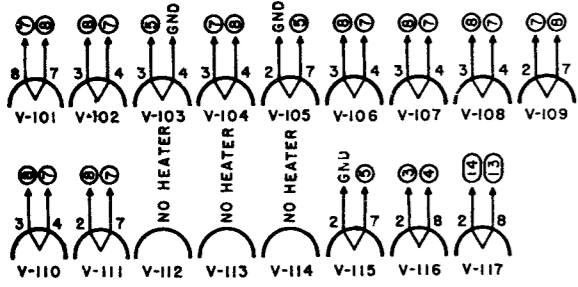
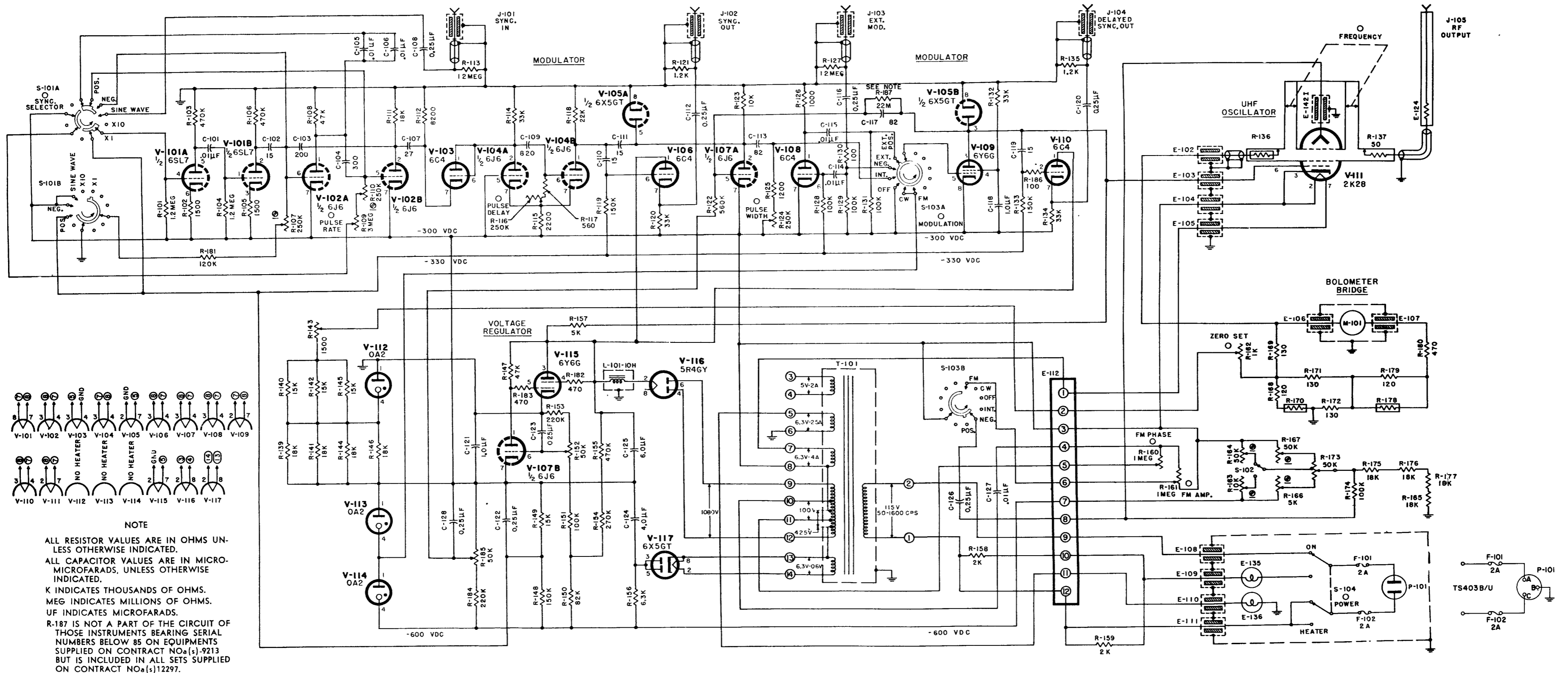

NOTE

ALL RESISTOR VALUES ARE IN OHMS UNLESS OTHERWISE INDICATED.
 ALL CAPACITOR VALUES ARE IN MICRO-MICROFARADS, UNLESS OTHERWISE INDICATED.
 K INDICATES THOUSANDS OF OHMS.
 MEG INDICATES MILLIONS OF OHMS.
 UF INDICATES MICROFARADS.
 R-187 IS NOT A PART OF THE CIRCUIT OF THOSE INSTRUMENTS BEARING SERIAL NUMBERS BELOW 85 ON EQUIPMENTS SUPPLIED ON CONTRACT NOa(s)-9213 BUT IS INCLUDED IN ALL SETS SUPPLIED ON CONTRACT NOa(s)12297.

Figure 7-1. Signal Generator TS-403/U, Schematic Diagram

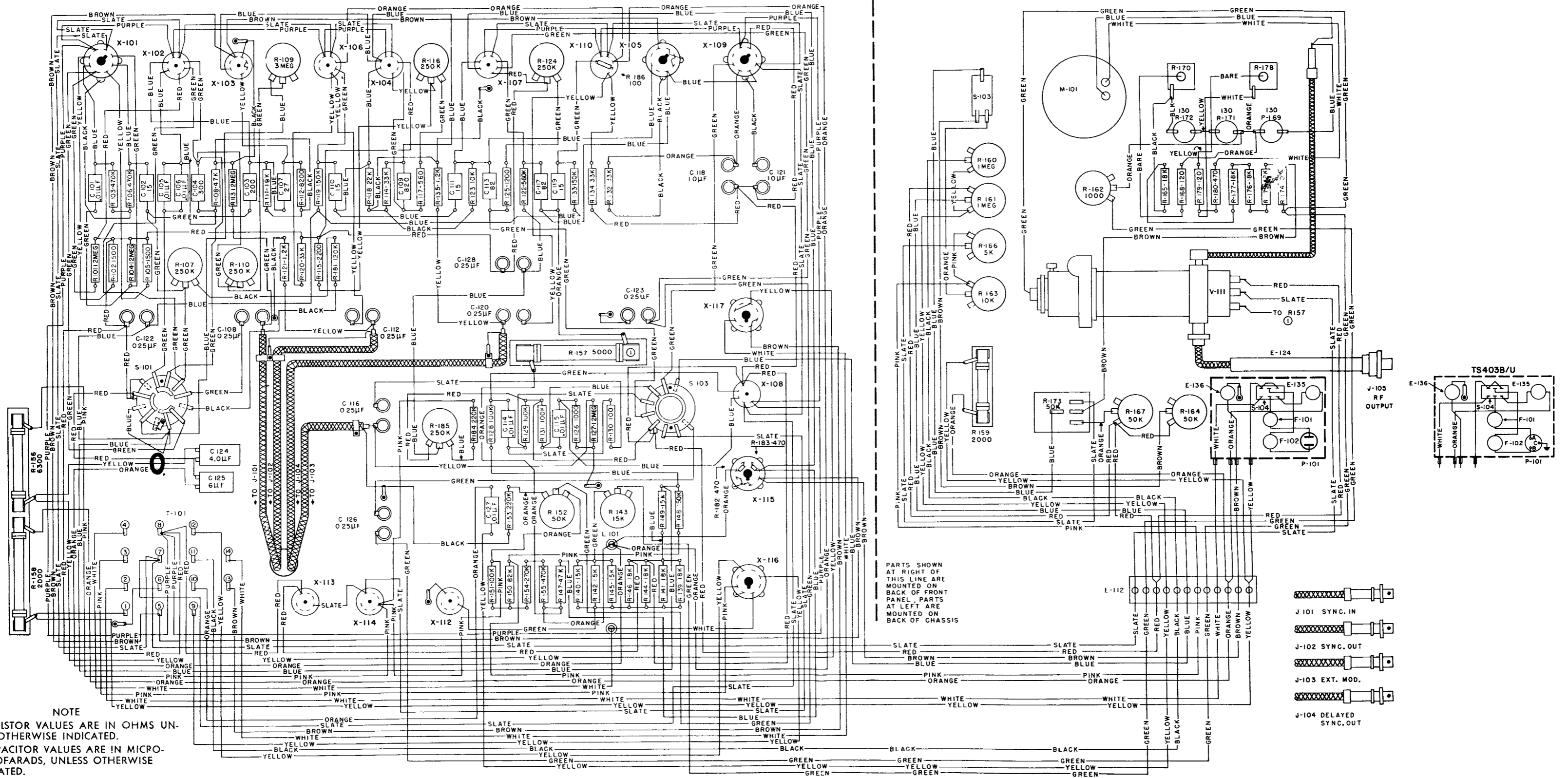

NOTE
 ALL RESISTOR VALUES ARE IN OHMS UNLESS OTHERWISE INDICATED.
 ALL CAPACITOR VALUES ARE IN MICRO-MICROFARADS, UNLESS OTHERWISE INDICATED.
 K INDICATES THOUSANDS OF OHMS.
 MEG INDICATES MILLIONS OF OHMS.
 UF INDICATES MICROFARADS.

PARTS SHOWN AT RIGHT OF THIS LINE ARE MOUNTED ON BACK OF FRONT PANEL. PARTS AT LEFT ARE MOUNTED ON BACK OF CHASSIS

Figure 7-2. Signal Generator TS-403/U, Practical Wiring Diagram

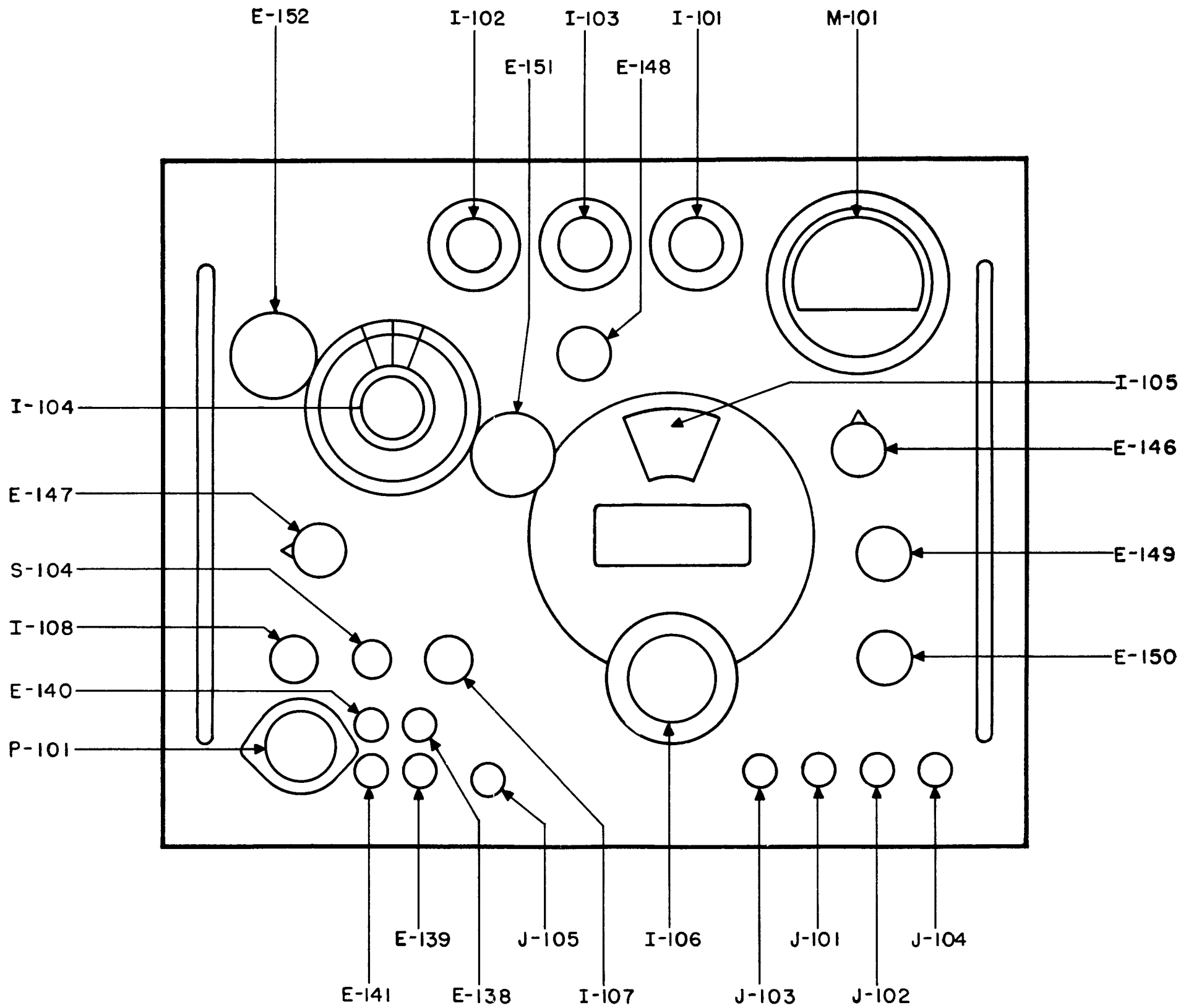

Figure Z-3. Signal Generator TS-403/U, Front Panel Controls

CONDITIONS OF MEASUREMENT

1. Waveshapes are shown on a 2500-microsecond time base. SYNC OUT pulse was used to trigger oscilloscope sweep.
2. Waveshapes were obtained when Signal Generator TS-403/U was synchronized with an external 1000 cps, 10-volt rms (28-volt peak-to-peak) sine wave (SYNC SELECTOR switch set to SINE WAVE position).
3. Pulse voltages shown are peak-to-peak voltages. The voltages should be regarded as approximations and may vary at least 20% depending upon age of tubes, method of measurement, etc.
4. Waveshapes were obtained with PULSE DELAY control set for 100 microseconds of delay and with PULSE WIDTH control set for 10 microseconds. Waveshapes will vary according to pulse repetition frequency and setting of controls.

NOTES

1. When oscilloscope is connected to this grid, spurious triggering or extreme jitter usually occurs. This is normal.
2. The amplitude of this voltage depends upon load into which SYNC OUT jack is working. Voltage shown is approximately maximum available.
3. The amplitude of this voltage depends upon load into which DELAYED SYNC OUT jack is working. Approximately 100 volts maximum is available.

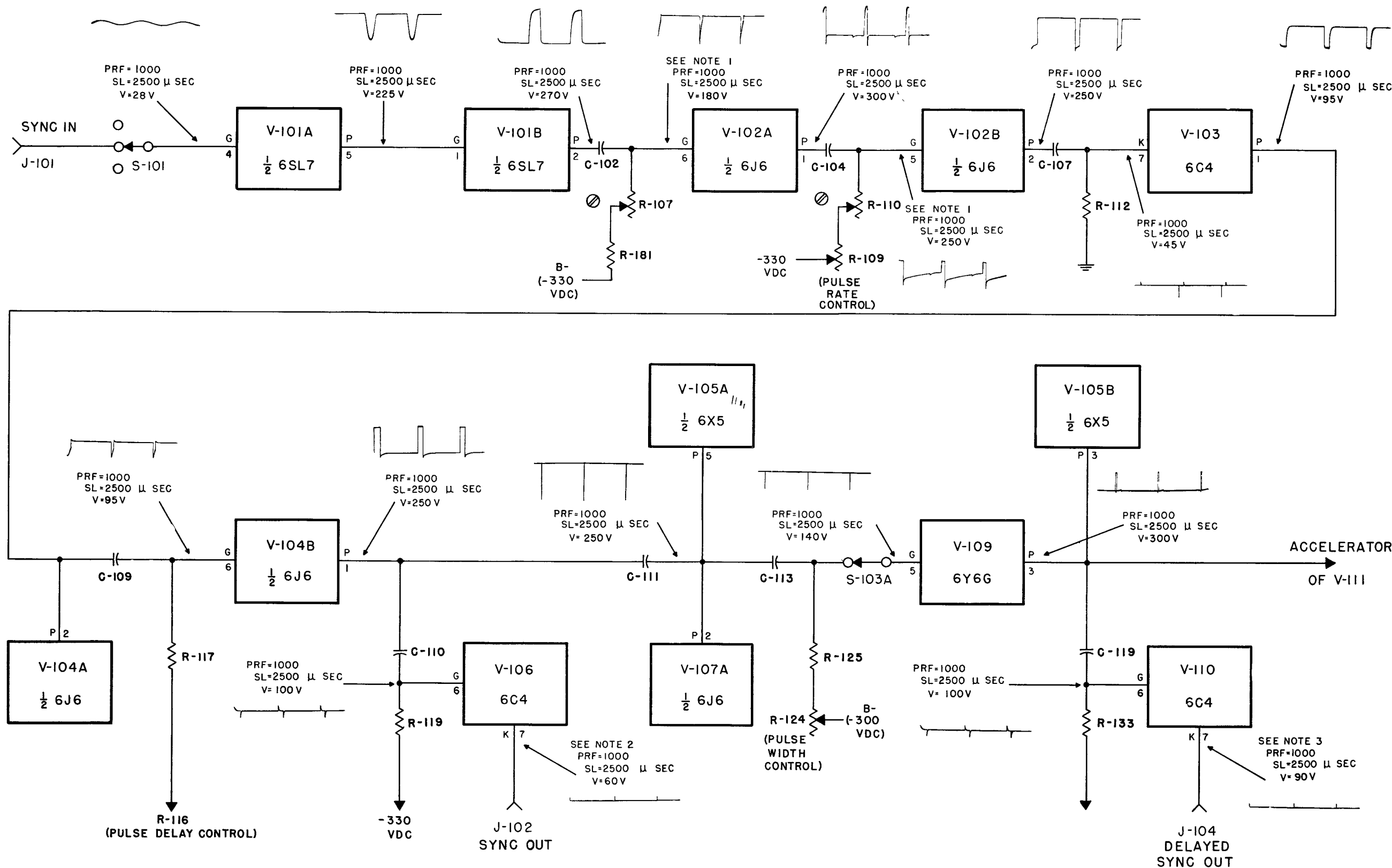

Figure 7-4. Signal Generator TS-403/U, Servicing Block Diagram

CONDITIONS OF MEASUREMENT

1. Voltages were measured with a 20,000-ohm-per-volt Simpson Model 260 Voltmeter.
2. Voltages were measured from the -300 volt supply to the pin shown. (The -300 volt supply is conveniently obtained at pin 8 of V-109.)
3. Resistances were measured to chassis (B+) from pin shown.
4. Voltages and resistances were measured with SYNC SELECTOR switch in SINE WAVE position and with modulation selector switch in OFF position.

NOTES

1. Voltage and resistance at this pin vary with setting of PULSE RATE control. Voltage varies from approximately -24 to -48 vdc and resistance from approximately 0.2 megohm to 3.5 megohm.
2. Voltage at this pin varies with setting of PULSE DELAY control over a range from approximately 86 to 106 volts.
3. Voltage and resistance at this pin vary with setting of PULSE DELAY control. Voltage varies from approximately +9 to +17 vdc; resistance varies from approximately 12K to 260K ohms.

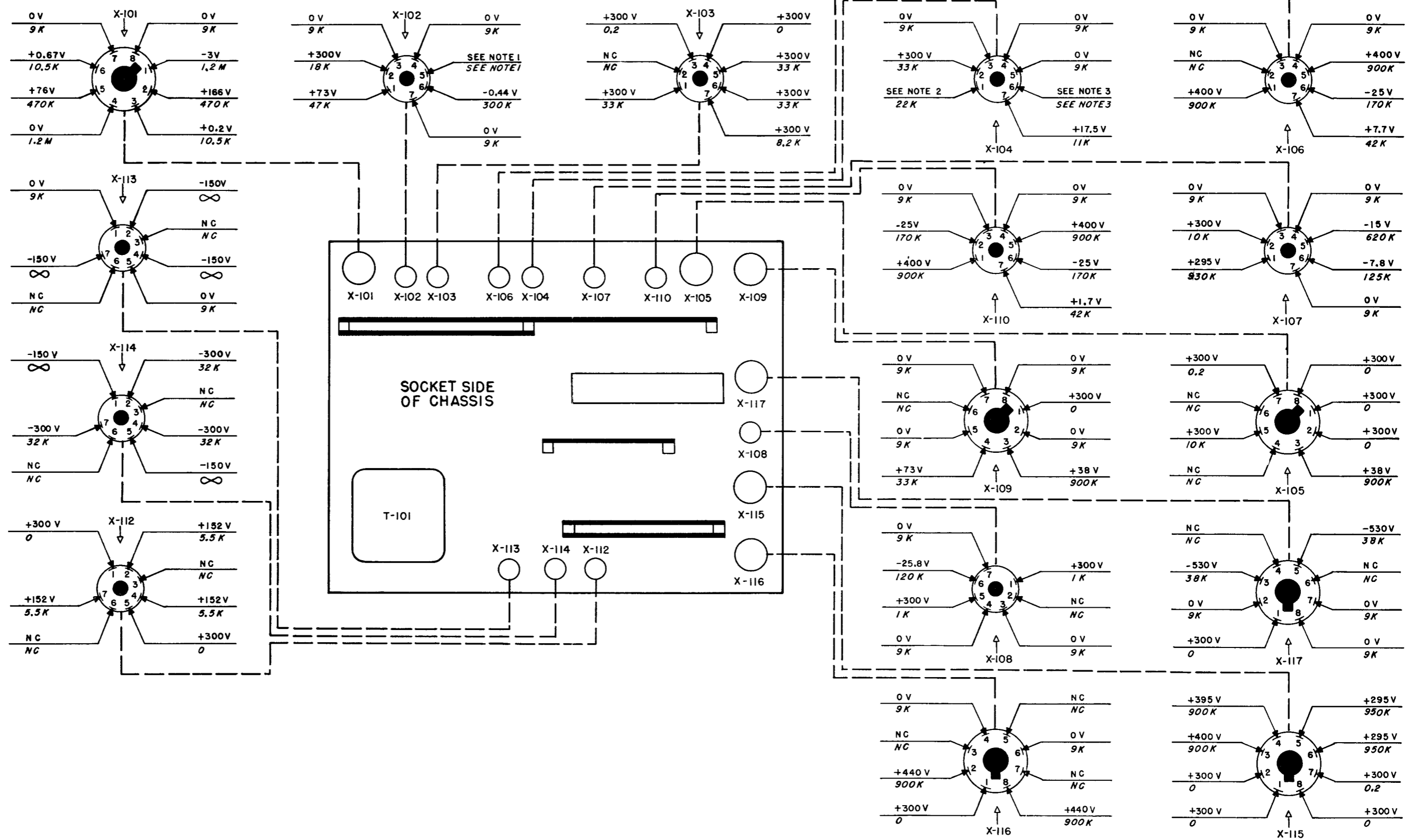
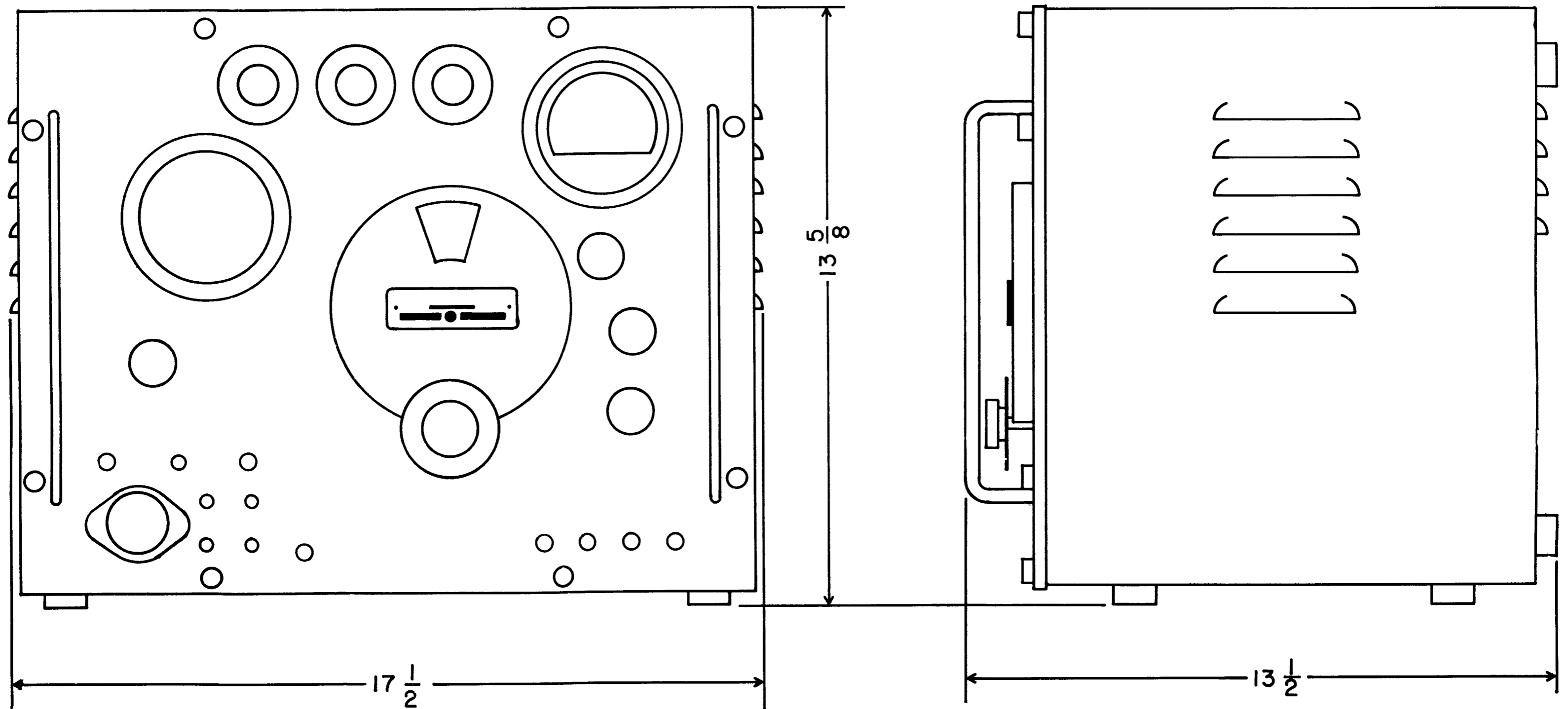

Figure 7-5. Signal Generator TS-403/U, Voltage (20,000-ohms-per-volt) and Resistance Diagram



NOTE:

ALL DIMENSIONS ARE GIVEN IN INCHES

Figure 7-7. Signal Generator TS-403/U, Overall Dimensions

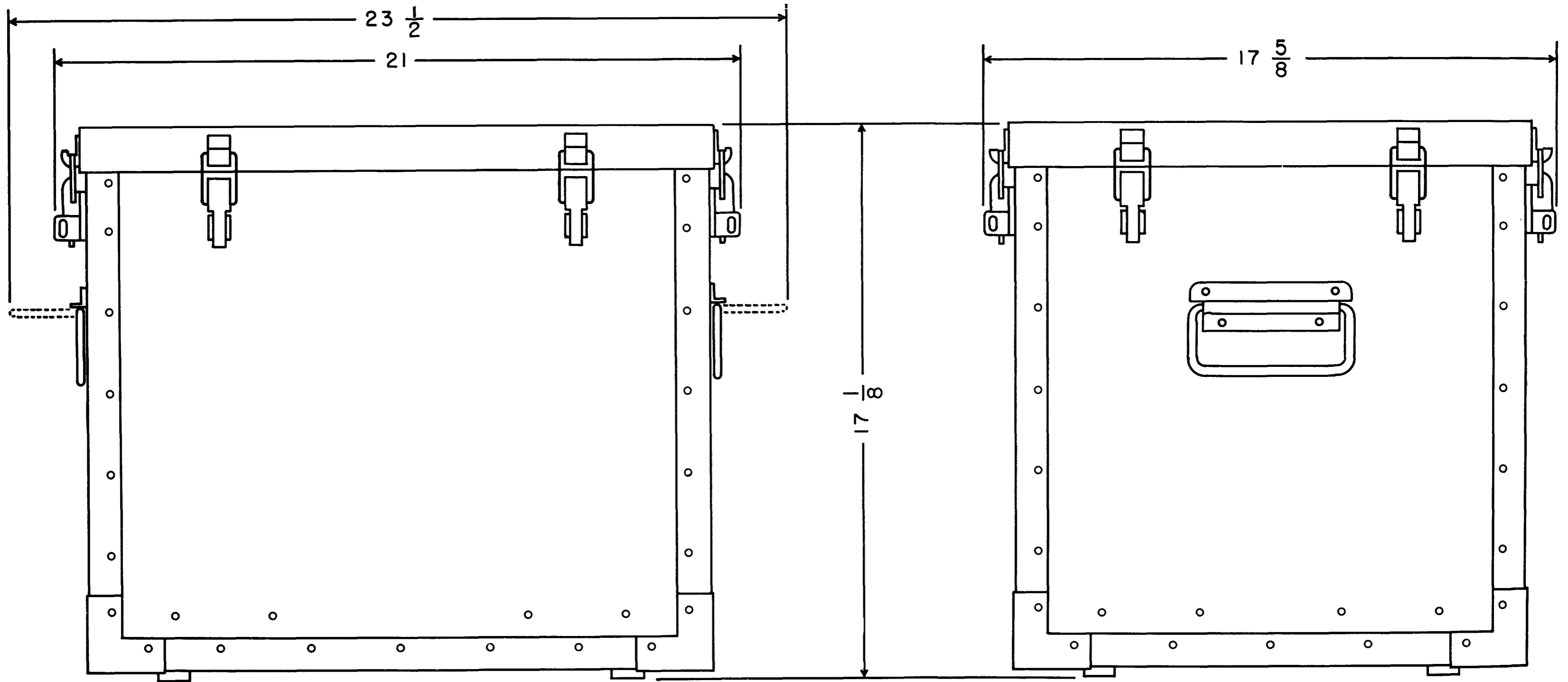

NOTE:

ALL DIMENSIONS ARE IN INCHES

Figure 7-8. Transit Case, CY-669/U, Overall Dimensions

NOTE:
ALL DIMENSION GIVEN IN INCHES

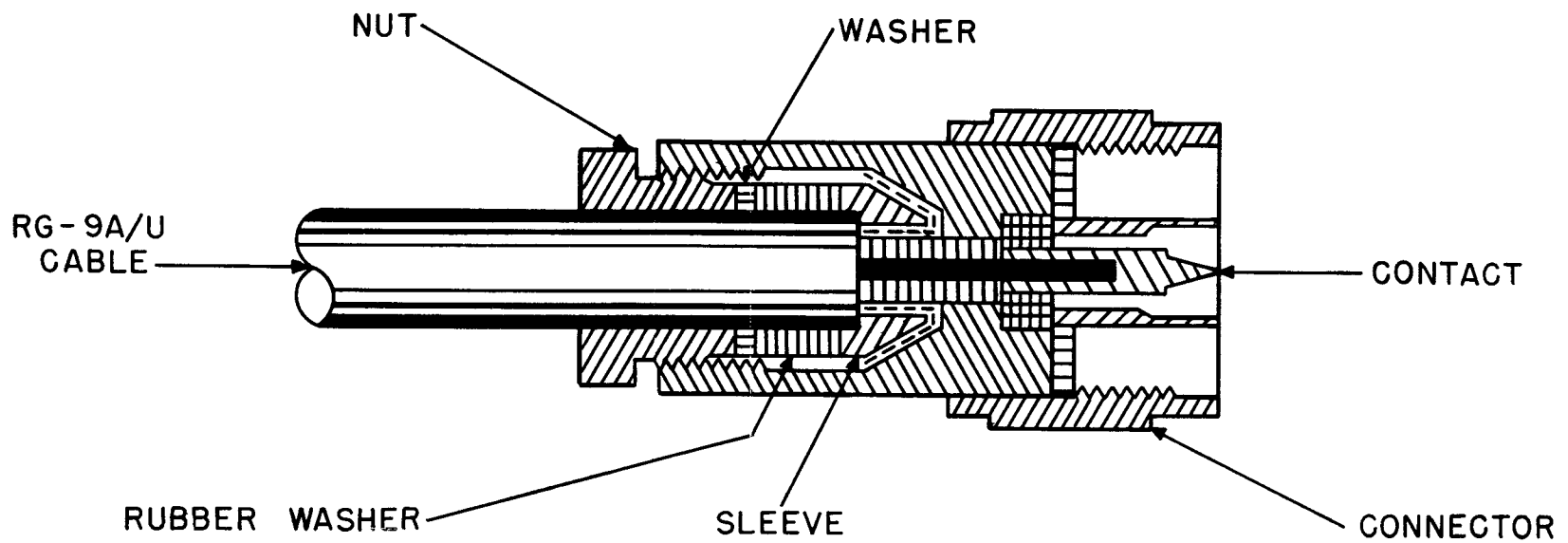
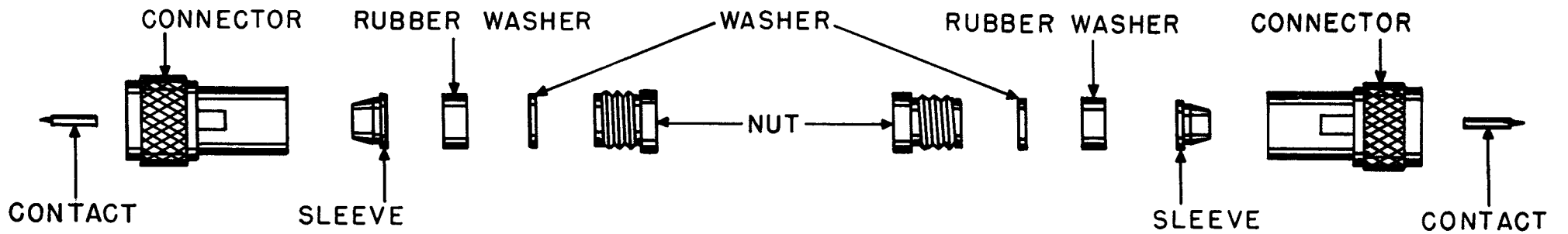
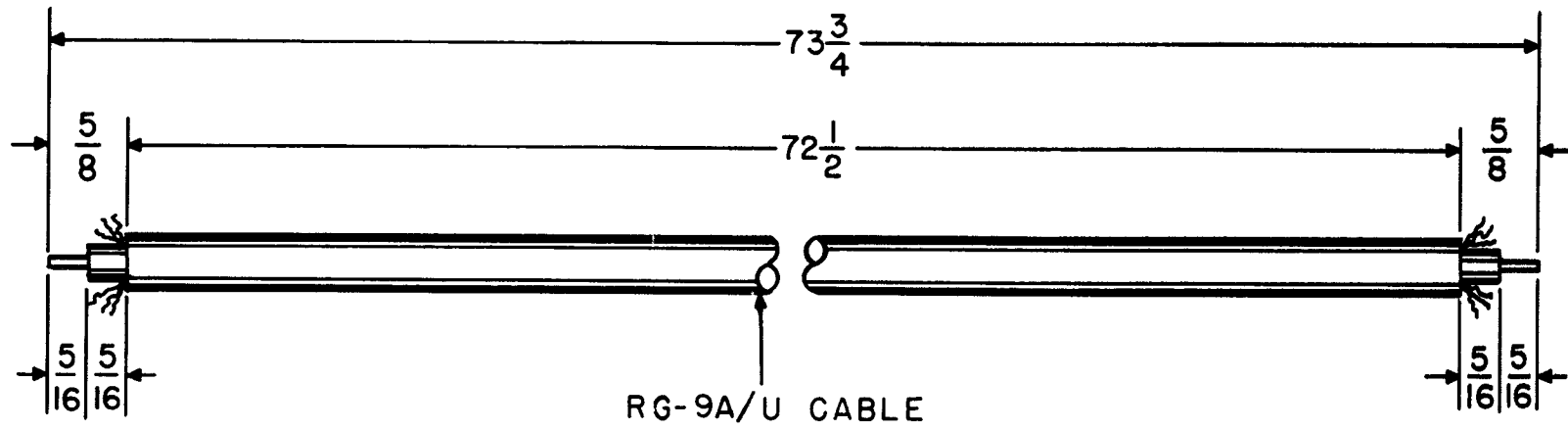

Figure 7-9. RF Cable CG-92B/U (6'), Fabrication Data

ASSEMBLY OF BNC CONNECTORS TO RG-58/U CABLE

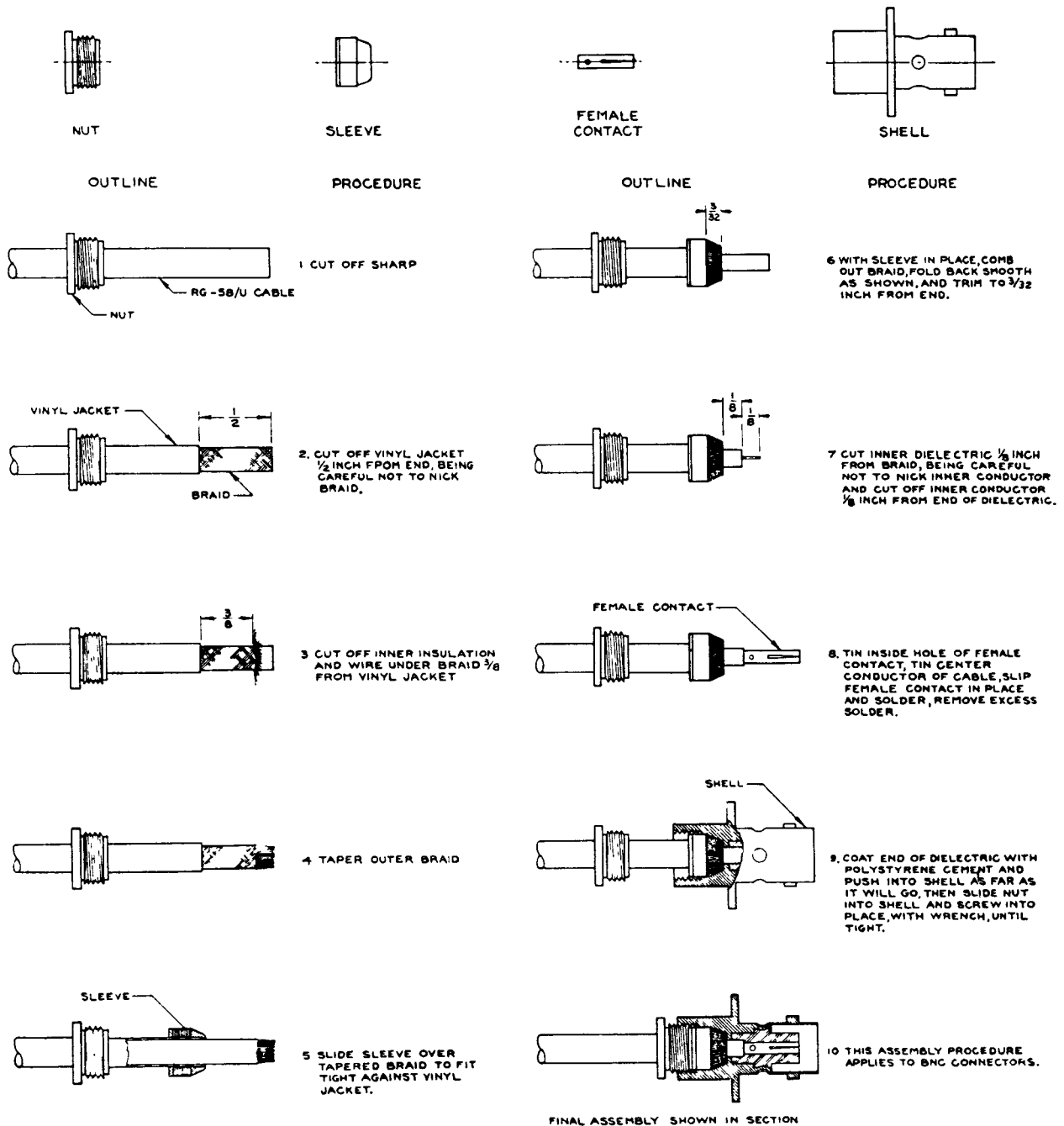

Figure 7-10. Video Cord CG-409/U (8' 2"), Fabrication Data

ALL DIMENSIONS GIVEN IN INCHES

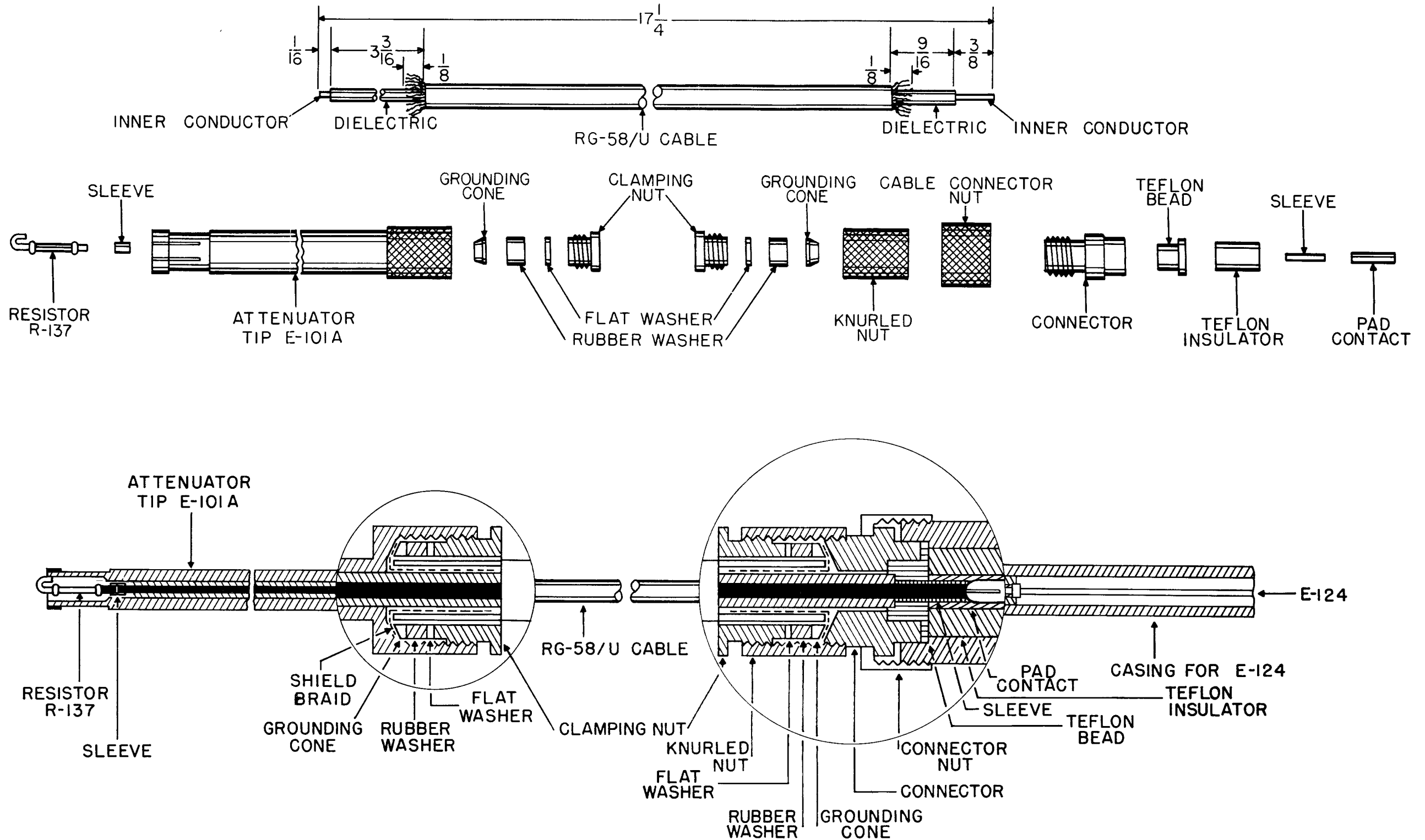

Figure 7-11. Attenuator Cable, Fabrication Data

INDEX

A	<i>Figure</i>	<i>Page</i>
Abbreviations, list of.....		6-1
Accessories, description of.....		1-2
Accessories, mounting of.....	1-3	1-3
Adjustments, electrical.....		4-5
Assembly, mechanical system.....		4-8
Attenuator cable, fabrication data.....	7-11	7-23
Attenuator dial assembled for index adjustment.....	4-36	4-17
Attenuator drive, front view.....	4-31	4-16
Attenuator drive, loading spring in place.....	4-40	4-18
Attenuator drive, rear view.....	4-33	4-16
Attenuator drive, spring-loading of pinion.....	4-32	4-16
Attenuator gear rack, assembly of.....	4-39	4-18
Attenuator index, position with controls set counter-clockwise.....	4-37	4-18
Attenuator, test set-up for calibrating.....	4-46	4-21
 B		
Brush assembly, alignment of.....	4-26	4-14
Brush assembly assembled.....	4-27	4-14
Brush assembly, parts comprising.....	4-25	4-13
Brush assembly and outer conductor, assembly.....	4-28	4-14
 C		
Cable fabrication data, attenuator cable.....	7-11	7-23
Cable fabrication data, video cable.....	7-10	7-21
Calibration.....		4-25
Characteristics, general electrical.....		1-1
 Circuits:		
Complete block diagram.....	3-1	3-0
Delayed sync out.....	3-15	3-9
Equivalent oscillator.....	3-2	3-0
External modulation.....	3-16	3-10
External negative pulse sync.....	3-10	3-7
External positive pulse sync.....	3-11	3-7
External sine wave sync.....	3-9	3-6
Free-running pulse rate multivibrator.....	3-8	3-5
Limiter and delay multivibrator.....	3-12	3-8
Repeller ac voltage for FM operation.....	3-18	3-10
Repeller voltage.....	3-5	3-2
RF monitor.....	3-6	3-3
Signal width multivibrator.....	3-14	3-9
Switching arrangement for CW and FM.....	3-17	3-10
Sync out pulse circuit.....	3-13	3-8
Color codes, resistor and capacitor.....		6-2
Controls, modulator.....		2-2
Controls, oscillator.....		2-1

D	<i>Figure</i>	<i>Page</i>
Delay multivibrator, theory of.....		3-7
DELAYED SYNC OUT terminal, function of.....		2-2
Description, general.....		1-2
Dimensions, overall.....	7-7	7-15
Dimensions of transit case.....	7-8	7-17
Drive housing, parts comprising.....	4-10	4-8
Drive system, assembled, front view.....	4-15	4-11
Drive system, assembled, left view.....	4-16	4-11
Drive system, assembled, right view.....	4-17	4-11
Drive system, lower, assembly of.....	4-13	4-9
Drive system, lower, parts comprising.....	4-12	4-9
Drive system, main, parts comprising.....	4-14	4-10
Drive system mounted on panel.....	4-44	4-20
Drive system, upper, assembly of.....	4-11	4-8
Drive system, upper, parts comprising.....	4-9	4-8
E		
E-124, cutaway view showing location.....	4-48	4-23
Equipment, function of.....		2-0
Equipment, purpose of.....		1-1
Equipment supplied.....		1-1
EXT MOD terminal, function of.....		2-4
F		
Fabrication data for RF Cable CG-92B/U (6').....	7-9	7-19
Fabrication data for video cable.....	7-10	7-21
FM AMPLITUDE control, function of.....		2-2
FM output.....		2-5
FM PHASE control, function of.....		2-2
Frequency range.....		1-1
G		
General characteristics.....		5-2
Grid contact clamping plate, assembly of.....	4-43	4-19
H		
Heater, operation of.....		2-5
I		
Index plate assembled.....	4-35	4-17
Inner grid contact ring, positioning of.....	4-42	4-19
Input terminals, function of.....		2-4
Internal impedance.....		5-3
K		
Klystron, reflex.....		3-0
Klystron, replacement of.....		4-3

	<i>Figure</i>	<i>Page</i>
L		
Lamps and tubes, table of		1-3
Limiter, theory of		3-7
Load, external		2-4
Lubrication		4-0
M		
Maintenance, preventive		4-0
Maintenance, test equipment required		4-0
Manufacturers, list of		6-1
Modulator, adjustment of		2-4
Modulator, block diagram of	3-7	3-4
Modulator, free-running operation		2-4
Modulator, how to synchronize externally		2-5
Modulation selector switch, operation of		2-1
Modulator, theory of		3-4
Modulator controls		2-2
Monitor and attenuator RF probe holders, assembly of	4-38	4-18
Monitor drive loading spring in place	4-41	4-19
O		
Operating controls, table of		2-3
Operating procedure, step-by-step		2-4
Operation		2-0
Operation, theory of		3-0
Ordering of spare parts		6-0
Oscillator, adjustment of		2-4
Oscillator and attenuator assembly mounted on panel	4-34	4-17
Oscillator assembly, overall view	4-1	4-1
Oscillator, cutaway view	3-3	3-1
Oscillator, how to modulate externally		2-5
Oscillator, theory of		3-0
Outer conductor, assembled view	4-29	4-15
OUTPUT ATTEN control, function of		2-1
Output RF probe, cutaway view	4-47	4-22
Output terminals, function of		2-2
P		
Potentiometer drive system, assembly of	4-21	4-12
Potentiometer drive assembly, oblique view	4-22	4-12
Potentiometer drive system, parts comprising	4-20	4-12
Potentiometer R-173, mounting bracket for	4-23	4-13
Potentiometer R-173, mounting bracket in place	4-24	4-13
Potentiometers, replacement of		4-5
POWER INPUT terminal, function of		2-4
POWER level meter, function of		2-3
Power output		2-1
Power required		1-1
POWER SET control, function of		2-1
Power supply, description of		3-11
POWER terminal		2-3
Practical wiring diagram	7-2	7-5

	<i>Figure</i>	<i>Page</i>
PULSE DELAY control, function of		2-2
PULSE RATE control, function of.....		2-2
Pulse rate multivibrator, theory of.....		3-5
PULSE WIDTH control, function of.....		2-2
Pulses, output, comparison of		2-4
 R		
Reference symbols.....	3-4	6-0
Repeller voltage characteristics		3-2
Replacement of impedance matching rod E-124.....		4-22
Replacement of resistor R-137.....		4-20
Replacement of thermistor R-136.....		4-23
Replaceable parts, table of.....		6-5
Resistor R-137, replacement of		4-20
RF Cable CG-92B/U (6'), fabrication data.....	7-9	7-19
RF monitor, theory of.....		3-3
RF oscillator, calibration of.....		4-27
RF output system, theory of.....		3-2
RF OUTPUT terminal, function of.....		2-2
RF Probe E-101, output; cutaway view.....	4-47	4-22
RF probe cap, removal of.....	4-7	4-7
RF Probe, monitor, cutaway view	4-49	4-24
RF Probe, monitor, removal of.....	4-8	4-7
RF probe, monitor, replacement of.....		4-7
RF probe, monitor, screws holding	4-6	4-7
RF transmission line E-142I	4-45	4-21
RF tuner in place, left view	4-30	4-16
 S		
Schematic diagram	7-1	7-3
Servicing block diagram.....	7-4	7-9
Servicing block diagram, discussion of.....		4-7
Signal generator useage considerations		5-3
Signal generator TS-403/U, back view with instrument case removed.....	5-1	5-4
Signal generator TS-403/U, bottom view with instrument case removed	5-3	5-6
Signal Generator TS-403/U, equipment supplied.....	1-1	1-0
Signal Generator TS-403/U, front panel controls.....	2-1	2-0
Signal Generator TS-403/U, front panel with controls numbered.....	2-2	2-1
Signal Generator TS-403/U, left view with instrument case removed.....	5-4	5-7
Signal Generator TS-403/U, oblique view.....	1-4	1-5
Signal Generator TS-403/U, overall dimensions	7-7	7-15
Signal Generator TS-403/U, practical wiring diagram.....	7-2	7-5
Signal Generator TS-403/U, schematic diagram.....	7-1	7-3
Signal Generator TS-403/U, servicing block diagram	7-4	7-9
Signal Generator TS-403/U, top view with instrument case removed.....	5-2	5-5
Signal Generator TS-403/U, voltage (1000-ohm/volt) diagram.....	7-6	7-13
Signal Generator TS-403/U, voltage (20,000-ohm/volt) and resistance diagram.....	7-5	7-11
Signal width multivibrator, theory of.....		3-8
Spare parts, ordering of.....		6-0

	<i>Figure</i>	<i>Page</i>
Standing wave ratio.....		5-3
Switch S-102, assembly of.....	4-18	4-11
Switch S-102, mounting of.....	4-19	4-12
Symbols, reference.....		6-0
SYNC IN terminal, function of.....		2-4
SYNC OUT terminal, function of.....		2-2
SYNC SELECTOR switch, function of.....		2-2
T		
Table of replaceable parts.....		6-5
Terminals, input and output.....		2-3
Test set-up for calibrating output attenuator.....	4-46	4-21
Thermistor R-136, replacement of.....		4-23
Tool attached to repeller lead.....	4-4	4-4
Tool H-101, mounting location.....	4-3	4-3
Transit Case CY-669/U, description of.....		1-2
Transit Case CY-669/U, oblique view.....	1-2	1-2
Transit Case CY-669/U, overall dimensions.....	7-8	7-17
Trigger, for external use.....		2-5
Trouble chart.....		4-2
Tubes and lamps, table of.....		1-3
Tube and lamp complement.....		5-1
Tube replacement.....		4-3
Tube replacement, shield E-142B removed.....	4-2	4-3
Tube replacement, V-111 released from contact fingers.....	4-5	4-5
Tuning dial, description of.....		2-1
Type designations, resistor and capacitor.....		6-2
U		
Use, signal generator, considerations involved.....		5-3
V		
Video cable, fabrication data.....	7-10	7-21
Voltage (20,000-ohms/volt) and resistance diagram.....	7-5	7-11
Voltage (1000-ohms/volt) diagram.....	7-6	7-13
W		
Winding data.....		4-28
Z		
ZERO SET control, function of.....		21