

**Please do not upload this copyright pdf document to any other website. Breach of copyright may result in a criminal conviction.**

This pdf document was generated by me Colin Hinson from a Crown copyright document held at R.A.F. Henlow Signals Museum. It is presented here (for free) under the Open Government Licence (O.G.L.) and this pdf version of the document is my copyright (along with the Crown Copyright) in much the same way as a photograph would be.

The document should have been downloaded from my website <https://blunham.com/Radar>, or any mirror site named on that site. If you downloaded it from elsewhere, please let me know (particularly if you were charged for it). You can contact me via my Genuki email page: <https://www.genuki.org.uk/big/eng/YKS/various?recipient=colin>

**You may not copy the file for onward transmission of the data nor attempt to make monetary gain by the use of these files. If you want someone else to have a copy of the file, point them at the website. (<https://blunham.com/Radar>). Please do not point them at the file itself as it may move or the site may be updated.**

It should be noted that most of the pages are identifiable as having been processed by me.

---

I put a lot of time into producing these files which is why you are met with this page when you open the file.

In order to generate this file, I need to scan the pages, split the double pages and remove any edge marks such as punch holes, clean up the pages, set the relevant pages to be all the same size and alignment. I then run Omnipage (OCR) to generate the searchable text and then generate the pdf file.

Hopefully after all that, I end up with a presentable file. If you find missing pages, pages in the wrong order, anything else wrong with the file or simply want to make a comment, please drop me a line (see above).

It is my hope that you find the file of use to you personally – I know that I would have liked to have found some of these files years ago – they would have saved me a lot of time !

Colin Hinson

In the village of Blunham, Bedfordshire.

AIR PUBLICATION  
**117E-0101-13D**

# **AUDIO AND VIDEO SIGNAL GENERATOR**

**6625-99-104-7574**

**(MARCONI INSTRUMENTS TF 1370A)**

## **GENERAL AND TECHNICAL INFORMATION AND SCALE OF SERVICING SPARES**

BY COMMAND OF THE DEFENCE COUNCIL

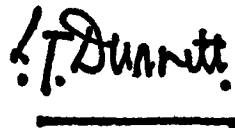

*J. Dunnett*

---

Ministry of Defence

FOR USE IN THE

ROYAL AIR FORCE

(Prepared by the Ministry of Aviation Supply)

A.L.4, Mar 71

## SUPPLEMENT

This instrument is the Marconi Instruments Wide Range R-C Oscillator, TF 1370A and is also known as Signal Generator, 6625-99-104-7574.

This Air Publication describes the latest models. Earlier models may be slightly different owing to the following changes:-

- |  |  |
|--|--|
| <p>(1) R30 value changed from 2.2 M<math>\Omega</math> to 1.8 M<math>\Omega</math> to improve output reaction.</p> <p>(1a) R30 changed from 1.8 M<math>\Omega</math> to 1 M<math>\Omega</math>. R130 (820 k<math>\Omega</math>) added in series with R30.</p> <p>(2) R34 value changed from 82 k<math>\Omega</math> to 120 k<math>\Omega</math>.</p> <p>(3) R38 (150 <math>\Omega</math>, <math>\frac{1}{2}</math> W) added between junction of R44/C40 and C27 to remove ripple.</p> <p>(4) R46 value changed from 2.7 k<math>\Omega</math> to 1.8 k<math>\Omega</math>.</p> <p>(5) R81 (33 <math>\Omega</math>, <math>\frac{1}{4}</math> W) has been replaced by RV13 (680 <math>\Omega</math>, <math>\frac{1}{4}</math> W) as it was not practical to select resistor in calibration.</p> <p>(6) R121 value changed from 10 k<math>\Omega</math> to 100 <math>\Omega</math> to stop frequency bounce.</p> <p>(7) R129 (4.7 k<math>\Omega</math>) added from pin 6 of V5 to RV10 to improve 'SAG' control.</p> | <p>(8) C32 value changed from 4 <math>\mu</math>F, 50 V working to 4 <math>\mu</math>F, 300 V working.</p> <p>(9) VT1 type 2G403 changed to type 2N3324</p> <p>(10) FS2 value changed from 250 mA to 500 mA.</p> <p>(11) Junction of R131 and VT2 collector was connected to MR3A.</p> <p>(12) The earth connection between mains socket, PLA, and the power supply chassis re-routed from PLA to output socket, SKTD, shroud on front panel via two paths around right-hand dish plate to form a shorted-turn loop, thereby reducing mains hum at the output socket.</p> <p>(13) R139 changed from 2.2 k<math>\Omega</math> to 1.5 k<math>\Omega</math>.</p> <p>(14) C8 (47 pF) and C6 (2.5-40 pF) (in parallel) removed. Were connected to Range Switch SAc contact opposite R3 as C4 is connected to contact opposite R1.</p> <p>(15) C2 (10 pF) replaced by C6 (2.5-40 pF).</p> <p>(16) C65 changed from 0.001 <math>\mu</math>F to 0.002 <math>\mu</math>F.</p> |
|--|--|

CORRIGENDA

TO

A.P. 117E - 0101 - 13  $\triangleright$

AUDIO AND VIDEO

SIGNAL GENERATOR TF 1370A

This instrument is the Marconi Instruments Wide Range R-C Oscillator, TF 1370A and is also known as Signal Generator, 6625-99-104-7574.

This Air Publication describes the latest models. Earlier models may be slightly different owing to the following changes:-

- (1) R30 value changed from 2.2 M $\Omega$  to 1.8 M $\Omega$  to improve output reaction.
- (2) R34 value changed from 82 k $\Omega$  to 120 k $\Omega$ .
- (3) R38 (150  $\Omega$ ,  $\frac{1}{2}$  W) added between junction of R44/C40 and C27 to remove ripple.
- (4) R46 value changed from 2.7 k $\Omega$  to 1.8 k $\Omega$ .
- (5) R81 (33 $\Omega$ , 1/4 W) has been replaced by RV13 (680  $\Omega$ , 1/4 W) as it was not practical to select resistor in calibration.
- (6) R121 value changed from 10 k $\Omega$  to 100  $\Omega$  to stop frequency bounce.
- (7) R129 (4.7 k $\Omega$ ) added from pin 6 of V5 to RV10 to improve 'SAG' control.
- (8) C32 value changed from 4  $\mu$ F, 50 V working to 4  $\mu$ F, 300 V working.
- (9) VT1 type 2G403 changed to type 2N3324.
- (10) FS2 value changed from 250 mA to 500 mA.
- (11) Junction of R131 and VT2 collector was connected to MR3A.
- (12) The earth connection between mains socket, PLA, and the power supply chassis re-routed from PLA to output socket, SKTD, shroud on front panel via two paths around right-hand dish plate to form a shorted-turn loop, thereby reducing mains hum at the output socket.

# CONTENTS

## Chapter 1 GENERAL INFORMATION

1.1	Features	...	...	...	...	3
1.2	Data summary	...	...	...	...	4
1.3	Accessories	...	...	...	...	5

## Chapter 2 OPERATION

2.1	Installation	...	...	...	...	8
2.2	Switching on	...	...	...	...	8
2.3	Sine and square wave outputs	...	...	...	...	8
2.4	Controls and connectors	...	...	...	...	8
2.5	Adjusting frequency	...	...	...	...	10
2.6	Setting output voltage	...	...	...	...	10
2.7	dB readings	...	...	...	...	13
2.8	Setting up audio standard output	...	...	...	...	14
2.9	Adjusting square wave sag and mark/space ratio	...	...	...	...	15
2.10	Use of accessories	...	...	...	...	15

## Chapter 3 TECHNICAL DESCRIPTION

3.1	Circuit arrangement	...	...	...	...	18
3.2	Oscillator	...	...	...	...	18
3.3	20 dB amplifier	...	...	...	...	19
3.4	Schmitt trigger	...	...	...	...	19
3.5	Output cathode follower	...	...	...	...	20
3.6	Output monitor	...	...	...	...	20
3.7	Output connections	...	...	...	...	20
3.8	Regulated h.t. supply	...	...	...	...	22
3.9	Regulated l.t. supply	...	...	...	...	22

## Chapter 4 MAINTENANCE

4.1	General	...	...	...	...	24
4.2	Fuses	...	...	...	...	24
4.3	Input supply voltage	...	...	...	...	24
4.4	Removing case or dust cover	...	...	...	...	25
4.5	Replacement of panel lamps	...	...	...	...	25
4.6	Replacement of valves and transistors	...	...	...	...	25
4.7	Preset adjustments	...	...	...	...	26
4.8	Drive cord	...	...	...	...	29
4.9	Functional checks	...	...	...	...	29

<b>COMPONENT LAYOUT ILLUSTRATIONS</b>	...	...	...	...	31
---------------------------------------	-----	-----	-----	-----	----

<b>REPLACEABLE PARTS</b>	...	...	...	...	35
--------------------------	-----	-----	-----	-----	----

<b>DECIBEL CONVERSION TABLE</b>	...	...	...	...	41
---------------------------------	-----	-----	-----	-----	----

Chapter 5 Not assigned

Chapter 6 Not assigned

## Chapter 7 CIRCUIT DIAGRAMS

Circuit notes

Fig. 1 Power supply - circuit

Fig. 2 Oscillator and squaring stages - switch details

Fig. 3 Oscillator and squaring stages - circuit

Fig. 4 Monitor and output stages - switch details

Fig. 5 Monitor and output stages - circuit

# I GENERAL INFORMATION

## 1.1 FEATURES

The TF 1370A is a general-purpose sine wave generator covering the frequency range 10 Hz to 10 MHz. It also delivers a high-quality square wave output at frequencies between 10 Hz and 100 kHz.

The instrument is primarily a signal source for measurements and tests on audio and video amplifiers and networks. With its four output impedances - 600, 130, 100, and 75  $\Omega$  - it is suitable for use with transmission lines, filters, attenuators, etc.

Among other applications as a sine wave generator is that of providing the excitation voltage for a.f. and r.f. bridges. And

the quality of the square wave output also renders the instrument particularly effective for such purposes as rapid testing of audio amplifier bandwidth.

The signal originates in a Wien bridge oscillator covering 10 Hz to 10 MHz in six decade bands, the top band extending from 1 to 10 MHz. A single scale is used for the four lower bands and separate scales for the two upper bands; this gives a total scale length of 270 mm and makes a 1% change in frequency easily discernible.

TF 1370AR is a rack-mounting version of the TF 1370 and is supplied, complete with dust cover, for mounting in a standard rack.



Fig. 1.1

## 1.2 DATA SUMMARY

### FREQUENCY

Range:	Sine waves : 10 Hz to 10 MHz in six decade bands. Square waves : 10 Hz to 100 kHz in four decade bands.
Accuracy:	Within $\pm 2\%$ $\pm 1$ Hz.
Stability:	Drift does not exceed $\pm 0.1\%$ over a 15 minute period after 1 hour warm-up.

### SINE WAVE OUTPUT

Range : (via attenuator)	1 mV to 3.16 V e.m.f. at switch selected source impedances of 75, 100, 130 and 600 $\Omega$ unbalanced. Controlled by attenuator with six 10 dB steps and potentiometer in conjunction with level monitor. Attenuator accuracy is $\pm 1$ dB overall on resistive load. Outputs from 10 $\mu$ V to 31.6 mV at 75 and 5 $\Omega$ are available by using x100 Attenuator Pad TM 6454.
Range : (direct)	Up to 31.6 V p.d. with loading according to table 2.1, at frequencies up to 1 MHz. Two ranges of up to 10 and 31.6 V are provided by switched potential divider and potentiometer in conjunction with level monitor. Nominal impedances are 650 $\Omega$ on 10 V range, and 25 $\Omega$ in series with 500 $\mu$ F on 31.6 V range.
Frequency response : (via attenuator and without adjusting meter)	<u>Relative to 1 kHz</u> Within $\pm 0.25$ dB from 100 Hz to 1 MHz. Within $\pm 0.5$ dB from 10 Hz to 100 Hz. Within $\pm 1$ dB from 1 MHz to 10 MHz.
Distortion factor :	<u>3 V output level</u> Less than : 2% from 20 Hz to 100 Hz 0.5% from 100 Hz to 100 kHz 1% from 100 kHz to 1 MHz 2% from 1 MHz to 4 MHz 5% from 4 MHz to 10 MHz  <u>30 V output level</u> Less than : 2% from 20 Hz to 100 Hz 1% from 100 Hz to 100 kHz 2% from 100 kHz to 1 MHz
Hum :	Less than 0.1% of full-scale output above 10 mV.

## SQUARE WAVE OUTPUT

Range :	1 mV to 3.16 V peak via attenuator, and up to 31.6 V peak direct with loading according to table 2.1. Other details as for sine wave output except that source impedance is increased by 250 $\Omega$ at maximum output step of attenuator.
Frequency response: (without adjusting meter)	<u>Relative to 1 kHz</u> Within $\pm 0.3$ dB from 10 Hz to 100 kHz.
Rise time :	0.75 $\mu$ sec or less at full-scale output. 0.4 $\mu$ sec or less at 1/3 full-scale output.
Sag :	Approximately 5% in a 2.2 k $\Omega$ load at 20 Hz. Adjustable by panel preset.
Mark/ space ratio :	50/50 $\pm 5\%$ . Adjustable by panel preset.

## LEVEL MONITOR

Voltage scales :	0 to 31.6 and 0 to 10; indicate r.m.s. value of sine wave and peak value of square wave with respect to zero.
Decibel scales :	0 to -20 with respect to full-scale; also 0 dB reference point indicating 1 V peak to peak sine wave or square wave across a 75 $\Omega$ load.
Accuracy :	$\pm 3\%$ of full-scale for sine waves up to 1 MHz; additional $\pm 2\%$ of reading for square waves, and for sine waves up to 10 MHz.

POWER SUPPLY : 200 to 250 V and 100 to 150 V, 45 to 65 Hz, 150 W.

DIMENSIONS & WEIGHT :	Height	Width	Depth	Weight
	360 mm	510 mm	280 mm	17 kg

## 1.3 ACCESSORIES

## Accessories supplied

One coaxial free plug, type BNC, Transradio Cat. No. BN1/7 (75  $\Omega$ ); for DIRECT or ATTEN output connections.



**Accessories available**

(1) UNBALANCED-TO-BALANCED TRANSFORMER TYPE TM 6221

This transformer provides balanced signals at 600, 200, or 150  $\Omega$  source impedance, and is for use with sine wave outputs in a frequency range 10 Hz to 100 kHz.

Fig. 1.2

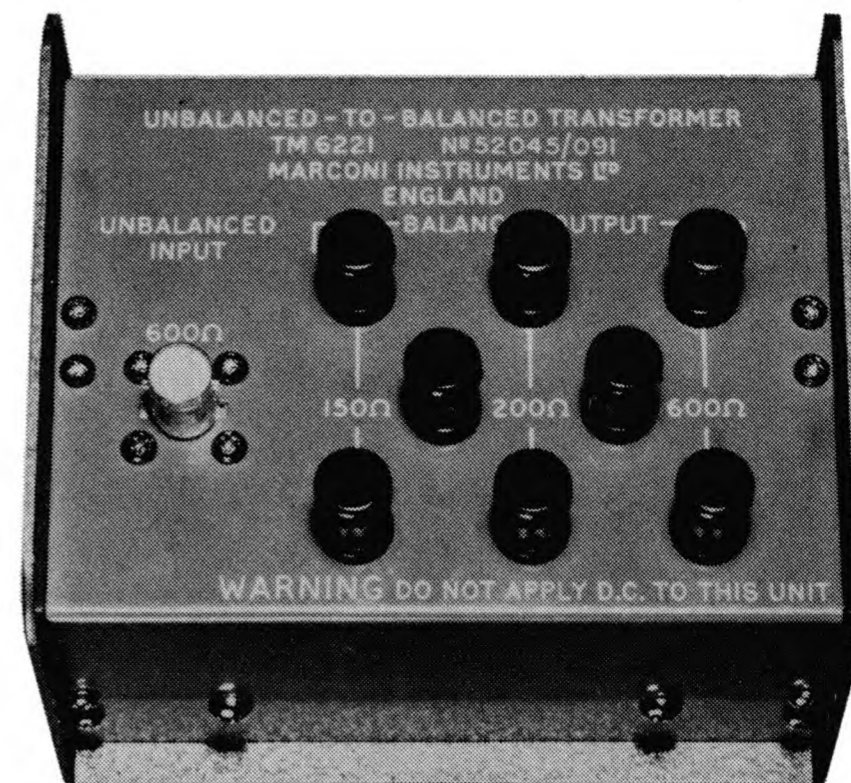

Connections :

BNC socket for input; terminals for outputs, centre-tap, and earth.

Impedance ratios :

600  $\Omega$  to 600, 200, and 150  $\Omega$ .

Insertion loss (at 1 kHz) :

0.5 dB approximately.

Out-of-balance :

Not exceeding 0.2 dB from 150 Hz to 50 kHz; not exceeding 1 dB at 20 Hz or 100 kHz.

Response at secondary :  
(with respect to 1 kHz)

$\pm 0.2$  dB from 150 Hz to 50 kHz; not below -1 dB at 20 Hz or 100 kHz.

Distortion factor :  
(loaded and fed by a pure sine wave at 3 V e.m.f.)

100 Hz to 50 kHz, not exceeding 0.2%; 70 Hz to 100 Hz and 50 kHz to 100 kHz, not exceeding 0.4%.

Dimensions & weight :

Height	Width	Depth	Weight
85 mm	125 mm	100 mm	1.1 kg

(2) x100 ATTENUATOR PAD TYPE TM 6454

This device enables reduced outputs to be obtained down to 10  $\mu$ V at a source impedance of 5  $\Omega$  or 75  $\Omega$ , and is for use with sine wave or square wave signals at all operating frequencies of the R-C Oscillator.

Fig. 1.3

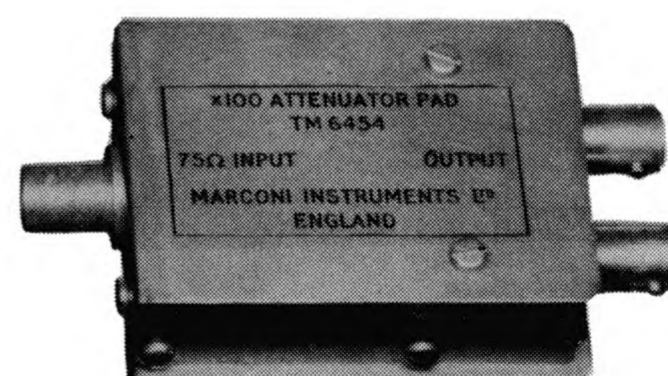

Connections :

Three BNC sockets.

Loss :

40 dB  $\pm 1$  dB.

Impedance :

Input, 75  $\Omega$ ; outputs, 75 and 5  $\Omega$ .

Maximum input :

6 V.

Dimensions & weight :

Height	Width	Depth	Weight
25 mm	95 mm	50 mm	120 g

(3) COAXIAL LEAD  
TYPE TM 4726/136

Primarily intended for connecting  
(1) or (2) above to the output sockets of  
the Oscillator.

Connections :	BNC plug at each end.
Impedance :	75 $\Omega$ .
Length :	0.9 m.

# 2 OPERATION

## 2.1 INSTALLATION

The instrument is normally despatched ready for a 240 V supply unless otherwise ordered. Before switching on be sure that the connections on the mains transformer are correct for the supply voltage to be used - see Section 4.3. If the instrument is supplied in a plastic cover, completely remove this to ensure adequate ventilation.

## 2.2 SWITCHING ON

Connect the power lead to the a. c. supply socket; when not in use this lead is stowed in the left-hand case handle recess. Switch ON the SUPPLY switch. The red pilot lamp should glow.

Allow several minutes to elapse for the instrument to warm up. But allow longer, say an hour, when the highest stability is required.

## 2.3 SINE AND SQUARE WAVE OUTPUTS

### Sine wave

Outputs from 1 mV to 3.16 V are available via a switched attenuator covering 60 dB in 10 dB steps. The signal level applied to the input of the attenuator is continuously variable and is monitored by a meter calibrated in open circuit voltage and decibels. The output impedance can be set to 75, 100, 130, or 600  $\Omega$ , as required.

Low outputs down to 10  $\mu$ V at 75 or 5  $\Omega$  can be obtained by using the x100 Attenuator Pad available as an optional accessory.

High outputs up to 31.6 V, at frequencies up to 1 MHz, are delivered at a separate outlet; this outlet is controlled by a switched potential divider with a continuously variable input, and the meter indicates the voltage across the load. Switching to a higher frequency band during high output operation automatically lights a warning lamp to show that this is not an operative condition.

### Square wave

Square wave outputs up to 31.6 V peak are available at frequencies up to 100 kHz. The warning lamp facility provided for high output sine wave operation also applies for square waves if a higher frequency band is selected. Output arrangements are similar to those for sine waves except that the meter indicates the peak amplitude with respect to zero, i. e., half the peak-to-peak voltage.

Both sag and mark/space ratio are adjustable by front panel presets. Below 50 Hz, the sag can be adjusted to zero for any particular load; above 50 Hz, one zero setting is valid for all loads. The mark/space preset enables the ratio to be brought exactly to 50/50.

## 2.4 CONTROLS AND CONNECTORS

- ① SUPPLY switch and indicator lamp.
- ② RANGE selector. Letters refer to scales on the dial, and numbers indicate the scale extremes. Illustration shows setting for 1 kHz.
- ③ FREQUENCY control.
- ④ FREQUENCY dial. Use scale indicated by setting of RANGE selector.
- ⑤ OUTPUT VOLTS selector. Selects sine wave or square wave operation, and output range at ATTEN or DIRECT output sockets. OFF position disconnects output without interrupting supplies.
- ⑥ SET OUTPUT control. Adjusts output voltage at ATTEN or DIRECT output sockets.
- ⑦ METER. Shows output at either ATTEN or DIRECT socket depending on settings.

of OUTPUT VOLTS SELECTOR and ATTENUATED OUTPUT switch.

Indicates peak value of square waves and r.m.s. value of sine waves. SQ and SINE marks correspond to 1 V peak-to-peak in a 75 Ω load.

- ⑧ ATTENUATED OUTPUT switch. Setting indicates full-scale meter deflection.
- ⑨ ATTEN IMPEDANCE switch. Indicates source impedance at ATTEN output socket on 'mV' settings of ATTENUATED OUTPUT switch. OFF position disconnects output without interrupting supplies.

- ⑩ ATTEN E.M.F. socket. Type BNC. For outputs up to 3.16 V.
- ⑪ DIRECT OUTPUT socket. Type BNC. For outputs up to 31.6 V.
- ⑫ WARNING CHECK RANGE lamp. Glows when an inadmissible combination of output range and frequency has been selected.
- ⑬ M/S preset. For fine adjustment of square wave mark/space ratio.
- ⑭ SAG preset. For zeroing square wave sag.

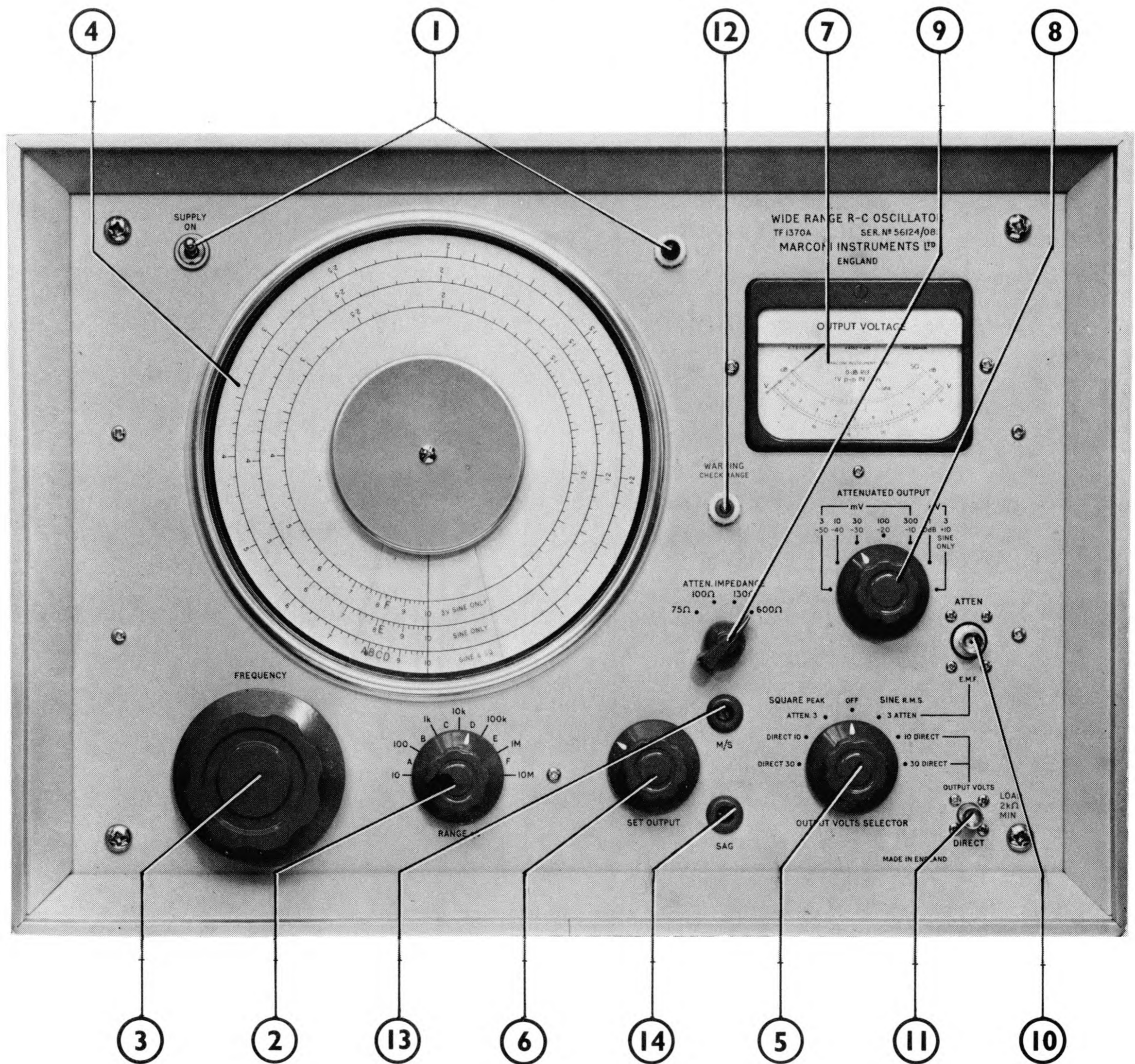

Fig. 2.1 Controls and connectors

## 2.5 ADJUSTING FREQUENCY

Turn the RANGE switch to select the frequency band and adjust the FREQUENCY tuning control for the required frequency.

## 2.6 SETTING OUTPUT VOLTAGE

The terms 'source impedance' or 'output impedance' are used in this manual with the meaning ascribed to them in BS 4014, i. e.

### Source impedance

The effective impedance of the source in the outlet with the signal generator switched on and with the output level indicator held at a constant value.

### Output impedance

The impedance of the source in the outlet without adjustment being made to the indicated output level, either manually or automatically.

Turn the OUTPUT VOLTS SELECTOR switch to the appropriate position for the output required. The settings of this switch for the various output conditions available are shown in Table 2.1.

### Notes :

- (i) If the OUTPUT VOLTS SELECTOR is set to any of the DIRECT positions and the RANGE selector is switched to above 1 Mc/s for sine waves, or above 100 kc/s for square waves, no output

TABLE 2.1

OUTPUT VOLTS SELECTOR at:	Output Impedance	Maximum frequency	Minimum load	Meter indicates
SQUARE, 30 DIRECT - for up to 31.6 V across load.	25 $\Omega$ in series with 500 $\mu$ F at DIRECT socket.	100 kc/s	2 k $\Omega$ (to avoid sag).	Peak volts at DIRECT socket.
SQUARE, 10 DIRECT - for up to 10 V across load.	650 $\Omega$ at DIRECT socket.	100 kc/s	10 k $\Omega$ (to obtain 10 V p.d.; but no sag if lower).	
SQUARE, 3 ATTEN - for up to 3.16 V source e. m. f.	ATTENUATED OUTPUT switch at 3 V : 250 $\Omega$ greater than indicated by ATTEN IMP switch.	100 kc/s	2 k $\Omega$ (to obtain 3 V e. m. f.; ATTEN IMP switch at 75 $\Omega$ ).	Peak value of e. m. f. at the source impedance indicated by ATTEN IMP switch.
	ATTENUATED OUTPUT switch at 1 V : 25 $\Omega$ greater than indicated by ATTEN IMP switch.	100 kc/s	2 k $\Omega$ (to obtain 1 V e. m. f.; ATTEN IMP switch at 75 $\Omega$ ).	
	ATTENUATED OUTPUT switch at 300 mV or less: as indicated by ATTEN IMP switch.	100 kc/s		

can be obtained. In this condition the WARNING CHECK RANGE lamp will glow.

- (ii) The OFF position enables you to remove the output without switching off the supply or disconnecting the load.

**CAUTION**

**D.C. content in output.** The output coupling capacitor in the R-C Oscillator is, of necessity, a high capacitance electrolytic type. This allows some d. c. leakage which may affect equipment connected to either outlet. The leakage voltage may amount to some 2% of the a. c. output, both at the DIRECT outlet when loaded with 2k $\Omega$ , and at the ATTEN outlet when matched with 75 $\Omega$ .

**Surges in output.** When switching the SUPPLY on or off, and when turning the OUTPUT VOLTS SELECTOR, d. c. surges lasting several seconds arise at the outlets. Depending on the switching operation, the surge open circuit voltage may be up to about twenty times the a. c. output provided by the settings of the SELECTOR and ATTENUATED OUTPUT switches. The output of the R-C Oscillator should be open or short circuited temporarily when the load is sensitive and might be damaged.

**Direct output, up to 30 V**

From the DIRECT output socket a sine wave or square wave of up to 10 V or up to 31.6 V can be obtained, depending on the

TABLE 2.1 (continued)

OUTPUT VOLTS SELECTOR at:	Output impedance	Maximum frequency	Minimum load	Meter indicates
OFF	No signal output available at DIRECT or ATTEN output sockets, but basic oscillator remains operative. With the ATTENUATED OUTPUT switch turned to its first five positions, the output resistance at the ATTEN output socket is indicated by the ATTEN IMP switch; when the ATTENUATED OUTPUT switch is in the 1 V position, add 30 $\Omega$ to the ATTEN IMP indication; when in the 3 V position, add 300 $\Omega$ .			
SINE, 3 ATTEN - for up to 3.16 V source e. m. f.	ATTENUATED OUTPUT switch at 3 V : 25 $\Omega$ greater than indicated by ATTEN IMP switch.	10 Mc/s		R. M. S. value of e. m. f. at the source impedance indicated by ATTEN IMP switch.
	ATTENUATED OUTPUT switch at 1 V or less : as indicated by ATTEN IMP switch.	10 Mc/s		
SINE, 10 DIRECT - for up to 10 V across load.	650 $\Omega$ at DIRECT socket.	1 Mc/s	10 k $\Omega$ (to obtain 10 V p. d. ; but no distortion if lower.	R. M. S. volts at DIRECT socket.
SINE, 30 DIRECT - for up to 31.6 V across load.	25 $\Omega$ in series with 500 $\mu$ F at DIRECT socket.	1 Mc/s	2 k $\Omega$ (to avoid distortion).	

position of the OUTPUT VOLTS SELECTOR and the SET OUTPUT control.

The meter, calibrated in peak values for square wave and r.m.s. for sine wave signals, indicates the voltage across the load at the DIRECT outlet; this voltage is adjusted by the SET OUTPUT control. The source impedance on the 10 V range is 490  $\Omega$ , and on the 30 V range it is 25  $\Omega$  in series with 500  $\mu\text{F}$ . The permissible external loads are shown in Table 2.1.

As a rule, when a square wave is taken from the DIRECT outlet, a short output cable should be used; a long cable may cause rounding of the square wave owing to loss of higher frequency components.

While the SELECTOR is at a DIRECT position output can be taken simultaneously from the ATTEN socket. But if the ATTENUATED OUTPUT switch is set to the 1 V or 3 V positions and the ATTEN outlet is loaded the meter will indicate incorrectly the voltage

at the DIRECT outlet. The output impedance at the ATTEN socket will be as for SQUARE ATTEN (see Table 2.1) for both sine and square waves.

**Attenuated output, 0 to 3 V**

When the OUTPUT VOLTS SELECTOR switch is turned to the SQUARE, 3 ATTEN or SINE, 3 ATTEN positions, the meter and the ATTENUATED OUTPUT switch together indicate the source e.m.f., i.e. the open circuit voltage at the ATTEN output socket.

The seven position ATTENUATED OUTPUT switch provides one +10 dB and five -10 dB steps, relative to the 0 dB position. According to the voltage required, the ATTENUATED OUTPUT switch should be set to the appropriate position. The voltage indicated by each switch position is the maximum e.m.f. obtainable and also the full-scale meter indication for this switch position; depending upon whether the switch

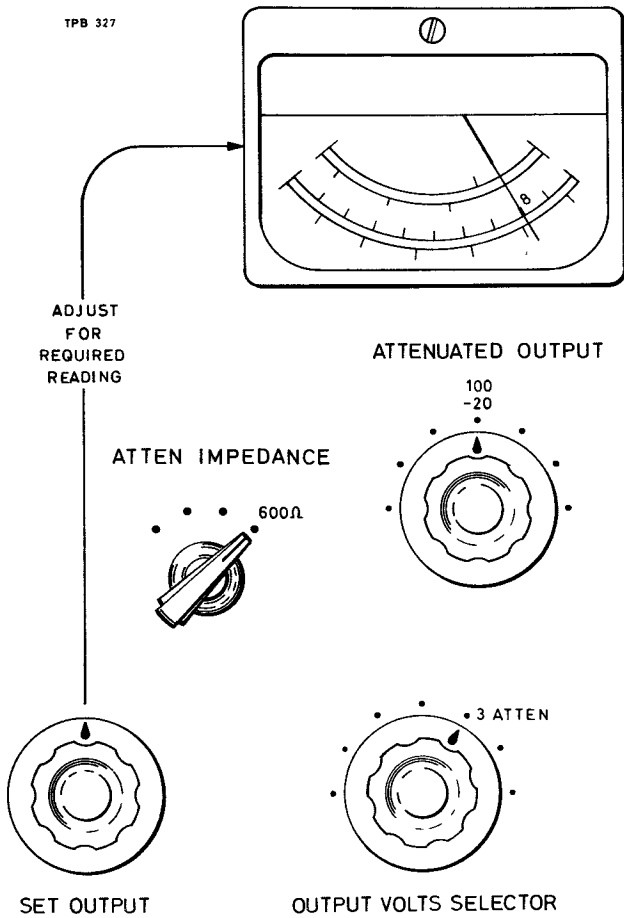

Fig. 2.2 Sine wave: 80 mV r.m.s. e.m.f. at 600 $\Omega$

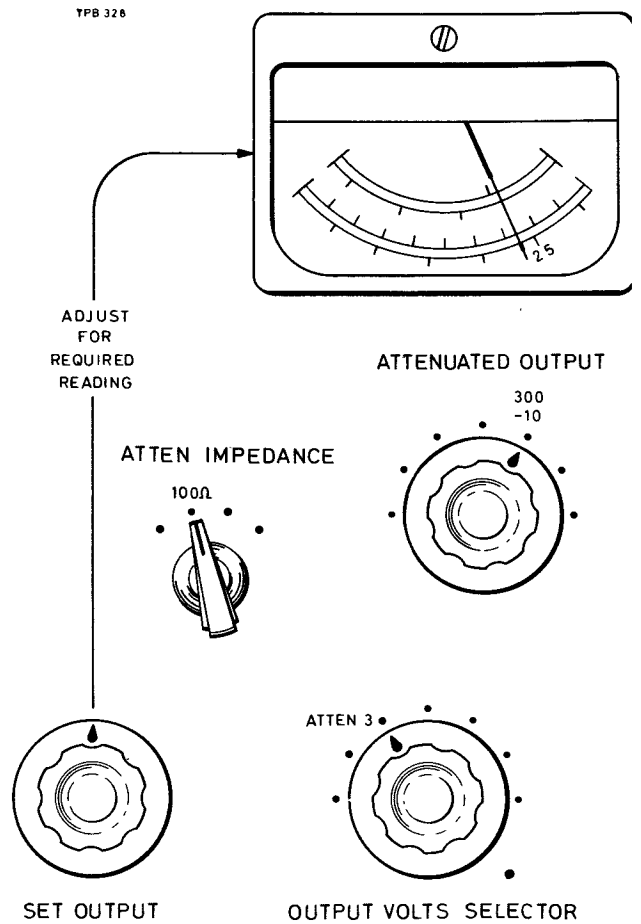

Fig. 2.3 Square wave: 240 mV peak e.m.f. at 100 $\Omega$

position figure commences with 1 or 3, the 10 V or 30 V scale of the meter should be referred to and the appropriate multiplying factor applied.

#### Examples :

- (i) If 80 mV is required, turn the ATTENUATED OUTPUT switch to 100 mV, and adjust the SET OUTPUT control to obtain a reading of 8 on the 10 V meter scale.
- (ii) If 240 mV is required, turn the ATTENUATED OUTPUT switch to 300 mV, and adjust the SET OUTPUT control to obtain a reading of 24 on the 30 V meter scale.

Turn the ATTEN IMPEDANCE switch to give the source impedance required.

When using sine wave outputs above 500 kc/s, it is recommended that there should be good matching between the instrument, output lead, and load, i. e., the ATTEN IMPEDANCE setting, the characteristic impedance of the output cable, and the impedance of the load should all have the same value. If the output cable is not matched above 500 kc/s, it may introduce a reactive component in the coupling that will modify the output actually obtained at the load. The effect increases with length of cable.

#### Example :

With the ATTEN IMPEDANCE switch turned to 600  $\Omega$  and using a 3 ft, 75  $\Omega$ , coaxial lead to connect a 600  $\Omega$  load to the instrument, the output voltage will be reduced by above 0.15 dB at 500 kc/s, and about 3 dB at 7 Mc/s.

It should be noted that it is not possible to obtain a zero meter reading when using square wave signals.

The rise time of the square wave signal is reduced proportionately with its output amplitude. So, for the shortest rise time, it is preferable to set the ATTENUATED OUTPUT switch so that the SET OUTPUT control can be adjusted to give the required

output at a low meter reading. Further, to retain the shape of the square wave, try to obtain good matching between the instrument, output cable and load as recommended above for sine waves over 500 kc/s. (Note that the true source impedance is increased if the ATTENUATED OUTPUT switch is set to 1 V or 3 V - see Table 2.1.) If it is not convenient to obtain good matching, the output cable should be kept short; say 3 feet or less. Failure to match a longer cable may cause loss in the higher frequency components of the square wave and result in rounding of its shape.

## 2.7 dB READINGS

### Reading relative dB levels

The top scale of the front panel meter is calibrated in dB relative to full-scale meter deflection. Changes of voltage reading on the meter scale may therefore be read in decibels by simply subtracting a lower level from a higher level.

When the ATTENUATED OUTPUT switch position is changed, each increment of 10 dB must be added to the relative meter indication obtained. Note any change of meter reading as the switch is turned, and reset the SET OUTPUT control if necessary (in particular, switching to +10 dB only increases square waves by 10 dB if the level indicated by the meter can be maintained.)

#### Examples :

- (a) The meter is first reading 800 mV, corresponding to -2 dB on the scale (with the ATTENUATED OUTPUT switch turned to 1 V). The output is then reduced to give a meter reading of 400 mV, corresponding to -8 dB on the scale. The signal reduction is given by the difference between the two dB readings, i. e.,  $(-2) - (-8) = 6$  dB signal reduction.
- (b) The meter is first reading 800 mV, corresponding to -2 dB on the scale with the ATTENUATED OUTPUT



switch turned to 1 V, 0 dB. The output is then reduced to give a meter reading of 40 mV, corresponding to -8 dB on the scale, with the switch turned (through 20 dB) to 100 mV, -20 dB. The signal reduction is given by the difference between the two dB indications, e. g.,

$$(-2) - [(-20) + (-8)] = 26 \text{ dB.}$$

### Using standard video ref level

Included on the top scale of the front panel meter are two calibration marks, SQ and SINE, indicating the standard level of 1 V peak-to-peak in a 75 Ω load (corresponding to 1 V peak e. m. f. at 75 Ω source impedance). The calibration mark SQ is at 0 dB and the calibration mark SINE is at -3 dB on the dB scale.

To obtain a level relative to these markings, set the ATTEN IMPEDANCE switch to 75 Ω and set the ATTENUATED

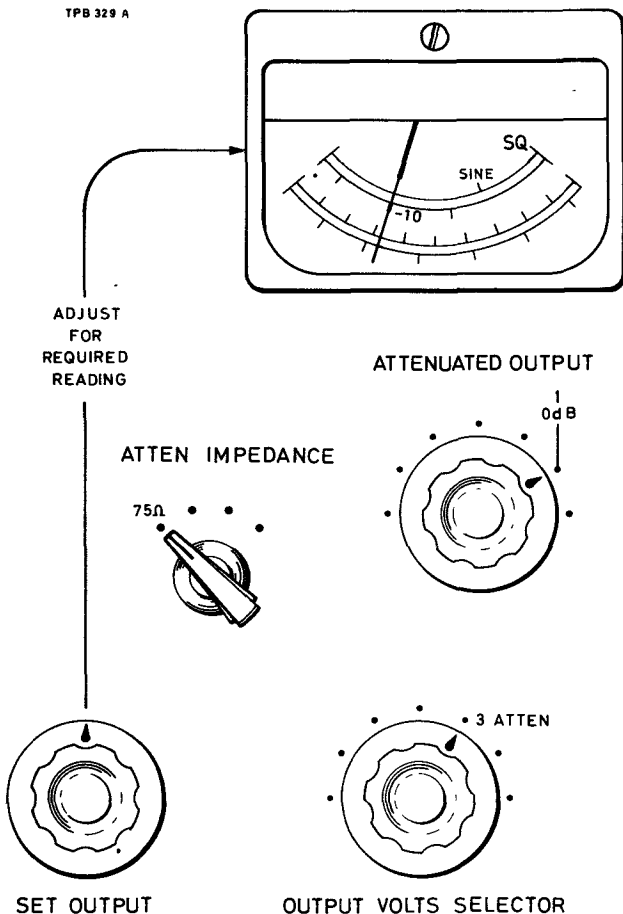

Fig. 2.4 Sine wave output: -7 dB rel. 1 V p-p across 75 Ω load

OUTPUT switch to 0 dB (1 V) and terminate the ATTENUATED OUTPUT socket in 75 Ω.

By reference to the dB scale and the calibration markings on the front panel meter adjust the SET OUTPUT control to obtain the required video output relative to the standard video reference levels

If, for example, a signal is required 7 dB below the appropriate reference level, for a square wave signal adjust the SET OUTPUT control to read -7 dB, and for a sine wave signal adjust the SET OUTPUT control to read -10 dB on the meter's dB scale.

### 2.8 SETTING UP AUDIO STANDARD OUTPUT

If a sine wave source is required at the audio standard of 1 mW in 600 Ω, or levels at 10 dB or 20 dB above the standard, proceed as follows :-

#### 1 mW (0 dBm) in 600Ω

- (i) Connect the external equipment to the ATTEN output socket.
- (ii) Turn the OUTPUT VOLTS SELECTOR switch to SINE, 3 ATTEN.
- (iii) Turn the ATTEN IMPEDANCE switch to 600 Ω.
- (iv) Turn the ATTENUATED OUTPUT switch to 3 V.
- (v) Adjust the SET OUTPUT control to give a meter reading of 1.55 V. (The meter indicates the e. m. f. at 600 Ω source impedance.)

#### 10 mW (+10 dBm) in 600Ω

- (i) Connect the external equipment, via a 600 Ω resistor, to the DIRECT output socket.
- (ii) Turn the OUTPUT VOLTS SELECTOR switch to SINE, 30 DIRECT.
- (iii) Adjust the SET OUTPUT control to give a meter reading of 4.9 V. (The meter indicates the e. m. f. at 600 Ω source impedance.)

**100 mW (+20 dBm) in 600 $\Omega$** 

- (i) Connect the external equipment, via a 600  $\Omega$  resistor, to the DIRECT output socket.
- (ii) Turn the OUTPUT VOLTS SELECTOR switch to SINE, 30 DIRECT.
- (iii) Adjust the SET OUTPUT control to give a meter reading of 15.5 V. (The meter indicates the e.m.f. at 600  $\Omega$  source impedance.)

**Note :** As the instrument load under these conditions is 1200  $\Omega$ , it is not advisable to obtain a meter reading greater than about 20 V, otherwise distortion will occur. The normal minimum load is 2 k $\Omega$  (see Table 2.1).

**2.9 ADJUSTING SQUARE WAVE SAG AND MARK/SPACE RATIO**

The SAG preset control on the front panel enables you to make readjustments, below about 100 c/s, to minimize the sag on the horizontal top and bottom of the square wave at any particular signal level and load conditions that comply with Table 2.1.

To make an adjustment proceed as follows :-

- (1) Connect the load to the instrument and set the controls to give the required signal output.
- (2) Connect an oscilloscope, having a flat response down to d.c. and an input impedance that is large compared with the load, so as to monitor the square wave signal.
- (3) Adjust the SAG preset control to give zero sag of the waveform viewed on the oscilloscope.

**Note :** At other conditions of load, frequency, and signal amplitude to those used above, there will be a variation in performance, and the SAG control should be reset as described in section 4.7.2 in order to restore the instrument to the standard condition.

**Mark/space ratio**

The M/S preset control on the front panel enables you to readjust the mark/space ratio of the square wave signal to exactly 50/50 at a particular frequency.

To make an adjustment, proceed as follows :-

- (1) Set the controls of the instrument to give the required frequency.
- (2) Connect an oscilloscope, having a response that is flat from d.c. to 1 Mc/s, so as to monitor the output signal.
- (3) Adjust the M/S preset control to give exactly the required mark/space ratio of the square wave, viewed on the oscilloscope.

**Note :** To restore the instrument to the standard condition, see section 4.7.1.

**2.10 USE OF ACCESSORIES****Unbalanced-to-Balanced Transformer Type TM 6221**

The transformer is for use with sine wave signals between 10 c/s and 100 kc/s, fed from a 600  $\Omega$  source. It provides balanced outputs at an impedance of 150, 200, and 600  $\Omega$  and has a centre-tapped secondary winding.

An output may be taken from one half of the various secondary windings, i.e.,

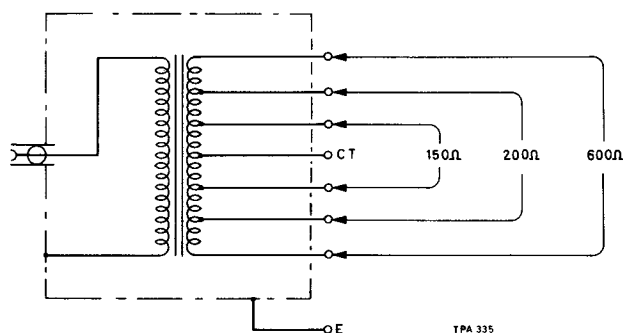

Fig. 2.5 Circuit of unbal—bal transformer

from one terminal of a pair and the centre tap. In these cases, the output impedance will be one quarter of the impedance marked at a particular terminal. The high frequency response may be slightly worsened.

**Example :**

If an output is taken from one 200 Ω terminal and the C. T. terminal, the output impedance will be 50 Ω - or if taken from one 150 Ω terminal and the C. T. terminal, the output impedance will be 37.5 Ω.

Connect the transformer input socket to the TF 1370A ATTEN output socket, by means of a coaxial lead fitted with BNC type plugs (e.g., TM 4726/136), and connect the external load to the appropriate terminals on the transformer. Turn the ATTEN IMPEDANCE switch to 600 Ω, the OUTPUT VOLTS SELECTOR switch to SINE, 3 ATTEN, and adjust the oscillator and the output voltage as described in sections 2.5 and 2.6.

The centre tap of the secondary winding on the transformer may be connected to its earthed terminal to obtain an output that is balanced with respect to earth, or, if this connection is not made, an output may be obtained that is floating or at some d. c. potential with respect to earth; the maximum d. c. potential allowable between the primary and the secondary windings is 200 V.

The secondary source e. m. f. between the 600 Ω terminals is the same as the e. m. f. indicated by the TF 1370A. For other output impedances Table 2.2 lists the multiplying factor necessary, due to the turns ratio of the transformer, that should be applied to the e. m. f. reading on the front panel meter to obtain the transformer secondary source e. m. f. When the transformer is loaded there is a small insertion loss; approximately 0.5 dB at 1 kc/s.

**CAUTION**

It is important that d. c. should not be allowed to flow in the windings of the transformer.

TABLE 2.2

Secondary source impedance	Secondary terminals	Secondary source e.m.f. — multiply e.m.f. indicated on TF 1370A by:
600 Ω	600 Ω & 600 Ω	1.0
200 Ω	200 Ω & 200 Ω	0.577
150 Ω	150 Ω & 150 Ω	0.5
50 Ω	200 Ω & C. T.	0.289
37.5 Ω	150 Ω & C. T.	0.25

**1 kc/s Band-Pass Filter Type TM 6222**

The 1 kc/s Band-Pass Filter is for use with the TF 1370A to give very pure outputs of 1 kc/s sine wave signals at a source impedance of 600 Ω.

Connect the Band-Pass Filter input socket to the TF 1370A ATTEN output socket by means of a coaxial lead fitted with BNC type plugs, and the two terminals on the Band-Pass Filter to the external load. Turn

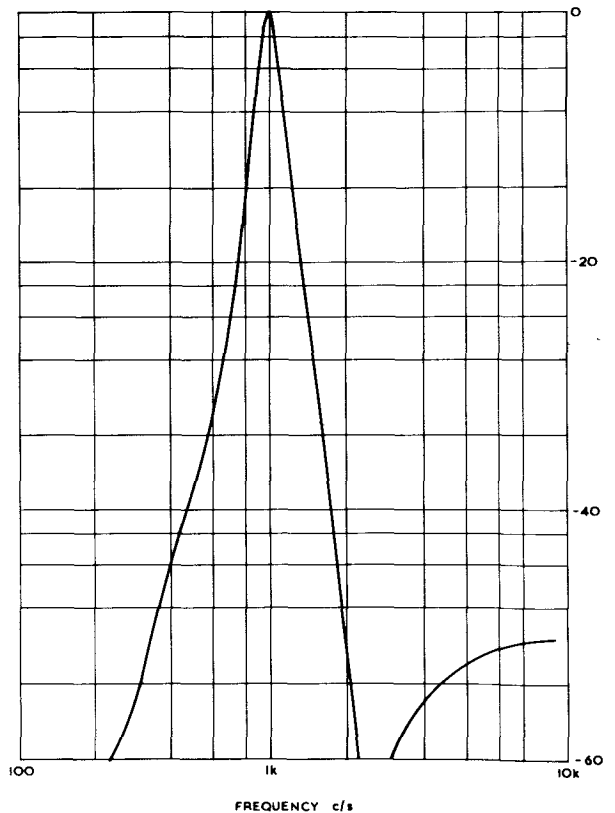

Fig. 2.6 Response curve of band-pass filter

the ATTEN IMPEDANCE switch to  $600\ \Omega$ , and the OUTPUT VOLTS SELECTOR switch to SINE, 3 ATTEN. Adjust the oscillator frequency to 1 kc/s and the output voltage to the required amplitude as described in sections 2.5 and 2.6 respectively. If a valve voltmeter is available, this should be connected across the load and the oscillator frequency adjusted for maximum valve voltmeter reading.

Assuming that the load is  $600\ \Omega$ , a signal voltage measured across the load will be about 10% below half the e. m. f. indicated by the front panel meter. To ascertain the exact signal voltage across the load, proceed as follows :-

- (i) Turn the ATTENUATED OUTPUT switch to 3 V.
- (ii) Adjust the SET OUTPUT control to give 3 V meter deflection.
- (iii) Connect a valve voltmeter, set to read 1.5 V, across the load and read the exact voltage.
- (iv) The difference between the TF 1370A e. m. f. reading and the valve voltmeter reading, expressed as a ratio, may then be used to determine accurately the voltage across the same load at other, lower, levels.

The filter can be used with the ATTEN IMPEDANCE switch turned to  $75\ \Omega$ ,  $100\ \Omega$

or  $130\ \Omega$ , if some worsening of the second harmonic content and a larger insertion loss is acceptable.

Note : The filter should never be used without a terminating load.

#### ×100 Attenuator Pad Type TM 6454

The x100 Attenuator Pad matches the  $75\ \Omega$  source impedance of the ATTEN output socket on the TF 1370A, and it is suitable for use with sine wave and square wave signals at all frequencies within the operating range of the instrument.

The Attenuator Pad has a BNC INPUT socket and two BNC OUTPUT sockets both giving 100 times e. m. f. attenuation. The input impedance is  $75\ \Omega$ ; the source impedance at one output socket is  $75\ \Omega$  and at the other it is  $5\ \Omega$ .

If, for any particular application, a  $5\ \Omega$  source impedance is required with less attenuation, then the signal from the TF 1370A may be fed into the  $75\ \Omega$  OUTPUT socket of the Attenuator Pad and the external load connected to the  $5\ \Omega$  OUTPUT socket. Under these circumstances the e. m. f. attenuation will be 30 times.

Note : The TF 1370A is not a fully screened signal generator and consequently errors in the signal level, due to leakage, may occur at  $\mu\text{V}$  signal levels at the highest frequencies.

# 3 TECHNICAL DESCRIPTION

## 3.1 CIRCUIT ARRANGEMENT

The circuits of the Wide Range R-C Oscillator are selected and combined in a number of ways by the panel controls. The Functional Diagram, Fig. 3.1 shows how the circuits are employed.

The basic oscillator is a Wien bridge type utilizing variable capacitance tuning and switched resistance range selection. For sine-wave outputs up to 3.16 V, the basic oscillator output voltage is fed direct to a cathode follower output stage: for all other sine wave outputs up to 31.6 V, the oscillator output signal is applied to the output stage via an amplifier. Square wave signals are obtained from a Schmitt circuit, which is triggered by the amplified sine wave from the basic oscillator. Square waves from the Schmitt circuit are applied to the cathode follower output stage.

The output cathode follower feeds either the DIRECT output socket, or, via an attenuator or a 75 Ω resistor, the ATTEN output socket. The attenuator introduces 60 dB attenuation in six 10 dB steps and has a source impedance of 75 Ω. An output monitor measures the voltage at the input to the attenuator, or across a 300 Ω resistor when the attenuator is not in circuit. The front panel meter is calibrated to indicate either the source e.m.f. at the ATTEN output socket or the p.d. at the DIRECT output socket.

## 3.2 OSCILLATOR

The basic oscillator, containing valve V1 to V4, is a Wien bridge type circuit. One arm of the bridge consists of a capacitor and a resistor in series, which are connected to a second arm consisting of a capacitor and a resistor in parallel.

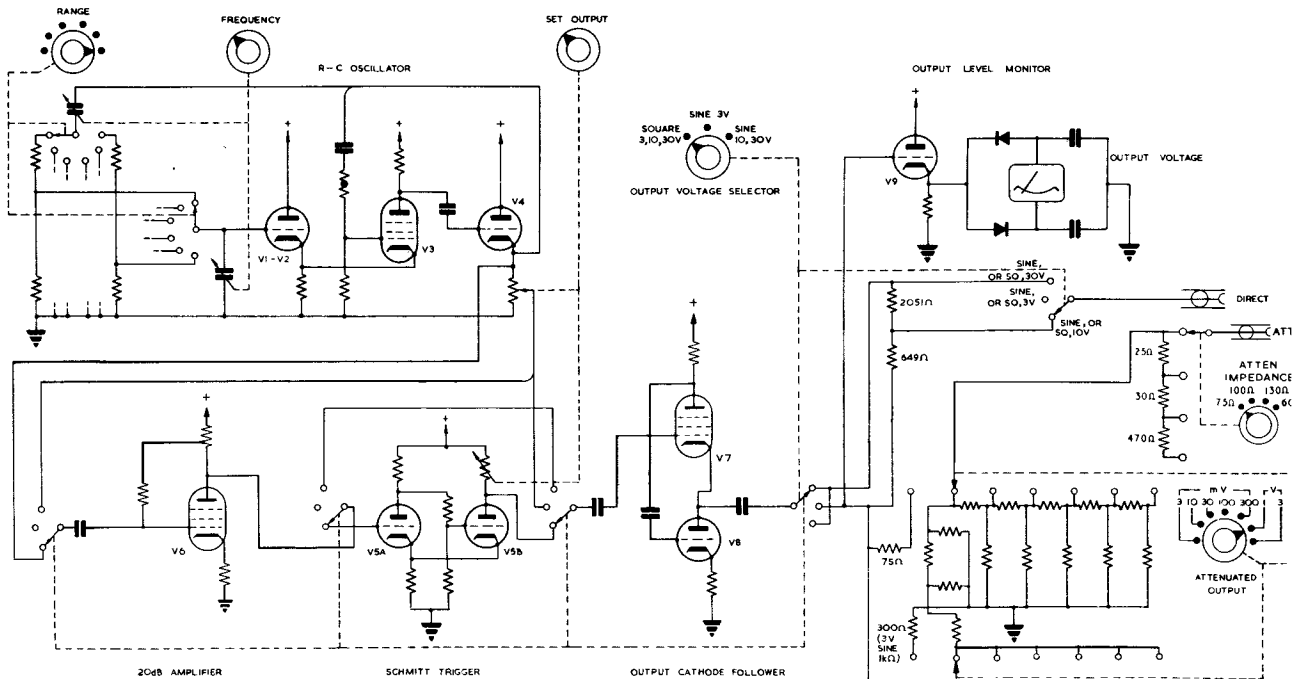

Fig. 3.1 Functional diagram

The series connected capacitor and resistor include variable capacitor C10 and one of the fixed resistors, R1, R3, R5, R7, R9, or R11; the parallel connected combination contains variable capacitor C11 and one of the resistors, R2, R4, R6, R8, R10, or R12. A particular pair of resistors is selected by the RANGE switch, SA, for each of the six frequency ranges, and the variable capacitors, C10 and C11, are ganged to provide tuning over each range. Preset variable resistors and preset variable capacitors are included in the bridge arms to enable the end frequencies of each range to be accurately set.

The second pair of arms of the bridge consist of thermistor TH1 and resistor R29.

Out-of-balance voltage developed by the bridge is applied between the control grid of V3, via capacitor C20, and the cathode of V3, via the two cathode followers V1 and V2 in cascade. The output voltage of V3 is applied - via cathode follower V4 - directly across the bridge circuit, thus forming the bridge supply voltage, which is maintained constant by thermistor TH1 controlling the degree of negative feedback.

### 3.3 20 dB AMPLIFIER

At all settings of the OUTPUT VOLTS SELECTOR except that giving sine waves up to 3 V, the output signal from the oscillator circuit is fed to the control grid of valve V6 from the cathode of V4 via resistor R114 for square wave operation, or via the SET OUTPUT potentiometer for sine wave operation. The amplified signal from the anode of V6 is then taken either to the Schmitt trigger (V5A and V5B) and thence to the output cathode follower, V7, for square wave output, or direct to V7 for DIRECT sine wave output.

When the RANGE switch is turned to ranges E or F for square wave output, or range F for DIRECT sine wave output the amplifier is rendered inoperative by removing the h. t. from V6. Simultaneously a voltage is applied to the WARNING CHECK RANGE neon indicator lamp. The necessary switching is effected by switch wafers SAk, SAj and SCj.

### 3.4 SCHMITT TRIGGER

The output voltage from the 20 dB amplifier is fed to the control grid of V5A in the Schmitt trigger circuit when the OUTPUT VOLTS SELECTOR switch, SC, is turned to the first three clockwise positions, i. e., the SQUARE, 3, 10, or 30 settings.

The Schmitt circuit, containing the two triode sections V5A and B, is triggered by the sine wave output signal from the 20 dB amplifier. One triode is held conducting while the other triode is non-conducting; the polarity of the sine wave signal applied to the control grid of the first triode section, V5A, decides which one of the two sections is conducting at any instant. To enable the switching of condition to occur at the precise base line of the sine wave input voltage, the control grid of V5A is biased by a voltage obtained from the slider of the M/S potentiometer, RV9, which is a preset control accessible at the front panel. The grid of V5A is d. c. coupled to the anode of V6; R83, the anode load of V6, forms part of the resistance chain from which the grid bias of V5A is obtained.

Preset capacitor C28, connected between the anode of V5A and the grid of V5B, is included to improve the frequency response of the coupling circuit, and is set for the best rise time. Capacitor C59, connected between the grids of the two triode sections, bucks out any curvature on the negative excursions of the square wave output signal, particularly at the higher frequencies.

The output from the Schmitt trigger circuit is fed from the anode of V5B to the grid of cathode follower V7, in the output stage, via switch SCe, capacitor C30, and resistor R49. The amplitude of the signal is controlled by varying the value of the anode load of V5B; this is achieved by variable resistor RV8A and resistor R46.

The rise time of the signal at the anode of the second triode, V5B, depends upon the value of its anode load, and reduces proportionately with the output level; so for the best performance, the amplitude of the signal should be adjusted for a front panel meter reading of about 1/3 of f. s. d.

Potentiometer RV8A is mechanically ganged to RV8B in the oscillator circuit, and the combined potentiometers function as the SET OUTPUT control.

The preset SAG control on the front panel, RV10, adjusts the flatness of the horizontal part of the output signal waveform. This correction, mainly necessary below 100 c/s, is achieved by introducing into the waveform some curvature in opposition to the sag caused by the coupling capacitors following the Schmitt circuit. The correcting circuit consists of capacitor C32, resistor R46, a part of the SET OUTPUT control RV8A according to its setting, and variable resistor RV10. The inclusion of RV8A in the SAG control circuit ensures that the horizontal flatness of the waveform is largely independent of the SET OUTPUT control setting, particularly for outputs up to 1/3 of full-scale front-panel meter indication.

### 3.5 OUTPUT CATHODE FOLLOWER

The output voltage from the basic oscillator, the 20 dB amplifier, or the Schmitt trigger circuit, is fed to the control-grid of output cathode follower V7, depending upon the setting of the OUTPUT VOLTS SELECTOR switch, SC.

The shunt-compensated cathode follower output stage contains two pentodes, V7 and V8, connected in series. The lower pentode, V8, is triode connected and forms the cathode load of the upper pentode, V7. The signal voltage developed across resistor R50 in the anode circuit of V7, is fed via capacitor C35 to the control grid of V8, thus supplementing the output signal at the cathode of V7. The output stage introduces only an extremely small amount of distortion and has an output impedance of about 15  $\Omega$ .

The signal voltage is taken from the cathode of V7 and feeds the DIRECT or the ATTEN output socket via the output attenuation networks, according to the position of the OUTPUT VOLTS SELECTOR switch.

### 3.6 OUTPUT MONITOR

The output monitor circuit, containing meter M1 and diodes MR1 and MR2, functions as a push-pull mean-reading rectifier circuit

fed via cathode follower V9. The meter scale is calibrated in r. m. s. values for sine waves and peak readings for square waves. Potentiometer RV13 is connected in circuit when measuring square wave voltages and is short circuited for sine wave measurements, the circuit having a greater sensitivity to square wave inputs.

Potentiometer RV11 connected in series with the meter sets the sensitivity of the meter. Capacitors C43 and C44 provide the necessary a. c. path for the rectifying diodes and in addition C44 prevents d. c. flowing between the positive cathode of V9 and earth via diode MR1 and the meter. Capacitor C45 is included in the circuit to reduce the d. c. leakage current in capacitor C44, which would normally affect the meter indication. C45 charges up through resistor R60 to near the potential of the cathode of V9, leaving only a small d. c. polarizing potential across capacitors C43 and C44. Capacitors C66 and C67 function as by-pass capacitors. They prevent any r. f. currents, which may be induced in the connecting leads, from passing through the meter.

### 3.7 OUTPUT CONNECTIONS

Output from the cathode follower V7 is fed to either the DIRECT or the ATTEN output socket via attenuation and impedance adjusting networks, arranged according to the position of the OUTPUT VOLTS SELECTOR switch, SC, as follows :-

- (1) SINE or SQUARE, 30 DIRECT :  
Output from V7 is fed via C36 and C37, and switch SC, to the DIRECT output socket at a source impedance of 25  $\Omega$ . The output monitor measures one tenth of the output voltage, i. e., measures the voltage appearing across the 300  $\Omega$  input impedance to the step attenuator circuit (or the 300  $\Omega$  resistor R59) that is connected in series with R64 and R65. The meter calibration on the lower scale, 0-31.6 V, indicates the actual voltage at the DIRECT output socket.
- (2) SINE, or SQUARE, 10 DIRECT :  
Output from V7 is fed via C36 and C37

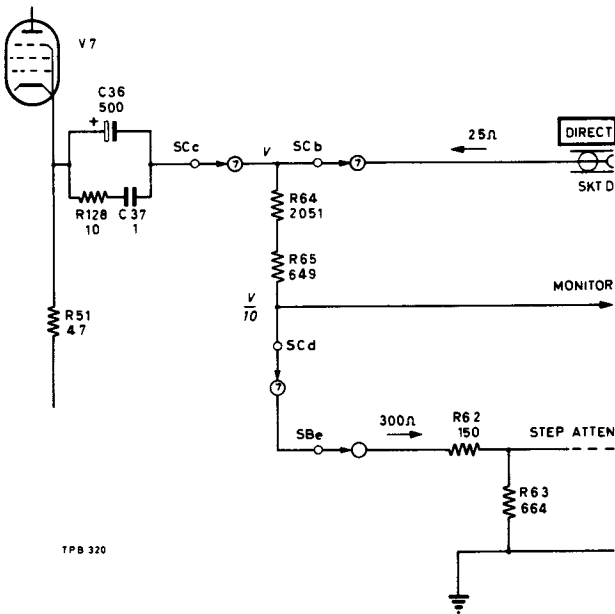

Fig. 3.2 'SINE 30 DIRECT' circuit

and switch SC, to resistor R64. The signal output is taken from the junction R64/R65 and is one third of the voltage from the cathode of V7. The source impedance is 650 Ω. The output monitor measures one tenth of the voltage from V7, i. e., measures the voltage appearing across the 300 Ω input impedance to the attenuator circuit (or the 300 Ω resistor R59) that is connected in series with R64 and R65.

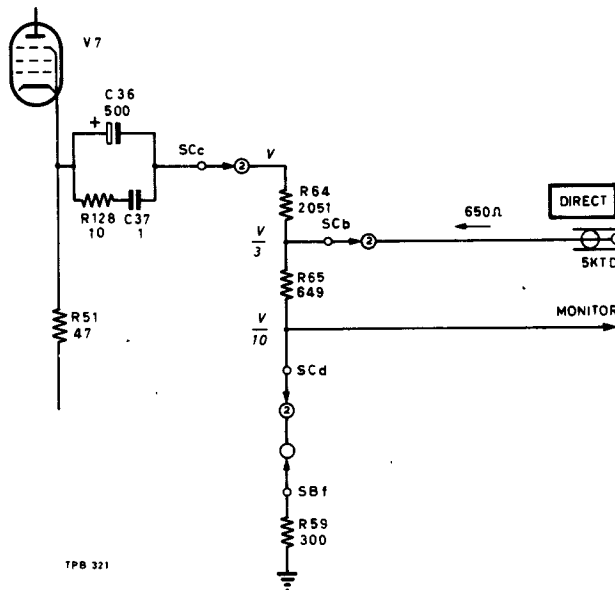

Fig. 3.3 'SQUARE 10 DIRECT' circuit

(3)

The meter calibration on the centre scale, 0-10 V, indicates the actual voltage at the DIRECT output socket.

SINE, 3 ATTEN :

Output from V7 is applied via C36 and C37 to the step attenuator network feeding the ATTEN outlet. The attenuator network includes a chain of six 10 dB sections, which are progressively withdrawn as the ATTENUATED OUTPUT switch, SB, is turned clockwise. At the seventh position, 3 V, SB substitutes a 75 Ω series resistor, R68.

Source impedance at the ATTEN outlet is selected by the ATTEN IMPEDANCE switch SE. When this is set to

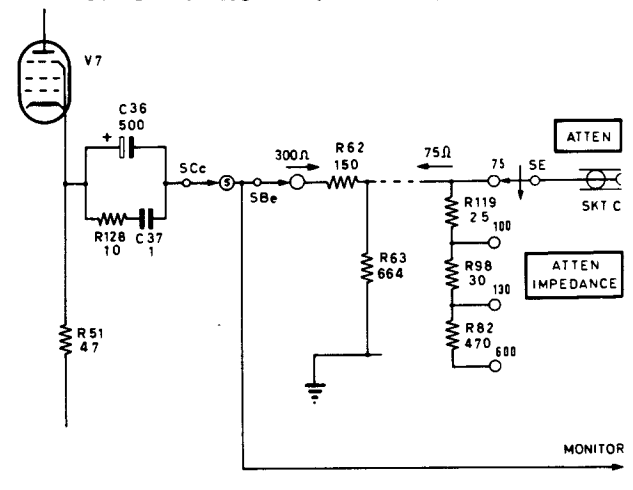

Fig. 3.4 'SINE 3 ATTEN' circuit

75 Ω, the source impedance is the 75 Ω output impedance presented by the stages of the step attenuator except that, if SB is set to 3 V, the 75 Ω series resistor combines with the output impedance of V7 giving an output impedance of approximately 100 Ω at the outlet. However, the source impedance remains 75 Ω.

Turning the ATTEN IMPEDANCE switch to 100, 130 and 600 Ω adds R119, 25 Ω, R98, 30 Ω and R82, 470 Ω, cumulatively in series with the ATTEN outlet.

The output monitor measures the voltage from V7 and indicates the source e. m. f. in series with the selected source impedance. The meter scales



should be read in conjunction with the setting of SB. When SB is set to 3 V, since the monitor indicates the voltage at the point where V7 feeds the 75 Ω series resistor, it therefore indicates the e. m. f. at the selected nominal source impedance, excluding the output impedance of V7.

R59 ensures a leakage path for the electrolytic capacitor C36 if a load is not connected when SB is in the 3 V position.

(4) SQUARE, 3 ATTEN :

The output circuit arrangement is the same as that described for SINE, 3 ATTEN, except that the step attenuator network receives its input from C36 and C37 via R64 and R65. The long CR time constant provided by this path is necessary to avoid sag of the

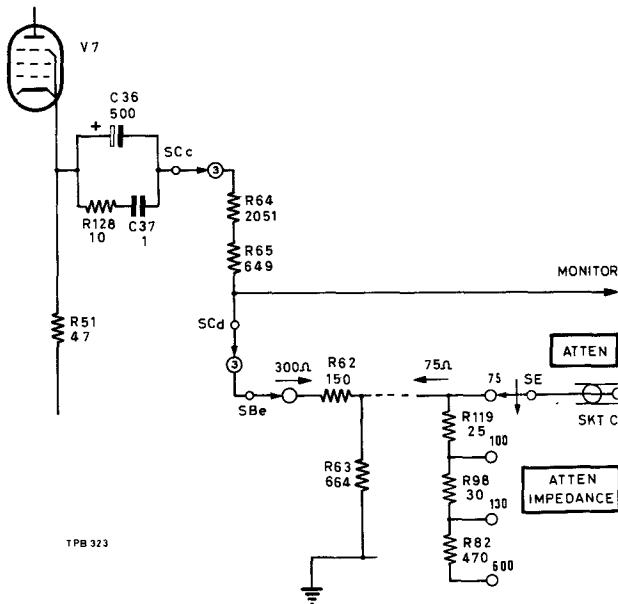

Fig. 3.5 'SQUARE 3 ATTEN' circuit

square wave. However, the presence of R64 and R65 has the effect of raising the output impedance at the ATTEN outlet as the ATTENUATED OUTPUT switch, SB, is turned to positions of high output (see Table 2.1 in section 2.6).

The output monitor measures the voltage at the 300 Ω input of the attenuator chain (or across R59) and indicates the source e. m. f. in series with the selected nominal source impedance.

3.8 REGULATED H.T. SUPPLY

The power unit, containing valves V11 to V14, supplies an unregulated 400V to the output cathode follower and a regulated 285 V to the remaining stages in the instrument.

Double triode V11 has its two sections connected in parallel and functions as a series regulator. The shunt amplifier that controls V11 includes double triodes V12 and V13. The error voltage input to this amplifier is the difference between (i) a fraction of the h. t. potential, obtained from the slider of the potentiometer RV12, and (ii) the reference potential developed by stabilizer V14. These two potentials are individually applied to the grids of the two cathode coupled triodes of V13. Any change of h. t. potential applied via RV12 to V13 is reinforced by the other half of V13, which draws its anode current from the resistor chain feeding RV12. The half of V13 to which RV12 is connected is coupled to the cathode of V12B in a cascade arrangement.

The amplified error voltage appearing across resistor R100 in the anode circuit of V12B is fed via cathode follower V12A to the control grids of series regulator V11.

3.9 REGULATED L.T. SUPPLY

The l. t. d. c. to the basic oscillator, V1 to V4, is provided by the regulated l. t. supply.

Secondary winding LT3 on mains transformer T1 supplies 11 V a. c. via bi-phase rectifier MR3 (A and B), at nominal mains input.

Transistors VT1, VT2 and VT3 form a stabilizer circuit consisting of an amplifier, an emitter follower and a series regulator. Part of the output voltage, taken via RV15, is compared by the amplifier with a reference voltage provided by a Zener diode, MR8. The resultant error signal is fed to the base

of the series regulator, VT3, by the emitter follower, thereby controlling VT3 and keeping the output voltage constant.

Preset potentiometer RV15 is set to give an output voltage of 6.3 V.

# 4 MAINTENANCE

## 4.1 GENERAL

The maintenance information in this handbook should enable you to carry out any adjustments and tests that are likely to be required on this instrument.

For routine inspection or fault location follow the instructions given in Section 4.8. Valve failure is the most probable cause of trouble and this can often be diagnosed by checking the static voltages on the circuit diagram. Where performance is marginal, the source of trouble can often be identified by moving to a higher tap on the mains transformer, which effectively decreases the supply voltage; this may exaggerate the weakness and make it easier to trace.

Always look out for obvious signs of failure, such as cold valves, burnt-out resistors and other overheating symptoms, flash-over marks and blown fuses. Inspect for intermittent contacts in components or joints by noting changes in performance caused by gently tapping them with an insulated prod - but be careful of high voltages.

In case of difficulties that cannot be resolved or for general advice on servicing or maintaining your instrument, please contact our Service Division at the address given on the back cover, or your nearest Marconi Instruments representative. Always mention the type number and serial number of your instrument.

If the instrument is being returned for repair please indicate clearly the nature of the fault or work you require to be done.

## 4.2 FUSES

The circuits of the Wide Range R-C Oscillator are protected by three fuses : a 2 A fuse, FS1, in series with the line supply and connected between the SUPPLY switch and the mains transformer, T1; a 500 mA fuse, FS2, in series with the h.t. secondary winding on T1; a 2 A fuse, FS3, in series

with the centre tap on the LT3 secondary winding on T1. Fuses FS2, and FS3 are the slow action type, which reduces the possibility of surge currents blowing them if the instrument is switched off and on in quick succession.

The three fuses are retained in screw-in holders which are situated on the back panel, adjacent to the mains input plug.

Note : Switch the supply OFF and remove the mains input socket before replacing a fuse.

## 4.3 INPUT SUPPLY VOLTAGE

Mains transformer T1 has two separate tapped primary windings. By means of these windings, the Wide Range R-C Oscillator can be set to operate from supplies in the ranges 100 to 150 V and 200 to 250 V, 45 to 65 c/s.

To make an alteration to the mains supply taps on the transformer, first switch the supply OFF and remove the mains input socket, then remove the small plate on the rear cover of the instrument.

### WARNING

Before removing the rear plate covering the transformer ensure that the mains supply is disconnected.

There are two forms of adjustment :

(A) linking of the tags on the transformer to make the instrument suitable for one of the voltage ranges, and (B) tap selection for a particular operating voltage within the selected range.

(A) For supplies within the range 100 to 150 V, the major sections of the two primary windings must be connected in parallel by a link between the tags, marked '100/200 V' and 'TAP A',

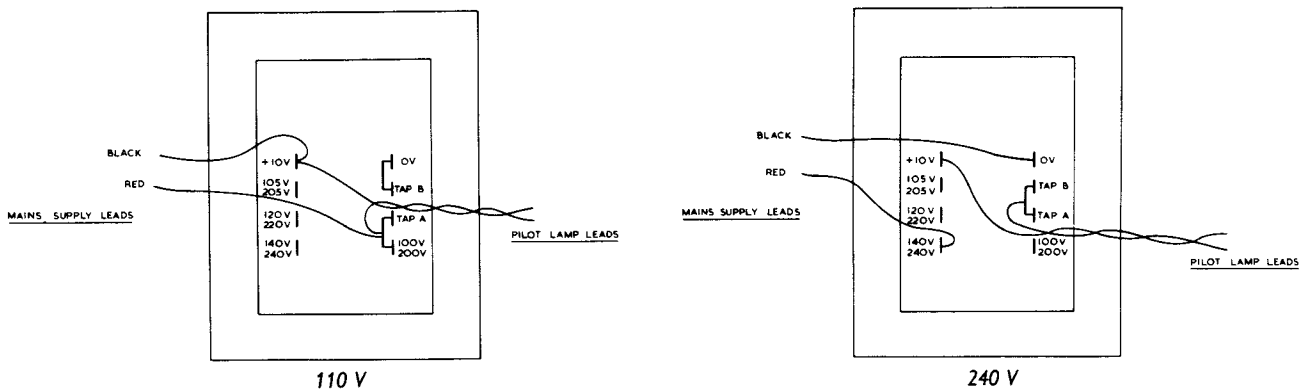

Fig. 4.1 Mains input connections

and another link between the tags marked 'TAP B' and '0 V' on the transformer.

For supplies within the range 200 to 250 V, the two primary windings must be connected in series by a single link between the tags marked 'TAP A' and 'TAP B' on the transformer.

- (B) For a particular voltage within either range, adjustment is made by connecting the red and the black sleeved wires to select the tags on the transformer appropriate to the supply voltage.

Fig. 4.1 shows two examples (for supplies of 110 V and 240 V) of connections on the transformer. Should the mains supply not correspond exactly to the tapplings provided, adjust to the nearest available combination.

The twisted pair of wires feeding 110 V a. c. to the neon front panel indicator lamp from the '+10 V' and the 'TAP A' tags on the transformer should not be disconnected.

#### 4.4 REMOVING CASE OR DUST COVER

To remove the case from a bench-mounting TF 1370A : place the instrument face down on a flat surface; unplug the mains lead; unscrew the four coin-slotted screws holding the rear cover and case.

To remove the dust cover from a rack-mounting version, TF 1370AR : remove the plate on the back of it by slackening

the 4 BA screw and sliding the plate upwards and backwards; unplug the mains lead; remove the four screws on the back of the dust cover and pull it away from the instrument.

#### Removing the chassis cover

To remove the cover enclosing the underside and lower rear half of the chassis: place the instrument face downwards on a flat surface; remove the sixteen 4 BA securing screws; and lift the cover away from the chassis.

#### 4.5 REPLACEMENT OF PANEL LAMPS

Before either panel indicator lamp can be replaced, the leads to the lamp must first be unsoldered from the tag strip mounting on the chassis. The securing nut on the lamp to be replaced can then be removed and the lamp assembly withdrawn from its mounting hole in the front panel. Note that the lamps have different voltage ratings.

#### 4.6 REPLACEMENT OF VALVES AND TRANSISTORS

- ▶ All valves and transistors may normally be replaced without special selection. However, (i) if any of the valves V11 to V14, or any transistor, is replaced, reference should be made to Section 4.7.8, (ii) if any of the valves V1 to V4 is replaced, it is advisable to check that the frequency calibration and the valve currents are correct as described in Section 4.7.5 and 4.7.6. ◀

## 4.7 PRESET ADJUSTMENTS

### 4.7.1 RV9—Mark/space ratio

The M/S preset control, on the front panel, enables the mark/space ratio of square wave output signals to be set so that a 50/50 ratio is obtained under general conditions (see section 2.9 for adjustments under particular conditions). To make this adjustment, proceed as follows :-

- (1) Connect an oscilloscope, with a response that is flat from d.c. to 1 Mc/s, to the DIRECT output socket.
- (2) Turn the OUTPUT VOLTS SELECTOR switch to SQUARE, 30 DIRECT and adjust the SET OUTPUT control to give a meter deflection of about full-scale deflection.
- (3) Adjust the M/S control to give a 50/50 ratio of the waveform viewed on the oscilloscope, at 2 kc/s.

In general, immediately after the above adjustment, the mark/space ratio should be 50/50 within about 2% at all frequencies.

### 4.7.2 RV10—Sag

The SAG preset control, on the front panel, enables the R-C Oscillator to be adjusted for minimum sag under general conditions (see Section 2.9 for adjustments under particular conditions). To make this adjustment, proceed as follows :-

- (1) Connect an oscilloscope, with a flat response down to d.c. and an input impedance of not less than 20 k $\Omega$ , to the DIRECT output socket. There should be no other load on the R-C Oscillator.
- (2) Turn the OUTPUT VOLTS SELECTOR switch to SQUARE, 30 DIRECT and the SET OUTPUT control to give a meter deflection of full-scale at a frequency setting of 10 c/s.

- (3) Adjust the SAG control to give zero sag of the waveform viewed on the oscilloscope.

After the above adjustment, the sag with a load of 2 k $\Omega$  and meter readings down to 1/3 full-scale should not exceed about 5%. The percentage of sag is expressed as the ratio of the amplitude loss at the end of each half cycle to half the total peak-to-peak amplitude of the signal, multiplied by 100.

### 4.7.3 C28—Rise and fall time

The rise and fall time of the square wave signal is adjusted by the preset capacitor, C28, which is situated alongside the Schmitt trigger valve, V5, and is accessible from the top of the chassis. To make an adjustment to C28 proceed as follows :-

- (1) Connect an oscilloscope, capable of measuring rise times between 0.25 and 1  $\mu$ sec, to the ATTEN output socket using a 3 ft, 75  $\Omega$ , coaxial connecting cable.
- (2) Turn the OUTPUT VOLTS SELECTOR switch to SQUARE, 3 ATTEN, the ATTENUATED OUTPUT switch to 1 V and the ATTEN IMPEDANCE switch to 75  $\Omega$ .
- (3) Tune the instrument to any frequency between 10 c/s and 100 kc/s and adjust the SET OUTPUT control to give a meter deflection about 1/3 of full-scale.
- (4) Adjust the preset capacitor C28 to produce the squarest waveform, viewed on the oscilloscope.

### 4.7.4 RV11 AND RV13—Output monitor sensitivity

The sensitivity of the output monitor circuit may be adjusted by means of the preset resistor RV11, which is accessible through a hole in the left-hand side of the instrument case, as follows :-

- (1) Connect a standardized valve voltmeter, set to read 3.16 V to the ATTEN output socket.

- (2) Tune the Oscillator to 2 kc/s, turn the OUTPUT VOLTS SELECTOR switch to SINE, 3 ATTEN, the ATTENUATED OUTPUT switch to 3 V, and the ATTEN IMPEDANCE switch to 75 Ω.
- (3) Adjust the SET OUTPUT control to produce a valve voltmeter reading of exactly 3.16 V.
- (4) Adjust the preset control RV11, situated on the left hand side of the chassis, to give a full-scale front panel meter reading.
- (5) Connect an oscilloscope to the DIRECT output socket.
- (6) Tune the oscillator to 50 kc/s and set the OUTPUT VOLTS SELECTOR to SINE DIRECT 30.
- (7) Adjust the SET OUTPUT control to give 30 V r.m.s. indicated on the panel meter and note the peak-to-peak amplitude of the oscilloscope trace.
- (8) Turn the OUTPUT VOLTS SELECTOR to SQUARE DIRECT 30 and readjust the SET OUTPUT control so that the peak-to-peak amplitude of the oscilloscope trace is 0.707 of the sine wave trace amplitude previously noted.
- (9) Adjust RV13 for full scale deflection on the panel meter.

- (2) Turn the OUTPUT VOLTS SELECTOR switch to SINE, 3 ATTEN and the ATTENUATED OUTPUT switch to 1 V.
- (3) At each position of the RANGE switch, set the FREQUENCY dial alternately to indicate the two frequencies shown for each range in Table 3.1 and adjust the corresponding preset controls shown in the table so that the frequency of the output is correct.

Note : To some degree, the preset capacitor and resistor for each range are inter-dependent; both these components should therefore be rechecked after their initial adjustment. Further, if on range F it is necessary to adjust C1, it may also be necessary to adjust C4 as described in Section 4.7.7. Resistors RV1 to RV6 are accessible upon removing the plate over the cut-out in the chassis cover.

TABLE 3.1

Range	Preset component	Frequency
A	RV6	20 c/s
A	C9	100 c/s
B	RV5	100 c/s
B	C7	1 kc/s
C	RV4	1 kc/s
C	C5	10 kc/s
D	RV3	10 kc/s
D	C3	100 kc/s
E	RV2	100 kc/s
E	C6	1 Mc/s
F	RV1	1 Mc/s
F	C1	10 Mc/s

**4.7.5 RV1 to RV6, C1 to C9— Oscillator circuit frequency adjustments**

If one or more of the valves V1 to V4 in the basic oscillator are replaced, it is advisable to check that the frequency calibration is correct and, if necessary, adjust the appropriate preset control shown in Table 3.1. To make an adjustment proceed as follows :-

- (1) Connect a counter, or other accurate frequency determining instrument, having an input sensitivity better than 500 mV and a frequency range 20 c/s to 10 Mc/s to the ATTEN output socket.

**4.7.6 Oscillator circuit d.c. conditions**

If any of the valves in the basic oscillator circuit, V1 to V4, are replaced it is

necessary to check that d. c. conditions remain correct.

Connect a voltmeter (e. g., Avometer model 8) between the anode (pin 7) of V2 and chassis. Check that the voltage is 150 V. If it is not adjust RV7 to bring it to this figure and then reseal the potentiometer.

Note : After making this adjustment it is advisable to check that the oscillator frequency calibration is correct as described in section 4.7.5.

#### 4.7.7 C4—Output frequency response (range F)

The frequency response of the output voltage at frequencies between 1 and 10 Mc/s can be adjusted by the preset capacitor C4. This adjustment affects the oscillator frequency and, if adjustments are made to C4, it may be necessary to readjust the preset capacitor C1 (see Section 4.7.5). To make an adjustment to C4, proceed as follows :-

- (1) Turn the RANGE switch to F, the OUTPUT VOLTS SELECTOR switch to SINE, 3 ATTEN, the ATTENUATED OUTPUT switch to 1 V, and the ATTEN IMPEDANCE switch to 75  $\Omega$ .
- (2) Connect to the ATTEN output socket a 75  $\Omega$  load, a valve voltmeter set to read above 0.5 V, and a counter or other frequency measuring instrument capable of measuring between 1 and 10 Mc/s.
- (3) Turn the FREQUENCY dial to read 1 Mc/s and note the valve voltmeter reading.
- (4) Turn the FREQUENCY dial slowly to the 10 Mc/s position, noting the difference in the valve voltmeter reading from that obtained in (3). If this difference reading is greater than  $\pm 0.5$  dB, adjust C4 slightly.
- (5) Check that the oscillator frequency is correct at the 10 Mc/s setting of the dial and, if necessary, readjust C1.

Note : It may be necessary to readjust RV1 with the frequency dial set at 1 Mc/s. The preset components C1, C4, and RV1 are all interdependent and the adjustment of any one of these controls may affect the correct setting of the other two.

#### 4.7.8 RV12 and RV15—Regulated h.t. and l.t. supplies

Following the replacement of any valve, transistor, or component in the regulated h.t. or l.t. power circuits, it is advisable to check and, if necessary, reset the d. c. output voltages of the circuits as follows :-

##### H.T. regulated voltage

- (1) Apply a supply voltage that matches the setting of the mains transformer tapings.
- (2) Connect a voltmeter, set to measure 285 V d. c., between the cathode (pin 6) of V11 and chassis.
- (3) Adjust the preset potentiometer RV12, which is mounted on the chassis beside the mains transformer T1, to obtain a voltmeter reading of 285 V.

Note : Any adjustments made to the h. t. regulated power unit may affect the l. t. regulated supply voltage; following such adjustments, the latter should therefore be checked.

##### L.T. regulated voltage

- (1) Apply a supply voltage that matches the setting of the mains transformer tapings.
- (2) Check that the regulated h. t. voltage is correctly adjusted, as described above.
- (3) Connect a voltmeter, set to measure 6.3 V d. c., between the two feed-through capacitors, C57 and C62. These two capacitors serve as term-

inating tags for the two windings on the bifilar wound choke L2-L3, and are mounted on the left hand side of the chassis. (The feed-through capacitors are fragile and may fracture if care is not exercised when attaching leads).

- (4) Adjust the potentiometer RV15, situated on printed board, TM 7942, to obtain a voltmeter reading of 6.3 V.

#### 4.8 DRIVE CORD

The layout of the drive cord for variable capacitor C10 and C11 is shown in Fig. 4.2.

#### 4.9 FUNCTIONAL CHECKS

The following sequence of tests may be used as a periodic check on performance or as a general fault-finding procedure to establish which part of the instrument is not working correctly.

##### Apparatus required

- (a) Valve voltmeter, to measure 2 to 40 V up to 10 MHz; e.g. Marconi Instruments TF 1041 or TF 2600.
- (b) Measuring oscilloscope, d. c. to 10 MHz, with low-capacitance probe, 10 Hz to 10 MHz; e.g., Marconi Instruments TF 2210 or TF 2204 with probe TM 8110.

- (1) Connect the valve voltmeter to the cathode of V4 (Test Point A). Check that the voltage near the centre of each frequency range is about 4 to 6 V. Replace the valve voltmeter with the oscilloscope and probe. Check that the waveform is free from distortion on each range.
- (2) Switch to RANGE C, SINE, 3 ATTEN, ATTEN IMPEDANCE 75  $\Omega$  and connect a 75  $\Omega$  load to the ATTEN output socket. Connect the valve voltmeter to Test Point B. Tune the oscillator to about

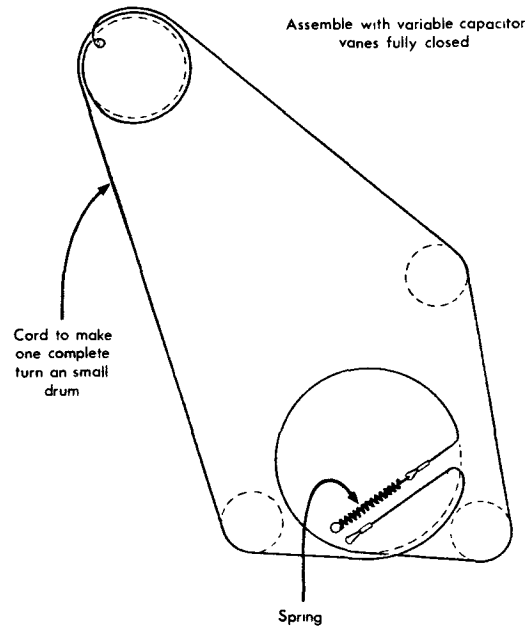

Fig. 4.2 Drive cord layout

2 kHz and check that a reading of 3.16 V can be obtained on the valve voltmeter by adjusting the SET OUTPUT control. Then use the oscilloscope to check for absence of distortion at this voltage.

- (3) Switch to the 100 mV ATTENUATED OUTPUT range and readjust the SET OUTPUT control for 3.16 V at Test Point B. Switch to SINE, 10 DIRECT and check that the valve voltmeter reading does not change by more than about 5%. Using the oscilloscope, note that the waveform at the DIRECT socket is free from distortion.

Readjust the SET OUTPUT control for 3.16 V and check that the DIRECT output is 10 V  $\pm 1\%$ . Switch to SINE, 30 DIRECT and note that the DIRECT output rises to 31.6 V  $\pm 1\%$  while the voltage at Test Point B does not alter with the attenuator at any step or with the load removed.



- (4) Connect a 2.2 k $\Omega$  load to the DIRECT output socket. Monitor the output with the oscilloscope and see that the square wave has a peak-to-peak value about 0.7 of that of the 30 V sine wave. By turning the SET OUTPUT control check that an output of 64 V peak-to-peak can be obtained. Switch to SQUARE, 10 DIRECT and note that the output falls to about a third.
- (5) Connect the oscilloscope to the direct to output socket. Monitor the 'Sine 30 direct' and 'Square 30 direct' signals on ranges A to D and note that on range F the sine output disappears, and on ranges E and F the square output disappears, while a warning lamp lights to indicate each of the three incorrect output selections.

Note: On 'Sine 30 direct' range F, the signal does not entirely disappear, and can be seen to be a distorted sine wave of less than 1 V amplitude. ◀

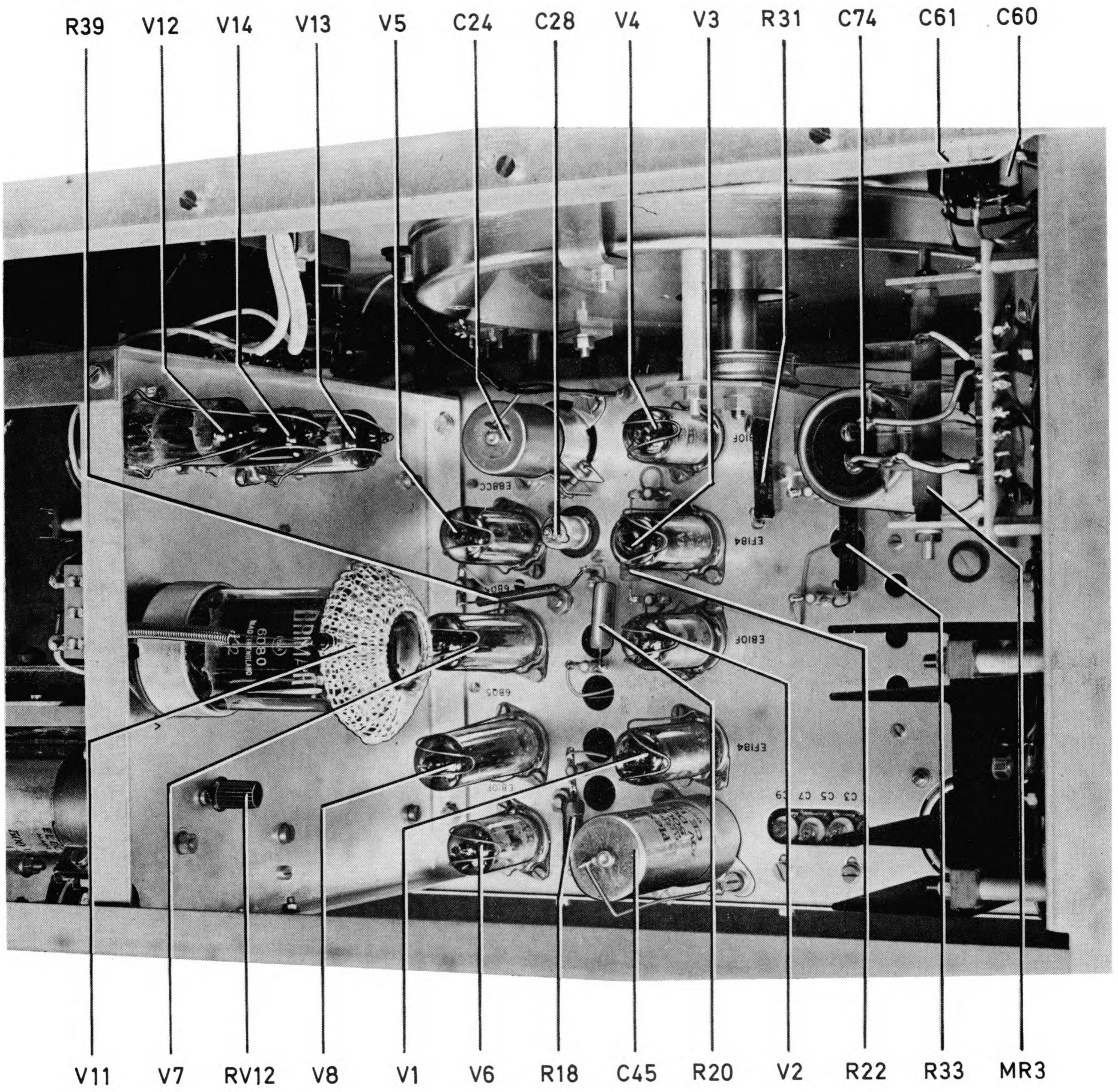

Fig. 4.2 Component layout—top

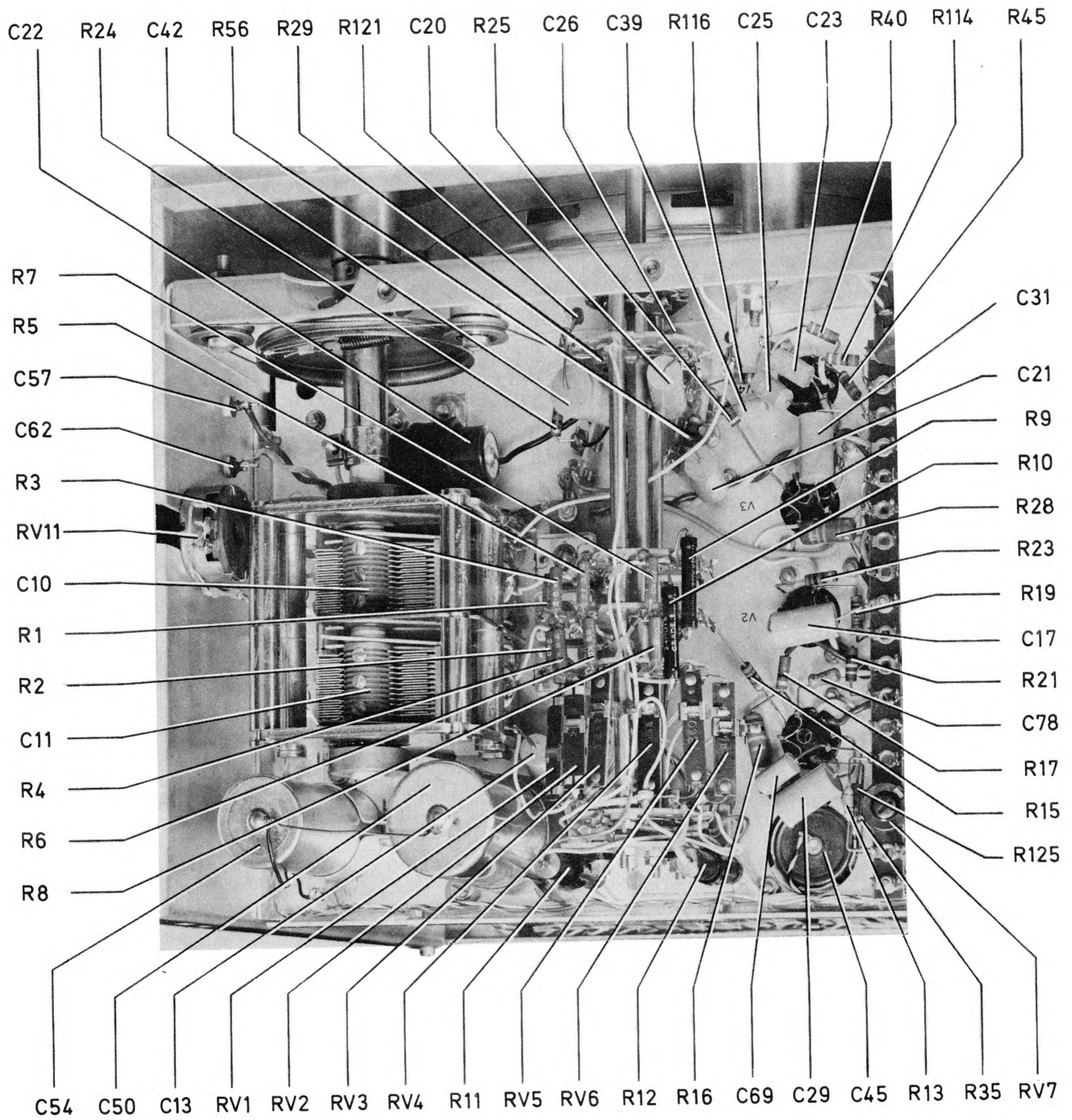

Fig. 4.3 Component layout—bottom left

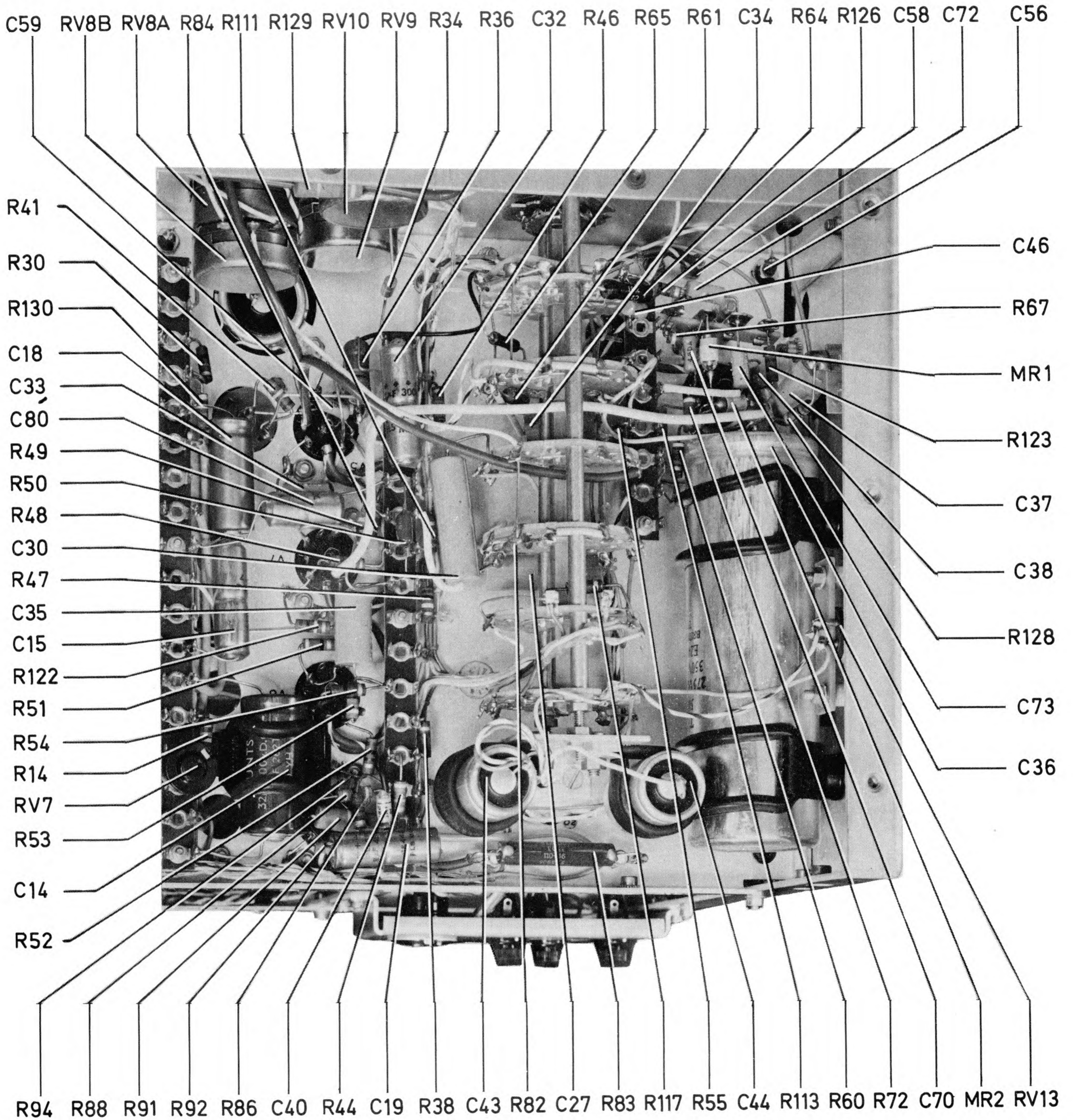

Fig. 4.4 Component layout—bottom right

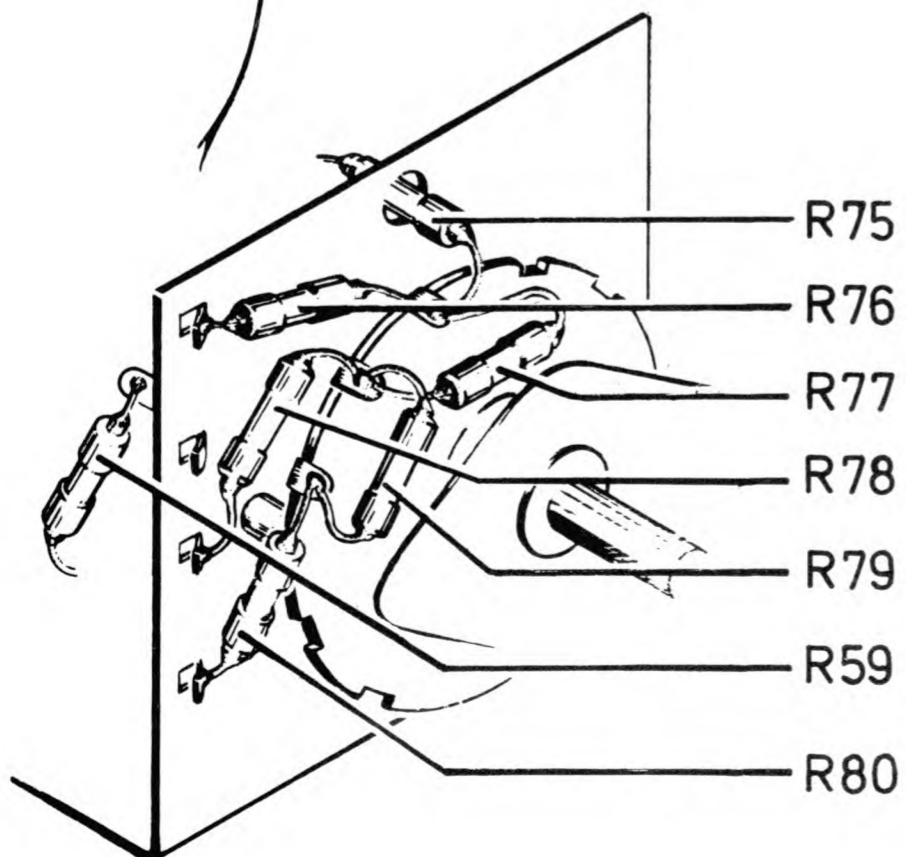
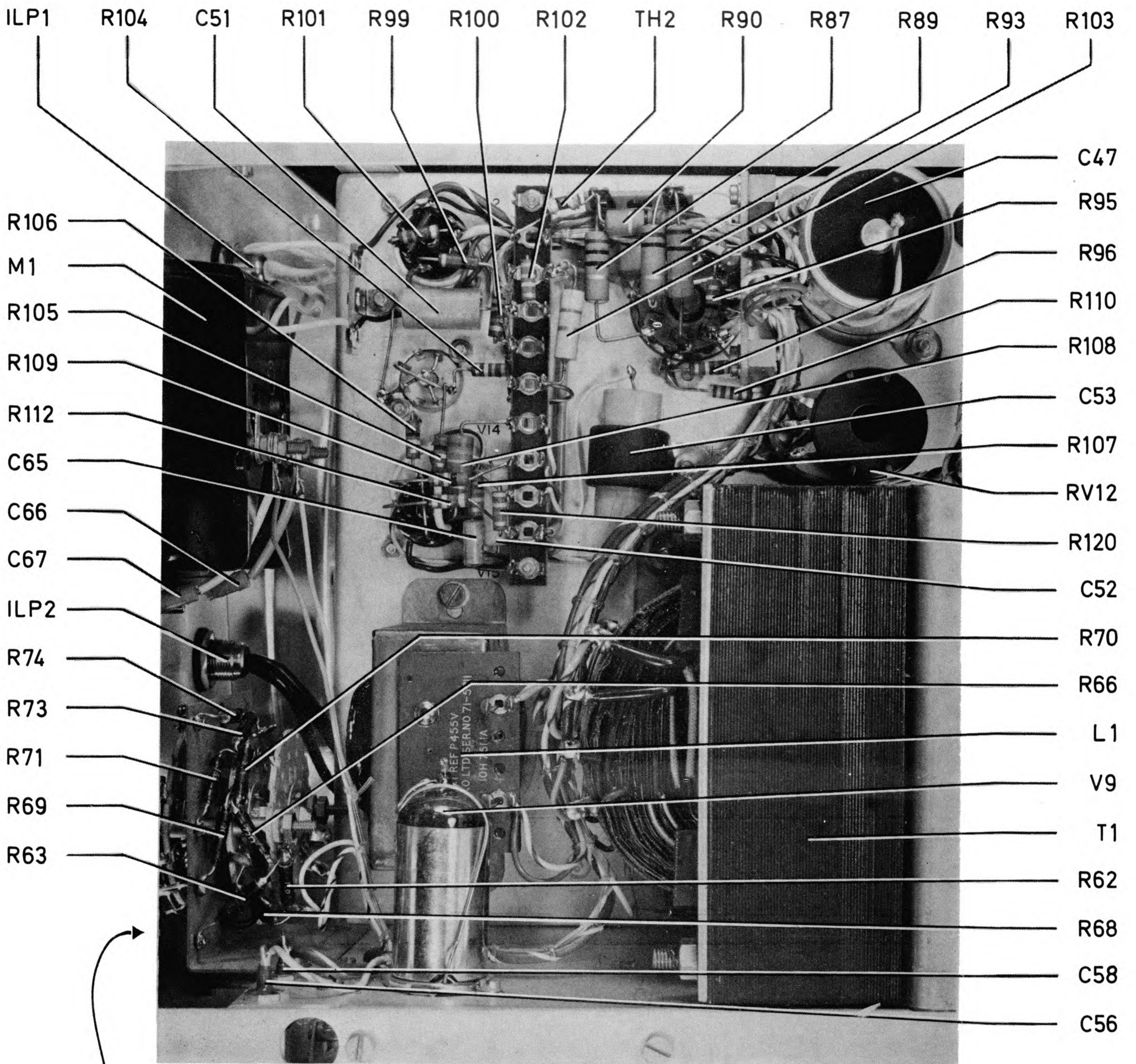

Fig. 4.5 Component layout—right side

**REPLACEABLE PARTS****Introduction**

This section lists replaceable parts in alphabetical order of their circuit references, with miscellaneous parts at the end of the list. The following abbreviations and symbols are used:-

Carb	:	carbon
Cer	:	ceramic
Elec	:	electrolytic
Log	:	logarithmic law
Met film	:	metal film
Met ox	:	metal oxide film
Min	:	minimum value
TE	:	total excursion
Var	:	variable (or preset)
WW	:	wire-wound
*	:	value selected during test; nominal value listed

Components fitted in an instrument may differ from those listed in this chapter. Whenever there is such a difference, use a replacement of the same type and value as found in the instrument.

Circuit reference	Description	M.I. code
-------------------	-------------	-----------

**Capacitors**

C1	Var mica	2.5-40pF	26857-203
C2	not used		
C3	Var mica	3-30pF	26852-533
C4	Var mica	2.5-40pF	26857-203
C5	Var mica	3-30pF	26852-533
C6	Var mica	2.5-40pF	26857-203
C7	Var mica	3-30pF	26852-533
C8	not used		
C9	Var mica	3-30pF	26852-533
C10	Var air,	} 14-532pF	26832-903
C11	ganged		

Circuit reference	Description	M.I. code
C12	Cer 56pF ±5% 750V	26324-164
C13	Paper 0.1μF ±10% 350V	26174-174
C14	Elec 32μF +50% -20% 300V	26417-485
C15	Elec 25μF +100% -20% 70V	26417-145
C16	Paper .001μF ±10% 500V	26174-125
C17	Paper 0.1μF ±10% 350V	26174-174
C18	Elec 4μF +100% -20% 350V	26417-459
C19	Elec 2μF +50% -20% 450V	26417-457
C20	Paper 0.5μF ±10% 150V	26174-179
C21	Paper 0.1μF ±10% 350V	26174-174
C22	Elec 32μF +50% -20% 300V	26417-485
C23	Paper .01μF ±10% 400V	26174-147
C24	Elec 330μF +50% -20% 100V	26417-691
C25	Paper .01μF ±10% 400V	26174-147
C26	Paper 0.1μF ±10% 350V	26174-174
C27	Paper 0.5μF ±10% 150V	26174-179
C28	Var air 3-30pF	26814-409
C29	Plastic 0.1μF ±10% 350V	26174-174
C30	Paper 0.5μF ±10% 150V	26174-179
C31	Paper 0.1μF ±10% 350V	26174-174
C32	Elec 4μF +100% -20% 300V	26417-458
C33	Paper .01μF ±10% 400V	26174-147
C34	Paper 0.1μF ±10% 350V	26174-174
C35	Paper 0.1μF ±10% 350V	26174-174
C36	Elec 500μF +50% -20% 275V	26417-696
C37	Paper 0.1μF ±10% 350V	26174-174
C38	Paper .01μF ±10% 400V	26174-147
C39	Paper .001μF ±10% 500V	26174-125
C40	Plastic 82pF ±2pF 350V	26516-225
C41	Not used	
C42	Paper 0.5μF ±10% 350V	26174-179
C43	Elec 500μF +100% -20% 25V	26417-228
C44	Elec 500μF +100% -20% 25V	26417-228
C45	Elec 500μF +100% -20% 70V	26417-230
C46	Cer 47pF ±10% 750V	26324-835
C47	Elec 100μF +50% -20% 500V	26462-136
C48	Not used	
C49	Not used	
C50	Elec 100μF +50% -20% 500V	26417-687
C51	Paper 0.1μF ±10% 350V	26174-174

Replaceable parts

Circuit reference	Description	M.I. code	Circuit reference	Description	M.I. code
C52	Paper 0.1 $\mu$ F $\pm$ 10% 350V	26174-174	<b>Inductors</b>		
C53	Paper 1 $\mu$ F $\pm$ 10% 250V	26174-188	L1	Choke 10H 75mA	23642-121
C54	Elec 100 $\mu$ F +50% -20% 450V	26427-548	L2	Choke	TB 34440
C55	Not used		L3	Choke	TB 34440
C56	Cer 1000pF $\pm$ 20% 500V	26373-256	<b>Meter</b>		
C57	Cer 4700pF min 500V	26373-665	M1	200 $\Omega$ 1mA f.s.d.	TM 3970/102
C58	Cer 4700pF min 500V	26373-665	<b>Semiconductor diodes</b>		
C59	Cer 1pF $\pm$ 0.5pF 750V	26324-403	MR1	HD1841	28331-365
C60	Paper .001 $\mu$ F $\pm$ 10% 500V	26174-125	MR2	HD1841	28331-365
C61	Paper .001 $\mu$ F $\pm$ 10% 500V	26174-125	MR3A	} GEC type SX631-V1P1	28359-435
C62	Cer 4700pF min 500V	26373-665	MR3B		
C63	Cer 4700pF min 500V	26373-665	MR4	Lucas type DD058	28358-817
C64	Cer 4700pF min 500V	26373-665	MR5	Lucas type DD058	28358-817
C65	Paper .002 $\mu$ F $\pm$ 10% 500V	26174-126	MR6	Lucas type DD058	28358-817
C66	Paper .001 $\mu$ F $\pm$ 10% 500V	26174-125	MR7	Lucas type DD058	28358-817
C67	Paper .001 $\mu$ F $\pm$ 10% 500V	26174-125	MR8	Zener ZB4.7	28371-376
C68	Not used		<b>Plugs</b>		
C69	Paper .01 $\mu$ F $\pm$ 10% 400V	26174-147	PLA	3 pin 5 amp	23423-151
C72	Paper .001 $\mu$ F $\pm$ 10% 500V	26174-126	<b>Resistors</b>		
C73	Paper .001 $\mu$ F $\pm$ 10% 500V	26174-126	(Unless otherwise stated, tolerance refers to initial selection and rating refers to 70°C)		
C74	Elec 2500 $\mu$ F +50% -20% 50V	26427-134	R1	Met film 250 $\Omega$ $\pm$ 1% $\frac{1}{4}$ W	24636-701
C75	Elec 250 $\mu$ F +100% -20% 25V	26417-167	R2	Met film 240 $\Omega$ $\pm$ 1% $\frac{1}{4}$ W	24636-605
C76	Elec 100 $\mu$ F +100% -20% 25V	26417-158	R3	Met film 2.6k $\Omega$ $\pm$ $\frac{1}{2}$ % $\frac{1}{4}$ W	24635-102
C77	Elec 100 $\mu$ F +100% -20% 25V	26417-158	R4	Met film 2.5k $\Omega$ $\pm$ $\frac{1}{2}$ % $\frac{1}{4}$ W	24635-101
C78	Cer 4.7pF $\pm$ 0.5pF 750V	26324-055	R5	Met film 27.3k $\Omega$ $\pm$ $\frac{1}{2}$ % $\frac{1}{4}$ W	24635-552
C79	Paper .01 $\mu$ F $\pm$ 10% 400V	26174-147	R6	Met film 25k $\Omega$ $\pm$ $\frac{1}{2}$ % $\frac{1}{4}$ W	24635-551
C80	Elec 1 $\mu$ F +50% -20% 450V	26417-453	R7	Met film 273k $\Omega$ $\pm$ $\frac{1}{2}$ % $\frac{1}{4}$ W	24635-752
C81	Cer 15pF $\pm$ 0.25pF 750V	26324-712	R8	Met film 260k $\Omega$ $\pm$ $\frac{1}{2}$ % $\frac{1}{4}$ W	24635-751
C82	Plas 0.1 $\mu$ F $\pm$ 10% 400V	26555-475	R9	Carb film 2.73M $\Omega$ $\pm$ 1% $\frac{3}{4}$ W	24177-273
<b>Fuses</b>			R10	Carb film 2.6M $\Omega$ $\pm$ 1% $\frac{3}{4}$ W	24177-260
FS1	2A	23411-007	R11	Carb film 27M $\Omega$ $\pm$ 2% 2W	24228-027
FS2	500mA	23411-056	R12	Carb film 30M $\Omega$ $\pm$ 2% 2W	24228-030
FS3	2A	23411-060	R13	Met ox 220k $\Omega$ $\pm$ 7% TE $\frac{3}{8}$ W/55°C	24552-143
<b>Indicating lamps</b>					
ILP1	110V neon, red	23733-115			
ILP2	300V neon, amber	23733-121			

it nce	Description	M.I. code	Circuit reference	Description	M.I. code
Met ox	39kΩ ±2% ¼W	24511-624	R53	Met ox 4.7Ω ±2% ¼W	24511-537
Met ox	100Ω ±2% ¼W	24511-550	R54	Met ox 1MΩ ±2% ½W	24573-145
Met ox	10kΩ ±2% ¼W	24511-610	R55	Met ox 1MΩ ±2% ¼W	24573-145
Met ox	68Ω ±2% ¼W	24511-543	R56	Met ox 100Ω ±2% ¼W	24511-550
Met ox	4.7kΩ ±5% 3W	24588-143	R57	Met ox 470Ω ±2% ¼W	24511-569
Met ox	36Ω ±7% TE ¾W/55°C	24552-034	R58	Met ox 6.8kΩ ±2% ½W	24573-093
Met ox	1.2kΩ ±5% 3W	24588-128	R59	Carb film 300Ω ±1% ¼W	24133-300
Met ox	10kΩ ±2% ¼W	24511-610	R60	Met ox 4.7kΩ ±2% ¼W	24511-600
Met ox	6.8kΩ ±5% 3W	24588-146	R61	Met ox 680Ω ±2% ¼W	24511-576
Met ox	100Ω ±2% ¼W	24511-550	R62	Carb film 150Ω ±1% ¼W	24133-150
Met ox	10Ω ±2% ¼W	24511-520	R63	Carb film 664Ω ±1% ¼W	24133-664
Met ox	4.7Ω ±2% ¼W	24511-537	R64	Carb film 2051Ω ±1% ½W	24158-470
Met ox	4.7kΩ ±2% ¼W	24511-626	R65	Carb film 649Ω ±1% ¼W	24133-649
Not used			R66	Carb film 72Ω ±1% ¼W	24132-720
Met ox	22kΩ ±5% 2W	24587-258	R67	Met ox 470Ω ±2% ¼W	24511-569
Met film	250Ω ±1% ¼W	24636-701	R68	Carb film 75Ω ±1% ¼W	24132-750
Met ox	1.0MΩ ±2% ½W	24573-145	R69	Carb film 201Ω ±1% ¼W	24133-201
WW	2.2kΩ ±5% 4½W	25126-588	R70	Carb film 213Ω ±1% ¼W	24133-213
Met ox	6.8kΩ ±2% ¼W	24511-606	R71	Carb film 144Ω ±1% ¼W	24133-144
WW	2.2kΩ ±5% 4½W	25126-588	R72	Met ox 470Ω ±2% ¼W	24511-569
Met ox	120kΩ ±7% TE ¾W/55°C	24552-137	R73	Carb film 213Ω ±1% ¼W	24133-213
Met ox	68kΩ ±2% ¼W	24511-631	R74	Carb film 144Ω ±1% ¼W	24133-144
Met ox	10kΩ ±5% 2W	24587-250	R75	Carb film 213Ω ±1% ¼W	24133-213
Not used			R76	Carb film 144Ω ±1% ¼W	24133-144
Met ox	150Ω ±2% ¼W	24511-554	R77	Carb film 213Ω ±1% ¼W	24133-213
WW	15kΩ ±5% 5W/20°C	25336-544	R78	Carb film 144Ω ±1% ¼W	24133-144
Met ox	820kΩ ±2% ½W	24573-143	R79	Carb film 213Ω ±1% ¼W	24133-213
Met ox	150kΩ ±2% ¼W	24511-639	R80	Carb film 99Ω ±1% ¼W	24132-990
Met ox	220kΩ ±2% ¼W	24511-643	R81	Not used	
Not used			R82	Carb film 470Ω ±1% ¼W	24133-470
Met ox	4.7kΩ ±2% ¼W	24511-626	R83	WW 4.7kΩ ±5% 4½W	25126-600
Met ox	22Ω ±2% ¼W	24511-528	R84	Met ox 4.7kΩ ±2% ¼W	24511-600
Met ox	1.8kΩ ±2% ¼W	24511-586	R85	Not used	
Met ox	100kΩ ±2% ¼W	24511-635	R86	Carb 10MΩ ±10% ¼W	24322-991
Met ox	220kΩ ±2% ¼W	24511-643	R87	Met ox 10Ω ±2% ½W	24573-025
Met ox	4.7Ω ±2% ¼W	24511-537	R88	Met ox 4.7Ω ±2% ¼W	24511-537
WW	470Ω ±5% 1½W	25123-067	R89	Met ox 1kΩ ±2% ½W	24573-073
Met ox	4.7Ω ±2% ¼W	24511-537	R90	Met ox 10Ω ±2% ½W	24573-025
Met ox	100Ω ±2% ¼W	24511-550	R91	Met ox 22kΩ ±2% ½W	24573-105





Circuit reference	Description	M.I. code	Circuit reference	Description	M.I. code
<b>Switches</b>			V6	E810F	28154-667
SA	RANGE	44324-806	V7	6BQ5	28154-557
SB	ATTENUATED OUTPUT	44325-104	V8	6BQ5	28154-557
SC	OUTPUT VOLTS SELECTOR	44325-203	V9	6BW7	28154-492
SD	SUPPLY	44334-003	V10	Not used	
SE	Z ATTEN	44323-109	V11	6080	28123-647
			V12	12AX7	28124-302
<b>Sockets</b>			V13	12AX7	28124-302
SKTC	Coaxial 75Ω BNC	23443-453	V14	85A2	28216-237
SKTD	Coaxial 75Ω BNC	23443-423			
<b>Transformer</b>			<b>Transistors</b>		
T1	Mains	TM5151/26	VT1	Texas type 2N3324	28424-356
			VT2	Mullard type ACY17	28426-497
			VT3	Brush type 2N1553	28424-886
<b>Thermistors</b>			<b>Knobs</b>		
TH1	STC type A14	25683-263		RANGE	31145-102
TH2	STC type CZ3	25683-644		SET OUTPUT	31145-102
<b>Valves</b>				OUTPUT V SEL	31145-102
V1	EF184	28154-627		ATTEN OUTPUT	31145-102
V2	E810F	28154-667		FREQUENCY	41142-418
V3	EF184	28154-627		Z ATTEN	41144-201
V4	E810F	28154-667			
V5	E88CC	28124-727			

# DECIBEL CONVERSION TABLE

<i>Ratio Down</i>			<i>Ratio Up</i>		
VOLTAGE	POWER	DECIBELS	VOLTAGE	POWER	
1.0	1.0	0	1.0	1.0	
.9886	.9772	.1	1.012	1.023	
.9772	.9550	.2	1.023	1.047	
.9661	.9333	.3	1.035	1.072	
.9550	.9120	.4	1.047	1.096	
.9441	.8913	.5	1.059	1.122	
.9333	.8710	.6	1.072	1.148	
.9226	.8511	.7	1.084	1.175	
.9120	.8318	.8	1.096	1.202	
.9016	.8128	.9	1.109	1.230	
.8913	.7943	1.0	1.122	1.259	
.8710	.7586	1.2	1.148	1.318	
.8511	.7244	1.4	1.175	1.380	
.8318	.6918	1.6	1.202	1.445	
.8128	.6607	1.8	1.230	1.514	
.7943	.6310	2.0	1.259	1.585	
.7762	.6026	2.2	1.288	1.660	
.7586	.5754	2.4	1.318	1.738	
.7413	.5495	2.6	1.349	1.820	
.7244	.5248	2.8	1.380	1.905	
.7079	.5012	3.0	1.413	1.995	
.6683	.4467	3.5	1.496	2.239	
.6310	.3981	4.0	1.585	2.512	
.5957	.3548	4.5	1.679	2.818	
.5623	.3162	5.0	1.778	3.162	
.5309	.2818	5.5	1.884	3.548	
.5012	.2512	6	1.995	3.981	
.4467	.1995	7	2.239	5.012	
.3981	.1585	8	2.512	6.310	
.3548	.1259	9	2.818	7.943	
.3162	.1000	10	3.162	10.000	
.2818	.07943	11	3.548	12.59	
.2512	.06310	12	3.981	15.85	
.2239	.05012	13	4.467	19.95	
.1995	.03981	14	5.012	25.12	
.1778	.03162	15	5.623	31.62	

## DECIBEL CONVERSION TABLE

<i>Ratio Down</i>			<i>Ratio Up</i>	
<i>VOLTAGE</i>	<i>POWER</i>	<i>DECIBELS</i>	<i>VOLTAGE</i>	<i>POWER</i>
·1585	·02512	<b>16</b>	6·310	39·81
·1413	·01995	<b>17</b>	7·079	50·12
·1259	·01585	<b>18</b>	7·943	63·10
·1122	·01259	<b>19</b>	8·913	79·43
·1000	·01000	<b>20</b>	10·000	100·00
·07943	·006310	<b>22</b>	12·59	158·5
·06310	·003981	<b>24</b>	15·85	251·2
·05012	·002512	<b>26</b>	19·95	398·1
·03981	·001585	<b>28</b>	25·12	631·0
·03162	·001000	<b>30</b>	31·62	1,000
·02512	·0006310	<b>32</b>	39·81	1,585
·01995	·0003981	<b>34</b>	50·12	2,512
·01585	·0002512	<b>36</b>	63·10	3,981
·01259	·0001585	<b>38</b>	79·43	6,310
·01000	·0001000	<b>40</b>	100·00	10,000
·007943	·00006310	<b>42</b>	125·9	15,850
·006310	·00003981	<b>44</b>	158·5	25,120
·005012	·00002512	<b>46</b>	199·5	39,810
·003981	·00001585	<b>48</b>	251·2	63,100
·003162	·00001000	<b>50</b>	316·2	100,000
·002512	6·310 × 10 <sup>-6</sup>	<b>52</b>	398·1	158,500
·001995	3·981 × 10 <sup>-6</sup>	<b>54</b>	501·2	251,200
·001585	2·512 × 10 <sup>-6</sup>	<b>56</b>	631·0	398,100
·001259	1·585 × 10 <sup>-6</sup>	<b>58</b>	794·3	631,000
·001000	10 <sup>-6</sup>	<b>60</b>	1,000	10 <sup>6</sup>
·0005623	3·162 × 10 <sup>-7</sup>	<b>65</b>	1,778	3·162 × 10 <sup>6</sup>
·0003162	10 <sup>-7</sup>	<b>70</b>	3,162	10 <sup>7</sup>
·0001778	3·162 × 10 <sup>-8</sup>	<b>75</b>	5,623	3·162 × 10 <sup>7</sup>
·0001000	10 <sup>-8</sup>	<b>80</b>	10,000	10 <sup>8</sup>
·00005623	3·162 × 10 <sup>-9</sup>	<b>85</b>	17,780	3·162 × 10 <sup>8</sup>
·00003162	10 <sup>-9</sup>	<b>90</b>	31,620	10 <sup>9</sup>
·00001000	10 <sup>-10</sup>	<b>100</b>	100,000	10 <sup>10</sup>
3·162 × 10 <sup>-6</sup>	10 <sup>-11</sup>	<b>110</b>	316,200	10 <sup>11</sup>
10 <sup>-6</sup>	10 <sup>-12</sup>	<b>120</b>	10 <sup>6</sup>	10 <sup>12</sup>
3·162 × 10 <sup>-7</sup>	10 <sup>-13</sup>	<b>130</b>	3·162 × 10 <sup>6</sup>	10 <sup>13</sup>
10 <sup>-7</sup>	10 <sup>-14</sup>	<b>140</b>	10 <sup>7</sup>	10 <sup>14</sup>

# Circuit diagrams

## CIRCUIT NOTES

### 1. COMPONENT VALUES

Resistors: No suffix = ohms, k = kilohms, M = megohms

Capacitors: No suffix = microfarads, p = picofarads.

\* Value selected during test; nominal value shown.

### 2. VOLTAGES

Shown in italics. These are d.c. and relative to chassis unless otherwise indicated. Measured with a 20 k $\Omega$ /V meter on highest convenient range and with controls set as follows:-

OUTPUT V SEL. on SQUARE -30-DIRECT  
RANGE on A, B, C or D.

### 3. SYMBOLS

 preset component

 arrow indicates clockwise rotation of knob

 panel marking

 test point

### 4. SWITCHES

Rotary switches are drawn schematically.

Numbers or letters indicate control knob setting as shown in key diagrams.

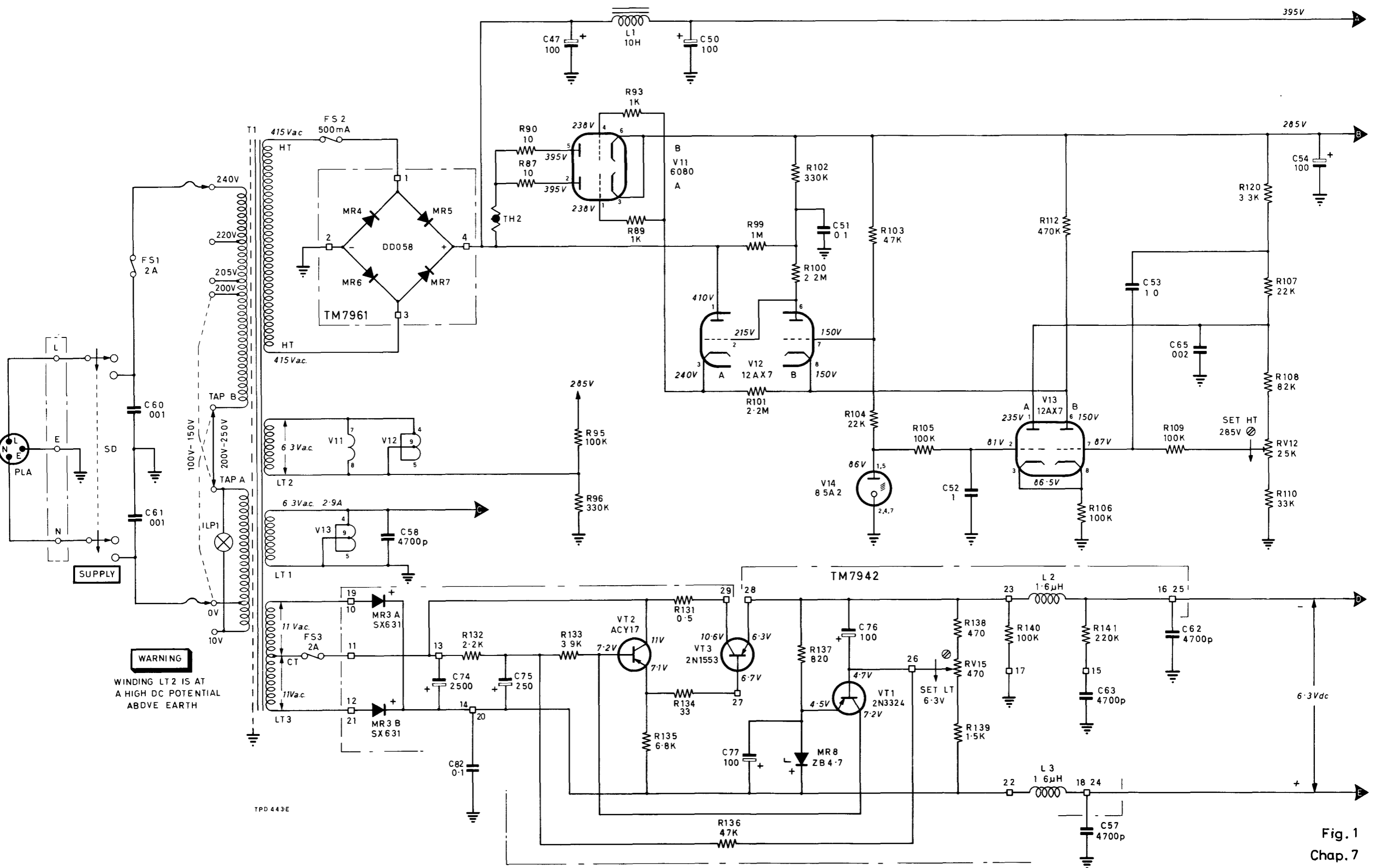
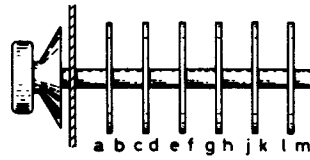

Fig.1

Fig. 1  
Chap. 7  
Page 2/4

Power supply - circuit

TPD 2262



SEQUENCE OF SECTIONS

Plan of sections viewed from knob end  
with switch in fully counter clockwise position

**S B**

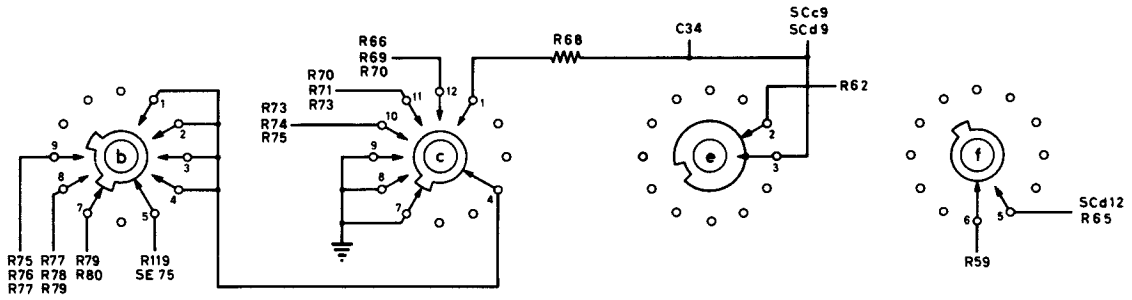

**S C**

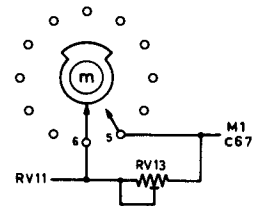
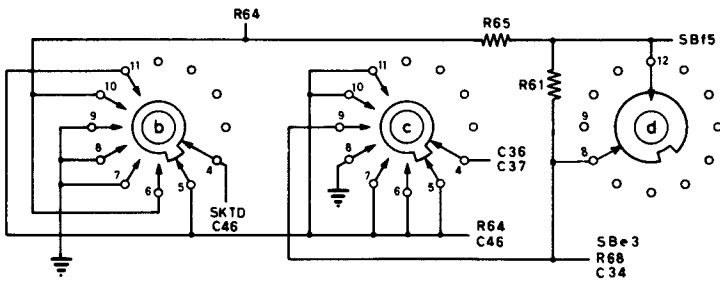

Fig. 2 Monitor and output stages - switch details

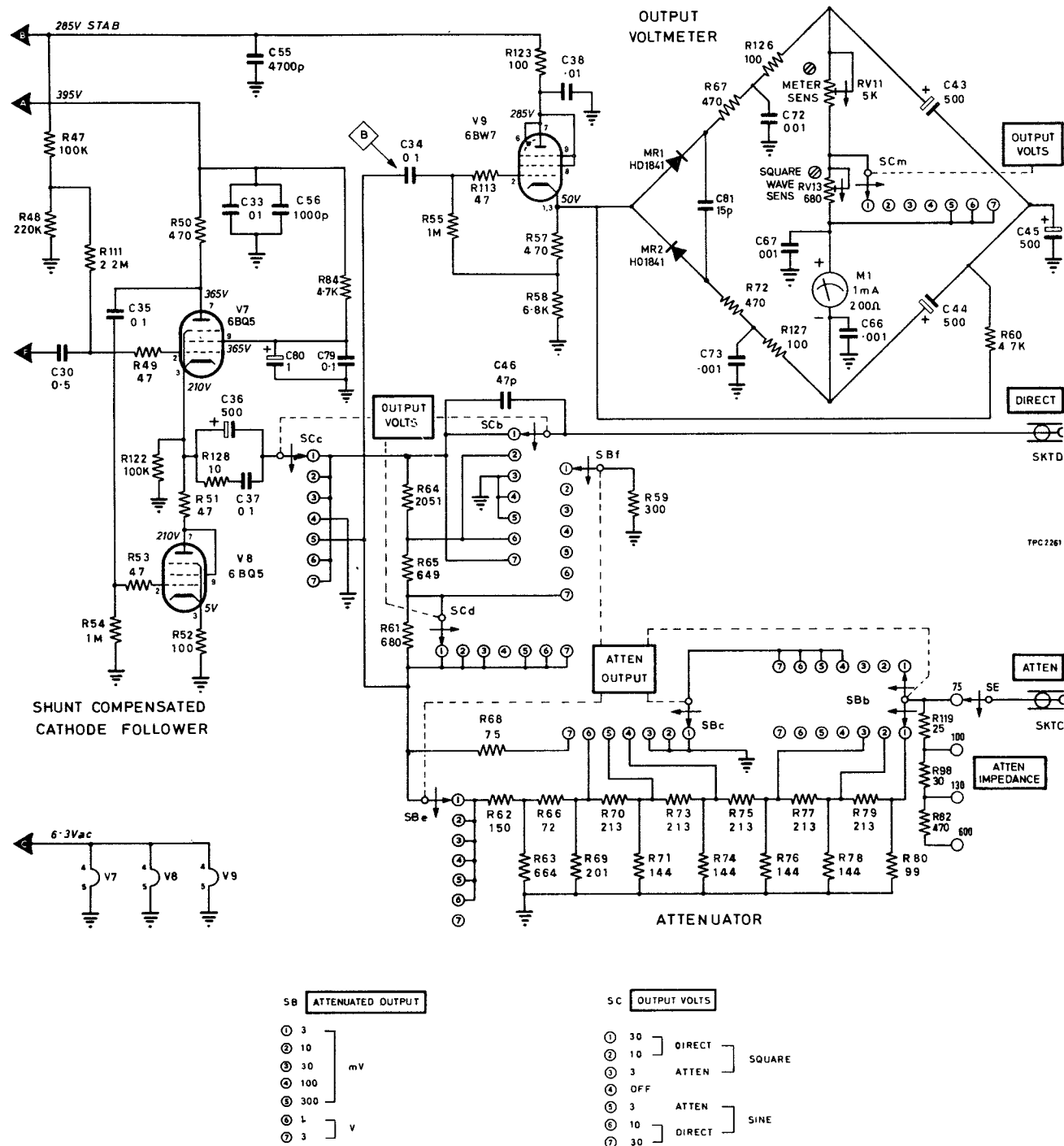
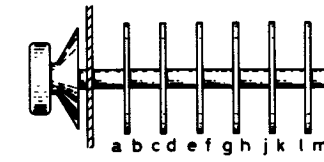

Fig. 3 Monitor and output stages - circuit

TPD 2262



SEQUENCE OF SECTIONS

Plan of sections viewed from knob end with switch in fully counter clockwise position

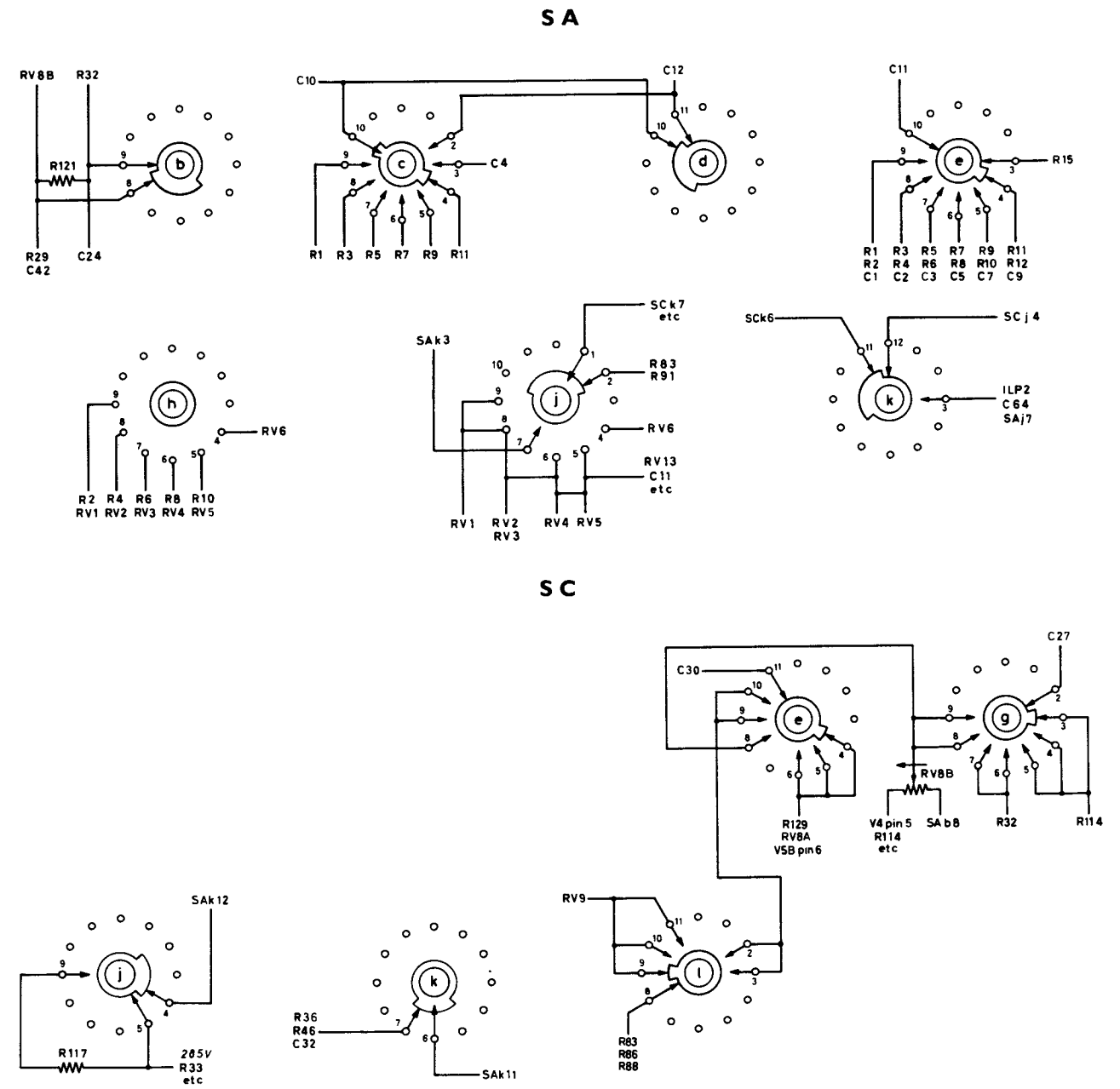

Fig. 4 Oscillator and squaring stages - switch details



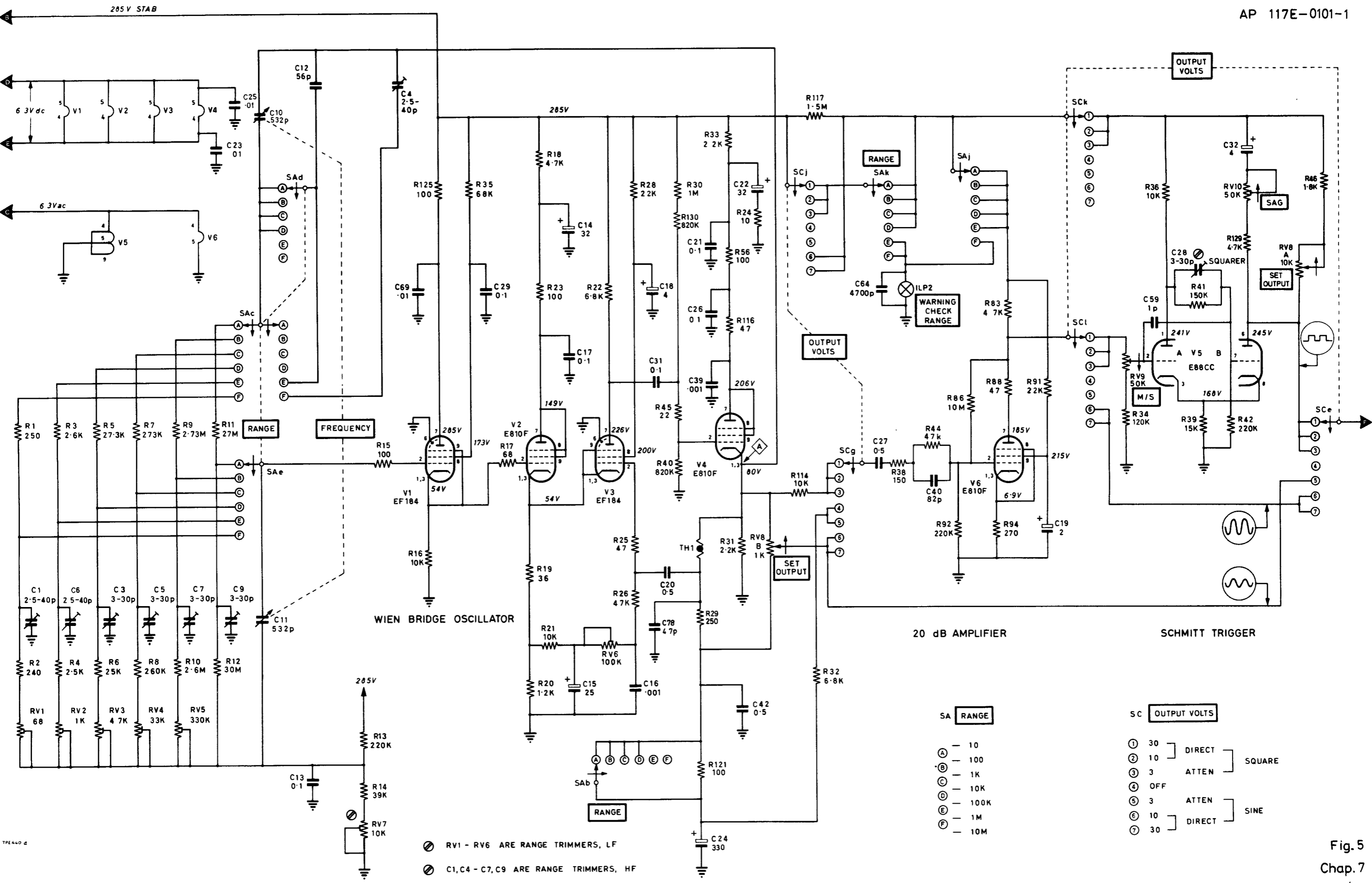

Fig.5

Oscillator and squaring stages—circuit

TOPIC 3D

SCALE OF SERVICING SPARES

FOR

AUDIO AND VIDEO SIGNAL GENERATOR

6625-99-104-7574

Note. Topic 3D cancelled.

For Illustrated Parts List, see A. P. 117E-0101-3A.