

This document was generated by me Colin Hinson from a document held at Henlow Signals Museum. It is presented here (for free) and this version of the document is my copyright (along with the Signals Museum) in much the same way as a photograph would be. Be aware that breach of copyright can result in a criminal record.

The document should have been downloaded from my website <https://blunham.com/Radar>, if you downloaded it from elsewhere, please let me know (particularly if you were charged for it). You can contact me via my Genuki email page:

<https://www.genuki.org.uk/big/eng/YKS/various?recipient=colin>

You may not copy the file for onward transmission of the data nor attempt to make monetary gain by the use of these files. If you want someone else to have a copy of the file, please point them at the website (<https://blunham.com/Radar>).

Please do not point them at the file itself as the file may move or be updated.

I put a lot of time into producing these files which is why you are met with this page when you open the file.

In order to generate this file, I need to scan the pages, split the double pages and remove any edge marks such as punch holes, clean up the pages, set the relevant pages to be all the same size and alignment. I then run Omnipage (OCR) to generate the searchable text and then generate the pdf file.

Hopefully after all that, I end up with a presentable file. If you find missing pages, pages in the wrong order, anything else wrong with the file or simply want to make a comment, please drop me a line (see above).

It is my hope that you find the file of use to you personally – I know that I would have liked to have found some of these files years ago – they would have saved me a lot of time !

Colin Hinson

In the village of Blunham, Bedfordshire.

INSTRUCTION BOOK
FOR
OPERATION AND MAINTENANCE
OF
TEST EQUIPMENT IE-19-A

Manufactured by
BENDIX RADIO
DIVISION OF BENDIX AVIATION CORPORATION
Baltimore, Maryland, U. S. A.

ORDER NO'S.
657-Phila-42
97-WF-42
4567-Phila-42
151-WF-42
4046-WF-42
1346-WF-43



PUBLISHED BY AUTHORITY
OF
THE CHIEF SIGNAL OFFICER

October 10, 1942

INSTRUCTION BOOK
FOR
OPERATION AND MAINTENANCE
OF
TEST EQUIPMENT IE-19-A

Manufactured by
BENDIX RADIO
DIVISION OF BENDIX AVIATION CORPORATION
Baltimore, Maryland, U. S. A.

ORDER NO'S.
657-Phila-42
97-WF-42
4567-Phila-42
151-WF-42
4046-WF-42
1346-WF-43

PUBLISHED BY AUTHORITY
OF
THE CHIEF SIGNAL OFFICER

October 10, 1942

DESTRUCTION OF ABANDONED MATERIEL IN THE COMBAT ZONE

In case it should become necessary to prevent the capture of this equipment, and when ordered to do so, *DESTROY IT SO THAT NO PART OF IT CAN BE SALVAGED, RECOGNIZED, OR USED BY THE ENEMY. BURN ALL PAPERS AND BOOKS.*

MEANS:

1. Explosives, when provided.
2. Hammers, axes, sledges, or whatever heavy object is readily available.
3. Burning by means of incendiaries such as gasoline, oil, paper, or wood.
4. Grenades and shots from available arms.
5. Where possible, and time permits, bury all debris or dispose of it in streams or other bodies of water.

PROCEDURE:

1. Obliterate all identifying marks. Destroy nameplates and circuit labels.
2. Demolish all panels, castings, switch- and instrument-boards.
3. Destroy all controls, switches, relays, connections and meters.
4. Rip out all wiring in electrical equipment. Smash gas, oil, and water cooling systems in gas-engine generators, etc.
5. Smash every electrical or mechanical part whether rotating, moving, or fixed.
6. Break up all operating instruments such as keys, phones, microphones, etc.
7. Destroy all classes of carrying cases, straps, containers, etc.

SAFETY NOTICE

DO NOT CHANGE TUBES OR MAKE ADJUSTMENTS INSIDE SIGNAL GENERATOR UNLESS POWER SWITCH IS "OFF".

NEVER SHUT OFF RADIO SET SCR-522-A WITH THE SHIFTER SLIDES DISENGAGED, AS THIS WILL RESULT IN FAILURE TO TURN ON THE TRANSMITTER AND RECEIVER IF ONE PARTICULAR CHANNEL PUSH-BUTTON IS PRESSED ON RADIO CONTROL BOX BC-602-A (SEE PARAGRAPHS *9a* AND *9c*).

REPORT OF MAJOR FAILURE

In the event of major failure of any of the component units of this equipment, a report shall be submitted in the form indicated below. Copies of this report shall be forwarded to the Chief of Signal Section, Air Service Command, Patterson Field, Fairfield, Ohio, and to the Director, Signal Corps Aircraft Signal Service, Wright Field, Ohio.

1. Contract or order number.
2. Organization and station.
3. Nomenclature of equipment.
4. Nomenclature of component unit.
5. Date and nature of failure.
6. Type of airplane in which installed.
7. Recommendations.

TABLE OF CONTENTS

<i>Par.</i>	SECTION I—GENERAL DESCRIPTION	<i>Page</i>
1.	GENERAL	1
2.	COMPONENTS, DIMENSIONS, AND WEIGHTS	1
3.	ADDITIONAL EQUIPMENT REQUIRED	2
4.	POWER CONSUMPTION	2
	<i>a. Signal Generator I-130-A</i>	2
	<i>b. Field Strength Meter I-95-A</i>	2
5.	DESCRIPTION OF PRINCIPAL COMPONENTS	2
	<i>a. Signal Generator I-130-A</i>	2
	<i>b. Test Set I-139-A</i>	5
	<i>c. Battery Box BX-33-A</i>	5
	<i>d. Field Strength Meter I-95-A</i>	5
	<i>e. Set of Special Tools</i>	5
	<i>f. Chest CH-93-A</i>	7

SECTION II—EMPLOYMENT

6.	INITIAL PROCEDURE	9
7.	INSTALLATION	9
	<i>a. Battery Box BX-33-A Batteries</i>	9
	<i>b. Field Strength Meter I-95-A Batteries</i>	10
	<i>c. Vacuum Tubes</i>	11
	<i>d. Fuses</i>	11
8.	PREPARATION FOR USE	11
	<i>a. Battery Box BX-33-A</i>	11
	<i>b. Signal Generator I-130-A</i>	12
	<i>c. Field Strength Meter I-95-A</i>	12
9.	OPERATION	12
	<i>a. Radio Transmitter BC-625-A Channel Alignment</i>	12
	<i>b. Significance of Meter Readings</i>	15
	<i>c. Radio Receiver BC-624-A Channel Alignment</i>	16
	<i>d. Field Strength Meter I-95-A</i>	21
10.	ADJUSTMENTS FOR FIELD UPKEEP	21

SECTION III—FUNCTIONING OF PARTS

11.	SIGNAL GENERATOR I-130-A	23
12.	TEST SET I-139-A	25
13.	FIELD STRENGTH METER I-95-A	25

TABLE OF CONTENTS—(Continued)

<i>Par.</i>	SECTION IV—SERVICING AND REPAIR	<i>Page</i>
14.	REPLACEMENT OF VACUUM TUBES	29
	<i>a. Signal Generator I-130-A</i>	29
	<i>b. Field Strength Meter I-95-A</i>	29
15.	TROUBLE LOCATION	29
	<i>a. Signal Generator I-130-A</i>	29
	<i>b. Field Strength Meter I-95-A</i>	32
16.	VOLTAGES AT TUBE SOCKETS AND OTHER IMPORTANT CIRCUIT TERMINATIONS	32
	<i>a. Signal Generator I-130-A</i>	32
	<i>b. Field Strength Meter I-95-A</i>	32
	<i>c. Voltage Analysis Table</i>	32
17.	CONTINUITY TEST TABLES	34
	<i>a. Signal Generator I-130-A</i>	34
	<i>b. Field Strength Meter I-95-A</i>	36
	<i>c. Test Set I-139-A</i>	39
18.	SERVICING SIGNAL GENERATOR I-130-A	39
	<i>a. Removal of Variable Capacitor Assembly</i>	39
	<i>b. Alignment and Tracking of Signal Generator I-130-A</i>	42
	<i>c. Alignment of Crystal Tuning Capacitor 714</i>	46
19.	POWER OUTPUT MEASUREMENTS	46
	<i>a. R-F Output (Using Master Oscillator)</i>	46
	<i>b. R-F Output (Using Crystal Oscillator)</i>	46
SECTION V—APPENDIX		
20.	TABLE OF REPLACEABLE PARTS	48
	<i>a. Field Strength Meter I-95-A</i>	48
	<i>b. Signal Generator I-130-A</i>	48
	<i>c. Test Set I-139-A</i>	53
	<i>d. Battery Box BX-33-A</i>	53
	<i>e. Set of Special Tools</i>	53
21.	INTERCHANGEABLE PARTS	54
22.	RMA COLOR CODE FOR RESISTORS AND CAPACITORS	54
23.	ADDRESSES OF MANUFACTURERS	56

LIST OF ILLUSTRATIONS

<i>Figure No.</i>	<i>Title</i>	<i>Page</i>
Figure 1	—Test Equipment IE-19-A, Complete	xii
Figure 2	—Signal Generator I-130-A, Front View, Cover Removed	3
Figure 3	—Cord CD-477	3
Figure 4	—Test Set I-139-A, Front View	3
Figure 5	—Battery Box BX-33-A, Top View, Cover Open	4
Figure 6	—Field Strength Meter I-95-A, Front View	6
Figure 7	—Set of Special Tools, Open	7
Figure 8	—Battery Box BX-33-A, Wiring Diagram	9
Figure 9	—Field Strength Meter I-95-A, Wiring Diagram	11
Figure 10	—Radio Set SCR-522-A, Transmitter-Receiver Assembly	13
Figure 11	—Test Equipment IE-19-A, Complete Schematic Circuit Diagram	22
Figure 12	—Signal Generator I-130-A, R-F Unit, Rear View	24
Figure 13	—Signal Generator I-130-A, R-F Unit, Bottom Oblique View	25
Figure 14	—Signal Generator I-130-A, Modulator Unit, Rear View	26
Figure 15	—Signal Generator I-130-A, Modulator Unit, Disassembled View	26
Figure 16	—Test Set I-139-A, Interior View	27
Figure 17	—Field Strength Meter I-95-A, Interior View	27
Figure 18	—Field Strength Meter I-95-A, With Front Panel Guard	28
Figure 19	—Field Strength Meter I-95-A, Case	28
Figure 20	—Signal Generator I-130-A, Tube Socket Layout and Voltage Diagram	30
Figure 21	—Field Strength Meter I-95-A, Tube Socket Layout and Voltage Diagram	31
Figure 22	—Signal Generator I-130-A, R-F Unit, Top View, Front Panel Removed	37
Figure 23	—Signal Generator I-130-A, R-F Unit, Right Oblique View	38
Figure 24	—Signal Generator I-130-A, R-F Unit, Rear of Front Panel	38
Figure 25	—Signal Generator I-130-A, R-F Unit, Front Panel Removed	39
Figure 26	—Signal Generator I-130-A, R-F Unit, Dial Removed	40
Figure 27	—Signal Generator I-130-A, R-F Unit, Gear Assembly Removed	41
Figure 28	—Signal Generator I-130-A, R-F Unit, Variable Capacitor Assembly	42
Figure 29	—Signal Generator I-130-A, R-F Unit, Wiring Diagram	43
Figure 30	—Signal Generator I-130-A, Modulator Unit, Wiring Diagram	44
Figure 31	—Signal Generator I-130-A, Interconnecting Cable, Wiring Diagram	44
Figure 32	—Radio Sets SCR-522-A and SCR-542-A, Complete Schematic Circuit Diagram	57

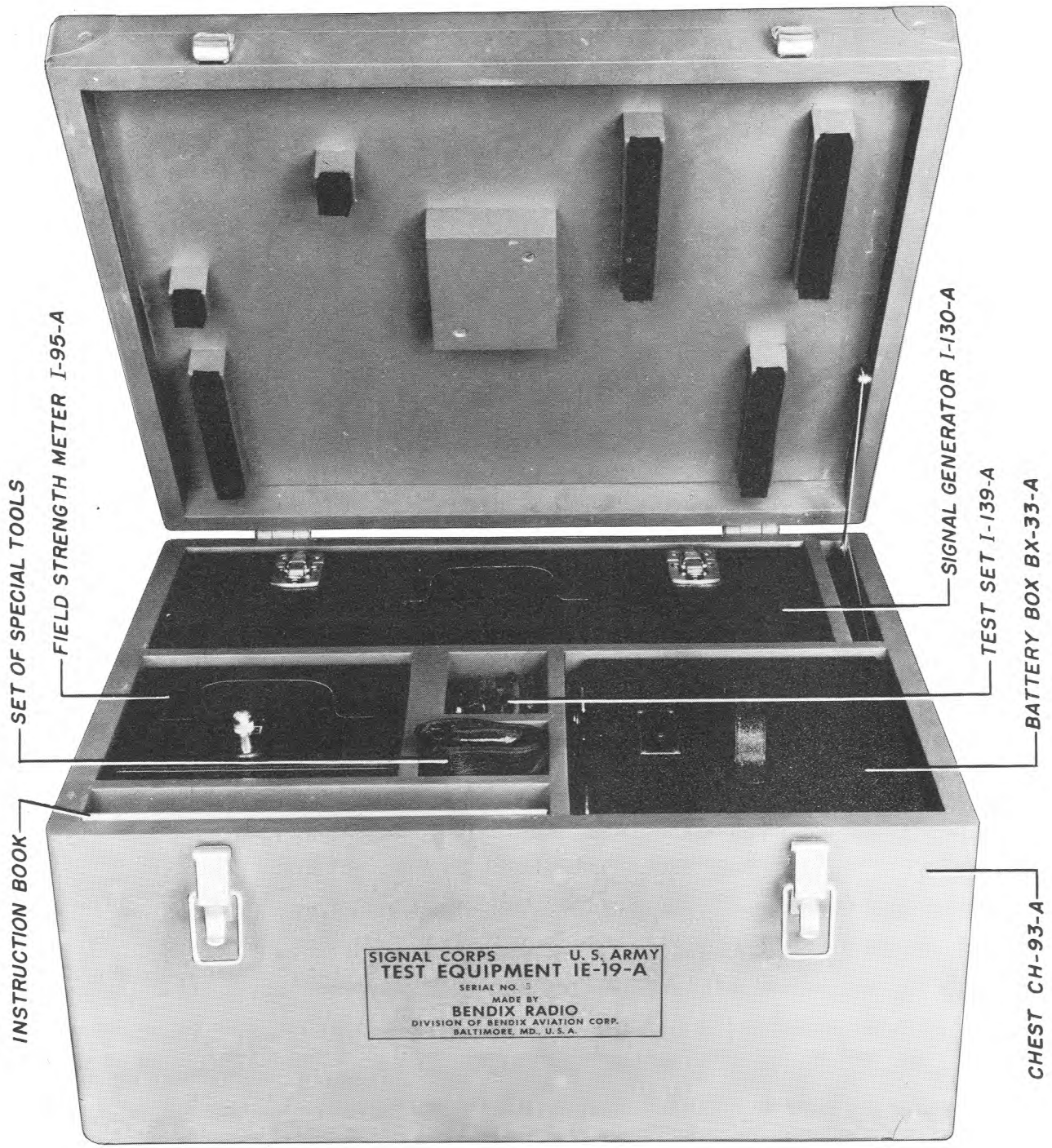

FIGURE 1—TEST EQUIPMENT IE-19-A, COMPLETE

INSTRUCTION BOOK
for
OPERATION AND MAINTENANCE
OF
TEST EQUIPMENT IE-19-A

SECTION I
GENERAL DESCRIPTION

1. General
2. Components, Dimensions, and Weights
3. Additional Equipment Required
4. Power Consumption
5. Description of Principal Components

1. GENERAL

Test Equipment IE-19-A is intended for use in aligning the channels of Radio Sets SCR-522-A, SCR-522-T2, SCR-542-A, and SCR-542-T2. The test equipment is especially designed for use inside or near the aircraft in which the radio sets are installed.

Radio Set SCR-522-T2 is identical with Radio Set SCR-522-A, and Radio Set SCR-542-T2 is identical with Radio Set SCR-542-A. Radio Set SCR-542-A (14 volt operation) is the same as Radio Set SCR-522-A (28 volt operation) except for the dynamotor unit. In this instruction book, future reference will be made to Radio Set SCR-522-A only.

2. COMPONENTS, DIMENSIONS, AND WEIGHTS

Test Equipment IE-19-A consists of the following component units:

<i>Quantity</i>	<i>U. S. Signal Corps Description</i>	<i>Overall Dimensions (Inches)</i>	<i>Weight (Lbs.)</i>
1	Signal Generator I-130-A, Includes: 1 Cord CD-477 1 Set of Vacuum Tubes, Consisting of the Following U. S. Army Types: 2 ea. Tube VT-202 3 ea. Tube VT-203	19 x 9 $\frac{3}{4}$ x 7 $\frac{9}{16}$ 60 long	27.2 (complete)
1	Battery Box BX-33-A, Includes: 3 "A" Battery Jumpers 2 "A" Battery Leads	9 $\frac{3}{8}$ x 8 $\frac{1}{2}$ x 8 $\frac{11}{16}$	9.5 (complete but not including batteries)
1	Test Set I-139-A		1.1 (complete)

GENERAL DESCRIPTION

<i>Quantity</i>	<i>U. S. Signal Corps Description</i>	<i>Overall Dimensions (Inches)</i>	<i>Weight (Lbs.)</i>
1	Field Strength Meter I-95-A, Includes: 1 Tube VT-172	8½ x 7 ⁵ / ₁₆ x 7¼	10.7 (complete but not including batteries)
1	Chest CH-93-A	11 x 19½ x 22 ³ / ₄	48.5
1	Set of Special Tools Consisting of: 1 Tool Roll 1 Spanner Wrench, Large 1 Spanner Wrench, Medium 1 Spanner Wrench, Small 2 #6 Bristo Set Screw Wrenches 1 Lamp Cap Remover 1 Alignment Tool 1 Lamp Extractor 2 #10 Allen Set Screw Wrenches 2 #8 Allen Set Screw Wrenches		3.8

3. ADDITIONAL EQUIPMENT REQUIRED

For operation of Test Equipment IE-19-A, the following additional items will be required: eight Battery BA-2 (U. S. Army Signal Corps "B" batteries) five Battery BA-23 (U. S. Army Signal Corps "A" batteries) and suitable Crystal Units DC-11-A. For battery-installation instructions see paragraphs 7a and 7b.

4. POWER CONSUMPTION

a. Signal Generator I-130-A

With the "M.O.-CRYSTAL" switch in "M.O." position, the power consumption of Signal Generator I-130-A is 4.4 watts. With the "M.O.-CRYSTAL" switch in "CRYSTAL" position, the power consumption is 5.8 watts.

b. Field Strength Meter I-95-A

The total power consumption of Field Strength Meter I-95-A is 0.87 watts.

5. DESCRIPTION OF PRINCIPAL COMPONENTS

a. Signal Generator I-130-A

Signal Generator I-130-A is used in tuning Radio Transmitter BC-625-A and Radio Receiver BC-624-A and produces tone-modulated signals in the frequency range 100-156 megacycles. The modulation frequency is 1000 cycles. The output

is variable from nearly zero to over 5000 microvolts.

The metal carrying case, which contains all the components of the signal generator, is divided into three compartments (see FIGURE 2).

The "R.F. SIGNAL GENERATOR" is located in the left side compartment of the carrying case (see FIGURE 2). Two alternative oscillator circuits may be selected by means of the "M.O.-CRYSTAL" switch (see FIGURE 2). With the "M.O.-CRYSTAL" switch in "M.O." position, the r-f signal generator utilizes a Hartley oscillator circuit; and with this switch in "CRYSTAL" position, a crystal-controlled oscillator circuit is employed, the plate of which is tuned to the second crystal harmonic. The "R.F. OUTPUT" socket is located in the upper left corner of the "R.F. SIGNAL GENERATOR" panel.

The center compartment (see FIGURE 2) contains the modulator unit which modulates the output of the r-f signal generator. The primary-power input from Battery Box BX-33-A enters a 4-contact socket located on the panel of the modulator unit and is controlled by the "POWER ON-OFF" switch.

The right side compartment contains Cord CD-477 (see FIGURE 3), the coaxial r-f transmission line, which is designed to connect Signal Generator I-130-A to Socket SO-153 on Rack FT-244-A (part of Radio Set SCR-522-A).

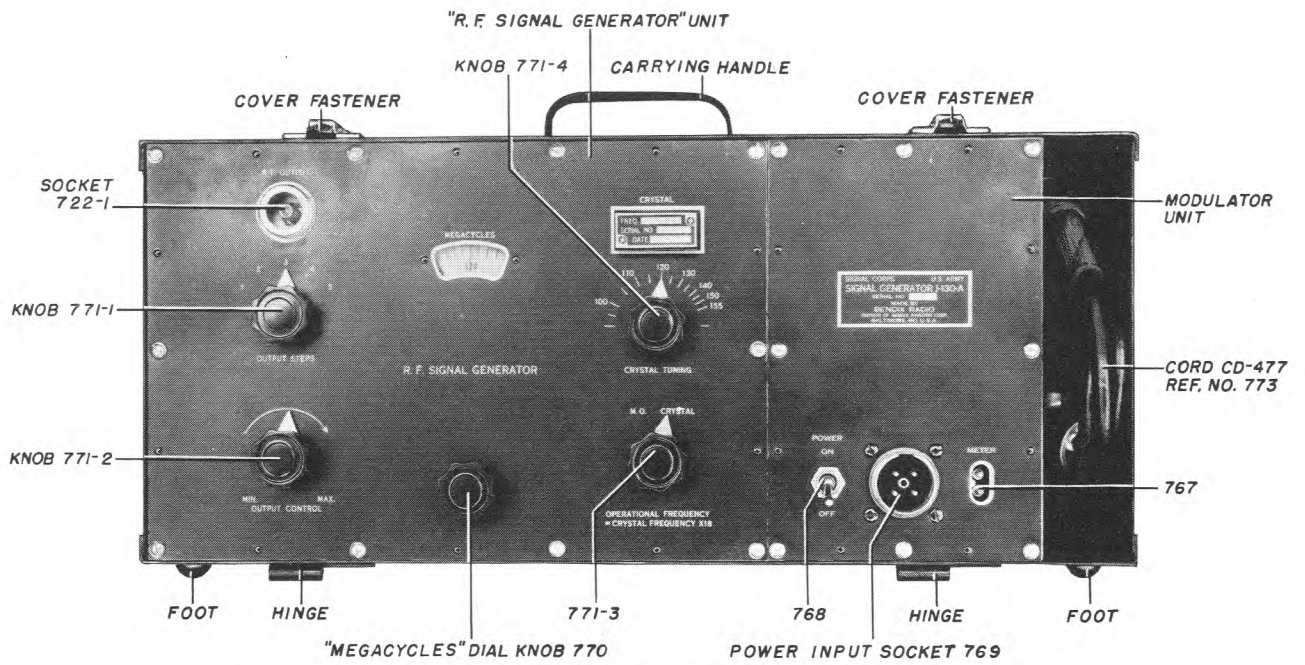

FIGURE 2—SIGNAL GENERATOR I-130-A, FRONT VIEW, COVER REMOVED

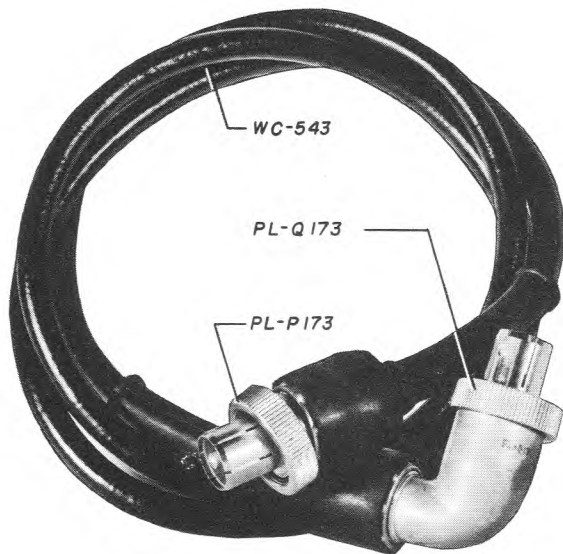

FIGURE 3—CORD CD-477

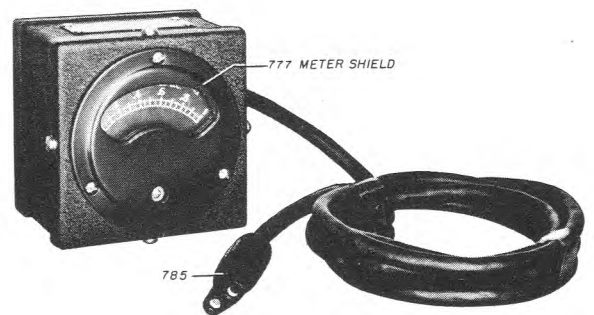

FIGURE 4—TEST SET I-139-A, FRONT VIEW

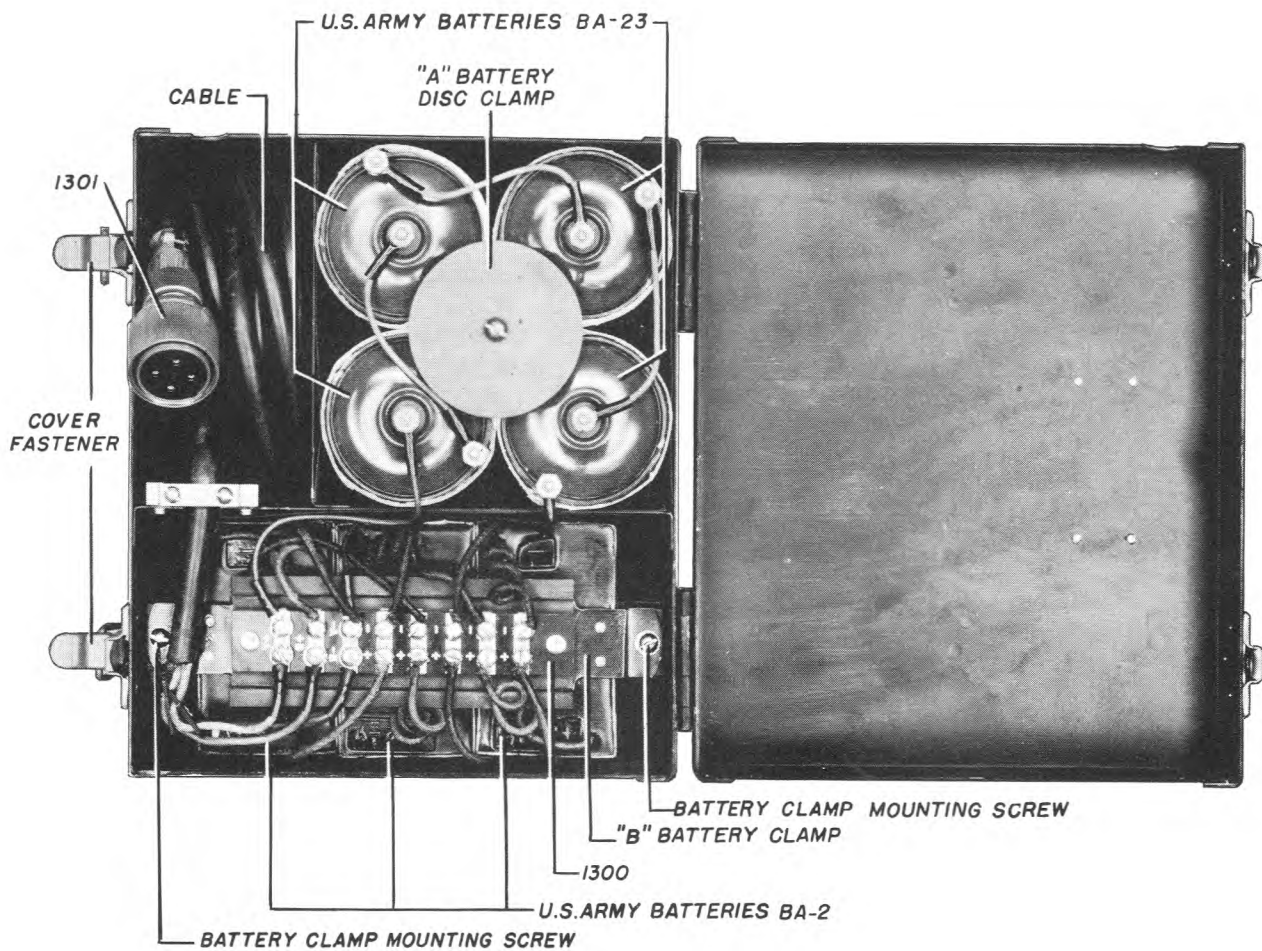

FIGURE 5—BATTERY BOX BX-33-A, TOP VIEW, COVER OPEN

GENERAL DESCRIPTION

The cover of Signal Generator I-130-A is hinged to the carrying case. The cover may be removed by raising it slightly and separating the hinge sections.

b. Test Set I-139-A

Test Set I-139-A (see FIGURE 4) is a circuit meter designed for use in tuning Radio Transmitter BC-625-A, Radio Receiver BC-624-A, and Signal Generator I-130-A. The currents measured by the test set are listed in the following table.

d. Field Strength Meter I-95-A

Field Strength Meter I-95-A (see FIGURE 6) is an uncalibrated vacuum-tube voltmeter designed to indicate the relative field strength and frequency of the radiation from the antenna of Radio Set SCR-522-A. This instrument may also be used to indicate modulation of the carrier. The field strength meter consists of a metal case on which the front panel and rear cover are mounted (see FIGURES 17, 18, and 19). A telescopic antenna, a front panel guard and all the electrical

<i>Equipment To Be Tuned</i>	<i>Switch Position</i>	<i>Current Measured</i>	<i>Full Scale Deflection</i>
Radio Receiver BC-624-A	—	R-F Amp. Plate	8.5 MA
Radio Transmitter BC-625-A	“METER SWITCH” Position “1”	1st Harmonic Amp. Plate	50 MA
	“METER SWITCH” Position “2”	2nd Harmonic Amp. Plate	100 MA
	“METER SWITCH” Position “3”	Power Amplifier Plate	100 MA
	“METER SWITCH” Position “4”	R-F Indicator Diode	1 MA
	“METER SWITCH” Position “5”	Power Amplifier Grid	2 MA
	“METER SWITCH” Position “6”	Not Used	—
Signal Generator I-130-A	“M.O.—CRYSTAL” Switch in “M.O.”	Power Amp. Plate and Modulator Plate	20 MA
	“M.O.—CRYSTAL” Switch in “CRYSTAL”	Distortion Amp. Plate, Power Amp. Plate, and Modulator Plate	20 MA

c. Battery Box BX-33-A

Battery Box BX-33-A is designed to contain six Battery BA-2 (U.S. Army Signal Corps “B” batteries) and four Battery BA-23 (U. S. Army Signal Corps “A” batteries). The ten-foot battery supply cable, when not in use, is stored in a compartment of the battery box (see FIGURE 5).

components (except the batteries) of the field strength meter are mounted on the front panel. The batteries, comprising two Battery BA-2 (22½ volt) and one Battery BA-23 (1½ volt), are not normally supplied with the equipment.

e. Set of Special Tools

The set of special tools provides equipment which is used in disassembling plugs, extracting

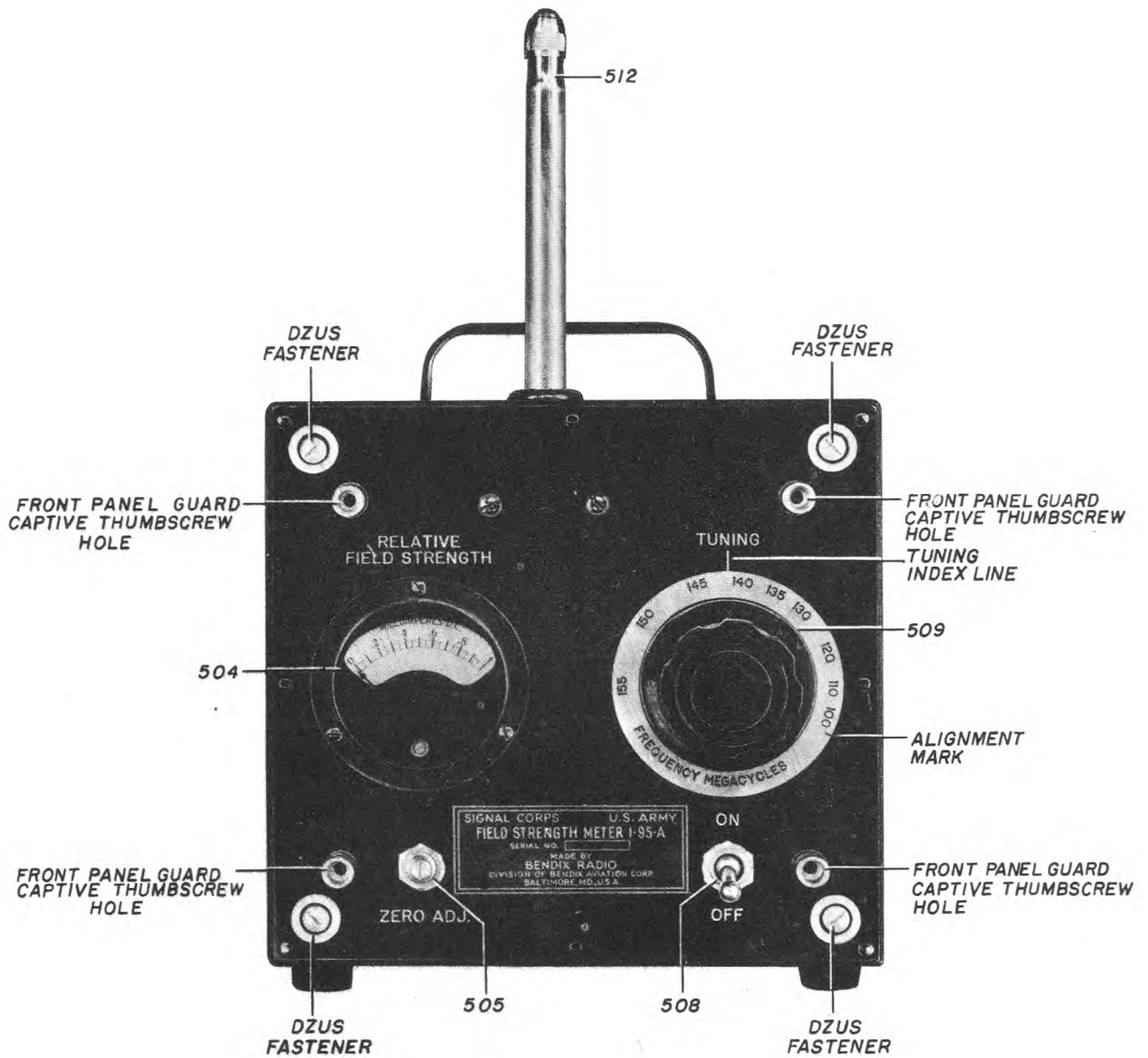

FIGURE 6—FIELD STRENGTH METER I-95-A, FRONT VIEW

GENERAL DESCRIPTION

and replacing indicator lamps, loosening set screws, and aligning the transmitter and receiver (see FIGURE 7).

f. Chest CH-93-A

Chest CH-93-A is designed for use in storing or

transporting Test Equipment IE-19-A. Each component unit of Test Equipment IE-19-A fits into a separate compartment and requires no special packing in the chest (see FIGURE 1).

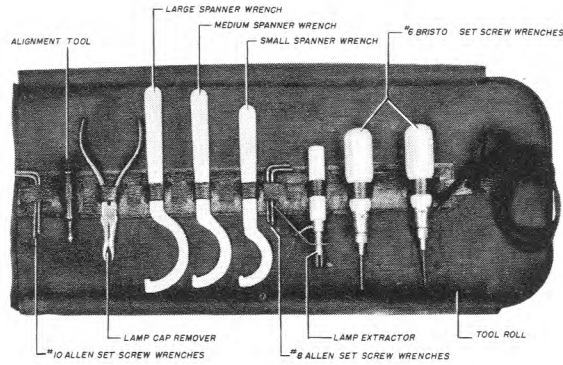

FIGURE 7—SET OF SPECIAL TOOLS. OPEN

SECTION II EMPLOYMENT

6. Initial Procedure
7. Installation
8. Preparation for Use
9. Operation
10. Adjustments for Field Upkeep

6. INITIAL PROCEDURE

When shipped from the factory, the components of Test Equipment IE-19-A are packed in Chest CH-93-A, and all vacuum tubes are installed in their respective sockets. After unpacking, all be installed in Battery Box BX-33-A (see FIGURES 5 and 8). Loosen the cover fasteners and lift the cover (see FIGURE 5). Remove the five wire jumpers

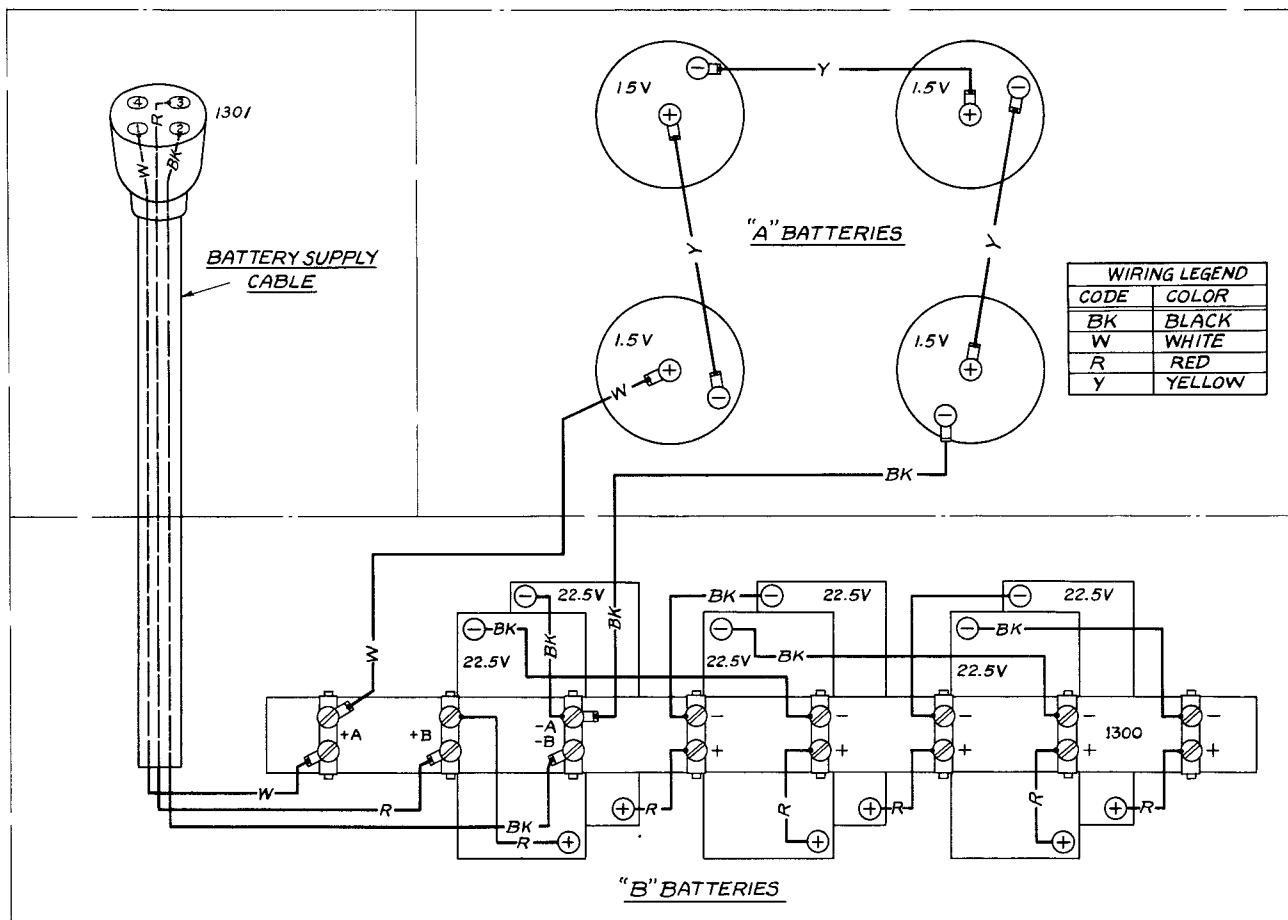

FIGURE 8—BATTERY BOX BX-33-A, WIRING DIAGRAM

parts should be thoroughly inspected for possible damage during shipment. The test equipment is shipped from the factory without batteries.

7. INSTALLATION

a. Battery Box BX-33-A Batteries

Six Battery BA-2 and four Battery BA-23 must

from the bottom of the "A" battery compartment. Three of these jumpers are yellow and are 3⁵/₈ inches long. Two of these jumpers are 5¹/₄ inches long; one is white and the other is black.

Remove the two terminal board mounting screws (see FIGURE 5) which secure the "B" battery clamp. Place the six "B" batteries (Battery

EMPLOYMENT

BA-2) in the "B" battery compartment. The "B" batteries should form two layers of three batteries each, one layer on top of the other. Each battery should be placed upright. Place the "B" battery clamp on top of the "B" batteries and replace the two terminal board mounting screws. Fasten the "B" battery clamp securely to prevent shifting of batteries. Wire the batteries as shown in FIGURE 8. This results in a series connection.

CAUTION: NEVER CONNECT A RED AND BLACK LEAD FROM THE SAME BATTERY TO "—" AND "+" TERMINALS ON THE SAME SHORTING STRIP AS THIS WILL CAUSE A SHORT CIRCUIT OF BATTERY.

Remove the screw which secures the "A" battery disc clamp to the spacer rod. Place four "A" batteries (Battery BA-23) in the "A" battery compartment. Place the "A" battery disc clamp on top of the "A" batteries and tighten the clamp. Connect the "A" batteries in series using the $3\frac{5}{8}$ inch yellow jumpers, as shown in FIGURE 8. Each yellow jumper is to connect the center "+" terminal of one battery to the outside "—" terminal of another battery. With the four batteries thus connected with the three yellow jumpers, one center "+" terminal of one battery and one outside "—" terminal of another battery remain unconnected. Connect the $5\frac{1}{4}$ -inch white jumper from the unconnected center "+" terminal of one battery to the "+A" terminal on the terminal board, and the $5\frac{1}{4}$ -inch black jumper from the unconnected outside "—" terminal of the other battery to the "-A-B" terminal of the terminal board.

CAUTION: NEVER CONNECT A JUMPER FROM THE OUTSIDE "—" TERMINAL TO THE CENTER "+" TERMINAL OF THE SAME BATTERY AS THIS WILL DRAIN THE BATTERIES.

Examine the cable to make certain that the white lead is connected to the "+A", the red lead to the "+B", and the black lead to the "-A-B" terminal of the terminal board.

The voltage between contacts 1 and 2 of the battery cable plug is approximately 6 volts, and between contacts 2 and 3, approximately 135 volts. If no reading or a low reading results, the wiring should be checked. Contact 4 of the battery cable plug is not used.

b. Field Strength Meter I-95-A Batteries

One Battery BA-23 ("A" battery, $1\frac{1}{2}$ V) and two Battery BA-2 ("B" batteries, $22\frac{1}{2}$ V) are required for operation of Field Strength Meter I-95-A. Battery information is given on the rear cover of the instrument (see FIGURE 17). To install these batteries, first loosen the four Dzus fasteners in the four corners of the rear cover of the field strength meter and remove the cover.

Loosen the battery-retaining-strap mounting screws sufficiently to allow insertion of the batteries between the retaining strap and the rear cover (see FIGURE 17). Place Battery BA-23 ("A" battery) in the curved portion of the battery retaining strap. Place two Battery BA-2 ("B" batteries) in the retaining strap side by side above Battery BA-23 with their identification labels facing the terminal board on top of the retaining-strap assembly. The Battery BA-2 ("B" batteries) should be so positioned that their flexible pigtail leads will face the interior of the field strength meter when the rear cover is reassembled to the case. Fasten the battery-retaining strap to the rear cover by tightening the strap-mounting screws. Make certain that the three batteries are firmly secured against slipping.

When making connections, refer to FIGURE 9. Connect the red "+ $22\frac{1}{2}$ V" lead of one Battery BA-2 to one of the "+B" terminals of the terminal board.

WARNING: THE NEGATIVE SIDE OF "RELATIVE FIELD STRENGTH" MILLIAMMETER 504 IS CONNECTED TO GROUND. TO PREVENT DAMAGE TO THIS MILLIAMMETER, BE CAREFUL NOT TO GROUND THE B+ (+ $22\frac{1}{2}$ V) BATTERY LEADS.

Connect the black "—" lead of this same battery to one of the "+-B" terminals. Connect the red "+ $22\frac{1}{2}$ V" lead of the second Battery BA-2 to the second "+-B" terminal and connect the black "—" lead to one of the "-B" terminals of the terminal board.

The cable leads of the field strength meter are provided with identification tabs. Connect the red "+B" lead to the second "+B" terminal of the terminal board (see FIGURE 9). Connect the black-white "-B" lead to the second "-B" terminal. Connect the brown "+A" lead to the center (positive) terminal of Battery BA-23 and connect

EMPLOYMENT

the black “-A” lead to the outside (negative) terminal of this battery. Refasten the rear cover to the case of the field strength meter. When replacing the front panel guard on the field strength meter, make certain that the “ON-OFF” switch is in the “OFF” position, otherwise the guard will not fit the front panel. This is a safety device to make certain that the batteries will not deliver current when the meter is not in use.

A-B-, and contact 3 is B+. The voltage between contacts 1 and 2 should be 6 volts, and between contacts 2 and 3, 135 volts.

“A” batteries should be replaced when the voltage drops below 4½ volts under load, and “B” batteries should be replaced when the voltage drops below 110 volts under load.

If no voltmeters are available, Test Set I-139-A may be adapted for use as a voltmeter. To utilize

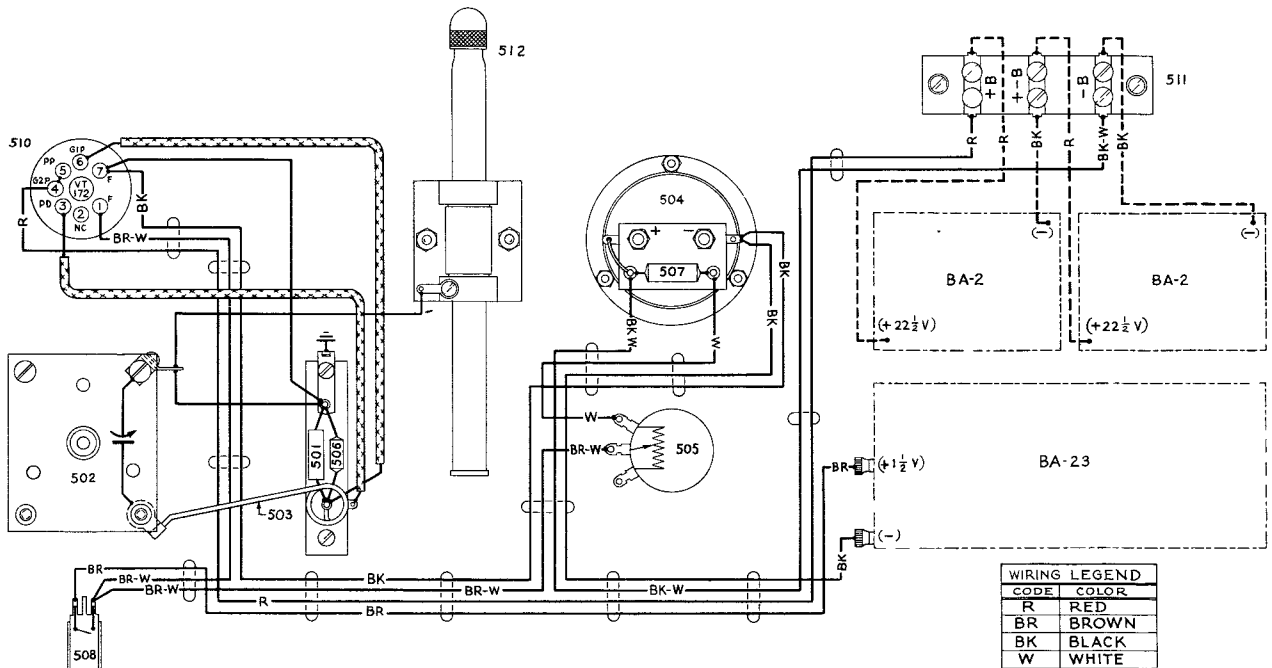

FIGURE 9—FIELD STRENGTH METER I-95-A, WIRING DIAGRAM

c. Vacuum Tubes

This equipment is furnished with all vacuum tubes installed.

d. Fuses

No fuses are used in this equipment.

8. PREPARATION FOR USE

a. Battery Box BX-33-A

After installing batteries and before using Battery Box BX-33-A, check the voltage and polarity of the cable plug. Contact 1 is A+, contact 2 is

Test Set I-139-A as a 0—200V voltmeter, place a 200,000-ohm, 1 watt precision resistor in series with one contact of the test meter plug. The “B” battery reading must be greater than 0.55 on the 0—1 ma scale. To utilize Test Set I-139-A as a 0—10V voltmeter, place a 10,000-ohm, 1 watt precision resistor in series with one contact of the test meter plug. The “A” battery reading must be greater than 0.45 on the 0—1 ma scale. Both voltage readings are to be taken under load.

A hole provided in the side of Battery Box BX-33-A permits the cable to protrude from the battery box when the cover is closed. When not

EMPLOYMENT

in use the cable should be stored in the compartment provided (see FIGURE 5).

b. Signal Generator I-130-A

Loosen the two cover fasteners, and raise the cover. The cover may be left attached or may be removed if Signal Generator I-130-A is to be used while lying on its side; however if the generator is set upright, the cover must be removed. To remove the cover, simply slide it to allow the hinge sections to separate.

Plug the battery cable of Battery Box BX-33-A into the power-input socket of Signal Generator I-130-A (see FIGURE 2). Place the "POWER ON-OFF" switch in the "ON" position. Allow one minute for the tubes to warm up. Insert the plug of Test Set I-139-A into the "METER" socket of Signal Generator I-130-A. Plug into the "CRYSTAL" socket a crystal whose frequency is one-eighteenth of the desired operating frequency. Place the "OUTPUT CONTROL" on "MAX." and place the "OUTPUT STEPS" control on step "5". Set the "M.O.-CRYSTAL" switch at "CRYSTAL" and adjust the "CRYSTAL TUNING" control to the frequency representing the eighteenth harmonic of the r-f crystal used, this being the desired output frequency. The correct setting will produce a small dip in the milliammeter of Test Set I-139-A. Adjust the "MEGACYCLES" dial control for an additional dip at the same frequency. The meter reading should be approximately one-half of full scale or more before the signal generator is tuned. If the meter reading is low, check the battery voltage.

c. Field Strength Meter I-95-A

Loosen the four captive thumbscrews, located near the four corners of the field strength meter, and remove the front panel guard (see FIGURE 18).

Place the "ON-OFF" switch in the "ON" position. With no signal being received, the "RELATIVE FIELD STRENGTH" milliammeter should read zero. If this is not the case, adjust the "ZERO ADJ." screw (located to the left of the nameplate) until the indicator is exactly on zero (see FIGURE 6).

The front panel guard cannot be replaced unless the "ON-OFF" switch is in the "OFF" position.

9. OPERATION

NOTE: When using Test Equipment IE-19-A for aligning the channels of Radio Set SCR-522-A, the radio set should be installed in the aircraft and connected for operation by means of Radio Control Box BC-602-A. Refer to Figure 10 for location of the tuning and adjustment controls on the transmitter, receiver, and rack of Radio Set SCR-522-A.

a. Radio Transmitter BC-625-A Channel Alignment

NOTE: If the transmitter and receiver fail to operate when a channel pushbutton is pressed on Radio Control Box BC-602-A, press another channel pushbutton, then again press the pushbutton for the desired channel. Transmission and reception should now be possible.

The failure to operate when the desired channel pushbutton is pressed the first time is due to the fact that the frequency shifter was in the released position for that channel when the pushbutton was pressed. That is, the channel had previously been selected, the release pushbutton 426 had been pressed once, and the equipment left in this condition. Any attempt to re-select this channel on the control box will result in starting the dynamotor unit without actuating the slides for this particular channel.

(1) The following components of Test Equipment IE-19-A are required for transmitter tuning: Field Strength Meter I-95-A and Test Set I-139-A.

(2) WHEN BEING TUNED, RADIO TRANSMITTER BC-625-A MUST BE INSIDE CASE CS-80-A, WITH RADIO RECEIVER BC-624-A CONNECTED.

NOTE: IF THE TRANSMITTER IS TUNED WHILE REMOVED FROM THE CASE, THE ADDITIONAL CAPACITANCES INTRODUCED BY REPLACING THE TRANSMITTER IN THE CASE WOULD TEND TO UPSET THE TUNING ADJUSTMENTS.

(3) If the receiver and transmitter covers are closed, loosen the Dzus fasteners pinning them

EMPLOYMENT

to the center cover. Raise the covers slightly and slide them away from the control panels.

(4) The crystal chosen for any transmitter channel should have a fundamental frequency one-eighteenth of the desired output frequency (fundamental frequencies appear on the crystal holder nameplate).

(5) With the airplane antenna plugged in, install crystals of the desired frequencies in

motor unit should start and the frequency-shifter mechanism should operate, shifting the equipment to channel "D". Press the channel-release pushbutton located on Rack FT-244-A. This will release the frequency shifter mechanism. Loosen the four transmitter tuning-control locknuts slightly by turning them counterclockwise. Press channel "A" pushbutton on the radio control box.

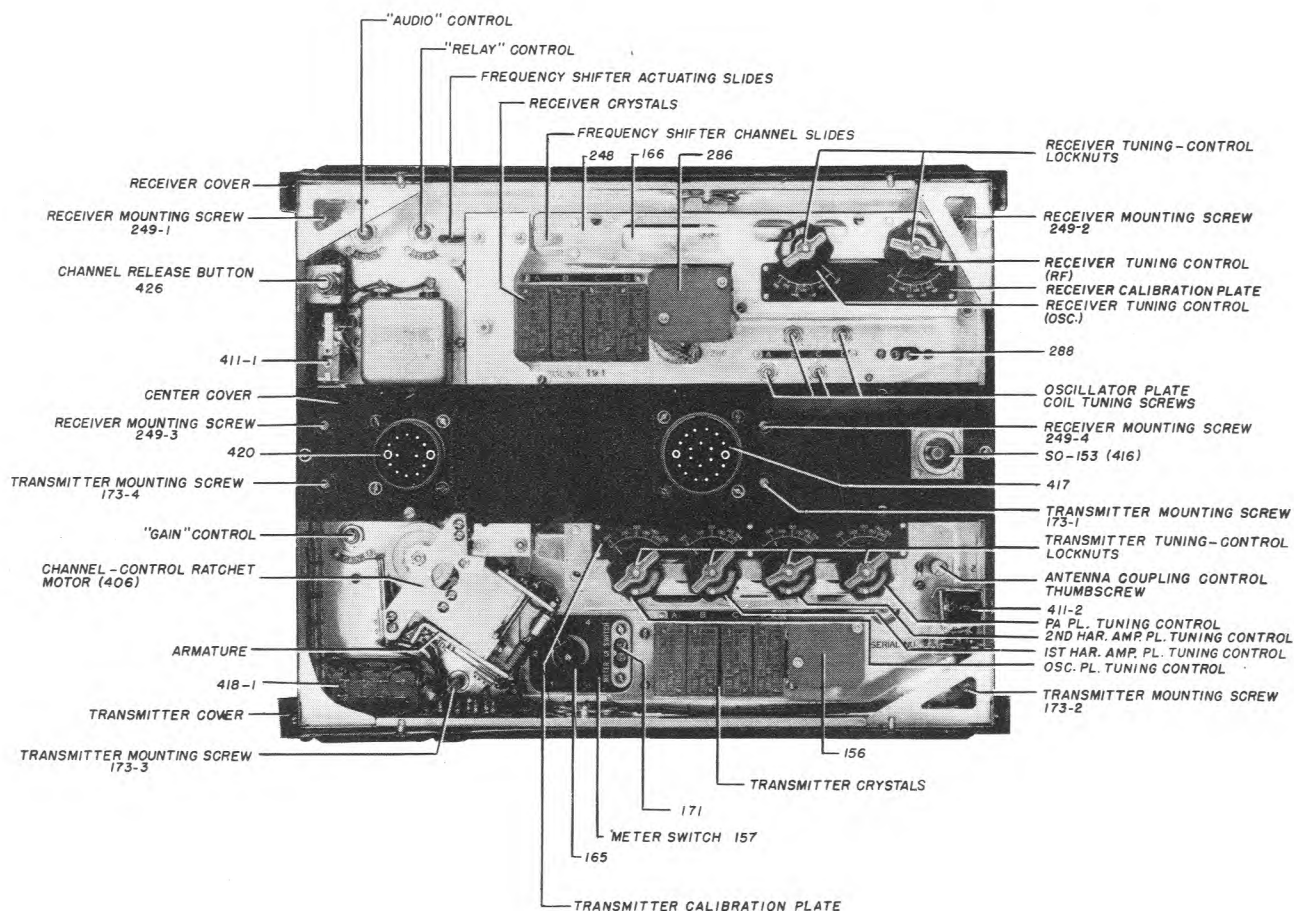

FIGURE 10—RADIO SET SCR-522-A, TRANSMITTER-RECEIVER ASSEMBLY

the crystal sockets. Plug the cord of Test Set I-139-A into the two-prong transmitter test-milliammeter socket 171 located on the right side of the transmitter "METER SWITCH" (see FIGURE 10).

Press channel "D" pushbutton on the panel of Radio Control Box BC-602-A. The dyna-

NOTE: Whenever a channel is selected on Radio Control Box BC-602-A, the switching mechanism will select and release channels in the sequence "A", "B", "C", "D" until the desired channel is selected. For example, if channel "A" has already been selected, channels "B" and "C" will be switched on and off

EMPLOYMENT

before channel "D" is reached. If channels "B" and "C" are already aligned and the tuning-control locknuts are loose when channel "D" pushbutton is pressed, channels "B" and "C" will be jarred out of adjustment by the impact of the shifter actuating slides. However, if tuning is done in the order "A", "B", "C", "D", it is not necessary to disturb previously aligned channels before reaching the channel to be tuned. For example, when channel "C" pushbutton is in the depressed position, channel "D" can be selected without actuating the slides for any other channel.

Allow about one minute for the tubes to warm up. Tube warm-up can be observed by an indication on Test Set I-139-A with the transmitter "METER SWITCH" in position 3. Throw the "T-R-REM." lever switch (on the radio-control-box panel) to "T".

(6) Tuning Operation No. 1

(a) Place the transmitter "METER SWITCH" in position "1".

(b) Adjust the oscillator plate tuning control (first tuning control at the left on the transmitter control panel) for a maximum reading of Test Set I-139-A.

CAUTION: Guard against tuning to an undesired harmonic by making certain that the scale indication of the tuning control as indicated on the transmitter calibration plate is approximately equal to the output frequency being tuned.

(7) Tuning Operation No. 2

(a) Place the "METER SWITCH" in position "2".

(b) Apply the procedure given in paragraph 9a(6)(b) using the second tuning control from the left.

(8) Tuning Operation No. 3

(a) Place the "METER SWITCH" in position "3".

(b) Apply the procedure given in paragraph 9a(6)(b), using the third tuning control from the left.

(c) With the "METER SWITCH" still in position "3", adjust the fourth tuning

control from the left for minimum reading of Test Set I-139-A.

(d) The test set reading must fall between 0.6 and 0.75.

(e) If the test set reading is more than 0.75, slide the antenna-coupling control (see FIGURE 10) to the right until the reading is less than 0.75.

(f) Retune the third and fourth tuning controls.

(9) Adjustments for Remaining Channels.

To tune channel "B", press pushbutton "B" on the panel of Radio Control Box BC-602-A and follow the same tuning procedure outlined for channel "A" in paragraphs 9a(6) to 9a(8) inclusive. However, do not change the antenna coupling adjustment unless the meter reading is more than 0.75. Tune channels "C" and "D" in like manner.

(10) If an antenna coupling adjustment has been made for any channel in addition to channel "A", select the next channels in the order "A", "B", "C", "D", checking each channel "D", "A", and "B", in that order and check the meter reading.

(11) If antenna-coupling readjustments have to be made for any channel, retune the third and fourth tuning controls for that particular channel and repeat the cycle, if necessary, checking all three preceding channels in correct sequence. When this is done, all four channels should be adjusted for a meter reading of less than 0.75.

(12) If the meter reads 0.75 for one channel and less than 0.6 for any of the remaining three, do not attempt to readjust the antenna coupling control at all.

(13) Press the channel-release pushbutton and tighten all transmitter tuning-control locknuts by turning them clockwise.

(14) With the tuning control locknuts tightened and with the transmitter "METER SWITCH" in position "5", the meter reading for all channels should normally be full-scale or more. Any reading greater than half-scale

EMPLOYMENT

is satisfactory. If this condition is not achieved for any channel, readjust the third tuning control for a maximum meter reading ("METER SWITCH" position "5"), retuning that particular channel in accordance with the procedure in paragraph 9a(17).

Now, with the tuning control locknuts tightened, there is a positioning detent which makes it possible to turn the tuning controls slightly, in either direction, against spring pressure. In some cases a large amount of torque is necessary to rotate the controls. With the transmitter "METER SWITCH" in position "4", all tuning controls, on all channels, can be checked by rotating them in both directions against the positioning detent, and by noting a decrease in the meter reading as the tuning controls are rotated in either direction. If an *immediate* decrease in meter reading is not noted for any particular tuning control for any channel, retune that particular channel in accordance with paragraph 9a(17).

This completes the tuning of Radio Transmitter BC-625-A.

(15) After making the antenna-coupling adjustment, a sustained note in the microphone should result in modulation of the carrier. This can be checked by first tuning in the unmodulated carrier on Field Strength Meter I-95-A and then noting an increase in the peak reading of the "RELATIVE FIELD STRENGTH" milliammeter when the carrier is modulated.

(16) Resonance of a secondary tuned circuit such as an antenna-matching device may be tested by a small neon bulb, a thermocouple milliammeter, or a flashlight bulb, either one of which would indicate resonance in this circuit or a portion of it. Correct adjustment of the secondary circuit is indicated by an increase in brilliancy of either one of these above mentioned bulbs, or an increased meter reading.

NEVER SHUT OFF RADIO SET SCR-522-A WITH THE SHIFTER SLIDES DIS-ENGAGED, AS THIS WILL RESULT IN FAILURE TO TURN ON THE TRANSMITTER AND RECEIVER IF ONE PAR-

TICULAR CHANNEL PUSHBUTTON IS PRESSED ON RADIO CONTROL BOX BC-602-A (SEE PARAGRAPHS 9a AND 9c).

(17) Procedure for Tuning One Channel Only

If it is known that one channel is out of adjustment, it may be tuned without disturbing other channels. Refer to paragraph 9a(5). The following is a brief summary of procedure.

(a) Press the channel-selector pushbutton (on Radio Control Box BC-602-A) corresponding to the channel *preceding* the desired channel in the sequence "A", "B", "C", "D".

(b) Press the channel-release pushbutton (on the rack).

(c) Loosen all transmitter tuning-control locknuts.

(d) Press the selector pushbutton corresponding to the desired channel.

(e) Tune the desired channel [see paragraphs 9a(6) to 9a(8)].

(f) Press the channel-release pushbutton.

(g) Tighten all transmitter tuning-control locknuts.

(h) Press the channel-release pushbutton.

(i) Check the output as described in paragraphs 19a and 19b.

(18) Adjustment of "GAIN" Control

With Radio Set SCR-522-A installed in the aircraft and with any channel switched on, all channels tuned, and the airplane engines running, adjust the "GAIN" control for normal voice level under conditions of normal operation. A setting of one-half turn clockwise from the extreme counter-clockwise position is usually satisfactory. This adjustment, once made, is good for all channels.

b. Significance of Meter Readings

In general, a meter reading on Test Set I-139-A greater than 0.75 with the transmitter "METER SWITCH" in any position indicates a defect in the equipment or improper adjustment. An exception to this generalization occurs when the transmitter "METER SWITCH" is in position "5",

EMPLOYMENT

in which case some of the vacuum tubes used may cause a full-scale or even an off-scale reading. This is a desirable condition. A simple method of remembering the approximate meter readings for various switch positions is suggested by the fact that for "METER SWITCH" positions "1", "2", and "3" respectively, Test Set I-139-A readings are, respectively, 4, 5, and 6. Although these figures are typical and desirable, the reading of 6 for switch position "3" cannot usually be retained for different frequency channels because of the variable load characteristic of the antenna. Therefore, the transmitter antenna-coupling control should be adjusted for a compromise load, averaging approximately 0.63, with no reading over 0.75 (on the meter scale) for the four frequency channels being used.

R-F diode current is measured with the "METER SWITCH" in position "4". This switch position is seldom used. The reading obtained is purely relative, without quantitative significance, and is equivalent to a neon-bulb indication of r-f voltage across the final amplifier tank inductor.

The Test Set I-139-A reading obtained with the "METER SWITCH" in position "5" is another variable quantity. Transmitting-tube data sheets describe grid "drive" or grid current as "approximate, subject to wide variations depending on the impedance of the load circuit". It is desirable that this current be as large as possible (even off-scale) but this is not possible with some of the tubes being used. The real test of satisfactory adjustment is whether or not "upward modulation" of the carrier results [see paragraph 9d(3)]. This can easily be tested by means of Field Strength Meter I-95-A.

It is reasonable to assume that half-scale or higher meter readings, with the "METER SWITCH" in position "5", are satisfactory although there are exceptions to this rule.

It should be noted that there is an "idle" or standing plate current resulting in a meter reading of approximately 0.4 when the "METER SWITCH" is in position "3" and Radio Set SCR-522-A is in the *receive* condition. This is normal and correct and indicates the existence of a load on the modulator at all times. If this current is abnormally high, an open or short

circuit is indicated in the -150V bias supply from Dynamotor Unit PE-94-A.

With the "METER SWITCH" in position "4", it should be noted that there is a small emission current in the r-f diode in the "standby" condition.

Position "6" is an "off" or open switch position.

The reading of Field Strength Meter I-95-A must be interpreted in a relative sense only. It is necessary to always locate the instrument in the same relative position with respect to the transmitting antenna and the surrounding objects. The meter reading is then to be compared with a reading obtained from an installation known to be satisfactory.

c. Radio Receiver BC-624-A Channel Alignment

NOTE: If the transmitter and receiver fail to operate when a channel pushbutton is pressed on Radio Control Box BC-602-A, press another channel pushbutton, then again press the pushbutton for the desired channel. Transmission and reception should now be possible.

The failure to operate when the desired channel pushbutton is pressed the first time is due to the fact that the frequency shifter was in the released position for that channel when the pushbutton was pressed. That is, the channel had previously been selected, the release pushbutton 426 had been pressed once, and the equipment left in this condition. Any attempt to re-select this channel on the control box will result in starting the dynamotor unit without actuating the slides for this particular channel.

(1) Test Equipment IE-19-A and a headset or an output meter are required for receiver tuning. Refer to FIGURE 10 for location of tuning and adjustment controls of Radio Set SCR-522-A.

(2) A receiver crystal is identified by the fundamental frequency (kc) which appears on the crystal nameplate.

Finding the correct receiver crystal for a particular receiver channel is therefore the same as finding the correct fundamental frequency (f =kilocycles) of the crystal to be used. The fundamental crystal frequency (f)

EMPLOYMENT

may be determined from the expression

$$f = \frac{f_r - 12}{H} \times 1000$$

where f_r is the frequency in megacycles to which the receiver is to be tuned and H is the receiver crystal harmonic used (see table below). The receiver crystal harmonic (H) used depends only on the frequency (f_r) to be tuned in, and is given in the following table.

<i>Frequency (f_r)</i>	<i>Receiver Crystal Harmonic (H)</i>
100—108 mc	11
108—116 mc	12
116—124 mc	13
124—132 mc	14
132—140 mc	15
140—148 mc	16
148—156 mc	17
156 mc	18

(3) Adjustment of Signal Generator I-130-A (Using Crystal)

(a) Insert a transmitter crystal into the "CRYSTAL" socket of the signal generator. This crystal should have a fundamental frequency one-eighteenth of the receiver frequency to be tuned. If no transmitter crystal is available, refer to paragraphs 9c(6), 9c(7) and 9c(8) (see FIGURE 2).

(b) Connect Cord CD-477 to the "R.F. OUTPUT" socket on the signal generator and to the antenna socket, Socket SO-153, on Rack FT-244-A (see FIGURE 10). Connect Test Set I-139-A to the signal generator "METER" socket.

(c) Plug Battery Box BX-33-A cable into the signal-generator four-pin socket located to the left of the "METER" socket. Throw the signal-generator "POWER ON-OFF" switch to "ON".

(d) Set the signal-generator "M.O.-CRYSTAL" switch at "CRYSTAL".

(e) Place the "OUTPUT CONTROL" on "MAX." (extreme clockwise position) and place the "OUTPUT STEPS" control on step "5".

(f) After allowing about one minute for the tubes to warm up, adjust the "CRYSTAL TUNING" control to the frequency to be tuned. If this adjustment is correct, a small dip will be observed in the test milliammeter (Test Set I-139-A). Adjust the "MEGACYCLES" dial control for an additional dip (approximately at the same dial setting as the receiver channel frequency being tuned). Now connect Test Set I-139-A to the receiver test-milliammeter socket 288.

(4) Tuning Adjustments for Channel "A" (Using Crystal in Signal Generator)

(a) Install the proper crystal in the socket for receiver channel "A".

(b) Press channel "D" pushbutton of Radio Control Box BC-602-A [see note in paragraph 9a(5)].

(c) Press the channel-release pushbutton located on the rack.

(d) Loosen the two receiver tuning-control locknuts by turning them counter-clockwise. Tighten the two locknuts just enough to exert a slight pressure on the cam pile-up, otherwise vibration may change the position of the cam, which would introduce considerable set-up error.

(e) Press channel "A" pushbutton of the radio control box. After allowing about one minute for the receiver vacuum tubes to warm up, throw the "T-R-REM." lever switch on the panel of Radio Control Box BC-602-A to "R", or center position.

(f) Turn the two receiver tuning controls to the desired frequency as indicated on the calibration plate.

(g) Connect a suitable headset across terminals 1 and 3 of socket 802 on Junction Box JB-29-A. Rotate the receiver "AUDIO" and "RELAY" controls to their maximum clockwise rotation positions.

(h) Back out the channel "A" oscillator plate-coil tuning screw so that about three to five threads of the screw protrude from the coil-mounting insert. The higher the crystal frequency, the further the plate-

EMPLOYMENT

coil screw must be backed out of the coil-mounting insert, thus obtaining the necessary inductance to permit the oscillator to start.

When the oscillator starts, the signal should be heard. If not, simultaneously adjust the receiver radio frequency and oscillator tuning controls slightly, and if necessary, turn the channel "A" oscillator plate-coil tuning screw still further counterclockwise until the signal is heard.

When the signal is heard, rotate the oscillator plate-coil tuning screw clockwise until the signal suddenly ceases, then rotate the screw counterclockwise to a position at least three quarters of a turn past the point at which the signal is first heard (i. e., the position at which the oscillator starts). The additional three quarters of a turn is required for a stable adjustment of the crystal oscillator. If this results in an appreciable reduction of output, continue turning the screw counterclockwise until the output is increased as much as possible. This adjustment should be rechecked after completing paragraphs 9c(4) (i) and 9c(4) (j).

(i) Turn the "OUTPUT CONTROL" to "MIN." position. Place the "OUTPUT STEPS" control in position "1" or "2" and then turn the "OUTPUT CONTROL" clockwise until the signal is just audible in the headset.

(j) Readjust the receiver tuning controls and the signal generator "CRYSTAL TUNING" control for maximum audio output. Rotate the "OUTPUT CONTROL" counterclockwise, if necessary, to keep the peaked output at low level in the headset. This may require repeated readjustments. Recheck the adjustment of the crystal oscillator tuning screw.

(k) If an output-power meter or an a-c voltmeter of suitable range is available, either one of these instruments would be helpful in making final tuning adjustments. Connect the meter in place of, or in parallel with the headset. The load

presented by either type of instrument should be adjusted for 4000 ohms if the yellow wire going to the receiver audio-output transformer 296 is connected to terminal No. 7, or 300 ohms if this wire is connected to terminal No. 6. This output-meter load should be connected across terminals No. 1 and 3 of socket 802 or 1 and 4 of socket 804 of Junction Box JB-29-A.

Test Set I-139-A (part of Test Equipment IE-19-A) may be plugged into the receiver socket 288 and the tuning procedure followed as before except that instead of tuning for maximum audio output, tune for a small dip or minimum reading of the test set. The signal generator output should be reduced to the lowest level at which it is possible to obtain an indication of change of current as the receiver tuning controls are adjusted.

(5) Adjustments for Remaining Channels (Using Crystal in Signal Generator).

To adjust the remaining channels, press channel "B" pushbutton on Radio Control Box BC-602-A and follow the same tuning procedure outlined for channel "A" in paragraphs 9c(3) (e), 9c(3) (f), 9c(4) (a), 9c(4) (f), 9c(4) (g), 9c(4) (h), 9c(4) (i), and 9c(4) (j).

CAUTION: TUNE ALL CHANNELS IN THE SEQUENCE "A", "B", "C", "D", SO THAT PREVIOUSLY ALIGNED CHANNELS WILL NOT BE DETUNED [SEE PARAGRAPH 9a(5)].

NOTE: The tuning instructions for channel "A" will hold good for channel "B" only if the letter "B" is substituted for "A" wherever the crystal, the channel, and the oscillator plate-coil tuning screw are mentioned. This note likewise applies when tuning channels "C" and "D". Tune channels "C" and "D" in like manner, after which press the channel-release pushbutton and tighten the two receiver tuning-control locknuts by turning them *tightly* clockwise. Recheck all channels for satisfactory receiver output.

EMPLOYMENT

(6) Adjustment of Signal Generator I-130-A
(Using Master Oscillator)

The procedure for employing the signal-generator master oscillator is the same as the procedure for using the crystal oscillator except that the "CRYSTAL TUNING" control is not touched, the "M.O.-CRYSTAL" switch is set at "M.O." and the signal generator is tuned by means of the "MEGACYCLES" dial control only (see FIGURE 2). Allow about one minute for the tubes to warm up.

(7) Tuning Adjustment for Channel "A"
(Using Signal Generator Master Oscillator).

(a) Make certain that proper crystals are installed in receiver crystal sockets [see paragraph 9c(2)]. Press channel "D" pushbutton of Radio Control Box BC-602-A.

(b) Press the channel-release pushbutton located on the rack.

(c) Loosen the two receiver tuning-control locknuts by turning them counterclockwise. Tighten the locknuts just enough to exert a slight pressure on the cam pile-up.

(d) Press channel "A" pushbutton of the radio control box. After allowing about one minute for the receiver vacuum tubes to warm up, throw the "T-R-REM." lever switch on the panel of Radio Control Box BC-602-A to "R" or center position.

(e) Turn the receiver tuning controls to the desired frequency on the calibration plate.

(f) Using the alignment tool or a small screwdriver, turn the crystal oscillator plate-coil tuning screw for channel "A" to the position at which about 3 to 5 threads protrude from the coil-mounting insert. The higher the crystal frequency, the further the plate-coil screw must be backed out of the coil-mounting insert, thus obtaining the necessary inductance to permit the oscillator to start.

(g) With a headset connected to junction box socket 802, terminals No. 1 and 3,

place the signal generator "OUTPUT STEPS" control on step "5" and set the "OUTPUT CONTROL" at "MAX." (extreme clockwise position).

(h) Set the signal generator "MEGACYCLES" dial control at the frequency being tuned and then adjust the receiver tuning controls until the modulated signal is heard in the headphones. This may require several readjustments.

(i) Turn the oscillator plate-coil tuning screw for channel "A" clockwise until the modulated signal suddenly ceases.

(j) Turn the crystal oscillator plate-coil tuning screw counterclockwise until the signal is heard again. An additional three-quarters of a full turn in a counterclockwise direction is necessary for a stable adjustment of the crystal oscillator. If this results in reduced output, continue turning the screw counterclockwise until the output is increased as much as possible.

(k) Turn the signal generator "OUTPUT CONTROL" to "MIN." Place the "OUTPUT STEPS" control in position "1" or "2" and then turn the "OUTPUT CONTROL" clockwise until the signal is just audible.

(l) Readjust the receiver tuning controls and the signal generator "MEGACYCLES" dial control for maximum audio output. Rotate the "OUTPUT CONTROL" counterclockwise, if necessary, to keep the peaked output at a low level in the headset. The final setting of the receiver tuning controls should be near the calibrated settings for the desired frequency.

(8) Tuning Adjustments for Remaining Channels
(Using Signal Generator Master Oscillator)

To tune the remaining channels, press channel "B" pushbutton on Radio Control Box BC-602-A and follow the same tuning procedure outlined for channel "A" in paragraphs 9c(6) and 9c(7).

EMPLOYMENT

CAUTION: TUNE ALL CHANNELS IN THE SEQUENCE "A", "B", "C", AND "D" SO THAT PREVIOUSLY ALIGNED CHANNELS WILL NOT BE DETUNED [SEE PARAGRAPH 9a(5)]. NOTE: The tuning instructions for channel "A" will hold good for channel "B" only if the letter "B" is substituted for "A" wherever the crystal, the channel, and the oscillator plate-coil tuning screw are mentioned. This note, likewise applies when tuning channels "C" and "D". Tune channels "C" and "D" in like manner, after which press the channel-release pushbutton and tighten the two receiver tuning-control locknuts by turning them tightly clockwise. Recheck all channels for satisfactory receiver output.

This completes the tuning of the receiver. However, if at any time it is necessary to tune one receiver channel only, the following procedure applies.

(9) Procedure for Tuning One Channel Only

If one channel is out of adjustment, it may be tuned without disturbing the other channels.

(a) Press the pushbutton (on Radio Control Box BC-602-A) corresponding to the channel *preceding* the desired channel in the sequence "A", "B", "C", and "D". In other words, if retuning channel "B", press pushbutton "A", if retuning channel "A", press pushbutton "D", etc.

(b) Press the channel-release pushbutton.

(c) Loosen the receiver tuning-control locknuts.

(d) Press the channel-selector button for the desired channel.

(e) Tune the desired channel as described in paragraphs 9c(1) to 9c(4) (j) or 9c(6) to 9c(7) (l), ignoring reference to channel "A" and substituting the applicable letter.

(f) Press the channel-release pushbutton.

(g) Tighten the receiver tuning-control locknuts.

(h) Press the channel-release pushbutton to re-select the channel just tuned.

(i) Recheck all channels for satisfactory receiver output.

NEVER SHUT OFF RADIO SET SCR-522-A WITH THE SHIFTER SLIDES DIS-ENGAGED, AS THIS WILL RESULT IN FAILURE TO TURN ON THE TRANSMITTER AND RECEIVER IF ONE PARTICULAR CHANNEL PUSHBUTTON IS PRESSED ON RADIO CONTROL BOX BC-602-A (SEE PARAGRAPHS 9a AND 9c).

(10) Adjustment of Radio Receiver BC-624-A "AUDIO" Control

The receiver output transformer 296 is provided with three output impedance taps: terminal No. 5, 50 ohms; terminal No. 6, 300 ohms, and terminal No. 7, 4000 ohms. In some equipments, the output lead is connected to terminal No. 6 and in others, to terminal No. 7. If the output connection is made to terminal No. 7, a drop of yellow paint is placed on the screwdriver slot of the "AUDIO" control. The exact setting of the "AUDIO" volume control depends on the headphones being used and the volume desired by the pilot. However, for standard Army phones, turn the "AUDIO" control fully clockwise when transformer terminal No. 6 is used, and about one third of a turn counterclockwise from the extreme clockwise position when terminal No. 7 is used. This setting is only approximate and the pilot should be contacted and the volume increased or decreased as desired. If Jack Box BC-629-B is used, set the receiver "AUDIO" control in the extreme clockwise position. The pilot can adjust the audio volume to a desirable level by means of the jack box "AUDIO" control which is part of Jack Box BC-629-B. If the pilot desires more volume and the audio output is connected to terminal No. 6, transfer the output connection to terminal No. 7.

(11) Adjustment of Radio Receiver BC-624-A "RELAY" Control

This is the last adjustment to be made on the receiver and it should be done with the antenna connected, the equipment operating

EMPLOYMENT

on any channel, and no signal being received. First rotate the "RELAY" control to the extreme clockwise position and then turn it slowly *counterclockwise* until a noticeable drop in noise results (approximately 20 db); continue the counterclockwise rotation for a very small fraction of a turn. This adjustment can normally be made without having the engines running. However, if the adjustment has been checked and the pilot still complains of excessive noise in the phones at all times, adjust the "RELAY" control while the engines are running but omit the above-mentioned small fraction of a turn.

NEVER SHUT OFF RADIO SET SCR-522-A WITH THE SHIFTER SLIDES DIS-ENGAGED, AS THIS WILL RESULT IN FAILURE TO TURN ON THE TRANSMITTER AND RECEIVER IF ONE PARTICULAR CHANNEL PUSHBUTTON IS PRESSED ON RADIO CONTROL BOX BC-602-A (SEE PARAGRAPHS 9a AND 9c).

d. Field Strength Meter I-95-A

WARNING: Objects or people located near or between the radiating source and the field strength meter may be responsible for shadows or reflections which cause erratic meter readings. Make certain that no such interference is affecting the operation of the instrument. For final transmitter tests the best location of the field strength meter is on a wing of the aircraft. When using the instrument never allow the lowest section of the antenna to remain inserted inside the case. This precaution is necessary to prevent the antenna from affecting the tuned circuit and throwing the "TUNING" dial off calibration.

Remove the four captive thumbscrews located near the four corners of the field strength meter and remove the front panel guard.

(1) Zero Correction

With the "ON-OFF" switch turned "ON" and with no signal being received, the "RELATIVE FIELD STRENGTH" milliammeter (see FIGURE 6) should read zero. If this is not the case, adjust the "ZERO ADJ." screw (located to the left of the nameplate) until the indicator is exactly on zero.

(2) Transmitter Antenna-Radiation Test

With a signal being received and with the field strength meter placed within 25 feet of the antenna of Radio Transmitter BC-625-A, adjust the "TUNING" dial to obtain a peak reading of the "RELATIVE FIELD STRENGTH" milliammeter. The telescopic antenna may be extended or shortened to increase or decrease the milliammeter reading. The approximate frequency of the received signal may be read directly from the "TUNING" dial.

(3) Modulation Test

Tune in the unmodulated carrier and note the peak reading of the "RELATIVE FIELD STRENGTH" milliammeter. Speak or whistle into a microphone connected to one of the jack boxes. "Upward modulation" is indicated by a noticeable increase in the peak reading of the milliammeter. If no increase in the peak reading of the milliammeter is noted, check for modulation using an external receiver.

(4) Contactor Relay Test

Turn the field strength meter "TUNING" dial to the frequency corresponding to channel "D". Press any control-box channel-selector pushbutton "A", "B", or "C". Allow about one minute for the tubes of the transmitter-receiver assembly to warm up. Connect together the two wires of the junction box-to-contactor cord. The transmitter-receiver assembly will then shift to channel "D" which is indicated by a sudden rise of current in the "RELATIVE FIELD STRENGTH" milliammeter.

10. ADJUSTMENTS FOR FIELD UPKEEP

If the total "A" battery voltage under load drops below 4.5 volts in the signal generator or 1.2 volts in the field strength meter, or if the total "B" battery voltage under load drops below 110 volts in the signal generator or 37 volts in the field strength meter, replace the defective batteries (see paragraphs 7a and 7b).

If tubes have to be replaced, refer to paragraphs 14a and 14b.

SECTION III

FUNCTIONING OF PARTS

11. Signal Generator I-130-A
12. Test Set I-139-A
13. Field Strength Meter I-95-A

11. SIGNAL GENERATOR I-130-A

For a general description of the signal generator, refer to paragraph 5a. The schematic circuit diagram is given in FIGURE 11. Operating power is obtained from Battery Box BX-33-A.

The r-f signal generator employs Tube VT-202 as a master oscillator, connected in a Hartley circuit. The tuned grid circuit consists of the tapped inductor 716, variable capacitor 712A, and trimmer capacitor 713-1, and covers the frequency range 33.3—52 mc. Filament voltage is applied through choke 748 and is by-passed by capacitor 702-1.

The master oscillator output is coupled to the control grid of Tube VT-203, the power-amplifier, through capacitor 703-4. The power amplifier plate circuit, comprising inductor 717, variable capacitor 712B and trimmer capacitor 713-2, is tuned to the third harmonic (100—156 mc) of the master oscillator output frequency. Capacitors 712A and 712B are ganged to permit simultaneous tuning of the master oscillator and power amplifier circuits by means of the "MEGACYCLES" dial control located on the "R.F. SIGNAL GENERATOR" panel (see FIGURE 2). The r-f output inductor 718 is inductively coupled to the power amplifier plate inductor 717 and is directly connected to the "R.F. OUTPUT" socket 722-1.

An alternative (crystal) oscillator circuit may be chosen by means of the "M.O.-CRYSTAL" switch 752. With this switch in "CRYSTAL" position, power is applied to the heaters of Tube VT-203, the crystal-oscillator, and Tube VT-203, the distortion-amplifier.

With the "M.O.-CRYSTAL" switch 752 in "M.O." position, the tuned circuit in the plate circuit of the crystal-oscillator tube is disconnected and power is applied to the heater of the master oscillator. The crystal oscillator tube is connected to a Colpitts circuit formed by the crystal constants, the capacitors 704-1, 704-2 and 705, resistor 728-1, and the chokes 750-1 and

750-2. The plate circuit, consisting of inductor 719, variable capacitor 714, and blocking capacitor 706-1, is tuned to the second crystal harmonic. Tuning is accomplished by means of the "CRYSTAL TUNING" control located on the panel (see FIGURE 2).

Capacitor 703-3 couples the crystal-oscillator output to the grid of Tube VT-203, the distortion-amplifier, the plate circuit of which is tuned to the third harmonic (33.3–52 mc) of the crystal-oscillator output. When the crystal oscillator is in use, the grid circuit of the decommissioned master oscillator becomes the plate circuit (716, 712A, 713-1) of the distortion amplifier. The distortion-amplifier output is then coupled to the power-amplifier grid through capacitor 703-1 and the same circuit elements which would otherwise couple the master oscillator tube to the power amplifier. The power-amplifier output frequency (100–156 mcs) is the third multiple of the output frequency of the distortion amplifier. Since the overall frequency-multiplication factor is 18, the crystal-oscillator circuit may employ the same crystals as Radio Transmitter BC-625-A. The power amplifier is modulated by an audio tone of approximately 1000 cps generated by the modulator stage. The plate voltage of the master oscillator and crystal oscillator may be varied by means of the "OUTPUT STEPS" control 756 and the "OUTPUT CONTROL" 757. With the "OUTPUT STEPS" control in position "1", the plate voltage may be varied by means of the "OUTPUT CONTROL" from zero to 20% of the total voltage available. Each succeeding step of the "OUTPUT STEPS" control increases the voltage range by 20%.

When step "5" is in use, all of the available voltage may be obtained. These controls function as signal attenuators, since by reducing the oscillator plate voltage they also reduce the signal output.

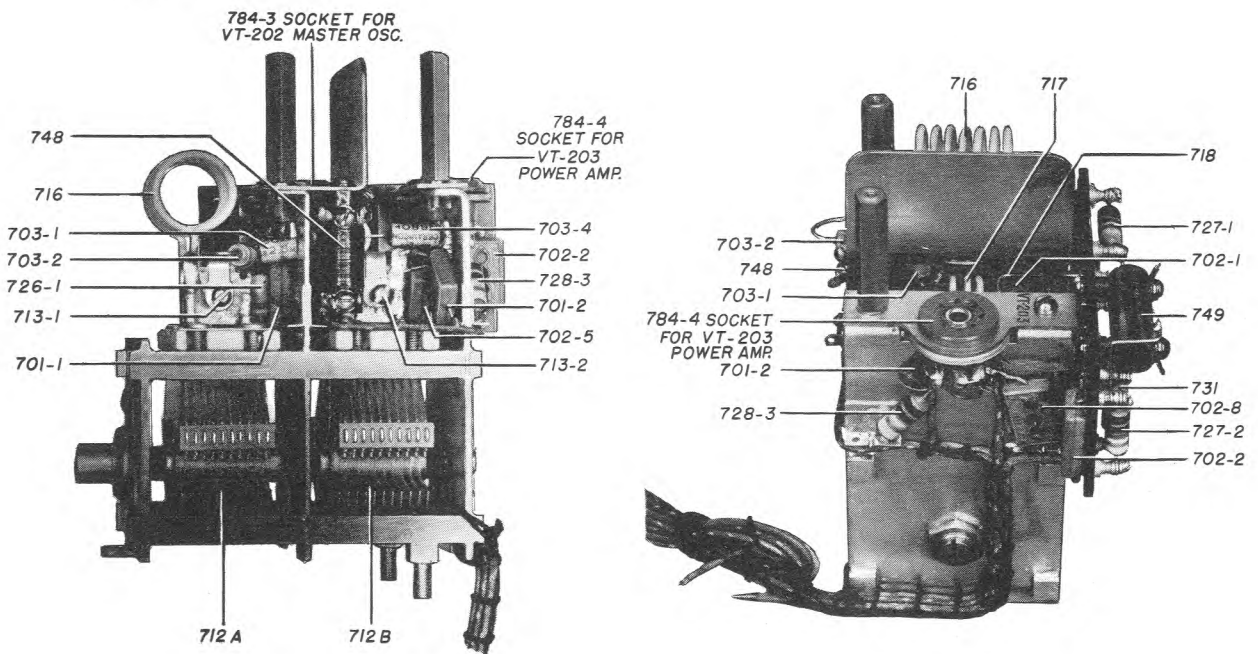
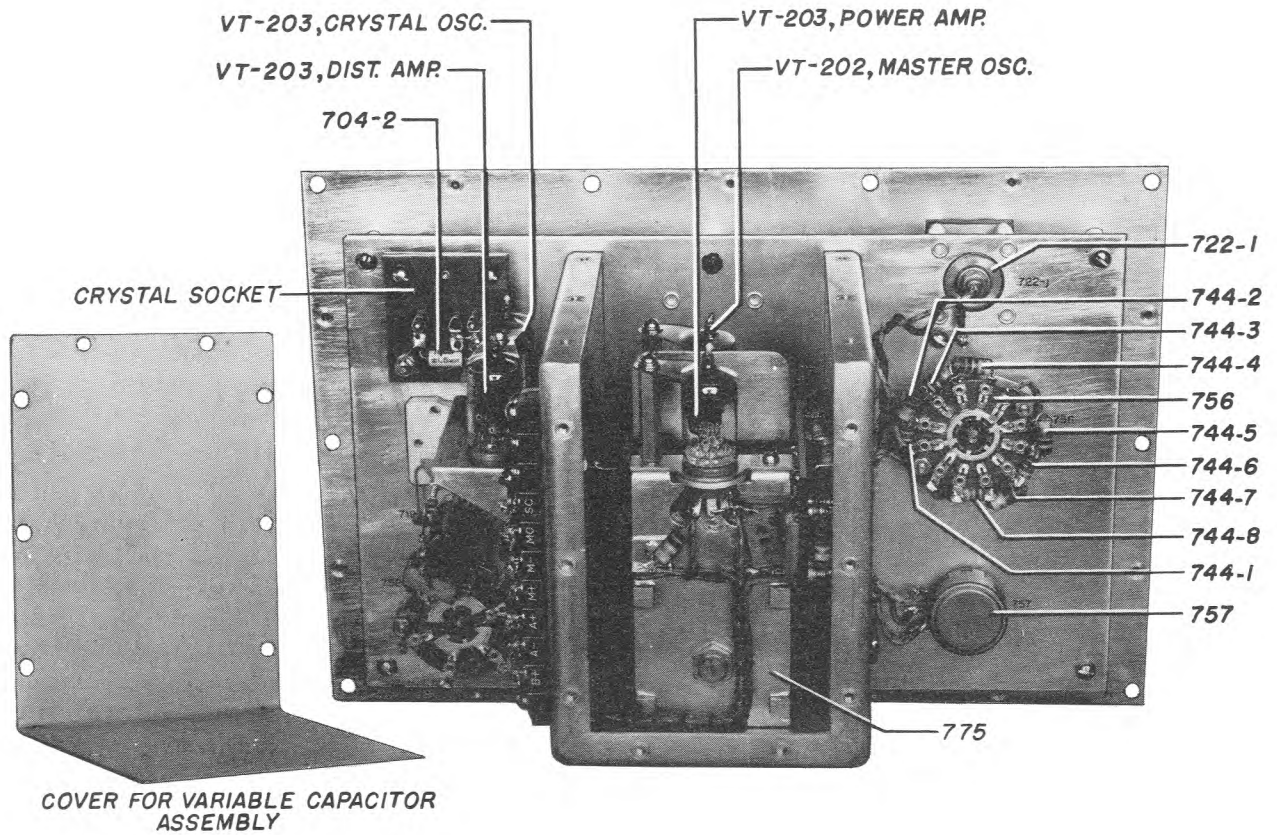

FIGURE 12—SIGNAL GENERATOR I-130-A, R-F UNIT, REAR VIEW

FUNCTIONING OF PARTS

Tube VT-202, the modulator, is connected in a Hartley oscillator circuit, the feedback impedance consisting of transformer 765 and capacitor 707. Resistor 732 is the grid leak. The 1000-cycle signal is applied through resistor 731 to the screen grid of the power amplifier Tube VT-203, resulting in modulation of the r-f signal-generator carrier.

voltages induced in its variable-length antenna. This antenna has approximately a one-quarter-wave characteristic and its length may be increased or decreased to accommodate a weak or strong signal respectively. The antenna is coupled by a common short length of wire in the tuned circuit comprising fixed capacitor 501, inductor 503, and the variable tuning capacitor 502 which

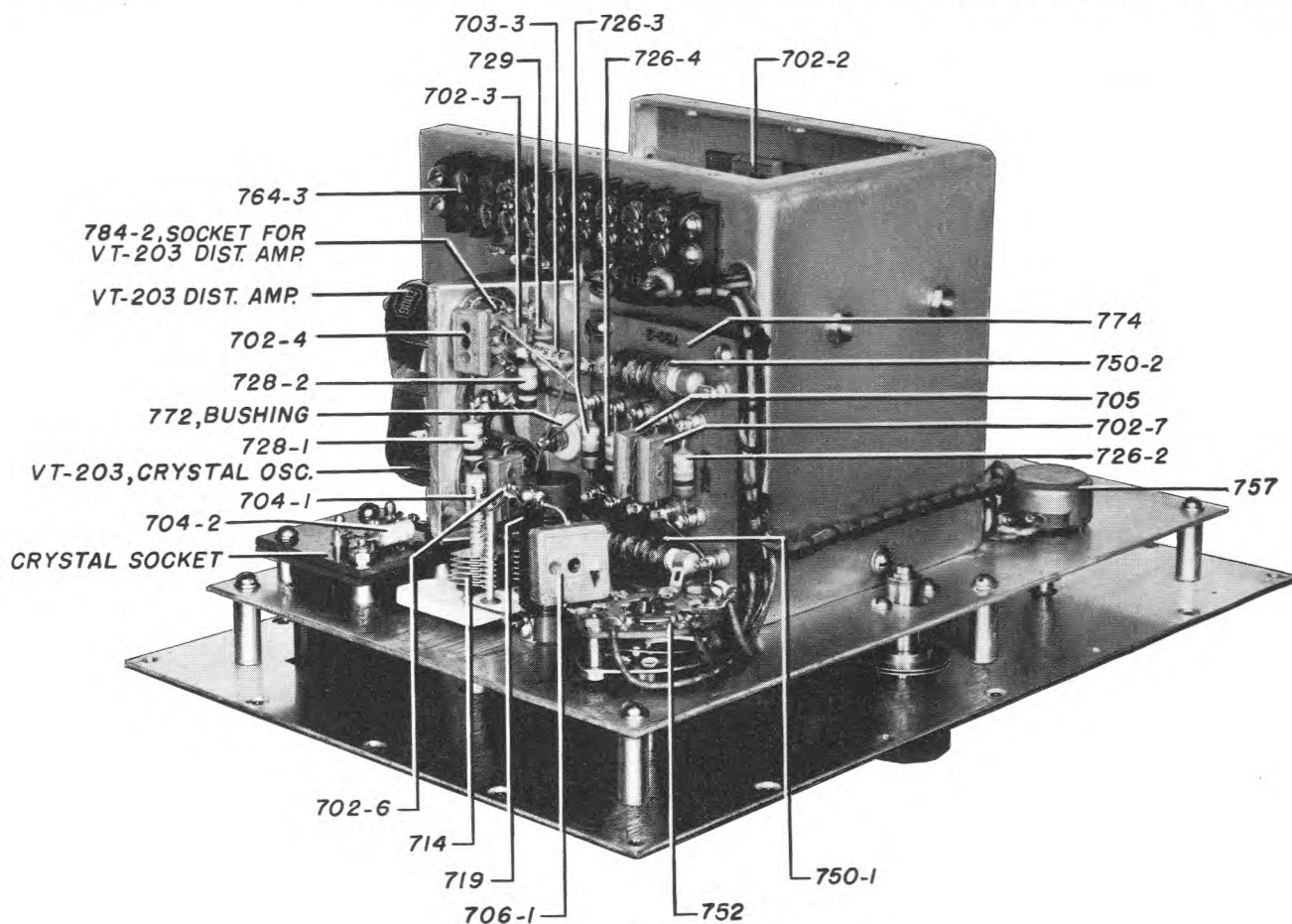

FIGURE 13—SIGNAL GENERATOR I-130-A, R-F UNIT, BOTTOM OBLIQUE VIEW

12. TEST SET I-139-A

The O-1 ma d-c meter 759 in series with resistor 739 is connected across the test-set plug (see FIGURE 11). The combined series resistance of the meter and resistor is 75 ohms.

13. FIELD STRENGTH METER I-95-A

Field Strength Meter I-95-A is an uncalibrated vacuum-tube voltmeter designed to register

is adjusted by means of the "TUNING" dial on the front panel (see FIGURE 6). The tuned circuit may be made to resonate at any frequency within the range 100-156 mc.

With switch 508 closed (see FIGURE 11) and no signal being received, a steady space current flows in Tube VT-172. This current would normally cause a downward deflection of milliammeter 504 if it were not for the fact the variable resistor 505 is adjusted so that milliammeter 504 reads

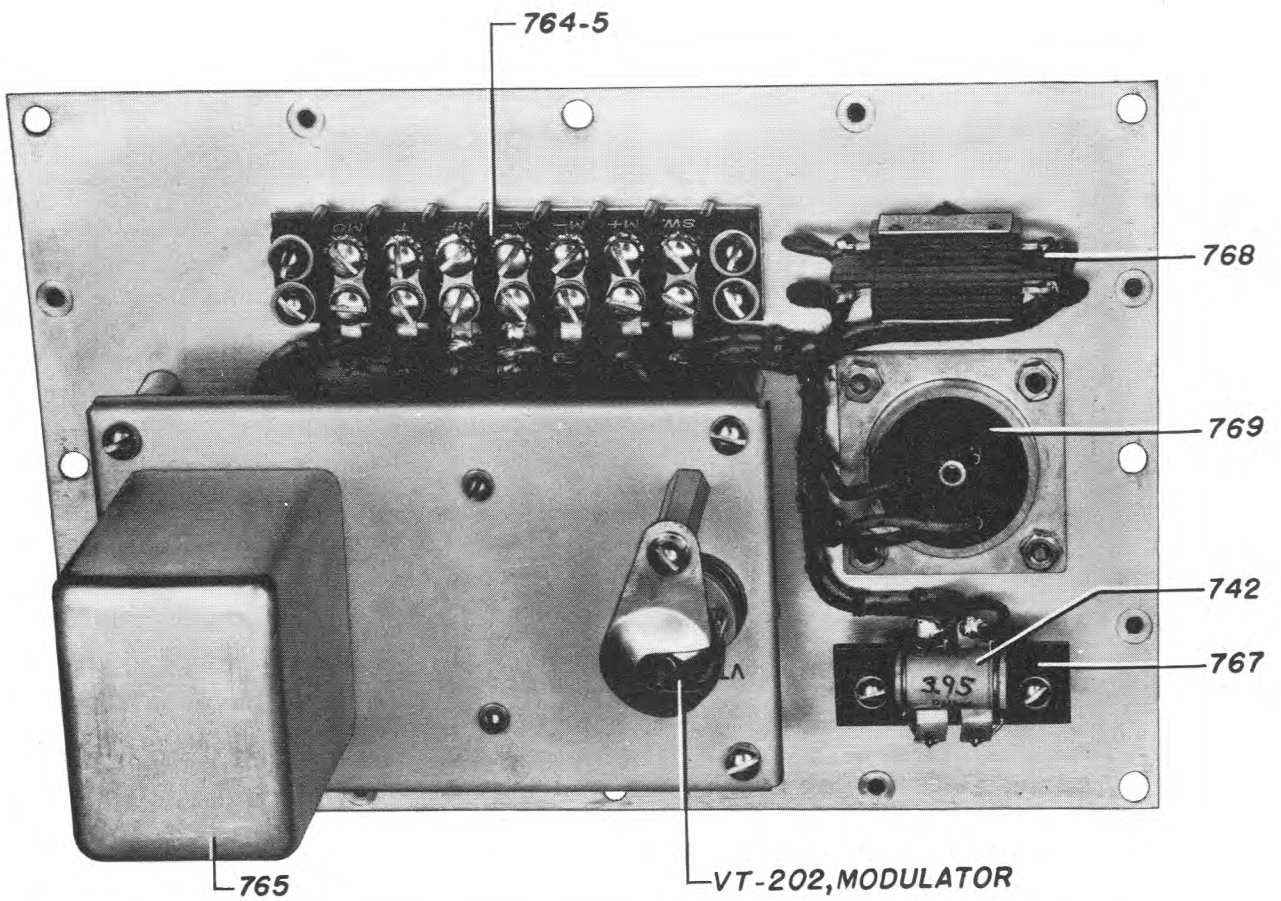

FIGURE 14—SIGNAL GENERATOR I-130-A, MODULATOR UNIT, REAR VIEW

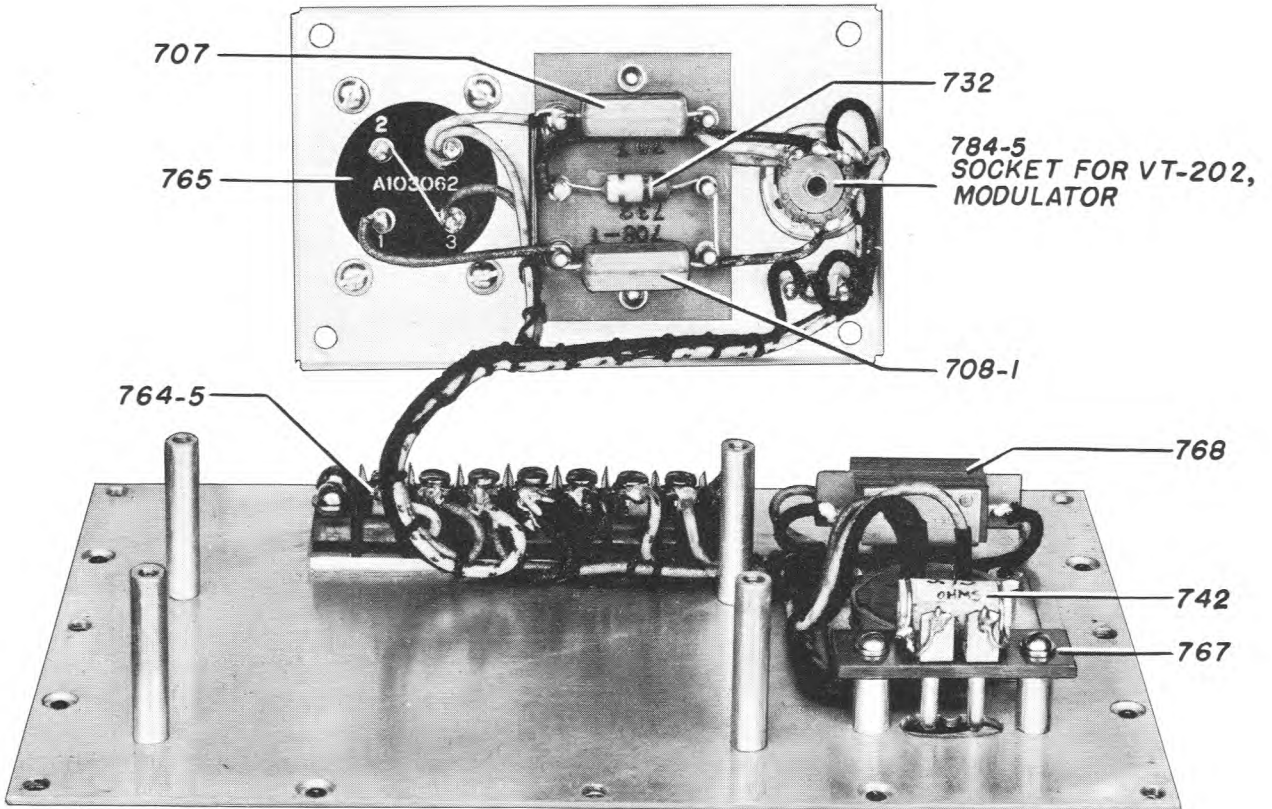

FIGURE 15—SIGNAL GENERATOR I-130-A, MODULATOR UNIT, DISASSEMBLED VIEW

FUNCTIONING OF PARTS

zero. This means that the space current flowing through the milliammeter is exactly counterbalanced by the opposing "A" battery current. Resistor 505 requires readjustment from time to time to compensate for variations in battery voltage and tube characteristics.

When the tuned circuit is in resonance with a received signal, the signal voltage is tapped from inductor 503 and applied to the diode plate of the diode-triode, Tube VT-172. The rectified diode-current voltage is then dropped through resistor

506 and impressed on the control grid of Tube VT-172, making the grid more negative and decreasing the space current in the tube. When the

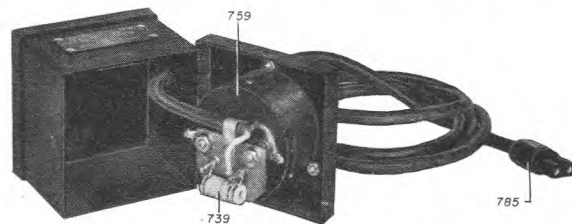

FIGURE 16—TEST SET I-139-A, INTERIOR VIEW

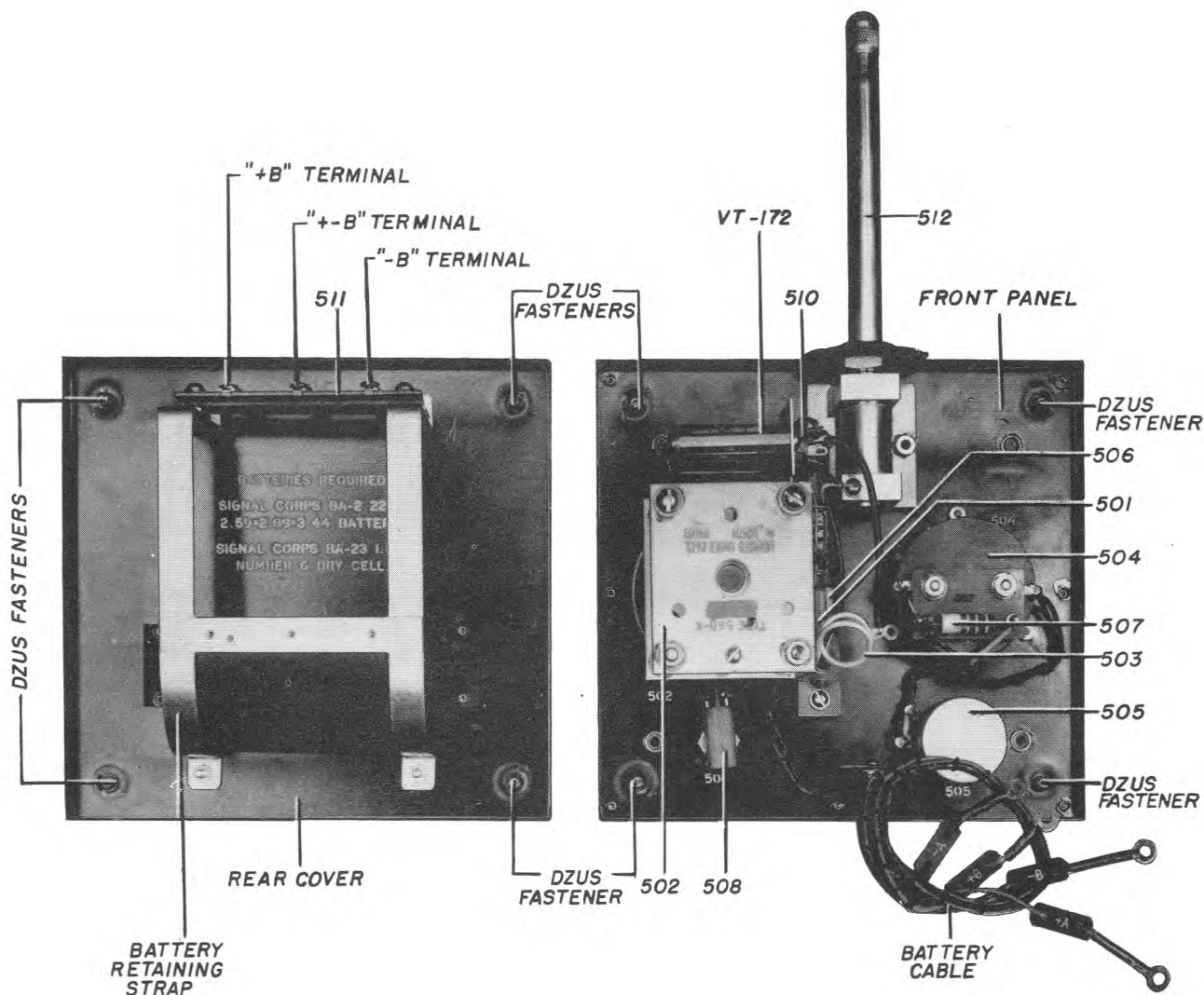

FIGURE 17—FIELD STRENGTH METER I-95-A, INTERIOR VIEW

FUNCTIONING OF PARTS

opposing "A" battery current is greater than the space current, there is an upward deflection of milliammeter 504. The magnitude of the milliammeter deflection is proportional to the difference between the opposing "A" battery and space cur-

to ground) of the signal voltage applied to the diode plate of Tube VT-172. The field strength meter is intended for use within a radius of approximately 25 feet, measured from the antenna of Radio Transmitter BC-625-A. Note that a

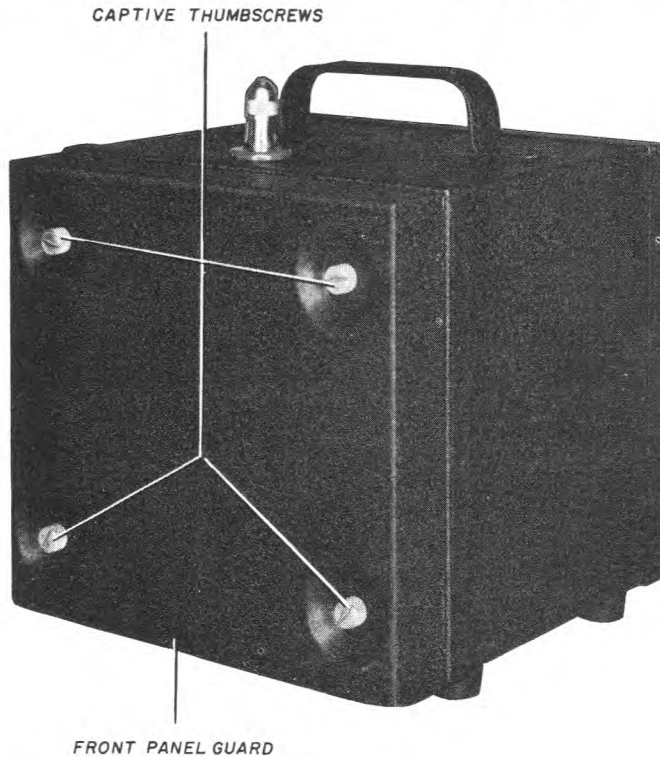

FIGURE 18—FIELD STRENGTH METER I-95-A, WITH FRONT PANEL GUARD

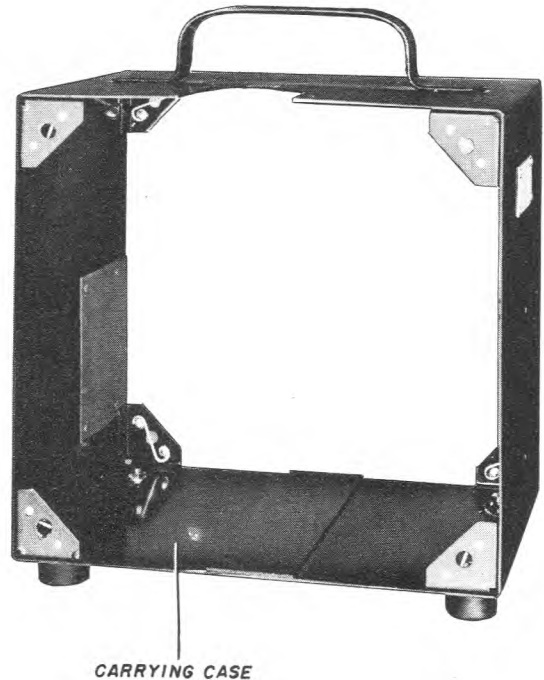

FIGURE 19—FIELD STRENGTH METER I-95-A, CASE

rents, and this difference is in turn proportional to the voltage impressed on the control grid, or to the strength of the received signal. The limiting resistor 507 prevents damage to the milliammeter from an excessively large deflection.

Capacitor 501 maintains the d-c voltage across resistor 506 near the r-f peak value (with respect

modulated signal causes a greater deflection of the milliammeter than the unmodulated carrier, due to the higher voltages induced in the antenna by a modulated wave. The field strength meter may therefore be used to indicate modulation of the carrier of Radio Transmitter BC-625-A [see paragraph 9a(15)].

SECTION IV

SERVICING AND REPAIR

14. Replacement of Vacuum Tubes
15. Trouble Location
16. Voltages at Tube Sockets and Other Important Circuit Terminations
17. Continuity Test Tables
18. Servicing Signal Generator I-130-A
19. Power Output Measurements

14. REPLACEMENT OF VACUUM TUBES

a. Signal Generator I-130-A

If vacuum tubes are to be replaced, loosen the cover fasteners and raise the cover (see FIGURE 2). If the power cable is plugged in, remove it.

To remove vacuum tubes in the r-f signal generator, remove the ten screws which secure the "R.F. SIGNAL GENERATOR" panel to the carrying case of Signal Generator I-130-A and lift out the front panel. The crystal oscillator, Tube VT-203 and the distortion amplifier, Tube VT-203 are located on a shelf and may be replaced by turning aside the tube clamps, extracting old tubes, inserting new tubes and replacing tube clamps.

To replace the master oscillator, Tube VT-202, and the power amplifier, Tube VT-203, the variable capacitor assembly cover must first be removed by loosening the fourteen retaining screws. This exposes these two tubes which may now be replaced. Adjust the tube clamps and replace the variable capacitor assembly cover.

To replace the modulator, Tube VT-202, remove the eight screws which secure the modulator section to the carrying case of Signal Generator I-130-A and lift the section out. This makes the tube accessible.

b. Field Strength Meter I-95-A

Loosen the four captive screws and remove front panel guard. Loosen the four Dzus fasteners located in the four corners of the front panel and remove the front panel. Tube VT-172 is now exposed and may be replaced.

15. TROUBLE LOCATION

The following general principle should be remembered and constantly followed in connection with this equipment:

When looking for trouble, always examine all the simple causes of failure first.

Many good radio equipments have been ruined by internal alterations when the service failure was due to a cable, a plug, a power supply, or a tube. This equipment is electrically a complicated system, depending upon precise design, workmanship, and adjustment for successful operation. Inspections and operations performed on the interior of this equipment, which are suggested in the following paragraphs, should be done only as a last resort and after it is certain that the fault is not to be found outside the equipment.

a. Signal Generator I-130-A

(1) Check battery voltages under load, and battery wiring.

(2) If improper or no operation is obtained with the "M.O.-CRYSTAL" switch in "CRYSTAL" position only, check crystal by replacing with a spare crystal.

(3) Remove unit from case (see paragraph 14) and check terminal board connections and voltages. Check continuity (see paragraph 17a).

(4) Manipulate the "M.O.-CRYSTAL" switch 752 and note that the heater of the master oscillator tube will glow when switch 752 is in "M.O." position, and that the crystal oscillator and distortion amplifier tube heaters will glow when switch 752 is in the "CRYSTAL" position.

The modulator and power amplifier tube heaters should glow regardless of "M.O.-

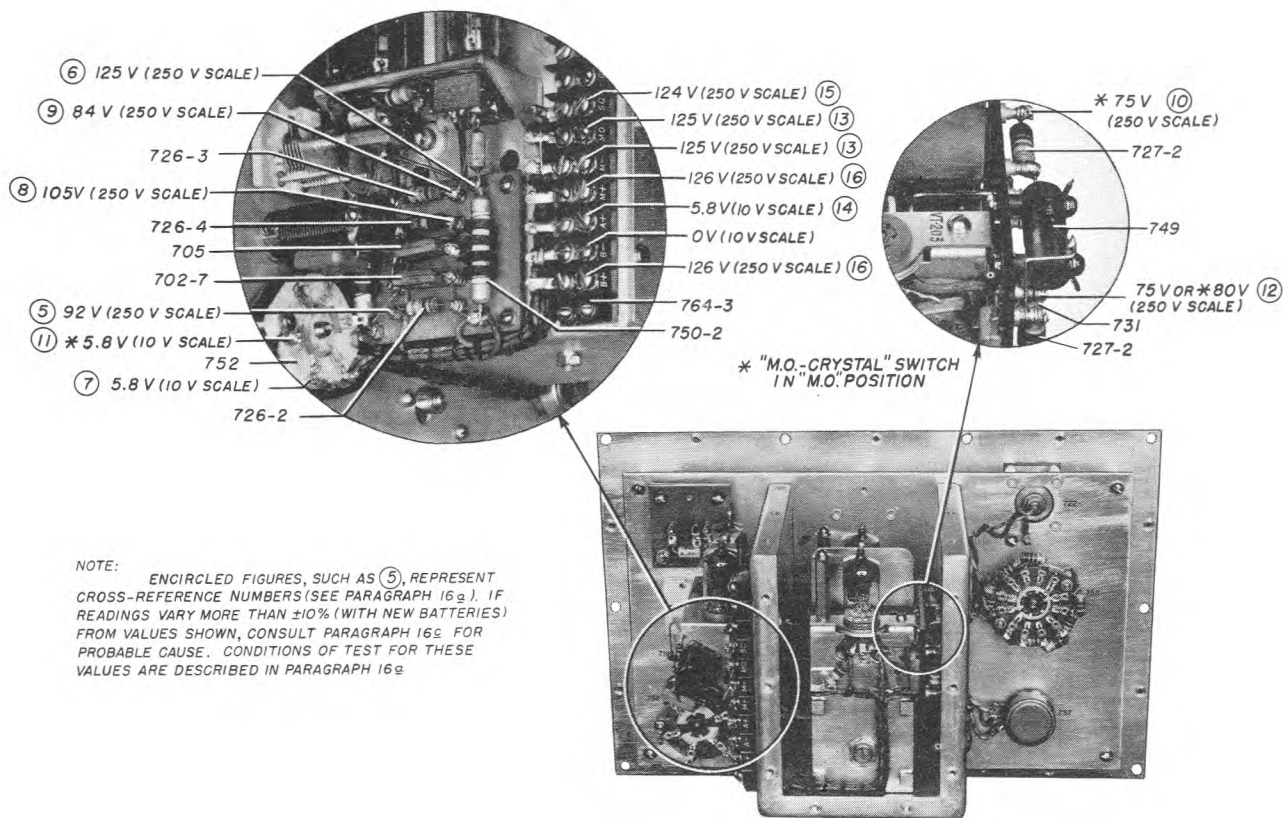
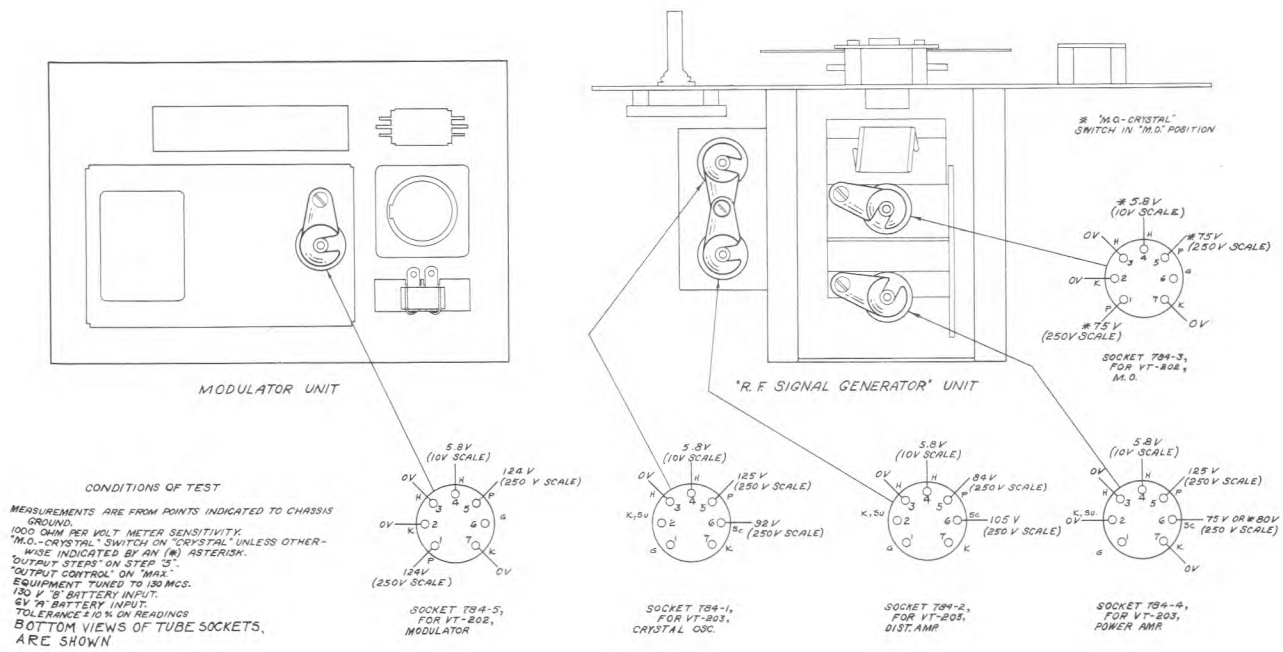
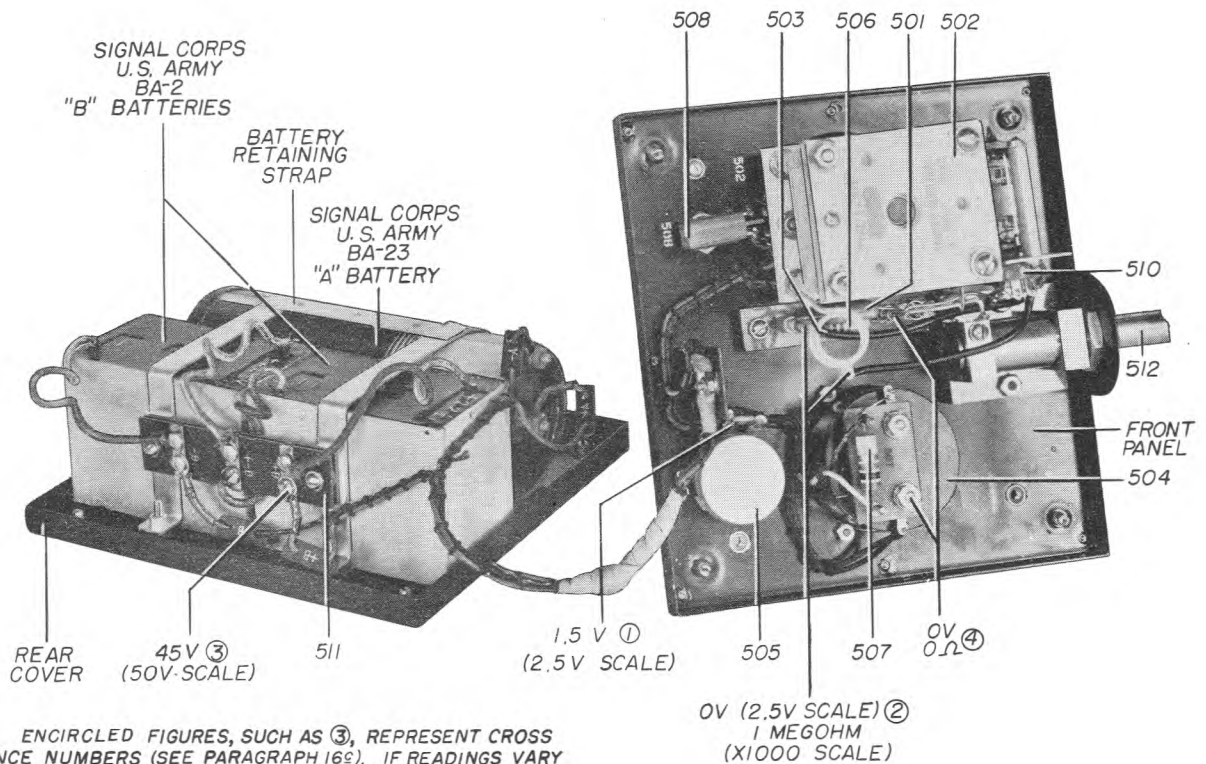
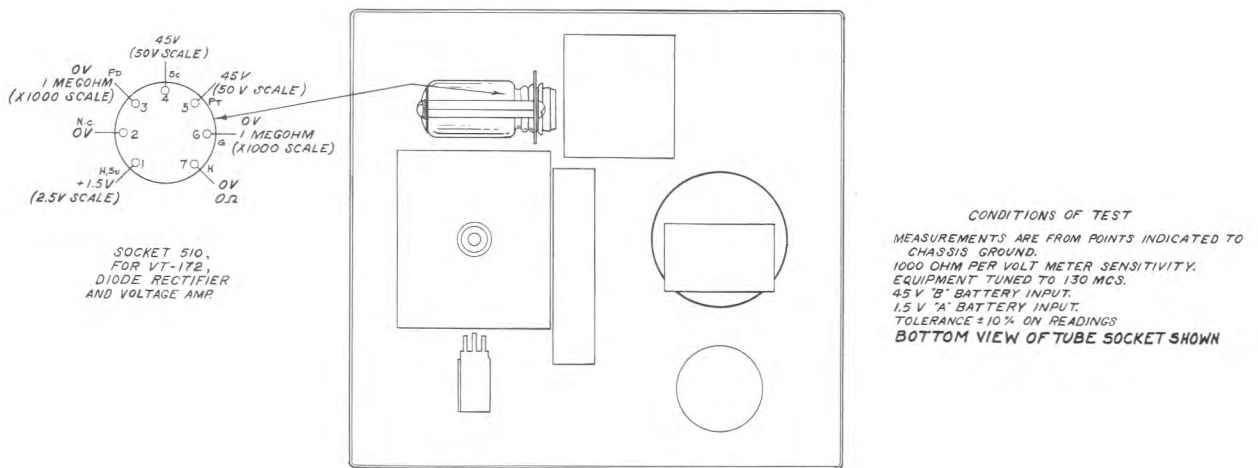

FIGURE 20—SIGNAL GENERATOR I-130-A, TUBE SOCKET LAYOUT AND VOLTAGE DIAGRAM



NOTE: ENCIRCLED FIGURES, SUCH AS ③, REPRESENT CROSS REFERENCE NUMBERS (SEE PARAGRAPH 16₂). IF READINGS VARY MORE THAN ±10% FROM VALUES SHOWN, (WITH NEW BATTERIES), CONSULT PARAGRAPH 10₄ FOR PROBABLE CAUSES. CONDITIONS OF TEST ARE DESCRIBED IN PARAGRAPH 16₅

FIGURE 21—FIELD STRENGTH METER I-95-A, TUBE SOCKET LAYOUT AND VOLTAGE DIAGRAM

SERVICING AND REPAIR

CRYSTAL" switch positions. Test vacuum tubes in tube checker.

(5) Examine cables and wiring for broken wires. Examine switch and socket contacts. Examine solder joints for corrosion. Note if dials and controls are secure to shafts. Examine variable capacitors for dirt and bent plates. Check individual components for failure.

b. Field Strength Meter I-95-A

Place "ON-OFF" switch in "ON" position and extend antenna. With no signal received, adjust "ZERO ADJ." control 505 until "RELATIVE FIELD STRENGTH" milliammeter reads zero.

If meter reads backwards, regardless of manipulation of the "ZERO ADJ." control, the resistor 507 is probably open.

If meter registers, regardless of manipulation of "TUNING" dial, the tube may be defective, the plate connection open, or Field Strength Meter I-95-A may be near excessively strong signals.

If meter reads low when a signal is received, the batteries may be weak, the tube may be defective, the instrument may be in a "shadow", or the antenna may not be completely extended.

If the meter reading fluctuates, see if persons or objects are moving about in the vicinity; check transmitter antenna connections, and check battery connections and voltages.

If it is impossible to obtain a meter reading, check circuit voltages and continuity (see paragraph 17b). Examine cables and wiring for broken wires. Examine switch and socket contacts. Examine solder joints for corrosion. Check individual components for failure.

16. VOLTAGES AT TUBE SOCKETS AND OTHER IMPORTANT CIRCUIT TERMINATIONS

a. Signal Generator I-130-A

Insert plug of Battery Box BX-33-A into the power input socket 769 of Signal Generator I-130-A. Insert plug of Test Set I-139-A into

"METER" socket 767 of Signal Generator I-130-A. Insert a crystal into the "CRYSTAL" socket such that the output frequency is approximately 130 mc.

Remove "R.F. SIGNAL GENERATOR" from its compartment but do not disconnect cable.

Place "POWER ON-OFF" switch in "ON" position and tune signal generator.

Set the "OUTPUT STEPS" control on step "5", the "OUTPUT CONTROL" on "MAX.", and the "M.O.-CRYSTAL" switch at "CRYSTAL".

Measurements are to be made from points indicated in FIGURE 20 to the chassis. These represent the most accessible points for measurements of tube socket voltages. Use a meter having a sensitivity of 1000 ohms per volt, such as a Weston Selective Analyzer, Model 665, Type 2, which is part of Test Set I-56-A. If using a meter having a sensitivity of 1000 ohms per volt but with different scales, use the scales most nearly approximating those specified in FIGURE 20.

b. Field Strength Meter I-95-A

Loosen the four captive thumbscrews and remove the front panel guard. Loosen the four Dzus fasteners in the front panel and remove the panel.

Set "ON-OFF" switch in "ON" position and measure voltages from points indicated on FIGURE 21 to chassis. Measure voltages with a meter having a sensitivity of 1000 ohms per volt, such as Weston Selective Analyzer, Model 665, Type 2, which is part of Test Set I-56-A.

c. Voltage Analysis Table

If measured voltages differ more than 10% from voltages indicated on Figures 20 and 21, the following table will help locate the cause.

The figure in column headed "Figure Reference Number" represents the encircled figure following the voltages given in Figures 20 and 21. The probable cause of an incorrect reading may be found by reference to this table.

SECTION II EMPLOYMENT

6. Initial Procedure
7. Installation
8. Preparation for Use
9. Operation
10. Adjustments for Field Upkeep

6. INITIAL PROCEDURE

When shipped from the factory, the components of Test Equipment IE-19-A are packed in Chest CH-93-A, and all vacuum tubes are installed in their respective sockets. After unpacking, all

be installed in Battery Box BX-33-A (see FIGURES 5 and 8).

Loosen the cover fasteners and lift the cover (see FIGURE 5). Remove the five wire jumpers

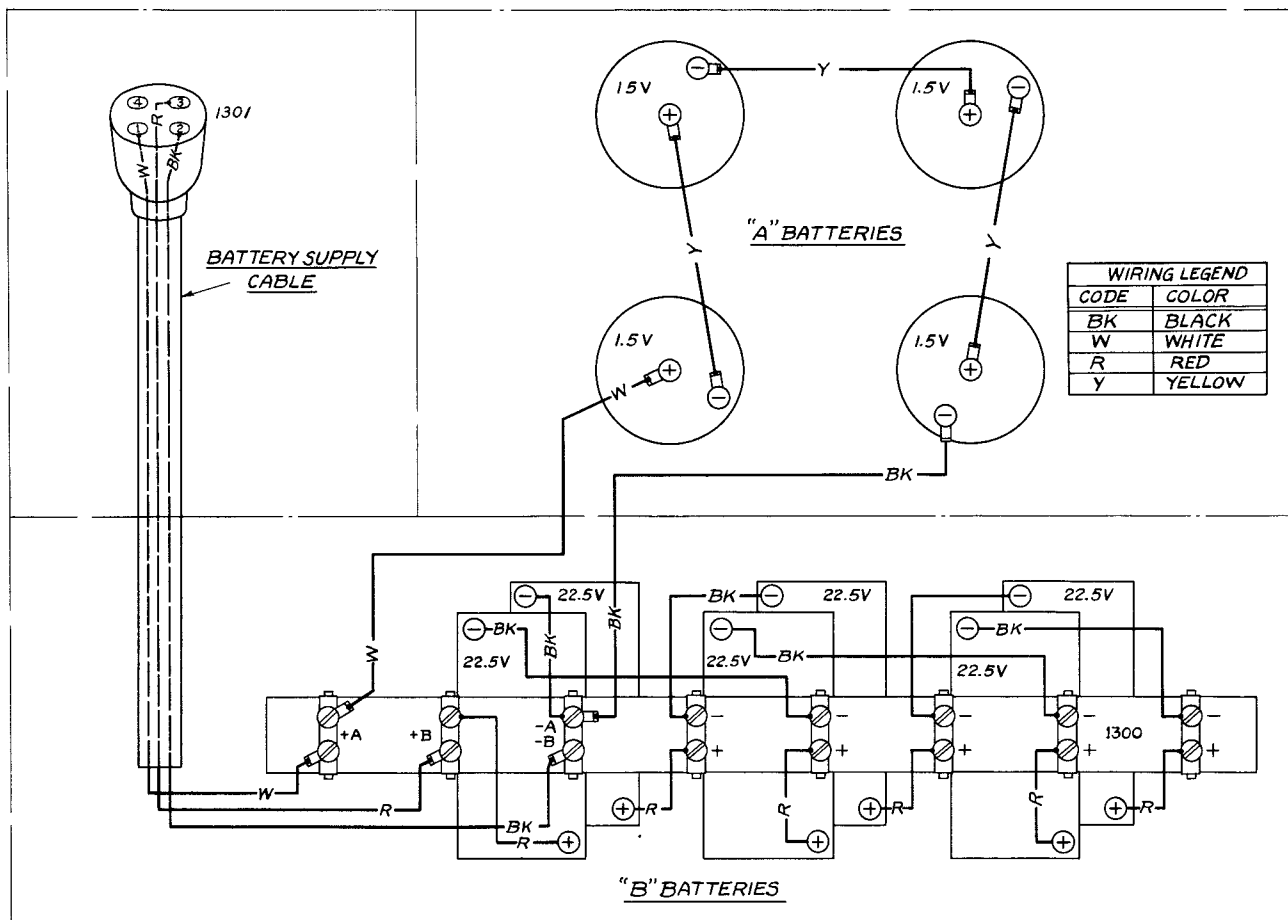

FIGURE 8—BATTERY BOX BX-33-A, WIRING DIAGRAM

parts should be thoroughly inspected for possible damage during shipment. The test equipment is shipped from the factory without batteries.

7. INSTALLATION

a. Battery Box BX-33-A Batteries

Six Battery BA-2 and four Battery BA-23 must

from the bottom of the "A" battery compartment. Three of these jumpers are yellow and are 3⁵/₈ inches long. Two of these jumpers are 5¹/₄ inches long; one is white and the other is black.

Remove the two terminal board mounting screws (see FIGURE 5) which secure the "B" battery clamp. Place the six "B" batteries (Battery

EMPLOYMENT

BA-2) in the "B" battery compartment. The "B" batteries should form two layers of three batteries each, one layer on top of the other. Each battery should be placed upright. Place the "B" battery clamp on top of the "B" batteries and replace the two terminal board mounting screws. Fasten the "B" battery clamp securely to prevent shifting of batteries. Wire the batteries as shown in FIGURE 8. This results in a series connection.

CAUTION: NEVER CONNECT A RED AND BLACK LEAD FROM THE SAME BATTERY TO "—" AND "+" TERMINALS ON THE SAME SHORTING STRIP AS THIS WILL CAUSE A SHORT CIRCUIT OF BATTERY.

Remove the screw which secures the "A" battery disc clamp to the spacer rod. Place four "A" batteries (Battery BA-23) in the "A" battery compartment. Place the "A" battery disc clamp on top of the "A" batteries and tighten the clamp. Connect the "A" batteries in series using the $3\frac{5}{8}$ inch yellow jumpers, as shown in FIGURE 8. Each yellow jumper is to connect the center "+" terminal of one battery to the outside "—" terminal of another battery. With the four batteries thus connected with the three yellow jumpers, one center "+" terminal of one battery and one outside "—" terminal of another battery remain unconnected. Connect the $5\frac{1}{4}$ -inch white jumper from the unconnected center "+" terminal of one battery to the "+A" terminal on the terminal board, and the $5\frac{1}{4}$ -inch black jumper from the unconnected outside "—" terminal of the other battery to the "-A-B" terminal of the terminal board.

CAUTION: NEVER CONNECT A JUMPER FROM THE OUTSIDE "—" TERMINAL TO THE CENTER "+" TERMINAL OF THE SAME BATTERY AS THIS WILL DRAIN THE BATTERIES.

Examine the cable to make certain that the white lead is connected to the "+A", the red lead to the "+B", and the black lead to the "-A-B" terminal of the terminal board.

The voltage between contacts 1 and 2 of the battery cable plug is approximately 6 volts, and between contacts 2 and 3, approximately 135 volts. If no reading or a low reading results, the wiring should be checked. Contact 4 of the battery cable plug is not used.

b. Field Strength Meter I-95-A Batteries

One Battery BA-23 ("A" battery, $1\frac{1}{2}$ V) and two Battery BA-2 ("B" batteries, $22\frac{1}{2}$ V) are required for operation of Field Strength Meter I-95-A. Battery information is given on the rear cover of the instrument (see FIGURE 17). To install these batteries, first loosen the four Dzus fasteners in the four corners of the rear cover of the field strength meter and remove the cover.

Loosen the battery-retaining-strap mounting screws sufficiently to allow insertion of the batteries between the retaining strap and the rear cover (see FIGURE 17). Place Battery BA-23 ("A" battery) in the curved portion of the battery retaining strap. Place two Battery BA-2 ("B" batteries) in the retaining strap side by side above Battery BA-23 with their identification labels facing the terminal board on top of the retaining-strap assembly. The Battery BA-2 ("B" batteries) should be so positioned that their flexible pigtail leads will face the interior of the field strength meter when the rear cover is reassembled to the case. Fasten the battery-retaining strap to the rear cover by tightening the strap-mounting screws. Make certain that the three batteries are firmly secured against slipping.

When making connections, refer to FIGURE 9. Connect the red "+ $22\frac{1}{2}$ V" lead of one Battery BA-2 to one of the "+B" terminals of the terminal board.

WARNING: THE NEGATIVE SIDE OF "RELATIVE FIELD STRENGTH" MILLIAMMETER 504 IS CONNECTED TO GROUND. TO PREVENT DAMAGE TO THIS MILLIAMMETER, BE CAREFUL NOT TO GROUND THE B+ (+ $22\frac{1}{2}$ V) BATTERY LEADS.

Connect the black "—" lead of this same battery to one of the "+-B" terminals. Connect the red "+ $22\frac{1}{2}$ V" lead of the second Battery BA-2 to the second "+-B" terminal and connect the black "—" lead to one of the "-B" terminals of the terminal board.

The cable leads of the field strength meter are provided with identification tabs. Connect the red "+B" lead to the second "+B" terminal of the terminal board (see FIGURE 9). Connect the black-white "-B" lead to the second "-B" terminal. Connect the brown "+A" lead to the center (positive) terminal of Battery BA-23 and connect

EMPLOYMENT

the black “-A” lead to the outside (negative) terminal of this battery. Refasten the rear cover to the case of the field strength meter. When replacing the front panel guard on the field strength meter, make certain that the “ON-OFF” switch is in the “OFF” position, otherwise the guard will not fit the front panel. This is a safety device to make certain that the batteries will not deliver current when the meter is not in use.

A-B-, and contact 3 is B+. The voltage between contacts 1 and 2 should be 6 volts, and between contacts 2 and 3, 135 volts.

“A” batteries should be replaced when the voltage drops below 4½ volts under load, and “B” batteries should be replaced when the voltage drops below 110 volts under load.

If no voltmeters are available, Test Set I-139-A may be adapted for use as a voltmeter. To utilize

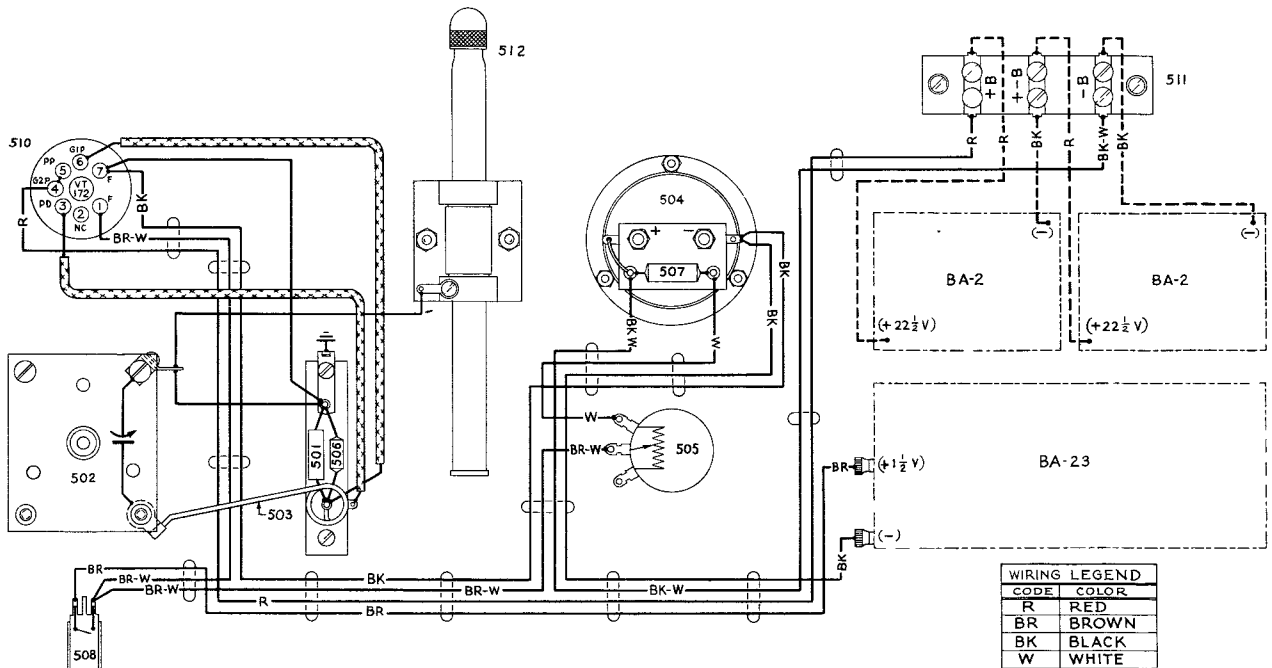

FIGURE 9—FIELD STRENGTH METER I-95-A, WIRING DIAGRAM

c. Vacuum Tubes

This equipment is furnished with all vacuum tubes installed.

d. Fuses

No fuses are used in this equipment.

8. PREPARATION FOR USE

a. Battery Box BX-33-A

After installing batteries and before using Battery Box BX-33-A, check the voltage and polarity of the cable plug. Contact 1 is A+, contact 2 is

Test Set I-139-A as a 0—200V voltmeter, place a 200,000-ohm, 1 watt precision resistor in series with one contact of the test meter plug. The “B” battery reading must be greater than 0.55 on the 0—1 ma scale. To utilize Test Set I-139-A as a 0—10V voltmeter, place a 10,000-ohm, 1 watt precision resistor in series with one contact of the test meter plug. The “A” battery reading must be greater than 0.45 on the 0—1 ma scale. Both voltage readings are to be taken under load.

A hole provided in the side of Battery Box BX-33-A permits the cable to protrude from the battery box when the cover is closed. When not

EMPLOYMENT

in use the cable should be stored in the compartment provided (see FIGURE 5).

b. Signal Generator I-130-A

Loosen the two cover fasteners, and raise the cover. The cover may be left attached or may be removed if Signal Generator I-130-A is to be used while lying on its side; however if the generator is set upright, the cover must be removed. To remove the cover, simply slide it to allow the hinge sections to separate.

Plug the battery cable of Battery Box BX-33-A into the power-input socket of Signal Generator I-130-A (see FIGURE 2). Place the "POWER ON-OFF" switch in the "ON" position. Allow one minute for the tubes to warm up. Insert the plug of Test Set I-139-A into the "METER" socket of Signal Generator I-130-A. Plug into the "CRYSTAL" socket a crystal whose frequency is one-eighteenth of the desired operating frequency. Place the "OUTPUT CONTROL" on "MAX." and place the "OUTPUT STEPS" control on step "5". Set the "M.O.-CRYSTAL" switch at "CRYSTAL" and adjust the "CRYSTAL TUNING" control to the frequency representing the eighteenth harmonic of the r-f crystal used, this being the desired output frequency. The correct setting will produce a small dip in the milliammeter of Test Set I-139-A. Adjust the "MEGACYCLES" dial control for an additional dip at the same frequency. The meter reading should be approximately one-half of full scale or more before the signal generator is tuned. If the meter reading is low, check the battery voltage.

c. Field Strength Meter I-95-A

Loosen the four captive thumbscrews, located near the four corners of the field strength meter, and remove the front panel guard (see FIGURE 18).

Place the "ON-OFF" switch in the "ON" position. With no signal being received, the "RELATIVE FIELD STRENGTH" milliammeter should read zero. If this is not the case, adjust the "ZERO ADJ." screw (located to the left of the nameplate) until the indicator is exactly on zero (see FIGURE 6).

The front panel guard cannot be replaced unless the "ON-OFF" switch is in the "OFF" position.

9. OPERATION

NOTE: When using Test Equipment IE-19-A for aligning the channels of Radio Set SCR-522-A, the radio set should be installed in the aircraft and connected for operation by means of Radio Control Box BC-602-A. Refer to Figure 10 for location of the tuning and adjustment controls on the transmitter, receiver, and rack of Radio Set SCR-522-A.

a. Radio Transmitter BC-625-A Channel Alignment

NOTE: If the transmitter and receiver fail to operate when a channel pushbutton is pressed on Radio Control Box BC-602-A, press another channel pushbutton, then again press the pushbutton for the desired channel. Transmission and reception should now be possible.

The failure to operate when the desired channel pushbutton is pressed the first time is due to the fact that the frequency shifter was in the released position for that channel when the pushbutton was pressed. That is, the channel had previously been selected, the release pushbutton 426 had been pressed once, and the equipment left in this condition. Any attempt to re-select this channel on the control box will result in starting the dynamotor unit without actuating the slides for this particular channel.

(1) The following components of Test Equipment IE-19-A are required for transmitter tuning: Field Strength Meter I-95-A and Test Set I-139-A.

(2) WHEN BEING TUNED, RADIO TRANSMITTER BC-625-A MUST BE INSIDE CASE CS-80-A, WITH RADIO RECEIVER BC-624-A CONNECTED.

NOTE: IF THE TRANSMITTER IS TUNED WHILE REMOVED FROM THE CASE, THE ADDITIONAL CAPACITANCES INTRODUCED BY REPLACING THE TRANSMITTER IN THE CASE WOULD TEND TO UPSET THE TUNING ADJUSTMENTS.

(3) If the receiver and transmitter covers are closed, loosen the Dzus fasteners pinning them

EMPLOYMENT

to the center cover. Raise the covers slightly and slide them away from the control panels.

(4) The crystal chosen for any transmitter channel should have a fundamental frequency one-eighteenth of the desired output frequency (fundamental frequencies appear on the crystal holder nameplate).

(5) With the airplane antenna plugged in, install crystals of the desired frequencies in

motor unit should start and the frequency-shifter mechanism should operate, shifting the equipment to channel "D". Press the channel-release pushbutton located on Rack FT-244-A. This will release the frequency shifter mechanism. Loosen the four transmitter tuning-control locknuts slightly by turning them counterclockwise. Press channel "A" pushbutton on the radio control box.

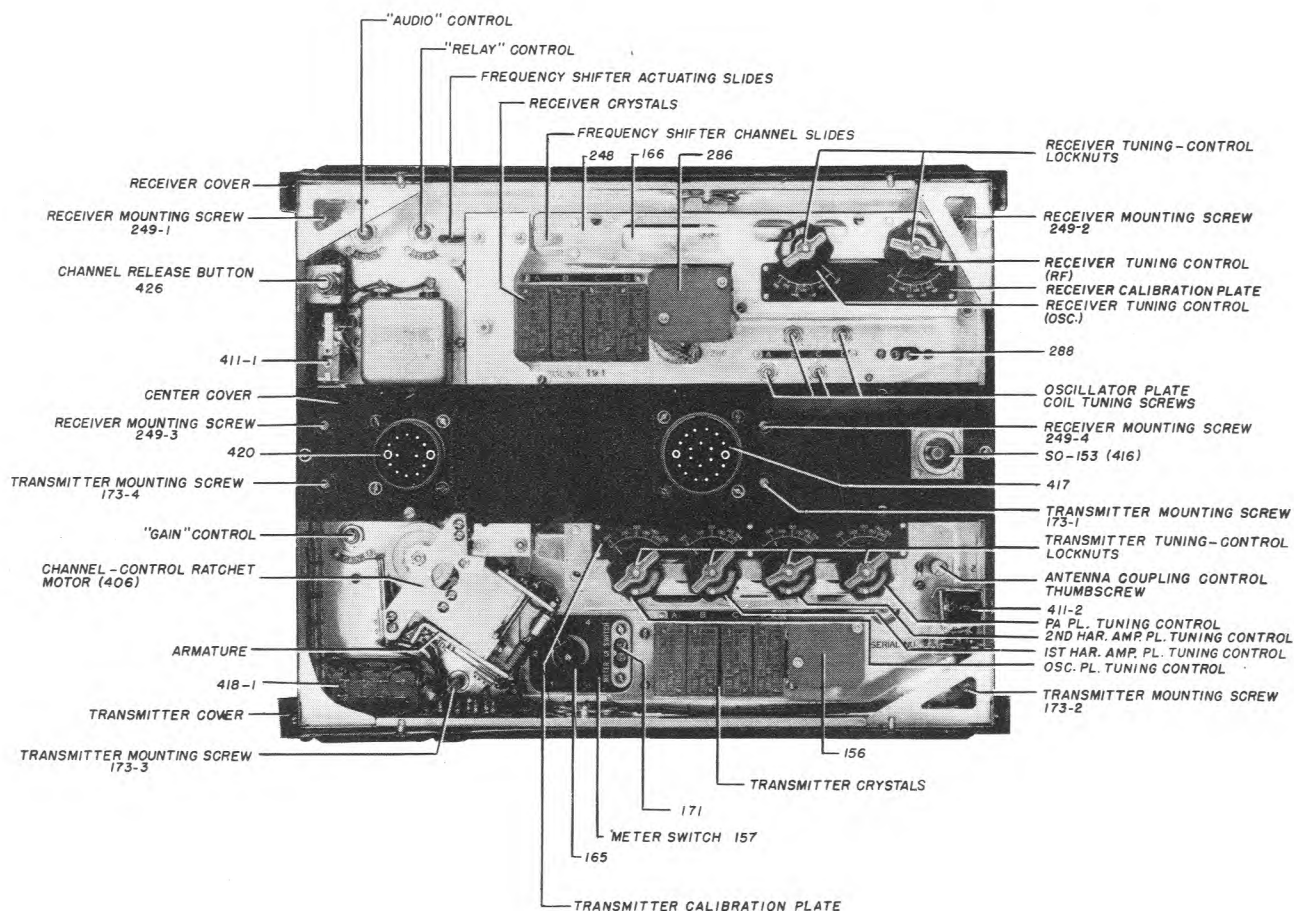

FIGURE 10—RADIO SET SCR-522-A, TRANSMITTER-RECEIVER ASSEMBLY

the crystal sockets. Plug the cord of Test Set I-139-A into the two-prong transmitter test-milliammeter socket 171 located on the right side of the transmitter "METER SWITCH" (see FIGURE 10).

Press channel "D" pushbutton on the panel of Radio Control Box BC-602-A. The dyna-

NOTE: Whenever a channel is selected on Radio Control Box BC-602-A, the switching mechanism will select and release channels in the sequence "A", "B", "C", "D" until the desired channel is selected. For example, if channel "A" has already been selected, channels "B" and "C" will be switched on and off

EMPLOYMENT

before channel "D" is reached. If channels "B" and "C" are already aligned and the tuning-control locknuts are loose when channel "D" pushbutton is pressed, channels "B" and "C" will be jarred out of adjustment by the impact of the shifter actuating slides. However, if tuning is done in the order "A", "B", "C", "D", it is not necessary to disturb previously aligned channels before reaching the channel to be tuned. For example, when channel "C" pushbutton is in the depressed position, channel "D" can be selected without actuating the slides for any other channel.

Allow about one minute for the tubes to warm up. Tube warm-up can be observed by an indication on Test Set I-139-A with the transmitter "METER SWITCH" in position 3. Throw the "T-R-REM." lever switch (on the radio-control-box panel) to "T".

(6) Tuning Operation No. 1

(a) Place the transmitter "METER SWITCH" in position "1".

(b) Adjust the oscillator plate tuning control (first tuning control at the left on the transmitter control panel) for a maximum reading of Test Set I-139-A.

CAUTION: Guard against tuning to an undesired harmonic by making certain that the scale indication of the tuning control as indicated on the transmitter calibration plate is approximately equal to the output frequency being tuned.

(7) Tuning Operation No. 2

(a) Place the "METER SWITCH" in position "2".

(b) Apply the procedure given in paragraph 9a(6)(b) using the second tuning control from the left.

(8) Tuning Operation No. 3

(a) Place the "METER SWITCH" in position "3".

(b) Apply the procedure given in paragraph 9a(6)(b), using the third tuning control from the left.

(c) With the "METER SWITCH" still in position "3", adjust the fourth tuning

control from the left for minimum reading of Test Set I-139-A.

(d) The test set reading must fall between 0.6 and 0.75.

(e) If the test set reading is more than 0.75, slide the antenna-coupling control (see FIGURE 10) to the right until the reading is less than 0.75.

(f) Retune the third and fourth tuning controls.

(9) Adjustments for Remaining Channels.

To tune channel "B", press pushbutton "B" on the panel of Radio Control Box BC-602-A and follow the same tuning procedure outlined for channel "A" in paragraphs 9a(6) to 9a(8) inclusive. However, do not change the antenna coupling adjustment unless the meter reading is more than 0.75. Tune channels "C" and "D" in like manner.

(10) If an antenna coupling adjustment has been made for any channel in addition to channel "A", select the next channels in the order "A", "B", "C", "D", checking each channel "D", "A", and "B", in that order and check the meter reading.

(11) If antenna-coupling readjustments have to be made for any channel, retune the third and fourth tuning controls for that particular channel and repeat the cycle, if necessary, checking all three preceding channels in correct sequence. When this is done, all four channels should be adjusted for a meter reading of less than 0.75.

(12) If the meter reads 0.75 for one channel and less than 0.6 for any of the remaining three, do not attempt to readjust the antenna coupling control at all.

(13) Press the channel-release pushbutton and tighten all transmitter tuning-control locknuts by turning them clockwise.

(14) With the tuning control locknuts tightened and with the transmitter "METER SWITCH" in position "5", the meter reading for all channels should normally be full-scale or more. Any reading greater than half-scale

EMPLOYMENT

is satisfactory. If this condition is not achieved for any channel, readjust the third tuning control for a maximum meter reading ("METER SWITCH" position "5"), retuning that particular channel in accordance with the procedure in paragraph 9a(17).

Now, with the tuning control locknuts tightened, there is a positioning detent which makes it possible to turn the tuning controls slightly, in either direction, against spring pressure. In some cases a large amount of torque is necessary to rotate the controls. With the transmitter "METER SWITCH" in position "4", all tuning controls, on all channels, can be checked by rotating them in both directions against the positioning detent, and by noting a decrease in the meter reading as the tuning controls are rotated in either direction. If an *immediate* decrease in meter reading is not noted for any particular tuning control for any channel, retune that particular channel in accordance with paragraph 9a(17).

This completes the tuning of Radio Transmitter BC-625-A.

(15) After making the antenna-coupling adjustment, a sustained note in the microphone should result in modulation of the carrier. This can be checked by first tuning in the unmodulated carrier on Field Strength Meter I-95-A and then noting an increase in the peak reading of the "RELATIVE FIELD STRENGTH" milliammeter when the carrier is modulated.

(16) Resonance of a secondary tuned circuit such as an antenna-matching device may be tested by a small neon bulb, a thermocouple milliammeter, or a flashlight bulb, either one of which would indicate resonance in this circuit or a portion of it. Correct adjustment of the secondary circuit is indicated by an increase in brilliancy of either one of these above mentioned bulbs, or an increased meter reading.

NEVER SHUT OFF RADIO SET SCR-522-A WITH THE SHIFTER SLIDES DIS-ENGAGED, AS THIS WILL RESULT IN FAILURE TO TURN ON THE TRANSMITTER AND RECEIVER IF ONE PAR-

TICULAR CHANNEL PUSHBUTTON IS PRESSED ON RADIO CONTROL BOX BC-602-A (SEE PARAGRAPHS 9a AND 9c).

(17) Procedure for Tuning One Channel Only

If it is known that one channel is out of adjustment, it may be tuned without disturbing other channels. Refer to paragraph 9a(5). The following is a brief summary of procedure.

(a) Press the channel-selector pushbutton (on Radio Control Box BC-602-A) corresponding to the channel *preceding* the desired channel in the sequence "A", "B", "C", "D".

(b) Press the channel-release pushbutton (on the rack).

(c) Loosen all transmitter tuning-control locknuts.

(d) Press the selector pushbutton corresponding to the desired channel.

(e) Tune the desired channel [see paragraphs 9a(6) to 9a(8)].

(f) Press the channel-release pushbutton.

(g) Tighten all transmitter tuning-control locknuts.

(h) Press the channel-release pushbutton.

(i) Check the output as described in paragraphs 19a and 19b.

(18) Adjustment of "GAIN" Control

With Radio Set SCR-522-A installed in the aircraft and with any channel switched on, all channels tuned, and the airplane engines running, adjust the "GAIN" control for normal voice level under conditions of normal operation. A setting of one-half turn clockwise from the extreme counter-clockwise position is usually satisfactory. This adjustment, once made, is good for all channels.

b. Significance of Meter Readings

In general, a meter reading on Test Set I-139-A greater than 0.75 with the transmitter "METER SWITCH" in any position indicates a defect in the equipment or improper adjustment. An exception to this generalization occurs when the transmitter "METER SWITCH" is in position "5",

EMPLOYMENT

in which case some of the vacuum tubes used may cause a full-scale or even an off-scale reading. This is a desirable condition. A simple method of remembering the approximate meter readings for various switch positions is suggested by the fact that for "METER SWITCH" positions "1", "2", and "3" respectively, Test Set I-139-A readings are, respectively, 4, 5, and 6. Although these figures are typical and desirable, the reading of 6 for switch position "3" cannot usually be retained for different frequency channels because of the variable load characteristic of the antenna. Therefore, the transmitter antenna-coupling control should be adjusted for a compromise load, averaging approximately 0.63, with no reading over 0.75 (on the meter scale) for the four frequency channels being used.

R-F diode current is measured with the "METER SWITCH" in position "4". This switch position is seldom used. The reading obtained is purely relative, without quantitative significance, and is equivalent to a neon-bulb indication of r-f voltage across the final amplifier tank inductor.

The Test Set I-139-A reading obtained with the "METER SWITCH" in position "5" is another variable quantity. Transmitting-tube data sheets describe grid "drive" or grid current as "approximate, subject to wide variations depending on the impedance of the load circuit". It is desirable that this current be as large as possible (even off-scale) but this is not possible with some of the tubes being used. The real test of satisfactory adjustment is whether or not "upward modulation" of the carrier results [see paragraph 9d(3)]. This can easily be tested by means of Field Strength Meter I-95-A.

It is reasonable to assume that half-scale or higher meter readings, with the "METER SWITCH" in position "5", are satisfactory although there are exceptions to this rule.

It should be noted that there is an "idle" or standing plate current resulting in a meter reading of approximately 0.4 when the "METER SWITCH" is in position "3" and Radio Set SCR-522-A is in the *receive* condition. This is normal and correct and indicates the existence of a load on the modulator at all times. If this current is abnormally high, an open or short

circuit is indicated in the -150V bias supply from Dynamotor Unit PE-94-A.

With the "METER SWITCH" in position "4", it should be noted that there is a small emission current in the r-f diode in the "standby" condition.

Position "6" is an "off" or open switch position.

The reading of Field Strength Meter I-95-A must be interpreted in a relative sense only. It is necessary to always locate the instrument in the same relative position with respect to the transmitting antenna and the surrounding objects. The meter reading is then to be compared with a reading obtained from an installation known to be satisfactory.

c. Radio Receiver BC-624-A Channel Alignment

NOTE: If the transmitter and receiver fail to operate when a channel pushbutton is pressed on Radio Control Box BC-602-A, press another channel pushbutton, then again press the pushbutton for the desired channel. Transmission and reception should now be possible.

The failure to operate when the desired channel pushbutton is pressed the first time is due to the fact that the frequency shifter was in the released position for that channel when the pushbutton was pressed. That is, the channel had previously been selected, the release pushbutton 426 had been pressed once, and the equipment left in this condition. Any attempt to re-select this channel on the control box will result in starting the dynamotor unit without actuating the slides for this particular channel.

(1) Test Equipment IE-19-A and a headset or an output meter are required for receiver tuning. Refer to FIGURE 10 for location of tuning and adjustment controls of Radio Set SCR-522-A.

(2) A receiver crystal is identified by the fundamental frequency (kc) which appears on the crystal nameplate.

Finding the correct receiver crystal for a particular receiver channel is therefore the same as finding the correct fundamental frequency (f =kilocycles) of the crystal to be used. The fundamental crystal frequency (f)

EMPLOYMENT

may be determined from the expression

$$f = \frac{f_r - 12}{H} \times 1000$$

where f_r is the frequency in megacycles to which the receiver is to be tuned and H is the receiver crystal harmonic used (see table below). The receiver crystal harmonic (H) used depends only on the frequency (f_r) to be tuned in, and is given in the following table.

<i>Frequency (f_r)</i>	<i>Receiver Crystal Harmonic (H)</i>
100—108 mc	11
108—116 mc	12
116—124 mc	13
124—132 mc	14
132—140 mc	15
140—148 mc	16
148—156 mc	17
156 mc	18

(3) Adjustment of Signal Generator I-130-A (Using Crystal)

(a) Insert a transmitter crystal into the "CRYSTAL" socket of the signal generator. This crystal should have a fundamental frequency one-eighteenth of the receiver frequency to be tuned. If no transmitter crystal is available, refer to paragraphs 9c(6), 9c(7) and 9c(8) (see FIGURE 2).

(b) Connect Cord CD-477 to the "R.F. OUTPUT" socket on the signal generator and to the antenna socket, Socket SO-153, on Rack FT-244-A (see FIGURE 10). Connect Test Set I-139-A to the signal generator "METER" socket.

(c) Plug Battery Box BX-33-A cable into the signal-generator four-pin socket located to the left of the "METER" socket. Throw the signal-generator "POWER ON-OFF" switch to "ON".

(d) Set the signal-generator "M.O.-CRYSTAL" switch at "CRYSTAL".

(e) Place the "OUTPUT CONTROL" on "MAX." (extreme clockwise position) and place the "OUTPUT STEPS" control on step "5".

(f) After allowing about one minute for the tubes to warm up, adjust the "CRYSTAL TUNING" control to the frequency to be tuned. If this adjustment is correct, a small dip will be observed in the test milliammeter (Test Set I-139-A). Adjust the "MEGACYCLES" dial control for an additional dip (approximately at the same dial setting as the receiver channel frequency being tuned). Now connect Test Set I-139-A to the receiver test-milliammeter socket 288.

(4) Tuning Adjustments for Channel "A" (Using Crystal in Signal Generator)

(a) Install the proper crystal in the socket for receiver channel "A".

(b) Press channel "D" pushbutton of Radio Control Box BC-602-A [see note in paragraph 9a(5)].

(c) Press the channel-release pushbutton located on the rack.

(d) Loosen the two receiver tuning-control locknuts by turning them counter-clockwise. Tighten the two locknuts just enough to exert a slight pressure on the cam pile-up, otherwise vibration may change the position of the cam, which would introduce considerable set-up error.

(e) Press channel "A" pushbutton of the radio control box. After allowing about one minute for the receiver vacuum tubes to warm up, throw the "T-R-REM." lever switch on the panel of Radio Control Box BC-602-A to "R", or center position.

(f) Turn the two receiver tuning controls to the desired frequency as indicated on the calibration plate.

(g) Connect a suitable headset across terminals 1 and 3 of socket 802 on Junction Box JB-29-A. Rotate the receiver "AUDIO" and "RELAY" controls to their maximum clockwise rotation positions.

(h) Back out the channel "A" oscillator plate-coil tuning screw so that about three to five threads of the screw protrude from the coil-mounting insert. The higher the crystal frequency, the further the plate-

EMPLOYMENT

coil screw must be backed out of the coil-mounting insert, thus obtaining the necessary inductance to permit the oscillator to start.

When the oscillator starts, the signal should be heard. If not, simultaneously adjust the receiver radio frequency and oscillator tuning controls slightly, and if necessary, turn the channel "A" oscillator plate-coil tuning screw still further counterclockwise until the signal is heard.

When the signal is heard, rotate the oscillator plate-coil tuning screw clockwise until the signal suddenly ceases, then rotate the screw counterclockwise to a position at least three quarters of a turn past the point at which the signal is first heard (i. e., the position at which the oscillator starts). The additional three quarters of a turn is required for a stable adjustment of the crystal oscillator. If this results in an appreciable reduction of output, continue turning the screw counterclockwise until the output is increased as much as possible. This adjustment should be rechecked after completing paragraphs 9c(4) (i) and 9c(4) (j).

(i) Turn the "OUTPUT CONTROL" to "MIN." position. Place the "OUTPUT STEPS" control in position "1" or "2" and then turn the "OUTPUT CONTROL" clockwise until the signal is just audible in the headset.

(j) Readjust the receiver tuning controls and the signal generator "CRYSTAL TUNING" control for maximum audio output. Rotate the "OUTPUT CONTROL" counterclockwise, if necessary, to keep the peaked output at low level in the headset. This may require repeated readjustments. Recheck the adjustment of the crystal oscillator tuning screw.

(k) If an output-power meter or an a-c voltmeter of suitable range is available, either one of these instruments would be helpful in making final tuning adjustments. Connect the meter in place of, or in parallel with the headset. The load

presented by either type of instrument should be adjusted for 4000 ohms if the yellow wire going to the receiver audio-output transformer 296 is connected to terminal No. 7, or 300 ohms if this wire is connected to terminal No. 6. This output-meter load should be connected across terminals No. 1 and 3 of socket 802 or 1 and 4 of socket 804 of Junction Box JB-29-A.

Test Set I-139-A (part of Test Equipment IE-19-A) may be plugged into the receiver socket 288 and the tuning procedure followed as before except that instead of tuning for maximum audio output, tune for a small dip or minimum reading of the test set. The signal generator output should be reduced to the lowest level at which it is possible to obtain an indication of change of current as the receiver tuning controls are adjusted.

(5) Adjustments for Remaining Channels (Using Crystal in Signal Generator).

To adjust the remaining channels, press channel "B" pushbutton on Radio Control Box BC-602-A and follow the same tuning procedure outlined for channel "A" in paragraphs 9c(3) (e), 9c(3) (f), 9c(4) (a), 9c(4) (f), 9c(4) (g), 9c(4) (h), 9c(4) (i), and 9c(4) (j).

CAUTION: TUNE ALL CHANNELS IN THE SEQUENCE "A", "B", "C", "D", SO THAT PREVIOUSLY ALIGNED CHANNELS WILL NOT BE DETUNED [SEE PARAGRAPH 9a(5)].

NOTE: The tuning instructions for channel "A" will hold good for channel "B" only if the letter "B" is substituted for "A" wherever the crystal, the channel, and the oscillator plate-coil tuning screw are mentioned. This note likewise applies when tuning channels "C" and "D". Tune channels "C" and "D" in like manner, after which press the channel-release pushbutton and tighten the two receiver tuning-control locknuts by turning them *tightly* clockwise. Recheck all channels for satisfactory receiver output.

EMPLOYMENT

(6) Adjustment of Signal Generator I-130-A
(Using Master Oscillator)

The procedure for employing the signal-generator master oscillator is the same as the procedure for using the crystal oscillator except that the "CRYSTAL TUNING" control is not touched, the "M.O.-CRYSTAL" switch is set at "M.O." and the signal generator is tuned by means of the "MEGACYCLES" dial control only (see FIGURE 2). Allow about one minute for the tubes to warm up.

(7) Tuning Adjustment for Channel "A"
(Using Signal Generator Master Oscillator).

(a) Make certain that proper crystals are installed in receiver crystal sockets [see paragraph 9c(2)]. Press channel "D" pushbutton of Radio Control Box BC-602-A.

(b) Press the channel-release pushbutton located on the rack.

(c) Loosen the two receiver tuning-control locknuts by turning them counterclockwise. Tighten the locknuts just enough to exert a slight pressure on the cam pile-up.

(d) Press channel "A" pushbutton of the radio control box. After allowing about one minute for the receiver vacuum tubes to warm up, throw the "T-R-REM." lever switch on the panel of Radio Control Box BC-602-A to "R" or center position.

(e) Turn the receiver tuning controls to the desired frequency on the calibration plate.

(f) Using the alignment tool or a small screwdriver, turn the crystal oscillator plate-coil tuning screw for channel "A" to the position at which about 3 to 5 threads protrude from the coil-mounting insert. The higher the crystal frequency, the further the plate-coil screw must be backed out of the coil-mounting insert, thus obtaining the necessary inductance to permit the oscillator to start.

(g) With a headset connected to junction box socket 802, terminals No. 1 and 3,

place the signal generator "OUTPUT STEPS" control on step "5" and set the "OUTPUT CONTROL" at "MAX." (extreme clockwise position).

(h) Set the signal generator "MEGACYCLES" dial control at the frequency being tuned and then adjust the receiver tuning controls until the modulated signal is heard in the headphones. This may require several readjustments.

(i) Turn the oscillator plate-coil tuning screw for channel "A" clockwise until the modulated signal suddenly ceases.

(j) Turn the crystal oscillator plate-coil tuning screw counterclockwise until the signal is heard again. An additional three-quarters of a full turn in a counterclockwise direction is necessary for a stable adjustment of the crystal oscillator. If this results in reduced output, continue turning the screw counterclockwise until the output is increased as much as possible.

(k) Turn the signal generator "OUTPUT CONTROL" to "MIN." Place the "OUTPUT STEPS" control in position "1" or "2" and then turn the "OUTPUT CONTROL" clockwise until the signal is just audible.

(l) Readjust the receiver tuning controls and the signal generator "MEGACYCLES" dial control for maximum audio output. Rotate the "OUTPUT CONTROL" counterclockwise, if necessary, to keep the peaked output at a low level in the headset. The final setting of the receiver tuning controls should be near the calibrated settings for the desired frequency.

(8) Tuning Adjustments for Remaining Channels
(Using Signal Generator Master Oscillator)

To tune the remaining channels, press channel "B" pushbutton on Radio Control Box BC-602-A and follow the same tuning procedure outlined for channel "A" in paragraphs 9c(6) and 9c(7).

EMPLOYMENT

CAUTION: TUNE ALL CHANNELS IN THE SEQUENCE "A", "B", "C", AND "D" SO THAT PREVIOUSLY ALIGNED CHANNELS WILL NOT BE DETUNED [SEE PARAGRAPH 9a(5)]. NOTE: The tuning instructions for channel "A" will hold good for channel "B" only if the letter "B" is substituted for "A" wherever the crystal, the channel, and the oscillator plate-coil tuning screw are mentioned. This note, likewise applies when tuning channels "C" and "D". Tune channels "C" and "D" in like manner, after which press the channel-release pushbutton and tighten the two receiver tuning-control locknuts by turning them tightly clockwise. Recheck all channels for satisfactory receiver output.

This completes the tuning of the receiver. However, if at any time it is necessary to tune one receiver channel only, the following procedure applies.

(9) Procedure for Tuning One Channel Only

If one channel is out of adjustment, it may be tuned without disturbing the other channels.

(a) Press the pushbutton (on Radio Control Box BC-602-A) corresponding to the channel *preceding* the desired channel in the sequence "A", "B", "C", and "D". In other words, if retuning channel "B", press pushbutton "A", if retuning channel "A", press pushbutton "D", etc.

(b) Press the channel-release pushbutton.

(c) Loosen the receiver tuning-control locknuts.

(d) Press the channel-selector button for the desired channel.

(e) Tune the desired channel as described in paragraphs 9c(1) to 9c(4) (j) or 9c(6) to 9c(7) (l), ignoring reference to channel "A" and substituting the applicable letter.

(f) Press the channel-release pushbutton.

(g) Tighten the receiver tuning-control locknuts.

(h) Press the channel-release pushbutton to re-select the channel just tuned.

(i) Recheck all channels for satisfactory receiver output.

NEVER SHUT OFF RADIO SET SCR-522-A WITH THE SHIFTER SLIDES DIS-ENGAGED, AS THIS WILL RESULT IN FAILURE TO TURN ON THE TRANSMITTER AND RECEIVER IF ONE PARTICULAR CHANNEL PUSHBUTTON IS PRESSED ON RADIO CONTROL BOX BC-602-A (SEE PARAGRAPHS 9a AND 9c).

(10) Adjustment of Radio Receiver BC-624-A "AUDIO" Control

The receiver output transformer 296 is provided with three output impedance taps: terminal No. 5, 50 ohms; terminal No. 6, 300 ohms, and terminal No. 7, 4000 ohms. In some equipments, the output lead is connected to terminal No. 6 and in others, to terminal No. 7. If the output connection is made to terminal No. 7, a drop of yellow paint is placed on the screwdriver slot of the "AUDIO" control. The exact setting of the "AUDIO" volume control depends on the headphones being used and the volume desired by the pilot. However, for standard Army phones, turn the "AUDIO" control fully clockwise when transformer terminal No. 6 is used, and about one third of a turn counterclockwise from the extreme clockwise position when terminal No. 7 is used. This setting is only approximate and the pilot should be contacted and the volume increased or decreased as desired. If Jack Box BC-629-B is used, set the receiver "AUDIO" control in the extreme clockwise position. The pilot can adjust the audio volume to a desirable level by means of the jack box "AUDIO" control which is part of Jack Box BC-629-B. If the pilot desires more volume and the audio output is connected to terminal No. 6, transfer the output connection to terminal No. 7.

(11) Adjustment of Radio Receiver BC-624-A "RELAY" Control

This is the last adjustment to be made on the receiver and it should be done with the antenna connected, the equipment operating

EMPLOYMENT

on any channel, and no signal being received. First rotate the "RELAY" control to the extreme clockwise position and then turn it slowly *counterclockwise* until a noticeable drop in noise results (approximately 20 db); continue the counterclockwise rotation for a very small fraction of a turn. This adjustment can normally be made without having the engines running. However, if the adjustment has been checked and the pilot still complains of excessive noise in the phones at all times, adjust the "RELAY" control while the engines are running but omit the above-mentioned small fraction of a turn.

NEVER SHUT OFF RADIO SET SCR-522-A WITH THE SHIFTER SLIDES DIS-ENGAGED, AS THIS WILL RESULT IN FAILURE TO TURN ON THE TRANSMITTER AND RECEIVER IF ONE PARTICULAR CHANNEL PUSHBUTTON IS PRESSED ON RADIO CONTROL BOX BC-602-A (SEE PARAGRAPHS 9a AND 9c).

d. Field Strength Meter I-95-A

WARNING: Objects or people located near or between the radiating source and the field strength meter may be responsible for shadows or reflections which cause erratic meter readings. Make certain that no such interference is affecting the operation of the instrument. For final transmitter tests the best location of the field strength meter is on a wing of the aircraft. When using the instrument never allow the lowest section of the antenna to remain inserted inside the case. This precaution is necessary to prevent the antenna from affecting the tuned circuit and throwing the "TUNING" dial off calibration.

Remove the four captive thumbscrews located near the four corners of the field strength meter and remove the front panel guard.

(1) Zero Correction

With the "ON-OFF" switch turned "ON" and with no signal being received, the "RELATIVE FIELD STRENGTH" milliammeter (see FIGURE 6) should read zero. If this is not the case, adjust the "ZERO ADJ." screw (located to the left of the nameplate) until the indicator is exactly on zero.

(2) Transmitter Antenna-Radiation Test

With a signal being received and with the field strength meter placed within 25 feet of the antenna of Radio Transmitter BC-625-A, adjust the "TUNING" dial to obtain a peak reading of the "RELATIVE FIELD STRENGTH" milliammeter. The telescopic antenna may be extended or shortened to increase or decrease the milliammeter reading. The approximate frequency of the received signal may be read directly from the "TUNING" dial.

(3) Modulation Test

Tune in the unmodulated carrier and note the peak reading of the "RELATIVE FIELD STRENGTH" milliammeter. Speak or whistle into a microphone connected to one of the jack boxes. "Upward modulation" is indicated by a noticeable increase in the peak reading of the milliammeter. If no increase in the peak reading of the milliammeter is noted, check for modulation using an external receiver.

(4) Contactor Relay Test

Turn the field strength meter "TUNING" dial to the frequency corresponding to channel "D". Press any control-box channel-selector pushbutton "A", "B", or "C". Allow about one minute for the tubes of the transmitter-receiver assembly to warm up. Connect together the two wires of the junction box-to-contactor cord. The transmitter-receiver assembly will then shift to channel "D" which is indicated by a sudden rise of current in the "RELATIVE FIELD STRENGTH" milliammeter.

10. ADJUSTMENTS FOR FIELD UPKEEP

If the total "A" battery voltage under load drops below 4.5 volts in the signal generator or 1.2 volts in the field strength meter, or if the total "B" battery voltage under load drops below 110 volts in the signal generator or 37 volts in the field strength meter, replace the defective batteries (see paragraphs 7a and 7b).

If tubes have to be replaced, refer to paragraphs 14a and 14b.

FIGURE 11—TEST EQUIPMENT IE-19-A, COMPLETE SCHEMATIC CIRCUIT DIAGRAM

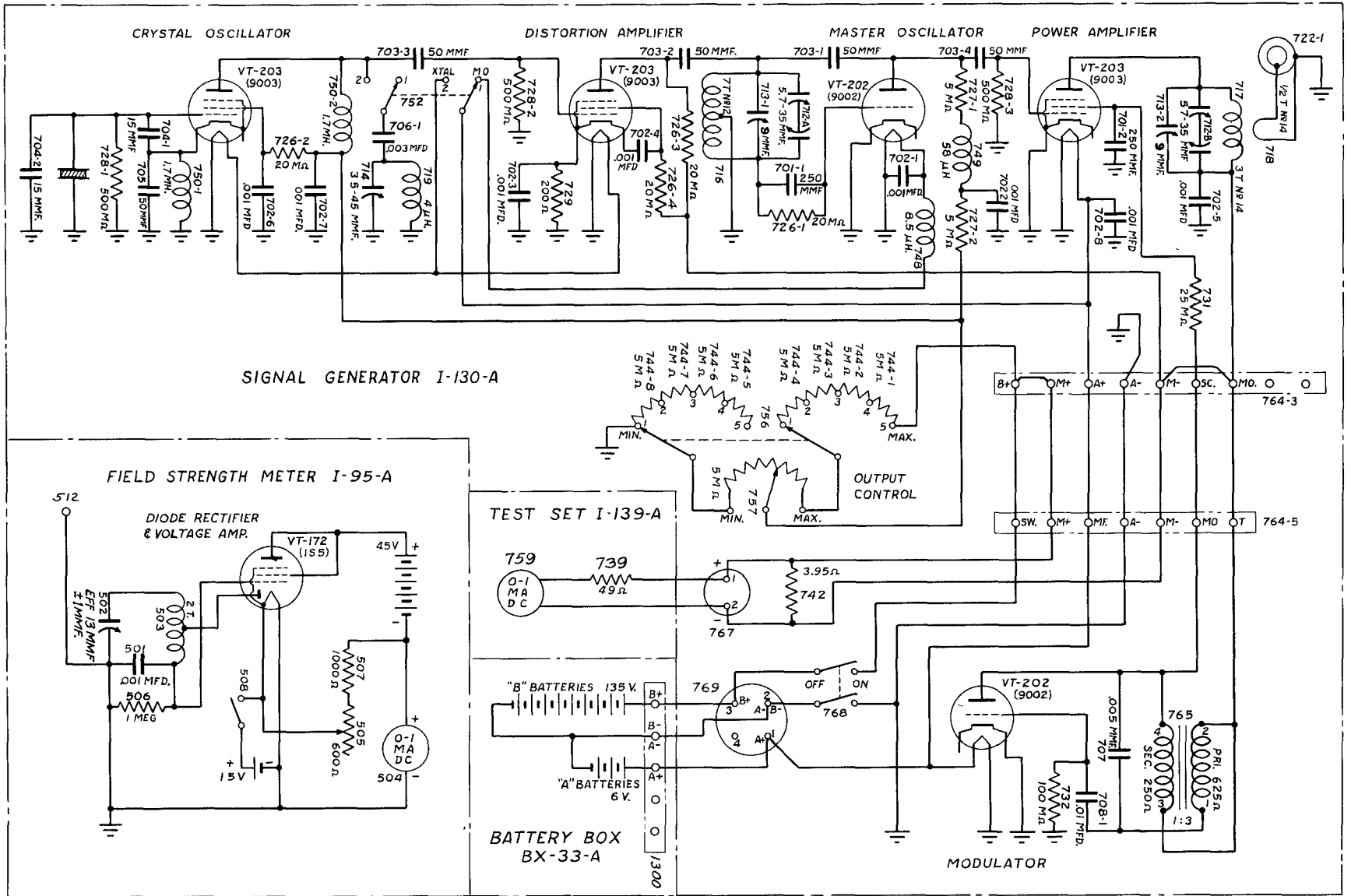

SECTION III

FUNCTIONING OF PARTS

11. Signal Generator I-130-A
12. Test Set I-139-A
13. Field Strength Meter I-95-A

11. SIGNAL GENERATOR I-130-A

For a general description of the signal generator, refer to paragraph 5a. The schematic circuit diagram is given in FIGURE 11. Operating power is obtained from Battery Box BX-33-A.

The r-f signal generator employs Tube VT-202 as a master oscillator, connected in a Hartley circuit. The tuned grid circuit consists of the tapped inductor 716, variable capacitor 712A, and trimmer capacitor 713-1, and covers the frequency range 33.3—52 mc. Filament voltage is applied through choke 748 and is by-passed by capacitor 702-1.

The master oscillator output is coupled to the control grid of Tube VT-203, the power-amplifier, through capacitor 703-4. The power amplifier plate circuit, comprising inductor 717, variable capacitor 712B and trimmer capacitor 713-2, is tuned to the third harmonic (100—156 mc) of the master oscillator output frequency. Capacitors 712A and 712B are ganged to permit simultaneous tuning of the master oscillator and power amplifier circuits by means of the "MEGACYCLES" dial control located on the "R.F. SIGNAL GENERATOR" panel (see FIGURE 2). The r-f output inductor 718 is inductively coupled to the power amplifier plate inductor 717 and is directly connected to the "R.F. OUTPUT" socket 722-1.

An alternative (crystal) oscillator circuit may be chosen by means of the "M.O.-CRYSTAL" switch 752. With this switch in "CRYSTAL" position, power is applied to the heaters of Tube VT-203, the crystal-oscillator, and Tube VT-203, the distortion-amplifier.

With the "M.O.-CRYSTAL" switch 752 in "M.O." position, the tuned circuit in the plate circuit of the crystal-oscillator tube is disconnected and power is applied to the heater of the master oscillator. The crystal oscillator tube is connected to a Colpitts circuit formed by the crystal constants, the capacitors 704-1, 704-2 and 705, resistor 728-1, and the chokes 750-1 and

750-2. The plate circuit, consisting of inductor 719, variable capacitor 714, and blocking capacitor 706-1, is tuned to the second crystal harmonic. Tuning is accomplished by means of the "CRYSTAL TUNING" control located on the panel (see FIGURE 2).

Capacitor 703-3 couples the crystal-oscillator output to the grid of Tube VT-203, the distortion-amplifier, the plate circuit of which is tuned to the third harmonic (33.3—52 mc) of the crystal-oscillator output. When the crystal oscillator is in use, the grid circuit of the decommissioned master oscillator becomes the plate circuit (716, 712A, 713-1) of the distortion amplifier. The distortion-amplifier output is then coupled to the power-amplifier grid through capacitor 703-1 and the same circuit elements which would otherwise couple the master oscillator tube to the power amplifier. The power-amplifier output frequency (100—156 mcs) is the third multiple of the output frequency of the distortion amplifier. Since the overall frequency-multiplication factor is 18, the crystal-oscillator circuit may employ the same crystals as Radio Transmitter BC-625-A. The power amplifier is modulated by an audio tone of approximately 1000 cps generated by the modulator stage. The plate voltage of the master oscillator and crystal oscillator may be varied by means of the "OUTPUT STEPS" control 756 and the "OUTPUT CONTROL" 757. With the "OUTPUT STEPS" control in position "1", the plate voltage may be varied by means of the "OUTPUT CONTROL" from zero to 20% of the total voltage available. Each succeeding step of the "OUTPUT STEPS" control increases the voltage range by 20%.

When step "5" is in use, all of the available voltage may be obtained. These controls function as signal attenuators, since by reducing the oscillator plate voltage they also reduce the signal output.

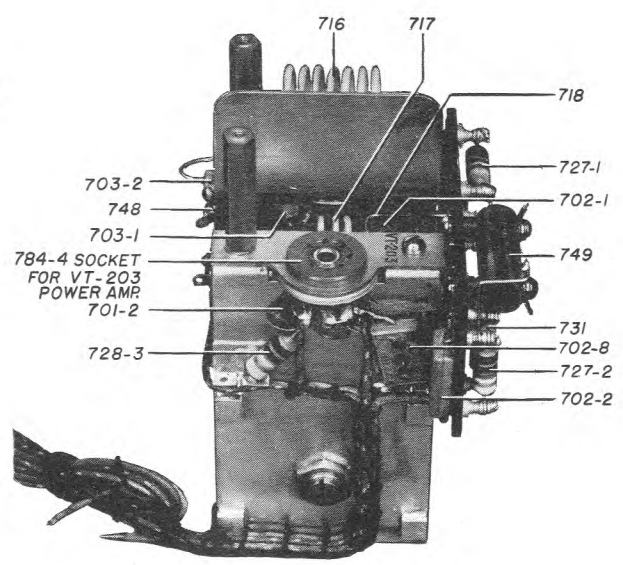
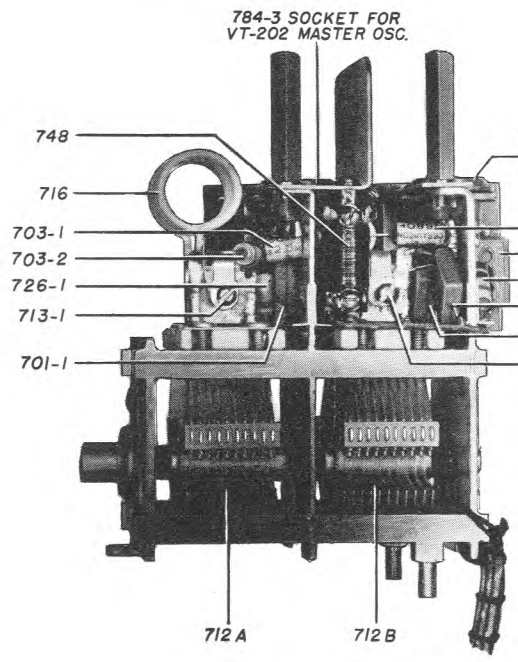
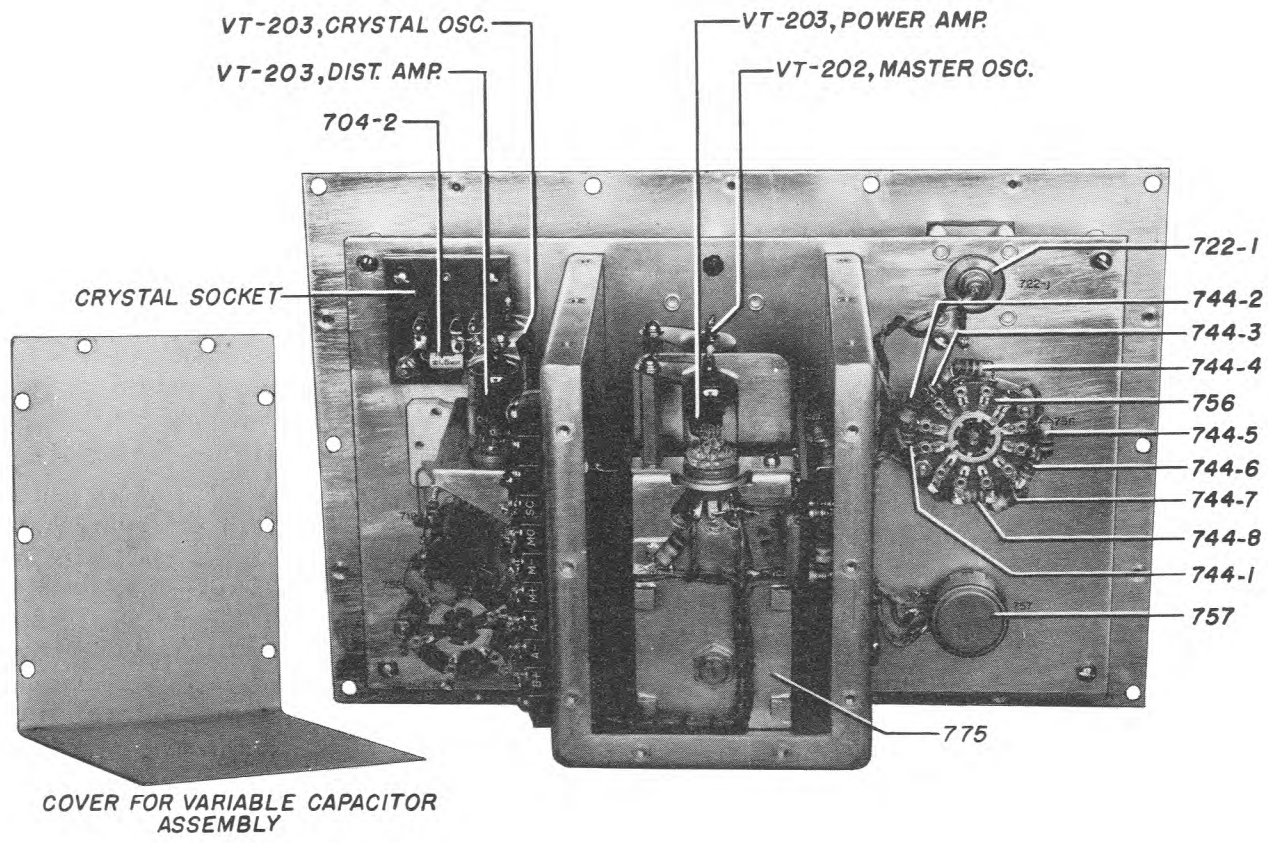

FIGURE 12—SIGNAL GENERATOR I-130-A, R-F UNIT, REAR VIEW

FUNCTIONING OF PARTS

Tube VT-202, the modulator, is connected in a Hartley oscillator circuit, the feedback impedance consisting of transformer 765 and capacitor 707. Resistor 732 is the grid leak. The 1000-cycle signal is applied through resistor 731 to the screen grid of the power amplifier Tube VT-203, resulting in modulation of the r-f signal-generator carrier.

voltages induced in its variable-length antenna. This antenna has approximately a one-quarter-wave characteristic and its length may be increased or decreased to accommodate a weak or strong signal respectively. The antenna is coupled by a common short length of wire in the tuned circuit comprising fixed capacitor 501, inductor 503, and the variable tuning capacitor 502 which

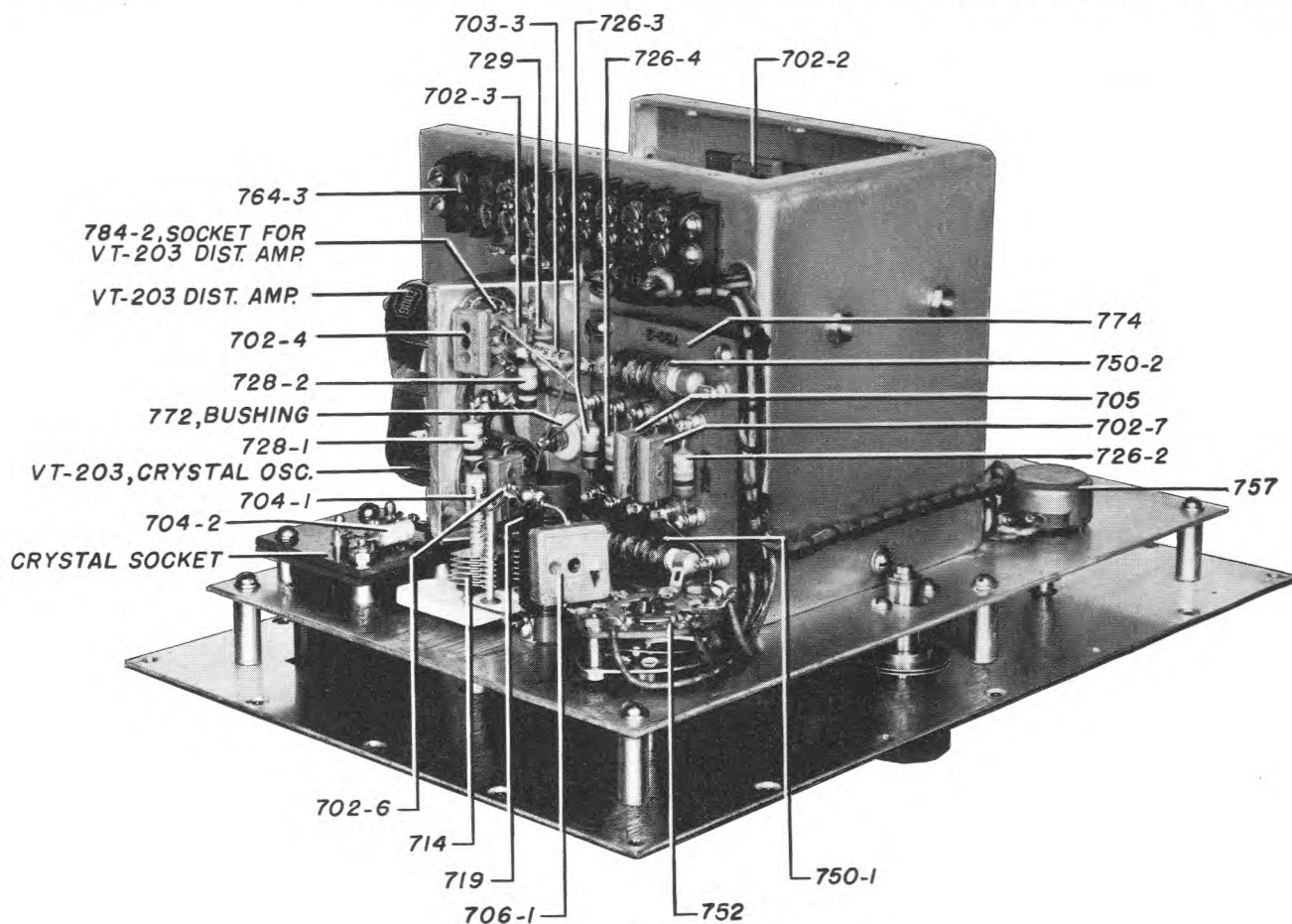

FIGURE 13—SIGNAL GENERATOR I-130-A, R-F UNIT, BOTTOM OBLIQUE VIEW

12. TEST SET I-139-A

The O-1 ma d-c meter 759 in series with resistor 739 is connected across the test-set plug (see FIGURE 11). The combined series resistance of the meter and resistor is 75 ohms.

13. FIELD STRENGTH METER I-95-A

Field Strength Meter I-95-A is an uncalibrated vacuum-tube voltmeter designed to register

is adjusted by means of the "TUNING" dial on the front panel (see FIGURE 6). The tuned circuit may be made to resonate at any frequency within the range 100-156 mc.

With switch 508 closed (see FIGURE 11) and no signal being received, a steady space current flows in Tube VT-172. This current would normally cause a downward deflection of milliammeter 504 if it were not for the fact the variable resistor 505 is adjusted so that milliammeter 504 reads

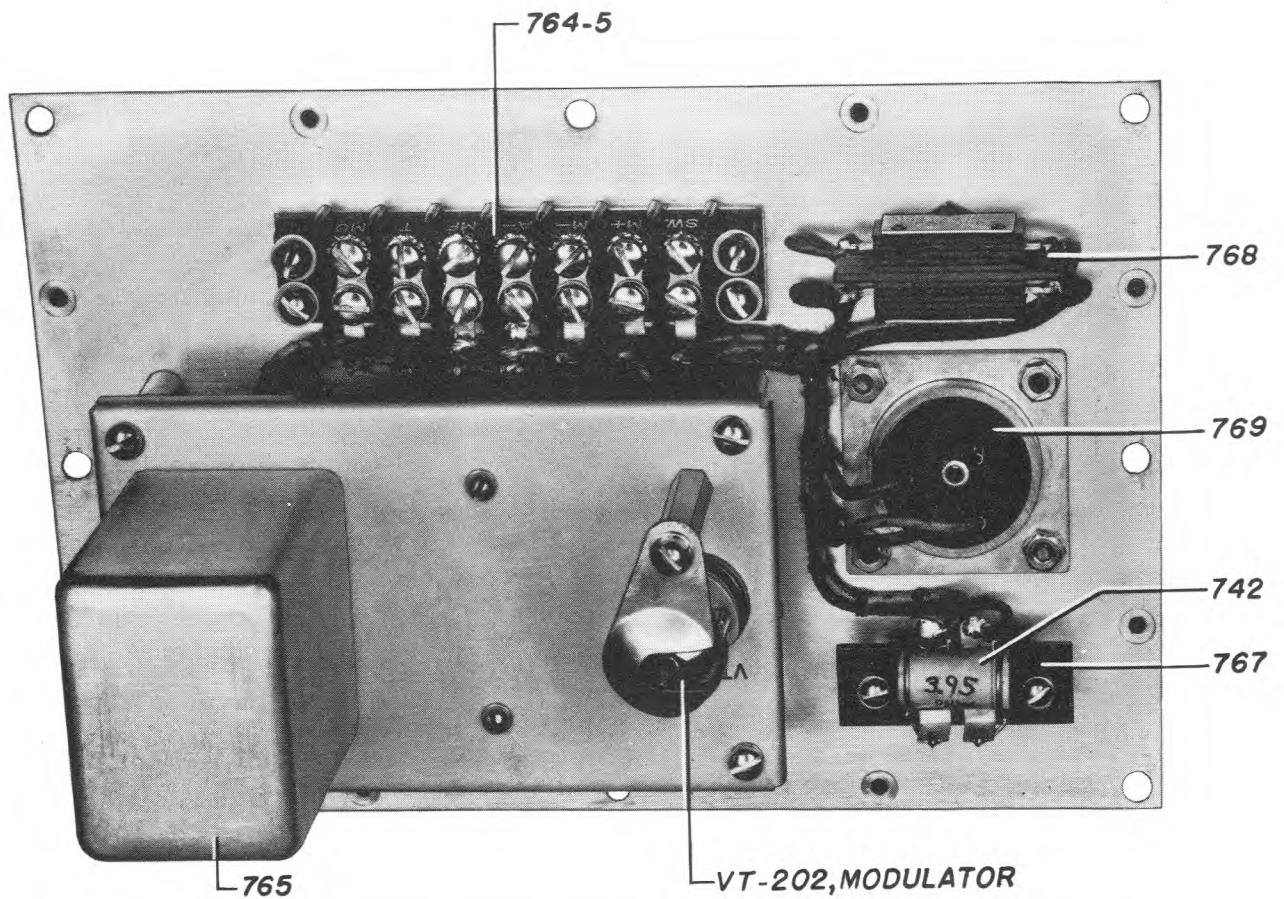

FIGURE 14—SIGNAL GENERATOR I-130-A, MODULATOR UNIT, REAR VIEW

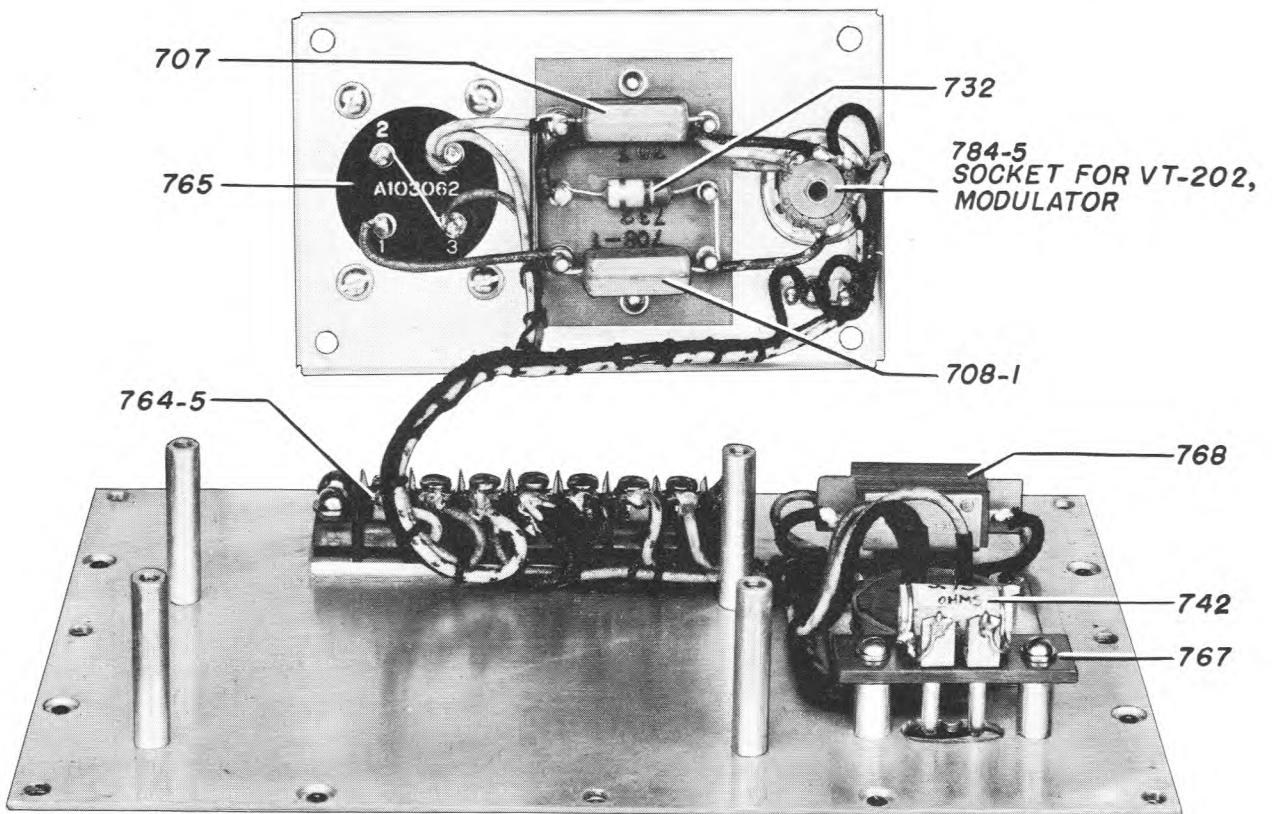

FIGURE 15—SIGNAL GENERATOR I-130-A, MODULATOR UNIT, DISASSEMBLED VIEW

FUNCTIONING OF PARTS

zero. This means that the space current flowing through the milliammeter is exactly counterbalanced by the opposing "A" battery current. Resistor 505 requires readjustment from time to time to compensate for variations in battery voltage and tube characteristics.

When the tuned circuit is in resonance with a received signal, the signal voltage is tapped from inductor 503 and applied to the diode plate of the diode-triode, Tube VT-172. The rectified diode-current voltage is then dropped through resistor

506 and impressed on the control grid of Tube VT-172, making the grid more negative and decreasing the space current in the tube. When the

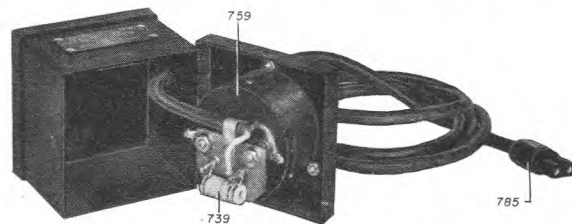

FIGURE 16—TEST SET I-139-A, INTERIOR VIEW

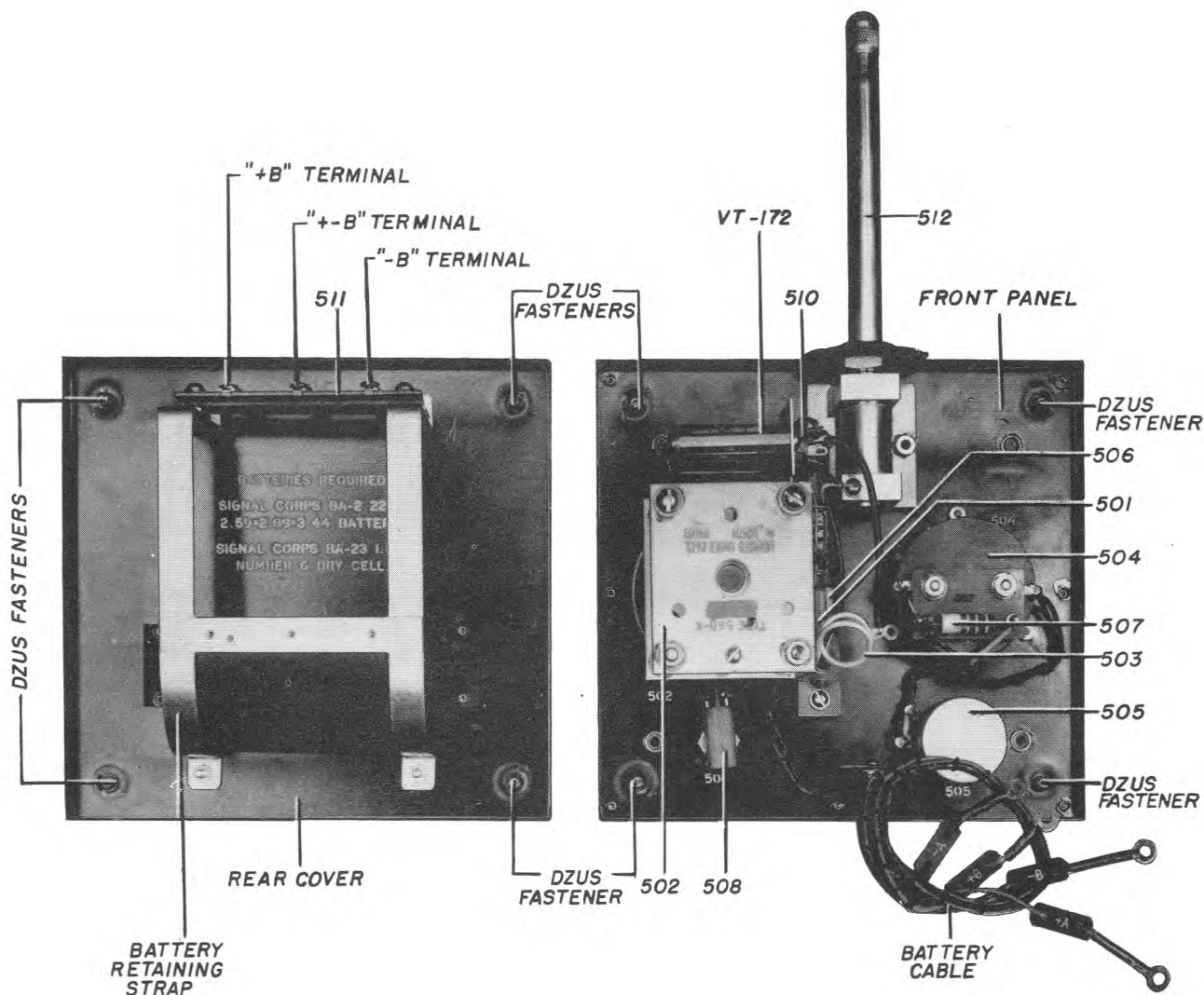

FIGURE 17—FIELD STRENGTH METER I-95-A, INTERIOR VIEW

FUNCTIONING OF PARTS

opposing "A" battery current is greater than the space current, there is an upward deflection of milliammeter 504. The magnitude of the milliammeter deflection is proportional to the difference between the opposing "A" battery and space cur-

to ground) of the signal voltage applied to the diode plate of Tube VT-172. The field strength meter is intended for use within a radius of approximately 25 feet, measured from the antenna of Radio Transmitter BC-625-A. Note that a

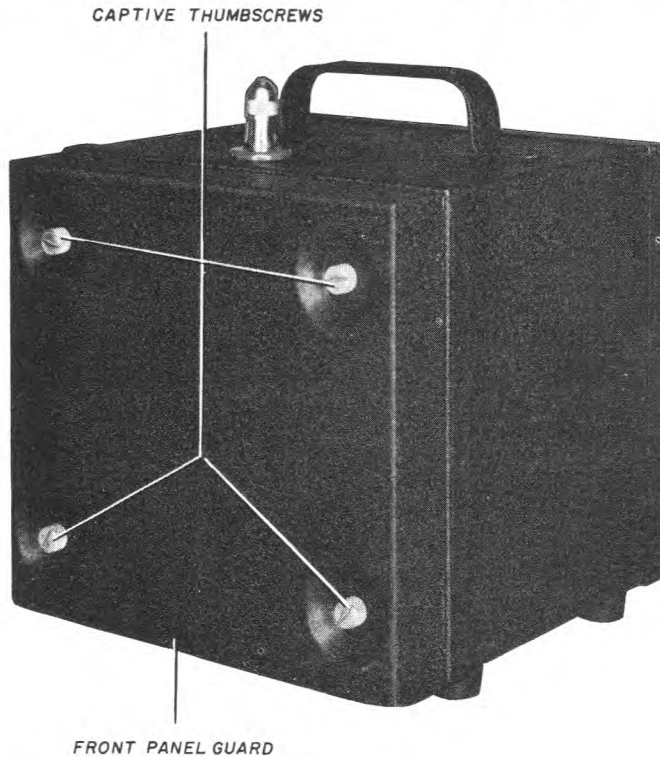

FIGURE 18—FIELD STRENGTH METER I-95-A, WITH FRONT PANEL GUARD

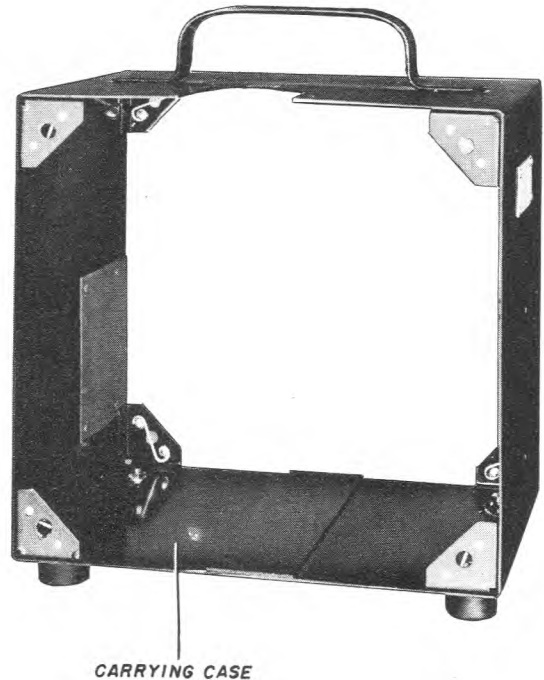

FIGURE 19—FIELD STRENGTH METER I-95-A, CASE

rents, and this difference is in turn proportional to the voltage impressed on the control grid, or to the strength of the received signal. The limiting resistor 507 prevents damage to the milliammeter from an excessively large deflection.

Capacitor 501 maintains the d-c voltage across resistor 506 near the r-f peak value (with respect

modulated signal causes a greater deflection of the milliammeter than the unmodulated carrier, due to the higher voltages induced in the antenna by a modulated wave. The field strength meter may therefore be used to indicate modulation of the carrier of Radio Transmitter BC-625-A [see paragraph 9a(15)].

GENERAL DESCRIPTION

The cover of Signal Generator I-130-A is hinged to the carrying case. The cover may be removed by raising it slightly and separating the hinge sections.

b. Test Set I-139-A

Test Set I-139-A (see FIGURE 4) is a circuit meter designed for use in tuning Radio Transmitter BC-625-A, Radio Receiver BC-624-A, and Signal Generator I-130-A. The currents measured by the test set are listed in the following table.

d. Field Strength Meter I-95-A

Field Strength Meter I-95-A (see FIGURE 6) is an uncalibrated vacuum-tube voltmeter designed to indicate the relative field strength and frequency of the radiation from the antenna of Radio Set SCR-522-A. This instrument may also be used to indicate modulation of the carrier. The field strength meter consists of a metal case on which the front panel and rear cover are mounted (see FIGURES 17, 18, and 19). A telescopic antenna, a front panel guard and all the electrical

<i>Equipment To Be Tuned</i>	<i>Switch Position</i>	<i>Current Measured</i>	<i>Full Scale Deflection</i>
Radio Receiver BC-624-A	—	R-F Amp. Plate	8.5 MA
Radio Transmitter BC-625-A	“METER SWITCH” Position “1”	1st Harmonic Amp. Plate	50 MA
	“METER SWITCH” Position “2”	2nd Harmonic Amp. Plate	100 MA
	“METER SWITCH” Position “3”	Power Amplifier Plate	100 MA
	“METER SWITCH” Position “4”	R-F Indicator Diode	1 MA
	“METER SWITCH” Position “5”	Power Amplifier Grid	2 MA
	“METER SWITCH” Position “6”	Not Used	—
Signal Generator I-130-A	“M.O.—CRYSTAL” Switch in “M.O.”	Power Amp. Plate and Modulator Plate	20 MA
	“M.O.—CRYSTAL” Switch in “CRYSTAL”	Distortion Amp. Plate, Power Amp. Plate, and Modulator Plate	20 MA

c. Battery Box BX-33-A

Battery Box BX-33-A is designed to contain six Battery BA-2 (U.S. Army Signal Corps “B” batteries) and four Battery BA-23 (U. S. Army Signal Corps “A” batteries). The ten-foot battery supply cable, when not in use, is stored in a compartment of the battery box (see FIGURE 5).

components (except the batteries) of the field strength meter are mounted on the front panel. The batteries, comprising two Battery BA-2 (22½ volt) and one Battery BA-23 (1½ volt), are not normally supplied with the equipment.

e. Set of Special Tools

The set of special tools provides equipment which is used in disassembling plugs, extracting

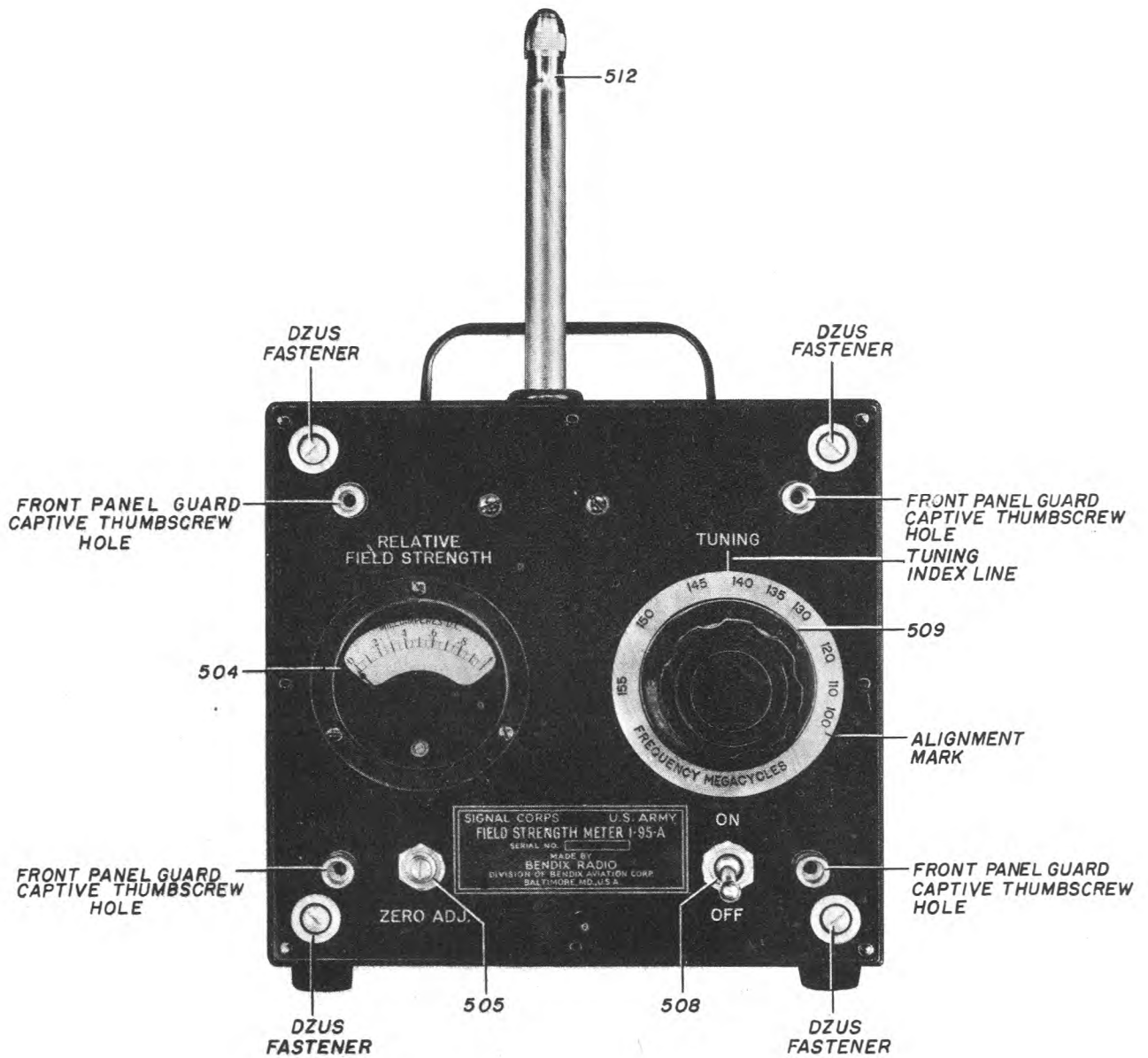

FIGURE 6—FIELD STRENGTH METER I-95-A, FRONT VIEW

GENERAL DESCRIPTION

and replacing indicator lamps, loosening set screws, and aligning the transmitter and receiver (see FIGURE 7).

f. Chest CH-93-A

Chest CH-93-A is designed for use in storing or

transporting Test Equipment IE-19-A. Each component unit of Test Equipment IE-19-A fits into a separate compartment and requires no special packing in the chest (see FIGURE 1).

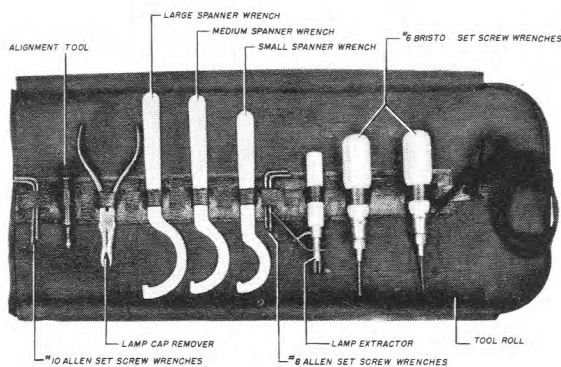

FIGURE 7—SET OF SPECIAL TOOLS. OPEN

SECTION IV

SERVICING AND REPAIR

14. Replacement of Vacuum Tubes
15. Trouble Location
16. Voltages at Tube Sockets and Other Important Circuit Terminations
17. Continuity Test Tables
18. Servicing Signal Generator I-130-A
19. Power Output Measurements

14. REPLACEMENT OF VACUUM TUBES

a. Signal Generator I-130-A

If vacuum tubes are to be replaced, loosen the cover fasteners and raise the cover (see FIGURE 2). If the power cable is plugged in, remove it.

To remove vacuum tubes in the r-f signal generator, remove the ten screws which secure the "R.F. SIGNAL GENERATOR" panel to the carrying case of Signal Generator I-130-A and lift out the front panel. The crystal oscillator, Tube VT-203 and the distortion amplifier, Tube VT-203 are located on a shelf and may be replaced by turning aside the tube clamps, extracting old tubes, inserting new tubes and replacing tube clamps.

To replace the master oscillator, Tube VT-202, and the power amplifier, Tube VT-203, the variable capacitor assembly cover must first be removed by loosening the fourteen retaining screws. This exposes these two tubes which may now be replaced. Adjust the tube clamps and replace the variable capacitor assembly cover.

To replace the modulator, Tube VT-202, remove the eight screws which secure the modulator section to the carrying case of Signal Generator I-130-A and lift the section out. This makes the tube accessible.

b. Field Strength Meter I-95-A

Loosen the four captive screws and remove front panel guard. Loosen the four Dzus fasteners located in the four corners of the front panel and remove the front panel. Tube VT-172 is now exposed and may be replaced.

15. TROUBLE LOCATION

The following general principle should be remembered and constantly followed in connection with this equipment:

When looking for trouble, always examine all the simple causes of failure first.

Many good radio equipments have been ruined by internal alterations when the service failure was due to a cable, a plug, a power supply, or a tube. This equipment is electrically a complicated system, depending upon precise design, workmanship, and adjustment for successful operation. Inspections and operations performed on the interior of this equipment, which are suggested in the following paragraphs, should be done only as a last resort and after it is certain that the fault is not to be found outside the equipment.

a. Signal Generator I-130-A

(1) Check battery voltages under load, and battery wiring.

(2) If improper or no operation is obtained with the "M.O.-CRYSTAL" switch in "CRYSTAL" position only, check crystal by replacing with a spare crystal.

(3) Remove unit from case (see paragraph 14) and check terminal board connections and voltages. Check continuity (see paragraph 17a).

(4) Manipulate the "M.O.-CRYSTAL" switch 752 and note that the heater of the master oscillator tube will glow when switch 752 is in "M.O." position, and that the crystal oscillator and distortion amplifier tube heaters will glow when switch 752 is in the "CRYSTAL" position.

The modulator and power amplifier tube heaters should glow regardless of "M.O.-

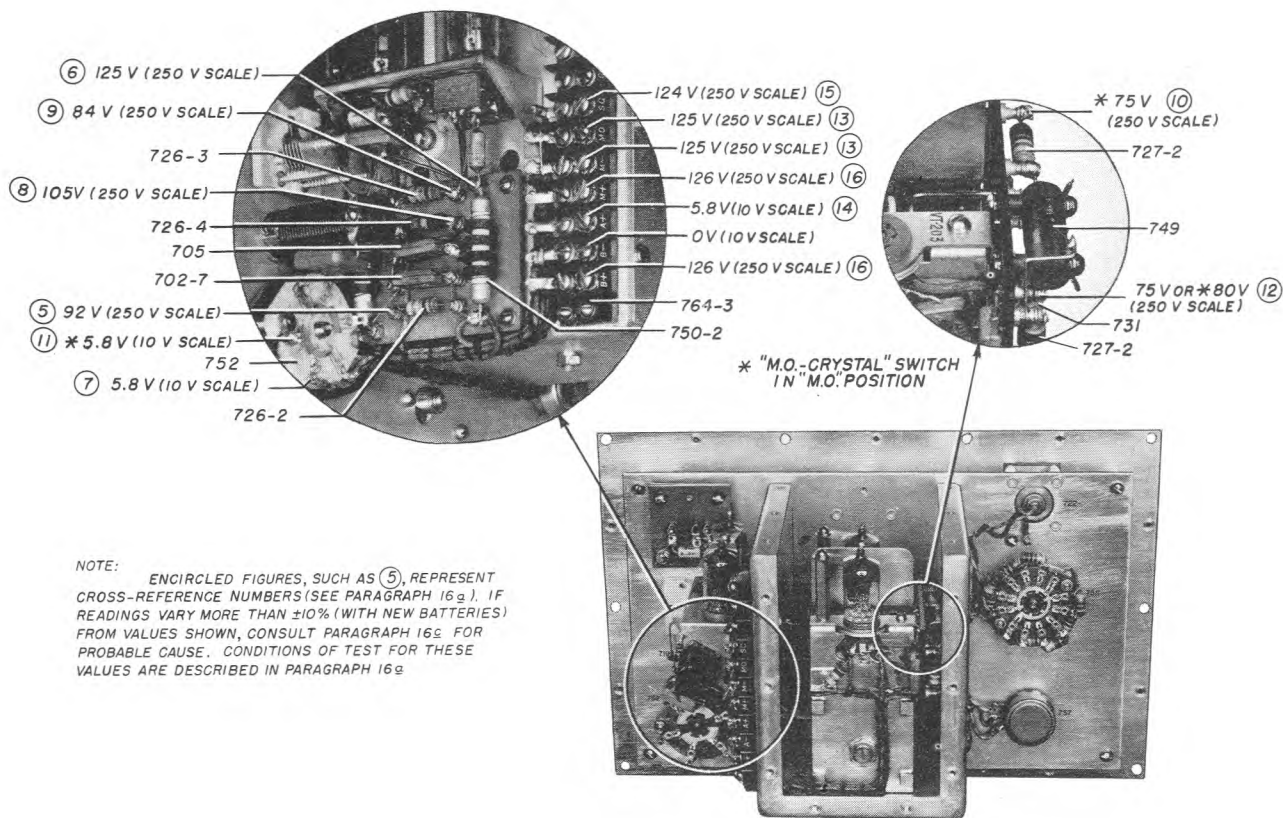
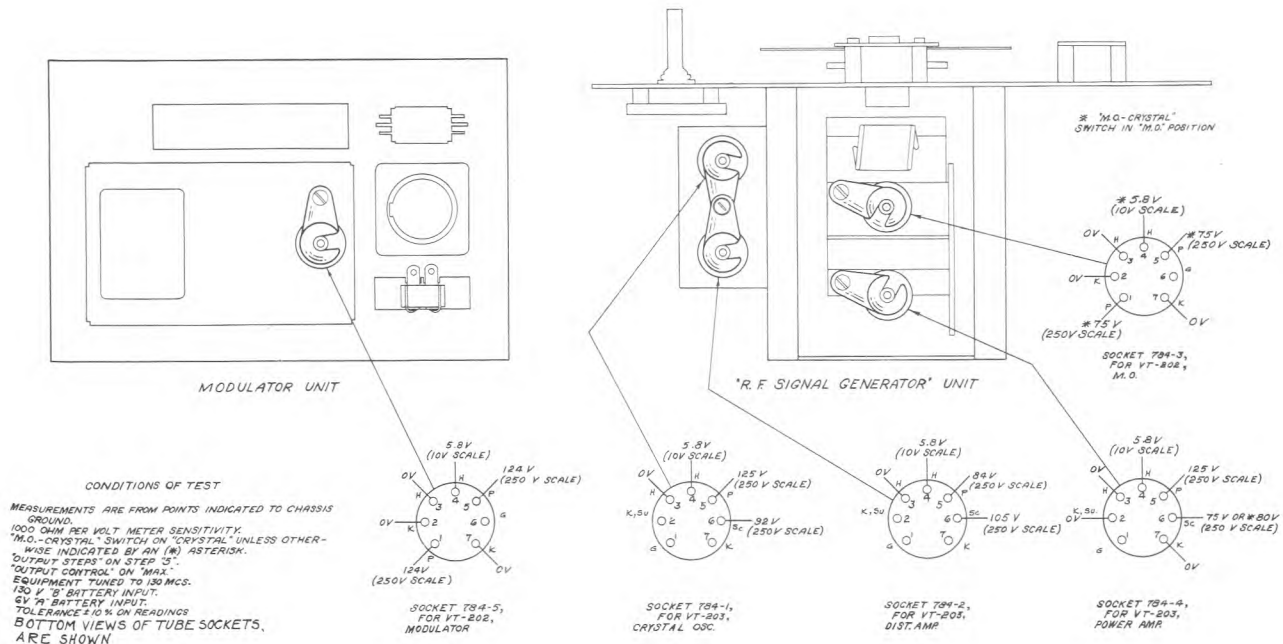
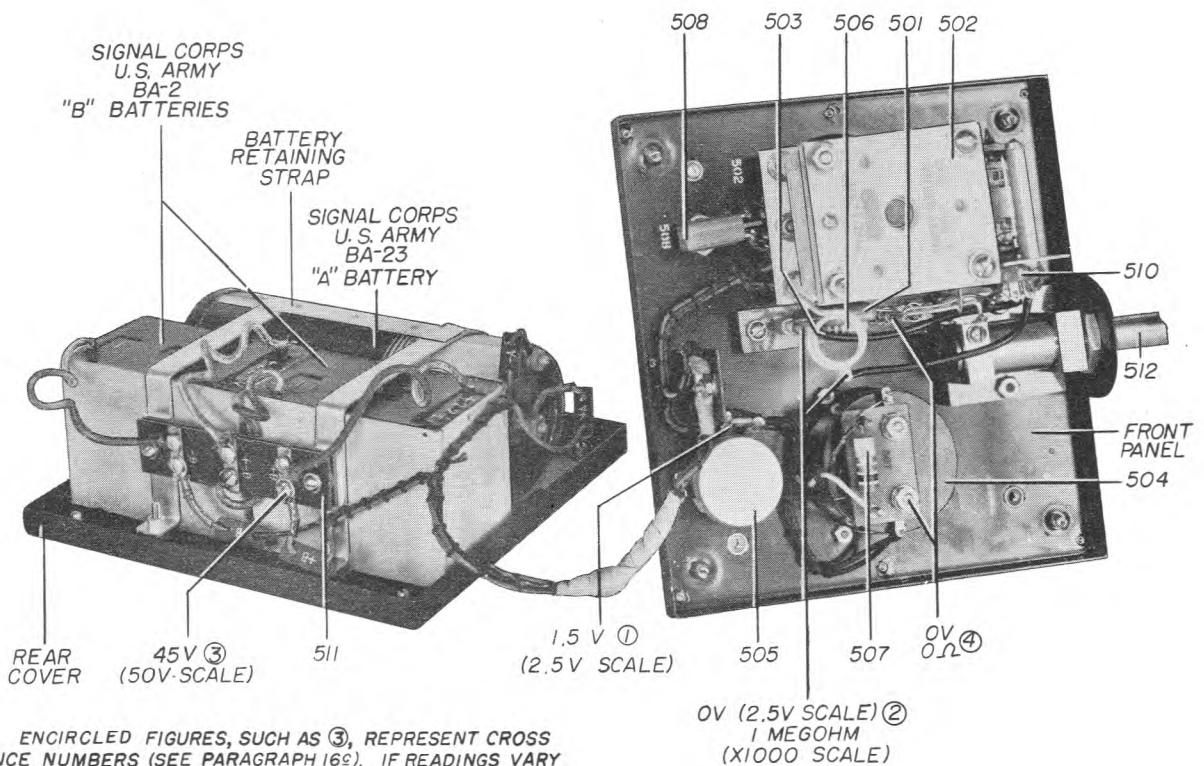
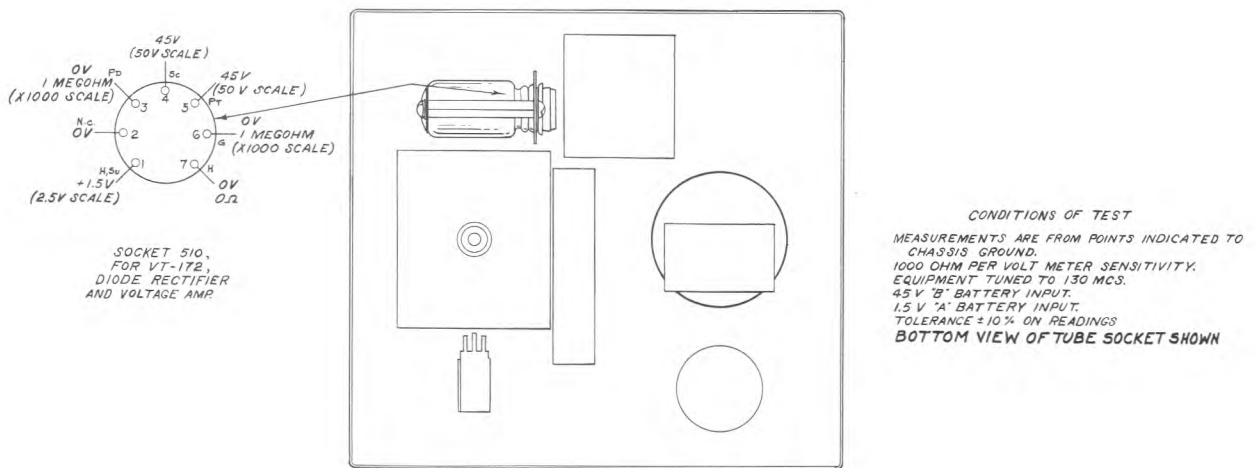

FIGURE 20—SIGNAL GENERATOR I-130-A, TUBE SOCKET LAYOUT AND VOLTAGE DIAGRAM



NOTE: ENCIRCLED FIGURES, SUCH AS ③, REPRESENT CROSS REFERENCE NUMBERS (SEE PARAGRAPH 16₂). IF READINGS VARY MORE THAN ±10% FROM VALUES SHOWN, (WITH NEW BATTERIES), CONSULT PARAGRAPH 10₄ FOR PROBABLE CAUSES. CONDITIONS OF TEST ARE DESCRIBED IN PARAGRAPH 16₅

FIGURE 21—FIELD STRENGTH METER I-95-A, TUBE SOCKET LAYOUT AND VOLTAGE DIAGRAM

SERVICING AND REPAIR

Figure
Reference
Number

Element Tested

Incorrect
Reading

Probable Causes of Incorrect Reading

①	Tube VT-172, heater, socket 510, pin #1.	Low or 0 (Below 1.3V)	"A" battery depleted; open in switch 508; open in wiring, or +A or -A cable leads disconnected from battery.
②	Tube VT-172, diode plate and pentode grid, socket 510, pins #3 and #6.	0 Ω Infinity Ω	Shorted capacitors 501 or 502. Open resistor 506; open inductor 503; broken center tap of 503, or open wiring.
③	Tube VT-172, pentode screen grid and pentode plate, socket 510, pins #4 and #5.	Low or 0 (Below 35V)	Batteries depleted; open wiring; broken cable leads, or open in meter 504.
④	Tube VT-172, heater, socket 510, pin #7.	Infinity Ω	Open wiring.
⑤	Tube VT-203, crystal osc. screen grid, socket 784-1, pin #6.	Low or 0	Shorted capacitor 702-6, 702-7, 706-1; open resistor 726-2, or causes listed in reference ⑥.
		High	Shorted resistor 726-2.
⑥	Tube VT-203, crystal osc. plate, socket 784-1, pin #5.	Low or 0	Open choke 750-2; open resistor 757; defective switch 756; defective socket 769; shorted capacitor 702-7, or open wiring.
⑦	Tube VT-203, crystal osc. heater, socket 784-1, pin #4, and Tube VT-203, distortion amp. heater, socket 784-2, pin #4.	Low or 0	Defective switch 752; defective socket 769; broken cable leads; open wiring, or shorted capacitor 702-8.
⑧	Tube VT-203, distortion amp. screen grid, socket 784-2, pin #6.	Low or 0	Shorted capacitor 702-4 or 702-5; open resistor 726-4; defective switch 768; defective socket 769; broken wires in cable, or defective wiring.
		High	Shorted or lowered value of resistor 726-4.
⑨	Tube VT-203, distortion amp. plate, socket 784-2 pin #5.	Low or 0	Open resistor 726-3; shorted capacitor 703-2, or causes listed in ⑧, above.
		High	Shorted resistor 726-3.
⑩	Tube VT-202, master osc. plate, socket 784-3, pins #1 and #5:	Low or 0	Open resistors 727-1 or 727-2; open choke 749; shorted capacitor 702-2, or causes listed in ⑥, above.
⑪	Tube VT-202, master osc. heater, socket 784-3, pin #4.	Low or 0	Open choke 748; shorted capacitor 702-1, or causes listed in ⑦, above.

SERVICING AND REPAIR

<i>Figure Reference Number</i>	<i>Element Tested</i>	<i>Incorrect Reading</i>	<i>Probable Causes of Incorrect Reading</i>
⑫	Tube VT-203, power amp. screen grid, socket 784-4, pin # 6.	Low or 0 High	Shorted capacitor 701-2, or 702-5; defective switch 768; open resistor 731, or open transformer 765. Lowered value, or short of resistor 731.
⑬	Tube VT-203, power amp. plate, socket 784-4, pin # 5.	Low or 0	Defective switch 768; shorted capacitor 702-5, or grounded secondary of transformer 765.
⑭	Tube VT-202, modulator heater, Tube VT-203, power amp. heater, socket 784-4, pin # 4, and socket 784-5, pin # 4.	Low or 0	Shorted capacitor 702-8, 702-1, or defective switch 768.
⑮	Tube VT-202, modulator plate, socket 784-5, pins # 1 and # 5.	Low or 0	Shorted capacitor 702-5; open or grounded transformer 765, or defective switch 768.

17. CONTINUITY TEST TABLES

a. Signal Generator I-130-A

Use Test Set I-56-A for making resistance measurements. Keep tubes and crystal in sockets. Set "OUTPUT CONTROL" and "OUTPUT STEPS" control in extreme clockwise positions. Set "M.O.-CRYSTAL" switch on "CRYSTAL".

Disconnect battery cable. DISCONNECT TEST SET I-139-A FROM "METER" SOCKET 767.

<i>Test</i>	<i>Ref. No.</i>	<i>Terminal Designation</i>	<i>To</i>	<i>Control Position, If Not Normal</i>	<i>Ohmmeter Scale Used</i>	<i>Resistance (Ohms)</i>	<i>Probable Cause of Incorrect Reading</i>
1	764-3	SC	Gnd	..	RX100	25,000	Open secondary of transformer 765; shorted capacitors 701-2, 702-2, 702-4, 702-5, 702-6, 702-7, 703-2, 706-1, 708-1; open resistors 742, 756, 757; grounded screen grid in power amplifier tube, or grounded 765.
2	764-3	MO	Gnd	..	RX100	25,000	Open resistors 742, 757 or 744-5 to 744-8, inclusive; shorted capacitors 701-2, 702-2, 702-4, 702-5, 702-6, 702-7, 703-2, 706-1, 708-1; grounded screen grid in power amplifier tube, or grounded 765.
3	764-3	M -	Gnd	..	RX100	25,000	Same as 2.
4	764-3	M +	Gnd	..	RX100	25,000	Open resistors 757 or 744-5 to 744-8, inclusive; shorted capacitors 701-2, 702-2, 702-4, 702-5, 702-6, 702-7, 703-2, 706-1, 708-1; grounded screen grid in power amplifier tube, or grounded 765.
5	764-3	A -	Gnd	..	R	0	Broken lead.

SERVICING AND REPAIR

Test	Ref. No.	Terminal Designation	To	Control Position, If Not Normal	Ohmmeter Scale Used	Resistance (Ohms)	Probable Cause of Incorrect Reading
6	764-3	B+	Gnd	Output step "1"	RX100	25,000	Open resistors 744-1 to 744-4 inclusive.
7	764-3	B+	Gnd		RX100	25,000	Same as 4.
8	784-1	1	Gnd		RX1000	500,000	Open resistor 728-1; shorted capacitors 704-1, 704-2, or grounded grid in crystal oscillator.
9	784-1	7	Gnd	..	R	33	Open choke 750-1, or shorted capacitor 705.
10	784-1	6	Gnd	..	RX100	45,000	Same as 4.
11	784-1	5	Gnd	..	RX100	25,000	Same as 4.
12	784-2	1	Gnd	..	RX1000	500,000	Open resistor 728-2; shorted capacitor 703-3, or grounded grid in distortion amplifier tube.
13	784-2	7	Gnd	..	R	200	Open resistor 729, or shorted capacitor 702-3, 702-4.
14	784-2	6	Gnd	..	RX100	**45,000	Open resistors 726-4, 742, 757, or 744-5 to 744-8 inclusive; shorted capacitors 702-4, 702-5, 703-2, 708-1, or grounded 765.
15	784-2	5	Gnd	..	RX100	45,000	Open resistors 726-3, 742, 757, or 744-5 to 744-8 inclusive; shorted capacitors 702-4, 702-5, 703-2, 708-1, or grounded 765.
16	784-3	6	Gnd	..	RX100	20,000	Open resistor 726-1; shorted capacitor 701-1, or grounded grid in master oscillator tube.
17	784-3	5	Gnd	..	RX100	35,000	Open resistors 727-1, 727-2, 757 or 744-5 to 744-8 inclusive; shorted capacitors 701-2, 702-2, 702-6, 702-7, 703-1, 706-1; open choke 749, or grounded screen grid in power amplifier tube.
18	784-4	1	Gnd	..	RX1000	500,000	Open resistor 728-3, or shorted capacitor 703-4.
19	784-4	6	Gnd	..	RX1000	50,000	Open resistors 731, 742, 757 or 744-5 to 744-8 inclusive; shorted capacitors 701-2, 702-4, 702-5, 702-6, 702-7, 703-2, 706-1, or grounded 765.
20	784-4	5	Gnd	..	RX100	25,000	Open resistors 742, 757 or 744-5 to 744-8 inclusive; shorted capacitors 701-2, 702-4, 702-5, 703-2, 708-1, or grounded 765.
MODULATOR CABLE REMOVED							
21	764-3	SC	Gnd	"M.O."	RX1000	Open	Shorted capacitor 701-2, or grounded screen grid in power amplifier tube.
22	764-3	MO	Gnd	"M.O."	RX1000	Open	Shorted capacitors 702-4, 702-5, 703-2.
23	764-3	M-	Gnd	"M.O."	RX1000	Open	Same as 22.

SERVICING AND REPAIR

Test	Ref. No.	Terminal Designation	To	Control Position, If Not Normal	Ohmmeter Scale Used	Resistance (Ohms)	Probable Cause of Incorrect Reading
24	764-3	M +	Gnd	"M.O."	RX100	25,000	Open resistors 757 or 744-5 to 744-8 inclusive, or shorted capacitors 702-2, 702-6, 702-7, 703-1.
25	764-3	B +	Gnd	"M.O."	RX100	25,000	Same as 24.
26	764-3	A -	Gnd	"M.O." or "CRYSTAL"	R	0	Open ground lead.
27	764-5	M -	764-5, Term. M +	*	R	3.95	Open resistor 742.
28	764-5	MO	764-5, Term. T	..	R	250	Open secondary of transformer 765, or shorted capacitor 707.
29	764-5	T	765, Term. 1	..	R	625	Open primary of transformer 765, or shorted capacitor 707.
30	764-5	MO	Gnd	..	RX1000	Open	Shorted capacitor 708-1; shorted plate in modulator tube, or transformer 765 winding shorted to ground.
31	769	2	769, Pin 3	Power Switch "ON"	RX1000	Open	Grounded or shorted switch 768.
32	769	1	769, Pin 2	Power Switch "OFF"	RX1000	Open	Same as 31.

* Meter disconnected.

Switch 756 resistors, 5000 ohms each.

** On equipments which use Ref. No. 730 in place of Ref. No. 726-4 this valve will be 85,000 ohms.

b. Field Strength Meter I-95-A

Use Test Set I-56-A for making resistance measurements. REMOVE VACUUM TUBE FROM SOCKET. Turn power switch "OFF" and disconnect B+ supply.

CAUTION: RESISTANCE MEASUREMENTS SHOULD BE MADE WITH MILLIAMMETER 504 DISCONNECTED TO PREVENT DAMAGE TO MILLIAMMETER.

Test	Ref. No.	Terminal Designation	To	Control Position, If Not Normal	Ohmmeter Scale Used	Resistance (Ohms)	Probable Cause of Incorrect Reading
33	504	Positive side	505, Arm	505 in extreme counter-clockwise position	RX10	1600	Open resistors 505 or 507.
34	510	6	Gnd	..	RX1000	1 megohm	Open resistor 506, or shorted capacitor 501.
35	510	3	Gnd	..	RX1000	1 megohm	Same as 34.

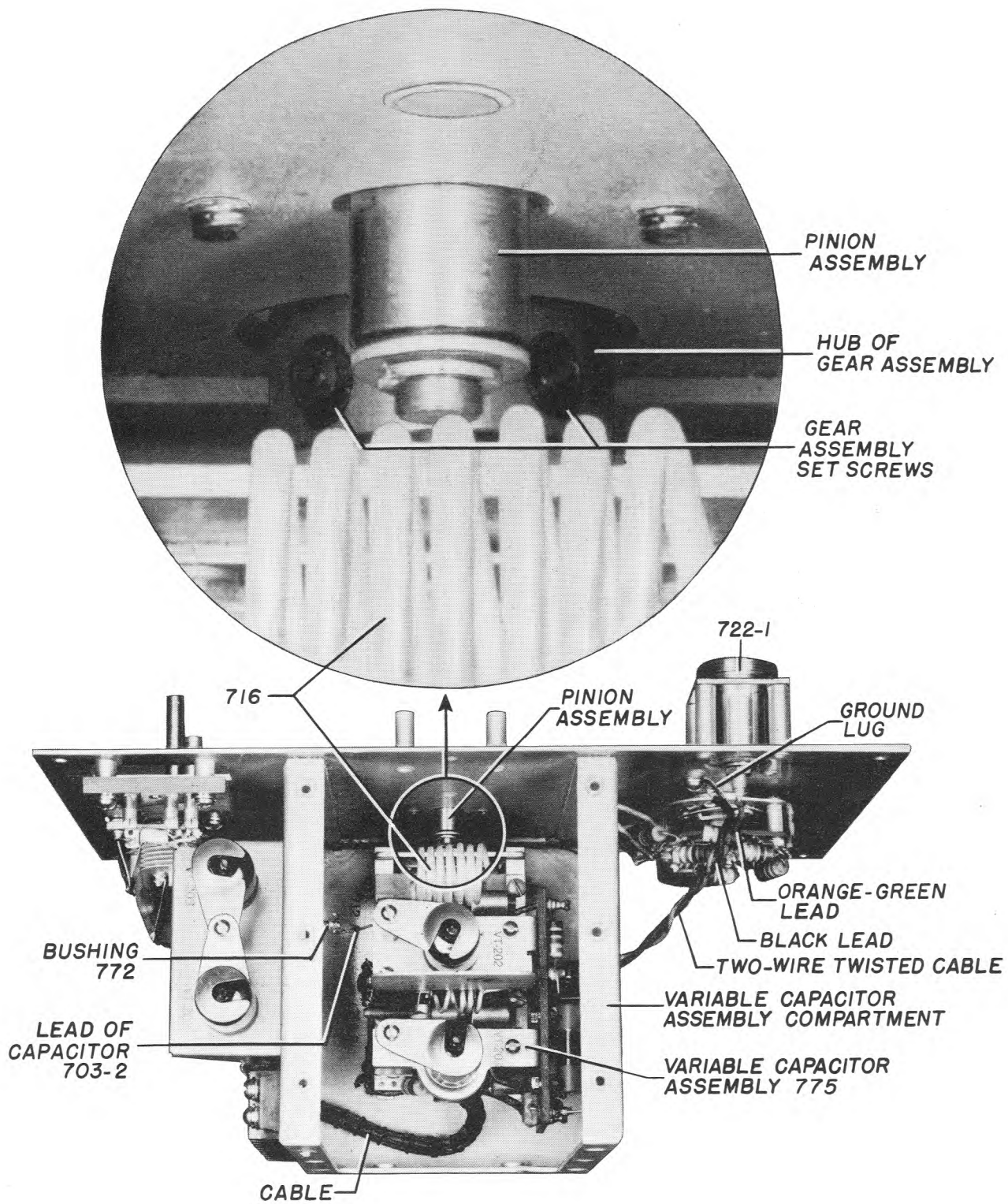

FIGURE 22—SIGNAL GENERATOR I-130-A, R-F UNIT, TOP VIEW, FRONT PANEL REMOVED

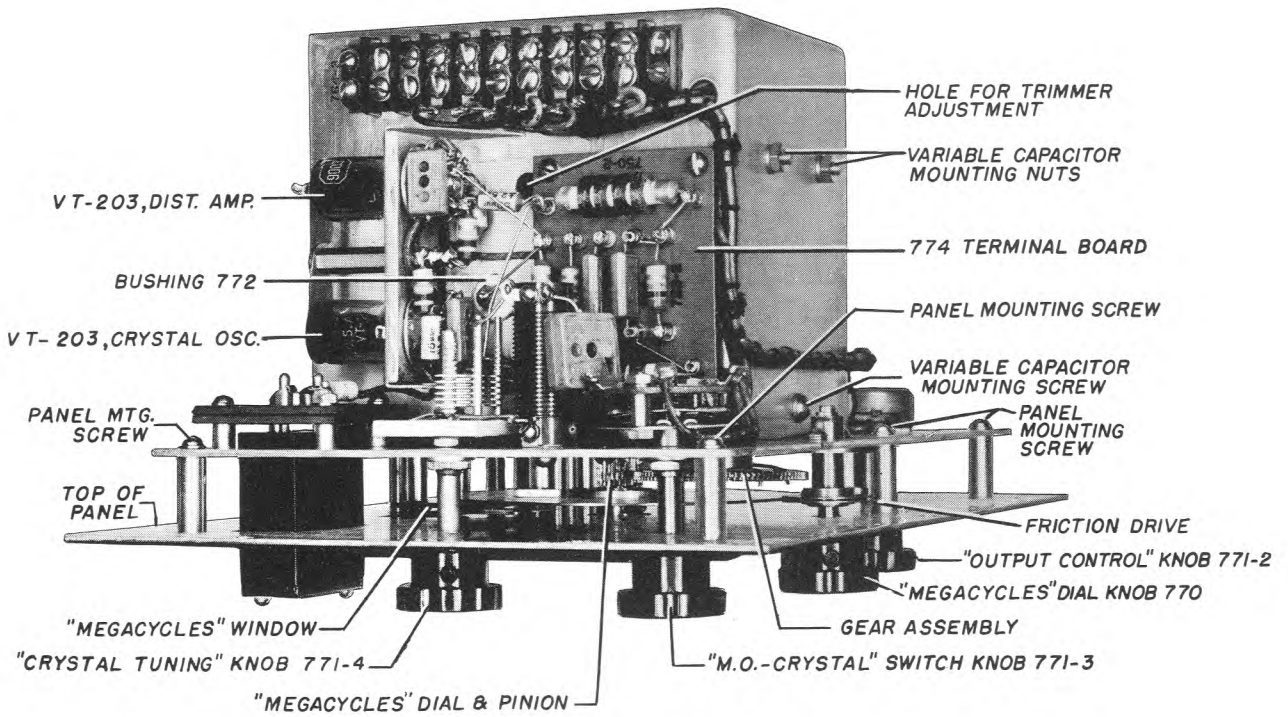

FIGURE 23—SIGNAL GENERATOR I-130-A, R-F UNIT, RIGHT OBLIQUE VIEW

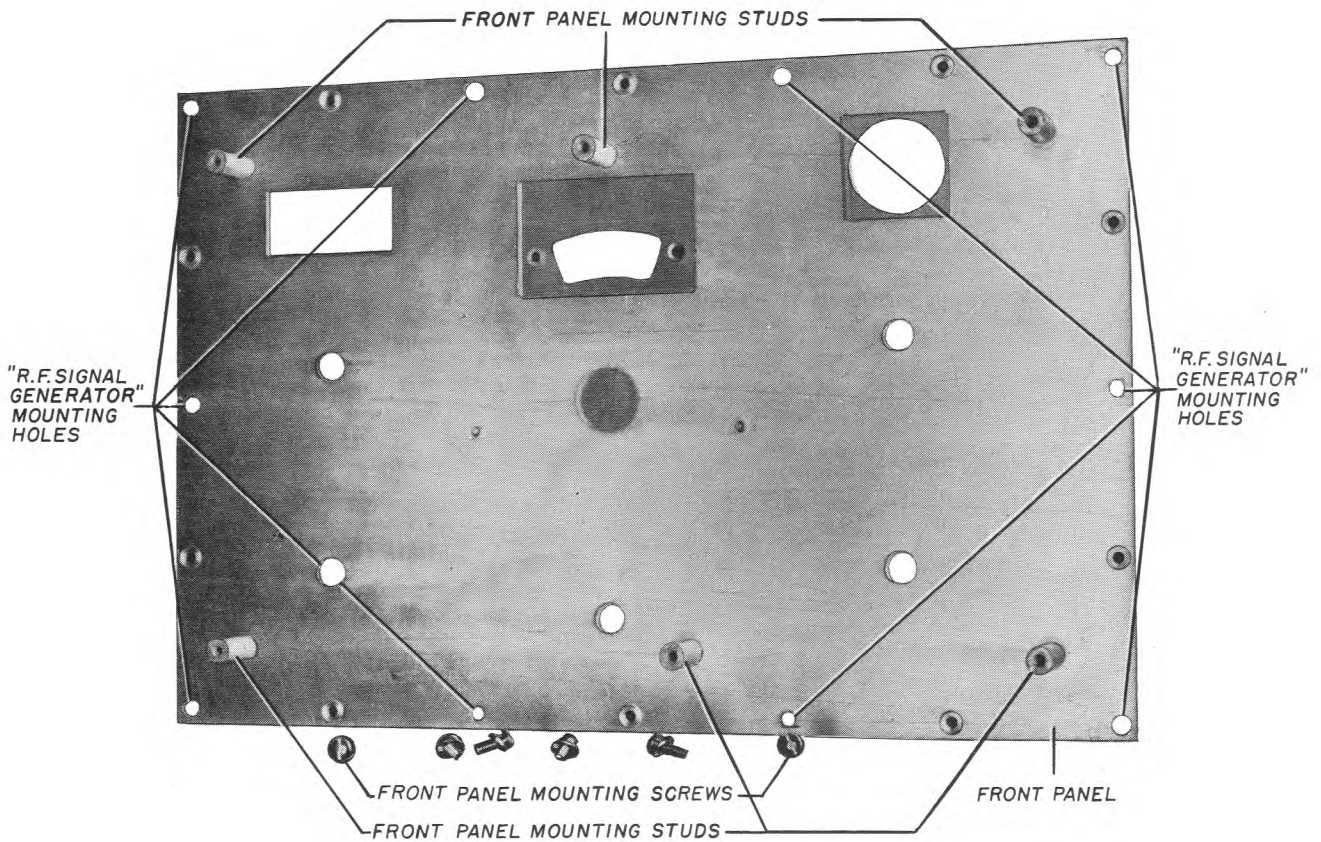

FIGURE 24—SIGNAL GENERATOR I-130-A, R-F UNIT, REAR OF FRONT PANEL

SERVICING AND REPAIR

c. Test Set I-139-A

To check the resistance of resistor 739, open the test set and place the ohmmeter leads across the resistor. The resistance of 739 should be 49 ohms. **DO NOT ATTEMPT TO PLACE THE OHMMETER LEADS ACROSS THE TEST SET PLUG TERMINALS, AS THIS MAY DAMAGE MILLIAMMETER 759.**

(3) Remove the 14 screws holding the variable-capacitor assembly cover and remove the cover (see FIGURE 12).

(4) Unsolder capacitor 703-2 from bushing 772 (see FIGURE 22). Unsolder the orange-green lead of the twisted cable from socket 722-1 (see FIGURE 22) and unsolder the black lead from the ground lug. Draw this cable

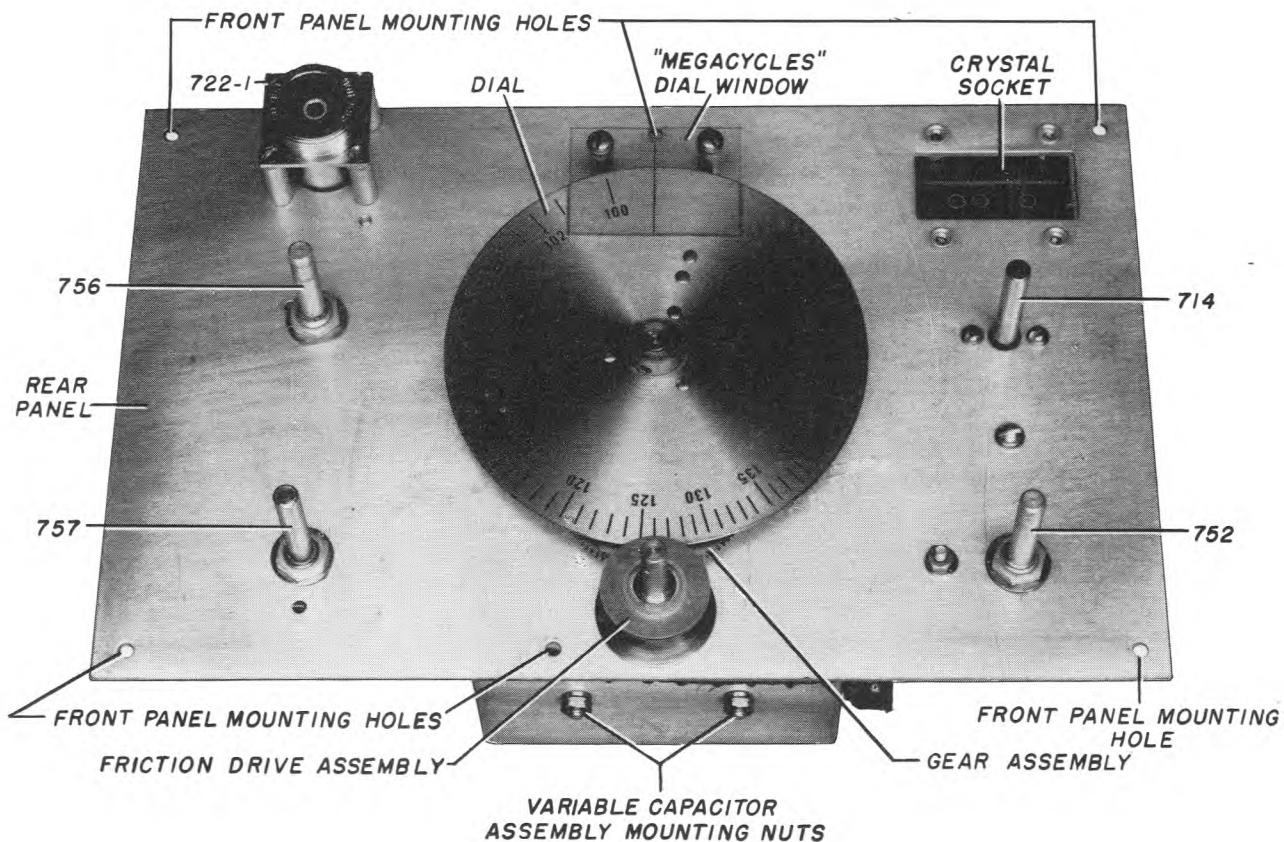

FIGURE 25—SIGNAL GENERATOR I-130-A, R-F UNIT, FRONT PANEL REMOVED

18. SERVICING SIGNAL GENERATOR I-130-A

a. Removal of Variable Capacitor Assembly

(1) Remove the ten mounting screws from the "R.F. SIGNAL GENERATOR" panel (see FIGURE 2) and lift the r-f unit out of its compartment.

(2) Disconnect the cable from terminal board 764-3. This completely separates the r-f unit from the modulator unit and case.

through the small eyelet into the variable-capacitor-assembly compartment.

(5) Soften the glyptal on the control-knob set screws, loosen the screws with a #8 Allen set-screw wrench, and remove the control knobs. Remove the 6 front-panel mounting screws (see FIGURE 23). Remove the front panel (see FIGURE 24).

(6) Remove the "MEGACYCLES" window and the two screws which secure the friction

SERVICING AND REPAIR

drive (see FIGURE 25). Draw friction drive assembly *away* from dial and lift it out. Remove the dial, using a #6 four-flute Bristo set-screw wrench.

(7) Rotate the gear assembly to make accessible the set screws fastening it to the variable-capacitor shaft. Loosen set screws and pull gear assembly away from shaft (see FIGURES 26 and 27).

repairs. If complete removal is required, disconnect cable wiring.

(9) In reassembling the variable-capacitor assembly, reverse the disassembly procedure and refer to the wiring diagram, FIGURE 29. Before replacing the split gears, lubricate the teeth sparingly with Royco No. 6A. The two gears of the split-gear assembly should be rotated against the spring pressure for a dis-

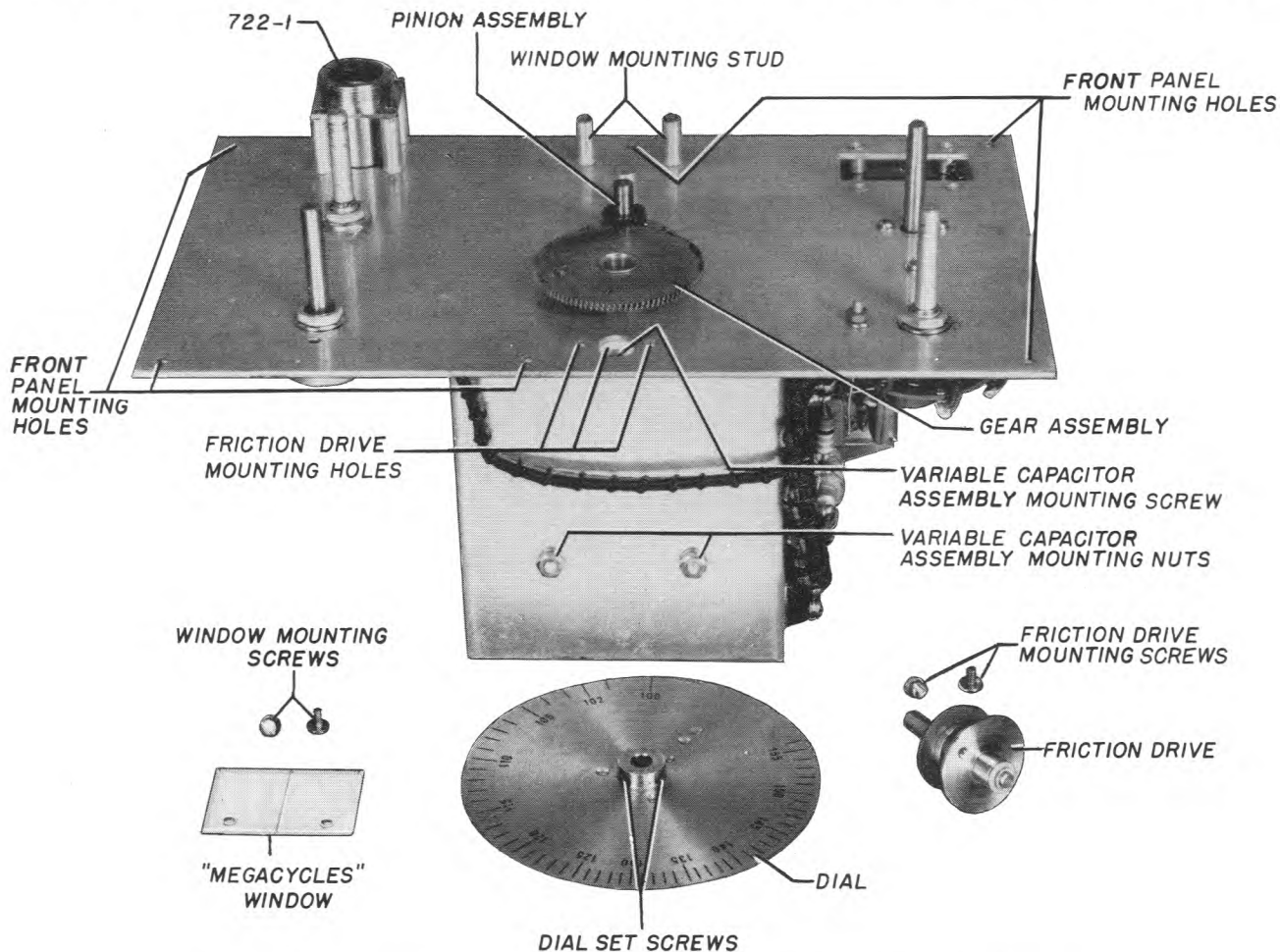

FIGURE 26—SIGNAL GENERATOR I-130-A, R-F UNIT, DIAL REMOVED

(8) Remove the screw and the two nuts which secure the variable-capacitor assembly to the compartment shield (see FIGURE 26). The variable-capacitor assembly may now be lifted out of the compartment (see FIGURE 28). Complete removal is not possible because of cable connections, and is not necessary for most

tance of three teeth, and held in this position while being fitted over the variable-capacitor shaft, and then the gear teeth should be meshed with the pinion-assembly teeth. Turn the "MEGACYCLES" dial to the 100-mc calibration mark, then completely mesh the capacitor plates and tighten the set screws.

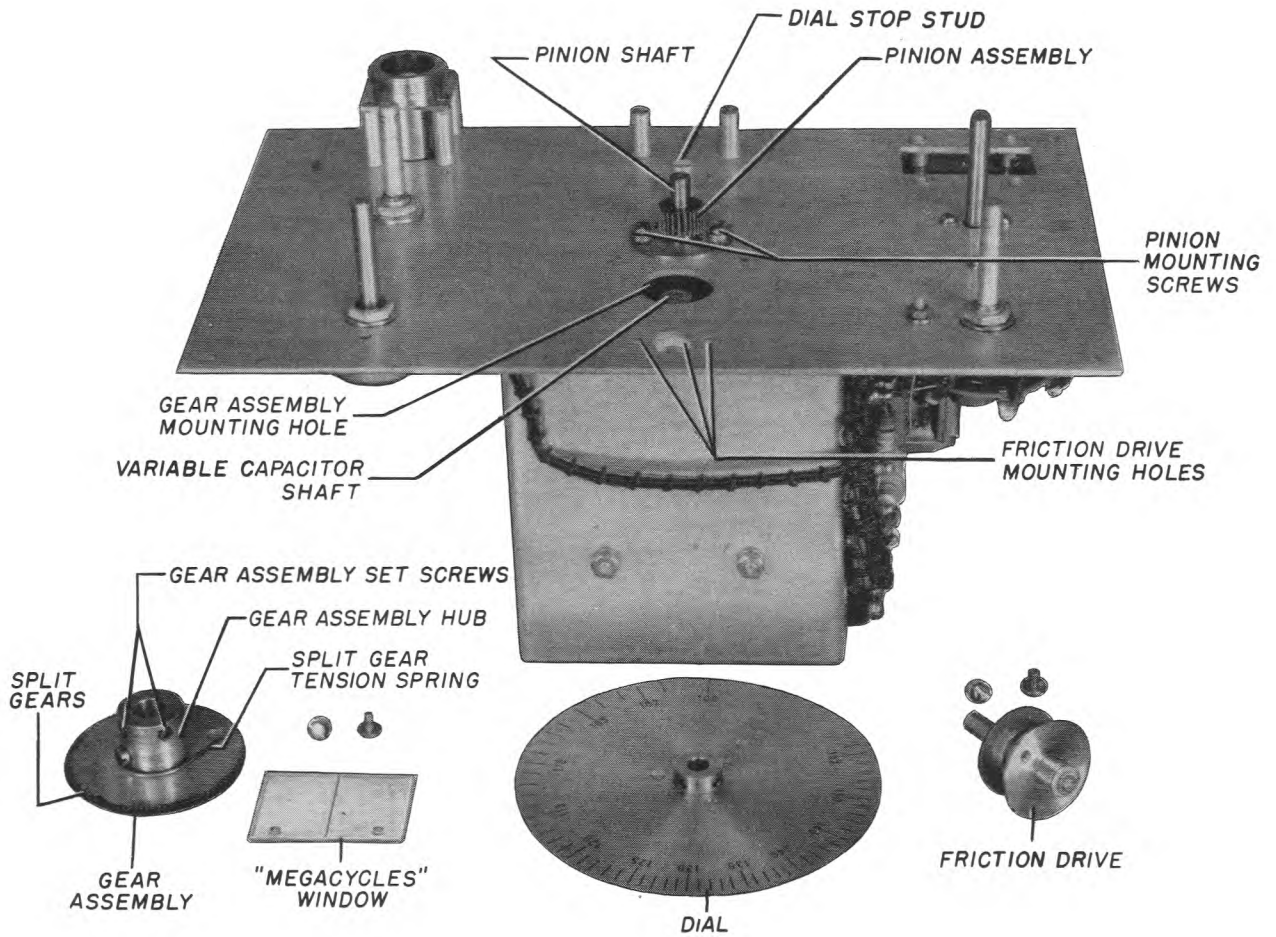

FIGURE 27—SIGNAL GENERATOR I-130-A, R-F UNIT, GEAR ASSEMBLY REMOVED

SERVICING AND REPAIR

Before reassembling the variable-capacitor assembly cover or the front panel, however, align the r-f oscillator unit in accordance with the instructions in paragraph 18b.

b. Alignment and Tracking of Signal Generator I-130-A

(1) If the variable-capacitor assembly has been removed, follow instructions in para-

removed it must be connected to terminal board 764-3 as shown in FIGURE 31.

(3) Plug the cable of Battery Box BX-33-A into the power input socket 769, and plug Test Set I-139-A into the "METER" socket 767 of Signal Generator I-130-A (see FIGURE 2).

(4) Place the shafts of the "OUTPUT CONTROL" 757 and the "OUTPUT STEPS" con-

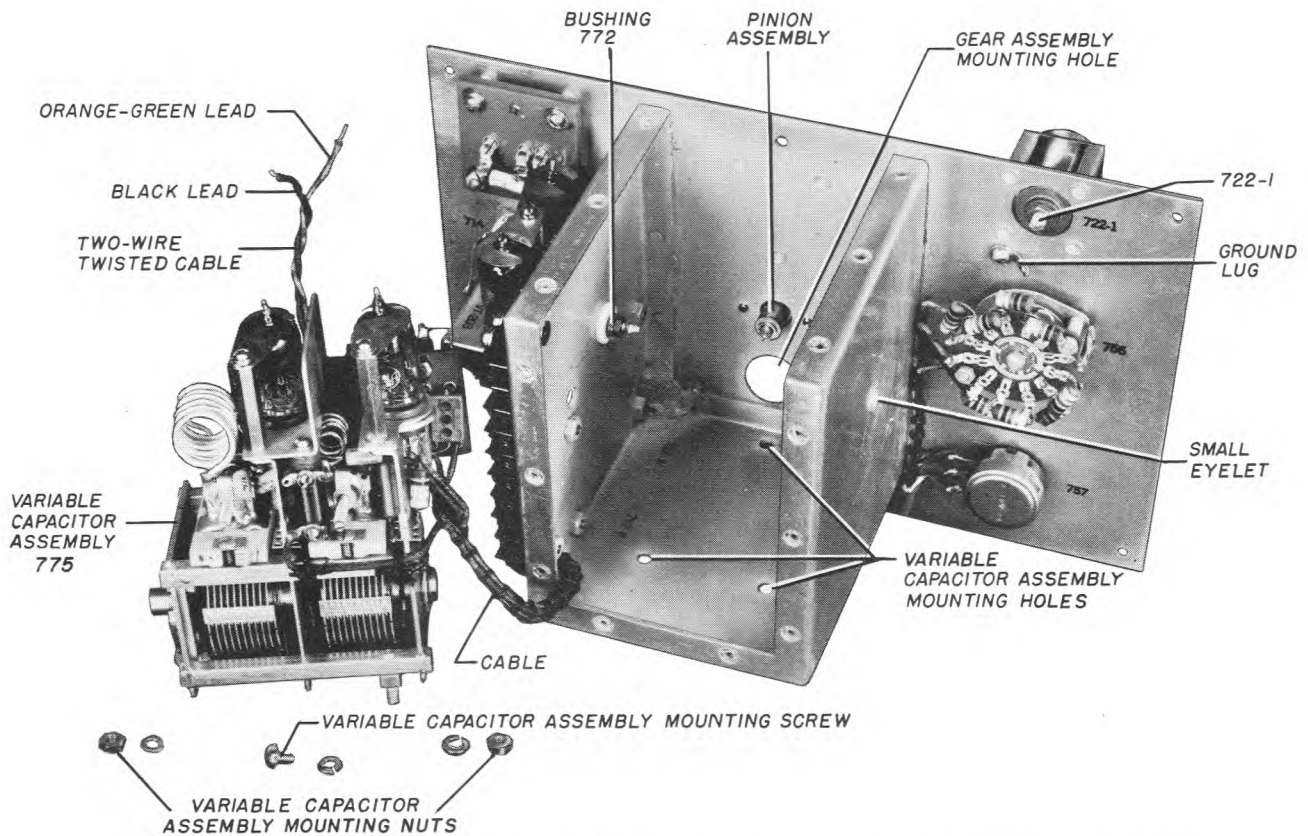

FIGURE 28—SIGNAL GENERATOR I-130-A, R-F UNIT, VARIABLE CAPACITOR ASSEMBLY

graph 18a(9). If the variable-capacitor assembly has not been removed, the front panel must be removed as described in paragraphs 18a(1) to 18a(5), inclusive, and the control knobs temporarily reassembled to their respective shafts. Tighten the control knob set screws, but do not apply glyptal to them.

(2) If the interconnecting cable has been

removed, it must be connected to terminal board 764-3 as shown in FIGURE 31. Rotate the "M.O.-CRYSTAL" switch 752 to the left hand position ("M.O."). See FIGURE 25. Turn the "POWER ON-OFF" switch "ON".

(5) Connect Plug PL-P173 of Cord CD-477 to the input of a Hallicrafter S-27 receiver. If a Hallicrafter S-27 is not available, Radio

FIGURE 29—SIGNAL GENERATOR I-130-A, R-F UNIT, WIRING DIAGRAM

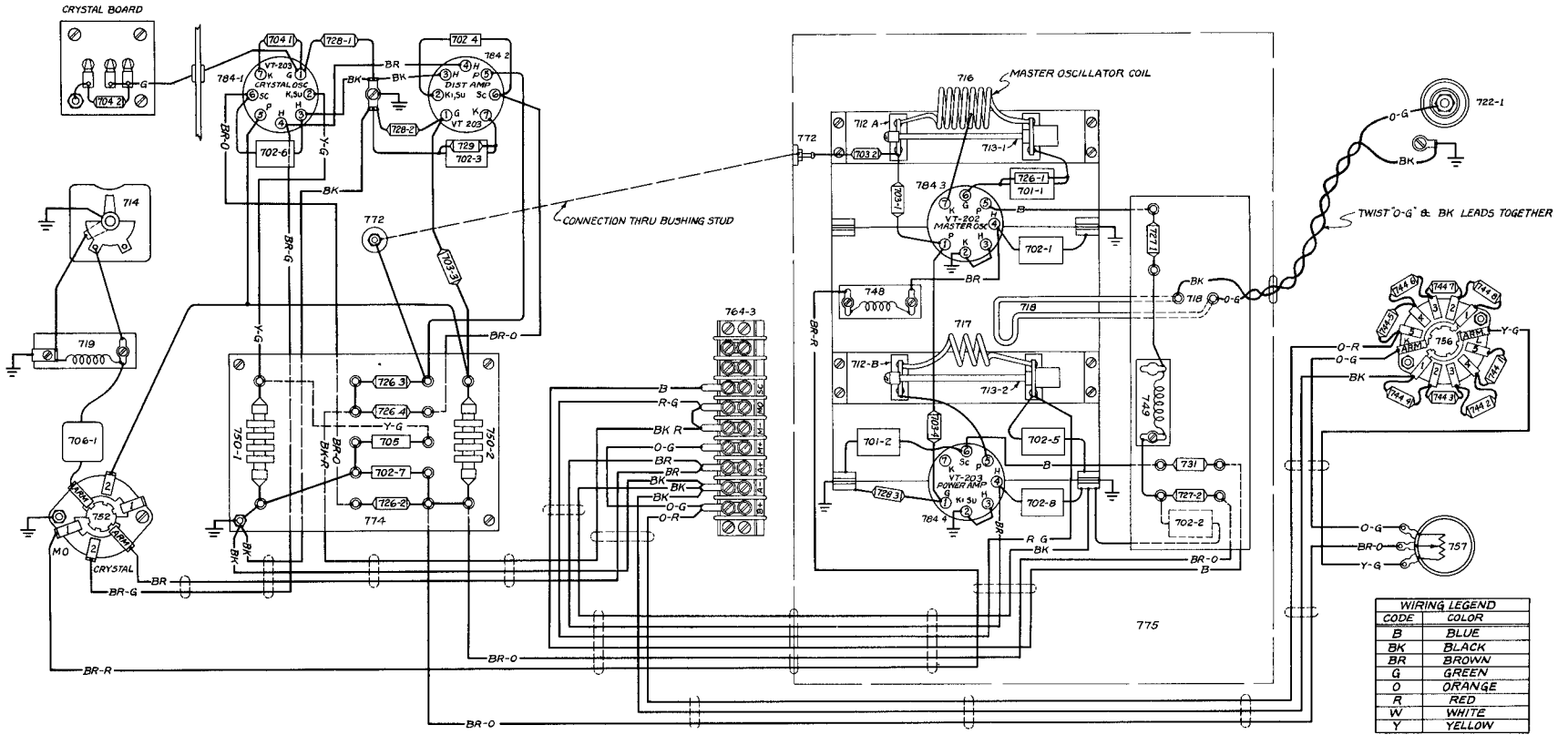

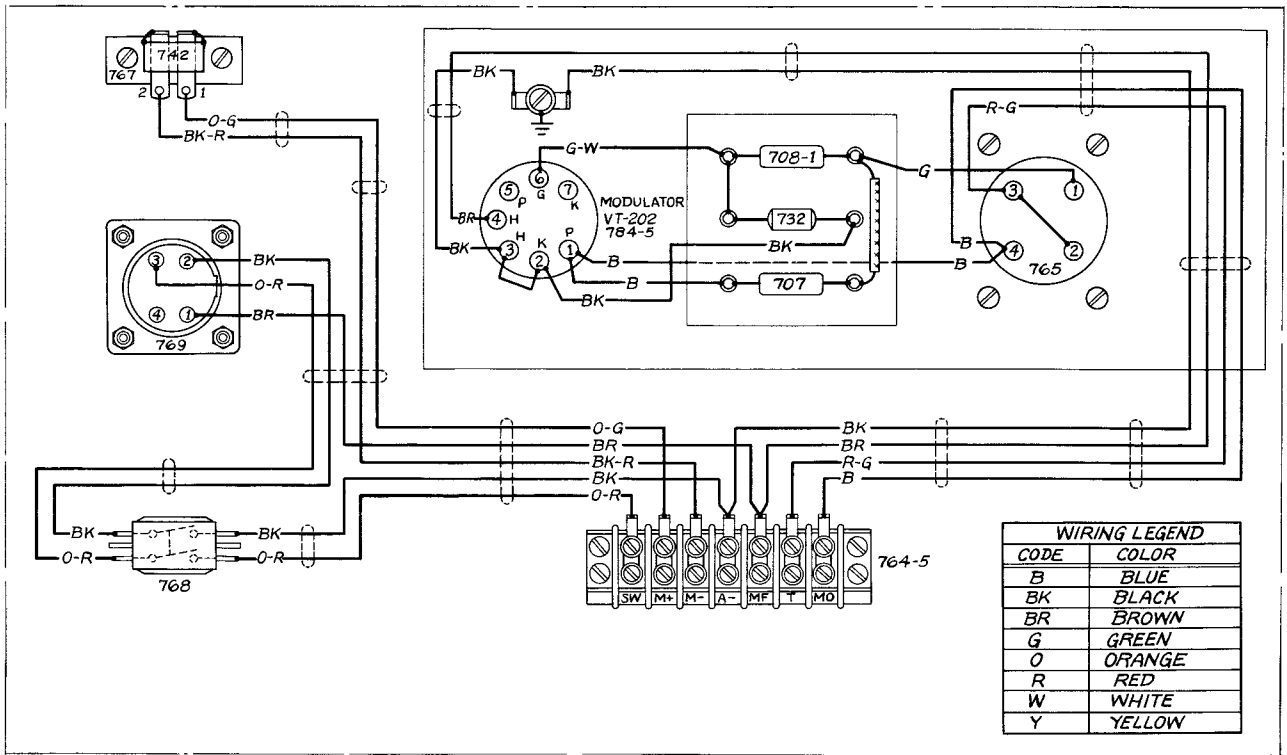

FIGURE 30—SIGNAL GENERATOR I-130-A, MODULATOR UNIT, WIRING DIAGRAM

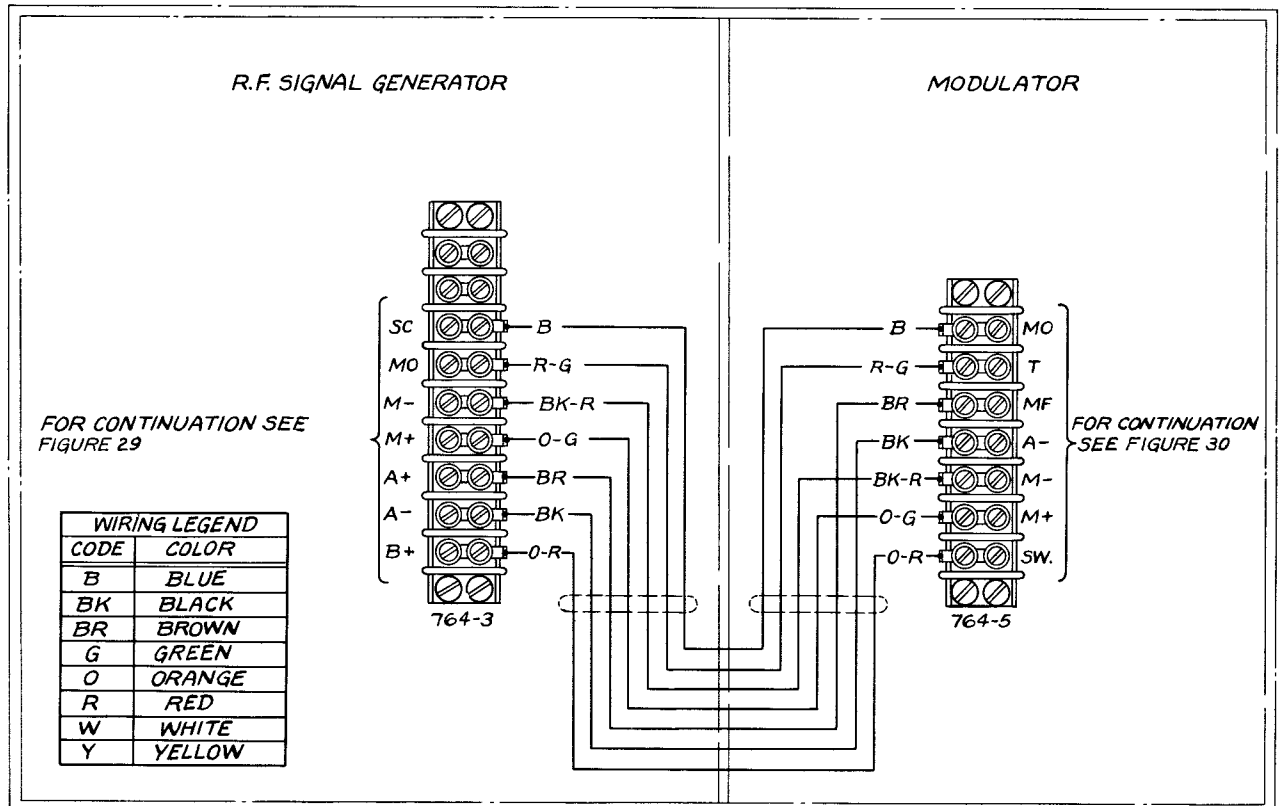

FIGURE 31—SIGNAL GENERATOR I-130-A, INTERCONNECTING CABLE, WIRING DIAGRAM

SERVICING AND REPAIR

Receiver BC-639-A (part of SCS-2 system) or any equivalent receiver, provided with a BFO and which operates in the frequency range 33—52 mc or a harmonic thereof, may be used. If using the S-27, tune the receiver to the second harmonic of the signal-generator master oscillator, because the fundamental is outside the receiver tuning range. If using Radio Receiver BC-639-A, tune the receiver to the third harmonic of the signal-generator master oscillator.

The following discussion makes use of the Hallicrafter S-27 receiver only, but if another suitable receiver is used, tune this receiver to the applicable frequency. Use a *good* ground on Signal Generator I-130-A and all other equipment employed for test purposes.

In performing the master-oscillator alignment procedure, described in paragraphs 18b(8) to 18b(10), inclusive, place the receiver BFO control "ON".

(6) Remove the cover from the variable capacitor assembly. Connect an insulated wire to the center contact of Plug PL-Q173 and place the insulated end near the master oscillator inductor 716. The degree of coupling must be determined by the output desired. Replace but do not fasten the variable capacitor assembly cover.

(7) CAUTION: WHENEVER AN ADJUSTMENT IS TO BE MADE, THE "POWER ON-OFF" SWITCH MUST BE PLACED IN THE "OFF" POSITION. THE VARIABLE CAPACITOR ASSEMBLY COVER REMOVED, THE ADJUSTMENT MADE, THE VARIABLE CAPACITOR ASSEMBLY COVER REPLACED, THEN THE "POWER ON-OFF" SWITCH SET IN THE "ON" POSITION. IF THIS PROCEDURE IS NOT FOLLOWED, INJURY TO PERSONNEL OR EQUIPMENT OR IMPROPER ADJUSTMENT MAY RESULT.

(8) Turn the equipments "ON". Set the receiver on 66.6+ mc. Rock the "MEGACYCLES" dial around "100" until the signal is heard. If the dial reading is more than "100" when the signal is heard, spread the turns of inductor 716 until resonance is ob-

tained at "100". If the dial reading is less than "100", *compress* the turns of inductor 716.

(9) Tune the receiver to 52 megacycles. Set the "MEGACYCLES" dial on "156" mc. Adjust the trimmer capacitor 713-1 for resonance. A hole is provided for the alignment tool in the shield compartment.

(10) Repeat adjustments of inductor 716 and trimmer capacitor 713-1 as described in paragraphs 18b(8) and 18b(9) until the calibration is on frequency at both ends of the dial.

(11) Remove the coupling wire and connect Plug PL-Q173 of Cord CD-477 to the "R.F. OUTPUT" socket 722-1.

(12) Set receiver and "MEGACYCLES" dial on 100 mc. Adjust power amplifier inductor 717 by compressing or spreading the turns until maximum output is obtained. Take output readings with the variable capacitor assembly cover in place on the shield compartment.

(13) Set receiver tuning and "MEGACYCLES" dial on 156 mc. Adjust trimmer capacitor 713-2 for maximum output. A hole is provided for the alignment tool in shield compartment. The variable capacitor assembly cover must be on for this adjustment.

(14) Repeat adjustments of inductor 717 and trimmer 713-2 as described in paragraphs 18b(12) and 18b(13) until maximum power output is obtained at both ends of the dial.

(15) Insert a 5555.555-kc crystal into the "CRYSTAL" socket (see FIGURE 2). Set the "M.O.-CRYSTAL" switch on "CRYSTAL". Plug Test Set I-139-A into the "METER" socket.

(16) Tune the "CRYSTAL TUNING" control knob 771-4 for a dip in the meter reading of Test Set I-139-A. This will occur at only one point throughout the dial. Tune the "MEGACYCLES" dial (near the "100" mc reading) for a further dip in the meter reading of Test Set I-139-A.

(17) Tune the receiver to the exact frequency using the S METER or an output meter as an indicator. Set "M.O.-CRYSTAL" switch at "M.O." and tune the "MEGACYCLES" dial for maximum output.

SERVICING AND REPAIR

(18) Loosen the set screws on the "MEGACYCLES" dial hub. Set dial on the "100" mc mark. Tighten set screws. Check calibration at 100 mc, 120 mc, 140 mc, and 156 mc.

(19) If the calibration is off more than one half of any one megacycle division, the coil and trimmer adjustments will have to be done over again.

(20) After all adjustments are satisfactorily completed, the knobs should be removed, the front panel mounted, and the knobs replaced. Apply glyptal to set screws on all knobs, except the "CRYSTAL TUNING" control knob 771-4, and tighten the set screws.

c. Alignment of Crystal Tuning Capacitor 714

(1) Place the "M.O.-CRYSTAL" switch on "CRYSTAL". Place a 5555.555-kc crystal in the "CRYSTAL" socket (see FIGURE 2). Test Set I-139-A should be plugged into the "METER" socket. Tune the "CRYSTAL TUNING" control knob 771-4 for a small dip in the meter reading of Test Set I-139-A, and set pointer exactly at "100" mc.

(2) Place an 8666.666-kc crystal in the "CRYSTAL" socket. Tune the "CRYSTAL TUNING" control for a small dip in the meter reading, and set the pointer exactly at "156" mc.

(3) If calibration is off more than one half of any one dial division, carefully bend the outside plate of variable capacitor 714. Recheck at 100 and 156 mc.

(4) When the "CRYSTAL TUNING" calibration is completed, apply glyptal and tighten set screws of knob 771-4. Check performance as described in paragraph 19.

19. POWER OUTPUT MEASUREMENTS

Make the following performance tests on Signal Generator I-130-A. Use a *good* ground connection on all equipments. New batteries must be used in Battery Box BX-33-A.

a. R-F Output (Using Master Oscillator)

(1) Plug one end of Cord CD-477 into the signal generator "R.F. OUTPUT" socket and connect the other end to the antenna binding post of a Hallicrafter S-27 receiver or equivalent, using a short length of No. 14 wire. Turn the receiver BFO control "OFF" and place the signal generator "OUTPUT STEPS" control and "OUTPUT CONTROL" in the extreme clockwise position. Set the "M.O.-CRYSTAL" switch at "M.O.". Set the "MEGACYCLES" dial control at the desired frequency and very accurately tune the receiver to the signal-generator output frequency. Record the reading of the receiver carrier indicator meter.

(2) Remove Cord CD-477 from the signal-generator "R.F. OUTPUT" socket and connect it to the output binding posts of a Ferris Signal Generator, Model 18C, or equivalent. With the modulation on, tune the Ferris 18C to the same frequency as that of Signal Generator I-130-A. Adjust the Ferris 18C output voltage to give a reading on the receiver carrier indicator meter equal to the reading obtained in (1) above.

(3) Record the output-voltage reading of the Ferris Signal Generator. This is the master oscillator output voltage of Signal Generator I-130-A.

<i>R-F OUTPUT (USING MASTER OSCILLATOR)</i>		
<i>Test Frequency</i>	<i>Output</i>	
	<i>Normal</i>	<i>Minimum</i>
100 mc	72,000 μ V	5000 μ V
156 mc	75,000 μ V	5000 μ V

b. R-F OUTPUT (Using Crystal Oscillator)

(1) Set the signal-generator "M.O.-CRYSTAL" switch at "CRYSTAL" and place the plug of Test Set I-139-A into the "METER" socket. With a crystal of the desired frequency in-

SERVICING AND REPAIR

stalled in the "CRYSTAL" socket, adjust the "CRYSTAL TUNING" control to the eighteenth harmonic of the crystal. With this control set at the frequency which results in a dip in the test set, adjust the "MEGACYCLES" dial control for an additional dip at approximately the same frequency. Very accurately tune the Hallicrafter S-27 receiver to the signal-generator output frequency. Record the reading of the receiver carrier indicator meter.

(2) Repeat the procedure given in paragraphs 19a(2) and 19a(3).

<i>R-F OUTPUT (USING CRYSTAL OSCILLATOR)</i>		
<i>Test Frequency</i>	<i>Output</i>	
	<i>Normal</i>	<i>Minimum</i>
100 mc	39,000 μV	5000 μV
156 mc	25,000 μV	5000 μV

SECTION V

APPENDIX

20. Table of Replaceable Parts
21. Interchangeable Parts
22. RMA Color Code for Resistors and Capacitors
23. Addresses of Manufacturers

20. TABLE OF REPLACEABLE PARTS

As a result of shortages of critical materials, it may be necessary for the contractor to substitute less critical materials in some instances. The data supplied in this book regarding electrical parts is correct as of the date of publication.

To assure that adequate replacement parts are obtained, it is imperative that replacement parts be ordered not only by the contractor's drawing number as it appears in the instruction book but also by the Ref. No. assigned to a particular part.

a. Field Strength Meter I-95-A (British Ref. No. 110S/20)

Circuit Ref. No.	Stock No.	Name	Description	Function	Mfr.	Drawing Numbers		British Ref. No.
						Bendix	Signal Corps	
501		Capacitor	.001 mfd $\pm 5\%$, Mica, 500V DCW, C.D. Type 1WL, Aero Type 1467, Mica Type W	Grid Isolating	C. D., Aero, Mica	A102967-2*		110C/2992
502		Capacitor	Eff. Cap. 13 mmf ± 1 mmf Variable, Special	Resonating	Bendix	AL73610-1		110C/3376
503		Inductor	2 Turns, Special	Resonating	Bendix	AC58277-1		110C/2963
504		Milliammeter	0-1 MA D-C, Type 506	Tuning Meter	Weston	C58225-1		110C/434
505		Resistor	600 Ω , Variable, WW, Type W, Modified	Meter Balancing	I. R. C.	A28257-1		110C/283
506		Resistor	1 meg. $\pm 5\%$, $\frac{1}{2}$ W, Ceramic	Grid Loading	Erie	A18004-105		110C/1677
507		Resistor	1000 Ω $\pm 5\%$, 1W, Ceramic	Limiting	Erie	A18158-102		110C/2922
508		Switch	SPST, Toggle	"ON-OFF" Switch	H. & H.	A104049		110F/505
509		"TUNING" Dial	100-156 mc, Knob and Dial Assembly	Tuning	Bendix	C58468		110M/2316
510		Socket, Tube	7-Contact, Miniature, Type 78-7PT	For Tube VT-172	Amph.	A102980		110H/933
511		Terminal Strip	3-Contact, Type 5-7	Battery and Cable Connection	Jones	A103928		110M/2330
512		Antenna	27 $\frac{1}{4}$ " Extended, 7 $\frac{1}{32}$ " Retracted	Signal Reception	Ward Prod	C58162		110B/211
VT-172		Vacuum Tube	Diode Pentode, Type 1S5	Diode Rectifier and Voltage Amp.	RCA, Ken. .			110E/181

b. Signal Generator I-130-A

701-1		Capacitor	250 mmf $\pm 5\%$, 500V DCW, Mica, C.D. Type 5 WL, Aero Type 1468	Master Osc. Grid	C.D., Aero	C56312-251		110C/2126
701-2		.	Same as 701-1	Power Amp. Screen Bypass

* Some F. S. Meters are equipped with an equivalent C.D. capacitor, Bendix Drwg. No. A14237-8

Circuit Ref. No.	Stock No.	Name	Description	Function	Mfr.	Drawing Numbers		British Ref. No.
						Bendix	Signal Corps	
702-1		Capacitor	.001 mfd $\pm 5\%$, 500V DCW, Mica, C.D. Type 5WL, Aero Type 1468	Master Osc. Fil. Bypass	C.D., Aero	C56314-102 (Alternate Bendix part number, C60288-102)	110C/2957	
702-2	.		Same as 702-1	Master Osc. Plate Filter Bypass	.	.	.	
702-3	.		Same as 702-1	Distortion Amp. Cathode Bypass	.	.	.	
702-4	.		Same as 702-1	Distortion Amp. Screen Bypass	.	.	.	
702-5	.		Same as 702-1	Power Amp. HV Bypass	.	.	.	
702-6	.		Same as 702-1	Crystal Osc. Screen Bypass	.	.	.	
702-7	.		Same as 702-1	Crystal Osc. HV Bypass	.	.	.	
702-8	.		Same as 702-1	Power Amp. Fil. Bypass	.	.	.	
703-1		Capacitor	50 mmf ± 2.5 mmf, Ceramic, Type N680K	Master Osc. Plate Blocking	Erie	A18182-7	110C/22	
703-2	.		Same as 703-1	Distortion Amp. Plate Coupling	.	.	.	
703-3	.		Same as 703-1	Distortion Amp. Grid Coupling	.	.	.	
703-4	.		Same as 703-1	Power Amp. Grid Coupling	.	.	.	
704-1		Capacitor	15 mmf ± 0.5 mmf, Ceramic, Type NPOL	Crystal Osc. Feedback	Erie	A18182-18	110C/2935	
704-2	.		Same as 704-1	R-F Crystal Shunt	.	.	.	
705		Capacitor	50 mmf $\pm 2\%$, 500V DCW, Mica, C.D. Type 5WL, Aero Type 1468	Crystal Osc. Cathode Bypass	C.D., Aero	C56313-500	110C/2956	
706-1		Capacitor	.003 mfd $\pm 5\%$, 500V DCW, Mica, C.D. Type 1WL, Aero Type 1467	Crystal Osc. Plate Blocking	C.D., Aero	C56311-302	110C/2954	
707		Capacitor	.005 mfd $\pm 5\%$, 300V DCW, Mica, C.D. Type 1WL, Aero Type 1467	Mod. Feedback	C.D., Aero	C56311-502	110C/2955	
708-1		Capacitor	.01 mfd $\pm 5\%$, 300V DCW, Mica, C.D. Type 1WL, Aero Type 1467	Mod. Grid Coupling	C.D., Aero	C56311-103	110C/121	
712A	}	Capacitor	2-Section, Variable, Stators in Series, Cap Each Section 6.2 mmf Min, 36.0 mmf Max	Master Osc. Grid or Distortion Amp. Plate Tuning	G. Inst.	L73318	110C/2987	
712B				Power Amp. Plate Tuning				
713-1		Capacitor	Variable	Trimmer for 712A	G. Inst.	Part of L73318	.	
713-2	.		Same as 713-1	Trimmer for 712B	.	Part of L73318	.	

APPENDIX

Par. 20b

Circuit Ref. No.	Stock No.	Name	Description	Function	Mfr.	Drawing Numbers		British Ref. No.
						Bendix	Signal Corps	
714		Capacitor	Variable, 3.5 mmf Min, 45 mmf Max, Type HF	Crystal Osc. Plate Tuning	Hamm	A104841		110C/3027
716		Inductor	7 turns #12 Silver Plated Copper Wire	Distortion Amp. Plate or Master Osc. Grid Tuning	Bendix	A105972		110C/3028
717		Inductor	3 Turns #14 Silver Plated Copper Wire	Power Amp. Plate Tuning	Bendix	A105973		110C/3029
718		Inductor	1/2 Turn #14 Silver Plated Copper Wire	Coupling, Power Amp. to "R.F. OUTPUT" Socket	Bendix	AA106183-1		110C/3032
719		Inductor	4 μH ±2%, 23 Turns #24 A.W.G. Enameled Wire	Crystal Osc. Plate Tuning	Bendix	AC58786-1		110C/2975
722-1		Socket	1-Contact	"R.F. OUTPUT" Socket	Bendix	AC58136-1		110H/585
726-1		Resistor	20,000Ω ±5%, 1/4W, Ceramic	Master Osc. Grid Bias	Erie	A18001-203		110C/2898
726-2	.		Same as 726-1	Crystal Osc. Screen Bias
726-3	.		Same as 726-1	Distortion Amp. Plate Dropping
726-4**	.		Same as 726-1	Distortion Amp. Screen Dropping
727-1		Resistor	5000Ω ±5%, 1/4W, Ceramic	Master Osc. Plate Dropping	Erie	A18001-502		110C/2900
727-2	.		Same as 727-1	Master Osc. Plate Filter
728-1		Resistor	500,000Ω ±5%, 1/4W, Ceramic	Crystal Oscillator Grid Leak	Erie	A18001-504		110C/301
728-2	.		Same as 728-1	Distortion Amp. Grid Bias
728-3	.		Same as 728-1	Power Amp. Grid Bias
729		Resistor	200Ω ±5%, 1/4W, Ceramic	Distortion Amp. Cathode Bias	Erie	A18001-201		110C/2897
730**		Resistor	60,000Ω ±5%, 1/4W, Ceramic	Distortion Amp. Screen Dropping	Erie	A18001-603		110C/2901
731		Resistor	25,000Ω ±5%, 1/4W, Ceramic	Power Amp. Screen Dropping	Erie	A18001-253		110C/2899
732		Resistor	100,000Ω ±5%, 1/4W, Ceramic	Modulator Grid Leak	Erie	A18001-104		110C/1212
742		Resistor	3.95Ω ±1%, 5W, WW, Ceramic Form, Type 181	Meter Shunt	Shall	A18254-8		110C/2942
744-1		Resistor	5000Ω ±5%, 1/4W, Ceramic, Part of 756	R-F Output Attenuator	Erie	A18001-502		110C/2900
744-2	.		Same as 744-1	R-F Output Attenuator
744-3	.		Same as 744-1	R-F Output Attenuator

** Earlier models of Signal Generators use Ref. No. 730 in place of Ref. No. 726-4

Circuit Ref. No.	Stock No.	Name	Description	Function	Mfr.	Drawing Numbers		British Ref. No.
						Bendix	Signal Corps	
744-4	.		Same as 744-1	R-F Output Attenuator
744-5	.		Same as 744-1	R-F Output Attenuator
744-6	.		Same as 744-1	R-F Output Attenuator
744-7	.		Same as 744-1	R-F Output Attenuator
744-8	.		Same as 744-1	R-F Output Attenuator
748	Reactor		8.5 μ H \pm 5%, 40 Turns #28 A. W. G. Enameled Wire	Master Osc. Filament Choke	Bendix	AC58902-1		110C/2977
749	Reactor		58 μ H \pm 5%, 95 Turns #38 A. W. G. Enameled Wire	Master Osc. Plate Choke	Bendix	AC58903-1		110C/2978
750-1	Reactor		1.7 MH \pm 3%, 125 MA, 40 Ω , Universal Winding, Treated by Bendix	Crystal Osc. Cathode Choke	Coto	A1666-1		110C/2894
750-2	.		Same as 750-1	Crystal Osc. Plate Choke
752	Switch		DPDT, 1-Section, 2-Position, Type H	"M.O.-CRYSTAL"	Oak	C58769		110F/496
756	Switch		2-Pole, 5-Position, 1-Section, Type H	"OUTPUT STEPS"	Oak	C58798		110F/497
757	Potentiometer		5000 Ω , Type J Bradleyometer	Signal Attenuator	Allen-B	A106184		110C/3033
764-3	Terminal Strip		9-Terminal, #9-140	R-F Sig. Gen. Cable Connections	Jones	C58669		110M/2320
764-5	Terminal Strip		7-Terminal, #7-140	Modulator, Cable Connections	Jones	C59297		110M/2732
765	Transformer		Freq. 500 & 1000 cps; Turns Ratio 3-1; Resistance Primary 625 Ω , Secondary 250 Ω ; Inductance Primary & Secondary in Series, 4.83H	Modulator	Bendix	A103062		110K/715
767	Socket		2-Contact	Test Set Connection	Bendix	AA107514		110H/939
768	Switch		DPST, Toggle	"POWER ON OFF"	H & H	A106048		110F/506
769	Socket		4-Contact	Power Input	Bendix	AA102436-4		110H/920
770	Knob		Tuning Knob, Modified	"MEGACYCLES" Dial Control	G.R.	A106047		110M/2339
771-1	Knob		Knob and Pointer Assembly	"OUTPUT STEPS" Control	G.R.	A106046		110M/2338
771-2	.		Same as 771-1	"OUTPUT CONTROL"
771-3	.		Same as 771-1	"M.O.-CRYSTAL" Switch
771-4	.		Same as 771-1	"CRYSTAL TUNING" Control
772	Bushing		1/2" OD, Isolantite, Wax Treated	Insulating	Isol.	A4143		110M/1831

Circuit Ref. No.	Stock No.	Name	Description	Function	Mfr.	Drawing Numbers		British Ref. No.
						Bendix	Signal Corps	
773		Cord CD-477	Coaxial Cable, 5 ft. Long, Includes One Plug PL-P173 and One Plug PL-Q173	R-F Transmission Line	Bendix	AL72996-3		110H/848
774		Resistor & Capacitor Board	Board, Complete with Terminals and Ref. No's. 702-7, 705, 726-2, 726-3, 730, 750-1 and 750-2	Circuit Component Mounting	Bendix	AC58799-1		110A/469
775		Variable Capacitor Assembly	Complete Assembly of Master Osc. and Power Amp. Circuit Components	See Text	Bendix	AN91152-1		110C/3375
784-1		Socket, Tube	7-Contact, Molded Bakelite, Type 78-7PT, Complete with Type 2-9 Retainer Ring	For Tube VT-203, Crystal Osc.	Amph.	A102980		110H/933
784-2	.		Same as 784-1	For Tube VT-203, Distortion Amp.
784-3	.		Same as 784-1	For Tube VT-202, Master Osc.
784-4	.		Same as 784-1	For Tube VT-203, Power Amp.
784-5	.		Same as 784-1	For Tube VT-202, Modulator
VT-202		Vacuum Tube	Detector Amplifier Triode, Type 9002	Modulator	RCA, Ken.	.	.	110E/188
VT-203		Vacuum Tube	Super-Control Amplifier Pentode, Type 9003	Power Amplifier	RCA, Ken.	.	.	110E/189
VT-203		Vacuum Tube	Super-Control Amplifier Pentode, Type 9003	Distortion Amplifier	RCA, Ken.	.	.	110E/189
VT-203		Vacuum Tube	Super-Control Amplifier Pentode, Type 9003	Crystal Oscillator	RCA, Ken.	.	.	110E/189
VT-202		Vacuum Tube	Detector Amplifier Triode, Type 9002	Master Oscillator	RCA, Ken.	.	.	110E/188

Circuit Ref. No.	Stock No.	Name	Description	Function	Mfr.	Drawing Numbers		British Ref. No.
						Bendix	Signal Corps	
c. Test Set I-139-A								
739		Resistor	49Ω ±1%, 5W, WW, Ceramic Form, Type 181	MA Multiplier	Shall	A18254-4		110C/2939
759		Milliammeter	0-1 MA D-C, Aircraft Movement, Type 506	Circuit Meter	Weston	C58225-1		110A/434
777		Shield	2 9/16 Diameter, Brass	Meter Crystal Shield	Elec. Spec.	A103900		110M/2573
785		Plug	2-Contact	Test Set Plug	Bendix	AC58220-1		110H/1186
d. Battery Box BX-33-A								
1300		Terminal Strip	8-Contact, #8-7	Battery Connections	Jones	A107517		110M/2305
1301		Plug	4-Contact, PL-P167	Battery Cable Plug	Amph.	AC57974-8		10H/403
1302		Cable Clamp	5/8-24 Threads, Cat. No. AN3057-4	Clamp	Amph.	A107649		110M/2764
1303		Adapter	5/8-24 Threads, 11/16-24 Tap	Plug Adapter	Bendix	A107648		110M/2763
e. Set of Special Tools								
.		Spanner Wrench	Stamped "FOR LARGE PLUG"	Plug Disassembly	Bendix	A104821		110M/2336
.		Spanner Wrench	Stamped "FOR MEDIUM PLUG"	Plug Disassembly	Bendix	A104820		110M/2335
.		Spanner Wrench	Stamped "FOR SMALL PLUG"	Plug Disassembly	Bendix	A104819		110M/2334
.		Tool Roll	Approximately 17 3/4" x 7 5/8" in Open Pos., Loops for 15 Tools; for T-51 Spintite Set	Tool Holder	Walden	C58480		110M/2317
.		Set Screw Wrench	For #6 Four-Flute Bristo Set Screw	.	Bristol	A107573		110M/2342
.		Set Screw Wrench	For #10 Allen Set Screw	.	Allen	A18190-10		110M/2311
.		Lamp Cap Remover	Cat. No. TA-44	Lamp Cap Remover	Electric Sales	A104356		110M/2333
.		Lamp Extractor	Part 553A	Lamp Extractor	W. E.	A104355		110M/2332
.		Alignment Tool	Type TL-138B	Alignment Tool	Bendix	AB13045		110M/818
.		Set Screw Wrench	For #8 Allen Set Screw	.	Allen	A18190-8		110M/2731

APPENDIX

21. INTERCHANGEABLE PARTS

Tube socket 510 of Field Strength Meter I-95-A is identical with tube sockets 784 of Signal Generator I-130-A.

Meter 504 of Field Strength Meter I-95-A is identical with meter 759 of Test Set I-139-A.

22. RMA COLOR CODE FOR RESISTORS AND CAPACITORS

Color	Significant Figure	Decimal Multiplier	Tolerance	Voltage Rating
Black	0	1
Brown	1	10	1%	100 Volts
Red	2	100	2%	200 Volts
Orange	3	1,000	300 Volts
Yellow	4	10,000	400 Volts
Green	5	100,000	5%	500 Volts
Blue	6	1,000,000	600 Volts
Violet	7	10,000,000	700 Volts
Gray	8	100,000,000	800 Volts
White	9	1,000,000,000
Gold	—	0.1	5%
Silver	—	0.01	10%
No Color	—	—	20%	500 Volts

RESISTORS

The nominal resistance value of fixed composition resistors is indicated in two manners. The one in most common use indicates the value by bands of color, as follows:

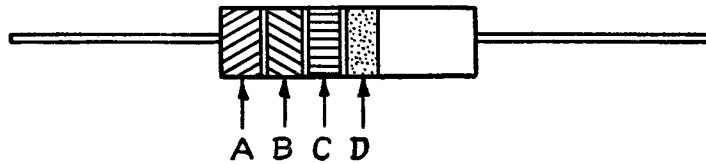

Band A indicates the first significant figure of the resistance of the resistor.

Band B indicates the second significant figure.

Band C indicates the decimal multiplier.

Band D, if any, indicates the tolerance limits about the nominal resistance value.

The least common system used for indicating nominal resistance value is as follows:

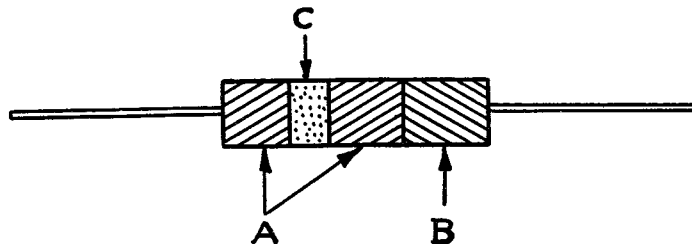

The body (A) of the resistor is colored to represent the first significant figure of the resistance value. One end (B) is colored to represent the second significant figure, and a band or dot (C) of color, located within the body color, indicates the decimal multiplier.

APPENDIX

CAPACITORS

Two systems for color coding small fixed capacitors are in use. In either case, capacity is expressed in micromicrofarads, and some means to avoid ambiguity in interpretation of colors is provided. An arrow pointing from left to right, or the manufacturer's name is generally used.

In general, capacitors having a working voltage of 500 volts are coded by means of three dots of color as follows:

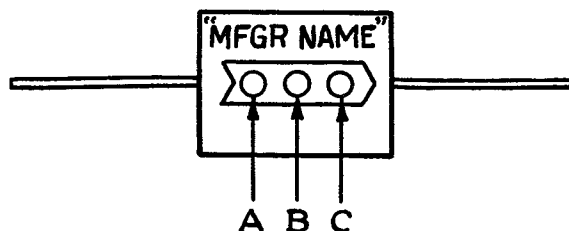

Dot A indicates the first significant figure of the capacitance of the capacitor.

Dot B indicates the second significant figure.

Dot C indicates the decimal multiplier.

An additional dot is sometimes shown when the working voltage is other than 500 volts. This dot indicates the voltage rating of the condenser.

A second system now coming into common use involves six dots of color as follows:

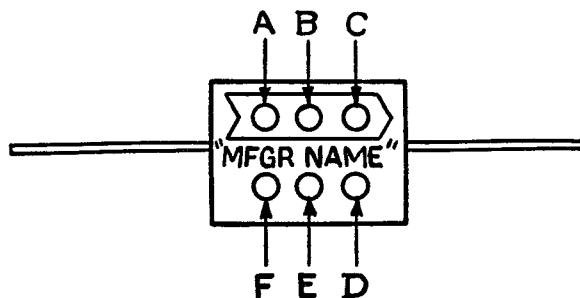

Dot A indicates the first significant figure of the capacitance of the capacitor.

Dot B indicates the second significant figure.

Dot C indicates the third significant figure.

Dot D indicates the decimal multiplier.

Dot E indicates the tolerance about the nominal capacitance value.

Dot F indicates the voltage rating of the capacitor.

APPENDIX

23. ADDRESSES OF MANUFACTURERS

<i>Abbreviation</i>	<i>Manufacturer</i>	<i>Address</i>
Allen	Allen Manufacturing Co.	Hartford, Conn.
Allen-B	Allen-Bradley Co.	Milwaukee, Wis.
Amph.	American Phenolic Corp.	1250 Van Buren St., Chicago, Ill.
Bendix	Bendix Radio Division of Bendix Aviation Corporation	Baltimore, Maryland
Bristol	Bristol Company	Waterbury, Conn.
C. D.	Cornell-Dubilier Electric Corporation	1000 Hamilton Blvd., S. Plainfield, N. J.
Coto	Coto Coil Company	73 Williard St., Providence, R. I.
Electric Sales	American Automatic Electric Sales Co.	1033 W. Van Buren St., Chicago, Ill.
Elec. Spec.	Electric Speciality Mfg. Co.	Cedar Rapids, Iowa
Erie	Erie Resistor Corporation	644 West 12th St., Erie, Pennsylvania
G. Inst.	General Instrument Corp.	829 Newark Ave., Elizabeth, N. J.
G. R.	General Radio Company	30 State St., Cambridge, Mass.
Hamm	Hammarlund Mfg. Co., Inc.	424 W. 33rd St., New York, N. Y.
H & H	Arrow-Hart & Hegeman Co.	3201 Arch St., Philadelphia, Penna.
Isol.	Isolantite, Inc.	Belleville, N. J.
I. R. C.	International Resistance Co.	401 N. Broad St., Philadelphia, Penna.
Jones	Howard B. Jones Company	2300 Wabansia Ave., Chicago, Ill.
Ken.	Ken-Rad Tube and Lamp Corp.	Owensboro, Ky.
Oak	Oak Manufacturing Co.	1260 S. Clybourne Ave., Chicago, Ill.
RCA	RCA Radiotron Div., RCA Manufacturing Co., Inc.	401 Bergen St., Harrison, N. J.
Shall	Shallcross Manufacturing Co.	700 Parker Ave., Collingdale, Pa.
Walden	The Stevens Walden Mfg. Co.	Worcester, Mass.
Ward Prod	Ward Products Corp.	1523 E. 45th St., Cleveland, Ohio
W. E.	Western Electric Co.	300 Central Ave., Kearney, N. J.
Weston	Weston Electric Instrument Corp.	Frelinghuysen Ave., Newark, N. J.

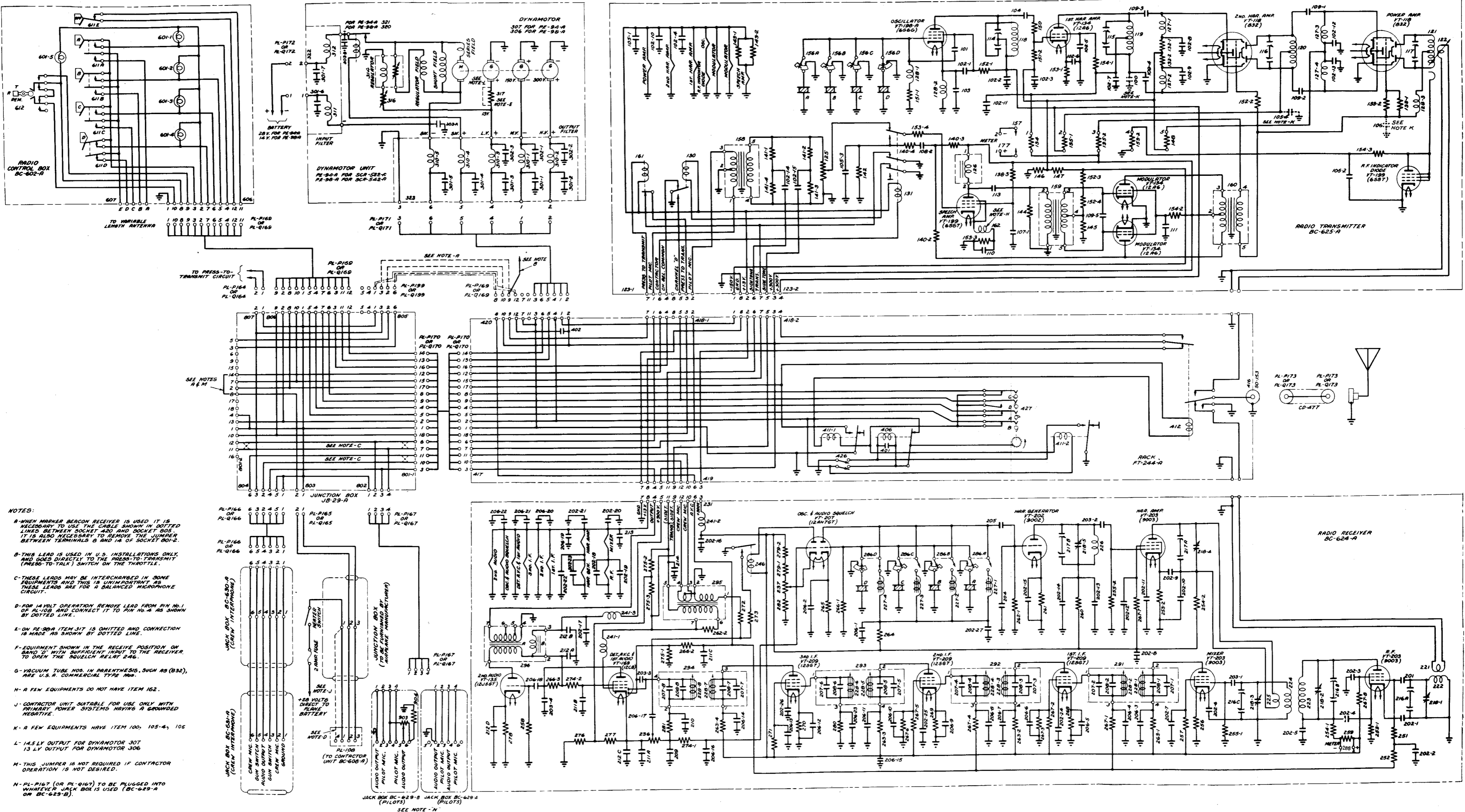

- NOTES:**
- A-WHEN MARKER BEACON RECEIVER IS USED IT IS NECESSARY TO USE THE CABLE SHOWN IN DOTTED LINES BETWEEN SOCKET 420 AND SOCKET 805. IT IS ALSO NECESSARY TO REMOVE THE JUMPER BETWEEN TERMINALS 8 AND 14 OF SOCKET 801-E.
 - B-THIS LEAD IS USED IN U.S. INSTALLATIONS ONLY, AND GOES DIRECTLY TO THE PRESS-TO-TRANSMIT (PRESS-TO-TALK) SWITCH ON THE THROTTLE.
 - C-THese LEADS MAY BE INTERCHANGED IN SOME EQUIPMENTS AND THIS IS UNIMPORTANT AS THESE LEADS ARE FOR A BALANCED MICROPHONE CIRCUIT.
 - D-FOR 14 VOLT OPERATION REMOVE LEAD FROM PIN NO. 1 OF PL-108 AND CONNECT IT TO PIN NO. 4 AS SHOWN BY DOTTED LINE.
 - E-ON PE-90A ITEM 317 IS OMITTED AND CONNECTION IS MADE AS SHOWN BY DOTTED LINE.
 - F-EQUIPMENT SHOWN IN THE RECEIVE POSITION ON SAND 'D' WITH SUFFICIENT INPUT TO THE RECEIVER, TO OPEN THE SQUELCH RELAY 246.
 - G-VACUUM TUBE MOD. IN PARENTHESIS, SUCH AS (B32), ARE U.S.A. COMMERCIAL TYPE NOS.
 - H-A FEW EQUIPMENTS DO NOT HAVE ITEM 162.
 - J-CONTRACTOR UNIT SUITABLE FOR USE ONLY WITH PRIMARY POWER SYSTEMS HAVING A GROUNDED NEGATIVE.
 - K-A FEW EQUIPMENTS HAVE ITEM 100; 105-4, 106.
 - L-14.5 LV OUTPUT FOR DYNAMOTOR 307
13 LV OUTPUT FOR DYNAMOTOR 306
 - M-THIS JUMPER IS NOT REQUIRED IF CONTRACTOR OPERATION IS NOT DESIRED.
 - N-PL-167 (OR PL-167) TO BE PLUGGED INTO WHATEVER JACK BOX IS USED (BC-629-A OR BC-629-B).

FIGURE 32—RADIO SETS SCR-522-A AND SCR-542-A, COMPLETE SCHEMATIC CIRCUIT DIAGRAM