

Please do not upload this copyright pdf document to any other website. Breach of copyright may result in a criminal conviction.

This pdf document was generated by me Colin Hinson from a Crown copyright document held at R.A.F. Henlow Signals Museum. It is presented here (for free) under the Open Government Licence (O.G.L.) and this pdf version of the document is my copyright (along with the Crown Copyright) in much the same way as a photograph would be.

The document should have been downloaded from my website <https://blunham.com/Radar>, or any mirror site named on that site. If you downloaded it from elsewhere, please let me know (particularly if you were charged for it). You can contact me via my Genuki email page: <https://www.genuki.org.uk/big/eng/YKS/various?recipient=colin>

You may not copy the file for onward transmission of the data nor attempt to make monetary gain by the use of these files. If you want someone else to have a copy of the file, point them at the website. (<https://blunham.com/Radar>). Please do not point them at the file itself as it may move or the site may be updated.

It should be noted that most of the pages are identifiable as having been processed by me.

I put a lot of time into producing these files which is why you are met with this page when you open the file.

In order to generate this file, I need to scan the pages, split the double pages and remove any edge marks such as punch holes, clean up the pages, set the relevant pages to be all the same size and alignment. I then run Omnipage (OCR) to generate the searchable text and then generate the pdf file.

Hopefully after all that, I end up with a presentable file. If you find missing pages, pages in the wrong order, anything else wrong with the file or simply want to make a comment, please drop me a line (see above).

It is my hope that you find the file of use to you personally – I know that I would have liked to have found some of these files years ago – they would have saved me a lot of time !

Colin Hinson

In the village of Blunham, Bedfordshire.

A.P. 2528A

Volume I

SECOND EDITION

Superseding A.P.2528A, provisional
issue, dated January 1944.

JULY 1945

TRANSMITTER-RECEIVER, TR.1143A.

*Prepared by direction of the
Minister of Aircraft Production*

Howard Sate

*Promulgated by order of the
Air Council*

A. S. H. [Signature]

AIR MINISTRY

NOTE TO READERS

Air Ministry Orders and Vol. II, Part 1 leaflets either in this A.P., or in the A.P.'s listed below, or even in some others, may affect the subject matter of this publication. Where possible, Amendment Lists are issued to bring this volume into line, but it is not always practicable to do so, for example, when a modification has not been embodied in all the stores in service.

When an Order or leaflet is found to contradict any portion of this publication, the Order or leaflet is to be taken as the over-riding authority.

When this volume is amended by the insertion of new leaves the new or amended technical information is indicated by a vertical line in the outer margin. This line is merely to denote a change and is not to be taken as a mark of emphasis.

Each such leaf is marked in the top left-hand corner of the right hand page with the number of the A. L. with which it was issued.

LIST OF PUBLICATIONS ON ASSOCIATED EQUIPMENT

Air Diagram 2528	TR.1143A — Circuit and Interconnection Diagram. One of these should be obtained by the reader for use in conjunction with this book.
A.P.2879J	Test Set, Type 145.
A.P.2528E	V.H.F. Beam Approach Airborne Equipment.
A.P.1186D	Electrical Equipment (Airborne).

TRANSMITTER-RECEIVER, TR.1143A

LIST OF CONTENTS

	<i>Para.</i>		<i>Para.</i>
Concise details		Electric controller type 3	83
Introduction	1	Mechanical action of controller	88
General description	6	Control circuits	94
Associated equipment	9	The ON-OFF circuit	95
Essential associated equipment	10	The T-R control (relay A-R)	96
Aerial	11	The press-to-transmit control (relay C)	98
Microphones and telephones	12	MCW control (relay F)	99
Electric controller type 3	14	Channel selection	100
Power unit	15	Channel selection in detail	105
Optional associated equipment	17	F-relay and contactor operation	109
Junction box type 17A or 17B	18	The series-break contacts on the controller	111
Press-to-transmit switch	19	Channel selection mechanism	112
VHF beam approach	20	Mechanical action	113
Morse key	22	Tuning-condenser slide mechanism	116
Nomenclature	23	Slide actuating mechanism	120
Receiver unit type 71	27	The power units type 15 and 16	121
RF amplifier	29	Tuning procedure	123
The local oscillator	33	Transmitter tuning	125
The first detector (or mixer) stage	39	Neutralization	135
The IF stages	41	Receiver tuning	142
The second detector stage	42	Precautions and care	150
The limiter	44	Junction box 17A or 17B	153
Automatic volume control	46	Dismantling	154
The muting circuit	50	Transmitter unit type 50	159
Amplifier unit type 165	54	Receiver unit type 71	173
Amplification of receiver output	58	Amplifier unit type 165	183
The two microphone circuits	62	Relay unit	185
Transmitter modulation	67	Selector motor unit	190
MCW tone generator	68	Main chassis (top tray)	199
Transmitter unit type 50	70	Re-assembling	208
Crystal oscillator	72	Transmitter	216
Frequency multiplier stages	73	Receiver	217
The PA output stage	78	R.T.I.M. No. 625	Appendix I
The main tray (chassis assembly type 13)	80	List of parts	Appendix II

LIST OF ILLUSTRATIONS

	<i>Fig.</i>
TR. 1143A—general view	1
TR. 1143A—top covers slid back	2
Main tray	3
Block-diagram	4
Open-wire installation	5
Standard single-seater installation (showing plug nomenclature)	6
Set plug nomenclature	7
Pilot-crew installation I	8
Pilot-crew installation II	9
Amplifier unit type 165	10
Amplifier unit—underside	11
Electric controller type 3	12
Electric controller type 3 (layout)	13
Control circuits I (On-off, TR and MCW)	14
Control circuits II (motors and H relay)	15
Bench layout for tuning	16
Receiver type 71, circuit	17
Receiver type 71, wiring diagram (on reverse of 17)	18
Amplifier type 165, circuit	19
Amplifier type 165, wiring diagram (on reverse of 19)	20
Transmitter type 50, circuit	21
Transmitter type 50, wiring diagram (on reverse of 21)	22
TR. 1143A—tuning mechanism	23
Perspective of tuning cams (on reverse of 23)	24
Wiring diagram of electric controller, type 3	25
Wiring diagram of tuning motor (on reverse of 25)	26
Wiring diagram of main tray	27
Wiring diagram of relay unit (on reverse of 27)	28
Junction-box type 17A or 17B, circuit	29
Junction-box type 17B, wiring diagram (on reverse of 29)	30
BA amplifier and aerial circuit	31
Power unit type 15 or 16 circuit (on reverse of 31)	32
TR. 1143A, circuit and interconnection diagram	33
Power unit	34

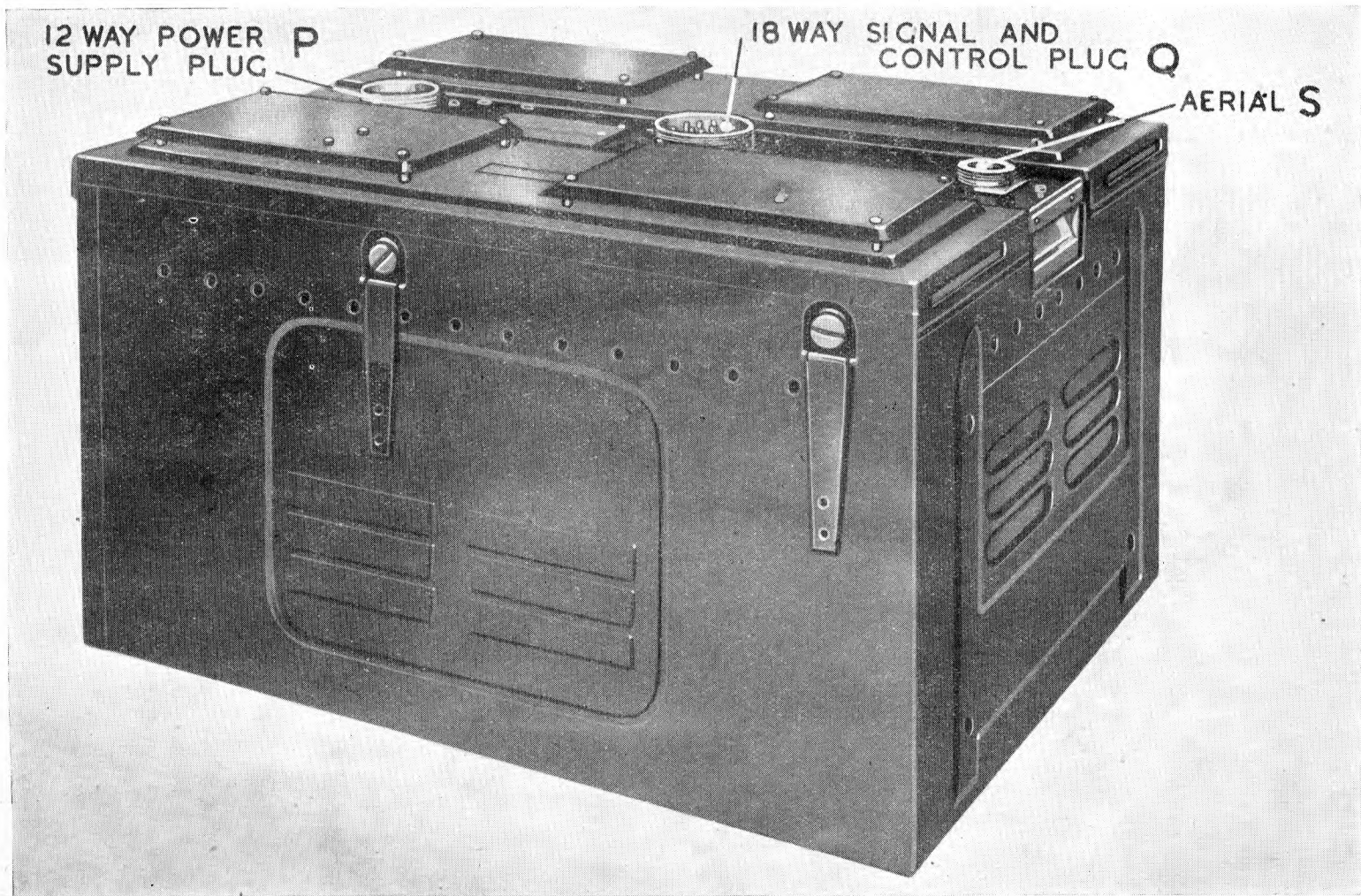

Fig. 1—TR. 1143A—general view.

CONCISE DETAILS TRANSMITTER-RECEIVER TR. 1143A.

Purpose of Equipment	For aircraft communication.		
Special features	Four preset remotely controlled, automatically-tuned frequency channels.		
Type of wave	RT and MCW.		
Frequency range	100-124 Mc/s.		
Frequency stability	Crystal controlled. Separate crystals for Transmitter and Receiver.		
Crystal multiplication factor	18.		
Intermediate Frequency	9.72 Mc/s ($\pm .02\%$).		
Percentage Modulation	100% modulation with 212 volts output from modulator. MCW modulation—greater than 85%.		
Sensitivity	30 microvolts (measured using a 14 ohm source fed through 50 ohms, with muting relay rendered in operative) gives .075 volts receiver output.		
Selectivity	Within the following limits:—80 kc/s overall bandwidth at 6dB down and 280 kc/s overall bandwidth at 40dB. down. The set is intended to work at 180 kc/s channel spacings.		
Output impedance	To match :— (1) 5 pairs of high impedance telephone types 16 (approximately 5,000 ohms). or (2) 5 pairs of low impedance telephones type 32 (approximately 30 ohms).		
Amplifier Class	Intercommunication and Receiver Amplifier Class A. Modulator.—Class AB1. Transmitter Output—Class B.		
Microphone type	Electromagnetic.		
Valves	<i>Receiver type</i> 71.	<i>Amp. type</i> 165.	<i>Transmitter type</i> 50.
	4 VR91	2 VR56 (CV1056)	1 VR53
	1 VT52	1 VR55	1 VT52
	2 VR53	2 VT52	2 VT501 (V3 & V4)
	1 VR55		2 VT501 or VT501A (V5 & V6)
	1 VR92		1 VR92
Power Consumption	215 watts in received condition. 295 watts in transmit condition.		
Power Output	Transmitter—5 watts (with VT501 as V5 and V6). 4 watts (with VT501A as V5 and V6). Amplifier— 200 milliwatts when there is a 100 microvolt input to the receiver.		
Stores Reference	10D/13273.		
Approximate overall dimensions	16 inches by 13 inches by 10½ inches.		
Weight	46 lbs. (excluding power unit).		
Associated Equipment	Controller Electric type 3. (10J/26) Power Unit type 15 or 16 (10K/36 or 10K/37). Junction Box type 17A or 17B. (10A/12649 or 10A/12650). Beam Approach Amplifier type A1271 (10U/549). Suppressor type H No. 2 (5C/1005). Aerial Aircraft type 147 (for metal skinned aircraft) 10B/13339. Aerial Aircraft type 179 (for non-metal skinned aircraft) 10B/1188. Connector Sets to suit Aircraft. Test set type 5A 10S/20. Test set type 11 10S/12049. Test set type 98 10S/13036. Test rig type 30 10S/711. Test set type 145 10S/561.		

TRANSMITTER-RECEIVER, TR.1143A

INTRODUCTION.

1. The Transmitter-receiver TR 1143A is an airborne radio communication equipment which may be operated on any one of four pre-determined frequencies, within the 100 to 124 Mc/s. band. Under normal conditions a range of 125 miles air-to-air or air-to-ground may be expected when the aircraft is at a height of 10,000 ft.

2. Communication is normally by R/T, but arrangements can be made for the radiation of MCW morse transmissions by certain modifications should this be desired. The normal facility is that of contactor operation, where the transmitter radiates an MCW signal, at intervals determined by the contactor, on channel D, reverting to whatever other channel may be in use on the cessation of the contactor impulse. The modulation frequency is approximately 1,000 cycles per second.

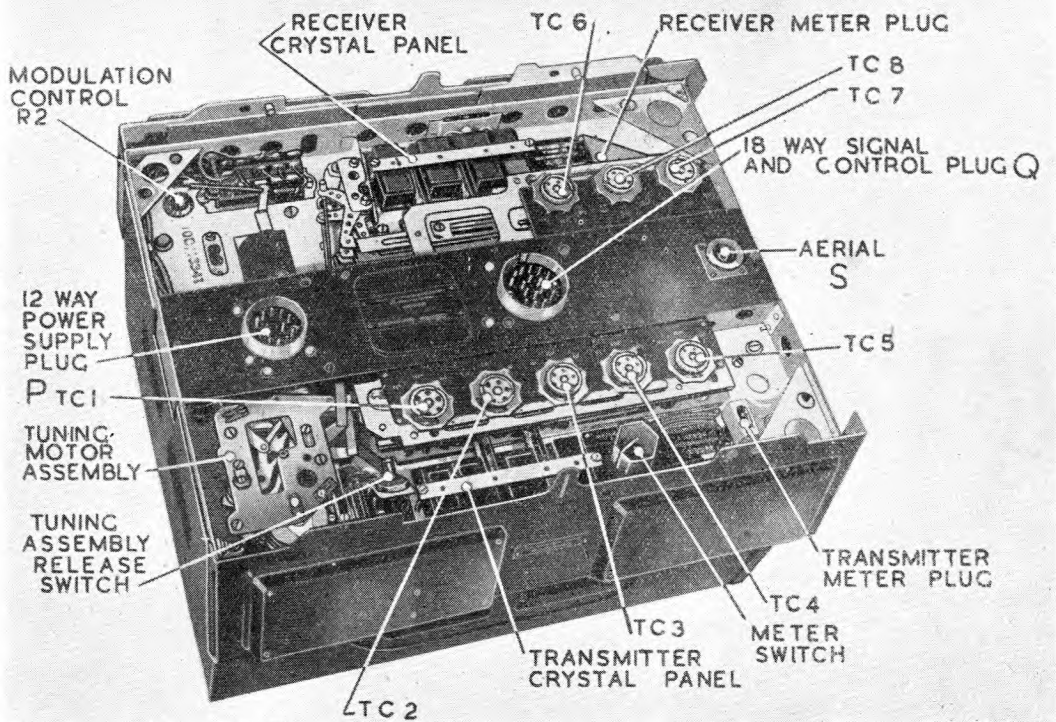

Fig. 2—TR. 1143A—top covers slid back.

3. The TR 1143A requires the connection of a Controller, microphone-telephone head sets, a Power Unit, and a suitable aerial. The Electric Controller has five push buttons—one for switching off the set, and the other four for selection of any one of the four pre-determined frequency channels. A switch is included for changing from the Receive to the Transmit condition.

4. The associated power unit uses a Rotary Transformer. Two types of Power Units are available. One is for a 12 volt DC supply, and the other for a 24 volt DC supply. To change a complete TR 1143A installation from 12 volt working, to 24 volt working, it is therefore only necessary to interchange the low voltage power unit for the higher voltage one.

5. The TR 1143A measures 16 inches by 13 inches and is 10½ inches in depth. The latter measurement includes W-plugs. The weight of the set alone is 46 pounds, but the addition of the associated equipment—Controller, Power Unit, BA Amplifier, Junction Box and interconnection harness, brings the total weight up to approximately 104 lbs.

RECEIVER

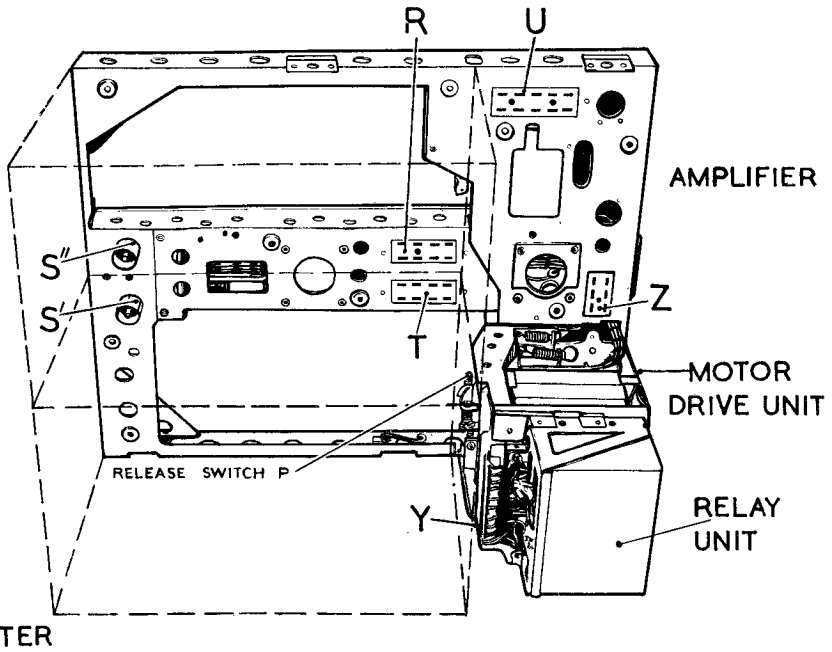

Fig. 3—Main tray.

GENERAL DESCRIPTION

6. The TR 1143A is fixed in a metal case by 4 Dzus fasteners—see figure 1. Figure 2 shows the set after four other small Dzus fasteners have been released, so that the top covers could be slid back. The covers have revealed the Chassis Assembly type 13, usually called the Main Tray, which is constructed of mild steel. This Main Tray is about 1½ inches deep and forms the structural basis of the set, being the frame to which all the individual units are fastened. The central channel section contains the three outgoing plugs: a twelve-pin W-plug P, which connects to the power

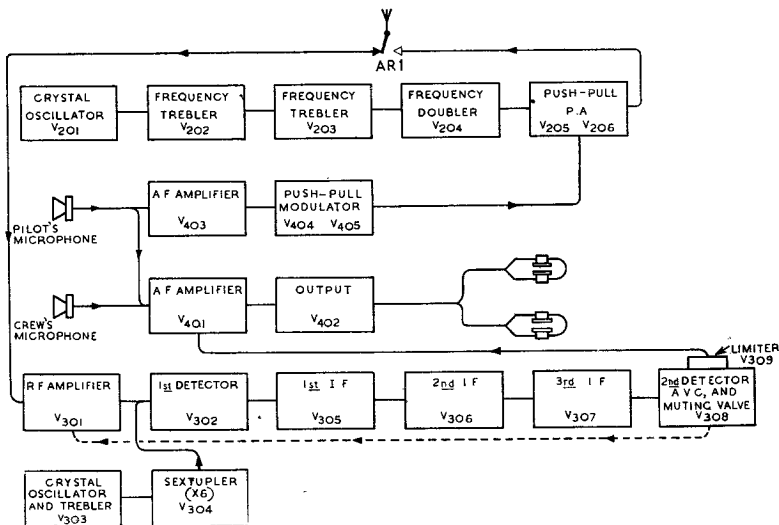

Fig. 4—Block-diagram.

unit, an eighteen-pin W-plug Q which connects with the Controller and the microphones and telephones, and a coaxial socket S for the aerial feeder. On each side of this central panel are the two sliding covers which reveal the Transmitter and Tuning Motors, on one side, and the Receiver and Amplifier on the other side, of the central panel. All the tuning controls and crystals are

then accessible. The other sides of the transmitter-receiver are protected by the metal case. To the reverse side of the Main Tray is secured a relay, two filter networks and eight plugs and sockets. These sockets form the complete electrical connections to the five units of the TR 1143A: the *Transmitter type 50*, the *Receiver type 71*, the *Amplifier type 165*, the *Motor Drive Unit type 12* and the *Relay Unit type 48*.

7. There are no other electrical connections to these units, other than these plugs and sockets, which considerably facilitates the dismantling of the set.

8. Transmitter, Receiver and Amplifier are each fastened by 3 or 4 screws (painted red) to the Main Tray. Figure 3 illustrates the system by which the units are assembled. Figure 27 is a diagram of the *underside* of the Main Tray and gives the wiring details. Figure 33 shows the electrical interconnections and the components.

ASSOCIATED EQUIPMENT.

9. The reader is referred to Figures 5, 6, 8 and 9, which show typical installations of the TR 1143A and its associated equipment.

Essential Associated Equipment.

10. Before a TR 1143A can be used it is necessary to have the following items:—

- (i) Aerial and connectors.
- (ii) Microphone and telephones with connectors.
- (iii) Electric Controller type 3 with connectors.
- (iv) Power unit type 15 or 16 with connectors and an appropriate source of power.

Aerial.

11. It is usual to use an Aircraft aerial type 147 for aircraft with metal skins or an Aircraft aerial type 179 for aircraft which do not have metal skins. However, other aerial systems are in use for specialised aircraft, and the reader should consult the Airframe Publication for the aircraft in question.

Microphones and Telephones.

12. The amplifier of the TR 1143A has been designed for the standard Electromagnetic Microphone. As normally connected, this amplifier has an output impedance of 5,000 ohms, and it will feed satisfactorily up to 5 pairs of British high impedance telephones type 16.

13. However, should it be desired to use British low impedance telephones type 32, an extra tapping point is available on the output transformer, giving an output impedance of 30 ohms. The connection of the outgoing lead to this tapping point will enable up to five pairs of the low impedance telephones to be used. Should it be necessary to use American 600 ohm head sets, it is recommended that the separate ear pieces to these head sets be rewired in parallel, in place of their normal series connection. The telephone sets then present an impedance of 150 ohms, and they can be treated for matching purposes as British low impedance types.

Electric Controller type 3.

14. All the essential controls for the TR 1143A are incorporated in this unit. It has five buttons: A, B, C, D, and OFF. Depression of any of the first four buttons switches on the set, and causes the channel selection mechanism to set the tuning condensers and crystal switches for the corresponding preset frequency. Depression of the last button switches off the set. An additional switch (sometimes called a key) determines whether the set is in the transmit or the receive condition. This switch also controls the optional Press-to-transmit operation. It is normally spring-loaded to stay in the R position, but a catch can be moved to provide locking of the T position. The REM (Press-to-Transmit) position is self-locking at all times. Figure 12 gives a view of this Controller. It is connected to the set via the 12-pin W-plug—at its rear, and the set cannot be operated without proper connection of this controller.

Power Unit.

15. The Power Unit is a rotary transformer with three output circuits. HT (300 volts), GB or MT (150 volts) and LT (12 volts). An on-off switch relay is incorporated and ripple removing networks are included in all of the outgoing and in-going leads. In view of the importance of constant LT voltages for the heaters of the valves of the set, the Power Unit contains a voltage regulator of the carbon-pile type in the LT circuit. The GB and HT voltages are not so regulated.

16. Although separated from the TR 1143A the Power Unit is of such a physical size that it may be neatly mounted adjacent to the transmitter-receiver, and is usually strapped to it. There are two types of Power Units available, and they differ principally in the operating voltages required to drive them. Power Unit type 15 is for 12 volt DC supply systems, while the Power Unit type 16 works on a 24 volt DC supply. Thus no alteration to the TR 1143A itself is required when changing over from the low voltage supply to the higher voltage supply of 24 volts. The Power Unit merely has to be unplugged and replaced by the type 16.

Optional Associated Equipment.

17. Desirable in a TR 1143A installation, but not essential, are the following items:—
- (i) Junction Box type 17A, or 17B.
 - (ii) Press-to-transmit switch.
 - (iii) VHF Beam Approach System.
 - (iv) Morse key, and press for I/C.

Junction Box type 17A or 17B.

18. The TR 1143A can be connected with its associated equipment without use of a junction box (see figure 5) but this is not the usual method. Normal installations are shown in figures 6, 8 and 9, and it will be noted that these use the Junction Box as a focal point for the connections. Two types of Junction Box are available. Their internal connections are identical, but the plugs are reversed in the type 17B so that it is a mirror-image of the type 17A.

Press-to-Transmit Switch.

19. The usual method of changing the TR 1143A from its normal condition of reception to that of transmission, is by depression of the T-R switch on the controller. This switch has a third position—REM, meaning remote control. A press button switch of the type used for firing guns (5D/534) can be mounted in any convenient position, such as on the control column. If this switch is connected to terminals 1 and 5 on plug D of the Junction Box or to plug H of the Junction Box, or to pins 3 and 9 of the plug P on the set itself (see figures 1 and 33) and the switch on the Controller placed at REM, then the press button switch controls the transmit-receive operation of the set. Pressure on the button causes the set to transmit and on release of the button the set reverts to reception. This facility is optional, but it has obvious operational advantages.

VHF Beam Approach.

20. For use on VHF Beam Approach System the TR 1143A requires the addition of Beam Approach Amplifier type A127, and an Aerial System type 62 (this particular aerial system is more than a simple aerial—it includes a diode detecting circuit). This Aerial connects with the Amplifier, and the Amplifier is joined to the main installation via a Connector type 692 to plug G of the Junction Box. An additional BA on-off circuit has to be wired in as well. Figures 31 and 33 give the circuit and installation details of such a Beam Approach System. It should be noted that if a Beam Approach Amplifier is not being used, plug G on the Junction Box must have inserted a dummy socket strapping terminals 8 and 14, or the MCW system will be inoperative.

21. For details of the VHF Beam Approach system the reader is referred to AP 2528E—VHF Beam Approach Airborne Equipment.

Morse Key.

22. The set may, under certain operational conditions, be required to give MCW transmissions. The morse key for sending such transmissions should be connected to plug A—see figure 33. The equipment is set to transmit by the switch on the Controller and the morse key operated in the usual way. No other adjustments are required. *The TR 1143A must have been modified according to R.T.I.M.625 for this use. See paragraph 218.*

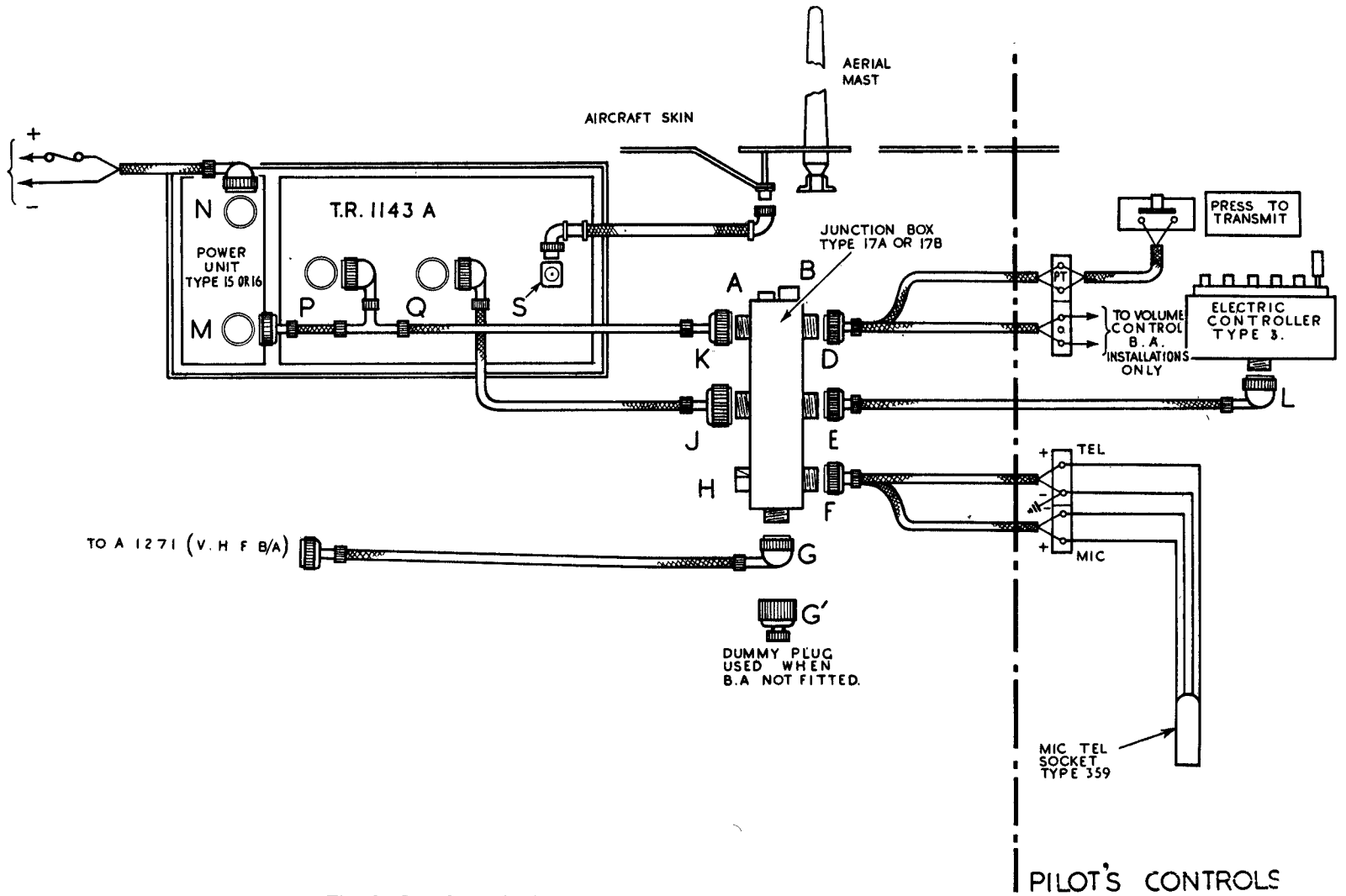

Fig. 6—Standard single-seater installation (showing plug nomenclature).

NOMENCLATURE.

23. The components of the TR 1143A are designated by 3 suffixes, e.g., C501, R239. The "hundreds" figure indicates the particular unit containing the component. Table A shows the units with their associated component designations.

TABLE A.

<i>Unit.</i>	<i>Component Reference.</i>	<i>Unit.</i>	<i>Component Reference.</i>
Power Unit	000 to 099	Receiver	300 to 399
Chassis	100 to 199	Amplifier	400 to 499
Transmitter	200 to 299	Control Motor	500 to 599

24. To avoid congestion the hundreds suffix has been omitted from most of the diagrams and description, but it should be re-inserted by the reader for external reference.

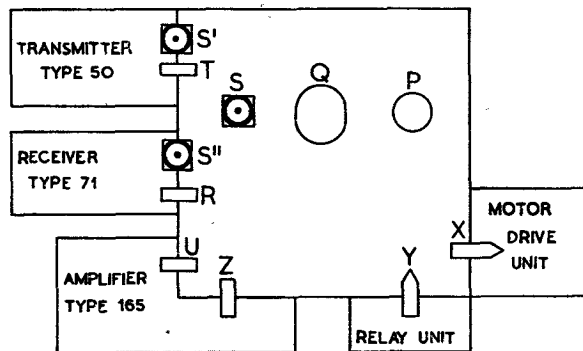

Fig. 7—Set plug nomenclature.

25. Standard detached relay annotation has been used. Relay coils are represented by a small rectangle containing figures showing the resistance of the coils in ohms. Near the rectangle, a reference, e.g., F/3 indicates the letter by which the relay is known and the number of contacts operated by the relay armature. In the text the relay is usually mentioned by its letter only. The actual contacts numbered in this case F1, F2, F3 appear wherever it is convenient to show them in the circuit and not necessarily near the rectangle used to indicate the coil. The relay letter followed by the number in the text can be taken to represent a relay contact.

26. Each plug in the installation has been given an identification letter and connections to pins are referred to by this letter, followed by the number of the pin—e.g., Q20 for pin 20 to plug Q. The context of the matter will make it clear to the reader as to whether it is a relay contact or a plug terminal to which reference is being made. Figures 6 and 7 show the letters allotted to the various plugs.

RECEIVER UNIT TYPE 71.

27. The receiver is a superheterodyne employing one RF stage, mixer, three intermediate frequency stages, and a diode detector. The local oscillator uses any one of four crystals and two stages of frequency multiplication. Automatic Volume Control is applied to the RF stage and the first two IF stages, and a muting system is incorporated to silence the set when no signal is being received. A limiter in the output silences the set when large interfering pulses of short duration are radiated by any other equipment the aircraft may be carrying.

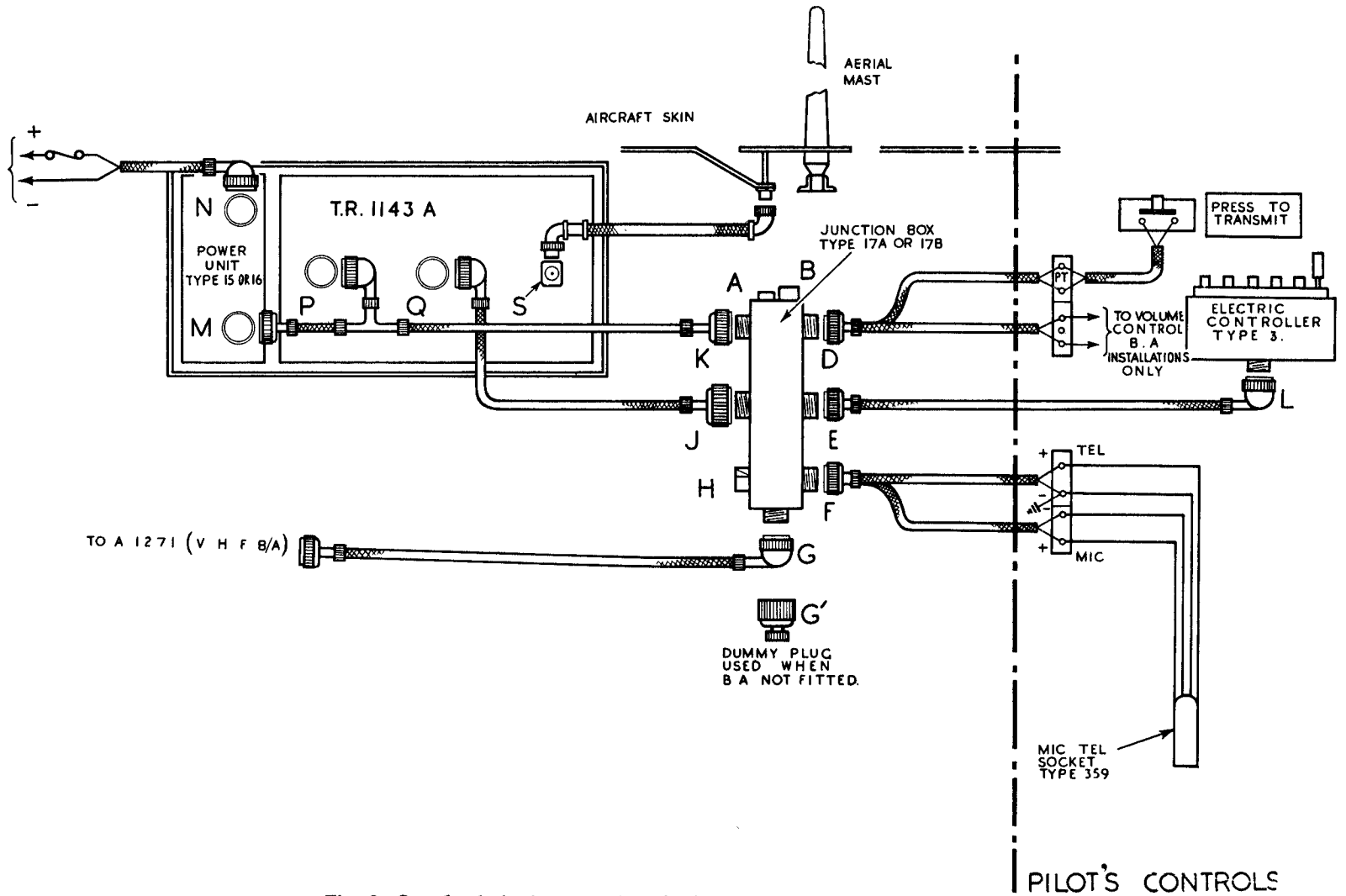

Fig. 6—Standard single-seater installation (showing plug nomenclature).

NOMENCLATURE.

23. The components of the TR 1143A are designated by 3 suffixes, e.g., C501, R239. The "hundreds" figure indicates the particular unit containing the component. Table A shows the units with their associated component designations.

TABLE A.

<i>Unit.</i>	<i>Component Reference.</i>	<i>Unit.</i>	<i>Component Reference.</i>
Power Unit	000 to 099	Receiver	300 to 399
Chassis	100 to 199	Amplifier	400 to 499
Transmitter	200 to 299	Control Motor	500 to 599

24. To avoid congestion the hundreds suffix has been omitted from most of the diagrams and description, but it should be re-inserted by the reader for external reference.

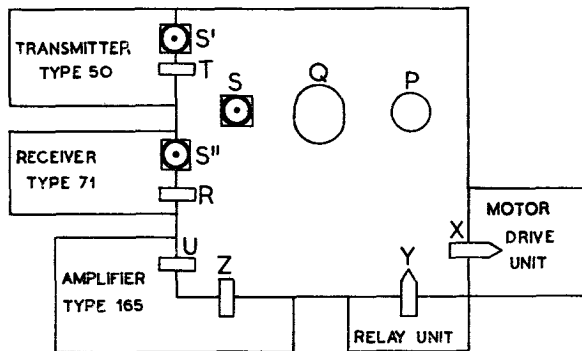

Fig. 7—Set plug nomenclature.

25. Standard detached relay annotation has been used. Relay coils are represented by a small rectangle containing figures showing the resistance of the coils in ohms. Near the rectangle, a reference, e.g., F/3 indicates the letter by which the relay is known and the number of contacts operated by the relay armature. In the text the relay is usually mentioned by its letter only. The actual contacts numbered in this case F1, F2, F3 appear wherever it is convenient to show them in the circuit and not necessarily near the rectangle used to indicate the coil. The relay letter followed by the number in the text can be taken to represent a relay contact.

26. Each plug in the installation has been given an identification letter and connections to pins are referred to by this letter, followed by the number of the pin—e.g., Q20 for pin 20 to plug Q. The context of the matter will make it clear to the reader as to whether it is a relay contact or a plug terminal to which reference is being made. Figures 6 and 7 show the letters allotted to the various plugs.

RECEIVER UNIT TYPE 71.

27. The receiver is a superheterodyne employing one RF stage, mixer, three intermediate frequency stages, and a diode detector. The local oscillator uses any one of four crystals and two stages of frequency multiplication. Automatic Volume Control is applied to the RF stage and the first two IF stages, and a muting system is incorporated to silence the set when no signal is being received. A limiter in the output silences the set when large interfering pulses of short duration are radiated by any other equipment the aircraft may be carrying.

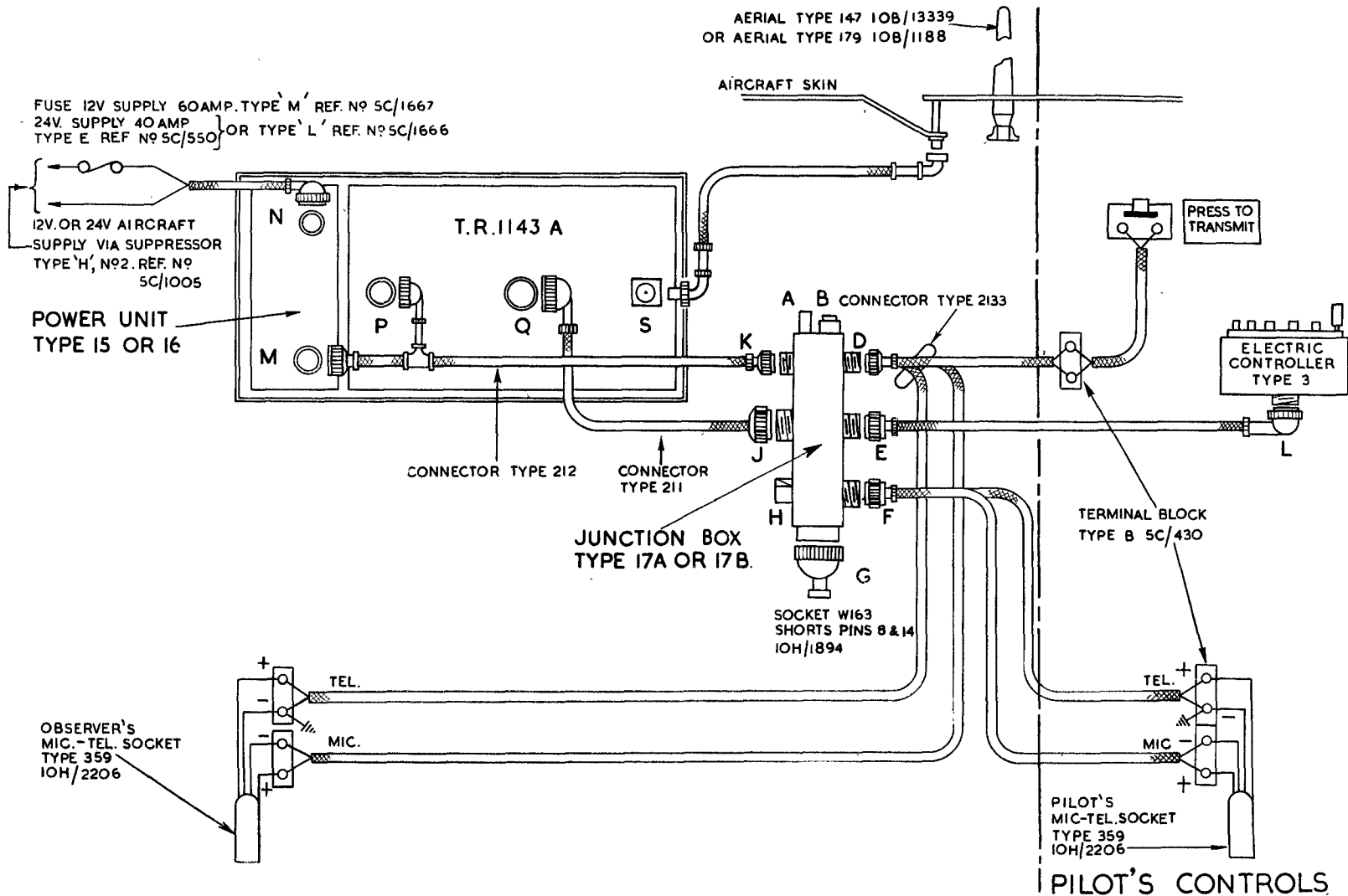

Fig. 8—Pilot-crew installation I.

FUSE 12V. SUPPLY 60 AMP.
 TYPE 'M' REF. No. 5C/1667
 24V. SUPPLY. 40 AMP.
 TYPE 'E' REF. No. 5C/550

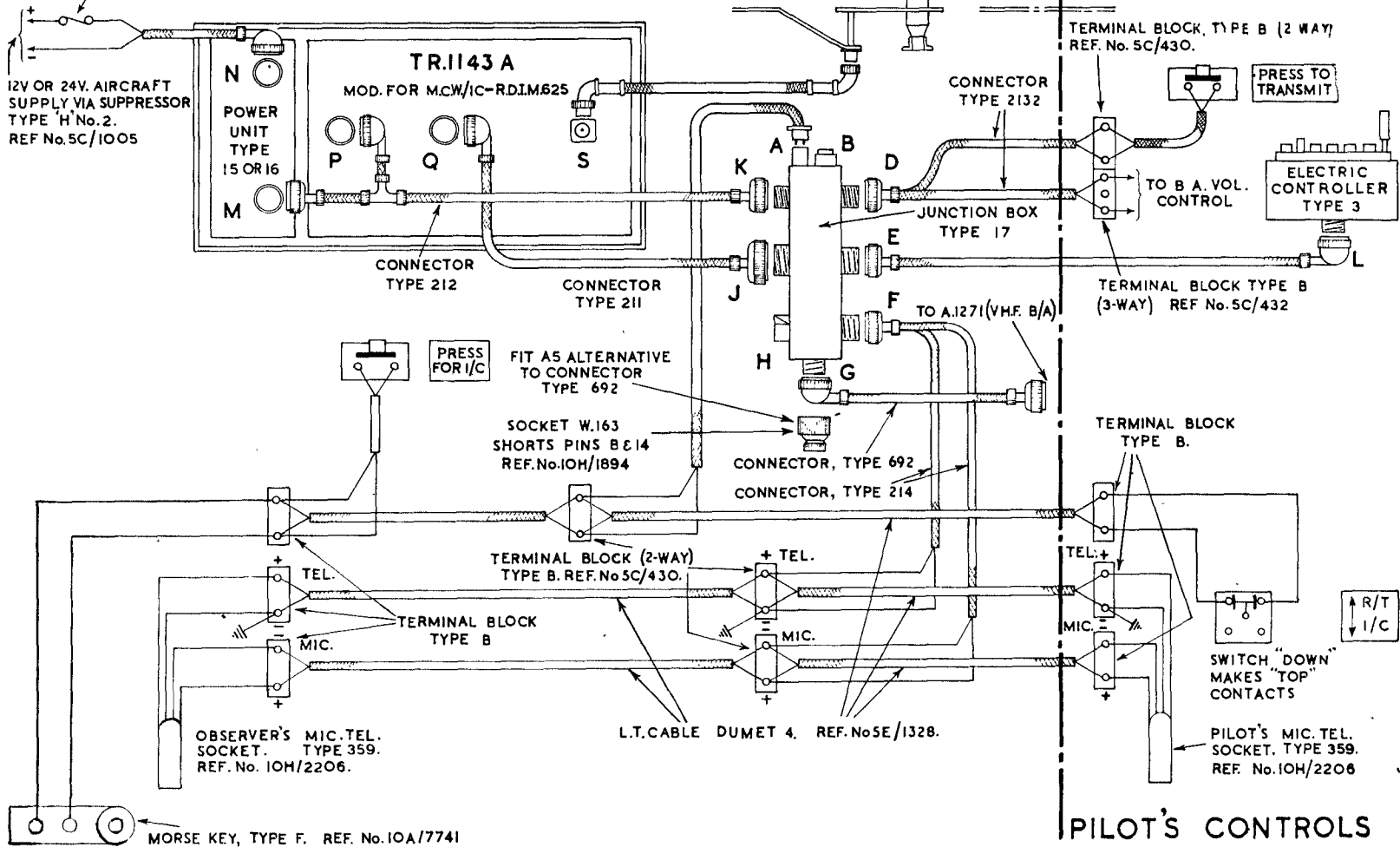

Fig. 9—Pilot-crew installation II.

A.P.2528A, Vol. I

28. Figure 4, the block diagram of the whole set, shows the receiver at the two lower levels. Figure 17 shows the receiver circuit in detail. The stages are outlined in the table below :—

TABLE B.

<i>Circuit Ref.</i>	<i>Valve Type.</i>	<i>Description.</i>	<i>Function.</i>
V301	VR91—10E/92	RF pentode	RF Amplifier.
V302	VR91—10E/92	RF pentode	Additive mixer, or first detector.
V303	VT52—10E/11398	Output pentode	Crystal oscillator and frequency trebler.
V304	VR91—10E/92	RF pentode	Frequency sextupler.
V305	VR53—10E/11399	Variable- μ RF pentode	First IF amplifier.
V306	VR53—10E/11399	Variable- μ RF pentode	Second IF amplifier.
V307	VR91—10E/92	RF pentode	Third IF amplifier.
V308	VR55—10E/11401	Double-diode- triode	First diode—Detector. Second diode—AVC rectifier. Triode—Muter.
V309	VR92—10E/105	Diode	Limiter.

RF Amplifier.

29. The RF Amplifier uses a conventional circuit. The grid circuit L1C2 is connected to the aerial through the three micromicrofarad integral condenser C1. (This condenser is in parallel with a 10K resistance R1, which acts as a static leak). The tuned circuit L1C2 feeds the grid of V1 through a blocking condenser C4 so that the steady (DC) voltage on the grid is determined solely by the AVC line. As in all the other receiver stages, self bias is used.

30. The anode circuit of V1 and the grid circuit of V2 form a band-pass tuning arrangement. This ensures adequate pre-mixer selectivity for the rejection of images caused by other radiations on adjacent channels. The three variable condensers C2, C14 and C20 which tune the grid and anode band-pass circuits respectively, of the RF stage V1, are all ganged together to Tuning control number 7 (TC7)—See figures 17 and 2.

31. The amplified RF output of the first stage is fed through the blocking condenser C24 to appear across the 100K resistor R14. Voltages from the local oscillator also appear across this resistor.

32. The first stage anode circuit is decoupled by the network C13, R10 and C10, while the screen is fed through R5 with a condenser C5 preventing the development of RF voltages across R5. In parallel with the anode series resistor R11 (8.3 ohms) is connected the receiver meter plug (see figures 17 and 2) so that the anode current changes may be measured during the setting up process.

The Local Oscillator.

33. The Local Oscillator is frequency controlled by a crystal connected to valve V3 in a Colpitts circuit. V3 acts as a trebler, extracting the third harmonic of the crystal by its tuned anode circuit and the subsequent stage V4 acts as a sextupler. The output of V4 is mixed with the RF output of V1 across R14. The crystal frequency is thus one eighteenth of the desired local oscillator frequency. The actual crystal used may be one of four—A, B, C or D, according to which button has been depressed on the Controller.

34. For the purposes of the crystal oscillation V3 should be regarded as a triode, where G2, the screening grid of the VT52, acts as the triode anode. This "anode" is earthy (owing to C7), the cathode circuit being capacitive. Circuit L2 and C11 (tuned by TC8) is not at resonance, the inductance being small at the frequency of the crystal. TC8 is not a critical control, and needs only to be adjusted when low activity crystals are in use. C75 places a fairly large capacity between the grid circuit and the cathode. Since the crystal is connected between the grid circuit and earth, the cathode is effectively "tapped across" the crystal by the capacity C75, and that of the capacitive circuit around C11, in the familiar Colpitts manner.

35. L16, R61 and the stray capacity form a highly damped resonant circuit, which in combination with L15 and C76, reduces the input damping of the valve upon the crystal—a feature which makes the use of certain low activity crystals possible.

36. The electron stream in V3 is thus fluctuating at the frequency of the crystal oscillations. This stream passes through the mesh of the screening grid (the effective “anode” for the crystal oscillator), on to the actual anode of the VT52. The anode circuit L3 C15 is tuned to the third harmonic of the crystal frequency. Both the anode and the screen of V3 are decoupled by C30, R9 and C7 and self bias is provided by the resistors R6 and R7.

37. The trebled crystal frequency appearing in the V3 anode circuit is fed through C22 to V4 (a VR91) the sextupler. This valve works in class C conditions. (The grid current flowing through R12 provides a sufficient number of electrons to charge C22 negatively, but only so long as grid current flows. There being no cathode biasing resistor, this results in class C working).

38. This causes extensive generation of harmonics by V4 so that although the anode circuit, L6, and C26, is tuned to the sixth harmonic, the voltage output is quite considerable. C26 and C15 (V3 anode circuit) are ganged to control TC6. TC6 is the critical oscillator tuning control, TC8 being very “flat.” R13 and C18 keep the screen potential of V4 at a suitably low value, and R18, C72 and C19 decouple the anode circuit. The output of V4 is eighteen times the crystal frequency and it is fed through the small condenser C34 to R14.

The First Detector (or mixer) stage.

39. The local oscillator output and the RF output are combined at the resistor R14. Before the difference frequency can be obtained, detection (or rectification) is necessary. V2 has a large self biasing, resistance (R17, 1K) which enables it to function as an anode-bend detector. The condenser C27 (·01 microfarads) maintains constant the biasing voltage.

40. The anode load of the first detector valve V2 is an IF transformer tuned to the intermediate frequency of 9·72 Mc/s. Thus the difference between the local oscillator frequency and the RF must always be 9·72 Mc/s. If the frequency of the received transmission is F , the local oscillator frequency will be $F - 9·72$ Mc/s. The local oscillator frequency is made lower (it could be 9·72 Mc/s. greater than F) than the signal frequency in the interests of stability. The frequency of the crystal required for the local oscillator will be
$$F_r = \frac{F - 9·72}{18} \text{ Mc/s.} = \frac{F}{18} = 540 \text{ kc/s.}$$

Note :—The crystal frequency for the transmitter is $(F \div 18)$ Mc/s. Therefore, the receiver crystal is always $\frac{9·72}{18}$ Mc/s. = 540 kc/s., lower than the transmitter crystal frequency.

The IF stages.

41. The first and second IF stages are identical and are of conventional design. Iron-cored permeability tuned IF transformers are used throughout, with resistance damping to give the requisite band-width of 80 kc/s. at 6dB down. V5 and V6—the first and second IF stage valves—are both VR53s which are variable- μ types. AVC is applied to both of these valves. Their screens are maintained at a constant potential by means of potential dividers with decoupling condensers (R22, R21 and C36 ; R27, R26 and C42), and bias is by means of cathode resistors with by-passing condensers (R23, C38 and R28, C43).

42. The third IF stage uses a VR91 valve V7. AVC is not applied to this stage. A single screen resistor (R30, 47K) is used instead of a potential divider, and a slightly higher cathode bias resistor (R31 330 ohms) than is usual for this type of valve, render this stage difficult to overload on a large signal—a necessary quality in a stage following so much amplification. The output of the IF transformer connected to the anode of V7 goes to the second detector.

The Second Detector Stage.

43. A diode (D1 of the double-diode-triode V8, a VR55) rectifies the output of the IF amplifiers. The secondary of the IF transformer does not have the usual 100K damping resistance, as the damping of the diode circuit is rather greater than the grid input damping of the IF valves.

The diode load resistance is R36 (22K), and the rectifying condenser is C52 (50 micromicrofarads). The circuit is arranged so that negative voltages corresponding to the IF voltages, appear at the junction of C52 and R36. C51 (50 micromicrofarads) and R33 (39K) form a filter to prevent the appearance of intermediate frequencies across R34.

The Limiter.

44. In the detector circuit, is an additional diode V9—a separate VR92. This acts as a limiter for large pulses of interference which are sometimes developed by other items of airborne equipment. V9 is normally in the conducting state and therefore may be regarded as a fairly low resistance. The rectified output from R36 then passes to R34. R34 is the volume control (pre-set) and the requisite output is tapped off. C54 (.1 microfarads) is a blocking condenser to prevent the negative DC carrier level from reaching the amplifier. R40 and C58 give extra filtering, and the receiver output goes through pins R1 and U3 to the input transformer T2 of the Intercommunication and Receiver Amplifier.

45. However, should an excessively large signal appear, V9 stops conducting, and there is no output from the receiver. The cathode of V9 is held by the long time constant circuit R62 (220k) and C77 (.01 microfarads) at a value equal to the mean level of the carrier being received. Modulations of this carrier appear as varying negative-going voltages across R36, and are thus applied to the anode of V9. Normal modulation does not drive the anode of V9 sufficiently negative to make the diode non-conductive, but a large pulse of interference will do so. For the duration of the interfering pulse, V9 is therefore a high resistance and there is no output from the receiver. This limiting system is particularly effective against radar interference, where the pulses though large, are very short in duration. The quieting of the receiver for such short periods does not interfere seriously with the intelligibility of the speech, but the irritating note it causes in the ear of the pilot is eliminated.

Automatic Volume Control.

46. Delayed AVC is provided by the diode D2. It works on the mean carrier level and is therefore not affected by the modulation intensity of the carrier. It has very little effect when the carrier output at this point is less than 10 volts, but comes in quite sharply above this. For inputs varying from 100 microvolts to 100 millivolts the output is maintained within 6dBs. Diode D1, the detector, provides a negative rectified voltage proportional to the carrier. This is applied to D2, the AVC diode, via R35 (470K) and C57 (0.1 μ F). This network decouples D2 from affecting the receiver output, and having a long time constant (approximately 1/20 of a second) effectively "irons" out the modulation voltages, leaving only the mean carrier voltages to modify the state of D2.

47. The delay voltage for the AVC diode D2 is obtained from the double potential divider, formed firstly by R41, R42, and R57, with R60, and with R47, R58 and R59, and secondly by R46, R45, R44 and R43, with R35, R33 and R36. Figure 17A shows this rather more clearly than does figure 17. These potentiometers are arranged so that if D2 were removed the AVC delay voltage at the point A (on figure 17A) would be +10 volts. As D2 is in circuit, the resistance chain R35, R33 and R36 is practically short-circuited, and the voltage at the point A is zero. Thus the AVC voltage is zero until the rectified output from D1 via R35 (this negative voltage being proportional to the carrier amplitude) becomes just over 10 volts negative. D2 then ceases to conduct and the excess of signal voltage over delay voltage, is applied as AVC. If the rectified signal is -9 volts, D2 conducts and the AVC voltage is zero. But if a stronger signal is received, giving a rectified output of -11 volts, D2 stops conducting and -1 volt is applied to the AVC line. Further increases of the carrier value cause larger negative voltages across C57, which provide further biasing to the AVC circuits.

48. R56, C6, R20 and C33, R25 and C40, form decoupling networks to ensure that the AVC line applies only steady biasing voltages to the control valves V1, the RF amplifier, V5 and V6, the first and second IF amplifiers.

49. The AVC time constant is of the order of 1/20th of a second. All normal modulation frequencies are of considerably shorter cycle duration than this. However, it is found that when Beam Approach is in use, there is a tendency to clip the dashes of the BA transmission and render them difficult to distinguish from the dots. Therefore, when BA is in use, it is necessary to increase the time-constant of the AVC circuit. Reference to figure 33 shows a lead from C57, through terminals R2, P8, K6, G3, to contact A5 of relay A/5 in the BA amplifier A.1271. This relay is

energised when the BA system is in use, and then contact A5 connects a 2 μ F condenser (C5 of the A.1271) in parallel with C57 on the receiver. The AVC time constant is now about one second, so the dashes of the BA transmission are not marred by any AVC effect.

The Muting Circuit.

50. Under "no signal" conditions when there is no radiation of a carrier, the AVC voltage is zero, and the set unduly amplifies atmospheric noise. To avoid the disturbing effects of the "crackle" on the pilot's hearing, a muting system is used. It consists principally of the triode section of valve V8, and the relay A. Contacts A1 and A2 are wired in parallel, and when closed by the operation of the relay, connect the low resistance R339 (4.75K) across the receiver output, thus reducing it to a negligible amount.

51. The negative DC output from the detector is fed to the grid of the triode V8 via a long time constant circuit R38 and C36 (2.2M and .02 microfarads). This circuit decouples the triode from affecting the detector circuit, and prevents the modulation voltages from operating the muting system. C55 decouples the 3,000 ohms relay coil.

52. When no carrier is being received, the detector provides no negative voltage to the grid of the triode, which therefore conducts, operating relay A. The operated contacts A1 and A2 mute the receiver. When a carrier voltage appears, the grid of the triode goes negative, reducing the anode current so that relay A releases, and the receiver operates normally. Small adjustments in the anode potential of V8 may be made by means of the potentiometer R60, should compensation for valve changes be required.

53. Should this muting arrangement be considered for some operational reason undesirable the best method of stopping it functioning, is by removal of the armature of the relay and careful storage in some convenient adjacent space. Damaging the relay by bending the contact blades is strongly deprecated.

AMPLIFIER UNIT, TYPE 165.

54. Figure 19 shows the circuit of the amplifier and figures 10 and 11 give two photographs of it. This amplifier has four functions:—

- (i) The amplification of the receiver output.
- (ii) Crew intercommunication amplification.
- (iii) Modulation of the transmitter.
- (iv) The generation of MCW tone modulation.

55. There are two ways of connecting up the TR 1143A installation. One way precludes the use of BA equipment, but arranges so that the pilot only can modulate the transmitter, although all members of the crew can hear the pilot and the receiver output at all times, and can converse with each other. For this arrangement, the crew microphones and telephones are connected to plug D of the junction box, while the pilot's are connected to plug F.

56. However, if BA is used, plug D is required for the BA volume control (see figure 33) and pilots and crews headsets are all paralld to plug F. The crew can then modulate the transmitter when the pilot switches the system to transmit.

57. The amplifier is divisible into two sections (see figures 4 and 19):—
- (i) The intercommunication and receiver amplifier.
 - (ii) The modulator.

Table C shows the valves in use:—

TABLE C.

Circuit Ref.	Valve type.	Description.	Function.
V401	VR56 (CV1056) 10E/11402— 10CV/1056	RF pentode	AF amplifier } Intercommunication and Receiver Amplifier.
V402	VR55 (CV1055) 10E/11401 10CV/1055	double-diode- triode	
V403	VR56 (CV1056) 10E/11402— 10CV/1056	RF pentode	AF amplifier } Modulation.
V4045	VT52—10E/11398	Output pentodes	

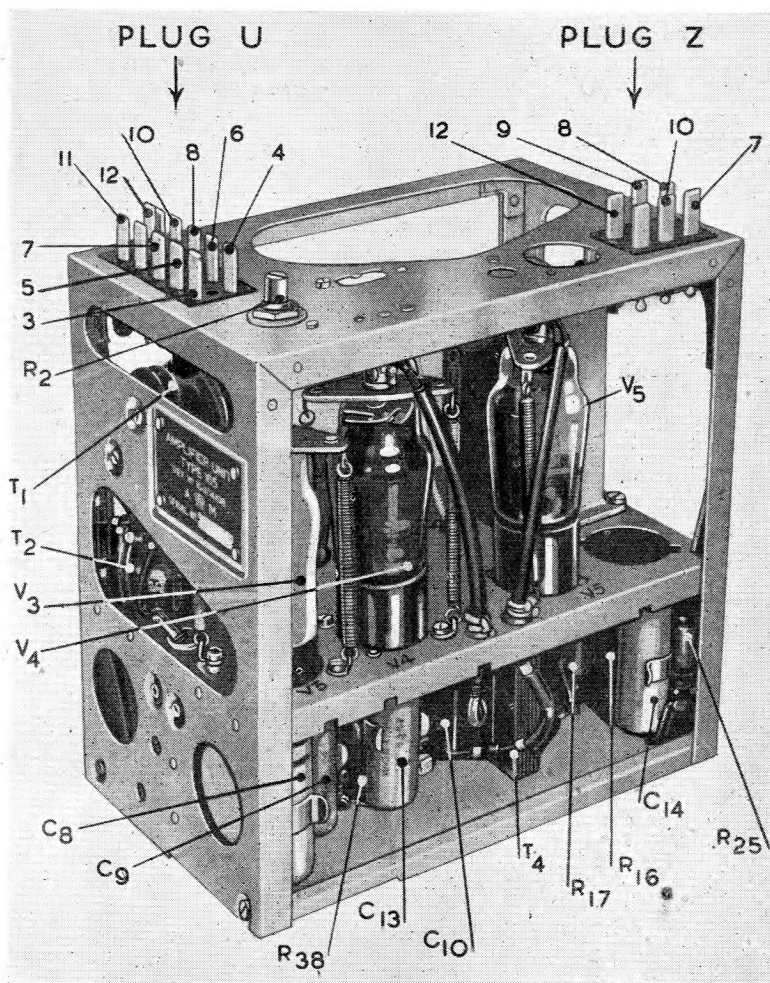

Fig. 10—Amplifier unit type 165.

Amplification of Receiver Output.

58. The receiver output is fed through the pins R1 and U3 to the high impedance primary of transformer T2. The secondary of T2 feeds the valve V1 through the bridge network R3, 4, 5 and 6. V1 is a high gain pentode, a VR56, and uses cathode self-bias. A portion of the total cathode resistance (R8, 600 ohms) is un-bypassed. The rest of the cathode resistance R9, 3.3k is by-passed by the condenser C3, .25 microfarads.

59. V1 has conventional screen and anode circuits for high voltage gain and feeds the output valve V2. V2 is a double-diode-triode, but the diodes are not used nor are they connected. V2 derives its bias from the amplifier grid-bias potentiometer, R14, 15, 16 and 17. C6 and R12 decouple the bias supply to V2. The output from V2 is taken through the transformer T3. This transformer has two taps—one for high impedance telephones and the other for low impedance telephones. It is normally connected for the former.

60. From the high impedance secondary of transformer T3 a portion of the output is fed through the network R13 and C7 (1M and 100 micromicrofarads) to the cathode of V1, where it develops an antiphase voltage across R8. This constitutes negative feedback, and as the network R13, C7 attenuates frequencies above 1,500 cycles per second, rather less than those below, negative feedback at the higher frequency is greater. Hence this circuit tends to counteract the tendency towards the loss of the lower audio frequencies usually encountered in telephones. The negative

feedback also reduces the effective output impedance of the amplifier, which results in its being less critical regarding the number of telephones it is used to feed. Up to five pairs of telephones may be connected without noticeable loss of volume.

61. The output to the telephones goes via the pins U10, Q3, J3, D4 and F3. It makes no difference to the telephone connections whether plug D or plug F is used.

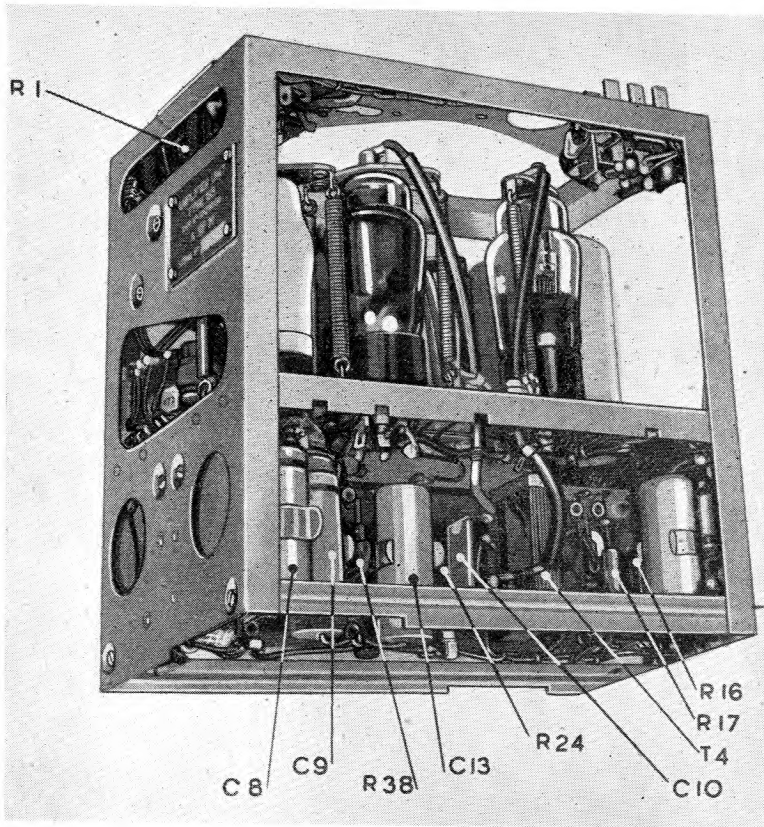

Fig. 11—Amplifier unit—underside.

The Two Microphone Circuits.

62. There are two microphone circuits both balanced with respect to earth :—

- (i) *Using plug F on the Function Box.* Circuit is :—
F2,4—J6,7—Q6,7—Z10,9 to transformer T1.
- (ii) *Using plug D on the Function Box.* Circuit is :—
D2,6—J10,11—Q10,11—U5,6 to transformer T2.

63. Circuit 1 connects to the modulator and is normally the pilot's circuit. A portion of the output from the secondary of T1 is fed back (side-tone) into the bridge circuit at the input of V1.

64. This sidetone is amplified and can be heard in all the telephones. Thus the pilot can communicate with the other members of the crew, by speaking while the set is in the normal (i.e.; receive) condition. To transmit, he speaks with the controller key at position T. His speech is still fed to all telephones.

65. Circuit 2 connects the microphones from plug D to the low impedance balanced primary winding of transformer T2. Any speech from these microphones is amplified and can be heard in all telephones—but these microphones cannot modulate the transmitter.

66. The above is the original and correct method of wiring the TR.1143A circuits, but it cannot be used when the BA system is installed. For the BA system circuit number 2 is used for volume control, a variable damping resistance being placed across the balanced low impedance primary transformer T2. This couples with the high impedance primary winding connected to the Receiver, and so damps and reduces the Receiver output. The crew microphones are then connected to circuit number 1 and intercommunication is effected via the side-tone line from T1 to V1.

Transmitter Modulation.

67. Circuit 1 feeds Transformer T1, the output from which appears across the variable potentiometer R2. The tap from this goes to contact F1 (through Z12, Y11 and 12) and thence to the grid (through Y9 and 10, Z8) of valve V3. This is a VR56 used as an AF amplifier, and is the first stage of the modulator. Cathode bias is used, and as in the case of V1, a portion of the total cathode resistance is left un-by-passed, for the application of negative feedback from the output transformer T5. V3 is transformer coupled by T4 to the push-pull output stage of the modulator. The centre tap of the secondary is taken to the grid bias potential divider, and the value of the grid bias applied to the output valves V4 and V5 is such as to work them in Class AB1. These valves are VT52 output pentodes. Their anodes are connected to transformer T5, the HT being applied to a centre tap. The continuation at the V4 end of the winding steps up the anode voltage swing still more, since it is acting as an auto transformer. The output is taken from this winding through pin U11 to pin T6 of the transmitter. This wire carries HT (from U12 through the transformer T5), the amplitude of which varies according to the speech modulations. This is the modulated HT for the final stage of the transmitter.

MCW Tone-Generator.

68. An audio frequency oscillation of the order of 1,000 cycles per second is required for the MCW transmission. This is achieved by arranging for positive feedback over the two stages of the modulator. The potential divider R23 (connected to the anode of V4) and R22 (connected to the HT—earthly for AC) feeds a portion of the output of V4 to the network C12, C11, R21 and R20. This network attenuates considerably, but discriminates in favour of feedback voltages of the order of 1,000 cycles per second. These are fed to Z7 and Y7 and 8. When relay F is not operated they therefore have no effect. But when the relay is operated and contact F1 changes over, the feedback voltages are applied to the grid of V3, from which T1 is disconnected.

69. The modulator then becomes an audio oscillator generating a 1,000 cycles per second tone, which modulates the transmitter. A small fraction of the tone is fed through R36 (2·2M) to the cathode of V1 of the amplifier so that the pilot and crew are aware of the MCW radiation.

TRANSMITTER UNIT TYPE 50.

70. Figure 22 shows the general layout of the transmitter and the block diagram figure 4 shows the five stages :—V1 crystal oscillator, V2 trebler, V3 trebler, V4 doubler, V5 and 6 push-pull power amplifier. Starting from the end where the crystals are plugged in, the layout on the chassis is in order Stage 1, 2, 3 and 4 with the valves on one side and their associated tuning circuits on the opposite side of the chassis, although the inductance L4 of the tuner circuit of the fourth stage is mounted below the chassis. At the end in a screened compartment (see figure 22) is the push-pull output stage. There is no ganging of the tuning condensers in the transmitter, each stage having its own tuning control, making a total of five.

71. The valves used in the various stages are shewn in the table below :—

TABLE D

<i>Circuit Ref.</i>	<i>Type.</i>	<i>Description.</i>	<i>Function.</i>
V201	VR53 —10E /11399	Variable-mu pentode	Crystal oscillator
V202	VT52 —10E /11398	RF beam power tetrode	Frequency trebler
V203	VT501 —10E /389	RF beam power tetrode	Frequency trebler
V204	VT501 —10E /389	RF beam power tetrode	Frequency doubler
V205 and V206	VT501 —10E /389 or VT501A—10E /784	RF beam power tetrodes	Push-pull power amplifier output
V207	VR92 —10E /105	Diode	Meter rectifier

Crystal Oscillator.

72. The selected crystal is connected directly to the grid of V1, the crystal oscillator valve. A DC path for the grid is provided by R1. The tuned circuit in the anode of V1, L1 and TC1 resonates at the frequency of the crystal. Conventional anode and screen decoupling is used. The circuit is analogous to a tuned anode-tuned grid oscillator. Since an HF pentode having negligible Miller effect is used, there is a possibility that the anode-control grid capacity will be too low to sustain oscillations, so a small condenser (C1, 1.6 micromicrofarads) is connected between anode and grid.

Frequency Multiplier stages.

73. The output from the crystal oscillator is taken through the blocking condenser C5 to the grid circuit of the first trebler valve V2. The grid circuit of V2, like those of all the succeeding stages consists of a resistor with a choke in series. Considerable grid bias (about 90 volts) is applied to all of the Frequency Multiplier stages so that they are working in class C conditions for extensive harmonic generation. TC2 tunes L2 to treble the crystal frequency.

74. The second frequency trebler uses a circuit similar to that of V2, except that a potentiometer is used to hold the screen voltage constant. This stage handles rather more power and a VT501 is used. TC3 tunes L3 to nine times the crystal frequency.

75. The final frequency multiplier stage is V4 which doubles the frequency to become eighteen times the crystal frequency. This valve handles considerable power, being biased even more negatively. It is also a VT501.

76. It should be noted that only VT501 valves are suitable for the positions V3 and V4. The lower grade VT501A cannot be used here, as their variable screening grid characteristics preclude their being fed from the relatively high resistance potentiometers. The anode circuit—TC4 and L4—of V4 is tuned to the final transmission frequency. HT is fed through a centre tap on the coil L4 so that a balanced push-pull output can be obtained. This centre tap is effectively earthed by the condenser C17 (500 $\mu\mu\text{f}$) but to prevent undue damping should the input impedances of the following PA valves be out of balance, a resistor (R11, 1K) and a choke (L8) is inserted between the coil centre tap and the condenser C17. To aid the balancing of the circuit C16 (8 microfarads) is connected from the "opposite" end of the circuit TC4—L4 to earth, to simulate the capacity with which the valve V4 loads its end of the circuit. The output is taken through the blocking condensers C21 and C22 to the push-pull PA stage.

77. To avoid excessive damping by the grid input impedances of the PA valves, these condensers are tapped on to points some way in towards the "earthy" centre tap.

The PA Output Stage.

78. This is of conventional design and uses two VT501 valves. VT501A valves may be used quite satisfactorily, but a slight drop in output may be expected, depending upon the particular specimen inserted. Modulation of the Transmitter is accomplished at this stage, both the anodes and the screens of V5 and V6 being fed from the modulator transformer T405. The screen voltages are taken off the potentiometer R38, and R36 and R37, to ensure a reasonably linear modulation characteristic. Neutralizing is effected by the condensers C19 and C20. A six-way two-pole switch connected to the Meter socket, permits measurements of the anode currents of valves V2, 3, 4 and 5-6, in positions 1, 2, 3 and 4 respectively, and the grid current of valves V5-6 in position 6.

79. Position 5 affords a measurement of the Transmitter output, as it connects the meter across a portion of the load resistance of diode, which rectifies the output of the transmitter through the condenser C31—which is merely a plate located near the output coil.

THE MAIN TRAY (Chassis Assembly Type 13).

80. The Main Tray is the structural basis of the whole set. Electrically, its principal function is that of interconnexion between the outgoing plugs S, P and Q, and the plugs to the five units: S' and T for the Transmitter, S'' and R for the Receiver, U and Z for the Amplifier, Y for the Relay unit, and X for the Motor Drive unit.

back to R as soon as the pressure is released. However, by operating the projection 18 just above it, it can be made to lock itself in the T position, requiring to be pushed back to the R position when the transmission is ended. Movement to the right—a self-locking position—transfers the T-R control to the press-to-transmit switch. The lamp LR stays lit but it extinguishes if the press-to-transmit button is depressed. This button springs back as soon as finger pressure is removed from it, allowing the set to revert to reception.

86. The five buttons on the Controller are self-locking. One button will always be in the depressed position but the operation of any other, mechanically restores the previously depressed button. If two buttons are pressed together neither will lock.

87. The electrical action of the Controller switches is discussed under the heading of Control Circuits. The mechanical action is best appreciated by the examination of an actual Controller, but for those readers who have not access to one, the following description is included.

Mechanical action of Controller.

88. Referring to figure 13, the controller, shown in the illustration, is seen to be fitted with a key switch, five press-buttons and five jack-mounted pilot lamps, which are annotated in accordance with figure 33. The lamp caps are covered by a shield incorporating a dark slide for night flying; this is operated by the control (1), and is secured by the screws (2).

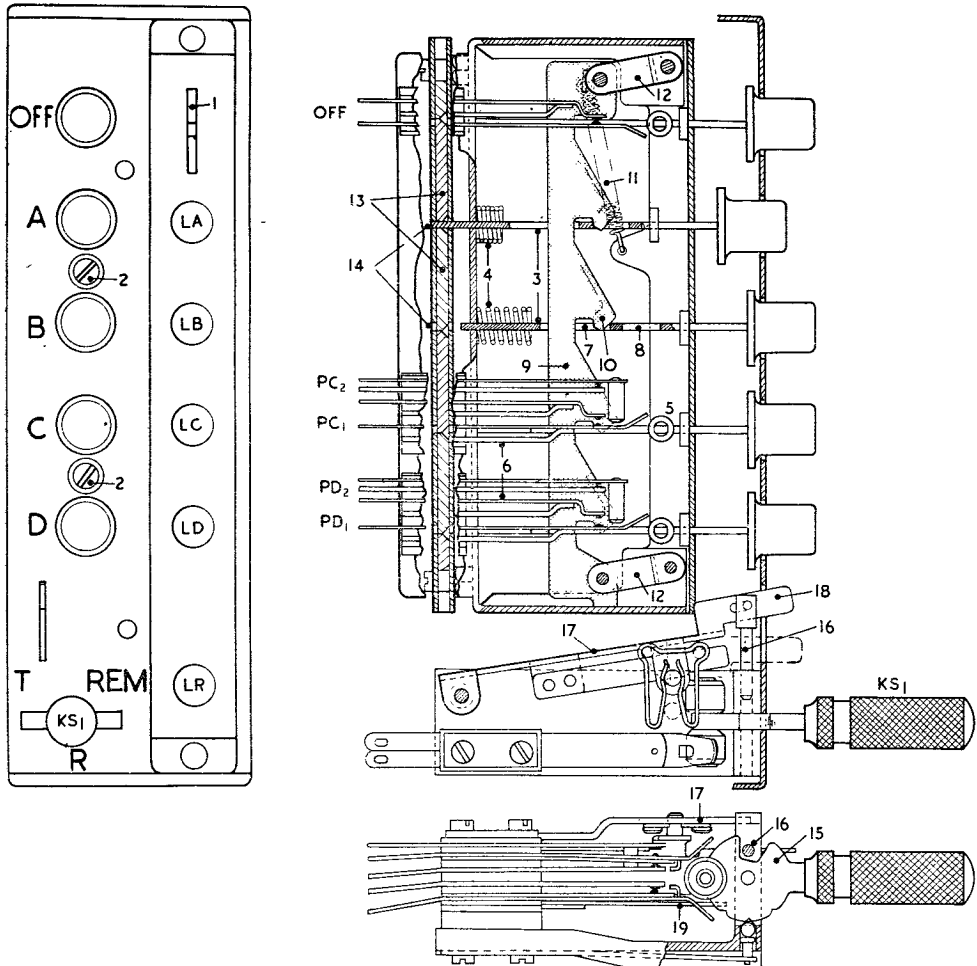

Fig. 13—Electric controller type 3 (layout).

81. However, it does contain a few components which are not suitable for location in the units themselves. The most important of these is the Aerial Relay AR, which changes over the set from reception to transmission. Also mounted on the Main Tray is a decoupling network R101 and C104 for the grid bias supply, and a smoothing circuit consisting of a choke CH101 and three condensers C101, 102 and 103. This latter ensures a ripple-free supply to the valves of the inter-communication amplifier, and the first valve of the modulator—stages particularly susceptible to supply noises.

82. The bench wiring diagram of the Main Tray, figure 27, shews all the components, plugs and the wiring. Figure 33 has a simpler layout of the theoretical connexions.

ELECTRIC CONTROLLER TYPE 3.

83. The entire operation of the TR.1143A, once it has been set up for its four pre-determined channels, is effected by means of the Electric Controller Type 3. This control system is used so that the set itself may be stowed in any desired place in the aircraft, while the smaller Control unit can be installed wherever it is most convenient for operation. Figure 12 shows a photograph of the Controller Type 3, figure 13 the mechanism and switch contacts, and figure 33 the circuit diagram. The relations of the Controller switches to other parts of the circuit is more clearly illustrated in the subsequent section on the control circuits.

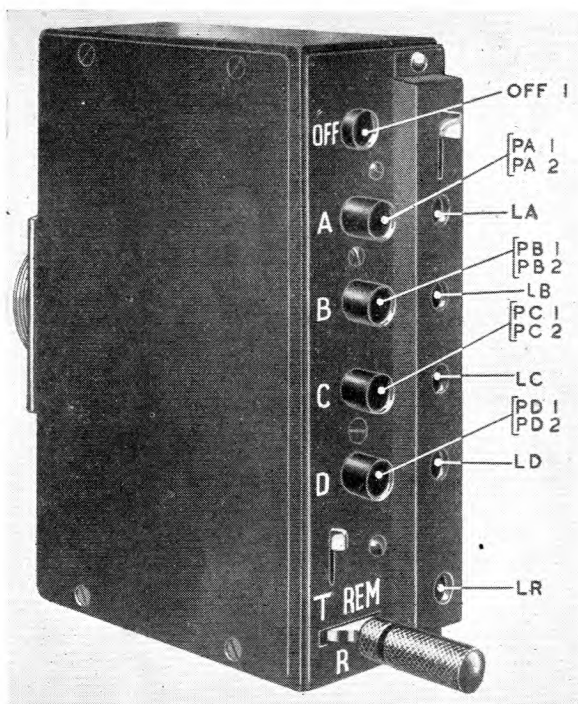

Fig. 12—Electric controller type 3.

84. Pressure on the OFF button de-energises relay N, and the supply is cut off from the motor of the power supply unit. The whole set is then quite dead. Pressure of any of the buttons A, B, C or D, starts the motor of the power unit by lifting the OFF button, restoring all supplies. The lamp adjacent to the depressed button, lights. (The red lamp marked LR also lights if the set is at Receive). The control marked 1, figure 13, operates a slide which darkens all the lamps, should this be required for night flying conditions.

85. The switch below the push buttons has three positions. The central and normal position is marked R. In this position the lamp LR is on. Moving the switch to the left to the position marked T, extinguishes LR and transfers the HT supply from the receiver to the transmitter, which may then be modulated. Normally the switch has to be held in this position, as it springs

89. In the sectional view, the plungers (3) of the press-buttons are seen each fitted with springs (4) which normally maintain them in the outward position, and with buffers (5) which operate the switch mechanism (6). The plungers are also fitted with slots (7) and (8), which engage with the detent lever (9).

90. When any button is depressed, the leading face of the slot (7), presses against the chamfered face (10) of the detent lever, and forces it upwards against the tension of the spring (11), motion being permitted by the links (12).

91. When the plunger has completed a full stroke, the detent enters the slot (8) and resumes its normal position owing to the spring (11). The preliminary upward movement of the detent when any plunger is depressed releases any buttons previously depressed, which will return to the outward position under the influence of the springs (4).

92. If two or more buttons are depressed simultaneously, only one of them can engage with the detent, as the other will be prevented from completing its travel by a drift block interlock consisting of the cam plates (13) which are designed always to cover all but one of the exit slots (14) for the plungers, and are moved by the end of the plungers due to their bevelled faces. If the buttons simultaneously depressed are exactly in step with each other, none of them will be able to advance to the locking position.

93. The key switch also shown in plan below, is seen to be of normal design, except that the toggle (15) is cut away. A pin (16) on the hinged side (17) which may be moved by the projection (18) which extends through the face of the controller, engages with the cut on (15) and prevents the key switch, from being set in the REM position. At the same time the spring (19) engages with the other side of the toggle, and prevents "locking" of the key switch in the "transmit" position.

CONTROL CIRCUITS

94. For discussion it is convenient to divide the Control Circuits into two parts. The first section deals with:—

- (i) The ON-OFF switching (Relay N.)
- (ii) The T-R control (Relay AR.)
- (iii) The press-to-transmit control (Relay C.)
- (iv) MCW operation (Relay F.)

The second section describes the electrical aspect of the channel selection and tuning mechanism. Relay H and the Drive and Selector motors are the principal items involved.

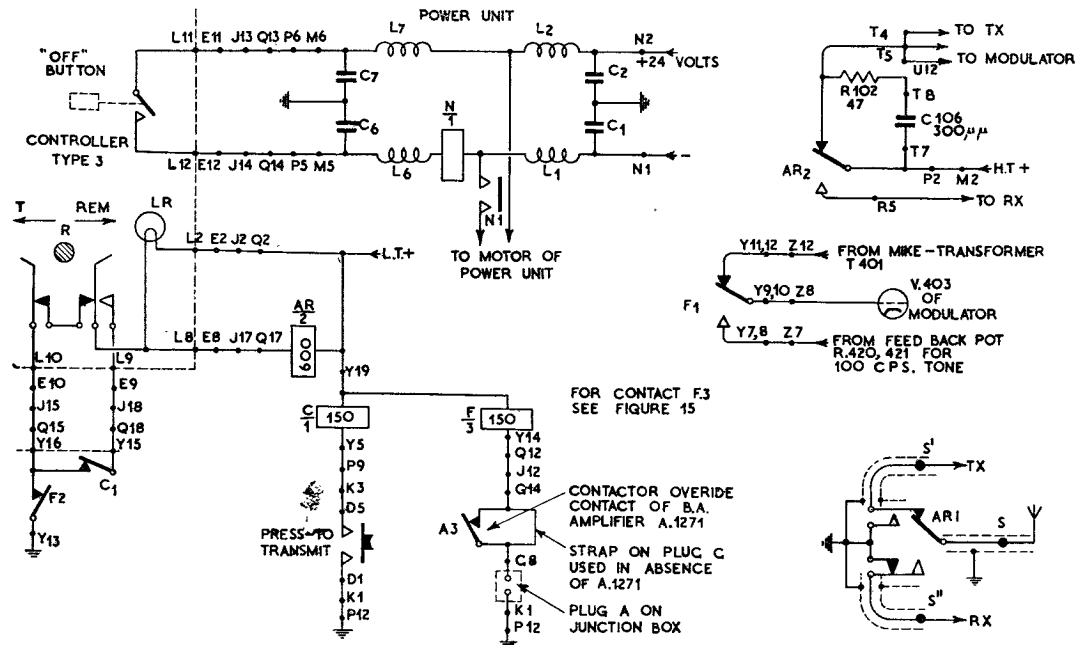

Fig. 14—Control circuits I (on-off, TR and MCW).

The ON-OFF Circuit.

95. This is controlled by the buttons on the Controller. The OFF button breaks its contact when depressed. When one of the channel buttons is pressed, the mechanism raises the OFF button, and the contact is made. Figure 14 shows there is now a circuit for the supply through the coil of the N relay, which therefore operates. Contact N1 then applies the supply to the motor of the rotary transformer, which then generates the HT, LT and GB to the Main Tray.

The T-R Control (Relay AR).

96. The change-over of the set from transmission to reception is effected by the AR relay. It has two sets of contacts. The first set is for changing over the aerial, from the receiver to the transmitter. These contacts are wired to the aerial plugs for the Receiver and the Transmitter on the Main Tray, and to the outgoing aerial socket, by co-axial feeder, and have special earthed balancing blades between the actuating springs. These balancing blades are designed so that their distributed inductance and capacity simulate the L-C characteristics of the co-axial feeder, to avoid discontinuity in the transmission line characteristic. The blades are also arranged to short out the unused section of feeder. Contacts AR2 change over the HT supply, from the receiver to the transmitter and the modulator. In the normal state—that is, the receive condition—the AR relay is energised. This has been arranged because a relay is more stable when energised; for example, manœuvres involving a high value of G are much less likely to affect it.

97. When the T-R switch is in the normal position the circuit for the AR relay is as follows :—
 LT + - AR Relay - Q17, J17, E8, L8 - TR switch - L10, E10, J15, Q15, Y16 - contact F2 (normally closed) - Y13 - earth.

When the T-R switch is moved to the T position, this circuit is broken; relay AR releases, and the set changes to transmission. There is a similar circuit for the lamp LR, which is therefore extinguished while transmitting.

The Press-to-Transmit Control (Relay C).

98. When the T-R switch is placed at REM, the circuit maintaining Relay AR is :—
 LT + - Relay AR - Q17, J17, E8, L8 - T-R switch - L9, E9, J18, Q18, Y15 - contact C1 (normally closed) - contact F2 (normally closed) - Y13 - earth.

The transmit-receive control of the set is now transferred to Relay C. The operation of C opens contact C1 and the circuit for Relay AR is then broken. The circuit to operate Relay C is :—

- LT + - Y19 - Relay C - Y5, P9, K3, D5 - press-to-transmit switch (made, for transmission) - D1, K1, P12, - earth.

MCW Control (Relay F).

99. It will be noted that at all times the T-R condition is under the control of Relay F. The operation of Relay F opens contact F2, thus breaking the circuit for Relay AR, and so the set transmits. Contact F1, when operated, causes the modulator to become a 1,000 cps. tone generator—see paragraph 68 on the modulator. Contact F3, as connected when the set leaves the manufacturers, overrides the channel selection of the Controller, and changes the set over to channel D. The action of this is explained in the subsequent section. The operation of Relay F thus causes the set to transmit the MCW tone on channel D. When the relay is relaxed, the set reverts to its original condition to whatever channel the Controller is set. The circuit for Relay F is :—

- LT + - Y19 - Relay F - Y14, Q12, J12, G14 - through the shorted BA amplifier contact A5/or the strapped plug when BA is not used - G8 - plug A - K1, P12 - earth.

The control of Relay F is thus vested in plug A. As wired on leaving the manufacturer, plug A is for connection to a contactor.

Channel Selection.

100. The TR.1143A is tuned to the required channel by means of two motors. The variable condensers of the transmitter and the receiver are turned to their pre-tuned setting each by four slide bars, any one of which may be engaged. It is the function of the *Selector Motor* to decide which of the four slide bars is to be actuated, according to selection established by the Controller buttons. The *Drive Motor* operates a system of levers and cranks (see figure 23) to implement the action of the Selector Motor, and it drives home the slide bars to locate the variable condensers.

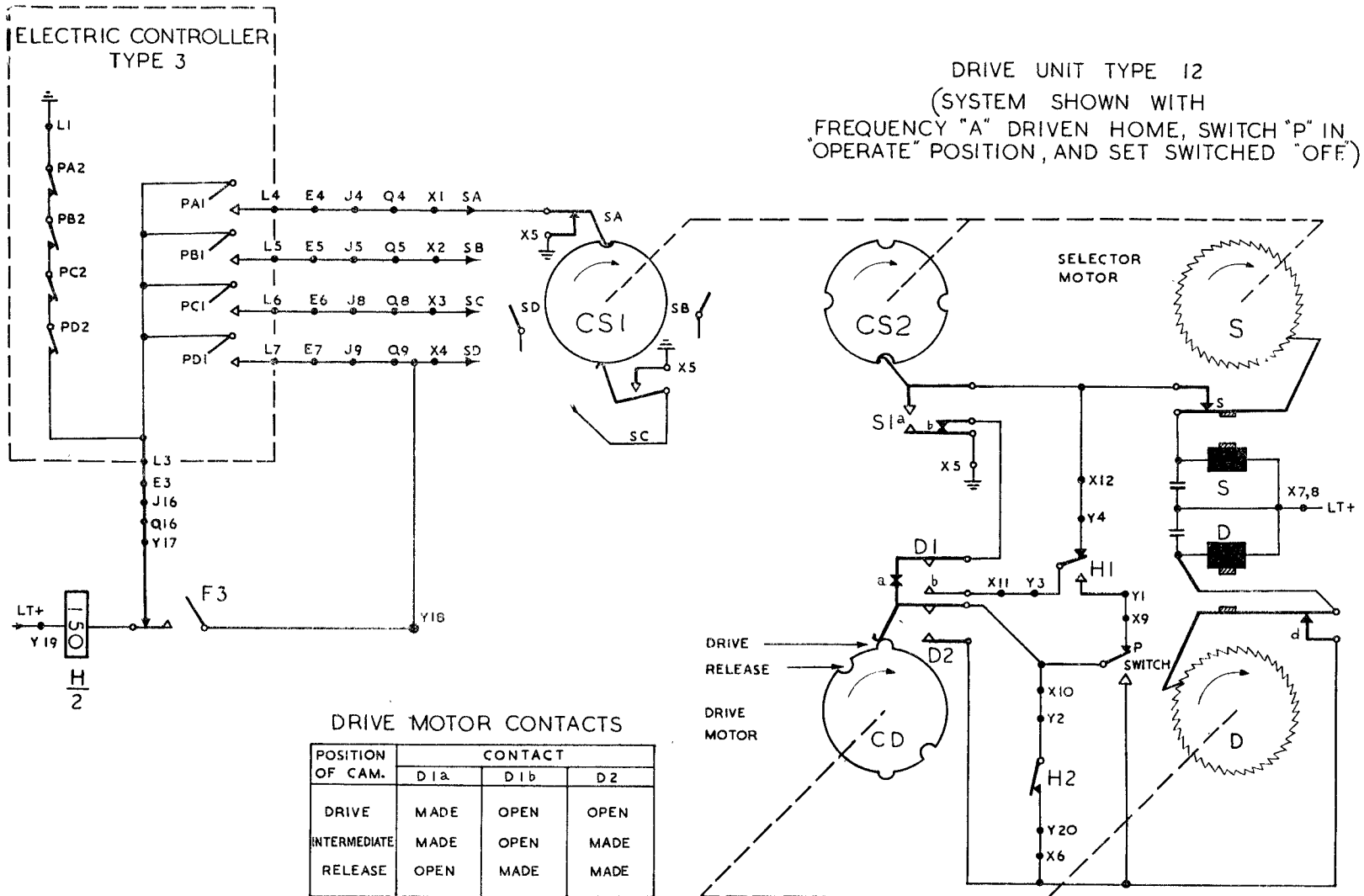

Fig. 15—Control circuits II (Motors and H relay).

101. The motors both operate on the "pecking" principle, in the manner of a uniselector. A claw is pulled against spring-pressure by a magnet coil (S or D), breaking a contact (s or d) as it does so. This contact is in series with the coil, so the claw does a series of to-and-fro movements. It engages with a ratchet and on each movement pulls round the ratchet one tooth. It works at the approximate speed of 15 teeth per second, and so gives a slow but powerful torque.

102. Reference should be made to figure 15. The Drive Motor D drives a cam CD operating a three-position set of contacts, D1a, D1b and D2. The table in the diagram shows the circumstances under which these contacts are opened or closed. The Selector Motor drives two cams, CS1 and CS2.

103. When a different channel button on the Controller is pressed the motors perform the following actions :—

- (i) Motor D turns through 40 degrees from the Drive position to the Release position. (See figure 23). This releases the slide which has been locking the variable condensers on the last frequency channel.
- (ii) Motor S rotates and selects the slide appropriate to the new channel required.
- (iii) Motor D starts up again and turns through 140 degrees to drive home the selected slide, which forces the tuning condensers to their new position and locks them there.

104. The motors are controlled by their cam switches and by Relay H. Relay H is the channel-change relay and is operated in the normal condition.

Channel Selection in detail.

105. Suppose the set is on channel A, and button C on the Controller is pressed. Contact PC1 on the Controller is now closed but contact PA1 is opened. Since cam CS1 is earthing contact SA, there is now no through circuit for Relay H, which becomes de-energised. The releasing of contact H2 makes a circuit for Motor D :—

LT + - D - d - X6, Y20 - H2 - Y2, X10 - D1a - S1b - X5 - earth.

Motor D starts, and cam CD rotates. Contact D2 makes as CD moves the drive cam elevation away, so that premature make of Relay H will not stop the action. When cam CD arrives at the "release" indentation, contact D1a opens; the circuit for Motor D is broken: D stops. The slides are now all released. The S Motor now starts, over the circuit :—

LT + - S - s - X12, Y4 - H1 - Y3, X11 - D1b (made in release position of CD)
- S1b - X5 - earth.

As soon as cam CS2 starts, S1a closes (S1b opening), affording a direct earth for the S Motor. After rotation through 90 degrees, S1 changes over and the S Motor will only continue rotation if Relay H1 has not been made, so as to break the circuit quoted above. Thus, once S has been started it will only stop on one of the four notches of CS2. The cam CS1 has only one notch. and its function is best described by saying that it "searches" for the earthed contact applied by the Controller, and then operates Relay H, thus stopping the selecting sequence. In the example taken, cam CS1 will rotate until the notch is opposite the C position when contact SC applies an earth through the depressed button PC1 and F3 to operate Relay H. Contact H1 changes over and breaks the S Motor circuit. The circuit operating relay H is :—

LT + - Y19 - Relay H - F3 - Y17, Q16, J16, E3, L3 - PC1 - L6, E6, J8, Q8, X3 - SC - X5 - earth.

The Selector Motor is now stopped in position C. The C cam (item 50 on figure 23) has raised the driving lever (32) so that the latter is ready to push home the slides corresponding to channel C, as soon as the Drive Motor starts.

The operation of relay H has completed a circuit for the D motor :—

LT + - D - d - D2 - switch P - Xa, Y1 - H1 - Y3, X11 - D1b - S1b - X5 - earth.

The Drive Motor Starts from the Release position. Its circuit is maintained :—

LT + - D - d - D2 - D1a - S1b - X5 - earth.

Motor D continues driving over the 140 degree section, pushing home the C slide bars as it does so, turning the condensers to positions at which they were originally set up for channel C, and switching in the C crystals for the Transmitter and the Receiver.

106. Cam CD finally arrives at the "Drive" elevation, having turned through 180 degrees since the action began. Contact D2 opens at this point, and breaks the D-motor circuit, which therefore stops. The new channel has been selected and the system is stable, until either a different channel button on the Controller is pressed, or the switch P is operated.

Action of P-switch.

107. It can be seen from the foregoing description that the stable state of the control system is at the "Drive" position. To dismantle the set it is necessary to disengage the mechanism from the slide-bars, that is, to allow the system to reach the "Release" state and to stay there. Operating the switch P, the Tuning Assembly Release Switch effects this. Figure 2 shows the physical location of this switch, while figure 15 shows its situation in the theoretical circuit.

108. Operating P starts Motor D over the following circuit:—

LT+ - D - d - P switch - D1a - S1b - X5 - earth.

D rotates until cam CD has moved through 40 degrees to the "release" indentation, when D1a opens. The slide-bars are now free. The set cannot now be operated until P is returned to its normal position. Switch P is so positioned that the covers cannot be closed while P is in the release position. This is to reduce the possibility of the set being installed in an aircraft with P released.

F-Relay and contactor operation.

109. It has been shown how the operation of contact F1 causes the Modulator to send a 1,000 cps. audio tone, and how F2 changes the set to the Transmit condition—see paragraph 99. Contact F3 overrides the Controller, by breaking the circuit through the selector Motor cam CS1 and the depressed push-button, to relay H. This relay releases and the selection of a new channel starts. This channel will be D, because the operated contact F3 has arranged that relay H will be made through the circuit:—

LT+ - Relay H - Contact F3 (made) - Y18 - X4 - SD - X5 - earth when the S motor has arrived at channel D.

When F is released, the original channel corresponding to the depressed button on the Controller, is re-selected.

110. This sequence is for Contactor operation. However, many TR.1143A sets in service have been modified according to RTIM 625. When this modification has been effected, the shorting of plug A on the junction box operates relay F, which acts as follows:—

(i) When the T-R switch is at Transmit.

The transmitter radiates the 1,000 cps. MCW tone
on the channel in use.

(ii) When the T-R switch is at Receive:—

The receiver is muted so that intercommunication can be effected in the absence of the receiver background noise.

Relevant sections of this RTIM are quoted at the end of this book. The reader may like to make pencil modifications to the appropriate figures in this book, in case he encounters modified TR.1143A sets. There should be no difficulty in following the modified action of relay F, as the Contactor system is the more complicated.

The series-break contacts on the Controller.

111. The reader may be curious as to the purpose of the contacts PA2, PB2, PC2 and PD2 on the Controller, as under normal conditions they are all in series, and one always will be broken (except when the set is switched off, when, of course, relay H cannot be energised). The reason is that it is possible that a button may be pressed so lightly, that although it releases the one previously depressed, it may not itself lock, and all buttons will be out. Under these conditions, the Selector Motor would search in vain for an earthed contact, and keep rotating continuously,

with the possibility of overheating and the likelihood of severe discharge of the batteries. However, this possibility is prevented by the operation of relay H over the circuit :—

LT+ - Relay H - contact F3 - Y17, Q16, J16, E3, L3 - PD2 - PC2 - PB2 - PA2 - L1 - earth.

The Selector Motor is therefore stopped, and it will only restart when the button is properly pressed home.

CHANNEL SELECTION MECHANISM

112. Figure 23 shows the mechanical system which transfers the torque of the Selector and Drive Motors into movements of the slide bars. Figure 24 shows a perspective view of the tuning cams, which are operated by the slide bars to drive the variable condensers to their pre-set tuning points. Only one slide is shown in the diagram. The reader should visualize four of them, mounted on top of each other. The crystal switches (item 17 of figure 23) should also be imagined as doubled in the vertical plane. Figure 24 shows the order in which the items of the tuning cams are assembled. It should be noted that it may be found that on some of the more recent models of the TR.1143A, items 7, 6 and 8 may have been omitted, and replaced by a plain washer, and a friction disc, as shown in figure 24A.

Mechanical action.

113. Referring to figure 23 the shaft (30) of the driving motor carries two diametrically opposite operating pins (31). These are normally at rest in the positions shown, but during the process of changing channels they first rotate through 40 deg. to the position shown in dotted lines, pause there while the selector motor is selecting the new channel, and then rotate a further 140 deg. During the first 40 deg. the pin (31) escapes from the recess (54) in the operated driving lever (32) which returns to the unoperated position (49) under the restoring influence of the spring (51). During the ensuing pause, selection of the appropriate driving lever by the selector motor is carried out as follows.

114. The selector motor shaft (48) carries four cams (50) at levels corresponding to the four driving levers. The cams rotate with the selector motor shaft and each driving lever in turn is moved by its associated cam from the normal position (49) to the selected position (47), the suitably profiled faces (37) of the driving levers acting as cam followers under the tension of the springs (51). When the selector motor comes to rest as already described when dealing with the electrical features of the motors (paragraph 105) it will be holding the driving lever appropriate to the channel required in the selected position (47).

115. The above selection having been accomplished, the driving motor again starts to rotate, the pin (31) engages in the driving lever recess (52) and rotation continues through 140 degrees until the movement of the driving lever (32) has, through the agency of the toggle mechanism, slide operating arms (41)—(19) and pull rods (22), driven home the appropriate tuning condenser slides. The driving motor then comes to rest. When a fresh channel is required, the driving motor again turns through 40 degrees and the operated driving lever (32) returns to its normal position (49). The restoration of the driving lever, by operating the toggle mechanism, allows the transmitter slide (1) to return under the action of the slide restoring springs (53). Bouncing of the slide is prevented by the braking action of the leaf springs (56). At the same time the receiver slide is restored by a similar process.

Tuning-condenser slide mechanism.

116. This mechanism is illustrated in figure 23. The required channel is selected by driving home one of four slides, which turns the appropriate cams associated with the spindles of the transmitter and receiver tuning condensers and then locks them in position. The detailed operation of the sliding mechanism is as follows, and the manner in which it is driven will be found in the preceding section dealing with the motors.

117. The top slide (1) of the transmitter and (2) of the receiver are shown in the operated position in figure 23; the remaining slides (3) and (4) (indicated by dotted lines) are all in the released position. In figure 21 the slides are all shown released. The slides are held in the unoperated position by the slide restoring springs (53). The slides are suitably spaced by means

of spacers (5) on the slide locating pillars (6) so that each slide controls one tuning cam on each condenser spindle. There are eight tuning cams (10) separated by locking balls (8) and guide washers (7) on each condenser spindle and, when all the slides are withdrawn, the spindles and the cams locked to them can turn freely in the wider end of the large holes cut away in the slides. During the process of tuning, the spindles are set to the required position and then held by the spacing washers and friction discs to the cams by tightening a knurled knob. The washers (7), and locking balls (8) engage in grooves (9) in the condenser spindles, and thus prevent movement of any cam, relative to the condenser spindle, other than the cam held by the driven slide.

118. When any slide commences its travel the guide faces (12) of the shaped holes in that slide engage with the cam projections (11) and, during the initial motion of the slide, rotate the tuning condensers until the cams are all in line. When the cams have been positioned in this way the slide is driven fully home, the cams being finally secured by means of the detents (13) which engage with the cam noses (14) and with the fixed pillars (15). The detent levers are spring-loaded by helical springs (16). The crystal switches (17) on the transmitter and receiver take the form of relay springs mounted in double pairs, one above the other. When any slide is driven home it operates the "change-over" spring contacts for the required crystal by means of a small insulated roller (18) carried on the cam slide. The contacts associated with the other three channels remain in the "unoperated" position, thus short-circuiting the crystals not in use.

119. Should it be necessary to dismantle any condenser spindle assembly the greatest care must be taken to ensure that all the individual items (washers, discs, cams, etc.) are returned to the precise relative positions in which they were formerly located.

Slide actuating mechanism.

120. The tuning condenser slide mechanism and the tuning motors having been described, it remains to be shown how the motion of the driving levers from the position (49) to (47) and thence to (32) operates the slides (1) and (2). This is performed by means of the slide actuating mechanism in the following way:—The motion of the driving lever is determined by the shape of the slotted guide face (33) engaging with a fixed guide pin (34) and by a toggle mechanism consisting of the lever (35) and bell crank (36) (whose respective pivots (38) and (39) are fixed) and the link (40). A transmitter slide operating arm (41) which operates the slide (1) has two slotted guide faces (42) and (43) which, in conjunction with the fixed pins (44) and (45), act as guides. The slide operating arm is moved by the toggle mechanism, one end of the bell crank engaging in the cut-away drive surface (46). Simultaneously, the other end of the bell crank (36) which is provided with the engagement hook (27) operates a pull rod (22). The latter drives a receiver slide (2) by means of another bell crank (19) pivoted at (20). The pull rod is secured at the motor end by the pull-rod pin (26). The pins are retained in contact with the hook by projections on the swivelling pull-rod locking pieces (28), these projections engaging with the slots (29) in the split end of the pull rods. At the other end the pull rod is threaded and passes through the pivot (24) and is held in position by the pull rod adjusting nut (23) locking nut (55) and spring (25). The bell crank spring (21) normally holds the bell crank lever (19) in the unoperated position shown in dotted lines.

THE POWER UNITS TYPE 15 AND 16.

121. The power units types 15 and 16 are used with the TR.1143A to enable the equipment to be operated from 12 or 24-volt general aircraft supplies. The power unit type 15 comprises a rotary transformer type U, a voltage regulator, type G and coils and condensers for the suppression of radio frequency interference. Power unit type 16 is similar except that it incorporates a rotary transformer type V, operating on 24 volts, instead of type U (12 volts) and also an L.T. circuit resistance R2 (0.3 ohms). A circuit diagram of the power unit type 16 appears in figure 32.

122. A rotary transformer provides low, medium, and high tension outputs for the radio equipment. The medium tension output is used to provide grid bias for the amplifier unit, type 381 and the transmitter unit type 46. A steady output voltage is maintained, by the action of the voltage regulator, from an input voltage varying between 10.8 and 14 volts in the power unit, type 15 and between 21.6 and 29 volts in the power unit, type 16. This regulator controls the current flowing through the boost field, F3. The operating coil of the voltage regulator is connected in series with the ballast resistor R1 across the low tension output of the rotary transformer. Any

increase in this output voltage would increase the magnetic pull of the regulator coil, thereby reducing the pressure applied by a control spring to the carbon pile and increasing the resistance of the pile. Since the carbon pile is connected in series with the boost field the field strength will be reduced, thus maintaining a constant output from the rotary transformer. Conversely, any tendency for the low tension output voltage to fall will increase the boost field strength and still maintain the output constant. No adjustment should be made to the carbon pile or the ballast resistor R1 without reference to A.P.1186D, Vol. I, Sect. 2, Chap. 3, which contains all necessary information on these Power Units.

TUNING PROCEDURE

123. The layout used for tuning is shown in figure 16 and a test set type 5A, is connected to the transmitter-receiver as shown. A 12 or 24-volt battery of capacity 250 or 125 ampere hours, should be used according to whether a power unit, type 15 or type 16, is employed. With the test set type 5A, it is essential that an artificial aerial type 14, should be used.

124. Having completed the connection of the test circuit, the necessary crystals and valves should be fitted in position in the transmitter, receiver and amplifier. It should be noted that the operational frequency of the transmitter is 18 times the resonant frequency of the crystals, while the frequency F_r of the receiver crystals in kc/s. may be determined by the formula :—

$$F_r = F_t - 540 \text{ kc/s.}$$

where F_t = transmitter crystal frequency in kc/s.

Transmitter tuning.

125. The meter sockets of the test set type 5A, should be connected to the transmitter and receiver metering plugs, and the artificial aerial type 14 connected to the aerial socket. The transmitter-receiver should then be switched on using the button on the controller corresponding to the lowest frequency, setting the key switch to TRANSMIT and retaining it in this position. After allowing approximately two minutes for the equipment to warm up, tuning may be started as follows.

126. Reference should now be made to figure 2. Set the switch P on the drive unit in the RELEASE position (pointing outwards from the cover) and loosen the locking nuts on the condenser spindles about $1\frac{1}{2}$ turns counter-clockwise, from fully locked position set the meter switch on the transmitter to position 1 and that on the test set to the TRANS., ANODE position. The switch P should be reset in the operate position (lying flat) and the appropriate tuning condensers TC1, TC2, TC3, TC4 and TC5 should be set by movement of the pointer, to the approximate frequency. TC1 should be adjusted until the current indicated on the test set meter is a maximum, or greater than Full Scale Deflection.

127. The condenser TC2 should next be adjusted until the current indicated with the meter switch in position 2, is a maximum and the condenser TC3 and TC4 should be similarly adjusted with the meter switch in positions 3 and 4 respectively.

128. The meter switch should then be set in position 5, and the condenser TC5 carefully tuned to the maximum meter reading. This completes the preliminary tuning operation, which should be performed as rapidly as possible to avoid overloading the valves.

129. The meter switch should now be turned to position 6 in order to measure the total grid current of V5 and V6. Condensers TC4, TC3 and TC2 should be carefully readjusted in that order to obtain a maximum reading in position 6. Note this reading. Detune TC1 in the high frequency direction to give a final reading of the meter, when the meter is in position 6, 5 divisions (i.e., approximately 10%) below the maximum obtainable. If the reading is now less than 35, a new valve is probably necessary.

130. The high frequency end of the scale may be identified by noting that the anode current of V2, when the meter switch is at position 1, decreases more gradually than when TC1 is moved in the lower frequency direction.

131. The tuning process should then be carried out on the other channels in order of increasing frequency, procedure being the same as before. After tuning all four channels, the switch P should be set in the RELEASE position and the tuning condensers locking nuts gently turned clockwise using

12 VOLT ACCUMULATOR FOR POWER UNIT, TYPE 15.
24VOLT ACCUMULATOR FOR POWER UNIT, TYPE 16.

USE HEAVY GAUGE CABLE,
DUCEL 37 SUITABLE

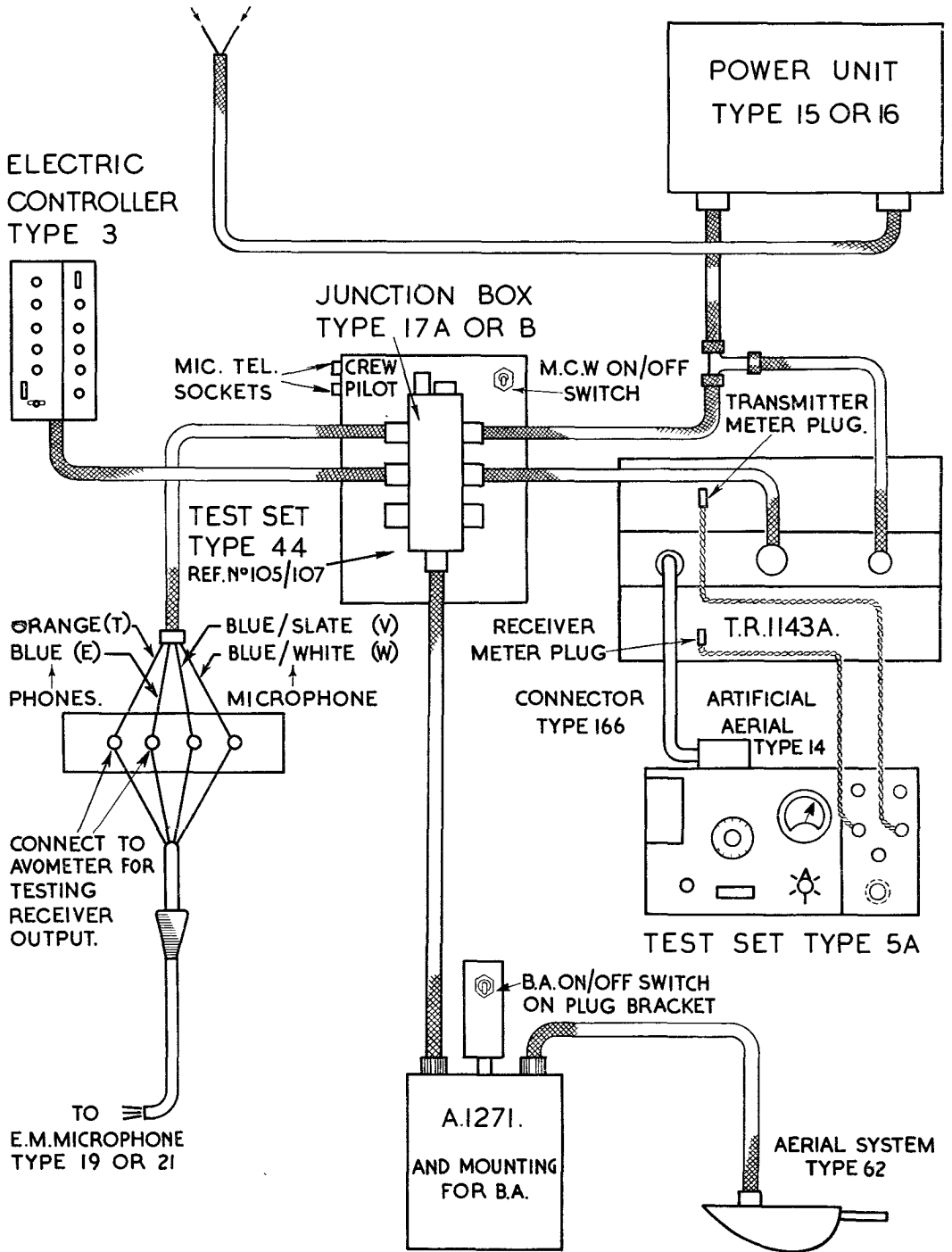

Fig. 16—Bench layout for tuning.

the knurled clamp nuts. Continue movement until nut is tight. This locks the cam assemblies. Finally reset the switch P in the OPERATING position and read meter current in all six positions at all four frequencies. A large change of current in any position at the different frequencies will indicate mistuning, which should be corrected by repeating the tuning procedure of the stage affected.

132. When the transmitter is finally tuned, the meter readings should lie within the limits given in the following table. These values are to some extent dependent on the frequency and tend to increase as the frequency increases. If the readings fall very far outside the specified limits even after thoroughly rechecking all tuning adjustments, reference should be made to the instructions given in paragraph 216 under the heading "Dismantling."

Switch position	1	2	3	4	5	6
Not greater than	100+	85	100	65	50	*
Not less than	42	40	60	50	40	35

* see paragraph 129 above.

These figures assume that the power unit supplies the following voltages on load :—

H.T.—300 volts.

Bias—150 volts at generator or 120 volts at transmitter.

L.T.—12.6 volts at transmitter or 13.1 volts at generator.

133. If any difficulty is experienced in tuning the transmitter to obtain the required output or grid current, one or more of the valves may need renewal. A faulty valve is usually indicated by the fact that when the set is tuned, the anode current of the earlier valves will be high while those of the subsequent valves will be low. When changing the valves, it is convenient to remove the top cap connection by leverage using the end of a screwdriver. When two valves have a common retainer, both caps and retainer should be removed before changing the valve. In the case of the valves V5 and V6, the locking clamp at the base of the valve should be loosened by unscrewing the clamping screw.

134. A check of the efficiency of the valves may be made by checking the anode current of each valve when its anode circuit is tuned. This entails tuning TC2 (see figure 2) with the meter switch in position 1, TC3 in position 2, TC4 in position 3, TC5 in position 4. A pronounced dip should be observed at resonance in each case.

Neutralization.

135. Neutralization of the output stage may be necessitated after changing the output valves or for other reasons. A check of the neutralization may be made after releasing the switch P, switching the equipment to TRANSMIT and short-circuiting the contactor contacts A of the junction box so as to set the amplifier oscillating and applying high modulation voltage to V5, V6 (figure 21) in the transmitter. With the meter switch in position 5, verify that whatever the relative position of TC4 and TC5 within the complete frequency range, no meter reading is observed in these conditions. If *no* meter reading is observed the transmitter is correctly neutralized.

136. If as a result of the test described in the preceding paragraph, output current *is* found in the meter position 5, it will be necessary to re-neutralize the transmitter by proceeding as follows : Remove the amplifier unit, set the equipment at TRANSMIT and after inserting a 6,225 kc/s. crystal, or a crystal of the nearest frequency to this available, tune the set as described in paragraphs 125 to 132, then set the switch to position 6 and adjust TC4 to maximum. Then switch to position 5 and adjust TC5 to maximum. If the reading exceeds *one* division, full scale corresponding to 100, readjust neutralization condensers C19 and C20, until the meter reading becomes *less* than one division, and repeat the test procedure described in paragraph 135.

137. The neutralizing condensers are adjusted by moving the shutter upwards or downwards after loosening the clamping screws. These should only be loose enough to permit easy movement of the shutter when pushed down by a screwdriver applied as a lever between the tabs on the shutter and the chassis. When making final adjustments, it is advisable to tighten one of the clamping screws and pivot the opposite side of the shutter down as necessary.

138. As a guide to the directions of movement necessary, if the frequency at which a reading was obtained under the conditions described in paragraph 136 lies at the low frequency end of the frequency range, move the shutter upwards, and if at the high frequency end, move the shutter downwards. Adjustment should be continued until conditions given in paragraph 136 are satisfied, and the operation should again be checked in accordance with the tests given in paragraph 136.

139. Note, as regards changing valves, that the valve even if unsuitable in one position may frequently be useful in another position, that is, a valve which will not perform in a proper manner as a frequency trebler V3 (figure 21) or doubler V4 may be suitable for use as an output valve in position V5 or V6.

140. Apart from poor neutralization, apparent trouble in tuning the output stage involving low output reading in position 5 with normal performance of the valves V5 and V6, may be caused by failure of the monitor valve V7 or by the wrong setting of the monitor coupling condenser C31. If the lock nuts of the movable disc of this component have become loose, C31 may possibly have been set too far away from TC5. The normal position of the disc is approximately $\frac{3}{8}$ inch from the nearest point of the stand-off insulator.

141. If difficulty is experienced in tuning TC2, TC3 or TC4 at the extreme ends of the frequency scale, this may be due to either C10 or C14 having become displaced, due to maintenance repairs or careless handling, from their correct positions so that they are in close proximity to the chassis or other earthed component. Alternatively a valve fault may cause this trouble.

Receiver tuning.

142. The receiver is similarly tuned, after inserting the crystals and loosening the tuning cam locking nuts by about one turn as before. The test set control switch should be moved to the position REC.AGC. and the key switch on the controller set to RECEIVE. The press button corresponding to the lowest operating frequency should then be depressed after resetting the switch P to the operate position.

143. The test set should then be set in operation at the required frequency, using the appropriate crystal. The output should be set at the maximum. The frequency of the receiver crystal (F_r) is given by the expression

$$F_r = F_t - 540 \text{ kc/s.}$$

Where F_t = transmitter crystal frequency.

144. The receiver unit tuning condensers should then be set manually to the approximate operating frequency selected and adjusted in the following manner.

145. Swing TC6, TC7 and TC8 until an audio output is heard. With large output from the test set, type 5A, many responses may be obtained whilst swinging TC6 hence it is important to reduce this output until the response corresponding to the smallest input is obtained. Having identified the correct response in this manner TC6, TC7 and TC8 should be adjusted in that order until the maximum sensitivity is obtained.

146. Particular attention should be given to the adjustment of TC8. This controls the tuning of the cathode feed-back circuit to the crystal and provided that the crystal in use is of normal activity the characteristic of this circuit will be flat and no definite tuning point may be obtainable. In all cases it is important that TC8 should be set to the same approximate scale setting as TC6 so that if, for any reason the activity of the crystal in use should decrease, the cathode feed-back circuit will be correctly tuned to assist the requisite drive from the anode circuit of V3.

147. The tuning operations described may first be carried out aurally as stated, but the final tuning should be carried out using the meter in the test set, and adjusting until the maximum "backing-off" is observed. The test set output must be reduced during the final tuning until a "backing-off" of approximately ten scale divisions is obtained. Under these conditions, more accurate settings of TC6 and TC7 will be obtainable.

148. The tuning operations should be performed for the three higher frequencies, in ascending order, switch P released, and the mechanisms finally locked, as described for adjustment of the transmitter. The switch P should then be reset in the operate position, and the tuning checked by reading the current at each frequency in turn using the same output setting for the test set, but resetting the test frequency each time. The current readings at each frequency should be approximately equal.

149. On completion of the tuning, the instrument should be installed in the aircraft and connected up. A test set, type 11, 11A or 98 should be used to check the radiation of the transmitter on all frequencies and the output tuning condenser readjusted, if necessary, to obtain maximum output. Instructions for the setting of the lock of the T-R switch of the controller electric are to be obtained from the Signals Officer.

PRECAUTIONS AND CARE

150. The equipment should be kept in good, clean condition throughout, any dust being removed by blowing out with clean, dry air wherever necessary. All key, relay and plug contacts should be cleaned at intervals with carbon tetrachloride, care being taken not to deform them in the process. Suitable procedure is to pour a few drops of the liquid over the contacts, then operate the contacts manually several times. Moving parts of the tuning mechanism and tuning motor, etc., should periodically be lubricated with a trace of anti-freezing oil, applied to the bearings with the end of a piece of wire dipped in the oil. *No oil should be applied to the variable condenser cam assemblies, nor to switch contacts nor insulators.*

151. *On no account should any of the trimming condensers on the receiver ganged condensers, nor the IF tuning adjustments be interfered with except by authorised personnel provided with the appropriate testing equipment. The same applies to the preset variable resistance controls on the receiver and amplifier.*

Controller.

152. Apart from contact cleaning and lubrication of the press-button mechanism and key switch detent, the controller should need no maintenance. Renewal of the pilot lamps, when necessary, may be effected by removing the front plate assembly, held by two screws, extracting the lamp cap with pliers, and withdrawing the affected lamp by means of the GPO extractor type 5, 10AB/6.

Junction Box, 17a or 17b.

153. Remove all the connectors from the Junction Box. Examine all the connectors for attachment to the Breeze metallic sleeving. See that the knurled locking nuts are undamaged. Check for continuity the wiring of the Junction Box. Figures 29 and 30 will be helpful when doing this.

DISMANTLING

154. Remove outer casing by releasing four large Dzus fasteners and lift set out. Clean outer case.

155. Remove two slide-back metal covers, 10A/13014 and 10A/13015, by unscrewing retaining screws at each end.

156. *Ensure that all selector mechanism is at RELEASE, i.e., that all selector fingers are disengaged from slide bars controlling rotation of transmitters and receiver tuning condensers. If this is not already so, connect set to a supply and operate release switch P on top of motor unit.*

157. Remove centre metal cover 10A/13013, bearing TR.1143A serial and reference numbers, by unscrewing four nickel-plated round head screws and four nickel-plated cheese head screws. No black enamelled screws need be removed. Removal of this cover exposes the aerial change-over relay and all connections of the Jones sockets into which the transmitter, receiver and amplifier chassis plug.

158. Remove transmitter, receiver and amplifier chassis by removing red painted screws (four for transmitter, three for receiver, three for amplifier). If the whole chassis is stood on the end nearest the selector mechanism, the transmitter, receiver and amplifier will ease out gradually without distortion of the chassis.

Transmitter unit, type 50.

159. Remove crystals. Check for wear on small insulating cylindrical washers which operate the crystal switch contacts. Clean crystal switch contacts.

160. Remove end and side panels to expose valves.

161. Remove valves and examine valve pins and caps for security and cleanliness. Examine valve holders and retaining clips and springs. Check that valve holder contacts are gripping the valve pins, and close any loose ones. Clean valve pins with carbon tetrachloride. Examine braided flexible lead to valve top cap clips for evidence of fraying and renew if necessary.

162. Ensure that the braided leads to the valve caps of the VT.501 valves in the second trebler and doubler stages (V3 and V4 of figure 22) are not long enough to permit them to earth against the chassis under vibration.

163. Inspect coils for security and check for foreign matter or dust between tuning condenser vanes. Remove all dirt by means of blower.

164. Screens exist between the variable condensers TC1—TC2—TC4. In some cases the washers on the condenser assembly pillars project to a degree where they touch these screens. In such cases (with the exception of TC4) the side of the washer nearest the screen is to be filed flat using a small flat file. Care must be taken to remove the filings after this operation. The screen between TC3 and TC4 should be pressed firmly against TC4 so that it cannot vibrate.

165. Check that condenser spindle extensions are not loose, that the flexible couplers grip the spindles of the condensers and that the selector mechanism is tight.

166. Check all four selector slides for cleanliness, freedom of movement and their prompt return to neutral position when free. Anti-freeze oil may be used sparingly on the slides, care being taken to ensure that it is not allowed to reach the condenser assemblies which are not intended to be oiled.

167. If meter switch contacts are dirty, clean with small camel-hair brush moistened with carbon tetrachloride.

168. Inspect wiring for dry joints and security.

169. Clean out the under chassis, particularly near the R.F. sections of the circuit, using a small soft brush and/or a blower. *Do not distort the R.F. wiring or coils in any way and do not twist either condensers or resistors on their end wires.*

170. Inspect all screw connections and component supports and tighten where necessary.

171. Clean or blow out dust that may be lodged between the two flat metal plates mounted together and running from the aerial coupling coil (L6 of figure 22) to the aerial socket.

172. Replace valves, retaining clips, etc., and metal panels.

Receiver unit, type 71.

173. Remove crystals. Check for wear on small insulating cylindrical washers which operate crystal switch contacts. Clean crystal switch contacts.

174. Remove valves and check as in paragraph 161 above. Care must be used in the extraction of the VR.91's. *USE EXTRACTOR VR91—10A/14074.*

175. Inspect components above and below chassis for security and cleanliness. Use blower to remove dust. *Do not distort R.F. coils or wiring.*

176. Inspect tuning condenser vanes for freedom of movement and cleanliness. See paragraph 163 above re cleaning. Pay particular attention to oscillator tuning condenser TC8 which, because of its position, is liable to be overlooked.

177. Check condenser tuning spindle extensions for looseness. Check the flexible couplers and the selector mechanism.

178. Do *NOT* move settings of any of the small trimming condensers nor the I.F. transformer adjustments.

179. Check muting relay adjustment and clean contacts.

180. Check selector slides as in paragraph 166 above.

181. Clean out the aerial coaxial socket and check wiring.

182. Replace valves, retaining clips and bands. Ensure that the top cap connections are secure when fitted and that their flexible leads are not frayed. In the case of the oscillator valve VT.52 (V3, figure 18) ensure that the top cap connection does not make contact with the earthed screening can.

Amplifier unit, type 165.

183. Remove valves and deal with them and their holders as in paragraph 161 above.

184. Examine components and wiring for security and cleanliness. Clean with blower.

Relay unit.

185. Turn the main chassis over carefully with the "W" sockets undermost and with the selector motor nearest the front of the bench. The relay unit is now uppermost and may be removed by releasing two Dzus fasteners which are on a cross member between the relay unit and the selector motor assembly. Remove unit by sliding and lifting, and remove the dust cover which is retained by one screw.

186. Inspect row of knife connections arranged in ten pairs. Clean carefully without distorting or shorting any connections.

187. Clean relay contacts carefully. Depress each relay armature manually and see that it opens and closes contacts and has not become dislodged from its normal pivoting position.

188. Examine wiring and connections and check security of relays.

189. Replace dust cover carefully.

Selector motor unit.

190. Place main chassis in normal position, i.e., aerial relay uppermost.

191. Lift off each of the four extension rod yokes going to receiver selector fingers across the top of the chassis (see figure 23). These rod yokes are each held in position on the selector motor bell cranks (point 26) by a thin leaf spring which normally prevents them slipping off. Gently lift each spring and ease the rod yoke free, starting with the topmost. When all four are free and clear of the selector motor mechanism, and *not before*, the three screws holding the selector motor unit to the main chassis may be unscrewed and the unit withdrawn upwards.

192. By depressing and releasing manually the selector motor and driving motor armatures, the normal movement of the mechanism may be observed in slow motion. Check that each ratchet movement is working correctly.

193. The longer armature found underneath the release switch operates the cams and insulating discs associated with the leaf spring contacts. These should be inspected and the relative movement of the contacts checked. Clean carefully.

194. The other motor armature should be operated manually through a whole cycle and the movement and return of the selector fingers checked.

195. Other contacts on the leaf spring should be cleaned carefully, care being taken not to distort them.

196. Anti-freeze oil must be used sparingly and then only on the working bearings, cog teeth and sliding parts.

197. Check wiring (see figure 26).

198. Leave all selector fingers and bell crank levers in neutral position.

Main chassis (top tray).

199. Clean all dust from chassis with small soft brush and/or blower.

200. Check return springs on receiver selector fingers.

201. Inspect all wiring and connections for security (see figure 27).

202. Inspect all knife connections into which slide the appropriate connections of the motor unit and relay unit, and, where these show signs of being opened unduly, careful repositioning should be done.

203. Aerial Relay Unit. This unit is attached to the main chassis by three screws which are accessible from the top of the chassis. They can be readily identified by observing the underside of the main chassis near the two aerial sockets into which the transmitter and receiver plug.

204. Clean relay contacts.

205. Clean between strips connecting aerial sockets and relay leaf springs. *Do not distort them in any way.*

206. Clean dust from insulating material inside and outside of the three aerial sockets.

207. Check wiring and connections for security (see figure 27).

RE-ASSEMBLING

208. Replace aerial change-over assembly.

209. Replace relay unit, carefully engaging knife contacts.

210. Replace selector motor unit. Do not screw down tightly at this stage. Connect up extension rod yokes to bell crank levers in original position.

211. Replace amplifier and screw to chassis firmly.

212. Replace receiver. Screw up to chassis firmly, ensuring that the selector fingers on the main chassis register with the appropriate channel slides on the receiver.

213. Replace transmitter and screw up to chassis firmly.

214. Now loosen and line up selector motor mechanism so that the selector fingers on the motor unit engage correctly with the slide bars on the transmitter chassis and screw up tightly when positioned.

215. The operation of channel changing should now be checked in the following manner :

Transmitter.

216. Connect up the set and put the T-R switch to transmit. Tune the transmitter as described in paragraphs 125 to 134, on at least three of the frequencies, as widely separated as possible. Note the reading of the grid current (meter in position 6), for each of the frequencies after locking up. Operate the Controller to change from the extreme frequencies to the middle frequencies several times. Then take the grid current readings for each of the frequencies again. These readings should not have changed by more than 10 divisions, however often the changes have been made. Should discrepancies occur, then the tuning mechanism should be checked for slipping, and the system re-checked after any necessary adjustments have been made.

Receiver.

217. Tune up the receiver in the manner described in paragraphs 142 to 148, for at least three widely separated frequencies. Select a frequency near the middle of the band, and note AVC current reading on the meter. Operate all the push buttons several times in succession, and return to the chosen mid-frequency. The reading of the meter should not have changed. If there is any alteration, then the tuning mechanism must be rechecked for slipping.

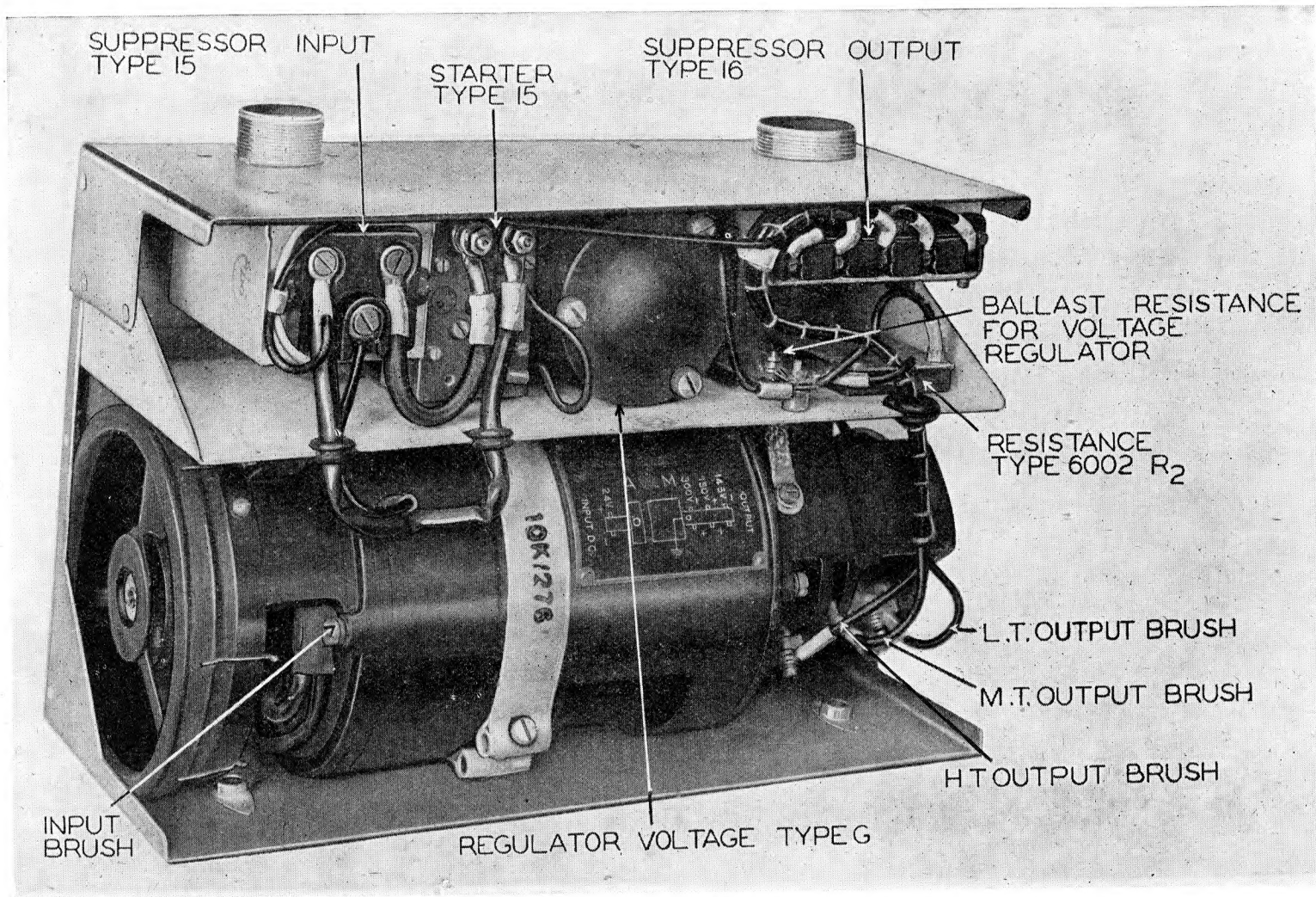

Fig. 34—Power unit, type 16, view with cover removed.

APPENDIX I.

RADIO TECHNICAL INFORMATION MEMORANDUM NO. 625

Transmitter-receiver Type T.R.1143A—Modification
for MCW (W/T) operation, manual receiver muting
and improved intercommunication.

*NOTE: THIS MEMORANDUM IS NO AUTHORITY FOR THE MODIFICATION TO
BE MADE.*

1. When transmitter-receiver, type TR.1143A is modified in the manner described in this memorandum the above facilities will be made available. In addition it will be possible to obtain satisfactory results from two of these sets when they are installed in a single aircraft.

MCW and Muting.

2. Since 'contactor' operation is no longer required, the F relay in the transmitter-receiver is now employed to provide MCW operation and manual receiver muting. When the modifications have been made, a push-button switch or morse key is connected across the 'contactor' socket A. If the key on the controller electric is switched to R, operation of the push-button or switch will mute the receiver for satisfactory intercommunication. If the key is switched to T, the push-button or morse key can be used for MCW operation.

Improved Intercomm.

3. The amplifier unit of the transmitter-receiver is modified to give improved intercomm. and satisfactory 'side-tone' level when MCW is used, and also to make the intercomm. level independent of the modulation control setting when the unit is modified to obtain improved intercomm.

4. It should be noted that for optimum performance not more than two microphones should be switched on at any one time and equalised telephones should be employed. (Low impedance, type 32, Stores Ref. 10A/13466; High impedance, type 16, Stores Ref. 10A/12401).

5. The undermentioned equipment is required:—

<i>Item.</i>	<i>Stores Reference.</i>	<i>Nomenclature.</i>	<i>Quantity.</i>
1	5E/1780	Wire, copper, tinned No. 20 S.W.G.	As Reqd.
2	5F/1910	Tubing, insulating grade E	"
3	5E/2001	Cable, electric Uniflexmet 2.5	"
4	5F/1297	Tubing, insulating $\frac{3}{8}$ in.	"
5	5F/451	Tape, insulating, adhesive, $\frac{1}{2}$ in.	"
6	10C/11125	Condenser type 3361 (0.05 μ F tubular)	1
7	10C/11565	Condenser type 3534 (500 μ F silvered mica)	1
8	10C/11691	Resistance type 525 (100,000 ohms, $\frac{1}{2}$ watt, insulated)	3
9	10C/589	Resistance type 827 (270,000 ohms, $\frac{1}{2}$ watt, insulated)	1
10	10C/130	Resistance, type 598 (1 megohm, $\frac{1}{2}$ watt, insulated)	1
11	10C/989	Resistance type 989 (470,000 ohms, $\frac{1}{4}$ watt)	
	OR		
	10C/992	Resistance type 992 (560,000 ohms, $\frac{1}{4}$ watt)	1 "
	OR		
	10C/10316	Resistance type 3277 (680,000 ohms, $\frac{1}{4}$ watt)	
12	10E/11398	Valve type VT52	1

6. The procedure is as follows:—

Relay Unit.

7. This is to be modified so that the relay F may be used to cause self-oscillation of the modulator section of the audio unit (for MCW operation) and to mute the receiver; thus the "contactor radiation on D" facility is deleted.

8. In the following, the tags on the relay unit connector Y are numbered in sequence from 1 to 20, tag number 20 being at the same end of the unit as relay F.

9. Remove the lead between tag number 16 on the 20-way connector Y and a contact on relay F.

10. Identify the lead between tag number 13 on the 20-way connector Y and a contact on relay F; disconnect this lead from Relay F, shorten it and connect the free end to tag number 16 on the 20-way connector.

11. Remove the lead between tag number 17 on the 20-way connector and a contact on relay F.

12. Identify the lead between H relay coil connection tag and a contact on relay F; disconnect this lead from relay F and transfer the free end to number 17 on the 20-way connector Y.

13. Connect a lead between the F relay contact referred to in paragraph 229 and tag number 13 on the 20-way connector Y.

14. Connect 0.05 μ F condenser type 3361 across the coil connection tags of relay F as follows :—

15. The condenser is to be anchored to the relay mounting plates by looping a piece of insulated 20 SWG wire round the condenser and through two of the holes in the plate, the ends of the wire being twisted together and soldered to secure.

16. The wire ends of the condenser are to be kept short and are to be covered with insulating tubing.

17. If the outer foil connection of the condenser is indicated by a coloured band the wire at this end of the condenser is to be soldered to that coil tag which already connects to tag number 19 on the 20-way connector Y. The other wire of the condenser is to be soldered to the remaining coil connection tag.

Receiver Unit.

18. This is to be modified to provide manual muting.

19. Remove the receiver unit from the chassis. Connect a short length of insulated wire between pole number 3 on the receiver 8 pole Jones plug and the soldering tag which is a junction point for leads from the 0.1 μ F audio feed condenser C54, the 4,700 ohm resistance R39 and the 68,000 ohm resistance R40. This tag is situated in the top corner of the R39—R40 tag board. Do not replace the receiver unit at this stage.

Main Chassis.

20. This is to be modified for manual receiver muting.

21. Remove the transmitter and amplifier units and the central cover from the chassis.

22. Remove the lead connected to tag number 18 of the 20-way relay unit connector Y on the main chassis, tape the end and bind to the cableform.

23. Connect a length of Uniflexmet 2.5 between pole number 3 of the 8 pole receiver Jones socket U and tag number 18 referred to above, in the following manner :—

24. The lead is to follow the route of the existing cableform and is to be bound to it with thread at several points. The lead must also be covered with insulating tubing, a break being made in the tubing at the point where the lead passes on earthing tag near the relay box. (If this tag does not exist, it will be necessary to fit one). Connection is to be made between the earthing tag and the metal braiding of the lead by means of a piece of 20 SWG wire. Care should be taken to ensure that the screened lead is kept clear of any connecting sockets.

25. Interchange the connections to poles numbers 9 and 10 of the Amplifier 6-way Jones plug Z on the Main Tray.

Amplifier Unit.

26. This is to be modified to give improved Intercomm.

27. Remove the screened lead that runs from the junction of the 1 megohm resistance R418 and the 100 μ F condenser C407 to the transformer T403.

27A ~~Remove~~ Disconnect the screened lead which is connected to the junction of C407 and R408, and prepare end for another joint.

28. Remove the 600 ohm resistance R412 and replace it by a piece of insulated wire.
29. Remove the resistance R413 and condenser C407.
30. Identify the 300 μF condenser C407 situated behind the screen at one end of the amplifier, one end of which can be seen. Without removing the screens, carefully cut the connection between this end of the condenser and the adjacent soldering tag.
31. Remove the lead that connects one end of the 200K resistance R407 to one end of the 1 megohm resistance R406. This wire runs behind the component tag board.
32. Connect a 100K $\frac{1}{2}$ watt resistance type 525 between socket number 4 on the holder for valve V402 and pin "OP" on the transformer T403.
33. Connect a 100K resistance type 525 between pin "OP" and the spare pin between pins "OP" and "IP."
34. Connect a 1 megohm $\frac{1}{2}$ watt resistance type 598 between the spare pin and pin "IP."
35. Connect a lead from the spare pin to the end of resistance R407 from which a lead was removed in paragraph 31.
36. Remove the 2.2 megohm resistance, R411 and replace it by a $\frac{1}{4}$ watt or $\frac{1}{2}$ watt insulated resistance of a value from 470K to 680K. This change may have been already made. (R.T.I.M. Number 553 refers).
37. One end of R411 is strapped to one end of the adjacent 0.1 μF condenser C409. Remove this strap.
38. Transfer the remaining lead at this end of C409 to the now vacant end of R411.
39. Connect a lead from the vacant end of C409 to socket number 4 on the holder for valve V402.
40. Insulate the wire ends of a 500 μF condenser type 3534. Connect one end of this condenser to that end of the 0.005 μF condenser C405 which is already connected (by a screened lead) to the top cap (control grid) connection of valve V402. Connect the other end of the 500 μF condenser to the earth pin marked "1" on transformer T405. The condenser leads should be kept as short as possible and the condenser positioned to be clear of other components.
41. Locate the 2.2 megohm R36 resistance situated on the 6 pole Jones plug, one end of which is connected to a small insulated tag at the end of the ~~insulated tag~~ ^{next to C406}. Remove the lead which is connected between this tag and socket number 8 on the side tone amplifier valve holder V401 (VR55) and R ~~connected to the terminal~~ ^{Uniflexmet joint referred to in 27A, a} ~~connected to the terminal~~ ^{insulated tag, and pole number 3 on the} ~~connected to the terminal~~ ^{10 pole Jones plug U. The metal braiding of the cable is to be earthed by means of 20 SWG wire} ~~connected to the terminal~~ ^{to the metal braiding of other wires in the cableform, and the cable is to be bound to the cableform} ~~connected to the terminal~~ ^{with thread. If there is an earthing tag on the cover of the modulation control, anchor the Uniflex} ~~connected to the terminal~~ ^{met to this, with 20 SWG wire. Left-hand top terminal of T2. Insulate thro' joint and box} ~~connected to the terminal~~ ^{screening.}
42. Connect a length of ~~insulated tag~~ ^{Uniflexmet} between the ~~insulated tag~~ ^{insulated tag} and pole number 3 on the 10 pole Jones plug U. The metal braiding of the cable is to be earthed by means of 20 SWG wire to the metal braiding of other wires in the cableform, and the cable is to be bound to the cableform with thread. If there is an earthing tag on the cover of the modulation control, anchor the Uniflex met to this, with 20 SWG wire. Left-hand top terminal of T2. Insulate thro' joint and box screening.
43. Replace the 2.2 megohm resistance R36 by a 270K $\frac{1}{2}$ watt insulated resistance type 827.
44. Remove the lead connected to pole number 12 on the 6 pole Jones plug Z and transfer it to pole number 11 on the same plug.
45. Connect a 100K $\frac{1}{2}$ watt insulated resistance type 525 between poles numbers 11 and 12 on the 6 pole Jones plug Z.
46. Replace valve V402 (VR55) by a valve type VT52.
47. Replace the transmitter, receiver and amplifier units and the central cover of the chassis.

Identification of Modified Equipments.

48. When a transmitter-receiver type TR.1143A has been modified as described above the following is to be clearly marked on the central cover of the chassis:—

"MODIFIED FOR M.C.W. W/T: REC. MUTING—
IMPROVED I/C (R.T.I.M. NUMBER 625)."

Addendum Number 1 to R.T.I.M. 625.

49. Due to the introduction of a manufacturing change in transmitter-receivers type TR.1143A, the above Memorandum requires amendment.

50. In later issues of amplifier unit type 165, the 2·2 megohm resistance which was previously situated on the 6 pole Jones plug has been repositioned on the underside of the chassis. Consequently *in such cases* the instructions given in R.T.I.M. Number 625, paragraphs 258, 259 and 260 above, are replaced as follows :—

51. Locate the 2·2 megohm R36 resistance situated under the chassis at the extreme left hand end of the tag board below “V1” and “V2.” Remove the connection between the lower end of this 2·2 megohm resistance and the upper tag at the extreme right hand end of the same tag board (i.e., the tag which connects to socket number 8 on the holder for valve V401 (VR56)).

52. Connect a length of uniflexmet 2·5 cable (encased in insulating tubing) between the now vacant end of the 2·2 megohm resistance and pole number 3 of the 10 pole Jones plug U, as follows :—

53. The lead from the 2·2 megohm resistance is to run vertically up to the top of the tag board, through the large slot in the metal screen and across the underside of the chassis to the corner adjacent to the spare ‘valve-holder’ hole. The lead then passes through the ‘valve-holder’ hole, up the adjacent angle-piece of the chassis, past the outside edge of the 6 pole Jones plug and follows the route of the existing screened cable along the angle of the top chassis to pole number 3 of the 10 pole Jones plug.

54. The metal braiding of the uniflexmet is to be earthed, by means of 20 SWG wire, to the metal braiding of the existing cable at the point where it passes through the ‘valve-holder’ hole and again to the braiding of the existing cable near the modulation control. If there is an earthing tag on the cover of the modulation control anchor the uniflexmet cable to this tag with 20 SWG wire.

55. The new lead is to be bound with thread to the existing screened leads at several points.

56. Replace the 2·2 megohm resistance R36, referred to in paragraph 275 above, by a 270K $\frac{1}{2}$ watt insulated resistance type 827.

APPENDIX II

LIST OF PARTS

This list of parts is issued for information only. When ordering spares for this equipment, reference should be made to Volume III of this publication (if available) or to the appropriate section of A.P.1086.

MAIN TRAY—CHASSIS ASSEMBLY TYPE 13

<i>Circuit Reference</i>	<i>Stores Reference Number</i>	<i>Nomenclature</i>	<i>Qty.</i>	<i>Details</i>
CH1	10D/13341	Chassis Assembly, type 13 Choke, L.F. type 158	1	TR.1143A main tray 3,500 turns on moulded former, laminated core.
	10C/3770			
	10H/1913	Clip, type 45	1	Condenser strap, hook type. Fixed one end.
	10H/1914	Clip, type 46	1	Condenser scrap, angular. Fixed both ends.
C1, C2, C3, C4	10C/3863	Condensers, type 1952	4	2 μ F. 500V. D.C. working, paper, metal case 3.187" \times 2" \times 0.75", without fixing tags. G.E.C. 86889.
C6	10C/745	Condenser, type 831	1	300 μ F \pm 15%, 350V. D.C. working, mica, moulded, wires, small. Dubilier 635.
Y	10H/1912	Jack, type 26	1	20 pole (10 \times 2 way) flat contacts 0.25" crs. strip mtd.
P Q X	10H/395	Plug, W.202	1	12 pole, panel mtg. square flange.
	10H/396	Plug, W.203	1	18 pole, panel mtg. sq. flange.
	10H/1911	Plug, type 382	1	Jack plug 12 pole (6 \times 2 way) 0.25" crs. Flat contacts.
AR 2	10F/1478	Relay Units, type 74	1	Aerial changeover, complete with SP. coaxial socket.
	10F/1479	1 Relay Magnetic, type 506	—	PO. 600 type. 150 ohms. \pm 7 ohms. 1b. before m. and 1m. before b. 1 c/o. (Fitted with screw 10F/1890).
	10H/4794	2 Plugs, type 607	—	SP. coaxial, panel mtg. Flange 0.75" \times 1". 3 fixing holes 0.093" d. (Fits socket, type 86). Receiving and Transmitting.
R1	10W/1089	Resistance, type 1089	1	3900 ohms \pm 10% $\frac{1}{2}$ watt. R.M.A.8.
R2	10W/6412	Resistance, type 6412	1	47 ohms, \pm 10% $\frac{1}{2}$ watt. R.M.A.8.
U	10H/3897	Socket, type 516	1	10 pole, moulded, rectangular, knife contacts, without brackets. S.T. & C. LP.115189.
T. & R.	{ 10H/3898	Sockets, type 517, or	2	8 pole, moulded, rectangular, knife contacts, without brackets. E. K. Cole 123111.
		Sockets, type 301		
Z	10H/3899	Socket, type 518	1	6 pole, moulded, rectangular, knife contacts, without brackets. S. T. & C. LP.115187.
	27H/1740	Springs, Dzus, Part No. 100	4	
	27H/.....	Springs, Dzus, Part No. S3-1	2	
	27H/...	Springs, Dzus, Part No. S3-2	4	
RECEIVER SECTION				
	10P/13052	Receiver Unit, type 71		Plug-in unit. Complete with valves. Similar to type 19 but with variable muting circuit.
	10H/1908	Block, Terminal, type 4	1	Loaded ebonite 1.5" \times 0.37" \times 0.12" fitted with 2 connector pins.
	10A/19073	Bush, type 171	1	Brass, external thread $\frac{1}{2}$ B.S.F \times 0.12" shoulder 0.31" d. \times 0.19", Hex. head 0.37" A/flats. Length overall 0.42"
				For retaining Inductance, type 695.

<i>Circuit Reference</i>	<i>Stores Reference Number</i>	<i>Nomenclature</i>	<i>Qty.</i>	<i>Details</i>
	10A/15531	Bracket, type 281	1	Double angle. MS. 21 S.W.G. 1.56" × 0.81".
	10A/13025	Caps, Valve, type 13	4	For mounting Resistance, type 2594. Unscreened, reinforced. For valves 0.25" d. top cap. Benjamin 75/548.
	10C/13560	Choke unit, type 45	1	Consists of L16, L17, C76, R61 and tagboard type 22. Compensates for low activity crystals.
L16, L17	10C/13561	1-Choke, H.F., type 564		45 Turns 0.0092" d. en. cu. wire, 5.3 μH. ± 5%, 0.4 ohm. and 1 wave wound coil 41 μH. ± 5%, 1.8 ohm. wound on vulcanite former 0.25" dia. × 1.5".
C76	10C/94	1-Condenser, type 609		300 μμF. ± 15%, 350V. D.C. wkg. mica, moulded, wires.
R61	10W/1847	1-Resistance, type 1847		2,200 ohms, ± 20%, ½ watt. R.M.A.8
	10A/19079	1-Tagboard, type 522		SRBP 1.75" × 1.37" × 0.06" 2 fixing holes 0.12" d. × 1.31" centres. Fitted with 4 tags.
	10A/19074	Clamp, type 237	1	Brass 0.71" × 0.34" × 0.12" with hole tapped ¼" BSF. For retaining Inductance, type 695.
		<i>Capacitors</i>		
C54, C57, C77	10C/11126	Condensers, type 3362	3	0.1 μF. ± 20%, 350V. D.C. wkg. paper, tubular.
C55	10C/11125	Condenser, type 3361	1	0.05 μF. ± 20%, 500V. D.C. wkg. paper, tubular.
C56	10C/11124	Condenser, type 3360	1	0.02 μF. ± 20%, 750V. D.C. wkg. paper, tubular.
C8, C27, C33, C36, C38, C40, C42, C43, C47, C48, C60, C63, C64, C65, C66, C69, C70, C71, C73	10C/244	Condensers, type 635	19	0.01 μF. ± 15%, 350V. D.C. wkg. mica, moulded, wires.
C7, C10, C21, C30, C31, C39, C45, C50, C59	10C/14251	Condensers, type 4703	9	0.005 μF. ± 20%, 750V. D.C. wkg. mica, moulded, wires.
C58, C72	10C/24	Condensers, type 580	2	0.002 μF. ± 15%, 350V. D.C. wkg. mica, moulded, wires.
C5, C6, C13, C19, C61, C62, C67, C68	10C/745	Condensers, type 831	9	300 μμF. ± 15%, 350V. D.C. wkg. mica, moulded, wires.
C28, C35, C37, C41, C44, C46, C49, C53, C74	10C/5880	Condensers, type 3228	9	75 μμF. ± 1 μμF. 350V. D.C. wkg. protected silvered mica.
C51	10C/4762	Condenser, type 2494	1	50 μμF. ± 20%, 500V. D.C. wkg. ceramic disc.
C52	10C/15914	Condenser, type 5289	1	47 μμF. ± 10%, 500V. D.C. wkg., ceramic disc.
C9	10C/3853	Condenser, type 1942	1	40 μμF. ± 0.5 μμF. 500V. D.C. wkg. ceramic disc.
C22, C75	10C/3200	Condensers, type 1555	2	20 μμF. ± 10%, 500V, D.C. wkg. ceramic disc.
C4	10C/3503	Condenser, type 1729	1	8 μμF. ± 0.5 μμF. 500V. D.C. wkg. ceramic disc.
C24	10C/3861	Condenser, type 1950	1	5 μμF. ± 0.5 μμF. 500V. D.C. wkg. ceramic disc.
C1, C34	10C/3859	Condensers, type 1948	2	3 μμF. ± 0.5 μμF. 500 V. D.C. wkg. ceramic disc.
C3, C12, C17, C23, C29	10C/3670	Condensers, type 1856	5	2.2—9.7 μμF. Trimmer, air tubular, with S.R.B.P. mtg. plate. Mullard E.7851. Formerly 10C/3857, type 1946.

Circuit Reference	Stores Reference Number	Nomenclature	Qty.	Details
C11	10C/3855	Condenser, type 1944	1	3.2—20 $\mu\mu\text{F}$. variable, air, ceramic end plate.
	10P/33	Crank, operating	1	Bent lever with bush and pin
	10P/34	Crank, balance	1	Lever, bush, pin and weight.
	10P/35	Links, coupling	2	S.R.B.P. 0.5" \times 0.25" \times 0.016" with keyholes
	10P/36	Link, coupling	1	Metal strip with bakelite ends
	10P/32	Spring, Tension (Anti-backlash)	1	Helical 3.06" \times 0.12" d. 1" close winding hook ends. Connecting links 10P/35.
C2, C14, C20	10C/3856	Condenser, type 1945	1	3 gang, variable, air, 3.5-20 $\mu\mu\text{F}$., each section, connected to TC7.
	10C/12564	Condenser Unit, type 107	1	Includes TC6 two gang condenser and tuning inductances as below :
C15, C26	10C/3858	1-Condenser, type 1947	2	gang, variable, air, 3.5-20 $\mu\mu\text{F}$. each section, connected to TC6.
L6	10C/12576	1-Inductance, type 759	3	Turns 14 S.W.G. cut wire sil. pl. mtd. on S.R.B.P. panel 1.25" \times 0.69" with brass tag plates.
L3	10C/12577	1-Inductance, type 760	2	6 μH . 6+11 Turns 30 S.W.G. cu. wire on vulcanite former, mtd. on S.R.B.P. panel 1.25" \times 0.69" with brass tag plates.
	10P/30	Condenser Drive Unit	1	Cam mechanism for driving 3 variable condensers TC6, TC7 and TC8 selecting 4 positions.
	10A/15093	3-Knobs, type 293		MS. Ni. Pl. 0.87" d. \times 0.16" knurled, tapped for 4 B.A. shaft.
	10A/15094	3-Pointers, type 21		MS. Ni. Pl. 1.37" d. \times 0.016" with pointer 0.75" r. and slot to limit movement. Bushed to fit splined shaft.
	10P/31	12-Springs, Tension		Helical 1.19" \times 0.09" d. 0.4" close winding, hook ends.
	10R/45	4-Springs, Tension		Nickel piano wire 31 S.W.G. 0.14" o/d. \times 1" between crs. of loops 170—250 grms. to extend 3".
	10A/19048	3-Washers, Spring		Ni. Sil. 32 S.W.G. 0.62" o/d. Hole 0.156" d. dished 0.5" r.
	10A/14834	Drive flexible, type 15	1	Synthetic paper tube with flexible spring coupling each end, complete with 4-8 B.A. \times 0.12" ch. hd. screws, length o/all 1.37" approx.
	10A/14835	Drive flexible, type 16	1	As type 15 but 1.94" long approx.
	10D/2203	Diode Limiter Units	1	Complete assembly less valve on SRBP board 3.62" \times 1.62" \times 0.06".
C77	10C/11126	1 Condenser, type 3362		0.1 μF . \pm 20%, 350V. D.C. wkg. paper, tubular.
C52	10C/15914	1 Condenser, type 5289		47 μF . \pm 10%, 500V. D.C. wkg. ceramic disc.
	10H/1923	1 Holder, valve, type 155		RCL/130.31 CCA470K. Small diode, moulded, horizontal, for VR92 valve.
R62	10W/6471	1 Resistance, type 6471		220,000 ohm. \pm 20%, $\frac{1}{2}$ watt. R.M.A.8.
R33	10W/1853	1 Resistance, type 8/81		39,000 ohm. \pm 10%, $\frac{1}{2}$ watt. R.M.A.8.

<i>Circuit Reference</i>	<i>Stores Reference Number</i>	<i>Nomenclature</i>	<i>Qty.</i>	<i>Details</i>
R36	10W/6838	1 Resistance, type 6838	1	22,000 ohm. $\pm 20\%$, $\frac{1}{2}$ watt. R.M.A.8.
R63	10W/6408	1 Resistance, type 6408	1	42 ohm. $\pm 2\%$, 36 SWG. Eureka wire DSC on S.R.B.P. former 2" \times 0.5" \times 0.062".
	10H/11579	Holders, Valve, type 28	4	International octal. S.R.B.P. sheet. Plessey.
	10H/4134	Holders, Valve, type 264		
	10H/3237	Holders, Valve, type 238		
	10A/13023	Mountings, type 124 (Crystal Unit)	1	Crystal holder and switch S.R.B.P. panel, to mt. 4 crystal units type A, or U.S. pattern.
R2	10A/13990 10C/539	1 Cap, valve, type 35 1 Resistance, type 805		Unscreened, Ni. Sil. 0.26" I/D. 47,000 ohm., $\pm 10\%$, $\frac{1}{2}$ watt. R.M.A.8.
R3	10C/7754	1 Resistance, type 7754		47 ohm., $\pm 20\%$, $\frac{1}{2}$ watt. R.M.A.8.
	10A/13024	2 Spring sets		2 b before m. Ni. Sil. springs with contacts, mounted on bracket, for switching in crystals.
L4, L5	10C/3827	Inductances, type 256	2	2 Turns 14 S.W.G. cu. wire sil. pl. Band pass coils.
	10C/12201	Inductance, type 695	1	12.5 μ H. 2.5 ohm. 28 Turns, full wave wound 0.0148"d. cu. wire on vulcanite former 0.5" \times 1.37".
	10B/13354	Insulators, type 336	4	Stand-off, ceramic without screw and nut. Eddystone 1019 Modified.
R	10H/323	Plug, type 194	1	8 pole, flat contacts, moulded, rectangular, without brackets. Jones type. E. K. Cole A.12310
A/2	10F/773	Relay, Magnetic, type 272	1	P.O. 600 type 2 makes, 2850-3150 ohms. Fitted with screw 10F/1890 G.E.C. Spec. 1252.
Resistors				
R43, R44, R45, R46	10W/1593	Resistances, type 1593	5	2.2 meg. $\pm 10\%$, $\frac{1}{2}$ watt. R.M.A.8.
R35	10W/6413	Resistance, type 6413	1	470,000 ohms $\pm 5\%$, $\frac{1}{2}$ watt. R.M.A.8.
R62	10W/6417	Resistance, type 6417	1	220,000 ohms $\pm 20\%$, $\frac{1}{2}$ watt. R.M.A.8.
R13, R14, R21, R26, R 56	10W/11691	Resistances, type 525	5	100,000 ohms $\pm 10\%$, $\frac{1}{2}$ watt. R.M.A.8.
R4, R12, R20, R25	10W/6840	Resistances, type 6840	4	100,000 ohms $\pm 20\%$, $\frac{1}{2}$ watt. R.M.A.8.
R22, R27, R40	10/6321	Resistances, type 6321	3	68,000 ohms $\pm 10\%$, $\frac{1}{2}$ watt. R.M.A.8.
R2, R5, R15,	10W/539	Resistances, type 805	5	47,000 ohms $\pm 10\%$, $\frac{1}{2}$ watt. R.M.A.8.
R30, R42, R59	10W/6081	Resistances, type 6081	1	47,000 ohms $\pm 20\%$, $\frac{1}{2}$ watt. R.M.A.8.
R33	10W/1853	Resistance, type 881	1	39,000 ohms $\pm 10\%$, $\frac{1}{2}$ watt. R.M.A.8.
R37	10W/6086	Resistance, type 6086	1	33,000 ohms $\pm 20\%$, $\frac{1}{2}$ watt. R.M.A.8.
R41, R47, R57, R58	10W/334	Resistances, type 751	4	22,000 ohms $\pm 10\%$, 1 watt. R.M.A.2.
R1	10W/27	Resistance, type 544	1	10,000 ohms $\pm 10\%$, $\frac{1}{2}$ watt. R.M.A.8.

<i>Circuit Reference</i>	<i>Stores Reference Number</i>	<i>Nomenclature</i>	<i>Qty.</i>	<i>Details</i>
R10, R18, R19, R24, R29, R32 R39	10W /6079	Resistances, type 6079	6	10,000 ohms $\pm 20\%$, $\frac{1}{2}$ watt. R.M.A.8.
	10W /1850	Resistance, type 8 /17	1	4,700 ohms $\pm 20\%$, $\frac{1}{2}$ watt. R.M.A.8.
R9	10W /6417	Resistance, type 6417	1	2,200 ohms $\pm 20\%$, 1 watt. R.M.A.2.
R61	10W /1847	Resistance, type 1847	1	2,200 ohms $\pm 20\%$, $\frac{1}{2}$ watt. R.M.A.8.
R6, R7	10W /6416	Resistances, type 6416	2	1,800 ohms $\pm 10\%$, $\frac{1}{2}$ watt. R.M.A.8.
R17	10W /11678	Resistance, type 512	1	1,000 ohms $\pm 10\%$, $\frac{1}{2}$ watt. R.M.A.8.
R23. R28, R31	10W /6082	Resistances, type 6082	3	330 ohms. $\pm 20\%$, $\frac{1}{2}$ watt. R.M.A.8.
R8	10W /6080	Resistance, type 6080	1	220 ohms $\pm 20\%$, $\frac{1}{2}$ watt. R.M.A.8.
R3, R48 R34	10W /7754	Resistances, type 7754	2	47 ohms $\pm 20\%$, $\frac{1}{2}$ watt. R.M.A.8.
	10W /9204	Resistance, type 2534	1	200,000 ohms. $\frac{1}{4}$ watt, potentiometer, carbon, graded, small, tropical. Spindle 0.25" d. \times 0.56" screwdriver slot.
R60	10W /9267	Resistance, type 2594	1	5,000 ohms. 1 watt, potentiometer wire wound, moulded case 0.81" d. with cap. Tropical. Spindle 0.25" d. \times 0.31" screwdriver slot. Colvern 210.
R11	10W /6315	Resistance, type 6315	1	8.5 ohm. shunt, complete with 2 pole plug.
	10A /12989	Retainers, valve, type 15	3	Rubber, moulded, domed top with hole for valve cap. For retaining VR.53, VR.55.
	10A /13094	Retainers, valve, type 19	4	Spring steel. For VR.91. Carr Fastener S75 /536.
	10A /15809	Screen, type 143	1	Valve Aluminium, 1.5" d. \times 2.87". Threaded 8 TPI. at base, with internal compression spring to retain valves. Hussey Dawson & Co.
	10P /13019	Socket and coil	1	S.P. coaxial socket with coil for Aerial.
	10P /13062	Support, valve holder	1	MS. cup 25S .W.G., 1.75" d. \times 0.37" deep, 1 hole 1.26" d. and 2 holes 0.116" d. at 1.5" crs.
	10A /19204	Supports, Crystal retaining strap (4 crystal)	2	M.S. Strip 19 S.W.G., 1.56" \times 0.21". With M.S. pillar 0.97" \times 0.218" d. riveted centrally.
	10A /15816	Strap, Crystal retaining (4 crystal)	1	M.S. 19 S.W.G., 4.625" long \times 0.37" wide with 4 holes 0.147" d. at 0.78" crs., for retaining 4 crystal units, Type A or American pattern. With 2 screws, captive 5 B.A. fitted.
		<i>Tagboards</i>		
	10A /14075	Tagboard, type 73	1	S.R.B.P. 2.56" \times 0.43" \times 0.06" fitted with 5 tags.
	10A /14076	Tagboards, type 74	2	S.R.B.P. 2.25" \times 0.43" \times 0.06" fitted with 4 tags.
	10A /14077	Tagboard, type 75	1	S.R.B.P. 1.87" \times 0.43" \times 0.06" fitted with 3 tags.
	10A /14078	Tagboards, type 76	2	S.R.B.P. 1.31" \times 0.43" \times 0.06" fitted with 2 tags.
	10A /19075	Tagboard, type 518	1	S.R.B.P. 1.87" \times 0.5" \times 0.06" fitted with 2-6 B.A. bushes and 6 tags.

<i>Circuit Reference</i>	<i>Stores Reference Number</i>	<i>Nomenclature</i>	<i>Qty.</i>	<i>Details</i>
C28, C35 C37, C41	10A/19076	Tagboard, type 519	1	S.R.B.P. 3.75"×2"×0.06" fitted with mtg. bracket each end and 14 tags.
	10A/19077	Tagboard, type 520	1	S.R.B.P. 4.19"×2"×0.06" fitted with mtg. bracket each end, 3 condenser clips and 17 tags.
	10A/19078	Tagboard, type 521	1	S.R.B.P. 1.75"×1.84"×0.06" fitted with 3 tags and 1 condenser clip.
	10P/13063	Tube, anode screening	1	Brass 27 S.W.G., 0.22"d.×2.87" Cad. pl.
	10K/1094	<i>Transformers</i> Transformers, type 1169	2	1st and 2nd I.F. (with top-cap connectors to valve grids).
	10C/2648	2-Condensers, type 1264		75 μF.±2%, 350V. D.C. wkg., protected silvered mica.
	10K/1177	1-Cover, protection		Clip-in type, open ends, Ni. Sil. sheet 0.02"×0.87"×0.5"×0.56".
	10C/12578	1-Core, iron dust, type 1		0.37"d×0.5" on brass spindle 3.31" long.
	10C/12579	1-Core, iron dust, type 2		0.37"d×0.5" on brass spindle 1.5" long.
	10C/12580	2-Inductances, type 761		2.77 μH. 0.123 ohms 17 Turns 0.0148"d. cu. wire on former 0.5"d.×1.37".
R49, R50, R51, R52	10W/11691	2-Resistances, type 525		100,000 ohms±10%, ½ watt. R.M.A.8.
	10A/15532	2-Springs, compression, type 53		Helical, 7 convolution 0.25"d.×0.75" free length.
	10K/1095	<i>Transformers</i> , type 1170	1	3rd I.F.
	10C/2648	2-Condensers, type 1264		75 μF.±2%, 350V. D.C. wkg. protected silvered mica.
	10K/1177	1-Cover, protection		Clip-in type, open ends, Ni. Sil. sheet 0.02"×0.87"×0.5"×0.56"
	10C/12578	1-Core, iron dust, type 1		Clip-in type, open ends, Ni. Sil. sheet 0.02"×0.87"×0.5"×0.56"
	10C/12579	1-Core, iron dust, type 2		0.37"d.×0.5" on brass spindle 1.5" long.
	10C/12580	2-Inductances, type 761		2.77 μH. 0.123 ohms 17 Turns 0.0148"d. cu. wire on former 0.5"d.×1.37".
	10W/11691	2-Resistances, type 525		100,000 ohms.±10%, ½ watt. R.M.A. 8.
	10A/15532	2-Springs, compression, type 53		Helical, 7 convolution 0.25"d.×0.75" free length.
	10K/1096	<i>Transformers</i> , type 1171	1	4th I.F.
	10C/2648	2-Condensers, type 1264		75 μF.±2%, 350V. D.C. wkg. protected silvered mica.
	10K/1177	1-Cover, protection		Clip-in type, open ends, Ni. Sil., sheet 0.02"×0.87"×0.5"×0.56".
	10C/12578	1-Core, iron dust, type 1		Clip-in type, open ends, Ni. Sil. sheet 0.02"×0.87"×0.5"×0.56".
	10C/12579	1-Core, iron dust, type 2		0.37"d.×0.5" on brass spindle 1.5" long.
	10C/12580	2-Inductances, type 761		2.77 μH 0.123 ohms. 17 turns 0.0148"d. cu. wire on former 0.5"d.×1.37"
	10W/11691	1-Resistances type 525		100,000 ohms.±10%, ½ watt. R.M.A.8.
	10A/15532	2-Springs, compression type 53		Helical, 7 convolution 0.25"d.×0.75" free length.

Circuit Reference	Stores Reference Number	Nomenclature	Qty.	Details
	10E/11398	Valves Valve, VT.52	1	(EL.32)
	10E/11399	Valves, VR.53	2	(EF.9)
	10E/11401	Valve, VR.55 (CV.1055—10CV./1055)	1	(EBC.33)
	10E/92	Valves, VR.91	4	(EF.50)
	10E/105	Valve, VR.92 (CV.1092-10CV./1092)	1	(EA.50)

TRANSMITTER SECTION

	10D/1234 10B/27	Transmitter Unit Type 50 Beads, insulating	40	Plug-in unit, complete with valves. Ceramic 0.22" O/D. x 0.25", tapered, cupped, 0.09" d. hole. Harbourne, Birmingham No. 2056.
	10R/13032	Bushes, locking-band	2	M.S. 0.37" O/D. x 0.31" I/D., cross drilled 0.116" d.
	10A/13025	Caps, valve, type 13	4	Unscreened, reinforced. For valve with 0.25" d. top cap. Benjamin 75/548.
	10C/3806	Choke, H.F. type 197	1	16 turns 23 S.W.G. En. Cu. wire on loaded ebonite former 0.34" d. x 1".
	10C/3807	Chokes, H.F. type 198	3	33.3 μ H. 2 ohm. 110 turns 36 S.W.G. cu. wire, on loaded ebonite former 0.37" d. x 1.5", mounted on S.R.B.P. base 2" x 0.6" x 0.06".
	10C/80	Choke, H.F. type 54	1	1.2 \pm 10% milli. /H. 22 ohms. Eddystone 1010 (formerly 10G/3808, type 199).
TC1	10C/3850	Condenser, type 1939	1	3-24 μ F. variable, air, ceramic end plates.
TC4	10C/3851	Condenser, type 1940	1	3-12.5 μ F. variable, air, ceramic end plates.
TC2, TC3	10C/12204	Condensers, type 3823	2	3-2-20 μ F. variable, air, ceramic end plates.
TC5	10C/12205	Condenser, type 3824	1	2-8 — 6.1 μ F. variable, air, ceramic end plates.
C3, C8	10C/964	Condensers, type 896	2	0.005 μ F. \pm 15%, 500V. D.C. wkg., mica, moulded, wires.
C2, C6, C7	10C/499	Condensers, type 737	3	0.005 μ F. \pm 15%, 350V. D.C. wkg., mica, moulded, wires.
C15, C25, C27, C28, C33	10C/651	Condensers, type 782	5	0.001 μ F. \pm 15%, 350V. D.C. wkg., mica, moulded, wires.
C4, C9, C26	10C/10512	Condensers, type 379	3	0.001 μ F. \pm 15%, 750V. D.C. wkg., mica, moulded, tags.
C12, C13, C17, C18, C29, C30	10C/958	Condensers, type 890	6	500 μ F. \pm 15% 750V. D.C. wkg., mica, moulded, tags.
C34	10C/94	Condenser, type 609	1	500 μ F. \pm 15% 350V. D.C. wkg., mica, moulded, wires. Dubilier 635.
C23, C24	10C/3196	Condenser, type 1551	2	300 μ F. \pm 15%, 350V. D.C. wkg., mica, moulded, wires. Dubilier 690W. or TCC.H2. Case A.
C35	10C/4268	Condenser, type 2212	1	200 μ F. \pm 15%, 350V. D.C. wkg., mica, moulded, wires.
C3	10C/4920	Condenser, type 2610	1	200 μ F. \pm 5%, 500V. D.C. wkg., ceramic, tubular.
C10, C14	10C/3436	Condensers, type 1687	2	100 μ F. \pm 5%, 500V. D.C. wkg., ceramic cup.
C21, C22	10C/3200	Condensers, type 1555	2	20 μ F. \pm 10%, 500V. D.C. wkg., ceramic disc.
C16	10C/5357	Condenser, type 2905	1	8 μ F. \pm 10%, 500V. D.C. wkg., ceramic cup.

<i>Circuit Reference</i>	<i>Stores Reference Number</i>	<i>Nomenclature</i>	<i>Qty.</i>	<i>Details</i>
	10R/44	Condenser Drive Units	1	Cam mechanism for driving 5 variable condensers, selecting 4 positions.
	10A/15093	5 Knobs, type 293	—	M.S. Ni. P. 0·87" d. 0·16" knurled. Tapped for 4 B.A. shaft.
	10A/15094	5 Pointers, type 21	—	M.S. Ni. P. 1·37" d. × 0·016" with pointer 0·75" radius, and slot to limit movement.
	10R/45	4 Springs, tension	—	Helical 0·14" d. × 1·16", ring ends.
	10R/13014	20 Springs, tension	—	Helical 0·11" d. × 1·19", 0·4" close winding, hook ends.
	10A/13029	Cover, type 61	1	Side. M.S. sheet 7·31" × 5·75" with insulating plate riveted on.
	10A/13030	Cover, type 62	1	End. M.S. Sheet 5·8" × 5·75".
	10A/14834	Drive, flexible, type 15	1	Synthetic paper tube with flexible spring coupling each end. Complete with 4-8 B.A. ch. hd. screws. Length o/all 1·37" approx.
	10A/14836	Drives, flexible, type 17	3	Synthetic paper tube with flexible spring coupling each end. Complete with 4-8 B.A. ch. hd. screws. Length o/all 3·94" approx.
	10A/14837	Drive, flexible, type 18	1	Synthetic paper tube with flexible spring coupling each end. Complete with 4-8 B.A. ch. hd. screws. Length o/all 4·06" approx.
	10H/11579	10C/3816	6	Int. Octal. S.R.B.P. Plessey.
		Inductance, type 250	1	18·28 μH. 0·25 ohm. Tubular former 0·87" d. × 2".
	10C/3817	Inductance, type 251	1	20·02 μF. 0·023 ohm. Single layer cu. wire, widely spaced, on tubular former 0·87" d. × 2".
	10C/3818	Inductance, type 252	1	358 μH. 10 ohm. Loaded ebonite former 0·4" d. × 1·62" with 8 grooves. 6 grooves wound with 455·5 turns 38 S.W.G. on cu. wire.
	10C/3825	Inductance, type 254	1	3·5 turns 0·12" d. cu. wire. Sil. Pl. extended ends.
	10C/5381	Inductance, type 456	1	5 turns 0·12" d. cu. wire. Sil. Pl. with a spill one turn from each end.
	10C/12200	Inductance, type 694	1	21·2 μH. 2·5 ohm. 86·5 turns 38 S.W.G. cu. wire on loaded ebonite former 0·37" d. × 2".
	10B/499	Insulators, type 197	2	Stand-off. Ceramic. Tinned top screw. Edystone ceramic moulding.
	10B/13354	Insulators, type 336	2	Stand-off. Ceramic. Eddystone 1019.
	10A/11839	Knob, type 11	1	Moulded, black, 1·5" × 1" × 0·93" high. Engraved white line.
	10R/13031	Locking-bands	2	Ni. Sil. 27 S.W.G. × 0·37" wide. To clamp round base of VT.501.
	10T/88	Monitoring Units, Type 7	1	S.R.B.P. panel 4·75" × 3" × 0·06".
	10H/1930	1 Connector, type 687	—	Copper braid with valve cap for VR.92.
C32, C33	10C/651	2 Condensers, type 782	—	0·001 μF. ±15%, 350V. D.C. working, mica, moulded, wires.
	10H/150	1 Holder, valve, type 40	—	3 pin for small diode VR.92. Belling Lee L.357.
	10B/13354	1 Insulator, type 336	—	Stand-off. Ceramic. Eddystone 1019.
R33	10W/991	1 Resistance, type 991	—	6,800 ohm. ±10%, ½ watt.
R34	10W/1743	1 Resistance, type 1743	—	27 ohm. ±10%, ½ watt.

Circuit Reference	Stores Reference Number	Nomenclature	Qty.	Details
R1	10A/13034	Mountings, Type 127	1	Crystal holder and switch. S.R.B.P. panel to mt. 4 crystal units type A or U.S. pattern.
	10C/993	1 Resistance, type 993	—	100,000 ohm. $\pm 20\%$, $\frac{1}{2}$ watt. R.M.A. 9.
	10A/13035	2 Spring-sets	—	2b. before m. Ni. Sil. springs with contacts mtd. on bracket.
	10C/3882	Plate, Condenser, Neutralizing, type 3	1	L.H. Brass Link. Fixed connection to variable condenser.
	10C/3883	Plate, Condenser, Neutralizing, type 4	1	R.H. otherwise as type 3.
	10C/3884	Plate, Condenser, Neutralizing, type 5	1	Moveable, slotted steel plate.
	10C/12202	Plate, Condenser, Neutralizing, type 7	1	L.H. Brass Link. Fixed connection to insulator and variable condenser.
	10C/12203	Plate, Condenser, Neutralizing, type 8	1	R.H., otherwise as type 7.
	10H/323	Plug, type 194	1	8 pole, flat contacts, moulded, rectangular, without brackets.
	10H/1931	Plug, type 389	1	2 pole, shrouded.
R3	10W/6840	<i>Resistors</i> Resistance, type 6840	1	100,000 ohm $\pm 20\%$, $\frac{1}{2}$ watt. R.M.A.8.
R1, R5	10W/11691	Resistances, type 525	2	100,000 ohm $\pm 10\%$, $\frac{1}{2}$ watt. R.M.A.8.
R13, R14	10W/15327	Resistances, type 4036	2	56,000 ohm $\pm 5\%$, 6 watt. Erg. 18.
R38	10W/539	Resistance, type 805	1	47,000 ohm $\pm 10\%$, $\frac{1}{2}$ watt. R.M.A.8.
R8, R10	10W/6910	Resistances, type 6910	2	39,000 ohm $\pm 10\%$, $\frac{1}{2}$ watt. R.M.A. 9.
R9, R12	10W/15325	Resistances, type 4034	2	16,000 ohm $\pm 5\%$, 6 watt. Erg. 17.
R2, R15, R16	10W/11683	Resistances, type 517	3	15,000 ohm $\pm 10\%$, $\frac{1}{2}$ watt. R.M.A. 8.
R36, R37	10W/7755	Resistances, type 7755	2	9,100 ohm $\pm 5\%$, 1 watt. R.M.A.2.
R27, R28, R29, R30	10W/7756	Resistances, type 7756	4	6,200 ohm $\pm 5\%$, $\frac{1}{2}$ watt. R.M.A.8.
R20, R21	10W/11678	Resistances, type 512	2	1,000 ohm $\pm 10\%$, $\frac{1}{2}$ watt. R.M.A.8.
R11	10W/9792	Resistance, type 3003	1	1,000 ohm $\pm 20\%$, 2 watt. R.M.A.1.
R18, R19	10W/7753	Resistances, type 7753	2	620 ohm. $\pm 5\%$, 1 watt. R.M.A.2.
R4, R31, R32, R26	10W/7754	Resistances, type 7754	4	47 ohm. $\pm 20\%$, $\frac{1}{2}$ watt. R.M.A.8.
R17	10W/1606	Resistance, type 1606	1	33 ohm $\pm 10\%$, $\frac{1}{2}$ watt. R.M.A.8.
R22, R23, R24, R25	10W/6411	Resistance, type 6411	1	10·72, 1·92, 1·92 and 0·76 ohm $\pm 5\%$, wire wound on S.R.B.P., strip 4" \times 0·5" \times 0·06". G.E.C.
	10A/13036	Retainer, valve, type 16	1	S.R.B.P. 2·69" \times 0·87" \times 0·09", with 2 holes 0·44"d. at 1·81" crs., helical tension spring fitted at centre, 2 retain, 2 valves.
	10A/13037	Retainer, valve, type 17	1	As type 16, but with tubular screen fitted over tension spring.
	10R/13022	Screws and nuts, valve clamp	2	6 B.A. \times 1·31" ch. hd. and 6 B.A. sq. nut.
	10R/47	Socket and Coupling	1	S.P. Coaxial socket fitted with inductive coupling.
	10F/777	Meter Switch, type 597	1	Rotary, 2 wafer, each S.P., 6 positions, non-shorting.

<i>Circuit Reference</i>	<i>Stores Reference Number</i>	<i>Nomenclature</i>	<i>Qty.</i>	<i>Details</i>
	10A/19204	Supports, crystal retaining strap (4 crystal)	2	M.S. Strip, 19 S.W.G. 1.56" × 0.21". With M.S. pillar 0.97" × 0.218" d. riveted centrally.
	10A/15816	Strap, crystal retaining (4 crystal)	1	M.S. 19 S.W.G. 4.625" long × 0.37" wide, with 4 holes 0.147" d. at 0.78" crs. For retaining 4 crystal units type A or American pattern. Fitted with 2.5 B.A. captive screws.
	10A/14083	Tagboards, type 78	4	S.R.B.P. 0.75" × 0.4" × 0.06". Single fixing hole 0.116" d. Fitted with 1 tag.
	10A/14085	Tagboard, type 80	1	S.R.B.P. 2.25" × 0.44" × 0.06". Fitted with 3 tags.
	10A/15273	Tagboard, type 268	1	S.R.B.P. 2.25" × 0.44" × 0.06". Fitted with 4 tags and mounting bracket each end.
	10A/19065	Tagboard, type 510	1	S.R.B.P. 1.87" × 1.44" × 0.06". Fitted with 8 tags, metal strip riveted on.
	10A/19066	Tagboard, type 511	1	S.R.B.P. 1.87" × 1.44" × 0.6", with angle bracket fixing, 6 tags.
	10A/19067	Tagboard, type 512	1	S.R.B.P. 3.37" × 2.5" × 0.06". Fitted with 2 condenser plates and 4 tags.
V2	10E/11398	Valve, VT.52	1	
V1	10E/11399	Valve, VR. 53	1	
V7	10E/105	Valve, VR. 92 (CV.1092-10CV/1092)	1	
V3, V4	10E/389	Valves, VT.501	2	
V5, V6	10E/389	Valves, VT.501 or	2	
	10E/784	Valves, VT.501A		

AMPLIFIER SECTION

	10U/14108	Amplifying Unit, Type 165		(Complete with valves).
	10A/13025	Caps, valve, type 13	5	Unscreened, re-inforced, for valves with 0.25" d. top cap. Benjamin 75/548.
		<i>Capacitors</i>		
C3, C4, C8, C9, C13, C14	10C/8382	Condensers, type 172	6	0.25 μF. ± 15%, 350V. D.C. wkg., paper, tubular.
C6	10C/10165	Condenser, type 386	1	0.1 μF. ± 15% 360 V.D.C. wkg., paper, tubular.
C5	10C/14251	Condenser, type 4703	1	0.005 μF. ± 20%, 750V. D.C. wkg., mica, moulded, wires.
C11	10C/651	Condenser, type 782	1	0.001 μF. ± 15%, 350V. D.C. wkg., mica, moulded, wires.
C1, 12	10C/3196	Condensers, type 1551	2	300 μμF. ± 15%, 350V. D.C. wkg., mica, moulded, wires.
C7	10C/2006	Condenser, type 918	1	100 μμF. ± 5%, 350V. D.C. wkg., protected silvered mica.

Circuit Reference	Stores Reference Number	Nomenclature	Qty.	Details
	10A/15095	Distance-pieces	2	Brass tube 0.19" O/D. × 0.12" I/D. × 0.5". For use with screens type 120.
	10H/11579	Holders, Valve, type 28	5	Int. octal, S.R.B.P. Plessey.
	10H/4134	Holders, Valve, type 264		
	10U/70	Plates, earthing	4	Int. octal moulded. Benjamin 75/593A. For earthing transformer laminations.
		<i>Plugs</i>		
U	10H/307	Plug, type 184	1	10 pole, flat contacts, moulded, rectangular, without brackets. S.T & C. LP.115195.
Z	10H/1523	Plug, type 360	1	6 pole, flat contacts, moulded, rectangular, without brackets. E. K. Cole A.12310.
		<i>Resistors</i>		
R36	10W/996	Resistance, type 996	1	2.2 meg. ± 20%, ¼ watt. R.M.A.9.
R10	10W/6322	Resistance, type 6322	1	1 meg. ± 20%, ½ watt. R.M.A.8.
R13	10W/1889	Resistance, type 9/31	1	1 meg. ± 20%, ¼ watt. R.M.A.9.
R21	10W/11384	Resistance, type 480	1	1 meg. ± 10%, ¼ watt. R.M.A.9.
R11	10W/10350	Resistance, type 3303	1	680,000 ohm. ± 20%, ¼ watt. R.M.A.9.
R19	10W/6319	Resistance, type 6319	1	680,000 ohm ± 20%, ½ watt. R.M.A.8.
R22, R23	10W/1884	Resistances, type 9/29	2	470,000 ohm ± 20%, ¼ watt. R.M.A.9.
R7	10W/11692	Resistance, type 526	1	200,000 ohm ± 10%, ½ watt. R.M.A.8.
R12	10W/993	Resistance, type 993	1	100,000 ohm ± 20%, ¼ watt. R.M.A.9.
R17	10W/6321	Resistance, type 6321	1	68,000 ohm ± 10%, ½ watt. R.M.A.8.
R1	10W/1882	Resistance, type 9/23	1	47,000 ohm ± 20%, ¼ watt. R.M.A.9.
R15	10W/11683	Resistance, type 517	1	15,000 ohm ± 10%, ½ watt. R.M.A.8.
R24, R25	10W/27	Resistances, type 544	2	10,000 ohm ± 10%, ½ watt. R.M.A.8.
R20	10W/114	Resistance, type 582	1	6,800 ohm ± 10%, ¼ watt. R.M.A.9.
R16	10W/6244	Resistance, type 6244	1	7,500 ohm ± 10%, ½ watt. R.M.A.8.
R14	10W/753	Resistance, type 891	1	4,700 ohm ± 10%, ½ watt. R.M.A.8.
R9	10W/6324	Resistance, type 6324	1	3,300 ohm ± 10%, ½ watt. R.M.A.8.
R8, R18	10W/6120	Resistances, type 6120	2	620 ohm ± 5%, ½ watt. R.M.A.8.
R35	10W/9595	Resistance, type 2846	1	125 ohm ± 2.5%, wire wound, woolcard type, 0.62" sq. G.E.C.
R38	10W/9597	Resistance, type 2848	1	31.5 ohm. ± 0.5 ohm., wire wound, woolcard type, 0.62". G.E.C.
R37	10W/9596	Resistance, type 2847	1	1.5 ohm. ± 5%, wire wound, woolcard type, 0.62" sq. G.E.C.
R2	10W/9203	Resistance, type 2533	1	1 meg., ± 20%, potentiometer, carbon, linear, small. Spindle 0.25"d. × 0.56", screwdriver slot. G.E.C.

<i>Circuit Reference</i>	<i>Stores Reference Number</i>	<i>Nomenclature</i>	<i>Qty.</i>	<i>Details</i>
R3, R4, R5, R6	10C 3749	Resistance-Condenser unit, type 113	1	S.R.B.P. panel 2.25" × 2" × 0.06" fitted with 4 resistances 1 meg. ± 5%, ¼ watt, specially selected (bridge network). In case of breakdown complete unit 10C/3749 to be changed. It includes one condenser type 831 — 10C.745. 300 μF. ± 15%, 350V. DC. working, mica, moulded, wires.
C1	10A 13767	Retainers, valve, type 48	5	S.R.B.P. oval 0.81" × 1.87", centre hole 0.43"d. Tags each end.
	10A 17875	Springs, tension, type 94	10	Helical, tension, 25 S.W.G. 0.6" O/D. × 1.62". For use with Retainers, valve, type 48. Formerly 10U/71 Springs, Valve, Retainer.
	10A 15096	Screen, type 120	1	M.S. 22 S.W.G. 2.25" × 2", with plates tapped 6 B.A. riveted on.
	10U 189	Support Bars	2	M.S. 22 S.W.G. 7.09" × 0.5" ribbed. 2 fixing holes 0.12"d.
		<i>Tagboards</i>		
	10A 14088	Tagboard, type 81	1	S.R.B.P. 0.84" × 0.4" × 0.06", single fixing hole fitted with 1 tag.
	10A 19068	Tagboard, type 513	1	S.R.B.P. 2.25" × 2" × 0.06", fitted with 7 tags and 1 condenser clip.
	10A 19069	Tagboard, type 514	1	As type 513, but opposite hand.
	10A 19070	Tagboard, type 515	1	S.R.B.P. 2" × 2.5" × 0.06", fitted with 10 tags.
	10A 19071	Tagboard, type 516	1	S.R.B.P. 5.75" × 2.12" × 0.06". Fitted with 10 tags, 3 condenser clips and 3-6 B.A. bushes.
	10A 19072	Tagboard, type 517	1	S.R.B.P. 5.75" × 2.12" × 0.06". Fitted with 17 tags, 3 condenser clips and 3-6 B.A. bushes.
		<i>Transformers</i>		
	T404	10K 469	Transformer, type 510	1
T403	10K 470	Transformer, type 511	1	Output transformer
T401	10K 471	Transformer, type 512	1	Input transformer.
T402	10K 472	Transformer, type 513	1	Input transformer, 2 Prim. 2 Secs
T405	10K 473	Transformer, type 514	1	Modulator transformer.
	<i>Valves</i>			
V4, V5	10E 11398	Valves, V.T.52	2	
V2	10E 11401	Valve, V.R.55 (CV.1055—10CV 1055)	1	
V1, V3	10E 11402	Valves, V.R.56 (CV.1056—10CV 1056)	2	

CONTROLLER

	10J 26	Electric Controller, Type 3		Remote, 4 positions and off, push button operated, complete with 12V. lamps.
	10J 68	Cable form Controller Electric, type 3	1	Main wiring assembly, complete.
	10A 10495	Caps, lamp, type 1 or	4	Green P.O. No. 2/1B.
	10A 14185	Cap lamp, type 31		

<i>Circuit Reference</i>	<i>Stores Reference Number</i>	<i>Nomenclature</i>	<i>Qty.</i>	<i>Details</i>
	10A/9105	Cap lamp, type 3	1	Murphy, Drg. W.C.17718. Opal P.O. No. 2/1A.
	10A/14186	Cap lamp, type 32	1	Opal, moulded, translucent. Murphy Drg. WC.17719.
	10A/15038	Cover, type 63	1	Bottom MS., with hole for plug W.202 and 4 anchor nuts. P.O. No. 10, Tropical finish.
	10H/461 5L/1141	Jacks, lamp, type 2 Lamps, filament, 12V. Jack type, P.O. No. 2	5	
	10J/69	Mask, lamp type 2	5	Top cover with sliding mask for 5 light positions.
	10H/395	Plug, W202 — plug L.	1	12 pole, panel mtg. sq. flange.
	10J/70	Spacers, paxolin	10	0.25" o/d. × 0.12" × 0.875".
	10F/2742	T-R switch, type 1599	1	P.O. type lever key, with special cam with 2 locating holes and special positive locking mechan- ism, 1st side B., 2nd side C.
	10F/11777	1 Handle switch	—	Ebonite, knurled 0.37" d. × 1.25".
	10F/779	1 Locking-plate	—	Lever with pin to engage locating holes in cam, with spring.
	10F/716	Push-button switch, type 564	1	5 digit push button assembly, interlocking, 4 spring-sets C and 1 set 2B.
	10A/11562	5 Knobs, type 12	—	Moulded, Red 0.5" long × 0.375" d. with flange 0.531" d. × 0.062" thick "+" section slot 0.053" wide. Murphy VC.18181
	10F/780	5 Springs, plunger	—	Compression helical 25 S.W.G., 0.218" i/d. × 0.75".
	10F/781	1 Spring tension	—	Helical, 28 S.W.G. 0.125" o/d. × 0.875".
	10FB/817	or Switch, type 1158	1	As type 564, but with 5 spring sets C.
POWER UNIT TYPE 15 — 12 VOLT				
	10K/36	Power Unit, type 15	1	12V. Input. Complete.
	10K/12065	Rotary transformer, type U	1	Input: 12V. D.C. Output: 300V. 0.26 Amps. D.C. 150V. 0.01 Amps D.C. 13-14.5V. 4.9 Amps. D.C.
	5U/1577	Regulator, voltage carbon pile pile, type G.	1	Complete with ballast resistance. Newton Type D.III.
	5U/1028	1 Ballast Resistance	—	Semi-adjustable.
	10K/274	Bases Power Units 15 and 16	16	M.S. 16 S.W.G. 12.31" × 8.1" × 5.026" high. Assembly of base plate, generator cradle and side plates.
	5E/87	Cable, Electric, L.T., Uniflex 37	8"	Single core, 195/0.010" V.I.R. cotton braided yellow.
	5E/1361	Cables, Electric L.T. Unicel 37		
	5E/1358	Cable, Electric, L.T., Unicel 4	11' 2"	Single core, 23/0.0076" V.I.R. cotton braided, yellow.
	10K/275	Cover, type 43	1	M.S. 12.44" × 8.03" × 4.5" high, open sides perforated ends.
	10H/376	Holder, Fuse type 13	1	Moulded, panel mtg., one hole fixing. Takes 1.25" glass cartridge fuse Belling Lee L.356.
	10H/238	Fuse, type 29	1	500 m/A. 1.25", glass cartridge. Belling Lee, Bulgin, etc.
	10K/391	Panel, power units 15 and 16	1	M.S. 16 S.W.G., 12.12" × 5.09", with side fixing plates bent back 2" deep.

Circuit Reference	Stores Reference Number	Nomenclature	Qty.	Details
C1 and C2 N C3, C4, C5, C6, C7 M	10F/13065	Starter, type 14—relay N.	1	12V. 40 Amps., single pole, continuous rating.
	10K/276	Strap, generator retaining	1	Spring steel, 28 S.W.G., 0.94" wide × 15". Complete with captive screw and block.
	10A/12781	Suppressor type 15	1	Input: 2 leg, 1 stage L1 C1, L2 C2.
	10C/11119	2 Condensers, type 3355	—	0.001 μF ± 15%, 350V. D.C. wkg., mics, moulded, tags.
	10H/397	1 Plug type W.204—plug N.	—	2 pole, 19 Amps., sq. flange, panel mtg.
	10A/12782	Suppressor type 16	1	Output: 5 leg, 1 stage
	10C/8010	5 Condensers, type 133	—	0.002 μF. ± 15%, 350V. D.C. wkg., mica, moulded, tags.
	10H/394	1 plug, W.201—plug M.	—	6 pole, H.T., 4 Amps., sq. flange, panel mounting.
	5F/494	Tubing insulating L.T. 1/16" d.	20"	
	10K/200	Case, Transit, Power units, 15 and 16	1	
10A/9334	4 Mountings, Anti-Vibration, type 4		Load 6 lb. medium duty, rubber disc shallow pedestal.	
10A/17619	4 Mountings, Anti-Vibration, type 685		Load 6 lb., medium duty, equi-flexible, all metal, shallow pedestal	

• POWER UNIT TYPE 16 — 24 VOLT

10K/37	Power Units, type 16 Rotary Transformer, type V.	1	24V. Input, complete. Input: 24V. D.C. Output: 300V., 0.26 Amps., D.C. 150V., 0.01 Amps., D.C. 13-14.5V., 4.9 Amps., D.C.
10K/12068			
5U/1577	Regulator, voltage, carbon pile, type G	1	Complete with ballast resistance.
5U/1028	1 Ballast Resistance	—	Semi-adjustable
10K/274	Base, Power Unit, 15 & 16	1	M.S. 16 S.W.G., 12.31" × 8.1" × 5.026" high assy. of base plate, generator. Cradle and side plates.
5E/87	Cable, Electric, L.T. Uniflex 37	} 8"	Single core, 195/010" VIR. cotton braided, yellow.
5E/1361	Cable, Electric, L.T. Unicel 37		
5E/84	Cable, Electric, Uniflex 4		
10K/275	Cover, type 43	1	M.S. 12.44" × 8.03" × 4.5" high, open sides, perforated ends.
10H/376	Holder, Fuse, type 13	1	Moulded, panel mounting one hole fixing takes 1.25" glass cartridge fuse. Belling Lee L.356.
10H/238	Fuse, type 29	1	500 mA, 1.25" glass cartridge. Belling Lee. Bulgin, etc.
10K/391	Panel Power Units, 15 & 16	1	M.S. 16 S.W.G. 12.12 × 5.09", with side fixing plates bent back 2" deep.
10W/6002	Resistance, type 6002	1	0.3 ohm, $\pm 0\%$, -10% , 7.5 watt wire wound. 7 turns 0.0113" × 0.187" wide. "Advance" resistance tape on mica former 3.75" × 1.81" × 0.06" L.T. output.
10F/13066	Starter, type 15	1	24V. 40 Amp., single pole continuous rating.
10K/276	Strap, generator retaining	1	Spring steel 28 S.W.G., 0.94" wide × 15" complete with captive screw and block.
10A/12781	Suppressor, type 15	1	Input 2 leg, 1 stage.

Circuit Reference	Stores Reference Number	Nomenclature	Qty.	Details
C1, C2	10C 11119	2 Condensers, type 3355		0.001 μ F. \pm 15%, 350V. D.C. wkg., mica, moulded, tags.
N	10H 397	1 Plug, W.204	—	2 pole, 19 Amp., sq. flange, panel mounting.
C3, C4, C5, C6, C7	10A 12782	Suppressor, type 16	1	Output, 5 leg, 1 stage.
M	10C 8010	5 Condensers, type 133		0.002 μ F. \pm 15%, 350V. D.C. wkg., mica, moulded, tags.
	10H 394	1 Plug, W.201	—	6 Pole, H.T., 4 Amp., sq. flange, panel mounting.
	5F 494	Tubing, insulating, L.T. 1/16" d.	20"	
	10K 200	Case, Transit, Power Unit 15 & 16	1	
	10A 9334	4 Mountings, Anti-Vibration, type 4	—	Load 6 lb. medium duty, rubber disc shallow pedestal.
	10A 17619	4 Mountings, Anti-Vibration, type 685	—	Load 6 lb. medium duty equi-flexible, all metal, shallow pedestal

TR.1143A — PRINCIPAL ITEMS AND ACCESSORIES

	10D 13273	Transmitter-receiver, type TR.1143A		4 channel, press to Transmit, crystal controllers. Complete with valves.
	10U 14108	AMPLIFYING UNIT, type 165	1	Plug-in unit complete with valves.
	10D 13341	CHASSIS ASSEMBLY, type 13	1	Main tray.
	10D 13052	RECEIVING UNIT, type 71	1	Plug-in unit complete with valves.
	10D 1234	TRANSMITTER UNIT, type 50	1	Plug-in unit complete with valves.
	10D 629	BELLCRANK - LEVER ASSEMBLY	1	Condenser drive links. 4 levers, assembled between mtg. brackets.
	10D 630	4-Springs, tension	—	Helical, 30 S.W.G., 0.75" \times 0.12" d.
	10D 631	CASE, TR.1143, TR.1430	1	Main cover, complete 16" \times 12.5" \times 8.5" ventilated.
	10D 632	4-Spring fasteners, straight	—	Spring steel clip, fitted with 1 Dzus Turnbutton A35, and 1 Dzus Grommet 375.
	10A 15097	COVER, type 284	1	Centre top, 15.87" \times 3.19" with lipped side edges and cutaways. Main instruments label riveted on.
	10A 13014	COVER, type 58	1	Top, Receiver side, hinged dust cover with supports. Ventilated.
	27H 2076	2-Dzus Turnbuttons, Part No. A3-25	—	
	10A 13015	COVER, type 59	1	Top, Transmitter side, hinged dust cover with supports. Ventilated
	27H 2076	2-Dzus Turnbuttons, Part No. A3-25	1	
	10D 635	DRIVE UNIT, type 12	1	Electromagnetic, ratchet drive, 4 cam, condenser tuning.
C501, 502	10C 3869	1-Condenser, type 1958	—	1-1 μ F. 250V. D.C. wkg. paper rectangular metal case 2" \times 1.8" \times 0.75" back fixing, tags.
	10D 637	1-Coil	—	15 ohm, iron core, bobbin wound
	10D 638	1-Coil	—	9 ohm, iron core, bobbin wound
X	10H 1903	1-Jack, type 25	—	12 pole (6 \times 2).
R1	10W 8344	1-Resistance, type 8344	—	10 ohm \pm 10% wire wound, ceramic former 0.28" d. \times 0.59". Tropical G.P.O. No. 9240.
	10D 642	1-Shaft, Drive	—	Assembly of shaft, ratchet wheel
	10D 643	1-Shaft, Cam	—	Assembly of shaft, ratchet wheel and 4 cams.

<i>Circuit Reference</i>	<i>Stores Reference Number</i>	<i>Nomenclature</i>	<i>Qty.</i>	<i>Details</i>
P switch	10D/644	4-Springs, Toggle arm return		Tension, helical 0.25" o/d. x 0.87" loop ends.
	10A/15538	2-Springs, leaf type 10	—	Flat with lip. For restraining driving and selector ratchet wheel.
	10D/639	1-Spring Set	—	4 makes 1m, before b. Assembly of Ni. Sil. spring with contacts.
	10D/640	1-Spring set	—	Cam operated, mtd. on bracket. 1 make, 1 m before b. Assembly of Ni. Sil. springs with contacts.
	10F/1578	2-Spring sets, type 13	—	Complete with mtg. bracket. 1 break. Assy. of Ni. Sil. springs with contacts.
	10F/10338	1-Switch, type 152		SP. on/off moulded—P switch.
	10D/645	Links, Adjustable	4	M.S. rod 0.06" d. screwed 10 BA. one end, spring clip other end. Used between Bellcrank lever assy. and Condenser Drive Unit.
	10D/646	1-Bush, grooved	—	Steel 0.12" d. with 0.070" d. hole and "V" groove at end.
	10D/647	1-Nut, Hex. special	—	Steel, 10BA. with "V" groove.
	10D/648	1-Spring, Compression	—	Helical, 0.078" I.d. x 2".
	10F/13239	Relay Units, type 48		
	10A/13027	1-Cover, type 60	—	M.S. Tinned, 4" x 3.12" x 1.73".
	27H/2037	2 Dzus Turnbuttons, Part No. A3—20		
	10H/1915	1 Plug Y, type 383	—	20 pole (2x10) Jack plug with bracket.
	10F/770	Relay F, type 269	—	P.O. 600 type 150±7 ohm 1 b before m. 1 break and 1 m before b. fitted with screw 10F/1890.
	10F/771	Relay H, Magnetic, type 270	—	P.O. 600 type 150±7 ohms 1 b before m. and 1 break. Fitted with screw 10F/1890.
	10F/1480	Relay C, Magnetic, type 507	—	P.O. 600 type. 150±7 ohm. 1 break. Fitted with screw 10F/1890.
	10D/649	Screws, Instrument, Fixing	3	2 BA. x 0.37" Head 0.218" x 1.31 shoulder 0.31" d. x 0.12".
	10D/650	Screws, Cover, Fixing	4	6 BA. x 0.25" Head 0.28" d. x 0.046" shoulder 0.156" d. x 0.12"
		Accessories.		
	10A/13602	Adjuster, type 19		Steel, knurled end. For adjusting link mechanism.
	10D/324	Case, transit, TR.1143 series	1	Common case with provision for denoting contacts.
	10X/.....	Crystal Units, type A.	8	Frequencies as authorised.
10A/13016	Extractors, type 7		Valve extractor. Slotted tube.	
10DB/425	Keys, air trimmer, adjusting		For trimming Mullard Concentr Condenser	
10A/12649	Box, Junction, type 17A	} 1		
	OR			
10A/12650	Box, Junction, type 17B	} 1		
	OR			
10J/26	Controller, Electric, type 3	1		
10K/36	Power Unit, type 15	} 1	12V.	
	OR			
10K/37	Power Unit, type 16	1	24V.	

<i>Circuit Reference</i>	<i>Stores Reference Number</i>	<i>Nomenclature</i>	<i>Qty.</i>	<i>Details</i>
P switch	10D/644	4-Springs, Toggle arm return		Tension, helical 0.25"o/d. × 0.87" loop ends.
	10A/15538	2-Springs, leaf type 10	—	Flat with lip. For restraining driving and selector ratchet wheel.
	10D/639	1-Spring Set	—	4 makes 1m, before b. Assembly of Ni. Sil. spring with contacts. Cam operated, mtd. on bracket.
	10D/640	1-Spring set	—	1 make, 1 m before b. Assembly of Ni. Sil. springs with contacts. Complete with mtg. bracket.
	10F/1578	2-Spring sets, type 13	—	1 break. Assy. of Ni. Sil. springs with contacts.
	10F/10338	1-Switch, type 152		SP. on/off moulded—P switch.
	10D/645	Links, Adjustable	4	M.S. rod 0.06" d. screwed 10 BA. one end, spring clip other end. Used between Bellcrank lever assy. and Condenser Drive Unit.
	10D/646	1-Bush, grooved	—	Steel 0.12" d. with 0.070" d. hole and "V" groove at end.
	10D/647	1-Nut, Hex. special	—	Steel, 10BA. with "V" groove.
	10D/648	1-Spring, Compression	—	Helical, 0.078" I.d. × 2".
	10F/13239	Relay Units, type 48		
	10A/13027	1-Cover, type 60	—	M.S. Tinned, 4" × 3.12" × 1.73".
	27H/2037	2 Dzus Turnbuttons, Part No. A3—20		
	10H/1915	1 Plug Y, type 383	—	20 pole (2 × 10) Jack plug with bracket.
	10F/770	Relay F, type 269	—	P.O. 600 type 150 ± 7 ohm 1 b before m. 1 break and 1 m before b. fitted with screw 10F/1890.
	10F/771	Relay H, Magnetic, type 270	—	P.O. 600 type 150 ± 7 ohms 1 b. before m. and 1 break. Fitted with screw 10F/1890.
	10F/1480	Relay C, Magnetic, type 507	—	P.O. 600 type. 150 ± 7 ohm. 1 break. Fitted with screw 10F/1890.
	10D/649	Screws, Instrument, Fixing	3	2 BA. × 0.37" Head 0.218" × 1.31" shoulder 0.31" d. × 0.12".
	10D/650	Screws, Cover, Fixing	4	6 BA. × 0.25" Head 0.28" d. × 0.046" shoulder 0.156" d. × 0.12".
		Accessories.		
	10A/13602	Adjuster, type 19		Steel, knurled end. For adjusting link mechanism.
	10D/324	Case, transit, TR.1143 series	1	Common case with provision for denoting contacts.
	10X/.....	Crystal Units, type A.	8	Frequencies as authorised.
	10A/13016	Extractors, type 7		Valve extractor. Slotted tube.
	10DB/425	Keys, air trimmer, adjusting		For trimming Mullard Concentric Condenser
	10A/12649	Box, Junction, type 17A	} 1	
10A/12650	OR Box, Junction, type 17B			
10J/26	Controller, Electric, type 3	1		
10K/36	Power Unit, type 15	} 1	12V.	
10K/37	OR Power Unit, type 16		24V.	

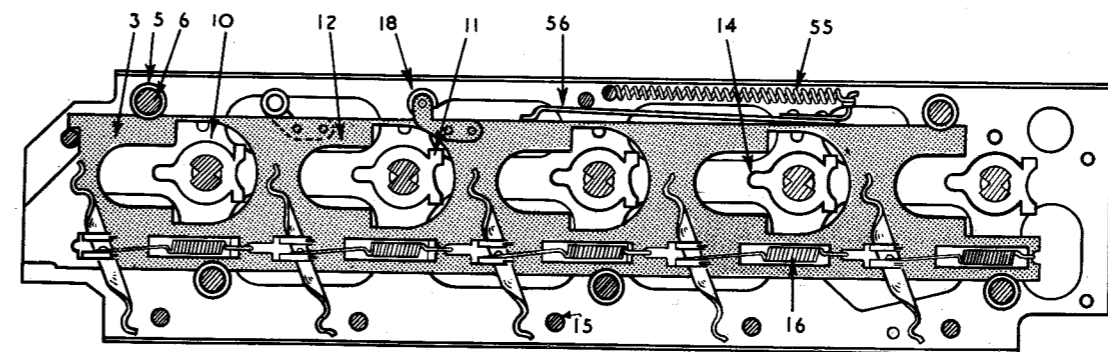
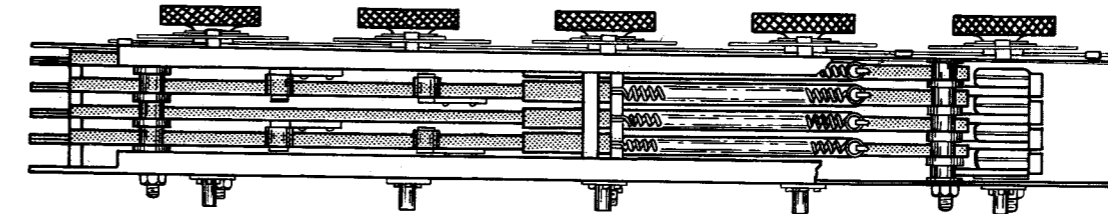
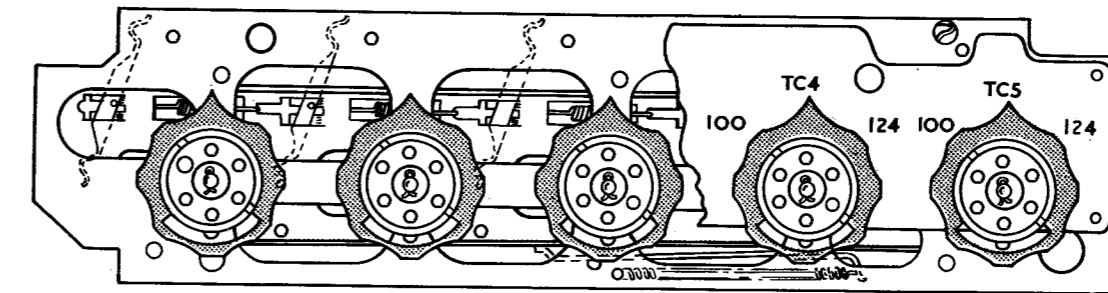
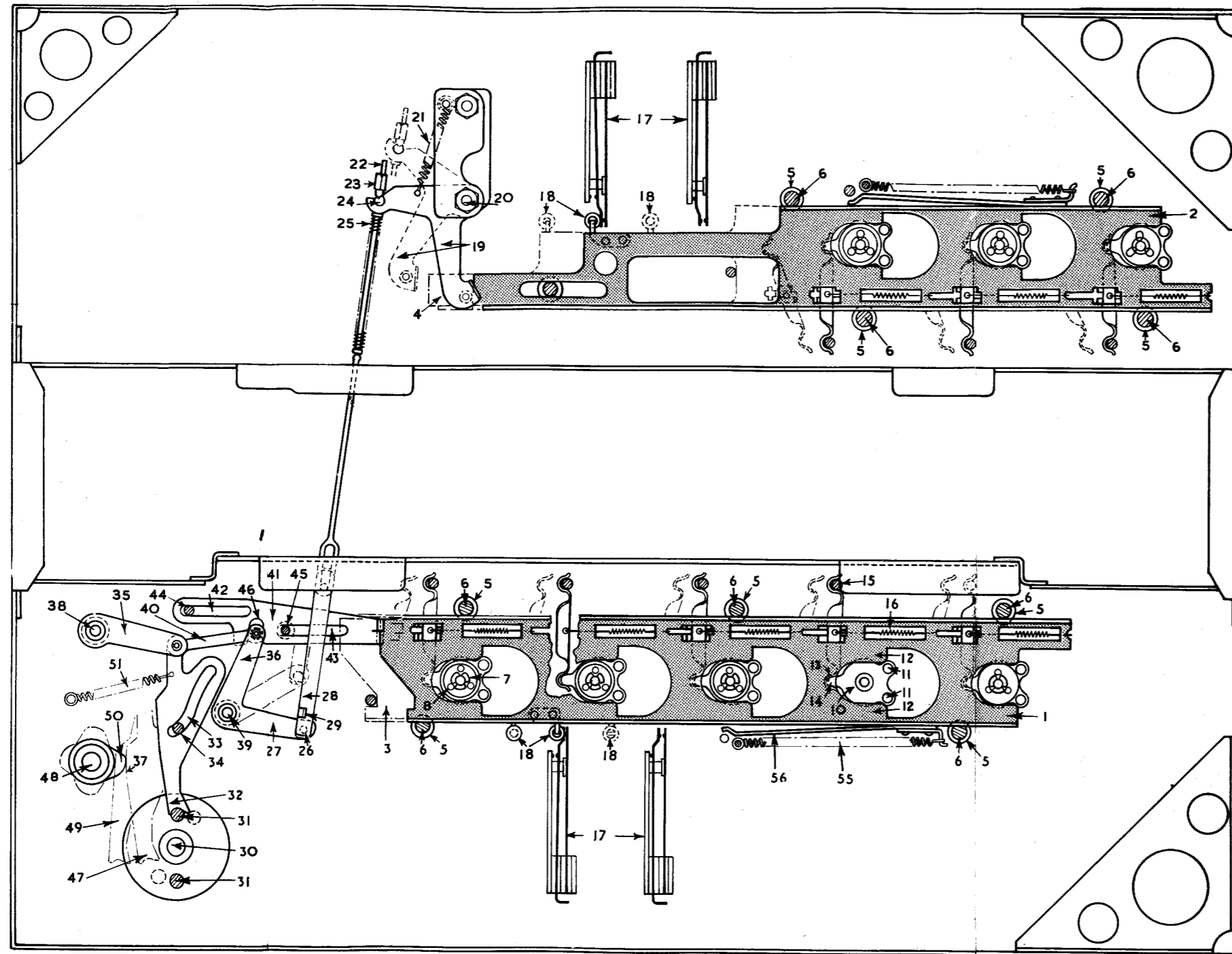

- 1 TRANSMITTER SLIDE OPERATED POSITION
- 2 RECEIVER SLIDE OPERATED POSITION
- 3 TRANSMITTER SLIDE UNOPERATED POSITION
- 4 RECEIVER SLIDE UNOPERATED POSITION
- 5 SPACING WASHERS
- 6 GUIDE PINS
- 7 GUIDE WASHERS
- 8 LOCKING BALLS
- 9 LOCKING GROOVES
- 10 TUNING CAMS
- 11 CAM PROJECTIONS
- 12 CAM GUIDES
- 13 DETENTS
- 14 CAM NOSES
- 15 DETENT PILLARS
- 16 DETENT SPRINGS
- 17 CRYSTAL SWITCHES
- 18 CRYSTAL SWITCH OPERATORS
- 19 BELL-CRANK LEVERS
- 20 BELL-CRANK PIVOTS
- 21 BELL-CRANK SPRINGS
- 22 PULL ROD
- 23 PULL ROD ADJUSTERS
- 24 PULL ROD PIVOTS
- 25 PULL ROD SPRINGS
- 26 PULL ROD PINS
- 27 MOTOR HOOK
- 28 PULL ROD LOCK
- 29 PULL ROD SLOT
- 30 DRIVING MOTOR SHAFT
- 31 DRIVING MOTOR OPERATING PIN
- 32 DRIVING LEVER (DRIVEN HOME)
- 33 DRIVING LEVER GUIDE FACE
- 34 DRIVING LEVER GUIDE PIN
- 35 TOGGLE LEVER
- 36 CRANK
- 37 TOGGLE LEVER SELECTOR FACE
- 38 TOGGLE LEVER PIVOT
- 39 TOGGLE CRANK PIVOT
- 40 TOGGLE LINK
- 41 TRANSMITTER DRIVE LEVER
- 42 GUIDE FACE FOR 41
- 43 GUIDE FACE FOR 41
- 44 GUIDE FOR 42
- 45 GUIDE FOR 43
- 46 DRIVE SURFACE OF 41
- 47 DRIVING LEVER (SELECTED POSITION)
- 48 SELECTOR PIN
- 49 DRIVING LEVER (NORMAL POSITION)
- 50 SELECTOR CAM
- 51 TOGGLE LEVER RETAINING SPRING
- 52 TOGGLE LEVER (SELECTED POSITION)
- 53 TOGGLE LEVER (NORMAL POSITION)
- 54 DRIVING RECESS
- 55 SLIDE SPRINGS
- 56 LEAF SPRINGS

FIG. 23. T.R.1143A TUNING MECHANISM

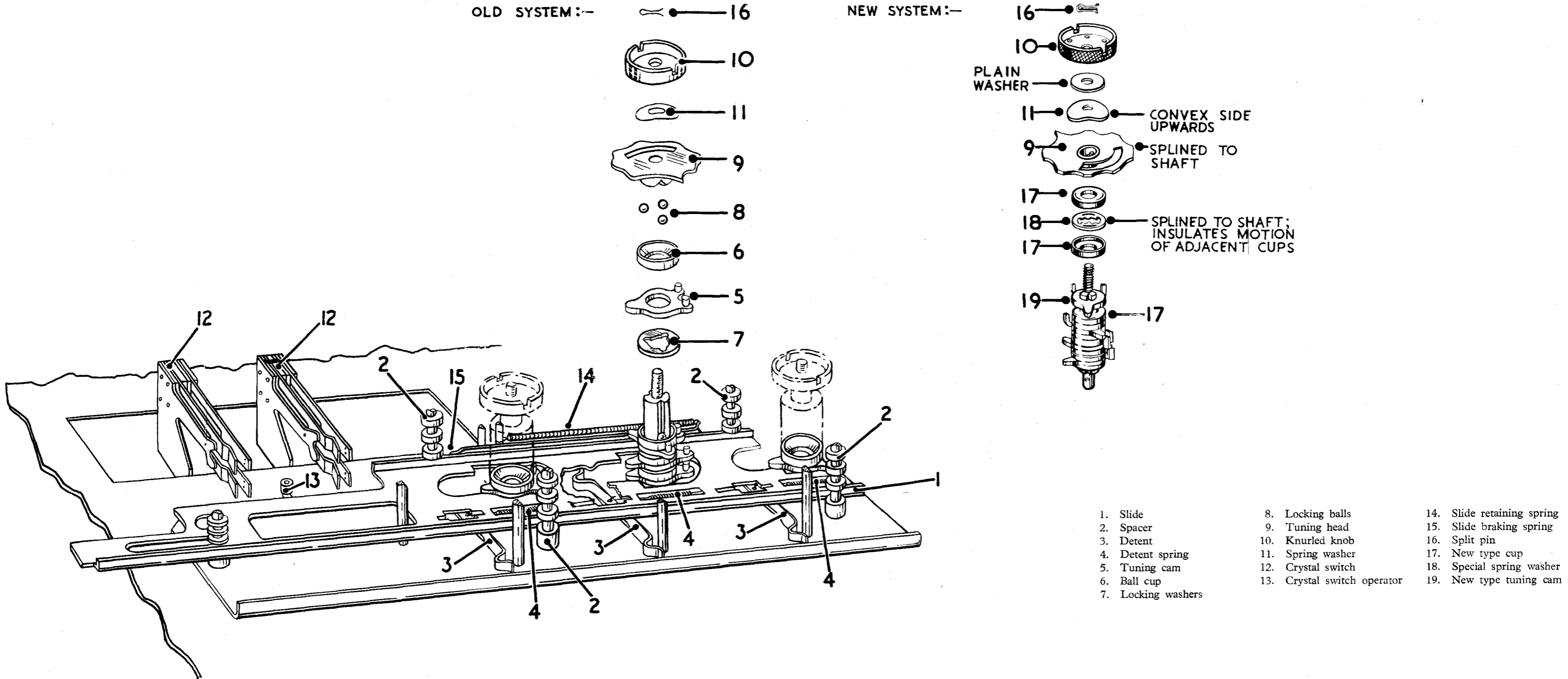
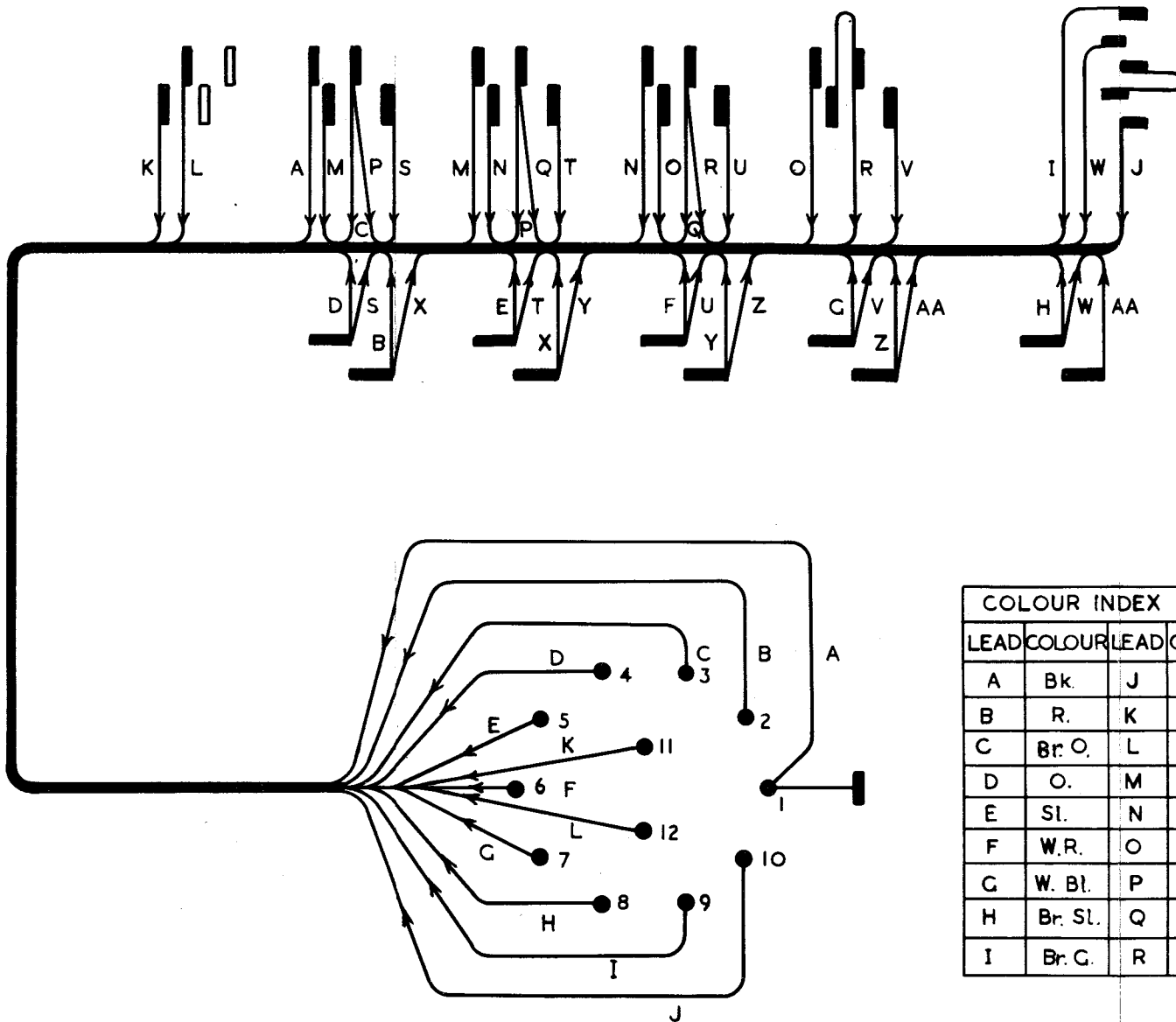
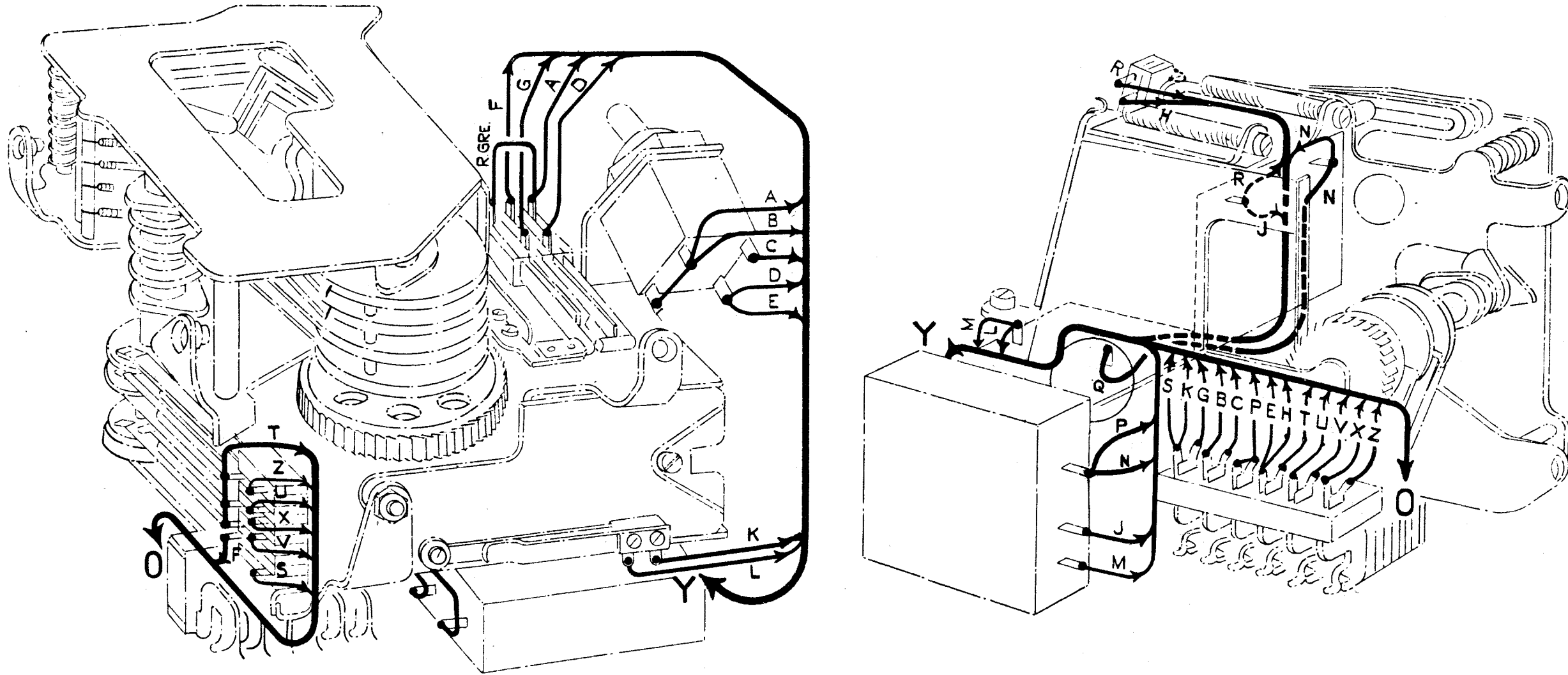

FIG. 24 PERSPECTIVE OF TUNING CAMS



COLOUR INDEX TO LEADS.					
LEAD	COLOUR	LEAD	COLOUR	LEAD	COLOUR
A	Bk.	J	Br. Bl.	S	O.
B	R.	K	Br. Bk.	T	Sl.
C	Br. O.	L	Br. R.	U	W. R.
D	O.	M	Bk.	V	W. Bl.
E	Sl.	N	Bk.	W	Br. Sl.
F	W. R.	O	Bk.	X	R.
G	W. Bl.	P	Br. O.	Y	R.
H	Br. Sl.	Q	Br. O.	Z	R.
I	Br. G.	R	Br. O.	AA	R.

FIG 25. WIRING DIAGRAM OF ELECTRIC CONTROLLER, TYPE 3



COLOUR INDEX TO LEADS																						
LEAD	A	B	C	D	E	F	G	H	J	K	L	M	N	P	Q	R	S	T	U	V	X	Z
COLOUR	R-	R-	R-	O-	O-	BLU-	R-	O-	O-	R-	R-	R	W	W	W	O	R-	BLK.	SL.	R-	BR.	BLU
OR						W	SL.	W		BR							BR		BLK			BR.
LEAD	GRE.	GRE	BLU.	W.	W.	W.																BR.

FIG. 26 - WIRING DIAGRAM OF TUNING MOTOR

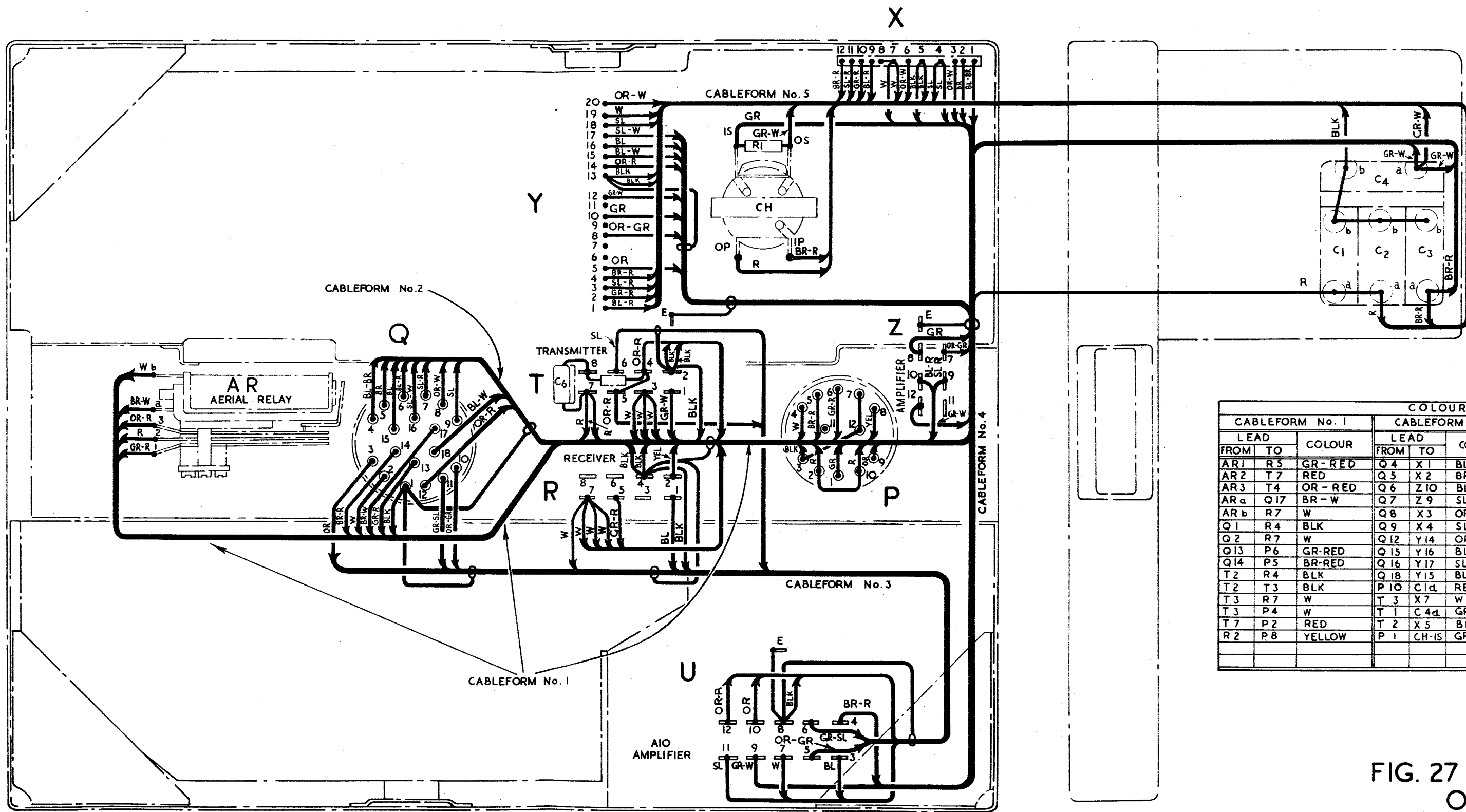

COLOUR INDEX TO LEADS.

CABLEFORM No. 1			CABLEFORM No. 2			CABLEFORM No. 3			CABLEFORM No. 4			CABLEFORM No. 5		
LEAD	FROM	TO	LEAD	FROM	TO	LEAD	FROM	TO	LEAD	FROM	TO	LEAD	FROM	TO
AR1	R5	GR-RED	Q4	X1	BL-BR	Q3	U10	OR	U4	C3a	BR-RED	Y1	X9	BL-RED
AR2	T7	RED	Q5	X2	BR	Q10	U5	OR-GR	U9	C4a	GR-W	Y2	X10	GR-RED
AR3	T4	OR-RED	Q6	Z10	BL-RED	Q11	U6	GR-SL	Z12	Y12	GR-W	Y3	X11	SL-RED
ARa	Q17	BR-W	Q7	Z9	SL-RED	R7	U7	W	P9	Y5	OR	Y4	X12	BR-RED
ARb	R7	W	Q8	X3	OR-W	R1	U3	BL	Z8	Y10	GR	Y13	X5	BLK
Q1	R4	BLK	Q9	X4	SL	R4	U8	BLK	Z7	Y8	OR-GR	Y13	C4b	BLK
Q2	R7	W	Q12	Y14	OR-RED	T5	U12	OR-RED				Y18	X4	SL
Q13	P6	GR-RED	Q15	Y16	BL	T6	U11	SL				Y19	X7/8	W
Q14	P5	BR-RED	Q16	Y17	SL-W							Y20	X6	OR-W
T2	R4	BLK	Q18	Y15	BL-W							CHOS	C4a	GR-W
T2	T3	BLK	P10	C1d	RED							CHOP	C2a	RED
T3	R7	W	T3	X7	W							CH-IP	C3a	BR-RED
T3	P4	W	T1	C4d	GR-W									
T7	P2	RED	T2	X5	BLK									
R2	P8	YELLOW	P1	CH-IS	GR									

FIG. 27 WIRING DIAGRAM OF MAIN TRAY

COLOUR INDEX TO LEADS

LEAD	COLOUR OF LEAD	LEAD	COLOUR OF LEAD
A	R. Blu.	K	R.O.
B	R. Gr.	L	Blu. W.
C	R. SL.	M	Blu.
D	R. Br.	N	Br. W.
E	O.	O	Blu.
F	W.	P	Sl. W.
G	Gr. O.	Q	Sl.
H	Gr.	R	W.
I	Gr. W.	S	W.
J	Blk.	T	O.-W.

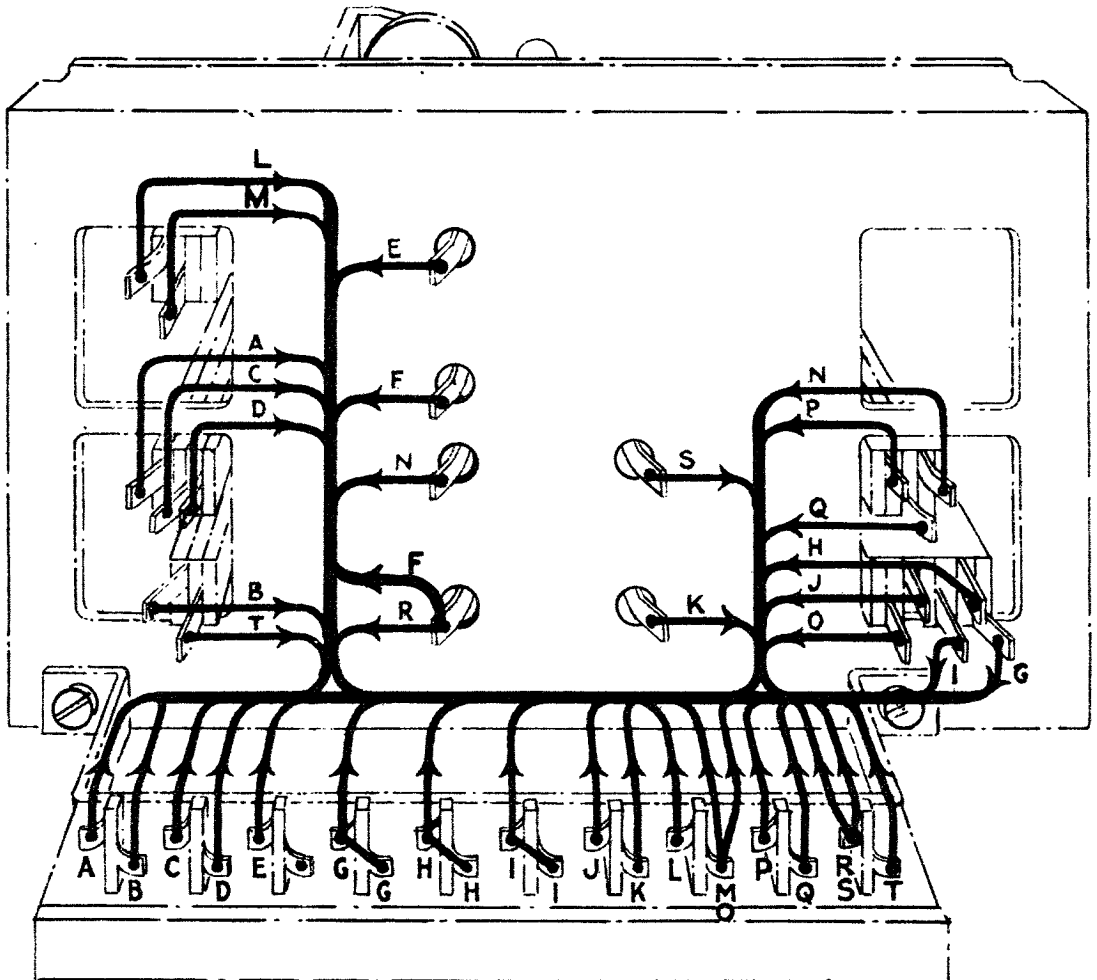

FIG. 28 - WIRING DIAGRAM OF RELAY UNIT

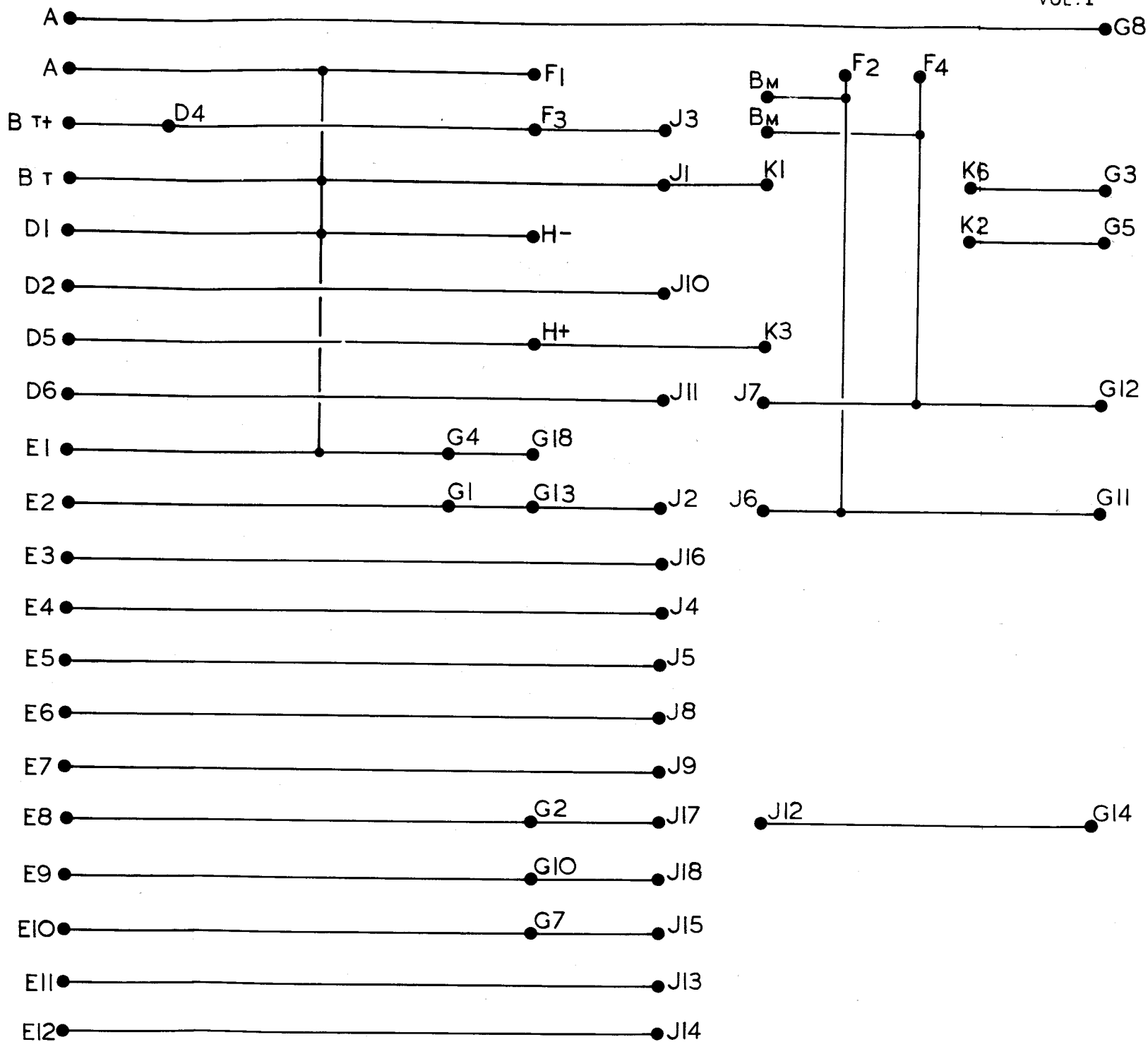
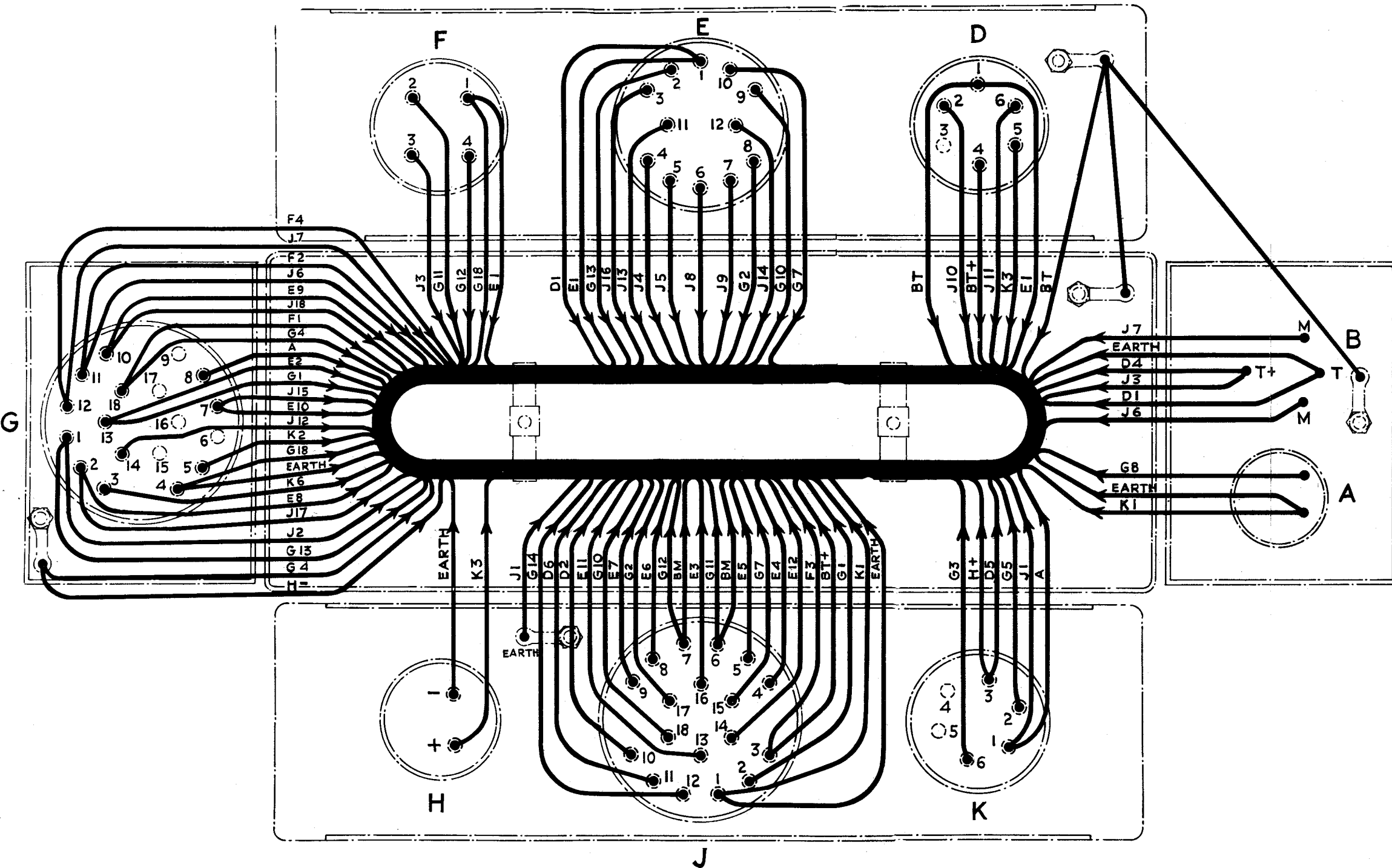

FIG. 29. JUNCTION BOX, TYPE 17A OR 17B, CIRCUIT



COLOUR INDEX TO LEADS				
PLUG	LEAD	COLOUR OF LEAD	PLUG	LEAD
A	"	BLK.	G	EARTH TAG 8
"	"	BR.	B	T
"	"	BLK.	K	1
A	"	BLK.	D	1
B	T	BLK.	D	4
"	T+	BLU. SCREENED.	J	3
"	"	BLU. "	"	6
"	M	GRE. SCREENED	"	7
"	"	W. BLK. "	"	10
D	1	BLK.	E	1
"	2	W.O. SCREENED	J	10
"	6	W. SL. "	"	11
"	5	R. GRE.	K	3
E	1	BLK.	F	1
"	2	R.	G	13
"	3	BR. O.	J	16
"	4	O.	"	4
"	5	SL.	"	5
"	6	W.R.	"	8
"	7	W. BLU.	"	9
"	8	BR. SL.	G	2
"	9	BR. GRE.	"	10
"	10	BR. BLU.	"	7
"	11	BR. BLK.	J	13
"	12	BR. R.	"	14
F	1	BLK.	G	18
"	2	GRE. SCREENED	"	11
"	4	W. BLK. "	"	12
"	3	BLU. "	J	3
G	1	R.	G	13
"	2	BR. SL.	J	17
"	3	Y.	K	6
"	4	BLK.	"	EARTH TAG
"	5	R.	K	2
"	7	BR. BLU.	J	15
"	10	BR. GRE.	"	18
"	11	GRE SCREENED	J	6
"	12	W. BLK. "	"	7
"	13	R.	G	1
"	14	W. GRE.	J	12
"	1	R.	"	2
"	4	BLK.	G	18
H	-	BLK.	"	EARTH TAG
"	+	R. GRE.	K	3
J	1	BLK.	"	EARTH TAG
"	"	BLK.	K	J

FIG. 30. JUNCTION BOX, TYPE 17B, WIRING DIAGRAM

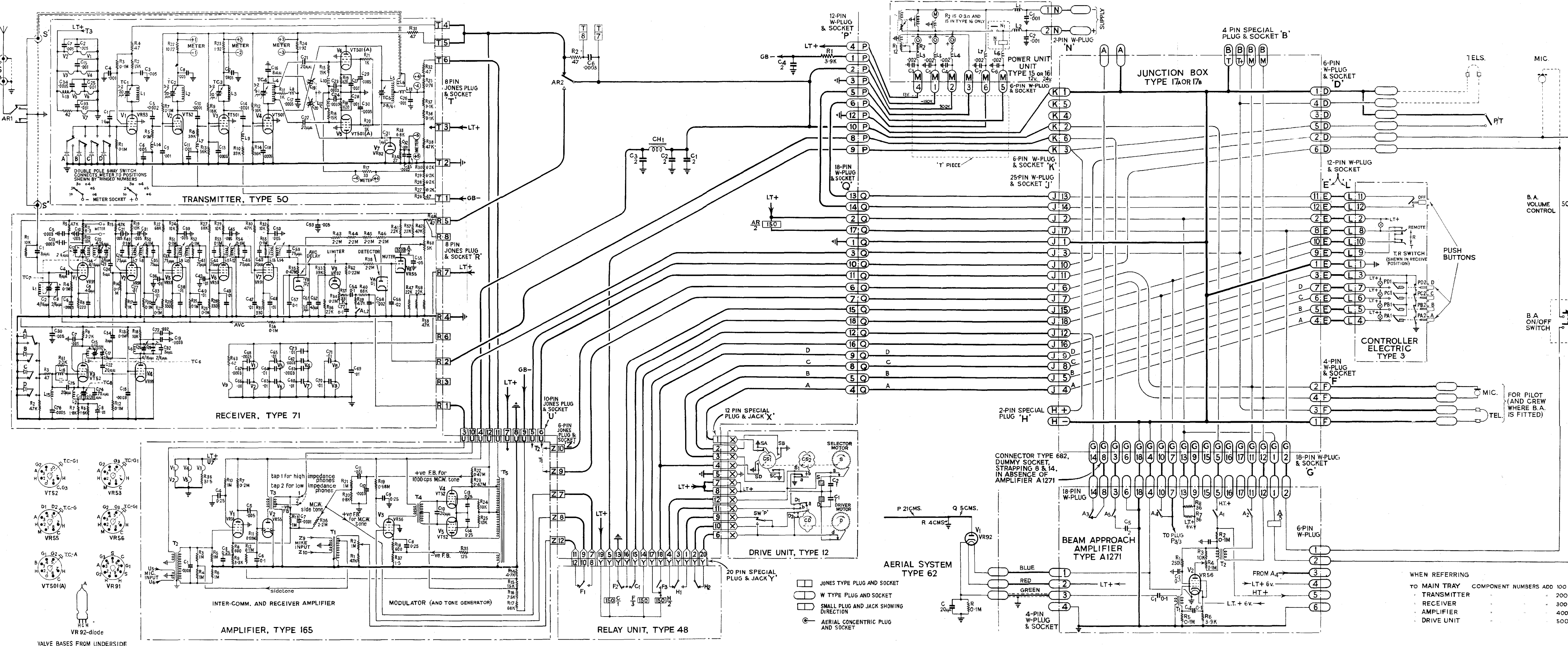

FIG. 33. T.R.1143A CIRCUIT AND INTERCONNECTION DIAGRAM