

Please do not upload this copyright pdf document to any other website. Breach of copyright may result in a criminal conviction.

This pdf document was generated by me Colin Hinson from a Crown copyright document held at R.A.F. Henlow Signals Museum. It is presented here (for free) under the Open Government Licence (O.G.L.) and this pdf version of the document is my copyright (along with the Crown Copyright) in much the same way as a photograph would be.

The document should have been downloaded from my website <https://blunham.com/Radar>, or any mirror site named on that site. If you downloaded it from elsewhere, please let me know (particularly if you were charged for it). You can contact me via my Genuki email page: <https://www.genuki.org.uk/big/eng/YKS/various?recipient=colin>

You may not copy the file for onward transmission of the data nor attempt to make monetary gain by the use of these files. If you want someone else to have a copy of the file, point them at the website. (<https://blunham.com/Radar>). Please do not point them at the file itself as it may move or the site may be updated.

It should be noted that most of the pages are identifiable as having been processed by me.

I put a lot of time into producing these files which is why you are met with this page when you open the file.

In order to generate this file, I need to scan the pages, split the double pages and remove any edge marks such as punch holes, clean up the pages, set the relevant pages to be all the same size and alignment. I then run Omnipage (OCR) to generate the searchable text and then generate the pdf file.

Hopefully after all that, I end up with a presentable file. If you find missing pages, pages in the wrong order, anything else wrong with the file or simply want to make a comment, please drop me a line (see above).

It is my hope that you find the file of use to you personally – I know that I would have liked to have found some of these files years ago – they would have saved me a lot of time !

Colin Hinson

In the village of Blunham, Bedfordshire.

SECRET

736

Copy No. 538

THE SECOND WORLD WAR
1939-1945
ROYAL AIR FORCE

SIGNALS
VOLUME VI
RADIO IN MARITIME WARFARE



ISSUED BY THE AIR MINISTRY (A.H.B.)
1954

SECRET

THE SECOND WORLD WAR
1939-1945
ROYAL AIR FORCE

SIGNALS

VOLUME VI

RADIO IN MARITIME WARFARE

Promulgated for the information and guidance of all concerned.

By Command of the Air Council,

J. H. Barwell.

ISSUED BY THE AIR MINISTRY (A.H.B.)

1954

Preface

During the Second World War scientific developments in radar were used by the Royal Air Force throughout the wide range of its operational responsibilities to bring the maximum effect of air power to bear against the enemy. Those developments and their applications to the various functional roles of the Royal Air Force are dealt with in the appropriate volumes of the Signals history. The employment of radar in defensive air action is related in Volume IV—Radar in Raid Reporting, and in Volume V—Fighter Control and Interception. The development and use of radar in the bombing offensive is included in Volume III—Aircraft Radio. The more highly specialised nature and the importance of the tasks of Coastal Command in the war at sea are, however, considered to justify treatment in a separate volume of the Signals history. This monograph, therefore, deals with the development, production, and operational use of airborne radio in the maritime war.¹

The subject is extensive and complex and the scope of this volume is therefore limited to matters concerning radar for the detection, location, and attack of enemy submarines and surface vessels. The part played by the Intelligence services is not included in this narrative, nor is the use of radio to enable aircraft engaged on escort duties to establish contact with their convoys.

The wider role and activities of the Royal Air Force in the war at sea are related in the Air Ministry narrative 'The R.A.F. in Maritime War.' The present volume may be regarded, in some respects, as companion to the comprehensive operational narrative.

¹ For specialised use of radar in air/sea rescue work *see* A.P. 3232, 'Air/Sea Rescue.'

RADIO IN MARITIME WARFARE

Contents

	<i>Page</i>
PREFACE	iii
INTRODUCTION	x
 PART I.—METRIC A.S.V. 	
Chapter 1. Early Development of Metric A.S.V.	3
<i>First Experiments with Airborne Radar—Development of Aerial Systems—Naval and Air Staff Policy—Trials with A.S.V. Mark I against Submarine.</i>	
Chapter 2. A.S.V. Mark I and A.S.V. Mark II	16
<i>A.S.V. Mark I Installation Programme—The Background of Events—Development of A.S.V. Mark II.</i>	
Chapter 3. Development of Long-Range A.S.V.	25
<i>Experiments and Trials—Installation of L.R.A.S.V. in Whitley aircraft—Development of Yagi Homing Arrays—Development of Aerial Change-Over Switches.</i>	
Chapter 4. Installation of A.S.V. Mark II in Anti-U-Boat Aircraft	37
<i>Sunderland—Wellington—Catalina—Hudson—Liberator—Fortress.</i>	
Chapter 5. The Operational Use of Metric A.S.V. against U-Boats	4-
<i>Shortcomings of A.S.V.—Requirement for Pilots Indicators—Need for Improved A.S.V. Training—New Aircrew Category—Need for Better A.S.V. Layout—Attempts to improve standard of A.S.V. Watchkeeping—Recorder and Bellringer—Requirement for Radio Altimeter—Disappearing Contacts—Need for Illuminants—German Search Receiver, Metox R.600A—A.S.V. Flooding—Attenuators—Vixen.</i>	
Chapter 6. Operational Use of Metric A.S.V. in Anti-Surface Vessel Strike Role	6
<i>Beaufort—Hampden—Beaufighter—Operational Use in Home Waters—Operational Use in the Mediterranean Sea—Rooster—A.S.V. Jamming—Value of A.S.V. Mark II.</i>	

PART II.—CENTIMETRIC A.S.V. AND UNDER-WATER DETECTION DEVICES

Page

Chapter 7. Early Development of Centimetric A.S.V. in the United Kingdom	77
<i>Early Centimetric A.I. Experiments—The Tizard Mission to the U.S.A.—First Experiments with Centimetric A.S.V. in the United Kingdom—Urgent Requirements for Improvement of A.S.V.—First Centimetric A.S.V. Installation—Decision to Manufacture Centimetric A.S.V.—Development of High-Power Metric A.S.V.—Experiments on 50-Centimetre Wavelength—Comparative Trials of High-Power Metric, 50-Centimetre and 10-Centimetre A.S.V.—Operational Requirement for 10-Centimetre A.S.V.—Priority changed from Defensive to Offensive Radio Equipment—Clarification of A.S.V. Development Programme.</i>	
Chapter 8. Development of Centimetric A.S.V. in the U.S.A.	90
<i>Choice of Aircraft for Centimetric A.S.V. Installation—Radiation Laboratory Experimental Installation—Change of Policy regarding Aircraft—DMS.1000—Service Trials of Experimental Liberator Installations—Further change of Policy regarding Aircraft—Substitution of SCR.517B for DMS.1000 Production—Production Order for A.S.G.—Decision on Aircraft Policy—DMS.1000 Installations in Liberators—Improvement of Installation Facilities—Commencement of A.S.V. Fitting Programme.</i>	
Chapter 9. Development of Centimetric A.S.V. in the United Kingdom	100
<i>Delays in Production—Project to combine A.S.V. and H2S—Effects of Priority of Bomber Offensive on Development Programme—Decision to use Magnetron in H2S/A.S.V.—Decision to use H2S in A.S.V. role—Change of Production Programme.</i>	
Chapter 10. Preparation of H2S for A.S.V. Role	111
<i>Aircraft Requirements for Anti-U-Boat Campaign—Trial of H2S in A.S.V. Role—Pilot's Indicator—Scanner Location on Wellington Aircraft—Controversy regarding date of first operational use of H2S—Drawbacks of Wellington XI Installations.</i>	
Chapter 11. Introduction of 10-Centimetre A.S.V.	121
<i>Preparations for Coastal Command Installation Programme—Prototype Installations—Initial Setbacks with Installation Programme—Service Trials of A.S.V. Mark III—Discussions on Comparative Priority of Command Requirements—Discussions on Quantity of Equipment to be held as Spares—Modifications to A.S.V. Mark III—Introduction into Operational Use of 10-Centimetre A.S.V.—Operational Gondola—Operation Encluse.</i>	
Chapter 12. Installation of 10-Centimetre A.S.V.	133
<i>Analysis of Air Operations against U-Boats—Installation of A.S.V. Mark III in Wellington Aircraft—Installation of A.S.V. Mark III in Halifax Aircraft—Installation of A.S.V. Mark V in Liberator Aircraft—Shortage of Test Gear—Training of Personnel—Modifications to A.S.V. Mark V.</i>	
Chapter 13. German Counter-measures	144
<i>Schnorchel—Infra-Red Ray and Thermal Radiation Counter-measures—Reduction of Radar-reflecting properties of U-Boats—U-Boat Radar—Radar Decoys, Aphrodite and Thetis—Group Sailing Tactics—The Magic Eye—Search Receivers.</i>	

	<i>Page</i>
Chapter 14. Allied Counter-measures	163
<i>Measures against Radar Decoys—Measures against U-Boat Radar—Measures against Search Receivers—A.S.V. Mark XI—Development of A.S.V. Mark VI—A.S.V. Marks VII and X—Trial Installation of A.S.V. Mark VI—Requirement for A.S.V. Marks VII, VIII and X—Relative Priorities of Coastal and Bomber Commands—A.S.V. Mark VI Series Installation Programme.</i>	
Chapter 15. The Problem of the Submerged Submarine	185
<i>Disappearing Contacts—Viking Trials—The Training Problem (Aircrew)—Improvement of Servicing—Increased Responsibility of A.S.V. Operator—A.S.V. Bombsights, Marks I, II, III and IV—AN/APQ5 and AN/APQ5B Bombsights—Advent of Schnorchel—A.S.V. against Schnorchel—Improvement of A.S.V.—K-Band A.S.V.—A.S.V. Mark XVII—Use of Buoys against submerged U-Boats—Early Operational Requirements for Marker Buoys—‘High Tea’ Radio Sono-buoy—Sono-buoy barrier—Wirebasket Marks I and II—AN/CRN I and MX180A Buoys—Magnetic Anomaly Detector—U-Boat Detection by Aircraft at the End of the War—A.S.V. Requirements Abroad.</i>	
Chapter 16. Centimetric A.S.V. for Strike Aircraft	221
<i>A.S.V. Mark XII—Growth in Importance of Strike Aircraft—Operational Requirement for Radar Range Finder—A.S.V. Mark XVI—A.S.V. Mark XIII—A.S.V. Mark XV.</i>	

Tables

1. U-boat Sightings—August 1941 to May 1942.
2. Night Flying Hours, Sightings and Attacks June 1942–February 1943.
3. Performance of High Power Metric A.S.V. During Trials in March 1942.
4. Performance of 10-Centimetre A.S.V. During Trials in March 1942.
5. Performance of Radiation Laboratory 10-Centimetre A.S.V. During Trials in April/May 1942.
6. U-boat Strength in 1942.
7. Distribution of A.S.V./H2S at 11 April 1943.
8. A.S.V. Serviceability for January, February, March 1945.
9. U-boat Locations September 1941–August 1943.
10. U-boats Located by Aircraft Equipped with A.S.V. Bay of Biscay July 1943.
11. Ranges at which Initial Contacts against U-boats were obtained by A.S.V. February, March, April 1945.
12. Enemy Submarines Destroyed.

Appendices

1. Coastal Command Order of Battle, 3 September 1939.
2. Extracts from Coastal Command reports. March to October 1940.
3. Royal Air Force Delegation and other organisations in the United States of America.
4. Development of Leigh Light.
5. Development of Towed Reconnaissance Flare.
6. Specification of Requirements for Centimetre Wave A.S.V. by E. G. Bowen
27 January 1941.
7. Operational Requirements for A.S.V.
British Joint Policy 3 July 1942.
Sub-Committee on Airborne Radar 3 September 1942.
Radar Committee 2 October 1942.
8. Preliminary Report on Possible Counter-measures against H2S—January
1943.
9. Potential Enemy Action in Centimetric R.D.F.
Memorandum by Sir Robert Watson Watt.
10. T.R.E. Post Design Service.
11. Committees formed to deal with Radio Aspects of Maritime Warfare.
12. Coastal Command Development Unit, and Air/Sea Warfare Development
Unit.
13. Air Staff Specification for A.S.V. Bombsight.
14. 50-Centimetre A.S.V.
15. A.S.V. Mark VIII and Mark VIIIA.

Illustrations

	<i>Page</i>
Echo from H.M.S. <i>Courageous</i> , May 1938, range 8 miles	<i>Facing 14</i>
Receiver of A.S.V. Mark I	} <i>Between 30 and 31</i>
Receiver of A.S.V. Mark II	
Indicator of A.S.V. Mark II	
Typical Display on Indicator of A.S.V. Mark II	
Fields of Radiation of Single Dipole Aerial and Yagi Array ..	
Polar Diagrams of Whitley L.R.A.S.V. Installation	<i>Facing 38</i>
Whitley L.R.A.S.V. Installation	<i>Facing 39</i>
<i>(a)</i> General Arrangement.	
<i>(b)</i> Broadside Aerials.	
<i>(c)</i> Homing Transmitter Aerial.	
<i>(d)</i> Homing Receiver Aerial.	
A.S.V. Mark II in Hudson	<i>Between 54 and 55</i>
<i>(a)</i> Layout.	
<i>(b)</i> Receiver Array.	
<i>(c)</i> Transmitter Array—Front View.	
<i>(d)</i> Transmitter Array—Side View.	
Chin Scanner Positions	<i>Facing 134</i>
<i>(a)</i> Wellington.	
<i>(b)</i> Liberator.	
Layout of Radar Equipment in Halifax Mark II	<i>Facing 135</i>
Radar Search Equipment in a U-boat	<i>Facing 150</i>
The <i>Bali</i> Broad-Band Round Dipole Aerial	<i>Facing 151</i>
<i>Schnorchel</i> in Sea. View at Short Range, November 1944 ..	<i>Facing 198</i>
End Fire Array	225
A.S.V. Mark VIIIA (A.S.D.1)	<i>Facing 263</i>

INTRODUCTION

One of the primary responsibilities of the Royal Air Force in the Second World War was close co-operation with the Royal Navy in the protection of our sea-borne communications. This task fell, in the main, to Coastal Command, but it was not until an adequate number of long range aircraft became available and efficient airborne radar had been developed that the command was able to play its full part in the struggle at sea.

The key-note of German naval action in the Second World War was the disruption of the sea communications of Great Britain. The Versailles Treaty of 1919 strictly limited Germany's future naval force in number, type and tonnage ; it was to consist of surface vessels only and the building of submarines was expressly forbidden. In 1935 Hitler repudiated the treaty and by the London Naval Agreement of that year Germany was given the right to possess a tonnage of submarines equal to that of the British Commonwealth. The rising tension in 1939 caused Hitler to revise his plans for building battleships and cruisers, in place of which he substituted a naval force capable of operating against our communications but unsuitable for fleet actions.

While the major naval units constituted a 'Fleet in Being' and produced an ever present threat to our convoy routes, the U-boat remained the most potent weapon with which to implement the German policy of 'Strike and Evasion.' Both surface craft and U-boats derived every possible advantage, particularly in the Atlantic, from the space of the ocean, bad weather, poor visibility and darkness, and the first essential to any counter-measures lay in providing means of detection in such conditions.

Airborne radar (A.S.V.) for the detection of surfaced vessels from the air gave at least the partial answer and it is with the development of that device and its influence on the conduct of naval warfare that this monograph is mainly concerned.

The introduction of the *Schnorchel* and the high speed U-boat came at the close of the war and was too late to affect the issue. The inability of A.S.V. to detect *Schnorchel*, except in favourable circumstances, remained as an unsolved yet vital problem at the end of the war.

PART I
METRIC A.S.V.

CHAPTER 1

EARLY DEVELOPMENT OF METRIC A.S.V.

The primary role of Coastal Command was defined in the Air Ministry Directive to the Air Officer Commanding-in-Chief on 1 December 1937 as 'trade protection, reconnaissance and co-operation with the Royal Navy.'¹ It had long been recognised that reconnaissance would be the principal function of the Royal Air Force squadrons engaged in naval co-operation, and by 1 September 1937 the majority of squadrons of Coastal Command had been renamed General Reconnaissance squadrons.² The value to be attached to air reconnaissance reports, giving either positive or negative information of shipping in any particular area, depended on the range of vision from aircraft. Poor visibility was therefore a serious handicap to air reconnaissance since it restricted the area which could be inspected visually and thus increased the difficulties of making an effective search at sea and in keeping shipping under observation. These difficulties were largely overcome by the development of airborne radar devices which made it possible, even in adverse conditions and at night, to detect and locate surface vessels and also submarines when they were not completely submerged. The facility to see by radar also enabled aircraft to strike at their targets accurately in unfavourable conditions. Poor visibility, bad weather and darkness, which had previously limited the usefulness of aircraft in maritime operations, were no longer to afford the same degree of safe cover to the enemy. The new devices were to endow aircraft with unique advantages in protecting our own shipping and in finding and fighting the enemy at sea. Developments in radio-location were thus to bring progressive changes in the functions of aircraft engaged in maritime warfare.

First Experiments with Airborne Radar

During 1935 an experimental ground radar station was erected at Orfordness for the development of the new method of detecting aircraft by means of radio waves. Early in 1936 the Air Ministry acquired Bawdsey Manor as a centre for research work and as a second experimental radar station.³ The ultimate purpose of the experiments was to provide the air defence system with early warning information of the approach of hostile aircraft, so that they could be intercepted and destroyed before reaching their target areas. Remarkable success was achieved in the detection and location of aircraft, but it soon became evident that rapid changes of position of hostile aircraft could not be reported with sufficient accuracy and speed to enable air interceptions to be made at night or in conditions of poor visibility. An airborne radar installation was required in the fighter aircraft itself.⁴ Research on the problems of airborne radar was therefore begun at Bawdsey by Dr. E. G. Bowen and a small team of scientists.⁵

¹ A.M. File S.39593.

² A.H.B. Narrative: 'The R.A.F. in Maritime War.'

³ See Royal Air Force Signals History, Volume IV: 'Radar in Raid Reporting.'

⁴ A.M. File S.42439. Minutes of 16th Meeting of the Committee for Scientific Survey of Air Defence, 25 February 1936.

⁵ A. G. Touch, R. Hanbury Brown, P. A. Hibberd.

The task which confronted them was formidable. There was no previous experience of the use of the radar pulse technique in aircraft and the possibilities were unknown and unexplored. The development of the first airborne radar was to depend on a detailed study of the problems involved in the application of the new technique in aircraft, and on the initiative of the scientists concerned. Certain fundamental requirements of the proposed airborne radar were readily appreciated. It was known, for example, that the method of presentation used in the ground radar displays was not altogether suitable for aircraft, and that a higher degree of accuracy would be necessary in the airborne set for the final stages of interception and attack. As compared with the ground radar display, the range scale would have to be expanded and the pulse width reduced in order to show accurately the distance of targets at close range. The choice of a suitable wavelength was greatly restricted since the radiating and receiving elements of the aerials had to be resonant to the wave-frequency used and this determined their overall physical dimensions. For installation in fighter aircraft, the aerials, and therefore the wavelength, had to be as short as possible. Further, the choice of wavelength also depended on the development of radio valves having a suitable power rating at very high frequencies, and such valves were not yet available for quantity production. Consideration of the space available in the fighter aircraft, and the permissible size, weight and power supplies for the radar equipment, placed additional limitations on the design. These factors and others pointed the way to research, but it seemed to be a far cry from the massive aerial systems and the cumbersome equipment of the ground radar stations to a compact and efficient airborne radar.¹

It was first necessary to decide on the wavelength to be used, since it was the main controlling feature in the whole of the design. At the outset the airborne group realised that a wavelength of one or two metres would be most desirable but this could not be achieved until suitable valves were available. The decision was therefore made to use a wavelength of 6·7 metres. By December 1936, a radar receiving system, having the required characteristics, had been constructed for installation in an aircraft. Work had been concentrated on the receiving installation in order to find out if it were possible to pick up radar transmissions in the air, but a conveniently small transmitter had not yet been completed. The receiver was installed in a Heyford aircraft and was used for experiments in conjunction with a target aircraft and radar transmissions from a ground station.² The experiments gave practical proof for the first time that the radio energy reflected from one aircraft could be received in another. This was most encouraging and it was felt that the right approach was being made.

Early in 1937 a small transmitter was completed and installed in the Heyford alongside the receiver, and flight tests were made. Although the receiver was still not sufficiently sensitive to give reliable indications of other aircraft, echoes from the coast line, harbour installations and ships at sea, were observed whilst the aircraft was flying in the vicinity of Harwich, and the results were considered to be most promising.³ With good prospects of suitable valves

¹ See Royal Air Force Signals History, Volume III : 'Aircraft Radio,' for description of other difficulties encountered.

² See also Royal Air Force Signals History, Volume V : 'Fighter Control and Interception.'

³ Several years later the need for an equipment to locate ground targets became urgent, and the observations made on this flight gave considerable impetus to the development of H2S. (See also Royal Air Force Signals History, Volume III : 'Aircraft Radio.')

becoming available, the group then devoted its efforts to the development of an airborne installation on a shorter wavelength. By the summer of 1937 an experimental set of apparatus had been built up, to operate on a wavelength of $1\frac{1}{4}$ metres. It consisted of a pulse transmitter and modulator, a new receiver and cathode ray tube indicator, together with their various power supply units.¹ Separate single dipole aerial systems were provided for transmitting and receiving.

The successful operation of the very short wave equipment necessitated its being completely screened.² Screening was one of the major problems associated with the development of ultra short wave radio technique. Eventually the solution was to be found by pooling the knowledge of the Royal Aircraft Establishment, Farnborough, and of various firms in the radio industry. It involved the perfection of the aircraft bonding, by joining together electrically all metal parts of the aircraft, and the fitting of an engine ignition screening harness. By July 1937, an Anson aircraft had been sufficiently bonded and screened for the testing of the newly developed $1\frac{1}{4}$ metre radar equipment.

In view of the clear indications of coastline and ships which had been achieved with the earlier airborne radar, a trial flight was made over the sea, from Martlesham Heath, in August. The test met with immediate success; echoes were obtained from a 2,000 ton freighter at a distance of five miles.³ It was at once recognised that this advance had immense possibilities and it was decided to make further explorations in the use of radar for detecting ships at sea.

Fortuitously, a combined exercise for units of the Home Fleet and aircraft of Coastal Command had been arranged for 4 and 5 September 1937. On the evening of 3 September, Dr. Bowen took off from Martlesham in the Anson with the airborne radar with the object of trying to find the fleet as it made its way to the exercise area. The battleship *Rodney*, the cruiser *Southampton* and the aircraft carrier *Courageous* with four destroyers, were intercepted 10 miles southwest of Beachy Head. Several runs were made towards the ships at a height of 1,500 feet. Clear and unmistakable echoes were obtained at a maximum range of four miles.⁴

The following day, another flight was made. The weather steadily deteriorated during the day and the aircraft of Coastal Command were recalled by W/T before any sighting reports had been made, and had to remain inactive for 48 hours. The Anson was not fitted with W/T however and did not hear the recall signal, but continued its private reconnaissance. In extremely poor visibility H.M.S. *Courageous*, H.M.S. *Southampton* and attendant destroyers were found, with the assistance of the radar equipment, at a range of about nine miles. The Anson closed to visual range to confirm the identity of the units. The naval force commander, surmising that an attack by aircraft of Coastal Command was imminent, sent off aircraft from the carrier to give

¹ Transmitter valve was an American 'doorknob' triode generating about 75 watts at 300 megacycles per second. The aircraft D.C. supply was used to drive a rotary converter, to provide power at the required voltage.

² From high frequency currents, magnetos, electrical leads, discharges and sparking plugs of the aircraft.

³ A.H.B./IIE/187. Papers on Airborne Radar. A. G. Touch.

⁴ A.M. File S.42439.

chase. Echoes were obtained from them as they took off, at distances ranging from 1,000 to 3,000 feet from a height of 9,000.¹ H.M.S. *Rodney* had not been sighted however, and, deducing that it was northward, the *Anson* made off in that direction from the Fleet Air Arm aircraft and made an unsuccessful radar search. By then thick cloud extended from sea-level to 12,000 feet, and the *Anson*, being near the end of its endurance, returned to base. With the help of responses obtained from the coastline an accurate landfall was made.²

In spite of many difficulties, the research group had achieved success in at least one application of airborne radar. The scientists were encouraged enough to anticipate that eventually it would be possible to discover and locate ships at sea at distances up to 10 miles from low-flying aircraft, and to detect and to obtain bearings of other aircraft at distances less than the height at which the observing aircraft was flying.³ Meanwhile, members of the Committee for the Scientific Survey of Air Defence showed keen interest in the experiments. Professor E. V. Appleton was so impressed with the progress made that, on 3 October 1937, at a meeting of the Committee, he pleaded for a greater concentration of effort on the development work, which still occupied but a small part of the Bawdsey staff and facilities.⁴ The priority allotted in the Bawdsey research programme to the development of the new technique, known as R.D.F.2., was low compared with that given to the long-range early-warning ground radar system known as R.D.F.1., which was most urgently required. Three weeks later the chairman of the committee, Sir Henry Tizard, after a flight made in particularly bad weather and poor visibility, reported that he had personally observed the operation of R.D.F.2. He considered it promising in so far as the location of ships was concerned, though as yet unsuccessful for practical use against aircraft, and proposed that the work of developing it should go ahead as rapidly as possible.⁵ The Superintendent of the Bawdsey Research Station then reported to the committee that, during the course of his recent visit to the Mediterranean area, two Air Officers Commanding had emphasised to him the importance of fleet shadowing, for which R.D.F.2 appeared to be particularly suitable. The main and urgent requirement was, however, for an efficient early warning system, and little if any additional assistance appears to have been given to the development of R.D.F.2. for a maritime role.

The main factors influencing the design of airborne radar for the detection of surface vessels (A.S.V.), had been formulated in the course of research and experiment up to December 1937.⁶ It was already established that the effective range of detection was a function of the electro-magnetic field strength at the target due to the radiation from the airborne transmitter. Therefore, the power output of the transmitter and the radiation pattern of its aerial system were important factors in determining the range. Maximum range was found to be governed by the height of the aircraft and the size of the target ship. Long range results, however, could not be obtained owing to the low power characteristics of the valves which were then available for operating

¹ A.M. File S.42439.

² Narrator's interview with Dr. E. G. Bowen.

³ B.R.S. File B.R.S./4/4/200.

⁴ A.H.B./IVA/6/1. Committee for the Scientific Survey of Air Defence—Meetings.

⁵ A.H.B./IVA/6/1. Minutes of 35th meeting of C.S.S.A.D.

⁶ To enable the applications of radar to be distinguished, the title A.S.V. for Air to Surface Vessels, and A.I. for Air Interception were brought into use.

on the very short wavelengths suitable for airborne radar. There were two main considerations which limited the wavelength. First, only small aerials with their reflectors could be mounted on aircraft since aerial arrays increased the aerodynamic drag. Secondly, the minimum range of detection had to be as short as possible in order to make accurate readings possible during the final stages of approach to a target.¹ The minimum range requirement placed a rigid upper limit on the wavelength owing to the relationship between the wave-frequency and the pulse width.

The choice of wavelength was therefore inevitably restricted. Whilst long range detection called for high power output which could only be achieved by using longer wavelengths, the minimum range requirement and aerodynamic considerations both demanded the use of a very short wavelength. From the accumulated data it was calculated that, with the aerials and receivers then available, a practical A.S.V. transmitter would require a power output of at least one kilowatt. A compromise thus had to be made in the selection of the wavelength which so largely determined the design of the early A.S.V. equipment. Limitations in performance had to be accepted until a more efficient type of ultra short wave valve became available. In the meantime, in order to obtain a power output of one kilowatt, it was decided to use American valves, Type R.C.A. 888, which were most efficient when operating on a wavelength of about $1\frac{1}{2}$ metres. This resulted in the development of an A.S.V. installation for operation in the Anson on the new wavelength of $1\frac{1}{3}$ metres.² The whole installation represented an important advance in the development of A.S.V.³

Development of Aerial Systems

At that stage it was felt that until further progress had been achieved in the elimination of interference there was little else that could be done to improve the overall performance of the A.S.V. installation. Increased sensitivity would not give a better presentation of radar echoes whilst they were often completely obscured by interference signals on the cathode ray tube. Attention was therefore turned to the development of a more efficient aerial system for A.S.V. whilst the Royal Aircraft Establishment investigated screening problems. Three types of aerials had already been designed to direct the radiation over the area to be searched, which could be either ahead, or on the beam, or all round the aircraft. They were known as the 'forward,' 'sideways' and 'all round looking' aerial systems, and each could be used to search a different area relative to the aircraft. It was therefore necessary to select the most suitable of the aerials for adoption as standard and for further development.

In the forward-looking system the transmitting aerial radiated a fan-shaped beam in front of and below the aircraft, and search was confined to that area. The direction of the target was determined by means of two receiving aerials. They were designed to have overlapping lobes, and their mounting on the aircraft was so arranged that equal signals were obtained on both aerials only when the target was dead ahead. The signals were compared by switching

¹ Minimum range was defined as the point at which a returned echo emerged completely from the direct signal between transmitter and receiver.

² The transmitter gave the required peak power of one kilowatt and was pulse modulated by the squegging or self-modulating principle which eliminated the need for a large separate modulator.

³ B.R.S. File B.R.S./4/4/200.

the receiver alternately from one aerial to the other. By appropriately changing the line of flight of the aircraft, the signals could be equalised, and the aircraft 'homed' on the target.

The all-round looking system, as its name suggests, swept an area all round the aircraft. The aerials were horizontal dipoles; the transmitting aerial was mounted above the fuselage and rotated by hand, whilst the receiving aerial was below the fuselage and rotated mechanically at about 1,000 revolutions per minute. By means of a time base on the cathode ray tube, synchronised with the revolutions of the receiving dipole, the indicator gave both range and direction.

In the sideways-looking system the transmitting aerial directed a steady fixed narrow beam of radiation at right angles to the line of flight, thus making it possible to search an area to the side of the aircraft. By concentrating the radiation in a beam the range was increased and thereby the area of search was extended.

Between 10 and 12 May 1938, when units of the Home Fleet cruised from Spithead to Portland, the opportunity was taken to use them as targets for A.S.V. trials. A sideways-looking aerial system was used, having a Yagi array attached to the starboard wing-tip.¹ No indication of azimuth was possible, and responses could be obtained only when a target was at about 90 degrees to the line of flight on the starboard side. Photographic recording apparatus was installed in the aircraft to make a record of any echoes received on a continuously moving film. The capital ships were detected at ranges up to 15 miles, and indications of the number of ships and their relative positions were recorded.

Naval and Air Staff Policy

The results were so impressive that the Admiralty, unaware of the many difficulties still to be overcome, asked for the immediate delivery of six sets of the equipment. It was impossible at the time to comply with the request. The Air Ministry also regarded the development as being of vital importance since the visual methods of air reconnaissance at sea were often unreliable because of poor visibility, especially in the North Sea. It was the opinion of the Air Ministry that production could not be started until specifications were drawn up to define what was actually required operationally. It was considered to be imperative for Service trials to be held by Coastal Command as soon as possible.

When, therefore, in July 1938 the Admiralty requested a joint meeting at a very early date, to discuss 'the possibility of immediate production, without further development, of equipment suitable for fitting in reconnaissance aircraft, and to arrange priorities of allocation,' the Air Ministry agreed immediately.² A change in the agenda for discussion was proposed, however, in order to cover the following points:—

- (a) On what lines from a tactical point of view should development of radar ship search proceed?
- (b) What trials can be carried out and when?
- (c) What are the estimated requirements to meet the needs of the Admiralty and the Air Ministry?

¹ A Yagi array is a parasitic array in which each aerial consists of a radiating element with reflectors and directors.

² A.M. File S.45501.

The different lines of approach to the problem, illustrated by the items for the agenda, are interesting in view of the manner in which A.S.V. was subsequently rushed into service. It is also interesting to note that the accent was, until after the outbreak of war, on ship rather than submarine search. Those responsible for naval policy were far more concerned in preparing for a fleet action, and with measures to stop the entry of surface raiders into the Atlantic, than with anything the enemy air force or submarine fleet could attempt against our trade or lines of communication.¹ The development of the Asdic underwater submarine detector induced a reliance on the device which discouraged any research into the possibilities of using aircraft as a direct opponent of the submarine until less than one year before war began, when aircraft co-operation with the Anti-Submarine School was requested and the installation of Asdic in flying boats was suggested.² The false sense of security engendered by the partial success achieved by surface craft equipped with Asdic hindered appreciation of the value of A.S.V. as an anti-U-boat measure.

The conference, at which Coastal Command was also represented, was held on 3 August 1938 under the chairmanship of the Assistant Chief of the Air Staff, and the discussion centred on the form of A.S.V. likely to be most suitable for Service use.³ The transmitter and receiver did not present a problem since it was largely a matter of accepting the best equipment that technical resources could provide, but the method of search and the radar display presentation gave plenty of scope for discussion.⁴ The method of search would determine the type of aerials required although the choice of the method of search would itself be influenced by aerodynamic and other design limitations of possible aerial systems. Mr. R. A. Watson-Watt, Director of Communications Development at the Air Ministry, thought that the best method of search appeared to be the sideways-looking system which had already given good results in practical trials. He gave details of the other two systems and estimated that the forward-looking system would have a forward range of up to 15 miles and a width of 22 miles, whilst the all-round system would search up to 15 miles. The same transmitter could be used for both the sideways and forward-looking systems simultaneously. The addition of the latter would increase drag on the aircraft only slightly; the former reduced the top speed of the Anson by 5 miles per hour. The decisions finally made were:—

- (a) A demonstration of the sideways-looking and forward-looking systems was to be held in early September.
- (b) If the results were satisfactory 12 sets of each system were to be made available for future Service trials.
- (c) The Service trials were to be conducted in Sunderland, Hudson, Anson, Walrus and Swordfish aircraft.
- (d) Further development of the all-round system was to proceed without delay.

After the demonstration held in May the research group had continued to devote its attention to the production of a practical A.S.V. system for Service use. Their efforts had previously been hampered by the difficulty of obtaining aircraft. Before the war the Royal Air Force could afford to allocate only a

¹ A.H.B. Narrative: 'The R.A.F. in Maritime War.'

² A.H.B./IHK/36/8. Anti-Submarine Measures, December 1938–May 1943.

³ A.M. File S.45501.

⁴ Direct or photographic presentation.

few aircraft for experimental work, and scientists engaged in different fields of research were often forced to share the same aircraft, which as a rule was highly inconvenient. When it became clear that the work of the airborne radar group deserved exceptional facilities, a special flight, to be employed solely for conducting radar experiments, was formed in May 1938 at Martlesham Heath. It consisted of two Ansons and one Heyford, and also a Harrow for use as a target aircraft. Later, two Battles were added. This flight was to grow into a unit having an establishment of nearly one hundred aircraft of all types, based at Defford, before the end of the war.

The type and the design of the aerial system had yet to be decided. The relative merits of horizontal and vertical polarisation were investigated by fitting an Anson with both horizontal and vertical Yagi arrays and comparing their performances. To eliminate any possible inherent errors, each aerial array was used both as a horizontal and vertical radiator by putting the aircraft into the steepest possible dives and climbing until it practically 'stood on its tail.' Detection ranges against ships were similar, but echoes from the ground and sea were so large when using vertically polarised waves that they were quite useless for A.S.V. Horizontal polarisation was therefore adopted and always used thereafter as the standard method for A.S.V. radiation.

The various methods of search were given extensive trials. Experiments with all-round search were discontinued after a few months because the aerial system produced a pattern of radiation in the form of a figure of eight and the bearings of ships were determined from the minima. The result of this was that ships on different bearings but at similar ranges could be confused. Furthermore the aerial had low gain characteristics and therefore very little range. To produce beam radiation and P.P.I. presentation on a wavelength of $1\frac{1}{2}$ metres necessitated the use of an aerial system too large and unwieldy for installation in aircraft. A progress report made in December 1938 stated that indications of ships had been obtained on a cathode ray tube when using a radial time base rotating at the same speed as the aerial system.¹ The echo appeared as a circle with zeros of intensity at opposite ends of a diameter; the radius of the circle gave the range of the ship, and the gap in the circle indicated the bearing. 'All-round search,' the report concluded, 'has advantages in range, in coverage, and in that the results are presented in a simple pictorial manner.' The realisation of these advantages, however, had to be delayed until centimetric radar technique made it possible to construct rotating aeriels of a practical size.

The best results were obtained with a development of the sideways-looking system which consisted of Yagi arrays, with Sterba arrays as a stand-by aerial system.² Although the effect of the Yagi arrays festooned around the aircraft was frightening to the aerodynamic experts, the system was highly efficient. Capital ships were detected at distances up to 30 miles, and ships of 5,000 tons up to 15 miles. It seemed that all was set for an impressive demonstration in September 1938.

Unfortunately, the demonstration had to be cancelled. It was planned to coincide with a Home Fleet exercise, but critical developments in the international situation caused the location of the exercise to be radically changed

¹ A.M. File S.45501. Report by Dr. E. G. Bowen.

² The Sterba array consisted of a series of inter-connected half-wave dipoles.

at a late hour. The crisis also made it difficult to obtain the co-operation of operational aircraft from Coastal Command which, in view of the direct application of A.S.V. to the role of that command, were preferable to non-standard and non-operational aircraft for development work. When it was learnt that no demonstration could be given two staff officers of Headquarters Coastal Command visited Bawdsey to examine and discuss A.S.V. systems and equipment. On 21 September 1938 the Air Officer Commanding-in-Chief¹ informed the Air Ministry that, judging from what he had seen at the trials in May, and from the reports made by his staff officers after their visit, he considered that A.S.V. should be adopted immediately for inclusion in reconnaissance aircraft as standard equipment, and that new types of aircraft earmarked for his command should be brought into service with the equipment already installed.² He justifiably expressed his fears that the aerial arrays mounted on the main and tail planes of the Anson would, however, be dangerous if fitted to aircraft of higher performance.³

Although the experimental transmitters and receivers had almost reached their final form and were actually in production, one result of the cancellation of the September demonstration was that the design of the aerial system was still undecided.⁴ The choice lay between the sideways-looking long-range beam system, and the forward-looking homing system. The C.-in-C's opinion of parasitic aerial arrays found support amongst the officers of the Air Staff and the Royal Aircraft Establishment, who considered them to be too complex, aerodynamically unsound, and not easily applicable to every type of aircraft. Further development of the successful sideways-looking system with its Yagi arrays was therefore abandoned, and progress towards attaining efficient long range A.S.V. was thereby retarded by over two years. The objection to homing aerials was the restricted coverage they offered in a broadside direction. Simplification and adaptability to several different types of aircraft was demanded. Work therefore proceeded on the design and development of an efficient forward-looking system, free from structural and aerodynamic objections, which would also give good broadside coverage. The designing of such a system, with simple aerials suitable for a variety of aircraft, involved an elaborate development programme which was complicated by the introduction of dorsal gun turrets in aircraft then being designed. Progress was unavoidably restricted by the direction of practically all the available scientific resources to the installation of the ground radar stations of the Home Chain. Meanwhile considerable advances had been made at the R.A.E. in the solution of the interference and screening problems. As soon as a suitable type of

¹ Air Marshal Sir Frederick W. Bowhill.

² A.M. File S.45501.

³ During the 1938 experiments, the Anson was often flown when fitted with :—

Rotating half-wave dipole above the nose.

Horizontal Yagi on one wing.

Vertical Yagi along leading edge of the other wing.

Horizontal Yagi on one tailplane.

Vertical Yagi along leading edge of other tailplane.

Sterba broadside array between king post and tail.

The stalling speed was increased by 20 miles per hour and the undercarriage could not be retracted.

⁴ In August 1938 the first specifications for transmitter and receiver were completed. Initial production contracts for the transmitter were placed with Metropolitan-Vickers, and for the receiver with Cossors. The specifications were amended in October 1938. The transmitters were subsequently converted for use in A.I., but the receivers were unsatisfactory and were not accepted by the Service.

aerial was produced, the chief factor governing the speed at which aircraft could be fitted with A.S.V. would be the rate at which efficient screening could be incorporated.

With the growth of international tension during the period from September 1938 until the outbreak of war, the development of A.S.V. came to be regarded as being of less importance than the development of A.I. which had received but little attention in the course of the A.S.V. experiments. Whilst the Air Ministry concentrated on the improvement of the air defence system, by accelerating their measures for raid reporting and aircraft interception, the Admiralty was persistently pressing for the installation of A.S.V. in aircraft of the Fleet Air Arm. This latter task, however, could not be given priority over the radar reporting system and A.I. without prejudice to the preparedness of the air defence organisation. Only a small scientific staff of airborne radar specialists was available and whilst they were mostly engaged on A.I. development they could not undertake the application of A.S.V. to types of aircraft other than the Anson until additional scientific research workers were available. The two applications of airborne radar had, however, much in common, and the knowledge gained during the development of A.I. was to be of immense value when applied to A.S.V.

By the spring of 1939 good progress had been made towards the elimination of interference. Ignition screening was now standard equipment on most aircraft with the exception of some of the older types which were used for training. The new types of all-metal aircraft presented far less difficulty in the perfection of their bonding and their engines were fitted with specially designed magnetos and cowed sparking plugs. Also, by this time, A.S.V. aerial systems for metal aircraft had reached the design stage. The transmitting aerial was to be a highly directional Sterba array having four elements suspended from the normal horizontal aerial being used as a triatic. The receiving aerials were simple dipoles for mounting fore and aft on each side of the fuselage.¹

In June 1939 the Admiralty informed the Air Council that ' . . . they viewed with concern the apparently slow progress made towards the design of A.S.V. equipment for installation in Fleet Air Arm aircraft . . . ' The Air Council, on 6 July 1939, stated that a careful examination of the position showed no grounds for the suggestion but revealed, on the contrary, that considerable progress on A.S.V. had been made in spite of the fact that the main effort of the Bawdsey Experimental Station had necessarily been diverted.² A review of the A.S.V. position had been completed and it was believed, rather optimistically as it happened, that the abandonment of complex aerial systems had simplified the installation and made it possible to provide facilities for both beam search and homing alternately by means of a changeover switch. The adoption of simple dipole aerials, however, created complications since they were not so efficient as the somewhat elaborate arrays. Their reduced pick-up or gain gave a shorter range of detection and to compensate for this it was necessary to provide a more powerful transmitter.³ Specifications had therefore been prepared for a new high power transmitter, and also for an improved receiver to replace the large and rather insensitive model which had

¹ A.M. File S.45968.

² A.M. File S.45501.

³ The simple dipole aerial system consisted of radiators only; the structure of metal aircraft was used for directional purposes. No parasitic elements were used. The system gave only broad directional pattern, and therefore low gain.

been made by the firm of Cossors. The Air Council also pointed out that it would take several months before the new equipment could be made available for Service use.

Since September 1938 Headquarters Coastal Command had, on several occasions, asked for A.S.V. to be installed in the new types of aircraft which were in production. This was not possible before the outbreak of war because the design of the essential ancillary equipment such as aerials and power supplies had not been finally decided. Amongst many difficulties, the fitting of radio aerials on aircraft presented a complex problem. In addition to the aerials for A.S.V., aircraft required trailing, fixed, vertical, dipole and loop aerials for W/T and R/T communication, blind approach and direction finding. In so far as A.S.V. was concerned, it had been apparent since August 1938 that the details of an aerial system to suit the operational requirements could only be determined as a result of Service trials. However, it was not until 14 July 1939, when a conference was held at the Air Ministry to review the fitting of A.I.,¹ that a programme was also considered for the installation of A.S.V. in 18 aircraft for Service trials.² By then it had become apparent that, in order to determine details of aerial systems in relation to operational requirements, Service trials were urgently required. Orders for 24 transmitters and 24 combined indicator/receivers to the new specifications were placed with the firms of Metropolitan-Vickers and Pye Radio respectively. Power supply alternators, however, could not be made available for at least three months, whilst the output wave-form of the type of generator required was as yet unknown, and design data for power packs was undefined.

The preoccupation of the small airborne search radar group with the more immediate problems of aircraft interception had frustrated the development of A.S.V. to such an extent that on the eve of war no operational aircraft were fitted with A.S.V. and the equipment was not yet available. The number of scientists engaged on the tasks had been quite inadequate. Before the war very few first class scientists were attracted to work on defence problems owing to the poor conditions of service. Moreover, the establishments of civilian scientists at the R.A.E. and at Bawdsey were relatively far too small for the large volume of outstanding Service research problems in radio and electronics. Although the Royal Society had undertaken the registration and classification of the scientific manpower resources of the country, following the Munich crisis of 1938, large numbers of radio scientists could not be appointed for research and development work until Treasury approval was forthcoming.

Some experience of A.I. had already been gained by its operational users whilst it was in the development stage, and a great deal of thought had been given to its tactical use.³ On the other hand there had been little, if any, opportunity to decide the best way of applying A.S.V. technique to the solution of the tactical problems of Coastal Command, and no specific operational requirements had been formulated. The high degree of secrecy which was

¹ At the beginning of 1939 it was still doubtful whether A.I. was technically possible. Range measurements could be obtained but any form of direction finding seemed beyond solution.

² 6 in Fleet Air Arm, 6 in Coastal Command aircraft and 6 in reconnaissance type aircraft for trials in Australia.

³ No. 25 Squadron. See Royal Air Force Signals History, Volume V: 'Fighter Control and Interception.'

maintained regarding radar developments resulted in few Service officers really understanding its potentialities and being able to make practical proposals for its use. Service trials of A.S.V. were necessary in order to give a lead for further development.

Trials with A.S.V. Mark I against Submarine

During August 1938, when the research group was experimenting with A.S.V. against the smallest possible target, efforts had been made to detect metal posts resembling submarine periscopes. Low power equipment was used, and the range at which detection was possible was then considered to be too small to be practicable, so the tests were discontinued.¹ Immediately war began, the German U-boat fleet was deployed ready to take the offensive, and actually began its hostile activities on 3 September 1939.² Harrying tactics by aircraft on the U-boat lines of passage around the north of Scotland were begun, and on 13 November 1939 Headquarters Coastal Command issued a directive to the effect that action against U-boats was to be regarded as equal in importance to fleet reconnaissance duties.³ At a meeting of the Inter-Service R.D.F. Committee, held by the Assistant Chief of the Air Staff on 19 September 1939, the Admiralty, in agreement with Headquarters Coastal Command, expressed extreme anxiety for the completion of experiments to determine the efficiency of A.S.V. against submarines, and it was decided to hold trials with a Hudson immediately one was fitted with A.S.V. Mark I.⁴

The trials were conducted, not without difficulty,⁵ between 2 and 9 December 1939, off Gosport, against a surfaced submarine which manœuvred in the English Channel whilst the aircraft made range tests from various heights and for different aspects of the target.⁶ Performance could not be assessed accurately, because the submarine was nearly always within a few miles of other shipping thus making it difficult to identify the correct responses. Moreover, it had to be moving continuously, which, in conditions of low cloud, made it very hard to find and caused the angles of approach to be inaccurate. The maximum ranges obtained were $5\frac{1}{2}$ miles at 3,000 feet and $3\frac{1}{2}$ miles at 200 feet. Great difficulty was experienced in separating the echoes from sea-returns, and the important minimum range varied from $4\frac{1}{2}$ miles at 3,000 feet to $\frac{1}{2}$ mile at 200 feet.⁷ Thus the submarine was detected only when it was more than $4\frac{1}{2}$ miles

¹ A.H.B./IIE/187.

² S.S. *Athenia* was sunk off the north-west coast of Ireland.

³ A.H.B. Narrative: 'The R.A.F. in Maritime War.'

⁴ A.H.B./IHK/10/40, R.D.F.—D.D. of Ops. (N.C.). The Admiralty and Headquarters Coastal Command worked in close conjunction on the subject of A.S.V.

⁵ At a meeting attended by the captain of the submarine and the aircraft crew immediately before the trials, detailed methods of conducting the trials were agreed, and a system of recognition and signalling by Verey lights and aircraft identification lights was arranged. At the time and place appointed for the test, an aircraft appeared and the submarine began signalling, but was immediately bombed by the aircraft which was German. The submarine submerged for a while, and when it re-surfaced the Hudson had passed over the area and was searching elsewhere. Eventually an aircraft approached and the submarine again started signalling, this time only to be greeted by a burst of fire from a R.A.F. fighter, which remained in the vicinity of the re-submerged submarine for some time. Ultimately a very suspicious and wary submarine commander made contact with the puzzled crew of the Hudson, and the trials began. (Narrator's interview with Dr. E. G. Bowen.)

⁶ A.M. File S.45501.

⁷ When sea-returns are extensive, a considerable area of the sea in the immediate vicinity of the aircraft is not covered by A.S.V. search. It is within this area that it is important for an aircraft, homing to an attack, to be able to obtain accurate direction and range discriminations.



Echo from H.M.S. *Courageous*, May 1938, range 8 miles

and less than $5\frac{1}{2}$ miles distant from the aircraft at 3,000 feet, and between $3\frac{1}{2}$ miles and $\frac{1}{2}$ mile at 200 feet.¹ The results were disappointing and it was clear that considerable improvement in performance was required to make A.S.V. an effective weapon against U-boats. Nevertheless, the trials were of great value since they indicated the lines along which development should be made. The results were the best to be expected from the equipment itself, and efficiency could be increased only by concentrating and directing the aerial radiation in the form of a beam, as had previously been done in the Anson sideways-looking system of 1938.

¹ A.M. File S.45501.

CHAPTER 2

A.S.V. MARK I AND A.S.V. MARK II

Between December 1937 and August 1939 Coastal Command war plans had been formulated in detail in close conjunction with the Royal Navy. Joint planning and a series of combined exercises had resulted in the operational plans being closely related to naval strategic objectives.¹ The main features of the plans for naval co-operation were: North Sea reconnaissance, anti-submarine patrols and convoy escorts. The North Sea search was to detect fast German commerce raiders attempting to break out on to the Atlantic trade routes.² This involved an elaborate system of routine patrols, and did not envisage the use of A.S.V. The patrol lines were based on a visibility of ten miles, and thus depended on human vision to this range on both sides of the aircraft. The search area was extensive because air reconnaissance was ineffective during the hours of darkness. Moreover, provision had to be included for additional long distance patrols to try to find enemy vessels which might have slipped through the area during periods of bad weather and low visibility. An unfortunate but unavoidable aspect of the plan for searching the North Sea was that the patrols could not be really effective until the reconnaissance squadrons were re-armed with aircraft having adequate range and equipped with A.S.V.³ Large numbers of suitable aircraft were already on order by February 1939, but A.S.V. had not been ordered in quantity pending the results of Service trials of the initial production sets. On 23 August 1939, when the precautionary stage was initiated, Coastal Command squadrons began their reconnaissance patrols and A.S.V. became an immediate necessity.

The Air Ministry decided at once to adopt exceptional measures for the earliest possible improvisation of A.S.V. in a limited number of aircraft. Brief new specifications were quickly drawn up.² Urgent production contracts were made with the firm of Pye Radio for 200 combined A.S.V. receiver indicators based on the design of a standard television receiver, and with that of E. K. Cole for 200 A.S.V. transmitters of the type which had previously been ordered from Metropolitan Vickers and diverted to A.I. Dr. E. G. Bowen and his team of scientists, now considerably increased in number, were first moved from Bawdsey to Perth to avoid possible air attack, but that location was so inconvenient that on 5 November 1939 they moved again, this time to the R.A.F. Station, St. Athan, in S. Wales. Their functions at the station were to make prototype installations for the first available sets of A.S.V. (entitled A.S.V. Mark I) in the Hudson I and in Fleet Air Arm aircraft, to continue the development of A.S.V., and to supervise its installation and servicing with certain assistance from the parent unit, No. 32 Maintenance Unit.⁴ The development projects included a generator to enable aircraft A.S.V. installations

¹ A.H.B. Narrative: 'The R.A.F. in Maritime War.'

² A.M. File S.45968.

³ The new aircraft were to be Hudsons, Beauforts, Bothas, and Sunderlands, to replace Anson, Vildebeests III and IV, and old types of flying boats.

⁴ The Hudson I was the Air Ministry name for the American Lockheed B.14, of which the first batch were delivered to the United Kingdom in February 1939. See A.H.B. Narrative: 'The R.A.F. in Maritime War.'

to be tested on the ground, a wavemeter, test gear for bench testing the equipment before installation, and a special receiver for testing the efficiency of the electrical screening of aircraft.

The urgent operational requirement for A.S.V. raised the question of which types of aircraft were to be fitted and this was discussed at a conference at Headquarters Coastal Command on 31 October 1939.¹ Except for the flying boats, no aircraft had been specially designed for maritime reconnaissance. The projected re-equipment of most of the squadrons in the command with new types of aircraft would be entirely dependent on the rate of delivery of the aircraft from the makers. Under the impact of war, aircraft production might well be spasmodic at times. Each type of aircraft required its own individual installation of A.S.V. to be completed as a prototype for trial and approval. This involved intricate fitting and wiring, the design and provision of special fittings for power supplies and aerials with due consideration of weight distribution and space occupied in the aircraft. There had been no provision for the accommodation of A.S.V. in any of the new aircraft specifications. The dominant point, however, was that the command would have a changing variety of aircraft for many months to come and the maximum use of A.S.V. had to be made throughout this period of transition. Whilst it might be logical for technical and tactical reasons to select one type of aircraft for fitting, and to concentrate on a single specialist development, as had been done with A.I., there was always the possibility that the best aircraft for A.S.V. might not be selected.²

In these circumstances it was decided that A.S.V. was to be installed in Hudson, Sunderland, Botha and Beaufort aircraft, in that order of priority. Aircraft were to be fitted by No. 32 Maintenance Unit, landplanes at St. Athan and flying boats at Pembroke Dock.³ It had also been decided to fit A.S.V. in the Walrus and Swordfish naval aircraft, and close liaison between the Fleet Air Arm representatives and the A.S.V. group ensured that the A.S.V. installation in these types would cause the least possible interference with the existing equipment. The receiver was placed so that the appropriate member of the crew could use it conveniently and the aerial system was arranged to give the radar coverage most suitable for Fleet Air Arm purposes. By November 1939 Headquarters Coastal Command had decided the details of the A.S.V. installation and its performance requirements in the Hudson. Meanwhile the manufacturers had made good progress with the first 200 sets in spite of many war-time difficulties. One of these was the vexed question of priority of materials; ‘. . . when we inform sub-contractors that a matter has urgent priority, they are inclined to laugh and say “yes, so has everything else we are making”. . . .’⁴ The forward-looking search system consisted of simple dipoles which gave range and homing facilities, although the radiation spread sideways sufficiently to cover a limited area on either side of the heading of the aircraft.⁵ The installation was somewhat experimental

¹ A.M. File S.45501.

² A.H.B./IHK/10/40.

³ Prototype installations were also made in a Consolidated PBY and a Stranraer flying boat. The PBY was lost in flight, and Stranraers were replaced in squadrons by Catalinas. The prototype was used as an A.S.V. trainer.

⁴ A.M. File S.45968.

⁵ Receiving aerials consisted of two three-quarter wavelength dipoles placed horizontally, one outboard of each engine parallel to the leading edge of the main plane which acted as a reflector. The transmitter aerials, two quarter-wave rods, were placed on each side of the nose of the aircraft.

since the transmitter was far more powerful than any of its predecessors. The increase in power had been made possible by the use of valves, which became available just before the war began, called 'micropups,' which had a power rating of 5 kilowatts.

It was perhaps surprising that Ansons were left out of the A.S.V. installation programme whilst ten of the Coastal Command total of nineteen squadrons were still equipped with them.¹ Moreover, neither the Beaufort nor the Botha had been brought into Service use and there were as yet only two squadrons of Sunderlands and one of Hudsons in the whole of Coastal Command's forces.² The factors which caused the Air Ministry to omit the Anson were that there were serious technical difficulties which restricted quantity production of the engines used. Its range was inadequate even to patrol across the North Sea to Norway and return, and, also, it was obsolescent and was soon to be replaced although still in demand for flying training. The forward policy proposed for A.S.V. installations aimed at the maximum operational value being derived from the initial deliveries of the equipment.

The Air Officer Commanding-in-Chief, Coastal Command, dangerously short of aircraft, thought that A.S.V. should be installed in the Anson in spite of the difficulties, of which he was well aware. He pointed out that the greater part of the resources of his small command was fully engaged on the routine reconnaissance patrols of the North Sea and this was such a heavy commitment that very few aircraft were available for anti-submarine patrols and convoy protection. Since the latter tasks were mostly performed by Ansons, he considered that the limited number of aircraft would be more effective if they carried A.S.V. He insisted therefore, in spite of the fact that the Ansons would require extensive modification, including the design and production of special screening harness, that A.S.V. was to be fitted in them. Arrangements were being made to that end until the Director of Communication Development emphasised strongly that the tremendous effort involved in fitting Ansons would re-act unfavourably on progress with other more easily fitted aircraft of higher performance. As a result of these representations it was finally decided to install A.S.V. Mark I initially in 12 Hudson aircraft, and to defer the Anson project for a few months. By June 1940, when the re-arming of the Anson squadrons with more modern types of aircraft was imminent, the idea was abandoned. Thus, although the development flights had been made in Ansons, neither they nor any other wooden aircraft used A.S.V. operationally.³

By the middle of January 1940 No. 32 Maintenance Unit had installed A.S.V. Mark I in the first twelve Hudsons which were allotted to:—⁴

No. 224 Squadron, Leuchars	2 aircraft.
No. 233 Squadron, Leuchars	5 aircraft.
No. 220 Squadron, Thornaby	5 aircraft.

Thus in only four months A.S.V. Mark I passed from the design stage to operational use. Some of the components were unreliable, and test gear, spares, and instruction books were not yet available. Methods of adjusting frequency

¹ Coastal Command Battle Order at the outbreak of war is given as Appendix No. 1.

² Delivery of Beauforts was considerably retarded and the Botha was not brought into operational use.

³ Ansons were later fitted with A.S.V. Mark II and employed in training establishments.

⁴ C.C. File C.C./9104/1.

and measuring the power output were arbitrary and approximate because until the summer of 1940 no wavemeters were available. To test the equipment, the aircraft engine had to be run-up because suitable petrol-electric generating sets were not available.

Before its introduction to Service squadrons, the experimental models of A.S.V. had always been operated and serviced entirely by scientists of the research group. The Royal Air Force wireless mechanics who now became responsible for the servicing of the first issues of A.S.V. had not been trained in the principles of radar, and they had considerable difficulty in keeping the sets in operation. The stringent security measures applied to safeguard the secrecy of A.S.V. tended to encourage a belief that it was a highly complicated technique. Unfortunately, it was only possible to instruct crews in its technical and tactical use during the brief periods they spent at No. 32 M.U. whilst their aircraft were being fitted. The limitations of A.S.V. Mark I were realised by its designers, and it was recognised as being purely an interim measure. No Service trials had been held and exact knowledge of its shortcomings were not known. The Command Operational Research Section was not yet in existence, and there was no organisation to ensure that the research scientists were kept informed regarding its performance. The Director of Signals therefore arranged that squadrons should make monthly reports, which were to include details of modifications proposed to remedy minor defects with suggestions and criticisms calculated to improve the efficiency of A.S.V.¹ The responsibility for the successful use of A.S.V. and for overcoming its unpopularity amongst aircrew devolved largely on to the squadron signals officers who were being trained as radar specialists. Their experience and initiative were of great value when the design of A.S.V. Mark II came to be considered. Servicing and training were their main problems, and to assist them civilian technical officers were attached to squadrons as circumstances permitted.²

A.S.V. Mark I was, for some time, treated as an experimental device, and was employed mostly as an aid in the performance of the normal duties. In the early days, its two main uses were as an aid in making rendezvous with convoys which were frequently not in their estimated position, and as a warning of approaching coastline. Although it was used on anti-shiping and anti-submarine patrols its first main function was for navigational assistance.³ The consequent development of its use on reconnaissance and convoy escort duties is shown in extracts from squadron reports made at the end of February 1940 :—¹

Reconnaissance. A.S.V. is of great assistance in reconnaissance at night and in bad visibility. The detection of landfall is extremely helpful, but because of the presence of strong coastal echoes, coastal shipping reconnaissance presents great difficulties. The radius of search ahead and laterally is extended to a distance dependent on the size and aspect of the surface vessel.

¹ A.M. File S.3843.

² On some squadrons A.S.V. Mark I had to be introduced without instruction books, test gear or trained mechanics. Failures, especially in view of its lack of robustness and the fragility of the acorn valves, were consequently numerous, and aircrew inevitably became prejudiced against it as an unserviceable 'magic box' of little use.

³ On 19 November 1940 a Sunderland located a U-boat at a range of five miles with A.S.V. Mark I.

Convoy Escort. A.S.V. has enabled contact to be made with convoys at night and in extremely poor visibility. On two occasions contact was established in complete darkness, at distances of 12 and 20 miles, and on one occasion when visibility was only 500 yards, at a distance of 12 miles.

Attack. When the cloud base is below 1,500 feet an approach from any desired direction can be made to a ship which is otherwise invisible from the aircraft. Thus an element of surprise could be obtained by a diving attack from the clouds, emerging at the last stage at very close range.

The only aircraft other than the Hudsons to be fitted with A.S.V. at the beginning of 1940 was the Sunderland prototype in service with No. 210 Squadron. The captain's report of a convoy patrol flown in this aircraft, during February 1940, gives a good illustration of the value of A.S.V. at that time.¹ The patrol was typical, since the height at which it was flown was dictated by the weather and not by the capabilities of A.S.V. Pilots were not briefed to fly at the heights at which A.S.V. was most efficient, since there was not yet enough experience of its performance and accuracy or belief in its efficacy.

'The convoy's position was about 80 miles west of the Scillies. 10/10 nimbostratus cloud with base about 400 feet, and continuous rain, forced the aircraft to fly at a height of 300 feet above the water.

Visibility was about 500 yards. The given position was reached at 0840 hours, and search for the convoy begun. As the visibility was so bad, I decided to ascend to 1,500 feet in cloud to increase the range of the A.S.V. and fly down the track of the convoy in order to locate it. At 0857 hours the A.S.V. operator reported a contact to starboard, and contact was made on the front beam at a range of 12 miles. By slight alterations of course to keep the contact in the centre of the beam, and at the same time losing height till the surface of the sea became visible, part of the convoy was observed at about 500 yards distance at 0930 hours. Whilst approaching in this way, the A.S.V. operator reported that he could pick up 5 vessels at first, and gradually the number of vessels increased. The actual composition of the convoy was 10 merchant vessels and 2 destroyers spaced at large intervals.

The normal anti-submarine patrols were carried out in front of the convoy, each lasting 48 minutes. On the last leg back to the convoy the A.S.V. detected the ships and gave us their bearing 4 minutes before they could be seen, that is, at a range of about 6 miles. This decrease in range was due to :—

- (a) Height of aircraft now only 300 feet.
- (b) Ships were bow on, and did not give a good contact as in the first instance, when the approach was made from the beam.

On return to base, land was detected at a range of 10 miles from 400 feet. The point worthy of note is that although visibility by eye was only about 500 yards, it was still possible to carry out an anti-submarine patrol in front of the convoy because the A.S.V. equipment virtually increased the visibility distance by its range.'

¹ A.M. File S.3843.

When the Admiralty brought the convoy system into effect shortly after war began, the air staff officers of Coastal Command were continually devising and trying out methods of patrol and search to make sorties more effective and to economise in the number of aircraft used. The introduction of A.S.V. and the growth of confidence in its capabilities helped to simplify their problems.

The Background of Events

Coastal Command reports submitted to the Air Ministry between March and October 1940 show the growing operational value of A.S.V. to be '... one of the few bright prospects in the maritime war ...' during the period.¹ The German occupation of the Low Countries, France, Denmark and Norway, had entirely changed the complex pattern of the naval war and had a profound effect on Coastal Command's operational policy. Its reconnaissance responsibilities and commitments were extended over the entire coastline from the north of Norway to the Franco-Spanish border. Now the command had to anticipate fighter opposition to patrols as the enemy exploited his advantages and developed fighter and radar defences for his new-found naval bases. During the summer months of 1940 shipping losses due to sinkings by U-boats had risen to most alarming figures.² Also, in the course of the first year of the war, on several occasions major enemy naval units had penetrated into the Atlantic and returned to their North Sea bases undetected. They were able to evade reconnaissance patrols by skilfully taking advantage of darkness and bad weather and because the number of long-range aircraft fitted with A.S.V. was totally inadequate to watch the surface raiders in port or to make certain of their interception when they put to sea. When the British occupied Iceland in May 1940, and thereby gained a valuable strategical base, there were further demands on the limited resources of Coastal Command.

The standard routine reconnaissance patrols of the North Sea, which had not been very successful, were discontinued in May 1940 and replaced by a new system of detailed patrols. These were subsequently altered and extended as required to detect shipping and to cover the German preparations for the invasion of England which was planned for September 1940.² The most important patrols, and those which had to be made at night and in bad weather as anti-invasion measures, could only be flown by A.S.V. aircraft. The grave situation which had developed in the war at sea was soon to be followed, in September 1940, by the night bombing of London and other cities, whilst night fighters were as yet unable to intervene effectively since only a relatively small number had been fitted with A.I. During the grim days of the year 1940, neither A.S.V. nor A.I. was yet fully developed; the main effort with radar development and production had been devoted to the raid reporting system.

Throughout the year the ever-increasing requirements of the Services and the G.P.O. for communications and radar equipment greatly exceeded the manufacturing capabilities of the radio industry, although it was switched to war production and was backed up by a scheme making reserved occupations for civilian technicians. At first only a small proportion of the demands for

¹ See Appendix No. 2 for extracts from reports.

² A.H.B. Narrative: 'The R.A.F. in Maritime War.'

defence could be met at short notice and by the specified target dates for deliveries. The production of technical equipment for ground and airborne radar, and many other new radio devices of intricate design and construction, involved elaborate manufacturing processes.¹ Mass production called for a vast expansion of the industry and the training of thousands of new employees. Conflicting requirements were bound to arise and these were eventually settled by the allocation of priorities. Although A.S.V. suffered reverses in the field of priorities it was kept under active development, and by December 1940 25 Sunderlands and 24 Hudsons had been equipped with A.S.V. Mark I.

Development of A.S.V. Mark II

As soon as A.S.V. Mark I had been launched into operational use plans were made for the development and production of properly engineered equipment, A.S.V. Mark II. During January and February 1940 the technical design of A.S.V. Mark II was considered at a series of conferences. Early experience with A.S.V. Mark I in the squadrons had soon revealed its main mechanical and technical faults. It was not robust enough for Service use and it was difficult to maintain because many of its components were not conveniently accessible. In operation it had not proved to be entirely satisfactory owing to failures of certain components and excessive interference in the communications receiver which was mostly caused by the harmonics radiated by the A.S.V. transmitter. This prevented the keeping of a continuous listening watch, an essential requirement on patrol.² In the new A.S.V. Mark II there would be an opportunity to eliminate these shortcomings and to rectify other faults which had been brought to light in the squadrons' A.S.V. reports.

The different shapes and sizes of the various units of Mark I equipment caused installation difficulties, but these could easily be rectified by making the boxes and cables to standard sizes thus enabling aircraft contractors to make provision in advance for installations. This was important, because airborne radar was still widely regarded as a vague promise rather than as a positive accomplishment. Its designers and sponsors would be more likely to get what they wanted if they could put in for definite requirements when bids for space in aircraft were made in competition with the long-established claims for items such as guns, bombs, cameras and communications equipment. The Royal Aircraft Establishment undertook to compile a schedule of standard dimensions for A.S.V. units, plugs, sockets and cables. A.S.V. Mark I cathode ray tube circuits had been unsatisfactory under operational conditions, and the indicating unit was now required to be separate from the receiver. Arrangements were also made for the provision and connection of a second indicating unit if it should subsequently become necessary. Range scales were to be such that the whole length of trace on the cathode ray tube could be made to represent 10, 40 or 100 miles by the operation of a selector switch. The new transmitter was

¹ 'Radio' implies the use of electro-magnetic waves for wireless and radar purposes.

² Experience showed that it was necessary to use W/T filters with A.S.V. Mark II to allow normal communications to be continued when A.S.V. was switched on. They were ultimately designed and produced by the Royal Aircraft Establishment in forms suitable for the various types of W/T and R/T equipment used, and basically, consisted of an acceptor circuit shunted across the input of the wireless receiver in order to bypass A.S.V. signals. (A.M. File S.6425.)

to incorporate its own power supplies and to generate 7 kilowatts at peak power. A.S.V. Mark I on 214 megacycles per second was reported by the Admiralty to be causing serious interference with the reception of naval rotating beacons, and a frequency of 176 megacycles per second was selected for the new equipment.¹ The design of aerial systems, which were still in the experimental stage, required further development by the Royal Aircraft Establishment.²

The A.S.V. contracting firms, E. K. Cole for transmitters, and Pye Radio for receivers, were asked in February 1940 to undertake the development and production of equipment on the lines of the new specifications. They estimated that development models of the new transmitter would be completed in 3 to 4 months, and of receivers and indicators in 4 to 6 months. On the basis of a bulk order for 4,000, delivery of production sets of equipment could begin on 1 August 1940. As far as could be foreseen, installation of all A.S.V. Mark I equipment then on order would be completed at about the same time as delivery of A.S.V. Mark II began, so the decision was made to stop production of Mark I when the original contract expired. The programme for fitting A.S.V. Mark I, and developing, producing and introducing A.S.V. Mark II, therefore appeared to be straightforward, but the delays in completing the staff work, and the events of the next few months, made it quite impossible to follow the plan.

The estimates made by E. K. Cole and Pye Radio were very ambitious for a project involving such a wide range of design and development work. By the beginning of April, however, good progress had been made by both firms, working on a basis of good will and co-operation. Unfortunately the importance of A.S.V. was not generally realised and adequately emphasised and because of departmental delays during the processes of framing purchasing specifications and obtaining financial approval, the firms had received neither contracts nor official instructions to proceed. Thus the development engineers were working without the proper documents and authority, and consequently the firms were unable to obtain priority materials or to order fabricated items and components from their sub-contractors. In their uncertainty the firms were unable to see their way to purchase or reserve materials and the special plant and tools required for production.³ During April, formal action was taken to place contracts and to establish the companies' confidence. At the beginning of June, production was begun and new delivery dates were soon calculated. Progress with A.S.V. was then hampered once again by a sudden demand for priority production of A.I. equipment. This was the result of a decision of the Night Interception Committee that precedence over A.S.V. was to be given to A.I. as it was the more urgent requirement.⁴

In order to make the earliest possible improvements in the night fighter defences E. K. Cole were instructed to build 70 A.I. transmitters on the highest priority, and 80 of the available 140 A.S.V. Mark I transmitters were diverted to A.I. This was not the only setback suffered by A.S.V. Pye's were asked to increase their production of C.H.L. ground station radar equipment for improving the early warning system, and Headquarters Fighter Command presented an

¹ A.S.V. used by the Fleet Air Arm remained on 214 megacycles per second.

² A.M. File S.45968.

³ A.M. File S.45968.

⁴ A.M. File S.3984. Minutes of 4th Meeting of Night Interception Committee, 2 May 1940, ' . . . A.I. for 100 Blenheims should take precedence over further A.S.V. fitting as it is a more urgent problem. . . . ' See also Royal Air Force Signals History, Volume V: ' Fighter Control and Interception. '

urgent demand for a large quantity of V.H.F. equipment which was also being made by E. K. Cole. Although the radio industry was rapidly expanding, all of these immediate operational requirements were for the production of highly specialised equipment which only admitted single tender contract action to avoid delay. The defence of the home front against bombing had to come first and the limited production capacity of the firms engaged on A.S.V. was overtaxed. The inevitable result was a serious delay in A.S.V. manufacture and this was further aggravated by bomb damage to some of the factories concerned.

By the middle of October 140 A.S.V. transmitters, 45 receivers and 80 indicating units had been delivered to the Service.¹ This was far less than the numbers forecast originally but nevertheless it was a creditable achievement. Thereafter, production increased rapidly, and before the end of March 1941 over 2,000 transmitters and 1,000 receivers and indicators had been delivered to the Royal Air Force. Unfortunately both firms worked independently, on entirely different technical lines, to achieve the same ends, although they were both subject to co-ordination by a representative of the Royal Aircraft Establishment. During the drawn-out process of development and production, the circuits of the original models were altered in order to take advantage of improvements in cathode ray tube design. Subsequently, complications arose because indicators made by the one firm would not work in conjunction with receivers made by the other until suitable modifications were incorporated.²

A.S.V. Mark II was the first light-weight radar set to be properly engineered and produced in large numbers and was soon in great demand for many applications other than A.S.V. ; component parts were used on ships of the Royal Navy, in searchlight control and in homing beacon equipment for parachute troops. There was no comparable development in the United States of America at the time and it was the first A.S.V. equipment to be installed in American aircraft. Later, identical equipment was manufactured on a very wide scale in the U.S.A. and Canada.³

¹ A.M. File S.4919.

² M.A.P. File S.B. 8740, Part II. Pye Indicator Type 6 was modified by reversing receiver signal output leads and restoration diodes in indicator.

³ American sets A.S.E. and S.C.R. 521 (A.S.V. Mark IIB).

CHAPTER 3

DEVELOPMENT OF LONG-RANGE A.S.V.

After informal discussions with Mr. R. A. Watson-Watt and officers of Headquarters Coastal Command, Dr. E. G. Bowen submitted his proposals for the development of a long range A.S.V. system to the Superintendent of the Air Ministry Research Establishment on 6 February 1940.¹ The choice lay between Sterba and Yagi broadside arrays designed to give maximum lobes of radiation at right angles to the line of flight. Sterba arrays were selected because they were more convenient from a radio engineering point of view and more acceptable aerodynamically.² Even so, the arrays proposed were too large to be fitted to the smaller types of reconnaissance aircraft such as the Hudson; a Sunderland or Whitley would be required for the experiments. Headquarters Coastal Command considered that the larger type of aircraft with its greater endurance could then be used specifically for making anti-U-boat sweeps over large areas as distinct from the normal routine use of A.S.V. Thus it became the original intention to equip only a few aircraft for specialist anti-U-boat purposes. The requirement was for detection only; at that time, reconnaissance aircraft were required to signal enemy sighting reports to their appropriate Area Combined Operations Room in order that a surface striking force might be detailed to locate the U-boat by asdic, and to sink it. Accurate bombing of U-boats by aircraft was considered impracticable with the anti-submarine bombs available at the outbreak of war, and Headquarters Coastal Command was pressing for the supply of effective depth-charges.³ Aircraft were usually seen or heard by the submarine crew before the vessel was actually sighted by the aircraft and this gave U-boats the opportunity to 'crash dive' and so to evade attack. Accurate bombing of U-boats at night was not possible because aircraft altimeters giving reliable readings below 500 feet were not yet available.⁴

The Superintendent of A.M.R.E., Mr. A. P. Rowe, approved the proposals for the long range A.S.V. anti-U-boat aircraft.¹ He considered that once a U-boat had been detected at long range ordinary navigational methods would enable the aircraft to be flown within a mile or two of its position but the addition of a forward looking system to enable homing to be made more accurately would be of great value, particularly at night. In his opinion, it was important to link up A.S.V. with the operational need to bomb the U-boat as soon as it had been located. Within a few months the importance of these

¹ M.A.P. File S.B. 8740.

² To produce a narrow beam of radiation with metric A.S.V. a large aerial system was required. For the wavelength of A.S.V. Mark I an aerial of approximately 20 feet was required to produce a beam of 12 degrees.

³ See Volume I R.A.F. Armament History: 'Bombs and Bombing Equipment.' The under-water path of the bombs was unpredictable, particularly when released from low altitudes, and the lethal range was small.

⁴ A list of items on which research was required to improve existing applications of airborne radar was compiled on 17 October 1939, and included the use of A.S.V. for bombing submarines and ships. (B.R.S./4/4/200.)

statements was to be proved by bitter experience. The opinion generally held was that there was little or no need for homing aerials since the range of the forward-looking system was much less than that of the sideways-looking system and a certain amount of dead-reckoning navigation would always be required until the target was within range.¹ It was doubted whether much greater accuracy could be achieved with A.S.V. homing until aircraft could be flown accurately at night and in poor visibility at heights of about 100 feet above the sea.

On 14 November 1939 the Air Council, well aware of the increasing importance of radio in the wartime activities of the Royal Air Force, had appointed Air Marshal Sir Philip Joubert de la Ferte to the newly-created post of Assistant Chief of the Air Staff (Radio). He was to be responsible for² :—

- (a) Co-ordinating all aspects of radar which were the direct responsibility of the Air Ministry.
- (b) Ensuring that action was taken with the utmost despatch to remedy any deficiencies of equipment and personnel.
- (c) Advising the Director of Signals on radar organisation and training.
- (d) Advising the Director of Communications Development on developments of radar to meet the needs of the Royal Air Force.

As soon as he was made aware of the new project, the A.C.A.S. (R) gave orders for long range A.S.V. experiments to begin immediately. In March 1940 a Whitley aircraft, chosen because its flat fuselage surfaces were suitable for the type of aerial to be used, was sent to No. 32 Maintenance Unit, St. Athan. If the experiments were successful the A.C.A.S. (R) intended that the equipment should be transferred in a suitable form to a Sunderland for Service trials, and eventually fitted to standard maritime reconnaissance aircraft. It was planned that the Whitley prototype should be fitted with both ordinary and long range A.S.V. so that sufficient experience and technical knowledge of both installations would result in the development of a single technique.¹ The experiments were to be made, under the supervision of Mr. R. Hanbury Brown, with the utmost despatch, and it was anticipated that they would take about one month to complete.³

Progress was delayed by changes in the location of the experiments. At the outbreak of war, the normal research functions of the Air Ministry Research Establishment were increased by the addition of responsibility for development and production of airborne radar. As a purely research establishment, it had been staffed mainly by scientists and did not require the engineering staff and facilities necessary for development on a large scale. Scientists, although proficient at designing and building experimental models, were not so adept at constructing sets which could be readily produced and easily maintained. The nucleus of the group working on A.S.V. at St. Athan had extensive and unique experience of the experimental and research stages of airborne radar development, but they were of necessity being employed on the routine duties of installation, training and servicing.⁴ Moreover, although the organisator

¹ A.M. File S.4363.

² C.C. File C.C./S.9108.

³ A.M. File S.45501.

⁴ B.R.S. File B.R.S./4/38/10. 5 January 1940.

of No. 32 Maintenance Unit was easily adapted to accept an extensive aircraft fitting programme, it was not suitable for the early development of experimental equipment.

The sequence of research, development, installation, trials, training, servicing and maintenance was not being carried through efficiently, and this was made clear in Dr. Bowen's progress report for January 1940. It had not been possible to continue research to its proper conclusions, real development was non-existent, installation was hurried, training of personnel was sketchy, and little or no provision was made for maintenance.¹ A.S.V. was being rushed into production before arrangements were made for training and before an organisation had been devised for the servicing and maintenance of the equipment in the squadrons, although it was already apparent that A.S.V. was indispensable.

In April, the responsibility for development of A.S.V. projects, including long range A.S.V., was transferred to the Royal Aircraft Establishment from the Air Ministry Research Establishment,² whilst the latter remained responsible for A.S.V. research. Mr. R. Hanbury Brown, and his assistant research scientists working on L.R.A.S.V. development, were attached to the R.A.E. and continued their experiments at Christchurch. At the time of the transfer, the Whitley had been fitted with generators and a modified A.S.V. Mark I transmitter. Modification of an A.S.V. Mark I receiver, the provision of two separate cathode ray tubes with linear time bases, and the detailed designs of the aerial arrays were almost complete.

The period of reorganisation, with its consequent moves of staff and equipment, incurred inevitable delays, and it was not until July 1940 that the Whitley L.R.A.S.V. prototype was ready for flight trials against submarines and shipping. Ranges obtained against the former, from various heights, were :—³

<i>Height of Aircraft.</i>	<i>Aspect of Submarine.</i>	<i>Maximum Range.</i>	<i>Minimum Range.</i>
500 feet	Broadside	10 miles	2½ miles
1,000 feet	Broadside	10 miles	2½-3 miles
1,000 feet	Broadside	15 miles	2½-3 miles
2,000 feet	Broadside	20 miles	4-5 miles
1,000 feet	Bows on	7 miles	2½-3 miles
1,500 feet	Bows on	10 miles	not recorded
2,000 feet	Bows on	12 miles	not recorded.

Small ships were detected at distances of 35 miles from a height of 3,000 feet ; rocky coastline was seen from ranges up to 100 miles and flat coastline up to 30 miles from heights above 1,500 feet. Although the results were not quite so good as was originally estimated, they were a great improvement on those obtained previously.⁴

¹ A.M. File S.45501.

² A.M.R.E. became the Telecommunication Research Establishment in May 1940.

³ M.A.P. File S.B. 8740.

⁴ The figures obtained by the Service for average contact ranges were usually lower than those obtained during trials, because all targets were not picked up at the extreme tip of the beam. Other factors were the lower standard of servicing under active service conditions, and fatigue of the operator ; the need for intense concentration was great since during a patrol of many hours duration, the contacts infrequently obtained lasted only 25 to 30 seconds.

The news of the success of the trials was received with enthusiasm by both the Admiralty and Coastal Command. With the fall of France in May 1940 the German Navy and Air Force had obtained the valuable strategical advantage of bases in western France on the flank of our vital stream of seaborne supplies. British shipping consequently abandoned the Southern Approaches from the Atlantic Ocean and was forced to use the North-Western Approaches. By the middle of July this was the main convoy route by which seaborne supplies were brought to Great Britain. The U-boats then concentrated their attacks in the area off the north-west coast of Ireland, and a new phase of U-boat warfare in the Atlantic began. Meanwhile, the threat of invasion had become very real. The gravity of the situation was intensified by the increasing successes of the U-boats. Coastal Command was anxious to seize on to any device which would help to track down and destroy enemy submarines.¹ Various magnetic detection systems were considered and some were tried, but the best chance of success was seen to be in the maximum possible application of A.S.V. against U-boats. Representatives of the Admiralty, Coastal Command and T.R.E. reviewed the developments at a conference on 9 September 1940. After the first trials, long range A.S.V. was immediately recognised as an urgent operational requirement. Unfortunately, the needs of the situation were so pressing that L.R.A.S.V. had to be rushed into service on a makeshift basis, with the result that its ultimate development as an efficient anti-U-boat weapon was delayed.

Installation of L.R.A.S.V. in Whitley Aircraft

The type of aircraft in which the equipment was to be installed presented the first problem. The aerial arrays had proved to be less bulky than was at first envisaged, and a large aircraft was no longer technically necessary. An aircraft of long endurance was, however, operationally preferable.² The Whitley, designed for employment as a heavy bomber, was not necessarily the best type of aircraft for anti-U-boat operations. But precious time would, it seemed, be saved if the Whitleys were chosen because the development and fitting of arrays to standard reconnaissance aircraft, such as the Sunderland and Hudson, involved a delay of at least two months and this was unacceptable. As with the initial A.S.V. Mark I fitting programme, the pressure of events at the time was too strong to allow a cautious approach to the problem. A flight of 5 Whitleys had to be fitted for immediate use on special anti-U-boat operations to fill the time-gap until L.R.A.S.V. could be installed in standard reconnaissance aircraft.

By the end of July 1940 the great advantage conferred on L.R.A.S.V. by the addition of forward-looking arrays was becoming increasingly apparent as it was appreciated that accurate homing to a U-boat was essential. In the absence of A.S.V. homing it was the practice to turn the aircraft through the requisite 90 degrees when a target was located on the beam, and to fly towards it on dead-reckoning navigation. The wide turning radius of the Whitley, the effect of wind on aircraft tracks, the movements of the target, and the very fleeting nature of the contacts obtained by L.R.A.S.V., made this technique inaccurate and almost impracticable. The fitting of forward-looking arrays, however, threatened to delay the introduction of L.R.A.S.V. by at least one or two months; it entailed not only the making and

¹ M.A.P. File S.B. 8740.

² A.M. File S.4363.

fitting of the aerials, but also the means for switching over from the search to the homing system and vice-versa.¹ Our shipping losses were then increasing at such an alarming rate that even small delays could not be entertained, and homing aerials and changeover switches were not therefore included as immediate requirements for the Whitley flight.

The A.S.V. equipment installed in the L.R.A.S.V. prototype was a modified form of A.S.V. Mark I and production of this equipment had stopped when the initial delivery of 200 sets was completed. Of these, 80 had been diverted for use as A.I., and the remainder were being used by squadrons.² To obtain only the 10 sets required to fit and maintain 5 Whitleys would have been difficult enough, but there was the probability that large numbers of L.R.A.S.V. aircraft would be required at short notice if the system fulfilled its promise of success. The immediate plan for fitting the first five Whitleys with L.R.A.S.V. therefore had to be adaptable for expansion. Three methods were considered:—

- (a) Recover sufficient Mark I equipment from the squadrons of Coastal Command.
- (b) Re-design and develop L.R.A.S.V. aerial systems to operate on the A.S.V. Mark II frequency of 176 megacycles per second.
- (c) Modify Mark II equipment to operate on the Mark I frequency of 214 megacycles per second for which the arrays had been designed.

Not only was Mark I equipment difficult to obtain in any quantity, but for use as L.R.A.S.V. it required considerable modification. Mark II equipment, just beginning to leave the production lines and soon likely to be available in large numbers, could readily be converted to operate on 214 megacycles per second. The continued use of this frequency was admitted to be undesirable and agreement to abandon its use by 1 January 1941 had been reached with the Admiralty in February 1940, but the T.R.E. estimated that the development of a long range aerial system for the Mark II frequency would take at least one month.¹ Admiralty pressure for the immediate introduction of L.R.A.S.V. on the highest priority influenced the decision, made in September 1940, to regard the time factor as all-important. A.S.V. Mark II equipment, modified to operate on 214 megacycles per second, was to be used for L.R.A.S.V. In addition, in order to provide for future requirements, the T.R.E. and R.A.E. were instructed to develop as soon as possible a long range aerial system, of the best aerodynamic design, for the correct Mark II frequency (176 megacycles per second), a forward looking homing system to be used in conjunction with L.R.A.S.V. and a high frequency switch to enable both the long range and homing systems to be used at the same time. This new version of L.R.A.S.V. adapted from A.S.V. Mark II equipment was to be suitable for installation in Hudson and Sunderland aircraft.

The task of modifying A.S.V. Mark II was allotted to the Royal Aircraft Establishment, and No. 32 Maintenance Unit was made responsible for manufacturing and fitting the aerial arrays and also for the installation of the equipment. On 7 August 1940, A.C.A.S. (R) had made arrangements for the immediate delivery to No. 32 M.U. of 5 Whitleys. At the request of the A.O.C.-in-C. Coastal Command these were to form a special L.R.A.S.V. Flight of

¹ A.M. File S.4363.

² M.A.P. File S.B. 8740.

No. 502 Squadron. This squadron, based at Aldergrove in Northern Ireland, was equipped with Ansons, but was due to be re-armed with another twin-engined type of aircraft, the Botha, which, however, never reached the operational squadrons.¹

The experimental L.R.A.S.V. prototype Whitley arrived at St. Athan on 17 August 1940; its arrays and instrument lay-out were to be copied, and manufacture of the necessary parts was put in hand.² The other Whitleys arrived five days later, and several unforeseen difficulties soon became apparent. The aircraft were not of the same Mark as the prototype and revision of the layout was essential. For the experiments and trials the prototype had been fitted with arrays on the starboard side only, and it had been envisaged that similar arrays could quite simply be fitted to the port side. In fact, the arrays were not interchangeable; the position of the aircraft entrance door made it necessary to design and construct an entirely different port side aerial array. To add to the task, the original programme of fitting only 5 Whitleys was increased almost immediately.³

From March until June 1940, U-boats had been sinking an average of nearly 50,000 tons of merchant shipping per month. During June, July and August sinkings had mounted to 250,000 tons per month. The need for a large number of aircraft equipped with an A.S.V. system more effective than Mark I as installed in Hudsons, became very evident.⁴

By the end of August 1940 the number of operational aircraft to be fitted with L.R.A.S.V. had been increased from 5 to 42; Nos. 502 and 612 Squadrons were to be completely re-armed with L.R.A.S.V. Whitleys. The decision not only made the programme more comprehensive but more complicated. The first job of the two squadrons was to concentrate on the flying training made necessary by changing their type of aircraft. Although working on 24-hour shifts, No. 32 M.U. could fit only as many aircraft as were delivered to them. The requirements of L.R.A.S.V. fitting were not allowed to interfere with flying training. That, combined with bad weather and a lack of pilots capable of flying in such conditions, considerably limited the number of aircraft received at the maintenance unit. To make the necessary structural modifications, fit aerals and install equipment before aircraft left the production lines was then thought to be impracticable. The number of aircraft affected was comparatively small, and the aircraft firm was not in a position to determine which individual aircraft of its total output of Whitleys would eventually be allotted to L.R.A.S.V. squadrons. Equipment modifications were proving a less complex problem. In September the firm of Pye Radio was called in to assist the R.A.E. with its task; in December this makeshift arrangement was changed and formal contracts were made with Pye's to produce 100 L.R.A.S.V. receivers and with E. K. Cole for a similar number of transmitters.³ Nevertheless, many failures occurred on the test benches and during air tests. In spite of all the efforts of the maintenance unit, the output of completed

¹ In the maritime role the Botha was overloaded and underpowered. It was eventually used in a limited way for navigation and air gunnery training.

² The original Whitley arrays consisted of two centre fed Sterba receiving arrays mounted on each side of the aircraft, using the fuselage as a screen, and a transmitting array of eight half-wave elements mounted on the fuselage on four posts.

³ A.M. File S.4363.

⁴ A.H.B. Narrative: 'The R.A.F. in Maritime War.'

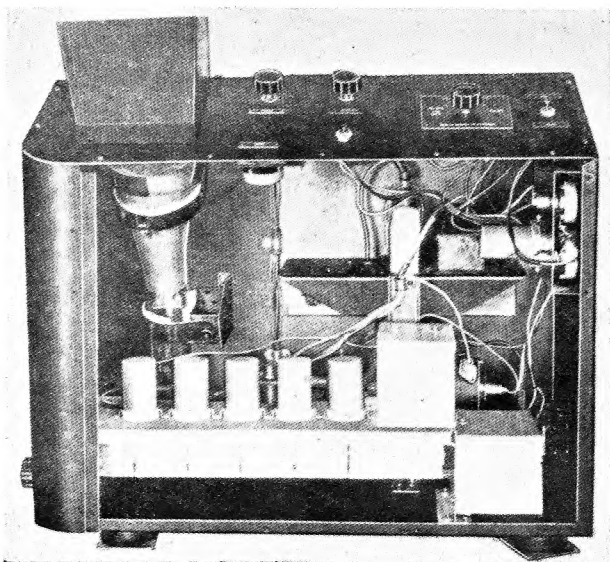

Receiver of A.S.V. Mark I

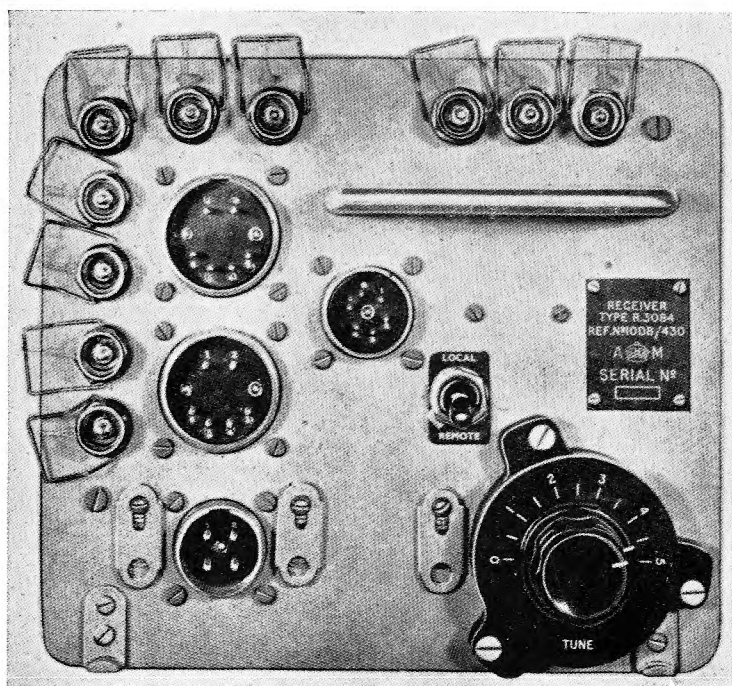

Receiver of A.S.V. Mark II

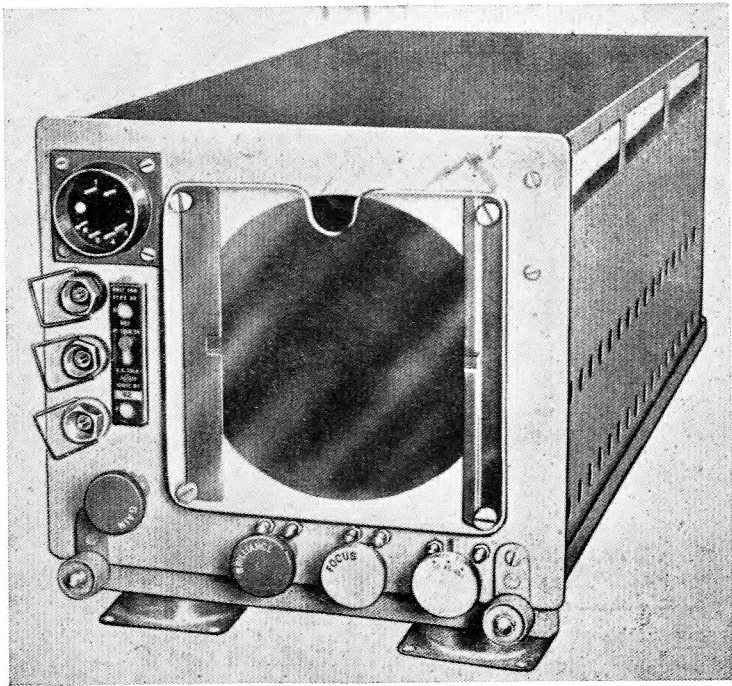

Indicator of A.S.V. Mark II

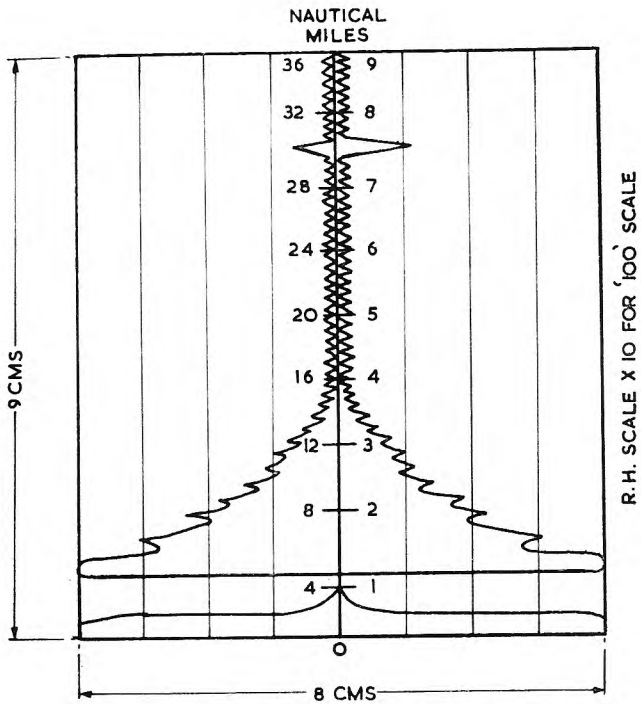

Typical Display on Indicator of A.S.V. Mark II

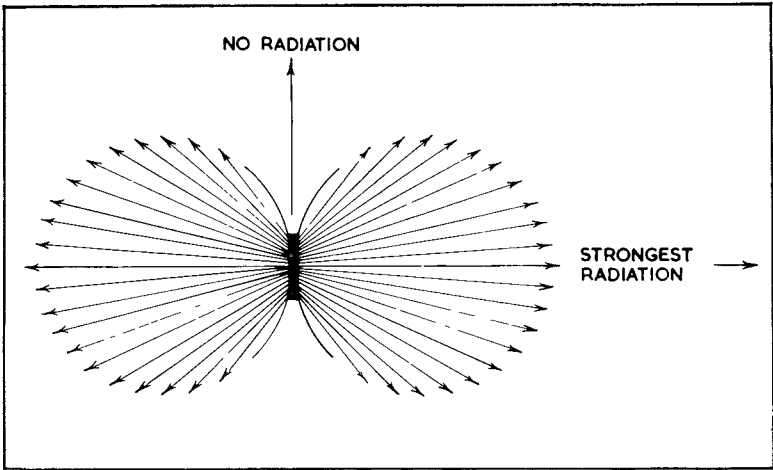

Single Dipole Aerial

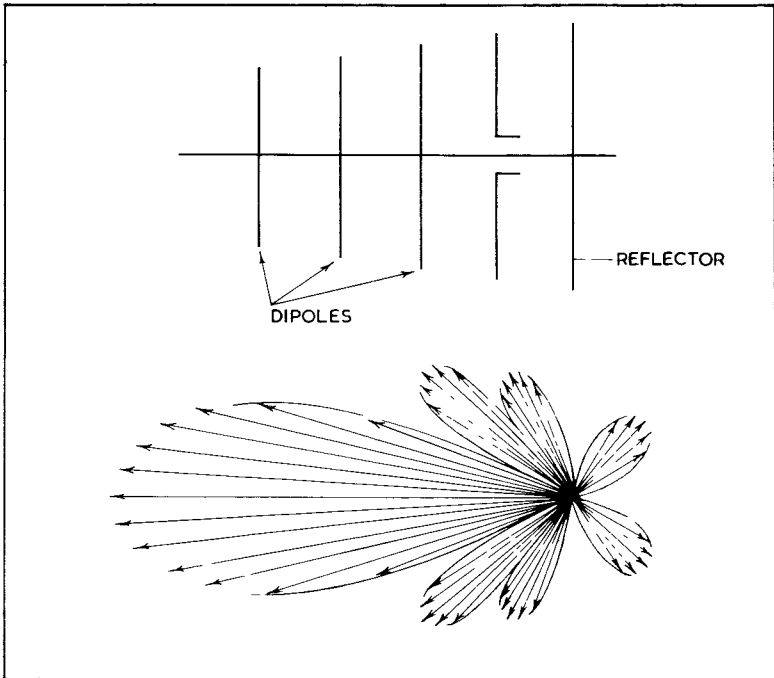

Yagi Array

FIELDS OF RADIATION OF SINGLE DIPOLE AERIAL
AND YAGI ARRAY

L.R.A.S.V. installations in Whitleys was so low that, by the end of the year, the L.R.A.S.V. installation had to be adopted as a standard modification. The aircraft manufacturers were thus made responsible for modifying the aircraft, installing the equipment, and fitting the aerials.¹

Development of Yagi Homing Arrays

Meanwhile difficulties were being encountered in the development of aerial systems for standard A.S.V., and it was found that the A.S.V. Mark I Hudson dipoles were limited in effectiveness and were not suitable for L.R.A.S.V. homing since they suffered from mis-matching and inadequate weather-proofing. The use of the aircraft structure as a reflector imposed limitations on the overall performance and resulted in a low aerial gain and liability to 'squin't.' The need for a more efficient aerial system had been realised at the beginning of 1940 when A.S.V. requirements were discussed and further research on aerial systems had been recommended. The research scientists keenly desired to employ a Yagi system but the Air Staff attitude still echoed the opinion expressed by the A.O.C.-in-C., Coastal Command, in September 1938 when he considered that the Yagi system would be dangerous in an aircraft of high performance, although feasible in an Anson.² This criticism was justified at the time it was made, but it referred to the Yagi broadside arrays which had been employed for a sideways looking system. The difficulty was referred to the A.C.A.S. (R) who, on 13 February 1940, suggested that the Royal Aircraft Establishment be asked to examine the problem and make a very early report.³ At that time many different developments of airborne radar were in being, and the main point at issue apparently became confused with the problem of long range arrays, on which experiments had been re-commenced. The aerial designers wished to develop a Yagi forward-looking system while the L.R.A.S.V. experimenters were seeking an efficient beamed sideways-looking system, and preferred Sterba to Yagi broadside arrays because they caused less drag and presented a more simple engineering problem. The Yagi project was therefore dropped.⁴ Development of a suitable L.R.A.S.V. homing system was thus restricted to improving the efficiency of the existing dipole aerials, mainly by altering their dimensions.⁵ The standard aimed at, in the absence of any detailed specific requirement, was a better general performance than had previously been obtained.² Work on the project was, as with all L.R.A.S.V. development, governed by the need to produce something quickly.

The possibilities of enlarging the role of L.R.A.S.V. aircraft to include homing and attack in addition to detection of U-boats was being discussed by the Admiralty and Headquarters Coastal Command.⁶ In September 1940 the Royal Navy offered to place a submarine at the disposal of Coastal Command for extensive trials immediately A.S.V. homing became available, in order to ascertain the most effective tactics to be used by L.R.A.S.V. aircraft. Early in that month the Whitley L.R.A.S.V. prototype arrived at T.R.E. Christchurch on completion of its being used as a model at No. 32 Maintenance Unit, and by

¹ No. 502 Squadron was not completely fitted with equipment and beam aerials until the beginning of December; by October only six aircraft had been received. Half of No. 612 Squadron was fitted by the end of November. (M.A.P. File S.B. 8740.)

² A.M. File S.45501.

³ M.A.P. File S.B. 8740.

⁴ A.M. File S.45970.

⁵ A.M. File S.4363.

⁶ M.A.P. File S.B. 8740.

the end of the month it was fitted with homing aerials similar to those used on Hudsons but reduced in size. The performance of these smaller aerials was judged to be satisfactory and production of 50 sets of the aerials was confidently begun.¹ On 16 October anti-submarine trials were started, but were soon abandoned because the very limited ranges obtained with the new homing aerials were quite inadequate and usually inaccurate. It was quite clear that all future policy regarding the installation of L.R.A.S.V. depended on the early provision of a satisfactory homing system. Until this had been done the fitting of L.R.A.S.V. was to be confined to aircraft of Nos. 502 and 612 Whitley Squadrons, which would have to make the best possible use of the equipment until an improved version became available.²

The need for reliable and effective A.S.V. was becoming increasingly critical. In October 1940, as part of their general war against British commerce, the Germans began using battle cruisers as raiders in the Atlantic Ocean. They showed skill in taking advantage of bad weather, and, in spite of intensive flying, Coastal Command aircraft were unable to find them. The Inspector General of the R.A.F. after a visit to No. 612 Squadron reported ' . . . they have however only the beam aerials at present, and until they get the forward-looking aerials, they will be gravely handicapped in their work. . . . '³

The T.R.E. was instructed, in October 1940, to begin immediate development, on the highest priority, of a suitable Yagi homing system. Aerials were to be streamlined as much as possible, but, as had been forecast by the A.C.A.S.(R) in February, a slight reduction in aircraft performance could be accepted in view of the operational advantages to be gained.

By the end of November, the Whitley L.R.A.S.V. prototype was equipped with Yagi homing arrays, and was sent to the Aeroplane and Armament Experimental Establishment at Boscombe Down for handling trials.⁴ An appreciable loss of speed, a heavy nose down tendency during dives, and unsatisfactory lateral control at low speeds were expected. A. & A.E.E. reported however that control and handling were not adversely affected by the addition of the aerials, and the loss of full-throttle speed amounted to no more than 7 or 8 miles per hour.

A few days after the completion of the handling trials, tests were made against a submarine when the ranges obtained were:—³

Submarine at full buoyancy	15 miles abeam 12 miles ahead
Submarine trimmed to conning tower	8 miles abeam
Minimum ranges	$\frac{1}{8}$ to $\frac{1}{4}$ mile

¹ M.A.P. File S.B. 8740.

² The psychological prejudice invariably encountered with the introduction of a new technical device was present in Nos. 502 and 612 Squadrons. The first successful use of an A.S.V. beacon did much to stimulate aircrew interest in A.S.V. as a worth-while anti-U-boat equipment. See Royal Air Force Signals History, Volume III, ' Aircraft Radio,' for the development of A.S.V. beacons.

³ A.M. File S.4363.

⁴ The Yagi array consisted of:—

Transmitting aerials. Horizontal array of 2 directors and 1 reflector underneath nose.

Receiving aerials. Two horizontal arrays, one on each wing, with axes raked out at 20° (later 17½°) to line of flight.

Yagi homing aerials were immediately made an operational requirement of the highest priority for all L.R.A.S.V. aircraft, and this added further complications to the development of L.R.A.S.V. which had already been in progress for nearly a year. The subsequent stages in the attainment of full efficiency were to be by no means straightforward. The aerials used successfully in the trials were experimental models and far from finished products; re-design and final aerodynamic clearance were essential before the manufacture of properly designed and approved aerials could be started. Structural alterations to the aircraft, to improve stressing at aerial fixing points, and new 'homing to long range' change-over switches were still required.

It was not until 30 December 1940, which was two days after L.R.A.S.V. had been recommended by the Aircraft Equipment Committee as an official modification, that the firm of Armstrong-Whitworth was given instructions to prepare modifications for:—

(a) Installation of Yagi homing aerials and manufacture of 100 sets of the modification parts required, and

(b) Installation of L.R.A.S.V. equipment and beam aerial arrays.¹

The modifications, when prepared, were to be submitted to the Airframe Modifications Committee for approval. Work on the modifications was to be given precedence over all other modifications being handled by the firm, and the first aircraft was expected to be ready by the end of January 1941. Unfortunately, however, there were further causes for delay. The original drawings, made in great haste, contained errors, and the contractors found it impossible to allot the high priority demanded because '... nearly everything is first class priority, and production of airframes will suffer if there is a diversion of effort to making these parts. ...' Also, the materials with which to make the parts were in very short supply.²

At the beginning of February 1941, the Air Officer Commanding-in-Chief Coastal Command, at whose request No. 612 Squadron was being given homing aerials before No. 502 Squadron, complained that the fitting of the first aircraft with this all-important part of L.R.A.S.V. would not be completed before 6 February and that unless the existing arrangements were changed for the better, three months would pass before No. 612 Squadron was completed and No. 502 Squadron begun.³ He had decided on No. 612 Squadron being first to be fitted with homing aerials because No. 502 Squadron was shortly to be re-equipped with Wellingtons.

On 6 March, the Prime Minister, appreciating that a vigorous Spring offensive by U-boats would be opened as soon as the weather improved, called for very special measures to be taken against them, and issued the Battle of the Atlantic directive. In it he demanded that for the following four months top priority in the war effort was to be given to operations against U-boats at sea, in harbour and in building yards.² Interest in the production of effective A.S.V. was immediately intensified. On 16 March the Chief of the Air Staff expressed to the A.C.A.S. (R) his dismay at the tardiness shown in the provision of homing aerials for L.R.A.S.V. aircraft, stating '... I need hardly say that everything connected with the protection of trade is now in

¹ M.A.P. File S.B. 8740.

² A.M. File S.6425.

³ A.M. File S.4363.

the first priority, with night interception a good second. . . .¹ An appeal for assistance was made to the Ministry of Aircraft Production. Lord Beaverbrook then sent a personal letter to all the firms concerned, stressing the urgency of the L.R.A.S.V. requirement. By the end of March all aircraft of No. 612 Squadron had been fitted and work on No. 502 Squadron's aircraft had already been started.

Development of Aerial Change-Over Switches

In August 1940, although homing aerials had not been considered to be an immediately essential part of the L.R.A.S.V. system, the development of a high frequency switch to make possible the synchronous use of both broadside and homing aerials had been ordered as an urgent requirement.² When, in September, fitting of Whitley L.R.A.S.V. aircraft with dipole homing aerials was begun, the problem of how to change from sweeping to homing immediately arose, and a method had to be found and used until switch development was completed. The T.R.E. originally estimated that this would take from one to two months, but quickly discovered that difficulties encountered with technical design would considerably extend the period of development. Consequently, although he did not like the means proposed, the A.C.A.S. (R) agreed to its adoption but only as a short-term measure.³ The method used an arrangement for a systematic change-over between broadside and homing aerials, at intervals of time calculated relative to groundspeed, by the use of alternative plugs and sockets to connect the aerial feeders with the transmitter and receiver. The sponsors of the scheme thought this was a completely satisfactory solution to the problem because the plugs and sockets were to be located near the operator and changing them would be, theoretically, a simple and swift transaction.⁴ In practice, however, it involved unplugging and re-connecting several leads at every operation. This process proved to be not only fatiguing for the operator, but almost impracticable for locating targets by means of A.S.V. because of the time taken to change the connections. The introduction of the Yagi homing array strongly emphasised the urgent need for a switch; previously the poor performance of the dipole aerial system had made its provision less important. Although efficiency of homing had been greatly improved, without an equally effective means of switching it was not possible to search completely any specific area of the sea, nor to change over from detection to location without excessive delay. Experience with L.R.A.S.V. had shown that maximum range could be increased $2\frac{1}{2}$ times by flying at 4,000 instead of 1,000 feet, but only at the expense of increasing the range of sea returns from 3 to 5 miles and consequently widening the lane in which targets were free from A.S.V. detection. The time taken and fatigue caused by plug changing encouraged the continual employment of broadside aerials only, and therefore increased the possibilities of missing contacts.

¹ State of A.S.V. Fitting in Operational Aircraft—March 1941.

Type	No. Opl.	Standard A.S.V.	L.R.A.S.V.
Hudson	119	36	—
Whitley	35	—	31
Sunderland ..	27	7	2
Wellington ..	24	—	2
Catalina	6	—	—
	211	43	35

² A.M. File S.4363.

³ A.M. File S.6425.

⁴ M.A.P. File S.B. 8740.

The change-over switches under development were designed to be hand-operated, and consisted of Type 458 transmitter switch and Type 459 receiver switch. When the design stage was completed, development contracts were given to the firms of Hopkins for Type 458, and Tyler's for Type 459. In March 1941 the contractors were given a production order for 200 complete switches, and each promised to deliver 12 hand-made models early in April, by which time the R.A.E. hoped to have completed the design of an automatic relay-operated switch. Fundamental faults in design caused deliveries to be delayed, and hand-made prototypes were not finally approved by the R.A.E. until May, when a new estimate was made for their delivery by the end of that month. By the middle of June, only 6 Type 459 switches were ready for use.¹

Although the supply in bulk of complete switches by the middle of July 1941 was confidently anticipated by the contractors, the prolonged delay in production caused grave concern. Not only were switches urgently required for L.R.A.S.V. Whitleys and Wellingtons, but also for incorporation in the L.R.A.S.V. installations of the newly acquired and sorely-needed Catalinas and Liberators. In July, Headquarters Coastal Command reaffirmed and emphasised the existing possibility and dangers of missing L.R.A.S.V. contacts. The Commander-in-Chief was considering the practicability of insisting that aircraft fitted with Yagi arrays should discontinue altogether the use of broadside arrays, and raised an operational requirement for '... the elimination of the possibility of existing L.R.A.S.V. aircraft failing to detect objects which will be passed in the sea returns of the beam aerials . . .', suggesting that it could be done by use of an automatic change-over switch. Design of such a switch had just been completed by the Royal Aircraft Establishment, and the Air Ministry was seeking a suitable firm to undertake its production. The Telecommunication Research Establishment was investigating the feasibility of using a mechanical remote control for hand-operated switches, and the possibilities of providing continuous and simultaneous sideways and forward looking by using a common aerial. This system, known as Common T and R, consisted of an arrangement of spark gaps and resonant elements which permitted the transmitter and receiver to share one aerial, thereby greatly simplifying the mechanical problems of A.S.V. installation and operation.²

Progress in the development and provision of change-over switches was still unsatisfactory in November 1941, and this supported the school of thought which advocated the abolition of broadside arrays. They described these arrays as 'built-in headwinds', and sought to have them eliminated: a course which would also do away with the need for the unobtainable switches.¹ The large areas on the A.S.V. tubes which were taken up by sea returns still caused anxiety, and the range of broadside arrays was, on the average, only about 25 per cent greater than that of the Yagi homing arrays. The critics were, of course, justified, but this was not the time to reduce the range. It was vitally necessary to increase the distance at which U-boats could be detected, and there was therefore no possibility of dispensing with the broadside arrays until something better became available. The requirement for switches remained, and the Directorate of Communications Development conducted an investigation to collect all possible evidence on the design and workmanship

¹ A.M. File S.6425.

² M.A.P. File S.B. 2193.

of the switches then being produced.¹ The main troubles were caused by faults in mechanical design, and appropriate action was taken to clear them by modifications.

Efforts to improve the design were continued in 1942, but complete efficiency was not obtained, and the supply position continued to be disappointing.² In September 1942 the need for an improved switch became a matter of the utmost urgency. The use of a motor-operated switch was investigated, but the project was abandoned in view of the time required for development and production. The anticipated early introduction of centimetric A.S.V., and the possibility of introducing the Common T and R unit also influenced this decision. The Service trials of this unit had been completed in August and since it was cheap and easily manufactured, it was expected to be available in quantity by February 1943.

¹ A.M. File S.45501.

² M.A.P. File S.B. 8740.

CHAPTER 4

INSTALLATION OF A.S.V. MARK II IN ANTI-U-BOAT AIRCRAFT

The fitting of anti-U-boat squadrons with A.S.V. Mark II and long range aerial arrays was a slow process in spite of the importance accorded to the task by the Prime Minister. A heavy strain was put on the radio industry as the number of aircraft to be fitted with airborne radar increased. Shortages of materials caused delays in production and the wide variety of the types of aircraft used, both British and American, involved additional complications. Technical difficulties were encountered with aerial arrays for several types of aircraft, and it was not always possible to ensure that the A.S.V. installations provided means for homing to U-boats in order to deliver an attack in addition to the primary task of locating them. Opportunity for further development was for a long time limited by the urgent need to put equipment to operational use with the minimum of delay.¹

Sir Henry Tizard, on 23 April 1942, informed the Radio Sub-Committee of the War Cabinet that development of A.S.V. had been neglected, and improvement of it lagged behind that of other radar devices. He thought it self-evident that defeat could be avoided and victory achieved only by retaining command of the seas, and that if at any time priorities clashed, preference should always be given to developments which promised to increase markedly Allied offensive power in the maritime war.²

Sunderland

At the same time as the number of Whitleys to be fitted with L.R.A.S.V. was increased, plans were made for installing the equipment in other types of aircraft for Coastal Command. As soon as work on the Whitleys was completed a prototype installation was to be made in a Sunderland and when this was satisfactory, all Sunderland aircraft were to be fitted. The first Sunderland L.R.A.S.V. installation was begun in September 1940. It incorporated beam arrays similar to those of the Whitley but designed to operate on the correct A.S.V. Mark II frequency of 176 megacycles per second, and in addition there was a forward-looking dipole aerial system. The prototype was completed early in December but results of the first trials were disappointing, the maximum range obtained against coastline being only 5 miles. Again, an effort had been made to produce something quickly. Adequate prior consideration had not been given to the new problems of installation in the flying boat, with the result that improvised mechanical and radio fitting was inefficient. Investigation revealed that certain radio and engineering faults would have to be eradicated before any improvement in performance could be obtained. It was therefore decided to improve the aerial matching, to replace the Sterba arrays by stacked horizontal dipoles, and to install a Yagi type homing aerial

¹ Minutes of 3rd Meeting of Air/Sea Interception Committee, 23 October 1941.

² Radio Policy Sub-Committee, War Cabinet, Paper No. 42/44.

in place of the forward-looking dipole system. To provide flexibility, aerial change-over switches were also to be fitted. Meanwhile, A.S.V. was urgently required for the new Sunderlands then leaving the production lines. As an interim measure they were fitted with standard A.S.V. Mark II, and separate arrangements were made for the conversion to A.S.V. Mark II of the A.S.V. Mark I aircraft already in service.¹

Throughout the early part of 1941 C.C.D.U. trials were conducted as development progressed, and preparations were made for new aircraft to be equipped with L.R.A.S.V. whilst still on the production line. In May 1941 the first aircraft to be completely fitted with L.R.A.S.V. by the contractors was sent to the C.C.D.U. for Service trials.² Results were promising but the matching of feeders to the transmitter arrays still required improvement. Feeder systems for different types of aircraft presented individual problems and a system designed for one particular type of aircraft could seldom be made to work effectively in other types. In this instance, the adaptation of the feeder system to the Sunderland was achieved with very satisfactory results. The direction finding properties of the forward-looking aerial system were found to be particularly accurate and effective. In June 1941 Shorts and other contractors began delivery, from production, of the flying boats already modified for A.S.V. and arrangements were made for the retrospective fitting of 30 operational aircraft in the squadrons to be undertaken whenever they became available.¹ The installation and conversion programme was not to be without its difficulties. The mechanical features of the long range installation were never completely satisfactory and recurrent faults were mostly caused by the action of sea water on aerial and insulating systems. Although many of the faults might have appeared trivial individually, cumulatively they were sufficient to make the installation, and hence the aircraft, operationally useless until precious time and skilled labour had been used to remedy them. In many instances as many as 100 man hours work by radio fitters were needed to bring a L.R.A.S.V. installation up to a fully serviceable state.

Immediately L.R.A.S.V. Sunderlands began operational service, the Commander-in-Chief, Coastal Command, expressed dissatisfaction with the layout of the equipment and demanded improvements. Staff officers of his Headquarters had been present at every layout conference, and accepted it as the best possible compromise, but a fresh series of conferences began in December 1941. A mock-up of a new layout was generally approved subject to certain alterations in April 1942, and a trial installation received final approval in July 1942. This included hand-operated change-over switches which had to be accepted until automatic switches became available. The C-in-C. was also particularly perturbed by the effect of beam arrays on aircraft performance, a fear which had been expressed exactly three years previously. The eagerly awaited supply from the U.S.A. of flying boats of high performance had become somewhat uncertain, and the low cruising speed of the only operational flying boat, the Sunderland, was causing him considerable anxiety. An improvement in performance was a matter of great importance and the T.R.E. and the R.A.E. were asked to investigate on high priority the possibilities of reducing drag caused by external A.S.V. fittings. Subsequently this requirement proved to be a most important factor when A.S.V. was redesigned.¹

¹ A.M. File S.4364.

² See Appendix No. 12 for notes on the C.C.D.U.

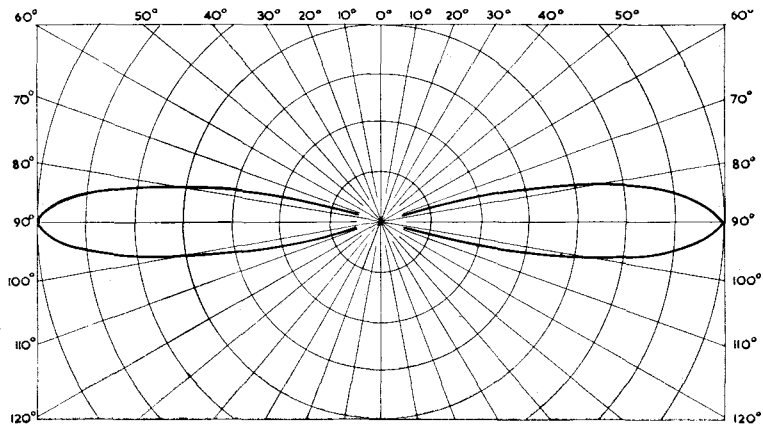

Broadside Aerials

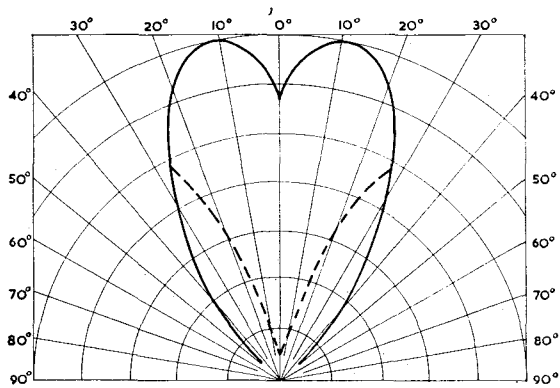

Homing Aerials

POLAR DIAGRAMS OF WHITLEY L.R.A.S.V. INSTALLATION

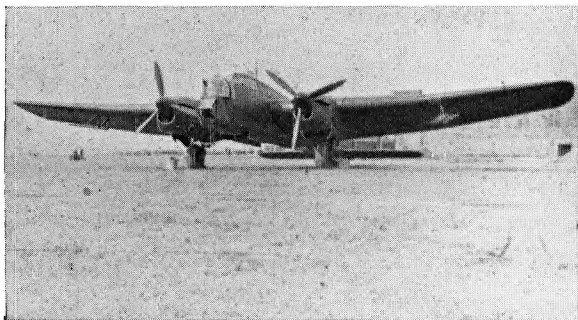

General Arrangement

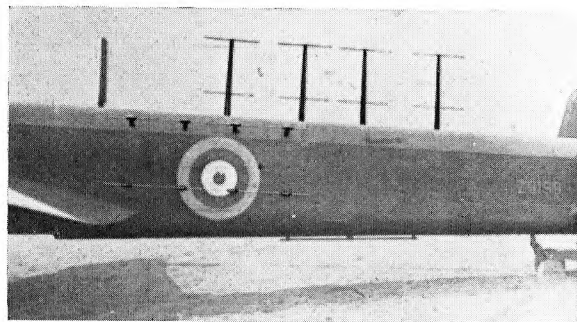

Broadside Aerials

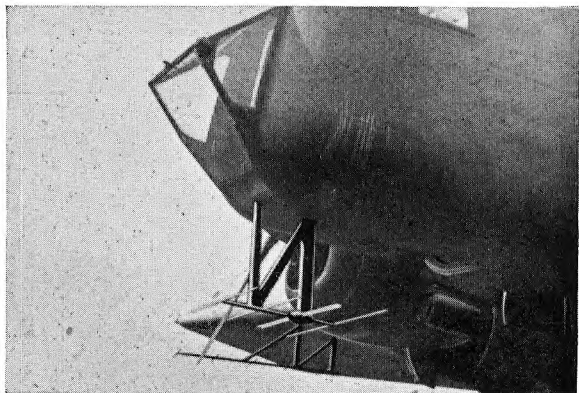

Homing Transmitter Aerial

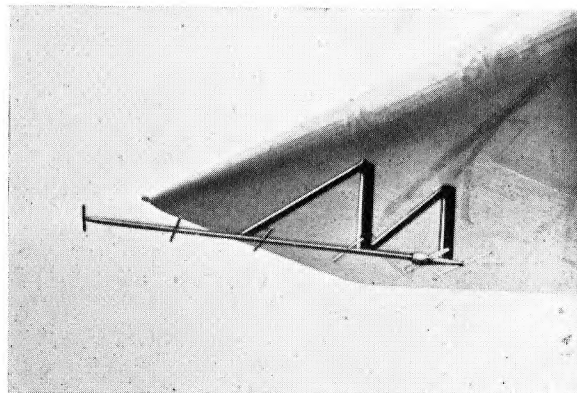

Homing Receiver Aerial

Wellington

In November 1940 installation of L.R.A.S.V. in a squadron of Wellingtons was approved subject to the development of a successful prototype.¹ Vickers, the makers of the aircraft, agreed to accept responsibility for design and development, in addition to installation on the production line, whilst the Telecommunications Research Establishment was instructed to act in an advisory and supervisory capacity.² A prototype installation with beam arrays only, consisting of stacked horizontal dipoles as used eventually for L.R.A.S.V. Sunderlands, and operating on the standard A.S.V. Mark II frequency, was completed in December. In January 1941, after conducting trials, Headquarters Coastal Command expressed satisfaction with the equipment and arrays, and Vickers began to manufacture the fittings and to develop suitable Yagi homing arrays. Before the end of March, 8 Wellingtons fitted with both beam and Yagi aerials had been delivered to No. 221 Squadron, and a further 40 aircraft were being prepared at an output rate of 4 per week. The system of development and installation on the production line by the manufacturers of the aircraft was very much more successful than the method used for the Whitley. In March 1941 the Wellington L.R.A.S.V. installation was adopted as the standard and basic model for any future L.R.A.S.V. installation.

Catalina

At the end of 1940 the Air Staff made L.R.A.S.V. an operational requirement for the Catalina aircraft shortly to be supplied from the U.S.A. and ordered a prototype to be made as soon as an aircraft became available. In order to minimise the amount of retrospective action that might otherwise be necessary, the British Air Commission in Washington was also asked to try to initiate the development of a prototype L.R.A.S.V. installation in the U.S.A.³ This was completed at the end of March 1941, but lacked forward-looking aerials because when the requirement was originally stated, information of the latest developments in homing aerials was not available.² In March the first of the contract aircraft arrived in the United Kingdom and was allocated for prototype installation as a matter of the utmost urgency. Insufficient was known of the lines of development of the U.S.A. prototype to enable any work to be started preparatory to fitting, and standard A.S.V. Mark II was installed, as an interim measure, in the initial deliveries of aircraft in order that they could be used operationally until the prototype was completed and available. By the beginning of June some 25 Catalinas had been fitted with standard A.S.V. Mark II and installation of the L.R.A.S.V. prototype was in progress. The standard installation was giving far from satisfactory results but improvements were delayed until certain junction boxes and cables could be obtained.

Service trials of L.R.A.S.V., the installation of which had presented another new set of problems, began in August, and supplies of material were arranged to enable 48 aircraft to be converted from standard to L.R.A.S.V. Retrospective conversion to L.R.A.S.V. proved to be a very slow process mainly because of the difficulty of releasing aircraft from operations, and an average of 10 days per aircraft was required, but by the autumn of 1942 the task was completed.

¹ No. 221 Squadron.

² A.M. File S.6425.

³ See Appendix No. 3 for details of the British Air Commission.

Hudson

The fitting of Hudsons with standard A.S.V. Mark II entailed considerable modification to the aircraft after they arrived in the United Kingdom from the United States of America, and there was a consequent delay in delivery to squadrons.¹ By the spring of 1941 however, arrangements were completed for incorporating the essential A.S.V. fittings during construction at the aircraft firms, and the strain on the extremely limited resources for modifying aircraft built in the U.S.A. was to some extent relieved. When, in March, Headquarters Coastal Command requested an investigation into the possibility of improving the performance of A.S.V. Mark II in Hudsons by modifying the design and introducing Yagi forward-looking arrays as used in Long-Range A.S.V., the Air Ministry was faced with a difficult problem. Apart from the congestion caused by the need for retrospective fitting of American aircraft on arrival in the United Kingdom—several hundreds were awaiting fitting with communications and other Service equipment—the new Marks of Hudson would shortly be arriving already prepared for the installation of standard A.S.V. Mark II.¹

A.S.V. in Hudson aircraft, however, was not very effective, and did not meet requirements when the aircraft were used for convoy protection. A proposal was made in March to install in them L.R.A.S.V. modified to make possible sideways, forward and backward looking, in order that aircraft might be enabled to provide early warning of enemy aircraft in addition to seaborne raiders. Many discussions ensued.² Mr. R. A. Watson-Watt and the A.C.A.S.(R) considered that a backward-looking beam would be of doubtful value. If a response were obtained from such a beam, no homing could be made until the aircraft had been turned through 180°. When an aircraft was engaged on the special task of providing early warning of an air attack on a convoy, the beam might possibly be of assistance, but an aircraft fitted with normal aerials would be much more easily handled, and if properly operated would provide equally effective cover. The aircraft would also certainly be used for ordinary maritime reconnaissance duties as well as for such a special task, and the backward-looking beam would then confuse the operator. It was unlikely that a backward-looking beam could be combined with a split forward-looking beam for reasons of space; a single beam would have to be incorporated, and consequently directional properties would be decreased. A compromise was reached with the suggestion that Hudsons should be fitted with a suitable modified form of the Wellington L.R.A.S.V. system.¹

By June 1941 however, it had become clear that if the performance of A.S.V. Mark II could be brought up to the standard of the original specification, no revolutionary change was required. Higher standards of training and servicing were already going a long way to achieve this aim. The general operational requirement was also, with experience, becoming more apparent. In August 1941 the L.R.A.S.V. Hudson project was dropped, and the fitting of Hudsons with a modified version of the Yagi forward-looking system as used with L.R.A.S.V. was at last begun. To effect a compromise between maximum sideways coverage, adequate forward-looking range, and accurate homing, the number of elements in the Yagis was reduced, and the already

¹ A.M. File S.6425.

² M.A.P. File S.B. 8740.

splayed receiver Yagis were splayed still further, on the lines of the Beaufort installation then being developed for torpedo-strike operations. The layout of instruments in the aircraft was also altered to make A.S.V. operating more convenient, and the installation became the standard for medium sized aircraft.

Liberator

In March 1941 the Air Staff made L.R.A.S.V. an operational requirement for the Liberator Mark I aircraft which would shortly be arriving from the U.S.A. for employment against U-boats in areas beyond the range of Sunderlands.¹ Responsibility for the co-ordination of development, which included investigating the effect of mid-upper gun turrets on broadside arrays, was taken over by the firm of Handley Page. The first aircraft arrived in the United Kingdom in April, and a prototype was successfully completed in June, when No. 120 Squadron was formed with the few aircraft available, and general fitting began.² Unfortunately, the Liberator Mark I was not produced in quantity; in the U.S.A. it was regarded as being merely a stepping stone to the production of the Mark II and Mark III versions which were designed as bomber aircraft. Of the limited number originally made available to Coastal Command, a high percentage was re-allocated for use as transports to Ferry Command, B.O.A.C., and communication flights, because the cruising range and endurance of the Mark I were suitable for their purposes. When at the end of 1941 and beginning of 1942 Liberator IIs were delivered to the United Kingdom for employment in bomber squadrons, a few were lent by Bomber Command to Coastal Command to replace wastage in No. 120 Squadron. Since, however, they were essentially Bomber Command aircraft, modifications for L.R.A.S.V. installation were not permitted.³ Considerable uncertainty existed in Coastal Command regarding the Mark and quantity of Liberators with which it would eventually be supplied, and the command had been informed that the external dimensions and internal layout of Mark II and III differed radically from those of Mark I, and therefore would require an entirely new L.R.A.S.V. installation. In February 1942, when but a few L.R.A.S.V. Liberators I remained in service, development of a Mark II prototype installation was suggested. Thus, in the event of either the restrictions on modification of bomber aircraft being lifted, or of No. 120 Squadron being re-equipped with Mark II Liberators, delays would be reduced to a minimum. As with Mark I, however, production of Mark II was limited and temporary, and a prototype was consequently not developed. At the beginning of July 1942 the first deliveries of Mark III aircraft to the United Kingdom were made. No. 120 Squadron received a few of the aircraft, and since it was by then known that Mark III was to be the Liberator on which production would be concentrated, was very anxious to have L.R.A.S.V. installed. In the middle of July 1942 the squadron received permission to attempt installation of a spare Liberator Mark I L.R.A.S.V. equipment, but with forward-looking arrays only; broadside arrays were not to be attempted.⁴

The trial installation was completed on 5 August 1942. Performance of the A.S.V. was by no means satisfactory, but the experiment served a very

¹ M.A.P. File S.B. 8740. No. 120 Sqdn. made its first operational sortie with L.R.A.S.V., September 1941.

² A.M. File S.6425.

³ A.M. File S.6425, Part II.

⁴ Liberators Mark III were being delivered to the United Kingdom without A.S.V. until the installation in the U.S.A. of centimetric A.S.V. could be undertaken.

useful purpose by demonstrating that Liberator Mark I equipment could be installed in a Liberator Mark III, that such installation was within normal squadron capabilities, and that the assistance of an expert to match arrays was required if optimum performance was to be obtained. An operational requirement for complete L.R.A.S.V. for Liberators Mark III was not raised until 11 August 1942. At that time C.C.D.U. trials of a Common T and R unit were proving successful, and its incorporation was suggested, so that there would be no need for broadside arrays which reduced aircraft performance and took many man-hours to fit.¹ In August 1942 considerable doubt existed regarding the production date of the T and R unit, and the command was forced to reconsider its requirement, since, as full L.R.A.S.V. was considered essential, broadside arrays would have to be accepted. The Commander-in-Chief finally accepted, as an interim measure, a plan to fit Liberator Mark III aircraft with only forward-looking Yagis, of the same design as those fitted to Liberators Mark I, on the understanding that the aircraft would later, when opportunity arose, and a suitable design had been evolved, be equipped with Common T and R. A high priority commitment to install complete L.R.A.S.V. in twelve Liberator IIIA aircraft to be based in Ceylon then arose, and commencement of a general fitting programme was retarded. The anxiety felt by the squadron commander for the safety of his aircraft and crews during the approaching winter if A.S.V. was not made available emphasised the tremendous growth in confidence and faith in the equipment. Some progress was slowly made, and by June 1943 both Nos. 120 and 86 Squadrons were completely fitted with full L.R.A.S.V. and Common T and R units.

Fortress

At the beginning of 1942 the principle of a maritime long-range force of landplanes was approved, and all Fortress aircraft shortly to be received from the U.S.A. were promised to Coastal Command.² Preparations were made to re-equip No. 220 Squadron with Fortress IIA in January 1942, but Liberators and Fortresses were being supplied to the R.A.F. by the U.S.A. to assist in the bombing offensive, and opinion there was restive about their employment in the maritime war. In consequence, delivery of aircraft to Coastal Command was delayed, and it was not until April 1942 that the squadron received its first 2 Fortresses and then they were Mark I.

Two L.R.A.S.V. prototype installations were made, one in the United States of America and one in the United Kingdom.¹ Originally it was hoped that the American version would meet the operational requirement, and that it would be necessary to apply the British version only to the first 18 aircraft which were being supplied without A.S.V. Trials of the American installation proved, however, that the broadside arrays were virtually useless, and that the performance of the forward-looking system was about 80 per cent of that obtained with the Hudson Yagi array. After several attempts to improve efficiency of the broadside arrays the Royal Aircraft Establishment abandoned the scheme and turned its attention to fitting British arrays to American installations, but further delays were caused by serious difficulties with aerial matching.

¹ A.M. File S.6425, Part II.

² A.H.B. Narrative : ' The R.A.F. in Maritime War. '

The British trial installation was completed at the end of June 1942 and was generally approved after Service trials. Another and serious delay was caused, however, by a hold up in the official acceptance procedure; a delay which was likely to be very much increased after August 1942 because of the already heavy commitments being undertaken by the overburdened modification centres. In that month the Air Ministry enquired whether Yagi arrays designed in the U.S.A. for Fortress Mark II could be made available off production and sent over quickly to obviate the delay occasioned by having to wait for production of British Yagis, although the A.O.C.-in-C. Coastal Command queried the wisdom of using American forward-looking systems in view of the time necessarily taken to strengthen the aerials and re-match them to British broadside arrays. He felt that it would be more advantageous to emphasise very strongly the urgent need for rapid production in the U.S.A. of centimetric A.S.V., but in August 1942 agreed to accept Fortresses fitted with American Yagi forward-looking systems only as the number of aircraft involved was comparatively small.¹

¹ A.H.B./IHK/54/12/5 (A). Operational Requirements—A.S.V. Fitting.

CHAPTER 5

THE OPERATIONAL USE OF METRIC A.S.V. AGAINST U-BOATS

In August 1940 the tactical employment of U-boats was fundamentally changed. Their main successes had been gained against independently routed single ships and stragglers from convoys; escorted convoys had usually been left well alone. More and more shipping consequently sailed in convoy but in August surfaced U-boats began night attacks against convoys. By March 1941 U-boat tactics consisted of the shadowing of a convoy from the earliest possible moment by a single U-boat which did not make any effort to attack but was responsible for reporting the convoy position, course and speed in order that an interception in force by other U-boats might be made. Such tactics could be defeated by escort aircraft forcing the shadower to remain submerged so that contact was lost, and several convoys sailed unscathed as a result of close air escort. A new policy for the employment of aircraft was then adopted, and only those convoys threatened or actually attacked received close air support. Aircraft thus released from convoy escort were used on sweeps over areas thought to contain U-boats, and the latter consequently retired beyond the range of Coastal Command aircraft. Shipping losses in mid-Atlantic and off the west coast of Africa remained high, however.

By July 1941 an increase in the number of available aircraft and a more widespread use of A.S.V. Mark II facilitated the maintenance of anti-U-boat patrols accurately positioned across the routes used by U-boats travelling to and from their bases in the Bay of Biscay. This was considered to be the most effective manner of using anti-U-boat aircraft of medium range.¹ Between 1 March and 31 July only 4 sightings were obtained with A.S.V. although 61 were obtained visually.² By September 1941 the extent of these anti-U-boat patrols was considerably increased, and more frequent sightings enabled U-boat routes to be plotted. Aircraft patrols were placed where they were most likely to sight U-boats during the hours of daylight, because night attacks were impracticable. Altimeters were not sufficiently accurate to permit night attacks to be made at less than 500 feet. The predominant difficulties were the inability to identify the type of target by A.S.V. contacts and the absence of means to illuminate the targets. Only a very rough idea of the nature of a contact could be made from the size of an A.S.V. blip, which varied with bulk rather than displacement, the amount of freeboard, the material of which the target was constructed, the distance at which it was detected, and the height of the aircraft at the time of detection. The blip obtained from a submarine could not be distinguished from that obtained from a small surface vessel, and for political reasons it was important that

¹ ' . . . The Bay is the trunk of the Atlantic U-boat menace, the roots being in the Biscay ports and the branches spreading far and wide. . . . ' Extract from a joint memorandum to the Combined Chiefs of Staff from Headquarters Coastal Command, the Admiralty, and the United States Navy in April 1943.

² See Table No. 1.

neutral vessels and the multitude of French fishing boats sailing the Bay of Biscay should not be attacked. Illumination in floodlight or silhouette was essential, and was eventually provided by the Leigh Light, but at that time it was only in the development stage.¹

The steadily rising offensive in the Bay forced U-boats on passage to submerge during most of the daylight hours, and their consequent slow transit of the danger area reduced the time they were able to spend in operational areas. The great potential of aircraft for harassing and hunting U-boats was thoroughly appreciated even though ability to attack successfully was limited. Of the 77 U-boat sightings made in August/September 1941, 13 only were made initially by means of A.S.V. ; 3 by L.R.A.S.V. on broadside aerials, 8 by L.R.A.S.V. on forward aerials, and 2 by standard A.S.V. The fact that first locations were predominantly made by visual sighting led to misgivings about the practical value of A.S.V. in finding U-boats by day. An exhaustive analysis of conditions prevailing on the occasion when sightings were made revealed some important facts.² The maximum range obtained was 8 miles and the average 5 miles. A.S.V. watchkeeping was often inefficient because of fatigue suffered by the operator and because many aircraft were still not fitted with filters, so that A.S.V. had to be switched off when W/T was required. Equipment was frequently unserviceable, and the heights at which patrols were flown were not conducive to optimum performance. The efficiency of L.R.A.S.V. was rated at 60 per cent and standard A.S.V. at 9 per cent. Although A.S.V. had undoubtedly increased the number of sightings, possibly by 15 or 20 per cent, and its value in other ways had been immense, it was obvious that many shortcomings, both technical and tactical, were present in A.S.V. technique.

Shortcomings of A.S.V.

General dissatisfaction with the results obtained led to the formation in November 1941 of an expert A.S.V. examination party whose duty it was to increase the efficiency of A.S.V. whilst the task of radical re-design was being undertaken. The party's terms of reference were wide, and it included installation revision, operational use, and training and maintenance members who were empowered to visit squadrons to investigate all aspects of A.S.V. and whenever possible to effect improvements on the spot.³

In a relatively short time the examination party shed much light on many shortcomings.⁴ Accurate technical information was not promptly being made available to units, and a lack of such primary essentials as circuit diagrams made servicing unnecessarily difficult. The equipment suffered from several recurrent defects, some of which could be eradicated by the substitution of better quality components. There was a serious shortage of test equipment and spares since, for several months after November 1940, the installation programme absorbed all such items of equipment as they left production. Schedules setting forth complete inspection and servicing routines were urgently required.⁵

¹ See Appendix No. 4 : 'Development of Leigh Light.'

² Air/Sea Interception Committee Paper No. 13.

³ Air/Sea Interception Committee Paper No. 18.

⁴ C.C. File S.7010/10/6.

⁵ ' . . . As a result of experience it is considered necessary by Air Ministry that Headquarters Coastal Command should advise squadrons equipped with L.R.A.S.V. aircraft that on no account are broadside aerial arrays to be used for foot-hold or hand-hold, and ladders must not be placed against them. . . .' Extract from Air Ministry letter S.7230/Sigs. 4, dated 4 January 1941.

Squadrons often received aircraft in which installations were incomplete and untested. In most aircraft, the A.S.V. installation was located so that one member of the crew, usually the navigator or wireless operator, would attempt to keep A.S.V. watch in addition to performing his normal duties. This encouraged a general feeling that A.S.V. was 'nobody's child.' The position of the installation in the aircraft made continuous watch-keeping irksome, and by obstructing free passage through the aircraft made an efficient and continuous watch impossible. The difficulties of an A.S.V. operator were increased by the employment of an unsatisfactory rubber vizor which caused eye-strain and premature fatigue. It had been realised in November 1940, when operational use of L.R.A.S.V. began, that it would be very difficult and tiring for one operator to keep an effective watch continuously for long periods. Relief could be provided by an addition to the number of crew members but the increased weight and the reduction in aircraft performance had to be avoided if possible. It was therefore proposed to ease the strain on the A.S.V. operator by providing a second indicator unit in the pilot's cockpit.

Requirement for Pilots' Indicators

Arrangements had been made in September 1940 to install a standard indicator unit in the navigator station of L.R.A.S.V. Whitleys as well as in the A.S.V. operator station but the limited space available and the size of the A.S.V. equipment made it difficult to find suitable positions for these items. At the end of the year, however, a similar installation in the blind-flying panel in front of the second pilot station in L.R.A.S.V. Sunderlands became an operational requirement.¹ The many set-backs encountered initially with the Sunderland L.R.A.S.V. system caused the indicator project to be held in abeyance. Early in 1941 the T.R.E. designed and began development of a 4-inch cathode ray tube indicator unit specifically for fitting to an instrument dashboard and disassociated from the customary electrical circuit and controls which were to be located elsewhere as conveniently as possible for tuning.² It was made an operational requirement for all A.S.V. aircraft in June 1941. By then, when development was fairly well advanced, the T.R.E. had begun consideration of some blind bombing proposals which implied the employment of a spot indicator.³ Such an indicator, although unsuitable in its original form, could without great difficulty be used as a basis for development of a pilot's indicator, and be made available for demonstration in approximately ten weeks. Headquarters Coastal Command favoured this system, similar to that used for A.I., because it promised better resolution and gave better indications in bright daylight than the 4-inch indicator tube.⁴

The spot indicator involved considerable complications both in aircraft wiring and in the A.S.V. receiver. A manual strobing unit, and subsequently automatic following, had to be incorporated. Development of both the 4-inch tube and spot indicators was requested, in order that comparative trials might eventually be held to assess relative usefulness. During this period of further

¹ A.M. File S.4364.

² For development of Pilots' Indicators for A.I., see Royal Air Force Signals History, Volume V: 'Fighter Control and Interception.'

³ A.M. File S.6425.

⁴ A spot of light indicated whether target was to port or starboard by movement to left or right of a central vertical line, and indicated range by movement up and down the datum line.

development, when the great value of a pilot's indicator to the attainment of efficient A.S.V. was continually emphasised, a further possibility was considered at the T.R.E. The idea was to provide meter dial readings instead of cathode ray tube presentation, because such indicators could be of more robust construction and could be observed more easily in daylight.¹ During the closing months of 1941 and the early part of 1942, the three types of pilot's indicator underwent extensive Service trials and many difficulties were encountered. It was impossible to find really good positions for the indicators to be convenient for viewing the range scale figures which were necessarily very small. Also, the indicators were still not brilliant enough to be read easily in daylight. The vizors provided were not entirely suitable and observers found themselves unable to accustom their eyes to the sudden change of light demanded. The difficulties, although very disappointing, were by no means insurmountable.

The British Air Commission in Washington had continued to take great pains to ensure that arrangements were made for the inclusion of a pilot's indicator in A.S.V. installations produced in the U.S.A. In July 1942, however, the operational requirement was cancelled by Headquarters Coastal Command, who stressed that improvement of the standard of A.S.V. operators should be the aim, rather than the undermining of their self-confidence by the provision of a means by which their statements and powers of concentration could be checked by other crew members.² The conditions were different from those in fighter aircraft equipped with A.I., where a spot indicator was required to enable a pilot to anticipate the operator's instruction in order to save valuable time in an interception and to avoid unnecessary and prolonged oscillations.

Need for Improved A.S.V. Training

The majority of A.S.V. operators were self-trained, or had been semi-trained by unit personnel; the few who had passed through a school had not apparently been taught the tactical importance and operational possibilities of A.S.V. As early as February 1940, the standard of training had been the subject of many complaints and the provision of a training centre and training equipment was made an immediate operational requirement.³ At that time, the instruction received by operators was of necessity only sketchy, since it consisted merely of knowledge gained during the short time they spent at No. 32 M.U. whilst collecting A.S.V. aircraft. T.R.E. scientists were attached to squadrons operating with A.S.V. aircraft, to assist in servicing, impart instruction, report recurrent defects and endeavour to remedy faults, but from a training point of view this arrangement was by no means ideal. There were too many difficulties to be overcome. The necessity for thorough and complete training was realised by Headquarters Coastal Command who issued an instruction to squadron commanders in December 1940 to make A.S.V. operators and other members of aircrew available for lectures and ground training to the fullest extent possible and to allot an A.S.V. aircraft for air training.¹ Conditions often made it impracticable to arrange lectures and other ground training in advance since A.S.V. aircraft with their crews were frequently ordered on operational flights and detachments at short notice. Squadron commanders were able to spare neither personnel nor aircraft for purely training flights,

¹ M.A.P. File S.B. 8740.

² M.A.P. File S.B. 8740, Part II. Headquarters Coastal Command letter C.C./57012/14/ Plans, dated 12 July 1942.

³ A.M. File S.45501.

especially those of L.R.A.S.V. Whitley squadrons who were faced not only with the normal difficulties created by re-arming with a new type of aircraft and by heavy operational demands but also by the most appalling weather which considerably curtailed flying and servicing during the winter of 1940/41.

The training of radio mechanics too was inadequate. In January 1940 24 men completed a far from comprehensive course begun at Martlesham in November 1939, and although some courses were held at Yatesbury in July 1940, it was not until January 1941 that, at Prestwick, mechanic and operator training was properly instituted. Even then training was delayed for two months until aircraft fitted with A.S.V. Mark II were received, and when the school was finally established, the standards reached were far below those required. The instructors responsible for mechanics had little or no knowledge of squadron work, and those for operators but slight understanding of tactical and operational requirements. Squadron radio officers, however, were generally very sound technically, on excellent terms with flying personnel, and aware of the possibilities of A.S.V.

New Aircrew Category

On 15 January 1942 the examination party made many recommendations to the Air/Sea Interception Committee for action considered necessary to remedy the main faults of A.S.V., including :—

- (a) A.S.V. watch to be kept at all times by a specially trained operator who was to have no other concurrent duty. A Radio Operator trade similar to that of Radio Observer in Fighter Command to be instituted.
- (b) Specially designed A.S.V. watching stations to be provided in all aircraft employed on maritime operations.
- (c) Accurate radio altimeters to be installed in all A.S.V. aircraft.¹

The Air Officer Commanding-in-Chief Coastal Command was not perfectly satisfied that an A.S.V. operator could be regarded as being exactly in the same class as the Radio Observer of Fighter Command, who was required to have certain special qualities. He fully agreed, however, that recognition in some form should be given to skill in the use of A.S.V. On 8 February 1942 he recommended to the Air Ministry the provision in each aircraft of 3 wireless operators specially trained in A.S.V. work, in order to secure a higher standard of A.S.V. operating and an efficient watch throughout the appropriate periods of every flight, and suggested that some financial inducement should be offered to encourage qualification in A.S.V. operating.² The Air Ministry gave strong support to the proposal, and some few months later a new aircrew category of Wireless Operator/Air Gunner (Coastal) was established.³

Need for Better A.S.V. Layout

Aircraft for maritime operations had of course been designed long before A.S.V. was developed, and obviously contained no specific A.S.V. station. Moreover, whenever suitable accommodation was sought for A.S.V. equipment, the claims of the more widely known and understood requirements, such as

¹ C.C. File S.7010/10/6.

² To allow for 1 on A.S.V. watch,
1 on W/T watch,
1 resting.

³ C.C. File S.7407/Training.

communications, armament and navigation equipment, were already firmly established. The A.S.V. station in the Whitley, for example, was situated midway along the dark, cramped, funnel-like fuselage where the operator, facing athwartships, sat on the uncomfortable Elsan, huddled forward, quite remote from the rest of the crew, trying his best not to miss a blip which if and when it did arrive, lasted no longer than 25 to 30 seconds. In April 1941 Sir Henry Tizard expressed great dissatisfaction with this very poor layout and discovered that no Coastal Command representative had been consulted when the experimental installation was made.¹ As a result of the investigation he instigated, steps were taken to ensure that operational experience would be utilised when future layouts were planned. Full A.S.V. efficiency demanded a darkened cabin in which hoods and vizors would not be necessary, and with a comfortable seat from which the indicator could be viewed without physical strain.² Different stations were tried in all types of A.S.V. aircraft, but with little success except in Sunderlands and Beauforts. It was found possible, however, to introduce many refinements although it was somewhat late to attempt drastic changes in the internal layout of aircraft which were rapidly becoming obsolescent.

Attempts to Improve Standard of A.S.V. Watchkeeping—Recorder and Bellringer

When the importance of efficient and continuous A.S.V. watchkeeping was fully appreciated, interest in an automatic recorder, such as had been used in the 1938 experiments, was revived. The original proposal for L.R.A.S.V. contained suggestions for the incorporation of a recording system, mainly for tactical reasons, and suggested three methods; pencil recording on a paper roll moving slowly in front of the cathode ray tube, photographic recording, or facsimile radio transmissions to the Area Combined Operations Room where the picture could be produced on a duplicate C.R.T. Experiments were begun but on low priority and with a primarily tactical aspect. Various methods were tried with but little success, including those of taking photographs of the C.R.T. display frequently enough to preclude the possibility of missing an echo, and adapting newspaper picture printers for the purpose.³ An Asdic receiver was ingeniously used as the basis for another system, and, after trials, was considered by the C.C.D.U. to be a valuable aid to shipping reconnaissance in coastal waters.

Assistance in anti-U-boat operations was the main requirement at the time. After further development, modified and improved equipment was installed in October 1941 for trials in a Wellington, to ascertain if the employment of a recorder would alleviate the strain of watchkeeping and thus increase A.S.V. efficiency.¹ The results were disappointing. At or near maximum range, spurious dots resembling authentic blips appeared on the record and although caused by noise signals they could not safely be disregarded. The maximum useful and reliable range of the recorder was therefore considerably less than that of the A.S.V. equipment. Another defect inherent in the system, which made further development useless, was failure to cover the gap caused by sea-returns. The recorder had no value as an anti-U-boat device and since U-boats were the main objective of Coastal Command aircraft, its application in an anti-shipping role, which may have proved useful, was not again seriously

¹ A.M. File S.6425.

² M.A.P. File S.B. 8740, Part II.

³ M.A.P. File S.B. 8740.

considered.¹ It was a complicated piece of equipment and would have been a further burden on already heavily-laden servicing facilities and personnel. Steps had already been taken to ensure that crews included enough members, trained in A.S.V., to allow a continuous and efficient A.S.V. watch to be maintained. The recorder project was therefore abandoned, as was also development by the T.R.E. of an automatic alarm device, known as Bellringer, which was designed to give audible warning of the appearance of an echo on the cathode ray tube.²

Requirement for Radio Altimeter

The degree of success obtained on operations, particularly against U-boats, depended to a large extent on the willingness of pilots to conduct searches at the optimum height of A.S.V. Pilots were prone, however, to fly beneath cloud when the weather was overcast, no matter how low, as they did not trust the altimeter as a means by which they could descend through clouds to make a visual sighting. A drop in atmospheric pressure between point of take-off and point of A.S.V. detection, in conjunction with reasonable calibration error, would sometimes make the standard Kolsman static-head altimeter read a height up to about 1,000 feet more than the true height of an aircraft above sea-level. Consequently, if the drop in pressure were not accurately forecast, a pilot could be so misled by his altimeter as to fly into the sea. Even if he were able to pre-set his altimeter to the correct local barometric pressure and assume that calibration was correct, then the time lag on readings during descent, coupled with changes of pressure within and around the cockpit at different speeds, made its readings of doubtful accuracy at very low altitudes. This part of the problem was not solved until January 1943 when the Royal Aircraft Establishment successfully completed a series of experiments with all types of maritime reconnaissance aircraft, in which static vent holes were cut in hulls and fuselages at carefully selected points where pressure inside and outside was enabled to equalise at all speeds.³ In addition to its importance in A.S.V. reconnaissance, an altimeter which was accurate at very low altitude was essential for offensive action against U-boats on dark nights and in bad visibility. The types of weapon in use limited successful attacks to heights varying from 120 to 500 feet.

When the examination party made its recommendations, radio altimeters had already been an operational requirement of high priority for some time. Although it was not until February 1941 that a detailed specification for an altimeter which was independent of barometric pressure was formulated,⁴ development appeared at the time to be well advanced in three differing techniques; electrostatic field, radar sounding, and frequency modulation.⁵ E.M.I. evolved an instrument in which the interference effect of ground or sea surfaces with the electrostatic field between electrodes of a condenser,

¹ A.M. File S.9011.

² A.M. File S.6425.

³ C.C. File S.7012/13.

⁴ *Range.* To indicate on a meter between 2,000 feet and 20 feet.

Ambiguity. No ambiguity to occur below a height of 500 feet.

Weight. To be reduced to the lowest possible figure, a target figure being 30 lb. exclusive of power supply but including rotary transformer.

Power Consumption. To be kept as low as possible, a target figure being 100 watts.

Power Supply. The rotary transformer to be run from a 24-volt battery supply liable to vary from 21 to 29 volts during use.

⁵ M.A.P. File S.B. 8740. See Royal Air Force Signals History, Volume III: 'Aircraft Radio,' for development and installation of radio altimeters.

located beneath an aircraft, gave an indication of height ; it was given the Service nomenclature Type 5. Prototypes underwent Service trials in May 1941, when accurate readings were obtained between 0 and 60 feet in a Whitley and 0 and 120 feet in a Wellington. Final type approval was given and a production contract placed ; the instrument was of value to the Service generally, but for maritime operations the ranges were inadequate.¹ Interest was therefore focused on radio altimeters, known as Type 2, being developed by Standard Telephones and Cables Limited, designed to operate between 30 and 1,500 feet, and corresponding more closely with Air Staff specifications. Radio altimeter Type 2 was an adaptation of an instrument developed in the United States of America by the Western Electric Company in which linear frequency modulation was used, but its power consumption was so heavy that the increased electrical load could not be supplied without major modifications and the project was therefore dropped.²

Meanwhile, the T.R.E. was developing a similar instrument, termed Type 4, which at first appeared to offer a simple solution to the problem. By August 1942, however, when the rather confused situation was reviewed by the Air/Sea Interception Committee, a satisfactory altimeter had not been produced.³ More difficulties had been encountered with Type 2 than had been expected. Early models contained many defects, but in spite of numerous modifications a general installation programme was not possible. A number of models of Type 4, of which the best gave readings from 0-100 feet and up to 4,000 feet, with an average error of $1\frac{1}{2}$ per cent to 2 per cent up to 1,000 feet, had been given trials, and its performance was more likely to meet universal operational requirements.¹ Even with the highest priority, however, bulk production could not have been started before September/October 1943. The possibility was studied of adopting Type 2 as an interim measure until Type 4 was available at the cost of accepting the consequent considerable effort required to change installations.

The British Air Commission had been made aware of the urgent requirement for a radio altimeter, and had studied American work in this field. Through the Joint Radio Bureau, a common operational requirement and specification had been drawn up, acceptable to all the Services of both countries. By September 1942 it became clear that, in general, reliance would have to be placed on obtaining equipment to this specification from the U.S.A.⁴ The absence of the prime factor, an efficient altimeter, seriously retarded the effective employment of A.S.V. as an aid in attacking surface vessels and submarines at night and in poor visibility. Towards the close of 1943, installation of American Type A.Y.D. radio altimeters was begun in Wellington and Beaufighter aircraft, by which time metric A.S.V. was being superseded by centimetric A.S.V.⁵

Disappearing Contacts

The vulnerability of A.S.V. transmissions to detection by search receivers installed in submarines had been appreciated when A.S.V. was first introduced and the practicability of a shipborne receiver was proved in trials conducted

¹ Minutes of 8th meeting Air/Sea Interception Committee, 28 May 1942.

² A.M. File S.6425. Type 1 was an earlier and heavier version of Type 2. Type 3 was a lightweight development of Type 2, designed for use in the Fleet Air Arm.

³ Minutes of 10th meeting Air/Sea Interception Committee, 6 August 1942.

⁴ Minutes of 12th meeting Air/Sea Interception Committee, 15 December 1942.

⁵ A.M. File C.S. 21402.

with British submarines and aircraft. Approaching A.S.V. aircraft were detected at a distance of 70 miles, and a progressive increase or decrease of signals strength clearly indicated when range was opening or closing. Since, however, A.S.V. had first to prove itself an effective and worthwhile device, but little attention was paid initially to planning action to be taken if and when German search receivers were put into operation.¹

During July and August 1941 reports by pilots to the effect that many A.S.V. indications faded out as range was closed gave rise to suspicions that the Germans had begun to employ search receivers, and being so warned dived before aircraft were within visual sighting distance. In an immediate effort to test the validity of the suspicions, the Air Officer Commanding-in-Chief Coastal Command ordered A.S.V. silence to be maintained in the Bay of Biscay area during alternate weeks from 18 August for the ensuing 28 days ; 528 hours were flown with A.S.V. switched off and 541 with A.S.V. switched on.² With A.S.V. in operation 5 visual, 2 A.S.V., and 1 simultaneous sightings were made, and during the A.S.V. silence period, 3 visuals. No apparent disadvantage resulted from the use of A.S.V.

In September 1941 examination of all available evidence revealed that disappearing contacts might equally well be caused by large waves, whales, porpoises, and flotsam ; there was no particular reason to suspect that they were caused by the use of search receivers.³ Examination of a U-boat of up-to-date design captured in August confirmed these conclusions, for it contained no indications of the provision of special equipment for detecting radar transmissions. Improvements were made to the existing system of reporting sightings and attacks, and the Coastal Command Operational Research Section was instructed to conduct further research. Whilst more concrete evidence was awaited, pilots continued to use A.S.V. on the assumption that U-boats did not carry search receivers. In fact, the Germans were slow to start development of such equipment, even when they became aware of the wavelength and form of transmission of A.S.V. Their first reaction was the use of both shore-based and airborne jammers, but, except in the Mediterranean Sea, operations took place too far away from the coastline for the former to be effective. To make the airborne jammers successful would have required far more aircraft than were available. Also, it would have been most uneconomic and would have disclosed the location of those areas where action by U-boats was contemplated. It was not until the summer of 1942 that efforts were made by the Germans to produce a search receiver.

Need for Illuminants

The activities of the expert examination party led to a higher standard of A.S.V. operating during 1942 but the results continued to be disappointing during the first five months of the year. Insufficient aircraft were fitted with A.S.V., especially the Long Range version, to make operations decisive. Although from the introduction of A.S.V. Mark I until the end of February 1942 over 2,300 A.S.V. receivers and 3,400 A.S.V. transmitters had been delivered to the R.A.F., the number which had actually been installed in aircraft was just over 650 ; 284 Hudsons, 123 Whitleys, 64 Sunderlands.

¹ Minutes of 1st meeting of Air/Sea Interception Committee, 14 August 1941.

² C.C. O.R.S. Report No. 140.

³ Minutes of 2nd meeting Air/Sea Interception Committee, 11 September 1941.

59 Wellingtons, 61 Catalinas, 58 Beauforts and 8 Liberators.¹ Of these many had been lost, and those available were dispersed for operations in the Far East, the Indian Ocean, West Africa, Gibraltar, the Mediterranean Sea, the Atlantic Ocean, the Bay of Biscay, with convoys to Russia, and on long range reconnaissance with the Home Fleet. U-boat operations were concentrated mainly against independently routed shipping off the seaboard of the United States of America and West Africa. Between September and the end of November 1941, however, every one of the 13 U-boats detailed to penetrate into the Mediterranean to attack British sea communications to North Africa and to protect the supply lines of the Italian forces, succeeded in passing through the Strait of Gibraltar undetected.

Following the successful U-boat attack on H.M.S. *Ark Royal* on 13 November the Strait was patrolled by aircraft fitted with A.S.V. Mark II; Catalinas, reinforced in December by Sunderlands and Hudsons, by day, and Fleet Air Arm aircraft by night. Although the performance of standard A.S.V. Mark II as installed in Catalinas was indifferent, U-boats were forced to dive by day so far westward, that continuous submerged passage of the Strait was impossible and surfacing in the narrows at night was made obligatory. During darkness A.S.V. Swordfish met with some success; the fact that they were small, slow, manoeuvrable, open cockpit aircraft operating in good weather made less noticeable the absence of really efficient illuminants.

In the eastern Mediterranean, the number of aircraft available for anti-U-boat operations was very limited, and of these only very few were equipped with A.S.V. At the end of 1941, L.R.A.S.V. had been installed in one Sunderland and standard A.S.V. in 2 Sunderlands and half a squadron of Fleet Air Arm Swordfish.² Allied shipping was mainly confined to the coastal belt between Port Said and Benghazi which offered a restricted hunting field to U-boats since the possibilities of evasive routeing were very limited. Since U-boats concentrated on this route however, they also were comparatively vulnerable. The R.A.F. anti-U-boat problem in this area was therefore not the same as in Coastal Command, in whose areas U-boats were very widely dispersed. A.S.V. aircraft were normally used for convoy patrols and anti-submarine hunts in locations where U-boats were likely to be awaiting convoys, whilst aircraft without A.S.V. were used for daylight sweeps. The vast majority of sightings were made by A.S.V. aircraft, but the Sunderlands were unable to guarantee an attack after a night sighting, and in May 1942 14 A.S.V. contacts were followed into minimum range and then lost because the aircraft had no suitable means of illuminating the target. However, as at Gibraltar, and for the same reasons, Swordfish were particularly successful.³

In the Bay of Biscay, where flying conditions were usually far from ideal, night patrols were comparatively fruitless. The chief weakness lay in the difficulty of homing to and seeing a target. The U-boat Command exploited this weakness by remaining submerged long enough during daylight to avoid the day offensive, and by surfacing at night. Experience made it clear that aircraft were of little use at night unless fitted with L.R.A.S.V., and that the value of L.R.A.S.V. itself was diminished by the absence of an

¹ M.A.P. File S.B. 8740, Part II.

² O.R.S. (M.E.) Report No. R.5.

³ O.R.S. (M.E.) Report No. R.20. A.H.B./IHK/24/172. Extracts of O.R.S. (M.E.) Reports, October 1941 to September 1943.

effective illuminant to turn promising A.S.V. contacts into positive sightings, and to enable immediate attacks to be made.¹

The necessity for illumination to increase the efficiency of A.S.V. at night had been realised at the A.M.R.E. at a very early stage of A.S.V. development. The Superintendent, Mr. A. P. Rowe, wrote on 6 November 1939 ' . . . I assume that submarines are more likely to be surfaced at night than during the day and that, for reasons associated with an assumed immunity from attack, the state of readiness to submerge is less at night than by day ; for example, crews may be " taking the air " on deck. The A.S.V. equipment should enable a surfaced submarine to be detected at a range of 10 miles, and should enable an aircraft to home to the submarine to within two or three hundred yards ; homing would not be sufficiently accurate for bombing. I do not know the gliding angle of modern aircraft, but flaps may make the figure one in eight or even one in ten, which means that, from a moderate altitude, an aircraft could glide over a distance equal to the maximum range of detection of the submarine. Having thus achieved surprise, it is suggested that a parachute flare should be released immediately before a bombing attack. No element in this proposal is novel, but it would seem important to conduct experiments to determine if there are any difficulties associated with the field of illumination of the flare in relation to the accuracy of homing. . . .'² Although No. 217 Squadron had already conducted experiments at Tangmere with towed parachute flares for night reconnaissance as early as 1938, it was not until L.R.A.S.V. Whitleys began operations towards the end of 1940 that active measures were taken to further the development of flares and flare technique.³ Technical difficulties existed, because to be effective it was essential that target illumination should be both powerful enough and of sufficient duration to enable pilots to identify a target and fly towards it before reaching bomb or depth-charge release point.

The technique most commonly used in night operations was one in which an aircraft was homed to the target by A.S.V. whilst direction and degree of drift were estimated from the changes of course involved. When approximately $1\frac{1}{2}$ miles from the target, and at a height of about 2,500 feet, parachute flares were dropped at short intervals and the aircraft manoeuvred whilst losing height so that the target was placed midway between the flares and the aircraft, when an attack was made. Although an attacking aircraft could safely fly low over the sea in the reflected beam of a distant flare without the aid of a direct reading altimeter, flying was often liable to be hazardous at first when the flares had to be laid. To add to this difficulty, the parachute flares were unreliable and frequently failed to ignite. The technique was therefore periodically abandoned and only used again because no better method was available. Between May 1941 and May 1942 A.S.V. aircraft spent some 2,000 hours in the operational areas over the Bay of Biscay at night. But only in bright moonlight was an A.S.V. sighting likely to lead to an attack.⁴

¹ In night operations 1 L.R.A.S.V. aircraft was estimated to be equal in value to 5 non-A.S.V. aircraft. A.H.B./IHK/10/40.

² M.A.P. File S.B. 8740.

³ See Appendix No. 5 for details of flare development.

⁴ It was not until January 1944 that suitable high intensity flares were developed and produced ; thereafter they were used with a high degree of success against U-boats by A.S.V. aircraft of Nos. 58 and 502 Squadrons (Halifax aircraft), although their floodlight effect was not acceptable near convoys or other Allied shipping.

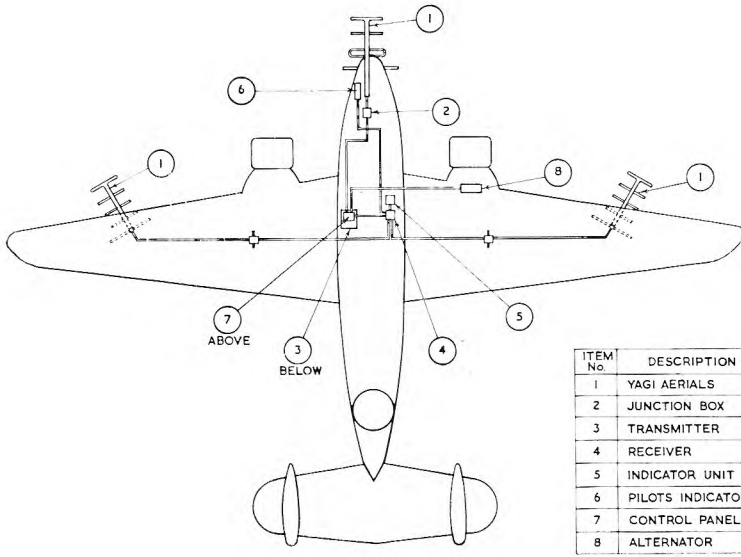

Layout

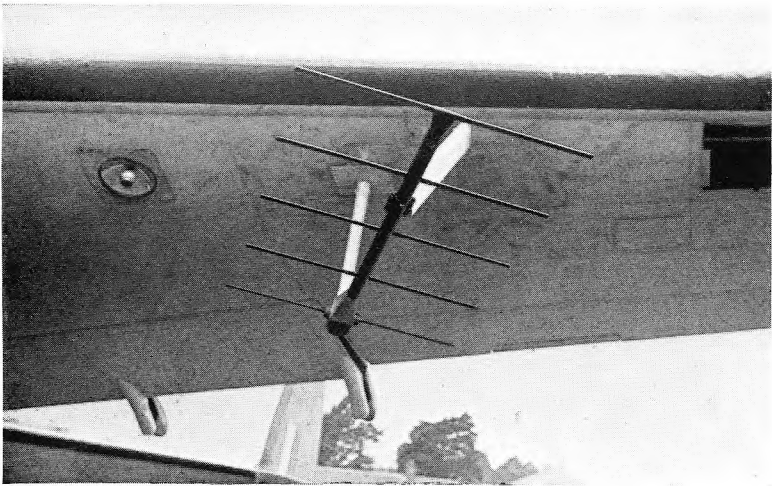

Receiver Array

A.S.V. MARK II IN HUDSON

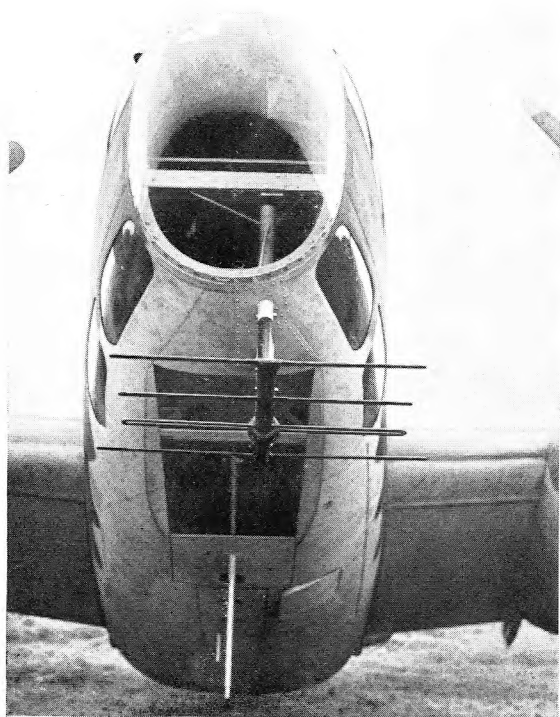

Transmitter Array—Front View

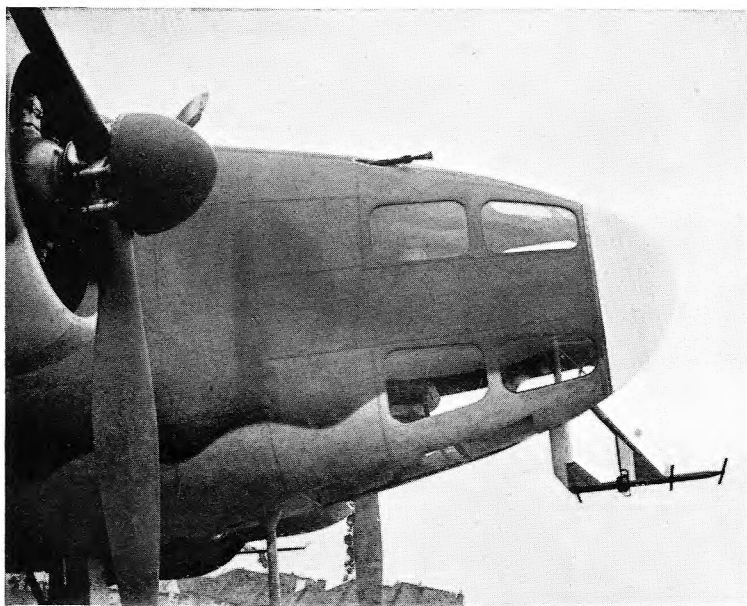

Transmitter Array—Side View

A.S.V. MARK II IN HUDSON

Not until the advent of the Leigh Light was successful illumination ultimately achieved. During the night of 3/4 June 1942 No. 172 Squadron L.R.A.S.V. Wellingtons fitted with Leigh Lights took part for the first time in night operations over the Bay of Biscay and one of them quickly made two sightings and one successful attack. During June and July only 5 Leigh Light L.R.A.S.V. Wellingtons were available for operations, but their 11 night sightings and 6 night attacks had an effect on U-boat tactics out of all proportion to the 1 U-boat sunk and 2 damaged as a result. The comparative safety hitherto enjoyed by U-boats in transit during the hours of darkness had disappeared. Surviving U-boats took back to their bases reports of sudden surprise location by a dazzling light followed immediately by depth-charge explosions all around them. On 24 June Admiral Dönitz, Flag Officer U-boats, reversed U-boat sailing orders; '. . . Because of the very great danger from the air, U-boats are to proceed submerged day and night in the Bay of Biscay and are to surface only to charge batteries. . . .' On 2 July he asked for *Luftwaffe* reinforcements to deal with R.A.F. aircraft '. . . who had made the surface passage of U-boats a risky proceeding both by day and night. . . .' On 16 July further orders were issued '. . . As the danger of unexpected attacks from radar equipped aircraft is greater by night than by day, in future U-boats will proceed by day. . . .'¹ The change of tactics admirably suited aircraft of Coastal Command engaged in daylight operations and they were quick to reap the benefit.

Thus, within a few weeks, the outlook of the U-boat war was radically changed by the addition of effective target illumination to L.R.A.S.V., and the comparative ineffectiveness of methods previously used was thrown into sharp relief.² Yet one more factor was also vividly highlighted. The specialist training of Leigh Light aircraft crews was intensive and included very thorough instruction and practice in all aspects of A.S.V. The skill shown by A.S.V. operators played a major part in the successes obtained; the utmost importance of thorough training in A.S.V. technique was strongly emphasised and thereafter a much higher standard was always demanded.

German Search Receiver—Metox R600A

A far reaching effect of the successful night attacks was the stimulation of German activity in producing counter-measures to A.S.V. The enemy had been well aware of its use since the spring when an aircraft equipped with A.S.V. Mark II was captured in Tunisia. The fact that it was in general use may, or may not, have been fully appreciated, but interest in providing counter-measures against it had not been very lively. The spate of effective night attacks by aircraft against U-boats in the Bay was quickly linked with its use however, and high priority was given to the development by the Communications Experimental Command of a search receiver. Early in August experimental prototypes were installed in three U-boats for operational trials. Reports on them were favourable, warning of approaching A.S.V. aircraft being received at distances of 30 miles, well outside the location range of the aircraft.³ Admiral Dönitz immediately decided not to wait for further refinements to be made but to have all U-boats equipped as soon as possible.

¹ Admiralty Translation P.G.30309b.

² See Table No. 2.

³ Admiralty Translation P.G.30310b.

The German radio industry was apparently already overburdened by requirements of the *Luftwaffe*, so that the contract for quantity production of a search receiver Type R.600A was given to two Parisian firms, Metox and Grandin. Emphasis was placed on speed of production, simplicity and quantity; quality was not so important. The resultant makeshift equipment operated between frequency limits of 113 and 500 megacycles per second, and the precarious use of harmonics was relied upon to cover the higher frequencies of the band. Single-frequency tuning was employed and search of the frequency spectrum entailed tedious manual operation. The operator listened for a high pitched note in his headphones, set gain control to a pre-determined value, and then rotated a switch which had three positions corresponding to three ranges. If the note was audible on one position only, a range of 50 miles was indicated, on two, medium range, and if only on the third, 8 miles or less; thus range was directly related to signal strength. The aerial was at first a crude affair mounted on a wooden crosspiece and had to be carried up through the conning tower to the bridge and operated by hand. These two facts were to prove important: the direct dependence of range assessment on signal strength, in view of subsequent Allied employment of attenuators, and the clumsiness of the aerial system because it prevented the use of search receivers during the closing stages of attacks against convoys when instant readiness to submerge was vitally necessary, thus rendering the U-boats vulnerable to detection by metric A.S.V. Many U-boats were equipped by mid-September and were often detailed to escort damaged U-boats not so fitted, through the Bay.¹ By the end of the year receivers were installed in practically all U-boats at sea.

The almost total absence of night sightings during September gave rise to grave concern at Headquarters Coastal Command but the main reason for it was not immediately fully appreciated.² The fact that it was the period during which maximum seasonal interference to A.S.V. from tunny-fishing boats was experienced, considered in conjunction with suspicions that U-boats were either submerging at night or had stopped using the Bay as a transit area, tended to make unconvincing any evidence that employment of search receivers had at last begun. A continued decrease in the proportion of sightings to flying hours by day and night, coupled with information from intelligence sources, engendered the belief in October that receivers were in fact being used and that U-boats were probably once more surfacing at night and submerging during daylight.³ As an immediate measure, pending completion of further investigations by the Air/Sea Interception Committee and a special panel of the R.D.F. Board, Headquarters Coastal Command on 7 October introduced new instructions on the operational use of A.S.V.

In the hope of keeping U-boats submerged at night, constant A.S.V. night patrols were flown in the inner Bay by Leigh Light aircraft, and by other aircraft which dropped flares periodically. Normal patrols were flown during daylight but A.S.V. was used only when visibility was poor and then only for periods of 10 seconds every 15 minutes. It was reasoned that if the night patrols succeeded in their aim, then the day patrols might reasonably expect to find and attack surfaced U-boats. In order to reduce the advantage given by the search receiver by day, it was proposed that as soon as a blip was

¹ Admiralty Translation P.G.30311.

² C.C. File S.7050/4.

³ C.C. File S.7050.

obtained, bearing and distance of the contact should be estimated and A.S.V. switched off until the target was thought to be very near, when A.S.V. was to be switched on again to simplify the final approach. Detailed C.C.D.U. trials, however, showed that switching off A.S.V., or in fact, any similar sudden action, became immediately apparent to a listener, and was tantamount to broadcasting that an attack was about to develop, and the proposal was not adopted.¹

A.S.V. Flooding

The night procedure was slightly modified in November when flare-carrying L.R.A.S.V. Whitleys of No. 502 Squadron acted as 'scarecrows' with A.S.V. switched on, whilst Leigh Light aircraft used A.S.V. only intermittently. In spite of these tactics the proportion of sightings obtained remained very low. The value of anti-U-boat aircraft had decreased considerably and the urgent need to substitute centimetric for metric A.S.V. was strongly emphasised. Threatened convoys were given a higher intensity of close support at the expense of patrols over the Bay, and A.S.V. aircraft reverted in effect to their original role of location. Whilst pressure was applied to obtain centimetric A.S.V. from the United States of America and higher priority for its development in the United Kingdom, fresh ways of using A.S.V. Mark II, including its operation on various different wavelengths, were proposed. Amongst them was a system of A.S.V. flooding in which Liberators only were to be used for daylight patrols, and all other A.S.V. aircraft, except those fitted with Leigh Light, were to operate at night as flooding aircraft.² A.S.V. was to be used continuously by the flooders whilst they flew on tracks arranged so as to make possible the reception of A.S.V. transmissions by U-boats making the passage of the flooded area with such continuous frequency that diving on every occasion would be impracticable, and U-boats would be forced to remain either surfaced or submerged. At the same time Leigh Light aircraft were to fly over the same area, but with A.S.V. switched on only at set intervals, in the hope of catching surfaced U-boats by surprise.³

The accurate practical navigation required was, however, considered to be a difficult and serious problem,⁴ and although the proposal was first made in November it was not until 23 December that A.S.V. flooding was attempted, and then for only two nights.⁵ Meanwhile work was started on the design and development of 100-kilowatt equipment, A.S.V. Mark IIA, for increasing the area flooded by each aircraft and thus reducing the total number of aircraft required. Six sets were installed in Sunderlands in the spring of 1943, and were used for flooding operations on eleven nights between 24 March and 17 April, with a slight yet important difference from the original plan. Operations were confined to a very narrow area from the northern to the southern limits of the outer Bay. By then centimetric A.S.V. was being used and the number of A.S.V. sightings rose to 25 during April, but it is interesting to observe that

¹ A.M. File C.S. 16620.

² C.C. O.R.S. Report No. 210. C.C. File S.7050.

³ C.C. File S.7050.

⁴ Air Position Indicators were considered essential to ease the complicated navigation entailed by the scheme, but were being delivered on the highest priority to Bomber Command, and in particular to its Pathfinder Force, and it was unlikely that they would become available to Coastal Command for many months.

⁵ H.Q. No. 19 Group O.R.B., January 1943.

6 of the sightings were made with A.S.V. Mark II.¹ The eagerly awaited introduction in the Service of the new form of A.S.V. caused interest in A.S.V. Mark IIA to recede somewhat; further development was abandoned and production was curtailed to only 12 sets.²

When the provision of counter-measures to the inevitable centimetre wave search receivers was studied and discussed in March 1943, the possibilities of flooding on centimetre waves were carefully considered. It was assumed to be potentially of more value than metric A.S.V. flooding, because of the sweeping beam technique of centimetre radar. The possibility of A.S.V. Mark III being stultified by a search receiver caused the keenest anxiety, and the practicability of a quick change from 10-centimetre to 3-centimetre wavelength was discussed. The pros and cons were weighed, and it was decided that once the Germans produced a centimetric band search receiver, they could easily deal with changes of wavelength in that band. It was considered advisable to accept the position when the receiver came into operation and to prepare for it by concentrating on increasing the power of 10-centimetre A.S.V. and the employment of attenuators.³

Attenuators—Vixen

In order to investigate the degree of vulnerability of A.S.V. transmissions, trials had been conducted by the Coastal Command Development Unit and the Enemy Investigation Group of the Telecommunications Research Establishment during the summer of 1942. As a result of the trials it was clearly indicated that not only was it possible for metric A.S.V. transmissions to be received by German shipborne receivers Types *Fuge VII* and *E.K.*, but that the approximate range of the aircraft and whether range was opening or closing could be estimated from the strength of signals received.⁴ At the 10th meeting of the Air/Sea Interception Committee on 6 August 1942 it was suggested that the simplest counter-measures to German search receivers would be a wilful reduction of signal strength as the origin of an A.S.V. indication was approached in order to give an impression that the aircraft was opening rather than closing range. At that time, however, the general feeling was that the best antidote was the projected change to centimetre wavelengths which would make the metric search receivers useless if and when they were brought into operation.

An A.S.V. panel of the R.D.F. Board was appointed to assess further the probability of U-boats using search receivers. On 26 November 1942 the panel reported that although direct evidence of receivers being used was still not available, probability was sufficiently high to justify the use of several differing frequencies for A.S.V. Mark II, the employment of tactics such as had already been put into effect, and investigation by research establishments into the possibility of flooding, and operation of A.S.V. on reduced power.⁵ The final report of the panel was made on 16 January 1943. In it was stated that '... the countering of enemy listening to attacking aircraft might be

¹ S.C.R. 517C used December 1942 (U.S.A.A.F.).

A.S.V. Mark IV used February 1943 (DMS. 1000).

A.S.V. Mark III used March 1943.

A.S.V. Mark V used April 1943.

² H.Q. No. 19 Group O.R.B., January 1943, and A.H.B. Narrative: 'The R.A.F. in Maritime War.'

³ Despatch on Coastal Command Operations by Air Chief Marshal Sir John C. Slessor.

⁴ C.C.D.U. Report. C.C.D.U./155/6/Sigs. 24 June 1942.

⁵ S.I.C. Report No. 41, 26 November 1942.

considerably assisted by reducing A.S.V. transmitter power after the first A.S.V. contact. This would have the advantage that when A.S.V. was switched on again for final attacks, the U-boats receiving a signal of less or at most equal intensity to the original signal, would be denied warning of imminent attack. . . .’ The A.S.V. panel then recommended that the minimum technical retrospective modification required to give, at will, approximately half normal A.S.V. range should be worked out, but also recommended that the scheme should not be adopted immediately, but should be considered when more data became available.¹ The main factor influencing the decision not to adopt attenuation immediately was the conviction of the Royal Aircraft Establishment that development and production of an attenuator would require considerable technical and manufacturing effort.²

On 21 April 1943 the Air Officer Commanding-in-Chief Coastal Command raised an operational requirement for an attenuating device, and in that month there was produced, as a ‘private venture’ within the command, a device which achieved the required performance in a very simple way.³ A length of twin cable was connected as a stub at a suitable point on the transmitter aerial feeder, and terminated in a half-wave lecher bent into a circular arc. This was enclosed in an earthed metal box and a sliding shorting bar was controlled by a knob on the outside. By rotating the knob between pre-set stops, it was possible to vary the stub impedance from zero, giving reduced power, to infinity, giving normal performance. Preliminary Service trials showed that in the latter position, normal performance of A.S.V. Mark II was not affected, and when in the zero position, the echo from a 1,000-ton ship could be kept above the noise level down to a range of 2 miles. Pulse recurrence frequency decreased very slightly during attenuation, but the transmitter remained stable. The code word Vixen was allotted to the counter-measure and the Royal Aircraft Establishment was asked to investigate the device and issue memoranda concerning its construction, installation, and use.

Meanwhile, at the beginning of 1943, disappearing contacts were experienced in the Mediterranean. U-boat commanders had received strict instructions that they were not to attempt passage of the Strait of Gibraltar unless their boats were equipped with serviceable search receivers.⁴ During this period of intense pre-occupation of the United Kingdom with the U-boat war in the North Atlantic and the Bay, Headquarters Coastal Command prepared tactical memoranda for the Air Ministry and by the summer of 1943 units engaged in maritime operations in oversea theatres were fully informed about the enemy search technique and of our developments undertaken to provide counter-measures. Successful Service trials of Vixen were conducted by the Coastal Command Development Unit during the early summer of 1943, and it was made a requirement of the highest priority for all Leigh Light aircraft fitted with A.S.V. Mark II.⁵ The Hudsons of No. 48 Squadron at Gibraltar were already equipped with the squadron’s own version of Vixen, but fitting of home-based aircraft did not begin until November and was not completed until February 1944, by which time the majority had already been fitted with centimetric A.S.V.⁶

¹ C.C. File S.7050/24.

² M.A.P. File S.B. 8740, Part II.

³ C.C. File S.9108, Part III.

⁴ Admiralty Translation P.G.30314a.

⁵ Coastal Command Progress Report No. 3. A.H.B./ITM/a3/1g.

⁶ Coastal Command Progress Reports No. 8 and 9. C.C. File S.7446.

Development and manufacture of attenuators for centimetric A.S.V. was undertaken both in the United States of America and in the United Kingdom. Technical difficulties imposed many limitations. Whilst efforts were being made to provide fully automatic attenuation, manual controls were used, and the wavelength was varied continuously during the run-in. This necessitated continual manipulation of the local oscillator control which was undesirable during a homing run because the control suffered from backlash.¹ Satisfactory setting up under Service conditions was almost impracticable and resulted in loss of power. General fitting of attenuators, designed for employment against a surfaced U-boat, coincided with the advent of *Schnorchel*, against which A.S.V. contacts were so short and indistinct that an attenuator was of no great practical value and caused more trouble for the average A.S.V. operator than for the search receiver operator. The range of A.S.V. contacts was so short that a search receiver operator could receive warning before the attenuator was brought into operation, and at the beginning of 1945 there was no positive evidence that the enemy was using search receivers with *Schnorchel*. The operational requirement for attenuators was therefore temporarily cancelled in February 1945, but since a change of U-boat tactics might well again have established a need for effective attenuation, development was continued on low priority.²

¹ A.H.B./IIk/85/87/(A). Radar Airborne Policy.

² A.H.B./IIk/85/87/(B). Radar Airborne Policy.

CHAPTER 6

OPERATIONAL USE OF METRIC A.S.V. IN ANTI-SURFACE VESSEL STRIKE ROLE

Hudson, Whitley, Wellington, Liberator, Fortress, Sunderland and Catalina aircraft were fitted with A.S.V. for anti-U-boat and reconnaissance operations. For a considerable period of time the Royal Air Force was ill-equipped to take advantage of the opportunities to attack surface vessels provided by successful reconnaissance. For obvious reasons the Fleet Air Arm alone had an accepted anti-ship strike role at the beginning of the war, but 24 aircraft of Bomber Command stood by daily at short notice of readiness to act as an air striking force.¹ Escorted bombers operated sporadically against enemy shipping during 1940 and 1941, but had little or no effect on German tactics of openly sailing destroyers, supply ships, barges and other surface craft through the Straits of Dover in daylight, and towards the end of June 1941 the amount of shipping leaving and entering ports on the west coast of France, singly and in convoy, increased considerably.² A.S.V. Mark II aircraft were employed on routine reconnaissance patrols at night over the Bay and when visibility was poor; when contact was made the sighting was reported to base and shadowing continued, whilst a strike force was despatched if the target was considered to be sufficiently important. Experience showed that the length of time which elapsed between a sighting and the arrival of a strike force made it difficult for the latter to locate the target, and the operation was usually abortive.

The plans made for the concerted action to be taken by Coastal, Bomber and Fighter Commands in the event of the *Scharnhorst*, *Gneisenau*, and *Hipper* breaking out of Brest emphasized that once the enemy ships had been located, the success of an air attack largely depended on the accuracy with which strike aircraft homed to the shadowing aircraft.³ This had posed a problem since the beginning of the war, primarily because the striking force was drawn from a command other than the one providing the shadowing aircraft; Bomber Command crews were not trained in navigation over extensive sea areas, or in homing. Consequently, on 27 December 1941, Headquarters Coastal Command requested Headquarters Bomber Command to provide two aircraft to practise homing to a Coastal Command aircraft. Although the desirability of such an exercise was realised, no aircraft could be spared until 9 January 1942 when a Stirling endeavoured to home to a Hudson in an area 60 miles to the west of the Scilly Isles. As a result of the lack of success, signals procedure for homing was amended. Although on 27 February 1942 the problem was again reviewed it was not until 10 April 1942 that further exercises were held.⁴

¹ Two squadrons of Vildebeests, Nos. 22 and 42, represented the sole torpedo bomber force of Coastal Command. Their low speed and limited radius of action made them useless and they never played a part in operations.

² C.C. File S.7010/20/3.

³ The plans included special reconnaissance patrols off Brest by aircraft equipped with A.S.V., from April 1941 until February 1942. Faulty manipulation of the A.S.V. Mark II equipment in a Hudson on patrol at a critical time facilitated the undetected escape of the German ships. For full details of the patrols and the break through the English Channel, see A.H.B. Narrative: 'The R.A.F. in Maritime War.'

⁴ A.H.B. Narrative: 'The R.A.F. in Maritime War.' See also Royal Air Force Signals History, Volume III: 'Aircraft Radio.'

Beaufort

Preparations for rearming Nos. 22 and 42 Squadrons with Beauforts began at the end of 1939, but the squadrons were not operationally effective until September 1940. Although the A.C.A.S.(R) had asked in February 1940 for the development of an experimental A.S.V. Mark I installation in the Beaufort, other A.S.V. requirements of higher priority had delayed the project and the prototype was not designed.¹ In September 1941 the need for having A.S.V. in the Beaufort was emphasised by a proposal to use the aircraft for attacks on shipping at night.² In June 1940 development of an A.S.V. Mark II prototype was initiated at the Bristol Aeroplane Company and it was anticipated that a retrospective fitting programme would begin in August 1940. General installation of A.S.V. in Beauforts was, however, to be delayed for over one year. Progress in the provision of a prototype was very slow. New torpedo-bomber tactics were continuously being evolved, and the resultant operational requirements changed. Requirements which conflicted strongly with A.S.V. were those for Marconi W/T communications equipment and for armament, because the amount of suitable space in the aircraft was extremely limited. They remained predominant factors throughout the period of development of A.S.V. for Beauforts, and until the summer of 1941 fears were expressed that A.S.V. would reduce the already restricted operational range of the aircraft.³ Work on the high priority A.I. programme absorbed all available personnel, and for a considerable time no aerials were available.

At the beginning of March 1941 the contractors completed a prototype installation for trials, but unfortunately it was not successful. No. 32 M.U., in conjunction with the R.A.E., then used the original components to build a revised experimental installation in order that operational and technical performance might be investigated before further development was undertaken. Trials conducted at the end of March 1941 showed that the aerial system was too dependent on the structure of the aircraft and could not be accepted. Meanwhile, it had become increasingly obvious that the only worthwhile torpedo-bomber in service with the R.A.F. ought to be fitted with A.S.V. of suitable performance; efficient forward-looking with clearly defined homing was essential. Work on the design of an effective system was begun by the T.R.E. in May 1941.⁴ In June 1941 the T.R.E. proposed the employment of two Yagi receiving arrays mounted on the mainplane at points six feet inboard of the wing tips and pointing outwards at an angle of 20° from the fore and aft line of the aircraft, and a Yagi transmitting array affixed centrally in the nose. However, the Director of Operational Requirements had recently called for the mounting of 2 Vickers gas-operated guns in the nose, and the Yagi transmitting array, as designed, could not therefore be incorporated.⁴ To avoid further delay employment of the existing quarter-wave dipole system

¹ A.M. File S.4368.

² In September 1941, to develop the technique of intercepting shipping in the dark and in bad weather, it was decided to form a Shipping Interception Flight for attacks on shipping in the Straits of Dover. The intention was to use A.S.V. Beauforts on dark nights to find enemy shipping, to illuminate the targets with flares, and attack them with torpedoes or bombs. The aircraft were to be assisted by the use of ground control. The scheme never got under way, although one or two attacks were made with unobserved results. (Despatch on Operation of Coastal Command.)

³ A.M. File S.6425.

⁴ A.M. File S.4368.

was proposed, but the new A.O.C.-in-C. Coastal Command had had, as A.C.A.S.(R), ample opportunities of evaluating the effect of piecemeal development enforced by circumstances, and preferred to accept further delay whilst a more satisfactory solution to the problem was sought.

The T.R.E. designed and fitted new arrays by August 1941. The two receiving arrays consisted of an excited dipole and four directors, and the transmitting array of an excited folded dipole, two directors and a reflector.¹ The C.C.D.U. conducted trials, and good ranges, adequate accuracy in homing, and a good area of forward search were obtained.² Satisfaction with both layout and performance was expressed by H.Q. C.C. and contracts were placed with Bristols, where arrangements had already been made to ensure that Yagi arrays could be fitted to mainplanes on the production line.³ Yet further delay occurred however; between termination of the development contract and the beginning of bulk production, shortage of raw materials caused the manufacture of aerial matching units to be suspended. This difficulty was cleared eventually, and before the end of 1941 all Beauforts leaving the aircraft factory were fitted with A.S.V. Mark II.

Hampden

The A.S.V.-fitted Beauforts of Coastal Command were transferred to the Middle East Command for operations in the Mediterranean during the early months of 1942.⁴ Since Beaufighters were not then available, Hampdens were employed in home waters, with no great success, as a stop-gap as strike aircraft. Several operations were made at night, usually in moonlight or nautical twilight. The procedure for night strikes differed from that of day attacks in that the force did not take off immediately on receipt of a sighting report but waited long enough to ensure that they arrived at the target after sunset. There were many difficulties, the greatest of which was caused by the navigational errors of both reconnaissance and strike aircraft. It was considered that with the assistance of L.R.A.S.V. practically all aircraft would find the target and an operational requirement for forward-looking L.R.A.S.V. was immediately submitted.⁵ The layout for a prototype installation was agreed in April 1942 at Handley Page's, and a mock-up completed at Boulton and Paul's in June. Production of a trial installation was however very tardy, and eventually the contract was given to Cunliffe Owen's instead of to the other firms. Development of an aerial system was also delayed by shortage of Yagis and discussions regarding their suitability and location. Meanwhile the radar officer of No. 16 Group fitted a Hampden with A.S.V. Mark II, overcoming the aerial problem by employing what were in effect cut-down Yagis, and obtained reasonably good results although the installation was only intended to be a 'lash-up' for experimental and training purposes. Its performance against surface vessels was judged by H.Q. C.C. to be sufficiently good to be operationally useful, and squadrons were eager to fit their own aircraft in a similar manner, but were handicapped by the fact that no official

¹ Transmitting array was similar to that used for L.R.A.S.V. Wellington.

² At 3,500 feet, 80 miles against coastline, 40 miles against ships of 10,000 tons and 30 miles against ships of the order of 100 tons.

³ A.M. File S.4368.

⁴ No. 22 Squadron—January 1942.

No. 42 Squadron—May 1942.

No. 86 Squadron—August 1942.

⁵ A.M. File S.6425.

modification had been approved, and demands for equipment and materials could not be met. The Air Ministry awaited the result of Service trials with the official prototype installation before ruling whether the operational requirement was practicable. The trial installation had still not been completed by the end of September 1942, and, since the Hampdens was shortly to be replaced by the Beaufighter, the Air Officer Commanding-in-Chief, Coastal Command suggested that the official operational requirement should be cancelled, whilst installation of standard A.S.V. Mark II should be continued under squadron arrangements.¹ In January 1943 it became evident, however, that Hampdens would most likely be retained for some considerable time, and impetus was given to a programme of fitting the official L.R.A.S.V. equipment to all operational aircraft, whilst the Hampdens which were replacing Hudsons for medium range meteorological flights were equipped with A.S.V. Mark II by squadron personnel.² In March 1943 the number of Hampdens to be fitted with L.R.A.S.V. was 100, and a programme of 30 per month was expected to begin at the end of April. By June 1943 the requirement was changed to standard A.S.V., and 2 Hampdens so equipped were sent to the C.C.D.U. for Service trials. The position of the transmitter was unsatisfactory and the task of re-positioning it was made a Coastal Command modification, as was also the fitting of Yagi homing arrays. General fitting began at L.M.S. Derby in September 1943, and about 30 aircraft were equipped by the end of the month.³

Beaufighter

Although it was not until September 1942 that Beaufighters were accepted as specialised torpedo aircraft, the A.C.A.S. (R) had initiated investigations into the possibilities of using long range Beaufighters for long distance interceptions over the sea as early as November 1940, but was faced with the same problem as existed with the Beaufort; space and weight limitations.⁴ L.R.A.S.V. and W/T or V.H.F. R.T. were required if the ideal was to be attained, but space precluded the installation of both radar and communication equipments, whilst the ability of the second member of the crew to operate the two simultaneously during the course of a sortie was doubted. In view of the vital need for good communication facilities in strike and shadowing aircraft, the W/T requirement was given higher priority. In any event, installation of bulky L.R.A.S.V. equipment, even without additional wireless sets, was impracticable.⁵ However, the successful experiments in the summer of 1941 with centimetric A.I. designed for fighters caused consideration to be given to its employment in an anti-shipping role. The Air/Sea Interception Committee at its sixth meeting on 12 March 1942 decided that tests were to be made to define the value of A.I. Mark VII against ships, and the extent to which it could be used as a form of A.S.V. Trials were conducted between March and May 1942, with indifferent results. Since in any event only a limited number of A.I. Mark VII sets were being produced, and those for a specific requirement of Fighter Command, further trials were made with A.I. Mark VIII.⁶ The employment of equipment for a purpose other than for which it was designed was symptomatic of the

¹ C.C. File S.9108/21.

² A.M. File S.6425, Part II.

³ Coastal Command Progress Reports Nos. 1, 2, 3, 4, 5. A.H.B./IIM/a3/1g.

⁴ A.M. File S.6425.

⁵ Minutes of 27th meeting Interception Committee, 1 May 1941.

⁶ Air/Sea Interception Committee Paper No. 25.

time, when urgency predominated, and inevitably left something to be desired in performance in its new function.

In August 1942 development of a standard A.S.V. Mark II prototype was begun. A major complication quickly became apparent. It was hoped at first that Beaufort Yagi aerial systems might be used, but that was not possible because of the location of petrol tanks in the mainplane, and because of the Beaufighter's greater speed, for which the Yagis were not sufficiently stressed.¹ The requirements of A.S.V. were to make possible Rooster homing to shadowing aircraft, to enable radar contact with the target to be made when attacking range was reached, and to indicate correct torpedo release point by accurate assessment of range.² The high performance required of Yagi aerials in other maritime roles was not necessary. Furthermore it was essential that the Beaufighter should be easily manoeuvrable and capable of making a get-away quickly after delivering an attack. In view of the effect of Yagi aerials on aircraft performance, Headquarters Coastal Command did not want Yagi receiver aerials, but were prepared to accept Yagi transmitter aerials if necessary.¹

The Royal Aircraft Establishment undertook development of suitable aerial systems, and flight trials were finally conducted in April 1943. Then it was found that both A.S.V. and aircraft performance were greatly improved if the Yagi transmitter aerial was removed, and Common T and R substituted.³ The provision of urgently required A.S.V. had already taken a long time, and although the Common T and R installation was preferable from both technical and aerodynamic aspects general fitting of Beaufighters with A.S.V. Mark II and standard aerial arrays was commenced in June 1943.⁴ Modification to Common T and R by squadrons was planned, but in August responsibility for the task was transferred to H.Q. No. 43 Group. Meanwhile in July, a trial installation of A.I. Mark VIII was cleared, but consideration of its application as A.S.V. was postponed as equipment in quantity was not available.⁵ By the end of September, 30 aircraft had been fitted with A.S.V., of which, however, only 7 had Common T and R, because a hold-up had occurred in the supply of coupling boxes.⁶ In February 1944 Beaufighters equipped with A.I. Mark VIII began leaving the factories, but their employment was confined to anti-flak and fighter escort duties; A.S.V. Mark II was to be the equipment of Beaufighter torpedo aircraft until the advent of A.S.V. Mark XII, an adaptation of A.I. Mark VIII, at the end of the year.⁷

Operational Use in Home Waters

During the autumn and winter of 1941 the torpedo attacks and minelaying tactics of E-boats were a very active and real menace to convoys sailing off the east coast of England. The routes they used to and from the convoys were necessarily so far distant from the coast that warning could not normally be given by coastal radar stations in time to enable interceptions to be made by light naval forces. It had proved extremely difficult for aircraft to attack effectively during the hours of darkness, particularly as E-boat operations were

¹ A.M. File S.6425, Part II.

² C.C. File S.9108/21.

³ M.A.P. File S.B. 8740, Part II.

⁴ Coastal Command Progress Report No. 1. A.H.B./IIm/a3/1g.

⁵ Coastal Command Progress Report No. 2. A.H.B./IIm/a2/1g.

⁶ Coastal Command Progress Report No. 3. A.H.B./IIm/a2/1g.

⁷ A.H.B./IIk/85/87(B). Radar Airborne Policy. See also Chapter 16 for details of A.S.V. Mark XII.

usually limited to nights when visibility was very poor.¹ It was therefore decided to attempt to use a L.R.A.S.V. Whitley, in the role of an airborne radar station under the control of a C.H.L. and in co-operation with light naval forces. Experiments conducted with motor gunboats off Yarmouth between 8 and 14 February 1942 showed promise, but an efficient system of control was difficult and impracticable because the height at which the Whitley had to fly, to make effective use of A.S.V., precluded reliable tracking by the C.H.L. at the long distances involved. A modified scheme was put into effect on 10 March 1942 using Hudsons instead of Whitleys because they were less vulnerable to fighters. To overcome the weakness of the original plan, the aircraft attempted to determine accurately their own positions, with the assistance of A.S.V. beacons,² passed relevant information by W/T direct to the M.G.B.s which were stationed in convenient areas 25 to 30 miles off-shore, and dropped lines of flares to guide them to the location of the E-boats. The modified scheme was given only a limited trial, during which 10 patrols but no attacks were made, because of the shortage of A.S.V. Hudsons and the transference of E-boat activities from the east coast to the English Channel, where their approaches were covered by shore radar stations. It did, however, form the basis of an interception technique which was used with considerable success in the last few weeks of the war. Then, Wellingtons were equipped with A.S.V. Mark III with north-seeking plan position indicators, which enabled the aircraft to pass to motor torpedo-boats, by V.H.F. radio telephony, their true bearing and distance from the enemy force when both surface forces were sufficiently close together to be seen on the screen, a distance of about 12 miles.³ In September 1942 an urgent need for a torpedo bombing strike force arose. Attacks against enemy shipping off the Dutch and German coasts were of cardinal importance, and low level bombing as previously used was no longer practicable as targets were too strongly defended. Beaufighters were selected as suitable aircraft but were by no means fully equipped for the function. Headquarters Coastal Command agreed to accept their introduction in two stages; the first, consisting of a limited number of semi-modified fighter aircraft less A.S.V., radio altimeters and other specialised equipment, and the second, fully modified aircraft which were expected to be available in the spring of 1943. In November 1942 an attack was made by a Beaufighter wing on shipping off the Hague. It was not a success but several valuable lessons were learnt, and from April 1943 strike forces operated effectively.⁴ Thus, until the spring of 1943, A.S.V. did not play a very large part in air attacks against shipping in home waters.⁵

Operational Use in the Mediterranean Sea

In the Mediterranean however, A.S.V. had already proved itself invaluable. There, enemy shipping rather than U-boats provided the most important targets and anti-shipping operations were vital, since the success of the campaign to drive the Italo-German forces from North Africa was dependent at least as much on destruction of enemy tankers and other supply ships as on anything else, and were perhaps the most effective contribution of metric A.S.V. to the war effort. In the very early days of the war radar equipment was despatched

¹ C.C. File S.15206.

² Installed at Bawdsey, Hopton and Happingburgh.

³ Despatch on operations of Coastal Command by Air Chief Marshal Sir Sholto Douglas.

⁴ A.H.B. Narrative: 'The R.A.F. in Maritime War.'

⁵ See also Chapter 16.

to the Middle East by air and sea but there was no organisation in the command to identify the equipment and to ensure that it reached the right destination. Most of it found its way to maintenance units where it remained unidentified and unused. This state of affairs continued until in October 1940 a separate Radio Branch was formed at Headquarters Middle East, followed in December by the formation of a Radio Installation and Maintenance Unit. Depots and maintenance units were then combed to locate and collect equipment and energetic action taken to ensure that the most efficient use was made of it.¹ Towards the end of 1941 a few aircraft equipped with L.R.A.S.V. operated from Malta, and at least 50 per cent of the total number of night sightings were made by A.S.V. aircraft; night reconnaissance without A.S.V. was considered to be of little worth, and all strikes made at night were assisted by A.S.V.² Reinforcement aircraft had been arriving without A.S.V. or in various stages of incomplete fitting. By the beginning of 1942 agreement had been reached with the Air Ministry that all aircraft sent to the Middle East for operations in search of, and for attack against, shipping should be fitted with A.S.V. and it was arranged that Beauforts should be completely equipped before despatch. Wellingtons were used experimentally as torpedo bombers at night, but the danger of over-specialising aircraft was realised; Wellingtons, modified for the torpedo role, could not be operated as bombers. The Air Ministry agreed in February, however, that all deliveries of a newer type, Wellington Mark VIII, would be fitted with radio altimeter, A.S.V. and Rooster.³

Rooster

During August 1941 a series of trials had been conducted by the C.C.D.U. to investigate the possibilities of using A.S.V. as an aid to air-to-air homing at night and in poor visibility. The existing M.F. D/F loop method was crude, involved breaking W/T silence, and required visual contact, such as station-keeping lights, in the final stages. From the trials emerged a technique in which an aircraft fitted with modified I.F.F. and a dipole aerial acted as homer to A.S.V. aircraft.⁴ A minimum practical range of $\frac{1}{4}$ mile, and a maximum of 40 to 50 miles, were obtained. A further development followed immediately.

Seven months previously the Officer Commanding C.C.D.U. had proposed to H.Q. C.C. a method of using A.S.V. for air-to-air communications.⁵ He suggested that an I.F.F. beacon when triggered by A.S.V. would cause a steady blip to appear. If the beacon transmissions were keyed, the blip would re-act accordingly, and if the A.S.V. transmissions were keyed, the beacon would similarly be triggered. Thus aircraft intercommunication by radar could be established; a great advantage was that signals would be confined to the beam of the transmitter and to optical range, affording a greater measure of security than was possible with wireless communication.⁶ There had been no apparent reaction to the proposal, so the opportunity was taken during the homing trials of conducting unofficial practical experiments. Two-way communication was established with ease, both in close formation and up to a range of 20 miles. The C.C.D.U. strongly recommended that all A.S.V. aircraft be fitted with the appropriately modified I.F.F. beacon, eventually known as

¹ See Royal Air Force Signals History, Volume IV: 'Radar in Raid Reporting.'

² O.R.S. (M.E.) Report No. 4.

³ A.M. File S.5223.

⁴ C.C.D.U. Report No. T.41/1, 14 August 1941.

⁵ C.C.D.U./452/3/P2, 1 January 1941.

⁶ C.C.D.U. Report No. U.43/1, 17 August 1941.

Rooster, to facilitate rendezvous, mutual identification, station-keeping and inter-communication, and during September conducted trials with Hudson, Beaufort and Whitley aircraft. Maximum ranges up to 90 miles and a practicable range of 60 miles were achieved at a height of 2,000 feet. Rooster was used by No. 19 Group aircraft to a minor degree only in May 1942, but the possibility of its use by the anti-shipping forces in the Mediterranean was quickly realised by H.Q. R.A.F., Middle East.

Because of the conditions of very good visibility which prevailed, A.S.V. was not a requirement during daylight hours when visual range was greater than that obtained with A.S.V. Mark II. The few aircraft that were fitted with A.S.V. were therefore used only for reconnaissance duties at night, and there was little to choose between the efficiency of daylight operations without A.S.V., and A.S.V. night operations, in the matter of search and location.¹ But the difficulty of ensuring that strike aircraft reached and attacked a target at night remained.² The method adopted was as follows. When an enemy convoy was located during daylight, shadowing was continued by non-A.S.V. aircraft until relieved at nightfall by an A.S.V. aircraft fitted with Rooster, which then signalled to base the position, heading, and speed, of the target.³ About 30 minutes after the Rooster aircraft had taken off, it was followed by a strike force of which only one aircraft needed to be fitted with A.S.V. and Rooster, that of the leader, who intercepted the signalled message direct, or received it when re-broadcast by base. The shadower, after transmitting the message, climbed to at least 4,000 feet and switched on Rooster, with which he acted as homer. As the strike force closed range, the shadower or leader dropped parachute flares to silhouette the target. On many occasions the strike force leader homed to Rooster before he had received the W/T message.

Rooster was also used to great advantage for daylight strikes when, as frequently happened in mid-1942, strike forces were called upon to operate at extreme operational range.⁴ In order to avoid radar detection, to be less easily visible, to conform to torpedo-dropping height, and as protection against fighters, strike aircraft flew as low as 50 to 100 feet. At such heights both visual and A.S.V. ranges were of course small, but accurate navigation was essential since there was no time to spare for searching for the target. To achieve reasonable A.S.V. range either the strike aircraft or the reconnaissance aircraft was required to be at a reasonable height. A Rooster reconnaissance aircraft therefore orbited at a height between 5,000 and 10,000 feet in the vicinity of the target, and ranges of 85 miles were thus achieved. This system was first used operationally in June 1942 in connection with the convoy operations Harpoon and Vigorous to Malta.

For action in conjunction with reconnaissance aircraft some naval units were fitted with Rooster. A surface strike force usually left harbour at dusk, and an A.S.V. aircraft some time later. When in the vicinity of the operational area the aircraft homed first to the ship-borne Rooster and then began its search. After locating the target, the aircraft climbed and, using A.S.V. and Rooster, obtained bearing and distance of the strike force from it and passed the information to the ships.³ Bad weather, and the usual complexity of air to ship communication, combined with other factors to spoil success on a

¹ O.R.S. (M.E.) Reports Nos. R.33 and R.37.

² In the latter part of 1941, mainly Wellington bombers and F.A.A. Swordfish.

³ O.R.S. (M.E.) Report No. 4.

⁴ O.R.S. (M.E.) Report No. R.22.

number of occasions, but the technique showed great promise and was extended to air co-operation with submarines fitted with Rooster.¹ The complications of normal methods of communication between aircraft and submarine soon led to the adoption of keyed Rooster. The procedure normally used was for the submarine to be positioned along an enemy convoy track ahead of the convoy's estimated position. When the aircraft obtained an A.S.V. contact it circled the convoy at a radius of 30 miles, keeping A.S.V. watch on broadside aeriels, until the submarine Rooster was detected. Then the submarine's bearing and distance from the target was obtained and passed to it. Ranges of 40 to 50 miles and keying speeds of 6 to 8 words per minute were usual. Rooster failures occurred in its earlier days when the beacon frequency was a fixed one of 176 megacycles per second because aircraft A.S.V. sets were sometimes off frequency, but an improvement was effected when the Royal Navy introduced a Rooster which was modified to sweep rapidly between 173 and 179 megacycles per second.

The Director of Naval Co-operation at the Air Ministry on 17 August 1942 referred reports of the successful use of Rooster in the Mediterranean to the Air/Sea Interception Committee.² He suggested that trials should be undertaken without delay with a view to improving the technique and examining further its potentiality for other applications. The committee decided on 17 September that ' . . . the possibilities of development were primarily in naval spheres . . . ' and asked H.Q. C.C. to discuss the matter with the Admiralty in order that recommendations might be made.³ Ever-increasing suspicion that the enemy had begun operating metric search receivers caused the possibility of compromise of Rooster/A.S.V. communications to be considered. However, the danger was thought to be far from serious, and H.Q. C.C. decided in November 1942 to develop Rooster communication and homing for use against E-boats off the east coast. Trials were held with Hudsons and motor gun-boats in the North Sea, and reliable two-way communication achieved at a range of 30 miles when the aircraft was over 1,000 feet. On 12 June 1943, H.Q. C.C. raised an operational requirement for Rooster as an aid to strengthen the weakness of aircraft/ship communications.⁴

A.S.V. Jamming

Reconnaissance aircraft operating over the central and eastern Mediterranean first reported deliberate jamming of A.S.V. towards the end of August 1942, and it became more and more serious during September and October.⁵ Until the beginning of November when the Eighth Army began its advance, the main enemy supply route was between the western end of Crete and Tobruk, although a certain amount of shipping took a more westerly route to Tripoli and Benghazi. During the whole of this period aircraft made intensive attacks against convoys, attacks of first importance to success of the campaign. They were made almost exclusively at night and relied to a very great degree on the ability of A.S.V. aircraft to find the enemy and enable strike forces to take action.

The vulnerability of A.S.V. to jamming had been obvious from its inception, and in July 1938 when its application was discussed at the Air Ministry, the

¹ O.R.S. (M.E.) Report No. R.20.

² C.C. File S.14408/7.

³ O.R.S. (M.E.) Report No. R.26.

⁴ Air/Sea Interception Committee Paper No. 33.

⁵ Air/Sea Interception Committee Paper No. 40.

Director of Communications Development spoke of the possibility of jamming but was of the opinion that such an obstacle could be overcome by the employment for A.S.V. of different wavelengths, and by changing them at intervals.¹ It was felt too that jamming would not be extensively used since A.S.V. wavelengths imposed a severe limitation on the practicable range of jammers and an enemy would have to face the risk of interfering seriously with his own radio transmissions made within the frequency band of A.S.V.² For the first two years of the war the suppositions proved to be well founded, for those responsible for German jamming had great difficulty in obtaining permission to use the counter-measures to the extent that they wished.

Although previously the Germans had made experimental jamming transmissions on occasions to cover actions by their aircraft, the first time they deliberately jammed all ground stations in a specific area for any length of time was when the *Gneisnau* and *Scharnhorst* escaped from Brest on 11 February 1942. On the same day an A.S.V. Hudson failed to obtain responses from the French coastline and on 23 February a Catalina suffered a similar experience off the Norwegian coast. On both occasions the A.S.V. equipment was tested when the aircraft returned to base, and was found to be working normally. The similarity of the two experiences created at the T.R.E. a conviction that intentional jamming was responsible, and attention was drawn to the danger of the enemy exploiting the low 'split' frequency of A.S.V. Mark II. Consideration of the use of separate transmitting and receiving paraboloids was recommended and meanwhile measures for reporting and investigating further incidents were introduced on 2 March 1942.³

Aircrews of A.S.V. aircraft were informed that two types of jamming, termed Daisy, would most likely be experienced: one in which sea returns diminished, and no echoes were obtained from land or ships, and another which caused the trace to become a blurred and smoky line or covered the screen with spidery patterns blotting out the normal presentation. Experience soon showed the necessity for a precise and comprehensive questionnaire to make the new reporting procedure effective. The T.R.E. quickly designed and produced a revised pro-forma and at the same time completed the script of a film to be used for anti-jamming training. The importance of methodical and careful reporting and analysis daily became more evident. Certain technical faults in aircraft, such as a badly-adjusted carbon-pile voltage regulator, gave rise to effects similar to those caused by jamming. The same effects were also created by the standard aircraft W/T transmitter when operated on certain frequencies, especially that of 6,000 kilocycles per second used by No. 18 Group aircraft as the main day reconnaissance frequency.⁴ The process of sorting the possibly real from spurious jamming became increasingly difficult, and emphasised an essential need for thoroughness. By the middle of May it became apparent that at least 30 per cent of jamming incidents reported by Coastal Command aircraft could not be attributed to the enemy, and of the remainder four only could be accepted as deliberate jamming. Intentional jamming of A.S.V. was on a scale remarkably smaller than that of other radar equipment in the

¹ A.M. File S.45501.

² See Royal Air Force Signals History, Volume IV: 'Radar in Raid Reporting,' Appendix No. 18, for an account of research on jamming, 1935-1939.

³ H.Q. Coastal Command Operational Procedure Instruction No. 4.

⁴ Harmonics injected into A.S.V. receiver.

areas covered by Coastal Command. An appreciation by the T.R.E. made in June 1942 led to the conclusion that since German I.F.F. was operated on 176 megacycles per second, the enemy was liable to jam A.S.V. only when his I.F.F. could safely be sacrificed, and the ground transmitters used for interrogating I.F.F. also produced a jamming effect. The obvious counter-measure to A.S.V. jamming, whether intentional or otherwise, was the projected change to centrimetric wavelengths.

The Mediterranean theatre of operations was the area in which A.S.V. jamming was to be mainly concentrated. An invasion of Malta was planned for the summer of 1942, and included in the plan was an intensive jamming campaign. The Germans found that they were able to receive A.S.V. transmissions at extraordinary long ranges in the Mediterranean area, and *Karl* type jamming transmitters were sited alongside receivers on high points of the coastline of Sicily, Greece and Crete, ensuring the closest co-operation between the Signals Intelligence and Radio Counter-measures Services. An airborne jammer, *Kobald*, was also used but proved to be of doubtful value, and suffered a disadvantage in that it could be installed only in large aircraft, and the Germans therefore relied mainly on a network of coastal stations.¹

From the middle of July 1942 Malta was the focal point of a jamming barrage aimed at all types of radio equipment. There was no clear evidence however, of effort aimed specifically against A.S.V. until towards the end of August, after which instances were reported from various parts of the Mediterranean. Three strike aircraft were completely unable to make contact with their target on 27 September, when their A.S.V. displays were saturated at a range of 120 miles from Crete, although their height was only 100 feet. A.H.Q. Mediterranean had already signalled to the Air Ministry on 18 August 1942 ' . . . Jamming is very serious when the aircraft is within the zone of interference. It is practically impossible to work through the jamming and large land masses can only be detected as shadows at very much reduced ranges. Effective ranges on shipping are reduced to 10 miles, and the certainty of deductions at these ranges is problematical. . . .'² The Air Ministry immediately arranged the transfer to Malta of a scientific officer of the T.R.E. who had already had valuable experience of anti-jamming devices. As a result of his surveys and reports, he was later in the year joined by another T.R.E. scientist to advise on counter-measures.³ A.S.V. sets were quickly modified by re-positioning the lecher line shorting link and introducing additional radio frequency and local oscillator stages to permit a rapid change of frequency from 174 to 191 megacycles per second. Although this modification promised well on the workshops bench, on operations the resultant excessive attenuation

¹ A.D.1. (K) Report No. 380/1945.

Karl I. Standard jamming transmitter designed to cover frequencies 90 to 250 megacycles per second in 4 bands. Employed 4 valves, Type L.S. 180, and power output was between 300 and 500 watts. Modulated by the standard Mont Couple 150 kilocycle modulation on which 100 cycle tone from an unsmoothed 50 cycle source of supply was imposed. Type of modulation could not be changed in the field.

Karl II. Improvement of *Karl I.*, and substantially 2 *Karl I* units with a common feed. Modified so that any desired type of modulation could be substituted in the field, thus obviating the necessity of returning the transmitter to the factory as was done with *Karl I.* Output was 2 kilowatts.

Kobald. Airborne set designed specially to jam A.S.V., and was originally used in the Mediterranean in conjunction with *Karl I.* In effect one half of a *Karl I* unit.

² C.C. File S.9094/20.

³ Mr. G. C. Barker and Mr. R. C. Light.

of the critically tuned aerials made it impracticable. Further schemes were tried, which, although they may have made the process of monitoring more difficult for the enemy, were evidently not adequately effective and in many instances required more specialised crew training than could be undertaken in Malta.¹ Units were very much dependent on their own initiative and resource. When a home command encountered a serious problem it was able to turn for help to the scientific establishments with their expert and their specialised research equipment. To what extent the Air Officer Commanding Royal Air Force Mediterranean was able to rely on assistance from outside his own command is perhaps best illustrated by quoting from a letter he wrote to the Air Ministry on 1 November 1942 ' . . . I would like to point out that although we have endeavoured to supply the Air Ministry with all available information concerning enemy jamming of radar, we have received no news of the type of jamming you have encountered in England, and of the success which you have had in overcoming it. I do feel that it is vital for us to pool our knowledge so that time is not wasted in duplicating our lines of research. I should therefore appreciate very much if your department would keep us posted on the types and characteristics of jamming in England, and of the counter-measures which you have found to be successful. We, in return, will do our utmost to present you with an up-to-date picture of the jamming war in Malta. . . . '² Arrangements were made to supply Malta with the current information required through the medium of fortnightly summaries from the T.R.E.

No comprehensive scientific investigation of A.S.V. jamming was possible since almost the only sources of information were the reports brought back by operational aircraft which, in spite of the special system of recording employed, could be no more than superficial; the primary role of the aircrews was to find their convoys rather than to investigate jamming. The command was dangerously short of A.S.V. aircraft and reluctant to divert any for purely investigation purposes. Consequently, analysis of jamming could only be mainly conjectural, in view of the often inconclusive and contradictory evidence available.³ But it became apparent that, although airborne jammers were used in the vicinity of important convoys, the main effort came from a network of ground-based jammers, the sites of which were chosen with due regard to the convoy routes which they were designed to cover.⁴ The area affected by each jammer was broadly that within 100 miles of each station, within which the effect was apparent down to sea level as a result of the high power employed. The convoy route between Crete and Tobruk was well covered but routes further to the west, forced upon the enemy by the advance of the Eighth Army, were less effectively covered, and reliance was placed on concentration of jamming effort at terminal and focal points.

Although A.S.V. jamming might often have been successful in screening the location of small craft, including U-boats and E-boats, once the initial shock of the introduction was overcome it did not prevent A.S.V. aircraft from accomplishing their main purpose, the location of large vessels, normally in

¹ C.C. File S.9094/20.

³ O.R.S. (M.E.) Report No. R.26.

² A.H.Q. Med. File M.S./5460/Sigs.

⁴ Some reports suggested that jammers were installed in the ships themselves, but this was thought most improbable, since such an arrangement would provide a method of homing to the ships from comparatively long range.

convoy. Such targets gave A.S.V. returns definite enough to be seen through jamming, and a search operation was usually based on fairly accurately estimated points of interception which left the aircraft only a small gap to be filled by A.S.V. Also A.S.V. was used entirely as a means of location and not as an aid to the actual attack. Jamming might well have proved a much more serious hindrance had reliance been placed on A.S.V. ranging and blind bombing equipment.

No really effective counter-measure equipment was evolved for incorporation in A.S.V. Mark II, but several palliatives were tested, and all involved frequency change.¹ De-tuning expedients also assisted A.S.V. operators, and experience showed that jamming had less effect when broadside rather than homing aerials were used. In August 1942 a series of tests under operational conditions were made by an officer of the R.A.E. in order to ascertain the nature of A.S.V. jamming and to test the effectiveness of specially modified receivers.² Results were encouraging and the receivers conferred a definite advantage when certain forms of jamming were encountered. Active consideration of how the new centimetric technique would fare against the heaviest jamming conceivable was stimulated. Because of the narrowness of the scanning beam it was liable to respond to a jammer only at the brief instant when the beam 'looked' at it during rotation, so that a large number of jammers dispersed in azimuth around the aircraft would be required. They would have to be sited on or close to the target it was desired to protect, and would therefore provide a means of homing. Progressive re-arming with centimetric A.S.V. forced the problem of jamming into the background and, finally, out of sight.

Value of A.S.V. Mark II

At the end of three years of intensive research, development, and war experience of airborne radar, there had been evolved in A.S.V. Mark II an invaluable air/sea radar search device. Figures showed that the use of A.S.V. by day had, up to the time of its eclipse by the German search receiver, increased the number of daylight attacks against U-boats by 20 per cent. There was also a significant tendency for attacks against U-boats made as a result of A.S.V. contact to be more effective than those made after visual sightings, because of the greater element of surprise. Analysis of night attacks made between August 1941 and the end of September 1942 showed that of a total

¹ O.R.S. (M.E.) Report No. R.26.

- (a) Spot frequencies. Provision of two or more spot frequencies with provision for rapid change-over. More than one aircraft was sent to a given area, each lined up on a different pair of frequencies in the band, in order to overload enemy jamming resources and leave some frequencies clear.
- (b) Stomach Pump. Transmitter frequency changed frequently and at will, and receiver set up accordingly. More effective than (a).
- (c) Wobulator. Transmitter underwent periodic and continuous change in frequency, and receiver capable of being set to any frequency within Wobulated band. Enemy unable to determine receiver frequency, which could be changed at will. Enemy incapable of jamming whole 'Wobulation' band at one time.

² A.M. File C.S. 16620.

A.S.V. Mark II was modified to include :—

- (a) A narrow band IF rejection filter, tuneable over a range of several megacycles per second. Chiefly useful for rejecting CW and LF AMCW.
- (b) A differentiating AC coupling between second detector and LF stage. This could be switched in and out at will.
- (c) Filter circuits in the anode of the LF valve. One filter was a low pass network with a fixed cut-off of 400 kilocycles per second ; the other was a rejector circuit tuning from 200 to 400 kilocycles per second.

of 31 attacks only two had been made without the use of A.S.V. ; and those two occurred during periods of bright moonlight. It was therefore evident that successful night attack against U-boats was practically impossible without A.S.V.¹ The potentialities of A.S.V., and the lines along which it should be developed, were more clearly recognised. For nearly every difficulty which was to be encountered with centimetric A.S.V. in the days to come there could be found a precedent, basically similar, in the earlier experiences with metric A.S.V., from which guidance was obtained.

¹ Despatch on Operations of Coastal Command by Air Chief Marshal Sir Philip Joubert de la Ferte.

PART II

**CENTIMETRIC A.S.V. AND UNDER-WATER
DETECTION DEVICES**

CHAPTER 7

EARLY DEVELOPMENT OF CENTIMETRIC A.S.V. IN THE UNITED KINGDOM

By the end of 1938 the development of all-round search with metric A.S.V. had reached the stage when practical experiments were necessary and the equipment was therefore installed in an aircraft. The receiving aerial was rotated mechanically, but difficulty was experienced in rotating the transmitting aerial in a similar manner and the first experiments were made with a fixed transmitter aerial. The system operated successfully as an experimental installation, but the impracticability of producing efficient aircraft aerials of suitable size for use with metric wavelengths caused further development to be abandoned. The use of centimetric wavelengths would have enabled smaller aerials to be employed. The general nature of aerials and feeders most suitable for centimetric wavelengths had already been established theoretically.¹ It had also been determined that efficient oscillatory circuits could be made by using metal cavities proportioned to resonate electrically at such wavelengths. Enough preliminary work had been done before the war to indicate that the development of an all-round looking technique on centimetric wavelengths would almost certainly be possible as soon as suitable valves became available.

Early Centimetric A.I. Experiments

The need for an all-round search system was by no means forgotten and on 9 February 1940 the requirement for research and development was resuscitated.² The inability of ordinary radio valves to function at the high frequency of centimetric wavelengths was still a hindrance to progress and two special types of valves, the klystron and the split anode magnetron, which could be made to oscillate at ultra high frequencies, did not develop enough power to be effective. During the spring of 1940 attempts were made to develop A.I. on other wavelengths in the centimetre band which at the time did not offer so many immediate technical difficulties as a wavelength of 10 centimetres.

Whilst experiments were still only in the research stage, further developments on a wavelength of 10 centimetres were greatly facilitated by the invention of the Randall-Boot magnetron, and more particularly by an improved version constructed by the General Electric Company.³ It made possible a pulse output of 10 kilowatts on that wavelength. Research and development on 10 centimetre equipment were consequently given priority over experimental work on other wavelengths. The Clarendon Laboratory, the Admiralty Signals Establishment, Electrical and Musical Instruments Limited, and Standard Telephones and Cables Limited, conducted research on receiving valves ; the

¹ The possibility of using wavelengths of about one centimetre had been mooted by Mr. R. A. Watson-Watt as early as February 1936, but the technical difficulties of obtaining sufficient power at such wavelengths were, at that time, insurmountable. (Minutes of 16th meeting C.S.S.A.D., 25 February 1936.)

² A.M. File S.45501.

³ See Royal Air Force Signals History, Volume IV : ' Radar in Raid Reporting,' for development of high power pulsed magnetron.

Air Ministry Research Establishment at Dundee studied ultra high frequency circuits ; and the A.M.R.E. airborne research group at St. Athan investigated beam scanning methods.

Centimetric radar equipment was used successfully for the first time in August 1940 when scientists of the Telecommunications Research Establishment at Worth Matravers detected, from the ground, a Battle aircraft in flight 6 miles away, and a submarine's conning tower at a distance of 4 miles.¹ In November and December tests were conducted against small ships and submarines. The latter were detected at a distance of 7 miles when surfaced and at 4½ miles when only the conning tower was above the surface.² All that remained was ' . . . to put it in an aeroplane. . . .'³ The broad outlines of an ultra-high frequency radar system had been decided but it was to be a long process to convert the experimental set into an aircraft equipment capable of reasonable serviceability under active service conditions.

The Tizard Mission to the U.S.A.

The Admiralty, in May 1940, had insisted that all-round search for naval aircraft was a firm requirement of the highest priority. Various interim measures to meet the requirement with metric A.S.V. had been discussed with the Air Ministry, but finally both the Air and Naval Staffs agreed that the only fruitful line of development was centimetre A.S.V. ; it was, optimistically, hoped that such development would be completed within one year.⁴ Attention and priority were, however, focused on improvement of the air defence system. Although the scientific manpower and laboratory facilities might have been sufficient to enable research to be conducted on both centimetric A.I. and centimetric A.S.V. simultaneously, early and complete development and production of both projects was quite out of the question.⁵ The resources of the United Kingdom for manufacturing new radio devices were fully engaged on war production. The need for centimetric A.I. was considered, at the time, to be more urgent than the need for centimetric A.S.V. The improvement of existing metric wave equipment and methods of using it were the immediate practical requirements for A.S.V. It was largely in an endeavour to use the almost unlimited radio research and production capacity of the United States of America that, in April 1940, a proposal was made to interchange secret technical information between the British and American governments. This was a delicate matter since the U.S.A. was still maintaining its neutrality. The decision to give away the secrets of scientific research was most important on account of its far reaching implications, but the enormous potential capacity of the United States of America for radio development and engineering offered the only prospect of satisfying our vital needs.⁶

¹ A.M.R.E. became T.R.E. on moving from Dundee to Worth Matravers on 5 May 1940.

² T.R.E. File D.1295. A group of scientists of the Admiralty Signals Establishment accepted an invitation to stay at Worth Matravers for six months to take advantage of the successful experiments. They developed experimental 10-centimetre equipment for installation in corvettes, which was an outstanding success and which became the first centimetre radar device to be used against U-boats. (T.R.E. File 4/4/458.) It was not, however, until much later that centimetric radar was in general use in H.M. ships.

³ See Royal Air Force Signals History, Volume V : ' Fighter Control and Interception,' for details of development of centimetric A.I.

⁴ A.M. File S.45501.

⁵ T.R.E. File D.1144.

⁶ The most important single British disclosure was, perhaps, the details of the cavity magnetron valve.

In August 1940 a Technical Mission was sent to the U.S.A., headed by Sir Henry Tizard, a scientist of international eminence, who combined the wide knowledge needed with a complete understanding of current operational requirements.¹ The Ministry of Aircraft Production was represented on the mission by Dr. E. G. Bowen, whose collaboration and guidance were to prove of great value to the Massachusetts Institute of Technology.² In October 1940 he discussed with the Microwave Committee plans for the development and production of 10-centimetre A.I., since this was considered to be the most suitable project to be undertaken in the U.S.A. In November the Institute began work in its newly opened Radiation Laboratory, which soon became an important centre for the development of centimetric airborne radar equipment.³ Rapid progress was made on the first project and in January 1941, Dr. E. G. Bowen formulated specifications of the requirements for centimetric A.S.V. and fostered an active interest in its possibilities although he himself had to concentrate on the development of A.I. He suggested that a beam of radiation should be projected from a convenient point on the aircraft and made to rotate at a speed not slower than one revolution per second; returned signals were to be fed to the simplest possible indicating device so that the plan position of vessels and coastline in the vicinity of the aircraft could easily be seen.⁴

First Experiments with Centimetric A.S.V. in the United Kingdom

Meanwhile in the United Kingdom research on 10-centimetre A.I. was energetically continued at the T.R.E., whilst a small group of scientists investigated the possibilities of applying the technique to the requirements of A.S.V.⁵ The development of immediate and effective measures against German night bombers was of paramount importance, and consequently received more attention than work on A.S.V. Although A.I. research and experiments produced information of value to the A.S.V. group, especially in relation to sea returns, detailed calculations for the design of an A.S.V. scanner with its driving system and display presentation were not possible.⁶ It was difficult for the A.S.V. group to obtain suitable radio components and they could not be spared the unrestricted use of one aircraft. The group had to make do with whatever materials and facilities were readily available. As one of their improvisations, the helical scanning system, used in the early A.I. experiments, had to be used for experimental work on both H2S and A.S.V.⁷

In May 1941 T.R.E. representatives discussed with the research staff of the firm of Nash and Thompson the possibilities of designing an A.S.V. scanner system, housed in a perspex cupola, to be fixed to the underside of an aircraft, and preliminary investigations to that end were begun.⁷ By then, development of 10-centimetre A.S.V. had reached such an advanced stage in the U.S.A.

¹ A.M. File S.4471.

² A.M. File S.5799. Dr. E. G. Bowen took with him samples of:—

- | | | |
|--|-------|---------|
| (a) Type E1189 air-cooled high power magnetron | | 10 cm. |
| (b) Type VT90 micropup | | 100 cm. |
| (c) Type E 1130 milli-micropup | | 20 cm. |

(T.R.E. File 4/4/450.)

³ See Appendix No. 3 for notes on the Radiation Laboratory.

⁴ See Appendix No. 6 for complete specification.

⁵ Successful flight trials of a Blenheim equipped with 10-centimetre A.I. were conducted in March 1941.

⁶ Flight trials of A.I. installed in a Blenheim showed that sea returns were greater with vertical polarisation than with horizontal polarisation. (A.M. File C.S. 13468.)

⁷ T.R.E. File D.1144.

that the Ministry of Aircraft Production, in June, confirmed proposals for further development and production to be left entirely to the Americans.¹ Active interest, however, continued at the T.R.E. on a reduced scale, and in July proposals were made for the installation of 10-centimetre A.S.V. in a Wellington. The intention was to fit the aircraft with a standard retractable under turret containing an oil driven parabolic reflector with a centimetric aerial assembly rotating in the horizontal plane, and also a transmitter unit. The receiver control power unit, modulator unit, high voltage supply unit, and display unit were to be installed in the aircraft in approximately the same position as the L.R.A.S.V. Mark II units. Nash and Thompson promised to have a scanning system housed in a turret ready for fitting to the aircraft by the middle of August 1941, and it was estimated that the installation would be completed and available for flight trials by the end of that month.

On 27 September 1941, when an A.S.V. installation programme was discussed at a conference at the Air Ministry, the Wellington project had not yet been started.² The possibility of installing scanning equipment in blisters under each wing of an aircraft had, however, been pursued by the T.R.E. Preliminary investigations revealed that streamlined wing cells would present only one-third of the drag created by the L.R.A.S.V. Mark II aerial arrays. This would greatly simplify the task of installing centimetric A.S.V. in flying boats which presented their own peculiar problems. Another advantage to be gained by fixing the aerials on the main planes would be that the guns in the nose would not have to be removed from certain types of aircraft. This was an important consideration which came to have a bearing on the course eventually taken with the Wellington XI.³ The great variety of types of aircraft allocated to Coastal Command presented a formidable problem when A.S.V. installations were contemplated since every change of equipment entailed a vast programme of work. The allotted aircraft included Beaufort I, Beaufort II, Ventura, Whitley, Wellington, Hudson, Liberator I, Sunderland, Catalina, Mariner and Coronado.⁴ The only available information on the performance and characteristics of 50-centimetre A.S.V. had been gained from hearsay and could not be supported by known facts, whilst no useful purpose could be served by consideration of 3-centimetre A.S.V. which was still in the embryonic stage of development.⁵ A.S.V. equipment for wavelengths of 10 centimetres was larger and heavier than for metric wavelengths and thus called for detailed attention to the disposition of its various units in the space available. Also for 10-centimetre A.S.V. the scanning mechanism had to be installed to give good all-round looking without seriously affecting the performance. The meeting therefore recommended that research work on the provision of wing blisters should be continued. Four weeks later, at the third meeting of the Air/Sea Interception Committee, a general discussion followed a statement by the Superintendent of the T.R.E. that ' . . . comparatively little development work had been done with A.S.V., and it would be of great value to the T.R.E. if a more detailed indication could be given of the direction in which existing A.S.V. was not satisfactory. . . .'⁶

¹ See Chapter 8 for details of development in the U.S.A.

² A.H.B./IHK/10/40—R.D.F.D.D. of Ops. (N.C.).

³ A.M. File S.45501.

⁴ The Mariner and Coronado aircraft did not materialise.

⁵ See Appendix No. 14 for details of 50-centimetre A.S.V.

⁶ Minutes of 3rd Meeting, 23 October 1941.

As a result, the Director of Radar, on 3 November 1941, convened a meeting with the object of defining the lines on which A.S.V. should be developed in the United Kingdom, to meet the existing and expected operational requirements of Coastal Command.¹

Urgent Requirement for Improvement of A.S.V.

The task was by no means straightforward. The inadequacy of metric A.S.V., after its brief spell of great success in the summer, was causing great concern. Unfortunately, development of the centimetric technique was not far enough advanced to provide positive evidence of its potentialities. Scientific investigations had established the fact that L.R.A.S.V. had reached its theoretical maximum performance. No improvement could be expected as the result of modifications to the receiver or by fitting the new Yagi arrays. Greater ranges of detection could only be obtained by raising the power of the transmitter to 100 kilowatts. Development possibilities to be considered were therefore :—

- (a) High Power 1½-metre A.S.V. Installation of a 100 kilowatt transmitter would, it was estimated, increase effective anti-submarine range by 30 per cent. This involved incorporation in the aircraft power supply system of a 1,200 watt alternator, doubling transmitter weight, and increasing its size by 30 per cent. Delivery in quantity of 100 kilowatt transmitters and associated power units could not be expected before August 1942.
- (b) High Power 50-centimetre A.S.V. Calculations showed that a system operating on a wavelength of 50 centimetres, with a 100 kilowatt transmitter, might double the existing maximum range against submarines. Its smaller aerial arrays would create much less drag than the metric wavelength arrays and this appeared to be a very definite advantage over the L.R.A.S.V. system. The sizes and weights of the component units were not available at the meeting, but the sponsors of the installation were of the opinion that it would be especially suitable for aircraft of the Royal Navy. Delivery in quantity could not be expected to begin for nine months or one year.²
- (c) 10-centimetre A.S.V. Performance of 10-centimetre A.S.V. was expected to be an improvement on that of metric A.S.V. but not so good as that of 50-centimetre A.S.V. It offered a great advantage over both, since it would afford from 270 to 360 degrees of angular coverage, according to the type of installation, and greater security against enemy interference. A disadvantage was that it could be installed only in large aircraft because of its bulk. Power supplies presented the same problems as for the high power equipment operating on longer wavelengths. Production in quantity might be possible by the autumn of 1942.
- (d) 3-centimetre A.S.V. 3-centimetre A.S.V. was still in the very early research stage and no reliable data was then available.

¹ C.C. File 9094/12.

² The aerial array in plan looked like an arrowhead. A central arm carried the transmitter aerial whilst the two side arms, which were inclined at about 20 degrees to the central arm, carried the receiver aeriels. The whole array was supported from the nose of the aircraft by three legs, and was extremely compact and easy to fit. (A.M. File C.S. 16766.)

After consideration of the various factors the meeting decided to recommend for consideration by the Air/Sea Interception Committee a three-stage development programme for aircraft of Coastal Command :—

- Stage I .. High Power 1½-metre installations were to be developed quickly, produced in quantity, and brought into operational use as early as possible.
- Stage II .. Was to be dependent on the outcome of trials to compare the merits of the 10-centimetre and 50-centimetre systems.
- Stage III .. The final development was to aim at providing 3-centimetre A.S.V. suitable for installation in all types of aircraft.

Twelve days later the conference resumed discussion, and then recommended that High Power 1½-metre A.S.V. was also to be included in the trials as a possible candidate for accelerated development and production, mainly because it did not entail unknown major aircraft modifications. The programme was accepted by the committee at its 4th meeting on 20 November 1941. Research and development of A.S.V. in the United Kingdom were consequently dispersed over three commitments, not one of which had any definite priority over another. At that particular time it was not easy to decide in favour of one definite course of action. The installation, servicing, and tactical employment of, and questions concerning radio operators and mechanics for, the existing metric system were all under review. At the same time there was a possibility that the installation of 10-centimetre equipment might prove to be impracticable in any but the largest aircraft, and there was also some doubt whether suitable aircraft would be allocated to Coastal Command.¹ Complications were added by the difficulties of estimating the time required for production in quantity and for completing installation in operational aircraft. The difficulties were due to the competing priorities for development and manufacture. Overall, there was the impending change of the A.S.V. wavelength, which made it necessary to give the most careful consideration to the requirements for beacons and blind approach and interrogator facilities used in conjunction with A.S.V.²

First Centimetric A.S.V. Installation

It was not until the beginning of 1942 that, as a result of strong pressure from the Admiralty and of the demands of the Commander-in-Chief, the principle of a maritime force of long-range landplanes was approved, and the decision was then made to allocate to Coastal Command the Fortresses expected to arrive from the U.S.A. during the ensuing year. Headquarters Coastal Command was not satisfied by this allocation because of the relatively short range of the Fortress; the Liberator was preferred. The position regarding future provision of centimetric A.S.V. was confused.³ Hopes were entertained by the Air Staff that the Fortresses would arrive already fitted with centimetric A.S.V., but centimetric work in the U.S.A. had been concentrated on a Liberator installation and it was extremely unlikely that Fortress installations would be available when the aircraft were delivered. It was considered to be imperative

¹ A.M. File C.S. 16766.

² See Royal Air Force Signals History, Volume III : ' Aircraft Radio,' for details of navigational and blind landing systems.

³ T.R.E. File D.1144.

that higher priority should be allotted to the development and production of centimetric A.S.V. in the United Kingdom if the Fortresses or any other heavy bombers were to be fitted and converted to the Coastal Command role.¹

At the T.R.E. the A.S.V. group was at last able to assume full control of the prototype Wellington in which the centimetric A.S.V. installation had only just been completed. This aircraft had for some time been taken over by the higher priority A.I. group and it was about to be claimed by the H2S group. In acquiring the aircraft they were fortunate since the importance of H2S had been increased by the personal interest of the Prime Minister in the development of methods to improve the accuracy and concentration of all-weather bombing.² Flight trials of the Wellington were made in January and February 1942. The installation was purely experimental and no attempt had been made to make it suitable for operational use.³ It included a scanner and mirror (28 inches by 15 inches) housed in a retractable under turret with 360 degrees rotation. No elevation tilt was used since the vertical beam was sufficiently wide to give the required coverage at the altitude envisaged. Presentation included a 6-inch A scope for measurement purposes and a 9-inch electro magnetic plan position indicator. Because a submarine could not be made available for use as a target, trials were conducted against two small surface vessels, one of which, the *Titlark*, had a metal superstructure similar in size and shape to a conning tower.⁴ The official report of the trials states that the maximum ranges obtained against the *Titlark* were 12 miles at 1,500 feet and 8 miles at 500 feet, with sea returns varying from half a mile in a dead calm sea to 2 miles in a moderate sea.

The Chief Signals Officer of Coastal Command who participated in the trials was rather more enthusiastic. ' . . . we observed two minesweepers from various angles,' he reported, ' and the maximum range either ahead or astern appeared to be about 15 miles irrespective of whether we flew at 500 feet or 1,500 feet. The presentation of the small ships was very clear indeed ; they appeared generally as two firm and separate bright arcs, each one-eighth of an inch long. Whereas the performance against the minesweepers from 1,500 feet was about equal to that of a L.R.A.S.V. Wellington or L.R.A.S.V. Whitley on their forward-looking aerials, the performance at 500 feet was much better, and the signal clearer than that which we could expect with L.R.A.S.V. at low altitude. . . . '

Decision to Manufacture Centimetric A.S.V.

The Director of Radar was so impressed by the performance of the equipment that, on 27 February 1942, he obtained approval for 200 sets of 10-centimetre A.S.V., with appropriate spares and test gear, to be produced urgently for installation in the larger types of aircraft likely to be used in Coastal Command. The types were the Sunderland and possibly the Fortress and the Liberator. The equipment would act as an insurance against possible failure of the A.S.V. projects in the U.S.A., and against possible non-allotment to the R.A.F. Financial authority was obtained on 14 March 1942 and development and pre-production contracts were placed with Ferranti's who began work on the

¹ A.M. File C.S. 10183. The R.A.F. Delegation had already formed the opinion that only American equipment should be installed in American aircraft. This eventually became the general policy.

² T.R.E. File D.1144.

³ T.R.E. File D.1142.

⁴ A.M. File C.S. 10183.

project in March 1942. The firm promised to deliver 4 sets in November 1942, 12 in December, 25 in January 1943 and 50 per month thereafter.¹

The scanning system used in the prototype Wellington was quite unsuitable for use with the Sunderland flying boats which constituted the main long range reconnaissance force of Coastal Command, and for which the new A.S.V. was required.² Experiments with wing blisters had progressed to the extent that in December 1941 a development contract had been placed with the firm of Metropolitan Vickers for a double mirror synchronised scanning system. During February 1942 a Whitley had been fitted with an experimental model of the double mirror system and with 10-centimetre A.S.V. as a preparatory step to the fitting of a Sunderland prototype. The two mirrors were housed under the wings in perspex nacelles with a mechanical method of synchronisation.³ Wind tunnel tests had shown that their effect on aileron control was negligible, and flight trials showed that the system was satisfactory provided that the aerials were carefully matched. The makers of the Sunderland, Short Bros., considered that the arrangement was a practical one for flying boats. Metropolitan Vickers, on the other hand, were experiencing difficulty in developing the scanning system to production standard. They could not promise a final prototype model before mid-September 1942, whilst quantity production could not be started before January or February 1943; moreover, a production contract had not been placed with them.

During the first three years of the war there was sometimes a tendency to imagine that if a firm was told 'verbally' that a job was likely to be given to them it was up to the firm to do the rest. Without an official contract, however, controlled materials and components were extremely difficult to obtain. It was, perhaps, scarcely to be expected that the firms of Ferranti and Metropolitan Vickers would complete their development programmes quickly since neither firm had been given any clear and firm indication that production orders would follow in the normal way. In any event, even if such orders were received, they would have to face the competition of other high priority production contracts.

A sense of real urgency in connection with A.S.V. was still lacking.⁴ The current policy was to hold a complete A.S.V. equipment as spare for every equipment installed in operational aircraft, one scanner system was required for every two sets produced, and the major portion of the airframe structural modifications was that entailed by installation of the scanners.¹ Consequently, although the sets would most probably be available, the Service could not expect 10-centimetre A.S.V. in Sunderlands before May 1943 especially since the detailed requirements by aircraft type and number had not been determined.

¹ A.M. File C.S. 10183.

² One of three ordered on development contract No. S.B. 22602/C.31A from Nash and Thompson. The design was purely experimental and unsuitable for production. The contract was closed in August 1942 as the second and third scanners were not required. (T.R.E. File D.1144.) Contracts for electrical H2S scanners had been placed with Metropolitan Vickers, and for hydraulic H2S scanners with Nash and Thompson, in January 1942.

³ The mirrors were two truncated paraboloids (28 inches by 16 inches by 7 inches), each of which was fed by a waveguide of rectangular metal tubing located along the inside of the mainplane. The waveguide feed was mechanically switched from one mirror to the other 60 times per minute. (T.R.E. File D.1144.)

⁴ T.R.E. File D.1144.

Development of High Power Metric A.S.V.

Meanwhile, in accordance with the decision reached by the Air/Sea Interception Committee in November 1941, work had proceeded on the development of High Power $1\frac{1}{2}$ -metre equipment. Because of its size, weight, and power requirements, it was likely to be suitable for installation only in the larger types of aircraft. Its development was accompanied by the incorporation of so many improvements such as motor-driven transmitter switches and Common T and R aerials that it resulted in radical re-design to become what was practically a new Mark of metric A.S.V. The T.R.E. favoured development of Common T and R aerials for broadside arrays only in conjunction with transmitter-switching so that combined sideways and forward looking, or forward looking, or sideways looking, might be selected at will.¹ By February 1942 a 100 kilowatt transmitter had been installed in one aircraft, and transmitter-switched Common T and R broadside aerials in another, but no experiments had been made with the two together. Although acceptance of such a system would eliminate the need for the receiver aerial switch motor, which had always been unreliable, there was no proof that it would be any more effective.

The Air Officer Commanding-in-Chief Coastal Command was not enthusiastic about the High Power $1\frac{1}{2}$ -metre system. He considered that it would be preferable to develop satisfactory continuous viewing with the existing L.R.A.S.V. for Wellingtons, Whitleys, Hudsons, Beauforts, Catalinas and Sunderlands; to proceed with 50-centimetre A.S.V. for Venturas; and to concentrate on the development of 10-centimetre A.S.V. for the Fortresses, Liberators and Sunderlands. He feared that there was a tendency to drift away from the agreed development programme and to consider the perfection of High Power $1\frac{1}{2}$ -metre A.S.V. as the most desirable course.² He had in mind the probability that metric A.S.V. would soon be stultified by German listening devices about which he already had a certain amount of information.

Experiments on 50-Centimetre Wavelength

In February 1940 experiments had been initiated in the use of a wavelength of 50 centimetres for A.I. At that time the facilities and man-power available were so limited that further experiments proposed by the General Electric Company were discouraged, since, if they had been successful, they would have delayed the final development of A.I.³ The indications were that the overall size of the A.I. equipment would be large and unsuitable for any type of fighter aircraft then planned. Compared with the existing metric wavelength A.I., transmitting power output and receiver sensitivity would be reduced and since it would not be possible to obtain much additional gain from the aerial system envisaged, the maximum range of detection would be no greater.³ General research on centimetric wavelengths continued, however, and various types of valves were used in endeavours to obtain increased power output. Some enthusiasm was shown for Samuel valves with which an output of 30 watts was obtained on a wavelength of 30 centimetres and nearly one kilowatt on 80 centimetres.⁴

By April 1940, the National Physical Laboratory at Teddington had obtained an output of 1.5 kilowatts on 50 centimetres by employing a magnetron with series modulation.⁵ The merits of shorter wavelengths for A.I. were

¹ C.C. File S.9096/1.

² A.M. File C.S. 16765.

³ T.R.E. File 4/38/10.

⁴ T.R.E. File 4/7/14.

⁵ T.R.E. File 4/7/14, Part II.

discussed at a meeting held in the General Electric Company research laboratory at Wembley in June 1940.¹ The conclusion was reached that if a simple dipole aerial system were used and the wavelength reduced whilst transmitter power and receiver sensitivity remained unchanged, the received signal would be proportionately reduced. Such reduction could be offset by employing directive aeri-als, but this would entail a corresponding restriction in the area of search. The use of shorter wavelengths coupled with scanning appeared to offer a solution to the problem of obtaining increased ranges. It was thought that improved receivers and greater transmitter power output could be obtained using a wavelength of 50 centimetres, since an amplification of 15 to 20 decibels had already been achieved on that wavelength with a 'deflected beam tube.'

The success of the 10-centimetre tests in August 1940 caused active interest in the development of 50-centimetre equipment to flag, but in November, in answer to an expressed need of the Admiralty, further experiments were conducted in an attempt to increase the signal to noise ratio.² Very little development appears to have occurred during 1941, and it was not until November of that year, when the various methods of obtaining effective A.S.V. were investigated, that the possibility of using the 50-centimetre wavelengths for High Power A.S.V. was resurrected.³

Comparative Trials of High Power Metric, 50-Centimetre and 10-Centimetre A.S.V.

The trials, to determine the relative merits of the various A.S.V. techniques, requested by the Air/Sea Interception Committee at its 4th meeting on 20 November 1941, took place at Ballykelly, Northern Ireland, between 16 and 23 March 1942. It had been hoped that the 10-centimetre A.S.V. Liberator prototype, which had recently completed flight trials in the U.S.A., would participate in the tests but unfortunately technical short-comings unconnected with the A.S.V. installation made that impossible. Aircraft unserviceability and temporary defects in the radar equipments caused difficulties in making a true assessment of the three systems under test.

The 50-centimetre equipment had been installed in an Anson, and included a 100 kilowatt transmitter similar to that used for the High Power 1½-metre installation. The results were disappointing, and its performance was considerably below that which had been confidently predicted.⁴

The High Power 1½-metre equipment was installed in a Wellington using standard homing and broadside aerial arrays. The transmitter was an experimental model of 100 kilowatts using NT. 99 valves and rotary spark gap modulation, and the receiver was the standard model for A.S.V. Mark II. The transmitter changeover switch for changing from homing to beam search

¹ T.R.E. File 4/38/10.

² T.R.E. File 4/4/450.

³ A.M. File C.S. 16766. See Appendix No. 14.

⁴ A.M. File C.16766 and C.C. File S.9108, Part III.

<i>Submarine Fully Surfaced—Beam On</i>		
<i>A/C Height</i>	<i>Max. Range</i>	<i>Sea Returns</i>
<i>in feet</i>	<i>in miles</i>	<i>in miles</i>
200	5½	1
500	4	1¼
1,200	7½	2

was of special design, but the receiver changeover switch was normal, and the layout was as used for standard L.R.A.S.V. Mark II installations in Wellingtons. Two submarines were used as targets on different runs, operating mostly at a distance of about 7 miles north of the mouth of Lough Foyle, cruising usually along an east-west line. Because of this proximity to land most of the runs were made with homing aerials only, approaching from the north. Even so, land returns became troublesome at a distance of 18 miles, and restricted the heights at which trials could be conducted. The reliable maximum ranges with homing aerials, against a fully surfaced submarine, were 14 miles at 1,500 feet, 11 miles at 1,000 feet, and $7\frac{1}{2}$ miles at 500 feet, and against a submarine trimmed down were $7\frac{1}{2}$ miles at 1,500 feet, 6 miles at 1,000 feet and $4\frac{1}{2}$ miles at 500 feet. Minimum range varied from 3 miles to 1 mile.¹ It was thought that an increase of about 20 per cent might be expected when the broadside arrays were used.

The prototype Wellington was used to demonstrate the performance of 10-centimetre A.S.V. and produced the more impressive figures.² For average weather conditions the most effective operational height appeared to vary from 500 to 800 feet, and when the sea was calm, 2,000 feet. Large convoys were detected at ranges up to 40 miles from a height of 500 feet. Clear indications of coastline were obtained at a distance of 60 miles over the sea from the same height with good detail showing at about 15 miles. These distances were somewhat less at a height of 1,500 feet. Other aircraft in flight could be observed at a range of 10 miles and their approximate direction of flight could be determined. Reliable maximum ranges against a fully surfaced submarine were 12 miles at 500 feet and 10 miles at 250 feet, with minimum ranges varying from $2\frac{1}{2}$ to $\frac{1}{2}$ miles.

Operational Requirement for 10-Centimetre A.S.V.

Immediately after the trials, on 25 March 1942, Headquarters Coastal Command informed the Air Ministry that 10-centimetre A.S.V., even though it had not then reached a very advanced stage of development, was a very definite operational requirement. 50-centimetre A.S.V. appeared to offer no advantages over metric A.S.V. which, even with increased power, was vulnerable to detection by German search receivers, and created considerable aerodynamic drag.³ Opinion at the Air Ministry was that even if the performance of the 50-centimetre installation in an improved form only equalled that of metric A.S.V., the fact that its aerial system offered far less drag made its further development important especially for naval aircraft for which a 10-centimetre installation might prove impracticable.⁴

Priority changed from Defensive to Offensive Radio Equipment

By the spring of 1942, fears of an invasion were considerably allayed and the importance of defensive measures became less vital. In April 1942 the Prime Minister directed that '... offensive radio equipment must take precedence over defensive equipment ...'⁵ This pronouncement did little to increase direct active interest in the production of A.S.V. however, for A.S.V. was

¹ C.C. File S.9108, Part III. See Table No. 3.

² A.M. File C.S. 10183. See Table No. 4.

³ C.C. File S.9108, Part III.

⁴ A.M. File C.48100/52.

⁵ A.H.B./ID/12/200. Priorities of Production.

generally regarded as equipment used in a purely defensive role even when its employment facilitated the destruction of U-boats. Only devices which made more effective the bombing of targets in Germany and enemy-occupied territory were considered to be offensive radio equipments. The offensive in air/sea warfare was the bombing of docks and U-boat pens and minelaying. Consequently, the main effect of the Prime Minister's directive was that H2S supplanted A.I. as the focal point of airborne radar development, and the demands made on the radio industry and scientific establishments by the development of H2S thus delayed the supply of components and the provision of facilities for the development of A.S.V., which instead of remaining as a variant of A.I. became a modification of H2S.¹ Development of both High Power 1½-metre and 50-centimetre A.S.V. had reached the point at which it was proposed to designate them A.S.V. (L) Mark III and A.S.V. (H) Mark III. The operational results obtained with metric A.S.V. in the first five months of 1942 were extremely disappointing and our shipping losses were very heavy.²

Clarification of A.S.V. Development Programme

The Air/Sea Interception Committee had, during the past few months, become so involved with the many and varied tactical aspects of attack that but little attention had been paid to the main problem of detection and location and to solving it by the provision of more effective equipment. However, at its 8th meeting on 28 May 1942 the committee, basing its discussions on a paper produced by the Director of Radar, attempted to tackle the problem in earnest. Firstly the specific requirements of A.S.V. equipment were formulated.³ It was to provide long range detection over a wide area in all directions from the aircraft, to enable the target to be closed, and to establish the type of target detected. Accuracy of range and direction were to be such that blind attacks might be made, and all the required characteristics were to be retained throughout the full range of operational heights of aircraft in which A.S.V. was installed. Then, after studying those requirements, the performance data of different A.S.V. techniques, the development and production positions, and the problems set by the processes of modification and installation, the committee decided that A.S.V. equipments operating on wavelengths above 10 centimetres were to be considered obsolescent. Production of 10-centimetre A.S.V. was to be undertaken on the highest priority for installation without delay, both retrospectively and in aircraft production lines, in Sunderland, Wellington VIII and Whitley VII aircraft. American 10-centimetre A.S.V. was to be installed in all American landplanes and flying boats allocated to Coastal Command. As a matter of urgency, 3-centimetre A.S.V. was to be developed and put into production for naval aircraft, Hudsons and Beauforts.⁴

¹ H2S was an airborne centimetric wavelength radar installation which gave P.P.I. indication of the terrain over which an aircraft was flown, and discriminated between built-up areas, open country, and water. See also Royal Air Force Signals History, Volume III : 'Aircraft Radio.'

² Allied merchant vessels sunk were 124 in May and 140 in June. The monthly average total for 1942 was 90 ; for 1941, 35.

³ See Appendix No. 7. The review prepared by the Director of Radar as S.I.C. 27, dated 14 May 1942, was used as the basis for the British Joint Policy on A.S.V. Requirements dated 3 July 1942.

⁴ Minutes of 8th Meeting of Air/Sea Interception Committee, 28 May 1942. It was also decided to designate the various types of equipment during their development phases, as :—

3-centimetre A.S.V.	A.S.V.X.
10-centimetre A.S.V.	A.S.V.S.
50-centimetre A.S.V.	A.S.V.L.

The way seemed to be clear, but there remained much to be done, and unfortunately all available resources were not immediately concentrated on the new programme. The Air Ministry, on 5 June 1942, informed the Ministry of Aircraft Production of the decisions so that all directorates and research and development establishments might be suitably instructed.¹ Improvement and further development of metric A.S.V. were to be confined to essential immediate requirements such as the incorporation of anti-jamming devices and slight modifications to enable more efficient receiver valves to be used, and development of 50-centimetre A.S.V. was to be discontinued.

¹ A.M. File C.S. 16765.

CHAPTER 8

DEVELOPMENT OF CENTIMETRIC A.S.V. IN THE U.S.A.

Meanwhile the production of 10-centimetre A.S.V. in the U.S.A. had not been so rapid as was originally hoped and expected. At that time the stimulus for development of airborne radar came from the British scientists in the U.S.A., and their attention had been focused principally on A.I. In April 1941 an American 10-centimetre A.I. equipment, the SCR. 520 prototype, designed at the Bell Telephone Laboratories, and installed in a B.18 aircraft, was given flight trials in the role of A.S.V.¹ The radiation beam was directed by a paraboloid mirror in the nose of the aircraft and gave a forward coverage of 180 degrees which, it was estimated, could easily be increased to at least 270 degrees in a Liberator. Results of the trials were encouraging but although the equipment was thoroughly sound in design and reliable in operation, it was heavy and cumbersome.

Originally it was intended for installation in an aircraft then being developed in which considerable space was available for the large modulator envisaged, which consisted of two bulky cylindrical units joined in the centre in the form of an H. A contract for development and production of SCR.520 had been given to Western Electric, but all their work was based on the fact that space was not a limiting factor. As a result of the successful issue of the trials, a further contract was given to the same firm to convert and develop SCR.520 for use as A.S.V., but the type of aircraft for which it was intended was not indicated. It was evidently not fully appreciated that the size and type of aircraft in which it might be installed were important factors in the design of A.S.V., since the development, known as SCR.517, was based on the same large and heavy modulator.²

In the meantime, the advance made with centimetric technique in the U.S.A., as the result of information disclosed by the Tizard Mission and the active collaboration of its members with their American counterparts, had greatly impressed responsible authorities in the U.K., where such progress could only have been made at the sacrifice of other vitally important work. Tremendous efforts were being made in the U.S.A. to 'give us the tools' and British personnel were required only to give a lead and provide guidance; the man-power cost to the United Kingdom was very small indeed. Consequently, from the spring of 1941, the number of British scientists sent to the U.S.A. was increased. A logical approach to the attainment of effective development was shown when, in June 1941, one of the additional scientists, Dr. E. M. Robinson, was instructed to study closely the many aspects of A.S.V. Mark II operations before leaving for Washington to assist with the development of centimetric A.S.V. He divided his time between the Headquarters, the Development Unit, and operational squadrons of Coastal Command, and discussed their numerous problems with the Commander-in-Chief, Air and Technical Staff officers, research scientists and squadron personnel.³

¹ S.I.C. Paper No. 6.

² A.M. File C.S. 16787.

³ A.M. File C.S. 13468.

Choice of Aircraft for Centimetric A.S.V. Installations

The question of what types of American aircraft were most likely to be allocated to Coastal Command, and for which of them centimetric A.S.V. should be designed, was investigated. Those already available, Liberators, Fortresses, Catalinas and Hudsons, were examined to enable the most efficient layouts to be planned ; several flights in A.S.V. aircraft impressed Dr. E. M. Robinson with the extreme importance of a good A.S.V. layout and the need for a comfortable and accessible operating station. Choice of the most suitable aircraft was not difficult. Only the flying boats and the Liberator met Coastal Command requirements for radius of action and warload, and scanner location presented difficulties on flying boats. The size of a 10-centimetre A.S.V. installation precluded the Hudson from serious consideration. An installation for the Liberator was therefore selected as that on which development should be concentrated, although at that time the possibility of the command receiving further Liberators was very slender indeed.

The decision proved eventually to be a wise one ; the all-important early experimental work proceeded undisturbed in spite of the many vacillations of policy regarding the types of aircraft to be employed on maritime operations which were to affect the speed with which centimetric A.S.V. was developed in the U.K. Experience gained with metric A.S.V. in all its stages from design to operational use strongly emphasised one vital point ; determined efforts were to be made to ensure delivery coincident with the arrival of fitted aircraft, of unit and component spares, tools, test equipment, handbooks, and trained mechanics. The British Air Commission¹ in Washington was authorised by the Air Ministry and the Ministry of Aircraft Production to retain one of Bomber Command's allocation of Liberators for use as a 10-centimetre A.S.V. prototype, and to arrange with the United States Army Air Corps for the necessary structural alterations to be undertaken.²

Radiation Laboratory Experimental Installation

Whilst SCR.517 was being developed by Western Electric, the Radiation Laboratory of the Massachusetts Institute of Technology, with the help of the British team of scientists, designed and built a considerably more advanced equipment, much less cumbersome and more closely allied to A.S.V. specifications.³ This was installed in the Liberator II AL.507, which had been obtained for prototyping. Plexiglass fairings had been constructed under the nose to take a rotating paraboloid, and existing equipment re-arranged to provide an efficient A.S.V. position freely accessible. Between August and December 1941, when in the U.K. the centimetric A.S.V. group were struggling to complete the prototype Wellington, a great amount of valuable work was being accomplished by the Radiation Laboratory, and much of what was done during that period set a pattern for all later productions. In September 1941, when work on AL.507 was well advanced, the British Air Commission began strenuously to

¹ See Appendix No. 3 for notes on the British Air Commission.

² A.M. File C.S. 13468.

³ Originally a valve mixer which greatly reduced the attainable sensitivity and ranges was used in the Plan Position Indicator unit circuit. The designers were committed to it because the T.R.E. technique incorporating soft rhumbatrons was not then known to them, and three months elapsed before a crystal mixer was used. The P.P.I. circuit was rejected by the B.A.C. because its many inter-dependent pre-set controls could not be maintained in adjustment outside a laboratory. The rejection quickly led to the invention of the clamping circuit of the P.P.I. (A.M. File C.S. 13468.)

advocate the allocation of a second Liberator, to encourage further development, to stimulate interest in A.S.V. amongst the Services of the U.S.A., to ensure adequate operational trials, and to lessen the risk entailed in having the centimetric A.S.V. programme entirely dependent on only one aircraft.

Change of Policy regarding Aircraft

By then, however, the Air Staff had decided that no more Liberators were to be allocated to Coastal Command, and there was therefore no requirement for A.S.V. installations in them. The much smaller Ventura was being considered as a possible substitution and a prototype was wanted.¹ Dr. E. G. Bowen was at the time in England to discuss with the Air Ministry, T.R.E., and Headquarters Coastal Command, progress in development of A.S.V. technique on both sides of the Atlantic, and to learn the latest operational requirements. He stressed the fact that 10-centimetre A.S.V. could be installed in the Ventura only at the expense of transferring all navigation facilities from the nose of the aircraft to a position aft of the cockpit in order to allow a scanner to be accommodated, and that this would involve considerable modification. Such a layout was impracticable since a Ventura crew consisted of only pilot and observer.²

The feasibility of developing prototype installations for Catalina, Mariner and Coronado aircraft was thereupon considered. Equipping the latter two types would entail only comparatively minor modifications, but to effect a satisfactory installation in the Catalina involved removal of practically all existing facilities from the nose. Although only one aircraft of any particular type was normally needed for development of a prototype, such development was of little use if the structural alterations made necessary were extensive to the point of causing serious delays in aircraft production. The issue was neither a straightforward nor an uncommon one. If modifications were to be incorporated on production lines, then exact details would be required by the British Air Commission, who in turn would have to convince U.S.A. Service authorities and aircraft contractors that the alterations were essential. Retrospective modification of aircraft already delivered to the Royal Air Force was impracticable.¹ The Air Ministry had already begun to suffer criticism from the American Embassy for delay in making use operationally of American aircraft because various modifications were being incorporated at centres in the United Kingdom, and the structural alterations necessitated by the installation of 10-centimetre A.S.V. in some aircraft were more drastic than any yet attempted.² The requirement for installations in aircraft other than the Ventura was therefore cancelled in October 1941.

Early in November the British Air Commission pointed out to the Ministry of Aircraft Production that G.R. Venturas would not be available before the autumn of 1942, and consequently the required prototype could be made only in a Bomber Command type of Ventura, deliveries of which were just beginning. The value of such an experimental test bed was questionable because the aircraft was barely large enough to take the equipment, the installation of which would result in an increase of drag, involve sacrifice of war-load, and seriously interfere with a satisfactory crew arrangement. The degree of success achieved in trials depended not only on the technical efficiency of an installation but also on the

¹ A.M. File C.S. 16787.

² A.M. File C.S. 13468.

operational qualities of the aircraft and practicability of equipment layout. Deficiency in the latter factors might prejudice effective employment of the former. The need for a second Liberator was again pleaded, and reasons additional to those originally given were stated. The Services of the United States of America were not particularly interested in A.S.V. installation in aircraft of the Ventura type, but were showing some degree of interest in the Liberator prototype. The rate of production of the Liberator had increased to one per day, and because aircraft were retained for a considerable period in modification centres in the United Kingdom for the completion of such work as fitting gun turrets and changing navigator stations, it was possible that aircraft production might quickly exceed the rate at which they could be delivered to Bomber Command operational units. Although no change was made in the official policy regarding Venturas, on 20 November 1941 the Air Ministry agreed to release another Liberator, AL.596, for centimetric A.S.V. experiments.¹

DMS.1000

By that time facilities for making by hand a small quantity of model-shop equipment had been completed at the Institute of Technology, and the Radiation Laboratory had begun design of a set called DMS.1000 in which the operational requirements of Coastal Command were closely followed and the most up-to-date technique incorporated. Encouraged by a request from the Ministry of Aircraft Production for five equipments, the British Air Commission placed an order for 12 sets of hand-made model-shop versions of DMS.1000.² On 10 December 1941, at about the same time as the experimental Wellington prototype was completed at the T.R.E., air tests of the first experimental Radiation Laboratory installation in Liberator AL.507 were started. Because of aircraft unserviceability and power supply difficulties, the trials were not completed until the end of February 1942, coincident with the trials against the *Titlark* in the United Kingdom. The experience and knowledge gained during that period were fed back into the design of DMS.1000, the order for which was increased to 275 production installations complete with spares, tools, accessories and test equipment, because the results obtained with the Laboratory model engendered in personnel of the British Air Commission great confidence in the successful outcome of the development.²

Service Trials of Experimental Liberator Installations

In March 1942, whilst arrangements were completed for the Liberator AL.596 installation to be serviced and operated by scientists of the Radiation Laboratory and radio mechanics of the Royal Canadian Air Force, Liberator AL.507 was made ready for Service trials in the United Kingdom, where it was hoped that the aircraft would take part in the Ballykelly trials of the different A.S.V. techniques.³ The aerial, which served for both transmission and reception, was a small dipole set at the focus of a paraboloidal reflector housed in the plexiglass nose blister. The reflector could be rotated about a vertical axis so that the narrow beam of radiation swept through 260 degrees. Echoes were displayed both on the A.S.V. operator's 9-inch P.P.I tube and on a 5-inch tube mounted between the first and second pilot positions, and were indicated by a

¹ A.M. File C.S. 16787.

² A.M. File C.S. 13468.

³ Four R.C.A.F. radio mechanics were given centimetric A.S.V. training, supervised by Dr. E. M. Robinson who compiled a handbook to meet and keep pace with the requirement for instruction. (A.M. File C.S. 13468.)

brightening of the time-base line at the appropriate range. The screens were given long after-glow so that as the time-base swept around, a record of the echoes was left, being renewed with each revolution of the reflector. Each P.P.I. tube was provided with a brilliance control and scales which could be illuminated at will. When the 10-50-150 miles range-switch, similar to that used with A.S.V. Mark II, was closed, there appeared on the time-base a bright spot which the operator made to coincide with the echo and enabled range to be read from the dial of the range control.¹

Service trials were conducted at Nutts Corner, Northern Ireland, during April and May 1942, under the auspices of Coastal Command Development Unit with the assistance of Mr. G. A. Fowler, a research scientist of the Massachusetts Institute of Technology, Dr. E. M. Robinson, and Squadron Leader E. I. R. McGregor of the R.A.F. Delegation.² The primary purpose of the trials was that of establishing operational performance at various heights and in differing sea conditions against surfaced submarines and small surface vessels; the secondary purpose was that of discovering weaknesses from the servicing aspect and ways and means of improving the A.S.V. layout. Good ranges were obtained against the different targets.³ Sea returns extended from 3 to 8 miles according to the state of the sea, and made blips difficult but not impossible to follow for the last mile or two. Misgivings had been felt whether the reflecting properties of storm centres would be such as to make 10-centimetre A.S.V. useless in bad weather. The trials showed that rain squalls during heavy storms certainly produced echoes, but not to the extent that efficiency was materially reduced. It appeared that the greater range of the centimetric technique and its more straightforward presentation of information would enable changes to be made in the operational methods then being used with metric A.S.V. Tactical procedure for employment of the latter had been devised to overcome its limited field of detection and poor discrimination; the new equipment provided a more or less faithful map of the sea below and around the aircraft, and rendered special technique and the complication of changing from broadside to homing aials unnecessary. But as was to be expected in an experimental installation it was not without its shortcomings. The power supply was a source of considerable trouble, the siting of various controls required improvement, the system of range determination was far from ideal, and homing became progressively more difficult as range decreased. Many of the faults were, however, already known, and suitable measures had been adopted to prevent their recurrence in DMS.1000. All seemed set fair for rapid progress free from the many pitfalls which had attended the development of metric A.S.V. and the frustrations hindering development of centimetric A.S.V. in the United Kingdom. However, two events quickly complicated matters.

Further Change in Policy regarding Aircraft

The first was when in March 1942 the British Air Commission was instructed by the Air Ministry to concentrate on the rapid installation of centimetric A.S.V., not in Liberators, but in Fortresses, deliveries of which to the R.A.F. were expected to begin in August.⁴ In January 1942 the Air Ministry had approved the principle of a long range maritime force of land-planes in addition to flying

¹ C.C.D.U. Report No. 51.

² See Appendix No. 3 for notes on R.A.F. Delegation.

³ C.C. File S.9108/19 C.C.D.U. Report No. 51. See Table No. 5.

⁴ A.M. File C.S. 16787.

boats, and had decided that Coastal Command should be allotted all Fortresses received from the U.S.A. ; they had been found unsuitable for operation by Bomber Command. The A.O.C.-in-C. Coastal Command considered that neither the Fortress nor the Sunderland, still less the Wellington and Whitley, were long range aircraft by Battle of the Atlantic standards, and pressed for the allocation of centimetric A.S.V. Liberators which he had at one time been led to expect.

Substitution of SCR.517B for DMS.1000 Production

The second complication arose when, whilst Liberator AL.507 and the people most actively interested in the development and production of DMS.1000 were in Northern Ireland, the United States War Department, in the interests of standardisation, cancelled the production order for DMS.1000 in favour of SCR.517B¹ which had been selected as the standard equipment for the United States Army Air Corps.² This decision was no doubt affected to some extent by a misunderstanding which had occurred in April 1942 at an otherwise successful demonstration, attended by General Arnold, of the experimental centimetric A.S.V. in Liberator AL.596, when he was misled to believe that he was being shown SCR.517B in a Liberator III. The British Air Commission, aware of the urgent need for centimetric A.S.V., accepted the substitution and placed an order for 500 sets, acting on the assumption that the equipment fulfilled R.A.F. requirements. When the Service trials party returned in AL.507 to the U.S.A. the misapprehension was quickly corrected. Although the conservative design and good solid engineering of SCR.517B gave promise of reliability, it was less sensitive than an equipment using crystal mixers, unnecessarily complicated, awkward to install in the nose of any but the largest aircraft, and in performance was generally inferior to DMS.1000.

During the AL.507 trials great enthusiasm had been shown for the pilot's indicator tube which was superior to those developed in the United Kingdom for metric A.S.V. It overcame many of the objections previously raised, and agreement had been reached that such a device should be retained in American aircraft in spite of the existing policy, which was to be reconsidered when more experience had been gained. No provision for a pilot's indicator was made in the SCR.517B.³ Faced with these facts the British Air Commission tried unsuccessfully to get the requisition for DMS.1000 production reinstated but they were only able to retain the original small order for model-shop equipment.² It was foreseen that delivery in quantity of SCR.517B was likely to be considerably delayed because of the type of components and method of production employed. Also, the separation of design and manufacture, in this instance between Bell Telephone Laboratories and Western Electric, tended to create an inflexible situation and increased the difficulties of incorporating in production equipments any modifications found necessary as the result of operational experience. Although structural alterations to Fortress II aircraft would take at least four months, anxiety was felt as to whether SCR.517B would be available in sufficient time and quantity to enable a fitting programme to be arranged. General Arnold, in response to urgent requests from the Chief of the Air Staff, who emphasised

¹ Western Electric production model of SCR. 517.

² A.M. File C.S. 13468.

³ By October 1942 the Americans had become convinced of the need for remote indicators. (A.M. File C.S. 17067.)

the urgency of the need for centimetric A.S.V. and the inability of U.K. resources to meet it, generously promised to release one-third of current U.S.A. production; unfortunately he was of the opinion after the AL.596 A.S.V. demonstration that SCR.517B was already being produced in quantity.¹

Production Order for A.S.G.

Meanwhile increased interest in A.S.V. projects had recently been shown by the United States Navy. Before it was flown to the United Kingdom for Service trials, AL.507 was demonstrated at Washington in the presence of senior officers of the United States Navy, Army and Air Corps, with the object of showing the potentialities of A.S.V. with P.P.I. presentation and so encouraging the Services of the United States of America to plan the installation of similar equipment. At the instigation of Commander L. V. Berkner, U.S.N., who witnessed the demonstrations, the United States Navy made arrangements with the Radiation Laboratory to place a development contract with Philco for an installation, A.S.G., to be used in 'blimps'. Its characteristics were similar to those of DMS.1000, in it were incorporated the most modern centimetric techniques, and its design was greatly influenced by experience gained with the experimental equipments in AL.507 and AL.596. Development had been placed in the hands of a firm anxious to make a good reputation in a new field, and the use of components likely to create difficulties had been eliminated so that production could be accelerated.² The British Air Commission therefore obtained permission from the United States Navy Bureau of Aeronautics³ to place a requisition for 500 sets of A.S.G. modified for installation in aircraft and called A.S.G.1, a notably light and compact equipment.⁴ The order for SCR.517B, the reliability of which could be depended upon in view of the proved capabilities of Western Electric, was retained as a standby should the Philco equipment prove to be a failure.¹

Decision on Aircraft Policy

The aircraft aspect of centimetric A.S.V. development meanwhile changed too. In April Air Marshal Sir John Slessor visited Washington to discuss with General Arnold future allocations of American aircraft to the R.A.F. General Arnold was desirous that the R.A.F. should be allotted Liberator rather than Fortress aircraft because since the U.S.A. had become actively engaged in the war over a world-wide area, he was striving to build up his own strategic bombing forces, and had always favoured the Fortress for that purpose. The misunderstanding at the AL.596 demonstration had, however, misled him not only about the equipment but also about the aircraft. AL.596 was a Liberator II and not a Liberator III as he had been given to think, and his proposals for allotting Liberators were in terms of Liberator III. In

¹ A.M. File C.S. 16787.

² A.M. File C.S. 13468.

Monthly Production Forecast			
1942	SCR.517B	A.S.G.1	
June	5	—	
July	5	—	
August	30	—	
September	35	30	
October	} Rising	45	
November		75	
December		125	
	100		

³ See Appendix No. 3 for notes on Bureau of Aeronautics.

⁴ A.M. File C.S. 13468.

these aircraft the crew stations were different, and to complete structural modifications for any production set of centimetric A.S.V. would take at least four months and not four days as he thought. From the point of view of time taken, therefore, there was little to choose between the Fortress or Liberator, and it was unlikely that either could be delivered fitted with other than experimental centimetric A.S.V. before October 1942. Before then, only metric A.S.V. could be installed. With Fortresses, there would be no interruptions in the delivery of aircraft equipped with A.S.V. Mark II, which had already begun, but with Liberators there would be a further gap of at least two months whilst metric A.S.V. equipment was engineered and installed.

The setbacks which had accompanied the installation of metric A.S.V. in Fortresses in the U.S.A. discouraged similar attempts with the Liberator. A satisfactory Liberator A.S.V. Mark II prototype had not been made. The fitting of suitable aerial arrays was thought to present little difficulty in view of experience gained by Coastal Command with the Liberator I, but internal arrangements would require careful study, and conditions at that time were unfavourable. A programme for installing A.S.V. Mark II in Fortresses, and commitments of the United States Army Air Corps, were saturating the facilities at Wright Field, and the possibility of equipping Liberators with metric A.S.V. in less than two months after a new contract had been negotiated between Wright Field and American Airlines (La Guardia, New York) was remote, especially since it was more than probable that the civilian airline would be reluctant to accept such a small contract. Insistence on the installation of metric A.S.V. could easily cause delay to the centimetric A.S.V. programme, and time would be lost rather than gained.¹ Sir John Slessor appreciated that the Liberator III was the better aircraft for the maritime role, especially as a modification to its fuel system to increase its radius of action would be completed before the end of the year, and General Arnold was more than willing to assist the R.A.F. in getting supplies of that aircraft.² It was therefore decided to concentrate on installing centimetric A.S.V. in Liberator III aircraft, and, until that could be accomplished, to accept Liberator III aircraft without A.S.V. and Fortresses equipped with A.S.V. Mark II.

DMS.1000 Installations in Liberators

The decision, which was confirmed in July, considerably simplified the problem which had for so long confronted those responsible for providing the R.A.F. with the sorely needed centimetric equipment, and made it possible for them to tackle in earnest the task of getting centimetric A.S.V. ready for operational use.³ The most effective layout was sought for DMS.1000 equipments, which were expected to be available within a short time. Eventually a location on the flight deck immediately behind the pilot was selected as that most adequate and freely accessible for the A.S.V. operators station; modification to the nose was almost identical with that incorporated in AL.507 and AL.596, but the fact that the navigator was stationed there in a Liberator GR Mark V necessitated a slight change in location of the modulator and transmitter.⁴

¹ A.M. File C.S. 16765.

² A.M. File C.S. 16787.

³ By July 1942 a Fortress trial installation had been advanced to the stage of a wooden mock-up equipment and a few minor structural alterations; it was subsequently equipped with DMS.1000 and allotted to the R.A.F.

⁴ Liberator Mark III modified for Coastal Command requirements was renamed Liberator G.R. Mark V.

It had not been possible to develop a factory process for making large fairings of plexiglass, and impregnated plywood was used instead. As had been feared, however, the speed at which structural modifications to the aircraft, entailing about 1,500 man-hours per fuselage, could be made, lagged behind the speed with which the radar equipment was produced.

Improvement of Installation Facilities

At first the Modification Centre was located at La Guardia, New York, but the airfield was required by Air Transport Command, so delay was increased by the move of the centre to Fort Worth, Texas, which entailed educating another contracting firm on what was required of it.¹ The long distances involved and the method of exercising control further complicated matters. The centre was not under the control of the British Air Commission, who had to pass their instructions through Wright Field, Dayton, via the War Department, Washington. The British Air Commission persistently pressed for a modification centre under British control, and at the end of the year Louisville was selected as the location of a centre predominantly for the modification of aircraft allotted to the Royal Air Force. Until the summer of 1943, when fitting began at Louisville, modification programmes for the United States Services took precedence, and the desperate efforts made to have 10 Liberators modified per month had little effect at first.

Not until early December 1942 did constant pressure at all levels cause the U.S.A. War Department to review the reasons for the lack of progress with the R.A.F. programme.² Then came an urgent plea from the Prime Minister to the President to provide 30 Liberators fitted with centimetric A.S.V., and a personal message from the Chief of the Air Staff to General Arnold asking him to accelerate the centimetric A.S.V. installation programme.³ An investigation of the modification centre organisation was made by the U.S.A. Army authorities, and two engineers responsible only to the War Department were placed in control with orders to get the aircraft out.⁴ The United States Navy authorities assigned A.S.G.1 equipments to the British Air Commission which would otherwise have gone to themselves, and 40 sets and an even larger number of the ancillary aircraft fittings were made available; by the summer of 1943 nearly 150 equipped Liberators had been delivered from Fort Worth.

Commencement of A.S.V. Fitting Programme

At intervals between October 1942 and February 1943 seven Liberators and one Fortress equipped with model-shop versions of DMS.1000 and containing replacement spares and test equipment were flown to Prestwick.⁵ In October 1942 a mock-up of an A.S.G.1 equipped Liberator was completed in spite of difficulties encountered in the process of fitting naval equipment to army aircraft.⁶ Layout was similar to that for DMS.1000, but the transmitter and

¹ C.C. File S.9108/19/1.

² A.M. File C.S. 13468.

³ A.H.B./ID/3/932. C.A.S. Folder H2S and A.S.V.

⁴ A.M. File C.S. 16765.

⁵ The Liberators included AL. 507. After the demonstrations and trials made in April and May 1942, AL. 507 and AL. 596 were engaged, manned by experienced crews of No. 120 Squadron R.A.F., in operations against U-boats off the American seaboard. A successful daylight attack was made on the second sortie but, as with metric A.S.V., effective attacks could not be made at night because of inability to identify a target on the initial approach without effective illuminants.

⁶ Cables and plugs had to be especially made; the shock mountings supplied by the Navy were too solid; suitable motor-alternators had to be provided.

modulator occupied much less space and made possible a welcome improvement in the working conditions of the navigator. Concurrently an SCR.517B Liberator prototype was begun so that an alternative installation could be provided should A.S.G. 1, which had undergone no airborne trials, prove to be a failure. The wisdom of the decision to install two different equipments in the Liberator was doubted at the Air Ministry because of the complications caused by the employment of a multiplicity of types of A.S.V., and the British Air Commission were advised to install either A.S.G.1 or SCR.517B followed by SCR.717. Production delays were, however, unpredictable and it was not possible to forecast which would be available in quantity first. Arbitrary selection of one type would obviously simplify servicing, maintenance and training but would also involve a gamble whereby delivery of fitted aircraft might be seriously delayed or interrupted because the particular type might not be available.¹ The Liberator G.R.V. was one of the few aircraft in which the cumbersome SCR.517B could be installed without seriously restricting other facilities; the scanner and modulator were housed in the ventral gun turret to leave the navigator station unimpaired, and to facilitate the provision of all-round looking.²

Thus it was not until the end of 1942 that the Air Officer Commanding-in-Chief Coastal Command received material evidence of the lively endeavour being made in the U.S.A. to provide his squadrons with the equipment and aircraft he so urgently required. Those most closely affected in the United Kingdom were not always fully aware of the intricate problems encountered by personnel of the British Air Commission, one of whom was moved to inform the T.R.E. that ' . . . After all, we at B.A.C. are your allies, just like the Chinese and the Bolivians. . . . '³ Apart from the more obvious difficulties raised by the change in policy regarding allocation of aircraft there were other comparatively minor ones which all, however, played a part in delaying attainment. In the United Kingdom there was prevalent a perhaps natural tendency to regard the U.S.A. as a vast well-stocked radio shop which in fact was by no means the case. A great deal of time and trouble were spent on the dull routine details of procuring materials and equipment. The situation was not eased, although possibly enlivened when, for example, in reply to a request for carbon flour for making resistances, the B.A.C. received an enquiry from one of the big wheat companies to whom a well-meaning government department had passed the requisition.

¹ A.M. File C.S. 16787.

² Fifty sets of modification parts for each installation, the A.S.G. 1 nose and the SCR.517B ventral turret, were ordered for possible retrospective fitting in the U.K. It was doubted whether retrospective fitting could be carried out in the U.K. unless the scanner and modulator were housed in the gun turret. (A.M. File C.S. 17067.)

³ T.R.E. File D.1295.

CHAPTER 9

DEVELOPMENT OF CENTIMETRIC A.S.V. IN THE UNITED KINGDOM

The progress made with 10-centimetre A.S.V. in the United Kingdom was even less encouraging than that made in the U.S.A. Although instructions to produce it on the highest priority had been given in June 1942, when requests were made for trial installations in Sunderland, Wellington, Whitley, and, later, Beaufort, Shetland and Buckingham aircraft, no concrete plan to co-ordinate installation and production had been made.

Delays in Production

By September 1942 10-centimetre A.S.V. was still far from ready for introduction into Service use. The first model of the Ferranti development contract was not delivered to the T.R.E. until July 1942, and then the T.R.E. found that it was necessary to demand a large number of modifications which involved the changing of an appreciable number of components.¹ One reason for the state of affairs appears to have been the shortage of development engineers in the firm, which was also engaged in the production of other high priority equipment including I.F.F. This is instanced by the fact that when the original receiver was supplied by the T.R.E. as a working functional model for development as an engineered prototype, a mechanical engineer employed by Ferranti's was made responsible for the layout of the panel and chassis, but he did not fully appreciate the necessary electrical requirements of R.F. circuits. The receiver, when delivered to the T.R.E., was unusable, and the electrical circuits had to be changed to conform with the physical layout provided, necessitating various changes in components.² Hopes were entertained that a second, modified, model would be delivered by the end of the month, September 1942, but it was doubtful whether the T.R.E. would be able to complete its tests and give approval for further manufacture to be started until the end of October 1942. Until that approval was granted and the firm had been advised what further changes had to be made, completion of the drawings and work on the engineering of 200 sets for operational use could not begin. Until the full details of final design were firmly established it was not possible to forecast definite dates, but even if it were assumed that the T.R.E. would approve the second model without major changes, delivery in quantity could not be expected before May 1943.³ Ferranti's task had been slightly lightened when in August 1942 the firm was informed that a policy decision had been made to the effect that devices which merely repeated to a pilot information already made available to an operator were not required, and work on the development of a pilot's indicator was therefore stopped.

¹ Ferranti placed the number as high as 40 per cent of the whole. Investigation revealed however that the figure of 40 per cent included the substitution of preferred values for resistors; had the correct values been used initially the percentage would have been very much reduced. (T.R.E. File D.1144.)

² T.R.E. File D.1144.

³ A.M. File C.S. 10183.

The location of a scanner system in a Wellington required careful planning. The value of A.S.V. lay in its combination with the Leigh Light, and the searchlight was housed in the under turret, the housing chosen for the scanner in the experimental prototype. The use of the double mirror system then being developed for the Sunderland was considered, but the fact that well-defined oscillation of the mainplane during flight was a characteristic of the aircraft made its fitting inadvisable. In July a position for a single mirror system, consisting of one half of the Sunderland system, was selected. It was below the fuselage and between the bomb bay and entrance door. This enabled a Mark XVIII torpedo with a large warhead to be carried, but it was by no means certain that this position for the scanner would not limit the effective area of illumination of the searchlight, and arrangements were made for experiments to be conducted to ascertain the degree of interference caused by the scanner system.¹ A contract for 200 Sunderland scanning systems, suitable for use as either double or single mirror installations, had been placed with Metropolitan Vickers, and the first models were expected to arrive at the T.R.E. midway through September 1942. At the beginning of August 1942 the T.R.E. had therefore requested that two Wellington VIII aircraft be modified by that date in order that scanners might be fitted as soon as they became available.² T.R.E. envisaged using the aircraft for experimental work including anti-submarine trials, acceptance tests, and servicing training, but excluding extended trials in combination with a Leigh Light installation. The T.R.E. considered that the evolution of effective tactical employment of the combination was sufficiently important to warrant the allotment of an aircraft solely for that purpose as distinct from ordinary A.S.V. trials. A Leigh Light A.S.V.S. prototype could be completed by the beginning of December 1942, but only if the scanner and electrical units were ready in good time; aircraft manufacturers were not usually prepared to expend man-hours on trial installation modifications until they were in possession of all the items of equipment required. Meanwhile, whilst the actual scanning and electrical units were awaited, installations with mock space models made of wood were being tried in Sunderland, Wellington VIII and Whitley aircraft.¹

Such was the position when meetings were held at the Air Ministry in August and September 1942 to discuss the implications of introducing A.S.V. Mark III, as A.S.V.S. was to be termed at the end of the development stage, into the Service and the progress already made to that end.³ The first meeting, on 11 August 1942, decided that the dates on which delivery in quantity could be expected were too far off for realistic consideration of the co-ordination of aircraft and equipment production programmes, and discussion was therefore limited in the main to planning trial installations.⁴

¹ T.R.E. File D.1144.

² Leigh Light Wellington shortly to be superseded by Wellington XII.

³ A.M. File C.S. 16786.

⁴ Financial authority to order an additional 1,000 sets from Ferranti had been received a few days before the meeting.

Date	Production Forecasts			
	Ferranti (Possibility of up to 4 months delay)		Metro Vickers	
	Monthly	Total	Monthly	Total
November 1942	4	4	—	—
December ..	12	16	20	20
January 1943	25	41	45	65
February ..	50	91	45	110
March ..	50	141	45	155
April ..	50	191	45	200
May ..	9	200	—	—

Trial installations for Sunderland and Wellington VIII (Leigh Light) aircraft were to be made simultaneously and on equal priority, and work on a trial installation for Whitley aircraft was stopped since employment in Coastal Command of that type of aircraft was likely to be discontinued before the production programmes were in full swing.¹ A number of other arrangements were also made. A.S.V. Mark III was, if at all possible, to be introduced to one squadron at a time; each squadron was to be completely equipped before the fitting of another was begun. A pool of test gear which was to be common to the various main centimetric radar equipments was to be organised on a basis of one set of test gear to five sets of main equipment, and from this pool all requirements for A.S.V. test gear would be met. Workshops based on those designed for A.I. Mark VIII were to be provided on a squadron basis.² Spares were to be provisioned to schedules calculated by personnel of the T.R.E., who also undertook the task of training in centimetre wavelength technique sufficient radar officers and tradesmen to service the first 200 A.S.V. installations, after which sufficient equipments could be made available to the radio schools to enable training and conversion courses to be undertaken in time for the general introduction of A.S.V. Mark III. T.R.E. representatives expressed concern about the inaccessibility to servicing personnel of secret technical documents, and after some discussion the meeting agreed that there were three requirements for technical publications:—

- (a) A non-secret document with diagrams of the arrangement of units, wiring and similar information.
- (b) A secret document with all technical details, circuit diagrams and performance data.
- (c) A confidential servicing manual with full details of periodic and daily inspections and fault-finding instructions.

The second conference, on 11 September 1942, learnt that it would be mid-November before the first Ferranti models were ready for trials, and that production in quantity might begin in March 1943. Metropolitan Vickers had reported that they would be unable to start making 200 scanning units until February 1943.¹

The aggravated delay in production at last caused grave anxiety in view of the heavy shipping losses being sustained. The Commander-in-Chief, Coastal Command, was concerned about the slow rate of progress, and the Ministry of Aircraft Production was asked if anything could possibly be done to bring production nearer the original target dates.³ Sir Robert Renwick conducted an investigation; it was found that the vexed question of priority for delivery of components was extremely complicated because at least 65 different projects had been given the highest priority.⁴ The demands of the H2S programme, for which the priority was theoretically the same as that of A.S.V., had in fact precedence over A.S.V. because of the keen interest in H2S progress shown by the War Cabinet, and this effectively prevented bringing forward the dates by which A.S.V. could be delivered.

¹ A.M. File C.S. 16786.

² Two extra A.S.V. servicing workshops were to be held by Command H.Q. to cater for the rapid movement of squadrons to airfields where no workshop facilities existed.

³ C.C. File S.9108/19.

⁴ Sir Robert Renwick held the appointment of Controller of Communications at the Air Ministry and Controller of Communications Equipment at the Ministry of Aircraft Production, and was thus in a position to exercise a unique degree of co-ordination between operational requirements and organisation of production.

Project to combine A.S.V. and H2S

Such a possibility had been foreseen some months earlier. On 8 January 1942 Electrical and Musical Industries Limited had been given a production contract for 1,500 H2S equipments ; on 26 January 1942 the contractors were asked to produce, by hand-tooled methods, 200 sets before October 1942, three or four months before quantity production could be expected to start.¹ On 22 January 1942 Sir Henry Tizard, in a minute to the A.C.A.S., stated ' . . . I am surprised to find that the development of centimetric A.S.V. is not being regarded as one of the highest priority. The accurate location and attack of ships under conditions of low visibility is of such supreme importance to the war that I have thought no effort should be spared in improving existing methods . . .'² He followed up by writing to the Chief of the Air Staff on 3 March 1942 deploring the fact that so much attention and pressure was being focused and brought to bear on the development of H2S to the detriment of progress with A.S.V.S.³

The Chief of the Air Staff was, however, understandably reluctant to do anything which would retard progress with H2S. For some months the Prime Minister had been concerned about the comparative failure of the bombing offensive against Germany and the heavy losses incurred. He had authorised the employment of a high proportion of the resources of the United Kingdom to increase the production of heavy bombers, and continually stressed how vital it was to treat as a matter of extreme urgency all measures likely to increase the number of them that accurately bombed the target. Information received from the U.S.A. indicated that whilst experiments being conducted there with centimetric A.S.V. were meeting with considerable success, efforts at 'town detection' were not doing so well. To assess the relative importance of the two applications was not easy. The entry of the U.S.A. into the war had given U-boats plenty of worthwhile and comparatively easy targets immediately off the American seaboard so that just at that time convoys were comparatively free from attack on the eastern side of the Atlantic, and the need for centimetric A.S.V. appeared to be less pressing than that for H2S. The C.A.S. was therefore relying on satisfactory development, production and installation of centimetric A.S.V. in the U.S.A., and had arranged that the Fortresses being allocated to Coastal Command from August 1942 onwards should be equipped with it ; he had stressed the importance of avoiding delay.⁴ However, enquiries he made as a result of Sir Henry Tizard's representations caused him to be keenly interested in the prospects of combining H2S and A.S.V. functions in one set of equipment when such a possibility was suggested in March 1942 by the T.R.E.⁵

The electrical units and scanning systems needed for both closely resembled each other in certain circumstances, and a combination of the two would eliminate duplication of effort during development and production, and render unnecessary the competition for components and materials which would be inevitable once production stages were reached.⁵ One of the few fundamental differences, but a very important one, was that H2S did not necessarily involve the use of the magnetron, a component considered to be

¹ A.M. File C.30305/46.

² A.H.B./ID/12/193. Aids to Target Finding.

³ A.H.B./ID/3/1791. Navigational Aids.

⁴ A.H.B./ID/3/1791.

⁵ T.R.E. File D.1738.

essential for A.S.V.¹ The cupola, scanner, and scanner drive arrangements which constituted the major problem of aircraft modification could, it was thought, be made identical, and four general possibilities presented themselves. They were :—

- (a) Construction of a single complete equipment suitable for both applications.
- (b) Construction of scanning equipment common to both, but using for H2S the units being developed by E.M.I., and for A.S.V., units based on A.I. Mark VIII design.
- (c) Construction of scanning equipment common to both, but using for H2S the units being developed by E.M.I., and for A.S.V. those being developed by Ferranti.
- (d) The use, as H2S, of the A.S.V.S. being developed by Ferranti.

The first was, from a technical point of view, the ideal approach, and operationally it opened up the prospect of increasing considerably the flexibility of bomber type aircraft fitted with the equipment since it appeared, superficially, that they could be used in both the bomber and maritime roles.² Such a measure was, however, made impossible by the Cabinet ruling that magnetrons were not to be carried over enemy territory.³ The second approach appeared to offer a quick method of obtaining centimetric A.S.V., since the necessary modifications to units of A.I. Mark VIII, which was to be produced in quantity by the General Electric Company from August 1942 onwards, could be incorporated without much difficulty.⁴ A suitable display unit would have to be designed and produced separately, but could possibly be made identical with that required for H2S. A major complication would be introduced by the necessity for evolving a satisfactory method of installation in aircraft to ensure that both A.S.V. and H2S could easily and quickly be accommodated, because the former would comprise six units and the latter four. The complication was further aggravated in the third possibility. The units were already being developed but by different firms, and very close liaison between the A.S.V. and H2S groups at the T.R.E. would be essential to ensure that the scanning system being designed for H2S would be suitable for A.S.V. A.S.V. performance to be expected from the H2S equipment under development, because of its use of the klystron instead of the magnetron, was only slightly, if any, better than that of L.R.A.S.V. Mark II ; a maximum range against big ships of 20 miles, and against submarines of no more than 5 miles ; far short of Coastal Command requirements.

The advantages of the first possibility were overwhelming, but were vetoed by the firm decision that the magnetron was not to be used.⁵ T.R.E. opinion was that if the ruling could not be revoked, then development and production contracts for 1,500 units, based on A.I. Mark VIII design but using as many components as possible that were common to H2S, should be placed with

¹ Details of the magnetron were known only to the Allies, whilst the klystron had been fully described in the scientific press of the world. The magnetron was practically indestructible and its use over enemy territory was therefore forbidden ; it could, however, be flown over the sea, since in such circumstances the possibility of it being captured by the enemy was remote.

² T.R.E. File D.1738.

³ See Royal Air Force Signals History, Volume III : ' Aircraft Radio.'

⁴ See Royal Air Force Signals History, Volume V : ' Fighter Control and Interception.'

⁵ The choice of klystron or magnetron was made difficult only by operational considerations ; technically there was little doubt that the magnetron was the more suitable.

E.M.I. : should the time factor prove to be unacceptable, then, as an interim measure, a limited number of A.S.V. sets might be obtained by modifying some of the first A.I. Mark VIII equipments to leave the production lines. The Minister of Aircraft Production, during the course of a visit to the T.R.E. on 15 March 1942 agreed that the plan of using one firm, E.M.I., to make both A.S.V. and H2S with as many units as possible common to both, should be put into effect.¹ Also the C.A.S. ruled that if any additional facilities were required to ensure that such development proceeded with the greatest urgency, then such facilities were to be found.² T.R.E. and E.M.I. representatives together evolved a possible system for putting the plan into practice, which was discussed at a conference on 24 March 1942.³

The cupola, scanner, aerials, magslip and cabling could be made common by changing only the aerials and cabling of the H2S system already being developed by E.M.I. The power unit, receiver and timing circuits, control box and indicator unit could be made common by modification of the units already designed for H2S by the same firm. A.S.V. required three more special units, magnetron transmitter box, modulator and an additional power unit : H2S required only an additional combined klystron transmitter box and modulator. The magnetron transmitter box would be identical with that of A.I. Mark VIII, the A.S.V. modulator could be a slight modification of A.I. Mark VIII, and the additional power unit was to be a new unit based on A.I. Mark VIII design. The combined klystron transmitter box and modulator had not been made because of technical problems not then solved, but the basic designs would not have to be altered. During detailed discussion of ways and means to put such a system into effect with the minimum of delay, the fact that it had not been definitely established that a klystron unit would be operationally satisfactory was stressed ; it might prove necessary to use the magnetron for H2S despite the security policy.³

The Gramophone Company, a manufacturing associate of E.M.I., was given a contract to design and develop H2S/A.S.V. and E.M.I. was asked to make 15 pre-production models ; the M.A.P. was to provide the firm with 15 sets of A.I. Mark VIII units. E.M.I. estimated that, assuming all necessary information already in the possession of the T.R.E. was made available without delay, some models might be completed at the end of August 1942 and the remainder during the autumn. If final approval of the prototype was then obtained without any delay, production could begin six months later. Subsequently the original production contract of 1,500 H2S equipments was changed to one for 1,500 complete H2S/A.S.V. equipments. On 29 December 1942 the T.R.E. informed E.M.I. that ' . . . several of the units of the universal system are already being prototyped by other firms, such as B.T.H. The additional units which will be required for, and are particular to, the next Mark of H2S/A.S.V. will naturally be developed at E.M.I. but some time must elapse before functional designs to meet operational requirements which have only just been stated can be worked out. A reorganisation has been effected within T.R.E. to co-ordinate development of universal units . . . '

Effects of Priority of Bomber Offensive on Development Programme

Whilst development of the A.S.V.S. project was continued by Ferranti the Prime Minister and Lord Cherwell continued to evince an ever-increasing urgent interest in the H2S/A.S.V. project but always from the aspect of its

¹ A.M. File C.30305/46.

² A.H.B./ID/3/1791.

³ T.R.E. File D.1738.

application to bombing, to such an extent that its potentialities as A.S.V. became completely submerged, and work was concentrated on the H2S components. Flight tests in the role of A.S.V. could not be contemplated until H2S was undergoing final Service trials.¹ Despite the high priority allotted to it, a satisfactory rate of progress was difficult to maintain. The scientists were continuously hindered in their efforts to achieve finality in design by changes in operational requirements, and until all the many details of design were settled production could not begin. Initially, the promise shown during the early A.I. experiments that indication of built-up areas would be possible was considered sufficient to warrant enthusiastic encouragement, but as development advanced, higher standards of accuracy and increased versatility were demanded: they involved radical re-design.²

The position was consequently reviewed in May 1942 when the Air Staff re-formulated the minimum requirements: ability to home to a built-up area from a distance of 15 miles when flying at 15,000 feet, and to bomb with sufficient accuracy to guarantee that bombs would fall within an industrial or other area selected as a target; if no delay or interference in the progress of development were entailed, ability to determine the identity of a specific area or target was desirable.³ The method of presenting information would also have to be modified to meet Bomber Command requirements. Both for H2S and A.S.V. the vertical datum line through the centre of the cathode ray tube display had been synchronous with the line of flight of the aircraft, and a blip appearing vertically above the centre indicated re-radiation from an object directly ahead. But as navigators worked on plotting charts with north always at the top, and measured in azimuth all tracks, courses, and bearings from true north, the advantages to be gained from a P.P.I. presentation in which a blip indicated the position of an object in relation to true north rather than the fore and aft axis of the aircraft were manifest. The centre of the C.R.T. screen could be taken as the position of the aircraft and blips made to drift across the screen; it needed little imagination to consider the display as the stationary factor, that is, the area over which the aircraft was flying, and the centre of the screen as the changing factor, that is the track of the aircraft.²

A major set-back to progress occurred on 7 June 1942 when the H2S/A.S.V. Halifax prototype crashed and was totally wrecked whilst on a test flight. Loss of the experimental equipment was sufficiently unfortunate in itself, but flying in the aircraft were five of the comparatively small group of scientists actively engaged on the development, and they were all killed.⁴ A second prototype was, fortunately, available and efforts were resumed, but with little real success. Even when a magnetron was used results were at first far from satisfactory, and those obtained with a klystron were poor in spite of intensive development work undertaken by the T.R.E. to produce a klystron capable of giving 5 to 10 kilowatts peak power. The tests were confined to the H2S units; no bench or flight trials had been made with A.S.V. by the end of June 1942, when it became apparent that there were but slight hopes of obtaining the

¹ T.R.E. File D.1738.

² See Royal Air Force Signals History, Volume III: 'Aircraft Radio.'

³ A.H.B./ID/3/1791.

⁴ A.H.B./ID/12/195, H2S and H2S/A.S.V. Those killed included Messrs. Blumlein, Blythen, Browne of E.M.I. and Hensby of T.R.E.

required maximum range of 15 miles with the types of klystron available.¹ The possibility of using unstrapped, as distinct from strapped, magnetrons, because they were less secret, was mooted. But plans had been made for a large output of klystrons, and not magnetrons, for H2S units, and although there would be no difficulty in supplying the latter for the first 1,500 combined equipments, the extra output required immediately afterwards might have meant one year's delay. The original estimated requirements of magnetrons had been 20,000, later increased to 50,000 to allow for contingencies, but complete substitution for klystrons would entail the production of possibly as many as 100,000.² The klystron was, however, except in the opinion of a minority, technically undesirable, and the substitution of magnetrons would help to bring forward the date on which equipment could be introduced into the Service.

Decision to use Magnetron in H2S/A.S.V.

In June 1942 the Prime Minister, profoundly disturbed by the slow rate of progress being made with H2S, gave orders that all-out attempts were to be made to have it installed in two squadrons of heavy bombers by October 1942, ' . . . the main thing is to hit the target, and this we can do with H2S. All other items are of course useful but nothing like so urgent. . . .'³ That sufficient magnetrons might be available to enable the directive to be complied with was a reasonable probability, but the possibility of producing satisfactory klystrons in time was remote, and might even prove to be impossible. A firm decision was required quickly so that development might be concentrated on one or the other. However, besides technical problems there were several other points demanding careful consideration. One was the effect on A.S.V. production; the Chief of the Air Staff was assured that the incorporation of magnetrons in the H2S version of H2S/A.S.V. would not react unfavourably on the magnetron requirement of Coastal Command. There was also the important question of security.⁴ It was quite possible that the Germans had already developed a klystron valve with a performance similar to or better than that of the versions being used in the United Kingdom but the chances of their having developed a magnetron valve were regarded as slight. Although once they acquired a working model they would almost certainly discover the principles of its construction, to develop it and engineer sufficient for operational use would, it was considered, take them from 12 to 18 months. The Commander-in-Chief, Bomber Command was of the opinion that the value to the bombing offensive of two pathfinder force squadrons equipped with magnetron H2S would be so great that the equipment ought to be brought into operational use as soon as it could be made ready, but the Chief of the Air Staff felt that a decision to allow the magnetron to be used over enemy territory during the approaching winter months could not be made immediately since it should be dependent on the strategic situation which prevailed then.

On 15 July 1942, the Secretary of State for Air, the Chief of the Air Staff, the Minister of Aircraft Production, the Commander-in-Chief of Bomber Command and Lord Cherwell agreed that, although results of the final trials

¹ T.R.E. File D.1740.

² Within one year the large number of differing types of magnetrons which were required for centimetric equipment led to a serious decrease in total production because of the various special tools and test equipments involved. Radar Board 570, 31 August, 1943.

³ A.H.B./ID/3/1791.

⁴ A.H.B./IIE/6/60, H2S—Minutes of Meetings.

of magnetron H2S were not then available, production should be concentrated on the magnetron, and development and production of the klystron should be discontinued.¹ A final decision as to whether H2S using the magnetron valve should be employed on operations during the coming winter was to be made later in the light of circumstances which might then exist.² Meanwhile every precaution was taken to prevent the equipment falling into enemy hands.³

Permission to go ahead with the magnetron considerably eased the processes of development and production, and an output of 200 sets before the end of the year was confidently predicted. A crash programme was initiated; E.M.I. undertook to make 50 sets by hand, using every advantage to be derived from the granting of highest priority, and the Research Prototype Unit undertook the manufacture of 150 sets. The latter unit was to work on H2S only, recruiting and training fresh labour and extending its existing premises. At the suggestion of the Prime Minister, when he confirmed the decisions, all production arrangements were placed in the hands of Sir Robert Renwick for co-ordination and administration.⁴ The Air Staff agreed to allow other work to be stopped if necessary so that the commitment might be fulfilled.⁵ The immediate task was to equip 24 Stirlings and 24 Halifaxes of Nos. 7 and 35 Squadrons of the pathfinder force so that they would be ready for operations by December 1942.

Decision to use H2S in A.S.V. role

The successful employment by the Germans of their search receivers against metric A.S.V. made the plight of Coastal Command serious in the autumn of 1942. No longer was only a better A.S.V. performance sought; a radical change of wavelength had become essential and the need for it was urgent. Sir Robert Renwick's investigation had shown that there was no hope of obtaining Ferranti equipment before the spring of 1943 at the earliest. Faced with this fact, the A.O.C.-in-C. Coastal Command decided that the only solution to his problem lay in the employment of H2S as A.S.V., and on 15 September

¹ The C.A.S. thought that the potentialities of the klystron for use in radar equipment other than H2S should be examined, and a small amount of research and development was therefore continued. (A.M. File C.S. 30305/46.)

² A.H.B./IIE/6/60.

³ A.H.B./ID/3/1791. The difficulties encountered during attempts to develop satisfactory magnetron destruction devices encouraged a belief that the klystron would eventually prove to be the more suitable valve for H2S. Experiments conducted at the R.A.E. revealed that the minimum amount of high explosive required to destroy a magnetron was two ounces, and as such a charge would cause considerable damage to an aircraft it was necessary to contain the explosive in a box. Several types of boxes were tried but no satisfactory solution to the problem was found. Trials made with thermite were disappointing in that the quantity of thermite required weighed five times as much as the apparatus itself, and the degree of destruction which even this amount caused was much less than that which resulted from the use of high explosive. Quite apart from the considerable weight involved by destruction devices, there was always present the probability that the magnetron could fairly easily be reconstructed from the resultant pieces. Methods of ejecting the pieces from the aircraft simultaneously with destruction were experimented with but they involved a large recoil which might seriously affect the aircraft structure. The use of powerful acids was also considered, but in September 1942 efforts to achieve complete destruction were abandoned, although experiments on burning out the valve by means of an electrical charge were continued. This method proved to be impracticable. The best that could be done was the provision of two small detonators which rendered the magnetron unusable. (T.R.E. File D.1738.)

⁴ A.H.B./ID/12/195.

⁵ A.M. File C.S. 13548.

1942 appealed for assistance to the A.O.C.-in-C. Bomber Command.¹ The C.-in-C. Bomber Command was, however, anxiously awaiting the belated arrival of H2S for his own aircraft and was unable to agree to do anything to support the production of other electrical equipment at the expense of equipment for Bomber Command.

However, representations made to the Chief of the Air Staff by the Chief of the Naval Staff, Sir Dudley Pound, on 20 September, met with more success.² On 24 September 1942 the Vice-Chief of the Air Staff ruled that 40 sets from the current crash production programme were to be diverted, as an emergency measure, to Coastal Command for use as A.S.V. in 20 Leigh Light Wellingtons once 84 sets had been made available for the two pathfinder squadrons of Bomber Command.³ No practical trials had been conducted but calculations based on seemingly sound technical data indicated that the range performance of H2S applied to an A.S.V. role was 15 per cent less than that which was expected from A.S.V.S. when used with a single scanner, and approximately the same when double scanners with wave guides were used ; in either circumstance it would be a considerable improvement on the performance of metric A.S.V. and would provide the change of wavelength so urgently required. There appeared to be no logical reason why the equipment should not prove to be satisfactory although it did not completely fulfil all operational requirements and the arrangement was described as 'a justifiable gamble.' Some loss of brilliance on the indicator unit was expected, and the rotation speed of the scanner might be too high, but the necessary modifications could be incorporated if considered essential and if they did not involve further delay. The proposal was accepted by the Commander-in-Chief, Coastal Command, as an expedient, subject to the success of flight trials which he wanted to be undertaken immediately, and provided that every effort was made to bring the technical performance nearer that of A.S.V.S.⁴

Change of Production Programme

The implications of the new plan were discussed at a series of conferences convened by Sir Robert Renwick during the last week of September and early in October, when the programmes for production of H2S and A.S.V. were reviewed and reorganised.

The diversion proposal had been made originally in an endeavour to fill the gap until development of A.S.V. was completed and production started. The H2S crash production programme was expected to yield 200 equipments by the end of 1942. The Gramophone Company anticipated being able to deliver a further 80 from their main production lines in April 1943, 120 in May, and 200 per month thereafter until the contract for 1,500 was fulfilled. The Research Prototype Unit was confident of producing an output of 60 to 70 per month until the Gramophone Company production started.

The real urgency of the need for effective centimetric A.S.V. caused its acquisition to be regarded as being equally important as that of H2S, and had revived practical interest in the possibilities of a universal H2S/A.S.V./A.I. system ; the T.R.E. undertook to complete the final design by the end of the year and estimated that production could begin in August 1943. Ferranti's were

¹ C.C. File S.9108.

³ A.M. File C.S. 13548.

² A.H.B./ID/12/195.

⁴ A.M. File C.S. 17067.

unable to promise more than 25 A.S.V. Mark III equipments by March 1943, but hoped to be able to deliver the bulk of their contract for 200 by August 1943. Pressure was being exerted on Ferranti's not only by the Ministry of Aircraft Production for A.S.V. and other equipment, but also by the Admiralty and the Ministry of Supply for the completion of other high priority contracts.¹

It seemed probable that total Service requirements for H2S/A.S.V. would be for some 3,000 sets by December 1943. Sir Robert Renwick decided that in view of the T.R.E. forecast that production of universal equipment would begin in August 1943 it was reasonable to ensure that the current production of H2S should be continued until that month, especially since the modified H2S equipment was likely to prove satisfactory to Coastal Command. That resolved the problem to one of obtaining a further 1,000 sets by the end of 1943. The Ferranti contract for 200 production equipments of what was originally intended to be A.S.V. Mark III was cancelled; six A.S.V.S. development models were however to be completed as quickly as possible since the T.R.E. was most anxious to use them in the development of the universal system. The firm was to be indemnified for work already done, and was given another contract to produce the extra 1,000 sets of H2S required, delivery of the first 100 of which was to begin in May 1943. There was no longer a requirement for the single mirror scanner system then being developed by Metropolitan Vickers; the Type 3 scanner used with H2S could, with slight modification, be made suitable for Wellington installations, but the development models were to be completed, and, as with A.S.V.S., delivered to the T.R.E. for use in conjunction with the universal system. Main production was to be confined to the double mirror systems for Sunderlands and 20 were to be completed in March, 25 in April and thereafter 30 per month.² On 28 October 1942 the Assistant Chief of the Air Staff (Operations) approved the plan for increasing the production of H2S to provide a substitute for the cancelled A.S.V. Mark III contract subject to satisfactory H2S flight trials being conducted immediately.³

By means of these arrangements the production and installation of radio and scanning units, common to both Bomber and Coastal Commands, were planned to meet their requirements for the year 1943, and thus 10-centimetre A.S.V., which began in 1940 as a modification of A.I., became a modification of H2S in 1942. It was thought that the amalgamation of design, production, and installation would prove to be advantageous inasmuch as it made more realistic the possibility of centimetric equipment being available for Coastal Command during the first few months of 1943, when A.S.V.S. would still have been in its development phases. It appeared that the requirements of Coastal Command were to be met without detriment to the Bomber Command H2S programme. The disadvantage incurred by the slight decrease in operational efficiency of modified H2S, as compared with that of the original A.S.V. Mark III, was considered to be more than outweighed by the benefits likely to be gained by being able to put centimetric A.S.V. to operational use during the approaching winter.³

¹ A.H.B./IIE/6/60.

² T.R.E. File D.1738.

³ A.M. File C.S. 17067.

PREPARATION OF H2S FOR A.S.V. ROLE

During the autumn of 1942 anti-U-boat operations off the American seaboard became increasingly effective and U-boat commanders were forced to seek targets farther out in the ocean beyond range of shore-based aircraft. Attacks against convoys in mid-Atlantic were intensified, and the extension of the areas in which U-boats were active made evasive routing of convoys more and more difficult. The Germans made good use of supply boats for refuelling operational U-boats whilst they were still in their patrol zones so that U-boat activities were not only more intensive but also more sustained. The Royal Air Force could not provide sufficient air cover in mid-Atlantic, where the heaviest shipping losses were being suffered, because that area was beyond the radius of action of practically all the aircraft then in service with Coastal Command.¹ Very long range aircraft were urgently required, but the Prime Minister was naturally most anxious that their allocation should not be made at the expense of the rapidly mounting night bombing offensive against Germany. However, it was expected that an even larger number of U-boats, operating in every ocean, would have to be faced in 1943, and the date selected for the joint invasion of north-west Africa, which would involve the successful sailing of a considerable number of vital convoys, was drawing near. The situation was ominous, and in an endeavour to give the same impulse to the battle against U-boats as had been successfully applied to the battle against night bombers the Prime Minister formed the War Cabinet Anti-U-boat Warfare Committee. He himself presided at the first meeting, held at No. 10 Downing Street on 4 November 1942, when all aspects of the maritime war were carefully reviewed.²

Aircraft Requirements for the Anti-U-Boat Campaign

To provide air cover for the danger area in mid-Atlantic 40 aircraft with an operational range of 2,500 miles were an urgent requirement. In Coastal Command there were 39 Liberators fitted with L.R.A.S.V. Mark II, 6 of which were suitable for the role of Very Long Range aircraft.³ Over the Bay of Biscay, Whitley, Wellington and Hudson aircraft were operating in the inner zone, and Catalinas, Liberators and Sunderlands in the outer zone where greater distances were flown.⁴ The Admiralty hoped that operations in the outer zone might ultimately be carried out by a considerably smaller number of long-range aircraft equipped with centimetric A.S.V. when they became available and proposed that 24 Liberator III and 60 Wellington XI and XII should be used for operations over the Bay of Biscay; a requirement for the appropriate number of centimetric A.S.V. installations was stated.

¹ A.H.B. Narrative: 'The R.A.F. in Maritime War.' The area in mid-Atlantic became known as the 'Gap.'

² Minutes of 1st Meeting War Cabinet Anti-U-boat Warfare Committee, 4 November 1942.

³ Action was initiated to convert the remainder to V.L.R. aircraft. Seven were expected to be ready by the end of November, 16 by the end of December, and the conversion completed by the end of February.

⁴ About 100 aircraft were being employed in the two zones.

The Air Staff and the Admiralty discussed the proposal; long range aircraft could be provided for the outer zone without affecting the strength of Bomber Command only if the U.S.A. could be persuaded to release immediately 30 Liberators already fitted with centimetric A.S.V. Otherwise the possibilities of alternative propositions made by the Chief of the Air Staff could be considered. The first, and the one which least affected Bomber Command, was the handing over at once to Coastal Command of 20 Halifaxes, already on loan from the bomber force, together with another 10 Halifaxes. The alternative was to give Coastal Command Halifaxes straight from the production line and to defer withdrawal of the bomber squadrons until the new squadrons were operationally effective. The first proposal, it was estimated, would retard the Bomber Command expansion programme by about two weeks, and the second four weeks. For the inner zone Wellington XI and Wellington XII aircraft were to be provided; the former for daylight operations and the latter for Leigh Light work at night. The 40 H2S equipments to be diverted to Coastal Command were to be installed in the first 20 Wellington XII aircraft due to come off the production line at the beginning of 1943, and the Chief of the Air Staff suggested the possibility of diverting another 80 H2S installations from Bomber Command, 40 in February and 40 in March, with which to equip 2 squadrons of Wellington XI. The Prime Minister was, however, reluctant to deprive Bomber Command of so large a number of equipments, and at the third meeting of the committee, on 18 November 1942, the production situation of H2S and A.S.V. was discussed. It was decided that ' . . . the position was not altogether clear . . . ', and an investigation was initiated with a view to evolving methods of expediting production.¹

Two days later the Prime Minister appealed to the President of the U.S.A. for assistance, sending a personal telegram in which he explained how the enemy use of search receivers had made metric A.S.V. ineffective in the Bay of Biscay, the transit area for U-boats going to and from the American seaboard. He pointed out that no improvement in the situation could be expected until a sufficient number of centimetric A.S.V. equipments were available in the right sort of aircraft.² It was possible to achieve some success in the inner zone by modifying and diverting for installation in Wellington Leigh Light aircraft some H2S equipment originally destined for Bomber Command, but a more difficult situation existed in the outer zone where centimetric A.S.V. and aircraft of longer range were required. The Liberators already allocated to the R.A.F. were being converted for very long range operations in mid-Atlantic where large numbers of ships had been sunk. ' . . . This leaves us,' he continued, ' with no aircraft of adequate range for the outer zone unless we make a further diversion from the small force of long range bombers responsible for the air offensive against Germany. Even if this diversion were made a considerable time would necessarily elapse before the essential equipment could be modified and installed. I am most reluctant to reduce the weight of bombs we are able to drop on Germany as I believe it is of great importance that this offensive should be maintained and developed to the utmost of our ability throughout the winter months. I would therefore ask you Mr. President to consider the immediate allocation of some 30 Liberators equipped with centimetric A.S.V. from the supplies which I understand are now available in

¹ Minutes of 3rd Meeting War Cabinet Anti-U-boat Warfare Committee, 18 November 1942.

² A.H.B./ID/3/932.

the U.S.A. These aircraft would be put to work immediately in an area where they would make a direct contribution to the American war effort. . . .'

At the same time the Chief of the Air Staff sent a personal message to General Arnold asking him to do all possible to accelerate the installation of centimetric A.S.V. in Liberators allotted to the R.A.F. But the demand for Liberator aircraft for operations in the many and varied theatres of war was much greater than the current supply, and the main A.S.V. production programmes were not yet well under way; on 2 December 1942 Mr. Harry Hopkins, on behalf of President Roosevelt, assured the Prime Minister that although the gravity of the U-boat menace in European waters was well understood in the U.S.A., acute shortages of both aircraft and equipment precluded an immediate permanent assignment to the R.A.F. of Liberators fitted with centimetric A.S.V.¹ He offered, however, to provide A.S.V. for the 4 Liberators to be assigned each month to the R.A.F. under the terms of the Arnold-Towers-Slessor Agreement and suggested that 21 Liberators fitted with 10-centimetre A.S.V. which were being sent to Europe to operate under the control of General Eisenhower should be allocated for such employment as might be agreed between he and the British authorities.²

The Chief of the Air Staff, on receipt of the Hopkins telegram, felt that the proposals contained in it did not provide a satisfactory solution to his problem, since the 21 Liberators were liable to be diverted at any time, and some of them might almost certainly be required to operate over the Mediterranean Sea. The 4 Liberators being assigned each month were required for covering the gap in mid-Atlantic and would not therefore be able to afford direct assistance to operations over the Bay of Biscay. The Anti-U-boat Warfare Committee consequently decided at its 5th meeting, on 2 December 1942, that the arrangements for allotting 20 new Halifax aircraft to Coastal Command should be confirmed.³

On the same day that the appeal to the President of the U.S.A. was made Sir Stafford Cripps convened a meeting to find out whether A.S.V. production had been retarded by the higher priority given to the development and production of H2S, and to discuss methods whereby it could be accelerated. Probably because Coastal Command aircraft were likely to be equipped with centimetric equipment some months sooner than had originally been planned as the result of diverting H2S from Bomber Command, the consensus of opinion of the meeting was that the development and production of H2S had not hindered the progress of A.S.V., but had in fact quickened it. Ability to meet the requirements of Coastal and Bomber Commands, both in time and in quantity, was confidently predicted.

Trial of H2S in A.S.V. Role

Whilst the quantities and types of operational aircraft to be fitted with centimetric A.S.V. were being deliberated, setbacks with the equipment and

¹ A.H.B./ID/3/932.

² This referred to Nos. 1 and 2 U.S.A.A.F. Squadrons. Nine were already en route, 4 were practically ready to go, and the remainder were due to leave the U.S.A. by mid-December. The aircraft had been withdrawn from anti-U-boat operations in Atlantic and Pacific waters where they might again be urgently required later, so the arrangement was subject to change, but it was intended that they should be used in a manner best suited to further common Allied interests. They were, in fact, eventually operated from United Kingdom bases over the Bay of Biscay.

³ Minutes of 5th Meeting War Cabinet Anti-U-boat Warfare Committee, 2 December 1942.

trial installations were being experienced. On 27 October 1942 the Chief Signals Officer of Coastal Command examined the performance of a Stirling H2S installation when used in an A.S.V. role during a flight trial conducted against a convoy of nine small ships and against an almost submerged wreck in Liverpool Bay.¹ Arrangements had been made to adjust the scanner, but the technical performance of the installation was expected to be no more than 80 per cent of what would ultimately be obtained from a similar installation in a Wellington.² The maximum range obtained against the convoy was 7 miles from 1,500 feet, and the average was about $4\frac{1}{2}$ miles. Although the ships were relatively close together, individual blips were quite distinct, but were apt to fade before the operator had time to count them. In the opinion of the C.S.O. this was due to lack of after-glow rather than to insufficient brilliance and he considered that the period of after-glow should be doubled. Against the wreck the maximum ranges varied from 4 to 5 miles, and the minimum range was about 700 feet, from a height of 1,500 feet.

It appeared that although the installation was likely to be fairly satisfactory in Leigh Light aircraft, the direction finding properties were not so good as those of A.S.V. Mark II with Yagi arrays. The A.O.C.-in-C., Coastal Command, expressed disappointment with the results and was most anxious to be assured that they were not truly representative of the equipment even in its interim form. Happily the T.R.E. discovered two days later that by an unfortunate mistake the trial had been made with the scanner tilted in the H2S position instead of being correctly adjusted for A.S.V. ; consequently the indifferent results were by no means indicative of the probable A.S.V. performance. Further tests were made to evolve a wave guide feed in an endeavour to eliminate the necessity for accurate setting-up of scanner adjustments and to increase the distance at which targets could be located.¹ The minimum performance aimed at was effective location, at a distance of 11 miles, of a fully surfaced submarine in any sea conditions, from an aircraft flying between height limits of 500 and 1,500 feet. A number of minor modifications that could speedily be incorporated were planned, including the introduction of P.P.I. limiting into all equipments other than the first 40 a specimen of which, it was hoped, could be demonstrated by the end of November in a Wellington VIII. P.P.I. limiting would probably make unnecessary the doubling of after-glow, but it was decided that if after the demonstrations longer after-glow remained an operational requirement, it could be provided by fitting a modified screen to the cathode ray tube as was being done with the first 40 sets to be diverted for A.S.V.² Although a smaller range scale in the region of 0-5 miles seemed very desirable, its incorporation involved considerable delay, and in order to effect a reasonable compromise with what was required for H2S, it was decided to standardise range scales at 0-10, 0-30 and 0-50 miles. Further trials of the Stirling H2S installation were conducted, with the scanner properly adjusted, during the first week of November 1942, when an A.S.V. marker buoy was located at distances up to 7 miles.

Pilot's Indicator

Whilst these efforts to obtain satisfactory A.S.V. were being made the question of the desirability or otherwise of a pilot's indicator had again been raised. The unreliability of A.I. Mark V had helped to stiffen the prejudice

¹ A.M. File C.S. 17067.

² T.R.E. File D.1738.

against such an indicator, but the Liberator AL.507 installation had demonstrated during the trials at Ballykelly that an efficient instrument could be designed and that its addition to an A.S.V. installation conferred great advantages. By the end of September 1942 it had become apparent that such a device would probably become one of the operational requirements for A.S.V., the subject of protracted consideration since the R.D.F. Policy Sub-Committee of the War Cabinet had, in January 1942, invited the Admiralty, the War Office, and the Air Ministry to define what they felt to be the vital operational requirements for centimetric wavelength equipment.¹

In July 1942 the R.A.F. Delegation requested the Radar Committee of the Combined Communications Board at Washington to study the recommendations which had been accepted in the United Kingdom.² The Airborne Radar Sub-Committee, under the aegis of the Board, examined the recommendations and in September 1942 tentatively proposed amendments which included the employment of A.S.V. to assist in the interception of enemy aircraft that might take advantage of cloud cover to attack convoys protected by A.S.V. aircraft. The modifications required to enable an approximate estimation of elevation to be made were not considered to be extensive nor to have any adverse effect on normal use of the installation.³ The implication that interrogation facilities must inevitably form an integral part of the primary A.S.V. equipment was questioned. In the U.S.A. it was considered that there was no need for direct interrogation of secure beacons by primary A.S.V. transmitters operating on centimetric wavelengths; it was thought preferable that the transmitters should be capable of transmitting specially coded pulses for unlocking a beacon in addition to primary location transmission. The sub-committee was reluctant to recommend P.P.I. display as a requirement in all A.S.V. installations and favoured the use of Types B and BB scanners in certain circumstances. It felt, too, that installation difficulties, particularly with small aircraft, attendant on the provision of all-round looking A.S.V. as opposed to 180 degrees forward-looking, would outweigh some of the operational advantages gained.

The British Joint Communications Board considered that the A.I. facility was not essential in A.S.V., and should not be incorporated if it involved complication of installation and operation, but agreed that P.P.I. presentation with a radial time-base might be replaced by other methods of display when they had been proved satisfactory on Service trials. The Board also agreed that for small aircraft, all-round looking could be considered as being most desirable rather than absolutely essential, and that the interrogation facilities should be separated from the main equipment both for identification and for use with beacons. Amongst the many and varied requirements finally recommended by the Radar Committee of the Combined Communications Board on 2 October 1942 was ' . . . a simple form of indicator should in addition be provided for the pilot, which he may or may not use at his convenience . . .'⁴ On 18 November 1942 contracts were placed with The Gramophone Company for the design, development and production of a second indicator unit for A.S.V. installations.¹

¹ T.R.E. File D.1738.

² A.M. File C.S. 16766. See Appendix No. 3 for notes on the Combined Communications Board.

³ S.I.C. 37.

⁴ A.M. File C.S. 16766. See Appendix No. 7.

Scanner Location on Wellington Aircraft

In August 1942 arrangements had been made for a trial installation of A.S.V.S. to be made in a Wellington VIII. In October 1942, before that installation had been completed, trial installations of H2S modified for A.S.V. were required in Wellington VIII and Wellington XII aircraft. The latter were not due off the factory production lines before January 1943, however, so the Wellington VIII trial installations were to be used as prototypes for the Wellington XII. The position selected at the beginning of August for the housing of the scanner unit proved to be, as had been anticipated, unsatisfactory for aircraft fitted with the Leigh Light since it obstructed the searchlight beam. Results of tests made with a mock-up installation inside a hangar were reported on 5 October 1942.¹ To clear the scanner unit it was necessary to depress the searchlight beam through 4 degrees and consequently a target could only just be located at a distance of one mile. Headquarters Coastal Command considered the scanner position to be acceptable for Wellington XI aircraft, which were to be used only on daylight operations, provided that interference with the carriage of a full load of bombs did not occur. For Leigh Light Wellingtons a new siting, immediately under the nose of the aircraft, which became known as the 'chin,' was agreed upon on 6 October 1942; it necessitated redesign by the Vickers aircraft factory of the mounting arrangements, and consequently still further delayed the completion of a trial installation.²

Controversy regarding Date of First Operational use of H2S

The Bomber Development Unit completed a series of Service trials of Stirling and Halifax H2S prototypes in December 1942, and Air Ministry permission was requested to operate with H2S as soon as Nos. 7 and 35 Squadrons were equipped and trained. In the opinion of the C.-in-C. Bomber Command, its use in a small number of aircraft at an early date would immediately increase his ability to attack effectively important targets at long ranges whilst the hours of darkness were still long enough to enable the more distant objectives to be reached. He thought that it would be unwise to wait until the whole bomber force had been equipped. The decision which had been deferred in July was now of greater urgency in view of the greater emphasis being placed on the value of centimetric A.S.V. in the maritime war.

On 4 September 1942 the Chief of the Air Staff had informed the Chief of the Naval Staff of progress made with the development of magnetron H2S. He explained that although experiments were being made to incorporate self-destructive devices, he realised that the decision to use the magnetron over enemy territory was a very important one affecting all three Services.³ In fact, the Radio Sub-Committee had only recently ruled that before equipment working on a wavelength of 10 centimetres or under was used in areas where it was likely to fall into enemy hands the matter was to be referred to the Sub-Committee, who would, if necessary, obtain a ruling from the Chiefs of Staff Committee.⁴ On 8 October 1942, after the diversion of H2S equipment to Coastal Command had been authorised, the Chief of the Naval Staff had asked

¹ A.M. File C.S. 17067.

² A.M. File C.S. 16765.

³ When, in November 1942, Coastal Command received from the U.S.A. a Liberator equipped with centimetric A.S.V. restrictions were placed on its operational employment. Centimetric A.S.V. could not be used within 100 miles of enemy-held coastline. (A.H.B./IHK/24/209, A.S.V. and H2S.)

⁴ A.H.B./ID/12/195.

to be reassured that the policy still held good in view of the fact that the success of centimetric A.S.V. depended to a large extent on its ability to defeat the German search receiver, and surprise was therefore an essential factor.¹ The position had been further complicated by the U.S.A. having already made a provisional approach to the Radio Board with the suggestion that the current production rate of 10-centimetre airborne radar equipment was such that its free use, at the discretion of Commanders-in-Chief, was warranted. The Americans, particularly the United States Navy, were inclined to leave the use of such equipment to the discretion of task force commanders. Such delegation of authority might easily have prejudiced security, since the equipment might have been used for minor operations before it was required for major operations. The Chief of the Air Staff, whilst in favour of using H2S in the pathfinder force as soon as two squadrons were equipped and trained, thought it desirable to know what action the Germans could take to counter its use if they obtained possession of a set fairly quickly.² In the United Kingdom no really determined effort had been made to devise counter-measures for H2S,³ although on 23 November 1942 the Director of Communications Development authorised a series of flight trials to determine whether counter-measures were feasible. A small decoy had proved to be much less effective than was expected.⁴

A meeting, under the chairmanship of the Secretary of State for Air, on 8 December 1942 agreed that the question of the date on which H2S should be brought into operational use should be referred to the Radio Board.⁵ The alternative dates suggested were 1 January and 1 March 1943. The Board was requested to advise the Chiefs of Staff to obtain the sanction of the Combined Chiefs of Staff to its introduction on 1 January. The members of the Radio Board accepted the possibility that the enemy might already be developing centimetric radar although there was no evidence to support the conjecture. Ground radar stations in the United Kingdom had, however, been operating on centimetric wavelengths for more than a year, and radiation might well have been intercepted, and employment of the centimetric technique thus indicated to the enemy. The Board considered that the use of H2S by two pathfinder squadrons during January and February 1943 would undoubtedly be of great value to Bomber Command, and that the capture of H2S a month or two earlier than might be otherwise possible would not be of great help to the enemy.⁶

Opposition was received from the Admiralty, who felt that the period of two months was important in relation to the anti-U-boat campaign; if there were the slightest chance of H2S falling into the hands of the enemy, its operational use should be deferred until a sufficiently large number of equipments was available to enable its effect to be overwhelming. Reference to the Chiefs of Staff was postponed until some agreement could be reached. The Admiralty viewpoint was that while it might take the Germans twelve months to develop equipment capable of actively countering H2S, production of a search receiver for the 10-centimetre waveband was a much more simple matter. Should H2S be captured in January, installation of appropriate receivers in all

¹ A.M. File C.30305/46.

³ Sir Henry Tizard. 8 December 1943.

⁴ T.R.E. File D.1738. See Appendix No. 8.

⁵ Formerly Radio Policy Sub-Committee.

² A.H.B./ID/3/932.

⁶ A.H.B./ID/3/932.

U-boats could be completed by June 1943. The Chief of the Air Staff thought that it might be extremely difficult to design an effective receiver, for although the very fine adjustment demanded for the reception of microwave radiations presented no great difficulty in a laboratory, it would not be so easy in a U-boat; and he regarded 10 centimetre A.S.V. as being only a stop-gap until 3-centimetre A.S.V. became available.

The Radio Board, on 18 December 1942, was asked as a matter of great urgency to re-examine the technical aspects and to determine the probable effect on the war at sea if an H2S installation was lost to the enemy in the first week of January instead of the first week in March. Sir Robert Watson Watt prepared a detailed appreciation in which he concluded that, assuming the enemy had little or no knowledge of centimetric radar technique, the time factor following the capture of H2S was likely to be—¹

- (a) 2 to 3 months to develop a search receiver in addition to the time taken for every U-boat at sea to return to base for fitting.
- (b) 2 to 3 months to develop other countermeasures in their simplest form, and 12 months in more advanced form.
- (c) 12 to 18 months to develop devices similar to H2S.

The Radio Board, directed by Sir Stafford Cripps, studied the conclusions and decided that the capture of H2S in January would to some extent expedite the use of countermeasures and would shorten the period of maximum usefulness of 10-centimetre A.S.V. by some two months. The Board was of the opinion that if and when search receivers were manufactured their 'bandwidth' would also cover the 3-centimetre wavelength, but, despite the use of such receivers, judicious choice of tactics and employment of attenuators could enable successful A.S.V. attacks to be made.

On 22 December 1942 the Prime Minister presided over a meeting of the Chiefs of Staff Committee at which the findings of the Radio Board were discussed.² It was for decision which was of greater importance; the value to be gained by the use of H2S in the pathfinder force during January and February, or the possible adverse effect on the war at sea of the earlier capture of the equipment by the enemy. The advantages to be obtained from an early release were outlined by the Chief of the Air Staff, and the Chief of the Naval Staff gave reasons for the anxiety felt by the Admiralty, who considered that the U-boat war was fast approaching a crisis and wished to avoid compromise of the equipment until the last possible moment.³ The Prime Minister, in his summing up, declared that assessment on a quantitative basis of the results of the earlier release was not possible, but were the scales in balance he would have tipped them in favour of the war at sea. It seemed to him, however, that the value accrued to Bomber Command would be of greater benefit to the general war effort than would be the probable advantages to the anti-U-boat campaign conferred by a deferred release. At the beginning of 1943 the Combined Chiefs of Staff sanctioned the immediate use of H2S over enemy occupied territory.⁴

¹ A.H.B./ID/3/932. See Appendix No. 10.

² C.O.S. (42) 204th meeting. A.H.B./ID/3/932.

³ See Table No. 6.

⁴ A.H.B./ID/3/932.

Drawbacks of Wellington XI Installations

When the decision to add 40 Wellington XI aircraft to the H2S/A.S.V. installation programme was made in November, the T.R.E. strongly advocated its reconsideration.¹ They urged that if an overriding need existed for the employment of centimetric A.S.V. at the earliest possible date, the objective would be achieved more satisfactorily by the diversion of the Halifax and Stirling aircraft then being fitted with H2S/A.S.V. for Bomber Command. The fitting programme was already in progress and well organised, and the aircraft could be used almost immediately for A.S.V. operations. In the opinion of the T.R.E. the performance of the installation in an A.S.V. role would not be appreciably less than that which would be obtained with the Wellington XI installation, and the longer endurance of Halifaxes and Stirlings would give greatly increased periods of effective search. Moreover, in order to accommodate H2S/A.S.V. in a Wellington XI the front gun turret would have to be abandoned, and since the aircraft were intended for employment on daylight operations, this seemed to constitute a serious operational disadvantage.²

Various possible locations for the scanner unit had been considered. The original position which had proved to be unsatisfactory for aircraft equipped with Leigh Light apparatus but acceptable for other Wellington aircraft was recognised as being preferable. The use of that position, on the underside of the fuselage, was, however, not possible if the installation was to be ready by the required date because it entailed structural modifications.³ The aircraft manufacturers, Vickers, were studying the implications but did not expect to have a completed design ready before the end of March 1943. Concurrently the feasibility of housing the scanner in the mid-upper turret was being investigated at the T.R.E. The only scheme which would allow Wellington XI aircraft to be fitted without undue delay appeared to be the mounting of the scanner unit in the top half of a Wellington XII nose piece which could be housed in the space left vacant by removal of the front gun turret. By so doing, some degree of upward-looking and about 180 degrees of forward-looking could be provided. In the circumstances the C.-in-C. Coastal Command agreed to dispense with the front turret.³ The T.R.E. compared this restriction of the area of search with the all-round looking to be expected from the Halifax and Stirling and pointed out that the method of installation would be confined to only the 40 aircraft required urgently ; thereafter the scanner would be housed

¹ T.R.E. File D.1114.

² Until the autumn of 1942 it had been exceptional for a U-boat to stay on the surface and engage aircraft with its A.A. armament. The increasing element of surprise created by use of the Leigh Light, and more effective daylight tactical approaches, forced Admiral Donitz to consider the idea of retaliation by U-boats caught on the surface. In October 1942 he stated that aircraft were the greatest danger to U-boats, and that improved A.A. armament was being provided ; some Atlantic-based boats had already been fitted with a 20-millimetre cannon or 2 heavy machine guns by September. In anything but a calm sea a U-boat was a wet, cramped, unstable and most unsatisfactory gun platform and the use of armament against aircraft depended entirely on the mentality of the commander and the prevalent sea condition. The ample warning of the approach of aircraft provided by search receivers, however, caused a marked increase in the number of incidents when the guns were used because U-boat commanders were able to pick favourable conditions to man the armament instead of diving ; in November and December 15 and 9 instances were recorded. Although more often than not the accuracy of the A.A. shooting was not great, a movement for better and additional front guns for aircraft engaged on both day and night sorties was initiated. (A.H.B. Narrative : 'The R.A.F. in Maritime War.')

³ A.M. File C.S. 17067.

on the underside and the front gun turret retained.¹ The aircraft structural alterations and the serious loss of fire-power entailed seemed to be out of all proportion to any immediate advantage that might be gained.

The background against which the matter was debated was much the same as when L.R.A.S.V. was hurriedly introduced into operational squadrons ; the time factor tended to overshadow all others. Any means of completing the installation of centimetric equipment in two squadrons of Wellington XI two months earlier than might normally be expected was desirable. The scanner system was an integral part of both A.S.V. and the aircraft in which it was installed, and the type of aircraft used, and the purpose for which it was required, therefore required careful consideration. The Director of Radar agreed with the T.R.E. comments on the Wellington XI plan.² That two months could be gained was far from certain, he thought, and the attempt could be made only at the cost of disrupting the Bomber Command and probably the Wellington XII installation programmes. Since the original decision to equip Bomber Command aircraft with H2S had been made, the task of installing H2S/A.S.V. in Wellington XII aircraft before they left the aircraft production lines had already been added. A further addition, to equip immediately 40 Wellington XI aircraft, might easily cause a total breakdown and result in failure to complete installation in any type of aircraft within the allotted time. There was not only a shortage of both H2S/A.S.V. and associated test equipment, but also a lack of skilled personnel for fitting parties, servicing, and correction of technical defects.¹ Postponement of the Wellington XI programmes until the spring of 1943 would, it was urged by the Director of Radar, ensure that all three fitting programmes would have a smooth flow of wastage replacement aircraft following immediately behind the initial issue of equipped aircraft. This would give reasonable prospects of providing the essential minimum of personnel, facilities, spares and test equipment, and interfere least with the provision of pathfinder force and Leigh Light aircraft.²

The Chief of the Air Staff was against substituting Halifaxes or Stirlings for Wellingtons, since it could only be done at the expense of Bomber Command and reminded the War Cabinet Anti-U-boat Warfare Committee on 25 November 1942 that the proposed plan was, with all its disadvantages, purely an interim measure necessitated by inability to provide suitable long range aircraft in sufficient quantity.³ If the government of the U.S.A. was able to accede to the request for 30 Liberators equipped with centimetric A.S.V. the need for such a measure would disappear. The committee agreed, however, that if serious difficulties were encountered, the possibility of substituting Halifax and Stirling aircraft would be re-considered, and if for any reason the fitting programmes fell behind schedule, the Wellington XI installation was to be regarded as being of the lowest priority.

¹ T R.E. File D.1144.

² A.M. File C.S. 17067.

³ Minutes of 4th meeting War Cabinet Anti-U-boat Warfare Committee, 25 November 1942.

INTRODUCTION OF 10-CENTIMETRE A.S.V.

Preparations for Coastal Command Installation Programme

The decision to install H2S in Coastal Command aircraft meant that the arrangements already planned to facilitate the introduction into the Service of centimetric A.S.V. had perforce to be advanced by several months and improvised to meet the new set of conditions which had arisen.¹ The difficulties to be overcome were not confined only to those of installation, training, and the provision of test equipment. The sets being produced by E.M.I. and the R.P.U. did not supply the interrogator facilities which were necessary to enable aircraft employed on maritime operations to use ground/air/shipborne responder beacons.² Measures for the incorporation of such facilities were immediately and energetically pursued by T.R.E. personnel. A schedule of necessary modifications was prepared, in conjunction with E.M.I., and complete drawings and detailed lists of components were made available by 19 November 1942.³ Headquarters Coastal Command expressed willingness to accept the initial allocation of 40 H2S sets without modification in order to avoid delay. It was hoped that retrospective action might be taken later to incorporate the modifications. At the T.R.E., however, it was felt that a grave error was being made by not insisting on the inclusion of beacon facilities from the commencement of production, since the work involved was straightforward and occupied but little time.⁴ Those sets were earmarked for 20 Wellington XII aircraft, and it was agreed that installation should be carried out by personnel of the Special Installation Unit at Defford. All ensuing installation work was to be done at No. 30 Maintenance Unit and, if it became essential, also at No. 32 Maintenance Unit. The danger of assuming that the specialised methods employed at the S.I.U. could be applied at maintenance units was not unforeseen. It was accepted that the urgency of the initial fitting programme demanded special methods. An endeavour was therefore made to ensure that a normal installation technique would be introduced when the responsibility for fitting aircraft was assumed by a maintenance unit, and this was confidently expected to be possible in January 1943.

By the end of November five fitting parties were available and another five were being trained at the S.I.U., but only a low standard of skill had been attained because of the lack of equipment with which to demonstrate and perform practical work. The T.R.E. was awaiting delivery of 16 of the first equipments to be produced and used for A.S.V., for training and further experimental purposes.¹ By this date however, only sufficient equipment for fitting H2S in 12 Halifaxes of Bomber Command had then been produced. Detailed

¹ A.M. File C.S. 17067.

² T.R.E. File D.1738. See Royal Air Force Signals History, Volume III : 'Aircraft Radio.'

³ The Air Ministry and the Ministry of Aircraft Production agreed on 17 November 1942 that only two installation numbers would be used for H2S/A.S.V. equipment :—

A.R.I. 5119 for E.M.I./R.P.U. version, absorbing A.R.I. 5094 and A.R.I. 5516.

A.R.I. 5153 for Gramophone Co./Ferranti version, absorbing A.R.I. 5505 and A.R.I. 5517.

⁴ T.R.E. File D.1738.

arrangements were proposed for operating and servicing personnel to be given preliminary courses at the T.R.E. until Technical Training Command was able to undertake the commitment completely. Also, the T.R.E. agreed to produce operating and servicing instructional pamphlets by 1 January 1943.¹

Prototype Installations

Two Wellington VIII prototype installations were eventually completed in December 1942; the uncertain policy regarding the Mark of aircraft to be fitted had tended to increase delay already caused by the main difference between the H2S and A.S.V. installations, the siting of the scanner units. Power for the installation was derived from a 1,200 watt generator and peak output of the transmitter, which was based on a CV 64 magnetron, was 50 kilowatts. One stage of amplification was given to the output of a crystal mixer on a frequency of 13.5 megacycles per second to raise the signal level before passing to the main I.F. strip in the receiver. The receiver was divided into two parts, an I.F. and a timing strip. The I.F. strip contained six stages of I.F. amplification, a diode second detector, and a mixer stage giving a gain of two to the video signals. The overall I.F. bandwidth was 6 megacycles per second, an unduly wide response originally intended to counter frequency drift in the local oscillator. The timing strip produced and mixed a range marker, a Leigh Light marker normally pre-set at one mile, and a line-of-flight marker. Its output was fed to the mixer in the I.F. strip, so that the resultant output of the receiver contained both video signals and markers. The indicator unit contained two electrostatic cathode ray tubes, one of 6 inch and the other 2½ inch diameter. The 6-inch tube was used for the P.P.I. and was given afterglow of one second's duration. The 2½-inch tube was used for tuning and presenting position information for metric wave beacons and BABS approach systems.

To provide the constant north stabilised P.P.I. presentation required for H2S a control unit Type 218 was used, but to obviate the confusion caused when homing to an A.S.V. target the datum line was synchronised with the line of flight of the aircraft. The scanner mirror had an azimuth aperture of 28 inches and an elevator aperture of 15 inches, and was rotated at between 50 and 60 revolutions per minute by a 24 volt motor. The elevation pattern was unsymmetrical, the main beam being displaced below the horizontal, and elevation scanning was not used. The main controls for operating the equipment were centralised in a switch unit Type 207B, on the side of which was the range drum with a detachable scale. For H2S a scale giving ground range

¹ A.M. File C.S. 17067.

T.R.E. Training Programme		
1 Dec. -15 Dec.	6 radio mechanics	No. 172 Squadron.
15 Dec. - 1 Jan.	6 radio mechanics	No. 172 Squadron.
15 Dec. - 1 Jan.	1 radio officer	H.Q.C.C.
15 Dec. -15 Jan.	2 radio N.C.Os.	No. 172 Squadron.
15 Dec. -15 Jan.	1 radio officer	No. 172 Squadron.
15 Jan. - 1 Feb.	2 radio officers	Tech. Training Cmd.
15 Jan. - 1 Feb.	2 radio N.C.Os.	Maintenance Unit.
15 Jan. - 1 Feb.	6 radio mechanics	(supernumerary).
1 Feb. -15 Feb.	6 radio mechanics	No. 179 Squadron.
1 Feb. -15 Feb.	1 radio officer	H.Q.C.C.
1 Feb. - 1 Mar.	2 radio N.C.Os.	No. 179 Squadron.
1 Feb. - 1 Mar.	1 radio officer	No. 179 Squadron.
15 Feb. - 1 Mar.	6 radio mechanics	No. 179 Squadron.

with bombing times was used, marked in statute miles. For A.S.V. the scale gave slant range only, in nautical miles. The range marker and the scale of the picture on the P.P.I. were not changed simultaneously. The smaller scale of 0-50 miles or 50-100 miles was used with a 0-100 miles marker. Then, as the aircraft closed with a target, the time-base was switched to the 0-30 miles scan, whilst the marker was left on 0-100 miles. Thus any blip on which the range marker had been set whilst on a small scale picture, remained adjacent on the larger scale picture. When the target had been identified the marker was switched to 0-30 miles, and the target was re-selected. This operation was repeated until the 0-10 mile time-base and the 0-10 range marker were reached. The beginning of the range trace on the P.P.I. could be advanced so that zero range corresponded to a finite distance from the centre of the P.P.I. This distorted the picture but gave a much more open scale for short distances, and improved the accuracy of homing to a target.

Initial Setbacks with Installation Programme

At the beginning of 1943 it was evident that operational aircraft would not be equipped with centimetric A.S.V. by the dates which had been so confidently forecast mainly because neither the equipment nor the aircraft had been made available. R.P.U., expected to deliver 16 equipments during December 1942, still showed no signs of beginning production, and it appeared that its output would not exceed 10 per week even when production did begin, being limited mainly by a lack of testing facilities. Arrangements had been made for Siemens to manufacture the test gear associated with A.S.V./H2S but it too was not yet available, and, until it was, the manufacturing and installation programmes were dependent on the small quantity of test gear which could be made by the T.R.E. E.M.I. had delivered 61 of the 63 equipments which it had promised, but many of them had necessarily been allocated for training, testing and research purposes. Some were already unserviceable, and the remainder were required as spare sets for the 12 Halifax and the Stirling installations which had been completed for Bomber Command. The current output of E.M.I. was also earmarked for Bomber Command aircraft.¹ The provision of equipment for Coastal Command was entirely dependent on the output of the R.P.U. But even had the equipment been produced as had been estimated, full implementation of the plan, made in November 1942, to equip 20 Wellington XII aircraft, would not have been possible. To accomplish this, it was essential that the A.S.V. Mark III installation was incorporated in the main assembly lines at the aircraft factories, and technical troubles other than those connected with radar had delayed Vickers production of Wellington XII aircraft.² Also, serious difficulties, caused principally by the Type 64 modulator, had been encountered with the Wellington prototype installation. On 13 January 1943, the Director of R.D.F. reported to Sir Robert Renwick that ' . . . the A.S.V./H2S position seems to grow grimmer daily. . . . ' At the end of January the Chief of the Air Staff stated categorically that ' . . . the M.A.P. programme had been far too optimistic. . . . '³

As a result of the delays in the production of equipment it became necessary continually to revise the fitting programme. The introduction of A.S.V./H2S

¹ A.M. File C.S. 13548.

² H2S/A.S.V. installation as fitted in Coastal Command aircraft was known as A.S.V. Mark III.

³ A.M. File C.S. 17067.

into the Service was only achieved by overcoming the many difficulties caused by shortages of components for both installations and by the conflicting priorities of Bomber and Coastal Commands.

Teething troubles were already being experienced with the few equipments which had been manufactured, and the persistent unserviceability was causing serious misgivings. Improved types of filament and pulse transformers had been incorporated, but a major cause of unserviceability was the carbon pile in the voltage control panel. Modifications recommended to increase the number of flying hours per fault included the addition of a stabilising device to the carbon pile and the incorporation of improved condensers and transformers. Because a satisfactory type of transformer was not immediately available an alternative was adopted as a temporary measure, but after an initial provision supplies unaccountably ceased.¹

By 19 January 1943, however, Sir Robert Renwick was able to report that five equipments had been completed by the R.P.U. and had satisfactorily passed intensive tests.² Replacements for the components which had led to the low rate of serviceability were becoming available, and a prototype Wellington installation had been completed. Two pathfinder squadrons of Bomber Command had been equipped with H2S and were ready to begin operations, but had no spare sets or components. A start had been made with the fitting of six Wellingtons XII for No. 172 Squadron, Coastal Command. Previous experience of airborne radar had, however, convinced the Technical Branch of the Air Ministry that for the sustained and effective use of a new type of airborne radar equipment it was necessary for squadrons to hold one complete spare set of equipment for every fitted aircraft, and, in addition, an ample supply of those components which were most frequently needed as replacements. On 20 January 1943 the Anti-U-boat Warfare Committee was forced to decide whether fitting should be continued in accordance with the agreed programme and the need to provide spares ignored or whether a much smaller number of aircraft should be fitted, and each provided with a spare set as originally planned. The provision of spare sets for aircraft already completed would obviously increase the delay in the Coastal Command programme. The committee eventually agreed that the six Wellington installations should be completed, and thereafter sets should be allocated alternately to Bomber and Coastal Commands until such time as 50 per cent reserves were available for all aircraft fitted.³ It was stipulated that the decision did not imply an alteration in the approved policy of holding 100 per cent spares. By the middle of February 1943 the total number of sets completed by the R.P.U. had risen to 55. Seven Wellington XII aircraft had been completed and handed over to Coastal Command, three were undergoing flight trials, and the Wellington prototype had arrived at Chivenor for Service trials.

Service Trials of A.S.V. Mark III

Although the C.C.D.U. was still in existence, arrangements had been made by Headquarters Coastal Command for the A.S.V. Mark III trials to be undertaken by an operational squadron. This proved to be far from satisfactory. Crews normally engaged on operational duties were detailed to carry out the trials when not required for anti-U-boat sorties, and the aircraft were often

¹ A.M. File C.S. 13548.

² A.U. 43(19).

³ Minutes of 3rd meeting War Cabinet Anti-U-boat Warfare Committee, 1943.

used for routine flying training flights.¹ Little real progress was therefore made; the trials lacked organisation and a definite objective. There was no precise directive to cover such matters as the measurement of maximum and minimum ranges at different heights against different aspects of a target submarine, and of direction-finding and tracking. Range measurements were attempted only against British submarines in transit to and from their operational areas, when they were surrounded by escorts, and the resultant observations were confused and of little practical use. It was essential that a submarine should be made available for several days simply and solely for target purposes, and the submarine commander given precise instructions about his task. Perhaps the reason why an operational unit, No. 172 Squadron, and not the C.C.D.U. was selected to undertake the Service trials was that A.S.V. Mark III was not regarded as a new equipment involving a new technique but was considered to be merely an improved version of the A.S.V. systems which had been used in Coastal Command squadrons for over two years.

On 3 March 1943 the Director General of Signals suggested that it might be of great value to undertake intensive trials and demonstrations of a Liberator equipped with DMS.1000, a Liberator with A.S.G.I and a Wellington XII with A.S.V. Mark III, to determine quickly the best tactics, collect performance data, and to smooth out any major shortcomings. He added that the crews used for this purpose would form a valuable and experienced nucleus for the C.C.D.U. The C.-in-C. Coastal Command, however, did not think such trials were necessary because '... Coastal Command squadrons were already A.S.V.-minded and keen to get the new equipment, and in this way differ from Bomber Command where the whole idea was quite new...'¹ The Director of R.D.F. emphasised the need for impressing on the squadron the great potential value of the new equipment and, since it had been accepted straight off the drawing board, only the enthusiastic co-operation of the crews and the Post Design division of the T.R.E. could quickly overcome the initial and inevitable setbacks.² One flight of No. 172 Squadron was, on 22 February, taken off operational duties at the expense of a temporary decrease of the Bay of Biscay patrols, and, armed with the seven Wellington XII fitted with A.S.V. Mark III, ordered to concentrate on trials and training.³ All personnel were screened from posting for three months, but unfortunately the Wellington XII airframes and engines were not free from the faults customary with new equipment, and the conversion training of crews was consequently prolonged.⁴ Facilities for servicing aircraft were limited, and priority was of necessity given to the Wellington VIII aircraft required for operational sorties. A shortage of labour and materials, coupled with a spell of bad weather, delayed the completion of radar servicing workshops, and Headquarters Coastal Command experienced difficulty in providing sufficient servicing personnel.⁵ The training of aircrews was rushed and sketchy because of the lack of suitable facilities, and this, combined with technical limitations of the equipment itself resulted in the detection ranges against submarines being only about half of what had been expected.⁶

Operators, accustomed to metric A.S.V., encountered serious difficulties with the new technique. With A.S.V. Mark II the display on the C.R.T. was steady.

¹ A.M. File C.S. 17067.

² See Appendix No. 10 for notes on T.R.E. Post Design Service.

³ A.U. 43(47).

⁴ A.H.B./IHK/24/209.

⁵ C.C. File S.9108/19/1.

⁶ A.H.B./IIE/244. History of T.R.E. Post Design Services.

A path was swept with the fixed aerials, and the gain control was set to give a reasonable noise and/or sea return amplitude and then left alone; flutters and fading were not over-troublesome. With the P.P.I. of A.S.V. Mark III, however, although coast lines and convoys, which gave a fair picture with reasonable definition dependent on range, were easily interpreted, location of small targets was more difficult. The difficulty increased with the roughness of the sea. To obtain the best performance, it was necessary for the operator to adjust the gain control with range in order to prevent saturation, and the setting required might vary considerably according to the state of the sea and the surface wind direction. When searching, or homing, fading added a further difficulty. In the Wellington installation the azimuth scanning system rotated at 60 r.p.m.,¹ so the beam illuminated the target for a fraction of a second only, and when this coincided with fading, especially in or near the sea returns, operating required continuous and close attention.

Discussions on Comparative Priority of Command Requirements

By the end of February 1943 it became clear that a considerable gap existed between the Air Staff requirements and the predictable production and fitting capacities.² The success which had attended the first use of H2S by the pathfinder squadrons of Bomber Command, and the ever growing emphasis on the need for centrimetric A.S.V. in the anti-U-boat war, caused the requirements to be stepped up both in quantity and urgency.³ It became necessary therefore to examine them closely in relation to the probable installation capacity which could be made available and where the requirements could not be met, to modify them and evolve a definite order of priority.⁴ The Directorate of Bombing Operations maintained that the priority of allocation to Bomber Command should be increased at the expense of Coastal Command. The current tactical principle for employment of a bomber force of nearly 50 squadrons was concentration of attack, and, it was argued, H2S enabled the pathfinder squadrons to locate and mark targets for the main force to concentrate attacks against them in an effective manner that had not previously been possible.

To ensure effective marking in sustained operations, a minimum of four squadrons equipped with H2S was required, whilst six squadrons were considered desirable to extend the period of marking throughout the entire attack. This would ensure that there were enough markers on the ground at any one time to reduce the effect of individual aiming errors and thus to provide a pattern of markers of which the centre would be on or near the aiming mark. For these reasons it was contended that H2S provided on a scale sufficient to equip immediately six pathfinder squadrons would be of a value out of all proportion to the number of equipments involved, whilst in Coastal Command each equipment could have but a very limited value, and it is interesting to note, in view of what was to happen during the next three months, that even that value was questioned. ' . . . It is sometimes suggested that the main function of anti-submarine reconnaissance lies not so much in the actual sinkings which result as in the lengthening of the operational sortie of the submarine. This is borne out by comparison between the effort expended and the number of kills.

¹ 30 r.p.m. in the Sunderland.

² A.H.B./IIJ/70/603 A.S.V. Policy.

³ H2S was first used operationally by pathfinder squadrons on the night of 30/31 January 1943 for a raid on Hamburg.

⁴ A.H.B./II/69/215A. H2S.

Ten centimetre A.S.V. may cause a slight increase in the number of kills, but these are in any case likely to be so small as to have little or no effect on the U-boat campaign. Attacks on construction yards would probably destroy a greater number. Thus, from the point of view of submarine destruction, there can be no strong grounds for denying to Bomber Command the vitally important initial equipment required for the pathfinder force. If we consider the value of 10-centimetre A.S.V. in forcing submarines to remain below the surface and thus reducing their operational efficiency, we must come to the conclusion that it is not as effective as the lower frequency equipments which can be detected by the enemy. The submarines submerge immediately they realise the A.S.V. aircraft are within range. To cause the maximum interference to submarines in transit, we should, it seems, aim at covering the largest area of sea with A.S.V. signals that can be detected by the enemy. The fitting of 10-centimetre A.S.V. equipment is a direct contravention of this principle . . .'

At a meeting held on 12 March 1943 under the chairmanship of the A.C.A.S. (Ops.) at which the general policy of installation of A.S.V./H2S in aircraft of Coastal and Bomber Commands was discussed, it was finally agreed that the commands should be equipped as follows¹ :—

		<i>Coastal Command.</i>	<i>Bomber Command.</i>
By 31 March	..	3 squadrons	2½ squadrons
„ 30 April	..	3½ squadrons	3 „
„ 31 May	..	6 „	4½ „
„ 30 June	..	6 squadrons + 1 overseas	5½ „
„ 31 July	..	7 „ + 2 „	7½ „
„ 31 August	..	9½ „ + 2 „	10⅔ „
30 September	..	11 „ + 2 „	13 „

With this order of priority as a guide, allocation of the weekly output of equipment was governed by a number of fluctuating factors, examined each week by the Director of R.D.F. and Sir Robert Renwick, which included² :—

- (a) Casualties, losses and technical breakdowns during the previous weeks.
- (b) Output of aircraft available for fitting.
- (c) Ratio of serviceable to unserviceable sets held by squadrons, both in aircraft and as spares.
- (d) Progress already made with aircraft at the installation units.
- (e) Progress of training on squadrons.
- (f) Availability of spare components.

Discussions on Quantity of Equipment to be held as Spares

The quantity of equipment to be held in reserve continued to be the subject of many discussions at the Air Ministry and in the Anti-U-boat Warfare Committee. At the end of February the Director of R.D.F. said that in his opinion maintenance of 100 per cent spares in squadrons was a wise policy which had been amply proved by past experience of new equipments such as A.I. Marks IV and VII and A.S.V. Mark II, and thought that the difficulties with which those responsible for the A.S.V./H2S fitting programme had recurrently to contend arose mainly from a disregard of this need. Any relaxation of aiming at 100 per cent inevitably resulted in temporary shortages which

¹ A.H.B./II/69/215A.

² A.H.B./ID/12/195.

limited operational use and training. The Chief of the Air Staff on 4 March 1943 stated that in his view the ideal arrangement was that, instead of fixing an arbitrary percentage of spares, there should be just sufficient serviceable sets at any one time to enable all available aircraft to operate, with no equipment left over; serviceable sets kept on the ground were wasted sets.¹ He wanted a reduction made in the number of sets and components held in reserve for fitted aircraft in order that additional aircraft might be equipped. The C.s-in-C. of Bomber and Coastal Commands were asked to study the problem and to calculate their requirements.

In general both commands were content to operate with less than 100 per cent reserve equipments; Coastal Command considered that 25 to 30 per cent would probably be sufficient, but the command's lack of operational experience with A.S.V. Mark III made accurate assessment impossible. Bomber Command was holding just over 50 per cent spare equipments and was managing with great difficulty to maintain about 75 per cent serviceability in the squadrons. Although it was doubted whether 100 per cent serviceability could be obtained unless one serviceable set were held in reserve for every set fitted in an aircraft, in the circumstances Bomber Command would endeavour to operate with 50 to 60 per cent spares. Bomber Command suffered more casualties since their aircraft were more often subject to damage than those of Coastal Command, and consequently it was natural that a higher percentage of equipment would be required for them. But both commands suffered one difficulty in common; technical failures occurred most frequently in certain components, and those components could only be obtained by 'cannibalising' serviceable equipments, obviously a wasteful procedure, or by applying to the T.R.E. who controlled such spares as existed and helped whenever possible.

It was not practicable merely to manufacture an increased number of those components which were recurrently defective; the fundamental design was faulty and complete re-designing was necessary. It could only be after the A.S.V./H2S equipment had been in operational use for several months and when the inevitable modifications had reached a more or less stabilised form, that independent production of certain individual components could be economically undertaken. Until then spare components had to be held as complete spare sets. The Chief of the Air Staff agreed that the existence of a large number of unserviceable sets would have to be accepted, but he considered it essential that the ratio of serviceable spare sets to fitted aircraft should be considerably reduced, in order that the number of completed aircraft delivered to the commands might be quickly increased.

Modifications to A.S.V. Mark III

The main faults experienced with the original A.S.V. Mark III installations, later known as A.S.V. Mark IIIA, were caused by faulty crystals, unsatisfactory pulse transformers and blower motors, errors in the manufacture of certain small units, instability of voltage control panels, and interference which gave rise to an effect known as windmilling.² The customary ground checks proved unreliable, and often an installation which appeared to be quite serviceable on test gave a very poor performance in the air, the main cause being a lack of sensitivity caused by the faulty crystals. Later a signal generator was used to

¹ A.H.B./ID/3/932(A).

² A.H.B./IIE/244.

check over-all sensitivity.¹ The T.R.E. Post Design Service, the manufacturers, and the Service technicians, working in unfavourable conditions and handicapped by the shortage of serviceable spare components, managed to achieve some degree of operational serviceability with No. 172 Squadron's Wellington XII installations. As a result of their experiences they proposed a series of modifications which were agreed in April 1944, and the modified installations became known as A.S.V. Mark IIIB.²

Amongst the more important and earliest of these modifications was the introduction in March 1943 of waveguide-fed scanners. Others included the replacement of the P.P.I. tube by one with a more satisfactory after-glow; the provision of an extended range scale on the switch unit; the supply of canvas covers to reduce the number of failures in wet weather, and blackout curtains to enable the equipment to be used in daylight; and the addition of a sea return discriminator. As modifications were incorporated the reliability of A.S.V. Mark III showed a marked increase. By March the average number of flying hours per fault had risen from 5 to 12, and gradually the causes of failure became less attributable to defects in specific components and were more evenly distributed over the entire apparatus. In addition the lower altitudes at which the installation was flown in the A.S.V. role compared with the usual heights for H2S sorties also helped to improve the standard of serviceability.³ By the end of 1943 the number of flying hours per fault had risen to 100, helped largely by the increase in experience gained by the servicing mechanics. During the last few months of the war the serviceability rose to about 200 hours per fault.

Introduction into Operational Use of 10-Centimetre A.S.V.

Early in March 1943 the initial programme of fitting and rearming No. 172 Squadron was completed; the squadron made its first operational sortie with A.S.V. Mark III on 1 March 1943 and achieved its first U-boat sighting with the installation on the night of 17/18 March 1943. A Leigh Light Wellington of No. 172 Squadron equipped with A.S.V. Mark III attacked and damaged a U-boat during the night 4/5 March 1943, but the aircraft was itself shot down so it is not known if the initial sighting was made with A.S.V. By then No. 224 Liberator Squadron had received 7 Liberators equipped with DMS. 1000, 3 with A.S.G.1, and 1 with S.C.R.517B and was employed on daylight operations over the Bay of Biscay.⁴ DMS. 1000 had proved to be rather unreliable, and rapid and efficient servicing was hampered by the awkwardness of the equipment's location. A recurrent fault was mechanical breakdown of filament transformers. The installation was purely experimental however, and technical experience gained with it had been of benefit to the A.S.G. equipment which was replacing it. The first U-boat sighting to be obtained with DMS. 1000 was made on 26 February 1943 when, fittingly enough, the aircraft was A.L. 507; the installation was withdrawn from operational

¹ T.R.E. Monograph: 'A.S.V.'

² A.S.V. Mark III, with modifications incorporated by Coastal Command, was designated A.S.V. Mark IIIA, and with both Coastal and Bomber Command modifications incorporated in the production lines, A.S.V. Mark IIIB.

³ C.C. File S.9108/19/2.

⁴ C.C. File S.14406.

DMS. 1000 was designated A.S.V. Mark IV.

A.S.G. was designated A.S.V. Mark V.

service in the autumn of that year. The average maximum ranges obtained with DMS. 1000 were :—

Fishing vessels	9 miles
Single ships	16 miles
Convoys	30 miles

The initial introduction of A.S.G.1 into squadron use was not marked with great success. The servicing personnel had been trained on DMS. 1000, and there was a shortage of test gear and, to some extent, spares.¹ The availability of a few spare sets did not, with any type of airborne radar, imply availability of spare components and connectors. Components could be obtained to a limited extent by cannibalising complete sets of equipment, but the shortage of connectors was a great disadvantage. Aircrew training was strictly limited by the availability of aircraft and could only be carried out at the expense of operational flying. This was remedied when a training flight for American A.S.V. was set up in April at Beaulieu, where No. 224 Squadron was based.

The capabilities of A.S.G.1 were not understood, for there had been no Service trials, but in April arrangements were made for the C.C.D.U. to investigate the operational performance of the equipment. It quickly became obvious that an organisation was required to facilitate the introduction of American A.S.V. to the Service in the same way that the Post Design Service was helping with A.S.V. Mark III. It was necessary, in view of the modifications and technical information required by the R.A.F., firstly to constitute a British design authority which was authorised to regard itself for all intents and purposes as the actual designer of the equipment, and secondly to ensure that expert technical assistance was available from the U.S.A. as nearly as possible coincident with the arrival of the equipment itself. To assist with DMS. 1000 two officers of the Electronics Training Group had been sent from the U.S.A. to the United Kingdom. Their assistance was of such great value that later it became normal practice for American technical officers to work with the Post Design Service, and the T.R.E. was able to foster the introduction of American, in addition to British, A.S.V. installations.²

Because of the identification problem associated with new equipment, the spares position might have been worse. Early in February 1943 however, the Director General of Signals had issued a warning that a very large number of Liberators already fitted with centimetric A.S.V. and carrying spare equipment would be arriving in the United Kingdom during the next few months and a careful handling organisation would be necessary to ensure a smooth introduction into the Service of so much equipment with which it was unfamiliar. He emphasised that it would not be sufficient merely to provide adequate spares and test gear; timely arrangements for their correct allocation and distribution were essential. Already seven DMS. 1000 Liberators and six fitted with A.S.G.1 had arrived at Prestwick, carrying not only running but also base spares.¹ The equipment branch of the Air Ministry immediately made arrangements with Scottish Aviation Ltd., the firm which was modifying the aircraft before they were delivered to the Service, for the boxes of running spares which accompanied every aircraft to be retained in the aircraft. To guard against loss, checking lists were prepared. The base spares, which

¹ A.M. File C.S. 16787.

² A.H.B./IIE/244.

were flown in some of the aircraft only, were sealed and despatched to No. 61 Maintenance Unit, from where they could be issued only on the instructions of E.47 at the Air Ministry. To facilitate A.S.V. servicing in No. 224 Squadron a limited quantity of base spares for DMS. 1000 and A.S.G.1 were sent straight to Beaulieu. The instructions were speedily complied with and the first consignment of equipment was despatched to the maintenance unit on 23 February. The Royal Air Force Delegation was requested to take action to facilitate identification by normal equipment procedure, and until complete identification was ensured, no disposal for storage away from the maintenance unit was permitted.¹

The lack of operator training and the absence of a sufficient quantity of suitable test gear, without which the power output of the transmitter and the sensitivity of the receiver could not be determined accurately, caused the performance of A.S.G. to be extremely variable during the first weeks of its operational use.² That it was stabilised in a very short time is shown by a report of the Coastal Command Operational Research Section, who analysed the maximum contact ranges obtained with A.S.G.1 in No. 224 Squadron and A.S.V. Mark III in No. 172 Squadron during April 1943 and produced the following A.S.V. performance comparisons³:—

<i>Target.</i>		<i>No. 224 Squadron.</i>	<i>No. 172 Squadron.</i>
Submarine		10.4 miles.	6.5 miles.
Fishing vessels		11.4 miles.	6.7 miles.
Single ships		16.3 miles.	8.9 miles.
Convoys		31.7 miles.	12.6 miles.
Coastline		62.0 miles.	32.0 miles.
Aircraft		9.9 miles.	5.0 miles.

Delivery of fitted aircraft to No. 224 Squadron from Prestwick had been delayed because the modification of Very Long Range Liberators had been given priority over the modification of the Medium Range Liberators destined for employment on Bay of Biscay patrols. Study of German documents makes it quite plain that by the end of 1942 it was air support to convoys that was feared most, and the main disposition of U-boats was consequently located in mid-Atlantic where they could be reached only by V.L.R. aircraft, and then only when the weather was favourable.⁴ In January 1943 Admiral Dönitz began re-deploying U-boats in record numbers to that area in mid-Atlantic known as the 'Gap' and at the Casablanca Conference where it was decided that measures to defeat the U-boats were to be the first charge on Allied resources, the provision of V.L.R. shore-based aircraft was agreed to be a matter of the greatest urgency. Only one V.L.R. squadron, No. 120, was then available to operate in mid-Atlantic, and that squadron was equipped with A.S.V. Mark II. Range of action was the all-important factor, and for several months the air patrols in the 'Gap' relied mainly on metric A.S.V. and visual observation.

¹ A.H.B./IIJ/70/603. A.S.V. Policy.

² No. 224 Squadron obtained its first sighting with A.S.V. Mark V on 4 April 1943 and its first U-boat kill on 3 July 1943.

³ A.H.B./IIJ/70/603. Isolated instances of long range contacts obtained with A.S.G.1 were 70 miles against S.S. *Queen Mary* and 70 miles against a convoy.

⁴ Admiralty Translations P.G.30309a-30314b.

Operation Gondola

Aircraft of Nos. 1 and 2 U.S.A.A.F. Squadrons, equipped with Liberators fitted with S.C.R. 517C, began arriving in the United Kingdom in November 1942 and the first sighting to be made with that equipment occurred on 31 December 1942.¹ At first the results were somewhat indifferent as was to be expected from a combination of untried equipment and inexperienced crews. During Operation Gondola however, between 6 and 15 February, the first successful daylight attack was made as the result of an A.S.V. sighting on 10 February 1943.² The operation resulted in a heartening increase in the ratio of sightings to flying hours over the Bay of Biscay compared with what had been obtained in January. This was largely due to the ability of the Liberators to cover the outer area of the Bay previously unattainable by the United Kingdom based aircraft, and because few of the aircraft engaged on the operation used metric A.S.V. The U-boat commanders were given a false sense of security when no signals were heard in their search receivers and did not expect to see aircraft so far out in the Bay. Unfortunately, the two squadrons were transferred from St. Eval to Morocco early in March 1943 just when their intensive training with S.C.R. 517C was beginning to achieve results.³

Operation Enclose

After Operation Gondola, air operations over the Bay of Biscay reverted to their former degree of intensity, and the number of U-boat sightings fell to the former low level. The drastic decrease in the number of sightings, coupled with the knowledge that by the middle of March the number of Wellington XII aircraft fitted with A.S.V. Mark III might be increasing comparatively rapidly, encouraged another high intensity operation to be planned. This was called Operation Enclose, and was carried out between 20 and 28 March 1943. By then 32 Wellington XII aircraft had been fitted, 20 of which had been allocated to No. 172 Squadron and 10 to No. 407 Squadron.⁴ During the hours of darkness the Leigh Light A.S.V. Mark III aircraft of No. 172 Squadron operated in conjunction with Sunderlands fitted with A.S.V. Mark II which were used for A.S.V. flooding tactics. It is now known that 41 U-boats were in or crossed the area during the operation. By day 16 sightings resulting in 10 attacks were obtained, and by night 10 sightings and 5 attacks. The A.S.V. Mark III aircraft were responsible for 9 of the sightings, 1 U-boat sunk and 1 U-boat seriously damaged.⁵ In his War Diary Admiral Dönitz noted on 23 March 1943 that the Bay of Biscay route was becoming dangerous; from November 1942 until January 1943 Allied aircraft had been comparatively ineffective, but since February their effect had increased to an alarming extent, especially when large numbers of U-boats were returning from major convoy operations; he concluded his remarks with ' . . . there will be further losses.'

¹ A.M. File C.S. 16787.

² See A.H.B. Narrative: 'The R.A.F. in Maritime War' for details of Operation Gondola.

³ See A.H.B. Narrative: 'The R.A.F. in Maritime War' for the reasons for the transfer.

⁴ A.M. File C.S. 6425, Part II. (The A.S.V. was temporarily removed from 7 aircraft of No. 407 Squadron for security reasons. C.C. File S.14406.)

⁵ A.H.B. Narrative: 'The R.A.F. in Maritime War.'

INSTALLATION OF 10-CENTIMETRE A.S.V.

Analysis of Air Operations against U-boats

The improvement achieved in Bay of Biscay operations was not allowed to give a false perspective to the anti-U-boat campaign as a whole. On 17 March 1943 the Prime Minister stated that convoy patrols should be given priority over the Bay patrols which, according to statistics, paid a smaller dividend.¹ An exhaustive analysis of air operations carried out by Coastal Command since the middle of 1943 was made by the Air Officer Commanding-in-Chief. The outstanding point which emerged was that whilst aircraft engaged on protection of threatened convoys had made one sighting for every 29 hours flown, to achieve a sighting in the Bay had required 164 hours between June and September 1942, 312 hours between October 1942 and February 1943, and 170 hours from then until the third week in March.² Until the threat of U-boat packs to convoys was relaxed the C.-in-C. Coastal Command proposed to give priority to close cover of threatened convoys where possible in preference to an all-out Bay offensive, although that did not mean that operations over the Bay were to be entirely abandoned. That area had originally been chosen as the most productive for the type of aircraft allocated to Coastal Command, and the shortage of V.L.R. aircraft which could be used for protecting convoys in the middle of the Atlantic was likely to persist for a long time. The Bay operations, although comparatively expensive and uneconomical, were well within the range of Coastal Command aircraft, and were therefore to be continued. One factor which increased the ratio of flying hours to sighting in the Bay of Biscay was the presence of French tunny fishing craft in the operational area. Analysis of reconnaissance reports revealed that investigation of the A.S.V. indications caused by fishing craft reduced the effectiveness of night sorties by 25 per cent. Later, during May 1943, action was initiated against them. Leaflets were dropped on tunny fishing ports, and, over a limited period, on any tunny fishers found at sea, informing them that attacks without warning would be made in the 'sink at sight' area after 1 June 1943.³

On 28 March 1943 the Admiralty, whilst agreeing with the policy of concentrating all suitable aircraft around threatened convoys, advanced the view that opportunities for convoy escort aircraft to attack U-boats were irregular whereas in the Bay of Biscay U-boat transits were occurring about 120 times every month. The Admiralty therefore called for the addition of 70 long range aircraft to the Bay offensive until the time came when the Germans took effective counter-measures against 10-centimetre A.S.V. Then the addition would have to be increased to 190 aircraft. The Admiralty appreciation argued that since the installation of appropriate search receivers in U-boats was more than likely to take place in the near future, the immediate transfer from Bomber Command of that number of aircraft was recommended;

¹ Minutes of 11th meeting Anti-U-boat Warfare Committee.

² Search receivers could not be used during the final stages of an attack against a convoy.

³ Minutes of 18th meeting Anti-U-boat Warfare Committee.

‘ . . . a small price to pay for the difference between success or failure in the Bay of Biscay’¹ The appreciation was, however, based on a mass of theoretical assumptions made by the Admiralty Operational Research Section and ignored the important factor that Bomber Command squadrons would need a long period of intensive training and re-equipment before they could effectively influence the anti U-boat campaign, and their transfer would mean, in the words of the Prime Minister, ‘ . . . a reduction in the bombing offensive at an extremely critical time’² Only limited resources were available to meet all defensive and offensive needs and the results in each sphere of air operations would have to be commensurate with the forces employed. Two facts were indisputable. The area immediately surrounding a threatened convoy was the most productive for attacks against U-boats at that time, and the main bases of U-boats at sea were in the Bay of Biscay.³ The C.-in-C. Coastal Command decided to strengthen the air offensive over the Bay, but not at the expense of convoy protection or Bomber Command. Temporary increases in establishment of squadrons were to be made and re-deployment of medium range squadrons already in Coastal Command were to be effected. From 6 April to 13 April 1943 Operation Enclave was to be repeated.

Installation of A.S.V. Mark III in Wellington Aircraft

By then the equipping of both Nos. 172 and 407 Squadrons with A.S.V. Mark III Wellington XII aircraft had been completed. Controversy about the respective claims of Coastal and Bomber Commands for the available equipment still continued. Bomber Command had received sufficient H2S aircraft to meet the needs of the pathfinder force, but considered it essential that the main force should also be equipped to ensure that all bombs dropped were concentrated in the centre of the target area. The Prime Minister regarded the provision of additional H2S installations as being of the utmost importance, but did not want it to be at the expense of sets already delivered to Coastal Command. The installation programme still lagged behind schedule, but the delays were occasioned by ‘ real ’ production shortages of the radar equipment, airframes and engines.⁴ The difficulties included not only technical problems but those caused by labour shortages and strikes. The delays would most certainly have been aggravated had the equipments produced under the ‘ crash ’ programme not been so closely and effectively controlled from the moment they left the manufacturers until their installation in aircraft or allocation as spares. Had the process been left to the normal equipment procedure then in force many ‘ artificial ’ shortages would undoubtedly have occurred, as happened later in 1943. Then, although production, despatch of equipment, and installation progress were supervised, it was not possible to prevent improper or undesirable issues from manufacturers and stores. Such issues created difficulties for the supply organisation since all estimated requirements for the latest items of equipment could not be met. Moreover, commands,

¹ A.U. (43) 98.

² A.H.B./1D/3/1843(B). C.A.S. Folder: Anti-Submarine Operations in the Bay of Biscay.

³ Air escorts, in conjunction with surface anti-U-boat escorts, even when unable to attack U-boats effectively, as they were to all intents and purposes from 1939 to the middle of 1942 and from the middle of 1944 to 1945, almost entirely prevented U-boats from attacking convoys. Of the 600 ships sunk in convoy in the Atlantic and home waters by U-boats, not less than 90 per cent were sunk when no air escort was present. (Naval Staff History: The Defeat of the Enemy Attack on Shipping 1939–1945.)

⁴ See Table No. 7.

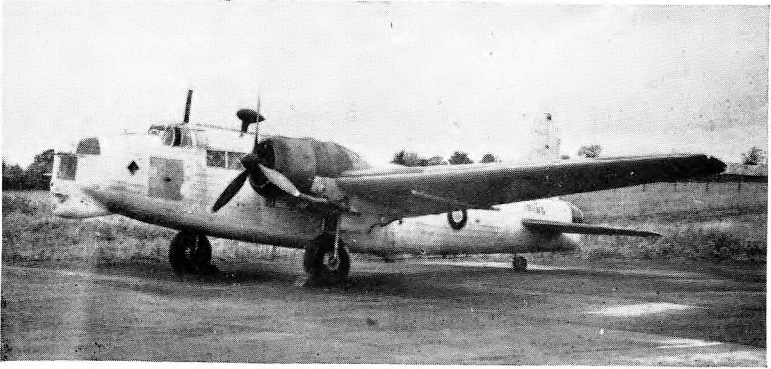

Wellington



Liberator

CHIN SCANNER POSITIONS

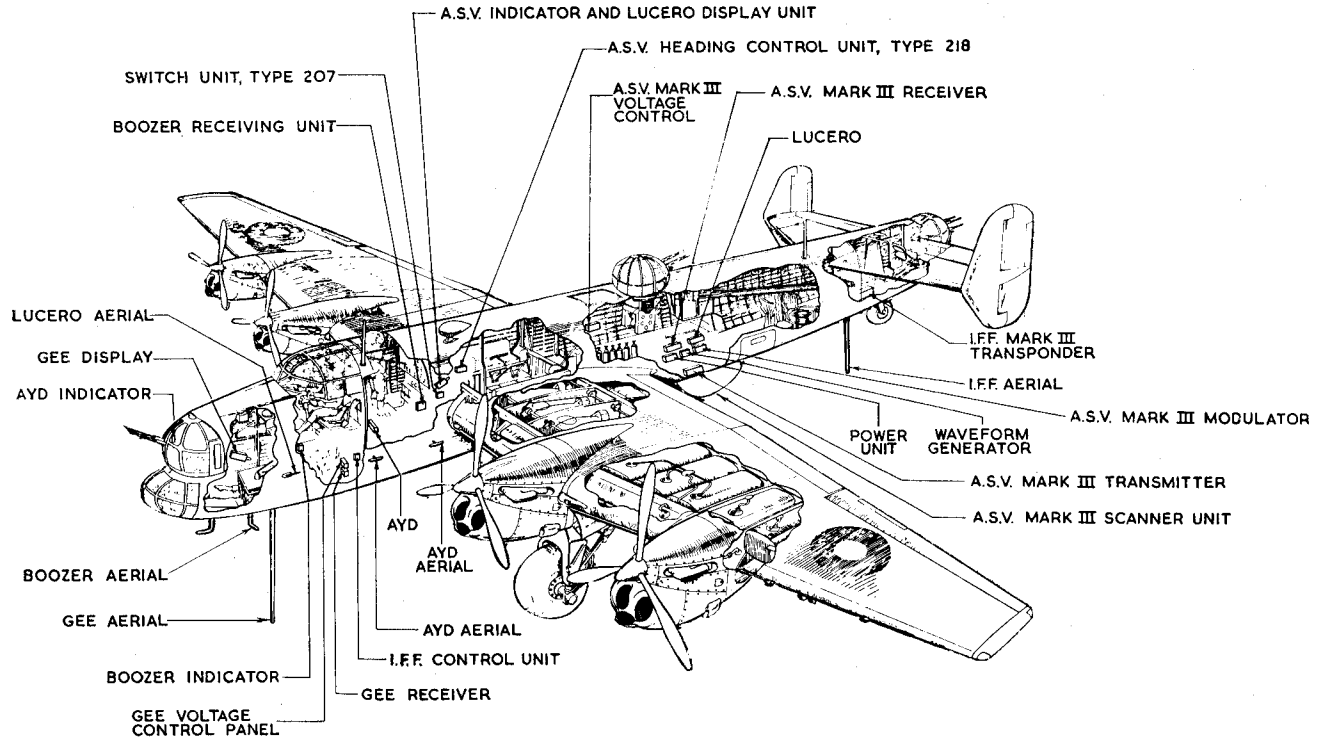

Layout of Radar Equipment in Halifax Mark II

groups and stations could not provide accurate and up-to-date information regarding the disposal of items issued to them but not installed in aircraft.¹

Operation Enclose 2 was carried out with slightly fewer aircraft than had been used for Enclose 1. 25 U-boats were in the area, and 11 sightings and 4 attacks resulted. For the first time sightings by day were in the minority, indicating that U-boats were then surfacing only at night.² Metric A.S.V. flooding was again employed at night and Sunderlands fitted with A.S.V. Mark II achieved 5 sightings but, not being equipped with suitable illuminants, made only 1 attack. 3 Leigh Light Catalinas fitted with A.S.V. Mark II and No. 172 Squadron also operated at night. The Wellingtons obtained only 3 sightings but carried out 2 attacks, sinking 1 U-boat and damaging another. Aircraft fitted with metric A.S.V. thus obtained the majority of night sightings, and the operation appears to have been the one and only successful use of metric A.S.V. flooding.

By the middle of April both Nos. 172 and 407 Squadrons were armed with Wellington XII aircraft fitted with A.S.V. Mark III and Leigh Lights, 16 Liberators equipped with centimetric A.S.V. were included in No. 283 Squadron, 5 in No. 86 Squadron, 7 in No. 59 Squadron, and No. 58 Squadron had just received its first medium range Halifax fitted with A.S.V. Mark III.³ From 13 April until the end of the month, another operation, Operation Derange, was carried out over a different area of the Bay. The number of aircraft engaged was increased by three squadrons, including No. 407 Squadron. 19 sightings and 10 attacks were achieved by day, and 17 sightings and 12 attacks by night.⁴ They included a batch of 7 night attacks made by A.S.V. Mark III aircraft of which no warning was received in the Metox receiver. Not only was the U-boat Command's faith in the 'Magic Eye' broken, but Admiral Dönitz was forced into what proved to be a series of tactical blunders. In May 1943 his losses were so high that a crisis was reached in the U-boat war.⁵

Installation of A.S.V. Mark III in Halifax Aircraft

The programme for the provision of Halifax aircraft for employment in the Bay offensive had become very complex since the Chief of the Air Staff first outlined his proposals in November 1942. Then, the Anti-U-boat Warfare Committee had agreed that 24 Halifaxes for two squadrons should be equipped with A.S.V./H2S and allocated to Coastal Command, and the Halifaxes on loan from Bomber Command should be retained until the new squadrons were operational. However, the plan for equipping the pathfinder squadrons of Bomber Command and later the main force with H2S had first call on what Halifaxes became available, and proposals were made for using Fortresses or Liberators, with or without centimetric A.S.V., for operations over the outer zone of the Bay.

In December 1942 it was decided to allocate A.S.V. Mark III Halifaxes to Coastal Command at the rate of 6 in January, 14 in February, 4 in March, 2 in April and 2 in May. Later that month the programme was modified ;

¹ A.M. File C.S. 13548.

² A.H.B. Narrative : ' The R.A.F. in Maritime War.'

³ C.C. File S.14406. The Liberators of No. 224 Squadron comprised 6 with DMS. 1000, one with S.C.R. 517B and 9 with A.S.G.I. The Liberators of the other squadrons were fitted with A.S.G.I.

⁴ A.H.B. Narrative : ' The R.A.F. in Maritime War.'

⁵ Admiralty Translation P.G.30324. See Chapter 13.

only one of the Halifax squadrons was to consist of the standard medium range aircraft, and the second was to be converted to V.L.R. Halifaxes, to be equipped with A.S.V. Mark III by March 1943. In January, the non-arrival in Coastal Command of the expected V.L.R. Liberators from the U.S.A. caused the Anti-U-boat Warfare Committee to enquire if the provision of V.L.R. Halifaxes could be accelerated.¹ But when the delivery of H2S aircraft to Bomber Command began to lag behind schedule the firm engaged on modifying Halifaxes was instructed to concentrate on the bomber version and Halifaxes already fitted for delivery to Coastal Command were sent in January 1943 to Holmesley South where the A.S.V. mountings, wiring and scanners were removed so that the aircraft could be diverted to Bomber Command.² In February the fitting programme was amended to 12 Halifaxes to be equipped for Coastal Command by the end of March.³ A further complication was added by the increasingly urgent need for V.L.R. aircraft for the protection of Atlantic convoys. The need for aircraft to cover the 'Gap' had become so urgent that the C-in-C. Coastal Command agreed to accept V.L.R. Halifaxes without A.S.V. Mark III for No. 502 Squadron and undertook to have them equipped with A.S.V. Mark II under squadron arrangements. In order, however, to equip the second squadron with A.S.V. Mark III, the priority of the Halifax and Wellington installation programmes had first to be decided. On 8 January the C-in-C. Coastal Command had stated that the modification of Halifaxes to the V.L.R. role was the most important requirement, and he was prepared to accept Wellington XI aircraft without A.S.V. until retrospective fitting became possible.⁴

Previously, in October 1942, Headquarters Coastal Command, in order to avoid delay with the installation of A.S.V. Mark III in Wellington XI aircraft, had agreed to accept the loss of the front gun turret provided that a full load of bombs could be carried since the aircraft were required for daylight sorties in the Bay offensive. Vickers had therefore initiated a crash programme which resulted in the first 30 aircraft being delivered in February and March without front turrets and torpedo fittings. Meanwhile, however, an urgent requirement had arisen for an air striking force to be employed against blockade runners, which, by hugging the northern Spanish coast, were operating beyond the effective range of Beaufighters. The Wellington XIs, it had been hoped by Coastal Command, would fulfil this requirement. The lag in the A.S.V. production schedule and the priority of the Wellington XII installation programme precluded the installation of A.S.V. Mark III in the Wellington XI. The 30 aircraft were therefore of little operational use either against U-boats or surface vessels, except possibly for night strikes which was an obviously uneconomical proposition.⁵

In March 1943, therefore, in order that he might make fuller use of limited resources, the new C-in-C. of Coastal Command informed the Chief of the Air Staff that he wished to have the 30 aircraft and future productions of the Wellington XI fitted with A.S.V. Mark II, Yagi aerials, front turrets, and torpedo fittings, until the Wellington XI could be engineered, without the

¹ The average time taken between date of allocation of American aircraft and arrival in the United Kingdom was two months.

² A.M. File C.30305/46.

³ A.M. File C.S. 13485.

⁴ A.H.B./ID/8/444. V.C.A.S. Folder 'Navigation Aids.'

⁵ The Wellington XI was not used as an anti-U-boat aircraft.

removal of turrets, for A.S.V. Mark III.¹ Arrangements were made to this end, and although no delivery date could be given, it was estimated that the work could be done at the rate of 3 per week. As a result of the change of command the priority of Coastal Command A.S.V. Mark III requirements underwent changes, but by the end of March it had been stabilised as² :—

1. 2 Wellington XII squadrons.
2. 1 M.R. Halifax squadron.
3. 1 V.L.R. Halifax squadron.
4. All other Wellington XII squadrons.
5. All Sunderland squadrons.

By the end of April No. 58 (M.R. Halifax) Squadron had received 13 aircraft equipped with A.S.V. Mark III and it was expected that the installation programme for No. 502 (V.L.R. Halifax) Squadron would be completed by 31 May 1943.³ However, the conflicting requirements of Coastal and Bomber Commands, and the limited capacity for modifications at Cunliffe Owen's, were again to react to Coastal Command's disadvantage, and at the end of that month only 4 of the squadron's aircraft had been equipped.⁴ By then it had been found that the V.L.R. Halifaxes of No. 502 Squadron did not have sufficient radius of action for effective employment in the mid-Atlantic battles, and until the autumn of 1943 they were used, with the M.R. Halifaxes of No. 58 Squadron, for daylight sorties over the Bay of Biscay. There, because the aircraft lacked front guns, the squadron operated beyond the range of German aircraft and gave valuable service in the outer zone.⁵ During the period when the Bay offensive was achieving a considerable number of sinkings, centimetric A.S.V. was not used on the mid-Atlantic patrols, and the successes obtained served to emphasise the importance of keen visual observation and resolution in attack, combined with full use of metric A.S.V.

As early as February 1943 Dönitz was blaming air cover for the reduction in sinkings by U-boats in the Atlantic and reported that operations against convoys escorted by aircraft were not practicable. He considered that in the absence of adequate air cover, surface escorts alone could not break up or shake off a pack of determined U-boats. On 24 May 1943 he wrote ' . . . in the last few days circumstances have arisen which indicate a crisis in the U-boat war and force us to make a decision. These circumstances are the heavy losses which have occurred. . . . U-boat losses in the Atlantic were 14 in February, 13 in March, 12 in April, but up to 22 May they are already at least 31 . . . heavy losses can be borne if they are accompanied by correspondingly heavy ship sinking, but in May the sinking rate per U-boat has declined to 10,000 tons whereas not long ago it was about 100,000 tons. The May losses have therefore reached an impossible height. . . . '⁶

The technical performance of A.S.V. Mark III in the Halifax was at first very disappointing, and compared unfavourably with the Wellington XII installations. The Post Design Service carried out sensitivity investigation for one month at St. Eval, after which useful ranges were obtained. Early in 1944 the Operational Research Section of Coastal Command completed a detailed investigation of the A.S.V. logs of Nos. 58 and 502 Squadrons. Two

¹ A.H.B./IIK/24/209.

³ A.M. File C.S. 13548.

² A.M. File C.30305/46, Part II.

⁴ C.C. File S.14406.

⁵ Removal of front gun turrets was an essential part of the modification to convert Halifax to V.L.R. aircraft.

⁶ Admiralty Translation P.G.30324.

periods were selected; April to June 1943 and November 1943 to January 1944. The tasks of assessment and comparison of the performance data were complicated because the majority of the sorties made during the first period were flown by day, and those in the second period by night. Naturally, the ranges logged during daylight sorties did not always provide an accurate report of A.S.V. performance since radar contacts were often made only after a target had already been observed visually. The investigation revealed that there was a very effective increase, as much as 40 per cent against small targets, in the average maximum range at which contacts were made after the first period, doubtless mainly because the operators had gained more experience. It also disclosed that variations of the heights at which A.S.V. sorties were flown made very little difference to the ranges obtained. The majority of sorties, particularly during the second period reviewed, were flown at 3,000 feet or below. During the first period the average maximum range against coastal convoys was 17 miles; this was increased to 18 miles during the second period. Against fishing vessels the range increased from 8 to 11 miles; against aircraft from 5½ to 8 miles; against individual ships from 11 to 13 miles. During the first period no U-boat contacts were obtained, but in the second the average maximum range of 15 contacts was nearly 11 miles.

Installation of A.S.V. Mark V in Liberator Aircraft

The Liberator G.R. Mark V conversion programme which had been started at Fort Worth, Texas, at the end of 1942, suffered setbacks of a similar nature to those of its counterpart in the United Kingdom. At first aircraft were allocated at the rate of 4 per month, and 30 were received as the 1942 allotment. Of these 7 were equipped with DMS. 1000, 2 with S.C.R. 517B, and 20 with A.S.G.1.¹

One prototype S.C.R. 517B installation was flown to the United Kingdom at the end of January 1943.² This was eventually allotted to No. 224 Squadron, so that a thorough examination might be made, trials conducted, and the merits and demerits of the ventral installation investigated. A pilot's indicator was not included and no provision for S.C.R. 729 was made.³ The second prototype installation overcame these deficiencies and also included an A.Y.D. radio altimeter.⁴ The main purpose of the second installation was to obtain full data about cabling and brackets in view of the possibility that it might become necessary to make extensive use of S.C.R. 517B in the event of technical failure or production and procurement difficulties with A.S.G. 1. Another reason was the advisability of showing an active interest in U.S. Army Air Corps equipment to facilitate the supply of S.C.R. 517C should it ever become a requirement.

Meanwhile, the policy of the Army Air Corps regarding the type of installation to be used in their aircraft became less clearly defined. In February, consultations with the United States Navy were held to investigate the possibility

¹ A.M. File C.S. 16787.

² Liberator G.R. VFL. 958.

³ American equivalent of 'Lucero' and was later used as 'Rebecca' in Transport Command. Lucero was an interrogator responder designed as an adjunct to centimetric wave equipment to enable 1½ metre responder beacons and I.F.F. to be interrogated. Rebecca was an airborne radar homing equipment usually used in conjunction with the Lucero ground beacon. See Royal Air Force Signals History, Volume III: 'Aircraft Radio.'

⁴ Liberator G.R. FL. 979.

of the adoption of A.S.G. as the principal centimetric A.S.V. installation for Army Air Corps aircraft. Such standardisation would result in economy of manufacturing resources, simplification of training, and facilitation of servicing and maintenance. The A.S.G. equipment was easier to install than S.C.R. 517C and was superior in performance. Also, the rate at which Western Electric manufactured equipments continued to be comparatively slow, whilst Philco was proving to be not only more flexible and adaptable in introducing modifications dictated by Service requirements, but production was rapidly increasing.¹ It appeared most likely that the supply of A.S.G. could be sufficiently increased to meet the requirements of both the American Services and the R.A.F. The Philco firm was producing about 150 sets per month, hoped to double the output in March, and to exceed 600 sets per month by June 1943. The U.S. Navy and Army requirements were both expected to be about 300 per month by then. The R.A.F. requirement was being met at a rate of about 40 per month and arrangements had already been made to increase this allotment to 80. The U.S. Navy requirements included equipments to install in U.S. Navy aircraft such as the Mariner which at that time were intended for the R.A.F.¹

The production of A.S.G. 1 was scheduled to cease at the end of March, when it was to be followed immediately by an improved version of the equipment designated as A.S.G. 3. The slight differences between A.S.G. 1 and A.S.G. 3 were mainly in the methods of packaging the components, although the output power of A.S.G. 3 was slightly greater than that of A.S.G. 1. In the new version the pre-amplifier, local oscillator and T.R. box were mounted underneath the modulator set. The gain in compactness was, however, completely offset by the fact that access was rendered more difficult. Both Philco and the U.S. Navy Department had stated that no adjustment other than an initial one would be required, but in fact to change the crystal and the T.R. box necessitated raising the modulator. The receiver gain control was an improvement on that of A.S.G. 1, and a video gain, or contrast control, had been added. With the change from A.S.G. 1 to A.S.G. 3, the opportunity was taken to move the position of the main Liberator installation from the blister under the nose to an inverted hemispherical dome affixed in place of the ventral turret. The dome was made of fibre glass which was damp proof and had better transmission characteristics than plywood. Unfortunately it entailed the use of a longer flexible cabling for remote tuning of the local oscillator because it had to be taken through the bomb bay, and backlash resulted. The Royal Air Force Delegation repeatedly but unsuccessfully urged the U.S. Navy Department to change this form of drive, and recommended to the Air Ministry that if it proved too difficult to operate, the possibility of using an R.A.E. teleflex drive should be investigated.

Unforeseen manufacturing difficulties delayed delivery of A.S.G. 3 for about three weeks, and in order to make full use of the time whilst aircraft were awaiting modification at Fort Worth, installation of A.S.G.1 was continued. The number of installations was limited, however, by the Air Ministry requirement for a reserve of 100 per cent spare sets to be maintained and by the number of A.S.G.1 equipments which were available.¹ The supply of A.S.G.1 during March fell below expectations as the changeover from A.S.G.1 to A.S.G.3

¹ A.M. File C.S. 16787.

caused production to decrease, and the acquisition of A.S.G. for the R.A.F. turned out to be less easy than had been expected. Competition between the U.S. Navy and the Royal Air Force Delegation for deliveries was keen, but in general enough equipment to meet requirements was obtained by strong pressure being applied at assignment meetings and by close observation by the Royal Air Force Delegation of the actual production position. The process was not made any easier by the uncertainty of the Army Air Corps policy on A.S.V. requirements.

During this period the Air Corps staff was faced with the choice of S.C.R. 517B and C, S.C.R. 717A and B, A.S.G.1 and 3. All had been prototyped with the exception of A.S.G.3, and the S.C.R. 517 series was in good supply.¹ The majority of radio mechanics had been trained to service S.C.R. 517, the remainder S.C.R. 717, but no training on A.S.G. had yet been given. On several occasions the Army Air Corps stated that it would use the A.S.G. series, or the A.S.G. and S.C.R. 717 series, exclusively. The final decision was dependent largely on the extent to which A.S.G. production could be increased and whether A.S.G. equipment could be effectively installed in all the various types of aircraft for which A.S.V. was needed.² The position was not made less involved by the reorganisation of H.Q. Army Air Corps on 29 March 1943.³ Fortunately by May 1943 the main interest of the Army Air Corps became focused on the S.C.R. 517 and S.C.R. 717 series, and the supply of A.S.G.3 to the R.A.F. became less problematical.⁴

Shortage of Test Gear

One main drawback persisted. The principal items of A.S.G. test equipment included a volt/ohm milliammeter similar to an avometer, V.H.F. signal generator, pulse generator test oscilloscope, audio oscillator, test set Type LZ (U.S. Navy) or Type I.E. 57 (U.S. Army), centimetric standing wave indicator Type O and centimetric wavemeter Type D-1430 O. No standard set of test equipment was produced either for the Army or the Navy, and it was necessary to obtain each item separately by assignment. Only a small quantity of the special items had been produced because both the Army and Navy had failed to decide upon schedules of their requirements for test gear in time to allow delivery of it to be in step with delivery of sets of A.S.G. In March 1943 the M.A.P. was informed by the B.A.C. that field test sets for testing transmitter output and receiver sensitivity of A.S.G. whilst it was installed in an aircraft would not be available for some months. Testing was therefore to be based on the use of echo boxes, permanently installed in each aircraft, in conjunction with the heavy test sets Type LZ or I.E. 57 installed in radar workshops.

It was thought that the echo box would enable an overall check of the installation to be made, and should it indicate poor performance which could not be improved by normal adjustments, the suspected units were to be removed to the

¹ SCR. 717 was a 'small package' installation with many of the SCR. 517 characteristics but designed to be less awkward to install. (A.M. File C.S. 13468).

² A.M. File C.S. 16787.

³ See A.H.B. Narrative: 'The R.A.F. in Maritime War.'

⁴ In September 1943, 350 equipments were requisitioned to facilitate completion of the Oboe programme. The transmitter and units became integral parts of Oboe Mark II and those components not required were used as A.S.V. spares.

radar workshops for test with the heavier test gear.¹ In practice, however, the echo boxes were not sufficiently accurate to be of any real use, and the shortage of test gear became critical. Provision of A.S.V. equipment and test gear for the R.A.F. was the responsibility of the D.C.D. and D.R.P. representatives at the B.A.C. and of the Director of Signals at the Royal Air Force Delegation, but while the D. of S. could press for action he could not order action. Co-operation between the various branches was not complete until the gravity of the situation in April 1943 brought matters to a head. The D.R.P. branch had failed to raise demands in October 1942 when the B.A.C. branch had completed drawings and schedules of R.A.F. requirements, but eventually the D.G.E. and the M.A.P. issued specific instructions that all necessary action was to be taken immediately to ascertain the precise requirements and to ensure that A.S.G. requirements were met.²

Training of Personnel

By the middle of May 135 Liberators had been allocated to the R.A.F. ; eight had been diverted from the modification programme for training and transport roles, and of the remainder 98 had been despatched from Forth Worth for delivery to the United Kingdom.³ At the beginning of the Liberator G.R. V conversion programme it had been foreseen that the inevitable requirement for radio mechanics fully trained to service the American installations could not be met simultaneously with the delivery of fitted aircraft if training was confined to the United Kingdom. The Air Ministry had therefore been asked by the Royal Air Force Delegation in October 1942 for agreement to a proposal that suitable R.C.A.F. personnel should be diverted from the output of the Radar School at Clinton, Ontario, Canada, and given supplementary training in a Service training establishment in the U.S.A. Agreement was received in December 1942 when Air Ministry approval was given to the diversion of 10 officers and 100 airmen, and the first course was started at the Naval Air Technical Training Centre, Corpus Christi, Texas, on 11 January 1943. In order to catch up with the flow of aircraft the first courses were restricted to four weeks but as soon as the output of trained personnel, an average of 10 per course, overtook the rate at which aircraft were modified, on a scale of one mechanic per aircraft, the courses were extended to six weeks, and instruction on radar equipment other than A.S.V. which was likely to be installed in Coastal Command aircraft was included. Trainees were sent to Fort Worth from Corpus Christi to spend 7 to 10 days studying, and becoming familiar with, details of aircraft installation. They were then flown, whenever practicable, to the United Kingdom in the Liberator G.R. V aircraft which had been equipped at Forth Worth. With the completion of arrangements whereby all A.S.G. installation and testing was carried out by personnel provided by civilian contractors, it became no longer possible to give the practical training at Forth Worth, and Royal Air Force Delegation personnel therefore supervised a short course on installation at the R.A.F. Ferry Command Station, Dorval.⁴

¹ A.H.B./IHK/24/209.

² A.M. File C.S. 16787.

³ At the beginning of June Nos. 53, 59, 86 and 224 Squadrons were armed with A.S.G./Liberator V.

⁴ A.M. File C.S. 16787. In addition, an operational training unit was established at Nassau in the Bahamas.

Modifications to A.S.V. Mark V

It was not possible to conduct Service trials, or thorough flight trials of any sort, of the A.S.G. installations in the U.S.A., but during the first delivery flights across the Atlantic, efforts were made to carry out tests. It was discovered that a great deal of attention had to be paid to the use of the tilt control. To obtain uniform coverage over 360 degrees it was essential that the axis of rotation of the spinner should be perpendicular to the earth's surface. In practice this was found to be most difficult to ensure because in flight with varying overall weight and airspeed the angle between the fore and aft axis of the aircraft and the horizontal varied by four or five degrees. During a long flight as the weight decreased with the consumption of fuel so the nose gradually dropped. During the Atlantic crossings a fairly uniform coverage was obtained with the tilt set at about three degrees down initially and then gradually reduced to zero by the end of the flight. Service trials were arranged to determine the conditions under which normal operational sorties should be made. Short experience of operational use showed that whilst airborne failures of A.S.G. were few, and reliability soon was stabilised at about 150 flying hours per failure, there were a large number of minor defects which needed remedy. They could be divided into two principal groups, functional defects and equipment failures. The former included defects associated with the operational performance of the installation which did not necessarily render it unserviceable, and which required modification rather than replacement. The latter included failures of valves, transformers, resistors and similar components.

The more important functional defects were¹ :—

- (a) The method of arrangement of gain control on the valves of the I.F. strip was such that, since no control existed on the two preamplifier valves, the second of these valves frequently overloaded on strong signals so that discrimination between echoes of different amplitudes was not always possible. As a result, when trying to follow a small target such as a U-boat through sea-returns, discrimination was not obtained unless tilt was intelligently controlled.
- (b) The elevator motor operated too quickly so that accurate tilt setting was not always easy.
- (c) Very serious time-base jitter or multiple traces sometimes occurred and was the reason for many contacts being lost. It was caused by small voltage fluctuations due to mechanical vibrations in the carbon pile regulator which was difficult of access.
- (d) The magnetron blower motor caused interference which produced spots on the P.P.I., sometimes to such an extent that small signals could not be distinguished.

Most of the modulator valves showed a much higher failure rate than receiver indicator valves, occasioned mainly by poor construction, since many of the valves were found to be unserviceable when taken from the manufacturers' cartons. During the summer of 1943 both Coastal Command and the British Air Commission initiated many modifications. The amount of gain control was increased, reception of weak signals and signals at close range was improved, and an open centre P.P.I. display was incorporated. Adjustment of the carbon

¹ A.M. File C.S. 13468.

pile was very critical ; it was found that the position of greatest stability was usually obtained by adjustment slightly off the point of best voltage regulation. After September 1943 an improvement was made when the regulator was mounted separately from the inverter. More robust types of valve were used but continued for a considerable period to be a major cause of breakdowns because of excessive vibration occasioned by over-stiff shock mountings.

As a result of misunderstandings and poorly compiled squadron returns, it was reported that serviceability and performance of A.S.V. Mark V were steadily and continuously falling away during the summer and autumn of 1943. These caused serious concern in the British Air Commission in view of the fact that similar conditions were not being experienced by the American units using the equipment, and especially when it was learnt that Post Design Service personnel had been withdrawn from squadrons. An investigation carried out in November 1943 revealed that generally, in spite of the acute shortage of field test gear, the standard of serviceability had remained constant at approximately 130 hours flown operationally for every failure, a few hours better than with A.S.V. Mark III. The rapid and effective measures taken to remedy the defects, which were not fundamental, soon made A.S.V. Marks VA and VB the most reliable of A.S.V. installations ; a remarkable achievement in view of the fact that A.S.G. was taken into Service use 'straight from the drawing board' with no trials other than the flight tests made at Fort Worth.¹

¹ See Table No. 8.

GERMAN COUNTER-MEASURES

It was not so much the technical efficiency of A.S.V. and its tactical application as the nature of the reactions of Admiral Dönitz and his staff to its use that made it so effective during 1943. Dönitz was always inclined to over-estimate the part played by, and the ranges obtained with, A.S.V. and shipborne radar in Allied operations against U-boats, and the illogical attitude created by his obsession caused him to adopt one mistaken tactic after another. He confused the results obtained by the use of those devices with the excellent work of the various Allied intelligence services, and attributed to radar the location of U-boat dispositions, purposely deployed by him far beyond the range of shore-based aircraft, when Allied convoys were evasively routed as the result of effective application of information derived from intelligence sources. He seems to have been incapable of crediting Allied radio intelligence services with the ability to obtain even as much information as his own gave him from time to time and his deeply-rooted belief in the power of A.S.V. to detect targets at very long ranges caused him to ignore the obvious fact that U-boats could be sighted visually at appreciable distances during daylight in good visibility.¹ In actual fact, over 90 per cent of the U-boats located by aircraft during the convoy battles in the North Atlantic between August 1942 and May 1943 were initially detected visually; the aircraft were equipped with metric A.S.V. against which U-boats were adequately safeguarded. The main successes obtained with both metric and centimetric A.S.V. occurred in the transit areas at night, when visual reconnaissance was impracticable; the radar operators of the Leigh Light squadrons were more highly trained and the aircrew generally more conscious of the vital importance of A.S.V. than were those of the other squadrons engaged in the anti-U-boat campaign.

As a result of the success achieved by Operation Derange during April 1943 and his consequent realisation that the Magic Eye² had failed, on 28 April

¹ For instance, the German appreciation of the use of HF/DF against U-boats appears to have both over-rated and under-rated its value until late in the war. The accuracy of shore-based HF/DF was over-rated, but the potentialities of ship-borne HF/DF seems to have been very much under-rated, and, in fact, practically ignored. This was reflected in the W/T signals procedure used by U-boats, which was apparently based on the principle that W/T silence was to be strictly maintained until the target was within reach, but might be abandoned once the battle was about to be joined. During an attack on a convoy between 4 and 9 February 1943, for example, the U-boats taking part made 108 transmissions during a period of 72 hours. By the end of the war, U-boat H.F. communications systems had reached a very advanced stage of development. One, known as *Kurier*, involved a transmission of very short duration (a signal of about seven letters in two-fifths of a second) and a continuously varying schedule of frequencies. Such a signal was too short to interfere with W/T communications by normal methods on the same frequency and the whole H.F. band was thus available. The authorised recipient could readily set up special equipment on the pre-determined frequencies at the receiving end but a disadvantage was suffered in that the receiving equipment was too complex for installation in a U-boat, and *Kurier* could only be used for broadcasting messages; inevitably, consequently, the need arose for re-broadcasts. Extensible rod aerials were being developed for the Type XXI and Type XXIII boats which would make possible transmission at *Schnorchel* depths, and experiments were being conducted with expendable transmitting buoys which could be released from a U-boat to make a pre-determined signal some time later. (C.B. 04050/45(6).)

² Described later in this chapter.

Dönitz signalled permission to all U-boats in the Bay of Biscay area to remain submerged at night, and to surface only long enough to recharge batteries during daylight. He stated that ' . . . the enemy has at his disposal a radar device especially effective in aircraft which our boats are powerless to guard against . . . ' and assured U-boat commanders that every effort was being made to develop and install equipment capable of detecting the A.S.V. employed by the Allies. On 3 May he circulated to all U-boat flotillas a long situation report on Allied radar.¹ ' . . . Radar, more than any other means of location, is able to pick up the submarine while it is still at very long range, especially from aircraft, and by additional measurement the position can be pinpointed. Thus, quite naturally, the enemy eagerly seized upon radar from its earliest stages as an exceptionally valuable weapon in the fight against submarines. The Anglo-Americans have far greater reserves of manpower and materials to throw into the task of developing and manufacturing, and doubtless are using a high percentage of these reserves for radar research, that is, for anti-submarine measures, which they consider the most important part of their war effort. Hence the enemy has the upper hand in this field and we are forced to use our resources mainly for counter-measures to render the enemy location ineffective in order to protect our own boats, and the development and manufacture of radar gear for them to use offensively has to take second place. . . ' Dönitz then went on to describe the success which had followed the introduction of the R600A search receiver in the autumn of 1942, and continued ' . . . however, during the last few weeks enemy superiority has again increased, thus threatening U-boats and their chances of attack. . . ' The U-boat Command was aware that A.S.V. was sometimes used only intermittently because the Germans had captured a copy of a Coastal Command tactical memorandum and similar tactics were being employed by the *Luftwaffe*, and was also aware of the effects of A.S.V. flooding, but was uncertain whether the Allies were flooding intentionally.

The main conclusions reached in the report were that intermittent use of A.S.V. had sometimes been effective and required a counter-measure, that more efficient search receivers were needed and that it was possible that Allied aircraft were using methods other than radar for locating U-boats. The possibility that the Allies might be using centimetric equipment was not mentioned. Some boats had been equipped with oscillographs² in addition to the Magic Eye in an attempt to obtain A.S.V. indications, but in order to glean more information arrangements were made in May for two U-boats, especially equipped with several experimental receivers capable of covering a very wide waveband, and carrying radar specialists, to conduct an investigation whilst cruising in the operational area of the Bay of Biscay. U-boat commanders were warned that until current experiments had been completed and satisfactory equipment evolved, search receivers could not be regarded as reliable warning devices. Simultaneously with the development of more effective search receivers, aerial systems which would enable them to be used when boats were at diving readiness were also being designed. Interception of radar emissions was considered by Dönitz to be a vital requirement ; it was to him imperative that U-boats were given equipment which would enable them to confirm immediately, whilst surfaced or submerged, the presence of any form of radar location activity and

¹ Admiralty Translation P.G.30323.

² Oscillographs were used both to distinguish radar pulses from other signals and to determine the pulse frequency by comparison with a calibrated heterodyne oscillator.

to determine quickly, and at least approximately, the direction from whence it came. Comparatively, U-boat radar was considered unimportant; the number of U-boats fitted with it was too small for its real worth to be evaluated, but arrangements were initiated for a U-boat equipped with radar and including in its complement a radar specialist to operate in the Atlantic Ocean so that an assessment of its suitability and value might be made.¹

The reversal of U-boat tactics ordered by Dönitz on 28 April 1943 naturally caused the number of sightings and attacks obtained by the Allies during daylight to increase and those at night to decrease.² Although U-boats had occasionally remained on the surface to defend themselves with anti-aircraft fire since the autumn of 1942, U-boat commanders had received no official encouragement, and the standard anti-aircraft armament had not been improved or increased. The heavy casualties suffered during the first week of May 1943, which was reminiscent of the period in 1942 before the introduction of the R600A search receiver, resulted in defensive anti-aircraft measures being seriously considered.³ An instruction issued to all U-boat commanders stated that it was advisable to remain surfaced and fight back with anti-aircraft guns if the commander was not certain that he could submerge to a safe depth before the aircraft attacked, and advocated new tactics to be used. Meanwhile action was taken to increase U-boat A/A fire-power and to provide U-boats especially equipped to act as A/A escorts to those boats which had been damaged and were unable to submerge. In operational orders warning was given that aircraft would most likely be encountered anywhere in the Bay of Biscay as far out as 15 degrees west, some with and some without radar, some using searchlights and some using flares, and some using infra-red or ultra-violet rays for short-range location.⁴ But it was not until the end of 1943, when it was just too late, that decisive action to provide effective counter-measures was initiated with the appointment of Professor Kuepfmüller as Chief of the Naval Scientific Staff.

Schnorchel

Acting on the assumption that a U-boat was bound to be detected by radar whilst it was on the surface, and that continual diving was a council of despair, German technicians set about developing a means whereby a U-boat could operate whilst still submerged. The ultimate aim was production of a U-boat which would be a true submarine vessel in that it would be able to operate under water without need to surface at all once it was at sea. As a first step *Schnorchel* was developed. The Dutch had equipped their submarines with an air intake as early as 1940, but had used it only to ventilate them, and whilst the U-boat campaign was successful the Germans did not develop the device. The German *Schnorchel* consisted of a vertical tube, raised and lowered by hydraulic pressure, by means of which air was sucked in and engine exhaust gases discharged whilst the U-boat was submerged. A U-boat equipped with *Schnorchel* was able to cruise below the surface of the sea for the whole of its

¹ The production of radar equipment was seriously disrupted by the bombing offensive against Germany.

² Operation *Derange* was continued throughout May 1943. During the first week of that month 23 day and 3 night sightings were reported; 21 attacks were made, and four U-boats were sunk and three damaged.

³ The heavy losses also revived an opinion held by Donitz in February 1943 that treachery might be responsible. In May 1943 an immediate change in U-boat Command cypher settings was ordered, and all possible sources of intelligence leakage were checked.

⁴ Admiralty Translation P.G.30324.

sortie until its fuel was used up, and underwater refuelling from a supply boat was not impracticable. The tube usually extended only a few feet above the surface and could in rough seas cut through the waves. Clearly such a target would be much more difficult to detect than a surfaced submarine, and in rough seas might be impossible to locate from aircraft either visually or by radar. The intermediate type of U-boat to which *Schmorchel* was fitted was the Type XXI. Its hull was streamlined and it was designed as a true submarine; consequently its underwater speed was as high as 16 knots, which could be maintained for long periods.

Infra-red Ray and Thermal Radiation Countermeasures

The Germans had since 1941 expended considerable resources on research and development of infra-red receivers for their night-fighter aircraft.¹ With one type of receiver, the *Spanner*, infra-red reflections from a target aircraft were picked up at ranges up to just over 300 yards in conditions of clear visibility, but the range was greatly reduced in cloudy weather.² Another, known as *Kiel*, was developed for homing to the exhausts of bomber aircraft and ranges of nearly 5 miles were reported.³ The enemy considered that the Allies might make use of infra-red rays, and the heat radiation of U-boats, if and when search receivers and anti-radar protection were made truly effective. When, therefore, during the spring of 1943, some U-boat commanders reported that they had observed a dull, red glow emanating from aircraft and surface vessels immediately before they made night attacks against a U-boat, the possibility of an infra-red system being used to cover the gaps caused by sea returns on radar apparatus was immediately accepted.⁴ The fact that the alleged infra-red emanations could be seen without the aid of image converters gave rise to the supposition that infra-red rays which could not be seen with the naked eye were also being used, and constituted an even greater danger. Admiral Dönitz thereupon demanded that the practicability of protection and decoy measures against infra-red location should be immediately investigated. U-boats were subsequently covered with protective paint containing ingredients which reduced the effectiveness of infra-red and ultra-violet rays, and reduced range of detection to about one-third of what it otherwise would have been. Also, chemicals which rendered any oil reaching the surface non-fluorescent under ultra-violet rays were mixed with fuel and lubricating oils.

A device known as *Flamingo I* was developed to give warning against searchlights fitted with infra-red filters and a number were put into operation, whilst investigation U-boats were fitted with special equipment for detecting ultra-violet rays. The process of operating *Flamingo* was very difficult and complicated, and therefore the negative reports which were rendered did not immediately convince the U-boat Command that infra-red rays were not being used and trials were continued throughout the summer of 1943. Although no

¹ In the United Kingdom infra-red technique was developed to help overcome the difficulty of air to air identification at night, and equipment known as Type F was fitted to Beaufighters and Mosquitos. (A.I.C. 158.)

² A.D.I.(K) Report No. 370/1945.

³ A.D.I.(K) Report No. 336/1945. *Kiel* consisted essentially of a photocell mounted at the focus of a scanning mirror, with cathode ray tube presentation.

⁴ Because blue/white lights had also been reported, the possibility of ultra-violet rays being used was also considered. In September 1943 the possibility of using infra-red to assist in distinguishing U-boat from fishing vessel contacts during the last stage of an A.S.V. approach was being considered by Headquarters Coastal Command.

supporting evidence had been offered, the U-boat Command, baffled by the successes obtained by Allied aircraft, was prepared to believe that location devices utilising as a basis magnetic, acoustic and thermal systems were also being employed; heat radiation from the Diesel exhausts was regarded as being especially vulnerable to detection.¹ *Flamingo II* was developed as a means of detecting aircraft exhaust radiation, and in the summer of 1944, when it was decided that aircraft exhausts had been screened, *Flamingo III* was also developed to detect genuine heat, as distinct from near infra-red, radiations. Successful tests of U-boat heat radiation were conducted in the autumn of 1944 with the aid of shore-based detector equipment mounted about 70 feet above sea-level. In consequence, since it was considered that even more impressive results could be obtained with airborne equipment, all U-boat exhaust leads were run under the water-level.

Reduction of Radar-reflecting Properties of U-boats

Research into the possibility of producing materials which would not reflect radio waves had been started in Germany by Professor Esau in 1937, and had been advanced to the stage when it was proved that the type of material and the thickness used had to be varied according to the wavelengths against which protection was required.² When Admiral Dönitz became aware that radar location was being used effectively against U-boats he arranged for the experiments to be resumed in the hope of discovering a means of preventing U-boats from giving off radar echoes altogether or at least reducing the size of the echo on wavelengths in the 155 to 750 centimetres wave-band. In general, two principles were followed: deflection of the radar emissions away from the radar receiver by the use of slanting, bent or roughened surfaces, and absorption by a suitable substance in the same way that visible light is absorbed by matt black paint. Early tests with absorbent plastic covering indicated that reflection could be reduced by 50 per cent, and later, in the research laboratories, reflection was practically eliminated. When, however, the apparently successful substance was applied to a U-boat results did not fulfil the promise shown by the laboratory tests.³

In July 1943 Hitler was informed that little progress had been made with the 'black' submarine, so-called because the absorbent substances used was very dark in colour; it was difficult to meet the requirements of a good non-reflecting agent which would also withstand the worst sea conditions.⁴ The research

¹ A U-boat used its two Diesel engines when surfaced, and its two electric motors when submerged, for propulsion. The maximum speed when submerged was about nine knots, but this could be maintained for only about two hours before the batteries were discharged; normal cruising speed under-water was three knots. A German engineer, *Walther*, invented a turbine that ran on special fuel and did not rely on atmospheric air but obtained its essential oxygen from tanks of hydrogen peroxide, and could therefore replace the Diesels and electric motors. It was, however, discovered too late to be used during the war.

² A.D.I. (K) 367/1945. The absorption material had to be thicker than one quarter of the longest wavelength to be absorbed.

³ The first form of anti-radar covering was *Bachem* netting. Its use in calm seas considerably reduced U-boat speed, and it was not able to withstand high seas for any appreciable length of time.

⁴ Fuehrer's Conferences on Naval Forces, Volume III. At that time the most promising substance was a plastic called *Trollifol*. Attempts were made in the United Kingdom to achieve invisibility against radar for Allied landing craft by use of laminated plastics, but without much success, and in October 1944 the Radio Research Laboratory published a paper on 'The theory of reduction of submarine echoes by shielding screens' (R.R.L./411/99). Its conclusions indicated that reduction greater than 20 per cent might be achieved.

physicists were still hopeful, however, possibly because the advent of *Schnorchel* considerably eased their problems; it would no longer be necessary to evolve a protective covering as large and as strong as was previously required. With *Schnorchel* the surface of the sea was, in effect, used as an anti-radar screen, and the practical difficulties of protecting the residual area above sea-level were reduced to manageable proportions. By the end of the war they were, theoretically, within sight of their goal—a submarine which could not be distinguished by radar from the surrounding water. Development of protective covering was completed and production had begun, but the fitting of operational U-boats had not been started.¹ Protection against radar on wavelengths of 3 centimetres and upwards was promised; an increase in radar power would, it was considered, be ineffective. A coating called *Jauman* was thought to be the most effective. It was made up of spaced, graduated layers of semi-conducting paper, and reduced radar detection range to about 15 per cent of that normally obtained without the absorbent. It had to be pre-fabricated and could only be used on flat or cylindrical surfaces.

U-boat Radar

The earliest radar installation with which U-boats were equipped was manufactured by *Gema*, a firm which made all the early German naval radar equipment, but being heavy, bulky and subject to frequent breakdown, it was abandoned in the autumn of 1943 in favour of a modified version of the *Luftwaffe* A.S.V. set *Fu. G2000* or *Hohentwiel*, manufactured by *Lorenz*. Although frequently modified, this remained the standard equipment until the end of the war. Further development was retarded because in the U-boat Command priority was given to anti-radar measures and because although ultimately the Germans realised that the real requirement was for equipment operating in the centimetric waveband, their comparatively slow progress in valve development made it impossible for them to produce really high powered sets. German centimetric equipment was merely a copy of Allied equipment, and priority of production was given to A.I. for fighter aircraft. Low powered equipment was of no practical use as an aircraft location or warning device, and so, since this facility was required in addition to surface vessel location, two entirely different sets were needed, an immense disadvantage in so cramped a vessel as a U-boat. An aircraft warning system, the *Lessing*, was eventually developed after the appointment of Professor Kuepfmüller. It was a modification of the *Luftwaffe Freya* set, and incorporated a simple aerial system consisting of a single vertical dipole, giving complete all-round cover without indication of bearing; by the end of the war it had been installed in only a very few U-boats.²

Radar Decoys—*Aphrodite* and *Thetis*

The end of May 1943 was the end of a definite phase in the Allied anti-U-boat offensive in the Bay of Biscay. At a conference, presided over by Hitler, on 14 May 1943 Admiral Dönitz had already reported ' . . . we are at present facing the greatest crisis in submarine warfare, since the enemy, by means of new location devices, for the first time makes fighting impossible and is causing us heavy losses . . . furthermore, at the present time the only outbound route for submarines is a narrow lane in the Bay of Biscay. This passage is

¹ By the end of March 1945 between 100 and 150 U-boats had been treated with a substance which caused the *Schnorchel* echo to be reduced slightly. (C.B. 04050/45(6).)

² C.B. 04050/45(6).

so difficult that it now takes a submarine ten days to get through. . . .’ At another conference, at the end of the month, he again emphasised to Hitler that the determining factor in the submarine war was the efficacy of aircraft fitted with effective search equipment and he estimated that 65 per cent of U-boat losses occurred when the boats were either in transit or lying in wait, and the remainder near the convoys they sought to attack.¹ He assured Hitler that effective counter-measures would eventually be found, but meanwhile it was impossible to foretell to what extent U-boat warfare would again be effective. He had withdrawn his forces from the North Atlantic to an area west of the Azores in the hope of encountering less air opposition there, but intended to resume attacks against convoys in the North Atlantic when new and suitable weapons and devices were made available. He had raised an operational requirement for an efficient search receiver, and all U-boats had been ordered to operate on only one electric motor at night to facilitate aural detection of aircraft until such equipment had been installed. The feasibility of developing sound locators capable of withstanding the effects of diving and all sea conditions when fitted to conning towers was being investigated. The possibility of jamming or dispersing radar emissions was also being considered.² A jammer which did not automatically adjust itself to the wavelengths of the transmissions could, he thought, be too easily rendered ineffective by a change of wavelength, and the range from a U-boat installation would be very limited but experimental work had been initiated.

Experimental measures to protect U-boat conning towers against radar detection had shown that it was possible to reduce their radar reflecting properties by 70 per cent, and it was assumed that a similar reduction in radar location range could thus be effected, but such measures were still far from ready for operational use. Development of a satisfactory U-boat radar installation capable of detecting the presence of aircraft had not been completed, the main difficulty being that the process of searching took too long as radiation was in the form of a narrow beam. Dönitz believed that only in the matter of deception did he have anything to offer; with a balloon device known as *Aphrodite* and with surface buoys, which were to be used in the Bay of Biscay during June 1943.

Aphrodite consisted of a balloon, 28 to 36 inches in diameter, filled with nitrogen, and connected to a plate anchor by about 60 yards of wire rope to which three strips of aluminium foil, each about 13 feet long, were attached at intervals of about 9 yards. The radar echoes reflected by the foil strips caused blips almost similar to those reflected by a U-boat to be shown on an A.S.V. indicator; the anchor steadied the balloon to limit its movements which would otherwise disclose the fact that the blips were not those of a U-boat. Satisfactory tests had been conducted in the Baltic Sea, but for obvious reasons its operational use would be confined to hours of darkness and bad visibility.³

The surface radar decoy buoy, known as *Thetis*, of which there were eventually several Marks, consisted basically of a float on which was mounted a wooden,

¹ Fuehrer's Conferences on Naval Forces, Volume III, Part II, Chapter IX. This was, of course, to be expected, since a U-boat spent most of its cruising time, six to eight weeks, in transit or lying in wait.

² *Karl* jammers were used against A.S.V. until the end of the war, particularly along the length of the Adriatic and along the Norwegian coast at points where coastal convoys were offered no protection against A.S.V. by islands.

³ Admiralty Translation P.G.30325.

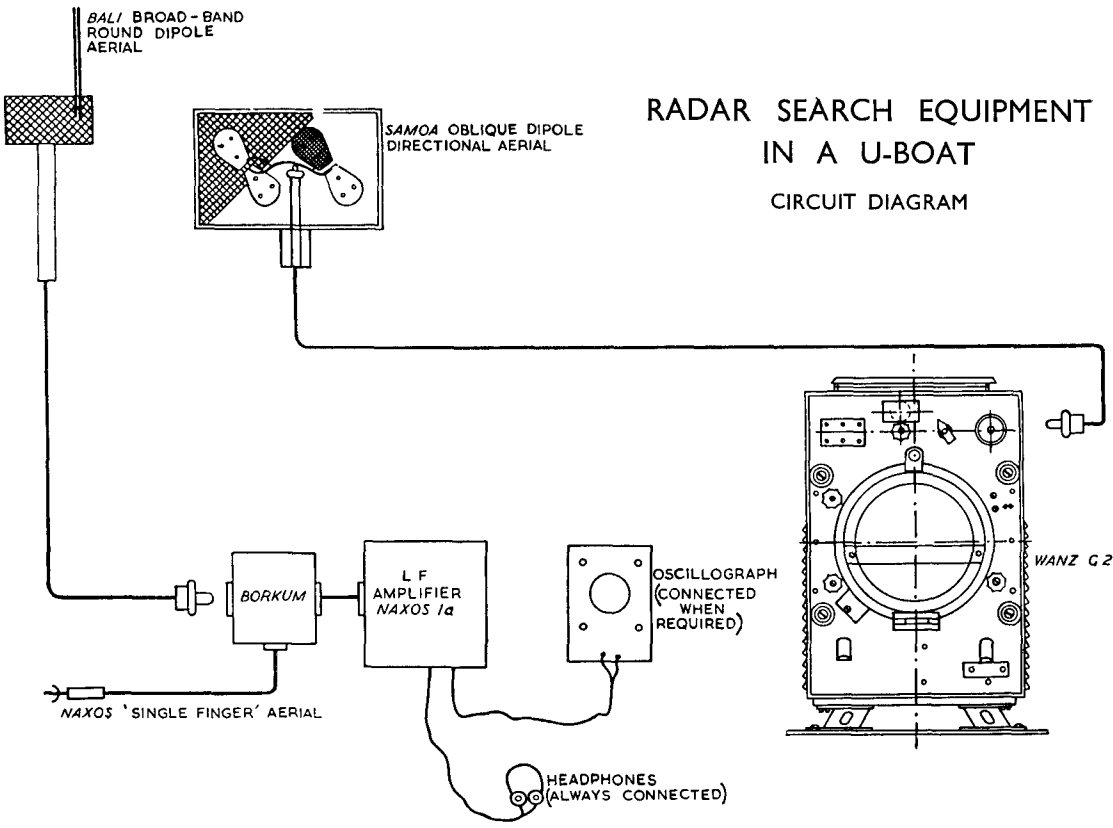

RADAR SEARCH EQUIPMENT IN A U-BOAT CIRCUIT DIAGRAM

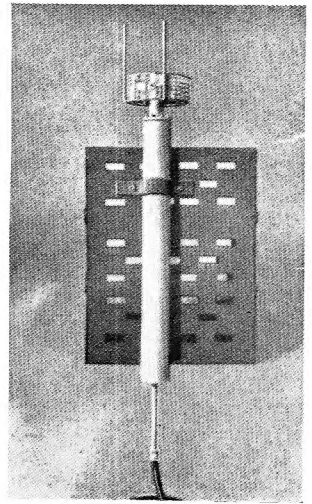
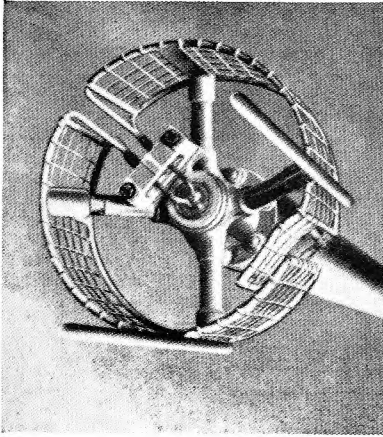
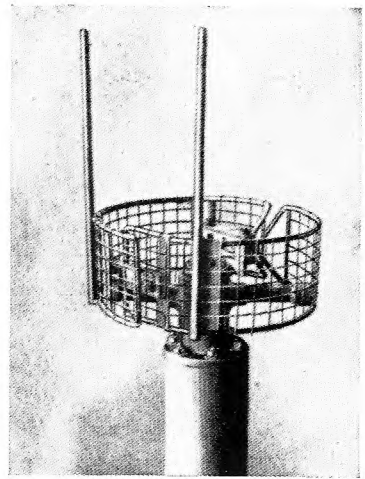
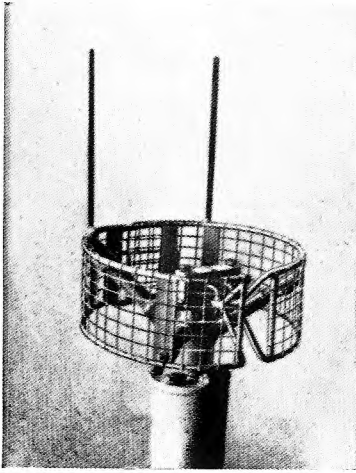

The *Bali* Broad-Band Round Dipole Aerial

collapsible, pole usually about 12 feet high.¹ At intervals of about 18 inches along the pole were metal collars each of which carried six strips of metal foil. The buoys were awkward to assemble and launch, and the process of 'sowing' them was a laborious one; since up to 30 were carried they took up a lot of valuable space in a U-boat. They were not used operationally until January 1944 when 10 U-boats each laid 10 to 15 buoys at intervals of 25 miles in the Bay of Biscay between the 100 fathom line and longitude 10 degrees west. Although, in May 1944, the German Radio Intelligence Service reported that numerous A.S.V. location signals, followed by cancellations, were being transmitted by aircraft in areas when no U-boats were positioned but in which *Thetis* buoys had been laid, generally *Thetis* operations met with but little success.²

Group Sailing Tactics

After the first week of May 1943, during Operation Derange, aircraft of Coastal Command achieved 71 sightings and 43 attacks, all during daylight sorties.³ When it was realised that the U-boats were surfacing only by day the number of day sorties was increased at the expense of night sorties, and after 20 May even the Leigh Light aircraft were switched to day operations. Of the 43 U-boats attacked, only 17 used their A/A guns; the remainder apparently decided that it was possible to submerge to a safe depth. On 29 May 1943 the U-boat Command made a major tactical decision. In an attempt to increase the difficulty of detection of U-boats by aircraft, and to enable U-boats which had been located to fight back more effectively, the convoy principle was adopted, and all returning U-boats which were on that day still west of 16 degrees west were instructed to continue the passage through the Bay in groups of up to four boats. Rendezvous positions were given for 31 May and 1 June. A similar procedure was introduced for outgoing boats which, after leaving port, were to assemble at pre-arranged points in groups of three to six. They were to leave the French coast in daylight, surfaced, and the commanders were given strict orders that they were not to dive if attacked by aircraft but to fight back with maximum fire-power. The groups were to submerge at night, maintain prescribed speeds, surface at dawn, reform into groups, and proceed as before, until 15 degrees west was reached when they were to disperse. Fighter escort was to be provided as far out as possible but especially at rendezvous points. The order was not, however, implemented before the end of May, and during the last two days of the month 12 U-boats were sighted of which 10 were attacked. Six remained on the surface and fought back, shooting down one aircraft and wounding the crew of another, but two U-boats were sunk.

The plan obviously could not be put into effect immediately by inward-bound boats, and was successful with outward bound boats for only a few days; in mid-June 1943 three groups of outward bound U-boats were sighted and engaged by Coastal Command aircraft. As a result Admiral Dönitz gave orders that boats were still to sail in groups, but were to remain submerged for as long as possible surfacing by day only long enough to check positions and

¹ *Thetis* IIC covered from 180 to 120 centimetres and was the most extensively used of the various Marks. In the later stages of the war, *Thetis* S, *Thetis* US and *Thetis* IVS, all covering 10 centimetres, were sometimes used.

² Admiralty Translation P.G.30346.

³ A.H.B. Narrative: 'The R.A.F. in Maritime War.'

charge batteries. Aircraft, taking advantage of any cloud cover available, continued to sight and attack U-boats during the periods in which they were surfaced. Outward-bounds were therefore ordered to remain in port until further additions to their A/A armament had been made. The purpose of group sailing tactics, to increase the amount of A/A which could be brought to bear against aircraft, was accomplished; about 50 per cent of attacking aircraft were hit and as many as 11 per cent shot down during July and August 1943. But important factors had been overlooked or disregarded. In order to keep in touch with each other it was necessary for the U-boats to surface frequently during a greater part of the transit time. An A.S.V. contact or visual sighting consequently gained a much larger reward; aiming bombs or depth charges against surfaced U-boats was much more accurate than against U-boats which had crash-dived; and the determination of crews to sink their targets was not lessened by the A/A fire. Once the problem of finding the most effective way of concentrating aircraft at the sighting point had been solved it was not always essential for the locating aircraft to attack immediately after sighting.¹ It could orbit the boats at the limit of or beyond A/A armament range and await re-inforcements of aircraft and surface vessels; immediately its guns were abandoned for a crash dive a U-boat was vulnerable to attack.

Between 13 and 30 June 1943, of the thirty-two U-boats which attempted to traverse the Bay only eleven were undetected. Two were sunk by surface craft and one by aircraft; six were so badly damaged that they were forced to return to base. During the month fifty-three visual sightings were obtained by aircraft, whilst only six were made with A.S.V.² The tactics adopted by the U-boat Command in an attempt to lessen the risk of its boats being detected by the aid of scientific devices afforded aircraft crews numerous opportunities of locating them visually during daylight hours, and Coastal Command tactics were aimed at forcing the U-boats to continue submerging at night and to surface as much as possible during the day.³ Leigh Light aircraft were therefore switched back to night sorties. The great value of A.S.V. at that time was that possession of it enabled the Allies to 'call the tune' because of the German reaction to its use. The extreme importance of maintaining an efficient visual lookout by day, and the indispensibility of A.S.V. at night, was emphasised.⁴ The Allied blockade of the Bay of Biscay was continued throughout July 1943. The demands made on the battery capacities of

¹ On 20 June 1943 arrangements were made for anti-U-boat forces of the Royal Navy to keep station in the Bay so that they were able to take advantage quickly of sightings made by aircraft.

² A.H.B. Narrative: 'The R.A.F. in Maritime War.'

1 June	Halifax O/58	..	A.S.V. Mark III	1 U/B at 5½ miles.
6 June	L/L Wellington P/179	A.S.V. Mark II	..	1 U/B at 6 miles (night).
14 June	Sunderland V/228	A.S.V. Mark II	..	3 U/B at 20 miles.
16 June	Liberator C/59	..	A.S.V. Mark V	.. 3 U/B at 13 miles.
18 June	Liberator B/59	..	A.S.V. Mark V	.. 2 U/B at 17 miles.
21 June	Liberator E/59	..	A.S.V. Mark V	.. 2 U/B at 16 miles.

³ A.H.B. Narrative: 'The R.A.F. in Maritime War.' See Table No. 9.

⁴ There still existed amongst aircrew a tendency to use A.S.V. during daylight only when forced to do so by circumstances and then principally as a navigational aid. The noticeable lack of enthusiasm, which had persisted from the early days of its introduction into operational use, caused fewer contacts to be obtained than the technical performance of the various Marks of A.S.V. had led the Air Staff and scientific establishments to expect, and the difference between the results obtained by the Leigh Light squadrons and other squadrons was very marked. In the same way, with visual reconnaissance, there was a distinct psychological prejudice against the use of binoculars.

U-boats were frequently too great, and boats with completely run down batteries were forced to remain on the surface and fight their way through. Relatively few boats were in transit during the latter part of the month, and most of them were sighted and attacked by aircraft. During the last four days a special effort was made by the U-boat Command, and eleven boats, including a group of large supply boats which were urgently needed to refuel operational U-boats in the outer patrol areas, put out to sea ; all were sunk.¹ In 40 instances initial sighting was made visually, and in 21 by A.S.V. Twenty of the twenty-one A.S.V. sightings were made during daylight hours, and the majority of them with A.S.V. Mark V.² The marked superiority in performance of the installation was made evident ; the average detection ranges obtained with it were estimated by Headquarters Coastal Command to be nearly 70 per cent greater than with A.S.V. Mark III.³

During the first two days of August 1943 two more U-boats were sunk. Dönitz recalled to bases all outward bound boats, and all group sailings were cancelled. Incoming boats were ordered to hug closely the Spanish coastline, in order that land returns and echoes from fishing vessels might frustrate A.S.V. search ; no further sailings from the French ports were to be made until the degree of success attendant upon this manoeuvre was known. Dönitz reported to Hitler that surfaced passage of the Bay was impracticable, and submerged passage made over-great demands on battery capacities ; the U-boat campaign was seriously disrupted.⁴ It appeared that the only solution to their problem lay in the use of *Schnorchel*, a practical demonstration of which had been given in July 1943, and U-boats propelled by the *Walther* turbine engine, but they would not be available for some considerable time.

The Magic Eye

The sightings obtained during daylight sorties by Nos. 1 and 2 U.S.A.A.F. Squadrons and at night by No. 172 Squadron in February and March 1943 caused the U-boat Command to suspect that the Allies had changed the wavelength of A.S.V., but the Signals Staff were unable to decide whether it was above or below the limits of the Metox R.600A search receiver. Their suspicions were intensified by reports received from U-boats operating during February in the Caribbean area, where American aircraft fitted with 10-centimetre A.S.V. had been operating. One of the Caribbean U-boat commanders submitted a very detailed report when he returned to base at the end of February. The telegraphist had adapted the visual tuning device normally used in his W.T. receiver to the circuit of the R.600A search receiver. He had noticed that, on some occasions, just before the presence of Allied aircraft was observed by the look-out, visible indications were present in the device although no audible warnings were being received in his headphones. As the R.600A was a super-heterodyne receiver, it was possible that a beat between the fundamental frequency of 10-centimetre A.S.V. and a harmonic of the local oscillator was obtained, but only when A.S.V. was operated with high power in the vicinity of the U-boat, or, of course, the indications might have been caused by metric A.S.V. emissions. These facts were not fully appreciated by the Signals Staff

¹ The Germans lost 34 U-boats during July 1943. The loss of the supply boats was a tremendous setback to their plans.

² A.H.B. Narrative : ' The R.A.F. in Maritime War.' See Table No. 10.

³ A.M. File C.S. 13468, Part II.

⁴ Fuehrer's Conferences on Naval Forces, Volume III.

at the U-boat Command, who were convinced that the 'Magic Eye,' as the device was named, provided the solution to their problem. Its immediate installation in all U-boats was ordered, and commanders were instructed to submit reports on its performance.

At about the same time the Germans were fortuitously presented with the real answer when a Bomber Command aircraft equipped with H2S was shot down over Holland. The radar equipment was taken from the aircraft and, although badly damaged, was identified by the *Luftwaffe*, and their report on the discovery was made available to the Naval Command.¹ This should have been sufficient to arouse suspicion that A.S.V. aircraft were using a wavelength below the bandwidth covered by the Metox receiver. In fact, Admiral Dönitz noted in his War Diary on 5 March 1943 that indication of the wavelength being used by the Allies might be obtained from the report. Apparently, however, the U-boat Command was convinced that the 'Magic Eye' would enable U-boat commanders to neutralise the A.S.V. technique of the Allies. The possibility of there being a close connection between the captured H2S and the new surprise attacks by aircraft was ignored, and complete reliance was placed on the Metox R.600A search receivers in which the 'Magic Eye' had been incorporated.

Search Receivers

When search receivers were first taken into operational use by the U-boat Command the possibility that their self-radiation might enable suitably equipped aircraft to home on them had been carefully considered. Trials, however, emphasised the great difficulty of effectively using an airborne receiver to pick up radiation signals when the search receiver was used to sweep continuously over a waveband, and the danger was thought to be slight enough to be ignored. As its plight became more and more desperate the command tried every measure but the right one in its attempt to avoid location by aircraft. Although by June 1943 detailed information of the captured H2S had been widely circulated, the possibility that centimetric A.S.V. was being used was not seriously considered. In fact, the majority of German radar experts doubted whether centimetric radar could be used in other than very large aircraft, and very much overestimated the difficulties of centimetric wavelength technique. From March to May 1943 well over 1,000 indications of radar emissions made in the metric waveband had been received, and the number of aircraft approach runs that had been undetected was estimated to be less than 5 per cent of the whole. It was realised by the U-boat Command signals staff that the design of the R.600A search receiver contained inherent faults; they, and the known fact that the Allies often used A.S.V. only intermittently, were thought to be sound reasons for occasional failure to detect radar emissions.

That the majority of the heavy losses suffered during July 1943 could be attributed to Allied aircraft was accepted without question by the U-boat Command, and further investigation of receiver radiation was undertaken during that month. A series of trials indicated that radiation from the R.600A could be detected by an airborne receiver as far distant as 30 miles. The Naval Communications Staff arrived at the conclusion that the radiations could be used to a much greater extent, and at far greater ranges, than had at first been

¹ The salient features of H2S were described in a technical intelligence summary circulated by the German Air Ministry on 6 June 1943. (Naval Staff Report C.B. 04050/45(6).)

thought possible. It was suspected that Allied aircraft no longer needed to use radar but were equipped with a receiver specially designed to detect, and home on, R.600A. Suspicions were heightened when apparatus thought to be such a receiver was found in a captured Coastal Command aircraft.¹ As a precaution, commanders of U-boats entering the Bay by the Spanish coast route early in August 1943 were ordered not to use their search receivers, and to reduce to a minimum their use of communications equipment. Although aircraft had been able to take advantage of the fact that U-boats were vulnerable during the final stage of their attack against convoys when the clumsiness of the aerial system made it necessary to switch off the search receiver, the U-boat losses incurred as a result appeared to be relatively small compared with those sustained during the transit of the Bay when a larger number of targets was offered and a greater number of aircraft was employed. Admiral Dönitz, who, of course, was not to know that the proportion of sightings to flying hours was much higher near convoys than in the Bay, used the assumption that losses were smaller as an argument in favour of the radiation theory ; since U-boats did not use their search receivers when near a convoy, and because fewer were sunk during that stage of an operational sortie than during the transit and lying in wait stages, the receiver was the direct cause of the increased success of the Allies. Hitler, too, was similarly convinced and believed that what had previously been a baffling problem had at last been solved and ' . . . a great step forward had been taken. . . .'²

U-boats already in port were not allowed to put to sea until they had been equipped with *Wanz GI* in place of R.600A ; commanders of U-boats already at sea were ordered not to use their search receivers at all when visibility was good, and to ensure that when they were used in conditions of poor visibility the tuning was continuously changed.³ If radar emissions were received, U-boats were not to remain tuned to the wavelength for purposes of confirmation, but were to submerge immediately. The use of one after another of the standard communications receivers was forbidden whilst extensive tests of their radiation properties were undertaken and, as sinkings continued, commanders of U-boats in the Bay of Biscay were ordered to receive routine wireless messages whilst submerged, using very low frequency equipment and the D/F loop aerial. The few boats equipped with radar were ordered to use it instead of R.600A, whilst technical establishments continued their investigations of radiation phenomena. But by then U-boat commanders had become deeply suspicious of all their electronic equipment and had lost faith in the various measures proposed by the technical staffs ; the reaction of the majority was a strong disinclination, which persisted until the end of the war, to use radar as a warning device against

¹ Probably one of the first Wellingtons to be fitted with ' Greenbottle ' which was abandoned by its crew over southern England and flew unmanned into France. (See Chapter 14 for details of ' Greenbottle '.)

² Fuehrer's Conferences on Naval Forces, Volume III, Part II, Chapter IX.

³ The introduction of *Wanz GI*, a heterodyne receiver which automatically swept the waveband between 120 and 180 centimetres and gave optical indication of received signals, had been eagerly awaited by Dönitz since May 1943. A few wave indicators had been developed by the firm of *Hagenuk* in collaboration with the German Army Ordnance Department. They were monitoring receivers with automatic tuning and cathode ray tube presentation. One of the developments, known at first as *Cyperm*, was completed in June 1943, when it was adapted as the *Wanz GI* search receiver. It was a complicated piece of equipment and was liable to frequent failures. Not only was its radiation estimated to be very much less than that of R.600A but of a different nature which would probably not be recognised by aircraft receiver operators. (Admiralty Translation P.G.30329.)

aircraft. Further trials of *Wanz GI* were held at sea as near as practicable to the operational area of the Bay of Biscay. The plan to resume operations against Atlantic convoys at the end of July was abandoned until all U-boats had been equipped with *Wanz GI*, *Aphrodite*, and new acoustic torpedo weapons.¹

Confusion and uncertainty were magnified when, as the result of their latest investigations, the technical establishments again reported that although homing on search receiver radiations was possible, it was so difficult as to be impracticable, whilst careful examination by qualified personnel of reports rendered by U-boat commanders revealed that only in very few instances did they provide any evidence that such homing had been employed against U-boats. Fortunately for the Allies, at this stage, on 13 August 1943, the German Naval Communications Bureau reported that a captured R.A.F. pilot of Coastal Command, when interrogated in *Oberursel* transit camp, had stated that R.A.F. aircraft scarcely ever used A.S.V. but relied almost entirely on radiation from German search receivers for detection and homing. He volunteered the information that the radiations could be detected at distances up to 90 miles by aircraft flying at heights between 1,000 and 4,000 feet, and that A.S.V. was switched on for short periods only, merely to allow closing ranges to be checked.² Admiral Dönitz realised that the pilot might be deliberately misleading his interrogators, especially as the ranges he had given were most unlikely, but because the U-boat situation was so grave he was willing to grasp at any straw, and in spite of the reports from the technical establishments, decided that the statement must be accepted. He contended that although it was obvious that if U-boat commanders did not use search receivers the risks they ran of being located by aircraft radar were very considerable, they were risks with which the officers of the U-boat Command were familiar, whilst those they took when using search receivers were quite unknown and possibly much greater; he considered that it was better to accept a known danger than to hazard U-boats to an unpredictable extent. The use of search receivers in all operational areas was therefore forbidden whilst attempts were made to eliminate entirely the radiation from *Wanz GI*, production and installation of which were given the highest priority.

A number of U-boats were equipped with *Wanz GI* by the middle of August 1943 and left their bases at the end of the month and at the beginning of September 1943 for operations in the Atlantic and the Mediterranean. Announcing the new campaign, Admiral Dönitz signalled to all commanders the information that the reasons for the inexplicable losses of U-boats in the past few months had been discovered. It had been thought that they were due to a new, undetectable location method, but it had now been firmly established that the radiation of the search receivers previously used was responsible. Their U-boats had been fitted with a warning device for detecting radar emissions on the primary wave-band, they were equipped with the new homing torpedoes, and their *flak* armament had been strengthened. The fight was therefore to be resumed with renewed intensity and determination.³

News of the progress of the U-boats through the Bay was closely followed by Dönitz. The tactics of remaining submerged for the maximum possible time and of independent routing were successful. To his great relief it appeared

¹ Reports of successful use of *Aphrodite* had been received from the Mediterranean.

² See also A.H.B. Narrative: 'The R.A.F. in Maritime War.'

³ Admiralty Translation P.G.30330.

that the situation had appreciably improved. In spite of the activities of a large force of aircraft, very few reports of surprise attacks were received. This, perhaps, was more than probably due to the fact that by then U-boat commanders so thoroughly distrusted their warning equipment that the *Wanz GI* was but rarely switched on, and they were consequently unable to report on its efficacy. Dönitz was jubilant enough to write on 3 September 1943 that ' . . . the enemy was searching feverishly . . . ', and he reported that the danger of the blockade had subsided. Almost on the same day one U-boat commander did report that he had been attacked by a Leigh light aircraft before any warning indication had been received in the *Wanz*. This caused Dönitz to write, on 6 September 1943 ' . . . only further observations will enable us to say whether this was a chance sighting or whether the aircraft radar was working on a centimetric wavelength. . . . '

The real reason was at last suspected. During the summer of 1943, because added responsibility for production had restricted the capacity for research and development of the Naval Communications Research Command, and in order to broaden the basis of radar research generally, the naval organisation had been placed under the control of a national organisation for high frequency research, and Professor Esau, a leading exponent of centimetric wave research, was appointed to co-ordinate the radio and radar policies of the German Navy and the *Luftwaffe*.¹ He was well aware of the Allied use of airborne 10-centimetre radar and of the measures taken by the *Luftwaffe* to counter it.² During the summer a *Luftwaffe Staffel*, armed with *Heinkel III* and *Junkers 88* aircraft in which special search receivers, including *Naxos*, had been installed, was formed for the purpose of investigating Allied A.S.V. emissions over a wide band of wavelengths, principally in order that the feasibility of jamming measures might be studied. In September 1943 the unit reported that the 10-centimetre wavelength was being used extensively.³ Fortunately, however, uncertainty and indecision still reigned supreme in the U-boat Command, and U-boat commanders were informed by signal on 13 September that ' . . . the situation has fundamentally altered in your favour. . . . '

The group of 19 U-boats sent into the Atlantic resumed the battle against convoys between 19 and 23 September after being encouraged by a signal from Dönitz, ' . . . this struggle is decisive for our nation's future . . . the Fuehrer is watching every phase of your struggle. Attack! Follow up! Sink! . . . ' Commanders were instructed that the primary purpose of *Wanz* was to guard against surprise air attacks whilst U-boats were in transit or on patrol. When action was joined, an indication in *Wanz* was not to be acted upon unless aircraft were sighted visually. *Aphrodite* was to be used to confuse Allied convoy defences during night attacks. Not surprisingly, since the Allied aircraft engaged in the operations relied mainly on visual observation and were equipped with metric and not centimetric A.S.V., Dönitz received no reports of surprise attacks,⁴ and complete confidence in the *Wanz GI* was engendered, although on

¹ C.B. 04050/45(6).

² A requirement for a receiver to enable night-fighters to home on beamed transmissions had been raised by the *Luftwaffe* in March 1943. Little effective progress was made until *Naxos* was designed and developed. With *Naxos* it was possible to receive emissions made on wavelengths between 8 and 10 centimetres but it was not possible to discriminate between separate wavelengths in that band. (A.D.I.(K) No. 369/1945.)

³ A.D.I.(K) Report No. 380/45.

⁴ Three U-boats were destroyed and three more were probably damaged. Six merchant vessels were lost. (A.H.B. Narrative: 'The R.A.F. in Maritime War.')

25 September progress made with the development of a *Naxos* receiver modified for installation in a U-boat was casually noted in the War Diary ; he did not have long to wait for what should have been obvious proof that his approach to the solution of his problem was wrong.¹ The group of U-boats detailed for operations in the Mediterranean met with heavy and sustained attacks, delivered by aircraft, equipped with A.S.V. Mark III, of No. 179 Squadron based on Gibraltar, of which no warnings were received, between 23 and 26 September. Although one U-boat succeeded in getting through, the others were beaten back, and Dönitz ordered that further attempts to enter the Mediterranean were to be abandoned until *Naxos Ia* had been fitted.

Despite the Gibraltar experience the Chief of the German Naval Communications Department was not convinced that the use of a centimetric wavelength was the cause of the attacks. He found it difficult to believe that all instances of undetected attacks delivered since early in 1943 could be ascribed to centimetric A.S.V. especially in view of the freedom from surprise of the Atlantic U-boats. Faith in the radiation theory was hard to remove. Meanwhile, during October 1943, *Naxos Ia* was installed in several U-boats, five of which were despatched to effect penetration of the Strait of Gibraltar. One was sunk, at night, by an aircraft of No. 179 Squadron, and two were destroyed by co-operating ships of the Royal Navy after they had been located and attacked by aircraft of that squadron. Although the two U-boat commanders who got through reported the successful employment of *Naxos* this decisive defeat, coupled with serious losses sustained in the Atlantic during October, completely discredited the theory that centimetric radar was being used, and firmly re-established the fear of all forms of radiation. The convoy offensive was abandoned, investigation of thermal radiation was intensified, and the use of *Wanz G1* and all short-wave communications receivers was prohibited. As rapidly as possible the search receiver was replaced by the modified version, *Wanz G2*, guaranteed to be practically free from radiation, and a new short-wave communications receiver and *Borkum* were rushed into service in November 1943.

An important and far reaching outcome of the full acceptance of the radiation theory in the summer of 1943 was that the major part of German naval radio research had been directed towards the design and development of 'non-radiating' metric-wave search receivers and measures against location methods other than radar. The use of heterodyne circuits in search receivers was abandoned and *Borkum*, which employed crystal detection and low-frequency amplification, was developed on the highest priority whilst efforts were made to reduce even further the radiation of *Wanz G1*. Although the crystal detector principle made *Borkum* completely free from self-radiation, it also made it insensitive and therefore capable of reception only at comparatively short ranges. It had no tuning control and was designed to receive all radar emissions in the broad band of 75 to 300 centimetres. The signals received were heard as a whistle in a loudspeaker or headphones. *Naxos Ia* also used a broad band crystal detector covering the waveband 8 to 10 centimetres. Its theoretical maximum range was only 5 miles because its aerial system was inefficient, and because it was a makeshift piece of equipment. It was crudely manufactured and far from robust, and its performance therefore inevitably

¹ A provisional technical publication on *Naxos Ia*, the U-boat version of the aircraft *Naxos* installation, was published in September 1943.

fell short of what was expected when in practical operational use. The aerial system was mounted on a pole and involved the use of a long coil of flexible cable, all of which had to be passed below through the conning tower when preparations to dive were made; a nerve-wracking experience for an officer of the watch when a few seconds made all the difference to survival. Similarly, the equipment had to be passed up to the deck before watch could be opened after surfacing. On the very early models spray caused a further marked loss of efficiency; its short range, unreliability, and other disadvantages led many U-boat commanders to believe that its use was not worthwhile.¹

In spite of the fact that Allied use of a centimetric wavelength was discredited, the installation in operational U-boats of *Naxos Ia* was continued, because its amplifier unit was used for both the *Borkum* detector and the pulse oscillograph. The deficiencies of the crude aerial system, known as *Biskaya-Kreuz*, which had been used with the R600A receivers, and of the aerial system used with *Naxos Ia*, led to a demand for a pressure-tight aerial. This resulted in the development of a round dipole system, known as *Bali I*, which was used with *Borkum*. When *Schnorchel* was taken into operational use, *Bali I* was fitted to the tube, and, in addition to its employment with the search receiver, was also used for short-wave wireless reception when the U-boat was *Schnorchelling*; *Borkum* was suitably modified.² *Bali I* was designed to cover the waveband 80 to 330 centimetres, but eventually experience showed that radar emissions made on the 10-centimetre wavelength were received by the *Borkum/Bali I* combination when the source was close enough to break through, and at the beginning of 1945 U-boat commanders were informed that warning of aircraft using 10-centimetre A.S.V. could be obtained at short ranges up to 1,000 metres when a U-boat was *Schnorchelling*.³

In December 1943, Admiral Dönitz, harassed by the conflicting advice and continued failures of his technical advisers, at last made an effective attempt to ensure that scientific research and development were co-ordinated and directed to fulfil operational requirements.⁴ The manner in which the action was initiated is noteworthy in view of its adherence to the 'Fuehrer' principle. On 13 December 1943, as Commander-in-Chief of the German Navy, he informed all naval commands that '. . . For some months past the enemy has rendered the U-boat war ineffective. He has achieved this object not through superior tactics or strategy, but through his superiority in the field of science; this finds its expression in the modern battle weapon—detection. By this means he has torn our sole offensive weapon in the war against the Anglo-Saxon from our hands. It is essential to victory that we make good our scientific disparity and thereby restore to the U-boat its fighting qualities. I have therefore ordered the creation of a Naval Scientific Directional Staff, with its headquarters in Berlin, in addition to other measures already taken. I have nominated Professor Kuepfmüller as head of this staff and directly

¹ C.C. File S.13310.

² *Borkum* was switched off when the *Hohentwiel* radar set was used for surface or air search.

³ Admiralty Translation P.G. 30948. B d U. Standing Orders—Radar. *Bali II* was eventually developed to cover the waveband 40 to 80 centimetres but had not been used operationally by the end of the war.

⁴ Installation of *Korfu*, a tunable magnetron receiver covering the band between 8 and 12 centimetres, was completed in four U-boats in December 1943; not only did it require very skilled operation but it also radiated strongly, and its employment was therefore abandoned.

subordinate to myself. Professor Kuepfmüller is invested by me with all necessary authority for the execution of his duties. All naval authorities are ordered to give every assistance to the head of the Naval Scientific Directional Staff, his staff, and subordinates. . . .¹

Thereafter every aspect of radio warfare was surveyed and practical measures to meet every contingency were taken; the deficiencies of the German Naval Intelligence and Planning Staff were at last overcome. The main requirements of the U-boat Command which had to be fulfilled were means to enable a U-boat to remain, at will, invisible for indefinite periods; equipment to make it possible for the U-boat to locate Allied aircraft and surface vessels by radar or interception of radar; and facilities for confusing Allied location methods. The completion of the special investigation U-boats was hastened, and groups of scientists and technicians were formed to put into effect the practical measures evolved.²

At the beginning of 1944 the U-boat Command decided that the Allies were replacing metric A.S.V. with centimetric A.S.V. in high performance aircraft, leaving metric A.S.V. only in a number of Sunderlands and Liberators.³ It was apparent that the first essential need was the provision of an improved search receiver for the 10-centimetre waveband, which, even if only a makeshift, would at least give ample warning and provide a margin of sensitivity against the loss of efficiency inevitable in operational conditions. Because of its lack of radiation the crystal detector principle was adhered to and attention was concentrated on the development of an aerial system which would enable greater ranges to be achieved. In April 1944 production of *Cuba 1a*, or *Fliege*, was begun.⁴ With this system in ideal conditions range was increased up to about 35 miles against A.S.V. Mark V in an aircraft flying at 1,000 feet. Although it was a great improvement it still suffered from the disadvantage, as in fact did all centimetric aerials used operationally in U-boats until the end of the war, that it had to be moved below every time the U-boat submerged and brought on deck again after surfacing. Meanwhile, employment by the Allies of the 3-centimetre wavelength was discovered when an AN/APS 3 installation was recovered from a crashed U.S.A.A.F. aircraft, and on this occasion no time was lost in effecting suitable counter-measures.

¹ Admiralty Translation P.G. 33587.

² The long-anticipated action of sending to sea the specially equipped U-boats was taken when *U.406* sailed on 5 January 1944. It was sunk by H.M.S. *Spey* on 18 January; a leading German radar scientist, Dr. Greven, was captured. A second boat, *U.473*, left port on 24 April 1944 and was destroyed by H.M.S. *Starling*, *Wild Goose* and *Wren*, on 5 May 1944.

³ Admiralty Translation P.G. 33587. Between mid-February and mid-May 1944 the number of aircraft warnings received in *Naxos* and *Wanz* was stated to be:—

Area	<i>Naxos</i>	<i>Wanz</i>
Biscay	258	43
North Atlantic	384	55
Caribbean	21	—
Africa	15	1

Reports from U-boat commanders indicated that in the eastern Mediterranean metric A.S.V. was predominant; off Corsica, Sardinia and western Italy both 10-centimetre and metric A.S.V. were used; in the English Channel the whole waveband from 3 metres to 3 centimetres was being employed.

⁴ With *Cuba 1a* or *Fliege*, greater sensitivity and therefore longer range was obtained by the use of a vertical section of a parabolic reflector. Sensitivity was retained over a wide azimuth. The fact that it was restricted in elevation from the horizontal to some 5 or 10 degrees above the horizon was considered to be immaterial from a search aspect.

By the end of May 1944 *Mucke*, an electromagnetic horn aerial, was ready for operational use.¹ Both *Mucke* and *Cuba Ia* were connected to the amplifier of an improved *Naxos*, called *Naxos II*, and the resultant equipment was known as *Tunis*; to obtain the sensitivity necessary for range the desirable property of all-round looking had been sacrificed. Both *Tunis* and *Borkum* were installed in operational U-boats but *Tunis* could not be used until the U-boat was fully surfaced, when it was rotated on the bridge by the operator who always followed immediately behind the commander. Cable still had to be dragged up and down through the conning tower hatch. Consequently U-boats using it were still vulnerable to surprise attack immediately after breaking the surface. *Tunis*, was, however, simple to operate and quite dependable in normal operational conditions.²

Tests conducted by the Allies with a captured *Tunis* installation indicated that operational ranges might be expected to vary from 20 miles against A.S.V. at 500 feet to 40 miles at 2,000 feet, ranges greater than those obtained by A.S.V. against U-boats. It was not used very frequently by U-boat commanders who still nourished the seeds of mistrust sown during the summer of 1943, and it was not introduced into general operational use until after the advent of *Schnorchel*. By then caution had become their watchword and use of *Schnorchel*, although it limited offensive potentiality, did offer protection against all aircraft whether they were or were not equipped with detection devices, whereas commanders could not be certain that *Tunis* would always be a safeguard against any possible new forms of radar.

Another search receiver installation for 3-centimetre and 9-centimetre wavelengths, designed for use in small surface craft with no power supply but also used very occasionally in U-boats in the final stages of the war, was *Liliput*. It consisted of a receiver head and a portable pulse amplifier powered by batteries. The receiver head was secured to a flying helmet to which earphones were fitted. The helmet was worn by an operator, who also carried the aerial on his head, and the amplifier was buckled to his body. Direction finding was accomplished by the operator turning his head or his whole body while at the same time listening-out. Its range was very small but it had an advantage over *Tunis* since no outboard lead through the conning tower was required, and the operator had freedom of movement on the bridge.³

Since both *Tunis* and *Liliput* could be used only whilst the U-boat was surfaced, and obviously conferred no advantage when used against aircraft which were not using A.S.V., the majority of commanders preferred to remain submerged and be safe rather than to surface for the purpose of seeking a target.

Thus, again, the fear of radar dictated U-boat tactics. But *Schnorchel* alone did not render them completely immune from the dangers of air attack, for even when equipped with *Bali I*, whenever they did surface it was with the knowledge that an aircraft might be in the offing. A suitable pressure-tight aerial system permanently attached to the conning tower and all-round

¹ *Mucke* had a beam width of only about 15 degrees and therefore made search difficult, but bearings of 3 centimetre radar emissions obtained with it were quite accurate.

² Both the *Mucke* and *Cuba Ia* aeriels were tested every 15 minutes during operation with *Puck* test gear. *Puck* was developed to meet the requirement for handy, easily manufactured equipment to provide swift, although relatively inexact, checks on performance of radar sets and search receivers. *Puck 10* and *Puck 3* covered 10 centimetres and 3 centimetres respectively.

³ Admiralty Translation P.G. 27518.

looking were two urgent requirements, but their development presented great technical difficulties which had not been completely overcome by the end of the war. A solution to the problem was sought in two directions. In the first the provision of several aerials facing different points of the compass was involved. Eventually four were found to be enough, but three systems had been tried before *Cuba II* was evolved, and that was not pressurised. Then followed *Cuba III* which was pressurised but covered only the 10-centimetre band. Finally, *Athos* was developed to the stage of operational trials, in one U-boat, by May 1945. *Athos* and its associated equipment fulfilled the requirement. It was very ingeniously designed. The waveband of $2\frac{1}{2}$ to 11 centimetres was covered by two aerial heads constructed in such a manner that had the Allies begun to use another wavelength outside the band, a further suitable aerial head could easily have been added. *Flamingo II* was incorporated in the system and the remainder of the equipment included four separate amplifiers. Continuous presentation of bearings on a cathode ray tube was a notable feature. The second line of development was based on the use of a high-speed spinning aerial *Naxos ZM* which rotated at about 1,300 revolutions per minute, and also included cathode ray tube presentation. A spot of light was made to rotate around the edge of the tube in synchronisation with the rotation of the aerial and the spot was then suppressed except when a signal was being received. Thus all signals received appeared as bright spots around the periphery of the tube which was calibrated in degrees, and from which the relative bearings could be obtained. The device had been fitted in some E-boats but the U-boat version was not ready for operational use by the time hostilities ceased.¹

¹ C.B. 04050/45(6).

ALLIED COUNTER-MEASURES

Measures against Radar Decoys

On 12 June 1943, at about the time when Admiral Dönitz was preparing to begin the employment of radar decoys, the Commander-in-Chief Coastal Command forwarded to the Air Ministry a detailed appreciation of the problem that would be posed should the Germans resort to the use of decoy buoys, and recommended courses of action to be taken if the threat materialised.¹ Although the appreciation had of necessity to contain many assumptions and approximations, since the characteristics and capabilities of decoy buoys were unknown, it served to indicate that it was reasonable to suppose that if identification of buoys for what they were proved to be difficult, and if they were used in sufficient quantity, U-boats might be able to effect a comparatively safe transit route through the Bay of Biscay. The difficulties with which the enemy would be faced when endeavouring to evolve successful decoy measures were anticipated. For instance, the dimensions of decoy buoys would be limited by the need to design them so that they could be laid by aircraft and U-boats in addition to surface vessels; sea currents and winds would tend to disperse them; the responses obtained from them might be appreciably different from those of a U-boat and the range at which contact was made appreciably less. The Commander-in-Chief considered that an investigation of the possibility of decoy buoys being used by the enemy should be treated as a matter of the greatest urgency. On 23 June 1943 the matter was discussed by the Radio-U-Committee who decided that a team should be formed to conduct such an investigation, and that reports on the mechanical, electrical, and tactical aspects should be prepared as soon as possible.² Less than one month later preliminary trials were already being undertaken by the C.C.D.U. and, as a result of information disclosed by a German prisoner-of-war, tests against balloon reflectors were included in the trials programme.³

By the middle of August 1943 trials with a number of small buoys had been completed, and several models of balloon decoys had been made ready.⁴ The buoys gave A.S.V. indications similar to those of a submarine at about six miles range, but were so vulnerable to visual sighting that it was clear that they could be operationally effective only at night. To increase the range to 15 miles and thus improve their efficacy, much larger and heavier buoys would be required; obviously an impracticable proposition from a German point of view.

Meanwhile German instructions on the use of *Aphrodite* had been obtained. They contained no detailed information about the construction of the reflectors, but it was assumed that they would be effective against both metric and centimetric A.S.V. It seemed that *Aphrodite* was intended to provide a

¹ A.H.B./1D/12/195.

² Minutes of 8th meeting Radio-U-Committee. C.C. File S.9117/14/1.

³ Minutes of 10th meeting.

⁴ Minutes of 11th meeting.

number of radar responses to create confusion, mainly at night, in areas where anti-U-boat patrols were normally undertaken, and in the vicinity of convoys just before an attack was initiated, in the hope that Leigh Light aircraft would be prompted to switch on their searchlights and consequently disclose their positions.¹

The C.C.D.U. trials were continued during August and September 1943. The results obtained demonstrated that portable surface buoys capable of simulating U-boat responses against centimetric A.S.V. were practicable, although against metric A.S.V. the range was far short of that normally obtained against U-boats: balloon decoy responses could be mistaken for those of a partly submerged U-boat.² The results of extensive trials undertaken by the Admiralty and the United States Navy showed no marked differences from those obtained by the C.C.D.U. Although readily detected by ship-borne radar, *Aphrodite* responses were not easily detected with 10 and 3 centimetre A.S.V. Headquarters Coastal Command obtained evidence that the Germans used *Aphrodite* to a considerable extent, but no reports of A.S.V. contacts against it were received.

Measures against U-boat Radar

The possibility that U-boats might eventually be equipped with radar was mooted in the United Kingdom in August 1941 when it was anticipated that such an installation would most likely be designed for forward-looking to facilitate attack against surface vessels rather than for upward-looking for location or warning of aircraft. The responsibility for devising and maintaining a monitor service for the purpose of discovering if and when such radar was used and on what wavelength was therefore made that of the Admiralty until November 1942 when it was transferred to Headquarters Coastal Command.³ The search receivers used until then were not very effective as with them it was possible to listen out to only one spot frequency at a time, and the service was closed down until suitable equipment could be obtained.⁴ Requirements were raised for airborne receivers to enable the task to be fulfilled in two stages; to discover first the waveband, and then to ascertain the precise wavelength. A number of T.R.E. scientists had been working directly with the Y Service but by the summer of 1942 the monitoring of known enemy systems was becoming a matter of routine rather than scientific research, and their employment in that capacity was no longer essential. T.R.E. assistance was therefore withdrawn and was concentrated instead on the designing of the more elaborate equipment, automatically operated self-recording receivers, required for investigating unknown enemy radar activity.

Development of two receivers, ultimately designated Bagful and Blonde, was envisaged. Bagful was designed to fulfil the need for maximum endurance consistent with the minimum of information for employment in the first stage of investigations, and Blonde was designed to afford the maximum of information, if necessary at the expense of endurance, for the second. Bagful was entirely automatic so that its use did not entail the provision of a special operator in operational aircraft, and recorded on a paper tape, over a pre-selected waveband, the exact wavelength and time of occurrence of any signal

¹ U-boat Commanders were instructed to take care that *Aphrodite* was not released whenever there was a good chance that it might drift across a convoy.

² C.C.D.U. Report 43/57, 11 October 1943.

³ C.C. File S.9094/4/1.

⁴ C.C. File S.9117/14/1.

exceeding a minimum field strength. It could be used to maintain economically for up to twenty-four hours a consistent search for signals, particularly those on centimetric wavelengths, which were likely to occur only infrequently anywhere in a wide waveband when the probability of detection by occasional manually-operated search was low. Blonde was designed to analyse and record automatically all the significant characteristics of any particular radar emissions so that effective radio counter-measures could be employed against it.¹

Active interest in the provision of suitable receivers was stimulated in the spring of 1943 when the Anti-U-Boat Warfare Committee began discussions of the problems posed by U-boat radar; in January 1943 prisoner-of-war statements had indicated that an installation to operate on the waveband 80 to 90 centimetres was being manufactured by *Gema*. On 7 April 1943 Sir Robert Watson Watt stated that there was no evidence to show that U-boats were equipped with radar for the express purpose of locating aircraft, although it was almost certain that some were equipped with it for surface vessel location.² He considered that the Germans were most likely to exploit fully the advantages conferred by the use of search receivers before they adopted upward-looking radar because reception of its emissions would enable aircraft to home to a U-boat from distances of about 100 miles, and U-boat commanders would be well aware of the existence of such an eventuality. In the event of such radar being installed therefore it was unlikely that it would be used very often or for very long periods. This in fact proved to be a correct assumption; the German fear of radiation reached to such an extent that at no time did U-boat commanders like using their radar equipment. The committee had to decide whether the issues at stake were important enough to justify sacrificing progress on other items of the radio development programme in order to complete rapidly design, development and manufacture of monitoring and homing receivers and their aerial systems. As no single priority list for radio requirements had ever been compiled it was not possible to estimate the implications of giving priority to such work. The Chief of the Air Staff was not convinced that the reception by aircraft of U-boat radar emissions would result in the sinking of many U-boats but thought that development of special apparatus was of the utmost importance; in his view it was, however, more urgently required for the purpose of analysing the whole of the German radar system of night air defence. Professor P. M. S. Blackett considered that a prototype receiver which covered the wavelength known to be used by U-boats for surface vessel location should be developed as quickly as possible; it was probable that no major alteration would be required should it subsequently be found that the wavelength used for aircraft location or warning was different.³ He reminded the committee that Allied submarines were using radar with great success to obtain warning of the approach of enemy aircraft. At the suggestion of Lord Cherwell the Radio Board was invited to report as soon as

¹ T.R.E. Monograph: 'The Radio War.'

² Minutes of 14th meeting of War Cabinet Anti-U-boat Warfare Committee.

³ On 21 April 1943 the C.-in-C. Coastal Command pointed out that such a receiver would have an immediate application in convoy escort aircraft against U-boats using radar for location of, and ranging on, surface vessels, especially at night. Later, when Allied successes against U-boats accentuated the urgency of the enemy's need for more protection, it was thought probable that the anti-surface vessel radar might be modified for use against aircraft by changing only the aerial systems. (A.M. File C.516766. C.C. File S.9117/14/1.)

possible on the implications of according the highest priority to the development and manufacture of suitable receivers and to set out in general terms a priority list for all radio research and development projects.

In June 1943 evidence, obtained on this occasion from photographic interpretation sources, again indicated that U-boat anti-surface vessel radar worked on or near a wavelength of 80 centimetres. Although development of Bagful and Blonde had been accelerated, without adverse affect on other development work, delivery of Bagful to Coastal Command was not expected to begin until the end of August 1943, and manufacture of Blonde would not be started until the end of July.¹ As an immediate measure twelve aircraft of Nos. 58 and 502 Squadrons were therefore equipped during July with Boozer suitably modified for the purpose of testing the correctness of the assumption that 80 centimetres was approximately the wavelength used by the enemy.² Boozer was a manually-operated receiver which could be modified to cover any selected wavelength within a narrow waveband chosen for investigation. It gave visual indications of the reception of a signal and entailed the addition of a special operator to an aircraft crew. Initially it had been designed for use in Coastal Command, but was developed for use in Bomber Command as a tail-warning device when an urgent operational requirement had arisen.³ As the probable enemy waveband was already closely, and comparatively firmly, defined, the T.R.E. began development of a suitable homing system. Arrangements were made for a Liberator and a Wellington XII⁴ to be prototyped¹ on the highest priority for modified Serrate, later given the codename Greenbottle, and a transmitter to operate on the enemy wavelength, for use in conjunction with the Serrate prototype so that tactics might be determined, was made an urgent requirement.⁴ If the prototypes were successful, Greenbottle was to be installed in all Liberators and Leigh Light Wellingtons of Coastal Command.⁵ Modified Serrate, or Greenbottle, consisted of an A.S.V. Mark II receiver slightly modified to give azimuthal indications only between wavelengths of 75 and 100 centimetres, and a Fleet Air Arm type of indicator unit.

Delay in the supply of aerials protracted the Boozer installation programme, and by the middle of August 1943 only two aircraft were in operational use; the precise wavelengths used by the enemy had not been firmly established. Installation in both squadrons was, however, completed by the middle of September. At that time the Wellington Greenbottle prototype was awaiting trials at the C.C.D.U., 50 sets of Greenbottle and associated aerial arrays were ready for installation, and 19 Bagful receivers had been allocated to Coastal Command.⁶ Installation of Greenbottle in the aircraft of No. 407 Squadron was completed in October 1943 and that of Bagful in Nos. 172 and 612 Squadron in November 1943.

¹ Minutes of 22nd meeting of War Cabinet Anti-U-boat Warfare Committee, 15 July 1943. The Coastal Command requirement for Blonde was cancelled before the end of the year because this equipment could more appropriately be used by aircraft fully engaged on special investigation duties.

² Minutes of 8th meeting of Radio-U-Committee, 23 June 1943.

³ A.M. File C.S. 16766. See Royal Air Force Signals History, Volume III: 'Aircraft Radio,' for details of its employment in Bomber Command.

⁴ C.C. File S.9117/14.

⁵ C.C. File 57446.

⁶ Minutes of 12th meeting Radio-U-Committee, 15 September 1943. In October 1943 Headquarters Coastal Command stated that a reduction of the allocation from 19 to 12 would be acceptable if the sets could be put to profitable use elsewhere. (A.H.B./I/K/54/12/5 (B).)

Until employment by the Germans of *Schnorchel* made U-boat radar investigations unnecessary, a considerable number of sorties were made by Coastal Command aircraft equipped with Bagful, Boozer and Greenbottle, but because only limited use of radar was made by U-boat commanders, no contacts that could be identified positively as U-boats were obtained.¹ During the spring of 1944 many signals were recorded, but they could not be so related in any way with visual or A.S.V. sightings; the majority probably emanated from coastal radar stations and E-boats.²

Measures against Search Receivers

The development of counter-measures to centimetric-wave search receivers and action to improve the performance of A.S.V. were initiated as soon as A.S.V. Mark III was introduced into operational use.³ Development of 3-centimetre A.S.V. had reached only the research stage when in February 1942 the Air/Sea Interception Committee had made the decision that ultimately all A.S.V. installations were to operate on that wavelength. The heavy convoy losses suffered in mid-Atlantic during the winter of 1941/42 emphasised the need for air-cover in that area, and whilst the provision of suitable shore-based aircraft was awaited, increased use was made of carrier-borne aircraft, and attempts to improve their efficacy were intensified. The envisaged characteristics and dimensions of 3-centimetre A.S.V. made it especially suitable for installation in the small aircraft used by the Fleet Air Arm. Therefore, whilst 10-centimetre A.S.V. was being developed for Coastal Command, progress was made with the provision of the shorter wavelength equipment for the Fleet Air Arm.

At the end of 1941 a small group at the T.R.E. had begun work on the design of a 3-centimetre installation for Barracuda aircraft, then being planned as a replacement torpedo-bomber reconnaissance aircraft for the Swordfish, and the first problem arose. Allowance had to be made for the carriage of a torpedo, which necessitated fitting the scanner unit at the rear of the aircraft. Apart

¹ A number of U-boats, especially when surfaced because of *Schnorchel* or battery trouble, used radar bearing for blind firing of their A/A guns at extreme range against aircraft in an attempt to force them away. A Halifax was shot down over the Bay of Biscay on 12 March 1944 by U-boat *U.311*. The commander reported that warning of the approach of the aircraft was given by his radar set, and firing was controlled by radar (Admiralty Translation P.G.30342). Good results with *Hohentwiel* were also reported in August and September 1944.

² C.C. File S.14401/3.

³ A.M. File C.S. 16766. Throughout the period of development of H2S Lord Cherwell had evinced a lively interest in the likelihood of effective counter-measures being employed by the enemy, and in February 1943 suggested the use of variable wavelengths. He asked the T.R.E. to calculate the minimum modifications which would be required to enable H2S to cover a waveband between 8.7 and 9.3 centimetres. There was, however, no practicable method of achieving his aim. The magnetron had a spread of one millimetre which could, if desired, be increased slightly during manufacture by changing the straps; a spread of two millimetres could probably have been effected in the R.F. circuit, and rather less in the aeriels and H.F. connectors; the local oscillators covered about three millimetres. The only means of extending the overall waveband of 10-centimetre H2S entailed manufacturing equipments to work on separate wavebands. Thus, to achieve cover over a waveband six millimetres wide, it would most probably have been necessary to have three separate H2S installations working on wavelengths of 8.8, 9.0 and 9.2 centimetres, each with its own individual aeriels, H.F. connectors, transmitters, and local oscillators. A further disadvantage of the scheme was that the components and aerial systems were such that a change in wavelength over a band of 6 millimetres would have decreased very noticeably the ranges at which targets could be detected. When a change of wavelength became an operational requirement a more logical and practicable approach appeared to be the employment of equipment working on a wavelength of 3 centimetres. (T.R.E. File D.1738 and C.C. File S.9117/14.)

from the interference with forward viewing, this meant that only a small nacelle could be fitted in order that safe ground clearance might be ensured, and an 18-inch mirror had necessarily to be adopted. When the need for the A.S.V. became urgent the Barracuda had not reached the production stage, so a 3-centimetre A.S.V. installation was planned for Swordfish which would be flown from small escort carriers. For the convoy escort role torpedoes were unnecessary and the scanner could therefore be slung between the struts of the fixed undercarriage, and development of a larger mirror than that planned for the Barracuda was begun, whilst the T.R.E. planned to use as far as possible units which would be common to both 3-centimetre A.S.V. and 3-centimetre H2S.

A.S.V. Mark XI

Fairey Aviation received a Swordfish to modify for use as a prototype in July 1942. Equal priority was accorded the Swordfish and Barracuda installations, but various difficulties, unconnected with radar, encountered with the Barracuda eventually caused work to be concentrated on the former, particularly when in the winter of 1942/43 convoy losses in mid-Atlantic were even heavier than during the previous winter. The Swordfish installation, which became A.S.V. Mark XI, was so much more bulky than A.S.V. Mark II that in order to make space for it one of the aircrew of three normally carried had to be dispensed with, and the aircraft fuselage was re-designed for a crew of two.¹ After the inevitable set-backs and delays, mainly occasioned by the technical difficulties involved in the development of a new valve to work efficiently on a wavelength of 3 centimetres and the mastery of the technique for bending and coupling together waveguides, the first pre-production equipment was installed in a Swordfish at Defford in February 1943.² Experimental flight trials were successfully undertaken in March and April, and the ensuing production and installation programmes were devised entirely for the Fleet Air Arm.³

Development of A.S.V. Mark VI

At an informal meeting held at the T.R.E. on 7 February 1943 it was agreed that future development of A.S.V. for Coastal Command should aim at the evolution of a high-efficiency installation based on transmitter power of

¹ T.R.E. File D.1738, Part II. One way of overcoming the difficulty of lack of space for A.S.V. in naval aircraft was to mount the equipment externally in a streamlined case rather like a bomb. This was done with the American lightweight 3 centimetre equipment (AN/APS 4) known as ASH or A.S.V. Mark IX. It was probably the first radar set to be designed for external mounting on an aircraft, and was extensively miniaturised to the extent of loss of performance in some aspects. ASH was intended for use both as A.S.V. and A.I. and for fitting to any type of aircraft, and was in fact used by the R.A.F. as A.I. Mark XV. (*See also Royal Air Force Signals History, Volume V: 'Fighter Control and Interception.'*)

² Encouragement was given to the small T.R.E. group engaged on the project when, in December 1942, a set of experimental units was flown in a Hudson and good results were obtained, although much impromptu repair work and adjustment was required during the flight.

³ A.M. File C.S. 16766. The experimental trials indicated that an effective anti-U-boat sweep along a lane 14 miles wide was possible, and a maximum range of 40 miles against an escort carrier was obtained; the installation offered a means of carrying out anti-U-boat patrols around a convoy while keeping the convoy itself under observation on the P.P.I. The provision of additional equipments took some time, and three months passed before two more Swordfish could be prepared and three observers specially trained for Service trials which, however, were completed by August 1943. The observers then formed the nucleus of a training squadron and by November 1943 a fully-trained operational squadron was ready to embark. Aircraft equipped with A.S.V. Mark XI were used for escorting convoys to and from the U.S.A., Africa and Russia, and a shore-based squadron did excellent work against small craft in the English Channel just before and after D-day.

200 kilowatts and incorporating aids to blind bombing. The alternative, development of an installation in which performance was sacrificed to security, was considered to be less progressive.

In anticipation of an official operational requirement, design and development of a suitable transmitter to form part of a universal H2S/A.S.V. installation was undertaken and it was expected that an experimental prototype would be completed by August 1943.¹ In March 1943, when A.S.V. Mark III was being introduced into operational use, the Commander-in-Chief Coastal Command urged the War Cabinet Anti-U-boat Warfare Committee to investigate closely every possible counter-measure to the employment by the enemy of a centimetric-wave search receiver, and requested that the matter be treated with the same energy and determination that had characterised the solution of the night interception problem.²

The technical performance and reliability of centimetric A.S.V. were disappointing during its early days. Not only did Coastal Command require a safeguard against search receivers but also longer detection ranges, and on 21 April 1943 the Commander-in-Chief requested that development of both an efficient attenuator and of High-Power A.S.V. Mark III to enable U-boats to be detected at distances of at least 20 miles, be urged with the highest priority. When such detection ranges could be obtained by operational squadrons the number of aircraft required to search effectively any given area would be much reduced and the effect of centimetric-wave search receivers to some extent neutralised.³ The ranges at which the receivers were likely to be effective were not known, and there was always a tendency to over-estimate their capabilities and effectiveness; it was felt that use by the enemy of a search receiver would completely nullify the efficacy of 10-centimetre A.S.V. Later, when information from various sources indicated that receivers were in operational use, tactics were improvised on the assumption that search receivers would out-range A.S.V. They included prohibition during an approach of 'searchlighting' the target, sector scan, or change of scan rate, since such changes would indicate to the receiver operator that radar contact had been made and the U-boat could take evasive action.⁴ That the U-boat would dive immediately a warning indication was received was considered unlikely.

¹ A.M. File C.S. 16766.

² A.U. (43) 84.

³ A.M. File C.S. 16766. It was foreseen that a disadvantage of High Power A.S.V. was that its use would very likely cause an appreciable increase in the number of unwanted indications, such as those of fishing vessels, with consequent diversion of effort, but this was accepted.

⁴ In June 1943 restrictions were not placed on the use of A.S.V. Mark II at night, but it was not used during daylight except when visibility was less than three miles or the aircraft was above thick cloud. It could also be used purely as a navigational aid when going on and off patrol. When A.S.V. Mark II was used by day, if a blip faded and the operator was reasonably certain that it had been caused by a U-boat, A.S.V. was switched off and the aircraft was flown at least 20 miles away from the suspected contact, except when the aircraft was engaged on convoy escort duty. About half an hour later the aircraft returned at a height which promised the maximum amount of surprise. If no sighting was then obtained the patrol was continued in the normal manner. No restrictions were placed on the use of centimetric A.S.V. Leigh Light aircraft whenever possible flew on patrol at 1,500 feet, then considered to be the most effective height for A.S.V. Shortly afterwards this was changed to 500 feet. In August 1943 the procedure was changed. It was no longer automatically assumed that fading was an indication that the contact was spurious or that the U-boat had dived. The A.S.V. operator, immediately he had a blip, passed the approximate range and bearing to the pilot who turned on to the bearing in order to close range as quickly as possible. If fading then occurred course was maintained until it was estimated that range had been closed. If no further blip was obtained and no visual sighting was made, the patrol was continued in the normal manner. (Coastal Command Tactical Instructions Nos. 41 and 42.)

On 27 May 1943 the Director of Communications Development confirmed that the 200 kilowatt transmitter would be ready, and an attenuator incorporated, by August 1943. The Commander-in-Chief in June 1943 re-stated his requirements in greater detail. In his opinion, provided that the enemy did not resort to widespread employment of effective decoy buoys, the simplest method of defeating both search receivers and U-boat radar was to raise to the maximum the detection range of A.S.V. ; no lasting advantage could be expected from trying to evade U-boat warning devices by continually changing wavelengths. The requirements were listed under the headings Performance, Weight, Power Control, Scanner, Presentation, Range Scale, Remote Indicator, and Navigational Facilities.¹ The detection range was to be the maximum obtainable with available aircraft power supply, and the weight of the installation was not to exceed 700 lb. An attenuator was required, and the scanner was to be such that it did not interfere with installation of a bombsight and armament in the aircraft nose, with the Leigh Light, or with rocket projectile installations. The presentation for search and navigation was to be P.P.I. with good backward-looking for drift determination ; for attack, either P.P.I. with Split or B Scan so that homing might be accurate.² The range scales were to be 100, 50, 25 and 7 miles. Remote indicators for the use of the pilot and the Leigh Light operators were other requirements. That for the pilot was to be in the form of a small dial calibrated in degrees with pointer indications ; a cathode ray tube was considered to be unsuitable. If practicable the Leigh Light operator's A.S.V. indicator and his Leigh Light azimuth indicator were to share the same dial so that when both pointers were aligned the light was directed towards the target. The choice of method by which the indicators were to be operated, automatic lock-and-follow or manual, depended on which one enabled the target to be followed furthest through sea returns. If, however, lock-and-follow was incorporated it was essential that the A.S.V. operator should be able to revert to manual control at will and it was important that when a blip could no longer be followed on the cathode ray tube, information was shown on the indicator dials.³ Rooster, beacon interrogation and BABS facilities were also required.

The specification had been drawn up in collaboration with T.R.E. scientists who envisaged dividing development into several stages, each complete in itself, aiming at a final system incorporating all the requirements. Initially, centimetric A.S.V. had been developed from A.I. and H2S ; its further development became a successive series of modifications of the original equipment. The inadequacy of engineering and production capacities in the United Kingdom made it impossible to redesign completely each airborne radar system, so the series of each equipment bore a strong family resemblance to those which had already appeared, and many units were used in successive Marks with little or no modification.

¹ A.M. File C.S. 16766.

² B Scan was a range azimuth display which presented azimuth by means of deflection of the spot to right or left of a vertical line in the centre of the cathode ray tube, whilst range was displayed as the distance above a horizontal line near the bottom of the tube. An echo appeared as a short bright horizontal line.

³ Trials had proved that the lock-and-follow system with remote indicators for the pilot and Leigh Light operator was superior to the existing technique, in which the radar operator gave verbal instructions for homing, but it was considered that the enemy might take advantage of the characteristics of the continuous transmission of a locked scanner. (A.H.B./IHK/54/12/5(B).)

Development of the high-power installation was so planned that only the minimum possible changes to A.S.V. Mark III were involved.¹ The main points of interest wherein it differed were the scanner, the high-power transmitter, and the attenuator. The scanner, Type 67, was a modified version of that used in A.S.V. Mark III, with a waveguide horn arranged to reduce sea-clutter and to enable a more constant signal to be obtained whilst the aircraft was homed to a target. The attenuator was designed for insertion in the waveguide run between the transmitter unit and the scanner, and was remotely controlled. It was required that when the attenuator was operated the magnetron frequency did not change and so give a false indication of signal strength. The Type 53 attenuator used with A.S.V. Mark VI fulfilled this condition, but had one undesirable feature in so far as it attenuated the received signal in addition to the transmitter power, thus losing about half of its tactical value.² The first stage of the new installation, eventually designated A.S.V. Mark VI, was to be the introduction of a 200 kilowatt transmitter and an attenuator; it was considered that sufficient equipment could be manufactured in 1943 to enable two squadrons to be equipped by the end of the year. The second stage, independent of the first, was to be an increase in the accuracy of direction-finding by using the Split technique to enable A.S.V. to be directly coupled with blind bombing. If practicable automatic lock-and-follow as used in A.I. Mark IX was to be incorporated at this stage, which was to be known as A.S.V. Mark VIA. If it were then found possible to follow through sea returns with the automatic system, the third stage was to be further developed in order to bring about completely automatic control of the Leigh Light. The final stage would be the addition of blind bombing facilities to the equipment evolved from the first three stages.

The operational requirements, and the methods proposed to meet them, were accepted by the Air Staff, who thought it was essential that the target date for completion of development of the first stage, the end of August 1943, was met, as evidence from intelligence sources indicated that the Germans were preparing to listen out for radar emissions in the 10-centimetre waveband.³ On 4 July 1943 the Director of Radar informed the Director of Communications Development that the specifications forwarded by the Commander-in-Chief were to be regarded as representative of the official views of the Air Ministry, and urged development ' . . . as a matter of the greatest operational importance . . . '

A.S.V. Mark VII and Mark X

At the same time the Director of Radar, although he, too, was of the opinion that a change of wavelength was by no means the complete answer to the search receiver, agreed with a request made by the Commander-in-Chief that preliminary arrangements should be made for installing the 3-centimetre version of H2S, known as H2X, for which a production order of 200, to be delivered by the end of 1943, had been placed, in Wellington XII and XIV aircraft of Coastal Command in addition to aircraft of Bomber Command.⁴ It was

¹ T.R.E. Monograph : ' A.S.V. '

² A new version, known as Type 58, was eventually designed to overcome this difficulty.

³ This probably referred to the activities of the *Luftwaffe* in developing the *Naxos* receiver for use against H2S.

⁴ A.M. File C.S. 16766. The T.R.E. had also suggested, in May 1943, that since, owing to a change in stated requirements, a number of A.S.V. Mark XI installations would be surplus to naval requirements in 1944, conversion kits should be prepared so that at least one squadron of Coastal Command could be modified to operate with A.S.V. on a wavelength of 3 centimetres immediately the Germans began using search receivers effective in the 10-centimetre waveband.

considered that the H2X equipment was likely to prove most effective for night operations, that the enemy would find it difficult to devise counter-measures quickly, and that the conversion of aircraft and crews from 10-centimetre to 3-centimetre installation would be a relatively simple matter requiring no change in training and no major development and modification programmes. The Commander-in-Chief strongly recommended that Coastal Command should be given priority over pathfinder squadrons to the extent of having one squadron equipped by October, before Bomber Command operations with H2X were started.¹ The existing 10-centimetre H2S was not providing sufficiently good discrimination to ensure positive recognition of towns, or of targets within towns, in densely built-up areas, and wave-guide scanners were being developed to improve definition. On 4 July 1943 the Prime Minister informed Sir Robert Renwick that ' . . . as we extend our main radius of operations beyond range of Oboe² H2S will become more and more important. I am anxious you should spare no pains to speed up improved H2S . . . if extra staff is required it should be obtained, even should this mean slowing up work of lower priority. . . .'³ Trials were to be undertaken so that the merits of H2S with waveguide scanners, H2X, and A.S.G./A.S.D. might be compared. Until the trials had been completed it was not possible to make a definite decision regarding the allocation of the 200 H2X equipments. On 9 July 1943 the Chief of the Air Staff provisionally agreed that, subject to the outcome of the trials, the H2X output should be allocated for installation in three Lancaster squadrons of Bomber Command as H2X, and in one Wellington squadron of Coastal Command as A.S.V. Mark VII by the end of 1943. He added a further proviso to the effect that the programme was to be reviewed later in the year and confirmed or changed according to the strategic situation then prevailing; it was too early to judge the trend of the war against U-boats and the extent to which search receivers might prove effective against 10-centimetre A.S.V. There was much to be said for confining the use of 3-centimetre equipment to Coastal Command for some time after its introduction, as the change of wavelength might prove to be of considerable importance to the anti-U-boat war, and its loss over the Continent before it had been used operationally over the Bay and the Atlantic for any appreciable length of time might warn the enemy that another search receiver was required.¹ A 3-centimetre adaptation of A.S.G., AN/APS 15, was concurrently being developed in the U.S.A., and, on the assumption that the technical performance of the British and American equipments were comparable, an American radar mission to the United Kingdom, the Compton Mission, had been asked and had agreed to make available 100 Liberator GRV aircraft fitted with AN/APS 15; deliveries were due to begin in December 1943.

Originally, in the spring of 1943, the British Air Commission intended that A.S.G. should be converted to operate on the 3-centimetre wavelength with a minimum number of changes. To that end a hybrid of A.S.G. and A.S.D., the X-band installation used by the United States Navy, was evolved for installation in Liberators of Coastal Command. At that time the U.S.A.A.F. had no requirement for H2S, but by the summer the situation had changed considerably.⁴ The original simplified design of A.S.G./A.S.D., planned for production

¹ A.H.B./IHK/54/12/5(B).

² Berlin was beyond the range of Oboe. See Royal Air Force Signals History, Volume III: 'Aircraft Radio,' for details of H2X and Oboe.

³ A.H.B./1D/12/195.

⁴ See Royal Air Force Signals History, Volume III—'Aircraft Radio.'

in small quantities, was changed and considerably complicated as AN/APS 15 to meet the specifications of the U.S. Eighth A.F. The current requirements of the United States Navy were met by A.S.D., and in the new circumstances the Navy was unable to sponsor the development and production of an additional X-band installation.¹ AN/APS 15, the Coastal Command version of which was known as A.S.V. Mark X, was being developed primarily for an H2S role. It was a complicated installation, providing all-round coverage with a sector scan of any multiple of 30 degrees, centred in any direction. It incorporated, amongst other features, interchangeable high and low altitude mirrors, the latter being used for A.S.V.; a crystal controlled 'range unit' for accurate range marked to facilitate precision bombing; a 'sweep delay' selector by means of which the start of the timebase could be delayed in multiples of 10 miles up to a maximum of 200 miles, thus permitting detailed examination of a distant target and a maximum range of 300 miles which was of use for beacons; a separate optional second indicator; a separate A scope for monitoring purposes and altitude measurement; and manual tilt control from 20 degrees up to 20 degrees down with remote heading indicator.²

Trial Installation of A.S.V. Mark VI

On 17 August 1943 the Director of Radar requested that arrangements be made for a crash programme to be initiated with the object of providing Coastal Command with as many high-powered installations as possible in 1943. The crash programme was to produce, by 31 December 1943, 100 A.S.V. Mark VI, and by 1 April 1944, 100 A.S.V. Mark VIA and 100 kits for converting A.S.V. Mark VI to A.S.V. Mark VIA. It involved not only development and manufacture of the components, but also its installation in aircraft, and consequently provision of the essential aircraft fittings. Development of the prototype A.S.V. Mark VI transmitter took a longer time than had been anticipated because of unforeseen difficulties encountered in the high frequency circuits, but in September 1943 the T.R.E. was ready to begin fitting a trial installation in a Wellington XIV.³ No aircraft had been allotted for the purpose however, and without a trial installation the manufacture of aircraft fittings could not be started, since design drawings could not be made. Further delay was therefore certain.

In October 1943 the Commander-in-Chief informed the Air Ministry that there was strong evidence to support the belief that the enemy was at last

¹ A.M. File C.S. 23288.

² T.R.E. Monograph: 'A.S.V.' The scanner employed in the A.S.V. Mark X version of AN/APS 15 was a 29-inch paraboloid, in which the tilt setting was too fine, and ranges obtained were often poor because of maladjustment of the tilt control. The other main units consisted of a transmitter/receiver, receiver indicator unit, control unit, computer and range unit. No installation of A.S.V. Mark X was undertaken in the United Kingdom, the only equipments used being those which arrived in Liberators fitted in the U.S.A. A notable feature of the Liberator installation was a retractable turret, situated in the aft portion of the aircraft, which carried the scanner and the transmitter/converter unit. The remainder of the equipment was located in the navigator's compartment immediately behind the pilot, with a second indicator on the navigator's table. For Coastal Command operations very few modifications were found necessary, a notable exception being the addition of a sea-clutter filter. Shortly before the end of the war with Germany a later version, AN/APS 15A or A.S.V. Mark XA, arrived in the United Kingdom. It contained many minor improvements. The range scales were changed from 5, 20, 50 and 100 miles to 50, 100 miles and a variable scan adjustable from 5 to 30 miles; a feature found extremely useful by Coastal Command squadrons.

³ The equipment had been installed in the nose of a Wellington IX for flight trials, and very encouraging results had been obtained. (A.H.B./IHK/54/12/5B.)

employing the long-anticipated centimetric receiver, and unless suitable alternative equipment was made available quickly the success of the Bay offensive would be hopelessly prejudiced. He pointed out that 10-centimetre A.S.V. had been used by Coastal Command for over nine months, and counter-measures to the search receivers had become ' . . . a matter of immediate practical importance after a period of grace considerably longer than we had any right to expect. . . .'¹

Requirement for A.S.V. Marks VII, VIII and X

It was extremely uncertain whether the target dates for the equipping of two squadrons with A.S.V. Mark VI could be met. Service trials of the prototype installation had not been started, and the prospect of obtaining more than about 30 equipments from the manufacturers before the end of December was remote. The plan to equip one squadron with 3-centimetre A.S.V. had not been put into effect although the contingency which it was intended to meet had become a matter of some certainty. The Commander-in-Chief considered that at least two squadrons should be fully equipped and trained with A.S.V. Mark VII by the end of the year ; he asked for an immediate allocation of 10 sets to enable initial fitting and training to be started, to be followed by 10 in mid-November and 30 in early December. The adoption of special measures to accelerate production of A.S.V. Mark VII was strongly urged.² However, even if these requests were fulfilled only a very limited number of aircraft would be suitably equipped to nullify the use of the new search receiver, and the Commander-in-Chief considered it essential that the number should be increased by all possible means. One of his proposals was the installation of A.S.V. Mark VI or VIA in Halifaxes as soon as a programme could be undertaken without prejudicing the Wellington installation programme. Another was the retrospective installation of A.S.V. Mark X in three squadrons of Liberators which were to be equipped with Leigh Lights. But all such measures were only immediate ones to meet an emergency.

It was necessary to decide the long-term policy for anti-U-boat aircraft. The Commander-in-Chief outlined his recommendations based on the assumption that by September 1944 the anti-U-boat force of Coastal Command would comprise 10 Liberator Squadrons, 7 Sunderland, 2 Fortress, 3 Catalina, 5 Wellington or replacement, and 2 Hudson or replacement. He proposed that the Liberators and Fortresses should be equipped with A.S.V. Mark X ; Catalinas with A.S.V. Mark VIII ; Wellingtons, and Warwicks if introduced into Coastal Command, with A.S.V. Mark VIA and A.S.V. Mark VII if the power and the range of the latter could be increased and if lock-and-follow could be incorporated.³

Relative Priorities of Coastal and Bomber Commands

Whilst the relative claims of Bomber Command, Coastal Command, and the Fleet Air Arm to the expected output of 3-centimetre equipment were being discussed by the Anti-U-boat Warfare Committee on 27 October 1943, the Coastal Command requirements and proposals were considered at meetings held at the Air Ministry. At one meeting the Commander-in-Chief pointed out that, although the installation in U-boats of new receivers was still only suspected as evidence was not completely convincing, the number of U-boats

¹ A.M. File C.S. 16766.

² The crash programme included an order for 50 sets of A.S.V. Mark VII by the end of December.

³ A.M. File C.S. 16766. See Appendix No. 15 for details of A.S.V. Marks VIII and VIIIA.

sunk in the Bay of Biscay by aircraft had decreased considerably over the past three months; 14 in July, 4 in the first week of August, 4 during the remainder of August, and 1 in September.¹ Although it was not claimed that the drop in effectiveness was entirely, or even substantially, due to employment by the enemy of search receivers, he thought it was nevertheless a clear indication of the desirability of the early introduction of either 3-centimetre A.S.V. or A.S.V. Mark VI. It was for the meeting to decide to what extent Coastal and Bomber Command requirements would be met from the scheduled production programmes.

No further orders beyond the original 200 H2X installations had been placed, and a setback had occurred in production; only 100 at the most could be expected by the end of the year and 100 by February 1944. It was clear that the output would fall short of requirements. On the assumption that the immediate need of Coastal Command was only for the 50 sets which had been included in the crash programme, the equivalent of three very scantily equipped squadrons would be left for Bomber Command and there would be insufficient spares to last for more than three months; a major disadvantage since general production was not likely to be effective for at least another twelve months. Headquarters Bomber Command, after ten months experience of 10-centimetre H2S, estimated that its use afforded good results on only one raid of four and consequently its efficiency was not rated very highly; its degree of definition was not very marked and raids on Berlin, at that time becoming increasingly important, were still far from effective. It was confidently expected that target definition would be greatly improved with H2X, and that its use might well result in an average of at least two good raids in every four; the implications were considerable. Bomber Command, acting on the basis that the number of sets available would be no more than 200, had planned to absorb the total output in order to equip and maintain three pathfinder force squadrons throughout 1944 until a new Mark of H2S was in general supply, although the real requirement was for six squadrons. Speed in equipping the squadrons was essential since it was during the winter months that they would probably be employed to the maximum possible extent. In view of the urgent nature of Bomber Command's need, various ways, other than that of diverting H2X, in which Coastal Command requirements might be met were discussed. One was the transfer of the A.S.V. Mark VIII equipments already installed in 36 Venturas, aircraft which were unsuitable for anti-U-boat operations and were employed on meteorological sorties, to Wellington XIV Leigh Light aircraft.² It was also pointed out that 30 sets of AN/APS 15 would become available in December 1943 for retrospective fitting in one or two squadrons of Liberators and it was hoped that 30 sets of A.S.V. Mark VIIIA would be delivered from the U.S.A. at the same time for retrospective installation in Catalinas.³ In the

¹ A.M. File C.S. 16766.

² A.S.V. Mark VIIIA was eventually installed in Catalina aircraft. A few sets of the equipment were flown to the United Kingdom in February 1944, shortly before the arrival of the first Catalina to be completely equipped under the direction of the British Air Commission. A British version of the equipment, slightly different from the American, was developed by the firm of Saunders Roe, at Beaumaris, where Catalina installations were changed from A.S.V. Mark II to A.S.V. Mark VIIIA. (Later at Felixstowe.) Flight trials, followed by Service trials, were undertaken in May 1944. The first squadron to receive the new equipment was No. 210 Squadron, formed at Sullom Voe in June 1944. The T.R.E. installed A.S.V. Mark VIIIA in a Warwick used for air/sea rescue duties, but because of lack of priority its Service trials were never completed.

³ Two-hundred sets of AN/APS 15 had originally been expected but the U.S. Eighth A.F. urgently needed the equipment for employment in the H2S role.

circumstances the Commander-in-Chief decided that he would be satisfied if only one of his squadrons was equipped with A.S.V. Mark VII. The meeting therefore recommended that the H2X output should be so allocated that one squadron of Bomber Command, followed by one squadron of Coastal Command could be fitted, after which the remaining equipments would be installed in Bomber Command aircraft.¹

The Air Staff, after considering the recommendations, was of the opinion that in view of the slender supply position and the need to provision for spares over a period of twelve months it would be in the common interest to allocate the whole of the output to Bomber Command.² The use of H2X in pathfinder aircraft, by greatly improving definition and thus notably increasing the reliability with which targets could be plainly marked for the main bombing force, would be of direct assistance to the Admiralty and to Coastal Command in the war against the U-boats. It has been calculated that over recent months bombing operations had reduced U-boat production by as much as 40 to 50 per cent; even if this estimate was over-optimistic it was thought likely that the effect of a great improvement of bombing accuracy would transcend that which could reasonably be expected from one squadron of Coastal Command. Also, the main value of A.S.V. Mark VII to Coastal Command lay in the use of a different wavelength, probably only a temporary advantage and possibly an illusory one; it was quite possible that a 10-centimetre search receiver could also detect emissions made on 3 centimetres, and in any event it was but a short step from listening out on 3 centimetres. The Chief of the Air Staff, agreeing with the conclusions arrived at by the Air Staff, decided that it would be unwise to divert any H2X equipment from Bomber Command; both the Naval Staff and Headquarters Coastal Command were prepared to accept the ruling, especially since recent evidence had made it doubtful whether in fact the enemy had made much progress in fitting an effective search receiver.³ They were most anxious, however, that higher priority should be given to the manufacture and installation of A.S.V. Mark VI and that the installation of A.S.V. Mark X should be expedited; the necessary action was immediately initiated by the Deputy Chief of the Air Staff.⁴

Already, at another meeting held on 27 October under the chairmanship of Sir Robert Renwick, arrangements for the provision of A.S.V. Marks VI and VIA had been discussed.⁵ A Wellington aircraft to be used for a trial installation of A.S.V. Mark VI was expected to be available that day, but completion of Service trials and essential drawings before the end of November could not be promised because of higher priority previously accorded to other projects at the Special Installation Unit. The A.S.V. Mark VI trial installation was therefore given first priority, and the A.S.V. Mark VIA trial installation second, over all installation tasks other than the Oboe Mark II prototype, and the first six Service installations were to be undertaken by the Special Installation Unit.

However, shortly before the end of November it became only too apparent that both the H2X and the A.S.V. Mark VI production programmes were falling badly behind schedule. Unless some emergency action was taken, by the end of the year only ten aircraft could be fitted with H2X for Bomber

¹ A.M. File C.S. 16766.

³ A.H.B./I/K/54/12/5(B).

⁵ A.M. File C.S. 20338.

² A.H.B./1D/12/201. 3-Centimetric A.S.V.

⁴ A.H.B./1D/12/201.

Command whilst it was doubtful if as many as 25 A.S.V. Mark VI installations could be delivered to Coastal Command. The two programmes were correlated inasmuch as the production of scanners for A.S.V. Mark VI interfered with the production of scanners for H2X and the fitting capacity of the Special Installation Unit was limited.¹

The Director General of Signals, in view of the war situation at the time and the importance of actively supporting the bombing offensive, strongly recommended applying all possible pressure to the H2X programme even at the expense of delaying further the introduction of A.S.V. Mark VI to Coastal Command. He estimated that by giving the H2X programme priority until the middle of January it would be possible to fit about six aircraft by 4 December and four aircraft per week subsequently. The lag in A.S.V. Mark VI scanner production would unavoidably be increased and the fitting of Coastal Command aircraft could not be started at the Special Installation Unit until the middle of January 1944. By that time No. 32 Maintenance Unit would be able to undertake the installation of H2X.

At the end of November Bomber Command employed two H2X aircraft as pathfinders for attacks against Berlin. The technical performance of the equipment justified the claims that had been made for it. Target definition was very good and the accuracy of bombing was an outstanding advance on that obtained with H2S. The Air Staff considered that if H2X could be installed in an adequate number of pathfinder aircraft, Bomber Command would be enabled to attack targets with a very fair degree of accuracy at any range within the scope of bomber aircraft, irrespective of the amount of cloud over enemy territory. In fact, heavy cloud conditions, instead of militating against effective bombing could be instrumental in assisting operations of Bomber Command and minimising its casualties; bad weather at home bases and severe icing conditions would probably be the only limiting factors. The Air Staff felt strongly that full advantage should be taken of the long winter nights immediately ahead. The scheme proposed by the Director General of Signals would enable the pathfinder force to be equipped with the minimum number of H2X aircraft sufficient to make attacks effective by the end of December. Since the U-boat Command had adopted a safety-first policy and had dropped the offensive role the anti-U-boat war had become rather comatose; U-boat Commanders rarely exposed themselves to the risk of air attack and shipping losses were comparatively slight. Bomber Command operations appeared to be reducing U-boat production and were obviously of immense value to the air offensive as a whole and to the maintenance of air supremacy which was so essential. A defensive policy had been forced on the *Luftwaffe* and the German aircraft industry was diverted to the production of fighter instead of bomber aircraft. Even that production was being much reduced by bombing raids while fighter losses were increased. Therefore, although faced with the prospect of receiving in Coastal Command only about six A.S.V. Mark VI aircraft by the end of January 1944 the Commander-in-Chief and the Admiralty agreed to accept the modified installation programme.

A.S.V. Mark VI Series—Installation Programme

Early in December 1943 Headquarters Coastal Command produced an installation plan based on the assumption that there would be no gap between the A.S.V. Mark VIA programme and bulk production of A.S.V. Mark VIB.²

¹ A.H.B./ID/12/201. 3-Centimetre A.S.V.

² A.M. File C.S. 20338.

In fact, both A.S.V. Mark VI and A.S.V. Mark VIA were to have a considerably longer operational life than was originally intended as A.S.V. Mark VIB was not in use with Service squadrons when hostilities with Germany were ended. Five Wellington XIV squadrons¹ were to be equipped from the crash programme and other types of aircraft including the Warwick V were to await the output from main production.² Then, five squadrons of Wellington XIV and seven squadrons of Sunderland V were to be equipped with A.S.V. Mark VIB and VIC respectively. The possibility of installing A.S.V. Mark VIB in Liberators was also considered although in general the policy of using American equipment only in American aircraft was strongly upheld. With the advent of the centimetric wave search receiver A.S.V. Mark V had apparently lost much of its effectiveness, particularly as it did not incorporate an attenuator.³ But there was little chance of expanding production sufficiently to equip Liberators because of the acute shortage of magnetrons Type CV. 64 which were used in A.S.V. Mark VIB. However, the Commander-in-Chief Coastal Command was most anxious that a trial installation should be made as an urgent requirement so that if it ultimately became possible to arrange a Liberator installation programme delay would be reduced to a minimum. The possibility of substituting A.S.V. Mark X for A.S.V. Mark V was also discussed, but it had become apparent that the supply of that installation to the R.A.F. was likely to be seriously limited by the pressing need of the U.S. Eighth A.F. to use AN/APS 15 as H2S. Detailed arrangements for quantity production of A.S.V. Mark VIB had not then been made and forecasted dates for delivery were purely speculative. Several units of A.S.V. Mark VIA and Mark VIB would not be interchangeable; it was therefore essential that the R.P.U. should not only manufacture the 200 equipments already on order but should also continue afterwards to turn out enough to maintain the 200 in service. After the first six aircraft had been fitted at the S.I.U., the remainder of the installation work was to be done at No. 32 M.U. or by specially trained fitting parties at Chivenor.²

By this time information from prisoners-of-war and other sources left no doubt that U-boats were equipped with search receivers effective on the 10-centimetre wavelength, and A.S.V. tactics were adjusted to meet the situation. For example, aircraft fitted with A.S.V. Mark III when employed on daylight patrols used A.S.V. only for navigation or when visibility was less than 3 miles. Those fitted with A.S.V. Mark V established a homing course in the shortest possible time after obtaining a contact and then stopped the scanner in a position looking aft when the trace on the P.P.I. was between 170 and 190 degrees. The subsequent approach was made by dead reckoning navigation and normal A.S.V. watch was resumed if no target was found.⁴

The need for an effective counter-measure had now become urgent and in mid-December the progress made with the A.S.V. Mark VI series was reviewed. The Wellington A.S.V. Mark VI trial installation had been inspected and, subject to certain modifications, on which T.R.E. scientists were working, had

¹ Nos. 172, 179, 304, 407 and 612 Squadrons.

² A.M. File C.S. 20338.

³ Later, attenuators operated by a small motor were incorporated but were not satisfactory as, during operation, the magnetrons were pulled off frequency and the local oscillator had to be retuned. Transformers were inserted in the coaxial lines to minimise this effect.

⁴ A.H.B./1D/12/197.

been found acceptable. Development models of the scanner system had been received from the firm of Nash and Thompson by the T.R.E., where it was hoped that, after modifications had been incorporated, type approval would be possible within a few days. The supply of magnetrons was likely to be a limiting factor in progress; B.T.H. were unable to accept production orders, and output was consequently entirely dependent on G.E.C., who were producing 20 per month. The manufacture of Type 53 attenuators by the R.P.U. was progressing satisfactorily, but the design drawings of connectors could not be completed until the trial installation had received final approval. If sufficient equipment could be made available by the beginning of January 1944, the S.I.U. would be able to begin fitting six aircraft by the middle of the month, but the task of installation was expected to be a difficult one and to take 2,000 man hours for each aircraft even if the necessary modifications of nose armament and armour plating was undertaken beforehand by squadron personnel, and it was foreseen that it would not be an easy matter to arrange the transfer of aircraft from operational employment for any great length of time.¹

Some progress had been made with the development of A.S.V. Mark VIA, although difficulty with the strobe and control units was anticipated. If the problems met with in those units were quickly and satisfactorily solved, a development model could be completed for type approval before the end of January 1944. The essential difference between A.S.V. Mark VIA and A.S.V. Mark VI was the ability to change the scanner, Type 68, from simple rotation which gave an ordinary P.P.I. picture to locking the target in azimuth. (The spread of the beam in the vertical plane made elevation locking unnecessary.)

More details of the technical requirements of A.S.V. Mark VIB were awaited before the basis for development and production could be decided. Since the equipment was intended to be the standard A.S.V. installation for British-built maritime aircraft of the Royal Air Force, the removal of the faults which would be inherent in A.S.V. Marks VI and VIA because of their *ad hoc* development from H2S was essential.

A.S.V. Mark VI was installed in six aircraft of No. 612 Squadron by the S.I.U. in February 1944; thereafter the responsibility for further installation was made that of No. 43 Group.² By the end of March fitting of the squadron was completed, and the R.P.U. had produced 43 equipments. Difficulty had been experienced with the provision of wave-guides which were being produced by No. 32 M.U. until supplies became available from production contracts. Although there was a shortage of driving motors, 30 scanners Type 67 had been delivered. Trouble with wave-guides, which eventually had to be re-designed, was also experienced in the development of A.S.V. Mark VIA, and in spite of its high priority the trial installation was not expected to be ready before the end of April 1944. Again, experience was proving that priority meant little if essential pieces of equipment were not obtainable. However, it was confidently anticipated that about 15 equipments would be produced by the R.P.U. in May and ten aircraft installations completed in June 1944.

The progress made with the development and towards production of the units special to A.S.V. Mark VIB was discussed at the Air Ministry on 31 March 1944.³ The three items which it was thought were likely to cause most trouble

¹ A.M. File C.S. 20338.

² C.C. File S.7446.

³ A.H.B./IIE/6/60.

were the power unit, amplifier unit and attenuator Type 58. The anticipated date of type approval for the first two units was mid-June 1944. A development contract had been placed with B.T.H. for the attenuator, but the firm had recently reported that because of other high priority work development could not be started for about two months. The Gramophone Company expected to be able to make available a model of the indicator unit early in April, but would not be able to begin work on the development contract for magnetic type indicators until June 1944. It was decided that the possibility of the R.P.U. making a limited number of attenuators to cover the delay created by the inability of B.T.H. to meet the urgency of the requirement should be investigated, and to extend the A.S.V. Mark VIA crash programme until December 1944 in order to avoid a hiatus in delivery of equipment, since it was obvious that the production of A.S.V. Mark VIB would not begin for some months. The items also used in H2S could be made available from the existing production schedules in August 1944, but the outlook in so far as the units still under development were concerned was obscure.¹

By July 1944 four Wellington XIV squadrons were equipped with A.S.V. Mark VI, and one, No. 179 Squadron, was still using A.S.V. Mark IIIB.² Of the remainder of the R.A.F. element of the Coastal Command anti-U-boat force, two Halifax M.R. squadrons were equipped with A.S.V. Mark IIIB;³ five Liberator M.R. squadrons with A.S.V. Mark V; one Liberator V.L.R. squadron with A.S.V. Mark V, one with A.S.V. Mark VA, and one with both A.S.V. Mark VA and A.S.V. Mark II;⁴ one Fortress squadron with A.S.V. Mark II (L.R.A.S.V.);⁵ one Sunderland squadron with A.S.V. Mark II (L.R.A.S.V.), five with A.S.V. Mark IIIC, and one with A.S.V. Mark II (L.R.A.S.V.) and A.S.V. Mark IIIC;⁶ three Catalina squadrons with A.S.V. Mark II (L.R.A.S.V.), and one partially equipped with A.S.V. Mark VIIIA.⁷ The re-equipment of the Wellington squadrons with A.S.V. Mark VIA was expected to begin in August 1944 and a trial installation of A.S.V. Mark VIC in a Sunderland had been started. When A.S.V.S. had first been developed by the T.R.E. it was intended as a Sunderland installation, but a problem peculiar to flying boats was encountered in the provision of all-round looking. It was found that a synchronised double-scanner installation using one scanner under each mainplane was necessary. When H2S superseded the original A.S.V.S. only very little alteration of the double-scanner system was required, and otherwise the Sunderland installation A.S.V. Mark IIIC resembled normal A.S.V. Mark IIIB. The scanners were designed with wave-guide feed throughout, and the transmission of power along the mainplanes was effected by wave-guides. It was, fortunately, possible to take the next step, to high-power equipment, without serious alteration to what was a complicated system. The addition of azimuth-locking facilities, as incorporated in A.S.V. Mark VIA would, however, have required major changes, and was not worthwhile since Sunderlands were not

¹ A.M. File C.S. 20338, Part II.

² Nos. 172, 304, 407 and 612 Squadrons. (C.C. File S.7446.)

³ Nos. 58 and 502 Squadrons.

⁴ Nos. 53, 206, 224, 311, 547 Squadrons, No. 59 Squadron, No. 120 Squadron and No. 86 Squadron.

⁵ No. 220 Squadron.

⁶ No. 10 Squadron, Nos. 201, 228, 330, 422, 461 Squadrons, and No. 423 Squadron.

⁷ Nos. 162, 202, 333 Squadrons and No. 210 Squadron. The force also included Nos. 103, 105, 110 Squadrons, armed with Liberators, of the United States Navy.

equipped with Leigh Lights. Consequently the high-power installation in the Sunderland, known as A.S.V. Mark VIC, although based on A.S.V. Mark VIB units, used the original A.S.V.S. scanner system.¹

On 21 July 1944 the Commander-in-Chief, Coastal Command complained to the Air Ministry that the progress made towards the provision of A.S.V. Mark VIB was most unsatisfactory; ' . . . This equipment incorporates lock-and-follow, attenuator, sea-return eliminator, automatic indication of azimuth to Leigh Light operator and pilot, and range indication to the pilot. All these features are essential to the efficient conduct of Leigh Light operations in the face of enemy counter-measures. The introduction of this equipment was agreed upon early in 1943 and development was put in hand with a view to introduction into service this autumn. The programme has, however, been subject to numerous delays, with the result that the date of introduction has receded further every month. It would appear that there is now little prospect of production starting before the spring of 1945. I view this delay with the gravest concern, and would stress the serious repercussions which lack of this equipment would have on the anti-U-boat operations of this command . . . I would be grateful if I could be given a complete statement of the position and details of the factors governing the date of introduction. . . .'²

Until development of the various units was completed no reliable estimate of production dates could be made, and the real reasons for the continued setbacks in the development of A.S.V. Mark VIB were not clear-cut. Undoubtedly at that stage of the war everyone connected with design, development and production had many projects other than A.S.V. with which to contend, and all requirements were urgent and of high priority. Even before the initial phases of design were completed difficulties were encountered, for drawing offices had obvious limitations in space and the number of qualified draughtsmen available, and could only cope with a specific amount of work at any one time. The completion of trial installations, and therefore the whole process of development and manufacture, was consequently adversely affected. As with signals traffic there was prevalent a tendency to increase the priority of everything, so making priority ineffective. The speed of development was governed by the speed at which components were made available and without them development was mainly only theoretical; for instance, one limiting factor in airborne radar was the occasional non-availability of preferred types of magnetron valves.

On 27 July 1944, the Director of Radar informed Sir Robert Renwick and the Director General of Signals that he had never been able to obtain a clear statement of the probable date of introduction of A.S.V. Mark VIB into Service use, or of the factors which were contributing to the retardment of the programme and was therefore unable to supply the Commander-in-Chief with the information he had asked for. In order to clarify the position meetings attended by the directors of the various development and production branches concerned were held on 1, 16 and 24 August 1944.³

It transpired that completion of the development of the scanner Type 68 and the attenuator Type 58 posed the principal problem.³ Metropolitan Vickers, already heavily loaded with urgent work, were encountering a great deal of trouble in evolving and manufacturing a satisfactory wave-guide switch for the

¹ T.R.E. Monograph: 'A.S.V.'

² A.M. File C.S. 20338, Part II.

³ C.C. File S.14403/6.

scanner, and found it impossible to forecast when production could be started. T.R.E. scientists were giving the firm all the assistance they could to solve the problem, but they, too, were attempting to undertake a great volume of high-priority commitments. By 24 August seven scanners had been delivered to T.R.E. for type approval and endurance tests, but the completion of such tests would take an appreciable amount of time. Conditions were similar in the firm of B.T.H. where the attenuators were being developed and manufactured.¹ The firm was unable to give a reasonable estimate of the date on which production could be started ; making the device effective involved moulding polythene on a reactor ring to very critical tolerances and a satisfactory method of doing this had not been evolved. Efforts to find the correct answer were handicapped by the necessity to urge forward the development of 'Rugger Scrum,' an army radar equipment for giving early warning and some degree of fire control, which was a modification of A.I. Mark IX. But experience obtained with attenuators Type 53 emphasised that an improved version was an urgent necessity.²

As a result of the meetings various decisions were made. The firm of B.I. had found a method of overcoming the difficulties of making reactor rings, and had produced samples, about 70 per cent of which appeared to be satisfactory, for the R.P.U. It was decided that B.I. should make the rings for both B.T.H. and R.P.U. attenuators Type 58, and the employment of any other contractors that could help was authorised. By this means it was hoped to manufacture 30 complete attenuators on a crash programme during October 1944.

For some months the changing trend of the war had caused oversea operational requirements to increase in importance and had enlarged and complicated the scope of A.S.V. installation programmes, for it was no longer sufficient to study primarily the needs of home-based squadrons. Amongst other plans, squadrons in the Mediterranean Allied Air Force, in addition to squadrons of Coastal Command, were to be re-armed with Warwick V aircraft equipped with A.S.V. VIB, and a trial installation had originally been requested in January 1944.³ It had then been hoped that Wellington XIV and Warwick V aircraft would be equipped with the equipment on the aircraft production lines from September 1944 onwards, the Wellington installations having the higher priority. In August the projected Warwick trial installation, for which no drawings had been made, was given priority over that of the Wellington, the drawings for which had been nearly completed, and arrangements made for Warwicks to be fitted on the production line only ; no retrospective installations were to be made. The output of equipped Warwicks was expected to begin in January 1945 when installation of A.S.V. Mark VIB on the production lines was also anticipated. The initial output of Warwicks was earmarked for M.A.A.F.

The prospect of obtaining 30 A.S.V. Mark VIA installations in October was considered to be reasonably bright, and the Commander-in-Chief, Coastal Command was informed that, from that month onwards, as an interim measure until A.S.V. Mark VIB installation could be started, 30 Wellingtons per month would be equipped with A.S.V. Mark VIA incorporating attenuator Type 58. The Commander-in-Chief accepted the proposal whilst pointing out that the attenuator always had been an essential part of the installation. Work on the

¹ Waveguides were essential because of the high power used, and the high power made a satisfactory design of attenuator far from easy.

² A.M. File C.S. 20338, Part II.

³ A.M. File C.S. 20338.

Sunderland A.S.V. Mark VIC trial installation was almost completed, and it was confidently hoped that installation on the production lines would begin before the end of 1944.

Meanwhile, however, serious trouble had been experienced with A.S.V. Mark VI installations; several instances of fire breaking out in the modulator Type 158, used also in Marks VIA and B, had occurred when supplied with power from the Type UKX generator with which Wellington and Warwick aircraft were fitted. The fire danger, but not the risk of continual breakdowns, was eliminated at the end of August 1944 by repositioning certain insulating materials in the modulator. A suitable generator, Type UO, could not be made available from production before March 1945, and it was proposed to the Commander-in-Chief that the A.S.V. Mark VIA and VIB programmes should be deferred until that month. A suggestion that Wellingtons might be equipped with A.S.V. Mark VIIIA to tide over the period between October and March was put to him, but the C.-in-C. turned it down because it would be against the policy that American A.S.V. should not be installed in British aircraft and because A.S.V. Mark VIIIA provided neither lock-and-follow nor attenuator facilities, and could not be installed concurrently with the Mark II Low Level bombsight and Leigh Light controls. He was prepared to accept the risk of frequent modulator breakdowns with A.S.V. Mark VI, since, if an adequate number of spare modulators was supplied, the lower standard of reliability would not have an excessively adverse effect on operations and because the only existing alternative was the grounding of all aircraft equipped with it. He urged that an immediate solution to the power supply problem should be treated as a matter of the greatest urgency. By the middle of September an experimental installation of one method of overcoming the faults had been satisfactorily flight tested at the T.R.E., and arrangements were made to introduce the modification of No. 32 M.U. as an immediate measure, both retrospectively and in future aircraft installations of A.S.V. Mark VI and A.S.V. Mark VIA. A second and preferable method was made the subject of extended flight trials with a view to its adoption for A.S.V. Mark VIB until Type UO generators were available or as an alternative to them.¹ The modulator, too, was re-designed and was produced as Type 158A from the end of September 1944, by which time the determined efforts made to clear the major faults of the scanner Type 68 had also met with success.

In January 1945 Headquarters Coastal Command proposed, and the Air Staff agreed, that the seven Wellington squadrons of the command should retain their aircraft rather than re-arm with Warwicks as had been planned in order that an efficient medium-range force might be provided during the ensuing six months; re-arming would inevitably have involved taking aircraft away from operations at a critical point in the war against U-boats. The Wellingtons were to be equipped with A.S.V. Mark VIA and the one squadron that had been re-armed, No. 179, with A.S.V. Mark VIB, as and when the equipments became available. Wellingtons and Warwicks were still being fitted with A.S.V. Mark II on the production lines, but the former were being fitted retrospectively with A.S.V. Mark VIA by No. 32 M.U. at the rate of 18 per month, and it was estimated that at the end of April 1945 Coastal Command

¹ In place of the UKX generator two Type O generators were adapted to drive a motor generator Type 4. (A.M. File C.S. 20338, Part II.)

would have approximately 50 A.S.V. Mark VI and 60 A.S.V. Mark VIA installations in Wellington XIV aircraft. The replacement of the A.S.V. Mark III Warwicks of No. 179 Squadron with production line aircraft equipped with A.S.V. Mark VIB when they became available could only be a gradual process. To accelerate the change-over, arrangements were made to allocate a proportion of the initial output by diverting them from M.A.A.F. who were to receive instead the A.S.V. Mark III aircraft withdrawn from No. 179 Squadron.¹

By the end of January 1945, 89 attenuators Type 58 had been produced but since they had not been used operationally it was not known if they were satisfactory. Another 16 had passed the B.T.H. tests but had been recalled by the firm because trouble was being experienced with the polythene mould resonator ring made by B.I. When they eventually reached the Service it was discovered that the attenuators could not be incorporated in A.S.V. installations until their containers had been re-fabricated, and accurate setting up was difficult in Service conditions. In the following months the operational value of attenuators was re-considered in relation to past experience and in particular to the change in U-boat tactics made possible by *Schnorchel*. Past experience was inconclusive because of the technical limitations of the Type 53 and because it was far from certain that U-boat crews had maintained a search receiver watch. Against *Schnorchel* A.S.V. range was so small that a decrease in power could not be borne, and if search receivers were used U-boats could receive ample warning of the presence of aircraft before an attenuator could be brought into use. In view therefore of its lack of effectiveness against *Schnorchel* and of the production and servicing difficulties that were entailed, the requirement for attenuator Type 58 was cancelled in February 1945, but 200 were held in reserve against a possible change in the tactical situation whilst Service trials at the Air/Sea Warfare Development Unit were continued on low priority. Production of attenuators in the U.S.A. had for some time been continued only to meet the requirements of the R.A.F., and this too was brought to an end. Further development for use with future Marks of A.S.V. was continued in case U-boats at some time reverted to surfaced tactics but, as with the trials, on low priority only.²

When the war with Germany ended on 8 May 1945, the first of the Warwicks to be equipped with A.S.V. Mark VIB had just been delivered to No. 179 Squadron; three Wellington squadrons were using A.S.V. Mark VI, three A.S.V. Mark VIA and one A.S.V. Mark III³. The Sunderland squadrons were 'armed' mainly with Mark III aircraft equipped with A.S.V. Mark IIIC, although Nos. 228 and 461 squadrons had received a few Mark V aircraft equipped with A.S.V. VIC.⁴ Nos. 58 and 502 Halifax M.R. Squadrons were using A.S.V. Mark IIIB, Nos. 220 and 311 Liberator Squadrons A.S.V. Mark VA in which attenuators were being incorporated, and the remainder of the Liberator squadrons A.S.V. Mark X.⁵ Three Catalina squadrons were equipped with A.S.V. Mark VIIIA,⁶ and both long range and standard versions of A.S.V. Mark II were in service with the Halifaxes, Fortresses, Warwicks I, Hudsons and Sea Otters of the meteorological and air/sea rescue squadrons.

¹ A.M. File C.S. 20338, Part I.

² A.H.B./IIK/85/87/(B).

³ Nos. 14, 36, 304 Squadrons, and Nos. 172, 407, 612 Squadrons, No. 524 Squadron.

⁴ Nos. 10, 201, 228, 330, 422, 423, and 461 Squadrons.

⁵ Nos. 53, 59, 86, 120, 206, 224 and 547 Squadrons.

⁶ Nos. 202, 210 and 333 Squadrons.

THE PROBLEM OF THE SUBMERGED SUBMARINE

Although Coastal Command operations in the last two weeks of August 1943 were hampered by an increase in the activity of German aircraft and by spells of bad flying weather, the Vice-Chief of the Naval Staff was able to report that ' . . . shipping losses during August 1943 were the lowest since November 1941, and for the first time more U-boats had been sunk by the Allies than had been Allied merchant ships by U-boats. . . .'¹ Failure of the tactics of group sailing and remaining on the surface to engage aircraft with anti-aircraft fire caused the U-boat Command to revert in the autumn to the policy of making the passage of the Bay of Biscay whilst submerged. U-boats surfaced only at night and then for the absolute minimum time in which batteries could be charged; an average of three hours, often in one-hourly periods, in every 24 hours. During that period of 24 hours a U-boat was able to cover between 80 and 100 miles. Thus the chances of obtaining sightings were considerably reduced, and the importance of effective A.S.V. search and target illumination during the hours of darkness notably increased. In consequence of the changed tactics Coastal Command had its first experience of extensive, sustained, and concentrated winter night search throughout the winter months of 1943/1944. Previous winter night offensives were not comparable; in 1941/1942 aircraft were not equipped with effective illuminants and 1942/1943 search receivers had given U-boats temporary ascendancy over A.S.V. aircraft. In view of the size of the air force employed and the number of U-boats estimated to be making the Bay passage the results were extremely disappointing. The estimations were based both on information obtained from radio intelligence and on inference from observed cycles of U-boat activity in operational areas. During the quarter October, November, and December 1943 there were sighted at night only about 25 to 30 per cent of the number which was expected on the basis of the estimated traffic, the amount of flying, and the width of path swept by A.S.V.

Viking Trials

Even when allowances had been made for the use by U-boats of radar and *Naxos*, and for factors such as operator fatigue and the effects of sea returns on centimetric A.S.V. presentation, the efficiency of night search was obviously low. At first the assumptions that the U-boat Command had abandoned the normal transit routes and had concentrated on the route through Spanish territorial waters, and that all disappearing contacts were caused by the use of search receivers and U-boat radar, were accepted, but thorough investigation by the Coastal Command Operational Research Section revealed that undoubtedly other factors were also responsible and would have to be eliminated before the projected landings in Normandy took place. Accordingly, in January 1944, a submarine, H.M.S. *Viking*, was allocated to Coastal Command

¹ Minutes of War Cabinet Anti-U-boat Warfare Committee, 8 September 1943.

by the Admiralty for employment in special trials undertaken for the purpose of uncovering faults in air search technique. The submarine, equipped with radar, cruised at will within an area of some 1,250 square miles whilst aircraft fitted with A.S.V. Marks III and V, some with Leigh Lights, were released from operational squadrons in order to endeavour to sight it; the submarine used its radar to plot the movements of aircraft in its vicinity. From analysis of the *Viking* radar log and pilots reports, and with knowledge of the performance to be expected from A.S.V., it was possible to determine how many contacts should have been obtained by the aircraft.¹ The number of contacts actually made was about what was expected, but a large proportion did not lead to the sightings that should have been obtained and were classified by the aircrews as disappearing contacts. These instances, investigation revealed, could be attributed not only to operator fatigue and the effect of sea returns, which could be remedied by shorter watches and the provision of sea return eliminators but also to inefficient A.S.V. operating and homing.

The Training Problem—Aircrew

It was evident that the standard of aircrew training had fallen considerably and in January 1944 the Commander-in-Chief Coastal Command addressed a letter on the subject to all of his squadron and station commanders who were in any way directly concerned with the anti-U-boat campaign.² In it he stated that ' . . . the year 1943 has seen the repulse and defeat of the enemy's main U-boat effort, an effort which, if it had succeeded, would have destroyed all hopes of invasion of the Continent during the coming year. In this defeat Coastal Command played a prominent part. . . . Our shipping losses have averaged just under 300,000 tons per month during 1943 as compared with 700,000 tons per month in 1942, and we may fairly claim to be masters of the situation. The result of all this has been to induce, if not a feeling of complacency, at least an inevitable tendency to slacken off after the heavy strain of the previous year. This tendency is not fully apparent and is largely unconscious, but it does take the form of a feeling which is very widespread at all levels, from aircrew to headquarters staff, that now the U-boat is defeated there is little more for Coastal Command to do but mark time and await the hour when we are transported to other tasks and climes. It is to correct this impression that I am writing to you. The appalling losses sustained by the enemy during the summer have inevitably produced a considerable lowering, both in efficiency and morale, amongst U-boat crews; but the latter is certainly not broken, and with the present and possibly temporary policy of the German High Command, which is conditioned by one main principle—to avoid serious losses—it will not be broken except by two things—the military defeat of Germany or another crushing defeat of the U-boats on the high seas. As a result of the enemy's policy of extreme caution coupled with the disinclination of U-boat commanders to press home their attacks, not only have shipping losses been satisfactorily low, but the number of U-boats destroyed has fallen off disappointingly; only about 5 or 6 were destroyed in December despite the fact that there were as many U-boats at sea as in previous months. Despite our low shipping losses it is nevertheless clear, both from the public statements of German leaders and the dispositions of U-boats at sea, that the enemy may

¹ A.I.C. No. 172.

² C.-in-C./124. 23 January 1944. Coastal Command O.R.B.

still hope to stage a big enough come-back to threaten the success of the Second Front, though his hopes of ultimate victory by means of his U-boat offensive must have greatly receded. The factors to be taken into consideration are :—

- (a) The number of operational U-boats in existence at the end of 1943 is at least as high as at the beginning of 1943, despite the losses sustained during the year. There are approximately 60 at sea in the North Atlantic at present with as many more immediately available in reserve.
- (b) The enemy has introduced a number of new weapons, such as the acoustic torpedo, with which he claims, and genuinely believes he has achieved, great success against escorting forces. (He has greatly exaggerated the successes which he has in fact achieved.) This will at least serve to bolster his morale.
- (c) An increased use is being made of radar counter-measures, as for example, search receivers and radar decoys such as the *Aphrodite* balloon.
- (d) The enemy is still improving his anti-aircraft equipment.
- (e) The enemy has very considerably strengthened his long range air reconnaissance squadrons operating from the Biscay coast. With *Junker 290s*, *Heinkel 177s*, *Bu. 222s* it is clearly his intention to locate, report and shadow our convoys—thereafter to assemble his U-boats in an attacking concentration without having to subject them to the risks of air attack during assembly as would be inevitable if shadowing were left to U-boats as heretofore.

A possible conclusion is that all these measures are due solely to the necessity of keeping the U-boat fleet in being not only to contain our anti-U-boat forces, but above all because the overt abandonment of the U-boat war would be a shattering blow to German morale. Nevertheless it would be risky to base our plans on such an assumption, and we have no choice but to conclude that within the limits mentioned above :—

- (a) The enemy, even while persevering with his cautious tactics, may hope to achieve a somewhat greater success in the way of sinkings than in the last two months without exposing his U-boats to excessive losses and his crews' morale to heavy blows.
- (b) He will be in a position at a critical moment in Second Front operations to make a final vicious effort to interfere with our Atlantic communications at a moment when every ship crossing the Atlantic will count.

There is no doubt that the enemy will make a supreme effort with all weapons, whether they be rockets or U-boats, to disrupt our invasion preparations, especially at the moment when first landings are being made. If this is so, and the enemy throws caution to the winds, Coastal Command may yet have its greatest test and its supreme opportunity in the coming months. If we can make our greatest killing and finally shatter the U-boat crews' morale, Coastal Command will have played a decisive part in the final breaking of the enemy's will to resist.

I realise how soul-destroying it is to fly the ocean day after day and night after night only to draw blank. We inevitably incline to the belief that there is nothing there to sight ; but with so many U-boats at sea that cannot be true. No U-boat can remain submerged for ever and I am convinced that we are not taking full advantage of every opportunity presented to us. The fewer our chances of sighting, the more vital is the need that no opportunity shall be missed. You have the finest radar equipment in the world BUT are you using it to the best advantage? I want all you squadron commanders to institute a real " radar drive " in your squadrons and ensure that every one of your W.O.Ms., W.OP./A.G.s and navigators becomes 100 per cent efficient. Do not be satisfied with a contact at 10 or 12 miles, find out why you did not get it at 20 miles—keep your own squadron record book and beat up the duds. Make sure you complete your training task conscientiously each month and for the time being put the highest priority and the greatest emphasis on radar. During the first half of this month, out of 31 sightings, **all but 2 were the result of radar contacts**—that speaks for itself. This does not mean that navigation, bombing and gunning should be neglected, but we have had more experience of these subjects than we have of radar, and radar is our trump card. If we are to get only a few sightings, then we must make certain of killing those few U-boats, and in a night attack you will seldom be given the opportunity of making a second run.

Although this letter is marked " Most Secret " I want station and squadron commanders to bring these facts to the attention of all concerned, particularly of the operational aircrew who gave us the victory in 1943 and I know can be relied upon to give us an even greater victory in 1944 if the occasion presents itself. . . . Provided that we bring the same qualities to bear as before and improve our skill to the maximum extent with the improved weapons in our hands, we need have no cause for anxiety. . . .'

The problems of A.S.V. homing and target illumination were more intricate than had perhaps been generally realised, and more intensive night training was essential. Although provision had been made for advanced and tactical training in bombing and gunnery by establishing in each group of Coastal Command an armament practice camp to which all crews were sent periodically for refresher training and instruction on the most recent developments, there was no corresponding organisation to meet the requirements for A.S.V. and target illumination.¹ To some extent this was due to the persistent lack of an adequate number of the necessary installations. In addition to the operational training units a radar training section, consisting of three Wellington aircraft and a small staff, had been established at Chivenor. This section not only undertook the initial training of No. 172 Squadron and all other squadrons as they were re-equipped first with A.S.V. Mark III and later with A.S.V. Mark VI, but also that of replacement crews as they arrived from O.T.U.s where the required A.S.V. could not be provided for those units. Squadrons were taken off operations in order to undergo intensive night training before D-day, and the formation of a Radar and Leigh Light Training Unit was planned. In September 1944, however, Headquarters Coastal Command reluctantly decided that at that time, such a project, entailing essential increases in establishment of aircraft, crews, and instructors, and the provision

¹ C.C. File S.7451, Part II.

of an airfield with an adjacent flying boat base, was too ambitious in the prevailing circumstances. Command commitments were already heavy, and every available aircraft and all available personnel were required for operations. The plans that had been prepared were therefore held in abeyance for post-war discussion.¹

Improvement of Servicing

The shortage of equipment and instructors had also adversely affected the standard of training of servicing personnel. Consequently, in September 1943, Headquarters Coastal Command established a special independent group of trained and experienced maintenance personnel, known as the Central Maintenance Group, as a central pool from which experts could be despatched to squadrons when an urgent need arose. The group was divided into two parties, the Central Repair and Investigation Party, and the Mobile Crash Party. The first party was equipped with a standard radar workshop fitted out as a sub-laboratory, with suitable power supplies and test gear to enable complete repairs and investigations to be undertaken, and to facilitate routine calibration of all squadron test gear, thus ensuring one standard throughout the command. The terms of reference were :—

- (a) Checking, repair and overhaul of all squadron test gear.
- (b) Furnishing of latest technical information on all radar installations.
- (c) Prototype introduction of circuit modifications.
- (d) Compilation of modification pamphlets.
- (e) Investigation of squadron maintenance or modification suggestions.
- (f) Repair, in emergency, of equipments returned as being beyond unit capacity to repair.

The second party was equipped with a fast utility type of vehicle fitted out to carry three technicians and suitable test gear. Its terms of reference were :—

- (a) Assistance to squadrons on introduction of new installations.
- (b) Routine checks of squadron test equipment.
- (c) Assistance as requested for emergency measures or when problems beyond unit solution demanded expert guidance.
- (d) Investigation of squadron maintenance, servicing and daily inspection routines, and advice and suggestions for improvement.

The shortage of radar mechanics persisted, and the standard of servicing suffered. Early in 1945 T.R.E. scientists began an investigation of servicing methods and conducted experiments to discover how A.S.V. performance in the Service compared with the theoretical maximum performance of which an A.S.V. installation was capable. A combined team of T.R.E. and Coastal Command investigators spent about six weeks at Chivenor whilst they examined thoroughly the A.S.V. Mark VI installation in several aircraft. They found that, on an average, performance was much below that which could be obtained by careful tuning and adjustment, and that performance of some installations was considerably below the expected maximum ; against a small target such as *Schnorchel* the reduction was equivalent to reducing the effective range by as

¹ C.C. File S.7451.

much as 70 per cent. It was also found that the use of a standard target for purpose of alignment, or of tuning, or of performance comparison, was very misleading, for the responses received were so subject to variation that it was impossible to obtain any degree of constancy in the standards set. Also, the judgment of performance was difficult, for a variation in performance might have had little effect on the size of a large echo at short range, whilst effect on a small echo at longer range might have been disastrous. Consequently, when examining the large responses usually obtained from the normal standard target, a loss of performance sufficient to make an installation useless at long ranges might not have been discerned. A new method of assessing performance was worked out and instituted in all squadrons equipped with the A.S.V. Marks III and VI series.

The investigation also revealed that almost all of the loss of performance in an A.S.V. installation could be traced to the T.R. box. This was in accordance with theory since the principal factors governing performance were transmitter output, transmitter feeder and aerial efficiency, receiver feeder and aerial efficiency, and receiver signal to noise ratio. The efficiency of aerial and feeder systems could not be altered to any great extent. The receiver signal to noise ratio was determined almost entirely in the first stage of reception; the crystal detector in the T.R. box. Methods of adjusting T.R. boxes to obtain the best possible performance were evolved. The most common cause of defective performance was the condition of crystals, a high percentage being unserviceable even before use because they had been exposed to intense R.F. fields which damaged them. Specially screened wrappings and boxes were therefore devised. It was found that by paying sufficient attention to the checking of performance, and the subsequent tuning and adjustment of A.S.V. equipment, it was possible to improve the performance of all A.S.V. installations to very nearly that which the investigators were able to obtain from any one installation, which was close to the maximum of which the installation was capable.

During April and May 1945 experiments to decide whether daily inspections of airborne radar installations were beneficial were conducted at Chivenor, and it was decided that they served no useful purpose. In fact, the incidence of unserviceability was slightly less when daily inspections were not performed than when the full routine inspections were undertaken. In view of those findings, and the serious shortage of radar mechanics, routine daily and between-flight inspections were discontinued.¹

Increased Responsibility of A.S.V. Operator

However, even when the introduction of new servicing technique tended to increase and standardise the attainable performance, differences in the skill of individual radar operators affected the relative search efficiency of aircraft A.S.V. installations, and investigations revealed that if 15 per cent of the least skilled operators had been eliminated by an adequate test before being trained as radar operators, the overall search efficiency of squadrons would have been increased by some 20 per cent.² Operators of below average skill did not improve with operational experience as had been hoped; it had become evident that more careful selection was necessary before training was begun.

¹ C.C. File S.7451.

² C.C.O.R.S. Report No. 331, 14 February 1945.

In the spring of 1944 the Commander-in-Chief informed the Air Ministry of the urgent need for raising the standard of wireless operators (air) in Coastal Command.¹ The introduction of more advanced and complicated radar equipment, and the problems created by the German use of *Schnorchel*, had emphasised more than ever the need for competent operators if the anti-U-boat campaign was to be successfully prosecuted and if the full benefits of the new equipment were to be realised. *Ad hoc* measures had improved the standard of proficiency, but the Commander-in-Chief stressed the urgency of the need for a much higher mental and educational standard for operators, and thought that perhaps a university degree might be made an essential qualification. He did not propose that all the sub-standard wireless operators should be weeded out *en bloc* and replaced by men of a higher calibre, but rather that the change should be made by a gradual replacement at normal wastage rates; a long-term policy that would affect not only Coastal Command but also squadrons employed in the maritime role in oversea commands.

The Air Staff supported his views, and agreed that even if it were practicable it would be a mistake at that stage of the war, in May 1944, to attempt to replace large numbers of operators who, although not up to the required standard, were nevertheless experienced. In Bomber Command H2S was operated by the navigator, and the opinion of the Air Staff was that the responsibility of the Coastal Command wireless operator (air) was akin to that of the Bomber Command navigator. In order to be efficient, he had to show mental agility and the ability to interpret A.S.V. indications quickly and accurately. It was doubted whether the possession of academic qualifications was essential, although experience with A.I. operators had shown that a high academic standard resulted in increased proficiency. The Director General of Signals suggested that in view of the increased responsibility of A.S.V. operators, and the obvious need for a higher standard, a new aircrew category of higher status than wireless operator was required. It was proposed that navigator (W) cadets who had completed a course at the Radio School, Cranwell, but had not yet begun their navigation training, and a small percentage, about 10 to 15 per cent, of the operators already in Coastal Command, might well form the nucleus of the new category. Volunteers who were available for aircrew training within the R.A.F. manpower allotment were classified according to their suitability and aptitude, and those in the highest classification were reserved for pilot, navigator and bomb-aimer training. Introduction of the new aircrew status involved augmenting considerably the size of the intake into the top classification, and this could only be accomplished by relaxing the standard in order to include the best men normally placed in a lower category.

Consequently, on 21 June 1944, the Air Member for Personnel held a conference at the Air Ministry to consider the implications of introducing a new aircrew category tentatively known as Radar Operator (Air).² It was generally agreed that a higher standard of operator was required in Coastal Command, but the necessity for a new aircrew category was questionable. It was thought that better material, coupled with proper and careful selection for A.S.V. aptitude, which hitherto had not been attempted, might meet the requirement until the status and qualifications of aircrew in general were reviewed, and action to this end was taken.

¹ A.H.B./ID/12/99. Coastal Command Organisation.

² A.H.B./ID/12/99.

A.S.V. Bombsights

The Viking trials revealed that many of the failures to convert radar contacts into attacks were due to systematic errors in the final approach to the target. They were due to insufficient allowance being made for relative drift. Frequently a blip was obtained and action taken to home on it, sight, and attack the U-boat, but the aircraft was flown to the wrong spot and nothing was seen in the Leigh Light beam.¹ A radar bombsight became an important operational requirement. The development of ranging and homing devices to enable A.S.V. to be used throughout the sequence of an attack had been started early in the war by the A.M.R.E., where the importance of linking A.S.V. location with A.S.V. bombing had been quickly recognised.

Mark I A.S.V. Bombsight

The first instrument to be developed, the Mark I A.S.V. Bombsight, was taken over by the C.C.D.U. for Service trials in May 1941.² With it the line of approach was maintained in the normal manner, the initial stage with A.S.V. and the final stage visually, but ranging was semi-automatic. Bombs could be automatically released at a distance from the target appropriate to a pre-set height.³ The bombsight was installed in a Wellington, a Beaufort and a Whitley, and the average results of the trials were assessed as 300 feet in line error and 150 feet in range error against stationary targets from 600 feet.⁴ Six models were manufactured for operational employment by the Ship Interception Unit of No. 217 Squadron, but because crews could not be kept together long enough to ensure adequate training, use of the bombsight was abandoned, and in April 1942, became obsolete.⁵

Mark II A.S.V. Bombsight

During the course of the trials of the Mark I, a Mark II prototype was installed in a Wellington of an operational squadron; another instance of an attempt to find a short cut by omitting Service trials. With the Mark II, ranging was fully automatic, and a strobed spot indicator was used for determining the line of approach and drift correction. It involved a slight modification to A.S.V. Mark II and the addition of a strobe unit. Reports of results obtained on operational sorties could not be accepted as truly indicative of its potential performance, but in November 1941 the Air/Sea Interception Committee formed a special sub-committee to study, amongst other torpedo-attack problems, the application of the Mark II A.S.V. bombsight to torpedo launching, for which accurate measurement of large angles in azimuth was more important than range measurement. Torpedo attacks against surface vessels normally involved operations in areas within the range of the enemy early warning radar system, and consequently strike sorties were flown at very low level, about 20 to 50 feet above the sea, to escape detection. At such heights A.S.V. Mark II was, of course, not very effective for search. Trials of the sight in this role were delayed

¹ The tactic of Constant Bearing Approach, in which allowance was made for target and wind velocities, was introduced by Headquarters Coastal Command to take the place of the Curve of Pursuit method used hitherto. (C.C. File S.7451.)

² S.I.C. 11.

³ A calibrating unit and an electronic stop-watch were used in conjunction with A.S.V. Mark II.

⁴ C.C. File S.7010/10/6.

⁵ S.I.C. 25.

because only one model had been made, and both it and the aircraft in which it was installed were seriously damaged by enemy action. It was expected that against a ship taking evasive action, the line error would be 600 feet and the range error 210 feet ; there was, however, a possibility of hits being obtained with a stick of bombs.¹ In January 1942 orders were placed for three Mark II sights to be manufactured and installed in Wellingtons. The effectiveness of both Mark I and Mark II depended on the accuracy of homing with A.S.V. Mark II, and this was lessened by the differential fading which occurred at the crucial stage of the final approach because there was too much space between the two homing Yagis.² The T.R.E. embodied a closing-speed computer in one of the sights and fitted close-spaced Yagis to the aircraft in which it was installed, and in September 1942 trials were conducted against a 120-ton trawler. Indicator spot jitter prevented allowance for drift being made accurately, and the trials showed that the sight was of no practical use against a vessel smaller than a destroyer, and was therefore of no value in the anti-U-boat campaign, mainly because of the inherent limitations of metric A.S.V. Further development and manufacture of the Mark II A.S.V. bombsight were abandoned in December 1942, and work on the design of a centimetric A.S.V. bombsight was begun, but on very low priority ; it was intended that the bombsight project should not be allowed to interfere with the development of the main A.S.V. equipment.

Mark III and Mark IV A.S.V. Bombsights³

The Mark III A.S.V. bombsight was an integral part of A.S.V. Mark VIA. With it the target signal was strobed ; this permitted the scanner to be locked on it and automatically held. Presentation to the pilot was achieved by means of two pointers on the dial of one meter, one showing range and the other azimuth. It was necessary to start the bombing run at a range of 5 miles and at as low an altitude as possible to make slant range nearly equal to ground range. Accuracy decreased above 500 feet. The Mark IV A.S.V. bombsight was an experimental attempt, eventually abandoned, to lock on a signal without locking the scanner in order to do away with the weight of the scanner locking mechanism.⁴

AN/APQ5 and AN/APQ5B Bombsights

With the introduction of A.S.V. Mark III into operational use in the spring of 1943, the early provision of a bombsight for use against U-boats became more important, and it was decided that development and manufacture could more effectively be undertaken in the U.S.A. The operational requirement, and the experience gained with metric A.S.V. bombsights, were stated by the British Air Commission, and by September 1943 development models of a low altitude bombsight AN/A.P.Q.5 had been completed. It was designed for use in conjunction with AN/A.P.S.15 and a Norden bombsight, and required no modification to the A.S.V. equipment other than installation of a potentiometer on the scanner for azimuth synchronisation of the display. Since AN/A.P.S.15 had been designed with this end in view, and included the necessary cabling,

¹ S.I.C. 30.

² Determined by dimensions of fuselage, engine nacelles and propeller 'discs.'

³ For details of the Mark V A.S.V. bombsight, see Appendix No. 14.

⁴ A.M. File C.28968/46.

this was not difficult, and the Norden sight was already a fitting in all Liberator GRV aircraft. Two prototype installations were completed, and a Royal Air Force crew conducted successful trials in the region of the Bahamas in September 1943; both aircraft were flown to the United Kingdom for C.C.D.U. trials at the end of the year. AN/A.P.Q.5 computed relative drift, and for set heights and bomb or depth charge characteristics, calculated the release range. After initial A.S.V. contact, the A.S.V. operator switched to sector scan and directed the pilot towards the target. The bomb-aimer took over as soon as the blip appeared on his separate indicator, and manually adjusted a range marker to coincide with it. He then switched to a 'track' function of the sight by means of which his display represented 1 mile in length centred about the range-marker, or target, the whole moving at the ground-speed pre-set on the instrument. If the speed had been set correctly the target remained co-incident with the range-marker; if not, re-adjustment of the ground-speed control corrected the computer. The bomb-aimer kept the target centred in azimuth by adjusting a control connected to the automatic pilot which made the necessary correction in course, and he thus controlled the aircraft during the bombing approach. As range closed to half a mile from the release point a bombing marker moved up from the bottom of the screen. When the two markers joined, release was automatically effected.¹

When, at the beginning of 1944, the urgency of the need for an A.S.V. bombsight became apparent, recommendations were made by the Air Ministry that AN/APQ 5 should be installed, at centres in the United Kingdom or in the U.S.A., in all Coastal Command Liberators equipped with A.S.V. Mark X. Thereafter the installation policy vacillated, as the urgency of the needs in different theatres of war was considered. In the spring of 1944 priority was given to installation in two Liberator squadrons for operations in the Far East; if performance of the sight fulfilled expectations another four squadrons of A.C.S.E.A. were to be equipped, primarily for use against surface vessels. Within a short space of time however it became obvious that the number of equipments that could be made available before 1945 was very small, and the Air Staff decided to wait until a realistic estimate of quantity and dates could be authoritatively stated before making a final decision as the tactical situation was in a state of flux.

Meanwhile the original design of AN/APQ 5 was undergoing the normal processes of improvement as experience was gained, and production in quantity of the modified version AN/APQ 5B was expected to begin in July 1944. In that month the British Air Commission was informed by the Ministry of Aircraft Production that the existing location of the sight in Liberator VI aircraft was not satisfactory and was unacceptable for operational squadrons; the bombsight caused congestion in the nose compartment in which was situated the navigator station. The AN/APQ 5B equipment, therefore, was to be installed only in Liberators in which the crew station layout was revised with the navigator on the flight deck and the wireless operator on the command deck.² The American authorities considered the changes to be essential in all aircraft equipped with A.S.V. Mark X, and made special arrangements to modify all such aircraft during the remainder of 1944. After modification,

¹ T.R.E. Monograph: 'A.S.V.'

² In July 1944 general installation of AN/APQ 5 in Liberators allotted to the R.A.F. had not been started.

the nomenclature of the aircraft was changed from Liberator Mark VI to Liberator Mark VIII. By early 1945 the entire output of Liberators would, it was estimated, be equipped with A.S.V. Mark X.

The Air Ministry had intended to allot to Coastal Command Liberator VI aircraft equipped with A.S.V. Mark X, and to A.C.S.E.A. those with A.S.V. Mark V, all equipped with A.S.V. bombsights. The new conditions again complicated the situation. Only 35 Liberator VIII fitted with AN/APQ 5B were expected to be available for the Royal Air Force between November 1944 and January 1945. After February 1945 an entirely new version of the Liberator, equipped with A.S.V. Mark X and AN/APQ 5B, but otherwise differing considerably from the Marks VI and VIII aircraft, was expected to become available in large numbers. The need for the bombsight for use against U-boats had become an urgent requirement in Coastal Command by the summer of 1944. The scientific and technical facilities in the United Kingdom were more suited for overcoming the teething difficulties of new equipment than the limited facilities available in A.C.S.E.A. where the sight was required mainly for use against surface vessels. Consequently, the Air Staff decided to allocate to Coastal Command all the output of 35 except four, two of which were to go to A.C.S.E.A. and two to the training establishment at Nassau for familiarisation and training purposes.

The programme was not fulfilled according to plan, and delivery from modification centres was retarded. The B.A.C. attributed this to the usual delay in the production of the equipment itself, the vacillating policy of allocation, and the decision that Liberators VI fitted with the sight were not acceptable. The Air Ministry decided to equip retrospectively in the United Kingdom all Liberator VIII aircraft which were received, if the AN/APQ 5B equipments, test gear, ground trainers, operating and servicing instructions could be obtained. In August 1944 however the B.A.C. advised that shipment of the equipment which was then available would seriously prejudice the fitting of aircraft at modification centres. The B.A.C. considered that the extent of modification required made it highly inadvisable to attempt an installation programme outside the centres.

In September 1944 the situation again changed. The prospect of obtaining Liberators VIII already equipped with the bombsight by the end of 1944 had brightened considerably, and the original estimate of 35 had been increased to 52. It was also apparent that the new type of Liberator (Liberator B24K) could not be introduced until some appreciable time after the forecast date of February 1945 and deliveries of Liberators Mark VIII were expected to continue until June 1945. The Air Staff consequently planned to 'arm' one A.C.S.E.A. squadron with the completely equipped Liberator VIII aircraft. By October 1944 however, it had become clear that in spite of endeavours by the B.A.C. to increase the speed of provision, the major part of the winter anti-U-boat battle would be finished before squadrons were equipped with and trained in the use of AN/APQ 5B.

Eventually the Liberator VIII AN/APQ 5B prototype arrived in the United Kingdom on 30 November 1944 and was flown to the C.C.D.U. for Service trials. At the Ministry of Aircraft Production the Directorate for Production of Canadian and American aircraft had planned for the delivery of 40 equipped aircraft to Coastal Command in February 1945. At the beginning of the year

they had a stock of 29 aircraft not fitted with AN/APQ 5B and had received only six aircraft in which the installation had been completed. The planned delivery was therefore impossible, and four factors likely to delay it further were :—

- (a) The contractors had not had an opportunity of assessing the difference between unequipped Liberator VIII aircraft and those in which the installation had been made in so far as the standard range of modifications was affected.
- (b) The modification standard to which Liberator VIII aircraft were prepared had increased considerably since the programme was initiated. To install AN/APQ 5B involved three major modifications for which the services of skilled electricians were essential.
- (c) A number of skilled electricians had recently been called up for the Forces under the National Service Act and the Ministry of Labour was unable to supply contractors with replacements ; a serious shortage of skilled labour existed.
- (d) Bad weather had held up the ferrying of modified aircraft.

A further complication was likely to arise because Liberators were being manufactured by the Ford company in 1945, instead of by the Consolidated company, and although of the same dimensions, the aircraft differed in structure, detailed construction and wiring. The D.P.C.A. contractors for their part were fully aware of the urgency of the commitment and were making every effort to turn out as many aircraft as possible in the very difficult conditions which prevailed.

Meanwhile, the Service trials conducted by the C.C.D.U. were successfully completed. By March 1945 two squadrons of Coastal Command were equipped with AN/APQ 5B and began training. As a result of recommendations made by the Air/Sea Warfare Development Unit, the training consisted of five hours ground instruction followed by five hours of air practices during which 30 bombs were dropped.¹ No. 206 Squadron made its first attack with the bomb-sight after an A.S.V. contact on 3 April 1945, and No. 547 Squadron on 6 May 1945.² The squadrons were employed on operations against shipping and U-boats in the Kattegat and the Baltic, and did not obtain experience against *Schnorchel* in the short time available. Of 14 assessed attacks made against surfaced U-boats only two resulted in any apparent damage, and although insufficient conclusive evidence could be obtained, the poor results seemed to be caused largely by range errors.

A staff officer of Headquarters Coastal Command who accompanied No. 206 Squadron on operations reported that ' . . . The main reasons for lack of good results were the unusual conditions under which the squadrons were operating. The orders were to find and attack U-boats, and ships were to be attacked only if an aircraft had nearly reached the prudent limit of endurance and was starved for a U-boat attack. All targets were to be identified and the Leigh Light was to be switched on for this purpose. Because of this policy the great advantage of AN/APQ 5B in making feasible a complete surprise attack was

¹ A.S.W.D.U. Report No. 45/40. See Appendix No. 12 for notes on the formation of A.S.W.D.U.

² C.C.O.R.S. Report No. 366.

lost. . . . It was normal in the Kattegat and Skagerrak to have anywhere from 3 to 25 radar contacts on the screen at any one time, and naturally the great proportion of these contacts were ships, and a lot of these ships were naval vessels. Crews were only able to make a shrewd guess at what they were homing to and those last 15 or 20 seconds with the Leigh Light on usually provided some surprise worthy of contributing generously to the bombing error. When a more formidable than hoped-for target was illuminated, the best defensive was certainly a strong offensive and therefore attacks were invariably pressed home. During the last few seconds of the run-in the bomber was probably not impervious to the gunfire, or to the running commentary and captain's orders. Nor would he be helped by changes of altitude which were to be expected in the usual run of circumstances. . . .'¹

It is probable that the changes, involving change of speed, were responsible for the range errors; that line errors were only about 40 yards indicated the potentialities of the bombsight. It was unfortunate that the bombsight was brought into service so late in the war, for many of the contacts on *Schnorchel*, both visual and A.S.V., which were obtained by Coastal Command aircraft might have been converted into attacks with a reasonable chance of success; without an A.S.V. bombsight and computer the blips were often lost before bombs or depth-charges could be dropped. Frequently blips were obtained when nothing could be seen visually even with the aid of the Leigh Light; these might well have been *Schnorchels* hidden amongst the waves.

Advent of *Schnorchel*

U-boat commanders adopted, after the autumn of 1943, a mode of existence which favoured survival rather than effective employment. In March 1944 the U-boat Command reported that ' . . . As the present radar interception gear cannot pick up all the location frequencies used by the enemy, or, because of technical inadequacy and damage to the aerials caused by sea impact, locations that are capable of being intercepted are not intercepted, sudden attacks by naval or air forces often occur without previous warning. It is therefore not surprising that with the constant danger of being attacked and the unreliability of radar interception, many boats, especially those with young inexperienced commanders, are purely defensive in their outlook. . . .'² German strategy was aimed at keeping the U-boat fleet in being until new types, Types XXI and XXVI, could be made ready for operations. Such U-boats, which were approaching operational status at the end of the war, would have been very effective because of their high submerged speed made possible by the new methods of propulsion. Meanwhile, it was the intention of the Germans to retain enough serviceable operational U-boats to make it necessary for the Allies to continue the employment in a maritime role of a large number of squadrons which otherwise might have been used against Germany in other roles. The Allies, however, were able to land in the United Kingdom sufficient troops and supplies to enable the liberation of Europe to be undertaken.

At the beginning of 1944, the Germans, awaiting the inevitable invasion, held their U-boats in readiness in the Biscay, Baltic and Norwegian ports. The lull in U-boat activity ended with the Allied landings in Normandy on 6 June 1944. The Allies appreciated that U-boats were a serious potential

¹ C.C.O.R.S. Report No. 336.

² Admiralty Translation P.G.30342.

threat to the success of the operation. The size of the U-boat fleet was such that mass attacks against the convoys in the English Channel from both flanks might have saturated the defences and inflicted severe losses during the critical days. Intensive air operations in the Channel, its approaches, and the Bay of Biscay area were conducted in addition to close support of the convoys. As soon as the landings began, the U-boats left their Biscay bases and the majority set up defensive patrols off the ports to counter possible invasion attempts in that area, and made no attempt to enter the Channel. When attacked by aircraft they remained on the surface and fought back with their much improved A/A armament. In the first five days six were sunk and five seriously damaged. After that surfaced tactics were abandoned and the *Schnorchel* phase began. By then, however, the beach-head was secure. Between mid-May 1944 and the end of July 1944, Coastal Command sank 23 U-boats, damaged 25, and shared the sinking of two more with surface craft.¹ During this period the Norway-based U-boats endeavoured to reinforce the Biscay U-boats, but very few got through to them; aircraft sank 17 and damaged 11 in Norwegian waters.

A.S.V. against *Schnorchel*

Schnorchel not only made U-boat location difficult, but when a *Schnorchel* U-boat was detected, the probability of an attack being successful was less than against a surfaced U-boat.² When the operational use of *Schnorchel* began, A.S.V. operators were ordered to use the smaller range-scales, such as that which extended only to 10 miles, since it was hoped that this would make it easier to detect the small targets. However, this meant in practice that contact ranges against many non-*Schnorchel* targets were limited to the range-scale in use. Consequently even those targets which were expected to cause a large blip at 10 miles were not picked up until they had got well inside that range. A possible reason was the 'slow' reaction time of operators; it was usual for a blip to be on the screen for about one minute before it was spotted. Also, operators tended to scan only the middle of the screen and contacts were lost because the outer edge of the P.P.I. was not given sufficient attention. Investigation revealed that when searching for a given type of target, a range scale about double the average range at which the target might be expected to produce a blip should be chosen.³

Visual search was relatively more productive than A.S.V. search during daylight hours as occasional sightings at relatively long ranges were made of the exhaust smoke that sometimes accompanied the use of *Schnorchel*. Increased stress was placed on the importance of binoculars for visual observation especially in view of the ease with which waterspouts could be mistaken for *Schnorchels* and the most favourable altitudes determined. Tactics were modified to take into account the decreased sweep widths of both A.S.V. and visual search, and during daylight the two methods of search were combined.

The Allies were not able to produce any really effective counter-measures to *Schnorchel* by the end of the war although they established that it could be detected by A.S.V. at a range of 4 or 5 miles in calm to moderate sea conditions,

¹ Thirty-one aircraft were lost through enemy action and 17 through other causes.

² *Schnorchelling* U-boats could dive much faster than fully surfaced U-boats, probably in about five seconds as opposed to 30 seconds. Consequently the proportion of attacks to sightings decreased.

³ C.C.O.R.S. Report No. 331.



Schnorchel in sea. View at short range, November 1944

but A.S.V. effectiveness was even further reduced in rougher seas because of the effect of sea returns. In theory, even such a small target as a *Schnorchel* should have been comparatively easy to detect, at considerable ranges, with high power A.S.V. on 10 or 3 centimetre wavelengths, but difficulty was encountered because the *Schnorchel* was almost invariably obscured by sea returns, and an increase of A.S.V. discrimination became a major requirement. Reduction in the amplitude of sea returns could be obtained by manipulation of the spinner elevation, but this required considerable skill and entailed a serious risk of losing the target. An attempt was made therefore to discriminate between sea returns which were transitory, and the comparatively stable returns from a target. To effect this a small differential box, known as a sea-returns discriminator, was plugged into the input of the indicator unit. It contained a simple 'time constant' filter which eliminated the higher frequencies, thus smoothing out clutter from sea returns and making it easier to distinguish a *Schnorchel* blip.¹

Because the number of A.S.V. contacts obtained against *Schnorchel* was small, there was insufficient data available to enable dogmatic comparisons of the various Marks of A.S.V. to be made.² At the end of November 1944 A.S.V. Mark X used in conjunction with the AN/APQ 5B bombsight was considered by Headquarters Coastal Command to be the most promising anti-*Schnorchel* equipment immediately available, but an increase in discrimination between the target and sea returns was required. The Air Ministry therefore instructed the Royal Air Force Delegation to request the U.S.A. Radiation Laboratory scientists to investigate the possibility of an improvement in performance being effected in AN/APS 15 for an anti-*Schnorchel* role. T.R.E. scientists were already tackling the problem with British A.S.V., and early reports indicated that they would be able to effect very considerable improvement. The methods adopted included not only the time constant circuit but also range stabilisation of the P.P.I. so that the target blip remained stationary whilst the sea return echoes moved; the use of either long afterglow or dual cathode ray tubes to integrate the signals from sea returns; the use of narrow beam widths, very short pulse lengths and wide band receivers; and the use of 1½ centimetre or K band equipment with 3 and 6 foot scanners.³ In the U.S.A., however, interest naturally was mainly focused on the 'offensive war' being waged in the Pacific, rather than on the 'defensive war' of the Atlantic.

Range trials, or even exercises, against *Schnorchel* targets, gave no indication of the relative merits of different Marks of A.S.V. for detecting *Schnorchel* on operational sorties. The essential difference between practices and operations was that in the former the operators knew that a contact was to be expected and A.S.V. operators accordingly adjusted the tilt of the scanner during a run-in. In operations this was not so, and the advantages of a narrow beam were to some extent nullified. The number of contacts made against surfaced or *Schnorchelling* U-boats was proportional not only to the path swept, based on operational detection ranges, but also on the efficiency of search. The latter depended on various factors including operator fatigue and the difficulty of distinguishing the target blip from sea-returns. The efficiency of contacting *Schnorchel* was about only 10 per cent compared with an efficiency of 50 per cent in contacting surfaced U-boats, even when full allowance had been made

¹ A.I.C. 159.

² C.C.O.R.S. Report No. 334.

³ A.H.B./I/K/85/87(B).

for the reduced ranges on *Schnorchel* and the increased percentage obscured by sea returns. The types of A.S.V. and aircraft which had the best performance against surfaced U-boats were not necessarily the most effective against *Schnorchel*.

The best operational results, both by day and night, were obtained by Wellingtons equipped with A.S.V. Mark VI and Warwicks with A.S.V. Mark III. The reason might have been that both aircraft had excellent lookout positions and were easily manoeuvrable, thus enabling contacts to be turned into sightings. But generally *Schnorchel* sightings could not be turned into attacks, and the utmost that could normally be accomplished was the marking of the point at which a sighting had been made so that closely co-operating surface craft could be brought in to attack. Operational results gave no indication of the superiority of 3-centimetre A.S.V. which had been expected because of its higher degree of definition. However, the fact that both A.S.V. Mark VIIIA and A.S.V. Mark X incorporated adjustable tilt control might have contributed to the disappointing performance, for the number of contacts obtained in the area immediately ahead of aircraft fitted with those installations was very low indeed, and could have been occasioned by the position of the scanner and incorrect adjustment of tilt.¹

The tactics employed by *Schnorchel* U-boats towards the end of the war involved practically no surfaced operations. With increasing experience in the use of *Schnorchel*, and awareness of their comparative immunity from attack, after January 1945 U-boat commanders showed a more offensive spirit. In transit, navigation was performed by dead reckoning, by radio fixes obtained from the chain of 'Elektra-Sonne' beacons, by echo sounder and by periscope bearings of lights or landmarks.² The usual methods of evading Allied attacks were by lying on the sea-bottom or by cruising at about 3 knots as silently as possible by using the electric motors. The *Schnorchel* enabled U-boats to operate once again, with comparative safety, in inshore areas which had previously been too dangerous for them on account of aircraft attacks. They could operate in such areas by remaining on the bottom most of the time and coming to *Schnorchel* depth to charge batteries.

Improvement of A.S.V.

Aircraft were robbed of the advantage hitherto conferred by A.S.V. and the onus of destroying U-boats fell on surface craft working in close co-operation with aircraft. With the advent of *Schnorchel* and its potentially severe threat, the existing organisation for research and development of A.S.V. underwent a radical change. Hitherto, responsibility for the improvement of both H2S and A.S.V. had been vested in the same division at the T.R.E. In January 1945 a Sea War division was formed. It consisted of two groups, one concerned with the urgent investigation of the possibility of modifying existing A.S.V. installations and of $1\frac{1}{4}$ -centimetre, or K band, A.S.V., and the other with the speedy development of high power 3-centimetre equipment to be known as A.S.V. Mark XVII.

A paper on the requirements for the development of A.S.V. was prepared as a basis for discussion at the T.R.E., by the Air Interception Committee, and

¹ The forward view of the scanner was obstructed by the nose of the aircraft.

² For details of the *Elektra-Sonne* system, see Royal Air Force Signals History, Volume VII: 'Radio Counter-Measures.'

by Headquarters Coastal Command staff officers. The command considered that basically three types of radar were required for maritime operations.¹ Classified in accordance with the type of operations for which they would be used they were :—

- (a) Anti-U-boat, and medium altitude anti-shipping, operations.
- (b) Fighter reconnaissance, fighter, and torpedo operations requiring both search and ranging facilities.
- (c) As for (b) but requiring ranging facilities only.

The basic requirements for the anti-U-boat and anti-shipping roles were the best possible detection range and target discrimination, and ability of an aircraft to attack effectively an unseen target. The installation was to be as small and as light as was compatible with maximum performance. Detailed requirements included :—

- (a) All round gapless cover. If this could not be provided, a 60 degree gap astern was permissible if, for anti-shipping aircraft, some form of tail warning were made possible. Beam ranges were of the utmost importance.
- (b) Presentation was to be P.P.I. with scan distortion correction and with facilities for the display to be stabilised to a heading or to north as required. A second P.P.I. was to be available to the navigator and its orientation was to be independent of that of the A.S.V. operator. Every effort was to be made to eliminate all parallax errors.
- (c) There was to be no gap in cover from minimum to maximum range.
- (d) Azimuth accuracy was not to be less than plus or minus one degree.
- (e) The maximum range on a target such as *Schnorchel* was to be as high as possible and sea returns were to be reduced to an absolute minimum. Target/sea return discrimination was to be the highest possible.
- (f) Complete stabilisation in elevation of the scanner was required so that the aerial system was unaffected by large changes in attitude of aircraft such as those encountered on long-range sorties and during an approach to attack.
- (g) Fully automatic blind bombing facilities including the use of a ' memory circuit ' to permit the bombing of U-boats which dived during a bombing run. The facilities were required for operations between 100 and 5,000 feet, and the mean radial error was to be less than 50 yards from 5,000 feet. It was of the utmost importance that the line error was kept at a minimum.
- (h) Facilities for homing to any type of transmission made by the enemy were to be incorporated although the frequency might be pre-set before flight.
- (j) Facilities for both ' on ' and ' off ' frequency beacons and radar approach aids were to be available.

¹ A.I.C. 184. A.H.B./IHK/85/88(A).

- (k) An efficient I.F.F. system was required and was to be such that it gave less warning to the enemy than did the use of the emissions of the main equipment. It was also to be capable of discriminating both in range and azimuth, and was to display the indication direct on the target echo on the P.P.I.
- (l) An attenuator for transmitter power was to be incorporated in such a way that receiver sensitivity was unaffected.
- (m) A computer was to be incorporated so that the velocity of a target relative to the aircraft could be quickly determined.
- (n) Facilities were to be available so that the range and bearing of any target could be displayed on a dial for the benefit of the pilot.
- (o) The range scales were to be variable so that they could be set up to obtain the maximum display for each type of target: U-boats, small ships, large ships, convoys and coastline.
- (p) It was desirable that the system should be capable of radiating on more than one wavelength in order to confuse enemy counter-measures.
- (q) Automatic warning of the presence of a contact was also desirable. If it were possible to divide the P.P.I. into sectors for this purpose, then the problem of detecting a second contact whilst the operator was concentrating on a previous contact might be solved.
- (r) The installation was to be fully tropicalised and capable of being operated at heights up to 10,000 feet. Particular attention was to be paid to waterproofing of equipment and cabling.
- (s) It was to be provided with daily inspection servicing points to enable units to be checked 'in situ,' and it was to be possible to connect a ground power supply without disturbing the aircraft power supply.
- (t) The whole installation was to be efficiently screened, and provision was to be made for supplying suppression pulses for external communication equipment.
- (u) It was to be possible to switch on and off frequently, at any normal altitude, H.T. supply for the modulator without detrimental effect on the installation.
- (v) Units of equipment were to be completely interchangeable irrespective of the number of contractors engaged in their manufacture.
- (w) The equipment was required to operate at all engine speeds met within normal Service use including range flying conditions. The power supply was to be so designed that the operation of other equipment in the aircraft did not affect the radar.
- (x) Automatic control was essential but provision for manual tuning by the A.S.V. operator was also required.
- (y) Equipment was to be so designed that it did not adversely affect to a marked degree the handling and performance of the aircraft in which it was installed.
- (z) The number of units was to be kept as low as possible, and they were to be designed with a view to ease of servicing with the minimum of special test gear.

Generally, T.R.E. scientists agreed with the broad proposals, and in particular liked the emphasis placed on simplicity, small number of units, and ease of servicing.¹ The design of British A.S.V. from Mark III onwards had suffered from drawbacks largely resulting from the original equipment being an adaptation of H2S. In the circumstances this had been unavoidable but they felt strongly that when a future design of A.S.V. was planned, the particular requirements of an installation associated with the maritime role should be kept in mind. The experts at the T.R.E. were convinced that the equipment could be made considerably less complicated and easier to service if it were intended for that role alone and if no attempt were made to duplicate its functions. Their main disagreement with the Coastal Command recommendations was with the proposals to use A.S.V. as a tail warning device and for homing to enemy transmissions. They also considered that any move to compromise simplicity and efficiency by the addition of such extra functions should be ruthlessly discarded. If tail warning were to be a firm requirement, it should be provided by some equipment other than the A.S.V. It certainly appeared attractive to be able to use the A.S.V. scanner for homing, but the existing technique did not permit wide-band working. The facilities for search with such a system would be extremely limited in wavelength cover, and the effectiveness of A.S.V. for search would be much reduced. Further comments were that performance should be of primary importance in heavy aircraft and that a decrease in weight of the equipment should only be made when it could be done without sacrifice of that performance. The amount of azimuth cover obtainable with A.S.V. was generally more dependent on the type of aircraft than on the equipment. If aircraft could be designed around A.S.V., the provision of all-round cover would be much simplified.

They were not convinced that scan distortion correction was essential, and thought that it would be cumbersome to have two displays stabilised, one to heading, the other to north; it would be quite easy to split two P.P.I. units, each including its own phases, and to have both stabilised to north. It was impossible to achieve the accuracy asked for from a P.P.I. T.R.E. experiments on the best form of display for detecting *Schnorchel* amongst sea returns indicated that a second display to the A.S.V. operator would be necessary, since when near a target he would want some form of expanded display, possibly range azimuth. It could be arranged that when the A.S.V. operator switched over to expanded display, the navigator would still retain his own P.P.I. presentation. The operational value of an attenuator was questionable; it added complication and could be a source of loss of power and efficiency.

The need for a computer other than that incorporated in the bombsight was doubted, and no justification for the extra complication involved in displaying range and bearing on a dial for the pilot could be seen. If it were done automatically the complication would be enormous, and if it were done simply from the A.S.V. operator's control setting it seemed hardly worth while. Operation on more than one wavelength could be achieved reasonably only by the inclusion of extra T.R. boxes, and in any event a loss of efficiency would arise through the compromise which would have to be made in the design of the wave-guide run and aerial system. If an automatic warning device was to be of any real value, a considerable complication of circuits would be involved, and even

¹ A.I.C. 189. 9 February 1945. A.H.B./I/K/85/88(A).

then would be likely to cause more harm than good by giving false warnings. The T.R.E. scientists were surprised that no mention had been made of the Leigh Light and pointed out that the facilities available in the blind bombing computer could provide the necessary data for the Leigh Light operator.

Headquarters Coastal Command accepted most of the T.R.E. comments, but emphasised that an urgent requirement existed for some equipment which would enable ships to be distinguished from other aircraft. If this were possible, it would be of great advantage if the facility could be incorporated in A.S.V.¹ In addition, anxiety was expressed that the possibility of an automatic warning device should not be too quickly discounted, as it would be of very considerable assistance in eliminating crew fatigue. The existing mechanical, as distinct from automatic, arrangements of providing the Leigh Light operator with data were considered to be adequate.

Meanwhile the Chief of the Air Staff had impressed upon the Ministry of Aircraft Production the seriousness of the *Schnorchel* threat to convoys, and informed the appropriate research, development and production branches of the urgency of the need for improved A.S.V. If the work involved in meeting the requirements were likely to have serious repercussions on the urgent needs of Bomber and South-East Asia Commands, the relative priorities were to be considered, and allocations made in accordance with operational needs.² It was generally felt that everything possible was being done, and in view of the complexity of the problem posed by *Schnorchel*, it did not necessarily mean that an increase of priority over H2S and A.G.L.T. development would ensure success. It was therefore considered that there was no justification for reducing the effort being applied to those developments.³

K-band A.S.V.

Apart from modification of existing equipments to effect an improvement in performance against *Schnorchel*, the production of new equipment operating on a wavelength of 1¼-centimetres, known as K band, was envisaged, on the assumption that its very short pulses and narrow beam width would give a very high ratio of target to sea return discrimination. Until December 1944 the only application of K band which had been proposed was the provision of sufficient H2S Mark VI equipments for one or two Lancaster squadrons and six Mosquito aircraft of the pathfinder force of Bomber Command, and 100 sets were being manufactured.⁴

Experimental A.S.V. equipments, with a power output of 20 to 30 kilowatts, were made up at the T.R.E. by adapting H2S Mark VI units, and were installed in a Warwick, a Lancaster and a Wellington. Several anti-*Schnorchel* trials were conducted during December 1944. The results were not outstandingly good; the maximum ranges obtained were 4½ to 5¾ miles in a calm sea, and 4½ miles, with sea returns of over 3 miles, in a moderate sea. Further development was abandoned in favour of that of high-power 3-centimetre equipment for the following reasons. The technique was new, and equipment would probably be unreliable for some time because of teething troubles. What few units were

¹ Minutes of 18th meeting Air Interception Committee, 15 March 1945.

² A.H.B./IIK/85/87(B).

³ A.G.L.T. was an airborne radar equipment used for automatic gun-laying.

⁴ A.H.B./IIK/85/87(B). See also Royal Air Force Signals History, Volume III: 'Aircraft Radio,' for details of H2S Mark VI and A.G.L.T.

available were already earmarked for the H2S Mark VI programme. Radiation on K band was more readily absorbed by the atmosphere; absorption and scattering because of rain were more pronounced on the shorter wavelengths and were the cause of a great deal of trouble during the experiments. It had not been fully appreciated that sea returns on the $1\frac{1}{4}$ -centimetre wavelength would be greater than those on the 3-centimetre wavelength, or X band, and that this would offset any advantage to be gained by narrower beam width.¹

A.S.V. Mark XVII

An attempt was made to increase the power output of 3-centimetre A.S.V. to that of A.S.V. Mark VI—200 kilowatts—and the development was given the nomenclature A.S.V. Mark XVII. A T.R. unit, incorporating a magnetron then in small scale hand-made production, MX52, was developed, but only 120 kilowatts output power could be achieved. For the scanner system a large mirror with an aperture of 3 feet 6 inches by 2 feet 3 inches was designed to obtain more gain and increased discrimination against sea returns. The Warwick GRV was selected as the type of aircraft to be fitted with A.S.V. Mark XVII. The installation interfered with the beam of the Leigh Light, but Headquarters Coastal Command accepted the drawback. A much greater difficulty lay in the fact that it was necessary to design and build a deeper nacelle to house the mirror.² The other units were adapted from A.S.V. Marks XI and XIII.³ Provisioning for a crash production programme of 100 equipments was initiated in January 1945, and Vickers anticipated delivering the first modified aircraft at the end of March or early in April 1945. The firm planned to modify a production line aircraft and to produce 29 modification kits. However, it was foreseen that if modifications of the power supply system and the fitting of a larger nacelle were to be undertaken in the Service, considerable difficulty and delay would be encountered, for it was necessary partially to re-build the aircraft. Consequently, in March 1945, arrangements were made for modifications and aircraft fittings to be incorporated on the production line; sufficient aircraft to equip one squadron, No. 179, with wastage, were required by June 1945.

Although a great deal of work was put into the A.S.V. Mark XVII programme, both at the T.R.E. and at the contractors, unforeseen difficulties in the production of a suitable magnetron were encountered, and A.S.V. Mark XVII was not ready for operational use when the war with Germany ended.⁴ During June 1945 an experimental A.S.V. Mark XVII installation was, with A.S.V. Mark VIA, A.S.V. Mark X, and H2S Mark VI installations, used for special and extensive ground anti-*Schnorchel* tests at Llandudno.⁵ The main fact to emerge from the trials was that it was very difficult to detect *Schnorchel* in any sea conditions

¹ T.R.E. Monograph 'A.S.V.'

² A.H.B./IIE/116. *Schnorchel* and A.S.V. Mark XVII.

³ 3-centimetre installations developed for the Fleet Air Arm.

⁴ A.H.B./IIK/92/1.

⁵ A.H.B./IIK/85/88(A). A.S.V. Mark X was used to try out the several modifications designed for the improvement of A.S.V. against *Schnorchel*. They included short time constant, instantaneous automatic gain control, swept gain (gain varying with range), and offset expanded sector scan. Swept gain was, theoretically, set so that the sea returns at any range could only reach a fixed amplitude less than saturation, and thereby allowed the wanted signal to be seen above them. Offset expanded sector scan spread out sea returns which normally were crowded together in the centre of a P.P.I.; the arc from the wanted signal was also stretched, making it easier to see among the generally more rapidly varying sea returns. (T.R.E. Report T.1882.)

other than calm, and that in rough seas it was impossible. With the introduction of anti-radar protective covering on the *Schnorchel* head, detection of U-boats, except when they were surfaced, would be impossible. However, the best possible use had to be made of existing A.S.V. technique, and the most promising development appeared to be that followed with A.S.V. Mark XVII. The incorporation of refinements such as a stabilised scanner, B Scope presentation and sector scan for search and homing and P.P.I. for navigation, range stabilisation and the highest possible pulse recurrence frequency, would enable the performance to be improved.¹ Although A.S.V. Mark XVII was produced too late for the war against Germany, much valuable experience for the future design of A.S.V. had been gained.²

Use of Buoys against Submerged U-boats

Schnorchel had its disadvantages. The offensive power of U-boats was reduced as they lost the mobility of surfaced operations for the relatively low speed of *Schnorchel* operations. The efficiency of the periscope watch was impaired when the boat was at *Schnorchel* depth, and the noise of the engines rendered hydrophones practically useless; *Schnorchelling* U-boats could be detected by surface vessels without being able to listen-out themselves. The noise output of a *Schnorchelling* U-boat was high, and towards the end of the war advantage was taken of it by the use of sono-buoys, one of the several means, other than A.S.V., developed by the Allies to enable U-boats to be attacked. The possibilities of using such devices as a means of detecting submerged submarines were investigated on the introduction of *Schnorchel*.

Early Operational Requirements for Marker Buoys

In May 1941 Headquarters Coastal Command had requested that consideration should be given to the possibility of providing a device for the detection of submerged submarines. It was suggested that it could be in the form of either a directional microphone or an asdic fitted in a buoy which could be dropped from an aircraft in a manner similar to that employed for an A.S.V. marker buoy, later to be known as Wirebasket, then being developed.³ It was thought that the directional microphone, giving bearings only, would be simple to develop and produce, whilst the asdic device, giving both bearing and range, would take longer. The only other method being considered at that time was then known as the Magnetic Detection of Submarines (M.D.S.) and later as the Magnetic Anomaly Detector, which had been given trials during the past few months. Unfortunately, it did not provide a range of more than 200 feet against a submerged submarine, and was therefore of limited tactical value.

It had been realised early in the war that great advantages would accrue to anti-U-boat air operations if the area in which a U-boat had been located and forced to submerge could be patrolled continuously until it was compelled to re-surface in order to recharge batteries. A hunt to exhaustion was normally beyond the resources of Coastal Command, however, and the lack of effective illuminants and radio altimeters made continuous night patrols impracticable. Proposals for sea-marker devices which would facilitate homing of relieving

¹ A.H.B./I/K/85/88(A). Sector scan and increased pulse recurrence frequency enlarged the number of pulses on a target in any given time interval and improved the chances of seeing it, particularly as the signal in any but a very calm sea faded quite rapidly.

² See Table No. 11.

³ A.H.B./I/K/12/54/5(A). Operational Requirements—R.D.F. Development.

aircraft had been put forward in 1940, but at the Air Ministry it was decided that for various technical reasons the probable results would not justify the amount of effort which would have to be expended in the development of such a device.¹ It was considered that an asdic buoy would be a bulky and heavy equipment necessitating special apparatus to prevent it from revolving and to keep it on a definite azimuth bearing. Estimations indicated that its range would not exceed $1\frac{1}{2}$ miles, so that a submerged submarine could quickly be clear of it; within 20 minutes if its speed were 6 knots. A contact would therefore require to be attacked quickly, or a large number of buoys would have to be dropped in the area, an impracticable proposition. Experience showed, however, that one of the more serious limitations to air/sea co-operation in the location and hunting of U-boats was the speed of the escort vessels, and a device was required to bridge the time interval between the initial aircraft sighting and the arrival of surface craft.

In May 1941, because all resources in the United Kingdom were fully employed, the Ministry of Aircraft Production informed the Central Scientific Office at Washington of the problem and the requirement for an acoustic buoy. Professor P. M. S. Blackett thought that the Bell Laboratories would not find development difficult and suggested to them certain lines along which it could be undertaken. He considered that the buoy should be stowable in the standard bomb racks of an aircraft and should be as light and as small as possible with, as an upper limit, the size and weight of a 500 pound anti-submarine bomb. Release from low altitudes, 50 to 200 feet, should be possible at speeds up to 170 knots; a parachute was required to reduce the speed of entry into the water. The buoy, when floating on the surface, could be rotated slowly and continuously by a small screw or paddle. The sound picked up by the directional microphone fitted to it could be amplified and transmitted by radio from a low power transmitter and aerial to an aircraft. The range of reception needed to be only 5 to 10 miles. The buoy could be fitted with a magnetic compass which would allow a radio signal to be given automatically when the microphone reception director was pointing to a cardinal point of the compass, say north. Then the bearing of the source of the sound relative to the buoy could be determined by the time between the north signal and the maximum signal. By the autumn of 1941 design and development of an acoustic buoy had been started in the U.S.A., and radio sono-buoys were in production by May 1943.

‘High Tea’ Radio Sono-buoy

Radio sono-buoys, known as High Tea, were first used by the Americans in conjunction with their Mine Mark XXIV,² to obtain information regarding the results of attacks with the mine and to obtain data on which to develop the most effective tactical use of it. High Tea equipment comprised two main items: an expendable buoy³ and an airborne receiver.⁴ The buoy, a limited quantity of which could be carried in an aircraft, contained a compact, battery-operated, frequency-modulated radio transmitter. It was designed so that it

¹ A.H.B./IHK/12/54/5(A).

² The Mark XXIV airborne mine was designed to home on a submerged submarine. Its effectiveness depended greatly on the height and speed at which it was dropped, and the angle at which it entered the water. Its homing ranges depended on the depth and speed of the submarine.

³ Known in the U.S.A. as A.N./C.R.T. 1 and 1A.

⁴ Known in the U.S.A. as A.N./ARR. 3.

could be parachuted from an aircraft through the flare chute, and, on impact with the water, release a hydrophone which was suspended about 20 feet below the surface of the sea. Sounds picked up by the hydrophone were amplified and transmitted by the buoy, which had a lifetime of three hours before scuttling itself. As a number of different frequency channels were made available it was possible to use a number of buoys simultaneously. The airborne receiver picked up the signals at ranges up to 10 miles. Direction finding facilities were not incorporated in High Tea.

Headquarters Coastal Command made High Tea an operational requirement in June 1943, when a quantity sufficient to equip 18 Liberators was requested. Through the good offices of the naval staff of the American Embassy, 24 receivers and 146 buoys were made available for trials in July 1943. The C.C.D.U. began Service trials in August 1943, using a Liberator.¹ The submarine taking part submerged to a depth of 70 feet at a distance of 1,500 yards from the buoy, cruised for 27 minutes at 4 knots, and surfaced at the same distance from the opposite side of the buoy. Analysis of the log maintained by the observer in the aircraft revealed that the beat of the submarine's propeller shaft was always clearly distinguishable, in spite of extraneous noises thought to be caused by water lapping against the buoy, and could be received at ranges up to 9 miles when flying at 200-300 feet. The trials revealed that ranges fluctuated considerably from day to day, and in rough seas were appreciably less than in calm seas. The fluctuation was considered to be caused to some degree by changes in the position of a buoy relative to the submarine, since louder signals were received when the submarine was 'head on' to the buoy. Also, it was found that receiver operators could not maintain watch efficiently for spells longer than half an hour, as they became tired and were inclined to imagine engine noises when none existed. In September 1943 the requirement was enlarged to enable one Halifax and six Liberator squadrons to be equipped and receivers were installed in Halifax and Wellington aircraft for trials.

However, great difficulty was experienced in obtaining further supplies because American production was inadequate to meet all commitments, and the progress of installation and additional trials was necessarily slow. They did indicate that the Wellington was less suitable than the Halifax and Liberator for sono-buoy operations because the high noise level of the aircraft made reception difficult. It was also found possible to improve the aerial system in all three types of aircraft. Originally the aerial projected obliquely from the underside of the aircraft into the slipstream of one engine. It was too long to be placed in position when the aircraft was on the ground, and during flight the slipstream made locking difficult. Eventually the aerial was re-positioned so that it projected vertically from the top of the aircraft. Meanwhile extensive trials, attended by officers of Coastal Command, were conducted in Florida. They confirmed that sono-buoys not only enabled aircraft to identify doubtful A.S.V. contacts, and oil slicks, as being of submarine origin, but also made it possible for them either to track submerged submarines whilst homing other aircraft or surface vessels, or to attack if carrying a Mark XXIV mine. In the latter instance the sono-buoy technique required a high standard of training. It was essential to estimate the position of the U-boat quickly and accurately enough to be within the limits of the homing ranges of the mine, since the time

¹ C.C. File S.14141/15.

involved in laying additional buoys could allow the U-boat to reach a depth and maintain a speed at which it would be safe from the mine. A great advantage of this form of attack was that High Tea also enabled the aircraft to ascertain whether or not the submarine was still under way after the explosion.

The difficulties of supply had not been overcome by April 1944, when the possibility of production being started in the United Kingdom was mooted by the Aircraft Anti-U-boat Warfare Committee. At that time, however, the addition of yet another production programme would obviously be very problematical, and even if begun would yield no results for at least one year.¹ The most recent requirement submitted to the United States had been for 450 receivers and 3,500 buoys, and it was still hoped that they might be made available during May 1944. In that crucial month the Commander-in-Chief, Coastal Command, requested Sir Robert Renwick and Admiral Stark, U.S.N., to urge the appropriate authorities in the United States to hasten and to increase supplies for employment in home waters.² No buoys or receivers had been allocated to Coastal Command since the original delivery in June 1943; what remained of them were being conserved for future operational use and training had come to a standstill. At the end of May 1944 a steady stream of supplies, which continued throughout the year, began to arrive. Exercises were conducted during July and August in order to develop tactics and to take full advantage of American experience, and to train aircrews to differentiate the multiple noises emitted by the transmitters.³ The results obtained were encouraging, although in some instances aircraft failed to extend the sono-buoy pattern sufficiently early to be effective. Reception ranges varied considerably according to the state of the sea, target speed and depth, condition of buoys, and difference in noise output of the submarines, but average ranges for various sea states were established.⁴

Between June 1944 and December 1944 sono-buoys were dropped operationally by Coastal Command aircraft on 118 recorded occasions; 13 were classified as positive, 8 possibly positive and 97 as negative. Too many were dropped when circumstances were such that chances of success were negligible, and too few when there was either evidence or likelihood of the presence of a U-boat. Frequently only one buoy was used against a suspected target, an inadequate measure at any time; experience and trials showed that a minimum basic pattern of five buoys was essential.⁵ A standard pattern consisting of one buoy at each corner of a square of sides 3 miles in length and one in the centre, as near as possible to the noise origin, was recommended. It was considered that when a positive contact was obtained, it was necessary to divert, as quickly as possible, other aircraft to the area to continue the hunt and to deliver an attack if the opportunity presented itself. Unfortunately an adequate sono-buoy log was not maintained by aircrews during this period, and a thorough analysis could not therefore be made. It was established however, that a U-boat cruising at periscope depth in 30–40 fathoms of water, when sea

¹ A.H.B./IIC/91/1(A). Minutes of 98th meeting.

² Coastal Command O.R.B, Appendix 146.

³ Gramophone records made in the United States had been used hitherto for basic training.

⁴ For instance, the average range obtained when seas were moderate and the submarine cruising at 3 knots at a depth of 100 feet was 750 yards. Extreme ranges varied from 90 yards against a target moving at 3 knots at a depth of 250 feet when seas were rough to 6,000 yards when its speed was 7 knots at a depth of 60 feet in calm seas.

⁵ C.C.O.R.S. Report No. 339.

conditions were calm, could be heard at a distance of 6,500 yards when its speed was 3 knots, and at 8,000 yards when it was 5 knots. In moderate or rough seas the ranges were reduced by one-half; when U-boat speed was below 3 knots the maximum range was 2,000–3,000 yards in calm seas and 1,000 yards in rough.

High Tea had not proved to be as effective as was hoped in area search. Attention was therefore given to its potentialities for convoy protection. It was proposed that sticks of sono-buoys should be laid continuously around a convoy by escorting aircraft which were to operate in conjunction with surface craft. Several drawbacks were apparent, chief amongst them being the considerable noise output of the convoys and surface escorts, the large number of aircraft required to lay sufficient buoys, and the lack of direction-finding facilities in the equipment. The sono-buoy technique had consequently not been used for close convoy protection when the war ended. Extensive trials were undertaken in Florida early in 1945 of a directional radio sonio buoy; the bearing of a submarine from the buoy was determined to within 10 degrees. Results indicated that, provided celerity was shown in all aspects of its use, the equipment would be of value against fast, submerged U-boats, but it could not be made available in time for use operationally by Coastal Command.

Sono-buoy Barrier

By the beginning of 1945 the inshore activities of *Schnorchelling* U-boats made the provision of acoustic barriers, and the necessary organisation for watching, tracking, and attacking any U-boat detected, an operational requirement.¹ The type of barrier that seemed to be most practical was one made with a line of moored radio sonio-buoys placed across a known U-boat route or harbour entrance; it was estimated that in average conditions there would be a 25 per cent chance of detecting a U-boat *Schnorchelling* through it, and in favourable conditions the chances would be more than 50 per cent. If a U-boat were likely to *Schnorchel* for about 60 per cent of its time on passage through the barrier, there was thought to be a better than 15 per cent chance, and sometimes a better than 30 per cent chance, of detection. Suitable patterns were calculated; the pattern and spacing were governed by factors other than purely acoustic ones, such as ability to discriminate between buoys transmitting on the same frequency, the interval between successive listening to any given buoy, and the availability of buoys and aircraft. The brief endurance of the High Tea expendable buoy made the maintenance of such a barrier impracticable; an endurance of three days was considered to be the optimum.² Two types of buoy were required, one for laying by surface vessels

¹ Aircraft Anti-U-boat Committee Paper ACAUB 45.

² In January 1945 the Commander-in-Chief Coastal Command submitted to the Admiralty a design for a long-life sono-buoy. The radio equipment of High Tea was to be installed in a buoy containing a power supply capable of maintaining it in continuous operation for a period of about three weeks. Because of its bulk the long-life buoy could only have been laid by surface craft, and it was proposed that it should be used in conjunction with booms to which it could be moored. The buoys were to be monitored by aircraft or surface vessels equipped with the appropriate receiver. An average hydrophone range of 1½ miles and radio range to aircraft of about 10 miles were expected. The first Service trials of the prototype were conducted at Portsmouth in February 1945, and it was found that modifications to reduce buoyancy and to eliminate noise caused by the contact of the sea with the casing were required. However, its performance was considered to be inferior to that of the three-day buoy, and in view of the fact that it would have to be removed from its moorings every three weeks for servicing and then moored again it offered no great advantages. No operational requirement was therefore submitted.

and one for dropping by aircraft.¹ The prototype of the airborne buoy was developed by using the transmitter and hydrophone of the High Tea buoy in conjunction with batteries which had a working life of 72 hours ; they were installed in a large watertight canister which incorporated a self-sinking device.² Because of its size and weight the buoy was parachuted from bomb carriers instead of flare chutes ; the parachute release gear operated automatically on impact. By May 1945 the first barrier had been successfully laid by aircraft. It was found that a high standard of training was necessary to monitor the barrier efficiently, since the employment of a large number of buoys made it difficult to locate any one in particular. No U-boats were detected and the war ended before further barriers could be laid.³

Wirebasket Marks I and II

The possibilities of a radio marker buoy were first discussed by the Air/Sea Interception Committee in October 1941 ; preliminary experiments undertaken by the C.C.D.U. had shown that a floating buoy fitted with an I.F.F. beacon could be used as a homer by aircraft equipped with A.S.V., and that such a buoy when dropped from an aircraft could act as a sea marker and datum point for search.⁴ Development work on the buoy, eventually known as Wirebasket Mark I, had been conducted by the R.A.E. during May 1941, when it had been found possible to include suitable apparatus in a cylinder, measuring 50 by 10½ inches and weighing about 150 pounds, which could be dropped from a standard bomb-rack. A small parachute with a static cord and an aerial mast, self-erecting after impact, were attached. The I.F.F. beacon was designed to operate for a period of at least 18 hours and a destructive charge was automatically fired after 24 hours. At the beginning of October 1941 trials were made of two buoys, one operating on a fixed wavelength and the other sweeping through a waveband. As a result the swept waveband buoy was considered to be more suitable for operational use, although its mechanism was unsatisfactory. It was ascertained that homing to such a buoy was not only practicable, but that ranges of 40 miles at 2,000 feet to over 50 miles at 4,000 feet would be possible. The Air/Sea Interception Committee decided that a self-destructive device was a requirement and that the sweep should not only be as rapid as possible but also irregular.

In January 1942 three modified buoys were sent by the R.A.E. to the C.C.D.U. for trials. Dropping tests were unsuccessful as the buoys were not sufficiently watertight but reasonably good results were obtained with one buoy which had been placed, and not dropped, in the sea. A development contract for 50 watertight buoys was placed with Vickers, and further trials in varying sea conditions were continued by the R.A.E. By May 1942 experience showed that serious operational limitations were imposed by the pitching and rolling of the buoys in a rough sea. On 28 May 1942 the Director of Communications Development recommended that the only practical way to provide stability and to improve performance lay in the development of a design based on that

¹ A.H.B./IVA/42/7.

² The complete buoy weighed 64 pounds.

³ In April 1945 a limited number of wire recorders were made available for use with sono-buoys. The recorder was used to record everything heard by the High Tea operator. When the recording was played back experienced personnel were able to assess the signals received and a permanent record was made. (H.Q.C.C., O.R.B., April 1945.)

⁴ A.H.B./IIE/33/1.

of the 500 pounds G.P. or A.S. bomb. At the same time, the Commander-in-Chief Coastal Command stated that, in view of the poor performance of Wirebasket, it was possible that the operational requirement would be cancelled. In July 1942 the Air/Sea Interception Committee decided that development should be continued, and that the question of requirements should be raised again when performance could be more accurately determined.¹

Throughout the remainder of 1942, and during 1943, work was continued, but teething troubles were numerous and the progress of development was retarded to such an extent that no estimate could be made of the date when production in quantity was likely to be started. No sooner were faults in the design of the casing cleared than a shortage of suitable valves occurred.² C.C.D.U. trials continued to produce unsatisfactory results, which in all instances were attributed to technical failures, and although the valve situation was eventually cleared by May 1944, when financial approval for 1,000 buoys had been obtained from the Treasury by the Air Ministry, further complications had meanwhile arisen with the transmitter and casing.³ An improved version, as a result of intensive modification, consisted of a light-weight buoy which could be launched from the flare chute of an aircraft; including the telescopic mast and stabiliser it weighed about 50 pounds. Its continuous transmissions on 176 and 214 megacycles per second could be received from a range of 20 miles at 3,000 feet, and it possessed a minimum endurance of 5 hours in a sea temperature of 5 degrees centigrade. In May 1944 Headquarters Coastal Command doubted the wisdom of proceeding further with the new version of Wirebasket however, and suggested that it might be possible to adapt the sono-buoy container which had already proved itself to be a simpler device. The suggestion was fully discussed at a meeting of the Air Interception Committee, and it was decided that whilst production of Wirebasket in its existing form should be requested, consideration should simultaneously be given to use of the sono-buoy container as an alternative.

Accordingly, in June 1944, another 35 buoys were sent to the C.C.D.U. for trials. 18 were dropped, of which 7 were successful, the failures being occasioned by faulty igniters. The Director of Radar was dubious of proceeding with further production unless about 80 per cent of the remaining buoys were dropped successfully, but the Director of Communications Development considered that incorporation of a new type of igniter would make the buoys effective. Trials were continued during July and August 1944, and by the end an overall operational efficiency of 90 per cent was obtained. Meanwhile the R.A.E. conducted trials of 25 specially modified buoys, of which only 5 failed to operate, and in August 1944 recommended that production in quantity should be undertaken once minor alterations to facilitate manufacture and reliability had been made.⁴ At the end of February 1945 deliveries from the main production programme began, and Service trials were undertaken by the Air/Sea Warfare Development Unit in April. 19 buoys were dropped, of which only 8 were satisfactory, and the ranges obtained from those were much less than those obtained in previous trials. Of the 11 failures, 10 were attributed to faulty igniters, and one to an incorrect launching. When

¹ A.H.B./II/69/173. S.I.C. 29.

² C.V. 93, the only suitable type, was being produced in small quantities only.

³ Eleven buoys in February 1944, and 38 in March 1944, were sent to the C.C.D.U. for trials.

⁴ C.C. File S.14408/9/1.

modified igniters had been received, the trials were continued, and 14 buoys were dropped, of which 10 were failures ; 7 were attributed to faulty sinker mast igniters and 3 to transmitter mast igniters. For the purpose of the trials not only A.S.V. Mark II but also Rebecca IIB, Lucero, and SCR 729 were used in the aircraft. The maximum range obtained was 9 miles at 5,000 feet with A.S.V. Mark II. The Air/Sea Warfare Development Unit considered that the tests were useful only to determine the cause of the decrease in ranges compared with those obtained with pre-production buoys ; the buoys were not acceptable for operational use.¹

The Director of Radar in May 1945 stated that in view of the abnormally long period of development required to bring Wirebasket to the production stage, and of the unusually protracted trials undertaken in attempts to clear the innumerable defects encountered in production, he felt that further production was unjustified unless a firm assurance could be given that the existing defects could be cleared immediately. On 4 June 1945 the Director of Communications Development reported that the A.S.W.D.U. trials had been made with buoys which were not fitted with the recommended type of detonator, and had not been tested at the factory with the specified type of test gear. As a result oscillator coils had not been adjusted to give maximum output and ranges had consequently been reduced. R.A.E. trials held in May 1945 produced more satisfactory results. Of 20 drops 16 were successful and ranges obtained with Lucero were about 6 miles at 1,000 feet and 9 miles at 3,000 feet. New manufacturing conditions were evolved and adequate ranges and reliability were expected.¹

In August 1944 the Air Ministry had requested the R.A.E. to re-design the buoy as Wirebasket Mark II, and a target date for main production in May 1945 was set. It was decided that the limitations imposed by the standard flare chute should be avoided, and Wirebasket Mark II was to be dropped from bomb racks. It was required for use in conjunction with A.S.V. Mark II, Lucero Mark II, and Rebecca Mark IIB, and the design allowed for provision of plug-in radio boxes capable of operation in different wavebands. Transmissions were to be uncoded, and although it was thought coded transmissions might be required in the future, the incorporation of coding facilities was not allowed to interfere with development of the main equipment. The ranges required in the specification were 20 miles at 3,000 feet and 40 miles at 5,000 feet.² Development had not been completed when the war with Germany ended.

AN/CRN I and MX 180A Buoys

The American marker buoy, AN/CRN I, used wireless transmissions instead of radar pulses, and possessed advantages over Wirebasket in that greater ranges were obtainable and the only aircraft equipment required for homing was a radio compass. A continuous wave signal, interrupted every 30 seconds by a code letter, was transmitted in the frequency band of 1,400 to 1,750 kilocycles per second, and the transmitter had an endurance of 12 hours after it had been switched on at a pre-set time by an automatic timing mechanism. In normal conditions its range extended to 50 miles. Two telescopic steel cases housed the equipment, and after immersion the outer case automatically

¹ A.H.B./IHK/85/87(C).

² A.H.B./IHK/85/87(A).

lowered itself to act as a stabilising keel. A soluble plug at the top of the casing enabled the buoy to scuttle itself after 50 to 60 hours immersion.¹ The dimensions of the buoy precluded launching from the flare chutes fitted to the majority of Coastal Command aircraft and necessitated release from bomb racks. A main disadvantage was that it could facilitate the homing of U-boats if dropped near a convoy. The Aircraft Anti-U-boat Committee in September 1944 suggested that it might be used as an interim measure until Wirebasket was available in quantity. In the same month Headquarters Coastal Command raised an operational requirement and requested the allotment of just under 5,000 buoys. At the same time an urgent operational requirement was stated for an initial allocation of 500 American radar reflector marker buoys MX 180A.²

In order to block any particular area and to prevent the passage of U-boats to and from their bases through that area, it was necessary for aircraft to fly continuous chain patrols across the area at calculated time intervals. This required very accurate navigation to ensure that the calculated tracks and time intervals were maintained by successive aircraft. That accuracy could only be maintained by the use of landmarks or of radar navigational systems such as Gee or Loran. In some areas, the Iceland-Faeroes passage for example, there were neither adequate radar navigational systems nor landmarks. Headquarters Coastal Command considered that in such areas the difficulty might be overcome by the employment of radar or W.T. marker buoys as navigation 'landmarks,' and recommended that sufficient AN/CRN I and MX 180A should be obtained in order that trials might be undertaken at the C.C.D.U.² Very promising reports on both equipments were received during the early stages of their development, but the prospects of securing any considerable quantity were not reassuring because of the active interest shown by the United States Navy authorities.

By the beginning of 1945 development work on the new I.F.F. Mark V system had been started in the U.S.A. by the Combined Research Group, who sought specifications for radar buoys.³ The Director of Radar recommended that endurance should be a maximum of 5 hours before automatic sinking; weight should be less than 20 pounds; dimensions should be suitable for launching from standard flare chute or alternatively from standard 250 pound bomb carriers; range should be from 10 miles at 500 feet to 40 miles at 5,000 feet. The Air Staff felt that ranges at the lower heights, and the endurance, should be greater, and that the research group should be given more latitude in the matter of dimensions, and were anxious that the new development should not interfere with development of AN/CRN I. In March 1945, however, the procurement orders for AN/CRN I were suspended pending its re-design after failures had occurred during its employment in American waters, and none of the developments had been completed by the end of the war.

Magnetic Anomaly Detector

A device for the magnetic detection of submarines was first developed by Professor E. J. Williams, and was based on the principle that when a coil passed through a magnetic field the current momentarily induced in the coil could be

¹ C.C. File S.14148.

² A.H.B./IHK/85/87(A).

³ A.H.B./IHK/85/87(B). See Royal Air Force Signals History, Volume V: 'Fighter Control and Interception,' for details of I.F.F. Mark V.

indicated on a galvanometer; when fitted in an aircraft and flown over the sea it might pass through the magnetic fields of a sunken wreck, or surface vessel, or a submerged submarine, the presence of which would be made known to the aircrew.

An experimental prototype, M.D.S. Mark I, was installed in a Sunderland in February 1941, and trials were conducted by the C.C.D.U. in February and March. The maximum range obtainable was 200 feet, the minimum range of the operational requirement. Although in April 1941 arrangements were made for a modified version, M.D.S. Mark II, to be installed by Shorts on the Sunderland production line, further development and installation were discontinued because of its limited tactical value.¹ However, in the spring of 1942, U-boats in transit through the Bay of Biscay were surfacing only at night, when lack of effective illuminants rendered A.S.V. ineffective, and interest in M.D.S. was revived, and M.D.S. Marks I and II were put into production. By May 1942 ten Whitleys of No. 502 Squadron had been equipped, some with Mark I and some with Mark II. Trials were conducted against a submarine off Dartmouth, but the results were unsatisfactory; further installation was abandoned although 40 Mark I and 60 Mark II equipments remained on order.² The advent of the Leigh Light and the subsequent success of A.S.V. caused interest in M.D.S. to lapse, and in September 1942 it was decided that no further development of magnetic detection devices should be undertaken in the United Kingdom.³

Development had been continued in the U.S.A. in 1941 both by the National Defence Research Committee, and at the Naval Ordnance and Bell Laboratories, but based on a different principle from that used for M.D.S.; the equipment, M.A.D., described variously as Magnetic Anti-Submarine Detector, Magnetic Airborne Detector, and Magnetic Anomaly Detector, consisted essentially of a very sensitive magnetometer with which the presence of submerged submarines⁴ could be detected by the anomaly or disturbance produced by their permanent and induced magnetism in the pattern of the earth's magnetic field. A detector head was installed in the tail of the aircraft, and comprised the detector and stabilising element. The latter, in conjunction with the electronic equipment and servo-motors, maintained the detector element in such a position that it always pointed along the direction of the earth's magnetic field. The electronic equipment, including an amplifier and a recorder, were situated in the navigator's compartment, and all contacts were recorded on a tape calibrated with a time-scale.⁵ Although contacts on wrecks, ships and rocks were recorded in addition to those on submarines, a certain amount of discrimination was obtained from the period and amplitude of a contact. The original M.A.D. equipment was installed in United States Navy blimps at the beginning of 1942, and after further development, in landplanes and Catalina flying boats. Ultimately the two development groups differed in their methods of overcoming a main difficulty, the magnetism of the aircraft itself. In one, eventually known as M.A.D. Mark VI, the magnetic field of the aircraft was compensated for by placing interconnected detector coils in the wing tips. In the other, later M.A.D.

¹ A.H.B. Narrative: 'The R.A.F. in Maritime War.'

² Minutes of 1st and 2nd meetings of Coastal Command Committee on Anti-U-boat Warfare.

³ Minutes of the 4th meeting of Coastal Command Committee on Anti-U-boat Warfare.

⁴ Also, naturally, wrecks and surface craft.

⁵ A.H.B./IHK/69/13. M.A.D. equipment. The units in the tail weighed about 35 pounds, and those in the navigator's compartment about 220 pounds.

Mark X, the detector coil was housed in a small streamlined non-magnetic housing and towed beneath the aircraft on a cable about 80 to 100 feet long.

In view of favourable reports received from the U.S.A., Headquarters Coastal Command requested the provision of two M.A.D. equipments for operational trials, and they were received in August 1942. Trials were then attempted with a Liberator installation, but were a failure because of the high degree of magnetism contained in the aircraft. An installation was therefore made in a Catalina. All the aircraft control cables, except the main rudder control, were replaced by non-magnetic cables for a distance of about 25 feet from the detector head, and the chain and sprocket driving the elevator trimming tab were replaced by a pulley and a non-magnetic cable system. Range depended on the amount of background disturbances produced by the pitching and rolling of the aircraft and the geological nature of the sea bottom, which contains magnetic material. In November 1942 an area of the Irish Sea was surveyed and found suitable for trials, although the background interference of the sea bed was two or three times as great as that expected from the Atlantic. On 29 and 30 November trials to determine the maximum range and the tactical value were conducted by the R.A.E. and C.C.D.U. against a 1,400-ton submarine.¹ As a result, it was reported that with M.A.D., even in its existing form, it was possible to shadow a submarine submerged to a depth of 300 to 400 feet for a long time ; to follow the course of a submarine accurately, and to indicate its course by means of flares on the surface of the sea ; and with a trained operator, to estimate approximately the depth of a submerged submarine, its position relative to the aircraft, and its speed. A main disadvantage was that M.A.D. was not effective in an area where the geological structure of the sea bed, or surrounding country if in narrow waters, was highly magnetic. Recommendations were made that the M.A.D. equipment, although known to be only an early development model, should be given further trials in an operational area such as Gibraltar, where the chances of encountering a U-boat were high. On 15 December 1942 the Air/Sea Interception Committee requested the Ministry of Aircraft Production to order a further six sets of similar equipment, and six sets of the latest type being developed in the U.S.A.

A second series of trials was begun in home waters on 27 December 1942, but after a few minutes the equipment became unserviceable, and after numerous attempts had been made to service the equipment locally it was found necessary to return the aircraft to its base. After repeated unsuccessful attempts, including replacement of major components, had been made to render the equipment serviceable, it was decided to remove the apparatus and return it to the R.A.E. The submarine allotted for the trials was of only 470 tons displacement, and during the short period when the equipment worked properly, effective range was found to be only about 200 feet. The C.-in.-C., Coastal Command, considered that further trials would not be justified at that stage because M.A.D. was very limited in its application ; was difficult to install, and involved replacement of various aircraft components by other parts made of non-magnetic material ; was fragile and difficult to service ; required extensive training in its use and the allocation of a submarine for that training ; and because the Catalina, suitably modified, was the only anti-U-boat aircraft in which M.A.D. could be installed. Consequently, after the Admiralty had discussed the

¹ A.H.B./IHK/69/13.

matter with Headquarters Coastal Command, the Secretary of State for Air informed the War Cabinet Anti-U-boat Warfare Committee in February 1943 that in view of the large amount of development required before M.A.D. could be used effectively in operations, and the considerable doubt about its efficacy in the future, the Air Ministry proposed to cancel orders for the existing type. Close liaison with development in the U.S.A. was to be maintained, and Headquarters Coastal Command was prepared to offer any facilities that might be required for trials of American aircraft fitted with later types of M.A.D.

During May 1943 trials of airborne radar and electrical anti-U-boat equipments were staged for several days at Key West, Florida, and included amongst them were sono-buoys and M.A.D. Mark VI. The latter was used in conjunction with M.A.B.S., a magnetic automatic bombsight.¹

The magnetic indication of a submerged submarine was momentary and occurred when the aircraft was almost directly above it. For effective attack, therefore, the usual method of release in which the dropped weapon retained forward momentum at the speed of the aircraft was useless. The M.A.B.S. was designed to be used in conjunction with explosive releases so that bombs and flares, known as retrobombs and retroflares, were propelled backwards at the same speed as that of the aircraft, and consequently dropped vertically. If a response were indicated in either of the two recorders attached to the wing-tip detector units, or in both but with differing intensity, a retroflare was released. If the indications in both recorders were equal, a stick of retrobombs was discharged. To provide a spread corresponding to that of a stick of conventional bombs, the retrobombs were shot out at various angles to fall in a pattern, and were made to explode on contact only. Trials had established the weight of 65 pounds as the optimum for the retrobombs, and 25 were carried as the normal load in a Catalina.¹ If, by use of M.A.D., the presence of a submerged submarine were suspected, a retroflare or smoke float was released. The aircraft then flew on a 'clover leaf' pattern course and released another on the next indication and continued until the growing line showed a definite track. When the track was firmly established the aircraft flew along it and fired a pattern of retrobombs either on M.A.D. indication or just ahead of the most recently released smoke float or flare. If the attack were unsuccessful, the hunt could be continued by other aircraft or by surface vessels.² If difficulty were experienced in obtaining the first indication, or if it were subsequently lost, expendable radio sono-buoys were used. This seemingly protracted procedure had certain very definite advantages.³ The U-boat commander would be ignorant of the fact that he had been detected until the contact bomb exploded. A fairly accurate and easily visible indication of a U-boat track was made of which surface craft could take full advantage. Disadvantages of the system against submerged submarines were that if the U-boat dived to below 400 feet it was outside detection range, and to obtain effective range it was necessary for the aircraft to fly below 100 feet, an impracticable proposition on long anti-U-boat sweeps over the open sea.⁴

After the Florida tests, Air Commodore A. F. Lang of the R.A.F. Delegation, reported to the Air Ministry that ' . . . the tests are the first of which we are

¹ A.H.B./IHK/69/13.

² M.A.D. aircraft operated singly or in pairs.

³ A.H.B. Narrative: 'The R.A.F. in Maritime War.'

⁴ It was of no use against a surfaced U-boat because of the U-boat's speed, its anti-aircraft armament, and the danger of the aircraft being hit by contact bomb fragments.

aware in which the M.A.D. equipment has shown any real promise as an aid in submarine killing operations, and it is noteworthy that it is only when this essentially short range submarine detecting device is used in conjunction with some sort of air position indicator,¹ sono-buoys, M.A.B.S., and sticks of retro-bombs, that encouraging operational results have been forthcoming. It is also to be noted that M.A.D. Mark VI equipment, which gives a certain amount of D/F indication, was used, without which the M.A.B.S. would be of very much less use . . .'.² The Director of Operations (Naval Co-operation) was asked to assess the value of the equipment with a view to installation in British aircraft, and in July 1943 suggested to the Director of Radar that, as No. 63 Squadron of the United States Navy, armed with amphibian Catalinas, which was to form part of the reinforcement of the Bay of Biscay operations in July 1943, was equipped with M.A.D. Mark VI, it would be advisable to await the results obtained on its sorties before introducing the equipment into Coastal Command.

M.A.D. was not, however, suitable for use on extended patrols in the deep and open waters of the outer bay. The squadron was transferred to the Moroccan Sea Frontier in January 1944, and immediately illustrated the full advantages bestowed by M.A.D. when used against submerged U-boats attempting to penetrate the Strait of Gibraltar.³ Three U-boats were sunk or shared with surface craft by mid-May 1944, and the block patrols maintained by the squadron were a major contribution to the decision made by Admiral Dönitz on 20 May 1944 to abandon attempts to reinforce the U-boat force in the Mediterranean because of the strong opposition encountered in the Strait. A conference was held at Headquarters Coastal Command on 16 January 1945 at which the Officer Commanding No. 63 Squadron described the tactical employment, limitations and operational performance of M.A.D. The main object of the meeting was to discuss in what areas of home waters M.A.D. could most profitably be employed. The Strait of Gibraltar had proved to be an ideal area for M.A.D. operations, and it was suggested that, as far as possible, employment of M.A.D. aircraft based in the United Kingdom should be confined to barrier patrols in a small area, and to follow-up searches after a sighting had been made. Various likely areas were discussed, but most of them were rejected because they were unsuitable geologically, were too large, or contained too many wrecks. Eventually a promising area, with a high degree of U-boat probability, in which surface vessels were experiencing poor asdic and hydrophone conditions, was selected, and a detachment of No. 63 Squadron was based at Upottery, Devonshire.⁴ Although not so successful as

¹ An odograph was used. It was a gyroscopically stabilised D.R. tracker which recorded the track of the aircraft. Corrections for wind speed and direction and for height were included.

² A.H.B./IHK/69/13. Trials of R.D.F. and Electrical Airborne Anti-Submarine Equipment, held at Key West, Florida, 17-22 May 1943.

³ A.H.B. Narrative: 'The R.A.F. in Maritime War.' In June 1944 United States Navy blimps equipped with M.A.D. were sent to the Moroccan Sea Frontier for the purpose of augmenting the barrier in the Strait of Gibraltar, but their efficacy on operations could not be determined because of the cessation of U-boat traffic. In trials, flying at 100 feet at an airspeed of 50 knots, they had shown a search efficiency of 90 per cent. At the end of October 1944 Admiral Stark, United States Navy, suggested to the War Cabinet Anti-U-boat Warfare Committee the possibility of employing blimps equipped with M.A.D. for detecting U-boats resting on the sea bed in coastal waters around the United Kingdom. The provision of suitable bases presented difficulties; those, the comparative lack of success in home waters of No. 63 Squadron, and the dependence on weather conditions of blimp operations, were still under discussion at the end of the war.

⁴ C.C. File S.14401/22.

they had been in the Mediterranean, M.A.D. aircraft effected one more U-boat kill before the end of the war, on 30 April 1945, in the South-Western Approaches.¹

U-boat Detection by Aircraft at the End of the War

The security of our shipping from attack by submarines is vital to our existence, and during the war with Germany the U-boat menace was very serious. At the climax of the Battle of the Atlantic, from the beginning of January 1943 until the end of April 1943, the convoy loss rate was 1.6 per cent, with a maximum during March 1943 of 2.7 per cent. In the same period the loss rate of independently routed ships was 2.8 per cent, with a maximum of 5.3 per cent in March.² The continuance of those rates of loss would have implied our defeat.³ It is clear that Germany could have defeated us by concentrating on our sea-borne trade, and attempts to do so during the period 1939-1943 were frustrated largely by our use of aircraft.⁴ After 1943 technical development of U-boats tended increasingly to reduce the efficacy of aircraft used against them, and at the end of the war the Germans had nearly completed development of the true submarine, as distinct from submersible, vessel. Considerable progress had been made in the design of propulsion units of the *Walther* type, enabling high speeds to be maintained under water, and making it possible for U-boats to attack convoys whilst submerged. Also, design tended towards the attainment of much greater operating depths and silent propulsion.

The problem facing anti-U-boat aircraft at the end of the war was the location and destruction of submerged rather than surfaced U-boats. Four methods, other than visual reconnaissance, of detecting and locating *Schnorchelling* U-boats were available; A.S.V., radio acoustic buoys, magnetic detection, and U-boat radar interception.

The A.S.V. installations in operational use were effective only against U-boats which were surfaced, and in calm seas, against *Schnorchel* tubes. Against surfaced U-boats A.S.V. performance was good, and A.S.V. could be used for searching extensive sea areas. Its efficiency against *Schnorchel* in the best of conditions was, however, low, and with the introduction of effective anti-radar covering, which was imminent, would have been lessened even further. The main difficulty was that of discriminating between the target echo and sea returns, and developments were being made to overcome it.

¹ A.H.B./IHK/85/88(A). On 23 January 1945 the Chief of the Air Staff requested information regarding the latest development and the availability of M.A.D. equipment, and suggested that its potentiality as a surface craft detecting device for use in shallow waters might be investigated. The Admiralty had already completed preliminary experiments, during which it was found that the magnetic field of even a degaussed ship seriously affected the accuracy of M.A.D. and had not undertaken further trials. At the R.A.E., however, it was thought that ship-borne M.A.D. was a practical proposition if carried in such a way that it was clear of the ship's magnetic field, which was estimated to extend to a distance of at least 100 feet around the vessel, and suggested that it might be installed in a suitably constructed craft and towed behind the ship. In spite of the comparatively small range of M.A.D. it held advantages over asdic for inshore operations inasmuch as, in the hands of a skilled operator, it should enable a U-boat to be distinguished from a wreck, it was not affected by temperature layers, and because whereas asdic was comparatively ineffective in all shallow waters, M.A.D. could be made effective in some areas. The Admiralty had considered the possibility but the surface craft in which M.A.D. would have been employed were already required to tow, for another purpose, a device which would have seriously interfered with M.A.D. (A.H.B./IHK/85/105.)

² A.H.B. Narrative: 'The R.A.F. in Maritime War.'

³ A.H.B./ID/12/285. The Operational Control of Coastal Command.

⁴ See Table No. 12.

Experience had shown that it was possible to locate and track a submerged U-boat by means of a pattern of sono-buoys dropped over an area in which its presence was suspected. The number of non-directional buoys required, however, increased operating difficulties and would have enabled a fast-moving U-boat to escape. The difficulties might have been greatly reduced were the buoys directional, in which case perhaps only two would have been required for each pattern, although they would most likely have been heavier and more bulky. All forms of acoustic buoy suffered from the common disadvantage that they were dependent upon U-boat propeller noises, and were ineffective against a U-boat which avoided cavitation. Because of background noises, caused by the motion of the sea, which increased as the roughness of the sea increased, it was difficult for an operator to identify U-boat noise as such, especially if ships were present in the area.¹ Air-launched asdic buoys were not developed, and it was doubtful whether they would have been effective at ranges greater than $\frac{1}{2}$ to 1 mile.

Although magnetic detection had met with some success, its technical and tactical limitations had become apparent. The technical limitations were such that it was doubtful whether its range could be increased by more than 400 feet, and its range and scope were so small that a prohibitive number of aircraft would be required to search a wide area. To achieve any success with M.A.D. it was necessary to have a fairly accurate knowledge of a U-boat's position or to confine search to restricted waters where submerged passage at no great depth was enforced by geographical considerations.

Although they had not been used extensively, it had been shown that it was technically feasible to produce airborne receivers capable of locating, and homing to, U-boat radar emissions.

A.S.V. Requirements Abroad

The general policy regarding the requirements of commands abroad for A.S.V. was mainly directed by the relative operational importance of the home and overseas commands in accordance with the general development of the war. A great part of the capacity of the United Kingdom for technical research, development and production, in addition to allocations of equipment from the United States of America, was utilised for aircraft of Coastal Command. Generally, after Coastal Command had been fully equipped with a new type of A.S.V. installation, it was the practice of the Air Staff to divert some of the equipment to overseas commands in accordance with relative aircraft programmes and current operational priorities. After the liberation of Europe, thought increasingly turned towards the requirements of the overseas theatres of war, and especially to the Far East. The anti-submarine role was still of considerable importance, but relatively the proportion of strike aircraft was expected to be larger than in the United Kingdom, and it was thought likely that aircraft equipped with A.S.V. would be employed not only in an anti-submarine role but also for shadowing surface vessels with a view to homing strike aircraft to them. In such circumstances strike aircraft required A.S.V. which provided radar ranging in addition to search facilities, and at the end of the war the requirement was being met by A.S.V. Mark XII in Beaufighters, and A.S.V. Mark XIII in Brigands and Sunderlands.

¹ In large areas, other than home waters, sono-buoys were rendered ineffective by noises produced by large shoals of certain types of crustacea.

CHAPTER 16

CENTIMETRIC A.S.V. FOR STRIKE AIRCRAFT

On 12 June 1943 the Commander-in-Chief Coastal Command informed the Air Ministry of his detailed operational requirements for A.S.V. in strike aircraft.¹ The size and weight of the installation were to be kept to a minimum, and 180 degrees of scan in a forward direction was required. Very accurate estimation of distance was needed at ranges between 50 and 2,000 yards, at heights not exceeding 1,000 feet, for the final stages of torpedo and rocket projectile attacks. Precise indication, by means of a light or a buzzer, was to be given to the pilot when aircraft reached a predetermined distance from a target. During an attack the radio operator could not pass range information over the aircraft intercommunication system because he was fully engaged on other duties, and would be unable to concentrate his attention on an A.S.V. display. In the final stage of a torpedo attack the target should never be more than 30 degrees from the aircraft heading, and it was essential that vessels outside that sector should be disregarded by the range indicator, which was not to be affected by sea returns. For attacks made with rocket projectiles the sector could be reduced to 5 degrees from the heading, or alternatively, lock and follow would be accepted. Although facilities for fully blind line and elevation sighting were considered to be desirable, they were not put forward as an operational requirement at that stage of development. Rooster and Lucero facilities were required, but it was particularly important that their aerials should be designed to interfere as little as possible with aircraft performance. Range/azimuth presentation was preferred to other methods, and range scales for 5, 20 and 100 miles were to be provided.

Broadly therefore, the requirement for strike aircraft was an A.S.V. installation capable of scanning over a wide arc during the search for a target and over a narrow arc when an attack was being made. It was also required to determine range accurately, particularly for making attacks with rocket projectiles.²

A.S.V. Mark XII

Production of A.S.V. Mark XI for the Fleet Air Arm was about to begin. With the addition of the required ranging unit it might have been the ideal installation for the purpose, but the Admiralty required all available production of A.S.V. Mark XI for at least one year. The Coastal Command requirement could not be met by A.I. Mark VIII in its existing form, but it seemed possible that it might be met if the scanner of the A.I. Mark VIII installation could be stopped in the central position for the delivery of an attack.³ Consequently

¹ A.H.B./IHK/10/40 and A.M. File C.S. 16766.

² Unlike a bullet, the rocket projectile tended to follow the aircraft line of flight, rather than the line of sight.

³ A.M. File C.S. 16766. See also Chapter VI. For further details of A.I. Mark VIII, see Royal Air Force Signals History, Volume V: 'Fighter Control and Interception.'

it was decided to modify A.I. Mark VIII, which was available in large quantities, and already being installed in the night-fighter version of the Beaufighter on the aircraft assembly lines.¹

Experimental flights with the modified A.I. Mark VIII, known as A.S.V. Mark XII, were conducted by the T.R.E., and on 19 October 1943, at a meeting held at the Air Ministry, the Director of Communications Development intimated that trials had shown promise of achieving the required standard of performance at a reasonably early date. The spot range-finding facilities were provided by the addition of a strobe unit, Type 68.² A drawback of the installation was the scanning system. The type of scan provided by the A.I. Mark VIII system was a spiral in the vertical plane, and for strike aircraft purposes search in the horizontal plane only was required. Traces similar to those of A.S.V. Mark II were used for presentation; blips obtained when the scanner was to port or starboard appeared on the left or right hand traces respectively. A target dead ahead showed as equal signals on both traces, and except for the fact that the target was to one side or the other, no more precise bearing could be obtained without manœuvring the aircraft to bring the target immediately in front of it. It was realised that the scanning system was unsuitable for the A.S.V. role, and early in 1944 the T.R.E. obtained permission to substitute, in an experimental installation, an H2S type of scanner and range/azimuth presentation for search purposes, with facilities for stopping the scanner in the dead-ahead position when range-finding was required. Incorporation of such a modification in production installations would, it was considered, have caused a long delay in the introduction of A.S.V. Mark XII to operational squadrons, and it was therefore not developed beyond the experimental stage.

In April 1944 Headquarters Coastal Command made A.S.V. Mark XII an operational requirement for all aircraft of seven Beaufighter squadrons, including the anti-flak escorts. Following this a crash programme was initiated in the summer for scanners and strobe units to enable 200 installations to be completed, and arrangements were made for main production to begin in December 1944.³ It quickly became clear that the main obstacle to rapid progress would be the scanner system, which required extensive modifications. By December less than 20 scanners had been delivered although 80 strobe units had been produced; main production was deferred until February 1945. A Beaufighter trial installation was cleared in September 1944, and delivery to the Coastal Command preparation pool of aircraft equipped with A.S.V. Mark XII and Lucero began in December 1944. In January 1945 the Coastal Command requirement was changed. A.S.V. Mark XII was to be installed in only three squadrons of which two were fitted for torpedo and one for rocket attack.⁴ The acute shortage of servicing personnel and the demands already

¹ The Beaufighter X was the principal strike wing aircraft used in the Royal Air Force until the end of the war, when replacement by the Mosquito VI had begun.

² Strobe Types 67 and 68 formed the basis of range-finding for A.S.V. installed in strike aircraft. The same principle was used in both. The purpose of the strobe unit was the examination of all the echoes received during a short period of time occurring at a known interval after the transmitter pulse, that is at a given range from the aircraft. When a target return occurred at the predetermined range it was made to operate a relay which completed a lamp or horn circuit. To ensure that the circuit was always in its most sensitive condition independent of the background conditions, such as sea returns, the gain of the A.S.V. amplifier was automatically controlled. (T.R.E. Monograph: 'A.S.V.')

³ C.C. File S.1440/11 and A.M. File C.S. 22018.

⁴ Nos. 236, 254, 489 Squadrons.

being made on manufacturers made it undesirable to install A.S.V. if the need for it were not vital. Whilst A.S.V. Mark XII was regarded as a valuable asset for radar ranging from torpedo aircraft, it was not expected to be of great assistance to rocket projectile Beaufighters operating during daylight.¹ Only No. 236 Squadron was likely to be used for rocket projectile attacks at night, and then A.S.V. would confer advantages for both search and radar ranging. By February 1945 three Beaufighters fitted with A.S.V. Mark XII had reached operational units, five were in use at an O.T.U., and 19 were in the preparation pool.² By the middle of April 1945, 30 operational and 28 non-operational A.S.V. equipped Beaufighters were in service with Coastal Command.

Growth in Importance of Strike Aircraft

The operational employment of A.S.V. Mark XII was confined to the early months of 1945, but the results showed without doubt that search radar was an important, if not an essential, requirement for aircraft of a strike wing. Earlier in the war, the immobilisation and destruction of most of the larger units of the German Navy, culminating in the sinking of the *Scharnhorst*, had reduced the number of potential targets for anti-shipping forces. There remained, however, the possibility of an enemy surface raider breaking out into the Atlantic and E-boats continued to present a difficult problem until the war ended. During this period anti-shipping operations assumed greater importance. German coastal shipping was then the main target for strike aircraft since it was an essential element in the German transport system.³ Also, when the enemy lost the use of the Biscay bases for U-boat warfare, attacks against shipping off the Norwegian coast became of greater significance as the Germans relied largely on sea-routes to keep the Norwegian U-boat bases supplied. Surfaced U-boats sheltering in the Norwegian leads were also sought out by strike wing aircraft. Although some use could be made of the road and rail communications in Norway, the bulk of the oil and equipment needed to maintain U-boat operations had to be shipped along the coastal shipping route. Raw materials such as timber and iron ore, and German troops and military equipment evacuated from Norway for re-inforcement of the battle-fronts in Europe had similarly to be shipped down the Norwegian coast.

Attacks against shipping were therefore of primary importance in that they had a direct effect on the two outstanding German offensives, the U-boat war and the land battle. An indication of the great value attached to shipping by the enemy could be gained from the large-scale air and surface protection which it was given. The convoys that did sail by day, for not all sailed by night, were escorted by large numbers of the latest types of fighter aircraft, and the anti-shipping offensive therefore indirectly affected the bombing offensive against Germany.

Operational Requirement for Radar Range Finder

The A.S.V. Mark XII installation in the Beaufighter quickly became popular with personnel of the strike squadrons, who appreciated the advantages it conferred and because it lacked the usual teething troubles of a new equipment. These had been largely overcome when the main units were used in the A.I. role. A.S.V. Mark XII had, however, one great disadvantage, the effect of

¹ A.H.B./IIJ/70/605.

² A.M. File C.S. 22018.

³ A.H.B./ID/12/99.

its size and weight, about 470 pounds, on the tactical use of the aircraft. It was of primary importance for strike aircraft to carry, in addition to search and ranging facilities, a means of accurate navigation within their radius of action. They also had to have communications equipment to maintain contact with base so that the whole strike force could be quickly concentrated against suitable targets. For these purposes, both Gee and W/T equipment were carried before the introduction of A.S.V. The installation of A.S.V. Mark II had made it necessary to omit one of these, and at the beginning of 1944 Headquarters Coastal Command stated a requirement for a small light-weight aircraft radar installation which would fulfil the spot range-finder function and also permit the carrying of the Gee and W/T in addition to the requirement for a comprehensive A.S.V. installation. The range-finder was to be completely automatic, with direct presentation to the pilot. Range information was to be presented as spot range and/or rate of change of range, and target discrimination was to be limited to a sector from 4 degrees port to 4 degrees starboard. Range accuracy of plus or minus 50 yards at a range of 1,000 yards was required.¹

A.S.V. Mark XVI

At the T.R.E. consideration was given to the design of a new system based on the strobe units Types 67 and 68 developed for A.S.V. Mark XII, and for A.S.V. Mark XIII, a Fleet Air Arm installation, and a light-weight H.F. unit being developed for A.S.V. Mark XIII. In May 1944, however, the T.R.E. recommended the adoption of a miniaturised unit, known as LHTR, which had been developed in the U.S.A., for use with a strobe unit Type 68 in an installation to be known as A.S.V. Mark XVI. LHTR was likely to be available in quantities which would permit its immediate supply, and would provide a means of meeting the Coastal Command requirements without further delay.²

In June 1944 the Air Ministry forwarded to Headquarters Coastal Command specifications for various forms of radar range finding, from which A.S.V. Mark XVI was selected as being the most suitable if the beam width was no more than 8 degrees. In August 1944, when experimental flight trials of A.S.V. Mark XVI were initiated, the installation was made an operational requirement for all Beaufighters of Coastal Command, and was intended as a replacement for A.S.V. Mark XII.³ In A.S.V. Mark XVI the radar controls were limited to on/off switches, a range-setting knob calibrated at 200 feet intervals between 2,000 feet and 9,000 feet, and a sensitivity control which could be pre-set on the ground for a single-seater aircraft installation. When a target was at the pre-set range the pilot was informed by a lamp or hooter.

Meanwhile, the need of the U.S.A. Services for LHTR units had become such that the entire output for 1944 was likely to be absorbed by them. Arrangements were made for six pre-production models to be flown over for Service trials, and the British Air Commission was requested to endeavour to obtain 100 units per month from January 1945 onwards. In September 1944 the

¹ A.H.B./IIC/85/85(A).

² LHTR was a completely pressurised unit, using miniature components, which included transmitting and receiving valves, T.R. system, modulator, and I.F. amplifier. It was built around the 'Lighthouse' valve which was used as a transmitter and as a local oscillator. The valve was so constructed that it was just capable of stable oscillation at the wavelength used, 11.7 centimetres, although with wide variations of peak power between different specimens.

³ A.M. File C.S. 23460.

T.R.E. reported that performance of the pre-production units was not up to expectations ; no further samples were available and further development of A.S.V. Mark XVI would probably be delayed.¹ In addition, the fitting of Rebecca was proving to be difficult and was likely to prolong the completion of a trial installation. Although it remained a firm requirement for the final installation, the Air Ministry decided that it was not essential in the prototype. Experimental flights were continued during October and November and a development contract for A.S.V. Mark XVI was placed with the firm of G.E.C. Output from the main programme was expected to be 100 installations per month from February 1945 onwards if delivery of 100 LHTR units per month began in January 1945.

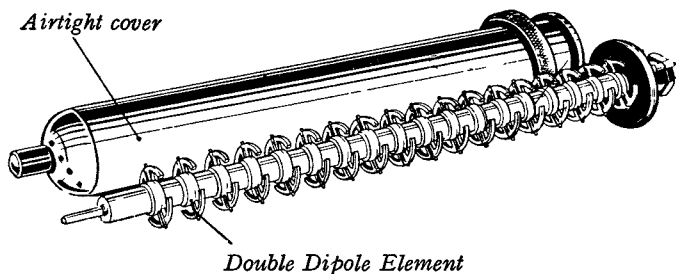

END FIRE ARRAY, COVER REMOVED

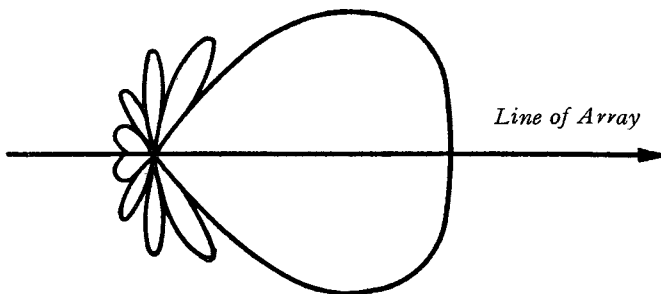

TYPICAL FIELD STRENGTH DIAGRAM

At the beginning of 1945 the Commander-in-Chief Coastal Command requested that a trial installation of A.S.V. Mark XVI should be made in a Mosquito VI, the type of aircraft which was shortly to replace the Beaufighter X in strike wings. The aerial system used in the Beaufighter installation was fixed and radiated straight ahead of the aircraft, so that discrimination in azimuth against unwanted targets depended on the beam width. It incorporated a reflector dish, or mirror, which was mounted in the perspex nose of the aircraft. To install such a mirror in the Mosquito involved removal of the .303 guns and structural alteration of the airframe, and would consequently entail considerable delay. The advantages of reducing modifications were fully appreciated at Headquarters Coastal Command, where the

¹ In September 1944 the British Air Commission was able to offer the Air Ministry 120 'Falcon' equipments produced by an American sub-contractor and not required by the U.S.A.A.F. The Falcon, or AN/APG13, was a light-weight radar ranging equipment containing LHTR, and the offer was accepted in order that the LHTR units might be used for A.S.V. Mark XVI.

possibilities of an alternative system, an end-fire aerial array, which was simpler to install and would, apparently, permit the guns to be retained, were studied.¹ The maximum beam width considered to be tolerable for strike aircraft A.S.V. installations was 8 degrees; the Beaufighter installation would provide one of about 7 degrees, and the Mosquito installation with end-fire array one of at least 14 degrees. There was consequently some doubt, especially at the T.R.E., whether the end-fire array would afford the necessary standard of discrimination against ships in convoy, and it was possible that attacks against isolated targets only could be made, but the information then available on the performance of the two systems was insufficient to enable a definite preference for one or the other to be stated. It was therefore suggested that trials should be undertaken simultaneously with both installations in order to ascertain whether the advantage of simplicity and retention of armament offered by the end-fire array was off-set by a distinct decrease in performance.

By March 1945, however, a mirror of smaller dimensions, 23 inches diameter compared with 28 inches, was being developed. This could be fitted to a Mosquito VI with the minimum of structural alterations although removal of the guns was still necessary, and a small perspex nose would have to be substituted for the standard metal nose cap. Arrangements were therefore made for the experimental installation in a Mosquito, then being undertaken, to include the smaller mirror as an alternative to the end-fire array; it was expected to give a beam width about 20 degrees greater than that of the 28-inch mirror.² Hopes were entertained that the smaller mirror would not only enable the immediate operational requirement to be met but would also be suitable for installation in the Mosquitoes being modified to carry 'Uncle Tom'; for this purpose blast trials with the small perspex cap were requested.³ A sight for use in conjunction with large rocket projectiles was under development at the Royal Aircraft Establishment, and it was designed to accept radar ranging.⁴ The joint Air and Naval Staff requirements for the sight specified that it was to be effective in bad visibility by day, when only fleeting glimpses of the target might be obtained, and at night. Ultimately, therefore, radar search facilities in addition to radar ranging would be required.⁵ Information on the performance of the 28-inch mirror installation was to be obtained from

¹ The mirror, or reflector dish, was a circular paraboloid fed by a horizontal dipole. The dipole unit was protected, both mechanically and against losses caused by high humidity, by being enclosed in a perspex globe. The end-fire array, designed for use on single-engined aircraft, was an aerial system enclosed in a pressurised cylinder 24 inches long and 3 inches in diameter. It was installed so that the long axis of the unit was approximately in the line of flight.

² A.M. File C.S. 23460.

³ 'Uncle Tom' was a large, high-speed rocket projectile with proximity fuze being especially developed for use by British aircraft against capital ships of the Japanese Navy. It consisted of a motor, 10.25 inches in diameter, weighing 400 pounds, to which was attached a head, 10.5 inches in diameter, weighing 600 pounds. The complete rocket weighed approximately 1,030 pounds and had an overall length of 8 feet 8 inches. It was still being developed when the war ended. (A.H.B. Narrative: 'The R.A.F. in Maritime War'.)

⁴ The exact function of radar was to give preliminary warning to the pilot at a range approximately 3,000 feet greater than that for release, allowing him some 6 to 10 seconds to get the target in sight, and then to provide the actual firing signal at the pre-set release range.

⁵ A.H.B./IHK/85/87(B).

flight trials of the Beaufighter X then being equipped with A.S.V. Mark XVI at Defford. Performance of each installation could then be compared when trials of the 23-inch mirror fitted to the Mosquito had been completed. Should the smaller mirror prove to be unsuitable it would be necessary to fit the Mosquito with a large perspex nose, which would involve major structural alterations to the airframe; the 'Uncle Tom' prototype would have to be similarly fitted and further blast trials undertaken. If, however, the large perspex nose did not withstand blast, it would be necessary to employ the 23-inch mirror, or even end-fire arrays, on 'Uncle Tom' Mosquitoes.

Such was the situation in March 1945 when it became apparent that the end-fire array was not so simple to fit as had at first been thought. In particular, it was unlikely that the aircraft armament could be retained since the siting of the LHTR unit with relation to a scanner or other aerial system was critical, and the distance between the two components was required to be as short as possible. The best position for the LHTR and the Type 68 strobe unit was in the nose of the aircraft against the armoured bulkhead, and this necessitated removal of the guns. Consequently, one of the advantages previously envisaged was lost, and the Commander-in-Chief Coastal Command decided that further work on end-fire arrays was not justified and was prepared to accept a trial installation using only the 23-inch mirror in the Mosquito.

In April 1945, the operational requirement for A.S.V. Mark XVI to be installed in Beaufighters was cancelled by Headquarters Coastal Command. By then it had become possible to obtain operational experience with the Beaufighter A.S.V. Mark XII installations, and it had become clear that search and homing facilities, not available in A.S.V. Mark XVI, greatly increased the effectiveness of aircraft at night. This was an important consideration in view of the prevalent enemy tactics of moving his convoys mainly during the hours of darkness. It was decided that the operational rocket projectile Mosquitos should be equipped with A.S.V. Mark XV, expected to be available in 1946, and that A.S.V. Mark XVI was to be installed in the six Mosquitos which were to be used for 'Uncle Tom' trials. By June 1945 it had been determined that the nose of the Mosquito VI could be satisfactorily modified to enable the 28-inch mirror to be used, and further work on the 23-inch mirror installation was abandoned. Brigand I aircraft were being equipped with A.S.V. Mark XIII on the aircraft factory assembly lines, and their suitability as a replacement for Beaufighters of a strike wing was being judged when the war with Germany ended.

In view of the possibility that the aircraft might prove to be unsuitable, and as an insurance against delay in delivery to Coastal Command if they were, trials of the Mosquito VI in the torpedo-carrying role had been initiated. The requirement for ranging facilities was to be met with A.S.V. Mark XVI.¹ In July 1945, therefore, the A.S.W.D.U. was instructed to conduct Service trials of A.S.V. Mark XVI installed in Mosquito VI aircraft, to determine its accuracy and efficiency in torpedo and rocket projectile ranging, its ability to discriminate between ships in a typical coastal convoy, and the maximum range at which accuracy could be expected.²

¹ H.Q.C.C., O.R.B. June 1945. A.M. File 23460.

² C.C. File S.14403/15/2.

A.S.V. Mark XIII

A.S.V. Mark XIII was developed from A.S.V. Mark XI for the Fleet Air Arm.¹ The great war-time expansion of the various applications of airborne radar, and the discovery of new techniques and materials, had emphasised that a large measure of re-design of components was possible and would be of considerable benefit. The first requirement was that all components should be of the smallest possible size. The need for miniaturisation to the utmost extent, for Fleet Air Arm aircraft in particular, had been emphasised by experience with A.S.V. Mark XI. Miniaturisation had not been, of course, a first consideration in the development of components for commercial radio and production facilities were tied to the old type of component. Manufacturers were already fully occupied keeping pace with demands for their products and could spare little effort for the new techniques and materials associated with miniaturisation. Official development was not neglected, however, and during 1943 a group, under Dr. A. T. Starr, was formed at the T.R.E. to concentrate on guiding the development of new components and generally to investigate special forms of construction, such as pressurisation, which would tend to make for a higher degree of serviceability of airborne equipment in all conditions.²

When work on A.S.V. Mark XIII was begun, the important requirement of miniaturisation had to be ignored in order to meet the urgent demand for 'the best that can be produced quickly' or the equipment would have appeared in very different guise. Great pains were taken to re-design the display and the H.F. unit. Refinement of the indicator unit, especially the provision of range calibration markers, was realised to be of great value in extending the operational usefulness of any A.S.V. installation. The principal points in the re-design of the H.F. unit, to take advantage of the experience gained with A.S.V. Mark XI, were a reduction in weight, automatic tuning with manual tuning as a standby, and the introduction of an improved magnetron and local oscillator. Scanners for the A.S.V. Mark XIII installation were also re-designed, and the desirability of stabilising the mirror of the scanner system against roll of the aircraft, particularly when the A.S.V. system was required to give range and/or bearing information, was accepted. The indicator unit was designed to provide three types of display on the cathode ray tube and included electronic range markers, sea clutter filter, slant range correction to the P.P.I. display, and a special display to meet the azimuth requirements of the Mark V A.S.V. bombsight.³ Complete pressurisation of the units was also included in the design specification. Since miniaturised components could not be used it was inevitable that the indicator unit was considerably larger than that used in A.S.V. Mark XI. Special attention was paid to tropicalisation and all possible precautions were taken to prevent breakdown in tropical conditions.⁴ A.S.V. Mark XIII enabled spot ranging on individual targets

¹ Eventually sub-divided as :—

A.S.V. Mark XIII A—Fleet Air Arm and Mosquito aircraft. A.S.V. Mark XI with greater power output, improved indicator, ranging unit, and all-round looking.

A.S.V. Mark XIII B—Beaufighter and Brigand aircraft. A.S.V. Mark XIII A with forward-looking roll stabilised scanner.

² T.R.E. Monograph : 'A.S.V.'

³ A.S.V. Mark XIV.

⁴ A.H.B./IIE/193/1. T.R.E. Report No. T.1778. When the war with Germany ended plans were being made for the installation of A.S.V. Mark XIII in Sunderland IV aircraft for operations in the Far East, and Warwick V aircraft of No. 179 Squadron. (A.M. File C.S. 23121.)

to be made between the ranges of 1,000 and 9,000 yards, and indicated aurally and visually the weapon firing point. Its use in conjunction with the rocket projectile sight and 'Uncle Tom' was under consideration at the end of the war, when production was about to begin, since it provided more comprehensive facilities than A.S.V. Mark XVI. The installation was, however, a more complex undertaking, and the increase in weight, to 500 pounds, to provide search facilities, was considerable.¹

A.S.V. Mark XV

In order that the practical problems encountered by Dr. A. T. Starr's group should be brought out for consideration, its work was ultimately directed towards the production of a fully miniaturised A.S.V. installation, A.S.V. Mark XV. The principal units of the system were completely pressurised and both size and weight, about 200 pounds, were approximately half those of A.S.V. Mark XIII. However, during the last few months of the war, under the stimulus of effective technical developments in U-boats, the ever-increasing importance of A.S.V. in the anti-shipping role, and the development of new weapons for aircraft in that role, many new airborne radar techniques were being evolved. By September 1945 the design of A.S.V. Mark XV was already considered to be out of date. It contained no provision for scanner tilt, which was necessary for operations at medium altitudes; it had no sector scan, which was a requirement for homing to small targets. Range calibrating circuits were not incorporated and various circuit refinements which were of assistance in following small targets through sea returns were not included. At the T.R.E. it was considered that if A.S.V. Mark XV were re-designed in the light of more recent knowledge, its weight and bulk could be considerably reduced. Miniaturisation had not been used as much as it might have been, particularly in the indicator unit, which was required to be as small as possible for use in aircraft in which the operator's position was likely to be cramped. In September 1945, therefore, the development of a more up-to-date version of A.S.V. Mark XV was proposed. It was envisaged that the installation would be sufficiently small to allow its use in strike aircraft, with adequate performance and sufficiently comprehensive facilities for long range maritime aircraft.²

¹ A.H.B./IIK/85/87(B). The total weight of A.S.V. Mark XVI, including power supply, was 85 pounds with end-fire array and 95 pounds with mirror.

² A.H.B./IIK/92/1.

TABLE No. 1
U-boat Sightings—August 1941 to May 1942

Month.	Total number of sightings made by anti-U-boat aircraft.	Initial sightings made visually.	Average range in miles.	Initial sightings made with A.S.V.	Average range in miles.
<i>1941</i>					
August ..	28	22	2.5	6	4.7
September	39	32	3.25	7	4.7
October ..	28	25	4	3	5
November	12	11	5.2	1	5
December	17	13	3.5	4	8
<i>1942</i>					
January ..	6	4	4.5	2	4.75
February	12	11	3.2	1	7
March ..	10	8	3.2	2	5
April ..	19	15	6	4	7
May ..	33	32	5	1	5

TABLE No. 2
Night Flying Hours, Sightings, and Attacks June 1942–February 1943

Year.	Month.	Metric A.S.V. and Leigh Light.			Metric A.S.V. without Leigh Light.		
		Hours.	Sightings.	Attacks.	Hours.	Sightings.	Attacks.
1942	June ..	235	7	3 (1 sunk)	266	—	—
	July ..	370	4	3	152	—	—
	August ..	179	1	—	172	—	—
	September	284	1	1	281	—	—
	October	454	1	1	321	—	—
	November	640	1	1	512	2	1
1943	December	581	2	2	533	2	1
	January	376	3	2	450	—	—
	February	653	4	2 (1 sunk)	559	—	—

TABLE No. 3

Performance of High Power Metric A.S.V. during Trials in March 1942

Aircraft Height.	Maximum Range.	Sea Returns.	Range at which blips faded.
<i>(a) Submarine Fully Surfaced :—</i>			
<i>feet</i>	<i>miles</i>	<i>miles</i>	<i>miles</i>
1,500	14	3	8½ - 7½
1,500	14½	3	9 - 7½
1,500	14	2	11 - 8
1,500	16	2	12 - 9
1,000	11	1½	9 - 7
1,000	11	1½	9 - 7
500	8	1½	—
500	7½	1½	6 - 5
500	8	1	6 - 5
500	7½	1	—
<i>(b) Submarine Trimmed to Conning Tower :—</i>			
<i>feet</i>	<i>miles</i>	<i>miles</i>	} No fading until within 2 miles of submarine.
1,500	8	3	
1,500	7½	3	
1,000	6¼	2¼	
1,000	6	2¼	
500	4½	1½	
500	4½	1½	

TABLE No. 4

Performance of 10-Centimetre A.S.V. during Trials in March 1942

Aircraft Height.	Range.	
	Maximum.	Minimum.
<i>(a) Fully surfaced submarine. Beam on :—</i>		
<i>feet</i>	<i>miles</i>	<i>miles</i>
1,500	13	1
1,500	7	2
1,000	12	1
1,000	8	1
750	14	$\frac{1}{2}$
500	12	$2\frac{1}{2}$
500	8	$\frac{3}{4}$
<i>(b) Trimmed down. Beam on :—</i>		
<i>feet</i>	<i>miles</i>	<i>miles</i>
1,500	15	2
1,000	16	$\frac{1}{2}$
750	$10\frac{1}{2}$	$\frac{1}{2}$
600	9	$\frac{1}{2}$
400	12	$\frac{1}{2}$
250	10	$\frac{1}{2}$
<i>(c) Trimmed down. End on :—</i>		
<i>feet</i>	<i>miles</i>	<i>mile</i>
250	8	$\frac{1}{2}$
100	5	$\frac{1}{2}$
50	$4\frac{1}{2}$	$\frac{1}{4}$

TABLE No. 5

Performance of Radiation Laboratory 10-Centimetre A.S.V. during Trials in April/May 1942

Target.	Aircraft height in feet.	Tonnage.	Aspect.	Maximum range in miles.
Submarine fully surfaced	3,000	—	Beam on	15½
" " "	2,000	—	Beam on	15
" " "	1,000	—	Beam on	15
" " "	3,000	—	End on ..	12
" " "	2,000	—	End on ..	10
" " "	1,000	—	End on ..	8
" " "	3,000	—	Quarter on	12½
" " "	2,000	—	Quarter on	7
" " "	1,000	—	Quarter on	3
Submarine trimmed down	1,000	—	—	12
Surface vessel	3,000	23,000	Beam on	28
" "	2,000	23,000	Beam on	25
" "	2,000	23,000	Quarter on	23
" "	1,000	23,000	Quarter on	21
" "	3,000	1,500	Beam on	24
" "	2,000	1,500	Beam on	20
" "	1,000	1,500	Beam on	18
" "	2,000	1,000	Beam on	15
" "	1,000	1,000	Beam on	13
" "	2,000	1,000	End on ..	13
" "	1,000	1,000	End on ..	11
" "	3,000	250	Beam on	9
" "	2,000	250	Beam on	7
" "	1,000	250	Beam on	8

For full report on the trials, *see also* 'Radiation Laboratory Report No. 103-1.' (Central Radio Bureau Reference 42/297/A/M.S.)

TABLE No. 6

U-boat Strength in 1942

	Jan.	Feb.	Mar.	Apr.	May	Jun.	July	Aug.	Sept.	Oct.	Nov.	Dec.
Total U-boat fleet	247	257	272	283	296	313	331	342	353	361	370	380
Number based in the Atlantic.	62	70	80	80	89	90	101	113	131	157	158	154
Number based in other operational areas.	27	31	31	39	39	40	39	39	38	35	47	49
U-boats lost from all causes.	3	2	6	3	4	3	11	10	11	16	13	5

TABLE No. 7

Distribution of A.S.V./H2S at 11 April 1943

<i>Bomber Command</i> :—			
In aircraft	42	
Serviceable spares in squadrons	11	
Unserviceable spares in squadrons	11	
		—	64
<i>Coastal Command</i> :—			
In aircraft	35	
Serviceable spares in squadrons	4	
Unserviceable spares in squadrons	4	
		—	43
<i>Ministry of Aircraft Production</i> :—			
For use as test standards at contractors and R.P.U.	9	
Awaiting allocation	6	
In process of installation	10	
Being repaired	8	
		—	33
<i>Training Establishments</i> :—			
		21	
		—	21
<i>Malta</i> :—			
In aircraft	4	
Spares	4	
		—	8
	Total	169
Lost by enemy action and crashes	13	
	Total	182

TABLE No. 8

A.S.V. Serviceability for January, February, March 1945

Type of A.S.V.	Coastal Command Average.	
	Hours per fault.	Sorties per fault.
Mark IIIA, B, C	185·6	23·3
Mark VA, B	485·5	55
Mark VI	99·2	13·2
Mark VIA	159·8	19·4
Mark VIIIA	194·6	16·7
Mark X	297·5	33·1

(Coastal Command Signals Review, May 1945.)

TABLE No. 9
U-boat Locations September 1941–August 1943

Period		ATLANTIC CONVOY AREAS Initial Location Method					TRANSIT ROUTE AREAS Initial Location Method				
Number of Months.	Dates.	Visual.		A.S.V.		Percentage obtained with A.S.V.	Visual.		A.S.V.		Percentage obtained with A.S.V.
		Day.	Night.	Day.	Night.		Day.	Night.	Day.	Night.	
9	Sept. 1941 .. May 1942 ..	} 57	1	11	—	18·3	86	7	12	5	15·5
5	June 1942 .. Oct. 1942 ..	} 100	1	10	1	9·8	113	1	24	19	27·4
4	Nov. 1942 .. Feb. 1943 ..	} 88	—	6	2	8·3	140	2	9	43	26·8
3	Mar. 1943 .. May 1943 ..	} 189	3	14	7	9·8	116	3	11	44	31·6
3	June 1943 .. Aug. 1943 ..	} 11	—	2	—	15·4	87	1	26	5	26

TABLE No. 10

U-boats Located by Aircraft Equipped with A.S.V.
Bay of Biscay, July 1943

July 1943.	Type of aircraft.	A/C letter and Sqdn.	Mark of A.S.V.	Target located.	Range in miles.	Result.
1	Liberator	D/53	V	2 U/B .. } 2 destroyers	32	
2	Liberator	J/224	V	2 U/B	18	1 U/B S/D.*
3	L/L Wellington	R/172	III	1 U/B (night)	13	1 U/B sunk.
3	Liberator	D/53	V	2 U/B	20	
3	Liberator	D/53	V	1 U/B	12	1 U/B S/D.
3	Liberator	J/224	V	1 U/B	10	1 U/B sunk.
7	Liberator	P/53	V	2 U/B	10	
7	Liberator	D/53	V	1 U/B	12	
10	Liberator	E/59	V	1 U/B	15	
14	Liberator	L/86	V	1 U/B	15	
17	Liberator	P/224	V	1 U/B	18	
18	U.S.A.A.F. Liberator	P/4	S.C.R. 717A	1 U/B	20	
19	Liberator	J/86	V	2 U/B	22	
19	Liberator	H/59	V	1 U/B	20	
20	U.S.A.A.F. Liberator	F/19	S.C.R. 717A	2 U/B	24	
20	U.S.A.A.F. Liberator	F/19	S.C.R. 717A	1 U/B	13	1 U/B sunk.
24	L/L Wellington	Q/172	III	1 U/B	16	1 U/B sunk.
28	U.S.A.A.F. Liberator	Y/4	S.C.R. 717A	1 U/B	9	
29	L/L Wellington	G/172	III	1 U/B	6	1 U/B sunk.
30	Halifax	S/502	II		7	
30	Liberator	O/53	V	3 U/B	18	1 U/B sunk.
31	Halifax	T/502	III		18	

* Seriously damaged.

TABLE No. 11

Ranges at which Initial Contacts against U-boats were Obtained by A.S.V.
February, March, April 1945

Mark of A.S.V.	Schnorchel or Periscope.				Conning Tower.				Fully Surfaced.			
	No. of Contacts.	Range in miles.			No. of Contacts.	Range in miles.			No. of Contacts.	Range in miles.		
		Max.	Min.	Av.		Max.	Min.	Av.		Max.	Min.	Av.
III	2	4	2	3	—	—	—	—	—	—	—	—
V VA	1	5	5	5	1	7	7	7	8	21	6	10·4
VB	2	7	7	7	1	5	5	5	4	15	6	10·3
VI	1	6	6	6	1	11	11	11	1	6	6	6
VIIIA	1	5	5	5	—	—	—	—	—	—	—	—
X	1	1	1	1	1	5	5	5	5	14	5·5	8·7

TABLE No. 12

Enemy Submarines Destroyed¹

(a) *German submarines* :—

	1939.	1940.	1941.	1942.	1943.	Total 1939-43.	Grand Total 1939-45.
Land based maritime aircraft—British.	—	1	3	24	83	111	} 247
Land based maritime aircraft—American.	—	—	—	11½	31	42½	
Shared	—	—	—	—	2	2	
Shipborne aircraft—British and U.S.A.	—	1	—	1	24	26	} 43
Shared by land based and shipborne aircraft.	—	—	—	1	—	1	} 2
Shared by land based aircraft and ships.	—	2	1	5	10	18	} 32
Shared by shipborne aircraft and ships.	—	—	1	—	3	4	} 15
Mines laid by aircraft—R.A.F. and F.A.A.	—	—	—	3	2	5	} 18
Air bombing—R.A.F. and U.S.A.A.F.	—	—	—	—	1	1	} 63
Totals	—	4	5	45½	156	210½	420
Ships—British	5	11	25	28	47	116	} 246
Ships—U.S.A.	—	—	—	5½	10	15½	
Shared	—	—	—	—	2	2	
Mines laid by ships—British.	3	2	—	—	—	5	} 9
Mines laid by ships—U.S.A.	—	—	—	—	—	—	} 9
Submarines—British ..	1	2	1	2	5	11	} 21
Submarines—U.S.A. ..	—	—	—	—	—	—	} 21
Totals	9	15	26	35½	64	149½	276
Other causes (including U.S.S.R. and accidents).	—	1	4	4	12	21	} 88
Unknown causes	—	3	—	2	5	10	
Grand Totals ..	9	23	35	87	237	391	784

(b) *Italian submarines* :—

By Allied ships and submarines	<i>Total</i>
By Allied aircraft—land based and shipborne	56
At sea	11
In harbour (bombing raids)	3
Shared by aircraft and ships	5
Other causes	10
	85

¹ Extract from Naval Staff History—The Defeat of the Enemy Attack on Shipping, 1939-1945.

COASTAL COMMAND—ORDER OF BATTLE

3 September 1939

Group.	Squadron.	Location.	Type of Aircraft.	Range in miles.	Endurance in hours.
15	204	Mount Batten	Sunderland ..	850	12½
	210	Pembroke Dock	Sunderland ..	—	—
	228	Pembroke Dock	London ..	225	5½
	217 (part)	Warmwell ..	Anson ..	255	4½
	512 (Aux. A.F.)	Aldergrove ..	Anson ..	—	—
	217 (part)	Carew Cheriton	Anson ..	—	—
16	42	Bircham Newton	Vildebeest	185	4¼
	206	Bircham Newton	Anson ..	—	—
	22	Thorney Island	Vildebeest ..	—	—
	48 (part)	Thorney Island	Anson ..	—	—
	500 (Aux. A.F.)	Detling ..	Anson ..	—	—
	48 (part)	Detling ..	Anson ..	—	—
48 (part)	Guernsey Airport	Anson ..	—	—	
18	201	Sullom Voe ..	London ..	—	—
	209	Invergordon ..	Stranraer ..	330	7¼
	240	Invergordon ..	London ..	—	—
	220	Thornaby ..	Anson ..	—	—
	608 (Aux. A.F.)	Thornaby ..	Anson ..	—	—
	224	Leuchars ..	Hudson ..	490	6
	233	Leuchars ..	Anson ..	—	—
	269	Montrose ..	Anson ..	—	—
612 (Aux. A.F.)	Dyce	Anson ..	—	—	

10 squadrons of Ansons, 4 of which were Auxiliary Air Force squadrons recently brought up to strength and still not completely trained.

1 squadron of Hudsons. Aircraft had only recently been received and squadron was in consequence not fully operational.

2 squadrons of Sunderland I flying boats }
 3 squadrons of London flying boats .. } Already obsolescent.
 1 squadron of Stranraer flying boats .. }

2 squadrons of Vildebeests. Sole strike force. Aircraft obsolescent.

APPENDIX No. 2

EXTRACTS FROM HEADQUARTERS COASTAL COMMAND MONTHLY SUMMARY OF WAR WORK. MARCH-OCTOBER 1940

March

A.S.V. is developing into the most promising child in the Command, and the results obtained have been an encouragement and a help to the crews of all aircraft fitted with the equipment.

April

A standard cross-over patrol using A.S.V. is now a daily routine . . . Two A.S.V. aircraft have been insisted on daily for the standard dusk patrols and Groups have been advised that, in general, when tracks have been ordered, some aircraft may be omitted if A.S.V. aircraft are used.

May

The fitting of A.S.V. to Hudsons and Sunderlands has continued, but at a slow pace owing to lack of equipment. Results from aircraft continue to give satisfaction, and full account of the proved capability of A.S.V. has been taken when planning sweeps and searches.

June

During the latter part of May, the following patrols using A.S.V. were ordered from time to time.

These have since been ordered as standard daily patrols :—

- (a) An area 100 miles wide, from the vicinity of the Fortes to the Tees, in a direction E.N.E., and up to 240 miles from the coast.

This patrol is carried out from dawn to dusk.

- (b) An area between parallels 55° N. and 53° N., with four aircraft carried out to a distance 180 miles from the coast. This patrol is continued after dark.

Routine patrols were laid down in June in addition to those detailed above, as follows :—

- (a) Continuous patrols during hours of darkness by one A.S.V. aircraft along a line 25 miles eastwards of shipping route from Humber to Orfordness.

- (b) Continuous cross-over patrol from the Shetlands to 200 miles due North during daylight in order to observe movements of enemy warships.

July

Continuous cross-over patrols are carried out by Sunderland aircraft to the North and East of the Shetlands.

August

It has become normal practice to use A.S.V. to increase the effectiveness of our anti-invasion patrols in the North Sea and to economise in aircraft. Further, during poor visibility, when certain standard North Sea patrols would be impracticable or of little value, a coastwise patrol 30 miles off shore during hours of darkness is flown by a Hudson with A.S.V.

October

A.S.V. equipment in Sunderland aircraft has made it possible to do more work with convoys at night than has hitherto been regarded as practicable or safe. Not only has it been possible to locate the convoys and maintain a patrol in the area without the help of moonlight, but the assistance of A.S.V. in making landfall gives pilots confidence and lessens the risk inherent in operating flying boats from Oban at night or in bad visibility.

APPENDIX No. 3

ROYAL AIR FORCE DELEGATION AND OTHER ORGANISATIONS IN THE U.S.A.

An organisation known as the British Supply Board was in existence in the U.S.A. in September 1939. This was expanded to become the British Supply Mission, of which ten members in March 1940 formed the newly-created British Air Commission.¹ In July 1941 the R.A.F. Delegation was formed to facilitate the fulfilment of the operational requirements of the R.A.F. for equipment and trained personnel. The structure of organisation naturally followed that of the parent bodies in the U.K., the Air Ministry and the Ministry of Aircraft Production. When the latter became a Ministry separate from the Air Ministry, a similar division was made in the U.S.A. The R.A.F. Delegation became a counterpart of the Air Ministry

¹ Three years later B.A.C. comprised 1,200 personnel, of whom 160 were based in the U.K.

and the B.A.C. of the Ministry of Aircraft Production. Certain branches, however, retained a joint interest ; for example, Movements and Contracts, and the B.A.C. continued to provide the R.A.F. Delegation with accounting services for stores, staff recruited locally, office equipment and transport.¹

British Air Commission

The main branches of the B.A.C. were Administrative, Technical and Supply. Radio was dealt with by two branches ; the Chief of Development Radio (C.D.R.) was responsible to the Controller of Technical Services, and the Director of Radio Supply (D.R.S.) was responsible to the Controller of Procurement and Supply. The functions of the C.D.R. were analogous to those of the department responsible for the experimental work conducted under the auspices of D.C.D. in M.A.P., whilst those of D.R.S. were akin to the duties of the H.Q. staff of D.C.D., with the addition of responsibility of progressing. The C.D.R. staff were mainly specialists in particular applications of radio, recruited from T.R.E. and R.A.E., and the D.R.S. staff were mainly re-inforced to some degree by personnel from the Directorate of Radio Production in M.A.P. From the outset C.D.R. personnel, with war experience gained in the U.K. guided the early development of radio applications. With the large and rapid growth of radio laboratories in the U.S.A., and the diversion of the electronics industry to war production, C.D.R. assumed responsibility for keeping the U.S.A. authorities informed of radio development in the U.K., for acquainting the U.K. authorities with the latest news of development in the U.S.A., and for maintaining liaison with the technical progress made with R.A.F. requirements. C.D.R. Headquarters was in Washington, but its members necessarily spent much time travelling since the laboratories and establishments with which they were concerned were scattered over a wide area ; an important factor which was not always readily appreciated in the U.K. The importance of a particular laboratory or establishment often justified individual representation ; this was provided for example at the Radiation Laboratory, Massachusetts Institute of Technology, Cambridge, and at the Aircraft Radio Laboratory, Wright Field, Dayton, Ohio. The D.R.S. staff was not required to travel so extensively or so frequently, since it was more concerned with negotiations with U.S.A. authorities in Washington regarding specifications, programmes and progress.

Royal Air Force Delegation

The main branches were Administration and Finance, Intelligence, Personnel, Plans, Signals, Supply and Organisation, Training and Equipment. The functions of the Director of Signals were parallel with those of the C.D.R., but were more concerned with the operational aspect of radio equipment and its installation in aircraft. He had important responsibilities on assignment committees for radio equipment. His staff was closely concerned with training establishments including O.T.U.s., and, in common with the C.D.R. staff, had to travel over a wide area to maintain liaison with the great number of units concerned with radio.

Radiation Laboratory

The Office of Scientific Research and Development was formed in June 1941 for the purpose of securing adequate provision for research on scientific and medical problems relating to national defence. Its functions were to advise the President and to develop and co-ordinate plans for scientific research, and it worked in collaboration with the War and Navy Departments. One of its main committees was the National Defense Research Committee, which controlled several research divisions, of which those concerned with radar and R.C.M. were of interest to the B.A.C. The instrument of the Radar Division was the Radiation Laboratory of the Massachusetts Institute of Technology, Cambridge, Massachusetts. The Laboratory offered its services in an advisory and consultant capacity to the Navy and War Departments, and also initiated projects from its own conception, or, for example, at the suggestion of B.A.C. representatives attached to it. Its main work lay in the micro-wave field, and most of its applications were radar. The Laboratory was organised in eleven divisions of which eight were technical. Of the eight,

¹ In July 1940 a member directly responsible to the Director General of Equipment was established in B.A.C. In June 1941 the post was transferred to R.A.F. Delegation.

four were devoted to applications, and four to components and servicing. Thus there was a high degree of specialisation in the groups into which the divisions were sub-divided. Each group had a chairman, and the chairmen, with the heads of divisions, constituted a Co-ordination Committee. At a higher level of representation there was a Steering Committee.

Aircraft Radio Laboratory, Wright Field, Dayton, Ohio

The executive instrument for procurement of equipment in the United States Army was the Procurement District. One of the largest of these, and the one which centralised engineering development activities was the Material Centre at Wright Field, which combined Fiscal Administration, Procurement Control and Technical Functions. The technical function was exercised by the Engineering Division which had a number of laboratories not unlike those of the Royal Aircraft Establishment, Farnborough, except that control was vested in Army Air Corps officers and not civilians. One of the laboratories was the aircraft Radio Laboratory which maintained in working order bench models of all types of airborne radio equipment with which the Army Air Corps was concerned. It also had excellent workshop and hangar facilities for trial installation and some 30 aircraft, in addition to an active interest in the aircraft based at Boston Airport for employment by the Radiation Laboratory, and a trials airfield at Boca Raton, Florida, where an average of 360 good flying days were obtained every year. Many new airborne projects were contracted out for development by firms and the Radiation Laboratory. When the latter was nominated as consultant, the Laboratory assumed responsibility for the development, but when it was nominated as adviser direct responsibility was assumed by the firm, and the Laboratory gave assistance only at the request of the contractor. In all instances the Aircraft Radio Laboratory was responsible to the Army Air Staff for the meeting of operational requirements, and to the Army Signals Corps for technical matters. All orders to firms and arrangements for financial authority were initiated by the A.R.L. which therefore bore responsibility for the planning of a project and the execution of the various measures to ensure its progress. At the procurement stage the Wright Field Communications Procurement District took over, and installations were carried out at one or the other of the 20 Modification Centres attached to the aircraft manufacturing plants in the U.S.A. under the direction of the Airplane Modification Section. The Army Air Corps had no separate Development Units as had the R.A.F., there was but little liaison with Operational Research Sections, and the A.R.L. was completely responsible for the success or failure of an installation.

Bureau of Aeronautics

In the Department of the Navy there were seven Bureaux, one of which, the Bureau of Aeronautics, was responsible for ' . . . all that relates to the design, construction, fitting out, testing, repair and alteration of naval and marine corps aircraft and . . . instruments, equipment and accessories pertaining thereto. . . . ' In radio matters it was found convenient to centralise responsibility for design, procurement, and installation in a single division of the Bureau. Research and Development were carried out by the Naval Research Laboratory situated at Belle Vue within a few miles of Washington and thus adjacent to the Radio Division. It resembled the Admiralty Signals Establishment in that it was commanded by serving officers but staffed mainly by civilians ; its scope, however, was much wider. Its relations with other laboratories and radio industry were similar to those of the Army Air Corps laboratories.

Combined Chiefs of Staff

The Combined Chiefs of Staff in Washington controlled the design, development, distribution and employment of all forms of radio. Some control over radio for air operation was earlier exercised by the Joint Aircraft Committee which had established a Joint Radio Board responsible for standardisation and a Radio Requirements Sub-committee to assign radio equipment between the Allied Air Services. The functions of the Joint Aircraft Committee were continued and co-ordinated with those of the committees under the Combined Chiefs of Staff.

Radar Research and Development Committee

The Radar Research and Development Committee was established in 1943 with a specific interest in radar as distinct from radio-communications and counter-measures. Co-ordination between the R.R. and D.C. and sub-committees of the Combined Communications Board was achieved by inter-locking membership.

Combined Communications Board

The Combined Communications Board comprised representatives as follows :—

	United States Army	2
	United States Navy	2
British	Royal Navy	1
	Army	1
	Royal Air Force	1
	Canada	1
	Australia	1
	New Zealand	1

The Board functioned through a number of committees of which the executive agency was the Combined Co-ordinating Committee consisting of 1 member from each of the U.S. Army, the U.S. Navy, The Royal Air Force and the Army. There were some 30 sub-committees in 5 groups. Each committee normally contained 6 United States representatives and 6 British Commonwealth representatives under a United States chairman. The groups were :—

- (a) Planning Group 1 committee for long-term planning.
- (b) Operations (X) Group .. 4 committees: Security, Counter-measures, Enemy Intelligence.
- (c) Operations (A) Group .. 9 committees: Technical aspects of communications, Radar, Navigational aids.
- (d) Operations (B) Group .. 11 committees: Organisation, Procedures, Callsigns, Time and Weather.
- (e) Material Group 4 committees: Research, Development, Standardisation, Procurement, Precedence.

Joint Radio Board

The Joint Radio Board was established in November 1941, before the United States of America entered the war. Its terms of reference were :—

‘ To deal solely with technical radio problems and the standardisation of material between the Service. The Board shall investigate, study, and report on questions relative to the national defence referred to it by proper authority and involving naval and military characteristics of radio equipment and technical radio problems. . . . It shall have the duty of originating consideration of each subject when in its judgement necessary, and is responsible for recommending to the Joint Aircraft Committee whatever it considers essential to establish the sufficiency and efficiency of co-ordination and standardisation between the United States and the British Services.’

APPENDIX No. 4

DEVELOPMENT OF LEIGH LIGHT¹

Concurrently with development of the Turbinlite for fighter operations,² the Leigh Light was developed for anti-U-boat and anti-shipping operations. In October 1940 Squadron Leader H. de V. Leigh suggested that effective illumination for use with A.S.V. could be provided by the employment of a Naval searchlight projector. He proposed that for experimental purposes a searchlight should be installed in the turret underneath the fuselage of one of the Wellingtons already equipped with a powerful generating set for anti-magnetic mine operations. The light was to be remotely controlled and used in conjunction with the A.S.V. equipment

¹ See Appendix X of Volume II and Appendix VI of Volume III of A.H.B. Narrative: ‘The R.A.F. in Maritime War’ for further details.

² See Royal Air Force Signals History, Volume V: ‘Fighter Control and Interception.’

so that just before an A.S.V. contact faded at a range of about one mile, the light could be switched on and the target held in the beam. A prototype installation was completed by January 1941, when it was confirmed that fortunately the Wellington was able to carry an effective depth-charge load and a full complement of petrol in addition to the A.S.V., searchlight and generator. The first night trials were not held until late in March because of bad weather and aircraft un-serviceability, but were then encouragingly successful, and further trials held early in May established beyond doubt that direct illumination from A.S.V. aircraft was a practical proposition. The generator was replaced by standard accumulators and the process of evolving technique and simplifying equipment to facilitate production was begun.

Meanwhile, however, many people mixed up the Leigh Light project with the Turbinlite system, although they were two different approaches to the attainment of two different objectives. As a result, in May the Air Ministry decided that further development was to be conducted by C.C.D.U. under the technical direction of the inventor of the Turbinlite, and in June the A.O.C.-in-C., much perturbed about the long outstanding requirement for illumination, requested that two A.S.V. Wellingtons should be immediately fitted with Turbinlite. By August 1941 those most directly concerned with the application of A.S.V. to anti-U-boat warfare had grave doubts about the suitability of Turbinlite, and the C.-in-C. requested that 6 Catalinas and 6 Wellingtons be fitted with Leigh Light as a matter of extreme urgency. In June, design of a standard nacelle installation for fitting in Catalinas and Sunderlands had been started, and when, in November 1941, Headquarters adopted officially the Leigh Light as the standard method of illumination, development was well advanced.

The first operational sortie was made from Chivenor on 8 February 1942, but by May only five Leigh Light Wellingtons had been delivered to the squadron, No. 172, which had been formed to exploit the new weapon. The Air Ministry insisted upon operational experience being gained before increased production and installation in Catalinas and Liberators were approved. Thus, when No. 172 Squadron began operations in earnest on 4 June 1942, it was unfortunately with four aircraft only. By the end of 1942 the Leigh Light was firmly established as an extremely valuable adjunct to A.S.V., and before the end of the war was instrumental in the destruction of 27 U-boats and the damaging of 31. Success in attack depended mainly on the skill of the A.S.V. operator, and intensive training was required before a sufficiently high standard was reached.

APPENDIX No. 5

THE TOWED RECONNAISSANCE (AIR/SEA) FLARE¹

In 1937 a member of the Signals Staff at Headquarters Coastal Command invented an air/sea reconnaissance flare device to be towed by aircraft, and devised a method in which observing aircraft disposed some four miles distant on either side of the towed flare, searched in its reflected beams. Use of the reflected flare of a beam was not a new idea, but properly co-ordinated searches or strikes by means of it had never been systematically and scientifically developed. Previously numerous flares were dropped above the estimated point of interception of a target in the hope that one would fortuitously floodlight the target. Floodlighting had been the aim although naturally targets had, on occasions, been revealed in the beam of one of the many flares dropped, but floodlighting alone was virtually useless as a method of search and attack.

No. 217 Squadron began trials of the Towed Reconnaissance Flare in May 1938. From the beginning all shipping in the areas swept was located and readily identified; two observing aircraft were able to sweep about 50 square miles per flare every three and a half minutes. The advent of A.S.V. as a search device apparently lulled Headquarters Coastal Command into a belief that illuminants would no longer be required, and T.R.F. development was discontinued. When it was realised that illumination of the target was still essential for identification and attack even when A.S.V. was used for search and location, interest in flare technique was revived, but as an addition to, and not a substitution for, A.S.V. Meanwhile

¹ A.H.B. Narrative: 'The R.A.F. in Maritime War,' Volume III, Appendix VII.

the Fleet Air Arm had continued development of the T.R.F. in its basic form but as a towed target. During the evacuation of Dunkirk the target aircraft were hastily improvised for use of T.R.F. in the role for which it was originally intended. Its success impressed the Air Officer Commanding-in-Chief Coastal Command, but he was most unfortunately misled to envisage the towing aircraft reconnoitring in the floodlight of its own flare. He strongly advocated resuscitation of development of the T.R.F. and No. 206 Squadron was equipped with a small number of hand-made installations. In the absence of adequate instructions, they were used operationally as floodlight illumination, the towing aircraft doing its own observing and unsuccessfully attempting attacks without the aid of parachute flares. Tactical and technical trials had meanwhile been recommenced by C.C.D.U. in May 1941, but progress was very slow, and the Development Unit also omitted to use supplementary flares once the target had been located by the T.R.F. technique. Consequently in April 1942 the C.C.D.U. recommended that the T.R.F. ' . . . is impracticable as an aid to attacking submarine by aircraft . . . ' and development was again discontinued. Its potential value as an alternative to A.S.V. for night search is debatable since effective employment entailed the use of one towing and two observing aircraft, but at no period of its development could it have provided what was most urgently required, illumination as a supplementary aid to A.S.V.

APPENDIX No. 6

**SPECIFICATION OF REQUIREMENTS FOR CENTIMETRE WAVE
A.S.V. SYSTEM BY E. G. BOWEN, 27 JANUARY 1941**

1. General Requirements

The requirements of an A.S.V. system are that patrol aircraft should :—

- (a) Be able to detect and locate the position of surface craft at night or under conditions of poor visibility.
- (b) Sweep the maximum area of sea in the shortest possible time.
- (c) Be able to home on to any vessel or vessels in this area.
- (d) Perform blind bombing accurately.
- (e) Have continuous indications of the positions of all ships within range on the simplest possible indicating device.

2. General Specification

Existing methods of ship detection on 1½ metres satisfy some but not all of the above requirements.

The Homing System in which overlapping beams are thrown forward from the aircraft satisfies 1(a) and 1(c).

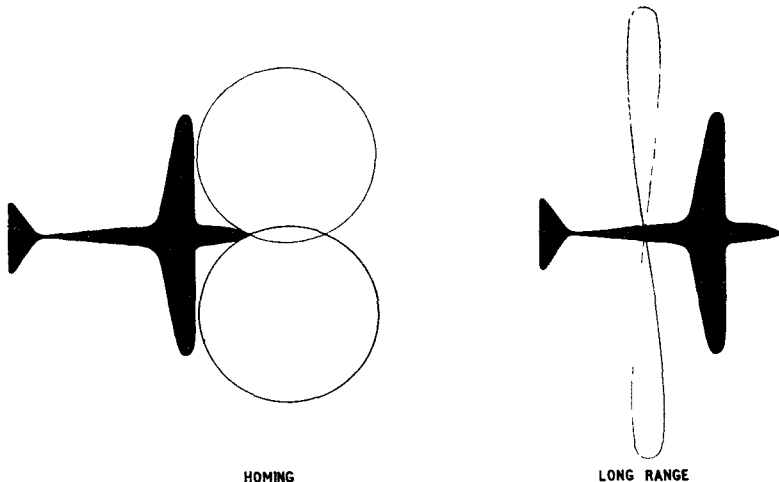

The *Long Range System* in which narrow beams are projected sideways from the aircraft is designed to satisfy 1(a) and 1(b), but does not perform the homing function 1(c) unless auxiliary aerials are fitted.

The present methods of indication leave much to be desired, and the accuracy is certainly not good enough for bombing through the overcast. From experience to date it is very doubtful whether conditions 1(d) and 1(e) could ever be met on wavelengths longer than 10 centimetre.

A suggested centimetre wave design which would satisfy all but 1(d) of the above requirements is, as follows :—

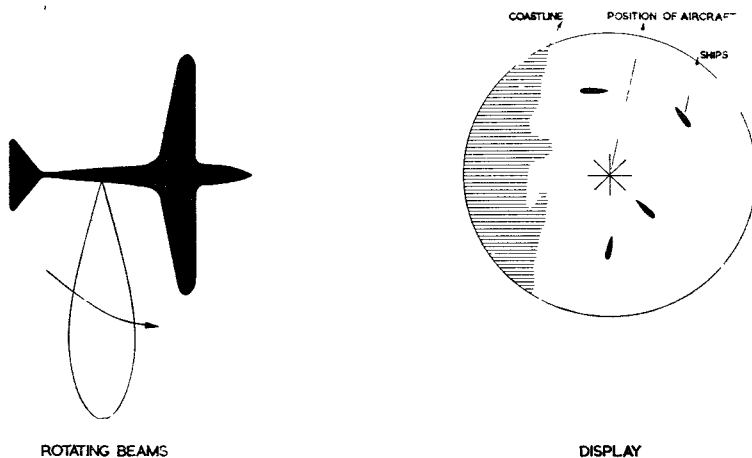

A centimetre wave beam is projected from a convenient point on the aircraft, and made to rotate at a speed not slower than one revolution per second. Returned signals are fed to the face of a cathode ray tube or equivalent mechanical-optical device so as to give plan position of ships and coastline in the vicinity. The advantages of the system are obvious as a ship search and navigational device, and the tactical operations which may be carried out are :—

- (a) Search of a wide sea area.
- (b) Homing on any vessel within range.
- (c) Continuous spotting and following of vessels overnight; an operation which is difficult with existing apparatus because of the restricted coverage.

3. Detailed Specifications

(a) **Choice of a Wavelength.** In order to obtain a sufficiently narrow beam with a reasonable aperture, the wavelength should be below 10 centimetres. The success of the Bell Laboratory magnetron design at 8.4 centimetres suggests that this wave-length should be adopted for airborne ship detection equipment.

(b) **The Aerial System.** The radiator, which would be common to transmitter and receiver, should, in the first instance, be a flat horn of aperture approximately 30 inches by 6 inches mounted amidships on the aircraft above or below the fuselage. It should be capable of rotation about a vertical axis at a speed faster than one revolution per second, and be fed through a single line along the axis of rotation. The beam width would be approximately plus or minus 7 degrees for 6 decibels down in the horizontal plane, approximately a circle diagram in the vertical plane. This spread in vertical distribution represents a waste of energy, but appears unavoidable if frontal area of the radiating system is to be kept down.

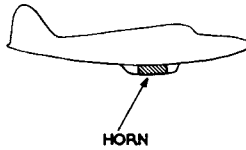

If the space is available in the nose of the aircraft and backward looking is abandoned, a simplified version of the A.I. system might be adopted, giving perhaps twice the maximum ranges, but in the forward direction only.

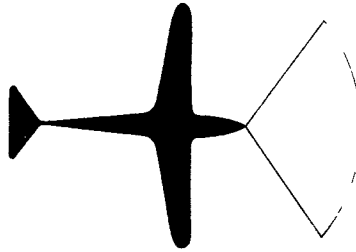

(c) **The Transmitter.** The transmitter should use the Bell Laboratory version of the British E.1189 magnetron and have the following characteristics :—

Wavelength	8.4 cms.
Peak output	50 kilowatts.
Pulse width	2 microseconds.
Recurrence frequency	2,000 per second.

(d) **The Receiver.** The receiver would be of conventional centimetre wave design using a crystal mixer, and a velocity modulated local oscillator in the absence of a suitable triode. The I.F. amplifier should have a 1' megacycle' band-width and its rectified output should be capable of modulating the intensity of a cathode ray tube beam or other light source. The receiver should operate on the same aerial as the transmitter, and would have to include a buffer stage to protect it from the direct signal. Since minimum range is not a dominant requirement it is unnecessary to suppress the direct signal at any other point in the receiver.

(e) **The Indicating Device.** The plan position indicator might be a cathode ray tube with delay screen and radial time-base, or the mechanical-optical equivalent. The mechanical method had advantages of simplicity, ruggedness and probably ease in maintaining a picture of constant intensity.

4. Anticipated Performance

From the data available on reflections from ships and ground objects it is anticipated that the maximum range of detection of the above equipment on different targets would be :—

Submarines	5 miles.
Destroyers	10 miles.
Capital ships	20 miles.
Coastline	50 miles.

Range accuracy would be better than plus or minus 5 degrees, and bearing accuracy plus or minus 3 degrees.

5. Bombing through Overcast

It is unlikely that equipment designed for adequate spotting and following could also have sufficient accuracy for blind bombing. In the first instance, it would be necessary to design special centimetre wave equipment for this particular purpose, combining it with all-round looking at a later date if this were found possible.

January 27 1941.

APPENDIX No. 7

OPERATIONAL REQUIREMENTS FOR A.S.V. BRITISH JOINT POLICY 3 JULY 1942

The Aim of A.S.V.

The primary function of A.S.V. is to provide a means for aircraft to locate, and home on to, enemy shipping beyond visual range, thereby increasing the search area of individual aircraft. Secondly, A.S.V. is required to enable aircraft to locate and home on to friendly shipping convoys, to whom they are providing air escort protection. Thirdly, A.S.V. is required to provide a means whereby an aircraft can fix its position, home to a base on land or water, and thereafter, if necessary, make a beam approach with the minimum of external human aid.

Requirements to Meet the Aim

A.S.V. equipment should provide long range detection over a wide field in all directions from the aircraft. It should provide immediate indications as to whether a detected vessel or aircraft is friendly or doubtful. The indication should enable the detached target to be closed, and include information on the type of target. The accuracy given in range and direction should be such as to enable blind bombing or torpedo attack to be carried out. These characteristics should be retained throughout the full range of operational heights of the type of aircraft in which the A.S.V. equipment is fitted.

A.S.V. should provide aircraft of a striking force despatched to attack enemy shipping with means of homing on to a beacon carried in a reconnaissance aeroplane shadowing the enemy force.

The third requirement will be met by A.S.V. equipment which enables the aircraft to position itself by, and home on to, coded beacons from long ranges, together with the ability to receive directional indications from special beacons with sufficient accuracy to enable a beam approach to be executed.

A.S.V. equipments should give full display of information to the operator and incorporate the maximum of automatic control. A simple form of indicator should, in addition, be provided for the pilot, which he may or may not use, at his convenience.

Detailed Operational Requirements for Future A.S.V. Equipment

All future A.S.V. equipment should aim at fulfilling the following requirements :—

- (a) (i) All-round location in plan.
- (ii) P.P.I. form of presentation, with a similar form for a pilot's indicator.
- (b) Maximum range from aircraft at 1,000 feet should not be less than :—
 - (i) Against submarine, conning tower only 10 miles.
 - (ii) Against submarine awash 20 miles.
 - (iii) Against single ship of 1,000 tons 20 miles.
 - (iv) Against battleships 40 miles.
 - (v) Against E-boats (aircraft at 500 feet) 10 miles.

- (c) Beacons should be readable up to ranges of at least 100 miles.
- (d) Direction finding should be accurate to $\pm \frac{1}{2}$ degree within 10 degrees of the dead ahead position, with no sensible time lag in the electrical equipment in order to enable it to be used with blind bombing or blind torpedo attack equipment.
- (e) It must give an immediate identification to the crew as to whether the target is friend or doubtful. Some method of identification of friendly targets is of paramount importance.
- (f) The pilot and observer of aircraft fitted with A.S.V. should have visual indications given them of the A.S.V. beam approach system.
- (g) Equipment should incorporate anti-jamming devices to enable it to function in spite of enemy attempts to interfere with the performance of the equipment.
- (h) It should provide, when required, an aural indication of the presence of a target.
- (i) Beacon coding and I.F.F. from friendly ships or aircraft should be readable by both the pilot and the observer.
- (j) The equipment is to be suitable for use at all heights between 50 and 15,000 feet.

OPERATIONAL REQUIREMENTS FOR A.S.V. AS REVISED BY SUB-COMMITTEE ON AIRBORNE RADAR 3 SEPTEMBER 1942

The Aim of A.S.V.

The primary function of A.S.V. is to provide a means for aircraft to locate, to close, and to attack enemy shipping beyond visual range, thereby increasing the effective search area of individual aircraft. It should further provide information to assist in the location of enemy aircraft when early warning information is available.

(Secondly and thirdly as before.)

Requirements to Meet the Aim

A.S.V. equipment should provide long range detection over a wide field in all directions from the aircraft. It should provide for display of information to determine if detected aircraft is friendly or doubtful. The indication should enable the detached target to be closed, and include information on the type of target. The accuracy given in range and direction should be such as to enable blind bombing or torpedo attack to be carried out. These characteristics should be retained throughout the full range of operational heights of the type of aircraft in which the A.S.V. equipment is fitted.

A.S.V. should provide aircraft of a striking force despatched to attack enemy shipping with means of homing on to a beacon carried in a reconnaissance aircraft shadowing the enemy force.

The third requirement will be met by A.S.V. equipment which enables the aircraft to position itself by, and home on to, secure coded beacons from long ranges, together with the ability to receive directional indications from special beacons with sufficient accuracy to enable a beam approach to be executed.

A.S.V. equipments should give full display of information to the operator and incorporate the maximum of automatic control. A simple form of indicator should, in addition, be provided for the pilot, which he may, or may not, use at his own convenience.

Detailed Recommendations

All future A.S.V. equipment should aim at fulfilling the following requirements :—

- (a) (i) It is essential to afford location in plan in all forward directions and it is desirable to afford such location in all directions.
- (ii) P.P.I. or other appropriate map type presentation should be used, and a pilot's indicator of appropriate characteristic incorporated in the installation.
- (b) Maximum ranges from aircraft at 1,000 feet should not be less than :—
(as before with the addition of :)
 - (vi) Against aircraft 8 miles.
The minimum range as not limited by sea return shall not exceed 1,000 feet and preferably shall be of the order of 400 feet.
- (c) As before.
- (d) Azimuth should be accurately indicated in all directions represented to not more than plus or minus 3 degrees and within 10 degrees of the dead ahead position to within plus or minus 1 degree, with no sensible time lag in the electrical equipment in order to enable it to be used with blind bombing or blind torpedo attack equipment.
- (e) It must provide for the introduction on the display of an immediate identification to the crews as to whether the target is friendly or doubtful. Some method of identification of friendly targets is of paramount importance.
- (f) The pilot and A.S.V. operator should both have visual indications given them of the A.S.V. beam approach system.
- (g) (As before) with addition of —Provision should be made to prevent saturation of any amplifier in the system to permit homing on the jamming transmitter.
- (h) (As before.)
- (i) (As before.)
- (j) The equipment should be suitable for use at all heights up to 15,000 feet.
- (k) It is desirable that provision should be included to enable estimation of angular elevation of enemy aircraft to assist in their location.

OPERATIONAL REQUIREMENTS FOR A.S.V. RADAR COMMITTEE 2 OCTOBER 1942

The Aim of A.S.V.

(Primary function as before.)

(Secondary function as before.)

Thirdly, A.S.V. is required to provide a means whereby an aircraft can fix its position, home on to a base on land or water, and thereafter, if necessary, make a beam approach with the minimum of external human aid. Such provisions as may be necessary to interrogate beacons from the A.S.V. directly, or alternately from ancillary apparatus, and appropriately to receive and display the response, depend on policy decisions as to the nature of the beacon system generally adopted.

Requirements to Meet the Aim

A.S.V. equipment should provide long range detection over a wide field in all directions from the aircraft. It should provide for display of information to determine if detected craft is friendly or doubtful. The indication should enable the detected target to be closed, and include display of information on the type of target. The accuracy given in range and direction should be such as to enable low altitude

blind bombing or torpedo attack to be carried out. These characteristics should be retained throughout the full range of operational heights of the type of aircraft in which the A.S.V. equipment is fitted.

(As before.)

(As before.)

(As before.)

Detailed Recommendations

(a) (i) As before.

(ii) As before.

(b) As before.

(c) As before.

(d) Azimuth should be indicated in all directions represented to not more than plus or minus 3 degrees error and within 10 degrees of the dead ahead position to within plus or minus 1 degree error and desirably within plus or minus $\frac{1}{2}$ degree, deteriorating to a maximum of 3 degrees at 25 degrees from dead ahead position, with no sensible time lag in the electrical equipment in order to enable it to be used with low altitude blind bombing or blind torpedo attack equipment.

(e) (As before.)

(f) (As before.)

(g) (As before.)

(h) (As before.)

(i) (As before.)

(j) (As before.)

(k) (As before.)

APPENDIX No. 8

PRELIMINARY REPORT ON POSSIBLE COUNTER-MEASURES AGAINST H2S, JANUARY 1943

The possible counter-measures against the 10-centimetre system can be divided into two classes. The first class contains those schemes which intend to jam or blot out the H2S signals on the P.P.I. presentation. The second class contains those schemes whose intention is to confuse the H2S picture or to produce false signals which appear as a town on the P.P.I. tube. Of the many known types of jamming in the first class, the following were tried :—

(a) Unmodulated C.W.

(b) Frequency modulated C.W.

(c) I.F. frequency amplitude modulated C.W.

In the second class, the following schemes were considered :—

(d) Simulating an echo from a town with the signal reflected from corner reflectors.

(e) Possible signal from a patch of Window.

(f) Producing a fake town signal from a ground transmitter triggered by the H2S transmitter pulse.

Results of Tests

(a) **Unmodulated C.W.** For this type of jamming it was necessary to build a transmitter of at least 1 to 2 watts, tunable over the 10-centimetre wavebands. The only valve available was the early Sperry klystron. The transmitter was tuned to the centre of the 9.2 centimetre band of magnetrons and set up in an open space with usual output lines and a dipole-fed 12-inch paraboloid. With careful tuning, rough thermo-couple measurements gave about 3 watts for the output

power. Preliminary tests against a roof installation of H2S were fairly successful so flight tests were made. The results of several flights over the ground transmitter showed an effective jam or blanking out of a 90 degree arc of the P.P.I. tube at ranges under 4 miles with usual receiver gain settings. With full gain a range of 5 to 6 miles on the C.W. would be obtained. A much larger paraboloid of 4 feet was installed to check greater ranges but no aircraft was available for testing.

(b) Frequency Modulated C.W. A Heyl tube was used in this test with a mechanically driven vibrator in the line resonator to give frequency modulation. The output of the tube was only about $\frac{1}{2}$ watt on C.W. Tests on the ground showed effective jamming at short ranges against H2S installed in an aircraft, but the power was too low to obtain any jamming signal on several flight tests.

(c) I.F. Modulated C.W. For this test a very low-powered split anode magnetron was used as the transmitter. The old type of magnetron used was modulated on the anode with a $13\frac{1}{2}$ megacycles per second oscillating voltage. The percentage of modulation was about 10. The results obtained show that H2S can be jammed by the sidebands of this modulated transmitter producing a $13\frac{1}{2}$ mcs signal in the crystal mixer. However, the expected limitations on the strength of this signal, modulation, R.F. loss in receiver antenna system, etc., etc., were soon evident. The low-powered magnetron jammed effectively over short distances but test flights were not considered practical.

(d) Signal from Corner Reflectors. The well known efficiency of the so-called corner reflector for returning signals to our radar sets made this appear a likely device. Therefore, large numbers of these were built, each reflector being half of a diagonally cut 6 feet cube. A large number of flights were made in an attempt to detect these corner reflectors in numbers up to 75. For these flights the corner reflectors were faced in approximately the same direction with the same tilt and runs were made over them at various heights between 7,000 and 10,000 feet. In no case could a signal from the corner reflectors be located at even short ranges and almost grazing incidence. At these low angles the signal scattered from the ground is a minimum and the reflected signal from the corner reflectors should be a maximum. Later tests have shown that the signal from a town is generally 10 to 15 decibels up on the scattered ground return. Therefore it appears that very great numbers of corner reflectors would be necessary to simulate the echo from a town. Furthermore, we must multiply this number by 4 in order to have the corner reflectors give the same signal for every line of approach. In view of the large amount of metal and work necessary for their construction, corner reflectors do not appear very practicable as a scheme for decoy towns.

(e) Possible Signal from Window. It has not been possible to investigate this possibility because of the shortage of aircraft and security difficulties of Window. However, it does appear that a very large and concentrated area of Window would be needed since signals from towns are rather strong.

(f) Fake Town Signal. To produce this signal a high-powered pulse klystron, OPK.4, was used as a transmitter. This valve was modulated with a 10 kilovolt, 8 ampere, 2 microsecond pulse from a modified Type 64 modulator, and the output was about 4 to 8 kilowatts peak power. This output was fed through the usual matching stubs to a dipole feeding into a 12-inch paraboloid. In order to lock the decoy signal to the H2S scan a separate centimetric receiver was tuned to the aircraft transmitter signal. The 1 microsecond pulses from the receiver were used to trigger the modulator multi-vibrator. Thus the receiver was tuned to the H2S transmitter and the klystron pulse output was locked to the H2S scan. This resulted in 2 microsecond pulse appearing on the H2S P.P.I. presentation. Preliminary results show that this signal could surely be confused with a town at long ranges, say from 30 to 10 or 15 miles. Here, however, the failure to spread in range would make the decoy discoverable. This deception would surely hinder blind navigation on H2S and by switching the decoy transmitter to wider pulses the deception could be carried to even shorter ranges. Further results and pictures to show the P.P.I. tube under jamming could not be obtained because of the shortage of aircraft for flight trials.

Conclusions

From these preliminary results, together with the generally known facts on enemy jamming, it appears possible that C.W. jamming will be an early menace. Though the enemy may experience some difficulty in obtaining power and coverage, the narrow band of the C.W.64 and the very broad polar diagrams of the H2S scanner make this type of jamming dangerous. As regards the other class of counter-measures, confusing the H2S picture, the widespread use of decoys at present would suggest the corner reflector town, but this does not seem practicable.

APPENDIX No. 9

POTENTIAL ENEMY ACTION IN CENTIMETRIC R.D.F. MEMORANDUM BY SIR ROBERT WATSON WATT

The enemy may derive knowledge of the function of our radio devices from three sources :—

- (a) Interception of emitted signals.
- (b) Secret Agents.
- (c) Capture of equipment.

The enemy may apply the information so derived to two main objectives :—

- (a) That of denying us the full fruits of the use of the equipment.
- (b) That of embodiment of some or all of the technique in equipments to be used against us.

The question posed to the Radio Board by the Chiefs of Staff Committee requires some examination of the degree to which the capture of specific equipments at a specific time would aid the enemy, primarily in denying us the full enjoyment of related equipments, but secondarily in aiding his use of related equipment.

To deny us full enjoyment, the enemy may follow one of four courses :—

- (a) He may employ technical or tactical means for avoiding the return to us of the tactical information which our equipment seeks to provide.
- (b) He may jam our reception technically by more or less standard radio methods.
- (c) He may confuse the interpretation of the returned intelligence by a diffuse overlaying system.
- (d) He may provide clearly defined but misleading intelligence by the construction of radio decoys.

In order to take avoiding action, such as the submerging action which may be taken by a U-boat subjected to A.S.V. search, he required the warning given by an R.D.F. installation of his own or the warning given by a listening equipment capable of receiving and interpreting the radio signals from ours. The capture of our equipment is not necessary to the development of his own submarine-borne R.D.F. equipment; it is for examination whether the capture would notably accelerate his development of a listening system. Before he can devise a useful listening system he must know the frequency band in which our equipment works. This may be determined accurately from captured equipment, but it can be inferred with sufficient certainty without such capture. We have for nearly 2 years been sending powerful signals on 10-centimetre wavelengths across the Straits of Dover. We have for about a year been sending much stronger signals on the same wavelength across to Cherbourg. We have for some months been operating A.I. equipment on 10 centimetres close up to the coastline of occupied territory. We have for over 2 years been making R.D.F. transmissions from H.M. ships. H.M.S. *Prince of Wales*, containing two R.D.F. installations working on 10 centimetres wavelength is lying in comparatively shallow water, buoyed by the Japanese, and the Japanese have, according to Ministry of Economic Warfare Intelligence, recently ordered from the Germans, signal generators on 10-centimetre wavelengths.

Having determined the order of wavelength on which to listen, the enemy can, with great ease, set up a simple crystal receiver followed by an audio-frequency amplifier which, when installed in a submarine, would detect and permit the interpretation of 10 centimetre R.D.F. signals from aircraft within optical range, that is, up to ranges of about 100 miles for normal flying heights. This simple receiver would not require retuning to enable it to listen to signals on any wavelength between 8 and 12 centimetres and would have to be carefully designed if it were to exclude signals on 3 centimetres.

The capture of sample equipment need not be a major contribution to the decision to fit listening sets. The period required to pass from information about a centimetric aid to bombing to an inference about centimetric aids to U-boat location may, in my view, be very short indeed—probably less than 2 weeks. The design and manufacture of the simple crystal receiver envisaged could be carried through within a period of 2 or 3 months at most. The installation could be completed within the normal stay of a U-boat at its European base.

By spreading the operational frequencies of the airborne equipment over such a band as can be permitted by a single standard equipment, with different magnetron valves only, some inconvenience can and should be imposed on the enemy. A spread of 100 megacycles per second is certainly, and of 150 megacycles per second probably, permissible. The line of reasoning which might carry the enemy, without capture of equipment, to the conclusion that we are using or are about to use airborne 10 centimetre equipment has been used successfully by ourselves. The discovery of a 57 centimetre equipment in *Graf Spee* and of 53 centimetre on the ground led us to expect that German airborne A.I. would operate in a band of 50 to 60 centimetres wavelength; in fact it has now been heard on 61 centimetres, identified as airborne, and correlated with night interception operations.

It is not to be assumed that the listening technique necessarily denies us the use of A.S.V. on the wavelength to which the enemy listens. There is a comparatively simple combination of technical and tactical means by which A.S.V. attack can be made without the enemy being aware that the A.S.V. aircraft is heading for him or approaching him.

In order to do normal radio jamming the enemy requires :—

- (a) A knowledge of the frequency band, and
- (b) The technical means for sending out considerable powers on wavelengths selected by us and variable by us at our discretion.

He must, therefore, have a tunable transmitter of considerable power. Had we not developed so successfully as we have, the high-powered magnetron, we should have by now a high-powered klystron with considerable flexibility in tuning. This development would have followed normally from material published in the United States before 1939. It would also be a normal development along the same line to have a tunable local oscillator valve for a precise monitoring receiver. Work on these devices, and on airborne R.D.F. equipment working on 10 centimetres, was proceeding in the United States (before their entry into the war) under conditions in which security could not be as good as in full wartime conditions. It may, therefore, be surmised that the enemy has had available to him the information, the intelligence and the ingenuity required for the design of effective jamming equipment on 10 centimetres. That we are not aware of its existence may be due to one of several causes, among them :—

- (a) The fact that he has not in fact developed the equipment.
- (b) The fact that he has not judged the time ripe for operational application.
- (c) That our listening watch is insufficiently full to discover his transmissions.

It is true that 10 centimetre R.D.F. equipment is still achieving surprise when used in attack by surface anti-U-boat craft: it is also true that our listening watch has not yet established the existence of enemy shipborne R.D.F. (which may however with some certainty be inferred from the precision of his gunnery from capital ships). It may be argued that the failure of the enemy to avail himself of any protective measures against 10 centimetre R.D.F. proves that he has not yet appreciated the fact of its use, in spite of the material available to him from which to make the necessary deductions.

The enemy may confuse our air centimetric R.D.F. system by means which have been discussed in the earlier proceedings of the Board. We have prisoner-of-war statements, of unknown credibility, that the enemy is aware of this possible technique and of our alleged use of it. The capture of our centimetric equipment might accelerate, but would not be necessary to his development of, such means.

In order to mislead us by decoy systems, the enemy might set up passive responders to simulate the objects (by land and by sea) for which we are conducting our airborne R.D.F. search. The capture of equipment might accelerate, but would not be necessary to initiate, development work by the enemy in this direction. He might, and probably with greater effect after capture of an equipment, set up active decoys in the form of repeater systems on our I.F.F. principle, but working on centimetric wavelengths each simulating responses from a substantial area. The capture of equipment would at once be an important stimulus, and an important aid to such development.

The second major advantage which the enemy might derive from the capture of our equipment would be the development of similar devices for use against us. From the capture of an H2S equipment he might well proceed to the development of a centimetric A.I. equipment which would be much better than his existing A.I. The protection of our bombers against the effects of such equipment is well advanced. We have also just reached the stage of having our riposte to the use by his bombers of countermeasures to our centimetric A.I. equipment against our night fighters if he should develop such methods.

He may develop, by direct copying or by modification, a centimetric A.S.V. installation, against which we have such protection as is given by listening receivers or by submarine-borne R.D.F.

He might copy directly the technique and the function of H2S for use against us. I doubt personally whether he requires this aid to such bombing attacks, on this country at least, as he may have in contemplation.

I would offer again as a personal estimate, the opinion that none of these devices for use against us can be introduced on an operationally valuable scale in less than 12 months. It is probable that a period of 15 months would be required, and not improbable that 18 months might be necessary.

If we assume that the enemy has little or no present knowledge of centimetric R.D.F. technique, the time factor following the capture of H2S, is in my estimate likely to be as follows :—

- (a) To develop a listening system which could help a submarine to submerge before our attack. Some 2 to 3 months for development, followed by a delay until each submarine then at sea has returned to its home base for fitting.
- (b) Counter-measures to deny us full enjoyment of the device, in their simplest form some 2 to 3 months, in fuller form some 12 months.
- (c) Development of similar devices against us, 12 to 18 months.

APPENDIX No. 10

T.R.E. POST DESIGN SERVICE

The T.R.E. Post Design Service was a direct descendant of the Service Liaison Section, a small team of scientists which had been formed to assist the rapid and efficient introduction of the first centimetric wave airborne equipment, A.I. Mark VII. The team made a thorough study of the installation, flew with it, trained operators and mechanics, made by hand the bulk of the necessary test gear and distributed vital spares, such as pulse transformers, magnetrons and high voltage plugs, where they were most needed.¹ The value of the ' After Sales Service ' had been quickly appreciated at the Ministry of Aircraft Production and at the Air Ministry. During

¹ See Royal Air Force Signals History, Volume V : ' Fighter Control and Interception.'

the period of development of A.S.V./H2S it had been realised that similar and extended services would be of mutual benefit to the research establishment and the Royal Air Force. Technical advice and assistance on ground radar equipments were obtainable from No. 60 Group, and on communication equipments from the R.A.E., but no parallel organisation for airborne radar equipment existed.

In November 1942, therefore, in addition to the formal introduction of the Fighter Command Service Liaison Group, two new groups had been formed, known as the Coastal and Bomber Command Service Liaison Groups. At the same time a co-ordinator was appointed within T.R.E. to ensure that the methods used by T.R.E. to introduce radar equipment and by R.A.E. to introduce communications equipment were standardised as much as possible, and to obtain agreement on the scope of services to be rendered. It was decided that the organisation inside T.R.E. should be based on commands rather than on equipments in order that closer contact with officers in the Air Ministry, the Ministry of Aircraft Production and any one command might be achieved. Each Command Liaison Group was divided into an organisation section and technical field parties. The organisation section considered a proposal as a whole, decided what action should be taken on each aspect of the introduction of a new equipment and made the appropriate long-term recommendations. The functions of the new division at T.R.E. had thus been made much wider in scope than those of the original A.I. Mark VII team, and the name was changed from Service Liaison to Post Design Services.

As soon as a definite programme was decided upon, the P.D.S. division was responsible for carefully reviewing, with particular attention to their being completed in time for the initial introduction to the Service of an equipment, the following activities :—

Provision of test gear, descriptive documents, servicing instructions, draft A.M.Os., training equipment, training films, and any particularly difficult spare components. Training of servicing personnel and instructors for R.A.F. schools, and the introduction of modifications.

The function of the field parties was to continue, on squadrons, the early training of the servicing mechanics, and to ensure that the equipment was serviced and operated as nearly as possible as it was originally designed with the maximum of efficiency. This did not preclude the introduction of modifications, but it did ensure that modifications were not introduced in any haphazard manner and followed a properly authorised channel.

APPENDIX No. 11

COMMITTEES FORMED TO DEAL WITH RADIO ASPECTS OF MARITIME WARFARE

The Air Defence Sub-Committee, under the chairmanship of the Secretary of State for Air, before the war dealt with the general problems of air defence on behalf of the Committee of Imperial Defence, and was advised on scientific aspects by the Committee for Scientific Survey of Air Defence, formed on 28 January 1935 under the chairmanship of Sir Henry Tizard. During the war several committees were brought into being to formulate, each at its own level, policy and doctrine for the employment of airborne weapons in conjunction with seaborne weapons, against enemy surface vessels and submarines, and radar was a main feature of their deliberations. Although a separate committee at each level was to be expected, the responsibilities of Coastal Command to both the Admiralty and the Air Ministry complicated procedure to some extent, and resulted in duplication of effort, but co-ordination was effective, and duplication often ensured that the subject matter was dealt with very thoroughly.

The Night Interception Committee

At the outbreak of war, a process of decentralisation of committees for the purpose of more detailed specialisation was set in train. On 14 March 1940, the Air Ministry formed the Night Interception Committee under the chairmanship of the Deputy

Chief of Air Staff, ' . . . to co-ordinate all work on the problem of night interception, to initiate action to this end, and to keep a close watch on progress in each line of development ' The work of the committee soon, however, extended beyond night interception, and progressively dealt more and more with problems of air interception of surface vessels and U-boats.

The Air Interception Committee

In July 1940 the Night Interception Committee recognised the broadening of its field, and adopted the new title of the Air Interception Committee, including amongst its members a representative of the Air Officer Commanding-in-Chief Coastal Command.

The Air/Sea Interception Committee

As the maritime aspect of the Air Interception Committee developed, it became desirable to place air to air, and air to sea interception problems in the hands of two separate committees, and at its 31st meeting on 3 July 1941, the committee resolved to adopt the division. On 24 July 1941 it was decided to form the Air/Sea Interception Committee under the chairmanship of the Chief of the Air Staff, with representatives from the Air Ministry, the Admiralty, the Ministry of Aircraft Production and Headquarters Coastal Command. The new committee held its first meeting on 14 August 1941.

The Admiralty/Coastal Command Standing Committee on Aircraft Anti-Submarine Operations¹

When operational control of Coastal Command was transferred to the Admiralty, a need was felt for closer liaison between the Admiralty and Headquarters Coastal Command on anti-submarine tactics, although it was the responsibility of the Air Officer Commanding-in-Chief to employ his air forces as he thought to achieve the aim. The desired co-ordination was effected by a joint committee called the Admiralty/Coastal Command Standing Committee on Aircraft Anti-Submarine Operations, first convened under the chairmanship of the Director of Anti-Submarine Warfare on 26 June 1941. The chairman directed discussion along two main lines :—

- (a) What could be done immediately, with existing weapons and resources, to improve the killing power of an aircraft against a U-boat.
- (b) What could be done in the future by producing new weapons or devices to effect a further improvement.

Aircraft Anti-U-Boat Weapons Sub-Committee

Before long the committee became entangled in the more specialised technical aspect of anti-submarine weapons, and on 9 July 1941 the Aircraft Anti-U-boat Weapons Sub-Committee was formed to assess the value of airborne weapons against U-boats, and to advise the Aircraft Anti-U-boat Committee on those matters. The Air Ministry, the Admiralty and the Ministry of Aircraft Production were represented under the chairmanship of the Director of Scientific Research.

The Admiralty/Coastal Command Night Attack Sub-Committee

As the problem of night attack against U-boats became more urgent it became necessary to form a specialist sub-committee to deal with it. Consequently on 22 September 1941 the Night Attack Sub-Committee came into being with representatives from the Admiralty, the Air Ministry and the Ministry of Aircraft Production under the chairmanship of Professor Blackett of Headquarters Coastal Command. It had as its terms of reference the study of tactical employment of aircraft against U-boats at night, and, of course, advised its parent committee on that subject, until on 25 March 1942, it was replaced by the Coastal Command Committee on Anti-Submarine Warfare.

¹ This committee should not be confused with the Admiralty/Coastal Command Standing Committee, which dealt with the much broader aspect of the fighting efficiency of Coastal Command as a whole in relation to its responsibility to the Admiralty.

The Coastal Command Committee on Anti-Submarine Warfare

By virtue of its terms of reference and in the absence of a Coastal Command Committee with sufficiently wide representation, the Standing Committee sometimes found itself dealing with tactics of air/sea warfare which were entirely the responsibility of the Air Officer Commanding-in-Chief. He therefore, on 8 May 1942, convened the Coastal Command Committee on Anti-Submarine Warfare under his chairmanship, and explained that his new committee had wider terms of reference than the Night Attack Sub-Committee which it replaced, and would relieve the Standing Committee of certain purely Royal Air Force matters. The Admiralty, the Air Ministry and the Ministry of Aircraft Production were well represented and altogether some 43 members attended the first meeting. Shortly after the appointment of Air Marshal J. C. Slessor as Air Officer Commanding-in-Chief, he reviewed the status of the Committee and promptly obtained approval for it to be transferred to the Air Ministry on 13 February 1943.

The Admiralty Radio-U-Committee

The Admiralty Radio-U-Committee was formed in March 1943 and given the task of studying the signals and radar aspects of anti-U-boat warfare. The Air Ministry, the Ministry of Aircraft Production, and Headquarters Coastal Command were represented at its meetings held at the Air Ministry.

The Admiralty Radar-U-Committee and W/T-U-Committees

At the 13th meeting of the Radio-U-Committee on 1 December 1943, it was proposed that in view of the recent transfer of radar responsibility from the Directorate of the Signal Division to the newly-formed Directorate of Radio Equipment, the committee should be replaced by two committees; a radar committee to deal with the radar aspect of anti-U-boat tactics, and a W/T committee to deal with the signals aspect. The proposal was approved by the Admiralty on 9 December 1943. The Radar-U-Committee held its first meeting on 22 December under the chairmanship of the Director of Radio Equipment, with representatives from the Air Ministry, the Ministry of Aircraft Production and Headquarters Coastal Command as members, and the W/T-U-Committee, with similar membership, on 5 January 1944 under the chairmanship of the Director of the Signals Division.

The terms of reference of the Radar-U-Committee were:—

- (a) To cover the whole field of radar development in connection with anti-U-boat warfare.
- (b) To communicate the results of its detailed considerations to one or more of the following committees:—
 - (i) Admiralty U-boat Warfare Committee.
 - (ii) Air Interception Committee.
 - (iii) Aircraft Anti-U-boat Committee.
 - (iv) Aircraft Anti-Ship Committee.
- (c) On receipt of approval from a higher committee, to initiate the necessary action through its members, and progress development to the point at which final recommendation might be made for production and tactical employment.

The terms of reference of the W/T-U-Committee were similar but related, of course, to W/T and direction finding equipment and technique, with a rider.

- (d) To review constantly all signals matters of mutual concern to the Admiralty and Headquarters Coastal Command, and to concert any action necessary to improve and maintain signals efficiency.

It was from these two specialist committees that the policy for the tactical development of radio equipment used against the U-boat was first issued in co-ordinated form. They were the instruments which the Signals and Radio staffs of the Admiralty, the Air Ministry and Headquarters Coastal Command used to tackle any problem common to all three.

COASTAL COMMAND DEVELOPMENT UNIT AND AIR/SEA WARFARE DEVELOPMENT UNIT

After the formation of the Fighter Interception Unit at Tangmere in April 1940 it became clear that trials under Service conditions of new airborne radar equipment provided information which was extremely valuable to those concerned with its design and development. The F.I.U. naturally limited its trials to types of A.I. equipment, and the lack of a similar unit to conduct trials with A.S.V. was keenly felt by the Air Ministry Research Establishment.¹ For a variety of reasons it was not practical for the Special Duty Flight to conduct elaborate trials; the main concern of that unit was to provide the flight trials of equipment whilst it was still in the experimental stage. The location of the S.D.F., Christchurch, and its lack of contact with operational groups made a very unsuitable basis for a Service trials unit.

To some extent the Fleet Air Arm Service Trials Unit filled the gap, but the methods by which the Fleet Air Arm wished to use A.S.V. were inevitably different from those envisaged by Coastal Command, and the full operational value of A.S.V. to Coastal Command was therefore apt to be overlooked.

The A.M.R.E. consequently suggested in July 1940 that the organisation of the trials unit for Coastal Command should be similar to that of F.I.U., and that its terms of reference should cover trials of new, undeveloped equipment and all production installations. It would thus undertake the first operational tests of A.S.V. Mark II and L.R.A.S.V. The location of the unit obviously depended on considerations not known at the A.M.R.E. but it was proposed that it should not be far removed from the scene of actual operations whilst remaining, if possible, within reach of areas where strong enemy opposition was unlikely to be encountered. The A.M.R.E. recommended that the unit should be equipped with all types of aircraft used by the command, including flying boats. It was evident that without such a trials unit it would be impossible to develop to the full the tactics which A.S.V. made possible, and in the opinion of A.M.R.E. an immediate task was the development of a technique for using A.S.V. for blind bombing and torpedo attacks against surface vessels.²

On 18 October 1940 the Coastal Command Development Unit was formed to conduct Service trials of, and to examine and develop tactical employment of, existing and new radio devices.³ Its primary function was the evolution of A.S.V., but it soon became involved with many other types of equipment, so inextricably interdependent were their purposes.

The unit was established at Carew Cheriton, Pembrokeshire, with one of each type of Coastal Command operational aircraft, flying boats being based as a detachment at Pembroke Dock,⁴ and was placed under the command of Headquarters No. 15 Group,⁵ but Headquarters Coastal Command retained operational control to safeguard the unit from being side-tracked from its primary rôle into day-to-day operations and to facilitate rapid exchange of information. Difficulties were soon encountered because the absence of workshop facilities at Carew Cheriton complicated the servicing of an ever-varying assortment of some fifteen aircraft and the technical equipment associated with them, and the runways were inadequate and often dangerous.

The disadvantage of having only one aircraft of each type and one set of each new equipment was quickly felt. Although C.C.D.U. trials were supposed to have been of a purely tactical nature there was inevitably a long phase of technical

¹ Later, Telecommunications Research Establishment.

² C.C. File S.9108/36.

³ The first official trial, to test the performance of Long Range A.S.V. in a Sunderland, began on 14 December 1940.

⁴ To gain access to the North Atlantic and the Bay of Biscay, detachments were stationed at Limavady in Northern Ireland, and St. Eval.

⁵ Until H.Q. No. 15 Group moved from Mount Batten to Liverpool and H.Q. No. 19 Group took its place and assumed command of the C.C.D.U.

development trials in the preliminary stages. Experience showed that until the performance of a new device had been fully investigated by flying laboratory tests, tactical trials, with their requirement for complicated administrative preparation, were of little use. The system of arranging trials was haphazard until May 1941, when Headquarters Coastal Command assumed responsibility for the detailed allocation of tasks, the allotment of priorities, and co-ordination. A serious drawback at first was inability to obtain easily a submarine for employment as target, but after a conference and demonstration in April 1941, Sir Henry Tizard brought the matter to a head. In May 1941 the Commander-in-Chief, Western Approaches, arranged to make a dummy training submarine available at Holyhead, but unfortunately it was withdrawn after one brief period of trials. In July 1941, however, arrangements were made for the use of an H class submarine, with which the first trials were completed on 7 August 1941. Although an improvement, this was but an expedient, a submarine available at very short notice in the immediate vicinity being the true requirement. In December 1941 the unit was transferred to Ballykelly in Northern Ireland where submarines were more easily obtainable and open waters more accessible, but in June 1942 another move was made, to Tain in north-eastern Scotland, geographically remote and badly placed for liaison with all organisations with which contact was important. Yet another move was made in April 1943, this time to Dale in Pembrokeshire, and in September of that year the unit returned to the vicinity of its birthplace when it settled at Angle.¹ In March 1945 it was absorbed in the Air/Sea Warfare Development Unit, which was formed to undertake all forms of tactical development for maritime air forces. It was organised in anti-ship and anti-U-boat sections, and included a Fleet Air Arm section to work in conjunction with the R.A.F. anti-ship section. In addition to work carried out for the Air Ministry and the Admiralty, it undertook tactical trials of anti-ship weapons, ancillary equipment and methods on behalf of all R.A.F. commands. Requests for tactical trials to be undertaken, and tactical problems to be studied, were co-ordinated by the Director of Tactics, and requests relating to technical matters such as modifications, by the Assistant Chief of Air Staff (Technical Requirements), at the Air Ministry.²

APPENDIX No. 13

AIR STAFF SPECIFICATION FOR A.S.V. BOMBSIGHT

Production models of A.S.V. Mark XIII, a development of A.S.V. Mark XI for installation in Fleet Air Arm aircraft, were expected to be ready for operational use by July 1945. It was designed to provide a high degree of definition against small targets, and the intention was to use in conjunction with it an A.S.V. bombsight of British design and manufacture, A.S.V. Bombsight Mark V. The combination of the two equipments was known as A.S.V. Mark XIV. The bombsight was originally intended for installation in Barracuda aircraft of the Fleet Air Arm and was therefore designed for a range of speeds from 105 to 170 miles per hour, and for operation by one member of the crew, which meant that azimuth corrections had to be given verbally to the pilot instead of by means of electrical indicators or by direct control of the automatic pilot.³ In view of Coastal Command's urgent requirement, however, the possibility of its use in the Royal Air Force was contemplated. The first prototype to be received from the development contractor was so badly engineered that it was not accepted by the T.R.E., where it was considered not worth while to install the sight in Coastal Command aircraft. If the work was done over again, and the speed range extended up to 200 miles per hour, production could not be expected until the spring of 1946, and an extension of the upper speed limit to 280 miles per hour would involve complete re-design and a further delay of at least six months.

Use of the Mark V bombsight involved a steady run-up of two minutes duration, and it was more than probable that electronic computer technique would develop during the next two years to such an extent that an aircraft using it would be given

¹ C.C.D.U., O.R.B.

² A.H.B./ID/12/99. Coastal Command Organisation.

³ A.H.B./IIC/85/87(C).

a much greater degree of tactical freedom ; the existing form of A.S.V. bombsight was likely to become obsolete in the very near future. The Director of Radar therefore recommended in June 1945 that T.R.E. should produce hand-made A.S.V. Mark V bombsights which could be given Service trials in order to obtain data on which to base specifications for a long-term bombsight.

The Director of Armament Requirements accordingly circulated around the Air Staff a draft specification for an A.S.V. bombsight and on 30 July 1945 a meeting was held to formulate the final Air Staff requirement. It was decided at the meeting that development of the sight should be completed by the end of 1946 and that it should be ready for Service use by the end of 1947. This decision was made only after considerable discussion, since it was thought by many present that the sight should be a long-term project to be developed by the end of 1950.

The final decision was influenced by the facts that data on future anti-shipping weapons would not be available for some time, there was no British blind-bombing sight in service for anti-shipping or anti-U-boat operations, T.R.E. required guidance quickly on future development, and that although the requirement would specify the bombsight to be ready for service in two or three years, it would not necessitate production unless it was still a requirement at that time.

The requirements formulated were for a bombsight which would enable aircraft to attack shipping both at anchor and under way when the target could not be seen because of darkness or bad weather. The sight was required for use in all R.A.F. aircraft fitted with A.S.V. and H2S equipment, and was therefore to be self-contained and designed to operate with all current and projected marks of A.S.V. and H2S equipment. It was to be capable of being operated by the Bomb Aimer or Radar Operator, and was to be linked with the automatic pilot ; of being used for the attack on whatever targets the main A.S.V. equipment could see and discriminate ; and of operating in reasonable sea and weather conditions and when only intermittent responses were being received. It was to be designed to allow accurate aiming of the full range of anti-submarine, general purpose, medium capacity armour piercing and other capital ship bombs, depth charges and homing weapons that had to be dropped within the vicinity of the target. It was required to work between the heights of 50 and 7,000 feet ; it was desirable that the upper limit of the height range should be extended as far as possible provided that the accuracy of the sight in the lower height band was not impaired. The limits of the approach speed were to be taken as 100 knots and 550 knots ; the run-up to the target was not to entail holding a steady course. It was considered important that use of the sight should not impose upon the aircraft any restrictions on manoeuvre, and was to allow for a drift angle of 30 degrees to port and to starboard. The sight was to be fully tropicalised, reliable, easy to maintain under active service conditions, robust, fully protected against interference, and suitable for quantity production.

The requirements were subject to amendment in the light of results obtained from the Service trials of A.S.V. Bombsight Mark V and the sight was to be developed in parallel with other radar developments, particularly in connection with submarines. It was originally intended that the sight should be a joint Naval/Air Staff requirement, but the Admiralty was unable to agree that the bombsight would meet Fleet Air Arm requirements unless weight and space limitations were clearly defined. The Air Staff, however, was unwilling to restrict development by imposing such limitations ; the sight was therefore a Royal Air Force requirement although the Admiralty wished to be associated with its development and kept informed of its progress.

50-CENTIMETRE A.S.V.

When the Germans began fitting U-boats with search receivers, the possibility of using 50-centimetre A.S.V. was considered. However, the equipment had been installed in one Anson only, and although the A.S.V. Panel suggested that the employment on anti-U-boat patrols of that aircraft might persuade the enemy to believe that a change on a large scale to 50-centimetre A.S.V. was contemplated, the R.D.F. Board did not agree.¹ At the request of the Director of Communications Development, Service trials were undertaken in October 1942 by the C.C.D.U. who reported that the installation showed sufficient promise to justify its employment in operational aircraft; it was not, however, used on operations at any time.

On 30 November the possibility of using 50-centimetre A.S.V. was revived when the British Air Commission suggested that an attempt to defeat the German search receiver might be made by utilising American A.S.B. equipment which operated on a wavelength of 58 centimetres, a model of which was in the possession of the T.R.E. The Chief of the Air Staff was advised by the Director-General of Signals, after agreement had been expressed by the Commander-in-Chief Coastal Command, that the wavelength was an unsatisfactory compromise between $1\frac{1}{2}$ metres and 20 centimetres. He was of the opinion that even if the process of installation proved to be simple, several months would pass before the equipment could be obtained in quantity from the U.S.A. and before Coastal Command aircraft could be prototyped and equipped. Moreover, the Royal Air Force was already faced with the problem of installing, operating and maintaining a diversity of A.S.V. installations, including A.S.V. Mark II, DMS.1,000, A.S.G.1, SCR.517, SCR.717 and A.S.V. Mark III, and the addition of yet another type of A.S.V. was to be avoided if at all possible. The examination of A.S.B. installation problems was considered to be worthwhile, and if they were not serious, the Ministry of Aircraft Production could be asked to obtain 250 sets from the U.S.A. as an 'insurance policy' against an unexpected major failure of the A.S.V. Mark III system. Meanwhile, any emphasis and effort expended on obtaining and fitting A.S.B. would have detracted from concentration on the main object, to install and operate A.S.V. Mark III in Wellington XI and XII, Sunderland and Halifax aircraft as soon as possible.²

In February 1943 the employment of A.S.B. was again proposed. Then the suggestion was that the equipment should be modified to operate on a wavelength of 61 centimetres in order that the German search receiver might be countered, for it was then believed that German airborne radar operated on that wavelength and that German monitoring operators would therefore be instructed to ignore transmissions made on it. Estimations indicated that about 30 sets of A.S.B. could be obtained in approximately three months, and that all necessary modifications could be completed in four months. The Commander-in-Chief, Coastal Command, rejected the proposal because technical and production resources would have been diverted from the vital task of completing the 10-centimetre A.S.V. installation and 3-centimetre A.S.V. development programmes.³

A final attempt to introduce 50-centimetre A.S.V. into operational use was made in July 1943 when the Director of Radar suggested its employment as a temporary measure. By then a number of A.S.B. equipments were available in the United Kingdom, and arrangements were initiated to install one in a Wellington XII or XIV aircraft for Service trials at the C.C.D.U. Shortage of aircraft defeated this plan and the project was eventually abandoned.⁴

¹ A.M. File C.S. 23295.

² A.H.B./IHK/24/209. A.S.V. and H2S.

³ A.M. File C.48100/52, Part II.

⁴ A.M. File C.S. 10183.

A.S.V. MARK VIII AND MARK VIII A

A.S.V. Mark VIII was the American 3-centimetre A.S.V. equipment A.S.D., and was used by Coastal Command only in Venturas for meteorological flights between January and March 1944. A.S.V. Mark VIII was soon replaced by the production version of the equipment, A.S.V. Mark VIII A or A.S.D.1. The installation was exceptional in that it was designed and developed specifically for the A.S.V. role instead of being an adaptation of H2S. The installation weighed about 260 pounds and consisted of the scanning system, transmitter/receiver, modulator, rectifier, receiver amplifier, indicator, azimuth calibrator and control unit. The scanning system included an 18 inch diameter paraboloid, waveguide fed from the back, the waveguide exciting a dipole with reflector. The T.R. unit was designed to be mounted immediately behind the scanner unit and both were shaped to fit into a tapered nacelle which was located above the cockpit and between the two aircraft propellers. It contained the magnetron, crystal mixer and head amplifier with suitable monitoring circuits. The modulator, a standard pressurised Philco, common to several American equipments, contained pulse forming and shaping circuits, hard valve modulator and power supplies. The rectifier was merely a power unit; it carried no controls and could be stowed anywhere in the aircraft. The receiver amplifier contained the I.F. strip, A.F.C. circuits, video amplifier, and cathode ray tube deflection circuits.

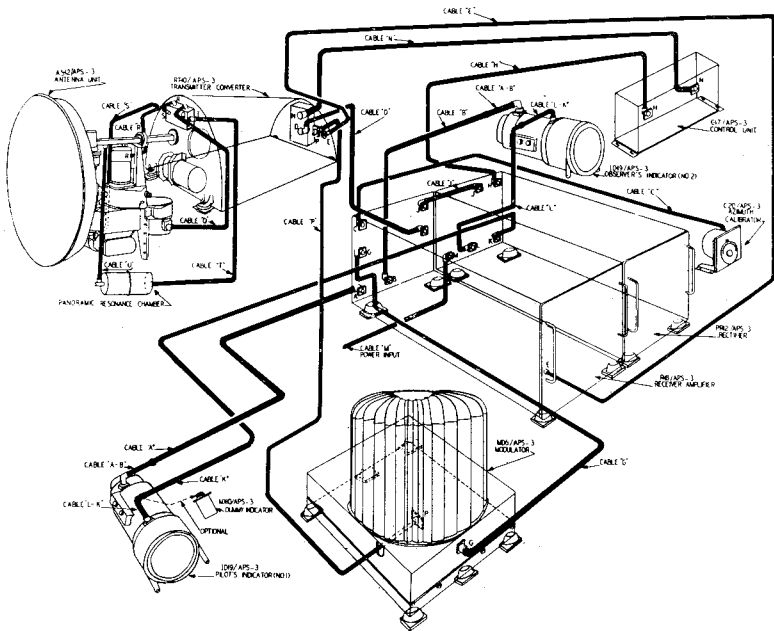

A.S.V. Mark VIII A (A.S.D.1)

A large number of pre-set controls were mounted on the front panel but it was not necessary to touch them during flight. The automatic frequency control was similar to that used in many American equipments. The indicators were very compact, containing only an electro-magnetic 5 inch cathode ray tube with brilliance and focus controls, the case being shaped to fit the C.R.T. B Scope display was used. The control unit, which clipped on to the rectifier unit and shared its shock mounts, contained the main on-and-off switch and all controls necessary during flight except the azimuth calibrator. The azimuth calibrator was a calibrated

potentiometer which enabled the azimuth of any target to be read very accurately. All the cabling sockets of A.S.V. Mark VIIIA were located on the backs of the units thus facilitating a clean layout but rendering servicing very difficult. Very few modifications, the chief of which was the incorporation of a sea-return discriminator, were necessary to make the equipment acceptable for use in Coastal Command. Its standard of serviceability was good although it was susceptible to dampness which caused excessive cable trouble ; eventually all American cables were replaced with British cables.