TEXAS INSTRUMENTS



MULTIPAGE TELETEXT DECODER
USER GUIDE

CF72407
Revision 1

ADVANCE INFORMATION documents contain information on new products in the sampling or pre-production phase of development. Data and specifications are subject to change without notice

I2C BUS INTERFACE.....	1
I2C BUS INTERFACE HARDWARE	2
HARDWARE REGISTERS.....	7
CONFIGURATION REGISTER READ OPERATION	8
CONFIGURATION REGISTER WRITE OPERATION	9
DECODER HARDWARE REGISTERS.....	11
TELETEXT FRONT END REGISTERS.....	14
MEMORY CONFIGURATION REGISTERS.....	15
VIDEO DISPLAY PROCESSOR (VDP).....	20
PHASE LOCKED LOOP (PLL).....	32
PLL CONTROL REGISTERS.....	38
PLL MAIN TECHNICAL DATA	39
TELETEXT ERROR COUNTING.....	44
VPS ERROR COUNTING	45
EXTENDED FULL SCREEN COLOUR.....	46
EXTENDED CURSOR FUNCTIONS.....	47
COLOUR PALETTE	49
TELETEXT	51
DISPLAY A TELETEXT PAGE.....	52
DISPLAY NEXT OR PREVIOUS TELETEXT PAGE	54
TELETEXT PAGE ACQUISITION TABLE	59
SINGLE TELETEXT PAGE ACQUISITION	61
SINGLE TELETEXT SUBPAGE ACQUISITION	63
MULTIPLE TELETEXT PAGE ACQUISITION.....	65
TELETEXT PAGE STATUS.....	68
READ DATA FROM A TELETEXT PAGE.....	75
WRITE DATA TO A TELETEXT PAGE.....	80
TELETEXT PAGE HOLD ON/OFF	83
MENU PAGES	85
ALLOCATE MEMORY FOR MENU PAGES.....	86
INVENTORY PAGE ON / OFF	87
DISPLAY MENU PAGE	90
INITIALISE MENU PAGE	91
READ DATA FROM MENU PAGE	94
WRITE TO MENU PAGE.....	96
COPY DATA FROM MENU PAGE TO MENU PAGE.....	98
COPY TELETEXT DATA TO A MENU PAGE.....	101
CHARACTER SETS.....	105
CHARACTER SET COMMANDS	106
ALLOCATE MEMORY FOR CHARACTER SETS	108
COPY CHARACTERS FROM FONT ROM TO DRAM	110
DOWNLOAD A CHARACTER SET VIA I2C-BUS	112
TOP	115
VERIFY TOP TABLE RECEPTION.....	116
TOP TABLE PROCESSING	117
REPORT DIRECT CHOICE PAGE NUMBERS.....	128
DISPLAY.....	129
ENABLE DISPLAY ROWS	130
REPORT DISPLAY PAGE.....	131
DISPLAY TIME.....	132
DISPLAY TIME OFF.....	134
ENABLE ROLLING HEADER	135

DISABLE ROLLING HEADER	136
DISPLAY PAGE HOLD ON/OFF.....	137
GHOST ROWS	139
ENABLE GHOST ROW RECEPTION	140
READ GHOST ROW DATA.....	143
PACKET 26.....	151
ALLOCATE MEMORY FOR PACKET 26 TABLES	152
INITIALISE PACKET 26 TABLES	153
LOAD ACCENT TABLE.....	154
LOAD G2 LOOKUP TABLE.....	155
LOAD G3 LOOKUP TABLE.....	156
FLOF	157
REPORT FLOF LINKS.....	158
PDC / VPS.....	161
PDC DATA READ	162
VPS PROCESSED DATA READ.....	164
VPS COMPATIBLE DATA READ	166
VPS RAW DATA READ	167
MISCELLANEOUS.....	169
POWER ON RESET.....	170
SOFTWARE RESET	171
TELETEXT RECEPTION ENABLE.....	172
TELETEXT RECEPTION DISABLE.....	173
SELECT TELETEXT MODE	174
DECODER STATUS	176
CHANNEL CHANGE	182
CHANNEL CHANGE (NON-DESTRUCTIVE)	183
CHANGE TELETEXT BUFFER SIZE	184
INITALISE PALETTE.....	185
APPENDIX A.....	187
THE PAGE PRIORITY SYSTEM.....	188
APPENDIX B.....	191
THE FLOF SYSTEM	192

I2C BUS INTERFACE

I2C BUS INTERFACE HARDWARE

This section describes the I2C interface and its usage to control the operation of the Multipage decoder. It does not contain the electrical and timing specification of the I2C bus. For detailed information on this issue read the manual *I2C Bus Specification* from Philips. The I2C bus address for this device is 22hex.

Note: Philips is the patent holder of the I2C bus standard.

Introduction

The CF72407 Teletext decoder is an I2C slave device. Under the control of an I2C master the CF72407 may act as a transmitter of status and data (Master Read Mode) or as a receiver of commands and data (Master Write Mode).

I2C Interface Pins

The I2C interface consists of two pins:

1. SDA - Serial Data.
2. SCL - Serial Clock.

Both SDA and SCL are bi-directional lines, connected to a positive 5V supply voltage by a pull up resistor. The output stages of SDA and SCL are open drain outputs. The micro processor always generates SCL for all data transfers.

Data validity

Data on the SDA line must be stable during the HIGH period of the clock. The HIGH or LOW state of the data line may only change when the clock signal on the SCL line is LOW (Figure 1).

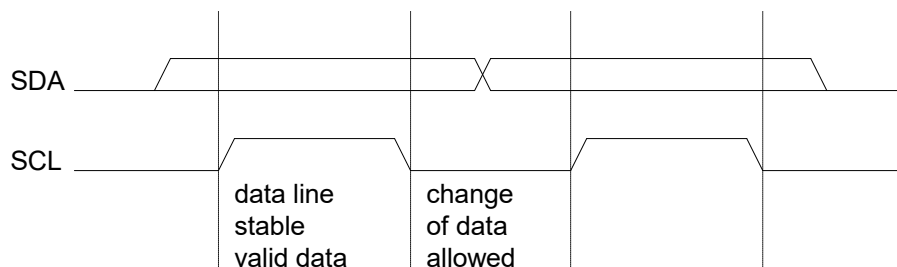

Figure 1: Bit Transfer

Start and Stop conditions

The CF72407 detects the Start and Stop conditions generated by the I2C -- bus master as follows. A HIGH to LOW transition of the SDA line while SCL is HIGH indicates a **Start Condition**. A LOW to HIGH transition of the SDA line while SCL is HIGH indicates a **Stop Condition**.

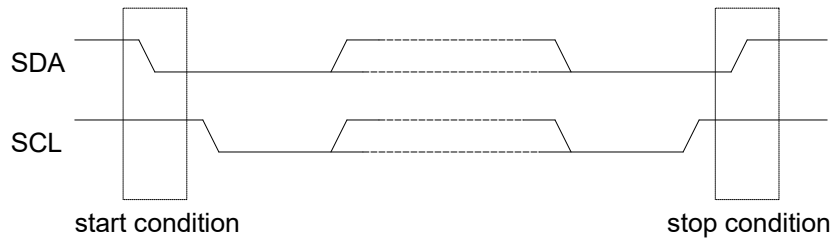

Figure 2: Start and Stop condition

DATA TRANSFER

Byte Format

The total number of bytes transmitted per transfer is unrestricted. The acknowledge bit terminates each byte. The device sends the most significant bit of the byte first (Figure 3).

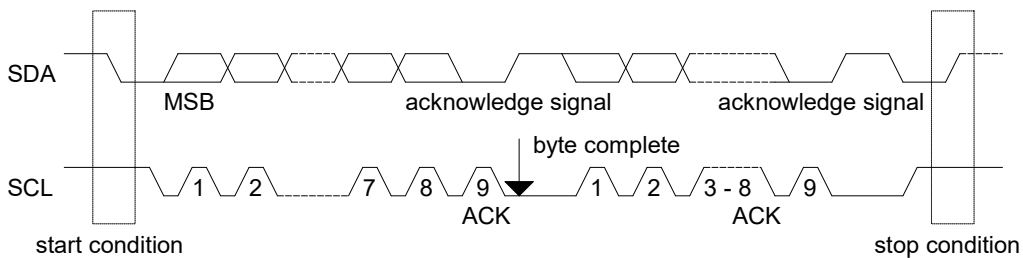

Figure 3: Data Transfer

Acknowledge

In conformance with the I2C specifications, data transfer uses acknowledge bit mechanism. Following each 8 bit data transfer, the master must generate a 9th clock that is the acknowledge pulse (Figure 4). When writing data to the CF72407, on the 9th clock pulse, the master releases the SDA line. As acknowledgement that it has received the data, the CF72407 will pull down the SDA line during the 9th clock pulse so that the SDA line is stable during the high period of this clock pulse. When the master reads data from the CF72407 during the 9th clock pulse, the CF72407 will release the SDA line thus allowing the master to generate an acknowledge by pulling the SDA line low.

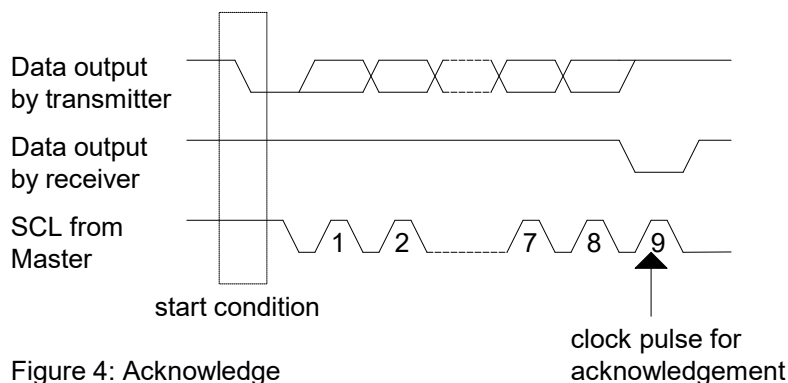

Figure 4: Acknowledge

Handshake

Although the CF72407 is able to receive or send bytes of data at the maximum data rate, it may need more time for internal processing. In this case the CF72407 will use the clock synchronising mechanism on a byte level as specified by the I2C specification to slow down the data transfer.

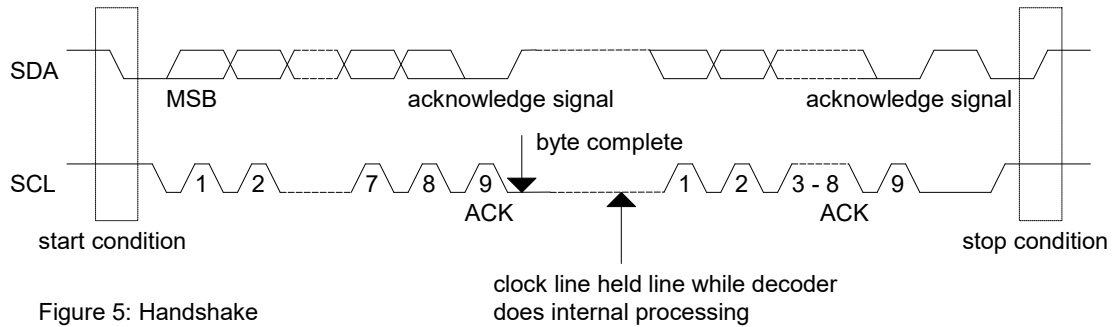

Figure 5: Handshake

Formats

Data transfers follow the format shown in Figure 6 and Figure 7. For a typical transfer, after the start condition, a slave address is send by the master. The address will be 7 bits long and the 8th bit is a data direction bit (R/W). A "zero" indicates a transmission by the master (write) and a "one" indicates a request for data by the master (read). The master will conclude the data transfer either by a stop condition (Figure 6) or by another start condition (Figure 7) generated by the master. The micro controller can conclude a request for data (R/W bit set to 1) by not sending the acknowledge pulse (release SDA during the 9th clock) after receiving the last byte. This is to avoid conflicts in generating STOP or START conditions on the bus.

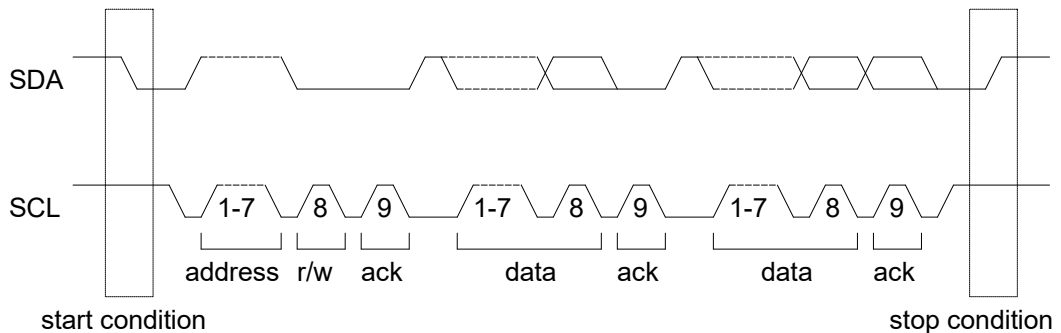

Figure: 6

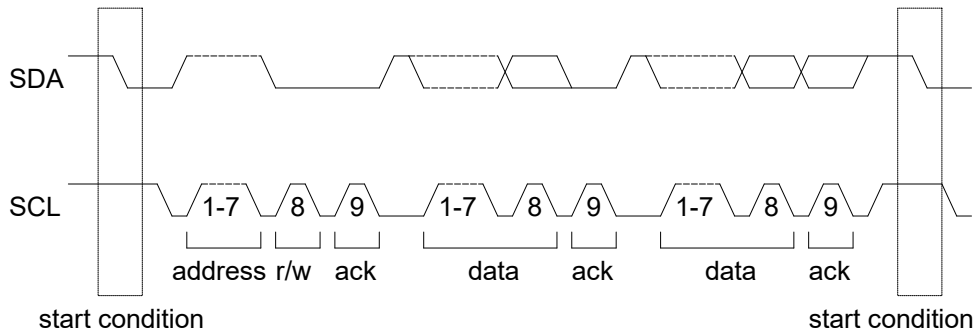

Figure: 7

ADDRESSING

Slave Address

The CF72407 evaluates the first byte after a valid Start condition against its own address. The decoder's address is 0010001 (binary), when it receives this address the CF72407 responds with an acknowledge bit. The first byte after a start condition is:

MSB							LSB
0	0	1	0	0	0	1	R/W

I2C Slave Address

General Call Address

The CF72407 does not acknowledge the general call address.

I2C Bus Operation

The CF72407 I2C internal control software has an 16 byte wide input and output buffer. The CF72407 will execute the command sent to it either if a Stop condition, another Start condition or when the input buffer is full (16 bytes). Each command requires a specific number of bytes and the decoder will ignore any additional bytes. After receiving an I2C command the decoder will always return a status byte. This byte informs the micro controller if the command contains any errors. If the microprocessor reads more data bytes from the decoder than specified by a command, the extra bytes will be undefined.

The status byte can be one of the following:

Status	Description
00	COMMAND ACCEPTED
01	COMMAND REJECTED Due to an incorrect number of bytes for the command or an invalid data
02	COMMAND REJECTED Due to an invalid command code
03	COMMAND REJECTED Due to an error that occurred while the command was being processed
04	BUSY The decoder has initiated a time consuming command. It will continue to return this status code as long as the command has not completed. Upon completion of the command it will return an appropriate status (i.e. 00 or 03). If a write to the device is initiated during this busy condition, the SCL line will be held low until the command has completed and the decoder can continue.

Any other command status indicates a FATAL error during I2C bus communication.

HARDWARE REGISTERS

CONFIGURATION REGISTER READ OPERATION

With the command described below the programmer will be able to read the register content of the configuration registers. When the decoder receives this command, it will send the register content to the master controller starting at the register address received with the command.

The decoder will ignore the command if the register address is outside the specified range.

I2C Command Format

MSB							LSB	
0	0	1	0	0	0	1	R/W	I2C Slave Address R/W = 0
0	0	0	0	0	0	0	0	Command code (0x00)
0	0	0	A4	A3	A2	A1	A0	Register Address
0	0	1	0	0	0	1	R/W	I2C Slave Address R/W = 1
ST7	ST6	ST5	ST4	ST3	ST2	ST1	ST0	Command Status
D7	D6	D5	D4	D3	D2	D1	D0	Data Byte 1
.	
.	
D7	D6	D5	D4	D3	D2	D1	D0	Last Data Byte

Register Address

The command contains the address of the first register. The decoder will increment the register address automatically after a master read access.

A[0..4]: Valid register addresses are in the range from 0..24(hex).

Command Status

The command returns the following status codes:

ST[0..7]	Description
00	COMMAND ACCEPTED
01	COMMAND REJECTED Due to an incorrect number of bytes for the command or an invalid register address
02	INVALID COMMAND CODE

Data Bytes

The data bytes will carry the control bits for the addressed register. Thus any bit combination is possible.

CONFIGURATION REGISTER WRITE OPERATION

With the command described below the programmer will be able to write into these registers. When the decoder receives this command it will transfer the data bytes that follow to the appropriate registers starting at the register address received with the command.

The decoder will ignore the command if the register address is outside the specified range.

NOTE: *IT IS RECOMMENDED THAT A READ, MODIFY, WRITE APPROACH IS USED IN CHANGING THE CONTENTS OF THE CONTROL REGISTERS. ALL UNUSED BITS IN A REGISTER SHOULD ALWAYS BE SET TO ZERO, IN ORDER TO GUARANTEE COMPATIBILITY WITH FUTURE DECODERS.*

I2C command format

MSB							LSB	
0	0	1	0	0	0	1	R/W	I2C Slave Address R/W = 0
0	0	0	0	0	0	0	1	Command code (0x01)
0	0	0	A4	A3	A2	A1	A0	Register Address
D7	D6	D5	D4	D3	D2	D1	D0	Data Byte 1
.	
.	
D7	D6	D5	D4	D3	D2	D1	D0	Last Data Byte
0	0	1	0	0	0	1	R/W	I2C Slave Address R/W = 1
ST7	ST6	ST5	ST4	ST3	ST2	ST1	ST0	Command Status

Register Address

The command contains the address of the first register. The decoder will increment the register address automatically after a master write access.

A[0..4]: Valid register addresses are in the range from 0..24(hex).

Data Bytes

The data bytes will carry the control bits for the addressed register. Thus any bit combination is possible.

Command Status

The command returns the following status codes:

ST[0..7]	Description
00	COMMAND ACCEPTED
01	COMMAND REJECTED Due to an incorrect number of bytes for the command or an invalid register address
02	INVALID COMMAND CODE

DECODER HARDWARE REGISTERS

The decoder contains a set of hardware registers to which the system programmer has direct access. He can write or read the contents of these registers. There are four groups of registers.

- PLL configuration registers.
- Display processor (VDP) related control registers.
- Memory configuration registers.
- Teletext Front end and quality control registers.

This section describes the function of each register and how to access the registers.

NOTE: *IT IS RECOMMENDED THAT A READ, MODIFY, WRITE APPROACH IS USED IN CHANGING THE CONTENTS OF THE CONTROL REGISTERS. ALL UNUSED BITS IN A REGISTER SHOULD ALWAYS BE SET TO ZERO, IN ORDER TO GUARANTEE COMPATIBILITY WITH FUTURE DECODERS.*

Hardware Register Address Map

Below is the register address map. The commands write to and read from configuration registers will explain how the programmer can access these hardware registers. The definition of the different hardware registers and their control bits will be explained in the sections

- Phase locked loop (PLL)
- Display processor (VDP)
- Memory Interface (DRAM)
- Teletext Front End (TTX).

REGISTER MAP

Register No.	Description	Default Value
00	Not used	00 h
01	Teletext Framing Code	27 h
02	Memory Configuration 1	00 h
03	Memory Configuration 2	00 h
04	Memory Configuration 3	** h
05	Language Control	08 h
06	Display Control 1	00 h
07	Display Control 2	00 h
08	Display Control 3	00 h
09	Display Control 4	03 h
0A	Display Control 5	00 h
0B	Cursor Row	00 h
0C	Cursor Column	00 h
0D	Picture Vertical Position	21 h
0E	Picture Horizontal Position	94 h
0F	Full Screen Colour Control	00 h
10	PLL Configuration 1	00 h
11	PLL Configuration 2	01 h
12	PLL Configuration 3	07 h
13	PFAST	55 h
14	PSLOW	04 h
15	IFAST	08 h
16	ISLOW	01 h
17	PNORM	10 h
18	Quality Detector Coefficient 1	BB h
19	Quality Detector Coefficient 2	45 h
1A	Teletext Disable Threshold	0B h
1B	Teletext Enable Threshold	05 h
1C	PLL Lock Disable Threshold	28 h
1D	PLL Lock Enable Threshold	20 h
1E	Sync Signal Quality MSB	--
1F	Sync Signal Quality LSB	--
20	Max. Phase Error	--
21	Phase Error Limit	08 h
22	Error Packet Count	--
23	Error MS Byte	--
24	Error LS Byte	--
25	VPS Error Packet Count	--
26	VPS Error Count	--

**** Note:** The default values are valid for no video, connected to CF72407. The value of Memory Configuration 3, register depends on the connected DRAM type. It is 0 for TMS4464, 4 for TMS44C256, and 8 for TMS44400.

EXTENDED REGISTER MAP - M407 MODE ONLY

The following extended register for the 407 mode. These registers are only available when the **M407** bit, in VDP control register 4, is set.

Register No.	Description	Default Value
27	Extended Full Screen Colour	--
28	Cursor End Column	--
29	Cursor Colour Register 1	--
2A	Cursor Colour Register 2	--
2B	Cursor Colour Register 3	--
2C	Colour Palette Background Register 0	(BLACK)
2D	Colour Palette Background Register 1	(RED)
2E	Colour Palette Background Register 2	(GREEN)
2F	Colour Palette Background Register 3	(YELLOW)
30	Colour Palette Background Register 4	(BLUE)
31	Colour Palette Background Register 5	(MAGENTA)
32	Colour Palette Background Register 6	(CYAN)
33	Colour Palette Background Register 7	(WHITE)
34	Colour Palette Foreground Register 0	(BLACK)
35	Colour Palette Foreground Register 1	(RED)
36	Colour Palette Foreground Register 2	(GREEN)
37	Colour Palette Foreground Register 3	(YELLOW)
38	Colour Palette Foreground Register 4	(BLUE)
39	Colour Palette Foreground Register 5	(MAGENTA)
3A	Colour Palette Foreground Register 6	(CYAN)
3B	Colour Palette Foreground Register 7	(WHITE)
3C	Colour Palette Background Register 8	--
3D	Colour Palette Foreground Register 8	--

TELETEXT FRONT END REGISTERS

Register No	Description	Default Value
00	Not used	00 h
01	Teletext Framing Code	27 h

Framing Code Register 1.

The framing code used in Western Europe is 27hex. Writing a different value to this register will change the Framing Code.

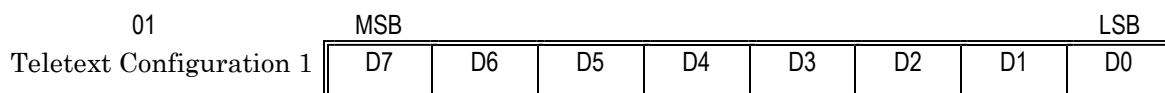

MEMORY CONFIGURATION REGISTERS

The CF72407 will support three DRAM types with a 4-bit data bus width only. The embedded DRAM controller will generate all signals required by the DRAM's. Thus there is no extra hardware required. The decoder contains logic that is able to detect automatically the size of the memory connected to the decoder.

Memory Type	Number of DRAMS required	Memory Size
TMS4464	1	32K
TMS4464	2	64K
TMS44C256	1	128K
TMS44C256	2	256K
TMS44400	1	512K
TMS44400	2	1024K

Four control registers are available for the system programmer to configure the memory. The section below will describe the control registers and the meaning of all control bits used in them. The register map shown previously is a part of the hardware registers as explained in the section **DECODER HARDWARE REGISTERS**.

Register No	Description	Default Value
02	Memory Configuration 1	00
03	Memory Configuration 2	08
04	Memory Configuration 3	09
05	Language Control	08

Memory Configuration Register 1.

This register controls the allocation of the external character sets. The command **ALLOCATE MEMORY FOR EXTERNAL CHARACTER SETS** will overwrite this register.

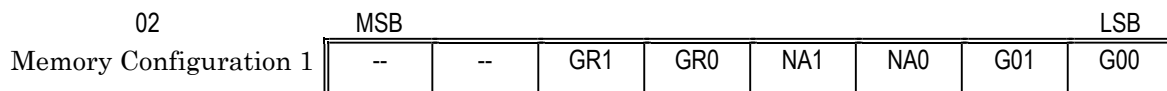

- G00 First G0 character set is allocated
- G01 Second G0 character set is allocated
- NA0 First extended character set is allocated
- NA1 Second extended character set is allocated
- GR0 First G1 (graphics) character set is allocated
- GR1 Second G1 (graphics) character set is allocated

Note: The system programmer **MUST NOT** alter (overwrite) the content of control register 1. If he does it, the decoder may not function correctly. The decoder will automatically set this register to the correct values in response to the I2C Character Set Allocation commands.

Memory size required for external character sets

Character Set	Character Codes	Memory Size
G00	20..7F hex	1440 bytes
G01	20..7F hex	1440 bytes
NA0	80..FF hex	1920 bytes
NA1	80..FF hex	1920 bytes
GR0	20..7F hex	1440 bytes
GR1	20..7F hex	1440 bytes

Memory Configuration Register 2.

This register selects which of the external character sets will provide pixel data for the VDP.



- G00EN First G0 character set enabled
- G01EN Second G0 character set enabled
- NA0EN First extended character set enabled
- NA1EN Second extended character set enabled
- GR0EN First G1 (graphics) character set enabled
- GR1EN Second G1 (graphics) character set enabled
- GR0BE Blast through enabled on first G1 character set
- GR1BE Blast through enabled on second G1 character set

G0 Character Set Selection

G01EN	G00EN	
0	0	The VDP will fetch the G0 pixel data from the internal character font ROM
0	1	The VDP will fetch the G0 pixel data from the external G00 character set. The VDP will default to the internal character set if G00 is not allocated
1	0	The VDP will fetch the G0 pixel data from the external G01 character set. The VDP will default to the internal character set if G01 is not allocated
1	1	NOT VALID. The VDP will default to the internal character set.

National Option Character Set Selection

The bits NA1EN and NA0EN select the national (extended) character set.

NA1EN	NA0EN	
0	0	The VDP will fetch the national character pixel data from the internal character font ROM.
0	1	The VDP will fetch the national option pixel data from the external NA0 character set. The VDP will default to the internal character set if NA0 has not been allocated.
1	0	The VDP will fetch the national option pixel data from the external NA1 character set. The VDP will default to the internal character set if NA1 has not been allocated.
1	1	NOT VALID. The VDP will default to the internal character set.

Graphic Character Set Selection

The two enable bits **GR1EN** and **GR0EN** determine from which character set the VDP should fetch the graphic symbols when it is in graphic mode. All graphic features, such as blast through alpha characters, work even when the pixel image is in an external character set. It is possible to disable the blast through characters for an external graphics character set.

GR1EN	GR0EN	
0	0	Enable Block Graphics. The VDP will fetch the graphic pixels from internal logic.
0	1	The VDP will fetch the graphic pixels from the external GR0 character set. The VDP will fall back to block graphic mode if GR0 is not allocated.
1	0	The VDP will fetch the graphic pixels from the external GR1 character set. The VDP will fall back to block graphic mode if GR1 is not allocated.
1	1	NOT VALID. The VDP will default to block graphic mode.

Graphic Blast through Characters

The World System Teletext Specification (WSTS) specifies the character codes' 40(hex) to 5F(hex) inclusive as Blast through characters.

The programmer can enable or disable the character blast through feature when the VDP is fetching pixels from external graphic character sets, but cannot disable it when the VDP is using the internal block graphic symbols. When enabled, the logic will fetch the pixel information from the selected G0 character set. When not enabled, the logic will fetch the pixel information from the appropriate graphics character set.

GR0BE	
0	Disable Blast through for the GR0 graphic.
1	Enable Blast through for the GR0 graphic set.

GR1BE	
0	Disable Blast through for the GR1 graphic.
1	Enable Blast through for the GR1 graphic set.

Memory Configuration Register 3

With the control bits contained in this register, the programmer has control over the national character correction logic. When he switches it off then he will have access to the

ASCII characters stored in the default G0 set as specified by WSTS. Furthermore he can force the correction logic to support up to eight national languages when he sets the FULL control bit.

Note: *Eight national option character sets are only available when the external character sets are in use.*

The figure below shows the bit map and the state of the individual bits after a hardware reset (power on) or a software reset.

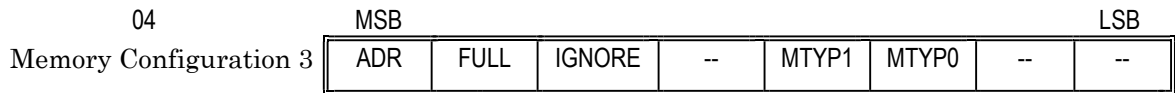

ADR For INTERNAL use only
 FULL Enable all eight C12..C14 translation tables
 IGNORE Disable C12..C14 national option translation
 MTYP[0..1] Memory type

ADR	
--	This is an internal control bit. Use of ADR may cause the decoder to function incorrectly.

IGNORE	
0	Enable the conversion logic for the national character sets. The C12, C13 and C14 control bits of the Teletext page specify the conversion of the national characters.
1	Disable the conversion logic for the national character sets. The default G0 character set defines all the characters.

FULL	
0	The decoder only supports the standard six national languages. Non-supported national languages will default to English.
1	The decoder will support eight national languages. See the table below.

Note: *The FULL bit is only for use with the external character sets. When used in conjunction with the internal character set, the last two of the national option codes will not translate to any known national character.*

National Character Mapping for ROM and DRAM

C12	C13	C14	FULL	Teletext National Options	Character Code Range
0	0	0	--	English	80..8F Hex
0	0	1	--	German	A0..AF Hex
0	1	0	--	Swedish	90..9F Hex
0	1	1	--	Italian	B0..BF Hex
1	0	0	--	French	C0..CF Hex
1	0	1	--	Spanish	D0..DF Hex
1	1	0	0	English by default	80..8F Hex
1	1	0	1	User defined	E0..EF Hex
1	1	1	0	English by default	80..8F Hex
1	1	1	1	User defined	F0..FF Hex

Memory Type

The control bits MITYP[0..1] must reflect which DRAM is in use with the decoder. The decoder will automatically detect which DRAM configuration is in use and sets the control bits accordingly.

Note: Alteration of these control bits will cause the decoder to function incorrectly.

Memory Type

MPTY1	MTYY0	
0	0	TMS4464
0	1	TMS44C256
1	0	TMS44400
1	1	NOT USED

Language Control

This is for INTERNAL USE by the Teletext decoder. The decoder will update this register using the C12, C13 and C14 bits of the current Teletext display page.

05	MSB							LSB
Language Control	--	--	--	--	C14	C13	C12	--

VIDEO DISPLAY PROCESSOR (VDP)

The VDP is the part of the system that generates the picture (alpha numeric or graphic symbols) on the screen for a 625 line (PAL) or 525 line (NTSC) environment. To do so, the VDP will address the display page in a sequential order, starting at row 0 column 0 and ending at row 25 column 39 in PAL mode whereas row 19 is the last line in NTSC mode. It is possible to display a total of 1040 character. In PAL and NTSC mode a character uses a matrix of 12*10 pixels (horizontal = 12 and vertical = 10 pixels).

VDP Control Registers

A set of ten registers provides control for all the VDP functions.

Register No.	Description	Default Value
06	Display Control 1	00 h
07	Display Control 2	00 h
08	Display Control 3	00 h
09	Display Control 4	03 h
0A	Display Control 5	00 h
0B	Cursor Row	00 h
0C	Cursor Column	00 h
0D	Picture Vertical Position	21 h
0E	Picture Horizontal Position	94 h
0F	Full Screen Colour Control	00 h

VDP Display Control Register 1

This register provides the Teletext subtitle and newsflash functions. The appropriate control bits from the header of the Teletext pages will overwrite this register. These bits will not change as long as a menu page is being displayed.

06	MSB	LSB								
Display Control 1	<table border="1" style="width: 100%; height: 20px;"> <tr> <td style="width: 12.5%; text-align: center;">--</td> <td style="width: 12.5%; text-align: center;">--</td> <td style="width: 12.5%; text-align: center;">--</td> <td style="width: 12.5%; text-align: center;">--</td> <td style="width: 12.5%; text-align: center;">C6</td> <td style="width: 12.5%; text-align: center;">C5</td> <td style="width: 12.5%; text-align: center;">--</td> <td style="width: 12.5%; text-align: center;">--</td> </tr> </table>	--	--	--	--	C6	C5	--	--	
--	--	--	--	C6	C5	--	--			

C6 Teletext SUBTITLE bit
 C5 Teletext NEWSFLASH bit

C6	
0	Subtitle function not in use.
1	Display of a Teletext subtitle. This control bit overrides the MIX control bit.

C5	
0	Newsflash function disabled.
1	Display of a Teletext newsflash. This control bit overrides the MIX control bit.

VDP Display Control Register 2

This register provides the Teletext Inhibit Display and Suppress header functions. The appropriate control bits from the header of the Teletext pages will overwrite this register. These bits will not change as long as a menu page is being displayed.

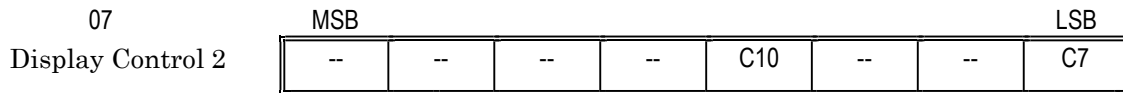

C10 Teletext INHIBIT DISPLAY bit
 C7 Teletext SUPPRESS HEADER bit

C7	
0	Suppress header function is not active.
1	Display of row zero is “suppressed” including the time portion of the display.

C10	
0	Inhibit display is not active
1	Display of rows one to twenty-four is suppressed, row zero will still be displayed. This control bit overrides the effect of the SPH control bit.

VDP Display Control Register 3

Global VDP control functions.

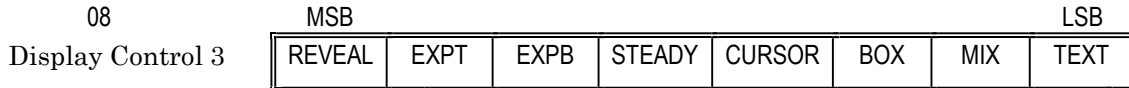

REVEAL Reveals concealed characters
 EXPT Expand upper half of display
 EXPB Expand lower half of display
 STEADY Disable cursor flashing
 CURSOR Enable cursor
 BOX Enable VDP box mode
 MIX Enable VDP mix mode
 TEXT Enable VDP display

TEXT	
0	Disable the VDP display function. All other display related control bits have no function in this case.
1	Enable the VDP display function. The VDP will fetch characters from the display page. The mode of operation depends on the state of the control bits MIX, BOX, BOXR0 and BOXR24.

Interaction of the BOX and MIX Control Bits

Note: The two control bits BOX and MIX will affect the VDP outputs, but the TEXT bit will be delayed until the following frame Sync. This has the effect that when either the BOX or MIX controls bits change from a '1' to a '0', simultaneously with a change of the TEXT bit from '1' to '0', the decoder briefly flashes into Teletext mode

before correctly displaying the TV picture. A recommendation to avoid this 'flash' it is to change the TEXT bit to '0' when changing from a BOX/MIX, to a TV picture display.

BOX	BOXR0	BOXR24	MIX	
0	0	0	0	VDP is in text mode. It will display the content of the display page and it will react on the serial attributes embedded in the data stream.
0	0	0	1	VDP is in mixed mode. Superimpose the character foreground pixels onto the TV picture and suppresses the background colour. The display will respond to the BOX and UNBOX control characters that are serial attributes embedded in the display page.
1	0	0	--	Enable Global BOX mode.
1	--	1	--	Enable Global BOX mode and insert both foreground and background pixels of row 24 into the picture.
1	1	--	--	Enable Global BOX mode and insert both foreground and background pixels of the header row.

CURSOR	
0	Disable Cursor display.
1	Enable Cursor display. See the M407 table below for the definition of this bit

STEADY	
0	Enable Cursor flashing. Thus the cursor will flash at a rate of 160ms in PAL mode and 135ms in NTSC mode
1	Disable Cursor flashing. Steady non-flashing cursor is visible on the screen.

EXPB	
0	Disable expand bottom.
1	Enable expand Top. The lines that are in expand mode depend on whether the current mode PAL or NTSC. PAL mode (control bit PAL/NTSC = 0) Display rows twelve to row twenty-three in double height. Display row twenty-four and twenty-five in normal height. NTSC mode (control bit PAL/NTSC = 1) Display rows ten to nineteen in double height. Display row 24 in normal height. Row 25 is disabled in NTSC mode.

Note: Double height row will be displayed in Quad height. When both control bits EXPT and EXPB are set to one, EXPB will be ignored.

EXPT	
0	Disable expand top.
1	Enable expand top of the display page. The lines that are in expand mode depend on whether the current mode PAL or NTSC. PAL mode (control bit PAL/NTSC = 0) Display rows zero to row eleven in double height. Display rows twenty-four and twenty-five in normal height. NTSC mode (control bit PAL/NTSC = 1) Display rows zero to nine in double height. Display row 24 is in normal height. Row 25 is disabled in NTSC mode.

REVEAL	
0	Reveal mode is inactive. Thus when the VDP finds the conceal control code then it will display space characters instead of the hidden characters
1	The VDP will display all concealed characters.

VDP Display Control Register 4

This register is under the control of the programmer only. The figure below shows the bit map.



- NTSC Enable 525 line mode (default is 625 line mode)
- PDOWN Power down RGB output drivers
- SPBLK Special blanking signal
- R25FRT Display row 25 before row 24 (default is 24 before 25)
- R24BOT Display row 24 at bottom of screen (defaults to top of screen)
- R25BOT Display row 25 at bottom of screen (defaults to top of screen)

SPBLK	Special blanking signal.
0	Normal.
1	Special blanking, see the DATA SHEET for the specification.

Note: For details of the **SPBLK** signal please see the data sheet

BDEL	
0	Normal blanking signal.
1	The blanking output is delayed by one character.

R25BOT	
0	Display row twenty-five at the top of the screen.
1	Display row twenty-five at the bottom of the screen. Set bits R25ON or BOXR25 to enable this function. Refer to the tables <i>Display order of rows</i> for more information.

R24BOT	
0	Display row twenty-four at the top of the screen.
1	Display row twenty-four at the bottom of the screen. Refer to the tables <i>Display order of rows</i> for more information.

R25FRT	
0	Display twenty-four before row twenty-five.
1	Display row twenty-five before row twenty-four. This function is active when the value of the control bits R25BOT and R24BOT are identical. The tables <i>Display order of rows</i> contains more information. This control bit has no effect in NTSC mode (control bit NTSC = 1).

NTSC	
0	The IC is in PAL mode (625 lines). The display consists of a maximum of 26 text lines using a character cell of 12*10 pixels.
1	The IC is in NTSC mode (525 lines). The display consists of 21 lines using a character cell of 12*10 pixels. These are the rows 0 to 19 and row 24. Row 24 offers the same functions as described by control registers two and three.

PDOWN	
0	Enable the RGB outputs.
1	Disable the RGB outputs. This will reduce the power consumption of the device.

Note: The “current sources” must be active, before the *TEXT* control bit is set. This is because the current sources require some time to stabilise there outputs.

M407	
0	307 compatibility mode. The VDP function is identical to the 307.
1	Enables 407 extended functions.

407 Extended Functions

The **M407** control bit enables the 407 extended functions. These included a colour pallette and a programmable length cursor. The operation of the **M407** bit in conjunction with the cursor control bits **STEADY** and **CURSOR** is given in the following table:

M407	STEADY	CURSOR	
0	--	0	Cursor is disabled.
0	--	1	Cursor is enabled. The cursor will be visible at the character position as specified by the Cursor ROW (0..25) and Column (0..39) control registers. In TEXT and MIX mode, the cursor is as a square of 12*10 pixels in the current foreground colour, with the character pixels in the current background colour. If the background colour and foreground colour are the same, then the VDP will use the inverse background colour. This will guarantee that the cursor is visible under all circumstances. The STEADY bit defines if the cursor is flashing or non-flashing.
1	0	0	Cursor is disabled.
1	0	1	Cursor is enabled. The cursor will flash, by alternating the colour of the foreground pixels between the foreground and background colours.
1	1	0	Cursor is enabled. The cursor will flash, by alternating the colour of the background pixels between the background and foreground colours.
1	1	1	Cursor is enabled. The cursor will not flash.

VDP Display Control Register 5

This register is under the control of the programmer only. The figure below shows the bit map.



- R25ON Enable row 25
- R24ON Enable row 24 (overrides C10)
- DR1TO23 Enable display rows one to twenty-three (overrides C10)
- R0ON Enable header row (overrides C7)
- BOXR25 Box row 25
- BOXR24 Box row 24 (overrides C10)
- BOXR0 Box header row (overrides C7)
- BOXR

BOXR0	
0	Disable function
1	Display row zero in BOX mode. This command will display the background as well as the foreground for row zero even when MIX is active. This command will override the C7 (suppress header) control bit.

BOXR24	
0	Disable function
1	Display row twenty-four in BOX mode. This command will display the background as well as the foreground for row twenty-four even when MIX is active. When set this bit overrides the function of the C10 control bit.

BOXR25	
0	Disable function
1	Display row twenty-five in BOX mode. The display will show the background as well as the foreground for row twenty-five even when MIX is active.

R00N	
0	Disable function
1	Enable row zero overriding the Teletext control bits. See the table <i>Interaction of the Display Control Bits</i> for details.

DR1TO23	
0	Disable Function. .
1	Enable rows one to twenty-three overriding the Teletext control bits. See the table <i>Interaction of the Display Control Bits</i> for details.

R24ON	
0	Disable Function
1	Enable row twenty-four. See the table <i>Interaction of the Display Control Bits</i> for details.

R25ON	
0	Disable display of row 25
1	Enable display of row twenty-five. The control bits R25BOT , R24BOT and R25FRT determine the position of row 25 on the screen.

Display Control and Display Modes

This section will explain the different display modes and the interaction of the various display control bits. The VDP will distinguish among five display modes. These are

- Picture mode.
- Teletext display mode.
- Mix mode.
- Box mode.

Picture Mode

Disable the VDP RGB and Blanking outputs. Setting the **TEXT** control bit is zero disables the VDP outputs. All other display control bits will have no effect in this mode.

Teletext Display Mode

Setting the **TEXT** control bit to one, enables Teletext display mode. In this mode the VDP will display a complete Teletext page, e.g. all rows starting at row zero to twenty-four inclusive.

Teletext Mix Mode

Setting both the **TEXT** and **MIX** control bits enables Teletext mix mode. Mix mode superimposes the character foreground pixels over the TV picture and suppresses the background colour. The foreground colour will respond to the colour control characters embedded in the Teletext data stream. The display will also respond to the **BOX** and **UNBOX** Teletext control characters.

Teletext Box Mode

Setting both the **TEXT** and **BOX** bits to one enables BOX mode. The VDP will respond to the **BOX** and **UNBOX** control characters embedded in the display page. When the VDP operates in box mode then it will deactivate the **BLANK** signal outside the box. This inserts the box into the TV picture.

Display Order of Rows 0..25 in PAL Mode

The display order of rows zero to twenty-five depends on various control bits. The table below shows the control bits and their effect on display order.

Note	R24ON	R25ON	R25FRT	R24BOT	R25BOT	Display Order
1	0	0	--	0	--	R24, R0..R23
1	0	0	--	1	--	R0..R23, R24
1	0	1	0	0	0	R24, R25, R0..R23
1	0	1	1	0	0	R25, R24, R0..R23
1	0	1	--	0	1	R24, R0..R23, R25
1	0	1	--	1	0	R25, R0..R23, R24
1	0	1	0	1	1	R0..R23, R24, R25
1	0	1	1	1	1	R0..R23, R25, R24
0	1	0	--	0	--	R24, R0..R23, R25
0	1	0	--	1	--	R0..R23, R24, R25
0	1	1	0	0	0	R24, R25, R0..R23
0	1	1	1	0	0	R25, R24, R0..R23
0	1	1	--	0	1	R24, R0..R23, R25
0	1	1	--	1	0	R25, R0..R23, R24
0	1	1	0	1	1	R0..R23, R24, R25
0	1	1	1	1	1	R0..R23, R25, R24

Note 1: In normal Teletext operation row 24 will follow the control bits shown in the table **Interaction of the Display Control Bits**.

Note 2: **R24ON** overrides the display control bits, e.g. row 24 is always displayed.

Note: The VDP always will generate the addresses for all rows. The display of the rows is determined by the controls bits described in the table **Interaction of the Display Control Bits**. When the state of the control bit **R25ON** or **BOXR25** is changed, the vertical picture position should also be altered.

Display Order of Rows 0..19 and row 24 in NTSC Mode

In NTSC mode it is possible to display only twenty-one rows. The table below shows the display order of rows zero to nineteen and row twenty-four. NTSC mode disables the display of row twenty-five.

R24ON	R25ON	R25FRT	R24BOT	R25BOT	Display Order
0	--	--	--	--	R0..R19
1	--	--	0	--	R24, R0..R19
1	--	--	1	--	R0..R19, R24

Row 24 Display

Row twenty-four is part of the normal Teletext page and behaves in an identical manner as rows one to twenty-three.

Row 25 Display

Row twenty-five is an additional display row that is independent from the Teletext display page. The screen position of row twenty-five depends on the control bits **R24BOT**, **R25BOT** and **R25FRT**.

Interaction of the Display Control Bits

The truth table below shows the interaction of all the display control bits:

C10	C7	R0ON	DR1TO23	R24ON	R25ON	BOXR0	BOXR24	BOXR25	
									Row 0
--	--	--	--	--	--	1	--	--	Yes
--	--	1	--	--	--	0	--	--	Yes
1	--	0	--	--	--	0	--	--	Yes
0	0	0	--	--	--	0	--	--	Yes
0	1	0	--	--	--	0	--	--	No
									Row 1..23
--	--	--	1	--	--	--	--	--	Yes
0	--	0	0	0	--	--	--	--	Yes
--	--	--	0	1	--	--	--	--	No
--	--	1	0	0	--	--	--	--	No
1	--	0	0	0	--	--	--	--	No
									Row 25
--	--	--	--	--	--	--	--	1	Yes
--	--	--	--	--	1	--	--	0	Yes
--	--	--	--	--	0	--	--	0	No
									Row 24
--	--	--	--	--	--	--	1	--	Yes
--	--	--	--	1	--	--	0	--	Yes
0	--	0	0	0	--	--	0	--	Yes
1	--	--	--	0	--	--	0	--	No
0	--	1	--	0	--	--	0	--	No

407 Extended Functions

The **M407** control bit enables the 407 extended functions. When the **M407** bit is set the display control bits **BOXR**, **BOXR24**, and **BOXR25** provide the extended functions given in the following tables:

Extended Functions, PAL mode.

BOXR	BOXR24	BOXR25	Display Function
0	0	0	Box off
0	0	1	Box R25
0	1	0	Box R24
0	1	1	Box R24 and R25
1	0	0	Box R23, R24 and R25
1	0	1	Box R22, R23, R24 and R25
1	1	0	Box R21, R22, R23, R24 and R25
1	1	1	Box R20, R21, R22, R23, R24 and R25

Extended Functions, NTSC mode.

BOXR	BOXR24	BOXR25	Display Function
0	0	--	Box off
0	1	--	Box R24
1	0	0	Box R19 and R24
1	0	1	Box R18, R19 and R24
1	1	0	Box R17, R18, R19 and R24
1	1	1	Box R16, R17, R18, R19 and R24

Cursor Row & Column Control Register

The programmer can position the cursor on each character location of the display. The position is determined by the value of the cursor row and column control register. These registers are under control of the programmer only. He can modify the cursor position when he writes a new value into these registers using the command *Write configuration registers*.

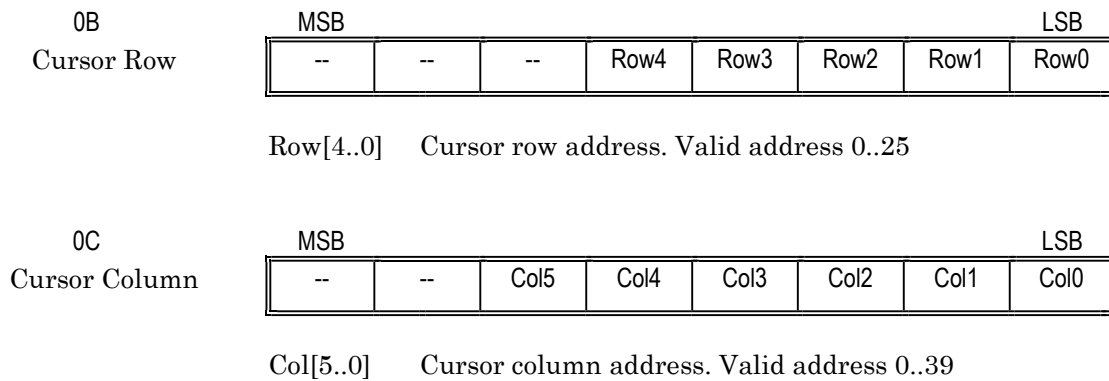

Text Picture Vertical & Horizontal Position

When required, the programmer can redefine the default picture position on the screen. He can move it in all four directions when he overwrites the contents of the vertical and horizontal picture position registers. In the horizontal direction, the picture can be moved within a 52us window. It conforms to the TV signal specification. These registers are under control of the programmer only.

CF72407 MULTIPAGE

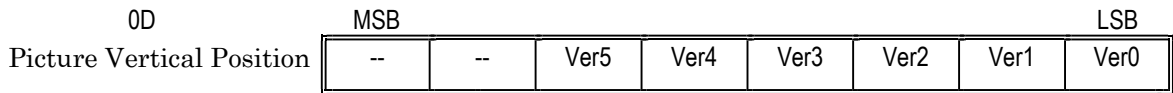

Ver[5..0] Defines start of display picture w.r.t. Frame Sync. This value should not exceed 0x37 (hex).

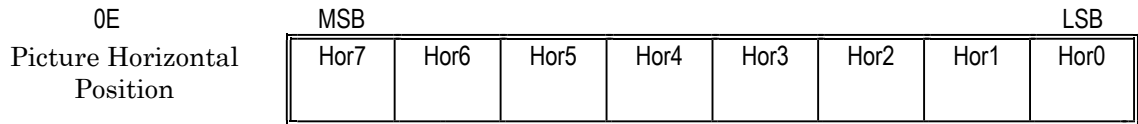

Hor[7..0] Defines start of display line w.r.t. Line Sync. This value should not exceed 0xE0 (hex).

In the vertical direction, the picture can be moved to start at line 24 or end at line 310. This assumes PAL mode. In the horizontal direction, the picture can be moved within a 52µs window as shown below. This conforms to the TV signal specification.

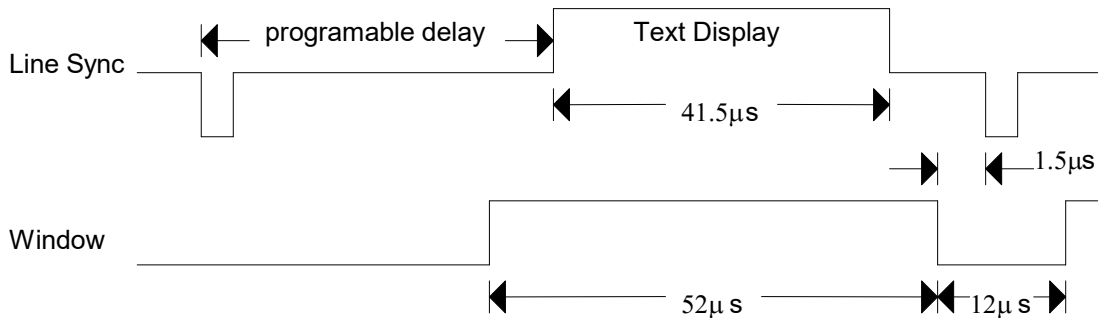

Full Screen Colour Control Register

This decoder enables the programmer to surround the text display with a colour. Refer to the picture below. He can select one of the eight possible colours. Furthermore he can determine whether the full screen colour should be used as the default background colour for the text display.

Note: The full screen colour will be suppressed in MIX mode.

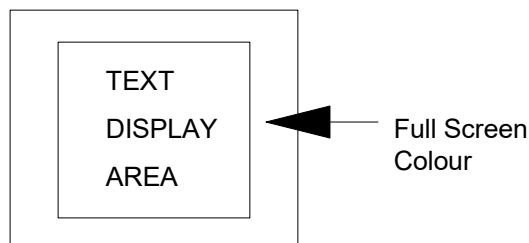

Hardware Registers



TEXTBG FSC[2..0] defines default Teletext background colour
FRAME FSC[2..0] defines colour of picture overscan area
FSC[2..0] Full screen colour (uses level one Teletext colour code)

FSC2	FSC1	FSC0	Colour
0	0	0	Black
0	0	1	Red
0	1	0	Green
0	1	1	Yellow
1	0	0	Blue
1	0	1	Magenta
1	1	0	Cyan
1	1	1	White

FRAME	
0	The text field will be surrounded by the black colour.
1	Full screen colour mode is enabled. The colour defined by the bits FSC[0..2] will surround the Teletext display field. It will be active inside the 52us window only. Vertically the full screen colour will start at line 24 and end at line 310 in PAL mode. In NTSC mode the colour starts at line 20 and ends at line 260.

TXTBG	
0	The background colour for the Teletext field is black.
1	The colour defined by the control bits FSC[0..2] will be adopted as the default background colour for the Teletext page.

PHASE LOCKED LOOP (PLL)

The main purpose of the PLL is to lock the internal generated display clock to the applied Sync signal(s) e.g. the reference signal for the PLL. The PLL is able to lock to the composite Sync (separated from the video) or to horizontal and vertical Sync pulses generated externally. The external Sync mode is called Slave Sync Mode within this specification. For example, the slave Sync signal(s) will be generated by the deflection processor in a TV set.

The main advantage of this PLL is that:

- It automatically detects whether the source of the Sync signal is a VCR or standard broadcast TV signal.
- It will automatically lock to VCR Sync signal e.g. the PLL will compensate the phase jumps of the Sync pulses without any interaction from the programmer.
- It will follow a line frequency tolerance of +/- 5% (64us +/- 5%).

Locking is required in order to generate a display free of jitters in text, box or on screen display mode (OSD). The PLL is also used as the main timing generator for the following signals.

- Pixel clock for the display processor (VDP).
- Interlaced or non interlaced Sync used for generating both the Teletext and for the composite Sync output.
- WINDOW used to enable and disable the data slicer.

More and more foreign TV stations can be received via satellite and some of them are using the NTSC standard. Furthermore a lot of the new TV sets are able to receive different TV standards (called Multi Standard). For this reason the PAL / NTSC feature has been implemented. This will enable the programmer to select whether the PLL and the display processor should work in a 625 line (PAL) or 525 line (NTSC) line environment. The advantage of this is, that he can display on screen information in PAL and NTSC mode.

Note: *In NTSC mode it is not possible to receive Teletext. This is not supported by the decoder.*

Inside the PLL, there is a set of registers available for the system programmer so that he can configure the PLL as required for the application.

Note: *The PLL can be configured any time even during operation, but for proper operation the system programmer should follow the rules described below:*

a) Whenever possible the PLL should be configured after power on reset or when a power fail occurred. This assumes that the default set-ups do not meet the required configuration.

b) Force the VDP to picture mode before the PLL control register is modified. In this case the television viewer will not see any flicker on the screen when another Sync source is selected.

PLL Configuration Registers

Three control registers are available for the system programmer to configure the PLL for his needs. The figure below shows the register map of the PLL configuration registers. They are a part of the decoder hardware registers described in the section **Hardware Configuration Registers**. The programmer can access the PLL control registers with the **Configuration Register write and read** commands.

Register No.	Description	Default Value
10	PLL Configuration 1	00 h
11	PLL Configuration 2	01 h
12	PLL Configuration 3	07 h

PLL Configuration Register 1

The bits of this register are used to control the main functions of the PLL like:

- Internal generated Interlaced or non interlaced composite Sync.
- Programmable polarity of the Sync input signals.
- Selection of the different deflection processors that will be supported.
- Behaviour of the field output signal.

10	MSB							LSB
PLL Configuration 1	PFIELD	DFIELD	PHVSLV	PHSLV	SLVM1	SLVM0	SYNC1	SYNC0

PFIELD Polarity of field output signal
 DFIELD Disables field output signal
 PHVSLV Polarity of vertical slave Sync
 PHSLV Polarity of horizontal slave Sync
 SLVM[1..0] Slave Sync mode
 SYNC[1..0] Generated Sync mode

Internal Generated Sync

The bits **SYNC[0..1]** in conjunction with the **TEXT**, **MIX** and **BOX** bits (located in a VDP control register) determine the type of the internal generated Sync. This Sync is then used by the VDP for the display generation. The programmer can route this Sync to the composite Sync output of the decoder if it is required by the application. This is controlled via the second control register. The table below will show the programmer which type of Sync will be generated depending on the state of the control bits.

Note: **TEXTON = TEXT & !MIX & !BOX**

TEXTON	SYNC1	SYNC0	
0	--	0	312 / 313 non interlaced Sync.
0	--	1	312,5 / 312,5 interlaced Sync.
1	0	--	312 / 312 non interlaced Sync.
1	1	0	312 / 313 non interlaced Sync.
1	1	1	312,5 / 312,5 interlaced Sync.

Slave Mode Selection

As mentioned earlier, the display PLL will be able to lock to the composite Sync of the video or to an external generated Sync. This is under control of the programmer that means he can select the mode that is required by the application. He can switch between the different modes during operation too, but he should be aware that the PLL needs some time to lock to the other Sync signal. Depending on the selected mode, the decoder will take the Sync signal(s) from different device pins.

In Slave Sync Mode, the decoder will route through the signals applied to the device pins **SLVHSYNC** and **SLVHVSYNC** to the display PLL. The PLL then will take the horizontal Sync information from the signal **SLVHSYNC** and the vertical Sync from **SLVHVSYNC**. The signal applied to **CSYNC** will be ignored by the display PLL but it is required for the Teletext reception logic. In composite Sync mode the signal applied to the pin **CSYNC** will be used. The signals **SLVHSYNC** and **SLVHVSYNC** will be ignored.

SLVM1	SLVM0	
0	0	The display PLL will lock to the composite Sync output signal of the data slicer.
0	1	Slave Sync mode 1
1	0	Slave Sync mode 2
1	1	Slave Sync mode 3

Slave Sync Polarity Selection

The polarity of the input signals **SLVHSYNC** and **SLVHVSYNC** are programmable.

PHSLV	
0	The line locking logic of the PLL will be triggered by the positive going edge of the SLVHSYNC signal.
1	The line locking logic of the PLL will be triggered by the negative going edge of the SLVHSYNC signal.

PHVSLV	
0	The frame detection logic of the PLL will look for active high SLVHVSYNC signal.
1	The frame detection logic of the PLL will look for active low SLVHVSYNC signal.

Field Output Signal

The decoder provides a field output signal. It can be disabled if not required and the polarity can also be programmed. This signal behaves in the same way for both modes PAL and NTSC.

DFIELD	
0	The field output is enabled. The polarity of the signal is determined by PFIELD .
1	The field output is disabled. The output is always forced to a low state.

PFIELD	
0	The field output is active high during the first field and active low on the second field.
1	The field output is active low during the first field and active high on the second field.

PLL Configuration Register 2

With the control bits contained in this register, the programmer can determine which Sync should be routed to the two Sync output lines (analogue Sync & digital Sync output). He has the option to select:

- The internal generated Sync. It is generated by the PLL.
- The slave Sync input signal **SLVHSYNC** (only for digital Sync output).
- The slave Sync input signal from **SLVHVSYNC** (only for the digital Sync output).

Furthermore he has control over the analogue switch that will route the video or the internal generated Sync to the analogue Sync output. Refer to the PLL configuration register 1 for more information on Sync generation.

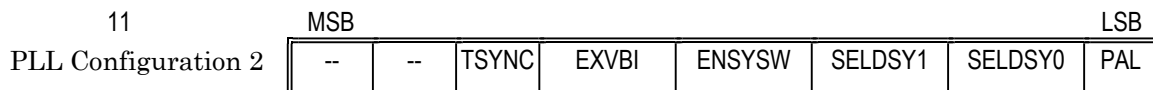

- TSYNC Analogue Sync control
- EXVBI Extended VBI window
- ENSYSW Analogue output mode
- SELDSY[1..0] Digital Sync output mode
- PAL Enable generation of 625 line Sync (defaults to 625 lines)

PAL / NTSC Mode

With the PAL control bit the programmer can force the PLL to generate either a 625 line or a 525 line TV composite Sync signal. This Sync then is used to control the display processor.

Note: *In NTSC mode it is not possible to receive Teletext. This is not supported by the decoder. When this bit is altered than the control bit **NTSC** in the VDP should also be modified.*

PAL	
0	NTSC mode. The PLL will generate a 525 line composite Sync signal.
1	PAL mode. The PLL will generate a 625 line composite Sync signal.

Specify Sync Outputs

As mentioned earlier, this device has two Sync outputs. An analogue Sync that can be used for TV applications and a digital output that is normally used for VCR applications. With the control bits **SELDSY[0..1]** the programmer can determine which Sync is connected to the digital Sync output.

SELDSY1	SELDSY0	
0	--	The composite Sync generated by the PLL will be switched through to the digital Sync output.
1	0	The signal applied to the pin SLVHSYNC will be routed through to the digital Sync output.
1	1	The signal applied to the pin SLVHVSYNC will be routed through to the digital Sync output.

Note: The input signals **SLVHSYNC** and **SLVHVSYNC** are bypassed on the polarity selection logic. They are connected to the Sync multiplexer directly. Thus the input and output polarity will be the same.

Analogue Sync Switch

The analogue Sync signal is normally used for TV applications where a Sync amplitude of about 300mV is required. This signal then is used by the deflection processor. In text mode, the internal generated Sync will be switched to the ACSYNC pin. Thus the TV will lock to this Sync. This will guarantee a jitter free picture in text mode even when the video signal is weak or bad. In picture, BOX and MIX mode the TV must lock onto the Sync received with the video. Therefore the video will be switched through to the analogue Sync output. In mix or box mode when the video is too bad, the PLL of the decoder cannot lock to the Sync of the video, in this situation the ENSYSW control bit determines whether the internal generated sync or the external video is switched through to the output.

Note: The state of **ENSYSW** has no function when **TEXT** mode is selected. It is only of interest in **MIX** or **BOX** mode.

ENSYSW	
0	The video should be switched through to the analogue Sync output (ACSYNC) when the video is bad.
1	The internal generated Sync should be switched through to the analogue Sync output (ACSYNC) when the video is bad.

The **TSYNC** controls the analogue sync source during MIX and BOX modes.

TSYNC	
0	Video is passed through the analogue sync in MIX and BOX mode
1	The internally generated sync is passed through the analogue sync in MIX and BOX mode.

Extended VBI Selection

The state of the control bit **EXVBI** determines on which TV line the decoder will enable reception of Teletext data.

EXVBI	
0	Enable Teletext reception starting at line 6..22, and 318..335.
1	Enable Teletext reception starting at line 2..22, and 315..335.

PLL Configuration Register 3

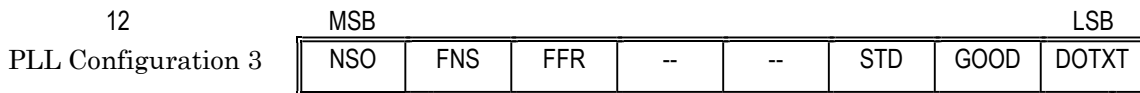

- DOTXT Teletext processing enabled. (write only)
- GOOD Sync signal quality is good. (write only)
- STD Standard TV signal being received. (write only)
- FFR Force Free Run mode.
- FNS Force non-standard signal detection.
- NSO Disable non-standard signal detection.

PLL operating mode status

Note: The three bits **DOTXT**, **GOOD**, and **STD** overwrite the corresponding internal bits of the PLL. The decoder updates these internal bits once per TV field. The decoder returns the current status of these bits with the software command 'Decoder Status'.

DOTXT	
0	Teletext reception has been disabled by the PLL algorithm.
1	Teletext operation is enabled.

GOOD	
0	The PLL recognises the SYNC signal quality to be BAD
1	The PLL recognises the SYNC signal quality as being ACCEPTABLE

STD	
0	The Sync signal is from a non-standard (i.e. VCR) signal source.
1	The Sync signal is within the range of a standard TV signal.

FFR	
0	Disable FFR Function
1	Force Free Run - Forces the PLL into free run mode regardless of the current PLL mode. FFR overrides the function of FNS and NSO.

FNS	
0	Disable FNS Function
1	Force Non-Standard - Forces the PLL into non-standard (VCR) mode regardless of the current PLL mode. FNS overrides the function of NSO.

NSO	
0	Disable NSO Function
1	Non-Standard Override - Disables the non-Standard (VCR) signal detection of the PLL.

PLL CONTROL REGISTERS

The coefficients and thresholds are well defined and initialised at power on reset. For the time being we would recommend the content of any of the registers shown in the map below should not be altered.

Register No.	Description	Default Value
13	PFAST	55h
14	PSLOW	04h
15	IFAST	08h
16	ISLOW	01h
17	PNORM	10h
18	Quality Detector Coefficient 1	BBh
19	Quality Detector Coefficient 2	45h
1A	Teletext Disable Threshold	0Bh
1B	Teletext Enable Threshold	05h
1C	PLL Lock Disable Threshold	28h
1D	PLL Lock Enable Threshold	20h
1E	Sync Signal Quality MSB	--
1F	Sync Signal Quality LSB	--
20	Max. Phase Error	--
21	Phase Error Limit	08h

PLL MAIN TECHNICAL DATA

Clock frequency	-	69.375Mhz (6 phases)
Phase difference of input clocks	-	2.4ns
Clock period tc	-	14.4ns
Measuring range for phase errors	-	$\pm 511 \times tc = \pm 7.36\mu s$
Resolution of phase error	-	tc
Range of the controller correction value	-	$(-370 \times tc)$ to $((370 + 5 \div 6) \times tc)$
Therefore possible locking range	-	17045Hz to 14423Hz
Resolution of correction value	-	2.4ns

There are two methods implemented to modify the output line frequency. The first one can be seen as a coarse adjustment by changing the pixel clock period. Normally one pixel clock has a period of $6 \times tc$. This period can be extended or reduced to $7 \times tc$ and $5 \times tc$ respectively. There is a special decoding scheme implemented to have a regular distribution of the pixel position to be modified in one line.

The second method is the fine adjustment of the line frequency by selecting one of the six input clock phases. Doing this a resolution of $tc \div 6$ can be reached which is needed for standard video signals, as our tests have shown.

The controller algorithm itself is calculated by the ALU. To reduce the calculation time we have a special 22-bit adder and shifter implemented, which is used for the 8 bit by 10 bit multiplication. The algorithm itself is a normal PI-controller with switchable coefficients. The assignment of the 22 bit variable to the controller input and output value is as follows:

Bits	Description
Bit 12 - 21	Phase error in 2's complement (input) or number of pixels to modify (output).
Bit 11	-
Bit 10	Number of phases to increment (only output).
Bit 9	-
Bit 0 - 8	Additional resolution for calculating the I - term of the controller algorithm.

The controller algorithm has the following transfer function:

$$H(z) = \frac{K + K \frac{T_0}{T_i} - 1}{1 - z^{-1}}$$

$$T_0 = \frac{1}{\text{line frequency}} \quad (\text{nominal } \frac{1}{15625} \text{ Hz} = 64\mu s)$$

K = gain (represented either by PNORM, PFAST or PSLOW, divided by 256)

Ti = integral - action time (represented either by IFAST or ISLOW, divided by 256)

It's implemented as a recursive algorithm using the following equation:

$$u(n) = q_0 \times e(n) + s(n)$$

$$s(n) = s(n - 1) + q_1 \times e(n - 1)$$

n = actual sampling period

u = controller output value

e = measured phase error

s = integral part

Ranges for the controller coefficients are:

$$0.996(-0.034 \text{ dB}) \geq K \geq 0.0039(-48 \text{ dB})$$

$$16 \times 10^{-3} (\text{cutoff frequency} = 10 \text{ Hz}) \leq T_i \leq 64 \times 10^{-6} (\text{cutoff frequency} = 2477 \text{ Hz})$$

The PLL is implemented as a two stage system, a coarse adjustment system that allows fast but approximate locking of the PLL and a fine tuning system that allows the small and precise adjustments.

The following sections use these abbreviations:

Abbreviation	Meaning	Where to find
Section	Range of quality values (see below)	
NSO	Non Standard detection Off	Reg. 0x12, Bit 7
FNS	Force Non Standard Mode	Reg. 0x12, Bit 6
FFR	Force Free Run	Reg. 0x12, Bit 5
PhErr	The result of the comparison: Max. Phase Error > Phase Error Limit	Reg. 0x20 and 0x21
Non Standard Counter	Counter used by the PLL to distinguish between Standard and Non-Standard signals	Internal register
H-locked	PLL is horizontal locked	Internal control signal
STDSIG	Sync is a standard signal	Internal control signal
SYNC1	Determines generated sync type	Reg. 0x10, Bit 1
TEXTON	Decoder is in TEXT mode.	Reg. 0x08, Bit 0, 1, 2
SLVMODE	Decoder is in slave sync mode	Reg. 0x10, Bit 0, 1
GOOD	PLL is locked to external video	Reg. 0x12, Bit 1 and 'Decoder Status'
STD	Decoder is in standard signal mode	Reg. 0x12, Bit 2 and 'Decoder Status'
DOTXT	Teletext reception is enabled	Reg. 0x12, Bit0 and 'Decoder Status'
COEFF	Selected coefficient set	
SM	Coefficients for Standard mode	Reg. 0x13..0x17
NSM	Coefficients for Non Standard mode	Reg. 0x13..0x17
BSIG	Coefficients for bad signal quality	Reg. 0x13..0x17
SLAVE	Coefficients for slave mode	Reg. 0x13..0x17
---	Value does not change	
x	Value doesn't care	

PLL non-standard signal detection

On a field base the maximum measured phase error between incoming Sync signal and the internal reference Sync is determined. The phase error is measured in steps of 57.6ns and can be read by the host CPU from the register **Max. Phase Error**. For example a value of **MaxPhaseError = 8** means the maximum detected phase error for the last field of the video signal was $8 \times 57.6 \text{ ns} = 460.8 \text{ ns}$.

In line 256 the **Max. Phase Error** is compared to an acceptable limit (**Phase Error Limit**), which can be defined using register 21H. Dependent on the result of this comparison the internal algorithm increments or decrements (for details see the following table) the Non Standard counter. The counter range is from 0..100. At values greater than 50 the PLL assumes an Non-Standard Signal.

The following table shows the way the Non Standard Counter works:

Section	PHERR	H-locked	NSO	FNS	FFR	Non Standard Counter
I, II	x	x	1	x	x	---
I, II	x	x	x	1	x	---
I, II	x	x	x	x	1	---
I	0	1	0	0	0	-1
I	0	0	0	0	0	+4
I	1	x	0	0	0	+4
II	x	1	0	0	0	-1
II	x	0	0	0	0	+4
III, IV, V	x	x	x	x	x	---

Quality Detection

The base for the signal quality measurement is the output of the Sync separator, which in turn depends on the signal to noise ratio of the input video signal. In order to measure the signal quality, the **CSYNC** input signal is integrated for one complete video line (64µs) and the maximum reached counter value for this time period is stored. The integrator counts up if **CSYNC = 'L'** and counts down if **CSYNC = 'H'**. Only video lines between the begin of the VBI (see register 0x11, Bit 4) and line 256 are measured. The resolution of the digital integrator is one pixel clock period that is 86.4ns. For each line the reached integrator value is compared to the nominal one that is $4.7\mu\text{s} \div 86.4\text{ns} = 54$. Any difference of the actual value to the nominal one is seen as an error and the absolute value of this error will be read by the quality detector software once per line for further processing.

Further processing means, for one field the average error value of all the lines is calculated and will then additionally be low-pass filtered. The actual output value of the low-pass filter is then compared to the different thresholds and can be read by the host CPU from register 1FH **Signal Quality MSB**.

As explained above this error can be in the range of 0 (no noise) to 63 (maximum error, e.g. no Sync found). Four different thresholds are defined, which are compared to the actual Signal Quality once per field and the appropriate action will be taken:

Signal Quality MSB \geq Teletext Disable Threshold : disable Teletext reception

Signal Quality MSB < Teletext Enable Threshold : enable Teletext reception

Signal Quality MSB \geq PLL Disable Threshold : PLL free-running

Signal Quality MSB < PLL Enable Threshold : synchronise PLL to Sync input.

These thresholds divide the quality range into five different sections as shown in the following diagram:

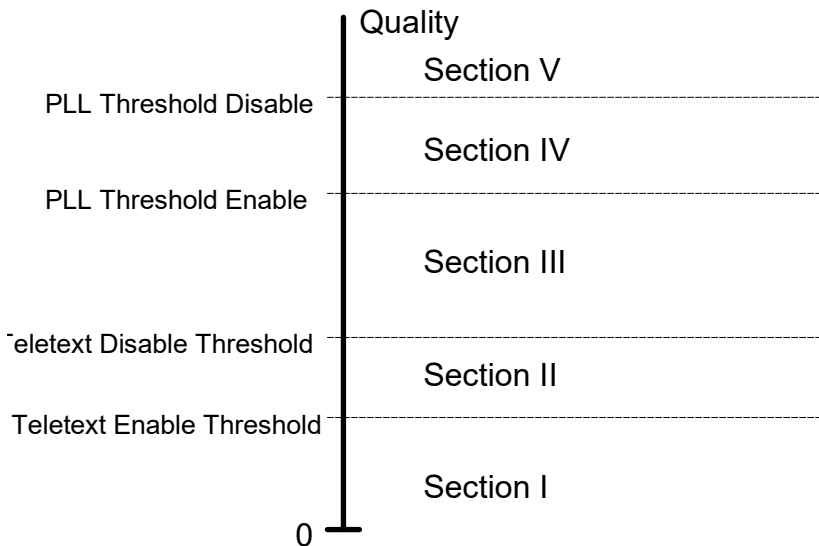

The low pass filter for the quality detector uses the following transfer function

$$H(z) = \frac{b0 \times z}{256 \times z - a1}$$

Where the coefficients are “b0” and “a1”. Sampling clock frequency is 50Hz (T = 20ms). The default coefficients are:

$$b0 = 69 \quad a1 = 187 \quad fg = 2.5 \text{ Hz}$$

The following equations can be used to calculate the coefficients based on a selected **-3dB** corner frequency (**fg**) of the transfer function:

$$b0 = \text{int}(256 \times (1 - e^{-2 \cdot \pi \cdot fg \cdot T})) = \text{int}(256 \times (1 - e^{-0.04 \cdot \pi \cdot fg}))$$

$$a1 = 256 - b0$$

Usage of the Coefficients

The table below illustrates the interaction between the quality values and external control signals.

Hardware Registers

Section	NSO	FNS	FFR	STDSIG	SYNC1	TEXT	SLVMODE	GOOD	STD	DOTXT	COEFF
I	0	0	0	1	x	x	0	1	1	1	SM
I	0	0	0	1	x	x	1	1	1	1	SLAVE
I	0	0	0	0	1	x	x	1	0	1	NSM
I	0	0	0	0	0	0	x	1	0	1	NSM
I	0	0	0	0	0	1	x	0	0	1	NSM
I	x	x	1	x	x	x	x	0	1	1	SM
I	x	1	0	x	1	x	x	1	0	1	NSM
I	x	1	0	x	0	0	x	1	0	1	NSM
I	x	1	0	x	0	1	x	0	0	1	NSM
I	1	0	0	x	x	x	x	1	1	1	SM
II	0	0	0	1	x	x	x	---	---	---	---
II	0	0	0	0	1	x	x	---	0	---	NSM
II	0	0	0	0	0	0	x	---	0	---	NSM
II	0	0	0	0	0	1	x	0	0	---	NSM
II	x	x	1	x	x	x	x	0	1	---	---
II	x	1	0	x	1	x	x	---	0	---	NSM
II	x	1	0	x	0	0	x	---	0	---	NSM
II	x	1	0	x	0	1	x	0	0	---	NSM
II	1	0	0	x	x	x	x	---	---	---	---
III, IV, V	x	x	0	x	x	x	1	---	1	0	---
III, IV, V	x	x	1	x	x	x	1	0	1	0	---
III	x	x	0	x	x	0	0	1	1	0	BSIG
III	x	x	0	x	x	1	0	0	1	0	BSIG
III	x	x	1	x	x	x	0	0	1	0	BSIG
IV	x	x	0	x	x	0	0	---	1	0	BSIG
IV	x	x	0	x	x	1	0	0	1	0	BSIG
IV	x	x	1	x	x	x	0	0	1	0	BSIG
V	x	x	x	x	x	x	0	0	1	0	---

The PLL coefficients are used differently, depending on the current mode of the PLL and the current operating conditions. The four operating conditions are:

1. PLL not locked, measured phase error $\geq (64 \times 14.4ns)$.
2. PLL not locked, measured phase error $< (64 \times 14.4ns)$.
3. PLL locked, calculate I-term, measured phase error $\geq (2 \times 14.4ns)$
4. PLL locked, don't update I-term, measured phase error $< (2 \times 14.4ns)$

The use of the coefficients in the different modes and conditions is as follows:

	1	2	3	4
Standard Mode (SM)	PNORM ISLOW	PNORM ISLOW	PSLOW ISLOW	PSLOW 0
Slave-Sync Mode (SLAVE)	PNORM ISLOW	PNORM IFAST	PFAST ISLOW	PSLOW 0
Bad Signal Mode (BSIG)	PNORM 0	PNORM 0	PSLOW 0	PSLOW 0
non-standard Mode (NSM)	PFAST ISLOW	PFAST IFAST	PFAST IFAST	PFAST 0

TELETEXT ERROR COUNTING

The Teletext Error counting registers provide an indication of the amount of errors seen in the Teletext data being stored into memory. The error counting is initiated by overwriting the three registers with zero. The decoder will then start to count the Hamming and Parity errors contained in the Teletext page data that the decoder is storing into memory. After every packet has been stored the *Packet Count* is incremented and the error count from this packet is added to the *Error MSB* and *Error LSB*. The errors are accumulated until the *Packet Count* reaches 255. When the errors from 255 packets have been counted the system is frozen. It will remain frozen until the error counting registers are once again overwritten with zeros.

Register No.	Description	Default Value
22	Error Packet Count	--
23	Error MS Byte	--
24	Error LS Byte	--

VPS ERROR COUNTING

The VPS error counting registers provide an indication of the number of VPS lines containing errors. The error counting is initiated by overwriting the two registers with zero. The decoder will then start to count the number of VPS lines not processed due to errors in the line. After every VPS line is received the **VPS Packet Count** is incremented and if the line contains errors the **VPS Error Count** is also incremented. The errors are accumulated until the **Packet Count** reaches 255. When the errors from 255 VPS lines have been counted the system is frozen. It will remain frozen until the VPS error counting registers are once again overwritten with zeros.

Register No.	Description	Default Value
25	VPS Error Packet Count	--
26	VPS Error Count	--

EXTENDED FULL SCREEN COLOUR

When the M407 bit is set, register 0Fhex is redefined and together with an additional register 27hex, define the extended full screen colour functions.

Register No.	Description	Default Value
0F	Extended Full Screen Colour	--
27	Extended Full Screen Colour	--

Full Screen Colour Register 1

Register 0Fhex is redefined, containing extra control bits and also the RED portion of the background colour.

0F	MSB							LSB
Full Screen Colour	TEXTBG	FRAME	CONT	WSTBG	--	RED2	RED1	RED0

FRAME	
0	The text field will be surrounded by the black colour.
1	Full screen colour mode is enabled. The colour defined by the bits RED[0..2] , GREEN[0..2] and BLUE[0..2] will surround the Teletext display field.

TXTBG	
0	The background colour for the Teletext field will be taken from the black entry of the colour palette.
1	The colour defined by the control bits RED[0..2] , GREEN[0..2] and BLUE[0..2] will be adopted as the default background colour for the Teletext page.

CONT	
0	The contrast output is inactive the output pin is always low.
1	The contrast output is active.

WSTBG	
0	Default mode, the 'Teletext Black Background' serial attribute sets the background colour to black.
1	The 'Teletext Black Background' serial attribute sets the background colour to the current background colour as defined by the TXTBG bit.

Full Screen Colour Register 2

Contains the BLUE and GREEN portions of the background colour.

27	MSB							LSB
Full Screen Colour	--	BLUE2	BLUE1	BLUE0	--	GREEN2	GREEN1	GREEN0

EXTENDED CURSOR FUNCTIONS

When the **M407** bit is set, the cursor function is changed to provide a variable length, variable colour cursor. The variable length cursor is defined by providing a start and end column for the cursor. It is possible to fully specify the foreground and background colours of the cursor.

Register No.	Description	Default Value
0B	Cursor Row	--
0C	Cursor Start Column	--
28	Cursor End Column	--
29	Cursor Colour Register 1	--
2A	Cursor Colour Register 2	--
2B	Cursor Colour Register 3	--

Cursor Position and Length

0B	MSB	LSB								
Cursor Row	<table style="width: 100%; border-collapse: collapse;"> <tr> <td style="width: 12.5%; text-align: center;">--</td> <td style="width: 12.5%; text-align: center;">--</td> <td style="width: 12.5%; text-align: center;">--</td> <td style="width: 12.5%; text-align: center;">Row4</td> <td style="width: 12.5%; text-align: center;">Row3</td> <td style="width: 12.5%; text-align: center;">Row2</td> <td style="width: 12.5%; text-align: center;">Row1</td> <td style="width: 12.5%; text-align: center;">Row0</td> </tr> </table>	--	--	--	Row4	Row3	Row2	Row1	Row0	
--	--	--	Row4	Row3	Row2	Row1	Row0			

Row[4..0] Cursor row address. Valid address 0..25

0C	MSB	LSB								
Cursor Start Column	<table style="width: 100%; border-collapse: collapse;"> <tr> <td style="width: 12.5%; text-align: center;">--</td> <td style="width: 12.5%; text-align: center;">--</td> <td style="width: 12.5%; text-align: center;">Col5</td> <td style="width: 12.5%; text-align: center;">Col4</td> <td style="width: 12.5%; text-align: center;">Col3</td> <td style="width: 12.5%; text-align: center;">Col2</td> <td style="width: 12.5%; text-align: center;">Col1</td> <td style="width: 12.5%; text-align: center;">Col0</td> </tr> </table>	--	--	Col5	Col4	Col3	Col2	Col1	Col0	
--	--	Col5	Col4	Col3	Col2	Col1	Col0			

Col[5..0] Cursor Start column address. Valid address 0..39

28	MSB	LSB								
Cursor End Column	<table style="width: 100%; border-collapse: collapse;"> <tr> <td style="width: 12.5%; text-align: center;">--</td> <td style="width: 12.5%; text-align: center;">--</td> <td style="width: 12.5%; text-align: center;">End5</td> <td style="width: 12.5%; text-align: center;">End4</td> <td style="width: 12.5%; text-align: center;">End3</td> <td style="width: 12.5%; text-align: center;">End2</td> <td style="width: 12.5%; text-align: center;">End1</td> <td style="width: 12.5%; text-align: center;">End0</td> </tr> </table>	--	--	End5	End4	End3	End2	End1	End0	
--	--	End5	End4	End3	End2	End1	End0			

End[5..0] Cursor End column address. Valid address 0..39

Cursor Colour

29	MSB	LSB								
Cursor Colour Register 1	<table style="width: 100%; border-collapse: collapse;"> <tr> <td style="width: 12.5%; text-align: center;">0</td> <td style="width: 12.5%; text-align: center;">BG2</td> <td style="width: 12.5%; text-align: center;">BG1</td> <td style="width: 12.5%; text-align: center;">BG0</td> <td style="width: 12.5%; text-align: center;">0</td> <td style="width: 12.5%; text-align: center;">BR2</td> <td style="width: 12.5%; text-align: center;">BR1</td> <td style="width: 12.5%; text-align: center;">BR0</td> </tr> </table>	0	BG2	BG1	BG0	0	BR2	BR1	BR0	
0	BG2	BG1	BG0	0	BR2	BR1	BR0			

BG[2..0] Cursor background green colour
BR[2..0] Cursor background red colour

2A	MSB	LSB								
Cursor Colour Register 2	<table style="width: 100%; border-collapse: collapse;"> <tr> <td style="width: 12.5%; text-align: center;">0</td> <td style="width: 12.5%; text-align: center;">FB2</td> <td style="width: 12.5%; text-align: center;">FB1</td> <td style="width: 12.5%; text-align: center;">FB0</td> <td style="width: 12.5%; text-align: center;">0</td> <td style="width: 12.5%; text-align: center;">BB2</td> <td style="width: 12.5%; text-align: center;">BB1</td> <td style="width: 12.5%; text-align: center;">BB0</td> </tr> </table>	0	FB2	FB1	FB0	0	BB2	BB1	BB0	
0	FB2	FB1	FB0	0	BB2	BB1	BB0			

FB[2..0] Cursor foreground blue colour
BB[2..0] Cursor background blue colour

CF72407 MULTIPAGE

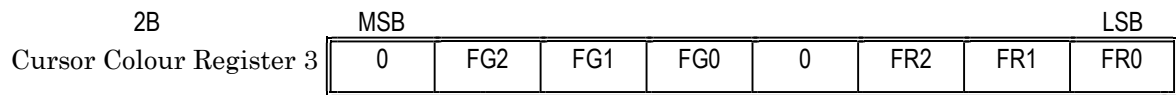

FG[2..0] Cursor foreground green colour
FR[2..0] Cursor foreground red colour

COLOUR PALETTE

It is possible to redefine the eight foreground and eight background colours by writing the desired colours to registers 0x2Chex to 0x3D. Writing to the palette registers, writes the new colours to a palette buffer. This palette buffer will then be copied to the palette hardware the next time a Teletext display page or a Menu display page command is received. On reset the palette buffer and the palette hardware are programmed with the Teletext Level 1 colours.

Register No.	Description	Default Value
2C	Colour Palette Background Register 0	(BLACK)
2D	Colour Palette Background Register 1	(RED)
2E	Colour Palette Background Register 2	(GREEN)
2F	Colour Palette Background Register 3	(YELLOW)
30	Colour Palette Background Register 4	(BLUE)
31	Colour Palette Background Register 5	(MAGENTA)
32	Colour Palette Background Register 6	(CYAN)
33	Colour Palette Background Register 7	(WHITE)
34	Colour Palette Foreground Register 0	(BLACK)
35	Colour Palette Foreground Register 1	(RED)
36	Colour Palette Foreground Register 2	(GREEN)
37	Colour Palette Foreground Register 3	(YELLOW)
38	Colour Palette Foreground Register 4	(BLUE)
39	Colour Palette Foreground Register 5	(MAGENTA)
3A	Colour Palette Foreground Register 6	(CYAN)
3B	Colour Palette Foreground Register 7	(WHITE)
3C	Colour Palette Background Register 8	--
3D	Colour Palette Foreground Register 8	--

Background Colours

The background registers 0 to 7 define the RED[2..0], GREEN[2..0] and BLUE[1..0] bits of the colours.

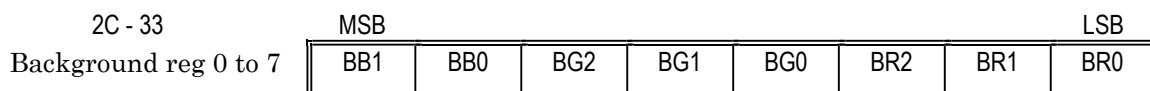

BR[2..0] Background red
 BG[2..0] Background green
 BB[1..0] Background blue (two lsb's only)

The 8 blue msb's are defined in background register 8. The lsb of register 8 provides the blue msb for background register 0 and the msb of register 8 provides the blue msb for register 7.

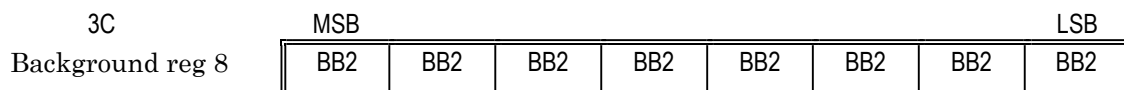

BB2 Background blue msb's for registers 0 to 7

Foreground Colours

The foreground registers 0 to 7 define the RED[2..0], GREEN[2..0] and BLUE[1..0] bits of the colours.

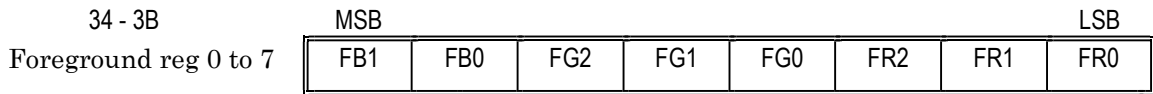

FR[2..0] Foreground red
FG[2..0] Foreground green
FB[1..0] Foreground blue (two lsb's only)

The 8 blue msb's are defined in foreground register 8. The lsb of register 8 provides the blue msb for foreground register 0 and the msb of register 8 provides the blue msb for register 7.

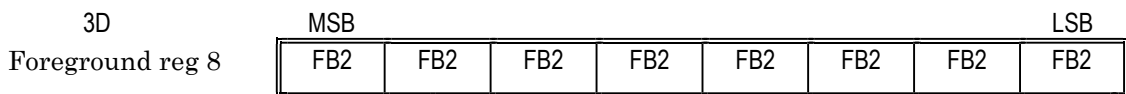

FB2 Foreground blue msb's for registers 0 to 7

TELETEXT

DISPLAY A TELETEXT PAGE

When this command is received the decoder will display the Teletext page as specified by the command. Since the display page is totally independent from the page store, first the decoder will load the requested page number into the acquisition circuit of the display page, then it will check whether the requested page is enabled in the page acquisition table. If it is enabled then the decoder will:

- Copy the page data from the page store to the display page provided data for this page has been received or:
- If the requested page is not enabled for capture then the decoder will display a rolling header and search for the requested page.
- Copy the programmable colour palette registers to the palette hardware registers.

If the page is only captured in the display page then the contents of the page will be lost (overwritten) every time when another page (menu or Teletext page) is displayed. If the display page was on **HOLD** (refer to the **Display page hold on/off** command), this command will release the page from **HOLD**. This command will automatically perform a **Display Time Off** command. The first eight characters of the header row will not be overwritten when the display page is updated.

I2C Command format

MSB				LSB				
0	0	1	0	0	0	1	R/W	I2C Slave Address R/W = 0
0	0	0	0	1	1	0	1	Command code (0x0D)
0	0	0	0	0	MAG2	MAG1	MAG0	Magazine and Options
PT3	PT2	PT1	PT0	PU3	PU2	PU1	PU0	Page number
0	0	STH1	STH0	SH3	SH2	SH1	SH0	Subpage MSB
0	ST2	ST1	ST0	SU3	SU2	SU1	SU0	Subpage LSB
0	0	1	0	0	0	1	R/W	I2C Slave Address R/W = 1
ST7	ST6	ST5	ST4	ST3	ST2	ST1	ST0	Command Status

Teletext Page Number

- MAG[0..2]:** Magazine number from 0..7.
PU[0..3]: Page number units from 0..Fhex.
PT[0..3]: Page number tens from 0..Fhex.
STH[0..1]: Subpage number thousands from 0..3.
SH[0..3]: Subpage number hundreds from 0..Fhex.
ST[0..2]: Subpage number tens from 0..7.
SU[0..3]: Subpage number units from 0..Fhex.

The subpage number must always be supplied with the command. When a specific subpage is not required then the subpage field in the command should be set to "DON'T CARE". Don't care is indicated by setting the subpage entry to 0x3F7F.

Note: *The decoder will not check the validity of the Teletext page number. It will only perform a logical AND operation to make sure that the page numbers (magazine, page tens and units and the subpage number) are not above the upper limit before the decoder starts processing.*

Command Status

The command returns the following status codes:

ST[0..7]	Description
00	COMMAND ACCEPTED
01	COMMAND REJECTED Due to an incorrect number of bytes for the command
02	INVALID COMMAND CODE

DISPLAY NEXT OR PREVIOUS TELETEXT PAGE

The main intention of this command is to enable the system programmer to step easily through the Teletext data base. It offers him powerful page searching features which includes packet 27 link processing when the internal FLOF system is enabled. Please refer to the command **SELECT TELETEXT MODE** for more information on support modes.

Note: *This command does not support a user defined FLOF system. In this case the programmer has to do all the page selection and link processing by himself. The command REPORT FLOF LINKS will provide him some support.*

This command does not support TOP mode. The command TOP TABLE PROCESSING provides extended display features in TOP mode.

This command will automatically perform a Display Time Off command

Following the command status byte the decoder will report the page number of the page that will be displayed next. The decoder will send a terminator byte (code FF(hex)) after the last byte of the page number has been reported if the master continues to read. The terminator will be repeated as long as the master continues to read.

I2C Command format

MSB				LSB				
0	0	1	0	0	0	1	R/W	I2C Slave Address R/W = 0
0	0	0	0	1	1	1	0	Command code (0x0E)
0	0	RO	DPN	DP3	DP2	DP1	DP0	Command Option
0	0	1	0	0	0	1	R/W	I2C Slave Address R/W = 1
ST7	ST6	ST5	ST4	ST3	ST2	ST1	ST0	Command Status
0	0	0	0	0	MAG2	MAG1	MAG0	Magazine
PT3	PT2	PT1	PT0	PU3	PU2	PU1	PU0	Page number
0	0	STH1	STH0	SH3	SH2	SH1	SH0	Subpage MSB
0	ST2	ST1	ST0	SU3	SU2	SU1	SU0	Subpage LSB

Command Option

The control bits DP[0..3] determine the operation of this command. The FLOF mode must be set prior to the use of this command with the command **SELECT TELETEXT MODE**. The decoder will execute the command as follows:

- The decoder will copy the page from memory to the display page when data for this page has been received

Teletext Commands

- The decoder will display a rolling header if no data has been received so far. The decoder will treat the header as specified by the command **ENABLE / DISABLE ROLLING HEADER**.
- Copy the programmable colour palette registers to the palette hardware registers.

R0	
0	DISPLAY TELETEXT PAGE The new Teletext page is displayed.
1	REPORT ONLY Display of the new Teletext page is inhibited. This option will causes the next/previous page number to be reported without changing the display to this page. This bit is ignored by the <i>display index page commands</i> .

DPN	
0	SEARCH ALL PAGE NUMBERS The command will search all pages, both hex and decimal page numbers.
1	DECIMAL PAGE NUMBERS ONLY The command will search only the pages with decimal page numbers.

DP3	DP2	DP1	DP0	
0	0	0	0	<p>DISPLAY DEFAULT INDEX PAGE 100 The decoder will display the default index page 100.</p>
0	0	0	1	<p>DISPLAY INITIAL PAGE AS SPECIFIED BY PACKET 8/30 Causes the Initial page, as specified by packet 8/30, to be displayed. Page 100 should be displayed as a fall back page if packet 8/30 cannot be processed or when packet 8/30 is not transmitted. When this option is received the decoder will perform the following actions:</p> <ul style="list-style-type: none"> a) Initialise the page acquisition circuit of the display page with page 100. b) If page 100 is already in memory copy it to the display page. c) Return page 100 to the master controller. d) Enable processing of packet 8/30 format 1. Same as the option in command ENABLE GHOST ROW RECEPTION. e) Wait till packet 8/30 is transmitted again. f) Processes the links and initialise the page acquisition circuit of the display page with the page number of the initial page. g) display the initial page when it is transmitted again or copies it from memory when it is already stored.
0	0	1	0	<p>DISPLAY NEXT MAIN PAGE STORED IN MEMORY Starting at the current displayed main page (subpage number set to don't care) the decoder will search forwards through the page acquisition table to find the next page and copy it to the display page. The decoder will step through the whole data base. On the last entry of the page acquisition table, the decoder will wrap round to the first entry of the table and continue searching from there.</p>
0	0	1	1	<p>DISPLAY PREVIOUS PAGE STORED IN MEMORY Starting at the current displayed main page (subpage number set to don't care) the decoder will search backwards through the page acquisition table to find the previous main page and copy it to the display page. The decoder will step through the whole data base. On the first entry of the page acquisition table, the decoder will wrap round to the last entry of the table and continue searching from there.</p>
0	1	0	0	<p>DISPLAY NEXT SUBPAGE STORED IN MEMORY Starting at the current displayed subpage the decoder will search forwards through the subpage chain to find the next subpage and copy it to the display page. The decoder will sort the subpage numbers in order to display it in a line of ascent. When the last subpage has been displayed then the decoder will go the next main page and display the lowest subpage stored for this page. This enables the system programmer to step through all subpages and main pages stored in memory. On the last entry of the page acquisition table (last main page), the decoder will wrap round to the first entry of the table and continue searching from there.</p>

0	1	0	1	<p>DISPLAY PREVIOUS SUBPAGE STORED IN MEMORY</p> <p>Starting at the current displayed subpage the decoder will search backwards through the subpage chain to find the previous subpage and copy it to the display page. The decoder will sort the subpage numbers in order to display it in a line of ascent. When the first subpage has been displayed then the decoder will go the previous main page and display the highest subpage stored for this page. This enables the system programmer to step through all subpages and main pages stored in memory. On the first entry of the page acquisition table (first main page), the decoder will wrap round to the last entry of the table and continue searching from there.</p> <p>NOTE: THIS COMMAND DOES NOT FUNCTION CORRECTLY IN THE CF72407. THE INCORRECT SUBPAGE IS SELECTED WHEN THE COMMAND MOVES OVER A PAGE BOUNDARY.</p>
---	---	---	---	--

FLOF Commands

The following options should only be used when the implemented **FLOF** system is used. It provides powerful page searching features and automatic page selection with reduced software overhead in the external micro controller. The decoder will process packet 27 and display the requested page when it receives one of the **FLOF** commands.

Note: *The decoder will perform all the required actions as specified for the implemented **FLOF** system if **FLOF** mode has been enabled before. Please refer to sections **SELECT TELETEXT MODE** and **APPENDIX B** for more information.*

*This command does not support a user defined **FLOF** system. In this case the programmer has to do all the page selection and link processing by himself. The command **REPORT FLOF LINKS** will provide him some support.*

*The decoder will reject the command if packet 27 is not available in memory or **FLOF** mode is not enabled.*

The decoder will reject this command if there is no link for the next page. Thus the currently displayed page will remain on the screen.

DP3	DP2	DP1	DP0	
0	1	1	0	DISPLAY NEXT PAGE AS SPECIFIED BY THE FIRST LINK Causes the page, as specified by the first link in packet 27 to be displayed.
0	1	1	1	DISPLAY NEXT PAGE AS SPECIFIED BY THE SECOND LINK Causes the page, as specified by the second link in packet 27 to be displayed.
1	0	0	0	DISPLAY NEXT PAGE AS SPECIFIED BY THE THIRD LINK Causes the page, as specified by the third link in packet 27 to be displayed.
1	0	0	1	DISPLAY NEXT PAGE AS SPECIFIED BY THE FORTH LINK Causes the page, as specified by the forth link in packet 27 to be displayed.
1	0	1	0	DISPLAY NEXT PAGE AS SPECIFIED BY THE SIXTH LINK Causes the page, as specified by the sixth link (INDEX PAGE) in packet 27 to be displayed.

Command Status

The currently displayed page will remain on the screen if the command has been rejected. Furthermore, the status will be reported as long as the master is in read mode e.g. the decoder will not report a page number.

ST[0..7]	Description
00	COMMAND ACCEPTED
01	COMMAND REJECTED Due to an incorrect number of bytes for the command or an invalid command option.
02	INVALID COMMAND CODE
03	PROCESS ERROR This status code will be returned when the decoder could not find a page in memory.

TELETEXT PAGE ACQUISITION TABLE

With the decoder it is possible to enable up to 2048 Teletext pages and depending on the memory option it is able to receive approximately 1000 Teletext pages. All enabled pages are received within one transmission cycle, and are updated every time the page is re-transmitted. To handle this huge number of pages the decoder requires a mechanism that allows it to check which pages are enabled for capture and which is/are not. Therefore a **Page Acquisition Table** has been built which enables the decoder to work out quickly which page(s) needs to be captured and stored. This table contains information such as **Rolling Page**, **Capture all Subpages** etc. which is selected by the system programmer when he enables a page with one of the appropriate commands. When a page is enabled or disabled from capture then the decoder needs to rearrange the memory. This is described briefly in the following section.

MEMORY MANAGEMENT

It is possible to enable more pages in the acquisition table than there is memory available to the device. The situation is even more complicated if capture all subpages is enabled. This is because in a normal Teletext environment the decoder has no information of how many subpages are attached to a Teletext page. Especially when in this mode the decoder can run out of memory.

The memory management implemented in this decoder only allocates the required amount of memory to store the transmitted data, thus the decoder will not know how much memory to allocate before a complete page is received. The memory occupied by a page depends on two facts:

- On the number of Teletext rows received for this page.
- How the decoder should handle Ghost row data.

While a new page is being received, the decoder dynamically allocates memory for each new row when it comes in. This has the advantage that no memory is wasted for Teletext rows or pages that are not transmitted. These rows will be replaced with space characters when they are displayed or when the master is reading it out. If the memory is full and the decoder still receives data that should be stored then, it will try to free memory for this page by deleting the Teletext page with the lowest priority.

If Ghost row reception is enabled too then the memory required for one page heavily depends on the Ghost row options selected by the system programmer and on the amount of data received for this page.

PAGE PRIORITY NUMBERS

It is possible to supply a 16bit priority number with all page enable commands. When the decoder runs out of memory, as described above, the priority numbers are used to determine which page can be deleted to make more memory available. The operation of the page priority system is described in the appendix A.

SMALL MEMORIES

The decoder is capable of enabling 2048 Teletext pages. The internal page table to store all 2048 entries is quite large. If the small memory option (e.g. 64K bytes or less) is used the size of the page table in relation to the total available memory is prohibitively large. So for the small memory option the number of possible enabled pages is limited to 128.

RE-ENABLING TELETEXT PAGES

When receiving an enable command for a previously enabled page, one of two actions may be performed. If the requested mode, **REQ[0..1]**, is the same as the previous entry the decoder just updates the capture mode, **CAP[0..1]**, and the priority number to the new values. If the requested mode, **REQ[0..1]**, is different all entries for this page will be deleted and then re-enabled with the new modes at the new priority.

SINGLE TELETEXT PAGE ACQUISITION

When the decoder receives this command, it will add / delete the requested Teletext page to / from the page acquisition table.

I2C-bus command format

MSB							LSB	
0	0	1	0	0	0	1	R/W	I2C Slave Address R/W = 0
0	0	0	0	0	1	0	0	Command code (0x04)
REQ1	REQ0	CAP1	CAP0	0	MAG2	MAG1	MAG0	
PT3	PT2	PT1	PT0	PU3	PU2	PU1	PU0	
P15	P14	P13	P12	P11	P10	P9	P8	Priority Number
P7	P6	P5	P4	P3	P2	P1	P0	
0	0	1	0	0	0	1	R/W	I2C Slave Address R/W = 1
ST7	ST6	ST5	ST4	ST3	ST2	ST1	ST0	Command Status
P15	P14	P13	P12	P11	P10	P9	P8	Actual priority Number
P7	P6	P5	P4	P3	P2	P1	P0	

Teletext Page Number

- MAG[0..2]: Magazine number from 0..7.
- PU[0..3]: Page number units from 0..F-hex.
- PT[0..3]: Page number tens from 0..F-hex.

Note: The decoder will not check the validity of the Teletext page number. It will only perform a logical AND operation to make sure that the page numbers (magazine, page tens and units) are not above the upper limit before the decoder starts processing.

Teletext Priority Number

- P[0..15]: A 16bit priority number that is used by the decoder to determine which pages may be removed from memory if there is not sufficient memory to store all the enabled pages.(see the appendix for further details).

If the given priority number is of a lower priority than the lowest already enabled, the decoder will automatically assign the next lowest priority to this page. The actual priority number assigned to the page is returned in the two bytes following the command status.

If the page acquisition table is full and the given priority number is of a higher priority than the lowest already enabled. The decoder will delete the page with the lowest priority before the command is executed.

Command Options

The control bits **CAP[0..1]** determine how the page data is to be stored in memory

CAP1	CAP0	
0	0	Parity
0	1	8-bit Data. Only rows 1-25 will be in 8-bit format. Row 0 will always be processed.
1	0	4Bit Hamming.
1	1	Additional Information.

The control bits **REQ[0..1]** determine which function is requested. Please see also Note 4 of this command. It explains how the decoder behaves when the master re-enables Teletext pages.

REQ1	REQ0	
0	0	ENABLE PAGE FOR CAPTURE WITH ROLLING SUBPAGE. The page number received with the command will be enabled for capture in the page acquisition table. If there are subpages transmitted then the decoder will display it as rolling page e.g. only the memory for one page will be allocated.
0	1	ENABLE PAGE AND SUBPAGES FOR CAPTURE. With this option the decoder will enable the page number received with the command for capture. It also will enable Capture all Subpages that means the decoder will store all subpages attached to the main page when they arrive.
1	0	REMOVE PAGE FROM THE PAGE ACQUISITION TABLE. The decoder will delete the received page number and all associated subpages from the page acquisition table. Thus all data stored so far will be lost. Although not required for this function a priority number must be supplied with the command.
1	1	Not Used

Command Status

The command returns the following status codes:

ST[0..7]	Description
00	COMMAND ACCEPTED
01	COMMAND REJECTED Due to an incorrect number of bytes for the command.
02	INVALID COMMAND CODE
03	PROCESS ERROR This status code will be returned when: a) The master controller has requested a PAGE DELETE but the page is not enabled. b) Page Acquisition Table overflow. On a small memory system (up to 64k-bytes), the decoder uses a reduced page acquisition table with only 128 entries.

SINGLE TELETEXT SUBPAGE ACQUISITION

When the decoder receives this command, it will add / delete the requested Teletext subpage to / from the page acquisition table.

I2C-bus command format

MSB							LSB	
0	0	1	0	0	0	1	R/W	I2C Slave Address R/W = 0
0	0	0	1	1	1	1	1	Command code (0x1F)
0	REQ	CAP1	CAP0	0	MAG2	MAG1	MAG0	
PT3	PT2	PT1	PT0	PU3	PU2	PU1	PU0	
0	0	STH1	STH0	SH3	SH2	SH1	SH0	
0	ST2	ST1	ST0	SU3	SU2	SU1	SU0	
P15	P14	P13	P12	P11	P10	P9	P8	Priority Number
P7	P6	P5	P4	P3	P2	P1	P0	
0	0	1	0	0	0	1	R/W	I2C Slave Address R/W = 1
ST7	ST6	ST5	ST4	ST3	ST2	ST1	ST0	Command Status

Teletext Page Number

- MAG[0..2]:** Magazine number from 0..7.
- PU[0..3]:** Page number units from 0..F-hex.
- PT[0..3]:** Page number tens from 0..F-hex.
- STH[0..1]:** Subpage number thousands from 0..3
- SH[0..3]:** Subpage number hundreds from 0..F
- ST[0..2]:** Subpage number units from 0..7.
- SU[0..3]:** Subpage number units from 0..F-hex.

Note: The decoder will not check the validity of the Teletext page number. It will only perform a logical AND operation to make sure that the page numbers (magazine, page tens and units and the subpage number) are not above the upper limit before the decoder starts processing.

Teletext Priority Number

- P[0..15]:** A 16bit priority number that is used by the decoder to determine which pages may be removed from memory if there is not sufficient memory to store all the enabled pages.(see the appendix for further details)

Command Options

The control bits **CAP[0..1]** determine how the page data is to be stored in memory. These control bit are associated with the page number and not with a particular subpage.

CAP1	CAP0	
0	0	Parity
0	1	8-bit Data. Only rows 1-25 will be in 8-bit format. Row 0 will always be processed.
1	0	4Bit Hamming.
1	1	Additional Information.

REQ	
0	ENABLE SUBPAGE FOR CAPTURE The subpage number received with the command will be enabled for capture in the page acquisition table.
1	DELETE SUBPAGE FROM THE ACQUISITION TABLE The decoder will delete the received subpage number from the page acquisition table. All other subpages in this chain remain active and stored in memory. If capture all subpages have been selected before than the decoder will redefine this to capture particular subpages.

Command Status

The command returns the following status codes:

ST[0..7]	Description
00	COMMAND ACCEPTED
01	COMMAND REJECTED Due to an incorrect number of bytes for the command.
02	INVALID COMMAND CODE
03	PROCESS ERROR This status code will be returned when: a) The master controller has requested a PAGE DELETE but the page is not enabled. b) Page Acquisition Table overflow. On a small memory system (up to 64k-bytes), the decoder uses a reduced page acquisition table with only 128 entries.

MULTIPLE TELETEXT PAGE ACQUISITION

When the decoder receives this command, it will add / delete the requested Teletext pages to / from the page acquisition table. The first and last page are determined by the two page numbers specified in this command..

Note: *The decoder will enable or disable all pages that are outside the specified boundary if the last page number, received with the command, is smaller than the first page number. This is because the decoder will wrap round to the beginning of the page acquisition table (page 800) when it reaches the entry for page 7FF and continues from there till the last page number is reached.*

*On a small memory system (up to 64k-bytes) the decoder will terminate the command with a status **Process Error** if it could not enable all the requested pages.*

I2C-bus command format

MSB				LSB				
0	0	1	0	0	0	1	R/W	I2C Slave Address R/W = 0
0	0	1	0	0	0	0	0	Command code (0x20)
REQ1	REQ0	CAP1	CAP0	HPN	MAG2	MAG1	MAG0	First page of block
PT3	PT2	PT1	PT0	PU3	PU2	PU1	PU0	
DEC	0	0	0	0	MAG2	MAG1	MAG0	Last page of block
PT3	PT2	PT1	PT0	PU3	PU2	PU1	PU0	
P15	P14	P13	P12	P11	P10	P9	P8	Priority Number
P7	P6	P5	P4	P3	P2	P1	P0	
0	0	1	0	0	0	1	R/W	I2C Slave Address R/W = 1
ST7	ST6	ST5	ST4	ST3	ST2	ST1	ST0	Command Status

Teletext Page Number

MAG[0..2]: Magazine number from 0..7.
PU[0..3]: Page number units from 0..F-hex.
PT[0..3]: Page number tens from 0..F-hex.

Note: *The decoder will not check the validity of the Teletext page number. It will only perform a logical AND operation to make sure that the page numbers (magazine, page tens and units and the subpage number) are not above the upper limit before the decoder starts processing.*

Teletext Priority Number

P[0..15]: A 16bit priority number that is used by the decoder to determine which pages may be removed from memory if there is not sufficient memory to store all the enabled pages (see the appendix for further details).

If the page acquisition table is full and the given priority number is of a higher priority than the lowest already enabled. The decoder will delete the page with the lowest priority before the command is executed.

Command Options

The control bits **CAP[0..1]** determine how the page data is to be stored in memory

CAP1	CAP0	
0	0	Parity
0	1	8-bit Data. Only rows 1-25 will be in 8-bit format. Row 0 will always be processed.
1	0	4Bit Hamming.
1	1	Additional Information.

The controls bits **REQ[0..1]** determine which function is requested.

REQ1	REQ0	
0	0	ENABLE BLOCK OF PAGES FOR CAPTURE WITH ROLLING SUBPAGE The page numbers specified by the command will be enabled for capture in the page acquisition table. If there are subpages transmitted then the decoder will display it as rolling page e.g. only the memory for one page will be allocated.
0	1	ENABLE BLOCK OF PAGES AND SUBPAGES FOR CAPTURE With this option the decoder will enable the whole block of pages for capture as requested by the command. It also will enable Capture all Subpages that means the decoder will store all subpages attached to the main pages when they arrive.
1	0	REMOVE BLOCK OF PAGES FROM THE PAGE ACQUISITION TABLE The decoder will delete the selected page numbers and all associated subpages from the page acquisition table. Thus all data stored so far will be lost.
1	1	Not Used

HPN	
0	Only the decimal page numbers within the block will be enabled. All hex page numbers will be ignored.
1	All pages in the block to be enabled, including all of the HEX numbers.

DEC	
0	Pages are allocated starting with the <i>first</i> page of the block and incrementing the page number until the <i>last</i> page of the block is allocated.
1	Pages are allocated starting with the <i>last</i> page of the block and decrementing the page number until the <i>first</i> page of the block is allocated.

Command Status

The command returns the following status codes:

ST[0..7]	Description
00	COMMAND ACCEPTED
01	COMMAND REJECTED Due to an incorrect number of bytes for the command.
02	INVALID COMMAND CODE
03	PROCESS ERROR This status code will be returned when: a) The master controller has requested a PAGE DELETE but the page is not enabled. b) Page Acquisition Table overflow. On a small memory system (up to 64k-bytes), the decoder uses a reduced page acquisition table with only 128 entries.

TELETEXT PAGE STATUS

This command offers the system programmer the possibility to check the current status of Teletext pages. The information encoded in the page status informs the system programmer whether:

- The page is enabled for capture.
- The page is present in memory.
- The page capture priority.
- The page is on hold.
- The received data is stored as 8-bit data, 7-bit parity corrected page, 4-bit Hamming coded page or Additional information table (special coding).
- Rolling page is selected for this page.

When the decoder receives this command it will send the status of the first page as described below. This is not necessarily the status of the page requested by the command because this depends on the options set in the command option byte. If the status of more than one page is required then the master controller continues to read after the status of the first page is sent. The decoder will continue to send status information of all pages in a line of ascent going through all subpages, main pages and magazines. This is controlled by several control bits. The decoder will send a termination byte after it has sent the status of the last page (highest page number). The terminator will be reported as long as the master continues to read.

Special protocols are used to minimise the number of bytes sent to the master controller. The protocol depends on the option bits received in the command. For more information, refer to the section **Report Protocols** described later in this command.

I2C Bus Command Format

MSB							LSB	
0	0	1	0	0	0	1	R/W	I2C Slave Address R/W = 0
0	0	0	0	0	1	1	1	Command code (0x07)
NSCH	0	0	PRI0	HPN	S2	S1	S0	Command Options
0	0	0	0	0	MAG2	MAG1	MAG0	Magazine
PT3	PT2	PT1	PT0	PU3	PU2	PU1	PU0	Page Number
0	0	1	0	0	0	1	R/W	I2C Slave Address R/W = 1
ST7	ST6	ST5	ST4	ST3	ST2	ST1	ST0	Command Status
								Page Status

General Information

The page acquisition table starts with magazine 8. The first entry corresponds to page 800. The last entry is page 7FF. Subpages are handled differently because it is unknown how many subpages are in the transmission cycle. For this reason the status reported is different from that of the main pages. This is shown in the section **Report Protocols**. Normally the report starts with the page number received in the command and continues in a line of ascent through all magazines, pages and subpages. Searching through subpages is dependant on the options selected in this command.

Note: *The system programmer should be aware of the fact that the decoder allocates memory for a subpage when it is received except when capture specific subpages is enabled. Therefore, the decoder can only report the status of those subpages that have been received so far or of those subpages that has been particularity enabled for capture with the command **SINGLE TELETEXT SUBPAGE ACQUISITION**.*

S2	S1	S0	Report Page Status
0	0	0	REPORT STATUS OF ALL ENABLED MAIN PAGES With this option the decoder will report the status of all enabled main pages. The status that will be sent to the master controller is the current entry in the page acquisition table for this page. The meaning of the different status bits is explained in the section <i>Control bits used in the page acquisition table</i> later in this command. Report protocol 1 will be used for this option.
0	0	1	REPORT STATUS OF ALL ENABLED TELETEXT PAGES With this option the decoder will report the status of all enabled main pages including the attached subpages captured so far, starting at the page number received with the command. Report protocol 2 will be used for this option.
0	1	0	Reserved for future use.
0	1	1	Reserved for future use.
1	0	0	Reserved for future use.
1	0	1	Reserved for future use.
1	1	0	Reserved for future use.
1	1	1	Reserved for future use.

HPN	
0	The decoder will only report the status of pages with a decimal page number. The pages with hexadecimal page numbers are omitted from the report.
1	The decoder will report the status of ALL pages including the hexadecimal page numbers.

PRIO	
0	The decoder does not report the page priority. It will be omitted from the report.
1	The decoder will report the page priority.

NSCH	
0	If the page number specified by the command does not exist the decoder will search through the page acquisition table in ascending order until a page entry is found. The command will start reporting the page status information from this new page.
1	If the specified page does not exist the command will report an error.

Teletext Page Numbers

- MAG[0..2]:** Magazine number from 0..7.
- PU[0..3]:** Page number units from 0..F-hex.
- PT[0..3]:** Page number tens from 0..F-hex.

Note: The decoder will not check the validity of the Teletext page number. It will only perform a logical AND operation to make sure that the page numbers (magazine, page tens and units) are not above the upper limit before the decoder starts processing.

Command Status

The command returns the following status codes:



ST[0..7]	Description
00	COMMAND ACCEPTED
01	COMMAND REJECTED Due to an incorrect number of bytes for the command or an invalid command option.
02	INVALID COMMAND CODE

Report Protocols

Two main protocols were developed to report the page status. The protocol depends on the option **S[0..2]** selected in this command. Each of them is optimised to send as few bytes as possible back to the master controller.

Protocol 1

Protocol 1 is used to report the page status of all enabled main pages. The first two bytes contain the magazine and page number and the third is the status information of this page. The meaning of the status bits is described later in this command. The 4th and 5th byte will report the page priority number if the **PRO** control bit is set.

Note: *The decoder will return FF(hex) instead of the magazine code when the status of the last page number has been reported.*

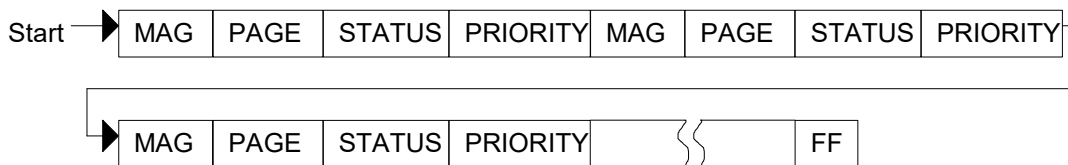

Encoding schema of MAG, PAGE, STATUS and PRIORITY

0	0	0	0	0	MAG2	MAG1	MAG0
PT3	PT2	PT1	PT0	PU3	PU2	PU1	PU0
PAGEN	PROLL	ALLSP	HOLD	--	PHERE	--	--
P15	P14	P13	P12	P11	P10	P9	P8
P7	P6	P5	P4	P3	P2	P1	P0

- MAG[0..2]:** Magazine number from 0..7.
- PU[0..3]:** Page units from 0..15.
- PT[0..3]:** Page tens from 0..15.
- P[0..15]:** Page priority number.

Status byte

The page acquisition table contains an entry for all main pages. It will inform him in which state a page is in and it also informs him which options have been selected when this page was enabled for capture. The meaning of the different bits is explained below.

Note: This table does not contain the status of subpages. Subpages are handled in a different way. This is described in protocol 2.

PAGEEN	
0	This page is not enabled for capture. Thus all other control bits are undefined.
1	This page is enabled for capture.

Note: The explanation of the bits below assumes that the page is enabled (PAGEEN = 1). If it is disabled, the state of all the other control bits is undefined.

ALLSP	PROLL	
0	0	CAPTURE OF SPECIFIC SUBPAGES Capture of specific subpages has been enabled. The decoder will only capture the selected subpages.
--	1	ROLLING SUBPAGE(S) Rolling subpage has been enabled. Thus, the decoder will overwrite the page content of this page whenever another subpage of this page is received.
1	0	CAPTURE OF ALL PAGES Capture of all pages has been enabled for this page. The decoder will store all subpages attached to this page when they are received.

HOLD	
0	This page is not on hold. The whole page will be updated every time when this page is received again.
1	This page and all associated subpages are on hold that means that the page will not be updated when it is received.

PHERE	
0	So far the decoder has not received the header of this page.
1	The decoder has stored the header of this page.

Protocol 2

As mentioned earlier there does not exist an equivalent page table for subpages as it is used for main pages. The reason for this is that the decoder does not know how many subpages are actually attached (transmitted) to each of the main pages. Thus the decoder will allocate memory for the page data when it is received.

The picture below shows how the protocol is structured. It begins with the main page number (magazine and page number) and its status (described in protocol 1) followed by a subpage number where the page status of the subpage is encoded. This way has been chosen to reduce to number of bytes transmitted back the master controller.

Note: The subpage number is not valid if the state of control bit **PHERE** = 0 is reported in the status byte of the main page. In this case the decoder will set the **LASTSP** bit in the subpage number to signal that the next reported byte will be the magazine byte.

With this protocol the decoder will always return a subpage number even when no subpages are stored for this page or when rolling subpage is enabled.

The decoder will return FF(hex) instead of the magazine code when the status of the last page number has been reported. This code will be repeated as long as the master continues to read.

The protocol example below assumes that the page acquisition table contains the following information

- No subpage is available for the first page.
- Subpages are stored in memory for the second main page.
- No subpage is stored for the third main page.

Following synonyms are used

MAG = Magazine number
PAGE = Teletext page number (tens and units)
STATUS = As described in protocol 1.
SUBPAGE = Subpage number
L = This letter stands for **LASTSP** explained later in this section.

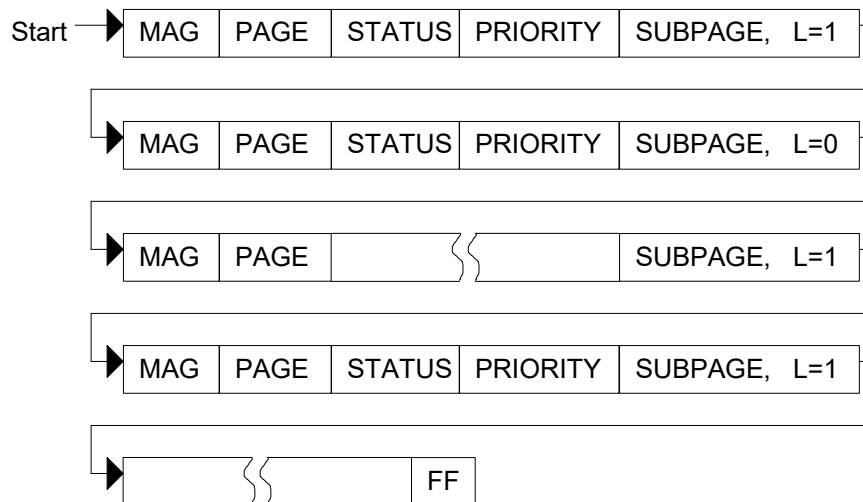

Subpage Status Byte Encoding

As mentioned before the page status information of the subpage is encoded in the unused bits of the subpage number as shown below.

0	PRESENT	SPTH1	SPTH0	SPH3	SPH2	SPH1	SPH0
LASTSP	SPT2	SPT1	SPT0	SPU3	SPU2	SPU1	SPU0

Subpage number, Status and Control bit

SPTH[0..1]: Subpage number thousands from 0..3.
SPH[0..3]: Subpage number hundreds from 0..F-hex.
SPT[0..2]: Subpage number tens from 0..7.
SPU[0..3]: Subpage number units from 0..F-hex.

CF72407 MULTIPAGE

PRESENT	
0	This subpage is not present in memory e.g. the decoder is looking for data. This status condition can only occur when capture specific subpages is enabled.
1	This page is present in memory e.g. data has been received.

LASTSP	
0	This is not the last subpage in this chain. The decoder will continue to report the status of subpages
1	This was the last subpage in this chain. The decoder will change the report protocol. It will continue with the next magazine and main page number as shown in protocol 2.

READ DATA FROM A TELETEXT PAGE

This command should be used when the micro controller wants to read data from a Teletext page. The decoder will then send the received bytes to the micro controller. The memory address (row and column) will be incremented or decremented automatically depending on the control bits in the command. The location of the first byte is specified by row and column received in the command. To be flexible for future Teletext spec. changes, processing options were added.

The programmer should be aware of the fact that the decoder will return space characters if he tries to read data from a page that is enabled for capture but no data were received so far. It also needs to be noted that the decoder will wrap round to row zero and column zero if the master continues to read after the last byte was send. The last byte is located at row 25 and column 39.

Note: *It is not possible to read from the display page with this command. For reading from the display page see **READ DATA FROM MENU PAGE**. To get information about the control bits for the display page, see **CONFIGURATION REGISTER READ OPERATION** (VDP section).*

*It is possible for a Teletext page to be changed or cleared during a read operation. It is therefore recommended that the page be placed on **HOLD** before preceding with the read command.*

I2C command format

MSB				LSB				
0	0	1	0	0	0	1	R/W	I2C Slave Address R/W = 0
0	0	0	0	1	0	1	0	Command code (0x0A)
MINC	0	0	0	MDEC	0	DPR1	DPR0	Command Options
0	0	0	0	0	MAG2	MAG1	MAG0	Magazine
PT3	PT2	PT1	PT0	PU3	PU2	PU1	PU0	Page Number
0	0	STH1	STH0	SH3	SH2	SH1	SH0	Subpage MSB
0	ST2	ST1	ST0	SU3	SU2	SU1	SU0	Subpage LSB
0	0	0	ROW4	ROW3	ROW2	ROW1	ROW0	Row
0	0	COL5	COL4	COL3	COL2	COL1	COL0	Column
0	0	1	0	0	0	1	R/W	I2C Slave Address R/W = 1
ST7	ST6	ST5	ST4	ST3	ST2	ST1	ST0	Command Status
D7	D6	D5	D4	D3	D2	D1	D0	Data Byte 1
								Repeated data bytes
D7	D6	D5	D4	D3	D2	D1	D0	Data Byte N

Page Structure

This section describes how the decoder organises a page in memory. It is important to notice that the first eight bytes of row zero will contain decoder related data, page and subpage number and page control data as received with the header row. In order to occupy the least amount of bytes the decoder will compress the data so that it fit into eight bytes.

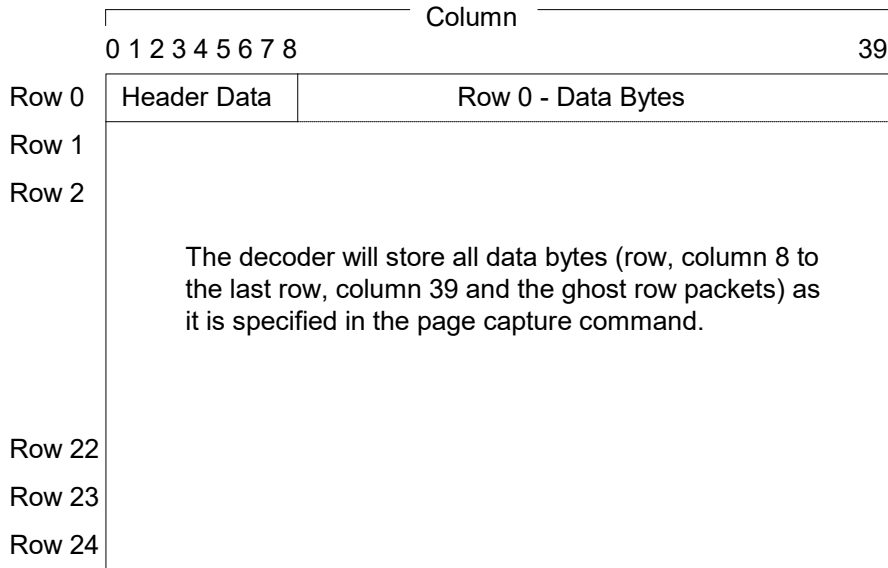

Data format and encoding of the first eight bytes in row zero

The decoder uses the first eight bytes of row zero to store

- Decoder related data (3-bytes located in column 0..2)
- page number (1-byte, located in column 3)
- subpage number (2-bytes, located in column 4,5) and the
- page control bits for control group A and B (2-bytes, located in column 6,7).

D7	D6	D5	D4	D3	D2	D1	D0	Decoder data 1
D7	D6	D5	D4	D3	D2	D1	D0	Decoder data 2
D7	D6	D5	D4	D3	D2	D1	D0	Decoder data 3
PT3	PT2	PT1	PT0	PU3	PU2	PU1	PU0	Page Number
0	0	STH1	STH0	SH3	SH2	SH1	SH0	Subpage MSB
0	ST2	ST1	ST0	SU3	SU2	SU1	SU0	Subpage LSB
0	0	C6	C5	C10	C9	C8	C7	Control group A
0	0	SCAP1	SCAP0	C14	C13	C12	C11	Control group B

D[0..7]: Data bits used by the decoder.
PU[0..3]: Page number units from 0..F-hex.
PT[0..3]: Page number tens from 0..F-hex.
STH[0..1]: Subpage number thousands from 0..3.
SH[0..3]: Subpage number hundreds from 0..F-hex.
ST[0..2]: Subpage number tens from 0..7.
SU[0..3]: Subpage number units from 0..F-hex.
C6 Subtitle

C5	Newsflash
C10	Inhibit Display
C9	Interrupted Sequence
C8	Update
C7	Suppress Header
C12,13,14	National language selection
C11	Magazine Serial
SCAP[0..1]	For internal use only.

Command Option

The reason for including this option, was to control processing of the Teletext data while the I2C-bus master is reading data. The selected processing option is active as long as the master controller does not terminate the read mode. The row and column address of the command determine where the decoder must start with the report. When 6-bit Hamming decoding is requested, the row and column should point to the first byte of this group. This must be guaranteed by the system programmer otherwise he will receive incorrect data.

Note: *The decoder will also perform the requested function on the first eight bytes of row zero. Thus, if these bytes are needed externally the 8-bit data read option should be used.*

DPR1	DPR0	
0	0	<p>EIGHT BIT DATA</p> <p>With this option the decoder will return the data as they are stored. Thus the data format depends on the option that was given when the page was enabled for capture.</p> <p>Note: <i>This option must be selected to read the content of a normal Teletext page. In this case the decoder will return parity and Hamming corrected data. This presumes that parity correction is enabled for this page.</i></p>
0	1	<p>PARITY CORRECTION</p> <p>Parity corrected data is requested by the master. This option is useful when data is stored in 8-bit format. For example, if the Teletext specification is changed in the future then this option might be helpful. One example is TOP, were special encoded index pages were added. The decoder will perform a parity correction on all bytes before they are send to the master. If there is a parity error then bit 8 of the returned byte will be set to one, otherwise it will be set to zero.</p> <p>Note: <i>The programmer should be aware that ALL bytes will be parity corrected before they are reported even if the stored bytes are not parity protected.</i></p>
1	0	<p>FOUR BIT HAMMING DECODING.</p> <p>Four bit Hamming decoding is required on all data bytes. D0..D3 will carry the data bits. D4..7 are set to zero if no Hamming error was found otherwise bit D7 will be set to one.</p> <p>Note: <i>The programmer should be aware that ALL bytes will be Hamming corrected before they are reported even if the stored bytes are not Hamming protected.</i></p>
1	1	<p>SIX BIT HAMMING DECODING.</p> <p>Six bit Hamming decoding is required on each three byte group.</p>

MDEC	
0	This option is ignored
1	The page address (row and column) will be decremented by one after a byte has been reported. <i>Note: The decoder will ignore the state of the MDEC option when the MINC option is set.</i>

MINC	
0	This option is ignored.
1	The page address (row and column) will be incremented by one after a byte has been reported.

Teletext Page Numbers

- MAG[0..2]:** Magazine number from 0..7.
PU[0..3]: Page number units from 0..F-hex.
PT[0..3]: Page number tens from 0..F-hex.
STH[0..1]: Subpage number thousands from 0..3.
SH[0..3]: Subpage number hundreds from 0..F-hex.
ST[0..2]: Subpage number tens from 0..7.
SU[0..3]: Subpage number units from 0..F-hex.
ROW[0..4]: The value is valid in the range of 0..25.
COL[0..5]: Any value in the range of 0..39-decimal is valid.

The subpage number must always be supplied with the command. When a specific subpage is not required then the subpage field in the command should be set to "DON'T CARE". Don't care is indicated by setting the subpage entry to 0x3F7F.

***Note:** The decoder will not check the validity of the Teletext page number. It will only perform a logical AND operation to make sure that the page numbers (magazine, page tens and units and the subpage number) are not above the upper limit before the decoder starts processing.*

Command Status

The command returns the following status codes:

ST[0..7]	Description
00	COMMAND ACCEPTED
01	COMMAND REJECTED Due to an incorrect number of bytes for the command or the ROW and COLUMN address is out of range.
02	INVALID COMMAND CODE
03	COMMAND REJECTED Page was not enabled for capture or Page is not in memory yet

WRITE DATA TO A TELETEXT PAGE

Write user defined data to a Teletext page. The memory address (row and column) will be incremented or decremented automatically depending on the control bits in the command. The location of the first byte is specified by row and column received in the command. The Teletext must already be enabled for the write command to be successful. Also to stop the page from being overwritten by reception of new Teletext data, it is suggested that the page could be placed on hold as long as the user written data is required.

I2C command format

MSB				LSB				
0	0	1	0	0	0	1	R/W	I2C Slave Address R/W = 0
0	0	1	0	0	1	1	0	Command code (0x26)
MINC	0	0	0	MDEC	0	0	0	Command Options
0	0	0	0	0	MAG2	MAG1	MAG0	Magazine
PT3	PT2	PT1	PT0	PU3	PU2	PU1	PU0	Page Number
0	0	STH1	STH0	SH3	SH2	SH1	SH0	Subpage MSB
0	ST2	ST1	ST0	SU3	SU2	SU1	SU0	Subpage LSB
0	0	0	ROW4	ROW3	ROW2	ROW1	ROW0	Row
0	0	COL5	COL4	COL3	COL2	COL1	COL0	Column
D7	D6	D5	D4	D3	D2	D1	D0	Data Byte 1
								Repeated data bytes
D7	D6	D5	D4	D3	D2	D1	D0	Data Byte N
0	0	1	0	0	0	1	R/W	I2C Slave Address R/W = 1
ST7	ST6	ST5	ST4	ST3	ST2	ST1	ST0	Command Status

Page Structure

This section describes how the decoder organises a page in memory. It is important to notice that the first eight bytes of row zero will contain decoder related data, page and subpage number and page control data as received with the header row.

WRITING TO THE FIRST EIGHT BYTES OF ROW 0 WILL CAUSE UNPRIDICTABLE RESULTS!.

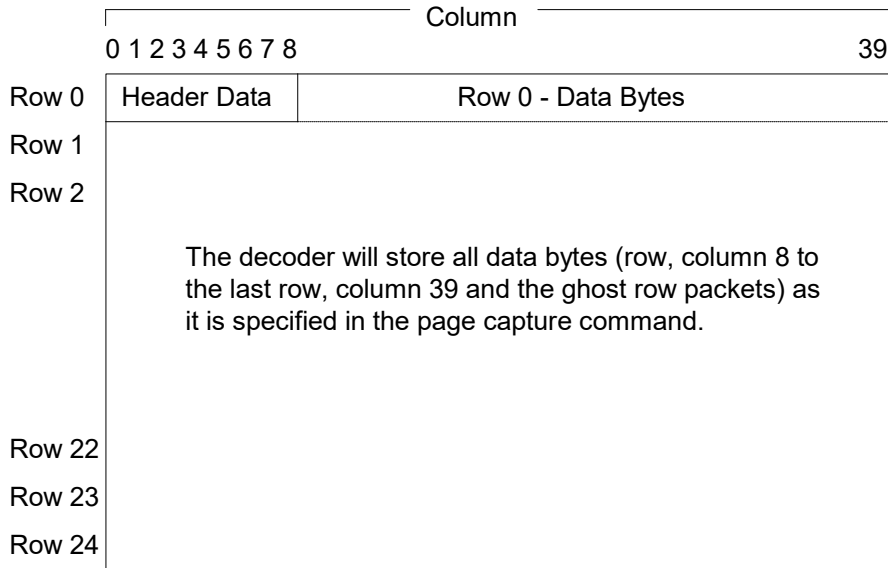

Command Option

There are two command options which determine whether the Teletext write pointer is to be incremented or decremented.

MDEC	
0	This option is ignored
1	The page address (row and column) will be decremented by one after a byte has been wrtitten. <i>Note: The decoder will ignore the state of the MDEC option when the MINC option is set.</i>

MINC	
0	This option is ignored.
1	The page address (row and column) will be incremented by one after a byte has been written.

Teletext Page Numbers

- MAG[0..2]:** Magazine number from 0..7.
- PU[0..3]:** Page number units from 0..F-hex.
- PT[0..3]:** Page number tens from 0..F-hex.
- STH[0..1]:** Subpage number thousands from 0..3.
- SH[0..3]:** Subpage number hundreds from 0..F-hex.
- ST[0..2]:** Subpage number tens from 0..7.
- SU[0..3]:** Subpage number units from 0..F-hex.
- ROW[0..4]:** The value is valid in the range of 0..25.
- COL[0..5]:** Any value in the range of 0..39-decimal is valid.

The subpage number must always be supplied with the command. When a specific subpage is not required then the subpage field in the command should be set to "DON'T CARE". Don't care is indicated by setting the subpage entry to 0x3F7F.

Note: The decoder will not check the validity of the Teletext page number. It will only perform a logical AND operation to make sure that the page numbers (magazine,

page tens and units and the subpage number) are not above the upper limit before the decoder starts processing.

Command Status

The command returns the following status codes:

ST[0..7]	Description
00	COMMAND ACCEPTED
01	COMMAND REJECTED Due to an incorrect number of bytes for the command or the ROW and COLUMN address is out of range.
02	INVALID COMMAND CODE
03	COMMAND REJECTED Page was not enabled for capture or Page is not in memory yet

TELETEXT PAGE HOLD ON/OFF

With this command the system programmer is able to put an individual Teletext page on hold or release it from hold. Placing a Teletext page on hold prevents the page from being updated when it is transmitted again.

Note: *This command works only on Teletext pages that have been enabled for capture in the page acquisition table.*

*This command will **NOT** set the display page on hold even when the same page is being displayed. The command **DISPLAY PAGE HOLD ON/OFF** should be used for this function*

*If the decoder is currently receiving the Teletext page when the **HOLD** command is sent, the page will not be placed on **HOLD** until page reception is complete.*

I2C-bus command format

MSB							LSB	
0	0	1	0	0	0	1	R/W	I2C Slave Address R/W = 0
0	0	0	0	0	1	1	0	Command code (0x06)
PHOLD	0	0	0	0	MAG2	MAG1	MAG0	Magazine and Option
PT3	PT2	PT1	PT0	PU3	PU2	PU1	PU0	Page number
0	0	1	0	0	0	1	R/W	I2C Slave Address R/W = 1
ST7	ST6	ST5	ST4	ST3	ST2	ST1	ST0	Command Status

PHOLD	
0	RELEASE BACKGROUND TELETEXT PAGE FROM HOLD With this option the decoder will release the requested page from hold e.g. the decoder will reset the HOLD bit in the page acquisition table of the addressed Teletext page. The decoder will update the released page and all associated subpages whenever one of these pages is transmitted again.
1	PUT TELETEXT BACKGROUND PAGE ON HOLD With this option the decoder will stop updating the addressed Teletext page. When a page is put on hold the decoder will automatically put all attached subpages of the selected page on hold too.

Teletext Page Number

- MAG[0..2]:** Magazine number from 0..7.
- PU[0..3]:** Page number units from 0..F-hex.
- PT[0..3]:** Page number tens from 0..F-hex

Note: *The decoder will not check the validity of the Teletext page number. It will only perform a logical AND operation to make sure that the page numbers (magazine,*

page tens and units) are not above the upper limit before the decoder starts processing

Command Status

The command returns the following status codes:

ST[0..7]	Description
00	COMMAND ACCEPTED
01	COMMAND REJECTED Due to an incorrect number of bytes for the command
02	INVALID COMMAND CODE

MENU PAGES

ALLOCATE MEMORY FOR MENU PAGES

For on screen display purposes (OSD), or to store some other data the system programmer requires memory that is under his control. This is to enable him to create pages with special outlook, e.g. help instructions, TV channel information, analogue bars for intensity and so forth. Within this specification, this type of memory is called a *Menu Page*.

The system programmer can request up to 63 menu pages from the decoder provided the external DRAM is big enough. Each page will occupy 1040 bytes of memory (26 rows * 40 bytes). The decoder will reject this command if there is not enough memory available.

Note: *The system programmer should be aware that the currently existing memory organisation will be destroyed every time he sends this command. This means, all Teletext pages stored previously are lost and must be recaptured.*

I2C-bus command format

MSB						LSB		
0	0	1	0	0	0	1	R/W	I2C Slave Address R/W = 0
0	0	0	0	0	0	1	0	Command code (0x02)
0	0	D5	D4	D3	D2	D1	D0	Number of Pages
0	0	1	0	0	0	1	R/W	I2C Slave Address R/W = 1
ST7	ST6	ST5	ST4	ST3	ST2	ST1	ST0	Command Status

D[0..5]: This value determines how many menu pages should be allocated. Any value from 0..63 is valid. When all bits of the command option byte are set to zero, all previously allocated menu pages will be released from memory. The only menu page that remains allocated is the display page.

Command Status

The command returns the following status codes:

ST[0..7]	Description
00	COMMAND ACCEPTED
01	COMMAND REJECTED Due to an incorrect number of bytes for the command
02	INVALID COMMAND CODE
03	PROCESS ERROR The decoder cannot allocate the requested menu pages due to lack of memory e.g. the DRAM is too small.

INVENTORY PAGE ON / OFF

On request the decoder will form an inventory page of all transmitted Teletext pages including the hex pages (page 100..8FF). The decoder will use menu page 1 as the inventory page when it is enabled otherwise it will reject the command

Whenever a header is received the decoder will process it and set the appropriate status bits in the inventory page. The inventory page contains information about

- Page header has not been received so far
- Page transmitted without subpages
- Subpages are attached to a particular page .
- Subtitle page and
- Newsflash page.

The system programmer should be aware that:

- The decoder will only **SET** the appropriate status bit in the inventory page when a header has been received. It will not clear it. Thus, for proper operation, the inventory page or particular page entries should be cleared on a regular basis by the master controller. This will make sure that the data are up to date and reflect the actual state of the transmitted Teletext data base
- The decoder will set the subpage status flag when it receives a header with a subpage number greater than zero and less than 3F7F
- The decoder will reject the command if menu page one has not been enabled.

Note: *When an alarm page is transmitted the decoder will always set the flag subpages attached because in this case the time (hours and minutes) is encoded in the subpage number. When an alarm page is enabled with the option **CAPTURE ALL SUBPAGES** the decoder might run out of memory. This is because the alarm page is transmitted every minute with another subpage code and the decoder will allocate memory for every new subpage when it is received*

To enable the decoder to form the inventory page correctly we propose the following procedure:

1. Allocate menu page 1
2. Clear menu page 1.
3. Enable inventory page.
4. Use the menu page read, write or initialise commands to access the data

When the inventory page is no longer required it can be disabled with the same command. When it is disabled the decoder will no longer write into the inventory page when a header is received. Thus, it can be used by the system programmer for other purposes

I2C-bus command format

MSB							LSB	
0	0	1	0	0	0	1	R/W	I2C Slave Address R/W = 0
0	0	1	0	1	1	0	0	Command code (0x2C)
0	0	0	0	0	0	0	EN	Command Option
0	0	1	0	0	0	1	R/W	I2C Slave Address R/W = 1
ST7	ST6	ST5	ST4	ST3	ST2	ST1	ST0	Command Status

EN	
0	DISABLE INVENTORY PAGE The decoder will stop updating the inventory page.
1	ENABLE INVENTORY PAGE The decoder will update menu page 1 with the transmission data.

Command Status

The command returns the following status codes:

ST[0..7]	Description
00	COMMAND ACCEPTED
01	COMMAND REJECTED Due to an incorrect number of bytes for the command or menu page one is not allocated.
02	INVALID COMMAND CODE

Data Organisation of the Inventory Page

The figure below shows the data organisation of the inventory page. One byte will carry the information of two pages starting at magazine 8 page 0. As shown in the **Encoding Schema of one byte** the least significant 4 bits will carry the status for the odd pages whereas the most significant 4 bits carry the information for the even pages. To access the inventory page the menu page read, write or initialise commands should be used.

Organisation of the Inventory Page

	Column												
	0		1		2			37		38		39	
Row 0	000	001	002	003	004	005		04A	04B	04C	04D	04E	04F
Row 1	050	051	052	053	054	055		09A	09B	09C	09D	04E	04F
Row 24	780	781	782	783	784	785		7CA	7CB	7CC	7CD	7CE	7CF
Row 25	7D0	7D1	7D2	7D3	7D4	7D5		7FE	7FF				
								37					

Encoding Schema of one Byte

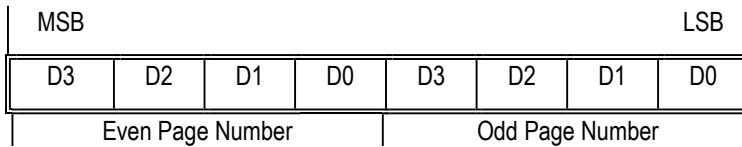

D0	
0	Teletext page is not in the transmission cycle or the decoder has not received a header for this page since the status bits of this page has been cleared by the master controller. In this case all other status bits should be ignored.
1	Teletext page is in the transmission cycle

D1	
0	Not a newsflash page.
1	Newsflash page.

D2	
0	Not a subtitle page.
1	Subtitle page.

D3	
0	Till now the decoder has not received a subpage number in the range of 0001 to 3F7E.
1	The decoder has received a subpage code in the range of 0001 to 3F7E. Please see also the note about alarm pages in the preface of this command

DISPLAY MENU PAGE

When the decoder receives this command, it will copy the requested menu page to the display page. All 26 rows (row 0..25) of this menu page will be copied. This places the decoder into “menu page mode”, which stops all Teletext updates of the display page.

- This command will destroy (overwrite) the content of the display page. Thus the data stored in the display page is lost if it is not stored in another page (Teletext page or menu page).
- Copy the programmable colour palette registers to the palette hardware registers.

The decoder will reject this command if the requested menu page is not allocated. Thus the content of the display page remains unchanged.

I2C-bus command format

MSB							LSB	
0	0	1	0	0	0	1	R/W	I2C Slave Address R/W = 0
0	0	0	0	1	1	0	0	Command code (0x0C)
0	0	D5	D4	D3	D2	D1	D0	Menu Page Number
0	0	1	0	0	0	1	R/W	I2C Slave Address R/W = 1
ST7	ST6	ST5	ST4	ST3	ST2	ST1	ST0	Command Status

Menu Page Number

Any value from 0..63 is valid. The programmer should be aware that menu page zero is always the display page.

Command Status

The command returns the following status codes:

ST[0..7]	Description
00	COMMAND ACCEPTED
01	COMMAND REJECTED Due to an incorrect number of bytes for the command or the menu page is not allocated.
02	INVALID COMMAND CODE

INITIALISE MENU PAGE

When the decoder receives this command, it will initialise the selected menu page with the **Init-code** supplied with the command. Initialisation to zero is required if menu page one is used as an inventory page. The first and last location are specified by the two rows and column addresses embedded in the command.

This command is a so called “Background Command”, while the decoder executes this command it can not receive a new I2C command. Instead it will block the I2C bus until it is completed. However it is possible to read back whether the command is still active. The decoder will return a command status of 04 as it remains active. Upon completion a command status of 00 or 03 will be returned.

The command will be rejected if the addressed menu page is not allocated. The decoder will flag this in the status byte.

I2C-bus command format

MSB				LSB				
0	0	1	0	0	0	1	R/W	I2C Slave Address R/W = 0
0	0	0	1	0	0	1	0	Command code (0x12)
0	0	WIND	0	0	0	0	0	Command Options
0	0	M5	M4	M3	M2	M1	M0	Menu Page
0	0	0	ROW4	ROW3	ROW2	ROW1	ROW0	Source Start Row
0	0	COL5	COL4	COL3	COL2	COL1	COL0	Source Start Column
0	0	0	ROW4	ROW3	ROW2	ROW1	ROW0	Source End Row
0	0	COL5	COL4	COL3	COL2	COL1	COL0	Source End Column
17	16	15	14	13	12	11	10	Init-Code
0	0	1	0	0	0	1	R/W	I2C Slave Address R/W = 1
ST7	ST6	ST5	ST4	ST3	ST2	ST1	ST0	Command Status

Command Option

WIND	
0	Window clear function is disabled and the normal clear function is enabled. Thus the decoder will initialise the selected memory locations as shown in examples 1 & 2.
1	Window clear function is enabled and the normal clear function is disabled. Thus the decoder will initialise all selected memory locations as shown in example 3 & 4.

M[0..5]: The address of the menu page to be cleared, a menu address of zero will cause the display page to be cleared.

ROW[0..4]: Any value from 0..25 is valid for both the start and last row addresses.
COL[0..5]: Any value from 0..39-decimal is valid for both the start and last column.
I[0..7]: Menu page Initialisation code. This 8-bit value will be used to initialise the are of the menu page specified by **ROW**, **COL** and **WIND**.

Command Status

The command returns the following status codes:

ST[0..7]	Description
00	COMMAND ACCEPTED
01	COMMAND REJECTED Due to an incorrect number of bytes for the command, or the row/column addresses are out of range, or the page is not allocated.
02	INVALID COMMAND CODE
04	DECODER IS BUSY The decoder is clearing the requested menu page. This status will be sent as long as the decoder is clearing the page.

Normal Clear Function

The start address (first row and column group) in example one is set to row 13 and column 3 and the end address is set to row 15 column 36. In example two the start address is set to row 15 column 36 and the end address to row 13 column 3.

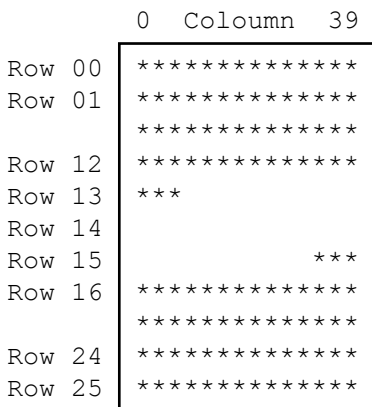

Example 1 (WIND = 0)

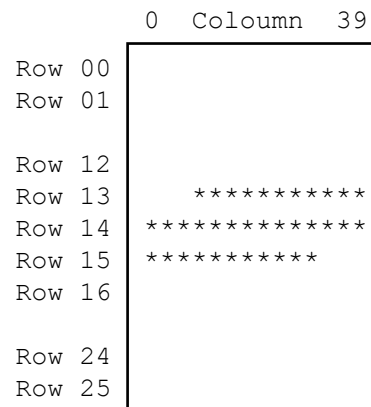

Example 2 (WIND = 1)

Window Clear Function

The start address (first row and column group) in example three is set to row 13 and column 3 and the end address is set to row 15 column 36. In this case the decoder will initialise all memory locations that are inside the specified co-ordinates (Start row & column and Last row & column). In example four the start co-ordinate is set to row 16 column 3 and the end co-ordinate is set to row 12 column 36.

Menu Page Commands

0 Coloumn 39

Row 00	*****
Row 01	*****

Row 12	*****
Row 13	***
Row 14	***
Row 15	***
Row 16	*****

Row 24	*****
Row 25	*****

Example 3 (WIND = 0)

0 Coloumn 39

Row 00	***	***
Row 01	***	***
	***	***
Row 12	***	***
Row 13	*****	***
Row 14	*****	***
Row 15	*****	***
Row 16	***	***
	***	***
Row 24	***	***
Row 25	***	***

Example 4 (WIND = 1)

READ DATA FROM MENU PAGE

This command must be used when the micro controller wants to read data from a menu page. The decoder will send the requested data to the micro controller when it receives this command. The start address is specified by the row and column address received with the command. The page address will wrap round from row 25 column 39 to row 0 and column 0. The decoder will always supply 8-bit data.

The decoder will ignore the command if the selected page has not been allocated or the received row and column values are outside their specified range.

I2C-bus command format

MSB				LSB				
0	0	1	0	0	0	1	R/W	I2C Slave Address R/W = 0
0	0	0	1	0	0	0	0	Command code (0x10)
0	0	0	0	DEC	0	0	0	Command Options
0	0	M5	M4	M3	M2	M1	M0	Menu Page
0	0	0	ROW4	ROW3	ROW2	ROW1	ROW0	Row
0	0	COL5	COL4	COL3	COL2	COL1	COL0	Column
0	0	1	0	0	0	1	R/W	I2C Slave Address R/W = 1
ST7	ST6	ST5	ST4	ST3	ST2	ST1	ST0	Command Status
D7	D6	D5	D4	D3	D2	D1	D0	Data byte 1
D7	D6	D5	D4	D3	D2	D1	D0	Data byte N

Command Option

DEC	
0	The page address (row and column) should be incremented by one after a byte has been reported.
1	The page address (row and column) will be decremented by one after a byte has been reported.

- M[5..0]:** The menu page from which data is to be read. A menu page address of zero will address the display page. Values from [0..63] are valid.
- ROW[0..4]:** Any value from 0..25 is valid for all menu pages including the display page.
- COL[0..5]:** Any value from 0..39 is valid.

Command Status

The command returns the following status codes:

ST[0..7]	Description
00	COMMAND ACCEPTED
01	COMMAND REJECTED Due to an incorrect number of bytes for the command, or the row/column addresses are out of range, or the menu page is not allocated.
02	INVALID COMMAND CODE

Data

These are the data bits stored in the selected menu page.

Note: The data bits will always be reported as 8-bit data.

WRITE TO MENU PAGE

With this command the programmer can write information into a menu page. The data received via the I2C-bus will be copied to the selected menu page starting at the address defined by row and column.

The page address will wrap round from row 25, column 39 to row 0, column 0 during continuous writes. It also wraps round from row 0, column 0 to row 25, column 39 if MDEC = 1.

Note: *The display page is treated as menu page zero. All modifications made in rows 0..25 in the display page will be lost when another page is displayed*

If the selected page is not allocated or the row and column values are out of their specified range then the decoder will ignore the command.

I2C-bus command format

MSB				LSB				
0	0	1	0	0	0	1	RW	I2C Slave Address R/W = 0
0	0	0	1	0	0	0	1	Command code (0x11)
0	0	0	0	DEC	0	0	0	Command Options
0	0	M5	M4	M3	M2	M1	M0	Menu Page
0	0	0	ROW4	ROW3	ROW2	ROW1	ROW0	Row
0	0	COL5	COL4	COL3	COL2	COL1	COL0	Column
D7	D6	D5	D4	D3	D2	D1	D0	Data Byte 1
D7	D6	D5	D4	D3	D2	D1	D0	Data Byte N
0	0	1	0	0	0	1	RW	I2C Slave Address R/W = 1
ST7	ST6	ST5	ST4	ST3	ST2	ST1	ST0	Command Status

Command Option

DEC	
0	The page address (row and column) should be incremented by one after a byte is written.
1	The page address (row and column) will be decremented by one after a byte is written.

M[5..0]: The menu page to which data is to be written. A menu page address of zero will address the display page. [0..63]

ROW[0..4]: Any value from 0..25 is valid for all menu pages including the display page.

COL[0..5]: Any value from 0..39 is valid.

Data

These are the data bytes received via the I2C-bus. The decoder will write it to the selected menu page, starting at the row and column address received with the command.

Note: The data bits will always be treated as 8-bit data.

Command Status

The command returns the following status codes:

ST[0..7]	Description
00	COMMAND ACCEPTED
01	COMMAND REJECTED Due to an incorrect number of bytes for the command, or the row/column addresses are out of range, or the specified menu page is not allocated.
02	INVALID COMMAND CODE

COPY DATA FROM MENU PAGE TO MENU PAGE

This command enables the system programmer to copy selected data from one menu page to another menu page. This command can be useful if data from several pages should be collected into one page.

I2C-bus command format

MSB							LSB	
0	0	1	0	0	0	1	RW	I2C Slave Address R/W = 0
0	0	0	1	1	1	0	1	Command code (0x1D)
0	0	WIND	0	0	0	0	0	Command Options
0	0	M5	M4	M3	M2	M1	M0	Source Menu Page
0	0	0	ROW4	ROW3	ROW2	ROW1	ROW0	Source Start Row
0	0	COL5	COL4	COL3	COL2	COL1	COL0	Source Start Column
0	0	0	ROW4	ROW3	ROW2	ROW1	ROW0	Source End Row
0	0	COL5	COL4	COL3	COL2	COL1	COL0	Source End Column
0	0	M5	M4	M3	M2	M1	M0	Destination Menu Page
0	0	0	ROW4	ROW3	ROW2	ROW1	ROW0	Destination Row
0	0	COL5	COL4	COL3	COL2	COL1	COL0	Destination Column
0	0	1	0	0	0	1	RW	I2C Slave Address R/W = 1
ST7	ST6	ST5	ST4	ST3	ST2	ST1	ST0	Command Status

Command Option

WIND	
0	Window copy function is disabled and the normal copy function is enabled. Thus the decoder will copy the characters as shown in example 1
1	Window copy function is enabled and the normal copy function is disabled. Thus the decoder will copy window as shown in example 2.

Character Source Address

The decoder will transfer the data bytes from the source menu page to the destination menu page. The numbers of characters to copy are specified by the two row and column groups following the source menu page number. The decoder will copy the bytes into the specified menu page starting at the location as specified by the start row and column. On a normal copy request (**WIND = 0**) the decoder will start the copy process at the location as specified by the start address (row and column) and stop after it has copied the byte specified by the stop address (row and column). The decoder will copy the data bytes in a line of ascent. If a window copy function is requested (**WIND = 1**) the decoder will treat the start and stop addresses as co-ordinate points. It will copy all characters that are located inside this area.

In order to guarantee proper operation the system programmer should make sure that the stop address (row and/or column) is equal or higher than the start address.

Menu Page (Destination Address)

The decoder will copy the bytes to the specified menu page starting at the location as specified by the start address (row and column) when a normal copy function is requested. The system programmer should be aware that the decoder will wrap round to row zero column zero when the last address location (row 25, column 39) has been reached and the copy process is not finished.

If a window copy is requested then the start address will be treated as a reference co-ordinates for the first character. All characters that are selected by the source co-ordinates will be copied relative to this reference point.

The command will be rejected if at least one of the values of the menu page number, row or column value is outside their specified range. The command will also be rejected if the requested menu page is not allocated.

ROW[4..0]: Any value from 0..25 is valid.
COL[5..0]: Any value from 0..39 is valid.
M[5..0]: Menu page number. Any value from 0..63 is valid.

Command Status

The command returns the following status codes:

ST[0..7]	Description
00	COMMAND ACCEPTED
01	COMMAND REJECTED Due to an incorrect number of bytes for the command, or the row/column addresses are out of range or one of the menu pages is not allocated.
02	INVALID COMMAND CODE
04	DECODER IS BUSY The decoder is copying the requested menu page. This status will be sent as long as the decoder is clearing the page.

Copy Examples

Depending on the state of the control bit **WIND** the decoder will perform a normal copy operation (**WIND = 0**) or a window copy operation (**WIND = 1**). Both examples assume the same command parameters for the start and stop addresses. Start Address Row = 12, Column = 3 and Stop Address Row = 22 and Column = 35. On a normal copy operation (example 1) the decoder will copy all characters starting at row 12 column 3 to row 22 column 35 in a line of ascent. In example two the start and stop addresses are the top left and the bottom right co-ordinates of a window. All data inside the window is copied.

0 Coloumn 39

Row 00	
Row 01	
Row 12	*****
Row 13	*****
Row 14	*****
Row 15	*****
Row 22	*****
Row 24	
Row 25	

Example 1 (WIND = 0)
Normal Copy

0 Coloumn 39

Row 00	
Row 01	Start Co-ordinate
Row 12	*****
Row 13	*****
Row 14	*****
Row 15	*****
Row 22	*****
Row 24	
Row 25	Stop Co-ordinate

Example 2 (WIND = 1)
Window Copy

COPY TELETEXT DATA TO A MENU PAGE

This command enables the system programmer to copy selected data from a Teletext page to a menu page. For example, this command can be used to copy the title of a page from the Additional Information Table (TOP mode) into the display page. In order to support future requirements a language translation option has been added. When this option is enabled the decoder will convert all national option characters to the requested language while it is copying data.

Note: *It is possible for a Teletext page to be changed or cleared during a read operation. It is therefore recommended that the page is placed on HOLD before preceding with the read command.*

I2C-bus command format

MSB				LSB				
0	0	1	0	0	0	1	R/W	I2C Slave Address R/W = 0
0	0	0	1	1	1	0	0	Command code (0x1C)
0	0	WIND	0	0	0	0	0	Command Options
0	0	0	0	0	MAG2	MAG1	MAG0	Magazine number
PT3	PT2	PT1	PT0	PU3	PU2	PT1	PU0	Page number
0	0	STH1	STH0	SH3	SH2	SH1	SH0	Subpage MSB
0	ST2	ST1	ST0	SU3	SU2	SU1	SU0	Subpage LSB
0	0	0	ROW4	ROW3	ROW2	ROW1	ROW0	Source Start Row
0	0	COL5	COL4	COL3	COL2	COL1	COL0	Source Start Column
0	0	0	ROW4	ROW3	ROW2	ROW1	ROW0	Source End Row
0	0	COL5	COL4	COL3	COL2	COL1	COL0	Source End Column
0	0	M5	M4	M3	M2	M1	M0	Destination Menu Page
0	0	0	ROW4	ROW3	ROW2	ROW1	ROW0	Destination Row
0	0	COL5	COL4	COL3	COL2	COL1	COL0	Destination Column
0	0	1	0	0	0	1	R/W	I2C Slave Address R/W = 1
ST7	ST6	ST5	ST4	ST3	ST2	ST1	ST0	Command Status

Command Option

WIND	
0	Window copy function is disabled and the normal copy function is enabled. Thus the decoder will copy the characters as shown in example 1.
1	Window copy function is enabled and the normal copy function is disabled. Thus the decoder will copy window as shown in example 2.

Source Address (Teletext Page)

The Teletext page number specifies from which page the decoder should copy the data. The decoder will reject the command if:

- The selected page is not enabled for capture.
- No data has been received so far.

MAG[0..2]: Magazine number from 0..7.
PU[0..3]: Page number units from 0..Fhex.
PT[0..3]: Page number tens from 0..Fhex.
STH[0..1]: Subpage number thousands from 0..3.
SH[0..3]: Subpage number hundreds from 0..Fhex.
ST[0..2]: Subpage number tens from 0..7.
SU[0..3]: Subpage number units from 0..Fhex.

The subpage number must always be supplied with the command. When a specific subpage is not required then the subpage field in the command should be set to "DON'T CARE". Don't care is indicated by setting the subpage entry to 0x3F7F.

Teletext Page Row and Column Addresses

These four bytes specify the first and last character location. Depending on the requested copy function (normal or window copy) the decoder will treat these parameters differently. On a normal copy request (**WIND = 0**) the decoder will start the copy process at the location as specified by the start address (row and column) and stop after it has copied the byte specified by the stop address (row and column). The decoder will copy the data bytes in a line of ascent. If a window copy function is requested (**WIND = 1**) the decoder will treat the start and stop addresses as co-ordinate points. It will copy all characters that are located inside this area.

In order to guarantee proper operation the system programmer should make sure that the stop address (row and/or column) is equal or greater than the start address.

ROW[0..4]: Any value from 0..25 is valid.
COL[0..5]: Any value from 0..39 is valid.

Menu Page (Destination Address)

The decoder will copy the bytes to the specified menu page starting at the location as specified by the start address (row and column) when a normal copy function is requested. The system programmer should be aware that the decoder will wrap round to row zero column zero when the last address location (row 25, column 39) has been reached and the copy process is not finished.

If a window copy is requested then the start address will be treated as a reference co-ordinate for the first character. All characters that are selected by the source co-ordinates will be copied relative to this reference point.

The command will be rejected if at least one of the values of the menu page number, row or column is outside their specified range. The command will also be rejected if the requested menu page is not allocated.

ROW[0..4]: Any value from 0..25 is valid.
COL[0..5]: Any value from 0..39 is valid.

M[5..0]: Menu page number. Any value from 0..63 is valid.

Command Status

The command returns the following status codes:

ST[0..7]	Description
00	COMMAND ACCEPTED
01	COMMAND REJECTED Due to an incorrect number of bytes for the command, or the row/column addresses are out of range, or the menu page is not allocated or the Teletext page is not enabled or the Teletext page has not been received.
02	INVALID COMMAND CODE
04	DECODER IS BUSY The decoder is copying the requested Teletext page data, this status will be sent as long as the decoder is copying the data.

Copy Examples

Depending on the state of the control bit **WIND** the decoder will perform a normal copy operation (**WIND = 0**) or a window copy operation (**WIND = 1**). Both examples assume the same command parameters for the start and stop addresses. Start Address Row = 12, Column = 3 and Stop Address Row = 22 and Column = 35.

On a normal copy operation (example 1) the decoder will copy all characters starting at row 12 column 3 to row 22 column 35 in a line of ascent. In example two the start and stop addresses are the top left and the bottom right co-ordinates of a window. All data inside the window is copied.

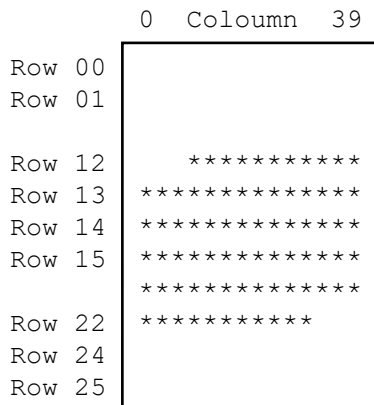

Example 1 (WIND = 0)
Normal Copy

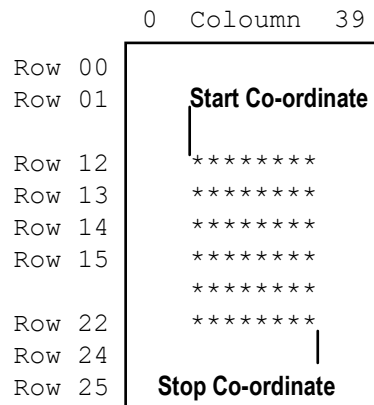

Example 2 (WIND = 1)
Window Copy

CHARACTER SETS

CHARACTER SET COMMANDS

The multipage decoder has a built in default character set stored in a character font ROM. It contains the G0 characters (20(hex)..7F(hex)) as specified in the World System Teletext Specification (WSTS) issued in February 1990 plus the six standard European national option character sets. The national characters are stored from ROM address 80(hex) to DF(hex). All character spaces that are not occupied by national characters are filled with special characters. The ROM character set is shown in the data sheet. If the programmer wants to display characters different from the default ROM characters then he has the option to allocate memory in DRAM for this purpose. In total he can download up to two complete character sets (20(hex)..FF(hex)) plus two graphic character sets to the external DRAM. The advantages of this feature are:

- This decoder is usable throughout to whole of Europe because all the national characters, which are not available in the character ROM, can be downloaded via the I2C-bus.
- If required the programmer is able to define its own graphic symbols. Thus enabling him to produce a more detailed display, than is possible with the Teletext block graphics.
- This decoder is also usable for applications outside Europe because completely new characters or character sets, for instance Japanese, can be downloaded and displayed.

Note: *It needs to be noted that the appropriate character set must be allocated in **DRAM** before any characters from this can be redefined. For example: there is an application where three different national characters are required. In this case, the programmer must allocate one complete national character set in **DRAM**. After he has allocated the character set, he can invoke the character copy routine. This will copy the character pixels of all national characters from internal **ROM** to **DRAM**. Then the programmer can overwrite the three characters with the new pixel information.*

*For more information about allocation and invocation of external character sets it is recommended that the section **DRAM Control Registers** is read.*

Character ROM and DRAM Organisation

This section gives an overview of the character maps used for the character font ROM and for the **DRAM**.

ROM Character Map

The national characters are stored from 80(hex) to FF(hex) as shown below. During Teletext reception all the national option characters will be converted automatically so that they point to a character position of the selected language. The language will be selected by the control bits **C12..C14** received with the Teletext header row. Only six of the eight possible national options (languages) are supported by the characters pre-defined in the character font **ROM**. The decoder will select English language as the default when a none supported language option is received and when the **FULL** control bit in **DRAM** control register 2 is set to zero. To have all characters from 0x20 to 0xFF available the **IGNORE** bit in **DRAM** control register three should be set to 1. This disables the national option conversion logic.

Multipage Character ROM Address Map

	2	3	4	5	6	7	8	9	A	B	C	D	E	F
0														
1		GO					E	S	G	I	F	S	S	S
2		CHARACTER					N	K	E	T	R	P	P	P
3		SET					G	A	R	A	E	A	E	E
4		AND					L	N	M	L	N	I	C	C
5		ASCII					I	D	A	I	C	N	I	I
6		CHARACTERS					S	I	N	A	H	I	A	A
7							H	N		N		S	L	L
8								A				H		
9								V						
A								I						
B								A						
C								N						
D														
E														
F														

DRAM Character Map

As far as the G0 character set is concerned there is no difference in size and addressing compared to the internal character font ROM. Whereas the size of the national option character set has been expanded to its full size. Therefore it is possible to define eight national option character sets as they are specified by the WSTS.

Note: The programmer must set the **FULL** control bit in the **DRAM** control register three so that the conversion logic is enabled for these two additional national options. When this bit is not set the decoder will behave as described in the section **Character ROM Map**. The table below shows the addresses where the different languages must be placed.

	2	3	4	5	6	7	8	9	A	B	C	D	E	F
0														
1		GO					E	S	G	I	F	S	U	U
2		CHARACTER					N	K	E	T	R	P	S	S
3		SET					G	A	R	A	E	A	E	E
4		AND					L	N	M	L	N	I	R	R
5		ASCII					I	D	A	I	C	N		
6		CHARACTERS					S	I	N	A	H	I	D	D
7							H	N		N		S	E	E
8								A				H	F	F
9								V					I	I
A								I					N	N
B								A					E	E
C								N					D	D
D														
E														
F														

ALLOCATE MEMORY FOR CHARACTER SETS

Before the programmer can use external defined character sets he has to allocate memory. The currently existing memory organisation will be destroyed when this command is executed. This will clear all Teletext and Menu pages from memory.

MSB						LSB		
0	0	1	0	0	0	1	R/W	I2C Slave Address R/W = 0
0	0	1	0	0	1	0	0	Command code (0x24)
0	0	GR1	GR0	NA1	NA0	G01	G00	Command option
0	0	1	0	0	0	1	R/W	I2C Slave Address R/W = 1
ST7	ST6	ST5	ST4	ST3	ST2	ST1	ST0	Command Status

Command description

GR1	
0	Do not allocate memory for the GR1 character set
1	Allocate memory for the GR1 character set

GR0	
0	Do not allocate memory for the GR0 character set
1	Allocate memory for the GR0 character set

NA1	
0	Do not allocate memory for the NA1 character set
1	Allocate memory for the NA1 character set

NA0	
0	Do not allocate memory for the NA0 character set
1	Allocate memory for the NA0 character set

G01	
0	Do not allocate memory for the G01 character set
1	Allocate memory for the G01 character set

G00	
0	Do not allocate memory for the G00 character set
1	Allocate memory for the G00 character set

The following table shows the amount of memory that is reserved for each character set:

Character Set Commands

Character Set	Character Codes	Memory Size
G00	20..7F hex	1440 bytes
G01	20..7F hex	1440 bytes
NA0	80..FF hex	1920 bytes
NA1	80..FF hex	1920 bytes
GR0	20..7F hex	1440 bytes
GR1	20..7F hex	1440 bytes

Command Status

The command returns the following status codes:

ST[0..7]	Description
00	COMMAND ACCEPTED
01	COMMAND REJECTED Due to an incorrect number of bytes for the command
02	INVALID COMMAND CODE

COPY CHARACTERS FROM FONT ROM TO DRAM

This command is used to copy characters from any ROM location to any external character location.

This command is a so called “Background Command”, while the decoder executes this command it can not receive a new I2C command. Instead it will block the I2C bus until it is completed. However it is possible to read back whether the command is still active. The decoder will return a command status of 04 as it remains active. Upon completion a command status of 00 or 03 will be returned.

Note: To prevent the VDP from displaying rubbish it is recommended to that the VDP is switched to picture mode while as the character copy process takes place.

I2C-bus command format

MSB				LSB				
0	0	1	0	0	0	1	R/W	I2C Slave Address R/W = 0
0	0	0	1	0	1	1	1	Command code (0x17)
0	0	0	0	0	DST2	DST1	DST0	Command Options
D7	D6	D5	D4	D3	D2	D1	D0	ROM Character Code
EC7	EC6	EC5	EC4	EC3	EC2	EC1	EC0	External Character
N7	N6	N5	N4	N3	N2	N1	N0	Number of Characters to copy
0	0	1	0	0	0	1	R/W	I2C Slave Address R/W = 1
ST7	ST6	ST5	ST4	ST3	ST2	ST1	ST0	Command Status

Source and Destination Character

- D[0..7]:** Source Character Any value from 20(hex) to FF(hex) is valid.
- EC[0..7]:** Destination Character The decoder will copy the pixel image of the source character to the destination character position specified by **EC[0..7]** and **DEST[0..2]**. The value of **EC[0..7]** must be in the range of 20(hex) to 7F(hex) if the destination character set is **G00**, **G01**, **GR0** or **GR1**. If the pixel data should be copied to an extended character set **NA0** or **NA1** then the value of **EC[0..7]** must be in the range of 80(hex) to FF(hex).
- N[0..7]:** Specifies the number of characters to be copied starting from **D[0..7]** and **EC[0..7]**, after each character is copied both **D[0..7]** and **EC[0..7]** are incremented to point to the next character. The command will be terminated if the end of the destination character set is encountered before all **N[0..7]** characters have been copied.

Command Option

This command option specifies to which external character set the selected character should be copied.

DST2	DST1	DST0	
0	0	0	The selected ROM block will be copied to the first G0 character set (G00).
0	0	1	The selected ROM block will be copied to the second G0 character set (G01).
0	1	0	The selected ROM block will be copied to the first national character set (NA0).
0	1	1	The selected ROM block will be copied to the second national character set (NA1).
1	0	0	The selected ROM block will be copied to the first graphic character set (GR0).
1	0	1	The selected ROM block will be copied to the second graphic character set (GR1).
1	1	0	Default G00.
1	1	1	Default G00.

Command Status

The command returns the following status codes:

ST[0..7]	Description
00	COMMAND ACCEPTED
01	COMMAND REJECTED Due to an incorrect number of bytes for the command
02	INVALID COMMAND CODE
04	DECODER IS BUSY This status will be returned when the decoder is busy executing an I2C-bus command (page clear, character copy etc.).

DOWNLOAD A CHARACTER SET VIA I2C-BUS

With this command, the programmer can download his own character pixel data to the external character set via the I2C Bus.

When the decoder receives this command it will transfer the pixel data to the selected character set starting at the character specified by the command. The first received pixel data will always be copied to line zero of the 10*12 pixel character matrices. When the decoder has received the pixel data for a complete character (15 bytes) it will then transfer it to the specified character position. The decoder then will increment the character address and transfer the next character image to this position and so forth. Thus, the master controller can transfer complete character sets in a line of ascent.

Note: *The decoder will ignore the pixel data if less than 15 bytes has been received for a character and the master terminates transmission.*

If the external character address exceeds the character set boundary, the decoder will ignore all following pixel data.

The decoder will ignore this command if the selected character set is not allocated. If the command is ignored, all transmitted pixel data will be thrown away.

I2C-bus command format

MSB							LSB	
0	0	1	0	0	0	1	R/W	I2C Slave Address R/W = 0
0	0	0	1	1	0	0	0	Command code (0x18)
0	0	0	0	0	DST2	DST1	DST0	Command Options
D7	D6	D5	D4	D3	D2	D1	D0	External Character
P7	P6	P5	P4	P3	P2	P1	P0	Pixel Data 1
P7	P6	P5	P4	P3	P2	P1	P0	Pixel Data N
0	0	1	0	0	0	1	R/W	I2C Slave Address R/W = 1
ST7	ST6	ST5	ST4	ST3	ST2	ST1	ST0	Command Status

Command Option

This command option specifies to which external character set the selected character should be downloaded.

Character Set Commands

DST2	DST1	DST0	
0	0	0	The selected ROM block will be copied to the first G0 character set (G00).
0	0	1	The selected ROM block will be copied to the second G0 character set (G01).
0	1	0	The selected ROM block will be copied to the first national character set (NA0).
0	1	1	The selected ROM block will be copied to the second national character set (NA1).
1	0	0	The selected ROM block will be copied to the first graphic character set (GR0).
1	0	1	The selected ROM block will be copied to the second graphic character set (GR1).
1	1	0	Default G00.
1	1	1	Default G00.

External Character

This value determines the first character that will be modified. The first pixel packet will be copied to line zero of this character matrix. The value of the external character must be in the range of 20(hex) to 7F(hex) when a G0 character set (G00, G01) or a graphic character set (GR0, GR1) is selected and in the range of 80(hex) to FF(hex) when an extended character set (NA0, NA1) is selected.

Pixel Data

A matrix of 10*12 pixels represents one character. The picture below shows this organisation.

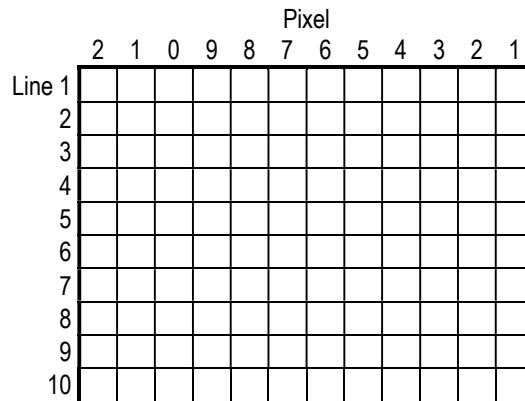

The following figure shows how the pixel information is split up into bytes for downloading to the decoder.

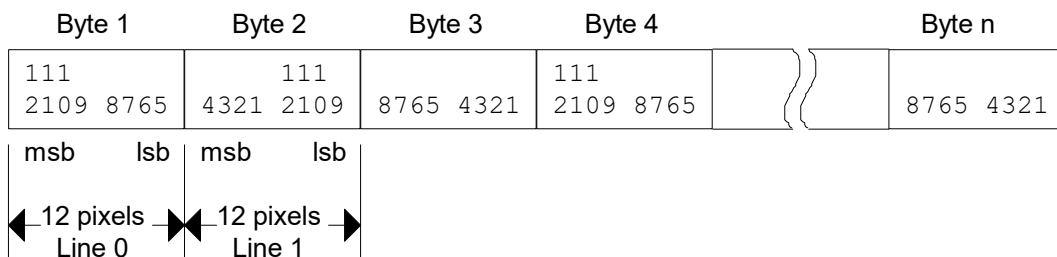

Command Status

The command returns the following status codes:

ST[0..7]	Description
00	COMMAND ACCEPTED
01	COMMAND REJECTED Due to an incorrect number of bytes for the command or the selected character set has not been allocated
02	INVALID COMMAND CODE

TOP

VERIFY TOP TABLE RECEPTION

This command is used to verify the reception of the TOP tables.

I2C-bus command format

MSB							LSB	
0	0	1	0	0	0	1	RW	I2C Slave Address R/W = 0
0	0	0	0	1	0	0	0	Command code (0x08)
0	0	0	0	0	0	AI	MP	Command Options
0	0	1	0	0	0	1	RW	I2C Slave Address R/W = 1
ST7	ST6	ST5	ST4	ST3	ST2	ST1	ST0	Command Status
R7	R6	R5	R4	R3	R2	R1	R0	Table Search Result

Command Options

The command options specify which of the TOP tables are to be verified

MP	AI	
0	0	Check for Basic Top table only.
0	1	Check for Basic Top table and the Additional information tables
1	0	Check for Basic Top table and the Multipage tables
1	1	Check for Basic Top table and both the Additional information and Multipage tables

Table Search Result

After reporting the command status, an additional byte is transmitted giving the outcome of the table search.

R[7..0]	
0x00	All of the specified tables are in memory
0xff	One or more of the specified table can not be found

Command Status

The command returns the following status codes:

ST[0..7]	Description
00	COMMAND ACCEPTED
01	COMMAND REJECTED Due to an incorrect number of bytes for the command
02	INVALID COMMAND CODE

TOP TABLE PROCESSING

This command will process the BASIC TOP TABLE and report the following:

- Page numbers for a selected set of pages. eg. Block, Group or TV pages.....
- Page number(s) of all Basic Top Table(s).
- Page number(s) of all Multipage Table(s).
- Page number(s) of all Additional Information Table(s).
- Page Title

Basic Top Table

The page number(s) of the Basic Top Tables are specified by the Top Specification in the form of YF03Fxx (Y = magazine, F0 = page number, 3F = subpage thousands and hundreds and XX = Don't care). This enables the broadcasters to send up to eight Basic Top Tables in parallel magazine mode.

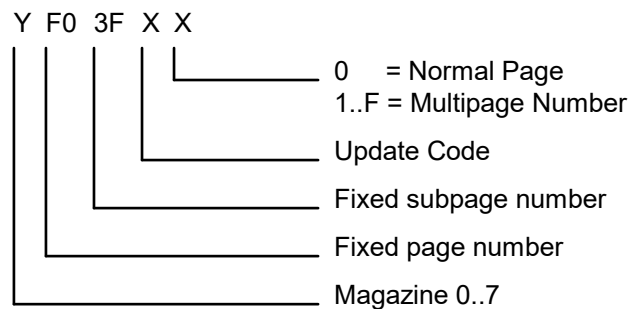

This command will report the data in such a form that it can be used easily by the system programmer to develop a TOP decoder system with little software overhead in his micro controller. For example, when the programmer wants to capture all block index pages, he only needs to send one Top command and the decoder will report all block page numbers. All pages can then be enabled for capture in the page acquisition table. This can be done with only two commands compared to the huge amount of software required to process the TOP Table in the micro controller. The title search option of this command in conjunction with the copy command will enable the system programmer to generate its own table(s) of contents with only two commands.

The decoder will reject the command if TOP mode is not enabled or when the page number or the command options are not within the specified range. Refer to the command **Select Teletext Mode** for more information on the supported Teletext modes.

Note: *If the programmer requires more information from the Basic TOP Table as it is provided by this command then he can read out the contents of the Table via the normal **READ DATA FROM A TELETEXT PAGE** command.*

This command has a variable command length e.g. the decoder expects three additional bytes for the menu page, row and column when the **COPY** bit is set.

I2C-Bus Format No Copy Title and No Page Enable

MSB							LSB	
0	0	1	0	0	0	1	R/W	I2C Slave Address R/W = 0
0	0	0	1	1	0	0	1	Command code (0x19)
OP2	OP1	OP0	PINC	PDEC	CO2	CO1	CO0	Command Option 1
REQ1	REQ0	ENP =0	COPY =0	TITL1	TITL0	DISP	PNUM	Command Option 2
0	0	0	0	0	MAG2	MAG1	MAG0	TOP Index
PT3	PT2	PT1	PT0	PU3	PU2	PU1	PU0	
L3	L2	L1	L0	H3	H2	H1	H0	Search codes
0	0	1	0	0	0	1	R/W	I2C Slave Address R/W = 1
ST7	ST6	ST5	ST4	ST3	ST2	ST1	ST0	Command Status

I2C-Bus Format No Copy Title, but with Page Enable

MSB							LSB	
0	0	1	0	0	0	1	R/W	I2C Slave Address R/W = 0
0	0	0	1	1	0	0	1	Command code (0x19)
OP2	OP1	OP0	PINC	PDEC	CO2	CO1	CO0	Command Option 1
REQ1	REQ0	ENP =1	COPY =0	TITL1	TITL0	DISP	PNUM	Command Option 2
0	0	0	0	0	MAG2	MAG1	MAG0	TOP Index
PT3	PT2	PT1	PT0	PU3	PU2	PU1	PU0	
L3	L2	L1	L0	H3	H2	H1	H0	Search codes
P15	P14	P13	P12	P11	P10	P9	P8	Enable Priority
P7	P6	P5	P4	P3	P2	P1	P0	
0	0	1	0	0	0	1	R/W	I2C Slave Address R/W = 1
ST7	ST6	ST5	ST4	ST3	ST2	ST1	ST0	Command Status
P15	P14	P13	P12	P11	P10	P9	P8	Priority of last enabled page
P7	P6	P5	P4	P3	P2	P1	P0	

I2C-Bus Format with Copy Title, but no Page Enable

MSB				LSB				
0	0	1	0	0	0	1	R/W	I2C Slave Address R/W = 0
0	0	0	1	1	0	0	1	Command code (0x19)
OP2	OP1	OP0	PINC	PDEC	CO2	CO1	CO0	Command Option 1
REQ1	REQ0	ENP =0	COPY =1	TITL1	TITL0	DISP	PNUM	Command Option 2
0	0	0	0	0	MAG2	MAG1	MAG0	TOP Index
PT3	PT2	PT1	PT0	PU3	PU2	PU1	PU0	
L3	L2	L1	L0	H3	H2	H1	H0	Search codes
0	0	D5	D4	D3	D2	D1	D0	Menu Page
0	0	0	R4	R3	R2	R1	R0	Row
0	0	C5	C4	C3	C2	C1	C0	Column
0	0	1	0	0	0	1	R/W	I2C Slave Address R/W = 1
ST7	ST6	ST5	ST4	ST3	ST2	ST1	ST0	Command Status

I2C-Bus Format with Copy Title and Page Enable

MSB				LSB				
0	0	1	0	0	0	1	R/W	I2C Slave Address R/W = 0
0	0	0	1	1	0	0	1	Command code (0x19)
OP2	OP1	OP0	PINC	PDEC	CO2	CO1	CO0	Command Option 1
REQ1	REQ0	ENP =1	COPY =1	TITL1	TITL0	DISP	PNUM	Command Option 2
0	0	0	0	0	MAG2	MAG1	MAG0	TOP Index
PT3	PT2	PT1	PT0	PU3	PU2	PU1	PU0	
L3	L2	L1	L0	H3	H2	H1	H0	Search codes
0	0	D5	D4	D3	D2	D1	D0	Menu Page
0	0	0	R4	R3	R2	R1	R0	Row
0	0	C5	C4	C3	C2	C1	C0	Column
P15	P14	P13	P12	P11	P10	P9	P8	Enable Priority
P7	P6	P5	P4	P3	P2	P1	P0	
0	0	1	0	0	0	1	R/W	I2C Slave Address R/W = 1
ST7	ST6	ST5	ST4	ST3	ST2	ST1	ST0	Command Status
P15	P14	P13	P12	P11	P10	P9	P8	Priority of last enabled page
P7	P6	P5	P4	P3	P2	P1	P0	

Command Options

The content of these bytes informs the decoder which function is requested by the master controller. The page number (magazine, page tens and units) received with the command will be used by the decoder as an index to the selected Basic Top Table from where the processing or searching will begin. When the decoder is searching for a title then it will search through all Basic Top Tables and Additional Information Tables.

PINC	
0	Ignore this option
1	INCREMENT THE TOP TABLE INDEX The decoder will increment the TOP table index given with this command before the search of the table is started.

PDEC	
0	Ignore this option
1	DECREMENT THE TOP TABLE INDEX The decoder will decrement the TOP table index given with this command before the search of the table is started.

Note: Simultaneously setting both the **PINC** and **PDEC** options is not a valid option. If they are both set then the **PINC** and **PDEC** options are ignored.

PNUM	
0	DO NOT REPORT PAGE NUMBER(S) Reporting of page numbers is not required.
1	REPORT PAGE NUMBER(S) The decoder will report the Teletext page number(s) and its corresponding BASIC TOP TABLE entry as requested by the function code CO[0..4]. The three bytes send to the master controller are encoded as shown in Protocol 1.

DISP	
0	DO NOT DISPLAY THE TELETEXT PAGE The decoder will not copy the selected Teletext page to the display page.
1	DISPLAY TELETEXT PAGE The decoder will copy the selected Teletext page to the display.

Page Enable

The options **ENP** and **REQ[0..1]** can be used, to enable for capture, all the pages reported by the command.

ENP	
0	Options ENP and REQ[0..1] are ignored
1	ENABLE PAGES All top pages found as a result of the command are enabled for capture. Options REQ[0..1] specified the capture mode.

REQ1	REQ0	
0	0	ENABLE PAGE FOR CAPTURE WITH ROLLING SUBPAGE. The page number received with the command will be enabled for capture in the page acquisition table. If there are subpages transmitted then the decoder will display it as rolling page e.g. only the memory for one page will be allocated.
0	1	ENABLE PAGE AND SUBPAGES FOR CAPTURE. With this option the decoder will enable the page number received with the command for capture. It also will enable Capture all Subpages that means the decoder will store all subpages attached to the main page when they arrive.
1	0	REMOVE PAGE FROM THE PAGE ACQUISITION TABLE. The decoder will delete the received page number and all associated subpages from the page acquisition table. Thus all data stored so far will be lost. Although not required for this function a priority number must be supplied with the command.
1	1	Not Used

Report Title(s)

The decoder will search for the title of the requested Teletext page. To do so, it will check whether additional information is transmitted for the requested page then it will process the links of the specified Basic Top Table(s) to get the page numbers of the Additional Information Tables and then searches for the title. When the title is found, it will be send to

the master controller using report protocol 3. Please see also section **EXECUTION ORDER OF THE ADDITIONAL CONTROL BITS** for more information.

TITL1	TITL0	
0	0	DO NOT REPORT TITLE(S) Reporting of title(s) is not required.
0	1	REPORT TITLE (OPTION 1) The decoder will report 17 bytes as stored in the Additional Information Table, starting with the byte following the page number (4-bytes reserved for future use, one byte for the direct choice code and 12-bytes for the title).
1	0	REPORT TITLE (OPTION 2) The decoder will report 13 bytes as stored in the Additional Information Table starting with the direct choice code. Following the direct choice code the 12-bytes for the title will be reported.
1	1	REPORT TITLE (OPTION 3) The decoder will only report the title (12-bytes) as stored in the Additional Information Table.

Copy Title

When the **COPY** bit is set then the decoder will search for the title as requested by the control bits **CO[0..2]** and **OP[0..2]** and copy it to the selected menu page, starting at the memory location as specified by row and column received with the command.

Note: *At least one of the options **PNUM** or **TITL[0..1]** must be set for this command to be executed.*

*Individual characters within the titles will be translated to the appropriate national option characters, determined by the **C12..C14** header bits of the Additional Information page containing the title.*

Additional Processing Options

These additional processing options are global to the options defined by the **CO[0..2]** control bits.

OP2	OP1	OP0	
0	0	0	DON'T CARE The decoder will not use these control bits when it executes a command.
0	0	1	STAY IN GROUP (WRAP ROUND) The decoder will not leave a group. It will wrap round to the first or last page in the group when it reaches the upper or lower group boundary and continue to process the Basic-Top-Table. The decoder will send a terminator byte (Code FF(hex)) when it has processed the complete group.
0	1	0	STAY IN BLOCK (WRAP ROUND IN BLOCK) The decoder will not leave a block. It will wrap round to the first or last page in the block when it reaches the upper or lower block boundary and continue to process the Basic-Top-Table. The decoder will send a terminator byte (Code FF(hex)) when it has processed the complete block.
0	1	1	STOP AT A GROUP BOUNDARY (DO NOT WRAP) Depending on the requested function the decoder will search till the end or to the beginning of a group. When a group boundary is reached, the decoder will send a terminator byte (Code FF(hex)).
1	0	0	STOP AT A BLOCK BOUNDARY (DO NOT WRAP) Depending on the requested function the decoder will search till the end or to the beginning of a block. When a block boundary is reached, the decoder will send a terminator byte (Code FF(hex)).
1	0	1	Reserved for future use.
1	1	0	Reserved for future use.
1	1	1	Reserved for future use.

Execution Order of the Additional Control Bits

As shown below, the decoder will execute the **TITL[0..1]**, **COPY**, **DISP** and **PNUM** bits in a loop if the requested function operates on more than one page:

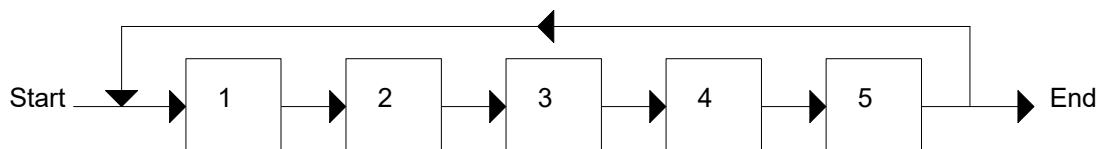

1. **SEARCH FOR A (NEXT) PAGE**
Search for the requested page in the Basic-Top-Table. Searching is controlled by the **OP[0..2]** and **CO[0..2]** control bits.
2. **REPORT PAGE NUMBER**
The decoder will report the page number of the selected page when the **PNUM** bit is set otherwise it will skip this function.
3. **COPY TITLE**
The decoder will search for the title as requested by the control bits **CO[0..2]** and **OP[0..2]** and copy it to the selected menu page, starting at the memory location as specified by row and column received with the command.
4. **REPORT TITLE**

The decoder will report the title as specified by the **TITL[0..1]** control bits.

5. DISPLAY PAGE

The decoder will copy the selected page to the display page when the **DISP** bit is set.

Requested Command

The control bits **CO[0..2]** determine the main function. Whereas the **OP[0..3]**, **TITL[0..1]**, **DISP** and **PNUM** are used to control the searching and reporting operation.

Unless otherwise noted the decoder will treat the page number (magazine, page tens and units) received with the command as an index to the selected Basic-Top-Table from where the processing will begin.

CO2	CO1	CO0	
0	0	0	SEARCH FOR ALL BASIC TOP TABLES Starting at the magazine received with the command the decoder will search through the page acquisition table to see if data has been received for pages with a page number YF03Fxx (Y = magazine, F0 = page number, 3F = subpage thousands and hundreds and XX = Don't care). The decoder will report all the Basic Top Table page numbers followed by a terminator byte with the code FF(hex). The decoder will ignore the option bits OP[0..2] and TITL[0..1] . Report protocol 2 will be used to report the page numbers.
0	0	1	SEARCH FOR MULTIPAGE TABLES The decoder will process all page linking tables (rows 21 and 22) of all Basic-TOP-Tables YF03FXX, search for the Multipage table(s), and report the page numbers followed by a FF(hex) termination byte. Report protocol 2 will be used to report the page numbers.
0	1	0	SEARCH FOR ADDITIONAL INFORMATION TABLES The decoder will process all page linking tables (rows 21 and 22) of all Basic-TOP-Tables YF03FXX, search for all Additional Information Table(s), and report the page numbers followed by a FF(hex) termination byte. Report protocol 2 will be used to report the page numbers.
0	1	1	REQUESTED PAGE The decoder will only operate on the page number received with the command and perform the functions as requested by the additional option bits OP[0..3] , TITL[0..1] , COPY , DISP and PNUM .
1	0	0	SEARCH FORWARD THROUGH THE TOP TABLE The decoder will search through the basic TOP table entries, in ascending order, for an entry that matches the <i>Search Code</i> . Data protocol 1 or 3 is used.
1	0	1	SEARCH BACKWARDS THROUGH THE TOP TABLE The decoder will search through the basic TOP table entries, in descending order, for an entry that matches the <i>Search Code</i> . Data protocol 1 or 3 is used.
1	1	0	Reserved for future use.
1	1	1	Reserved for future use.

Teletext Page Number

The page number received with the command will be used

- To determine which Basic-Top-Table must be used.

- As an index to the selected Basic-Top-Table in order to get the code broadcasted for this page.

MAG[0..2]: Magazine number from 0..7. The magazine number specifies from which magazine the requested data should be extracted.

PU[0..3]: Page number units from 0..9(hex).

PT[0..3]: Page number tens from 0..9(hex).

Search Code

The decoder searches through the basic TOP table looking for specified entries in the table. A match is found when the TOP table entry t satisfies the condition $Ln \leq t \leq Hn$. Where Ln is specified bits the **L[0..3]** bits in the command and Hn is specified by the **H[0..3]** bits.

Menu Page

The menu page number determines to which menu page the title should be copied when the **COPY** control bit is set. The title is copied to the menu page at the location specified by **Row (R[0..7])** and **Column (C[0..7])**.

D[0..5]: Menu page = 0: The display page is selected. Thus the master wants to copy the title to the display page.
Menu page > 0: Another menu page is selected. The command will be ignored if the requested menu page is not allocated.

R[0..4]: Any value from 0..25 is valid for all menu pages including the display page.

C[0..5]: Any value from 0..39 is valid.

Command Status

The command returns the following status codes:

ST[0..7]	Description
00	COMMAND ACCEPTED
01	COMMAND REJECTED Due to an incorrect number of bytes for the command.
02	INVALID COMMAND CODE
04	DECODER IS BUSY This status will be returned when the decoder is busy executing an I2C-bus command (page clear, character copy etc.).

Data Report Protocols

Three different data protocols are used to report the requested data. The protocol depends on the option requested by the command and on how many control bits are set within the same command.

Data Protocol 1

This protocol is used to report page numbers of all type of pages such as block index page(s), group index page(s), normal page(s), subtitle page(s) direct choice page(s) and the corresponding content of the Basic Top Table. When all page numbers have been reported an FF(hex) termination byte will be sent.

1	1	1	1	1	1	1	1
0	0	0	0	0	MAG2	MAG1	MAG0
PT3	PT2	PT1	PT0	PU3	PU2	PU1	PU0
0	0	0	0	D3	D2	D1	D0

Terminator

OR:

Magazine

Page tens and units

Code from Basic-TOP-Table

- MAG[0..2]:** Magazine number from 0..7.
- PU[0..3]:** Page number units from 0..F-hex.
- PT[0..3]:** Page number tens from 0..F-hex.
- D[0..3]:** Hamming corrected data bits.

Data Protocol 2

This protocol is used to report the page number(s) of the Basic Top Table(s), Multipage Table(s) and Additional Information Table(s). When all page numbers have been reported an FF(hex) termination byte will be sent.

1	1	1	1	1	1	1	1
0	0	0	0	0	MAG2	MAG1	MAG0
PT3	PT2	PT1	PT0	PU3	PU2	PU1	PU0
0	0	STH1	STH0	SH3	SH2	SH1	SH0
0	ST2	ST1	ST0	SU3	SU2	SU1	SU0

Terminator

OR:

Magazine

Page tens and units

Subpage MSB

Subpage LSB

- MAG[0..2]:** Magazine number from 0..7.
- PU[0..3]:** Page number units from 0..Fhex.
- PT[0..3]:** Page number tens from 0..Fhex.
- STH[0..1]:** Subpage number thousands from 0..3.
- SH[0..3]:** Subpage number hundreds from 0..Fhex.
- ST[0..2]:** Subpage number tens from 0..7.
- SU[0..3]:** Subpage number units from 0..Fhex.

Data Protocol 3

Data protocol 3 is used to return a TOP TITLE as well as the page number. In all other respects it is identical to protocol 1 above.

TOP Commands

1	1	1	1	1	1	1	1
0	0	0	0	0	MAG2	MAG1	MAG0
PT3	PT2	PT1	PT0	PU3	PU2	PU1	PU0
H	0	0	0	D3	D2	D1	D0
T7	T6	T5	T4	T3	T2	T1	T0
T7	T6	T5	T4	T3	T2	T1	T0

Terminator

OR:

Magazine

Page tens and units

BTT Entry

Title Byte 0

Title Byte 11

REPORT DIRECT CHOICE PAGE NUMBERS

The TOP additional information tables contain references to so called DIRECT CHOICE PAGES this command can be used to report the page numbers related to a given direct choice code.

The page numbers will be reported immediately following the command status code. The tables may contain more than one page number for a given direct choice code, all the page numbers will be reported in the order in which they are found within the tables. When all the numbers for the given code have been reported, the hex code 0xFF which is reported immediately following the last page number

I2C-bus command format

MSB				LSB				
0	0	1	0	0	0	1	RW	I2C Slave Address R/W = 0
0	0	1	0	0	1	0	1	Command code (0x25)
0	0	0	0	DW3	DW2	DW1	DW0	Direct choice code
0	0	1	0	0	0	1	RW	I2C Slave Address R/W = 1
ST7	ST6	ST5	ST4	ST3	ST2	ST1	ST0	Command Status
0	0	0	0	0	MAG2	MAG1	MAG0	First page number
PT3	PT2	PT1	PT0	PU3	PU2	PU1	PU0	
0	0	0	0	0	MAG2	MAG1	MAG0	Last page number
PT3	PT2	PT1	PT0	PU3	PU2	PU1	PU0	
1	1	1	1	1	1	1	1	Terminator

Command Status

The command returns the following status codes:

ST[0..7]	Description
00	COMMAND ACCEPTED
01	COMMAND REJECTED Due to an incorrect number of bytes for the command
02	INVALID COMMAND CODE

DISPLAY

ENABLE DISPLAY ROWS

It is possible to specify the operation of display rows 24 and 25. Rows 24 and 25 may be enabled as part of the normal Teletext page, to be overwritten by incoming Teletext data.

On power up the decoder will default to **D24=0** and **D25=0**.

I2C-bus command format

MSB						LSB		
0	0	1	0	0	0	1	RW	I2C Slave Address R/W = 0
0	0	1	0	1	1	1	0	Command code (0x2E)
0	0	0	0	0	D24	D25	0	Command Options

Command Options

D24	
0	Packet 24 is not used as a Teletext display row and may be overwritten by the external processor.
1	Packet 24 is part of the normal Teletext page

D25	
0	Packet 25 is not used as a Teletext display row and may be overwritten by the external processor.
1	Packet 25 is part of the normal Teletext page

Command Status

The command returns the following status codes:

ST[0..7]	Description
00	COMMAND ACCEPTED
01	COMMAND REJECTED Due to an incorrect number of bytes for the command
02	INVALID COMMAND CODE

REPORT DISPLAY PAGE

This command returns the magazine, page and subpage number of the currently displayed page. If the header is rolling this command will return the magazine, page and subpage number of the page the decoder is searching for.

I2C Command Format

MSB							LSB	
0	0	1	0	0	0	1	R/W	I2C Slave Address R/W = 0
0	0	1	0	1	0	0	1	Command code (0x29)
0	0	1	0	0	0	1	R/W	I2C Slave Address R/W = 1
ST7	ST6	ST5	ST4	ST3	ST2	ST1	ST0	Command Status
0	0	0	0	0	M2	M1	M0	Magazine number
PT3	PT2	PT1	PT0	PU3	PU2	PU1	PU0	Page number tens and units
0	0	STH0	STH1	SH3	SH2	SH1	SH0	Subpage thousands and hundreds
0	ST2	ST1	ST0	SU3	SU2	SU1	SU0	Subpage tens and units

Command Options

- M[0..2]:** Magazine number of the current displayed page
- PT[0..3]:** Page number tens of the current displayed page
- PU[0..3]:** Page number units of the current displayed page
- STH[0..1]:** Subpage number thousands of the current displayed page
- SH[0..3]:** Subpage number hundreds of the current displayed page
- ST[0..2]:** Subpage number tens of the current displayed page
- SU[0..3]:** Subpage number units of the current displayed page

Command Status

The command returns the following status codes:

ST[0..7]	Description
00	COMMAND ACCEPTED
01	COMMAND REJECTED Due to an incorrect number of bytes for the command
02	INVALID COMMAND CODE

DISPLAY TIME

In serial magazine mode the decoder will copy the time received on each header to the display page whereas in parallel magazine mode the time will be taken from the magazine of the last displayed Teletext page. After power up the time will be taken from page 100 or from the initial page as specified by packet 8/30. This presumes that packet 8/30 is transmitted.

The time will remain on the screen as long as the master controller does not send a command to:

- Display Next/Previous Teletext page
- Display time off
- Display a menu page
- Display a Teletext page

Note: *This command will only copy the Teletext time to the required position of the display. Initialisation of the VDP and other control registers must be independently programmed, including all extra control characters required to display the time (e.g. BOX and DOUBLE HEIGHT control characters).*

I2C-bus command format

MSB				LSB				
0	0	1	0	0	0	1	RW	I2C Slave Address R/W = 0
0	0	0	1	1	0	1	1	Command code (0x1B)
0	0	0	ROW4	ROW3	ROW2	ROW1	ROW0	Row
0	0	COL5	COL4	COL3	COL2	COL1	COL0	Column
0	0	1	0	0	0	1	RW	I2C Slave Address R/W = 1
ST7	ST6	ST5	ST4	ST3	ST2	ST1	ST0	Command Status

Screen Position

The position where the time should be displayed on the screen is specified by row and column received with the command.

- ROW[0..4]:** Any value from 0..25 is valid.
COL[0..5]: Any value from 0..39(decimal) is valid.

Command Status

The command returns the following status codes:

Display Commands

ST[0..7]	Description
00	COMMAND ACCEPTED
01	COMMAND REJECTED Due to an incorrect number of bytes for the command Invalid row or column number
02	INVALID COMMAND CODE

DISPLAY TIME OFF

Terminate the display of the Teletext time.

I2C Command Format

MSB							LSB
0	0	1	0	0	0	1	R/W
0	0	1	0	1	0	1	1

I2C Slave Address
R/W = 0

Command code (0x2B)

Command Status

The command returns the following status codes:

ST[0..7]	Description
00	COMMAND ACCEPTED
01	COMMAND REJECTED Due to an incorrect number of bytes for the command
02	INVALID COMMAND CODE

ENABLE ROLLING HEADER

Enable the rolling of the header, of the display page. If a request to display a Teletext page is received by the decoder and the page is not in memory, the decoder will start searching for the page. During this search all headers will be displayed, in green, in row zero of the display page.

I2C-bus command format

MSB							LSB	
0	0	1	0	0	0	1	R/W	I2C Slave Address R/W = 0
0	0	1	0	0	0	1	0	Command code (0x22)
0	0	1	0	0	0	1	R/W	I2C Slave Address R/W = 1
ST7	ST6	ST5	ST4	ST3	ST2	ST1	ST0	Command Status

Command Status

The command returns the following status codes:

ST[0..7]	Description
00	COMMAND ACCEPTED
02	INVALID COMMAND CODE

DISABLE ROLLING HEADER

Disable rolling of the header of the display page. If a request to display a Teletext page is received by the decoder and the page is not in memory, the decoder will start searching for the page. During this search the header of the display page will not be updated. This allows an appropriate message to be written to the header of the display page.

I2C-bus command format

MSB							LSB	
0	0	1	0	0	0	1	R/W	I2C Slave Address R/W = 0
0	0	1	0	0	0	1	1	Command code (0x23)
0	0	1	0	0	0	1	R/W	I2C Slave Address R/W = 1
ST7	ST6	ST5	ST4	ST3	ST2	ST1	ST0	Command Status

Command Status

The command returns the following status codes:

ST[0..7]	Description
00	COMMAND ACCEPTED
02	INVALID COMMAND CODE

DISPLAY PAGE HOLD ON/OFF

When the display page is on hold, the decoder will not update the page content when it is transmitted again. The clock (last 8 characters of row zero) portion of the page will always be updated

The capture of the display page is totally independent from the capture of the pages in the page store (background pages). So putting the display page in on hold, will not affect the page in the page store, even if they have the same page number.

Sending this command with the **DHOLD** bit set to zero or copying another Teletext page to the display page will release a previously held page.

Note: If the decoder is currently receiving the display page when the HOLD command is sent, the page will not be placed on HOLD until page reception is complete.

I2C-bus command format

MSB							LSB	
0	0	1	0	0	0	1	R/W	I2C Slave Address R/W = 0
0	0	1	1	0	1	0	0	Command code (0x34)
0	DHOLD	0	0	0	0	0	0	Command Options
0	0	1	0	0	0	1	R/W	I2C Slave Address R/W = 1
ST7	ST6	ST5	ST4	ST3	ST2	ST1	ST0	Command Status

DHOLD	
0	RELEASE DISPLAY PAGE FROM HOLD The decoder will release the display page from hold.
1	HOLD DISPLAY PAGE The decoder will set the display page on hold.

Command Status

The command returns the following status codes:

ST[0..7]	Description
00	COMMAND ACCEPTED
02	INVALID COMMAND CODE

GHOST ROWS

ENABLE GHOST ROW RECEPTION

After power on, or a software reset, the reception of Ghost rows is disabled. Reception of particular Ghost rows can be enabled using this command. If a page related Ghost row is enabled, then this option is active for all pages in all magazines. The memory required to store the data depends on the amount of data transmitted for the page and on the options selected in this command. Magazine related Ghost rows will be stored separately for each magazine. Packet 31 is not supported.

I2C-bus command format

MSB							LSB	
0	0	1	0	0	0	1	R/W	I2C Slave Address R/W = 0
0	0	0	0	0	1	0	1	Command code (0x05)
P26D	P29D	P28D	P830P1	P830P2	P26S	P27S	P28S	Command Option 1
P26P	0	0	0	0	P29S	P30S	P830S	Command Option 2
0	0	1	0	0	0	1	R/W	I2C Slave Address R/W = 1
ST7	ST6	ST5	ST4	ST3	ST2	ST1	ST0	Command Status

Command Option 1 & 2

The options available for the different Ghost packets, is different for each packet. This is because not all packets are fully specified by the World System Teletext Specification (WSTS) issued in February 1990. Unless specified otherwise in this document, the decoder will process the Ghost rows as specified in the WSTS.

Packet 24 and 25

Packets 24 and 25 are treated as normal Teletext rows. The decoder will allocate memory for row 24 and 25 when those rows are received and the related page is enabled for capture.

Packet 26

Packet 26 can be stored and/or automatically processed as defined in the following table:

P26P	P26D	P26S	
0	--	0	Disable reception of packet 26.
0	0	1	Enable reception of packet 26. The data will be stored as 8bit data (they won't be processed).
0	1	1	Enable reception of packet 26. All data in packets 26 are processed as specified in the WSTS before they are stored.
1	--	--	Same as the previous option (011). In addition the decoder will automatically process the extended display characters specified in the packets.

Packet 27

The decoder will only process data packets with a designation code of 0 to 3, which carry the page links. All data packets with another designation code will be stored as 8-bit data provided data storage is also enabled.

P27S	
0	Packets 27 data won't be stored.
1	Packet 27 will be stored and processed.

Packet 28

The decoder will only stored this packet. No internal processing is performed on the information contained within the packet.

P28D	P28S	
--	0	Packet 28 is disabled.
0	1	Packet 28 is enabled and will be stored as 8bit data.
1	1	Packet 28 is enabled and parity and hamming processing will be carried out before the packet is stored.

Packet 29

The decoder will only stored this packet. No internal processing is performed on the information contained within the packet. Enabling packet 29 will cause the decoder memory to be cleared of all Teletext and menu pages.

P29D	P29S	
--	0	Packet 29 is disabled.
0	1	Packet 29 is enabled and will be stored as 8bit data.
1	1	Packet 29 is enabled and parity and hamming processing will be carried out before the packet is stored.

Packet 30

The decoder will only stored this packet. No internal processing is performed on the information contained within the packet. Enabling packet 29 will cause the decoder memory to be cleared of all Teletext and menu pages.

P30S	
0	Disable packets 1/30 to 7/30.
1	Enable packets 1/30 to 7/30 for capture. All data is stored as 8 bit data.

Packet 8/30 (Broadcast Service Data)

Packet 8/30 is an independent packet that carries broadcast service data. This packet can have up to 16 designation codes, but only two are fully specified in the WSTS. These are the codes X000 (format 1) and X100 (format 2). When enabled, the decoder will process these two formats and store the processed data. If a packet with a different designation code is received, then it will be stored as 8-bit data provided data storage is enabled.

P830P1	P830P2	P830S	
--	--	0	Packet 8/30 is disabled.
0	0	1	Packet 8/30 is enabled and all packets will be stored in 8 bit data format.
1	--	1	Packet 8/30 is enabled and FORMAT 1 packets will be decoded as specified in the WSTS.
--	1	1	Packet 8/30 is enabled and FORMAT 2 packets will be decoded as specified in the WSTS.

Packet 8/30 Format 2

The four different interleave packets of Format 2 8/30 are separated and stored separately inside the decoder, by changing the designation/Interleave codes before the packet is stored. When reading the data for the Format 2, using the **READ GHOST ROW** command, all that is required is to specify the changed designation code of the interleave packet to be read.

The following tables specifies the designation codes for use with the **READ GHOST ROW** command.

Transmitted Designation Code	LC1	LC0	Designation Code for Read Command
0	--	--	0
1	0	0	1
1	0	1	2
1	1	0	3
1	1	1	4

Command Status

The command returns the following status codes:

ST[0..7]	Description
00	COMMAND ACCEPTED
01	COMMAND REJECTED Due to an incorrect number of bytes for the command
02	INVALID COMMAND CODE
03	PROCESS ERROR The decoder cannot allocate the requested menu pages due to lack of memory e.g. the DRAM is too small.

READ GHOST ROW DATA

When the decoder receives this command, it will report the requested data provided it is in memory.

The decoder will reject the command if the selected packet data is not in memory or when the values of the packet, column or designation code are out of its specified range.

In case the micro controller continues reading when the column address exceeds the value 39, the column address will wrap round to zero.

I2C command format

MSB				LSB				
0	0	1	0	0	0	1	R/W	I2C Slave Address R/W = 0
0	0	0	0	1	0	1	1	Command code (0x0B)
0	0	0	0	0	0	DPR1	DPR0	Command Options
0	0	0	0	0	MAG2	MAG1	MAG0	Magazine
PT3	PT2	PT1	PT0	PU3	PU2	PU1	PU0	Page Number
0	0	STH1	STH0	SH3	SH2	SH1	SH0	Subpage MSB
0	ST2	ST1	ST0	SU3	SU2	SU1	SU0	Subpage LSB
0	0	0	ROW4	ROW3	ROW2	ROW1	ROW0	Row
0	0	COL5	COL4	COL3	COL2	COL1	COL0	Column
0	0	0	0	D3	D2	D1	D0	Designation Code
0	0	1	0	0	0	1	R/W	I2C Slave Address R/W = 1
ST7	ST6	ST5	ST4	ST3	ST2	ST1	ST0	Command Status
								Repeated data bytes

Command Option

The location of the data from which the decoder should start processing, is determined by the column address, packet number and if required by the designation code.

DPR1	DPR0	
0	0	Performs no processing when reading the ghost row data.
0	1	The decoder will perform parity correction on all bytes as they are read. If a parity error is found, the 7th bit of the appropriate data byte will be set.
1	0	The decoder will perform hamming correction on all bytes as they are read. The bits D0 to D3 will carry the data, D4 to D6 will always be set to zero. A Hamming error is flagged by setting bit D7 to one.
1	1	The decoder will perform a three byte Hamming check and correction starting at the memory location as specified by the column address in this command.

Teletext Page Number

- MAG[0..2]:** Magazine number from 0..7.
- PU[0..3]:** Page number units from 0..F-hex.
- PT[0..3]:** Page number tens from 0..F-hex.
- STH[0..1]:** Subpage number thousands from 0..3.
- SH[0..3]:** Subpage number hundreds from 0..F-hex.
- ST[0..2]:** Subpage number tens from 0..7.
- SU[0..3]:** Subpage number units from 0..F-hex.
- ROW[0..4]:** Packet number (Ghost row) Any value from 26..30 is valid.
- COL[0..5]:** Column Address Column address where the decoder should start to report data. Any value in the range of 0..39 is valid. The programmer must take care of the data structure when he sets up the column address value, especially when six bit Hamming checking is selected.
- D[3..0]:** Designation Code The designation code selects a particular data packet out of the Ghost packet. The decoder will search for this data packet. The command will be ignored if the requested data is not present in memory. Any value in the range of 0..15 is valid for the designation code.
- DATA:** The data transmitted to the master. Normally 40-bytes will be sent for both the processed and unprocessed data. The format of the data bits in the bytes depends on whether or not the packet data must be processed and on the processing options selected by this command. The different formats are explained in more detail in the section **Data Formats**.

The subpage number must always be supplied with the command. When a specific subpage is not required then the subpage field in the command should be set to "DON'T CARE". Don't care is indicated by setting the subpage entry to 0x3F7F. When addressing the magazine related packets, the subpage number is ignored.

Command Status

The command returns the following status codes:

ST[0..7]	Description
00	COMMAND ACCEPTED
01	COMMAND REJECTED Due to an incorrect number of bytes for the command or the COLUMN address is out of range, or the DESIGNATION code is incorrect.
02	INVALID COMMAND CODE

Data Formats and Protocols

This section describes the different data formats and protocols used by the decoder to report the ghost row data.

Basic Byte Structure

The figure below shows the basic structure of a byte used by the decoder and it explains the meaning of the synonyms used in it.

MSB				LSB				
D8	D7	D6	D5	D4	D3	D2	D1	Data Bits
H								Hamming Error Flag
P								Parity Error Flag

Four Bit Hamming Correction

When requested, the decoder will perform a 4-bit Hamming check / correction on all bytes starting at the location as specified by the command. The Hamming corrected data is then loaded into the 4 least significant bits of the byte. If a Hamming error is found then the Hamming error flag (H) will be set to one, otherwise it will be set to zero. This assumes that the data is stored as 8-bit raw data.

MSB				LSB				
H	0	0	0	D4	D3	D2	D1	Data Bits

Parity Correction

When requested, the decoder will perform parity check on all bytes starting at the location as specified by the command. The parity checked data is then loaded into the 7 least significant bits of the byte. If a parity error is found then the parity error flag (H) will be set to one, otherwise it will be set to zero. This assumes that the data is stored as 8-bit raw data.

MSB				LSB				
P	D7	D6	D5	D4	D3	D2	D1	Data Bits

Twenty four Bit Hamming Correction

When requested, the decoder will perform three byte Hamming check / correction on all bytes starting at the location as specified by the command. The Hamming corrected data is then reformatted in a three byte data stream as shown below. The 18-data bits are ordered as specified for packet 26. If a hamming error is found then the hamming error flag (H) will be set to one, otherwise it will be set to zero. This assumes that the data that is to be processed is stored as 8-bit raw data.

MSB				LSB				
H	0	D6	D5	D4	D3	D2	D1	Byte 1
0	0	0	D11	D10	D9	D8	D7	Byte 2
0	D18	D17	D16	D15	D14	D13	D12	Byte 3

Packet 26 Data Formats

Two data encoding schemes (protocols) are used to report packet 26 data. Protocol 2 is used when 8-bit data is requested. The decoder will not perform any processing on the data.

Protocol 1 Processed Packet 26 Data

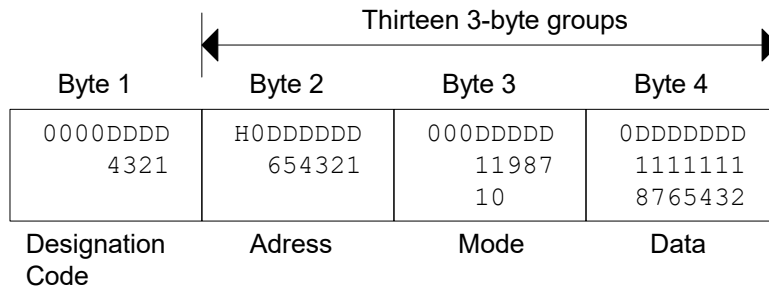

Protocol 2 Unprocessed Packet 26 Data

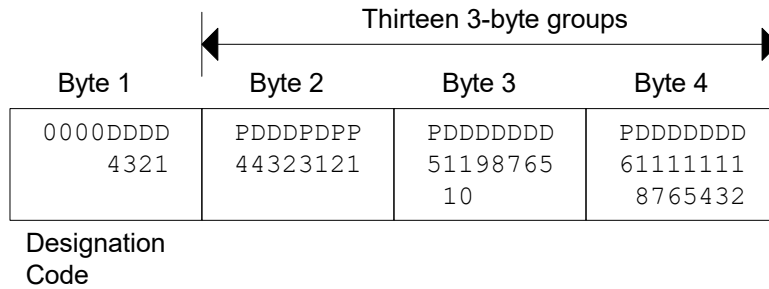

Packet 27 Protocol

Two protocols are used to report packet 27 data. The designation codes 0..3 will be reported using protocol 2. All other designation codes, if enabled, will be reported using protocol 1.

Protocol 1 - Unprocessed Packet 27 Data

Byte 1	Byte 2	Byte 38	Byte 39	Byte 40
0000DDDD	DPDPPDPP 4 3 2 1	DPDPPDPP 4 3 2 1	DDDDDDDD 87654321	DDDDDDDD 87654321

Designation
Code

Protocol 2 - Processed Packet 27 Data

Byte 1	Byte 2	Byte 3	Byte 4	Byte 5	Byte 6	Byte 7
0000DDDD	H000DDDD 4321	H000DDDD 4321	H000DDDD 4321	H000DDDD 4321	H000DDDD 4321	H000DDDD 4321

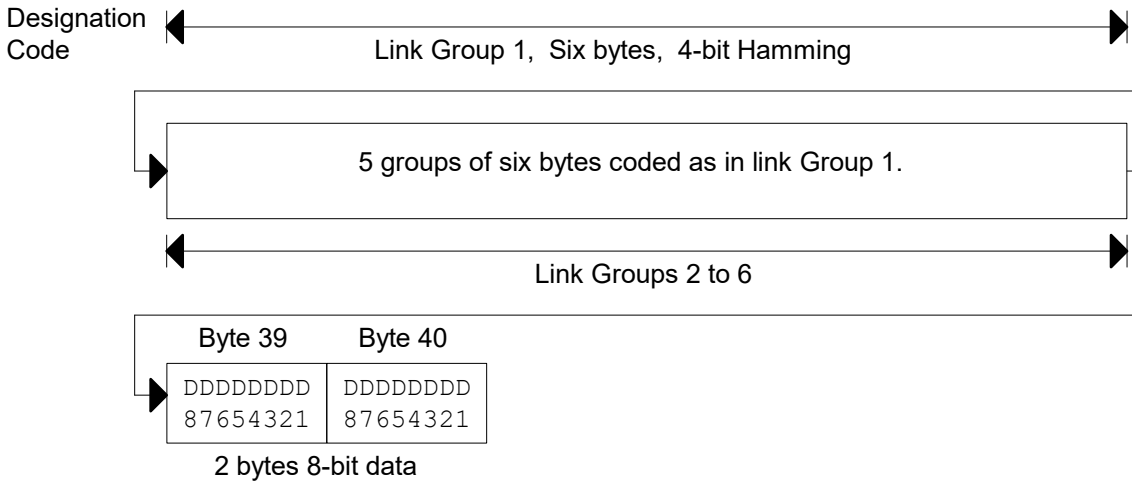

Packet 28/29 Protocol

The same protocols are used for packet 28 and 29 as it is used for packet 26 described earlier in this section.

Packet 30 Protocol

Packet 30 will always be stored as 8bit data.

Protocol for Packet 8/30

This is the Broadcast Service Packet. Packet 8/30 is a magazine independent packet that carries broadcast service data. This packet can have up to 16 designation codes, but only two are fully specified by the WSTS. These are the codes X000 (Format 1) and X100 (Format 2). When enabled, the decoder will process the data of these two formats and store it as shown below. If a packet with a different designation code is received, then it will be stored as 8-bit data provided data storage is enabled. In this case if the programmer wants to read processed data, then he must use the processing features of this command.

CF72407 MULTIPAGE

Packet 8/30 Format 1 Unprocessed

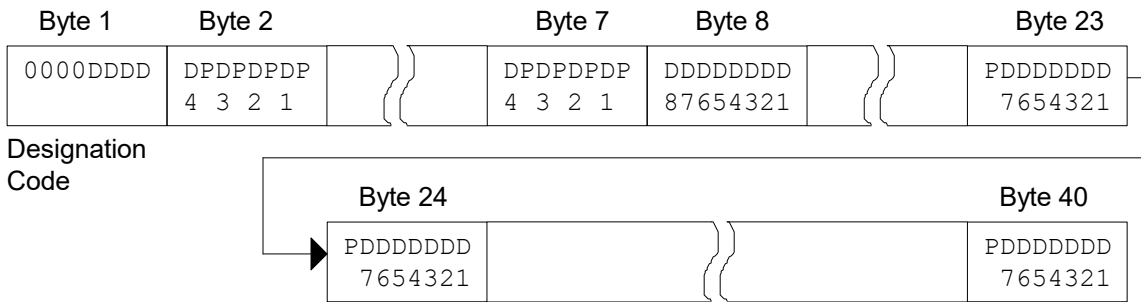

Packet 8/30 Format 1 Processed

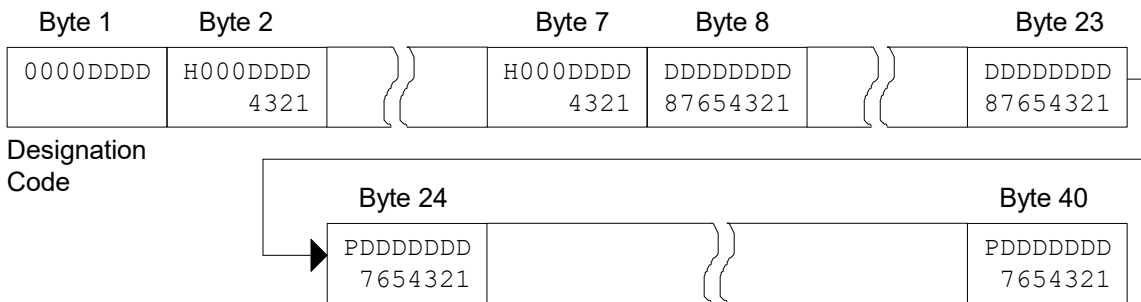

Note: The letter H in the first eight bytes is used to report a Hamming error.

H	
0	No Hamming error was found.
1	Hamming error was found.

Packet 8/30 Format 2 Unprocessed

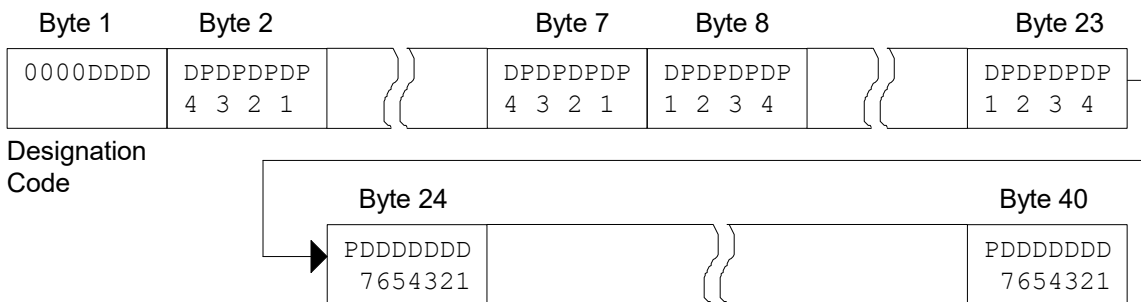

Ghost Row Commands

Packet 8/30 Format 2 Processed

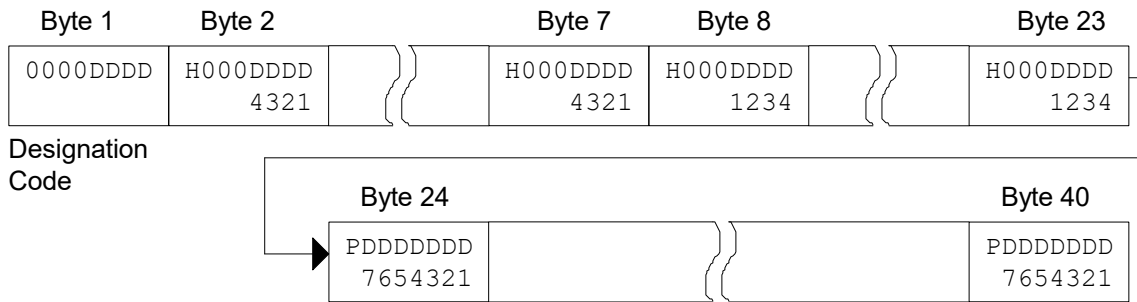

PACKET 26

ALLOCATE MEMORY FOR PACKET 26 TABLES

This command allocates the memory for the packet 26 lookup tables (G2, G3 and Accent table). It also enables packet 26 processing and loads the lookup tables for default Spanish.

Note: *Memory organisation will be changed. This will result in all the Teletext and menu pages, that are currently in memory, being deleted.*

MSB							LSB	
0	0	1	0	0	0	1	R/W	I2C Slave Address R/W = 0
0	0	1	1	0	0	1	1	Command code (0x33)
0	0	1	0	0	0	1	R/W	I2C Slave Address R/W = 1
ST7	ST6	ST5	ST4	ST3	ST2	ST1	ST0	Command Status

Command Status

The command returns the following status codes:

ST[0..7]	Description
00	COMMAND ACCEPTED
01	COMMAND REJECTED Due to an incorrect number of bytes for the command
02	INVALID COMMAND CODE

INITIALISE PACKET 26 TABLES

This command allows the programmer to initialise the packet 26 lookup tables (G2, G3 and Accent table) to default Spanish or to clear the tables.

MSB							LSB	
0	0	1	0	0	0	1	R/W	I2C Slave Address R/W = 0
0	0	1	1	0	0	1	0	Command code (0x32)
0	0	DA	D3	D2	CA	C3	C2	Command option
0	0	1	0	0	0	1	R/W	I2C Slave Address R/W = 1
ST7	ST6	ST5	ST4	ST3	ST2	ST1	ST0	Command Status

Command Options

DA	CA	
0	0	Leave the accent table as it is.
0	1	Clear the Accent table
1	--	Load the accent table with the default Spanish lookup table

D2	C2	
0	0	Leave the G2 lookup table as it is.
0	1	Clear the G2 lookup table
1	--	Load the G2 table with the default Spanish lookup table

D3	C3	
0	0	Leave the G3 lookup table as it is.
0	1	Clear the G3 lookup table
1	--	Load the G3 table with the default Spanish lookup table

Command Status

The command returns the following status codes:

ST[0..7]	Description
00	COMMAND ACCEPTED
01	COMMAND REJECTED Due to an incorrect number of bytes for the command or the packet 26 lookup table memory has not been allocated
02	INVALID COMMAND CODE

LOAD ACCENT TABLE

This command can be used to download a user defined Accent lookup table for the packet 26 processing. It will overwrite the internal used Accent lookup table. The programmer needs to load the lookup table only if he wants to support other countries than the default Spain.

MSB							LSB	
0	0	1	0	0	0	1	R/W	I2C Slave Address R/W = 0
0	0	1	0	1	1	1	1	Command Code (0x2f)
0	0	0	M4	M3	M2	M1	M0	Character Mode
0	C6	C5	C4	C3	C2	C1	C0	Character Code
R7	R6	R5	R4	R3	R2	R1	R0	Replacement Code
.	
.	
0	0	0	M4	M3	M2	M1	M0	Character Mode
0	C6	C5	C4	C3	C2	C1	C0	Character Code
R7	R6	R5	R4	R3	R2	R1	R0	Replacement Code
0	0	1	0	0	0	1	R/W	I2C Slave Address R/W = 1
ST7	ST6	ST5	ST4	ST3	ST2	ST1	ST0	Command Status

Character Code **C[0..7]** is the code of the character that should be replaced by the code of the replacement character. If **C[0..7]** or **M[0..4]** is out of range this triple of **M[0..4]**, **C[0..7]** and **R[0..7]** will be skipped.

If a packet 26 requests the mode **M[0..4] = 0x10** the decoder won't change the character code. Therefore it is not possible to download a mode **M[0..4] = 0x10**.

M[0..4]: 0x11..0x1f
C[0..7]: 0x40..0xff
R[0..7]: 0x00..0xff

Command Status

The command returns the following status codes:

ST[0..7]	Description
00	COMMAND ACCEPTED
01	COMMAND REJECTED Due to an incorrect number of bytes for the command
02	INVALID COMMAND CODE

LOAD G2 LOOKUP TABLE

This command can be used to download a user defined G2 lookup table for the packet 26 processing. It will overwrite the internal used G2 lookup table. The programmer needs to load the lookup table only if he wants to support other countries than the default Spain.

MSB							LSB	
0	0	1	0	0	0	1	R/W	I2C Slave Address R/W = 0
0	0	1	1	0	0	0	0	Command Code (0x30)
0	C6	C5	C4	C3	C2	C1	C0	Character Code
R7	R6	R5	R4	R3	R2	R1	R0	Replacement Code
.	
.	
0	C6	C5	C4	C3	C2	C1	C0	Character Code
R7	R6	R5	R4	R3	R2	R1	R0	Replacement Code
0	0	1	0	0	0	1	R/W	I2C Slave Address R/W = 1
ST7	ST6	ST5	ST4	ST3	ST2	ST1	ST0	Command Status

Character Code **C[0..7]** is the code of the character that should be replaced by the code of the replacement character. If **C[0..7]** is out of range this couple of **C[0..7]** and **R[0..7]** will be skipped

C[0..7]: 0x20..0xff

R[0..7]: 0x00..0xff

Command Status

The command returns the following status codes:

ST[0..7]	Description
00	COMMAND ACCEPTED
01	COMMAND REJECTED Due to an incorrect number of bytes for the command
02	INVALID COMMAND CODE

LOAD G3 LOOKUP TABLE

This command can be used to download a user defined G3 lookup table for the packet 26 processing. It will override the internal used G3 lookup table. The programmer needs to load the lookup table only if he wants to support other countries than the default Spain.

MSB							LSB	
0	0	1	0	0	0	1	R/W	I2C Slave Address R/W = 0
0	0	1	1	0	0	0	1	Command Code (0x31)
0	C6	C5	C4	C3	C2	C1	C0	Character Code
R7	R6	R5	R4	R3	R2	R1	R0	Replacement Code
.	
.	
0	C6	C5	C4	C3	C2	C1	C0	Character Code
R7	R6	R5	R4	R3	R2	R1	R0	Replacement Code
0	0	1	0	0	0	1	R/W	I2C Slave Address R/W = 1
ST7	ST6	ST5	ST4	ST3	ST2	ST1	ST0	Command Status

Command Options

Character Code **C[0..7]** is the code of the character that should be replaced by the code of the replacement character. If **C[0..7]** is out of range this couple of **C[0..7]** and **R[0..7]** will be skipped

C[0..7]: 0x20..0xff
R[0..7]: 0x00..0xff

Command Status

The command returns the following status codes:

ST[0..7]	Description
00	COMMAND ACCEPTED
01	COMMAND REJECTED Due to an incorrect number of bytes for the command
02	INVALID COMMAND CODE

FLOF

REPORT FLOF LINKS

This command will report the **FLOF** links of the requested page. The decoder will reject the command if the requested page has not been enabled for capture or, no data has been received so far or the page number is outside its specified range.

I2C-bus command format

MSB				LSB				
0	0	1	0	0	0	1	R/W	I2C Slave Address R/W = 0
0	0	1	0	0	0	0	1	Command code (0x21)
SUB	0	LNK2	LNK1	LNK0	MAG2	MAG1	MAG0	Magazine and Options
PT3	PT2	PT1	PT0	PU3	PU2	PU1	PU0	Page Number
0	0	STH1	STH0	SH3	SH2	SH1	SH0	Subpage MSB
0	ST2	ST1	ST0	SU3	SU2	SU1	SU0	Subpage LSB
0	0	1	0	0	0	1	R/W	I2C Slave Address R/W = 1
ST7	ST6	ST5	ST4	ST3	ST2	ST1	ST0	Command Status
HAM	0	0	0	0	MAG2	MAG1	MAG0	First Link Magazine
PT3	PT2	PT1	PT0	PU3	PU2	PU1	PU0	
0	0	STH1	STH0	SH3	SH2	SH1	SH0	
0	ST2	ST1	ST0	SU3	SU2	SU1	SU0	
								Links 2 to 5
HAM	0	0	0	0	MAG2	MAG1	MAG0	Last Link Magazine
PT3	PT2	PT1	PT0	PU3	PU2	PU1	PU0	
0	0	STH1	STH0	SH3	SH2	SH1	SH0	
0	ST2	ST1	ST0	SU3	SU2	SU1	SU0	
1	1	1	1	1	1	1	1	Terminator

Command Options

The **LNK[0..2]** bits specifies from which link the decoder should start to report the page numbers.

LNK[0..2]	
0	START REPORT WITH THE FIRST LINK The decoder will start the report with the page number of the first link as specified in packet 27.
1	START REPORT WITH THE SECOND LINK The decoder will start the report with the page number of the second link as specified in packet 27.
2	START REPORT WITH THE THIRD LINK The decoder will start the report with the page number of the third link as specified in packet 27.
3	START REPORT WITH THE FOURTH LINK The decoder will start the report with the page number of the fourth link as specified in packet 27.
4	START REPORT WITH THE FIFTH LINK The decoder will start the report with the page number of the fifth link as specified in packet 27.
5	START REPORT WITH THE SIXTH LINK The decoder will start the report with the page number of the sixth link as specified in packet 27.

SUB	
0	DO NOT REPORT SUBPAGE NUMBER(S) OF THE FLOF LINKS The decoder will omit the subpage numbers from the report protocol e.g. only the magazine, page tens and page units will be sent. With this option the decoder will not perform a Hamming check on the subpage number.
1	REPORT SUBPAGE NUMBER(S) OF THE LINK PAGES The decoder will also report the subpage numbers as shown in the report protocol. If a Hamming error is detected in one of the subpage numbers then the HAM bit will be set too.

Teletext Page Numbers

- MAG[0..2]: Magazine number from 0..7.
- PU[0..3]: Page number units from 0..F(hex).
- PT[0..3]: Page number tens from 0..F(hex).
- SPTH[0..1]: Subpage number thousands from 0..3.
- SPH[0..3]: Subpage number hundreds from 0..F(hex).
- SPT[0..2]: Subpage number tens from 0..7.
- SPU[0..3]: Subpage number units from 0..F(hex).

The subpage number must always be supplied with the command. When a specific subpage is not required then the subpage field in the command should be set to "DON'T CARE". Don't care is indicated by setting the subpage entry to 0x3F7F.

HAM	
0	No Hamming error has been detected on the reported link.
1	A Hamming error has been detected on the reported link.

Command Status

The command returns the following status codes:

ST[0..7]	Description
00	COMMAND ACCEPTED
01	COMMAND REJECTED Due to an incorrect number of bytes for the command.
02	OTHER COMMAND FAILURE The command has been rejected due to reception of an incorrect command code, or Packet 27 of the requested page is not in memory, or The requested page is not enabled for capture.

PDC / VPS

PDC DATA READ

When enabled, the decoders stores 8/30 format 2 packets. Each of the four possible interleave packets will be stored separately. An option given with the command specifies which of the four interleave packets is to be read out. The data is extracted and assembled into the PDC fields before being read out. After a packet has been read out the data is internally marked invalid until the next packet 8/30 format 2 with the same interleave is received. If the command is received during this invalid data period a status code of 5 will be returned.

I2C Command Format

MSB							LSB	
0	0	1	0	0	0	1	R/W	I2C Slave Address R/W = 0
0	0	0	1	0	1	1	0	Command code (0x16)
0	0	0	0	0	0	IL1	IL0	8/30 Interleave
0	0	1	0	0	0	1	R/W	I2C Slave Address R/W = 1
ST7	ST6	ST5	ST4	ST3	ST2	ST1	ST0	Command Status
PI7	PI6	PI5	PI4	PI3	PI2	PI1	PI0	Program Identification
C7	C6	C5	C4	C3	C2	C1	C0	Country Code
0	0	0	D4	D3	D2	D1	D0	Day
0	0	0	0	M3	M2	M1	M0	Month
0	0	0	H4	H3	H2	H1	H0	Hour
0	0	MN5	MN4	MN3	MN2	MN1	MN0	Minute
PCS3	PCS2	PCS1	PCS0	?	?	?	?	PDC Byte 5
PTY7	PTY6	PTY5	PTY4	PTY3	PTY2	PTY1	PTY0	Program Type

Command Options

The Option IL[0..1] specifies which of the four interleave packets to read.

IL1	IL0	
0	0	Read packet with interleave LCI = 0
0	1	Read packet with interleave LCI = 1
1	0	Read packet with interleave LCI = 2
1	1	Read packet with interleave LCI = 3

Returned Data

PI[0..7]: The programme identification as extracted from CNI b9 to b10 and CNI b11 to b16.

C[0..7]: The country code as extracted from CNI b1 to b8.

- D[0..4]:** Day as extracted from PIL b1 to b5.
- M[0..3]:** Month as extracted from PIL b6 to b9.
- H[0..4]:** Hour as extracted from PIL b10 to b14.
- MN[0..5]:** Minute as extracted from PIL b15 to b20.
- PCS[0..1]:** Status of analogue sound PCS b1 to b2.
- PTY[0..7]:** Programme type as extracted from PTY b1 to b7.

Command Status

The command returns the following status codes:

ST[0..7]	Description
00	COMMAND ACCEPTED
01	COMMAND REJECTED Due to an incorrect number of bytes for the command.
02	OTHER COMMAND FAILURE The command has been rejected because packet 8/30 is not enabled for capture or the specified interleave is not valid.
05	PACKET NOT RECEIVED A new packet 8/30 has not been received since the last time the command was last executed

VPS PROCESSED DATA READ

When enabled, the decoders stores VPS packets. The data is extracted and assembled into the VPS fields before being read out. After a packet has been read out the data is internally marked invalid until the next VPS packet is received. If the command is received during this invalid data period a status code of 5 will be returned.

I2C Command Format

MSB							LSB	
0	0	1	0	0	0	1	R/W	I2C Slave Address R/W = 0
0	0	0	0	1	0	0	1	Command code (0x09)
0	0	1	0	0	0	1	R/W	I2C Slave Address R/W = 1
ST7	ST6	ST5	ST4	ST3	ST2	ST1	ST0	Command Status
PI7	PI6	PI5	PI4	PI3	PI2	PI1	PI0	Program Identification
0	0	0	0	C3	C2	C1	C0	Country Code
0	0	0	D4	D3	D2	D1	D0	Day
0	0	0	0	M3	M2	M1	M0	Month
0	0	0	H4	H3	H2	H1	H0	Hour
0	0	MN5	MN4	MN3	MN2	MN1	MN0	Minute
PCS3	PCS2	PCS1	PCS0	CNI3	CNI2	CNI1	CNI0	VPS Byte 5
PTY7	PTY6	PTY5	PTY4	PTY3	PTY2	PTY1	PTY0	Program Type

Returnd Data

- PI[0..7]:** The programme identification as extracted from CNI b9 to b10 and CNI b11 to b16.
- C[0..3]:** The country code as extracted from CNI b1 to b8.
- D[0..4]:** Day as extracted from PIL b1 to b5.
- M[0..3]:** Month as extracted from PIL b6 to b9.
- H[0..4]:** Hour as extracted from PIL b10 to b14.
- MN[0..5]:** Minute as extracted from PIL b15 to b20.
- PCS[0..1]:** Status of analoge sound PCS b1 to b2.
- CNI[0..3]:** Vps Enhancment functions.
- PTY[0..7]:** Programme type as extracted from PTY b1 to b7.

Command Status

The command returns the following status codes:

ST[0..7]	Description
00	COMMAND ACCEPTED
01	COMMAND REJECTED Due to an incorrect number of bytes for the command.
05	PACKET NOT RECEIVED A new VPS packet has not been received since the last time the command was last executed

VPS COMPATIBLE DATA READ

This command provides a VPS interface that provides the data in the same format as existing one chip VPS decoders. After a packet has been read out the data is internally marked invalid until the next VPS packet is received. If the command is received during this invalid data period a status code of 5 will be returned.

I2C Command Format

MSB							LSB	
0	0	1	0	0	0	1	R/W	I2C Slave Address R/W = 0
0	0	0	1	0	0	1	1	Command code (0x13)
0	0	1	0	0	0	1	R/W	I2C Slave Address R/W = 1
ST7	ST6	ST5	ST4	ST3	ST2	ST1	ST0	Command Status
D7	D6	D5	D4	D3	D2	D1	D0	VPS Byte 11
D7	D6	D5	D4	D3	D2	D1	D0	VPS Byte 12
D7	D6	D5	D4	D3	D2	D1	D0	VPS Byte 13
D7	D6	D5	D4	D3	D2	D1	D0	VPS Byte 14
D7	D6	D5	D4	D3	D2	D1	D0	VPS Byte 5
D7	D6	D5	D4	D3	D2	D1	D0	VPS Byte 15

Command Status

The command returns the following status codes:

ST[0..7]	Description
00	COMMAND ACCEPTED
01	COMMAND REJECTED Due to an incorrect number of bytes for the command.
05	PACKET NOT RECEIVED A new VPS packet has not been received since the last time the command was last executed

VPS RAW DATA READ

It is possible to read out the VPS data exactly as it is stored in memory. This allows access to parts of the VPS data that is currently not relevant to PDC. The command also gives access to the second field VPS line.

I2C Command Format

MSB				LSB				
0	0	1	0	0	0	1	R/W	I2C Slave Address R/W = 0
0	0	0	0	1	1	1	1	Command code (0x0F)
0	SFP	0	0	B3	B2	B1	B0	Command Options
0	0	1	0	0	0	1	R/W	I2C Slave Address R/W = 1
ST7	ST6	ST5	ST4	ST3	ST2	ST1	ST0	Command Status
E0	E1	E2	E3	D3	D2	D1	D0	VPS Nibble 0
E0	E1	E2	E3	D3	D2	D1	D0	VPS Nibble n

Command Options

SPF	
0	Read VPS packet from the first field.
1	Read VPS packet from the second field.

B[0..3]: Specifies the VPS packet byte from which reading is to start.

Returned Data

Each VPS byte is returned as two consecutive nibbles. Each nibbles contains four data bits and the corresponding four error bits.

D[0..3]: Data bits.
E[0..3]: Error bits.

Command Status

The command returns the following status codes:

ST[0..7]	Description
00	COMMAND ACCEPTED
01	COMMAND REJECTED Due to an incorrect number of bytes for the command.
05	PACKET NOT RECEIVED A new VPS packet has not been received since the last time the command was last executed

MISCELLANEOUS

POWER ON RESET

On power up or after a power failure, the reset logic of the decoder will initialise the system to its default state, overwriting any previous system configuration. The reset logic will perform the following:

- Clear the page acquisition table.
- Disable Ghost row reception.
- Clear the TOP table found flag.
- Delete all character set tables and all menu pages from memory.
- Switches the display processor (VDP) to picture mode.
- Initialise the PLL configuration registers to their default values.

SOFTWARE RESET

When this command is received, the decoder will initialise all internal registers and pointers in the same way as it is done when a hardware reset occurs, except that the power on reset flag will not be set. This flag is located in the System Status register. On reset the decoder will perform the following:

- All registers will be set to their initial value.
- All allocated menu pages will be released. If required afterwards they must be reloaded before Teletext reception is enabled. This is because any memory allocation command will destroy the memory organisation of the Teletext pages that is currently in use.
- The page acquisition table will be cleared. This has the consequence that all Teletext pages, which are stored in memory, are lost.
- All external allocated character sets will be released. If a character set is required later then it must be allocated and restored. This is because any memory allocation command will destroy the memory organisation of the Teletext pages that is currently in use.

I2C-bus command format

MSB							LSB	
0	0	1	0	0	0	1	R/W	I2C Slave Address R/W = 0
0	0	0	1	0	1	0	0	Command code (0x14)
0	0	1	0	0	0	1	R/W	I2C Slave Address R/W = 1
ST7	ST6	ST5	ST4	ST3	ST2	ST1	ST0	Command Status

Command Status

The command returns the following status codes:

ST[0..7]	Description
00	COMMAND ACCEPTED
02	INVALID COMMAND CODE

TELETEXT RECEPTION ENABLE

Enables Teletext reception. Teletext reception is automatically enabled after reset.

I2C-bus command format

MSB							LSB	
0	0	1	0	0	0	1	R/W	I2C Slave Address R/W = 0
0	0	1	1	0	1	0	1	Command code (0x35)
0	0	1	0	0	0	1	R/W	I2C Slave Address R/W = 1
ST7	ST6	ST5	ST4	ST3	ST2	ST1	ST0	Command Status

Command Status

The command returns the following status codes:

ST[0..7]	Description
00	COMMAND ACCEPTED
02	INVALID COMMAND CODE

TELETEXT RECEPTION DISABLE

Disables Teletext reception until a 'Teletext Reception Enable' command is received or the device is reset.

I2C-bus command format

MSB							LSB	
0	0	1	0	0	0	1	R/W	I2C Slave Address R/W = 0
0	0	1	1	0	1	1	0	Command code (0x36)
0	0	1	0	0	0	1	R/W	I2C Slave Address R/W = 1
ST7	ST6	ST5	ST4	ST3	ST2	ST1	ST0	Command Status

Command Status

The command returns the following status codes:

ST[0..7]	Description
00	COMMAND ACCEPTED
02	INVALID COMMAND CODE

SELECT TELETEXT MODE

This command is used to set extended Teletext mode operations, NORMAL, FLOF or TOP processing.

Normal Teletext Operation

This is the default Teletext mode. All pages must be enabled or disabled for (from) capture by the micro controller. Flof mode is disabled and any TOP tables are deleted from memory.

FLOF Mode Operation

The decoder will perform all actions as required for the implemented FLOF system described in APPENDIX B. All the page capture and link processing will be done automatically by the decoder.

TOP Mode Operation

The decoder provides basic support functions for TOP. The Basic TOP table(s) will be automatically enabled and captured. Depending on the MPT and AIT control bits the decoder will also process the link information received with the Basic-TOP-Table and enable the Multipage and/or Additional Information Table(s) for capture automatically.

I2C-bus command format

MSB						LSB		
0	0	1	0	0	0	1	R/W	I2C Slave Address R/W = 0
0	0	0	0	0	0	1	1	Command code (0x03)
MPT	AIT	0	0	0	0	Tm1	Tm0	Command Options
0	0	1	0	0	0	1	R/W	I2C Slave Address R/W = 1
ST7	ST6	ST5	ST4	ST3	ST2	ST1	ST0	Command Status

Teletext Mode Selection

The control bits TM[0..1] specify the required Teletext mode.

TM1	TM0	
0	0	NORMAL TELETEXT OPERATION The decoder will disable all TOP pages (Basic TOP Table, Multipage Table and all Additional information Tables) in the page acquisition table and it also will disable the FLOF mode.
0	1	FLOF MODE This option will start FLOF operation.
1	0	TOP MODE This option will start TOP operation.
1	1	Reserved for future use.

Note: TOP and FLOF can both be enabled at the same time, e.g. the CF72407 will then support a shared TOP and FLOF system.

Multipage and Additional Information Table Control

The additional control bits MPT and AIT force the decoder to enable and process the Multipage and Additional Information Table(s) automatically when they are received.

MPT	
0	Multipage Table reception is disabled.
1	The decoder will enable, process and store the Multipage Table automatically.

AIT	
0	Additional Information Table reception is disabled.
1	The decoder will enable, process and store the Additional Information Table automatically.

DECODER STATUS

Reports the System status flags.

Optionally the Power on Reset bit, the Ghost row flags, the Top Table Update flag and the display page update bit can be cleared with the same command.

I2C-bus command format

MSB							LSB	
0	0	1	0	0	0	1	R/W	I2C Slave Address R/W = 0
0	0	0	1	0	1	0	1	Command code (0x15)
CNM	0	0	CBBTT	CTOP	CLRES	CLRUP	CLRP	Command Options
0	0	1	0	0	0	1	R/W	I2C Slave Address R/W = 1
ST7	ST6	ST5	ST4	ST3	ST2	ST1	ST0	Command Status
D15	D14	D13	D12	D11	D10	D9	D8	Memory Size
D7	D6	D5	D4	D3	D2	D1	D0	
								System Status 1
								System Status 2
								System Status 3
								System Status 4
								System Status 5

Command Status

The command returns the following status codes:

ST[0..7]	Description
00	COMMAND ACCEPTED
01	COMMAND REJECTED Due to an incorrect number of bytes for the command
02	INVALID COMMAND CODE

Command Options

CNM	Description
0	Do not clear the NOMEM bit after the current state of it has been reported.
1	Clear the NOMEM bit after the current state has been reported.

MISCELLANEOUS Commands

CLRES	
0	The state of the RESET bit remains unchanged.
1	Clear the RESET bit after the current state has been reported.

CLRUP	
0	The state of the UPDATE bit remains unchanged.
1	Clear the UPDATE bit in status byte 1 after the current state has been reported.

CLRP	
0	No function.
1	The decoder will clear all bits of the status byte 3 and the TOP bit in status byte 1 as well.

CTOP	
0	The state of the TOP control bit remains unchanged.
1	The decoder will clear the TOP bit in status byte 1 after its current status has been reported.

CBTT	
0	The state of the BTTUPD flag remains unchanged.
1	The decoder will reset the BTTUPD bit in status byte 1 after it has reported the current status.

Free Memory

The content of these two bytes will specify how much memory is currently free. It will be reported as a number of free rows, where one row represents 40 bytes of free memory.

D[0..15]: The number of free rows that are currently available in the memory. One row consists of 40 bytes. D0 is being the LSB.

System Status Byte 1

The figure below shows the bit map and the state of the individual bits after a hardware reset (power on or power fail).

NOMEM	IVTP	GTXTEN	BTTUPD	TOP	RESET	UPDATE	SERIAL
0	0	--	0	0	1	0	0

GTXTEN	
0	Teletext reception has been disabled by the decoder.
1	Teletext reception is enabled.

UPDATE	
0	The update bit in the header row of the currently displayed page has not been set since it has been cleared the last time.
1	The update bit in the header row of the currently displayed page was set.

RESET	
0	No power on reset or power fail has occurred since this bit was cleared.
1	A power on reset or power fail occurred. Thus the decoder was reset by the hardware and it has initialised all registers to their default values. The decoder will clear this bit when the CLRES bit is set to zero in the command option byte.

TOP	
0	No TOP tables seen so far.
1	The decoder has received at least one of the Basic Top Tables (page number YF0). Y stands for magazine 1..8.

BTTUPD	
0	None of the Basic Top Tables have been updated.
1	At least one of the Basic Top Tables have been updated. The decoder will set this bit whenever it recognises that the update code (subpage tens) has changed.

SERIAL	
0	The decoder operates in a non serial Teletext environment.
1	Serial magazine mode is in use.

IVTP	
0	Inventory page is not enabled.
1	Inventory page is enabled.

NOMEM	
0	Memory is not full.
1	Memory overflow occurred.

System Status Byte 2

The figure below shows the bit map and the state of the individual bits after a hardware reset (power on reset or power fail).

0	GHR	HDR	HELD	PALSIG	STD	GOOD	DOTEXT
	1	--	--	--	--	--	--

DOTEXT	
0	The quality of the composite Sync is so bad that Teletext reception has been terminated. This will prevent the decoder from copying corrupted data into memory.
1	The quality of the composite Sync is good. Thus the decoder has enabled Teletext reception.

GOOD	
0	The quality of the received composite Sync is so bad that the PLL cannot lock to it. Therefore the PLL has been switched to free run mode. The PLL will lock again when the signal quality crosses the internally specified threshold. Teletext reception will be disabled long before the PLL has lost synchronisation. <i>Note: This condition cannot occur when slave Sync mode has been enabled. Therefore the GOOD bit will always be set in slave Sync mode.</i>
1	The quality of the applied composite Sync is good. Therefore the PLL will lock to the composite Sync.

Standard Sync

The decoder will detect phase jumps on the line Sync. Normally phase jumps can occur when the video is coming from a VCR. The VCR specification allows phase jumps of about 1.5us. When the decoder detects a phase jump of greater than 1.5us on more than 25 continues fields then it will reset the **STD** bit.

STD	
0	The decoder has detected a phase jump.
1	The decoder has not detected a phase jump.

*Note: The phase jump detection does not work when slave Sync mode has been selected. Therefore the bit **STD** will always be set to 1.*

PAL / NTSC Detection

The decoder will automatically detect whether a **PAL** or **NTSC** compatible composite Sync signal has been applied to the device pin **CSYNC**. This will be flagged by the **PALSIG** bit.

PALSIG	
0	The Sync signals fed into the decoder conforms to the NTSC (525 line) standard.
1	The Sync signals fed into the decoder conforms to the PAL (625 line) standard.

*Note: The system programmer must be aware that the state of **PALSIG** will be ambiguous when the bit **DOTEXT** is set to zero.*

HELD	
0	The display page is not in HOLD MODE e.g. the decoder will update the display page whenever the selected Teletext page is transmitted again.
1	The display page is on HOLD. The decoder will only update the time.

HDR	
0	Header is not rolling
1	The decoder is searching for a Teletext page and the header is currently being rolled

GHR	
0	NO ROLLING HEADER With the exception of the time portion of the header, this option will disable the rolling of the header when the decoder is searching for a page.
1	ROLLING HEADER Whenever the decoder is searching for a page, it will display a rolling header.

System Status Byte 3

This status byte contains information on whether or not a particular Ghost row has been seen in the transmission cycle. When the decoder receives a Ghost row then it will set the appropriate packet flag.

Note: *The decoder will not reset these flags. The programmer can do this when he sets the **CLRP** bit in the command option byte. The programmer should be aware that the status he will receive reflects only the situation since the last time these bits were cleared.*

The figure below shows the bit map and the state of the individual bits after a hardware reset (power on or power fail).

P8/30	P30	P29	P28	P27	P26	P25	P24
0	0	0	0	0	0	0	0

P24	
0	No packet 24 has been received so far.
1	Packet 24 has been received.

P25	
0	No packet 25 has been received so far.
1	Packet 25 has been received.

P26	
0	No packet 26 has been received so far.
1	Packet 26 has been received.

P27	
0	No packet 27 has been received so far.
1	Packet 27 has been received. The master controller can decide whether or not FLOF mode should be invoked.

P28	
0	No packet 28 has been received so far.
1	Packet 28 has been received

P29	
0	No packet 29 has been received so far.
1	Packet 29 has been received.

P30	
0	No packet 30 has been received so far.
1	Packet 30 has been received.

P8/30	
0	No packet 8/30 has been received so far.
1	Packet 8/30 is in the transmission cycle.

System Status Byte 4

This status byte contains information on the validity of the stored VPS/PDC data.

VPSSEEN	VPSOK	PDCOK	--	--	--	--	--
0	0	0	--	--	--	--	--

VPSSEEN	
0	No VPS packets received.
1	At least one VPS line 16 packet has been received.

VPSOK	
0	No VPS packets
1	At least one VPS packet is stored in memory.

PDCOK	
0	No 8/30 format 2 packets
1	At least one format 2 8/30 packet is stroed in memory.

System Status Byte 5

Pll field bit. FIELD is a direct output from the internal Pll hardware, it will toggle on each successive field.

FIELD	--	--	--	--	--	--	--
--	--	--	--	--	--	--	--

CHANNEL CHANGE

The change channel command indicates to the decoder that the Source of the Teletext signal has changed. Upon receiving this command the decoder performs the following actions:

- Resets the decoder memory and clears the Teletext page acquisition table
- Closes the display page if a Teletext page is currently being received
- Clears the Display page
- Reinitialises the FLOF system
- Selects page 100 to the display page
- Reinitialises the Decoder status registers one and decoder status register three

I2C Command Format

MSB							LSB	
0	0	1	0	0	0	1	R/W	I2C Slave Address R/W = 0
0	0	1	0	1	1	0	1	Command code (0x2d)
0	0	1	0	0	0	1	R/W	I2C Slave Address R/W = 1
ST7	ST6	ST5	ST4	ST3	ST2	ST1	ST0	Command Status

Command Status

The command returns the following status codes:

ST[0..7]	Description
00	COMMAND ACCEPTED
01	COMMAND REJECTED Due to an incorrect number of bytes for the command
02	INVALID COMMAND CODE

CHANNEL CHANGE (NON-DESTRUCTIVE)

This command is almost identical to the previous command, except for the way Teletext pages are initialised. In the previous command a destructive initialisation is performed which deletes all the Teletext pages and their entries in the acquisition table. This command will delete all the pages from memory but will leave all the entries in the acquisition table intact.

I2C Command Format

MSB							LSB	
0	0	1	0	0	0	1	R/W	I2C Slave Address R/W = 0
0	0	1	0	0	1	1	1	Command code (0x27)
0	0	1	0	0	0	1	R/W	I2C Slave Address R/W = 1
ST7	ST6	ST5	ST4	ST3	ST2	ST1	ST0	Command Status

Command Status

The command returns the following status codes:

ST[0..7]	Description
00	COMMAND ACCEPTED
01	COMMAND REJECTED Due to an incorrect number of bytes for the command
02	INVALID COMMAND CODE

CHANGE TELETEXT BUFFER SIZE

Used to change the size of the Teletext receive buffer. The default value is 48 rows.

Note: This command affects the memory organisation

I2C Command Format

MSB							LSB	
0	0	1	0	0	0	1	R/W	I2C Slave Address R/W = 0
0	0	1	0	1	0	0	0	Command code (0x28)
R7	R6	R5	R4	R3	R2	R1	R0	Rows
0	0	1	0	0	0	1	R/W	I2C Slave Address R/W = 1
ST7	ST6	ST5	ST4	ST3	ST2	ST1	ST0	Command Status

Command Options

R[0..7]: 0x10..0xff, New size of Teletext receive buffer in rows.

Command Status

The command returns the following status codes:

ST[0..7]	Description
00	COMMAND ACCEPTED
01	COMMAND REJECTED Due to an incorrect number of bytes for the command
02	INVALID COMMAND CODE

INITIALISE PALETTE

Initialise palette loads the palette buffer with the default Teletext Level 1 colours. The palette buffer will then be copied to the palette hardware the next time a Teletext page or a Menu page is displayed.

I2C Command Format

MSB							LSB	
0	0	1	0	0	0	1	R/W	I2C Slave Address R/W = 0
0	0	1	0	1	0	1	0	Command code (0x2A)
0	0	1	0	0	0	1	R/W	I2C Slave Address R/W = 1
ST7	ST6	ST5	ST4	ST3	ST2	ST1	ST0	Command Status

Command Status

The command returns the following status codes:

ST[0..7]	Description
00	COMMAND ACCEPTED
01	COMMAND REJECTED Due to an incorrect number of bytes for the command
02	INVALID COMMAND CODE

APPENDIX A

THE PAGE PRIORITY SYSTEM

The Multipage Teletext decoder includes a simple page priority system that enables the decoder to recover automatically from memory overflow situations. It does this by continually deleting the lowest priority pages until there is enough free memory to store all the remaining pages. Associated with each Teletext page within the decoder is a 16 bit priority number that allows every page to have a unique priority value. Each of the three enable commands includes a 16 bit priority value that is used to initially set the priority number for the page that is enabled. The enable algorithm is as follows:

```
if
    page already enabled
then
    if
        new priority is higher than old priority
    then
        set page priority to new priority
        for
            all pages in the page table
        do
            if
                page priority less than or equal to the new priority
            then
                increment the page priority number
            end if
        end for
    end if
else
    enable page and set page priority to new priority
    for
        all pages in the page table
    do
        if
            page priority less than or equal to the new priority
        then
            increment the page priority number
        end if
    end for
end if
```

When the decoder is capturing pages and runs out of memory it simply deletes the page with the lowest priority number. When a page is deleted the following algorithm is executed:

```
delete page from memory
for
    all pages in the page table
do
    if
        page priority less than or equal to the deleted pages' priority
    then
        decrement the page priority number
    end if
end for
```

The priority numbers

The page priority number for a page can be **0** or a number between **1** and **2048** where **1** is the highest priority and **2048** the lowest priority. The value **0** is a special case. A page that has a priority value of **0** it will never be deleted from memory, even if the decoder runs out

APPENDIX A - THE PRIORITY SYSTEM

of memory. If a page is enabled with a priority number that is lower than any priority in the page table. The page will be placed at the end of the priority list with the next lowest priority number, which may not be the same as the number received with the command.

APPENDIX B

THE FLOF SYSTEM

The FLOF system on the CF72407 is very simple. When the display changes to a new page the packet 27 links for the page are decoded. The decoded links are then enabled for capture using the page priority system. The red link is enabled with priority one the green link with priority two, the yellow link with priority three, the cyan link with priority four the unused link if it exists with priority five and final the index link is enabled with priority six. If the new link pages already exist in the page table then only the priority number is updated. Using the priority system this way ensures that the latest pages have a high priority and the least recently used pages have the lowest priority. The decoder keeps enabling the FLOF pages using the priority table until the decoder runs out of memory. The priority system will then automatically delete the pages with the lowest priority to make room for the new pages the deleted pages are by definition the least recently used ones. The number of pages that are retained in the memory as the user moves around the FLOF links is only limited by the size of the memory in use.